

Mechanics Department

Engineering
Library

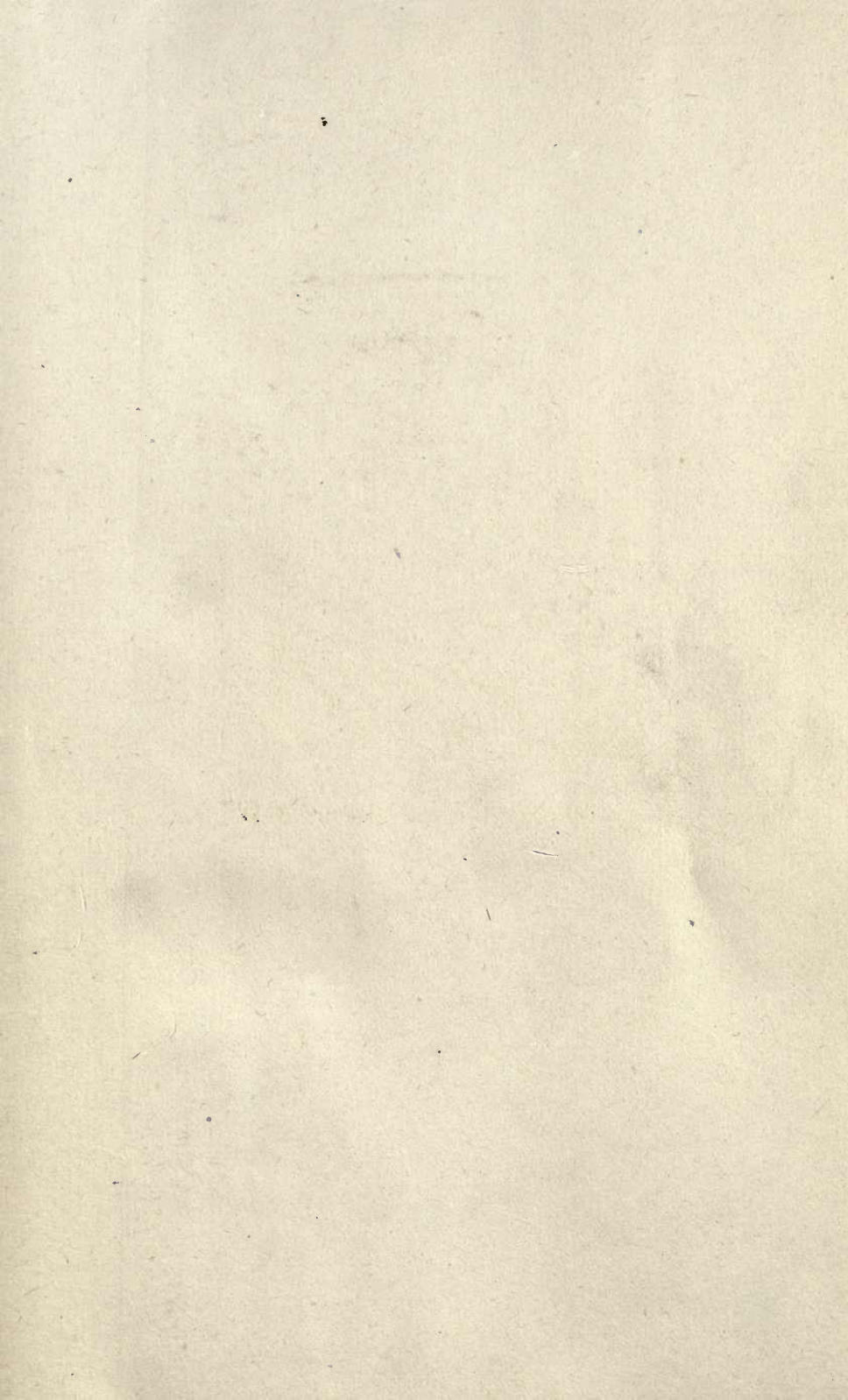



**THE AMERICAN MACHINIST
SHOP NOTE BOOK**

THE AMERICAN MACHINIST SHOP NOTE BOOK

*A Collection of Articles, Written for the American
Machinist by Practical Men, Covering a Wide
Variety of Machine Shop Activities and
Giving the Solutions of Problems that
have Arisen in Machine Shops
the World Over*

COMPILED BY

E. A. SUVERKROP

*Associate Editor American Machinist,
Member A. S. M. E.*

FIRST EDITION

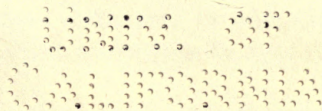

PUBLISHED BY

AMERICAN MACHINIST

MCGRAW-HILL BOOK COMPANY, INC.

SOLE SELLING AGENTS

239 WEST 39TH STREET, NEW YORK

1919

TJ1165

S75

Engineering
Library

COPYRIGHT, 1919, BY THE
McGRAW-HILL COMPANY, INC.

TO THE
LIBRARY OF THE
McGRAW-HILL COMPANY, INC.

PREFACE

Many of the kinks shown in this book are from your own pen or from the pens of men you have known and worked with. They are the solutions of problems similar to those that you and I and all other mechanical men bump into. Few of us have access to a file of the *American Machinist*, but even when such a file is within reach it is often difficult to find what is wanted. The object of this kink-book is to preserve in permanent and accessible form selected articles covering work performed on various machine tools.

A book like this is of twofold value :

First—It shows exactly how a certain specific job was successfully accomplished. Unfortunately it is seldom that the other man's device or method can be used by others exactly as it was used by him. Either the work itself is somewhat different or the shop equipment is not the same. Only where all the conditions are similar can we use the other man's device in its entirety for our work.

Second—To a far greater degree is such a book valuable because of what it suggests. This function of suggestion is limited only by the ability and resourcefulness of those who find their suggestions here. A kink here elaborated in connection with a milling machine may with slight alterations be applicable to the lathe, drill press or planer.

The field of machine-shop work is so wide that no book can cover it, but the experiences gathered in this compilation can be of great assistance to the ingenious mechanic in suggesting a way out of his troubles.

THE COMPILER

CONTENTS

Section 1

DRAFTING AND DESIGN

	PAGE
KEEPING DOWN EXPENSES IN THE DRAFTING DEPARTMENT	1
THEORETICAL VS. PRACTICAL ACCURACY	3
EFFICIENCY IN SPECIAL-MACHINERY DESIGN	4
MAKING DRAWINGS FOR PATTERNAKER AND MACHINIST	5
CHANGING PART LISTS	7
DRAFTING-TABLE COVER	7
ALLOWANCE FOR CLEARANCE IN CORED HOLES	7
TABLE OF ANGLES FOR DIVIDING CIRCLES AND LAYING OUT POLYGONS	9
PROPORTIONING A BORING BAR FOR MAXIMUM STIFFNESS	10
CHART FOR DETERMINING OF PULLEY CROWN DIMENSIONS	12
CAMS FOR SMALL AUTOMATIC MACHINERY	13
ROLLER BEARINGS IN MACHINE-TOOL DESIGN	13
PACKING FOR EXPORT	17
GRAPHICAL GEOMETRICAL PROGRESSION BY MEANS OF THE SLIDE RULE	18
INFLUENCE OF CENTRIFUGAL FORCE ON THE PULLING POWER OF A BELT	19
BLUEPRINTS FROM PENCILLED TRACINGS	20
SPEEDING UP THE OLD BLUEPRINT MACHINE	21
GUARD FOR DRAWING TABLE	23
BLOTTING OUT DIMENSIONS ON BLUEPRINTS	24
EXTENSION FOR USE IN DRAWING LARGE RADII	24
SIMPLE ELLIPSOGRAPH	25

Section 2

PATTERNS AND FOUNDRY

FUSIBLE METAL FOR SOLDERING	26
PATTERNS FOR WORK WITH PROJECTING MEMBERS	27
BREAKING UP CAR WHEELS	27
TOOL FOR DRIVING BRADS	28
ADVANTAGES OF PLATE PATTERNS	28
CORE BOX DOWEL PINS	30
PATTERNS FOR LARGE BEARING CAPS	31
CASTING A STEEL WORM	32
TURNING SMALL BOSSES FOR USE IN PATTERN WORK	32
RAPPING PLATES FOR PATTERNS	33
A PATTERN PROTECTOR	34
MARKING WOOD PATTERNS FOR THE PURPOSE OF IDENTIFICATION	35
EFFICIENT HERRINGBONE GRATE PATTERNS	36

Section 3

FORGE SHOP, HARDENING AND TEMPERING

	PAGE
STANDARD MARKING FOR DISTINGUISHING THE VARIOUS STEELS	40
FORGED HIGH-SPEED BITS	41
OXYACETYLENE WELDING HIGH-SPEED STEEL TO MACHINE STEEL	41
ARC-WELDING HIGH-SPEED TOOL TIPS	43
ECONOMIZING HIGH-SPEED STEEL WITH THE ELECTRIC BUTT WONDER	44
COST OF WELDED HIGH-SPEED TOOLS	45
BRAZING STELLITE	46
SOME HARDENING KINKS	47
HARDENING HIGH-SPEED STEEL TOOLS	48
HARDENING FORMED HIGH-SPEED CUTTERS	50
REPAIRING A BROKEN CRANKSHAFT	52
REPAIR WORK FOR STEAM-HAMMER PISTONS	55
RECORDING CYLINDER AND PISTON REPAIRS	57
BALL-JOINT PISTON ROD FOR STEAM HAMMER	58
A SPRING-HEATING FURNACE	59
FURNACE FOR OIL-TEMPERING BATH	61
FORGING HIGH-SPEED STEEL	61
BENDING HEAVY PIPE IN THE BLACKSMITH SHOP	63
BENDING SHORT RODS HAVING THREADED ENDS	65
RECLAMATION OF MATERIAL IN THE SHOP	67
ANNEALING HARD SPOTS IN OXYACETYLENE REPAIRS	68
PREVENTING CRACKS IN HARDENING	68
TEMPERING THIN SNAP GAGES	69
BRAZING A BROKEN PAIR OF SCISSORS	70
SHRINKING ON A LARGE SLEEVE	71

Section 4

DRILLING MACHINE

POSITIVELY LOCATED DRILL JIG	73
AN ADJUSTABLE ANGLE IRON	74
MAKING ANGLE-FACED WASHERS	75
AN ADJUSTABLE JIG FOR DRILLING ROUND PIECES	76
CUTTING HOLES IN GLASS	77
A JIG FOR DRILLING STEEL DISKS	79
SMALL MOTOR-DRIVEN DRILLING MACHINE USED FOR TAPPING	80
INCREASING THE SIZE OF A SHELL REAMER	80
ECONOMICAL HIGH-SPEED STEEL COUNTERBORE	81
A RADIUS-CUTTING BORING BAR	82
FIXTURE FOR DRILLING SMALL HOLES	83
BORING ENGINE GUIDES	85
DRILL GIG FOR Y CONNECTIONS	85
REDUCTION HEAD FOR DRILLING MACHINE	86
DRILLING MACHINE MADE INTO A PRESS	87
SPECIAL COUNTERSINKING TOOL	88

CONTENTS

ix

	PAGE
RECESSING TOOL	89
DRILL-CENTERING DEVICE FOR V-BLOCKS	90
MACHINING BEVEL PINIONS	93
SIMPLE DRILLING JIG FOR USE ON A YOKE CASTING	94

Section 5

ENGINE LATHE

THREADING DIAL	96
BREAKAGE OF ROUGHING TOOLS	97
SPHERICAL TURNING WORK	98
A SAFETY LATHE DOG	99
CHUCK WRENCH REPAIRS	99
EMERGENCY FOLLOW REST	100
FACING THE BOSS ON A LARGE CASTING	100
ANGLES FOR SQUARE-THREADING TOOLS	101
FINISH-TURNING WITH STELLITE	102
SELF-CENTERING WORK CARRIER FOR USE IN A STEADYREST	103
QUICK REPAIR FOR TAIL SPINDLE OF LATHE	104
QUICK METHOD OF THREADING SMALL CAST-BRASS RINGS	105
IMPROVED LATHE CENTERS	106
CUTTING COARSE-PITCH SCREWS	107
CUTTING A WORM OF RAPID LEAD	108
NONSLIP EXPANDING MANDREL	109
SETTING A TAPER ATTACHMENT BY MEANS OF A DIAL INDICATOR	111
ABC-FORMING ATTACHMENT FOR LATHE AND SHAPER	111
OLD LATHE USED AS A BROACHING MACHINE	113
BROACHING HOLES ON THE LATHE	113
SIMPLE CALCULATION OF CUTTING TIME	115
A FLOATING REAMER HOLDER	115
JIG FOR TURNING ENDS OF SQUARE TOOLS	116
GANG TURNING FIXTURE	117
THREAD-CUTTING TOOL	118
CHUCK FOR NIPPLES AND STUDS	119
CORRECTING UNTRUE CENTER HOLES	119
PISTON-GROOVE SIZING	120

Section 6

THE MILLING MACHINE

TOOL FOR LAYING OUT WORK IN THE MILLING MACHINE	122
CROWNING PULLEY FACES ON THE MILLER	122
AN ADJUSTABLE V-BLOCK	124
DOING A LARGE JOB ON A SMALL MILLING MACHINE	124
THE MILLING-MACHINE VISE AS A SPECIAL MILLING FIXTURE	126
SETTING ANGLE FOR FLUTING TAPER REAMERS	128
POINTER TO SUPPLEMENT TABLE-FEED STOP ON MILLING MACHINE	129
CHART FOR DETERMINING APPROACH FOR MILLING CUTTERS	130

	PAGE
ADJUSTABLE LOCATING BUTTON	130
BORING A HOLE AROUND A CORNER	131
EFFICIENCY IN MILLING FIXTURES	132
AN ADJUSTABLE SIDE-MILLING CUTTER	133
A LATHE JOB ON A MILLING MACHINE	134
CLAMPING FLAT SQUARED WORK	135
ADJUSTABLE BORING-TOOL HOLDER FOR THE MILLING MACHINE	137
MILLING VISE FOR USE BETWEEN CENTERS	137
SETTING TOOL FOR USE WITH MILLING CUTTERS	138

Section 7

PLANER AND SHAPER

REPAIRING OLD PLANING MACHINES	139
A SHAPING MACHINE REPAIR JOB	141
MACHINING A LONG RECTANGULAR HOLE	141
ADJUSTABLE EXTENSION PLANING TOOL	143
A TOOL FOR INTERNAL PLANING	144
RADIUS PLANING TOOL	145
A REPAIR KINK ON A PLANING MACHINE	146
DEVICE FOR HOLDING LARGE JOB ON SHAPING MACHINE	147
CUTTING A NARROW SLOT WITH THE SHAPING MACHINE	148
SQUARING THE ENDS OF SMALL RECTANGULAR PIECES	149
TURNING AND BORING ATTACHMENT	149
DIVIDING ON A LATHE OR SHAPER	150

Section 8

TOOL MAKING

AUXILIARY BUSHING PLATE IN TOOLWORK	151
AN ECONOMICAL COUNTERBORE	154
BUTTONS FOR MEASURING ANGULAR WORK	155
CARTRIDGE-PUNCH TEMPLET	155
MAKING A CIRCULAR FORMING TOOL	156
CASEHARDENED JIG BUSHINGS	158
ADDING LIFE BY TAKING CARE OF A MICROMETER	158
GRINDING PRECISION TOOLS	159
LOCATING HOLES ON CLOSE CENTERS BY MEANS OF SPECIAL BUTTONS	160
A THREAD-GRINDING FIXTURE	161
MAKING A HEIGHT GAGE OUT OF A VERNIER CALIPER	163
A RADIUS TRUING FIXTURE FOR USE ON GRINDING WHEELS	165
ACCURATE SETTING DEVICE FOR INTERNAL GRINDING	166
TRANSFER GAGE FOR PIERCING DIES	168
USEFUL ANGLE PLATE	168

Section 9

DIE AND PRESS WORK

	PAGE
SHEET-METAL WORK	171
LOCATING SMALL HOLES ACCURATELY IN DIE WORK	173
ARRANGEMENT FOR A LARGE COMBINATION DIE	176
A WIRE BENDING DIE	177
PROGRESSIVE DIE FOR RUBBER WASHERS	178
PRODUCING A BULGE IN TUBING	180
MAKING PIERCING PUNCHES	181
PIERCING OPPOSITE SIDES OF THIN SHELLS	182
PRESS KINK FOR BLANKING CLOTH OR OTHER SOFT MATERIAL	183
SPRING-FORMING DIE	184
SOME PRESS-TOOL POINTERS	185
PIERCING OBLIQUE HOLES	188
A FREAK SHELL—ITS CAUSE AND CURE	189
BENDING DIES FOR TUBING	190
SPRING OPERATED PUNCH PILOT	191

Section 10

GAGES

GAGE GRINDING MACHINE	192
SPECIAL V-BLOCK FOR GRINDING WORK	194
DEVICE FOR MEASURING THREAD GAGES	194
PROBLEM IN GAGE TESTING	196
THE USE OF FEELER GAGES	196
ADJUSTABLE FEMALE THREAD GAGE	197
A GAGE FOR DEPTH OF RECESSES	198
FEELER GAGE FOR RECESSES	198
GRINDING CORRECT RADIUS ON A GAGE	198
BUILT-UP LIMIT SNAP GAGE	200
AN AMPLIFYING GAGE	201
INSPECTION GAGE	202
ERRORS IN MEASURING THREAD PITCH DIAMETERS WITH WIRES	203
PLASTER OF PARIS FOR SEALING HOLES IN GAGES	205
GRINDING SNAP GAGES	205

Section 11

GRINDING

KEEPING NOTES ON GRINDING	207
MOUNTING, BALANCING AND DRESSING GRINDING WHEELS	210
SAVING TIME AND ABRASIVE WHEELS	211
GRINDING THE EDGES OF CIRCULAR PLATES	211
WHEELS FOR TOOL AND CUTTER GRINDING	213

	PAGE
GRINDING THIN PIECES	215
RADIUS WHEEL-DRESSING FIXTURE	217
GRINDING A COUNTERSINK IN CHILLED CASTINGS	218
A FIXTURE FOR GRINDING	219
DIAMOND HOLDER FOR NORTON GRINDER	220

Section 12

BORING

PORTABLE CYLINDER-BORING MACHINE	221
A BAR FOR BORING A CHAMBER	224
BORING BAR FOR TORPEDO TUBES	225
BORING TAPER HOLES	225
BORING A 4-FT. HOLE IN AN 18-FT. SHIP CASTING	226
PRODUCTION CHUCK FOR A BORING MILL	229
DRIVING-BOX CHUCK	229
CENTERING WORK WITH GRADUATED WEDGES	233

Section 13

GEARING

DECIMAL-EQUIVALENT TABLE USEFUL IN GEAR WORK	235
INTERMITTENT WORM GEAR	237
FORMULA FOR OBTAINING CUTTING ANGLE OF HELICAL GEARS	238

Section 14

SCREW MACHINE

MACHINING A 5 $\frac{3}{4}$ -IN. PISTON ON A 3 $\frac{1}{4}$ -IN. GRIDLEY AUTOMATIC	239
TIME STUDIES IN SCREW-MACHINE PRACTICE	242
SLOTING AND SHAPING IN THE AUTOMATIC SCREW MACHINE	242
GUARD FOR DEFLECTING COMPOUND	245
TOOL FOR REMOVING BURRS FROM JAM NUTS	245
SENSITIVE TAP AND DIE HOLDER	246
THREAD ROLLING IN THE AUTOMATIC SCREW MACHINE	247
HOLLOW SETSCREW AS AN "ADAPTER"	251

Section 15

SHOP TOOLS, APPLIANCES AND EXPEDIENTS

CONSERVATION VS. EFFICIENCY	253
IMPROVED DRIP CAN FOR HANGERS	254
METHOD OF RECLAIMING WASTE	254
INSTALLING OVERHEAD APPARATUS REDUCES OVERHEAD EXPENSE	255
ECONOMY IN HACKSAW BLADES	256
REPAIRING BELT SHIFTER	257

CONTENTS

xiii

	PAGE
AIR-HOIST PISTON PACKING	257
SECURING CRANE HOOKS	258
POWER DEVICE FOR "SPOTTING-IN" PARTS	259
IMPROVED HALF-ROUND TAPER REAMER	261
HOLDER FOR COUNTERSUNK HEAD BOLTS	261
TAPPING BRONZE FEED NUTS	262
PORTABLE PRONY BRAKE	263
BUSHING A LOOSE PULLEY	264
SURFACE-GAGE KINK	264
OPERATING VALVE FOR PNEUMATIC CHUCKS	264
HANDY TOTE BOX	266
DRILLING THIN STOCK	266
TEMPLET FOR MARKING OFF FLANGES	268
IMPROVED HERMAPHRODITE CALIPER	270
WHITE SURFACE FOR LAYOUT	270
IMPROVED GEAR PULLER	270
BOLTS STUCK IN SOCKET WRENCH IN BOLT-CUTTER	272
DEMAGNETIZING HIGH-SPEED STEEL	272
RAISING THE "VISIBILITY" OF THE OIL HOLES IN SHADOWED POSITIONS	272
A BRAKE FOR HIGH-SPEED MACHINES	273
LENGTH OF BELTING IN COILS	273
EXPANDING AIR CHUCK	274
TUBE-BENDING DEVICE	276
CONCEALED SPRING FOR USE ON A RATCHET PAWL	276
AN EMERGENCY REPAIR JOB	277
OVERCOMING LOOSE-PULLEY TROUBLE ON A SPECIAL DRIVE	279
COOLING A SMALL AIR COMPRESSOR	280
SMALL STUD GEAR FOR ENGINE LATHE	281
OPERATING SIGNAL BELLS FROM A GENERATOR	282
SPEED-REDUCTION DEVICE WITH NOVEL AND VALUABLE FEATURES	283
AN ADJUSTABLE GEAR FOR ELIMINATING BACKLASH	284
ELIMINATING BREAKAGE OF BOLTS ON HIGH-SPEED MACHINERY	285
A PNEUMATIC RAM	285
CUTTING A KEYWAY ON A LARGE PULLEY	287
AN EMERGENCY REAMER	288
CROWNING A LARGE PULLEY	288
WHY BELTS JUMP	289
FASTENING LOCKNUTS	289
KEEPING BELT GLUE IN A BOTTLE	289
PREVENTING GREASE-CUP TROUBLE	290
A MOLD FOR BABBITT HAMMERS	290
FIBER HAMMER	291
COMBINED HARD AND SOFT HAMMER	292
HOW TO KEEP A HAMMER ON THE HANDLE	293
INDEX	295

THE AMERICAN MACHINIST SHOP NOTE BOOK

SECTION I

DRAFTING AND DESIGN

KEEPING DOWN EXPENSES IN THE DRAFTING DEPARTMENT

THE ultimate object of the drafting department is to supply the factory and production departments with drawings or prints, and this should be done accurately and uniformly.

To begin with all drawings should be made in fixed sizes, and if the quantity is large these sizes are generally bought already cut; if not, then drawing paper may be bought in sizes 36 x 48 in. This size of sheet may be used for the layout of the machine or apparatus, but for detailing, smaller sheets are better; the 36 x 48-in. sheet may be divided into two sheets 24 x 36 in., or into four sheets 18 x 24 in. If these sizes are still too big they may be divided again into eight sheets 12 x 18 in. or 16 sheets each 9 x 12 in.

It will be seen that in all these divisions there is no waste paper; therefore, to sum up, one sheet of paper 36 x 48 in. will give two sheets 24 x 36 in., four sheets 18 x 24 in., eight sheets 12 x 18 in. or 16 sheets 9 x 12 in.

The same method applies to tracing cloth, which may be bought in sheets 36 x 48 in. or in rolls 48 in. wide.

Having been asked to cooperate with the supervisor in cutting down the expenses of the drafting department, which had been continually climbing, we found a large amount of layouts and old designs that were made on tan Saxon drawing paper in sizes 36 x 48 in. The other side of the paper was not used and was clean, so we cut up the sheets and used them for detailing, with

the result that we saved six months' supply of paper, and drawing paper at the present time comes high. If a good grade of drawing paper is being used (sized on both sides) save the drawings and use the other side later on.

We also incorporated the charge-up plan for stationery; that is, when a draftsman needs pencils, etc., they are charged against him as a matter of record, which tends to keep the men's wants uniform; also each tries to do with less than his neighbor. At the end of the month the lists are gone over, and it is gratifying to see how evenly the accounts balance—pencils, paper and erasers on the designers' account, and tracing cloth, ink and pens on the tracers' account.

One of the best time savers in the drafting department is a good system of filing prints. Much time is wasted in the drafting department looking for a print that should be on file. Some companies think that installing a filing system for prints is a needless expense. However the first cost is the only expense involved, as after that it only means paying a bright boy or girl to keep the system running right.

Compass lead, while not expensive, is worth saving. In our department we have dispensed with this article and our compass lead is obtained in the following manner: When a draftsman gets a drawing pencil from stock he turns in the stub of the old one, the lead in the stub being about 1 in. long. This stub is cut away and the lead saved, so this is given out for use in the drawing instruments. Lead in most every degree of hardness is collected in this way.

Another item of expense is tracing layouts and detail drawings for experimental work. Most designs undergo extensive changes before they finally go into production, and it is not necessary to have these traced on tracing cloth with ink. Drawings may be sent to the model room, and in order to keep them clean the machinist or model maker may put a piece of glass over the drawing while he is using it. If the model proves satisfactory the pencil drawings may then be traced for manufacturing purposes.

Shading and Cross-Sectioning. In sending out drawings from the drafting department there is a tendency on the part of the draftsman to do a maximum amount of shading and cross-sectioning. This looks very well, but if it detracts from the

accuracy of the drawing it should not be done. I have seen drawings that were perfection as far as display was concerned, but, when assembled, the parts made from these drawings represented a lot of junk.

Leave all fancy work for the display draftsman or the Patent Office draftsman, and send to the factory the correct dimensions rather than beautiful shading.

Many manufacturing plants will not allow cross-sectioning to be done with ink. The tracing is turned over, and all sectioned parts are filled in with black-carbon pencil, which is a faster method. At present, when raw material is so hard to get, the designer should use standard material wherever possible. The difference of a few thousandths of an inch in thickness may mean a month's delay in receiving the raw material at the factory. All manufacturing firms generally send out catalogs of their wares, which should be kept handy for the draftsman's reference.

This rule applies to screws, rivets, bolts, etc. The designer should remember that these are made in standard lengths, and will in all probability work into his design just as well as a special length.

THEORETICAL VS. PRACTICAL ACCURACY

I concede the facility with which theoretical dimensions may be laid down even to the n th decimal degree, but the physical limitations and restrictions in the way of applying these measurements are such as to lead me to doubt their practicability. Prof. Perry in a course of lectures to London workingmen pointed this out when he said: "What is the use of expressing the results of our calculations to the sixth or seventh decimal place, when for all practical purposes the last three or four are useless!" In an article on page 749, Vol. 47, *American Machinist*, on "Uses of the Sine Bar," the author says: "so we set the stud *B*, Fig. 1, 0.20795 higher than the stud *A*." Referring to the illustration we observe that the tool used for determining this measurement is a gage.

Now, is there a vernier upon which it is possible to measure—not estimate—accurately, to less than 0.001 in.?

I do not believe there are many toolmakers who would agree

to set a vernier even to 0.0005 in. and gamble next week's pay envelope on the accuracy of the result.

Assuming that we have a gage capable of being set, and a man capable of reading it to 0.00001 in., there are many other things that must be taken into consideration. In the measurement of angles by the use of the sine bar and plate we must be sure of the accuracy of the sine-bar studs, their relative positions on the bar, the absolute truth of the plates, etc., and must take into account the constant minute changes due to local temperature changes in handling, all of which tend to remove such a job from the scope of a toolroom and place it within that of a laboratory if we are to depend upon the accuracy of the results.

It was stated in a recent issue of the *American Machinist* that an American firm of some size refused an order for gages on the ground that they could not guarantee them to be correct to the fourth place of decimals. This is apt to cause one to wonder if a good deal of the so-called accuracy is not of a doubtful quality; at the same time, in the writer's opinion it points to a high degree of moral courage on the part of that firm, that might be followed by others to their advantage.

EFFICIENCY IN SPECIAL-MACHINERY DESIGN

Where the quantity of parts manufactured will warrant the expense, the special, single-purpose machine is a most important factor in the reduction of manufacturing costs.

Much of the trouble and difference of opinion regarding the correctness of design of machines of this class will be entirely eliminated if suggestions and ideas are solicited from those who are interested in the building of the machines. In this way, an understanding as to what will constitute the best machine for a certain purpose is arrived at before any work is started in the drawing room.

This coöperation will prove of undoubted advantage if the contemplated machine is new in type and there is no previous experience to serve as a guide. Quite often such a machine is started with a full-size or half-size layout that is a puzzle to the shop man who, because of his knowledge of the work that the machine is intended to do, is asked to give an opinion as to its practicality.

The maze of lines on a drawing for a machine of this kind may be clear enough to the designer and to those who have been in touch with it continually, but it will prove perplexing to the average man who is called on to give his opinion in the comparatively short space of time usually allowed for this purpose.

A better way is to start with a preliminary design, either one-eighth or one-quarter size, whichever is considered necessary, this drawing to show only enough lines to convey the general idea of the machine. This design may be submitted for criticism to those directly interested.

A discussion of the matter may change the entire scheme. This preliminary drawing is cheap to begin with and, being stripped of much detail, is readily understood.

MAKING DRAWINGS FOR PATTERNMAKER AND MACHINIST

The following method has been successfully used to provide permanent and complete drawings for both pattern and machine shops at practically no increased cost over the usual method.

The drawing is made in ink on tracing cloth in the regular way, but only such dimensions and notes as are required by the machine shop are filled in.

A vandyke or brown negative print is then made from the tracing. This print is filed as the regular machine-shop tracing, and from it prints are made for the machine shop, as required.

All patternmakers' dimensions and notes are added to the original tracing, from which pattern-shop prints are made when needed.

With this method the machine shop is supplied with positive prints instead of the usual negatives. If, for any reason, this is objectionable, and it is desired to furnish the usual negative print to the machine shop, a positive vandyke may be made from the original negative vandyke and the negative blueprints for the machine shop made from that.

If castings from the same pattern are to be machined to different dimensions, a positive vandyke is made from the original negative, blanking off in the printing all dimensions which are to be changed, as well as drawing numbers, notes, etc., not

needed, even including drawing lines if any are to be changed. The omitted numbers, dimensions, etc., are filled in, and a complete new tracing results at very small expense.

If a comparatively small number of blueprints are required, the vandyke may be made on paper; but if they are to be subjected to considerable handling, they should be made on cloth.

Another way that proves very satisfactory is to make the drawings for the machine shop in ink on tracing cloth, and the sketches for the patternmaker on pencil tracing cloth. The ink tracing has only the dimensions for the machinist, while the pencil tracing contains those for the patternmaker alone.

The pattern sketches are made full size whenever practicable, so that the patternmaker can if necessary scale the blueprints made from the pencil tracings. The drawings for the shop can be reduced to scale, all the machinist's dimensions being put on so that no scaling will be necessary. By this method each workman has the dimensions and notes he needs, and no others to confuse him. The pattern sketches are made directly on the pencil tracing cloth, thereby saving the time for tracing, while for the ink tracings a pencil drawing is first made and then traced on the cloth, unless the piece is simple; in that case it is drawn directly on the cloth in pencil and then inked. Sometimes it is not necessary to make a pattern sketch, because the patternmaker can work from the machinist's blueprint.

Drawings for gages, jigs and fixtures can be made on pencil tracing cloth and the blueprints sent to the shop. This is an easy and rapid way. A pencil tracing is sufficient, because only a few prints will be made. It may, in fact, be used but once, and it is therefore not wise to spend time to make an ink tracing.

Another method is to make the drawings on drawing paper, the drawing then being tacked on a light board and shellacked. When dry, it is ready to be sent to the shop. When returned to the drawing room, the surface is scrubbed with soap and water, the drawing removed from the board and filed away. The pencil tracing method is by far the better of the two for gages, jigs and fixtures. Small drawings can be protected in the shop by slipping them into holders made by bending over three edges of a sheet of tin. The face is covered by thin celluloid.

CHANGING PART LISTS

A scheme that eliminates re-inking the box lines on a tracing of a part list or a bill of material is to have the lettering on the opposite side of the tracing from the box lines. Thus when there is a change, the lettering will be the only inking erased, as the box lines, being on the opposite side of the tracing, are not touched by the eraser.

Care should be taken when the original is traced to see that, when the side with the lines is reversed, the guiding inclosure or box lines of the bill of material or part list will be in the correct positions.

DRAFTING-TABLE COVER

I know of no more convenient cover for the drafting table than a roller shade. It has the great drawback, however, that loose tracings are drawn into the roller occasionally and thus mysteriously disappear. In order to avoid this, I mount the

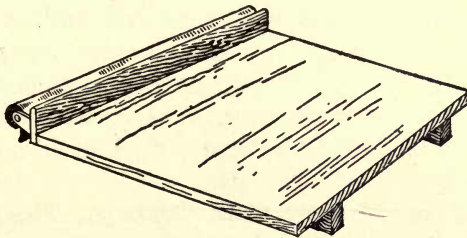

FIG. 1—DRAFTING TABLE COVER

roller shade on a strip of wood about the same length as the table; and this strip of wood I screw on the rear edge of the table. The upper edge of the strip should be from 2 to 3 in. above the top of the table.

ALLOWANCE FOR CLEARANCE IN CORED HOLES

The clearance necessary between certain parts of castings, the conditions that determine the differences in the amount of clearance allowed, can be learned only by blunders in the shops. Very seldom a hard and fast rule can be formulated; experience is the only sure guide.

One of the commonest cases is that of "black" bolts and the holes. It is more costly to drill holes through a considerable depth of solid metal than to core them; hence, the reason of using more often cored holes in preference to black, or turned, bolts in drilled holes. There are sometimes exceptional cases noted of special machines and special work. The general ob-

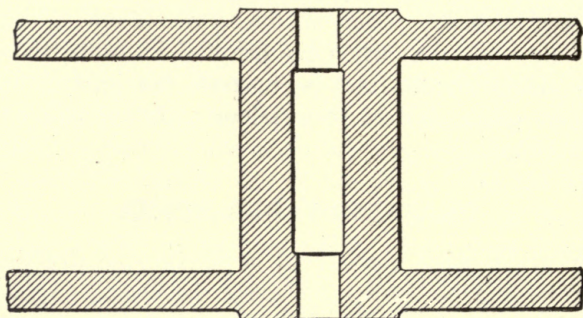

FIG. 2—CHAMBERED CORED HOLE

jection to cored holes is that the inaccuracy makes it impossible to fit the bolts closely in the holes and therefore the holes must be made larger in diameter than the bolts, figuring by the amount of expected inaccuracy. The clearance will vary between $\frac{1}{32}$ and $\frac{1}{8}$ in. or even more, depending entirely on the circumstances.

Length of Cores Important in Castings. The length of the core and the direction of it always have to be considered in deciding the amount of clearance to be given in cored holes; these are the most essential two points. It is easier to core a short hole true than a long one, and to insure exactness of a core set vertically in a mold than that of one laid horizontally and obliquely. For a short core set vertically and stayed with a top print, a slight allowance for clearance will suffice. But even then, with the core box made correctly to size and shape and the prints carefully fixed, the molder must insert the cores very accurately. For these conditions the clearance allowance will be from $\frac{1}{32}$ to $\frac{1}{16}$ in.

For cores of 3 or 4 in. in length, the increase of the allowance must be from $\frac{3}{32}$ to $\frac{1}{8}$ in.; from 4 to 5 in. long would need $\frac{1}{8}$ in. to compensate for inaccuracy of fixing; and when 5 or 6 in. are

exceeded, cores of small diameter cannot be depended on with even $\frac{1}{8}$ in. of clearance, on account of inaccurate setting and the liability of the core to be bent by the flow or pressure of the liquid metal. In cases of long, slender cores the holes should be given a large amount of clearance, or they should be preferably chambered as shown. The diameter of the chamber need not be much greater than that of the clearance hole. If the core becomes bent by the liquid pressure, it will cause no trouble, because it will not affect the short length of the clearance holes at the end. It also lessens the cost of drilling deep holes, as only the end portions need be reamed out.

Horizontal Cores. When holes are cored in horizontal positions, there is a general probability of greater inaccuracy, due to both the setting of the core and its bending, than when they are placed vertically. A horizontal core is almost always placed in pocket prints; and if the diameter does not correspond with the semi-diameter of the lower portion of the print, then the amount of the difference is always on the top side, and the core is set out of truth by that amount. The core will often become moved slightly in the print by reason of the sand having been broken and mended, or pressed and pushed out of place. To insure accuracy in cores set in drop prints, it is well to make a special core box, which will fill up the print impressions over the core, as well as core the actual hole, and to see that the dimensions of print and core coincide exactly, thus leaving to the molder nothing but to insert the core. Horizontal cores of considerable length are more liable than vertical cores to be curved lengthwise by the liquid pressure, as the curving is upward. Therefore, there is more reason why such cores should be chambered.

TABLE OF ANGLES FOR DIVIDING CIRCLES AND LAYING OUT POLYGONS

The following table will be found convenient for the draftsman or toolmaker. It is not included in the most commonly used reference handbooks:

Number of Sides or Segments		Angle	Number of Sides or Segments		Angle
	Deg.	Min.		Deg.	Min.
3	120	0	27	13	20
4	90	0	28	12	51
5	72	0	29	12	24

Number of Sides or Segments		Angle	Number of Sides or Segments		Angle
	Deg.	Min.		Deg.	Min.
6	60	0	30	12	0
7	51	25	31	11	37
8	45	0	32	11	15
9	40	0	33	10	54
10	36	0	34	10	35
11	32	43	35	10	17
12	30	0	36	10	0
13	27	41	37	9	44
14	25	43	38	9	28
15	24	0	39	9	14
16	22	30	40	9	0
17	21	10	41	8	47
18	20	0	42	8	34
19	18	57	43	8	22
20	18	0	44	8	11
21	17	8	45	8	0
22	16	22	46	7	50
23	15	39	47	7	40
24	15	0	48	7	30
25	14	24	49	7	21
26	13	51	50	7	12

PROPORTIONING A BORING BAR FOR MAXIMUM STIFFNESS

In the boring of 8-in. British shells under the severe conditions imposed by forced production, it was necessary to provide the stiffest possible boring bar. No computations for strength were made, as the bar was laid out as large as the space allowed. The first bars were made of steel castings, but it was found that to give the best service they would have to be made of hammered steel.

The difficulty was to get a bar that would bore clear to the end of the nose and yet be rigid enough without obstructing the washing out of the chips.

Fig. 3 shows the bar in three positions in the shell and indicates the points to be observed in the solution of the problem. In the upper figure the bar is seen in place for turning the cylindrical portion; in the second the nose is partly machined. It will be observed that as the tool approaches the center line of the shell the cross-section of the bar at the end of the shell increases and that the outline of the forward side has the same radius as the inside of the nose of the shell. The first bar was laid out with this part of the bar a straight line, but it was evi-

dent that this meant either excessive clearance at some points or interference at others. The best conditions were obtained by curving it as here shown.

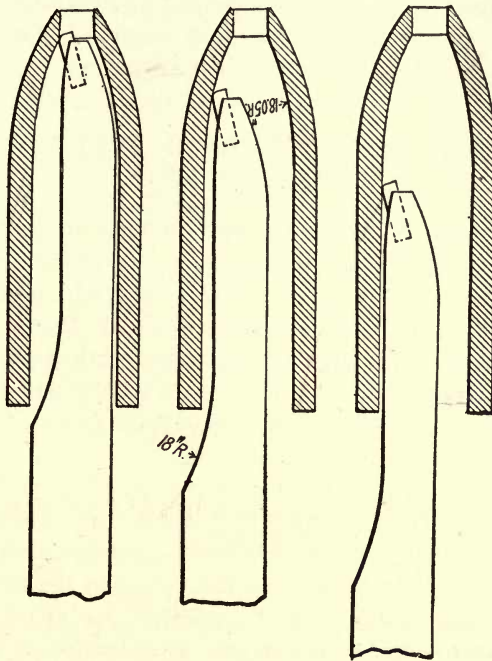

FIG. 3—VARIOUS POSITIONS OF BAR IN SHELL

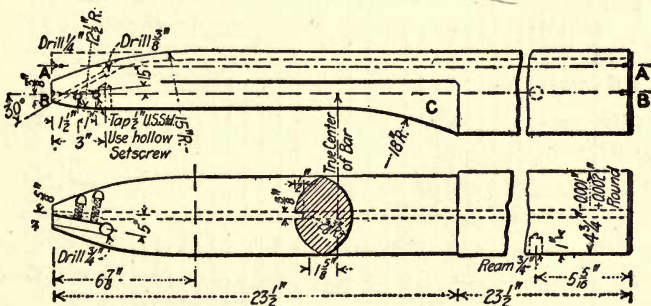

FIG. 4—SHOWING HOW THE BAR WAS MACHINED

In the making of the bar time was saved by first milling away the larger portion of the stock. Next it was suspended on the centers AA, Fig. 4, and the forward side turned, after which it

was transferred to the centers *BB*. To bring the part *C* down to a $2\frac{3}{8}$ -in. radius required handwork to a templet.

The angles of the tool slot are those found best after a lot of experimenting. The cooling compound was carried in a copper tube laid in the milled groove at the rear. This delivered it through the $\frac{1}{4}$ -in. hole to the very tip of the tool.

CHART FOR DETERMINING OF PULLEY CROWN DIMENSIONS

The subject of pulley crowns has been given a great deal of consideration by various authorities, but in every instance it is found impracticable to develop for height of crown a mathematical rule that will give uniform results.

It is noticeable that all rules for determining pulley crowns are given in terms of width of face of pulley and do not consider what is probably an equally important factor, the diameter of the pulley.

A given point on the crown of a pulley will travel farther in making a revolution than a given point at the edge of the rim; and a belt in passing over the pulley either stretches or slips at the edge or at its center line, in conforming to the pulley crown, an amount equal to half the difference of lengths of arc of contact at the crown and at the edge. This amount is proportion-

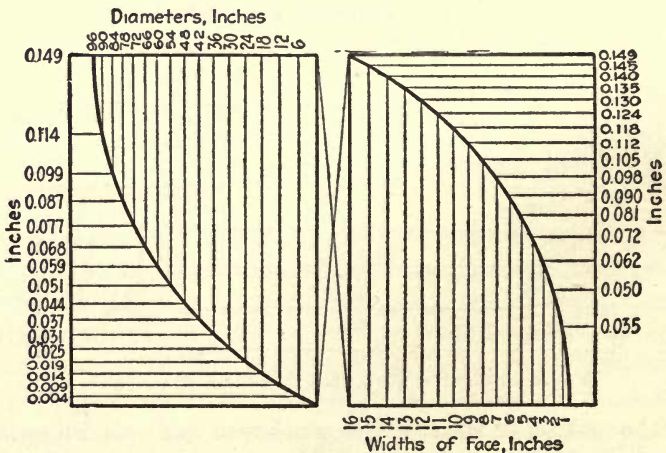

FIG. 5—CHART FOR DETERMINING PROPER CROWN FOR PULLEYS OF VARIOUS DIAMETERS AND WIDTHS

ately greater as the diameter of the pulley becomes smaller and is less as the diameter is increased.

The accompanying diagram Fig. 5 was developed with the diameter as a factor in determining the pulley crown. Referring to the diagram for "Widths of Face," the values given are determined by the relative heights of the ordinates and read direct. The diagram for "Diameter" is the same as that for "Widths of Face" inverted, the values of which are likewise determined by the heights of the ordinates and also read direct.

The sum of the values shown for a pulley of a given face and diameter is the height of the crown for the pulley. For example, required the height of crown a pulley of 48-in. diameter and 5-in. face. Reference to the diagram for 48-in. diameter shows the value 0.044 in., and for 5-in. face a value of 0.081 in. Then $0.044 + 0.081 = 0.125$ in., the height of crown required.

It will be observed that the table eliminates the width of face as a factor at 16-in. width and that diameters are given up to 8 ft. only. Pulleys of greater diameter are usually made for a specific drive, where other factors, such as speed, length of belt, are of contact, etc., can be given their proper consideration in establishing the crown.

CAMS FOR SMALL AUTOMATIC MACHINERY

The proportions Fig. 6 have been used by the writer in designing wall-paper printing machinery and cigar machinery. The proportions work out nicely for any sort of small automatic machinery where weight as well as strength is to be considered.

ROLLER BEARINGS IN MACHINE-TOOL DESIGN

Let us consider first the application of roller bearings to the countershaft. In many cases, the user has insured against trouble by equipping the boxes, clutches and loose pulleys of his countershafts with roller bearings.

Many advantages have been found in the use of this type of bearing, particularly in the use of the hollow helical roller. Rolling action is substituted for sliding friction, a saving in frictional load from 50 to 75 per cent. This results in a power saving which makes possible the use of the increased available

tional first cost for the countershaft equipped with the hollow helical roller. But this first cost may be regarded from two angles: If it were not justified by the advantages already discussed, it would be by the additional advantage of insurance.

Inefficient lubrication has been the cause of many failures of the plain bearing countershaft. By making possible a more efficient and more reliable system of lubrication, certainty of operation is insured.

With bearings in the countershafts which eliminate the possibility of a sticking clutch or loose pulley, and which give positive lubrication to all bearing surfaces, let us consider the added advantage of insurance. The reports of those who are using the hollow, helical type of roller bearing concur in this: The added cost of using this style of bearing is an investment on insurance which is worth while.

While a countershaft may be the most obvious point for using this type of roller bearing, the machine tool itself as we shall see, offers some interesting applications.

Let us stop for a moment and review briefly the essentials of machine design; namely: (1) Rigid construction in reference to particular function of machine. (2) Use of metals based on the granular structure of the metal in hard and soft state. (3) Lubrication. (4) Symmetry and simplicity of design. (5) Permanency of alignment. (6) Accessibility with regard to cleaning, lubrication and renewal of parts subject to wear.

Bearing friction in some classes of machines, is an important factor in determining the power cost of operation. The use of plain bearings necessitates provision for taking care of wear, either by providing for adjustment or by bushing, always with the idea of maintaining alignment.

It is a fact that the factors which determine the life of a machine tool are the bearings. The roller bearing of the hollow helical type will increase the first life of a machine tool. By first life we mean the period of useful life before the machine must be torn down for repairs or renewals. The reasons for this will be discussed further on.

It has been found in many cases that the manufacturing cost of a machine may be materially decreased by simplifying the design. In many cases the helical roller bearing has replaced the plain bearing, and a simpler design resulted. Fewer ma-

chining operations are necessary to accommodate the roller bearing. One of the reasons for this is the fact that no means need be provided for taking up wear.

When renewals must be made they can be taken care of quickly and simply. In most types of machine tools the designer faces the problem of vibration. So far as the writer is aware, the only satisfactory method of absorbing the vibration on machine tool spindles is by a large mass of metal surrounding the spindle. However, certain vibrations applicable to gear shafts, driving shafts, etc., are absorbed by the hollow helical roller, which possesses the quality of resiliency and absorbs shocks and vibrations without transmitting them to other portions of the machine tool.

On gear shafts the helical roller bearing has been found highly satisfactory. Permanency of alignment, a most desirable feature of gear shafts, is assured. This results in quiet running gears. Let us now review the points which the writer has endeavored to bring out briefly: From the foregoing, we see that the hollow helical roller bearings are commanding attention from the designer and manufacturer, as well as from the user, for several important reasons. (1) They make available additional power for use in production. (2) They assure absolute lubrication and require little attention. (3) They insure against shutdown. (4) They make possible a simpler, more symmetrical and often a less expensive design. (5) They assure permanency of alignment. (6) They absorb vibration and are quiet in operation. (7) They eliminate rubbing friction.

They command attention from superintendent and production engineer for the following additional reasons: They eliminate the problem of securing experienced help to scrape in and fit close-fitting babbitt or bronze bushings; they also make possible a greater production without additional investment.

MOVING MACHINERY

This applies to the moving of machinery or to the layout of a new shop or extensions to the old one, first, lay out to convenient scale on the drawing board a diagram of the floor space to be occupied, together with all permanent obstructions, as pillars, piping, etc. On a separate drawing lay out to the same scale

and in any convenient position, all tools, machines and work to be placed on the floor, marking each outline plainly for identification. With a pair of scissors cut out the pieces outlined on this second drawing and place them upon the first drawing, according to the previously determined arrangement; any interference will be promptly checked and the pieces may be moved about until a satisfactory arrangement is found; indeed, it would be an unusual case where such movement would not suggest a more advantageous arrangement than the one first planned.

We have located all machines for a new plant and have made several changes due to expansion, using this method with uniformly satisfactory results.

PACKING FOR EXPORT

Satisfactory packing cases or crates call for considerable skill in their design. This important work is usually relegated to the shipping clerk instead of the drafting room where it belongs.

During the last three years, because of the enormous volume of export tonnage moving through our ports, the handling of freight from cars to lighters and to steamers has been a severe tax on the packing which is employed by American manufacturers. The writer has always advocated the use of the best materials and methods in constructing of export packages, and has never believed that the additional cost was an item to merit serious consideration.

The foreign competition which all American manufacturers and exporters have had to meet, heretofore, will be more keen after the war, and packing will be as much an item of competition as price; for packing represents a condition of delivery, and its insufficiency and quality in use prior to the war, is still a hindrance to the American exporter's foreign trade. The object of manufacturers of export goods, should be to fortify themselves in the markets they are now serving, and which will be sought again by the countries at present out of the competition.

The company with which the writer is connected has always been willing to pay for packing that would deliver its manufactures and purchases at their destinations in first-class condition;

and it still adheres to that policy. This subject is a vital one for all exporters.

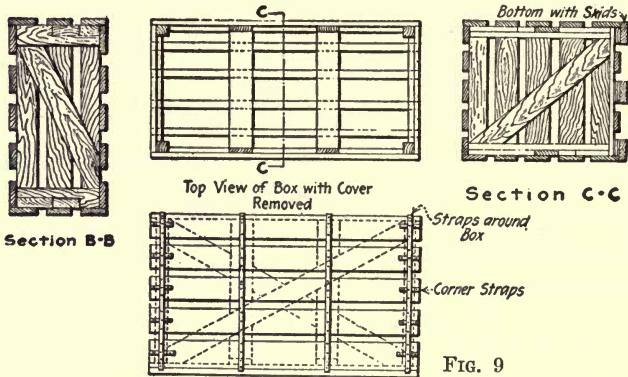
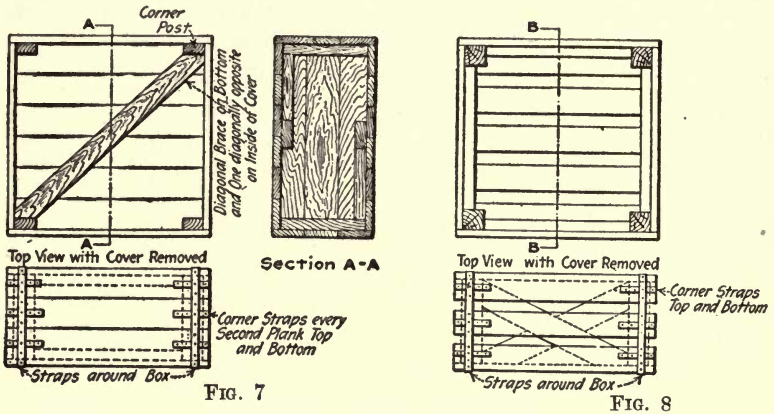

FIG. 7—PACKAGE FOR LIGHT MACHINERY
 FIG. 8—PACKAGE FOR MEDIUM MACHINERY
 FIG. 9—PACKAGE FOR HEAVY MACHINERY

GRAPHICAL GEOMETRICAL PROGRESSION BY MEANS OF THE SLIDE RULE

The writer has never seen published this method of finding the successive steps of a geometrical progression by means of the slide rule and from those with whom he has talked it does not appear to be of common knowledge. The method can best be explained by a definite example.

It is required to find six successive geometrical speeds between 25 r.p.m. and 360 r.p.m. (first and last speeds inclusive):

First, draw a straight, horizontal line and establish a point at the left end; remove the slide from the slide rule and lay it along the line with the 25 reading coinciding with the established point. Lay off on the line a length equal to the distance between the 25 and 360 readings upon the slide; now divide the length of line into five equal parts, giving six equidistant points along the line; replace the slide along the line, with 25 again at the established point, and it will be found that 25, 42.5, 73, 124, 212 and 360, the six successive geometrical steps, coincide with each point in the order of this rotation.

INFLUENCE OF CENTRIFUGAL FORCE ON THE PULLING POWER OF A BELT

Increasing the pulling power of a belt by an increased arc contact may not always give the desired results. The question came up, Will a changing of pulleys from 30-in. diameter to 36-in. diameter, with 500 r.p.m., give an increase in the horsepower transmitted by the belt?

The following calculations made by using the formulas given in one of the standard works on belting show the results that would be obtained. The factors to be considered are the cross-section of the belt, which for convenience is taken as $\frac{1}{4} \times 4$ in., or 1 sq. in.; the arc contact, which for equal driven and driving pulley is 180 deg.; and the coefficient of friction, as found by the formula

$$f = 0.54 - \frac{140}{500 + v}$$

The actual pulling power of the belt, which is the resultant of the different forces acting on the belt, may be found by the following formula:

$$p = \frac{(10^{0.00758f\theta} - 1)(2A - 0.00061036v^2)}{2 \times 10^{0.00758f\theta} + 1}$$

For a 30-in. pulley at 500 r.p.m., v equals 3927 ft.; and for a 36-in. pulley, 4712 ft. Then

$$f = 0.54 - \frac{140}{500 \times 3927} = 0.51;$$

$\theta =$ Arc contact in degrees;

$A = 240$, a value depending on the tension of the belt under working conditions.

$$10^{0.00758f\theta} = 10^{0.00758 \times 0.51 \times 180} = 10^{0.6995}$$

or

$$0.6995 \log 10 = \log 0.6995$$

The corresponding number is 5.007, or 5. Substituting the above values, we have:

$$p = \frac{4(2 \times 240 - 159.76)}{11} = 116.5$$

and the horsepower transmitted equals

$$H = \frac{pv}{33,000} = \frac{116.8 \times 3927}{33,000} = 13.8$$

Calculating in the same way for a 36-in. diameter pulley, we find $p = 94.4$, and $H = 13.4$, showing that the belt would transmit less power than in the first place. Under 2000 ft. per min., this centrifugal force need not be considered, but at speeds higher than 4000 ft. a steady decrease in the pulling power of the belt, under equal conditions, will be found.

BLUEPRINTS FROM PENCILED TRACINGS

If drawings made with pencil on tracing paper are not afterward traced with india ink on tracing cloth, the blueprints made from the paper tracings are sometimes indistinct. In the drafting room of one manufacturing company considerable annoyance was experienced in this respect after the company had adopted the system of making blueprints from tracing paper, on account of being rushed for time. There was more trouble after the drawings became old and less transparent. It was considered necessary to go over the drawings with pencil and make the lines heavier, but a better method was discovered.

The back of the tracing paper was painted with cocoanut oil with an ordinary paint brush, and then wiped clean. After this the drawings were hung up to dry. No oil was put on the side of the paper which contained the pencil marks, as it was desired to leave this side so that erasures and alterations could be made. When treated in this manner the tracing paper was

much more transparent and very good blueprints were produced.

The effect of the oil treatment is to not only make the paper more transparent but to make the pencil lines darker. This latter effect may be more imaginary than real, however.

SPEEDING UP THE OLD BLUEPRINT MACHINE

In a shop where the writer was employed some time ago we had an electric blueprinting machine of the vertical glass-cylinder type with a contact cloth that had to be rolled back and forth for inserting the tracings. We had trouble with our blueprint boys, who left us at the rate of about seven a year, and a maximum day's work was about 275 prints. We needed nearly double this number at times, and when we appealed to the manager for another machine he wanted to know if we wanted another one of the same kind.

He observed the cutting of the paper, the rolling back and forth of the contact cloth, winding up the escapement mechanism, getting the prints into the water, slushing them with a brush and then putting them on a rack to dry. Then he called the writer and said: "Let's make that thing continuous; let the printing, washing and drying be done by a motor so that all the boy needs to do is to put in the tracings, letting the prints come out dry at the other end where an extra boy can trim them."

After much sketching and discussion the continuous-printing machine shown in the illustration was evolved. The writer makes no claim to originality of design, but proposes to show how with little expense and by using material already at hand any blueprint machine of the type mentioned can be transformed into a machine of 100 per cent. efficiency. The general scheme only is shown, as space forbids details.

We procured a small slow-speed motor which we belted to a set of cone pulleys so arranged as to provide minute speed variations in order that the printing speed of the paper might be accommodated. The glass cylinder from the machine was mounted in a cradle formed by four felt-covered rolls of wood, which were driven at a common speed by means of bicycle chain and sprockets, the sensitized paper being therefore at rest in

respect to the cylinder and showed no tendency to slip. The tracings were inserted from below at the front of the machine and the entire width of the cylinder was kept covered.

In the wash tank the paper was sprayed from the under side by means of four pipes which were drilled with a row of small holes throughout their length. The spray coming from below caused considerable motion of the water and made the washing practically perfect, which fact was demonstrated by the non-fading qualities of the print when exposed to strong light.

The drier was made up of thin wood slats riveted at their ends to rubber belts. These belts ran over pulleys large enough

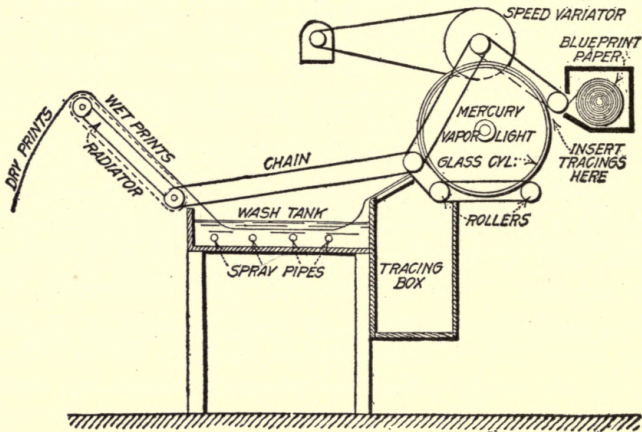

FIG. 10—AN IMPROVED BLUEPRINTING MACHINE

to admit a steam radiator of about 100 sq. ft. area between the running parts of the belts, the radiator being set at an angle of 45 deg. with the wash tank so that the drip would run back into the tank. The drier was in fact a belt conveyor, as the wet prints would not stand any pulling. After passing over the drier the tracings were allowed to fall into a large box, and the blueprint was cut up into 6-ft. sections for trimming.

One might think that this machine would need a very intelligent person to run it, but the fact is that two colored boys at \$4 per week ran it nicely.

On one occasion there was a lot of tables to print for new shop standards, etc., on 18 x 24-in. sheets. After eight hours' work

the prints were counted and there were 996. Thus the capacity of "Big Liz" had been nearly quadrupled.

GUARD FOR DRAWING TABLE

The illustration shows a simple means for eliminating a source of continual annoyance due to the rolling off of drawings and

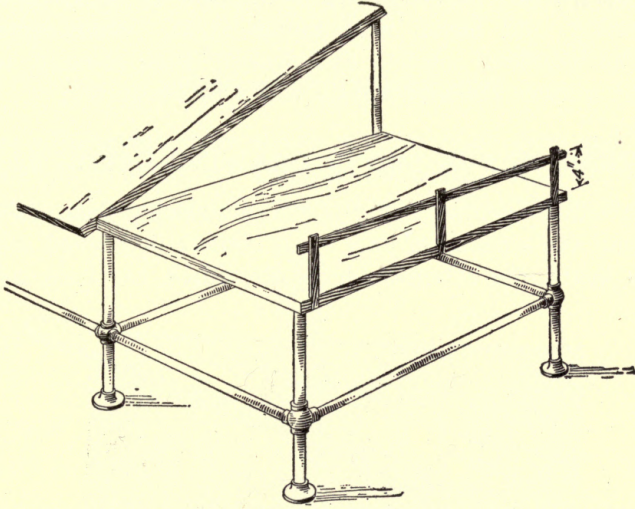

FIG. 11—A GUARD TO KEEP DRAWINGS FROM ROLLING OFF THE TABLE

tracings from the table. The stock used was 1-in. oak strips fastened by countersunk screws.

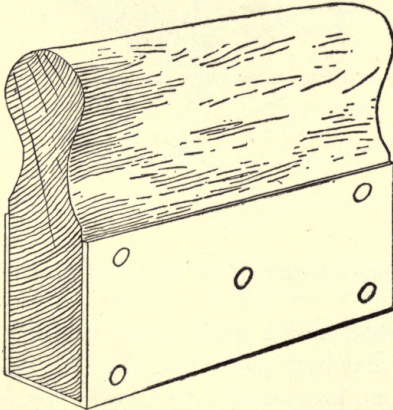

FIG. 12—PAD FOR BLEACHING BLUEPRINTS

BLOTTING OUT DIMENSIONS ON BLUEPRINTS

It is frequently necessary to blot out dimensions, etc., on blueprints and bills of materials. A good way to accomplish this is to cut a pine block Fig. 12 so its dimensions will be about the same as the space which it is desired to blot out and fold a strip of blotting paper over this end in the manner indicated in the illustration, and fasten with thumb tacks. When moistened with the bleaching solution and pressed down squarely on the print it whitens the spot exactly where it is required.

EXTENSION FOR USE IN DRAWING LARGE RADII

To avoid the necessity of removing a drawing from the board to permit the scribing of arcs whose centers lie beyond the edge of the board the extension here illustrated has been devised.

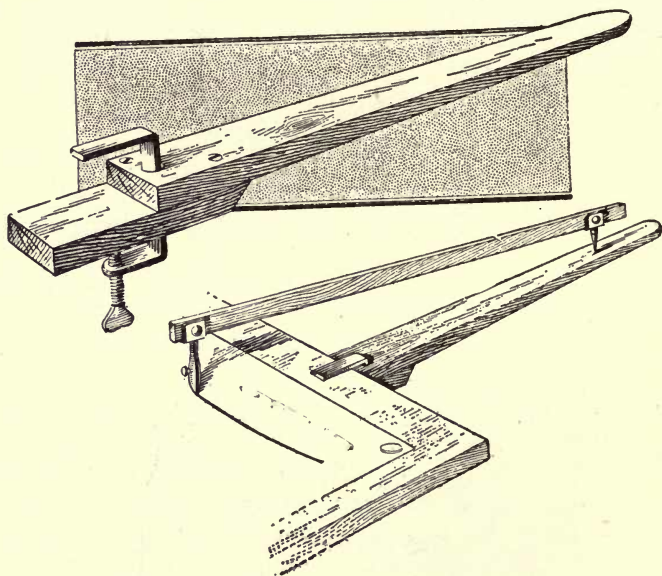

FIG. 13—EXTENSION FOR DRAWING LARGE RADII

Two pieces of wood and a small clamp are all that is required. A suitable width for both pieces is 2 in. The upper piece, which can be made 12 in. long, should be a trifle less in thickness than the drawing board at the base to enable the clamp to grip the

board. Both edges and the under side of the extension should taper toward the outer end in order to lighten it and give it a better appearance. A hole is bored through both pieces, after they are fastened together for the clamp to slide in easily. It will be seen that nothing projects above the drawing surface except the upper part of the clamp and that no difficulty will be experienced in drawing radius lines with trammel points or beam compass.

SIMPLE ELLIPSOGRAPH

The ellipsograph here shown will save you time and money, when you try to lay out elliptical templates, dies or anything of the sort. It is so simply made that the illustration is self-ex-

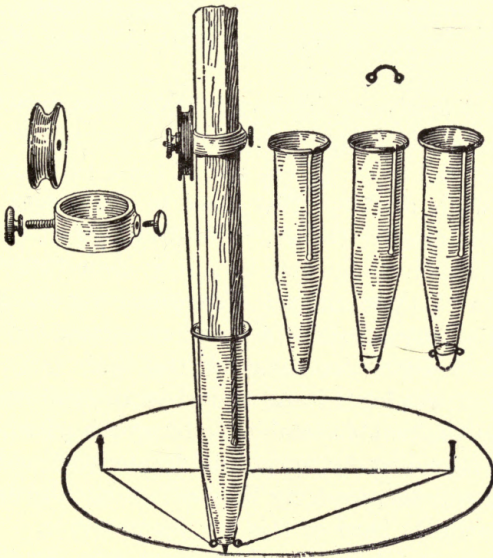

FIG. 14—COMPONENT PARTS AND ASSEMBLED ELLIPSOGRAPH

planatory. The pencil protector can be bought for 2c. A common pencil is always handy. A piece of catgut string (non-elastic), a ring and wheel and two setscrews complete the instrument.

SECTION II

PATTERNS AND FOUNDRY

FUSIBLE METAL FOR SOLDERING

SOME time ago, while doing pattern work, I received orders that the lead figures, or pattern numbers, should be attached with soft solder. The only solder available at the time was half and half. I attempted to use it, but soon found that the lowest heat which would cause it to flow was sufficient to melt or bring the figures to a soft spongy state in which they could not be moved.

I was about to give up in despair when I happened to remember a small piece of composition that had found its way into the corner of my tool box. It was one of those little curios that all mechanics, while drifting from place to place, pick up, only to toss into some obscure corner, little dreaming of the important uses to which such things may be put at some future time—and this was one of those times. This piece was fusible metal, a composition of bismuth, lead, tin and cadmium, and had a melting point of 60 deg. C., or about 140 deg. F.

The pattern was heated and tinned in the customary manner, except that the fusible metal took the place of solder. I surprised my shopmates by spreading the melted solder with my bare fingers and also used my fingers to align the figures, which remained perfectly hard at this low temperature.

Anyone who has tried to solder sheet zinc for the first time will remember how, with an iron too hot, a large hole is melted in the article being soldered. This trouble is eliminated with fusible metal, as the temperature required is much lower than the melting point of zinc.

Several good formulas for fusible metal may be found in the "American Machinist Handbook."

PATTERNS FOR WORK WITH PROJECTING MEMBERS

The tendency nowadays is to simplify patterns for the molder.

Assuming that the strips *A*, *B* and *C* are about $\frac{1}{2}$ in. in thickness and the body holding these strips is $2\frac{1}{4}$ in., I would make this part of the body in two pieces, parting the pattern at *D* with a narrow guide at *E*.

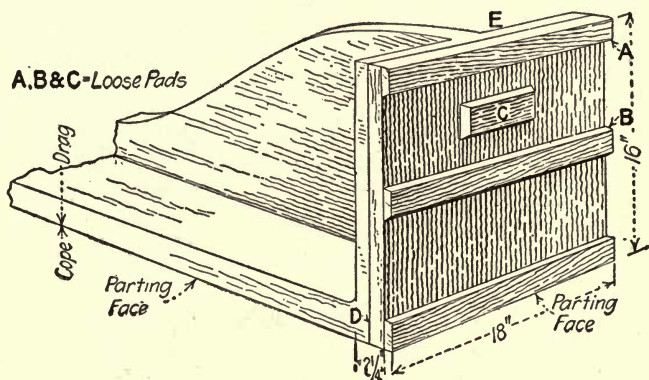

FIG. 15—IMPROVED PATTERN

In making the pattern in this way the body could be drawn from the mold, leaving the part with the strips *A*, *B* and *C* in the mold. After drawing the main body from the mold, this part with the strips can then be moved back into the opening left by the main pattern, and then withdrawn all in one operation. Making the pattern in this way would not require any great amount of skill on the part of the molder.

BREAKING UP CAR WHEELS

A large number of 24-in. car wheels were broken as follows: A piece of nickel steel 2 ft. long was turned tapering $\frac{3}{4}$ in. per ft., 3 in. and $4\frac{1}{2}$ in. at the ends. The bore of the wheels was $3\frac{1}{4}$ to $4\frac{1}{4}$ in. The wheels were placed in a 9-in. hydraulic wheel press, the tire side next to the ram, and the taper mandrel forced into the bore.

It required from 30 to 50 tons to split the wheels into pieces

of suitable size for a small foundry to handle. The time required was about 5 min. per wheel.

TOOL FOR DRIVING BRADS

The tool illustrated herewith is for driving brads in places where it would be difficult to use a hammer. The sectional view shows all parts lettered.

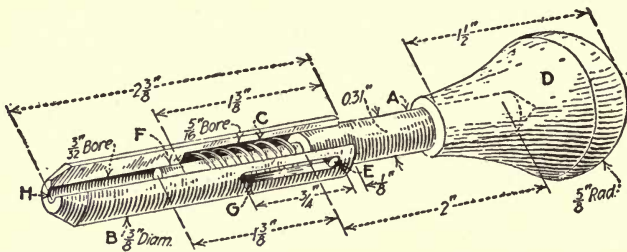

FIG. 16—BRAD DRIVER FOR PATTERNMAKERS

The plunger or driver *A* slides in the case *B*. The spring *C* holds the driver up, leaving the opening *H* in the case to introduce the brad, which is attracted and held by the plunger point *F*, which is magnetized. The length of plunger movement is regulated in each direction by the slot *G* in the case *B* and the stop pin *E*. This tool is a most convenient one for the patternmaker's tool box.

ADVANTAGES OF PLATE PATTERNS

My experience with metal plate patterns is somewhat limited. I have had considerable to do with the making and the molding of plate, or match-board, patterns made of wood. All, or nearly all, of these were intended for what were termed season, or model requirements and extras for stock and repairs. For the production of these castings wood plate patterns served the purpose.

Many of the troubles with plate patterns made of wood can be attributed to the patternmaker's limited knowledge of what is required and what constitutes a practical and well-made pattern. For example, I have seen plates made $\frac{5}{8}$ in. in thickness with plain flat battens at the ends, fastened with wire nails only,

the pattern varnish-finished in a slipshod manner. The reason given by the patternmaker was that a thin plate is light for the molder to handle and if made thicker the flask pins would not reach through, which is a rather lame excuse for spoiling an important and expensive piece of work.

I apply at least three coats of varnish to each half-pattern, also the board, before assembling the parts of the board. The width and length dimensions of the board are determined by the size of the flask that is to be used. The thickness I make 1 in., never less. I use cherry wood in the construction of both patterns and match board. The shape, dimensions and assembled batten, fastened with glue and screws, are shown in Fig. 17.

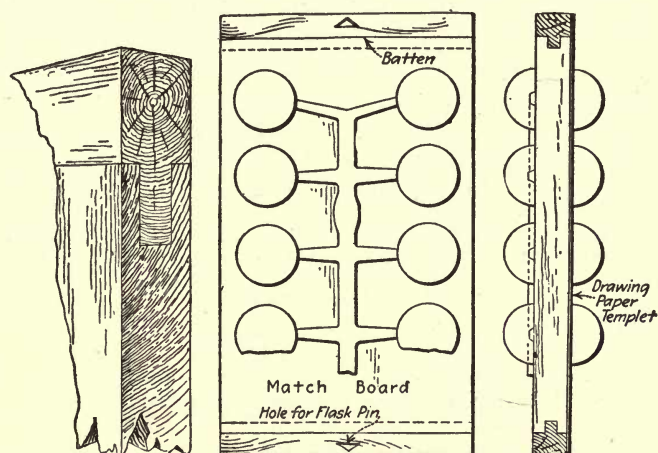

FIGS. 17 AND 18—METHOD OF SETTING THE BATTENS AND A SAMPLE MATCH BOARD PATTERN

Assembling and Matching. My method of assembling and matching the half-patterns on the plate, as shown in Fig. 18, is not common in pattern shops, but it is a simple way and practical. A sheet of drawing paper a little larger than the board is fastened with thumb-tacks to one side of the board. The paper is carefully trimmed flush with the edges of the board. The half-patterns are placed on the paper in their correct positions and temporarily fastened with fine wire nails driven through the patterns, the paper and into the board about $\frac{1}{4}$ in. In other words, these nails are nothing more than dowel pins.

With a knife made pointed and sharp, the paper is cut through

along the edges of the patterns. If this job is carefully done, the sheet of paper can be lifted away from the patterns and the plate, leaving the patterns and the paper under the patterns fastened to the board. Each half-pattern, the plate and the paper should be carefully marked in a way that will insure the return of the patterns and paper to their correct and relative positions on the board. The paper is transferred to the opposite face of the board, flush with the edges; the match halves of the patterns are placed in the holes in the paper and fastened in the way described above.

The job is now ready for the final fastening of the patterns to the board. The patterns are removed from the board, a coat of thick shellac is applied to the joint face of the patterns, and while the shellac is fresh, the pattern is securely clamped to the board and fastened with fine wire brads. When the pattern is finished, it is given a last coat of shellac.

The holes are cut and fitted to suit the pins on the flask that is to be used on that special job. Do not be guided by templets or measurements. See the flask; notice its condition. A good plate pattern and a rattle-trap flask do not work well together. Store your plate pattern on end in a special box made for the purpose. Wherever the pattern goes this box goes with it and saves much trouble.

CORE BOX DOWEL PINS

We have five plants situated in different locations. Four of these plants are using taper dowel-pins in core boxes and claim that they are the best and most satisfactory.

I claim that a straight dowel pin is the only correct pin to use for core boxes and will produce a more perfect core. I back this up for the reason that our foundry has less imperfect castings returned to them due to imperfect cores than any of the other plants. If a straight dowel pin is used, any particle of sand in the hole will be pushed through by the pin and the box allowed to close tight. If a taper dowel pin is used, any particle of sand left in the taper hole will stay there and the core will not be perfect, owing to the fact that the core box will not come together. This also applies to iron core boxes where the pin is driven through one-half of the core box. I also claim that it

takes more time to equip core boxes with taper dowel pins, consequently, they are more expensive.

PATTERNS FOR LARGE BEARING CAPS

I was working for a large manufacturing company, who up to this time, had been providing lubrication for the large bearings, by drilling and countersinking the caps for the bearings. It was decided to provide oil pockets or wells on all of the various bearings, and as their product included many styles and sizes of machines, and many sizes of bearings, it appeared to be somewhat of an undertaking. However, the drawings were all changed, and orders sent to our patternmaker to change the pattern to provide for an oil pocket to be cast integral with the caps.

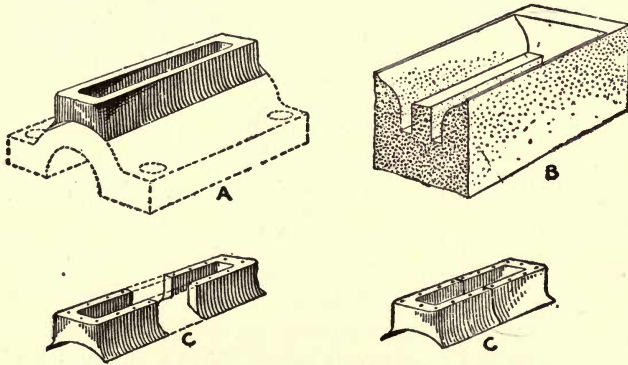

FIG. 19—THE LEAD PATTERN AND ITS APPLICATION

This is the way the patternmaker went about the job. He selected the largest cap and made a pattern *A*, Fig. 19, of wood of the oil pocket.

Then he made several molds, *B*, of plaster of paris and poured enough lead castings at one heat for the entire lot of patterns. The lead castings were fastened to the caps by brads, as shown at *C*; the lead bending to the contour of the wood pattern very readily. When he wished to provide for a shorter cap he would simply cut out the required amount from the center and join the ends, as shown at *C*. The lead was far more durable than wood, to say nothing of the saving of time and labor, if the usual method had been followed.

CASTING A STEEL WORM

In Fig. 20 is shown a worm that was used in bottom-dumping coal cars. The worms were steel castings, approximately $4\frac{3}{4}$ in. in diameter and $9\frac{1}{4}$ in. long. They were made a loose fit for a square steel shaft by which they were turned when dumping the bottom of the car. As very little power was required, they could be made fairly light. They were cast entirely in dry sand cores,

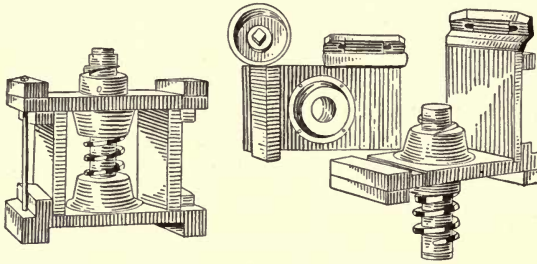

FIG. 20—ASSEMBLED AND DISASSEMBLED VIEWS OF WORM PATTERN

the boxes being constructed of hard wood, metal lined. The worm pattern was of cast iron, fitted with a babbitt nut at one end. The cone-shaped pieces, in the assembled view, are prints, the core box for these being shown at the top in the disassembled view. After being rammed, the worm was turned out and the box separated, being held together with two clamping bolts. Locating lugs were provided on the end and center cores so that they could be placed accurately in relation to one another.

TURNING SMALL BOSSES FOR USE IN PATTERN WORK

The following has been found a simple and quick method of turning bosses from 2-in. diameter down to the smallest size used on jig and fixture work for small parts of machinery.

In the illustration the wooden chuck is shown with the stock *A* glued thereon, and also shows the different steps followed in the method.

The order of procedure is as follows: True up the diameter of the stock *A* to the size of the fillet required and face off the stock. Mark off with dividers the circle *B*, which is the true diameter of the boss. Gage with marking gage the required

height or thickness of the boss, and this line should be gaged $\frac{3}{64}$ in. deep. Turn diameter and fillet as shown at *D*. The next operation is to cut off the boss if no hole for a dowel is to be drilled in the latter. To cut off, take cutting-in tool ($\frac{1}{8}$ -in. chisel) and using gage line as guide, cut into small enough diameter to break off as shown at *E*.

If it is desired to use the boss as a loose piece (using center dowel as shown at *F*) first, after turning, take diamond point tool and turn small countersink in the center of the boss, which should be turned exactly true as shown at *G*. Next using the

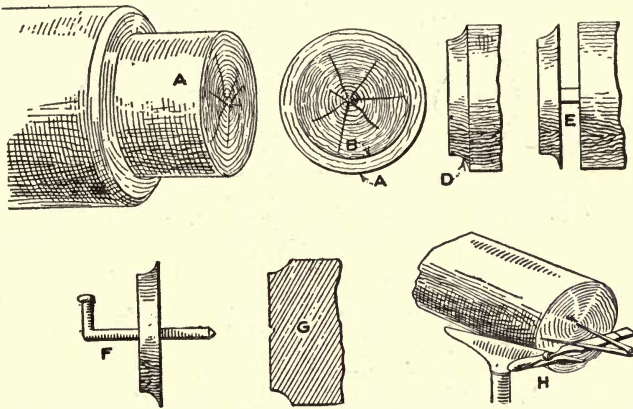

FIG. 21—TURNING SMALL BOSSES FOR PATTERNS

countersink as a center for a twist drill, bore a hole to the depth required. It is needless to add that the hole should be drilled before cutting in for thickness of the boss. Bosses up to $1\frac{1}{2}$ -in. diameter, and in almost any thickness, can be turned in the following manner without moving tool rest from its original position: First, set the tool rest to proper position for turning diameter; second, face off the end of the stock; third, set dividers to radius of circle, and setting a tool across tool rest as shown at *H*, locate center and scribe circle. After this operation proceed in the manner previously described to the conclusion of the job.

RAPPING PLATES FOR PATTERNS

Some patternmakers might call the following an expensive way of attaching the rapping plates to a pattern when only a

few castings are wanted, but rapping plates are only put on very large patterns and standard patterns from which a large number of castings are to be produced.

Attaching a single plate with screws to a pattern which is thin in section, is a rather difficult job for the patternmaker, as it soon works loose. The proper method is to put two plates on thin patterns in the manner shown in the sketch. The plates come in pairs: plain holes in one, tapped holes in the other, secured with brass screws screwed into the wood and plate.

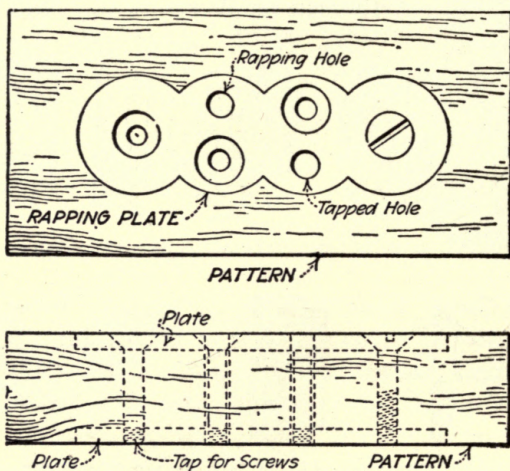

FIG. 22—RAPPING PLATE FOR THIN PATTERNS

The writer suggests to makers of rapping plates that stock plates be made with holes for wood screws in the outer circles; the inner circles having one hole for rapping and one tapped hole for lifting. To attach the plates more securely, without increasing their size, they should be made with four holes instead of two for the wood screws, thus doubling the security of the plate to the pattern when only one plate is put on. The zigzag position of the holes prevents splitting the wood.

A PATTERN PROTECTOR

While visiting a local firm recently I was somewhat interested in the way the foreman patternmaker "armored" his patterns, which I believe is worth copying in other shops. The method

adopted may be understood from the illustration, which is from memory. As will be seen the faces *A* and *B* are covered with thin sheet-iron plates, also the faces *C* and *D* on the boss, while the two core prints are made of mild steel.

This method adds considerably to the life of the patterns without adding the weight usual with iron patterns. It saves the

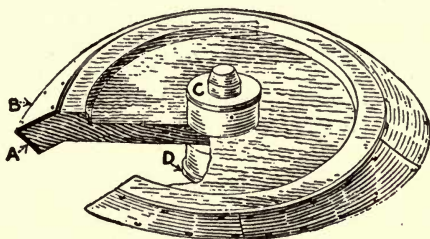

FIG. 23—A PATTERN PROTECTOR

molder a good deal of making up, which is necessary with a wood pattern when it has been used a few times. This foreman made no claims in this direction but he said: "It only protects my patterns, and if they want iron patterns later on they can have them."

MARKING WOOD PATTERNS FOR THE PURPOSE OF IDENTIFICATION

I have given quite a bit of study to the marking of wooden patterns that are sent to the foundry, and have arrived at the conclusion that I have found a new and cheap way of marking.

I had three common rubber stamps made with the company's name on them in letters $\frac{3}{8}$, $\frac{1}{4}$ and $\frac{1}{2}$ in. in size and also bought a common black inking pad.

After the pattern is finished and sand-papered, stamp an impression on the pattern in any convenient place, then take common white marking chalk and rub it all around the impression. Gently smooth the chalk over the impression with the finger until it is entirely covered (this prevents smudging the impression when shellacking), then apply a coat of yellow shellac over the impression. Be sure to use only one stroke of the brush, as more might cause the ink to spread. After this has dried apply as many more coats as the pattern requires, usually one more.

The pattern can now be shellacked all over with black shellac, painting around the impression.

This makes a very clear, cheap and lasting marking, and has all the other methods that I have seen beaten 50 ways.

EFFICIENT HERRINGBONE GRATE PATTERNS

As I have had considerable experience in making patterns for single- and double-angle herringbone grate bars for furnace and boiler fireboxes, also for catchbasin grates in various designs, my method may be an improvement on the one followed by many patternmakers.

Cutting and fitting—one at a time—the bars to the side frames is slow and tedious; especially is this true in the making of a herringbone grate pattern. One of several patterns for catchbasin grates recently made will serve as an example and will aid me to make clear the description of my method.

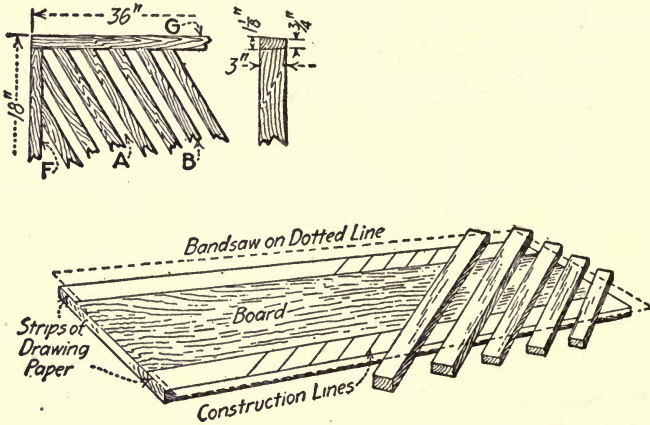

FIGS. 24 AND 25—PATTERNS FOR CATCHBASIN GRATE

A corner of the assembled pattern is shown in Fig. 24. The frame *FG* is made and varnish finished. The angle bars *B* are made and varnish finished on the flat sides only. In Fig. 25 is a board 1 in. thick and 6 in. wide, planed flat and true on one face. Strips of drawing paper 1 in. wide are fastened with glue at the edges of the planed surface; and construction lines are drawn across the face of the drawing paper, indicating the angle and position of the bars and the spaces. The bars are

“spot” glued to the drawing paper, wide face down. Remember, a *spot* of glue; a “slobber” of glue will spoil the job. When the glued spots have set, lay the frame on the “board side” of the bars, and mark along the inside edge. Tilt the band-saw table at the same angle as the inside of the frame, and band-saw along the line. If the marking and sawing are carefully done, the bars will drop into place in the frame without further fitting.

Varnish (not glue) the ends of each bar; assemble and fasten with wire nails, first drilling small holes to receive the nails. This is important. To remove the board, start each “spot,” using a wide chisel and hammer. A light, smart tap will do the job. Plane and finish the edge surfaces.

The following shows a method of making double herringbone grate bar patterns.

After having planed the stock for both the crosspieces and the frame, the block *A*, Fig. 26, was made to the exact size of the inside of the bar, the ends being tapered to fit the frame and the angled faces to fit the cross-pieces.

The pieces *C* were then made to the same length and taper as *A*, but about $\frac{1}{2}$ in. higher. These pieces are merely for additional guides for the back-saw. After mounting pieces *A* and *C* on the block *B*, I sawed the slot in the center and the sawing jig was ready. I then took *D*, one of the strips which was made for the cross-pieces, and in the manner shown, cut as many right-hand pieces as there were crosspieces in the bar; I then cut the same number of left-hand pieces.

These pieces were then taken to a surface plate *G* and all glued in pairs as shown at *E*, Fig. 27. While the glue was setting the frame *F*, Fig. 28, was made.

After the crosspieces had set, they were nailed both ways at the point (a scrap of the crosspiece strip being used to hold them in the vise), glue-cleaned and well shellacked. They were then put on the jig again and cut to the exact length of the block *A*, Fig. 26.

I have found that the back-saw, if carefully used, will make truer, cleaner cuts than the band-saw, and when the pieces *C* are located on the jig, the sawing of the ends is comparatively easy.

When the crosspieces have all been cut to length, the frame *F*

is turned upside down on the surface plate, as shown in Fig. 28, and the crosspieces glued in as shown at *E*.

Care must be taken to see that the first piece is set square, the others can then be set in like so many dominoes, proper spacing being accomplished by using little squares of wood the size of the required opening.

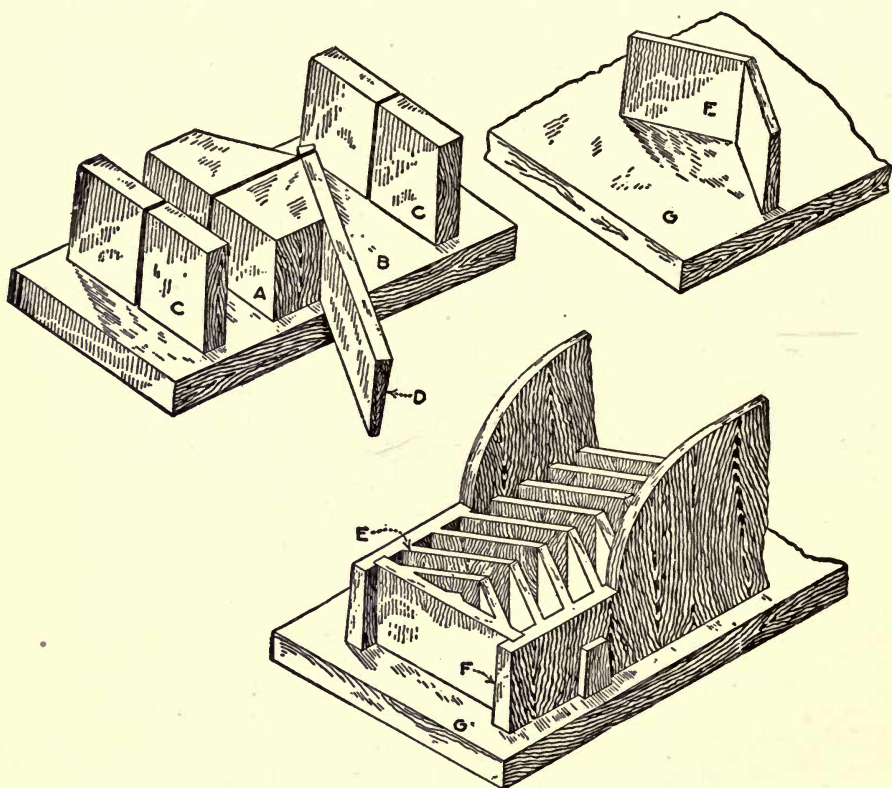

FIGS. 26, 27 AND 28—A METHOD OF MAKING GRATE PATTERNS

After approximately five crosspieces have been set in, the little squares that were used to space the first two can be picked out with a scriber and used again. Then the pieces that were used in the second space can be taken out, thus proceeding down the bar.

After the glue has properly set, the clamps are removed and each crosspiece is first drilled, then nailed in the frame. The

frame is then filleted with $\frac{1}{8}$ -in. fillet, finished and shellacked.

In this manner I have made bars from 18 in. to 6 ft. in length, and have cut from \$5 to \$15 per bar from the former cost of making.

SECTION III

FORGE SHOP, HARDENING AND TEMPERING

STANDARD MARKING FOR DISTINGUISHING THE VARIOUS STEELS

THERE is one thing in connection with steel which I think could be used to advantage throughout the country, and that is a universal color scheme for the marking of the various grades so that when steel is received by the consumer, jobber or dealer he would at once know machine steel from tool steel and tool steel from high speed, etc.

We have adopted certain markings, and these, with the reasons for our choice, are given below :

All machine steel and screw stock we mark white, as this is the general custom for low-carbon steel. Chrome-nickel and other alloy steels we mark with yellow. High-speed steel we mark red, as this seems to be so closely connected with the understanding of high-speed steels. This leaves for tool steel, the other principal color, blue.

Then, if you have a steel that is halfway between any of these ; for instance, an air-hardening steel that is neither tool steel nor high-speed, mark it blue and red. If you have a high-grade machine steel that is neither machine steel nor tool steel, mark it blue and white and the same with other combinations.

If this idea could be adopted by all the steel plants, it would save a great deal of confusion and expense. People constantly come to us asking whether stocks they have are tool steel or high speed, and even ask us to differentiate between tool steel and machine steel. This is a problem that is very difficult to solve unless a person is familiar with the various grades.

Of course from our experience we can quickly tell, but the ordinary supply house, and in fact most factories, cannot tell the

difference. With some such scheme of marking as the foregoing, however, all this trouble would be eliminated.

We mark the full length of the bar in stripes if it is a combination steel, but in a solid color if a known standard grade that agrees with the standard market. If we have any short ends they are always marked.

FORGED HIGH-SPEED BITS

I have had the experience with bits forged from high-speed steel that the lightest cut would take the edge off and ruin the tool.

To remedy this defect, I reharden them and draw the temper to a very light yellow, and with that temper it stands up just as well as the original piece did before it was hammered out.

OXYACETYLENE WELDING HIGH-SPEED STEEL TO MACHINE STEEL

Owing to the high cost of high-speed steel, the practice of welding high-speed steel tips to machine-steel shanks is of interest to manufacturers. Welding a high-speed steel tip to a machine-steel body for cutting off tools for automatic machinery has been more or less a difficult problem, owing to the shock the weld has to stand from the constant chatter of the stock against the tool.

Take two pieces of high-speed steel *A*, $\frac{3}{8}$ in. square by 2 in. long, and grind a $\frac{1}{4}$ -in. radius on the end of each. A rough machine-steel body is milled at both ends as illustrated at *B*. The parts are assembled and put in the jig *C*, which is made from two pieces of $\frac{3}{4} \times \frac{3}{4}$ -in. machine steel *D* and *E*. They are fastened with two clamps, *F*, made of flat steel held by $\frac{1}{2}$ - or $\frac{3}{8}$ -in. U-bolts *G*. Wing nuts should be used if at all possible, as they are easily and quickly adjusted.

The reason for using the jig is that when the flame of the torch is directed on the places to be welded it heats the tips and the body of the blade very quickly and causes the steel in the blade to expand before the jig has time to get very hot. These two bodies, when heated until they run at the weld, are forced together by their expansion, resulting in a better weld.

The work should be removed from the jig quickly and placed in powdered lime or bar sand, to prevent chilling and the for-

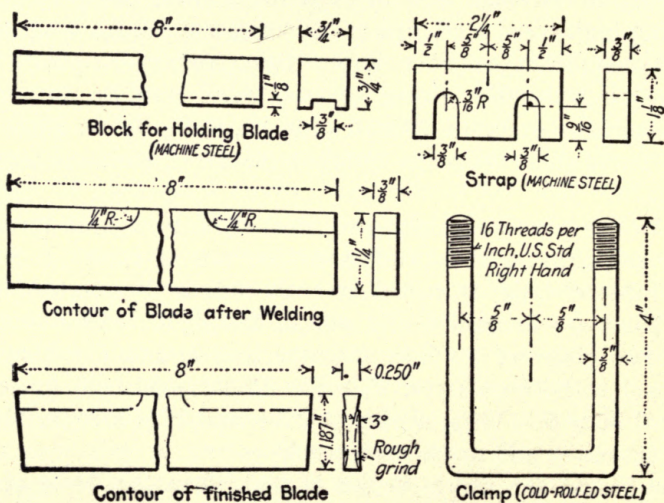
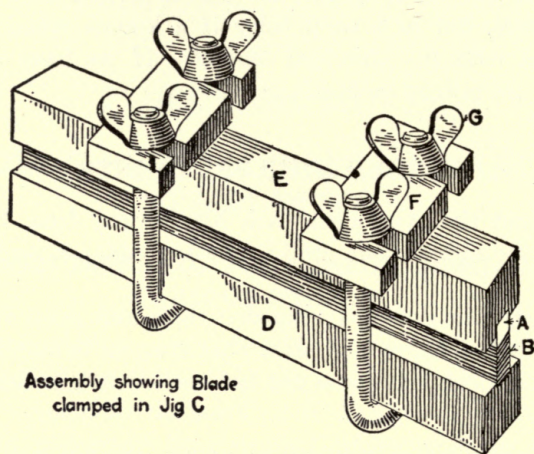

FIG. 29—JIG FOR WELDING HIGH SPEED STEEL TIPS TO MACHINE-STEEL BODIES

mation of hard brittle spots in the weld, which are difficult to machine even after the regular annealing process.

ARC-WELDING HIGH-SPEED TOOL TIPS

Arc-welding was brought prominently before the public by its use in restoring the broken engine castings of the interned German ships a short time ago. When breaking these castings the Germans thought they could not be repaired and that it would require a year or more to replace them. But even before the ships could be otherwise overhauled and made ready for transport service all the broken castings had been repaired and were as good as new. This achievement impressed the value of arc-welding on the minds of many shop managers, and in several plants castings and other parts of apparatus which in the past

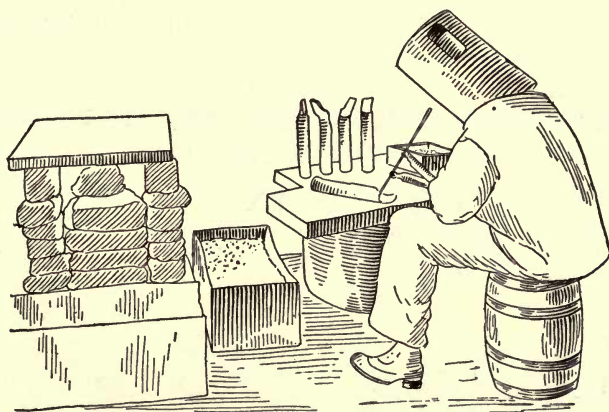

FIG. 30—WELDING HIGH-SPEED TIPS ONTO MILD-STEEL SHANKS

would have been scrapped as hopelessly damaged are now perfectly restored by the arc-welding process at small cost and great saving of time.

One large manufacturer working on munitions has installed a Westinghouse arc-welding equipment for the sole purpose of making tools for turning shells. Ordinarily these tools are made from high-speed steel and cost about \$12 each. This manufacturer uses high-speed steel for the tip of the tool only, welding it to a shank of carbon or machine-steel, and in this manner the tools are produced at a cost of \$2 to \$4.

For several weeks this plant has been turning out 240 welded tools a day, the men working in shifts of four, which is the capacity of this outfit.

The equipment consists of a 500-amp. arc-welding motor gen-

erator with standard control panel, and three outlet panels for metal-electrode welding and one special outlet panel for the use of either metal or graphite electrodes. The special panel is intended to take care of special filling or cutting processes that may be necessary, but ordinarily it is used in the same manner as other panels for making tools. These panels are distributed about the shops at advantageous points.

For toolmaking, which involves the hardest grades of steel, a preheating oven is used, not because it is necessary for making a perfect weld, but because otherwise the hard steel is likely to crack from unequal cooling and also because preheating makes it easier to finish the tool after the welding process has been completed. For ordinary arc-welding operations the preheating oven is never used.

ECONOMIZING HIGH-SPEED STEEL WITH THE ELECTRIC BUTT WELDER

The increased cost of high-speed steel has made it necessary to economize in its use in the shop. One way to do this is to put a short tip of high-speed steel on a carbon-steel shank. Va-

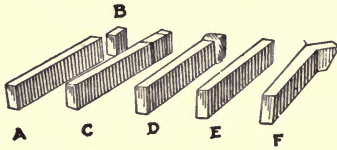

FIG. 31—BUILT-UP TURNING TOOL

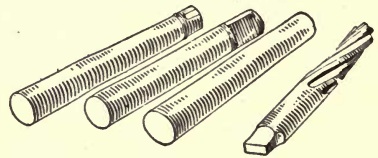

FIG. 32—BUILT-UP REAMER

rious methods of attaching this tip have been attempted, such as brazing, and also welding with the oxyacetylene torch.

The Reo Motor Car Co., Lansing, Mich., is using Winfield butt-welding machines for affixing the high-speed steel tip to carbon-steel shanks for cutting tools. The current required is 4 to 10 volts and 400 to 500-amp., depending upon the size of the tool section being welded. In Fig. 31 is shown a bent turning tool that has been made with the electric butt welder. The carbon-steel shank *A* and the high-speed steel tip *B* are first cut to length. For a bent tool this tip is made about $1\frac{1}{4}$ in. long. On a straight tool the tip is usually about 3 in. long. A piece of tin is spot welded over the joint of the two steel sections to hold

them in alignment, as shown at *C*. The tool is then held in the jaws of the butt welder, and the two pieces of steel are united. The average time required to make the butt weld is approximately ½ minute.

One of the tools as it comes from the machine is illustrated at *D*. The joint is ground off, as shown, by the tool *E*. The tool may be either bent or left straight, according to requirements. A bent tool may be seen at *F*.

At this factory, reamers have been built up in a manner similar to that described for turning tools. In Fig. 32 is shown the making of a reamer from the loose shank and tip to the ground and fluted reamer. For reamers the high-speed steel tip is approximately 2 in. long.

For the annealing operations that follow the dressing of the joint and subsequent bending the tools are put into an oven at 1600 deg. F., where they remain for approximately 6 hours. Then they are placed in lime to cool, remaining for from 7 to 10 hours. This process is merely a preventative against crystallization and is followed by the hardening process. For this operation the tools are heated to approximately 2200 deg. F. and are then quenched in kerosene or fish oil, being left in the liquid for from 3 to 5 hours.

The tools and reamers made by this process are giving satisfaction in service.

COST OF WELDED HIGH-SPEED TOOLS

The accompanying figures, from costs taken on a lot of 300 welded tools recently made, readily indicate the advantages of

COST OF 300 WELDED TOOLS

Labor:	
Saw	\$2.00
Shape	3.00
Blacksmith	3.00
Pack harden	1.60
Oxyacetylene weld	22.00
Rough grind	8.90
Gas harden	6.22
	\$46.72
Material, 320 lb., new cold-rolled stock	22.40
	\$69.12
Total	

tools with cheap steel shanks and welded high-speed steel cutting tips taken from the scrap box. At a total first cost of less than 24c., a tool was made that replaced the customary \$4 one in use in most shops.

BRAZING STELLITE

I have noticed the various articles printed in the *American Machinist* regarding the brazing of stellite to steel shanks. The Haynes company discovered a method of brazing stellite to steel shanks which is superior. By referring to Fig. 33, the reader will notice that a thin web *A* is left on the side opposite the cutting edge of the bit. This web is of course governed by the width of the bit and should be chamfered, as shown at the point *B*, at about a 45-deg. angle, and of a depth that is approximately $\frac{1}{2}$ of the total depth of the bit. The reason for leaving this web is to insure plenty of copper in the joint prior to lifting the tool from the fire.

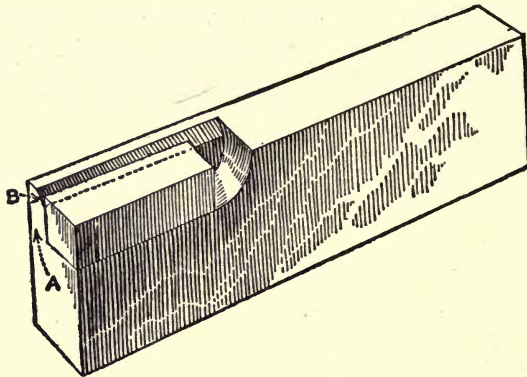

FIG. 33—METHOD OF SETTING A STELLITE BIT

Place the stellite tip and the shank in the forge, allowing both to soak in the fire and become white hot. Then place a thin sheet of copper between the steel shank and the stellite tip, applying borax freely. Bring the tool to a white or such heat as will soften the stellite slightly. From time to time additional copper should be melted—either from a piece of copper tube or copper sheet—and allowed to flow in the chamfer *B*, being careful to borax the joint freely before the copper is flowed in. In this way the copper will run down and wash away the dirt, and

at the same time exclude the air and do away with oxidation.

After the tool is brought to a point at which the stellite begins to soften it should be removed from the fire and squeezed slightly with a pair of tongs or any other convenient tool, such as a vise or press.

This method will require some practice and the maker of the tool should not be discouraged if his first braze is not a success, as we have found that these tools are capable of standing any strain up to a point of breaking the shank.

SOME HARDENING KINKS

Most of the articles on heat-treating and hardening are for the fellows with up-to-date furnaces and pyrometers and all that go with them. There is nothing for the little fellow who has only a forge in which to do his heat-treating and hardening. Here are a few kinks we have developed in a small toolroom where we have only a forge for such work. A few requisites for a forge are some pieces of channel iron, 6- and 4-in. sizes, say about 12 in. long, some good gas coke, a barrel of water and a tank of quenching oil. There should be a wire basket that can be easily lifted out. This is very handy and allows a number of pieces to be handled at once.

High-Speed Steel Taps. High-speed taps are difficult to harden because of the chance of blistering. The best method we have found is to use a piece of heavy channel iron in the fire, bank the fire around it and cover with a plate. Preheat the taps in the channel iron to a good red heat, using a moderate blast. Then with the poker make a hole in the fire under the channel iron and shut off the blast. This gives a small retort that is white hot. Hold the tap in this. It will quickly come to a yellow heat and can then be quenched in oil. To keep the tap from scaling, I use a compound of the following ingredients: 50 per cent. of corn meal, 20 of borax, 20 of common salt and 10 of crushed resin. When the tap gets a dull red heat, I put it in the compound for a minute and then put it back in the channel iron. This forms a coating that protects the threads and is easily washed off, at the same time it permits the work to quench quickly.

Carbon-Steel Tools. The same treatment can be used success-

fully for high-speed cutters. I also use the channel iron for hardening all carbon steel. If there are a number of small pieces, they can be all put in together, with no fear of burning them. To harden a long reamer, it is best to use a new piece of channel iron or one that is perfectly straight. Lay your reamer in the bottom and keep rolling it from side to side of the channel iron until you get the right heat. Then quench straight down in the water, moving the reamer slowly up and down until you feel that the steel has finished sizzling. Then take it out and let it cool in a warm oil bath. With a little practice you will be able to get the reamers nearly straight. Before hardening anything round that has to be ground, I drill a hole in the end about $\frac{3}{8}$ deep. After hardening I plug up the hole and then have a soft center to help get the piece fairly true. Be sure to plug the hole with a little putty before hardening.

A hard thing to make in the average small shop is a chuck wrench of the box type. The average chuckmaker does not leave enough room to permit a good heavy wall on the wrench. The result is that when the machinist gives his chuck an extra tightening, away goes his wrench. For box wrenches I have the most success with chrome-nickel steel. To heat-treat it, bring it to a good cherry heat and quench in oil until cold; then draw to a light blue.

HARDENING HIGH-SPEED STEEL TOOLS

We have experimented with the carbonizing treatment and have found that it is very difficult to regulate the thickness and uniformity of the skin. We have also found that the carbonized portion has a tendency to lift away from the rest of the body; and since the carbonizing extends over a considerable space of time, there is a decided leaning to grain growth in the carbonized section, which yields a very coarse and brittle edge. The increasing brittleness with increasing carbon content also must not be disregarded.

In the treatment of high-speed steel the first essential is to have a heat in which the atmosphere is not of a decarbonizing nature. Decarbonizing leads to oxidation, and oxidation causes heavy scaling. Blower or compressed air or dry steam is a suitable atomizer, but an excess of fuel should be used to prevent

excessive oxidation and scaling, which would prove ruinous to small fine tools.

The method of heat-treatment described applies to all our tools, from the smallest to the largest, which include heavy formed milling cutters, punches and dies, circular formed tools, taps and chaser dies. We have never been troubled with excessive scaling or changing in size, and microphotographs show a perfect, uniform, true hardness to the very center of the tool.

First, our tools are preheated to 1600 to 1700 deg. F. (the greater the cross-section of the tool the higher the temperature) in an overfired furnace in which oil is used as a fuel and steam as an atomizing agent. This heat-treating shortens the length of time for the hardening heat, which follows, and assures perfect and uniform assimilation of that heat.

The temperature of the hardening furnace, which is similar to the one used as a preheater, depends on the analysis of the steel, which, of course, must be known before any heat-treatment is attempted. The steels of lower tungsten content harden at much lower temperatures than those which contain the higher percentages. Having worked on all brands of steel, we have found that the temperatures can safely be included within the limits of 1950 to 2300 deg. F. The correct furnace temperature is essential, and the use of accurate, foolproof pyrometers equipped with rare-metal thermo-couples cannot be too strongly advised. Even in the small shop an expensive tool saved will more than offset the entire cost of the equipment.

The length of time in the hardening heat depends wholly on the size of the tool being hardened. It is essential to shorten this period of time as much as possible, and the piece should be allowed to stay in the furnace but a very short time after reaching the determined temperature. Moving the piece around in the furnace will promote uniform heating. Soaking at the hardening temperature may be essential on the larger sections, but should never be practiced on the smaller finer tools.

The universal quenching medium for high-speed steel is oil of such character that prolonged use will not cause it to thicken, for an extremely nonviscous mass must be used to insure the speedy transmission of the heat from the tool to the bath.

The chemical composition of high-speed steel permits the use of a higher tempering point than in ordinary carbon steels. It

is essential to use the maximum temperature, for tempering will preclude the possibility of cracking and will give a much tougher, stronger tool. Most high-speed steels will stand a temperature of 1000 deg. While it is not necessary to temper to this point, it is strongly recommended to use a temperature of 600 to 700 degrees.

This method can be carried out in any muffle to semi-muffle furnace, at the very front of which the preheating may be done satisfactorily, where the temperature ranges within preheating limits. For the hardening heat, it is only necessary to move the tool farther back on the hearth, where the desired heat may be obtained. Our loss by this method has been practically negligible. We have handled the finest and most particular tools, and from actual shop tests the efficiency of a tool heat-treated in this way is far greater than that of the tool heat-treated in any other way that we have ever used in our shop.

HARDENING FORMED HIGH-SPEED CUTTERS

Some time ago I had cause to experiment along these lines and found that the results were not altogether satisfactory. Tools were packed in charcoal in a cast-iron tube, placed in a gas furnace and heated from cold.

Temperatures over 1900 deg. F. were found to fuse the outside of the tool, completely ruining its form. Temperatures of 1750 to 1800 deg. F. produced a satisfactory surface hardness, but after the surface had been ground away the tool was not hard enough to give good results. This effect I attributed to overcarbonization of the steel. This also would account for the tendency of the cutters to crack when left too long in the furnace.

I found that by extremely careful heating according to steel makers' specifications, with special regard to the condition of the atmosphere in the furnace, it was possible to obtain a fairly high degree of hardness in a furnace kept at 2100 deg. F., without damaging the surface of the tool. I did not, however, have an opportunity of testing the actual performance of the cutter in use.

I have also tried a powder (called "HeTzy" and supplied by the Bennett Metal Treating Co., Elmwood, Conn.), that I under-

stand has been used with success by makers of high-speed steel cutters. The cutter to be hardened is packed in this powder and thoroughly heated at a temperature of from 1700 to 1750 deg. F., then quenched in oil; small pieces may simply be allowed to cool off in the air. I tried regular lathe tools hardened in this way and found that on cast iron and bronze good results were obtained, but the tool failed when cutting tough alloy steels.

There appears to be some doubt as to whether high-speed steel can be hardened successfully at low temperatures, when packed in charcoal or similar powders, and claims to success should be accepted only after tests have been made of the cutting powers of tools so hardened against tests under similar conditions.

Another writer says:

I have been using high-speed steel with varied results since it was first introduced and have tried a number of compounds recommended to protect the steel from oxidation, with little or no success until I tried coke dust. The coke is ordinary foundry coke, and forming cutters treated in dust made from it come out harder at a lower heat, are free from scale and pitting and will do better work. The coke dust can be procured from the screenings at the foundry or, better, take clean coke and grind it in an ordinary rattler by adding some scraps of iron. The finer it is ground the better results will be obtained.

Pack the cutters in an ordinary cast-iron box with a layer of coke, then a layer of the cutters, and so on until the box is full. Be sure to use plenty of coke. Heat in a furnace to 1740 to 1800 deg. F. for two or more hours, according to the size of the work, and quench in a light tempering oil. A mixture of 10 to 1 of lard oil and kerosene works well. The coke can be used to good advantage for pack hardening parts of machinery made from low-carbon steels, also cast and malleable iron, that require to be hardened on the surface. It may be necessary to add ground bone or burnt leather for some parts that must have a deeper and harder case than others.

Still another method is as follows:

It was found that cutters used for blocking gears would not stand up under the feed required of them. After some experimenting on our part, it was easily seen that to eliminate breakage the cutters must be drawn to toughen them, but not too much to cause excessive grinding.

The following method of handling gives good results: The cutters are preheated six at a time, held as in Fig. 34, to 1550 deg. F. and then submitted to a heat of 2330 to 2380 deg. (according to the amount of carbon) in the high-speed furnace. The cutters, however, are not allowed to reach this heat, but are handled faster by running it high. They are then plunged into oil at from 200 to 400 deg. and either kept moving or the oil circulated.

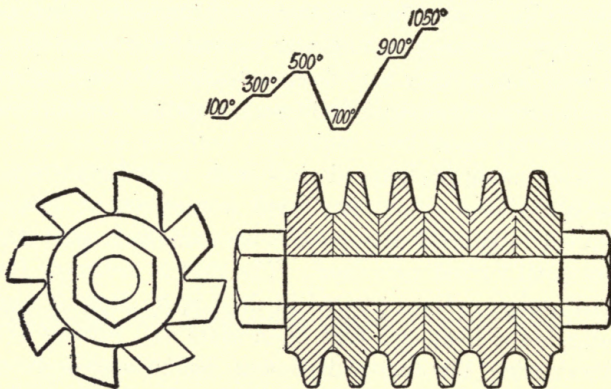

FIG. 34—CUTTER HOLDER AND CURVE SHOWING RELATION OF DRAWING TEMPERATURE TO HARDNESS

After removing the bolt, they are brought up gradually to 1050 deg., the drawing point, and cooled in oil. The curve above shows the relation of other drawing points to 1050 degrees.

Cutters treated as outlined above will block out a bevel-gear tooth 0.400 in. deep in 13 sec.—that is, a 48-tooth bevel will require 10 min. Under fair conditions, regarding hardness of stock to be machined and the state of repair of the machine, 40 gears may be blocked at one grind.

REPAIRING A BROKEN CRANKSHAFT

We were recently called upon to repair the crankshaft of a 10 x 20-in. steam engine which operated the pulp grinders at the local paper mills, it being important that the repair should be made in the shortest possible time as the mill depended upon this power unit for its supply of ground wood. A new forging could not be obtained in less than three weeks, and as this delay

was out of the question our only resort was to weld the broken shaft.

The shaft was broken at *A* and partially broken at *B*, as shown in Fig. 35. We had an oxyacetylene welding outfit, and our first

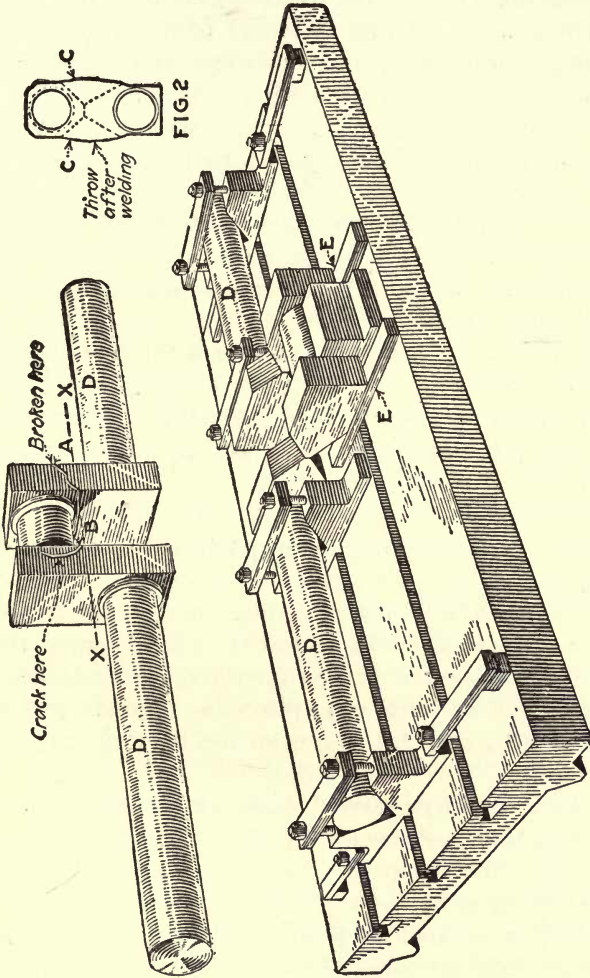

Fig. 35—THE BREAK AND HOW IT WAS REPAIRED

idea was to weld the shaft as it was, which could have been done at *A*, but the break at *B* was so located that it was impracticable to scarf off the sides to secure a sufficient bonding surface for the weld. We decided to cut the pin from the webs as at *X*

and substitute a new one, and in order to save the time necessary for turning the new pin after it had been welded in place we decided to finish it complete beforehand. This meant that the pin must be held firmly in perfect alignment with the main parts of the shaft during the welding process.

To do this we made four V-blocks with projecting lugs to match the groove in our planing machine, and another block of the same dimensions without the lug. As an extra precaution we turned the new pin $\frac{1}{16}$ in. oversize with the idea that we would have enough stock for re-turning in case anything happened to move the parts out of alignment during the welding process. At the same time we calculated that if the parts did come square it would only be necessary to rebore the crankpin box to fit the oversize pin, which would be a small job compared with re-turning the pin.

After the webs were cut off each was scarfed at an angle as indicated by the dotted lines at *C* and *C*. The whole was then assembled on the planing-machine, table *D* being fastened first; then the new pin was placed in its V-block and carefully lined up with the main parts of the shaft.

Two finished strips *E* were then bolted to the table to form a guide for the V-block holding the new pin, as it was thought that this block would have a tendency to move when heat was applied. To take care of this expansion the distance from center to center was made about $\frac{1}{16}$ in. less than the required throw.

Some of the straps are omitted for the sake of clearness. Asbestos paper and firebrick were placed underneath and around the pin and webs in order to protect the planing-machine table from the heat.

The welding was now started, heat being applied first to one side and then to the other with the idea of heating the webs uniformly. The building-up process was carried out in the same manner by alternating the torch from one web to the other to avoid distortion as much as possible and thus make it unnecessary to re-machine the pin and possibly the whole shaft. After one side of both webs was welded the whole was turned over and the process repeated upon the other side. During the welding process the bolts holding the pin were eased off slightly in order to allow the block to move outward in the guides.

After the weld was completed and the shaft had cooled suffi-

ciently it was put upon centers, tested for accuracy and found to be correct in every way. The engine has now been running approximately 60 days since the repair and is giving complete satisfaction.

It will be noticed that the new portion of the web was made wider than the original and resulted in a much stronger web, the middle section being built out to 7 in. instead of 5 as in the original.

REPAIR WORK FOR STEAM-HAMMER PISTONS

It seems to be a view quite generally held among a great many hammersmiths using steam hammers that, when any accident occurs to the piston of the hammer, causing it to break, nothing can be done except to replace the broken part with an entirely new piston, and that pistons to be serviceable must be forged out of one piece of steel. So this practice is often followed, no matter how large the piston head is; in many cases an enormously large billet is required to be of sufficient diameter for the head. For the past two or three years we have been disproving this theory by the continued use of several repaired pistons and heads, which are giving remarkably satisfactory service.

Several years ago the piston of our 1500-lb. steam hammer broke off several inches below the head. For such a break the suggestion of a weld would really be absurd, for the continued percussion stresses would quickly open the best of welds, whether forged, thermit welded or acetylene-torch welded. The piston head is about 12 in. in diameter, nearly double the size of any billet that we then had available, but we did have in the scrap pile a number of old high-carbon steel car axles that were sufficiently large to machine up to the diameter of the piston.

The manner in which the repair was made is illustrated where the parts *C* and *D* are shown. The broken stub of the piston was sawed from the head, and the latter was bored out and threaded to a diameter equivalent to that of the piston rod, a large fillet space being cut off the bottom edge to accommodate a corresponding fillet-like collar provided on the piston rod. The sketch of the piston rod also shows the precaution taken to provide a fillet, since it seemed possible that if there were any tendency

toward breakage of this new rod, it would occur at this point, which takes the full side twist of the head.

The rod was tightly screwed into the head; the threaded section was of sufficient length so that it projected slightly above the upper side of the head, and this projection was battered and peened over to prevent all possibility of the rod working loose. The repair was successful, and the hammer has been in constant daily use for over two years.

On two of our other steam hammers we have had occasion to bore out the cylinders, on one for excessive wear, on the other

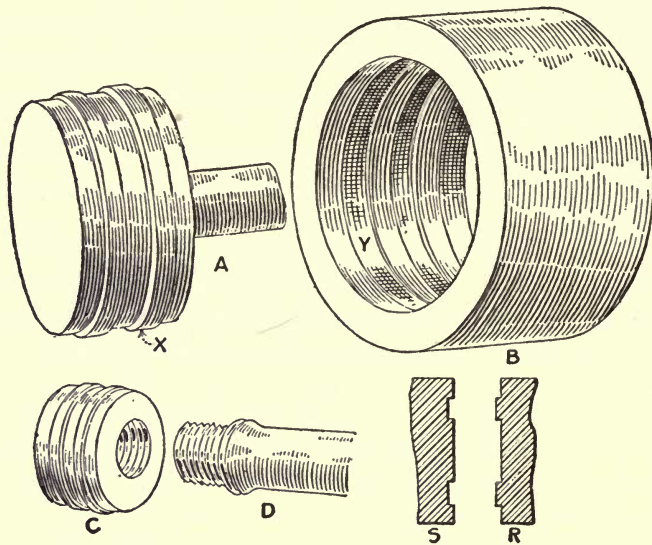

FIG. 36—STEAM HAMMER PISTON REPAIR

for the removal of deep grooves cut by a broken piston ring. Both times the amount of material removed from the inside walls was so great that there was no possibility of using the old piston heads, as they formerly were, by simply providing new rings.

Each of these pistons was turned down to 2 in. less diameter, leaving two ribs or bands, to act as keys, extending completely around their circumference, as shown at *X* in *A*. A shrink band of sufficient width and thickness to allow for the increased diameter of the cylinder was welded up as shown at *B*. The interior of this band was bored out, and the two grooves at *Y* were provided, $\frac{1}{8} \times \frac{3}{4}$ in., to match the bands that were left on the head.

The bore of the band is left $\frac{1}{32}$ in. less in diameter than the head, to give plenty of pressure upon shrinking.

When thus made, a band will expand enough when heated to a good red so that it will pass over the ribs of the thickness mentioned left on the piston head. The ribs and recesses are given a little taper on their edges, as indicated in the sectional views at *R* and *S*, so that there will be no chance for the band to hang on any of the edges of the ribs when it should be shrinking tightly into place. These sizes for ribs and grooves apply for heads that are left at least 10 in. or more in diameter; smaller pistons must have proportionately smaller ribs, grooves and shrinkage allowance.

After the band is shrunk on the head, the outside is turned off to match the inside diameter of the rebored cylinder, and new ring grooves are turned in its outside surface.

In making up new rings for such a piston, one point worth remembering, which probably must be explained to the machine-shop foreman, is that rings for a steam-hammer piston, unlike those for a plain steam engine, are not made of cast iron, but must be turned from a forged-steel band that the forge shop should have prepared while the other work is being done. Cast-iron rings are really most unsuitable, because the jar of the hammer in service will break up rings of this material in a few days; and these pieces will start in at once to score the inside walls of the cylinder.

The largest hammer that we have so far had occasion to repair in this manner is rated at 2500 lb., but both of those that we have so repaired have been in service for a long time with no signs to date that the rings are either loosening or slipping.

RECORDING CYLINDER AND PISTON REPAIRS

In the table, Fig. 37, is shown a method of keeping a record of steam hammer and cylinder repairs. It is also applicable for use in other classes of work, and provides a convenient method of keeping a repair record up to date. This record may be kept in any desired or convenient place on the cylinder, by space lined horizontally and vertically. On the horizontal lines are noted the dates of the repairs, while the vertical sub-divisions contain dimensions of the cylinder, piston, piston rings and

length of piston rod after each repair job; dimensions *B* and *C* refer to cylinder bore and piston-ring diameter respectively.

For example, in *B* column it is seen that on Sept. 14, 1914, the cylinder was bored to $14\frac{21}{32}$ in. and on Mar. 6, 1917, to 15 in. Records are similarly kept of repairs made on piston heads, piston rings and also on the piston rod; as the anvil base is always set on wood, which allows it to settle somewhat, provision is made to record the increased length of piston rod as required.

A method of attaching the piston head to the piston rod is shown in the illustration. We have used this method for a period of about three years with excellent results, and on hammers ranging from 2000 to 6000 pounds.

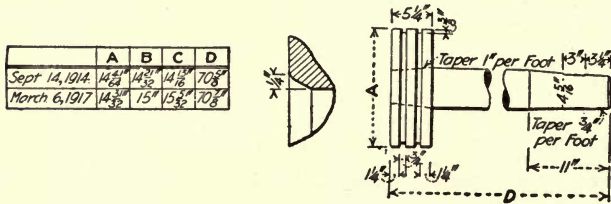

FIG. 37—RECORDING CYLINDER AND PISTON REPAIRS OF STEAM HAMMERS

The piston rod is tapered to fit and extend through a tapered opening in the piston head. The piston head is heated and shrunk on the rod, and the rod then well riveted.

The hammers referred to are probably worked as hard as any that might be found. During the period of three years they have been in service, they have operated practically without interruption 115 hours per week. The material hammered was of carbon and high-speed steel, neither of which yields readily under the hammer, especially the high-speed steel, and this constituted about 20 per cent. of our hammer work.

BALL-JOINT PISTON ROD FOR STEAM HAMMER

We were having a great deal of trouble with the breaking of piston rods in our steam hammer, and the breakage appeared to be caused by the larger dies striking at one side which caused the metal of the rod to crystallize. We had tried different kinds of steel without satisfactory results and at last decided to try

the ball-joint rod as shown in the accompanying illustration and that seems to have eliminated the trouble.

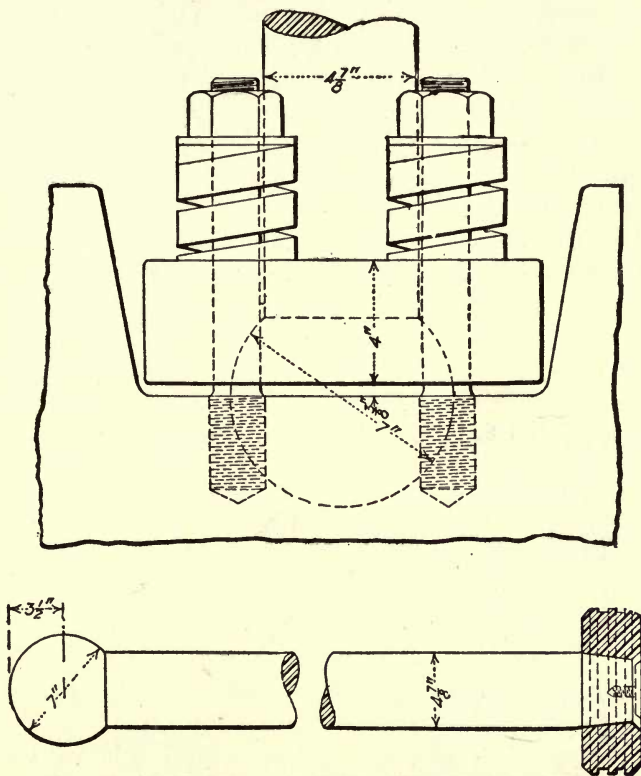

FIG. 38—BALL JOINT FOR STEAM HAMMER PISTON ROD

A SPRING-HEATING FURNACE

The accompanying illustration shows a furnace for heating and tempering the leaves of springs, and by the use of which excellent results have been obtained in the Renovo Shops of the Pennsylvania Railroad.

The furnace is 6 ft. 2 in. by 15 ft. over-all, and the corners are made rigid, and further reënforced by means of angle irons, which are held by three horizontal sets of bands or strips extending the length of the sides and ends of the furnace, and connected at the corners. The horizontal strips hold in place vertical plates, which are disposed at suitable points on the sides and ends, and serve to materially strengthen the latter.

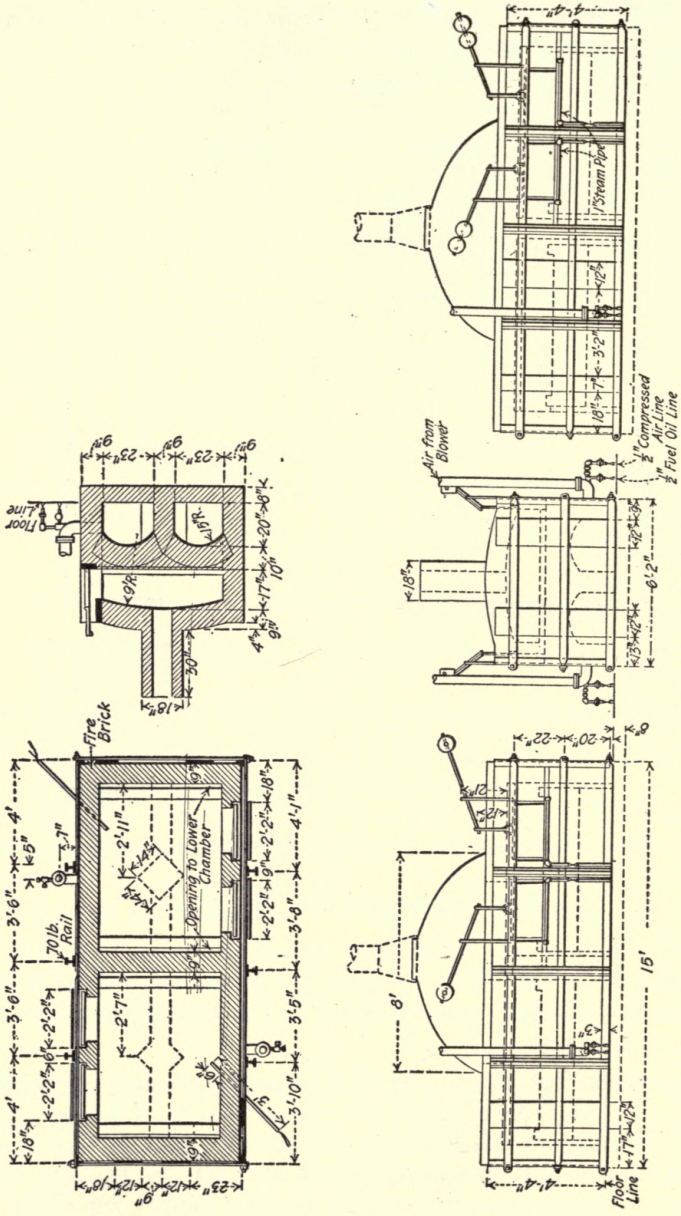

FIG. 39—A SPRING HEATING FURNACE

The side walls of the furnace are further reënforced by the use of 70-lb. steel rails, vertically located at required intervals.

Large pipes for supplying air from the blower enter the sides of the furnace in a straight line, as this has been found more satisfactory than when the pipes are led in on an angle.

The furnace can be supplied with air from the compressed-air system by means of a connection entering at the same point as the fuel oil. This arrangement is made to provide against a possible breakdown of the blower system. The blower pipe line is 3 in., and the oil and compressed-air lines, each $\frac{1}{2}$ in.

The doors of the compartments, of which there are two on each side and at opposite ends of the furnace, are raised and lowered by pivoted levers having ball weights, and which hold the doors in an open position when raised. Each of the compartments is equipped with a Thwing electrical pyrometer.

FURNACE FOR OIL-TEMPERING BATH

Fig. 40 shows a furnace designed for steel parts which require tempering in hot oil. It consists of a brick furnace inclosed in a steel jacket. In this is suspended an oil pan lined with a wire basket which may be raised and lowered by chains fastened on the end of a shaft supported by wrought-iron brackets at either end and operated by means of a crank. The basket is raised when the chains are wound around the shaft. A ratchet at one end holds the basket in position while it is being filled or emptied.

This is a very cheap device and a simple one to make, and as it requires very little attention the upkeep is a small item.

FORGING HIGH-SPEED STEEL

Trouble with high-speed steel breaking off and showing a coarse grain after being drawn down under the steam hammer invariably arises either through the steel having been worked at too low a heat or not having been properly annealed after drawing down.

It is essential in working high-speed steel to get it to as high a heat as that particular brand will stand. Work it until it is a bright red, then reheat. Never work it below a bright red.

If the steel to be drawn down is in long lengths, take a long heat; but never work it the full extent of the heat. Always leave

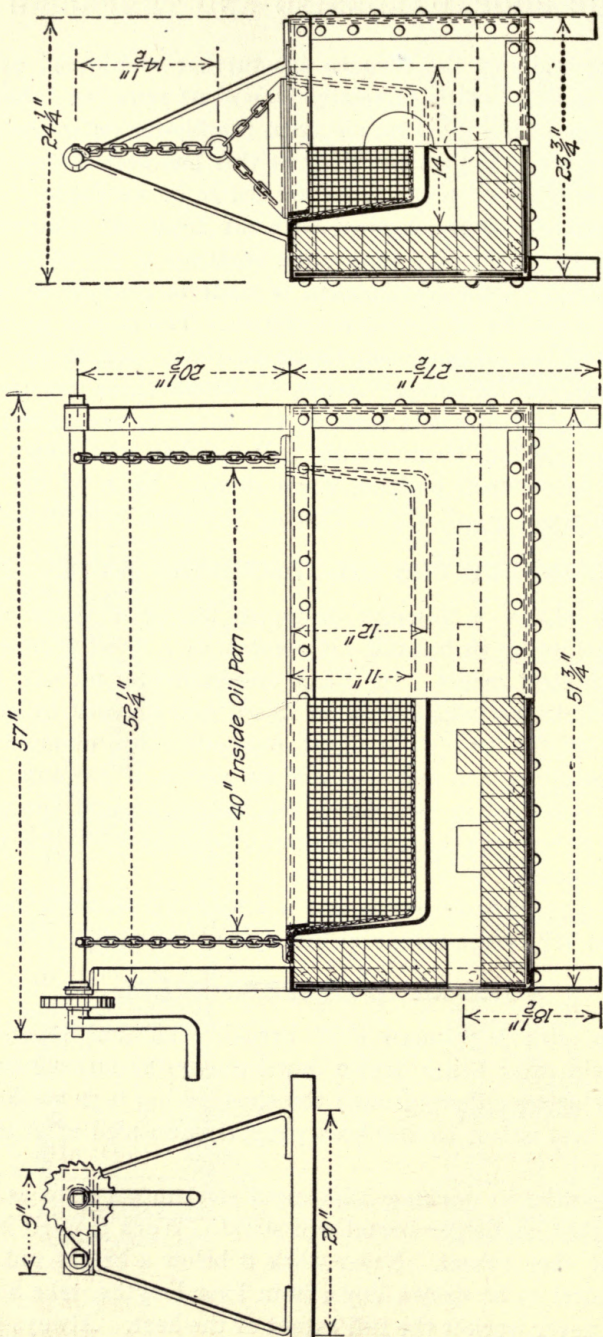

FIG. 40—FURNACE FOR OIL TEMPERING

a margin of at least 3 in. that is not touched by the hammer faces—that is, if the heat is 12 in. long, never work more than 9 in., as the last 3 in. is not quite as hot.

If short pieces, bar ends, etc., are being drawn down, it is possible to heat the pieces uniformly throughout. After all the pieces have been drawn to size, place them in a casehardening box, cover with old bone or leather that has been repeatedly through the casehardening furnace, seal with fireclay, place in a cold or moderately heated furnace, damper the fire and leave to cool off.

BENDING HEAVY PIPE IN THE BLACKSMITH SHOP

A few days ago one of our shops was called on to make a half-circle bend on the ends of four pieces of 3½-in. black iron pipe to be used for the ornamental railing of a new bridge. The circle was rather small for a pipe of this size; the radius allowed being only 18-in., while the specifications called for a smooth bend, free from kinks, and with no noticeable degree of flattening of the pipe. It was likewise desirable that there should be no coupling near the curved portion. This necessitated using a full 20-ft. length, which for this diameter of pipe is rather heavy to handle. For jobs of smaller sizes of pipes and in larger numbers, it might pay in such a case to rig up a bending jig similar to that shown in Fig. 41, on which the pipe is bent around a curved and grooved form *A* by means of a similarly grooved roller *B* fitted to the diameter of the pipe being handled, and located between the arms of an operating lever *C*.

However, for small quantities of job bending, the production of such a jig would be expensive, and so heavy as to be out of the question. For others, who may some day run into a task of the same nature, the following description of two methods of handling this work may be of interest.

The method illustrated requires a careful workman to get a smooth job, and though adaptable to the largest sizes of pipe, may require a tedious amount of work. Two stakes are required for the necessary leverage to pull the pipe around, and although these have in this case been illustrated as inserted in a plate *D*, the latter is in itself unnecessary although desirable for keeping the bend in a true plane.

The procedure consists of heating the pipe in a small spot at

a time on the inside of the bend, as shown in the shaded portion at *E*. If the heat should extend around to the outside of the pipe, this should be chilled with water immediately before bending, the object being to keep the outside cold to prevent flattening of the pipe while the pressure of the bending causes the inside to upset, and so furnishes the shorter radius for the inside.

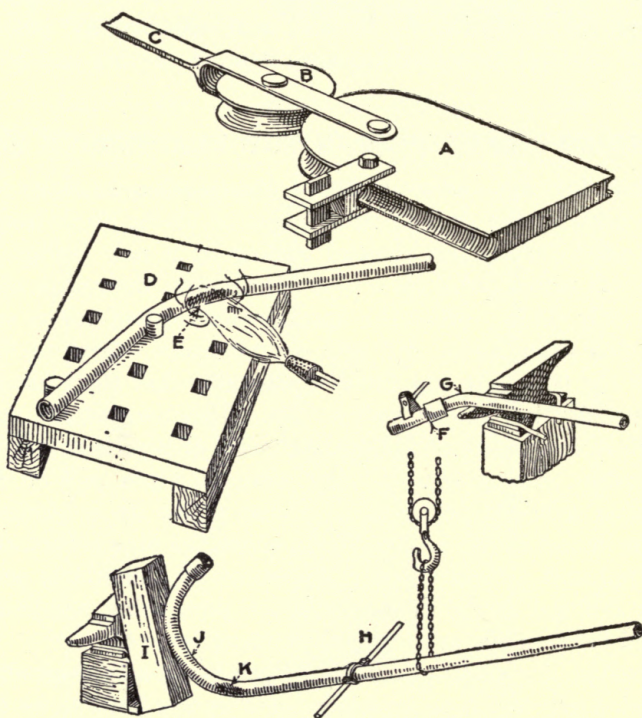

FIG. 41—VARIOUS METHODS OF BENDING PIPE

Only a very small portion of the pipe can be heated at a time, and should the pressure cause the inside to start to kink at any point, that place must be instantly chilled with water, and the bending continued further along. On account of the constant shifting of the heat on a very short portion at a time, the use of an oil-torch for heating is a great advantage, as it saves carrying the pipe to and from a forge, but the latter can be used if necessary.

The method that was used on the bridge-railing job is also

illustrated. A coupling and short length of pipe are temporarily fitted on the end at the start as shown at *F*. A short heat is taken close to the coupling at *G*; the pipe laid over the horn of an anvil and with a swage and sledge the bend is started; turning the pipe over on its side if necessary to work out any kinks or flattening that may occur while this first bend is being made. The added section of pipe is then removed and a quite different method continues the work. The clamped band handle *H* is now bolted on some distance back from the end; and the pipe itself is suspended by a block and sling so that it may be easily raised and lowered as necessary; and must be hung from a support far enough above it so that it may be swung pendulum fashion through a swing of three or four feet. A heavy wood block *I* for a "butting-post" is leaned up against a convenient anvil or wall, as shown.

A short heat is then taken on the pipe just beyond and adjoining the portion that was first bent. It is then swung like a ram against the block, and the force of the blow acting on the tangent of the first bend causes a continuation of the bending in this next section, while sufficient upsetting of the material takes place at the same time so that there is no flattening down of the outside, and the pipe holds up to its full form. This same procedure is continued for one section following another, and the pipe rolls up into forms as illustrated at *J*, where in this case the shaded portion *K* indicates the place where the bending is taking place. Care must be used that the bend does not run out of a true plane, and if there is any tendency toward doing so, the work must be laid on a faceplate or anvil and trued up.

In working these methods, the smith must work up to an inside templet, which has been made up for the radius of the inside of the bend; using care to keep each added bend close to the templet size to save any unnecessary bending or straightening of the work later on when it might not be so easily performed without reworking the whole piece.

BENDING SHORT RODS HAVING THREADED ENDS

There are many shops that have occasion to bend short rods with threaded ends, or long rods with the bend so close to the threaded portion that the operation must be performed after

threading; otherwise there would be no chance to get the die up to work.

In one shop these rods, one of which is shown in Fig. 42, were formerly bent by hand, the smith using a wooden mallet to avoid injuring the threads, the first turn being made over the horn of the anvil and the bend completed on a former.

As our requirements ran well into the thousands, this method was naturally too slow, and in casting about for a more efficient means of production, the bending fixture shown in Fig. 42 was

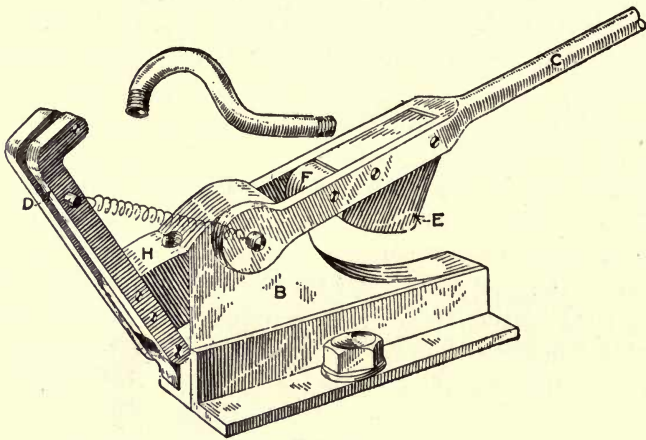

FIG. 42

finally evolved. A base *B* with its upper edge made to conform to the shape of the finished piece carries the two levers *C* and *D*. Firmly attached to lever *C* is a former *E* and a roller *F*. A jaw *H* is attached to lever *D*, which in construction was firmly clamped in closed position, and a pocket, half in the jaw and half in the base, was formed by drilling and tapping to fit the threaded end of the piece to be bent. In operation the lever *C* is thrown back, striking the end of lever *D* and opening the threaded pocket for the reception of the work. As lever *C* moves forward jaw *H* grips the threads on the hot rod, but as the pocket is fitted to them, it does not injure them. Continuing its movement, roller *F* carries the work around the formed surface until the final bend is accomplished by direct pressure delivered by former *E*. The helical spring shown exerts sufficient pressure upon jaw *H* to hold the work in position during the

bending operation. This fixture was entirely constructed in the blacksmith shop, and in use is bolted to an anvil as in Figs. 43 and 44 which show the fixture respectively in open and closed positions.

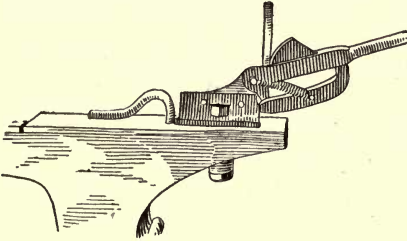

FIG. 43

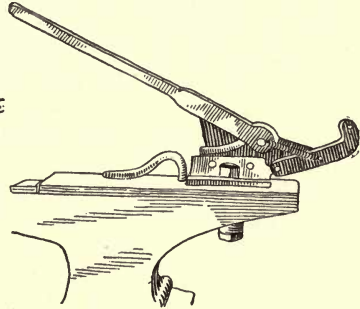

FIG. 44

With this fixture it was found possible to reduce the working time on a given number of pieces to one-fifth of that required by the hand method.

RECLAMATION OF MATERIAL IN THE SHOP

Conservation of materials as well as of time can be effected to a very appreciable degree in most manufacturing plants, by closer attention to the subject of reclamation. The scrapping of an article in many shops, means its consignment to the junk pile, from whence the chances of its recovery are remote.

The demands on the producers of unfinished products are becoming more and more insistent, and the conditions of waste could be reduced considerably if a systematic study were to be made of the general run of parts that form the bulk of scrapped material, and of their potentialities as reclaimed material.

Used bolts form a prolific sources of reclamation work, and are easily reworked. Steel T-rails are made to withstand hard usage, while the head split from a heavy steel rail is good material for making stubs for the business end of crowbars, set hammers, and swages for the forge shop, etc. Most of them will take a good temper and will weld readily and the reworking necessary to bring them to the required shape materially improves the steel.

ANNEALING HARD SPOTS IN OXYACETYLENE REPAIRS

These hard spots may be neutralized by the use of suitable fluxing. I know from experience, that borax used as a flux produces a good weld, thoroughly annealed, but when the same identical rod was used without borax, the weld could not be filed.

PREVENTING CRACKS IN HARDENING

The blacksmith in the small shop, whose equipment is usually very limited, often consisting of a forge, a small open hard-coal furnace, a barrel of water and a can of oil, is expected to, and usually can, produce good results if proper care is taken.

Too much cannot be said in favor of slow, careful heating, or against overheating.

My experience has taught me, however, not to take the work from the hardening bath and leave it exposed to the air if there is any heat left in it, because it is more liable to crack than if left in the bath until cold. The reason for this is not hard to find. In heating, plenty of time is taken for the work to heat evenly clear through, thus avoiding strains caused by quick and improper heating. Now in quenching in water, contraction is much more rapid than was the expansion while heating, and strains begin the moment the work touches the water. If the piece has any considerable size and is taken from the bath before it is cold and allowed to come to the air, expansion starts again from the inside so rapidly that the chilled hardened surface cracks before the strains can be relieved.

The method that I have been most successful with is to have the hardening bath about blood warm. When the work that is being hardened is nearly cold, it is taken from the water and instantly put into a can of oil, where it is allowed to finish cooling. The heat in the body of the tool will come to the surface more slowly, thus relieving the strain and overcoming much of the danger of cracking.

The temper should be drawn as soon as possible after hardening; but if this cannot be done for some hours, the work should be left in the oil until the tempering can be done. Forming dies and punch-press dies that are difficult to harden will seldom

crack if treated in this way. Small tools or pieces that are very troublesome because of peculiar shape may be hardened in a bath composed of 1 lb. corrosive sublimate, $\frac{1}{2}$ gal. vinegar and $\frac{1}{2}$ bbl. rainwater at a much lower heat than is required for clear water, the temper to be drawn in the usual way. This bath should be warmed the same as the water, and the work hardened in it should be also put in the oil. This solution works well on drill bushings, taps and dies, small punches and the like.

For high-speed steel in such a shop as the one I have just mentioned, and where a small hard-coal furnace is located, excellent results may be obtained in the following manner: Place on the fire a graphite crucible large enough to admit the work to be heated without touching the crucible. Build up brick as high as the top of the crucible; fill that with lead, and the space between the crucible and the brick with coal. When the lead begins to boil, skim it and cover its surface with fine charcoal. Now put on blast enough to bring the heat up to the degree wanted. If the lead is kept well covered with charcoal, it will not burn away. Preheat the work on the fire before it is put into the lead. A uniform heat is thus obtained. Some small particles of lead will stick to the work, but will scrape off easily after the tools are cold. Taps, dies, reamers, milling cutters and, in fact, all fine tools may be heated in this way without injuring their cutting edges.

The writer has used this method for a number of years and has had very few complaints. The tools thus hardened give as good satisfaction as those which were heated in an electric furnace.

TEMPERING THIN SNAP GAGES

On a recent large order of snap and angle gages for various gun and gun-carriage parts the company by whom I am employed experienced difficulty in getting the gages through the hardening without warping.

As the number to be made ran into the hundreds, the matter was given much thought, and several kinds of steel was experimented with. A few gages of mild steel were made up and sent out to a hardening concern to be carbonized, but they came back so badly warped that most of them broke in the straightening. The company then decided to do the tempering itself and use

Firth sterling special tool steel for all the gages, as these were so light that the cost of material was unimportant when compared with the results gained.

The method used in tempering the gages, some of which were 14 in. long and $\frac{3}{16}$ in. thick, while it may be "old stuff" to some, still worked beautifully and may serve to help others engaged on similar work. We made a shallow pan about 3 in. deep of heavy galvanized iron and placed in this an ordinary surface plate, the pan being considerably larger than the plate, which was, of course, selected to be a little longer and wider than the largest gage. We then filled the pan with good fish oil to about $\frac{1}{2}$ in. above the surface of the plate.

The gages had been first roughed out, annealed and then worked to size. They were heated in a cyanide bath to a medium-cherry red and the hardener simply laid them on the surface of the plate in the oil while his assistant placed over them a plane-surfaced weight fitted with handles so as to be easily handled. When I tell you that some of the gages 14. in. long cleaned up on the surface grinder with the removal of only 0.003 in. stock you will realize how simple and effective is this method.

Slitting saws or any other tools having a uniform thin section can be successfully hardened, and this cheap but effective rig will be an appreciable addition to any hardening or toolroom.

BRAZING A BROKEN PAIR OF SCISSORS

Some years ago when I was an apprentice in a small, old-fashioned shop in Aberdeen, Scotland, a novel repair job came under my notice, namely, brazing a pair of scissors which were broken in one of the legs just back of the pivot hole, as indicated in Fig. 45. As the break happened to be a clean one the following method was used to join the two pieces: A small dovetail was cut at each end of the broken parts, a piece was fitted to the dovetails and lightly tapped in with a small hammer to keep the parts in position while the brazing was done. To keep the temper from being drawn from the cutting edge during the brazing operation I was sent out to a near-by café for a potato into which the fitter stuck the scissor's leg, the potato practically covering the cutting part thereof, and just leaving

the part which was to be brazed sufficiently clear to allow the flame to be used. The operation was entirely successful and the scissors practically as sound as when new. The potato being moist served to keep the scissors' leg cool during the brazing.

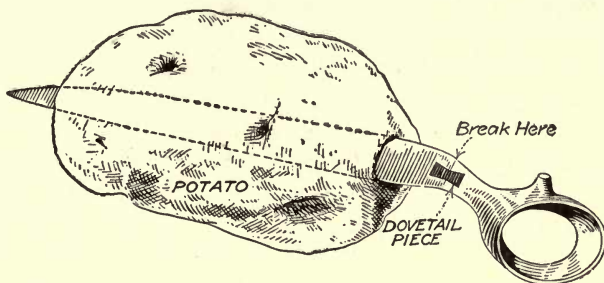

FIG. 45—POTATO USED TO KEEP BLADE COOL WHILE BRAZING

Needless to say I have never forgotten the somewhat unusual method and have since employed the idea for similar jobs.

SHRINKING ON A LARGE SLEEVE

I recently had to shrink a large bush on a long shaft. The job was an odd one in this shop, so I got all kinds of valuable information regarding it while I was preparing to do the work. The foreman said he thought it best to leave the bore in the

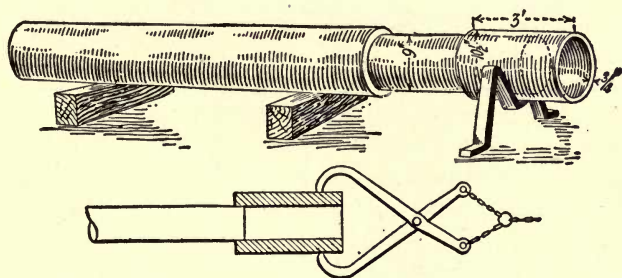

FIG. 46—HOW THE WORK WAS HELD

bush about $\frac{1}{64}$ in. smaller. I settled this dispute by getting out my "American Machinist Handbook" and, turning to page 231, found that about 0.005 in. was sufficient for a 9-in. bush.

If the bush of cast steel were made $\frac{1}{32}$ in. smaller than the

shaft, it no doubt would be so strained beyond its elastic limit that its grip would be greatly reduced.

A bush of this size and weight could be nicely slipped over a shaft when in a vertical position, but the shaft being too long we proceeded as shown. The shaft was supported upon two timbers and the bush supported a $\frac{1}{2}$ x 3-in. bent iron securely fastened to the floor, after the bush was lined up. We then heated it just a little hotter than mother's flat iron and shoved it home.

Do not attempt to put a bush of this size and weight over a shaft without some means of guiding it on parallel with the shaft, for it is almost sure to catch.

SECTION IV

DRILLING MACHINE

POSITIVELY LOCATED DRILL JIG

WITH this contrivance a piece with any number of holes may be jugged and drilled without any possibility of the jig rotating and becoming dangerous to the operator. Fig. 47 shows the arrangement.

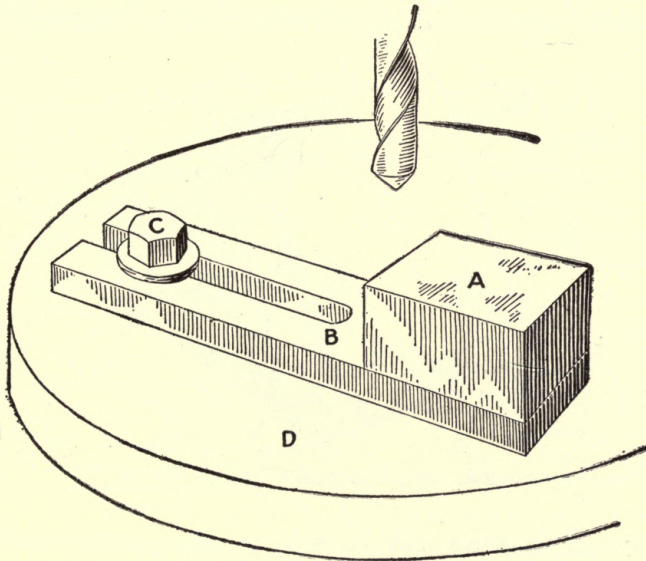

FIG. 47—POSITIVELY LOCATED DRILL JIG

A is the jig proper; *B* is a piece slotted as shown. It may be part of the jig or a piece attached to it in any manner best adapted to the general shape of the jig, so that it lies flat with the jig on the drill table. At *C* is a bolt threaded within the thickness of the piece *B* from the head of the bolt and having a diameter equal to the width of the slot, so that the piece can slide in any direction around the bolt.

The bolt is screwed into a hole tapped at one end of the drill table *D*. Then the jig can be slid to bring any hole into position directly beneath the drill, and the bolt will act as a stop and prevent the jig from rotating and working loose while drilling.

The jig can easily be taken from the table for inserting the work and may be dipped in a pail of washing soda for cleaning. The jig is easily positioned and easily handled.

AN ADJUSTABLE ANGLE IRON

After designing a drill jig for a piece of work that had five angular holes, besides a few straight ones, my next proposition was to design angle irons that would give the required angles.

Formerly all drill jigs used for drilling holes in a piece of work on an angle had a separate angle iron for each hole. My

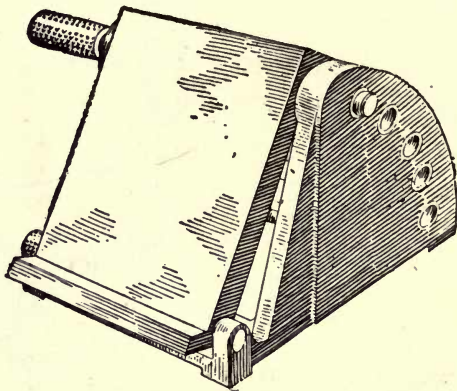

FIG. 48—ADJUSTABLE DRILL JIG

idea was to do away with all but one, thus cutting down expense.

Fig. 48 shows the main base made of cast iron, which holds the hardened and ground steel bushings that are inserted to give the different angles required.

The top plate, upon which the drill jig is set, swings on the lower pin and rests on the long locating pin with the knurled handle. The plate also has two small hardened steel plates screwed on, as shown. These take the wear on the hardened and ground steel locating pin.

It is well to stamp or in some way mark opposite each hole the angle it is for.

This angle iron proved very satisfactory, and the design was followed out in all others that were made. We found that the adjustable type not only cut down tool expense and the bother of having five angle irons around the drill press, but also considerably increased production.

MAKING ANGLE-FACED WASHERS

A large number of taper washers like the one shown in Fig. 49 were being called for made of duralumin. The first order was for 10,000 and the way we got at the job may be of interest. The blanks were punched accurately to size from sheets, after

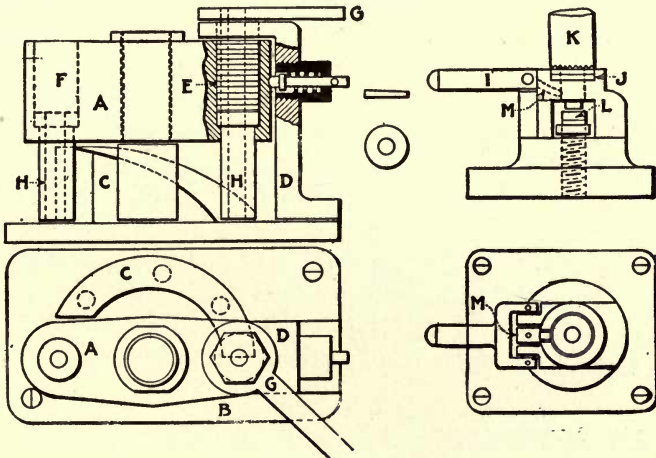

FIG. 49—FIXTURE FOR MAKING TAPERED WASHERS

which they were inserted in the fixture shown at the left for drilling the hole. This fixture was built up principally from scrap and is not difficult to make. The holder A had previously done duty as the bridge piece of a stop valve, and the baseplate B is made from mild-steel plate. The inclined-plane piece C was forged and pinned on as was bracket D. A number of washers are shown in position for drilling in recess E while recess F is ready for loading. The washers are clamped by the

threaded guide bushing, operated by means of the handle *G*, onto the bolster *H*.

A small sensitive drilling machine is used, and when the washers are in the position the power feed is put on and the operator then loads recess *F*. An automatic trip is used, and when drilling is completed handle *G* is pushed back and holder *A* turned half round, bringing the next dozen washers in position. When turning, bolster *H* travels up *C*, ejecting the finished washers, the operator catching these with his left hand. With this fixture practically continuous drilling is obtained and very little skill is required; in fact the most difficult part at first was to have the hand in position as the washers were ejected, otherwise some fell on the table and the remainder dropped back into the recess when the bolster dropped.

After the drilling the washers are placed in the chuck shown at the right, which is operated by handle *I*. Beneath the washer a steel washer *J* is placed as a packing piece. It raises the work slightly above the chuck and by means of the counter-bore *K* one side of the washer is faced, the depth being regulated by means of the pilot coming in contact with stop *L*. An ejector *M* is arranged in conjunction with handle *I* to lift the work when the handle is pushed down and the chuck released. For facing the opposite side of the washer the same fixture is used, with the substitution of a steel packing piece of exactly the same angle as a finished washer for the packing piece *J*. Although close limits are required for thickness and angle and smooth faces these methods proved very satisfactory.

AN ADJUSTABLE JIG FOR DRILLING ROUND PIECES

A handy tool for service around a sensitive drilling machine is shown in Fig. 50. Small Vs are located on both the fixed and the movable jaws, and T-slots are provided at each end for bolting in position any small work that may require holding in an upright position.

Brackets are provided to clamp in any position in the slots, and carry the flat adjustable bar which is designed to hold drill bushings of various inside diameters as well as a clamping screw to hold any work that may be placed in the adjustable V

formed by the conjunction of the interlocking jaws. The bar is graduated for convenience in bringing the drill bushing to center in whatever position the jaw may be.

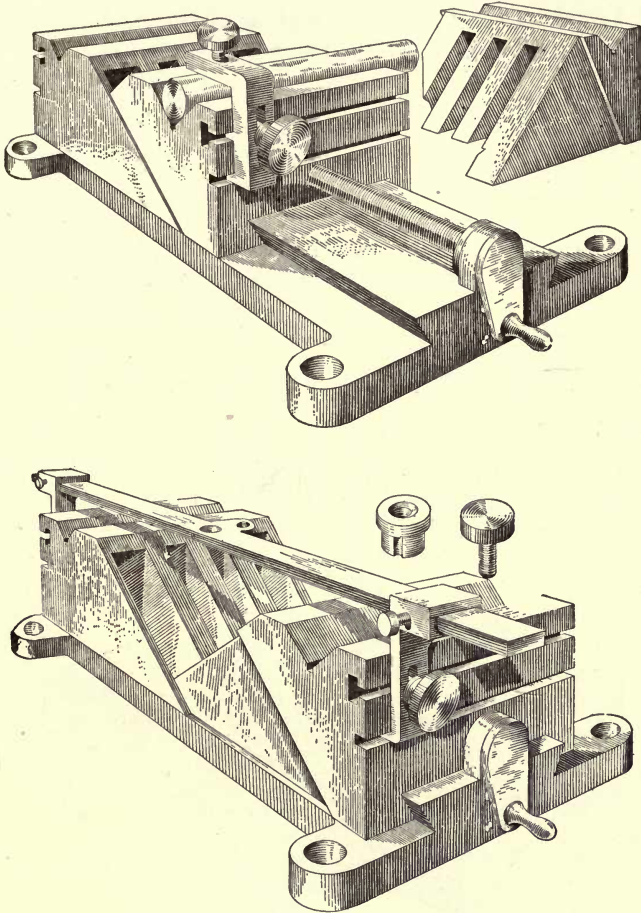

FIG. 50—AN ADJUSTABLE DRILL JIG

CUTTING HOLES IN GLASS

It is sometimes necessary on experimental work to drill holes in glass. A job of this kind came to us a short time ago, the work being to drill a $\frac{5}{8}$ -in. hole through the bottoms of six canning jars made of ordinary bottle glass.

If the glass is uniform in thickness and of a high grade, a hole can be drilled with a diamond drill, but where the thickness is not uniform and the glass is poor this cannot be done satisfactorily. It was found that where the bottom of the jar joined the sides the thickness of glass varied from $\frac{1}{8}$ to $\frac{1}{4}$ in. The result was that when we started to drill, the strain was

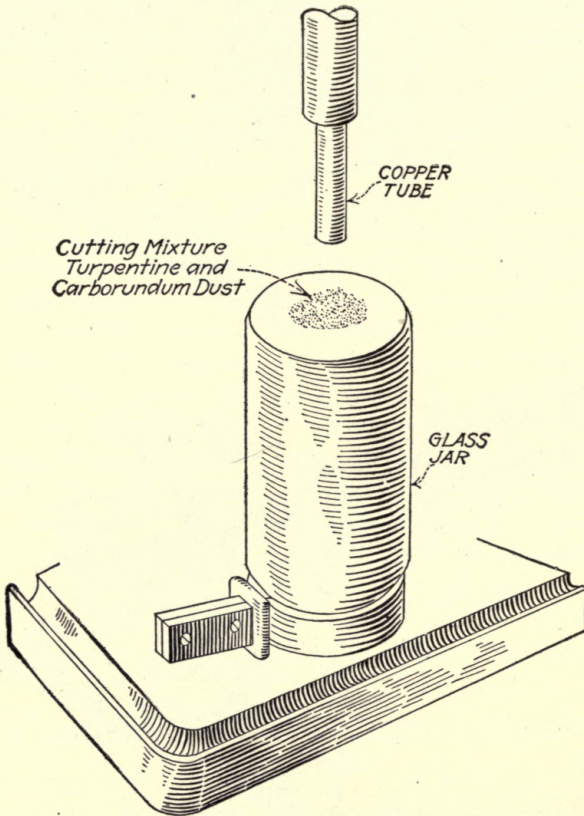

FIG. 51—DRILLING GLASS JARS

taken by the thin section of the bottom, which would crack and fall out.

After using different speeds and varying the cutting compounds the idea of drilling was given up and the following plan was hit upon, which worked successfully. We held a $\frac{5}{8}$ -in. copper tube in the chuck of a drilling machine and used turpen-

tine and carborundum dust for a cutting compound. The glass jar was placed on the table, inverted and firmly clamped. The operator put just enough pressure on the lever to keep the tool grinding and soon the hole was through.

We lost a few by this method, but it was because the bottoms were of varying thicknesses, also blowholes were found which tended to weaken the glass.

When selecting glass vessels to be drilled, select those that are of even thickness, and breakage will be practically eliminated. Fig. 51 is self-explanatory and shows the complete set-up.

Though I have not tried it I believe if the jar were set on a piece of felt and held by the hand the result would be as good as that obtained by clamping the jar.

A JIG FOR DRILLING STEEL DISKS

Fig. 52 shows a jig for centrally locating, drilling and reaming tool-steel disks. Besides being held between the jaws *A* and *B* the disk is held down by the bushing *C* that locates the hole. This bushing screws into the leaf of the jig and bears

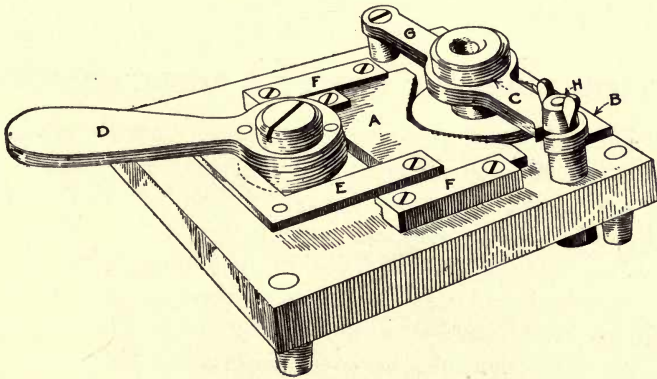

FIG. 52—JIG FOR DRILLING STEEL DISKS

upon the disk, thus preventing it from buckling, while the combination drill and reamer does its work.

The jaws are provided with fine teeth (about 50 to the inch) to hold the disk firmly and prevent it from turning. *A* is the sliding jaw, and it is actuated by the cam lever *D*. The yoke *E*

is not absolutely necessary, but it is an aid to rapid production.

The sliding jaw *A* is guided in its movement by the two pieces *F*. The leaf *G* turns upon a stud and is clamped in place by the thumbscrew *H*.

SMALL MOTOR-DRIVEN DRILLING MACHINE USED FOR TAPPING

I have been using a bench drilling machine for some time for the purpose of tapping small motor parts, such as rotors, journal boxes, frames, etc., driving by means of a d.-c. motor of $\frac{1}{2}$ hp. running 950 r.p.m. The reversal of the tap is accomplished by reversing the motor with a small switch operated by a treadle, a spring closing the circuit and running the motor forward, while pressure on the treadle reverses the motor and allows the tap to back out.

The field circuit in the motor is left closed to prevent sparking when the armature is reversed. To reduce tap breakage to the minimum the amount of torque is controlled by loosening or tightening the belt.

This idea, so far as I know, is original and I hope it may be of value to others.

INCREASING THE SIZE OF A SHELL REAMER

In the small job shop we get some strange work to do and have to do the best we can with the available equipment. In a hurry-up repair job it was necessary to ream four 3.005 in.-diameter holes in a gray-iron casting about 8 in. thick. These could be a plus-or-minus limit of 0.001 in. in diameter, but the holes must be round and straight. The casting, because of its size and shape, could not be handled in any lathe or boring mill we had, nor could the holes be bored with a bar without a lot of extra work, so I decided to drill and ream them. As we did not have an expanding reamer a mild-steel taper mandrel was fitted to a worn-out 3-in.-shell reamer, the mandrel being turned about 3 in. further than it would go into the reamer. A split bushing was then made to fill up the chamber in the center of reamer so that with this split bushing in place the hole in the reamer was a true taper hole.

The bushing was then sprung into the reamer, and both being brought to a good red heat the taper mandrel was driven in as quickly as possible until the reamer was stretched as much as was thought to be necessary. The reamer was then tempered, a new bar made for it, and it was ground to fit a collar that had been bored to 3.005 in. A test collar was then reamed, which proved to be right size. I did not grind the hole in the reamer nor the face of the flutes as would have been done if there had been sufficient time. By the time the reamer was ready the first hole in the casting had been drilled and reamed with a 3-in. standard reamer. The oversize reamer was then put through and the other holes machined in like manner. On installing this casting (in a hydraulic press) the job was found to be perfectly satisfactory and it was done in much less time than was anticipated.

ECONOMICAL HIGH-SPEED STEEL COUNTERBORE

In view of the present high price and the difficulty of obtaining high-speed steel, it behooves both designer and shop man to exercise their brains in the interest of conservation.

The accompanying sketch shows a method of making high-speed steel counterbores with a minimum of this expensive material.

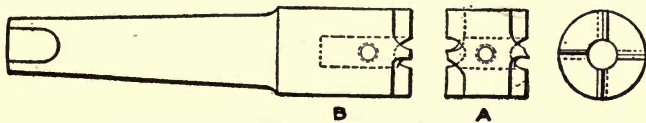

FIG. 53—ECONOMICAL HIGH-SPEED COUNTERBORE

The counterbore *A* is made double-ended with a center hole of suitable size passing clear through, and is tapped at the side, midway of its length, for a headless setscrew. The driver *B* is made of unhardened tool steel with same sized center hole as the counterbore; it is tapped on the side for the setscrew, and has teeth cut the same as in the counterbore, in order that the two parts will interlock when they are placed together. The pilot passes through the counterbore and is fastened by the setscrew in the driver. The setscrew in the counterbore is to prevent the

latter slipping off when pilots of the same size, or smaller, than the center hole are used.

A RADIUS-CUTTING BORING BAR

Having a steel casting to machine in a half circle with a 4-in. radius, and our lathe being too small to swing the casting, it may interest some of your readers to know how the work was done on a 21-in. upright drilling machine.

Fig. 54 shows the device assembled ready for work, also some of the details. Fig. 55 shows the work which has an opening

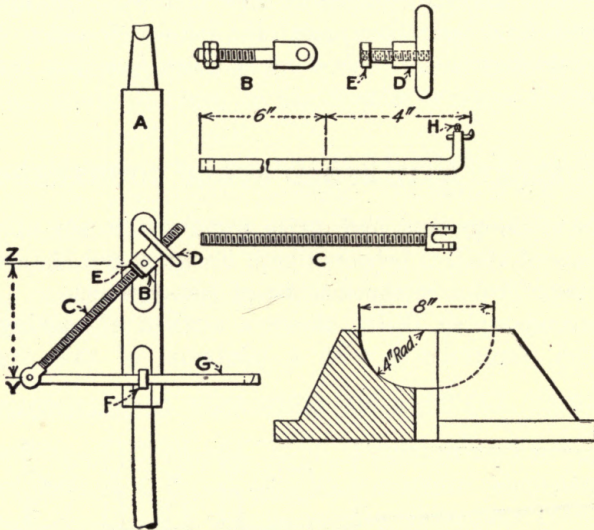

FIGS. 54 AND 55—THE BAR AND THE WORK

through it which permits the passage of the pilot of the boring bar. The boring bar A, Fig. 54, is similar to the one used in many shops for counterboring, and was made with a No. 2 Morse taper at its upper end, while the lower end was centered to run on a center secured to the base plate of the drilling machine, and running through the table of the latter. In this way the bar was kept from springing while taking a $\frac{1}{4}$ -in. cut.

A $\frac{5}{8}$ -in. hole was drilled through the bar, and it was then planed off on each side to afford a bearing for the stud B, the

shank of which was threaded and extended through the bar, and held in place by nuts. This stud *B* was provided with a $\frac{3}{4}$ -in. hole for the passage of the feed screw *C*, having a coupling yoke at its lower end, and receiving a feed nut *D*, which was made so that it would come up to the stud just tight enough to turn. The nut *D* was made with a $\frac{1}{2}$ -in., 20-thread hole tapped through, and was fitted on the feed screw, and extended through the opening in the stud *B*, where a collar *E* was pinned, so that the feed nut could turn freely and yet be securely fastened.

A $\frac{1}{2}$ -in. tapped hole was provided in the boring bar to receive a stud *F* on which the cutting bar *G* was pivoted. One end of cutting bar was journaled in the yoke of the feed screw. The cutting bar was of $\frac{3}{4}$ -in. square key stock, bent on one end to bring the cutting tool in line with the center of the bar, as shown at *H*.

Care should be taken to have the length of the cutting bar *G* from its center, where it is mounted on the stud *F* to the point of its connection with the feed screw, equal to the distance from *Y* to *Z*.

The action of the device is simple. When the drill is started the cutting tool is fed to the work by turning the feed nut *D*.

FIXTURE FOR DRILLING SMALL HOLES

In the production of percussion pellets for time fuses, the tooling on the automatic screw machines which produced these parts, was such that it was impossible to counterbore the small hole in the end of the pellet. This operation was therefore done

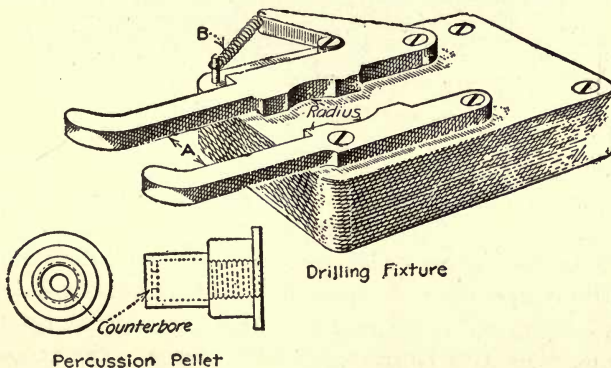

FIG. 56—FIXTURE FOR DRILLING SMALL HOLES

on a drilling machine with the fixture illustrated in Fig. 56. The base of the fixture was made as thin as possible so that the operator could rest arms and hands on the drilling-machine platen in order to operate the fixture with the least amount of effort. The handles were gripped in the left hand, and a definite number of pellets found their way through an orifice in an elevated box, down a chute to the drilling-machine platen.

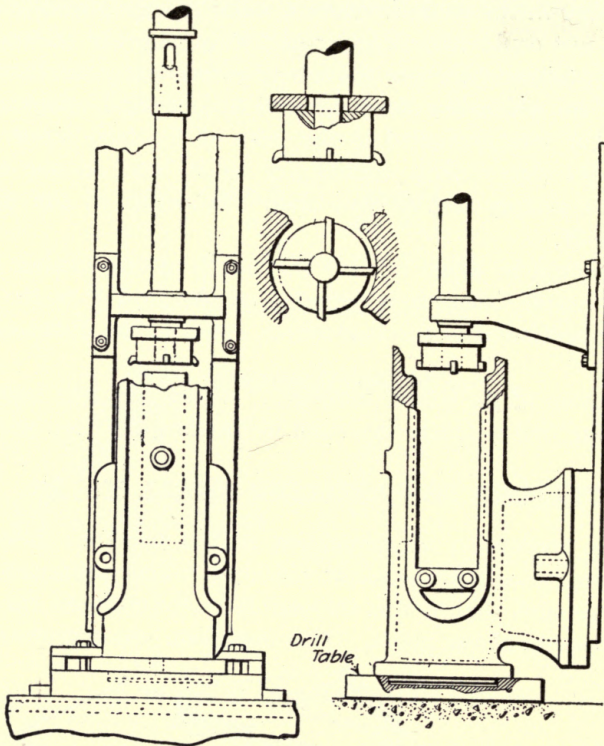

FIG. 57—BORING ENGINE GUIDES

The pellets were placed on their correct ends for drilling, and fed along one after the other. An undrilled pellet pushes one that is drilled out of the fixture down another chute and into a box. This feeding operation was done without interfering with the drilling operation, because the drill spindle was operated with a 5-ft. treadle. The spindle speed was 8000 r.p.m., and the production in 9 hours was 15,000 pieces. The recesses cut in the clamps *A*, center the pellet while the pilot on the counter-

bore, insures concentricity. The compression spring *B* for holding the clamps open was discarded, as the operator found it unnecessary for this class of work. For some kinds of work, however, it would be an advantage.

BORING ENGINE GUIDES

Fig. 57 shows how a small machine shop tackled the problem of boring the guides of a small engine. The only machine available for the job was an upright drilling machine. There was no possibility of supporting the bar at both ends, as the hole next to the table was too small. A guide was rigged up as shown, clamped to the sides of the drilling machine and the engine casting located on parallels. A boring head with the roughing tools in advance of the finishing tools, and a roller steady immediately behind them, made a good speed job.

DRILL JIG FOR Y CONNECTIONS

In the illustration is shown a simple and very effective drill jig for small Y-shaped castings. These castings, which are made

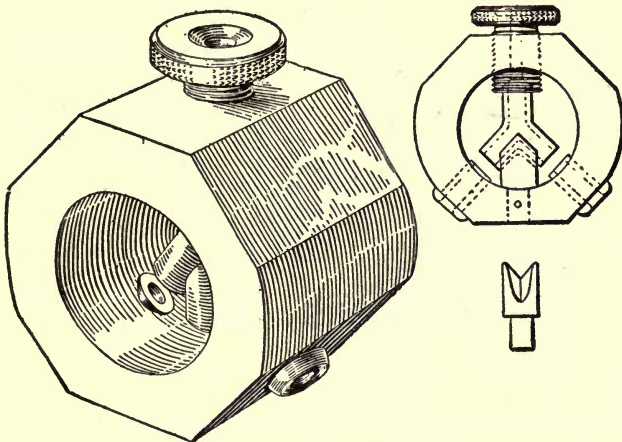

FIG. 58—DRILL JIG FOR Y CONNECTIONS

of brass, are used in considerable quantities as soldered unions in oil pipes, gas lines, etc. The holes are drilled for $\frac{1}{4}$ -in. tubing.

The body of the jig is of steel, about $1\frac{1}{4}$ in. thick, originally a round piece about 4 in. in diameter. The central hole is bored, and the piece is given six flats, as it is drilled from three directions.

The knurled screw bushing in the top is bell mouthed to center the casting, and forces it down into the double V-block milled from a round pin. A side view of the V-block is given; it has 90-deg. notches milled in 45 deg. each way from the center line.

The thread on the screw bushing is cut eight to the inch and $\frac{3}{4}$ in. in diameter. Two turns of this screw release the casting completely. As may be imagined, it is quite rapid in operation, the rate being about 175 to 200 pieces per hour per operator.

REDUCTION HEAD FOR DRILLING MACHINE

Fig. 59 shows a specially designed gear reduction head to be used in connection with the drilling-machine spindle, where low

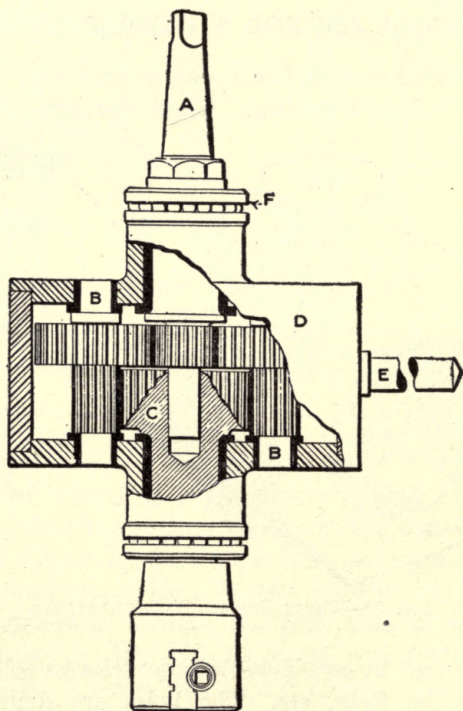

FIG. 59—GEARED REDUCTION HEAD

speeds are not available. This head may be designed to give any gear ratio required, according to the safety strength limit of the drilling spindle and the nature of the work being done. The head is able to clean up castings that have too large a projecting portion to be conveniently swung in a lathe, and as an auxiliary to the milling machine it will prove very handy.

At *A* is the driveshaft, fitted the drilling-machine spindle. The latter on its lower end, is cut to form a pinion, engaging in the two idler gears *B*. These idler gears are compound, having been stepped down, and in turn they engage in the reduction shaft *C*. The idler gears, being mounted in a floating case *D*, have a tendency to turn backward or creep around the reduction shaft when load is applied; but this action is prevented by applying to the case a rod *E*, which is allowed to rest on the upright of the drilling machine. There is a bearing of the extreme end of the shaft *A* in the shaft *C*; this gives rigidity and prevents wobble, while the ball races *F* take up all the end thrust.

A great variety of work can be done with this head, especially in experimental shops and jobbing shops. It will be found to be a very accurate and handy tool for reaming and in using fly cutters.

DRILLING MACHINE MADE INTO A PRESS

Having to pierce a great many holes varying from $\frac{1}{8}$ to $\frac{7}{16}$ in. in diameter in strip brass from No. 20 to No. 14 gage and in sheet steel No. 24 gage, I considered drilling too long an operation. Therefore, I constructed the attachment in Fig. 60, making of the drilling machine a very serviceable and efficient punch press. I removed the pinion that engages the rack on the quill and bushed the hole, allowing passage for the $\frac{1}{2}$ -in. bolt *A*. I then bent the piece of $1\frac{1}{2} \times \frac{5}{16}$ -in. flat iron *B*, forming the handle and half the toggle. Two straight pieces *C* of the same stock completed the toggle. Another piece of the same flat was bent into a U and drilled for a $\frac{1}{2}$ -in. bolt at *D*, so that it just rested on the top of the frame when the flat was up against the under side. A light tie-rod *E*, of $\frac{3}{8}$ -in. round iron threaded on the ends for nuts, held a section of 2-in. angle iron, thus supporting and taking the pressure from the table. The spindle was raised to its limit and locked by the take-up screws *F*. To elim-

inate any further motion, a $\frac{1}{4}$ -in. stud was passed through the tang slot and screwed into a tapped hole in the head *H*, the tightening screws of which were drawn up just so the head could slide on its ways *I*.

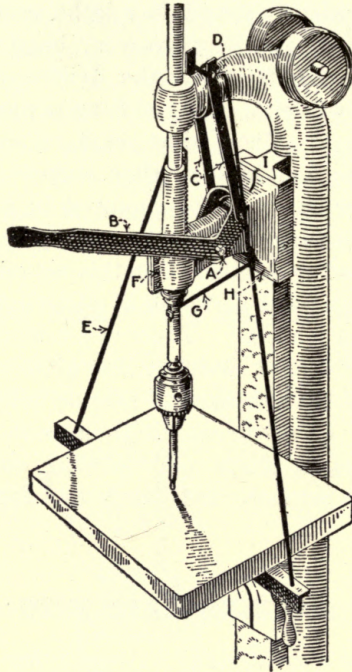

FIG. 60—DRILLING MACHINE USED AS A PUNCH PRESS

With this arrangement I secured a $\frac{3}{8}$ -in. stroke and pierced $\frac{1}{16}$ -in. holes in No. 20 gage brass without the slightest difficulty.

SPECIAL COUNTERSINKING TOOL

The device shown in Fig. 61 has been used successfully to countersink a hole where it breaks through into a slot, as designated at *C*. According to the dimensions given, of course, the tool is adaptable only to this particular job. However, it may suggest a principle that could be applied to similar conditions. *A* is a piece of $\frac{3}{16}$ -in. drill rod slotted to take the pivoted cutter *B*, which is kept in the position indicated at *B* by centrifugal force. On entering the hole in *C*, the extending end is shoved

back, which brings the lower end out into the slot in position to cut. A hardened collar serves as a stop to regulate the cut and prevents the cutter from digging into the work.

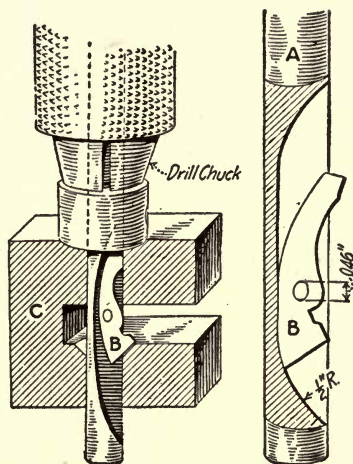

FIG. 61—SPECIAL COUNTERSINKING TOOL

RECESSING TOOL

The machining of a recess in a small cylinder to very accurate limits has caused considerable trouble, so I have designed for the operation the tool shown in Fig. 62. This tool can be applied to any vertical drilling-machine chuck or to any automatic lathe.

The guiding bushing *E* enters the bore of the cylinder to be recessed, until the end of the cylinder comes in contact with the stop ring *D*, which rides on the balls *M*. Further movement of the tool causes the driving shaft *A* to press against the spring *B*, and the tapered end of the driving shaft then engages in a conical hole in the sliding toolholder *C*, causing the tool to move radially and cut the recess.

The adjusting nut *F* limits the movement of the driving shaft, thus controlling the depth of the recess. The spring *H* returns the sliding toolholder to its original position, so that the tool is in the position shown in the sectional view. When thus located the drilling spindle is raised and the tool withdrawn from the hole without touching it.

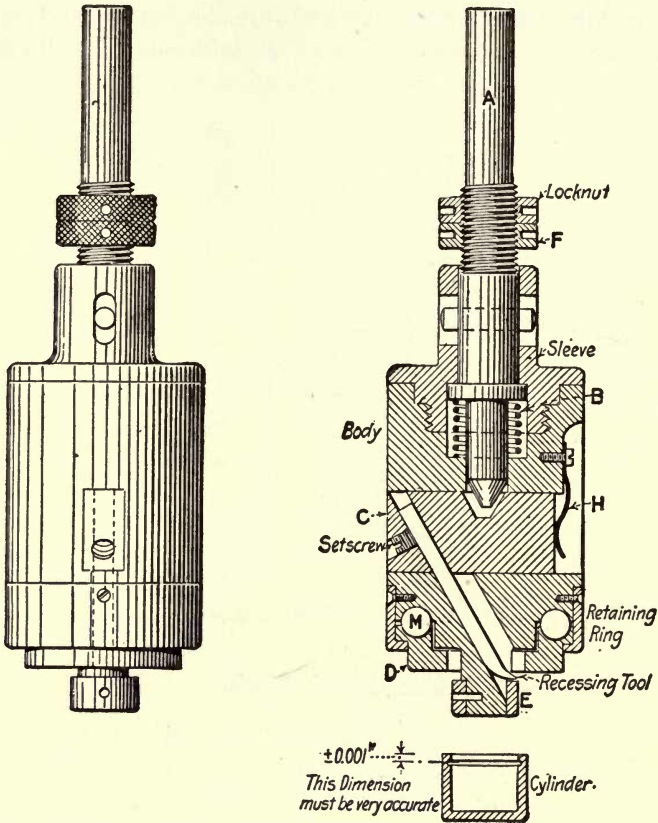

FIG. 62—RECESSING TOOL FOR ACCURATE WORK

DRILL-CENTERING DEVICE FOR V-BLOCKS

To make a quick and accurate job of drilling holes in small round stock such as may be required in the general work of the toolroom is not always an easy task. No matter how carefully the job may be laid off or how warily the drill may be coaxed to straddle the curved surface, the resulting hole is never a safe bet. The device illustrated in Fig. 63 stops the uncertainty and saves much time besides. In reality, it is an attachment for a V-block about the size of the ordinary tool-makers' block sold by the Starrett and the Brown & Sharpe companies. The size described here was designed for the kit of the workman at the bench, but the field of usefulness could easily be enlarged.

Made up on a little larger scale, it would be handy as a general toolroom fixture.

The capacity is for stock from $\frac{1}{16}$ to $1\frac{1}{4}$ in., and for holes from $\frac{1}{16}$ to $\frac{1}{4}$ in. The outside diameter of the bushings is $\frac{3}{8}$ in. They are a slip fit in the holder and are prevented from turning by a small set-screw tightened against a small flat, ground on the side. The holder is a close sliding fit between the ways and is clamped at any height by the thumb-screw at the back.

After the piece to be drilled is clamped down in the V, a bush-

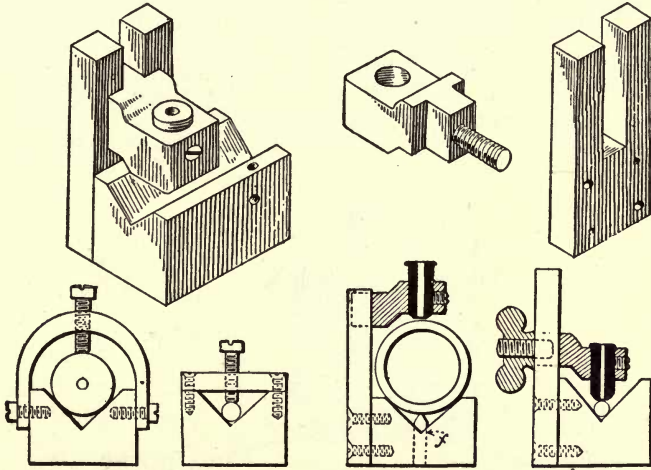

FIG. 63—V-BLOCK WITH BUSHING HOLDER

ing of the size desired is placed in the holder, which is then adjusted on the ways so as to bring the lower end of the bushing close to the work, thus dispensing with laying off or using care in centering. In slotting small cutter bars, for example, it is required that the bulk of stock be removed by drilling to leave the slots in shape for finishing with an end mill or the more primitive way—filing.

First, mark the center of the radius at one end of the slot and clamp the piece in position. Then with the V-block in place on the drill table or other flat plate, fasten a lathe dog or similar device on the free end of the work being drilled, so that the tail rests against the plate. This will keep the row of holes in line, and they can be so far overlapped that very little stock will be left, thus making a quick job in the finishing.

In connection with the slot drilling, it will be well to mention the sliding center point, which is placed at the bottom of the V, in the center line of the drill bushing. This center, having an angle somewhat sharper than a drill, is a close sliding fit so that it may be easily removed after the work is located and clamped in position. If a hole must be accurate in distance or angle with other parts, it can be marked and punched and this center point be brought up in the punch mark to locate it. The main use for the centering point, however, is to locate holes diametrically opposite in tubing or other work, as shown in the cross-section sketch. In drilling small holes through work of comparatively large diameter where the stock is tough, it is better to drill halfway through, then turn the piece halfway over, locate it and finish from the opposite side.

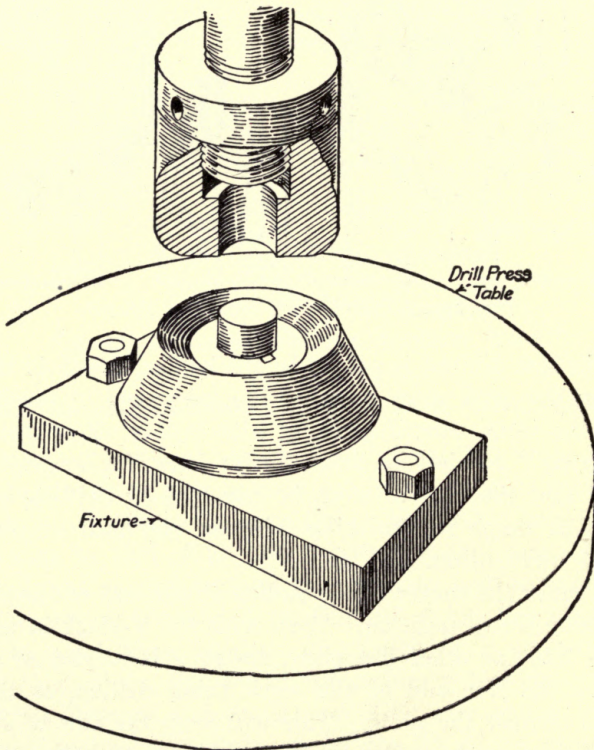

FIG. 64—SWEEP TOOL FACING THE BEVEL GEAR

MACHINING BEVEL PINIONS

About three years ago, while with a large auto concern in Detroit, I worked out a tool set-up for machining the main-bevel drive pinion shown in Figs. 64 and 65.

The first operation—to finish the taper hole and face back—is done in a screw machine or automatic turret lathe. Operation 2—keyseating—is done on any keyseater.

Operation 3—finishing the front face and angle—is done in a high-speed drill press by the tool shown in Fig. 64. The holding fixture consists of a hardened taper pin in a steel block with a fixed key. The gear is placed on the taper pin and swept to form and size by the high-speed facing-form tool in the drill-press spindle, which pilots on the taper pin in the table fixture. The end of the shank extends into the pilot hole in the form-fac-

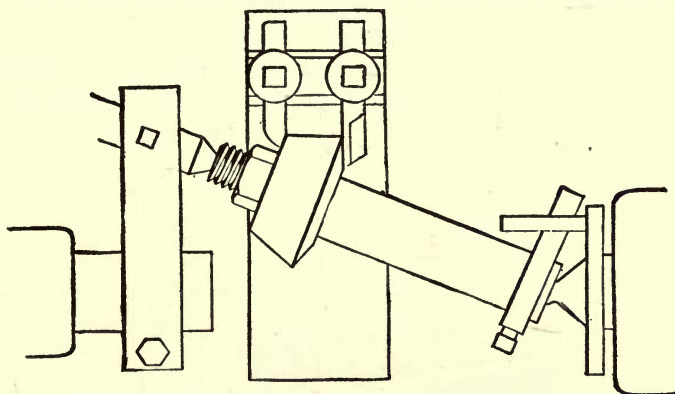

FIG. 65—THE LATHE SET UP FOR BACK AND FRONT

ing tool, and the form tool is threaded and secured by a locknut on the spindle. This allows an adjustment for grinding and also for maintaining the correct thickness of the blank, as the tool is forced by hand until the reduced end of the shank bears on the pilot of the taper pin, always assuring a close dimension.

Operation 4 is done in a lathe with the equipment sketched in Fig. 65. The headstock spindle is fitted with a ball center; the tailstock spindle has an arm with the center set at an angle and off center to correspond with the face angle of the pinion. The lathe is equipped with two toolposts, one for finishing the back angle and one for turning the outside diameter.

After the size is secured, the cross-slide is locked and not moved. When the cut is finished, the ball-center arbor with the gear is removed, the carriage run back, another arbor with gear put in, the back angle finished first by forcing the carriage back to a stop, then the outside cut started. While this is going across, the operator removes the finished gear from the second arbor and places an unfinished blank on it; consequently, a continuous operation is secured.

On operation 3—facing the end of the blank—it is possible to get 200 per hour from nickel alloy blanks about $3\frac{1}{4}$ in. in diameter.

On operation 4—facing the back angle and turning outside diameter—the rate was 25 per hour on the same-sized blank.

SIMPLE DRILLING JIG FOR USE ON A YOKE CASTING

The jig shown in Fig. 66 for drilling two $\frac{9}{16}$ -in. holes through the yoke casting *D* is inexpensive and can be quickly made.

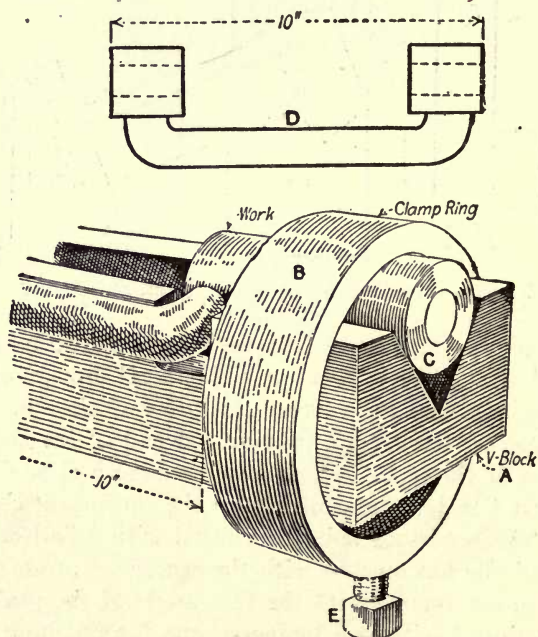

FIG. 66—DRILL JIG FOR A YOKE

One end of the jig is shown in the perspective; the opposite end is rigged up the same.

The V-block *A* and the two clamping rings *B* were made of scrap. The two pilot bushings *C* have the same diameter as the bearings to be drilled. The bushings *C* are clamped in the V-block *A* by means of the clamping ring *B* and the setscrews *E*.

Two lengths of the yoke castings *D* can be drilled on this jig, with overall dimensions of 10 and $8\frac{15}{16}$ in. respectively. The jig can be changed instantly for either job.

The drilling is done in a drilling machine, the jig resting on a center in the table. The top hole is drilled and the jig reversed for the other hole.

SECTION V

ENGINE LATHE

THREADING DIAL

ALTHOUGH the lathe is generally regarded as the simplest of all machine tools, it is doubtful if any mechanical feature is as little understood by the average mechanic as the lathe threading dial. If used according to the directions, it generally produces the desired result; but how and why is to most machinists a hidden mystery.

In order to explain fully the mechanism, certain things must be emphasized: First, most lathes have 6-pitch lead screws; next, the threading dial is divided into ten parts by five long and five short lines. By counting the number of teeth on the worm gear that meshes with the lead screw at the bottom of the dial shaft, it will be found that there are 38. Therefore, 30 turns of the lead screw will cause one revolution of the dial; or six turns of the 6-pitch lead screw, which is 1-in. travel, will move the dial one-fifth revolution, or from one long line to the next long line. The space between any two long lines or any two short lines on the dial represents 1-in. travel of the lead screw. The space between a long and a short line would consequently mean $\frac{1}{2}$ -in. travel of the lead screw. Therefore, when chasing threads which are an even number per inch, as eight, for example, the carriage can be moved from one line to the next, or $\frac{1}{2}$ in., which equals four threads of the eight on the work, thus allowing the threading tool to enter the work thread properly. Hence, the rule on the dial, "When chasing even threads, engage nut at any line."

For chasing odd threads, such as 13, it will be plainly seen that by moving the carriage one division of the dial, or $\frac{1}{2}$ in., the threading tool will be moved $\frac{1}{2}$ in. along the work, or $6\frac{1}{2}$ threads. If the nut is engaged at this point, the threading tool will enter the work at $6\frac{1}{2}$ threads, thus splitting the thread;

but by moving the carriage from a short line to a short line, the carriage is moved 1 in., or 13 threads, which allows the threading tool to enter the work thread properly. Hence, the rule on the dial, "When chasing odd threads, engage nut on short lines only," or on the long lines only, if that threading was started on a long line.

By observing the dial again, it will be seen that the long lines are numbered 1, 2, 3, 4 and 0. The following will explain why: Suppose the pitch of the work thread is $4\frac{1}{2}$. By moving the carriage one mark, or $\frac{1}{2}$ in., we get $2\frac{1}{4}$ threads on the work. This will not allow the tool to drop into the work thread. By moving the carriage from a long line to a long line, or 1 in., we get $4\frac{1}{2}$ threads on the work, which still will not allow the tool to engage the work thread. But by moving the carriage two long lines, or 2 in., we get nine threads on the work, which allows the threading tool to engage the work thread properly. Hence, the following rule, which I have never yet seen on a machine, but which is generally to be found under the hat of a good mechanic: "When chasing threads of a pitch involving one-half of the thread in each inch, as $4\frac{1}{2}$, engage the feed nut at line 1 for the first cut; for the second cut, skip one long line and engage on line 3; for the third cut, engage at 5, and so on until the thread is finished.

BREAKAGE OF ROUGHING TOOLS

Considerable trouble had been experienced in having high-speed roughing tools break in two in the middle directly under the screw of the toolpost. Sometimes they would even break when a very light cut was being taken.

On first thought, I attributed the breakage to cracks caused by a flaw in the steel or improper heat treatment, but upon making a very careful examination of a number of these fractures I could discern no trace of a flaw or crack in the steel.

I reduced this trouble to a minimum by placing under each tool, after it was placed in the toolpost, a piece of $\frac{1}{4}$ -in. flat iron the width of the tool and about 6 in. long. This, acting as a cushion, tended to overcome the unevenness of the bottom of the tool caused by redressing and treating.

SPHERICAL TURNING WORK

At the top in Fig. 67 is shown a low-pressure air compressor piston for which it was necessary to devise some rapid as well as accurate means of turning the spherical surface *A*. The work, illustrated in dotted lines, is placed on the cast-iron centering block *F*, which has a hardened steel-center bushing *G*, and fits snugly to the $6\frac{3}{4}$ in. inside diameter of the piston. On the other end is clamped a lathe dog *E*, driven by the faceplate, and the work is ready to put on the lathe.

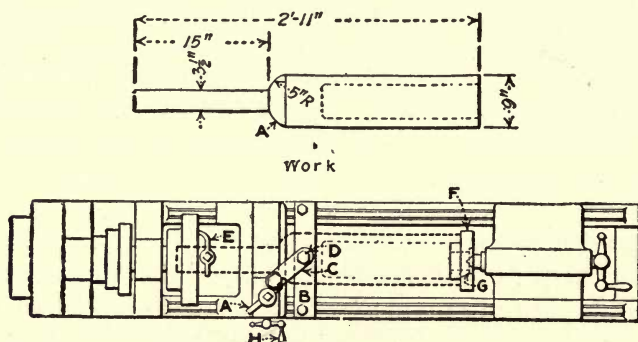

Turning Fixture
FIG. 67—SPHERICAL TURNING

B is a machinery steel plate about 3 in. wide and $1\frac{1}{4}$ in. thick, fastened securely to the bed of the lathe with 1-in. capscrews. The swivel link *C* is $1\frac{1}{2}$ in. wide by $\frac{5}{8}$ in. thick made from machinery steel and case-hardened. This link is fastened to the strip *B*, and to the cross slide by means of two case-hardened machinery steel studs *D*, allowing the link to swivel as the tool is fed in.

The tool is held in the toolholder on the cross slide, and the carriage is loose to allow free movement along the ways. As the cross-slide is fed in by the handwheel *H*, the link forces the carriage toward the head end and causes the tool to travel on the required radius. The center distance between the studs in the link *C* is 5 in., the same as the radius on the finished piston and the center of the stud *D*, and is located directly under the center of the radius on the piston. This rigging is inexpensive and efficient, giving highly satisfactory results.

A SAFETY LATHE DOG

Fig. 68 shows a means of making the ordinary lathe dog a safety one. A piece of cold-rolled steel *A* is bent in circular form with its ends flattened. These flattened ends are pro-

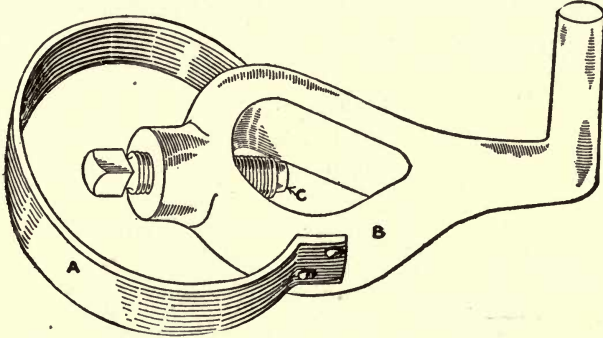

FIG. 68—SAFETY LATHE DOG

vided with holes to receive screws for attachment to the lathe dog *B* as shown. This steel piece is of such size that the clamping screw *C* is permitted to clear the opening in the dog which receives the stock.

CHUCK WRENCH REPAIRS

We had considerable breakage and wear on chuck wrenches and decided upon the following procedure: An apprentice was

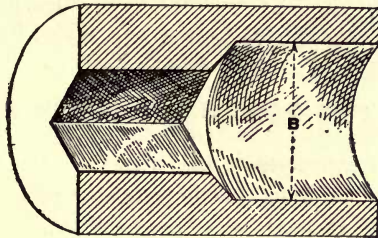

FIG. 69—CHUCK WRENCH END

given the job of turning up a number of bushings as shown in Fig. 69. The blacksmith heated them and drove a square drift through the small end. The hole at the end *B* was made a size suitable for a shrink fit on the shank of the old wrench.

EMERGENCY FOLLOW REST

A few days ago, while passing through the shop, I noticed an "old-timer" turning a small long shaft on a large lathe, an emergency job. His steadyrest jaws could not reach so small a shaft, and the shaft was too long to be turned without a rest of some description. He took a straight-tailed dog, put it on

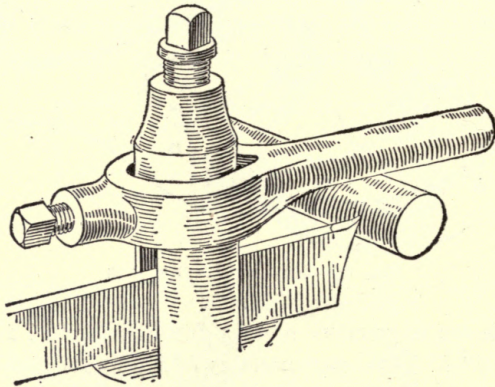

FIG. 70—EMERGENCY FOLLOW REST

over the tool post in the manner shown in Fig. 70 and adjusted it to bear upon the shaft. He had a follow rest that, so far as doing the work effectively, could not well be beaten. The job was turned smooth, without chatter and in record time.

When I felt obliged to commend him, he replied that he had used the same method years before.

FACING THE BOSS ON A LARGE CASTING

Some time ago some castings weighing about two tons each were delivered to our shop for the purpose of having a boss that was on one end of the castings faced off. There were no planing machines in the shop large enough to do the work nor had we any convenient means of handling such heavy pieces, therefore it was necessary not only to devise a way of removing the stock, but to do it in such a manner as to involve the least amount of handling, both of which requirements were met as here described.

The set-up is shown in Fig. 71. Two 18-in. I-beams were bolted to the floor plate of a radial drilling machine, parallel and a convenient distance apart, to which at one end was bolted the headstock of a lathe in position to bring the cone into alignment with the cone of the radial, the drive being by belt from the latter.

On the faceplate of the lathe was bolted a facing attachment.

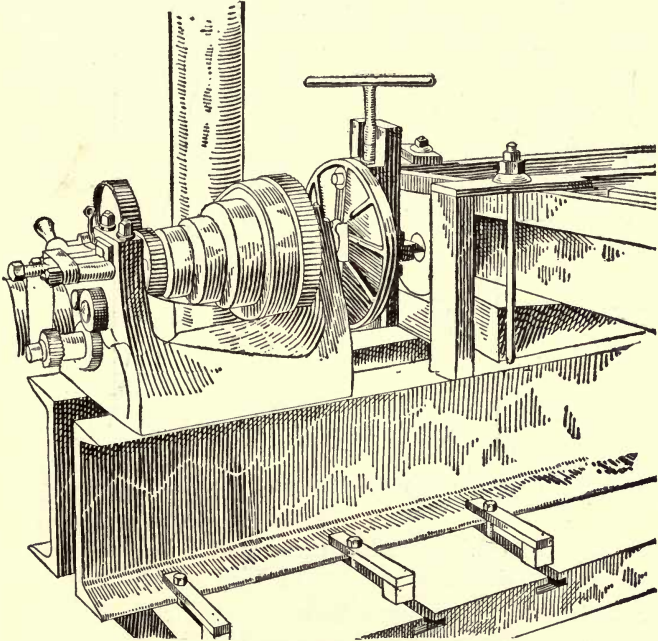

FIG. 71—FACING A BOSS ON A LARGE CASTING

The castings were put in place with a couple of chain blocks, bars, roller, etc., and secured in position by long T-head bolts running down to the slots in the floor plate.

The time required to face each casting was about 45 min., and the operation did not interfere with the continuous use of the drilling machine.

ANGLES FOR SQUARE-THREADING TOOLS

When cutting square threads some workmen are inclined to grind the tool as shown at *A*, Fig. 72, and while favorable re-

sults are sometimes obtained, the sketch *B* will enable the mechanic more readily to obtain the requisite clearance or angle.

The sides of the cutting tool must be inclined from a vertical line, the amount depending upon the diameter of the screw and the pitch of thread. The inclination of clearance may be obtained as shown at *C*.

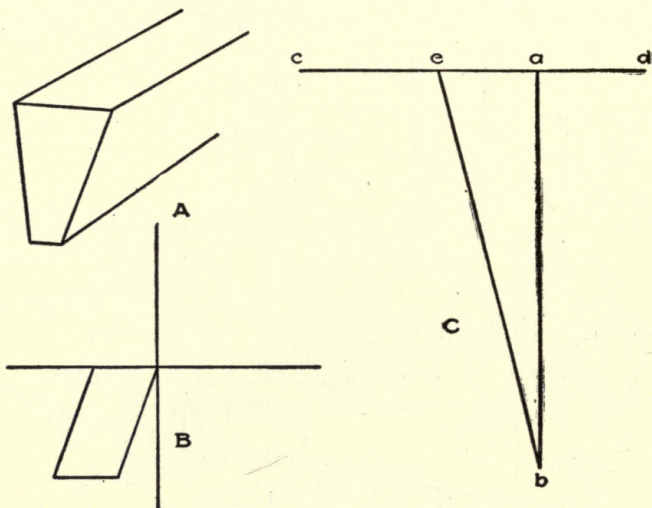

FIG. 72—ANGLES FOR SQUARE THREADING TOOLS

The line *ab* is vertical and at right angles to *cd*, and in length is equal to the circumference of the root of the thread. On *cd* lay off the point *e* a distance from *a* corresponding to the pitch of the thread. The line *be* represents the angle of the side of the thread. To insure sufficient clearance for the tool the side angle of the tool should be greater than the line drawn.

FINISH-TURNING WITH STELLITE

It is generally conceded that Stellite is not adapted to finish-turning steel shafting of any description. We have found lately, however, that we can produce an excellent finish at much greater speed than any other tools known, Fig. 73 showing how the operation was accomplished.

All of the particulars outlined are essential, as by eliminating any one of them it is impossible to get the proper results.

First we took a very broad-nosed tool, set the cutting edge about $\frac{1}{8}$ in. above center, giving it an angle of about 10 deg. for rough turning and 20 deg. for finishing-turning. We did this on an ordinary shaft-turning lathe, the tools being $2 \times \frac{5}{8} \times 4$ in., using our No. 2 Stellite at a surface speed of 97 ft., depth of cut $\frac{1}{32}$ in. and feeding 3 ft. per minute, turning six 30-ft. shafts to a 0.001 in. limit with one grind.

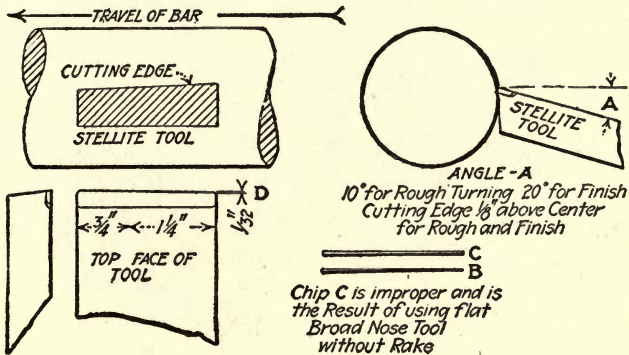

RECORD OF PERFORMANCE

Work - Open Hearth Steel Shafting
 Machine - Shaft Turning Lathe
 Tool - $2 \times \frac{5}{8} \times 4$ Stellite No. 2
 Surface Speed - 97 Feet
 Depth of Cut - $\frac{1}{32}$ "
 Feed - 3 Feet per Minute
 Remarks - Six 30 Feet Shafts turned
 to 0.001" Limit with one Grind

To get the required Polish and hold Shaft to Size Edge of Tool must taper back towards Center as shown at 'D' so that back Side of Tool takes a very Light Shaving Cut turning Chip as shown in 'B'

FIG. 73—FINISH BURNING WITH STELLITE

To produce this result we tapered the tool back, as shown at A, giving it $\frac{1}{32}$ -in. taper about $1\frac{1}{4}$ in. back. This leaves the tool cutting the full $1\frac{1}{4}$ in. and dragging the other $\frac{3}{4}$ in. with a side rake sufficient to cut a chip shown at B. We found that the shape indicated at C was incorrect and was the result of using a flat, broadnosed tool.

SELF-CENTERING WORK CARRIER FOR USE IN A STEADYREST

Fig. 74 shows a self-centering work carrier, or chuck, designed for the purpose of supporting unfinished bars of round section in the steadyrest when the number of pieces required is

too large to warrant centering each piece and turning a place for the steadyrest jaws and yet requires too accurate internal work to allow them to be run upon the rough surface of the bar.

The illustration is almost self-explanatory. The outer ring is of cast iron turned on the outside to receive the jaws of the

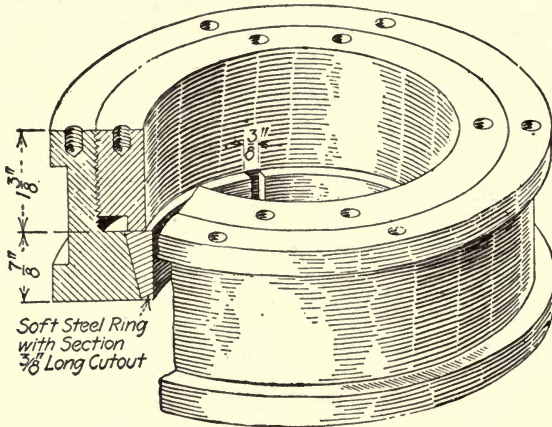

FIG. 74—RING CHUCK FOR THE STEADYREST

steadyrest, and on the inside a portion is threaded for the pressure ring, while the remainder is bored taper to fit the outside of the split clamping ring.

A clamping ring is required for each size of stock to be used. To tighten the carrier on the stock the outer ring is held by a spanner while the threaded pressure ring is turned in by a second spanner.

QUICK REPAIR FOR TAIL SPINDLE OF LATHE

Fig. 75 shows a quick-repair nut for the tail spindle of a lathe. I have charge of a number of lathes and cannot have them down very long for repairs, therefore I keep three of these nuts in stock at all times and a repair is made in 10 minutes.

Part *A* fits into part *B* and part *C* screws into part *B* against part *A*. A key in part *B* prevents part *A* from turning, and part *C* has a flat ground on it to let part *B* pass over the key that is in the tailstock. The reason for this flat is that the keyway in part *B* breaks through into the threaded hole.

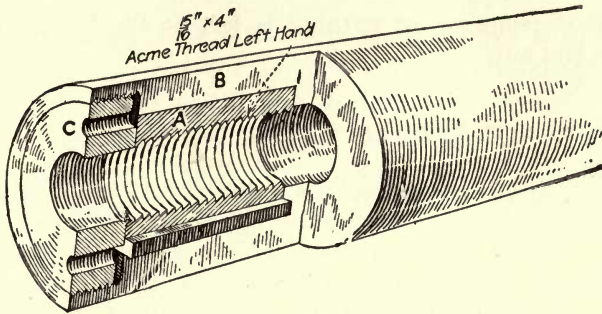

FIG. 75—RENEWABLE TAIL SPINDLE NUT

QUICK METHOD OF THREADING SMALL CAST-BRASS RINGS

Having several thousand small cast-brass rings upon which to cut external threads the writer proceeded to do the work in the manner shown in Fig. 76. The ring had a division through the center, which furnished a ready means of holding. A threading die was made from a square piece of steel and held

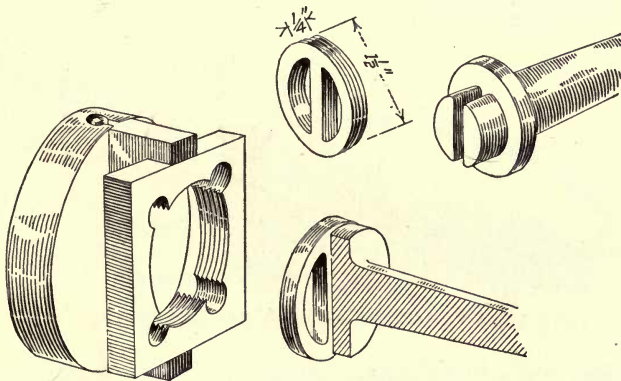

FIG. 76—THREADING BRASS RINGS

in the chuck of the speed lathe while the rings were fed up to and through the die by the hand-operated tail spindle.

The operation was continuous, the rings being fed clear through the die and dropped out of the opening between the chuck jaws. To prevent the rings from being thrown by the chuck a guard of wood was built over it, and far enough away

to prevent jamming an opening is left at the bottom for the rings to roll out.

IMPROVED LATHE CENTERS

A lathe center with a high-speed-steel insert seems to be little known except by those who have had trouble with carbon-steel centers. I have used centers of this material for eight years on speed and engine lathes up to 87 in. swing and upon various grades and weights of work up to 2500 lb., and during this period I have experienced no trouble from centers softening or seizing and wringing off in the work.

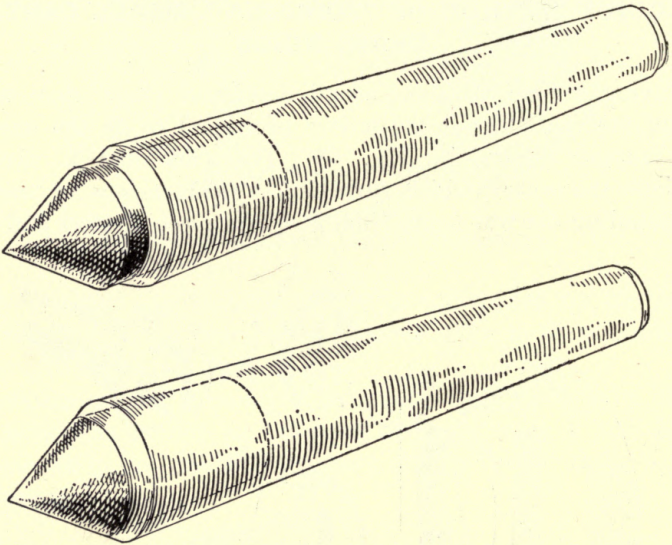

FIG. 77—STELLITE LATHE CENTER

I always use a plain center without oil grooves, and on heavy pieces I cut three narrow V-shaped grooves in the work.

Another writer adds: I would also mention that excellent results are being derived from the use of Stellite tips. Some of our work is on heavy forgings and we have had difficulty with burned centers.

The center shown in Fig. 77 has done away with this burning and there is little or no "ringing." Stellite has heat-resisting qualities superior to the best of high-speed steels. It is brittle,

but with ordinary care this characteristic is not a hindrance.

The base of the tip is ground so that a good shrink fit will result when inserted into the shank. Any sized tip can be made, but one fitting a $\frac{3}{4}$ -in. hole $\frac{3}{4}$ in. deep has given us satisfaction. The tip can be made to protrude $\frac{1}{16}$ in. or it can be finished flush. In case of the protruding tip the work will always be away from the carbon steel. Where oil is to be used a groove extending to the point is ground on the face.

CUTTING COARSE-PITCH SCREWS

I once had to rig up to cut a $2\frac{1}{2}$ -in. pitch thread on a 24-in. lathe with a four-pitch lead screw and no change gears for threads coarser than $\frac{1}{2}$ -in. pitch.

The only gears available for special rigging were a pair with cast teeth of $1\frac{1}{4}$ -in. pitch and having a ratio of $2\frac{1}{2}$ to 1. In

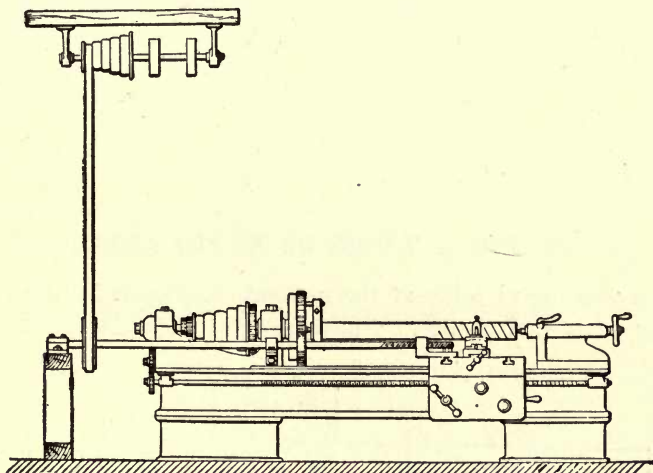

FIG. 78—COARSE THREAD CUTTING RIG

order to use these I had to have a screw of 1-in. pitch. This difficulty was overcome by making a new lead screw with a pitch of two threads per inch, which was substituted for the regular lead screw in the lathe. The nut was then babbitted to fit it, and with the lathe geared as it would have been to cut two threads per inch with the regular four-pitch lead screw, a left-

handed 1-in. pitch thread was cut on the end of a piece of $1\frac{15}{16}$ -in. shafting.

Fig. 78 will serve to explain the rest. The $1\frac{15}{16}$ -in. shaft was supported along the front of the lathe by one bearing fastened to the front of the headstock, and another carried by a trestle on the floor. The threaded end of the shaft ran in a babbitted nut fastened to the top of the lathe carriage, as shown. In order to furnish a satisfactory drive with reverse motion, the countershaft with its cone pulley and drive pulleys was turned end for end in its bearings. The drive pulleys on the lineshaft were shifted to line with the countershaft pulleys in their new position.

The larger of the two gears was bolted to the faceplate, and the smaller one was keyed to the $1\frac{15}{16}$ -in. shaft, on which was also mounted a 30-in. driving pulley, which was belted to the small step of the countershaft cone pulley. As the lathe was driven from the shaft which also acted as lead screw, there was no unusual stress on the lathe parts, and a heavy cut could be taken without danger of breakage. I believe the most unusual feature of the job was the making of the special lead screw with which to thread the $1\frac{15}{16}$ -in. shaft.

Another method is as follows:

CUTTING A WORM OF RAPID LEAD

After reading of some of the methods employed by others in cutting screw threads of very coarse pitch, when the lathe avail-

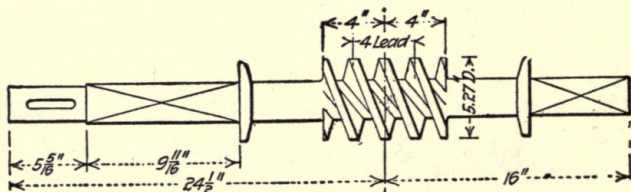

FIG. 79—THE WORK

able is not especially adapted to this class of work, the writer desires to describe the means he used to accomplish this purpose.

Fig. 79 shows the pieces required, the threaded portions of which were a trifle over $5\frac{1}{4}$ in. in diameter with double Acme

thread of 4-in. lead. The only lathe available was a 32-in. Pond with a four-pitch lead screw and a rather weak train of change gears; therefore the problem assumed formidable proportions until the following method was evolved.

The forgings were rough turned all over and then finish turned at all points between the faces of the collars, leaving the outside ends $\frac{1}{8}$ in. large. We next made a bushing 14 in. long by 5 in. in diameter and bored it to a slip fit over the long end of the forging, drilling and tapping it for ten $\frac{5}{8}$ -in. hollow-head setscrews. The bushing was then cut with a double square thread of 4-in. lead, the same as the worm to be cut.

With this master screw, as it had now become, in place on one of the forgings a casting suitably chambered to receive babbitt was placed over the screw and bolted to the carriage and a babbitt nut cast around the master screw.

With this arrangement we were able to proceed with the thread cutting in a very satisfactory manner, even less trouble being experienced than if a lathe with suitable lead screw and gearing had been used, for if the dog slipped no harm was done as the work and the master screw stopped or revolved together.

After one thread of the worm was cut it was necessary only to run the nut off the master screw and enter it upon the other lead in order to cut the other thread. As the smallest diameter of the nut would go over the tail spindle this could be done without releasing the work from the centers.

NONSLIP EXPANDING MANDREL

Fig. 80 shows a positive-drive expanding mandrel which was designed and constructed by the writer for the purpose of finishing some special bronze bushings, 18 in. long, $4\frac{3}{16}$ -in. bore, $4\frac{15}{16}$ in. in diameter, with a 6-in. diameter by $\frac{3}{4}$ -in. head or flange on one end, and having three equally spaced oil grooves, $\frac{1}{8} \times \frac{1}{16}$ in. deep broached clear through.

A holder of cast iron is bolted to the faceplate of the lathe and bored through to fit loosely over the mandrel. The taper pin passes loosely through the mandrel, serving as a driver and also holding the mandrel in place while changing the work. The mandrel *B* has two tapers as shown, and is threaded at a point midway between them. A corresponding sleeve *C* finished

to a nice fit in the bushings, has three slots cut in each end to a point about 1 in. from the center, and has one $\frac{1}{8} \times \frac{3}{32}$ -in. deep groove cut the whole length on the outside.

In operation, a piece of $\frac{1}{8}$ -in. drill rod is laid in this groove and the sleeve slipped into a bushing, one of the oil grooves covering the wire. The sleeve and bushing are then slipped over the mandrel, the thread run up by hand, the tail spindle brought up to place and a cut started. As soon as the tool takes hold, the bushing turning the sleeve through the medium of the wire in the oil groove, makes up the threads and expands the sleeve until the friction is sufficient to drive the work.

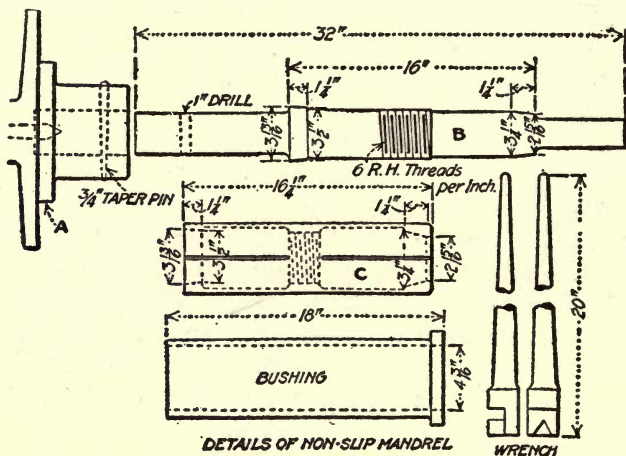

FIG. 80—DETAILS OF NONSLIP MANDREL

To release the work, the wrench is slipped on the head of the bushing with the V-shaped part in one of the oil grooves; the bushing is then turned back about one-half turn, when it can be taken off and the sleeve run off by hand ready for the next piece.

For this work, this mandrel has several advantages over the standard, four-blade expansion type: as the centers remain true, the work cannot slip, and only the bushing need be lifted into and out of the lathe. As the bushing is made in a single piece with three saw slots 120 deg. apart at each end and not in three individual pieces, one is not bothered by having it come apart or by accidentally mis-assembling it.

SETTING A TAPER ATTACHMENT BY MEANS OF A DIAL INDICATOR

My method of setting the lathe for turning tapers of various kinds is if possible to secure a piece having the same taper as the one to be cut—an end-mill, taper shank reamer, or similar tool. With this on the centers of the lathe and the dial indicator in the toolpost I adjust the taper attachment until the indicator will pass along the sample piece without movement of the pointer.

If no sample is obtainable I put a parallel piece on the centers, mark off a convenient distance, say 6 in., and adjust the taper attachment until the difference in the readings of the indicator at the two marked points equals the sine of half the included angle of the taper, calculated to a radius represented by the distance between the marked points. This method is equally serviceable in setting either the taper attachment or the compound rest for boring a taper hole in the lathe.

ARC-FORMING ATTACHMENT FOR LATHE AND SHAPER

Figs. 81, 82 and 83 show an attachment for forming radii on different kinds of work. It can be used on a shaper, a lathe and other machines, and if properly operated, good results are obtained. The mechanism may be best understood by studying Fig. 81, which shows the principle. The base *A* carries a slide *B*, and at right angles to this is a slide *C* on the member *D*. Also mounted on the base *A* is a worm gear *E* operated by the worm and handle. The worm gear is provided with a slot *G* passing through its center. In this slot is a stud *H*, which can be adjusted and secured at any distance from the center of the worm gear, within the confines of the slot. The upper end of this stud bears in a hole in an arm *I* secured to the top slide *C*.

For the sake of demonstrating, two pencil holders *J* are secured to the slide *C*. If the worm wheel *E* is caused to rotate, the pencils *K* will duplicate the path described by the center of the stud *H* around the axis of the wormwheel *G*. In this way, boring or turning can be done as indicated diagrammatically in Fig. 82.

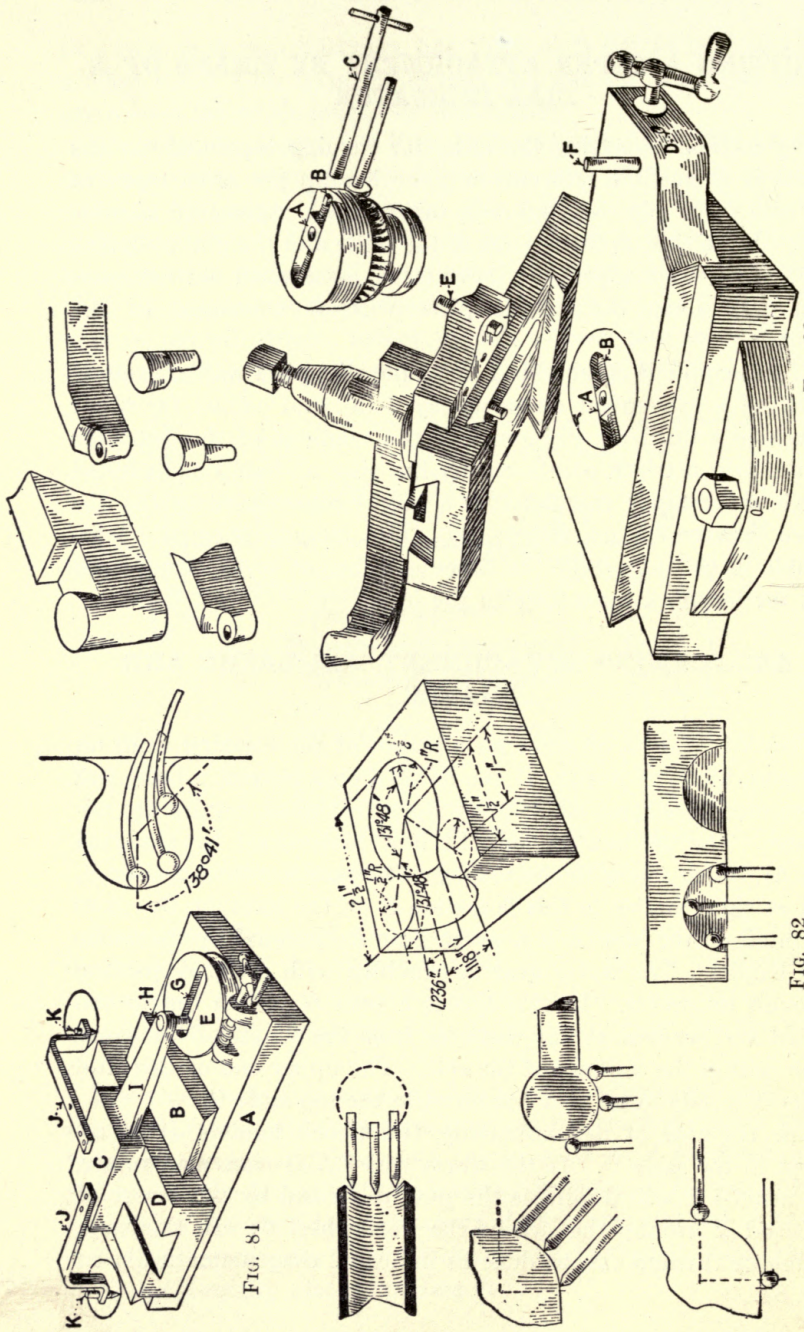

FIG. 83

FIGS. 81, 82 AND 83—ARC FORMING ATTACHMENT

FIG. 82

FIG. 81

In Fig. 83 is shown the outfit as designed for use, and also some forms of tools with inserted cutters. Referring to Fig. 83, the sliding block *A* is mounted on a screw *B*. The amount that *A* is off center determines the diameter of the circle to be turned or bored. The block *A* is set by means of a socket wrench *C* inserted through the hole *D* when the end of the screw *B* is in line with the inner end of the hole *D*. Two pins *E* and *F* are provided for ascertaining how much the block *A* has been set off center. The pin *E* is secured to the tool slide, while *F* is stationary in the bottom slide.

OLD LATHE USED AS A BROACHING MACHINE

An old hollow-spindle lathe that was no longer in use was made into a broaching machine in the following manner:

A nosepiece *A*, Fig. 84, was turned and fitted to the spindle.

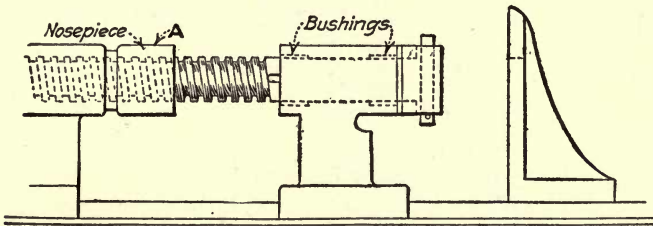

FIG. 84—LATHE AS A BROACHING MACHINE

The inside of the nosepiece was threaded to take the lead screw, which carried the broaches. Bushings in the tailstock supported the outer end of the lead screw. The carriage was tightened to the lathe bed, and behind it a heavy angle plate was fitted as a bolster for the work.

This arrangement made a good machine for broaching out numerous shop jobs.

Another broaching job was done in the lathe as follows:

BROACHING HOLES ON THE LATHE

The special toolpost for broaching on a lathe shown in Fig. 85 is intended only for toolroom work, and is designed to provide a method of accurately cutting square or other shaped holes in work not requiring duplication.

The external shell *A* is turned out of a solid block of steel of the shape of the base *B*, and drilled to receive bolts for attachment to the cross-slide *C*. This shell is bored out and threaded to receive the toolholding post. The shell *A* and post are slotted to receive the tool *E*, the slot in the shell being elongated to permit the vertical movement of post and the tool which it carries.

On the projecting upper end of the post, is a nut *F*, having

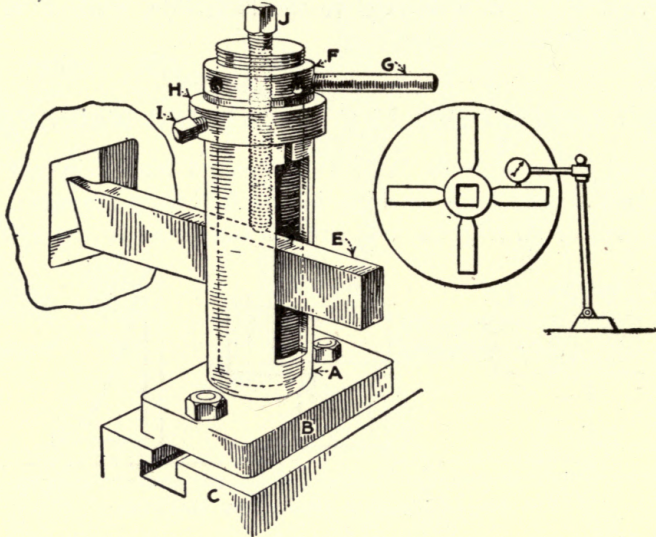

FIG. 85—TOOLPOST FOR BROACHING HOLES IN THE LATHE

a series of openings, in any one of which may be inserted a short rod or pin *G*, by means of which it may be turned to raise or lower the toolpost. The nut *F*, rests on a ring or collar *H*, which is clamped to the shell *A*, by means of the setscrew *I*. The vertical movement of the toolpost is obtained by turning the feed nut *F*.

The tool *E* is secured in position by a long setscrew *J*, which is located in a threaded opening in the toolpost.

In operation, the work is clamped in the chuck of a lathe and indicated by means of the chuck jaws. The lathe spindle is also clamped in position as needed. The hole to be broached is first bored round, then by feeding the lathe carriage lengthwise on the bed, and also feeding the cross-slide in the right direction

on its ways, a cut is started. In obtaining the vertical feed, the special toolpost described is brought into operation.

SIMPLE CALCULATION OF CUTTING TIME

A great deal has been said and written upon this subject; elaborate tables have been compiled; constants involving the calculation of speed expressed in terms of feet per minute have been worked out until the subject would seem to be exhausted.

The average mechanic does not take kindly to calculations of this kind, and cutting speed thus expressed does not appeal to him, but if he be a wide-awake fellow he will give the tool what it will reasonably stand—expressed shall we say, in certain lever positions, belts on certain cone-steps, or more briefly in revolutions per minute.

The mechanic, however, is interested in knowing how long it is going to take to finish the piece in hand; and if his lathe or milling machine is supplied with index plates showing revolutions per minute and feed constants for the various lever positions, the following simple calculation will suffice:

Let us say he has a cut 8 in. long (diameter does not matter) and his index plates show the spindle speed to be 55 and the feed 32, he simply multiplies the length of cut by the feed, and divides by the revolutions per minute thus:

$$\frac{8 \times 32}{55} = 4.65 +$$

indicating that the tool will make this cut in approximately 4.65 minutes.

A FLOATING REAMER HOLDER

The writer has had an opportunity to try a number of forms of floating and so-called floating reamer holders. Some work well until worn, others work indifferently from the start. We have adopted the form shown in Fig. 86, as being equal, if not superior, to most others, especially for hot-rolled or other tough steel work. It has been our experience that reamers give more trouble in this material than in either cast iron or brass.

The steel reamer *R* fits the standard $\frac{3}{8}$ -in.-per-ft. taper on the

holder *D*, and is driven by the two keys *K*. The holder is bored $\frac{1}{32}$ in. over the size of the small diameter of shank *S*, giving this amount of float. Holder *D* is drilled out beyond the counterbore to a suitable size to admit the hardened thrust plug *T*, and the steel ball. A similar hardened thrust plug is supported in the end of shank *S*. The counterbore for the ball allows about $\frac{1}{32}$ -in. play, and the holder and shank are kept separate laterally by the same amount. The entire thrust is taken by the ball and thrust plugs, allowing the reamer to follow the hole with very little effort.

Several forms of floating drivers were tried, but the two shown

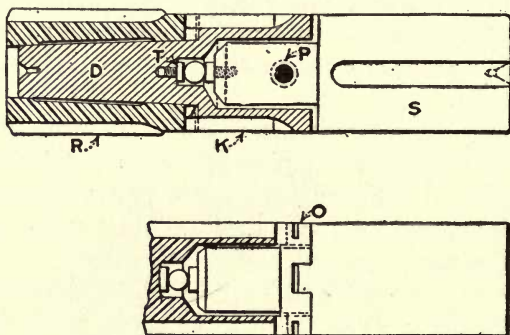

FIGS. 86 AND 87—FLOATING REAMER HOLDERS

work best. In Fig. 86, the drive is by a hardened pin *P*, a drive fit in shank *S*, but having $\frac{1}{32}$ -in. play in the holes in the driver. This works well for smaller size reamers, but wears out more rapidly than the form shown in Fig. 87. Here the drive is taken by the shackle ring *O*, which is the standard Oldham coupling drive.

JIG FOR TURNING ENDS OF SQUARE TOOLS

Fig. 88 shows a jig for use in turning 1-in. square tools on both ends. The jig *A* is of machinery steel and accommodates eight pieces of stock. It is 3 in. square and 10 in. long, and has a horizontal slot extending through it which receives the stock to be turned. The stock projects beyond the faces of the jig. The openings *C*, *E* and *F* in each end are for the purpose of receiving studs to be carried on the centers. There are eight

holes *D*, tapped in the upper face of the jig to receive safety-head setscrews which hold the stock in place for turning. After the stock is secured in position, the jig is placed in the lathe with the center studs at *C*, and the stock turned to length; then the

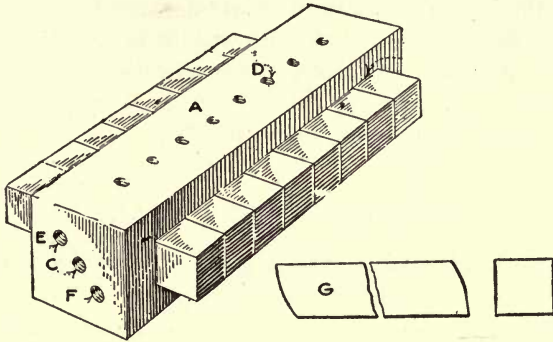

FIG. 88—JIG FOR TURNING ENDS OF SQUARE CUTTERS

center studs are moved to *E*. Turning the stock from this center position puts cutting clearance on one end. The center studs are then moved to *F*. Turning from this position puts clearance on the opposite end. A cutter with clearance on both ends is shown at *G*. This jig is also used for grinding the cutters, and has proved satisfactory.

GANG TURNING FIXTURE

Fig. 89 shows a fixture for turning several small pieces to a given radius. The old method was to drive the work into the

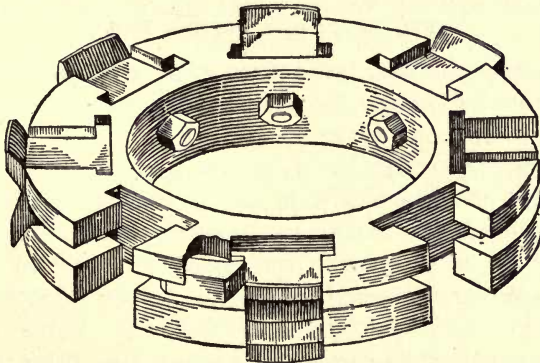

FIG. 89—GANG TURNING FIXTURE

grooves. They had to be driven out from the back of the face-plate when finished, and the work did not come true. The fixture had to be made out of malleable iron or steel. I devised the means shown of clamping the work with special T-head bolts.

This method has proved very satisfactory and does not distort the work. The fixture is made of cast iron, and the work can be put in and taken out in much less time than formerly. The same method could be used with other kinds of work, provided the lower part is larger than the upper.

THREAD-CUTTING TOOL

The cutter head swivels at *A*, Fig. 90, and is set to the angle lead
of the helix, $\frac{\text{pitch diameter} \times 3.1416}{\text{pitch diameter} \times 3.1416} = \text{tangent of helix}$. The
screw *B* adjusts the tension of the spring *C*, the screw *D* acts as

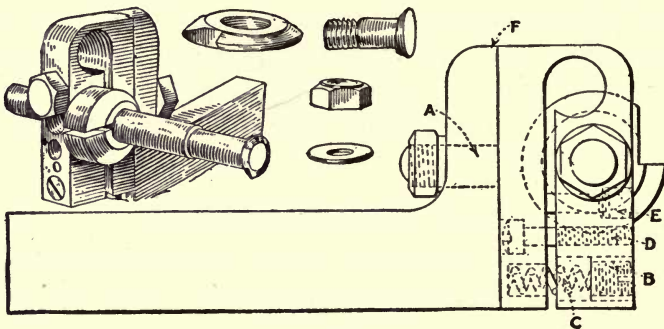

FIG. 90—THREAD CUTTING TOOL

a stop, so that the cutter will return to proper position after the cut; *E* is the lock-screw by which the tool may be locked for roughing external threads and to hold the tool rigid for internal cutting, using the cutter bar as shown in the illustration.

The great advantage of this tool is that the circular cutter may be removed from the holder for sharpening and be returned accurately to its position. The spring feature also insures a smooth, well-formed thread, so difficult to obtain with the fixed tool.

Any excessive cutting pressure is taken care of by the spring, when locked the tool is as rigid as a solid one.

CHUCK FOR NIPPLES AND STUDS

Fig. 91 shows an efficient chuck for nipples and studs. The body *A* is threaded to a shoulder to receive various sizes of nipple holders *B* and is slotted and bored for the wedge *C* and the plunger *D* respectively. The shank of the body *A* is turned down to facilitate chucking when the pipe machine is used.

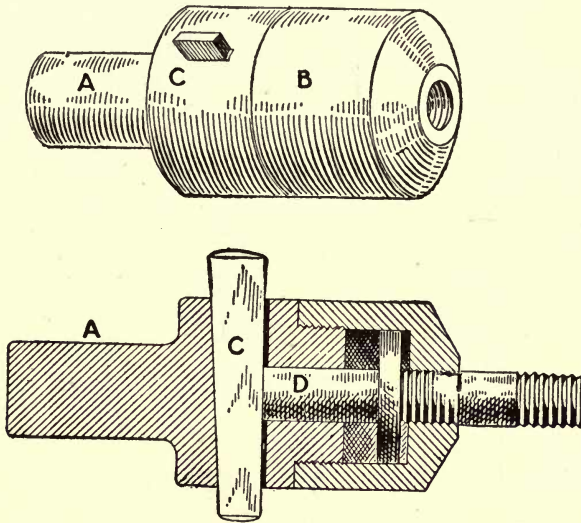

FIG. 91—CHUCK FOR NIPPLES AND STUDS

In operation, the wedge *C* is first driven home, thereby forcing the plunger *D* against the inner face of the nipple holder; the nipple is then screwed into place and the thread cut. To release, the wedge is loosened by a light blow, thus taking the pressure off the plunger, when the nipple can be easily removed by hand.

CORRECTING UNTRUE CENTER HOLES

I was given a job, one day, of turning down the end of a shaft to receive a gear. After swinging the shaft up on lathe centers, I found that the center holes had been drilled and reamed nearly $\frac{1}{32}$ in. off center, as shown at *A*, Fig. 92. There was but one remedy, and that was to correct the position of the center holes. The following method was successfully employed in doing this:

One end of the shaft was gripped in a chuck having four independent jaws; the other end was held in the steadyrest. The shaft was trued up nicely. A center-finding tool *B*, with one cutting edge, was placed in the toolpost, and with it a conical hole greater than 60 deg. was machined in the end of the shaft, as shown. Next, a half-round reamer *C*, having its cutting edge

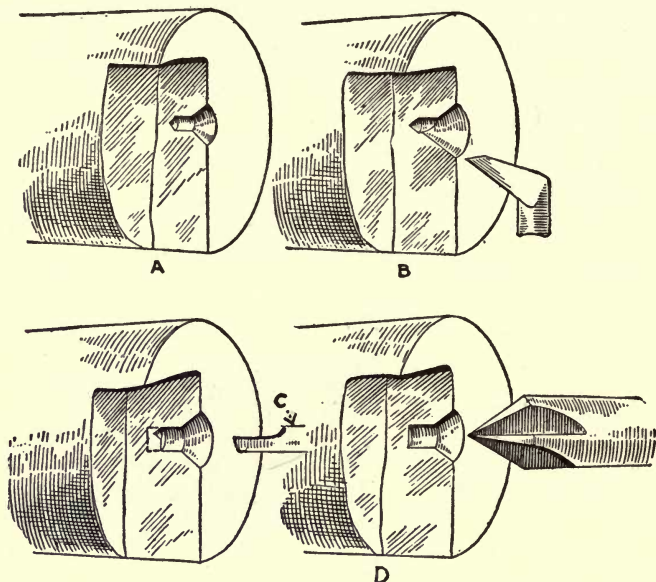

FIG. 92—CORRECTING UNTRUE CENTER HOLES

on the front end only and a diameter greater than the diameter of the conical hole at the point where the drilled hole breaks through, was made from drill rod. When ready, it was placed in a drill chuck and fed into the end of the shaft, by using the tailstock. Finally, the conical hole was brought to the proper angle by reaming with a standard center reamer *D*. The shaft was then removed, turned end for end, and the same operations performed.

PISTON-GROOVE SIZING

By adopting the following method for an unlimited number of automobile pistons to be grooved to a limit of plus or minus 0.0005 in., very satisfactory results were obtained. They were

roughed out in the usual manner on a screw machine, leaving the grooves, four in number, about 0.015 narrow and the outside diameter about $\frac{1}{16}$ large, then they were passed on to an engine lathe and finish turned to grinding size. The next thing on the program was to finish the grooves to size.

The piston was run between centers at not too hasty a speed, and a square-nosed tool the exact width of the groove was run in to the required depth. All would proceed well until a few pistons had been finish grooved, and then the tool would begin to cut small, so that the low limit gage would not go. This, of course, ordinarily necessitated a new tool being ground up. After grinding quite a number of tools, it became evident that some scheme must be found to save these pieces of $\frac{3}{8}$ -in. square tool steel.

The idea suddenly suggested itself to peen the tools as they became small, instead of taking them out of the toolholder. By a very slight tap with a small hammer the trick was accomplished, and our trouble vanished. When a tool showed signs of wear, all that was necessary was a light tap with the hammer. In this manner it was possible to finish piston grooves day in and day out with scarcely a stop. Practically every groove was made a perfect fit for the piston rings, which were finished to size on a surface grinding machine.

SECTION VI

THE MILLING MACHINE

TOOL FOR LAYING OUT WORK IN THE MILLING MACHINE

FIG. 93 shows a device which I find very helpful in laying out work on the milling machine where a series of holes is to be located at different points. The body of the tool has a hole to fit the arbor of the milling machine, and at a right angle thereto is a smaller hole to which is fitted a small prick punch held in position by a collar and spring as clearly shown in the sketch.

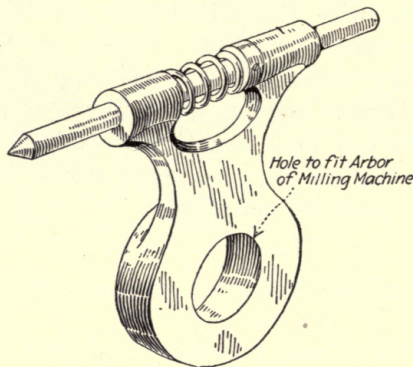

FIG. 93—TOOL FOR LAYING OUT WORK IN THE MILLING MACHINE

To use the tool it is clamped tightly on the arbor in the same manner as a cutter, care being taken to have the body set square with the table. Fasten the die blank to the milling-machine table and spot the center. Then by means of the indexes on the traverse and cross-screws any number of holes can be laid out in quick time and to good advantage.

CROWNING PULLEY FACES ON THE MILLER

In a shop the line of manufacture of which included large quantities of cast-iron pulleys, the turning of the crown face

got to be a considerable item of labor expense, as it was a slow operation and required closer attention because of the crown.

A fixture, or machine, like that shown in Fig. 94 was made, and its success was immediate.

Except for changing the pulleys and starting the cut the machine takes care of itself, and having finished a pulley (which it does in one revolution) it will run merrily along without damage until somebody gets ready to put on another casting.

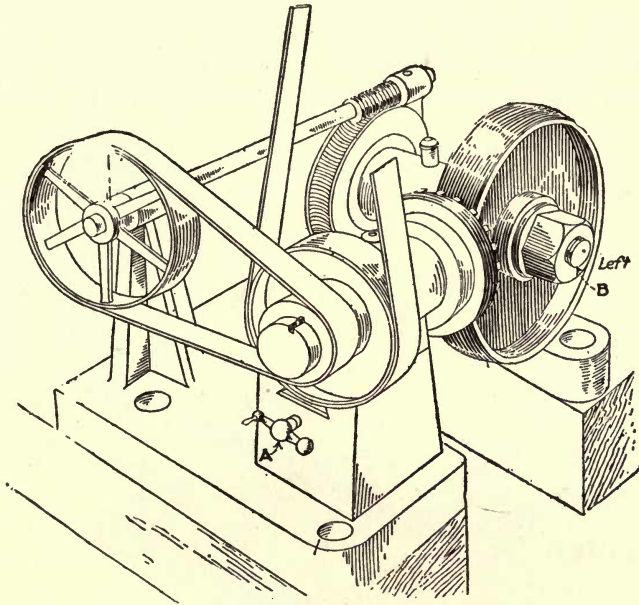

FIG. 94—CROWNING PULLEYS ON THE MILLER

It was made the duty of everyone, from the floor sweeper up, whenever he passed one of the machines that was running idle to take off the finished pulley and start a new one. Thus the labor cost was brought to a very low figure as the changing would almost always be done by someone who was waiting for a cut to run out on the milling or planing machine or by someone who for one reason or another could spare a moment without interfering with his regular work.

The drawing is self-explanatory. The diameter of the inserted-tooth cutter and the relation between the center lines of

the two shafts is so computed that the path of the cutters will leave the requisite amount of crown.

Whenever a man sees a machine idle and he has a moment to spare he simply turns back the handle *A* a turn or two, loosens the nut *B*, takes off the finished pulley, puts on a casting and runs up the cutter again to a fixed stop, at which time it is cutting the full depth required to size the pulley.

AN ADJUSTABLE V-BLOCK

Fig. 95 shows an adjustable V-block I am using for milling the surface of the casting shown in place in the sketch. The best means of locating the work seemed to be by a V-block;

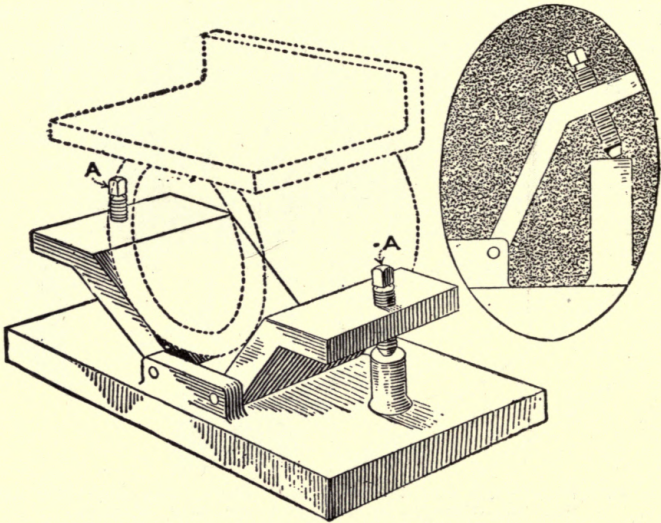

FIG. 95—ADJUSTABLE V-BLOCK

a solid one was tried, but gave trouble on account of excessive variation in the diameter of the boss on the castings, so I conceive the idea of making it adjustable, as shown, to compensate for variations. Adjustment is by means of setscrews *A*.

DOING A LARGE JOB ON A SMALL MILLING MACHINE

Several castings were to be machined, as shown in the upper right hand corner in Fig. 96. The work was ordinary shop

practice up to the point of cutting the slots across the face of the rim. A formed cutter was plainly the only tool to use that would insure interchangeability of the pairs of slots—two adjacent slots constituting a working pair in the special machine of which the wheels were to be a part. A limit of 0.008 in. was allowable in the spacing of the pairs of slots. The only machine

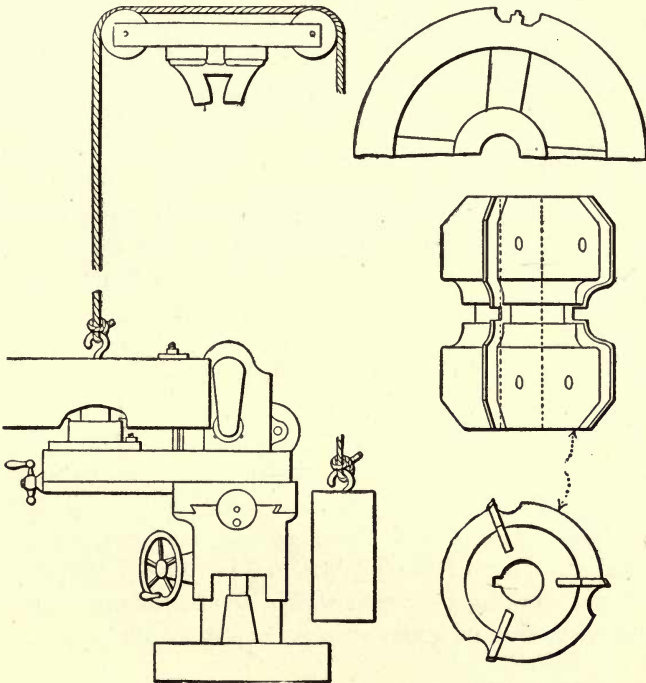

FIG. 96—DOING A LARGE JOB ON A SMALL MILLING MACHINE

available for the slotting was a No. 2 plain milling machine which was in good condition, but too small for such a job.

After the lathe work was finished, the rim was carefully laid out into 20 divisions, using a glass to secure accuracy and a line to indicate working depth marked before removing from the lathe. For each pair of slots milled, the wheel was set by the division marks from a fixed point on the face of the milling machine, again using the glass to insure close work. The finished parts showed this method to be quite accurate enough.

The castings were laid in a horizontal plane on the table of

the milling machine and the vertical (hand) feed used for cutting. A casting that served as a center stud and baseplate was made and the work was placed upon it. A parallel under the front and a clamping bolt completed the arrangement.

Owing to the size of the wheels the table had to be run out to its limit, causing it to overhang to such an extent that would have rendered feeding not only difficult but would have imposed serious strains upon the machine itself. The castings weighed 600 lb. each, nearly half the weight of the machine. To avoid trouble, the simple counterbalancing scheme shown in the drawing was adopted. An eye-bolt was screwed into the center stud, to which was fastened a rope that passed over two grooved pulleys and down in the rear of the machine to a counterweight. The weight was made 80 lb. heavier than the wheel casting and attachments. With the aid of this counterbalance the loaded table could be run up and down as easily as when empty and the possibility of distortion was removed.

The work was done with the formed cutter shown to the right. The body is of soft steel milled out for three blades which are held in place by two taper pins each. The blades were put in place in the blank body and the form turned on both. To give them the necessary clearance the blades were removed and $\frac{1}{8}$ in. was turned off the body. For hardening and tempering, the blades were replaced and the complete cutter treated. The finish and accuracy of the job produced were all that could be desired; the working time was within the bounds of good practice, and there was no great outlay for special tools.

THE MILLING-MACHINE VISE AS A SPECIAL MILLING FIXTURE

In most cases in repetition work a man can work much faster by using a quick-acting vise which is operated by lever and eccentric instead of a screw. I much prefer to have two vertical Vs, one near each end of the jaw; this results in increased speed of operations, and puts a more equal strain on the vise. I have always made the horizontal V as shown at *A* in Fig. 97.

This clearance at the upper part of the jaw renders it much easier to load and unload the vise because when the vise is open the work can be dropped into position where it will be definitely

located by the lower part of the V. If the jaw is of uniform thickness it too often happens that the work, especially if a short piece, falls between the jaws, resulting in loss of time and in annoyance.

Many times in milling flat surfaces, oil grooves, keyways, etc., in shafts or bolts, it is not possible to locate these parts with a shoulder against the jaws as the pieces to be machined may then

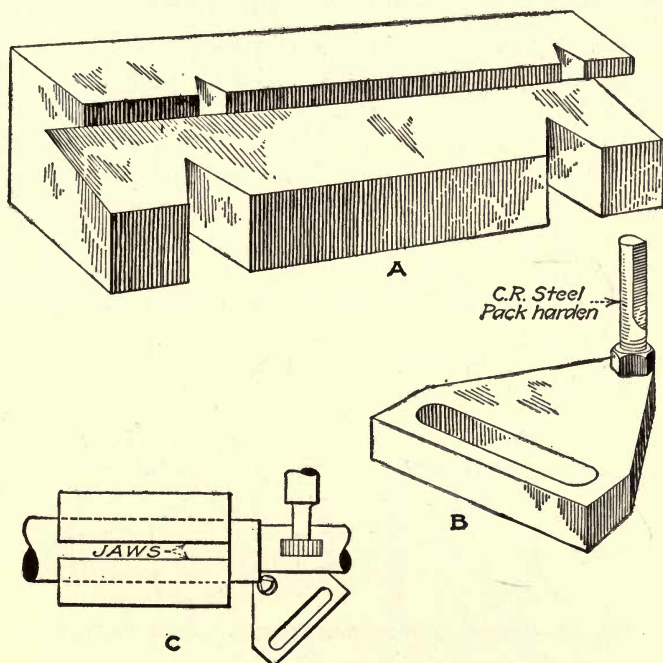

FIG. 97—MILLING MACHINE VISE JAW AND WORK STOP

project too far, resulting in chattering, or else may be too close to the jaws for the cutter to pass.

For all these cases, and they probably form the majority, I have used the tool shown at *B* with very satisfactory results.

The base of this tool is provided with a slot so that it can be clamped to the milling-machine table in any position. The stud is threaded at one end so that it may be turned to any desired position and then secured by means of the locknut. The stud is about as high as the top of the vise; it has two flat surfaces which form a knife edge, slightly rounded.

Whenever a milling operation has to be located accurately in relation to a shoulder the knife edge is used as at *C*, and no matter what variations there may be in the length of the pieces the relation of the milling operation and the shoulder used for locating will be absolutely uniform.

SETTING ANGLE FOR FLUTING TAPER REAMERS

A very handy shop kink is shown in Fig. 98 for the angular setting of milling-machine centers to insure even width of the land when fluting taper reamers.

Tables in various handbooks give the values of these angles for angular cutters, but only in increments of 5-deg. included

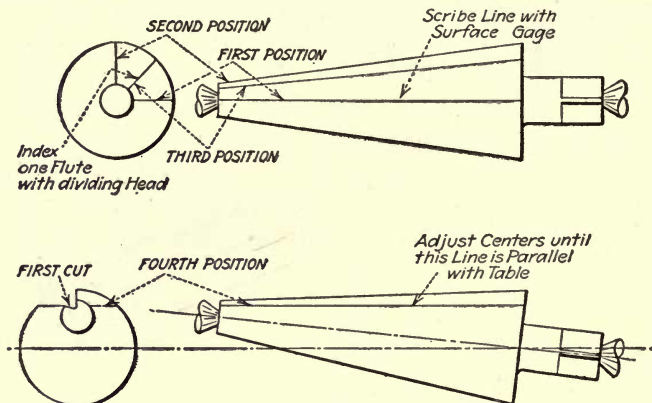

FIG. 98—SETTING ANGLE FOR FLUTING TAPER REAMERS

angle of the piece to be cut, while in the case of taper reamers this angle is more than likely to fall between the given settings.

Again, if the angle of the fluting cutter is changed the set angle must also be changed, whereas with my method the setting is independent of the angle of the fluting cutter, and furthermore one can set up a taper reamer or cutter by this method in the time that he is looking up the table.

By the cut-and-try method the toolmaker will make from four to six cuts (two for each trial) while with this method he can cut full depth the first time.

The sketch needs little explanation. With the centers in parallel position and a surface gage set to the center height draw a

line on the surface of the reamer to be cut (first position). Turn the dividing head one-quarter turn until this line is at the top (second position); then index back one tooth to third position. Now raise the dead center until this line is parallel with the surface of the table, testing for parallelism with the surface gage. It will readily be seen that this line represents the edge of the tooth next to the first one to be cut and that it will parallel the path of the fluting cutter.

POINTER TO SUPPLEMENT TABLE-FEED STOP ON MILLING MACHINE

The automatic stops furnished with our milling machine do not always operate at exactly the same place. In milling keyways with a narrower cutter than the keyway, etc., it makes a better-looking job to stop at exactly the same place at each cut, so I made up a pair of adjustable pointers, as shown in Fig. 99,

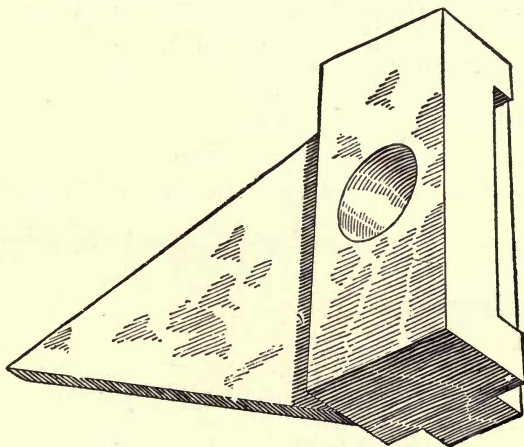

FIG. 99—POINTER TO SUPPLEMENT TABLE STOP

about 1 in. long, the pointer reaching to the saddle of the machine, upon which I made a line.

I set the pointer at the desired stopping place and watch it until it comes nearly to the line, then trip the feed and turn the screw by hand to zero on the dial plate. A second pointer that has been set in the same manner for the starting cut is a further convenience.

A dial indicator mounted on a bracket attached to the table slide and acting in conjunction with a stop attached to the miller table will be found exceptionally accurate and convenient for gaging the travel of the table.

CHART FOR DETERMINING APPROACH FOR MILLING CUTTERS

The chart shown in Fig. 100 is very simple.

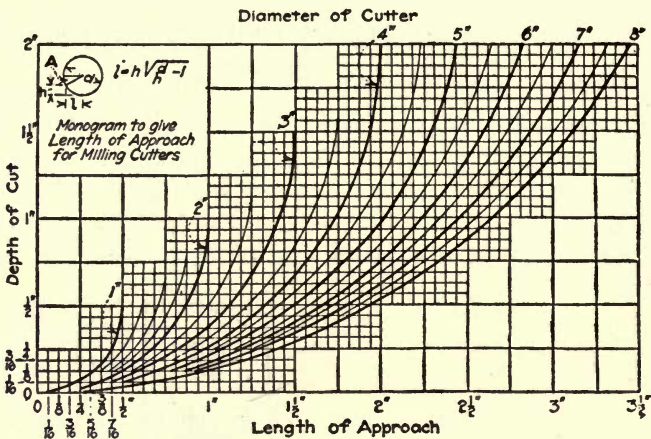

FIG. 100—CHART FOR DETERMINING APPROACH FOR MILLING CUTTERS

The formula at the top of the chart can be more simply expressed by $l = \frac{d}{2} \times \cosine A$.

ADJUSTABLE LOCATING BUTTON

A button or locating bar that can be adjusted to run dead true, is an exceptionally handy article on a milling machine or boring mill where accurate center distances are to be located. The bar

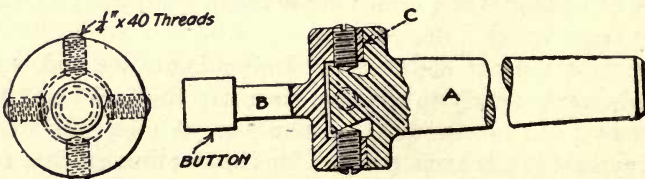

FIG. 101—ADJUSTABLE LOCATING BUTTON

is made in two parts consisting of shank *A* and button *B*. The part *A* is hardened all over and is ground square with the axis of *A* at *C*, and the button is ground and lapped to size. In use, the button is adjusted to run true by means of the four screws on the periphery.

BORING A HOLE AROUND A CORNER

If a man should ask you to design some means of boring a hole around a corner, you would probably wonder if he had not "fallen off the wagon." At least, that is what passed through my mind when the chief put the matter up to me in just such a manner.

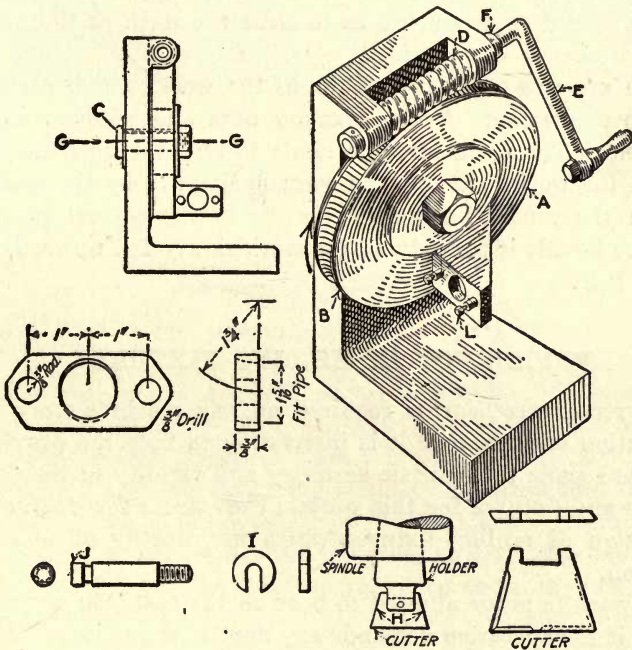

FIG. 102—BORING A HOLE AROUND A CORNER

The blueprint boy suggested using a rubber drill; but strange as it appears, the chief rejected the idea, much to the surprise and consternation of the kid. However, a glance at Fig. 102 will convince you that the problem is not as difficult as it sounds.

The work is a bronze casting with a $1\frac{1}{16}$ -in. hole bored on a

radius to fit a bent copper pipe. This casting has been milled to the required thickness, and two $\frac{3}{8}$ -in. holes have been drilled previous to the boring operation. The center hole is cast out with sufficient metal left to finish out in boring.

The fixture is a steel casting with generous base for clamping to the table. At *A* is a wormwheel, also of cast steel, with teeth halfway around in the direction of the arrow from the point *B*. This wheel has a rug cast on it to which the work is clamped, and is held to the base by a stud, which is keyed to it and held by a nut and washer. At *D* is the worm keyed to the crank *E* and held in position by two collars *F* pinned to the crank.

The bottom of the cutter should be on the center *GG*, and the sides *H* should be ground so as to clear the work as the hole is being bored.

There are two studs for clamping the work, which are used with slotted washers *I* and hexagon nuts and washers on the other end. The diameter *J* is made to slip through the $\frac{3}{8}$ -in. holes in the work. In use, the work is clamped by the studs at *L*, with the center line of the cutter in the correct position. Then the handle is turned and the work slowly fed upward, boring the hole.

EFFICIENCY IN MILLING FIXTURES

No greater precision is required on any machine work than on aviation engines, and it is interesting to note the provisions which are made for extreme accuracy and rigidity in the design of tools and fixtures for this work. Here are a few features in the design of milling fixtures which are worthy of note and imitation.

The work is never allowed to bear on the cast-iron surface of the jig if the operation demands any degree of accuracy. Hardened steel strips or pads are provided under all bearing points, as shown in the upper left hand corner in Fig. 103.

Locating pins are designed as in *Y*, especially those of the smaller diameters. A pin of uniform diameter will invariably get bent or battered out of alignment, but a pin like the one shown is good practically all the time. The large diameter is a drive fit in the jig casting, the smaller diameter is hardened

and ground to size, and the shoulder which is lapped to a true surface, insures the pin being kept in place.

A cutter which is used in place of the interlocking cutter is shown to the right. When interlocking cutters are worn they are ground and then packed up between the halves to maintain the original size of the face of the cutter. The one shown in the illustration is merely an inserted blade cutter. When it becomes dull it is reground and then every blade is offset to one side, so that the width of the cut can always be held the same.

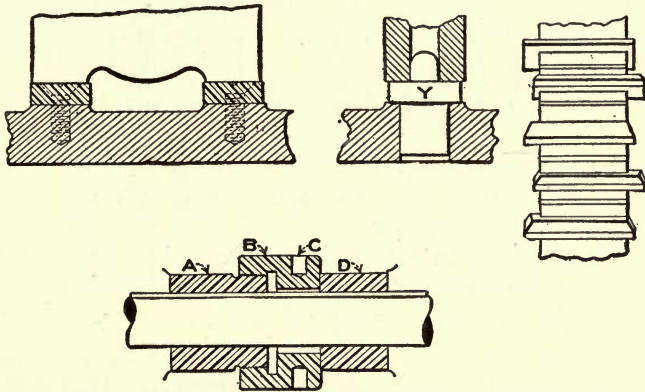

FIG. 103—VARIOUS MILLING KINKS

When cutters are adjusted, or are adjustable, the spacing between them changes. This is taken care of by means of the adjustable spacer sleeve as shown at the bottom in Fig. 103. It is merely a sleeve *A* bearing against one cutter and threaded for a nut *B*, which is turned by a pin in the holes *C*, and another solid sleeve *D* bearing against the other cutter. The only member which turns is the nut and this eliminates any wearing of sleeves against cutters.

AN ADJUSTABLE SIDE-MILLING CUTTER

This cutter is made in two parts; the adjacent sides are on an angle when assembled, as shown at *A* and *B* in Fig. 104. This is done in order that the cutter, when opened by a washer located in the center between the faces *C* and *D*, may be kept to proper thickness after it is ground. The reason for making the

adjacent sides of each part on an angle is that when the cutter is ground, and a washer wider than space *CD* is used, there will be an opening; and were the sides straight, a ridge would be left on the work. The parts are held together by two dowels *E* and *F*, in the recesses *G*, having their ends beneath the cutting surface.

In making these cutters the first thing done is to make the holes in the blanks, and then plane the angles. Each half is then

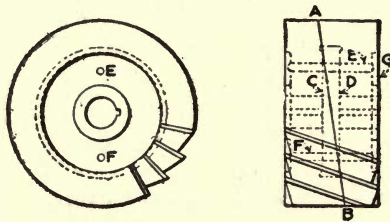

FIG. 104—ADJUSTABLE SLOT MILLING CUTTER

put on an arbor, and the recess in the center is turned out (faces *C* and *D*). The halves are then put together on a plug and drilled and reamed for the dowels *E* and *F*, after which they can be turned and milled as a whole in the usual way, except that care must be taken to keep the halves together. This cutter obviates the use of the expansion interlocking cutter, which is very difficult to make. This cutter is very satisfactory in use.

A LATHE JOB ON A MILLING MACHINE

A great deal has been written about the adaptability of the lathe. Fig. 105 shows what can be done on the milling machine when a lathe is not available. The illustration speaks so plainly that I think nothing need be said about the job other than to call attention to the fact, that the work was held for the first operation by four setscrews, one of which *A* is shown. These screws were equally spaced *A* in the housing, and had their bearing against the outside of the plate *B*, which is about $1\frac{1}{2}$ in. smaller in diameter than the work *D*. A lathe tool *C* is held in the vise.

In the small shop the miller should be provided with several face plates the largest of which is the full swing of the miller with the knee in its lowest position. With these and a tool held in the vise much chucking work can be done.

It is not always necessary to provide means for elevating the tool to the center height, for large work the vise can be placed near the end of the table if only the perimeter of the work is to be turned. Where the work must be faced across the entire face some sort of rigging must be provided to bring the tool to the center height of the miller spindle.

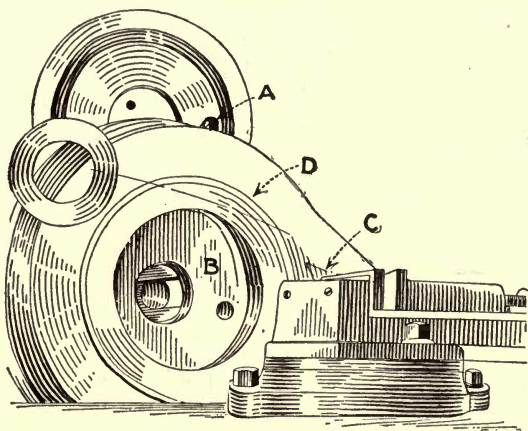

FIG. 105—A LATHE JOB ON A MILLING MACHINE

CLAMPING FLAT SQUARED WORK

A very simple one-action clamping device for rectangular pieces is illustrated in Fig. 106. The principle is shown clearly. The work is located by the stop-pins and is clamped against these pins by the screw *A* and the lever *B*. It will be readily seen from the illustration that by turning the clamping screw the work is forced against the pin *D* by the screw and against the pins *C* and *E* by the end of the lever *F*.

When the work is long, the swivel piece *H* may be added to the device to insure clamping against both of the pins on the long edge of the work. This principle also works very successfully when applied to a plate jig for local work. The small drill jig using this principle is shown clamped to the spot *X* by the screw *Y* and the lever *Z*. The advantage of this device lies in the fact that by tightening one screw we secure a clamp in two directions at right angles to each other, the clamp automatically adjusting itself.

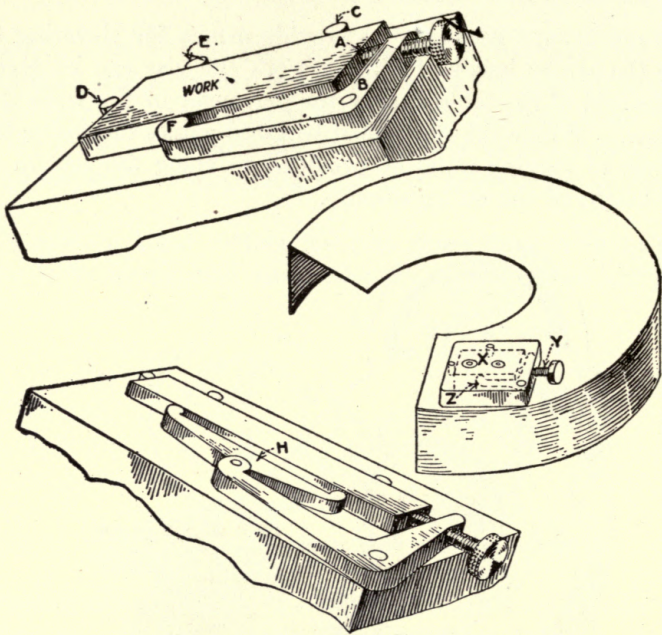

FIG. 106—CLAMPING FLAT SQUARED WORK

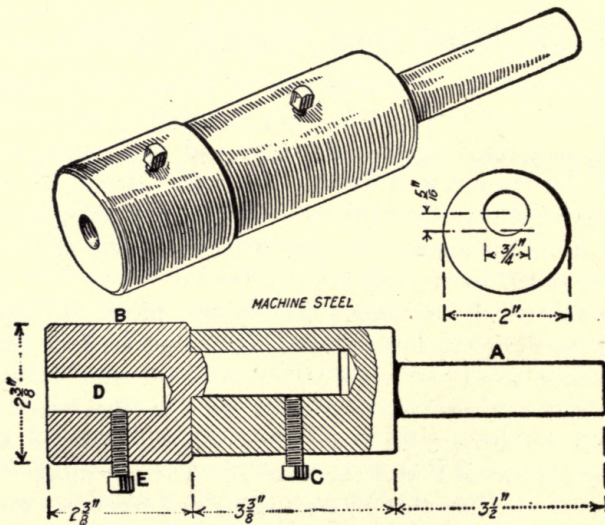

FIG. 107—ADJUSTABLE BORING TOOL HOLDER

ADJUSTABLE BORING-TOOL HOLDER FOR THE MILLING MACHINE

Fig. 107 shows an adjustable tool-holder which has the merit of being efficient and at the same time inexpensive.

It consists of the machine-steel shank *A* bored eccentrically to receive the tool holder *B*, which can be clamped in any position by the setscrew *C*. The boring tool or drill is carried in the hole *D* and fastened by the setscrew *E*.

In practice the shank is gripped in the chuck usually provided with a miller. Of course, the shank might be turned some standard taper to fit a standard arbor, if desired.

For light cuts on jig and fixture work, this tool has been found very useful; and it is certainly an inexpensive one to make. It will well repay the cost of material and labor, spent in its construction, where work of the character mentioned above is encountered.

MILLING VISE FOR USE BETWEEN CENTERS

Fig. 108 shows a milling vise to be used between centers and controlled by the index head. A set-up in the old type of vise takes considerable time, and each angular cut means a

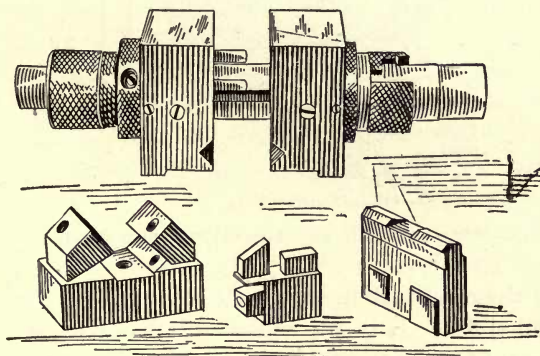

FIG. 108—MILLING VISE FOR USE BETWEEN CENTERS

new set-up. With this vise, after the work is once set up, it is possible to take cuts at any angle, as well as bore, drill and ream at any angle, as the vise is under the control of the index head at all times.

The mechanic will readily see its usefulness, as a movement of two spaces on the 18-hole circle gives an angle of one degree.

SETTING TOOL FOR USE WITH MILLING CUTTERS

Fig. 109 shows a small tool that I have found handy for setting milling cutters or lathe tools to center. It is easily made and is used on a combination square, as shown, by putting the head on any graduation and moving the small head to half the width of the cutter. The small head is made to slide on

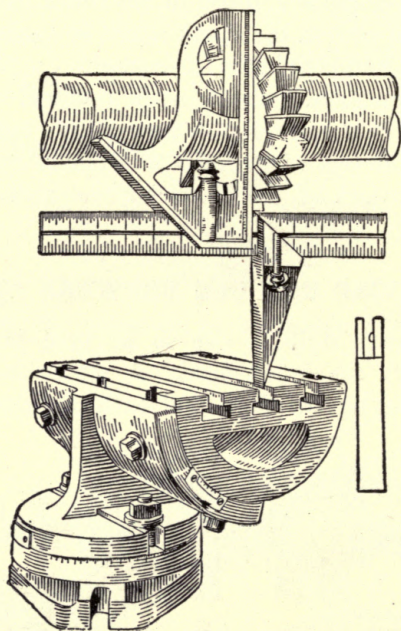

FIG. 109—SETTING TOOL FOR USE WITH THE MILLING VISE

the scale of the combination square in the same manner that the regular head slides. It is square with the blade on the one side, but the other side tapers at an acute angle from the edge of the scale to the end where it comes to a sharp point. This facilitates setting the cutter either in relation to the slots of the milling machine, locating point of jigs or fixtures or with relation to any convenient finished or unfinished parts of the work.

SECTION VII

PLANER AND SHAPER

REPAIRING OLD PLANING MACHINES

I WAS given a free-hand in overhauling a dozen old planing machines which had been in service from ten to thirty years and made by various manufacturers. They ranged from 20 in. to 36 in., in size. I found the T-slots and stop-pinholes badly worn and after measuring both on all the machines, I decided to make them uniform in order to interchange stops, studs, bolts, angle, squaring plates, etc. Securely clamping an electric end milling attachment to the rail head having the largest T-slots I procured a cutter that would just clean up the bottom, top and sides of the lower portion of the T-slots, leaving the sides of the upper portion to be planed later. I then threaded a 1-in. rod a little longer than the longest table, drilled and tapped the front end of each table to a tight fit for the feed screw, and then bushed and tapped an old 12-in. flanged pulley to fit the screw. I clamped a big angle plate on the floor, far enough ahead to clear, with a hole in line with feed screw. I next mounted a 6-in. pulley on an electric portable drilling machine spindle, and clamped the drilling machine to the floor with the pulley in line. I rigged up a wooden horse to support the screw when extended. With the planing machine drive and reverse belts off, and after a few trials with different feeds and by regulating the speed of the portable drilling machine, I milled the T-slots on each planing machine rapidly and accurately.

The table of each machine was then placed right side up under a radial drilling machine, and new holes were drilled where needed, and old and new holes reamed. Large holes were drilled in the chip boxes to facilitate cleaning. I then inverted the tables and counterbored each hole twice its diameter, and $1\frac{1}{2}$ times its diameter in depth. Round nuts were made of cold-rolled steel with a shoulder turned to clear one-half of the pin-

key drill and tap. The nuts were twice the stop-hole diameter deep on their threaded portion with a shoulder flush with the under side of the machine table. After pressing in the nuts I drilled and tapped half-and-half for $\frac{3}{8}$ -in. pin-keys, which were a tight fit, and were made of long rods cut off in 12-in. sections, forced in by a stud nut, sawed off and upset.

Planing the Ways. The ways of each planing machine base were then trued on a large new planing machine, and the table ways planed to fit, relieving the rack if necessary. I then planed the head slides, rebushed the bearings, and attended to all other needed repairs. Tables were scraped in and run for a week on rough work, after which I planed the sides and surface, also the sides of the grooves. I then planed T-nuts in long bars, $\frac{1}{2}$ in. below table surface, and a loose sliding fit in T-slots. T-nuts were then drilled in a simple sliding jig, spacing holes three times a bolt's diameter. I tapped them in long bar lengths in a small drilling machine, using one roughing and one finishing tap. The nut bars were then sawed off, making about two dozen for each planing machine. I next drilled, tapped and turned, then sawed off a large number of ordinary square head stops with a heavy-cuffed screw, making stops of various heights up to 4 in. I tapped these in the same way I did the T-slot nuts, except that the drilling machine table was tilted to place the setscrews in the stops on an angle. I also made a number of heavy high combination multi-parallels, stops and planing machine centers, using 2 x 6 in.; 2 x 8 in., and 2 x 12 in. steel slabs, cutting them at an angle on the cold-saw, drilling and marking them in pairs for the setscrews or stop centers. I held them to the planing machine table by a stud fitting stop-pinhole and a nut at the bottom of the stop-pinhole. These stops may be used in either direction, also as angle plates and parallels, and are cheap if rightly made. I drilled and slotted them for hexagonal nuts. I made a number of standard angle plates, and in making these I drilled them for stops as well as bolts, and made the backs support a standard angle, which I machined. I then made one long multiface angle plate full length of our longest small planing machine table. With keyway bolt slots, stop-pin holes, squaring lines, etc.

The studs next occupied my attention and I made them in large quantities scrapping all the miscellaneous hexagonal and

square nuts, and making a large number of double length hexagonal nuts with wrenches to fit. Nuts were kept on the studs with the length stamped on the end of each stud, while the stud dropped through a large plate near the planing machine.

A SHAPING MACHINE REPAIR JOB

Having a 14-in. shaping machine with ways for the ram badly worn, and having no planing machine available with sufficient room under the cross rail to permit truing up the ways, and since the top of the column was not worn, I adopted the following plan of doing the work: I stripped the shaping machine of ram and gibs, and secured a bar of cold-rolled steel *A*. Fig. 110,

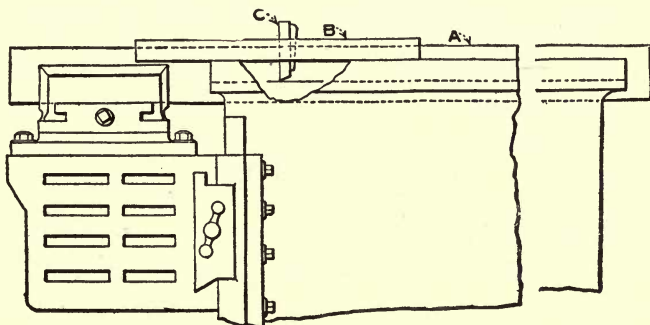

FIG. 110—RIG FOR SHAPING MACHINE

1 x 3 in. in the vise, the length of this bar being slightly in excess of that of the ways. The bar was set parallel with the bearings by the swivel vise. I then employed an old cast-iron bench plate *B*, with the flat-nosed tool *C* wedged in place as shown. By sliding the plate back and forth guided by the bar *A*, and using the cross-feed of the shaping machine, and feeding slightly at each stroke of the bench plate, a fair job was obtained, and I doubt whether or not the shaping machine could have been taken down, stripped and set up on a planing machine, and the work done in less time.

MACHINING A LONG RECTANGULAR HOLE

I had a block *A*, Fig. 111, of 3½ per cent. nickel steel 14½ x 3 x 5 in. Through this block I was required to machine a hole

0.50 x 1.0 in. with an allowance of 0.0005 in. in the sizes. The hole was to be straight throughout its length, parallel with the block, and the short sides of the hole square with the longer sides.

It was not permissible to cut the block in half, and mill the hole in the two parts. Making a series of long broaches, and broaching it, was out of the question as it would be an expensive operation, and I had no facilities for hardening and grinding the cutters, and no press that I could use to push the broach through.

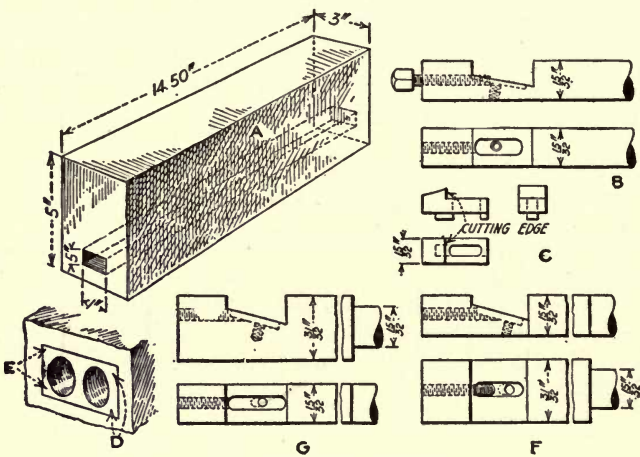

FIG. 111—THE WORK AND THE TOOLS

The only machines I had that I could depend upon to help me out were a 12-in. lathe and a 16-in. shaping machine. With these two machines my purpose was accomplished. I bolted an angle plate to the faceplate of the lathe, and drilled two parallel holes $\frac{1}{32}$ in. diameter through the block. Before running the $\frac{1}{32}$ -in. drill through I first drilled two smaller holes half-way through the block and then reversed it on the angle plate. In this way I kept the holes parallel. I then clamped the block down on the shaping machine table and made up a bar as shown at B. This bar was a few thousandths smaller than the hole and on it I had put a tool somewhat similar to those used for rifling gun barrels. This tool was held down on the inclined plane by a small machine screw, and was held back by the setscrew in the end of the bar. The chip tended to force it up the plane and the reverse stroke tended to push it down the plane, thus making

it safe to back out at any time. I made up a series of these tools of different heights, as the amount of adjustment for each was limited.

Starting with the smallest tool, and cutting on the back stroke of the shaping machine I squared out the two corners D $1\frac{15}{32}$ in. wide. I then changed the bar to the other hole and repeated the operation on the corners E . I then turned the bar 180 deg. and cut the wall between the holes half-way through, then placed the bar back in the other hole and removed the remaining wall.

This gave me a roughly squared hole $1\frac{15}{32} \times 3\frac{1}{32}$ in. I then made up bars F and G which employed the same principle as bar B . I roughed out the short size of the hole with the bar F , turning the bar 180 deg. several times so as to gradually correct what wave there might be in the length of the hole until the hole measured 0.490 in.

I then used bar G , and sized the opposite sides of the hole until it was within 0.0100 in. of size. Then changing to the bar F I finished the hole to 0.50 in., and then changed once more to bar G , and finished to 1.00 in.

It was necessary to make about four tools for each bar, and though this process might seem somewhat elaborate to some, it allowed me to accomplish results with the means I had at hand.

ADJUSTABLE EXTENSION PLANING TOOL

Fig. 112 shows an extension planing tool that is now being used in a large munition factory with considerable satisfaction. This tool can be used on short and long strokes, and may be of such length as the extension bar will permit. The

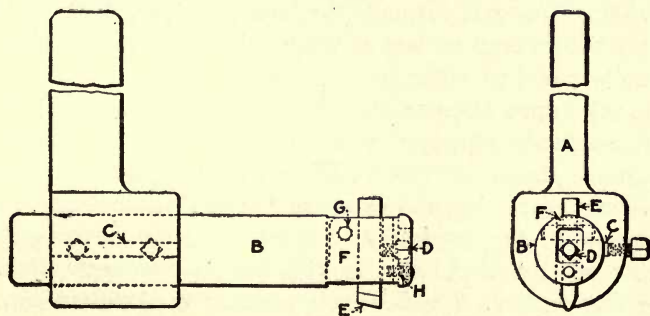

FIG. 112—ADJUSTABLE EXTENSION PLANING TOOL

holder *A* is secured in the tool block, which is immovably clamped in the clapper box. The extension bar *B* can be extended to meet the requirements of the work, and can be turned to plane at any desired angle, thus making it possible to plane a keyway in any location in the hole without disturbing the work after it is set up. The extension bar is tightly clamped by the gib *C* and setscrews. The tool *E* is held in position in the tool block *F* by setscrew *D*. The tool block swings on a taper pin *G*; a spring *H*, held in position by a headless setscrew, keeping the tool block down; while on the return stroke the tool is free to lift by overcoming the tension of the spring. The setscrew *D* is in an opening, which permits it to lift the tool block and also to receive a socket wrench for adjusting the tool. To obtain the best results and maximum rigidity from the extension tool, and its holding parts, they should all be case-hardened and ground. A neat fit is essential at all points.

A TOOL FOR INTERNAL PLANING

The internal-planing tool shown in Fig. 113 has several good features. It is ready for instant use in any planing or shaping machine and is held in the toolpost in the usual way. As the cutting tool lifts in the small clapper box at the end of the bar, the shank can and should be blocked at its upper end, making it very rigid. By turning the bar to the proper position the piece to be machined can be planed on the top, bottom or either side at one setting. The tool being of the toolholder type any shape of tool desired can be inserted.

If desired the bar can be made adjustable for length by threading and screwing it through the shank, as the clamping screw will hold the threaded bar as well or better than the plain bar, and no lock nut or collar is necessary.

The miniature clapper box on the end of the bar is pivoted upon the taper pin, and while firmly supported against the pressure of the cut is free to lift slightly on the return stroke. To prevent chattering and jumping due to its lightness the upper end, opposite the cutting point, rests upon a spring-actuated plunger set longitudinally in the bar at the point indicated in the illustration. The illustration does not of course show this plunger and spring, but, as its function is to steady the clapper

on the return stroke its location and construction are obvious.

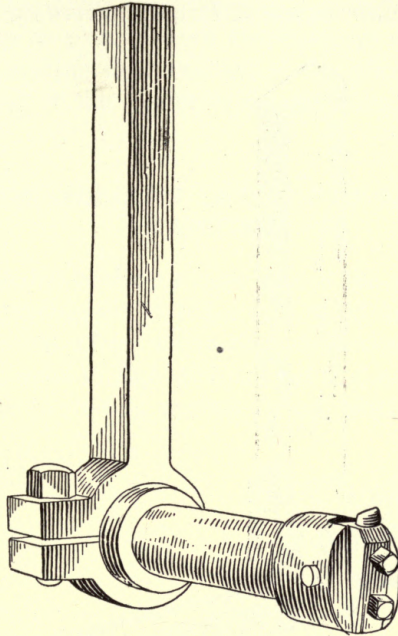

FIG. 113—INTERNAL PLANING TOOL

RADIUS PLANING TOOL

Fig. 114 shows a tool I have used for planing small radii. No clapper box is needed, as the cutter is placed just in front of the shank and thrust collar. A hole through the shank near the lower end receives the tool bar, the shank being split for some distance past the hole to allow for clamping the bar by means of the capscrew shown. A setscrew and hardened rod inserted from the rear end of the bar clamps the tool, which can be set to any desired radius by measuring over the bar with a micrometer.

Two holes are drilled at right angles through the outer end of the bar to allow for turning it with a lever. To turn a radius, the tension upon the bar should be so adjusted by the capscrew that the tool will not move of itself under pressure of the cut, but not tight enough to prevent it from being turned by means

of the pin. Very accurate and perfect work can be done with this tool, and there will be none of the chatter and trouble that usually accompanies the use of formed cutters for the purpose.

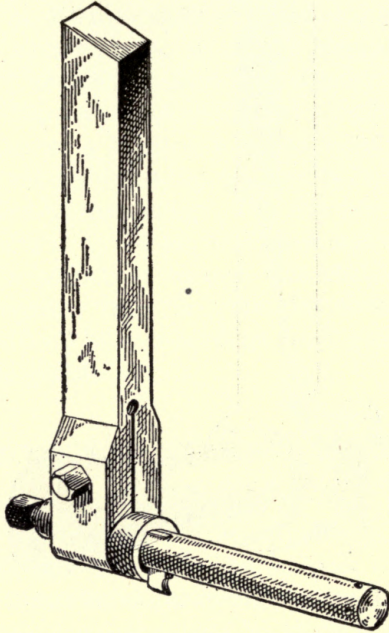

FIG. 114—RADIUS PLANING TOOL

A REPAIR KINK ON A PLANING MACHINE

Some time ago the cross-rail of our planing machine being badly in need of repair, and there being no other planing machine in the shop, we devised the following scheme for re-dressing it:

The cross-rail was removed from its normal position and set up on the table of the planing machine. A heavy plank was bolted to the housings where the cross-rail should be, and the head of a 25-in. Steptoe shaping machine firmly fastened to the plank.

By taking advantage of the swiveling feature we were able to run a cut in any required direction, and in the course of a short time the planing machine was in service again with a practically new cross-rail. The job can also be done by securing the worn

cross-rail to the floor, bolting an angle plate to the end of the table of the planer and securing the shaper head to the angle plate. This transforms the planer into a shaper. Much work that is too large to pass between the housings can be shaped in this way by mounting the cross-rail of the planer on angles secured to the end of the planer table, and securing the work to the floor.

DEVICE FOR HOLDING LARGE JOB ON SHAPING MACHINE

Here is a kink for holding a large job on the shaping machine. I had a large forming die to plane and could figure out no way to hold it, as it was 16 in. wider than the machine table and at no point did it come in line with the table slots. It was necessary to machine the whole surface in one setting, so I devised this rig.

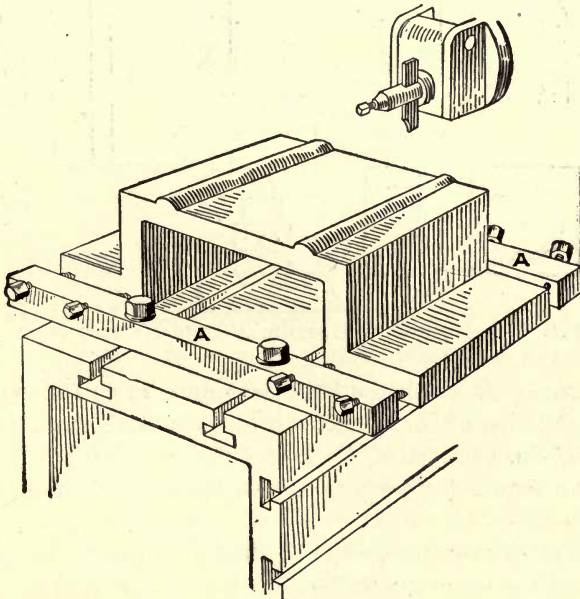

FIG. 115—THE HOLDING DEVICE

In Fig. 115, *A* are two pieces bolted to the table, each having four setscrews set at an angle, thus enabling me to get a firm hold on the work.

The outfit looks simple, but I find it a very handy means of accomplishing work that without something of the kind would be impossible.

CUTTING A NARROW SLOT WITH THE SHAPING MACHINE

Having a number of pieces to make like *A* in Fig. 116, I was confronted with the difficulty of cutting the slot which by reason of its great depth in relation to its width, and also of the limited amount of space available for chip clearance, presented an unusual problem.

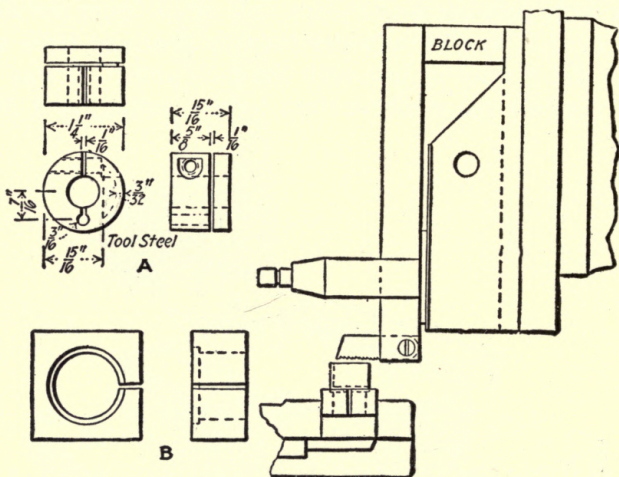

FIG. 116—METHOD OF CUTTING A DEEP NARROW SLOT

The manner in which the work was done is as follows: The tool was a section of heavy hacksaw blade fastened in a holder of 1-in. by $1\frac{1}{4}$ -in. cold-rolled steel, and the work was held in the split collar shown at *B*, which was in turn held in the shaping-machine vise.

The toolholder was blocked at the upper end to prevent it from lifting, and the cutting was done on the return stroke.

A slow speed was found desirable and close adjustment of the ram was necessary, but after getting started a substantial feed could be used, as each tooth of the saw did its own minute portion of the work and the chips were all pulled out clear of the piece, thus avoiding clogging and breaking the tool.

This method has proved so satisfactory that it has been applied to all work of this nature in the shop where I am employed.

SQUARING THE ENDS OF SMALL RECTANGULAR PIECES

When squaring the ends of small rectangular pieces in the shaper or miller, the piece may easily be set vertically in the vise or chuck by the following method:

By laying a small pair of parallels across the vise jaws and an adjustable square upon the parallels, as shown in Fig. 117,

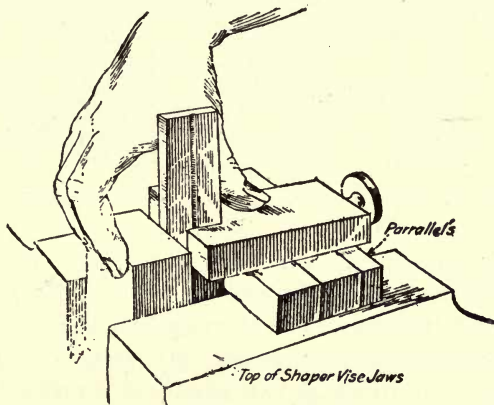

FIG. 117—METHOD OF SETTING A PIECE SQUARE

the thumb of the right hand may be utilized for holding the square firmly upon the parallels, while the index finger of the same hand will hold the piece firmly against the square. The left hand is then free to close the vise jaws upon the piece. This scheme is much better than the plan generally pursued, which is to allow the square to rest upon the bed of the vise, the operator tapping the piece until it is set in the desired position. Owing to the absence of light between the vise jaws, the latter method is not a sure one, and in addition too much time is consumed if the piece being machined is small.

TURNING AND BORING ATTACHMENT

There are many shops that are sometimes called on to do boring and turning jobs that are too large for the lathes at hand.

Where there is not enough of this work to warrant the investment in a boring mill, the attachment shown in Fig. 118 will be found very handy for these odd jobs.

This fixture is of simple construction, similar to circular milling attachments in general use. Part of the table shown at *A* is a worm gear, driven by a worm on the end of the shaft *B*.

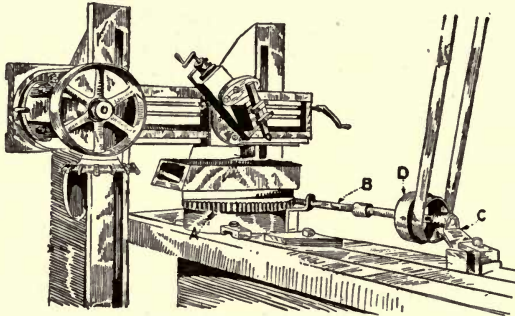

FIG. 118—A TURNING AND BORING ATTACHMENT FOR THE PLANER

This shaft is supported at the outer end by the bearing *C*, which is bolted to the planer table. Power is obtained through pulley *D*, which is driven from the lineshaft.

The planer shown in the illustration is also equipped with a milling attachment which is manufactured by the Adams Co., of Dubuque, Iowa. The two attachments make the planer a very useful tool for the small shop.

DIVIDING ON A LATHE OR SHAPER

As we have no miller or dividing head, when a job of circular dividing comes along we can generally find among the change gears of the lathes in the shop a gear that has the same number of teeth or a multiple of the number of divisions required.

We then fit a mandrel to this gear and to the work to be divided, place it on centers either in the lathe or shaper and after fitting a suitable stop to go into the space between the teeth on the gear are able to do a fair job. In an emergency we have cut gears in this way in the shaper.

SECTION VIII

TOOL MAKING

AUXILIARY BUSHING PLATE IN TOOLWORK

As the method of locating holes in jig work by the auxiliary bushing-plate method is practiced in very few shops, the majority of toolmakers are not familiar with its advantages in certain classes of jig and fixture work.

At the top in Fig. 119 are illustrated two of the most common types of bushing plates. They are made of cold-rolled or machine steel of convenient size, either straight or offset, as the nature of the work demands. A hole bored near one end holds a hardened, ground and lapped bushing at right angles to the under side of the plate. This bushing is pressed into place and remains a permanent part of the plate. A set of slip bushings is made to fit this bushing. As the auxiliary bushing plate is used mostly for work with medium- and small-sized holes, the permanent bushings *A*, if made $1\frac{1}{4}$ -in. inside diameter, will take care of any size hole 1 in. or less in diameter. At *B* are shown hook pins against which the pins *D* in the knurled collar of the slip bushings bear, thus preventing them from turning while in use. A typical slip bushing is shown at *E*. One of the bushing plates has a milled slot *C*, the purpose of which will be shown later.

In central illustration, Fig. 119, is shown clearly how the bushing plate is used for locating, drilling and reaming the bushing holes in a skeleton drill jig for an automobile-frame assembly. There were altogether 18 holes of $\frac{3}{4}$ -in. diameter to be drilled and reamed. The allowances for error for all center distances were plus or minus 0.0025 in. All the holes were laid out approximately, and the jig *A* was clamped on the cast-iron plate *B* by four U-clamps and kept clear of the plate *B* by four parallel blocks *C* to provide clearance for drills and reamers. The size of the plate *B* is determined by the sizes of the jobs that it

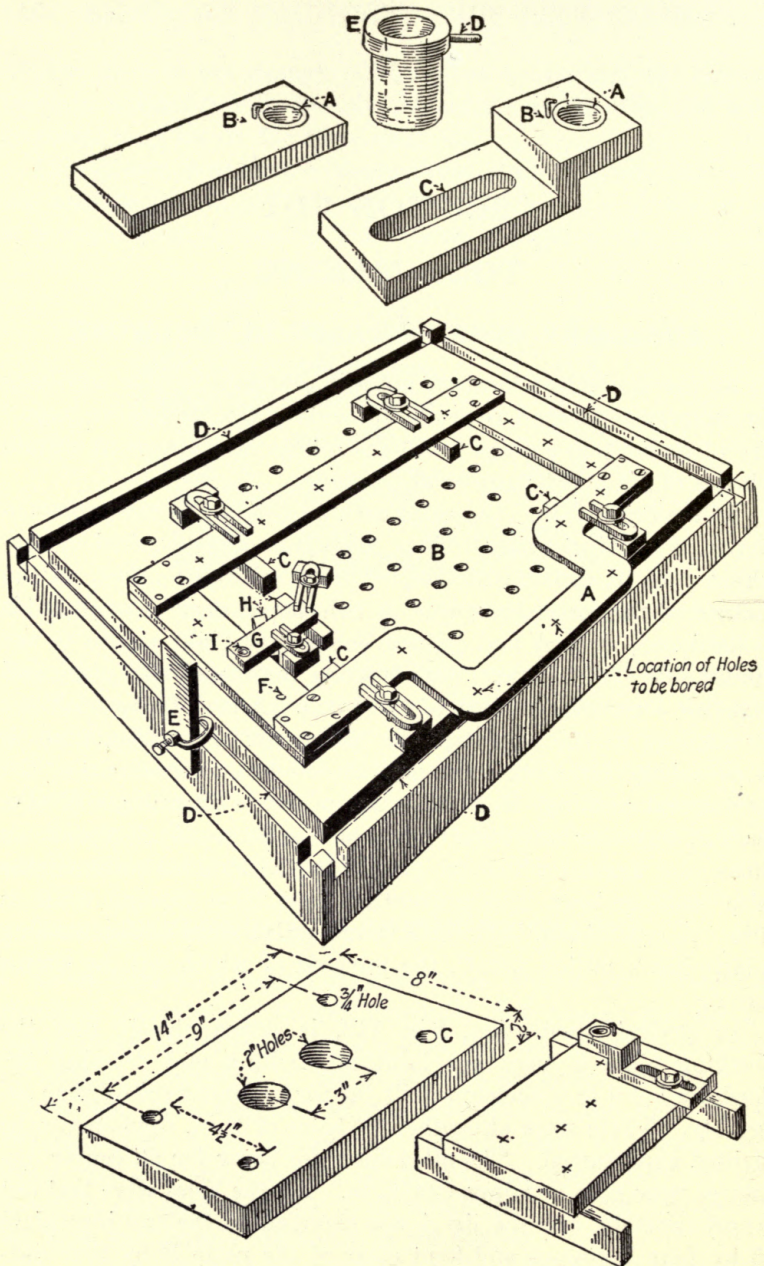

FIG. 119—AUXILIARY BUSHING PLATE

is to accommodate. The one shown is $2\frac{1}{2} \times 30 \times 40$ in.; it has both sides planed parallel and the edges squared all around.

A number of holes are drilled and tapped for tap bolts for holding the work and the bushing plate. The grooves *D* provide means for clamping the measuring block *E* to the edge of the plate *B*.

The method of locating, drilling and reaming the holes is as follows: The baseplate *B*, with the jig *A*, is laid on the table of a radial drilling machine, and the first hole *F* is drilled and reamed. The auxiliary bushing plate *G* is now set over the location of the next hole, its under side elevated about $\frac{1}{2}$ in. above the jig and resting on parallel blocks *H*. In rapping the bushing plate into position, a $\frac{3}{4}$ -in. plug is placed in the reamed hole *F*, and a $1\frac{1}{4}$ -in. ground plug in the hole *I* of the bushing plate. Measuring from the block *E* and the plug in *F*, it is easy to set the bushing plate *G* for the next hole. After the bushing plate is set, the plug is removed and a suitable slip bushing inserted in the hole *I*. The cycle of operations is just as it is in any drilling and reaming through a bushing. For subsequent holes the same procedure is repeated.

I should like to draw especial attention to the grooves *D*, and the measuring block *E*, two of which were made, although only one is used in connection with the job shown. The measuring blocks were made of tool steel $1 \times 2\frac{1}{2} \times 7$ in.; they were hardened and ground parallel on the 1-in. measurement. By this method of taking measurements from the squared edges of the baseplate, very accurate and quick settings of the bushing plate can be obtained.

In the bottom illustration, Fig. 119, is shown another way of using the auxiliary bushing plate. In this case the offset type of bushing plate is used. The dimensions of a top plate for a box jig are given. In this job six holes are called for, four of $\frac{3}{4}$ -in. diameter and two of 2-in. diameter. A job of this kind could be done by the button method. No baseplate was used on this job, and all drilling, boring and reaming were done on an ordinary sliding-head drilling machine. The bushing plate is held to the jig plate as shown. It might be well to mention that the hole *C* is drilled and reamed first in the ordinary way; for the rest of the holes the bushing plate is used, which is located accurately by means of a height gage and the surface plate. All

four edges of the jig plate are carefully squared, thus eliminating all uncertainty in locating the bushing plate. All the holes check up to within 0.001 in., which is 0.0005 in. closer than the greatest allowable error.

An interesting feature about this job is the boring of the two 2-in. holes. A 1-in. drill was used in the first place, then a $\frac{3}{4}$ -in. boring bar working through a $\frac{3}{4}$ -in. slip bushing till the hole had been enlarged to $1\frac{1}{2}$ in., after which a 1-in. boring bar and a 1-in. slip bushing were substituted and the hole bored to its finish size. The space between the offset of the bushing plate and the jig provides sufficient clearance for setting the boring tool bit and for calipering. By the aid of the slot *C*, in the upper illustration, the bushing plate can be secured to any position over a jig plate of large dimensions, provided there is a hole for the bolt.

AN ECONOMICAL COUNTERBORE

In these days of high-priced steel many ingenious ways have been devised whereby the waste of the steel has been brought down to a minimum. Fig. 120 shows a four-fluted counterbore. The body is made of high-speed steel and the rest is

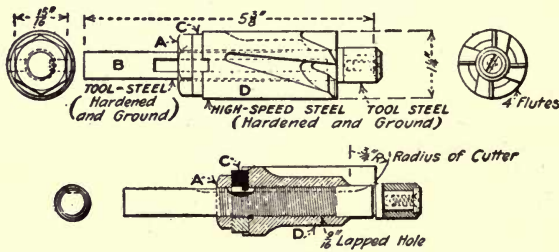

FIG. 120—AN ECONOMICAL COUNTERBORE

made of carbon tool steel. When it is necessary to grind the counterbore it is disassembled by unscrewing nut *A*, and pulling out the lock washer *C*, when the body *D* can then be pressed off. The body *D* should be a ring fit over spindle *B*. It can be seen that as the counterbore is ground off the nut and lock washer are brought closer to its end until there is hardly any of the body left. Another good feature of this counterbore is the movable pilot. The hole that this pilot was to run in was a very

particular one, with only 0.001 in. limit. The ordinary pilot would wear the hole large, but in this pilot there is no wear on the hole in work.

BUTTONS FOR MEASURING ANGULAR WORK

Fig. 121 shows buttons that may be used in measuring external and internal dovetails, table V's, triangular and irregular shaped pieces and similar work when it is impracticable and in most cases impossible to measure over sharp edges.

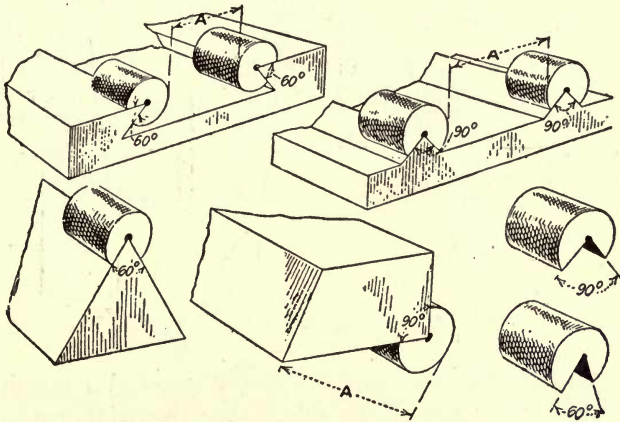

FIG. 121—BUTTONS FOR ANGULAR WORK

The buttons are cylindrical plugs with cutaway sectors. Angles of 60 deg. and 90 deg. will be found most useful, but they may be made of any angle and of any size. These buttons have a large field of usefulness in the toolroom, and considerably shorten the time required to check some classes of angular work.

CARTRIDGE-PUNCH TEMPLER

A simple and accurate gage for testing the formed ends of the punches is made as shown in Fig. 122.

A piece of sheet steel about No. 14 B. & S. gage is cut to size, and the outline of the punch is scribed on it. The portion inside the lines is then cut out and the opening filed to size. In use, the gage is placed over the end of the punch to be formed and held to the light. If the punch has not been reduced

enough, there will be a space between the end of the punch and the bottom of the gage. The punch is reduced until it touches the bottom of the gage, which should fit on without pressure. A more accurate method of making the gage is shown.

A reamer is made, the cutting end having the same form as the tapered end of the punch. A piece of sheet steel *B* is cut

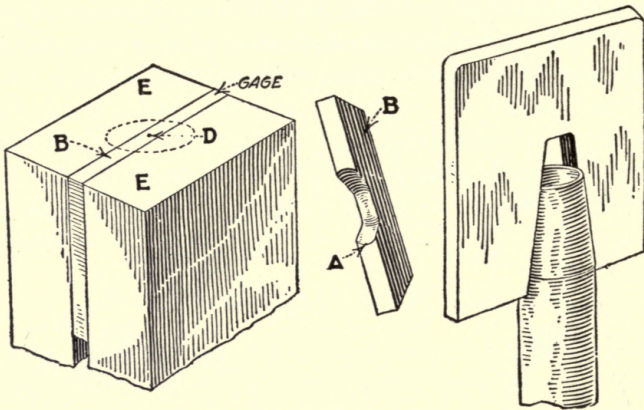

FIG. 122—CARTRIDGE PUNCH TEMPLT

to a convenient size; one side is squared up, and a punch mark *D* is made in the center of the side. It is then clamped between two blocks of steel *E* and centered in a lathe chuck by means of the punch mark. A hole is drilled and bored out to nearly the finished size and finished with the reamer. The plate is then taken out of the chuck, and the radius *A* is just filed out.

MAKING A CIRCULAR FORMING TOOL

A large number of circular forming tools as shown in Fig. 123, which were required in turning the base ends of shrapnel fuse bodies, called for accurate machining and with the exception of the surface *X*, were to be ground all over. To get the blanks ready for the forming operation was an easy proposition; however, the method of putting on the form may be interesting.

A block *B*, having an opening *Y*, was placed on the toolpost and rigidly clamped in position on the tool rest. This block had two slots milled in it at proper points, in which were located the cutting tools. Each of the cutting tools was pro-

vided with a slot to receive a stud to which the cutting tool was secured. Adjusting screws in the block were provided to engage the outer ends of the cutting tools, and hold the latter in position against rearward movement from the work. The depth of the cuts on the blank, as well as their position, was provided for by means of a guide piece *F*, which contacted with the side of the blank, and also with the flange on the mandrel.

After the milling and hardening operations, the forming tools were trued up on the internal grinding machine faceplate by slipping them over a removable plug piloted in the hollow

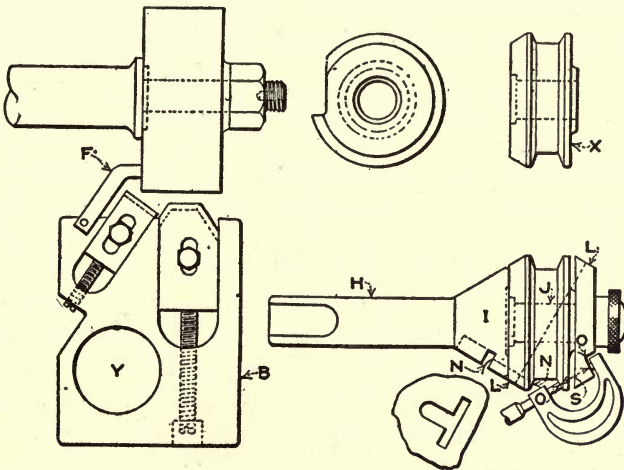

FIG. 123—MAKING A CIRCULAR FORMING TOOL

spindle, clamped and then ground to size in the holes. The end faces were then ground while on centers—the larger surface first, and then the smaller end—on the surface grinding machine. The various surfaces that made up the form came next.

Probably the most common method of checking angular forms is the use of a thin profile gage, trusting to the operator's sense of sight, and his guessing ability as to where and how much stock is to be removed.

The combined grinding mandrel and gage shown provided means for measuring with a micrometer and overcame the objectionable feature of guesswork as in profile gaging. The mandrel *H* was hardened and carefully ground all over. The tapered portion *I* formed a continuation of the front conical

section of the forming tools, with the diameter, before rounding the same as on the finished tool. The circular forming tools were slipped on the spindle *J*, of the mandrel bearing against the portion *I* and held in place by the nut. As shown, the surfaces *L*, *N*, and *O* were made parallel to directly opposing edges of the three angular surfaces. The measurements were taken from these parallel surfaces with micrometers.

The table of the universal grinding machine used was swung to suit each angle so that the face of the wheel could be used. Considerable time was saved by running through a large number at each setting, and with this method of checking, the production was unusually high-class for this character of work.

CASEHARDENED JIG BUSHINGS

In my opinion there is no advantage in the tool-steel bush over the casehardened bush, with regard to wearing properties. As the case is generally not less than 0.006 in. thick, the bush is scrapped for inaccuracy long before the softer core is reached.

The casehardened bush has the further advantage that, when forced into the body of the jig, the compression will be largely taken up by the soft core and very little of it communicated to the hardened case surrounding the bore of the bush. There is thus less likelihood of cracking the bushes, should the forcing allowance by any chance be big.

ADDING LIFE BY TAKING CARE OF A MICROMETER

For accurate work, the measuring faces of a micrometer should be perfectly parallel. To true up the anvil and the end of the spindle, I have made the device shown in Fig. 124. To

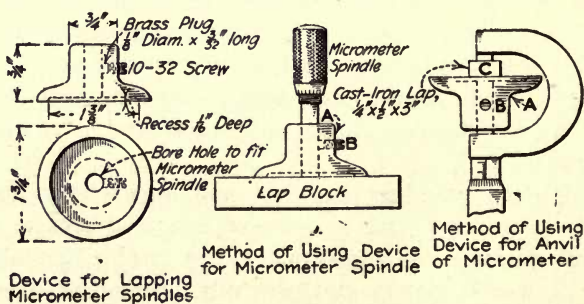

FIG. 124—METHOD OF TRUING A MICROMETER

use this, proceed as follows. Remove the spindle from the micrometer and insert it in the holder *A*, as shown. It is unnecessary to tighten the setscrew *B* for this operation. A little rubbing on a cast-iron lap plate will true up the end of the spindle. Now remove the spindle from the holder and, after cleaning thoroughly, replace it in the micrometer. Then put the holder *A* in position, as shown to the right. Tighten the screw *B*. The lap *C* is placed in position and the micrometer spindle adjusted so that it will just slide between the holder *A* and the anvil. The side next the anvil is of course charged with an abrasive. By rubbing *C* back and forth, the anvil is lapped true with the spindle. The lap *C* is about $2\frac{1}{2}$ in. long.

GRINDING PRECISION TOOLS

Many flat gages are now employed that invariably have to be scraped to precision before hardening, as there is no other available way that is profitable. This necessitates a scraping tool ground to required accuracy, even though the gages are ground and lapped.

Precision tools in reality are gages themselves, and require the skill of a gagemaker to produce an accurate job. Fig. 125 shows a gage which requires a form-tool composed of a series of very minute angles, and by no means a job for an unskilled mechanic. These angles being difficult to measure and there existing various ways they could be measured, some doubt arose as to which method would obtain the most accurate results. The following was adopted: Angle *A* was figured out trigonometrically. The protractor was set at proper angle, and the length of angle then obtained by means of size blocks 0.043 in. thick. Care should be taken to have point of blade sharp, that when under the magnifying glass the point will determine the extremity of angle. The 45-deg. angle was ground by originating an angle on the wheel and thus obtaining the sharp corner desired. From the side of the tool, angle *A*, to the beginning of the 45-deg. angle is 0.093 in. Now, setting small adjustable square 0.093 in. with size block and again using glass, grind 45-deg. angle until it comes even with point of blade. Care should be taken to have end of blade perfectly square and corners sharp. Depth 0.038 in. can be measured with depth gage.

Precision tools necessarily have to be backed off, and many times this is accomplished by two different settings, which is unnecessary. The writer's method, and perhaps one used elsewhere, is by means of square block attached to an angle iron as shown. By such means the double angle can be obtained, eliminating resetting for backing off.

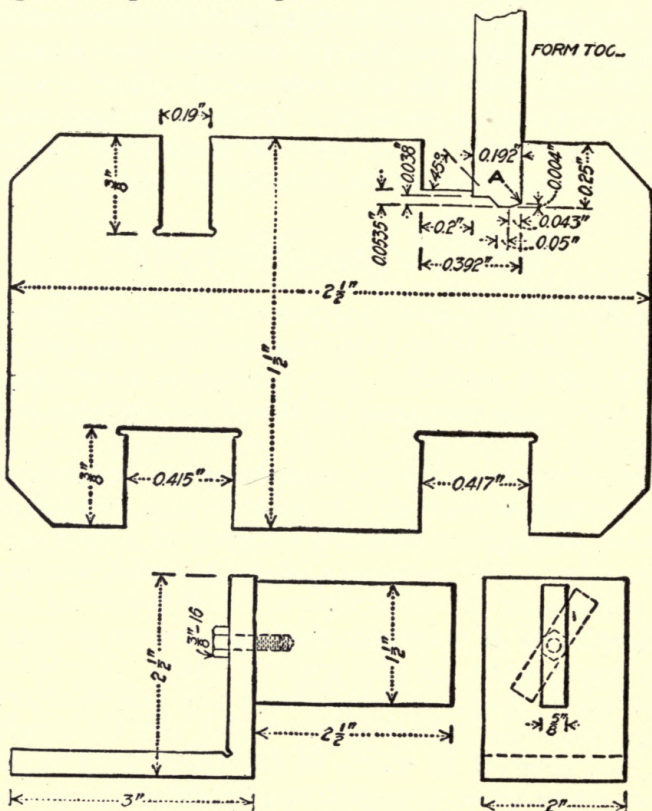

FIG. 125—METHOD OF OBTAINING GAGE ANGLES

The block is hardened and ground perfectly square all over, and is found useful on many other jobs besides precision tools.

LOCATING HOLES ON CLOSE CENTERS BY MEANS OF SPECIAL BUTTONS

Fig. 126 shows a part of a drilling fixture in which three holes were to be located too close together to allow the use

of a test indicator. The first time the job came up the holes were located and drilled one at a time, but this method consumed more time than was necessary and allowed greater opportunity for error than if all the buttons were located at one setting.

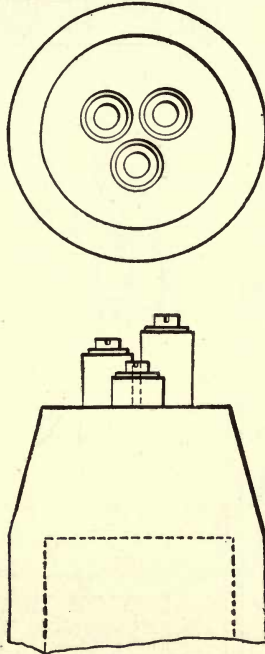
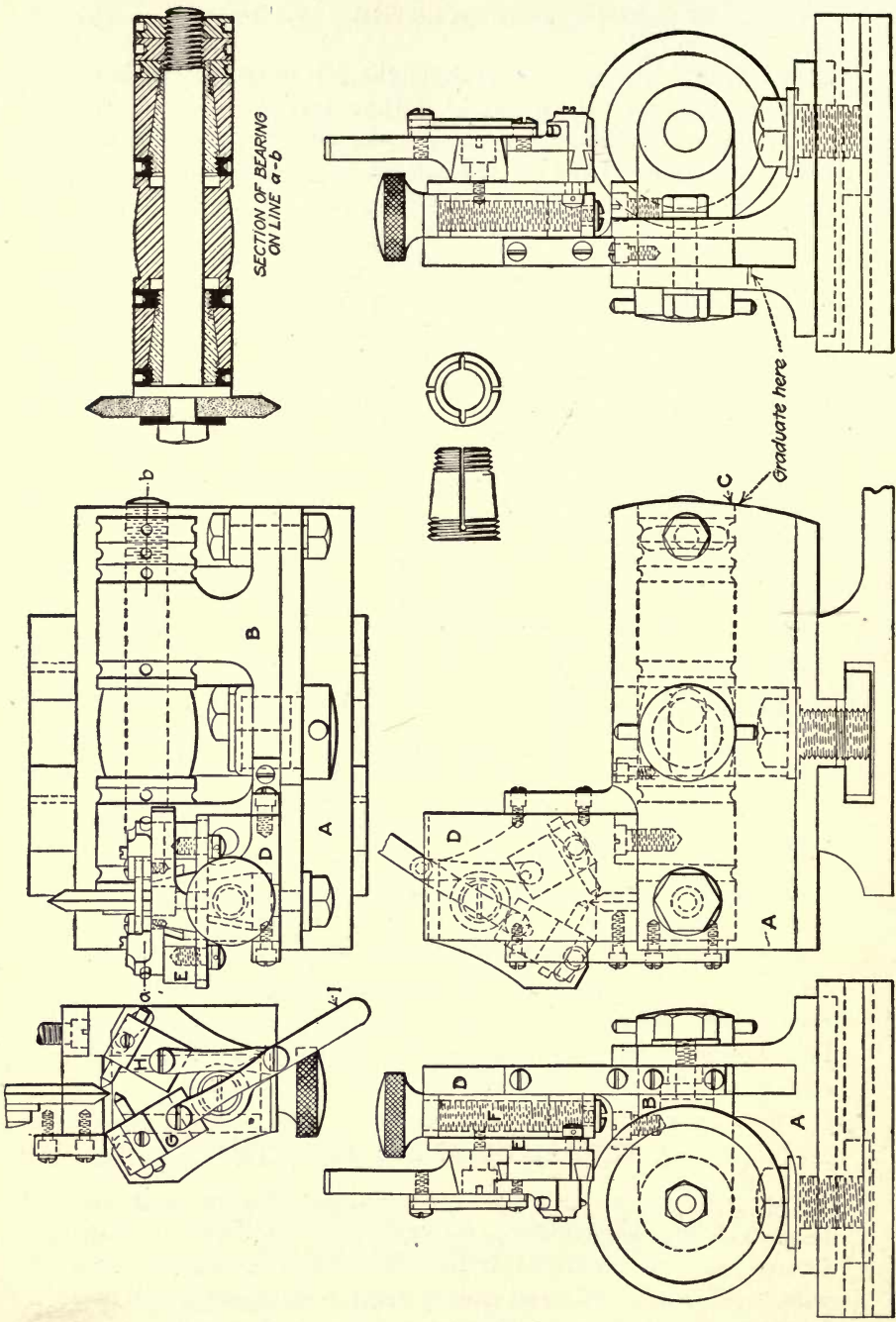

FIG. 126—LOCATING CLOSE CENTERS WITH SPECIAL BUTTONS

The second time the job was to be done, the writer was prepared with special buttons, one longer and one shorter than the regular set. This allowed all three buttons to be set at once, and by swinging up the longer one first the lathe man was enabled to center and bore them in succession.

A THREAD-GRINDING FIXTURE

Fig. 127 shows a fixture for grinding threads that can be used on the compound rest of any lathe. The body *A* of the fixture has a rib planed to fit the toolpost slot, and is provided with a collar-head bolt and square nut for clamping the fixture in position. The bracket *B* carrying the wheel spindle swivels



upon part *A*, the axis of the swivel being horizontal at right angles to the center line of the wheel spindle and opposite to the vertical center line of the wheel.

Means are provided for swiveling this bracket and for clamping it in whatever position may be necessary to make the plane of the wheel conform to the angle of the thread being ground; and as the axis upon which this movement takes place is coincident with the center of the wheel it follows that this adjustment does not affect the relative center positions of the wheel and the work to be ground.

One edge *C* of the swiveling bracket is finished and graduated so that the thread angle being known, it is but the work of a moment to tilt the wheel to a corresponding angle.

The bracket *B* has an extension *D* parallel to the vertical plane of the wheel, this extension carrying a slide *E* which is adjusted vertically by means of the screw *F*. Upon the face of this slide are mounted two smaller slides *G* and *H* with their lines of travel 30 deg. either side of the line of travel of the slide upon which they are mounted. These smaller slides are arranged to carry diamond toolholders directly over the center of the grinding wheel. They take their movement from the compound lever *I*, which causes first one diamond and then the other to pass over the angular surface of the wheel, dressing it whenever this is necessary.

As the part upon which the slide is mounted is integral with the wheel-carrying bracket, swiveling the latter about its axis does not affect the positions of the diamonds in relation to the wheel; therefore when once set the tools are always in position for truing the wheel.

The wheel spindle runs in tapered split-shell bearings providing ready means of adjustment to compensate for wear.

MAKING A HEIGHT GAGE OUT OF A VERNIER CALIPER

At the present time it is practically impossible to buy vernier height gages owing to the unprecedented demand for them, and the necessity of waiting, sometimes for long periods, for an opportunity to use the gage owned by the shop led me to use this otherwise unprofitable time in making an attachment for my

6-in. vernier caliper which would transform it into a height gage without interfering with its other sphere of usefulness.

Many toolmakers who do not possess a height gage own a 6-in. vernier caliper, and the few simple accessories shown in Fig. 128 will make of it a convertible tool that will perform the duties of either.

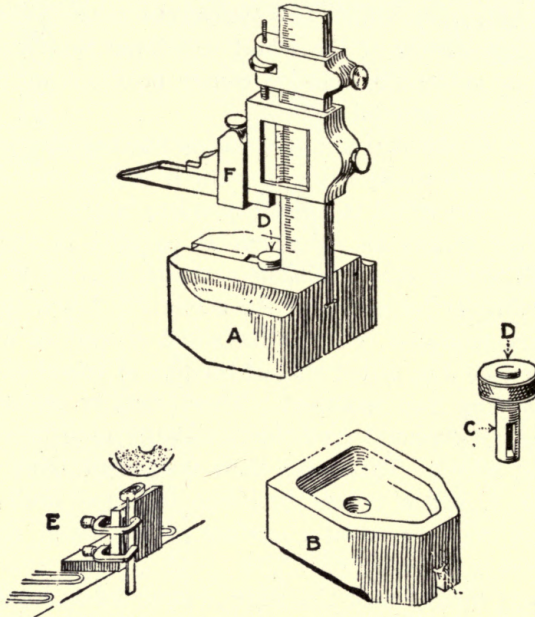

FIG. 128--CONVERTIBLE VERNIER HEIGHT GAGE AND CALIPER

I have my vernier caliper so equipped, and would not now exchange it for the regular tool, as its accuracy could not be surpassed by the latter and it is more convenient and adaptable.

The base, shown at *A* in the assembled tool and at *B* in a reversed position, is made of tool steel, the small holes indicated by the arrows being drilled clear through to facilitate grinding the bottom of the slot. The pocket on the underside serves to lighten the tool and to provide a recess for the nut which holds the parts together. The slotted stud *C* and its nut *D* are made of cold-rolled steel and should be casehardened to resist wear. The stud is a slip fit in the hole through the base, and the slot in the stud is made just large enough to allow the fixed jaw of the caliper to be easily set in place.

The slot in the base is of course accurately ground to fit the fixed jaw of the caliper, which should also have a light cut taken over the back to insure accuracy. The base should be ground on the bottom after assembling, the manner of holding the tool for these operations being shown at *E*.

A few passes over a good lapping block to remove the wheel marks will finish the base.

The scriber clamp shown at *F*, which can also be used to attach an indicator, is too familiar to need description.

A RADIUS TRUING FIXTURE FOR USE ON GRINDING WHEELS

It is essential on various classes of tool and die work that the radii be ground, therefore a radius truing fixture must be made to suit the purpose. There are many types of fixture in use in various parts of the country, some of which are simple and others complicated.

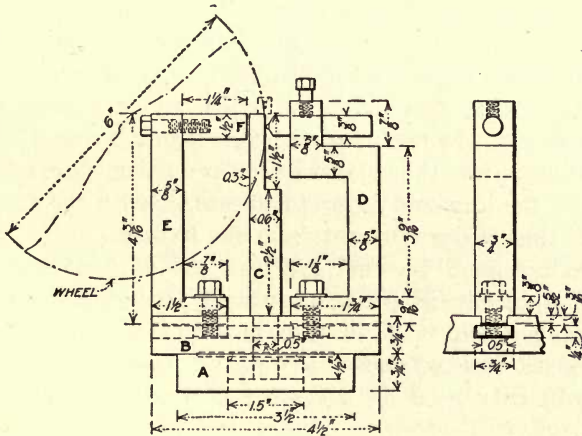

machine are casehardened, thus assuring accuracy of fitting and better wearing surfaces.

The base *A* is surface ground on the top and bottom, and the hole is ground to 1.500 in. diameter. On the plate *B* the 0.500-in. diameter hole, the 1.500-in. diameter projection and the surface that bears on the base *A* should be ground in one setting to insure precision.

The T-slot is ground to 0.500 in. in width, making it easy to center it with the 0.500-in. hole for the setting plug *C*. The shank of the plug *C* is ground to fit the 0.500-in. hole, while the body is ground to 0.600 in. in diameter. For about 1½ in. of its length one-half its diameter, or 0.300 in., is ground away, leaving a flat that exactly cuts the center line, and it is from this flat that all settings are made. A small projection about ⅝ in. in length and of suitable diameter is turned on the end of the plug to facilitate grinding, and should be eliminated after finishing. The diamond holder *D* is adjustable in the T-slot, and the shank of the diamond is also adjustable in the holder, thus allowing a wide range of adjustment.

The section *E* is for setting the diamond for truing internal radii and is also adjustable in the T-slot. By means of the size blocks the setting point *F* is adjusted to the correct distance from the center, the center plug being turned around if the desired radius is less than 0.300 in. The center plug is then removed and the diamond adjusted to contact with the face *F*, the section *E* then being removed from the fixture.

In making small internal radii on grinding wheels a small diamond especially adapted for this purpose is necessary and a radius smaller than 0.125 in. is impracticable. This fixture will accommodate wheels from 3 to 7 in., in diameter, which is the range ordinarily used on a Brown & Sharpe surface-grinding machine.

ACCURATE SETTING DEVICE FOR INTERNAL GRINDING

We do a great deal of internal grinding of small holes (⅝ to ¼ in. in diameter) in perforating dies. The perforating die-holes have a taper of 0.004 in. in 1 in., and the dowel holes are perfectly straight. The dies are mounted on master plates,

therefore all the holes in each die must be ground before the die on the master plate is disturbed, which means that the grinder must be set to grind 0.004 in. taper and also to grind perfectly straight on each die.

Not being able to depend on the graduations on the grinder for extreme accuracy, it was a case of more or less cut and try, and this consumed a great deal of time.

In order to reduce the time of setting the machine and to obtain a greater degree of accuracy, I made the attachment shown in Fig. 130. This device made it possible to set a machine in a

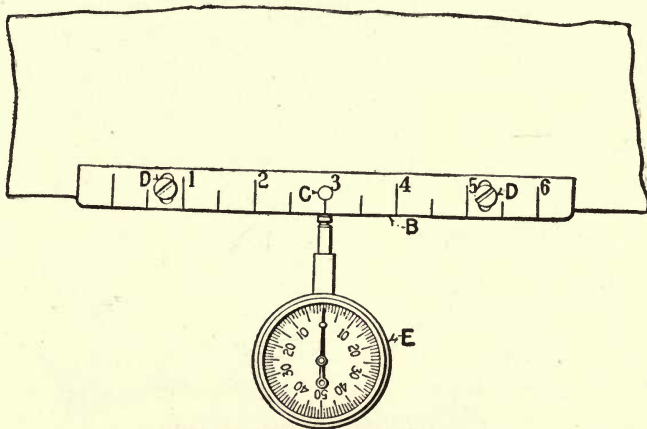

FIG. 130—THE SETTING DEVICE

very few minutes so that it would grind a perfectly straight hole or an accurately tapered hole without the usual experimenting.

A is the head on the internal grinder; *B* is an adjustable straight-edge $\frac{3}{16}$ x $\frac{3}{4}$ x 7 in. graduated in half inches, swiveled on a $\frac{3}{16}$ in. pin at *C* and slotted to allow adjustment on the $\frac{3}{16}$ -in. clamp screws at *DD*. The dial indicator *E* is mounted on the bracket, which is attached to the bed of the machine.

To set the straight-edge, chuck a piece of about $\frac{3}{4}$ -in. steel extending say $2\frac{1}{2}$ in. from the chuck, then external grind, setting the swivel table so that the machine is grinding parallel. Now set the straight-edge *A* so that the indicator shows it to be parallel with the travel of the table. After the straight-edge is set and clamped in this position, use the indicator to set the ma-

chine. Straight or tapered holes can then be ground with extreme accuracy.

TRANSFER GAGE FOR PIERCING DIES

Many times in making piercing dies with small holes it is necessary to use a very small drill and drill back from the bottom side with a larger drill in order to enter the taper reamer for making the clearance. On a thick die, if the small drill is run clear through to locate the larger drill on the other side, the small drill breaks easily and causes a lot of bother and loss of time in annealing and remarking the die. I have never seen any tool advertised to transfer the holes, but I have found that the transfer gage shown in Fig. 131 works very well in such cases.

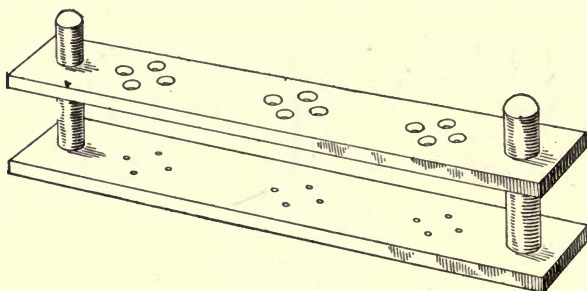

FIG. 131—THE TRANSFER GAGE

I have one of these which I made and have used for some time and I find that it is a very handy tool. To use it it is only necessary to run the small drill part way through, then put the die between the two plates of the gage and hold it so the drill hole lines up with one of the holes in the gage. Turn it over and mark the hole on the other side with a scribe to get the center for the larger hole. In this way a great deal of time and drill breakage is saved. The gage should be made of tool steel hardened to resist wear, but can be made of machine steel casehardened.

USEFUL ANGLE PLATE

Nearly every toolmaker carries a small angle iron in his kit. It is generally too small for most jobs, but, of course, it is made small, with the idea that it must fit into a certain space in the

owner's tool chest. In a great many shops, it is hard to find an accurate angle plate for tool or gage work, so I made one, shown in Fig. 132. It is not too large to go into my chest, and yet it is large enough to use in combination with a 5-in. sine bar.

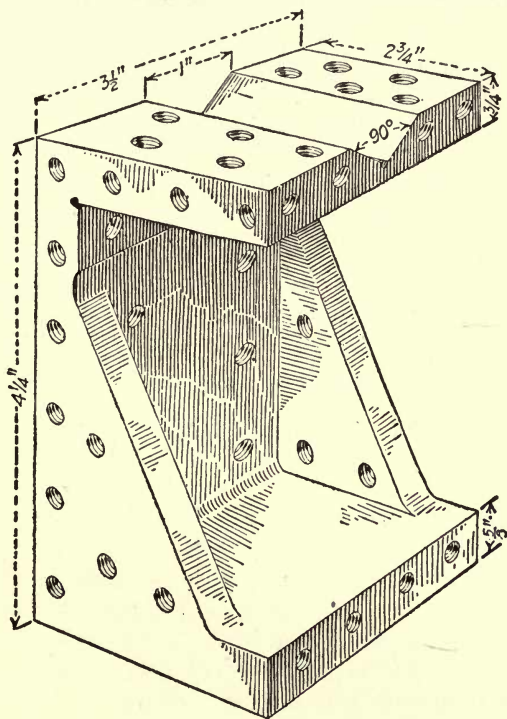

FIG. 132—THE ANGLE PLATE

It is made of cast iron and planed and hand scraped so that it is dead square every way. The 90-deg. V-slot in the top adds greatly to its usefulness. It is handy around the surface grinding machines. In fact, on a great deal of accurate grinding work I would hardly know how to get along without it. All finished surfaces are provided with $\frac{1}{4}$ -in. 20-thread tapped holes at intervals of $\frac{3}{4}$ in. to facilitate the clamping of work.

I notice that a good many toolmakers have angle plates made of steel, hardened and ground, but I prefer cast iron, as I find that a well-seasoned casting does not change shape so readily as the majority of grades of hardened steel. I have two other

angle plates besides the one shown here, one being made of cast iron and the other of hardened steel. My experience has led me to prefer cast iron, not only because it is easier to work in the first place and retains its accuracy to a greater degree, but because in case of necessity it is easier to correct by hand scraping.

SECTION IX

DIE AND PRESS WORK

SHEET-METAL WORK

At the present time when sheet-metal production is being made to fit all kinds of stamping and drawing operations, it is advisable to use this metal in many cases where castings and drop-forgings are used, and by making good tools—tools that are designed properly to produce accurate and finished pieces—the factory cost of production can be cut appreciably.

We all know that patterns and castings are necessary in many cases, but there are cases where tools can be employed to produce punchings that will fit in and do the work of castings with a much lower factory cost. The snagging, drilling, planing and milling of the castings is thus done away with by die-blanking, drawing, forming and piercing operations of the tools done on the one press and by the same operator, thus saving the moving of parts from one machine to another.

In using sheet steel it is essential to have the bends and breaks made across and not with the grain of the metal. However, this is not taken into consideration with deep stamping and forming steel, as this steel is dead soft and can be put in the die with any angle of the grain. Still on hot-rolled steel and hard sheet steel the practice mentioned is essential. Bending with the grain on hard steel is liable to make cracks and splits.

Some manufacturers in their specifications will state that certain steel will bend at right angles across the grain; other steel (softer) will bend flat on itself across the grain, but only at right angles with the grain. When making bends with the grain, and not being familiar with the steel, a rounding bend is safer than a sharp bend.

A good feature of cold-rolled steel is the very smooth surface that can be obtained. Invariably pieces that are made from very smooth steel do not need any grinding to fit them for the

plating bath, but a buffing- or soft-wheel operation is all that is required. This steel costs more to buy, but if these grinding operations are eliminated, then it is cheaper in the end to use a high-grade, smooth-surface steel.

Another thing to be reckoned with is the scarcity of copper and brass. Years ago sheet-metal articles were made of copper and brass for the reason that sheet steel would not do the work. Today, however, sheet steel can be obtained in almost any degree of softness, and this is largely taking the place of sheet brass and copper.

We have had complaints that steel would never fill the place of brass and copper, as the rust made it unfit for ornamental articles; even if nickeled it was not satisfactory, as when used in damp places the rust would work through the nickel plate and finally become very unsightly. To the manufacturer this need not be cause for worry, for if the steel parts are given a copper plating first, and then a nickel plating, the rust will never come through. Copper has better affinity for steel, or seems to hold better in solution than nickel. On the other hand, nickel will hold well on copper. Therefore, if the steel parts are given a copper-cyanide bath first, the nickel will hold and rusting will be overcome.

Castings that are used for heavy duty can be supplanted by steel stamping in some cases. We have used boiler plate for this work, and by heating it red hot it can be formed and drawn satisfactorily. Of course, this is for work where surface appearance does not count and where grinding and polishing are not necessary.

For marine work, steel fittings and punchings may be used satisfactorily, and if the parts are sherardized there is no chance of their rusting. It is the duty of every manufacturer to use steel wherever possible, and steel can easily be substituted for the more expensive materials, copper and brass.

Lastly, when using sheet metal, make stock layouts of the parts to be punched and determine the proper width before ordering. Then there will be a minimum of waste. Also by ordering multiples of the blank required, short ends are eliminated. Some blanks can be nested one with the other to save scrap. The writer has in mind a job in which by staggering the blanks the saving in scrap was nearly 30 per cent. over the old method.

LOCATING SMALL HOLES ACCURATELY IN DIE WORK

One of the difficult problems for the diemaker to solve is that of accurately locating holes of very small diameter, such as are often met with in small die work in model making. It frequently happens that several holes have to be located in a progressive or a piercing die. If the center distances of these holes may vary only 0.001 in. or less, it looks quite a problem sometimes, and more especially when the button method is out of the question on account of the button screw being larger than the diameter of the holes to be bored.

By the method here described, it is possible to locate such holes very accurately and also more quickly than by any other way that I have tried for this class of work, except, of course, with a special vernier-equipped die-boring machine. A good illustration of the principles involved can be had by following the various stages in the making of the progressive die blank for a clock-mechanism part, Fig. 133.

From this sketch it can be seen that a tolerance of only 0.0005 in. either way is allowed for the center distances of all three holes. The circular rack *A* is rough blanked in the same die, sufficient stock being left for a finish-shaving operation in another die.

The layout of the first die is given in the lower sketch. The blank, which is of No. 19 gage (0.0437-in.) cold-rolled steel, does not have to be held to close limits, with the exception of the circular back part. As this is finished in a later operation, spacing the three holes with sufficient accuracy comprises the real problem in this case.

The die opening *A* is worked out to a model, and the $\frac{3}{16}$ -in. holes *B*, *C* are bored part way through the die blank, the clearance holes being large enough for the full passage of slugs.

Two pieces of drill rod $\frac{3}{16}$ in. in diameter by $\frac{3}{16}$ in. long are next driven into these holes, and two $\frac{1}{8}$ -in. holes are drilled and reamed halfway into the die blank and the drill-rod plugs, as at *F*. The plugs are next removed, and the die blank, with the finished die opening *A*, is hardened. After hardening, this die opening is honed and retouched to fit the model. The drill-rod plugs, together with $\frac{1}{8}$ -in. dowel pins in holes *F*, are driven in,

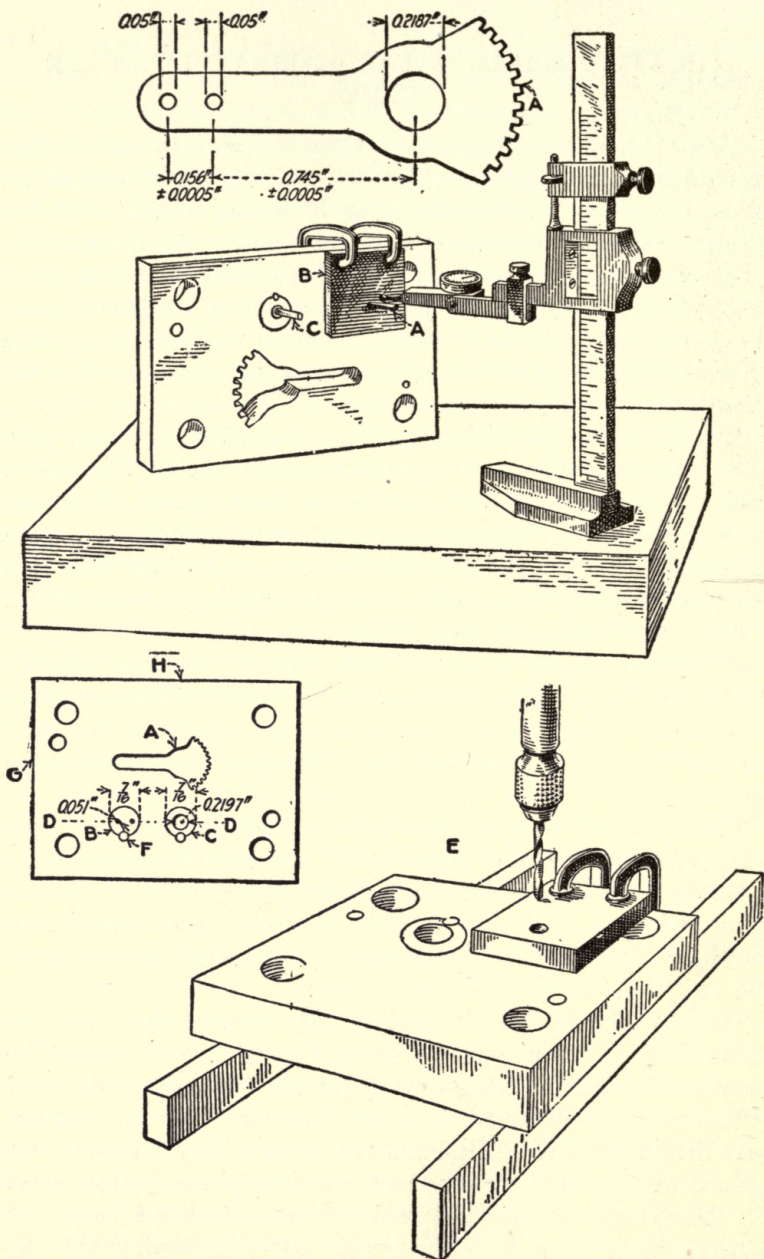

FIG. 133—LOCATING SMALL HOLES ACCURATELY

and the die blank is ground parallel on both faces. Also, the edges *G* and *H* are ground square, the edge *H* being parallel to the center line of the three holes. Grinding the edges *G* and *H* facilitates locating the button and the drill plate while the die blank is resting on those edges on the surface plate, as will be shown later.

Next the plug in the hole *C* is drilled and tapped for the button screw, and the button is set to the correct location by the usual method, using an indicator in the height gage and taking the necessary measurements from points of the finished die opening. The button thus secured is trued up, and the 0.2197-in. hole is bored out in the lathe. For the two 0.051-in. diameter holes the following method is employed: A piece of $\frac{3}{16}$ -in. flat cold-rolled steel is drilled so that a 0.051-in. rod is a good sliding fit in the hole, after which the cold-rolled steel plate is cyanided.

The upper figure shows the successive steps in locating and drilling the two 0.051-in. holes in the inserted drill-rod plug in the die blank. With a 0.051-in. plug *A*, in the drilled hole of the cyanided plate *B*, and a plug *C*, consisting of two diameters—namely, 0.2107 in. and 0.051 in.—concentric with each other (a good fit in the previously bored hole of the die), locating the plug *A* correctly for one of the small holes is but a matter of measuring with micrometers and the height gage from plug to plug, testing with the height gage as shown.

After the plug *A* with the plate *B* has been tapped into place, the plug *A* is removed and the die blank, with the drill plate held securely with clamps, is taken to a drilling machine. At *E*, is shown the die blank resting on parallels on the table of the drilling machine, preparatory to drilling the 0.051-in. hole. It might be said that the hole is first spotted through the drill plate with a 0.051-in. drill, then drilled right through with a drill a few thousandths less in diameter and finally reamed with a 0.051-in. twist drill, which has the corners rounded so as to produce a smooth hole. The drill plate is next removed and the remaining hole treated identically.

All three holes are now taper reamed from the back for clearance; both $\frac{7}{16}$ -in. drill-rod plugs are removed from the die blank and hardened, after which they are again pressed back in their respective holes, the $\frac{1}{8}$ -in. dowels lining them up to positions they occupied while being drilled and bored. A slight finishing

tween the stripper plate *A*, and the washers *D*, resting on shoulders of the bolster shown at *F*. Normally the force of the partly compressed spring is taken up between the screw heads and stripper plate or the thread of the screws. A good way to dispose of the slugs from small piercing punches is shown in the drawing. After the slugs have been pushed through the blank by the piercing punches *G*, they enter the holes *H* and follow the paths shown by the arrows being dropped back on the blank or on the outside at *I*.

A WIRE BENDING DIE

Referring to Fig. 135 the wire is pushed through the cutting block *A* to the stop *B*. The press is tripped; the cam

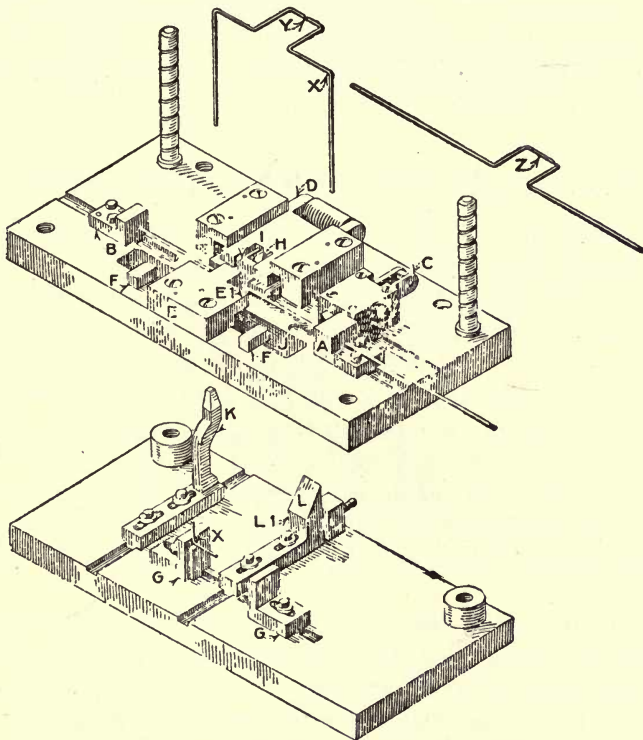

FIG. 135—WIRE BENDING DIE

punch *K* is entered between the rolls in the slide *C*, which moves forward cutting off the wire. *C* now remains stationary while

the bending slide *D* is moved forward by the cam punch *L* to the stationary punch *E*, forming the wire in the shape shown at *Z*. (In this bend the wire slides on the gage blocks *F*, which prevents the wire from getting under the corner of the bending punch *E* lettered *EI*.)

The slide *D* now becomes stationary by reason of the roll in *D* riding on the straight part of the cam *L* lettered *LI*. At this instant the punches *G* engage the wire at *X*, completing the bending operation. The chisel cutters *H* of which there are two, one in the stationary punch *E*, and one in the slide *D*, have severed the wire at *Y* with an angle point (for driving into wood) at the finish of the stroke of the slide *D*. This slide *D* is returned to its starting position by means of a spring in the die shoe. The stripper *I*, which is under the spring tension, ejects the wire from the shelf on slide *D*, allowing the wire to fall through the slot *J* in the die shoe into the separate boxes under the press.

PROGRESSIVE DIE FOR RUBBER WASHERS

The design of a die for punching hard-rubber washers illustrated in Fig. 136 embodies some interesting and novel features of construction. The die as it appears when assembled is shown and it can be seen that it is of the progressive type, or as it is sometimes called a "follow" die. The die shoe *A*, of cast iron, has the plate *B* mounted on it and held with seven fillister-head screws. The cutters are mounted on the die shoe, the punch proper consisting of five blocks of hard maple glued together, and held with screws to the cast-iron punch-holder. The construction of this being so simple that no further explanation is necessary. Hard rubber was the material worked on and it came in strips 3 in. wide.

The operation of the die is as follows: The stock is placed on the stripper plate, over the first punch *C*, and held against the stock guide. The punch block on descending, forces the rubber strip and the stripper plate down over the cutters till the sharp edge *F* has cut clear through the rubber and slightly into the hard maple block of the punch. On the upstroke of the press the stock is stripped by the aid of the six springs, and being moved further over, the stripper plate is located over the

next position by the pilot *G* entering the 1-in. hole pierced by punch *C*. In this position the six $\frac{3}{8}$ -in. holes are pierced, while with the same stroke of the press another 1-in. hole is added, which in turn is located over the pilot *G*, and the punch block on descending cuts out the finished washer by forcing it through the hollow punch *I*. Now a complete washer will drop through the opening *J* of the die shoe.

The section gives a few more important dimensions of a cutting

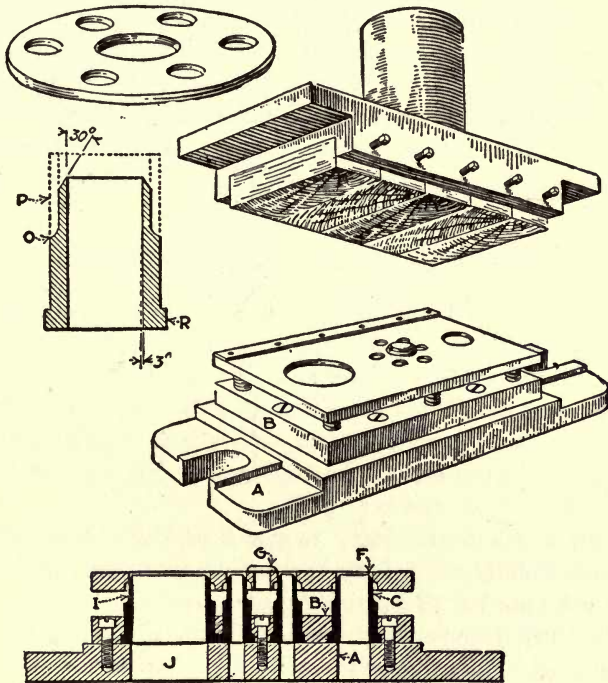

FIG. 136—RUBBER WASHER AND DIE WHICH PRODUCED IT

die, all of which were made of a good grade of tool steel, hardened and drawn to dark straw on the cutting edge, and made similar in proportion. It will be noted that the cutting angle is 30 deg., which was found to give entire satisfaction in hard rubber. The shoulder *O* accommodates the bushing *P*, shown in dotted lines, which is for the purpose of pressing the cutters out of the punch plate, when the cutting edges need regrinding. Three of these bushings were made, one for each different size of punch,

The diameter of these bushings is a few thousandths less than the hole for the corresponding punch in the punch plate.

In all rubber-washer punching, but especially for those of larger size, a progressive die made as the one just described, is much easier to make, and of longer life than a complicated compound die. It is also easily set up and operated in the punch press. When the punches become dull, they can be reground, and put back in a short time.

Care should be taken to have the bottom faces of the small cutters marked with a corresponding figure on the plate in order that each cutter may be put back in its proper place after grinding. Of course, this would not be necessary if all the cutters were made interchangeable as regards the outside diameter and depth of shoulder *R*, but this would hardly be practicable on account of the extra time needed to accomplish this result.

PRODUCING A BULGE IN TUBING

Soft-lead slugs can be inside tubing to do the bulging after which they can be melted out but much time, cost and labor can be saved by the use of cushion rubber slugs in the place of the lead slugs, and the rubber slugs can be used over and over again. After the pressure is relieved the rubber will return to its original shape and drop out of the tubing with little or no trouble, and may be used for the next piece.

I hardly think it necessary to use lead slugs, especially for soft copper tubing, as I have formed many shapes from brass, tin and light steel with a rubber punch.

In Fig. 137 is shown a common little shape that I have manufactured by the thousands, with a rubber punch—one piece of rubber serving for many hundred pieces. At *A* is shown the shell which is to be bulged. The die *B* is a block of steel slightly hollowed as at *C*, to receive the bottom of the bulge. The punch *D* is of hardened steel, close fitting, with the rubber pad screwed to its bottom. The size and amount of the bulge is determined by the adjustment of the stroke of the press. In the first operation the shell is drawn up on a No. 1½, toggle-action Bliss draw press, with the common blank-and-draw push-through type of dies, and the bulging operation is done on a 2-in. stroke Bliss No. 21.

The rubber pad on the bottom of the punch has a fillister-head machine screw *F* in its upper end to engage a threaded opening in the bottom of the punch. At *G* is shown a shell *I* produced in this manner, which has a slight bead running

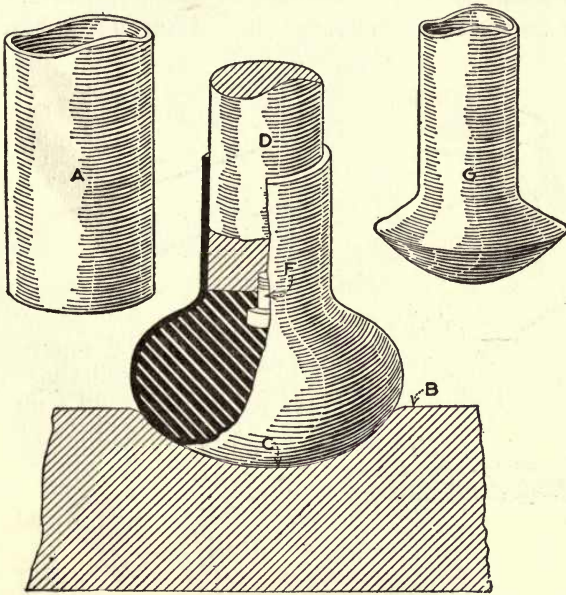

FIG. 137—METHOD OF BULGING SHELLS

around the center of the bulge. The complete shell was formed from the original straight-side shell in one operation. While the lead slug is practical, and will certainly do the trick, I think the rubber slug will be just as effective at less cost and less labor.

MAKING PIERCING PUNCHES

The method of making punches and the jig here illustrated may be of interest. In Fig. 138 is shown a finished piercing punch. In making these punches, a piece of steel of the required length is cut from the bar, heated on one end only, and then placed in the opening *A* between the jaws *B* and *C* of the jig shown. The jaw *B* is stationary and jaw *C* is moved about the pin *D* by the eccentric pin and handle *E*. This movement is very slight, being only enough to allow the punch to be easily

dropped into place and clamped so as to hold it firmly while the hot end is headed over.

The jaws *B* and *C* are lined with the steel blocks *G*, *H* and *J*. These blocks may be replaced when worn, or others of a different inside diameter may be inserted so that punches of different sizes may be made in the same jig. After being headed, the

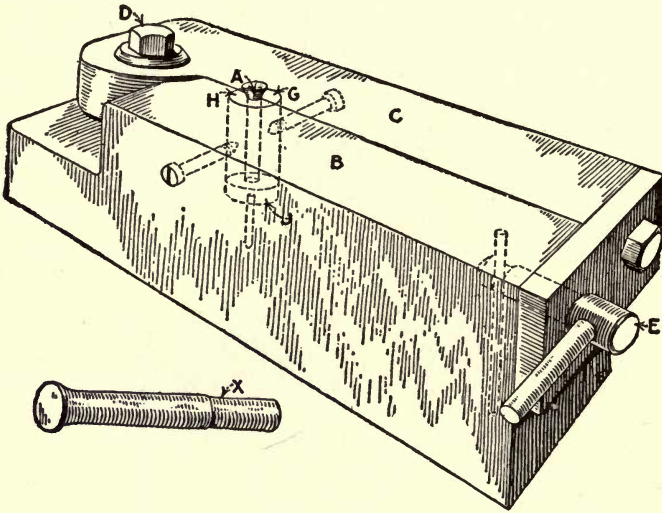

FIG. 138—THE PUNCH AND HEADING JIG

punch is chucked and the top of the head turned square with the body of the punch. It is then chucked a second time and filed for clearance at *X*, after which it is hardened and tempered for use. This jig has been found very satisfactory for this work and has paid for itself many times over.

PIERCING OPPOSITE SIDES OF THIN SHELLS

Some time ago I had several thousand drawn shells of tin which had to have two holes pierced opposite each other, and having nothing but a common punch press to do it with I rigged up the die shown in Fig. 139. In the cast-iron base *A* is fitted a slide *B* in which is a recess machined to take the two half-round dies *C*. The slide is supported upon the rods *D*, which in turn rest upon a rubber bumper which is under suffi-

cient tension to stand the piercing of the top hole. After that was punched, the ram, descending farther, caused the punch holder to force down the slide carrying the die until the other hole was pierced, by the stationary punch located in the base.

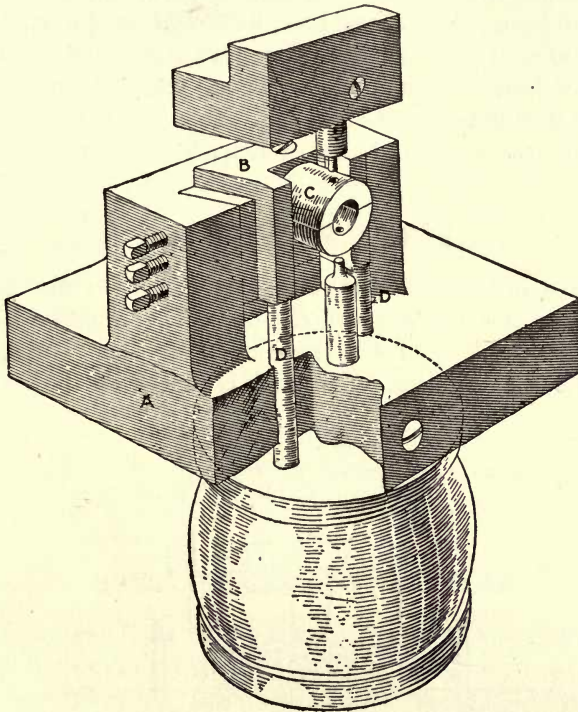

FIG. 139—TOOLS FOR PIERCING A THIN SHEET METAL SHELL

This arrangement worked very satisfactorily and as fast as could be expected. The punchings came out in the hole in the center of the die and when the press was inclined to a suitable angle they fell out.

PRESS KINK FOR BLANKING CLOTH OR OTHER SOFT MATERIAL

If you have a plain blanking punch and die, made for blanking sheet metal, and wish to use the die for blanking felt, cloth, flannel or other soft material, you can do so by running the job

with about 0.010 in. thick iron or tin under the cloth and next to the die.

Cloth blanks made in this way are just as good as those made from an expensive compound punch and die. Care should be taken to first grind the punch and die and put them in first-class condition. Also shear both materials to the same width, so that the work may be handled rapidly by the operator.

The foregoing plan was tried with red felt $\frac{1}{8}$ in. thick and the blanks that resulted were clean cut. One job was a double-hole washer, the other a round washer $\frac{3}{4}$ in. in diameter with a $\frac{1}{4}$ -in. hole.

SPRING-FORMING DIE

Fig. 140 represents the cross-section of a die for performing the last operation on the flat spring represented at X, while Y shows the spring as it comes to the die. The operation of this die is as follows: The work is placed on the lower part

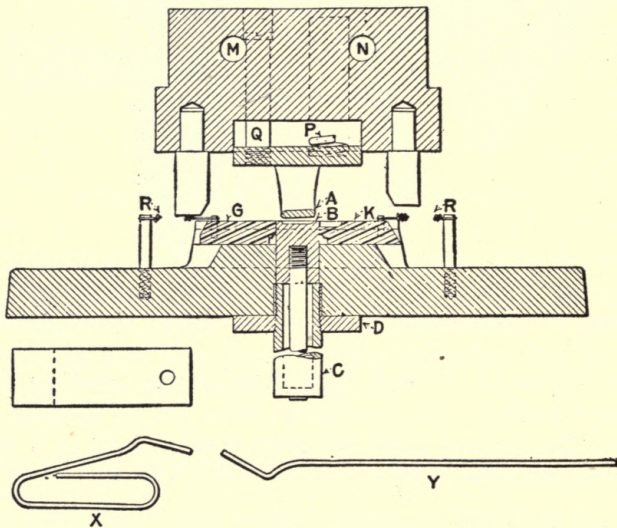

FIG. 140—CROSS SECTION OF SPRING FORMING DIE

of the die between small gage pins, which are not shown. The press is tripped; and as the upper part of the die descends, the ends of the spring are turned up in a vertical position by the L-shaped piece A forcing the steel down into the groove cut

through the square plunger head *B*. As the upper half of the die continues to descend, the plunger *B* is carried down against the action of a coil spring within the barrel *C*. The square steel plate *D* is threaded to fit the thread on *C* and is fastened to the cast-iron base of the die. The plunger *B* is forced nearly down to the top of the barrel *C* when the wedge engages the slide *G*, which is forced toward the center of the die and thus starts to form that end of the work around *A*. As the downward action continues, the other wedge engages the slide *K* and thus folds over the other end of the work.

While this part of the operation is being done, *B* is stationary and *A* is being forced upward against two heavy coil springs, only one of which is shown at *P*. These springs are located in diagonally opposite corners of the rectangular upper end of the steel part *A*. In the other two corners are hold-up bolts that also act as guide pins. One of these is shown at *Q*. As the head of the press ascends, the slides *G* and *K* are pulled back against stops by the coil springs *R*, as shown. There are two of these springs on each side, arranged in the form of a V, to pull on each slide. Bolts pass through the holes *M* and *N* to fasten the upper half of the die to the ram of the press.

SOME PRESS-TOOL POINTERS

I believe that there exists no greater diversity of opinion regarding the design of equipment than is to be found in shops that operate presses. During my experience I have encountered much equipment that was altogether too expensive, because it was not designed with an idea of being universal and for that reason was, to me, impractical.

It will be my object in the following to show what I believe to be the best practice in blanking, drawing and double-action equipment.

In Fig. 141 is shown a die for drawing shells, first operation. The recess in the upper side is made to the proper size for the blank. It need not be the full depth of the thickness of the stock, but merely enough to catch and center it. Dimension *A* is the length of the ironing surface. This will differ somewhat, according to the thickness of the stock, but need never be over $\frac{1}{4}$ in. for stock up to $\frac{3}{16}$ in. In machining, bore out the die about

0.015 in. smaller than the finished size, giving it an even curve as shown.

The center illustration at the top shows the wrong curve in drawing dies; this has a great tendency to stretch and thin the stock. At point *B*, the die should measure what it will when finished, leaving the ironing surface to be finished after harden-

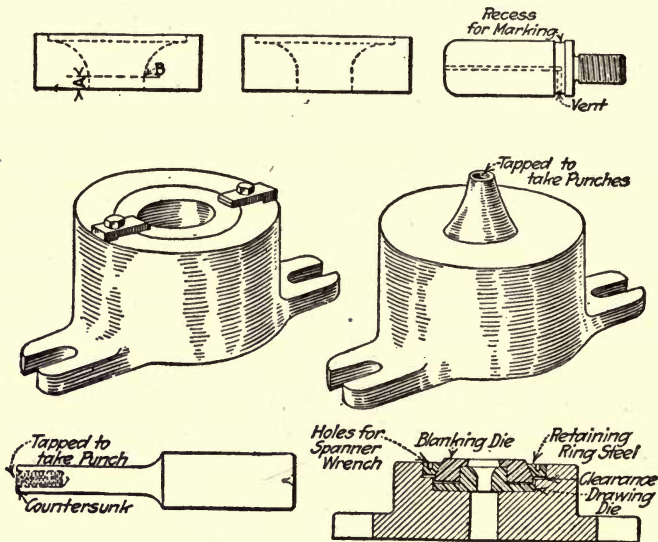

FIG. 141—DETAILS OF DIE, PUNCH AND HOLDERS

ing, by grinding. The curve can be finished in the lathe with a three-cornered scraper, then polished with a carborundum pencil and kerosene, and finally with fine emery cloth and oil. The quality of work turned out and the life of the die depend a great deal on the curve and its finish.

The die blanks can all be turned in a turret lathe. It is then only necessary for the toolmaker to true up the blank, bore out the die and polish.

About three sizes of die blanks will be found enough for the average run of work. This necessitates only three different sizes of die holders, and I believe the one shown will be found about as handy and inexpensive as could be desired. It is made of cast iron, bored out a sliding fit for the die blanks, and two holes tapped on opposite sides for capscrews, which draw down on the straps and hold the die in place. The ears on

the holder provide means for keeping the die holder on the bolster plate. When it is necessary to change dies, loosen the straps, lift out the die, slip in another, and the job is again ready to run.

Drawing punches are another interesting feature of press-tool equipment. The one shown will be found economical from every standpoint.

First decide upon the necessary sizes for the threaded end. Let us say $\frac{7}{16}$ in., $\frac{5}{8}$ in., $\frac{3}{4}$ in. These can be turned in the turret lathe, then cut off to the proper length for the punch. When it is desired to make up a set of punches, these pieces can be given to the toolmaker along with a suitable holder to strap on the faceplate. One of the small cast-iron die holders with hardened-steel plug in the center makes a good one. It is then a simple matter to true up the holder and turn as many punches as desired with one setting. Drawing punches should be ground slightly tapering, so that the work will strip more readily when withdrawing the punch.

The punch holder is shown in the lower left hand corner. When changing punches, fasten a dog onto the punch; a few blows with a hammer on the dog will loosen or tighten the punch. The punch holder should be hardened and ground all over.

I prefer the two-piece double-action dies, with the retaining ring in place, as shown at the lower left hand corner. They are self-centering throughout. The chief features in their favor are that when one-half breaks or wears out it can be replaced, and the die is as good as new. When experimenting with a new job either half can be ground larger and "doctored up" to get the desired result, something quite impossible with a one-piece die.

After a drawing die has run awhile, it will be quite likely to allow the work to come back with the punch. This is because the lower edge has become rounded. To remedy this, grind the under side by holding both edges of the hole against the circumference of an emery wheel, which will make it slightly cup shaped and give it a sharp edge to strip the work. Many die makers do not approve of stripping by means of the lower edge of the die and more or less complicated spring operated strippers are made to close around the punch after the work has been pushed clear through the die and stripper.

PIERCING OBLIQUE HOLES

The die illustrated in Fig. 142 was designed to pierce the holes in the piece shown. The cast-steel blank holder *A* is suspended from the cast-iron secondary ram *B* by the guide pins *C*, pressed in *A* and a sliding fit in *B*. The springs *D* transmit the power for the blank holder *A*. The links *E* were hinged on the second-

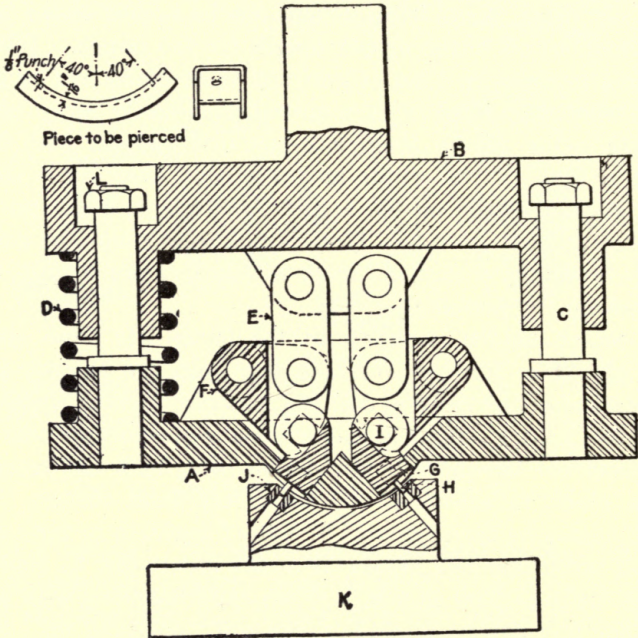

FIG. 142—DIE FOR PIERCING OBLIQUE HOLES

ary ram and on the punch forcers *F*, which in turn were pivoted in the lugs cast integral with the blank holder. The punch holders *G*, which are a sliding fit in *A*, carry the piercing punches *H*. The hardened-steel pin *I* is pressed into the punch holder *G* and serves as a rest for the forcer *F*, which is cut out square to allow for the angular movement of the punch holder. The button dies *J* are pressed into the cast-iron base *K*.

The illustration shows the die at the bottom of the stroke. The die operates as follows: The blank holder *A* and the secondary ram descend as a unit, until the blank holder strikes the

piece to be pierced, holding it securely on the die. The secondary ram continues its downward course, setting the toggle arrangement in motion, thus piercing the holes. On the return stroke the ram *B* ascends, withdrawing the piercing punches and stripping the work. The blank holder *A* remains stationary until the nuts *L* bottom in the counterbored holes. The ram and the holder then ascend as a unit.

A FREAK SHELL—ITS CAUSE AND CURE

Sometimes, when putting through a lot of brass shells similar to the one shown at *B*, Fig. 143, a number of so-called freak shells are discovered. For some unknown reason these are out of shape. While there are a number of causes that result in "freak shells," there are times when one can offer no good reason.

A good illustration of a freak shell is shown at *C*, while the shell as it should be is shown at *B*. The cause is this: When

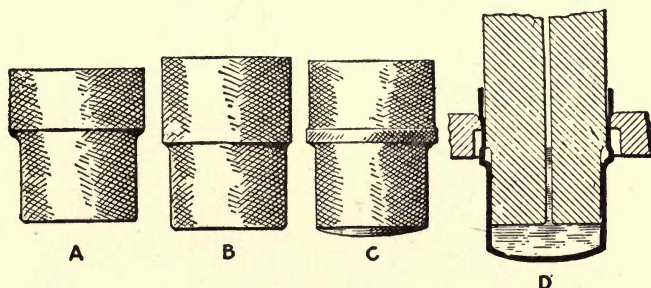

FIG. 143—FREAK SHELL AND HOW IT WAS MADE

redrawing the large diameter, an unusual amount of the soap-water lubricant used for redrawing the shells, was occasionally left in the bottom of a shell. As the solution could not escape quickly enough through the air hole in the ram when the punch descended, the result was that the solution ahead of the punch acted on the shell in a manner similar to that illustrated at *D*. This in turn caused the bulged part of the shell to be forced through the redrawing die *without being operated on by the punch*, which in turn caused this part of the shell to bulge after it was forced through the working part or edge of the die.

The cure for this trouble was a larger air hole in the punch, to

allow the water to escape, besides keeping the lubricant out of the shells as much as possible, preparatory to feeding them to the die.

BENDING DIES FOR TUBING

I submit the following described and illustrated method for accomplishing the work of bending seamless-steel tubing of $\frac{3}{4}$ in. diameter with 0.030 wall. As the tube will come in lengths of 10 or 12 ft. the first operation will be cutting the pieces to length, which can be quickly and satisfactorily performed with an abrasive-wheel cutting-off machine. These little machines will cut off

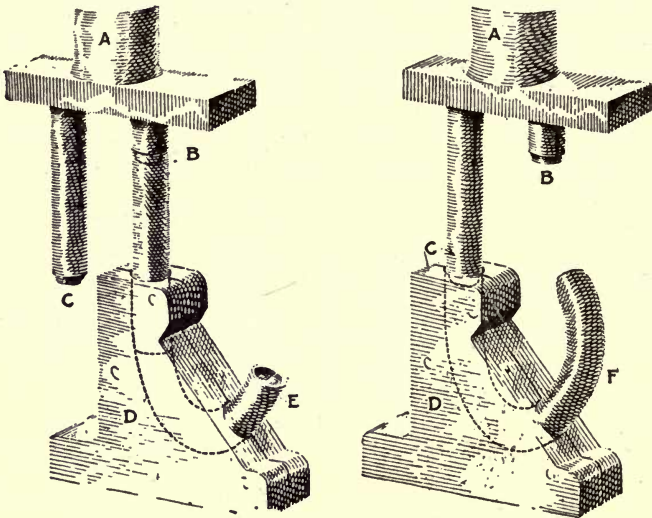

FIG. 144—THE FORMING OPERATION

tubing very rapidly; one installed by the writer for cutting off tubing about $\frac{1}{16}$ in. in diameter was operated by a boy at a piece-work price of 3c. a hundred pieces.

In order to form these pieces on the punch press, which has a 4-in. length of stroke, I would make the die shown in Fig. 144.

The punch holder *A* would contain two driving punches shouldered to fit the tube, as shown at *B* and *C*. The curling die *D* would be made in halves to facilitate machining the curved hole, and these halves would then be doweled and screwed together permanently. The die would have to be fitted to a sliding base,

as it would be necessary to employ one stroke of each punch in order to force the tube into the die to a distance of $7\frac{7}{8}$ inches.

With the die in the position shown at the left the first stroke of the short punch *B* would force the tube about $3\frac{3}{4}$ in. into the die. The operator would then slide the die to position shown at the right for the second stroke, and the long punch *C* would force the tube the remaining distance into the position shown at *E*. Another tube would then be inserted and the next stroke of punch *B* would force the first tube into the position *F*. Upon the following stroke the punch *C* would eject the finished tube from the die. A completely bent tube would thus be produced at every other stroke of the press.

The sliding die would of course have to be equipped with suitable guides and positive stops.

SPRING OPERATED PUNCH PILOT

The blanking of some pieces of $\frac{1}{8} \times 1\frac{1}{8}$ -in. cold-rolled sheet steel, into which a hole was also pierced, resulted in a split punch, due to an error of the operator in not properly locating the stock. The pilot used when this occurred was inserted in the blanking punch as shown to the left in Fig. 145. The punch

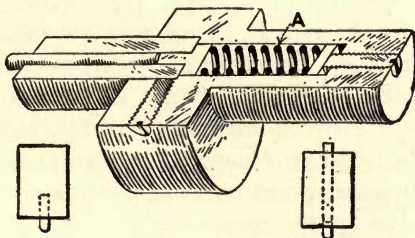

FIG. 145—VARIOUS TYPES OF PILOTS

was then drilled as shown at the right, which allowed the pilot to move backward into the punch in the event of a miss. This eliminated any further damage to the tools, but it was necessary to reset the tools whenever the operator made an error. In the sectional view is shown how all these difficulties were overcome. When a miss is made, the pilot is pushed back, and on the return stroke the spring *A* forces it back into position again.

SECTION X

GAGES

GAGE GRINDING MACHINE

Two machines or fixtures similar in general construction to the one shown in Fig. 146 were built a number of years ago for the sole purpose of grinding gages. They were found to be convenient and rapid.

At *A* is the grinder head and at *G* the sliding member, or platen, which is operated by the rack and pinion *P* and fitted to the base *H*. The head is movable on the ways, and the whole outfit is mounted on a cast-iron baseplate.

In practice the gage to be ground, shown at *X*, is clamped to the platen *J*. The grinder head is then brought to position for the wheel to engage the work. The straddle clamp *G* is then secured to the ways and the wheel fed to its cut by the graduated screw *H*.

The slide *J* is operated by the hand lever *L*. The depth of the cut is regulated by the stop *R*, the adjustment being made by the knurled-head screw *S*. One side of the gage being ground, the head is moved to the other side, or face, of the gage and the operation repeated. The work remaining in the same position insures the faces being ground parallel to each other, provided the same care is taken as would be the case when using any other method or machine for the same work.

The spindle *B* runs in the bronze bushings *C*. These bushings are made long enough to project beyond the inside faces of the casting to within about $\frac{1}{2}$ in. of each other, thus forming the bearing for the driving pulley *D*. A slot in the spindle allows the pin *E* to pass through with clearance all around. The pin is a light drive in the pulley. This arrangement provides a means for driving and also takes the belt pull off the spindle, thus insuring greater accuracy.

End play is taken up by the adjusting screw *F*, in the rear end of the spindle. This screw bears on the pin *E*, and as pres-

sure is applied the pulley is forced against the collar, and the flange on the shaft is brought up to its bearing on the face of the casting, thus effectually taking up all end motion. No provision

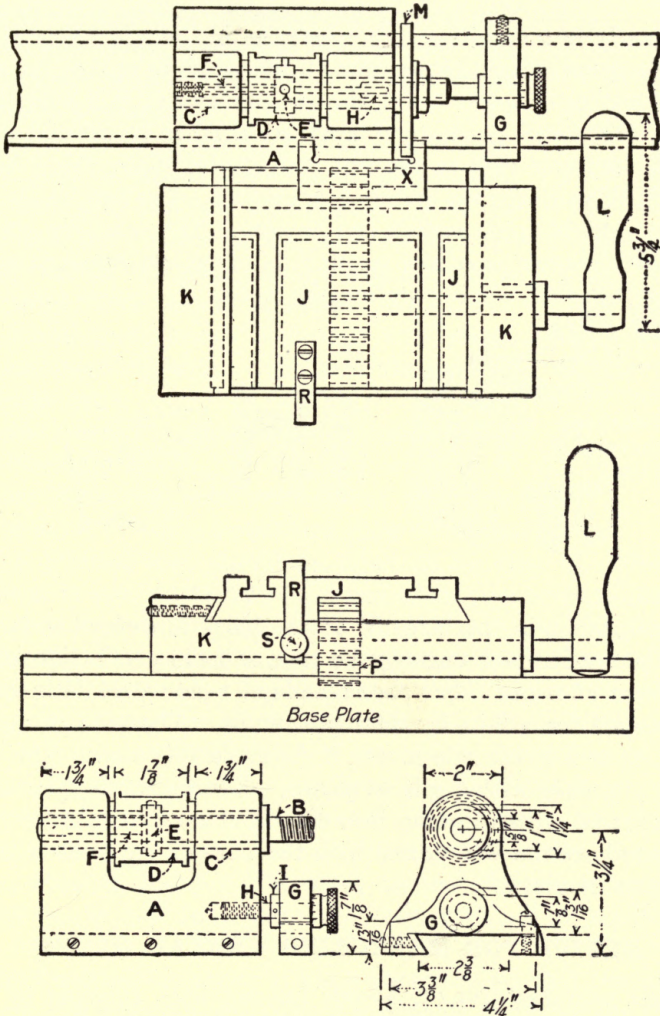

FIG. 146—THE GAGE GRINDING MACHINE

is made for wear of the bushings, although this could easily be provided for in the usual way with taper bushings and threading the collar.

The height of the platen *J* is such as to bring the center line of the work in line with the center of the spindle.

SPECIAL V-BLOCK FOR GRINDING WORK

Recently in a munition-shop gageroom in Canada I was called upon to grind certain gages upon all four sides as well as the end, at one setting of work; hence, the development of this V-block.

Fig. 147 shows a sample of work required to be ground upon all four sides as well as the end, and it also shows the V-block assembled ready for the grinding operation. The two 10-size 32-thread side-clamping screws can be seen. The ordinary clamping device shown over the small V is of course removed when rolling the block while grinding the work.

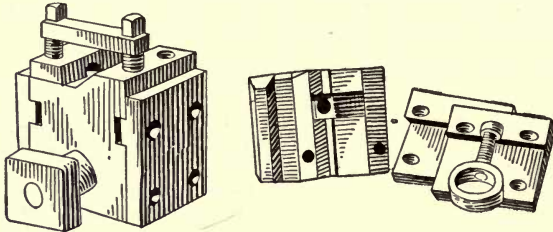

FIG. 147

The opening in the large V of the block is somewhat larger than the maximum-diameter yoke ring, so as to give a tightening movement of $\frac{1}{8}$ in. The yoke is made of rough stock $\frac{3}{8}$ in. wide and tapped for a $\frac{1}{4}$ -in. by 20-thread screw. The yoke clamping screw, as well as the side pieces, is shown in this view. The side pieces are made with a gib, as shown. Everything is accurately ground; and without going into details, it may be said that the aim is to have the V's central with the sides of the block with or without side pieces.

DEVICE FOR MEASURING THREAD GAGES

What manufacturer of threads has not been annoyed by the old, slow and somewhat inaccurate method of measuring thread gages with three wires? I certainly was much worried by the diversity of measurements taken in this manner by different inspectors on the same gage. After considerable thought, the rather simple device illustrated in Fig. 148 was evolved. It was

comparatively inexpensive and has proved to be very useful for the operations for which it was made.

It is made of a simple casting with a split hole bored in the top. A commercial micrometer head is set in the hole and held by a binding screw. A hardened, ground and lapped steel block is set into the base, the face of the block being set parallel to the face of the micrometer spindle.

Two of the wires are laid on the face of the block, and on top of these the gage is placed. The third wire is placed between the top of the gage and the spindle of the micrometer. By slowly rolling the gage through this contact, a very good "feel" can be obtained. Experience has shown that various inspectors will obtain the same reading, within very close limits, from the same gage.

Measurements can be checked by using standard blocks or plugs (without the wires). A further check as to the accuracy of the wires can be made by using a standard plug between the wires.

The greatest care should be taken to see that the wires are uniform in size, perfectly round and exact to a known diameter, since any error in the size of the wires is multiplied by three in the result. The easiest way to get accurate wires is to buy commercial sewing needles, lap them round and to a known size in sets of three, and cut off the tapered ends. To prove the accuracy of a gage it is advisable to use two or three sizes of three wires. The formula to be employed can be found in any good machinists' handbook. The device gives a range of measurements from 0 to 3 in. The one illustrated measures from 2 to 3 in., while by using a 1-in. block on top of the base measurements can be had from 1 to 2 in., and with a 2-in. block from 0 to 1 inch.

Since writing the above, it has occurred to me that two lapped prisms of a known height and of a suitable angle for the thread under inspection could be used in conjunction with the wires. It would also be necessary to have a flat lapped block the same thickness as the prisms are high. With these one could measure the outside diameter and single depth of thread of the gage.

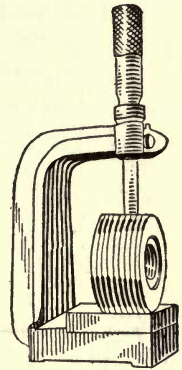

FIG. 148—THE
MEASURING
DEVICE

PROBLEM IN GAGE TESTING

The gage shown at *A*, Fig. 149, was given me to be "checked up." The angle on the test piece *B* was not given. Taking 0.152 in. as the side opposite and 0.1655 in. as the side adjacent, I found by the "American Machinist Handbook" that the angle was 42 deg. 34 min.

I made the test piece *B* of 1/8 B. & S. flat ground stock. To do this accurately, it was necessary to know the distance from the apex *C* to the base. Referring to *D*, the hypotenuse is 0.152 in.,

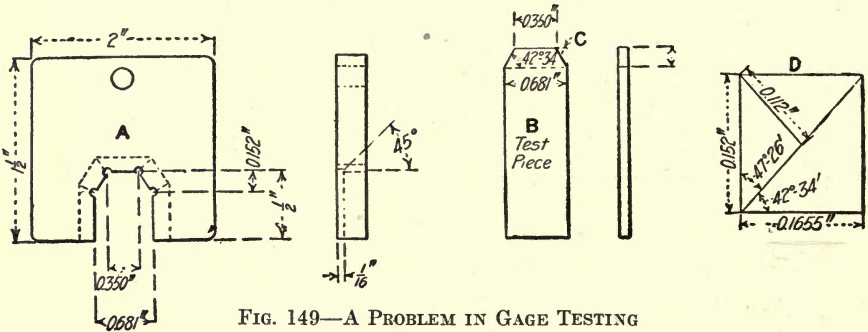

FIG. 149—A PROBLEM IN GAGE TESTING

and 0.73719 is the sine of 47 deg. 26 min. Multiplying 0.152 in. by 0.73719, we have 0.1120 in. as the distance from the point *C* to the face of the angle.

With the aid of a sine bar the test piece was then set up at an angle of 47 deg. 26 min. on an angle plate. The height gage was set to the corner *C*, and 0.112 in. was ground off each corner. All this should perhaps have been done in the drafting room; but few draftsmen make provision for the production of such work or give a thought as to how the toolmaker is to do it.

THE USE OF FEELER GAGES

Fig. 150 suggests another of the many uses to which the ordinary feeler gage may be put by the machinist who is not possessed of an internal micrometer.

The tube *A*, which can be of brass or any suitable material, is divided in the center by *B*, which is about 1/8 in. thick; the ends are drilled to take the steel rods *D* and *E*. The center of the tube has an opening *C*, to allow for the insertion of any desired feeler gage.

Suppose it is desired to bore a hole several thousandths of an inch larger than a diameter already turned. The gage is first adjusted to the finished diameter by means of the rod *D*, which

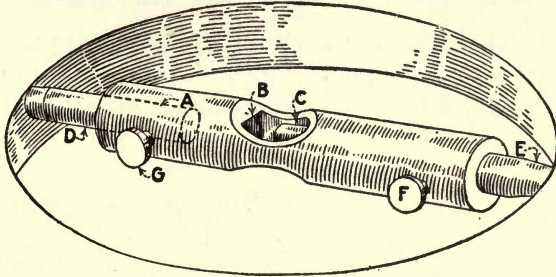

FIG. 150—INTERNAL GAGE USED WITH FEELER

is clamped in position by *G*. The feeler gage of required thickness to give the difference in diameter is then slipped between the inner face of the rod *E* and the portion *B*, and *E* is then clamped in position by *F*. The gage is then ready for use.

I saw this gage in the hands of an old mechanic who might now be considered out of date, but it certainly has all the accuracy, though perhaps lacking the convenience, of our more modern instruments.

ADJUSTABLE FEMALE THREAD GAGE

Fig. 151, which is self-explanatory, shows a female thread gage that has met with high favor in the place where I am

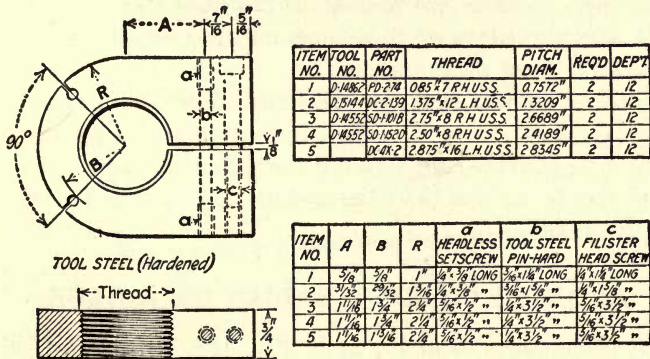

FIG. 151—ADJUSTABLE FEMALE THREAD GAGE

employed. I believe it will be of use to others. Notice the handy method of tabulating.

A GAGE FOR DEPTH OF RECESSES

Fig. 152 shows a form of feeler gage which is being used on airplane motor work. It consists of the feeler *A*, to which the knurled body *B* is attached by driving a dowel pin

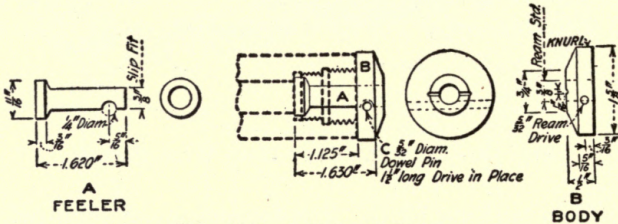

FIG. 152—A FEELER GAGE

C into a reamed hole in the body and engaging a recess in the feeler. The dotted lines indicate the part to be measured. The gage is very simple and has proved durable in service.

FEELER GAGE FOR RECESSES

Fig. 153 shows a gage for measuring the diameters of recesses. The recesses in the case on which the gage was employed had a limit of 0.010 in. The illustration shows the gage at the low limit. When at the high limit the end of the pin *A* is flush with the face *B*. The angle at the other end of the pin *A* is 45 deg. Pockets are formed in the gage *C*, to receive steel balls *D*, and the edges of these pockets are peened over to prevent the balls from dropping out.

The end of the pin *A*, having the angle face, abuts against one of the balls, and moves it outwardly in the desired degree. A setscrew *E* is provided for holding the pin *A* in place. The distance *G* should be less than the distance *H* to permit the passing of the gage.

GRINDING CORRECT RADIUS ON A GAGE

Given three gages to make, as in Fig. 154, I used the following method. Three blank pieces were machined on all flat sides,

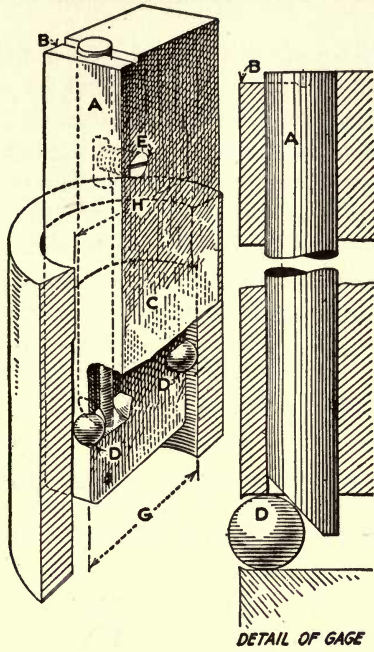

FIG. 153—FEELER GAGE FOR RECESSES

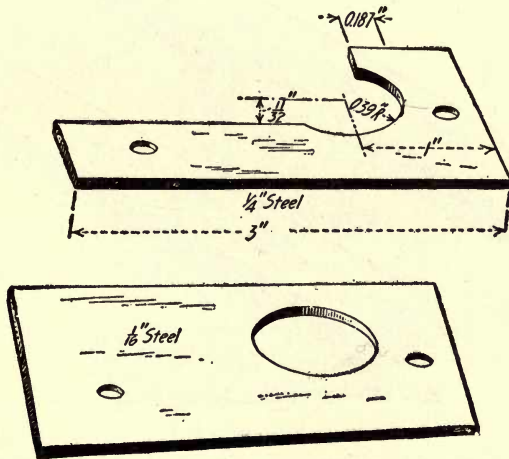

FIG. 154—THE GAGE AND TEMPLER

and another piece of $\frac{1}{16}$ -in. steel the same size was added. These were clamped together and drilled for two dowel pins. I laid out the large hole on the thin piece, as I kept this on top, clamped the pieces on the faceplate of the lathe and bored them out, leaving enough for grinding. The thin piece was then taken off and the others machined.

After hardening and grinding on the flat surfaces, I put the whole together with the dowel pins, the thin piece being on top. I then fastened them on the faceplate of a bench lathe and, indicating the hole true, I ground them out with an internal grinding attachment, making the hole 0.780 in. in diameter, thus giving me the correct radius.

BUILT-UP LIMIT SNAP GAGE

Several sets of snap gages of different sizes ranging from $1\frac{1}{2}$ to 4 in. were wanted in the machine shop. The company had taken a medium-sized order for screw-machine products; and as this was a special rush job, the necessary limit snap gages were needed in a hurry.

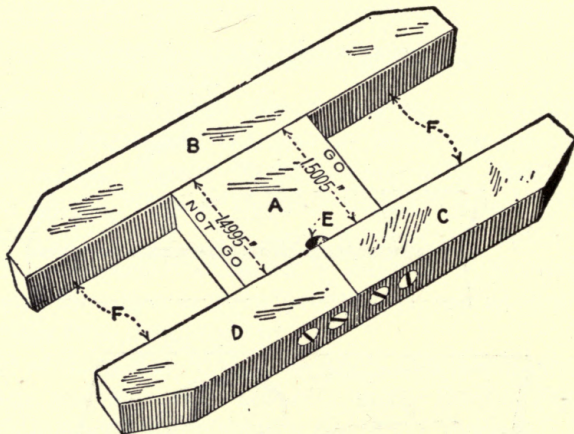

FIG. 155—BUILT-UP LIMIT SNAP GAGE

After due consideration a design was determined upon which gave a serviceable tool that could be made in a fraction of the time usually required in making the conventional limit snap gages. Fig. 155 shows the construction of one of these gages.

Although it is rather homely in appearance, it is just as accurate as any high-class snap gage.

The gage itself is made of four pieces—the sizing block *A* and the side pieces *B*, *C* and *D*—all of which are made of tool steel hardened and ground on their contact surfaces. The long side piece *B* is secured to the sizing block with three fillister-head screws, while the short pieces *C* and *D* are each held by two screws to the block *A*. The groove *E* in the sizing block is for the purpose of facilitating grinding to size. The gaging surfaces *F* of the side pieces were lapped smooth on a flat lap after grinding.

These gages were found to be satisfactory in every respect. They were accurate and durable; and when worn, all that was necessary in order to correct the error caused by wear was to remove the seven screws holding the various parts together, and lap the surfaces *F* straight and smooth.

AN AMPLIFYING GAGE

To assist in the rapid inspection of pieces made by students taking a course in machine work at the Ohio State University an amplifying gage has been devised by the instructors and built

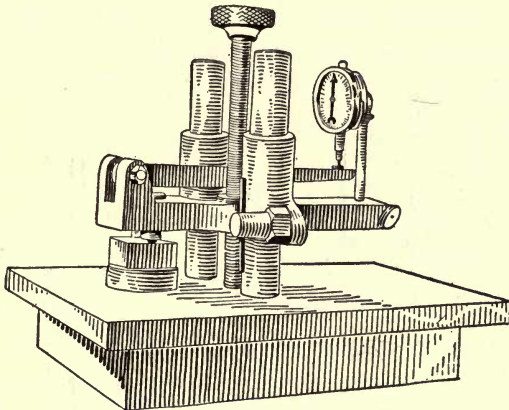

FIG. 156—AN AMPLIFYING GAGE

by students who are taking advanced work. As may be seen in Fig. 156 the principle is an old one. A lever having a ratio of 10 to 1 is employed, so that if the gaging point be raised 0.0001

in. the indicating end will be raised 0.001 in. A dial indicator is attached to the long end of the arm and its readings thus become 0.0001 in.

All moving parts are hardened and ground or lapped as nearly as possible. The base is of heavy surface-plate construction reinforced by ribs to absorb all vibration. *A* is a piece of hardened steel ground true and parallel which serves as an anvil on which the piece to be tested is placed. Adjustment is provided at *B* to bring the dial reading to zero, this first reading being obtained by a standard test block. With this instrument a number of pieces can be rapidly checked showing variation correctly to 0.0001 in.

We find this gage to be of material assistance to the student in making duplicate pieces, and while it seems very difficult for a beginner to judge the amount of pressure on the micrometer screw when taking readings to 0.0001 in., with this instrument the personal equation is practically eliminated.

INSPECTION GAGE

Fig. 157 shows a gage used mainly by the inspection departments. The inspector puts a number of parts to be gaged on the base *A* and then simply pushes the work under or through the gage. The same idea can be carried out for gaging work with several diameters and shoulders. All the parts are made of tool steel hardened and ground, and when necessary lapped.

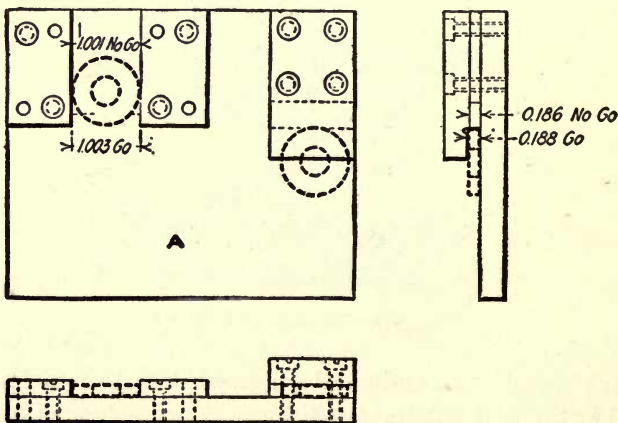

FIG. 157—THE INSPECTION GAGE

ERRORS IN MEASURING THREAD PITCH DIAMETERS WITH WIRES

The pitch diameter of threads measured by wires often differ from measurements taken with pitch micrometers.

With micrometers reading correctly there are four factors, any or all of which may cause the wires to give a different result. The first and most important is the size assumed for the wires themselves. Many seem to think that if the wires are known to be correct to 0.0001 in. the resulting pitch diameter will have

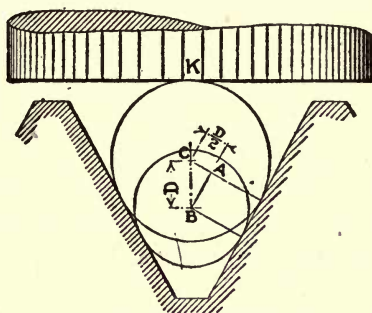

FIG. 158—HOW THE ERROR IS MULTIPLIED

like accuracy. A consideration of Fig. 158 will show this assumption 200 per cent. in error. Let the large circle represent the actual size of the wire, and the small circle the size assumed. If $\frac{D}{2}$ represents the difference in the radii then the error made in measuring the wire diameter was D in. For a 60 deg. thread it will be seen from the right triangle ABC that the assumed wire has its center a distance D nearer the thread axis than the center of the actual wire. The point of contact K between the micrometer and the actual wire has to advance, in order to get to a similar point on the assumed wire, this distance D plus the shortening of the radius $\frac{D}{2}$, or a total distance $\frac{3}{2}D$. That is, the plain micrometer reading, on one wire, will be in error $1\frac{1}{2}$ times as much as the measurement of the diameter of the single wire is in error. If the two wires on the other side of the thread have the same error as the single wire, the micrometer measurement has three times the error of the wire measure-

ment. For Whitworth threads the figure becomes 3.17. This means that wires measured with the common micrometer cannot be depended upon to give pitch diameter results closer than say 0.0002 in. Wherever possible wires should be measured in a precision machine such as Pratt & Whitney or at least checked with Johansson blocks.

Given wires of known diameter it is still necessary to handle them much as soap bubbles would be treated in order to prevent further error. Whereas pitch micrometers make line contacts on the threads, wires make theoretical point contacts and very little pressure will wedge them down into the threads sufficiently to distort the surface at the contact points. A good way to demonstrate this difference is to carefully measure two wires, and compare the sum of their diameters with what is obtained by crossing the two, and measuring overall.

A third factor arises from the nature of the surface on the sides of a lapped thread. Thread lapping is about the only kind of lapping where the cutting lines cannot be crossed. The motion of the cutting abrasive of the lap is always in helices concentric with the thread axis. The result is furrows and ridges which will be large or small according to the size of the abrasive grain but they are always there. If they are large the reading of pitch diameter is considerably affected by whether the wires make contact on the tops of ridges or lie in the furrows. Hence, checking the thread angle with sets of wires of different size can only be done accurately when the sides are quite smooth. It need only be mentioned that if the thread angle differs from the angle of the pitch micrometer spindle or anvil, medium-sized wires will give a lower reading than the micrometer on that account.

This may look like a clear case against wires, but when there is discrepancy between the results they give, and the pitch micrometer reading it is poor policy to convict the former without first cross-questioning the latter. The pitch micrometer has plenty of faults. If, for instance, thread gages are being measured, which are nearly uniform in pitch diameter, flat spots will develop on the sides of the spindle in a surprisingly short time. This is particularly so where the thread angle is wider than the spindle angle. In any case where pitch micrometers are used on a number of the same sized gages it is good policy to check frequently on a master of the same size set apart for this purpose.

From the above considerations there is no magic required to explain why the wires so often differ from the micrometer. In general the wires will be found to give a lower, rather than a higher reading.

PLASTER OF PARIS FOR SEALING HOLES IN GAGES

In the making of sectional gages, adjustable gages or various other mechanical devices, it is desirable to seal screw holes. The curiosity of man being always prevalent, it is wise also to seal the inspector's adjustment or the toolmaker's precision that they may not be tampered with.

Red sealing wax commonly used, suits the purpose, but it has been found from experience that sealing wax is difficult to apply to steel. It hardens too rapidly to get desired results, and often necessitates a second application. The idea of using plaster of paris came to the writer when several holes were to be sealed on some indicator gages; and as the holes were quite conspicuous, sealing wax was undesirable and did not properly fill them. Plaster of paris was tried and found superior to wax. The plaster dries rapidly and requires no haste in applying.

The proper way of using plaster is to get all materials in readiness before mixing the desired amount; and if numerous holes are to be sealed, it is even better to mix a very little at a time, thereby eliminating unnecessary waste.

A small scale can be used for mixing and applying; if after filling a hole the plaster is rough on top, moisten the scale slightly and pass it over the plaster with enough pressure to make the plaster flush with the top; scrape particles off and a neat appearance results.

Plaster is easily removed if need be, and moisture evaporates from it so rapidly, there is little danger of rust resulting from the water used in mixing.

GRINDING SNAP GAGES

I use what I call a "snap gage wheel," which is shown in Fig. 159. Of course, wheels that have been recessed on the sides by hand, have been used in some shops for years, but it is only recently that I have heard of a wheel-maker putting

one on the market, and then in only one size, that is $\frac{1}{2}$ in. face by 6 in. diameter. This is good for the average run of snap gage work, except in sizes of $\frac{5}{16}$ in. or less. Worn wheels may

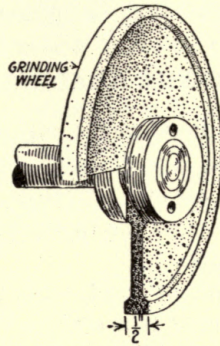

FIG. 159—SNAP GAGE WHEEL

be worked down to $\frac{1}{4}$ in. or even less on a pinch, but if this is done considerable care must be used to see that they are not handled roughly.

SECTION XI

GRINDING

KEEPING NOTES ON GRINDING

SOMEWHERE I have read, or have heard, that, provided enough steadyrests are used, it makes no difference whether or not the piece of work to be ground is long or short, solid or hollow—the same amount of stock can be removed per minute; but my own mind is far from being satisfied on this point. For one, I cannot grind long, slender work or thin tubing with anywhere near the same degree of rapidity that I can grind a solid bar. If it were possible to remove say $\frac{3}{4}$ cu.in. of stock per minute in the roughing operation from any piece, regardless of its length, tensile strength or cross-section area, and to remove $\frac{1}{8}$ cu.in. of metal per minute in the finishing operation continuously, then the keeping of performance notes would be a useless task and the matter of establishing piecework prices would resolve itself into the formula for finding amount of stock to be removed, $\frac{\pi L}{4}(D^2 - d^2)$, times the amount to be allowed the operator per cubic inch.

As things stand with me now, I sometimes am at a loss whether to estimate $\frac{1}{2}$ cu.in. a minute, less or more, and in all cases I make sure to verify my figures by looking through my notes of past performances for a sketch that most nearly approaches the one on which I am figuring.

My notes tell me that conditions must be very favorable to permit the operator to remove 1 cu.in. of stock per minute, except the operation by a draw-in cut, as in the rough grinding of crankshaft bearings made of soft drop forgings. In this I find that I can remove $1\frac{1}{2}$ cu.in. of stock per minute day in and day out, plus the handling of the shaft.

Notes Should Be Profitable to the Operator. Notes on grinding should not be kept by the operator solely for the purpose of being able at some indefinite date to estimate the grinding time

for others, but should be kept in a manner to enable him to profit daily by that which he has recorded. For instance, suppose that at a periodic interval of about every three weeks (long enough for him to forget the details of the job) some machinery steel shafts 26 in. long, 3 in. in diameter, and with 0.025 in. of stock to remove should come along for him to rough and finish grind at the rate of seven an hour, what wheel should he use, what work speed, what table traverse, and what depth of cut per pass? To find the most efficient combination he would have to juggle these variables until he hit upon the correct assortment to turn out his seven shafts per hour, but in the meantime valuable time (which means money to him if he is on piecework, and money to the company if he is on either piecework or daywork) would be lost. If notes on each shop job were kept, how easy it would be for him to set his machine approximately right the first time. For example, let us take this shaft on a 10 x 50-in. Norton plain grinding machine:

Shop Order Number—8454.

Article—Vertical shaft.

Material—Machinery steel.

ROUGH GRINDING

Wheel—24 combination N, Norton.

Work Speed—Cone pulley sixth step, fast lever.

Table Traverse—Cone pulley sixth step, fast lever.

Depth of Cut—0.002 in. per pass.

FINISH GRINDING

Wheel—24 combination M, Norton.

Work Speed—Cone pulley fourth step, slow lever.

Table Traverse—Cone pulley second step, slow lever.

Depth of Cut—0.0005 in. per pass.

Such notes could not help but prove of value, all the more so if accompanied by a sketch of the work with diameters and limits.

Use of Speed Tables. In my work as a cylindrical grinding-machine operator I wrote into my notebook a list of all work speeds and table traverse speeds for each pulley and then, when a new job came along, I was able to test out intelligently different combinations of speeds. In figuring work speeds I used a

constant that aided greatly in making the computation a simple mental example. It would have been possible to have made it more simple by the use of a graphical chart, but this was an afterthought that came much later. My method of determining pulley speeds and the use of the constant is worth illustrating. Taking a 10 x 50-in. Norton plain grinding machine on which I worked for several months, my notebook gave me the following speeds, together with the constant:

10 x 50-IN. NORTON, MACHINE NUMBER 988

Step on Pulley	R.p.m. of Work Drive			
	R.p.m. Fast Lever	Constant*	R.p.m. Slow Lever	Constant*
Fastest	193	50.5	76	19.9
2	137	35.9	56	14.7
3	110	28.8	46	12
4	95	24.9	38	10
5	82	21.5	33	8.6
6	74	19.4	29	7.6

$$* \text{ Constant} = \frac{\pi \times \text{r.p.m.}}{12}$$

TABLE TRAVERSE IN INCHES PER MINUTE

Step on Pulley	Fast Lever	Slow Lever
Fastest	148	50
2	120	40
3	100	33
4	88	29
5	75	25
6	67	22
7	60	20
8	55	18

Suppose that the 3-in. shaft mentioned should come to me for the first time and I decided, on looking it over, to try a rough-grinding work speed of 60 ft. per min. Sixty feet divided by the diameter 3 gives me 20. Looking at my list I find that the nearest constant to 20 is 19.4, and that I must run the work at the revolutions per minute the constant indicates, or 74-r.p.m. This is the sixth pulley step, using the fast lever. Now, with a grinding wheel 2 in. wide, it is correct to rough out with the full face of the wheel to each revolution of the work; therefore the revolutions per minute of the work times 2 in. will give the table traverse in inches. Then 74 times 2 equals 148 in. as the table

traverse, or the first pulley step, according to the list of speeds, using the fast lever.

Assuming 30 ft. per min. to be a good work speed in the finish grinding of such a shaft, I divide 30 by the diameter 3 and, looking at the list of speeds for the constant nearest to 10, I find that the belt for a work speed of 38 r.p.m., as indicated by the list, should be on the fourth pulley step, using the slow lever. In finish grinding using one-half the width of the wheel (1 in.) I have a table traverse of 38 in., or the second pulley step, and the slow lever.

Tables like this, on different machines, were of great help to me in my grinding.

Innumerable details only casually impressed on a person's memory cannot be considered a future asset. In the keeping of notes there is a feeling of a sense of reliance on one's own ability, backed up, not alone by a varied experience, but by positive, recorded, demonstrable facts.

MOUNTING, BALANCING AND DRESSING GRINDING WHEELS

In many of the factories where production grinding is being done, I have found that each operator is permitted to dismount his old wheel and remount a new one, dress off the sides if accuracy in width is desired with a straight in cut, and then balance. I have found by experiment that a considerable gain in production can be obtained by specializing on this work. The parts ground in this experiment were crankshafts, the concern having an output of between 600 and 700 per day.

A new operator will take two or three hours to set up a new wheel and usually requires the assistance of an older head besides. We were losing this amount of time from thirty to forty roughers weekly, by using the above method, and also several wheels, through the inability of operators to dress their wheels to proper size.

By training a special operator in this work we gained many hours of labor and also obtained better results in the size of our wheels. Using a grinding machine exclusively for this work, with an operator trained to this method, we obtained speed and accuracy.

Care should be taken to keep each wheel mounting clean from dirt and burred-up points. Aside from this no difficulty is experienced, as all grinding-machine spindles are ground to a standard taper and the mountings are interchangeable. To insure even better results two mountings should be numbered to correspond with the number of the machine on which they are used.

SAVING TIME AND ABRASIVE WHEELS

We have in use a great many special-form abrasive wheels for grinding and regrinding a certain class of tools. These forms require extreme precision and necessarily consumed a great deal of time in dressing the wheels. In removing these wheels from the spindle of the grinder and replacing them at a future time for regrinding the same job, it was always necessary to redress the wheel, owing to the fact that it was impossible to replace them on the spindle again so that they would run true. We bought a lot of abrasive-wheel centers (or bushings on which the wheels are mounted on this particular grinding machine), and instead of removing only the wheel we remove the entire abrasive-wheel center, leaving the wheel mounted on it while not in use. These abrasive-wheel centers are interchangeable on the No. 13 B. & S. universal grinder and the No. 2 B. & S. surface grinder. In this way they may be used on either machine, and when they are replaced they run perfectly true without redressing, only requiring redressing when they wear out of shape or become glazed. The cost of the abrasive-wheel centers is very small, in fact less than the cost of dressing some of our abrasive wheels.

We have at the present time at least fifty wheels of different shapes stored away that will not be removed from the emery-wheel centers until they are worn out.

GRINDING THE EDGES OF CIRCULAR PLATES

A unique method of revolving a circular plate during grinding operations on its edges, is shown in Fig. 160 of a device which takes its power from the traction of the wheels upon which the carriage runs while traveling back and forth past the surface of the grindstone.

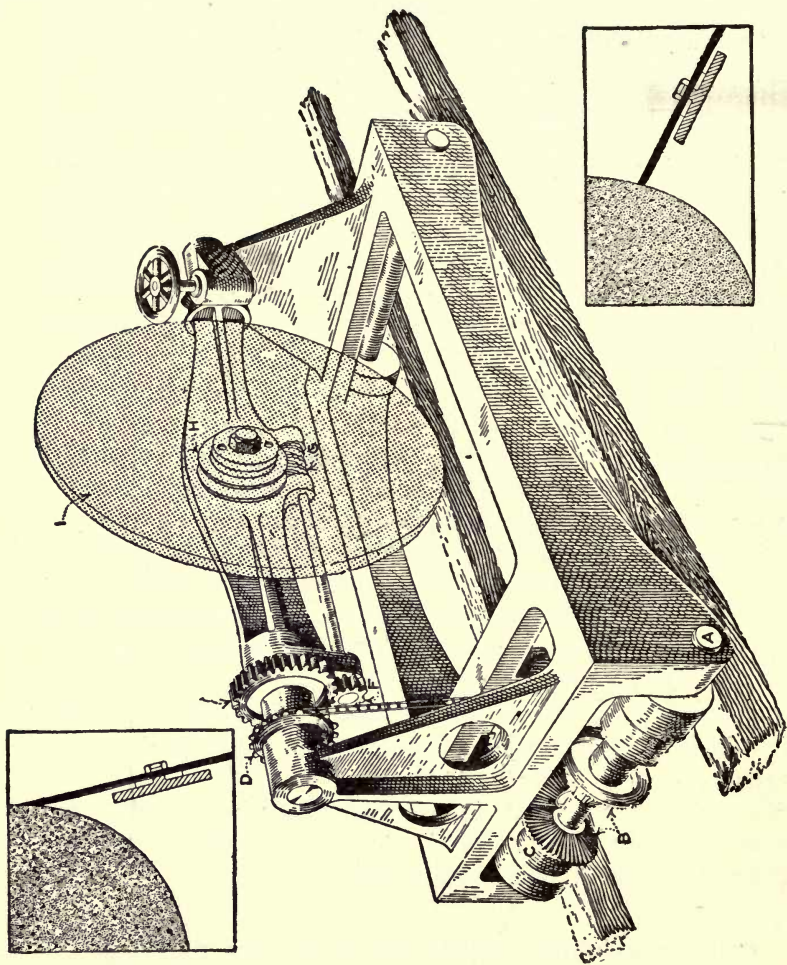

FIG. 160—GRINDING EDGES OF DISKS

The usual custom is to accomplish this movement by means of a countershaft and belt, the tendency of the latter being to lift the carriage away from the grinding medium, thereby causing a variation of pressure with resultant unevenness of work.

Two miter gears *B* mounted upon axle *A*, carry four pawls in their respective hubs; one set being operated by a right-hand, the other by a left-hand ratchet; these pawls and their springs are retained by the steel ring *C* which slips over the hub. The third miter, meshing with the two gears upon the axle, is mounted on the end of a short shaft lying parallel with the line of travel of the carriage; this shaft carries a sprocket which drives by means of the chain, the sprocket wheel *D* mounted upon a sleeve with the gear *E*.

This gear through the medium of the pinion *F*, the worm *G* and the wormwheel *H*, turns the disk *I* with a powerful and uniform movement in one direction regardless of the direction of movement of the carriage.

The transmission of power through the sleeve, gear and pinion allows the bar carrying the disk, to be turned upon its own axis for the purpose of tilting the disk to whatever angle may be required; this turning being accomplished by the worm and hand-wheel shown at the right.

This latter feature has been found to be very convenient in a number of instances.

WHEELS FOR TOOL AND CUTTER GRINDING

One of the most neglected places in a shop is the wheel rack of the universal tool- and cutter-grinding machine. I never yet have worked on a tool- and cutter-grinding machine where I did not feel like apologizing for my poor assortment of wheels. Neither have I seen in any factory a rack having an equipment of wheels that approached the ideal. Where the use of the machine is open to all toolmakers in a toolroom, the condition of the wheels is generally deplorable. A toolmaker as a rule will go to the machine, select a wheel (generally the best-looking wheel in the rack) and if it is not exactly the shape he wants he will unhesitatingly dress it with the diamond to suit himself. Sometimes this spoils the wheel for its original use.

The large majority of racks contain worn-down wheels in

plenty, and the operator usually has to make the best use of these that he can. This is not fair since the requirements of his work are such as to demand the use of the best wheels obtainable. Good operators are decidedly scarce, and one of the best ways to hold them in the factory is to give them the assortment of wheels for which they ask. To call down an operator for doing an indifferent job of grinding when the proper equipment for the work has not been furnished him, is one of the short cuts toward losing his services, especially if he has requested the purchase of some particular wheel and did not get it.

Toolroom foremen should familiarize themselves more completely with the particular needs of the tool- and cutter-grinding machines. If the operator is a man of sense and experience, and asks for a wheel of a certain grade and grain, give him that wheel. He surely must know what he wants, so do not overrule his judgment. Many a job that takes three hours to grind could be done in an hour if the wheel assortment were more varied as to grain, grade, shape and size. I remember not long ago, one toolroom foreman who persisted in buying for me such wheels as 80 and 100 L Norton when I specially requested 38-46 K and 38-60 K Norton. He did this while still admitting that I appeared to know more about grinding wheels than any man who had previously worked for him.

A hard wheel will inevitably cause temperature changes, and a consequent distortion of the work, even though the discoloration usually associated with excessive heat may not appear on the surface.

A good wheel list for the grinding of such carbon steel and high-speed work as plain milling-machine cutters, formed cutters, gear cutters and inserted-tooth milling cutters is not a formidable list to remember. Taking the Norton vitrified alundum wheel for example, the job can be done with one or the other of the following wheels: 38-46 J or K; 38-50 J; 38-60 I or J, and using 5000 surface ft. per min. as a wheel speed. There is nothing difficult to remember about this simple list of wheels, all of which should be in the wheel rack.

It is always important in giving the grain and grade of the wheel to state the maker's name, by reason of the fact that different wheel manufacturers have not adopted a universal method of marking.

GRINDING THIN PIECES

I was given a bunch of old hacksaw blades that had been worn out or broken in the power saw. From them I was to obtain stock to make size pieces for inspection purposes. These pieces were to start at 0.030 in. thick and run up to 0.050 in. thick, leaving stock to lap, each piece to be 0.001 in. thicker than the other. After grinding the teeth flush with the back of the blades, I clamped 10 of them together, side by side, and placed two flat vises parallel to one another and parallel to the wheel on the magnetic chuck. I put the saw blades in the vise, leaving them sticking up above the jaws about $\frac{3}{8}$ in.

The portion protruding above the jaws I clamped together with "Brownie clamps," one clamp to each vise and one in the space between the vises. These clamps were to hold the blades rigid. They also prevented chatter, which is likely to occur where uneven surfaces, due to hardening, are placed together. Moreover, when the jaws of the vise were opened to move the blades forward the proper length, the pieces were held together tightly enough so as to prevent movement of the blades, which would cause the ends of the blades to be uneven and make the pieces of unequal length. I then moved the table of the grinding machine in, cutting through the soft ends—with holes—and cut off about 2 in. This also served to square up the ends. The blades were then cut to $\frac{3}{4}$ in. lengths until the stock was used up. Before starting to rough the stock down, I dressed the surface of the magnetic chuck perfectly parallel with a 30-Q wheel, which is a very good wheel for cast iron.

Now my troubles started. I laid the stock flat on the chuck after dressing the wheel perfectly true with the diamond. I proceeded to rough all the pieces to the same size, using a cut of 0.001 in. per each feed across. For this operation I used a new 46-G wheel, which was the best I had at hand. It was $7\frac{1}{4} \times \frac{1}{2} \times 1\frac{1}{4}$ in. I demagnetized the chuck, then placed the pieces on a true surface plate (the inspector's) and indicated them with a "last-word indicator." I found that they had bowed in the middle about 0.003 in. I placed the pieces back on the chuck without magnetizing them, so as to grind the bow out. I would say that this was caused by two reasons—by friction of the wheel on the stock, causing heat, and by magnetism drawing the stock

down flat on the chuck, whereas by throwing the switch out, it relieved the stock and allowed it to return to its original shape.

The Second Method. This time I ground the bowed side parallel, then turned it down to the surface of the chuck, magnetizing it. I used a cut of 0.0002 in. on each cross-feed. I found that the stock bowed some, although not as much as before. This I believed was due to too much wheel surface causing an overabundance of heat. This would not do, so I thought of eliminating some of the cutting surface of the wheel by dressing the wheel to a little under $\frac{1}{8}$ in. wide. This plan also worked about the same as my second attempt, still causing too much heat, although hardly noticeable to my hand, yet enough to make a little bow in the stock.

By this time I was beginning to wonder if the foreman did not think I was spending too much time on the job, so I began to do some "tall thinking." If the heat from the wheel could be cut down or eliminated, the job would be "easy sailing." I used a pair of pliers and broke a piece from the wheel, perhaps $\frac{1}{2}$ in. deep and 2 in. long. On the other side of the wheel, just opposite to this, I broke out a piece of about the same size. I then dressed the face of the wheel with a diamond and went ahead with the job. Thus, I want to impress on my fellow readers, by hacking the face of the wheel the continuous friction of the wheel on the stock was broken, and there was not enough heat generated to spring the steel.

The Question of Safety. Perhaps some machinists would hesitate to use a wheel broken out like this, but by pinching off the pieces with pliers I believe the wheel is not strained as it would be by a blow from a hammer. Also, there is quite a difference in the centrifugal force in a wheel $\frac{1}{2}$ in. thick and of one $\frac{1}{8}$ in. thick.

I have since talked with gagemakers who have followed surface grinding for years, also with several toolmakers, and they had never heard of this little trick. I find that the usual method followed by them is to ignore the amount the work bows during grinding, the idea being merely to make the work of even thickness. When this has been accomplished it is removed from the magnetic chuck and peened straight. However, I offer this to those who have work of this character to do and who have experienced the same trouble that I had.

RADIUS WHEEL-DRESSING FIXTURE

Fig. 161 shows a radius-forming fixture for grinding wheels. It was designed and used very successfully on wheels for gages by R. G. Dorval, assistant foreman of the New England Westinghouse Co. It is a simple device, consisting of the head block *A*, which supports and carries a spindle *B*. On the outer end of the spindle is the frame *C*, and at the other end the handle *D* for moving the spindle and frame past the face of the grinding wheel.

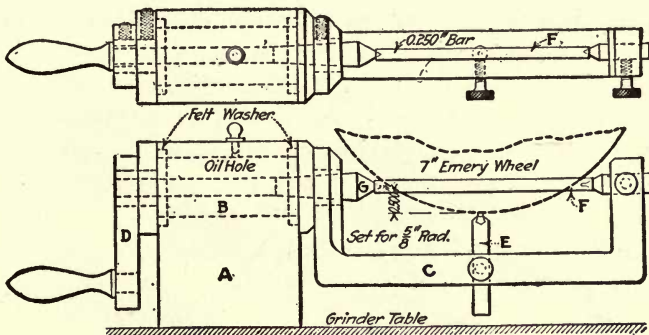

FIG. 161—RADIUS WHEEL DRESSING FIXTURE

The frame *C* carries the wheel-truing diamond *E*, which is swung past the face of the grinding wheel by means of the handle *D*. The setting of the diamond is the important part of this work and is readily accomplished by means of the test bar *F*, which in this case is 0.250 in. in diameter. As shown, this bar is centered at each end, requiring a special center *G* in the spindle *B*. In the later machines this center was omitted and a female center was bored in the end of the spindle itself. This change simply necessitated turning one end of the test bar with a 60-deg. point, the operation being the same as with the center shown.

Having the test bar of known diameter, it is easy to set the diamond by means of a standard gage block placed between the bar and the diamond point. The illustration shows the diamond set for a $\frac{5}{8}$ -in. radius, the diamond being $\frac{1}{2}$ in. below the test bar, making the radius $\frac{1}{2} + \frac{1}{8}$ in.

For making a concave radius it is necessary to set the diamond

point above the center to the desired amount. This can be accomplished in various ways by testing from the frame *C* with suitable blocks.

GRINDING A COUNTERSINK IN CHILLED CASTINGS

The casting shown enlarged in Fig. 162 is part of a manufactured article that is turned out in large quantities. The opening in the middle is made with a dry-sand core, and would be quite satisfactory but for the fact that the thin wall cools so quickly that it chills—a condition that would be unimportant except that it must be countersunk. A screw slides through the

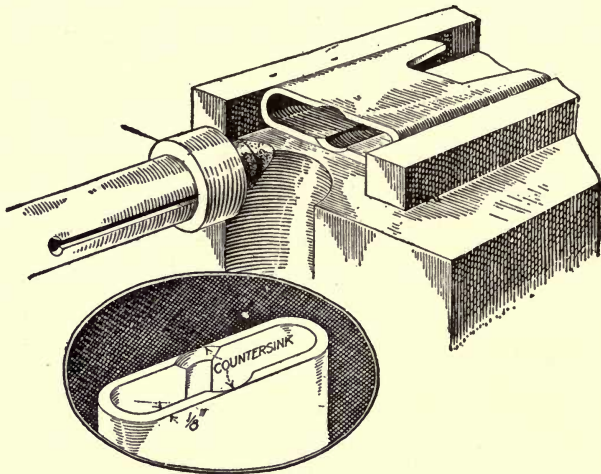

FIG. 162—THE WORK AND THE GRINDING DEVICE

enlarged part of the opening, and to prevent the threads from catching, the castings are countersunk or beveled at each end.

The chilled castings would ruin countersinks faster than they could be sharpened, and this work became the one slow operation on the job. For certain reasons it was not feasible to make the countersink a part of the core itself, and in the search for a better method, grinding was suggested and tried out with marked success.

The countersink grinding device was rigged up in the manner shown. Round sticks of crystolon held in a split chuck in the spindle of a grinding machine form the grinding medium.

A cushion of blotting paper surrounds the stick, which is tightened and trued up by four screws in the ring. As the stick wears the screws are loosened and the stick brought forward. The sticks are dressed to shape with a Huntington dresser, the only kind available in the shop, but reasonably satisfactory, as the sticks do not cut or groove to the extent one would think.

A sheet-steel table is adjusted to the right height to bring the slot in the castings central with the tool, and guides are loosely fitted at each side to control the pieces. The workman feeds the castings up by hand and judges the amount of bevel by his eye. Compared to the countersink method the grinding is a ten-to-one winner. Each night the workman has fifteen hundred pieces well done and his wheel is good for as many more. To do the same amount of work, a countersink of the best steel would have been sharpened many times and would have cost as much as several sticks of crystolon.

A FIXTURE FOR GRINDING

The fixture shown in Fig. 163 is designed for quantity production of small castings required to be finished on a disk

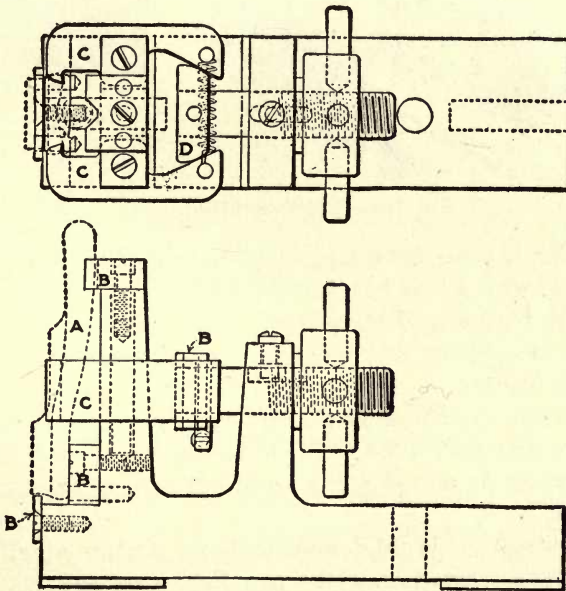

FIG. 163—GRINDING FIXTURE

grinding machine. The table should be fitted with a lever feed, allowing the fixture to be clamped to table. The fixture holds the part to be finished very firmly, and requires a minimum of time for changing.

Referring to the drawing, the casting *A* to be finished is placed against the locating stops *B*, between the jaws *C*. Turning the hand nut to the right draws back the shaft and cam *D*, which forces the jaws both inward and together on opposite sides of the work, that is, the work is pinched, and at the same time drawn firmly against the backstop. By changing the shape of the jaws, the fixture can be made to hold irregular work.

DIAMOND HOLDER FOR NORTON GRINDER

Fig. 164 shows a diamond holder used for truing an 18-in. wheel on a Norton 10 x 72-in. grinder.

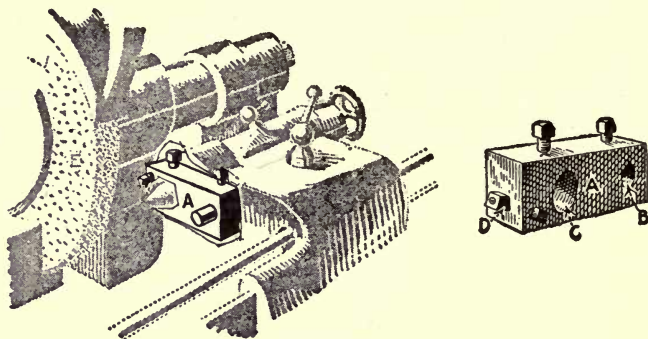

FIG. 164—A DIAMOND HOLDER

The holder is made from a piece of cold-rolled steel $A\ 1\frac{1}{2} \times 2\frac{1}{2} \times 6$ in. long, with a hole bored at *C* to fit the center spindle and one at *B* to fit the projecting post. The post was designed to hold a diamond holder and was furnished with the machine, but it had been broken.

A $\frac{1}{2}$ -in. hole was bored on the end to take a stud *D* in which was set the diamond, setscrews holding the small stud in place, so that it could be moved around and get even wear of the diamond point.

This construction is solid and does not chatter at all. The saving of time taken to put the new holder on and take it off fully compensates for the change.

SECTION XII

BORING

PORTABLE CYLINDER-BORING MACHINE

FIGS. 165 and 166 show assembly and details of a boring machine that was designed to re bore both upright and horizontal cylinders from 12 to 24 in. in diameter. For the larger bores a head with longer arms is used to avoid excessive overhang of the cutting tool.

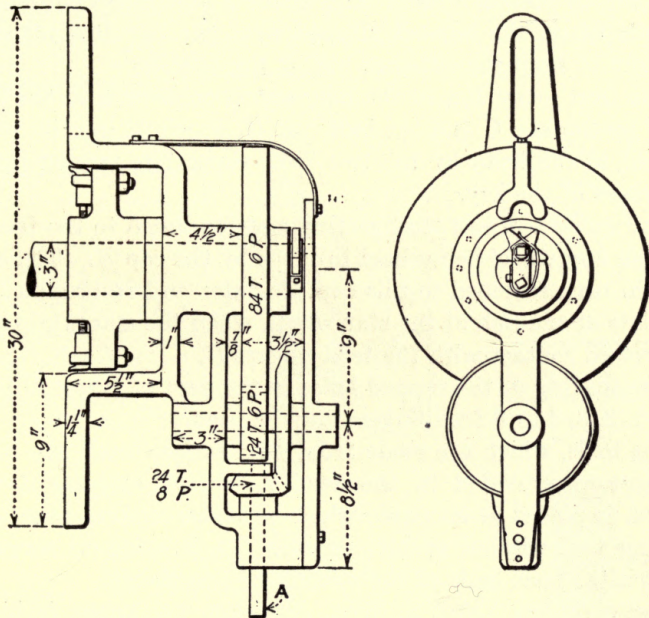

FIG. 165—CYLINDER BORING MACHINE

The outfit is driven by a small electric motor fastened to a pair of long skids upon which is placed sufficient weight of scrap iron to hold it in place against the belt pull. For small cylinders a small pulley on the motor is direct-connected by belt to a large pulley on the shaft A, Fig. 165; and for the larger cylin-

ders a countershaft is interposed on the skids with the motor to secure the necessary reduction in speed.

The performance of the outfit has been very satisfactory. The bevel gears make it possible to have the driving shaft in a horizontal position regardless of the position of the cylinder. The frame, gears and head are made of cast iron. The main bearing in which the boring bar rotates is machined to fit the bar, all other bearings being cored out large enough for babbitt metal to be run. The large gear made especially for this job is keyed to the bar with a hollow key, allowing the feed rod to pass through it.

The support *B*, Fig. 166, was made as shown for use on an upright cylinder to fit the gland opening in the cylinder head; it provides openings around its outer edge for the cuttings to drop through. A leather washer with about a 5-in. outside diameter—a tight fit on the bar—is slipped over the bar just above this support to keep the cuttings out of the bearing.

The feed screw lies in the bar, and is connected to the boring head by the key *C* and the half nut *D*, which fit into it; the key is held to the head by the two $\frac{1}{2}$ -in. capscrews tapped into the end holes of the key.

The star wheel is a steel casting and is pinned to the feed rod, the rod and wheel being held in place by the cap *E*. The spring *F* is in turn fastened to this cap, its outer end resting on one of the flats of the hub of the star wheel, when the star wheel points are not in contact with the feed fingers *G*.

The spacing of the tapped holes in the part of frame *H* is such that 1, 2, 3, 4 or 6 feed fingers may be used.

The tools, which are made from 1-in. square stock, are held in the groove provided in the head *I*, by the eyebolts *J*. This groove is placed at an angle which provides leading rake on the cutting tool without special forging. A backing-up screw sets against the back ends of the cutting tool as shown.

For cylinders above a 12-in. diameter, the frame is blocked out from the end of the cylinder to an extent equal to the thickness of the cutting tool, to allow a cut to be taken to the extreme end of the cylinder.

A small crank (not shown) is used to run the cutting head along the bar by hand, and a long socket wrench is used to loosen the nuts on the eye-bolts after the finishing cut is taken to avoid

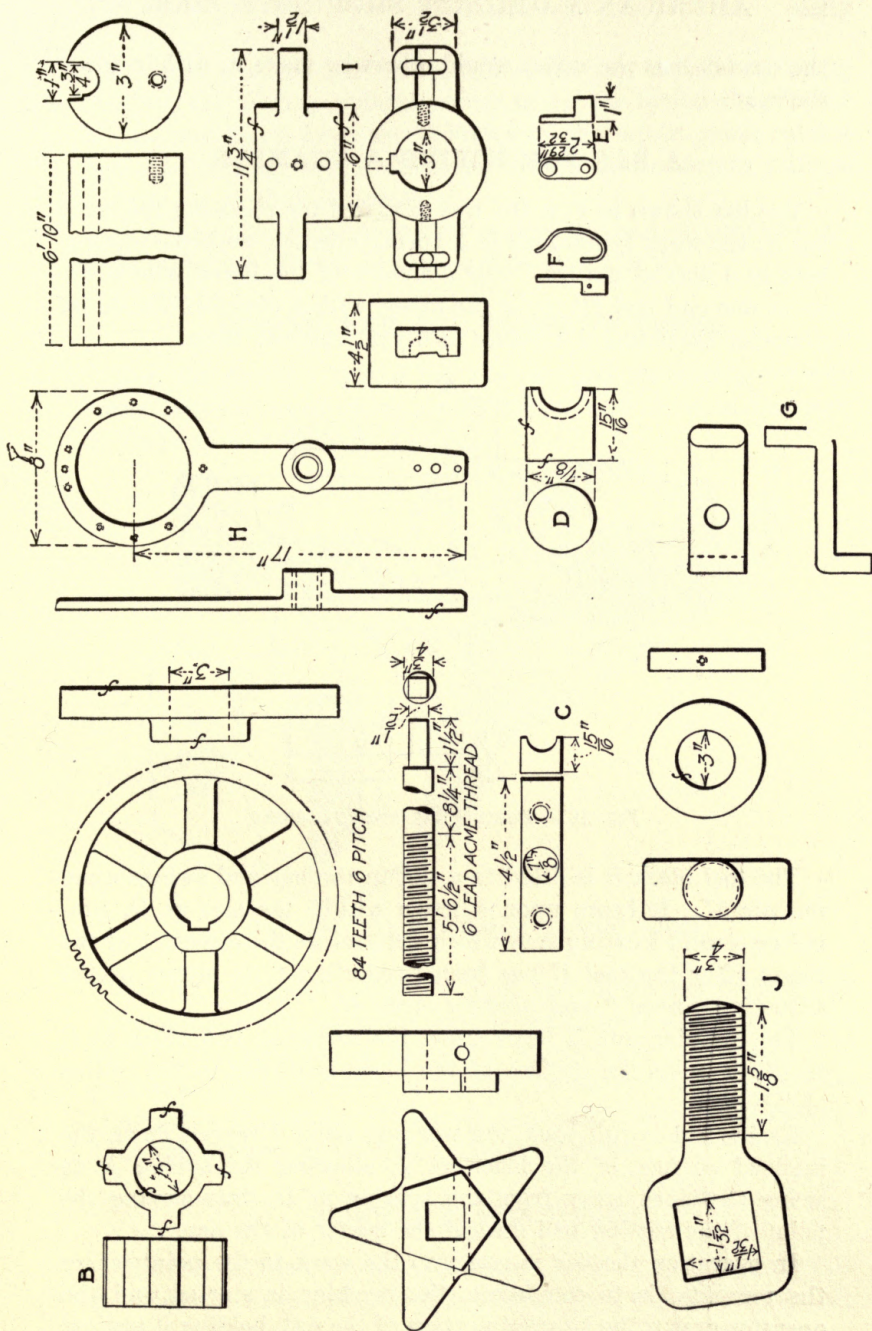

FIG. 166—DETAILS OF CYLINDER BORING MACHINE

the scratch that the cutter would otherwise make in withdrawing the head.

A BAR FOR BORING A CHAMBER

The bar shown in Fig. 167 was designed for recessing the casting *A*, the work being done in a boring machine with the casting held in a special fixture. The diameter of the bored hole is $2\frac{3}{8}$ in. at one end and $2\frac{1}{8}$ in. at the other, with a chamber $2\frac{1}{2}$ in. in diameter extending a distance of $6\frac{1}{4}$ in. between them.

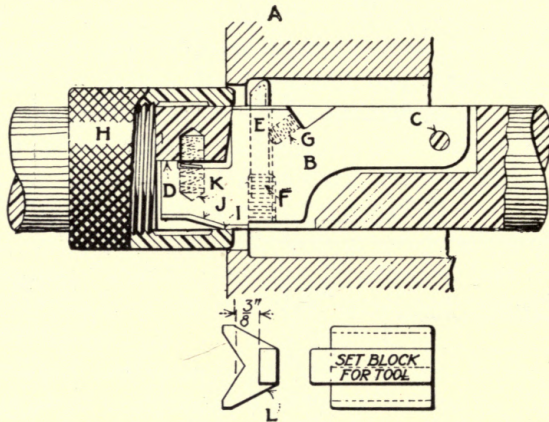

FIG. 167—BORING BAR FOR RECESSING

The tool block *B* is fitted to a slot in the bar and swings upon the pin *C*. It bears upon a ledge within the slot at *D*, providing a solid locating stop which determines the diameter of the recess after the tool *E* has been properly set by means of the adjusting screws *F* and binding screw *G*.

The annular nut *H* bears upon the swinging tool block at *I*, at which point the surface of the block conforms to the radius of the bar.

As the nut is run back, the working point *I* travels down the inclined surface of the block at *J*, allowing the spring *K* to swing the block away from the bearing at *D*, thus moving the point of the cutting tool toward the center of the bar.

In operation the bar is run into the work to the point where the recessing is to commence, the machine is started and the operator grasps the knurled portion of the nut, holding it against

the rotation of the bar. This causes the nut to advance along the bar, the bearing point *I* traveling up the inclined surface *J* of the tool block until the shoulder of the latter comes to rest against the ledge *D*, and the cutter is then in the correct position to bore the desired diameter.

A setting block by means of which the tool is properly set before putting the bar in the work is shown at *L*.

BORING BAR FOR TORPEDO TUBES

Fig. 168 shows a boring bar that is used for boring torpedo tubes, the sections of which are 18 ft. long and 21 in. in diameter. The tolerance is 0.010 in.

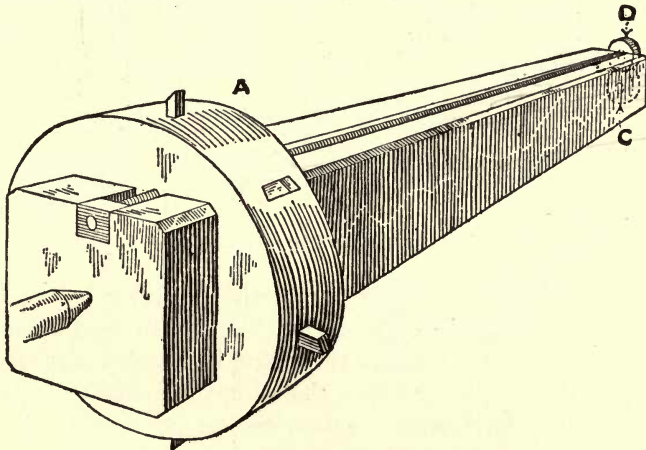

FIG. 168—BAR FOR BORING TORPEDO TUBES

The bar is square, is 20 ft. long and turns between centers. The ring *A* which holds the cutters slides back and forth on the bar and is controlled by the screw shown at *B*. The gear at *C* is secured on the tailstock center and meshes with gear *D*, which is keyed to the screw. There are six cutters in this bar and the time for boring one of these tubes is 12 hours.

BORING TAPER HOLES

Having occasion to bore some taper holes in work mounted on a boring-machine table, the following method was used with satisfactory results:

As shown in Fig. 169, the casting *A* was secured to the table with bolts, and an ordinary boring tool *B* set in the boring spindle. Guide bar *G* was mounted in the horizontal plane of the spindle and at the same angle with the spindle axis as the required taper.

The end of the slide of the boring tool was equipped with a hardened-steel adjustable button *P* with a spherical face.

Having the set-up arranged as noted, the gib screws *S* were tightened enough that the slide of the boring tool would hardly

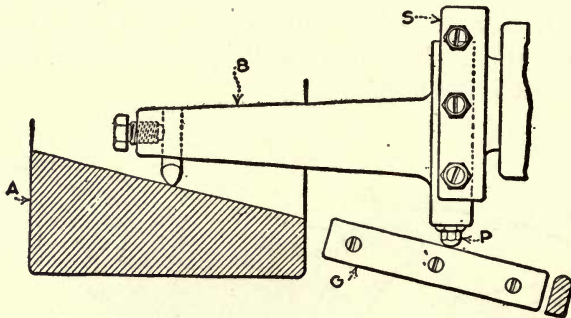

FIG. 169—ARRANGEMENT FOR BORING TAPER HOLES

move in the saddle. The guide bar was solidly bolted to the table, and upon starting up and putting a slow feed on spindle, the steel button *P* would hit the guide bar each revolution and move the slide in slightly, thus changing the diameter of the cut. The guide bar having been set to the proper taper, the result was a similar taper hole in the part being machined.

It should be noted that this method will not produce a smooth finish, but as in this case a taper bronze bushing was fitted, the character of the cut was of no consequence.

BORING A 4-FT. HOLE IN AN 18-FT. SHIP CASTING

Some time ago we had a steel boom-deck casting for a dredge come into the shop, which required boring out to allow for a brass bushing to overcome the friction. The casting was in halves, 18 ft. outside diameter with a bore of 4 ft. The bushing was to be $\frac{3}{4}$ in. thick and cut in two; each half to be held in place with countersunk screws. The top was to be faced back 6 in. so as to allow for a brass ring, shown at *Q*, Fig. 170,

which was dove-tailed to make an even joint. This ring had an outside diameter of 60 in. and an inside diameter of 48 in. and $\frac{3}{4}$ in. thick. The halves of the brass ring were also fastened in place by means of countersunk screws.

To accomplish the work we turned down a piece of steel 7 in. round and 3 ft. long as shown at *B*. We cut a keyway 2 ft. long to receive a key *C*, which fitted in a slot *D* of the boring-mill table *E*, shown at *S*. At the top end of the boring bar we bored out a 3-in. hole $1\frac{1}{2}$ in. deep, shown at *T*. We then made a shank, *F*, to fit into the toolpost head, the bottom

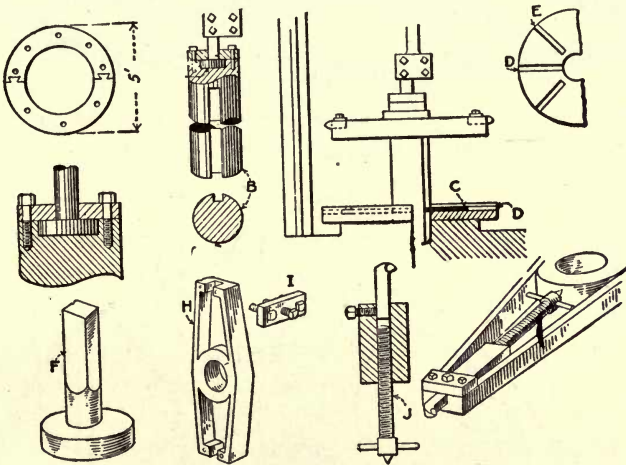

FIG. 170—RIGGING USED

having a boss fitting neatly into the 3-in. hole of the boring bar.

Thus we were able to use the feed of the machine, as the boring bar could revolve, being driven by the key *C*. We made a casting *H* of cast iron, bored and pressed on boring bar with two setscrews; a slot in each end for the tool which was held in place by a strap *I*. To face off we used a jackscrew *J*, while *X* illustrates the manner in which jackscrew worked the tool out. Being able to cut only one way it was necessary to use three different lengths of tools. Each half of the boom-deck casting was jacked up from the floor and bolted to housings of machine. Fig. 171 shows the work in progress, and Fig. 172 illustrates the work successfully completed and ready for shipment; the man in both illustrations shows comparative size.

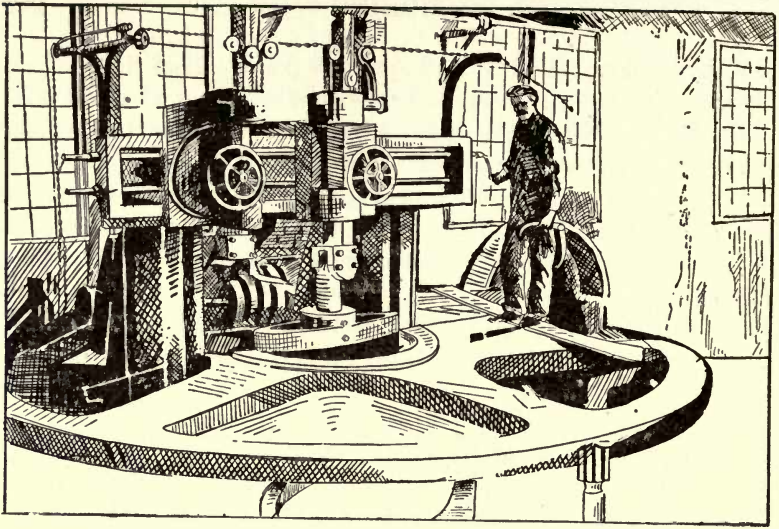

FIG. 171—THE CASTING ON THE BORING MILL

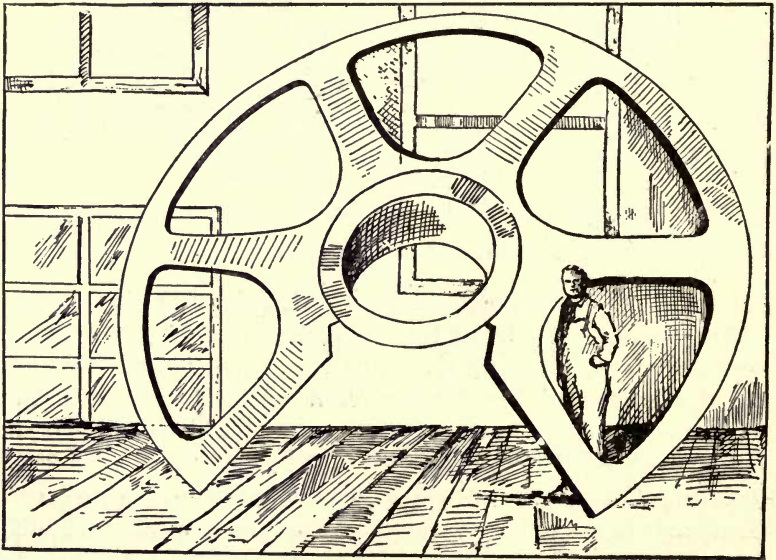

FIG. 172—THE FINISHED CASTING

PRODUCTION CHUCK FOR A BORING MILL

The chuck shown in Fig. 173 was designed for a boring-mill job. The piece to be machined is a cast bronze wormwheel, the only machining being in the hole and two side faces. The fixture as shown was built for rapid production. The sketch is not to scale, but it illustrates the idea.

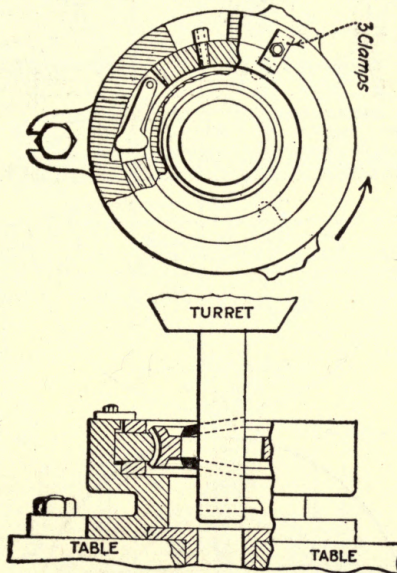
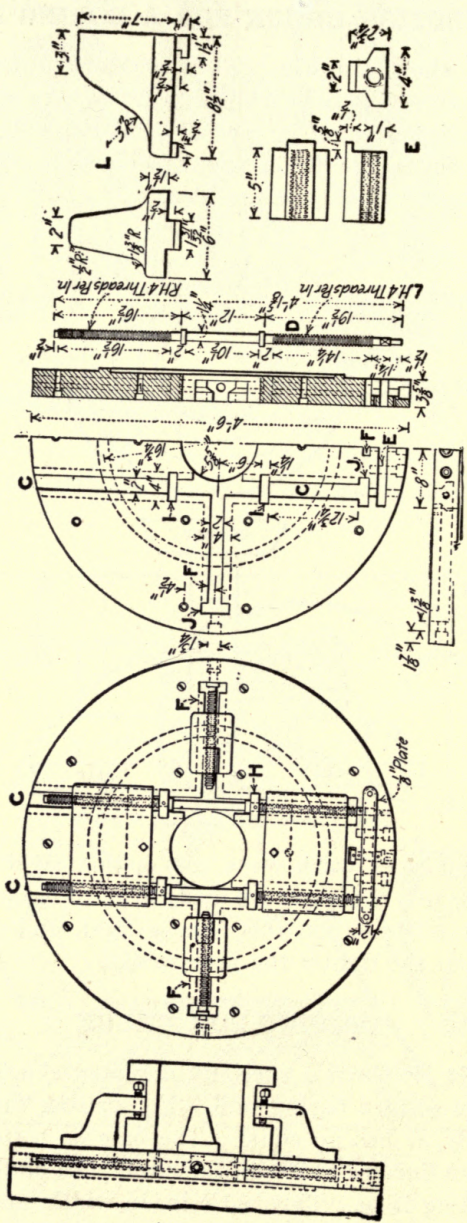

FIG. 173—BORING MILL CHUCK

The holding jaws work on a cam action tightened and released by a lever. The jaws are made to fit on the pitch diameter of the wheel. The cut in this case is light, and of course the heavier the cut the tighter the jaws wedge.

DRIVING-BOX CHUCK

In Fig. 174 is shown a specially designed chuck for holding driving boxes upon a boring mill. For getting them in proper center quickly, it has no equal. The base or bottom is a solid cast-iron piece finished to $3\frac{5}{8}$ -in. thickness. In addition, it has a ring protruding $\frac{1}{2}$ in. This is $1\frac{1}{2}$ in. in width, and the outside diameter of the ring is 35 in.; inside diameter, 32 in. This ring fits in a corresponding ring cut in the table of the boring mill.



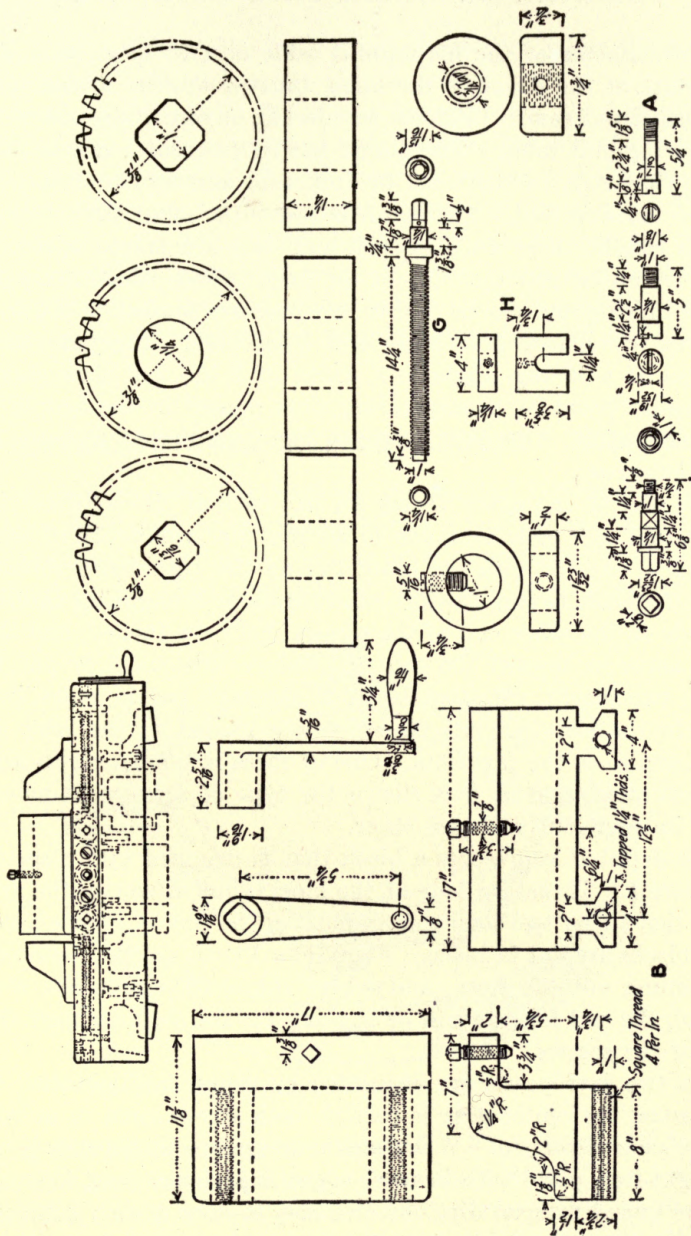

FIG. 174—DETAILS OF DRIVING BOX CHUCK

The diameter of the boring-mill table is 4 ft. 6 in., and the baseplate of the chuck is the same, thus presenting a neat and uniform appearance. Fifteen screws like *A* secure the chuck to the boring-mill table. The platen has in the center a hole $11\frac{1}{4}$ in. in diameter, for cuttings to drop into and also to clear the boring bar and tool. The detail *B* shows the main sliding jaws of the chuck; there are two such and they are moved apart or together up against the sides of the driving box, which are next to the driving-box shoes. These two jaws are planed on the bottom on two places 4 in. wide and 1 in. high. They are then beveled at a 30-deg. angle to a width of 2 in., and these parts are neatly fitted to corresponding slots planed in the bedplate, as shown at *C*. One jaw is tapped right- and one left-hand, to suit the screw.

One end of the screw *D* has $2\frac{1}{4}$ in. more of thread than the other, and care must be taken to see that just this much of both screws is screwed into the block having the right-hand thread. Then the block having the left-hand thread is brought up against threads on the other end of the screws; both are turned, and the jaws move in toward the center. Before this much is put in place, two blocks, given as detail *E*, must be put in place, one each in the slots marked *F*, which are planed in the table at right angles to the jaw slots. One of these is tapped right- and one left-hand, and at *G* is shown the type of screw that moves them independently of each other.

The detail *H* represents a block that is dropped into place in the slots *I*. There are four of the blocks, but of course the two jaws that fit on two long screws must all be put in before these four blocks are put in place. Four slots, like *J*, are for clearance in planing out the slots; and where the short screws are concerned, the end forms a rest or backing for the shoulder near the end of the screws.

The two jaw screws are connected by gears, as illustrated, so that when the center gear is turned, both screws turn in unison in the same direction. When all the gears are in place, a $\frac{1}{8}$ -in. wrought-iron plate with beveled edges is fastened over them as a gear guard to keep dirt out and also to keep a man's fingers out, a feature that is also important.

At *L* are shown details of one of the two blocks that are removable in order to put the driving box on or off. The base, or

plate, is of cast iron; the jaws are steel castings, while the gears are of soft or axle steel, as are also the pins.

The two small blocks shown are for adjusting the box along the large jaw faces, in order to bore more or less out of the part that rests on the axle. One of these blocks has to be taken out when the box is put on the machine or removed therefrom. That operation is easy, owing to the block being shorter than the part that moves it in against the box. When all jaws and setscrews are tightened up, it would take about as much of a lift to loosen the box as would be necessary to pull the machine off its foundation.

CENTERING WORK WITH GRADUATED WEDGES

For centering circular work on the vertical boring-mill table we have developed a method that effects a marked saving of time over the usual chucking and truing up with an indicator clamped in the toolpost. The ring gear *R*, Fig. 175, is clamped to the

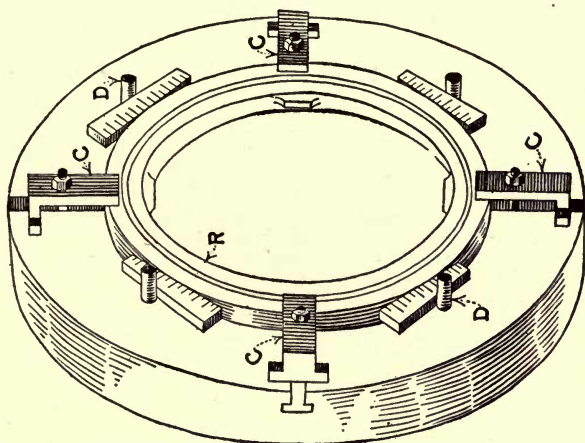

FIG. 175—GRADUATED WEDGES FOR CENTERING WORK

boring-mill table by four toe clamps *C*. Four dowels $1\frac{1}{2}$ in. in diameter are located equidistant from the center of the boring-mill table. Four wedges graduated in quarter-inches, as shown, are driven in between the ring and gear and the dowels. When the same marks line up with the centers of the dowels on opposite sides, it is evident that the casting is correctly centered,

Both dowels and wedges are hardened so that they are comparatively long lived. The centers of the dowel-pin holes are located by clamping a scriber in the toolpost, locating it the correct distance from the center, so that when the table is rotated, a circle is drawn on its face. When an air-operated jib crane is used, swinging directly over the table, the time for clamping and centering rarely exceeds two minutes, which is a saving of 700 per cent. over former methods.

SECTION XIII

GEARING

DECIMAL-EQUIVALENT TABLE USEFUL IN GEAR WORK

WHEN laying out gearing it is frequently desirable to consult handbooks for tables giving the decimal equivalents of common fractions. These tables of course, are of value if the diametral pitch of the gears under consideration corresponds to the denominators of fractions shown in the tables; but this coincidence does not always favor the person who makes the calculation. A complete table of decimal equivalents for those fractions which would be of greatest help, has long been desired, and as the center distances and diameters of gears are generally given in decimals, the need for such a table is obvious.

Consider for example, two spur gears of 22 diametral pitch, having 36 and 42 teeth: by dividing the sum of the teeth in both gears by twice the diametral pitch, we find the center distance to be $(36 + 42) \div (2 \times 22) = 78 \div 44 = 1\frac{3}{44}$ or $1\frac{17}{22}$.

From the accompanying table it will be found that $\frac{17}{22}$ equals 0.7727, hence the center distance is 1.7727 inch.

If the pitch diameter of some gear is to be found—for example a gear of 22 diametral pitch, having 36 teeth—we divide the number of teeth by the diametral pitch, with the result $36 \div 22 = 1\frac{14}{22}$. From the table $\frac{14}{22} = 0.6364$. Hence the pitch diameter of the gear equals 1.6364 in., while the outside diameter equals pitch diameter plus twice the addendum, thus: $1\frac{14}{22} + \frac{2}{22} = 1\frac{16}{22} = 1.7273$ inch.

When the outside diameter of the same gear is required, without knowing the pitch diameter, we add two to the number of teeth and divide the sum by the diametral pitch, giving $(2 + 36) \div 22 = 38 \div 22 = 1\frac{16}{22}$. According to the table $\frac{16}{22} = 0.7273$. Hence the outside diameter of the above gear equals 1.7273 inch.

DECIMAL EQUIVALENTS OF FRACTIONS OF AN INCH

Terms	1	2	3	4	5	6	7	8	9	10	11	12	13	14	15	16	17	18	19
3	0.3333	0.6667	0.7500	0.8000	0.8333	0.8571	0.8750	0.8889	0.9000	0.9167	0.9286	0.9375	0.9444	0.9500	0.9550	0.9600	0.9649	0.9700	0.9750
4	0.2500	0.5000	0.7500	0.8000	0.8333	0.8571	0.8750	0.8889	0.9000	0.9167	0.9286	0.9375	0.9444	0.9500	0.9550	0.9600	0.9649	0.9700	0.9750
5	0.2000	0.4000	0.6000	0.6667	0.7143	0.7500	0.7778	0.8000	0.8333	0.8571	0.8750	0.8889	0.9000	0.9167	0.9286	0.9375	0.9444	0.9500	0.9550
6	0.1667	0.3333	0.5000	0.5714	0.6250	0.6667	0.7000	0.7273	0.7500	0.7778	0.8000	0.8333	0.8571	0.8750	0.8889	0.9000	0.9167	0.9286	0.9375
7	0.1428	0.2857	0.4286	0.5000	0.5556	0.6000	0.6364	0.6667	0.7000	0.7273	0.7500	0.7778	0.8000	0.8333	0.8571	0.8750	0.8889	0.9000	0.9167
8	0.1250	0.2500	0.3750	0.4444	0.5000	0.5455	0.5833	0.6250	0.6667	0.7000	0.7273	0.7500	0.7778	0.8000	0.8333	0.8571	0.8750	0.8889	0.9000
9	0.1111	0.2222	0.3333	0.4000	0.4444	0.4815	0.5185	0.5556	0.5926	0.6296	0.6667	0.7037	0.7407	0.7778	0.8148	0.8519	0.8889	0.9259	0.9629
10	0.1000	0.2000	0.3000	0.4000	0.5000	0.6000	0.7000	0.8000	0.9000	0.9167	0.9286	0.9375	0.9444	0.9500	0.9550	0.9600	0.9649	0.9700	0.9750
11	0.0909	0.1818	0.2727	0.3636	0.4545	0.5455	0.6364	0.7273	0.8182	0.9091	0.9167	0.9286	0.9375	0.9444	0.9500	0.9550	0.9600	0.9649	0.9700
12	0.0833	0.1667	0.2500	0.3333	0.4167	0.5000	0.5833	0.6667	0.7500	0.8333	0.8571	0.8750	0.8889	0.9000	0.9167	0.9286	0.9375	0.9444	0.9500
14	0.0714	0.1428	0.2143	0.2857	0.3571	0.4286	0.5000	0.5714	0.6429	0.7143	0.7857	0.8571	0.9286	0.9375	0.9444	0.9500	0.9550	0.9600	0.9649
16	0.0625	0.1250	0.1875	0.2500	0.3125	0.3750	0.4375	0.5000	0.5625	0.6250	0.6875	0.7500	0.8125	0.8750	0.9375	0.9444	0.9500	0.9550	0.9600
18	0.0556	0.1111	0.1667	0.2222	0.2778	0.3333	0.3889	0.4444	0.5000	0.5556	0.6111	0.6667	0.7222	0.7778	0.8333	0.8889	0.9444	0.9500	0.9550
20	0.0500	0.1000	0.1500	0.2000	0.2500	0.3000	0.3500	0.4000	0.4500	0.5000	0.5500	0.6000	0.6500	0.7000	0.7500	0.8000	0.8500	0.9000	0.9500
22	0.0455	0.0910	0.1364	0.1818	0.2273	0.2727	0.3182	0.3636	0.4091	0.4545	0.5000	0.5455	0.5909	0.6364	0.6818	0.7273	0.7727	0.8182	0.8636
24	0.0417	0.0833	0.1250	0.1667	0.2083	0.2500	0.2917	0.3333	0.3750	0.4167	0.4583	0.5000	0.5417	0.5833	0.6250	0.6667	0.7083	0.7500	0.7917
26	0.0385	0.0771	0.1136	0.1500	0.1875	0.2250	0.2625	0.3000	0.3375	0.3750	0.4125	0.4500	0.4875	0.5250	0.5625	0.6000	0.6375	0.6750	0.7125
28	0.0357	0.0714	0.1071	0.1386	0.1714	0.2043	0.2371	0.2700	0.3029	0.3357	0.3686	0.4015	0.4343	0.4671	0.5000	0.5329	0.5657	0.5986	0.6314
30	0.0333	0.0667	0.1000	0.1333	0.1667	0.2000	0.2333	0.2667	0.3000	0.3333	0.3667	0.4000	0.4333	0.4667	0.5000	0.5333	0.5667	0.6000	0.6333
32	0.0312	0.0625	0.0938	0.1250	0.1562	0.1875	0.2188	0.2500	0.2812	0.3125	0.3437	0.3750	0.4062	0.4375	0.4687	0.5000	0.5312	0.5625	0.5937
36	0.0278	0.0556	0.0833	0.1111	0.1389	0.1672	0.1954	0.2237	0.2519	0.2802	0.3085	0.3368	0.3651	0.3934	0.4217	0.4500	0.4782	0.5065	0.5348
40	0.0250	0.0500	0.0750	0.1000	0.1250	0.1500	0.1750	0.2000	0.2250	0.2500	0.2750	0.3000	0.3250	0.3500	0.3750	0.4000	0.4250	0.4500	0.4750

Terms	20	21	22	23	24	25	26	27	28	29	30	31	32	33	34	35	36	37	38	39
3	0.0909	0.9545	0.9167	0.9583	0.9231	0.9615	0.9286	0.9643	0.9333	0.9667	0.9375	0.9687	0.9444	0.9722	0.9500	0.9750	0.9500	0.9750	0.9500	0.9750
4	0.0833	0.8750	0.8462	0.8889	0.8571	0.8959	0.8649	0.9037	0.8729	0.9117	0.8809	0.9197	0.8889	0.9277	0.8969	0.9357	0.9049	0.9437	0.9129	0.9517
5	0.0714	0.8000	0.7714	0.8148	0.7857	0.8286	0.7996	0.8425	0.8125	0.8554	0.8254	0.8683	0.8383	0.8812	0.8512	0.8941	0.8641	0.9070	0.8770	0.9200
6	0.0625	0.7500	0.7250	0.7667	0.7381	0.7796	0.7500	0.7915	0.7619	0.8034	0.7738	0.8153	0.7857	0.8271	0.7976	0.8391	0.8096	0.8511	0.8216	0.8631
7	0.0556	0.7000	0.6778	0.7182	0.6909	0.7314	0.7037	0.7442	0.7167	0.7571	0.7296	0.7701	0.7426	0.7831	0.7556	0.7961	0.7686	0.8091	0.7816	0.8231
8	0.0500	0.6667	0.6462	0.6857	0.6571	0.6966	0.6681	0.7076	0.6791	0.7186	0.6901	0.7296	0.7011	0.7406	0.7121	0.7516	0.7231	0.7626	0.7341	0.7736
9	0.0455	0.6250	0.6062	0.6452	0.6167	0.6557	0.6271	0.6661	0.6376	0.6766	0.6481	0.6871	0.6586	0.6976	0.6691	0.7081	0.6796	0.7186	0.6901	0.7291
10	0.0417	0.5833	0.5662	0.6042	0.5761	0.6141	0.5861	0.6241	0.5961	0.6341	0.6061	0.6441	0.6161	0.6541	0.6261	0.6641	0.6361	0.6741	0.6461	0.6841
11	0.0385	0.5500	0.5345	0.5725	0.5455	0.5845	0.5575	0.5965	0.5695	0.6085	0.5815	0.6205	0.5935	0.6325	0.6055	0.6445	0.6175	0.6565	0.6295	0.6685
12	0.0357	0.5182	0.5037	0.5412	0.5148	0.5523	0.5259	0.5634	0.5370	0.5745	0.5481	0.5856	0.5592	0.5967	0.5703	0.6078	0.5814	0.6193	0.5929	0.6304
13	0.0333	0.4875	0.4738	0.5102	0.4837	0.5201	0.4936	0.5300	0.5035	0.5400	0.5135	0.5500	0.5235	0.5600	0.5335	0.5700	0.5435	0.5800	0.5535	0.5900
14	0.0312	0.4583	0.4457	0.4821	0.4556	0.4920	0.4655	0.5019	0.4754	0.5118	0.4853	0.5217	0.4952	0.5316	0.5051	0.5415	0.5150	0.5514	0.5249	0.5613
15	0.0290	0.4300	0.4182	0.4545	0.4286	0.4649	0.4390	0.4753	0.4494	0.4857	0.4598	0.4961	0.4702	0.5065	0.4806	0.5169	0.4910	0.5272	0.5013	0.5375
16	0.0270	0.4037	0.3927	0.4281	0.4022	0.4376	0.4117	0.4470	0.4211	0.4564	0.4305	0.4658	0.4399	0.4752	0.4493	0.4846	0.4587	0.4940	0.4681	0.5034
17	0.0250	0.3786	0.3684	0.4037	0.3778	0.4131	0.3872	0.4225	0.3966	0.4319	0.4060	0.4413	0.4154	0.4507	0.4248	0.4601	0.4342	0.4695	0.4436	0.4789
18	0.0233	0.3545	0.3452	0.3803	0.3543	0.3894	0.3634	0.3985	0.3725	0.4076	0.3816	0.4167	0.3907	0.4258	0.3998	0.4349	0.4089	0.4440	0.4180	0.4531
19	0.0217	0.3313	0.3228	0.3577	0.3317	0.3666	0.3406	0.3755	0.3495	0.3844	0.3584	0.3933	0.3673	0.4022	0.3762	0.4111	0.3851	0.4200	0.3940	0.4389
20	0.0200	0.3091	0.3015	0.3363	0.3103	0.3451	0.3191	0.3539	0.3279	0.3627	0.3367	0.3715	0.3455	0.3803	0.3543	0.3891	0.3631	0.4039	0.3779	0.4227
21	0.0185	0.2877	0.2809	0.3156	0.2896	0.3243	0.3083	0.3430	0.3170	0.3517	0.3257	0.3604	0.3344	0.3691	0.3431	0.3778	0.3518	0.3925	0.3665	0.4112
22	0.0170	0.2672	0.2612	0.2958	0.2798	0.3144	0.2984	0.3330	0.3070	0.3416	0.3156	0.3502	0.3242	0.3588	0.3328	0.3674	0.3414	0.3820	0.3560	0.4006
23	0.0156	0.2476	0.2424	0.2770	0.2610	0.2956	0.2796	0.3142	0.2882	0.3228	0.2968	0.3314	0.3054	0.3400	0.3140	0.3486	0.3226	0.3632	0.3372	0.3818
24	0.0143	0.2288	0.2245	0.2589	0.2429	0.2775	0.2615	0.2961	0.2701	0.3047	0.2787	0.3133	0.2873	0.3219	0.2959	0.3305	0.3045	0.3451	0.3191	0.3637
25	0.0130	0.2109	0.2075	0.2418	0.2258	0.2604	0.2444	0.2790	0.2530	0.2876	0.2616	0.2962	0.2702	0.3048	0.2788	0.3134	0.2874	0.3280	0.3020	0.3506
26	0.0118	0.1938	0.1913	0.2261	0.2101	0.2447	0.2287	0.2633	0.2373	0.2719	0.2459	0.2805	0.2545	0.2891	0.2631	0.2977	0.2717	0.3123	0.2863	0.3299
27	0.0107	0.1775	0.1758	0.2101	0.1941	0.2287	0.2127	0.2473	0.2213	0.2559	0.2299	0.2645	0.2385	0.2731	0.2471	0.2817	0.2557	0.2963	0.2703	0.3139
28	0.0097	0.1619	0.1610	0.1952	0.1792	0.2138	0.1978	0.2324	0.2064	0.2410	0.2150	0.2496	0.2236	0.2582	0.2322					

I have found it a most useful table when calculating gear trains.

INTERMITTENT WORM GEAR

A worm gear used in connection with an automatic wire-working machine seems to offer great possibilities and adaptability in connection with automatic-machine design.

Fig. 177 shows sectional and end view of a three-piece intermittent gear, each section of which is intermittent and in which

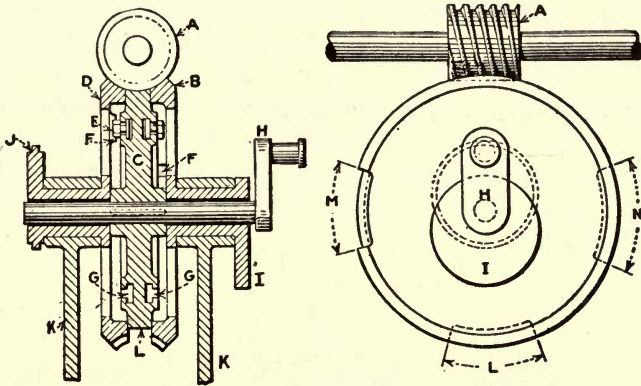

FIG. 177—THE INTERMITTENT WORM GEAR

the length of dwell can be regulated to perform the required function. *A* shows the worm; *B*, *C* and *D* are three sections that constitute a full worm gear; spaces *L*, *M* and *N* show teeth of the gear cut away to produce the dwell; *H*, *I* and *J* show a crankshaft and eccentric cams to produce the necessary mechanical movements. These, of course, may be designed to meet requirements. At *K* are housings of the machine. Section *C* of the worm is keyed to the shaft. This section has adjustable stops on either side, marked *E*, movable in T-slots *G*. They are adjusted through openings in the sidewalls of *B* and *D*, which have the stops *F*. These stops may also be made adjustable.

Each section of the worm makes a full revolution and a dwell, the length of time depending upon the relation of the stops *E* and *F* to each other. The machine in question was used to weave wire fence, which, while it cannot be called fine work, is rather exacting.

FORMULA FOR OBTAINING CUTTING ANGLE OF HELICAL GEARS

It is often required to replace spur gears with helical gears where the pitch diameter and number of teeth cannot be changed, as in speed boxes, etc. In this case a finer pitch cutter must be used, and the cutting angle made such as to give the correct proportion of tooth and space. While working out a problem of this kind it occurred to me that a shorter way than by circumferential pitch could be used. For example, given a change speed box with 6 diametral pitch spur gears, to replace them with helical gears of $6\frac{1}{2}$ diametral pitch. $6 \div 6.5 = 0.9230 =$

$\cos 22^\circ 30'$, which is the cutting angle. The formula is $\frac{A}{B} =$

$\cos C$; where A is the diametral pitch of the spur gear, B is the diametral pitch of the helical gear and C is the cutting angle of the helical gear.

SECTION XIV

SCREW MACHINE

MACHINING A 5 $\frac{3}{4}$ -IN. PISTON ON A 3 $\frac{1}{4}$ -IN. GRIDLEY AUTOMATIC

Not having a sufficient quantity of this work to warrant a special machine, and yet desiring to take advantage of the lower operating cost of the automatic, we designed the fixture here described and shown in Fig. 178 to accomplish the third operation which includes facing, turning and chamfering a 5 $\frac{3}{4}$ -in. gas-engine piston and cutting the oil and ring grooves.

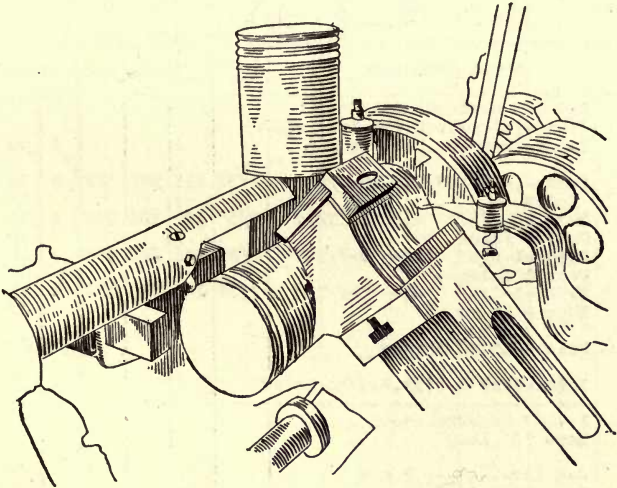

FIG. 178—FIXTURE FOR TURNING PISTONS

It is not possible to show all the tools in the picture. The forming-tool holder carries the tools for facing the end, chamfering, cutting the oil grooves and roughing the ring grooves to within $\frac{1}{4}$ in. of size. The rear block carries the tools for finishing the grooves to size.

The turning tool is carried in a 3-in. round cold-rolled steel bar which is operated by a fixture attached to the turret. The forward end of this bar slides in a bearing provided by a casting which is bolted to the head of the machine, and is cut away as shown to clear the main bearing. The actual bearing for this pilot bar is made by pouring babbitt around it after assembling. There are but two cams on the cam drum, one for the forward movement and one for the return. The turret is not indexed.

F. A. H. 5/23/17 TIME STUDY						Form 200-6-17-131			
NAME		SHAFT	82895	MAT. M. S.					
SYMBOL		X	PIECE NO. 623	OPER. NO. 1x1					
OPERATION TURN 4 DIAM. FOR GRIND FACE NECK ROUND CORNER									
TYPE		T & S	24" X 26"	OPERATOR Norum		MACH. NO. 266			
DETAIL OPERATIONS					Depth Cut	Cut Speed	R.P.M.	Feed	Minutes
Cut off shaft-Stock out & Clamp-Index-Neck for true up-Index-True up- Head to cut									3 08
Turn--1-13/16" -X- 19-5/8					1/32	111	236	025	3 35
Index---									37
Turn--1-9/16" -X- 3-11/16					1/8"	96	234	008	2 08
Face & Index									40
Turn--1-5/8" -X- 5-7/16"					3/32	132	310	008	2 10
Face & Index--									32
Turn--1-3/4" -X- 3-9/16"					1/32	142	310	008	1 42
Face & Index									33
File - Round corner									67
Index-Neck 3 diam. 1-Gage-Index									2 00
1 7-8" Machine steel Bars 16' long									
Get bar-----7 min.									
Prepare end-----3 "									
Machine time 8.93									
Handle " 7.17									
Stock Removed 2.3#									
Actual Floor to Floor Time								16 10	

FIG. 179—TIME STUDY SHEET

SCREW MACHINE PRACTICE



STUDY NO	DEPTH CUT	DIAM. STOCK	FEED	REV. P.M.	IN. P.M.	LENGTH TURN	LENGTH PIECE	MACH. NO.	MAT. MATERIAL	PIECE NO.	HAND TIME	SKETCH
9	1/32	1-1/2	.026	230	6	10-7/16	10-7/16	188	M.S.	X-768	1.90	
1	1/32	1-1/2	.012	234	2.8	11	18	266	M.S.	X-610	11.98	
5	1/32	1-1/2	.032	310	9.6	7-15/16	7-15/16	266	M.S.	H-641	2.75	
10	1/32	1-1/4	.023	310	7.1	10-5/8	10-5/8	266	M.S.	I-720C	.83	
10	1/32	1-3/16	.012	310	3.7	2-9/16	10-5/8	266	M.S.	I-720C	.83	
10	1/32	1-1/4	.031	310	9.6	10-5/8	10-5/8	266	M.S.	I-720C	.83	
10	1/32	1-3/16	.031	310	9.6	2-9/16	10-5/8	266	M.S.	I-720C	.83	
4	1/32	1-7/8	.023	310	7.1	19	19	266	M.S.	X-623	6.83	
4	1/32	1-13/16	.008	310	2.8	3-9/16	3-9/16	266	M.S.	X-623	6.83	
6	1/32	2-1/4	.012	234	2.8	6 1/2	6 1/2	266	M.S.	H-03691	1.75	

FIG. 180—CHART ON SCREW MACHINE PRACTICE

As the tools are all working at once the turning time covers the time of the operation.

The spindle speed is 48 r.p.m. The turning tool is No. 3 stellite, all the others being high-speed steel. The countershaft pulleys are arranged to use two 2 $\frac{3}{4}$ -in. double belts for driving.

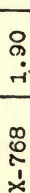
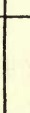
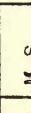
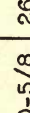
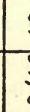
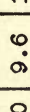
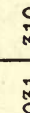
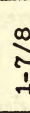
The work was formerly done on hand-operated screw machines with a working time of 1 hour for the operation. The time consumed by this method is 12 min., and four machines are handled by one operator.

TIME STUDIES IN SCREW-MACHINE PRACTICE

Time-study articles and charts relative to the output that can be reasonably expected from various machine tools are of great value to manufacturers of machinery. The chart illustrated in Fig. 179 is the result of time-study work in the screw-machine department of the Gisholt Machine Co., and is one of many compiled from a great number of time studies having corresponding speeds and feeds. Considerable care was required in laying out these charts that they might embrace as many different parts as possible, thereby assisting the rate setters in locating the proper time studies to follow.

If necessary, the chart may be used without the time studies, but to set a rate that is just to the operator, the hand-feed and handling time is required. The chart is self-explanatory and when used in conjunction with the time study illustrated, will aid in setting accurate rates. The work from which these charts were compiled was the product of hand-operated turret machines, which were belt driven through three-speed countershafts.

SLOTTING AND SHAPING IN THE AUTOMATIC SCREW MACHINE

The tools described, which are used as attachments for Brown & Sharpe automatic screw machines, were designed to include second, or hand, operations with the automatic machining of the parts shown.

At A, Fig. 181, is illustrated a stud that is completed in a No. 0 Brown & Sharpe automatic screw machine from $\frac{5}{8}$ -in. round

brass. The slotting was formerly done in a separate operation after being drilled in the drilling machine to remove stock. To shape this slot in the automatic screw machine, the spindle is stopped with a standard attachment, and stock is removed for slotting by drilling two holes with a special combination cross-drill and cutting-off attachment.

The special shaping-tool holder *B* is mounted in the turret and carries the bushing *C*, which supports the stem while shaping the slot. The shaping-tool holder *D* is a square plunger and is retained in the holder *B* by the plate *E* and the retainer screw *F*. The eccentric *G* is driven by the pulley shown mounted on

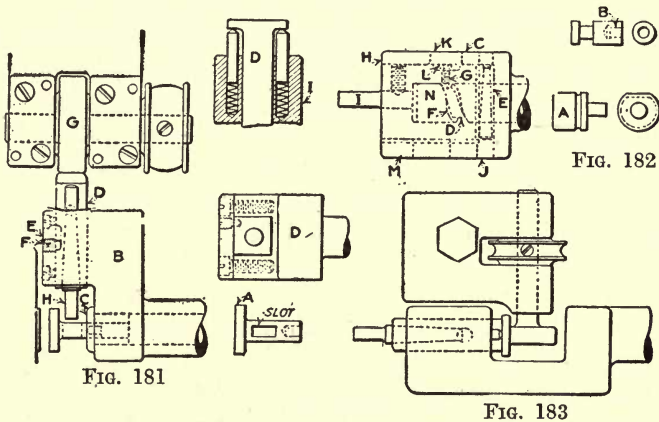

FIGS. 181, 182 AND 183—SLOTING AND SHAPING ATTACHMENT

the rear cross-slide giving motion to the slotting plunger *D* and the cutter *H*. A cross-section at *I* shows the spring plungers that keep the toolholder in contact with the eccentric *G*.

In operation the stem is turned with a box tool, the spindle stopped, and a hole cross-drilled to remove stock for one end of the slot; the drill is withdrawn and the stock fed forward and a second hole cross-drilled to remove stock for the other end of the slot. The cross-drill is then withdrawn, and the turret is indexed and advanced to bring the special shaping tool into line with one of the cross-drilled holes. It is caused to remain in this position by a dwell on the lead cam, while the rear cross-slide advances sufficiently for the eccentric to push the cutter through the work. The throw of the eccentric is equal to the diameter of the stem of the work plus clearance, and the speed

of the pulley is sufficient to give the cutter rapid motion, while the lead cam causes the turret to advance and then slowly withdraw, thus giving the cutter a fine feed to complete the length of the slot. The width of the cutter is the same as the width of the slot.

The cams are similar in design to those for operating swing or undercutting tools. After the work is completed, the lead cam causes the turret to dwell until the rear cross-slide has withdrawn sufficiently for the shaping tool to clear the work, at which point it has ceased operating and the turret may then be indexed. The feed of the lead cam for this shaping operation is 0.001 in.

Other parts that were successfully completed, including shaping cuts, are shown in Fig. 182. The economy of completing these parts in one setting is obvious. The piece *A* is made in a No. 2 Brown & Sharpe automatic turret forming machine from 0.750-in. soft machinery steel, extruded stock, the shape being the same as that shown. After the groove has been turned, the spindle is stopped with the flat side of the stock up. The groove is then completed by a shaping operation similar to that described above.

For such light cuts in soft brass and machinery steel as shown at *B*, the special shaping tool *C* may be used. This tool is self-contained, mounted in the turret and driven by the high-speed drilling attachment. The revolving shaft *D* carries a thrust collar *E* and the cam slot *F*, which through the roller at *G* give the bushing *H* and the cutter *I* a reciprocating motion. A hole at *J* provides a means of assembling the taper pin in the thrust collar, and the hole *K* provides for assembling the hexagon nut *L* on the roller *G*. A rectangular key is shown at *M*, and the straight slot *N* opening into the cam cut provides a means of assembling the shaft *D* into the bushing *H* after *G* has been assembled. This slot is located radially on the cam slot at the beginning of the return stroke, so as not to interfere with the roller *G*.

For machining heavier cuts than those shown in Fig. 182, the shaping tool, Fig. 183, may be used. The construction of the tool differs from that in Fig. 181 only in the application of the cutter, which is located longitudinally instead of transversely, and has clearance so it will cut on end.

GUARD FOR DEFLECTING COMPOUND

Manufacturers who are engaged in the production of munitions on $4\frac{1}{4}$ -in. single-spindle Gridley automatics utilizing cooling compound and individual circulating systems will find that guards similar to the one shown are great time savers.

I know of one battery of 52 machines running 24 hours a day which is using these guards, and since their adoption no time has been lost due to grinding the rotating stuffing-box to a better fit.

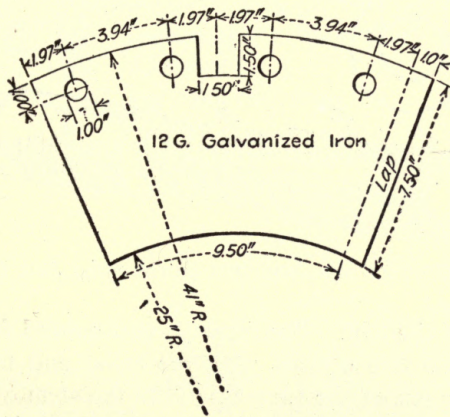

FIGS. 184—GUARD FOR DEFLECTING COMPOUND

Fig. 184 shows clearly how this hood is laid out on sheet metal. When cut out it is rolled into a frustum of a cone and the lap riveted or soldered. The hood is slipped over the draw-bar, where it projects through the turret. The four hose leads must be disconnected and then screwed in place through the four holes in the guard. This is all that is necessary to hold the hood in place, and there will be no more streams of compound shooting onto the floor.

TOOL FOR REMOVING BURRS FROM JAM NUTS

Recently a batch of $\frac{3}{8}$ -in. jam nuts that had been produced on an automatic screw machine had such a burr on one side that it interfered greatly with the assembly of the apparatus of which they formed a part. It was decided to remove this burr with

the hand screw machine, and the little tool shown in Fig. 185 was designed, which helped to do the trick.

The tool consists of three essential parts, a slotted sliding collar *A*, fitted to slide on the stem of the stud *B*, being held in normal position against the stop pin *C* by the spring *D*.

The tool is carried in one station of the turret and a suitable countersink in another. The purpose of the tool is to place the jam nut in the collet while the machine is running. This is accomplished by first placing the jam nut in the slot *E* at the

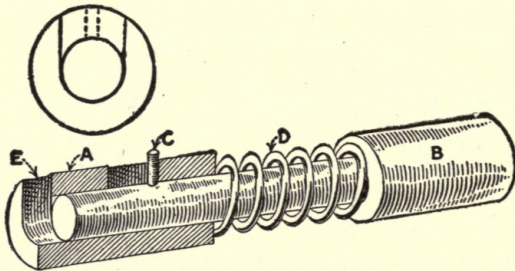

FIG. 185—TOOL FOR REMOVING BURRS FROM JAM NUTS

forward end of the tool. The turret is then moved forward until the collar comes into contact with the collet and the continued forward movement of the turret permits the stem of the stud to press the jam nut into the collet which is next quickly closed.

A stationary rod is secured inside of the spindle to prevent the jam nut entering too far. The countersink is next moved up and the burr removed. The rod also acts as an ejector, for the moment the collet is released the jam nut is ejected. With this equipment a girl can burr about seven hundred nuts per hour.

SENSITIVE TAP AND DIE HOLDER

A job came along a while ago that did not seem to fit our smallest turret lathe, and we were somewhat worried as to how it was to be done without undue breakage of taps.

The piece is shown in Fig. 186, and you will agree that the tapping of the No. 6-32 hole to the bottom in tobin bronze does not look real good for as heavy a machine as the No. 4 Bardons & Oliver, however we made the holder shown in Fig. 187. This worked so well that it has been used for other similar

jobs, like drilling and threading small parts on heavy turret machines.

In operation the knurled sleeve with the tap, drill or die secured in a suitable bushing is held lightly in the bare hand and

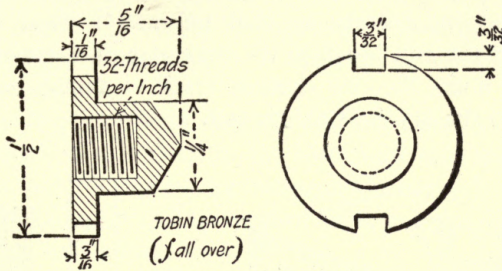

FIG. 186—THE WORK

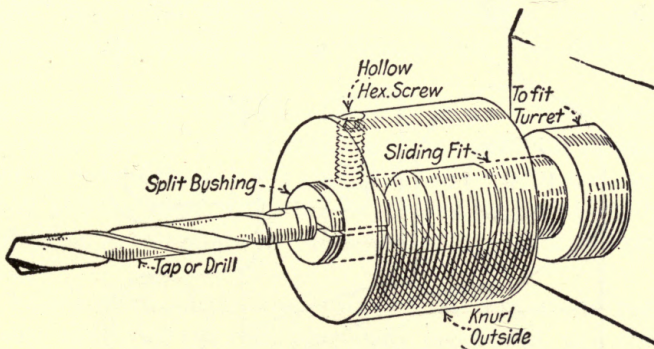

FIG. 187—THE TAPHOLDER

fed up against the work. When the hole is tapped to the bottom the sleeve turns around on the shank. This gives one ample time to reverse the machine and acts as a safety device to prevent breakage.

THREAD ROLLING IN THE AUTOMATIC SCREW MACHINE

My experience is confined entirely to brass, and chiefly to fine threads that were produced entirely by the roll, without any previous threading. The work was threaded on one end with a male thread and on the other with either a male or a female

thread. The rolling process was resorted to on the male-thread end, to avoid a second handling.

It has always seemed to me that theoretically the production of threads by this method should be impossible, and for this reason: The angle of the top of any thread is always less than the angle of the bottom, so that no matter what relation the diameter of the roll bears to the diameter of the work, it is impossible to make the two threads track or match at more than one point in the depth of the thread.

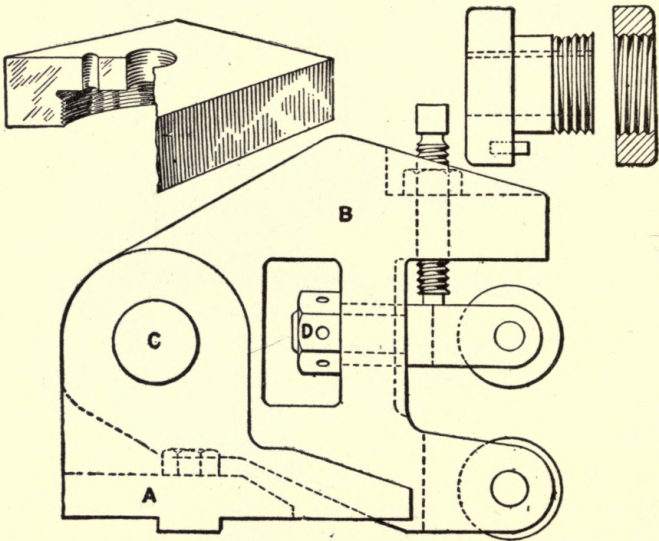

FIG. 188—FIXTURE, DRILL JIG AND ROLL HOLDER

This inevitably results in a sidewise crowding or strain between the threads of the roll and the work. Conditions are further aggravated by the fact that it is the top or weakest part of the thread roll that must sink the deepest into the work and form the bottom or strongest part of the thread on the work.

We were able to obtain little definite information as to the proportions of rolls, but the rule most favored seems to be to consider the pitch diameter of the work and to make the pitch diameter of the roll a multiple of it, adding the single depth of thread. The rolls that we made were two, three or four times the size of the work and correspondingly threaded double, triple or

quadruple, as the case might be, while the roll must be cut left hand to produce right-hand results.

This method was followed for a number of years, but was finally changed to rolls in which the top of the thread had the same helical angle as the bottom of the thread on work, so as to decrease as much as possible the sidewise crowding at the top of the roll thread, transferring it to the base of the thread. This was an improvement.

It is exceedingly difficult to get a roll tempered so that it will be hard enough to stand up to the work and soft enough not to break. We had no hardening refinements beyond a lead bath (no pyrometer) and an oil tempering bath, and we did not grind the rolls after hardening.

With the utmost care it seemed impossible to get any two of a lot of rolls to produce the same results as to length of service. We tried many brands and grades, but obtained the best results when we used Firth's Best Tool Steel, No. 4 temper.

The first, and for years the only, way in which rolls were used was to hold them in a rigid holder on the cross-slide at the same height as the work and, after the work has been formed, advance the roll at high speed to its full depth and as quickly withdraw it, allowing it to remain in contact with the work for only an instant.

A longer dwell on the high point of the cam would result in the side motion of the roll, previously mentioned, and then the whole thread would be stripped from the work, leaving the root diameter.

When we were so fortunate as to get a roll "just right" we could produce as high as 100,000 pieces with it before it wore out, but the process was very hard on the front spindle boxes, wearing them oblong in a comparatively short time, due to the sharp rise of the cam and resulting blow when roll and work came in contact.

Eventually we got some new Brown & Sharpe automatics and tried to develop a process that would give less pressure on the front bearing. We worked along the line of a holder in which could be two rolls capable of being adjusted to and from each other and clamped in position, the holder carrying the two rolls to have a slight oscillation to allow the rolls to center themselves

on the work. The rolls were to straddle the work, one passing over it and the other under.

At the bottom in Fig. 188 is given an idea of the first fixture made. It consisted of the base *A*, which was bolted to the cross-slide, and *B*, which held the rolls and had a limited movement on the pin *C*. As will be seen, the upper roll was carried in a fork which was tongued and grooved vertically to the part *B*, clamped by the nut *D* and held up to the work by the setscrew, as shown. The lower roll fitted the holder closely, but the upper one was free to move sideways on its pin about $\frac{1}{2}$ in., with the idea that it would crowd into the thread made by the lower roll as soon as a thread began to be formed and by dividing the work between two rolls would tend to more accurate work and longer service from the rolls.

Curiously enough it worked from the start for several thousand pieces, but the second time we attempted to set it up for a thread-rolling job it would not work at all.

A month or so later we tried it again, with the same result. As extended trial failed to disclose any reason, we gave it up as a failure.

The fixture just described was made as strong as the rather limited space on the cross-slide of a No. 0 B. & S. would permit, but was quite plainly not rigid enough to resist the side thrust of the rolls. At about this stage it became desirable to make this class of work on multiple spindle machines, where we had previously done so, using the method first described—that is, feeding a roll directly against the side of the work. It had worked very well when the machines were new, but the spindles and bearings had become worn, some more than others, and this made it impossible to secure work anywhere near the required limits from the different spindles, so we fell back on the double-roll idea, but with the following changes:

Having plenty of room on the cross-slide, we made a holder of machine steel that was many times stronger than the first one; in fact it was very heavy, but trial showed that it was none too strong. It is my recollection that the pin on which the oscillating member moved was about $1\frac{1}{2}$ in. in diameter and everything else in proportion.

We also abandoned the upper thread roll for a plain roll, which the nature of the work permitted. This roll did not, of course,

take bearing on the thread but on each side of it, and served to hold the thread roll up to the work. This arrangement worked after a fashion, but did not meet expectations.

We next altered the holder to accommodate two threaded rolls which were keyed to their spindles and these in turn geared together so that the two rolls were always in a fixed relation to each other.

The gears were inclosed in a tight case to keep out dirt, and by means of an adjustable idler between them it was possible to get a limited amount of adjustment between the rolls. This proved the best combination and produced better work than any of the others, with longer life to the rolls.

The threads we were to produce were 27 per inch, and the rolls were made with a quadruple thread, $6\frac{3}{4}$ threads per inch being cut several at a time on a gang arbor.

After chasing, they were screwed into the drill jig, in the upper left hand corner of Fig. 188, and a hole drilled. This hole located the thread always in the same place on the roll-holder bushing, to the right, and these bushings in turn were keyed to the geared spindles, which were made in one piece and rotated in hardened bushings.

In fitting up the holder we were careful to get the keys located in these two spindles so that the same roll could be placed either on the top or bottom spindle and be in correct relation to the other roll. The gears were marked in their proper timing to avoid trouble when replacing them in the holder.

This would seem like an expensive thing to make. However, I believe the results will justify it wherever such work must be done in large quantities, for it will produce more accurate work, will do this on a multiple spindle machine with worn bearings, and the work being divided between two rolls, which are held in positive relation to each other, the rolls will last longer.

These advantages will surely appeal to any one who has been up against this proposition.

HOLLOW SETSCREW AS AN "ADAPTER"

Trouble was experienced in tightening the screw that holds the rolls in the holder of the roller back rests on our Gridley automatic screw machines. It is necessary for this screw to be

placed in the curved portion of the tool slide. This makes it almost impossible to use a wrench on the screw, which must be securely tightened.

I took an ordinary blank hollow setscrew, drilled one end, and tapped it according to the size of the screw. I then inserted the regular bent hollow-setscrew wrench. In this manner the screw was tightened without any inconvenience.

This scheme is equally useful in any place where it is difficult to use an ordinary wrench. It is a device that can easily be secured in any machine shop, as all that is required is a piece of round steel of the proper length to allow for the necessary depth of the tapped hole and the insertion of the wrench at the opposite end.

SECTION XV

SHOP TOOLS, APPLIANCES AND EXPEDIENTS

CONSERVATION VS. EFFICIENCY

It has always been the writer's idea, and I suppose the idea of ninety-nine out of a hundred other persons, that conservation and efficiency are synonymous as applied to industrial plants. A few examples which have recently come to the attention of the writer have now led him to think otherwise. One of the cases that comes to mind is metal wheelbarrows. In the plant in mind there are not a great many of these in use, and when some part breaks it is found cheaper to buy a new barrow than to repair the old one. Were there more in use, it would undoubtedly pay to repair them, but a man assigned to repair a single barrow will waste so much time thinking about starting and in puttering around that repairing is not a paying proposition. Efficiency in this case counsels, buy a new one; conservation would repair the old. Another case where a difference in these word meanings is illustrated is in the separation of oil from chips. The plant did not have a great many oily chips, but a man with a small separator was employed to take care of what there were. Careful calculation showed that the man's wages were about twice the value of the oil he recovered. Conservation all right, but not efficiency! Had the amount of chips been great enough to warrant the purchase of a goodly sized separator, the case, of course, would have been entirely different.

Another instance which illustrates this point is that of separating coke or coal from the ashes of a boiler plant. In one case of a stoker-driven boiler, it was noticed there was considerable coal burned to coke, pulled out when cleaning fires. A laborer getting \$2.50 per day was put to work picking out the coke and got about 400 lb. per day. This, of course, did not pay his wages and the work was stopped; yet, when we think of

the present shortage of coal it seems a pity to let even this amount go to waste.

A plant in the same vicinity has a man pick over the ashes and record the weight of coal recovered during each shift. This has a good effect on the fireman, and while the picker does not earn his wages in coal recovered, he earns them indirectly in the coal saved by more care on the part of the fireman.

There are doubtless many instances much more important than the trivial ones mentioned, and it would seem that in these times of shortage of materials, it might be loyal to sacrifice efficiency if necessary, for the sake of conservation.

IMPROVED DRIP CAN FOR HANGERS

The usual drip can on a hanger is either a cast-iron cup or an old tin can. In a certain shop where new machinery is being installed with a view to saving all the time and material possible, several galvanized cans were made which are as long as the hanger bearing, and to the bottom of these cans a screw cap was added.

Any oil which drops of course goes into the can, and after a time the oiler merely unscrews the cap and saves every drop of oil, which is strained and used again.

METHOD OF RECLAIMING WASTE

The high cost of waste and rags used throughout the machine shop made it necessary to cast about for means to reduce our charges for this material, so we devised a washing arrangement, which was made up by our engineer out of some old pipe fittings. As shown in Fig. 189, a piece of 12-in. pipe was arranged with companion flanges on each end, a steam inlet in the side, and a drain at the bottom. A screen was then placed in the pipe about 4 in. above the steam inlet. The oily waste was placed in the washer above the screen by removing the companion flange, and then the whole mass was boiled by turning in the live steam, the condensation dripping down through the waste and carrying the oil and dirt off through the blow-off valve. While this crude washing did not turn out perfectly clean waste, it nevertheless took out such a large percent-

age of the oil, grit and dirt that the waste could be used for practically all purposes. The expenditure for new waste was thereby cut down between one-half and one-third each month.

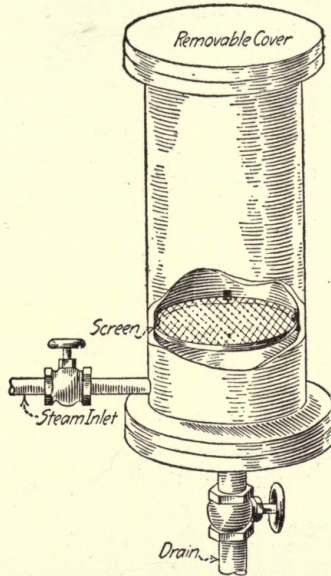

FIG. 189—APPARATUS FOR RECLAIMING WASTE

INSTALLING OVERHEAD APPARATUS REDUCES OVERHEAD EXPENSE

The small machine-manufacturing plant must use considerable ingenuity to secure the advantages that come to the large shop through quantity manufacture, without incurring too heavy charges. It is a comparatively simple matter in the large shop with a great volume of standardized work to arrange machine equipment so that pieces proceed from operation to operation with the least amount of handling and expense.

Fig. 190 shows an arrangement of millers by which the central swinging jig crane *A* permits the handling of work from one machine to another, all three millers *B*, *C* and *D* taking care of individual operations. One man operates these three machines, on which the tool and fixture set-up is permanent.

Another feature worthy of note in this illustration is the arrangement of overhead beams shown at *E*, which allows great flexibility in arranging countershafts. These beams consist of

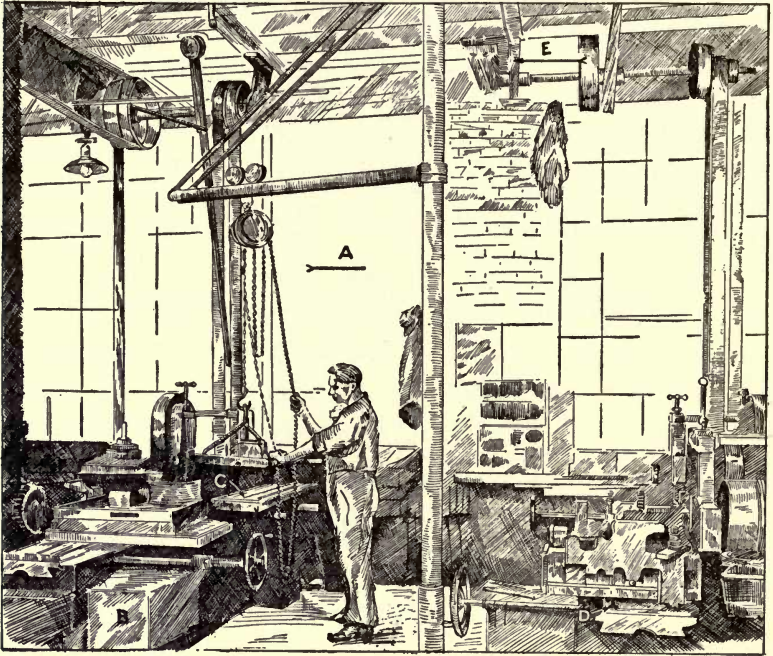

FIG. 190—CRANE ARRANGEMENT

two angle irons mounted back to back, with a space between them to receive bolts and cast-iron spacing blocks riveted in at intervals.

ECONOMY IN HACKSAW BLADES

For odd work I like a machine or two to spare, so as to let the blade jog through without much regard to time. This saves blades. The operator can easily push things on a rush job where the cost of a blade is as nothing compared to getting the work out quickly.

For repetition work I like a carefully selected machine of suitable size and power and a blade thin yet strong enough to carry sufficient weight to wear itself out on its later cuts. I fix a position for the weight which on a blade's first cut will not tear

out or destroy the sharp edges of the teeth; also, a cutting time that must not be exceeded per piece. The first cut takes less than this maximum time, and the operator increases the pressure as the time taken gets longer. A blade that is too thin breaks before being worn out, and one that is too thick takes a longer time before being worn out. An adjustment of the weight position and alteration of the time allowance will soon discover the best average conditions for any make of blade on standard work on any machine.

Most of the good brands of saws give satisfactory results if they are studied and conditions arranged to suit them. These conditions are very simply determined and are, I think, in actual operation more frequently than some writers believe.

REPAIRING BELT SHIFTER

The belt shifters of a planer that had been in use for a long time became so badly worn that it was necessary either to repair them or replace them with new ones. They were repaired in the following manner: Taper, dovetailed grooves $\frac{3}{16}$ in. deep and 2

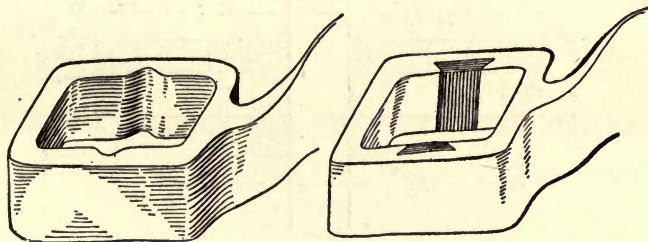

FIG. 191—STEEL INSERTS IN SHIFTER

in. long were filed at the worn places, pieces of hardened steel were fitted into the grooves, and the edges were rounded to conform with the shape of the shifter. This repair was made three years ago, and the plates do not show the slightest wear.

AIR-HOIST PISTON PACKING

Fig. 192 shows a method of making an air-hoist piston and cup leather that will give good service. I have made many such for use in an iron foundry where the hoists are used

to handle ladles of iron while "pouring off" machine floors. This service requires them to hold steadily at any height needed and subjects the hoist to considerable heat. The ring of square hemp packing *A* serves as a swab and distributes any heavy oil used to lubricate the piston and cylinder.

To assemble, slide the cup leather *B* into place, then the slashed sheet-iron disk *C*, and then the follow plate *D*, and

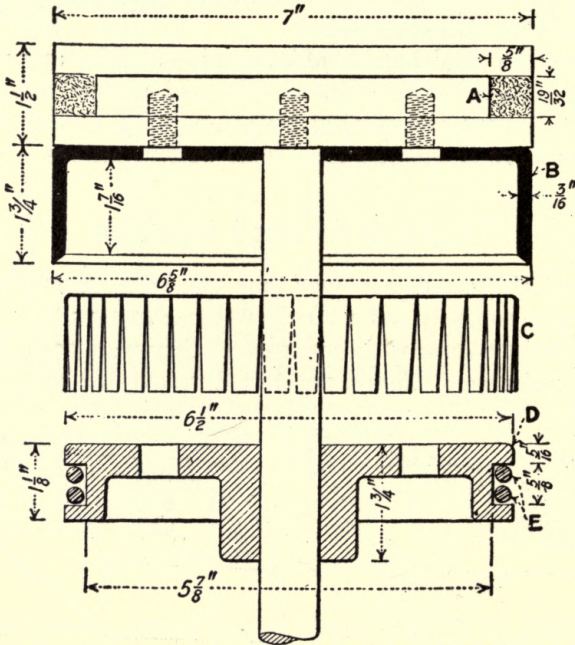

FIG. 192—AIR HOIST PISTON PACKING

tighten all with the cap screws. The 1/4-in. spring rings *E* should stand open 3/4 in. when spread and the ends butt when closed. Slip these into the follow-plate groove behind the sheet-iron disk and they will keep the edge of the cup leather tight against the cylinder wall all around, and the air pressure will finish the job. The piston should then slip in easily.

SECURING CRANE HOOKS

Trouble is often experienced in the foundry by the loosening and unscrewing of the nuts that support the hooks of cranes and

air hoists. Owing to the heat, dust and damp sand, the bearing surfaces become dry and rusty in spite of frequent oiling. I have known nuts to unscrew and come off entirely under the ordinary swiveling back and forth of the hook with its load, even though the nut had a $\frac{3}{8}$ -in. pin passing entirely through it

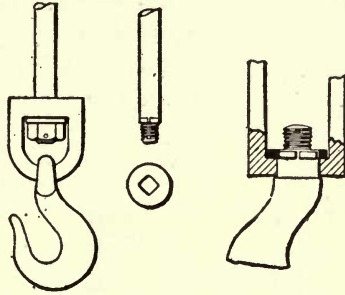

FIG. 193—SECURING CRANE HOOKS

and the hook stem. A washer of annealed tool steel, faced true on both sides and with a square hole to fit snugly on the squared end of the piston rod or hook stem, as shown, will stop the difficulty. Press the washer to its place with the nut, and pin the latter with a small pin, as shown in Fig. 193, to prevent loosening by jarring.

POWER DEVICE FOR "SPOTTING-IN" PARTS

When scraping in heavy parts of machine tools or bearings, it is often unhandy to keep a gang of helpers to aid a skilled mechanic to move the parts while "spotting" the work for scraping. In many places conditions are such that no special devices can be used for doing this work, but in shops producing large quantities of similar pieces such apparatus can sometimes readily be designed, or some stock device be placed upon this special job, with the result that only the skilled mechanic is needed upon the work, leaving the helpers free for other duties.

Such a device was recently seen by the writer in the shops of the Blanchard Machine Co., Cambridge, Mass. The head of this company's heavy, high-powered vertical surface grinder carries an electric motor built upon the shaft that drives the grinding wheel, making a compact and neat design, but requiring close, accurate, scraped fits upon its guides. While the motor

is capable of exerting over 30 hp., still the movements of the head must be accurately controlled, as the limits of accuracy in the output are often less than 0.0002 inch.

The gibs for these guides are scraped in the following manner: The column *A* upon which the vertical head *B* has its sliding fit is laid down horizontally, with the head in place. To the head is attached the piston rod *C* of an ordinary stock air hoist *D*, the cylinder being attached to the frame *E* of the machine. When the parts to be fitted are properly coated with red lead and the gibs fastened in their proper positions, the scraper hand merely operates the air-control lever *F* of the

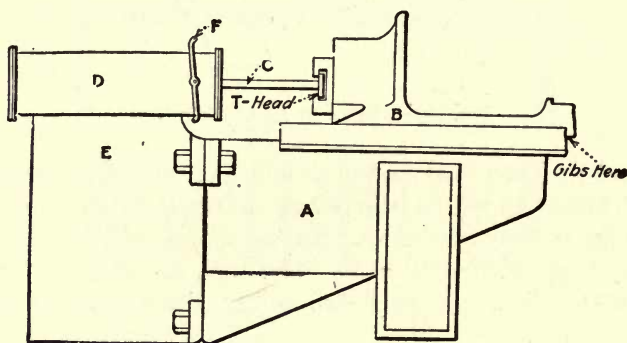

FIG. 194—POWER SPOTTING DEVICE

hoist. When the head slides forward to the predetermined point the operator reverses the hoist, bringing the head back to the initial point. As many strokes as may be required having been completed, the hoist is stopped, the gibs removed and examined and, if necessary, scraped and again marked as before.

It is simply a case of a standard device being put to a new use with good results. There is no pulling and hauling of heavy parts by a high-priced mechanic, nor any need to keep a gang of helpers within call. The work is done rapidly and better than by hand, the gibs can be set tighter, and as the power permits steady positive movement of the fitted parts, it is likely that more precise and positive spotting is secured, thus permitting work to be scraped with fewer trials. A similar device is in use at the shops of the Landis Tool Co., Waynesboro, Pa., and is giving satisfaction.

IMPROVED HALF-ROUND TAPER REAMER

Having a hurry job for a taper reamer and no fluted reamer of the size required, I concluded to try the old time-honored half-round, but before I started to cut it down to the center line

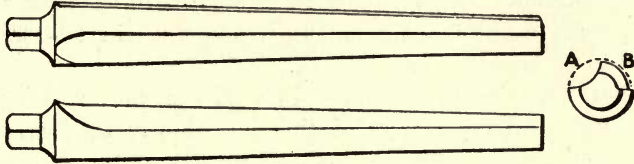

FIG. 195—HALF-ROUND TAPER REAMER

I commenced to think and reason if there was not some better way than cutting the metal away to the center line, which renders this tool so fragile.

Instead of reducing to the center line, after carefully drawing two center lines, I only cut slightly over one-quarter, as shown at *A* in Fig. 195. I then carefully backed off the one-quarter portion *B* at the back of the reamer. I then hardened and ground it on a small wheel to give a slightly concaved cut, stoned it, and was surprised to see the result. It is a fast-cutting tool and the only requisite is to keep the concaved cutting edge sharp.

HOLDER FOR COUNTERSUNK HEAD BOLTS

The device shown in Fig. 196 is for holding $\frac{3}{4}$ x $2\frac{1}{2}$ -in. countersunk head bolts while the thread is being cut in the bolt cutter. The holder, which is made of machine steel, case hardened, is securely clamped in the jaws of the bolt cutter with the slot in a vertical position, and extending ahead of the jaws. A bolt is then inserted into the slot, either from the top or the bottom, and pushed forward into the countersink.

The hardened key *A* is then put into the slot until the ring *B* rests on the holder. This brings the knife-edge of the key into line with the bolt head.

The screw *C* at the rear is then tightened, causing the knife-edge of the key to sink into the head of the bolt and preventing it from turning. To remove the bolt, the screw is loosened and

the key lifted out; when the bolt is pushed back, it will drop out.

TAPPING BRONZE FEED NUTS

Recently we had ten small bronze feed nuts to tap for a 10 x 32 U. S. thread. These nuts were to be used in the construction of a precision graduating machine, and the threads were required to be accurate and smooth.

At first we tried an ordinary 10 x 32 tap, but, although this tap was ground especially for this job, this method had to be abandoned before even one of the nuts was tapped, for the

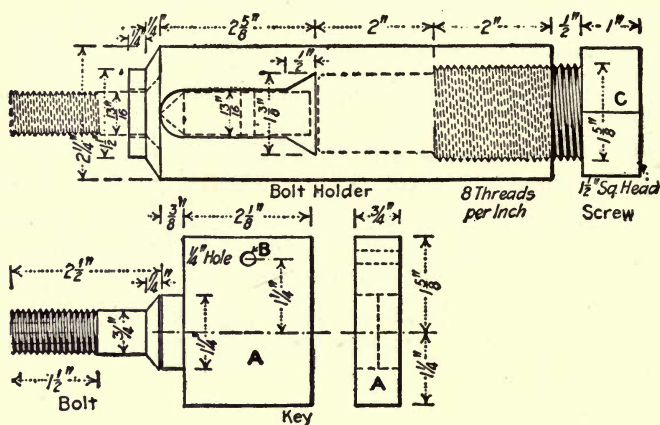

FIG. 196—HOLDER FOR COUNTERSUNK HEAD BOLTS

bronze would stick to the tap and clog between the teeth, tearing the threads. I nearly spoiled the nut with this tap.

Next we tried grinding a very long lead, or chamfer, on the tap, leaving about three threads full size; the flutes were undercut, to give a hook to the cutting edge of the lead. This also failed, due to the bronze sticking to the lead, just as it stuck to the teeth of the first tap.

At the third try we found the way to tap these bronze nuts accurately, smoothly, and what was equally important to us, quickly. We also avoided the annoying tap breakage, usually incidental to tapping bronze. Three taps were used, but of different sizes and the same pitch. First we followed the drill with an 8 x 32 tap. This took a light cut, and the metal did not stick

to the tap. We followed this tap with a $\frac{3}{16}$ x 32, which cut the thread deeper and, like the 8 x 32, cut easily and freely.

Lastly, the sizing tap, a 10 x 32, was put through, bringing the threads to size. Of these three taps, not one "picked up" metal. They all cut freely and produced a perfectly true and smooth thread. Nor was there, at any time, the slightest danger of a tap breaking. It seems, in tapping a tough, clinging metal, the best all-around method is to use taps of different diameters, but the same pitch of course; the smaller taps are then used to sort of rough out the threads, while the larger taps gradually bring the thread to size and produce the finish.

PORTABLE PRONY BRAKE

Fig. 197 shows a portable prony brake consisting of a belt about 4 ft. long and 2 in. wide. To one end is attached a spring scale *C*, having a capacity of 100 lb. The scale *D*, with a capacity of 25 lb., is fastened to the other end. Both scales

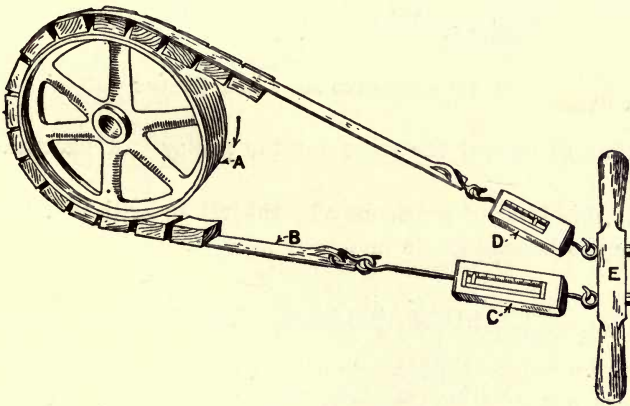

FIG. 197—PORTABLE PRONY BRAKE

are joined to a common handle *E*. The belt *B* must be very flexible and must be lined with hard-maple blocks where it comes in contact with the pulley. The blocks may be $\frac{1}{2}$ x 1 x 2 in. and should be attached with rivets having the heads countersunk in the wood.

In use, the belt is placed on the pulley *A* as shown; the handle

E is pulled until sufficient braking is secured. The scales are then read, and the reading on the small scale is subtracted from the reading on the large one. The remainder is multiplied by the peripheral speed of the pulley per minute, which gives the foot-pounds.

BUSHING A LOOSE PULLEY

Both the pulley and shaft were badly worn but the size of the shaft at *A*, Fig. 198, could not be changed. The illustration shows how the pulley was bored out and how the shaft was turned down. The bushing was bored an easy running fit for

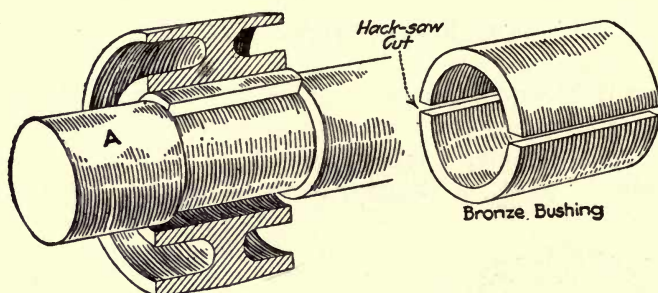

FIG. 198—BUSHING FOR LOOSE PULLEY

the shaft and turned the same for the pulley. A hacksaw did the rest.

While this kind of a job may be subject to criticism, there is one thing to be said in its favor—it worked.

SURFACE-GAGE KINK

A large number of duplicate castings had to be laid out with two holes out of line with each other, so I used two scriber points on the same surface gage and marked both lines in one operation. This reduced the working time on the job considerably without extra effort on my part.

OPERATING VALVE FOR PNEUMATIC CHUCKS

To overcome the objections usually found with three and four way cocks, the special air valve shown in the diagram is sug-

gested. This is a plain slide valve which, when the spindle is at its highest point, is held in the release position against the

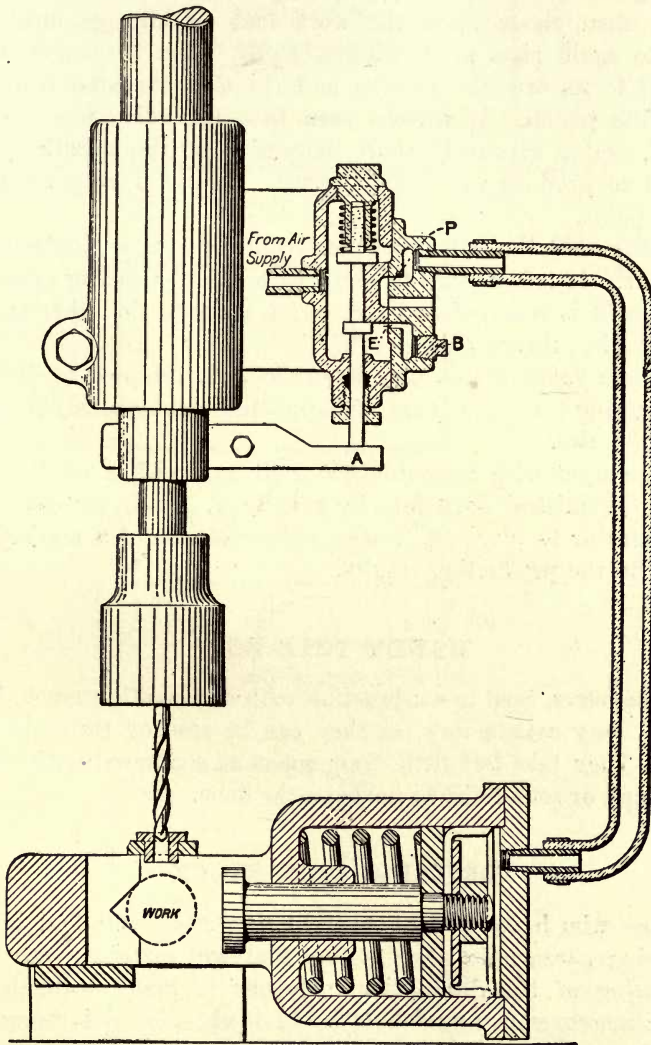

FIG. 199—SELF-ACTING AIR VALVE

pressure of the coil spring by the stop *A*, which is secured to, and is adjustable upon, the lower part of the spindle quill.

When the spindle is fed downward, either by hand or power

feed, the valve stem and valve are free to move, and are forced downward by the coil spring, uncovering the port *P* and admitting air behind the operating piston of the chuck. The chuck then closes upon the work and remains so until the spindle again rises to its highest point, when the valve is returned to its original position and the air exhausted from behind the piston. It will be seen that the valve has a short travel, and a relatively short movement of the spindle is required to produce the desired result. This is a very advantageous point.

In Fig. 199 the valve is shown connected to a single-acting cylinder. If it is desired to use it with a double-acting cylinder, the plug *B* is removed and connection made to the other end of the cylinder, through the port *E*.

While a valve of this type is particularly adapted to drilling and tapping machines, it may be applied advantageously to other machines also.

When used with an automatic drill and with a chuck from which the finished work falls by gravity, it is only necessary for the operator to place the work in the chuck, and a marked increase in the production results.

HANDY TOTE BOX

These boxes, used in conjunction with an elevating truck, have proved very satisfactory, as they can be stacked three or four high. They take but little floor space as compared with stacking rough or semi-finished parts on the floor.

DRILLING THIN STOCK

Those who have occasion to drill thin stock will find in the following paragraphs a suggestion that will certainly overcome chattering of the drill after it begins to break through the stock; moreover, a round hole is obtained. Nor is it necessary to make an expensive drill plate for drilling thin sheets.

Referring to Fig. 201, it will be seen that the drills are ground in such a manner that the outer edge *A* comes in contact with the stock. The center *B*, which is slightly in advance of the cutting edge of the drill, acts as a pilot to locate the drill in

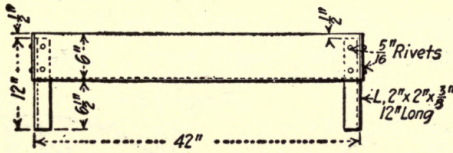
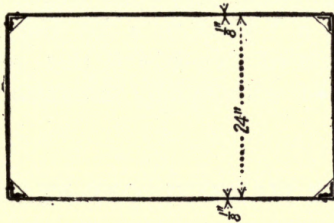
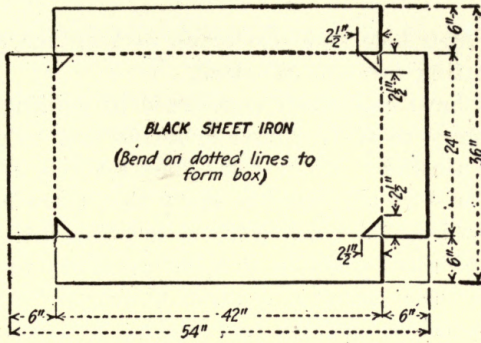

FIG. 200—HANDY TOTE BOX

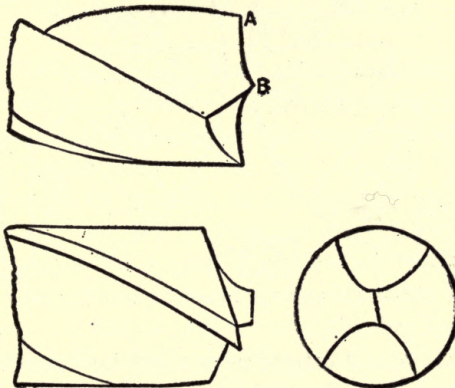

FIG. 201—DRILL POINT FOR THIN STOCK

the center punch hole and also tends to keep the drill steady while it is cutting through the stock.

Those who have had much experience in drilling thin stock with an ordinary twist drill have doubtless seen it go spinning round like a pinwheel, at the same time severely cutting their hand. They will be surprised to know that there is absolutely no need of holding the stock while it is being drilled. Again, contrary to the usual practice, it is not necessary to drill into a block or some other material in order to support the stock. It is really essential, to get the best results, to have no support whatever under the drill itself, only some means of supporting the stock; for instance, a V-block or a flat vise may be used. One of the good features of this drill is that very thin stock and even paper can be cut with equally satisfactory results and safety.

TEMPLET FOR MARKING OFF FLANGES

On the flanges of valves and fittings it often occurs that there is the same number of bolt or stud holes, but the pitch circle and outside diameter of the flanges vary Tables I and II give

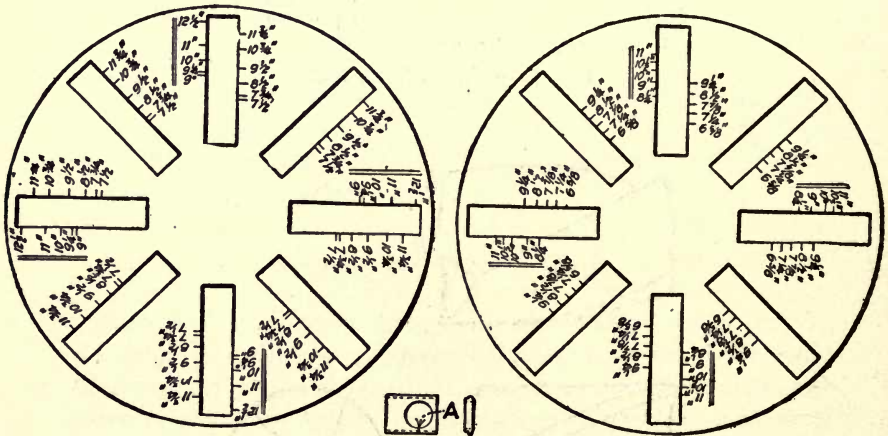

FIG. 202—TEMPLET FOR MARKING OFF FLANGES

the details of standard flanges with eight bolt and stud holes, as the case may be. The first table is for American standard low-pressure flanged valves and fittings, and the second table is for

American standard extra-heavy flanged valves and fittings. A templet for marking off these flanges is shown in Fig. 202, for eight equally pitched slots. One side of the templet, shown to the left, is for marking off the low-pressure flanges, and the opposite side, shown to the right, is for marking off the extra-heavy flanges. The figures on the templet carrying two parallel lines represent the outside diameters of the flanges, and the other figures the pitch-circle diameters. Suppose, for example, a standard low-pressure flanged valve is to be marked off with a 9½-in. pitch-circle diameter; the outside diameter of the flange in this

TABLE I. AMERICAN STANDARD LOW-PRESSURE FITTINGS

Diameter of Flange, In.	Diameter of Bolt Circle, In.	Number of Bolts	Size of Bolts, In.
9	7½	8	¾
9¼	7¾	8	¾
10	8½	8	¾
11	9½	8	¾
12½	10¾	8	¾
13½	11¾	8	¾

TABLE II. AMERICAN STANDARD EXTRA-HEAVY FITTINGS

Diameter of Flange, In.	Diameter of Bolt Circle, In.	Number of Bolts	Size of Bolts, In.
8¼	6⅝	8	¾
9	7¼	8	¾
10	7⅞	8	¾
10½	8½	8	¾
11	9¼	8	¾

FIG. 203—DETAILS OF PIPE FLANGES

case is 11 in. First, set the lines with 11 in. marked opposite until they correspond with the outside diameter of the flange at all four points. For marking off the holes, the small hardened piece *A*, shown in the center of Fig. 202, is used. This is checked down, as shown, to fit the slots in the templet and to be a nice sliding fit in it. With the sliding piece in place, the mark *A*, is brought opposite the required pitch-circle diameter, in this case 9½ in. The hole is then marked off either with a scribe or a ring punch. A handy tool for transferring holes is made of a piece of round cold rolled steel fitting the hole in *A* and with a short spur of hardened tool steel set eccentrically in the end.

IMPROVED HERMAPHRODITE CALIPER

Fig. 204 shows an improved hermaphrodite the design of which is somewhat out of the ordinary. The tool itself is made from a common pair of dividers, one leg of which is flat-

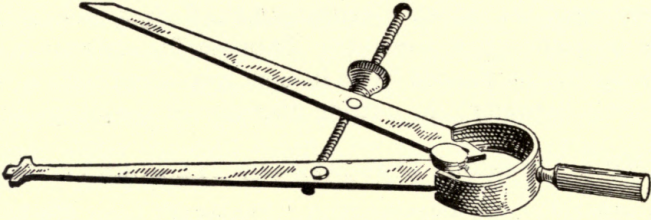

FIG. 204—IMPROVED HERMAPHRODITE CALIPER

tened and fashioned after the shape shown, so that it can be used for locating from inside or outside edges.

WHITE SURFACE FOR LAYOUT

For general layout work on both rough and finished surfaces, difficulty is usually experienced in getting a surface that will show a line plainly and not rub off too easily.

I have hit on a plan of mixing a little shellac with wood alcohol to make the chalk stick. Keep the alcohol in a can or bottle tightly corked, as it absorbs moisture from the atmosphere, and when so diluted will not dry so quickly. Put a handful of dry shellac in a gallon of wood alcohol. Take a small quantity of powdered chalk or whitening and mix as needed to the desired consistency, with the thin shellac solution. The result is a surface as easy to work on as drawing paper.

IMPROVED GEAR PULLER

Recently I was watching a machinist while he was engaged in removing a gear from the end of a shaft. I noticed that he was being put to considerable trouble and annoyance. In the first place, the gear was on the shaft quite some distance from the end, and was very tight. In order to start the gear, it was necessary to remove the long screw from the gear puller, owing to

the tendency of the screw to twist off when it was forced against the end of the shaft. After putting a short screw in the gear puller, and starting the gear, the man was obliged to put the long screw back in the gear puller. The machinist also had the annoying job of holding the gear puller straight and central with the shaft while turning up the screw against the end of the shaft, a job that makes a man wish he had three hands. To overcome this trouble a gear puller was built as illustrated in the sketch. To use this puller the large screw *B* is turned so that the end projects through *C* a short distance. The screw *A*

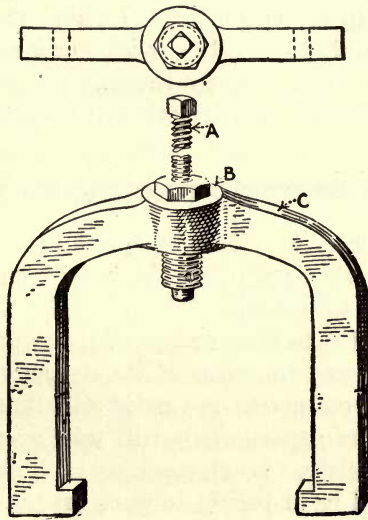

FIG. 205—IMPROVED GEAR PULLER

in turn projects somewhat through *B*. The gear puller is hooked to the gear to be removed, and the large screw *B* is turned to loosen and start the gear. When started, the long screw *A* is utilized to remove the gear the rest of the distance.

Some question might come up as to why a large screw, long enough to remove the gear and heavy enough to start the gear without distorting the screw, could not be used. In answer to this I would say that my main reason is that it was desired to make the gear puller as light as possible. As is generally known, the greatest difficulty in removing a gear or anything else of that nature is to get it started. Once started, it is a simple

matter to remove it the rest of the way. It is extremely annoying when the piece is almost off to find that the screw is in as far as it can go. This means the doubtful pleasure of backing the screw out and setting up all over again. With this gear puller the smaller screw can be made a good length, and the piece removed the first time.

BOLTS STUCK IN SOCKET WRENCH IN BOLT-CUTTER

While threading short bolts, holding them with a socket wrench clamped in the cutter jaws, I found that the bolt heads jammed in the socket after the thread was cut. This I overcame by drilling a hole entirely through the socket wrench and using a rod to drive the bolt out when it stuck in the socket.

DEMAGNETIZING HIGH-SPEED STEEL

A common method is to shift the piece back and forth across the poles. This will usually free the piece from magnetism, but I have known this to fail also.

Another method is to take a piece of tissue paper and place it between the piece and the poles of the demagnetizer. Shift the piece back and forth across the poles and thus draw the magnetism through the paper. This will take every trace of magnetism from the piece. I am speaking of high-speed steel and hope that this will be of benefit to some reader.

RAISING THE "VISIBILITY" OF THE OIL HOLES IN SHADOWED POSITIONS

In overhauling the machines and shafting in our shop we discovered that some oil holes were in shadowed positions somewhat difficult to see and were consequently liable to be overlooked. We painted a white ring around every oil hole on every bearing in the shop and believe the time taken in so marking these spots to have been well spent.

Oil holes that were formerly rather difficult to locate now show up plainly, a feature that makes them more apt to receive the proper attention.

A BRAKE FOR HIGH-SPEED MACHINES

We will assume that the machine is provided with the usual type of reversing countershaft having clutch pulleys for open and crossed belts, and that only one of these is required on the work the machine is doing. Place a piece of belt around the idle pulley, carry the ends up to the ceiling, and after stretching it tight fasten it by passing it under a piece of board, which is then screwed to the ceiling. This answers the purpose of a brake band, and the action is as follows: When the operator wishes to stop his machine he throws over the clutch lever, releasing the clutch in the driving pulley and engaging it in the pulley around which the band has been placed. The machine is brought to an immediate stop without undue jar, as of course there is a certain amount of slippage both of the brake band and the machine-driving belt. This is an ideal arrangement as has been proved by thorough trial on a number of current lathes used on time-fuse work where it has given entire satisfaction.

LENGTH OF BELTING IN COILS

To find the approximate length of a belt in a roll when closely coiled: Add together the diameter of the roll and the diameter of the center hole, both in inches. Divide by 2 to get the mean diameter. Multiply by the number of coils in the roll and by 3.1416, which will give the result in inches. Or divide by 12, and the result will be in feet.

Example—How many feet of belting in a roll 48 in. in diameter with a 6-in. center hole and 60 coils?

$$48 + 6 = 54; 54 \div 2 = 27$$

$$27 \times 60 \times 3.1416 = 5089\% \text{ in., or about } 424 \text{ ft.}$$

An abbreviation of the above method is as follows: Add together the diameter of the roll and the diameter of the center hole, both in inches; multiply by the number of coils in the roll and by 0.131. The result will be the approximate length in feet, regardless of the belt thickness. The 0.131 is obtained by dividing 3.1416 by the 2 and the 12 first mentioned. This method of checking our supply of belting has been in use by us for some time with perfect satisfaction.

EXPANDING AIR CHUCK

The chuck shown in Fig. 206 was designed to hold brass nuts during forming, but it will hold any similar work internally. It is operated by compressed air, the cylinder being at the other end of the spindle.

This chuck consists of a sleeve threaded on one end to fit the spindle and bored any convenient size, in this case 2 in., with a wall between having a $\frac{1}{2}$ -in. hole to guide the bolt that opens the jaws. The bolt is $\frac{1}{2}$ in., with a $\frac{3}{4}$ -in. head, and it has a 60-deg.

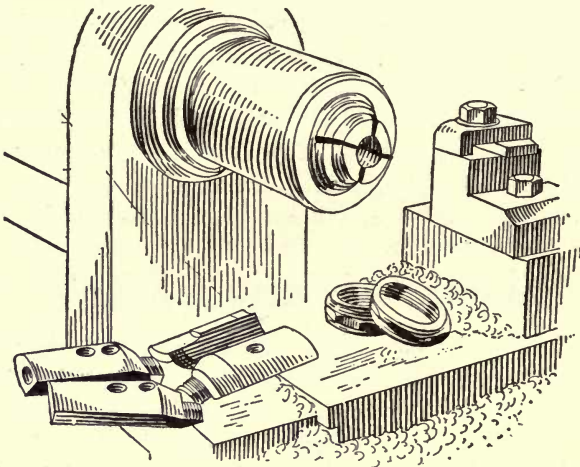

FIG. 206—EXPANDING AIR CHUCK

taper on the under side to fit the taper in the jaws. A 60-deg. taper is about right for a 6-in. air cylinder and 75 lb. air pressure.

Four holes in the sleeve are tapped for headless screws that extend through and fit loosely in the holes in the jaws, to keep them from coming out or turning. The jaws carry springs to make them close when released by the bolt. They are easy to make.

For work smaller than the hole in the sleeve, a piece of shafting the size of the hole can be cut off, faced on one end, then inserted in the sleeve, and the sleeve used as a jig to drill the holes in the jaws. One or two screws are put in to hold the jaw blank, and the whole fixture is screwed on the lathe spindle.

The projecting end is turned or threaded the required size, and the hole for the bolt is bored enough larger than the bolt to allow the jaws to close. The jaws are then numbered, taken out and sawed apart. Holes are drilled for springs, which are inserted.

When locked, the chuck is like a solid mandrel, and the nut or other work can be screwed on easily. When the operation is completed, the air is turned off, the jaws collapse, and the work comes off without stopping the machine.

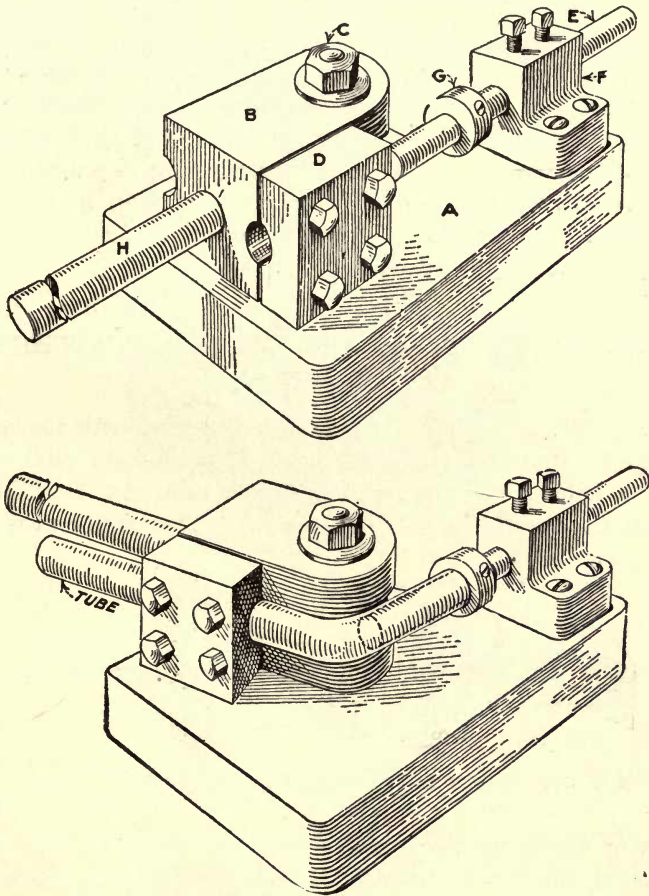

FIG. 207—TUBE BENDING DEVICE

TUBE-BENDING DEVICE

At *A*, Fig. 207, is a cast-iron base; *B*, the forming block, pivoted on the stud *C*, has a groove milled around its three sides, the radius of the tube to be bent. A clamp block *D* has a groove milled to correspond, but $\frac{1}{16}$ in. less in depth to allow for clamping. A block *F* holds in position the mandrel *E*, which is made of steel, slightly rounded on its front edge and hardened. It is to be a sliding fit in the tube. The block *B* is turned by the handle *H*. A collar *G* can be set to adjust the length of the bend.

In operating this device, open the clamp block *D*, slide the tubing into the opening between *B* and *D*, on the mandrel *E*, against the set collar *G*, and tighten the clamp block *D*. In grasping the handle *H*, bringing the forming block *B* around a half turn, it will be plainly seen that the tube is pulled off the mandrel without kinking or injuring the tubing in the least. The writer has tried this device on various diameters of brass tubing, and it works out perfectly.

CONCEALED SPRING FOR USE ON A RATCHET PAWL

In Fig. 208 to the left is shown a spring pawl with the spring concealed. One end of the spring is bent at right angles and enters a hole in the washer. The other end, also bent in the same manner, enters a hole in the pawl. This would provide a

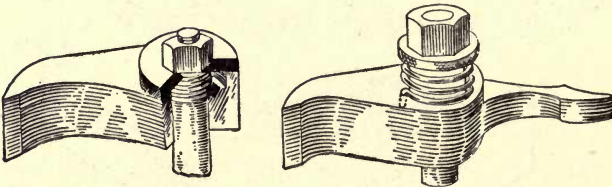

FIG. 208—PAWLS WITH CONCEALED AND EXPOSED SPRINGS

means of adjusting the washer, which in this case is knurled. In placing the washer against the stud shoulder and tightening the nut, the washer will be held in place and may be adjusted to give the desired tension.

The one to the right is on the same principle as the first, only the spring is not concealed. The collar is turned a loose fit for the spring.

AN EMERGENCY REPAIR JOB

Fig. 209 shows a device by which a difficult operation was done simply and rapidly and with such means as are at hand in any machine shop.

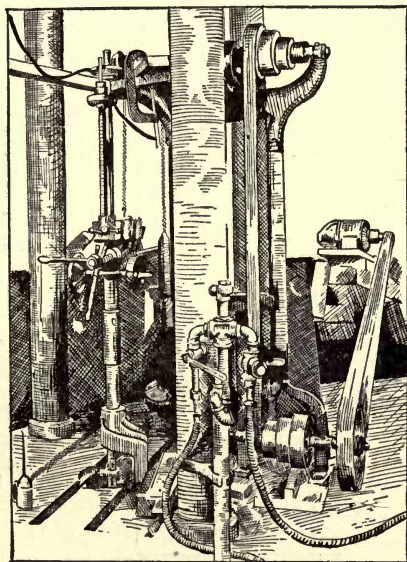

FIG. 209—TRUING A COUNTERBORED HOLE

In a large shell-forging plant, it became necessary to true up the counterbored holes used for centering the die holders on the bases of the 700-ton hydraulic presses. These bases were not only heavy and imbedded in concrete, but were more or less inaccessible due to the upper structure, the cylinder being supported at a height of several feet on four columns placed 4 ft. apart. The heavy work done on the presses having battered the counterbored holes out of true, it was decided to bore them out and put in removable bushings.

A 20-in. Superior drilling machine was removed from its base and clamped to the press base in the manner shown. An

1¾ in. deep, but so carefully was the work carried out that the job was finished to a limit of 0.002 in. in an average time of about 23 hours for each press.

OVERCOMING LOOSE-PULLEY TROUBLE ON A SPECIAL DRIVE

In Fig. 210 is shown the general arrangement of the driving pulleys on the shaft of an extractor (textile machine). A different size of pulley is mounted at each end of the shaft. When the machine is not in use the belt at each end is running idle on the loose pulley.

When winding goods on the drum, which is secured to the shaft, the belt is shifted to the large tight pulley, and the drum will then run at 27 r.p.m., while the small loose pulley runs at an approximate speed of 410 r.p.m.

The goods being all wound on the drum the belt is shifted back on the large loose pulley and the belt at the other end

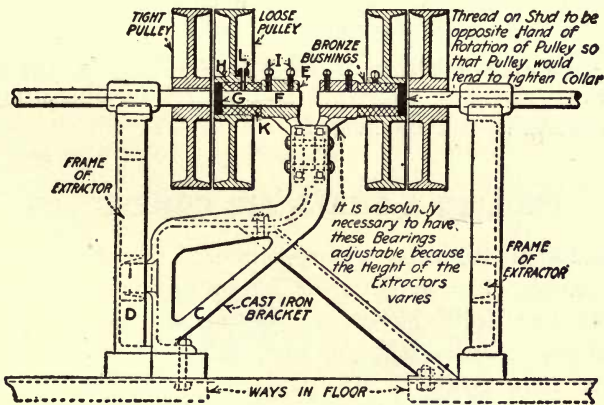

FIG. 211—IMPROVED METHOD OF MOUNTING PULLEY

moved to the small tight pulley, thus making the drum run about 410 r.p.m. The outcome is that the shaft revolving inside of the large loose pulley at this high speed acts as a lap; the result being the rapid wearing of the bushing in the pulley.

All kinds of bronze and wood bushings were tried, but none of these stood up very long, and the repair of the machines became quite an expense.

Finally the writer worked out the following plan, which has now been tried on two machines for about a year, and has been found to be successful as no bushings have had to be replaced on these machines during that time. Improvement, as applied to two machines, is shown in Fig. 211, and consists of a separate cast-iron stand *C*. This stand is secured to the side frame *D* of the machine. At the top of the stand *C* is fastened a cast-iron bearing bracket *E*, which serves to hold a stationary stud *F*. This stud which has a head *G* at one end large enough to be a running fit in the pulley hub *H*, is held in the bracket *E* by means of two setscrews *I*. The pulley is provided with a bronze bushing *K*, and an oiler *L* of the talcum-candle type. From the illustration it will be seen that the loose pulley is absolutely independent of the shaft. Consequently, no matter how fast the shaft may be running the loose pulley is not affected and the bushing does not wear out. I will say, however, that this plan was used only for holding the large, and slow-running pulley, because this one caused most of the trouble, and not much would be gained by mounting the small loose pulley in the same manner. While this improvement is used on textile machinery there is no reason why it could not be applied to all kinds of machinery where a somewhat similar set of operating conditions have to be contended with.

COOLING A SMALL AIR COMPRESSOR

Considerable difficulty was encountered in maintaining a sufficient supply of air because the compressor persisted in heating up. We had decided that the compressor was too small, and were about to order a larger unit when the writer decided to make a more complete investigation. While going over the water-cooling connections an air-compressor erector stopped in, and after a brief inspection explained the cause of our trouble.

The original water connection was made as to the left in Fig. 212. With this system of piping, a body of cooling water could not be maintained around the cylinder, but instead merely ran over the cylinder in a thin film, and out to waste. The compressor erector advised revising the water-cooling connection as per sketch *B*, from which it will be observed that the water jacket would be completely filled with water at all times. These

simple piping changes were made, and as a result we had an abundance of air.

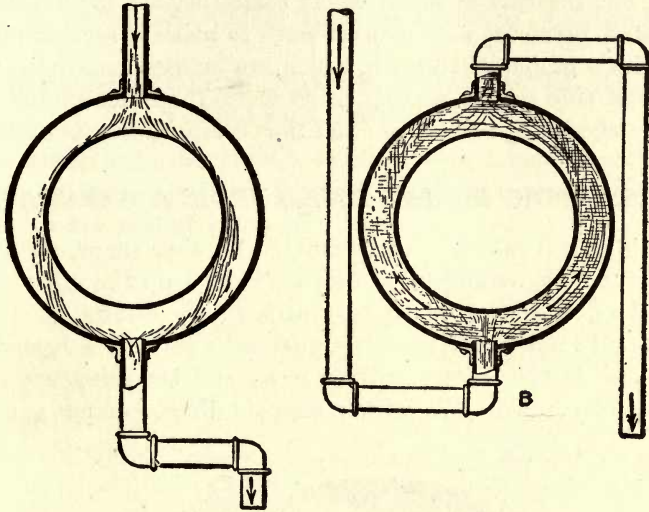

FIG. 212—ORIGINAL AND REARRANGED PIPING

SMALL STUD GEAR FOR ENGINE LATHE

On many screw-cutting lathes compounding becomes necessary earlier than otherwise, for the reason that the stud gear is already so small that to reduce its size further would mean to cut it open through the keyway.

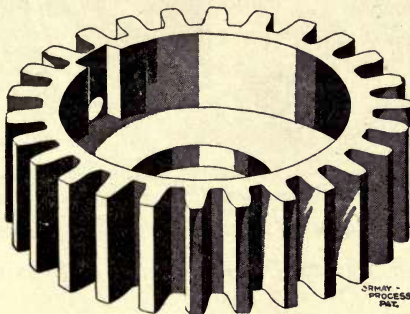

FIG. 213—REINFORCED PINION

To make it possible to use a stud gear with a minimum of diameter and of maximum strength the writer designed the

pinion shown in Fig. 213. As will be seen, the diameter of the gear could not well be decreased without cutting into the key-way, but the ring of metal which comes beyond the shoulder of the stud furnishes sufficient strength to make it serviceable.

With a pinion of 18 teeth, which can be used on a lathe whose smallest stud gear is usually of 36 teeth, the finest thread is immediately multiplied by two and thus compounding is avoided.

OPERATING SIGNAL BELLS FROM A GENERATOR

Thinking it might be of advantage to other shops, we wish to report a little arrangement that we rigged up the other day in our shop, which has given very satisfactory results.

We all know what trouble signal bells give on a battery circuit due to the battery getting weak and becoming a constant source of trouble. We have a six-pole direct current generator

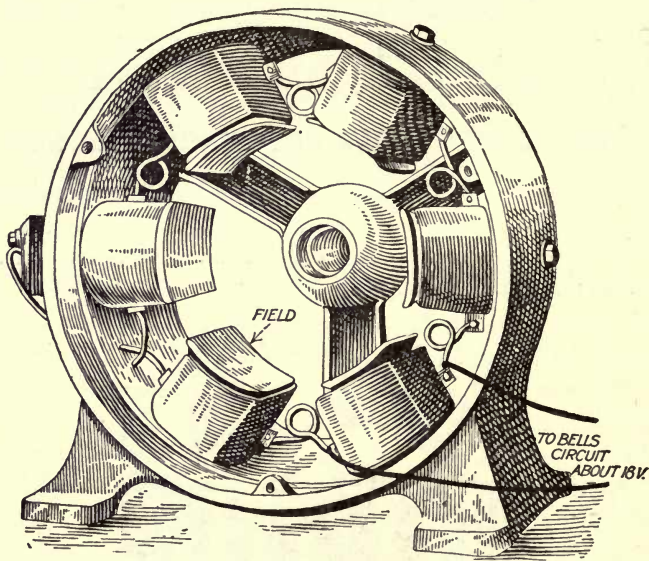

FIG. 214—BELL CONNECTION FROM DYNAMO

from which we take power from our shop. On each side of one of the field poles we connected a wire, which in turn is connected through a double pole switch to our signal-bell circuit, as shown in Fig. 214. This arrangement does not reduce the

efficiency of the generator to any appreciable extent, and it will ring as many bells as it is desired to put on. It has also eliminated all the battery trouble which we have had in the past.

SPEED-REDUCTION DEVICE WITH NOVEL AND VALUABLE FEATURES

The device here described and illustrated allows a variation in ratio by the simple expedient of changing a couple of gears not unlike the change gears of a lathe.

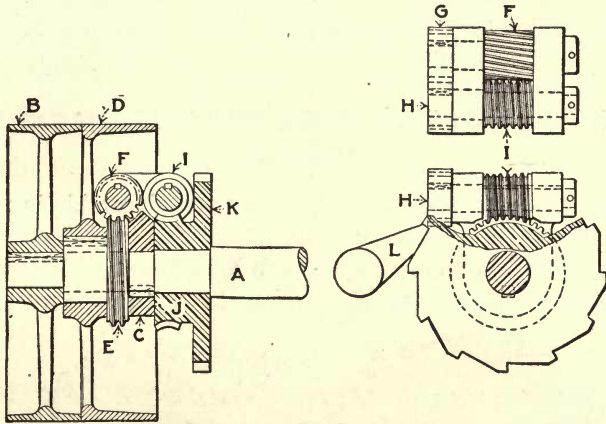

FIG. 215—SPEED REDUCTION DEVICE

Referring to Fig. 215, *A* is the shaft upon which is keyed the tight pulley *B* and the spider *C* which carries the reducing gears. *D* is a loose pulley upon the hub of which is the worm *E* meshing with wormwheel *F* keyed to a short shaft carried by the spider *C*. Upon the shaft with wormwheel *F*, and also keyed to it, is a gear *G* meshing with gear *H* upon a similar shaft which carries the worm *I*. This worm meshes with wormwheel *J* which is made integral with the ratchet *K*.

When the belt is on tight pulley *B* the whole mechanism revolves as a unit, but when the belt is shifted to loose pulley *D* the movement is as follows: The top of the pulley moving away from the observer moves the small wormwheel in a counter-clockwise direction. This worm, through the medium of gears *G* and *H*, drives worm *I* in the opposite direction, which would tend to drive the wormwheel *J* and ratchet *K* in a direction opposite to that of the driving pulley.

As movement in this direction is opposed by the pawl *L* it follows that the spider *C*, which it will be remembered is keyed to the shaft, will be forced to revolve in the same direction as the driving pulley and at a speed determined by the ratio of reduction in the gearing.

Let us suppose worm *E* to be single thread and wormwheel *F* to have 10 teeth, the same data to apply to worm and wormwheel *I* and *J* respectively. With gears of equal diameters at *G* and *H* the speed ratio would be as 1 to 100. This can be modified by using any desired ratio at *G* and *H*, it being necessary only to provide gears whose combined pitch radii equals the center distance of the two shafts.

AN ADJUSTABLE GEAR FOR ELIMINATING BACKLASH

A gear made in two parts, with one part adjustable in relation to the other, is shown in Fig. 216. The writer was having trouble with a train of gears on a grinding machine, the gear teeth wearing down quickly, owing to the presence of loose

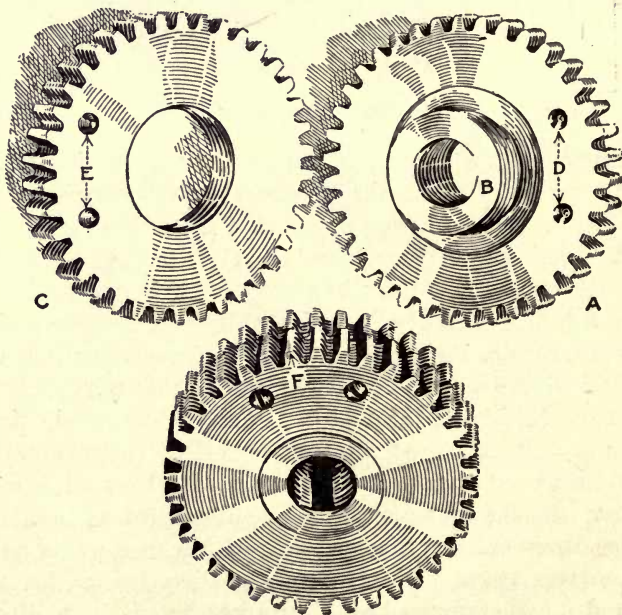

FIG. 216—ADJUSTABLE GEAR

emery, and becoming very noisy. As a means of overcoming this difficulty, this gear was devised.

Part *A* is made one-half the thickness of the required gear with hub *B*, the length of which is equal to the full thickness. This hub is threaded on its outer diameter and part *C*, also one-half the gear thickness, nicely fitted to it. Two conical seats *D* are machined in part *A* and two corresponding conical-pointed setscrews *E* tapped into part *C*. The center distance of the seats *D* is, however, greater than the corresponding distance *E* by an amount equal to nearly one-half the diameter of one setscrew. The parts are screwed tightly together, in which position one of the screws should come into alignment with its seat, and this screw is tightened. The other screw is now set down as far as it will go, but it will of course bear upon one side of its seat. With the parts in this relation the teeth are cut on the gear.

Now by loosening the first screw a trifle and tightening the the other the parts of the gear are turned slightly in relation to each other, as shown at *F* in the assembled drawing, adjusting the gear so that one-half drives in one direction and the other half drives in the reverse direction, thereby eliminating the backlash.

ELIMINATING BREAKAGE OF BOLTS ON HIGH-SPEED MACHINERY

After experiencing a great deal of trouble with the breakage of wedge bolts on the crankshaft and cross-head bearings of a high-speed air compressor, I eliminated it by the use of a copper washer about 0.012 in. thick under the head of the bolt. I believe this simple device will be equally effective on engine work or any other place where bolts are subjected to jar and vibration.

Where a nut is used there should be a copper washer under the nut as well as under the head of the bolt.

A PNEUMATIC RAM

Fig. 217 shows a pneumatic ram, or "gun," which is used around the shops for knocking bolts out of a locomotive frame or similar work, which is usually done with a sledge and which necessitates taking up an awkward position under the machine.

It will strike three or four times as fast as a man can with a sledge, and as it delivers a full blow every time it is much more efficient. The base is a casting, the under side of which is checkered so that it will not "walk around" when in use. The chamber of this base is threaded to take a piece of 3-in. extra-heavy pipe bored out smooth to form the cylinder. The ram should be

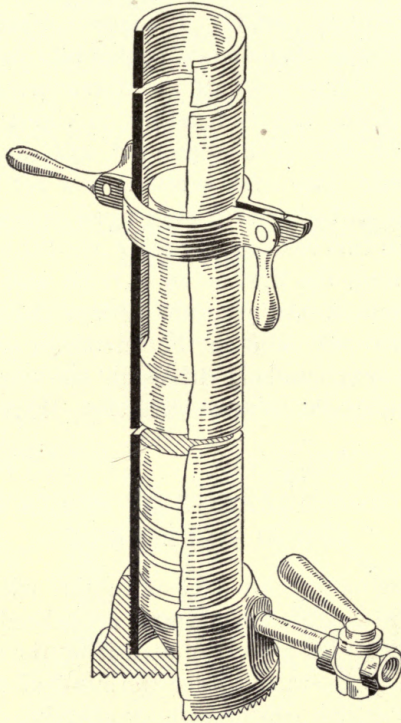

FIG. 217—PNEUMATIC RAM

a fairly close fit and its upper end reduced in diameter for about six inches of its length, so that it will not upset and stick in the cylinder. An ordinary plug cock forms the operating valve, the exhaust being through the waste orifice. To facilitate handling the tool and to hold it in position a pair of handles are provided. This device is not perhaps quite so quick in its action as the gun powder bolt drivers used in railroad shops for driving out bolts which have rusted in and stuck in their holes, but it is very much safer in use.

CUTTING A KEYWAY ON A LARGE PULLEY

Having occasion to cut a keyway in a pulley that was too large to be handled by the usual methods where a keyseating machine is not available I devised the kink shown in Fig. 218.

Take any piece of round iron *A* to fit the bore of the pulley

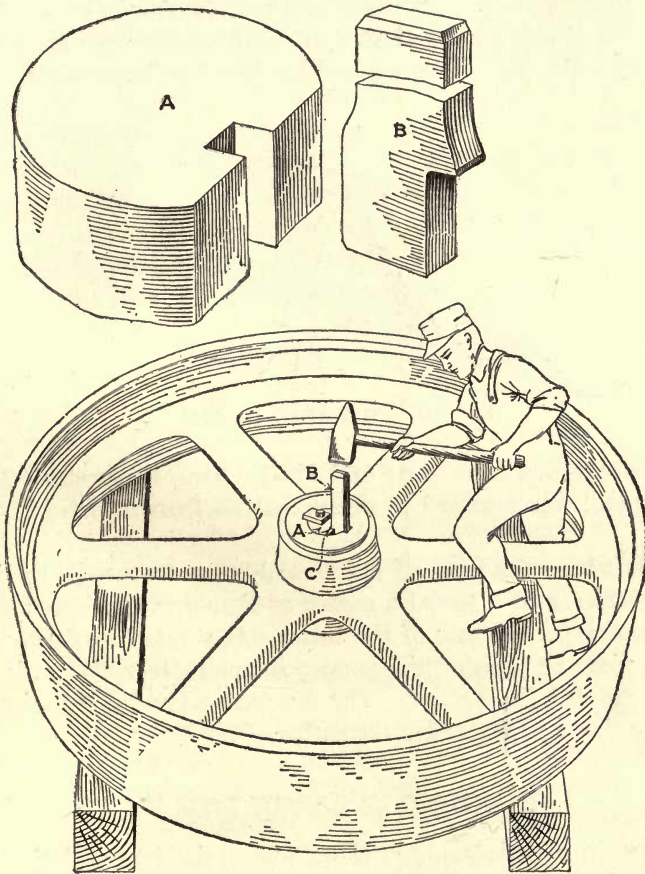

FIG. 218—THE WORK AND THE BROACH

and cut a keyway in it to match the one desired in the pulley, but deep enough to cover the broach *B*, which should be made a sliding fit.

By packing under the broach at *C* with successive pieces of

tin or other sheet metal and keeping the broach well lubricated a good keyway may be cut in the pulley in a very short time.

In our case the broach was driven through with a hammer as the work was too large to get into an arbor press.

AN EMERGENCY REAMER

Our millwright recently had occasion to ream the cast-iron sleeve of a clutch on our main drive, and as time was an important factor the reamer shown in Fig. 219 was improvised.

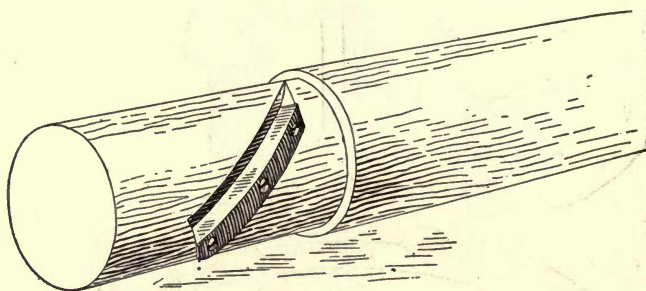

FIG. 219—IMPROVISED REAMER

The sleeve was 22 in. long and $3\frac{1}{16}$ in. bore, from which 0.007 in. of metal was removed in about half an hour of actual reaming.

He first turned a piece of hard wood 30 in. long to fit the hole to be reamed and inserted a cutter as shown in the illustration. The necessary curvature of the cutter was secured by forming it over a piece of pipe of the proper diameter to make it fit the recess chiseled in the bar. The cut was adjusted for size by packing tissue paper under the cutter.

CROWNING A LARGE PULLEY

It was in a little country shop, where the largest lathe was 16-in. swing, and the pulleys in question were about 30 in. in diameter.

I chucked a piece of pipe in the lathe a little longer than the bed, put the steadyrest as near the tail end of the lathe as possible, clamped the pulley on the end of the pipe, built a rest out of 2 x 4 scantling, made a turning tool out of an old file, and I

was ready for the job, which was done satisfactorily and in good time. This is probably not a new stunt to most oldtimers.

WHY BELTS JUMP

The real cause of leather belts jumping to the next cone pulley step, and in some cases twisting over is entirely due to the fact that some section of the belt is stretched more on one side than on the other. This is due to the fact that the strip of leather composing the belt has been cut too low down the side of the hide. The very best belts are always cut out of the center of the back of the hide as this part usually yields a leather about $\frac{3}{16}$ in. to $\frac{1}{4}$ in. thick, and the further you get from the center of the back, the thinner the leather obtained; hence, inferior quality and strength; the thinnest side stretching most. I have had to adopt balata belts in preference to leather, although I much prefer the leather for several reasons.

FASTENING LOCKNUTS

On some types of machines subjected to a large amount of vibration it is hard to prevent locknuts from working loose. If spring lock washers cannot be used, a thin copper washer covered with a dilute copper sulphate solution will take care of any tendency of the nuts to work loose. The copper washer, being soft, acts like a spring washer, and the solution tends to freeze the nuts and washer together.

KEEPING BELT GLUE IN BOTTLE

We used to keep our belt glue in an iron pot. After the first time it was used it was not much good, as it would often be months before it was needed again. It would then be pretty well dried out, requiring long heating before it was ready for use.

We now keep our belt glue in a bottle, heating it up in a pot of water. In this way it does not get hard, as it is not exposed to the air, and only a few minutes' heating makes it ready for use.

It is just as well to remember to put the bottle in cold water and heat gradually; do not immerse in boiling water.

PREVENTING GREASE-CUP TROUBLE

Much trouble has been experienced by green help screwing grease-cup plungers down and against the bottom of the cup. I have done away with this trouble by putting a sleeve between the handwheel and the cover. I make the sleeve exactly long enough so that the handle takes up against the sleeve just before the plunger reaches the bottom of the grease cup.

A MOLD FOR BABBITT HAMMERS

Manufacturers and machine builders who use a large number of babbitt hammer, or mauls, in their shops often find the ordinary hand mold a rather slow proposition and should be interested in the air-operated mold shown in Fig. 220. In a shop where a large number of babbitt hammers are used, often several hundred being made at one time, old methods proved too slow and the air-operated mold shown in the illustration was

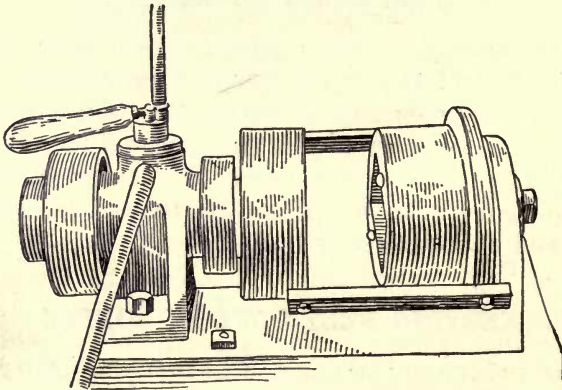

FIG. 220—MOLD FOR BABBITT HAMMERS

devised. It is of simple construction and can be easily made by any one familiar with machine work.

A cast-iron base has bolted to it the cylinder *A*, which carries a piston and piston rod on one end of which is fastened one-half of the mold *B*. On the upper part of the cylinder is a two-way valve *C* operated by the handle *D*. The inlet pipe *E* comes in from the back of the valve and the exhaust pipe *F* leads from the front. On the opposite end of the base and in alignment

with the cylinder is bolted a support *G* for the other half of the mold, the two halves being held in alignment when closed by the two wedge-shaped lugs *H*, which enter corresponding openings in the other half of the mold. The two straps *I* are slotted to receive bolts which hold them firmly to the outer half of the mold and prevent the half which is attached to the piston from turning. The pouring gate is above and a little back of the center so that any overflow of metal falls into a pan at the back of the mold and does not spatter on the workman.

The mold shown in the illustration is for a small hand hammer, but larger ones can readily be put on for mauls or for hammers with gas-pipe handles. The molds for the latter have an opening to receive the handle so that the metal can be poured around it.

In operation a movement of the handle *D* in one direction closes the molds, and throwing it in the opposite direction opens them for removal of the finished hammer.

FIBER HAMMER

The ordinary fiber hammer usually has some projection of a larger diameter than the fiber heads, so that if a workman misses hitting his work with the fiber face, he is pretty sure to strike

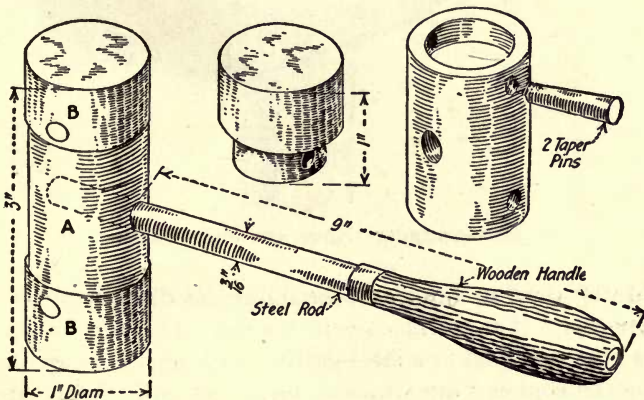

FIG. 221—FIBER HAMMER

it with the projection. Usually this projection is in the form of a threaded ring that retains the fiber head in the body of the

hammer. I made the hammer shown to overcome any such objection to its use.

It consists of a brass body *A*, bored at each end to receive the two fiber plugs *B*, which are held in by taper pins. When the fiber becomes worn, it is an easy matter to knock the taper pins out and put in new fiber. These pieces are drilled and taper-reamed in place and then pinned. There are no projections, as the fiber plugs are of the same diameter as the brass body of the hammer. A hammer made to the dimensions shown will be found far superior to small lead or babbitt hammers and will last almost indefinitely.

COMBINED HARD AND SOFT HAMMER

Fig. 222 shows a handy hammer to have around the shop, as it combines in one tool a hard and a soft hammer of suitable

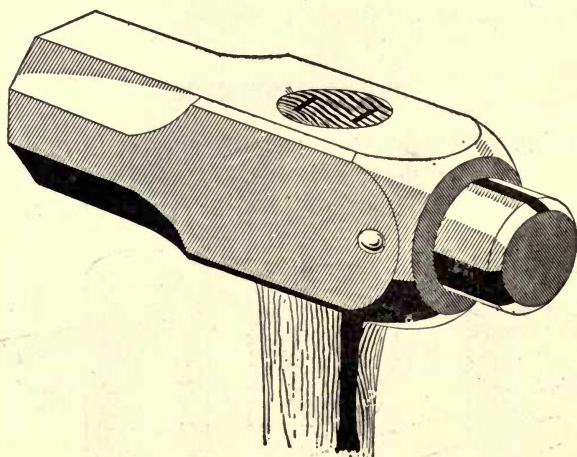

FIG. 222—COMBINED HARD AND SOFT HAMMER

weight for driving keys or assembling or disassembling other machine parts that are machined to a drive fit.

The hammer head is a steel casting with one end cored out to receive the copper plug which is forced in and further secured by the rivet passing through it and the casting.

The hammer weighs about five pounds.

HOW TO KEEP A HAMMER ON THE HANDLE

My hammer kept coming off the handle, so my shop partner put me next to this kink: I removed the iron wedge that was in

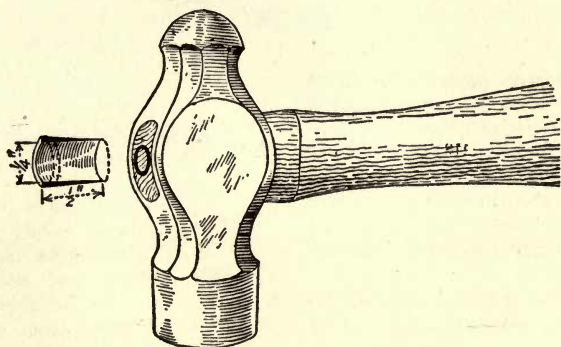
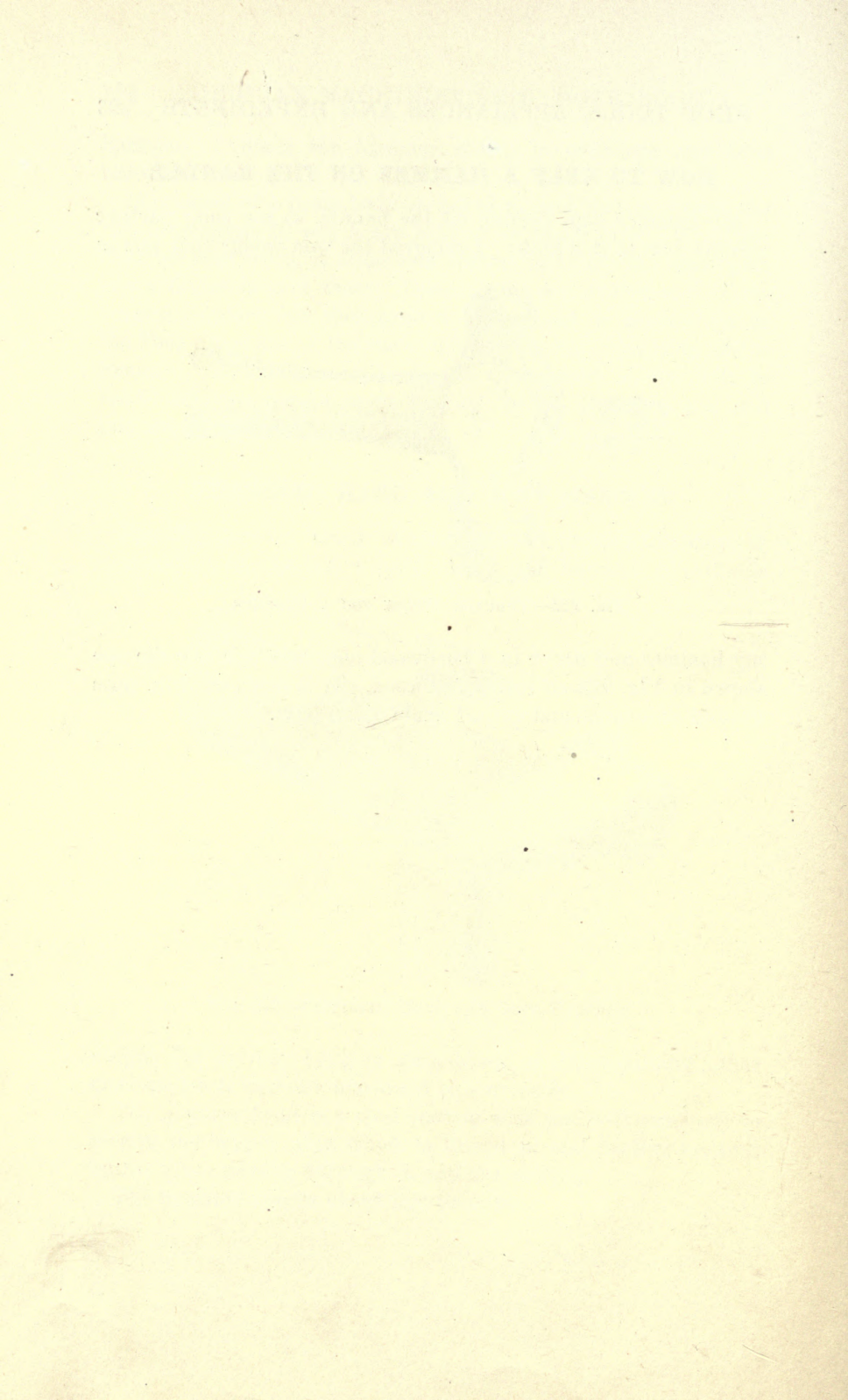

FIG. 223—TUBULAR WEDGE FOR A HAMMER

my hammer and drove in a hardwood one, then one like the one shown in Fig. 223 on top of the wood. It is made of $\frac{1}{4}$ -in. pipe ground to a taper and cut off about $\frac{1}{2}$ in. long.



INDEX

A

- Accuracy of doubtful quality, 4
- Accuracy, theoretical vs. practical, 3
- Air chuck, expanding, 274
- Air hoist, piston packing for, 257
- Angle iron, adjustable, 74
- Angle plate, tool makers' with V-slot, 168
- Annealing hard spots in oxyacetylene repairs, 68
- Annealing high speed steel, 45
- Arc shaping attachment for lathe or shaper, 111
- Arc welding high speed steel, 43

B

- Babbitt hammers, a mold for, 290
- Ball center, use of, 93
- Ball joint piston rod, 58
- Bearing caps, pattern for, 31
- Bells, operating signal, 282
- Belting, centrifugal force decreases pulling power of, 19
- Belting glue, keeping, 289
- Belting in coils, length of, 273
- Belting shifter repair, 257
- Belting, why belts jump, 289
- Bending fixture for tubes, 276
- Bending heavy pipe, 63
- Bending short rods, 65
- Bending wire, 177
- Bevel pinions, machining on drill press, 93
- Bleaching blueprints, 23
- Blue prints from pencil tracings, 20
- Blue prints local bleaching, 23
- Blue prints machine, increasing speed of, 21
- Bolt cutter, improved socket wrench for, 272

- Bolts, eliminating breakage of, 285
- Boring bar for chambering, 224
- Boring bar for 8-in. shells, 10, 11
- Boring bar for maximum stiffness, 10, 11
- Boring bar for radii, 82
- Boring bar for torpedo tubes, 225
- Boring chuck for a boring mill, 229
- Boring, driving box chuck, 229
- Boring engine guides, 85
- Boring head for the milling machine, 137
- Boring large holes on boring mill, 226
- Boring machine, portable cylinder, 221
- Boring mill centering work with wedges, 233
- Boring taper holes, 225
- Bosses, turning small, for patterns, 32
- Brad driver, 28
- Brake for high speed machines, 273
- Brake, portable prony, 263
- Brazing, preventing spread of heat while, 70
- Brazing stellite, 46
- Breakage of roughing tools, 97
- Breaking up car wheels, 27
- Broaching on the lathe, 113
- Bulging die for tubing, 180
- Bushing a loose pulley, 264
- Bushing case hardened jig, 158
- Bushing plate in tool work, 151
- Butt welding high speed steel, 44
- Buttons for angular work, 155
- Buttons, special, for close centers, 160

C

- Caliper, hermaphrodite, 270
- Cams, dimensions of, 14

- Cams for small machinery, 13
 Cartridge punches, templet for, 155
 Center holes, correcting untrue, 119
 Chuck, expanding air, 274
 Chuck for nipples and studs, 119
 Chuck wrench repairs, 99
 Circles, dividing, 9
 Cloth, die for, 183
 Compressor, cooling a small air, 280
 Conservation vs. efficiency, 253
 Cooling water for air compressor, 280
 Core box dowel pins, 30
 Cored holes, clearance for, 7
 Cores, horizontal, 9
 Cores, vertical, 8
 Cores, setting, correctly, 8
 Counterbore, an economical, 154
 Counterbore, double ended, 81
 Counterbore, high speed steel, 81
 Countersinking tool, special, 88
 Countersunk head bolts, holder for, 261
 Cracks in hardening, prevention of, 68
 Crane hooks, securing, 258
 Cranes in shops, 255
 Crank shaft repair, 52
 Cross holes in round stock, drilling, 90
 Cutters in multiple, hardening, 52
 Cutting odd pitch screws, 97
- D**
- Decimal equivalents of vulgar fractions, 236
 Design for new machines, preliminary, 5
 Diamond dresser, 220
 Die holder, 246
 Dies, transfer gage for piercing, 168
 Die work, bending dies for tubing, 190
 Die work, curve of throat of drawing dies, 186
 Die work, die for rubber washers, 178
 Die work, direction of grain of metal, 171
 Die work, double punch for increasing stroke, 190
 Die work, freak shell cause and cure, 189
 Die work, guide for blanks, 185
 Die work, ironing surface of drawing dies, 185
 Die work, large combination die, 176
 Die work, locating small holes accurately, 173
 Die work, making piercing punches, 181
 Die work, piercing opposite sides of thin shells, 182
 Die work, piercing oblique holes, 188
 Die work, preventing breakage of punch pilots, 191
 Die work, producing a bulge in tubing, 180
 Die work, rounding vs. short bends, 171
 Die work, spring forming die, 184
 Die work, spring punch pilots, 191
 Die work, standards in dies, punches and holders, 187
 Die work, press work as a substitute for forgings, 171
 Die work, use of drill plate in, 175
 Die work, vented punches in drawing, 186
 Die work, wire bending die, 177
 Dog, safety lathe, 99
 Dowel pins, 30
 Drafting supplies, checking issue of, 2
 Drafting table cover, 7
 Drafting, drawings for pattern makers and machinists, 5
 Drafting, shellacked drawings for the shop, 6
 Drafting table extension for large radii, 24
 Drafting table, guard for, 23
 Drill jig for cross holes, 90
 Drill jig for steel discs, 79
 Drill jig for yokes, 94
 Drill jig for Y-connections, 85
 Drill jig positively located, 73
 Drilling, adjustable jig for round work, 76
 Drilling cross holes in round stock, 90
 Drilling glass, 77
 Drilling machine fixture for small holes, 83

- Drilling machine for tapping, 80
 Drilling machine, making angle
 faced washers on a, 75
 Drilling machine, reduction head
 for, 86
 Drilling machine used as a press,
 87
 Drilling steel discs, 79
 Drilling thin stock, 266
 Drip can for hangers, 254
 Dynamometer, portable, 263
- E
- Electric welding high speed steel, 43
 Ellipsograph, 25
 Engine guides, boring, 85
 Export, packing machinery for, 17
- F
- Fiber hammer, 291
 Fixture for thread grinding, 161
 Flanges, American standard, 269
 Flanges, templet for marking, 268
 Follow rest, emergency, 100
 Forming die for springs, 184
 Forming tool, making a circular,
 156
 Furnace for oil tempering bath, 61
 Furnace for springs, 59
 Fusible metal, 26
- G
- Gage work, adjustable female thread
 gage, 197
 Gage work, amplifying gage, 201
 Gage work, built up snap gage, 200
 Gage work, checking up angles on,
 196
 Gage work, depth gage for recesses,
 198
 Gage work, errors due to thread mea-
 suring wires, 203
 Gage work, feeler gage, 196
 Gage work, feeler gage for recesses,
 198
 Gage work, gage grinding machine,
 192
 Gage work, grinding snap gages, 205
 Gage work, machine for grinding
 snap gages, 193
- Gage work, grinding interrupted ra-
 dii, 198
 Gage work, inspection gage, 202
 Gage work, measuring device for
 threads, 194
 Gage work, measuring threads with
 wires, 203
 Gage work, multiplying gage, 201
 Gage work, sealing gages with plas-
 ter of paris, 205
 Gage work, special V-block for grind-
 ing gages, 194
 Gage work, a tolerance gage, 202
 Gear, adjustable for eliminating
 backlash, 284
 Gearing, cutting angle for helical
 gears, 238
 Gearing, decimal equivalent table,
 235
 Gearing, intermittent worm, 237
 Gearing, puller for gears, 270
 Gearing, reducing gear, 283
 Geometrical progression, 18
 Glass, drilling holes in, 77, 78
 Graphical geometrical progression,
 18
 Grease cup trouble, preventing, 290
 Grinding, accurate setting device for
 internal, 166
 Grinding correct radius on gage,
 198
 Grinding countersink in chilled cast-
 ings, 218
 Grinding, diamond for Norton ma-
 chine, 220
 Grinding, disc grinding fixture, 219
 Grinding edges of circular plates,
 211
 Grinding, keeping notes on, 207
 Grinding, mounting, balancing and
 dressing wheels, 210
 Grinding, preventing spring in thin
 work, 215
 Grinding, radius wheel dressing fix-
 ture, 217
 Grinding, saving time with extra
 bushings, 211
 Grinding snap gages, 205
 Grinding thin pieces, 215
 Grinding wheels for tool and cut-
 ter grinding, 213
 Grinding wheels radius truing fix-
 ture, 165

H

- Hacksaw blades, economy in, 256
 Hacksaw blades used as shaper tools, 148
 Hammer, mold for babbitt, 290
 Hammer, efficient wedge for, 293
 Hangers, drip can for, 254
 Hard spots, annealing, 68
 Hardened work, soft centers for, 48
 Hardening cracks, preventing, 68
 Hardening high speed steel, 45, 48
 Height gage, vernier caliper as a, 153
 Helical gears, cutting angle of, 238
 High speed steel, annealing, 45
 High speed steel, arc welding tool tips, 43
 High speed steel, butt welding tips, 44
 High speed steel, coke as a protector, 51
 High speed steel cutters, hardening temperature, 50
 High speed steel, demagnetizing, 272
 High speed steel drawing temperatures, 49
 High speed steel, forging, 61
 High speed steel, hardening, 45
 High speed steel, mixture to prevent scaling, 47
 High speed steel quenching medium, 49
 Hydraulic cylinder, emergency repair of, 277

I

- Indicator dial for setting taper attachment, 111
 Indicator for table traverse of milling machine, 129
 Intermittent worm gear, 237

J

- Jig, adjustable for round work, 76
 Jig bushings, case hardened, 158
 Jig for drilling steel discs, 79
 Jig for drilling yokes, 94
 Jig for drilling Y-connections, 85
 Jig, positively located drill, 73

K

- Keyway cutting by hand, 287

L

- Lathe, angles for square threading tools, 101
 Lathe, arc forming attachment for, 111
 Lathe, calculating cutting time for, 115
 Lathe chuck for nipples and studs, 119
 Lathe, correcting center holes, 119
 Lathe, cutting coarse pitch screws, 107
 Lathe, cutting a worm of rapid lead, 108
 Lathe, dividing on, 150
 Lathe dog, safety, 99
 Lathe, emergency follow rest, 100
 Lathe, facing the boss on a large casting, 100
 Lathe, finish turning with stellite, 102
 Lathe, floating reamer holder for, 115
 Lathe, gang turning fixture, 117
 Lathe, high speed steel centers, 106
 Lathe jig for turning square tools, 116
 Lathe, nonslip expanding mandrel, 109
 Lathe, peening grooving tools, 120
 Lathe, self centering work carrier, 103
 Lathe, setting a taper attachment, 111
 Lathe, sizing piston ring grooves, 120
 Lathe, small stud gear for, 281
 Lathe, spring threading tool, 118
 Lathe, stellite centers, 106
 Lathe tail spindle repair, 104
 Lathe threading dial explained, 96
 Lathe, threading small castings, 105
 Lathe used as broaching machine, 113
 Layout tool for the milling machine, 122
 Layout, white surface for, 270
 Locating button, adjustable, 130
 Lock nuts, fastening, 289

Loose pulley, bushing a, 264
Loose pulley troubles, overcoming,
279

M

Machinery, layout of, 16
Machinery packing for export, 17
Machining bevel pinions, 93
Mandrel, expanding nonslip, 109
Marking, white for layout, 270
Micrometer anvils, lapping, 158
Milling machine, adjustable boring
tool holder, 137
Milling machine, adjustable locating
button, 130
Milling machine, adjustable side
milling cutter, 133
Milling machine, adjustable spacing
collar, 133
Milling machine, adjustable V-block,
124
Milling machine boring a curved
hole, 131
Milling machine, clamping flat
square work, 135
Milling machine, crowning pulley
faces, 122
Milling machine, cutter setting tool,
138
Milling machine, determining the ap-
proach of cutters, 130
Milling machine fixtures, efficiency
in, 123
Milling machine, fluting taper ream-
ers, 128
Milling machine indicator, 129
Milling machine, large job on a
small, 124
Milling machine, lathe job on a, 134
Milling machine, substitute for in-
ter-locking cutters, 133
Milling machine, tool for laying out
work, 122
Milling machine, two-way clamp
with one screw, 135
Milling machine vise as a special
fixture, 126
Milling machine vise for use between
centers, 137

N

Nipple chuck, 119

O

Oil holes, marking, 272
Oil tempering bath, 61
Oxyacetylene welding high speed
steel, 41

P

Packing for export, 17
Parts and stock, commercial sizes
of, 3
Parts lists, changing, 7
Patternmakers' brad driver, 28
Patterns, herring bone grate, 36
Patterns, marking, 35
Patterns, protectors for, 34
Patterns, rapping plates for, 33
Patterns with projecting members,
27
Pawl, concealed spring, 276
Pawl, exposed spring, 276
Plate patterns, assembling and ma-
chining, 29
Pencil tracings, blueprints from, 20
Pipe, bending heavy, 63
Piston rod, ball joint, 58
Planing machine, extension tool for,
143, 144
Planing machine, internal tool, 143,
144
Planing machine, milling T-slots in,
139
Planing machine, planing ways of,
140
Planing machine, radius tool, 145
Planing machine, repairing old, 139
Planing machine rigged as milling
machine, 139
Planing machine, studs for, 140
Planing machine, turning and bor-
ing attachment for, 149
Pneumatic chuck, expanding, 274
Pneumatic chuck, operating valve
for, 264
Pneumatic piston packing, 257
Polygons, laying out, 9
Precision tool grinding, 159
Press work, blanking cloth, etc., 183
Press work locating small holes ac-
curately, 173
Press work wire bending die, 177
Prints, filing, 2

- Prony brake, portable, 263
 Puller, improved gear, 270
 Pulley, bushing a loose, 264
 Pulleys, crowning on the miller, 122
 Pulleys, crowning large, 288
 Pulleys, crowns for various diameters and widths, 12
 Pulleys, repairing loose, 279
 Punches, heading jig for piercing, 182
 Punching on the drilling machine, 87
 Punching small holes in the drilling machine, 87
- Q
- Quenching medium for high speed steel, 49
- R
- Radii, drawing large, 24
 Ram, pneumatic, 285
 Rapping plates for patterns, 33
 Reamer, built up, 45
 Reamer, floating holder for, 115
 Reamer, fluting taper, 128
 Reamer improvised large, 288
 Recessing tool, 89
 Reclaiming materials, 67
 Reduction head for drilling machine, 86
 Repairs, recording, 57
 Roller bearings in machine tools, 13
 Rolling threads in the screw machine, 247
 Rustproofing, 172
- S
- Saving drawing paper, 1
 Scrap, reclaiming, 67
 Screw, angle for square threading tools, 101
 Screw cutting lathe threading dial explained, 96
 Screw, holder for flat head, 261
 Screw, cutting coarse pitch, 107
 Screw machine, burring tool, 245
 Screw machine guard for cutting compound, 245
 Screw machine, hollow set screw as adapter, 251
 Screw machine, machining piston in Gridley automatic, 239
 Screw machine, slotting and shaping in, 242
 Screw machine, tap and die holder for, 246
 Screws, threading small cast brass, 105
 Screw machine time study sheet, 240
 Screw machine, thread rolling in the, 247
 Shading and cross sectioning, 2
 Shaper, arc forming attachment for the, 111
 Shaping in the screw machine, 242
 Shaping machine, clamping large work on, 147
 Shaping machine, cutting narrow slots, 148
 Shaping machine, dividing on the, 150
 Shaping machine, extension tool for, 143, 144
 Shaping machine internal tool, 143, 144
 Shaping machine, machining rectangular hole in, 141
 Shaping machine radius tool, 145
 Shaping machine, repairing ways of, 141
 Shaping machine tool, hacksaw blade as, 148
 Shaping machine vise, squaring small work in, 149
 Sheet metal work, preventing rust in, 172
 Shell reamer, increasing size of, 80
 Shrinking allowance, 71
 Shrinking on a large sleeve, 71
 Slotting in the screw machine, 242
 Snap gage, built up limit, 200
 Snap gages grinding, 205
 Soft centers for hardened work, 48
 Soft hammer, a mold for, 290
 Soft hammer, combined hard and, 292
 Soft hammer fiber, 291
 Soldering, fusible metal for, 26
 Special machine design, 4
 Speed reduction device, 283
 Spherical turning attachment, 98
 Spotting in, power device for, 259
 Springs, furnace for, 59

Standard sizes for drawings, 1
 Steady rest, self centering work carrier, 103
 Steam hammer, ball joint piston rod for, 58
 Steam hammer piston repairs 55
 Steel, mixture for preventing scale on carbon, 47
 Steel, bits of high speed, 41
 Steels, standard marking for, 40
 Stellite, brazing, 46
 Studs, chuck for, 119
 Surface gage, two needle, 264

T

Taper attachment, setting with dial indicator, 111
 Taper holes, boring, 225
 Taper reamer, improved half round, 261
 Taper reamers setting angle for, 128
 Tap holder, 246
 Tapping full threads in bronze, 262
 Tapping on small drilling machine, 80
 Taps, hardening high speed steel, 47
 Templates for cartridge punches, 155
 Tempering thin snap gages, 69
 Thread grinding fixture, 161
 Thread rolling in the screw machine, 247
 Threading dial, explanation of the, 96
 Threading, external and internal tool for, 118
 Threading full threads in bronze, 262
 Threading small cast brass rings, 105
 Threading tools, angle of square, 101
 Time fuses, drilling fixture for, 83
 Time study sheet 240
 Tool making angle plate, 168
 Tool making, auxiliary bushing plate in, 151
 Tool making, buttons for measuring angular work, 155
 Tool making, cartridge punch template, 155
 Tool making, case hardened jig bushings, 158
 Tool making, economical counter-bore, 154

Tool making, grinding precision tools, 159
 Tool making, lapping a micrometer, 158
 Tool making, locating close holes, 160
 Tool making, making a circular forming tool, 156
 Tool making, radius truing device for grinding wheels, 165
 Tool making, setting for internal grinding, 166
 Tool making, thread grinding fixture, 161
 Tool making, transfer gage for piercing dies, 168
 Tool making, vernier caliper as a height gage, 163
 Tools, built up, 44
 Tools, cost of welded, 45
 Tote box, 266
 Tracing cloth, pencil, 6
 Tracings, blueprints from, 20
 Tubing, a bulging die for, 180
 Tube bending fixture 276
 Turning arcs, 111
 Turning, finishing with stellite, 102
 Turning, gang fixture for, 117
 Turning on the milling machine, 134
 Turning spherical work, 97

U

Undercutting tool, 89

V

V-block, adjustable, 124
 V-block, special, for grinding, 194
 Valve, air chuck operating, 264
 Vandykes on cloth and paper, 6
 Vernier caliper as a height gage 153

W

Washers, progressive die for rubber, 178
 Washers, making angle faced, on drill press, 75
 Waste reclaiming, 254
 Wedges used for centering, 233
 Welding high speed steel, 41
 Wheel puller, 270
 Wood, use of, in blanking dies, 179
 Worm, casting a, 32
 Worm, cutting a rapid lead, 108
 Worm gear, intermittent, 237

THIS BOOK IS DUE ON THE LAST DATE
STAMPED BELOW

AN INITIAL FINE OF 25 CENTS
WILL BE ASSESSED FOR FAILURE TO RETURN
THIS BOOK ON THE DATE DUE. THE PENALTY
WILL INCREASE TO 50 CENTS ON THE FOURTH
DAY AND TO \$1.00 ON THE SEVENTH DAY
OVERDUE.

ENGINEERING LIBRARY

MAY 16 1947

MAY 31 1947

JUN 7 1951

NOV 25 1990

U.C. BERKELEY LIBRARIES



C031968545

1165
578
Engineering
Library

404452

Sewerdrop

UNIVERSITY OF CALIFORNIA LIBRARY

