

UNITED STATES
DEPARTMENT OF AGRICULTURE
LIBRARY



BOOK NUMBER

1

Ex6R

v. 43,

July-Dec. 1920

GPO 8-7071

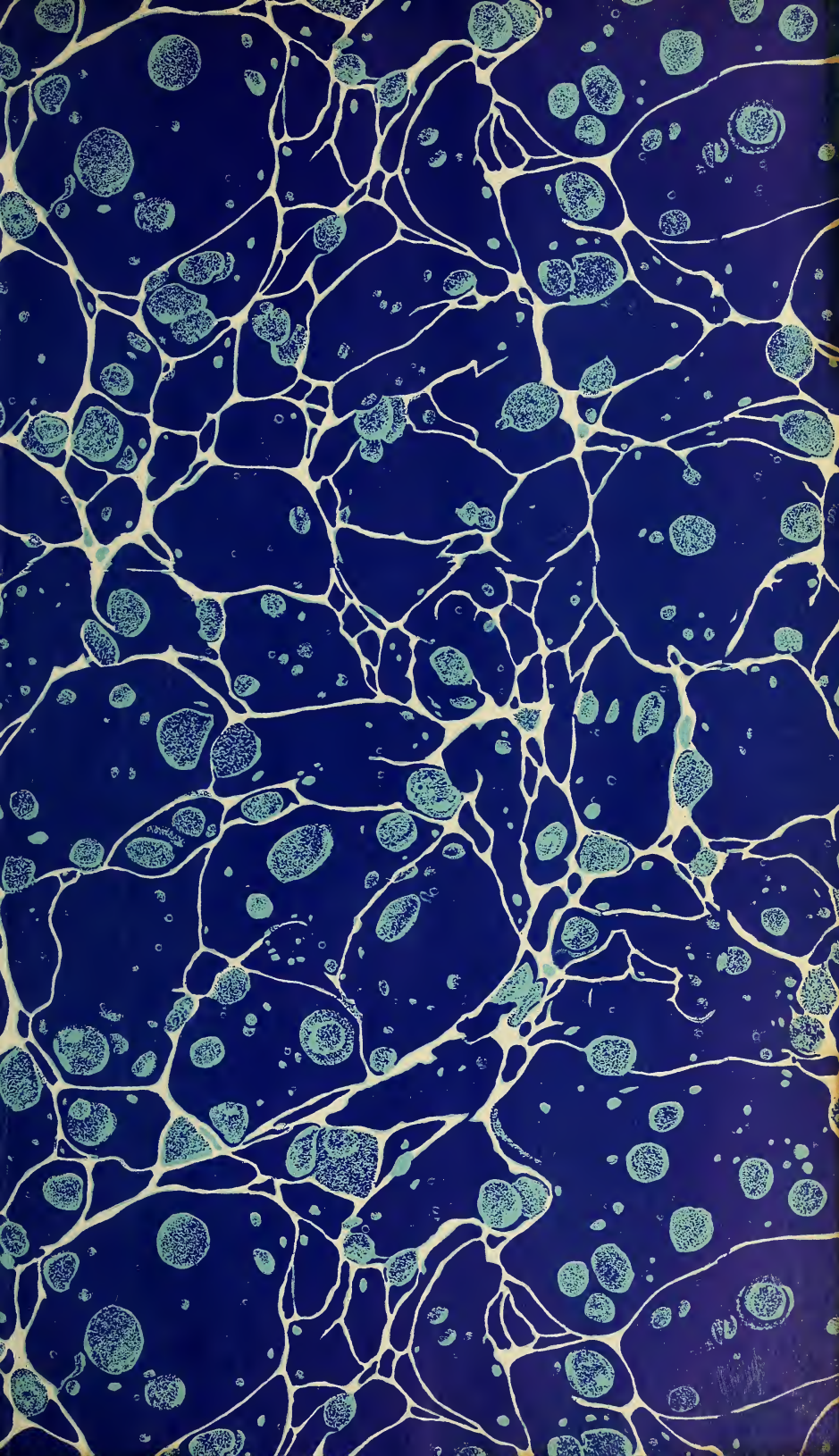





U. S. DEPARTMENT OF AGRICULTURE
STATES RELATIONS SERVICE
A. C. TRUE, DIRECTOR

EXPERIMENT STATION RECORD

VOLUME XLIII

JULY-DECEMBER, 1920



WASHINGTON
GOVERNMENT PRINTING OFFICE
1921

U. S. DEPARTMENT OF AGRICULTURE.

Scientific Bureaus.

WEATHER BUREAU—C. F. Marvin, *Chief*.
BUREAU OF ANIMAL INDUSTRY—J. R. Mohler, *Chief*.
BUREAU OF PLANT INDUSTRY—W. A. Taylor, *Chief*.
FOREST SERVICE—W. B. Greeley, *Forester*.
BUREAU OF SOILS—Milton Whitney, *Chief*.
BUREAU OF CHEMISTRY—W. G. Campbell, *Acting Chief*.
BUREAU OF ENTOMOLOGY—L. O. Howard, *Entomologist*.
BUREAU OF BIOLOGICAL SURVEY—E. W. Nelson, *Chief*.
BUREAU OF PUBLIC ROADS—T. H. MacDonald, *Director*.
BUREAU OF MARKETS AND CROP ESTIMATES—H. C. Taylor, *Chief*.
OFFICE OF FARM MANAGEMENT AND FARM ECONOMICS—G. W. Forster, *Acting Chief*.

STATES RELATIONS SERVICE—A. C. True, *Director*.

OFFICE OF EXPERIMENT STATIONS—E. W. Allen, *Chief*.

THE AGRICULTURAL EXPERIMENT STATIONS.

ALABAMA—

College Station: *Auburn*; D. T. Gray.¹
Canebrake Station: *Uniontown*; ———.
Tuskegee Station: *Tuskegee Institute*; G. W. Carver.¹

ALASKA—*Sitka*: C. C. Georgeson.²

ARIZONA—*Tucson*: J. J. Thorndber.¹

ARKANSAS—*Fayetteville*: Bradford Knapp.¹

CALIFORNIA—*Berkeley*: C. M. Haring.¹

COLORADO—*Fort Collins*: C. P. Gillette.¹

CONNECTICUT—

State Station: *New Haven*; } E. H. Jenkins.¹
Storrs Station: *Storrs*; }

DELAWARE—*Newark*: C. A. McCue.¹

FLORIDA—*Gainesville*: W. Newell.¹

GEORGIA—

Experiment: H. P. Stuckey.¹
Tifton: Coastal Plains Station; S. H. Starr.¹

GUAM—*Island of Guam*: C. W. Edwards.³

HAWAII—

Federal Station: *Honolulu*; J. M. Westgate.²
Sugar Planters' Station: *Honolulu*; H. P. Agee.¹

IDAHO—*Moscow*: E. J. Iddings.¹

ILLINOIS—*Urbana*: E. Davenport.¹

INDIANA—*La Fayette*: G. I. Christie.¹

IOWA—*Ames*: C. F. Curtiss.¹

KANSAS—*Manhattan*: F. D. Farrell.¹

KENTUCKY—*Lexington*: T. P. Cooper.¹

LOUISIANA—

State Station: *Baton Rouge*; }
Sugar Station: *Audubon Park, New Orleans*; } W. H. Dalrymple.
North La. Station: *Calhoun*; }
Rice Station: *Crowley*; }

MAINE—*Orono*: W. J. Morse.¹

MARYLAND—*College Park*: H. J. Patterson.¹

MASSACHUSETTS—*Amherst*: S. B. Haskell.¹

MICHIGAN—*East Lansing*: R. S. Shaw.¹

MINNESOTA—*University Farm, St. Paul*: W. C. Coffey.¹

MISSISSIPPI—*Agricultural College*: J. R. Ricks.¹

MISSOURI—

College Station: *Columbia*; F. B. Mumford.¹
Fruit Station: *Mountain Grove*; F. W. Faurot.

MONTANA—*Bozeman*: F. B. Linfield.¹

NEBRASKA—*Lincoln*: E. A. Burnett.¹

NEVADA—*Reno*: S. B. Doten.¹

NEW HAMPSHIRE—*Durham*: J. C. Kendall.¹

NEW JERSEY—*New Brunswick*: J. G. Lipman.¹

NEW MEXICO—*State College*: Fabian Garcia.¹

NEW YORK—

State Station: *Geneva*; R. W. Thatcher.¹

Cornell Station: *Ithaca*; A. R. Mann.¹

NORTH CAROLINA—*Raleigh*: B. W. Kilgore.¹

NORTH DAKOTA—*Agricultural College*: P. F. Trowbridge.¹

OHIO—*Wooster*: C. G. Williams.¹

OKLAHOMA—*Stillwater*: C. T. Dowell.¹

OREGON—*Corvallis*: J. T. Jardine.¹

PENNSYLVANIA—

State College: *R. L. Watts*.¹

State College: Institute of Animal Nutrition; H. P. Armsby.¹

PORTO RICO—

Federal Station: *Mayaguez*; D. W. May.²

Insular Station: *Rio Piedras*; E. D. Colón.¹

RHODE ISLAND—*Kingston*: B. L. Hartwell.¹

SOUTH CAROLINA—*Clemson College*: H. W. Barre.¹

SOUTH DAKOTA—*Brookings*: J. W. Wilson.¹

TENNESSEE—*Knoxville*: H. A. Morgan.¹

TEXAS—*College Station*: B. Youngblood.¹

UTAH—*Logan*: William Peterson.¹

VERMONT—*Burlington*: J. L. Hills.¹

VIRGINIA—

Blacksburg: A. W. Drinkard, jr.¹

Norfolk: Truck Station; T. C. Johnson.¹

VIRGIN ISLANDS—*St. Croix*: J. B. Thompson.¹

WASHINGTON—*Pullman*: E. C. Johnson.¹

WEST VIRGINIA—*Morgantown*: ———.

WISCONSIN—*Madison*: H. L. Russell.¹

WYOMING—*Laramie*: A. D. Faville.¹

¹ Director.

² Agronomist in charge.

³ Animal husbandman in charge.

EXPERIMENT STATION RECORD.

Editor: E. W. ALLEN, PH. D., *Chief, Office of Experiment Stations.*
Associate Editor: H. L. KNIGHT.

EDITORIAL DEPARTMENTS.

- Agricultural Chemistry and Agrotechny—SYBIL L. SMITH.
Meteorology, Soils, and Fertilizers { W. H. BEAL.
R. W. TRULLINGER.
Agricultural Botany, Bacteriology, and Plant Pathology { W. H. EVANS, Ph. D.
W. E. BOYD.
Field Crops—H. M. STEECE.
Horticulture and Forestry—E. J. GLASSON.
Economic Zoology and Entomology—W. A. HOOKER, D. V. M.
Foods and Human Nutrition { C. F. LANGWORTHY, Ph. D., D. Sc.
SYBIL L. SMITH.
Animal Husbandry, Dairying, and Dairy Farming—F. J. KELLEY.
Veterinary Medicine { W. A. HOOKER.
SYBIL L. SMITH.
Rural Engineering—R. W. TRULLINGER.
Rural Economics { E. MERRITT.
LOUISE MARBUT.
Agricultural Education { E. H. SHINN.
MARIE T. SPETHMANN.
Indexes—MARTHA C. GUNDLACH.

CONTENTS OF VOLUME XLIII.

EDITORIAL NOTES.

	Page.
The experiment stations and their funds-----	1
The price of delay-----	5
The Agricultural Appropriation Act, 1920-21-----	101
Some essentials of the research project-----	301
First convention of Canadian Society of Technical Agriculturists-----	401
The classification of abstracts in the <i>Record</i> -----	404
James Wilson, late Secretary of Agriculture-----	601
The thirty-fourth annual convention of the Association of Land-grant Colleges-----	701

STATION PUBLICATIONS ABSTRACTED.

ALABAMA COLLEGE STATION:

Bulletin 208, February, 1919-----	135
Bulletin 209, April, 1920-----	233
Bulletin 210, April, 1920-----	333
Circular 42, August, 1919-----	55
Circular 43, February, 1920-----	57, 98

ARIZONA STATION :		Page.
Bulletin 90, December, 1919.....		137
Twenty-ninth Annual Report, 1918.....		724,
733, 734, 740, 745, 749, 757, 764, 772, 775, 777, 788, 789, 798		
ARKANSAS STATION :		
Bulletin 165, February, 1920.....		137
Bulletin 166, February, 1920.....		436
Bulletin 168, February, 1920.....		530
Bulletin 169, June, 1920.....		530
Bulletin 170, June, 1920.....		763
Bulletin 171, June, 1920.....		739
Circular 49, March, 1920.....		531
CALIFORNIA STATION :		
Bulletin 319, March, 1920.....		238
Bulletin 320, April, 1920.....		250
Bulletin 321, May, 1920.....		716
Bulletin 322, June, 1920.....		715
Circular 218, April, 1920.....		576
Circular 219, May, 1920.....		724
Circular 220, July, 1920.....		717
Announcement of the California State dairy cow competition, 1920-1922, F. W. Woll and P. I. Dougherty.....		876
COLORADO STATION :		
Bulletin 252, December, 1919.....		163
Bulletin 254, January, 1920.....		144
Bulletin 255, January, 1920.....		141
Seed Laboratory Bulletin, vol. 1, No. 4, August, 1919.....		337
Thirty-second Annual Report, 1919.....		150, 157, 185, 197
CONNECTICUT STATE STATION :		
Bulletin 217, December, 1919.....		221
Bulletin 218, 1920.....		250
Bulletin 219, December, 1919.....		859
Bulletin 220, February, 1920.....		861
Bulletin of Information 9, October, 1919.....		326
Bulletin of Information 10, March, 1920.....		237
CONNECTICUT STORES STATION :		
Bulletin 103, September, 1919.....		584
Bulletin 104, September, 1919.....		767
Biennial Report, 1916-17.....		120, 197
FLORIDA STATION :		
Bulletin 156, April, 1920.....		335
Bulletin 157, June, 1920.....		775
GEORGIA STATION :		
Bulletin 130, November, 1919.....		136
Bulletin 131, November, 1919.....		136
Bulletin 132, December, 1919.....		127
Bulletin 133, December, 1919.....		147
Bulletin 134, December, 1919.....		139
Bulletin 135, December, 1919.....		146
Thirty-second Annual Report, 1919.....		197

IDAHO STATION :		Page.
Bulletin 117, August, 1919	-----	269
Bulletin 118, September, 1919	-----	227
Bulletin 119 (Annual Report, 1919), January, 1920	-----	98
Bulletin 120, March, 1920	-----	738
Bulletin 121, May, 1920	-----	739
Circular 9, August, 1919	-----	378
Circular 10, January, 1920	-----	650
Circular 11, January, 1920	-----	344
Circular 12, February, 1920	-----	814
Circular 13, May, 1920	-----	496
ILLINOIS STATION :		
Bulletin 225, March, 1920	-----	214
Bulletin 226, May, 1920	-----	571
Bulletin 227, June, 1920	-----	517
Bulletin 228, June, 1920	-----	579
Bulletin 229, July, 1920	-----	753
Circular 241, April, 1920	-----	847
Circular 242, July, 1920	-----	844
INDIANA STATION :		
Bulletin 232, September, 1919	-----	69
Bulletin 233, January, 1920	-----	34
Bulletin 234, September, 1919	-----	375
Bulletin 235, February, 1920	-----	375
Bulletin 236, February, 1920	-----	135
Bulletin 237, March, 1920	-----	570
Bulletin 238, March, 1920	-----	234
Bulletin 239, February, 1920	-----	325
Bulletin 240, September, 1919	-----	868
Bulletin 241, May, 1920	-----	818
Bulletin 242, May, 1920	-----	867
Bulletin 243, July, 1920	-----	867
Bulletin 244, June, 1920	-----	805
Bulletin 245, June, 1920	-----	870
Bulletin 246, June, 1920	-----	875
Bulletin 247, July, 1920	-----	856
Bulletin 249, September, 1920	-----	869
Bulletin 250, July, 1920	-----	835
Circular 94, December, 1919	-----	269
Circular 95, May, 1920	-----	661
Circular 96, May, 1920	-----	631
Circular 97, June, 1920	-----	682
Circular 98, July, 1920	-----	892
Thirty-second Annual Report, 1910	----- 330, 337, 345, 351, 375, 384, 395, 397	
IOWA STATION :		
Bulletin 191, November, 1919	-----	21
Bulletin 192, December, 1919	-----	38
Research Bulletin 53, November, 1919	-----	71
Research Bulletin 54, September, 1919	-----	76
Research Bulletin 55, September, 1919	-----	75
Research Bulletin 56, December, 1919	-----	432
Research Bulletin 57, January, 1920	-----	653

IOWA STATION—Continued.		Page.
Circular 63, December, 1919.....		89
Circular 64, March, 1920.....		875
Circular 65, March, 1920.....		235
Circular 66, March, 1920.....		235
KANSAS STATION :		
Technical Bulletin 7, June, 1920.....		763
Circular 80, March, 1920.....		176
Circular 81, June, 1920.....		576
Circular 82, June, 1920.....		677
Inspection Circular 9, April, 1919.....		682
Inspection Circular 10, December, 1919.....		729
Inspection Circular 11, December 31, 1919.....		674
KENTUCKY STATION :		
Bulletin 218, December 30, 1918.....		37
Bulletin 219, December 31, 1918.....		28
Bulletin 220, March 29, 1919.....		72
Bulletin 221, June 27, 1919.....		334
Bulletin 222, September, 1919.....		389
Bulletin 223, October, 1919.....		373
Bulletin 225, March, 1920.....		359
Bulletin 226, May 1, 1920.....		653
Circular 24, January, 1920.....		877
Thirty-first Annual Report, 1918, pt. 1.....		318,
	320, 324, 327, 331, 334, 339, 373, 397	
Thirty-second Annual Report, 1919, pt. 1.....		810,
	812, 814, 824, 834, 845, 847, 869, 871, 898	
LOUISIANA STATIONS :		
Bulletin 169, January, 1920.....		348
Bulletin 170, July, 1920.....		807
Thirty-first Annual Report, 1919.....	626, 630, 635, 659, 670, 673, 698	
MAINE STATION :		
Bulletin 281, October, 1919.....		175
Bulletin 282, December, 1919.....		159
Bulletin 283, December, 1919.....		174
Bulletin 285, March, 1920.....		641
Bulletin 286, May, 1920.....		677
Bulletin 287, May, 1920.....		645
Official Inspection 94, November, 1919.....		337, 339
Official Inspection 95, April, 1920.....		662
MARYLAND STATION :		
Bulletin 233, December, 1919.....		575
Bulletin 234, January, 1920.....		586
Bulletin 235, March, 1920.....		574
Bulletin 236, May, 1920.....		559
Thirty-second Annual Report, 1919.....	121, 133, 138, 143, 151, 154, 158, 197	
MASSACHUSETTS STATION :		
Bulletin 192, October, 1919.....	119, 146, 155, 158	
Bulletin 193, October, 1919.....		141
Bulletin 194, December, 1919.....		537
Bulletin 195, March, 1920.....		830, 845

MASSACHUSETTS STATION—Continued.

	Page.
Meteorological Bulletins 375-376, March-April, 1920-----	207
Meteorological Bulletins 377-378, May-June, 1920-----	511
Meteorological Bulletins 379-380, July-August, 1920-----	719

MICHIGAN STATION :

Bulletin 286, January, 1920-----	378
Bulletin 287, December, 1919-----	326
Technical Bulletin 45, August, 1919-----	124
Technical Bulletin 46, October, 1919-----	113
Technical Bulletin 47, November, 1919-----	114
Technical Bulletin 48, March, 1920-----	660
Special Bulletin 98, November, 1919-----	115
Special Bulletin 99, November, 1919-----	178
Special Bulletin 100, March, 1920-----	639
Special Bulletin 101, March, 1920-----	639
Circular 41, February, 1920-----	342
Circular 42, March, 1920-----	333
Circular 43, March, 1920-----	649
Quarterly Bulletin, vol. 2, No. 4, May, 1920-----	622,
	626, 639, 649, 660, 674, 677, 681, 688, 691, 698

MINNESOTA STATION :

Bulletin 188, March, 1920-----	420, 814
Bulletin 189, May, 1920-----	480
Report Duluth Substation, 1918-19-----	627, 636, 671, 674, 679, 698
Report Grand Rapids Substation, 1915-19-----	811,
	814, 822, 833, 839, 971, 876, 888, 898

MISSOURI STATION :

Bulletin 166, September, 1919-----	124
Bulletin 167, February, 1920-----	190
Bulletin 168, January, 1920-----	129
Bulletin 169, March, 1920-----	742
Bulletin 170, April, 1920-----	758
Bulletin 171, June, 1920-----	729
Bulletin 172 (Annual Report, 1919), June, 1920-----	712,
	721, 735, 741, 749, 757, 770, 772, 775, 776, 778, 784, 787, 793, 798
Research Bulletin 33, January, 1919-----	141
Research Bulletin 35, August, 1919-----	176
Research Bulletin 36, April, 1920-----	876
Circular 90, January, 1920-----	146
Circular 91, March, 1920-----	174
Circular 92, March, 1920-----	160
Circular 93, May, 1920-----	790
Circular 94, April, 1920-----	759
Circular 95, June, 1920-----	740
Circular 96, July, 1920-----	778
Circular 97, August, 1920-----	792

MONTANA STATION :

Bulletin 129, March, 1919-----	35
Bulletin 130, April, 1919-----	46
Bulletin 131, April, 1919-----	35, 68
Bulletin 132, June, 1919-----	738
Bulletin 133, December, 1919-----	758
Bulletin 134, January, 1920-----	770

MONTANA STATION—Continued.

	Page.
Circular 88, January, 1919-----	321
Circular 89, January, 1920-----	332
Special Circular 5, March, 1918-----	171
Special Circular 6, March, 1918-----	575
Special Circular 7, March, 1920-----	575

NEBRASKA STATION:

Research Bulletin 16, 1920-----	827
Research Bulletin 17, June, 1920-----	882
Research Bulletin 18, June, 1920-----	887
Circular 11, February, 1920-----	146
Circular 12, July, 1920-----	776
Thirty-third Annual Report, 1919-----	637, 644, 650, 672, 673, 675, 677, 698

NEVADA STATION:

Bulletin 98, January, 1920-----	77
Annual Report, 1919-----	228, 272, 273, 298

NEW HAMPSHIRE STATION:

Bulletin 192, June, 1919-----	29, 34, 36, 41, 44, 98
Bulletin 193, August, 1919-----	35
Bulletin 194, September, 1919-----	28
Technical Bulletin 13, December, 1917-----	28
Technical Bulletin 14, April, 1919-----	172
Circular 21, January, 1920-----	520
Scientific Contribution 13, September, 1919-----	842
Scientific Contribution 14, October, 1919-----	841

NEW JERSEY STATIONS:

Bulletin 336, April 28, 1919-----	69
Bulletin 338, October 1, 1919-----	173
Bulletin 339, October 13, 1919-----	37
Bulletin 340, December 30, 1919-----	326
Bulletin 341, January 26, 1920-----	129
Bulletin 342, May 3, 1920-----	671
Circular 109, May 15, 1919-----	373
Circular 110, July 10, 1919-----	162
Circular 111, April 17, 1919-----	162
Circular 112, July 10, 1919-----	153
Circular 113, July 10, 1919-----	141
Circular 114, September 1, 1919-----	140
Circular 115, January 1, 1920-----	188
Circular 116, February 1, 1920-----	37
Circular 117, February 1, 1920-----	37
Circular 118, February 1, 1920-----	37
Circular 119, February 1, 1920-----	37
Circular 120, February 1, 1920-----	37
Hints to Poultrymen, vol. 8—	
No. 7, April, 1920-----	173
No. 8, May, 1920-----	174
No. 9, June, 1920-----	468
No. 10, July, 1920-----	575
No. 11, August, 1920-----	787
No. 12, September, 1920-----	893

NEW MEXICO STATION :		Page.
Bulletin 122, February, 1920	-----	777
Bulletin 123, February, 1920	-----	738
Thirtieth Annual Report, 1919	-----	332,
		339, 345, 347, 352, 358, 374, 377, 378, 386, 397
NEW YORK CORNELL STATION :		
Bulletin 400, January, 1920	-----	469
Bulletin 401, January, 1920	-----	415
Bulletin 402, March, 1920	-----	455
Memoir 30, April, 1920	-----	469
Memoir 31, May, 1920	-----	872
Memoir 32, April, 1920	-----	812
Memoir 33, May, 1920	-----	855
NEW YORK STATE STATION :		
Bulletin 463 (popular edition), December, 1919	-----	544
Bulletin 464, July, 1919	-----	341
Bulletin 466, September, 1919	-----	535
Bulletin 467, December, 1919	-----	520
Bulletin 468, December, 1919	-----	574
Bulletin 470, December, 1919	-----	598
Bulletin 471, January, 1920	-----	626
Bulletin 472, February, 1920	-----	679
Technical Bulletin 66, January, 1919	-----	354
Technical Bulletin 69, June, 1919	-----	579
Technical Bulletin 70, June, 1919	-----	578
Technical Bulletin 71, June, 1919	-----	579
Technical Bulletin 72, June, 1919	-----	579
Technical Bulletin 74, December, 1919	-----	681
Technical Bulletin 75, January, 1920	-----	680
NORTH CAROLINA STATION :		
Farmers' Market Bulletin, vol. 7—		
No. 35, May 1, 1920	-----	394
No. 36, July 1, 1920	-----	595
No. 37, August 1, 1920	-----	794
Forty-second Annual Report, 1919	-----	411,
		424, 425, 427, 434, 449, 465, 467, 469, 490, 496
NORTH DAKOTA STATION :		
Bulletin 136 (Reports 1918-19), March, 1920	-----	319, 322, 332, 374, 385, 386, 397
Bulletin 137, May, 1920	-----	642
Special Bulletin, vol. 5—		
No. 16, February, 1920	-----	368
No. 17, March, 1920	-----	366
No. 18, April, 1920	-----	368
OHIO STATION :		
Bulletin 326, July, 1918	-----	486
Bulletin 338 (Thirty-eighth Annual Report), June, 1919	-----	397
Bulletin 339, April, 1920	-----	647
Monthly Bulletin, vol. 5—		
No. 2, February, 1920	-----	339, 340, 342, 356, 397
No. 3, March, 1920	-----	324, 334, 339, 341, 351, 397
No. 4, April, 1920	-----	322, 324, 340, 342, 377, 391, 397
No. 5, May, 1920	-----	333, 340, 341, 392, 397
No. 6, June, 1920	-----	725, 726, 740, 744, 746, 758, 798

OKLAHOMA STATION :		Page.
Bulletin 127, September, 1919.....		137
Bulletin 130, February, 1920.....		587
Circular 46, July, 1919.....		496
Twenty-eighth Annual Report, 1919.....	16, 32, 36, 44, 51, 58, 68, 70, 73, 79, 98	
OREGON STATION :		
Bulletin 166, February, 1920.....		145
Bulletin 167, January, 1920.....		21
Bulletin 168, February, 1920.....		75
Bulletin 169, April, 1920.....		755
Circular 21, March, 1920.....		129
PENNSYLVANIA STATION :		
Bulletin 160, December, 1919.....		544, 552
Bulletin 161, March, 1920.....		176
Annual Report, 1916.....	511, 514, 515, 519, 520, 533, 534, 536, 537, 538, 548, 554, 569, 570, 572, 576, 577, 579, 598	
PORTO RICO DEPARTMENT OF AGRICULTURE AND LABOR STATION :		
Bulletin 22, 1919.....		47
Circular 19 (Spanish edition), November, 1919.....		727
RHODE ISLAND STATION :		
Bulletin 181, January, 1920.....		674
Bulletin 182, May, 1920.....		643
Annual Feed Circular, May, 1920.....		672
SOUTH CAROLINA STATION :		
Bulletin 202, March, 1920.....		126
SOUTH DAKOTA STATION :		
Bulletin 187, December, 1919.....		235
Bulletin 188, March, 1920.....		873
TEXAS STATION :		
Bulletin 254, November, 1919.....	17, 33, 36, 37, 98	
Bulletin 255, December, 1919.....		258
Bulletin 256, December, 1919.....		561
Bulletin 257, December, 1919.....		758
Bulletin 258, December, 1919.....		229
Bulletin 259, January, 1920.....		724
Bulletin 260, January, 1920.....		846
Bulletin 261, April, 1920.....		845
Bulletin 262, April, 1920.....		870
Circular 19, December, 1919.....		281
Circular 20, February, 1920.....		240
Circular 21, April, 1920.....		496
Control Circular E, October, 1919.....		867
UTAH STATION :		
Bulletin 172, March, 1920.....		218
Bulletin 173, March, 1920.....		230
Circular 42, August, 1920.....		872
VERMONT STATION :		
Bulletin 212, July, 1918.....		197
Bulletin 213, June, 1919.....		178
Bulletin 214, June, 1919.....		154
Bulletin 215, June, 1919.....		153
Bulletin 216, March, 1920.....	428, 437, 464	

VIRGINIA STATION :		Page.
Technical Bulletin 20, June, 1920-----		874
VIRGINIA TRUCK STATION :		
Bulletin 25, October 1, 1917-----		98
Bulletin 29, October 1, 1919-----		451
WASHINGTON STATION :		
Bulletin 155 (Twenty-ninth Annual Report, 1919), March, 1920-----		715,
	722, 726, 736, 743, 749, 764, 772, 780, 784, 794, 798	
Popular Bulletin 117, October 14, 1919-----		384
Popular Bulletin 118, January, 1920-----		350
Popular Bulletin 119, February, 1920-----		242
Popular Bulletin 120, June, 1920-----		744
WASHINGTON STATION :		
Western Washington Station Monthly Bulletin, vol. 8—		
No. 1, April, 1920-----	155, 189, 197	
No. 2, May, 1920-----	333, 349, 392, 397	
No. 3, June, 1920-----	436, 496	
No. 4, July, 1920-----	675, 676, 689, 698	
No. 5, August, 1920-----	738, 798	
WEST VIRGINIA STATION :		
Bulletin 171, August, 1919-----		135
Bulletin 172, August, 1919-----		139
Bulletin 173, February, 1920-----		92
WISCONSIN STATION :		
Bulletin 306, April, 1919-----		622
Bulletin 310, April, 1920-----		257
Bulletin 311, April, 1920-----		335
Bulletin 312, June, 1920-----		622
Bulletin 313, June, 1920-----		771
WYOMING STATION :		
Bulletin 122, December, 1919-----		789
Bulletin 123, May, 1920-----		782
Bulletin 124, June, 1920-----		786
Bulletin 125, June, 1920-----		783
Circular 15, January, 1920-----		436
Twenty-ninth Annual Report, 1919-----	120, 134, 172, 179, 189, 197	
UNITED STATES DEPARTMENT OF AGRICULTURE PUBLICATIONS ABSTRACTED.		
Annual Reports, 1919-----		298
Bulletin 794, Waterfowl and Their Food Plants in the Sandhill Region of Nebraska-----		49
Bulletin 800, The Whorled Milkweed (<i>Asclepias galioides</i>) as a Poisonous Plant, C. D. Marsh, A. B. Clawson, J. F. Couch, and W. W. Eggleston--		470
Bulletin 810, European Foulbrood, G. F. White-----		58
Bulletin 812, The Clover and Alfalfa Seed Chalcis-fly, T. D. Urhahus-----		364
Bulletin 813, Citrus-fruit Improvement: A Study of Bud Variation in the Eureka Lemon, A. D. Shamel, L. B. Scott, C. S. Pomeroy, and C. L. Dyer--		440
Bulletin 814, The Standard Day's Work in Central Illinois, H. R. Tolley and L. M. Church-----		193
Bulletin 815, Citrus-fruit Improvement: A Study of Bud Variation in the Lisbon Lemon, A. D. Shamel, L. B. Scott, C. S. Pomeroy, and C. L. Dyer--		440

	Page.
Bulletin 817, Observations on the Life History of <i>Ascaris lumbricoides</i> , B. H. Ransom and W. D. Foster.....	275
Bulletin 820, Jack Pine, W. D. Sterrett.....	443
Bulletin 821, Frost Protection in Lemon Orchards, A. D. Shamel, L. B. Scott, and C. S. Pomeroy.....	440
Bulletin 823, Experiments with Kherson and Sixty-day Oats, C. W. War- burton and T. R. Stanton.....	639
Bulletin 824, Insect Powder, C. C. McDonnell, R. C. Roark, and G. L. Keenan.....	352
Bulletin 826, Generic Classification of the Hemipterous Family Aphididæ, A. C. Baker.....	758
Bulletin 828, Bacterial Wilt of Cucurbits, F. V. Rand and E. M. A. En- lows.....	245
Bulletin 820, Effect of Temperature on the Resistance to Wounding of Certain Small Fruits and Cherries, L. A. Hawkins and C. E. Sando....	39
Bulletin 831, Spillways for Reservoirs and Canals, A. T. Mitchelson....	787
Bulletin 832, The Flow of Water in Dredged Drainage Ditches, C. E. Ramser.....	478
Bulletin 833, Chrysanthemum Midge, C. A. Welgel and H. L. Sanford....	360
Bulletin 834, Black Grain-stem Sawfly of Europe in the United States, A. B. Gahan.....	363
Bulletin 835, Capillary Movement of Soil Moisture, W. W. McLaughlin..	722
Bulletin 836, Broom-corn Experiments at Woodward, Okla., B. E. Roth- geb and J. B. Sieglinger.....	232
Bulletin 837, Control of the Grapeberry Moth in Northern Ohio, H. G. Ingerson and G. A. Runner.....	454
Bulletin 838, Cypress Bark Scale, F. B. Herbert.....	452
Bulletin 839, The Microscopical Examination of Flour, G. L. Keenan and M. A. Lyons.....	313
Bulletin 840, A System of Records for Local Farmers' Mutual Fire In- surance Companies, V. N. Valgren.....	193
Bulletin 841, The Western Grass-stem Sawfly, C. N. Ainslie.....	259
Bulletin 843, The Bean Ladybird, F. H. Chittenden and H. O. Marsh.....	455
Bulletin 844, Sweet Clover Seed, H. S. Coe and J. N. Martin.....	640
Bulletin 845, Production of Lumber, Lath, and Shingles in 1918, F. H. Smith and A. H. Pierson.....	150
Bulletin 846, Examination of Frozen Egg Products and Interpretation of Results, H. W. Redfield.....	414
Bulletin 847, Roundheaded Apple-tree Borer: Its Life History and Con- trol, F. E. Brooks.....	760
Bulletin 848, An Economic Study of Small Farms Near Washington, D. C., W. C. Funk.....	691
Bulletin 849, City Milk Plants: Construction and Arrangement, E. Kelly and C. E. Clement.....	682
Bulletin 850, Rent Contracts in Typical Countries of the Wheat Belt, E. A. Boeger.....	290
Bulletin 851, Cost of Producing Apples in Five Counties in Western New York, 1910-1915, G. H. Miller.....	649
Bulletin 853, The Organization and Management of Farms in North- western Pennsylvania, E. D. Strait and H. M. Dixon.....	692
Bulletin 854, The Flow of Water in Drain Tile, D. L. Yarnell and S. M. Woodward.....	788
Bulletin 855, Saponified Cresol Solutions, J. M. Schaffer.....	273

Page.

Bulletin 856, Currant-grape Growing: A Promising New Industry, G. C. Husmann	837
Bulletin 857, A Modified Boerner Sampler, E. G. Boerner and E. H. Ropes.....	642
Bulletin 858, Requirements and Cost of Producing Market Milk in North-western Indiana, J. B. Bain and R. J. Posson.....	678
Bulletin 859, The Process of Ripening in the Tomato, Considered Especially from the Commercial Standpoint, C. E. Sando.....	834
Bulletin 860, The Organization of Cooperative Grain Elevator Companies, J. M. Mehl and O. B. Jesness.....	895
Bulletin 861, Marketing Eastern Grapes, D. Alleman.....	836
Bulletin 864, A Peach-sizing Machine, M. Stockton and J. F. Barghausen.....	836
Bulletin 865, A Classification of Ledger Accounts for Creameries, G. O. Knapp, B. B. Mason, and A. V. Swarthout.....	878
Bulletin 866, Pickering Sprays, F. C. Cook.....	843
Bulletin 867, The Castor-oil Industry, J. H. Shrader.....	802
Bulletin 873, The Shrinkage of Market Hay, H. B. McClure.....	825
Bulletin 874, Farm Land Values in Iowa, L. C. Gray and O. G. Lloyd.....	893
Bulletin 875, Cotton Boll Weevil Control by the Use of Poison, B. R. Coat and T. P. Cassidy.....	856
Bulletin 876, Hairy-vetch Seed Production in the United States, L. W. Kephart and R. McKee.....	831
Farmers' Bulletin 1072, Prickly Pear as Stock Feed, D. Griffiths.....	35
Farmers' Bulletin 1083, The Hessian Fly and How to Prevent Losses from It, W. R. Walton.....	55
Farmers' Bulletin 1085, Hog Lice and Hog Mange: Methods of Control and Eradication, M. Imes.....	688
Farmers' Bulletin 1086, How Insects Affect the Rice Crop, J. L. Webb.....	252
Farmers' Bulletin 1088, Selecting a Farm, E. H. Thomson.....	291
Farmers' Bulletin 1090, Rabbit Raising, N. Dearborn.....	365, 378
Farmers' Bulletin 1092, Prairie Rice Culture in the United States, C. E. Chambliss.....	139
Farmers' Bulletin 1093, Influence of the Tractor on Use of Horses, L. A. Reynoldson.....	690
Farmers' Bulletin 1094, The Alfalfa Caterpillar, V. L. Wildermuth.....	357
Farmers' Bulletin 1096, Frost and the Prevention of Damage by It.....	237
Farmers' Bulletin 1097, The Stable Fly: How to Prevent Its Annoyance and Its Losses to Live Stock, F. C. Bishop.....	362
Farmers' Bulletin 1099, Home Laundering, L. R. Balderston.....	792
Farmers' Bulletin 1100, Cooperative Marketing of Woodland Products, A. F. Hawes.....	345
Farmers' Bulletin 1101, The Argentine Ant as a Household Pest, E. R. Barber.....	259
Farmers' Bulletin 1103, Growing Irrigated Grain in Southern Idaho, L. C. Aicher.....	637
Farmers' Bulletin 1104, Book-lice or Psocids, E. A. Back.....	53
Farmers' Bulletin 1118, Dockage under the Federal Wheat Grades, R. H. Brown.....	535
Farmers' Bulletin 1120, Control of Apple Powdery Mildew, D. F. Fisher.....	549
Farmers' Bulletin 1125, Forage for the Cotton Belt, S. M. Tracy.....	638
Farmers' Bulletin 1126, Sudan Grass, H. N. Vinall.....	639
Farmers' Bulletin 1130, Carpet Grass, C. V. Piper and L. Carrier.....	233
Circular 73, The Work of the San Antonio Experiment Farm in 1918, C. R. Letteer.....	120, 134, 144, 153, 171

	Page.
Circular 75, The Work of the Yuma Reclamation Project Experiment Farm in 1918, R. E. Blair-----	318, 329, 339, 352, 376, 391, 392, 397
Circular 78, A Machine for Trimming Camphor Trees, G. A. Russell----	90
Circular 80, The Work in 1918 of the Newlands (Formerly the Truckee-Carson) Reclamation Project Experiment Farm, F. B. Headley-----	418, 420, 435, 437
Circular 81, <i>Astragalus tetrapterus</i> , a New Poisonous Plant of Utah and Nevada, C. D. Marsh and A. B. Clawson-----	77
Circular 86, The Work of the Huntley Reclamation Project Experiment Farm in 1918, D. Hansen-----	418, 435, 451, 465, 468
Circular 87, Sweet-clover Seed Screenings Not Injurious to Sheep, C. D. Marsh and G. C. Roe-----	464
Circular 88, Annual Report of the Governor of Alaska on the Alaska Game Law, 1919-----	350
Circular 89, Kudzu, C. V. Piper-----	334
Circular 90, Control of Watermelon Anthracnose by Spraying, F. C. Meier-----	348
Circular 91, The Land of Beautiful Water-----	543
Circular 92, The Jack Bean, C. V. Piper-----	233
Circular 93, The Development of the Peruvian Alfalfa Industry in the United States, H. L. Westover-----	528
Circular 94, TNT as a Blasting Explosive, C. E. Munroe and S. P. Howell-----	282
Circular 95, United States Grades for Northern-grown Onions, H. E. Truax-----	236
Circular 96, United States Grades for Potatoes, H. E. Truax-----	335
Circular 97, United States Grades for Bermuda Onions, H. E. Truax----	335
Circular 98, The Installation of Dust-collecting Fans on Thrashing Machines for the Prevention of Explosions and Fires and for Grain Cleaning, H. E. Roethe, jr., and E. N. Bates-----	390
Circular 99, United States Grades for Sweet Potatoes, H. E. Truax-----	336
Circular 100, Vacation on the White Mountain National Forest-----	747
Circular 101, The Whorled Milkweed, a Plant Poisonous to Live Stock, C. D. Marsh-----	471
Circular 102, The Migratory Bird Treaty-----	449
Circular 103, Mountain Outings on the Rainier National Forest-----	747
Circular 104, Fishing, Hunting, and Camping on the Cascade National Forest-----	747
Circular 109, Cocklebur, A. A. Hansen-----	832
Circular 112, Timber Depletion and the Answer-----	649
Circular 114, Motion Pictures of the U. S. Department of Agriculture, F. W. Perkins and G. R. Goergens-----	698
Circular 115, Alfalfa-----	733
Circular 120, Soy Bean-----	830
Circular 121, Velvet Beans-----	831
Yearbook, 1919-----	426, 428, 437, 439, 442, 449, 454, 464, 468, 471, 473, 474, 478, 483, 485, 486, 488, 489, 490, 492, 496
Weekly News Letter, vol. 7, Nos. 44-45, June 2-9, 1920-----	469
Weekly News Letter, vol. 7, No. 46, June 16, 1920-----	794
Weekly News Letter, vol. 7, Nos. 48-49, June 30-July 7, 1920-----	894
Weekly News Letter, vol. 8, No. 8, September 22, 1920-----	770

OFFICE OF THE SECRETARY :	Page.
Circular 150, Regulations of the Secretary of Agriculture under the United States Warehouse Act of August 11, 1916, as amended July 24, 1919.—Regulations for Wool Warehouses.....	571
Circular 151, Rules and Regulations of the Secretary of Agriculture under the Food Products Inspection Law of May 31, 1920.....	794
Circular 152, Value of Government Crop Reports [E. T. Meredith]---	794
 BUREAU OF ANIMAL INDUSTRY :	
State Sanitary Requirements Governing Admission of Live Stock.....	272
 BUREAU OF CHEMISTRY :	
The Food and Drug Manual, 1920.....	164
 BUREAU OF CROP ESTIMATES :	
Monthly Crop Reporter, vol. 6—	
No. 4, April, 1920.....	193
No. 5, May, 1920.....	294
No. 6, June, 1920.....	491
No. 7, July, 1920.....	694
No. 8, August, 1920.....	794
No. 9, September, 1920.....	896
 BUREAU OF MARKETS :	
Market Reporter—	
Volume 1—	
No. 14, April 3, 1920.....	179, 194
No. 15, April 10, 1920.....	194
No. 16, April 17, 1920.....	144, 178, 194
No. 17, April 24, 1920.....	194
No. 18, May 1, 1920.....	294
No. 19, May 8, 1920.....	294
No. 20, May 15, 1920.....	294
No. 21, May 22, 1920.....	294
No. 22, May 29, 1920.....	490
No. 23, June 5, 1920.....	490
No. 24, June 12, 1920.....	490
No. 25, June 19, 1920.....	490
No. 26, June 26, 1920.....	490
Volume 2—	
No. 1, July 3, 1920.....	595
No. 2, July 10, 1920.....	595
No. 3, July 17, 1920.....	595
No. 4, July 24, 1920.....	694
No. 5, July 31, 1920.....	694
No. 6, August 7, 1920.....	694
No. 7, August 14, 1920.....	794
No. 8, August 21, 1920.....	794
No. 9, August 28, 1920.....	794
No. 10, September 4, 1920.....	794
Fluid Milk Market Report, 1920, May Supplement, May 20, 1920.....	580
Service and Regulatory Announcements—	
No. 59, February 26, 1920.....	830
No. 61, June 2, 1920.....	896
No. 62, May 29, 1920.....	832

BUREAU OF PLANT INDUSTRY :

Page.

Inventory of Seeds and Plants Imported by the Office of Foreign Seed
and Plant Introduction during the Period from April 1 to June 30,
1916 -----

635

BUREAU OF PUBLIC ROADS :

Public Roads—

Volume 2—

No. 20, December, 1919----- 186
No. 21, January, 1920----- 387
No. 22, February, 1920----- 387
No. 23, March, 1920----- 387, 388
No. 24, April, 1920----- 591

Volume 3—

No. 25, May, 1920----- 689, 690
No. 26, June, 1920----- 790

BUREAU OF SOILS :

Field Operations, 1917—

Soil Survey in Alabama, Shelby County----- 511
Soil Survey in California, Ventura Area----- 512
Soil Survey in Florida, St. Johns County----- 719
Soil Survey in Iowa, Hamilton County----- 122
Soil Survey in Mississippi, Madison County----- 720
Soil Survey in Nebraska, Morrill County----- 209
Soil Survey in North Dakota, Sargent County----- 123
Soil Survey in Oregon, Yamhill County----- 512
Soil Survey in Texas, Lubbock County----- 512
Soil Survey in Virginia, Accomac County----- 513
Soil Survey in Virginia, Northampton County----- 513
Soil Survey in Wisconsin, Waupaca County----- 123

Field Operations, 1918—

Soil Survey in Delaware, Kent County----- 719
Soil Survey in Georgia, Pulaski County----- 811
Soil Survey in Louisiana, La Salle Parish----- 720
Soil Survey in North Dakota, Traill County----- 209
Soil Survey in South Carolina, Harry County----- 812
Soil Survey in West Virginia, Webster County----- 720

FEDERAL HORTICULTURAL BOARD :

Rules and Regulations Governing (1) Entry for Immediate Export,
(2) Entry for Immediate Transportation and Exportation in Bond,
and (3) Safeguarding the Arrival at a Port Where Entry or Land-
ing is not Intended of Prohibited Plants and Plant Products----- 741

WEATHER BUREAU :

National Weather and Crop Bulletin 17, 1920----- 118
National Weather and Crop Bulletin 18, 1920----- 119
Monthly Weather Review—
Volume 48—
Nos. 1-2, January-February, 1920----- 116, 117, 118, 119, 157
Nos. 3-4, March-April, 1920----- 509, 510
Nos. 5-6, May-June, 1920----- 717, 718
Supplement 16, 1920----- 15

WEATHER BUREAU—Continued.

Climatological Data—

Volume 6—

Nos. 11-12, January-February, 1920----- 511

Volume 7—

Nos. 1-2, January-February, 1920----- 810

Report, 1919 ----- 318

SCIENTIFIC CONTRIBUTIONS.¹

Adams, E. Q., The Absorption Spectra of the Nitric Esters of Glycerol----	801
Ainslie, G. G., The Cornpith Weevil (<i>Centrinus penicellus</i> Hbst.)-----	762
Allen, E. W., Organization of Investigation in Agriculture-----	698
Alsberg, C. L., The Government Scientist and the Conditions of the Service	798
Anderson, M. S., and W. H. Fry, Solid Phases Obtained by the Evaporation of Certain Soil Extracts-----	624
Ashe, W. W., Notes on Trees and Shrubs in the Vicinity of Washington--	222
Babcock, C. G., Some Poultry Lice and Mites Found in Colorado-----	660
Baird, W. P., Corn Experiments at the Judith Basin Substation-----	738
Baker, A. C., <i>Neotoxoptera violæ</i> and Its Allies-----	54
Baker, A. C., and M. L. Moles, A New Species of Aleyrodidæ Found on Azalea -----	557
Banks, N., and T. E. Snyder, A Revision of the Nearctic Termites, with Notes on Biology and Geographic Distribution-----	256
Barber, G. W., Concerning the Distribution of North American Cicadellidæ (Hemip.)-----	450
Barber, H. S., A New Tropical Weevil from Florida and Cuba-----	562
Barnes, H., Use of Water from Kings River, Calif., 1918-----	588
Bates, C. G., Tree Windbreaks as a Farm Asset-----	650
Baughman, W. F., and W. W. Skinner, The Determination of Iodid and Bromid in Mineral Waters and Brines-----	13
Bergman, H. F., The Effect of Cloudiness [on Submerged Cranberry Plants] -----	836
Bethel, E., <i>Puccinia subnitens</i> , and its Æcial Hosts, II-----	444
Blake, S. F., A Preliminary Revision of the North American and West Indian Avocados (<i>Persea</i> spp.)-----	239
Blake, S. F., Revision of the True Mahoganies (<i>Swietenia</i>)-----	241
Blake, S. F., Revision of <i>Ichthyomethia</i> , a Genus of Plants Used for Poisoning Fish-----	328
Böving, A. G., and A. B. Champlain, Larvæ of North American Beetles of the Family Cleridæ-----	854
Brandes, E. W., Artificial and Insect Transmission of Sugar Cane Mosaic--	547
Brandes, E. W., Banana Wilt-----	848
Braun, H., Presoak Method of Seed Treatment: A Means of Preventing Seed Injury Due to Chemical Disinfectants and of Increasing Germi- cidal Efficiency-----	844
Briggs, G., Guam Corn-----	638
Buc, H. E., Delicate Test for Strychnin-----	116
Burger, O. F., Causes of Decay in Citrus Fruits-----	41
Burger, O. F., Diseases of Fruit and Causes of Deterioration in Transit--	656
Burke, H. E., Collecting Some Little Known Buprestidæ-----	57

¹ Printed in scientific and technical publications outside the Department.

	Page.
Butler, O. M., The Relation of Research in Forest Products to Forest Administration	41
Byars, L. P., A. G. Johnson, and R. W. Leukel, The Wheat Nematode, <i>Tylenchus tritici</i> , Attacking Rye, Oats, Spelt, and Emmer.....	751
Caffrey, D. J., Facts Revealed in Two Years' Work with the European Corn Borer in Massachusetts.....	661
Carhart, A. H., Recreation in the Forests.....	442
Carsner, E., Susceptibility of Various Plants to Curly Top of Sugar Beet.....	752
Carter, W. T., jr., J. F. Stroud, and T. M. Bushnell, Investigations in Adapting the Automobile to Accurate Soil Survey and Road Traverse Work.....	281
Caudell, A. N., Zoraptera Not an Apterous Order.....	556
Chace, E. M., Maturity Work on Avocados.....	837
Chapin, R. M., The Diazometric Determination of Phenol, and Certain of Its Homologs.....	614
Chittenden, F. H., The Porto Rico Mole Cricket in South Carolina and Florida.....	159
Chittenden, F. H., A New Species of Phyllotreta.....	854
Clark, E. D., and L. H. Almy, A Chemical Study of Frozen Fish in Storage for Short and Long Periods.....	858
Cobb, N. A., Transference of Nematodes from Place to Place for Economic Purposes	449
Collins, G. N., and J. H. Kempton, A Teosinte-maize Hybrid.....	529
Combs, S., and J. B. Bain, A Study of the Factors Involved in Producing Milk in North Carolina.....	678
Cook, O. F., A Disorder of Cotton Plants in China: Club Leaf or Cyrtosis.....	446
Corbett, L. C., Cooperation in and Coordination of Investigational Work in Horticulture	642
Craighead, F. C., Direct Sunlight as a Factor in Forest Insect Control....	560
Cushman, R. A., Viereck's Family Labenidæ with the Description of a New Species of Apechoneura.....	60
Cushman, R. A., The North American Ichneumon Flies of the Tribes Lycorini, Polysphinctini, and Theroniini.....	857
Cushman, R. A., and S. A. Rohwer, Holarctic Tribes of the Ichneumon Flies of the Subfamily Ichneumoninæ (Pimplinæ).....	858
Cushman, R. A., and S. A. Rohwer, The North American Ichneumon Flies of the Tribe Accenitini.....	858
Darrow, G. M., Are Our Raspberries Derived from American or European Species?.....	439
Davidson, W. M., A New Myzocallis (Aphididæ: Homoptera).....	660
Davis, J. J., The Green Japanese Beetle Problem.....	362
Davis, J. J., The Green Japanese Beetle.....	558
Davis, R. O. E., and L. B. Olmstead, Preparation of Nitrogen and Hydrogen Mixture by Decomposition of Ammonia.....	220
De Bord, G. G., R. B. Edmondson, and C. Thom, Summary of Bureau of Chemistry Investigations of Poisoning Due to Ripe Olives.....	168
Dickson, J. G., and H. Johann, Production of Conidia in <i>Gibberella saubinetti</i>	545
Dixon, H. M., Farm Business Analysis Studies.....	792
Doolittle, S. P., and W. W. Gilbert, Seed Transmission of Cucurbit Mosaic by the Wild Cucumber.....	654
Dyar, H. G., A Second <i>Culex</i> of the Subgenus <i>Transculicia</i>	258
Dyar, H. G., New Moths from Mexico.....	258

Dyar, H. G., Note on the Subgenus <i>Neoculex</i> of <i>Culex</i>	258
Dyar, H. G., The Mosquitoes of British Columbia and Yukon Territory, Canada	258
Eldredge, I. F., The Management of Hardwood Forests in the Southern Appalachians	42
Elliott, C., Halo Blight of Oats.....	545
Fisher, W. S., and A. S. Nicolay, A Mexican Species of <i>Agrilus</i> Found in Arizona (Coleoptera)	57
Frear, W., O. Olson, and H. R. Kraybill, Tobacco Experiments [1915]....	533
Fulton, H. R., Decline of <i>Pseudomonas citri</i> in the Soil.....	551
Galloway, B. T., Giant Crown Galls from the Florida Everglades.....	444
Galpin, C. J., Farm Life Studies and Their Relation to Home Economics Work	595
Galpin, C. J., The Human Side of Farm Economy.....	793
Gibbs, H. D., Problems Investigated at the Color Laboratory, Bureau of Chemistry	14
Gibbs, H. D., The Production of Hydrochloric Acid from Chlorin and Water.....	712
Gillespie, L. J., Colorimetric Determination of Titration Curves without Buffer Mixtures	11
Gillespie, L. J., Colorimetric Determination of Hydrogen-ion Concentra- tion without Buffer Mixtures, with Especial Reference to Soils.....	211
Gillespie, L. J., Reduction Potentials of Bacterial Cultures and of Water- logged Soils	421
Gnadinger, C. B., Determination of Saccharin in Foods.....	115
Godfrey, G. H., <i>Sclerotinia ricini</i> n. sp. Parasitic on the Castor Bean (<i>Ricinus communis</i>)	849
Goldman, E. A., Mammals of Panama.....	849
Gould, H. P., Some Principles of Peach Growing.....	438
Graves, R. R., A Study of Guernsey Breeding.....	378
Griffiths, D., New and Old Species of <i>Opuntia</i>	222
Guthrie, J. D., Early English Forest Regulations.....	442
Hall, M. C., The Adult Tænioid Cestodes of Dogs and Cats, and of Re- lated Carnivores in North America.....	80
Harlan, H. V., Daily Development of Kernels of Hannchen Barley from Flowering to Maturity at Aberdeen, Idaho.....	826
Harlan, H. V., and S. Anthony, Development of Barley Kernels in Normal and Clipped Spikes and the Limitations of Awnless and Hooded Varieties	826
Harris, J. A., Practical Universality of Field Heterogeneity as a Factor Influencing Plat Yields.....	526
Harter, L. L., and J. L. Weimer, The Surface Rot of Sweet Potatoes...	752
Hartley, C., R. G. Pierce, and G. G. Hahn, Molding of Snow Smothered Nursery Stock.....	846
Harvey, R. B., The Relation Between the Total Acidity, the Concentration of the Hydrogen-ion, and the Taste of Acid Solutions.....	11
Harvey, R. B., Destruction of Zoöspores of Plant Disease Organisms by Natural Enemies	750
Hawkins, L. A., The Department of Agriculture Cold Storage Plant....	892
Hawley, L. F., and H. N. Calderwood, jr., Tar-still Operation in Hard- wood Distillation Plants.....	717
Headley, F. B., Unreliable Experimental Methods of Determining the Toxicity of Alkali Salts.....	814

	Page.
Heinrich, C., On Some Forest Lepidoptera, with Descriptions of New Species, Larvæ, and Pupæ-----	853
Hitchcock, A. S., Genera and Supergenera-----	729
Hitchcock, A. S., and A. Chase, Revisions of North American Grasses---	522
Hofmann, J. V., How Fires Destroy Our Forests-----	543
Hofmann, J. V., The Establishment of a Douglas Fir Forest-----	650
Holmes, A. D., Digestibility of Steam-cooked Soy Beans and Peanuts---	564
Hopkins, A. D., The Bioclimatic Law-----	718
Howard, L. O., The House Fly: Carrier of Disease-----	558
Howard, L. O., The European Corn Borer in America-----	661
Hume, A. N., and H. C. Gilbert, Barberry Eradication-----	546
Hungerford, C. W., Rust in Seed Wheat and Its Relation to Seedling Infection-----	546
Hunt, N. R., The "Iceless Refrigerator" as an Inoculation Chamber----	444
Hunter, A. C., A Pink Yeast Causing Spoilage in Oysters-----	663
Isely, D., A Synopsis of the Petiolate Wasps of the Family Eumenidæ (Hymenoptera) Found in America North of Mexico-----	60
Isely, D., and A. J. Ackerman, Some Features of the Codling Moth Problem in the Ozarks-----	357
Jackson, F. H., jr., Laboratory Tests of Granite Paving Block and Suggested Specifications-----	85
Jamieson, G. S., and W. F. Baughman, The Chemical Composition of Cottonseed Oil-----	502
Jardine, J. T., Efficient Regulation of Grazing in Relation to Timber Production-----	148
Johns, C. O., and H. C. Waterman, Some Proteins from the Georgia Velvet Bean, <i>Stizolobium deeringianum</i> -----	410
Johns, C. O., and A. J. Finks, Studies in Nutrition.—IV, The Nutritive Value of Peanut Flour as a Supplement to Wheat Flour-----	763
Kalmbach, E. R., The Crow, Bird Citizen of Every Land-----	50
Kay, A. O., Irrigation Practices-----	279
Kearney, T. H., The Relative Absorption by Soil of Sodium Carbonate and Sodium Chlorid-----	516
Kelley, F. J., Substitutes for the Words Homozygous and Heterozygous---	867
Kitchin, P. C., Preliminary Report on Chemical Weed Control in Coniferous Nurseries-----	42
Kittredge, J., Silvicultural Practice in Coppice-under-standard Forests of Eastern France-----	442
Kohman, E. F., and H. A. Shonle, The Digestibility of Chicken Skin-----	164
Kress, O., S. D. Wells and V. P. Edwardes, American Pulpwoods: The Suitability of Various Species of American Woods for Pulp and Paper Production-----	650
La Forge, F. B., Sedoheptose, a New Sugar from <i>Sedum spectabile</i> , II.---	801
La Forge, F. B., Volemite-----	801
La Forge, F. B., A Practical Study of Corncob Utilization-----	809
Langworthy, C. F., and H. J. Deuel, Digestibility of Raw Corn, Potato, and Wheat Starches-----	365
Leach, B. R., and J. W. Roberts, The Control of the Codling Moth and Apple Scab in Delaware-----	743
Le Clerc, J. A., and C. D. Garby, Pearl Barley: Its Manufacture and Composition-----	563
Lee, A. R., What and How to Feed for Satisfactory Egg Production-----	174
Lee, H. A., Behavior of the Citrus Canker Organism in the Soil-----	550

Le Fevre, E., Sauerkraut Production Controlled by Heat, with the Report of an Experiment.....	616
Leopold, A., The Forestry of the Prophets.....	148
Link, G. K. K., and M. W. Gardner, Market Pathology and Market Diseases of Vegetables.....	751
Livingston, G., The Banker's Part in Marketing.....	294
Livingston, G., Some Fundamental Problems in Marketing Farm Products.....	489
Lloyd, W. A., A History of the Agriculture of Ohio.....	486
Luginbill, P. On the Biology of <i>Aphis avenæ</i> Fab. in the Southeast with Causes Conducive to the Unusual Abundance of this Species as well as <i>Toxoptera graminum</i> Rond. during Certain Seasons.....	556
Lyman, G. R., The Advisory Board of American Plant Pathologists.....	443
Lynde, H. M., Studies of Maintenance Work on Drainage Ditches.....	280
McDowell, J. C., Dairying Turned the Trick.....	291
McKay, A. W., The Refrigeration of Fruit and Vegetable Shipments.....	339
MacMillan, H. G., Wind and the Distribution of Pathogenic Soil Organisms.....	842
McMurrin, S. M., Pecan Rosette in Relation to Soil Deficiencies.....	48
McMurrin, S. M., Preventing Wood Rot in Pecan Trees.....	48
Marlatt, C. L., Corn Borer from the Standpoint of Quarantine and General Control.....	661
Marsh, C. W., Poisonous Plants and the Department of Agriculture.....	470
Mathewson, W. E., The Combination of Fractionation with Spectrophotometry in Proximate Organic Analysis.....	503
Meier, F. C., Concerning Spoilage of Vegetables in Transit and Storage.....	656
Meredith, E. T., The Farmer and the Farm Market.....	91
Meredith, E. T., Forests as a Farm Crop.....	543
Merrill, E. C., Preliminary Study of Some of the Physical and Chemical Constants of Balsam Peru.....	116
Middleton, H. E., The Moisture Equivalent in Relation to the Mechanical Analysis of Soils.....	210
Moznette, G. F., The Red Spider Mite and Leaf Thrips on the Avocado and How They May be Controlled.....	53
Moznette, G. F., Control of Spot Insects of the Mango.....	54
Moznette, G. F., Dusting v. Spraying for the Control of Avocado Insect Pests.....	255
Moznette, G. F., Banana Root-borer.....	560
Moznette, G. F., Annotated List of the Injurious and Beneficial Insects of the Avocado in Florida.....	851
Munger, T. T., Forestry in the Douglas Fir Region.....	343
Nelson, E. K., Oil of <i>Rubieva multifida</i>	502
Nelson, E. K., The Composition of Oil of <i>Chenopodium</i> from Various Sources.....	502
Niles, W. B., and J. H. Rietz, Duration of Immunity against Hog Cholera Following Simultaneous Inoculation of Young Pigs.....	184
Oberholser, H. C., Fifth Annual List of Proposed Changes in the A. O. U. Check-list of North American Birds.....	50
Oberholser, H. C., Description of a New Clapper Rail from Florida.....	659
Olson, G. A., E. G. Schafer, M. A. McCall, and C. E. Hill [Report of Work with Field Crops in Washington].....	736
Palmer, A. H., California Precipitation.....	618
Passonneau, J. [Report of the Office of Farm Markets].....	794

Patten, H. E., and T. O. Kellems, Acidity of Ash-free and of Commercial Gelatin Solutions	801
Pearce, W. J., The Relation of Insect Losses to Sustained Forest Yield...	148
Peltier, G. L., and W. J. Frederich, Relative Susceptibility to Citrus Canker of Different Species and Hybrids of the Genus Citrus, Including the Wild Relatives	848
Pennington, M. E., The Development of a Standard Refrigerator Car.....	90
Peters, J. G., Cooperation between the Federal Government and the States...	441
Peyton, J. S., Forestry Movement of the Seventies in the Interior Department under Schurz	148
Pope, W. R., and W. H. Ross, Qualitative Method for the Detection of Borax in Mixed Fertilizers	312
Popenoe, W., Avocados, Particularly Guatemalans	342
Popenoe, W., Atlixco	835
Power, F. B., and V. K. Chesnut, The Odorous Constituents of Apples—Emanation of Acetaldehyde from the Ripe Fruit	711
Pritchard, F. J., and W. B. Clark, Effect of Spraying on Early Ripening of Tomato Fruit	656
Pritchard, F. J., and W. B. Clark, Effect of Copper Soap and of Bordeaux Soap Spray Mixtures on Control of Tomato Leaf Spot	846
Ramsey, G. B., Studies on the Viability of the Potato Blackleg Organism...	654
Rand, F. V., and W. D. Pierce, A Coordination of Our Knowledge of Insect Transmission in Plant and Animal Diseases	450
Ransom, B. H., A Newly-recognized Cause of Pulmonary Disease, <i>Ascaris lumbricoides</i>	80
Ransom, B. H., Intestinal Worms in Hogs and Stomach Worms in Sheep...	384
Reed, C. A., Pecan Grades and Standards	41
Reed, C. A., Pecan Varieties	41
Reed, C. A., The American Nut Industry as a Whole	240
Reed, C. A., Pecan Varieties, Grades, Standards, and Packages	441
Reed, G. M., and G. H. Dungan, Flag Smut and Take-all	844
Ridgway C. S., Further Study of Tobacco Burning Quality.—The Grain of the Tobacco Leaf	534
Rixford, G. P., A Non-splitting Smyrna Fig and its History	239
Rixford, G. P., Some Results of Fig Breeding by the U. S. Department of Agriculture	439
Rogers, L. A., A. O. Dahlberg, and A. C. Evans, The Cause and Control of "Buttons" in Sweetened Condensed Milk	779
Rohwer, S. A., Descriptions of Twenty-five New Species of North American Hymenoptera	857
Rohwer, S. A., The North American Ichneumon Flies of the Tribes Labenini, Rhyssini, Xoridini, Odontomerini, and Phytodietini	857
Rohwer, S. A., Three New Species of Indian Drynoid Parasites of Rice Leaf Hoppers	857
Rommel, G. M., The Horse Situation as I Saw It in Europe	674
Rosen H. R., and R. S. Kirby, A Comparative Morphological Study of <i>Æcia</i> of Four Different Rusts Found upon Barberries in North America	844
Ross, W. H., and R. B. Deemer, Methods for the Determination of Borax in Fertilizers and Fertilizer Materials	312
Sando, C. E., and H. H. Bartlett, Rutin, the Flavone Pigment of <i>Eschscholtzia californica</i>	632

Sarvis, J. T., Composition and Density of the Native Vegetation in the Vicinity of the Northern Great Plains Field Station-----	522
Sasscer, E. R., Important Foreign Insect Pests Collected on Imported Nursery Stock in 1919-----	352
Satterthwait, A. F., Notes on the Habits of <i>Calendra pertinax</i> Olivier----	762
Schroeder, E. C., A Review of Several Publications on Infectious Abortion Disease-----	784
Schultz, E. S., and D. Folsom, Transmission of the Mosaic Disease of Irish Potatoes-----	546
Schwartz, B., The Biological Relationships of Ascarids-----	380
Shamel, A. D., Results of Five Years' Individual Tree Performance Records with Pruned and Unpruned Lemon Trees-----	239
Shamel, A. D., The Conservation and Application of Manures-----	239
Shamel, A. D., Results of Individual Tree Performance Record Studies with Pruned and Unpruned Marsh Grapefruit Trees-----	439
Shamel, A. D., Origin of a Grapefruit Variety Having Pink-colored Fruits-----	440
Shamel, A. D., Bud Selection Investigation with Citrus Fruits-----	542
Shamel, A. D., Avocado Performance Records-----	837
Shapovalov, M., Is the Common Potato Scab Controllable by a Mere Rotation of Crops?-----	751
Shapovalov, M., and H. A. Edson, Wound Cork Formation in the Potato in Relation to Seed Piece Decay-----	732
Sheals, R. A., Report of the White Pine Blister Rust, State of Rhode Island, 1919, in Cooperation with the Bureau of Plant Industry, U. S. Department of Agriculture-----	658
Shinn, E. H., Lessons in Plant Production for Southern Schools-----	797
Skinner, J. J., and C. F. Noll, Field Tests on the Action of Fertilizers on Soil Aldehydes-----	519
Skinner, J. J., and F. R. Reid, The Influence of Phosphates on the Action of Alpha-crotonic Acid in Plants-----	131
Slocum, R. R., Methods of Pedigree Breeding at the Government Poultry Farm-----	675
Smith, E. B., Pressure of Green Concrete against Forms-----	389
Smith, F. H., Significant Trends in Lumber Production in the United States-----	44
Snell, W. H., Observations on the Relation of Insects to the Dissemination of <i>Cronartium ribicola</i> -----	754
Snyder, T. E., The Colonizing Reproductive Adults of Termites-----	556
Snyder, T. E., Protecting Buildings Against the White Ant-----	592
Spaulding, P., Scientific Research in 1919 [on White Pine Blister Rust]-----	249
Spencer, G. C., Potash from Kelp.—II, The Experimental Distillation of Kelp at Low Temperatures-----	630
Stevens, N. E., and A. H. Chivers, Fanning Strawberries in Relation to Keeping Quality-----	848
Taylor, M. W., The Overwintering of <i>Cronartium ribicola</i> on Ribes----	849
Tiemann, H. D., The Phenomena of Drying Wood-----	590
Tiemann, H. D., Phenomena of Drying Wood-----	591
Trullinger, R. W., The Farmer's Part in Bigger Crops-----	321
Vosbury, E. D., Avocado Varieties-----	342
Waggaman, W. H., and T. B. Turley, The Production of Phosphoric Acid by Smelting Phosphate Rock in a Fuel-fed Furnace-----	629

	Page.
Weber, F. C., and J. B. Wilson, The Food of the Small Sea Herring and Ammonia and Amins as End Products of its Decomposition.....	111
Weidman, R. H., A Study of Windfall Loss of Western Yellow Pine in Selection Cuttings Fifteen to Thirty Years Old.....	841
Weigel, C. A., and E. L. Chambers, The Strawberry Rootworm Injuring Roses in Greenhouses.....	362
Weston, W. H., jr., Philippine Downy Mildew of Maize.....	545
Wherry, E. T., Optical Properties of a Series of Heptitols.....	801
Whitney, M., The Fertilizer Situation.....	817
Wilcox, A. M., Notes and Descriptions of Species of Telenomus Having Ten-jointed Antennæ (Hymenoptera; Scelionidæ).....	857
Winston, J. R., and W. W. Yothers, Bordeaux-oil Emulsion.....	157
Woglum, R. S., Is It Safe to Fumigate While Trees are in Bloom?.....	54
Woglum, R. S., The Value of Weather Records in Fumigation.....	319
Woglum, R. S., Factors Influencing Fumigation Results.....	850
Woglum, R. S., and A. D. Borden, Control of the Citrophilus Mealy Bug....	557
Wolff, M. H., Plan of Relation of Forest Regulation to Forest Communities	441
Woodbury, T. D., California Forests and Forestry.....	442
Yothers, W. W., The Effects of the Freeze of February 2-4, 1917, on the Insect Pests and Mites on Citrus.....	554

ILLUSTRATION.

	Page.
FIG. 1.—New hydrogen electrode cell for continuous agitation.....	612

EXPERIMENT STATION RECORD.

VOL. 43.

JULY, 1920.

No. 1.

The combined revenue of the American experiment stations has reached an impressive figure. Indeed, taken at its face the amount is so impressive as to be misleading, and it may be disadvantageous to securing increased support unless properly interpreted. To avoid misunderstanding, an analysis is necessary to show the nature and source of these funds, to distinguish between gross and net receipts, and to bring out the quite miscellaneous duties they carry with them, some of which lie outside the field of experimental inquiry.

In view of the present interest in this matter, special effort was made in gathering the statistics for the fiscal year 1919 to secure returns which would be as accurate as possible, together with data as to their source, the way in which they were derived, and the nature of activity they provided for. The support of the stations is so joined with other features of the colleges, and their responsibilities are so diverse in many cases, that it is very difficult to assemble figures which actually represent their resources as research institutions. The following summary and interpretation, however, is made after considerable inquiry and eliminates some of the items which have tended to make previous summaries misleading.

The total revenue of the stations as reported for 1919 amounts to \$7,192,912. Of this sum, something over four million dollars was derived from Federal and State appropriations, while the remainder came from sales, fees, individual and community contributions, and miscellaneous sources. While the total is nearly a million dollars larger than in 1918, and approximately two million dollars larger than in the prewar year, the difference is more apparent than real. As shown below, it is largely accounted for by the increased value of the products sold and other income not wholly applicable to the station or the year in question.

It is a notable fact that the total appropriation for the State stations from Federal and State sources has shown practically no increase in the six years from 1914 to 1919 inclusive. The Federal fund has, of course, remained stationary. The State appropriation

for the fiscal year 1914 aggregated \$2,575,000; it was a little less for the three succeeding years, reached \$2,716,000 in 1918, and \$2,734,000 in 1919. The increase in this six-year period therefore was less than \$160,000, which is quite within the fluctuations in the total State appropriation from year to year.

The record shows that with 1914 the States ceased adding to their station appropriations, in marked contrast to the practice up to that time. In each of the three five-year periods immediately preceding 1914 the total State appropriation practically doubled, or increased in an even greater ratio. Thus, it grew from \$168,000 in 1894 to \$240,000 in 1899, to \$522,000 in 1904, to \$1,035,000 in 1909, and to \$2,575,000 in 1914.

The period since that time, it will be noted, corresponds with the World War and the development of extension work under the contributory plan of the Smith-Lever Act. There may be no connection between this halt in the appropriation for research and the new demands on the States for offsets to Federal appropriations for extension, but it seems not unlikely that the latter may have had an influence, along with other contributory causes. These offsets have steadily increased, and they have been multiplied by the passage of the Vocational Education Act and the Federal Road Act, until they have become a quite considerable charge upon the States. In the case of some States failure to increase the station appropriation may have been less a matter of indisposition than of expediency, when these and the various increased costs of State government are taken into account. The fact that in the aggregate the States have fully doubled the Federal appropriations is evidence of their interest and their disposition to share in the support of the stations. The inequality of the financial support is however a difficulty which constitutes a peculiar hardship to certain of the stations, some of which are outstanding in the character of their work.

The present State contribution is not to be understood as wholly direct appropriation for the station maintenance. In several instances the amount reported is an estimate of the college revenues devoted to research, or the allotment made by the college to the station. The latter is not alone for investigation, but in several instances is in consideration of special services, such as the carrying on of control work, the soil surveys, marketing enterprises, the maintenance of the college farm, or other features. The direct State appropriations also include considerable amounts of money for inspection work, and in a number of cases funds for purposes largely on the border line between station and extension work. At several institutions the facilities for instruction so far as the farm, dairy,

live stock, and orchards, are concerned, are provided and maintained by the stations out of their various funds, with little aid from the colleges. These conditions in the aggregate serve to considerably reduce the total budget under this head for experimental work.

The fees derived from inspection activities of various kinds have grown less rapidly than in the earlier years of the stations, due partially to the provision for these expenses in the State appropriations. Only eight stations report fees for such work, the total from that source being under \$400,000, fully two-thirds of which is received by two stations; but in numerous other cases, as mentioned above, the expenses of inspection are included in State appropriations or college allotments. Despite the tendency to assign such legal enforcements to State boards or departments of agriculture, inspection work still constitutes quite a feature of the station activities and accounts for considerable of the direct or indirect funds included in the total of seven millions. As the cost of the service comes out of this revenue, these inspection fees contribute but slightly to the revenues for experiment and investigation, the aggregate probably being fully offset by the amount for control work included in other cases in the direct State appropriation.

The sales fund has quite naturally increased in recent years by reason of the high prices of products and the larger areas involved. It usually includes the revenues from substations and from farms used in experiment, together with some tracts which at present are chiefly commercial. In the case of some sixteen stations, the amount reported covers the entire college farm rather than the portion or features devoted to investigation; and in several other instances it includes the revenues from farms which have been given to the institution and turned over to the station for management, largely as commercial ventures at present.

The growth of the sales fund has been quite steady for many years. In the fiscal year 1894 the amount returned from this source was only \$47,300; by 1900 it had nearly doubled, and in 1906, when the Adams fund came, it was over \$135,000. From that time it increased rapidly, doubling in the next four years, amounting to \$307,000 in 1914, to a half million in 1915-16, and close to seven hundred thousand in 1917. In 1918 it was over nine hundred thousand, and in 1919 upwards of a million four hundred thousand dollars. In several cases the amount is very large, ranging from \$50,000 to \$180,000 or over; in one case it is given as nearly \$186,000.

With the possible exception of the past two or three years, the increasing size of the returns from sales implies a larger scale of operations involving land, live stock, and farm products. Incidentally it serves to effectually acquit the stations of any possible charge that they are conducting their work increasingly on a

laboratory scale, showing that on the contrary they are operating under conditions which very largely conform to those of practice.

Although the amount reported under sales goes to swell the apparent income of the stations, the figures are for gross returns. It will be evident that to a very large extent they represent merely a turn-over of other funds, and hence are not to be counted as additional revenue. The original expenditure in producing the products sold usually came from other funds, and the sales represent the salvage on what is rarely a profitable enterprise from a commercial standpoint. Farms for experiment or for instruction are not ordinarily expected to be revenue producers.

It is evident therefore that this large item, representing approximately twenty per cent of the total station income, is only to a very slight extent to be regarded as a source of added revenue, the responsibility and time involved in the management of extensive enterprises to a great degree offsetting any net profit. It is true that the conduct of these large operations frequently places better facilities at the disposal of the stations, and enables them to carry out their practical experiments on a commercial scale. This advantage and the effect on the public are not to be overlooked.

Another large item of the revenues as reported falls under the head of "miscellaneous," amounting to approximately \$1,159,000. This is a convenient repository for items not easily classified elsewhere, consisting in part of allotments or estimated expenditures of the colleges for station enterprises, and the Federal appropriations for the insular stations amounting to \$190,000. It is found on investigation to include also balances brought forward from the previous year, aggregating nearly \$700,000. These balances are due largely to differences in the fiscal year, the maintenance of a circulating or operating fund, and the like. They were of course included in the returns for the preceding year, and they are found to be almost exactly offset by unexpended balances at the close of 1919. Hence they are not to be counted in the year's revenue. Correcting this miscellaneous item for the balances and the insular station funds leaves less than \$270,000 to be counted in the assets of the State stations for the year in question.

All things considered, therefore, the station revenues available for the administration and support of experiment and investigation in a fairly strict sense may be said to be limited practically to the Federal and State appropriations, and to less than \$270,000 derived from miscellaneous sources. There may be occasional residues under other heads, but these can not safely be counted on as net revenues. The total of seven million shrinks therefore to a little over four and a quarter million, and there are some considerations of late which

probably tend to reduce this amount in its strict application to experimental inquiry.

This revenue, as stated above, has shown practically no increase since 1914, up to which time it was growing steadily. The Adams fund was being added to year by year from 1906 to 1911, and in that time the State appropriations increased considerably over half a million, doubling between the latter date and 1914. It is perhaps cause for congratulation that the funds have been fully maintained during this period of unusual emergency, but it is clear that they do not begin to go as far, even though up to 1919 no very considerable increase in salaries had been made.

It is evident that the stations as a group came to the period of inflated prices with only a prewar revenue and with very unusual difficulties to face, not the least of which was the keen competition for workers. Fortunately some of the States have added to their appropriations in the past year, affording a measure of relief to the stations affected; but the conviction is forced that the great body of them have reached the limit of their ability to maintain a satisfactory output and keep step with the advance in the demands of teaching and extension.

It is clear from the above that the experiment station system can not properly be judged by the size of its budget, and this is equally true of the size of its staff, as many of those on it are only part time employees. Bare figures give a wrong impression of the amount of experiment and research which reasonably may be expected. It is especially important to avoid any confusion in this regard at a time when the actual pressure for funds is so keenly felt and measures are being considered for supplementing them.

The experiment stations have a proud record. They have been dominant factors in preparing the way for advancement in agricultural education and improved practice. They have not been extravagant or prodigal of their allotments, but have been led by the force of the growing demands and the stationary condition of their revenues to study economy to the utmost. In attempting to hold their own they have already endangered their efficiency, and have suffered serious inroads on a type of personnel which it has taken many years to develop.

No institution can hope at this time to maintain its position on a prewar revenue. With the increased cost of expert service, materials, labor, and everything that goes into research, it is manifestly impossible for an experiment station to do so. The price which is being paid for delay in meeting these higher costs is a heavy one, as becomes forcefully apparent when a study is made covering any considerable range of country. It is expressed in a slowing up of re-

search, a diminished force of attack, attention to questions of smaller range or simpler character, and a falling off in publication.

The results are evident in many ways. For one thing, new projects receive less study in their preparation, which is seen in a less clearly defined objective, less reference to the actual status of inquiry on the subject, and a less effective plan of attack. In many cases the heads of departments or leaders of important projects have become involved in a variety of exacting duties connected with college work or administration. It is the old story of combination men and divided time and interests, intensified by the growth of the colleges and the demands of teaching. These officers are attempting to retain the leadership of projects they originally inaugurated, after they have been largely diverted to other lines. The duties they have taken on frequently make it impracticable for them to maintain more than a quite general contact or advisory relation with the investigation. They are no longer able to participate actively in the projects, and the latter must be left to others in large measure to plan and perform if they are to be steadily progressive. Unless this is done the "leader" may become in reality a drag. In such case, the work instead of being original and aggressive, becomes increasingly routine and conventional; the results are not studied critically and built upon systematically, and publication often lapses for many years.

This is not a theoretical possibility but an actuality which is taking place all too frequently of late. It is the price of intentional but unreal economy—the attempt to keep up the showing and meet the pressing need on a prewar allowance. And it is a reversion or adherence to the old plan of placing nominal leadership in the department head, rather than developing leadership among those who are actually engaged in the work and on whom progress mainly depends. If the latter are held back by the absorption of the nominal leader in other matters or reluctance to relinquish control, the effect soon becomes evident in the character of the work or in suspended publication.

Of late the practice of dividing time with the college teaching or extension work seems on the increase, rather than otherwise. It is a result of straitened circumstances in part, and of the scarcity of experts; but in part it grows out of pressure upon the stations to use the surplus time of men not fully employed by their college duties. A portion of the salary, amounting to from \$200 to a quarter or a third of the whole, is assigned to the station on the assumption that the teacher will find time to render some service to the station. Responsibility for his so doing is usually left with the director, and the division is made on the motion of the college more often than at the request of the station for the assistance it is supposed to supply.

In many cases the arrangement is a disadvantageous one for the station, detracting from the efficient use of its funds and increasing the duties of administration. This is especially the case when the amount of time involved is small and fragmentary, consisting of odd intervals between classes or possibly only summer vacations. In such cases investigation is incidental to other exacting activities rather than a primary function. It is intermittent instead of being continuous; fragmentary, and hence often desultory. Frequently it is an added burden to persons who count themselves of the teaching staff. The salary involved is not sufficient to stimulate interest or carry much responsibility. From the standpoint of the station, the arrangement is wrong in both theory and practice. It diffuses the station funds too broadly, and it does not make proper provision for the orderly and efficient conduct of investigation.

With the present kind of problems, service which does not involve a considerable uninterrupted portion of the time of a worker who is genuinely interested does not suffice to meet the needs of investigation, and actually counts for but little. In the present cramped financial condition of most of the stations they need to have the full benefit of their resources, and to make the best possible use of them. If conditions were made more favorable the product of research might be quite materially increased, especially that which marks progress and represents new study and thought.

There is a feeling that in some respects too much effort continues to be directed toward minor problems. The stations have been criticized for this in the past, and especially for duplication of a kind which adds nothing really new and hence is unprofitable. Repetition which aims to secure local evidence to convince the public is admittedly in the nature of demonstration, for which there are now more effective agencies than the experiment stations.

The greatest need is for the stations to address themselves to the large questions, which call for their special skill and ability to solve. These are on the frontier; but in some cases the experimental work is still far back from the boundary of what is known, going over problems which differ only in respect to local or economic conditions from those traversed years ago. In other cases the experiments are not rounded out but represent the outlook and the labors of a single department, which alone can give only a one-sided, inconclusive result. We need to get beyond such defective organization of experimental work and provide for more critical examination of plans.

The conditions referred to do not reflect a change in ideals of the stations or belief that their work should be any less intensive and searching, but are largely a result of circumstances. They are a product of disrupted forces, of change enforced by competition, of

sharing time with other branches of the college, the distractions of other duties, and sometimes inadequacy of preparation. In the latter case, deficient vision, a lack of insight into the nature of the problems and of understanding of the methods of research, result in retarding investigation and diminish the general efficiency of the station force; and too often in such cases there is an absence of sufficient administrative supervision to overcome or minimize the effects.

One of the most serious aspects of the present situation is that relating to the personnel. The grade of workers and the incentive to adequate preparation are being held down by the maintenance of a dead level of salaries which does not recognize the superior qualities and training required for research. Surprisingly little progress has been made in propagating within the institutions the idea that investigation is a type of creative effort which calls for the highest training and ability it is possible to secure, and that as such it is entitled to special recognition in the matter of rank or compensation.

We say that research is paramount, is fundamental to all other functions of the college; that the experiment station is at the apex of the American system of agricultural education. No one disputes the statement—it seems to be frankly and unreservedly accepted; but there is a reserve about expressing it in terms of salary or advanced rank. As a result, many of the mature investigators whose work has attracted attention to them are going out into other lines, and very few young men are preparing themselves by severe training to take up this exacting line of original inquiry. The stations are obliged to recruit their forces from the best material to be found, frequently realizing that the men taken on do not fully conform to the standards of a few years ago.

It is time to realize and to express in concrete action the fact that the most profitable investment of research funds is in men and women of outstanding ability; that these are no less entitled to remuneration which recognizes their qualities than a similar class in the professions; and that if salary inducements are to be held down, either by the general attitude toward the teaching profession or otherwise, agricultural investigation at the colleges will continue to decline, more rapidly even than in recent years.

The interruptions and the letting down of research during the war had a more lasting effect than was anticipated. The staffs and their leaders were diverted; they were affected by the general state of mind which prevailed. It seems hard for them to return to a peace basis. Conditions are still against it. The readjustment is slow, and the depleted value of the station revenue stands as a distinct obstacle.

There is greater need of administrative leadership than ever before since the stations were well under way—of a kind that will

supply the animating spirit, and will arouse men to put forward the best there is in them. This is what constitutes real leadership. The investigator is by nature an optimist; he believes in the possibility of doing things that have never been done before, and that are worth while because they represent growth and progress. But he needs encouragement and support, and above all he needs the inspiration of opportunity.

Not only do present conditions call for unusual administrative attention to the station affairs, but the situation with respect to it emphasizes a frequent inadequacy. The activities of the station need study and sympathetic direction, contacts need to be closely maintained, and in not a few instances the product of investigation needs adequate presentation in order that the station and the author may receive credit and support through it. The deficiency in this regard is often another result of doubling up in duties to save money; and the unusually large attendance at the colleges, with the difficulty in securing teachers, has increased the burdens on both the administrative and working forces of the stations.

The occasion is in no sense one for pessimism or discouragement, but rather for plain speaking and right understanding. Those who are in closest touch with the situation are perhaps most optimistic and confident of the ultimate outcome. But it is highly important that there should be wider realization of the actual condition, and not only of what the effects may be but what they already are.

Already several of the States have come to the rescue with new or added appropriations, and there are many indications of the readiness of farmers' organizations and communities to contribute funds or facilities where the necessities are properly presented. Never has there been such a great body of sound public sentiment to support the growth of our agricultural institutions as there is today, and this sentiment is growing in force and understanding. It needs only to be informed and guided.

These things give much encouragement for the continued support of agricultural research. They give confidence in the belief that the keystone of the arch of agricultural education will not be allowed to disintegrate and weaken to the danger of the whole superstructure.

RECENT WORK IN AGRICULTURAL SCIENCE.

AGRICULTURAL CHEMISTRY—AGROTECHNY.

Manual of agricultural and food chemistry, C. RAVENNA (*Manuale di Analisi Chimica Agraria e Bromatologica. Bologna: N. Zanichelli, 1914, pp. XVIII+360, figs. 28*).—This manual of analytical chemistry contains selected methods for the quantitative analysis of soils, fertilizers, mineral constituents of plants, feeding stuffs, fungicides, potable waters, wines, vinegar, edible oils and fats, milk, butter, cheese, and flour. An appendix contains directions for the preparation of reagents and various tables to be used in connection with the analytical methods described.

Continuation and extension of work on vegetable proteins, T. B. OSBORNE and L. B. MENDEL (*Carnegie Inst. Washington Year Book, 17 (1918), pp. 302-310*).—This is the progress report for 1918 in continuation of work previously noted (*E. S. R., 40, p. 463*). The investigations outlined have been noted for the most part from other sources.

[**The urease content of seeds**], D. H. WESTER (*Chem. Weekbl., 16 (1919), No. 51, pp. 1548-1556*).—Two papers are presented.

I. *The urease content of domestic seeds* (pp. 1548-1551).—The urease content of 46 varieties of seeds was determined by the effect of glycerin extracts of the seeds upon known amounts of urea.

The seeds varied widely in their urease content, 15 showing no traces of urease and the others widely varying amounts as determined by enzym activity. This was true not only of different families but of different species in the same family. The highest enzym activity next to the soy bean and Canavalia was found in the seeds of *Cytisus laburnum*, *Geranium molle*, *Vicia silvatica*, and *Lupinus luteus*.

II. *The urease content of different varieties of soy beans* (pp. 1552-1556).—Determinations by the method noted above of the urea content of about 48 varieties of Asiatic and African soy beans are reported. All of the beans, whether old or fresh, possessed strong enzym action.

The adjustment of the reaction of bacteriological media, J. McINTOSH and W. A. M. SMART (*Lancet [London], 1919, II, No 17, pp. 723-726, fig. 1*).—This is a brief report of an investigation of the various processes of adjusting the reaction of bacteriological media, as a result of which the author concludes that, with certain precautions, the titration method is not only a reliable method of adjusting the reaction in routine practice, but by means of a specially prepared graph it can be used also to indicate pH values. Titration of the media at room temperature instead of at the boiling point is recommended on account of possible dissociation of the complex organic compounds of the media at higher temperature. Thymolphthalein is considered the most suitable indicator for titration on account of the sharpness of the end-point.

The colorimetric method recommended by Barnett and Chapman (E. S. R., 39, p. 9) is considered to be less accurate than has been stated on account of the difficulty in matching shades and the fact that the scale colors do not completely match those of the broth and are not permanent.

Directions are given for the preparation of ordinary and double-strength broth and the control of the reaction of the finished media. For the latter, instead of titrating the broth again, two small samples of the medium are diluted in test tubes with an equal amount of distilled water. To one tube is added 2 drops of 0.5 per cent alcohol solution of phenolphthalein and to the other 2 drops of 0.02 per cent solution of cresol red. If the reaction is correct (pH 7.6) no color change should occur in the first tube, while a rose or pink color develops in the second tube.

Iron sulphid as an indicator in acidimetry and a new quantitative method for the determination of zinc, J. HOUBEN (*Ber. Deut. Chem. Gesell.*, 52 (1919), No. 8, pp. 1613-1621).—The author suggests the use of iron sulphid as an indicator in acid-base titrations and also in the determination of zinc. For the latter the slightly acid solution of the zinc salt is saturated with hydrogen sulphid, a crystal of iron sulphate is added, and the mixture titrated with $N/4$ or $N/5$ sodium hydroxid or borax solution with constant shaking to the end point of a milk-coffee or milk-chocolate color.

Colorimetric determination of titration curves without buffer mixtures, L. J. GILLESPIE (*Jour. Amer. Chem. Soc.*, 42 (1920), No. 4, pp. 742-748, fig. 1).—The author describes a method devised at the Bureau of Plant Industry, U. S. Department of Agriculture, for securing titration curves colorimetrically without the use of buffer mixtures. In place of these mixtures a color standard is used consisting of a series of pairs of test tubes, one tube of each pair containing dilute alkali and the other dilute acid; and both containing together 10 drops of indicator solution of suitable strength, the drop ratio varying from 1:9 to 9:1. The indicators used are those recommended by Clark and Lubs (E. S. R., 36, p. 111). A table has been constructed giving the H-ion exponent for each pair of tubes with the different indicators and varying proportions of indicators as determined by means of the buffer mixtures of Clark and Lubs (E. S. R., 35, p. 801). The standard tubes are used in determining the H-ion exponent by a technique similar to that proposed by Barnett and Chapman (E. S. R., 39, p. 9) with the use of a single comparator.

The technique of the procedure is described in detail, and its value and limitations are discussed.

The relation between the total acidity, the concentration of the hydrogen-ion and the taste of acid solutions, R. B. HARVEY (*Jour. Amer. Chem. Soc.*, 42 (1920), No. 4, pp. 712-714, fig. 1).—To determine whether the taste of an acid solution is due to the H-ion concentration or the total acidity of the solution, a comparison was made at the Bureau of Plant Industry, U. S. Department of Agriculture, between the tastes of sodium acetate and acetic acid buffer mixtures at different H-ion concentrations and at different acidities for each H-ion concentration. The acid taste of the buffer solutions was expressed in terms of the normality of hydrochloric acid of the same degree of sourness, since at the dilutions used the H-ion concentration and total acidity of this acid were practically the same.

The sourness of the acetate-buffer solution as thus measured was found to be a function of both the H-ion concentration of the buffer solution and its total acidity. "It is desirable, therefore, in determining the acidity of acid foods to give both of these values in order that their desirability as edible products can be determined."

The gold numbers of protalbinic and lysalbinic acids, R. A. GORTNER (*Jour. Amer. Chem., Soc.*, 42 (1920), No. 3, pp. 595-597).—Determinations are reported from the Minnesota Experiment Station of the gold numbers of protalbinic and lysalbinic acids and also of various other colloidal substances with the following results: Dextrin, 125 to 150; soluble starch, 10 to 15; sodium oleate, 2 to 4; egg albumin, 0.08 to 0.1; gum arabic, 0.1 to 0.125; protalbinic acid, 0.15 to 0.2; lysalbinic acid, 0.1 to 0.125; and gelatin, 0.005 to 0.0125.

Since the results in the cases of gelatin, egg albumin, and gum arabic are in close agreement with those of other workers the values are thought to be reliable, and to indicate that the protective action of protalbinic and lysalbinic acids as measured by the gold number has been much overrated.

Potassium chlorate as a standardizing substance for solutions of alkali, H. B. VAN VALKENBURGH (*Jour. Amer. Chem. Soc.*, 42 (1920), No. 4, pp. 757-760).—A method of standardizing solutions of alkali is proposed which depends upon the reduction of potassium chlorate with sulphur dioxide and the standardization of the alkali with the amount of sulphuric acid thus formed as represented by the equation $3\text{SO}_2 + \text{KClO}_3 + 3\text{H}_2\text{O} = 3\text{H}_2\text{SO}_4 + \text{KCl}$.

It is stated that the best results are obtained by purifying the C. P. potassium chlorate by recrystallization, drying it from 4 to 6 hours at 240° C., boiling the solution in an open Erlenmeyer flask, and passing sulphur dioxide into the boiling solution for 30 minutes. Care should be taken to remove the excess of sulphur dioxide by boiling, after which the titration is conducted either in the hot or cold, using phenolphthalein as indicator.

Comparative results of the standardization of a solution of sodium hydroxide against potassium chlorate and against standard acid are reported. With the new method uniform results were obtained which agreed closely with those obtained with the standard acid.

Chemical changes in the composition of saccharin-bicarbonate tablets, O. BEYER (*Chem. Ztg.*, 43 (1919), No. 132, pp. 751, 752).—Analyses of saccharin tablets after having been stored for different lengths of time showed a progressive loss of CO₂ and of free saccharin. It is thought that sodium saccharinate is formed even in the manufacture of the tablets, and that this increases rapidly on standing. These changes decrease the solubility of the tablets.

Apparatus for the determination of melting points, L. M. DENNIS (*Jour. Indus. and Engin. Chem.*, 12 (1920), No. 4, pp. 366-368, figs. 2).—Descriptions and illustrations are given of two tubes of slightly different design to be used as the sulphuric acid containers in melting point determinations. The tubes are so constructed that when filled with sulphuric acid and heated the acid circulates through the tube and is maintained at constant temperature, thus avoiding the errors in melting point determinations due to uneven heating of the acid.

Acidity and acidimetry of soils.—I, Studies of the Hopkins and Pettit method for determining soil acidity, H. G. KNIGHT (*Jour. Indus. and Engin. Chem.*, 12 (1920), No. 4, pp. 340-344, figs. 2).—The discussions and criticisms in the literature of the Hopkins and Pettit method for determining soil acidity are reviewed, and laboratory studies of various points brought up in these discussions are reported from which the following conclusions are drawn:

“When normal solutions of potassium nitrate, potassium chlorid, sodium nitrate, sodium chlorid, and calcium chlorid were percolated through an acid soil all gave the same end titrations, using phenolphthalein as an indicator. This corroborates Hopkins' statements.

“The acidity of the salt extract of an acid soil is independent of the temperature within the range from 25° to 90° C.

"The precipitate formed in titrating the soil extract obtained by the Hopkins method absorbs the indicator to a marked extent. The end result depends upon the temperature, time, and amount of indicator used.

"The acidity of the first portions of the neutral salt extracts of an acid soil increases with increase in concentration of the neutral salts.

"The difference in absorption of calcium and potassium from solutions of their bases by an acid soil may be accounted for by precipitation effects.

"There is a marked basic exchange when a neutral salt solution is added to an acid soil, by which alumina is carried into solution. This, however, does not account for the total acidity of the solution.

"When acid soil is extracted with potassium acetate solution, a portion of acetic acid may be distilled off from the extract, showing the presence of free acid.

"Exchange of acid radicals when an acid soil is treated with a neutral salt solution was not noted."

A rapid and accurate method for determining nitrogen in nitrate of soda by the modified Devarda method and the use of the Davisson scrubber bulb, C. A. BUTT (*Jour. Indus. and Engin. Chem.*, 12 (1920), No. 4, pp. 352-354).—The procedure described involves the use of the Davisson scrubber (E. S. R., 40, p. 806) in the method essentially as described by Allen, a modification of which by Davisson and Parsons has been previously noted (E. S. R., 40, p. 711). The technique is as follows:

The sample is put through a 10-mesh sieve and mixed thoroughly, 17,034 gm. being then weighed into a 500 cc. volumetric flask, dissolved in 300 cc. of water, cooled, and made up to volume. After mixing thoroughly, 25 cc. of the solution is pipetted into a Kjeldahl flask of 500 to 650 cc. capacity, and to this are added 300 cc. of water, 3 gm. Devarda's alloy (75 per cent of which will pass a 20-mesh sieve), and 3 to 5 cc. 45° Baumé NaOH. The flask is connected at once with the Kjeldahl distilling apparatus fitted with the Davisson scrubber into which has been drawn 20 or 30 cc. of water, and the distillation conducted simultaneously with the reduction, the boiling being so regulated that from 175 to 200 cc. of distillate is collected in about one hour. The ammonia is absorbed in 21 cc. of $N/2$ H_2SO_4 and titrated as usual with methyl red as indicator.

Analyses are reported which indicate that exceptionally accurate results are obtained with this method, and that the presence of 1 gm. of sodium chlorid or sodium carbonate in the sample has no appreciable effect on the determination.

The determination of iodid and bromid in mineral waters and brines, W. F. BAUGHMAN and W. W. SKINNER (*Jour. Indus. and Engin. Chem.*, 12 (1920), No. 4, p. 358).—In this paper some results are reported of the iodid and bromid content of mixtures of iodid, bromid, and chlorid, as determined by combining the ferric sulphate method for iodid described in a previous contribution (E. S. R., 41, p. 12) with the chromic acid method for bromid (E. S. R., 42, p. 8). The general procedure is as follows:

The iodin is determined in one sample by the permanganate method. From another sample, which should contain not more than 0.1 gm. of bromin as bromid nor more than 10 gm. of total solids, the iodin is removed by oxidation with ferric sulphate and distillation with steam, the distillate being received in a potassium iodid solution. The residue in the distilling flask is transferred to a beaker, heated to boiling, and treated with ammonium or sodium hydroxid to precipitate the iron. After filtering and washing the precipitate with hot water the filtrate is evaporated to dryness and the bromid determined in the residue by the chromic acid procedure.

The iodine which has been absorbed in potassium iodide may be titrated with thio-sulphate and the results checked with those obtained by the permanganate method. The results obtained with permanganate are, however, uniformly higher and are considered more accurate. While the results for bromide are also low, the method outlined is considered to give more accurate results than any other method for the bromide content of such mixtures.

The quantitative microanalysis of foods and feeding stuffs, W. HERTER (*Ztschr. Untersuch. Nahr. u. Genussmitl.*, 38 (1919), No. 3-4, pp. 65-89, figs. 10).—This is a description of the author's method for the quantitative microanalysis of starch-containing food materials and feeding stuffs,¹ together with a discussion of the scope and reliability of the method.

Determination of lactose in altered milk, E. HILDT (*Ann. Chim. Analyt.*, 2. ser., 2 (1920), No. 2, pp. 43-46).—It is pointed out that samples of milk preserved with bichromate alter more or less in composition depending upon the season, and that this alteration is shown particularly in the content of lactose, which on standing undergoes partial hydrolysis. To determine the extent of this alteration the author proposes a series of calculations involving the use of factors consisting of the reducing power of definite quantities of hydrated, anhydrous, and hydrolyzed lactose. In hydrolyzing the lactose, benzene-sulphonic acid was used as a catalyzer as previously recommended (E. S. R., 40, p. 507).

Rapid method of estimating lead in cassia oil, O. F. LUBATTI (*Jour. Soc. Chem. Indus.*, 39 (1920), No. 3, pp. 35T, 36T, fig. 1).—In the method described the lead is estimated colorimetrically as follows:

Five cc. of the cassia oil is diluted to 20 cc. with 70 per cent alcohol, and 5 or 2.5 cc. of this solution (depending upon the estimated lead content) is pipetted into a 50 cc. Nessler tube of 2.5 cm. diameter and diluted to about 20 cc. with 90 per cent alcohol. A blank from lead-free cassia oil is similarly prepared, and to each of the tubes is added 1 cc. of ammonium sulphid solution. To the blank is then added, with thorough stirring, a standard lead solution in 90 per cent alcohol (1 cc.=0.0001 gm. of lead) until the color of the blank matches that of the sample when compared in the Duboseq colorimeter or a similar device. A special colorimeter devised by the author is described and illustrated.

The results obtained with commercial samples of cassia oil by this method and by the gravimetric procedure of extracting the lead with dilute nitric acid and precipitating as lead sulphate showed a close agreement, although the results obtained by the new method were slightly lower. Determinations of the lead-dissolving power of cassia oil indicated that the amount of lead absorbed increased with time to a maximum value of 0.074 after one month. The amount of lead in commercial samples as a result of the use of lead containers averaged from 0.04 to 0.06 per cent.

Problems investigated at the color laboratory, Bureau of Chemistry, H. D. GIBBS (*Chem. and Metallurg. Engin.*, 22 (1920), No. 9, pp. 405-407, figs. 2).—The author discusses briefly some of the problems which have been or are being investigated at the color laboratory of the Bureau of Chemistry, U. S. Department of Agriculture. These include the production of photographic sensitizing dyes; vapor phase chlorination, oxidation, and sulphonation; and various chemical problems undertaken for the Air Service during the war.

A previous statement of the objects and problems of the color laboratory has been noted from another source (E. S. R., 40, p. 16).

¹ W. Herter and W. Rasch, *Ztschr. Gesam. Getreidew.*, 6 (1914), No. 10-11, pp. 210, 211; 7 (1915), No. 2, pp. 39-42.

Determination of the saponification number of dark-colored resins, H. SALVATERRA (*Chem. Ztg.*, 43 (1919), No. 134, pp. 765, 766, figs. 3).—To avoid the difficulty of observing the end-point in the ordinary titration with phenolphthalein or other indicators in the case of dark colored resins, the author suggests two alternatives. In one, three samples of the resin are saponified in the usual way, using from 2 to 4 gm. of the substance in each saponification. One of these saponified samples is then titrated roughly with $N/2$ H_2SO_4 , using as an indicator 2 cc. of a 2 per cent alkali blue solution. The other samples, after cooling, are treated with about 0.5 cc. less H_2SO_4 than the amount used in the trial titration, made up to 200 cc. with alcohol, and filtered. An aliquot of the filtrate (100 cc.) is then titrated, using either alkali blue or phenolphthalein as indicator.

In the other method, saponification is completed as usual, after which a solution of barium chlorid is added and the heating continued for some time longer. This precipitates the barium soaps of the fatty acids and reacts with the excess of potassium hydroxid, liberating barium hydroxid.

The fumaric acid fermentation of sugar, C. WEHMER (*Ber. Deut. Chem. Gesell.*, 51 (1918), No. 14, pp. 1663–1668, figs. 6).—The author states that the fermentation of cane sugar by a variety of *Aspergillus* which he has named *A. fumaricus* results in the formation of a considerable amount of fumaric acid, together with a small amount of citric acid. The acid under ordinary conditions is formed in the free state as an oxidation product of the sugar. In the presence of calcium carbonate a crystalline mass of calcium fumarate is formed, which, on isolation and purification, crystallizes from a water solution in rosette-shaped crystals.

Microphotographs are given of calcium and lead fumarate and of the free fumaric acid.

Fruit cook book, R. MERTENS (*Obsteinkochbüchlein für den Bürgerlichen u. Feineren Haushalt. Wiesbaden: Rud. Bechtold & Co., 1918, 17, ed., rev., pp. VII+176, figs. 70*).—In the revision by E. Junge of this manual of directions for preserving fruit, special advice is given in regard to choice of methods and the selection of fruit during times of sugar shortage. The use of partially ripe fruit is discouraged on account of its lower content of sugar. Similarly the use of sugar-rich berries for wine making is discouraged on account of the loss of sugar during fermentation.

Drying problems of to-day, R. SCHMIDT (*Ztschr. Angew. Chem.*, 32 (1919), No. 30, Aufsatz., pp. 108–113; *abs. in Chem. Abs.*, 13 (1919), No. 23, p. 3253).—This is a general discussion of the practical problems involved in the successful dehydration of foods and feeding stuffs, with particular emphasis on the selection of the proper method for different materials, depending upon their structure and the ease with which they give up moisture.

The casein industry, J. PEDERSEN (*New Zeal. Jour. Agr.*, 19 (1919), No. 6, pp. 347–354).—With a view to obtaining a better quality of commercial casein in New Zealand, the author enumerates various causes contributing to poor-quality products and describes in detail several processes of manufacture, with their advantages and disadvantages.

METEOROLOGY.

Predicting minimum temperatures from hygrometric data, J. W. SMITH ET AL. (*U. S. Mo. Weather Rev. Sup. 16* (1920), pp. 76, pl. 1, figs. 52).—In addition to the leading paper by J. W. Smith, with an introduction by C. F. Marvin, an abstract of which has been previously noted (*E. S. R.*, 42, p. 619), this number contains shorter articles on Cape Cod Cranberry Frosts, by H. J. Franklin;

Forecasting Minimum Temperatures, by G. S. Bliss; Predicting Minimum Temperatures in the New Orleans, La., District, by I. M. Cline; Predicting Minimum Temperatures, by W. S. Belden; Minimum Temperature Forecasting at Roswell, N. Mex., by C. Hallenbeck; Frost and Minimum Temperature Studies in the Rio Grande Valley Project, U. S. Reclamation Service, by R. M. Shaver; Predicting of Minimum Temperatures in Colorado, by F. H. Brandenburg; Notes on Damage to Fruit by Low Temperatures—Prediction of Minimum Temperatures, by E. S. Nichols; Prediction of Minimum Temperatures in the Gunnison and Uncompahgre Valleys in Western Colorado Based on Data Recorded at Montrose, by F. W. Brist; Forecasting Minimum Temperatures in Utah, by J. C. Alter; Predicting Minimum Temperatures in the Walla Walla, Wash., Frost-warning District, by C. C. Garrett; Forecasting Minimum Temperatures in Oregon and California, by F. D. Young; A Statistical Method for Predicting Minimum Temperatures, by H. F. Alciatore; The Minimum Temperature, A Function of the Dew Point and Humidity, at 5 p. m. of the Preceding Day—Method of Determining this Function by Successive Approximations to Group Averages, by G. F. McEwen; and New Methods of Predicting Orchard Temperatures in the San Diego Citrus District, by H. F. Alciatore.

Forecasting frosts, B. A. KEEN (*Nature* [London], 104 (1920), No. 2618, pp. 450, 451).—The relative merits of different methods of temperature prediction are fully discussed in this article.

The relation between wind and evaporation, W. GALLENKAMP (*Met. Ztschr.* [Brunswick], 34 (1917), No. 1, pp. 24-29, figs. 5).—An apparatus for measuring this relation is described and results obtained with it are given.

Amount and temperature of evaporation and moisture need, W. KÖPPEN (*Met. Ztschr.* [Brunswick], 34 (1917), No. 2, pp. 49-58, figs. 8).—Data for air temperature, evaporation temperature, humidity, and amount of evaporation for Mauritius; Johannesburg; Bulawayo; Cairo; Devil's Peak Plantation, near Kapstadt, Africa; Windsor, New South Wales; Cordova, Argentina; and various places in Russia are summarized and analyzed. A general conclusion drawn is that the evaporation capacity is directly proportional to the aridity of the air. It is pointed out that this is a neglected field of investigation of great importance to plant production.

Amount and temperature of evaporation and moisture need, W. GALLENKAMP (*Met. Ztschr.* [Brunswick], 34 (1917), No. 10-11, pp. 349-354, figs. 8).—This article describes and discusses results obtained with an apparatus devised by the author for studying this question.

Effect of afforestation on hidden condensation, P. DESCOMBES (*Rev. Sci.* [Paris], 56 (1918), No. 16, pp. 490-492; *abs. in Internatl. Inst. Agr.* [Rome], *Internatl. Rev. Sci. and Pract. Agr.*, 10 (1919), No. 3, pp. 258, 259).—In this article the importance of afforestation in regulating the flow of water and increasing the amount retained in the soil is emphasized. It is maintained, moreover, that afforestation largely increases hidden condensation, that is, dew, mist, hoar frost, and the like, which, though not registered by the rain gauge, are often as important as rain.

The action of trees in withdrawing water from the atmosphere, P. DESCOMBES (*Compt. Rend. Acad. Sci.* [Paris], 169 (1919), No. 23, pp. 1106-1108; *abs. in Rev. Sci.* [Paris], 57 (1919), No. 24, pp. 754, 755).—The author reports observations which indicate that trees are active agents in causing condensation of atmospheric moisture in other forms than as rain, and that reforestation is an effective means of increasing and conserving the water supply.

Meteorological summary, 1918, R. B. HENDRIX (*Oklahoma Sta. Rpt.* 1919, p. 59).—A tabular monthly and annual summary of observations at the sta-

tion on temperature, precipitation, cloudiness, and wind is given. This shows that the mean annual temperature of the year was 58.1° F., as compared with a mean of 60.6° for 1893-1917. The lowest temperature recorded was -12° January 12, the highest 105° August 4. The precipitation was 40.07 in. as compared with the mean of 33.29 in.

Meteorological data, G. T. McNESS (*Texas Sta. Bul.* 254 (1919), pp. 4-6).—Observations on temperature, precipitation, humidity, evaporation, and wind velocity at the Nacogdoches substation, Texas, during the three years, 1916-18, are recorded.

The mean monthly temperature for the period was 65.94° F., the highest monthly temperature being 105° in July, 1917, the lowest 1° in January, 1918. The mean monthly humidity was 78.82 per cent; the average rainfall was 37.69 in. (18.15 in. of which fell during the crop-growing season, May-October); the average annual evaporation from a water surface was 46.46 in. The mean temperature of the crop-growing season was 75° .

"The growing season is comparatively long, and during the past three years the last freezing temperature in the spring occurred on March 18, 1917, and the first freeze in the fall on October 19 of the same year. In comparing the climatic conditions for the three years with the records for the past 20 years, we find that the average precipitation was below the normal of 45.69 in. The year 1917, with precipitation of 28.26 in., was the lowest for the 20 years that records have been reported. The precipitation for 1916 and 1918 came within 5 in. of the normal. This average shortage for the period has been the limiting factor in crop yields.

"The results obtained from the tests conducted with a variety of crops indicate that the earlier in the season plantings can be made the larger will be the yields."

Climatology, F. CATRAIN (*Rev. Agr.* [*Santo Domingo*], 14 (1918), No. 7, pp. 217-220; *abs. in Internatl. Inst. Agr.* [*Rome*], *Internatl. Rev. Sci. and Pract. Agr.*, 10 (1919), No. 3, pp. 252, 253).—This article summarizes and discusses eight years' observations at the city of Santo Domingo, on temperature, rainfall, and humidity, and on this basis attempts to forecast the probable success of various kinds of crops in the different districts of the southern coastal region of the Republic of Santo Domingo.

[Phenological observations in the British Islands], J. E. CLARK and H. B. ADAMES (*Quart. Jour. Roy. Met. Soc.* [*London*], 45 (1919), No. 192, pp. 285-309, figs. 2).—Observations at 110 stations during the year ended November 30, 1918, are summarized.

"The year 1918 exhibited, in the early months, a striking contrast to the persistent cold of 1917. Both years gave a most abnormal April cold spell. In 1918 this proved disastrous because of the previous forwardness. In 1917 no harm ensued. The mischief showed itself in ruined tree-fruit crops, mainly from direct destruction, but aided further by decreased resistance to aphids and caterpillar attack."

In discussing this paper, E. Gold brought out the fact that the isotherms and isophenes are far from correspondence, and suggested that possibly sunshine would provide the clue to the differences.

Meteorological review, C. FLAMMARION (*Ann. Astron. et Mét.* [*Paris*], 56 (1920), pp. 307-339, figs. 8).—Observations on pressure, temperature of the air and soil, humidity, precipitation, wind, sunshine, and cloudiness, in the region of Paris, are summarized for 1918 and compared with results of similar observations in previous years. Variations in the weather conditions of different seasons of the year are compared for a long period of years.

The rainfall régime of Tunis, G. GINESTOUS (*Dir. Gén. Agr., Com. et Colon. [Tunis], Bul., 22 (1918), No. 94, pp. 51-80, pls. 5*).—The amount and monthly and seasonal distribution of rainfall during the year ended November 30, 1918, are shown in tables and charts, and the outstanding facts are briefly discussed.

The winter rainfall (December to February) was deficient. The spring rainfall was above the normal and very favorable for crop growth. The summer was almost rainless except the first part of July. The autumn rainfall was slightly below normal.

SOILS—FERTILIZERS.

The organic matter of the soil: A study of the nitrogen distribution in different soil types, C. A. MORROW (*Thesis, Univ. Minn., 1918, pp. 79*).—A historical review of the subject is given, and studies of the nitrogen distribution in several different substances and soil types using the Van Slyke method are reported, including fibrin hydrolyzed in the presence of a mineral subsoil, a calcareous black grass peat, an acid sphagnum-covered peat hydrolyzed alone in the presence of a mineral subsoil and in the presence of stannous chlorid, an acid muck soil, seven samples of mineral surface soil, and extracts of a sphagnum-covered peat and of a calcareous black grass peat soluble in 1 per cent of hydrochloric acid, 4 per cent sodium hydroxid but precipitated by acid, and 4 per cent sodium hydroxid and not precipitated by acid. The seven mineral soils included Fargo clay loam, Fargo silt loam, Carrington silt loam, Hempstead silt loam, prairie-covered loess, and forest-covered loess. The following conclusions are drawn:

“The figures for the ammonia nitrogen in a protein analysis are not appreciably changed when the hydrolysis is carried out in the presence of an ignited mineral soil equal to 20 times the weight of the protein material. The ‘humin’ nitrogen is greatly increased by the addition of ignited mineral soil. It was shown that histidin nitrogen can not account for this increase, neither is it due to the presence of carbohydrates, since the soil lost all its organic matter on ignition. . . . Since practically all mineral soils give furfural on treatment with acid, it is very likely that a very considerable amount of the total humin nitrogen found is due to the presence of carbohydrates in the soil, which give rise to furfural during hydrolysis. This may combine with certain of the nitrogenous compounds and cause an increase in the humin nitrogen, as well as adsorb or occlude nitrogenous compounds in the humin formed from furfural by polymerization.

“This investigation of the distribution of organic nitrogen in the soil indicates a new fraction, the nature of which has not been previously recognized. This is the fraction of nitrogen removed from a colorless solution by calcium, iron, and aluminum hydroxids on the addition of calcium hydroxid. The nitrogen retained in this fraction must consist almost entirely of nonprotein material, since the organic substances in this precipitate have been shown to be colorless organic compounds adsorbed by or combined with the metallic hydroxids. This fraction has been reported as nitrogen precipitated by calcium hydroxid. The true humin nitrogen remains in the residual soil after hydrolysis, but in addition nonhumin nitrogenous compounds must also be retained in this fraction. The strength and volume of the hydrochloric acid used in hydrolysis has little effect on the nitrogen distribution of the hydrolysate, provided acid as strong as constant boiling acid is used in the proportion of at least two parts of acid to one of soil. Results gained from a study of different soils indicate that the organic nitrogen dissolves during

hydrolysis to almost the same extent regardless of the origin and nature of the soil.

"Some very interesting figures are found in the comparison of the different extracts from sphagnum-covered peat. The portion soluble in sodium hydroxid and not precipitated by hydrochloric acid gives a nitrogen distribution approximating very closely that of a normal plant protein. The nitrogen dissolving in the preliminary hydrochloric acid leaching shows a nitrogen distribution which is certainly not due exclusively to protein materials, e. g., an ammonia nitrogen percentage of 65.4 and amino-nitrogen-in-filtrate-from-bases of 17.11 per cent. When an attempt was made to isolate alcohol-soluble and salt-soluble proteins from the soil, the amounts obtained were so small that it seems safe to conclude that no appreciable quantities of these types of proteins are present. The most significant fact brought out by this study is that the organic nitrogen distribution in different soil types is very uniform."

The washing out of nitrates by drainage water from uncropped and unmanured land, E. J. RUSSELL and E. H. RICHARDS (*Jour. Agr. Sci. [England]*, 10 (1920), No. 1, pp. 22-43, figs. 7).—This article supplements and brings up to date a report by N. H. J. Miller, published in 1906, and also reviews all of the results of the work since 1877, when systematic determinations of nitric nitrogen and chlorin in the drainage water of the Rothamsted drain gauges were begun.

"Broadly speaking, the results show that uncropped land steadily and persistently loses nitrogen in the form of nitrates. This, of course, was known. The unexpected feature is the slowness with which the soil loses the power of producing nitrates from its own stock of nitrogenous compounds. At the beginning of the experiment the soil contained 0.146 per cent of nitrogen, about 3,500 lbs. per acre in the top 9 in.; it yielded up about 40 lbs. of nitrogen per acre per annum to the drainage water. At the end of nearly 50 years it still contains 0.099 per cent of nitrogen, or 2,380 lbs. in the top 9 in., and it still gives up to the drainage water 21 lbs. of nitric nitrogen per acre per annum, enough to produce a 15-bu. crop of wheat, although neither manure nor crop residues have been added during the whole of the period. If the curve showing the rate of fall continued its present course and without further slowing down, no less than 150 years would be needed for exhaustion of the nitrogen.

"So far as can be ascertained, the nitrogen lost from the soil appears wholly as nitrate in the drainage water. From the top 9 in. of the 20-in. and 60-in. gauges the nitrogen lost has been, respectively, 1,124 and 1,172 lbs. per acre. The nitric nitrogen in the drainage water amounts to 1,247 and 1,200 lbs per acre in the two gauges. These figures are arrived at by adding together the whole of the nitrate found and such estimated amounts as are possible for the first seven years before regular determinations were made, deducting nitrogen introduced by the rain. The subsoil is left out of account, but evidence is adduced to show that it contributes little if anything to the nitrate in the drainage water. Two items admittedly lack precision, being estimates only, but they are based on reasonable grounds and are probably not far wrong."

The nitrate in the drainage water showed a closer relationship to rainfall than to any other single factor, and nearly as clear a relationship to the quantity of water percolating through the gauges. It is found, however, that exceptionally wet or dry years have after effects which persist in the following season. "During an exceptionally wet year the soil not only loses a large amount of nitrate, but apparently to some extent the power of producing nitrate. . . . In some of the very dry years the opposite effect is seen; less nitrate is washed out than

is usual during the period, but more is washed out in the following year." On an average "1 in. of rain has for the past 25 years washed out 1 lb. of nitrogen, and for 15 years before that it washed out 1.1 lb.; only in the last 6 years is there any distinct sign of falling off."

The effect of temperature is largely masked by that of rainfall, although the data indicate a relationship between summer sunshine and the loss of nitrates during the following winter, the loss tending to be higher after a hot summer than after a cold one. It is noted, however, that this effect is not a simple one because a hot summer is usually also a dry one.

The recorded data for chlorin show a very close agreement between the amount in the rain water and that recovered in the drainage water. The amount of chlorin in the rain water during the 27 years of observation was 441.5 lbs. per acre, the amount in the drainage water being 441.53 lbs. for the 20-in. drain gauge, 455.8 lbs. for the 40-in. gauge, and 447.58 lbs. for the 60-in. gauge.

The relations existing between the soil and its water content, B. A. KEEN (*Jour. Agr. Sci. [England]*, 10 (1920), No. 1, pp. 44-71, figs. 2).—This paper, a contribution from the Rothamsted Experimental Station, summarizes a number of reports on the subject, particularly those which are based on the so-called colloidal hypothesis. The reports are discussed under the subjects of (1) soil moisture in general, (2) attempts to obtain a more complete theory of soil moisture relations, and (3) surface forces in soils and the colloidal hypothesis.

All the experiments discussed have a direct bearing on the soil solution considered as the nutrient medium for plant growth, and show that the soil and the soil solution are bound together by intimate relationships and that a change in the moisture content is reflected in the resulting alteration of all the complex variables involved. "Conclusions based on an examination of soil solution after it has been removed from the soil can not be regarded as necessarily quantitative, and it is open to doubt whether they are always qualitative."

The point emphasized as brought out in the experiments discussed is, therefore, that in all studies of soils it is necessary to recognize that the system soil+soil solution must be treated as a whole. "The relations between the soil and its moisture content are exceedingly complex, and considerations of surface films distributed over an inert mineral framework such as sand grains, are insufficient to explain the observed facts for they give rise to a classification of soil moisture into more or less arbitrary and water-tight compartments. . . . Study of the soil from the colloidal point of view appears to be the most promising way of obtaining further knowledge of these vital but intricate relationships."

The evaporation of water out of sanded and unsanded moor, TACKÉ and DENSCHE (*Mitt. Ver. Förd. Moorkultur Deut. Reiche*, 34 (1916), No. 24, pp. 454-463).—Several experiments extending over two years on the evaporation of moisture from moor soils which had been covered with sand, as compared with the evaporation from uncovered moor soils, are reported. While in some cases there was marked evaporation from the sanded soils, the results indicate that, in moor soils heavily saturated with water, evaporation is prevented by a sufficient covering with sand, and only in extraordinary cases when the sand covering itself becomes saturated with water will the evaporation of excess water out of the sand covering induce a stronger evaporation from the moor soil. Run-off was hindered on sand-covered moor soils.

The Trufast test for sour soil, E. O. FIPPIN (*Jour. Amer. Soc. Agron.*, 12 (1920), No. 2, pp. 65-68).—A new method for meeting the dominant requirements of the problem of so-called acid or sour soils is described.

The chemical principles employed in the method are as follows: To bring the acidity of the soil into liquid suspension where it can be measured, the soil is suspended in a strictly neutral solution of calcium nitrate of sp. gr. 1.3 at 76° F. After suspension in 60 cc. of this solution for from 5 to 10 minutes with thorough shaking, the mixture of soil and solution is filtered through a neutral filter paper and the first 15 or 20 drops of extract are rejected to correct for absorption of the paper. An aliquot portion of the soil extract, 15 cc., is used for titration. The alkali used in titration is a solution of sodium carbonate having a strength of N/49.5. The indicator used is methyl red which does not react freely to carbonates.

The amount of soil used in the test is 6.166 cc. The sample of soil is measured by liquid displacement. No heat is used, and the necessity for mathematical calculations is eliminated by the character of the outfit and the strength of the solution. The number of cubic centimeters of alkali required is read direct from the scale, the strength of the alkali in comparison with the volume of the soil used being such that each scale division represents a lime absorption equivalent to 500 lbs. of calcium oxid per acre 6 in. of soil. Every fourth division represents one ton, and these are numbered from the bottom.

The results of a few determinations of soil acidity by the method are given.

Reclaiming Iowa's "push" soils, L. W. FORMAN (*Iowa Sta. Bul. 191 (1919), pp. 162-176, figs. 7*).—This report deals with the so-called push soils of southern Iowa, which occur as small partially unproductive areas on hillsides where the surface loess soil is shallow and a heavy impervious clay subsoil appears near or at the surface. These soils occur in otherwise productive land in areas varying from $\frac{1}{10}$ to 1 or 2 acres. Seepage spots frequently occur in connection with push soils.

Analyses of samples of push soils show that they are not lacking in plant nutrients, but are deficient in organic matter and are acid in reaction. Phosphorus and nitrogen are generally found in sufficient amounts for good crop growth at present, but with increased crop production these elements will need to be applied. Five years' results from a field experiment on a typical push soil area show the value of drainage, deep tillage, manuring, and liming on the wheat, corn, oats, and soy beans of the rotation. Drainage is very essential for the reclamation of push soils and should be the first treatment practiced. Manuring proved a most valuable treatment and is recommended, especially in connection with drainage and deep plowing, which is distinctly profitable on push soils.

The improvement and irrigation requirement of wild meadow and tule land, W. L. POWERS and W. W. JOHNSTON (*Oregon Sta. Bul. 167 (1920), pp. 3-44, figs. 25*).—Experiments conducted as a phase of the Oregon Soil and Soil Water Investigations, in cooperation with the U. S. Department of Agriculture, are reported on the reclamation of the wild meadow and tule lands in eastern Oregon, which cover 355,000 and 160,000 acres, respectively. The wild meadow land comprises over one-third of the irrigated area of the State.

The chief soil types are silt loam and peat. The chief vegetation on the peat swamps is tules and flags mingled with wire and sugar grass, while the chief meadow grasses are redbud, blue joint, wire grass, and wild clovers. These swamp lands are irrigated by wild flooding from sloughs and canals led along the contour lines. The water table is raised and sheet water is kept on the surface until a short time before harvest, when part of it is removed by a crude system of drainage.

The average monthly precipitation for the summer months during the past five years has been slightly below normal. The temperature has been slightly

higher than normal. The evaporation for the five summer months has averaged about 33 in.

In the Chewaucan Basin alsike clover and timothy have yielded $3\frac{1}{2}$ tons an acre as compared to $\frac{3}{4}$ ton of native grass on adjoining land. The most economical yields per acre-inch have been obtained with 12 in. of irrigation water. The maximum yields have been obtained with about 18 in.

Alfalfa in Harney Basin has produced about 2 tons an acre, while native wild hay has averaged but $\frac{1}{2}$ ton an acre. At the Harney Valley substation from 6 to 10 in. depth of irrigation has given the best results with row crops. Field peas and grain have done best with 8 to 12 in., while with alfalfa the best results have been secured with 18 in.

In the Klamath Basin a duty of 12 in. has been found most profitable when the soil is saturated in the spring. In the Fort Klamath country the substitution of alsike clover and timothy for the native grasses has more than doubled the production of forage.

The results of the past five years show that an average depth of 18 in. of water on the field produced the maximum yield obtained. An average of 12 in. has given the largest yield per acre-inch. The average water cost of dry matter under good conditions for alsike and timothy has been 600 lbs. The water cost for wild hay has averaged 1,000 lbs. and over.

The coarse swamp vegetation can be replaced by pasturing and mowing, or by carefully burning off when the ground is still wet. Oats and field peas are suitable crops for the first year or two after reclamation; later, permanent alsike clover and timothy meadows can be established. On new land a moist, firm seed bed and inoculated clover seed are essential. The double corrugated roller is a good tool for firming peat soil. Rye, sweet clover, and copious irrigation following drainage help to reclaim alkali spots. Gypsum or sulphur aids the solution and removal of black alkali. The strip-border method of irrigation has been found the most successful. Subirrigating from field ditches has been successful on medium and shallow peat when underlaid with a retentive subsoil. Barnyard manure has given a good increase on shallow peat soils. Marked increases have been secured from the application of sulphur to alfalfa on swamp borders.

Fertilizer needs of marsh soils, A. R. WHITSON and H. W. ULLSPERGER (*Com. Fert.*, 20 (1920), No. 2, pp. 42, 46).—This paper, a contribution from the Wisconsin Experiment Station, reports data on the chemical composition of peat, muck, and marsh-border soils. It is stated that many of these soils are not acid, this being the case in the marshes in eastern and southern Wisconsin.

Peat, when dry, weighs but 12 to 20 lbs. to the cubic foot. Muck soil weighs from 40 to 50 lbs., while the marsh-border soils often run from 60 to 80 lbs. to the cubic foot. The chemical composition also varies, especially in regard to nitrogen, which shows about the same variation that the organic matter does. It is noted that the nitrogen content (pounds) of all marsh soils is very high compared with upland soils. Peats are exceptionally rich in nitrogen because they are composed almost entirely of organic matter. Peat soils as a rule are very low in the mineral elements—potassium and phosphorus. Mucks are better supplied with these two elements, though the potassium content is low in comparison with upland clay or silt loam. The marsh-border soils are well supplied with both potassium and phosphorus, as well as with nitrogen, and therefore have high cropping possibilities. Potassium is considered to be a common factor limiting crop yields on peat and muck soils.

The utilization of moors for soil improvement and for fertilization of crops, RIPPERT (*Mitt. Ver. Förd. Moorkultur Deut. Reiche*, 38 (1920), Nos. 2,

pp. 20-24; 3, pp. 30-36).—The results of a number of different experiments on the subject are reported.

Experiments on the treatment of waste soils with peat and moor soils which had been treated with from 20 to 40 per cent lime showed that the peat-lime mixture had a marked effect in increasing crop yields and in making available the nutrients in the soil. More extensive pot experiments with oats, in which peat litter was used treated with lime, showed that the peat-lime mixture alone was unfavorable. The addition of a mixture of peat and molasses also did not increase crop yields.

In further experiments, strongly decomposed moor soil was used which was treated with potassium carbonate. The moor soil alone had a favorable effect upon crop yield, and this was markedly increased by treatment with potassium carbonate.

A comparison of raw peat with peat treated with potassium carbonate and molasses on beets and potatoes showed that the raw peat had a favorable effect upon crop yield, but that the treated peat gave no better results than the raw peat, owing, it is thought, to the addition of organic nitrogen-free matter to the soil. Experiments with a bacterized peat showed the undoubted favorable action of such a peat fertilizer on the yield of potatoes.

Experiments by others bearing on the subject are also discussed and summarized.

Experiments in various methods of covering with sand and fertilizing upland peat bogs, J. HANSEN (*Tidsskr. Planteavl*, 26 (1919), No. 4, pp. 553-624).—Experiments conducted at the Askov Experiment Station during the years 1899 to 1916, inclusive, are reported, the main object of which was to observe the effect of covering a typical upland peat bog with a layer of mineral soil. The peat was from 3 to 5 meters (10 to 16 ft.) deep. Sections of the field were covered with 5.2 cm. and 10.4 cm. (2 and 4 in.) of sand which was then mixed with the peat soil to the depth of the plowed furrow.

The crops grown were rye, horse-beans, peas, potatoes, turnips, swedes, oats, clover, and grass. In the beginning there was a considerable decrease in the crop of rye, potatoes, turnips, swedes, and to some extent oats, as a result of covering with sand. During the later years of the experiment these crops, with the exception of potatoes, were much larger on sand covered soil than on uncovered soil. An average of the results of the whole period showed that rye was practically unaffected by the sand covering, and that potatoes gave the largest crop on uncovered soil and the smallest on soil thickly sand covered. The crop of turnips and swedes was somewhat smaller, but the yield in dry substance was about the same from covered soil as from uncovered soil. Oats yielded more grain and less straw on covered than on uncovered soil and the thickness of the covering was of little or no importance. Leguminous crops—clover and grass—showed a constant increase depending on the thickness of the covering.

In connection with the sand covering experiments, an experiment was conducted with stable manure plus artificial fertilizers and artificial fertilizers alone. The better results were obtained with artificial fertilizers alone.

Maintaining the soil fertility on Wisconsin dairy farms, F. L. MUSBACH (*Wis. Farmers' Insts. Bul.* 32 (1919), pp. 55-63 figs. 2).—Studies of the average income and outgo of phosphorus from 10 dairy farms in northwestern Wisconsin, where cream is the principal cash product, showed that more than one-third of the nitrogen, two-thirds of the potassium, and about one-sixth of the phosphorus disappeared. A study of the average income and outgo of phos-

phorus from 10 dairy farms on which in addition to whole milk some small grains were sold showed a loss of 15 per cent of phosphorus.

The results are taken to indicate that the increase in yield brought about through the growing of clover and the introduction of a rotative scheme of farming tends to extract larger amounts of phosphorus from the soil than would be the case otherwise. On the basis of these results the importance of carefully conserving the manure and of maintaining and, if possible, increasing the phosphorus supply of the soil is emphasized.

Soil fertility, E. H. GURNEY (*Proc. Roy. Soc. Queensland, 30 (1918), pp. 4-17*).—Considerable data relative to the fertility of Queensland soils is summarized from different sources. It is noted that 27 per cent of the Queensland soils have been found to have a low humus content, and the increase and maintenance of the organic matter in these soils is considered to be of the greatest importance.

Forest fertilization experiments in a heathered pine plantation, LUDWIG (*Ztschr. Forst u. Jagdw., 52 (1920), No. 1, pp. 42-51*).—Experiments on the treatment of a clayey sand forest soil covered with heather are reported, the purpose being to determine and correct the injurious influence of the heather and to establish a soil condition favorable to the development of pine trees. The experimental area, covering about 30 acres, was divided into 48 squares of equal area and the soil submitted to different treatments, including clearing and cultivation, clearing alone, cultivation alone, and different fertilizer treatments.

It was found that fertilization alone with mineral fertilizers neither favored the growth of pine trees nor reduced the growth of the heather, especially where the soil was uncultivated and the heather removed. A favorable action on the growth of pine trees was only obtained where the addition of plant nutrients was accompanied by an improvement of the physical condition of the soil. This was accomplished in two ways. The first consisted in covering the soil with a thick layer of humus-producing plant residues. In this case a mineral fertilizer was not necessary. Better results were obtained by growing soil improving plants on the experimental areas.

Season most favorable for applying barnyard manure, S. RHODIN (*Meddel. Centralanst. Försöksv. Jordbruksområdet, No. 183 (1919), pp. 32; also in K. Landtbr. Akad. Handl. och Tidskr., 58 (1919), No. 3, pp. 127-158; abs. in Chem. Abs., 14 (1920), No. 3, p. 307*).—Experiments with potatoes and beets showed that in all cases spring applications of barnyard manure gave much better results, both in total crop and dry matter, than fall or winter applications. The returns from fall applications averaged 50.4 per cent and those from winter applications 53.4 per cent of the returns from spring applications. Long exposure of the manure resulted in losses of ammonia and total nitrogen.

Observations on the guano of Sardinia, M. GIUA (*Gaz. Chim. Ital., 49 (1919), II, No. 5-6, pp. 246-249*).—The results of analyses of samples of bat guanos from caves in Sardinia are summarized. It is noted that within a particular layer there is a variation in composition from prevaillingly ammoniacal to prevaillingly phosphatic with a deficiency in nitrogen. Studies of certain deposits of recent origin, white in color and greasy in appearance, showed a considerable phosphatic content, accompanied by more or less calcium carbonate, silica, iron, aluminum, and magnesium oxids, and a small percentage of nitrate.

The demand and supply of fixed inorganic nitrogen in the United States, A. H. WHITE (*Chem. and Metallurg. Engin., 22 (1920), No. 8, pp. 369-371, fig. 1*).—This paper, a contribution from the University of Michigan, presents a

concise review of present and future needs for nitrogen and of the advantages claimed from the continuous operation of the Government nitrate plants to help supply industrial and agricultural requirements.

The commercial oxidation of ammonia, G. A. PERLEY (*Jour. Indus. and Engin. Chem.*, 12 (1920), Nos. 1, pp. 5-16; 2, pp. 119-129, figs. 5).—This paper, a contribution from the New Hampshire College, deals with the influence of the more important factors involved in the oxidation of ammonia, and reports the results of extensive research into the subject.

The caking of sulphate of ammonia, C. G. ATWATER and J. F. W. SCHULZE (*Chem. and Metallurg. Engin.*, 22 (1920), No. 8, pp. 373, 374).—Laboratory experiments are reported which indicate that the impurity in ammonium sulphate causing caking is pyridin sulphate. "This causes the sample to feel moist to the touch, and due to its presence in the sulphate the latter will take up moisture on damp days, only to lose it later with the decreasing humidity of the atmosphere to produce a decided caking effect. The amount of water taken up, as well as the resultant caking, is in proportion to the amount of pyridin sulphate present.

"By passing dry NH_3 gas through samples containing pyridin sulphate, pyridin is liberated and passes off. If the NH_3 is preheated, quicker and more thorough results are obtained. A treatment of the sulphate with very dilute ammonia liquor produces practically the same effect and in some cases would be more practical commercially. Ammonium sulphate may be produced by either of these simple methods freed of a major part of its original pyridin content. In this state it will not absorb an appreciable amount of moisture from the air and its caking will be negligible."

Potassium nitrate from the Chilean nitrate industry, P. F. HOLSTEIN (*Jour. Indus. and Engin. Chem.*, 12 (1920), No. 3, pp. 290-293, figs. 2).—Methods for the separation of the potash from Chilean nitrate are described, particularly fractional crystallization, evaporation, and refrigeration. It is stated that whatever method can be best used by a plant will depend on local conditions.

"The character of the ore and its potash content, the air temperature in summer and winter, the composition of the mother liquor, and numerous other factors must all be given consideration. Refrigeration will produce a higher grade nitrate at a much lower cost than will evaporation. On the other hand, evaporation, if properly carried out in the right type of evaporator, has the advantage that the water removed from the system may be used as additional wash water for washing the tailings in the boiling tanks, thus increasing the recovery of sodium nitrate."

It is noted that the average potassium nitrate content of all the nitrate shipped from Chile is about 2 per cent. On this basis the production of potassium nitrate in Chile during the year ended June 30, 1918, was about 130,000,000 lbs., representing about 30,000 tons of potash, or about 21 per cent of the total consumption in the United States.

The formation of the double salts of calcium and potassium sulphates at 100° C., E. ANDERSON and R. J. NESTELL (*Jour. Indus. and Engin. Chem.*, 12 (1920), No. 3, pp. 243-246, fig. 1).—Tests made, apparently in connection with the recovery of potash in cement mills, to determine the equilibrium concentration of potassium sulphate in solution in contact with solid gypsum and potassium penta-calcium sulphate on the one hand and solid syngenite and potassium penta-calcium sulphate on the other, at 100° C., indicate that these concentrations are "1.05 moles of K_2SO_4 per 1,000 moles H_2O for the former and 9.26 moles of K_2SO_4 per 1,000 moles H_2O for the latter equilibrium. The corre-

sponding values for calcium sulphate are 0.24 and 0.1 mole, respectively, per 1,000 moles H_2O ."

Potash in 1918, W. B. HICKS (*U. S. Geol. Survey, Min. Resources U. S., 1918, pt. 2, pp. IV+385-445*).—This bulletin deals with the production and use of potash and potash-bearing materials in the United States and foreign countries during 1918, and gives a general discussion of the industry in different parts of the world.

The production of potash-bearing materials in the United States in 1918 amounted to 207,686 short tons, equivalent to a total content of 54,803 short tons of potash. This production was nearly 70 per cent greater than in 1917 and represented about 22 per cent of the normal consumption in the country. In 1918 the production came from 10 distinct classes of raw materials. Natural brines furnished about 73 per cent of the output, the Nebraska lakes alone contributing about 53 per cent and Searles Lake, Cal., the second largest quantity from a single source. Kelp yielded about 9 per cent of the total production, followed by smaller contributions from molasses, alunite, cement, etc.

Potash materials marketed in 1918 varied greatly in composition and in content of potash. Crude mixed salts, containing from 20 to 28 per cent of potash and composed largely of carbonates and sulphates of sodium and potassium, constituted about 58 per cent of the output; muriate, containing 60 to 96 per cent of potassium chlorid, equivalent to 38 to 62 per cent of potash, about 24 per cent; sulphate, containing 35 to 51 per cent of potash, 6 per cent; and low-grade chlorid, crude carbonate, caustic, potash char and ash, cement and blast-furnace dust, and miscellaneous, the remainder. Most of the muriate was of low grade and much of it contained borax, while the larger portion of the sulphate was of high grade. Crude carbonate and caustic was largely the product made from wood ashes. As marketed, much of the carbonate contained about 70 per cent of potassium carbonate mixed with about 30 per cent of potassium sulphate and other impurities.

Approximately 53 per cent of the total production came from Nebraska, 34 per cent from California, 7 per cent from Utah, and the other 6 per cent from 18 other States and Porto Rico. The domestic production of refined potassium salts in 1918, exclusive of chlorids and sulphates, amounted to 53,661,676 lbs. and the sales amounted to 43,833,503 lbs.

Potassium salts (*U. S. House Represent., 66 Cong., 1 Sess., Com. Ways and Means Hearings on Potassium Salts, 1919, pp. 214*).—The details of the hearings before the Committee on Ways and Means of the House of Representatives, U. S. Congress, on a bill for the control of importation of potassium salts, are given.

Potash fertilizers (*Bd. Agr. and Fisheries [London], Leaflet 335 (1920), pp. 3*).—Brief popular information on the price, fertilizing value, and practical use of potash fertilizers in England is contained in this leaflet.

Phosphoric acid: Facts about the most important of mineral soil constituents, J. A. BROCK (*Facts About Sugar, 10 (1920), Nos. 3, p. 50; 4, pp. 70, 71*).—Brief information is given on the chemical composition of the common phosphatic fertilizers, factors in their availability, and their action in soil and toward plants.

I, The relative availability of acid phosphate and the native soil phosphates in the presence of pulverized limestone. II, Future of the agricultural lime industry, J. L. BURGESS (*N. C. Dept. Agr. Bul. 41 (1920), No. 3, pp. 24*).—In Part I of this bulletin a review and summary of a number of works by others on the availability of acid and native phosphate in the presence of lime are given, from which the conclusion is drawn that while acid phosphate

reverts to insoluble forms in the soil, those forms to which it reverts in the presence of lime are relatively less insoluble and more available than those to which it reverts in the presence of iron and aluminum compounds. It is therefore recommended that pulverized limestone be mixed with acid phosphate to prevent the formation of insoluble phosphates of iron and aluminum in the soil.

Part II is an address on the future of the agricultural lime industry.

Absorption of lime by soils, F. J. WARTH and MAUNG PO SAW (*Mem. Dept. Agr. India, Chem. Ser.*, 5 (1919), No. 6, pp. 157-172, pls. 7).—Experiments on the amount of lime absorbed from bicarbonate solution containing different amounts of lime and carbon dioxide by four different soils in Burma, two of acid reaction and two of alkaline reaction, are reported, and the method used in determining the lime absorption is described. The data on lime absorption by these soils is reported graphically.

The experiments are considered to have yielded definite information regarding conditions under which lime is removed from or absorbed by soils of different types. It is noted that the absorption must take place in a similar manner whether it is the organic or inorganic soil constituents which effect the absorption. The more usual form of absorption curve as worked out for potash can be roughly calculated for lime also from the data given, although the direct experimental determination can not be carried out without difficulty. The method used in determining lime absorption is based on the assumption that the amount of lime absorbed by a soil from a calcium bicarbonate solution will depend upon the concentrations of lime and carbon dioxide in solution.

The effect of zinc in soil tests with zinc and galvanized iron pots, S. D. CONNER (*Jour. Amer. Soc. Agron.*, 12 (1920), No. 2, pp. 61-64).—It was found in pot tests with five acid soils in paraffined galvanized iron pots at the Indiana Experiment Station that crops began to fail unexpectedly in the second season. Tests of the soils in which crops had failed showed the presence of water-soluble zinc salts in injurious amounts, especially in the untreated or insufficiently limed soils but not in soils to which sufficient lime had been added. It was noted that the paraffin coating had been granulated and that the soil acids and zinc salts had passed through it. This is considered to be unquestioned evidence that it is unsafe to use zinc-coated pots in acid soil tests until a satisfactory coating is found. In addition, this action of acid soils on zinc is considered to be evidence that soils contain true acids.

Nine references to literature bearing on the subjects are included.

The cleavage of betain by the bacteria of "guanol," A. KOCH and A. OELSNER (*Biochem. Ztschr.*, 94 (1919), No. 3-4, pp. 139-162).—Studies are reported which show that in the manufacture of guanol fertilizer the betain of the molasses sludge is decomposed by lower organisms which originate in the composting material used. Besides these were found molds which attack the betain, forming trimethylamin. In addition, the so-called betainobacter were found in guanol which split off the nitrogen as ammonia, of which very little is utilized.

It was also found that considerable quantities of carbon dioxide are formed by oxidation of the betain with methyl alcohol, formic acid, and small quantities of acetic acid as between-products.

Experiments with phos-pho-germs conducted at the experiment stations to determine its relative efficiency as compared with commercial fertilizers, T. C. JOHNSON (*Va. Dept. Agr. and Immigr. Bul.* 148 (1920), pp. 69, 70).—Experiments conducted at the Virginia Truck and Virginia College Experiment Stations are reported, showing that the phos-pho-germ used did not prove satisfactory as a fertilizer for kale, cabbage, Irish potatoes, and sweet potatoes in the truck-crop producing section of eastern Virginia.

Fertilizers, J. A. VOELCKER (*Jour. Roy. Agr. Soc. England*, 79 (1918), pp. 250-253; *abs. in Chem. Abs.*, 14 (1920), No. 3, p. 306).—Analyses of a number of samples of flue dust and blast furnace dust show the potash content to vary from 0.37 to 7.82 per cent. Analyses of refuse manures, leather, and lime are also discussed.

[**Commercial fertilizer law and registered brands of commercial fertilizers to December 31, 1919**] (*Ill. Dept. Agr. Bul.* 279 (1919), pp. 107-114).—This section of this bulletin contains the text of the Illinois fertilizer inspection law, and analyses of 144 samples of fertilizers and fertilizer materials registered for sale in the State during 1919.

Commercial fertilizers, H. E. CURTIS and W. RODES (*Kentucky Sta. Bul.* 219 (1918), pp. 163-259).—Analyses and valuations of samples of 724 different brands of fertilizers and fertilizer materials, collected for inspection in Kentucky during 1918, are reported. The results of these analyses show that in most cases the samples analyzed have come fully up to the guaranties, or, where there is a slight deficiency in one ingredient, it has been made up by an excess in one or both of the other ingredients.

Inspection of commercial fertilizers for 1919, T. O. SMITH (*New Hampshire Sta. Bul.* 194 (1919), pp. [14]).—This bulletin contains the text of the New Hampshire State fertilizer law, and reports the results of actual and guarantied analyses of 110 samples of fertilizers and fertilizing materials offered for sale during 1919.

Analyses of fertilizer—spring season, 1919 (*Bul. N. C. Dept. Agr.*, 40 (1919), No. 7, pp. 8).—This bulletin contains the results of analyses and valuations of 123 samples of fertilizers and fertilizer materials collected for inspection in North Carolina during the spring of 1919.

AGRICULTURAL BOTANY.

Physiology of the apple, O. R. BUTLER, T. O. SMITH, and B. E. CURRY (*New Hampshire Sta. Tech. Bul.* 13 (1917), pp. 3-21, pl. 1).—A report is given of studies on the distribution of food materials in the apple tree at different periods of vegetation. Determinations were made of the percentages of saccharose, reducing-sugars, starch, ether extract, ash, nitrogen, phosphorus, and potassium present in a summer's growth, in branches from one to five years old, and in large and small roots, the samples being taken at different stages of vegetation.

It is stated that in apple trees carbohydrates are stored as starch or as saccharose. At the awakening of vegetation, the hydrolysis of starch is more marked in two- and three-year-old branches, but is still not extensive. During the growing season saccharose and starch accumulate in small roots and in branches of two and three years. Fats are always present in the apple tree, apparently functioning as reserve food material. Reducing sugar is the translocation form for the carbohydrates. An account is given of its movement and transformation. Nitrogenous reserve materials are stored mainly in younger branches, from which they pass in spring to actively growing regions.

Ash is more abundant in young than in old organs. Translocation of ash material occurs from small roots to one-year-old branches in spring, but little or no migration occurs from the large roots or the older branches and trunk. As new growth develops, ash passes from the one-year-old branches into the shoots, and with the development of an absorbing root system the ash constituents enter the tree, raising the ash content of the small roots. The phosphorus required in building the first new tissues is obtained mainly from the

younger branches. The early translocation of potassium is limited, occurring mainly from older parts than those supplying phosphorus and nitrogen.

Report of the department of chemistry, T. O. SMITH (*New Hampshire Sta. Bul. 192 (1919), pp. 20-22*).—A brief report is made of cooperative work on the physiology of the apple, which is noted above, and an account given of studies of the relation of potassium to the growth of cereals. Wheat, corn, and buckwheat were grown in water and sand cultures, and it was found that all three species required a supply of potassium in addition to that stored in the seed itself within a few days after germination.

Induced changes in reserve materials in evergreen herbaceous leaves, G. M. TUTTLE (*Ann. Bot. [London], 33 (1919), No. 130, pp. 201-210, figs. 7*).—The author has made a study of reserves, alterations therein, and related occurrences, mainly in *Linnæa borealis*.

It is stated that in northwest Canada most evergreen plants are free from starch as early as October, when they are found to contain a considerable amount of oil. Exposure of *Linnæa* to higher temperature induces in darkness formation of starch, which is present in about two days, increasing until about the eighth day. The starch is in a highly divided state, the individual grains exhibiting Brownian movement. Conversion occurs in all healthy leaves. Low temperatures are dangerous to leaves filled with starch. The starch disappears after exposure for eight days to moderately low temperatures. Starch formation is associated with loss of oil content. Enzymes are present in material undergoing conversation. Lipase has also been demonstrated in such materials. Oxidases are present in the leaf of *Linnæa* even at low temperatures.

The compound interest law and plant growth, V. H. BLACKMAN (*Ann. Bot. [London], 33 (1919), No. 131, pp. 353-360*).—The author attempts to formulate in connection with plant growth conditions what has been called the compound-interest law. This is here claimed to be expressed approximately by the formulas $W_1 = W_0 e^{rt}$ or logarithm $e \frac{W_1}{W_0} = rt$, where W_0 is the initial weight, W_1 the final weight, r the rate, t the time, and e the base of natural logarithms. Seed weight, rate of increase, and time period are the basic factors. These are discussed in their relations.

The efficiency index, which appears from the data of early workers to be highest in the early stages of growth, afterward falling slightly, is claimed by the author to show, in studies on *Helianthus*, *Cannabis*, and *Nicotiana*, a sharp fall at the beginning of the reproductive period when the inflorescence first appears.

There is evidence that annual plants at the end of their period of growth may lose considerably in dry weight.

Seventeenth report of the Woburn Experimental Fruit Farm, S. U. PICKERING (*Woburn Expt. Fruit Farm Rpt., 17 (1920), pp. 89+315-325, pl. 1, figs. 3*).—Previous issues of this report have been noted (*E. S. R.*, 38, p. 540), as has also an explanation of the change in status of the institution (*E. S. R.*, 42, p. 104).

The main substance of the work herein reported is concerned with soil water, drainage, and the toxic action of plants on each other, being a continuation and in part a repetition of studies previously noted (*E. S. R.*, 26, p. 639). The work is reported and discussed in considerable detail as carried out with different plants, the grass employed being *Festuca pratensis*. It is claimed that the toxic action is practically the same whether the grass is grown in earth or sand and that it is not affected by the thoroughness with which the grass roots are separated from the tree roots.

Grassing over half of a plantation of standard trees of a strong-growing apple variety 25 years old reduced the crops 5 per cent during the first season and 50 to 90 per cent during the second. The removal of the grass before the third season resulted in no definite recovery during that season by these trees, which appeared to be permanently injured.

In case of such plants as mustard, tobacco, and tomato, where the experiments were conducted in pots, the surface crop was grown in a circular perforated tray, resting on the surface of the soil surrounding the plants. Besides grass, numerous other plants were grown as surface crops. The large number of instances with no exceptions supports the view that the deleterious effect of one plant on another is general and probably more marked in case of plants of the same kind, plants thus in all probability being affected by their own toxins.

No toxin has been identified, but the toxic agent appears to be easily oxidizable and after oxidation (which may be complete after 24 hours or may in certain cases practically or entirely keep pace with its production) it acts as a plant food. Apparently there is no exudation of toxic matter from the roots, and it is regarded as more likely that the toxic matter is some product of growth. A certain amount of recovery seems to occur in case of soft-wooded plants if the injury is not carried too far. The toxic action appeared to have no connection with carbon dioxide produced by surface growth, and was not counteracted by lime. Some results are not yet explained by previous experimentation.

In a study of the effects of plants on each other, it was found with undivided pots that the total amount of plant growth produced, when the mass of soil available is below a certain limit, is independent of the number of plants grown; that is, the total weight of individual plants is proportional to the area occupied by them. Root interference does not apply here and the same results are obtained in divided or in undivided pots. This was true only of plants of the same age. Older plants, where root interference is allowed, flourish at the expense of the younger ones, which may be reduced fully one-half as regards their normal growth. With mustard, a difference of four days in the ages of the plants present was sufficient to reduce the whole crop 20 per cent, this fact supposedly bearing directly on the advisability in preparing seed beds of employing seeds having a uniform germination period. This is also supposed to indicate the futility of attempting to fill up vacancies in a plantation by means of replants.

Interference of the portions above ground has but little effect on the amount of growth, but considerable effect on its character as being taller and more slender. Outside rows were stronger than inside rows. Explanations attributing this to the extra food supply are regarded as untenable.

Removal of the toxins from the soil by means of leaching with water has been found to result in greatly increased growth, though other factors are inseparably involved. Other observations and deductions are given.

A comparative account of the root-nodules of the Leguminosæ, E. R. SPRATT (*Ann. Bot. [London], 33 (1919), No. 130, pp. 189-199, pl. 1, figs. 5*).—This discussion includes, besides the legumes, other plants named which respond by the production of root nodules to attacks by *Bacillus radicicola* and which also actively assimilate nitrogen.

Root tubercles in legumes are said to be exogenous in origin, those of non-legumes being modified lateral roots. *B. radicicola* is connected with the assimilation of nitrogen from the air. Although this organism is polymorphic, cross inoculation occurs. The leguminous nodules are discussed in four groups.

The production of slime is connected with the amount of nitrogen fixed, and is influenced by the medium. The nature of the cell sap also influences the capabilities of the bacteria. The form of the nodule depends primarily on the nature of the environment of the host acting through the cell sap.

Observations on the anatomy of ash-wood with reference to water-conductivity, M. G. HOLMES (*Ann. Bot. [London]*, 33 (1919), No. 130, pp. 255-264, figs. 7).—The results obtained from a quantitative investigation of the constitution of ash wood in young shoots, with special reference to vessel content, have been discussed in comparison with similar data obtained for hazel wood. It is stated that on the whole there is a fall in absolute water conductivity and a rise in specific conductivity from the base of a shoot to its apex in both kinds of wood examined. The figures for specific conductivity are in general lower in ash than in hazel, but the water conducting elements are more numerous in hazel.

The floras of the outlying islands of New Zealand and their distribution, J. C. WILLIS (*Ann. Bot. [London]*, 33 (1919), No. 131, pp. 267-293, figs. 2).—In the present paper the author deals chiefly with the smaller islands that lie at some distance from New Zealand, but on the same submarine plateau, following up the work on the taxonomic distribution of the New Zealand flora given in preceding papers (*E. S. R.*, 42, p. 724). As previously, a number of suggested predictions are put to the test of actual count and tabulation, and the bearing of the results on the particular and general aspects of the problem are indicated with discussion.

The method of prediction and verification has, it is claimed, been employed as many as 32 times. It is shown that the floras of these islands must be very old, from their outlying positions. These islands have proportionately more families in common with Steward Island, whose flora is also old, than with New Zealand proper.

It is claimed that the age and area hypothesis has now been used successfully in case of 67 predictions. The facts are considered to show that the increase of area with age is the chief positive factor in determining the distribution of plants, barriers constituting the chief negative factor.

Variation in *Hevea brasiliensis*, S. WHITBY (*Ann. Bot. [London]*, 33 (1919), No. 131, pp. 313-321, fig. 1).—The data here presented with discussion refer to a population of 1,011 trees in their third year of tapping on a normal plantation area of seven-year-old Para rubber. They were intended to show the extent to which variation occurs in the amount of rubber yielded by individual trees of *H. brasiliensis* of like age and growing under like conditions, also the extent of possible correlation between yield of rubber and girth of trunk. Observations more or less incidental furnished information on the extent of variation in the rubber content of latex from individual trees and on some other points.

Strength of latex appeared to be characteristic and constant for individual trees. Yield, while affected by various causes, was comparatively constant when taken to cover a series of days (6 to 12). Correlation between yield and girth, while definite and positive, is not sufficient in its extent to warrant placing much emphasis on girth in thinning out.

Figures are given indicative of considerable possibilities in connection with seed selection to improve rubber yields.

Peculiarities of certain individual trees include a rapid discoloration of the latex, a tendency to rapid coagulation, and a marked cream-straw color in case of a few trees not marked by a high rubber content.

On double stocks, P. J. JARAMILLO and F. J. CHITTENDEN (*Jour. Roy. Hort. Soc.*, 44 (1919), pp. 74-82, pls. 2).—The authors have followed up the sugges-

tions and experimental results of Miss Saunders (E. S. R., 35, pp. 730, 731) to the effect that the high percentages of doubles among stocks is or may be due to unconscious selection by the garden workers of the more vigorous plants. They report having verified the figures presented by her, and suggest that the selection is best made at the time of transplanting rather than later when the plants have attained a larger size, as the proportion of doubles among the selections then made is much greater than among the selections made when the plants are potted. It is claimed that even in the poor strains the tendency of seedlings which early show vigor is in the same direction.

A new auxanometer, F. M. HAINES (*Ann. Bot. [London]*, 33 (1919), No. 130, pp. 181-188, figs. 2).—This is an account of an attempt by the author to secure, under laboratory conditions, records on a larger scale than heretofore made of the growth of plants while allowing the extension of observation thereon to cover at least three or four days. Though the work of testing as yet carried out is regarded as preliminary, it is claimed that satisfactory results have been obtained.

FIELD CROPS.

Report of agronomy department, M. A. BEESON (*Oklahoma Sta. Rpt. 1919*, pp. 18-26).—A study of the effect of lime and organic matter on impervious Kirkland upland soil showed that in this type of soil greater root development of kafir plants had taken place than where such plants had been grown on the Vernon and the Yahola soil types. It was found also that during a period of 3 years there had been a movement of organic matter into the second foot of soil on plats where barnyard manure and lime had been applied.

In a test with continuous wheat culture, with and without manure, in progress for 20 years, an average of 4.6 tons of manure per acre applied annually to the manured plats yielded an average of 22.91 bu. of wheat per acre as compared with 13.39 bu. secured on the unmanured plats.

The following varieties, given with their yields, ranked first in variety tests with different crops: Oats, Nicholson Improved 50.1 bu., Fulghum 42.3 bu.; wheat, Fulcaster 20.4 bu., Kanred 20 bu.; rye, Giant 24.7 bu., Abruzzi 18.2 bu.; barley, White Club 40.1 bu., Kingfisher 34 bu.; grain sorghum, Darso 12.75 bu., and Shrock kafir 10 bu. per acre. The highest yield in green forage, 2.75 tons per acre, was secured from Blackhull White kafir of the grain sorghums, while Dwarf Ashburn cane led with 5.5 tons among the sweet sorghums. The following leading varieties of crops are reported, without yield: Whip-poorwill Blackeye cowpea, Tennessee Red peanut, and Ohio soy bean.

In a crop rotation and fertility test, in which cotton, oats, cowpeas, and grain sorghum were grown, oats gave the greatest yield on the plats treated with manure and raw rock phosphate, and darso on the plats treated with phosphate, and on which the vines from the preceding cowpea crop had been turned under.

An alfalfa fertility test was conducted to determine the value of barnyard manure and lime on upland alfalfa. In 1918 the check plat yielded 2,021 lbs., the lime plat 3,210 lbs., the manure plat 6,817 lbs., and the manure and lime plat 7,662 lbs. of hay per acre. A comparison of lime and gypsum for upland alfalfa showed in 1918 that lime was superior to gypsum as a stimulative agent.

Results in plant breeding work showed that a cotton selection designated as Row 44 outyielded all other varieties at the station. This strain had a staple of from 1 to $1\frac{1}{8}$ in. and from 36 to 37 per cent of lint.

The standard Blackhull White kafir, selected for dwarfness, uniformity, and high yielding qualities, proved superior to any kafir grown at the station. A culture test with kafir emphasized the importance of keeping down all weeds from the growing crop. A plat, not plowed but with the grass kept down with-

out breaking the soil, stood second in yield, falling very little below the plowed or cultivated plats. In a test of planting kafir and cowpeas in alternate rows the results in 1918 were in favor of 42-in. rows of kafir without cowpeas in both yield of forage and grain. The average results of different rates of planting kafir in the row indicated that 8 to 12 in. between plants gave the highest yields.

Sudan grass was sown on four different dates from about the middle of April to the last of May. The seeding made April 12 gave the highest yield, and broadcasting at the rate of 40 lbs. to the acre proved the most satisfactory method of seeding. A comparison of different dates of seeding sweet clover resulted this year in good stands on all plats sown in March and April. Surface seeding produced a thicker stand than where the ordinary depth of seeding was followed. The use of oats as a nurse crop for the March seeding did not produce a favorable effect.

[Field crops work at the Nacogdoches substation], G. T. McNESS (*Texas Sta. Bul. 254 (1919), pp. 6-8, 10-21, 22, figs. 6*).—Acid phosphate, cottonseed meal, and potash were used singly and in combination as fertilizers for tobacco and corn. In the tobacco experiments 1,200 lbs. of cottonseed meal and 400 lbs. of acid phosphate per acre, the only application showing a marked increase over the use of no fertilizers, gave an increase of \$23.47 in the net return per acre. The plats receiving cottonseed meal produced the best quality of leaf in the test.

In the fertilizer tests with corn an application of 200 lbs. of cottonseed meal and 100 lbs. of acid phosphate per acre was found most profitable, especially on soils well provided with organic matter. In 1918 varieties of corn which had shown good results in previous tests were planted March 15, April 1, and April 17 for further comparison. The five leading varieties, in diminishing order of yield, were Surcropper, Brazos White, Chisholm, Oklahoma White Wonder, and Blount Prolific. Planting at the rates of 3,630 stalks and 4,840 stalks per acre gave in general the best results in a test on the rate of planting. Corn planted in rows either 3 or 6 ft. apart gave practically the same average yield. Planting cowpeas between the rows before the corn was 3 ft. high showed a tendency to reduce the yield of corn.

The results of a 4-year test with Mebane cotton planted on upland in rows 3 ft. apart indicated that 2 plants to the hill, and the hills 21 in. apart in the drill, is likely to give the highest yield of seed cotton. In a 3-year variety test Roundnose ranked first in the average yield of seed cotton per acre, with Rowden, producing a better staple, standing second. Among varieties not tested throughout the 3 years Chisholm ranked first in ginning percentage with 46.51 per cent of lint, being followed by Improved Champion with 45.8 per cent, Mexican Big Boll with 42.85 per cent, and Kasch with 42.22 per cent. A comparison of varieties with regard to length of lint showed that Snowflake ranked first with $1\frac{5}{8}$ in., Express second with $1\frac{3}{8}$ in., and Lone Star, Trice, and Acala third with $1\frac{1}{8}$ in.

In a 3-year test with 25 varieties of cowpeas unknown, Brabbam, Whippoorwill, Iron, Clay, and Iron-Blackeye, and in a similar experiment conducted for 6 years Clay, Unknown, New Era, Whippoorwill, Iron, and Groit led in average yield of seed in the order given. In 1917-18 Clay, Unknown, and Iron stood first in forage production, the average yield being 2,573, 2,366, and 2,147 lbs. per acre, respectively.

In 1916 Meyer T. S. No. 228, the leading variety in a test with soy beans, yielded 3,080 lbs., and in 1918 a single variety designated Biloxi yielded 3,980 lbs. of cured forage per acre. Four varieties of Canada field peas planted with oats on January 11 were injured by a low temperature of 15° F. in February, which reduced the yields. The highest yield of forage, 900 lbs. per acre, was secured

from the Blue Bell pea. A peanut culture test indicated that the rows should be as close as easy cultivation will allow. Peanuts planted with the pods cracked produced a slightly better stand than nuts planted with whole shells. In 1917 a 3-acre field at the station yielded 1,140 lbs. of hay and 18 bu. of nuts per acre.

Crop introduction tests were carried on with Sudan grass, sorghum, Teff grass, Russian flax, guandu or pigeon-pea, sesame, and *Amostra dehervillas*, a native of Brazil. Sudan grass gave the best yields when seeded in drills at the rate of 25 lbs. per acre. Russian flax seeded February 1, February 15, and March 7 yielded 274.5, 275, and 357.5 lbs. of seed per acre, respectively.

Of seven varieties of potatoes tested in 1916 Early Rose led with a yield of 123 bu. per acre, being followed by Dreer Early Standard and Bovee with 115.5 bu. In 1917, of the two varieties grown, Irish Cobbler yielded 86 bu. and Bliss Triumph 66 bu. per acre.

Variety tests of small grains, F. W. TAYLOR (*New Hampshire Sta. Bul. 192 (1919), p. 13*).—Results of tests made in 1918 of 3 varieties of spring wheat, 4 of barley, and 13 of oats are briefly reported. The leading varieties and their yields were as follows: Marquis spring wheat 22.1 bu., Vermont Champion barley, a two-rowed variety, 49.5 bu., and Swedish Select oats 86 bu. per acre. The average yield of wheat was 18 bu. and of barley 46.5 bu.

Disease-free sweet-corn seed, G. N. HOFFER (*Indiana Sta. Bul. 233 (1920), pp. 3-12, figs. 8*).—Experiments previously noted (*E. S. R.*, 40, p. 526) were continued in 1919 with a number of varieties and strains of sweet corn, the work being carried on in cooperation with the U. S. Department of Agriculture. Seed ears giving 100 per cent germination, but showing infection by certain harmful organisms, were compared with ears showing no infection, and the results repeatedly gave from 10 to 30 per cent increase in yield in favor of the ears apparently free of disease. The results of field observations indicated that planting too thickly in the hill or the drill either predisposes the plants to disease infection or otherwise interferes with their development, often making them stunted and barren.

In 1919 seed from apparently disease-free stalks, selected the preceding fall in Connecticut and compared at Bloomington, Ill., with seed from a bulk purchase from the same locality, resulted in an increase of about 23 per cent of cut corn in favor of the selected seed. Different grades of seed, selected on the basis of the physical appearance of the ears as indicating freedom from disease or the presence of infection, were compared at Hoopeston, Ill., with the result that differences in yield of from 0.1 to 1.5 tons per acre by the grades in each seed lot were obtained. The selection of the seed for this work was based on the absence of discoloration in the kernels and the cobs as indicating soundness and on deep yellow coloration of the butts of ears and of kernel tips and decay in the cobs as showing diseased condition.

Brief discussions are presented on sweet-corn canning problems, symptoms of root rots, importance of using the proper kind of seed corn, and control measures to avoid losses from root rots and other diseases.

[**Experiments with varieties of oats**], Å. ÅKERMAN (*Sveriges Utsädesför. Tidskr.*, 29 (1919), No. 5-6, pp. 224-226).—Three years' results with a number of varieties of oats, including several cross-bred sorts, are reported. The heaviest yield of grain, 3,563 kg. per hectare (99.5 bu. per acre) was secured from 01171 b, a cross between the Victory and Näsård varieties. This yield was closely followed by 01180 b, a cross between Victory and Crown oats, with 3,530 kg., and by Crown with 3,510 kg. of grain per hectare.

Effect of temperature on the keeping quality of potatoes, O. R. BUTLER (*New Hampshire Sta. Bul. 192 (1919), pp. 19, 20*).—In an experiment conducted

from January 26 to May 25, on the effect of reduced oxygen on the loss of weight of potatoes, tubers at a mean temperature of 9.39° C. (49° F.) stored in air lost 8.96 and 17.24 per cent of their weight, and in reduced oxygen 1.35 and 2.79 per cent in 90 and 120 days, respectively.

Prickly pear as stock feed, D. GRIFFITHS (*U. S. Dept. Agr., Farmers' Bul. 1072 (1920), pp. 3-24, figs. 8*).—This discusses the importance, forms, distribution, and feeding value of the prickly pear, together with the soil, moisture, and temperature requirements of the plant, and gives directions for its propagation, cultivation, and harvesting. Methods of feeding and shipping prickly pears are noted, and the stability of the spineless character is briefly considered.

Farm practice in growing sugar beets in the Billings region of Montana, S. B. NUCKOLS and E. L. CURRIER (*Montana Sta. Bul. 129 (1919), pp. 37, figs. 7*).—This bulletin is identical with Bulletin 735 of the U. S. Department of Agriculture (E. S. R., 40, p. 139).

Growing sunflowers in Montana, A. ATKINSON and J. B. NELSON (*Montana Sta. Bul. 131 (1919), pp. 3-11*).—A brief discussion of the characteristics and history of the cultivated sunflower is presented, and the results of tests on yields and methods of growing sunflowers are given.

In preliminary tests on the yields of the crop 36.8 tons of green silage material per acre was secured in 1915, and 31.07 tons in 1916. Dry land tests conducted in 1918 in 8 counties gave an average yield of 10.3 tons of silage per acre. Planting tests showed the largest returns from drilling in rows 30 to 36 in. apart. At the station the highest average yield for 1917-18, 41.1 tons of green forage per acre, was secured from rows 36 in. apart, while at the Huntley substation in 1918 the highest yield, 37.6 tons of silage per acre, was obtained from rows 20 in. apart. For planting, the use of the ordinary grain drill, set for rows 30 to 36 in. apart and adjusted to drop seeds 4 to 5 in. apart in the row is recommended. In 1918 the earliest planting, made at Bozeman April 29, gave the largest yields. The seed matured in only one of the 4 years the crop was tested at the station.

[**Regulations regarding the culture of tobacco in Spain**] (*Reglamento Ensayos del Cultivo del Tabaco en Españã. Madrid: Ser. Pub. Agr. Min. Fomento, 1919, pp. 24*).—These regulations pertain to licenses, methods of culture, and official inspection as prescribed and approved by the Government for the control of tobacco culture. An outline of the commissions and other administrative agencies charged with the enforcement of the regulations is also presented.

Results of seed tests for 1919, F. W. TAYLOR (*New Hampshire Sta. Bul. 193 (1919), pp. 19*).—The results for the year ended July 1, 1919, of analyzing 388 samples of seeds and testing their germination are given in tables. The work was conducted in accordance with the provision of the State pure seed law.

The forty-eighth annual report of the State seed control, K. DORPH-PETERSEN (*Tidsskr. Planteavl, 26 (1919), No. 4, pp. 625-682*).—This report discusses in general the activities pursued under the State seed control laws, and presents in detail the results of the seed inspection for the year ended June 30, 1919.

During the period covered 24,378 seed samples were tested, an increase of 5,136 samples over the preceding year. The results of germination and purity tests are given in tables and the frequency of occurrence of the principal weed seeds in the samples is noted. The relation of the results to the guaranties on the part of the seed dealers is pointed out. A financial statement for the year ended March 31, 1919, is also given.

HORTICULTURE.

Report of the department of horticulture, J. H. GOURLEY (*New Hampshire Sta. Bul. 192 (1919), pp. 27-31*).—In connection with the long-continued fruit bud formation study, the data on which are being prepared for publication, studies on the influence of light and of ringing and root pruning were commenced. A tent was erected over two Duchess apple trees in order to determine whether the fruit bud formation could be affected by a reduced intensity of sunlight. In one case the covering was a muslin cloth and in the other a cheesecloth. At the time of the present report a difference was observed between color of the foliage and fruit of the two trees. A decided contrast was also observed between the foliage under cover and a similar foliage not covered. In connection with this study soil and air temperature records are being taken, and an attempt is to be made to measure the intensity of the light under the two covers.

Attempts to propagate blueberries from cuttings have been unsuccessful, whereas the division and transplanting of rooted plants has given good results.

Some experimental work was conducted in the storage of root crops and cabbage. The conclusions drawn from this work were that if good cellar storage is available the storing of roots in pits is hardly advisable because the quality deteriorates faster than in cellar storage. Cabbage, on the other hand, when given proper protection comes out of the storage pit in better condition than when kept in cellar storage.

[**Report on horticultural investigations**], F. M. ROLFS (*Oklahoma Sta. Rpt. 1919, pp. 44-49*).—Observations on the blossom drop of tomatoes were continued by F. B. Cross during the year. So far as it was possible to determine no organism was associated with this trouble. There were numerous evidences of incomplete pollination, such as small fruit without seed and irregular fruit having a normal seed development on one side and few or no seeds on the other. Septoria leaf spot was specially abundant, and Fusarium wilt ruined a number of plants in two of the experimental plats. One or two very strictly physiological diseases were under close observation and will be reported on later. Mulching with straw again increased the yield. Irrigation proved beneficial, but somewhat less so than the straw mulch. Pruning increased the size, producing a high percentage of marketable fruit.

Some progress is reported on the studies of fruit bud development (E. S. R., 40, p. 638.) Spraying operations on these plats were somewhat interfered with by inclement weather conditions, consequently apple blotch and codling moth were prevalent. The bacterial leaf spot (*Bacterium pruni*) is still abundant on all stone fruit trees, and the influence of this organism on foliage and twigs of the trees is becoming more marked each year. During the past year the peach buds on the west side orchard were weakened by the attacks of this organism, and most of the buds were completely killed by June 1. The cherry buds were also more or less infected, the sweet cherries suffering more than the sour cherries. From the results of fruit bud studies during the past two years it appears that too late cultivation does not always give satisfactory results and in some cases tends to weaken the trees, making them more sensitive to winter injury. Mulching with straw on both the peach and cherry appears to stimulate fruit bud formation and tends to make them more resistant to cold.

[**Variety tests with truck crops**], G. T. McNESS (*Texas Sta. Bul. 254 (1919), pp. 21, 22*).—Brief notes are given on the value of different varieties of green peas, beans, radishes, lettuce, watermelons, and cantaloups for east Texas conditions, based on tests conducted at the Nacogdoches substation.

Some experiments with tomatoes, A. J. OLNEY (*Kentucky Sta. Bul. 218* (1918), pp. 149-159, pls. 6).—The results are given of a series of experiments with tomatoes started in the spring of 1916 to determine the effect of various methods of pruning and staking on the yield, earliness of ripening, and size of the individual fruits. Some data were also secured relative to methods of raising plants, planting distances, proper length of stakes, etc.

Summing up the results of three seasons' work, the author found that pot-grown plants were much more productive than flat-grown plants. Staking and pruning reduces the yield of marketable fruit per plant, but increases the yield per acre because of the the greater number of plants that may be set. Generally speaking, the yield per plant is in direct proportion to the number of bearing stems. On the whole, pruning to two stems has given the best results.

Pruning increased the size of the individual fruits, and pruned and staked tomatoes ripened approximately one week earlier than those untrained. Plants trained to two stems, set 2 by 4 ft. apart, yielded less per plant but much more per acre than similar plants set 4.5 by 5 ft. apart and also more per acre than untrained plants set 4.5 by 5 ft. apart. A range in length of stake from 4 ft. 2 in. to 5 ft. 6 in. has little effect on the total yields.

The author concludes that it does not pay to stake and prune tomatoes for the canning factory, although it may pay in the home garden or in very intensive trucking areas. The cost of stakes, the additional labor involved, and the greater number of plants required may be the limiting factors for profitable staking and pruning.

[Report on fertilizer experiments with tomatoes], G. T. McNESS (*Texas Sta. Bul. 254* (1919), pp. 8-10).—Tabular data are given on a 4-year experiment conducted at the Nacogdoches substation. Cottonseed meal, acid phosphate, sulphate of potash, nitrate of soda, and barnyard manure were used in the test.

Averaging the results for the 4-year period, 20 loads of stable manure gave much better yields and much greater profit than any other fertilizer used. Combinations of cottonseed meal with acid phosphate or with sulphate of potash gave much better results than when any of these three ingredients were used alone. An application of 200 lbs. of acid phosphate and 200 lbs. of cottonseed meal per acre gave a marked increase in yield and value after deducting the cost of the fertilizer. Two hundred lbs. of cottonseed meal and 50 lbs. of sulphate of potash per acre also gave good results.

Analyses of materials sold as insecticides and fungicides during 1919, C. S. CATHCART and R. L. WILLIS (*New Jersey Stas. Bul. 339* (1919), pp. 5-21).—Results are given of analyses of Paris green, lead arsenate, Bordeaux mixture, lime-sulphur solution and substitutes, soluble sulphur compounds, nicotin preparations, and miscellaneous materials sold in New Jersey during 1919.

[Spray calendars for orchard fruits] (*New Jersey Stas. Circs. 116* (1920), pp. 4, figs. 3; 117 (1920), pp. 4, figs. 3; 118 (1920), pp. 3, fig. 1; 119 (1920), pp. 3, fig. 1; 120 (1920), pp. 3, fig. 1).—A set of spray calendars for apples and quinces, peaches, pears, plums, and cherries, respectively. The present calendars have been adopted by the entomologist, plant pathologist, and acting horticulturist of the New Jersey Stations as being the most satisfactory for that State and supersede similar earlier circulars.

United States export trade in apples (*U. S. Dept. Com., Com. Rpts., No. 50* (1920), pp. 1207-1213).—The yearly exports and average annual prices of dried and green or ripe apples are given for the period of 1913-1919, inclusive, also the variations in quantity, value, and average price in the export trade

monthly during 1919, and the distribution of the exports by principal countries during November and December and for the calendar year 1919.

It is noted that during the five fiscal years, 1914-1918, the United Kingdom took 60 per cent of the quantity and 59 per cent of the value of the total exports of fresh apples from this country. Next to the United Kingdom, Canada, Argentina, Brazil, and Australia were the best markets during the war for American fresh apples. A brief history of the export prices from 1791 to January, 1920, is given; imports of green and dried apples for the first three-quarters of 1919 are shown; and the domestic production, the leading apple-producing sections, and the varieties produced in different regions are described.

Cold storage for Iowa apples.—A, Control of certain diseases of cold-stored apples; B, Changes of temperature in cold-stored apples, W. E. WHITEHOUSE (*Iowa Sta. Bul. 192 (1919), pp. 179-216, figs. 14*).—A report of progress made in the station's long-continued apple-storage investigations (E. S. R., 30, p. 41). The first part of the report contains the results of investigations and observations relative to the development and control of apple scald and certain apple rots. The second part discusses changes in temperature of cold-stored apples, as affected by different methods of packing the fruit. A bibliography of related literature is given, and the station's cold-storage plant is described.

Summing up the results of his study, the author concludes that temperature is a very important factor in the control of apple scald and of other more common diseases of apples in cold storage. A constant storage temperature not higher than 32° F. has given the best control of these diseases. It is concluded, however, that the losses in storage from apple rots may be practically eliminated by proper spraying, harvesting, handling, grading, and packing the fruit, keeping it at a constant low temperature and removing it from storage before the storage season for the particular variety in question closes. No correlation was found between the size of the apples and the amount of scald developing on them in storage, but the largest apples were generally attacked more quickly by rots in storage than smaller apples of the same variety, other things being equal. Apple scald makes fruit more susceptible to the entrance of rot fungi. *Alternaria* rot, which is a black fungus growth, develops readily on the badly scalded portions of the fruit and hastens decay. The author has had under observation an unidentified dry brown rot, which appeared on both Jonathan and Northwestern Greening apples, developing sunken areas in which the skin becomes a clear-brown color, varying from a medium to a rather light tone and remains unbroken. The flesh beneath becomes dry and brown, or brownish, to a depth of 0.125 to 0.25 in. All attempts to isolate a causal parasitic or saprophytic organism from the affected tissue have thus far failed.

Humidity was found to bear some relation to the development of apple scald, but was less important than temperature. Less scald developed in a relative humidity of from 60 to 70 per cent than in one of from 80 to 90 per cent. Wrapping apples in paper delayed the appearance of scald during storage. Paraffined paper retarded scald more than ordinary wrapping paper, but the difference was too slight to be of commercial importance. Immature fruit scalded readily in storage. Whatever the variety of apples under consideration it is in the best condition for cold storage when it is well colored and hard ripe. If the fruit must be picked early to avoid freezes it may be held at ordinary temperatures until it more nearly reaches the best degree of maturity for cold storing. Apples in prime maturity for cold storing will scald more quickly in common than in cold storage. Iowa-grown Mammoth Black Twig and Sheriff apples can be stored with only fair success in common storage houses, and should be allowed to get as much red color as possible before packing.

Observations on temperature changes in cold storage showed that it requires 30 to 60 hours to reduce the temperature of fruit in the center of a box or barrel from a temperature round 70° down to 35°, the temperature of apples in boxes being reduced sooner than that of apples in barrels. Unwrapped apples packed in boxes were more quickly affected by changes in storage temperatures than similar wrapped apples. Small changes in room temperatures do not materially change the temperature of fruit in the package, particularly of wrapped fruit. The author points out the importance of not exposing picked apples to the sun either in the orchard or in the packing shed, as they absorb considerable heat, and when first placed in cold storage apples which have absorbed heat during the day do not cool off readily at night even though the nights are comparatively cool. When the fruit is ready for storage it should be cooled to 32° as quickly as possible.

Fruit cool storage: Experiments with apples and pears, G. ESAM (*New Zeal. Jour. Agr.*, 20 (1920), No. 1, pp. 10-18).—The results are given of experiments conducted under the direction of the New Zealand Department of Agriculture at Hawke's Bay in 1919 to determine the effects of different methods of picking, handling, and packing apples and pears on the cold storage of fruit. In brief the results indicate that a good many faults attributed to cool storage lie in the unsatisfactory condition in which the fruit is often placed in store.

Effect of temperature on the resistance to wounding of certain small fruits and cherries, L. A. HAWKINS and C. E. SANDO (*U. S. Dept. Agr. Bul.* 830 (1920), pp. 6, fig. 1).—Puncturing experiments were conducted with red and black raspberries, blackberries, strawberries, and cherries, with the view of determining the influence of temperature on the resistance of the epidermis of the fruit to wounding. A modified Joly balance, here illustrated and described, was used in puncturing the fruit.

The results of these tests show that the average pressure required to puncture fruits that have been cooled is considerably more than that required for warm fruit. This was true not only for freshly picked, warm and cooled fruit, but also for fruit that was maintained at ice-box temperature (about 16° C.) for 24 hours, tested upon removal from the ice box, and tested again after warming to room temperature. Washing in tap water without lowering the temperature did not apparently increase the resistance of the fruit in puncturing. The test as conducted with red raspberries indicates that certain varieties may be more readily punctured either when fresh or after cold storage than others.

It is suggested that this increase in the resistance of the skin to mechanical injury is an important factor in the favorable results obtained in the prompt cooling and refrigeration of berries. It would seem also that the picking of berries in the early morning when they are cool, as is quite commonly practiced in some regions, would be decidedly advantageous since the evidence obtained indicates that berries moist with dew would not be more susceptible to injury than dry fruits. Although no attempt was made to determine the reason for the increase in resistance to puncture due to cooling the authors suggest that the surface of the fruit might be covered with a wax, which softened at the higher temperature but became hard and more resistant when colder. Another purely mechanical explanation is that the walls of the drupelets or of the external cells of the fruits have a lower coefficient of expansion than their contents. If this were the case the walls would be under greater strain at higher temperatures and would therefore puncture more easily.

An index of hardiness in peach buds, E. S. JOHNSTON (*Amer. Jour. Bot.*, 6 (1919), No. 9, pp. 373-379, figs. 2).—A contribution from the Maryland Ex-

periment Station, presenting the results of determinations of the moisture content of fruit buds of two varieties of peaches during the winter of 1918-19. The two varieties selected for this study were the Elberta and Greensboro, the latter of which is considered more hardy with respect to winter injury. Buds were selected from trees growing on high ground, on low ground, and from trees receiving varied fertilizer treatment. The determinations were made at monthly intervals beginning with November 8 and ending with March 7, a final analysis being made on March 28.

With few exceptions the amount of moisture in proportion to dry weight of the Elberta fruit buds was greater than that of the Greensboro buds. No great differences were apparent between the ratio values of buds taken from trees growing on high ground and from those growing on low ground. There was no uniformity of differences between trees receiving fertilizer treatments.

There was a marked seasonal increase in the water content of the fruit buds of both varieties, whether determinations from individual trees or from averages are considered. As the season advanced the difference between the water content of the fruit buds of the two varieties became more marked, the values for Elberta, the less hardy variety, being the greater.

These results suggest further investigation to determine whether this variation in moisture content is a varietal characteristic, and to what extent such moisture content values are related to hardiness of the fruit buds. A list is given of cited literature dealing with studies relating to the resistance of plants to low temperatures.

Productive small fruit culture, F. C. SEARS (*Philadelphia and London: J. B. Lippincott Co., 1920, pp. IX+368, pl. 1, figs. 196*).—This is one of a series of farm manuals edited by K. C. Davis. It treats in detail of the growing, harvesting, and marketing of strawberries, raspberries, blackberries, currants, gooseberries, and grapes.

The resistance to drought of various graft-stocks, H. SICARD (*Prog. Agr. et Vitic. (Ed. l'Est-Centre), 41 (1920), No. 11, pp. 256-262*).—A contribution from the Central Agricultural Society of Hérault, comprising notes on the drought resistance of a number of grape stocks.

The author concludes that for the deep, strong, calciferous soils included in the study the stocks best suited to resist a prolonged and intense drought are the hybrids of *Vinifera* × *Rupestris*. These have shown a notable superiority over pure American and America-American and even *Vinifera* × *Berlandieri* stocks.

The preservation of vines from spring frosts, L. DEGRULLY (*Prog. Agr. et Vitic. (Ed. l'Est-Centre), 41 (1920), No. 11, pp. 245-254, figs. 8*).—A popular discussion of different methods used with more or less success in protecting plants from spring frosts.

[**Report on fruit investigations**], S. L. AJREKAR (*Ann. Rpt. Dept. Agr. Bombay, 1917-18, pp. 75, 76*).—In continuation of a previous report by Burns (E. S. R., 42, p. 736), brief notes are given on experimental work for the year 1917-18 with the mango, citrus fruits, guava, papaya, grape, fig, banana, and other fruits.

[**Notes on bananas, citrus fruits, and spices**] (*Fiji Dept. Agr. Ann. Rpt. 1918, pp. 4-6*).—Notes are given on the life history of China and Gros Michel banana plants planted in 1917, together with an outline of selection studies to be conducted with the view of increasing the vitality of banana plants in Fiji. Tests of various citrus fruits and spices are briefly noted.

The cambuci (*Paivæa langsdorffii*), P. CAMPOS PORTO (*O. Cambuci. Rio de Janeiro: Jardim Bot., 1920, pp. 14, pl. 1, figs. 8*).—A contribution from the Botanical Garden of Rio de Janeiro describing a myrtaceous tree native to the

State of Sao Paulo, Brazil. This tree, it is believed, through cultivation and selection should prove of economic value, both as an ornamental and for its acid fruit, which is locally used in making cooling beverages, conserves, etc.

Necessity of selecting stocks in citrus propagation, H. J. WEBBER (*Cal. Citrogr.*, 5 (1920), No. 6, pp. 177, 198, 199, figs. 5).—A summary of experiments with citrus stocks conducted at the California citrus substation (E. S. R. 42, p. 537), in which the author emphasizes the importance of producing seedling stocks of known characters.

Injurious effects of the windstorm of November 20, 1919, H. S. REED (*Cal. Citrogr.*, 5 (1920), No. 6, pp. 178, 200, 201, figs. 2).—A contribution from the California citrus substation, discussing the nature and extent of injury to citrus trees in certain localities in southern California during the three days' windstorm which began on November 20, 1919. Tabular data are given which show temperature, wind, and humidity conditions at various stations during the storm.

Causes of decay in citrus fruits, O. F. BURGER (*Fla. Univ. Ext. Bul.* 24 (1920), pp. 22-25).—A contribution from the Bureau of Plant Industry of the U. S. Department of Agriculture, in which the author points out the relation of faulty methods of picking, handling, and packing to the subsequent development of fungi and bacteria in citrus fruits.

The classification of chestnut varieties, D. VIGIANI (*Staz. Sper. Agr. Ital.*, 52 (1919), No. 5-6, pp. 266-277).—The author reviews different methods used in classifying the European varieties of chestnuts and presents a classification of 74 varieties, based primarily on the general form of the nut and secondarily on the form of the apex.

Pecan varieties, C. A. REED (*Proc. Natl. Nut Growers' Assoc.*, 18 (1919), pp. 36-41).—A description of the better-known varieties of pecans, including also a classification of the varieties into groups. In these are separated varieties proved to be adapted to a large portion of the pecan territory, varieties adapted to the northern part of the pecan territory, new varieties, promising varieties, less promising varieties, varieties of doubtful value, and those that should be eliminated at once.

Pecan grades and standards, C. A. REED (*Proc. Natl. Nut Growers' Assoc.*, 18 (1919), pp. 80-83).—This is the report of the committee appointed by the National Nut Growers' Association to determine grades and standards for pecans. It reviews work undertaken along this line by the U. S. Department of Agriculture, and presents the committee's recommendations relative to the general principles involved in establishing sizes and grades.

The crisis in medicinal plants and our African colonies, F. CORTESI (*1st. Colon. Ital., Mem. e Monog. Colon., Ser. Econ. No. 3* (1919), pp. 36).—A compilation of official medicinal plants growing in Eritrea, Somali, and Libya, together with a bibliography and related commercial and statistical data. In view of the world shortage of medicinal plants, the author recommends the utilization of this hitherto practically unexploited source of supply.

FORESTRY.

The relation of research in forest products to forest administration, O. M. BUTLER (*Jour. Forestry*, 18 (1920), No. 3, pp. 275-283).—A discussion of research in forest products, with special reference to its influence upon forest practices.

Report of the department of forestry, K. W. WOODWARD (*New Hampshire Sta. Bul.* 192 (1919), pp. 26, 27).—Growth data are given on 6 sample forest areas planted in 1912. Of the species planted, Scotch pine, European larch, and

Norway spruce are growing thriftily. Red pine and Douglas fir are making less satisfactory growth, and white ash died on account of excessive moisture.

Experiments were started in 1912 to determine the best methods of thinning immature white pine stands. The work thus far conducted shows that white pine is seriously checked by overtopping hardwoods with the possible exception of gray birch. The removal of these overtopping hardwoods leads to an immediate increase in growth provided the pines have not been suppressed too long.

Preliminary report on chemical weed control in coniferous nurseries, P. C. KITCHIN (*Jour. Forestry*, 18 (1920), No. 2, pp. 157-159).—A brief summary of results thus far secured in several National Forest nurseries, including tabular data on work done by E. C. Rogers at the Savenac nursery, Haugan, Mont.

Although the work at Savenac was done primarily with the view of controlling damping-off fungi through the use of chemicals, records were also kept of weed growth on the various plats during 1917. The results secured indicate that zinc and copper salts may be efficient in destroying weeds shortly after germination, at least in the type of soil used. Experiments have been continued at Savenac with different strength solutions of copper sulphate, zinc sulphate, and zinc chlorid.

The management of hardwood forests in the southern Appalachians, I. F. ELDRIDGE (*Jour. Forestry*, 18 (1920), No. 3, pp. 284-291).—A discussion of the preparation of management plans applicable to the hardwood forests in the southern Appalachians, with special reference to the National Forests of that area.

Handbook of forest protection.—California forest fire laws, 1919 (*Sacramento: Cal. State Bd. Forestry, 1919, p. 57*).—The present handbook was prepared primarily for the State fire wardens and also to inform the general public of the statutes designed to prevent and extinguish forest fires outside the limits of incorporated towns and cities.

Organization for the national control of forest devastation, F. E. OLMSTED (*Jour. Forestry*, 18 (1920), No. 3, pp. 242-247).—The author here presents an outline indicating some of the fundamental principles which might govern in framing the essential administrative machinery for the national control of forest devastation.

The economics of private forestry, B. P. KIRKLAND (*Jour. Forestry*, 18 (1920), No. 3, pp. 214-217).—A contribution from the University of Washington, in which the author discusses certain misconceptions that have arisen with the commonly advanced point of view that private forestry is uneconomic. Special attention is given to the rights of private property, interest returns and capitalization, and taxation.

Shall we capitalize our forests? B. A. CHANDLER (*Jour. Forestry*, 18 (1920), No. 3, pp. 218-228).—A contribution from Cornell University, in which the author takes the stand that our forests should be capitalized and discusses different methods of financing forest operations.

Annual progress report upon State forest administration in South Australia for the year 1918-19, W. GILL (*Ann. Rpt. State Forest Admin. So. Aust., 1918-19, pp. 12, pls. 10*).—The usual progress report on the administration of the State forests in South Australia, including data on the area of forest reserves and plantations, tree planting operations, revenues, and expenditures. Several forest plantation plans are appended.

Afforestation in Zululand, J. S. HENKEL (*Rhodesia Agr. Jour.*, 17 (1920), No. 1, pp. 50-52).—Notes on the present condition of forest species that have been tested for a number of years at the Government experiment station at

Empangeni, Zululand. The best results have been secured with Eucalyptus. With a few exceptions, various kinds of conifers tested have not been a success.

Investigations on the bark-anatomy of Hevea, P. E. KEUCHENIUS (*Arch. Rubbercult. Nederland. Indië*, 4 (1920), No. 1, pp. 5-26, figs. 18).—A further contribution on the formation and development of latex rings in Hevea rubber trees (E. S. R., 40, p. 448). The author's method of studying latex rings is described.

The average yearly increase in latex rings was found to be correlated with the quality of soil and the girth increase, consequently only vigorous stocks should be used for building purposes. The rate of formation of latex rings is variable. Periods of strong growth and periods of little development may occur, hence the irregular arrangements of latex rings in Hevea.

High-yielding trees may deteriorate in yield when the original bark is tapped off, and poor trees may be improved by the same operation. From the standpoint of latex-ring renewal, a 6-year tapping system is preferable to a 4-year system.

The latex rings greatly increase in number in the inner part of the bark, hence trees infected with the brown bast disease should be scraped rather than peeled in order to preserve latex rings in the deeper uninfected portion of the bark. At the base of the stem the activity of the cambium for the formation of latex rings is greater than higher up.

Tapping experiments on Hevea brasiliensis, A. W. K. DE JONG (*Arch. Rubbercult. Nederland. Indië*, 4 (1920), No. 1, pp. 32-36).—A progress report on tapping experiments being conducted at the Buitenzorg Experimental Station (E. S. R., 40, p. 843).

Of the nine tapping systems tried in this experiment, two left cuts on a quarter seem to be the best for the growing conditions at Buitenzorg.

The influence of heavy tapping on the chemical constitution of the latex, W. H. ARISZ (*Arch. Rubbercult. Nederland. Indië*, 4 (1920), No. 1, pp. 27-31).—A review of analyses made by L. R. E. Schulz van Vlissingen at the Besoeki Experimental Station.

In the case of a tree tapped with a circular cut clear to the wood, the proportion between the resinous substances and the rubber remained constantly the same, and independent of the concentration of the rubber in the latex. During the first two weeks of tapping the concentration of the organic substances in the serum remained the same, but after this period the constitution of the serum changed through a shortage of organic matter.

The concentration of the nitrogenous substances in the latex remained about the same during the first few days of tapping, but afterwards decreased as much as one-half of the original concentration. A somewhat smaller shortage of nitrogenous matter also occurred in the rubber. The concentration of the inorganic substances in the serum remained practically the same.

Kauri-gum industry, R. P. GREVILLE (*New Zeal. Govt. Kauri-gum Off. Rpt.*, 5 (1919), pp. 7).—A progress report on the New Zealand Kauri-gum industry, including a financial statement for the year ended March 31, 1919.

The western larch (*Larix occidentalis*) on the Brocklesby Park Estate, Lincolnshire, W. B. HAVELOCK (*Quart. Jour. Forestry*, 14 (1920), No. 2, pp. 96-100).—Growth measurements are given on several lots of larch tree largely planted in 1912 in admixture with various other species.

European and Japanese larch at Brocklesby Park, W. B. HAVELOCK (*Quart. Jour. Forestry*, 14 (1920), No. 2, pp. 101-103).—Comparative data are given on the growth of several lots of Japanese and European larch planted on the above-noted estate in the spring of 1899.

Durability tests with inferior local woods, H. W. MOOR (*Bul. Dept. Agr. Trinidad and Tobago*, 18 (1919), No. 4, pp. 204-206).—A preliminary report is given on durability tests that are being conducted under the direction of the forest department of Trinidad, with the following six of the most inferior and least durable native species: Hog plum (*Spondias lutea*), mahoe (*Sterculia caribaea*), jiggerwood (*Bravaisia floribunda*), Bois Lais Lais, silk cotton (*Eriodendron anfractuosum*), and Chataigne (*Pachira insignis*). The data here presented deal with seasoning and impregnation operations conducted preliminary to the durability test.

Significant trends in lumber production in the United States, F. H. SMITH (*Amer. Forestry*, 26 (1920), No. 315, pp. 143-147, fig. 1).—The author presents and discusses tabular data showing the history of the lumber industry of the country at 10-year intervals from the middle of the last century. Data are also given showing the annual consumption of timber of various kinds in the United States.

DISEASES OF PLANTS.

Some practical applications of phytopathology, L. PETRI (*Alpe [Italy]*, 2. ser., 6 (1919), No. 6, pp. 125-136, figs. 2).—The author presents in this article (the first of a series) selected materials briefly illustrative of enterprises in different regions and in various fields as regards phytopathological studies and other activities.

Report of the department of botany, O. R. BUTLER (*New Hampshire Sta. Bul.* 192 (1919), pp. 17-19).—An account is given of the research work carried on in the department, which includes studies on the effect of fungicides and insecticides on plants, structure of the fruit spur of the apple, the toxic action of fungicides, the control of white pine blister rust on *Ribes*, and the control of snapdragon rust.

The work with cuprammonium washes has been previously noted (E. S. R., 38, p. 255). With Bordeaux mixture, the investigation has been continued, and it was found that transpiration was increased by spraying with a 1 per cent Bordeaux mixture, but the increased transpiration was not due to the copper salt but to the excess of lime. One per cent Bordeaux mixture was found to not stimulate plant growth, but had a depressing affect which was more marked in weak than in strong light. Data on the relative toxicity of cuprammonium washes the spores of *Plasmopara ribicola* are reported.

Field experiments on the control of snapdragon rust by means of dry sulphur proved ineffective under the temperature conditions prevailing.

Report of the botany department, C. O. CHAMBERS (*Oklahoma Sta. Rpt.* 1919, pp. 33, 34).—A study of the value of windbreaks as related to evaporation was impaired by the abundance and distribution of the rainfall. Studies on methods for combating smuts of grains and sorghums indicate the need of caution in following the instructions ordinarily given.

This report also includes notes of the plant disease survey. Among the more common plant diseases reported are wheat black chaff and apple scab, this being the first appearance in the State of these diseases. Importance also attaches to cereal rusts and smuts; false rust of corn; root rot and angular leaf spot of cotton; brown rot and scab of stone fruits; and leaf spot and wilt of tomato.

Annual report for 1917 of the botanist, R. H. BIFFEN (*Jour. Roy. Agr. Soc. England*, 78 (1917), pp. 201-209).—This report details with discussion the method now in use for testing and estimating the degree of purity of grass seeds. An account is also given of the relation of cereal crops to weather; of the potato crop as affected by late blight and other factors; of root, grass, and clover

crops; and very briefly, of specific plant diseases, those due to fungi having been generally less injurious this year than formerly.

Annual report for 1918 of the botanist, R. H. BIFFEN (*Jour. Roy. Agr. Soc. England*, 79 (1918), pp. 254-258).—This report deals principally with fungus diseases of plants, in particular of potato and wheat which have suffered principally during the year. Spraying with Bordeaux mixture proved beneficial. Wart disease is reported in fresh outbreaks, constituting an alarming advance toward the great potato-raising district of England.

Wheat was attacked in different sections by yellow rust (*Puccinia glumarum*), and by black rust (*P. graminis*). Bunt was unusually abundant. Loose smut of wheat was also common. Mildew was reported on all cereals, causing serious damage to wheat in one locality. Rotting of yellow globe mangolds during February proved to be due to *Botrytis*. Rust was reported on mangolds, also finger-and-toe, soft rot, and mildew (as affecting swedes). Reports were made on bean rust and clover sickness, and frequently of scab and canker on apples, brown rot on apples and plums, and rust on plums. Glassy disease of apples (causation obscure) was also reported.

[Report of] **laboratory for plant diseases, C. J. J. VAN HALL** (*Jaarb. Dept. Landb., Nijv. en Handel Nederland. Indië, 1917*, pp. 22-31).—In this portion of a report of wider scope, an account is given of diseases affecting plants and of related investigations and publications.

Notes on mycology during 1918, W. N. C. BELGRAVE (*Agr. Bul. Fed. Malay States*, 3 (1919), No. 7, pp. 141-143).—The mycological section has been chiefly engaged during the year with diseases of rubber.

The study of brown bast has yielded no positive results, no causal organisms having been identified. No serious epidemic of black stripe (*Phytophthora* sp.) developed during the year. Moldy rot (*Sphaeronema* sp.) was also held in check by weather conditions during most of the year. During the drought in the early part of 1918, a greenish-black mold appeared on recently tapped surfaces which proved to be due to a species of *Cladosporium*, and to be successfully treated by tarring. A canker of obscure causation produced extensive damage in one locality.

Following the drought, many estates suffered from yellowing and falling of the leaves, followed by die-back of the branches and in some cases by death of the tree. The fungi isolated include *Diplodia* sp., *Glæosporium* sp., *Colletotrichum* sp., *Cytospora* sp., and *Helminthosporium* sp. A soft heart rot starting from the stumps of broken branches yielded a fungus which proved to be a *Dædalea*, which reproduced the disease. The wet rot fungus originally described as *Poria hypolateritia* was provisionally named *Fomes pseudoferreus*. Diseases identified or investigated on other crops were *Glæosporium* sp. on pepper, *Sclerotium* sp. and bacteria on an imported variety of castor bean, and *Ustilaginoidea* sp. on rice.

Leaf-stripe of barley [in Scotland] (*Scot. Jour. Agr.*, 2 (1919), No. 4, pp. 535, 536).—The barley leaf stripe fungus (*Pleospora graminea*) is said to be present in nearly every field of barley, early sowings in cold soil giving large percentages (reaching 30 per cent) of infected plants. It is said to be more prevalent in 4- or 6-rowed barley than in 2-rowed varieties, also in the varieties with short, broad, and erect ears.

Seed treatments, constituting the only protection available, are outlined.

Barberry eradication, H. E. MORRIS (*Rpt. Proc. Mont. State Hort. Soc.*, 22 (1919), pp. 113-116).—After a discussion of barberry destruction operations, the author states that as a result of his own observations a considerable number of barberries were located in the western part of Montana and rusted

leaves were found in several localities which are indicated. In four cases stem rust was found on wheat, in every case closely associated with rusted barberry.

Studies in the physiology of parasitism.—V, Infection by *Colletotrichum lindemuthianum*, P. K. DEY (*Ann. Bot. [London]*, 33 (1919), No. 131, pp. 305–312, pl. 1).—This is a continuation of the series previously noted (E. S. R., 39, p. 247.

In the present work the author investigated the stages of development and infection in bean as occasioned by *C. lindemuthianum* in order to ascertain whether this fungus acts as does *Botrytis cinerea*. It is stated that the spore of *C. lindemuthianum* when germinating on bean produces a germ tube which develops into a thick-walled, dark-colored appressorium. This attaches itself closely to the surface of the bean pod by the help of a mucilaginous envelope. From this contact surface a peg-like infection hypha grows out which ruptures mechanically the cuticular layer and brings about a swelling of the subcuticular layers, supposedly by enzym action, without causing apparently any swelling, disorganizing, or other chemical action upon the cuticle.

The general conclusion reached is that the mechanism of penetration by *C. lindemuthianum* is in all respects similar to that of *B. cinerea*.

Blackleg—a destructive cabbage disease, R. E. VAUGHAN (*Canner*, 49 (1919), No. 2, pp. 59, 60, figs. 3).—Extensive losses were caused in portions of Wisconsin during 1918–19 by cabbage blackleg (*Phoma lingam*). No resistant varieties or strains have been found. Seed treatment with corrosive sublimate 1:500 provides the most satisfactory control measure, though rotation does much to check the disease.

The difficulties of growing red clover—clover sickness, and other causes of failure, A. AMOS (*Jour. Roy. Agr. Soc. England*, 79 (1918), pp. 68–88, figs. 5; *abs. in Rev. Appl. Ent., Ser. A*, 7 (1919), No. 11, pp. 441, 442).—Of the six groups of causes of failure in clover crops as here dealt with, the author discusses in some detail nematode attack (*Tylenchus devastatrix*), stem rot (*Sclerotinia trifoliorum*), and the alleged excretion of toxic substances by the clover plant as causing clover sickness. It is concluded that the evidence at hand to date as regards excretion of toxic substances is insufficient.

Nematode attack is best combated by avoiding all crops which are susceptible to this disease for at least eight years. Stem rot disease is also to be combated by rotation, avoiding for instance the planting of red clover within two years of beans.

Degeneration in potatoes, O. B. WHIPPLE (*Montana Sta. Bul.* 130 (1919), pp. 29, figs. 16).—The results are given of five years' observation and experimental work on the possible degeneration or running-out of potatoes. In the course of the experiments selection plats were maintained and planted on the tuber unit and tuber line plan.

The relation of degeneration to various physiological diseases is pointed out, and in case of spindle-sprout and yellow-top degeneration may take place suddenly and completely. Mosaic disease does not seem to be unlike curly dwarf in this respect, in which case the plants from a single tuber are either all normally vigorous, intermediate, or all typically curly dwarf degenerates. Curly dwarf is apparently unlike other forms in that the deterioration takes place gradually. Intermediate types exist that may be readily distinguished from normal vigorous plants. In special seed plats, the intermediate type should be eliminated before degeneration has advanced to a point where it seriously impairs yielding qualities. Foliage characteristics are said to be the most reliable indicators of degeneration tendencies. Depth of eyes of the tuber is said to be correlated with degeneration, and efforts to improve the types of existing varie-

ties by the selection of shallow-eyed seed tubers should be undertaken, according to the author, with extreme caution.

Rhizoctonia disease, or stem rot, on potatoes, D. G. O'BRIEN (*Scot. Jour. Agr.*, 2 (1919), No. 4, pp. 482-491, pls. 8, figs. 4).—In addition to a general account of the rot disease of potatoes caused by *R. solani* on potato tubers and also by *R. violacea* (*R. crocarum*) on the tuber or stem, a more detailed account is given of this disease, which was found by the author to be widespread in Scotland about two years previous to this report. A large percentage of market potatoes were affected, particularly those from the red soils of Scotland. A bibliography on the subject is appended.

Certification of stocks of varieties of the potato which are immune from wart disease (*Scot. Jour. Agr.*, 3 (1920), No. 1, pp. 52-66, pl. 1).—Recent reports show that potato wart disease is more widespread than was previously supposed in England and Scotland, large areas having now been declared infected.

Studies carried out during recent years encourage the hope of developing popular potato varieties immune to wart disease. The certification of seed in sufficient quantities after growing the crops under rigid inspection is expected to assure a supply of pure stocks of immune varieties. Good results have already begun to appear after a trial continuing for two years. This article is mainly concerned with the identification of rogues and of immature varieties and the prevention of deterioration from disease.

Eradication as a means of control in sugar cane mosaic or yellow-stripe, F. S. EARLE (*Porto Rico Dept. Agr. Sta. Bul.* 22 (1919), pp. 17).—In a previous publication (*E. S. R.*, 41, p. 347), suggestions were given for the control of the sugar cane mosaic which included eradication and the use of resistant or tolerant varieties. In the present publication, an account is given of a year's work on the control of the disease by the method of eradication. Eradication includes the planting only of healthy seed and, when suspected seed has been used, the frequent inspection of the field and removal of all plants showing disease. A survey was made of a number of plantations where this method had been put in practice, and it is believed that the cane mosaic or yellow-stripe disease can be controlled in this way in all regions where a supply of healthy seed can be obtained. In regions of complete infection, the establishment of healthy seed fields is necessary before a campaign of eradication can be undertaken.

Root-knot disease of tomatoes, R. ROBSON (*Jour. Roy. Hort. Soc.*, 44 (1919), pp. 31-67, pls. 4).—Records of experimentation carried out during 1915-1917 on tomato subsoils infested with *Heterodera radicola* are presented in tabular and other detail, with discussion. This experimentation, carried out under glass, was based on the assumption that the substances to be applied to the soil would inhibit or destroy the nematodes; that such substances if inhibitory to the tomatoes would gradually be carried downward by the processes involved in watering; that a layer of soil impregnated with inhibitory substance would prevent the ascent of the nematodes; and that the tomatoes would find adequate growth conditions above the poisonous layer.

It was found that sodium or potassium cyanid applied at half a ton per acre or corrosive sublimate at 3 cwt. will free the subsoil from nematodes at a cost of about £50 per acre. Carbolic acid, while effective, is more expensive. Cresylic acid is more expensive and less effective. Creosote applied pure is useless, though saponified creosotes tend to check nematodes. Several other substances are discussed in this connection.

Finger-and-toe [in turnips], J. A. SYMON (*Scot. Jour. Agr.*, 3 (1920), No. 1, pp. 34, 35).—The prevalence of finger-and-toe in turnips in the north of

Scotland is ascribed to insufficient available lime in the soil, the presence of cruciferous weeds in the field, or the carrying of infection by grazing animals.

Investigation during recent years has shown that lime dressings may have some advantage. Mangels should replace turnips where this is possible. Working the land in dry condition reduces infection. Resistant strains are preferable.

The brown rot diseases of fruit trees, with special reference to two biologic forms of *Monilia cinerea*, I. H. WORMALD (*Ann. Bot. [London]*, 33 (1919), No. 131, pp. 361-404, pls. 2).—The results of work here described are said to show that fruit trees in England are parasitized by *M. fructigena* and *M. cinerea*, each of these two species having two forms distinguished by the effects produced on mature apples inoculated under laboratory conditions. Of the two biological forms of *M. cinerea* one produces a blossom wilt and canker disease of apple, the other being limited to the single blossom originally inoculated.

A general discussion of the results recorded in the present article is reserved for correlation with certain physiological and cultural experiments.

The field treatment of Panama disease, P. W. MURRAY (*Ann. Rpt. Bd. Agr. and Dept. Pub. Gard. and Plantations Jamaica*, 1918, pp. 16, 17).—It is stated as a result of six years of practical experience that the method employed under difficult conditions against the Panama disease is so successful that no modification is yet required or practicable.

When the Panama disease was recognized as a root disease, spreading by direct contact between roots, it was decided that all bananas within extreme root range of a diseased tree should be destroyed and the whole area fenced and quarantined as infected. This procedure invariably insures success, whereas neglect or relaxation of this rule leads to a recurrence of the disease.

[Panama disease of banana], H. H. COUSINS (*Ann. Rpt. Bd. Agr. and Dept. Pub. Gard. and Plantations Jamaica*, 1919, p. 7).—Statistics of infection by Panama disease are given, running back as far as the appearance of this disease in 1911. The most recent reports are not so favorable as are those of the previous year above noted. Drastic steps have been taken. Experience has shown that early recognition of this disease is a most important factor in its control.

Inspection of plant diseases, H. G. COOTE (*Ann. Rpt. Bd. Agr. and Dept. Pub. Gard. and Plantations Jamaica*, 1919, pp. 19, 20).—In a report on coconut sanitation and replacement in eastern St. Thomas and Portland, it is stated that 80,000 trees were without discrimination cut down and burned as a result of the ravages of the hurricane occurring some months previously or of attack by the bud-rot fungus.

Wet weather immediately following this work, and the consequent accumulation of moisture and softening of the cell walls, led to a rapid recurrence of the disease. Many of the trees damaged by the hurricane were attacked in the renewing portions by the *Phytophthora* form of leaf bitten disease and finally gave way before the bud rot.

More on root rot, G. LEONE (*Agr. Colon. [Italy]*, 13 (1919), No. 9, pp. 354-355).—Further study of the root trouble of orange previously noted (E. S. R., 40, p. 851), has shown the presence in this connection of a nematode, which has not yet been identified.

Pecan rosette in relation to soil deficiencies, S. M. McMURRAN (*Amer. Nut Jour.*, 10 (1919), No. 3, pp. 38, 39, 43).—This is substantially the same as the information previously noted (E. S. R., 40, p. 544).

Preventing wood rot in pecan trees, S. M. McMURRAN (*Amer. Nut Jour.*, 10 (1919), No. 3, pp. 40, 41).—This information has been noted previously (E. S. R., 40, p. 158).

Experiments on the control of *Narcissus* eelworm in the field, J. K. RAMSBOTTOM (*Jour. Roy. Hort. Soc.*, 44 (1919), pp. 68-72, pl. 1, fig. 1; *abs. in Rev. Appl. Ent.*, Ser. A, 7 (1919), No. 8, pp. 355, 356).—Experiments with manures and chemical sterilizers were alike ineffective in freeing soils from nematode infection or in protecting crops from nematode attack.

Experimentation on different crops with a view to securing a rotation that would avoid or minimize nematode attack showed that *Tylenchus devastatrix* may become so adapted to a particular host species as not to attack with severity other host species. In a series of plants including rye, winter and spring oats, clover, alfalfa, peas, broad beans, rye-grass, onions, wheat, chives, buckwheat, and potatoes, tested as possible successors to *Narcissus* on ground infested with nematodes, onions only were seriously affected.

The Iceland poppy disease, C. C. BRITTELBANK (*Jour. Dept. Agr. Victoria*, 17 (1919), No. 11, p. 700).—It is stated that during the past few years a disease of poppy from which a species of *Phytophthora* has been isolated has killed off from 80 to 90 per cent of these plants. Symptoms are briefly described. Complete control is obtained by use of a 6:9:50 Burgundy mixture.

A destructive disease of seedling trees of *Thuja gigantea*, G. H. PETHYBRIDGE (*Quart. Jour. Forestry*, 13 (1919), No. 2, pp. 93-97).—An account is given regarding a brief study of a fungus attacking young larch, which proved to be a *Botrytis*; also of one causing failure of young *Thuja* trees subsequently identified as due to *Keithia thujina* and now found supposedly for the first time outside of North America.

A new leaf disease of *Hevea* caused by a mildew (*Oidium* sp.), P. ARENS (*Arch. Rubbercult. Nederland. Indië*, 2 (1918), No. 10, pp. 827-835).—A new mildew of young *Hevea* leaves is provisionally reported as present throughout Java. The foliage may be thinned to any degree, with corresponding effect on the trees. The organism is said to be an *Oidium*.

Lebbra and vaiolo of sumac, G. B. TRAVERSO (*Staz. Sper. Agr. Ital.*, 52 (1919), No. 5-6, pp. 213-225, pls. 2).—An account is given of two diseases of *Rhus coriaria* said to be new in Italy. The first shows itself in a leaf coloration and dieback and has been ascribed to *Eroascus purpurascens*. The other appears as a discoloration with minute spots and is ascribed to *Septoria rhoïna*, a supplementary description of which is furnished.

Reddening of sumac leaves, G. LO PRIORE and G. SCALIA (*Staz. Sper. Agr. Ital.*, 52 (1919), No. 5-6, pp. 227-237, pls. 2).—The authors describe *Eroascus* (*Taphrinella*) *purpurascens* as found in leaves of *Rhus copallina* in Massachusetts and Connecticut.

ECONOMIC ZOOLOGY—ENTOMOLOGY.

Waterfowl and their food plants in the sandhill region of Nebraska (*U. S. Dept. Agr. Bul.* 794 (1920), pp. 77, pls. 5).—This is the first of a series of papers designed to present information on the breeding, wintering, and hunting grounds of waterfowl in the United States. The report consists of two parts.

I. *Waterfowl in Nebraska*, H. C. Oberholser (pp. 3-35).—This is a report on the water birds, together with data on the numbers and species occurring during the breeding and hunting seasons in Nebraska, chiefly in the sandhill region, which information is a necessary basis for protective legislation. The sandhill region is an irregular area lying in the north-central part of the State, extending east and west for about 250 miles, north and south for about 140 miles, and occupying approximately one-fourth of the State. This area has

long been famous as a resort for water birds when migrating, consequently it has offered great inducements as a hunting ground and has attracted thousands of hunters from all parts of the country. This region not only harbors myriads of ducks during spring and autumn, but is one of the few extensive waterfowl breeding grounds remaining in the United States. The various breeding grounds in Brown, Cherry, Garden, and Morrill Counties were visited by the author in June, 1915. Practically all the lakes in central and eastern Cherry County were examined, and a large number of lakes in Garden and Morrill Counties were visited and careful observations made of the water birds living on them.

A general description is given of the sandhill region and an account of observations on the lakes of eastern Cherry County, with a list of water birds observed in June and October, 1915; the lakes at the head of the North Loup River, with a list of birds observed in June; the Cody lakes, with a list of birds observed in June; the lakes of Brown County, with a list of birds observed in June and October; the lakes of Garden and Morrill Counties, with lists of the birds observed in June and October; the Platte River, with a list of the birds observed in October; and the lakes of the North Platte Irrigation Project, with a list of the birds observed in October. An annotated list of water birds in the sandhill and Platte River regions of Nebraska follow (pp. 22-35).

The regulations issued by this Department under the Federal migratory bird law of 1913, which prohibit the spring shooting in the United States as a necessary means of protecting ducks during the spring migration and the early part of the breeding season, are said to have resulted in a steady increase of ducks in Nebraska.

II. *Wild-duck foods of the sandhill region of Nebraska*, W. L. McAtee (pp. 37-77).—This is a report on the vegetation of 44 lakes in the sandhill region, together with information on the value of the plants as wild-duck food and suggestions for improvements based upon notes and specimens collected from July to October, 1915, by R. Thomson. Lists are given of those plants taken on the different lakes.

The crow, bird citizen of every land, E. R. KAIMBACH (*Natl. Geogr. Mag.*, 37(1920), No. 4, pp. 322-337, figs. 10).

Fifth annual list of proposed changes in the A. O. U. Check-list of North American Birds, H. C. OBERHOLSER (*Auk*, 37 (1920), No. 2, pp. 274-285).

A hand list of British birds, E. HARTERT, F. C. R. JOURDAIN, N. F. TICEHURST, and H. F. WITHERBY (*London: Witherby & Co., 1912, pp. XII+237*).—This book lists 469 forms and shows their distribution in the British Isles and abroad.

Report of the departmental committee on the protection of wild birds, E. S. MONTAGU ET AL. (*London: Home Dept. [Gt. Brit.], 1919, pp. 44*).—This is a report of a committee of six appointed under the Wild Birds Protection Act for the protection of wild birds.

The fauna of British India, including Ceylon and Burma, edited by A. E. SHIPLEY and C. A. K. MARSHALL (*London: Taylor and Francis, 1910, pp. XIV+322, pls. 2, figs. 76*).—In this volume the Lamellicornia of the sub-families Cetoniinae and Dynastinae (pp. 256-314) are dealt with by G. J. Arrow. Descriptions are given of 241 forms of the Cetoniinae and 46 forms of the Dynastinae.

Insect behavior, P. G. HOWES (*Boston: Richard G. Badger [1919], pp. 176, pls. 68*).—In the preparation of this volume the author has aimed to produce a popular work which is in every way scientifically accurate. It consists of

24 chapters, of which chapters 2 to 8, inclusive, relative to insect studies, appeared in volume 1 of *Tropical Wild Life in British Guiana*, previously noted (E. S. R., 41, p. 546).

A nutritional study of insects, with special reference to microorganisms and their substrata, J. P. BAUMBERGER (*Jour. Expt. Zool.*, 28 (1919), No. 1, pp. 1-81, figs. 18).—"I have shown by experiments that *Drosophila* living in fermenting fruit are dependent for their food supply on the synthetic and absorptive powers of yeast cells. In a similar manner my study of the relation of *Musca domestica* to manure, of *Desmometopa* to decaying meat, and of *Sciara* and *Tyroglyphus* to decaying wood shows clearly that these arthropods also feed on microorganisms. I have also endeavored to account for the origin and development of this habit, to ascertain the probable extent of its occurrence, and to consider the known associations of animals with fungi in general. The experiments and considerations all tend to establish the principle that insects inhabiting fermenting and decaying substrata of low protein content usually feed upon the microorganisms present, and thus benefit by the power of the fungi to extract, absorb, and synthesize many nonprotein nitrogenous compounds."

A bibliography of seven pages is included.

Report of the entomological department, C. E. SANBORN (*Oklahoma Sta. Rpt. 1919*, pp. 40-44).—Honeybee paralysis appeared at the station apiary March 14, at a time when the bees were becoming quite active on plum, apricot, and peach blossoms. The fresh nectar used by the old bees in connection with pollen during cool, damp weather furnished a condition favorable to the development of the disease. Proper exposure to sunlight and well-drained hive stand locations proved to be the best means of control.

Reference is made to control work with the four-spotted cowpea weevil (*Bruchus quadrimaculatus*), a bulletin relating to which has been previously noted (E. S. R., 42, p. 856), and to crow-control work, an account of which has also been noted (E. S. R., 42, p. 355). Brief notes relating to the fish moth and the chicken mite are given.

[**Contributions on economic insects**] (*Ztschr. Angew. Ent.*, 6 (1919), No. 1, pp. 183, pls. 2, figs. 32).—Among the papers here presented are the following: The Granary and Rice Weevils (*Calandra granaria* and *C. oryza*) as Grain Pests, by E. Teichmann and A. Andres (pp. 1-24); On the Biology of the Mediterranean Flour Moth (*Ephestia kuehniella*), by F. Burkhardt (pp. 25-60); Investigations of the Simuliidae, by K. Friederichs (pp. 61-83); The Temperature of Bees and Their Brood, by Brünnich (pp. 84-92); Weather and the Mosquito Plague: A Biological Study, by Eskstein (pp. 93-105); a Bibliography of the Lice (Anoplura) Literature with an Alphabetical and Author Index to Same, together with a Host List, by H. Fahrenholz (pp. 106-160); and a List of Publications upon the Loss of Stock through Attacks by Simuliids, by K. Friederichs (pp. 161-167).

[**Entomological work in the Northern Division of Bombay Presidency in 1917-18**], P. C. PATIL (*Bombay Dept. Agr. Ann. Rpt. 1917-18*, p. 26).—The cotton bollworm is said to be successfully controlled by growing a few rows of okra (*Hibiscus esculentus*) around cotton as a trap crop, the bollworm showing a preference for okra. When attracted to okra it is easily destroyed by removing the affected plant. This remedy is said to have been adopted on the cotton-growing farms and has been recommended to cultivators.

The cotton woolly mite also affected the cotton crop on an unusually large scale, but gradually disappeared after the rain recommenced in September. The mango hopper is represented by two species, one of which attacks the

trunk, the other the leaves and blossoms. They are destroyed by three applications of rosin wash (15 gal.) and Incosopol (8 lbs.).

[Entomological work in the Konkan Division of Bombay Presidency, 1917-18], V. G. GOKHALE (*Bombay Dept. Agr. Ann. Rpt. 1917-18, pp. 62, 63*).—These notes relate particularly to the insect pests of rice, coconut, and the mango. Twelve species were observed to attack rice, of which three, namely, the rice stem borer (*Schoenobius bipunctifer*), an insect causing "nal" disease, and a hairy caterpillar which cuts the ear heads, caused serious injury.

In the North Konkan *S. bipunctifer* hibernated in the rice stubble until the beginning of the following monsoon. It caused a damage of 30 to 40 per cent to the late varieties of the monsoon crop in the low-lying fields near Ratnâgiri.

Division of entomology, C. H. KNOWLES (*Fiji Dept. Agr. Ann. Rpt. 1919, pp. 12-15*).—Notes are presented on the insects attacking coconut, cacao, banana, citrus, etc. A species of *Aspidiotus* is said to be a source of serious injury to the coconut palm; a leaf miner (*Promecotheca reichii*) attacks coconut, but is held in check by a chalcid parasite; the Japanese rose beetle (*Adoretus tenuimaculatus*) continues to attack cacao leaves and sometimes causes the death of young trees; and the banana borer (*Cosmopolites sordida* Chev.) is said to have been a very serious pest during the period under report. A predacious histereid beetle (*Plæsius javanus*) which attacks and checks *C. sordida* in Java, was introduced into Fiji.

Notes on the more important insects in sugar cane plantations in Fiji, R. VEITCH (*Bul. Ent. Research, 10 (1919), No. 1, pp. 21-39, figs. 8*).—The author concludes that the cane beetle borer (*Rhabdocnemis obscura* Boisd.); the sugar cane wireworms, of which there are several species, particularly *Simodactylus cinnamomeus* Boisd.; and white grubs, particularly *Rhopæa vestita* Arrow and *R. subnitida* Arrow, are the most important pests occurring in sugar cane fields in Fiji, each constituting an entomological problem of great importance. Other pests mentioned which are of minor importance include the small cane beetle borer (*Trochorrhopalus strangulatus* Gyl.), the rose beetle (*Adoretus versutus* Har.), several army worms ([*Cirphis*] *Heliophila unipuncta* Haw. and *H. loreyi* Dup.), the moth borer of cane (*Trachycentra chlorogramma* Meyr.), and the cane leaf miner (*Cosmopteryx* n. sp.), the leaf-hopper *Perkinsiella vitiensis* Kirk., the cane aleyrodid (*Aleyrodes comata* Mask.), the cane mealy bug (*Pseudococcus bromeliæ* Bouché), and locusts (*Locusta danica* L. and *Cyrtacanthacris guttulosa* Walk.). Other insects mentioned are the Mauritius bean army worm (*Prodenia litura* F.), the hornet *Polistes macænsis* F., and the Mauritius bean bug (*Brachyplatys pacificus* Dall.). The white grub parasite *Scolia manilæ* Ashm. has been introduced into Fiji from Hawaii.

Tobacco pests of Rhodesia, R. W. JACK (*Rhodesia Agr. Jour., 16 (1919), No. 6, pp. 542-548, pls. 5; 17 (1920), No. 1, pp. 28-33, pls. 5*).—In this revision of an earlier work¹ on the principal insect enemies of tobacco in Rhodesia the pests dealt with are four species of cutworms, particularly *Euxoa segetis* Schiff. and *Agrotis ypsilon* Rott., an account of which has been previously noted (E. S. R., 41, p. 62), the stem borer (*Phthorimæa heliopa* Lwr.), the potato tuber worm, the bollworm, *Lophygma exigua* Hubn. and *Prodenia litura* F., surface beetles, wireworms, grasshoppers, crickets, and the root gall worm (*Heterodera radicecola*).

It is pointed out that the principal tobacco insects in Rhodesia are those which cause injury to the seedbed and newly transplanted plants.

¹ Handbook of Tobacco Culture ([Salisbury, Rhodesia: Dept. Agr.], 1913).

The red spider mite and leaf thrips on the avocado and how they may be controlled, G. F. MOZNETTE (*Fla. Grower*, 21 (1920), No. 5, pp. 8, 9, figs. 2).—The red spider mite and the greenhouse thrips are the source of considerable damage to the avocado in Florida during the dry winter months, usually from the latter part of October until April. "Unlike most other red spiders which attack various other fruits, the red spider of the avocado confines its attacks to the upper surface of the foliage almost entirely, [and] this habit is also true of the thrips which infest the foliage of the avocado."

Orchards with red spider soon appear as if scorched by fire or badly beaten by the wind. The foliage attacked turns brown and drops prematurely. The red spider and thrips are not usually found on the same leaf. The red spider injury is the more severe. When they become active in the early fall while the fruit is still on the trees and are doing serious damage, the trees should be sprayed with fish-oil soap at the rate of 12 lbs. to 100 gal. of water plus blackleaf 40 at the rate of 1:900 in the diluted soap solution. "If the red spiders and thrips become abundant in the young grove which has not reached the bearing stage, lime-sulphur should be used at the rate of 1:50 plus blackleaf 40 at the rate of 1:900 in the diluted lime-sulphur solution. If the thrips are not present, the blackleaf 40 should be omitted.

"After the fruit has been picked and where the spiders and thrips continue to work, due to the temporary relief generally afforded by the use of fish-oil soap, it will be necessary to spray again, using the lime-sulphur at this time at the rate of 1:50 plus blackleaf 40 at the rate of 1:900 in the diluted lime-sulphur solution, the same as for the young grove. During the winter after the foliage has hardened, the writer has experienced no injury by the use of lime-sulphur as recommended above. Where the thrips are not present at this time, it will not be necessary to use the blackleaf 40 in combination with the lime-sulphur, as it is incorporated mainly for the thrips."

Mexican insects in poultry food: Mexican cantharides, Notonecta, Corixa, and Berosus, T. E. WALLIS (*Analyst*, 44 (1919), No. 521, pp. 284-287).—The author reports upon examinations made of poultry feeds containing dried insects from Mexico. He finds that there is a regular commerce in dried insects from Mexico for use in poultry feeds, and that the chief genera present are Notonecta and Corixa in varying proportions. Poultry eat such insects with avidity, and it appears that they form an excellent addition as a relish to poultry feed, no vesicant principle being present.

Book lice or psocids, E. A. BACK (*U. S. Dept. Agr., Farmers' Bul. 1104* (1920), pp. 4, fig. 1).—A brief popular account of psocids and means for control which should be resorted to when they become unusually abundant.

Methods of controlling grasshoppers (*Saskatchewan Dept. Agr., Weeds and Seed Branch Bul. 60* (1919), pp. 8, figs. 2).—Methods of grasshopper control are briefly outlined, including working drawings of a grasshopper catching machine.

Changa or mole cricket (Scapteriscus didactylus) (*Imp Dept. Agr. West Indies, Rpt. Agr. Dept. St. Lucia, 1918-19, p. 8*).—This insect is common throughout St. Lucia, having been a serious pest at the experiment station at Réunion, where it attacked new grass roads. Some of these roads, which were 15 ft. wide and 600 ft. long, were totally denuded of grass and the soil worked up to a loose fine tilth to a depth of 3 in.

It is pointed out that where this pest occurs in small patches on lawns it is easily checked by watering with whale-oil soap at the rate of 1 lb. to 5 gal. of water. In this way large numbers are forced to the surface and they can be collected.

Neotoxoptera violæ and its allies, A. C. BAKER (*Bul. Ent. Research*, 10 (1919), No. 1, pp. 45, 46, pl. 1).—The author's studies have led to the conclusion that the aphid *N. violæ* Theob., described in 1915 from violets in Africa, is an aberrant form of the species described by Pergande in 1900 as *Rhopalosiphum violæ*.

A contribution to the life history of the larch Chermes (Cnaphalodes strobilobius Kalt.), E. R. SPEYER (*Ann. Appl. Biol.*, 6 (1919), No. 2-3, pp. 171-182, pls. 2, fig. 1).—This report of studies includes a diagram representing every stage in the life cycle of the larch Chermes.

Control of spot insects of the mango, G. F. MOZNETTE (*Fla. Grower*, 21 (1920), No. 3, p. 8, figs. 3).—Of the several scale insects which attack the mango in Florida the tessellated scale and the mongo shield scale are said to be the most injurious and most generally distributed. As a means of control the author recommends either the use of oil emulsions or miscible oil at the rate of 1:66, first in December when the trees are dormant and again at the strength of 1:80 the latter part of March after the fruit has set. In every case where the oil sprays were used, about 90 per cent of the scales was killed and the red spiders were also destroyed.

Is it safe to fumigate while trees are in bloom? R. S. WOGLUM (*Cal. Citrogr.*, 5 (1920), No. 6, p. 190, fig. 1).—In experiments conducted in February, March, and April, 1908, more than 30 acres of Valencia and navel oranges were fumigated with potassium cyanid, the dosages ranging from 75 to a 200 per cent schedule. With dosages upwards to schedule 1 no injury resulted, but when a 200 per cent schedule was used many blossom were affected and dropped.

The author concludes that it is safe to fumigate with ordinary dosages right up to the time the fruit sets, provided the work is conducted according to the rules of careful practice.

The western wheat-head army worm, M. H. SWENK (*Bul. State Ent. Nebr.*, No. 8 (1918), pp. 4, fig. 1).—This is a brief account of the life history and means of control of (*Heliophila, Neleucania*) *Meliana albilinea limitata* Smith, which was a source of serious injury to late spring and durum wheat and, to a lesser extent, to late oats in Kimball, Cheyenne, and Deuel Counties, Nebr., during September, 1918. It attacked the heads, in most cases with one or two worms but in some instances with four or five worms to a head, working from the bottom up, almost entirely consuming the kernels, and frequently completely cutting off the head. While most of the injury was to standing grain, in several cases the worms continued working on the cut wheat in the shock, cutting off the heads and devouring the grain, and in one instance, at least, they were carried to the bin with the thrashed wheat and continued to work upon the grain.

The injury to wheat began the first week in September in Cheyenne County, and at about the same time injuries to oats and Sudan grass occurred in Deuel County. The injury in Cheyenne County was the more general and severe, in several cases amounting to the destruction of 50 per cent of the wheat in fields promising to run 25 bu. to the acre. In one case 300 acres of spring wheat that would have made at least 15 bu. per acre were a total loss. By the end of the fourth week in September the injuries had ceased over the entire infested area. In several instances on the dry land in the northwestern part of Kimball County promising wheat fields were damaged to the extent of 50 to 70 per cent.

The first generation adults emerge from overwintering pupæ and deposit their eggs in May in compact rows on grasses and grains, the clusters containing from 25 to 150. From three to ten days are required for the incuba-

tion of the eggs and about a month for the larvæ. Pupation takes place in loose cocoons in the ground. After about a month in the ground second generation moths appear, though some do not emerge until the following spring. The second generation moths appear during late July, August, and very early September and oviposit between the sheath and stalk of grasses or grains just below the upper blades. These larvæ reach maturity in September and enter the soil to pupate, going much deeper than those of the first generation, sometimes as deep as 6 in.

The pest is kept in check chiefly by parasites, of which there are several of importance. Control measures consist in the use of furrows or ditches, arsenicals, the prompt thrashing of grain, and cultural methods.

A bulletin on *Meliana albilinea* (Hüber) by Webster in Iowa, where it was a source of injury to timothy, has been noted (E. S. R., 25, p. 55).

Cutworms and army worms, W. C. COOK (*Off. State Ent. Minn. Circ. 52* (1920), pp. 8, figs. 13).—This popular account includes a key for the determination of the more common Minnesota cutworms.

Cotton worm control, W. E. HINDS (*Alabama Col. Sta. Circ. 42* (1919), pp. 63–68, figs. 9).—This is a discussion of control measures for the cotton worm.

Notes on Elachista with descriptions of new species (Microlepidoptera), A. F. BRAUN (*Ohio Jour. Sci.*, 20 (1920), No. 5, pp. 167–172).—Notes are given on 7 species, 4 of the 5 species described as new having been reared from mines of leaves of grasses and sedges. Many of the larvæ which feed on the basal overwintering leaves begin to mine in autumn, completing their growth early in spring. Some species are strictly confined to one species of grass as a food plant, and in some instances to certain parts of the plant. Most of the species are single-brooded.

The Hessian fly and how to prevent losses from it, W. R. WALTON (*U. S. Dept. Agr., Farmers' Bul. 1083* (1920), pp. 16, figs. 13).—A summary of information on the Hessian fly and means for its control.

The experimental infection in England of Anopheles plumbeus and A. bifurcatus, with Plasmodium vivax, B. BLACKLOCK and H. F. CARTER (*Ann. Trop. Med. and Parasitol.*, 13 (1920), No. 4, pp. 413–420).—"We have been able to infect laboratory-bred *A. plumbeus* with *P. vivax*. At 28° C. [82.4° F.] infections of the gut and salivary glands were obtained; at room temperature (maximum 26°, minimum 17°) gut infection only was obtained. We have also produced infection of the gut with *P. vivax* in the case of *A. bifurcatus* at 28°. This is, we consider, the first experimental evidence produced that *A. plumbeus* is capable of becoming infected with a malaria parasite. As regards *A. bifurcatus*, we have proved that in England the native form of this mosquito is capable of being infected with malaria at 28°."

Observations on Anopheles (Cœlodiæsis) plumbeus, Stephens, with special reference to its breeding places, occurrence in the Liverpool district, and possible connection with the spread of malaria, B. BLACKLOCK and H. F. CARTER (*Ann. Trop. Med. and Parasitol.*, 13 (1920), No. 4, pp. 421–444, fig. 1).—This paper includes a bibliography of four pages.

Warble flies (Hypoderma lineatum and H. bovis), S. HADWEN (*Canada Dept. Agr., Health Anim. Branch Bul. 27* (1919), pp. 24, pls. 2, figs. 23).—This is a summary of information on these two warble flies, based in part upon investigations previously noted (E. S. R., 39, p. 157). The present status of knowledge of the two species is summarized as follows:

"*H. lineatum* lays its eggs as early as April 15, but the usual laying period is during the month of May. At Agassiz they have never been captured later than May 30. *H. bovis* begins to lay in the early part of June and continues

up to the beginning of August. Between the last appearance of *H. lineatum* and the first of *H. bovis* there is usually a period of 10 days when the cattle are immune from attack of either species. *H. bovis* frightens the cattle much more than *H. lineatum*.

"The eggs take about a week to hatch; the larvæ bore through the skin in the coarser, porous parts, taking several hours in the process; at this stage they are about 1 mm. long. The lesions resulting from this penetration are caused partly by anaphylactic reactions and partly by bacterial invasion, those produced by *H. lineatum* being the more severe. For the skin lesions the name 'hypodermal rash' has been proposed.

"At this point there is a hiatus in the life history. It is not positively known how the larvæ reach the esophagus, where they are subsequently found; most likely they travel in the loose connective tissues under the skin up to the region of the throat and into the esophagus where the muscles bifurcate. Passing down the esophagus they follow the submucosa and are almost always found lying along the long axis of the canal. Whilst in the esophagus, small edematous swellings are found surrounding the grubs. These are sterile and are anaphylactic in character; the exudate contains large numbers of eosinophilic leucocytes. The earliest record made at Agassiz of larvæ in the esophagus was on August 15, when a larva 3.4 mm. long was found and several slightly larger. Continental observers have recorded smaller larvæ than this.

"*H. lineatum* makes its appearance in the backs of cattle about December 15, and *H. bovis* about a month later. The larvæ at this time have grown about 1.5 cm., and are similar in size to those which are found in the neural canal and under the skin. At this stage it is difficult to separate the larvæ of the two species, but Bishopp has recently discovered good distinguishing marks between them. The life histories overlap at this period, making it difficult to follow the migration, but in the latter part of the season (the middle of March) the last larvæ to leave the esophagus are at the paunch end. They pass out under the pleura and go to the neural canal, either up the crura of the diaphragm or up the posterior border of the ribs, entering the canal by the posterior foramen. The larva evidently makes use of the canal as an easy means of access to the lumbar region, the part of the animal which is best suited for passing its last stages within the host. The larvæ follow connective tissues exclusively, and no larvæ have been discovered in muscular tissue. The mature larvæ leave the animals' backs from the early part of the year up to the first days of July.

"The periods for the two species have not been fully worked out; but, judging from what records there are of the pupal period and the time of year that flies are on the wing, *H. lineatum* begins to emerge in February and finishes about May 1. *H. bovis* begins about May 1 and ends approximately on July 1. The average pupal period for *H. bovis* is 32.5 days for *H. lineatum* a little less. The duration of the life of the flies is short, seeing that they can not feed. This life history applies to Agassiz, B. C.; doubtless in other countries variations will be noticed, but the period spent by the larvæ within the host must be of the same duration, seeing that animals' temperatures are the same the world over."

As a means of prevention it is recommended that animals be housed during the heat of the day to prevent the flies laying upon them. Warble grubs should be squeezed out as early as possible during the year. This method will lessen the damage to animals and their hides. If the total eradication of the pest is attempted, cooperative measures must be undertaken.

Fruit flies of the genus *Dacus sensu latiore* (Diptera) from the Philippine Islands, N. BEZZI (*Philippine Jour. Sci.*, 15 (1919), No. 5, pp. 441-443,

pls. 2).—The author presents descriptions of 23 forms, of which 1 represents the genus *Batrocera*; 17 the genus *Chætodacus*, 12 of which are new; 4 the genus *Mellessis*, 2 of which are new; and 1 the genus *Monacrostichus*. Tables for the separation of the genera and species are included.

The construction of calcareous opercula by longicorn larvæ of the group Cerambycini (Coleoptera, Cerambycidae), C. F. C. BEESON ([*Indian Forest Bul. 38 (1919), pp. 10, pl. 1*]).—A paper presented before the zoological section of the Indian Science Congress held in Bombay in January, 1919.

An insect very injurious to the coconut palm (*Strategus quadrifoveatus*), M. A. CRESPO (*Rev. Agr. Puerto Rico, 4 (1920), No. 3, pp. 47, 48*).—This is a brief account of injury by a rhinoceros beetle.

***Rhodnius brethesi* n. sp.**, A. DA MATTA (*Abs. in Jour. Amer. Med. Assoc., 74 (1920), No. 16, p. 1134*).—This is a report of studies of the life history of a reduviid which the author has described as *R. brethesi* and which is an intermediate host for Chagas' trypanosome. This bug occurs in the Amazon region, where both *Trypanosoma cruzi* Chagas and the armadillo, its ancestral host, are encountered. This trypanosome does not seem to cause disease in the armadillo, and Chagas disease has never been known in human beings in that region.

A Mexican species of *Agrilus* found in Arizona (Coleoptera), W. S. FISHER and A. S. NICOLAY (*Ent. News, 31 (1920), No. 4, pp. 100-102*).—*Agrilus restrictus* Waterhouse is recorded from the Huachuca Mountains of Arizona.

Collecting some little known Buprestidæ, H. E. BURKE (*Proc. Ent. Soc. Wash., 22 (1920), No. 4, pp. 72-76*).

Report of entomologist, W. E. HINDS (*Alabama Col. Sta. Circ. 43 (1920), pp. 15-18*).—Particular attention was given in 1919 to the demonstration of the practicability of dusting for the control of the boll weevil. The increase in the yield brought about by dusting ranged up to a net profit of better than \$20 per acre, and on one field of 75 acres dusted by a dusting machine company there was an average profit of better than \$22 per acre.

It appears that the type of dusting machinery used in connection with boll weevil control can be utilized for the distribution of finely powdered sulphur for the control of the red spider. The sweet potato weevil occurring in the vicinity of Grand Bay is thought to have been brought under complete control in that section. Brief reference is also made to corn insect control work and to the pink bollworm of cotton.

A modern bee farm and its economic management, S. SIMMINS (*Heathfield, Sussex: Author, 1914, rev. ed., pp. XVI+479, pls. 12, figs. 109*).—This is a practical work based upon the author's experience and close observations extending over a period of more than 40 years. Chapters on bee paralysis, or the Isle of Wight disease, and on honey, its uses in health and disease, together with notes upon profitable grass farming and dairying and orchard planting as suitable auxiliary occupations for the beekeeper, are included.

Apiculture, R. HOMMELL (*Apiculture. Pars: J. B. Baillièrè & Sons, 1919, 3. ed., rev., pp. 501, figs. 183*).—This third edition of the work previously noted (E. S. R., 18, p. 358) forms a part of G. Wery's *Encyclopédie Agricole*.

Outapiaries and their management, M. G. DADANT (*Hamilton, Ill.: Amer. Bee Jour., 1919, pp. 124, figs. 61*).—Following a brief introduction the subject is dealt with under the headings of choosing a general location, selecting apiary sites, basis of placing the apiary, the apiary itself, general systems of management, winter and spring work, early summer work, the harvest, fall and early winter, moving bees, automobiles and trucks, and honey houses and equipment.

Self-recording invention for obtaining continuous weight variations in hives of bees. C. E. SANBORN (*Oklahoma Sta. Rpt. 1919, pp. 60, 61, fig. 1*).—The author describes an automatic, continuous weighing device which records the weight of a hive of bees or any other stationary object the weight of which may vary with the lapse of time. By the use of this invention the weight of a swarm of bees which may leave the hive and the time of departure, a honey flow or dearth, etc., may be accurately recorded.

European foulbrood. G. F. WHITE (*U. S. Dept. Agr. Bul. 810 (1920), pp. 39, pls. 8, figs. 6*).—This account is similar in nature to those by the author on sacbrood (E. S. R., 36, p. 659), Nosema disease (E. S. R., 41, p. 359), and America foulbrood (E. S. R., 42, p. 857). A brief summary of facts based upon the investigations reported, together with the conclusions drawn by the author, follow:

“European foulbrood is an infectious brood disease of bees caused by *Bacillus pluton*. All larvæ, worker, drone, and queen, are susceptible to the disease; adult bees are not. Man evidently is not susceptible to infection with *B. pluton* nor are the experimental animals. As far as is known, insects other than bees are not susceptible. Brood can be infected by feeding the colony a suspension of crushed larvæ sick or dead of the disease. This is described in the present paper as the indirect method. The virus contained in a single larva recently dead of European foulbrood will produce a considerable amount of disease when fed to a colony. The larvæ can be infected also by a more direct method. A fraction of a drop of a suspension of the stomach contents of a larva sick of the disease added with a capillary pipette directly to the food surrounding the larva to be inoculated will result in infection.

“*B. pluton* gains entrance to the larva by way of the mouth. The growth and multiplication of the parasite take place within the stomach (mid-intestine) of the larva and do not, during the life of the larva, get beyond the peritrophic membrane. The tissues, therefore, are not invaded by it. The secondary invaders in European foulbrood, *B. alvei*, *Streptococcus apis*, *Bacterium eurydice*, and *Bacillus orpheus*, rarely, if ever, invade the tissues until the larva is dead or nearly so. In a few instances in microtome sections rod forms have been encountered in the act of invading the tissues of living larvæ. The species, however, was not determined definitely. The period of incubation is slightly less than 3 days. Brood is susceptible to infection at all seasons of the year. More brood die of the disease during the first half of the brood-rearing season than during the second half.

“The writer has examined samples of the disease from Canada and the United States. From written reports it seems quite certain that it occurs also at least in Denmark, England, Germany, France, and Switzerland. Occurring as it does in this somewhat wide range of climatic conditions, the presence of the disease in any particular locality can not be attributed entirely to the prevailing climatic conditions. The quality of food obtained by the bees does not affect greatly, if at all, the course of the disease in the colony, although the quantity may affect it to a variable extent. Experimental colonies may be inoculated and kept in the apiary without transmitting the disease to others. This fact is of special importance, not only in connection with the technique of making studies on the disease, but also in the control of the malady.

“The thermal death point of *B. pluton* suspended in water is approximately 63° C. [145.4° F.] maintained for 10 minutes. When suspended in honey *B. pluton* is destroyed in 10 minutes at approximately 79°. Drying at room or incubator temperature *B. pluton* remains alive and virulent for approximately one year. When dry, *B. pluton* resisted the direct rays of the sun

for from 21 to 31 hours. When suspended in water, *B. pluton* was destroyed by the direct rays of the sun in from 5 to 6 hours. When suspended in honey and exposed to the direct rays of the sun, *B. pluton* was destroyed in from 3 to 4 hours. In the presence of fermentative processes in a 10 per cent sugar solution *B. pluton* was destroyed in from 3 to 5 days at incubator temperature and in from 11 to 21 days at room temperature. In a fermenting honey solution outdoors *B. pluton* was still alive and virulent after one month. In the presence of putrefactive processes at incubator temperature *B. pluton* was destroyed in from 7 to 13 days and at room temperature in from 21 to 35 days. In a putrefying medium at outdoor temperature *B. pluton* remained alive and virulent for more than 40 days. The maximum period has not been determined. In honey at room temperature *B. pluton* ceased to be virulent in from 3 to 7 months. Mixed with pollen, *B. pluton* remained alive and virulent for more than 7 months at room temperature and more than 10 months at refrigerator temperature, the maximum time not being determined. In 0.5 per cent carbolic acid solution *B. pluton* was destroyed in from 8 to 18 days; in 1 per cent it was destroyed in from 5 hours to 4 days, and in 2 and 4 per cent in less than 6 hours. The probability is that at these higher strengths of the solution minutes rather than hours are sufficient for the destruction of the virus. Experimental evidence indicates that at the present time drugs should not be depended upon in the treatment of European foulbrood.

“Robbing from diseased colonies of the apiary or from neighboring apiaries is the most likely manner in which European foulbrood is transmitted in nature. Brood combs containing diseased brood, if given to a healthy colony, serve as a medium for the transmission of the disease. European foulbrood is not likely to be transmitted by queens or drones. Whether they ever do so has not been demonstrated. As a rule a hive which has housed a European foulbrood colony should not be considered as a fruitful source of infection. The facts indicate that often such hives could be used with impunity for housing colonies without treatment. Flaming them inside certainly removes all danger. The transmission of European foulbrood by way of flowers, visited by bees from diseased colonies and subsequently by those from healthy ones, is not to be considered as a likely source of infection. Whether the water supply is ever a source of danger is not known. It is evidently not a fruitful source. The disease is not likely to be transmitted through the medium of the clothing or hands of the apiarist. Tools and bee supplies in general do not serve as means for the transmission of the disease in the absence of robbing from such sources.

“It is usually possible to diagnose European foulbrood from the symptoms alone. A definite diagnosis can be made from suitable samples by bacteriological methods. The prognosis in European foulbrood varies from very good to exceedingly grave. The tendency for a colony to recover entirely from the disease is much greater than in American foulbrood. Considered from the technical point of view, much is yet to be learned concerning European foulbrood. For practical purposes, however, it can be said that sufficient knowledge has been gained to make it possible for the beekeeper to devise a treatment which will be logical, efficient, and at the same time economical.”

A list is given of 20 references to the literature cited.

Nosema apis in hive bees, J. RENNIE and E. J. HARVEY (*Scot. Jour. Agr.*, 2 (1919), No. 4, pp. 511-532).—The authors differ from the view that *N. apis* is the cause of Isle of Wight disease. “Our main conclusion from a study of the presence of *N. apis* in bee colonies in this country is that this parasite is always a weakening factor, and in the presence of other adverse conditions favorable to the development of dysentery it may become seriously pathogenic to bee stocks. In ordinary circumstances we have not found it to destroy bee colonies

in the rapid and virulent manner common in Isle of Wight disease, although at the same time we are satisfied that Nosema-affected stocks do not yield the same amount of stores as healthy colonies."

A synopsis of the petiolate wasps of the family Eumenidæ (Hymenoptera), found in America north of Mexico, D. ISELY (*Ann. Ent. Soc. Amer.*, 10 (1917), No. 4, pp. 345-366).—This is a synopsis of the genera Eumenes and Zethus. The author recognizes 22 forms of Eumenes, 9 of which are new, and 5 of Zethus.

Viereck's family Labenidæ with the description of a new species of Apechoneura, R. A. CUSHMAN (*Proc. Ent. Soc. Wash.*, 22 (1920), No. 4, pp. 76-80, fig. 1).

Parthenogenesis in the pear-slug sawfly [California cerasi Linn.], H. E. EWING (*Ann. Ent. Soc. Amer.*, 10 (1917), No. 4, pp. 330-336).—"The males of our common pear- or cherry-slug sawfly must be very rare in certain parts of our country. The examination of several hundreds of individuals obtained at various times during the late spring and summer for three seasons at Ames, Iowa, and for two seasons at Corvallis, Oreg., failed to reveal a single male. The species is parthenogenetic, and successfully so for the offspring of the spring brood of females. The eggs deposited by spring-brood virgin females hatch and produce normal vigorous larvæ. These feed normally, later pupate, and finally produce adults. Unfertilized eggs produce females only.

"Parthenogenesis, when continued for the offspring of the second or summer brood of adults, gave larvæ, a considerable percentage of which failed to pupate. A considerable percentage successfully pupated but did not transform into the adult stage, and a very large percentage transformed into adult stage but did not emerge from the inclosing earthen cells. Only a single adult was reared from 109 of the second generation parthenogenetic larvæ. An orchard which was heavily infested with spring brood females, and in which no males were observed, produced an enormous number of second generation females, which produced in turn an increasing number of second brood larvæ, causing injury so serious as to kill outright several cherry trees of the orchard and to seriously injure all of the trees. From this enormous second brood of larvæ only a very few adults emerged the following spring.

"I am unable to account for the failure of these second brood larvæ to produce active adults unless it be on account of a lack of vigor due to the absence of fertilization for this brood, yet it is possible that this failure was due to other causes."

Studies on Rocky Mountain spotted fever, S. B. WOLBACH (*Jour. Med. Research*, 41 (1919), No. 1, pp. 197, pls. 21, figs. 15).—This is a monographic account of Rocky Mountain spotted fever, a disease of man, transmitted by *Dermacentor venustus* Banks. It includes a detailed report of the author's investigations, which have led him to conclude that a microorganism, for which the name *Dermacentroænus rickettsi* is proposed, is the causative agent. Reasons are presented for the conclusion that this organism is not a bacterium in the ordinary sense of the term. Its classification with the protozoa also presents difficulties, due chiefly to its minute size.

A list is given of 97 references to the literature.

FOODS—HUMAN NUTRITION.

The nation's food, R. PEARL (*Philadelphia and London: W. B. Saunders Co.*, 1920, pp. 274, figs. 42).—This book, which is the outcome of the author's work as chief of the statistical division of the U. S. Food Administration from June, 1917, to March, 1919, consists of an exhaustive statistical survey of the food

resources and food consumption of the United States covering the period from 1911 to 1918, inclusive.

The survey consisted essentially of a study of the amount of protein, fat, and carbohydrate annually produced in the United States in forms usable for human food, the proportions of these basic nutrients imported and exported annually, the amounts annually consumed as human food, their distribution among the several classes of food commodities, and the proportion of the total nutrient material consumed by domestic animals. For the purpose of the statistical analyses all nutritive materials produced and consumed were classified as (1) primary foods, including all plant materials used as human food or fractions of such materials, and all animals or animal products in which the animal gets its nourishment from some source other than the primary feeds and fodders as defined below; (2) primary feeds or fodders, including all plant materials or fractions of such materials used for the nourishment of domestic animals; and (3) secondary foods, including all edible products of animals used for human food, the animals being nourished with primary feeds and fodders. These classes were further subdivided into those used directly as harvested, without other sophistication than cooking, and those in a derivative or manufactured form.

The Year Books and the Monthly Crop Reports of the U. S. Department of Agriculture were used as the main sources for the production figures of primary products, and trade papers, census returns, etc., for the secondary products. Export and import figures were taken in main from official reports compiled by the U. S. Department of Commerce. In the compilation of nutrient values the factors of Atwater and Bryant were chiefly used. In reducing consumption data to a per capita basis the man-factor values adopted were from 0-5 years of age, 0.5; 6-13, 0.77; 14-18, males 1.00; 14-18, females 0.83; 19 on, male, 1.00; and 19 on, female, 0.83. The data throughout are expressed in both tabular and diagrammatic form.

In the final chapter, the consumption of human food in the United States, the calculations of food production, importation, and exportation in the preceding chapters have been utilized to determine the annual consumption in the United States of 20 or more staple commodities used as human food, and to discuss several problems centering about human food consumption, including (1) the relative degree to which primary as distinguished from secondary human foods contribute to the total nutritional intake of the population of the United States, (2) the relative proportion of the total nutritional intake furnished by the different food commodity classes, and (3) the per capita per diem consumption of food.

In general, the consumption figures show great uniformity from year to year. In the seven-year period considered, the greatest relative advance in consumption was in respect to fat while protein showed a slight falling off. Carbohydrate and calories of energy increased somewhat but to a less degree than fat. Of the average protein consumption during the whole period, 47 per cent came from primary sources and 53 from secondary sources, of the fat 18 and 82, carbohydrate 95 and 5, and calories 61 and 39 per cent, respectively, from primary and secondary sources. Concerning the relative proportion of the total food intake furnished by the different commodities, the grains were first in the contribution of protein, carbohydrate, and calories; meats were first in fat and second in protein and calories; and dairy products were second in fat and third in protein and calories. These three groups made up nearly 83 per cent of the total protein intake. The relative nutritional importance of the several food commodities as indicated by their energy content measured in calories was for the six years of 1911 to 1917 as follows; Wheat contributed

about 26 per cent of the total calories, pork normally about 16 per cent, dairy products 15 per cent, and sugar 7 per cent. Then came corn, beef, the vegetable oils, potatoes, poultry and eggs, other vegetables, and apples in decreasing order. The changes in 1917-18 showed the result of the efforts of the U. S. Food Administration in that the articles on which conservation was most strongly urged (wheat, beef, mutton, pork, and sugar) showed a decidedly lower consumption and rye, other cereals, nuts, and vegetables an increased consumption.

The average per capita per diem consumption as calculated from the total population, and the age-intake values was for the whole period as follows: Protein 120, fat 169, and carbohydrate 541 gm. with a total energy value of 4,288 calories. It is pointed out that this represents the gross consumption, and that by applying the estimated percentage deductions for edible wastage, the corresponding figures would be 114, 127, 433, and 3,424, respectively. These figures are in general agreement with the results of a number of American dietary studies which have been compiled for purposes of comparison, the corresponding figures being 95, 113, 447, and 3,185, respectively.

In conclusion it is emphasized that in calculating the food requirements of a nation "a considerable excess over any agreed-upon minimum physiological requirements must always be allowed, because there will inevitably be, in fact, a margin between actual gross consumption and net physiological ingestion or utilization." The gradually rising prices during the period since 1911 are thought to have brought about a slight narrowing of the margin between gross and net consumption.

As an appendix, a table is given indicating the consumption of nutrients in the form of feeds and fodder by domestic animals as determined by the same statistical plan followed in the case of human foods.

The modern science of food values, H. P. ARMSBY (*Yale Rev.*, 9 (1920), No. 2, pp. 330-345).—In this article the author takes stock of the contribution of modern science to our knowledge of food values and considers the fundamental importance of an adequate food supply and of rational measures of insuring it.

The days when food was so abundant in the United States that it could be used almost as one pleased, he points out, are gone never to return. "Even though we may hope to make an end of war we can not hope to escape from the world's continually growing demand for food. The density of population that can be supported is practically limited by the amount of solar energy which the farmer can recover in food products and the efficiency with which these products can be utilized as fuel for the human body. Any rational effort to extend this limit must include as its prime requirements not only a systematic development of agricultural production, such as is now being effected by national and State agencies, but also an equally systematic attention to the conservation and most efficient utilization of the products of the farm. The two are but different aspects of the one great problem of national nutrition. Without reflecting upon any existing agencies, surely it is high time that, along with military, naval, transportation, and manufacturing programs, this fundamental problem vital to our national existence and welfare, should be taken up in its entirety by some national agency charged with the investigation of the scientific and economic aspects of food supply and utilization, and with the diffusion of the knowledge, thus gained, among the people."

Further studies of qualitatively insufficient foods, A. AUER (*Biochem. Ztschr.*, 93 (1919), No. 1-2, pp. 1-15, figs. 2).—This is a continuation of the studies of Oseki previously noted (*E. S. R.*, 32, p. 561). White mice were fed

barley, oats, rye, and buckwheat, both decorticated and milled from the whole grain; raw, cooked, and commercially dehydrated potato; dried apples; and breads made from white flour, white flour with dried blood, and rye meal with dried blood.

The resulting weight curves of the animals fed dried apples, potato flakes, and raw potatoes all resembled in places the typical curve of inanition, and in others the curve resulting from a qualitatively insufficient diet. The other curves, with the exception of that of the rye blood bread, showed a qualitative insufficiency.

The results are considered to give further proof of the value of incorporating some of the bran in the flour, and to cast doubt on the advisability of using much commercially dried potato in bread making.

The resistance of red blood corpuscles under conditions of nitrogen deficiency and of inanition. D. ACÉL (*Biochem. Ztschr.*, 95 (1919), No. 3-4, pp. 211-219).—Data obtained in feeding experiments with dogs, mice, and guinea pigs are reported, which indicate that diets of sufficient energy value but producing a negative nitrogen balance have no effect on the red blood cells, while diets of insufficient energy value lower their resistance.

Brains and spinal cord of slaughtered animals as food materials. A. WEITZEL (*Arb. Reichsgesundheitsamt*, 51 (1919), No. 2, pp. 390-392).—Proximate analyses are reported of the brains and spinal cord of cows, pigs, and calves with a view to their utilization as food materials.

The brains were found to be slightly higher in protein and decidedly lower in ether-soluble substances (fat) than the spinal cord of the same animals. The highest values for both fat and protein were found in beef organs.

On account of their relatively high content in protein (8.22 to 10.44 per cent) and in fat (8.18 to 25 per cent), and the absence of carbohydrates, the author recommends the use of these materials as food for diabetic patients.

The composition of vegetables and their waste products. M. F. VON SCHLEINIZ (*Landw. Jahrb.*, 52 (1918), No. 2, pp. 131-278).—For the purpose of determining which vegetables should be considered as foods and which as luxuries, extensive analyses have been made of the edible portion, of the kitchen waste, and of the garden waste of the common vegetables. These analyses are assembled in the following tables:

Proximate analyses of the vegetables in terms of the dry and the fresh material, proximate analyses of the garden waste in percentage of the dry and of the fresh material, proximate analyses of the kitchen waste calculated to the same basis, and the weight in grams of the edible portion, and of the kitchen waste in 1 kg. of the vegetables as marketed. The vegetables included asparagus, rhubarb, head lettuce, kohlrabi tops, spinach, mangolds, beans, peas, cucumbers, onions, celery, carrots, red beets, swedes, cauliflower, red and white cabbage, Brussels sprouts, and kale.

Report on the antiberiberi vitamin content and antiscorbutic property of sun-dried vegetables. J. A. SHORTEN and C. ROY (*Indian Jour. Med. Research, Spec. Indian Sci. Cong. No.*, 1919, pp. 60-78, pls. 13, figs. 2).—With a view to determining to what extent sun-dried vegetable products can replace fresh vegetables in an army ration, carrots, onions, spinach, and cabbage sun-dried by the process described by Howard (*E. S. R.*, 41, p. 116) were tested for their content in antiberiberi vitamin by preventive feeding experiments with fowls, and for antiscorbutic vitamin by experiments with guinea pigs.

All of the vegetables possessed antineuritic properties, as shown by the fact that the addition of 5 gm. (dry) daily of the cooked vegetable was sufficient to prevent the onset of beriberi in fowls on a basal ration of polished rice. Carrots, cabbage, and onions showed antiscorbutic properties, in that 1.6 gm.

daily was sufficient to prevent scurvy in guinea pigs on a basal ration of oats, hay, and water. The dried spinach proved to have no antiscorbutic properties. "The reason for this difference is not obvious; but it may be that the antiscorbutic principle is very susceptible to desiccation and the delicate structure of the leaves of the plant does not afford so much protection to the contained vitamin as in the case of the more coarsely constructed vegetables."

Attention is called to the work of Givens and Cohen on the antiscorbutic property of desiccated vegetables (E. S. R., 40, p. 172), and it is pointed out that the "low dried" products are comparable to the sun-dried products which have been the subject of this study.

Directions for cooking the sun-dried vegetables and a table of their percentage composition are appended.

The use of apples and pears in bread making, H. MOHORČIČ (*Arch. Hyg.*, 88 (1918), No 1-2, pp. 56-89).—The literature on flour substitutes and on the nutritive value of fruits is reviewed, and a study is reported of the digestibility and food value of the so-called apple bread and pear bread made by a patented process involving the substitution of a considerable amount of these fruits for flour.

It was found possible to effect a saving of more than 15.28 per cent with the apple bread and 27.07 per cent with the pear bread. The absorption of the latter bread was similar to that of pumpnickel, and slightly less than that of the apple bread, which is recommended as a valuable war bread.

A list of 77 references to the literature is appended.

The use of horse-chestnuts as a flour substitute, W. PRAUSNITZ (*Arch. Hyg.*, 88 (1918), No. 1-2, pp. 49-55).—By washing ground horse-chestnuts with cold water a saponin-free product consisting largely of starch was obtained which is recommended as a flour substitute. Bread made from equal portions of horse-chestnut flour and wheat flour with a small amount of rice and fat proved palatable and easily digested.

On the digestibility of cocoa butter, I, J. A. GARDNER and F. W. FOX (*Biochem. Jour.*, 13 (1919), No. 4, pp. 368-377).—Attention is called to the investigations of Langworthy and Holmes on the digestibility of vegetable fats, including cocoa butter (E. S. R., 36, p. 860), and similar digestion experiments with cocoa butter are reported. In place of using the basal ration employed by these authors, the simple mixed diet used in the experiments of the Food Committee of the Royal Society on the digestibility of breads (E. S. R., 40, p. 657) was adopted as being more palatable and less likely to become distasteful. Cocoa butter was substituted for the butter of the original diet. Three subjects were used, and the experiment continued over a period of 10 days. In addition to determining the coefficients of digestibility in the customary way by taking the total ether extract of the feces to represent the actual quantity of undigested fat, the feces were subjected to a detailed analysis for true fat, free fatty acids, and fatty acids in the form of soap.

The coefficients of digestibility as determined from these figures were somewhat lower than when the total ether extract was used as representing the fat, the averages being 93.21 and 94.14 per cent, respectively. All of the subjects found the cocoa butter palatable, and no apparent digestive trouble was noted. In later quantitative experiments three out of four subjects consumed large quantities of the cocoa butter with no undesirable physiological disturbances.

The authors conclude that, while cocoa butter is rather less digestible than butter, it is satisfactorily utilized, and could be used with safety as a supplementary source of fat.

The utilization of yeast by the animal organism, W. VÖLTZ (*Biochem. Ztschr.*, 93 (1919), No. 1-2, pp. 101-105; *abs. in Chem. Abs.*, 13 (1919), No. 17,

p. 2066).—The author has found that living yeast cells remained alive for more than six hours in the digestive tract of dogs. After nine hours most of the cells were dead and about half of them digested. The digestive value of the yeast was correspondingly low, being about 53.3 per cent for the organic matter of the yeast and 46.6 per cent for the yeast protein.

The conclusion is drawn that yeast to be of value as a food should not be fed in the living state.

Sanitary food regulations, E. TOGNOLI (*La Vigilanza Igienica sulle Sostanze Alimentari*. Milan: Ulrico Hoepli, 1919, pp. XXIV+470).—This volume contains the Italian rules and regulations in regard to the principal food materials and condiments, together with brief statements concerning the analytical methods to be employed in determining whether these materials comply with the specified standards and the interpretation of the analytical results. An appendix contains regulations concerning metals to be used as kitchen utensils, etc., and a list of prohibited coloring matters, both organic and inorganic.

The influence of alkaline and acid hydrolysis on the absorption and utilization of proteins.—I, The utilization of hydrolyzed casein, J. MÜLLER and H. MURSCHHAUSER (*Biochem. Ztschr.*, 93 (1919), No. 1-2, pp. 34-43).—The extent of utilization of hydrolyzed casein, particularly casein hydrolyzed by alkali, was determined by feeding experiments conducted on dogs. The material under examination was fed with a basal ration of meat and the extent of absorption of protein measured from the difference between the nitrogen fed and that in the feces.

The percentage utilization of the casein treated in different ways was as follows: Unhydrolyzed 96.1 per cent, hydrolyzed with NaOH 59 and 59.3, hydrolyzed with NaOH and administered with opium 56.4, hydrolyzed by a commercial process 39, hydrolyzed with HCl 98.6, and protalbinic acid 29.

These results are thought to have an important bearing on the consideration of certain specially prepared proprietary foods and of hydrolyzed products as feeding stuffs.

Nitrogen partition in the urine of the races in Singapore, J. A. CAMPBELL (*Biochem. Jour.*, 13 (1919), No. 3, pp. 239-247).—This study supplements the data previously reported in the investigation of the metabolism of Asiatic races in Singapore (E. S. R., 41, p. 67), by data on the nitrogen partition in the urine and on the nonnitrogenous excretions of a Brahmin, a Chinese, a Tamil, a Malay (all subjects in the previous investigation), and of a Hindoo, a Eurasian, a Bengali, a Sikh, and a European. The European was a lecturer and the others students in the Singapore Medical School. The diets of the different subjects varied both quantitatively and qualitatively. The Brahmin and Hindoo were vegetarians, the European lived on an ordinary mixed diet, and the others on a mixed diet in which rice was the staple food. Urine analyses were made on seven-day samples preserved with a 5 per cent solution of thymol in chloroform.

The data obtained indicate that while the absolute quantities of total urea and uric acid nitrogen were much lower than the standard European figures, the percentages did not differ materially from the standard. With the exception of the Chinese, the European, and the Eurasian, the total nitrogen per kilogram of body weight was lower than the European standard in all subjects. The lowest figures were 0.11 gm. for the Brahmin and 0.127 for the Hindoo.

The absolute quantity of purin nitrogen was lower than the standard in all subjects except the Sikh. There was a wide variation in the percentage of purin nitrogen. The quantity of creatinin nitrogen was lower than the standard but the percentage was higher, which supports the theory that

creatinin is mainly of endogenous origin and is consequently not lowered greatly by reducing the protein intake.

The percentage of ammonia nitrogen was increased in all cases and the absolute amount in many cases. This confirms the previous observation. "It is considered that the excess is due to an increase of acid substances in the blood, owing to a disturbance in metabolism, and that the climate of Singapore may be responsible, since so many different subjects, living under such different circumstances and partaking of different diets, are similarly affected."

In regard to the nonnitrogenous excretion the ratio of phosphoric acid to total nitrogen was somewhat lower than the standard, indicating that the Singapore diets contained smaller quantities of absorbable phosphate. The amounts of sulphates followed closely the variations of the total nitrogen, the chlorids were somewhat lower, and the acidity considerably lower than the European standard.

In general the results of the investigation are considered to indicate that race apart from diet has no influence on the nitrogen partition and the nonnitrogenous excretions in the urine.

War edema in Turkish prisoners of war, J. I. ENRIGHT (*Lancet [London]*, 1 (1920), No. 6, pp. 314-316).—The author reports a further study of the edema in Turkish prisoners of war previously noted by Bigland (E. S. R., 42, p. 760).

A short summary is given of the principal features of the disease as observed in about 54 out of 300 or more cases. The diseases most commonly associated with the edema, either concurrently or as antecedents, were pellagra, dysentery, and malaria, pellagra being of most common occurrence. In discussing the possible causative factors, the fact that dietetic agency was involved was shown by the inadequacy of the food supply and the similarity of many of the cases to wet beriberi, scurvy, and the symptoms and physical signs noted by McCarrison in his experimentally-fed pigeons (E. S. R., 42, p. 463). In the latter comparison one striking difference was noted, in that while the suprarenal glands of the pigeons were always enlarged, the suprarenals of the victims of the edema were in all cases atrophied. That something more than food deficiency was involved was shown by the failure of the patients to respond to improved food conditions.

The theory is advanced that the edema was "due to a combination of two factors—food deficiency and debilitating diseases—e. g., malaria, dysentery, pulmonary tuberculosis, etc.—operating to produce a third factor—adrenal insufficiency—which is the immediate cause of the condition. Whether the food deficiency chronologically precedes the onset of the debilitating disease or vice versa can be only conjectural. I personally think that the debilitating disease or diseases occur first, and thus render the system more receptive of the deleterious influences that accrue from the subsequent food deficiency."

Nutrition laboratory, F. G. BENEDICT (*Carnegie Inst. Washington Year Book*, 17 (1918), pp. 219-232).—This is the usual annual report of the work of the nutrition laboratory of the Carnegie Institution (E. S. R., 40, p. 465). The publications of the year, which are abstracted in this report, have been previously noted from other sources.

ANIMAL PRODUCTION.

Posthumous works of Charles Otis Whitman, edited by O. RIDDLE and H. A. CARR (*Carnegie Inst. Washington Pub.* 257 (1919), vols. 1, pp. X+194, pls. 88, figs. 36; 2, pp. X+224, pls. 39, figs. 11; 3, pp. XI+161).—These three quarto volumes, containing many lithographic reproductions of colored and un-

colored drawings, constitute the record of 18 years' investigations of evolution, heredity, and behavior in pigeons. Forty-three species of wild pigeons collected in various parts of the world were bred in captivity and kept under observation to study their color patterns at different ages and their reproductive instincts. Many were crossed with other species and with domestic pigeons. At the time of Whitman's death in 1910 the work was still in active progress, and only a small fraction of the material in these volumes was in manuscript form. To Riddle fell the task of bringing to a conclusion such of the breeding operations as were well under way and of preparing for publication an account of the work based on Whitman's MSS., notebooks, and breeding records. Later the editorial treatment of the behavior studies (grouped to form vol. 3) was allotted to Carr. The title and an outline of the contents of each volume follow:

Orthogenetic evolution in pigeons (vol. 1).—Matters discussed include the origin and relationship of rock-pigeons as revealed by their color patterns, the turtle-dove pattern in the phylogeny of pigeons and in other orders of birds, frills and fundamental bars as plumage characters in pigeons (with notes on similar conditions in domestic fowls and geese), color mutations in pigeons, and several general topics dealing with the problem of organic evolution. The turtle-dove pattern (feathers with dark centers and light margins) is considered the primitive type in pigeons, and other patterns including the wild rock are held to have developed from this type by an orderly process of evolution in a definite direction.

Inheritance, fertility and the dominance of sex and color in hybrids of wild species of pigeons (vol. 2).—This volume is chiefly a record of experimental crosses. Most of the crosses were between different wild species or genera, because Whitman deemed purity of the original stock essential for inheritance investigations. As a consequence, the studies could not in general be continued beyond the first generation, owing to the sterility of hybrids.

Of the 17 chapters, only 5 are from Whitman's pen directly, viz, an introductory chapter on species hybrids in pigeons, and papers entitled Sex-limited Heredity in Crosses Involving Blond and White Ring-doves and Related Species; on the Nature and Basis of Heredity; Influence of the Spermatozoa of Pigeons on Rate of Development of Embryo; and On the Divisibility of Characters. The remaining chapters are detailed accounts by Riddle of the colors, sex, and fertility of the hybrids, based mainly on data tabulated by Whitman. The viewpoint with regard to sex determination and its relation to season, reproductive overwork and width of cross is the same as that expounded by Riddle in a number of previous papers, some of which have been noted (E. S. R., 33, p. 272; 35, p. 771; 37, p. 868; 39, p. 575).

The behavior of pigeons (vol. 3).—This volume consists of a detailed study of the mating instinct and reproductive cycle in pigeons, with briefer chapters on the voice, the homing instinct, and other instincts.

On the possibility of intranuclear transfer in homozygotes, J. P. LOTSÝ (*Genetica [The Hague]*, 1 (1919), No. 1, pp. 92-97, figs. 10).—A theoretical discussion of the possibility of mutations originating by the transfer of chromatin segments from one chromosome to a nonhomologous chromosome.

Problems of animal breeding, J. A. S. WATSON (*Scot. Jour. Agr.*, 2 (1919), No. 4, pp. 449-456).—A popular discussion, calling attention particularly to the undue amount of cattle crossing in Scotland and to the absurdity of the "family craze" in evaluating Shorthorn and Angus pedigrees.

The effect of feeding pars tuberalis and pars anterior propior of bovine pituitary glands upon the early development of the white rat, C. J. MARINUS (*Amer. Jour. Physiol.*, 49 (1919), No. 2, pp. 238-247).—A group of 53

young white rats fed for 12 weeks on a standard mixed grain diet plus fresh pars anterior propior of the pituitary gland (ox) exhibited a greater rate of growth than a control group fed beef muscle and the standard diet. They also showed a more rapid development of the reproductive system, as indicated by hypertrophy of the organs and by the earlier birth of young. A second experimental group of 37 individuals fed on pars tuberalis manifested no increased sexual development.

"This study has not shown that any of the functions ascribed to the anterior lobe as a whole are due to the pars tuberalis."

The feeding and improvement of live stock, M. DE CAMPOS PENTEADO (*A Alimentação e o Melhoramento do Gado. Sao Paulo: Sec. Agr., Com., e Obras Pub., 1918, 2. ed., pp. 71, figs. 34*).—A treatise on the cultivation of forage crops in Brazil and their utilization by live stock.

Sudan grass silage, C. T. DOWELL and W. G. FRIEDEMANN (*Oklahoma Sta. Rpt. 1919, pp. 55-58*).—Continuing the observations recorded in Bulletin 115 (E. S. R., 37, p. 672), the authors report the proximate composition of fresh and mature Sudan grass silage and determinations of the acid, sugar, and alcohol present in the samples. The silage was made in a galvanized iron cylindrical silo (4 by 9 ft.) during the season of 1918.

"Possibly the most important thing noticed in connection with this silage is that more reducing sugars were found in the mature silage than in the fresh silage. It should be noted also that there is only 0.1 per cent of sugar present in the fresh silage, and yet the silage was kept in perfect condition."

It is stated that the density was only 54 per cent of that of corn silage put up in a similar manner, but in spite of this indication of lack of compactness the spoilage was only 10.1 per cent by weight.

Feeding sunflowers, C. N. ARNETT, W. E. JOSEPH, and O. TRETSVEN (*Montana Sta. Bul. 131 (1919), pp. 13-29, figs. 4*).—Besides citing the results of a test of sunflower silage with dairy cows in 1916-17, previously noted from Bulletin 118 (E. S. R., 39, p. 182), the authors report additional tests of the silage with cows, pregnant ewes, and brood sows, and a trial of green sunflowers as a soiling crop.

Alfalfa hay and sunflower silage were compared in 1917-18, 16 milch cows divided into 2 groups being fed by the reversal method during 2 periods totaling 68 days. When alfalfa hay was sole roughage, 26.7 lbs. of it on the average was consumed daily per cow and the daily milk yield averaged 29 lbs. When alfalfa hay (limited) and sunflower silage was fed, the roughage ration averaged 10.9 lbs. of the former and 41.3 lbs. of the latter and the milk yield was 28.2 lbs. The consumption of grain (rolled oats, dried beet pulp, and cottonseed meal, 2:2:1) was substantially equal in both cases, viz, 10.5 lbs. daily. The cows became slightly heavier during alfalfa feeding. "The butterfat production was approximately the same. Allowing for the difference in gains in live weight and milk produced, it was found that 2.83 lbs. of sunflower silage were equal in feeding value to 1 lb. of good alfalfa hay under the conditions of this experiment. Under the same conditions 0.71 lb. of dry substance of sunflower silage was equivalent to 1 lb. of dry substance in alfalfa hay."

In 1918-19 two groups of 8 cows were fed during two 28-day periods to determine the relative value of silage made from sunflowers harvested (1) when 30 per cent and (2) when 90 per cent of the plants were in bloom. "The data presented show the cows when receiving the early-cut silage averaged a gain of 5.6 lbs. more in live weight during the 28 days and consumed on an average 0.15 lb. more grain, 0.11 lb. more hay, and 0.7 lb. more silage per head per day than during the period they were fed the late-cut silage. During the

period they received the late-cut silage they produced 0.75 lb. more milk containing 0.025 lb. more butter fat per day per cow than when fed the early-cut silage. . . . It is impossible to draw definite and guiding conclusions as to the proper stage of maturity for cutting sunflowers from this one experiment."

Six cows were used in a comparison of chopped green sunflowers and chopped green corn as supplements to pasture through two 28-day periods. During sunflower feeding the cows maintained their weight better than during corn feeding (when one cow went off feed), consumed somewhat more feed, and gave slightly more milk, and it is concluded that "chopped green sunflowers 30 to 40 per cent in bloom were equal to chopped green corn in the roasting ear stage as a soiling crop for dairy cows."

A comparison of sunflower silage and alfalfa hay in the winter ration of breeding ewes and a similar comparison (preliminary) with brood sows indicated in both cases that 2.5 lbs. of the silage is equivalent to 1 lb. of the hay. The approximate daily ration of a pregnant ewe during sunflower feeding consisted of 3 lbs. of alfalfa hay, 2.2 lbs. of the silage, and 0.2 lb. of oats. "No unfavorable results were obtained from feeding the silage to breeding ewes either before, during, or after lambing."

Four samples of sunflower silage taken at different depths had the following percentage composition: Crude protein 2.1, ether extract 0.5, crude fiber 6.8, other nitrogen-free extract 10.4, and ash 1.6. A digestion trial by W. E. Joseph and M. J. Blish (to be reported in detail later) indicated 1.24 lbs. digestible protein, 0.37 lb. digestible fat, and 10.13 lbs. digestible carbohydrate (including fiber), in 100 lbs. of the silage.

Commercial feeding stuffs, quarterly report, July 1 to September 30, 1919, E. G. PROULX ET AL. (*Indiana Sta. Bul. 232 (1919), pp. 3-60, figs. 2*).—This bulletin tabulates the proximate composition of 800 samples of feeding stuffs and the ingredients identified. The materials analyzed included alfalfa meal, barley feed, barley hulls, brewers' dried grains, corn bran, corn feed meal, corn germ meal, corn gluten feed, corn gluten meal, hominy feed, cottonseed meal, linseed meal, ground flaxseed screenings, rye middlings, wheat bran, middlings, red dog, wheat mixed feed, unhulled peanut oil-feed, tankage, meat scrap, and a variety of proprietary stock and poultry feeds, calf meals, and condimental foods.

Commercial feeding stuffs and registrations for 1919, C. S. CATHCART (*New Jersey Stas. Bul. 336 (1919), pp. 5-60*).—The report is made on 840 samples of feeding stuffs collected under the State law in 1919. Data as to the moisture, protein, fat and fiber content of the following products are given: Alfalfa meal, brewers' dried grains, yeast dried grains, malt sprouts, barley mixed feed, barley flour, buckwheat feed, buckwheat middlings, buckwheat offal, coconut oil meal, cottonseed feed, cottonseed meal, corn feed meal, corn gluten feed, corn gluten meal, corn and cob meal, hominy feed, corn and oats, dried beet pulp, linseed meal, peanut oil meal, rye bran, rye middlings, wheat bran, wheat feeding flour, wheat mixed feed, wheat middlings, wheat and rye middlings, and various proprietary mixed feeds, calf meals, and poultry feeds. The moisture, protein, fat, and phosphoric acid in samples of meat scrap, cracklings, and digester tankage are also reported. The prices of 17 feeding stuffs in 1919 and in the three preceding years are tabulated.

Karakule sheep and Persian lamb fur production, G. E. O'BRIEN (*Canada Dept. Agr., Live Stock Branch Pamphlet 15 (1918), pp. 3-8, figs. 5*).—A popular account of the production of Karakule wool (Broad-tail, Persian lamb, and Astrakan fur) in Canada. In Nova Scotia, it is stated, Karakule rams are

crossed with Lincoln, Cotswold, and Leicester ewes. The wool of the young cross-bred lambs is black, and in many cases has the desired curl.

The need for improved methods in handling sheepskins, J. W. MATHEWS (*Agr. Gaz. N. S. Wales, 31 (1920), No. 2, pp. 94-98*).—The author reports the valuations placed by fellmongers on country sheepskins dried in five ways under experimental conditions.

Skins dried in the sun were uniformly inferior to those dried under shelter without exposure to direct sunlight, and both classes were improved by painting the dried skins with a solution of sodium arsenate. Skins salted and cured immediately after flaying yielded the highest priced pelts, but the wool was so much impaired that the method is not recommended.

Preliminary report on (1) comparison of feeds for fattening hogs, (2) comparison of methods of preparation of barley for hog feed, C. P. THOMPSON (*Oklahoma Sta. Rpt. 1919, pp. 27-33*).—Two separate experiments are reported.

(1) Five lots of eight 140-lb. hogs (Duroc Jersey, Poland China, and cross-breds) were fed for 40 days beginning November 1, 1918. One lot received only table garbage and the others grain mixtures. The garbage-fed lot made the best daily gain (1.86 lbs. per head) and with a charge for garbage of 21 cts. per hundredweight was over four times as profitable as any other lot. The mixtures given the grain-fed lots (all grain ground) and the amounts of feed required for a pound of gain were as follows: Corn and tankage (12:1), 4.2 lbs.; corn, barley and tankage (6:6:1), 4.4 lbs.; barley and tankage (12:1) 5 lbs.; oats and tankage (16:1), 6.7 lbs. The average daily gains were, respectively, 1.82, 1.73, 1.48, and 1.34 lbs. per hog. Barley being cheaper than corn, the corn and barley mixture was slightly more profitable than the corn mixture.

(2) Three lots of five 90-lb. Duroc Jersey hogs were fed on barley (variously prepared) and tankage (12:1) for 70 days, and two similar lots were given free choice of barley and tankage in a self-feeder at the same time. Whole barley, dry, produced the same gain, whether self-fed or not, viz, 1.1 lbs. per head daily, and the self-fed lot consumed the same amount of barley and almost the same amount of tankage as the hand-fed lot. These two lots required 4.7 lbs. of grain for a pound of gain. Whole barley soaked and hand fed produced somewhat greater gains, but 5.1 lbs. of feed were required for a pound of gain and the lot thus fed yielded the least profit. Ground barley when hand-fed (moist) produced a daily gain of 1.27 lbs. per head, the highest observed, and when self-fed (dry) produced a gain of 1.19 lbs., the next highest; in both cases about 4.4 lbs. of feed were required for a pound of gain. The two lots receiving the ground grain were the most profitable ones fed, the self-fed lot ranking first.

The algaroba bean as a feed for hogs, L. A. HENKE (*Col. Hawaii Bul. 5 (1918), pp. 17-20*).—The meal made by grinding the pods (and beans) of the algaroba tree (*Prosopis juliflora*) was fed to five 25-lb. pigs out of the same litter. It was mixed in equal parts with wheat middlings when fed to three of the pigs and with rice bran when fed to the others. Linseed meal formed 4 per cent of the rations and salt 2 per cent. Green alfalfa or alfalfa pasture furnished the roughage, and the test lasted seven months.

The pigs fed the middlings mixture made an average daily gain of 0.45 lb. per head, and aside from alfalfa consumed 3.97 lbs. of feed per pound of gain. Those fed the rice bran mixture gained at the rate of 0.39 lb. a day, and required 5.2 lbs. of grain per pound of gain. Although the rice bran cost about \$20 less per ton than the middlings, it was not so economical a feed.

A third lot of three, litter mates to the others, were given cracked corn, wheat middlings, and rolled oats (1:1:1) plus linseed meal and salt. The

average daily gain was 0.54 lb., but despite the fact that only 3.3 lbs. of grain were required for a pound of gain this "standard corn-belt ration" was too costly in Hawaii to be fed profitably.

Hog-feeding experiments with a self-feeder, L. A. HENKE (*Col. Hawaii Bul. 6 (1919), pp. 24-27*).—Two experiments are reported as follows:

I. *Sweet potatoes v. cassava meal* (pp. 24-26).—A lot of three pigs were fed 20 lbs. of green alfalfa a day and were allowed free choice of sliced undried sweet potatoes, linseed meal, and tankage for 70 days beginning March 19, 1919. They made an average daily gain of 0.51 lb. per head and consumed 8.6 lbs. of concentrates per pound of gain. Of the feeds selected 76 per cent were sweet potatoes, 14 per cent linseed meal, and 10 per cent tankage. Another lot of three were fed similarly except that cassava meal (roots sliced, dried, and ground) replaced the sweet potatoes. The average daily gain was 0.4 lb., and excluding the alfalfa 4.6 lbs. of feed were required for a pound of gain. Cassava meal constituted 76 per cent of the concentrates eaten, linseed meal 18 per cent, and tankage 6 per cent. It is concluded that a pound of cassava meal is about equal in feeding value to 1.8 lbs. of the sweet potatoes.

II. *Feeds selected by hogs* (pp. 26, 27).—During the experiments noted above, a third lot, consisting of three 3-months-old Berkshires were given the choice of nine different feeds. The percentages selected were as follows: Sweet potatoes 38, cassava meal 22, rolled barley 11, corn 9, algaroba meal 7, rice bran 4, wheat middlings 3, linseed meal 3, and tankage 3. It is pointed out that the hogs ate local tropical crops like sweet potatoes and cassava in preference to high-priced imported feeds.

Studies on color in swine.—I, The hereditary relationship of the black of the Hampshire and the red of the Duroc-Jersey, O. LLOYD-JONES and J. M. EVVARD (*Iowa Sta. Research Bul. 53 (1919), pp. 203-208*).—Crosses are reported indicating that Hampshire black and Duroc-Jersey red form a simple pair of allelomorphs, with complete dominance of the black. Back-crossed on red the heterozygotes of the F_1 and subsequent generations produced 56 black and 66 self red young. Mated inter se the F_1 s produced 45 blacks and 21 self reds. These totals do not include the progeny of a registered Hampshire boar, heterozygous for black, some of whose red offspring showed black spots. This boar sired 13 black, 4 spotted, and 7 self red pigs by red sows, and 158 black, 15 spotted, and 15 self red pigs by heterozygous black sows out of crosses where no spotting occurred. "The amount of black on those 'spotted' pigs was small, consisting in general of from one to a dozen areas about the size of a dollar, scattered promiscuously over the coat." [This boar's production of the three classes of offspring renders untenable the hypothesis that the black, spotted, and red genes form a set of triple allelomorphs similar to the black extension set in other mammals.]

The Hampshire black, it is pointed out, differs genetically from the black of the Berkshire and the Poland-China inasmuch as individuals of the latter breeds crossed with Duroc-Jerseys produce young predominantly red but with black spots. Moreover, Berkshire and Poland-China black is known to be entirely recessive to the white of Yorkshires and Chester-Whites, whereas the authors state (on the basis of a Hampshire breeder's report and personal experience with one litter) that the Hampshire \times Chester White F_1 s are in general blue roans belted with white.

The inheritance of the white belt of Hampshires proved complicated and is not reported on.

History of the Duroc, R. J. EVANS ([*Chicago*]: James J. Doty Pub. Co., 1918, pp. 83, pls. 9).—An account of some famous Duroc-Jersey animals.

Hogs in Kansas, J. C. MOHLER (*Kans. State Bd. Agr. [Quart.] Rpt. 1918, Sept., pp. V+429, figs. 350*).—A somewhat exhaustive compilation of information for hog raisers.

Swine, N. ATHANASSOF (*Escola Agr. "Luiz de Queiroz," Piracicaba, Brazil, Bol. 1 (1919), pp. 75, pls. 2, figs. 22*).—This is an account of the swine industry in Brazil, and deals with breeds, breeding, feeding, fattening, and questions of hygiene. Three native breeds are recognized, the Canastrão (large), the Canastra (medium-sized), and the Tatù (small and apparently of Asiatic origin). Berkshires, Large Blacks, Poland-Chinas, and Duroc-Jerseys have been imported and used for crossing.

The effect of certain grain rations on the growth of the White Leghorn chick and their influence on subsequent egg-production, G. D. BUCKNER, A. M. PETER, R. H. WILKINS, and J. J. HOOPER (*Kentucky Sta. Bul. 220 (1919), pp. 3-20, pls. 4*).—This bulletin gives data as to (1) the growth in weight of 8 variously treated lots of White Leghorn chicks during the first 28 weeks of life, (2) the mortality during that period, and (3) the average egg production of 15 pullets from each lot. The work was mainly a continuation of a study of the importance of lysin in chick feeds reported in Bulletin 197 (*E. S. R., 34, p. 871*).

One lot (lot 4) were hatched and brooded by hens and had access to a blue grass pasture until the sixth week; the others were incubator chicks and were confined to a brooder house until 6 weeks old. The methods of feeding lots 1, 2, and 3 and the growth records of these lots were presented and discussed in a paper by Buckner and collaborators previously noted (*E. S. R., 41, p. 75*). Two other types of rations were tested with the remaining lots. Lot 5 were fed a dry mash of rolled oats, ground barley, rice bran, beef scrap, and bone meal (3:3:3:3:1), a scratch feed of "hominy," steeled oats, and rice (2:1:2) and once a day some of the mash moistened with skim milk. This ration was high in lysin of animal origin. Lots 6 and 8 were given a mash of wheat bran, sunflower seed, distillers' dried grains, and cottonseed meal (3:7:1:1) and a grain mixture of wheat, corn, and soy beans (2:2:7), the lysin content of the ration being high. Lot 8 had access to skim milk continuously, while the only animal feed given lot 6 was protein-free milk once a day with the wet mash. All lots received shredded cabbage and sprouted oats, and it is thought that the vitamin supply was ample in all cases. Any deficiency in a ration is therefore attributed to lack of necessary amino acids. The other experimental details and the main results may be summarized thus:

Influence of amount and source of lysin in feed and the feeding of skim milk on the growth and reproduction of chicks.

Character of feed.	Lot number.	Chicks alive at 28 weeks. ¹	Average weight at 28 weeks.			Average pullet egg records.
			Males.	Females.	Both sexes.	
			Kg.	Kg.	Kg.	
Cornell ration (chicks brooded by hens)...	4	50	1.75	1.45	1.60	148.3
Cornell ration:						
Including skim milk.....	3	42	1.59	1.12	1.36	142.4
Lacking skim milk.....	7	40	1.43	1.24	1.33	137.6
Plant feed low in lysin; no animal protein.	2	19			.81	
High lysin cotton seed meal and soy bean ration:						
Plus protein-free milk.....	6	15	.99	.78	.89	
Plus skim milk.....	8	43	1.54	1.26	1.40	166.8
High lysin soy bean ration, including skim milk.....	1	42	1.29	1.18	1.24	121.1
Plant feed low in lysin; beef scrap and skim milk fed.....	5	43	1.72	1.22	1.47	106.0

¹ Each lot consisted initially of 60 chicks.

The superior vitality of the hen-raised chicks is attributed in part to a larger and more varied diet in early life. The high egg records and satisfactory growth of lot 8 are held to indicate that "skim milk supplies some factor other than lysin, the lack of which, we believe, limits the nutritive power of the proteins in the grains fed to lot 6." Sexual development was retarded in lot 6 but not to the extent of lot 2, where sexes were indistinguishable at 28 weeks.

[Sources of protein feeds for poultry], H. EMBLETON (*Oklahoma Sta. Rpt. 1919*, pp. 50-52).—A brief report is made of some results secured in 1916-17 and 1917-18 from four pens of laying birds receiving, respectively, as part of their rations meat scrap, cottonseed meal, peanut meal, and a mixture of the latter two.

The cottonseed meal pen laid the heaviest eggs (averaging 54.4 gm.) but the fewest in number (106 per year). The eggs of the birds fed the mixed meals were the lightest in weight (49.7 gm.), but these birds averaged the most eggs per hen (132 a year), with the meat-scrap pen a close second (131 eggs). The peanut meal pen was intermediate with respect to size and number of eggs.

The early elimination of surplus cockerels, R. C. PUNNETT (*Jour. Bd. Agr. [London]*, 25 (1919), No. 11, pp. 1319-1323, fig. 1).—The author suggests the use of known facts about sex-linked inheritance in poultry to distinguish between the sexes of chicks at hatching by inherited color differences. The method would only be applicable where color varieties could be crossed, the cross-bred pullets serving as egg producers but not as breeders. The cross-bred male chicks would not be raised.

Fluctuations in the egg market, A. V. D. RINTOUL (*Jour. Dept. Agr. Victoria*, 18 (1920), No. 2, pp. 113-116).—A general discussion, with a table showing the wholesale price of eggs in Melbourne at semimonthly intervals from January 1, 1907, to February 1, 1920.

A relatively rare anomaly of the egg of the fowl, E. BUJARD (*Arch. Sci. Phys. et Nat. [Geneva]*, 4. ser., 44 (1917), No. 12, pp. 483-486; also in *Soc. Phys. et Hist. Nat. Genève, Compt. Rend.*, 34 (1917), pp. 69-72).—Three cases of ovum in ovo are described, and the approximately 50 similar cases recorded in the literature since 1654 are classified according to the completeness of the included egg (presence of yolk, shell, etc.) and other characteristics. The anomaly is attributed to antiperistaltic movements of the oviduct.

DAIRY FARMING—DAIRYING.

Valuable bulletins and circulars for the dairy farmer and the manufacturer of dairy products, C. H. ECKLES (*Univ. Minn. Agr. Ext. Div. Spec. Circ. 2* (1919), pp. 4).—A selected bibliography of dairying and dairy farming, giving particular attention to publications of the U. S. Department of Agriculture and of the State experiment stations.

Cassava meal as a feed for dairy cattle, L. A. HENKE (*Col. Hawaii Bul. 6* (1919), pp. 20, 21).—Cassava meal was used to replace entirely the corn and coconut meal of the grain ration (ground corn, brewers' grain, coconut meal, 2:2:1, plus varied amounts of linseed meal) fed a Holstein cow giving about 30 lbs. of milk daily, and was also used as a partial substitute for the grain mixture. The daily milk yield during three months of cassava feeding averaged nearly 2 lbs. greater than the yields during the month preceding and the month following this period, but the amount of grain consumed was also greater. The cassava meal proved very palatable.

Testing of pure-bred dairy cows, W. M. SINGLETON (*New Zeal. Jour. Agr.*, 20 (1920), No. 2, pp. 65-81, figs. 5).—This is a review of the operations of the

New Zealand certificate-of-record system for pure-bred dairy cows in 1919. A total of 1,260 certificates have been granted.

Investigation into milk yield of Ayrshire cows, J. F. TOCHER (*Trans. Highland and Agr. Soc. Scot.*, 5. ser., 31 (1919), pp. 237-256, figs. 7).—This is a preliminary report of a statistical analysis of the manuscript records of the Scottish Milk Records Association for the years 1911 and 1912. Tables and diagrams are presented to show the relationships of (1) yield of milk and percentage of fat, (2) length of lactation and yield of milk, (3) age of cow and yield of milk, (4) age of cow and percentage of fat, and (5) season of year when parturition took place and yield of milk.

The maximum amount of milk per lactation and the minimum percentage of fat occurred at the age of about 10 years. Cows calving from August to November produced more milk per lactation than those calving during other months, but the difference was due entirely to a longer average lactation period.

A table showing the frequency distribution of milk yields indicates that half the cows produced more than 6,000 lbs. of milk and 2 per cent more than 10,000 lbs. A frequency table for fat percentages based on this investigation is given in the paper noted below.

Variations in the composition of milk, J. F. TOCHER (*Scot. Jour. Agr.*, 2 (1919), No. 3, pp. 343-353).—In 384 mixed-herd samples of milk collected under the author's supervision the average fat percentage was 3.495 with a standard deviation of 0.549. The average percentage of solids-not-fat was 8.85 with a standard deviation of 0.375. In over 11,000 lactation records of Ayrshire cows collected by the Scottish Milk Records Association (see above) the mean percentage of fat was 3.727 and the standard deviation 0.324.

"The results of this paper show that the prescribed minima for butter fat [3 per cent] and for solids-not-fat [8.5 per cent] are artificial in character, and are based neither on the real minima found to exist for these constituents nor on an adequate study of the natural variations occurring in genuine milk."

The Irish milk supply, L. SMITH-GORDON (*Better Business*, 5 (1919), No. 1, pp. 11-36).—A series of notes on the sanitary quality, prices, and quantity of the market milk sold in Ireland. In addition to poor quality and high price there appears to be an actual scarcity of milk due to decrease in the number of cows, low average yields, and a wider use of milk for making butter, condensed milk, and milk powder. Legislation is recommended similar to the Ontario Milk Act (1911) giving full powers to local authorities both for supervision and for trading.

Milk products in America and Europe, W. DEMPSTER (*New Zeal. Jour. Agr.*, 20 (1920), No. 2, pp. 97-109; also in *New Zeal. Dairyman*, 24 (1920), No. 6, pp. 27, 28, 30, 33, 35, 36, 38, 40, 42).—This is a discussion of the extent of production, uses, and probable future uses throughout the world of milk powder, condensed milk, milk sugar, and casein. It is based upon the author's knowledge of the milk products industries in New Zealand and on data collected in the course of an official visit to the United States, Canada, England, and Holland, of which an account is given.

Production and prices of milk and of its chief derivatives (*Internatl. Inst. Agr. [Rome], Bur. Statis. Doc. Leaflets*, 3 (1919), No. 2, pp. 17-39).—A compilation of available statistics as to the production of milk, butter, and cheese in the principal countries of the world, with information as to prices in local markets.

The trade in milk and its derivatives (*Internatl. Inst. Agr. [Rome], Bur. Statis. Doc. Leaflets*, 3 (1919), No. 2, pp. 40-51).—Tabulated data are given as to the imports and exports of milk (fresh, condensed, dried etc.), cream, butter, and cheese by countries for the years 1913 to 1917.

The cooperative creamery, J. SORENSON (*N. Y. Produce Rev. and Amer. Cream.*, 49 (1919), No. 8, pp. 314, 316).—An address dealing with the status of the cooperative creamery in Minnesota. Cases of alleged unfair competition on the part of centralizers are cited.

Survey of typical Oregon farmers' creameries, E. ENGLUND (*Oregon Sta. Bul.* 168 (1920), pp. 24, figs. 5).—This is a discussion of the factors making for the success or failure of cooperative or quasi-cooperative creameries, based upon a survey of the business methods of 17 of the 24 such creameries in operation in Oregon in 1918.

It is concluded that success is mainly conditioned on the size of the business and the employment of a buttermaker capable of securing a high overrun and competent in business matters. Some creameries were established where a preliminary investigation would have shown the improbability of a large volume of business, while the business of some others has decreased through competition and the lack of a cooperative spirit among members. "In many cases farmers have discontinued patronizing their own creamery for the sake of 1 cent or a fraction of a cent more for a pound of butter fat paid at the time by some large, privately owned creamery." Large creameries were able to employ agents in the marketing centers.

The methods used in fixing the price of butter fat and in distributing the cost of gathering cream are discussed with regard to fairness to patrons and influence on the amount of business.

Study of Babcock test for butter fat in milk, D. E. BAILEY (*Jour. Dairy Sci.*, 2 (1919), No 5, pp. 331-373, fig. 1).—A summary of this investigation has been previously noted (*E. S. R.*, 41, p. 279). Tables record Babcock and gravimetric determinations of fat in each of the 190 samples analyzed lactometer readings, breed and age of cows, etc.

The volatile acid production of starters and of organisms isolated from them, E. W. HAMMER and D. E. BAILEY (*Iowa Sta. Research Bul.* 55 (1919), pp. 223-246).—A variety of observations are recorded concerning the volatile acidity of lactic starters and of milk cultures of organisms isolated from them.

Cultures of *Bacterium lactis acidi* picked from agar plates poured with starter gave a volatile acidity in milk distinctly lower than that given by the starter itself. Attempts to isolate a pure culture of this bacterium having high volatile acidity were unsuccessful, and none of the other organisms isolated from starters was found capable of producing high volatile acidity in pure cultures. However, mixed cultures of *B. lactis acidi* and certain of these associated organisms isolated by repeated transfers from starters (and incapable themselves of coagulating milk) gave a volatile acidity approximating that characteristic of good starters. "In no instance did the volatile acidity of either organism alone or the sum of the volatile acidities produced by the two organisms alone equal the volatile acidity of the two organisms in combination." It is concluded, therefore, that the associative action of the bacteria present is necessary for the development of the desired volatile acidity of starters.

The partial neutralization of acidity in cream, M. A. O'CALLAGHAN and A. A. RAMSAY (*Agr. Gaz. N. S. Wales*, 29 (1918), No. 2, pp. 115-127).—Observations are reported on the viscosity of cream neutralized with slaked lime and the chemical composition of butter made from such cream after pasteurization. The cream became thickened without regard to its age, acidity, or fat content, but the thickening effect disappeared on pasteurization. "The lime content of butter manufactured from cream in which lime has been used as the neutralizing agent falls within the average lime content of ordinary butters."

Sodium compounds, previously studied as neutralizing agents (E. S. R., 35, p. 277), were found to thin the cream.

Studies on formation of gas in sweetened condensed milk, B. W. HAMMER (*Iowa Sta. Research Bul. 54* (1919), pp. 211-220, figs. 2).—A yeast, *Torula lactis-condensi* n. sp., was isolated from sweetened condensed milk that had undergone gaseous fermentation after canning. When the organism was introduced into cans of unfermented milk of the same brand similar fermentations resulted.

The morphological, cultural, and biochemical characteristics of *T. lactis-condensi* are described. Its assignment to the genus *Torula* is tentative.

VETERINARY MEDICINE.

Principles of veterinary science, F. B. HADLEY (*Philadelphia and London: W. B. Saunders Co., 1920, pp. 420, figs. 101*).—This work is an amplification of the matter presented in the author's former publication on *The Horse in Health and Disease*, previously noted (E. S. R., 34, p. 794). The first part deals with the anatomy and physiology of animals (pp. 17-183), and the second part with the common diseases of animals (pp. 185-395).

Progress in immunity research during the war and the present status of immuno- and serum-therapy, W. EICHHOLZ-DARMSTADT (*Ztschr. Angew. Chem., 32* (1919), Nos. 94, Aufsatz., pp. 367, 368; 96, pp. 370, 371).—This is a brief survey of the progress made in Germany during the recent war in the diagnosis, prophylaxis, and therapy of contagious diseases through the application of the results of immunity research.

On the association of antitoxins with the proteins of immunized horse serum, A. HOMER (*Biochem. Jour., 14* (1920), No. 1, pp. 42-45).—In continuation of the studies on antitoxic sera (E. S. R., 41, p. 282), data are presented on the percentage precipitation of the antitoxins of antitetanic and of antidiphtheritic horse plasma by anhydrous sodium sulphate, and on the percentage of the total antitoxins precipitated with salt-soluble globulins of antidysenteric and antimeningitic horse sera.

Both in cresylised and in noncresylised plasma the precipitation of antitoxin with the proteins of the euglobulin-pseudoglobulin zone was greater in antitetanic than in antidiphtheritic plasma. The bulk of the antitoxins in antidysenteric and antimeningitic plasma was found to be associated with the proteins of the euglobulin and of the euglobulin-pseudoglobulin zones.

"The results of the present investigation are of interest, as they show that the various antitoxins are adsorbed by different protein fractions of horse serum, a phenomenon which can be regarded as an indication of differences in the molecular composition of the respective antitoxins."

The sterilization of lipovaccines, P. A. LEWIS and F. W. DODGE (*Jour. Expt. Med., 31* (1920), No. 2, pp. 169-175).—The authors refer to the methods of Whitmore and Fennel (E. S. R., 38, p. 782) and of Rosenow and Osterberg (E. S. R., 41, p. 377) for sterilizing lipovaccines, and suggest another method which depends upon the application of dry heat to the finished product.

The lipovaccines were prepared according to the method of Whitmore and Fennel, and the finished vaccines were heated to a temperature of 130° C. for 3 hours in an electric oven or to 120° for 12 hours. Pneumococcus and typhoid vaccines thus prepared were tested for their protective value for mice. The antigenic qualities of the pneumococcus vaccine were apparently not destroyed by this treatment, while those of the typhoid vaccine were greatly injured. Sufficient data have not been obtained to indicate the general value of this method.

The isolation of and search for anaplasma by the inoculation of the sheep or goat with suspected blood, J. LIGNIÈRES (*Bul. Soc. Path. Exot.*, 12 (1919), No. 10, pp. 774-779).—The inoculation of sheep and goats with *Piroplasma bigeminum* and *P. argentinum* produces no effect upon them and these organisms can not be recovered from their blood. The injection of the sheep or goat with blood containing both piroplasma and anaplasma is only positive for anaplasma. If in one to two months after inoculation 5 to 10 cc. of blood from sheep or goats is injected into a susceptible bovine intravenously or subcutaneously a pure anaplasmosis is produced. Injection of the sheep or goat with blood suspected of containing anaplasma and then injecting their blood into bovines is a simple and easy means of isolating the anaplasma. This method will greatly facilitate the preparation of an epidemiological chart in any region where anaplasmosis may exist.

The vaccination of bovines against anaplasmosis, J. LIGNIÈRES (*Bul. Soc. Path. Exot.*, 12 (1919), No. 10, pp. 765-774).—The author finds that *Anaplasma argentinum* becomes attenuated if inoculated into sheep and goats, and that the blood of such animals provides a vaccine for bovines against the more serious forms of anaplasmosis to which they are subject. The attenuation of *A. argentinum* is in proportion to the duration of its presence in the sheep or goat. It was found that, by the selection of those strains that are least virulent at first and passing them successively and at long intervals through the sheep or goat, such fixity in the attenuation of the virus is obtained that it may be employed to immunize with almost no danger. Since 1916 several hundred animals intended for breeding purposes have been vaccinated in this way with excellent results.

Arrow grass.—A new stock-poisoning plant (*Triglochin maritima*), C. E. FLEMING, N. F. PETERSON ET AL. (*Nevada Sta. Bul.* 98 (1920), pp. 21, figs. 10).—Recent experiments conducted by the station show that under certain conditions the grasslike plant commonly known as arrow grass is poisonous to both sheep and cattle. This plant looks like the common grasses, and often grows among them in wet soils, especially where the soil contains alkali. It contains an unknown substance which is sometimes broken up in the stomach of the animal, liberating hydrocyanic acid gas.

"Animals fatally poisoned by arrow grass breathe very rapidly at first; they tremble, breathe through the mouth, walk around stiffly, have spasms, and go down in convulsions. Later they breathe more slowly and with increasing difficulty, spasms continuing at intervals until death, which occurs in from half an hour to three hours. An animal must eat a large dose at one time in order to be poisoned. Small doses eaten at frequent intervals or moderate quantities eaten daily have no harmful effects. Arrow grass cut and dried in hay is far more dangerous and deadly than the green plant. When the body of any animal dead of arrow grass poisoning is cut up there is little indication of the cause of death. There is usually some congestion of the lungs and of the fourth stomach, but neither condition is characteristic of this plant alone. Because of the nature of the poison and because death follows poisoning so promptly, there is little hope of finding methods of treating and curing animals seriously poisoned by arrow grass. Places where arrow grass grows very thickly should be fenced off. Considerable effort should be made to prevent arrow grass from being cut, dried, and put up in hay."

Astragalus tetrapterus, a new poisonous plant of Utah and Nevada, C. D. MARSH and A. B. CLAWSON (*U. S. Dept. Agr., Dept. Circ.* 81 (1920), pp. 6, figs. 2).—Requests received in the late summer of 1916 for the investigation of losses of cattle on a range near Newcastle, Utah, led to the preliminary investi-

gations here reported. In a somewhat limited region, 6 or 8 cattle had died in 1915 and a number were sick in 1916. In a careful examination made of the range, a sick steer observed, said to be a typical case, was very weak, with a rough coat, staggered as it walked, and exhibited peculiar weaving movements of the hind legs.

A. tetrapterus plants were received in 1918 and 1919, and feeding experiments showed conclusively that it is poisonous to both cattle and sheep. It is a perennial leguminous plant which grows in the foothills and so far as known now is confined to southern Utah and western Nevada, although it is possible that further observation will show a wider range. It grows in scattering patches reaching a height of from 1 to 2 ft., but never in such large quantities as is the case with some of the recognized loco plants. It blooms early in June and generally dries up later in the summer.

The symptoms caused by this plant do not appear to be especially characteristic. There is staggering, the weakness being more pronounced in the hind legs, and in the case of a steer there were mild spasms with violent expirations. In a sheep which was killed by the plant, in addition to depression and weakness, there were salivation and nausea. It is thought that the range cases are due to the continued eating of rather small quantities, which would lead to the chronic condition.

No advice can be given as to treatment of poisoned animals until further investigations have been made. If animals become affected they should be removed to a location where they can get an abundance of feed.

Castor bean poisoning, T. MORESCHI (*Clin. Vet. [Milan], Rass. Polizia Sanit. e Ig., 42 (1919), No. 21-22, pp. 621-628; abs. in Vet. Rev., 4 (1920), No. 1, pp. 62, 63*).—The author's experiments show castor beans to be poisonous for carnivores as well as herbivores. The lesions induced by feeding the seeds are mainly intense hemorrhagic inflammation and local necroses of the mucous membrane of the stomach and intestines, marked renal congestion, and hyperemia of the spinal medulla and brain. Feeding experiments led to the conclusion that the poisonous principle is located in the kernel of the seeds and not in the coverings. Since the toxic principle of the seeds could not be extracted with ether, it is concluded that it can not be due to the oleoricin contained in the oil.

Absolute and relative disinfecting power of elements and chemical compounds, H. FRIEDENTHAL (*Biochem. Ztschr., 94 (1919), No. 1-2, pp. 47-68; abs. in Chem. Abs., 13 (1919), No. 23, p. 3210*).—In determining the disinfecting power of various chemicals the author takes as a measurement of the absolute disinfecting power the volume of a given culture medium which can be kept sterile by 1 gm. of the disinfectant; of the relative disinfecting power, the volume of the same medium which can be kept sterile at room temperature by the amount of the disinfectant which represents a lethal dose within 24 hours for 1 kg. weight of frog; and of the relative cost of the different disinfectants, the volume of culture medium which can be kept sterile by the amount of the disinfectant that can be purchased for a given price (1 mark).

Experimental data obtained with a large number of inorganic and organic chemicals are reported and discussed, the results as to the absolute power being so grouped as to emphasize the part played by each ion and the influence of the position of the metals in the periodic scale. The H-ion was found to have the most powerful antiseptic value. The salts of the heavy metals had a much higher value than corresponding salts of light metals. Borax and boric acid had approximately the same value, which was about 0.01 that of silver salts. Colloidal silver had a higher value than silver salts, and hydrogen peroxid and formaldehyde about the same value as the silver salts. Arsenious

acid had about the same strength as boric acid, and salvarsan about six times its strength.

Hydrogen peroxid headed the list of disinfectants arranged according to their relative disinfecting power, while salvarsan, phenol, sodium salicylate, and sodium perchlorate came at the end of the list.

Arranged according to the relative cost, formalin, naphthol, and lysoform were among the most inexpensive, and lysol and phenol the most expensive.

Flavin and its uses in veterinary practice, C. A. ZELL (*Amer. Jour. Vet. Med.*, 15 (1920), No. 4, pp. 144-147).—The author reviews briefly the studies of Browning, Gulbransen, et al. (E. S. R., 41, p. 188) on the value of acriflavin and proflavin as antiseptics, and reports the general results obtained in laboratory and field experiments in the application of these antiseptics to veterinary practice.

As proflavin in the laboratory tests proved to have stronger bactericidal powers for some of the common pathogenic organisms and acriflavin for others, a preparation containing both dyes was used in the field tests. Excellent results are reported with flavin treatment in a number of cases of suppurating wounds fistulæ, hemorrhagic septicemia, purpura hemorrhagica and pleural pneumonia. In the case of wounds abscesses etc., the affected places are packed with gauze saturated with the flavin solution. In cases of septicemia and other diseases of infectious origin, the antiseptic is injected intravenously in 1:1,000 dilution in normal salt solution.

The action of gum acacia on the circulation, W. M. BAYLISS (*Jour. Pharmacol. and Expt. Ther.*, 15 (1920), No. 1, pp. 29-74, figs. 6).—This is a discussion of various problems concerned with the action of gum acacia on the circulation for the purpose of raising a low arterial pressure, as previously noted (E. S. R., 36, p. 677).

It has been found that a 6 or 7 per cent solution of gum acacia in 0.9 per cent sodium chlorid can replace the blood lost through hemorrhage from various causes, unless the loss amounts to more than 75 per cent of the blood volume. Its effect is considered to be due to the impermeability of the blood vessels to colloids, resulting in the retention of the solution which has been injected. Since it has no chemical or drug-like action it can be used in large quantities. Other conditions in which it can be used with benefit are cases of wound shock, traumatic toxemia, loss of fluid from the blood in certain morbid conditions, cases in which intravenous injections are ineffective, in acidosis, and for perfusion of organs.

Experiments are cited which indicate that gum acacia does not produce anaphylaxis or hemolysis and does not agglutinate the blood corpuscles.

[Work with animal parasites], L. L. LEWIS (*Oklahoma Sta. Rpt. 1919*, pp. 53, 54).—In the treatment of stomach worms in sheep a 1 per cent solution of copper sulphate at the rate of 50 cc. for lambs under 1 year of age and 100 cc. for adults was used and repeated after 3 or 4 days with fairly good results. Treatment with copper sulphate and tobacco resulted in 95 to 99 per cent efficiency in removing stomach worms, 75 to 100 per cent for tapeworms, and 100 per cent for hookworms in experimental lambs.

In investigations of lungworms in sheep, experimental infestations were brought about by the oral administration of the ensheathed larval worms. Data on the life history of the sheep lungworm by Guberlet have been previously noted (E. S. R., 41, p. 878).

In the course of studies of the roundworms and tapeworms of poultry, it was demonstrated that *Hymenolepis carioca* may be transmitted to chickens by the stable fly, an account of which by Guberlet has been previously noted (E. S. R., 41, p. 881). Of the vermifuges tested for the removal of worms from

chickens both tobacco and lye proved fairly satisfactory. Tobacco is used at the rate of 0.5 teaspoonful to each bird. The tobacco is finely chopped and mixed with feed and cooked for 1 hour, the birds having previously fasted for 15 to 20 hours. The lye is used at the rate of 1 teaspoonful to 25 birds. It is mixed with the feed and cooked for 1.5 hours, the chickens having fasted for 15 hours before being fed the mixture. Both the lye and the tobacco removed from 50 to 75 per cent of the worms with a single treatment. A second treatment should be administered after 4 or 5 days.

The adult tænioid cestodes of dogs and cats, and of related carnivores in North America, M. C. HALL (*Proc. U. S. Natl. Mus.*, 55 (1920), pp. 1-94, figs. 80).—This paper includes keys dealing with each taxonomic group, from families to species of a given genus, a host list, and an 11-page bibliography.

Studies on Acari.—I. The genus Demodex, S. HIRST (*London: Brit. Mus. (Nat. Hist.)*, 1919, pp. 44, pls. 13, figs. 4; *rev. in Jour. Amer. Vet. Med. Assoc.*, 56 (1920), No. 5, pp. 512, 513).—This is a systematic account of acarids of the genus *Demodex*, all of which are skin parasites of microscopic size.

Sixteen species are recognized, of which 13 have been studied by the author. These are *D. folliculorum* from man; *D. canis* from dog, and the varieties, *D. canis ovis* from sheep and *D. canis erinacei* from hedgehog (*Erinaceus europæus*); *D. longior* from field mouse (*Apodemus sylvaticus*); *D. cati* from cat; *D. phylloides* from pig; *D. bovis* from cattle; *D. equi* from horse; *D. muscardini* from dormouse (*Muscardinus avellanarius*); *D. ermineæ* n. sp., from stoat (*Mustela erminea*); *D. arvicolæ* from field vole (*Microtus [Arvicola] agrestis*) and the varieties *D. arvicolæ musculi* from house mouse (*Mus musculus*); *D. arvicolæ apodemi* from field mouse (*A. sylvaticus*) in England, and *D. arvicolæ glareoli* from bank vole (*Evotomys glareolus britannicus*); *D. cuniculi* from rabbit (*Oryctolagus cuniculus*); *D. ratti* from brown rat (*Rattus norvegicus*); and *D. soricinus* from black rat (*R. rattus*) in England, brown rat (*R. norvegicus*), and shrew (*Sorex araneus castaneus*). The three species not seen by the author are *D. capræ* from goat, *D. cervi* from Sambar deer (*Cervus* sp.), and *D. phyllostomatis* from bat (*Phyllostoma hastatum*).

Resistance of Ascaris eggs, YOSHIDA and HOTTA (*Abs. in Jour. Amer. Med. Assoc.*, 73 (1919), No. 16, p. 1246).—The authors find that the eggs of *Ascaris* do not develop in urine, and that if left standing in it for a considerable time they all die. The experiments show that formalin and sulphuric acid do not affect the exterior coating of albumin, but they coagulate the albumin that surrounds the embryo and thus do not penetrate deep enough to reach the embryo. When the eggs are kept in a solution of glacial acetic acid and nitric acid for a long time, the albuminous membrane decays and the chitinous wall is exposed, but the embryos within the eggs develop as these drugs do not penetrate the chitinous membrane. Hydrochloric acid brings about a similar result, but phenol seems to kill the eggs in a shorter time.

A newly-recognized cause of pulmonary disease, Ascaris lumbricoides, B. H. RANSOM (*Jour. Amer. Med. Assoc.*, 73 (1919), No. 16, pp. 1210-1212).—The author here reviews the present status of knowledge of the biology of *A. lumbricoides* and the pathological condition caused by it. He emphasizes the importance of investigations of its relation to pulmonary troubles in human beings, particularly in young children. Referring to the records of Mosler in 1867 and of Lutz in 1888 of the occurrence of pulmonary symptoms in human beings following the experimental administration of *Ascaris* eggs, he concludes that in the light of our present knowledge these symptoms were probably due to the invasion of the lungs by migrating *Ascaris* larvae.

Accounts of this pest by the author and Foster have been previously noted (*E. S. R.*, 41, p. 285).

Parasitic mange (*Vet. Rev.*, 4 (1920), No. 1, pp. 36-40).—Abstracts are given of seven papers on the subject published during 1919.

The action of ether on rabic virus, P. REMLINGER (*Ann. Inst. Pasteur*, 33 (1919), No. 9, pp. 616-633; *abs. in Vet. Rev.*, 4 (1920), No. 1, pp. 30, 31).—This is a more detailed report, with additional evidence, of the immunizing properties of rabic virus attenuated by ether, previously noted from another source (*E. S. R.*, 39, p. 588).

Can the tuberculosis transmission rate be reduced? J. G. CUMMING (*Jour. Amer. Med. Assoc.*, 74 (1920), No. 16, pp. 1072-1074).—The possibility of transmitting tuberculosis by hand-to-mouth, object-to-mouth, and air-borne infection was studied by determining the presence of tubercle bacilli on eating utensils after being used by tuberculosis patients, on the same utensils after being washed with hot water, on the hands of patients, and in the air of tuberculosis wards. The procedure employed was in general to centrifuge washings from the respective sources and inject the sediment into guinea pigs.

Of the 31 guinea pigs injected with the wash water from spoons used by tuberculosis patients 11, or 35 per cent, died from tuberculosis. Of 36 animals injected with the rinse water from the same spoons 22, or 25 per cent, died from tuberculosis. Injections of hand-scrapings caused 4 deaths out of 7 animals, while none of the 11 animals injected with air washings died from tuberculosis.

These results are considered by the author to afford conclusive evidence that the eating utensil is the major avenue of tuberculosis transmission, and that in the control of the disease the universal application of the principle of thorough sterilization of eating utensils will accomplish more than any other single measure of practical application.

Further observations of tuberculin testing and retesting, H. W. TURNER (*Jour. Amer. Vet. Med. Assoc.*, 57 (1920), No. 1, pp. 28-32).—This paper, presented at the annual meeting of the American Veterinary Medical Association at New Orleans in November, 1919, gives further data regarding the value of tuberculin tests and retests as described by Marshall and Turner (*E. S. R.*, 38, p. 380).

Data obtained in testing animals from four different herds are reported. Of 222 animals tested subcutaneously 40 per cent reacted to the original test. In the 7-day retest conducted on 128 negative and 3 suspicious animals 20 per cent reacted. All of the generalized cases of tuberculosis reacted to the original as well as to the 7-day retest, a fact which appears to refute the accepted theory that advanced cases of tuberculosis do not always react to the tuberculin test. Many of the animals which were negative to the original test and positive to the retest showed slight but definite lesions on autopsy.

A 60-day retest on two herds composed of 214 animals is also reported. Of the 124 negative or suspicious cases in the original test, 46 reacted to the retest and showed lesions on autopsy. These results are thought to favor the early retest as shortening the time of exposure to infection.

The 7-day test is indicated "when animals have given unsatisfactory temperature measurements to the subcutaneous test, in herds where a large percentage of reactors to the subcutaneous test have been found, and in herds where, on postmortem examination, the reactors to the initial test show only slight lesions, indicating that the spreader has not been detected."

The problem of tuberculosis in cattle, V. A. MOORE (*Cornell Reading Course for the Farm*, No. 146 (1919), pp. 311-330).—"The purpose of this publication is to present anew certain essential facts regarding the nature of bovine tuberculosis, its economic and sanitary significance, the means by which it is disseminated, and the factors that must be considered if it is to be minimized and eventually eradicated."

Report of committee on infectious abortion, W. GILTNER, E. S. BAYARD, G. M. POTTER, E. C. SCHROEDER, and T. H. FERGUSON (*Amer. Jour. Vet. Med.*, 15 (1920), No. 4, pp. 154-156).—The report summarizes briefly the present knowledge of infectious abortion, and outlines the course of action which it is thought should be taken against the disease.

It is suggested that it may be necessary to enact and enforce laws against the misrepresentation of abortion-infected cattle that are sold for other purposes than immediate slaughter. The complement fixation and agglutination tests if properly applied, are endorsed as reliable means of detecting infection in a herd. It is recommended that these tests, particularly the agglutination test, be used more widely to protect abortion-free herds against abortion-infected cattle. As special precautionary methods the committee recommends the use, where possible, of special maternity stables for cows, and the universal pasteurization of dairy by-products distributed from the factory to the farm.

The education of the owners of live stock in facts concerning abortion disease is considered of the greatest importance in combating the disease.

Recent observations on contagious abortion of cattle, H. A. REID (*New Zeal. Jour. Agr.*, 19 (1919), No. 6, pp. 337-343).—This is a concise summary of the present status of the problem of contagious abortion in cattle from the standpoint of mode of infection, immunity, diagnosis, and preventive measures.

A new vaccine against contagious abortion, F. B. HADLEY (*Proc. Wis. Vet. Med. Assoc.*, 4 (1919), pp. 57-61, figs. 2).—The author recommends the use of live abortion bacilli as a protection vaccine against abortion in cattle, and describes the preparation of such a vaccine at the Wisconsin Experiment Station.

Existence of bovine spirochetosis in Brazil.—Transmission of the disease by *Margaropus australis*, E. BRUMPT (*Bul. Soc. Path. Exot.*, 12 (1919), No. 10, pp. 748-757, fig. 1).—The author records the spirochete infection of a cow by the eighth generation of ticks received from Brazil in 1915. These had lost their power to infect with *Piroplasma bigeminum* in the third generation and *P. argentinum* in the sixth generation, and had given no spirochetosis that could be detected in the blood in earlier generations. The affection induced was so mild, however, that without the aid of a microscope and thermometer the symptoms would have passed unnoticed. Immunity, or more correctly tolerance, is soon acquired, since greater numbers of infectious embryos produced no effect on the same cow 75 days after the first infection. The author holds that the name *Spirochata theileri* should apply in every case irrespective of the species to which the animal host belongs, and that *S. equi* and *S. ovina* are synonyms.

The action of asphyxiating gas on equines (*Vet. Rev.*, 4 (1920), No. 1, pp. 33-35).—Abstracts are here given of two papers, one by Plantureux on asphyxiating gas and the other by Quentin on the action of lachrymatory and "mustard" gas as well.

The microorganism causing infectious anemia of the horse and its pure cultivation, Y. MIYAGAWA, T. TANIGUCHI, M. NAGAO, and S. TAKEMOTO (*Abstr. in Jour. Amer. Vet. Med. Assoc.*, 56 (1920), No. 6, pp. 642-647).—This is an abstract by C. P. Fitch of an article translated from the Japanese by Noguchi. The authors' conclusions are as follows:

"We have obtained pure cultures of a spirochete from five out of six horses suffering from infectious anemia by the use of Noguchi's culture media. Some of the horses gave repeated positive cultures. By inoculation of the pure culture into normal horses we reproduced infectious anemia in five horses, and recovered from the five horses spirochetes which we cultivated to the fifth generation in some cases. The disease was reproduced in normal animals by the use of the second generation of a pure culture, and transmissions were

made to normal horses. The same was true of a third generation culture. We believe, therefore, that we have cultivated the virus of infectious anemia.

"The pathological findings and the anatomical findings in the horses inoculated with pure cultures or the organism correspond with those occurring in spontaneously infected horses. The infectivity of the blood from horses with infectious anemia disappears in 120 days when kept in the incubator at 37° C., but when transferred to the third generation during 130 days it continued viable. Cross immunity tests showed that the virus obtained in culture is identical with that found in the blood of infected horses. Neither the virus nor cultures confers complete immunity.

"The spirochetes were detected in the post-mortem material and in the peripheral blood of horses infected with the organism. Pfeiffer's reaction was positive. The organisms cultivated have the features characteristic of spirochetes. Colonies of peculiar characteristics formed on Noguchi's media. The organism belongs to the group of spirochetes. The spirochete is filterable. The organism is difficult to differentiate from *Spirochæta equi*."

A comparative study of the long bones in infectious equine anemia and other conditions, L. H. WRIGHT (*Jour. Amer. Vet. Med. Assoc.*, 56 (1920), No. 5, pp. 444-447).—A paper presented at the fifty-sixth annual meeting of the American Veterinary Medical Association, held at New Orleans in November, 1919.

Investigations on piroplasmosis of the horse in 1917, P. KNUTH, P. BEHN, and P. SCHULZE (*Ztschr. Veterinärk.*, 30 (1918), No. 6, pp. 241-264, pls. 3, figs. 9).—This is a report of investigations conducted at a special laboratory erected in Macedonia in 1917 with a view to determining whether army horses affected with piroplasmosis might not introduce ticks and piroplasma on their return to Germany.

Two forms of piroplasms in horses were distinguished, *Nuttallia equi* and (*Piroplasma*) *Babesia caballi*. Fifteen forms of ticks were found in Macedonia, of which 12 were taken from the horse. *Dermacentor reticulatus* was found in the spring on horses suffering from piroplasmosis and is thought to be the transmitter of piroplasmosis. *Rhipicephalus bursa* and *R. sanguineus*, particularly the former, are suspected of transmitting nuttalliosis. *Hyalomma aegyptium* was the only other form found on affected animals.

Borna disease in mules.—A contribution to the knowledge of Borna disease, G. DI DOMIZIO (*Clin. Vet. [Milan]*, *Rass. Polizia Sanit. e Ig.*, 42 (1919), No. 15-16, pp. 445-480, figs. 4; *abs. in Vet. Rev.*, 4 (1920), No. 1, pp. 29, 30).—This is an account of the occurrence of Borna disease among mules in the Dolomites, where it also attacks horses and asses. In addition to the acute form there is a subacute type in the mule that lasts for 20 to 40 days, with spinal symptoms more marked than in the same disease of the horse. The author opposes the view that this disease in the mule is a forage poisoning, and holds that it is an infectious disease due probably to a filterable virus. Further, it is not a meningitis, but essentially an encephalitis and myelitis, with disseminated lymphocytosis.

Transmission of canine piroplasmosis in France by *Dermacentor reticulatus*.—**Parasitic emboli in the capillaries of the encephalon**, E. BRUMPT (*Bul. Soc. Path. Exot.*, 12 (1919), No. 9, pp. 651-664, figs. 4).—French canine piroplasmosis is transmitted by the adult offspring of *D. reticulatus* females which have ingested virulent blood. Adult offspring of infected females which have developed as larvæ and nymphs on refractory animals, such as the hedgehog and the guinea pig, can transmit the infection. The larvæ and nymphs do not appear to transmit the disease even when they are the offspring of infected females; and, when they have ingested virulent blood, do not appear

to transmit the disease in the following stages. The multiplication of the parasite takes place more particularly in the capillaries of the brain and to a less extent in the kidneys and bone marrow.

Transmission of canine piroplasmosis in Tunis by Rhipicephalus sanguineus, E. BRUMPT (*Bul. Soc. Path. Exot.*, 12 (1919), No. 10, pp. 757-764, fig. 1).—Canine piroplasmosis in Tunis is transmitted by *R. sanguineus* adults which are the offspring of females that engorged on affected animals. The larvæ and nymphs from such infected females do not transmit the infection, but become pathogenic as soon as they become adults. Nymphs which have fed upon virulent blood do not transmit the disease when they become adults. It is pointed out that the affection is transmitted by three species, namely, *Hæmaphysalis leachi*, *R. sanguineus*, and *Dermacentor reticulatus*. A number of nymphs of *Ixodes ricinus* and *H. concinna* obtained from females which had fed upon a sick dog did not transmit the disease.

[**Fowl typhoid in France**], F. D'HERELLE (*Compt. Rend. Acad. Sci. [Paris]*, 169 (1919), Nos. 18, pp. 817-819; 20, pp. 932-934; *abs. in Vet. Rev.*, 4 (1920), No. 1, pp. 56, 57).—Two papers are presented.

I. *An epidemic of fowl typhoid* (pp. 817-819).—This paper describes a serious and extensive outbreak of fowl typhoid in France originating in the spring of 1916. From samples of the blood of 67 fowls which had succumbed to the disease *Bacterium sanguinarium* was isolated in 56 cases. In the remaining cases the blood was aseptic.

II. *The rôle of the bacteriophagous microbe in fowl typhoid* (pp. 932-934).—In connection with the outbreak of fowl typhoid noted above, the author has made observations which confirm his theory concerning the rôle of bacteriophagous microorganisms in the control of infectious diseases. He states that in the feces of fowls, as of all vertebrates, it is possible to demonstrate the presence of a filterable bacteriophagous organism which is the normal inhabitant of the intestine, and which is thought to bear the same relation to the pathogenic organism that the latter bears to the body of the vertebrate. Against a particular microorganism, as for example *B. sanguinarium*, the bacteriophage, which is first avirulent, becomes increasingly virulent with the ingestion of the pathogen by the host until a point may be reached at which the pathogen is destroyed. The transmission of bacteriophages with heightened virulence results in the sudden arrest of an outbreak of the disease. In other words, immunity to the disease is contagious as well as the disease itself.

The author states that immunization experiments based upon this principle are in progress in connection with the fowl typhoid epidemic, and are meeting with success.

The bacteriophagous microorganism, F. D'HERELLE (*Compt. Rend. Soc. Biol. [Paris]*, 82 (1919), No. 30, pp. 1237-1239).—A further discussion of the author's theory noted above.

Botulism in chickens, G. H. HART (*Jour. Amer. Vet. Med. Assoc.*, 57 (1920), No. 1, pp. 75-77, figs. 2).—An outbreak of botulism or limberneck in a flock of 800 fowls in Santa Clara County, Cal., resulting in the death of 643 of the fowls, is reported. The infection was traced to home-canned string beans which on account of a bad odor had been consigned to the garbage and later fed the hens.

This outbreak emphasizes the necessity of destroying all spoiled canned goods, or of thoroughly boiling them to destroy the toxin of *Bacillus botulinus* before feeding to poultry or other animals.

RURAL ENGINEERING.

Eighteenth annual report of the Reclamation Service, 1918-19, A. P. DAVIS (*Ann. Rpt. Reclamation Serv. [U. S.]*, 18 (1919), pp. 559, figs. 2).—This report covers the work of the U. S. Reclamation Service completed and in progress during the fiscal year ended June 30, 1919.

It is stated that during the present year the service is in a position to deliver water to about 1,600,000 acres of irrigable land covered by the crop census, of which about 1,120,000 are now being irrigated. Besides this, storage water is delivered from permanent reservoirs under special contracts to about 950,000 acres more. The projects that have been undertaken have been planned to provide for an area of about 3,200,000 acres.

Use of water on Reclamation Service projects, E. A. MORITZ (*Reclam. Rec. [U. S.]*, 11 (1920), No. 3, pp. 128-130).—Tables of data showing quantities of water used on projects of the U. S. Reclamation Service by months during 1918 are given.

Drainage as an anti-malaria measure, J. A. LEPRINCE (*Amer. Jour. Pub. Health*, 10 (1920), No. 2, pp. 120-123).—The author argues the necessity of liberal interpretation of laws, urges the cooperation of the health officer in drainage planning, and suggests the value of permanent improvements following a study of local conditions.

Louisiana State highways, C. M. KERR (*Proc. La. Engin. Soc.*, 1 (1915), No. 4, pp. 178-196, pls. 5).—The author briefly discusses the Louisiana State Highway Act and reviews expenditures and activities of the Highway Department.

The evolution of the public roads problem in the Province of Quebec, A. FRASER (*Jour. Engin. Inst. Canada*, 3 (1920), No. 3, pp. 135-141, fig. 1).—This article deals with the historical development of the roads administration in Quebec, Government roads policy and progress of public roads improvement during the last 15 years, and the present organization of the engineering staff of the Provincial Roads Department and its work.

[Foundation types for country roads] (*West. Highways Builder*, 2 (1920), No. 4, pp. 5, 21, figs. 4).—Types of foundations in common use for country roads are discussed by the Bureau of Public Roads of the U. S. Department of Agriculture.

Relation of highways to motor truck operating cost, A. H. BLANCHARD (*Engin. and Contract.*, 53 (1920), No. 9, pp. 238-240).—A discussion is given of the relation of highways to motor truck operating cost, which indicates that the probable cost of transport over highways outside of municipalities is not susceptible of an exact mathematical analysis. It is stated, however, that there is sufficient information from the combined experience of English and American highway authors to permit the drawing of certain general conclusions which will either warrant the installation or positive rejection of highway transport business. This is considered specially true on the basis that the installation of highway transport in a given community should not depend upon a narrow margin of profit.

Laboratory tests of granite paving block and suggested specifications, F. H. JACKSON, JR. (*Engin. and Contract.*, 53 (1920), No. 9, pp. 234-237, figs. 2).—Tests for granite paving block in present use are discussed, and experiments on granite block testing conducted by the Bureau of Public Roads of the U. S. Department of Agriculture, are reported.

The conclusions are drawn that none of the laboratory tests which have been used for testing granite block may be depended upon to give even reasonably concordant results. It was found that the abrasion test may be so modified as

to give results which will check within 0.4, or 10 per cent, of the range in coefficient of wear of granite block. The maximum range in coefficient of wear by the modified method, and including tests of good fresh stock from practically all of the commercial quarries, was from 6.5 to 10.5. Discoloration of granite block is not necessarily an evidence of disintegration. Disintegration which has progressed far enough to render the block unsuitable for paving purposes may be readily detected by means of the abrasion test. In order to place the question of tests of granite block on a definite basis, the author recommends that in the future specifications for quality include the one requirement of coefficient of wear, and that this value be determined by the modified abrasion test mentioned above.

An apparatus for determining the consistency of concrete, F. L. ROMAN (*Engin. and Contract.*, 53 (1920), No. 9, pp. 240, 241, fig. 1).—A number of experiments, conducted by the Illinois State Highway Department, are reported, from which it was found that an apparatus consisting of a truncated cone 12 in. high with 8 in. inside diameter at the base and 4 in. inside diameter at the top, will give results as regards consistency of concrete superior to all other truncated cones investigated. The truncated cone obtained was far better than a cylinder for determining the consistency of concrete by means of a slump test.

Concrete blocks: How to make and use them (*Concrete Utilities Bur. Pamphlet*), No. 12 [1919], pp. 17, figs. 17).—Brief popular information on the manufacture and use of concrete blocks is given. Drawings of equipment for manufacture are included.

The proper balancing of fuel, lubricant, and motor, W. F. PARISH (*Mech. Engin. [New York]*, 42 (1920), No. 3, Sect. 1, pp. 164-168, 193, figs. 8).—This is a study of the dilution of lubricating oils in internal combustion engines, especially for vehicle propulsion, by the fuel mixture, the purpose being to show the resulting losses of fuel, power, and lubricant.

Heat flow through cylinder walls, L. ILLMER (*Trans. Soc. Automotive Engin.*, 13 (1918), pt. 1, pp. 162-195, figs. 9).—The results of research into the speed limitations imposed upon high-duty internal combustion engines by excessive heat flow through the cylinder walls are reported.

It is pointed out that excessive heat flow raises the temperature of the bore and head walls unduly, resulting in lubricating and cracking troubles. It is shown that large bore engines reach their limiting bore temperatures at comparatively low rotative speeds, and that large high-speed engines are likely to suffer seriously from destructive heat flow effects. The determining factors which control heat flow are shown to be temperature, rotative speed, and relation of volume to cooling surface. Formulas are presented for the quantitative determination of heat flow, and a method is developed for critical analysis of the design characteristics of any normal gas or oil engine for heat flow effects. From a study of speed limits taken of numerous engines in various kinds of service, the desirable bore temperature limit was found to lie between 400 and 450° F. The combined temperature and pressure stress set up in a cylinder wall is analyzed, and formulas are deduced for its estimation. Other factors are discussed.

Report of the Inter-Departmental Committee on the employment of gas as a source of power, especially in motor vehicles in substitution for petrol and petroleum products, B. REDWOOD (*London: Govt.*, 1919, pp. 35, pls. 11, fig. 1).—This is the report of a committee appointed in 1917 in England to investigate (1) the substitution of gas for petrol and petroleum products as a source of power, especially for traction purposes, and (2) the manner in which such gas may be supplied, stored, carried, and used with convenience and safety.

The results of technical investigations are given together with graphs of data and drawings of apparatus perfected.

It is concluded that gas traction is fully as safe as any other system of mechanical traction, even when the gas is contained in exposed flexible containers, and that in its newer forms of application merits adoption as a commercial alternative to electric, petrol, and steam traction. The average traction equivalent of 1 gal. of petrol was found to be 250 cu. ft. of ordinary town gas.

"Semirigid containers made of rubber and canvas are unsatisfactory, but semirigid containers made of an inner rubber bag suitably restrained by an outer member of woven steel wire with metal end plates, and complying with . . . approved specification, appear to be satisfactory for internal pressures not exceeding 45 atmospheres, although results of endurance tests in service are not yet available. The time has come to approve and encourage the use of metal cylinders made of high-carbon or certain alloy steels to contain combustible gases at high pressures for traction purposes, and such metals can now be safely so employed for working pressure up to 2,250 lbs. on the square inch. Subject to the adoption of simple precautions specified, there is no risk of explosion with town gas during its compression into cylinders or its use from them. Wire-wound metal cylinders with removable ends held in place by screwed tension rods lose gas at the joints after the earlier stages of discharge, and are heavier for any given volume of gas than plain cylinders made of high-carbon or alloy steels."

The total cost of compressing gas into cylinders was found to vary between 30 and 70 cts. per 1,000 cu. ft. of free gas. The average power yields obtainable from an ordinary motor vehicle engine unaltered structurally as regards compression space are accepted as follows: Town gas of 450 B. t. u. per cubic foot, 91 per cent of petrol, suction producer gas of 210 B. t. u. per cubic foot, 87 per cent of petrol, and suction producer gas of 140 B. t. u. per cubic foot, 82 per cent of petrol.

"The risk of escape of unburnt carbon-monoxid gas from a suction-gas plant in a motor vehicle is not such as to call for the exercise of special precautions except while the vehicle is at rest overnight within an inclosed structure with the fire still burning in the producer. The water-feed to a portable suction-gas producer can be so adjusted as to increase the calorific value of the issuing gases by as much as 50 per cent on a consumption of water falling as low as 25 per cent by weight of the simultaneous consumption of anthracite or coke.

"Suction gas, employed alone or partly hydrogenated with water-gas, should in the near future prove a suitable alternative fuel for use in any internal-combustion engine primarily designed to run on alcohol. Physical difficulties of storage and conveyance in conjunction with allied considerations of cost render the use of liquefied hydrogen, methane, carbon monoxid, or ethylene, which gases are or may shortly become available for liquefaction on the large scale, commercially impracticable for traction work. There is an increase of weight when an absorbent material is introduced, compared with that when cylinders containing only gas under compression are used, for any given volume of free gas, and no saving in the total cubic space occupied. The necessary extra provision to utilize systems for enriching gas in any vehicle does not yield commensurate advantage, with possible but as yet unproved reservations in favor of the use of acetylene or naphthalene."

Fundamentals of tractor design, G. T. STRITE (*Trans. Soc. Automotive Engin.*, 13 (1918), pt. 1, pp. 196-204, fig. 1).—A discussion of tractor design, with
182230°—20—7

special reference to its development as a satisfactory farm and manufacturing utility, is given.

Some points in tractor design (*Tractor and Gas Engine Rev.*, 13 (1920), No. 2, pp. 12-15, figs. 10).—Charts are given showing graphically the change in some of the principal points of design of gas tractors through the years 1916, 1917, 1918, and 1919.

In 1916, 65 per cent of the tractor models had vertical engines; in 1917, 70 per cent; in 1918, 73 per cent; and in 1919, 76 per cent. In 1916, 77 per cent were equipped with high tension magnetos, 19 per cent with low tension magnetos, and 4 per cent with batteries. There was little change in the percentage of tractors using batteries during the four years, but low-tension magnetos were largely displaced by high-tension magnetos. In 1916, 69 per cent of tractor models had 4-cylinder motors and this percentage increased steadily to 80 in 1919. Two-cylinder motors decreased from 25 per cent in 1916 to 13 per cent in 1919.

In 1916, 27 per cent of the tractor models recommended gasoline for fuel and 73 per cent recommended kerosene. These percentages changed to 17 and 83, respectively, in 1919. The data show that more engines operate at a speed of from 700 to 900 r. p. m. than between any other limits. This tendency increased steadily during the four years, and the tendency to design at higher speeds also increased.

In 1916, 63 per cent of tractor models had four wheels and 31 per cent had three wheels. In 1919, 80 per cent had four wheels and 16 per cent three wheels. Two-wheel drive held the position of most importance during the four years. The most popular weight during the four years was from 4,000 to 6,000 lbs.

Fundamentals of tractor engine design, H. C. BUFFINGTON (*Trans. Soc. Automotive Engin.*, 13 (1918), pt. 1, pp. 208-214, figs. 6).—A study of tractor engine design is reported, particularly of the number of cylinders from the standpoint of simplicity and operation.

It is concluded that the 4-cylinder engine is the most adaptable and economical. A 2 or 3 bearing crankshaft, preferably the latter, with a stress not to exceed 12,000 lbs. per square inch and an explosion pressure of 300 lbs., is recommended. The crankpin diameter of the bearing should be about 57 per cent of the cylinder bore and the length 1.2 times the crankpin diameter. The stress on the front and center bearings should not exceed 400 lbs. per square inch and on the rear 250 lbs. per square inch. The stroke should be about 1.4 times the bore. Other points of design are brought out.

The ultimate type of tractor engine, H. L. HORNING (*Trans. Soc. Automotive Engin.*, 12 (1917), pt. 1, pp. 65-73, figs. 2).—An analysis is given of some of the factors that have influenced tractor development. It is stated that conditions on about 90 per cent of all farms require a 4-cylinder engine of between 16 and 40 h. p. operating on the 4-stroke cycle. The disadvantages of the 2-cylinder horizontal-opposed engine are summarized, and the following formula is given for use in calculating the most satisfactory operating speed of an engine: $S = \sqrt{\frac{3,000,000}{0.04545B^3}}$. In this formula, S is the most satisfactory working speed and B is the bore of the engine.

In conclusion, a number of the most important general themes of design are outlined, and particular mention is made of the lubrication system and of the special provisions required for kerosene-burning engines.

Principles of tractor engine cooling, A. B. MODINE (*Trans. Soc. Automotive Engin.*, 13 (1918), pt. 1, pp. 435-444, figs. 5).—The author discusses the radiator, air velocity, and fan power requirements as factors involved in engine

cooling. A formula for radiator sizing and recommendations for water circulation, air velocity, and fan details are given.

Tractor friction transmissions, C. A. TRASK (*Trans. Soc. Automotive Engin.*, 13 (1918), pt. 1, pp. 320-330, figs. 9).—Graphic data and formulas on power transmitting capacity, pressure application, slippage, operating speeds, and design and installation are given, and difficulties in practical application are discussed. Under friction transmission types the application of the friction type to a number of engines is explained and illustrated.

Lubrication of tractor engines, W. G. CLARK (*Trans. Soc. Automotive Engin.*, 13 (1918), pt. 1, pp. 445-454).—The author deals with the relation of lubrication to carburetion and ignition and with the importance of the proper selection of oil. It is stated that when apparently suitable oils have been selected they should be subjected to occasional laboratory and field tests. An explanation of the cold friction and power tests is given.

Standardizing tractor parts, G. T. STRITE (*Trans. Soc. Automotive Engin.*, 12 (1917), pt. 2, pp. 193-197).—The standardization of tractor parts is discussed, and some features of the standardization methods adopted by the Society of Automotive Engineers are pointed out, with particular reference to the size of tractor engines in relation to number of plows pulled.

The farm tractor in Iowa, E. V. COLLINS (*Iowa Sta. Circ. 63 (1919), pp. 8, fig. 1*).—This circular summarizes 228 reports covering the 1918 operating season for tractors in Iowa. Thirty-nine reports were secured by personal visits to farms and the remainder by mail. Data are also included on 44 tractors discarded or sold.

It was found that between 85 and 90 per cent of the tractors investigated are considered by their owners to be paying investments. The principal reason for failure of those that do not pay are lack of experience or patience on the part of the operator or the use of a tractor which is unreliable in construction or unsuited to the conditions. The tractors best adapted to field work in Iowa are the 2 and 3 plow outfits. Two-plow outfits should have a working speed of at least $2\frac{1}{2}$ miles per hour. The average 2-plow outfit has the advantage on soft ground due to its lighter weight. For belt work, especially on small thrashers and silage cutters, the average 3-plow outfit has an advantage. A kerosene-burning tractor is desirable from the standpoint of economy, but requires more skill on the part of the operator. Depreciation is usually the largest single item in the cost of operation and is controlled largely by careful selection and operation of the tractor.

Building a small track-laying tractor, F. H. COLVIN (*Amer. Mach.*, 52 (1920), No. 8, pp. 407-410, figs. 11).—This article describes some of the methods used in manufacturing a small track-laying agricultural tractor, special attention being given to convenience in handling the various parts. The illustrations include drilling, milling, and grinding operations together with special fixtures.

Use of artillery tractors on Salmon Lake Dam construction, Okanogan project, Wash., L. V. BRANCH (*Reclam. Rec. [U. S.]*, 11 (1920), No. 3, pp. 131-133, fig. 1).—Experience with three 10-ton artillery tractors of the caterpillar type equipped with engines developing 55 h. p. at 600 r. p. m. on hauling and elevating grader work in connection with irrigation dam construction is reported. Under normal conditions the tractors easily handled three 3-yard wagon trailers, but under adverse conditions of wet ground and grades they could handle only two. The tractors were found to be excellent stump and brush pullers, using a $\frac{3}{4}$ -in. steel cable.

On the basis of this experience the opinion is expressed that these tractors when used for transporting earth will show greater economy, as compared with

hauling with the teams, when the length of haul is greater than the average haul of 100 ft. and on poor roads and steep grades where teams must be given frequent rest periods. As the length of haul gets shorter and the roads and grades improve, the teams will prove the cheaper.

Agricultural machines essential for rational cultivation, B. H. HUNNICUTT (*As Machinas Agricolas Essenciaes para uma Lavoura Racional. Rio de Janeiro [Brazil]: Mendes, 1919, 2. ed., pp. 37, figs. 23*).—A number of different agricultural machines for seed-bed preparation, planting, and cultivation, including plows, harrows, seeders, and cultivators, are described and illustrated, and discussed with reference to their use in Brazilian agriculture.

A machine for trimming camphor trees, G. A. RUSSELL (*U. S. Dept. Agr., Dept. Circ. 78 (1920), pp. 8, figs. 4*).—This machine is described and illustrated and consists of six essential parts, as follows: (1) A truck fitted with proper framework of iron for the conveyance and support of the operating machinery, (2) an internal-combustion engine on the framework of the truck, (3) a cutting frame consisting of supports for the cutter bar and rocker arm, mounted on the framework of the truck and supported by springs which tend to lessen vibration, (4) a cutter bar held rigidly to the proper angle for cutting, with knives operated by means of gears, pitman rods, and rocker arm connected in the proper manner with the internal-combustion engine, (5) a reel for whipping the small camphor twigs, branches, and leaves into the cutting blades, and (6) canvas aprons to convey the several twigs, branches, and leaves into burlap bags carried at the rear of the truck and to dispose of this material in any manner desired by the operator.

The development of a standard refrigerator car, M. E. PENNINGTON (*A. S. R. E. Jour., 6 (1919), No. 1, pp. 1-24, figs. 7*).—This is a brief description of the essential features of the standard refrigerator car designed by the Bureau of Chemistry of the U. S. Department of Agriculture to protect perishables in transit.

Concrete farm buildings (*Concrete Utilities Bur. [Pamphlet], No. 8 [1919], pp. 29, figs. 19*).—This pamphlet deals with the construction of concrete farm buildings, including barns, cow-houses, and silos.

Concrete poultry houses and piggeries (*Concrete Utilities Bur. [Pamphlet], No. 7 [1919], pp. 16, figs. 12*).—Brief popular information is given on the construction of concrete poultry houses and hog houses.

Concrete greenhouses, hotbeds, and root cellars (*Concrete Utilities Bur. [Pamphlet], No. 10 [1919], pp. 12, figs. 12*).—Brief popular information on the construction of greenhouses, garden frames and hotbeds, and root cellars as practiced in England is given.

Concrete paths and pavements, curbs, and gutters (*Concrete Utilities Bur. [Pamphlet], No. 4 [1919], pp. 16, figs. 16*).—Practical information and working drawings are given for use in the construction of concrete sidewalks, curbs, and gutters.

Concrete troughs and wells (*Concrete Utilities Bur. [Pamphlet], No. 9 [1919], pp. 17, figs. 15*).—Brief popular information on the construction of concrete watering troughs and concrete linings and curbs for open wells is given.

The construction of cattle dipping tanks (*Nairobi: Pub. Works Dept., E. Africa Protect., 1918, pp. 1-15, 19-35, pls. 5*).—Detailed instructions and drawings are provided for three types of cattle dipping tanks, showing methods and operations to be used in construction.

The materials for the three types of tank described are concrete, masonry, and timber. It is stated that the concrete tank is the most expensive, but is the most permanent and requires a minimum of maintenance. A well-built

masonry tank of suitable stone is durable and costs slightly less than the concrete tank. The timber tank, although very much cheaper, is regarded only as a temporary structure with a life of about ten years. It is liable to give trouble in use, requires more attention in maintenance than either a concrete or masonry tank, and can seldom be economically constructed in East Africa except where suitable timber is available at a reasonable price. The most suitable stone for masonry work is one which can be easily dressed with a chisel and is fairly hard and compact. Very soft stone which can be cut out with an axe is considered undesirable.

Feeding alfalfa hay, H. C. GARDINER (*Natl. Wool Grower*, 10 (1920), No. 2, pp. 11-14, figs. 4).—Plans for feeding racks for sheep and cattle are given and discussed.

The design of these structures has been based on a feeding period of about 90 to 120 days. The basic principle of design is the presence of a hollow wall which acts as a feed chute from the principal bin. The purpose of these racks is to prevent loss in hay, it being stated that in the average feeding of alfalfa to sheep there is an approximate loss of from 15 to 20 per cent. Experience with these feed sheds for both cattle and sheep is briefly reviewed. While the cattle feeding rack is designed of sufficient strength to permit moving by an engine, it is concluded that they are best left in place and not moved, and that instead of erecting the rack on a sill it should be built on cement blocks or on a concrete wall.

How to build a straw stack (*Agr. Gaz. [London]*, 90 (1919), No. 2400, p. 678, figs. 8).—Brief practical information on the building of straw stacks is given.

It is stated that there is no necessity for forming a steep roof on a stack to make it turn the rain, and that a full and rounded top is even more effective. Sections of oblong and round stacks in course of erection are given, showing right and wrong methods. The stack should be begun in the middle, using a continuous ridge of hard trampled straw and be gradually built up from the center outward. In forming the outside walls the straw should be shaken out and made to slope downward at the extreme edge. It is considered better to use a hand fork in building a straw stack than an elevator attached to the thrasher.

RURAL ECONOMICS.

Rural socialization, N. L. SIMS (*Polit. Sci. Quart.*, 35 (1920), No. 1, pp. 54-76).—The four stages in the development of community consciousness, which the author considers is needed in most American rural communities, are said to be marked by the functioning first of the gregarious instinct, then the play impulse, the economic need, and lastly the cultural interest. He holds that the agency of pressure is unreliable, and that personal leadership springing from the country itself, and trained in communal outlook and the fundamentals of community building, is essential.

The farmer's place in American business, A. CAPPER (*New York: Natl. Com. Assoc. Advertising Clubs World*, 1920, pp. [11]; also in *Rpt. Proc. Farm Paper Conf. and Exhibit*, N. Y., 1920, pp. 61-66).—The author indicates the fundamental rôle of the farmer as a producer of wealth, and urges business interests to investigate and advertise to the farm market.

The farmer and the farm market, E. T. MEREDITH (*Rpt. Proc. Farm Paper Conf. and Exhibit*, N. Y., 1920, pp. 40-48).—This is an address before the Farm Paper Conference and Exhibit in New York City in January, 1920, in which is presented an account of the farmers' buying power and tastes.

Basic facts of prosperity in 1920, C. C. PARLIN (*Philadelphia: The Curtis Pub. Co., 1920, pp. 58, figs. 27*).—Many phases of and factors in trends in industry for the United States, mainly between 1910 and 1919, are discussed and graphically illustrated here. It is indicated that domestic production is the major factor in American industrial life and the farm market the largest single factor, that there has come about a large accumulation of savings and national capital, and that it is unlikely that food prices will return to a pre-war level, the farm industry seeming to have reached a permanently higher level of earning and spending.

Making money on high-priced land, H. B. MUNGER (*Wallaces' Farmer, 45 (1920), No. 10, pp. 761, 773, figs. 2*).—This article considers the labor income on farms in a certain section of northeastern Iowa as affected by the proportion of the total area in crops and pasture. Farmers having less than 20 per cent of the land in pasture received labor incomes of over \$400, but with an increase in pasture the labor incomes rapidly declined. Farmers with over 40 per cent in pasture not only had no labor incomes but lacked \$120 of making 5 per cent interest on their investment. An average labor income of —\$41 resulted where less than 60 per cent of the farm was in crops, as compared with a labor income of \$480 where more than 80 per cent was devoted to crops.

A difference in labor income of more than \$800 was found in comparing a group of farms containing 20 per cent and less of the farm in corn, and a group with over 50 per cent in corn, and this in spite of the fact that farms in the last group contained 165 acres as compared with 245 in the first. The basis for the present valuation of corn belt land is largely its desirability for corn production, and the price of level prairie lands in Iowa will probably be based more and more on corn production.

A study was made of the effect of varying crop yields on the profits of the farm, in which the group of farms on which crop yields were less than 85 per cent of the average of all farms showed an average income of —\$146. The group of farms which included those with crop yields of 115 per cent and over averaged 25 per cent better yields than the average of all farms and received \$760 for their labor. It is concluded that 25 per cent better crop yields than the average is a fair goal for which to strive.

A two-year farm management survey of Greenbrier and Monroe Counties, A. J. DADISMAN and C. F. SARLE (*West Virginia Sta. Bul. 173 (1920), pp. 34, figs. 12*).—A study is presented of 520 records from a two-year farm management survey of 260 farms in Greenbrier and Monroe Counties in southeastern West Virginia in 1914–15 and 1915–16. Of these farms 239 were operated by owners and 21 by tenants.

Of owner operated farms, 98 were beef farms or those on which 40 per cent or more of the total income came from beef cattle, 121 were general farms, their receipts being derived from both live stock and crops, and 20 were dairy farms deriving 40 per cent or more of their total receipts from the dairy. Averaging the two years, the beef farms made the largest family income, \$1,590, or nearly \$100 more than 5 per cent interest on the investment, and a labor income of \$94. The general farms made a family income of \$532, or a little less than 5 per cent interest on the investment for the two years, and a labor income of —\$60. The 20 dairy farms show a family income of \$1,268, which was 5 per cent interest on the investment and fair wages in addition, and a labor income of \$366. It is considered that the actual amount of man labor on crops and live stock per farm is probably the best measure of size of business, and by this the dairy farms show the biggest farm business and general farms the smallest. Tables are given showing farm earnings on 239 owner

farms of the three types, size of farm business, crop yields and return from live stock, utilization of labor, amount and distribution of investment, and sources of receipts.

The 98 beef farms ranged in size from 7 to more than 200 cattle units per farm, with an area of 70 to 1,000 acres of owned land and a total capital of from \$4,000 to more than \$100,000. The 20 farms with the smallest number of cattle units per farm, an average of 16, made a labor income of -\$176, the 20 farms with the largest, an average of 126, a labor income averaging \$919 for the two years. The 20 farms with the largest number of cattle units per farm returned \$5 per man day's work on crops and live stock the first year and \$4.16 the second, as compared with \$1.27 and \$1.74 on the 20 farms with the smallest number of cattle units per farm. Tables show the number of cattle units per farm, labor income, family income, and returns per man day's work on crops and live stock cattle units per farm and utilization of labor; total receipts and labor and family income; income per cattle unit and labor and family income; and percentage of total capital in working capital, labor income, and family income for the 98 beef farms.

A table is given showing that the 11 dairy farms with 14 cows or fewer made nearly 5 per cent on investment but no labor income. The 9 farms with more than 14 cows per farm made a labor income of \$672 the first year and \$1,004 the second. The crop index was much higher on the farms with larger herds, and the farms with larger herds were 50 per cent more efficient in the use of man labor than the farms with small herds. While dairying was the most profitable of the three types, it was not extensively practiced because markets for milk and cream were unsatisfactory and it was difficult to secure satisfactory labor.

In this study, data for either year show the same general tendencies as the average of both years.

First advice to would-be farmers, F. E. GREEN (*London: "Country Life," Ltd., 1919, pp. 190*).—This discussion of how to make a start in obtaining, stocking, and working a small holding contains chapters on learning to farm; choosing a farm; capital required; marketing your own produce; specializing on new side-lines; poultry and duck keeping; beekeeping; fruit-farming; cows, pigs, goats, and rabbits; useful hints; woman's place in agriculture; the plat of earth as a starting point; the rural allotment as a stepping-stone how to get a small holding; and farm colonies for discharged soldiers and sailors.

Handbook giving information regarding land settlement, agricultural training, and loans for returned soldiers (*Ottawa: Soldier Settlement Bd. Canada, 1919, pp. 20+4*).—This gives provisions of the Soldier Settlement Act of Canada, 1917.

Soldier settlement in Italy (*Scot. Jour. Agr., 3 (1920), No. 1, pp. 84-86*).—The organization and working of the "National Assistance of Soldiers and Sailors," previously noted (E. S. R., 42, p. 800), is described.

Report by the undersecretary for public lands under the Discharged Soldiers' Settlement Act of 1917, W. G. GRAHAM (*[Queensland Dept. Pub. Lands], Rpt. Discharged Soldiers' Settlement Act 1919, pp. 8*).—This gives information as to the locality, area, and cost of each block of land acquired under the act; the areas set apart for lease selections; and notes on the condition of all lands taken up under the act.

Agriculture in the Tropics for ex-soldiers, CARMODY (*United Empire [Gt. Brit.], n. ser., 10 (1919), No. 8, pp. 379-389*).—Information is given on agricultural conditions in the Tropics and other factors pertinent especially to community settlement.

[**Public lands and immigration laws of Bolivia**], W. A. REID (In *Bolivia. Washington: Bolivian Legation [1919], pp. 49-55, figs. 4*).—The area and kind of public lands available for colonization are briefly noted, together with a synopsis of Bolivian land and immigration laws.

The land settlement (Scotland) Act, 1919 (*Scot. Jour. Agr., 3 (1920), No. 1, pp. 45-52*).—The provisions of the new act of December 23, 1919, designed to amend previous legislation along the lines of the acquisition of small holdings and allotments, establishment of small holdings colonies, and the encouragement of land banks and cooperative societies, are reviewed.

Capital required for entry to farms (*Scot. Jour. Agr., 3 (1920), No. 1, pp. 66-76*).—Estimates based on practical experience are given of the capital required under present conditions to undertake enterprises of four types, including a mixed arable farm of 300 acres, a dairy farm in the southwest of Scotland of 210 acres, a sheep farm on mountain and heath land, and a poultry farm.

The fable of inferiority of agriculture in France, P. CAZIOT (*Jour. Agr. Prat., n. ser., 32 (1919), Nos. 45, pp. 907-909; 46, pp. 927-929*).—A comparative study of figures recently obtained by the French Ministry of Agriculture and of earlier estimates is made to show that on an equal area of equally select grain-growing land the yields per acre for France equal or even exceed those of Germany and of neighboring regions.

The condition of agriculture in Germany, F. SIMPICH (*U. S. Dept. Com., Com. Rpts., No. 77 (1920), pp. 6-9*).—This article shows that the yields of the principal crops in Germany declined in 1919 as compared with 1918, due to shortage of labor, fertilizers, work animals, and equipment. It is indicated also that Germany's importations from abroad of grain and feeding stuffs have been increasing during the last generation, although highly improved methods have kept her a prominent agrarian nation, and estimates for 1913 are compared with amounts obtained since the armistice from various grain-producing countries. It is said that her crop prospects are good, although the situation is complicated by the agricultural labor problem involved with the low wages offered, the support by the Ministry of Agriculture of the idea of a farm laborers' federation on the 8-hour basis, and the cutting off of labor immigration from Russia and Poland. Live stock numbers are short, farmers are slow to accept the Government Food Commission's price for grain, large acreages devoted to crops and vineyards have been lost under the terms of the treaty, and there is a conflict of interests between city and rural populations.

Agricultural purchase societies, K. GÄBEL (*Land u. Frau, 1 (1917), No. 6, pp. 41, 42, fig. 1*).—The origin and scope of cooperative purchase and sale and supply societies for rural districts of Germany are briefly noted.

Cooperative farming in Italy, L. SMITH-GORDON (*Better Business, 5 (1920), No. 2, pp. 81-101*).—A summary is given of the history and present position of cooperative labor and farming societies in Italy. Difficulties met and overcome in matters of acquisition of suitable land, provision of credit, and technical management are described, the information having been gained by the author while on personal visits to Italy.

Peasant cooperation and agrarian reform in Roumania, M. M. KNIGHT (*Polit. Sci. Quart., 35 (1920), No. 1, pp. 1-28*).—The growth of the popular banks and of peasant cooperatives, mainly from 1895-1919, is dealt with, following a brief historical introduction on the general economic and social foundation upon which the situation rests. The so-called expropriation law of 1918, by which all cultivable Crown and institutional lands, those of all foundations, all lands of subjects who were aliens by birth, marriage, or naturalization, and all rural lands belonging to absentees as well as lands

taken from private estates containing more than about 250 acres according to a graduated scale were paid for in government land bonds and given into the possession of peasant land associations to be parcelled out in lots of from about 12 to 50 acres, is described. Other post-war reforms are noted, and a table showing the growth of Roumanian cooperatives by kinds, number of members, capital, reserve funds, and buildings and installations according to figures furnished by the Roumanian Minister of Agriculture, is included.

Annual report on the working of the cooperative societies act in Burma for the year ended June 30, 1919 (*Ann. Rpt. Coop. Socs. Act, Burma, 1919*, pp. [3]+5+40).—This reports the administration, general progress, working, financial condition and rules and regulations of agricultural and nonagricultural societies, insurance societies, central banks, and others.

Economic conditions in some Deccan Canal areas, H. H. MANN (*Agr. Jour. India, 14 (1919), No. 5, pp. 804-810; also in Poona Agr. Col. Mag., 10 (1919), No. 4, pp. 194-199*).—The author characterizes in general the four canal areas of the Deccan, and particularly that irrigated by the Nira Canal, and shows that effort, capital, and water are being concentrated on the growing of sugar cane with certain economic effects such as increase of credit demands, circulation of money, and high interest rates. He points out that more attention to means of reducing costs of production, increasing yields, and improving the quality will be demanded than in the past.

Report of the Army Agricultural Committee, HARCOURT ET AL. (*London: [War Off.], 1919, pp. 18; abs. in Scot. Jour. Agr., 3 (1920), No. 1, pp. 78-80*).—The work of British Command agricultural committees and directorates and of the departments of agriculture in growing vegetables and live stock for local army and camp supplying, and farming and irrigation operations for food production at home and in French and Mesopotamian theaters and Salonika is reported upon. Tables are included summarizing cultivations and results of the Home Forces in 1918, and showing finances, total produce, areas cultivated to various crops, and seed issued.

Argentina's export trade during 1919, W. H. ROBERTSON (*U. S. Dept. Com., Com. Rpts., No. 54 (1920), pp. 1286, 1287*).—Tables show the destination of Argentina's chief exports in 1919, with comparisons of the total exports of each article for 1915, 1916, 1917, and 1918, and the quantities of the leading products exported during 1912, 1913, and 1914. An increase is shown in shipments during 1919, as compared with 1918, especially in the case of wheat, maize, quebracho logs, calfskins, and horsehides.

[Agricultural statistics for the United Kingdom, 1903-1917] (*Statis. Abs. United Kingdom 1903-1917, pp. 308-321*).—This continues brief statistical data as to prices and sales of grain, acreage of crops, and number of live stock previously noted (*E. S. R., 42, p. 90*).

Returns of produce of crops in Scotland (*Agr. Statis. Scotland, 7 (1918), pt. 2, pp. [2]+61-81*).—Information previously noted (*E. S. R., 42, p. 90*) is continued for a later year.

AGRICULTURAL EDUCATION.

The reorganization of agricultural education, S. PLISSONNIER (*La Réforme de L'Enseignement Agricole. Paris: H. Dunod & E. Pinat, 1919, pp. [7]+413, figs. 3*).—This volume of the Encyclopédie Parliamantaire des Sciences Politiques and Sociales is a reproduction, somewhat modified, of the principal parts of the report which the author prepared for the Commission of Agriculture of the Chamber of Deputies in support of the project for the reorganization of agricultural education in France, which the Chamber adopted in March, 1914.

It deals with (1) the necessity for agricultural education, including chapters on the progress of agriculture, the agricultural situation generally in France, and the history of agricultural education in France from the sixteenth century to 1912, inclusive; and (2) a discussion of the present status of agricultural education and of its reorganization according to schemes proposed since 1886 by various individuals and commissions, including chapters on higher, secondary, and continuation instruction for young men, agricultural home economics instruction for girls, the financial cost of reorganization, its economic results, and an exposition of the motives of a project presented by Jules Pams, together with parallel statements of the texts of this project and that of the Commission of Agriculture of the Chamber of Deputies, showing modifications made by the latter.

Appendixes give the text of the law of October 3, 1848, on the creation and organization of professional agricultural education, entrance examinations to the National Institute of Agriculture and the National schools of agriculture in 1912, the text of the law of July 30, 1875, providing for practical elementary instruction in agriculture, the report of the Syndical Association of Professors of Agriculture on instruction given in the higher primary schools, statistics of crop and animal production in a number of European countries in 1905, 1911, and 1912, etc.

Agricultural education, H. W. Potts (*Sydney: Roy. Agr. Soc. N. S. Wales*, [1918], pp. 8).—The author summarizes briefly the agencies that have been founded from time to time in New South Wales having a direct or indirect bearing on agricultural education. He states that many of these have been dislocated and their activities interfered with by the war. Attention is called to the need of bringing into active and well-organized operation every phase and method of stimulating production, in which the training and specific education of the rural population is of vital importance. Revision in salaries is recommended to meet the shortage of qualified and trained instructors in order to attract the best men to the long and expensive course of preparation for agricultural teaching. It is suggested further that the agricultural societies select farmers' sons who show an aptitude for the land and send them to college, inasmuch as it has been found that many farmers can not afford to do so.

The teaching of agriculture in secondary education, H. S. HILL (*Pract. Husb. Maine*, 9 (1920), No. 1, pp. 1-4, fig. 1).—A brief statement is given by the professor of agricultural education of the University of Maine on the condition of agricultural instruction in secondary schools in Maine under the State industrial act up to the passage of the Smith-Hughes Act. In summing up, he states that agricultural courses under the State act "failed to live up to their possibilities because many of the students in the courses were not interested in farming; because there was a lack of proper equipment; because the teachers were overloaded with teaching; and because there was no summer employment of teachers; and that the failure to live up to expectations was evidenced by the fact that 12 schools out of 20 abandoned the course after giving it a trial."

Agricultural education, E. MALDONADO (*Rev. Agr. [Santiago de Chile]*, 4 (1919), No. 3, pp. 87-92).—This is a brief discussion of agricultural education, in reply to a questionnaire, in which the author gives his views with reference to the distinction between the educational requirements of the farmer and the agricultural expert or agronomo.

In his opinion, agricultural instruction should be general, but permitting of specialization in accordance with each student's abilities. Instruction in the art of agriculture should enter not only into all the grades of higher, secondary, and elementary instruction, but also into the training of specialists. He believes that for admission to higher agricultural education institutions in Chile the

bachelor's degree should be required, and that if the scientific character which they should have were given to the courses in the Agricultural Institute of Santiago they would meet perfectly the objects of agricultural instruction. The professor of agriculture should be divested of all other functions and should be a scientific investigator, since at the moment when he abandons investigation for teaching he is transformed into a simple advocate of theories which become antiquated and very soon the instruction becomes routine, resulting in retrogression. In Chile, in his opinion, all national education should depend on the department of public instruction as a medium of linking together all programs of instruction on a uniform pedagogical basis.

[**Schools of agriculture in Brazil**] (*Almanak Agr. Brazil., 1919, pp. 43-45, 59, 78, 87, 88, 241, 242, figs. 8*).—Brief accounts are given of the instruction and equipment of the "Sao Bento" higher schools of agriculture and veterinary medicine in Pernambuco, located, respectively, in the municipality of S. Lourenco da Matta and Olinda; the Agricultural Institute of the State of Sao Paulo at Campinas; the Agricultural School of Parana at Curitiba; the Campineira Agricultural School at Campinas, Sao Paulo; and the Agricultural School of Pernambuco in the municipality of Jaboatao.

The one-hundredth anniversary of the agricultural high school of Hohenheim, A. MORGEN (*Fühling's Landw. Ztg., 67 (1918), No. 21-22, pp. 398-403*).—An account is given of the present status of the Agricultural High School and Agricultural Experiment Station at Hohenheim, together with brief statements concerning their historical development.

Field trips for classes in vocational agriculture, W. F. BRUCE (*Agr. Student, 26 (1920), No. 5, pp. 201-204, figs. 2*).—The author discusses the field trip as the basis rather than the accessory of instruction in vocational agriculture. He suggests taking a field trip whenever the class can learn more of value out on the farms than in the classroom. Each field trip should be preceded by a period of preparation, short and to the point, in which the class studies the problem for that trip in such a way as to make its solution on the trip possible. The class discussions following the trip should be reduced to as definite conclusions as practicable. Calculations of profits attained by the methods observed give the most decided conclusion.

The teaching of food values in the elementary schools, R. BIERY (*Jour. Home Econ., 10 (1918), No. 8, pp. 353-357*).—The author describes a series of lessons on food values and the selection of food given as an experiment to both boys and girls of the sixth grade of the University of Chicago elementary school. The results showed, it is stated, that this kind of subject matter can be taught to pupils of that age providing all technical information is reduced to terms comprehensible to them, and providing, also, that the work be vitalized by constant association with their outside interests. If these two requirements are met it should be possible to give a usable concept of food values in about 34 lessons.

Home project work in vocational home economics in secondary schools, M. G. ADAMS (*Jour. Home Econ., 10 (1918), No. 8, pp. 358-362*).—Instructions are given for conducting home project work in vocational home economics in secondary schools, including preliminary steps to be taken by the teacher, suggested projects possible for the four years of the course, and two types of first-year projects in the study of foods and of textiles and clothing, respectively, worked out in greater detail.

MISCELLANEOUS.

Annual report of the director of the experiment station on work done under the Local Experiment Law in 1919, J. F. DUGGAR (*Alabama Col. Sta. Circ. 43* (1920), pp. 5-31).—This includes a summarized report by the director of work in all departments conducted under this State law for 1918, a financial statement for the year, and detailed reports of heads of departments, including reports on boys' and girls' club work and other extension activities. The report of the entomologist is abstracted on page 57 of this issue.

Annual Report of Idaho Station, 1919 (*Idaho Sta. Bul. 119* (1920), pp. 12, fig. 1).—This contains the organization list, a report of the director, and financial statements for the Federal funds for the fiscal year ended June 30, 1919, and for the remaining funds for the fiscal year ended December 31, 1919.

Report of the New Hampshire Station for 1918 (*New Hampshire Sta. Bul. 192* (1919), pp. 35).—This contains the organization list; reports of the director and heads of departments, the experimental features of which are for the most part abstracted elsewhere in this issue; a financial statement for the fiscal year ended June 30, 1918; and a list of the station publications from 1888 to 1919.

Twenty-eighth Annual Report of Oklahoma Station (*Oklahoma Sta. Rpt. 1919*, pp. 62, fig. 1).—This contains the organization list, reports by the director and heads of departments, a meteorological summary, two special articles, and a financial statement for the fiscal year ended June 30, 1919. The experimental work reported is for the most part abstracted elsewhere in this issue.

Report of experiments at Substation No. 11, Nacogdoches, Texas, G. T. McNESS (*Texas Sta. Bul. 254* (1919), pp. 3-22, figs. 6).—The experimental work at this substation is briefly noted elsewhere in this issue.

Index [to Bulletins 1-25 of the Virginia Truck Station] (*Virginia Truck Sta. Bul. 25* (1917), pp. 7).—A subject index to these bulletins.

[Norwegian agricultural terminology], N. ODEGAARD (*Tidsskr. Norske Landbr.*, 27 (1920), No. 1, pp. 13-28).—A list of several hundred terms commonly occurring in Norwegian agricultural literature is given with definitions, and a discussion of the use of certain words in agricultural terminology is presented.

NOTES.

Alabama College.—Dr. Spright Dowell, State superintendent of education, has been elected president, beginning July 1. Dr. C. C. Thach, the former president, who has been on leave of absence on account of ill health, has been appointed president emeritus.

California University and Station.—Dean T. F. Hunt of the College of Agriculture will be on sabbatical leave of absence during the next year and will spend the time in studying agricultural problems in Europe. Walter Mulford, director of resident instruction, will be acting dean during his absence.

Dr. H. J. Webber, director of the station, has resigned to accept a commercial position in South Carolina. Dr. C. M. Haring, professor of veterinary science and veterinarian, has been appointed director beginning July 1.

C. V. Castle, instructor in animal husbandry, has resigned to accept a position with the U. S. Department of Agriculture. Dr. E. T. Bartholomew has been appointed assistant professor of plant pathology in the Citrus substation for a special study of lemon diseases. Dr. J. P. Bennett has been appointed instructor in pomology.

Delaware College.—Press reports announce the appointment as president of Dr. Walter Hullihen, dean of the University of the South, to succeed Dr. Samuel C. Mitchell, beginning September 1.

Indiana Station.—Joseph Oskamp, associate in pomology, has resigned to assume charge of horticultural work at the Missouri Fruit Station. The resignations are also noted of R. W. Crabb, James L. Poole, and C. C. Barkdell as deputy State chemists to engage in commercial work; Dillon S. Myers, as assistant county agent leader to become a county agent in Ohio; and Miss Nellie Tracy, as administrative assistant in charge of bulletin editing. I. C. Hoffman, of the Bureau of Plant Industry of the U. S. Department of Agriculture, has been appointed assistant in horticulture for truck crop studies. John Z. Sheridan has been appointed assistant in soils and crops.

Iowa College and Station.—The resignations to engage in commercial work are noted of Dr. Arthur W. Dox as chief chemist in the station and K. C. Ikeler as associate professor of animal husbandry.

Maryland University.—State legislation has recently been enacted whereby on July 1 the Maryland State College of Agriculture will be combined with the University of Maryland School of Medicine under the name of the University of Maryland. An appropriation of \$42,500 per annum was made for the medical school for the ensuing biennium, and \$186,476 in 1921 and \$165,416 in 1922 for the other departments of the university. An appropriation of \$203,000 was also made for buildings and equipment.

Mississippi Station.—The increased appropriations from the State Legislature for experimental work have enabled the station to make the following additions to its staff: D. C. Neal, plant pathologist of the Georgia State Board of Entomology, as plant pathologist; Earle E. Brintnall as dairy husbandman; J. C. C. Price, associate horticulturist of the Alabama College and Station, as horticulturist; F. C. Cottrell as agricultural engineer; W. E. Ayres, cotton specialist and assistant agronomist at the Arkansas Station, as plant pathol-

ogist to be located at the Delta Substation; and Harris F. Wallace as assistant to the director at the Holly Springs Substation. The legislature has also authorized a new substation, to be located in the brown loam area in Hinds County.

Cornell University.—Dr. Cornelius Betten, secretary of the college of agriculture, has been appointed vice-dean of resident instruction therein, beginning July 1.

New York State Station.—William O. Stone, assistant horticulturist, resigned May 1 to take up farming and has been succeeded by Thomas O. Sprague.

Oregon College and Station.—James T. Jardine, in charge of grazing studies in the Forest Service, U. S. Department of Agriculture, has been appointed director, beginning July 1. Dr. A. B. Cordley, the previous director, continues as dean of the school of agriculture. Other appointments include Earl B. Osborne and B. W. Rodenwold as assistant professors in animal husbandry, H. N. Colman as instructor in dairy husbandry, C. C. Ruth as assistant professor of farm crops, J. R. Nevius as instructor in farm crops, A. E. Brandt as instructor in farm mechanics, A. G. Lunn as professor of poultry husbandry, H. E. Cosby as instructor in poultry husbandry, and Ward Cretcher as instructor in soils.

Pennsylvania College and Station.—Graduate students have recently purchased at public auction the Joseph Priestley homestead at Northumberland, Pa. The house, which was built about 1795, is a frame structure, but is in a remarkable state of preservation. It is expected to dismantle and reerect it on the college campus as a memorial to Priestley, who built the house soon after his removal to this country and occupied it until his death in 1801. It is a two-story structure 45 by 50 ft., with a projection about 25 ft. square at each end. One of these projections was the workshop or laboratory.

The purchase has been made for the alumni of the college, but funds for its removal and re-erection have been promised by an unnamed donor. According to present plans, the reconstruction is to be along the old architectural lines, but modernized and adapted to some suitable use by the School of Natural Science.

Recent appointments include J. Robert Dawson as assistant professor of dairy husbandry extension, H. D. Munroe as assistant professor of poultry husbandry extension, and T. B. Charles as instructor in poultry husbandry. Dr. D. S. Fox, assistant professor of agronomy, has resigned, effective July 1.

Porto Rico Federal Station.—Thomas Bregger, a graduate student at Cornell University, has been appointed plant breeder.

West Virginia Station.—H. H. Hanson, chemist in charge of feeding stuff analysis, has been appointed State chemist of Delaware, in charge of a new laboratory which is to carry on the chemical and seed testing work of the State.

States Relations Service.—Alvin Dille, specialist in agricultural education and in charge of the investigations in agricultural instruction in schools since 1918, died June 13 after a sickness of several months' duration. Mr. Dille was born in 1876, was a graduate of Ohio Northern University and Ohio University, and had also attended summer courses in education in the Ohio State University, University of Chicago, and the Texas A. and M. College. His experience as a teacher of science and agriculture, as a superintendent of schools, and as a supervisor in the teaching of agriculture in Nueces County, Tex., had given him unusual insight into the problems confronting subcollegiate instruction in agriculture, and had rendered his services in the preparation of pedagogical material of great value.

EXPERIMENT STATION RECORD.

VOL. 43.

AUGUST, 1920.

No. 2.

In common with most activities of the Government, the Federal Department of Agriculture is financed primarily by annual appropriations. These appropriations are provided mainly by the Agricultural Appropriation Act, which prescribes in considerable detail most of the Department's lines of work for the ensuing year and limits quite definitely its allotments for these various purposes. For these reasons the passage of the act by Congress is an event of annual importance to the Department and to all who are interested in its activities.

The latest of these acts, covering the fiscal year ending June 30, 1921, was signed by President Wilson May 31, 1920. It carries appropriations aggregating \$31,712,784. This represents a decrease over the total in the corresponding act for the previous year of \$2,187,427, and is approximately \$6,000,000 less than the estimates made by the Department of its needs for the year.

The reduction in appropriations is divided among a large number of items, and affects the work of practically every bureau. It inevitably foreshadows a material curtailment of well-established projects and the complete elimination of other undertakings, some of them of long standing. Its seriousness is also increased by coming at a time when, as was pointed out by Secretary Meredith in discussing the situation, "a dollar, as we all know, buys much less of everything than it formerly bought and also does considerably less work. Even if all the appropriations had been retained at the old figures, therefore, the Department would have been seriously handicapped in carrying on its work effectively."

Notwithstanding the many reductions, most of the Department's allotments were, as a matter of fact, continued on the previous basis. In some cases increases were allowed, and a few new lines of work were authorized.

No alteration was made in the salary scales of the Department. All recommendations of salary increases were omitted from the estimates pending a report from the Congressional Joint Commission on Reclassification of Salaries in the District of Columbia, and no action was taken following the presentation of this report on March 12, 1920. A civil service retirement law was adopted, however, under

which a system of compulsory savings begins August 1, 1920, 2.5 per cent of all salaries being withheld from employees until their retirement or complete separation from the service.

Some of the largest reductions carried by the appropriation act, aggregating over \$300,000, were made in the direct allotments to the Bureau of Animal Industry. Also, the supplementary appropriation to the Department of \$1,000,000 to combat outbreaks of foot-and-mouth disease and other contagious and infectious diseases was practically eliminated, only \$50,000 being appropriated. This amount, together with certain unexpended balances, will provide about 550,000 for this purpose in case an emergency should arise.

The bureau funds for field work in the eradication of hog cholera were reduced from \$446,865 to \$192,200. This will involve a radical curtailment of the campaign, which has been carried on in thirty-six of the principal hog-raising States at an estimated annual saving to farmers of \$40,000,000 a year. It is announced that the field force of 140 specialists will be reduced to about 54, and that much of the cooperation with the States will have to be abandoned entirely.

The funds for tick eradication were reduced from \$741,980 to \$681,160, an allotment of \$50,000 for live stock and dairying demonstration work in cooperation with the States Relations Service being omitted altogether. In consequence, the Federal live stock demonstration work in areas freed of ticks will cease, and beef cattle specialists will be withdrawn from ten States and dairy specialists from six States in the South.

A net reduction of \$14,400 in the appropriation for the study of animal diseases will necessitate the abandonment in New York and Texas of cooperative work looking to the control of contagious abortion of cattle. Curtailment is also anticipated in the studies of stock-poisoning by plants, anthrax, tuberculosis, and various animal parasites. Another reduction is of \$23,600 for dourine eradication. For the tuberculosis campaign, the allotment for the payment of indemnities was decreased from \$1,000,000 to \$680,440, while that for administration and operating expenses was increased from \$500,000 to \$800,000.

A net reduction of \$12,750 in the funds for dairy investigations will oblige the Department to withdraw financial support of cooperative cow testing work in ten States, from cooperative work in improving the quality and increasing the use of dairy products in four States, and from the employment of dairy specialists for demonstration work in Nevada and Wyoming. There were also small decreases in the appropriations for experiments and demonstrations in live stock production in the cane-sugar and cotton dis-

tricts and for experiments in the breeding of horses for military purposes. On the other hand, a new item provides \$10,000 for live stock experiments and demonstrations with both beef and dairy animals by the Woodward, Okla., field station.

The meat inspection service receives \$892,580 as a supplement to the permanent appropriation of \$3,000,000 per annum. This is a net increase of \$24,300.

The largest reductions to any one bureau were from \$3,379,638 to \$3,004,394 in the Bureau of Plant Industry. In cereal investigations alone \$80,000 was cut off, involving a material modification of plans. Field stations in operation for several years are to be closed in nine States. Investigations of stem rust of cereals in progress in five States are to be discontinued, and other studies in fifteen States will be reduced in scope.

The field stations at San Antonio, Tex., and on the Umatilla, Oreg., and Newlands, Nev., reclamation projects will also be closed because of a reduction of \$20,000 in the allotment for studies of western irrigation agriculture. A similar reduction in the appropriation for studies of drug, poisonous, and oil plants involves the abandonment of cooperative work with drug crops, a material curtailment of a camphor-introduction project, and other readjustments. An appropriation of \$32,500 for biophysical investigations of the relation to plant growth of such factors as temperature, moisture, soils, and air was eliminated completely.

Increases of \$10,000 each were granted for studies of potato diseases, notably potato wart and "mosaic," and for soil fertility investigations with special reference to new fertilizer materials. There was also an increase of \$5,000 to increase the facilities for conducting seed testing work.

The new allotment for foreign seed and plant introduction is \$92,700. This is a decrease over the previous year, but attributable to the inclusion at that time of \$50,000 for the establishment of a plant inspection and detention station since located on a tract of fifty acres at Bell, Md.

Although eliminated by the Senate following the recommendation of Secretary Meredith, the Congressional seed distribution was eventually continued on the usual basis with an allotment of \$239,416. This is a net decrease of \$116,564 over the previous year.

The appropriations for the Forest Service aggregate \$5,870,822, with \$125,000 additional for cooperation with the States in fire protection under the Appalachian Forest Reserve Act, \$250,000 for general forest fire prevention, and \$50,000 for cooperation with the War Department in the maintenance of an air patrol for fire pre-

vention and suppression in the National Forests of the Pacific Coast and Rocky Mountains. The bulk of the appropriation is, as usual, to be used in the administration, protection, and development of the National Forests, which it is of interest to note returned in receipts for the fiscal year 1919 \$4,358,414.86. There were decreases from \$450,000 to \$400,000 in the funds for forest improvement work, from \$145,640 to \$120,640 for tree planting on the National Forests, from \$107,000 to \$87,000 for land classification and entry surveys, and from \$78,728 to \$50,000 for silvicultural investigations. The last-named of these reductions will necessitate the closing of three of the four forest experiment stations in the western National Forests, and the abandonment of most of the maintenance and reproduction studies now under way in the East and South. On the other hand, the item for forest products investigations was enlarged from \$173,260 to \$223,260, thus allowing further development of box tests and studies of the drying of woods, treatments to prevent losses by decay and fire, reduction of waste in lumber manufacture, and increased efficiency in pulp and paper making.

The Bureau of Chemistry received \$1,333,591, a net decrease of \$57,980. The appropriation for enforcing the Federal Food and Drug Act was reduced \$30,000, although in the words of the Secretary Meredith, "even with the present appropriation, the Department has been able to maintain the enforcement of that important law only with great difficulty and through the practice of the most rigid economy. With the reduced amount provided for next year and constantly increasing costs of operation, it will be necessary to cut down the force to such a point that the food and drugs consumed by the people of this country can not be safeguarded with the usual measure of thoroughness."

A new paragraph transfers to the Department the enforcement of the Federal Tea-Importation Act with an appropriation of \$40,000. This law, which antedates the Food and Drugs Act, is designed to prevent the importation of impure and unwholesome tea and has been under the jurisdiction of the Treasury Department. The transfer thus unifies the Federal inspection of imported foods.

A reduction of \$31,020, or over thirty per cent, was made in the bureau's allotment for studies of coloring materials. The appropriations for poultry and fish investigations were combined, with a net decrease of \$10,000. An increase of \$3,000 was granted for studies of sirup manufacture, and authority was given to use \$7,500 in experiments in the production of sirups, sugar, starch, dextrins, and other products from the sweet potato.

There is an increase from \$491,235 to \$542,215 for the Bureau of Soils. Of this, \$192,900, a net increase of \$67,400, is for the comple-

tion and operation of the experimental kelp potash plant at Summerland, Cal. This plant has been producing potash and its by-products in commercial quantities for some time, and it is estimated that the receipts in the fiscal year 1921 will more than cover all expenses of operation.

An increase of \$5,500 in the funds for the investigation of other fertilizer resources is to be used in the development of a process for the production of more concentrated phosphate fertilizers from low-grade raw materials. A modified blast furnace of semicommercial size is in course of construction at Arlington, Va.

The allotment for soil surveys was reduced from \$198,200 to \$178,900. Other activities of the bureau were continued without material change.

The funds allotted to the Bureau of Entomology aggregate \$1,123,460, and in addition \$400,000 (an increase of \$150,000) is provided elsewhere in the act to combat the spread of the European corn borer, and \$488,560 for the campaign to eradicate the pink bollworm of cotton. This is a net increase of \$34,860 over the corresponding items in the previous act, some projects being curtailed and others extended. For instance, \$75,000 additional is provided to extend the campaign for the control of the Japanese beetle, a serious enemy of orchards, vineyards, truck crops, ornamentals, shade trees, and many other plants, now established over an area of about 15,000 acres in Burlington and Camden Counties, in New Jersey. Another increase of \$24,600 is for experiments in the control of the cotton boll weevil by the use of calcium arsenate in dusting.

On the other hand, a reduction of \$7,590 in the amount provided for forest insect investigations will compel the abandonment of field stations in Colorado, Oregon, and California, and of all work in the Northwestern and Southeastern States on insect infestation of forests, cut timber, and forest products. The allotment for insects affecting truck crops and stored products was cut \$21,760, and \$10,000 of the remaining funds is to be diverted to a new project on the grain moth, so that considerable curtailment is necessitated on the project for the control of the sweet-potato weevil, and the closing of field stations for studies of sugar beet and potato insects in Colorado and berry and cabbage insects in North Carolina. Other reductions include \$10,000 for miscellaneous investigations, notably some of the systematic work and studies of pests affecting man and domestic animals; \$2,000 for the studies of tropical and subtropical plant insects; and \$52,650 for the campaign against the gipsy and brown-tail moths. Likewise the pink bollworm fund, administered by the Federal Horticultural Board, is reduced \$100,000, although

this insect, deemed possibly the most destructive enemy of cotton in the world, has now been found in several counties of Texas and three parishes of Louisiana.

Under the Bureau of Biological Survey, provision is made for experiments and demonstrations for the improvement of the reindeer industry in Alaska, and for the transfer from the Department of Commerce of its powers and duties as regards the protection of land fur-bearing animals in Alaska. The reindeer studies are to be in cooperation with the Bureau of Education, through whose efforts 171 animals were imported from Siberia in 1892, and which will continue to foster the industry among the natives of the region. The number of reindeer has now increased to about 200,000, and it is thought that fully 10,000,000 animals could be maintained within the Territory. The immediate projects contemplated include attempts to produce a larger animal through caribou crosses, and the study of several diseases. The initial appropriation for reindeer investigations is \$25,000 and that for the enforcement of the laws relating to fur-bearing animals \$15,000. The bureau also receives \$5,135 additional for the maintenance of its bird and game reservations. Its total for all purposes is \$785,885.

The appropriations of the Bureau of Crop Estimates were reduced from \$371,102 to \$318,656. This reduction is mainly in its field work, and involves the discontinuance of all special service except the regular monthly reports on the staple crops. The estimates which will thus be suspended include those made by specialists on cotton, tobacco, and rice, and the special forecasts on fruit and truck crops. A new provision in the act authorizes the cooperation with the bureau in its statistical work of the States Relations Service and other Federal, State, and local agencies, the report of the House Committee recommending the utilizing of the county agents in estimating crops.

The States Relations Service received a total of \$4,870,160, as compared with \$4,905,820 in the previous act and \$4,968,540 in its estimates. The reductions were mainly through the elimination of several low-paid positions on its statutory roll, and which had been vacant for some time. Some changes were also made in the allotments to the insular experiment stations, that in the Virgin Islands receiving an increase from \$15,000 to \$20,000 and Guam a reduction to \$15,000. The appropriation of \$16,360 for the work with farmers' institutes and agricultural schools was eliminated by the Senate, but ultimately restored in conference. The remaining items were continued unchanged, including \$1,440,000 for payments under the Hatch and Adams Acts, \$1,500,000 to supplement the permanent appropriation of \$3,580,000 under the Agricultural Extension Act, \$634,800 for farmers' cooperative demonstration work in the cotton

belt, \$715,720 for the corresponding work outside that territory, \$50,000 each for the experiment stations in Hawaii and Porto Rico, \$75,000 for those in Alaska, and \$44,300 for the Office of Home Economics.

The appropriations of the Bureau of Public Roads showed a reduction of \$79,300. The allotments for irrigation and drainage investigations were each diminished by \$20,000, making available \$62,440 and \$53,760, respectively. There was also a cut of \$35,000 in the funds for field experiments in road construction and maintenance, while a like sum was taken from the allotment for road building and maintenance studies and added to that for investigations of road materials. The aggregate of the funds for the bureau as carried in this act is \$515,020, but it is important to recall that in addition it receives large administrative funds under the Federal Aid Road Act of 1916 and a supplementary provision in the Post Office Appropriation Act of February 28, 1919. The Federal funds under these two acts for the fiscal year 1921, which is the final year for which appropriations have been made, amount to \$100,000,000, of which \$3,000,000 is available for administrative purposes.

The Bureau of Markets will receive \$2,538,709, a decrease from \$2,811,365. The reduction is divided among a number of items, \$30,000 being in the funds for studies in marketing and distributing farm products. This involves the discontinuance of work under way in twenty cities and also the studies of direct marketing by parcel post, express, and similar agencies. On the other hand, \$20,000 is allotted to a new project on methods of preventing deterioration of fruits and vegetables in transportation and storage. The market news service on fruit and vegetables and on live stock and meats, for which at one time 17,000 miles of leased wires were in operation, is to be further curtailed from the present 5,000-mile basis because of a reduction of \$58,680.

The appropriation for cooperation with the States in marketing work was reduced \$6,650. This cooperation now includes agricultural colleges and other agencies in twenty-eight States, and it had been intended to extend it to others. An allotment of \$15,780 for studies of cooperation among farmers was eliminated because of the transfer of this work to the Office of Farm Management and Home Economics.

The appropriation of \$35,000 granted the previous year to complete the work of the Domestic Wool Section of the War Industries Board was reduced to \$15,000. Another war-time appropriation of \$75,000 for the regulation of stockyard practices was eliminated.

No change was made in the funds for the enforcement of the U. S. Warehouse and Standard Containers Acts, but because of the

cessation of funds hitherto provided under the Wheat Price Guaranty Act of 1919 an apparent increase under the U. S. Cotton Futures Act was actually a reduction of \$70,100. There was also a net diminution of \$47,300 in the funds for the administration of the U. S. Grain Standards Act, and \$11,600 in those for grain standardization investigations. The field stations at Salt Lake City and Cleveland are to be closed, work elsewhere curtailed, and the promulgation of standards for milled rice deferred for at least a year.

The Plant Quarantine Act of 1912 was amended by providing for Federal regulation of nursery-stock movement from or into the District of Columbia and the control of plant diseases and insect pests within the District, and the Federal Horticultural Board was granted an increase from \$47,700 to \$125,450 to enforce the act. It is proposed to develop a more adequate port inspection service to cooperate with the Customs Service and State officials in the enforcement of quarantines against the entry of dangerous pests from foreign countries. The funds for enforcing the Insecticide Act were increased from \$123,940 to \$147,350.

The Office of the Secretary receives \$465,260. This is an apparent decrease of \$35,260, but is largely attributable to the provision of only one Assistant Secretary instead of two, and to the transfer to the Division of Publications of certain editorial functions, the Office of Information, and the Office of Exhibits.

The title of the Office of Farm Management was broadened into that of Office of Farm Management and Farm Economics. The total appropriations for the office were increased from \$302,590 to \$375,390, and the allotment which may be used in ascertaining the cost of production of the principal staple agricultural products from \$23,873 to \$78,873.

The funds of the Division of Publications were increased to \$374,090, of which \$70,000 is for exhibits at State, interstate, and international fairs held within the United States and the remainder for the preparation, illustration, and distribution of the Department publications and other illustrative material. Expenditures for printing and binding, however, were as usual appropriated for separately in the Sundry Civil Appropriation Act. This act carries \$725,000 for the purpose, of which \$47,000 is for the Weather Bureau and \$250,000 for farmers' bulletins. It also authorizes the continuance until June 30, 1921, of the various journals and other periodical publications of the Government, which under previous legislation would otherwise have been forced to cease publication at the adjournment of the last session of Congress. This action followed the veto by the President of the Legislative, Executive, and Judicial Appropriation Act, because of the inclusion therein of a clause which would

have authorized the Congressional Joint Committee on Printing to discontinue these periodicals at any time.

The work of the remaining branches of the Department was provided for substantially as at present. The Weather Bureau receives \$1,876,550 instead of \$1,880,210, and there are slight changes in the phraseology of some of the allotments. The Division of Accounts and Disbursements was granted \$49,820 and the Library \$54,480. For the miscellaneous expenses of the Department \$136,000 was made available, besides \$164,666 for rent in the District of Columbia.

As usual the act contains considerable general legislation. In addition to items already referred to, provision was made for the appointment of a Congressional Short-time Rural Credits Committee to report on the practicability of this type of credit legislation. This committee is composed of the chairman and two other members of the Senate and House committees on agriculture and banking, and \$5,000 is appropriated for its expenses. A yield of 5 bu. or less per acre of wheat in drought stricken regions was declared to be a crop failure, releasing farmers who had borrowed from the Government to purchase seed wheat.

The Secretary of Agriculture was authorized to acquire or purchase at a nominal price the tracts now occupied by four of the Department's field stations for the propagation, testing, and distributing of new crop plants. These tracts include about 80 acres at Chico, Cal., 60 acres at Bellingham, Wash., 25 acres at Buena Vista, Fla., and 46 acres at Savannah, Ga. A commission consisting of the Secretary and three other members of the Cabinet was appointed to report on the feasibility of utilizing the property formerly occupied by the Weather Bureau at Mount Weather, Va., as a sanitarium or home for disabled ex-service men or for other governmental purposes.

An element of special interest attaches to the new act in that it is probably the last to be made up by the House Committee on Agriculture. Under a recent change in the House rules the privilege of reporting measures making appropriations will henceforward be centralized in the Committee on Appropriations. This committee is to be enlarged to thirty-five members, and it is expected that to a subcommittee will be delegated the preparation of future agricultural appropriation bills and their management in the House. The Committee on Agriculture, which has performed this function continuously since the establishment of the Department and has exercised a very great influence on its development, is thus relieved of jurisdiction hereafter except as regards matters of new legislation. The change is hence a radical one, and its workings will be observed with much interest.

RECENT WORK IN AGRICULTURAL SCIENCE.

AGRICULTURAL CHEMISTRY—AGROTECHNY.

On the origin of the humin formed by the acid hydrolysis of proteins.—**IV, Hydrolysis in the presence of aldehydes.**—**III, Comparative hydrolysis of fibrin and gelatin in the presence of various aldehydes,** G. E. HOLM and R. A. GORTNER (*Jour. Amer. Chem. Soc.*, 42 (1920), No. 3, pp. 632-640, fig. 1).—The observations previously noted (*E. S. R.*, 38, p. 201) regarding the hydrolysis of fibrin and gelatin in the presence of formaldehyde have been extended to include a study of the effect of benzaldehyde, acetaldehyde, and butyric and isobutyric aldehydes.

As no fibrin such as was used in the previous experiments could be obtained, certain of the experiments with formaldehyde were also repeated with the new material, which consisted of commercial fibrin from blood purified by dissolving in 0.2 per cent NaOH, filtering through four double cheesecloths, precipitating with HCl, washing the precipitate until free of HCl, and drying and grinding the product. The method followed was the same as that used in the former experiments with the exception that hydrolysis was continued for 24 hours only, and that, in addition to the other determinations, the total amino nitrogen was determined in the filtrate from the soluble humin.

The data obtained with formaldehyde confirm the conclusions of the previous paper. With benzaldehyde in increasing amounts, there was an increase in the amount of insoluble humin up to a constant value, but no increase in ammonia or soluble humin. Since it has been shown by Gortner (*E. S. R.*, 36, p. 108) that when fibrin is hydrolyzed with HCl in the presence of benzaldehyde a large part of both tryptophan and tyrosin remain in the acid-insoluble humin, the maximum amount of insoluble humin is considered to be derived from tryptophan and tyrosin present in the gelatin and fibrin. As the insoluble humin obtained in the presence of formaldehyde has been shown in the preceding paper to be derived almost exclusively from tryptophan, the authors conclude that "by utilizing both the formaldehyde and benzaldehyde data one may estimate at least the minima tryptophan and tyrosin content of a protein."

The action of butyric and isobutyric aldehydes upon protein hydrolysis was similar to the action of benzaldehyde with the exception of the possible adsorption or occlusion of other nitrogen compounds due to polymerization of the aldehydes. Consistent results were not obtained with acetaldehyde, probably on account of its rapid polymerization.

The total amino nitrogen in the filtrate from the soluble humin fell rapidly with the addition of increasing amounts of formaldehyde, while there was at the most only a slight decrease in the amino nitrogen figures in the case of the other aldehydes.

"Our data confirm the conclusion that the formation of the black acid-insoluble humin in a normal protein hydrolysate (only protein and acid present) is dependent upon the presence of tryptophan in the protein molecule, and the only part which any of the other known amino acids has in such humin formation is to (perhaps) furnish an insignificant amount of nitrogen to the humin fraction through either adsorption or occlusion."

The origin of the humin formed by the acid hydrolysis of proteins.—V. R. A. GORTNER and G. E. HOLM (*Jour. Amer. Chem. Soc.*, 42 (1920), No. 4, pp. 821-827).—To further confirm the conclusion, noted above, that the black insoluble humin formed in protein hydrolysis is due to tryptophan in the presence of an aldehyde, 15 pure amino acids were mixed in various proportions and boiled with 20 per cent HCl, both in the presence and in the absence of formaldehyde.

The only experiment which yielded any insoluble humin nitrogen was that in which both tryptophan and aldehyde were present. The nitrogen secured in that fraction amounted to 95.5 per cent of the tryptophan nitrogen which had been added. This is thought to afford conclusive proof that the black insoluble humin is derived from tryptophan, and when the proper amount of aldehyde is present is a quantitative measure of the tryptophan present.

The evidence presented in an earlier paper (E. S. R., 38, p. 201) that soluble humin is derived from tyrosin was confirmed, for only those hydrolysates which contained both tyrosin and aldehyde yielded appreciable amounts of soluble humin. On account of the solubility of humin it can not, however, be used as a quantitative measurement of the tyrosin.

No evidence was secured in these experiments as to the nature of the phosphotungstic acid humin. When both tryptophan and formaldehyde were present in the proportions necessary for the maximum formation of insoluble humin there was less deamination than when either the aldehyde or tryptophan was absent. Cystin was not readily deaminized.

The food of the small sea herring and ammonia and amines as end products of its decomposition, F. C. WEBER and J. B. WILSON (*Jour. Amer. Chem. Soc.*, 42 (1920), No. 4, pp. 841-849).—This paper reports the results obtained in the chemical study of the herrings used in the sardine industry of Maine and of their feed, continuing the investigation previously noted (E. S. R., 40, p. 411) and supplementing the bacteriological studies of Obst (E. S. R., 40, p. 555).

Ammonia and amines were found in appreciable quantities in the different forms of herring feed (copepods and schizopods) which had undergone decomposition, in culture media in which the bacteria *Bacillus walfischrauschbrand* and *Bacillus B.*, commonly found associated with the feed, were grown, and in the contents of the digestive tract of "belly-blown" "feedy" fish. Skatol and indol were also identified in the culture media in which the bacteria had grown.

The results indicate that the decomposition of the feed is due to the action of the two bacteria which are always found associated with the feed, and is responsible for the bursting of the bellies of "feedy" fish and the occasional swelling and spoilage of canned sardines.

On amino-acids.—II, Hydroxyglutamic acid, H. D. DAKIN (*Biochem. Jour.*, 13 (1919), No. 4, pp. 398-429).—In continuation of the investigation previously noted (E. S. R., 40, p. 611), the results are reported of a further study of the new amino acid β -hydroxyglutamic acid, together with experiments on its synthesis and that of allied substances.

Although considerable difficulty was experienced in synthesizing the inactive acid the synthesis was finally effected with glutamic acid as a starting point. The intermediate steps in the synthesis and the methods which proved unsuccessful are outlined. The acid has been isolated from gliadin and glutenin by the method used in its isolation from caseinogen.

"When administered to a diabetic (phloridzinised) dog β -hydroxyglutamic acid yields 55 to 60 per cent of its weight as glucose, apparently three of its five carbon atoms being concerned in glucose formation. In this it resembles

glutamic acid, prolin, and ornithin, and it seems not unreasonable to regard the catabolic paths of all these acids as similar. The possibility of their conversion into glucose via malic and lactic acids is indicated."

The report contains a further description of the acid and of the preparation and properties of its strychnin and brucin salts and the similar salts of *d*-glutamic, *l*-aspartic, and *l*- α -pyrrolidonecarboxylic acids.

Fat chemistry and the fat industry in the years 1914-1918, A. GRÜN (*Chem. Ztg.*, 43 (1919), Nos. 127, pp. 717, 718; 130, pp. 737-739; 133, pp. 758-760; 136, pp. 778-781; 139, pp. 801-804; 142, pp. 821-824).—This is a review of the literature on fat during the years 1914-1918 arranged under the following headings: Economic situation, investigations on the constituents of fats, alterations on storage and cooking, derivatives of fatty acids (substitution products), analysis of fats, fat production, production of edible fats particularly by hydrogenation, drying oils and varnishes, sulphonated oils, fat cleavage, technical fatty acids, and soap.

On the mechanism of oxalic acid formation by *Aspergillus niger*, H. RAISTRICK and A. B. CLARK (*Biochem. Jour.*, 13 (1919), No. 4, pp. 329-344).—To determine the mechanism of oxalic acid production from sugar by *A. niger*, the organism was cultivated on synthetic media containing as the sole source of carbon salts of organic acids which might be possible intermediate compounds, and the amount of oxalic acid produced was estimated.

The one-carbon acid, formic acid, gave fairly good growth of the organism, but no oxalic acid was produced. Of the two-carbon acids, acetic acid gave good growth and good yields of oxalic acid, while glycollic and glyoxylic acids gave fairly good growth but no oxalic acid. The three-carbon acids (lactic, pyruvic, glyceric, malonic, and propionic) gave very good growth but only slight yield, if any, of oxalic acid. The four-carbon monobasic acids gave no growth and no production of oxalic acid, while the four-carbon dibasic acids (succinic, fumaric, malic, and tartaric) gave good growth and good yields of oxalic acid.

From these results it is concluded that the breakdown of the sugar molecule by *A. niger* probably takes place in two stages, involving first the production from one molecule of sugar of one molecule of acetic acid and one of oxalacetic acid through the intermediate formation of β - δ -diketoadipic acid. The oxalacetic acid on further hydrolysis gives acetic acid and oxalic acid. The acetic acid in each case oxidizes to oxalic acid. The intermediate production of oxalacetic acid is also thought to take place in the formation of citric and fumaric acids from sugar by the Aspergillaceae as noted by Currie (E. S. R., 37, p. 613) and by Wehmer (E. S. R., 43, p. 15).

Condensers, F. FRIEDRICHS (*Ztschr. Angew. Chem.*, 33 (1920), No. 8, *Aufsatz*, pp. 29-32, figs. 6).—A critical examination of the efficacy of various types of condensers is reported.

The efficiency of the Soxhlet type of condenser was found to be in no way proportional to the cost of recovery. A coil condenser with five windings was found to be the most efficient type, both for ordinary distillation and for use as a reflux condenser.

The determination of potassium as perchlorate, II, G. P. BAXTER and M. KOBAYASHI (*Jour. Amer. Chem. Soc.*, 42 (1920), No. 4, pp. 735-742).—A further study of the accuracy of the determination of potassium as perchlorate as recommended in an earlier contribution (E. S. R., 37, p. 110) is reported.

As a result the earlier recommendations are reiterated, with the exception that, in place of using a saturated solution of potassium perchlorate as a washing liquid, alcohol containing perchloric acid but no potassium perchlorate

is recommended. This change is considered necessary if sodium is present in any quantity on account of the occlusion of sodium perchlorate with the potassium perchlorate. If the amount of sodium is small, the use of a saturated solution of potassium perchlorate for the initial extraction is considered safe.

The use of solutions of ammonium citrate for the estimation of reverted calcium phosphate. C. S. ROBINSON (*Michigan Sta. Tech. Bul. 46 (1919), pp. 3-29*).—This bulletin consists of a discussion of the standardization of the ammonium citrate solutions used in the estimation of reverted calcium phosphate. The discussion is centered about the following points: (1) The preparation of ammonium citrate solutions having a definite reaction or composition; (2) the relation between composition and reaction; and (3) the relation between the reaction of the reagent and its solvent action on calcium phosphates both pure and in commercial fertilizers.

The comparative merits of the use of truly neutral solutions of ammonium citrate, solutions of triammonium citrate, and solutions of empirical composition are discussed from the literature on the subject and from experimental data obtained by the author. By an application to the method of Eastman and Hildebrand (*E. S. R., 32, p. 804*) of the standards prepared from potassium hydrogen phosphate and sodium hydroxid according to Clark and Lubs (*E. S. R., 37, p. 506*) with phenol red as an indicator, he has found it possible to obtain accurate neutral solutions of ammonium citrate. The composition of a neutral solution of ammonium citrate standardized by this method has been found to be 45.33 gm. NH_3 and 172 gm. $\text{C}_6\text{H}_5\text{O}_7$ per liter. The ratio of NH_3 to $\text{C}_6\text{H}_5\text{O}_7$ is 1:3.794 and the specific gravity of the solution 1.09 at 20° C.

Analytical data on the relation between the reaction of the reagent and its solvent action on calcium phosphates are presented from which the following conclusions are drawn:

“With commercial fertilizers the reaction of acid or neutral citrate solutions does not change during the determination but the alkalinity of alkaline solutions is decreased. With mixtures of pure calcium phosphates and calcium sulphate the reverse is true, i. e., acid and neutral solutions become more alkaline while alkaline ones do not change.

“With citrate solutions ranging in reaction from pH 6.6 to 7.8, the magnitude of the variation in the results of the analysis of calcium phosphate is usually small. There is, however, a distinct decrease in the solubility of both di- and tri-calcium phosphate with an increase in alkalinity. Precipitated tricalcium phosphate is much more readily soluble in ammonium citrate solution than is raw rock phosphate.”

In conclusion the author recommends the retention of the neutral solution of ammonium citrate as the reagent to be employed in the estimation of reverted calcium phosphate, but the replacement of the usual methods for preparing the solution by more accurate ones such as the one described in this study.

A bibliography of 54 titles is appended.

A rapid method for the identification of bacteria fermenting carbohydrates. J. BRONFENBRENNER and M. J. SCHLESINGER (*Amer. Jour. Pub. Health, 8 (1918), No. 12, pp. 922, 923*).—The method, which was devised to facilitate the bacteriological examination of feces in studies of cases of food poisoning, consists essentially in planting each of the suspected colonies into an agar drop, thus permitting a comparatively large number of bacteria to grow in a circumscribed area and thereby hastening the reaction. The lactose agar containing a suitable quantity of indicator, preferably the CR indicator, is deposited while hot in drops from sterile pipettes on the inner surface of the bottom of

an ordinary Petri dish. Each drop is inoculated with the material from individual suspected colonies, after which a fresh drop of the lactose agar is placed over each one of the primary drops, and the plate incubated in the usual way.

The determination of small amounts of sugar in the presence of higher and lower decomposition products, E. LAST (*Biochem. Ztschr.*, 93 (1919), No. 1-2, pp. 66-81).—A study of different methods of removing interfering protein decomposition products in the volumetric determination of glucose in biological solutions is reported with the following results:

The higher protein decomposition products (albumoses and peptones) which affect the accuracy of the glucose determination were best removed by precipitation with mercuric chlorid in neutral solution. The presence of acids or of excess of the sublimate rendered the method inaccurate. Good results were obtained on the addition of 2 gm. of the sublimate to 1 gm. of peptone. The results obtained with mercuric nitrate as a precipitant were also good if the reaction was carried out carefully. Both of these reagents also remove ereptone, the presence of which interferes with the reaction. Monamino acids were found to have no effect on the reaction.

Determination of glucose in the presence of lactose, E. HILDT (*Compt. Rend. Soc. Biol. [Paris]*, 82 (1919), No. 30, pp. 1241-1243)—For the determination of glucose in pathologic urines containing lactose the author recommends the volumetric Fehling method after the complete hydrolysis of the lactose with the use of benzene-sulphonic acid as a catalyzer, as previously recommended (E. S. R., 40, p. 507).

Studies in the heat resistant organisms of cold packed canned peas, R. NORMINGTON (*Michigan Sta. Tech. Bul.* 47 (1919), pp. 33).—This bulletin reports an investigation of the cause of occasional spoilage in home-canned vegetables. The study was conducted on 13 lots of peas canned according to the Government methods for cold pack canning, using Mason and Seal-fast quart and pint jars. One lot was heated in steam for 3 hours, 5 were cooked for 3 hours by the hot water bath method, and 7 were processed in the autoclave at 15 lbs. pressure for 40 minutes. One lot was canned the same day that the peas were picked, 2 lots were kept at room temperature over night, and all the others were kept in the refrigerator over night before canning.

Within two weeks spoilage began to occur, which amounted to 50.9 per cent of the autoclaved peas, 63.9 per cent of those cooked in the hot water bath, and 73.3 per cent of those cooked in steam. Of the autoclaved peas, spoilage occurred in 12.1 per cent of those autoclaved the same day as shelled, 51.9 per cent of those autoclaved for 40 minutes the day after shelling, and 87.2 per cent of those autoclaved for 1 hour the day after shelling. The high percentage of spoilage in this lot is attributed to the use of quart jars.

Bacteriological and chemical analyses, the latter by the methods employed by Falk, Bauman, and McGuire (E. S. R., 40, p. 712), were made of the contents of 5 jars from each of 2 lots in which the spoilage was complete, and the results obtained were confirmed by inoculating sterile peas under aerobic and anaerobic conditions with organisms similar to those obtained and determining their action. The morphological, cultural, and biochemical properties are given of 9 organisms isolated from the peas and the cultural characteristics when grown in sterile peas of *Bacillus subtilis*, *B. ramosus*, *B. mycoides*, and *B. mesentericus vulgatus*, the four species which corresponded most closely with the organisms isolated from the peas.

The organisms found were all spore-forming, all withstood from 10 to 15 lb. pressure in the autoclave for from 10 to 20 minutes, nearly all converted starch

to sugar, 7 caused peptonization in milk, all but 1 produced peptone from milk, and all but 1 produced gas in sterile peas but not in other media. An organism resembling *B. botulinus* was found in one can. The chemical analyses of peas inoculated with one of the organisms isolated showed an increase of ammonia in both peas and juice, an increase in creatinin in the peas alone, and an increase in acidity.

The conclusion drawn from the results of the investigation are as follows:

"The spoilage in cold packed canned peas is largely due to the presence of resistant spore-forming organisms which are not killed by the temperature attained in the prescribed method for processing. Therefore, before canning peas or other vegetables, the product should be very carefully washed to remove all soil or dust and thus remove the greater percentage of organisms.

"The time for processing of vegetables should be lengthened so that the center of the can may be at a high temperature sufficiently long to kill the more resistant organisms.

"The processing of all cold packed canned vegetables should be carried out by the steam pressure method to insure the greatest probability of success.

"The results obtained in the chemical analysis of spoiled peas suggest that the determination of creatinin and ammonia, especially the former, may serve to detect bacterial decomposition in this canned food product."

An extensive review of the literature of the bacteriology of canned foods is included.

Vinegar, Z. N. WYANT (*Michigan Sta. Spec. Bul.* 98 (1919), pp. 5-27, figs. 7).—This is a compilation of information from different sources on vinegar, including definitions of different varieties according to the Michigan Dairy and Food Laws, descriptions of various processes of manufacture, a discussion of vinegar diseases and methods for their control, general directions for making vinegar from fruit, grains, honey, maple sirup, glucose, molasses, tomatoes, and alcohol, and a short discussion of the use of the so-called vinegar "bees" or mixtures of yeasts and bacteria for the quick production of vinegar from a solution of sugar or molasses in water.

The use of pure cultures of vinegar yeast and bacteria is recommended as the best means of overcoming losses by off-fermentations and producing vinegar of better quality. Arrangements have been made by the bacteriological department of the college to supply pure cultures at cost to those who will carry out instructions carefully, observe all changes accurately, and report the changes and results.

Proceedings of the thirty-second annual convention of the Association of Official Agricultural Chemists, 1915 (*Jour. Assoc. Off. Agr. Chem.*, 3 (1917), No. 1, pp. 186; 3 (1919), No. 2, pp. 187-277).—This is a detailed report of the proceedings of the convention held at Washington, D. C., November 15-17, 1915. In addition to the usual reports special papers are included as follows:

Determination of Saccharin in Foods, by C. B. Gnadinger (pp. 25-32); Preparation of Organic Material for Determination of Phosphoric Acid and Potash in Aliquots of Same Solution, and New Method for Drying Ether and Sample in Determination of Ether Extract, by R. M. West (pp. 99-103); Lime Requirements of Some Acid Soils, by S. D. Conner (pp. 139, 140) (*E. S. R.*, 37, p. 420); Determination of Lime Requirements of Soils by Use of Calcium Bicarbonate, by L. P. Howard (pp. 141-144); Status of the Problem of Lime Requirement, by W. H. McIntire (pp. 144-149); Determination of Phosphorus in Soils, and Study of Soil Containing Residual Limestone, by H. A. Noyes (pp. 149-153);

Delicate Test for Strychnin, by H. E. Buc (p. 193); Preliminary Study of Some of the Physical and Chemical Constants of Balsam Peru, by E. C. Merrill (pp. 194-197); Inorganic Phosphorus in Animal Tissue, by F. M. Beegle (pp. 204-207); Investigations of the Kjeldahl Method for the Determination of Nitrogen, by I. K. Phelps and H. W. Dault (pp. 218-220); and Notes on Use of Potassium Permanganate in Determining Nitrogen by the Kjeldahl Method, by W. Frear, W. Thomas, and H. D. Edmiston (pp. 220-224).

METEOROLOGY.

Sunshine in the United States, J. B. KINCER (*U. S. Mo. Weather Rev.*, 48 (1920), No. 1, pp. 12-17, pls. 4, figs. 4).—Two methods of presenting sunshine data are discussed, namely, in actual hours and tenths and in percentages of the possible amount. "Charts and graphs are presented showing the mean solar time of sunrise and sunset and the average length of the day, sunrise to sunset, representing the possible maximum amount of sunshine for different seasons of the year. Included is a series of charts showing for each month the average amount of sunshine in hours per day; also charts and graphs showing the seasonal and annual distribution in percentages of the possible amount. Other charts show the percentage of days clear, partly cloudy, and cloudy, while the diurnal distribution of sunshine is also graphically shown. There is included a table showing for each month and for the year the average percentage of the possible amount of sunshine for all stations where continuous automatic records are made, which include practically all regular reporting stations. The basic data are for the 20-year period from 1895 to 1914, except that the percentages of the possible amount are for the 8-year period from 1905 to 1912."

As regards geographic distribution of sunshine, it is shown that "in the southeastern portions of the United States the spring months are the sunniest, while in much of the Ohio Valley and the Southwest June has a higher percentage of sunshine than any other month. July is the month of maximum in nearly half of the country, including all northern districts. The smallest percentage of the possible amount in much of the interior, and in the central and southern Pacific coast districts and southern plateau States, occurs in January, which is also the case in the Middle Atlantic States; in most other districts December is the cloudiest month. . . .

"In the late fall and during most of the winter much cloudy weather prevails in the Great Lakes and in western Montana, northern Idaho, and in Washington. . . . In extreme western Texas, most of New Mexico, and Arizona, and in southern California the winters, on the other hand, are sunny. . . . In the Gulf States the amount of sunshine in winter ranges from an average of 4 to 5 hours in December to 6 or 7 hours in February, the maximum amount occurring in the Florida Peninsula.

"With the advent of spring the amount of sunshine increases rapidly, especially in the more northern districts. . . . The maximum amount of sunshine during this season is received in the lower Colorado River Valley. . . . By May, there is an average of 9 to 10 hours of sunshine daily in the interior districts of the country.

"The increase in the amount of sunshine from winter to summer in the northern portion of the United States is very pronounced. . . . In the South the increases are not so pronounced. . . . East of the Rocky Mountains the geographic distribution of sunshine in summer is in general the reverse of that in winter, the northern districts receiving more than the southern. Much of the central and northern Great Plains usually receives in July

from 40 to 50 per cent more sunshine than occurs along the central and east Gulf coast. The maximum summer amount for the country as a whole is experienced in the Great Valley of California and over the western portion of the plateau region. The interior of California has almost continuous cloudless skies during the summer months. . . .

"In autumn, especially during October and November, much cloudy weather is experienced in the region of the Great Lakes, the upper Ohio Valley, and the far Northwest, where in some places the average daily amount in November is less than 2 hours, but at the same time the daily averages in portions of the Southwest are in excess of 9 hours. In the fall, there is a uniform and rather marked increase in the amount of sunshine from the northeastern to the southwestern portions of the country. In interior districts the averages for this season are mostly 7 or 8 hours daily. . . .

"In general, the amount of sunshine is less during the early morning hours, with a secondary minimum in the late afternoon. The greatest amount occurs near midday."

On observations of solar and sky radiations and their importance to climatology and biology and also to geophysics and astronomy, C. DORNO (*U. S. Mo. Weather Rev.*, 48 (1920), No. 1, pp. 18-24).—This is a translation of a paper summarizing the present knowledge on the subject.

It is shown that the solar constant is one of the most important in nature, since upon it depends all organic life, and that no other climatic element varies so greatly from place to place or from season to season in calorific, luminous, chemical, and bactericidal properties. "The solar radiation is by no means always similarly composed; the low sun is much richer in long-waved radiations (much redder) than the high sun, as everyone knows from experience. Also with the same elevation of the sun there exists a pronounced yearly march. The spring sunlight is—at least on the Alpine heights—much richer in heat rays, that of autumn much richer in the ultra-violet ones. The difference between sunlight and shadow light increases in marked degree with elevation of the sun and still more so with the color of the light, since the sky, as appearance teaches, is much richer in short-wave (blue) light than the sun with its long-wave rays (infra-red, red, and yellow). With middle sun elevations and cloudless sky, the red light of the sun falling on the horizontal surface is found to be 14 times stronger than that from the sky, while its brightness is only 11 times stronger, its chemical rays only 4.4 times, its pure ultra-violet (bactericidal) rays even less strong than those of the sky (only about half so powerful)."

The sun as a source of power (*U. S. Mo. Weather Rev.*, 48 (1920), No. 1, p. 17).—Various theories and proposals relating to the utilization of the sun's energy are briefly discussed, and it is stated that "in view of the declining natural resources of the world, the increasing studies in solar activity, and the application of electrical methods and devices, it is not idle to hope for an efficient and practical method of converting the sun's heat into usable commercial power."

How rainfall data may be used for determining road conditions, T. G. SHIPMAN (*U. S. Mo. Weather Rev.*, 48 (1920), No. 1, p. 33; *abs. in Bul. Amer. Met. Soc.*, 1 (1920), No. 3, p. 35).—This article notes briefly the results of an attempt to determine the effects of rainfall on highways so that telegraphic reports of rainfall can be utilized in making up the daily highway weather service bulletin of the U. S. Weather Bureau. It is based upon replies to a questionnaire regarding the condition of dirt roads in Arkansas, mainly under spring, late autumn, and early winter conditions. The general conclusion is

that, if the relation of rainfall to road condition has been previously studied, recent reports of rainfall may be useful in indicating road condition in the absence of actual reports on the subject.

Average free-air conditions as observed by means of kites at Drexel Aerological Station, Nebr., during the period November, 1915, to December, 1918, inclusive, W. R. GREGG (*U. S. Mo. Weather Rev.*, 48 (1920), No. 1, pp. 1-11, figs. 8).—This article presents the results of the free-air observations at Drexel, Nebr., in brief and convenient form for the information and use of artillery and aviation services. "Tables and figures give mean monthly, seasonal, and annual values of the different elements at various levels up to 5 km. The data are compared with similar data for Mount Weather, Blue Hill, and elsewhere, and a separate table contains comparative values of air density, as determined by different investigators for various parts of the world." One of the points of special interest discussed is the veering of winds with altitude.

A list of 12 references to literature on the subject is given.

Relation of winds to temperature in central Ohio, H. H. MARTIN (*U. S. Mo. Weather Rev.*, 48 (1920), No. 2, pp. 85, 86, figs. 2).—"This paper presents by table and graph the existing relation between the direction of the wind and the existing or current temperature, as well as the subsequent 24-hour temperature change. The data are taken from the records of the Columbus (Ohio) office, 1909-1918. . . .

"Under ordinary conditions, at Columbus, Ohio, it seems safe to consider the north, northeast, east, and southeast winds as prognostics of warmer weather 24 hours later, except in summer, when the east wind has no prognostic value; and the northwest, west, and south winds as prognostics of cooler conditions 24 hours later, except in summer, when the northwest wind is usually followed by higher temperatures. However, excepting the case of the east wind in winter, the true prognostic values are low and do not justify much reliance. Their value would be appreciable only when used in conjunction with other indications."

Smoke formations in air drainage, C. HALLENBECK (*U. S. Mo. Weather Rev.*, 48 (1920), No. 1, pp. 24, 25, fig. 1; *abs. in Bul. Amer. Met. Soc.*, 1 (1920), No. 3, p. 35).—In connection with a study of temperatures and orchard heating in the Roswell, N. Mex., fruit district, it was observed that during cold nights the tops of fruit trees may be frozen while the bottoms are uninjured. This was found to happen when air, cooled over the dry, open plains during a clear night, slid in a thin sheet out over the air of the valley. The movement of smoke early in the morning of December 9, 1919, showing this process in operation, is described and illustrated.

Spring frosts (*U. S. Dept. Agr., Natl. Weather and Crop Bul.*, No. 17 (1920), pp. 2, 3, figs. 2).—A chart is given which "shows for the country east of the Rocky Mountains the dates after which killing frost is likely to occur only 1 year in 10 on the average. After April 1 the chance of killing frost along the south Atlantic coast and in the southern portions of the Gulf States is only 10 per cent. The line for May 1 extends southwestward through central Virginia and western North Carolina, and then bends northwestward through eastern Tennessee and western Kentucky, and thence westward through the southern portions of Indiana, Illinois, Missouri, and extreme southern Kansas. In much of North Dakota and in the northern portions of Minnesota, Wisconsin, and Michigan, as well as in parts of New York and in northern New England, killing frost may be expected at least 1 year in 10 after June 1. This is the case also in the central and western Rocky Mountain Plateau States, except in a few favored localities."

Graphs are also given which "show the dates of last killing frost in spring for each of the 20 years from 1900 to 1919, inclusive, for [nine] selected localities, representing three belts, extending east and west across the country over the central and northern sections. It shows that for the belt represented by central Oklahoma, southern Tennessee, and eastern Virginia, killing frost did not occur during these 20 years after the end of April. At Omaha, Nebr., it occurred only twice as late as May, but did not occur after April at Cincinnati or Philadelphia. On the other hand, at Huron and Ithaca, it occurred after the close of April in all but 6, and at Wausau, Wis., in all but 2 of the 20 years. In each of these last three localities, it occurred once after the first of June during the 200-year period."

Weather observations, H. J. FRANKLIN (*Massachusetts Sta. Bul.* 192 (1919), pp. 138-140).—Winterkilling and frosts in relation to cranberry culture are briefly discussed on the basis of observations during 1917 and 1918 at the cranberry substation at Wareham, Mass. Reference is made to tests of a new method for computing minimum temperatures on nights in which frost conditions prevail. The author is of the opinion that "cranberry winterkilling usually is due to a drying out of the vines resulting from a freezing in of the roots that prohibits their taking in moisture to replace that given off by the leaves exposed to strong, dry winds."

Thunderstorms (*U. S. Dept. Agr., Natl. Weather and Crop Bul.*, No. 18 (1920), p. 2, fig. 1).—A chart showing the average annual number of days with thunderstorms for the different sections of the United States is given, and the frequency and distribution of the storms are briefly discussed.

Hail (*U. S. Dept. Agr., Natl. Weather and Crop Bul.*, No. 18 (1920), pp. 2, 3, fig. 1).—A chart showing the average annual number of days with hail during the frostless or crop-growing season, based on the records of all full reporting stations for the 20-year period 1895-1914, is given, and the distribution and frequency of hailstorms are discussed.

Monthly Weather Review (*U. S. Mo. Weather Rev.*, 48 (1920), Nos. 1, pp. 68, pls. 18, figs. 24; 2, pp. 69-126, pls. 35, figs. 7).—In addition to detailed summaries of meteorological, climatological, and seismological data and weather conditions for January and February, 1920, and bibliographical information, reprints, reviews, abstracts, and minor notes, these numbers contain the following contributions:

No. 1.—Average Free-air Conditions as Observed by Means of Kites at Drexel Aerological Station, Nebr., during the Period November, 1915, to December, 1918, Inclusive (illus.), by W. R. Gregg (see p. 118); Sunshine in the United States (illus.), by J. B. Kincer (see p. 116); The Sun as a Source of Power (see p. 117); On Observations of Solar and Sky Radiations and Their Importance to Climatology and Biology and Also to Geophysics and Astronomy, by C. Dorno (see p. 117); Smoke Formations in Air Drainage (illus.), by C. Hallenbeck (see p. 117); A Cloud Cross-section of a Winter Cyclone (illus.), by C. F. Brooks; Snow Crystals from the Crystallographic Standpoint (illus.), by E. T. Wherry; Would a Large Reservoir Increase Rainfall?; How Rainfall Data May Be Used for Determining Road Conditions, by T. G. Shipman (see p. 117); and Extraordinarily High Barometer Readings in Bering Sea, January 17, 1920, by A. H. Mellick.

No. 2.—Papers on Sleet and Glaze ("Ice Storms"); The Nature of Sleet and How it is Formed (illus.), by C. F. Brooks; A Weather Condition Which Produces Glaze in Northern New York, by D. F. Manning; Boundary Between a South Wind and an Underrunning Northeast Wind, by C. F. Brooks; The Precipitation of Sleet and the Formation of Glaze in the Eastern United States,

January 20 to 25, 1920, with Remarks on Forecasting (illus.), by C. L. Meisinger; Demoralization of Traffic in New York City by Snow and Sleet; Tremendous Snowstorm in Palestine, February 9-11, 1920, by O. A. Glazebrook; Note on Deep Northeast-Component Winds Observed January 27-31, 1920 (illus.), by S. Gottlich; Blizzards and Chinooks of the North Dakota Plains, by F. J. Bavendick; Weather Forecasting (illus.), by H. H. Clayton; Relation of Winds to Temperature in Central Ohio (illus.), by H. H. Martin (see p. 118); Altitude Determinations Based on Barometric Readings (illus.), by H. G. Cornthwaite; Comparison of Snow-board and Raingauge-can Measurements of Snowfall (illus.), by R. E. Horton; and Influence of the Wind on the Movements of Insects, by W. E. Hurd (see p. 157).

Weather review for 1916 and 1917, H. D. EDMOND (*Connecticut Storrs Sta. Rpt. 1916-17, pp. 471-483, fig. 1*).—Observations at Storrs, Conn., on temperature, precipitation, and length of growing season, are summarized in notes and tables.

The year 1916 was characterized by the longest frostless period recorded at this place during 30 years, 1888-1917, namely, from April 11 to October 18, 190 days. The mean annual temperature of 1917 was 45.1° F., 2.21° below the 30-year mean. The rainfall of that year was 3.81 in. below the 30-year mean of 43.98 in. The frostless period was 149 days. The mean annual temperature for the 30-year period has been 47.33°. The highest temperature was 99° July 3, 1912, the lowest -17° February 14, 1914, and December 30, 1917. The shortest frostless period recorded was 131 days, from May 24 to October 2, 1907. The average date of last killing frost in spring has been May 3, of the first killing frost in autumn, October 10. The greatest annual rainfall was 66.51 in. in 1901, the least 33.33 in. in 1894.

Climatic conditions, C. R. LETTEER (*U. S. Dept. Agr., Dept. Circ. 73 (1920), pp. 5-7*).—Observations at the San Antonio (Texas) Experiment Farm, on temperature, killing frosts, precipitation, evaporation, and wind velocity, 1907-1918, are summarized and briefly discussed.

The average temperature of the year 1918 was 68.5° F. The lowest temperature in the history of the farm, namely 9°, was recorded January 11. Several other cold spells occurred during the year, which "killed to the ground such subtropical fruits as oranges, pomegranates, figs, and olives. Even citranges were severely damaged by freezing. . . . Canada field peas were killed out completely, and winter oats were damaged rather severely by frost on two occasions. On the other hand, no late freezes occurred in the spring and a heavy crop of peaches and plums was set." The last killing frost in spring occurred February 21; the first in the fall, November 30.

The total precipitation, 27.06 in., was somewhat higher than the average, 24.63 in., but the rain was so distributed as to be unfavorable for crop production, the winter being very dry and the soil consequently deficient in moisture at the opening of the crop season. "The total evaporation from a free-water surface was 69.84 in. This was somewhat above the average of 68.36 in. for the 12-year period from 1907 to 1918, inclusive."

Meteorology report for 1918, F. E. HEPNER (*Wyoming Sta. Rpt. 1919, pp. 160-163*).—Monthly summaries of observations at Laramie, Wyo., on pressure, temperature, precipitation, humidity, wind, and cloudiness, are given.

The mean temperature of the year was 41.5° F., slightly above the normal. The mean temperature of June was 7.7° above the normal, and was the highest ever recorded at this place. "November was abnormally cold. April was colder than normal, so that agricultural operations were somewhat delayed. . . . The last freezing temperature in the spring occurred on May 20. A

temperature of 33° was observed on May 27, however, and though not so recorded, doubtless a killing frost occurred in low places. There was a light frost on June 30 that caused some damage to the more tender crops. There were several frosts in September, the first temperature of 32°, or lower, being recorded on September 6. Quite tender plants survived these frosts, however, and were not killed until October 19.

"The annual precipitation, 12.38 in., was 1.38 in. above normal; nearly 70 per cent of the total amount occurred between April 1 and September 30. The month of May was dry, the precipitation being nearly 1 in. below normal. Most of the other months except January were nearly normal or slightly above. The precipitation in July was exceptionally high, due to a single 2-hour storm during which 1.72 in. of water fell. Coming in such a short time, a large proportion of this water ran off into the streams and thus was of no benefit to the crops."

SOILS—FERTILIZERS.

Soil and fertility investigations, A. G. McCall et al. (Maryland Sta. Rpt. 1919, pp. XII-XXI).—A number of studies at the station are summarized.

An investigation of the nutrient requirements of wheat, buckwheat, and soy beans in sand and soil cultures to determine the best proportion of nutrient for the first 30 days of their growth period, and for two additional periods for wheat up to maturity, showed that the mineral food requirements of the wheat plant during the second growth period are substantially the same as for the first 30-day period. Results for the final growth period indicate that there is an increase in the physiological requirements for magnesium during the late stages in the development of the wheat plant. During the first growth period the proportion of nutrient salts that gave the highest growth rate for wheat also gave the highest growth rate for soy beans. Recent results strongly suggest that the physiological properties of a solution are not determined solely by the ionic proportions, but are conditioned as well upon the molecular combinations that may exist in the nutrient solution.

A study of the hourly and daily fluctuation in the temperature of the soil at 3, 6, and 24 in. below a bare surface and below a blue grass sod, covering a period of two years, showed that during very severe periods of cold weather when the ground was covered with snow there was a very marked difference in the temperature of bare and of cropped soil. On December 30, 1917, with the air temperature -12° F., the temperature at a depth of 3 in. under cropped soil was 31°, while at the same depth under bare soil the temperature went down to 22°. On January 1, 1918, with an air temperature -8°, the temperature under cropped soil was 30° and under bare soil surface 21°. It is considered evident that wheat seeded early enough to make a good growth before severe weather will have a much better chance to survive than wheat seeded late.

An investigation of the factors affecting the availability of the potassium compounds of the soil showed that the addition of lime in the form of calcium carbonate decreased the solubility of the soil potassium, while the addition of calcium oxid slightly increased the availability of potassium compounds. The addition of sodium chlorid very greatly increased the solubility of potassium, while gypsum or calcium sulphate had no appreciable effect. In another series of experiments green sand was composted with sulphur and manure in various combinations and supplied with sulfifying bacteria. An analysis of the water extract from these composts was made from time to time over a period of 23 weeks. In certain of these composts it was found that more than 40 per cent of the total potassium present in the mixture had been made water-

soluble. In the presence of a supply of organic matter the sulfofying bacteria appeared to promote the oxidation of the sulphur and the formation of sulphuric acid, which in turn acted upon the potash-bearing materials to liberate potassium.

Pot culture studies with wheat of the fertilizer requirements of four soils showed that for Leonardtown loam the seven pots giving the highest yields were those which received on the average approximately 1 part each of nitrate and muriate to 4 parts of acid phosphate. For Collington sandy loam the best proportions were 1 part nitrate, 4 parts acid phosphate, and 2 parts muriate. For Norfolk sand the proportions were 2 parts nitrate, 4 parts acid phosphate and 1 part muriate. For Sassafras loam the proportions were 1 part nitrate, 3 parts acid phosphate, and 1.7 parts muriate.

Green manuring experiments to test different methods of handling cowpeas and soy beans when used as a fertilizing crop for corn and to compare their value with that of buckwheat as a green manure crop showed that "while no striking increases in yield have been secured, the plats on which the green manuring crop was plowed down in the fall have been consistently better. On the average the increase in yield has not been sufficient to pay for the seed and for the extra labor involved in handling the green manuring crop."

Experiments to compare the availability of raw rock phosphate with that of acid phosphate on 23 plats upon which wheat and corn were grown alternately with clover are reported. The phosphates were added in amounts varying from 300 to 1,500 lbs. per acre. The acid phosphate was markedly superior to the raw rock phosphate on soil in a very low state of fertility and deficient in organic matter.

Experiments to compare the values of different forms of lime on acid soil showed that raw oyster shell gave a slightly greater yield of wheat than the raw limestone, but for the corn the increase was in favor of the limestone. Burned limestone gave a larger yield of wheat but a smaller yield of corn. Except for a slight difference in favor of the burned forms, there seemed to be little room for choice between the materials except in the matter of cost.

Several studies of the management of the more important soil types of the State and miscellaneous analyses of soil and fertilizer materials are also reported.

Importance of soil investigations to agriculture, J. KÖNIG (*Fühling's Landw. Ztg.*, 67 (1918), No. 21-22, pp. 404-424).—The author summarizes special studies on different phases of the physics and chemistry of soils as conducted and published by him from time to time.

On the angle of repose of wet sand, A. G. WEBSTER (*Proc. Natl. Acad. Sci.*, 5 (1919), No. 7, pp. 263-265, fig. 1).—Experiments are reported which showed that when a certain degree of wetness is passed sand acts like a plastic substance, the degree of plasticity and also the limiting slope depending upon the relative amounts of water and sand. For dry sand the angle of repose was found to be about 33°, but as water was gradually added a certain amount of positive cohesion was shown, permitting the sand to remain in equilibrium vertically and even to overhang. The limit was reached when the proportion of water to sand was about 1:5. Beyond this degree of wetness the angle rapidly decreased.

Soil survey of Hamilton County, Iowa, K. ESPE and L. E. LINDLEY (*U. S. Dept. Agr., Adv. Sheets Field Oper. Bur. Soils, 1917, pp. 30, fig. 1, map 1*).—This survey, made in cooperation with the Iowa Experiment Station, deals with the soils of an area of 364,800 acres lying just northwest of the center of Iowa. The county lies just inside the eastward limit of the region covered by the

Wisconsin glaciation. In general, the surface consists of broad level plains between belts of gently undulating land. There is no marked relief. The area as a whole has poor natural drainage. The soils of the county are of glacial origin and are characterized by a deep, rich black color. Loam soils predominate.

Including peat, muck, and meadow, 14 soil types of 8 series are mapped, the most important of which are the Webster loam, which covers 58 per cent of the area, and the Carrington loam covering 27.8 per cent. It is noted that small areas of alkali soil occur around former ponds and sloughs, and that the salt accumulations are injurious to most cultivated crops.

Soil survey of Sargent County, N. Dak., F. Z. HUTTON, B. H. HENDRICKSON, M. THOMAS, and S. BUSTER (*U. S. Dept. Agr., Adv. Sheets Field Oper. Bur. Soils, 1917, pp. 41, fig. 1, map 1*).—This survey, made in cooperation with the North Dakota Experiment Station, deals with the soils of an area of 533,760 acres in southeastern North Dakota. The area comprises three physiographic divisions, namely, the Sheyenne Delta, a rolling treeless prairie, and an old sandy lake bed. Drainage is poorly established. The soils of the area are of glacial origin. Including dunesand, 27 soil types of 10 series are mapped, of which the Barnes silt loam and the Barnes loam cover 51.3 and 7.1 per cent of the area, respectively.

Soil survey of Waupaca County, Wis., W. J. GEIB, C. LOUNSBURY, and M. O. TOSTERUD (*U. S. Dept. Agr., Adv. Sheets Field Oper. Bur. Soils, 1917, pp. 51, fig. 1, map 1*).—This survey, made in cooperation with the State of Wisconsin, deals with the soils of an area of 485,760 acres, situated a little east of the center of Wisconsin. All of the county lies within the region covered by the late Wisconsin ice sheet.

The soils range in texture from sand to clay, with a large area of cumulose soil, and are largely of glacial origin. Including peat, 28 soil types of 10 series are mapped. Peat occupies the greatest individual area, covering 15.4 per cent of the county. The Gloucester fine sandy loam and the Kewaunee fine sandy loam cover 12.6 and 10.4 per cent of the area, respectively. It is stated that the Gloucester series includes a number of extensive desirable soils. The peat land consists of numerous low-lying marshy areas in which the soil consists of organic matter in varying stages of decomposition. Little of the peat area has been reclaimed and used for farming.

Development of unused lands, H. T. CORY, F. W. HANNA, ET AL. (*U. S. House Represent., 66. Cong., 1. Sess., Doc. 262, pp. 184; abs. in Engin. News-Rec., 84 (1920), No. 8, pp. 375-377*).—This is a detailed report on possible projects for the reclamation and development of unused lands in the United States, which demonstrates that in most of the States there are great bodies of unused lands which, with drainage or clearing, can be made available at a comparatively small cost for farms.

It is pointed out that by no means are all of the unused lands properly subject to reclamation for agricultural purposes. Some of the swamp and overflow lands would be far more useful as reservoir sites, for flood control, or river regulation. Some of the States presenting little opportunity for the reclamation of either arid, wet, or cut-over lands afford chances for profitable reclamation by fertilization, correction of soil reaction, and proper tillage. Examples of such lands are found in some of the Mississippi Valley States. Attention is called to New England as an extreme case of the local need for agricultural development. It is stated that the largest areas open to colonization in the southern division of the country are the cut-over lands. In this connection, the necessity for drainage and consequent elimination of mosquitoes is emphasized.

It is estimated that in the northern division of the country cut-over lands alone total an area of 22,483,000 acres, of which 10,237,000 acres are apparently considered to be available for community settlement. The acreage of swamp and overflow lands in the north is estimated to be 22,866,000 acres, of which 1,176,000 acres are available for settlement.

Relation of bacteria to soil productivity, J. C. BEAVERS (*Canad. Power Farmer*, 25 (1920), No. 3, pp. 16, 18, 20, fig. 1).—This paper, a contribution from the Indiana Experiment Station, is a popular discussion of the functions of bacteria in soil in promoting soil fertility and of the influence of different cultural treatments thereon.

The periodic influence of the time of year on the process of nitrification, O. LEMMERMANN and L. WICHERS (*Centbl. Bakt. [etc.]*, 2. Abt., 50 (1920), No. 1-4, pp. 33-43, fig. 1).—Experiments on nitrification in soils are reported, the results of which are taken to indicate that the hitherto advanced proofs of a direct periodic influence of the time of year on the life activities of soil organisms independent of temperature and other physical weathering influences are insufficient. It is stated that all previous data correspond with the results of these experiments.

It is concluded that if a direct influence of time of year could be established, the already great number of unknown and uncontrollable factors in soil bacteriology would be increased.

The occurrence of "volutin" in Azotobacter chroococcum, E. W. SCHMIDT (*Centbl. Bakt. [etc.]*, 2. Abt., 50 (1920), No. 1-4, pp. 44, 45).—Experiments are briefly reported which indicate that *A. chroococcum* contains considerable volutin. This is in contradiction of previous findings of others.

Handling farm manure, F. L. DULEY (*Missouri Sta. Bul.* 166 (1919), pp. 3-29, figs. 13).—This bulletin deals with the conservation and proper use of farm manure in accordance with practice found best under Missouri conditions.

It has been found that manure should be spread while fresh, if possible, and that plenty of bedding should be used to absorb the liquid manure. Manure exposed to the weather four or five months may lose from one-third to one-half of its plant food. Fermentation during storage may be reduced by keeping the manure compact and moist or by storing in concrete pits under cover. It is stated that for the average farm, applications of from 6 to 8 tons of manure per acre once in a rotation should give satisfactory returns, and that the careful farmer should be able to return manure at the rate of about 2 tons per acre annually to his cultivated land. Manure is usually best applied before corn and plowed under or used as a top-dressing for wheat. It may often be applied with profit to hay or grasslands.

"According to the Missouri experiments and at present prices for farm products, manure is worth more than \$4 a ton when spread on the land. At normal prices it is worth approximately \$2.50 a ton. To get the most profit from manure and at the same time most nearly maintain a well-balanced condition of soil fertility, it is good practice to reinforce each ton of manure with 25 to 40 lbs. of acid phosphate or 40 to 80 lbs. of rock phosphate. When acid phosphate is used it may be applied with the manure or it may be drilled when seeding some small grain crop in the rotation."

The effect of fertilizer salts treatments on the composition of the soil extracts, C. H. SPURWAY (*Michigan Sta. Tech. Bul.* 45 (1919), pp. 3-18).—Data are presented to show the effects of additions of potassium chlorid, acid phosphate, hydrated lime, calcium sulphate, sodium chlorid, sodium nitrate, tricalcium phosphate, monocalcium phosphate, and calcium carbonate to two alkaline and two acid sandy-loam soils on the composition of their water

extracts. One gm. of each treatment was added to 1 kg. of soil, the soil saturated with distilled water, and leached with 3 liters of water in 500 cc. portions after standing two days. A second leaching was made after another period of 15 days. Both extracts were then analyzed. The more prominent results obtained are summarized as follows:

In general the silica of the alkaline soils was found to be more soluble than that of the acid soils. Results for the first leachings varied, but less silica was found in the second leachings from the treatments than in the checks as the rule. With but two exceptions all the treatments increased the quantities of phosphorus in all the extracts.

The acid radicals of the salts potassium chlorid, calcium sulphate, sodium chlorid, and sodium nitrate appeared in the first extracts in relatively greater quantities than the basic radicals, and their combinations were readily leached from the soils; the second extracts contained only small quantities of these acid radicals. This was not the case with calcium carbonate and the phosphates.

The basic radicals of the salts potassium chlorid, calcium sulphate, sodium chlorid, and sodium nitrate occurred in the second extracts in considerable quantities, but only to a small extent in the chemical combinations added. More calcium was found in the second extracts than in the first in case of the hydrated lime, tricalcium phosphate (except one instance), monocalcium phosphate, and calcium carbonate treatments. Excepting one case, more calcium was found in the extracts from the calcium carbonate treatments than the hydrated lime treatments. All the treatments excepting tricalcium phosphate increased the quantities of magnesium in the first extracts, as did treatments of hydrated lime, monocalcium phosphate, and calcium carbonate in the second extracts. Other magnesium results varied considerably. Potassium chlorid, monocalcium phosphate, and calcium carbonate increased the quantities of sodium found in all the extracts. A considerable variation was noted in case of the other treatments. The general effect of the treatments other than potassium chlorid was to depress the quantities of potassium in the extracts.

Quantities of iron and aluminum were markedly increased in the second extracts by the phosphates, calcium carbonate, sodium nitrate, and calcium sulphate. Monocalcium phosphate increased the iron and aluminum in the first extracts, and aluminum was also increased in these portions by hydrated lime, sodium chlorid, and calcium carbonate. The quantities of fixed carbon dioxid were in general reduced in the first extracts, except in case of the hydrated lime and calcium carbonate treatments, while this component was markedly increased in the second extracts by all treatments.

A list of 33 references to literature bearing on the subject is appended.

Action and use of new fertilizers, SCHNEIDEWIND (*Jahrb. Deut. Landw. Gesell.*, 34 (1919), No. 2, pp. 305-313).—A summary is given of a number of experiments with new nitrogenous, phosphatic, and potassic fertilizers in Germany under wartime conditions with different crops on wet and dry sand soils and loess loam soils.

It was found that artificial sodium nitrate and calcium nitrate gave as good general results as Chilean nitrate. They can be effectively applied in the spring before planting to all common crops, and are especially fitted for use as top-dressings. Next to these in effectiveness were the potash and sodium-ammonium nitrates, which also gave good results as top-dressings. Synthetic ammonium sulphate, sodium-ammonium sulphate, ammonium chlorid, ammonium nitrate, and the different urea compounds gave approximately as good results as common ammonium sulphate, and it is recommended that they be used in the same

manner but, if possible, they should always be applied before the planting of summer crops on deep, fertile, heavy soils, and on winter crops in the fall before planting. These fertilizers should be used as top-dressings only on winter grain on light and medium soils in the spring.

Experiments with lime nitrogen on rye, wheat, and sugar beets on loess loam soil showed that the best results were obtained when it was added before planting or as top-dressings drilled in, while the poorest results were obtained by broad-spread top-dressings. Experiments with potatoes on sand soil with different potash fertilizers showed that by the use of a 40 per cent potash salt as a spring application there was a marked reduction in starch content, while by the use of potassium sulphate in the spring the starch content was increased and the greatest absolute amount of starch produced. It is concluded that potassium sulphate and potash magnesium sulphate may be similarly used with successful results on potatoes.

Calcium cyanamid, E. MIÈGE (*Vie Agr. et Rurale*, 16 (1920), No. 13, pp. 211-213).—A large number of experiments by others are summarized to show that calcium cyanamid is innocuous to crops and valuable as a fertilizer.

The winning of potassium nitrate and ammonium sulphate from raw potash salts—a new method for ammonia fixation, H. HAMPEL (*Chem. Ztg.*, 43 (1919), Nos. 113, pp. 617-619; 115, pp. 634-636, figs. 2).—A process is described for the fixation of coke-oven ammonia with the aid of the sulphuric acid combined in carnallite and kainit, and data is given from experience at different German plants to show that the process is feasible and profitable.

Trona potash: A progress report, C. P. BLACKWELL and G. H. COLLINGS (*South Carolina Sta. Bul.* 202 (1920), pp. 24).—This is a progress report of experiments with Trona potash and borax, giving observations of results on crops in the field and the results of field and greenhouse experiments.

Field observations in the summer of 1919 led to the belief that crops had been greatly damaged by the use of Trona potash. Trona potash used as a source of potash in fertilizer tests, with cotton, corn, and oats, however, did not show any greater loss on the average than has been produced by German muriate in previous years, but gave widely different results on different plats in the same experiment. A special test with corn and cotton started in July showed no injury from Trona potash or borax with any of the treatments used. Distribution of rainfall seemed to be an important factor in determining the influence of potash fertilizer.

In a plat test of potash materials with cotton, Trona potash gave a reduced yield with 900 lbs. of an 8:3:8 fertilizer per acre. Lighter applications gave no indications of injury as compared with Nebraska potash and cement dust.

In a greenhouse test, sand maintained at 6 per cent moisture proved to be insufficient to furnish the optimum moisture requirements of the cotton planted. Sand maintained at 18 per cent moisture seemed to be able to furnish the optimum moisture requirements of the cotton planted. Applications of Trona potash ranging from 25 to 1,000 lbs. per acre and analyzing 17.75 per cent anhydrous borax appeared to be harmless in their power to prevent the germination of the cotton and corn seed under the conditions of the experiment, and to prevent the normal growth of young cotton plants up to the time the experiment was discontinued. At this time the young plants were 10 in. in height. Similar applications of Trona potash to corn did not prevent the normal growth of the young corn plants. Applications of Nebraska potash ranging from 200 to 1,000 lbs. per acre and analyzing 0.34 per cent anhydrous borax, and applications of commercial borax ranging from 54 to 400 lbs. per acre, also appeared unable to prevent the germination and growth of both cotton and corn.

Potash and bromin in Texas lakes (*Amer. Fert.*, 52 (1920), No. 8, pp. 72, 73).—It is stated that brines that contain potash and bromin have been discovered in alkali lakes in Gaines, Lynn, and Terry Counties, Tex. These lakes range in area from about 35 to 7,000 acres. The sands that form the bottoms of the lakes are impregnated to a depth of from 5 to 20 ft. or more with brine that is composed essentially of the chlorids of sodium, magnesium, and potassium.

Analyses of samples showed potassium contents of 3.96 and 4.08 per cent. Analyses made by the U. S. Geological Survey showed potassium chlorid contents of 7.51 and 7.78 per cent from the same lakes.

Phosphatic slags, J. VANDORMAEL (*Jour. Soc. Natl. Agr. Belg.*, 2 (1920), No. 9, pp. 92, 93).—Analyses of different phosphatic slags are reported and briefly discussed, to show that, aside from the basic calcium phosphate, phosphatic slags contain not only elements such as phosphorus, calcium, and silicon, which are normally necessary in the construction of plant tissues, but also diastatic elements such as manganese and sulphur in soluble form.

A new method for rendering insoluble phosphates available, T. E. KEITT and A. W. MURRAY (*Georgia Sta. Bul.* 132 (1919), pp. 51–58).—Experiments are reported which were undertaken to determine the influence of composting commercial organic ammoniates, ground rock phosphate, and rich soil on the availability of the phosphorus content of the ground rock phosphate, and on the loss of ammonia from the organic ammoniate due to composting. Seven compost heaps were made, using cottonseed meal as the source of ammonia and Florida pebble phosphate as the source of phosphate.

The results include that any attempt at covering the heaps is valueless as far as the amount of available phosphate is concerned. The highest percentage was obtained where there was no attempt to control the temperature. The Florida pebble showed a higher availability in the laboratory test than the Florida soft phosphate. However, at the end of four weeks composting the Florida soft phosphate showed the higher availability. There was a considerable loss of nitrogen from each of the heaps. This, and the fact that there was generally some loss of phosphoric acid, is taken to indicate that some loss may have been due to leaching when the heaps were wetted.

It is concluded that a part of the phosphoric acid content of raw rock phosphate can be made available by composting with cottonseed meal, some being converted to a water-soluble form. There was a marked increase over the first determinations of water-soluble phosphoric acid, which can be accounted for by the water-soluble content of the cottonseed meal.

The liberation of native soil potassium induced by different calcic and magnesian materials, as measured by lysimeter leachings, W. H. MACINTIRE (*Soil Sci.*, 8 (1919), No. 5, pp. 337–395, figs. 21).—This paper, a contribution from the Tennessee Experiment Station, reports lysimeter experiments with Cumberland loam and Cherokee sandy loam soils. The Cumberland loam experiments included 46 tanks with and without subsoil receiving varying amounts of nine different forms of lime and magnesia, and data were secured on the total potassium leached during each of five years. Twenty-two tanks were used with the Cherokee sandy loam to study the effect of single light applications of burnt lime, burnt magnesia, limestone, and dolomite upon the outgo of potassium. Observations were also made on the potassium-liberating tendencies of calcium and magnesium sulphate derived from ferrous sulphate, iron pyrites, or sulphur when these three materials were used alone and together with light and heavy applications of lime or magnesia.

“The results from these two residual soils demonstrate that the original free soil-water leachings are richer in potassium salts than they are when

they become impregnated in slight or excessive degree with calcium or magnesium bicarbonate derived from any one of the several forms of these two alkali earths. Furthermore, excepting in the case of the Cumberland loam, the excessive and impractical 32-ton and 100-ton CaO treatments, nothing that has been developed would suggest the possibility that the lime, magnesia, or their several chemical or mineral carbonate treatments have so altered the original form of soil potassium as to render any residual portion of it more available or beneficial to plant growth."

A list of 34 references to literature bearing on the subject is included.

The lime factor in permanent soil improvement.—I, Rotations without legumes, J. G. LIPMAN and A. W. BLAIR (*Soil Sci.*, 9 (1920), No. 2, pp. 83-90).—In experiments conducted at the New Jersey Experiment Stations, lime in carbonate form was used on a loam soil at the rate of 1 ton per acre for the first five years and 2 tons for the second five years, in a 5-year rotation of corn, oats, wheat, and two years of timothy. No legume crops were introduced. Twenty $\frac{1}{2}$ -acre plats with different nitrogen treatment were thus limed, and 20 similar plats with parallel nitrogen treatment were left without lime.

The total yields of dry matter and of nitrogen for the 10-year period were essentially the same for the two sections.

Analyses of the soil made soon after the work was started and again at the end of each 5-year period showed that there was a loss of nitrogen from both the limed and unlimed sections. However, the loss from the limed section was distinctly greater than from the unlimed section. Thus, at the end of the 10-year period there was a positive loss rather than gain from the use of lime. From this work it would appear that the practice of using lime on light to medium heavy soils, when leguminous crops are not grown in the rotation, may be questionable. Under such conditions it is quite possible that a slightly acid reaction may be desirable to prevent the too rapid oxidation of organic matter.

A list of six references to literature bearing on the subject is included.

The lime factor in permanent soil improvement.—II, Rotations with legumes, J. G. LIPMAN and A. W. BLAIR (*Soil Sci.*, 9 (1920), No. 2, pp. 91-114).—In this paper, continuing work noted above, an attempt is made to show the influence of lime in four different rotation systems, all of which include some legume crops. In each 5-year rotation there were seven plats, one unlimed, one each that received 1,000, 2,000, and 4,000 lbs. per acre of calcium limestone, and one each that received like amounts of magnesian limestone. Legume crops were introduced in each rotation either as one of the main crops or as a green manure crop between the main crops. Acid phosphate and muriate of potash were used in liberal amounts. Light applications of commercial nitrogenous fertilizers were made. No farm manure was used.

During the 10 years the limed plats, with only slight exceptions, yielded distinctly larger crops and more total nitrogen than the unlimed plats. In most cases the yields were larger with the 2,000 and 4,000-lb. applications than with the 1,000-lb. application. The two forms of limestone gave quite similar results. There appeared to be a slight difference in favor of the magnesium limestone. In the majority of cases the percentage of nitrogen was higher in crops from the limed than from the unlimed plats. The use of lime thus resulted in a gain in both quantity of the crop produced and also in the quality. Analyses of the soil showed, in a number of cases, a higher nitrogen content for limed than for unlimed plats; in other cases the two were about on a level as to nitrogen content, and in a few cases there was apparently a depletion of the nitrogen in the limed plats.

This work, taken in connection with the above report, is taken to indicate that in using lime emphasis should be laid on its power to make conditions favorable for the organisms associated with leguminous crops rather than on its power simply to neutralize soil acids.

Two references to literature bearing on the subject are included.

Peat industry reference book, F. T. GISSING (*London: Charles Griffin & Co., Ltd., 1920, pp. XXIV+292, figs. 30*).—This is a compilation of scientific data on the obtaining and industrial utilization of peat, and includes a digest of reports from Canada, the United States, South America, Sweden, Norway, and France. It consists of eight sections. Section I deals with the formation, classification, and composition of peat. Sections following deal with the working of peat, the treatment of raw material, peat and peat products as solid fuel, distillation of peat, and peat gas. The largest single section is devoted to uses and products of peat other than fuel, including its use as a fertilizer, as a fertilizer carrier, as bacterized peat, and as a source of nitrogen. A final section gives miscellaneous information, formulas, and tables.

Inspection of commercial fertilizers in Missouri, 1919, F. B. MUMFORD and L. D. HAIGH (*Missouri Sta. Bul. 168 (1920), pp. 3-55*).—This bulletin contains the results of actual and guaranteed analyses and valuations of 383 samples of fertilizers and fertilizer materials offered for sale in Missouri during 1919, together with data on the power of limestones and similar materials to neutralize soil acidity, and a list of brands and guaranteed analyses of fertilizers registered and offered for sale in Missouri for 1920.

Results of the analyses of the fertilizer samples are taken to indicate that normal conditions in the manufacturing control of fertilizers have very nearly returned. The improvement in meeting guaranties has obtained for all constituents except total phosphoric acid. Apparently the difficulties in keeping this constituent up to the guaranty are not yet eliminated. Out of the 383 samples analyzed, 64, or 16.7 per cent, gave a valuation below the guaranty.

Fertilizer registrations for 1920, C. S. CATHCART (*New Jersey Stat. Bul. 341 (1920), pp. 5-38*).—This bulletin contains a list of fertilizers and fertilizer materials registered for sale in New Jersey for the year 1920, together with their guaranties.

Commercial fertilizers, R. H. ROBINSON (*Oregon Sta. Circ. 21 (1920), pp. 15*).—This bulletin reports the results of analyses under the Oregon State fertilizer inspection law of 57 samples of fertilizers and fertilizing materials, 6 samples of land plaster, and 1 sample of limestone offered for sale in the State during 1919.

The consumer is advised to purchase high-grade fertilizer, that is, a fertilizer having a total plant-nutrient content of 14 per cent or above.

AGRICULTURAL BOTANY.

On the floras of certain islets outlying from Stewart Island (New Zealand), J. C. WILLIS (*Ann. Bot. [London], 33 (1919), No. 132, pp. 479-484, fig. 1*).—Illustrative data with discussion are offered in support of the claim that, for restricted areas like New Zealand and its neighboring islands, age and area can be relied upon to explain the general composition of any floras that may occur.

The rôle of sedges in some Colorado plant communities, F. RAMALEY (*Amer. Jour. Bot., 6 (1919), No. 3, pp. 120-130, figs. 2*).—This is a report of studies in all the life zones from the plains to alpine heights in northern Colorado.

The various genera of Cyperaceæ are considered in order, but chief attention is given to *Carex*, with a statement of the association types in which species of this genus are prominent. The several associations belonging to these types are characterized as to ecological relations and floristic composition. It is pointed out that most sedges belong to the early stages of succession in the vegetation of a region. A list is given of 44 species of *Carex*, of which 20 are classed as water and marsh plants, 9 as species of meadow or other mesophytic situation, and 15 as species of xerophytic habitats.

The ecologic subterranean anatomy of some plants of a prairie province in central Iowa, A. HAYDEN (*Amer. Jour. Bot.*, 6 (1919), No. 3, pp. 87-105, pls. 14).—A study of the minute anatomy of the subterranean organs of prairie plants as here outlined is said to show that there is a tendency to the production of prominent mechanical tissue in plants of dry habitats and to the reduction of parenchymatous tissue, though the latter is prominent in plants of moist habitats, while aerenchyma is notable in plants of swamp habitat. The vascular tissue is variable in quantity, seemingly more or less subject to systematic variation. The subterranean stem is predominant as an equivalent of the primary root, especially in moist lowland regions. It is more efficient than the root in propagation. Primary roots which show secondary thickening resemble stems in their concentric manner of expansion. The stem has an area of pith, which serves as a reservoir for water and hence increases its efficiency for radial distribution.

Some observations on the tuber of *Phylloglossum*, T. G. B. OSBORN (*Ann. Bot. [London]*, 33 (1919), No. 132, pp. 485-516, pl. 1, figs. 43).—A new method of vegetative reproduction is noted for *P. drummondii*, which occurs in South Australia as a member of the geophytic element in the flora of an area subject to prolonged summer desiccation. An adaptive variation in the length of the tuber stalk tends to locate the tuber at a depth of about 1 cm. The new method consists in regeneration from leaves which have been injured or detached. This method is described with discussion.

The sprouting of woody plants and the influence of external factors thereon, O. KÜHN (*Jahrb. Wiss. Bot. [Pringsheim]*, 57 (1916), No. 1, pp. 1-16, figs. 5).—Light and the presence of nutritive salts influenced the sprouting of woody plants which, however, has no necessary connection with the rest period.

Viability of detached root-cap cells, L. KNUDSON (*Amer. Jour. Bot.*, 6 (1919), No. 7, pp. 309, 310).—Having noted and tested the viability of detached root-cap cells, the author gives accounts of the survival of such cells for 71 days.

Studies on growth and change of form in vegetating points, O. SCHÜEPP (*Jahrb. Wiss. Bot. [Pringsheim]*, 57 (1916), No. 1, pp. 17-79, figs. 16).—The investigations here noted are considered to support the view that a stimulus from the surface leads to the arrangement of the meristemic cells parallel to the surface and to consequent flatness of the layer. Failure of such stimulus may lead to unregulated growth and an anomalous thickness.

The periodic differentiation of the growing point is primary, following, however, a continued stimulation from the surface affecting the meristemic cells.

A study of some factors in the chemical stimulation of the growth of *Aspergillus niger*, R. A. STEINBERG (*Amer. Jour. Bot.*, 6 (1919), Nos. 8, pp. 330-356, figs. 2; 9, pp. 357-372).—It is stated that increased acidity of the Pfeffer nutrient solution within limits produces in *A. niger* a growth stimulation similar to that obtained by adding salts of certain heavy metals, but less in amount, the appearance of the cultures being the same in some respects as

in case of zinc cultures. Increase in acidity of the nutrient solution supplements the action of such heavy metals as zinc and iron.

Salts of such stimulating heavy metals hydrolyze as a rule in an aqueous solution, resulting in an increase of acidity which may be rendered more effective through membrane concentration. Sodium silicate furnishes an exception to this rule of increase in acidity. Such progressive increase in the acidity of a culture is largely a result of activities of the organism, and may in turn be concerned also in the acceleration of growth and in the retardation of spore formation.

The influence of phosphates on the action of alpha-crotonic acid on plants, J. J. SKINNER and F. R. REID (*Amer. Jour. Bot.*, 6 (1919), No. 4, pp. 167-180, figs. 9).—This investigation comprises a study of the effects of α -crotonic acid on plants grown in pure water and in nutrient solutions composed of phosphate salts with sodium nitrate and potassium sulphate. α -crotonic acid was isolated from soil characteristic of certain infertile spots near Marshall, Tex., which have been increasing in size during observations extending over several years, and which are herein briefly described as favorable areas for an accumulation of organic acids.

α -crotonic acid at strengths of 25 to 50 parts per million was found to reduce growth from 35 to 50 per cent in case of wheat in nutrient culture solutions of calcium acid phosphate, sodium nitrate, and potassium sulphates prepared according to the triangular system. Phosphates exerted an ameliorating effect, regardless of the basic or acidic character of the salt. It is also claimed that alkaline salts lessen the injurious influence of crotonic acid.

The influence of light upon the action of stomata and its relation to the transpiration of certain grains, J. GRAY and G. J. PEIRCE (*Amer. Jour. Bot.*, 6 (1919), No. 4, pp. 131-155, figs. 18).—The authors find that the stomata of barley, wheat, oats, and rye plants open with light and close with darkness, variations in the light intensity exerting an influence within limits on the degree of stomatal opening.

Opening and closing being accomplished by the changes in the shape of the guard cells in the stomata, a minimum amount of moisture in the soil is required by each species in order to produce and maintain the turgidity of the guard cells without which changes in their shape are impossible. The moisture, soil, and light requirements of different species are essentially alike, though not identical.

Negative pressure and water utilization in transpiring shoots, M. NORDHAUSEN (*Jahrb. Wiss. Bot. [Pringsheim]*, 58 (1917), No. 2, pp. 295-335, figs. 5).—The author considers that the force of cohesion, while sufficient to cause considerable negative pressure, is not alone sufficient to meet observed normal requirements of plants as regards water supply.

Osmotic pressures in the potato plant at various stages of growth, B. F. LUTMAN (*Amer. Jour. Bot.*, 6 (1919), No. 5, pp. 181-202, figs. 2).—The potato plant, early in the season, shows the highest osmotic pressure in the sap from young stalks and leaves. During July and August, osmotic pressure in the stalks is higher than that in the younger portions, this being due to the presence of sugar, particularly cane sugar. In September, osmotic pressure is highest in the young leaves. Osmotic pressure of the sap in growing tubers is always low, and that in the roots is the lowest in the plant. Osmotic pressure in older is higher than in younger plants, due to larger amounts of inorganic salts, but in very old plants it drops in consequence of partial removal of soluble materials.

Cell growth in relation to supply of energy by protoplasts, J. M. JANSE (*Jahrb. Wiss. Bot. [Pringsheim]*, 58 (1917), No. 2, pp. 221-236).—This is an

account of both the physical and chemical aspects of energy supply for cell growth.

The structure of protoplasm, R. A. HARPER (*Amer. Jour. Bot.*, 6 (1919), No. 7, pp. 273-300).—This review concludes by expressing the opinion of the author that the older attempts to solve the problem of protoplasmic behavior by the assumption that protoplasm is composed of physiological units, biophores, determiners, plasomes, pangens, etc., and the newer conception that its essential elements are unit factors are being merged in the conception that the structure of protoplasm is the structure of the cell as an organized system and itself the unit in all the complex interactions by which the egg develops into the specialized differentiated many-celled organism.

The origin and nature of the mucilage in the cacti and in certain other plants, F. E. LLOYD (*Amer. Jour. Bot.* 6 (1919), No. 4, pp. 156-166).—The author finds that mucilage in the cacti, mallows, and tragacanth arises within specialized parenchyma cells by hydrolysis of the cellulose wall, which is not secondarily thickened. The mucilage, which shows lamination determined by water content, is not laid down as a secondary layer. It is not secreted within the protoplast, nor is it yet a secretion thrown out as mucilage from the outer surface of the protoplasm. The lamination may be predetermined by the apposed layers of cellulose in the original cell wall. The mucilage adsorbs certain dyes with great vigor, others with lesser and different degrees of vigor, and still others not at all. The viscosity of the mucilage is lowered by those dyes which are adsorbed, at a rate and to an extent in direct relation to the degree of adsorption.

Anthocyanin of *Beta vulgaris*, F. M. ANDREWS (*Proc. Ind. Acad. Sci.*, 1917, p. 167).—The anthocyanin of *B. vulgaris* affords one of the examples where the pigment forms in the subterranean parts. A strong solution of such anthocyanin will preserve its normal color in a test tube placed in darkness for more than a week. In direct sunlight it will retain its normal bright color for a week or more, until disorganized by bacterial action, which change finally occurs in the anthocyanin solution in the dark.

Chlorophyllless wheat plants, B. KALT (*Ztschr. Pflanzenzücht.*, 4 (1916), No. 2, pp. 143-150).—Morphological and physiological studies on barley and rye are reported, which are said to agree as to general results with those reported by Nilsson-Ehle (E. S. R., 31, p. 329).

The temperature-coefficient of photosynthesis: A reply to criticism, A. M. SMITH (*Ann. Bot. [London]*, 33 (1919), No. 133, pp. 517-536, figs. 2).—This is a discussion of recent contributions on the relations between photosynthesis and temperature, in particular those by Brown and Heise (E. S. R., 39, p. 225), and by Brown alone (E. S. R., 41, p. 429).

Theory regarding phototropism, C. E. B. BREMEKAMP (*Rec. Trav. Bot. Néerland.*, 15 (1918), No. 2, pp. 123-184, figs. 14).—Two factors are supposed to operate in connection with the phenomenon of phototropism, namely, the difference between the antagonistic portions as regards number of light-sensitive areas and the time within which this difference is maintained. A growth-promoting influence may be exerted by those portions within which a growth-inhibiting substance may be produced under illumination.

The transmission of phototropic stimulation, A. PAÁL (*Jahrb. Wiss. Bot. [Pringsheim]*, 58 (1918), No. 3, pp. 406-458, pl. 1, figs. 9).—A detailed account is given of the author's experiments on the transmission of stimulation past interruptions (with simple sectioning or with colloid layer interposed). The course of the stimulus was studied, as were also wound curvature and growth regulation in this connection.

Further studies on symbiosis between *Ardisia crispa* and its bacteria.—II, The plants without bacteria, H. MIEHE (*Jahrb. Wiss. Bot. [Pringsheim]*, 58 (1917), No. 1, pp. 29-65, figs. 10).—This contribution, in contrast to those previously noted (E. S. R., 28, p. 35; 29, p. 30), deals with *A. crispa* as free from bacteria. Respecting the relations between the symbionts, it is regarded as safe to say only that these relations are very intimate, involving under natural conditions the normal development of the host.

Venation and senescence of polyembryonic citrus plants, M. R. ENSIGN (*Amer. Jour. Bot.*, 6 (1919), No. 8, pp. 311-329, figs. 6).—It is stated that 43.18 per cent of the seeds of *Citrus grandis* produce polyembryonic shoots. An account is given of the apparent relations between leaf venation and other features of *C. grandis*.

Studies concerning the evolutionary status of polycotyledony, J. T. BUCHHOLZ (*Amer. Jour. Bot.*, 6 (1919), No. 3, pp. 106-119, figs. 26).—The author has studied the ontogeny of the cotyledons in the various living conifers for modern evolutionary tendencies in hope of obtaining a criterion to determine the actual present direction of this particular evolution of the cotyledons.

The results of this study show that in a number of conifers fusions of the cotyledons occur during their embryonic development. No evidences of splitting cotyledons were found in any species. Cotyledonary fusion has given rise to cotyledonary tubes in some species. Polycotyledony is thought to have been the primitive condition. The facts deduced are considered to show that the primitive gymnosperm embryo had numerous cotyledons imperfectly cyclic and variable in number, probably derived from spirally arranged leaves that became cyclic in the cotyledonary node. Dicotyledony was attained either by a general fusion of cotyledons in two groups or by an extremely bilabiate development of a cotyledonary tube; monocotyledony resulted from a cotyledonary tube becoming unilabiate.

Flax blooms, T. TAMMES (*Rec. Trav. Bot. Néerland.*, 15 (1918), No. 2, pp. 185-227, figs. 21).—This study is concerned with structures and relations as noted in flax blooms in connection with possibilities and probabilities regarding fertilization.

FIELD CROPS.

Farm crop investigations, J. E. METZGER ET AL. (*Maryland Sta. Rpt. 1919*, pp. XXII-XXVI).—Ten different projects, including work with corn, cowpeas, soy beans, tobacco, oats, wheat, crop rotations, and forage, green manure, and cover crops are described, and some of the results secured are briefly noted.

Of 16 varieties of corn tested the past year, in 5 different places in the State, Boone County White, Johnson County White, Excelsior, Thomas, and Funk Yellow Dent were among those giving the best results. The highest yield of silage was secured from Cocke Prolific, Johnson County White, Boone County White, and Excelsior. The results obtained with the different varieties varied greatly. In general two plants per hill gave larger yields of shelled corn, but less stover, than was secured from three plants per hill.

In tests with cowpeas, begun in 1909, Wonderful, Whippoorwill, Groit, New Era, Gray Crowder, and Black are recorded as having given the best results. The work with soy beans, undertaken in 1910, showed that Virginia, Wilson, Cloud, Ito San, Peking, Edna, Medium Yellow, and Mammoth Yellow were the most successful varieties.

Experiments conducted since 1915 on the production of sweet corn seed indicated that home-grown seed produced larger plants and gave higher

yields than were obtained from northern-grown seed. The removal of suckers had no material effect on the yields.

The production and distribution of Maryland Mammoth tobacco seed showed that the variety seldom failed to outyield greatly the varieties commonly grown.

Variety tests with winter oats in progress since 1908 are reported as having been interrupted several times by severe winter conditions. The varieties giving the best results were Culberson, Bicknell, and Winter Turf. The highest single yield, 64 bu. per acre, was made by Bicknell.

In the wheat variety tests, which have been running since 1890, the leading varieties during the past 12 years were Bearded, Purple Straw, Dietz, Longberry, Mammoth Red, Currell Prolific, and China. Fulcaster, Gold Coin, Rudy, and Leap Prolific also gave good yields.

[Field crops] work of the San Antonio experiment farm in 1918, C. R. LETTEER (*U. S. Dept. Agr., Dept. Circ. 73 (1920), pp. 3-5, 7-29, figs. 3*).—Work with cotton, corn, Dwarf milo, oats for grain and hay, sorghum, Sudan grass, Rhodes grass, green manure crops, and flax embracing rotation, tillage, and variety tests were continued along the same general lines as heretofore noted (*E. S. R.*, 39, p. 835). Agricultural conditions in the region, the scope of the work at the farm, and the results of the different experiments are briefly described. The season of 1918, as stated, was a very poor one for crop production.

With the exception of oats for hay and for grain the 1918 yields of all the crops in the rotation experiments are reported as below the average for the 10-year period. A marked advantage of rotation over continuous culture was pointed out in 1918 by the yields of cotton and sorghum and by the better control of certain weeds and plant diseases, particularly Johnson grass and cotton root rot. For the past three years early preparation of the land was an advantage during periods of drought. The influence of subsoiling on crop production was insufficient to justify the practice. The use of 16 tons of barnyard manure per acre gave comparatively large increases in the yields of cotton, corn, and milo in 1918, but the average results for the 9-year period did not warrant the expense of purchasing and hauling the manure although they pointed out the value of handling properly and applying the manure produced on the farm. The use of cowpeas, rye, and field peas as green manures at the farm has failed to give perceptible increases in crop yields. Cowpeas planted between wide-spaced rows did not increase the yield of corn, and it was observed that when not planted until the corn is 2 to 3 ft. high cowpeas will not decrease the yield appreciably.

The grain yields of all varieties of sorghum grown in 1918 were rather low owing to midge damage, and the yields of stover were more indicative of the value of the varieties tested. Sunrise kafir yielded approximately $2\frac{1}{2}$ tons per acre, being outyielded only by Dwarf milo, but the kafir forage was much superior to that from milo.

While the yields of flax in 1918 were much better than in the two preceding years, they ranged from only 2.2 to 9 bu. per acre and are not considered large enough to encourage growing flax in place of the staple crops commonly grown. In tests with beans, Henderson Bush Lima survived the hot weather fairly well and indicated that with irrigation it probably could be made profitable. Blackeye cowpeas included in these tests gave by far the best yield.

[Report of the] agronomy department, A. F. VASS (*Wyoming Sta. Rpt. 1919, pp. 150, 151*).—The year's results with small grains are regarded as indicating that early seeding, although growth at first may be slow, tends to ripen

the plants somewhat earlier than when the seeding is made later. Of different crops tested the best results were secured with Marquis wheat, Hannchen barley, Swedish Select and Abundance oats, and Rural New Yorker, Netted Gem, and Late Ohio potatoes.

Experiments with buckwheat, F. W. STEMPLE (*West Virginia Sta. Bul. 171 (1919), pp. 3-12*).—The results of earlier experiments with buckwheat by the station, here reviewed, and which pertained largely to the use of fertilizers, have been previously noted (*E. S. R., 15, p. 465*). This bulletin presents data secured in work carried on from 1914 to 1919, and which embraced variety tests, together with experiments on the preparation of the seed bed, rate and method of seeding, and the use of buckwheat as a nurse crop.

Land plowed May 6 and seeded July 18 gave as an average for three years an increase of 8.65 bu. per acre over land plowed July 1 and seeded July 18. While the results were not strictly comparable, they are regarded as indicating that broadcasting and drilling buckwheat are of equal value. The yields increased gradually with the increase in the rate of seeding from 2 to 6 pk. per acre, but the use of 4 pk. seemed in general most satisfactory. The average yield for four years of Japanese buckwheat was greater by 3.78 bu. per acre than the average yield of Silver Hull, and growing the two varieties mixed did not give a better average yield than was secured from growing Japanese by itself. Early and late plowing did not seem to affect the results secured from different rates and methods of seeding and from the varieties compared. One year's results did not indicate buckwheat to be a good nurse crop.

The modified rag doll and germinator box, B. H. DUDDLESTON (*Indiana Sta. Bul. 236 (1920), pp. 3-12, figs. 7*).—A description is given of a modification of the rag doll method of testing seed corn. The modified rag doll described is recommended to supplement the sawdust limestone germinator previously noted (*E. S. R., 40, p. 526*). Detailed descriptions are given on the preparation and use of the doll and germinator box. The great advantage of the method as pointed out is the detection of not only the dead, partly dead, or weak ears, but also of those that are infected although germinating, and thus making it possible to obtain seed corn of high vigor together with freedom of disease.

Comparison of peanut meal, cottonseed meal, velvet bean meal, ammonium sulphate, and nitrate of soda as fertilizers for corn and cotton, E. F. CAUTHEN (*Alabama Sta. Bul. 208 (1919), pp. 3-6*).—In these experiments, conducted at the station in 1917 and 1918, corn received in addition to 240 lbs. of acid phosphate per acre either 100 lbs. of nitrate of soda, 80 lbs. of ammonium sulphate, 200 lbs. cottonseed meal, 310 lbs. peanut meal, or 400 lbs. of velvet bean meal. The quantity of nitrogen furnished by the different materials was practically the same for all plats. In the cotton experiments in addition to a basal application of 160 lbs. acid phosphate and 20 lbs. sulphate of potash per acre either 140 lbs. of nitrate of soda, 351 lbs. of cottonseed meal, 452 lbs. of peanut meal, or 754 lbs. of velvet bean meal per acre, furnishing practically equal quantities of nitrogen, was used. The results are given in tables with brief comment.

In comparing the average yields of corn secured and assuming the availability of nitrogen in nitrate of soda as 100 per cent, the relative availability of the nitrogen in the different substances was approximately as follows: Sulphate of ammonia 94 per cent, peanut meal 84, cottonseed meal 65, and velvet bean meal 28 per cent. Similarly the results in the test with cotton indicated an availability of 93.8 per cent for cottonseed meal, 90.9 for peanut meal, and 78.7 per cent for velvet bean meal. It is pointed out that the cotton plant, which received all of its fertilizer before planting, has a longer growing period

than the corn plant to which three-fourths of the nitrogen was applied late as a side application, and that for this reason the cotton plant was able to utilize a larger percentage of the nitrogen in the slowly nitrifying velvet bean meal.

A comparison of certain raw phosphates with acid phosphate for fertilizing cotton, T. E. KEITT and A. W. MURRAY (*Georgia Sta. Bul. 131 (1919), pp. 39-45*).—Tests were made on a comparatively poor soil, a similar soil with a cover crop of oats turned under, and on a very fertile soil to determine the value of different phosphates for fertilizing cotton. The phosphates were applied at the rate of 400 lbs. per acre and mixed with dried blood and Nebraska potash so that 800 lbs. of the mixture furnished 3 per cent each of available nitrogen and potash in addition to the available phosphoric acid present in the particular phosphate used. The surface area exposed by the different phosphates as applied was calculated to determine a possible relation between this factor and the crop yield. The method of calculating the surface area of the phosphate particles is described, and the different experimental results are shown in tables.

On the soil with the cover crop turned under, Florida soft phosphate proved least efficient, while Tennessee brown, Florida pebble, and Tennessee blue phosphates all produced higher increased total yields than those secured with acid phosphate. In every test at the station during the year acid phosphate showed a marked influence on earliness of maturity. The plats receiving Tennessee blue phosphate matured earlier than those treated with the other raw phosphates.

Florida soft phosphate, which had the smallest surface area, gave the lowest yield, but the results from the other raw phosphates were not absolutely in the order of their relative surface area. On the very fertile soil, where phosphorus was not a limiting factor, higher yields were obtained from the Florida pebble and Florida soft phosphates than from the other phosphates tested. On the soil in a medium state of fertility, where phosphorus was distinctly a limiting factor, acid phosphate in every case produced the highest yield to October 1, as well as the highest total yield.

An experiment with nitrogen as a top-dressing on plats treated with acid phosphate, Florida soft phosphate, and Florida pebble phosphate resulted in a marked increase in yield on the plat which had received acid phosphate.

The results of these experiments are not considered as indicating that Florida soft phosphate possesses any advantage over the other raw phosphates as a source of phosphorus for cotton on Piedmont soils. The experiments, conducted for only one year, will be continued to study the residual effects of the different raw phosphates.

The influence of certain factors on the time of opening of cotton, T. E. KEITT and A. W. MURRAY (*Georgia Sta. Bul. 130 (1919), pp. 21-34, figs. 3*).—The experiments reported were conducted to determine the influence of variety, character of soil, quantity and kind of fertilizer, top-dressing, source of phosphorus, percentage of potash, and the use of lime to revert soluble phosphates on the maturity of cotton.

In a test of 22 varieties of cotton Piedmont Cleveland and Steinheimer Cleveland led in amount picked to October 1, and these two strains with Allen Cleveland and Scott Cleveland were among the five varieties giving the highest yields to October 1. The four Cleveland strains mentioned, together with Alabama Station Cleveland No. 721 and Georgia Station Cleveland No. 521, led all others in total yield.

The fertilizer work was conducted on heavy clay, medium clay, and sandy soil. On the heavy clay soil the largest total yield, the highest yield to October

1, and the highest percentage of cotton opened, up to that date, were obtained from the use of 600 lbs. per acre of an 8:3:2 fertilizer application. Good results on this soil were secured also from the use of 200 lbs. per acre of an 8:3:3 application.

The medium clay soil was of a type on which cotton is likely to rust, and consequently the use of 600 lbs. of an 8:3:9 application, which furnished the largest quantity of potash, gave the highest yield. The application of 600 lbs. per acre of an 8:3:6 fertilizer mixture gave the highest yield to October 1, while 600 lbs. per acre of an 8:3:0 application, containing no potash, gave a very poor yield.

On the sandy soil the highest yield was secured where 600 lbs. per acre of an 8:3:6 application was used, but the largest yield to October 1 was obtained where an 8:3:3 fertilizer was applied at the same rate.

Application of acid phosphate and Tennessee blue rock phosphate seemed to hasten the ripening of cotton, while the use of other raw rock phosphates, including Florida soft, Florida pebble, and Tennessee brown, appeared mainly to have delayed maturity. Lime applied with acid phosphate also seemed to have delayed ripening.

Experiments in top-dressing in 1919 resulted in a very profitable increase in yield from a late application of a mixture of sulphate of ammonia and nitrate of soda. The use of potash with nitrogen in top-dressing did not seem to have retarded maturity but it gave no profit.

Growing cotton in Arizona, G. E. THOMPSON and C. J. WOOD (*Arizona Sta. Bul. 90 (1919)*, pp. 265-275, figs. 5).—This bulletin is a brief popular treatise on growing cotton in Arizona, including notes on the irrigation of cotton, the value of American Egyptian cotton for the region, and the disadvantages of relying on volunteering or rationing for a cotton crop.

Darso, M. A. BEESON and A. DAANE (*Oklahoma Sta. Bul. 127 (1919)*, pp. 19, figs. 9).—A description of darso is given, a comparison of the plant with Black-hull White kafir is presented, cultural methods are described, and results of experiments with the crop are reported.

Darso, a grain sorghum of unknown origin, is regarded as a probable cross between a saccharin and a nonsaccharin sorghum. It is described as a leafy, stocky sorghum, red seeded, drought resistant, early maturing, and very uniform in height. Analyses made by the station showed that darso contained a higher percentage of total sugars than was found in kafir or feterita. The chemical composition of the grain and of the forage proved to be very nearly the same as that of the grain and forage of Blackhull White kafir.

The results of a single feeding test with hogs, by C. T. Dowell, seemed to indicate that in feeding value darso is not equal to Blackhull White kafir. A digestion experiment with sheep showed that the nutrients from the two plants were about equally digestible.

In a six-year variety test of grain sorghums darso produced the largest average yield, outyielding Blackhull White kafir by about 3 bu. per acre. Being a dwarf plant the yield of forage was less than that of Blackhull White kafir. It was found also that darso as compared with Blackhull White kafir had the greater capacity to withstand relatively long periods of dry weather.

Report of oats experiments, 1908-1919, M. NELSON and L. W. OSBORN (*Arkansas Sta. Bul. 165 (1920)*, pp. 3-32, figs. 2).—This bulletin describes the importance and extent of oats production in Arkansas, and reports largely in tabular form the results of variety and cultural experiments with winter and spring oats at the station and in other parts of the State. The recommendations given are based on the experimental data secured.

The results indicated that winter oats may be grown successfully in Arkansas when proper attention is given to the selection of varieties and the different cultural requirements. The varieties recommended for the northern part and the higher elevations of the west central part of the State are Turf and Culberson, for the lower elevations of the west central part the red oats varieties, and for the southern part Fulghum and the ordinary red oats varieties, Appler, Hundred-bushel, Bancroft, Ferguson 71, and Cook. It is suggested that Dwarf Culberson and other early maturing Culberson selections may prove more satisfactory than the red oats varieties on account of their greater winter resistance, and that the usual Turf strains are not adapted to southern Arkansas because of late maturity and possible injuries from heat and rust.

With regard to soil preparation the results indicated the importance of a firm seedbed in reducing the extent of winterkilling. It is stated that a firm seedbed may be secured by plowing at least 6 in. deep from the latter part of July to the earlier part of September and double disking and harrowing immediately after plowing. It was found that winter oats seeded with an ordinary grain drill or with an open furrow drill are much less affected by winter weather than when broadcasted. Early seeded as compared with late seeded winter oats were observed to be less subject to winterkilling. Seeding dates recommended for the different sections of the State are as follows: Northeastern, September 10 to October 10; west central, September 20 to October 20; and southern, October 1 to November 1. The earlier dates mentioned in each instance are considered preferable. Proper drainage and good soil fertility were noted also as efficient factors in reducing winter injury to the crop.

For spring seeding the strains of early maturing red oats, such as Burt and Fulghum, are considered best. Early northern varieties, including Iowa 103, gave good results when grown for hay, but proved less certain for yield or quality of grain. The importance of early seeding is dwelt upon, and the dates of safe seeding for different parts of the State are given as follows: Northeastern, February 25 to March 15; west central, February 15 to March 1, and southern, February 1 to February 25. Seeding at the rate of 10 pk. per acre, with a grain drill, or from 12 to 14 pk., when the seed is broadcasted, is recommended.

[**Experiments with potatoes**], C. O. APPLEMAN ET AL. (*Maryland Sta. Rpt. 1919, pp. XLVI-XLVII*).—Several projects bearing on the behavior of potato tubers in the ground during growth and after the death of the vines, on the quality and seed value of the tubers as influenced by storage conditions, and on the production and growth of sprouts on potato tubers, are described, and some of the more important results are briefly reported.

Earlier results in studying the effect of various storage conditions on the quality and seed value of potatoes have been previously noted (E. S. R., 29, p. 230; 34, p. 523). More recently it has been shown that the seed value of potatoes is greatly reduced when the tubers are in cold storage for a long time after they have emerged from their rest period. The poor keeping quality of potatoes after a period of cold storage was found to be due largely to very high respiration in the tubers for a time after they came from cold storage, which favors decay, especially when ventilation is inadequate, through the heat and moisture produced. It was found also that the degree of ventilation greatly influences the chemical changes in stored tubers.

Some of the data pertaining to the growth and production of sprouts on potato tubers have been noted previously (E. S. R., 39, p. 536). Later results

have indicated that the vigor of the sprout under equal conditions determines the vigor of the plant. In the varieties studied it was found that the number and distribution of the first generation sprouts produced under favorable growing conditions are a good indication of the relative seed value of the tubers.

From a study of the changes occurring in McCormick potatoes, after the vines have been killed by frost, it is pointed out that under these conditions the growth processes in the underground parts of the plant continue for some time. This tends to form small tubers at the expense of the large tubers, and therefore makes it advisable to harvest the potatoes as soon as possible after a killing frost. It is stated that sometimes, under the conditions described, small tubers are formed on the surface of the larger ones.

Prairie rice culture in the United States, C. E. CHAMBLISS (*U. S. Dept. Agr., Farmers' Bul. 1092 (1920), pp. 26, figs. 13*).—The extent and importance of the industry is briefly considered, the general requirements of prairie rice culture are discussed, and directions for the various cultural operations involved are given. The sources of irrigation water and the method of applying it are described, and the more important varieties adapted to the conditions of the prairie rice regions are noted.

Soy bean experiments, F. W. STEMPLE (*West Virginia Sta. Bul. 172 (1919), pp. 3-19, figs. 3*).—The progress of soy bean culture in West Virginia is reviewed, descriptive data of varieties tested at the station are tabulated, and the results of various cultural experiments are reported.

In general, Wilson was the best seed-producing variety tested at the station, the average yield for five years being 17.01 bu. per acre. Peking, a small seeded variety, gave an average of 16.19 bu. per acre for the same period. A comparison of soy beans and cowpeas as hay crops showed an average yield of 2.48 tons of soy-bean hay and of 1.7 tons of cowpea hay per acre. The varieties recommended as high seed and hay producers are Wilson, Peking, Virginia, Arlington, Roosevelt, and Jet.

An experiment in growing soy beans for hay in combination with other crops resulted in better yields and in more readily curing of the hay than when the soy beans were grown alone. Soy beans grown with either Sudan grass or millet proved very satisfactory. Soy beans and corn in 1915 produced 10.16 tons of silage per acre as compared with 8.97 tons where corn alone was grown. A rotation experiment with corn, soy beans, or Sudan grass and rye gave data indicating that combinations of these crops giving three yields in two years are possible.

In seeding tests, soy beans sown in rows 30 in. apart at the rate of 3 pk. per acre produced an average of 3.5 tons of hay per acre on five plats, while similarly solid drilling at the rate of 6 pk. per acre gave a yield of 3.45 tons. Seedings made June 1 at 6 different rates, ranging from 3 to 8 pk. per acre, gave in all instances higher yields than were obtained from similar seedings made June 19 and July 3.

The results of harvesting the crop at different stages of maturity indicated that the highest yields of green or uncured material, dry matter, and protein are obtained when the crop is harvested with the pods fairly well filled out and the leaves just beginning to turn in color. The yields and the composition of the hay when the crop was harvested at different stages of growth are given in tables. Lime applied shortly before sowing soy beans had a comparatively limited effect on the yield.

Further studies in fertilizing and storing sweet potatoes, H. P. STUCKEY (*Georgia Sta. Bul. 134 (1919), pp. 75-87*).—Earlier work on these subjects has been previously noted (*E. S. R., 31, p. 436*). The experiments here reported, in

progress since 1914, were conducted to determine the effects of an excessive amount, of a single fertilizer element on yield, keeping qualities, texture, quality, and color of the sweet potato.

Six $\frac{1}{6}$ -acre plats on a Cecil clay loam soil, planted with Myers Early sweet potato, were treated annually with the following quantities of fertilizer per acre: Plat 1, 24 tons barnyard manure; plat 2, 2,100 lbs. 16 per cent. acid phosphate; plat 3, 900 lbs. sulphate of potash; plat 4, 1,500 lbs. nitrate of soda; plat 5, 1,800 lbs. complete fertilizer; and plat 6, no fertilizer. During the 6-year period, 1914-1919, the yields generally declined. The plat receiving barnyard manure stood first in yield the first 2 years, and the plat receiving the complete fertilizer stood first the remaining 4 years of the period. For the entire 12-year period, beginning with 1908, the greatest average yield was secured from the complete fertilizer plat, the barnyard manure plat standing a close second. The increases in yields over the check plat showed that these heavy applications had not been profitable.

In 1919 plat 4 was divided into 2 equal parts, 1 receiving the usual application of nitrate of soda and the other the same amount of nitrogen in the form of sulphate of ammonia. The part treated with sulphate of ammonia yielded 40.36 bu. more per acre than was secured on the part treated with nitrate of soda, this increase being considered due possibly to an unfavorable action of a residue of sodium in the soil resulting from 11 consecutive annual applications of that substance. The use of sulphate of ammonia also seemed to have reduced an infection of black rot and to have improved greatly the mechanical condition of the soil where it followed nitrate of soda.

The plats receiving large amounts of nitrogenous fertilizers gave potatoes of a lighter yellow color and a somewhat poorer flavor than those produced on the other plats. The acid phosphate plat and the check plat produced potatoes of the best quality and finest texture. Potash seemed to have very little influence in this connection.

In storage tests the potatoes from the check plat showed the highest average percentage keeping through the winter, but results in general varied so that definite conclusions regarding the relation of fertilizer to keeping qualities are not drawn. In similar test in 1915-16 with sweet potatoes grown for the first time on an area of Cecil clay loam and one of Cecil sandy loam, red and gray soils, respectively, the amount of rot on March 1 was 12.28 per cent in the crop from the red soil and 4.61 per cent in the one from the gray soil. A study of the loss in weight during storage from November 5 to March 1 showed an average total loss in the sweet potatoes from the 6 differently treated plats of 16.6 per cent, while the average loss in moisture was only 3.73 per cent. It is pointed out that the loss of moisture does not indicate the actual loss in weight of sweet potatoes in storage, and that the difference here shown is doubtless due to the breaking down of carbohydrates and the resultant evolution of carbon dioxide.

Cooperative fertilizer work with other southern stations resulted at this station, where sweet potatoes were grown in 1919 on a quite fertile Cecil clay loam soil treated with different combinations and amounts of acid phosphate, sulphate of potash, cottonseed meal, and sulphate of ammonia, in the best yield from the 8:3:3 formula, closely followed by 8:3:6 and 8:6:6 formulas of phosphoric acid, nitrogen, and potash, respectively. The yields on the check plats were considerably lower than those on the plats which had received fertilizer treatment.

Sweet potato culture and storage in New Jersey, R. W. DEBAUN (*New Jersey Stas. Circ. 114* (1919), pp. 3-31, figs. 19).—This circular is a popular

treatise on the culture and storage of sweet potatoes in New Jersey, including descriptions of the important phases of growing the crop and handling it from harvesting to marketing.

The supply and distribution of Connecticut Valley cigar leaf tobacco, S. H. DEVAULT (*Massachusetts Sta. Bul. 193 (1919), pp. VI+143-230, pls. 9, figs. 15*).—This bulletin presents the history of Connecticut Valley tobacco production and the cigar industry, and discusses marketing Connecticut Valley cigar leaf tobacco. In the historical treatment of the subject statistics are presented showing the growth of the industry, and other topics dealt with include distribution of acreage, types of cigar leaf tobacco, tobacco soils, varieties of sun-grown and shade-grown tobacco, yields, cost of production, tobacco insurance, and tenancy.

The discussion of marketing traces the handling of manufactured tobacco from the producer to the manufacturer, points out the functions of the various parties involved in the sale of the product, gives statistics showing the quantities handled, describes the preparation of the tobacco for market by the grower and the packer, considers the cost of the packer's preparations and that of storage, lists freight rates to principal manufacturing centers and shipments and receipts of tobacco at local shipping points during recent years, enumerates the grades, standards and principal varieties, and reviews the situation with regard to prices and their distribution among farmer, landowner, and dealer.

The bulletin concludes with a brief note on cooperation in marketing tobacco, recommendations regarding the tobacco industry in the region, a list of references to tobacco literature, and a reproduction of the by-laws of tobacco growers' associations.

Whorled milkweed, the worst stock-poisoning plant in Colorado, W. L. MAY (*Colorado Sta. Bul. 255 (1920), pp. 3-39, figs. 29*).—This bulletin discusses the losses caused by whorled milkweed (*Asclepias galioides*) when eaten by stock, describes the plant, and outlines its distribution with a view to its better identification, points out the conditions under which poisoning occurs, and reports the results of eradication studies. It is stated that the plant is well distributed in southern Colorado in irrigated sections from 5,000 to 7,000 ft. in altitude. The plant is recognized also as a very persistent weed. The most promising eradication measure tried was grubbing or plowing out the plants just before the seed ripens, followed by grubbing out any green shoots that may appear later in the fall, and then planting a heavy smother crop, such as winter wheat. In one experiment 3 applications, during a dry summer, of 10 lbs. of salt in 5 gal. of water on an area 10 ft. in diameter did not kill the plants in 1918 but prevented their appearance in 1919.

Common thistles, J. G. FISKE (*New Jersey Stas. Circ. 113 (1919), pp. 7, figs. 5*).—Descriptions of the Canada thistle (*Cirsium arvense*), bull thistle (*C. lanceolatum*), and sow thistle (*Sonchus arvensis*) are given, mainly with reference to their distinguishing characters, manner of spreading, economic importance, and methods of control and eradication.

HORTICULTURE.

An investigation in transplanting, J. C. WHITTEN (*Missouri Sta. Research Bul. 33 (1919), pp. 3-73, pls. 4, fig. 1*).—Following several years of preliminary observations, the station began a definite investigation in 1908, with a view to recording accurately the results of fall and spring planting of various kinds of trees and other plants, and, if possible, to determine the reason for any difference in the behavior of the trees. The results of this investigation are

presented in detail, together with the results of some minor studies relating to transplanting. The literature of the subject is briefly reviewed, and a bibliography is appended.

A review of the literature dealing with the season of transplanting led the author to conclude that, for the most part, those who recommend spring planting based their opinion upon experience in sections where winter conditions are trying, while those who recommend fall planting based their advice upon experience in the milder fruit-growing sections. Where fall planting is recommended, the desirability of planting in very early autumn, so as to give time for the roots of the trees to become better established before fall weather approaches, is emphasized. Experience at the Missouri Experiment Station, however, shows that this does not hold true under conditions in that State; for, whereas fall planting for hardy fruit trees and most of the hardy deciduous trees and shrubs has given better results than spring planting, late fall planting has given better results than early fall planting. Trees planted in early fall dry out more during the fall and winter than do those planted in late fall. The apparent reason for this is that their parts are less thoroughly ripened or not fully at rest at the time of early planting. Early fall in Missouri is followed by a period of high atmospherical temperatures and often by dry weather. Apple trees planted in the fall usually begin new root formation about the first of January from the sides of the lower main roots after the surface soil has frozen. Early fall-planted trees have begun root growth no earlier than late fall-planted trees.

Fall-planted trees mulched during the winter have made slightly poorer growth than those not mulched. The soil about the mulched trees dries and warms more slowly even where the mulch is removed in early spring. Young apple trees having their branches pruned back in autumn made better growth the following season than trees pruned back in spring. This was true whether or not the trees were transplanted. Branches pruned back evaporate more water through the wounds than do similar branches which are not pruned, for the first few days only. After the first few days the pruned branches lose less water throughout the winter than those which are not pruned. The wound made in pruning back a twig, or a slight wound anywhere on a twig, stimulates greater growth of adjacent buds. A wound made just above a bud stimulates greater growth than a similar wound made below or at the side of a bud. Wounds made in autumn stimulate greater growth the following season than do similar wounds made in spring.

Late spring planting has given as good results as early spring planting, providing the trees are kept dormant until they are planted. The trees "heeled in" for planting may be held dormant until late spring, sometimes until early June, by lifting them out of the trench, turning them over and again heeling them in, in the same trench as often as their buds show indication of starting. Sour cherries usually suffer a mortality of one-third to one-half of the number of trees when planted in spring, but suffer no appreciable mortality when planted in late fall. On the other hand, peaches and most species which are subject to considerable injury under Missouri conditions succeed best when planted in the spring. Coniferous evergreens do best when transplanted just as their new growth is starting in the late spring. Under moist soil and weather conditions, they may be transplanted in early autumn with satisfactory results. Certain trees, such as persimmons, native walnuts, chestnuts, hickories, and pecans, have given the best results by planting just as their new leaves are pushing out in spring. They do not transplant successfully when fully dormant either in fall or early spring. Magnolias have done best when transplanted during their early blossoming period; the tulip and sweet gum trees

just as their buds were bursting; and most of the other slightly tender deciduous species before their buds start growth.

The Station's experience has shown that in transplanting fruit trees, the roots generally should be set no deeper than they stood in the nursery; especially if the trees are set in the spring, at which time the soil is slow in warming to the depth of the lower roots. The tendency of trees in the orchards of this region to lean toward the northeast may be overcome in part by proper orientation of the tree when it is set in the orchard. In planting the tree, the side that grows heaviest in the nursery should be set toward the southwest. The author recommends careful planting in holes sufficiently large enough to accommodate the main roots without their being bent or twisted. Fibrous roots should be pruned away before planting and the tops of young fruit trees should be pruned back, the degree of pruning differing with the character and habit of growth of the species. The roots of fruit trees should not be allowed to freeze in handling, as it has been found that they may be injured even by a few degrees of frost.

Attention is called to the fact that garden vegetables such as cabbage, tomatoes, etc., will endure lower temperatures and greater extremes of drought without injury after transplanting if grown slowly in the forcing bed. Such vegetables grown in a seed bed of sandy soil, low in plant food, watered sparingly, and ventilated freely, have large fibrous root systems, short thick, firm woody stems, and a concentrated sap of low freezing point; vegetables grown in a seed bed of rich soil, highly manured, abundantly watered, and in a high temperature with little ventilation have scanty root systems, long stems, luxuriant leaves, succulence, and a less concentrated sap of higher freezing point.

[Report on horticultural investigations at the Maryland Experiment Station], W. R. BALLARD, E. C. AUCHTER, T. H. WHITE, and A. WHITE (*Maryland Sta. Rpt. 1919, pp. XXVI-XXXVI*).—A test of the Kniffin, umbrella, fan, and Munson systems of pruning and training grapes begun in 1914 has shown that any of these systems are satisfactory if properly carried out. Several varieties and hybrids of the *Vinifera* grapes have been under test since 1914. These grapes are grafted on phylloxera resistant roots and are laid down and covered with earth for winter protection. Some of the vines have died, others have made little growth, and a few are vigorous, although little fruit has been produced thus far. Of various stocks tested for Delaware grapes, the best growth has been made on the Clinton stock. As a result of grape breeding investigations 800 seedlings have been secured, of which approximately 450 are fruiting. The most promising crosses are Winchell×Worden and Diamond×Clinton. Promising parents in this work are Iona, Winchell, and Diamond.

In a variety test of quinces, the Orange variety has been most resistant to fire blight, which is the greatest single factor in the failure of quince bushes to live and thrive. Preliminary observations indicate that the tarnished plant bug is largely responsible for twig infections.

An attempt to produce uniform stock for apples by propagating varieties from cuttings has been unsuccessful thus far. Breeding experiments are being conducted with the view of producing good varieties of early apples with good red color and shipping qualities and also good varieties of pears resistant to blight. Thus far about 250 apple seedlings have fruited, of which 15 are promising enough to propagate. Among some 100 pear seedlings that have fruited, a few are promising with reference to blight resistance, although the quality of the fruit has not been fully determined.

Experiments in nut culture have shown that most of the southern varieties of pecans are not hardy enough for Maryland conditions. Hardy types were

found more satisfactory. Persian walnuts suffer from blight, winter injury, and bud worm. The indications are that the greatest promise for the nut industry in Maryland lies with the native black walnuts and the Japanese walnuts.

In connection with variety tests of vegetables, some disease-resistant varieties of cabbage, celery, lettuce, and melons have been discovered. In a study of the plant food requirements of asparagus, certain of the plats received stable manure at the rate of 10 tons per acre, and others an amount of commercial fertilizer costing as much as the application of manure. Larger yields have been noted from the plats receiving the commercial fertilizer. The yield is greater when the fertilizer has been applied early in the spring. In a similar study conducted with several other vegetables, applications of manure at the rate of 4, 8, and 12 tons per acre were compared with financially equivalent amounts of fertilizers. Generally speaking, the manure and fertilizers have both greatly increased the yield, the manure giving slightly greater yields than the financially equivalent amounts of commercial fertilizer. Plats receiving fertilizers alone were slightly better than those receiving a combination of manure and fertilizer.

Observations have been made for a number of years relative to the possible variation in plants by growing them for successive generations in soil treated with large amounts of plant food. The most striking variation was that of the cherry tomato on soil treated with large amounts of dried blood (E. S. R. 29, p. 339). Generally speaking, during the 12 years various plants have been under treatment they have not changed. The work, as a whole, shows that vigorous seeds and plants come from parents that are grown under food conditions that promote vigorous plant growth.

As a result of the breeding work with vegetables, some good varieties of tomatoes have been produced especially with reference to size and solidity. Less progress has been made in producing varieties especially adapted to Maryland conditions. Two promising varieties of late cabbage have also been bred.

Handling spinach (*U. S. Dept. Agr., Market Rpt., 1 (1920), No. 16, p. 246*).—At the request of various shippers and transportation agents, investigations have been conducted by the Bureau of Markets in cooperation with the Bureau of Plant Industry to determine the factors involved in the safe transportation of spinach and other winter vegetables. Based on this investigation, directions are given for handling spinach, with special reference to the prevention of decay, wilt, and overheating in long-distance shipments.

Grades for tomatoes (*U. S. Dept. Agr., Market Rpt., 1 (1920), No. 16, pp. 241, 247*).—This article contains grade specifications proposed by the Bureau of Markets tentatively for use in marketing tomatoes. These grades are based on observations and investigations made in most of the important producing sections and large markets. They represent the best commercial practice.

[**Report on horticultural work at the San Antonio experiment farm in 1918**], C. R. LETTEER (*U. S. Dept. Agr., Dept. Circ. 73 (1920), pp. 29-32*).—The results for 1918 of variety tests at San Antonio, Tex., of peaches, plums, apricots, almonds, grapes, and miscellaneous fruits are briefly noted.

Orchard survey of Fremont County, E. P. SANDSTEN and C. M. TOMPKINS (*Colorado Sta. Bul. 254 (1920), pp. 3-28, figs. 3*).—Results are given of a statistical survey of the apple, cherry, plum, prune, peach, apricot, and pear orchards of Fremont County, Colo., with reference to their distribution, acreage, number of trees, age, and condition. General information is also given relative to the soils and climatology and the general condition of the orchards and crops grown in the orchards, together with some historical data on fruit growing in the county.

Fertilizers for Oregon orchards (*Oregon Sta. Bul. 166 (1920), pp. 3-48, figs. 5*).—This bulletin contains an introductory paper, *Fertilizers for Oregon Orchards*, by C. I. Lewis (pp. 3-15), which briefly discusses the general status of orchard fertility in Oregon and summarizes the results of orchard fertilizer studies thus far conducted at the station and at the branch stations, together with the following two papers reporting recent results secured by the branch stations in the Rogue River and Hood River Valleys in some cooperative experiments dealing with the use of nitrogenous fertilizers for fruit trees (E. S. R., 35, p. 235); *Nitrogen Fertilizers for Fruit Trees in the Rogue River Valley*, by F. C. Reimer (pp. 16-26); and *Recent Experiments with Nitrate of Soda in Bearing Orchards in Hood River Valley*, by G. G. Brown (pp. 27-48).

The experiments in the Rogue River Valley were conducted in pear, apple, and peach orchards. Briefly summarized, soil analysis, as well as the results produced on yields by the fertilizer treatments, indicated that lack of nitrogen is the limiting factor in some of these orchards. In the tests with apples, particularly, although there were variations between different varieties in response to the fertilizers, the increases in the yield of fruit on all the plats have been so large that even with the prevailing high cost of nitrogenous fertilizers their use has proved very profitable. The indications are that on heavy soils which usually show a fair amount of nitrogen in the soil, the use of commercial fertilizers for fruit trees will not prove profitable at the present time. Thus far, it is still a question whether it will prove profitable to use phosphorus in addition to nitrogen in some of these orchards. The experiment is being continued with a view to determining more conclusive results relative to the value of both phosphorus and potash when used in conjunction with nitrogen. It is recommended that wherever fruit trees are not given entirely satisfactory results, applications of either nitrate of soda, nitrate of lime, or sulphate of ammonia, be made to at least 10 typical trees in the orchard to determine whether nitrogen is needed. To secure quick results, an application of 10 lbs. per tree should be made in the case of old apple and pear trees, and 3 lbs. per tree in the case of large peach trees.

The experimental work in the Hood River Valley has included, in addition to a determination of the value of nitrogenous fertilizers for fruit trees, a study of the relation of shade crops, such as clover and alfalfa to the use of these fertilizers as affecting tree growth and production, together with observations on the blossoming habits and percentages of fruit set where nitrate of soda and sulphate of ammonia have been used on Newtown and Spitzenberg apples covering a wide range of conditions.

The results thus far secured in this work indicate that in cases where the orchards are not yielding satisfactorily nitrogen is the important missing element. The general experience has been that where more than two consecutive heavy applications of nitrate are made, even to trees badly in need of this fertilizer, color is often unduly sacrificed. On the other hand, sizes have tended to run large, in some cases unduly large. The sacrifice of deep color is often increased when heavy pruning, green manuring, excessive irrigation, or cultivation accompanies the application of nitrate. It is considered largely a problem for the grower to decide how much he can afford to sacrifice in the matter of color in order to obtain the increased size and consequently larger yields.

Studies have been made in tree response under two distinctly different types of soil management: (1) Where clover was grown, pastured, and plowed under; and (2) where alfalfa has been growing for a number of years. The few results thus far secured are in favor of the latter system of management as far as color in the Spitzenberg is concerned, and it appears that the use of a small

amount of nitrate of soda may supplement this practice whenever trees begin to lack vigor.

Where trees are lacking in vigor, because of insufficient nitrogen, fruit does not set well and the tendency toward alternate year-bearing is encouraged, but when this element is furnished in sufficient quantity, either through the use of shade crops or fertilizers, the percentage of blossoms setting fruit is greatly increased and the tendency toward alternate-bearing apparently retarded. On the heavier soils where green manurial crops, such as clover, are turned under, the necessity of using nitrate of soda in addition the same year is greatly reduced or entirely eliminated, especially where the trees are making normal growth. Both the Yellow Newtown and the Spitzenberg seem to be alternate bearers, and even under some fertilizer treatments all remained so; on the other hand, certain of the treatments have resulted in three heavy successive crops with both varieties. This result is attributed more to the probability that all factors involved, such as tillage, irrigation, pruning, fertilizing, etc., were working in harmony, rather than to the effect of the fertilizer alone. It is suggested that experiments conducted along this line in which all the factors are controlled, as they can not be in cooperative work, might show that both the Yellow Newtown and the Spitzenberg can be made to be annual bearers.

Pruning the apple, V. R. GARDNER (*Missouri Sta. Circ. 90 (1920)*, pp. 20, figs. 11).—In this circular the author briefly discusses several phases of training fruit trees and gives practical instructions for pruning young apple trees, trees that are just coming into bearing, and bearing trees.

Spraying peaches, H. P. STUCKEY and B. B. HIGGINS (*Georgia Sta. Bul. 135 (1919)*, pp. 93–101).—Practical directions are given for spraying peaches, with special reference to the control of scab, brown rot, leaf curl, curculio, San José scale, and the peach-tree borer.

The results are given of a test of the effect of varying strengths of lime-sulphur on peach foliage. The densities used ranged from 1.003 to 1.008. Solutions having densities of 1.003 and 1.004 did not injure the foliage at all, but stronger solutions caused more or less injury.

Strawberries in Nebraska, C. C. WIGGANS (*Nebraska Sta. Circ. 11 (1920)*, pp. 7, figs. 2).—Practical instructions are given for growing strawberries, with special reference to home plantings.

Report of the cranberry substation from 1917–1919, H. J. FRANKLIN (*Massachusetts Sta. Bul. 192 (1919)*, pp. 105–141).—The substation work during 1917 was continued largely along lines previously reported (*E. S. R.*, 39, p. 47). The chief lines of work consisted of the storage tests, the work with fungus diseases noted on page 155, and work with insects on page 157. In 1918, the storage tests were largely suspended, and special attention was given to frost predicting, based on previous weather records, as noted on page 119.

Among the results secured from the storage tests, it was found that in the case of sprayed and unsprayed lots of cranberries stored at 0, 5, 15, and 20° C., respectively, in all cases, the softening of the fruit was greater with the higher temperatures. There appears to be no definite relation between air and humidity and the rate of decay among the fruit. Berries kept as well in very moist air as in drier air, unless they were actually wet. Two experiments conducted in this connection show clearly the harmful effect of wetness among stored cranberries. Lack of ventilation was again found to affect cranberry storage adversely; on the other hand, too much ventilation in cranberry crates leads to serious shrinkage. In some tests of closed *v.* open crates, the average increase in loss due to decay in the closed crates was less than one-half the average increase in loss due to size shrinkage in the open ones. Ventilation is essential to the

coloring of berries picked green, hence green or partly colored fruit in particular should be stored and shipped in ventilated containers.

In view of the frequent recommendation that cranberries should be stored in water to keep them a long time, a number of tests were conducted along this line. The results indicate that most of the berries thus stored soon soften from smothering, somewhat more spoilage occurring among the green than among the ripe berries. In the work conducted during 1918, ungraded fruit apparently kept better than graded fruit, thereby contradicting the results of experiments previously reported. Admixtures of cranberry leaves or of decayed berries with the stored fruit tended to promote decay. In a test of two different types of separators, the amount of mechanical injury was practically the same. In some shipping tests in which barrels were compared with crates as containers, the results were somewhat in favor of shipping in crates. Cranberries shipped without being run through a separator reached the market in a better condition than lots separated before shipment.

The experience for 1918 with two plats on the station bog that have not been sanded since the fall of 1909 is presented in tabular form and compared with previous years. Since 1915 their average productiveness has fallen distinctly below that of their checks. For the past three years the vines have been much thinner than those of the surrounding bog. The yields and relative keeping quality of berries grown on the different fertilizer plats in 1917 and 1918 are tabulated. These data are further compared with results of previous years since 1911. The experience with these plats as a whole indicates that the advantage of any slight increase in yield that may have been caused by the fertilizers has been much more than balanced by the cost of the treatment, the deterioration in the quality of the fruit, the greater cost of picking due to the increased vine growth, and the incursion of weeds.

The preliminary work in blueberry culture was somewhat extended, and a number of swamp bushes selected for the quantity and quality of fruit they bore were brought into the station plantation. Buds of selected strains developed by F. V. Coville, of the Bureau of Plant Industry of the U. S. Department of Agriculture, were inserted on a number of the bushes.

Work with *Vitis rotundifolia*, a species of muscadine grapes, H. P. STUCKEY (*Georgia Sta. Bul.* 133 (1919), pp. 62-74, pls. 4, figs. 5).—This comprises a preliminary report of investigations with *V. rotundifolia* that have been under way at the station since 1909. The practical phases of the work and some of the more outstanding points of the breeding investigations are here discussed, and citations are given to similar studies by other investigators.

In conformity with previous results the author found that practically all varieties of this class of grapes are self-sterile. During the last three years an effort has been made to determine the underlying causes of self-sterility through a study of microspore development. Briefly summarized, it was found that the pollen from staminate vines develops in a normal way, while that from pistillate or fruitful vines develop in a normal way until the pollen grains are well formed, at which time there is a degeneration of the generative nuclei. Thus far the only positive distinction known between the male and the female vines is the difference between the flowers of the two vines. The female vines produce flowers with short and usually recurved stamens and well-developed ovules. The male vines produce flowers with long, upright stamens, having large anthers, and with inconspicuous and aborted ovules. The male vines bear no fruit at all. Since the work was begun more than two thousand seedling vines resulting from various crosses have been brought into bearing, and approximately one-half male and one-half females have occurred in all the plantings.

Out of more than a thousand bearing vines examined the color of the tendrils and new growth invariably corresponded to the color of the fruit—green tendrils and new growth giving light fruit and dark or reddish colored tendrils and new growth giving black or reddish black fruit. In all crosses black is dominant and white or light a pure recessive. With this knowledge at hand it is possible in breeding work to select the parent vines in such a way as to produce the desired color in the off spring. In view of the fact that the ovule for each seed is fertilized by a separate pollen grain it is possible to obtain two or more hybrid plants, with different male parents from the same grape. This was demonstrated in the case of seedlings from a cross of Scuppernong×dark male. In studying the quality of the fruit from a number of the crosses it was observed that certain males were much more prepotent than others in stamping good quality on the fruit of their progeny. Out of the crosses made a large majority were eliminated soon after they came into bearing. Six vines have been selected as being worthy of introduction as new varieties and are here described; they are the Hunt, Irene, November, Qualitas, Spalding, and Stuckey.

Notes are given on the yields of some of the older *Rotundifolia* varieties tested at the station; strains of Scuppernongs, methods of planting, pruning, and the uses of the fruit.

Fruit and fruit products of South Africa, R. A. DAVIS (*So. African Jour. Indus.*, 2 (1919), Nos. 8, pp. 774-783; 9, pp. 853-866; 10, pp. 1138-1148; *abs. in Cal. Fruit News*, 61 (1920), No. 1657, pp. 4, 5, 9).—A compilation of information relative to the fruits, fruit industry, and production in various districts of the Union of South Africa.

Flowering plants and ferns, J. C. WILLIS (*Cambridge, Eng.: Univ. Press*, 1919, 4. ed., rev., pp. XII+712+LV, figs. 50).—A dictionary of flowering plants and ferns, the present edition of which has been completely revised and brought up to date as far as possible.

FORESTRY.

The forestry of the Prophets, A. LEOPOLD (*Jour. Forestry*, 18 (1920), No. 4, pp. 412-419).—The author presents notes relating to forestry in ancient times based upon a study of the Books of the Prophets of the Old Testament.

Forestry movement of the seventies, in the Interior Department, under Schurz, J. S. PEYTON (*Jour. Forestry*, 8 (1920), No. 4, pp. 391-405).—A historical review of early activities for the protection and systematic administration of the public timberlands of the United States.

Efficient regulation of grazing in relation to timber production, J. T. JARDINE (*Jour. Forestry*, 18 (1920), No. 4, pp. 367-382).—The author examines the major data secured from various grazing operations on western National Forests during the past few years, and presents certain conclusions and suggestions based thereon relative to the management of grazing on timbered lands of the West.

The relation of insect losses to sustained forest yield, W. J. PEARCE (*Jour. Forestry*, 18 (1920), No. 4, pp. 406-411).—A brief general discussion of forest insect control work on the National Forests in its relation to forest management.

Standing timber insurance, W. R. BROWN (*Jour. Forestry*, 18 (1920), No. 4, pp. 338-345).—The Timber Lands Mutual Fire Insurance Company of Concord, N. H., was organized under the laws of New Hampshire in 1917, primarily to establish the principle of timberland insurance. It was later absorbed by an older fire insurance company. The author presents several conclusions based

on experience gathered during the organization and life of the above company relative to important factors governing successful timberland insurance, and gives a sample of the form used in applying for timberland insurance.

The Jonson "absolute form quotient" as an expression of taper, H. CLAUGHTON-WALLIN and F. McVICKER (*Jour. Forestry*, 18 (1920), No. 4, pp. 346-357).—The authors present data secured from investigations conducted in Ontario and in British Columbia with several different timber species to determine the value of the Jonson "absolute form quotient" (E. S. R., 39, p. 247) as an expression of taper in Canadian trees.

Generally speaking, better results have been secured with Jonson's method in Ontario than in British Columbia, where root swelling and bark of very varying thickness in the virgin forests has influenced the results. Nevertheless, it is believed that the theory is of great value, even in the big timber, in reducing the number of field measurements required to prepare an ordinary volume table.

The forests of Quebec, G. C. PICHÉ (*Jour. Engin. Inst. Canada*, 3 (1920), No. 5, pp. 229-238).—A statistical account of the forests of Quebec with reference to their area, classification, administration, activities in reforestation, lumber industries, etc., including a discussion of future forest development in the Province.

The management of second growth white pine in central New England, R. T. FISHER and E. I. TERRY (*Jour. Forestry*, 18 (1920), No. 4, pp. 358, 366).—A summary of conclusions based upon an extended study of the management of the white pine forest type in central Massachusetts and southern New Hampshire.

The hardwoods of Australia and their economics, R. T. BAKER (*N. S. Wales, Technol. Mus., Tech. Ed. Ser. No. 23, 1919, pp. XVI+522, pls. 74, figs. 198*).—A contribution from the Technological Museum, New South Wales, comprising a manual of information relative to the hardwoods of Australia and their use. Part 1 treats, in general, of the types of hardness and various physical properties of timber and contains classifications of the principal hardwoods, with reference both to the color and comparative combustibility of the timbers. In part 2, the individual species are described in botanical sequence. Under each species is given the description, uses, and anatomical features of the timber, together with a systematic description and geographical range of the species. For the more important species, photographic illustrations are given of cross, radial, and tangential wood sections, together with illustrations of the wood in natural colors. Part 3 contains technical articles dealing with the determination of specific timbers, nomenclature, seasoning, and preservation of timber, together with an account of the various architectural, engineering, and miscellaneous uses of Australian hardwoods.

The improvement of West African rubbers, C. VAN PELT (*Inst. Colon. Marseille, Bul. Caoutchoucs*, No. 1 (1920), pp. 58).—This report embraces the results of a mission to French Guiana and the Ivory Coast, conducted with the view of determining methods of improving the rubber industries of those countries.

Vegetation of Philippine Mountains, the relation between the environment and physical types at different altitudes, W. H. BROWN ([*Philippine*] *Bur. Sci., Dept. Agr. and Nat. Resources, Pub. 13 (1919), pp. 434, pls. 41, figs. 30*).—A contribution from the Bureau of Science of the Philippine Department of Agriculture and Natural Resources.

The paper contains a general discussion of plant formations occurring at different levels on the eastern slope of Mount Maquiling, Luzon, with detailed

descriptions of limited areas in which trees of each species have been counted and the chief measurements of all individuals taken. By means of these measurements, the physical characteristics of the different formations are compared and studied in connection with the measurements of such environmental factors as temperature, light intensity, rainfall, soil moisture, humidity, evaporation, and wind velocity. A briefer comparative study was also made of the vegetation on Mount Banahao, Luzon.

A list of the species considered, together with authorities and native names, is given at the end of the paper.

Dry zone afforestation and reclamation of waste land, A. E. P. GRIESSEN (*Jour. Roy. Hort. Soc.* 45 (1919), No. 1, pp. 98-112, pls. 4, figs. 2).—An account of dry land afforestation work being conducted in the vicinity of Delhi, India, including lists showing the original flora or vegetation traced in 1912-13, species introduced that are doing well, and species introduced that grow indifferently.

Progress report on forest administration in the Northwest Frontier Province for the year 1918-19, R. PARNELL (*Rpt. Forest Admin. Northwest Frontier Prov.*, 1918-19, pp. [XI]+15+[XXVI], pl. 1).—A progress report on the administration and management of the State forests in the Northwest Frontier Province of India for the year 1918-19. Important data relative to alterations in forest areas, forest surveys, grazing, production, yields in major and minor forest products, revenues, expenditures, etc., are appended in tabular form. A summary is also given of the progress of forest administration for the five-year period 1914-15 to 1918-19.

Progress report of forest administration in Baluchistan for 1918-19, MUHAMMED AFZAL (*Rpt. Forest Admin. Baluchistan*, 1918-19, pp. [6]+19).—A report similar to the above on the administration and management of the State forests in Baluchistan.

Forests, forestry, and forestal products (*Off. Year Book Aust.*, 12 (1901-1918), pp. 403-413).—A statistical report on the forest reserves and areas in the various States of Australia in 1917, activities of the State forestry departments, forestal industries, and production and quantities of timber and other forest products imported and exported during the period 1913 to 1917-18.

Production of lumber, lath, and shingles in 1918, F. H. SMITH and A. H. PIERSON (*U. S. Dept. Agr. Bul.* 845 (1920), pp. 47, figs. 3).—A contribution from the Forest Service containing detailed statistics of the 1918 production of lumber, lath, and shingles in the continental United States, with comparative figures from previous annual reports. The production is given by classes of mills, by States, and by kinds of wood.

The total quantity of lumber reported cut in 1918 by 14,753 mills was 29,362,020,000 ft. b. m. The estimated total lumber production by 22,546 mills was 31,890,494,000 ft. b. m., a decrease of 11 per cent from the 1917 estimate.

DISEASES OF PLANTS.

Report of the botanist, J. G. LEACH (*Colorado Sta. Rpt.* 1919, pp. 13-17).—Brief accounts are given of the various lines of work in progress. In the investigation with fungus diseases, particular attention has been paid to the control of cereal smuts, and experiments conducted are said to have demonstrated conclusively the efficiency of the standard formaldehyde treatments.

Fungus diseases of garden crops [in Iowa], J. C. GILMAN (*Iowa Agr.*, 20 (1919), No. 2, pp. 47-52, figs. 8).—A somewhat generalized account is given of the results of observation and experimentation in connection with such garden troubles as seed bed diseases, also potato blackleg, black scurf, early blight,

and late blight; such cabbage diseases as blackleg, black rot, and yellows; tomato diseases, chief of which is the wilt caused by a fungus similar to that causing cabbage yellows; cucumber and melon diseases, particularly bacterial wilt; bean diseases, of which anthracnose is the most important; and asparagus rust, the chief protection against which is to grow rust-proof varieties.

Plant disease investigations, J. B. S. NORTON ET AL. (Maryland Sta. Rpt. 1919, pp. XLVIII-LII).—Among the investigations reported upon are a study of tomato blight due to *Septoria lycopersici*, Sclerotinia fruit rot, Fusarium wilt resistant tomatoes, control of leaf blight of tomato, some studies on diseases of seeds, the life history of Mycosphaerella, etc.

In a study of the tomato blight, it was found that the conidial form of *S. lycopersici* was able to withstand temperatures near zero, and was present on tomato waste in the spring. High temperature and humidity were found to favor infection. Certain varieties of tomatoes in the seedling stage, at least, were found more susceptible than others to infection. Many other solanaceous plants, especially horse nettle, eggplant, and potato are subject to attack by this fungus.

In investigations with Sclerotinia fruit rot, the relative abundance of blossom blight and the apothecial stage of the fungus were determined. It was found that the petals and other parts of the flowers affected by the ascospores may carry the disease along to the stage when injured or ripening fruits may be attacked.

In an effort to secure strains of canning tomatoes resistant to the wilt fungus, strains of good yield and quality have been developed. These are being given rather wide planting throughout the State.

For the control of the leaf blight of tomato, the author recommends the use of Bordeaux mixture to which resin fish oil soap was added as a sticker. In order to avoid the mechanical injury to plants under ordinary conditions, it is recommended that the rows be 6 ft. apart and the plants spaced 3 ft. apart in the row.

Report of the microbiologist, 1917-18, S. F. ASHBY (Ann. Rpt. Bd. Agr. and Dept. Pub. Gard. and Plantations Jamaica, 1918, pp. 33, 34).—Panama disease (wilt) has been found in new areas. Studies on banana soils reveal the presence of two species of Fusarium. It is stated, however, that a form absolutely identical with that producing the disease as regards such characters as growth, reproduction, and odor has not yet been found in the soil.

Coconut bud rot, causing loss in the eastern parishes, is described. A fungus resembling Phytophthora (possibly *Pythium palmivorum*, said to cause a coconut bud rot in India) has been isolated from the heartleaf spots, from water-soaked tissue of the limb of the heartleaf, and from the husks of fully grown but immature nuts. Another fungus, a Phytophthora, has been isolated from different parts of the tree.

Leaf-bitten diseases have been extensively treated with promising results in spite of hurricane injury.

Gall disease of sweet potatoes, due apparently to *Albugo* sp., showed further extension. The disease of pimento associated with fire blight symptoms was again observed. The causal fungus was isolated and yielded a perfect fruiting stage, proving its identity with *Rostrella coffea*. A rot of yams was found to be caused by *Corticium vagum solani*. Potato late blight (*Phytophthora infestans*) appeared at several points. Honeycomb defect of copra was found to be due to *Bacillus mesentericus vulgatus*. The strain is markedly thermophilic, withstanding 150° F. Sulphur fumes are preventive.

Report of the microbiologist, 1918-19, S. F. ASHBY (Ann. Rpt. Bd. Agr. and Dept. Pub. Gard. and Plantations Jamaica, 1919, p. 26).—Some evidence was

obtained that the trash used as mulch or floating banana débris may spread the Panama disease (banana wilt).

Coconut bud rot killed many trees in the eastern parishes. The disease, which appears first in the heartleaves, is said to be due to a fungus closely related to *Pythium palmivorum*, the cause of bud rot of coconuts and of palmyras in India. Some sprouts from nurseries were found infected by the fungus. The same fungus caused a form of leaf-bitten disease in the same districts. This disease has been reproduced by pouring cultures of the fungus into the hearts of young trees. The most prevalent form of leaf-bitten disease continued to be caused by the pineapple fungus (*Thielaviopsis paradoxa*), which showed a considerable increase following the hurricane of 1917. Mention is made also of corn smut (*Ustilago maydis*), coffee thread blight (*Pellicularia koleroga*), sugar cane rind disease (*Melanconium sacchari*), potato early blight (*Macrosporium solani*), potato late blight (*Phytophthora infestans*), sweet potato white rust (*Albugo ipomœe panduranae*), and sweet potato soft gall (*Albugo* sp.).

Vegetable pathology [Algeria] (*Exposé Situation Gén. Algérie, 1918, pp. 514, 515*).—During January, 1917, the pathological station took up the study of a pod disease of bean due to *Uromyces appendiculatus*, which ordinarily attacks the stem and leaves. A bacterial disease of crucifers, particularly in cauliflower, was caused by *Bacterium maculicolum*. In November, a leaf disease was developed by *Zizyphus vulgaris*, due to a fungus, *Phakopsora zizyphi vulgaris*, up to the present time supposedly confined to Japan, China, and neighboring regions.

During July and August, study was made by the station staff at various points of a disease causing death of grapevines. The trouble appeared to be physiological. *Rhus oxyacantha* suffered from attack by a parasitic fungus, *Exobasidium hesperidum*, which is treated as a new species.

Phytopathological review (*Agr. Colon. [Italy], 13 (1919), No. 9, pp. 356-362*).—This review notes a disease of walnut in South Africa which is ascribed to *Bacterium juglandis*; rose diseases in Trinidad due to *Diplocarpon rosa*, *Cercospora rosicola*, and *Sphaerotheca pannosa*; and a variety of sugar cane immune to mosaic disease. Accounts are also included of animals injurious to economic plants.

Diseases of plants new to Victoria, C. C. BRITTLEBANK (*Jour. Dept. Agr. Victoria, 17 (1919), No. 10, pp. 626-629, figs. 2*).—Anthracnose of lettuce, *Didymana (Marssonina) perforans*, has been recognized as causing anthracnose on garden lettuce in a suburb of Melbourne, which was grown from imported seed. The disease was checked with a 6:4:80 Bordeaux spray.

In the spring of 1916, passion-fruit vines were attacked by a fungus, which proved to be *Botrytis cinerea*, at points where the vines had been fastened to the trellis and thus slightly injured. A somewhat similar injury was caused by *Sclerotinia* sp. Both fungi have been largely held in check by removal of diseased portions and several applications of Burgundy mixture at a 6:4:40 strength.

Notes on the genus Balansia, A. M. KING (*So. African Jour. Sci., 15 (1919), No. 8, pp. 670-673, pl. 1, figs. 4*).—An account is given of what is supposed to be a causal fungus associated with rapid, erect, and otherwise abnormal growth in *Cymodon dactylon*, which grass abounds in Pretoria. The fungus is assigned to the genus Balansia.

Green manurial crops and "take-all," C. C. BRITTLEBANK (*Jour. Dept. Agr. Victoria, 17 (1919), No. 3, pp. 171-174*).—It is stated that during the past season take-all or white-heads (*Ophiobolus graminis*) has developed to a more or less serious extent in all the green manurial plats at the State Research

Farm, Werrabee. Data obtained from one year's study indicate that an alkaline soil favors the development of the disease. An account is given of the system of rotation followed in the green manurial plats and the percentage of disease observed in the various wheat crops grown during 1918. A list of hosts of the fungus is given; also an account of rainfall at this point, which seems to be connected with the development of this disease.

The bacterial blight of beans, E. M. DOIDGE (*So. African Jour. Sci.*, 15 (1919), No. 7, pp. 503-505).—Investigations following numerous complaints of a discoloration and malformation of field beans showed the trouble to be due to an organism apparently identical with *Bacterium phaseoli*.

Diseases of celery, W. S. KROUT (*New Jersey Stas. Circ.* 112 (1919), pp. 12, figs. 7).—Popular notes are given on different diseases of celery, together with suggestions on methods of control. These include sanitation, proper culture, seed bed and soil sterilization, and spraying. As a result of spraying experiments conducted by the author, a net profit of \$324 per acre is reported.

Experiments in root rot control, C. R. LETTEER (*U. S. Dept. Agr., Dept. Circ.* 73 (1920), pp. 32-34).—In continuation of investigations previously reported (*E. S. R.*, 39, p. 852), the author gives an account of additional experiments at San Antonio, Texas, in soil treatment, mulches, and the effect of excavations for the control of root rot due to *Oozonium omnivorum*.

The results in 1918 showed no beneficial effect of the acid phosphate treatment in reducing root rot infection, and the application of oat straw and coarse manure and other mulches was without effect on the spread of root rot, the disease being fully as prevalent on the mulched areas as on adjacent land. In order to determine the depth at which the root rot infection takes place, excavations were made 18, 32, and 48 in. in depth in a field badly infected with root rot. From some of these holes the soil was hauled away and the holes filled with fresh soil from fields which had not been cropped in several years, while from others the soil was thrown out, allowed to remain a few days, and returned to the holes in nearly the same order as before. Cotton was again planted in the fields including the excavated areas, and the results indicate that the root rot is in the soil and is removed with the soil.

Onion smut, R. E. VAUGHAN and J. C. WALKER (*Wis. Hort.*, 10 (1920), No. 8, pp. 133, 145, figs. 2).—Onion smut is said to cause losses in Wisconsin amounting in some fields to more than 50 per cent. Onion plants with four or five leaves are much more resistant than are those which are just starting. The formaldehyde treatment is said to be effective if properly applied to the seed. Treatment during 1913-1918 gave increased results, averaging 328 bu. per acre. Directions are given for the preparation and application of the remedy.

Resistance of potato tubers to scab, B. F. LUTMAN (*Vermont Sta. Bul.* 215 (1919), pp. 3-30, pls. 5).—In a study on the potato scab, the author has investigated the resistance of varieties to attack. Repeated plantings made between 1914 and 1917 on the same soil showed that the percentage of scab increases even if no manure or lime is added to the soil. Marked resistance to scab was found in the true russet types of tubers. The semirusset types showed some scab resistance, while the white, thin-skinned varieties appeared to be most susceptible.

In order to determine the reason for the resistance on the part of the russet types, a study was made of the relation of thickness of skin of potato tubers to their resistance to scab. It was found that the thickness of skin determines the resistance of the tubers to scab, while color plays no rôle in the resistance. All russet varieties appeared at least moderately resistant. The application of fertilizers and chemicals was found to affect to some extent the amount of

scab. Sulphur and ammonium sulphate tend to decrease the amount of scab and lime and manure to increase it. The skin structure of the tuber seems to be but slightly affected by the application of fertilizers, at least on sandy soil. It is believed that any changes the fertilizers may bring about in the prevalence of scab are due to their effect on the numbers or pathogenicity of the organisms rather than on the tuber itself.

Potato leaf roll, F. W. NEGER (*Deut. Landw. Presse*, 45 (1918), No. 76, pp. 469, 470, figs. 4).—The author makes a first report of data obtained in studies regarding the etiology of potato leaf roll. These data are said to have shown a very close relation between this condition and the presence of starch in the superficial cells of the leaf.

Tip burn of the potato and other plants, B. F. LUTMAN (*Vermont Sta. Bul.* 214 (1919), pp. 3-28, pls. 2, figs. 9).—According to the author, tip burn is one of the most important limiting factors in potato production, being exceeded only by the Colorado beetle and late blight. Tip burn of the potato is said to be due to excessive heat and sunshine during late July and early August, the advance of the tip burn occurring only on hot brilliant days, while during cloudy cool weather it makes no progress. An inordinate transpiration from portions of the leaflets directly affected results in a wilting from which the parts seriously injured do not recover. High osmotic pressure of the sap of the stalks of the plants as compared to that from the leaves undoubtedly aggravates the disease. The author found that tip burn can be simulated in the greenhouse even in early spring by directing an excess of sunlight on any portion of the potato foliage. Tip burn may be largely prevented by shading and to some extent by application of Bordeaux mixture. Early varieties in general are affected sooner and more seriously than late ones. The foliage of the latter often survives the attack and renews growth in September.

The spindling sprout disease of potato tubers, C. O. APPLEMAN (*Maryland Sta. Rpt.* 1919, p. XLV).—Considerable progress is said to have been made in locating the physiological disturbance. Several successful attempts were made in producing the disease by artificial means.

Tomato diseases, C. C. BRITTLEBANK (*Jour. Dept. Agr. Victoria*, 17 (1919), Nos. 4, pp. 231-235; 8, pp. 498-500).—A descriptive account is given of tomato diseases found in Victoria, including leaf mold (*Alternaria solani*), leaf spot, blight or rust (*Septoria lycopersici*), wilt (*Fusarium solani*), Sclerotium disease (*Sclerotinia* sp.), root rot (*Rhizoctonia solani*), Irish potato blight (*Phytophthora infestans*), and brown rot or wilt (*Bacillus solanacearum*).

To these the author now adds a new tomato disease, proposing the name "spotted wilt." This disease has appeared within the last three years on tomato plants, its origin and mode of introduction being unknown. No causal organism has yet been isolated, and no control method has been devised. The period of greatest virulence of this disease coincides with the prevalence of swarms of canary flies or jassids, the plants recovering to a considerable extent afterwards, though some plants still show the presence of the disease. This is said to be the most serious disease that the local grower has had to meet. During the present season, fully 50 per cent of suburban garden plants have been destroyed. In the country districts the disease has made considerable progress, and diseased plants have been found in nearly all parts of Victoria. Symptoms of the disease are described. The author suspects that this disease may be identical with one which has been under investigation in the United States by Selby (E. S. R., 8, p. 991), and later by Howitt and Stone (E. S. R., 36, p. 350).

Apparently fumigation does not cause the disease, which is thought to be physiological in character, possibly in some way connected with some chemical or physical deficiency in the soil, which is apparently overcome by sterilization.

[Apple] fungus diseases and their treatment, J. FARRELL (*Jour. Dept. Agr. Victoria, 17 (1919), Nos. 3, pp. 148-157, figs. 6; 5, pp. 287-295, figs. 4; 8, pp. 449-463, figs. 6*).—In addition to reports on experience with animals detrimental to apple-growing interests, the author gives an account of such injurious diseases as black spot (*Venturia inæqualis*); of the effects of remedies in this connection, including injuries to the fruit; of root fungus (*Armillaria mellea*); of fungi attacking immature apples in storage or transit, including bitter rot (*Glaeosporium fructigenum*), moldy rot, and moldy core (*Penicillium glaucum*); crinkle; bitter pit; Jonathan spot and freckles; Jonathan scald; and sleepiness.

Shothole fungi which affect cherry trees, H. J. DARWENT (*Jour. Dept. Agr. So. Aust., 23 (1919), No. 1, p. 31*).—Spraying tests against shothole fungi on cherry trees gave perfect control with Bordeaux, fair success with Burgundy spray, and no benefit from the use of lime sulphur.

Diseases and insect pests of blackberries, loganberries, and strawberries, A. FRANK (*Washington Sta., West Wash. Sta. Mo. Bul., 8 (1920), No. 1, pp. 14-16, figs. 2*).—Notes are given on anthracnose, gall, and orange rust of blackberries and loganberries, and on leaf spot, mildew, and Rhizoctonia of strawberries, together with suggestions for their control. Brief accounts are also given of insect pests attacking these crops.

Fungus diseases [of cranberry plants], H. J. FRANKLIN (*Massachusetts Sta. Bul. 192 (1919), pp. 105-111*).—The investigations of cranberry diseases were carried on in cooperation with the U. S. Department of Agriculture, Bureau of Plant Industry, and consisted mainly in experiments for the control of various diseases through spraying, attention to the flooding of the bogs, etc.

Copper sulphate added to the June flowage in 1917 was without positive results. Arsenate of lead proved to have positive fungicidal value when sprayed on plants of the Early Black variety, but the specific fungi affected by the treatment were not determined. Blackleaf 40 tested in 1917-18 gave no evidence of disease control.

Several bogs were seriously affected by rose bloom due to *Exobasidium oxycocci*, the greatest damage being done to the late varieties. Flooding the bogs in June and after 46 hours withdrawing the water and drying the plants killed the diseased shoots in all parts of the bog. Spraying with Scalecide was without benefit. Iron sulphate applied in sufficient strength to prevent the development of the diseased shoots is considered a practicable means of control. Attention to the flooding of the bogs apparently offers the most satisfactory means of control, as the author reports that he has never found rose bloom on bogs regularly reflooded after picking.

Notes are given of the diseases due to *Sporonema oxycocci*, *Fusicoccum putrefaciens*, and *Glomerella cingulata vaccinii* in relation to their control by flooding.

Copper fungicides for vine diseases, F. DE CASTELLA (*Jour. Dept. Agr. Victoria, 17 (1919), Nos. 2, pp. 104-112; 8, pp. 483-489*).—A discussion is given of the constitution, preparation, chemistry, and properties of copper fungicides, with practical directions for their employment.

Burgundy mixture as usually prepared locally is said to show several serious defects. The precipitate is apt to contain copper in the carbonate form. While this possesses fungicidal power, the basic sulphate form is preferable, as this gives greater stability, less scalding of the foliage, and greater fungicidal capacity. Burgundy mixture differs radically from Bordeaux mixture, in which excess of lime does not present the same undesirable features.

A discussion is also given regarding the properties and cost of both basic and neutral copper acetates.

Citrus blast, H. S. FAWCETT (*Cal. Citrogr.*, 5 (1919), No. 1, p. 3, figs. 3).—The information now at hand regarding citrus blast in counties of northern California is briefly presented.

Citrus blast is a bacterial disease apparently confined at present to northern California during the winter and early spring. The organism destroys leaves, kills fruiting twigs, and forms reddish-brown scabs on live twigs and shoots, usually at the base of the leaf petiole, but does not attack the growing fruit. The effects differ with varieties, navel oranges being most severely injured, lemons but slightly affected. A relationship appears probable between the severity of the disease and direction of the prevailing wind, distribution of rainfall, weakness of the tree from neglect or age, and time of maturity of the leaves and branches of the year before. Citrus blast may readily be mistaken for a relatively unimportant disease characterized by a sudden dying back of twigs at the base of which the bark has split and the gum oozed out. This, however, occurs in the summer and fall after dry, hot weather in any orange growing portion of the State.

Phytophthora faberi, the cause of coconut bud rot in the Philippines, O. A. REINKING (*Philippine Jour. Sci.*, 14 (1919), No. 1, pp. 131-150, pls. 3; *abs. in Agr. News [Barbados]*, 18 (1919), No. 461, pp. 414, 415).—In a report on studies still in progress, the author states that *P. faberi* is the basically causal organism in relation with coconut bud rot in the Philippines, though other organisms, notably one similar to *Bacillus coli*, may quickly follow the original attack and may obscure the original causal organism without being able to initiate the disease.

Enormous losses are caused annually by the disease, which abounds in humid sections and in thickly planted groves. A number of other plants are susceptible to attack, among these coconut, cacao, Hevea, and papaya.

Trees once severely infected do not recover. All parts must be destroyed, as the organism lives saprophytically in dead host trees. Spaces between the trees should be not less than 10 meters (33 feet) each way.

Walnut bacteriosis, E. M. DOIDGE (*So. African Jour. Sci.*, 15 (1919), No. 6, pp. 407-412).—During the past season the identity of the South African walnut blight with the walnut bacteriosis of California was established, and investigations were carried out as to the extent of its occurrence, which is indicated. The disease had been present, supposedly, for some years in this region. From the economic point of view the phase of most serious importance is the bacteriosis on the young nuts, from which the organism has been isolated repeatedly, as also from the spot on the leaves. A brief discussion is given of the morphology, cultural and other characters, and favoring conditions.

A preliminary investigation into a disease attacking young Cupressus plants, A. M. BOTTOMLEY (*So. African Jour. Sci.*, 15 (1919), No. 8, pp. 613-617, pls. 4).—A disease manifested in severe outbreaks on *Cupressus torulosa* and *C. arizonica* at Belfast, Transvaal, is said to be due to a fungus believed to be identical with the Phoma described by Hahn, Hartley, and Pierce (*E. S. R.*, 38, p. 53). A closely related or identical trouble on *C. macrocarpa* is ascribed to a fungus also identified as a Phoma, possibly of a different species. An account is given of a study of this trouble.

A high sensitivity of the spores to copper sulphate leads to the recommendation of Bordeaux mixture as a control measure.

Notes on the morphology and life history of Uromyces aloës, V. A. PUTTERILL (*So. African Jour. Sci.*, 15 (1919), No. 8, pp. 656-662, pls. 2, figs. 6).—This is an account of studies on *U. aloës*, the cause of rust in Aloes, which is said to have wide distribution, similar to that of its host. Biological species of the fungus may exist.

ECONOMIC ZOOLOGY—ENTOMOLOGY.

Bordeaux-oil emulsions, J. R. WINSTON and W. W. YOTHERS (*Fla. Grower*, 21 (1920), No. 3, p. 9, fig. 1).—This is a brief report of tests in Florida commenced during the early fall of 1917 with a view to combining Bordeaux mixture and oil emulsion. It was found that any dilution of the various oil emulsions combined readily with any strength of Bordeaux likely to be used, and that there were no detrimental effects upon either of the constituents.

Rather thorough trials were made in bearing groves at various points in the State during the scab-spraying seasons of 1918 and 1919. In the course of this work the trees were sprayed at all stages of growth, but no one grove was sprayed more than three times with this combination. Both the cold-stirred and boiled-oil emulsions were used in the tests. Tests were also made in an experimental nursery at Orlando on seedling grapefruit, rough lemon, and sour orange nursery stock. "A part of this nursery was sprayed with 3:4:50 Bordeaux mixture and another part with Bordeaux-oil emulsion (3:4:50 Bordeaux plus 0.5 per cent oil emulsion). The applications were made at weekly intervals beginning in March and ending in October, 1919. Usually the ordinary boiled-oil emulsion was used, but occasionally the proprietary emulsions . . . were substituted. All of these emulsions served equally well."

All brands of commercial oil emulsions and miscible oils tested and the Government formulas for "cold-stirred" and "boiled-oil" emulsions were found to mix readily with Bordeaux mixture. "Bordeaux-oil emulsion settled less rapidly and spread more evenly than plain Bordeaux. Bordeaux-oil emulsion adhered to the sprayed parts as well or better than plain Bordeaux. This combination was successfully made with various types of untreated hard water, shallow well, and lake waters.

"The presence of the oil neither increased nor decreased the effectiveness of Bordeaux against citrus scab. More than 20,000 gal. of this combination was applied on fruit, twigs, and foliage of all commercial varieties, at all stages of growth, including the full-bloom period, during all weather conditions which permit of spraying operations, and no spray injury was observed. Where the bloom spray was applied, oil emulsion was used at the rate of 0.5 per cent oil. It thus appears that oil emulsion combined with Bordeaux mixture has less tendency to injure tender growth than emulsion alone. . . .

"The results to date of tests with the Bordeaux-oil emulsion mixture have been highly satisfactory, and indicate that it will prove very effective in the control of certain fungus diseases of citrus and that its use is not followed by injury to the trees or fruit or by abnormal increase of scale insects."

An account of work with linseed-oil Bordeaux by Berger has been previously noted (*E. S. R.*, 41, p. 355).

The influence of temperature and other physical agents on the insecticidal power of chloropicrin, G. BERTRAND, BROcq-ROUSSEAU, and DASSONVILLE (*Compt. Rend. Acad. Sci. [Paris]*, 169 (1919), No. 22, pp. 1059-1061).—In the employment of chloropicrin against insects, light and moisture appear to have little influence, but temperature is an important factor, the rapidity of its action increasing as the temperature rises.

Influence of the wind on the movement of insects, W. E. HURD (*U. S. Mo. Weather Rev.*, 48 (1920), No. 2, pp. 94-98).—This is a comprehensive review of the more important literature relating to the dissemination of adult and larval insects by the wind. A list is given of the 23 references to the literature.

Report of the entomologist, C. P. GILLETTE (*Colorado Sta. Rpt.* 1919, pp. 22-25).—The work of the year is briefly reported upon.

The year was an exceedingly unfavorable one for normal results in work with the codling moth. Its ravages were extremely severe in most of the apple-growing sections of the State, due apparently to the unusually warm summer.

In work with the western bean beetle (*Epilachna corrupta*), good results were obtained in its control by the use of arsenite of zinc or arsenate of lead. The number of broods in the locality of the station has been determined as one and a very small fraction of a second.

The beet web-worm (*Loxostege sticticalis*) appeared in unusually large numbers in the Fort Collins-Greeley district of northern Colorado during the summer, thousands of acres of sugar beets being eaten to the ground after the tops had grown to the height of 10 or 12 in. While in many of the fields nothing but a few of the stronger midribs of the leaves were left standing, the recovery of the beets was quite remarkable, so that many of the fields seemed to make almost a full growth of tops. It is thought, however, that the tonnage of beets per acre must have been greatly reduced. Tests of Paris green, calcium arsenate, magnesium arsenate, and arsenate of lead showed all to be satisfactory when applied in double the ordinary strengths used for control of ordinary leaf-eating caterpillars.

The alfalfa weevil continued to spread in Delta County and has been traced several miles to the south and west beyond the area found to be infested the previous year. One small area of slight infestation was discovered on the mesa two miles west of Montrose.

Insect investigations, E. N. CORY ET AL. (*Maryland Sta. Rpt. 1919*, pp. LIII-LVII).—Brief reports are made on the 22 projects relating to insects and their control.

In control work with the woolly aphis 8 per cent pine tar creosote emulsion applied twice a year proved efficient in controlling the aphids, and no injuries were caused to the trees except in a few instances where the nature of the soil was such that the creosote and natural water were held around the tree practically throughout the year. An annotated list of the Halticini of College Park and vicinity, of which 48 species are recognized, has been prepared for publication.

[**Work with cranberry insects, 1917-1919**], H. J. FRANKLIN (*Massachusetts Sta. Bul. 192 (1919)*, pp. 126-133).—This report of work with insect enemies of the cranberry is in continuation of that for the year 1916 (E. S. R., 39, p. 60).

A bog on which the spanworm (*Epelis truncataria faxonii* Minot) was numerous in 1917 was reflowed for a period of three days commencing June 20, and while the moths were either destroyed or driven ashore apparently little or no harm was done to the eggs, for the worms appeared in great numbers in July. They were successfully controlled, however, by a single application of arsenate of lead paste, 6 lbs. to 50 gal. of water. The cranberry root grub (*Amphicomma vulpina* Hentz) found occasionally in great numbers in the sand covering of bogs, where it works very much like the rootworm (*Rhabdopterus picipes*), feeding mainly on the small roots, occasionally destroys large patches of vines. Work with the spittle insect (*Clastoptera vittata* Ball) shows it to be very injurious, and that it ought to be controlled wherever it becomes abundant on a bog. This is readily accomplished by applying blackleaf 40, 1 part to 800 parts of water, to which soap has been added. Adults of this species have been reared from eight food plants. The most important parasite of the cranberry tipworm (*Dasyneura vaccinii* Smith) has been identified by Gahan as *Ceraphron pallidiventris* Ashm.

Work with the gipsy moth confirms the results of previous years, showing that the eggs do not endure very late holding of the winter water. Experiments show that blackleaf 40 used at the rate of 1 part to 400 parts of water will kill the worms in their early stages. The black-head fireworm was found to be controlled by the use of blackleaf 40, 1 part to 400 parts of water, and it has replaced arsenate of lead for controlling this pest. "Treatment of the spittle insect, the gipsy moth, and the first brood of the fireworm with the same application of blackleaf 40 is practicable on bogs that are winter flowed but not reflowed. The use of arsenate of lead with the blackleaf 40 in spraying for the fireworm and the gipsy moth is probably advisable, for the arsenate whitens the spray and so marks where it is applied, thus reducing the liability of leaving areas unsprayed. It also adds to the insecticidal value of the spray, and, as shown elsewhere in this report, gives it a fungicidal value when it is used on Early Black vines. Whale-oil soap is preferable to resin fish-oil soap for use with blackleaf 40, especially if arsenate of lead is added, for the arsenate and the resin soap make a burning combination."

The eggs of the cranberry fruitworm were parasited by *Trichogramma minuta* to the extent of from 83 to 89 per cent on dry bogs and from 29 to 88 per cent on those with winter flowage in 1917, and from 36 to 89 per cent on dry bogs, and from 0 to 15 per cent on flowed bogs in 1918. The results show that the fruitworm may be smothered by heavy sanding, but that the sand must be applied after pupation, which is completed the middle of June, to be effective. The black cutworm appeared in August on a large part of a bog which had been flowed from early July to July 10.

Distribution of shade tree insects in 1919, W. O. HOLLISTER (*Jour. Econ. Ent.*, 13 (1920), No. 1, pp. 143-146).—This reports upon the distribution east of the Mississippi and north of the Mason and Dixon Line of the more important insect enemies of shade trees.

An invasion of British Guiana by locusts in 1917, G. E. BODKIN and L. D. CLEARE (*Bul. Ent. Research*, 9 (1919), No. 4, pp. 341-357, figs. 8).—The senior author discusses the previous locust infestation of British Guiana, the infestation of 1917, and the campaign conducted. An account of the life history of the *Schistocerca* species concerned is given by the junior author.

The Porto Rico mole cricket in South Carolina and Florida, F. H. CHITTENDEN (*Jour. Econ. Ent.*, 13 (1920), No. 1, pp. 149, 150).—The occurrence of *Scapteriscus vicinus* Scud. in South Carolina and Florida is recorded.

Three pink and green aphids of the rose, E. M. PATCH (*Maine Sta. Bul.* 282 (1919), pp. 205-248).—The author has found that there are at least three species of plant lice belonging to the genus *Macrosiphum* that are common on the rose in Maine, and that each of these has two distinct color varieties, one pink and one green.

M. rosa proper, the first of these, maintains a continuous residence upon the rose and is not known to migrate. *M. solanifolii*, the second, deposits its eggs upon the rose in the fall, where it may be found in heavy colonies during the spring and early summer, when it migrates for the most part to a great variety of summer plants, though it may, besides, keep up its connection with the rose during the summer. It is a source of serious injury to the potato in many parts of the United States, due to its direct attack and also indirectly as a carrier of mosaic disease as reported by Schultz et al. (*E. S. R.*, 42, p. 47). The third is a species here described as new under the name *M. pseudorosa*, and to which the present account chiefly relates. The species was first collected from golden ragwort (*Senecio aureus*) July 3, 1918, together with *M. solanifolii* from which it is easily separated by its black antenna and cornicles. Further

search revealed its presence on the numerous wild roses growing on the bank of the Penobscot near the ragwort. By transfer from wild rose to ragwort, it was shown to be capable of living upon ragwort and its progeny of maturing upon the secondary host plant. It is thought that *M. pseudorosæ* may prove to be a synonym of *rosæformis* Das which occurs in India, where it is known as the "Punjab rose aphid."

Descriptions are given of the alate and apterous viviparous females. A key for the separation of this new species from other members of the genus occurring in eastern United States is included.

The paper concludes with a description of eleven new species of *Macrosiphum* of which but little is as yet known, all of which were collected in Maine, namely: *M. carpinicolens* from leaves of blue beech; *M. ptericolens* from fronds of bracken fern (*Pteris aquilina*) and from lady fern (*Athyrium filix-femina*); *M. diervillæ* from wild bush honeysuckle (*Diervilla lonicera*); *M. impatiensicolens* from stem of terminal shoots of *Impatiens biflora*; *M. amelanchiericolens* from *Amelanchier spicata*; *M. onagræ* from evening primrose (*Oenothera biennis*); *M. pseudocoryli* from ironwood (*Ostrya virginiana*) and from hazel bush (*Corylus rostrata*); *M. pseudodirhodum* from terminal shoots, buds, and tender leaves of greenhouse roses and wild rose; *M. gravioris* from *Solidago*; *M. eupatoricolens* from the common species on Joe-Pye weed (*Eupatorium purpureum*); and *M. lanceolatum* from goldenrod (*Solidago lanceolata*).

This bulletin also includes part 6 (pp. 219-248) of the author's Food Plant Catalogue of the Aphididæ of the World, in continuation of the parts previously noted (E. S. R., 39, p. 657.)

Determination of the sex of the offspring from a single pair of *Pediculus vestimenti*, K. FOOT (*Biol. Bul. Mar. Biol. Lab. Woods Hole, 37 (1919), No. 6, pp. 385-387*).—In the determination of the sex the author has dissected the nymphs without waiting for them to mature.

Bagworms destructive in Missouri, L. HASEMAN (*Missouri Sta. Circ. 92 (1920), pp. 4, figs. 4*).—This is a brief popular account of the bagworm, which occurs periodically in great abundance in Missouri.

On the effects produced by the attacks of the pink bollworm on the yield of cotton seed and lint in Egypt, L. H. GOUGH (*Bul. Ent. Research, 9 (1919), No. 4, pp. 279-324, pl. 1, figs. 6*).—A summary is first given of the established facts concerning the life history of (*Gelechia*) *Pectinophora gossypiella*. This is followed by a discussion of the rate of increase of damage in Egypt since 1911, and of investigations of the nature and amount of damage done under the headings of weight of sound seeds and germination of sound seeds from attacked bolls; number of seeds, sound or attacked, developed in attacked bolls; effect of *Pectinophora* attack on the amount of lint produced, and a calculation of the damage done. A large part of the data are presented in tabular form. Notes on observations made in 1917-18 relate to the rate of increase of *Pectinophora* in 1917, observations on resting larvæ, *Pectinophora* in seed stores, and a destruction of the larvæ in seed as carried out on a commercial scale in ginneries.

It appears that in some manner the pink bollworm causes some of the sound seeds developing in attacked bolls to lose weight, and there appears to be no doubt that this indirectly affects the germination of sound seeds. Since any factor that can affect a developing seed can also affect the quantity of lint produced by that seed, it appears that *Pectinophora* attack must affect the amount of lint produced, (1) by reducing the number of seeds matured per boll, (2) by reducing the average weight of the sound seeds produced in attacked bolls, and (3) by disturbing the development of immature attacked seeds.

The author records 54,000 moths as caught during the year by a 25-candle-power electric trap-light placed in a seed-store. Investigations of the destruction of larvæ in the seed by heat, as is now required of ginners by law, show perfect germination to be obtained from seed treated at temperatures of 65 to 69° C. (149 to 156.2° F.). It is recommended that, in view of these results, ginners employing heat treatment work their machines for temperatures of 60 to 65° C., rather than from 55 to 60° C.

A bibliography of 5 pages is included.

Some data on codling moth control in the Grand Junction district in Colorado. C. P. GILLETTE and G. M. LIST (*Proc. Soc. Prom. Agr. Sci.*, 39 (1919), pp. 113-123, figs. 4).—This is a report of investigations conducted in the Grand Valley in Colorado.

Attention is first called to the fact that while entomologists in other States report as high as 90 to 95 per cent of worm-free apples as a result of two or three applications of arsenical poison, growers in some of the orchard sections of Colorado seldom get better than 70 or 80 per cent worm-free apples after 5, 6, or even 7 thorough sprayings, it being the usual thing for growers in the lower Grand Valley to make this number of applications for codling-moth control. The more important conclusions arrived at as a result of the data presented are as follows:

"The climatic conditions at Grand Junction are very favorable for the development of the codling moth, and especially for carrying a large brood of worms over winter, extending the time of moth emergence so as to cause a considerable overlapping of the first and second broods. The tendency of the larval broods to overlap is increased by sudden low temperatures, often lasting several days, after the moths of the first spring brood have begun to lay eggs. There is normally a partial, and sometimes a considerable, portion of a third brood of the codling moth in the Grand Junction section, which materially increases the number of worms to enter the apples about the last of August and during September. The failure to get satisfactory control of this insect by spraying is not due to failure in making good calyx spray in the better cared for orchards, but to the abundance of the insect and its continuous performance throughout the growing season.

"The greatest need of the orchardists in this section is a reliable chart that will show the rise and fall in numbers of larvæ hatching throughout the summer, which would fix the best dates to spray, but this can be satisfactorily accomplished only by a competent entomologist in the field throughout the summer.

"The codling moth under present conditions can not be well controlled in the lower Grand Valley in Colorado by means of a calyx spray and one or two cover sprays. Burlap bands properly applied and attended are a very important aid, and will lessen the late brood by fully 30 to 40 per cent. Stings or shallow burrows through the skin of the apple are nearly all due to worms being poisoned while attempting to enter the fruit that has been given a poisonous cover spray."

European corn borer in broom corn. W. R. WALTON (*Jour. Econ. Ent.*, 13 (1920), No. 1, p. 147).—From 1 to 5 per cent of the stalks of broom corn in a shipment of 97 bales, each weighing about 200 lbs., which originated in the territory of Venetia, northern Italy, was found upon receipt at New York in February, 1920, to be infested by the European corn borer (*Pyrausta nubilalis* Hubn).

Method of procedure in pink bollworm eradication work in Texas. E. E. SCHOOL (*Jour. Econ. Ent.*, 13 (1920), No. 1, pp. 38-44, pl. 1).—This is an account of the eradication work with *Pectinophora gossypiella* carried on in Texas.

The European corn borer problem, E. P. FELT (*Jour. Econ. Ent.*, 13 (1920), No. 1, pp. 59-91).—This is a general exposition of the European corn borer problem, followed by a discussion of the subject by C. L. Marlatt (pp. 73-86) and others.

The mosquito must go, T. J. HEADLEE and M. CARROLL (*New Jersey Stat. Circ.* 111 (1919), pp. 3-44, figs. 11).—This is a discussion of the mosquito problem in New Jersey, in which the results already obtained are reviewed and the work still to be accomplished is set forth. The benefits obtained from mosquito elimination are emphasized, and correspondence relating to the subject is appended.

State laws concerning mosquito control work in New Jersey (*New Jersey Stat. Circ.* 110 (1919), pp. 8).—The texts of the laws relating to mosquito control in New Jersey are here brought together.

Anopheles quadrimaculatus and A. punctipennis in salt water, F. E. CHIDESTER (*Science*, n. ser., 51 (1920), No. 1314, pp. 244, 245).—The author records the rearing of several adults of *A. quadrimaculatus* and *A. punctipennis* from larvæ taken in brackish water.

Notes on poisoning the boll weevil, W. NEWELL and E. K. BYNUM (*Jour. Econ. Ent.*, 13 (1920), No. 1, pp. 123-136, pl. 1, figs. 5).—This is a report of an investigation made to determine whether the presence of dew or rain water on cotton plants is necessary to the effective use of arsenates. The results have been summarized as follows:

"The mortality among boll weevils on cotton plants treated with lead and calcium arsenates and kept protected from all rain and dew was appreciably higher than the mortality on plants similarly treated but exposed to dew and normal precipitation. As the presence of dew or rain water on the cotton plants does not increase the effectiveness of either lead or calcium arsenate as a boll weevil poison, it is evident that mortality from the use of either poisons is brought about by ingestion of the poison with the weevil's food and not by drinking the so-called 'poisoned dew.'

"Dew collected from cotton plants treated with lead arsenate at the rate of approximately 8 lbs. per acre was found, upon analysis, to contain 6.7 parts of arsenic per million. Dew from plants treated with calcium arsenate at the same rate was found to contain from 10 to 43.5 parts of arsenic per million. The dew was collected only from cotton leaves that showed a distinct, thorough white coating of the arsenates.

"Boll weevil deprived of all food and having dew from treated plants as the only source of moisture suffered a greater mortality than boll weevils confined on clear water, showing that the dew contained sufficient arsenic to produce death when the weevils were compelled to take the dew and no other food or water over a period of several days. However, such a condition does not occur in cotton fields. When boll weevils had access to food in the form of nonpoisoned cotton squares and, at the same time, to dew from treated plants, no mortality resulted, showing that the weevil can be poisoned under normal conditions only by poisoning its food."

The following conclusions have been drawn: "As the boll weevil is poisoned largely or entirely through taking poison with its food, machinery for applying the poison to the cotton plants should be so designed as to apply the poison primarily to the squares, bolls, and terminal buds, rather than to the foliage. The greatest mortality among the boll weevils occurred on the third day following application of the arsenates and fell off rapidly after the seventh day, indicating that, other things being equal, application should be at intervals of a week, or less, apart."

Some new injurious weevils from Asia, G. A. K. MARSHALL (*Bul. Ent. Research*, 9 (1919), No. 4, pp. 273-277, pl. 1).—The species here described as new are *Antinia theivora*, found feeding on tea plants in West Java; *Dyscerus fletcheri*, found boring into growing apple fruits and also breeding in logs of chir pine; (*Pinus longifolia*), in Assam and the United Provinces; *D. malignus*, puncturing apple fruits in Assam; and *Alcides mali*, boring in the shoots of apple trees in Assam.

Two *Rhynchophora* found feeding in sweet potatoes, O. W. ROSEWELL (*Jour. Econ. Ent.*, 13 (1920), No. 1, p. 148).—*Xyleborinus pecanis* Hopk. and *Platypus compositus* Say are said to have damaged sweet potatoes in various parts of Louisiana.

Preliminary notes on the value of winter protection for bees, J. H. MERRILL (*Jour. Econ. Ent.*, 13 (1920), No. 1, pp. 99-111, figs. 5).—"Directions have been given in previous publications as to the method for giving bees winter protection. The purpose of this work is to secure data showing the necessity of using this winter protection. Six hives containing a known amount of honey and a known number of bees were placed on scales, and daily readings taken of all changes in weight. Three of these hives were sheltered by a windbreak while the others were not. Each set of three consisted of one one-story hive, one two-story hive, and one packed hive. In addition to making daily readings of the changes in weights, a general weighing was made at the beginning of the honey flow in the spring to determine the number of bees in the colonies on that date.

"These observations show that the two-story hive is preferable to the one-story hive and the packed hive is much to be preferred over the unpacked hive. It was also shown that a windbreak is very essential, especially to colonies which have no other form of winter protection. The effect of a severe winter was found to be less injurious to the overwintering of bees than an open winter. Colonies which are packed for the winter consume more stores owing to the fact that more stores are necessary, due to increased brood rearing."

Honey as a carrier of intestinal diseases, W. G. SACKETT (*Colorado Sta. Bul.* 252 (1919), pp. 3-18).—This is a report of two series of studies made of the longevity of ten forms of bacteria of the colon-typhoid group in extracted honey. An extra fine, extracted, alfalfa honey which crystallized readily at 20° C. (68° F.) was used in the investigation. In determining the effects of concentration upon the bacteria studied, the honey was diluted with physiological salt solution to percentages varying from 0 to 90. The first series of experiments was conducted with new fall honey, the acidity of which expressed as formic acid was 0.11 per cent; the second series with fall honey six months old, the acidity of which was 0.09 per cent.

In the first series *Bacillus typhosus* remained alive in pure honey for 48 hours; in dilutions above 50 per cent, it was dead after 24 hours. After 48 hours it had disappeared from the 50 per cent solution; after 3 days it was alive only in the 10 per cent and in the salt solution control, and after 4 days it was present only in the control, where it was still alive after 40 days. In the second series, *B. typhosus* was no longer present in the pure honey after 24 hours and was absent from the dilutions above 50 per cent in 10 hours. After 24 hours, it had disappeared from the 30, 40, and 50 per cent dilutions; after 48 and 72 hours it was no longer present in the 20 and 10 per cent dilutions, respectively.

In the first series, *B. paratyphosus* B was among the most sensitive organisms studied, having disappeared from the pure honey in 48 hours and altogether from dilutions above 30 per cent in 24 hours. In the second series, it

was dead in the pure honey in 24 hours, and after 10 hours all were dead in the dilutions above 20 per cent. In the first series *B. paratyphosus* A exhibited about the same degree of injury from the higher concentration as *B. paratyphosus* B, being dead after 24 hours in pure honey and all dilutions above 30 per cent. In the second series, it was dead in the pure honey after 24 hours, and in 10 hours in dilutions above 20 per cent.

In the first series, *B. dysenteriae* was destroyed in the pure honey in dilutions above 40 per cent in 10 hours. In the second series, it was present in the pure honey after 5 hours but absent after 10, and had disappeared in 5 hours in all dilutions above 20 per cent. Other bacteria tested are *B. fecalis alkaligenes*, *B. proteus vulgaris*, *B. suipestifer*, *B. coli communis*, *B. enteritidis*, and *B. lactis arogenes*.

"The failure of the organisms to die out as readily in the concentrated honey as in the dilutions was rather surprising. A possible explanation of this suggests itself in the physical state of the sugar particle in the honey. Assuming the honey to have been a saturated solution, and this appears to have been the case, there is a probability that we had here a colloidal solution with low osmotic pressure. In such a solution, plasmolysis would take place relatively slowly. When water was added, as in the dilutions, some of the colloidal sugar passed over into molecular solution, the osmotic pressure increased, and plasmolysis became more active."

The results show the longevity of the typhoid-colon group in honey to be very limited, and the probability of honey acting as a carrier of typhoid fever and other diseases is very slight.

Note on *Eriopyga incincta* Morr., F. M. WADLEY (*Jour. Econ. Ent.*, 13 (1920), No. 1, p. 148).—Biological notes are given on this cutworm-like caterpillar. It was abundant at Wichita, Kans., during the spring of 1918, having been found in great numbers in small areas of alfalfa and about the edges of gardens.

The present status of the control of *Dermacentor venustus* Banks in the Bitter Root Valley, Mont., and new data concerning the habits of the tick, R. R. PARKER (*Jour. Econ. Ent.*, 13 (1920), No. 1, pp. 31-37).—This paper includes data on the migration of *D. venustus* and the reaction of engorged seed ticks to light.

FOODS—HUMAN NUTRITION.

The food and drug manual (*U. S. Dept. Agr., Bur. Chem., Food and Drug Manual*, Jan. 26, 1920, pp. 155, figs. 4).—This manual, which supersedes one published in 1911, gives complete instructions regarding the procedure to be followed by officials, analysts, and inspectors of the Bureau of Chemistry, U. S. Department of Agriculture, in the enforcement of the Food and Drugs Act of 1906.

The digestibility of chicken skin, E. F. KOHMAN and H. A. SHONLE (*Jour. Biol. Chem.*, 41 (1920), No. 4, pp. 469-472).—Two metabolism experiments on human subjects are reported in which from 65.1 to 67.5 per cent of the nitrogen of the diet was supplied by chicken skin freed from extraneous fat and fried in balls. The skin as used had 26.3 per cent of fat and 3.03 per cent of nitrogen. The experimental period was preceded and followed by periods of the same length in which the same amount of nitrogen was supplied by meat, eggs, and milk, the basal diet throughout consisting of apples, prunes, oranges, lettuce, tomatoes, sugar, tapioca, bread, potatoes, and butter.

The percentage utilization of nitrogen in the three periods was 87.02, 85.61, 84.94, respectively, for one of the subjects and 83.69, 83, and 86.49 for the other.

The conclusion is drawn that the nitrogen of chicken skin is as well utilized as that of meat, eggs, and milk.

The extraction of "fat-soluble vitamin" from green foods, T. B. OSBORNE and L. B. MENDEL (*Proc. Soc. Expt. Biol. and Med.*, 16 (1919), No. 6, pp. 98, 99).—The authors state that they have obtained potent preparations of fat-soluble vitamin from plant tissues, such as spinach leaves and young clover by drying the material in a current of air at about 60° C., extracting with U. S. P. ether, and evaporating the extract on starch. These preparations fed in daily quantities equivalent to from 1 to 2 gm. of the dried plant promoted recovery and renewal of growth in rats on diets deficient in fat-soluble vitamin.

It is pointed out that these results are contrary to those obtained by McCollum, Simmonds, and Pitz, previously noted (*E. S. R.*, 36, p. 61).

Nutritive factors in plant tissues.—IV, Fat-soluble vitamin, T. B. OSBORNE and L. B. MENDEL (*Jour. Biol. Chem.*, 41 (1920), No. 4, pp. 549–565, figs. 11).—In continuation of the investigation previously noted (*E. S. R.*, 42, p. 759), a study is reported of the potency of green vegetables, roots, etc., as sources of fat-soluble vitamin as compared with milk, fat, egg, etc. Growing rats were fed the various products apart from the basal food mixture in daily doses of approximately 0.1 gm. of the substance air-dried at 60° C. or less and ground to a powder. For purposes of comparison a series of rats was fed 0.1 gm. of butter fat daily instead of the dried vegetables, this amount representing from 1 to 1.4 per cent of the food mixture.

With this amount of butter, good growth results were obtained for about 80 days. In comparison with this, two rats receiving only 0.1 gm. of tomato daily grew rapidly to exceptionally large adult size and showed no signs of a failure of nutrition at the end of 394 days. It is thought that the very rapid growth in this series of experiments may have been due in part to the richness of the tomato in water-soluble vitamin and possibly also to its content of antiscorbutic vitamin. Alfalfa, clover, timothy, and spinach in amounts of 0.1 gm. of the dried substance furnished relatively as much of this vitamin as does 0.1 gm. of butter fat.

The growth results with carrots were not quite so satisfactory and with cabbage the least satisfactory. That the partial failure of cabbage was not due to drying is considered satisfactorily proved from the positive results obtained with the other dried vegetables. In the experiments with potatoes large quantities were used (20 per cent of the food). The fact that two of the rats grew to large size on the potato food indicated that the tuber can not be entirely devoid of fat-soluble vitamin.

"The newer studies indicating the richness of many types of plant tissues in those nutritive properties termed vitamins place the dietary importance of the green vegetables in an entirely new light. It emphasizes their use to supplement the refined foods of the modern food industry, which furnish products rich in proteins, fats, and carbohydrates but in many cases comparatively deficient in the vitamins. The facts cited in the present investigation, along with others recently published, serve as an added reminder that the fat-soluble vitamin need not be sought solely in foods known to be rich in fats."

Milk as a source of water-soluble vitamin.—II, T. B. OSBORNE and L. B. MENDEL (*Jour. Biol. Chem.*, 41 (1920), No. 4, pp. 515–523, figs. 4).—To determine whether the necessity of a relatively large quantity of milk as a source of water-soluble vitamin in the feeding experiments with rats previously noted (*E. S. R.*, 39, p. 570) might not be due to inferior quality of the milk from a vitamin standpoint owing to the winter diet of the cows, a further series of

experiments of similar nature was carried out using as the sole source of the water-soluble vitamin fresh unpasteurized milk from cows fed in open pasture.

The results of these experiments confirm in every way those reported in the previous contribution, even 15 cc. of the milk proving inferior to 0.2 gm. of dried brewer's yeast as a source of water-soluble vitamin. As a further attempt to explain the remarkable results obtained by Hopkins in experiments in which very small amounts of milk were used (E. S. R., 2S, p. 260), the diets used by him were imitated as closely as possible by using, as the salts, the ash from dog bread and whole oats. No essential difference in results was obtained, additions of 10 cc. of fresh milk proving inefficient as a source of water-soluble vitamin.

Attention is called to the recent studies on the antiscorbutic value of cow's milk, which indicate that milk is less valuable as an antiscorbutic than many of the raw fruits and vegetables.

Creation of vitamins in the intestines of rabbits receiving food sterilized at high temperature, P. PORTIER and L. RANDOIN (*Compt. Rend. Acad. Sci. [Paris]*, 170 (1920), No. 8, pp. 478-480).—In experimenting with rabbits on the sterilized vitamin-free diet previously described (E. S. R., 42, p. 365) the discovery was made that one of the rabbits through eating its own feces was able to survive and even gain in weight on a vitamin-free diet which caused the death of the remaining rabbits. Further experiments on the addition of rabbit feces to vitamin-free diets fed to other rabbits and to pigeons have confirmed the authors' conclusion that vitamins have been synthesized in the intestines of the rabbits. The theory is advanced that this synthesis has been effected through the agency of intestinal bacteria.

Accessory food factors in infant feeding (*Brit. Med. Jour.*, No. 3088 (1920), pp. 328, 329).—This is a résumé of a discussion on the influence of vitamins in infant feeding which took place at a meeting of the Section for the Study of Diseases of Children of the Royal Society of Medicine (England) on February 27, 1920. The discussion, which was opened by E. Mellanby, was confined principally to rickets as a deficiency disease.

Energy requirements of children from birth to puberty, F. G. BENEDICT (*Boston Med. and Surg. Jour.*, 181 (1919), No. 5, pp. 107-139, figs. 29).—The author, from the Nutrition Research Laboratory of the Carnegie Institution, presents and discusses data on the basal metabolism of healthy normal children from birth up to 8 days, and from 8 days to 14 years of age as determined by indirect calorimetry. The respiration chambers used in both series of experiments are described and illustrated, and the data are given in tables and curves.

The data on infants from birth up to 8 days of age were obtained at the Massachusetts General Hospital and the Boston Lying-in Hospital, and have been previously noted in part from another source (E. S. R., 42, p. 168). The average heat production per day of the 94 subjects was 143 calories, the heat production per kilogram of body weight 42 calories, and the heat production per square meter of body surface 612 calories. The average pulse rate of a newborn baby resting quietly was 112 per minute.

In obtaining data on growing children two methods were used, (1) that of studying relatively large numbers of infants of different sex, age, height, and weight and comparing the average values found, and (2) that of studying the same individual over a longer period of time. The data were obtained on normal children of wet nurses and on children in the New England Home for Little Wanderers. Some 25 children were studied over periods ranging from several months to three or four years. Attention was given to the selection of as normal children as possible with the exclusion of all of underweight.

As an example of the energy changes in the same individual the report is given of the results obtained on a girl baby from the age of 10 months to 4 years, 3.5 months. The total heat production in this subject rose sharply for about 2.25 years, after which it was reasonably uniform. The heat production per kilogram of body weight decreased from 70 calories per kilogram at one year to 44 at the end of the experimental period. The heat production per square meter of body surface decreased during the same period from 1,456 to 1,059 calories, which, it is pointed out, is strikingly at variance with the popular conception of a uniformity in heat production per square meter of body surface.

The general results in the group metabolism experiments may be summarized as follows: With both boys and girls the total caloric output increased with age and with weight. The curves of heat production per kilogram of body weight increased up to 1 year of age, after which there was a gradual decrease with no profound alteration in the metabolism at or about puberty. Similar curves were obtained when the heat production per kilogram of body weight was plotted against the total weight. Curves of heat production per square meter of surface plotted against age showed wide individual variations, but were characterized by very low values during the first week, a rapid rise at about 1 or 2 years, and then a steady decline to 14 or 15 years.

Figures for the basal heat production of boys and men per 24 hours referred to body weight were found to conform closely. A slightly greater break in the continuity of the curve was noted in the comparison of girls and women. A similar comparison of the heat production of boys and girls showed no difference up to about 8 kg., when the curve for boys rose perceptibly above that of girls until it reached 35 kg., after which the curve for girls rose above that for the boys. The curves of heat production per kilogram of body weight referred to total weight showed no sex differences until after about 10 kg. in weight, when the curve for the boys remained above that of the girls up to 31 kg. The curves of heat production per square meter of surface referred to weight showed no difference up to about 8 kg., after which the boys showed a somewhat higher metabolism. For weights above 10 kg. the average difference between the two sexes was about 75 calories per square meter per 24 hours.

In conclusion it is emphasized that these data represent only basal metabolism, and that the factor of the extra energy needs above the basal minimum in growing children is one of great variability and probably much larger than commonly believed.

Feeding the baby, A. C. JENSEN (*Missouri Agr. Col. Ext. Circ. 73 (1920)*, pp. 8).—This circular gives simple directions for weaning the well baby and for the proper selection and preparation of foods from the weaning period through the second year. Special emphasis is placed on the gradual training of the digestive tract to care for new food.

Nutrition clinics and classes: Their organization and conduct, W. R. P. EMERSON (*Boston Med. and Surg. Jour.*, 181 (1919), No. 5, pp. 139-141).—This is a brief description of methods of conducting nutrition clinics and classes for malnourished children.

A graphic method for balancing the Army ration, M. H. JACOBS (*Military Surg.*, 44 (1919), No. 6, pp. 600-611, figs. 3).—A graphic method for the proper balancing of the diet with respect to protein, fat, and energy content has been devised which is said to offer the advantages of requiring no previous acquaintance with the use of the terms calorie, protein, etc., of giving quantitative results without calculations, of furnishing a vivid picture of the nature of each

article of food and what it contributes to the end result, and of determining the cost of the menu at all stages of its construction.

The general principle of the method is to represent the energy, protein, and fat content of a definite amount of food by the lengths of three vertical parallel lines starting from a common base line. A different scale is chosen for each of the three parallel lines, so that the distance representing a given number of calories and the amounts of protein and fat thought appropriate to this energy are equal in length, giving a horizontal line as the upper boundary of the figure when the balance is perfect. The standard chosen is sufficient protein to supply 12.5 per cent and sufficient fat to supply about 25 per cent of the total energy. In the figures given to represent the balance of a few typical articles of food, 1 cm. on the energy line=100 calories, on the protein line=3.05 gm., and on the fat line 2.69 gm. Horizontal dotted lines measured in centimeters from the base line represent the cost in cents of the amount of material represented by the figures. To build up the day's menu, measurements of the different foods selected are added to the proper lines, the final lengths of the three lines indicating the balance of the ration.

Two appendixes are included, one outlining a suggested method of presenting the subject as simply as possible to mess sergeants and the other giving data on the quantities of nutritive constituents in the articles commonly used in Army messes, the energy per pound of the food material, and the lengths in centimeters of the lines used in representing graphically the energy, protein, and fat in a 0.1 lb. portion.

Deficiency diseases in the army, L. BRUNTZ and L. SPILLMANN (*Prog. Méd.* 2 (1919), pp. 9-13).—This is a general discussion of deficiency diseases in the French Army with particular reference to trench-foot.

Summary of Bureau of Chemistry investigations of poisoning due to ripe olives, G. G. DE BORD, R. B. EDMONDSON, and C. THOM (*Jour. Amer. Med. Assoc.*, 74 (1920), No. 18, pp. 1220, 1221).—This is a summary of the general findings in the investigation by the Bureau of Chemistry, U. S. Department of Agriculture, of ripe olive poisoning (*E. S. R.*, 42, p. 761).

In the investigation 2,161 commercial containers were examined, of which 560 were glass and 1,601 were tin. Cultures made from the first 500 containers showed that satisfactory odor and appearance were uniformly accompanied by sterility, while an offensive odor was noted on opening all the cans later proved to be infected with *Bacillus botulinus*.

B. botulinus of type A (*E. S. R.*, 42, p. 260) was isolated from the batches of olives responsible for the outbreaks in Ohio and Michigan (*E. S. R.*, 42, pp. 261, 262), in New York (*E. S. R.*, 42, p. 558), and in Tennessee, and was also found in bits of dried pimento stuffing from the inside of an empty bottle which had contained stuffed olives, apparently the cause of the death of five persons in Kalispell, Mont. Olive relish, which recently caused the death of one person in Richmond, Cal., was found to contain a toxin which indicated the presence of *B. botulinus*.

Many species of organisms other than *B. botulinus*, including members of the colon group and nonsporulating aerobes, were found in the samples examined, indicating that the amount of heat applied in the commercial processes employed was entirely inadequate for sterilization. The practice of shipping olives and holding them in water or weak brine is also thought to be undesirable in that during this holding period a container infected with any particular organism becomes contaminated throughout by the multiplication of the organism.

In conclusion, it is recommended that to prevent further outbreaks of botulism more efficient sterilization should be employed, shipping or holding in

brine solutions should be so modified as to exclude undesirable fermentations, and the same care and cleanliness should be used in the handling of olives as of any other perishable food product.

Botulism, E. C. DICKSON, G. S. BURKE, and E. S. WARD (*Arch. Inst. Med.*, 24 (1919), No. 6, pp. 581-599).—The investigation reported consists of experiments to test the resistance of spores of *Bacillus botulinus* to various sterilizing agencies including heat, dilute acids (lemon juice), and sugar, and tests of various methods of canning vegetables and fruits which had been inoculated with spores of *B. botulinus*.

The results of the experiments on the effect of heat upon the spores, as reported by Burke, have been previously noted from another source (E. S. R., 40, p. 558). Lemon juice in the concentration recommended by Cruess for canning vegetables (E. S. R., 36, p. 509) did not prevent the growth of the organism nor the development of toxin in the beef broth used as the culture medium. The amount of toxin was, however, considerably less than that in the control broth. The addition of lemon juice in varying concentrations to the spores of *B. botulinus* in brain medium lowered the thermal death point of the spores to a degree dependent on the concentration of the lemon juice, the temperature, and the length of the exposure. The Cruess method of canning vegetables with lemon juice, and the fractional method of sterilization described by Breazeale (E. R. S., 21, p. 278) both proved efficient in destroying the spores of *B. botulinus* with which the raw vegetables had been contaminated. The one-period cold-pack method described by Benson (E. S. R., 38, p. 12) proved inefficient under similar conditions.

Cane sugar in concentration up to 64 per cent did not prevent the growth of *B. botulinus* or the formation of its toxin in beef broth, although the toxin formation was inhibited to a certain extent. Apricots, peaches, and pears canned in sugar were found to be suitable mediums for the growth of *B. botulinus* and the development of its toxin. The one-period cold-pack method applied to peaches and prunes with or without sugar was found to be inefficient in killing the spores of *B. botulinus* with which the fruit had been inoculated, although the presence of the toxin in the product could not be determined in the usual way.

The significance of these results is discussed, and the conclusion is drawn that "even though the number of cases of poisoning caused by the ingestion of canned goods is small, they should not be disregarded. In view of the wide distribution of *B. botulinus* throughout the country it is important that the possibility of raw material being contaminated should always be borne in mind, and investigation should be undertaken to perfect methods of canning which will be efficient in destroying this resistant organism. Until this is done it will be necessary to instruct the public of the possible danger from existing methods of canning, and to urge that all canned food which shows the slightest sign of spoilage should be discarded."

ANIMAL PRODUCTION.

Concerning the causal factor in the hatching of the chick, with particular reference to the musculus complexus, A. G. POHLMAN (*Anat. Rec.*, 17 (1919), No. 2, pp. 89-104, figs. 1).—In a series of chicks ranging in age from the nineteenth day of incubation to the eighth day after hatching, the author reports the weights of the complexus muscle of the upper neck in both the fresh and dried states. The contraction of this muscle extends the head and according to F. Keibel, whose brief note¹ is presented in translation by the author, the muscle

¹Anat. Anz., 41 (1912), No. 13, pp. 381, 382.

is greatly enlarged at the time of hatching and causes the egg-tooth to push through the shell. The author found that this muscle attained its maximum weight on the day of hatching and decreased in size rapidly after hatching, but the proportion of dry matter in the muscle was lower at hatching than at any other time. Similar but less marked results were shown by the flexor muscle of the thigh which was selected as the control. It is concluded that the infiltrated complexus is incapable of pronounced contractions at hatching, and the following suggestions are offered as to the mechanism of hatching:

"The active muscular agent in breaking the shell comes about through a change in posture of the head and upper cervical vertebrae chiefly dependent on the musculus biventer and musculus spinalis. The reflex mechanism which touches off this muscle system is probably a respiratory reflex, not dependent on demand for oxygen, but dependent on distension of the abdomen, particularly the musculus levator ani, brought about through injection of the yolk sac [into the digestive tract]."

The lymph infiltration is attributed to this rapid absorption, and to the failure of the kidneys to take care of the excess of water. "Not until respiration sets in does the general edema disappear, which implies that most of the water in birds is excreted by the lungs, and also accounts for the ability of the newborn chick to go at least three days and perhaps four and even five days without water."

Emergency feeding in Sweden during the war, J. A. FRIES (*Natl. Stockman and Farmer*, 44 (1920), No. 3, pp. 98, 100).—The author presents a table based on results of Swedish investigators showing for *Phragmites communis* (a grass), the leaves of various trees, and wood pulp cellulose the proportions of organic matter digested by live stock and the number of feed units and amount of digestible protein per 100 kilograms. The successful use of cellulose as a partial substitute for oats for work horses and as a feed for cows is noted.

War-time feeding stuffs, M. KLING (*Die Kriegsfuttermittel. Stuttgart: Eugen Ulmer, 1918, pp. VII+214*).—Most of the material in this book is taken from the author's papers previously noted (E. S. R., 42, p. 369).

The production of feeding stuffs from plants in Germany, MÜLLER-LENIHARTZ (*Die Erzeugung von pflanzlichen Nährstoffen im Deutschen Reiche. Leipzig: Hans Wehner, 1917, pp. 32*).—A statistical study and estimate of the supply of plant material available for animal feeding.

Sesbania: A feeding stuff from South Africa (*Bul. Imp. Inst. [London], 17 (1919), No. 2, pp. 184-186*).—A sample of Sesbania seeds (thought to be *S. aculeata*) analyzed had the following percentage composition: Water 9.6, crude protein 32.9, fat 6.2, fiber 10.9, other carbohydrates 39, and ash 1.4. The seeds yielded no hydrocyanic acid.

The production and use of concentrated feeding stuffs, H. SVOBODA (*Die Erzeugung und Verwendung der Kraftfuttermittel. Vienna and Leipzig: A. Hartleben, 1915, pp. VII+600, figs. 59*).—This handbook deals with the conversion into feeding stuffs of a wide variety of agricultural and industrial by-products. Data as to the chemical composition of the feeds are assembled from various sources.

Microscopic control of feeds, W. KINZEL (*Mikroskopische Futtermittelkontrolle. Stuttgart: Eugen Ulmer, 1918, pp. 100*).—The author lists a large number of materials, mainly of plant origin, to be found in mixed feeds either as adulterants or as legitimate constituents, and discusses their identification under the microscope.

International trade in concentrated cattle foods (*Internatl. Inst. Agr. [Rome], Bur. Statis. Doc. Leaflets 3 (1919), No. 12, pp. 40*).—A compilation of

statistics of the exports, imports, and prices of residues from the milling, oil extraction, sugar making, brewing, and distilling industries throughout the world. In general the data cover the year 1918 and most of 1919 and continue similar compilations previously noted (E. S. R., 41, p. 176).

Proceedings of the twenty-first and twenty-second annual conventions of the American National Live Stock Association (*Proc. Amer. Natl. Live Stock Assoc.*, 21 (1918), pp. 197, pls. 16; 22 (1919), pp. 188, pls. 13).—These publications contain the addresses delivered during meetings held, respectively, at Salt Lake City in January, 1918, and at Denver in January, 1919, together with the committee reports presented and the texts of resolutions adopted. The 1918 meeting was concerned largely with the activities of the U. S. Food Administration in live stock matters.

A list of breeders of pure bred live stock in Montana (*Montana Sta. Spec. Circ.* 5 (1918), pp. 24).—The list is classified by breeds.

Final results of live stock for the year 1918-19, and report thereon, W. L. JOHNSTON (*So. Aust. Statis. Dept. Bul.* 2 (1919), pp. 4).—Statistics for the year ended June 30, 1919, as to the numbers of cattle, horses, sheep, pigs, goats, and other stock in the several political divisions of South Australia, together with information on the market prices of stock, the wool clip, and dairy production.

Swine, sheep, and goats in the Orient, C. O. LEVINE (*Jour. Heredity*, 11 (1920), No. 3, pp. 117-124, figs. 6).—The author gives an account of the swine industry in southern and western China, together with brief notes on the fat-tailed sheep and the native black and white meat goats of northern China.

In the vicinity of Canton the native hogs are of the lard type, are black and white in color, and have straight tails. "They are slow in maturing. Twelve hogs at the Canton Christian College in 1917 made an average gain, at six months of age, of about 0.65 of a pound on full feed. When one year old they usually weigh from 200 to 250 lbs. The average dressing per cent of 32 hogs butchered at the college in 1917 and 1918 was 72.5 per cent." Females not used for breeding are spayed. Large numbers of hogs are fed by concerns manufacturing rice wine. The hogs are fed for 200 to 250 days and when marketed weigh from 140 to 200 cattles (190 to 270 lbs.) About 6 lbs. of the dried rice wine by-product grains are required for a pound of gain. Other hogs are fed by householders in the villages, the feed being mainly a mixture of cheap grades of rice chop and rice bran.

In Yunnan and Szechuan the hogs, chiefly of the bacon type, are allowed to graze in the woods.

Irish cattle, R. C. AULD (*Live Stock Jour.* [London], 91 (1920), No. 2400, pp. 338, 340, 341, III).—The author discusses the ancient cattle of Ireland, particularly the polled breed, and discounts the theory of the Scandinavian origin of the polled cattle of Ireland and England.

Scottish pure bred live stock.—I, Aberdeen-Angus cattle, J. R. BARCLAY (*Scot. Jour. Agr.*, 2 (1919), No. 4, pp. 456-464, pls. 4).—A history of the breed and its distribution throughout the world, by the secretary of the Aberdeen-Angus Cattle Society.

Scottish pure bred live stock.—II, Shorthorn cattle, W. MACKAY (*Scot. Jour. Agr.*, 3 (1920), No. 1, pp. 6-16, pls. 4).—A history of the Shorthorn in Scotland, together with a discussion of the "Scottish" type and its popularity in other countries.

Experiments in crop utilization, C. R. LETTER (*U. S. Dept. Agr., Dept. Circ.* 73 (1920), pp. 34-38).—Experiments conducted at San Antonio, Tex., to determine the value of winter oats and Sudan grass for pasture are reported.

Two steers pastured on $1\frac{1}{2}$ acres of oats for 34 days made a daily gain of 2.5 lbs. each, which at 10 cts. per pound made the oat pasture worth \$11.27 per acre. On a similar basis Sudan grass pasture gave a value of \$11.45 per acre and furnished in addition 2,501 lbs. of hay per acre. When steers were fed on Sudan grass hay their gain in weight represented a value of \$7.36 per ton of hay. Adverse seasonal conditions interfered to some extent with the experiment, but the results are regarded as indicating that winter oats makes a very satisfactory pasture crop for beef cattle. The utilization of Sudan grass for pasture in view of the present prices of hay is thought questionable.

Cattle feeding trials with rice meal, N. S. MCGOWAN (*Rpt. Dept. Agr. Bihar and Orissa, 1917-18, pp. 8-13*).—Rice meal, peas, and mustard oil cake (4:4:3) was compared with oats and mustard oil cake (8:3) as a grain ration for 4 milch cows and 8 work oxen receiving durra fodder and mixed straw as roughage. During rice meal feeding the milk and butter fat yields of the cows and the rate of growth of the oxen were slightly lower than when oats were fed, but this was more than compensated for by the lower feed costs.

Some fundamental factors that determine progress in farm sheep breeding, E. G. RITZMAN (*New Hampshire Sta. Tech. Bul. 14 (1919), pp. 3-21*).—This bulletin consists of a reprint of the author's paper on ewes' milk previously noted (*E. S. R.*, 36, p. 569), an excerpt of his paper on the growth of lambs (*E. S. R.*, 38, p. 472), and unpublished material on multiple births, growth, and forced feeding of lambs. The discussion emphasizes the importance of the lamb crop in farm sheep breeding and the necessity of recognizing the ewe as the productive unit.

Growth data of lambs born singly and as twins are summarized. "A single lamb at birth is 24 per cent heavier than an average lamb born as twin. During the first 56 days (the period when ewes give the heaviest flow of milk and lambs depend most on milk diet), the single lamb grows faster than a twin which shares its milk with another, so that at the end of this period the single weighs 30 per cent more than an average twin. At 84 days the single weighs 25.6 per cent more than a twin. During this period lambs come to depend to a much larger extent on feed other than milk so that twins have a more nearly equal chance with a single for an abundance of suitable food." At 180 days a "single" weighs only 13.2 per cent more than an average twin, while a pair of twins is 76.6 per cent heavier than a "single."

A group of 133 lambs fed grain as early as they would consume it averaged 45 lbs. in weight at 12 weeks and 76.3 lbs. at 28 weeks. Another group not fed grain made the same growth up to 12 weeks, but at 52 weeks their average weight was only 67 lbs.

The effects of some of the most common sheep dips on wool, J. I. HARDY (*Wyoming Sta. Rpt. 1919, pp. 164-167*).—The force required to break locks of wool after dipping is recorded. Seven proprietary dips were tested and the breaking force varied from 277.3 to 258.4 gm. Since untreated wool broke at 284.6 gm., the effect of the dips is considered unimportant.

The reindeer and its domestication, B. LAUFER (*Amer. Anthropol. Assoc. Mem.*, 4 (1917), No. 2, pp. 91-147).—The author discusses the domestication of the reindeer, mainly from the standpoint of ethnology, and cites a number of Chinese references to the use of the reindeer in Manchuria and other parts of Asia.

Notes on reindeer nomadism, G. HATT (*Amer. Anthropol. Assoc. Mem.*, 6 (1919), No. 2, pp. 75-133, figs. 2).—An ethnological study dealing to some extent with the reindeer as a domestic animal in Finland and the Scandinavian Peninsula.

Swine feeding trial with bone glue as protein-sparing feed, AHR and C. MAYR (*Landw. Jahrb. Bayern*, 7 (1917), No. 8, pp. 669-691).—The author reports an 84-day test with 36 hogs, the results indicating that bone glue (osteocolla) is about equal to a mixture of fish meal and meat meal as a supplement to a protein-poor grain ration composed of barley and oat offals.

The swine of southern Albania, C. MANETTI (*Agr. Colon. [Italy]*, 13 (1919), No. 8, pp. 288-301, figs. 3).—The author reports observations on the physical characteristics (including a few body measurements) of the two chief breeds of swine in southern Albania, the native mountain breed and the Epirote breed.

Bibliography of the horse, G. R. MENNESSIER DE LA LANCE (*Essai de Bibliographie Hippique. Paris: Lucien Dorbon, vol. 1, 1915, pp. VII+760; vol. 2, 1917, pp. 736*).—The author has attempted to list and describe all works dealing with horses and cavalry published in French or Latin since the invention of printing. A number of biographical notes of authors are included.

The first two years of the Vineland contest: A study of the results obtained during the first two years at the Vineland international egg-laying and breeding contest, H. R. LEWIS, R. R. HANNAS, and E. H. WENE (*New Jersey Stat. Bul.* 338 (1919), pp. 5-96, pls. 7, figs. 31).—The authors tabulate and discuss various records secured during the first two years of the Vineland egg-laying contest begun November 1, 1916, and ended three years later. The contest started with 100 pens of 10 pullets each, which were trap-nested for two years. During the spring of 1918 a male was added to each pen and chicks were raised from the eggs. During the final year daughters of the original birds occupied the pens.

The data presented include the exhibition scores by breeds, egg records of individual birds each year, length of molting period, body weights of birds of different breeds, egg weights, feed consumption, amount of broodiness, financial returns, hatching and brooding results, and mortality. The interrelationship of many of these are shown by means of graphs. Some of the more important data have been noted from preliminary reports in *Hints to Poultrymen* (E. S. R., 41, p. 76; 42, p. 170). The following table compares the four breeds entered with respect to egg production and broodiness as pullets and as yearlings:

Egg production and broodiness of pullets and yearling hens.

Year.	Plymouth Rocks.			Rhode Island Reds.			Wyandottes.			Leghorns.		
	Eggs per bird.	Production.	Average time broody.	Eggs per bird.	Production.	Average time broody.	Eggs per bird.	Production.	Average time broody.	Eggs per bird.	Production.	Average time broody.
First.....	155.0	<i>Per ct.</i> 42.5	<i>Days.</i> 16.2	150.6	<i>Per ct.</i> 41.2	<i>Days.</i> 20.3	144.3	<i>Per ct.</i> 39.5	<i>Days.</i> 23.3	169.7	<i>Per ct.</i> 46.5	<i>Days.</i> 1.5
Second.....	119.1	32.6	18.8	117.2	32.1	24.5	115.4	31.6	21.4	137.6	37.7	2.9

A complete outline of the methods of managing the contest is included.

Standard scores of the birds at the second Vineland international egg-laying and breeding contest, R. R. HANNAS (*New Jersey Stat. Hints to Poultrymen*, 8 (1920), No. 7, pp. 4).—This publication lists the average scores of the birds, regarded as exhibition specimens, in each of the 100 pens entered in the second three-year egg-laying contest begun at Vineland, N. J., November 1, 1919.

"Birds entered at the new Vineland contest are eligible for registration and advanced registration. The first rule applying to the registration of birds is

that they must be free from standard disqualifications, and score at least 75 in order to be eligible for registration, regardless of the number of eggs they may lay."

Feeding baby chicks, H. L. KEMPSTER (*Missouri Sta. Circ.* 91 (1920), pp. 4).—This is a brief popular account of the principles of chick feeding. The importance of vitamins is noted.

Summer time and the pullets, W. C. THOMPSON (*New Jersey Stas. Hints to Poultrymen*, 8 (1920), No. 8, pp. 4).—The author notes points of importance in the care of the colony house and the range during the summer months.

What and how to feed for satisfactory egg production, A. R. LEE (*Rel. Poultry Jour.*, 27 (1920), No. 3, pp. 315, 316, 338, 339, 340, figs. 3).—This article includes an account of the methods of feeding poultry at the U. S. Experiment Farm at Beltsville, Md.

Marketing eggs in New York City (*N. Y. State Dept. Farms and Markets, Foods and Markets*, 1 (1919), No. 5, pp. 3-15, figs. 4).—An account of the sources of the New York City egg supply and the different methods of marketing, together with an outline of the classification of eggs adopted by the New York Mercantile Exchange.

Egg marketing: The consumer's viewpoint, H. D. PHILLIPS (*N. Y. State Dept. Farms and Markets, Foods and Markets*, 2 (1920), No. 17, pp. 3-39, figs. 8).—This paper treats principally of the seasonal fluctuations in the receipts, prices, and quality of eggs on the New York market, and the details of marketing and storing eggs.

The poultry industry of Orkney, A. F. SMITH (*Scot. Jour. Agr.*, 3 (1920), No. 1, pp. 87-89).—Statistics of egg exports from the Orkney Islands are presented, showing a very large export trade considering the area and population. Cooperative poultry societies have been active in securing high prices.

Theoretical and practical manual of poultry husbandry, T. PASCAL (*Manuale Teorico Pratico di Pollicoltura. Catania [Sicily]: Francesco Battiato, 1919, 3. ed., rev., pp. 283, figs. 19*).—This is a treatise on the feeding, breeding, management, and hygiene of the domestic fowl, which was given a prize by the Minister of Agriculture, Industry, and Commerce.

Rabbit culture and standard, W. F. ROTH and C. T. CORNMAN, edited by C. R. DEARDORFF (*Sellersville, Pa.: The Item Pub. Co., 1919, 4. ed., rev., pp. 128, figs. 36*).—The descriptions of varieties of domestic rabbits in the first edition (E. S. R., 33, p. 174) are slightly modified by the editor, who adds brief sections on rabbit houses, tanning the skins, and preparing the dressed rabbits for the table.

DAIRY FARMING—DAIRYING.

Report of progress on animal husbandry investigations in 1919, J. W. GOWEN (*Maine Sta. Bul.* 283 (1919), pp. 249-284, figs. 7).—As in previous reports of this series (E. S. R., 40, p. 872), the biologist of the station presents a summary of results of the cattle investigations under his charge.

Analyses of the advanced registry records of the Holstein, Guernsey, and Jersey breeds to determine the relationship between age at test and milk produced in 365 days have been completed, and three equations are presented expressing the yield as a function of the age. It is claimed that maximum milk yield occurs at the age of 8 years, 1 month, 13 days in the case of the Jersey breed; at 8 years, 4 months, 29 days in the case of the Holstein; and at 9 years, 8 months, 5 days in the case of the Guernsey.

The records of a herd of 88 Jersey cows were examined statistically to determine the accuracy with which the total production of a cow in her first five

lactations could be estimated from the production in one of the lactations. Only the first 8 months of each lactation were considered. The correlation between the 5-lactation milk total and the amount of milk given by the cows as two-year-olds was found to be +0.74. The correlation was higher when a later lactation was taken as the basis of estimate. Similar determinations are given for the relationship between butter fat percentage in the individual lactations and the average percentage of all five.

"The average correlation coefficient for the 7-day test of Holstein-Friesian cattle and the 365-day test, of which the 7-day test is a part, is +0.57. The average correlation coefficient for the 7-day test and 365-day test, of which the 7-day test is not a part, is +0.55."

The author reports 19 coefficients of correlation between the annual milk production of Registry of Merit Jersey cows and the score assigned by judges to the conformation of a particular body part, and to total score. The latter correlation is highest, being +0.194. Many of the coefficients are practically zero, but only one is negative. "The parts of the conformation having a distinctly significant relation to milk production of the cow were the milk veins, size, and condition of udder, the size and shape of rear udder, the shape and size of barrel, and the general appearance of the cow."

The 21 calves born in the cross-bred herd between October 15, 1918, and October 26, 1919, are listed, and the milk yields of 6 cross-bred heifers are presented in the form of graphs showing the changes in successive months of lactation. "The milk yield of the breeds seem to occupy the following relation: The low milk yield of the Aberdeen Angus is recessive to the higher milk yield of the Jersey. The Jersey milk yield is recessive to the higher milk yield of the Holstein-Friesian."

There are also included a revision of the estimates of the "transmitting qualities" of Guernsey sires given in the previous report, and abstracts of Bulletin 281 noted below, and of Pearl and Miner's paper on the milk of Ayrshire cows already noted (E. S. R., 42, p. 69).

Studies in milk secretion.—VII, Transmitting qualities of Jersey sires for milk yield, butter fat percentage, and butter fat, R. PEARL, J. W. GOWEN, and J. R. MINER (*Maine Sta. Bul. 281 (1919), pp. 89-164, figs. 3; pp. 165-204*).—The authors arrange 225 Jersey bulls in the order of their estimated "transmitting qualities" as determined for each sire by the difference between the production of his daughters and that of their dams. Only year records were used, and each bull considered had at least two Registry of Merit daughters out of Registry of Merit dams. To eliminate differences due to variations in age at testing, the records of each cow were corrected to a standard age by assuming that the ratio between her observed yield and her standard-age yield would be equal to the ration between the average of all cows tested at her age and the average of all cows tested at the standard age. Eight years was taken as the standard age of milk production and two years as the standard age for percentage of fat. Corrected amounts of butter fat were not computed for individual cows, but each group of dams and each group of daughters was credited with a butter-fat yield determined by multiplying the group's average milk yield as of eight years by the group's average fat percentage as of two years.

A bull whose daughters averaged higher in both milk yield and butter fat percentage than their dams is considered a superior sire; one whose daughters averaged less in both respects is considered inferior. On this basis there were 28 superior and 40 inferior sires. These two groups are subjected to a more detailed study with respect to their origins. The inferior sires were found to be somewhat more inbred as measured by Pearl's coefficients (E. S. R., 38, p. 269),

and to have had fewer immediate ancestors which were imported from the Island of Jersey.

"Study of the pedigrees of these two groups of sires discloses the fact that all the animals which appeared in the pedigrees of the superior sires on the male side of the pedigrees more than four times or on the female side of the pedigree more than three times also had appearance in the pedigrees of the sires inferior in their transmitting qualities. This fact alone makes it clear that the appearance of certain famous animals in a pedigree of a given bull is no guaranty of that particular bull's worth."

A section is devoted to the transmitting qualities of Jersey sires to their sons as determined by the production of the sons' daughters, and there is much discussion of individual breeding animals more or less famous in Jersey breed history.

The origin of the Ayrshire breed of cattle, C. DOUGLAS (*Trans. Highland and Agr. Soc. Scot.*, 5. ser., 31 (1919), pp. 133-151, figs. 8).—From a study of historical records and old drawings the author concludes that the Ayrshire breed originated toward the end of the eighteenth century, when brown cattle were imported from Holland and crossed with the native Kylo breed.

"That its value as a milk-yielding animal was originally derived in large measure from the Dutch cross may be regarded as certain. But the surviving pure descendants of the native breed—the Shetland and the almost extinct Irish cows—are also, in proportion to their size, deep milkers; and they have the peculiarity of giving large quantities of milk with a minimum of food and comfort."

A study of the birth weight of calves, C. H. ECKLES (*Missouri Sta. Research Bul.* 35 (1919), pp. 3-11, fig. 1).—Previously noted from another source (E. S. R., 42, p. 171).

Feeding and management of dairy cattle for official production, M. H. ROBERTS, JR. (*New York and London: Longmans, Green & Co.*, 1920, pp. XVII+294, pls. 45, figs. 21).—The author gives an account of the methods he uses in managing a large herd of Jersey cattle in New York State. The topics discussed include feeding methods, with particular reference to official testing, care of calves and bulls, work schedules, and fitting for exhibition. The advanced registry rules and systems of judging of the four major dairy breeds as adopted by the respective breed associations are also recorded, and an appendix consists of excerpts from New York statutes concerning dairy products.

The dairy record and feeding chart, M. H. ROBERTS, JR. (*New York and London: Longmans, Green & Co.*, 1920, pp. 216, fig. 1).—This is a blank record book, folio size. Each double page is provided with spaces for the daily feed and milk records of a cow during one year, and for weekly and monthly summaries of her milk and fat production, feed cost, and profit.

Computation of dairy rations (*Pennsylvania Sta. Bul.* 161 (1920), pp. 3-28, figs. 3).—This is a revision by A. A. Borland of Bulletin 143 previously noted (E. S. R., 36, p. 374). The changes are slight, the most important being in the table showing the relation between the digestible protein and the available energy of the grain mixture suitable for a given kind of roughage. The new values imply a somewhat narrower grain ration, particularly with nonleguminous roughages, and they change by uniform increments with decrease in milk yield and with increase in fat percentage. Cottonseed feed and the lowest grade of cottonseed meal are added to the list of feeding stuffs, and a new set of specimen grain rations is included.

Sudan grass as a supplementary pasture crop for dairy cattle, L. E. CALL and J. B. FIRCH (*Kansas Sta. Circ.* 80 (1920), pp. 4, fig. 1).—Six cows in milk

were kept on 5.4 acres of Sudan grass pasture for three months beginning July 10, 1919. Corn, bran, and linseed meal (4:2:1) was fed in proportion to the milk yield. The cows lost only slightly in weight in spite of a dry summer, and produced a total of 12,263 lbs. of milk and 389 lbs. of butter fat. In addition 7.33 tons of hay were harvested. It is estimated that each acre returned \$73.55 above the cost of the grain.

The growing of forage crops on dairy farms in Denmark, H. FABER (*Scot. Jour. Agr.*, 3 (1920), No. 1, pp. 16-26).—The growing of mangels, swedes, and various grasses and clovers on dairy farms in Denmark is described, and some account given of the work of the experimental stations at Tystofte and elsewhere in developing strains and studying the feeding values of different crops.

The dairy situation in Germany, R. BALDERSTON (*Hoard's Dairyman*, 59 (1920), No. 13, pp. 804, 805, 814-816, figs. 6).—The author, who was a member of an American committee engaged in relief work in Central Europe, tells of the supply, distribution, and rationing of milk in German cities during the winter of 1919-20, discusses the lack of concentrated feed and the low production per cow, and notes the substantial character of the initial equipment of creameries and milk plants which enabled them to operate during the war with a minimum replacement of parts.

The milk and dairies of Saigon, A. LAHILLE (*Bul. Écon. Indochine, n. ser.*, 22 (1919), No. 135, pp. 199-228, pls. 10).—The author reports analyses of a large number of samples of milk from individual cows in the neighborhood of Saigon, Cochinchina. Native Anamese cows, zebus of the so-called Singapore race, and crossbred cows are included. It is thought that the proportion of lactose is lower than in European milk, and that the butter yield is higher. Lactose is noted as the most stable constituent, the proportion not varying with the change from the rainy to the dry season.

The sanitary aspects of the milk supply of Saigon are also discussed.

A miniature dairy farm, R. C. LORIMER (*Jour. Dept. Agr. Victoria*, 17 (1919), No. 3, pp. 175-177, figs. 3).—An account of a profitable herd of five Jersey cows in the Rochester irrigation settlement in northern Victoria.

Jerseys in the drier districts, J. S. McFADZEAN (*Jour. Dept. Agr. Victoria*, 17 (1919), No. 2, pp. 87-92, figs. 7).—Two cases are cited of successful long-continued operation of dairy farms with Jersey cattle in the warm and somewhat arid northeastern section of Victoria. It is predicted that dairying will replace sheep grazing in this district with the advent of more settlers.

Cooperation and the milk supply of Calcutta: Result of experiments, J. T. DONOVAN (*Bengal, Bihar, and Orissa Coop. Jour.*, 5 (1920), No. 4, pp. 242-262).—The successful formation and operation of local cooperative societies of cowkeepers in 30 villages supplying milk to Calcutta is reported.

The milk is marketed directly by each society with the assistance of the union of cooperative societies, motor trucks being used for transportation where possible. The cows are milked by agents of the society. The cooperative system eliminates the "goalas" (professional milkers and milk peddlers) who, according to the author, adulterate the milk with dirty water and carry it in unwashed open cans with a bunch of straw or leaves added to prevent splashing and churning. The cooperatives have effected a marked improvement in the sanitary handling of the milk, and have induced members to increase the amount of milk produced by making the business profitable.

The first cooperative milk society was formed in 1917. The author believes that the initial prejudice has been overcome, and that in a short time societies will be organized in all the 2,700 villages whose milk is necessary to satisfy the needs of Calcutta.

The Detroit commission plan of city milk administration, W. O. HEDRICK and A. C. ANDERSON (*Michigan Sta. Spec. Bul. 99 (1919), pp. 30, figs. 5*).—The authors discuss the milk situation in Detroit with reference to demand, supplies, prices, and the influence of the war, and review the activities of the Detroit Milk Commission organized toward the end of 1917 at request of both producers and dealers.

The commission consisted of a former governor of the State, the Dairy and Food Commissioner, the State Market Director, and a representative each from the Michigan Agricultural College, the State Board of Agriculture, the women's clubs of the city, the Detroit Board of Commerce, and the Detroit Federation of Labor. The commission had the duty of maintaining an adequate supply of milk and of fixing just prices to producers and consumers. Prices were fixed on the basis of cost of production and cost of distribution. Producers' prices in any one season were made uniform throughout the Detroit area, and dealers' losses from paying market milk prices for surplus milk were prorated among the producers. The authors hold that the price-fixing method adopted is superior to alternative schemes of basing market milk prices on the current prices of butter fat, cheese, or other dairy commodities.

The commission introduced the practice of retailing milk by the "cash-and-carry" plan at 3 cts. a quart below the price of delivered milk, but consumers took so little interest that the experiment was soon abandoned.

The first report of the commission is given in an appendix.

Salient features in the testimony hearings of the Detroit milk commission, G. H. BROWNELL (*Mich. State Dairy and Food Commr. Ann. Rpt. 25 (1918), pp. 144-150*).—These pages include estimates of production costs furnished by the Michigan Agricultural College and summaries of testimony regarding cost of distribution.

Milk prices in 1919 (*U. S. Dept. Agr., Market Rptr., 1 (1920), No. 16, pp. 241, 253, fig. 1; also in Hoard's Dairyman, 49 (1920), No. 15, pp. 936, 937, fig. 1*).—Producers' prices for milk sold for city distribution, condensing, cheese making, and butter making during 1919 are tabulated by months and discussed.

"The fallacy of basing market milk or condensary milk prices on the price or value of milk for butter or cheese-making purposes is clearly emphasized by the month of February, when the bottom practically fell out of the butter and cheese markets and the price of creamery and cheese factory milk declined automatically with the price of butter and cheese, while the supply and demand for milk for condensing and market milk purposes was entirely stable and in no way affected by unsatisfactory conditions existing in the butter and cheese markets."

Should milk for cheese making be paid for according to its fat content? R. T. ARCHER and G. C. SAWERS (*Jour. Dept. Agr. Victoria, 18 (1920), No. 3, pp. 178, 179, fig. 1*).—The author states that a considerable number of Australian dairy farmers do not realize that milk rich in fat yields more cheese per pound than milk of low fat content, and he reports data from tests with five lots of milk to demonstrate this point.

Cold storage of cottage and other soft curd cheeses, H. B. ELLENBERGER (*Vermont Sta. Bul. 213 (1919), pp. 3-22*).—This bulletin reports preliminary cold-storage trials with soft-curd cheeses made in 1917 and noted from another source (*E. S. R., 40, p. 777*), and more elaborate trials in 1918 planned as a study of the influence of manufacturing methods, chemical composition, and similar factors on the flavor, texture, and marketability of the stored product. The 1918 lots of cheese were made in August, and most of these were taken out of storage the following December. Estimates of changes during the storage are based mainly on comparisons of judges' scores.

The cottage cheese made by the bakers' process held its flavor somewhat better than that made by the pot method. Neither type changed much during storage, but the pot cheese became somewhat more granular. Pasteurized milk cheese retained its flavor slightly better than raw-milk cheese. Moisture content, initial acidity, and the use of salt all seemed to be without important effect on the flavor or texture of the stored cheese. Certain lots kept in storage three months longer than the bulk of the cheese developed off flavors but were marketable.

The usual containers for the cottage cheese during storage were paraffined butter tubs lined with parchment paper. One lot put in an unparaffined unlined tub suffered marked loss in flavor. Cheese stored in a well-tinned ice-cream can retained its flavor about as well as that stored in the ordinary way.

A few lots of Neufchâtel and cream cheese were stored in the same way as the cottage cheese. The Neufchâtel kept its flavor well, but the cream cheese developed metallic and rancid flavors.

Pasteurization in cheese manufacture, C. STEVENSON (*New Zeal. Jour. Agr.*, 20 (1920), No. 1, pp. 5-9, fig. 1; also in *N. Y. Produce Rev. and Amer. Cream.*, 49 (1920), No. 23, pp. 1134, 1136, 1138).—The use of pasteurizers of the regenerative type in cheese factories is advocated, and the method and cost of operation is discussed. It is stated that a large number of factories in New Zealand now make cheese from pasteurized milk. "A number of tests have been made which show that the loss of fat in the whey is on an average 0.05 per cent less with pasteurized than with unpasteurized milk. With pasteurization there is practically no loss of fat in the cheese presses." It was also found that "practically no" additional rennet was required when milk was pasteurized.

Rind rot in cheese and the factors that cause it (*N. Y. Produce Rev. and Amer. Cream.*, 49 (1920), No. 22, pp. 1078, 1080).—Recent discussions in the dairy press and opinions of experienced cheese dealers are cited in opposition to the view of Doane (*E. S. R.*, 26, p. 172) that late paraffining conduces to rind rot.

Annual production report of manufactured dairy products and oleomargarin (*U. S. Dept. Agr., Market Rptr.*, 1 (1920), No. 14, pp. 214, 215).—Reports from manufacturers are tabulated, showing the amounts of 40 products or classes of products manufactured in the United States each month during 1918 and 1919. Creamery butter, whey butter, renovated or process butter, cheese (classified), condensed or evaporated milk (classified), sterilized milk, milk powder (classified), casein, milk sugar, ice cream, and oleomargarin (classified) are included.

VETERINARY MEDICINE.

[Report of] veterinary department, E. H. LEHNERT (*Wyoming Sta. Rpt.* 1919, pp. 157, 158).—In the work with necrobacillosis, it was found that a local application of Dakin's solution containing 10 per cent potassium permanganate is a very efficient treatment, having been used with success on five different ranches. In a variety of cases studied, undoubted cases of pneumonia in lambs and calves were found to be the result of necrophorus infection, and several cases of necrotic enteritis were also observed in calves and lambs. Experimental vaccination of affected animals with cultures of living *B. abortus*, using several strains, is under way. Brief reference is also made to tests of the action of several poisonous plants made in cooperation with the parasitology department, and to studies of the blood of animals affected with the swamp fever.

Annual administration reports of the civil veterinary department Madras Presidency for 1917-18 and 1918-19, D. A. D. AITCHISON (*Ann. Admin. Rpt. Civ. Vet. Dept. Madras Pres., 1917-18, pp. 25, pl. 1; 1918-19, pp. 20*).—The usual annual reports (E. S. R., 39, p. 283).

A study of the tonicity of the sphincter at the duodenal end of the common bile duct, with special reference to animals without a gall bladder, F. C. MANN (*Jour. Lab. and Clin. Med., 5 (1919), No. 2, pp. 107-110, fig. 1*).—The tone of the sphincter at the duodenal end of the common bile duct was studied in species of animals possessing a gall bladder (dog, cat, goat, rabbit, striped gopher, guinea pig) and in two species (rat, pocket gopher), in which the gall bladder is lacking.

It was found that "the tone of the sphincter under the experimental conditions studied varied considerably in the different animals and various species. In each species possessing a gall bladder, however, the sphincter was usually able to withstand a minimum pressure of from 75 to 100 mm. water. In the species lacking a gall bladder, the sphincter would not withstand pressure, or only pressure of less than 30 mm. water. While anatomic studies have shown that a sphincter is present in each species lacking a gall bladder, the sphincter does not seem to functionate appreciably."

Poisoning by eating potato tops, W. T. HERTSON (*Vet. Rec., 32 (1919), No. 1626, pp. 104, 105*).—This reports upon the loss of several cows as a result of their having gained access for a short time to a potato field where the tops were very green.

Beet molasses as a feed for weanling pigs, W. E. CARROLL (*Trans. Utah Acad. Sci., 1 (1908-1917), p. 205*).—This is a brief statement of feeding experiments with beet molasses in which 30 grade Tamworth pigs between 9 and 12 weeks of age were divided into three as nearly uniform lots as possible and fed a basal ration of 2 parts ground barley and 3 parts wheat shorts. Lot 1 received only the basal ration; lot 2 the basal ration and 1 lb. of beet molasses for each 100 lbs. live weight; and lot 3 the basal ration and 2 lbs. of the molasses for each 100 lbs. live weight. Feeding began July 23, and on August 28 two pigs in lot 3 died. None of those in the lots fed molasses were so thrifty as those of lot 1. The first death in lot 2 occurred September 18. At the close of the tests lots 2 and 3 each contained only 3 live pigs, while none had been lost from lot 1. The average live weight of the surviving pigs was 57 lbs. for those in lot 2 and 47 lbs. in lot 3, as against an average of 88 lbs. for the 10 pigs in lot 1.

The symptoms preceding death were loss of appetite, lack of thrift, and a partial loss of muscular control, resulting in a wobbling and uncertain gait. This muscular weakness sometimes lasted a day or two and then disappeared for a time. There was no scouring in any of the cases. No decided pathological condition was found (two of the cases) upon post-mortem examination, but the livers and kidneys were considerably congested.

The Seymour-Jones sublimate-formic acid method for the disinfection of anthrax-contaminated hides and skins, V. GEGENBAUER (*Arch. Hyg., 87 (1918), No. 7-8, pp. 289-315*).—The literature on the subject of the disinfection of hides and skins contaminated with anthrax spores is reviewed, and experiments are reported which not only confirm the conclusions of various authors that the Seymour-Jones corrosive sublimate-formic acid method is not efficient, but also show that even with a high concentration of the reagents and a longer time of exposure the anthrax spores if carefully washed free from the sublimate are capable of growing and of producing anthrax infection.

A similar investigation by Tilley has been previously noted (E. S. R., 33, p. 178).

Further investigations in regard to the optimal media for the after culture in testing disinfectants, K. SÜPFLE (*Arch. Hyg.*, 87 (1918), No. 5-6, pp. 232-234).—Continuing the investigation by Süpfle and Dengler previously noted (*E. S. R.*, 35, p. 279), the author has found the optimal media for obtaining after cultures of the streptococcus, diphtheria, and colon bacilli to be 1 per cent glucose bouillon with the addition of 5 per cent serum.

The starch iodine reaction and its use in colorimetric protein determinations in immunity processes, C. LANGE (*Biochem. Ztschr.*, 95 (1919), No. 1-2, pp. 46-84; *abs. in Zentbl. Biochem. u. Biophys.*, 21 (1919), No. 6, p. 296).—The author discusses the possibilities of the starch iodine reaction for determining by colorimetric methods the amount of proteins in a solution such as blood plasma or serum and the application of the method to the standardization of bacterial vaccines and to the analyses of immunity reactions. In experiments with dogs it has been shown that the injection of various bacteria is followed by an increase of proteins in the total plasma parallel with the increase in the agglutination titer.

Field observations in the control of abortion disease, G. M. POTTER (*Jour. Amer. Vet. Med. Assoc.*, 57 (1920), No. 2, pp. 152-160).—This paper consists of a report of an educational campaign which is being conducted under the auspices of the extension division of the Kansas State Agricultural College for the control of abortion according to the plan previously noted (*E. S. R.*, 40, p. 86). The general plan is reviewed, and observations made in connection with the campaign are noted. Among the points discussed are the immunity conferred by the disease as noted in the spontaneous subsidence of the disease, the tendency of offspring of naturally resistant mothers to inherit the same resistance, the transmission of the disease by ingestion of fresh discharges from cows that have aborted, and the natural period of incubation, which has been shown to be from three to five months.

The author states in conclusion that the greatest progress in the investigation and control of abortion can come only by a combination of laboratory investigation and field work.

The efficacy of normal sera in anthrax infection, F. V. HUTYRA and R. MANNINGER (*Centbl. Bakt. [etc.]*, 1. Abt., Orig., 83 (1919), No. 7, pp. 518, 519; *abs. in Jour. Amer. Vet. Med. Assoc.*, 57 (1920), No. 2, p. 188).—The authors report that normal horse, cow, and sheep sera have failed to protect rabbits against artificial anthrax infection, while the sera of horses and cows immunized against anthrax protected control animals.

Protective results obtained by other authors in the use of normal sera are explained on the ground that the animals furnishing such sera must have acquired a certain degree of immunity through feeding in infected pastures. It is suggested that this phenomenon probably occurs more frequently in the badly infected regions of Argentina than in Europe.

Botryomycosis, J. M'FADYEAN (*Jour. Compar. Path. and Ther.*, 32 (1919), No. 2, pp. 73-89, figs. 11).—This paper deals with the morphology of the botryomyces granules, identity of the Botryococcus and the *Staphylococcus pyogenes aureus*, botryomycosis in other species than the equine, and the lesions of botryomycosis. A list is given of 15 references to the literature.

Contribution to the determination of the value of polyvalent extracts for the serum diagnosis of glanders by the complement deviation reaction, including observations on the disappearance of glanders-specific deviating substances, W. FREILER and F. GRÄFE (*Centbl. Bakt. [etc.]*, 1. Abt., Orig., 83 (1919), No. 6, pp. 451-456).—New evidence is furnished that polyvalent extracts are preferable to monovalent for the diagnosis of glanders by the complement deviation method previously noted (*E. S. R.*, 42, p. 272). The case reports

given also illustrate in one or two cases the phenomenon of disappearance and reappearance of the complement deviating bodies.

On the specificity of *Babesia minor*, J. M. QUEVEDO (*Rev. Soc. Med. Vet. [Buenos Aires]*, 4 (1919), No. 6, pp. 170-175, figs. 3; *abs. in Vet. Rev.*, 4 (1920), No. 1, p. 113).—The author maintains that *B. minor* is the causative agent of "tristeza."

Clinical and anatomic-pathological aspects of American trypanosomiasis, C. CHAGAS (*New Orleans Med. and Surg. Jour.*, 72 (1920), No. 11, pp. 630-660, fig. 1).—In this translation by L. Ambrose of an article which appeared in 1916¹ and a translator's note, a summary is given of the present status of knowledge of Chagas' disease in Brazil due to *Trypanosoma cruzi*, which is transmitted by (*Conorhinus*) *Triatoma megistus*.

A tick-resistant condition in cattle, T. H. JOHNSTON and M. J. BANCROFT (*Proc. Roy. Soc. Queensland*, 30 (1918), pp. 219-317, figs. 3).—The data here presented have been summarized by the authors as follows:

"The cattle tick in Queensland may cause tick fever and tick worry. There exists a degree of resistance to tick fever, and this is largely influenced by individual idiosyncrasy, age, sex, and general health of the animal as well as by food and other conditions. Tick worry is at present a more serious complaint than tick fever in Queensland. It is apparently due, at least in part, to the injection of a toxin by the tick. Many cattle become habituated to tick infestation and this, in individual cases at least, leads to some degree of resistance. Such resistance is probably due to the formation of anti-tick poison bodies by the blood of the animal.

"Tick-resistant cattle are known from a number of Queensland localities. Asiatic breeds are tick resistant. Of the various breeds commonly met with in this State, Jerseys appear to be less affected than others by ticks. Tick resistance seems to be influenced by food only in so far as the latter affects the general health of the animal. The effect of the application of arsenical solutions to resistant cattle has not been satisfactorily determined. Perhaps the use of arsenical solutions prevents the realization of such resistance. Tick resistance persists, provided the resistant animal's health be maintained. The temperature of resistant animals appears to be normal. There is good reason to conclude that the resistant tendency is hereditarily transmissible.

"Although there is considerable positive evidence of the transmissibility of resistance by vaccination, we have not succeeded in proving it. In many cases the condition has been acquired naturally. We think that habituation is a step toward resistance, which seems to us to be a physiological reaction to the introduction of a tick toxin. The comparatively few-ticks which mature on resistant cattle appear to have their fertility, as a rule, somewhat impaired.

"Associated with tick resistance in many animals is an exudation of a lymph-like substance on the skin. This condition is quite distinct from the typical tick sore, though it is apparently a response to tick attack."

A 3-page list of the literature cited is included.

The bacteriology of the reproductive organs of the cow and its relation to that of the meconium of the calf, W. GILTNER and S. G. BANDEEN (*Jour. Amer. Vet. Med. Assoc.*, 57 (1920), No. 1, pp. 46-57).—This is a report of extensive studies of the bacterial flora of the uterus and vagina of cattle, conducted at the Michigan Experiment Station. The authors' summary of the work and the conclusions drawn are as follows:

"In this series of 12 pairs of cases of fetus and dam, bacteria were isolated from the uterus in 11 cases, and from the meconium in 9 cases. Since the

¹ Prensa Med. Argentina, 1916, III, pp. 125-127, 137, 138, 153-158.

flora of the digestive tube of the fetus or living calf necessarily changes very soon after the end of the intrauterine life, nothing was to be gained by making more than the initial examination of the meconium. As a result of the initial examination of the meconium and the uterus there were 3 of the 12 pairs of cases (uterus and meconium) that gave negative results. *Bacillus coli communior* and *Staphylococcus pyogenes aureus* were found in only one pair of cases. *B. coli communior* was found in three other pairs of cases, making its total appearance in 5 of the 12 pairs of cases or in 6 out of 9 cases of the meconium and 5 out of 11 cases of the uterus that showed any organisms at all. *S. pyogenes aureus* was found in a total of 3 uteri and in 4 meconia. *S. pyogenes bovis* was found in 2 pairs of cases and in a total of 4 uteri and in 2 meconia.

"The only other organism significant by its appearance in both uterus and meconium was a streptococcus of high virulence, except that in the pair of cases [designated] B. S. and B. S. A. there may have been an identity of a colon organism and a bacterium.

"We are therefore inclined to believe that *B. coli communior*, *S. pyogenes aureus*, and *S. pyogenes bovis* are very likely to occur in the uterus as well as in the digestive tube of the calf in cases of metritis. Dr. Stafseth has found similar organisms in the deeper layers of the mucosae in cases of metritis, and has not found *Bacterium abortus* in the deeper layers. . . . *B. abortus* was found only once in the uterus and in no case in meconium."

White or calf scours, W. L. WILLIAMS, W. A. HAGAN, and C. M. CARPENTER (*Jour. Amer. Vet. Med. Assoc.*, 57 (1920), No. 2, pp. 124-146, figs. 7; also in *Vet. Alumni Quart.* [Ohio State Univ.], 7 (1920), No. 4, pp. 305-328, figs. 8).—In this paper, presented at the annual meeting of the American Veterinary Medical Association at New Orleans in November, 1919, the authors discuss the causes and etiology of white scours or calf scours and describe methods for its prevention and cure.

Methods for prevention include the scientific handling of the infections of the genital organs of the mother prior to breeding; prevention of infection from the mother by not allowing the calves to suckle, by washing and disinfecting the udder of the cows before milk is drawn to feed the calves, and by feeding the calves from sterile vessels; prevention of infection from other calves by the use of clean isolated stalls; control of the infection in the digestive tract of the calves by not feeding milk until the animal is at least 24 hours old, by the use of high enemas of physiologic salt solution twice daily for several days, and by the use of calf-scours serum in doses of from 10 to 30 cc. twice daily for at least two days. When the calf is 24 hours of age a ration of whole milk equal to 2 per cent of its body weight is given twice daily, the amount being gradually increased after four or five days. If raw milk is used, that from the calf's own mother is recommended on account of the presence in it of antibodies against infection in the alimentary canal of the calf. Simultaneously with the first feed of milk and the third dose of serum the calf-scours bacterin should be given, commencing with doses of 1 cc. and increasing by 1 cc. each day until 10 or 12 cc. have been given. After the calf has thus acquired resistance to alimentary infections the use of boiled milk is recommended. This may also be used in place of raw milk from the start if calf-scours serum and bacterins are administered freely.

Similar methods are recommended for the treatment of calves suffering from scours or pneumonia. The food should be immediately withdrawn, high enemas given, and large doses of serum administered, followed by bacterins as soon as the diarrhea is checked.

Infestation of the skin, etc., of sheep by grass seeds, S. DODD (*Jour. Compar. Path. and Ther.*, 32 (1919), No. 2, pp. 90-95).—The condition in sheep due to the penetration of the skin, etc., by certain grass seeds is said to be a very common one and of some economic importance in parts of New South Wales.

Duration of immunity against hog cholera following simultaneous inoculation of young pigs, W. B. NILES and J. H. RIETZ (*Jour. Amer. Vet. Med. Assoc.*, 57 (1920), No. 2, pp. 176-182).—This contribution from the Bureau of Animal Industry, U. S. Department of Agriculture, consists of the reports of 12 experiments in which the efficacy of the simultaneous inoculation of young pigs was tested on 171 pigs varying from 7 days to 6 weeks of age at the time of the inoculation. These pigs, which were the offspring both of immune and nonimmune sows, were kept from exposure to hog cholera for varying periods of time, ranging from 5 months to 9 months and 26 days, and were then injected with 5 cc. of virus. All of the pigs proved immune to hog cholera, thus indicating that the simultaneous inoculation of young pigs confers a lasting immunity.

Note on the treatment of epizootic ulcerative lymphangitis of the horse, A. DELMER (*Rec. Méd. Vét.*, 95 (1919), No. 15-17, pp. 452-459, fig. 1; *abs. in Vet. Rev.*, 4 (1920), No. 1, p. 28).—The method of treating ulcerative lymphangitis suggested by the author consists in the opening of the abscesses with the actual cautery and the expression of the pus, which is caught on cotton wool in order to avoid further infection of the skin. The walls of the abscess are curetted as thoroughly as possible in order to remove the necrotic tissue entirely. The button cautery is then applied for the destruction of organisms and the arrest of hemorrhage produced by the curettage. This is followed by point firing over a portion of the limb sufficient to extend well beyond that part which is edematous. The punctures should involve the whole thickness of the skin and the subcutaneous tissue. The part of the limb point fired should then be briskly rubbed with mercurial ointment.

The treatment of mange in equines by chloropicrin, G. BERTRAND and DASSONVILLE (*Compt. Rend. Acad. Sci. [Paris]*, 169 (1919), No. 10, pp. 486-489).—The treatment of mange by fumigation with sulphur dioxide known as sulphuration is first described. Experiments with chloropicrin in which animals placed in chambers similar to those used for sulphuration were sprayed by means of a syringe at the rate of 1 oz. to each 50 cu. ft. are then reported upon. Horses thus treated were left in the chamber for 30 minutes and the treatment repeated in from two to three weeks. The head, which escaped the action of the fumes, was treated with ointment containing 100 parts by weight of vaseline to 2.5 by weight of chloropicrin. This treatment proved entirely successful. As compared with sulphuration it possesses a number of advantage. It reduces the period of exposure from 2 hours to 30 minutes, thus permitting the treatment of many more animals in the same time, is much simpler, is not so destructive to the collarettes used upon the animals, is less dangerous to use upon the animals, etc. The term chloropicrination is proposed by the authors for this treatment.

Experiments with sulphurous anhydrid in the treatment of mange in mules, W. PFENNINGER (*Schweiz. Arch. Tierheilk.*, 61 (1919), No. 9-10, pp. 333-341; *abs. in Vet. Rev.*, 4 (1920), No. 1, p. 40).—The author reports upon the sulphur dioxide treatment for mange at the Swiss mule depot at Sitten, conducted in sheet-iron chambers. Three hundred gm. (10.5 oz.) of sulphur was burned in a sheet-iron chamber 2.15 meters long, 1.15 meters wide, and 2.25 meters high (about 196 cu. ft.) and after five days was repeated. In bad

cases a third application was made. The results led to the conclusion that where the treatment of mange by sulphur dioxide is conducted with due precautions it is an excellent and harmless method.

RURAL ENGINEERING.

Work done under the agricultural engineer for the year ended June 30, 1917. W. M. SCHUTTE (*Ann. Rpt., Dept. Agr. Bombay, 1916-17, pp. 57-65*).—This is the report of the work done under the agricultural engineer, Bombay Presidency, for the year ended June 30, 1917, covering experimental well boring and water raising, mechanical cultivation, and oil-engine driving.

Irrigation in Oklahoma. M. R. BENTLEY (*Okl. Agr. Col. Ext. Div. Circ. 111 (1920), pp. [8], figs. 8*).—This circular contains information on past practice in irrigation in Oklahoma and discusses future possibilities. It is estimated that there are about 6,500 acres under irrigation in the State. Irrigation does not seem to pay except for garden and truck crops, in eastern and central Oklahoma, but field crops as well as truck crops have been irrigated profitably in the western part of the State.

It is concluded that reservoirs will be necessary for a considerable extension of irrigation in western Oklahoma. A study of the amount of water required for irrigation and of the supply available should be made before any money is spent on an irrigation system. The cost of maintaining and operating the plant as well as the first cost should be considered. Success or failure may depend on knowing when to apply water and how much water to apply. The irrigation of large areas from wells has not yet been successfully practiced in this State. The lath-tile system seems to be well suited to the irrigation of gardens.

Water requirements of crops. R. L. PARSHALL (*Colorado Sta. Rpt. 1919, pp. 30, 31*).—From 1911 to 1918 alfalfa, sugar beets, and grain were grown in buried concrete tanks with the water table maintained at 2, 3, 4, 5, and 6 ft. below the ground surface. The result in general indicated that the weight, size, sugar content, and purity of sugar beets tend to increase with the depth of the water table. Alfalfa with the water table at only 2 ft. below the surface did not make a good stand, while in all other tanks the growth did not appear to be influenced by the different depths of the water below the surface. The results with wheat and barley were not very definite, but an apparent increase in production proportional to the depth of the water table is reported.

A study of the conditions under which water of tidal saline creeks is utilized for crops production in Concan. V. G. GOKHALE (*Agr. Jour. India, 14 (1919), No. 3, pp. 422-430*).—Analyses are given of waters used in irrigation from the Amba River near Nagothna taken at intervals during the year. The creek waters are usually sweet during the monsoon, but after December their salinity increases and they become unsuitable for irrigation except for brinjal (*Solanum melongena*) and chilies (*Capsicum frutescens*), which grow more successfully under alkaline conditions than other native plants.

The regulation of water in the upland moors of Holstein. REISCHEL (*Mitt. Ver. Förd. Moorkultur Deut. Reiche, 37 (1919), No. 22, pp. 405-414, fig. 1*).—Methods of tile drainage employed in the reclamation of these moors are described.

Value of top soil as base for modern highways. D. S. HUMPHREY (*Engin. News-Rec., 84 (1920), No. 12, pp. 566, 567*).—The author relates experience on road building and advocates a departure from more or less standard practice by recommending that in road construction the earth's crust be left unmolested

as far as possible, and that the use of side ditches be avoided where it is possible to drain into the adjoining fields. The opinion that organic matter in soils used for highway construction is detrimental is contradicted.

Strengthening a county bridge to carry motor-truck traffic, M. GOODKIND (*Engin. News-Rec.*, 84 (1920), No. 13, pp. 617, 618, figs. 3).—The strengthening of two highway bridges having capacities of only 4 and 5 tons, respectively, by reinforcement with auxiliary channels, eyebeams, truss rods, and stiffener angles, is outlined. This resulted in increasing the capacity of both bridges to 12 tons at 16,000 lbs. unit stress.

Public Roads (*U. S. Dept. Agr., Public Roads*, 2 (1919), No. 20, pp. 56, figs. 10).—This number of this periodical contains the following articles: Papers and Discussions at the Highway Officials' Convention; The American Highway Problem, by A. R. Hirst; Survey of Southern States Highway Situation, by W. S. Keller; Highway Situation in the Pacific Coast States, by H. Nunn; New England Road Conditions, 1919 and 1920, by W. D. Sohler; The Situation in the Middle Atlantic States, by S. Knopf; Highway Situation in Central Western States, by F. R. White; The Motor Vehicle's Share in Highway Construction and Maintenance Cost, by S. E. Bradt; Problems of Administration—Proper Cooperation between Adjoining States, by A. H. Blanchard; Is State Supervision of Construction and Maintenance of all Highways Desirable? by B. H. Piepmeier; Proper Inspection in Development of Material Supplies for Heavy Programs, by A. B. Fletcher; Highway Department and Railroad Cooperation for Transportation of Materials, by A. G. Gutheim; Statement Submitted by the Highway Division of the Associated General Contractors, by R. G. Collins; Surveys and Plans and Suggested Changes to Meet the Shortage of Engineers, by P. St. J. Wilson; Relations with the Contractor—Influence of Fair Specifications and Inspection, by H. S. Mattimore; Pennsylvania's Lackawanna Trail, by A. C. Rapelje; and Federal-aid Project Approvals and Agreements, November, 1919.

Asphalt and allied substances: Their occurrence, modes of production, uses in the arts, and methods of testing, H. ABRAHAM (*New York: D. Van Nostrand Co.*, 1918, pp. XXV+606, figs. 208).—This treatise deals with the fabrication, merchandising, and application of bituminous products. It embraces (1) methods serving as a guide for the works chemist engaged in testing and analyzing raw and manufactured products, (2) data for use in blending and compounding mixtures, and (3) the principles underlying the practical use of bituminous products for structural purposes of interest to the engineer, contractor, and architect.

Concrete: How it is made (*Concrete Utilities Bur. [Pamphlet]*, No. 2 [1919], pp. 16, figs. 7).—Brief popular information is given on the selection of materials for proportioning, mixing, and placing of concrete.

Waterproofing engineering, J. ROSS (*New York: John Wiley & Sons, Inc.*, 1919, pp. 10+442, figs. 140).—In this book an effort is made to explain past and present methods and materials of waterproofing, to report investigations of their efficiency, and to establish standard methods and materials for general waterproofing. The value of a careful study of the whole subject of waterproofing by engineers is emphasized. The following chapters are included: Need and function of waterproofing, systems of waterproofing, impervious roofing, waterproofing expansion joints in masonry, waterproofing materials, waterproofing implements and machinery, technical and practical tests on waterproofing, waterproofing specifications, practical recipes and special formulas, waterproofing applied, cost data on materials, implements, and labor, and practical tables.

Motor vehicles and their engines, E. S. FRASER and R. B. JONES (*New York: D. Van Nostrand Co., 1919, pp. IV+352, figs. 278*).—This book presents a collection of elementary, theoretical and practical information for assistance in the operation, upkeep, and adjustment of mechanically propelled vehicles. The fundamentals of gas motor operation, as well as the care and operation of the principal accessories of motor vehicles, are discussed in detail. The last four chapters present the results of the authors' observations and experience on the economy and efficiency of operation of a large number of trucks, tractors, and automobiles.

Motor fuels, E. W. DEAN (*Jour. Franklin Inst., 189 (1920), No. 3, pp. 269-302, figs. 18*).—The object of this paper is to provide information of general interest regarding (1) the production and use of gasoline, (2) the physical and chemical properties of gasoline and the quality of the products marketed during 1917 and 1919, and (3) present tendencies in the development of substitutes for gasoline.

"As regards the real possibilities of gasoline substitutes, it now seems probable that oil shale may in the future prove an important source. . . . Another type of fuel which offers unlimited possibilities for the future and which is already being developed to a certain degree is alcohol. The problems to be solved before this comes into general use are apparently the development of cheaper methods of production and the development of suitable types of engines. . . .

"The type of gasoline substitute which is of most importance at the present time is the mixture of hydrocarbons obtained as a by-product in the coking of coal. . . . Benzol and other coal-tar distillates have certain disadvantages when compared with petroleum gasoline, but have other very marked advantages, particularly in freedom from tendency to knock. An additional advantage lies in the fact that they have a considerably higher calorific value per unit volume, and as this is the basis on which the user buys, he gets more for his money than he would from petroleum gasoline. . . .

"Petroleum gasoline is a type of fuel for which present equipment has been designed and for which it is eminently satisfactory. It is believed, therefore, that when striking claims are made for the superiority of any gasoline substitute these should not be taken too seriously. The substitute fuel should be given a fair trial, but the user should be satisfied if it is as good as gasoline and should not expect it to be notably superior."

The possibilities of new fuel mixtures for internal-combustion engines, E. HUMBOLDT (*Power, 50 (1919), No. 11, pp. 418-420, fig. 1*).—This article deals with the production of a cheaper and cleaner substitute for gasoline by mixing a small amount of ether and alcohol with engine distillate. Economical methods for the production of alcohol and ether are described.

From experiments it is concluded that the addition of alcohol to the ordinary petroleum fuels prevents them from leaving any carbon deposit in the engine and insures thorough, clean combustion. The addition of the ether insures a better solution of the alcohol in the hydrocarbon.

[Gasoline analyses], R. E. ROSE and E. T. CASLER (*Fla. Quart. Bul. Dept. Agr., 30 (1920), No. 1, pp. 118-144*).—Analyses of 344 samples of gasolines offered for sale in Florida during 1919 and taken by inspectors before the enforcement of the State gasoline inspection law, are reported, together with analyses of 28 samples of gasoline collected for official inspection under the inspection law in 1919.

[Kerosene analyses], R. E. ROSE and E. T. CASLER (*Fla. Quart. Bul. Dept. Agr., 30 (1920), No. 1, pp. 145-148*).—Analyses of 51 samples of kerosenes

offered for sale in Florida during 1919 and collected for inspection before the enforcement of the State inspection laws, and official analyses of 8 samples of kerosene collected for inspection under the law, are reported.

Machines for the planting and harvesting of potatoes, G. FISCHER (*Arb. Gesell. Förd. Baues u. Verwend. Kartoffeln*, No. 9 (1917), 2. ed., pp. 35, figs. 17).—This pamphlet describes, illustrates, and discusses the mechanical details of potato planting, digging, and sorting machines used in German agriculture.

The building estimator's reference book, F. R. WALKER (*Chicago: Author*, 1917, 2. ed., rev., pp. VII+1-29, 100-153, 200-253, 300-308, 400-473, 500-665, 700-895, 1000-1060, 1100-1381, 1400-1542, 1600-1788, 1900-1915, 2000-2025, 2100-2117, 2200-2207, 2300-2320, 2400-2437, 2500-2519, 2700-2725, 2800-2852, 2900-2906, 3000-3012, 3100-3115, 3200-3207, 3300, 3301, 3400-3418, 3501-3535, figs. 446).—This is a practical reference book for contractors and estimators engaged in estimating the cost of and in the construction of all classes of modern buildings. It gives the actual labor costs and methods employed in the erection of some present-day structures, together with necessary prices of material and quantities of labor entering into the estimate of cost of all classes of buildings.

Concrete-steel construction.—I, Buildings, H. T. EDDY and C. A. P. TURNER (*Minneapolis: [Authors]*, 1919, 2. ed., rev., pp. XVI+477+XXV, figs. 171).—This is a treatise on the elementary principles of design and execution of reinforced-concrete work in buildings and includes the following chapters: Concrete; general types of concrete floor construction; mechanics of stress; mechanics of permanent deformation and strain beyond the limits of elasticity; the chemical and mechanical energy of hardening of Portland cement concrete and work performed by it, etc.; simple beams; restrained and continuous beams; indirect stresses generated by bond shear and their laws of distribution; deflection and mode of operation as shown by contour lines, distribution of reactions and moments as shown by lines of zero shear; the continuous uniform slab on separated supports under uniform loading; reinforced concrete columns; unbalanced moments in monolithic floors and columns; experimental verification of the theory of flexure of concrete members; foundations; and elements of economic construction and cost of reinforced-concrete work.

Concrete cottages, small garages, and farm buildings, edited by A. LAKE-MAN (*London: Concrete Pubs., Ltd.*, 1918, pp. XII+170, pls. 30, figs. 110).—This book deals with the design of cottages and small buildings and their construction of concrete, and gives numerous examples of such structures. Construction methods and labor-saving devices are discussed, and sections are included on tile and fence-post making and the use of concrete on the farm.

Concrete floors, feeding floors, and footpaths (*Concrete Utilities Bur. [Pamphlet]*, No. 6 [1919], pp. 16, figs. 7).—Brief popular information on the construction of concrete feeding floors and sidewalks is given.

Concrete fences, gateposts, and walls (*Concrete Utilities Bur. [Pamphlet]*, No. 5 [1919], pp. 23, figs. 19).—This pamphlet deals with the construction of concrete fences and walls and with the manufacture of concrete fenceposts. Equipment for use in this work is described and illustrated.

Concrete tanks and cisterns (*Concrete Utilities Bur. [Pamphlet]*, No. 3 [1919], pp. 20, figs. 21).—Data on planning and construction of circular and rectangular tanks and cisterns of plain and reinforced concrete are given.

Standard poultry houses (*New Jersey Stas. Circ. 115* (1920), pp. 3-23, figs. 12).—This is a revision of Part 3 of Bulletin 325 of the stations, previously noted (*E. S. R.*, 41, p. 385). Three types of houses are described, namely, the New Jersey multiple unit laying house, the New Jersey farm unit laying house, and the New Jersey Vineland contest house. The last house is included on

account of the demand for plans and specifications and its high degree of efficiency when used for small flocks of laying birds.

A hover for the brooder stove, G. R. SHOUP (*Washington Sta., West. Wash. Sta. Mo. Bul.*, 8 (1920), No. 1, pp. 10-14, fig. 1).—A hover to be used in connection with a brooder stove for brooding chickens is described and illustrated. It is stated that a hover 96 in. in diameter is required to properly accommodate 1,000 chickens when five weeks old. A table is given showing the approximate size of hover required for various sized flocks of chickens from a day old up to four or five weeks old, based on an estimate of 40 chickens per square foot when first hatched and 20 chickens per square foot when four to five weeks old.

Screen wire cloth durability tests, J. W. SCOTT (*Wyoming Sta. Rpt.* 1919, p. 157).—A progress report of screen wire cloth tests, conducted in cooperation with the Bureau of Entomology of the U. S. Department of Agriculture, states that after two years all panels of wire are still intact, and that all grades of wire tested give good service in the Wyoming climate. To prevent serious weathering, screen wire should be painted when first put up and as often as once a year afterward.

Studies on the treatment and disposal of industrial wastes.—III, **The purification of tannery wastes**, H. B. HOMMON (*Pub. Health Serv. U. S., Pub. Health Bul.* 100 (1919), pp. 133, pls. 3).—Experiments on the purification and disposal of tannery wastes as conducted by the U. S. Public Health Service are described in considerable detail, and conclusions and recommendations presented.

The process of treatment recommended includes utilization of the dried sludge as a fertilizer. "Direct utilization of the liquid sludge to fertilize nearby land by means of tank wagons may be found more economical than the use of drying beds under certain conditions."

Studies of methods for the treatment and disposal of sewage.—**The treatment of sewage from single houses and small communities**, L. C. FRANK and C. P. RHYNUS (*Pub. Health Serv. U. S., Pub. Health Bul.* 101 (1919), pp. 117, pls. 13, figs. 12).—Several years' experiments conducted by the U. S. Public Health Service on residential and small community sewage purification and disposal are reported, covering the use of settling, septic, biolytic, and Imhoff tanks, and oxidation methods, such as broad and subsurface irrigation, intermittent sand filtration, treatment on contact beds, use of trickling filters, and the activated sludge method.

It was found that among the tank treatments for the removal of suspended solids plain settling tank treatment is not well adapted for use in small plants because of the necessity of frequent cleaning. Septic-tank treatment is adapted to use in small-plant conditions only in cases where the foul odors from the effluent will not have access to the outside air, or where the plant is sufficiently removed from habitations so that such access is unimportant. A short test also indicated that the biolytic tank is adapted for use in small plants under the conditions outlined for the septic tanks. The Imhoff tank is adapted to the conditions of very small and moderate-sized plants. Essential elements of design are a mean detention period of not less than 4.5 hours and sludge and scum chamber capacities of not less than 3.5 and 2.5 cu. ft. per capita, respectively.

Among the various oxidation methods, broad irrigation is not adapted to small-plant conditions. Under certain conditions, subsurface irrigation is well adapted to household and small community use. "The conditions under which this system may be relied upon, however, are not readily definable, nor can the actual local conditions be determined by superficial study. The system

involves grave possibilities of the pollution of ground water, near-by wells, and even distant springs. It ought never to be indiscriminately recommended for general use, nor should it be installed except under expert advice or under conditions that preclude the pollution of subsurface water supplies."

Intermittent sand filtration is adapted to small-plant conditions. The filter layer should be of fairly coarse sand, at least 24 in. and preferably 36 in. deep. About 45 sq. ft. of filter surface should be provided per capita if the water consumption is about 100 gal. per capita per day and 30 sq. ft. if the consumption is 20 gal. per capita per day, using intermediate areas for intermediate consumption values.

Contact beds are not recommended for use in small plants, and trickling filters are not adapted to small-plant conditions unless equipped with a sewage distributor which will be free from clogging difficulties. Lath is preferable to broken stone for small trickling filters, because of the greater size and clearness of the voids and the resulting decreased likelihood of clogging difficulties in the filter material. The laths are arranged in layers alternately at right angles to each other and with a horizontal clearance of about 3 in. It was found that 8 cu. ft. of such filter material per person is ample to produce a highly oxidized effluent, provided the depth of the filter material is at least 42 in. A filter depth of 5 or 6 ft. is suggested where practicable. When protected against low temperatures, it was found that very small trickling filters can be operated efficiently with a total fall as low as 48 in.

"That type of plant is best for a given case which gives the required degree of purification with the amount of fall and area of land available at the lowest cost and with the least attention. Where ample stream dilution and other local conditions make it sufficient to remove only the settling and floating solids, the Imhoff tank is recommended. Where it is necessary in addition to produce an oxidized effluent, a plant composed of a preliminary Imhoff tank, lath-trickling filter, and final Imhoff tank is in general considered most advantageous from all standpoints, except that of fall required. In situations in which the lack of available fall is the controlling feature, careful consideration should be given to the possibility of pumping the final effluent by water-jet pump or windmill, the difficulties of such procedure being conscientiously compared with the possible danger of soil pollution resulting from subsurface irrigation. There are many conditions under which the latter may properly be employed, but the fact can not be overemphasized that these conditions are not capable of exact definition nor of proper determination on the ground, except by an expert, and only then after considerable study. For all these reasons the lath-trickling filter device with suitable tank treatment, as described, is more confidently recommended for general use under all conditions than any other sewage-treatment device thus far available for the treatment of residential and small community sewage."

RURAL ECONOMICS.

Renting land in Missouri, O. R. JOHNSON and R. M. GREEN (*Missouri Sta. Bul. 167 (1920), pp. 52, figs. 6*).—This bulletin cites data obtained from 848 farms, representing all parts of the State of Missouri for the years 1912-1915, comparing the economic factors concerned in three common systems of renting land (1) for a share of all crops, (2) a share of the crop land and cash for the rest of the farm, and (3) a straight cash charge for the whole farm. Tabulations are made of the tenant's capital, yields and methods of renting, live stock on the tenant farm, crops grown, use of labor equipment, returns from live stock, source of income, and labor income for each of the three types. The

848 farms are grouped by land values to determine the average rent per acre paid under the different systems on land of the same value and the percentage of land value received as rent by owners. Four crops—corn, wheat, oats, and hay—were studied from the standpoint of the particular rate of rent charged for land for each, and the results are tabulated under the heads of rent paid under different rent systems, land value and cost of ground at different share-rent rates, yields on land renting at different rates, and relation between land values, yields, and rent paid, in bushels. Some similar data are given with reference to pasture land.

The conclusions arrived at from this comparative study are that the share tenant has less capital and the cash tenant most, and that the share tenant as a rule gets the more fertile land, his crop index being 93 per cent, while that of the cash tenant is 90.6 per cent. The share tenant is a better feeder of stock, makes \$138 more labor income than does the cash tenant, and pays the landlord nearly twice the interest on the investment that the cash tenant pays. On the same grade of land cash rent in Missouri is in general cheaper than share rent where crop failures are not more frequent than two years in five. It is indicated that cash renting necessitates more of a live-stock type of farming. Some of the advantages attributed to share renting are that the owner realizes on the average a higher return and has fairly close supervision over his farm, and the tenant usually gets a better farm and does not take the chance of having to pay a fixed rent even if crops fail. The two main disadvantages are that the owner must undertake the responsibility of deciding what land shall be cropped, and the tenant will be paying very high rent if he is a good farmer and will not be so free in his management as a cash tenant.

The conditions are about the same for the share-cash tenant as for the share tenant.

Present methods of leasing land involve uncertainty as to the length of time the tenant can remain on the land, insufficient legal protection of any improvements he may make on his own initiative, and protection to the owner against worthless tenants. It is urged that a system of leasing should be worked out which would allow a fair return on his investment to the landlord and on his labor to the tenant, with full protection to both, while at the same time assuring the tenant's realization of his ambition to own a farm and strengthening his position as a social force in the community. It is said also that some check on speculation in land is needed. Principles which should be embodied in lease contracts are reviewed from the standpoint of good agriculture, noting particularly the duration of lease, reservations, the rent to be paid, manner of paying cash rent, partnership, and twenty definite articles of agreement. Suggestive lease forms for the three systems are given.

An open letter to bankers, investors, and to experienced farmers, W. H. CRAWFORD (*Salem: Oreg. Land Settlement Comn., 1920*, pp. 4, figs. 4).—This leaflet describes the Farm Home Business Unit planned, equipped with buildings, live stock, and machinery, and sold on an easy payment plan to an experienced farmer by the Oregon Land Settlement Commission in order to establish the feasibility of State financing of land settlement.

Land settlement, H. A. SMITH (*N. S. Wales Statis. Register, 1917-18, pt. 9, pp. 501-544*).—Detailed information is given as to alienation and occupation of land by land divisions and land board districts as well as to rural holdings by divisions and counties of New South Wales.

American farmers' need for capital, E. H. THOMSON (*Ann. Amer. Acad. Polit. and Soc. Sci., 87 (1920), No. 176, pp. 89-94*).—The author reviews data

relating to the capital invested in farms in the United States in 1910, the relation of farm capital to income on farms operated by owners and on those operated by tenants, and the use of capital for farm improvements. It is pointed out that the three distinct forms of loans needed by farmers are the long-term or mortgage loan security by real estate; a shorter time loan or second mortgage, based partly upon real estate and partly upon personal property; and short-term or crop loans. The Federal Land Bank loans are designed to meet the requirements of farmers with sufficient capital, but second mortgages must be resorted to by younger men with more meager financial resources. It is said that the latter may eventually be operated by the farmers themselves cooperatively through farm bureaus, and that the short-term or crop loans are being made easier since the farmer has become an investor in Government securities.

Negro credit unions of North Carolina, T. B. PATTERSON (*South Workman*, 49 (1920), No. 4, pp. 180-183).—Credit unions are defined as societies of borrowers living in the same community organized on a limited shareholding basis for lending money to members, accepting deposits, paying withdrawals, buying supplies, etc. Certain general features of organization and the advantages of such unions are described, together with the origin and success of certain ones among the negroes in the South.

[Annual report of the Jewish agricultural and industrial aid society for 1919] (*Jewish Agr. and Indus. Aid Soc. Ann. Rpt. 1919*, pp. 53).—This continues information previously reported (*E. S. R.*, 41, p. 94).

Cooperative land mortgage credit for India, H. R. CROSTHWAITTE (*Agr. Jour. India*, 15 (1920), No. 1, pp. 16-31).—The author attempts to show that cooperative land mortgage credit is needed in India, and that it is possible on the conditions that the laws of the land be modified to favor an organized system of land mortgage credit, that owners of land will combine with each other, that the necessary organizing agency be provided, and that the sums of money required can be made available. In this connection he deals with problems of land tenure and circumstances affecting the market value of small holdings, outlines the machinery necessary for organization and the technical details of such a system, and lists the principal merits attaching to a mortgage credit association as an agency for providing the landowner with long term credit. He maintains that State guidance and supervision are necessary without, however, the use of State money either as subsidy or loan.

[The progress of agricultural cooperation in India for 1918-19], J. MACKENNA (*Rpt. Prog. Agr. India, 1918-19*, pp. 99-110, 158-161).—General notes are given on the progress of cooperative societies in particular Provinces, and also on the status of cooperative dairies and the progress of cattle insurance societies. Tabulations are made of the operations of noncredit agricultural societies for purchase and sale and production and of cattle insurance societies.

Causes of failure in cooperative societies, A. GIRARD (*Vie Agr. et Rurale*, 9 (1920), No. 9, pp. 141-144).—A summary of reasons given for failure of farmers' cooperatives in Canada and the United States is made here. Among the reasons most frequently given are failure to employ a highly competent manager, too small a membership, insufficient demand, too elaborate a program of activity, selling on too low a margin of profit, and opposition from without. The author urges particularly the importance of cash transactions.

Community organization, C. W. CALLARMAN (*Okla. Agr. Col., Ext. Div. Circ. 117* (1920), pp. 20).—A plan is presented here for community organization on the basis of a State farm council and federated county and community farm councils, outlining the duties of six committees—agricultural, social, civic beauty,

education, public health, and rural religious life. Suggestive constitutions and by-laws are outlined.

A system of records for local farmers' mutual fire insurance companies, V. N. VALGREN (*U. S. Dept. Agr. Bul. 840 (1920), pp. 23, figs. 12*).—The suggested system is based on a policy register plan, the books of which comprise a policy register, a book for increases and cancellations, a cash receipts book, a cash disbursements book, an index book or its equivalent in a set of index cards, and two intended for the keeping of a historical summary of the company's business in condensed form. Each of these are described in technical detail as to form and the making of entries. The making of an annual report is also described.

The standard day's work in central Illinois, H. R. TOLLEY and L. M. CHURCH (*U. S. Dept. Agr. Bul. 814 (1920), pp. 32, figs. 11*).—Estimates taken during the winter of 1918 and 1919 from nearly 600 farmers in McClean County, Ill., of the average number of acres covered per day in different farm operations, including plowing, harrowing, planting, cultivating, cutting, and husking corn; seeding, harvesting, and unloading grain, haying, and hauling and spreading manure, according to size of the implement or team or the average number of minutes required per load in handling hay, ear corn, oats, and manure are tabulated separately and summarized. Results obtained in this inquiry are compared with those previously noted (*E. S. R., 35, p. 892*), particularly as regards plowing, harrowing, and disking; operations on the corn crop; seeding and harvesting grain; and haying.

Farm labor, D. D. LESCOHIER (In *The Labor Market. New York: The Macmillan Co., 1919, pp. 276-306, figs. 3*).—The chapter under this title in the author's study of the labor market gives a survey of the farm labor demands of a number of typical States or sections as dependent upon differences in temperature, topography of the country, and type of crops raised. The points are emphasized that employment agencies and agricultural organizations interested in the farmers' supply of labor must study the local agriculture and adapt their policies to the particular demands of the community, and that diversified agriculture being the system which offers steady demand for skilled workers is therefore the only kind of agriculture which offers an economic inducement to competent farm hands. It is said that steady employment, wages that will support a family, houses for married men's families, and opportunities of welfare equal to those in our city employments must be assured for the development of a permanent class of reliable farm laborers.

Will agricultural prices fall? E. G. NOURSE (*Jour. Polit. Econ., 28 (1920), No. 3, pp. 189-218*).—The author sketches the growing concern for and activity of farmers' organizations in the maintenance of prices of agricultural products, together with those factors tending to force prices down, such as the waning of the European demand and of the inclination and ability of consumers at home to pay high prices, and the increased facility of long-distance transportation, which will almost inevitably bring cheaper products of new lands into competition with our home supply. It is maintained that the chief service and real power of the farmers' organizations will hereafter lie in learning the effective available demand for agricultural products and the sources and extent of rival supplies. It is said that a most promising line of endeavor will be also in protecting the farmers' net return by making costs move down in conformity with inevitable declines in selling prices, as well as in fostering productive and marketing efficiency and checking advances in transportation charges.

Monthly Crop Reporter (*U. S. Dept. Agr., Mo. Crop Rptr., 6 (1920), No. 4, pp. 33-40, fig. 1*).—The usual estimates, brief notes, and tabular data on acreage condition, production, farm and market value, and prices received for

important agricultural products are given. A statistical report showing the tendency toward increased diversification of crops in the South, a summary of the production of 21 important crops in the leading five States, 1917-1919, and of the farm labor supply and demand, April 1, 1918-1920, are included.

The Market Reporter (*U. S. Dept. Agr., Market Rptr., 1 (1920), Nos. 14, pp. 209-224, fig. 1; 15, pp. 225-240, fig. 1; 16, pp. 241-256, fig. 1; 17, pp. 257-272, fig. 1*).—In these numbers are continued the weekly and monthly summaries of movement, marketing, and prices of specified commodities, and tabulated data with interpretative text in regard to important classes of agricultural products.

Special articles on the potato market position and apple exports and imports, and a tabulated report of the annual production of manufactured dairy products and oleomargarine (see p. 179) are published in No. 14. In No. 15 are articles on the dominant position of American cotton shown by a review of the world situation, increased butter production in 1919, and Montana cattle movement in 1919; in No. 16 on milk prices in 1919 (see p. 178), grades for tomatoes (see p. 144), handling spinach (see p. 144), a monthly cold-storage report, and report of receipts and disposition of live stock at public stock yards for March; and in No. 17 on sugar beet seed supply, marketing Bermuda onions, and the dominant position of American cotton (continued from No. 15).

The economic rôle of our colonies during and after the war, R. CHUDEAU (*Assoc. Franç. Avanc. Sci., Confs., 1918, pp. 18-53, figs. 4*).—This deals principally with French Indo-China, Madagascar, and the French island colonies, giving the general geographic characteristics of each and describing their important vegetable and animal products. Certain characteristics of natives of these colonies as laborers are described. The improvements accomplished and needed, and the financial resources are noted.

AGRICULTURAL EDUCATION.

Annual report of the extension service for the year ending November 30, 1918 (*Mass. Agr. Col. Ext. Rpt. 1918, pp. 63, figs. 3*).—This is a report on the history, organization, and work during the year, of the extension service of the Massachusetts Agricultural College.

During the year there was a total enrollment of 103,603 boys and girls in the junior extension work. A plan was adopted whereby a high-school agricultural student who is enrolled in junior extension work may obtain, on entering the college, one point of credit for each year of such work performed during the high-school course, or a total of four credits. To meet the need of a regular publication of the extension service, the *Extension News* was issued as a bimonthly publication, the first number appearing in June, 1918.

State-aided vocational education in Massachusetts (*Ann. Rpt. Bd. Ed. [Mass.], 82 (1917-18), pp. 106-134, 218-263; also in Bul. Bd. Ed. Mass., No. 5 (1919), pp. 79*).—This is a report on the work in vocational education in Massachusetts in 1917-18, the special feature being the work done by the schools because of war needs. The 107 vocational schools in operation during the year included 9 homemaking day schools with a total enrollment of 450 students, 6 agricultural schools, 12 vocational agricultural departments in high schools, and 19 vocational agricultural departments for war emergency work only. The total expenditure of the agricultural schools was \$179,970, and of the agricultural departments \$37,468. The total earnings of vocational agricultural students from the farm and other work during the periods covered by their school attendance and their farm projects increased from \$11,100 in 1912 by a total of 70 pupils to \$124,669 by a total of 322 pupils.

Supervised home project and club work, F. L. KEM (*Ind. State Bd. Ed., Ed. Bul. 39 [1918], pp. 61, figs. 46*).—It is shown that in 1918 27,152 Indiana boys and girls (17,923 projects) produced \$363,833 worth of products at a net profit of \$227,908. Of the total reported results of project work as based on net profits, 98 per cent, it is held, were secured by those directly or indirectly paid for their services as club leaders. Those indirectly paid include the county agents, home demonstration agents, and vocational teachers. Attention is called to the close relationship between club work and the schools, conditions under which school credit is given for home project work, demonstration teams, and the social aspects of club work.

The Indiana State Board of Education this year officially recognized the vocational work of the State as being on a par with the high-school courses as commonly administered. The number of vocational agricultural departments decreased during the year to 33 because of the impossibility of securing trained teachers who could meet the requirements of the vocational law. Summaries of the boys' State corn contest in 1918, of pig club records for January, 1919, and of results secured by four club supervisors and by vocational teachers, are included.

Boys' and girls' club work in the United States (*Bul. Pan Amer. Union, 50 (1920), No. 3, pp. 300-311, figs. 11*).—This is an account of the development, present organization, and results of boys' and girls' club work in the United States.

Regulations for grants in aid of agricultural education and research in England and Wales [1919-20] (*London: Bd. Agr. and Fisheries (1919), pp. 11*).—This pamphlet sets forth the conditions under which the Government grants were awarded for the fiscal year beginning April 1, 1919, for agricultural education and research to universities, university colleges, agricultural colleges, and local education authorities in England and Wales. As a result of changes in these regulations, grants made to the councils have been more than doubled in the aggregate. The grant is now a definite proportion of the approved expenditure, and includes four-fifths of the salaries and expenses of the principal administrative officers in charge of agricultural and horticultural education and two-thirds of all other expenditures for agricultural education and its administration.

Developing the fruit industry, J. VERCIER (*Vie Agr. et Rurale, 16 (1920), No. 10, pp. 157, 158*).—It appears that thus far the principal aim of instruction in fruit culture in the schools of agriculture, horticulture, and arboriculture in France has been to give their students a general knowledge of the subject, with almost no attention to the commercial or industrial aim. It is stated that experiments in drying fruits have been attempted for a long time in the National School of Horticulture of Versailles, and also at some other agricultural institutions, but without results. The cider industry is said to be the only one in which real progress has been made. The author offers suggestions for the organization of special schools for the commercial and industrial arboricultural and fruit industries, but to begin with would establish only one such school, centralizing in it all the chances for success rather than creating a number of such institutions, perhaps insufficiently endowed. This school should cooperate with a strong research laboratory where questions of preserving could be carefully studied and made the object of instructive lectures and reports. Attention is called to a large German preserve manufacturing establishment at Lyon in a fruit production center, which has been sequestered and could be converted into such a school.

Rural science reader, S. B. MCCREADY (*Boston: D. C. Heath & Co., 1920, pp. XIV+310, pls. 28, figs. 105*).—This is the first book of a rural education series,

in which the author endeavors to represent in story form how the boys and girls in rural schools may be so instructed through the use of material drawn from their own environment as to become vitally interested and active in cooperative undertakings needed in training for rural citizenship. The stories, told by pupils, deal with studies of their own school, homes, farms, neighborhood, etc.; a teacher's community service, the making and using of school libraries and a school workshop; the school progress club, bird club, home and school club, and school egg circle; nature study excursions, school and home gardens, making arithmetic problems, farm bookkeeping, weeds, insect studies, school credits for work at home, apple show and orchard studies, potato contest, school fair, school lunch, play and games, the consolidated school, etc.

Suggestions on courses in agriculture for the Smith-Hughes high schools of Kentucky, McN. C. JAMES ([*Lexington*], *Ky.: Ky. State Bd. Vocat. Ed.*, pp. 54).—This bulletin contains a suggested four-year course for vocational work in agriculture and related sciences, including farm crops and horticulture in the first, animal husbandry, dairying, and poultry raising in the second, soils in the third, and farm mechanics and farm management in the fourth years; a topical outline of the course with suggestions for laboratory work; a list of suitable texts and reference books; suggestions for other library material, laboratory equipment for 20 pupils, the use of school land, and home project work; a list of suitable projects for Kentucky; and sources of supplementary and illustrative material in agriculture. It is stated that more than a score of high schools have met the requirements and are offering courses in vocational agriculture, household science, and industries.

The teaching of elementary soils, H. O. BUCKMAN (*Jour. Amer. Soc. Agron.*, 12 (1920), No. 2, pp. 55-57).—The author briefly reviews the evolution of methods of teaching soil science. In his opinion the science is now on such a basis that one general fundamental course seems preferable to the two or even three that are in many places offered in as many calendar terms to cover the subject. Recitation periods should be instituted in which the principles explained and emphasized in the lectures can be expanded and discussed, preferably with a textbook as a basis. Exercises emphasizing fundamental points should be substituted for the old style laboratory "experiments." In short, he believes that the whole course may be made a follow-up, the recitations on the lectures, and the laboratory on both.

Introductory courses in soils, R. S. SMITH (*Jour. Amer. Soc. Agron.*, 12 (1920), No. 2, pp. 58-60).—The author endeavors to state in broad terms a tentative outline of the general purpose to be attained by the introductory soils course. Referring to questions regarding laboratory work in soils, raised in an article by Karraker previously noted (*E. S. R.*, 41, p. 896), he believes that if the admittedly weak laboratory exercises in introductory soils courses are to be strengthened by revision, elimination, or addition in the most rational manner, their contribution to the attainment of the purpose of the work as a whole must be kept in mind and they must be made to conform to this purpose as well as to the best available knowledge. But something more than improvement or elimination of certain laboratory exercises is needed. The problems presented by the first soils course are becoming constantly and rapidly more difficult, due to the changes in the nature of the courses given in secondary schools. Attention is called to the need of the best collective effort of the men who are responsible for the teaching in the introductory soils courses in working out and agreeing on basic principles.

Household arts and the high school girl, N. G. GLADISH (*Jour. Home Econ.*, 11 (1919), No. 11, pp. 488-492).—This is a discussion of what to teach in a two-

year high school course in household arts, and of ways of stimulating the students' interest in the subject.

Vocational training for girls, G. GRAY (*Jour. Home Econ.*, 11 (1919), No. 11, pp. 493-497).—The question as to whether training in vocational home economics shall be given in the elementary school, the high school, or in classes organized for those who will have immediate need for it, is briefly discussed.

In the author's opinion, every possible opportunity for training in housekeeping and homemaking should be offered to those who are engaged in those occupations or those who are soon to engage in them, but that in the elementary and high schools girls should be given the kind of vocational work which will fit them to earn a living in some trade or business. There is great danger, it is stated, that with well-developed vocational home-economics courses in the high school there will be a tendency not to provide such courses for those out of school. It is urged that there be secured for women and girls a fair share of the Smith-Hughes money provided for industrial training.

MISCELLANEOUS.

Thirty-second Annual Report of Colorado Station, 1919 (*Colorado Sta. Rpt. 1919*, pp. 37).—This contains the organization list, a financial statement for the fiscal year ended June 30, 1919, a report of the director on the work of the station, and departmental reports. The experiment work reported is for the most part abstracted elsewhere in this issue.

Biennial Report of Connecticut Storrs Station, 1916-17 (*Connecticut Storrs Sta. Rpt. 1916-17*, pp. VIII+38+194-486, figs. 62).—This contains the organization list, a financial statement for the fiscal years ended June 30, 1916, and June 30, 1917, a report of the director, and reprints of Bulletins 90-99, previously noted. Meteorological data, noted on page 120, are appended.

Thirty-second Annual Report of Georgia Station, 1919 (*Georgia Sta. Rpt. 1919*, pp. 16).—This contains the organization list, reports by the president of the board of directors and the director of the station on its work during the year, and a financial statement for the fiscal year ended June 30, 1919.

Thirty-second Annual Report of Maryland Station, 1919 (*Maryland Sta. Rpt. 1919*, pp. LXI).—This contains the organization list; a report by the director on the organization, work, and publications of the station; and a financial statement for the fiscal year ended June 30, 1919. A list of the investigations in progress, with the object sought and results obtained, is included. The experimental work is for the most part abstracted elsewhere in this issue.

Thirty-first Annual Report of Vermont Station, 1918 (*Vermont Sta. Bul. 212* (1918), pp. 16).—This contains the organization list, a brief announcement concerning the station, a financial statement for the fiscal year ended June 30, 1918, and a report of the director on the work of the station.

Twenty-ninth Annual Report of Wyoming Station, 1919 (*Wyoming Sta. Rpt. 1919*, pp. 141-167, fig. 1).—This contains the organization list, a financial statement for the Federal funds for the fiscal year ended June 30, 1919, reports of the director and heads of departments, meteorological observations, and a special article noted on page 172. The experimental work reported is for the most part abstracted elsewhere in this issue.

Monthly bulletin of the Western Washington Substation (*Washington Sta., West. Wash. Sta. Mo. Bul.*, 8 (1920), No. 1, pp. 16, figs. 3).—In addition to articles abstracted elsewhere in this issue, this number contains brief articles on the following subjects: Care of the Dairy Cow at Calving Time, by E. G. Woodward; Care of Flock at Lambing Time, by C. M. Hubbard; Lawns, by J. L. Stahl; and Kale and Root Crops, by E. B. Stookey.

NOTES.

California University and Station.—The resignations are noted of Dr. J. Eliot Coit, professor of citriculture, to engage in business in southern California, and D. T. Batchelder, instructor in animal husbandry. Robert F. Miller, of the Texas College, has been appointed associate professor of animal husbandry, and will be acting head of the division during the leave of absence of Gordon H. True the ensuing year.

Colorado College.—R. A. McGinty, associate professor of horticulture, has resigned to engage in commercial work.

Delaware College and Station.—A committee of station workers, consisting of Dr. T. F. Manns, chairman, Dr. E. M. R. Lamkey, and L. R. Detjen, has been designated as a research committee. This committee is to review and pass upon all Adams Act projects and render assistance to project workers. It will also pass upon all research manuscripts submitted for publication.

An important two-day conference between station and extension workers was held recently to discuss important agricultural problems of crop production within the State.

Henry P. Scott, of Wilmington, has been appointed to the board of trustees. L. W. Tarr has been appointed chemist in the station, vice H. T. King, resigned, and B. Davison, assistant horticulturist, vice R. A. Nehf, resigned.

Idaho University and Station.—Dr. Ernest H. Lindley, president since 1917, has announced his acceptance of the chancellorship of the University of Kansas. H. A. Bendixen has been appointed assistant professor of dairy husbandry and assistant dairy husbandman, beginning July 1, and will have charge of the creamery instruction and the dairy manufacturing studies.

Illinois University.—Dr. David Kinley, professor of economics and dean of the graduate school, has been appointed president, in succession to Dr. E. J. James.

Purdue University and Station.—C. G. Woodbury has resigned as director of the station to become director of the raw products division of the National Cannery Association, beginning July 1. The administrative work of the station will be merged with that of the extension activities, under the direction of G. I. Christie, superintendent of agricultural extension. O. G. Lloyd, associate professor of farm management in the Iowa College and assistant chief in farm management in the Iowa Station, has been appointed head of the department of farm management, beginning July 1. C. O. Cromer, associate in crops, and W. B. Krueck, secretary of the stallion enrollment board, have resigned to engage in farming.

Iowa College and Station.—The semicentennial of the founding of the college was celebrated June 6-9, after a year's postponement. Among the special features of interest were a memorial service for the 103 men from the institution who gave their lives in the war, the subscription of about \$50,000 by the alumni and \$53,000 by the students toward a student and faculty social union building as a permanent memorial, and the presentation of a historical pageant symbolical of the college history.

Dr. E. D. Ball, professor of entomology and station entomologist, has been appointed Assistant Secretary of Agriculture and entered upon his duties June 14.

Kansas College and Station.—The enrollment of resident students in the division of agriculture during the school year which closed May 27 was 640, and in the entire institution, 3,376. The graduating class included 72 students in agriculture, 72 in home economics, 17 in veterinary medicine, 43 in general science, and 27 in engineering.

A soil fertility school, conducted by the department of agronomy in cooperation with the National Fertilizer Association, was held at the college during the week of June 1. The enrollment was 52, consisting mainly of employees of fertilizer companies belonging to the association.

The first annual sale of the Kansas Shorthorn Breeders' Association was held at the college May 26, when 55 registered Shorthorns brought an average price of \$455. The sale was topped by College Duchess 2d, a cow owned by the college, which sold for \$3,900.

H. H. Laude, agronomist in rice work at the Texas Station, has been appointed assistant professor of agronomy in charge of cooperative experiments. F. W. Atkeson, instructor in dairy husbandry and assistant dairy husbandman, has resigned to engage in commercial work.

Massachusetts College and Station.—Dr. J. K. Shaw, professor of horticulture and horticulturist in the West Virginia University and Station, has returned to Massachusetts as research professor of pomology. Fred E. Wheeler, instructor in dairy husbandry, has resigned to engage in commercial work and has been succeeded by Glenn E. Upton. Harlan P. Worthley has been appointed investigator in entomology.

Mississippi College.—Dr. W. H. Smith has resigned as president.

Montana Station.—H. E. Selby, instructor in farm management at the Oregon College, has been appointed assistant professor of farm management vice D. C. Wood, resigned, beginning July 1.

Nebraska University and Station.—Dr. George L. Peltier, professor of plant pathology and plant pathologist at the Alabama Station, has been appointed to a similar position in the college of agriculture and station, beginning July 1 and succeeding Dr. E. Mead Wilcox, whose resignation has been previously noted. R. W. Goss of the Bureau of Plant Industry, U. S. Department of Agriculture, has been appointed instructor in plant pathology and assistant pathologist in the station.

New Hampshire College and Station.—W. H. Wolff, assistant horticulturist, has resigned to become horticulturist with the Hampden County (Mass.) Improvement League.

New Jersey College and Stations.—Increased appropriations have been granted by the State Legislature for both the long and short courses of the college, together with \$20,000 to equip the new horticultural building. The stations received an increase in the printing funds and the allotment for poultry husbandry, seed inspection, farm demonstrations, cranberry studies, and potato and sweet potato experiments. An appropriation of \$4,000 has been made for organizing poultry exhibits in the State and awarding prizes for them, and \$5,000 has been promised to the new Bergen County Egg-laying and Breeding Contest, providing \$15,000 be raised locally. This amount is practically assured, and it is expected that the contest will open in the fall.

Inspection of creameries, milk-receiving stations, and calibration of glassware was provided, with an appropriation of \$3,000 for this purpose. A bonus act for State employees was passed, and also legislation authorizing the State

Department of Health and the stations to carry on experiments in sewage disposal and sewage plant control.

New Mexico Station.—J. D. Hungerford resigned as nutrition chemist May 15, to accept a commercial position.

New York State Station.—A State employees' pension law has recently been enacted which affects all workers in the station. The salient features of the law provide for voluntary retirement at 60 and compulsory retirement at 70 years. The amount of the pension is determined largely by the length of service and the salary at the time of retirement, but can in no case exceed one-half the salary at retirement. The law becomes effective in January, 1921.

A State appropriation of \$5,000 has been made at the request of fruit growers for a special investigation by the station of the merits of the new dusting methods for the control of insect pests and fungus diseases as compared with spraying.

Peter G. Ten Eyck of Albany has been appointed to the board of control, vice Parker Corning. John W. Bright, assistant bacteriologist, has resigned to accept a commercial position and has been succeeded by Myron W. Finch.

Oklahoma College and Station.—F. B. Cross, assistant professor of horticulture and assistant horticulturist, resigned May 1 to become a county agent in New Jersey.

Pennsylvania College and Station.—Esther S. Mixer, assistant in chemical agriculture, resigned June 30. Paul R. Guldin has been appointed associate professor of poultry husbandry; T. B. Charles, instructor in poultry husbandry; and A. S. Barnhart, assistant in club work extension.

South Dakota Station.—Some excellent results have been secured recently in feeding silage made from millet. In a feeding trial of 120 days, cattle made an exceptionally good gain and sold for nearly as much in the market as steers that had been fed on corn and oil meal.

Texas College.—John C. Burns, head of the department of animal husbandry, resigned July 1 to become southwestern field representative of the Texas Shorthorn Breeders' Association, with headquarters at Fort Worth.

Vermont University.—M. P. Rasmussen has been appointed farm management demonstrator in the extension service, beginning April 1.

Virginia Truck Station.—At the recent session of the legislature, an act was passed designating the station as one of the permanent State institutions. The president of the Virginia Agricultural College and the chairman of the board of control of the Virginia Station were made ex-officio members of the board of directors, and John G. Eberwine of Deans, Ben T. Gunter of Accomac, and Daniel W. Lindsey of Berkley Station have been appointed by the governor as the remaining members. The State has acquired title to the property upon which the station is located by donation from the local truckers' association, and increased appropriations have been granted for its maintenance and the extension of certain lines of work.

Wyoming University and Station.—J. C. Overpeck has been appointed assistant professor of agronomy and assistant agronomist, beginning June 5. Dr. James Poole, botanist of the station, has been granted a year's leave of absence for graduate work in Harvard University, beginning July 1.

ADDITIONAL COPIES

OF THIS PUBLICATION MAY BE PROCURED FROM
THE SUPERINTENDENT OF DOCUMENTS
GOVERNMENT PRINTING OFFICE
WASHINGTON, D. C.

AT

15 CENTS PER COPY
SUBSCRIPTION PRICE, \$1 PER VOL.

EXPERIMENT STATION RECORD.

VOL. 43.

ABSTRACT NUMBER.

No. 3.

RECENT WORK IN AGRICULTURAL SCIENCE.

AGRICULTURAL CHEMISTRY—AGROTECHNY.

The chemists' year book, 1918-19, F. W. ATACK and L. WHINYATES (*London: Sherratt & Hughes, 1919, 4. ed., vols. 1, pp. [6]+422, figs. 8; 2, pp. [4]+423-1146, figs. 14.*)—The fourth edition (1918-19) of this year book of chemistry contains, in addition to revisions of a general character, new sections on Analysis of Clays, Firebricks, and Silica Materials by J. W. Mellor, and on Agricultural Chemistry by E. J. Russell; and revisions of the sections on Dairy Products by G. D. Elsdon and A. D. Heywood, Crystallography by E. H. Rodd, Electrochemistry by F. M. Perkins, Water Analysis by D. R. Davey, Properties of Essential Oils by L. G. Radcliffe, Tannin Materials by W. Mather, and Alkaloids by E. Hope.

Progress in fat chemistry in 1918, W. FAHRION (*Chem. Umschau Geb. Fette, Oele, Wachse, u. Harze, 26 (1919), Nos. 16, pp. 197-199; 17, pp. 209-211; 18, pp. 221-223.*)—This is a review of the literature on theoretical (pp. 197-199), analytical (pp. 209-211), and technical (pp. 221-223) fat chemistry.

The rancidity of Philippine coconut oil, G. A. PERKINS (*Philippine Jour. Sci., 15 (1919), No. 5, pp. 463-474.*)—The conceptions of various authors concerning the cause and nature of the rancidity of oils, including the recent work of Brill and Parker (*E. S. R., 39, p. 108*), are reviewed, and experiments are reported in which the relative effect of various factors in the development of rancidity in edible coconut oil was determined. The rancidity factors studied were initial acidity, air, light, moisture, and the enzymes and nonfatty material present in the oil obtained by expression. The tests for rancidity included acidity determinations, iodine number (Hanus), fuchsin-aldehyde test, oxidizability value by a slight modification of the Issoglio test (*E. S. R., 37, p. 114*), and odor. From the analytical data obtained the following conclusions are drawn:

“In the type of rancidity of coconut oil studied, the first stage is a hydrolysis, the rapidity of which varies with the initial acidity and the amount of moisture present. Exclusive of any mold action, this hydrolysis may be somewhat accelerated by the action of air, light, and a fat-soluble enzyme. The second stage of rancidity is an oxidation of the free fatty acids. Possibly this involves also the oxidation of unhydrolyzed olein, but the amount of oxidation is dependent on the amount of hydrolysis. The oxidation is hastened by light and moisture, but light is not a necessary condition.”

As tests to determine the amount of deterioration in oil undergoing the ordinary type of rancidity, the author recommends the iodine number, the fuchsin-aldehyde test, and the oxidizability.

A new method for preparing esters of amino acids.—Composition of caseinogen, F. W. FOREMAN (*Biochem. Jour.*, 13 (1919), No. 4, pp. 378-397).—The method of preparing esters of amino acids by the hydrolysis of their dry lead salts with dry hydrochloric acid gas (E. S. R., 27, p. 501) has been applied to the products of the hydrolysis of casein by sulphuric acid and by hydrochloric acid, the former to determine the distribution of the nitrogen in the various fractions and to test the completeness of the esterification, and the latter to determine the effect of the process upon the yield of the nonamino acids and to throw some light upon the nature of the unidentified substances making up the deficit in protein analysis.

The hydrolysis with sulphuric acid showed that no less than 7 per cent of the nitrogen was lost in the barium sulphate precipitate formed when the acid was removed. The crude tyrosin contained 1.98 per cent of the total nitrogen, and the aqueous solution of amino acids from which the lead salts were prepared for esterification 88.38 per cent of the nitrogen. On precipitating the lead salts from the aqueous solution of amino acids 77.08 per cent of the total nitrogen was recovered in the dry lead salts, and in the filtrate containing the ester hydrochlorid after removing the lead chlorid the recovery was 75.02 per cent.

The percentage of nonamino acids recovered after the hydrolysis of caseinogen with hydrochloric acid and subsequent treatment according to the author's methods was as follows: Glycin 0.45, alanin 1.85, valin 7.93, leucin 9.7, prolin 7.63, and phenylalanin 3.88 per cent. The unesterified residue consisted largely of a sirupy material which was afterwards separated directly from the hydrolytic products, together with glutaminic and aspartic acids in the form of alcohol-insoluble salts. The yield by this modification was glutaminic acid 21.77, aspartic acid 1.77, and sirups 14.34 per cent. By adding to these figures of nonamino acids 3.41 per cent of unknown substances probably of peptid nature, 7.62 per cent of lysin, as reported by Van Slyke (E. S. R., 33, p. 408), and as figures for the other amino acids, ammonia, sulphur, and phosphorus the results selected by Osborne and Guest as most reliable (E. S. R., 25, p. 504), a total of 97.36 per cent was obtained. It is pointed out that as some of the products include the water of hydrolysis the total should be greater than 100 per cent.

The iron content of oils, fats, waxes, resins, gum resins, and gums; together with some determinations of silica and aluminum, M. GONNERMANN (*Biochem. Ztschr.*, 95 (1919), No. 5-6, pp. 286-295).—Determinations of the iron content of animal and vegetable fats and various waxes, resins, and gums are reported. Iron was found in amounts varying from a trace to as much as 29.7 per cent of the ash in all the substances examined, with the exception of the lipoids of horses' brains and Senegal gum.

A table is also given of determinations of silicic acid and aluminum in various plant and animal substances.

On the synthesis of sugars from formaldehyde, carbon dioxide, and water, A. J. EWART (*Proc. Roy. Soc. Victoria, n. ser.*, 31 (1919), No. 2, pp. 378-387, pl 1).—In continuation of work previously noted (E. S. R., 42, p. 527), the author reports investigations on the polymerization of formaldehyde to sugar by alkalis and alkaline carbonates.

"The main conditions for a high proportion of sugar are appropriate dilution and a temperature of 100° C. to 110° C. The by-products are formates and methyl alcohol mainly. At low temperatures little or no sugar is produced. The most rapid reaction is produced by sodium hydrate. In the presence of a neutral calcium salt the amount of sugar condensation is greatly in-

creased, less alkali is required, and less formate produced. Neutral barium and strontium salts are less effective as condensing catalytic agents.

"The best method is by running 7 to 8 cc. of 3.5 per cent sodium hydrate into 250 cc. of 0.8 per cent calcium formate containing 5 cc. of 40 per cent formaldehyde while boiling in a condensing flask. The reaction is completed in a few minutes, and as soon as a pale yellowish tinge appears all the formaldehyde has disappeared.

"The sugar mixture is optically inactive, and contains reducing pentoses and reducing fermentable hexoses. Carbon dioxide and water are readily polymerized to sugar by the aid of magnesium. The production of calcium tartrate [previously noted] during sugar synthesis has not been confirmed, and was possibly due to the use of an oxidized sample of formaldehyde."

The inversion of cane sugar during the storage of oranges, G. ANDRÉ (*Compt. Rend. Acad. Sci. [Paris]*, 170 (1920), Nos. 2, pp. 126-128; 5, pp. 292-295).—A study is reported of the changes taking place in the sugar content of oranges during storage in an aseptic medium.

Sections of a ripe orange were placed in a closed receptacle containing a few drops of toluene to prevent the development of molds. After four months these sections were analyzed for acidity calculated as citric acid, reducing sugars, and sucrose, and the analyses compared with similar ones made on other sections from the same fruit analyzed at the beginning of the period of storage. The results of these analyses showed that, while the content of citric acid had not changed appreciably, the sucrose had been converted to a considerable extent into reducing sugars. This hydrolysis is considered to have been caused by the presence of citric acid rather than of a sucrose.

Analyses of solutions of sucrose and citric acid in concentration approximating that of orange juice and kept for varying periods of time indicated that the hydrolysis of the sucrose is much slower in the orange in its natural state than in the synthetic solution. This is explained on the ground that in the tissues of the orange the mixture of sugars and citric acid is not homogeneous, the two materials being located in different cells across which the exchange of liquids is very slow. A further proof of this was furnished by experiments in which orange juice was analyzed in a similar manner, the inversion of sugar taking place much more rapidly than in the whole orange.

A series of analyses of orange juice heated and unheated, in the natural state, and neutralized, showed that the formation of invert sugar was not affected by heating or neutralizing the juice. In juice kept in a closed receptacle the inversion of the sucrose was less rapid than in juice exposed to the air.

The utilization of α -methylglucosid by *Aspergillus niger*, A. W. DOX and G. W. ROARK, JR. (*Jour. Biol. Chem.*, 41 (1920), No. 4, pp. 475-481).—The authors report a study of the extent to which *A. niger* can utilize α -methylglucosid, which had previously been found by Dox and Neidig (*E. S. R.*, 30, p. 11) to be a less favorable medium than the beta form for the growth of the fungus.

The results of the present study indicate that while *A. niger* grows very poorly on media containing α -methylglucosid as the only source of carbon, it grows readily on sucrose media in the presence of the glucosid. "A vigorous culture transferred entire to the glucosid medium without sucrose may use up the glucosid more rapidly than a culture obtained by direct inoculation of this medium with spores. If the original medium contained both sucrose and glucosid the latter disappears more rapidly from the second medium containing glucosid but no sucrose than when the original medium contained sucrose alone. Also, there was a slight difference between the activity of cultures before and after spore formation.

"A gradual cumulative adaptation through a number of generations cultivated on this substrate could not be demonstrated with any degree of certainty."

Substitutes from the plant kingdom, edited by L. DIELS (*Ersatzstoffe aus dem Pflanzenreich. Stuttgart: E. Schweizerbart, 1918, pp. [6]+418, figs. 412*).—This reference book, compiled by L. Diels, E. Gilg, P. Graebner, H. Harms, T. Loesener, and E. Aldrich, contains botanical descriptions of plants native to Germany from which can be prepared substitutes for ordinary food and industrial materials, together with chemical analyses in many cases of the resulting substitute. The subject matter is treated under the following headings: Salads and herbs, feeding stuffs, sugar, fruit, starches and flour, legumes, yeasts, mushrooms, fats and oils, alcoholic beverages, alkaloid-containing beverages, tobacco, spices, medicinal substances, soap substitutes, gums, rubber and gutta percha, resins, essential oils, textile materials, silk, and wood.

Occurrence of iodine in plants, E. WINTERSTEIN (*Hoppe-Seyler's Ztschr. Physiol. Chem., 104 (1918), No. 1, pp. 54-58*).—The method employed in determining the presence of iodine in plants consisted essentially in ashing the substance in alkaline solution, separating the iodides from the other salts by shaking with 95 per cent alcohol, evaporating the alcohol, dissolving the dry iodides in water, and treating the aqueous solution with nitrosyl sulphuric acid and chloroform, the iodine coloring the chloroform a deep red.

Small amounts of iodine were found in beets, potatoes, celery roots, head lettuce, and carrots. No iodine could be detected in the leaves of yew, pine, silver fir, beech, chestnut, nettle, spinach, cress, cherry, red clover, and grapevine; in the seeds of maize, rice, oats, barley, rye, wheat, chestnut, hemp, buckwheat, white and blue lupine, vetch, peas, soy beans, garden beans, pumpkin, and horse chestnut; in the fruit of apple, pear, and cherry; or in three varieties of mushrooms, eight samples of milk, and five varieties of cheese.

Iodometric studies, I. M. KOLTHOFF (*Pharm. Weekbl., 56 (1919), Nos. 25, pp. 878-888; 27, pp. 949-959; 30, pp. 1029-1035; 37, pp. 1298-1300; 38, pp. 1322-1326; 40, pp. 1366-1373; 42, pp. 1413-1420; 44, pp. 1466-1470; 47, pp. 1565-1568; 49, pp. 1618-1626; 57 (1920), No. 3, pp. 53-68; abs. in Chem. Abs., 13 (1919), No. 23, pp. 3103, 3104; 14 (1920), Nos. 1, pp. 34, 35; 5, pp. 504, 505*).—In continuation of the iodometric studies previously noted (*E. S. R., 41, p. 504*) the following topics are discussed: IX, The stability of sodium thiosulphate solutions; X, the determination and preservation of hydrogen peroxid solutions; XI, the determination of iodides; XII, the determination of iodides, bromides, and chlorides in the presence of one another; XIII, iodometric determination of arsenic acid; XIV, the titration of sulphurous acid and its salts; XV, the iodometric determination of sulphides; XVI, the determination of tin (with R. Heijde); XVII, the determination of iron; XVIII, the determination of ferri-cyanids and ferrocyanids; and XIX, the iodometric determination of acids.

A new 0.1 N calomel electrode design, A. E. KOEHLER (*Jour. Biol. Chem., 41 (1920), No. 4, pp. 619, 620, fig. 1*).—The electrode described is said to overcome the difficulties of change in normality of the N/10 KCl and of the tendency of the saturated KCl to creep. By a system of stopcocks the reservoirs containing the N/10 and saturated KCl may be connected with the H electrode when readings are to be made, after which, by proper manipulation, the solutions between the two reservoirs may be thoroughly washed out with fresh solutions from the reservoirs. An illustration is given of the essential features of the apparatus.

Studies on the quantitative determination of very small amounts of calcium magnesium and phosphorous in animal substances, L. DIENES (*Biochem. Ztschr., 95 (1919), No. 3-4, pp. 131-145*).—A critical study is reported

of various volumetric methods for the determination of small amounts of calcium, magnesium, and phosphorus in organic solutions such as blood.

Methods of chemical blood analysis, M. RICHTER-QUITTNER (*Biochem. Ztschr.*, 95 (1919), No. 3-4, pp. 179-204; 96 (1919), No. 1-3, pp. 92-105).—Two papers are presented.

I. *Criticism of methods for removing proteins* (Vol. 95, pp. 179-204).—The removal of the blood proteins is considered by the author to be the most important step in blood analysis. Various methods of accomplishing this are discussed from the literature and from experimental data, as the result of which the following recommendations are made:

The removal of proteins by salts of the heavy metals or by colloidal reagents is suitable for sugar determinations, and by heat coagulation for all constituents except chlorids and sugar. Dilute acids are recommended as follows: Phosphotungstic acid for uric acid; phosphomolybdic acid for residual nitrogen, sugar, and uric acid; metaphosphoric acid for chlorids; and trichloroacetic acid for residual nitrogen. Methyl alcohol can be used for chlorid determination and dialysis for residual nitrogen.

II. *A comparison of macro- and micro-methods* (Vol. 96, pp. 92-105).—This paper includes a summary of the requirements of a correct microanalysis of blood, a criticism of the original micro method of Bang, a critical examination of different micro methods for the determination of blood sugar, chlorids, and residual nitrogen, and descriptions of modified methods for these determinations.

The author is of the opinion that as blood is a colloidal solution one drop is not necessarily identical with a second drop, and consequently the use of from 1 to 3 drops as recommended by Bang is open to criticism as not furnishing a representative sample. From 2 to 3 cc. is recommended as the minimum amount which should be used.

Extensive references to the literature are appended to both papers.

Determination of the fibrin, globulin, and albumin nitrogen of blood plasma, G. E. CULLEN and D. D. VAN SLYKE (*Jour. Biol. Chem.*, 41 (1920), No. 4, pp. 587-597).—A method of determining plasma proteins is described which is based upon Kjeldahl determinations of the total nitrogen, fibrin nitrogen, filtrate nitrogen (consisting of albumin and nonprotein nitrogen), and the nonprotein nitrogen.

The total nitrogen determinations are made on 2 cc. of plasma, containing 0.5 per cent of potassium oxalate, by the regular Gunning-Kjeldahl method. The fibrin is precipitated by calcium chlorid from 5 cc. of the plasma, and is then washed free from other nitrogenous substances and determined by Kjeldahl. To determine the filtrate nitrogen, the globulin and fibrin are precipitated from 5 cc. of the plasma with the usual half saturation with ammonium sulphate, the ammonia of the ammonium sulphate in the filtrate is removed by distillation after adding magnesium oxid and alcohol, and the nitrogen is then determined. The nonprotein nitrogen is determined in the filtrate obtained by precipitating the protein from 5 cc. of plasma in 9 volumes of 2.5 per cent trichloroacetic acid. The globulin nitrogen is then calculated by subtracting the sum of the filtrate nitrogen and fibrin nitrogen from the total nitrogen, and the albumin nitrogen by subtracting nonprotein nitrogen from filtrate nitrogen.

The technique for the various determinations is described in detail.

Studies in the acetone concentration in blood, urine, and alveolar air, I.—A micromethod for the estimation of acetone in blood, based on the iodoform method, E. M. P. WIDMARK (*Biochem. Jour.*, 13 (1919), No. 4, pp. 430-445, figs. 2).—In the method described, which does not require more than 100 mg. of blood, the blood is drawn up from a prick in the finger or ear lobe

into a capillary pipette and brought into a 100 cc. flask in which has been placed 10 cc. of 1 per cent phosphoric acid. The flask is connected with a detachable twice-bent distillation tube which is blown out into a bulb just below the two bends and is drawn out at the end into a small opening about 0.25 mm. across. The receiver is a test tube 150 mm. by 15 mm., which is inclosed by a cooler, allowing a free circulation of water. In the receiving test tube are placed 3 cc. of $N/2$ NaOH and 2 cc. of $N/200$ iodine. The distillation is carried on for 100 seconds after the solution begins to boil. After the tube has stood for at least 3 minutes 3.5 cc. of $N/2H_2SO_4$ is added to the distillate, the solution stirred, 2 drops of 1 per cent starch solution added, and the titration carried out with $N/200$ sodium thiosulphate. A blank test is conducted in the same manner, and the titer of the iodine solution is determined by the difference in the amounts of thiosulphate used in the two tests.

The method, the details of which are given in full, is considered to be of sufficient accuracy for the determination of acetone in pathological cases such as diabetes, but not of sufficient delicacy for estimations of the acetone percentage in normal blood.

The determination of albumin in urine, O. MAYER (*Ztschr. Analyt. Chem.*, 58 (1919), No. 8, pp. 337-346).—The author makes use of a ring test to determine albumin in urine quantitatively as well as qualitatively. The reagent used is made by dissolving 10 gm. of mercuric chlorid, 25 gm. of citric acid, and 65 gm. of pure sodium chlorid in 500 gm. of hot water, and filtering after allowing it to stand for several days. To 5 cc. of this reagent in a conical glass receptacle placed in a slanting position is added from a fine pipette an equal amount of urine, and the time for the appearance of a white ring at the juncture of the two liquids noted. If the concentration of the protein is 0.001 per cent, the ring appears in from two to three minutes from the time the urine is added. Should the ring appear in less time, trial dilutions of the urine are made until the ring appears within the given time. The concentration of the albumin in the urine can then be determined from the dilution required.

Decomposition of hydrogen peroxid by the microorganisms isolated from pasteurized milk, M. FOUASSIER (*Compt. Rend. Acad. Sci. [Paris]*, 170 (1920), No. 2, pp. 145-147).—Attention is called to the fact that in samples of pasteurized milk to which hydrogen peroxid has been added immediately after pasteurization the peroxid disappears after some hours but before the milk shows any traces of acidity. Experimental evidence is given which indicates that this is caused by the presence in the milk of some spore-forming microorganisms which have resisted pasteurization.

The differentiation of agricultural seeds and feeding stuffs by means of serum reactions, J. BECKER (*Fuhling's Landw. Ztg.*, 67 (1918), No. 5-6, pp. 114-120; *abs. in Chem. Abs.*, 14 (1920), No. 5, p. 552).—A method is described for determining the genuineness and purity of seeds and feeding stuffs by means of the precipitin reaction between the extracts of the material and the serum of dogs immunized against the specific proteins of the pure material. Typical results of the application of the method to the examination of certain seeds are reported.

Nitrogen balance during the manufacture of sugar.—**Precipitation of the protein material of the sugar beet by sulphurous acid, bisulphites, and hydrosulphites**, E. SAILLARD (*Compt. Rend. Acad. Sci. [Paris]*, 170 (1920), No. 2, pp. 129, 130).—The author supplements his previous contribution on the composition of the different products obtained in the manufacture of sugar from the sugar beet (*E. S. R.*, 39, p. 417) by data on the nitrogen distribution in the

different products. In sugar factories in which the molasses is distilled and the vinasses burned, the average nitrogen distribution in percentage of total nitrogen of the beets is as follows: Carbonation cake 15 per cent, press cake 20, waste water 18, set free as ammonia 17, and set free during the incineration of the vinasse 30.

An investigation of the effect of sulphurous acids and sulphites on the nitrogenous material of the diffusion juice indicated that they precipitate nitrogenous matter to the same extent as does copper hydroxid, and precipitate the same polarizing material as does lead subacetate.

METEOROLOGY.

Influence of meteorological phenomena on plant growth (*Rev. Sci. [Paris]*, 58 (1920), No. 4, pp. 115, 116).—Reviewing briefly the work of Azzi of the University of Rome (*E. S. R.*, 42, p. 511) on the relation between critical periods in plant growth and the meteorological conditions such as rainfall, humidity, frosts, heat, and drought, it is noted specially that a lack of moisture at critical periods permanently impairs the growth and reduces the yield of wheat; a deficiency of heat similarly reduces the fruit crop. From observations on the subject it has been possible to determine the mean critical periods for different plants in different regions and to record the results on so-called phenoscopic charts. These charts show the critical periods and decisive meteorological factor for each cultivated plant which, in case of cereals for example, is the amount of moisture available at the time of germination, heading, flowering, or ripening. Three means of remedying decreased yield of wheat due to drought at critical periods are suggested: (1) Changing the time of seeding, (2) irrigation, and (3) selection or breeding of drought-resistant varieties.

Meteorological observations at the Massachusetts Agricultural Experiment Station, J. E. OSTRANDER and G. S. SMITH (*Massachusetts Sta. Met. Buls.* 375-376 (1920), pp. 4 each).—Summaries of observations at Amherst, Mass., on pressure, temperature, humidity, precipitation, wind, sunshine, cloudiness, and casual phenomena during March and April, 1920, are presented. The data are briefly discussed in general notes on the weather of each month.

The fifteenth report on meteorological observations at Wisley, R. H. CURTIS (*Jour. Roy. Hort. Soc.*, 45 (1919), No. 1, pp. 90-97, figs. 2).—Daily observations on temperature, rainfall, wind, and sunshine are summarized for each month of 1918 in notes, tables, and diagrams.

The outstanding feature of the weather of the year was the unusual wetness. The total rainfall (29.56 in.) was 23 per cent greater than the average, but its distribution was very uneven. "In July the amount of rain which was measured at the Gardens was double, and in September treble, the usual fall for those months; while in August it totaled but little more than $\frac{3}{4}$ in., or only one-third of the average amount. The only other months with a fall of rain of less than an inch were February and March, both of which were unusually dry."

Location of corn belt as dependent on inclination of earth's axis, J. W. REDWAY (*Bul. Amer. Met. Soc.*, 1 (1920), No. 3, pp. 30, 31).—The fact that corn is a more prolific crop in the zone which includes Kansas and Nebraska than in tropical regions is explained by the fact that, because of the obliquity of the sun's rays at the fortieth parallel, that area actually receives a much larger number of heat units per day than tropical regions where the sun is more directly overhead. "Corn is a plant requiring a steady warmth and

much of it. The warm days of the fortieth parallel are followed by warm nights. Within the Tropics the days are not warmer, and the nights are colder than in Kansas, during midsummer—and the corn plant responds to this condition."

Manual of meteorology, IV, N. SHAW (*Cambridge, Eng.: Univ. Press, 1919, pp. XVI+166, pls. 4, figs. 51*).—This part of this manual is based upon the results of a study of the relation of winds to the distribution of pressure at the surface of the earth and in the free atmosphere, "setting out what amounts almost to a general meteorological theory."

The study of the weather, E. H. CHAPMAN (*Cambridge, Eng.: Univ. Press, 1919, pp. XII+131, pls. 3, figs. 53; rev. in Sci. Prog. [London], 14 (1920), No. 56, p. 683*).—This book is intended primarily for use in schools, but so deals with the elementary phases of the subject as to be of somewhat wider usefulness.

Results of rainfall observations made in South Australia and the Northern Territory, H. A. HUNT ET AL. (*Melbourne: Bur. Met., 1918, pp. 421, pls. 21, figs. 15*).—This is the fourth of a series of reports designed to give ultimately a complete review of the rainfall of all of the States of the Commonwealth of Australia. "It contains tabulations of all available annual totals of rainfall and wet days to the year 1917 for 829 stations, as well as monthly totals to 1915 for about 200 of that number. . . . To make the work complete for reference and comparison, authentic annual (1878–1917), also average annual and monthly, rainfall maps have been included, together with notes on the annual variation and monthly distribution of the rainfall; and a record of notable meteorological events. Special attention has been given to the incidence of the summer and winter rainfalls and the resultant wheat yields in South Australia, and the data deduced are presented in tabular and map form. Appendixes contain monthly and yearly meteorological elements and normals for Adelaide and Darwin." Results of observations on rainfall and evaporation at Adelaide, Alice Springs, and Eucla are also included, as are data on floods, hailstorms, thunderstorms, windstorms, aurora australis, bush fires, droughts, earthquakes, fog bows, severe frosts and exceptional cold, excessive heat and heat waves, high tides, meteors, mirages, mock moon, plagues, pests, and live-stock diseases, snow, volcanic dust clouds, and waterspouts and cloud-bursts.

The average annual evaporation from a water surface at Alice Springs during 24 years was 95.98 in., the average rainfall 10.51 in.; at Eucla (6 years) 57.72 in. and 9.12 in., respectively; and at Adelaide (47 years) 54.42 and 20.73 in., respectively.

Australian rainfall and wheat yield (*Nature [London], 104 (1920), No. 2623, pp. 606, 607*).—Commenting upon the article noted above, it is stated that the data presented furnish "strong evidence of direct correlation between the wheat yield per acre and the rainfall of the previous winter. For South Australia and the Northern Territory the correlation coefficient works out at 0.61, with a probable error of 0.07."

Summer and winter rainfall and the wheat yield, H. A. HUNT ET AL. (*In Results of Rainfall Observations Made in South Australia and the Northern Territory. Melbourne: Bur. Met., 1918, pp. 73–110, pl. 1*).—Tables are given which show the amount of rainfall during each summer and the following winter or agricultural season (autumn, winter, spring) and the resultant wheat yields in the various counties in the agricultural districts of South Australia, 1859–1916. The same relation is also shown graphically in a map of the area.

It is shown that in recent seasons an increasing proportion of the wheat produced by South Australia has been grown outside of the line of rainfall

(14–16 in.) supposed to mark the boundary of profitable wheat production, the average yield per acre outside this line being $7\frac{1}{2}$ bu., as compared with $11\frac{1}{2}$ bu. inside the line. The average rainfall in the agricultural districts for the five summer months ended March 31, 1859–1916, was 3.6 in. and for the following winter months, April–October, 11.9 in., while the average wheat yield was 8.02 bu.

Some notes on California rainfall, C. E. GRUNSKY (*Jour. Electricity*, 44 (1920), No. 5, pp. 204–206, figs. 4).—Normals and departures from normals for both calendar and seasonal years (beginning July 1) and the average frequency of dry and wet years, based on observations at San Francisco and Sacramento from 1849 to 1919, inclusive, are shown in tables and diagrams, and the use of normals in the study of rainfall probabilities is briefly discussed.

SOILS—FERTILIZERS.

Soil making, E. J. RUSSELL (*Jour. Roy. Hort. Soc.*, 44 (1919), pp. 1–12).—The origin, composition, and treatment of normal agricultural soils are discussed, the general conclusion being drawn that the making of soil requires proper mineral matter, organic matter, and conditions suitable for the decomposition of the organic matter.

The care of the soil, H. E. P. HODSOLL (*Jour. Roy. Hort. Soc.*, 45 (1919), No. 1, pp. 22–28).—A brief review of the mechanical, chemical, and biological properties of soils is given, together with information as to their proper maintenance.

Soil survey of Morrill County, Nebr., F. A. HAYES, H. W. HAWKER, M. D. DAVIS, and V. H. SEABURY (*U. S. Dept. Agr., Adv. Sheets Field Oper. Bur. Soils*, 1917, pp. 69, fig. 1, map 1).—This survey, made in cooperation with the University of Nebraska, deals with the soils of an area of 906,880 acres in the extreme western part of Nebraska lying in the Great Plains region. By far the greater part of the county is well drained. The topography varies from flat in the alluvial lands to dissected and very steeply rolling in the rougher uplands.

The soils of the county are of residual eolian, alluvial, colluvial, and miscellaneous origin. Including dunesand, rough broken land, and riverwash, 39 soil types of 10 series are mapped, of which dunesand, covering 25.8 per cent of the area, is the most extensive individual type, followed by rough broken land, covering 10.7 per cent of the area, and Rosebud very fine sandy loam, covering 10.1 per cent.

Soil survey of Traill County, N. Dak., F. Z. HUTTON and E. NICHOLS (*U. S. Dept. Agr., Adv. Sheets Field Oper. Bur. Soils*, 1918, pp. 47, pl. 1, fig. 1, map 1).—This survey, made in cooperation with the North Dakota Experiment Station, deals with the soils of an area of 553,600 acres in the extreme eastern part of North Dakota, which comprises three main physiographic divisions, namely, glacial Lake Agassiz, glacial river delta, and upland or rolling prairie. The eastern and southern parts of the county are level and in places rather poorly drained. The northwestern part is level to gently undulating, high, and well drained. The southwestern corner of the county is high and well drained, with a rolling to hilly topography.

The soils of the county are of glacial, glacial lake, delta, and river-flood-plains origin. Twenty-three soil types of 8 series are mapped, of which the Bearden very fine sandy loam, Fargo clay, Fargo silty clay, and Bearden silt loam cover 22, 18.7, 13.4, and 13.2 per cent of the area, respectively. The Bearden series covers nearly half the area of the county.

The water economy of soil in relation to proper cultivation, choice of crop rotation with reference to shading, and the influence of deep rooting crops, R. TUCH (*Jahrb. Deut. Landw. Gesell.*, 34 (1919), No. 2, pp. 376-384).—A general discussion of soil water as affected by various factors, particularly cultivation and crops under German conditions, is given.

The influence of variations of ground-water level due to canals and mines on the utilization of soil for agriculture and forestry, KOEHNE (*Jahrb. Deut. Landw. Gesell.*, 34 (1919), No. 2, pp. 342-374, figs. 20).—Following an introduction covering the general features of the subject by Schurig, a report is given by the author on studies conducted in Germany in different localities of the effects of mines, canals, water works, and other industries on the water level in agricultural and garden soils. It is shown that these industries have a varying effect, depending upon their size and attending geologic circumstances. Considerable graphic data obtained from such studies are given, together with a description of the methods of study and precautions to be taken.

The moisture equivalent in relation to the mechanical analysis of soils, H. E. MIDDLETON (*Soil Sci.*, 9 (1920), No. 2, pp. 159-167, fig. 1).—Experiments conducted by the Bureau of Soils of the U. S. Department of Agriculture are reported, which showed that the moisture equivalent may not be used as a basis for the classification of soils, but may be of valuable assistance in the interpretation of the mechanical analysis. There is a direct relationship between the moisture equivalent and the percentages of sand, silt, and clay in the soil, as determined by mechanical analysis. This relation may be expressed as $0.063 \text{ sand} + 0.291 \text{ silt} + 0.426 \text{ clay} = \text{moisture equivalent}$. The presence of considerable amounts of organic matter in the soil tends to increase the moisture equivalent and to disturb the relation between the moisture equivalent and the mechanical analysis.

A new soil elutriator, W. GARDNER (*Soil Sci.*, 9 (1920), No. 3, pp. 191-195, figs. 2).—A new soil elutriator developed at the Utah Experiment Station is described and illustrated and its theory of operation discussed. The nature of the process involved is such that a steady stream of muddy water is introduced at the bottom of the smallest of a series of 19 cylindrical vessels, ranging in diameter in arithmetical progression from 4 to 40 cm. The stream leaves the first cylinder through a conical cap, entering the second through a conical base, and so on throughout the series.

Sampling soil plats, F. E. BEAR and G. M. McCLURE (*Soil Sci.*, 9 (1920), No. 1, pp. 65-75, figs. 4).—In a contribution from the Ohio State University, an experiment is reported to determine how to choose a composite which would accurately represent a plat for the particular day on which it was chosen.

Two plats of ground, each $\frac{1}{8}$ acre in size, were set aside for this test. Plat 1 was as uniform as could be secured on the experimental field, and plat 2 was chosen for its lack of uniformity. On the basis of this study it is concluded to be desirable to locate the samples of soil, for the composite representing each plat, uniformly over the plat. There appears to be no argument in favor of selecting separate samples of the surface and subsurface soil, but it is desirable that all samples be taken to a depth well beyond the plow line. According to the plan recommended the composite from each $\frac{1}{8}$ -acre plat would be made up of 20 samples, each chosen to a depth of 12 in. and arranged uniformly over the plat. In all subsequent samplings of these plats the location of the samples and the method of taking them should be as nearly an exact duplication of the first sampling as possible.

The influence of sand upon the concentration and reaction of a nutrient solution for plants, J. W. SHIVE (*Soil Sci.*, 9 (1920), No. 3, pp. 169-179).—

Studies conducted at the New Jersey Experiment Stations on the influence of washed sand of four different degrees of fineness, and of very fine unwashed sand, upon the reaction and concentration of a nutrient solution, are reported.

The solution was applied to the sand in culture pots to give a moisture content of 60 per cent of the water-retaining capacity of the sand in every case. The solution was renewed at stated intervals after as much as possible of the old solution had been extracted from the sand by suction. Tests were made of these solution samples for the hydrogen-ion concentration and for the total salt concentration, and the results of these tests were compared with those of similar tests of the original solution.

It was found that with the different grades of washed sand there was no evidence of the adsorption of salts or ions in sufficient amounts to alter materially either the reaction or the total salt concentration of the solution in contact with the solid particles of the substrata. The adsorptive capacity of the unwashed sand was sufficient to reduce the total salt concentration of the solution from 1.76 atmospheres to 1.61 atmospheres (average reduction of 8.5 per cent) during the first 24-hour interval. The reaction of the nutrient solution was not markedly altered by contact with the unwashed sand. By renewal of the nutrient solution the initial adsorptive effect of the unwashed sand was soon eliminated, apparently by saturating its adsorptive capacity. The adsorptive properties of the unwashed sand appeared to be due to the very finely divided colloidal or semicolloidal material which was removed from the sand in the process of washing.

Colorimetric determination of hydrogen-ion concentration without buffer mixtures, with especial reference to soils, L. J. GILLESPIE (*Soil Sci.*, 9 (1920), No. 2, pp. 115-136, fig. 1).—A simple technique as developed by the Bureau of Plant Industry of the U. S. Department of Agriculture is described in full for the preparation and use of a series of color standards for the colorimetric determination of the hydrogen-ion exponent. No buffer mixtures are required. From the method of calibration, however, any salt or protein errors will be the same as if the measurement had been made with the 0.05 M buffer mixtures of Clark and Lubs.

Each color standard consists of two test tubes, one tube containing dilute alkali and the other dilute acid. The tubes contain altogether 10 drops of indicator solution, the 10 being divided between the alkaline and the acid tubes in various drop-ratios. A table is given containing all the necessary data.

The method is based on a study of the nature of the color change of the indicators with change of hydrogen-ion exponent (pH). For all the indicators selected the following equation, which comes from the mass action law, was found to hold within the experimental error of the color readings: $\text{pH} = k + \log$ (drop-ratio). The indicators studied are from the selection of Clark and Lubs; and the values of the constant k of the equation, good to about 0.1 at 25-30°, are as follows: Bromphenol blue, 4.1; methyl red, 5; bromcresol purple, 6.3; bromthymol blue, 7.1; phenol red, 7.7; cresol red, 8.1; and thymol blue (alkaline range), 8.8. Soil extracts were prepared, water clear, by the use of colloidal iron solution. Measurement of the hydrogen-ion exponents of these extracts (from nine soils only) gave the same results as were obtained by the usual methods. Without further study, however, such use of colloidal iron can not be recommended for general use.

A list of 22 references to literature bearing on the subject is included.

The determination of ammonia in soil, D. J. MATTHEWS (*Jour. Agr. Sci. [England]*, 10 (1920), No. 1, pp. 72-85, figs. 2).—A method and a so-called aera-

tion apparatus are described and illustrated which, on test with heavy loam, heavy clay, light sand, heavily fertilized tomato-house soils, and calcareous soil, showed that ammonia can be recovered from soil with an efficiency of from 98.5 to 99.5 per cent in six hours in the apparatus. For most purposes it was sufficient to aerate the soil for three hours.

Highly fertilized glasshouse soils underwent partial decomposition in the cold with magnesia. In such cases it is stated that the soil should be aerated with magnesia and strong sodium chlorid solution for a definite time, say three hours. The complete recovery of added ammonia from a calcareous soil was difficult unless the soil was finely ground.

Soil reaction, A. DEMOLON (*Rev. Sci. [Paris]*, 58 (1920), No. 6, pp. 173-177).—This is a review of literature on the cause, nature, and determination of soil acidity, taking up both chemical and physical methods of determination and calling particular attention to the bacteriological method of studying soil acidity by means of the presence of *Azotobacter*. Works on the influence of acidity on fertilizers and vegetation and the correction of acidity by liming are also reviewed.

The effect of aeration and other factors on the lime requirement of a muck soil, S. S. WALKER (*Soil Sci.*, 9 (1920), No. 1, pp. 77-81).—Experiments conducted at the Louisiana Experiment Stations are reported in which a typical black muck soil was treated in various ways in order to study the effect of aeration and other factors on the lime requirement, as determined by the Johnson method.

It was found that the lime requirement of this soil was increased by air-drying. When the soil was kept moist and frequently stirred for a period of eight months the increase of acidity was decidedly less than when it was kept covered with water in a sealed jar. Soil which was first neutralized with calcium carbonate and then kept for a period of eight months, under either aerobic or anaerobic conditions, developed a great deal more acidity than did unneutralized soil under the same conditions. This is explained by the law of mass action. The lime requirement of all samples stored in a moist condition was increased, but the air-dried sample decreased in acidity during storage. It was emphasized that results obtained by the Johnson and similar methods are comparative rather than absolute, and that rigid conditions must be adhered to in using such methods.

The reaction of the soil as influenced by the decomposition of green manures, L. P. HOWARD (*Soil Sci.*, 9 (1920), No. 1, pp. 27-39).—Studies of the influence of green manures on the reaction of soil at the Rhode Island Experiment Station are reported. The plan followed consisted in sampling the soils at various periods during the season to follow changes in acidity and in organic matter.

While no conclusions seem to be warranted from the limited data obtained in the experiments, it was shown that there was practically no net increase in acidity during the years 1915 and 1916, finely ground limestone having been applied in 1914. In fact, there was no evidence that any acidity had resulted from the use of rye as a cover crop for a quarter of a century. The legumes, however, during the same time considerably increased the lime requirements. In the uncropped soils treated in the laboratory with an equal weight of green rye as compared with clover, the rye increased the lime requirement 300 to 400 lbs., or about twice as much as the clover, and the increase was maintained from July to December.

The comparative rate of decomposition of green and cured clover tops in soil, A. L. WHITING and W. R. SCHOONOVER (*Soil Sci.*, 9 (1920), No. 2, pp.

137-149).—Studies on the comparative rate of decomposition of green and of cured red clover tops in soil, conducted at the University of Illinois, are reported.

Curing retarded the rate of decomposition as measured by ammonification, nitrification, and loss of carbon in both laboratory and greenhouse experiments. The green clover produced nitrate very rapidly, with a maximum transformation in the laboratory experiment at 43 days of 35.8 per cent, while with the cured clover at the same period only 15.7 per cent of the nitrogen had been transformed. In the greenhouse experiment the green clover was well in the lead in nitrate production during the first two months. Green and cured red clover underwent the same kind of decomposition under aerobic conditions. With the oxygen supply limited, the types of decomposition of green and cured red clover were vastly different. There was no measurable loss or gain of nitrogen during the experiment. The loss of carbon and the change in the carbon-nitrogen ratios agreed with the other determinations in showing a difference in rate of decomposition between the green and the cured clover, but did not indicate a difference in kind.

The change which dehydration (curing) brought about in the rate of the initial decomposition appeared to be of a physical nature only. An explanatory hypothesis is advanced that dehydration resulted in a hardening and shriveling of the tissues, which interferes with the reentrance of water and consequently delays the decomposition because the bacteria must await the softening of the tissues before they are able to start their work, while with the green no such delay occurs, as the cells are already hydrated. Planting oats three days after treating the soil with green and cured clover resulted in serious injury which delayed growth. It was greater with the green clover.

Determination of the degree of decomposition of moor and peat samples, G. KEPPELER (*Mitt. Ver. Förd. Moorkult. Deut. Reiche*, 38 (1920), No. 1, pp. 3-8).—A method for the determination of the degree of decomposition of peat and moor soils is described, which is characterized as the percentage of total reduction process.

Tests of this method with different peat and moor soils, including two samples of brown coal, are reported, which show that sphagnum peats of recent origin, particularly the varieties which are used for peat litter, have a very low degree of decomposition which hardly exceeds 25 per cent, or, in other words, approximately 75 per cent of the original plant substance still exists in the peat. Samples of sphagnum peat of more ancient origin were much more strongly decomposed, the degree of decomposition varying between 70.9 and 78.8 per cent. Lowland moor soil samples also showed a rather high degree of decomposition which increased with the depth. Brown coal showed an almost 100 per cent degree of decomposition. Studies of a profile of a large moor were made for purposes of comparison, which gave approximately the same results.

It is concluded that while the method used needs considerable further tests with different kinds of peat, it has considerable usefulness and will give results which can answer numerous questions.

The humin acids, S. ODÉN (*Kolloidchem. Beihefte*, 11 (1919), No. 3-9, pp. 75-260, figs. 21).—The author in this work attempts to summarize the chemistry and physical chemistry of the natural humin acids, especially as they are thought to exist in soils. The first part deals purely with the chemistry and physics of humin acids, and the second part takes up these acids with reference to the formation of humus in soils.

It is maintained that humin acids are an essential constituent of the materials of soils characterized as humus, and in this respect play an important part as a result of their acid nature and their individual physical characteristics. It is stated that they are relatively easy to isolate in a fair state of purity. At-

tention is called to the fact, however, that there is no standard of purity for such substances by comparison with which their degree of purity can be accurately indicated. For this reason an apparent purification process may in reality serve to concentrate certain impurities.

On the other hand it is brought out that humin acids obtained in different ways and of different ages and biological history show so much similarity with reference to their composition, chemical constants, and their important chemical properties that there is no doubt such acids are substances of fixed constituents and properties, which are contaminated with different foreign substances consisting of humus acids, peat acids, soil acids, and the like. To a certain extent it is concluded with Berzelius, Hoppe-Seyler, Berthelot, and others that humus and humus acids are related to certain substances in the soil. While in this connection the author apparently is not much impressed with theories of adsorption, adsorption complexes, and adsorption decomposition, he considers it evident that humus bodies and humin acids occur in different dispersoid divisions. This physical condition is considered to be of striking importance for certain appearances, but in other reactions the inherent purely chemical properties play the most important part. In this connection he gives a rather extensive basic study of the laws of chemical mass action, hydrolysis, and disassociation appearances, together with a rather exhaustive discussion from the chemical standpoint.

A list of 386 references to literature bearing on the subject is included.

Nitrate production in field soils in Illinois, A. L. WHITING and W. R. SCHOONOVER (*Illinois Sta. Bul.* 225 (1920), pp. 21-63).—Four years' studies are reported which were undertaken in order to measure systematically the amount and rate of nitrate production in certain surface soils of Illinois, principally with respect to the influence exerted by seasonal changes, soil treatment, different crops, and rainfall.

It was found that the most important factor in increasing nitrate production is soil treatment. Raw rock phosphate was an important factor in increasing the amount of nitrate produced, and in good rotations the effect of rock phosphate was much greater than in poor rotations. The complete treatment with organic matter, phosphate, and limestone furnished the largest amount of nitrates, and at an earlier period than organic matter and limestone or organic matter alone.

It was further found that the nitrogen of red clover or of sweet clover plowed under in April or May furnished nitrate for the succeeding crop. Stable manure was efficient in nitrate production, especially when used with phosphate and limestone, but when applied alone it did not approach the rate and amount of production exhibited by the green sweet clover or green red clover. Active organic matter greatly increased the amount of nitrate in brown silt loam. Crop rotations in which legumes were used as green manure, and in which the crop sequence was such as not to have two crops in succession that are heavy feeders on nitrogen, were superior for nitrate production to rotations in which these points were ignored. With corn and soy beans, the maximum nitrate production occurred in most cases in June. On land in wheat and oats the largest production was found in May.

The most active period of production and accumulation of nitrates was during late spring and early summer. A second active period occurred frequently in the autumn, which is considered the second approach to optimum. Little nitrate production occurred in summer unless the weather was cool and there was a supply of available moisture. No evidence of nitrate production was

found in the winter. Crop residues were effective in preventing the loss of nitrates from leaching, as was also a growing crop occupying the soil.

"The period of greatest utilization of nitrates by corn, as judged by the decreases found in the nitrogen supply in the soil, coincides with the period of greatest visible increase in growth, which occurs usually between June 25 and July 15. The period of greatest utilization of nitrates for wheat and oats is earlier in the season than for corn, coming usually about the middle of May or early in June. It occurred in these studies earlier with wheat than with oats. The period of greatest utilization of nitrates, as well as the rate and amount of production, is directly related to soil treatment. In these studies the properly treated plats were taking in more nitrates and at an earlier period than those receiving poorer treatment. The recovery of efficiency in nitrate production occurred at an earlier date and in a greater degree on the plats receiving the proper soil treatment."

The formation of nitrates in a soil following the growth of red clover and of timothy, T. L. LYON, J. A. BIZZELL, and B. D. WILSON (*Soil Sci.*, 9 (1920), No. 1, pp. 53-64).—Experiments conducted at Cornell University, in which a sand soil of moderate fertility and good drainage and growing different crops was leached are reported. The leaching was accomplished while the crops were on the soil. The soil was abundantly limed and fertilized with acid phosphate, potassium chlorid, and dried blood. Six cylinders were planted to timothy and 6 to red clover. The soil in all cases was inoculated with *Bacillus radicicola*.

During the time the timothy and clover were growing, the soil was leached with distilled water from time to time. Nitrogen was determined in the drainage water and in the crops of timothy and clover. After these crops were removed, the soil was allowed to remain in fallow for a month, leached, and nitrogen determined in the drainage. Of the cylinders on which timothy had been grown, two were planted to oats, two to maize, and two kept free of vegetation. The clover cylinders were treated in the same way. All were leached from time to time and nitrogen determined in the drainage water and also in the crops.

There was little difference in the quantities of nitrogen leached from the timothy soil and clover soil during the time those two crops were growing on them. There was about six times as much nitrogen leached from the clover soil during the month that both soils stood fallow after the timothy and clover crops had been removed. There was only about twice as much nitrogen leached from the fallow clover soil as from the timothy soil during the next five months. At the end of this period the rate of nitrate production in the clover soil was little greater than in the timothy soil. The crops of oats and maize following clover were larger and contained more nitrogen than did those following timothy.

The experiment taken as a whole shows that under the same conditions of soil and treatment clover caused a greater production of available nitrogen than did timothy. This effect is shown in the nitrate content of the drainage water and the total nitrogen content of the oats and maize.

Nitrification in semiarid soils, W. P. KELLEY (*Brasil Agr.*, 4 (1919), Nos. 6, pp. 160-162; 7, pp. 202-205; 8, pp. 229-232; 9, pp. 251-254).—Experiments conducted at the University of California are reported.

It was found that the nitrification of dried blood, bone meal, and ammonium sulphate when used in different concentrations varied widely during four weeks' incubation. In certain soils in which nitrification with bone meal and ammonium sulphate was active, treatment with dried blood resulted in little

or no nitrification. Such amounts of dried blood as are used in practice produced active nitrification. An addition of bone meal equal in nitrogen content to an addition of 1 per cent of dried blood was apparently toxic to nitrification. Experience with a great diversity of soils from different localities showed that the incapacity to nitrify 1 per cent dried blood is not limited to any particular type of soil.

The conclusion is therefore drawn that California soils in general are capable of actively nitrifying the amounts of dried blood used in agricultural practice. Studies of the influence of alkali salts upon nitrification showed that the presence of 0.05 per cent sodium carbonate interfered with the nitrification of 1 per cent of dried blood, while 0.4 per cent sodium carbonate had no effect on 0.1 per cent of dried blood. The presence of 0.1 per cent of sodium carbonate was toxic to the nitrification of 0.15 per cent of ammonium sulphate, but was stimulating to the nitrification of 0.0625 per cent of ammonium sulphate.

In general, additions of an excess of nitrogenous substances resulted in an accumulation of nitrates.

A list of 35 references to literature bearing on the subject is included.

Some soil studies, W. P. HEADDEN (*Proc. Soc. Prom. Agr. Sci.*, 39 (1919), pp. 22-38).—Data on excessive nitrate accumulation obtained from studies of beet and wheat crops and the soils growing them at the Colorado Experiment Station are reviewed. It is concluded that "no refutation has as yet been made of the theory that the nitrogen of these nitrates is derived from the atmosphere through bacterial agencies."

The isolation and study of nitrifying bacteria, W. M. GIBBS (*Soil Sci.*, 8 (1919), No. 6, pp. 427-481, figs. 6).—Investigations conducted at the Idaho Experiment Station are reported, which were planned to study primarily the relations of the nitrifying bacteria in soils to their environment. The report deals with the work of isolation and the morphology of the organisms and presents the methods employed.

Pure cultures of *Nitrosomonas* and *Nitrobacter* were isolated from soil and cultivated on artificial media. Both developed readily on plates of washed agar or sillicic acid gel. The latter medium was more satisfactory in the work of isolation, disregarding its difficulty of preparation, but after pure cultures were secured washed agar was used with success. The colonies which developed on the plates were extremely small, and required the use of the microscope in the study of their characteristics. Isolated colonies were removed from the medium by means of a modification of the Barber apparatus.

It was found that pure cultures of either *Nitrosomonas* or *Nitrobacter* will produce no visible growth when inoculated into bouillon. In using bouillon as a purity test 0.5 cc. of the culture must be used as inoculum to give reliable results. Pure cultures of these organisms can be maintained in liquid medium for an indefinite period of time. The enrichment process with both *Nitrosomonas* and *Nitrobacter* can be continued for an indefinite period of time without the slightest loss of activity of the organisms. The F_{52} enrichment showed as great activity as any of the preceding generations. Neither the enrichment process nor the securing of superenrichment cultures will yield a pure culture of *Nitrosomonas* or *Nitrobacter* without the use of suitable solid media. By careful manipulation the number of nitrifying organisms in the enrichment cultures can be increased from relatively few to a number greater than 10,000,000 per cubic centimeter of the culture solution. Soil extract used to prepare the nutrient solutions for the cultivation of both *Nitrosomonas* and *Nitrobacter* did not prove toxic in either case. Sodium chlorid in a concentration of 1 per cent was very toxic toward *Nitrosomonas*.

A list of 67 references to works by others bearing on the subject is included.

Inoculation of legumes with nitragin (*Rev. Asoc. Rural Uruguay*, 48 (1919), No. 12, pp. 781-784).—This report summarizes the works of others bearing on the subject and deals with experience which indicates that nitragin is not applicable to all soils, especially those in poor tilth and those rich in nitrogen. It is concluded that the proper soil conditions under which nitragin may be effectively used are poverty in nitrogen, sufficiency of other fertility constituents, and moisture, and the soil neither acid nor excessively alkaline.

The protozoan fauna of the soils of New Jersey, C. R. FELLERS and F. E. ALLISON (*Soil Sci.*, 9 (1920), No. 1, pp. 1-25, figs. 4).—This paper, a contribution from the New Jersey Experiment Stations, presents studies on methods and media for culture and examination, excystation, reproduction, and distribution of the protozoan fauna of a large number of New Jersey soils of varying degrees of fertility and reaction. Most of the soils were sampled at a depth of from 1 to 4 in. and examined several times at different seasons with the use of several media.

Protozoa were found in all the soils examined, the number of species identified from any one soil varying from 2 to 28. Poor sandy acid or forest soils contained the least number of species, while fertile soils, rich in organic matter or with high water-holding capacity, contained the greatest number. Of the 104 species identified from New Jersey soils, 51 were ciliates, 35 were flagellates, 14 were rhizopods, and 4 were heliozoa. In addition to the protozoa, 10 genera of algæ and 6 of diatoms were identified. Nematodes were common, but rotifers or crustaceans were not encountered. Of the species classed as being abundant in the soil, 17 were ciliates, 6 were flagellates, and 1 a rhizopod. The ciliates outnumbered the flagellates in the number of species identified, but not in actual numbers of organisms in the soil. In point of numbers the rhizopods and heliozoa ranked third and fourth, respectively. No suctoria were encountered.

It is believed that in normal New Jersey soils protozoa exist mainly in a nontrophic state. Only two soils out of some hundred samples taken all over the State showed the presence of living protozoa on direct examination. In soils which were saturated with water for several hours, or in standing soil water, field ditches, and plow furrows limited numbers of protozoa were usually found.

The soil microfauna consists principally of those small, simple, and hardy protozoa which are able to withstand, by means of encystation or otherwise, such extremes of heat and cold, desiccation, aeration, etc., as are natural to their life in the soil. Practically all the species which were identified from the soil have also been found in the fresh-water lakes, ponds, pools, and streams of the State, but not in the same relative abundance. Some species which are abundant in soil are rarely encountered in fresh water, and vice versa several of the most common plankton organisms in the State are but rarely found in soil.

A new theory to replace the old "egg and germ" theory of distribution of protozoa in soil is put forth as follows: Some protozoa undoubtedly are spread by rain, winds, animals, and other natural forces, but it is not believed that these means are sufficient to account for the large number of organisms of many species found in all soils. Protozoa become active in soil whenever there is excessive moisture present for a period of several hours, and such conditions are common during prolonged rains, especially in the rainy seasons, during winter and spring thaws, in soils kept moist from seepage, and in poorly drained lands. Excystation takes place followed by a feeding period and consequent growth, then reproduction takes place. As conditions become unfavorable again, encystation begins or death occurs. Since all these processes may

take place in the course of a few hours (but usually requiring 24 hours at least for appreciable reproduction to take place), the whole life cycle of many protozoa may be completed in the soil.

A list of 40 references to literature bearing on the subject is included.

The value of barnyard manure on Utah soils, F. S. HARRIS (*Utah Sta. Bul.* 172 (1920), pp. 3-21, figs. 12).—Experiments on the value of farm manure in increasing the yield of sugar beets, potatoes, wheat, oats, and corn on irrigated and dry-farm soils in Utah are reported. Most of the experiments were conducted on deep rather fertile limestone soil.

It was found that manure applied to sugar beets at the rate of 10 tons to the acre gave an increase in yield of about 1 ton of beets for each ton of manure. Five tons to the acre gave nearly 2 tons of beets for each ton of manure, but where as much as 40 tons to the acre were applied the increase was only about 0.4 ton of beets for each ton of manure. Where potatoes were manured at the rate of 5 tons to the acre the yield was increased by nearly 13 bu. for each ton of manure, but where 40 tons were applied the increase was only 4.3 bu. for each ton. Manure applied to wheat gave an increased yield of 2 bu. for each ton of manure where 5 tons were applied, 1.13 bu. where 15 tons were applied, and only 0.33 bu. for each ton of manure where 40 tons were applied. Manure applied to oats gave an increase of 1.65, 1.21, and 0.36 bu. of grain, respectively, for each ton of manure when 5, 15, and 40 tons of manure to the acre were applied. The average of nine years of manure applied to corn gave an increase of 3.83 bu. of grain and 428 lbs. of stover, and 1.61 bu. of grain and 214 lbs. of stover, respectively, for each ton of manure when 5 and 15 tons were applied to the land each year.

The use of farm manure under dry-farming conditions did not seem to be so immediately profitable as under irrigation, but the residual effect of manure under dry farming was very marked. The use of manure on expensive crops, such as sugar beets and potatoes, gave a higher return for each ton of manure than when it was applied to wheat and oats.

Utilizing soil potash by means of intermediary crops, A. W. BLAIR (*Proc. Soc. Prom. Agr. Sci.*, 39 (1919), pp. 69-74).—Pot experiments with loam and sandy loam soil, conducted at the New Jersey Experiment Stations, are reported to determine the utilization of soil potash by rape, field peas, barley, buckwheat, and soy beans. The soils were limed and fertilized except with potash. It was found that the dry weights of these crops grown without potash were essentially the same as when grown with potassium sulphate on both soils.

"It appears that soy beans and perhaps some other plants have the habit of storing up an abnormal supply of potash where this is supplied in readily available form. . . . Here, then, are crops that can use rather large amounts of the soil potash when forced to do so, but if permitted, will also use additional commercial potash for which apparently there is no return. Such plants should be more widely used to liberate the locked-up potash of the mineral particles of soils rich in potash."

Nitrogen Products Committee.—Final report (*London: Min. Munitions War, 1919*, pp. VI+357, pls. 17, fig. 1; *abs. in Chem. Trade Jour. and Chem. Engin.*, 66 (1920), Nos. 1705, pp. 91-97; 1706, pp. 125-130).—This is the final report of the Nitrogen Products Committee, appointed in June, 1916, of which H. E. F. Goold-Adams was chairman, and including among others representatives from the Board of Agriculture and Fisheries, (1) to consider the relative advantages for England and for the British Empire of the various methods for the fixation of atmospheric nitrogen, from the point of view both of war and peace purposes, to ascertain their relative costs, and to advise on pro-

posals relevant thereto which may be submitted; (2) to examine into the supply of the raw materials required—e. g., pure nitrogen and hydrogen—and into the utilization of the by-products obtained; (3) to consider what steps can with advantage be taken to conserve and increase the national resources in nitrogen-bearing compounds and to limit their wastage; and (4) to carry out the experimental work necessary to arrive at definite conclusions as to the practicability and efficiency of such processes as may appear to the committee to be of value. The evidence dealing with the economics of the established synthetic and nonsynthetic processes is summarized in the following salient points and conclusions:

A metric ton of nitrogen gas can be separated from the air by modern liquefaction processes for less than £1. The market price of a metric ton of combined nitrogen in the United Kingdom prior to the war varied from £66 to £67 (in the forms of ammonium sulphate and Chile nitrate, respectively). The synthetic processes can produce a metric ton of combined nitrogen at a cost, from the factory, of from £20 to £30, whereas the lowest recorded market price in the United Kingdom for a metric ton of combined nitrogen (as ammonium sulphate) was £35.8 in 1897. The synthetic processes can produce a metric ton of concentrated (93 to 96 per cent) nitric acid for about half the cost by the Chile nitrate retort process, and a metric ton of combined nitrogen ready for the fertilizer market, as cyanamid or ammonium sulphate at a cost at the factory of about or even less than one-half the prewar market price of combined nitrogen in the United Kingdom.

The synthetic processes, with the exception of the arc process under favorable conditions as regards cheap water power, are not regarded as in a position to produce nitrate fertilizers at a sufficiently low cost to face the possible competition of Chile nitrate. This position may, however, be altered by the development of more economical methods of recovering oxides of nitrogen in the form of nitrate salts. The capital expenditure for installing the synthetic processes is not excessive, being somewhat less than or on a parity with the prewar market value of the annual production, except in the case of the arc process, for which the outlay is nearly twice the market value of the annual production. The facility with which oxygen and the rare gases of the atmosphere can be obtained as by-products in the manufacture of cyanamid and synthetic ammonia is an asset in favor of these processes for British conditions, on account of the fact that several important industries would derive a substantial advantage from the marketing of additional supplies of these gases at reasonable prices. The relative merits of the processes themselves, however, would probably not be affected by the prices obtainable for the by-products.

A number of appendixes are included on different processes for nitrogen recovery. The section on the recovery of nitrogen from peat presents the conclusion that it is doubtful whether the utilization of peat on a large scale for nitrogen recovery and power production is likely to result in the production of ammonium sulphate at the low costs sometimes put forward, or in the attainment of the high profits that have often been estimated.

The section on the recovery of nitrogen from sewage presents the conclusion that "from a consideration of the general conditions of modern sanitation, and from the evidence previously discussed, it is apparent that a very large proportion of the combined nitrogen excreted annually in domestic sewage is irrecoverable, at any rate by existing methods."

The present status of nitrogen fixation, A. H. WHITE (*Trans. Amer. Inst. Chem. Engin.*, 11 (1918), pp. 347-365, figs. 3).—This is the original of this report, previously noted from another source (*E. S. R.*, 41, p. 22).

Preparation of nitrogen and hydrogen mixture by decomposition of ammonia, R. O. E. DAVIS and L. B. OLMSTEAD (*Jour. Indus. and Engin. Chem.*, 12 (1920), No. 4, pp. 316, 317, figs. 2).—Experiments conducted by the Bureau of Soils of the U. S. Department of Agriculture in cooperation with the Nitrate Division of the U. S. War Department, on the preparation of a mixture of hydrogen and nitrogen in the ratio of 3H_2 to N_2 in amounts of several hundred cubic feet per day, are reported.

Anhydrous ammonia being easily obtained, it was decided to build an electric furnace to decompose it and use the decomposed gases as the required mixture of nitrogen and hydrogen. The furnace used is described.

Results using iron shavings as a catalyst and copper chips and turnings show that copper requires a temperature about 200°C . higher than iron and a longer contact. Because of the lower operating temperature and cheapness, iron was chosen in preference to copper as a catalyst.

The production of ammonia and formates from cyanids, ferrocyanids, and cyanized briquets, G. W. HEISE and H. E. FOOTE (*Jour. Indus. and Engin. Chem.*, 12 (1920), No. 4, pp. 331–336, figs. 2).—Studies on the formation of ammonia from sodium cyanid, sodium ferrocyanid, and cyanized briquets are reported.

Good yields of ammonia were obtained from sodium cyanid by steaming at 50 lbs. pressure. A quantitative yield was obtained at 200 lbs. The hydrolysis of ferrocyanids proceeded very slowly. A maximum yield of 46 per cent was obtained by steaming $4\frac{1}{2}$ hours at a pressure of 300 to 330 lbs. With cyanized briquets, yields averaging over 90 per cent were obtained in 30 to 45 minutes by steaming at 300 to 330 lbs.

To obtain satisfactory results with steam at atmospheric pressure, a temperature of 600°C . was necessary. High temperatures were necessary to obtain good results with steam at low pressure, while 400° with 100 lbs. pressure gave satisfactory results. At the temperatures involved in the experiments with saturated steam there were no indications of side reactions, only formates and ammonia being produced.

The winning of ammonia nitrogen out of liquid manure, urine, and other liquids containing ammonia, O. LEMMERMANN and H. WIESSMANN (*Mitt. Deut. Landw. Gesell.*, 33 (1918), No. 2, pp. 16–21; *abs. in Zentbl. Agr. Chem.*, 48 (1919), No. 1, pp. 8–10; *Chem. Zentbl.*, 1919, IV, No. 3, p. 77).—Experiments on a process for the separation of ammonia nitrogen from fermented liquid manure by use of a current of air are reported, in which the ammonia is intercepted by sulphuric, hydrochloric, phosphoric, and humic acids, and acid salts.

According to the absorbing material used, a liquid or solid product is obtained. The latter is obtained by use of sand, kieselguhr, or other absorbents. The liquid manure residue is said to be valuable for meadow fertilization. The rate of separation of the ammonia from the liquid manure by air blast depends upon the temperature and strength of the air blast and the ratio of quantity of air to quantity of liquid. The concentration of the liquid manure in its normal variations and the depth of the liquid appear to have little influence. An increase of the temperature to 50°C . (122°F .) markedly increased the separation.

The relative availability of nitrate nitrogen and commercial organic nitrogen.—Field and cylinder experiments, A. W. BLAIR (*Jour. Indus. and Engin. Chem.*, 12 (1920), No. 3, pp. 262–264).—Field and cylinder experiments on the relative availability of nitrates and organic materials conducted for 20

years at the New Jersey Experiment Stations are summarized, the substance of which has been previously noted from another source (E. S. R., 41, p. 627).

Vegetation experiments with new nitrogenous fertilizers, SCHOLZ (*Ztschr. Landw. Kammer Braunschweig.*, 88 (1919), No. 39, pp. 435-437).—Pot experiments with oats on sandy loam soil to compare the fertilizing values of sodium nitrate, ammonium sulphate, ammonium chlorid, sodium-ammonium nitrate, and potash-ammonium nitrate showed that the ammonium chlorid gave as large grain yields as ammonium sulphate. The best results were obtained with sodium nitrate. The results obtained with the sodium- and potassium-ammonium nitrates, while indicating increases, were smaller than with the other fertilizers.

Experiments on sand soil showed about the same results, except that they brought out the value of the potassium- and sodium-ammonium nitrates on this soil, especially the latter. While increases were obtained in all cases, it is recommended that extensive field experiments be conducted to bring out their true relative values.

Nitrogen bacteria fertilizers, NOLTE (*Ztschr. Landw. Kammer Braunschweig.*, 88 (1919), No. 39, pp. 437, 438).—Laboratory tests of three so-called nitrogen bacteria fertilizers, using a nutritive salt solution, are reported. It was found that two of the fertilizers contained free living nitrogen organisms which, however, were able to fix only small quantities of nitrogen under favorable conditions. A cropping experiment with oats and mustard on sand soil using the bacteria fertilizers with and without ammonium sulphate showed no marked action on the part of the bacteria fertilizers to indicate their value as sources of nitrogen.

The new valid regulations for the purchase and delivery of nitrogenous fertilizers, NOLTE (*Ztschr. Landw. Kammer Braunschweig.*, 88 (1919), No. 39, pp. 438-440).—Extracts are given from the German fertilizer laws regulating the sale and delivery of nitrogenous fertilizers.

Utilizing Imhoff sludge on land at Plainfield sewage works, J. R. DOWNES (*Engin. News-Rec.*, 84 (1920), No. 18, p. 859).—Experiments are reported on the use of Imhoff tank sludge on sandy soil.

Forty-two bushels of oats per acre were raised on this soil, receiving about 40 tons of sludge (containing 75 per cent moisture) per acre. The second year with 3 tons of sludge per acre, placed in the hills only, 50 bu. of corn were raised. It is stated that with sandy soil and a production of approximately 300 tons of sludge per acre per 1,000,000 gal. daily flow of sewage, this method of disposal requires between 20 and 25 acres of tillable land per 1,000,000 gal. daily capacity. At current prices for labor, gasoline, etc., it requires 45 cts. per cubic yard to dispose of the sludge in this manner.

On the basis of 50 bu. of corn per acre it required 1.56 man-hours actual labor to produce 1 bu., plowing to husking included, together with gasoline equal to 0.04 man-hour and the use of a horse for cultivation equal in value to 0.06 man-hour. Oats, plowing to thrashing included, required 0.76 man-hour per bushel.

Report on commercial fertilizers, 1919, E. H. JENKINS and E. M. BAILEY (*Connecticut State Sta. Bul.* 217 (1919), pp. 55-106).—This bulletin reports the results of analyses and valuations of 542 samples of fertilizers and fertilizer materials collected for inspection in Connecticut during 1919.

Fertilizer analyses [and registrations], A. F. WOODS and H. B. McDONNELL (*Md. Agr. Col. Quart.* No. 87 (1920), pp. 40).—This contains the results of actual and guaranteed analyses and valuations of 515 samples of fertilizers and fertilizer materials collected for inspection in Maryland from August, 1919, to February, 1920, inclusive, together with a list of 1919 and 1920 registrations.

AGRICULTURAL BOTANY.

Notes on trees and shrubs in the vicinity of Washington, W. W. ASHE (*Bul. Torrey Bot. Club*, 46 (1919), No. 6, pp. 221-226).—The author has found within the vicinity of Washington, D. C., a number of trees and shrubs which do not appear to have been recorded previously. The forms regarded as new species are named *Amelanchier sera* and *A. micropetala*; the new variety is *A. micropetala potomacensis*; and the new combinations proposed are *A. canadensis intermedia* and *Carya glabra hirsuta*.

New and old species of Opuntia, D. GRIFFITHS (*Bul. Torrey Bot. Club*, 46 (1919), No. 6, pp. 195-206, pls. 2).—The author here records facts obtained in the study of *Opuntia* spp. on the U. S. Department of Agriculture grounds at Chico, Cal. Of species which have long been under observation, eight are described for the first time, and two are recognized for the first time since originally described.

New species of Uredineæ, XI, J. C. ARTHUR (*Bul. Torrey Bot. Club*, 46 (1919), No. 4, pp. 107-125).—Since the issuance of the preceding number of this series (E. S. R., 40, p. 327), two errors have been corrected and are pointed out herein. A number of grass rusts are provisionally transferred.

The wholly new species herein proposed, about 16 in all, are taken from recent collections or more largely from herbarium material, partly from the Northern States, but more largely from the southern part of the United States, from Mexico, and from the West Indies.

The ancestry of maize.—A reply to criticism, P. WEATHERWAX (*Bul. Torrey Bot. Club*, 46 (1919), No. 7, pp. 275-278).—This is mainly a reply to Kempton (E. S. R., 41, p. 727). It is held that comparative morphology, which has been one of the most reliable and productive agents in establishing lasting theories of evolution, points out reasonable evidence of the direct origin of *Zea*, coordinately with *Euchlæna* and *Tripsacum*, from an ancestor long ago extinct. The three genera are thought to be different simply because they have lost different organs that were possessed by their progenitor and have specialized others to different degrees.

The pure line hypothesis and the inheritance of small variations, E. WARREN (*So. African Jour. Sci.*, 15 (1919), No. 7, pp. 535-567, pl. 1).—Following a brief discussion of certain aspects of Mendelism, an account is given of experimentation carried out to ascertain whether small casual variations can be inherited. This work, consisting in breeding experiments with nasturtiums (*Tropæolum minus* and *T. majus*), is detailed and tabulated with discussion, as are the results.

The main result of this investigation is to show that the so-called factors of the germ cell are variable in nature and are thus transmitted.

Half mutations and mass mutations, H. DE VRIES (*Ber. Deut. Bot. Gesell.*, 36 (1918), No. 4, pp. 193-198).—The author considers that his studies and observations show that mass mutations and half mutations play a very prominent part in the production of new forms among plants, both in a state of nature and under cultivation.

A petunia hybrid, H. RASMUSON (*Bot. Notiser*, No. 6 (1918), pp. 287-294).—As a result of studies carried out with hybrids of *Petunia nyctaginiflora* and *P. violacea*, the author states that the deeper colors were dominant over the lighter, and that blue anther coloration was dominant over yellow. The factors for deep flower coloration and blue anther coloration are inherited independently.

The *Oenotheras* as nuclear chimeras, J. P. LOTSY, H. N. KOOIMAN, and M. A. J. GOEDEWAAGEN (*Genetica [The Hague]*, 1 (1919), No. 1, pp. 7-69, fig. 1).—This is an account of a study during 1918 of the results of intercrossing among species of *Oenothera*, based on the hypothesis that the genus is, as regards its origin, a nuclear chimera. This hypothesis is considered to be supported by the extensive data here presented.

Some applications of the quadrat method, H. A. GLEASON (*Bul. Torrey Bot. Club*, 47 (1920), No. 1, pp. 21-33).—This is a discussion of the so-called quadrat method as used in ecological study, by which is meant the intensive study of the vegetation and environment of a definite and limited area known as a quadrat, or of a given number of such areas, in order to gain a comprehensive knowledge of the vegetation as a whole.

The values and errors pertaining to such a system are discussed. An account is given of the method employed and of the work done by the author during 1911-1915 at the Biological Station of the University of Michigan.

Experience has shown that better results are obtained if the plats are not contiguous, but judiciously distributed over the association. This method is appraised in comparison with others which are noted.

Ecology of *Tilia americana*.—I, Comparative studies of the foliar transpiring power, J. E. CRIBBS (*Bot. Gaz.*, 68 (1919), No. 4, pp. 262-286, figs. 13).—An account giving ecological and geographical details of studies on transpiration in *T. americana* states that cobalt chlorid standardized paper was found to be suitable for comparative studies in the relative transpiring power of leaves in the field.

The daily march of transpiration in *Tilia* varied greatly for the same leaf on different days, being influenced by relative humidity, temperature, light intensity, soil moisture, and presumably soil temperature. The foliar transpiring power of *Tilia* varied considerably in dune environments, the transpiring power being directly proportional to the relative exposure. The morning rise in the daily march was more rapid on the open sand, reaching here its maximum one to two hours earlier than in forested situations.

Where relative transpiration tends to develop a single mode past midday, the maximum is said to have shown a tendency to coincide with the maxima of temperature, relative humidity, and evaporating power of the air. The foliar transpiration index was influenced less by wind currents than was the porous cup atmometer. A second and lower mode may be developed about 4 p. m. No evidence of visible wilting occurred in *Tilia* on the open sand, though the so-called incipient drying was a common feature. The amount of growth water in the soil apparently has very little influence on the transpiration index unless it is reduced to the wilting coefficient.

The water economy of maritime plants, T. G. HILL (*Sci. Prog. [London]*, 14 (1919), No. 53, pp. 60-80, figs. 3).—In the present article an attempt is made to weave into a consecutive story the results obtained since 1904 in the botanical department of University College, London, in connection with the study of problems associated with the existence of maritime plants. These as here presented include the action of sodium chlorid; adaptation to varying salinity; transpiration; and absorption of water by aerial parts. Among the results and conclusions which are detailed in their several connections, it is stated that in case of *Salicornia* under natural conditions the crimson transpire more rapidly than do the apple green plants; the plants, whether crimson or apple green, from mixed sods transpire at a greater rate than do those of the same color from pure sods; and crimson plants either from a pure or a mixed sod transpire more rapidly

than do apple green plants from a mixed sod. The effect of locality upon transpiration is also noted.

It appears that succulence is not bound up with reduced transpiration rate. It was shown that aerial parts absorb sea water. The rate may be increased if transpiration be permitted after removal from the soil before immersion. The plants considered can make good some of their losses of water from the sea water, though not to so great an extent as from fresh water. They can take advantage of rain, dew, or sea water. They can also absorb water from the air. Finally, it is stated that parts of plants may, during drought, be kept alive by water derived from other portions.

Vegetation of undrained depressions on the Sacramento plains, F. RAMALEY (*Bot. Gaz.*, 68 (1919), No. 5, pp. 380-387, fig. 1).—The observations here recorded as made in 1917, chiefly in the neighborhood of Sacramento, Cal., extended in all directions for distances of 20 to 90 miles over an area most of which is exceedingly flat and low, various depressions containing standing water during portions of the spring. The vegetation of these depressions is very different from that of the usual grassland of the region, being composed of very few species with practically no introduced weeds. The depressions usually show a central area and a marginal zone, the former characterized by a dense growth of *Allocarya* or *Baeria*, and the latter by *Floerkea douglasii* and *Deschampsia danthonioides*. Subordinate species of both areas are noted, and the seasonal changes are indicated. A systematic list of species is given, 10 of which are noted as characteristic, 8 as frequent, and 11 as occasional.

Colloidal properties of bog water, G. B. RIGG and T. G. THOMPSON (*Bot. Gaz.*, 68 (1919), No. 5, pp. 367-379).—This paper is a report of work on the chemical analysis of bog water, the colloidal state in water, and the effects of this material on the growth of plants. Much of the work is now reported for the first time, but a brief general statement of a portion has been made previously (*E. S. R.*, 36, p. 320). It is also shown how the data as here given tend to explain current agricultural practice in bog utilization.

Bog water gives a precipitate on standing a few hours after saturation with electrolytes or on standing a year or more without electrolytes. The filtrate from the precipitation with ammonium sulphate is not, when dialyzed until free from sulphates, toxic to the root hairs of *Tradescantia* cuttings. Bog water, when dialyzed for the same length of time as this filtrate, is toxic to these root hairs. The distillate from bog water gives no precipitate with electrolytes, is much less acid than bog water, and is nontoxic to these root hairs. The toxicity of bog water to *Tradescantia* cuttings seems to be connected with the matter, in that it is in a colloidal state. The oxidation of this toxic matter to nontoxic matter seems to be a basis of agricultural practice in bringing bog lands into cultivation.

Physiological pre-determination: The influence of the physiological condition of the seed upon the course of subsequent growth and upon the yield.—II, Review of literature.—Chapter I, F. KIDD and C. WEST (*Ann. Appl. Biol.*, 5 (1918), No. 2, pp. 112-142, figs. 2).—This section of reports previously noted (*E. S. R.*, 40, p. 727) constitutes a critical review of literature bearing directly or indirectly on the present problem.

Relation of nutrient solution to composition and reaction of cell sap of barley, D. R. HOAGLAND (*Bot. Gaz.*, 68 (1919), No. 4, pp. 297-304).—As result of a study of sap expressed from barley plants grown in water, sand, and soil cultures under controlled conditions, the author states that the osmotic pressures in the sand and water cultures are effective in the cell sap of the tops and roots. Electrical condition of the nutrient solution has a marked influence on the conductivity of the sap, which is as marked for the tops as for the roots.

Sap from tops of all plants grown in sand and soil cultures or water cultures of different concentrations and reactions has almost the same pH concentration, approximately 6.0. Samples of sap from plants grown on six different soils under the same climatic conditions were found to have much greater concentration than that of the soil solution.

Semipermeable membranes in plants, A. RIPPEL (*Ber. Deut. Bot. Gesell.*, 36 (1918), No. 4, pp. 202-218).—This is largely a review of findings and views of other workers. The author holds that, while no completely satisfactory evidence has been obtained regarding the existence of semipermeability in chemically pure cellulose membranes, yet this property does reside in cell membranes generally except where they have undergone certain alterations which are indicated.

The influence of certain ductless gland substances on the growth of plant tissues, R. A. BUDINGTON (*Biol. Bul. Mar. Biol. Lab. Woods Hole*, 37 (1919), No. 3, pp. 188-193, fig. 1).—This paper reports the morphological effects of thyroid constituents on the growth of the root tips of *Allium*, the experiments being repeated three different years in midwinter and early spring, when the dormant period of growing of the bulbs is naturally terminating.

It appears that the growth of root tips of *Allium* is retarded by thyroid gland material in a degree approximately proportional to the amount present. The presence of this material in the nutrient fluid does not, however, modify the growth of the early leaves. Iodin as potassium iodid has no appreciable effect on growing root tips. Pituitary substances up to two grains of the desiccated gland and supra-renal substances up to one grain of desiccated gland in 120 cc. of nutritive solution have no effect on the growing root tips of *Allium*. It thus appears that thyroid constituents may influence protoplasmic action in cells other than those of animal tissues.

Ionization of air by plants, A. URSPRUNG and A. GOCKEL (*Ber. Deut. Bot. Gesell.*, 36 (1918), No. 4, pp. 184-192).—The authors state that the ionization observed by them is explainable on a purely physical basis, no support having been given by their studies to a supposed ionization of the air through physiological processes.

Chemical constituents of *Amaranthus retroflexus*, M. L. WOO (*Bot. Gaz.*, 68 (1919), No. 5, pp. 313-344, figs. 11).—The author finds that the organs of *A. retroflexus* contain a large amount of nitrate, the stem and branches being the primary storage organs for this constituent. The rate of nitrate absorption increases with the age of the plant. This high capacity for nitrate absorption and storage is thought to be an important factor in making *Amaranthus* a successful competitor against cultivated plants. Carbohydrates and nitrogen compounds show throughout the growing period fluctuations which are approximately in inverse ratio to each other. Analysis of the seeds shows a high content of organic and a low content of inorganic phosphorus. The distribution of nitrogen in seeds is in the same order as that of the phosphorus. The predominating sugars in the seeds are the polysaccharids. These compose nearly one-half of the total dry weight of the seeds.

Storied or tier-like structure of certain dicotyledonous woods, S. J. RECORD (*Bul. Torrey Bot. Club*, 46 (1919), No. 7, pp. 253-273).—A study has been made by the author of dicotyledonous woods characterized by a storied or tier-like arrangement of their secondary elements, representing a wide range of natural orders and families. The storied structure is found also in the secondary phloem. This structure appears on longitudinal sections, typically the tangential, as fine transverse striations or ripple marks often visible to the naked eye. They are constant enough in stems of considerable thickness to serve as a valuable diagnostic feature. In some woods pit areas on the fibers are in

seriation. In some instances also the cells of the wood parenchyma strands are arranged in secondary seriation, visible under the lens.

Mucilage or slime formation in the cacti, E. G. STEWART (*Bul. Torrey Bot. Club*, 46 (1919), No. 5, pp. 157-166, pl. 1).—Having studied mainly in this connection *Rhipsalis rhombea*, the author reports that he has found in cacti a transformation in the content of many cells in the growing regions into mucilage, which by absorbing water may simulate true growth and may be of importance in conserving and regulating the supply of water for the growing cells. Apparently the cell wall is not involved. The mucilage comes from the protoplasm and the formation begins between the cell wall and the protoplasm. As the mucilage increases the nucleus and cytoplasm give way to it until it completely fills the enlarged cell.

It is not held that all resins, gums, and mucilages are similarly formed. It is stated that the method of secretion here noted in connection with mucilage cells of the cacti is much more like that of the gland cells of animals than the more familiar method by a resinogenous layer of the cell wall as found in many trichomes.

Origin and development of the pycnidium, F. E. KEMPTON (*Bot. Gaz.*, 68 (1919), No. 4, pp. 233-261, pls. 6).—The author states that the origin and development of pycnidia may fall in either of two main methods, meristogenous and symphogenous, the latter being the less often found and variable and the former being resolvable into two modes, simple and compound with variations. Acervuli arise in the same manner as do pycnidia. The simple meristogenous development is more often found in the Sphæroopsidales, while the compound meristogenous and symphogenous modes are the more usual ones found in the Melanconiales and Tuberculariaceæ.

The formation of fruiting bodies by *Penicillium glaucum* in concentrated sugar solutions, N. BEZSSONOF (*Ber. Deut. Bot. Gesell.*, 36 (1918), No. 4, pp. 225-228).—The author states that in sugar solutions at concentrations approaching saturation *P. glaucum* continued to live and develop, giving evidence at high concentrations of a tendency to develop reproductive bodies.

The resistance of plants to cold, II, E. PANTANELLI (*Atti R. Accad. Lincei*, 5. ser., *Rend. Cl. Sci. Fis., Mat. e Nat.*, 27 (1918), I, No. 4, pp. 148-153).—In continuation of a report previously noted (*E. S. R.*, 39, p. 525), the author gives an account of work done mainly with sunflower, tomato, and maize subjected to different temperatures.

No direct relation was found to exist between resistance to cold and the alimentary value of the salts furnished to the plant. Nitrates depressed resistance. Potassium and phosphoric acid opposed the unfavorable effects of nitrates without directly raising resistance. No relation was found between resistance and developmental vigor. Concentration of the soil solution depressed resistance in maize, but was without effect on four other plants. No relation could be established between cell sap solute concentration and resistance to cold.

Generalizing the findings and deductions, the author states that the subtraction of heat beyond the point of minimum tolerance of cold is the essential cause of frost killing in case of plants. To this is opposed the natural resistance of plant organs. The formation of ice is only an accessory phenomenon.

Resistance is not related to cell sap concentration nor to content of acids or salts, but is related to the proportion of sugar which the cell retains during refrigeration. It is thought that sugar may serve as a source of energy in respiratory combustion, or else that it may protect the protoplasm against proteolysis or eventual autodigestion.

Alterations in cellular permeability and exchange at temperatures near freezing, E. PANTANELLI (*Atti R. Accad. Lincei*, 5. ser., *Rend. Cl. Sci. Fis., Mat.*

e Nat., 28 (1919), 1, No. 5-6, pp. 205-209).—The author has followed up the work above noted, employing as appropriate material the endocarp of the mandarin (*Citrus nobilis*), subjected to temperatures not below -5.5° C. (22.1° F.) maintained for nearly 12 hours after having ascertained that death from freezing occurs at -6° . This report gives the results of the first series of studies, in which the changes produced were reversed after immersion in water above 0° .

The present series of studies dealt with tissues kept dry or immersed in water or in solutions of mineral salts (sodium chlorid, acid potassium phosphate), sugars, alcohols, acids, and alkalis.

It is stated that cells in the endocarp of the mandarin, subjected to a temperature very near freezing, show a progressive augmentation of cellular permeability (evidenced by a rapid loss of water when kept in a dry space), and an exosmosis of substance from the tissues when immersed in water (favored by some substances which readily penetrate the cell, as glycerin, ethyl alcohol, citric acid). There is also a rapid destruction of sugars, limited only by the supply of substances which may be absorbed and utilized during respiration (glycerin, ethyl alcohol, citric acid), or of such substances as restrain exosmosis of sugars or of immediate products of respiration, as sodium chlorid, potassium phosphate, citric acid. The sugars (saccharose, glucose) present in the external liquid do not act in this way as they are not absorbed. A rapid autodigestion of protein also occurs.

The development of conceptions of photosynthesis since Ingen-Housz, H. A. SPOEHR (*Sci. Mo.*, 9 (1919), No. 1, pp. 32-46).—The examples of research and deduction as sketched herein are intended to illustrate the complexity of the problem of photosynthesis.

A plate method for isolating anaerobes, G. F. DICK (*Jour. Infect. Diseases*, 23 (1918), No. 6, pp. 578-579).—A method of plating anaerobes is described and discussed as being free from a number of difficulties usually encountered.

Modifications in the technique of Dick's plate method for isolating anaerobes, Z. NORTHRUP (*Jour. Bact.*, 4 (1919), No. 3, pp. 299, 300).—The author describes what are claimed to be desirable modifications in the technique of Dick's method above noted.

International catalogue of scientific literature. M—Botany (*Internatl. Cat. Sci. Lit.*, 14 (1919), pp. VIII+753).—The present volume consists of schedules (revised according to the decisions of the international convention of 1905) and indexes in four languages, an author catalogue, and a subject catalogue. The literature indexed is mainly that of 1914, but includes also portions of literature of 1901-1913 received too late for inclusion in previous issues (E. S. R., 37, p. 630).

International catalogue of scientific literature. R—Bacteriology, QR—Serum physiology (*Internatl. Cat. Sci. Lit.*, 13 (1918), pp. VIII+413+138+24).—This volume contains mainly the literature of 1913, but as in case of previous issues (E. S. R., 39, p. 190) includes some of earlier date.

FIELD CROPS.

Soil and climatic factors in relation to crop production on the Palouse silt loam of Idaho, P. P. PETERSON (*Idaho Sta. Bul.* 118 (1919), pp. 19, figs. 2).—This bulletin is a report of progress on tests with fertilizers and rotations begun in 1915 on 64 tenth-acre plats. Commercial fertilizers used as a surface dressing on winter wheat only are applied as follows: Nitrate of soda, 200 lbs.; acid phosphate, 100 lbs.; and muriate of potash, 100 lbs. per acre. Barnyard manure is applied at the rate of about 20 loads per acre. The following eight rotations are used: (1) Wheat, oats, and peas; (2) wheat, oats, and fallow;

(3) wheat, oats, and corn; (4) wheat, oats, and potatoes; (5) wheat continuously; (6) wheat, timothy, and clover two years, oats, and corn; (7) wheat, barley, potatoes, and oats; and (8) wheat, barley, oats, and corn. These rotations are based on the prevailing system of cropping with grain two years followed by one year fallow. The varieties grown are Red Russian wheat, Swedish-Select oats, Blue Prussian peas, Rustlers White Dent corn, White Winter barley, Gold Coin and Early Ohio potatoes, and Medium Red clover. Tabulated results are given with reference to the influence of fertilizers and manure, the effect of the preceding crop on yields of wheat and oats, and the influence of climate, principally precipitation and temperature.

The data secured in the fertilizer tests are regarded as indicating that nitrogen is most likely to be the limiting factor when the deficiency is a plant food element. Good results have been obtained with manure by using it as a surface dressing on wheat and by plowing it into the ground to be planted to corn.

Potatoes, followed in their order by fallow, peas, and corn, had the most beneficial effect on a succeeding wheat crop. Planting corn, peas, or potatoes proved much more economical than summer fallowing every third year. A comparison of gross incomes for four rotations showed that corn, giving the lowest income of all rotations in which crops were substituted for the summer fallow, gave \$22.44, potatoes \$39.66, and peas \$99.35 for the extra labor involved in growing the crop.

The general results further indicated that the quantity of moisture may prove a serious limiting factor in production on this type of soil, and that in its cultivation attention must be given to moisture conservation. Lack of rain and high temperatures during the growing period affected corn and potatoes much less than they did wheat, oats, or peas.

[Report of the] department of agronomy, C. S. KNIGHT (*Nevada Sta. Rpt. 1919, pp. 17-24*).—The results of irrigation experiments with alfalfa and wheat, previously reported in detail and noted (E. S. R., 41, p. 728), are briefly reviewed, and data secured in variety testing and crop improvement work are presented.

Row and plat tests were conducted with wheat, oats, and barley. Among wheat varieties, each grown in a row 100 ft. long, White Club, Galgalos Fife C. I. No. 2398, New Zealand, Defiance, and Colorado No. 50 led in average yield with the rates of 49.2, 49.0, 47.8, 47.5, and 47.1 bu. per acre, respectively. White Club and Colorado No. 50 had been grown five years and the other varieties four years. The leading varieties of oats in similar row tests were Early Mountain No. 2 C. I. 656, Early Mountain C. I. No. 754, and Black American, yielding respectively an average of 78.5, 64.8, and 58.2 bu. per acre for four years. The highest producing barley varieties and their average yields for three to five years were as follows: Swedish Gold, 84.6; Princess, 70.4; Trebi, 64.3; Chevalier, 62.8; Blue Ribbon, 60.8; and Moravian, 60.4 bu. per acre. The varieties mentioned are 2-rowed except Trebi, which is a 6-rowed variety. It is pointed out that Swedish Gold has a very short straw, which will prevent its introduction on a commercial basis.

In the plat tests seven varieties of wheat were grown from one to three years. White Club, grown for three years, ranked first with an average yield of 39.3 bu. per acre, being followed by Rieti, grown for two years with 34.5 bu., and Marquis, grown only one year with 33.1 bu. per acre. Of the six varieties of oats tested in a similar way Early Mountain No. 2 and Abundance, grown for two years, led with average yields of 39.5 and 28.9 bu. per acre, respectively, and Great Dakota, grown for three years, stood next with an average yield of

28.1 bu. The highest average yields of barley in the plat tests were secured from Chevalier, which yielded an average of 41.4 bu. per acre for three years; California Feed, 41.4 bu. for one year; and Moravian, 40.6 bu. for three years.

Experiments were conducted also with forage crops and potatoes. In a test of seven strains and varieties of alfalfa in 1917-18, North Dakota 27247 stood first in total yield with 5.99 tons of hay per acre for the first and second crop, being followed by Australian 23753 with 5.85 tons. The percentage of leaves to stems ranged from 37.1 to 40.6 per cent. In 1917-18 Russian sunflower gave an average yield of 43,046 lbs. of silage material per acre as compared with 27,258 lbs. for Improved Leaming corn, and 6,803 lbs. for Sudan grass. Grown in drill rows about 30 in. apart and cultivated Sudan grass gave an average of 1,051 lbs. of seed per acre for the four years 1915-1918. An average yield of 549 lbs. of beans per acre for four years is recorded for the California Large Mexican Pinto bean. Of five varieties of potatoes grown for the six years beginning 1913, Great Divide, Burbank, and Peerless were the heaviest producers, giving average yields of 241.4, 231.0, and 221.9 bu. per acre, respectively. Of a number of varieties introduced in 1917 White Rose and Producer ranked first with average yields of 429.9 and 414.4 bu. per acre, respectively, for the two years 1917-18. Pride of Multnomah, American Wonder, and Jones Russet stood next in the order mentioned.

Report of experiments, Substation No. 4, Beaumont, Tex., H. H. LAUDE (*Texas Sta. Bul. 258 (1919), pp. 5-20, figs. 6*).—This bulletin briefly notes the work of the substation and the weather conditions from 1915 to 1918, inclusive, and reports the results of experiments with rice, corn, cotton, Sudan grass, Japanese cane, and grain sorghums.

In fertilizer experiments with rice, as shown by four years' results, cottonseed meal at the rate of 300 lbs. per acre produced the largest average increase in yield, 552 lbs., while a combination of 50 lbs. of ammonium sulphate and 75 lbs. of acid phosphate per acre, giving only 30 lbs. of rice less, produced the largest profit. The use of this combination gave an average yield as good as that from 100 lbs. of ammonium sulphate alone. An application of 12,000 lbs. of barnyard manure per acre proved least effective in increasing the yield. Plowing either 5 or 8 in. deep in the fall, winter, or spring as compared with plowing 2 in. deep gave increases in yield more than sufficient to offset the extra cost of deeper plowing.

Five years' average results of sowing 60, 80, and 100 lbs. of re-cleaned seed rice per acre showed that the 80-lb. rate produced 93 lbs. and the 100-lb. rate 146 lbs. of rice more per acre than was secured from the 60-lb. rate. Five-year experiments in planting 1, 2, and 3 in. deep resulted slightly in favor of the medium depth. The best yields as determined by experiments on the time of seeding were obtained from seedings made from the middle of April to the first part of June. In each of three years mudding in the seed gave better results than those secured from drilling into moist ground. A five-year average gain of 585 lbs. of rice per acre was obtained through careful weed control over the ordinary method of growing the crop. Earlier work on the control of weeds in rice fields has been previously noted (*E. S. R., 41, p. 38*). Of a number of varieties under test T. S. No. 1583 stood up well, proved of extra good quality, and yielded several hundred pounds of rice more per acre than were produced by the common varieties grown in comparison.

Acid phosphate, cottonseed meal, and barnyard manure at the rates of 200, 300, and 12,000 lbs. per acre, respectively, were applied separately and in combination to corn in 1916. Barnyard manure and acid phosphate in combination gave an increase of 10.43 bu. per acre over the check plat, the manure

alone an increase of 9.58 bu., and cottonseed meal and acid phosphate combined an increase of 6.45 bu. Cottonseed meal and acid phosphate used alone gave only small increases in the yield of corn. In similar experiments with cotton the manure alone more than doubled the yield. Acid phosphate gave gains of over 200 lbs. of seed cotton per acre and cottonseed meal an increase of 64 lbs. For Sudan grass manure ranged first, acid phosphate second, and cottonseed meal third when applied in the quantities mentioned.

Based on the results of four years' tests the varieties Schieberle, Biggs Prolific, Hastings Prolific, Ferguson Yellow Dent, Fentress Strawberry, Thomas, Surcropper, and Chisholm are listed as the leading varieties of corn in the order of yield. The leading varieties of cotton tested in 1916-17 were Bank Account, Mebane, Mortgage Lifter, Union Big Boll, Cleveland Big Boll, and Hawkins with a range of an average of 633 to 522 lbs. of seed cotton per acre for the two years.

Seeding Sudan grass at five different rates ranging from 10 to 40 lbs. of seed per acre did not show marked differences in the yields. A yield of 9,592 lbs. per acre of green material produced 3,637 lbs. of cured hay, the proportion being approximately 2.6 to 1. Japanese cane proved to be the best crop of those tested for growing in rotation with rice. The results further indicated that Japanese cane under proper drainage conditions should be planted in the fall, and that 3 lines or about 3 tons of seed canes per acre is likely to give better results than thinner rates of seeding. The best grain sorghums tested were shallu, Blackbull White kafir, Pink kafir, Schrock kafir, and feterita. The production of grain by these crops was found uncertain on account of injury by the sorghum midge.

The duty of water in Cache Valley, Utah, F. S. HARRIS (*Utah Sta. Bul. 173 (1920), pp. 16, figs. 9.*)—This bulletin reviews the results of experiments, including a total of 991 tests extending over a period of 17 years, on the duty of water in irrigating sugar beets, potatoes, alfalfa, corn, wheat, and oats on a deep medium soil. The details of the experiments have been described previously (*E. S. R.*, 27, p. 819), and some of the results with several of the crops, discussed at greater length in earlier publications, are noted as follows: Corn (*E. S. R.*, 31, p. 428); wheat (*E. S. R.*, 36, p. 234); potatoes (*E. S. R.*, 37, p. 740); sugar beets (*E. S. R.*, 37, p. 741); and oats (*E. S. R.*, 41, p. 141). The annual and average monthly precipitation for the period 1902-1919, and the relation of the duty of water to yield, as indicated by the results, are shown graphically. The data reported refer to the amounts of water that actually soaked into the land.

The best results with sugar beets were secured with 15 to 30 acre in. of water, and it is believed that the use of more than 30 in. would probably never be warranted on this type of soil. The yield of potatoes increased with the duty of water up to 32½ acre in., but it dropped off rapidly when larger quantities were used. Alfalfa used water more advantageously than other crops in the experiments and increased in yield up to 50 in., but the smaller quantities were much more efficient. From 15 to 25 acre in. of water gave the best results with corn.

Among the crops under test wheat was least affected by the water applied, and 15 acre in. is regarded as generally the best quantity to use, although larger quantities produced slight increases in yield. Oats gave good returns with the duty of water ranging from 15 to 30 acre in. The results in general indicated that the proper diversification of crops makes possible the most efficient use of irrigation water.

[The effect of rotations on yield and profit from bog soils], A. GRANSTRÖM (*Svenska Mosskulturför. Tidskr.*, 34 (1920), No. 2, pp. 56-73, figs. 2).—The results of experiments conducted for eight years with four different rotations on bog soil are reported in detail and discussed. All rotations received annually 3,000 kg. of barnyard manure per hectare (2,670 lbs. per acre), in addition to commercial fertilizer applications varying somewhat in quantity and proportions according to the crops grown.

The most profitable rotation consisted of oats for green forage the first year, grass the second, third, and fourth years, oats for grain the fifth year, and field beets the sixth. This rotation gave a net profit of 335 kroner per hectare (\$36.34 per acre) with a cost of production of 11.7 öre (3 cts.) per feed unit (the equivalent in feeding value of 1 kg. of mixed concentrates).

Results of local field experiments on the comparative value of important varieties of different crops, P. BOLIN (*K. Landtbr. Akad. Handl. och Tidskr.*, 58 (1919), No. 5, pp. 253-281, figs. 7).—The results of cooperative experiments conducted for eight years in different parts of Sweden and on various types of soil are reported, and the precipitation records for May to August, inclusive, of each year for the different localities are given in graphic form.

Svalöf Stjärn rye gave an average yield of grain and straw about 5 per cent greater in each case than that secured from Petkus' rye. The increases in yields in favor of Stjärn rye were greater on clay soil than on sandy soil. Svalöf Improved Vasa rye gave an average yield of grain approximately 18 per cent higher, and an average yield of straw about 6 per cent lower, than was obtained from ordinary Vasa-rye. In winter resistance the two varieties stood very close together.

The average yield of grain of Svalöf Tule wheat 2 was only 3 per cent better than that of Svalöf Tule wheat 1, and this is not considered as outweighing its somewhat undesirable character of sprouting too readily. Weibull Iduna wheat compared with these two varieties in Svealand exhibited about the same yielding capacity, but in Värmland the Tule varieties gave the better yields, which is regarded as indicating that Iduna wheat ranks lower in hardness.

Segeer and Guldregn oats in southern and middle Sweden gave about equal average yields of grain, but it was found that on mineral soils Segeer outyielded Guldregn by about 2 per cent, while on soils rich in organic matter the yields were in favor of Guldregn by about 4 per cent. Guldregn oats also yielded a little better than Segeer under conditions of ample rainfall. Kron oats as compared with Segeer in southern and middle Sweden gave about 5 per cent more grain and 4 per cent more straw than was harvested from Segeer oats, but no data as to the comparative behavior of the varieties in other parts of the country or on different types of soil were obtained. A test of oats showed about 8 per cent greater yields of grain and 9 per cent of straw in favor of Svalöf Klock 3 as compared with Svalöf Klock 2, but the former produced only a very little more grain than was secured from Stormogul and yielded 10 per cent less straw. On sandy soils the difference in yields between Svalöf Klock 3 and Svalöf Klock 2 was somewhat less than on other soil types.

Weibull Monopol and Svalöf Solo peas produced about the same average yield of ripe peas, but Weibull Monopol gave about 6 per cent the more green substance.

Results of cooperative experiments, L. ARONSSON (*Malmö. Läns Hushåll. Sällsk. Kvartalskr.*, 1919, No. 4, pp. 415-458).—Sugar beets, field beets, and potatoes grown in 1918-19 on sandy and clay soil in general gave the best returns when treated with applications of complete fertilizer mixtures. In a

test conducted for a number of years, lime nitrogen as compared with nitrate of soda showed a relative effectiveness of 60 to 75 per cent when applied to sugar beets, and of 55 per cent when applied to field beets.

The results of variety tests in progress for four years showed that Pansar and Fylgia wheat gave higher yields of grain than were secured from Extra Squarehead, 2. In a test of different varieties of rye the best yields were obtained from Stjärn and Stål rye as compared with Bretagne and Petkus. The following varieties of spring-sown crops led in productiveness: Gull, Princess, and No. 0412 barley, Seger oats, and Svalöf Spring Squarehead and Svalöf Extra Club wheat.

Among different root crops, the leading varieties were Barres field beet, Bangholm Swedish turnip, Bortfeld and Yellow Tankard turnips, and Svalöf Champion, Gul Jätte 2, and Extra Vit Jätte carrots. Based on the results of comparative tests with potatoes, the varieties Arran Chief, King Edward, and Perle von Erfurt, late, medium, and early varieties, respectively, are recommended.

Barley fertilizer experiments, O. LEMMERMANN (*Wchnschr. Brau.*, 36 (1919), No. 48, pp. 355-358).—Experiments on the action of different fertilizers and soil amendments and on the influence of the cultural condition of soil on barley are reported.

Studies of the relative fertilizing values of different nitrogenous fertilizers for barley, including ammonium chlorid, sodium-ammonium nitrate, lime nitrogen, urea, guanol, sodium nitrate, and ammonium sulphate, are first reported. The results showed that the nitrate forms of fertilizer were the most effective. Urea, however, gave marked results, but guanol and lime nitrogen had little effect, the former being used at a small loss. The ammonium fertilizers also were not very effective. Better results can be obtained with ammonium fertilizers by mixing them deeply with the soil. Further studies with sodium nitrate and ammonium fertilizers indicated that their effectiveness increased with the size of application up to 80 lbs. per acre.

Experiments with barley soils which had not been fertilized with phosphate for 10 years showed no effect from applications of stable manure. Similar results were obtained with potash fertilization, and it was noted that there was no difference between the action of raw salts and that of high-grade salts. Further experiments with kainit and potassium chlorid showed that better results were obtained on barley with spring applications. The lime-magnesia ratio in soils was found not to be an important factor in large-scale barley growing.

Studies of the effect with different types of barley are also briefly noted.

Broom-corn experiments at Woodward, Okla., B. E. ROTHGEB and J. B. SIEGLINGER (*U. S. Dept. Agr. Bul.* 836 (1920), pp. 53, figs. 7).—The results of experiments with broom corn, covering a period of five years and embracing variety and cultural tests, are reported in detail, and the climatic and soil conditions of the region in which the work was carried on are described. The conclusions drawn are based on the data presented in tables and discussed.

It was found that all varieties tested produced high yields in favorable seasons, but that only adapted varieties yielded well in the less favorable seasons. Dwarf broom corn, which outyielded the Standard, is considered as requiring less water than the Standard variety, and therefore as better adapted to the conditions prevailing in the region concerned. Both groups were found to sucker, but the tendency was present to the greater degree in the Dwarf varieties.

Environmenting conditions largely influenced suckering and also the length and quality of the brush. The thick stands produced short brush and the thin stands long, coarse brush. Sowing the crop from May 1 to 15 or from June 15 to 30 proved best, as sowing at these times enabled the crop to avoid heading during the usually hot and dry weather of the middle of August. The most profitable stand for a series of years appeared to be 1 plant to 6 or 8 in. of row space with the rows 3.5 ft. apart. Nothing was gained by the method of spacing the rows 7 ft. apart and doubling the thickness of the plants in the row.

It was observed that harvesting when the seeds are in the dough stage gave a higher yield of brush than harvesting at an earlier date, and it was found also that the brush obtained when harvested at this stage is the best. The results of nursery work showed that much of the seed from commercial sources is of poor quality. Progress in developing strains producing a uniform quality of brush is reported.

Carpet grass, C. V. PIPER and L. CARRIER (*U. S. Dept. Agr., Farmers' Bul. 1130 (1920), pp. 12, figs. 5*).—Historical and descriptive notes on carpet grass are given, the value of the grass, with its climatic and soil requirements, is pointed out, and methods of establishing and maintaining carpet grass pastures of good carrying capacity are noted. The harvesting and cleaning of carpet grass seed are also briefly described.

Time of applying nitrate of soda to cotton, E. F. CAUTHEN and J. T. WILLIAMSON (*Alabama Sta. Bul. 209 (1920), pp. 3-15*).—The experiments reported were conducted at the station from 1910-1916, inclusive, and in 14 localities in the northern part of the State, which was still largely free from the boll weevil, and where results were secured in each case for only one year, although covering the period of 1914-1919, inclusive. The results for each series of tests are given in tables.

At the station 140 lbs. of nitrate of soda per acre was applied either at the time of planting, the first cultivation after thinning, the appearance of the first squares, or the appearance of the first blooms. A complete fertilizer consisting of 160 lbs. of acid phosphate, 100 lbs. of cottonseed meal, and 80 lbs. of kainit or its equivalent per acre was applied before each planting except in 1915 and 1916. The largest average increase in yield, 80 lbs. of seed cotton per acre, was secured from the application made at the first cultivation after thinning, or about 40 days after planting. These results were obtained either with slight or no boll weevil infestation.

The average results secured in the 14 local experiments indicated that nitrate of soda, at the rate of 100 lbs. per acre, gave the best results when applied at or before the appearance of the first squares. This same application made at the first cultivation after thinning was more effective than the use of 200 lbs. of cottonseed meal per acre when in each case 100 lbs. of nitrate of soda was added three weeks after the first blossoms appeared. Nitrate of soda at the rate of 200 lbs. per acre, 100 lbs. at the first cultivation after thinning, and 100 lbs. about three weeks after the beginning of the blossoming period, was more effective and slightly more profitable than the use of 100 lbs. applied at or before the time the first squares appeared.

The jack bean, C. V. PIPER (*U. S. Dept. Agr., Dept. Circ. 92 (1920), pp. 12, fig. 1*).—The plant is described, its history, botany, and culture are noted, and its value as green manure, green feed, hay, silage, and human food, and as a source of urease, a substance used in medicine, are discussed. The results of chemical analyses of the different parts of the plants, as compiled from various sources, are given in a table.

It is concluded that "any farmer interested is justified in trying the plant only in a small experimental plat. Under peculiar conditions it may possess local value enough to justify cultivation."

[**Experimental results and experiences in potato culture**], W. CHRISTIE (*Rationel Potetdyrkning. Nogen Forsøksresultater og Erfaringer. Stockholm: Ivar Hæggström, 1919, pp. 42-61*).—The results of fertilizer and cultural tests with potatoes are reported, and cultural directions are briefly presented.

The largest profit from supplementing barnyard manure with commercial fertilizers was secured when the supplemental application was complete. In a test in which 3,500 kg. per decare (about 15.5 tons per acre) of barnyard manure was used, the addition of 30 kg. of 20 per cent superphosphate, 15 kg. of 37 per cent potash salt, and 9 kg. of Norwegian nitrate gave the best yield. An application of 35 kg. of 20 per cent superphosphate, 20 kg. of 37 per cent potash salt, and 18 to 25 kg. of Norwegian nitrate per decare gave about as large a yield as was secured where 7,000 kg. of barnyard manure was applied to a like area.

The results of planting on different dates were generally in favor of planting about May 8. Distance experiments indicated that generally planting in rows 63 cm. (about 2 ft. apart) with the plants from 20 to 30 cm. apart in the row will prove most satisfactory. Medium sized seed tubers weighing from 40 to 60 gm. each were found most profitable. Planting whole tubers weighing 65 gm. each gave a somewhat larger yield than the same quantity and size of tubers planted as halves cut two weeks before planting, and cutting at this time showed an advantage over cutting immediately before planting. Among seven varieties tested General Cronje ranked first in starch content with 19.1 per cent. The highest yield of tubers and of dry matter was secured from Skaun, but this variety showed 17 per cent of diseased tubers while General Cronje showed only 5 per cent. In value of crop as based on tuber and starch production General Cronje ranked first and Skaun second.

Winter rape, C. FRUWIRTH (*Mitt. Deut. Landw. Gesell. Österr., No. 7 (1917), pp. 28*).—A brief popular treatise on the value and culture of winter rape, in which many of the cultural recommendations are based on results secured by different investigators. Statistics are given on the production, importation, and requirements of Austria-Hungary in 1913 of rapeseed oil and other allied products.

Soy beans in Indiana, A. T. WIANCKO and C. O. CROMER (*Indiana Sta. Bul. 238 (1920), pp. 3-16, figs. 9*).—This bulletin discusses the value and importance of the soy bean together with the various steps involved in the culture and management of the crop, and reports the results of experiments at the station.

Soy beans grown after wheat was harvested gave on an average for the four years 1909-1912 a total production of green tops and of roots, taken to the depth of 18 in. at the time of the first frost, amounting annually to 6.5 tons per acre and containing 92.7 lbs. of nitrogen. In experiments begun in 1915 the yields of wheat after soy beans in three rotations have averaged 32 bu. per acre as against 25.5 bu. where wheat followed corn in three other rotations.

Experiments with the Early Brown and Ito San varieties on methods and rates of seeding gave about equal yields of seed from drilling 30 lbs. of seed per acre in 28-in. rows for cultivation and from 60 to 90 lbs. of seed per acre drilled solid. For hay production drilling solid produced the largest yields.

The results of variety tests conducted from 1903 to 1919 are reported in tabular form. The medium early varieties Ito San, Early Brown, Elton, and Manchu, and the later varieties Hollybrook, Mikado, Haberlandt, and Medium Green are considered desirable for seed production or for planting with corn for silage, and Lexington, Sable, Medium Green, and Sherwood on account of their fine stemmed character and fair yielding capacity for hay production.

Soy beans in Iowa, H. D. HUGHES and F. S. WILKINS (*Iowa Sta. Circ. 65* (1920), pp. 4).—The importance of soy bean culture for different purposes is discussed, the requirements of the crop are enumerated, varieties adapted to Iowa conditions are recommended, and cultural directions are given. Soy beans have been grown at the station since 1910, and the better varieties are reported as having yielded from 15 to 25 bu. of seed and from 2.5 to 3.5 tons of hay per acre. The results of tests indicated that planting between May 1 and 20 is likely to be most satisfactory.

Sudan grass in Iowa, H. D. HUGHES and F. S. WILKINS (*Iowa Sta. Circ. 66* (1920), pp. 4).—The advantages of Sudan grass, as indicated by results secured at the station, are pointed out, directions for growing the crop are given, and the value of the grass for different purposes is discussed.

An average yield at the station of 3.47 tons of hay per acre and a range of from 2.2 to 5.9 tons per acre is reported. In the experience of the station seeding from May 25 to June 15 gave generally the best results, and seeding at the rates of 2.5, 5, and 10 lbs. per acre in rows 32 in. apart showed relatively little difference in production. For drilling or broadcasting from 10 to 15 lbs. of seed per acre is recommended.

The influence of length of wheat heads on resulting crops, A. N. HUME, M. CHAMPLIN, and M. FOWLDS (*South Dakota Sta. Bul. 187* (1919), pp. 139-158).—A study was made of the correlation between the length of parent head and yield of progeny in successive generations of Bluestem wheat (Minnesota 169). A number of relatively long heads and an equal number of relatively short heads from separate plants were secured in 1912, and the seeds planted in head rows alternately representing the long and short heads. Tables are given showing the relation as expressed in grams of grain per head row between length in centimeters of mother spike planted in 1913 and direct yield therefrom or yields of progeny in successive years.

From 1,200 plants grown under identical conditions 260 plants were selected which varied principally in the length of spike. Twenty seeds selected at random from each head were planted in individual head rows in 1913. In the years 1914-1918 the progeny of the rows were planted so that successive generations could be traced back to their individual mother plants, but no additional selection was practiced.

It was found that relatively long heads yielded slightly higher than similar heads on other plants in the first generation after the selection of mother heads, but this increase failed to persist in following generations. It is concluded that the length of central spike can not be considered as the indicator of the fitness of a given plant to serve as the mother plant of a line of progeny.

HORTICULTURE.

Plant breeding from horticultural standpoints, J. W. CROW (*Ontario Dept. Agr., Ann. Rpt. Agr. and Expt. Union, 41* (1919), pp. 50-52).—A brief general review of progress made in breeding horticultural plants, with special reference to breeding work in progress at the Ontario Agricultural College.

Pruning and economy of water, J. C. WHITTEN (*Univ. Cal. Jour. Agr., 6* (1920), No. 5, pp. 10, 27, 28).—A contribution from the University of California, in which the author calls attention to the importance of judicious pruning in spring or early summer as a means of reducing the draft upon soil moisture during a dry season.

The beneficial action of lime in lime-sulphur and lead arsenate combination spray, R. H. ROBINSON (*Jour. Econ. Ent., 12* (1919), No. 6, pp. 429-433).—A contribution from the Oregon Experiment Station.

A study was made of the changes that occurred when lime-sulphur diluted to summer spraying strength was mixed with lead hydrogen arsenate and with basic lead arsenate, and also to determine some means of overcoming the detrimental action on the insecticidal properties of lead arsenate when combined with lime-sulphur.

The results secured indicate that there is a considerable reaction between lime-sulphur and lead hydrogen arsenate when mixed for a combination spray, while the basic lead arsenate causes only a slight change in the lime-sulphur. Calculated from the original amount of lead hydrogen arsenate used, over 5 per cent of the arsenic was found in a soluble form, thus increasing the tendency to cause burning of foliage and other injury. The total polysulphid content was reduced over 35 per cent, thereby decreasing the efficiency of the lime-sulphur.

In view of the fact that basic lead arsenate is not available in large quantities and lead hydrogen arsenate must be used, an experiment was conducted to determine the value of lime in preventing the devitalizing reaction. It was found that the addition of slaked lime at the rate of 10 lbs. to 100 gal. of lime-sulphur previous to adding the lead arsenate, would prevent to a certain extent this reaction. The polysulphid content of the combined spray had decreased only a negligible amount, while the untreated lime-sulphur showed a loss of almost 50 per cent of its fungicidal and insecticidal properties. The presence of free lime prevented arsenic from going into solution as a soluble salt, whereas where no lime was added a high percentage of arsenate was found, indicating that over 12 per cent of the lead hydrogen arsenate was decomposed.

Gardens, their form and design, VISCOUNTESS WOLSELEY (*London: Edward Arnold, 1919, pp. XIX+284, figs. 148*).—This work contains suggestions on the form and design of both large and small gardens of various kinds. Attention is given primarily to the development of the garden as a whole rather than to the color and arrangement of individual plants. The successive chapters discuss entrances, hedged-in gardens, surprise gardens, formal flower beds, ornamental pots, treillage, topiary, winter-gardens, rock gardens, suburban gardens, paved gardens, garden houses and ornaments, kitchen gardens, public gardens, Italian vineyards, the natural arrangement of trees and shrubs, garden plans, and the future garden designer. A bibliography, chiefly of European literature, relating to the subject is appended.

The garden month by month; H. H. THOMAS (*London and New York: Cassell & Co., Ltd., pp. [VIII]+152, figs. 34*).—A monthly working calendar dealing with the necessary work of fruits, flowers, vegetables, and the greenhouse, prepared with special reference to conditions in Great Britain.

Preparation and care of a garden for vegetables, compiled by D. J. BRUMLEY, T. C. GRIER, and F. L. MINGE (*Floosmoor, Ill.: T. C. Grier, 1920, 2. ed., rev. and enl., pp. 51+[16]*).—A compilation of information on the culture and care of the more common vegetables.

[Brussels sprouts and carrots at Wisley in 1918] (*Jour. Roy. Hort. Soc., 45 (1919), No. 1, pp. 125-130*).—Data are given on variety tests of Brussels sprouts and carrots conducted at the Wisley garden in 1918.

United States grades for northern-grown onions, H. E. TRUAX (*U. S. Dept. Agr., Dept. Circ. 95 (1920), pp. 4*).—The grades here proposed are based upon extended investigations by the Bureau of Markets of this Department in centers of production and important markets. They have been carefully criticized by many prominent growers, shippers, and dealers, and it is believed that in their present form they will meet the requirements of the northern-grown onion trade.

Frost and the prevention of damage by it (*U. S. Dept. Agr., Farmers' Bul. 1096 (1920), pp. 48, figs. 26*).—A practical treatise on the prevention of frost injury, dealing more particularly with the protection of fruit trees.

Introductory considerations are given to the changes that take place at and near the earth's surface on a frosty night and the underlying principles of frost protection. The various methods and devices now being used for protection against frost are discussed in detail. The publication also includes a chapter on temperatures injurious to plants, blossoms and fruit, and a description of meteorological instruments and methods of determining temperatures and atmospheric moisture.

[**Report of the division of nursery inspection**], W. C. O'KANE (*N. H. Agr., 35 (1917-18), pp. 201-247, pl. 1*).—In addition to a brief review on the work of inspecting nursery stock during the biennial period ended August 31, 1918, the report contains an article on Fruit Farming in New Hampshire, with special reference to apples, in which information is given relative to the planting and care of new orchards and the renovation of old orchards.

New deciduous fruit station, W. L. HOWARD (*Univ. Cal. Jour. Agr., 6 (1920), No. 5, pp. 10, 27*).—The author outlines various projects that are being undertaken at the Deciduous Fruit Station, previously noted (*E. S. R., 42, p. 695*).

Report on the experimental orchard at Mitchell for 1919, C. M. HOBBS, D. B. JOHNSON, and R. A. SIMPSON (*Hoosier Hort., 1 (1920), No. 11, pp. 9-11*).—A brief review of progress made in the experimental orchard formerly belonging to the Indiana Horticultural Society and now belonging to the Indiana Experiment Station. A list is given of varieties of apples that have been removed as either worthless or so unsuited to southern Indiana conditions as to make their further trial unnecessary.

Pollination of deciduous fruits, W. P. TUFTS (*Univ. Cal. Jour. Agr., 6 (1920), No. 5, pp. 14, 15, 29, 30, figs. 3*).—A contribution from the University of California, in which the author briefly considers various factors influencing the pollination of fruit trees and gives a few general statements relative to the results secured by the university in pollination studies with various fruits.

[**Report on fruit production in Australia**] (*Off. Year Book Aust., 12 (1901-1918), pp. 367-373*).—A statistical report on the acreage, production, and export trade in fruits and fruit products in Australia for the period 1917-18, with comparative data for previous years.

Contributions from the Wisley Laboratory.—XXXV, Effect of grass on apple trees, A. N. RAWES and F. J. CHITTENDEN (*Jour. Roy. Hort. Soc., 45 (1919), No. 1, pp. 116-119*).—Data secured from a demonstration plat at Wisley are given with a view of showing the injurious effect of starting fruit trees in grass. The experimental plat was started in January, 1912, a portion of the trees being grown in turf, a portion with a 3-foot circle of bare soil about the stems of the trees, and another portion clean cultivated.

During the period 1912-1919 the growth of the trees with bare space about them has been consistently greater than that of the trees with grass up to their stems, but this growth has been exceeded in a marked measure by the trees in cultivated ground in every case in every year. There is a marked contrast between the color of the foliage of the trees in the cultivated ground and of those with grass about them, the latter being such more yellow in tinge. The few fruits produced on the latter trees have been on the whole smaller than the many fruits on the former trees.

The treatment of apple trees girdled by mice, E. M. STODDARD (*Connecticut State Sta. Bul. Inform. 10 (1920), pp. 7, figs. 8*).—The method of bridge-grafting apple trees that have been girdled by mice is described and illustrated. Methods for the prevention of girdling are also discussed.

Profitable apples for market (*Min. Agr. and Fisheries [London], Leaflet 134, rev. (1920), pp. 7*).—Descriptions are given of the chief varieties of apples which succeed in most locations in England, together with brief cultural notes.

Factors influencing the keeping qualities of apples and pears, E. L. OVERHOLSER (*West. Fruit Jobber, 7 (1920), No. 1, pp. 21-25*).—A contribution from the University of California, comprising an enumeration with brief discussion of various factors influencing the keeping qualities of apples and pears.

A summary of the results obtained in selecting and propagating Paradise stock, R. G. HATTON (*East Malling, Eng.: Wye Col. Fruit Expt. Sta., 1919, pp. 15, pls. 8*).—Work conducted at the Fruit Experiment Station of Wye College, East Malling, has shown the existence of a wide range of root systems of very different vigor and desirability that are generally classed as Paradise stock. In part 1 of this paper the various types observed are classified and described and discussed with reference to their relative merits. In part 2 the results are given of experiments in methods of propagating the most desirable types of Paradise stock.

Experimental dusting and spraying of peaches for 1919, W. W. CHASE (*Ga. State Bd. Ent. Circ. 30 (1920), pp. 13*).—Comparative dusting and spraying experiments were conducted near Fort Valley, Ga., in 1919 by the State Board of Entomology on a plat of about 1,200 8-year-old Elberta trees. The data secured are tabulated and discussed, and suggestions are given to growers relative to the principal factors responsible for unsuccessful results in commercial dusting operations during 1919.

The data secured from the spraying tests showed that dust mixtures of sulphur-lead arsenate in the right proportion effect as good control of brown rot as spraying with a combined insecticide and fungicide in water. They were far superior to the liquid spray in scab prevention. Dust mixtures were not so effective as spray in controlling curculio in varieties that ripen as late as the Elberta, but the spray was also unsatisfactory in this respect.

The comparative weakness of dust against curculio is considered to be the present principal drawback of the method. In this connection, it is pointed out that curculio was unusually prevalent in 1919. Dusting was done only three times, and it is suggested that when curculio is abundant a fourth application not longer than two weeks before harvest might effect better control. A mixture containing 5 per cent lead arsenate gave about the same effectiveness against curculio as mixtures containing twice that quantity.

Experimental work is to be continued with the view of developing a spraying formula and schedule better adapted for curculio control.

The principal parasites of the peach, W. W. CHASE (*Ga. Bd. Ent. Bul. 57 (1920), pp. 45, pls. 11*).—A revised edition of Bulletin 43 of this series (E. S. R., 35, p. 447).

Fig cuttings and their proper preparation and treatment, I. J. CONDIT (*Fig and Olive Jour., 4 (1920), No. 8, pp. 11, 12*).—A contribution from the Forkner (Cal.) Fig Experiment Station. It comprises a discussion of some of the points essential for success in growing fig cuttings.

Caprifigs and caprification, I. J. CONDIT (*California Sta. Bul. 319 (1920), pp. 341-375, figs. 23*).—This bulletin presents the latest information relative to the caprification of Smyrna figs in California. The history of caprification in California is briefly sketched, and the fig fruit and its structure, the classes of figs, the seasonal crops of the capri fig trees, together with the life history and habits of the fig wasp (*Blastophaga grossorum*) are considered in detail. The author then discusses methods of caprification, varieties of capri figs, effects of caprification upon different varieties of figs, the caprification of common figs, and the cost of caprification. Analyses of caprifig and uncaprifig figs are included.

A non-splitting Smyrna fig and its history, G. P. RIXFORD (*Fig and Olive Jour.*, 4 (1920), No. 8, pp. 9, 16).—The variety here described originated from certain cuttings which were imported from Asia Minor by the author in 1882 and planted on the Stanford University ranch. The U. S. Department of Agriculture has propagated and distributed the variety, and its value has been fairly well determined, especially in the San Joaquin Valley. The author now proposes to name the variety "Stanford" in honor of the late Governor Leland Stanford, founder of Leland Stanford Junior University.

The Kadota fig, W. S. CLARK (*Los Angeles, Cal.: The Fig and Olive Jour.*, pp. 44, figs. 20).—A treatise on the origin, planting, and care of this California fig variety.

The hybrid bearing grapes in 1919, E. PÉE-LABY (*Rev. Vitic.*, 52 (1920), No. 1338, pp. 131-134).—Notes are given on a number of direct-bearing hybrid grapes which, after several years of testing, have been found to possess real merit.

The table raisin hybrids, PÉE-LABY (*Vie Agr. et Rurale*, 16 (1920), No. 19, pp. 325-327).—Descriptive notes are given on a number of Franco-American grape hybrids that have been found to produce desirable table grapes.

Some observations concerning pollination of olives, L. O. BONNET (*Fig and Olive Jour.*, 4 (1920), No. 12, p. 4).—A contribution from the University of California discussing some of the causes of crop failure among olives, and giving the results for the first year of pollination experiments conducted at Pomona. These results strongly indicate that most olive trees bear better when cross-pollinated. They also indicate that as a rule large varieties of olives are more fertile than the smaller varieties.

A preliminary revision of the North American and West Indian avocados (*Persea* spp.), S. F. BLAKE (*Jour. Wash. Acad. Sci.*, 10 (1920), No. 1, pp. 9-20, figs. 2).—A contribution from the Bureau of Plant Industry, of U. S. Department of Agriculture, comprising a preliminary treatment of the relationship of the forms of the avocados which occur in Mexico, Central America, and the West Indies. The present revision is based upon material collected for several years by W. Popenoe.

The conservation and application of manures, A. D. SHAMEL (*Cal. Citrogr.*, 5 (1920), No. 7, pp. 213, 240-243, figs. 3).—A discussion of the utilization and application of manures for improving citrus orchard soil conditions in southern California, including some data secured from the California Fruit Growers' Exchange showing the extent to which manures are used in citrus orchards at the present time.

Results of five years' individual tree performance records with pruned and unpruned lemon trees, A. D. SHAMEL (*Cal. Citrogr.*, 5 (1920), No. 4, pp. 102, 122, 123, 128, figs. 3).—Observations were made on the yield of a number of Eureka lemon trees that had been injured by low temperature during the winter of 1912-13 and were subsequently pruned back to assist in their recovery. Some of the trees were severely pruned, others received moderate pruning, and others were left unpruned for the sake of comparison.

The results, in general, show that heavily-pruned trees produce considerably less fruit than lightly-pruned trees, and that lightly-pruned trees produce less fruit than unpruned trees without appreciably improving the commercial quality of the fruit. The fruits on the pruned trees grew more rapidly than the fruits on the unpruned trees. The author concludes in general that care must be taken to avoid too great a reduction in the bearing area of lemon trees. On the other hand, a certain amount of pruning seems justifiable because the fruit can be brought up to size more rapidly.

The planting, cultivation, and expression of coconuts, kernels, cacao, and edible vegetable oils and seeds of commerce, H. O. NEWLAND (*London: Charles Griffin & Co., Ltd., 1919, pp. 111, pls. 12*).—A small practical handbook for planters and others. Among the crops considered are the coconut, the peanut, shea nut, cacao bean, soy bean, cottonseed, sesame, Babassu, and Paraguay kernels, and miscellaneous nuts.

The American nut industry as a whole, C. A. REED (*Amer. Nut Jour., 12 (1920), No. 5, pp. 70, 71*).—A paper presented before the Western Walnut Growers' Association, in which the author briefly reviews the present status of nut growing in various sections of the country and enumerates a number of points of practical importance in the development of a national nut industry.

Patch-budding large limbs and trunks of pecan trees, J. A. EVANS (*Texas Sta. Circ. 20 (1920), pp. 3-7, figs. 2*).—The method of patch-budding pecan trees is described and illustrated.

[Plants suitable for Nebraska] (*Ann. Rpt. Nebr. State Hort. Soc., 50 (1919), pp. 84-111, figs. 6*).—A variety list is given of fruits suitable for planting in Nebraska, arranged according to the horticultural districts of the State, together with lists of forest trees, ornamental trees, shrubs, roses, vines, bulbs, and hedges for general planting in the State.

Blending colors in flowers, W. H. PHIPPS (*Flower Grower, 7 (1920), No. 5, p. 76, fig. 1*).—A discussion of this subject, including a color chart, prepared by the author, showing the primary colors that enter into various combinations of named colors and hues.

Seedling daffodils selected to grow on at Brodie Castle, I. BRODIE (*Jour. Roy. Hort. Soc., 45 (1919), No. 1, pp. 113-115*).—Brief notes are given on the character of seedlings resulting from a large number of crosses, together with a list of parent forms believed to be desirable for the beginner.

Germination of gladiolus seed, C. E. F. GERSDORFF (*Flower Grower, 7 (1920), No. 5, p. 73*).—The author here presents records of seed tests procured mostly from his own crosses, showing the time required for germination, the percentage of germination, and the percentage of corms harvested.

The time required for different lots of seed to germinate was not constant. Some of the seed germinated as early as the sixteenth day after planting, most of it germinated in 31 days, whereas a few lots required up to 85 days. The average percentage of germination was 60 per cent and the average percentage of corms harvested was 30, based on the total number of seeds planted.

Some of the newer peonies, W. F. CHRISTMAN (*Flower Grower, 7 (1920), No. 5, pp. 79-81, figs. 3*).—The author presents a descriptive list of a large number of what are considered the very best of the new peonies being propagated at the present time. In addition to the description of the variety, information is given relative to the originator and the year in which it was introduced, or is to be introduced, to the public.

Oriental poppies at Wisley, 1917 (*Jour. Roy. Hort. Soc., 45 (1919), No. 1, pp. 120-124*).—Data are given on a test of 80 stocks of oriental poppies conducted at the Wisley gardens.

Descriptive list of hardy and semihardy primulas, H. J. MOORE (*Gard. Chron. Amer., 24 (1920), No. 1, pp. 401, 402*).—Horticultural descriptions are given of 15 species and 7 standard varieties of primulas tested at the Queen Victoria Park, at Niagara Falls, Ontario. Although not all are entirely hardy, many beautiful kinds are with little protection so hardy that they survive the winter practically unharmed.

About roses, A. C. HOTTES (*Ohio Agr. Col. Ext. Bul., 15 (1919-20), No. 5, pp. 16, figs. 11*).—A popular treatise on the propagation, culture, and care of roses, including descriptions of some of the principal varieties in each group of roses.

FORESTRY.

The oak hornbeam woods of Hertfordshire, I-IV, E. J. SALISBURY (*Jour. Ecology*, 4 (1916), No. 2, pp. 83-117, pls. 2, figs. 5; 6 (1918), No. 1, pp. 14-52, figs. 2).—This paper is based chiefly upon detailed observations made during the past 5 years upon most of the more important woods in Hertfordshire. Information is given relative to the history and status of these woods, as well as to their climatic, edaphic, and light conditions and the existing flora of both uncoppiced and coppiced woods.

On the causes of failure of natural regeneration in British oakwoods, A. S. WATT (*Jour. Ecology*, 7 (1919), No. 3-4, pp. 173-203).—Results are given of a study of natural regeneration in different types of British oakwoods.

The author found that, aside from the destruction to acorns by herbivorous animals, mildew was an important factor in producing fatal effects on oak seedlings, especially in sandy soils. There were generally no inherent difficulties to prevent natural regeneration in damp oakwood, but in dry oakwood and oak birch-heath associations the supply of light to the seed beds was greatly diminished by the presence of bracken and the vitality of the seedlings impaired, thus materially assisting the fungus in its fatal effects.

The resin usufruct of the pine, L. SCHIERLINGER (*Naturw. Ztschr. Forst u. Landw.*, 17 (1919), No. 10-12, pp. 281-365).—A contribution from the Munich Forestry Experiment Station comprising a discussion of the factors governing the formation and flow of resin, together with the results of experimental tapping studies and practical recommendations for turpentine operations based on these studies.

Revision of the true mahoganies (Swietenia), S. F. BLAKE (*Jour. Wash. Acad. Sci.*, 10 (1920), No. 10, pp. 286-297, figs. 2).—A revision of the four previously determined species of *Swietenia*, together with a new species here described and named by the author as *S. cirrhata* n. sp.

Studies in the ecology of tropical rain forest, with special reference to the forests of South Brazil, R. C. MCLEAN (*Jour. Ecology*, 7 (1919), Nos. 1-2, pp. 5-54, pl. 1, figs. 22; 3-4, pp. 121-172, figs. 10).—The study here reported was conducted with a view to measuring the factors of moisture and illumination in the interior of the forests on the slopes of the hills and in the valleys around about Rio de Janeiro and southern Brazil, and to determine the influence of these factors on the undergrowth plants, morphologically and otherwise. Part 1 reports studies dealing with the factor of humidity and part 2 with that of illumination. Important facts brought out relative to the physiological status of the undergrowth are presented in a general summary. A descriptive ecology of the forest and a bibliography are appended.

Report of the division of forestry (War Dept. [U. S.], Ann. Rpt. Governor P. R., 19 (1919), pp. 701-703).—A brief statement of operations thus far conducted by the Porto Rico Forest Service, which was created on November 22, 1917.

Annual report on the forest administration in Ajmer-Merwara for the year 1918-19, SHAMBHOO DAT JOSHI (*Ann. Rpt. Forest Admin. Ajmer-Merwara, 1918-19, pp. 30*).—The usual report relative to the administration and management of the State forests of Ajmer-Merwara for the year 1918-19. Data relative to alterations in forest areas, forest surveys, working plans, forest protection and miscellaneous work, yields in major and minor forest products, revenues, expenditures, etc., are appended in tabular form.

The forests of Greece, J. MASSIAS (*Rev. Eaux et Forêts*, 57 (1919), No. 11, pp. 237-247).—An account is given of the forests of Greece, with reference to their

extent, distribution, composition, production, administration, and exploitation, and the laws dealing with forestry.

The lumber market in Italy and reconstruction requirements, N. C. BROWN (*U. S. Dept. Com., Bur. Foreign and Dom. Com., Spec. Agents Ser., No. 182 (1919), pp. 184, pls. 15, figs. 18*).—A report on the lumber market in Italy and the requirements for the next 5 or 10 years for reconstruction purposes, based on a study conducted by the Department of Commerce in cooperation with various lumber associations. An account is given of the general and economic conditions governing the use of lumber, foreign lumber requirements, methods of purchase, sale, distribution, etc., domestic production and its influence on imports, lumber exports, uses and treatment of lumber, special features affecting imports of lumber, and the probable trend of Italy's import trade in lumber.

DISEASES OF PLANTS.

Plant disease and the "vicious circle," J. B. HURRY (*Jour. Roy. Hort. Soc., 43 (1919), No. 2-3, pp. 309-315, fig. 1*).—This is a discussion of the perpetuation of disease (with favorable factors), the destruction of organs, the termination of life, and the production of materials favorable to the development of disease organisms.

Studies on plant cancers.—I, The mechanism of the formation of the leafy crown gall, M. LEVINE (*Bul. Torrey Bot. Club, 46 (1919), No. 11, pp. 447-452, pls. 2*).—Having supposedly shown in work with Levin (*E. S. R., 42, p. 841*), that certain leafy shoots claimed by Smith as a new type of crown gall are always secondary and subsequent to the development of crown gall, and that such development of such tissue into an organ does not occur in animal cancer, the author has followed up the idea that, as a consequence of Smith's claim, *Bacterium tumefaciens* inoculated into a plant in any region of totipotent cells (bud Anlage) known to produce leafy shoots normally should produce them under the added stimulus of the crown gall organism much more readily and in greater abundance. The studies carried out following this hypothesis are briefly indicated.

It was found that *B. tumefaciens*, inoculated into the marginal notches of a leaf of *Bryophyllum calycinum* where totipotent cells are present, results in the formation of a crown gall as readily as in other plants used for inoculation but without leafy shoots. Inoculation in the vicinity of a small bud causes the formation of a gall and interferes with the normal development of the bud or leafy shoot. Inoculation into the midvein of a young or old leaf detached from or attached to the mother plant results in the development of a large gall without the development of leafy shoots. Inoculation into the growing region of the stem of a young plant produces the ordinary crown gall with the occasional and subsequent development of a leafy shoot. Therefore the author claims *B. tumefaciens* does not cause the formation of leafy shoots in *B. calycinum*, but rather inhibits and retards their normal development when inoculated into the totipotent cells which appear at the leaf notches.

Swedish species of Taphrina, B. PALM (*Arkiv. Bot., 15 (1917), No. 4, pp. 1-41, figs. 9*).—An account is given with a bibliography of a considerable number of species of the genus *Taphrina* as found in Sweden (other localities also indicated), some of these being in parasitic relation with plants of economic importance.

Head smut of corn and sorghum, B. F. DANA and G. L. ZUNDEL (*Washington Sta. Pop. Bul. 119 (1920), pp. 6, figs. 4*).—A popular description is given of the head smut of corn and sorghum due to *Sphacelotheca reiliana*, which, it is

stated, has made its appearance in the vicinity of Pullman, Wash., in one case causing 40 per cent loss in the corn crop. Contrasts in characters are drawn up for the head smut and the common corn smut by which the new form can be readily recognized, and suggestions are given for control measures which include the destruction of diseased plants at the first appearance of smut and the elimination of other susceptible crops in rotation.

Report of the conference on sweet potato problems and on diseases of cotton, corn, and tomatoes (Washington: Advisory Bd. Amer. Plant Path., Amer. Phytopath. Soc., 1919, pp. 16).—At this conference (consisting of 46 persons who are listed as representing 13 States and the U. S. Department of Agriculture), which was in session at Birmingham, Ala., February 26–28, 1919, sweet potato problems were divided into those pertaining to field, storage, and marketing, respectively. Cotton diseases dealt with included wilt (*Fusarium vasinfectum*), anthracnose (*Glomerella gossypii*), angular leaf spot (*Bacterium malvacearum*), and Diplodia boll rot (*Diplodia gossypina*). Corn diseases were divided into root disease, *Fusarium* spp. largely, and brown spot (*Physoderma zea maydis*). Tomato diseases included Fusarium wilt (*F. lycopersici*), early blight (*Alternaria solani*), mosaic, blossom end rot, and Septoria leaf blight (*S. lycopersici*). A résumé is given of the discussion on the diseases and subjects relating thereto.

Additions to the list of plant diseases of economic importance in Indiana, G. A. OSNER (*Proc. Ind. Acad. Sci.*, 1917, pp. 145–147).—These additions to the lists furnished, respectively, by Pipal and the present author (E. S. R., 39, p. 547) represent collections made during the previous season and comprise diseases affecting about 17 economic plants.

Report on the work of the division of phytopathology [Mauritius], F. A. STOCKDALE (*Ann. Rpt. Dept. Agr., Mauritius, 1916, pp. 7, 8*).—No serious epidemics of fungus diseases occurred during the year, though the cyclone of May 26, causing serious damage to crops, favored attacks by fungi and bacteria during June. Sugar-cane root disease was reported as causing damage in one locality. Pithy deterioration of the stem was common in all Tanna varieties. Varying results were obtained from treatment of potato leaf disease (*Phytophthora infestans*) with Bordeaux mixture. A collar disease of pistache caused by a species of *Fusarium* was common in all parts of the island, but was controlled by dusting with a mixture of powdered copper sulphate and lime, the solution of the substances being effected by means of rain.

Pathological [report, Western Australia], D. A. HERBERT (*Dept. Agr. and Indus. West. Aust. Ann. Rpt. 1919, p. 29*).—The author reports the occurrence of various plant diseases. Among disorders of potatoes are mentioned Irish blight (*Phytophthora infestans*), wet rot or bacteriosis (*Bacillus solanacearum*), brown ring, Rhizoctonia rot, and nematodes. Scab may be produced locally either by some unfavorable soil constituent or by attacks of *Actinomyces chromogeneus*. Black rot somewhat resembles brown rot (*Fusarium solani*), the form having recently been identified for the first time locally, though apparently common.

Other economic plants are named in connection with diseases or attacking organisms, as apple, *Fusicladium dendriticum*; pear, *F. pirinum*; onion, downy mildew (*Peronospora schleideni*), and red root (of unknown causation); loquat, *F. dendriticum*; apricot, peach, and almond, shot hole (*Clasterosporium carpophilum*); orange, brown, rot, scab, melanose, corky tissue, sooty mold, exanthema, *Sphærella citri*, wither tip (*Phoma omnivora*); lemon, brown rot, wither tip (*P. omnivora*); wheat, take-all (*Ophiobolus graminis*), ear cockle, Septoria, smut, and rust; beet, eel-worm; red gum, a shelf fungus (*Polyporus*); rhubarb, root rot (*Armillaria mellea*); Freesia (*Heterosporium gracile*); alfalfa, root

fungus (*Rhizoctonia violacea*); vines, anthracnose and Oidium; cabbage, club root; and tomato, Irish blight, sleeping sickness, and *Septoria lycopersici*.

Plant pathology [New Zealand, 1918-19], A. H. COCKAYNE (*New Zeal. Dept. Agr., Indus., and Com. Ann. Rpt. 1918-19, pp. 41, 42*).—It has been shown that a fungus attacking young rootlets of flax causes destruction of the plants only when they have been weakened by adverse soil conditions. The peculiar feature noted for two seasons is the recovery of affected plants during the late autumn and winter followed by a recrudescence or return of the disease during the following summer. Artificial manures do not appear to have any marked effect on young leaf.

Dry rot of swedes, which is becoming very destructive, is being studied. Certain rapidly acting manures, as superphosphate, apparently increase the disease. Swedes growing slowly appear to suffer less than those which grow rapidly. Inoculation experiments have shown that swede dry rot is capable of infecting all classes of turnips and swedes.

A new species of Botrytis has been shown to cause rapid rotting of apples, especially from the eye end. Spores of the fungus appeared to be incapable of causing infection.

Grass rusts of unusual structure, J. C. ARTHUR and E. B. MAINS (*Bul. Torrey Bot. Club, 46 (1919), No. 10, pp. 411-415, figs. 2*).—Comparisons as here drawn show especially striking resemblances among the tropical rusts *Uredo ignava* on Bambos, *Puccinia pallescens* on Tripsacum, and *P. phakopsoroides* on Olyra, the last-named being described as a new species. The telia of the first-named species have not been found, but they are expected to resemble those of the other two species.

Seed treatment [against stinking smut], H. C. MÜLLER and E. MOLZ (*Deut. Landw. Presse, 45 (1918), No. 82, p. 509*).—This is an account of comparative tests made in 1918 with a proprietary preparation for treating seed grain for protection against stinking smut.

Control of cotton anthracnose and improvement of cotton in North Carolina, R. A. JEHLE and R. Y. WINTERS (*Bul. N. C. Dept. Agr., 41 (1920), No. 2, pp. 14-28, figs. 5*).—Work done by the authors and cooperating county agents shows that cotton anthracnose or boll rot, probably the most destructive local cotton disease, occurs in every part of the State where cotton is grown, causing more or less damage to the cotton crop every year. An account is given of the first appearance and subsequent progress of the disease, and injury caused thereby in the State. This disease is sometimes confused with the bacterial boll rot.

Control of cotton anthracnose is based upon the fact that the causal fungus may live at least one year in the soil on decaying fragments of cotton plants, and the second fact that seed from diseased bolls are almost certain to become infected. The corresponding control measures are rotation and careful management of seed at public gins. Seed improvement measures are dealt with in some detail.

Control of cotton wilt, R. A. JEHLE (*Bul. N. C. Dept. Agr., 41 (1920), No. 2, pp. 5-13, figs. 6*).—It is stated that cotton wilt, unlike anthracnose, is not distributed all over the State, but is limited to certain localities, sometimes even to certain farms. It is most prevalent and destructive in the coastal plains region of the State, being present in 22 counties. A fungus causing the wilt disease lives in the soil and is spread by agricultural implements, the feet of men and animals, and running water. It is usually more destructive and prevalent during the wet season, as the cotton plant is less able to resist the wilt during the period of rapid growth. The most uniformly satisfactory results as regards resistance is given by the variety Dixie, which is described. Wilt

can not be controlled by fertilizers or fungicides, and the presence of root knot or big root deprives even Dixie cotton of its power of resistance. An account is given of work in progress on control measures in several counties.

Bacterial wilt of cucurbits, F. V. RAND and E. M. A. ENLWS (*U. S. Dept. Agr. Bul. 828 (1920), pp. 43, pls. 4, figs. 10*).—In continuation of previous studies (*E. S. R.*, 35, p. 546), the results of more recent investigations are given, the present paper dealing with the relation of soil and insects to the distribution and control of the wilt due to *Bacillus tracheiphilus*.

Investigations have shown that the striped cucumber beetle (*Diabrotica vittata*) and the 12-spotted cucumber beetle (*D. duodecimpunctata*) are both summer carriers and probably the only means of summer transmission of the cucurbit wilt in the localities studied. Infection through the breathing pores of the plant is said not to occur, and introduction of virulent bacteria into the interior of the plant tissues is necessary for infection. It is claimed that the bacterial wilt of cucurbits does not winter-over in the soil and all seed tested have given negative results, indicating that the disease is not seed-borne. Considerable evidence has been obtained which indicates that the cucumber beetle acts as a winter carrier.

In studying various isolations of *B. tracheiphilus* in different hosts and localities, the authors found a tendency on the part of highly or weakly virulent organisms to reproduce their respective strains. Many, though not all, isolations of organisms highly virulent to cucumbers were found capable of infecting squashes to a greater or less degree. Cucumbers were found the most susceptible host species and watermelons the most resistant. Cantaloups are slightly more resistant than cucumbers, while the squash group stands next to watermelons in order of resistance.

Where the disease is likely to be severe, the authors recommend spraying with a 4:5:50 Bordeaux mixture to which 2 lbs. of lead arsenate powder has been added. Pulling the wilted vines during the early part of the season or as long as can be done without injuring the growth of the remaining plants, it is claimed, will also assist in controlling bacterial wilt. Where only a few plants are grown, as in garden plats, screening the hills with mosquito netting will prevent the appearance of the disease through the protection afforded from the beetles. For control in greenhouses, beetles should be kept out if possible, but if they gain entrance to the house hand picking is considered to be the only remedy to be recommended unless some fumigant can be found that will kill the beetles without injuring the cucumber plants.

[**Potato diseases, British Isles**] (*Gard. Chron.*, 3. ser., 66 (1919), No. 1706, p. 130).—Owing to the presence of potato wart disease in Montgomeryshire and Denbighshire, the Board of Agriculture certified the whole of these counties as infected areas, effective January 1, 1920. Permissible exceptions as regards planting are indicated.

Blackleg disease of potato is reported as spreading in connection with certain seed varieties in all parts of England and Wales, causing serious losses.

Wart resistant potatoes at Wisley, 1917 (*Jour. Roy. Hort. Soc.*, 43 (1918), No. 1, pp. 114-122).—The continued spread of potato wart disease, *Synchytrium endobioticum* (*Chrysofhyctis endobiotica*), giving rise to fears that the whole country may become infected, has stimulated experimentation looking to the development of resistant varieties. Descriptions are given of approximately 50 varieties more or less resistant, here classed as early, second early, and main crop or late varieties.

Diseases of flue-cured tobacco, F. A. WOLF and E. G. MOSS (*Bul. N. C. Dept. Agr.*, 40 (1919), No. 12, pp. 5-45, figs. 24).—This account, prepared primarily for the information of the grower, deals with tobacco wilt (*Bacterium*

solanacearum), root knot (*Heterodera radicolica*), root rot (*Thielavia basicola*), sore shank (*Rhizoctonia solani*, *Corticium vagum*), mosaic, frencing, wildfire (*B. tabacum*), angular leaf spot (*B. angulatum*), common leaf spot, frog eye (*Cercospora nicotianæ*), and crookneck.

Control of late blight of tomatoes in the Blue Ridge mountains, R. A. JEHLÉ, J. W. GOODMAN, and J. W. LINDLEY (*Bul. N. C. Dept. Agr.*, 40 (1919), No. 11, pp. 3-16, figs. 7).—Late blight as reported in North Carolina appears to be practically limited to the mountainous part of the State, being most destructive and prevalent in elevations above 2,000 ft. and increasing upward in this respect. It has been known in Avery and Mitchell Counties for more than 15 years, causing much injury. Attempts at control have been in most cases wholly or partially unsuccessful. Characteristics of the disease, which is caused by *Phytophthora infestans*, are described.

An account is given of work conducted in the two counties above mentioned. It has been found that late blight is controlled by spraying thoroughly with a 5:5:50 Bordeaux mixture every 10 days or 2 weeks, beginning as soon as the plants start growth after transplanting, and continuing during the season. The addition of 2½ lbs. of resin fish oil soap to the Bordeaux mixture gave increased yields only when *Septoria* leaf spot was present. Spraying is facilitated by staking the plants or tying them to some support.

Some fungus diseases of fruit trees, H. WORMALD (*Fruit, Flower, and Veg. Trades' Jour.* [London], 36 (1919), Nos. 25, pp. 679, 681, fig. 1; 26, pp. 705, 707, figs. 3; 37 (1920), Nos. 1, p. 5, figs. 3; 2, pp. 33, 35, figs. 2).—Besides a general discussion of fruit-tree diseases and remedies, the author gives a more particular account of apple and pear black spot or scab, *Venturia pomi* (*Fusicladium dendriticum*); apple mildew (*Podosphara leucotricha*); apple canker (*Nectria ditissima*); brown rot diseases, *Monilia* (*Sclerotinia*) *fructigena* and *M. cinerea*; silver leaf disease (*Stereum purpureum*); American gooseberry mildew (*Sphaerotheca mors-uvæ*); European gooseberry mildew (*Microsphaera grossulariæ*); die-back of gooseberry bushes, *Botrytis cinerea* (*Sclerotinia fuckeliana*); cherry leaf scorch (*Gnomonia erythrostoma*); peach leaf curl (*Exoascus deformans*); and crown gall (*Bacterium tumefaciens*).

The brown rot diseases of fruit trees, with special reference to two biologic forms of *Monilia cinerea*, II, H. WORMALD (*Ann. Bot.* [London], 34 (1920), No. 134, pp. 143-171, pls. 2).—An account is given of experimentation showing that the two biological forms of *M. cinerea* can be distinguished in the laboratory by the employment of biochemical methods. There is also a discussion of the value of the application of cultural methods in taxonomy, as illustrated by certain distinguishing characters exhibited by *M. fructigena*, *M. cinerea*, and an American form of *Monilia* when grown in pure cultures. It is claimed that there are in Britain two species of *Monilia* parasitic on *Pyrus* and *Prunus*, namely, *M. (Sclerotinia) fructigena* and *M. cinerea*, the distinguishing characteristics, occurrence, and behavior of which are discussed.

The destruction of *Ribes* by chemical means, W. S. REGAN (*Amer. Plant Pest Com. Bul.* 4 [1919], p. 12).—Study during three years of various chemicals for killing currant and gooseberry bushes has been made in the effort to find a cheaper means of destroying these plants than hand pulling. Fuel oil and dip oil have given good results, which are outlined in connection with a brief account of the treatment.

"Die-back" of the fig in California, I. J. CONDIT and H. J. STEVENS (*Fig and Olive Jour.*, 4 (1919), No. 4, pp. 11, 12).—Within the last two or three years, reports have been made in California of a peculiar die-back of the fig tree, appearing in the spring as the young shoots begin to push out.

During 1916 this condition was quite noticeable in orchards near Fresno and Merced, also in Los Angeles County. Two forms of this trouble are described in connection with their effects on the limbs. The disease has been thought to be caused by *Botrytis*. The present authors consider it more likely that the tree, slightly weakened by *Botrytis*, was rendered more susceptible to sunburn and to the attacks of other diseases which later caused its destruction. Just how the fungus enters the fig limb has not been thoroughly worked out. Very little is known regarding the *Sclerotinia libertiana* phase of the die-back. An account is given of laboratory studies on the organism.

Bud abortion—twig and leaflet drop of the orange—its possible relation to June drop, P. A. BONCQUET (*Cal. Citrogr.*, 4 (1919), No. 12, pp. 346, 347).—Study of June drop during two years has shown the coincident presence of a bud abortion of all kinds of orange trees, the navel orange being the most severely attacked. Twigs attacked, ranging from 5 mm. to 5 cm. in length, readily drop on being touched. Such an occurrence is frequently followed by double budding; the new buds may abort and a sickly twig die and drop. Late spring wood is usually affected, but it is sometimes found on the beginning fall growth. Apparently June drop is checked by use of Bordeaux mixture.

A new disease of coffee, W. J. DOWSON (*Brit. East Africa Dept. Agr., Div. Mycol. Leaflet 1* (1917), pp. 4).—A new disease made its appearance on coffee in 1917 in the Nairobi area and also up country. The trouble was found to be widespread following considerable rain.

The youngest apical leaves of the tree or those of a young primary near the top blacken and shrivel. The stalks and shoots show a dark discoloration in the interior. The disease appears to be caused by a species of *Phoma*. An account is given of the physiological effects, mode of infection, and appropriate remedial measures.

Trees showing early stages of the disease can be saved by topping them well below the discolored cortex. Trees in which the stems appear dead for a considerable distance can be saved by stumping within 8 in. of the ground. In cases in which the discoloration has come near the ground level the trees can not be saved. All trees which have been saved and adjacent trees should be sprayed with Bordeaux mixture at a 2:4:40 strength. Overbearing should be prevented. Precautionary spraying just before the commencement of the rains is recommended in order to kill the spores of *Phoma* and *Hemileia*.

Root diseases of the tea plant caused by fungi, C. BERNARD and B. PALM (*Dept. Landb., Nijv. en Handel [Dutch East Indies], Meded. Proefsta. Thee, No. 61* (1919), pp. 41).—This account is bibliographical and largely descriptive, indicating a number of causal organisms. *Ustilina zonata* forms the subject of the last chapter.

Experiments on the control of eelworm disease of Narcissus, J. K. RAMSBOTTOM (*Jour. Roy. Hort. Soc.*, 43 (1918), No. 1, pp. 65-78).—The author concludes that the preventive method which promises best results is that of soaking the bulbs for a period of 2 to 4 hours in water at a constant temperature of 110° F. It is believed that this will afford an economical means of combating the disease. Of course, such treatment will not prevent attack by nematodes present in the soil.

Mildew-resistant roses: With some suggestions as to increasing their number, W. EASLEA (*Jour. Roy. Hort. Soc.*, 43 (1919), No. 2-3, pp. 253-260).—A general discussion of rose varieties more or less resistant to mildew is followed by a classified list of such varieties.

Specialization of Peronospora on some Scrophulariaceæ, E. GÄUMANN (*Ann. Mycol.*, 16 (1918), No. 1-2, pp. 189-199, figs. 6).—An account is given of

Scrophulariaceæ, mainly species of *Veronica*, attacked by *Peronospora* spp., with developmental curves and descriptive accounts of the supposedly new species *P. agrestis*, *P. verna*, *P. arvensis*, *P. palustris*, *P. saxatilis*, *P. silvestris*, and *P. aquatica*.

The white pine blister rust situation (*Forest Leaves*, 17 (1919), No. 2, pp. 25, 26).—This contains a résumé of the report of the American Plant Pest Committee as previously noted (E. S. R., 41, p. 350) and a summary given by Metcalf (E. S. R., 41, pp. 352, 659) of the situation as existing at the time in the United States and in Canada.

White pine blister rust control in 1919, S. B. DETWILER (*Amer. Plant Pest Com. Bul.* 4 [1919], pp. 1-3).—The Fifth Annual International Blister Rust Conference was held at Albany, N. Y., December 8-9, 1919, under the auspices of the American Plant Pest Committee (E. S. R., 41, pp. 350, 351). Foresters and pathologists representing the New England States, New York, Pennsylvania, Wisconsin, Minnesota, and Canada were present.

In a summary of the report of this body it is stated that experiments conducted on an extensive scale since 1916 show that white pine blister rust can be controlled locally by destroying wild and cultivated currant and gooseberry bushes within a comparatively short distance of the pines, 200 to 300 yds. being sufficient to prevent serious damage under average forest conditions. This reduction of 50 per cent in the minimum width of the safety zone hitherto recommended is based on four years' scientific and practical field studies.

Unskilled laborers can be quickly taught to remove at least 95 per cent of the wild currant and gooseberry bushes in going over the ground once. Wild currants and gooseberries do not reproduce rapidly in an area that has been worked by an efficient crew. Bushes missed by the crews are usually small plants growing in underbrush, having less leaf surface than the average plant and causing proportionately less damage. On four control areas worked in 1916-17 no new pine infections could be found in 1919. The cost per area of destroying these bushes has been considerably decreased.

Blister rust infection on pines in the Northeastern States is increasing rapidly. Timber owners in infected regions who permit currant and gooseberry bushes to grow within 200 to 300 yds. of the white pine suffer severe loss. Cultivated black currants are especially susceptible to blister rust, but all kinds will cause serious damages to pines. White pine blister rust has not been found in the western half of the United States or in western Canada, where wild currants and gooseberries are abundant.

Resolutions adopted by the Fifth International Blister Rust Conference, Albany, N. Y., December 8 and 9, 1919 (*Amer. Plant Pest Com. Bul.* 4 [1919], pp. 4, 5).—The conference urgently recommends the complete destruction of all *Ribes* within 200 to 300 yds. of native and planted white pines in regions where blister rust is present or dangerously near. The conference also recommends a vigorous campaign for planting white pine with proper precautions against infection, estimating the value of 5-needled white pines in North America in 1919 at \$605,000,000.

Summary by States and regions [of white pine blister rust work, 1919], S. B. DETWILER (*Amer. Plant Pest Com. Bul.* 4 [1919], pp. 6-10).—A condensed account is given on the same plan as that previously noted (E. S. R., 41, p. 351), of work done and the situation existing in each of the New England States and in New York, New Jersey, Pennsylvania, Maryland, Virginia, West Virginia, Minnesota, Wisconsin, Michigan, and other States in the Central West. The Rocky Mountain and Pacific Coast regions seem to be clear of white pine blister rust. Scouting has been continued in these regions since 1917. A *Cronartium*

found on *Ribes* in several States has been identified as *Cronartium occidentale*, the alternate stage of a Peridermium occurring on the piñon pine, but harmless to white pine. *Ribes* presents 65 species indigenous to western North America, showing a range of adaptation to nearly every site condition occurring in these regions, and furnishing unbroken chains for the dissemination of white pine blister rust. A summary is given of the *Ribes* eradication data in the Northeastern States during 1919.

Scientific research in 1919 [on white pine blister rust], P. SPAULDING (*Amer. Plant Pest Com. Bul. 4* [1919], pp. 10, 11).—Investigations during 1919 were carried out in a manner similar to those of the previous year (E. S. R., 41, p. 351), being conducted principally by H. H. York at North Conway, N. H., and L. H. Pennington at Lewis, N. Y.

York found that aeciospores may be blown apparently for a distance of 15 or 20 miles, and may be carried 5,000 ft. still remaining viable. Other data regarding the viability of spores are given from which it was concluded that the character of the vegetation intervening between the *Ribes* and pines and the climatic conditions are vital factors in the distance across which sporidia may communicate the disease.

Pennington found the general conditions in the Adirondack section not quite so favorable for the distribution of spores as they were in the White Mountain section. The amount of infection of pines depends upon weather conditions, being favored by cool, moist situations protected from winds. In general, the number of infections in pine varies directly with the amount of *Ribes* leaf surface and inversely as the square of the distance from *Ribes*. Investigations on the cutting out of infections in pines was started in 1917 by Posey and Gravatt, 96 infections being thus treated. It is said that where the cut was made at 1½ in. distant from the affected part, the disease has not again reappeared.

Unless the conditions are exceptionally favorable for transfer of spores, 200 or 300 yds. is a sufficient distance to prevent infection of the pines by spores from *Ribes*. The cultivated black currant (*Ribes nigrum*) seems to be the most dangerous species in this connection.

Overwintering by means of aeciospores in cankers on pines and also by urediniospores on infected *Ribes* leaves has been proved. Quantity of infection of pines depends to a great extent upon the volume of spores produced by the infecting currants. The efficiency of eradication of *Ribes* depends upon the relative reduction of *Ribes* leafage, upon which directly depends the quantity of spores given off to infect pines.

Artificial infection of pines with *Cronartium ribicola*, G. P. CLINTON and F. A. McCORMICK (*Amer. Plant Pest Com. Bul. 4* [1919], p. 12).—This is a report of results of artificial infection of pines along the same lines as reported previously by Clinton (E. S. R., 41, p. 352).

Successful inoculations have been made on more than 150 young pines, something like 10,000 distinct infections having been secured, showing conclusively that infection takes place through stomata of the leaves. The first visible sign of infection is a minute yellow spot centering over the lines of the stomata on the under side of the leaf. Under greenhouse conditions these become evident within three months after inoculation, infection occurring within 24 hours. Leaves less than two years old have been abundantly infected. Within the stomatal cavity of infected leaves the formation of a peculiar swollen body occurs, from which a single hypha runs downward and soon gives rise to relatively large sclerotial bodies. The mycelium then extends into the vascular bundle of the leaf, which it follows downward until it reaches the twig, progress being quite rapid under conditions favorable to plant growth.

Pinus excelsa, *P. flexilis*, *P. koraiensis*, *P. cembra*, *P. densiflora*, *P. austriaca*, *P. resinosa*, and *P. sylvestris* were inoculated without success. No infections developed beyond the pycnial stage upon any species except *P. strobus*, although early stages of infection have been secured upon *P. lambertiana* and the two pitch pines, *P. pinea* and *P. sabiniana*. Tests have not yet been made with the piñon pines, *P. edulis* and *P. monophylla*. Details of these experiments have, in part, been published previously (E. S. R., 42, p. 247).

ECONOMIC ZOOLOGY—ENTOMOLOGY.

The zoological record, D. SHARP (*Zool. Rec.*, 52 (1915), pp. VI+[743]; 53 (1916), pp. IV+[687]; 54 (1917), pp. IV+[590]).—These catalogues, which are in continuation of those previously noted (E. S. R., 36, p. 151), index the literature in the main part for the years 1915, 1916, and 1917, respectively, but include also entries for earlier years that were received too late for inclusion in the respective volumes.

Control of the coyote in California, J. DIXON (*California Sta. Bul.* 320 (1920), pp. 379-397, figs. 7).—A brief account is first given of the habits of the coyote, particularly as relates to means of control. The methods of destruction are then considered under the headings of trapping, poisoning with strychnine, digging out dens containing young, and shooting.

Rats and mice as enemies of mankind, M. A. C. HINTON (*Brit. Mus. (Nat. Hist.)*, Econ. Ser., No. 8 (1918), pp. X+63, pls. 2, figs. 6).—The several parts of this paper deal with rats, house mice, the balance of nature, and the protection of Carnivora, and the structure and classification of the Muridæ, with a key to British species. A table showing the rate of increase in rat population possible in 1918 and a list of 18 references to the literature are also given.

A synoptical list of the Accipitres (diurnal birds of prey), H. K. SWANN (*London: John Wheldon & Co.*, 1919, pt. 1, pp. 38; pt. 2, pp. 39-74).—Part 1 of this list of the diurnal birds of prey deals with Sarcorhamphus to Accipiter; part 2 with Erythrotriorchis to Lophoætus.

Contribution to the knowledge of the biology of the arvicole in Apulia, G. MARTELLI (*Bol. Lab. Zool. Gen. e Agr. R. Scuola Super. Agr. Portici*, 13 (1919), pp. 193-316, figs. 32).—This is a report of studies of meadow mice and means for their control in Apulia, Italy, where they are the source of considerable loss.

Birds and tent caterpillars, A. A. SAUNDERS (*Auk*, 37 (1920), No. 2, pp. 312, 313).—The author reports observations made at Norwalk, Conn., during the spring of 1917, which indicate that the tent caterpillars were destroyed while small by insectivorous migrant birds, the arrival of the birds being coincident with the disappearance of the tent caterpillar. Their attack of the tent caterpillar may have been due to the scarcity of other insect food during the spring, which was late and cold. A parula warbler (*Compothlypis americana usneæ*) and a yellow-breasted chat (*Icteria virens virens*) were actually observed in the act of eating the caterpillars. Numerous empty nests, with holes such as a bird would make with its beak, furnished evidence that the birds had destroyed the half-grown caterpillars in this way.

Second note on certain peculiar fungus-parasites of living insects, R. THAXTER (*Bot. Gaz.*, 69 (1920), No. 1, pp. 27, pls. 5).—This continuation of the work previously noted (E. S. R., 33, p. 556) includes descriptions of 6 genera and 13 species new to science.

Nineteenth report of the State entomologist for 1919, W. E. BRITTON (*Connecticut State Sta. Bul.* 218 (1919), pp. 113-208, pls. 24, figs. 5).—The first

part of this report consists largely of accounts of the inspection of nurseries, imported nursery stock, imported bulbs, and apiaries. This is followed by an account of the gipsy and brown-tail moth work in 1919, by I. W. Davis (pp. 135-144). The white-pine weevil (*Pissodes strobi* Peck), which causes more damage to young white pines in Connecticut than any of its enemies, is next considered, a summary being given of the present status of knowledge of this weevil (pp. 144-155). A number of parasites of this pest have been reared in Connecticut, including *Cocloides pissodis* Ashm., *Habrobraconidea bicoloripes* Viereck, *Microbracon nanus* Prov., *Eurytoma pissodis* Girault, and *Rhopalicus suspensus* Ratz. A reduction of the amount of injury caused by it may be accomplished by removing and destroying the infested leaders.

The pine-bark aphid (*Chermes pinicorticis* Fitch), which has been found throughout Connecticut, is considered at some length (pp. 155-160). It was attacked by a number of insects, including lady beetles, a syrphid larva, and a chrysopid. Experiments to control the chrysanthemum gall midge (*Diarthronomyia hypogæa* Loew) are described by M. P. Zappe (pp. 161-165). The results obtained indicate that the pest is best attacked while it is still in the egg stage, or shortly afterward before the young larvæ are entirely within the leaf. Scalecide killed all eggs and young larvæ, but injured the foliage. Nicotin sulphate, 40 per cent, and soap, applied every 3 or 4 days, will control it.

A summary of information is given on the green clover worm (*Plathypena scabra* Fabr.) on beans (pp. 165-170). An outbreak of this worm occurred during the year 1919, and bean plants in nearly all parts of the State were suddenly riddled. The injury is caused by the larvæ which eat irregular holes in the leaves. Applications of arsenate-of-lead paste, 1 oz. to 1 gal. of water, caused destruction of all larvæ present, and only a few were living on the rows treated with blackleaf 40, 1 teaspoonful to 1 gal. water, with 1 oz. of laundry soap.

The present status of the European corn borer in the United States is briefly discussed (pp. 170-173). A native borer attacking corn (*Pyrausta ainsliei* Heinrich), a description and brief account of which by Heinrich has been noted (E. S. R., 42, p. 361) is next considered at some length (pp. 173-180). In examinations of the corn fields for the European corn borer (*P. nubilalis* Hubner) at Milford, a form later determined to be *P. ainsliei* was found on March 12. In investigations made from March 27 to May 10, this species was found in corn stalks in a number of towns, including Wethersfield, Cromwell, Middletown, Rocky Hill, Stratford, Orange, Woodbridge, and Hamden, and in New Haven. In nearly all of these towns the stalks of smartweed (*Polygonum*) in the corn fields contained the larvæ. *P. ainsliei* is said to occur throughout the eastern United States, from Massachusetts as far south as Tennessee and in Missouri, Kansas, and Illinois. No injury by it to tassels or ears was observed. Its injury to corn, so far observed in Connecticut, has not been of such extent or character as to indicate that control measures are necessary.

A brief account is next given of the common stalk borer (pp. 180-183), which is present every year in Connecticut and infests a large number of plants. A tachinid parasite reared from it has been determined as *Masicera myoidea* Desv. *Crambus præfectellus* Zinck is said to have injured corn in the vicinity of New Haven by boring into the side of the stalk near its base (pp. 183-185). The army worm appeared in considerable numbers in one locality. The smeared dagger moth [(*Apatela*) *Acronycta oblongata* S. & A.] was found feeding on corn at Brooklyn in July. The lined corn borer (*Hadena semicana*

Walk.) was found in corn fields at Farmington on June 16. and at Bloomfield on July 19. Brief reference is made to the occurrence of the bollworm and its injury to corn in Connecticut; also to several other insects attacking corn in 1919 including *Anaphothrips striatus* Osborn and (*Thrips*) *Plesiothrips perplexus* Beach, wireworms, and several noctuid caterpillars.

The parsnip web worm (*Depressaria heracliana* Linn.) was collected at Danbury where it was causing some injury. The mosquito work in 1919 is reported upon B. H. Walden (pp. 193-198). The report concludes with miscellaneous notes on some 20 different insect pests.

A reference list of the literature accompanies most of the accounts.

Division of insect suppression.—Plan and progress of work, 1917-18, W. C. O'KANE (*N. H. State Dept. Agr., Div. Insect Suppr. Circ. 12 [1919], pp. 22, pls. 6*).—This report for the biennium ended August 31, 1918, includes accounts of and maps showing the colonization of insect enemies of the gipsy and brown-tail moths, namely, *Anastatus bifasciatus*, *Schedius kuvanæ*, *Calosoma sycophanta*, *Compsilura concinnata*, *Apanteles lacteicolor*, etc.

Notes in connection with insect pests, F. WATTS (*West Indies Imp. Dept. Agr., Brit. Virgin Islands Agr. Dept. Rpt., 1918-19, pp. 7, 8*).—These notes relate to the leaf blister mite (*Eriophyes gossypii*); the cotton worm, which appeared in large numbers late in the season; a large longicorn beetle (*Batocera rubus*), which appeared in Tortola in 1914 and has increased rapidly, attacking and killing nearly all the native fig trees (*Ficus* spp.) growing on the hillsides; *Diaprepes abbreviatus*, which is a serious pest of citrus but was not so abundant as in some seasons; and the sweet potato worm (*Protoparce cingulata*), which was abundant late in the year in several districts.

Contributions to the knowledge of insect pests, IV, V, F. SILVESTRI (*Bol. Lab. Zool. Gen. e Agr. R. Scuola Super. Agr. Portici, 13 (1919), pp. 70-192, figs. 72; abs. in Rev. Appl. Ent., 8 (1920), Ser. A, No. 3, pp. 122-127*).—In continuation of the papers previously noted (E. S. R., 28, p. 559) part 4 (pp. 70-126) deals with the prune scale. (*Sphærolecanium prunastri* Fonsc.) and part 5 (pp. 127-192) with the hazelnut scale (*Eulecanium coryli* L.)

The natural enemies of these scales are dealt with at some length. Those attacking the prune scale include the lady beetle *Hyperaspis campestris* Herbst, the chalcidid parasites *Coccophagus scutellaris* (Dalm.), *C. howardi* Masi, *Phanodiscus aneus* (Dalm.), *Cerapterocerus mirabilis* (Westw.), *Pachyneuron coccorum* (L.), *Perissopterus zebra* (Kurdjumov), and *Microterys lunatus* (Dalm.), and *Pediculoides ventricosus* (Newp.), etc. Those attacking the hazelnut include the anthribid beetle *Anthribus fasciatus* Forster, and the chalcidid parasites *Encyrtus infidus* (Rossi), *Blastothrix sericca* (Dalm.), *Aphycus punctipes* (Dalm.), *A. phillippiae* Masi, and *Microterys sylvius* (Dalm.), etc.

Report of the entomologist, L. J. NEWMAN (*Dept. Agr. and Indus. West. Aust. Ann. Rpt. 1919, pp. 45-47*).—This is a brief report of the occurrence of and work with the more important insects of the year.

[**Report on**] entomology (*Rpt. Prog. Agr. India, 1918-19, pp. 71-78*).—This report deals briefly with the insect enemies of cotton, rice, sugar cane, tea and coffee, indigo, stored grain, etc.

Cotton insects in Porto Rico, E. G. SMYTH (*Ent. News, 31 (1920), No. 5, pp. 121-125*).—A brief account is given of the insects attacking cotton in Porto Rico.

How insects affect the rice crop, J. L. WEBB (*U. S. Dept. Agr., Farmers' Bul. 1086 (1920), pp. 9, figs. 4*).—This is a popular discussion of the more important insect enemies of rice in Louisiana, Texas, and Arkansas, but not as yet found in the rice fields of California. The rice water weevil (*Lissorhoptrus*

simplex Say), the larva of which attacks the rice roots and is commonly known as the "maggot" is the most important. A report of studies of this pest by Tucker has been previously noted (E. S. R., 27, p. 562).

The pentatomid bug *Oebalus pugnax* Fab., may reduce the yield, its attack being confined to late summer and early fall when the rice heads are forming, the mature and nearly mature bugs attacking the soft grains of rice. It is thought that a considerable amount of the injury and loss caused by it can be avoided by getting the crop in early in the spring.

The fall army worm occasionally becomes abundant in the rice fields in the spring before the rice is flooded, and unless prompt measures are taken it soon works great havoc. It is easily controlled, however, by flooding the fields and drowning out the worms.

The rice stalk-borer (*Chilo plejadellus* Zincken) is mentioned as occasionally causing injury, the feeding of the larva on the inner stalk causing the head to die before maturity. Several other insects are also mentioned as at times injuring the rice crop, including the southern corn rootworm, which attacks the rice seed after it is planted, completely destroying its power to produce a plant, and the rough-headed corn stalk-borer [(*Ligyrrus*) *Euethola rugiceps* Lec.] which attacks the main stem of the rice plant just above the roots, shredding it and causing the plant to die.

The best method of controlling insects in rice fields is summarized by the author as follows: "Plow fields in fall previous to planting time to kill pests in the soil. In the case of sod land, cultivate thoroughly in the fall. If fall plowing is not done, burn off all vegetation during winter to destroy pests overwintering in the dead grass and weeds. Three weeks after first flooding, drain fields for two weeks to prevent damage by root maggots. In case of caterpillar or worm attack upon the leaves, flood the field immediately. Keep down all weed growth around the field and on the levees separating the plats. This will greatly reduce attack by many minor species of insects which normally breed in these weeds.

Wheat and its pests, H. R. RATHBONE (Roy. Soc. [London], *Grain Pests (War) Com. Memo. 6 (1919), pp. 4*).—This is a brief summary of information on the more important enemies of wheat. The weevils, which are the most destructive and troublesome, are *Rhizopertha dominica*, the granary weevil, and the rice weevil. The first is very destructive and troublesome and at times it flies in millions; the second does the most damage, but being unable to fly is more easily controlled than the rice weevil. Many million bushels of wheat have been destroyed by these insects in Australia.

Report on the effect of air-tight storage upon grain insects, III, A. DENDY and H. D. ELKINGTON (*Rpts. Grain Pests (War) Com., Roy. Soc. [London], No. 6 (1920), pp. 51, fig. 1*).—This third part of the work previously noted (E. S. R., 40, p. 855) has been summarized by the authors as follows:

"Grain insects sealed up in air-tight vessels, with or without wheat, succumb as soon as the oxygen has been used up, a corresponding amount of carbon dioxid being produced. The only gases present in such sealed vessels, under normal conditions, are oxygen, nitrogen, and carbon dioxid. The amount of carbon dioxid given off by live wheat in air-tight vessels varies directly with the moisture content and the temperature. As regards moisture content there is a critical point, above which the production of carbon dioxid by wheat suddenly increases very greatly. This critical point varies with the temperature. For the temperature and wheats investigated it lies between 13.25 and 16.95 per cent. Above the critical point of moisture content wheat stored in air-tight receptacles very soon renders itself immune to the attacks of grain in-

sects, but below this point it takes a comparatively long time to do so. Data are given in the appropriate places.

"The amount of oxygen absorbed by live wheat of low moisture content is greater than the amount of carbon dioxide given off. At about 30° C. [86° F.] *Calandra oryza* gives off about 29.5 mg. (nearly a fifth of their own weight) of carbon dioxide in 24 hours, and at 20 to 21° only about 9.38 mg. Weight for weight *C. granaria* gives off rather less carbon dioxide than *C. oryza*, which is to be accounted for by its less active habits. The respiratory quotient for *C. oryza* is about 0.773 and for *C. granaria* about 0.815, indicating that the respiratory processes of these insects are perfectly normal.

"The complete absence of oxygen is alone sufficient to kill weevils without taking into account the presence of carbon dioxide, though they are able to remain alive for a considerable time when only small percentages of oxygen are present. The extent to which weevils are able to make use of oxygen in sealed vessels depends upon the percentage of that gas initially present.

"Carbon dioxide exerts a poisonous effect upon weevils apart altogether from the question of diminished oxygen pressure. Thus at 30 to 31° *C. oryza* was killed in less than 12 days in an atmosphere containing from 14.08 to 22.56 per cent of CO₂, though 13.88 per cent of O₂ still remained. Pure (moist) carbon dioxide is less fatal in its effects than carbon dioxide with a small admixture of oxygen. Pure (moist) carbon dioxide acts almost instantaneously as a narcotic, under the influence of which weevils may remain motionless for a long time without losing their power of recovery."

Report on the vitality and rate of multiplication of certain grain insects under various conditions of temperature and moisture, A. DENY and H. D. ELKINGTON (Rpts. Grain Pests (War) Com., Roy. Soc. [London], No. 7 (1920), pp. 52).—The results of the investigations here reported in detail have been summarized as follows:

"Under suitable conditions of temperature and moisture and with an abundant supply of wheat, *Calandra oryza* and *C. granaria* show a very high rate of increase and breed all the year round. The optimum temperature for the breeding of *C. oryza* and *C. granaria* is about 82° F., for *Rhizopertha dominica* somewhat higher. At all temperatures and under all conditions, when breeding takes place at all, *C. oryza* increases much more rapidly than *C. granaria*, the maximum observed for the former species being a 700-fold increase in 16 weeks, at an average temperature of 82.5°. For this reason *C. oryza* is a more serious danger than *C. granaria*, unless, indeed, in this country, the higher rate of increase is counterbalanced by the higher death rate of the adults in winter.

"At ordinary room temperatures in this country, both *C. oryza* and *C. granaria* multiply only during the warmer months of the year, the lower temperature limit for multiplication being probably about 65°, while for *Rhizopertha* it is probably about 70°. At ordinary room temperatures nearly all adults of *C. oryza* are killed off during the winter, but large numbers of larvae survive in the interior of the grains. The adults of *C. granaria*, on the other hand, survive the winter in large numbers, the death rate being little, if any, higher than at other times of the year. The adults of the three species show remarkable differences in their susceptibility to cold. After being kept at a temperature of 33 to 36° for 11 days, 91 out of 100 *C. granaria* recovered, only 3 out of 100 *C. oryza* showed very feeble signs of life, and none out of 100 *R. dominica* recovered.

"*R. dominica* is less susceptible to high temperatures than the two weevils, the lethal temperature for an exposure of three minutes being about 146°

for the former and between 120 and 131° for the latter (in the adult condition). An exposure to a temperature of 145.5° for five minutes is sufficient to kill the larvæ of *C. oryza*, and probably to sterilize the wheat completely as regards all insect life.

"Although a moist atmosphere is undoubtedly more favorable than a dry one for the two weevils, both species can live and multiply in a dry incubator, *C. oryza* increasing much more rapidly than *C. granaria* provided the initial moisture content of the grain is sufficiently high. Very dry wheat is less liable to attack by weevils than wheat with a moderate or high moisture content, but wheat readily absorbs moisture in a damp atmosphere and thereby becomes much more susceptible to weeviling. *Rhizopertha* can withstand dry conditions better than either of the two weevils.

"*C. oryza* and *C. granaria* are both likely to be serious pests in this country, but little is to be feared from *R. dominica* under ordinary temperature conditions. In addition to the damage done by actual consumption of the grain the presence of weevils results in extensive fouling with fecal matter, encouraging the absorption of moisture and the ultimate rotting of the whole mass. In large quantities of wheat the process of decay is doubtless accelerated by rise of temperature due partly to the presence of insects and partly to 'heating' of the wheat."

Dusting v. spraying for the control of avocado insect pests, G. F. MOZNETTE (*Fla. Grower*, 21 (1920), No. 14, pp. 8, 17, figs. 2).—The insects mentioned as of particular importance as enemies of the avocado in southern Florida are the avocado red spider (*Tetranychus yothersi* McGregor), greenhouse thrips, and a leaf-hopper (*Empoasca minuenda* Ball).

"The dusting method with dry dusting sulphur in a finely divided form was found to be equally effective in keeping avocado trees free from red spiders over as long a period of time as the spraying method with liquid lime-sulphur solution. The experiments proved that it is not necessary that the foliage of the avocado be covered with dew, as the dry sulphur adhered to the foliage over a considerable length of time.

"Sulphur in any of the combinations used did not control leaf thrip or leaf-hoppers, and nicotin sulphate as blackleaf 40 when combined with either lime-sulphur or dry dusting sulphur will destroy them. Dry dusting sulphur when charged with nicotin sulphate in the form of blackleaf 40 and applied to avocado foliage was readily removed by succeeding heavy dews and light rains after application. Apparently the liquid nicotin sulphate caused aggregation of the pulverized sulphur particles. Liquid lime-sulphur solution when combined with blackleaf 40 proved to be the most satisfactory combination used in combating the red spiders, leaf thrips, and leaf-hoppers, and remained effective against the red spiders as long as did the lime-sulphur solution applied alone.

"Where a grower has a medium-sized grove of avocados, which is usually the prevalent case up to the present time, and where a number of insects occur, spraying would be the more effective and cheaper method considering the price of sulphur and nicotin sulphate in the dust form compared with contact insecticides in the liquid form."

Important dried fruit insects in California, E. O. ESSIG (*Mo. Bul. Dept. Agr. Cal.*, 9 (1920), No. 3, Sup., pp. 119-125, figs. 5).—A brief account of the more important dried fruit insects and means for their control, particularly the Indian meal moth, the fig moth (*Ephestia cautella* Walk.), the dried fruit beetle (*Carpophilus hemipterus* Linn.), and the saw-toothed grain beetle (*Silvanus surinamensis* L.).

Spray calendar (*Ga. State Bd. Ent., Bul. 53 (1919), pp. 36, pls. 2, fig. 1*).—This furnishes practical information on insect pests and fungus diseases and directions for their control.

A revision of the Nearctic termites, with notes on biology and geographic distribution, N. BANKS and T. E. SNYDER (*U. S. Natl. Mus. Bul. 108 (1920), pp. VIII+228, pls. 35, figs. 70*).—In the preparation of this bulletin the senior author deals with the classification and is to be credited with the new species, and the junior author deals with the biology and geographic distribution.

Part 1 (pp. 1-85), which deals with the taxonomy, includes tables for the separation of families (Kalotermitidæ and Termitidæ), subfamilies, genera, and species. It is pointed out that there are now 36 species and 1 variety occurring in the United States, of which 17 species and 1 variety are here described as new. Of these the authors recognize 3 species as belonging to the genus *Termopsis*; 9 as belonging to *Kalotermes*, 6 of which are new; 1 to *Neotermes*; 3 to *Cryptotermes*, 1 new; 1 to *Prorhinotermes*; 9 species and 1 variety to *Reticulitermes*, 6 of which and 1 variety are new; 6 to *Amitermes*, 4 of which are new; 1 to *Anoplotermes*; 1 to *Nasutitermes* n. g.; and 2 to *Constrictotermes*. The revision is followed by a catalogue of Nearctic termites with synonymy (pp. 77-82) and an index to species, and a record of the location of existing type specimens of Nearctic termites.

The second part (pp. 87-211) consists of biological notes and is devoted to a discussion of the bionomics of Nearctic termites. References to biological or economic literature on the Nearctic species and a key based on the biology and prominent structural characters are included. A 10-page list of literature cited or read (pp. 198-206), part of which is annotated, arranged chronologically, is included. The work includes a full index to the subject matter.

The meadow plant bug, *Miris dolobratus* L. (*Leptopterna dolobrata* L.), A. TULLGREN (*K. Landtbr. Akad. Handl. och Tidskr., 58 (1919), No. 5, pp. 299-314, figs. 18; also in Meddel. Centralanst. Försöksv. Jordbruksområdet No. 182 (1919), pp. 19, figs. 18*).—This is an account of a plant bug which attacks cereals and grasses in many parts of Sweden. As a result of its attack the leaves and stalks of the plant become white and the spikes fail to develop normally.

A detailed account of the species in the United States by Osborn has been noted (*E. S. R., 40, p. 260*).

The grape scale in California, E. O. ESSIG (*Mo. Bul. Dept. Agr. Cal. (1920), No. 1-2, pp. 37-39, figs. 2*).—The author records the occurrence of the grape scale for the first time in California, a considerable number having been collected on the American vine of the Catawba variety at Oakland on November 7, 1919.

On the spermatogenesis of the louse (*Pediculus corporis* and *P. capitis*), with some observations on the maturation of the egg, L. DONCASTER and H. G. CANNON (*Quart. Jour. Micros. Sci. [London], n. ser., 64 (1920), No 255, pp. 303-328, pl. 1, fig. 1*).—The data have been summarized as follows:

"The somatic chromosome number of both sexes is twelve, but spermatogonial mitotic figures show only six. There is some evidence that these are double, and we ascribe the existence of the apparently haploid number in the spermatogonia to premature pairing. There is only one spermatocyte division, which is extremely unequal, leading to the separation of a minute polar-bodylike cell, which degenerates. The centrosome of the spermatid is double, and from each half an axial filament grows out, so that the developing spermatozoa have two conspicuous axial filaments. The development of the mitochondrial body is described. The acrosome is derived from a deeply staining body which appears in

the spermatocyte and becomes applied to the nucleus of the spermatid like a cap. The existence of a deeply stained rod of unknown origin and fate in the growing oöcyte and of a posterior mass of stained granules in the mature egg is shortly referred to. The egg nucleus undergoes two polar divisions, and fertilization appears to be essential if the egg is to develop.

"Breeding experiments did not confirm Hindle's observation that broods consisting only of males or only of females are frequent. Some broods with great preponderance of one or the other sex were obtained."

The pea moth: How to control it, C. L. FLUKE, JR. (*Wisconsin Sta. Bul. 310* (1920), pp. 12, figs. 9).—A pea moth which feeds within the pods on ripening peas and appears to be a species distinct from the European pea moth (*Laspeyresia nigricana* Steph.) occurs in the northeastern counties of Wisconsin and threatens the pea industry of the State. This insect is said to have been one of the principal pests of peas in Canada since 1893, having been introduced from Europe about that time, and has been reported from Michigan, but is not known to occur in any other State. The date of its introduction into Wisconsin is not known, but most of the Door County farmers seem to agree that they first observed the insect about 14 years ago.

The percentage of infested pods ranged from 2 to 21. The infestation of the previous year, however, was much heavier, counts showing that 10 to 50 per cent were attacked. It attacks all varieties of both garden and field peas, but no other host than peas is known. Late varieties of peas are more susceptible to attack than the earlier maturing forms, due entirely to the time of appearance of the moth and not to any varietal resistance of the peas.

Ten months of the year are spent by the pest in its winter cocoon, the other two months in activity near or on the pea plant. On reaching maturity in the fall the worms leave the pea pods, make their way a short distance into the soil, and construct a strong cocoon composed of soil particles, webbing and gluing them together, and then lining the interior with fine silky threads. Here they remain until late spring, when they change to pupæ, later coming out as adult moths. The moths begin to appear shortly after the pea vines start to bloom, the first moth in the field having been taken on July 14, the largest number on July 18, and the last one July 30.

The eggs are usually laid singly upon the pods (seldom upon very young pods), the leaves, the stems of the pea vines, or even on the stems and leaves of grasses or weeds growing in the pea fields. The first eggs were laid July 17, and a maximum was reached within 2 or 3 days, very few having been oviposited after the first of August. The incubation of the eggs varied from 7 to 10 days, depending upon the temperature. The first egg hatched July 23, and hatching continued until August 13.

When first hatched, the larvæ are pale, with the head and thoracic shield almost black. The full-grown worms are about one-half inch long, yellowish white in color, and with the spots on the sides of the body rather inconspicuous. The head and thorax are not so dark as when the larvæ are young. The few hairs that appear on the body are short, and pale in color. Upon hatching out, the young larvæ enter the growing or ripened pea pod through tiny holes which are hard to find after the frass is rubbed or blown off. Here they feed upon the peas, completing their growth in 16 to 26 days. From one to all the peas in the pods attacked by the larvæ are injured. When partly grown, the young worm forms a cocoon within the pods next to the peas, the peas forming one side of the cocoon, which is made up of accumulated frass webbed together. The larva then continues feeding, making irregular holes and often devouring as much as half of each pea.

Infested pods are not easy to detect, the only sure method of determining the presence of the worm being by opening the pod. The infestation seems to hasten maturity of the pods and sometimes causes them to blanch prematurely. Upon completing their growth, the larvæ leave the pods through small holes and seek suitable winter quarters. The larvæ began to emerge from the pods July 31, reached their maximum August 13, and continued to emerge until August 25. If the peas are still in the field, the larvæ enter the soil a short distance and construct their cocoons, thus making ready for the winter season. It often happens, however, that the peas are harvested and placed in the mow ready for thrashing before the pea moth larvæ are developed. In that case the worms on emerging find wintering quarters among the old pea vines, or in cracks, crevices, or other suitable places in the barn.

While a single season's experiments have not led to a determination of the best method of controlling this insect, they have led to the recommendation that early maturing varieties be selected and that the planting of the crop be made as early as possible in the spring.

The trap light was found to be ineffective, and spraying is impractical. The cultivation should be thorough, the peas thrashed within a day or two after harvesting, and the straw remaining after thrashing burned. Any of the vines that have escaped the mower and remain in the field should be raked together and burned. A map is given showing the distribution of the pea moth in Wisconsin and a diagram of its life history at Sturgeon Bay in 1919.

New moths from Mexico, H. G. DYAR (*Insecutor Inscitiæ Menstruus*, 8 (1920), No. 1-3, pp. 30-35).

Exterminating the mosquito, C. C. PAINTER (*Amer. City*, 22 (1920), No. 3, pp. 257-259, figs. 3).—This is a brief report in which profitable results are shown to have been obtained in extensive work in Nassau County, L. I.

A second Culex of the subgenus Transculicia, H. G. DYAR (*Insecutor Inscitiæ Menstruus*, 8 (1920), No. 1-3, pp. 27-29).

Note on the subgenus Neoculex of Culex, H. G. DYAR (*Insecutor Inscitiæ Menstruus*, 8 (1920), No. 1-3, p. 36).

The mosquitoes of British Columbia and Yukon Territory, Canada, H. G. DYAR (*Insecutor Inscitiæ Menstruus*, 8 (1920), No. 1-3, pp. 1-27, pl. 1).

A new Brazilian species of Anastrepha, M. BEZZI (*Bol. Lab. Zool. Gen. e Agr. R. Scuola Super. Agr. Portici*, 13 (1919), pp. 1-14, fig. 1).—Notes are presented on 10 species of fruit flies of the genus *Anastrepha* occurring in Brazil, of which *A. bistrigata* from the fruit of "Araxa" is described as new.

Combating the blow fly, W. A. RUSSELL and W. G. BROWN (*Sci. and Indus. [Aust.]*, 1 (1919), No. 8, pp. 487-489, fig. 1).—Attention is called to the fact that the use of arsenical preparations has given the most successful results in combating the blow fly of sheep. The arsenical is sprayed into the wool at the breach of the sheep by use of a strong power pump as they pass through a race such as is used for branding. It is stated that 6,000 sheep a day have been thus treated in an efficient manner.

The sweet potato weevil (*Cylas formicarius*), H. A. REYNOLDS (*Amer. Plant Pest Com. Bul.* 3 (1919), pp. 2, fig. 1).—A brief account of the sweet potato weevil, based in part upon Farmers' Bulletin 1020 (E. S. R., 40, p. 357), in which the importance of control work is emphasized.

The yam weevil (*Paleopus dioscoreæ* Pierce), G. B. MERRILL (*Quart. Bul. State Plant Bd. Fla.*, 4 (1920), No. 2, pp. 34, 35).—The author records the collection of this weevil in yams from Jamaica intercepted at Key West.

Beekeeping for beginners, H. B. PARKS (*Texas Sta. Bul.* 255 (1919), pp. 7-25, pls. 6).—This is a popular summary of information which replaces Bulletin 142, previously noted (E. S. R., 26, p. 456).

The beginner in bee culture, W. A. GOODACRE (*Dept. Agr. N. S. Wales, Farmers' Bul. 129 (1920), pp. 19, figs. 5*).—A popular summary of information.

American honey plants, F. C. PELLETT (*Hamilton, Ill.: Amer. Bee Jour., 1920, pp. 297, pl. 1, figs. 157*).—The important honey plants are here considered, together with those which are of special value to the beekeeper as sources of pollen, the arrangement being in alphabetical order. The more important plants are illustrated by reproductions of photographs, which are largely those of the author.

The Argentine ant as a household pest, E. R. BARBER (*U. S. Dept. Agr., Farmers' Bul. 1101 (1920), pp. 11, figs. 3*).—This presents information on the means of combating this pest in the household. Extended reports of studies on the species have been previously noted. (E. S. R., 35, p. 761; 39, p. 155.)

Some new parasites with remarks on the genus *Platygaster* (Hymenoptera), R. M. FOUTS (*Proc. Ent. Soc. Wash., 22 (1920), No. 4, pp. 61-72*).—This paper contains descriptions of 8 new species of Hymenoptera in the United States belonging to the superfamilies Serphidoidea and Mutilloidea. Among these are *Trissolcus edessæ* reared from the eggs of *Edessa bifida* Say at New Orleans, La.; *Paridris brevipennis* reared from the eggs of *Gryllus abbreviatus* Serv. at Brookings, S. Dak.; *Platygaster leguminicola* reared from the clover seed midge (*Dasyneura leguminicola* Lint.) at Forest Grove, Oreg.; *P. feltii* reared from the gall of *Walshomyia texana* Felt on cedar at Austin, Tex.; and *Cephalonomia kiefferi* reared from the rice weevil at Wellington, Kans.

Ichneumonid parasites of the European pine shoot moth (*Evetria buoliana* Schiff); *Perilampus batavus* n. sp., C. A. L. SMITS VAN BURGST (*Tijdschr. Ent., 61 (1918), No. 3-4, pp. 143-146*).—Reference is made to several parasites of this pest, and *P. batavus* is described as new.

The western grass-stem sawfly, C. N. AINSLIE (*U. S. Dept. Agr. Bul. 841 (1920), pp. 27, figs. 16*).—This is an account of *Cephus cinctus* Norton, a native species which has been gradually coming into prominence by reason of the change which the feeding habits of the larvæ have been undergoing subsequent to its discovery. Originally a grass feeder, it has become a serious menace to the grain growers of the Northwestern States because of its appetite for small grains, within the stems of which it now subsists. It was originally reared by Koebele in California in 1890 from larvæ that were mining in the stems of native grasses growing in the vicinity of Alameda. It is now known to inhabit the area bounded on the north by a line far into Canada; on the east by the Mississippi River, or probably a little east of that; on the south by latitude 36°; and by the Pacific Ocean on the west.

Species of *Agropyron* and *Elymus* appear to have been the original hosts of the larvæ but, since the modification of their feeding habits, 10 plants belonging to other genera including wheat, durum wheat, spelt, rye, and probably barley, are now attacked. Its choice of wheat for food has taken place, so far as known, only in North Dakota and western Canada, although it is probable that Montana wheat fields have been invaded. From present appearances, the author considers it probable that its attacks will be confined to vegetation growing within the area where spring wheat is sown.

About 50 eggs appear to be laid by a female, the egg being placed within the stem of the host plant, either in the stem cavity or in a hollow excavated by the ovipositor of the female. In order to rear the egg under observation, the author transferred it from the stem to a minute drop of water within a small thin watch glass, which was then immediately inverted on a grass slip and sealed with a ring of water to prevent undue evaporation. In order to continue the requisite moisture supply during a period of several days, it was found neces-

sary to invert over the sealed cell a large watch glass and over this in turn a tumbler. Six or 7 days are required for incubation of the egg.

There appear to be 5 larval instars, about 60 days being required for the larval development. When mature, the larva always seeks the extreme base of the stem where it soon begins its preparation for hibernation. It first cuts a V-shaped groove entirely around and inside the stem, usually at or a little above ground level. This groove never severs the root completely, but so weakens it that the upper stalk, swayed by the wind, will break off completely when dry, leaving a stub that is very characteristic of the work of this insect. In this way the larva provides for the easy escape of the adult in the following summer. The length of the stub thus formed varies greatly; in *Elymus condensatus*, it sometimes will project as much as 3 or 4 in. above the ground, while in other grasses, and especially in wheat, stubs easily can be found less than an inch in length in all. The longevity of the larvæ is quite remarkable, at least one larva having lived 3 years and 5 months in stubs set in sand indoors. The duration of the pupa period is not more than a week at the most. By splitting stubs of grass or grain in June, the author has repeatedly liberated adults, which, when free, were able to take instantly to wing. A life history diagram is given; also a key by S. A. Rohwer for the separation of *C. cinctus* and *C. pygmaeus*.

Pleurotropis utahensis Cwfd., which kills the larva after it has formed its hibernation cell, is the most common parasite. It is gregarious, as many as 12 of its larvæ having been taken from a single cell, but 5 or 6 is a more common number. It is estimated that possibly 10 per cent of the Cephus larvæ in native grasses in Utah, are destroyed by this parasite, but in Bottineau County, N. Dak., in some localities, it has killed more than 50 per cent of the larvæ in Bromus and timothy. But few parasites have been found in the stems of wheat, apparently due to the fact that they have not adjusted their habits to the modified feeding habit of Cephus. A braconid, *Microbracon cephi* Gahan, also attacks the larvæ in grass stems and kills them before maturity.

Because of the multiplication of useful parasites, it is probably inadvisable to mow infested grass in midsummer. Burning the stubble in the autumn or spring appears to have little effect upon Cephus larvae, since the inhabited stems have been cut at the ground level or below and are often covered with soil. Plowing from 5 to 6 in. in depth is thought to be the best remedy for the sawfly that can be suggested at present.

A brief reference is also made to *C. pygmaeus*, a well known European species, the habits of which resemble those of *C. cinctus* but which does not occur west of the Mississippi River.

Trombidium akamushi and similar mites from Japan, Korea, and Formosa, K. MIYASHIMA and T. OKUMURA (*Abs. in Rev. Appl. Ent.*, 7 (1919), Ser. B, No. 12, p. 182).—The authors consider *Leptus autumnalis* Shaw, occurring in Formosa, to be the same form as described from England. *Trombicula mediocris* Berlese, a similar form in Formosa, is closely related to *Trombicula* sp. reported from Java, but is quite different from the adult of the red mite *T. akamushi*.

FOODS—HUMAN NUTRITION.

Food industries, P. PETIT (*Les Industries de l'Alimentation*. Paris: Payot & Co., 1919, pp. 238, figs. 2).—This book gives a brief review of some of the more important food industries of France, with particular emphasis on the importations and exportations of the raw and finished material, the importance of the industries for the country, and means for furthering their de-

velopment. The industries treated are bread, sugar, oils and fats, beverages, alcohol, and canned foods.

The J. G. Forkner fig gardens recipes, J. G. FORKNER (*Fresno, Cal.: Author, 1919, [10]+78, figs. 2*).—A collection of recipes for the use of fresh and dried figs.

The bacteriology of ropy bread, E. SELIGMANN (*Centbl. Bakt. [etc.], 1. Abt., Orig., 83 (1919), No. 1, pp. 39-50, pl. 1*).—A bacteriological investigation of ropy bread is reported which indicated that the organisms responsible for the deterioration were chiefly varieties of *Bacillus mesentericus* and *B. viscosus*. The fact that ropiness appeared to be confined to wheat bread is attributed chiefly to the favorable conditions for growth of the organisms in such bread as compared with the common sour bread, the acidity of which exerts a harmful action on the organisms. The use of lactic acid in ordinary bread making is recommended as a means of preventing ropiness.

Dietotherapy, W. E. FITCH (*New York and London: D. Appleton & Co., 1918, vols. 1, pp. XXIV+816, figs. 49; 2, pp. XIII+798, figs. 13; 3, pp. XVII+929, figs. 8*).—This extensive reference work on human nutrition is designed particularly for 'medical practitioners, hospital internes, medical students, and students in domestic science and nurses' training schools. It consists of three volumes, volume 1 dealing with the chemistry and physiology of digestion and the classification and analysis of foods, volume 2 with nutrition and diet in health, and volume 3 with nutrition and diet in disease. In addition to the chapters written by the author, many of the sections in each volume have been contributed by well-known specialists in various phases of the science of nutrition.

Food poisoning and food infections, W. G. SAVAGE (*Cambridge: Univ. Press, 1920, pp. VIII+247, figs. 3*).—This volume embodies the material dealt with by the author in a special report to the Local Government Board (England) in 1913 (*E. S. R., 30, p. 167*), together with particulars of a number of cases of food poisoning reported subsequent to 1912, and a discussion of the causes, methods of investigation, and lines of prevention of such outbreaks. Extensive references to the literature are given at the end of each chapter.

[Food custom and disease].—Influenza-pneumonia as influenced by dish washing in 370 public institutions, J. G. CUMMING (*Amer. Jour. Pub. Health, 9 (1919), No. 11, pp. 849-853, fig. 2*).—From a study of the incidence of influenza-pneumonia in public institutions with a total population of 84,748, in which machine-washed eating utensils were used, as compared with institutions of the same type with a population of 167,438, in which hand-washed eating utensils were used, the author concludes that washing which sterilizes table utensils is of the greatest importance.

"Transmission of the potentially dangerous group of pneumonia-producing organisms, incident to promiscuous messing in the Army, in public institutions, in public eating places, and in the home, can be largely prevented by the disinfection of eating utensils with scalding water. The universal application of the principle of proper eating utensils disinfection will reduce enormously the prevalence of all sputum-borne infections. As is shown in the institutional population, the influenza case rate was reduced by 66 per cent and the mortality by 55 per cent through the use of machine-washed dishes. It is believed that a further reduction in these rates would have occurred had the full efficiency of all mechanical dishwashers been utilized by the use of boiling water. This principle applies to public eating places as well as to public institutions, and with equal force to the scalding of eating utensils in the private family. . . .

"The sputum-borne infections can be effectively controlled by blocking the major avenue of transmission [table utensils which are not sterilized]. The majority of influenza cases have arisen from the interchange of sputum

through contaminated eating utensils. By the elimination of this large group of cases there results an equal elimination of inanimate object contamination as well as a blocking of the major avenue of transmission."

Report on the present state of knowledge concerning accessory food factors (vitamins), F. G. HOPKINS ET AL. (*Natl. Health Ins., Med. Research Com. [Gt. Brit.], Spec. Rpt. Ser., No. 38 (1919), pp. 107, pls. 8, figs. 11*).—This report of the committee appointed by the Medical Research Committee (London) and the Lister Institute of Preventive Medicine "to consider and advise upon the best means for advancing and coordinating the various lines of inquiry into the modes of action of the factors in metabolism which are independent of the provision of energy" consists of a very complete summary and discussion of the present knowledge concerning accessory food factors or vitamins, including 206 references to the literature, most of which have been previously noted from the original sources.

The subject matter consists of an introductory chapter on the general significance of the accessory food factors, followed by chapters on the relation of these factors to growth, beriberi, and scurvy, the application of experimental work to the practical problem of human diets, including those of adults and of infants and children, rickets as a deficiency disease, and pellagra. The material is illustrated throughout by figures and tables, including valuable data on the relative occurrence in nature of the three recognized vitamins.

A memorandum on the importance of accessory factors in food which has been previously noted from another source (E. S. R., 41, p. 762) is included as an appendix.

[**Beriberi and scurvy**], P. HEHIR (*Indian Jour. Med. Research, Spec. Indian Sci. Cong. No., 1919, pp. 44-59, 79-82*).—These papers, which were presented at the medical research section of the Sixth Annual Indian Science Congress at Bombay in January, 1919, describe the outbreaks of beriberi occurring in the British troops and scurvy in the Indian troops in Mesopotamia in 1915 and 1916, particularly during the siege of Kut-el-Amara, and which led to the laboratory investigations of beriberi and scurvy and their relationship to the vitamin content of various food materials by Chick and Hume, previously noted (E. S. R., 38, pp. 481, 581; 40, p. 868).

Beriberi (pp. 44-59).—This paper describes the symptoms, treatment, and special features of the outbreak occurring during the siege, at which time the exact rations furnished the troops were known. All of the 155 cases were of the wet or dropsical nature. In about 40 per cent there was abdominal dropsy, in 50 per cent pulmonary edema, and in 10 per cent dropsy of the pericardium with cardiac dyspnea. The rations were both quantitatively and qualitatively inadequate, partial starvation in all cases preceding or accompanying the outbreak of beriberi. The prolonged use of tinned meat combined with ration biscuits or white bread is thought to be chiefly responsible for the beriberi, as the Indian troops whose ration contained atta and dhal did not contract the disease.

Scurvy (pp. 79-82).—During the siege noted above there were about 1,050 cases of scurvy, all but one of which were in the Indian troops. This high incidence of scurvy among the Indian troops and almost complete absence of it among the British troops is traced to the use by the latter of fresh meat toward the end of the siege, when the bullocks, horses, and mules were killed to eke out the diminishing food supplies. The Indians, who did not overcome their scruples against eating horseflesh, were the worst sufferers from scurvy. In the last period of the siege, although the men were rapidly losing weight on a starvation diet, the disease declined coincident with the use of about 3 oz.

per man of green herbs collected from the plains. It is emphasized that fresh meat alone without vegetables will not indefinitely postpone scurvy, but seems to delay its appearance. An increase in the meat rations for the Indians and the development of vegetable gardens for the stationary troops caused scurvy practically to disappear from Mesopotamia.

The treatment and management of diseases due to deficiency of diet: Scurvy and beriberi. W. H. WILLCOX (*Brit. Med. Jour. No. 3081 (1920), pp. 73-77, fig. 1*).—This is a general report of a special study of scurvy and beriberi from their clinical aspects and from the point of view of prevention and treatment, the study being made from May, 1916, to January, 1919, during the Mesopotamia campaign noted above.

The report discusses first the rations of the Indian troops at the period of greatest incidence of scurvy and of the later rations of both Indian and British troops, showing the means taken to correct the deficiencies in the former of antiscorbutic factors and in the latter of antiberiberi factors. The striking value of raw meat juice as an antiscorbutic is noted. Tamarind juice was considered to have some antiscorbutic properties and lime juice to have an uncertain value. The extract of yeast known as marmite proved of great value as a prophylactic against beriberi, as did also the incorporation of 25 per cent of atta in the bread served to the British troops. "It was owing to the adequate supply of fresh vegetables, fruit, and fresh meat that deficiency diseases were stamped out from the Mesopotamian Expeditionary Force after March, 1917."

A brief discussion is included of the etiology, symptoms, and treatment of scurvy and beriberi. In conclusion attention is called to the necessity of making adequate provision in army rations for the vitamin as well as the calorie requirement, and to the false economy in disregarding such requirements through financial considerations.

A previous contribution on the same subject has been noted from another source (*E. S. R., 40, p. 564*.)

Pellagra. A. VISWALINGAM (*Jour. Trop. Med. and Hyg. [London], 21 (1918), No. 15, pp. 153-158, pl. 1*).—Various theories regarding the cause of pellagra are reviewed briefly, and applied to the etiology of the disease as found among the Chinese field laborers in the Malay States.

Rejecting the maize theory, as maize is but little used by these people, evidence is given from which the conclusion is drawn that "both the deficiency theory and the parasitic theory may hold good in the etiology of the disease in this country. I am inclined to think that, in individuals whose vitality is lowered by exposure and hard work, some organism gains entry into the system by way of the alimentary canal and sets up a condition of intoxication, which manifests itself in the varied symptomatology seen in this disease. I also think that the disease in the early stage commences with gastro-intestinal trouble, followed later by cutaneous and mental symptoms. . . . The condition of chronic fibrosis observed in all the organs drained by the portal system seems to incriminate the alimentary canal as the portal of invasion of the organism, whatever that may be. The periodical exacerbation may be explained by the seasonal variations of flies and other insects, and partly by a variation in the resistance of the individual."

A summary is given of the symptomatology, diagnosis, prognosis, and treatment of the disease, and several case reports are included.

Some further observations on the etiology of "pellagra," A. VISWALINGAM (*Jour. Trop. Med. and Hyg. [London], 23 (1920), No. 4, pp. 46, 47*).—Further evidence is given in confirmation of the view expressed above that

both the deficiency and the parasite theory hold good in the etiology of the disease among the Chinese in the Malay States. The freedom of the Malay and Tamil laborers from the disease is thought to be due chiefly to the better quality of their diet, which includes a variety of fresh vegetables and more or less meat. That faulty diet is not solely responsible for the disease is shown by the seasonal recurrences of symptoms in patients placed in a hospital with adequate diets for considerable periods of time.

"Whether the infecting agent is an organism which enters the gastrointestinal system and produces a toxin which gets absorbed into the system and produces the varied symptomatology, or whether owing to a deficiency in the vitamins some deleterious products are created in the intestines and give rise to an intoxication of the system, it is difficult to say at present."

A study of the relation of diet to pellagra incidence in seven textile mill communities of South Carolina in 1916, J. GOLDBERGER, G. A. WHEELER, and E. SYDENSTRICKER (*Pub. Health Rpts. [U. S.]*, 35 (1920), No. 12, pp. 648-714, figs. 7).—This is a detailed report of the investigation of pellagra, a brief report of which has been previously noted from another source (*E. S. R.*, 40, p. 69).

Experimental rickets, J. KOCH (*Arch. Wiss. u. Prakt. Tierheilk.*, 45 (1919), No. 5-6, pp. 263-326, figs. 36).—On the basis of bacteriological and histological studies of the epiphysis and bones of rachitic children who had died of various infectious diseases, the theory is advanced that rickets is primarily the result of streptococcus infection. Further evidence in confirmation of this theory is presented in reports illustrated by photographs and microphotographs of the production of rickets in young dogs by artificial streptococcus infection.

In discussing the various theories which have been advanced in explanation of rickets, the author considers that other factors such as undernutrition bear the same relation to rickets as to tuberculosis. The primary cause of each of these diseases is a pathogenic organism which can more rapidly gain headway in a subject weakened by malnutrition or by other secondary factors.

The energy value of human urine in chronic undernutrition and in cases of cachexia, together with a contribution to the method of urine calorimetry, O. FÜRTH and H. KOZITSCHKEK (*Biochem. Ztschr.*, 96 (1919), No. 4-6, pp. 297-324, figs. 3).—Certain modifications in the technique of urine calorimetry are recommended, including the drying in a vacuum at room temperature after a brief evaporation on the water bath, the oxidation of the residue in a rather large platinum crucible, the use of a special ignition device, and measuring the volume of the water for the calorimeter instead of weighing it.

Determinations of the nitrogen and calorific value of the urine of chronically undernourished individuals showed variations of from 0.027 to 0.08 gm. N and 335 to 814 calories for 10 cc. of the urine with a calorific quotient or from 9 to 13.3 in comparison with normal values of from 7.5 to 9.5. The calorific quotient of the urine in various cachectic cases was also high (from 10.3 to 14.5). This increase in the calorific quotient is considered to be due to the progressive decomposition of the organ protoplasm with the separation of substances belonging to the group of hydroxyamino acids.

Studies of variations in the chemical composition of human blood, F. S. HAMMETT (*Jour. Biol. Chem.*, 41 (1920), No. 4, pp. 599-615).—A study is reported of the relative variability and reciprocal relations of the soluble nitrogenous compounds in the blood associated with protein metabolism, and of the total nitrogen and the sugar of the blood. Data are presented on the relative variability of the blood components for the individual, the relative variability of these constituents in a group series of bloods, the influence of the time of withdrawal of the blood on its composition, and the changes in the amounts, distri-

bution, and interrelations of the nitrogen of the various constituents which accompany the changes in the level of the total nonprotein nitrogen.

The blood samples were obtained from nurses and from patients suffering from mental disorder but presenting no evidence of metabolic disorder. No quantitative dietary regulation was attempted although the diet, being the usual hospital diet, was qualitatively uniform. The methods employed for the determination of the various constituents were in general those recommended by Folin and his associates (E. S. R., 29, p. 509; 41, p. 13). The results obtained are summarized as follows:

"While the total nitrogen, nonprotein nitrogenous constituents, and the sugar of the blood vary in the same individual from week to week, there is a tendency for the level of these variations to be characteristically individual. The sum of the average deviations of the constituents for any given individual may be an index of the metabolic stability of that individual.

"The order of relative variability of the constituents determined is creatinin, total nonprotein nitrogen, total nitrogen, creatin, sugar, uric acid, amino acid, urea, and rest nitrogen. A rough division can be made into groups of low, intermediate, and high variability.

"There is no practical difference between the absolute amounts of the constituents found in bloods taken 14 hours after eating, i. e., before breakfast, and 3.5 hours after this meal. The slightly lower values found before breakfast for the nonprotein, urea, and uric acid nitrogen are taken as meaning a lessened metabolism.

"The absolute amounts of the urea, creatin, uric acid, amino acid, and rest nitrogen tend to decrease with decrease in level of the total nonprotein nitrogen. The urea decreases to relatively the greatest extent. The absolute amount of creatinin is a constant for the individual and for the species. It is independent of quantitative changes in the level of the nonprotein nitrogen; of the changes in the concentrations of any of the other constituents determined; and of the individual variations in metabolic stability. There is no uniform quantitative relation between the amounts of the creatinin and creatin nitrogen in the blood.

"The distribution of the nonprotein nitrogen among urea and the other soluble nitrogenous constituents of the blood is dependent to a great degree upon the absolute amounts of the total nonprotein nitrogen present. The nitrogenous constituents of blood that are commonly found in the urine, e. g., urea, creatinin, and uric acid, seem to undergo the same type of absolute and relative change with change in level of the total nonprotein nitrogen of the blood as they do with the change from the high to low total nitrogen in the urine. The relative as well as the absolute decline in the urea nitrogen of the blood accompanying the decrease in the total nonprotein nitrogen is compensated for by a relatively lesser absolute decrease in all the other nitrogenous constituents, which results in an increase of the percentage of their nitrogen in terms of the nonprotein nitrogen. The only apparent interrelation existing between any of the individual constituents is that between the urea and the rest nitrogen. There is a tendency for a rise or fall in the blood urea to be accompanied by a change in the opposite direction of the rest nitrogen."

Alterations in the hemoglobin as well as the protein content of the blood serum due to muscular work and sweating, E. COHN (*Ztschr. Biol.*, 70 (1919), No. 6-8, pp. 366-370; *abs. in Chem. Abs.*, 14 (1920), No. 8, p. 1140).—Determinations of the hemoglobin and protein content of the blood of human subjects before and after muscular work and sweating showed no changes after muscular exercise unaccompanied by sweating, but a decrease in the hemoglobin and an increase in the protein of the blood in passive sweating. That

this was due to a compensatory flow of liquid from the muscles to the blood was proved by experiments on cats.

Contribution to the knowledge of the nonprotein nitrogen of human blood.—I, **Material on the general chemical pathology of the entire system**, J. FEIGL (*Biochem. Ztschr.*, 94 (1919), No. 1-2, pp. 84-128; *abs. in Chem. Abs.*, 13 (1919), No. 20, p. 2559).—This is a general summary and discussion of the significance of the variations in the nonprotein nitrogen of the blood in pathological conditions as reported by various authors.

Nutrition laboratory, F. G. BENEDICT (*Carnegie Inst. Wash. Year Book*, 18 (1919), pp. 265-276).—This is the usual annual report of the nutrition laboratory of the Carnegie Institution (E. S. R., 43, p. 66).

The additions to equipment during the year include a pursuit pendulum for testing the eye-hand pursuit coordination, a pursuit meter apparatus for recording adequacy of motor adjustment, and a respiration chamber for large animals which has been constructed at the New Hampshire Experiment Station and is being used in an investigation of the metabolism of full-grown steers during undernutrition and in the subsequent period of realimentation.

The report contains, as usual, brief accounts of investigations in progress and abstracts of publications issued during the year. These have for the most part been noted from the original sources.

ANIMAL PRODUCTION.

Experiments in the utilization of different feeding stuffs; with a note on the determination of the digestibility of protein, A. MORGEN, C. BEGER, and E. OHLMER (*Landw. Vers. Sta.*, 88 (1916), No. 3-4, pp. 243-260).—Digestion trials with sheep and 3-months-old pigs are reported. The following table gives the major results:

Digestion coefficients for various feeding stuffs.

Feeding stuff tested.	Sheep.					Swine.				
	Organic matter.	Crude protein.	Crude fat.	Crude fiber.	N-free extract.	Organic matter.	Crude protein.	Crude fat.	Crude fiber.	N-free extract.
Red ivory nut meal.	86.7	59.2	90.6	98.2	81.4
Gray ivory nut meal.	78.1	60.6	74.7	91.6	69.6
Red ivory nut chips.	75.7	126.3	93.4	86.0	74.3	74.9	46.7	88.5	85.5	73.1
Gray ivory nut chips.	74.7	60.5	132.3	77.7	83.8	77.6	57.1	15.8	84.4	82.9
Chopped hay.....	51.1	65.7	31.0	50.6	52.7
Hay meal.....	51.9	72.2	46.0	46.4	55.2	42.4	69.0	0.0	44.3	46.6
Reindeer moss.....	13.5	21.1	10.1	14.2	19.1

¹ Considered doubtful.

An African palm of the genus *Hyphæne* furnished the red "ivory-nut" by-products. The gray by-products were from the true ivory palm (genus *Phytelephas*). The meal in both cases contained more protein, more crude fiber, and more ash than the chips. "Reindeer moss" is the lichen *Cladonia rangiferina*.

It was also found that sheep digested 79.5 per cent of the organic matter in bone meal and 75.3 per cent of the organic matter in blood meal.

The digestion coefficients for protein given in the table were computed by ignoring the nitrogen in the pepsin HCl-soluble fraction of the feces (Stutzer's correction for excreted nitrogen). The feeds were all low in protein, and the

digestion coefficients were negative in several cases when total fecal nitrogen was used as the basis of computation. A section of the paper is devoted to a discussion of this matter.

Further investigations of the composition and digestibility of some war-time feeding stuffs, F. HONCAMP, O. NOLTE, and E. BLANCK (*Landw. Vers. Sta.*, 94 (1919), No. 3-4, pp. 153-180).—Tests of feeding stuffs in digestibility experiments with sheep are reported. The composition and digestion coefficients follow:

Composition and digestibility of war-time feeding stuffs.

Materials tested.	Composition (dry basis).				Digestibility.				
	Crude protein.	Crude fat.	Crude fiber.	N-free extract.	Organic matter.	Crude protein.	Crude fat.	Crude fiber.	N-free extract.
	<i>Per ct.</i>	<i>Per ct.</i>	<i>Per ct.</i>	<i>Per ct.</i>	<i>Per ct.</i>	<i>Per ct.</i>	<i>Per ct.</i>	<i>Per ct.</i>	<i>Per ct.</i>
Rumen feed.....	23.03	2.19	14.96	45.84	63.3	64.5	42.5	37.9	73.9
Glue feed.....	17.54	2.43	27.15	43.63	36.7	76.0	35.3	13.0	36.0
Chopped corn cobs.....	2.99	.84	35.58	59.46	53.1	.0	34.3	60.1	53.7
Waste sugar-beet seed and hulls.....	8.96	3.30	35.56	45.24	31.4	54.1	84.7	.0	49.2
Horse-bean bran.....	12.05	.53	42.82	42.22	70.0	54.1	95.8	68.3	76.3
Nettle meal.....	7.30	.76	49.23	36.63	36.5	55.4	61.9	28.2	43.4
Sugar-beet tails.....	7.34	.74	11.34	62.09	78.1	45.2	.0	71.6	85.6

The rumen feed was a mixture of molasses and the contents of the rumen of slaughtered cattle. The glue feed consisted of chaff, heather, herbaceous residues, and gelatinous material from animal cadavers. The nettle meal was a by-product of the nettle-fiber industry.

In the trials meadow hay formed the basic roughage. Poppy seed cake was used to supplement the sugar-beet seed and the corn cobs, linseed cake to supplement the nettle meal, and dried yeast to supplement the sugar-beet tails. The detailed data are given.

The hydrolysis of straw by the Beckmann process.—I, Influence of duration of hydrolysis on the extent of the nutritive material made available, G. FINGERLING and K. SCHMIDT (*Landw. Vers. Sta.*, 94 (1919), No. 3-4, pp. 115-152, fig. 1).—Sixteen digestion trials with sheep and 2 with steers were conducted to determine the nutritive value of rye straw treated by the Beckmann process¹ (hydrolysis with sodium hydroxid) for different periods. The straw was supplemented by linseed meal, various salts, and in some cases molasses. The following are the averages of the digestion coefficients for each period of treatment:

Average digestion coefficients (ruminants) for rye straw hydrolyzed with sodium hydroxid.

Constituent.	Duration of hydrolysis.					
	No treatment.	1.5 hours.	3 hours.	6 hours.	12 hours.	3 days.
	<i>Per cent.</i>	<i>Per cent.</i>	<i>Per cent.</i>	<i>Per cent.</i>	<i>Per cent.</i>	<i>Per cent.</i>
Organic matter.....	45.68	59.33	68.05	70.28	71.22	73.10
Crude fiber.....	58.02	69.21	77.50	79.78	80.94	72.25
N-free extract.....	40.15	48.10	57.58	57.28	60.30	78.52

The composition of the different samples of straw is also reported.

¹ E. Beckmann, Sitzber. Preuss. Akad. Wiss. 1919, pp. 275-285; abs. in Chem. Abs. 13(1919), No. 20, p. 2567.

Is the arrangement of the genes in the chromosome linear? W. E. CASTLE (*Proc. Natl. Acad. Sci.*, 5 (1919), No. 2, pp. 25-32, figs. 2).—The author suggests that the mutual crossover values of three-linked genes may be to each other as the sides of a triangle, and presents a diagram showing that this hypothesis gives concordant results (barring one conspicuous exception) when tested with data collected by Morgan and his collaborators as to the linkage relationships of the genes associated with the sex chromosome of *Drosophila melanogaster*. It is considered difficult to explain this result on the theory of the linear arrangement of genes on a chromosome.

The spatial relations of genes, A. H. STURTEVANT, C. B. BRIDGES, and T. H. MORGAN (*Proc. Natl. Acad. Sci.*, 5 (1919), No. 5, pp. 168-173).—A reply to Castle, in which the authors refuse to admit the possibility of a three-dimensional arrangement of a group of linked genes.

Are genes linear or nonlinear in arrangement? W. E. CASTLE (*Proc. Natl. Acad. Sci.*, 5 (1919), No. 11, pp. 500-506).—A reiteration of the author's theory of the nonlinear arrangement of genes.

Are the factors of heredity arranged in a line? H. J. MULLER (*Amer. Nat.*, 54 (1920), No. 631, pp. 97-121, figs. 4).—A reply to Castle, in which the author emphasizes the difficulties of combining linkage values derived from different breeding experiments.

The measurement of linkage, W. E. CASTLE (*Amer. Nat.*, 54 (1920), No. 632, pp. 264-267).—The author suggests that linkage be measured directly on a scale in which linkage strength is 100 when no crossovers occur and zero when there is 50 per cent crossing over. "Linkage strength" is defined as double the difference between 50 and the percentage of crossovers.

The probable errors of calculated linkage values, and the most accurate method of determining gametic from certain zygotic series, J. B. S. HALDANE (*Jour. Genetics*, 8 (1919), No. 4, pp. 291-297).—Considering two linked hereditary factors, the author derives formulas for the probable errors of their crossover values and reduplication values, (1) when these values are determined directly from a back cross of F_1 on the double recessive, and (2) when they are calculated from an F_2 array by a special method considered by the author to give the most probable values. The values based on the F_2 are found to be nearly as accurate as those derived from the back cross except in cases of strong repulsion.

The combination of linkage values, and the calculation of distances between the loci of linked factors, J. B. S. HALDANE (*Jour. Genetics*, 8 (1919), No. 4, pp. 299-309, fig. 1).—The author presents a general formula to show the mutual relationships between the crossover values of three linked factors, and derives a differential equation whose solution expresses the distance between the loci of two factors on a chromosome as a function of the proportion of crossing over between them. The differential equation is solved only for the limiting values, the solutions being $x=y$ and $x=-\frac{1}{2} \log_e (1-2y)$, where x is the distance and y the crossover proportion.

The first solution, which is Sturtevant's original hypothesis, would be accurate if the chromosomes were rigid rods, but it is in any case a close approximation whenever the proportion of crossovers is small. The second solution implies complete flexibility in the chromosome (i. e., secondary, tertiary, etc., crossovers occur strictly according to the laws of chance), and is approximated in practice when the distance is large. The author shows that the second solution flows from Trow's form of the reduplication theory (E. S. R., 28, p. 876). For the sex chromosome of *Drosophila melanogaster*, a weighted

average of the two limiting values was found to give a good fit to the published data of Morgan and Bridges, but no theoretical significance is claimed for this result.

The author proposes that the unit of distance defined by his equations be termed a "morgan." When the distance is small the percentage of crossovers gives approximately the number of centimorgans.

Chiasmatype and crossing over, E. B. WILSON and T. H. MORGAN (*Amer. Nat.*, 54 (1920), No. 632, pp. 193-219, figs. 8).—Each author discusses this topic independently, Wilson from the standpoint of a cytologist and Morgan from that of an experimental geneticist. Wilson points out that genetical speculation as to the mechanism of crossing over has outstripped cytological investigation of the behavior of chromosomes at synapsis, but he records his belief that the explanation of crossing over lies in some form of torsion of the chromosomes, though perhaps not in the original chiasmatype hypothesis.

Spermatogenesis of the dog, J. Y. MALONE (*Trans. Amer. Micros. Soc.*, 37 (1918), No. 2, pp. 97-110, pls. 2).—The diploid number of chromosomes in the male dog was found to be 21. The unpaired chromosome (X-element or sex chromosome) passes undivided to one pole at the first spermatocyte (reduction) division.

It is stated that the mature spermatozoa could be separated into two distinct classes on the basis of size.

Experimental degeneration in the testis of the dog, A. KUNTZ (*Anat. Rec.*, 17 (1919), No. 4, pp. 221-234, figs. 4).—The author reports a study of the degenerative changes in the seminal epithelium in the testes of two groups of dogs.

In dogs subjected to an operation in which the sympathetic nerve supply to the testes was eliminated the spermatocytes and spermatids became necrotic and gradually sloughed away. This degeneration resembled that produced by exposure to X-rays and also the condition described by Allen (*E. S. R.*, 42, p. 468) in rats fed on a diet deficient in water-soluble vitamin. Ligation and resection of the right ductus deferens produced a somewhat similar degeneration, but was characterized by a much more pronounced sloughing of the tissue. The interstitial tissue in both cases showed marked hypertrophy.

Notes on wool in India, A. H. SILVER and J. K. MEHTA (*Calcutta: Indian Munitions Bd.*, 1919, pp. [5]+89).—The authors discuss sheep breeding in India and the Indian wool trade, and present comprehensive statistics of wool production, imports and exports, prices, and woollen manufactures.

Stallion enrollment.—VIII [i. e. IX], **Report of stallion enrollment work for the year 1919 with lists of stallions and jacks enrolled**, H. E. MCCARTNEY (*Indiana Sta. Circ.* 94 (1919), pp. 92, fig. 1).—This report of the Stallion Enrollment Board consists mainly of a directory of enrollments and renewals for the calendar year of 1919, classified by counties. During the year there were enrolled 1,922 pure-bred stallions, 889 grade and scrub stallions, 787 registered jacks, and 390 grade and scrub jacks. With the exception of the registered jacks these totals are all lower than in 1918 (*E. S. R.*, 41, p. 178), but the proportion of pure-bred stallions is higher.

Feeding for egg production: Vegetable v. animal protein in egg production, P. MOORE (*Idaho Sta. Bul.* 117 (1919), pp. 11, fig. 1).—The plan and the first year's results of this investigation have been noted from a preliminary report (*E. S. R.*, 40, p. 670). The plan was changed March 1 of the third year (1918) and the experiment terminated the following summer because the supply of shorts was exhausted.

The production data cited consist of the relative egg records of the pens each year and the proportions of heavy and light eggs laid in the different

pens. Throughout the original experiment the pen fed the narrow (1:4.2) beef-scrap ration was superior in number and weight of eggs to that fed the wide (1:5.5) beef-scrap ration, and each of these did better than the two pens fed materials derived entirely from plants. In the second year another pen was added and fed a beef-scrap ration having an intermediate nutritive ratio (1:4.8). This pen laid more eggs and a larger proportion of heavy eggs than any other pen.

Beginning March 1, 1918, sour milk was added to the rations of the two pens hitherto receiving no proteins from an animal source. The egg records of these pens for the next 170 days nearly equaled that of the intermediate beef-scrap ration and were definitely higher than the egg records of the other beef-scrap pens.

DAIRY FARMING—DAIRYING.

Can home grown rations supply proteins of adequate quality and quantity for high milk production? E. B. HART and G. C. HUMPHREY (*Jour. Biol. Chem.*, 38 (1919), No. 3, pp. 515-527, figs. 5).—The authors report results of a study at the Wisconsin Experiment Station of the nitrogen metabolism of milch cows fed cereal grains without other protein except that derived from clover hay and corn silage. In the first 4-week period the grain ration consisted of ground oats alone, in the second of ground barley, in the third of ground corn, and in the fourth of a mixture of the three grains. The nutritive ratio was approximately 1:8.8, with a protein intake varying from 2.1 to 2.6 lbs. per head daily.

The experiments started with 3 cows. Only one of them, a Guernsey giving about 22 lbs. of milk a day, maintained her milk flow and remained in nitrogen equilibrium throughout the 16 weeks. The others, a small grade Jersey and a second Guernsey giving respectively about 35 and 32 lbs. of milk at the beginning, showed a marked negative nitrogen balance and declined markedly in milk production until nitrogen equilibrium was reached toward the end of the second period. These cows were then replaced by 2 Holsteins (giving about 30 lbs. of milk) in the hope that with a larger consumption of feed they could utilize the protein to maintain the milk flow. Both animals immediately showed pronounced negative balance and shrinkage in volume of milk.

It is thus considered impossible to furnish enough protein from the sources tested to enable a high-producing cow to maintain her yield. The percentage of nitrogen in the milk was not perceptibly changed during periods of negative balance.

“Undoubtedly the fact that generally in dairy practice the proteins used are of low production value and that the plane of protein intake often fed dairy cows is lower than it should be is partly responsible for the rapid decline in milk production during the progress of lactation. Probably more cows than imagined are in negative nitrogen balance during the early period of lactation and under such conditions rapidly decline in milk flow to offset the losses sustained by autolyzing tissue.”

Report of Rochester milk survey by the committee on public safety of the common council. C. E. NORTH (*Rochester, N. Y.: Rpt. Rochester Milk Survey, Comm. Pub. Safety, Com. Council, 1919, pp. 227, figs. 3*).—This survey was begun in July, 1919, and continued for over five months. The report covers (1) statistics of the Rochester milk supply, (2) results of a canvass among householders to determine the relation of family income to the amount of milk used, the consumption per child, and the ratio of expenditures for milk to total expenditures for food, (3) the cost of producing milk in the year ended April 30, 1919, on farms in Wyoming, Monroe, Wayne, and Living-

ston Counties supplying milk to Rochester, (4) the cost of hauling and shipping the milk, (5) dealer's distribution costs, (6) capital invested by dealers, and (7) sanitary condition of the milk supply and the need of pasteurization.

A feature of the report on the cost of production studies is the classification of the commodity costs according to the production per cow. These data follow:

Influence of average milk yield of cows on economy of market milk production (year's averages for the Rochester, N. Y., district.)

Milk production per cow.	Number of farms.	Cows per farm.	Grain consumed—		Silage, etc., consumed—		Hay, etc., consumed—		Human labor—		Production cost per 100 lbs.
			Per cow.	Per 100 lbs. milk.	Per cow.	Per 100 lbs. milk.	Per cow.	Per 100 lbs. milk.	Per cow.	Per 100 lbs. milk.	
<i>Lbs.</i>			<i>Lbs.</i>	<i>Lbs.</i>	<i>Lbs.</i>	<i>Lbs.</i>	<i>Lbs.</i>	<i>Lbs.</i>	<i>Hours.</i>	<i>Hours.</i>	
Under 4,000.....	9	17.8	1,381	48.6	5,194	182.8	4,738	166.8	170	6.0	\$7.10
4,001-5,000.....	16	18.4	1,661	35.5	7,087	151.6	4,752	101.7	192	4.1	4.88
5,001-6,000.....	27	17.9	2,023	37.1	11,285	207.2	3,199	58.7	196	3.6	4.37
6,001-7,000.....	39	16.3	2,480	38.3	11,263	174.0	3,410	52.7	213	3.3	4.02
7,001-8,000.....	23	14.6	3,250	43.6	10,657	143.1	4,074	54.7	233	3.1	4.01
8,001-9,000.....	15	17.3	4,342	52.1	12,880	154.7	3,548	42.6	221	2.6	3.72
9,001 and over.....	12	12.1	4,245	43.5	12,578	129.0	3,874	39.7	266	2.7	3.90
All cows.....	141	16.4	2,635	41.6	10,493	165.7	3,769	59.5	211	3.3	4.20

The average cost of feed and human labor was \$3.57 per 100 lbs. of milk produced, and the total gross cost (not including a managerial charge) was \$4.69. Milk was sold by producers at an average loss of 84 cts. per hundred-weight. Of the grain fed, 19 per cent was home grown and 17 per cent was brewers' grains. The latter was fed particularly to high-producing cows, and the necessity of hauling it increased the labor cost materially.

The distribution cost studies were based not only on an examination of dealers' books but also, and chiefly, on reports of trained inspectors, who made time and cost studies of each detail of the business as actually carried out in a number of concerns. The inspectors discovered many unsuspected inefficiencies in the utilization of labor in the operation of the milk plants, and these inefficiencies were found to be at least as important in increasing dealers' costs as inefficiencies in delivery and the overlap of routes.

"It is recommended that immediate steps be taken to bring about the centralization of the business of milk distribution in the city of Rochester, on the ground that the present competitive system is a menace to the public health because of insufficient sanitary care of the product and because of unnecessary and excessive expenses."

The estimation of the hygienic quality of milk sent raw to the market, A. GUILLAUME and H. THILO (*Bul. Sci. Pharmacol.*, 26 (1919), Nos. 4, pp. 151-168; 6, pp. 268-274).—The authors describe a scheme of milk control used in Rouen whereby the milk as received is subjected to acidity, reductase, and catalase tests. It is claimed that the milk is graded rapidly and accurately.

Notes on the methylene blue reductase test, R. B. TENNENT (*Queensland Agr. Jour.*, 13 (1920), No. 2, pp. 51-54).—The author reviews some of the work of previous investigators on the methylene blue reduction test, and reports several observations on the rapidity with which the dye was decolorized by milks containing different numbers of bacteria.

Is the milk of cows at the end of lactation suited for infant feeding? F. E. NOTTBOHN (*Biochem. Ztschr.*, 95 (1919), No. 1-2, pp. 1-23, figs. 4).—The author reviews the literature dealing with the influence of stage of lactation on the composition of cow's milk, and reports analyses of three samples of milk collected from cows late in lactation. The nutritive aspects of the matter are not discussed.

Practical cheese-making for smallholders, farmers, and others, E. YELD (*Leominster, Eng.: The Orphans' Ptg. Press, Ltd.*, 1919, 5. ed. rev. and enl., pp. 52+[3]).—The author gives directions for making cheese when only a small quantity of milk is available. Smallholders', Caerphilly, little Derby, Cheddar, little Hereford, single cream, and goats' milk cheeses are included.

[Michigan] dairy statistics (*Mich. State Dairy and Food Commr. Ann. Rpt.* 25 (1918), pp. 125-129, figs. 3).—The amounts of creamery butter, whey butter, renovated butter, various kinds of cheeses, casein, and the different classes of evaporated, condensed, and powdered milk manufactured in Michigan during the year ended June 30, 1918, are tabulated, while maps show the location of condenseries, creameries, and cheese factories. The increase in the condensing industry has cut down the amount of creamery butter produced.

VETERINARY MEDICINE.

State sanitary requirements governing admission of live stock (*U. S. Dept. Agr., Bur. Anim. Indus.*, 1920, pp. 67).—This is a pocket handbook in which information respecting the State requirements for live stock entering the various States, obtained from accredited officials of each State, is brought together for ready reference.

Reports of the live stock sanitary commissioner of the State of Maine on contagious diseases of animals, 1918 and 1919, B. BEARCE (*Rpt. Live Stock Sanit. Commr. Me.*, 1918, pp. 33; 1919, pp. 20).—These reports deal with the occurrence of and control work with infectious diseases of live stock in Maine, particular attention being given to the work with bovine tuberculosis.

Twelfth annual report of the State Live Stock Sanitary Board of North Dakota (*N. Dak. Live Stock Sanit. Bd., Ann. Rpt.*, 12 (1918), pp. 47).—This report on control work with live stock diseases includes a paper by W. F. Crewe on the Control and Eradication of Bovine Tuberculosis.

Department of veterinary science, E. RECORDS (*Nevada Sta. Rpt.* 1919, pp. 27-31).—A brief report is here given of the status of project work on equine anemia, a hemorrhagic disease among cattle, and contagious epithelioma in chickens.

In work with the hemorrhagic diseases, 8,829 head of cattle were vaccinated during the year with the bacterin prepared from several strains of *B. bovissepticum* in 5 cc. doses, followed in 10 to 12 days by a 2 cc. dose of living cultures of a single strain of *B. bovissepticum* which has lost its virulence for bovines. While this organism has not been definitely incriminated as the cause of the disease, favorable results were obtained. The preparation and distribution of antiserum prepared by hyperimmunizing horses with several strains of *B. bovissepticum* was continued, 127 affected animals having been treated.

Health of animals branch (*Rpt. Min. Agr. Canada*, 1919, pp. 65-70).—This report discusses the occurrence of and control work with hog cholera, mange in cattle and horses, glanders, dourine, sheep scab, anthrax, and tuberculosis.

Annual administration report of the Bombay Veterinary College and civil veterinary department in the Bombay Presidency (including Sind)

(*Ann. Admin. Rpt. Bombay Vet. Col. and Civ. Vet. Dept. Bombay, 1918-19, pp. 43*).—This is the usual annual report (E. S. R., 41, p. 777).

[**Research work with range plants poisonous to stock**], M. R. MILLER (*Nevada Sta. Rpt. 1919, pp. 32, 33*).—Two plants, one of the saltbushes (*Atriplex canescens*) and the wild chokeberry (*Prunus demissa*), were investigated by the author during the year. The work with *Atriplex* disclosed the presence of a saponin or a mixture of saponins to which it may be possible to ascribe some of the poisonous properties of the plant. *P. demissa* was shown to contain a cyanogenetic compound. The toxicity of this plant is undoubtedly due to the prussic acid generated by enzym or other action.

[**Studies of poisonous range plants**], C. E. FLEMING (*Nevada Sta. Rpt. 1919, pp. 39-43*).—It is pointed out that due to palatable forage on the range becoming gradually depleted, the range animals are forced to eat plants which formerly were seldom or never touched, and as a result the losses during late years have been on the increase. During the year under report, 30 different plants were studied, 211 separate feeding tests having been made. The plants which produced poisoning when fed the toxic and lethal doses, are here reported upon, as follows: *Triglochin maritima* (arrow grass), *Cicuta occidentalis*, *Asclepias mexicana*, *Artemisia spinescens*, *Tetradymia glabrata*, *Atriplex canescens*, *A. rosea*, *Delphinium andersonii*, *Halerpestis cymbalaria*, *Solidago spectabilis*, *Kalmia microphylla*, *Zygadenus paniculatus* (death camas), and *Z. venenosus* (death camas).

[**Saponified cresol solutions**], J. M. SCHAFFER (*U. S. Dept. Agr. Bul. 855 (1920), pp. 5*).—This paper describes a series of experiments undertaken with the object of preparing saponified cresol solutions which would be less expensive but no less effective than those in use at present. The standards for such a solution, as outlined by the Bureau of Animal Industry, U. S. Department of Agriculture, are as follows: "The product shall remain a homogeneous liquid when cooled to 32° F. It shall contain substantially no free oil, fatty acid, or excess alkali. It shall be readily soluble in cold distilled water; the solution shall be practically clear and shall contain no globules of undissolved oil or cresylic acid."

It was found that the objectionable feature of cresol-resin soap solutions, the clouding on dilution with water, was due to the hydrolysis of the rosin soap and the absorption of carbon dioxide from air, but that this could be retarded by substituting, for part of the rosin soap, soaps made from vegetable or fish oils. The length of time during which a 3 per cent solution of such saponified cresols remained clear was found to depend upon the amount of rosin soap present.

Saponified cresol solutions containing soaps made from several different vegetable oils and fish oils did not vary greatly in disinfecting power as determined by a modified Rideal-Walker test, but were somewhat inferior to the cresols made by using soap mixtures composed largely of rosin soap. The latter proved to have at least as great a disinfecting power as saponified cresol solutions made with linseed oil soap, and to be much cheaper.

[**Complementary and opsonic functions in their relation to immunity**], H. D. MOORE (*Jour. Immunol., 4 (1919), No. 6, pp. 425-441*).—The author reports a study at the Vermont Experiment Station of the properties of the sera of guinea pigs naturally deficient in complement.

Complement titrations in which positive and negative controls were employed indicated that the lack of complement was not due to the presence of anything interfering with the action of amboceptor. Biological tests applied to the blood serum of complement-deficient guinea pigs systematically immunized by

repeated inoculations showed the presence of bacteriolytic and agglutinating antibodies, and the animals showed more or less active immunity to the injected bacteria. Titration of the blood serum before and after the production of this active immunity gave practically the same results for complement titer.

In a comparative test of the resistance to infection of nonimmunized complement-deficient and complement-normal guinea pigs, 77 of 100 complement-deficient animals succumbed to the inoculation of live cultures of *Bacillus cholerae suis*, while only 20 of 100 similarly inoculated complement-normal animals died. This is thought to indicate that deficiency in complement is associated with deficiency in natural resistance to bacterial infection.

The phagocytic index of the serum of complement-deficient guinea pigs was found to be about one-half that of the complement-normal animals.

The determination of the number of bacteria in pure cultures, G. DICHTL (*Arch. Hyg.*, 89 (1920), Nos. 1-3, pp. 47-62).—A study of the effect of various factors on the accuracy of the method of estimating the number of bacteria in a suspension from the volume of the sediment on centrifuging is reported.

The water content of the agar serving as a culture medium was found to have no influence on the results. The period and temperature of incubation affected the results to the extent that young cultures contained more living organisms than old cultures, and that at a temperature of 22° C. the number of organisms remained at its maximum longer than at higher temperatures.

The sedimentation method is recommended as being simple and easy to manipulate, and as accurate as the more tedious counting method.

A method of standardizing bacterial suspensions, F. L. GATES (*Jour. Expt. Med.*, 31 (1920), No. 1, pp. 105-114, figs. 3).—The method described is based upon the observation that if a wire loop is gradually pushed down into a bacterial suspension, the depth at which the loop disappears will be determined by the opacity of the supervening column. An instrument is described by means of which the density of suspension or the number of bacteria may be measured by the length of the column of suspension required to cause the disappearance of a wire loop.

In using this method standards should be marked out for each observer by a comparison of the corrected depth of disappearance readings and the corresponding bacterial count. It is claimed that when such standards are established suspensions of the same organism can be estimated rapidly.

A plea for standard method of estimating the number of killed bacteria in suspension, W. E. KING and R. E. VORIES (*North Amer. Vet.*, 1 (1920), No. 1, pp. 13-18).—The authors describe briefly the method of estimating the approximate number of bacteria in a given suspension described by Hopkins (*E. S. R.*, 30, p. 780) and the one by Gates noted above, and present tables giving a comparison of the bacterial count of several well-known commercial vaccines as determined apparently by one of the above methods and the count as stated on the label.

The discrepancy in these figures and the irregular results obtained in inoculation experiments indicate, in the opinion of the authors, the necessity of the adoption of some standard method for the determination of the number of killed organisms in suspension.

The transmutation of bacteria, S. GURNEY-DIXON (*Cambridge: Univ. Press*, 1919, pp. XVIII+179; rev. in *Brit. Med. Jour.*, 3087 (1920), pp. 297, 298).—In this monograph the author discusses, on the basis of the literature and of ex-

periments of his own, the evidences of bacterial variation in relation to their bearing on the possibility of transmutation of species among bacteria, and advances a hypothesis as to the nature of disease. This hypothesis assumes that each separate symptom of disease may be attributable to a separate and distinct bacterial enzym, these bacterial enzymes being ultramicroscopic parasites of the bacteria capable of being dissociated from the organism to which a particular disease is attributed and becoming attached to another organism, thus producing the effect of transmutation.

Studies on pathogenic anaerobes.—I, Biology of *Bacillus welchii*, B. JABLONS (*Jour. Lab. and Clin. Med.*, 5 (1920), No. 6, pp. 374–383, figs. 2).—The morphology, cultural characteristics, biochemical properties, serologic characteristics, and pathogenic power of *B. welchii* are described with many references to the literature on the subject.

The differentiation of the paratyphoid enteritidis group.—VII, Irregular and variable strains, E. O. JORDAN (*Jour. Infect. Diseases*, 26 (1920), No. 5, pp. 427–434).—This is in continuation of the series previously noted (E. S. R., 41, p. 580).

***Bacillus enteritidis* infection in laboratory rats, P. R. CANNON** (*Jour. Infect. Diseases*, 26 (1920), No. 5, pp. 402–404).—“In an epidemic among white laboratory rats, extending over a period of four weeks, 45 of 52 died. An organism which is culturally and serologically identical with *B. enteritidis* was isolated from the heart blood of 31 of 35 rats examined. This organism, when injected intraperitoneally or subcutaneously into other rats, or when fed, caused the death of the rats, and the organism was recovered from the heart blood and spleen.”

Observations on the life history of *Ascaris lumbricoides*, B. H. RANSOM and W. D. FOSTER (*U. S. Dept. Agr. Bul. 817* (1920), pp. 47, figs. 6).—In this bulletin the authors review the present status of knowledge of the biology of *A. lumbricoides*, including data presented in papers previously noted (E. S. R., 43, p. 80), and present the results of further investigations, including the details of 23 feeding experiments conducted. The authors find the corresponding parasite of the pig (*A. suum* Goeze or *A. suilla* Dujardin) to be morphologically indistinguishable, and they probably are specifically identical. A 3-page bibliography is included. A general summary given by them is as follows:

“The embryos in the eggs of *A. suum* or *A. lumbricoides* in the presence of oxygen and moisture may reach full development in 10 days if incubated at a temperature of about 33° C. (91.4° F.); development proceeding more slowly at lower temperatures and being inhibited by the lack of oxygen or moisture. The shell of the egg is insoluble in many chemical reagents. Within the shell there is a thin membrane which is highly impermeable, and even more resistant to solution than the shell itself. The shell may be dissolved with anti-formin, leaving the embryo inclosed in the membrane, in which condition the embryo may continue active for several days.

“Hatching of the embryo may occur accidentally outside of the body of a host, but occurs normally only in the small intestine. Hatching also occurs if the egg is introduced beneath the skin. The factors that govern the hatching of *Ascaris* eggs are yet to be determined. Martin's conclusions that hatching is caused by alkaline, or even neutral solutions, acting at body temperature have not been confirmed. *Ascaris* eggs in large numbers may be conveniently obtained and developed to the infectious stage for experimental use by removing the eggs from the uteri of female worms and incubating them in a solution of formalin placed in shallow dishes and stirred every few days to insure sufficient aeration.

"If *Ascaris* eggs containing fully developed embryos are swallowed by rats, mice, guinea pigs, or rabbits, they hatch in the small intestine. Some of the newly hatched larvæ may be eliminated in the feces, but others penetrate the wall of the alimentary tract and, apparently aided by the circulation, migrate to the liver and lungs; they may also migrate to the spleen and thyroid and under the peritoneum of the abdominal cavity. Most of those entering the liver later migrate to the lungs. In the course of their migrations the larvæ undergo growth and development, reaching 5 to 10 times their original length before leaving the lungs, after which no material change occurs in size or structure. Larvæ that do not reach the lungs ultimately die and become encysted or absorbed by the surrounding tissues. From the lungs the larvæ crawl up the trachea, then down the esophagus, through the stomach, into the intestine, and finally pass out of the body in the feces. They may be found in the liver as early as 2 days after infection, in the lungs and trachea as early as 3 days after infection, and in the alimentary tract after their passage through the lungs as early as 6 days after infection. They are common in the lungs a week to 10 days after infection, becoming scarce in the liver as they become numerous in the lungs. Within a little over two weeks after infection all or practically all the larvæ are usually eliminated, but have been found still present and active in the liver, lungs, and alimentary tract as late as 23 days after infection.

"In young goats and lambs the larvæ of *A. suum*, after migrating through the lungs, settle down in the small intestine and undergo development approaching maturity, these animals thus being better adapted as hosts than rats, mice, guinea pigs, and rabbits. In pigs *Ascaris* larvæ, after migrating through the lungs, settle down in the small intestines and develop to maturity, and presumably the same cycle occurs in human beings. Rats and mice play no part in the normal life history of *Ascaris*. The behavior of the larvæ in these animals and in guinea pigs and rabbits may be considered simply an expression of imperfect adaptation of the parasites to existence in these hosts. In pigs and human beings *Ascaris* may develop to maturity within two and one-half months after infection. In guinea pigs the larvæ apparently reach a larger average size than in mice in the same length of time, and still larger in rabbits.

"Migrating *Ascaris* larvæ produce destructive lesions in the liver and lungs, especially in the latter. Some larvæ die during their migrations. Dead and degenerated larvæ have been found in the lungs as late as 86 days after infection, and in the liver 296 days after infection. The invasion of the lungs by *Ascaris* larvæ may result in a serious and sometimes fatal pneumonia, which appears in a week to 10 days after ingestion of the eggs.

"Young pigs are more susceptible to *Ascaris* infection than older animals, but may not entirely lose their susceptibility with advancing age. No evidence has been obtained that one infection with *Ascaris* renders animals less susceptible to later infections. If properly incubated *Ascaris* eggs are injected beneath the skin they will hatch, and the larvæ will migrate to the lungs, where they may be found a few days after injection of the eggs to have reached the same stage of development as they would if infection had occurred from swallowing the eggs. The larvæ of *Belascaris marginata* undergo migrations in rats similar to those of *A. suum* and *A. lumbricoides*.

"Immature stages of a nematode resembling and probably identical with *A. anoura* have been found in the lungs of a python, indicating that this species, like *A. lumbricoides* and *B. marginata*, migrates through the lungs, reaching, however, a more advanced development before moving into the alimentary

tract. The larvæ of *Hamonchus contortus* ingested by guinea pigs can be found in the lungs 2 days later, indicating the possibility that this species migrates through the lungs before finally establishing itself in the alimentary tract. Migration of the larvæ through the lungs is probably a common occurrence in the life cycle of nematodes whose adult stage occurs in the alimentary tract.

"Stewart's observations as to the migration of *Ascaris* larvæ through the lungs [E. S. R., 39, p. 587] have been confirmed, but his suggestion that rats and mice act as intermediate hosts is not tenable. No intermediate host is necessary, and human beings and pigs become infected with *Ascaris* as a result of swallowing the eggs of the parasite, and not as a result of swallowing food, water, or other substances that have been contaminated by the feces of rats or mice."

The present status of the diagnosis and control of glanders, R. REINHARDT (*Berlin. Tierärztl. Wchnschr.*, 35 (1919), Nos. 46, pp. 453-456; 47, pp. 465-468).—This is a survey of the progress since 1912 in the diagnosis and control of glanders. The methods discussed include the mallein test with its different methods of application, and the complement fixation, precipitation, agglutination, conglutination, and lipid fixation blood tests. Of the latter the author recommends the complement fixation test as the most valuable diagnostic method. Progress in clinical and immunization studies is also discussed briefly.

A new method for the serological diagnosis of glanders, E. MEINICKE and H. BLEY (*Berlin. Tierärztl. Wchnschr.*, 34 (1918), No. 10, pp. 93-95).—The method, known as the lipid fixation reaction, depends upon the fact that upon the addition of a culture of glanders bacilli to a mixture of the serum of a glandered animal and an alcoholic lipid-containing extract a flocculent precipitate is formed which is insoluble in salt solution. If normal serum is used or another bacterial antigen, the resulting flocculation readily dissolves in salt solution. The technique of the preparation of the four agents required, the serum, the extract of glanders bacilli, the organ (lipoid) extract, and the standard salt solution are described in detail, as is also the method of application of the test. For the lipid extract the author recommends horse hearts, although it is stated that other lipid-containing organs can also be used.

A comparison of the results obtained with this test and with the agglutination and complement fixation test is summarized as follows:

(1) Acute glanders: Positive results were obtained in 25 cases which also gave strong complement fixation and agglutination tests, in 4 cases which gave strong agglutination but negative complement fixation reaction, and in 4 cases with negative agglutination and positive complement fixation reaction.

(2) Chronic glanders: Sera reacting positively in the agglutination and complement fixation tests caused flocculation, the results sometimes being more and sometimes less marked than the other tests. Agglutinating but not complement binding sera gave positive lipid fixation reactions, while weakly complement binding but nonagglutinating sera gave negative lipid fixation reactions. In certain cases in which negative complement fixation and agglutination tests were obtained with positive lipid fixation, later tests gave positive results for either complement fixation or agglutination.

(3) Other cases: With foals suffering from glanders all three reactions were negative. Positive complement and lipid fixation reactions were obtained with the sera of mules.

(4) Nonsuspicious sera: In 3 per cent of the sera reacting negatively to the complement fixation and agglutination tests positive results were obtained with the lipid fixation test.

The significance of these results is discussed and the conclusion drawn that the lipid fixation reaction is as specific as the other serological tests.

The lipid fixation reaction, E. MEINICKE (*Berlin. Tierärztl. Wchnschr.*, 35 (1919), No. 44, pp. 425, 426).—Improvements in the technique of the lipid fixation reaction are outlined, including a new method for preparing the lipid extract which is said to give uniformly good extracts, a simple dilution method for the extract, and the use of a tuberculin preparation (T. O. A.) as a control antigen in place of the extract of colon bacilli recommended in the above paper.

As the result of further trial of the method the author states that by means of it fresh acute attacks of glanders can be detected much earlier than by other methods, and that in chronic cases positive results are obtained much more frequently than with the complement fixation method.

The tuberculosis complement fixation test, B. STIVELMAN (*Jour. Lab. and Clin. Med.*, 5 (1920), No. 7, pp. 453-456).—The author reports a study of the diagnostic and prognostic value of the complement fixation reaction for tuberculosis, as well as its relation to active and clinically inactive tuberculosis, as determined by observations of its use in 700 consecutive cases.

Positive reactions were obtained in 24 per cent of nontuberculous individuals and in only 52.4 per cent of the definitely tuberculous cases. Of 294 active cases, a positive reaction was obtained in 178, or 60.5 per cent, while of the 298 inactive cases 132, or 44.3 per cent, reacted positively.

The author concludes that "it would seem hazardous to permit the test in its present stage of development to influence our clinical judgment."

Stomach worms in sheep, L. J. HORLACHER (*Univ. Ky. Col. Agr., Ext. Div. Circ.* 78 (1920), pp. 8).—This is a popular account

Why hog cholera serum sometimes fails, G. H. CONN (*Swine World*, 7 (1920), No. 17, pp. 13, 14).—Failure to diagnose hog cholera accurately and to observe sanitary and hygienic measures in administering the serum are considered the chief causes of poor results sometimes experienced in the use of the serum.

Serum treatment of joint-ill, T. RIEGER (*Tierärztl. Rundschau*, 25 (1919), No. 28, pp. 309-311).—This is a brief discussion of the intravenous and subcutaneous methods of treating foals with serum from the mother in cases of joint-ill. The formation of abscesses following subcutaneous injection of the serum is attributed to imperfect cleansing of the surface at which the injection is made or to incomplete sterilization of the syringe. In the intravenous method the bactericidal action of the blood is thought to overcome the possible danger of infection of the subcutaneous method. The use of a large syringe capable of injecting 500 cc. of blood at one time is recommended for the intravenous method.

The immunity of common fowls to plague, P. C. FLU (*Meded. Geneesk. Lab. Weltevreden [Dutch East Indies]*, 3. Ser. A, No. 4 (1919), pp. 116-132).—The author reports that fowls inoculated with large amounts of a culture of plague bacilli capable of killing guinea pigs by the subcutaneous injection of a 0.0001 loop dose showed no signs of illness. Attempts to attribute this immunity of fowls to cholera indicated that it can be explained chiefly if not entirely by phagocytosis. The plague bacilli behave as foreign bodies circulating freely in the blood without loss of virulence until they are seized upon and destroyed by the phagocytes.

RURAL ENGINEERING.

American civil engineers' handbook, M. MERRIMAN ET AL. (*New York: John Wiley & Sons, Inc.*, 1920, 4. ed., rev. and enl., pp. [2]+1955, figs. 1118; rev. in *Engin. News-Rec.*, 84 (1920), No. 12, pp. 580-581).—This is the fourth revised

edition of this standard handbook. A new section of special importance on irrigation and drainage has been added.

Report on irrigation surveys and inspections, 1918-19, E. F. DRAKE and F. H. PETERS (*Dept. Int. Canada, Reclam. Serv., Rpt. Irrig. Surveys and Insp., 1918-19, pp. 67, pls. 3, fig. 1*).—This includes the report of the director of the Canadian Reclamation Service and the report of the Commissioner of Irrigation of Canada, including data on large irrigation projects and duty of water for 1918. Considerable data on duty of water are summarized, it being shown that the average depth for wheat, oats, and barley is 1.7 ft. and for alfalfa 2.18 ft.

Irrigation practices, A. O. KAY (*Fla. Univ. Ext. Bul. 24 (1920), pp. 45-48*).—Subsurface, surface, and overhead irrigation are briefly discussed.

The duty of water in the Pacific Northwest, J. C. STEVENS (*Proc. Amer. Soc. Civ. Engin., 46 (1920), No. 3, pp. 461-480, fig. 1*).—It is the object of this paper to suggest lines along which future research in duty of water should be conducted. The process is illustrated by an actual example and the correctness of the determination substantiated by results actually secured on projects where crop statistics and other data are available. Briefly stated, the determination of the duty of water consists in first fixing the average percentage of soil mixture that should be maintained for the particular soil and crops, and then finding a quantity of irrigation water that, with the precipitation and the unavoidable losses, will maintain that amount of soil moisture. This method makes the free soil moisture in the root zone of the plants the index of plant sufficiency.

Well waters for irrigation, C. VALLEJO (*Rev. Soc. Rural Córdoba [Argentina], 19 (1919), No. 360, pp. 4902-4907*).—Features of irrigation by well water in Argentina are reviewed. It is noted that in irrigated regions the well waters generally contained salt concentrations of about 270 parts per 100,000. In every case considerable sodium carbonate was present.

Water supply by means of cisterns, F. NIKOLAI (*Arch. Hyg., 86 (1917), No. 6-8, pp. 318-337, figs. 4*).—Laboratory and field experiments are reported which show that cistern water can be quickly, easily, and safely disinfected and rendered potable when treated with bleaching powder at the rate of 10 mg. per liter and after some hours neutralized with sodium hyposulphite.

A suggestion on a method for purifying water and its significance in laboratory practice and sanitary water analysis, G. A. LINHART (*Berkeley, Cal.: [Leaflet], 1919, pp. [2]*).—It was found that when alkali water was frozen into rectangular blocks of 250 lbs. the ice was perfectly clear except for a slab in the center varying from 6 to 8 per cent of the total weight of the cake. The clear ice in all cases analyzed to practically 100 per cent pure, all of the dissolved substances, as well as the suspended matter, having collected in the center slab. While this method of purifying water may prove, from a commercial standpoint, prohibitive for irrigation purposes, it is considered to offer a simple and accurate method of concentrating extremely dilute solutions for chemical analyses, for example, of water extracts of soils.

The action of water on lead, J. F. LIVERSEEGE and A. W. KNAPP (*Jour. Soc. Chem. Indus., 39 (1920), No. 3, pp. 27T, 32T, figs. 2*).—Experiments with a faintly alkaline natural water are reported with particular reference to the so-called erosion test, which is an estimation of the action of water on completely immersed sheet lead. The test is performed with bright lead in water with free access to air.

It is concluded that erosion is due to the action of oxygen in the presence of water, and that such variations as occur naturally in the percentage of oxygen present in the water produce no appreciable effect on the erosion.

It was found that one day is the most suitable period for the erosion test. Exposure to glass lowers the erosive ability of the water. The greater the depth at which the lead is immersed in the water, the slower the erosive action. The velocity of erosion falls as time proceeds. Variation in the volume of water does not appreciably affect erosion. For the untreated water the amount of lead eroded varies directly with the area of lead exposed. Small changes in the area of the water surface produce no appreciable effect on the erosion.

Erosion readily occurs in waters which contain no carbon dioxide. Such variations as occurred naturally in the percentage of carbon dioxide present in the water produced no appreciable effect on the erosion, but the presence of from 1 to 2 per cent of carbon dioxide causes a sudden change from erosion to plumbosolvency. Carbon dioxide dissolves lead more rapidly in the presence of oxygen. Given oxygen, the alkalinity of the water is the principal factor determining the amount of erosion.

Not only the amount but the kind of erosion depends chiefly on the alkalinity of the water. The addition of small quantities of calcium hydroxid, carbonate, and bicarbonate, or of potassium permanganate, decreases erosion. Calcium bicarbonate is the most effective preventive, as little as two parts per 100,000 being generally sufficient. Erosion occurs in the absence of bacteria. The bacteria in the water are not all destroyed by exposure to lead for six hours.

Water powers of the United States (*Elect. World*, 75 (1920), No. 12, pp. 654-659, figs. 6).—An analysis of developed and undeveloped sources of water power in the United States indicates that the total potential water power is 59,360,000 h. p., of which only 9,823,540 h. p. is developed.

Engineering for land drainage, C. G. ELLIOTT (*New York: John Wiley & Sons, Inc., 1919, 3. ed., rev., pp. XVIII+363, pl. 1, figs. 65*).—This is the third revised edition of this book (E. S. R., 26, p. 588).

The discussion of the hydraulics of flow in underdrains has been rewritten, and new tables for the discharge of tile drainage have been introduced which it is believed correspond closely to results obtained in practice. A diagram to facilitate the application of Kutter's formula in the design of ditches and canals has been added. Data on the history of drainage, on drainage by pumps, and on the drainage of irrigated lands have also been added.

Studies of maintenance work on drainage ditches, H. M. LYNDE (*Engin. News-Rec.* 84 (1920), No. 15, pp. 713-715, figs. 2).—Experiments on the clearing for maintenance of a drainage ditch in the flat coastal plain section of North Carolina are reported. The excavated material was sand occasionally mixed with clay and the ditch bottom was solid sand. The conclusion is drawn that such channels should be cleaned every year and the banks at 3 to 5-year intervals. The banks should be gone over each year and kept shrubbed as far back as the waste bank. All logs, trees, and stumps, as well as woody growth like willows, should be removed annually from the channel, and low-water channels should be opened through the sand bars.

Hydraulic-fill dams, A. HAZEN (*Proc. Amer. Soc. Civ. Engin.*, 46 (1920), No. 4, pp. 525-557, figs. 12).—Methods of testing hydraulic-fill dams are described, and an effort is made to analyze the conditions of stability. It is pointed out that it is not well to build a hydraulic-fill dam of material of which any large percentage consists of clay or of particles less than 0.01 mm. in diameter, and in general all such particles may well be wasted and excluded from the dam.

By reducing the construction pool to a minimum, and by controlling it and the quantities of water used for sluicing, the core material may be held to a certain degree of coarseness by wasting all smaller particles. An effective size of 0.01 mm. may reasonably be sought.

It is concluded that in practical dam construction one should "study by borings the actual consolidation of the material and adjust the construction of the upper parts of the dam to the demonstrated condition of that which lies below. Make the toes large enough to resist with an ample factor of safety the whole pressure of the core material as a liquid until there is demonstration of the solidification of the core to a point where horizontal pressure is eliminated. Increase the weight and solidity of toes by the use of rock fill placed hydraulically or otherwise.

"Stability is increased by compactness. It is worth while to watch voids closely and to make every effort to hold them at a minimum. The extra weight is advantageous, but security against compression and rearrangement with resulting temporary quicksand conditions can be best reached in this way."

The record of 100 dam failures, L. JORGENSEN (*Jour. Electricity*, 44 (1920), Nos. 6, pp. 274-276; 7, pp. 320, 321, figs. 5).—A list is given of more than 100 dams that have failed, including a short description of when and why they failed and in most cases their principal dimensions. All conceivable types of dams are included in the list with the exception of pure arch dams. It is stated that earth-fill dams fail quite frequently, apparently because in most cases water goes over the crest or sweeps under the cut-off wall. Rock-fill dams fail for similar reasons, while reinforced-concrete dams generally have failed by the water undermining the structure.

Protection of inclined soils against the washing of rain and irrigation waters, S. CALDIERI (*Rev. Agr., Com., y Trab. [Cuba]*, 2 (1919), Nos. 9, pp. 432-436; 10, pp. 504-508; 11, pp. 565-570, figs. 31).—This is a translation by A. Brambila of an article describing the Italian system of protecting sloping soils against washing and excessive erosion by irrigation and rain water by the use of terraces and ditches.

Control of water on hills, L. FRONZI (*Coltivatore*, 66 (1920), Nos. 6, pp. 154-158; 7, pp. 182-186, figs. 5).—Italian practice in the prevention of erosion in hilly soils by terracing and ditching is reviewed.

Investigations in adapting the automobile to accurate soil survey and road traverse work, W. T. CARTER, JR., J. F. STROUD, and T. M. BUSHNELL (*Texas Sta. Circ.* 19 (1919), pp. 3-9, figs. 6).—Methods used by the Texas Soil Survey, in cooperation with the Bureau of Soils of the U. S. Department of Agriculture, in the use of an automobile in soil survey work, are described and illustrated. The most successful device for making surveys consisted of a wheel running alongside of the car with an attached odometer which can be read from the car seat.

Experiments on the value of common rock salt and sulphur for killing live stumps, W. RUDOLFS (*Soil Sci.*, 9 (1920), No. 3, pp. 181-189, figs. 4).—Experiments conducted at Rutgers College are reported, which showed that applications of sulphur on high or low oak brush as a means of clearing land for agricultural purposes is of no value. Instead, sulphur seemed to have a stimulating effect upon the growth of live tree stumps.

Common rock salt, when applied to oak stumps which had been allowed to grow for several years, did not do much harm when applications of from 2 to 2½ tons per acre were given. When applied in amounts of ½ to 1 ton per acre these shrubs were stimulated, the salt acting as a fertilizer. In cases where trees had been cut in winter time and the brush burned at the place, the stumps were much retarded in their growth by applications of salt at the rate of ½ to 1½ tons per acre. When applications of 2 to 3 tons per acre were made, stumps of white oak and black oak were killed or so severely injured that death resulted. The best time to make salt applications is in the spring, just

before the leaves appear and when the sap stream is able to carry the chlorin to the buds and young leaves.

TNT as a blasting explosive, C. E. MUNROE and S. P. HOWELL (*U. S. Dept. Agr., Dept. Circ. 94 (1920), pp. 24, figs. 12*).—This report presents the results of an investigation conducted by the U. S. Bureau of Mines to discover the safest and best methods of utilizing TNT for industrial blasting purposes. It describes the physical and chemical properties of different grades of the explosive; gives precautions to be observed in handling, packing, and preparation of cartridges, and charging; presents the results of field tests in blasting stumps, rocks, and other work; and compares the results with those obtained from dynamite.

It was found that Grade III TNT can be successfully used for adobe shots of bowlders, for removing stumps, and for splitting logs; and will give results equal to those given by 40 per cent straight nitroglycerin dynamite. It detonates completely with a No. 8 electric detonator, detonates completely under water, and detonates completely after a moderate immersion in wet holes. It is concluded that the appearance of black smoke on detonation is not to be taken as an evidence of incomplete detonation.

Results obtained at the University of Wisconsin and the Bureau of Mines explosives experiment station are also reported. Experiments on the water-resisting properties of TNT showed that when both ends of cartridges of all grades of TNT are redipped and not punctured they withstand water fully as well as the dynamites. Grade III TNT in cartridges was found to resist water from 1 to 72 hours or more, the time depending upon the density at which packed and the nature of the cartridge. In all tests with Grade III TNT the cartridges that were packed easily withstood the water better than those that were packed hard. Grade III TNT had very much better water-resisting properties than either of the other grades of TNT, especially when loosely packed, and compared favorably with the dynamites tested.

Of the three common grades of TNT the only one recommended for use in wet holes in cartridge form is Grade III. Grades I and II may be used for wet work if packed in completely redipped paraffined cartridges, provided they can be charged without breaking the cartridges. No mention is made in these experiments of the variable effect in detonation which may be expected from submitting the TNT to different degrees of pressure.

Experiments on the effect of soil moisture on the efficiency of dynamite, previously noted (*E. S. R.*, 42, p. 384), are included.

Cement in 1918, E. F. BURCHARD (*U. S. Geol. Survey, Min. Resources U. S., 1918, pt. 2, pp. IV+565-627, figs. 3*).—Data on the production and use of cement in the United States and foreign countries during 1918 are reported. There was a marked decline in the output of cement in 1918, amounting to about 22 per cent as compared with the output of the previous year.

The physical properties of magnesia cement and magnesia cement compounds, R. J. ROARK (*Bul. Univ. Wis., Engin. Ser.*, 8 (1917), No. 5, pp. 257-331, figs. 39).—This bulletin presents the results of an experimental study of the physical properties of magnesia cement and magnesia cement compounds and of the factors affecting these properties. An important object of the investigation was the determination of physical tests which could be relied upon to indicate the suitability or unsuitability of particular cements or compounds for use as flooring material.

A description of magnesia cement, its manufacture and uses, is given, together with a summary of the results of chemical investigations.

Antiseptic treatment of timber, E. E. KING (*Cornell Civ. Engin.*, 28 (1920) No. 6, pp. 245-253, figs. 6).—Different processes for the preservative treatment of timber are briefly reviewed.

Relation between viscosity and penetrance of creosote into wood, E. BATEMAN (*Chem. and Metall. Engin.*, 22 (1920), No. 8, pp. 359, 360, figs. 2).—A mathematical analysis of available data on the subject is given, from which it is concluded that "a very definite relation exists between the viscosity of the oil and the depth of penetration, and that this relation is amenable to mathematical treatment.

"A change in temperature of the oil has no other effect than that of changing the viscosity. The presence of free carbon in tar-creosote solutions has apparently no other effect than would be expected from the increased viscosity. The following equations hold for longleaf pine and noble fir when the time of treatment is two hours and the pressure 75 lbs. per square inch:

Longitudinal penetration $yx=k$

Tangential penetration $y\sqrt{x^3}=k_2$

Radial penetration $yx^2=k_3$

where x is the penetration, y the absolute viscosity, k , k_2 , and k_3 constants. When the pressure and time of treatment are changed the power of x and the value of k are changed. Sufficient data are not available to work out the effect of changes in time and pressure. The measurement of the viscosity of oils intended for treatment is perhaps the most important measurement as far as penetrance is concerned.

An investigation of the protective values of structural steel paints, J. S. COYE (*Iowa Engin. Expt. Sta. Bul. 54 (1919)*, pp. 68, figs. 23).—Laboratory and field studies of the paints in common use for painting highway structures to determine their suitability for the purpose are reported.

It was found that gypsum and whiting are harmful when present to a much greater extent than 5 per cent of the pigment. In every case where these materials were present to a considerable extent the paint failed to protect and rusting usually began underneath the film. It is concluded that it is not safe to use carbon and graphite paints for the first coat on steel. Coal-tar paints are worthless for structural steel exposed to the atmosphere under ordinary conditions. Asphaltic base paints as a class should not be specified as a general structural-steel coating, although those which have withstood a good service test may be specified individually.

Red lead, sublimed blue lead, sublimed lead sulphate, and zinc and lead whites are very effective for first coats and produce good surfaces for repainting. Frequent repainting is necessary when they are used for field coats. Red lead, sublimed blue lead, sublimed lead sulphate, zinc lead white, white lead, or leaded zinc pigments are always safe pigments for a shop-coat paint.

Pure iron oxid paints may be safely used for a shop coat, but should preferably be mixed with about 10 per cent zinc or lead chromate. Iron oxid paints containing gypsum or whiting in any considerable extent are not serviceable for either shop or field coats on structural steel.

There are certain carbon paints on the market which produce such a strong, elastic, and impermeable film that they may be used for both shop or field coats for structural steel, provided the painting is done in a thoroughly good, workmanlike manner. Graphite or carbon paints, the pigment of which contains 20 per cent of basic lead chromate, zinc chromate, lead oxid, or sublimed lead sulphate, are good shop-coat paints, and also prove very serviceable for field coats. There is some indication that china wood oil should be excluded as a vehicle for

structural-steel paints, because of the fact that vehicles composed largely of this oil increase the tendency to check.

A list of paints known to be satisfactory for highway bridges, and standard specifications for highway bridge paints, are appended.

Highway classification undertaken by Bureau Public Roads (*Engin. News-Rec.*, 84 (1920), No. 13, pp. 635-637).—The program outlined by T. H. MacDonald, chief of the Bureau of Public Roads of the U. S. Department of Agriculture, as being undertaken in cooperation with the War Department, State highway departments, and local interests for the systematic development of highways on the basis of their service functions is briefly outlined.

Field manual (*Boise, Idaho: Dept. Pub. Works, Bur. Highways, 1919, pp. 46, figs. 8*).—This manual contains instructions to employees of the Idaho Bureau of Highways on Federal and State-aid road work.

Reinforced-concrete roads, J. H. WALKER (*Surveyor and Munic. and County Engin.*, 57 (1920), No. 1,459, pp. 7, 8).—Experience in England with concrete roads is briefly summarized with reference to factors affecting design.

A thickness of 10 in., consisting of an 8-in. base and a 2-in. wearing surface, is advocated. Proper reinforcement and the consequent elimination of expansion joints is considered most feasible, the reinforcement consisting of a top and bottom layer connected by diagonal tension members.

Reinforced-concrete road construction, I. F. SHELLARD (*Surveyor and Munic. and County Engin.*, 56 (1919), No. 1,458, pp. 415, 416).—Experience in the design and construction of a trial length of reinforced-concrete road is related. The concrete was one course, 6 in. thick, of 1 part cement, 1½ parts coarse sand, and 3 parts 1 and 2 in. crushed limestone. The reinforcement was placed 2 in. from the bottom. No transverse joints were provided, but there was a longitudinal joint the whole length. The road has carried excessive traffic for three months successfully.

Concrete road work: Special reference to available aggregates, A. N. JOHNSON (*Concrete [Detroit, Mich.]*, 16 (1920), No. 4, pp. 179-183).—Considerable information on the subject is summarized, including tabular data on the proportioning and quantities of aggregates.

Stresses in concrete roads.—Determining the correct position of reinforcement (*Surveyor and Munic. and County Engin.*, 57 (1920), No. 1,464, p. 138).—A brief analysis of the stresses in concrete roads on firm and on yielding foundations leads to the conclusion that a layer of reinforcement is desirable near the upper surface of the concrete, and that where lower reinforcement is necessary it is ineffective unless upper reinforcement is also used. It is further concluded that every yard of reinforced concrete road should be considered on its merits.

Reduction of labor in the computation of vertical curves, B. E. BREVID (*Engin. and Contract.*, 53 (1920), No. 14, p. 413, figs. 2).—A short method for the computation of vertical highway curves is given.

Can we afford to delay road improvement? H. J. FIXMER (*Engin. and Contract.*, 53 (1920), No. 14, pp. 406-408, figs. 2).—Graphic data are reported showing cost per vehicle and per ton-mile, based on daily traffic for roads of various annual costs and also the saving effected by improved roads. These indicate that in spite of high prices road building is justified.

Traffic on Iowa highways, T. R. AGG (*Iowa Agr. Col., Off. Pub.*, 18 (1920), No. 34, pp. 14, pls. 18, figs. 3).—An investigation is reported which was undertaken to secure data relative to the weight of each class of vehicles using Iowa highways.

Traffic weighings were made at seven stations selected with regard to possible variation in the weight of vehicles in different parts of the State. The

tonnage of traffic on Iowa highways was found to be considerably larger than has been generally supposed, which emphasizes the wisdom of constructing road surfaces of great durability. It is noted that a system of earth roads has been carrying a traffic that would be considered moderately heavy for a paved road.

Passenger automobiles overwhelmingly predominate in the present traffic. The present highways, because of the extreme variations in the condition of the surface, do not encourage the use of motor trucks; and the development of truck hauling, particularly for farm products, apparently has been held in abeyance pending the construction of suitable road surfaces. About 90 per cent of the tonnage of traffic on Iowa highways is motor driven.

The results of traffic weighings on a gravel surface indicates that the traffic is far beyond the capacity of a gravel road constructed with materials available in Iowa.

The use of electricity in agriculture, J. F. CROWLEY (*Jour. Roy. Soc. Arts*, 67 (1919), Nos. 3488, pp. 695-701; 3489, pp. 709-721; 3490, pp. 723-734, figs. 15; also in *Chem. News*, 119 (1919), Nos. 3106, pp. 193-195; 3107, pp. 204-206; 3111, pp. 252, 253; 3112, pp. 264, 265; 3113, pp. 275, 276; 120 (1920), Nos. 3118, pp. 25-28; 3119, pp. 37-40; 3120, pp. 49-52; 3121, pp. 66-68, figs. 15; abs. in *Sci. Abs.*, Sect. B—*Elect. Engin.*, 22 (1919), No. 264, p. 427).—This report deals with the adaptation of electricity to different agricultural works, including lighting and driving farm machinery, with special reference to its development in Germany. It is stated that the most striking lesson drawn from a study of the application of electricity to agriculture in Germany lies in the manner in which the thinly populated rural districts secured the advantages of a cheap supply of electricity. This was done mainly through rural cooperative societies. Some of these societies produced electricity themselves; some bought it in bulk and distributed it over their own system; while others combined to guarantee a certain consumption and thus secured cheap current.

The author is of the opinion that the conditions in England are such as to make the provision of electricity in rural districts a much simpler undertaking than in Germany, and that considerable progress would be made in the promotion of a cooperative movement. It is stated that there are over 428,000 farms of from 5 to 300 acres each in the United Kingdom, and it is estimated that to operate these electrically would consume not less than 4,000,000,000 units per annum.

Belting for power transmission, E. D. WILSON (*Trans. Amer. Inst. Chem. Engin.*, 11 (1918), pp. 237-245, figs. 4).—Tests of a number of belts made of single-ply leather, 4-ply Balata, single and double solid woven cotton, 4-ply friction surface rubber, and 4-ply stitched and filled canvas, are reported. The belts were tested on 24-in. pulleys of cast-iron, steel, and wood at speeds varying from 2,500 to 5,000 ft. per minute and tensions varying from 45 to 90 lbs. per inch of belt width.

It was found that all the belts, with the exception of leather, exhibited the same characteristics and showed inability to transmit power when slipping about 1½ per cent. The striking characteristic of all of the fabric belts is that they possess a very definite maximum capacity beyond which it is impossible to go. Leather belting possessed an overloading capacity of 60 per cent. It was concluded that these experiments prove that the cheapest belting material on a basis of the power actually transmitted is leather.

Motor truck design and construction, C. T. SCHAEFER (*New York: D. Van Nostrand Co.*, 1919, pp. VIII+318, figs. 292).—A compilation of data and practical information on the design and construction of motor trucks is given for the use of the engineer. The following chapters are included: The general layout of the chassis, the motor-truck engine—its construction and lubrication,

the motor-cooling system, carburetion and carburetors, ignition systems, governors and speed controlling devices, the clutch and transmission, universal joint and propeller shaft, the differential, the final drive, front and 4-wheel drives, motor-truck brakes, the front axle, steering gears and fundamental principles of steering mechanisms, motor-truck frames, power-plant mountings, springs and spring suspensions, the fuel-supply system, control, and muffler, motor-truck wheels, motor-truck tires and rims, and electric lighting and starting on commercial vehicles.

Relation of solid and pneumatic tires to motor-truck efficiency, S. V. NORTON (*Jour. Soc. Automotive Engin.*, 6 (1920), No. 4, pp. 208-214).—The author presents and analyzes considerable data on the use of solid and pneumatic tires on motor trucks, and suggests that in the present state of development the field for each type of tire may be separated into three classifications, namely, the imperative field, the economic field, and the optional field.

"The factors that would bring a truck within the first classification for solid tires are (1) if it travels over pavements not necessarily good, but having a reasonably hard road surface to provide traction, (2) if the delivery must positively reach its destination without fail at a promised time, (3) if the delivery must be made regularly on a given schedule in which the regularity is a more important factor than either speed or cost of delivery, and (4) if it carries heavy loads with frequent overloads beyond the rated capacity of the tires. Similarly the factors that would bring a truck within the imperative field for pneumatic tires are some combination of the following: (1) if it travels over surfaces on which traction can not be obtained by solid tires, and when the need for traction is such as to outweigh the item of cost, (2) if the need for speed of delivery is more important than its cost, and (3) if the merchandise carried is so perishable or fragile that it must be protected from road shocks, even at high cost.

"The factors that would bring a truck within the economic field for solid tires are (1) short hauls in cities where speed is relatively unimportant, (2) heavy loads with a tendency to overload, (3) traffic congestion which reduces average speed, (4) loading and unloading delays, and (5) need for low delivery cost. Similarly the factors that would bring a truck within the economic field for pneumatic tires are (1) road conditions which will not prematurely destroy the tires, (2) long hauls, (3) high average speed, (4) relatively light loads with no overloads, (5) good tire-service conditions, and (6) low cost subordinated to quick service."

Tests reveal relative values of pneumatic and solid tires, A. F. MASURY (*Engin. News-Rec.*, 84 (1920), No. 14, pp. 668-670, figs. 2).—Tests of different types and sizes of motor trucks subjected to different kinds and amounts of shock in excess of probable service shock, and observations of the effect of road impact on spring and tire equipment, as well as the effect of unsprung weight upon road impact, are reported. The trucks were operated at speeds of from 15 to 18 miles per hour.

The conclusions drawn are that the impact of a truck striking the ground after bounding over an obstruction is increased approximately as the square of the speed and as the weight, but inversely as the resiliency of the springs and tires. A further conclusion is drawn that a 7½-ton truck on pneumatic tires will do less damage to a road than a 5-ton truck on solid tires operating over the same route and at the same speeds.

Thirteen years of tractor development work, J. H. MCCOLLOUGH, JR. (*Agrimotor*, 2 (1919), No. 12, pp. 5-10, figs. 12).—An account is given of the trials encountered for 13 years in tractor development.

How they test tractors at Purdue University, C. H. BENJAMIN (*Agrimotor*, 3 (1920), No. 6, pp. 19, 20, figs. 2).—The laboratory equipment for testing tractors at Purdue University is briefly described and illustrated.

The plant itself consists of (1) a treadmill or moving platform, supported on driving wheels and idle rollers, and in its turn supporting the driving wheels or lags of the tractor; (2) a traction dynamometer to receive and measure the pull of the tractor; and (3) an absorption dynamometer to control and measure the energy transmitted through the treadmill and its supporting wheels. The plant is capable of testing tractors weighing as high as 12,000 lbs. on the driving wheels, and giving a drawbar pull of about 5,000 lbs. at a speed not to exceed 5 miles per hour. The tractors may be either single-wheel or double-wheel, front or rear drive, or of the caterpillar type, with maximum tread for the double-wheel tractor of 85 in. and a caterpillar length of 96 in., the face of the drivers not being greater than 26 in.

The Lincoln [tractor] trials, September, 1919, R. N. TWEEDY (*Better Business*, 5 (1920), No. 2, pp. 140-152).—The detailed data of these trials are reported.

Mechanical analysis of tractors at K. C. show, H. FARRINGTON and F. V. HERDMAN (*Agrimotor*, 3 (1920), No. 5, pp. 7-10, 30).—This is a mechanical analysis of 103 tractors of 66 different makes exhibited at the National Tractor Show at Kansas City, Mo., in February, 1920.

The outstanding features were the increase in the number of unit construction models, the increase in the number of all-purpose or small general-utility tractors and motor cultivators, and the arrival of the garden tractor. Prices ranged from \$310 to \$5,750, the average price of 99 machines being \$1,899. The weights ranged from 500 lbs. to 26,700 lbs., the average weight of 101 models being 6,326 lbs. The average (list) price per pound of all the tractors at the show was almost exactly 30 cts. The highest price per pound among the tractors proper was in the 2-plow class where it was 35.5 cents. The price per pound in the 3-plow and 4-plow classes was 33.2 cts.; in the 5-plow class, 24.8 cts.; in the 6-plow class, 27.9 cts.; in the 8-plow class, 19.9 cts.; and in the 10-plow class, 24.3 cts.

Of the 103 tractor models at the show, 91 were machines of the wheel type and 12 of the crawler or tracklaying type. Eighty models had 4-cylinder engines, 16 had 2-cylinder engines, 4 had 6-cylinder engines, and 3 had 1-cylinder engines. The vertical type of engine heavily preponderated with 83 adherents, as against 20 of the horizontal type.

Six reference tables covering prices and specifications are included.

1920 tractor and implement blue book (*St. Louis, Co.: Midland Pub. Co., 1920, pp. 415*).—This handbook contains classified data on implements and implement manufacturers, and complete specifications for farm tractors, motor cultivators, tractor plows, silo fillers, grain thrashers, huskers and shredders, and tractor accessories.

A tractor engine test, C. A. NORMAN and B. STOCKELETH (*Jour. Soc. Automotive Engin.*, 6 (1920), No. 2, pp. 99-106, figs. 21).—Experiments conducted at the Ohio State University on a 4-cylinder tractor engine burning both kerosene and gasoline, to determine what constitutes the best adjustment for an engine, are reported. The mechanical details of the engine are described fully. The engine was run as far as possible at a series of set speeds with the throttle locked in a wide-open position. At each speed the temperature of the air to the carburetor was held successively at certain fixed points, usually 70, 85, 100, 120, 160, 200, and 240° F. The results are graphically reported.

At lower speeds the power was influenced very little by variation in ratios of mixture between rather wide limits. Practically no variation appeared up to 400 r. p. m. throughout the whole range of workable mixtures. At 500 r. p. m. it was possible to operate the engine on mixtures of less than 8 lbs. of air per pound of fuel, although at a very marked sacrifice of power. From 9.5 lbs. up to over 17 lbs. the power remained practically constant. At 600 r. p. m. a drop in power was noticeable with air quantities exceeding 14 to 15 lbs. per pound of fuel. At higher speeds the range of constant and optimum power became narrower until at 900 and 1,000 r. p. m. there was a decided peak at about 10.5 to 11 lbs. of air per pound of fuel.

The influence of increased richness of mixture on fuel economy was uniformly toward a greater fuel consumption. At higher speeds very lean mixtures likewise showed an increase in the fuel consumption per brake-horsepower. The general effect of air heating was to reduce power, but the fuel economy, especially at the higher speeds, was not affected very much by variations in the air temperature. The fuel economy at a ratio of 12:1 varied but little with the speed from 400 to 1,000 r. p. m. However, a fuel economy fully 20 to 25 per cent better than that at 12:1 was obtained by using weaker mixtures.

It is concluded that while rich mixtures and low temperatures give maximum power, leaner mixtures and higher temperatures are conducive to the greatest fuel economy. It is noted that the greatest economy occurred at from speeds of from 400 to 600 r. p. m. The conclusion is also drawn, in connection with increased air temperature, that the mixture just prior to combustion, although at a slightly different temperature, is almost in the same state of evaporation in all cases.

The problem of good valves for the tractor, W. C. WILLARD (*Agrimotor*, 3 (1920), No. 4, pp. 112, 114, figs. 5).—This is a brief treatise summarizing experience in the design and manufacture of valves for tractor engines.

Comparing tractor speeds with power, C. E. FRUDDEN (*Agrimotor*, 3 (1920), No. 4, p. 60, fig. 1).—Data are reported to show the effect of higher plowing speeds upon the power required from the tractor engine.

Graphic data show the relation between power, number of plows, and speed of travel as expressed by the formula, horsepower= $N \times S \times 3.6$, in which the horsepower is expressed as brake-horsepower of the engine; N equals the number of 14-in. plows; S equals speed in miles per hour; and 3.6 equals an experimental factor. "According to this formula . . . a tractor engine of 25 b. h. p. can pull two plows at 3.5 miles per hour, three plows at 2.33 miles per hour, or four plows at 1.75 miles per hour. Or, on the same basis, the power required for general satisfaction when pulling three 14-in. plows will vary as follows: 21.6 h. p. for three plows at 2 miles per hour, 27 h. p. for three plows at 2½ miles per hour, 32.4 h. p. for three plows at 3 miles per hour, or 37.8 h. p. for three plows at 3½ miles per hour. . . ."

"If, as is often said, the tendency is toward higher plowing speeds, tractors will require larger engines in proportion to the increase in speed plus the deficiency now existing in a great many outfits to bring them up to the standards here set forth."

The design of light tractor plows, J. J. BERGIN (*Impl. and Mach. Rev.*, 45 (1920), No. 539, pp. 1632-1634).—The author analyzes the design of light tractor plows with reference to conditions in Ireland, and presents the following specifications for what he considers to be the model design for a tractor plow suited to small and medium farms and light and medium land:

(1) Weight about 3½ cwt.; (2) to turn 2 furrows 9 to 10 in. wide; (3) fitted with digging or semidigging breasts and have tail pieces fitted; (4)

breasts to be adequately stayed, not necessarily with adjustable stays; (5) sole-plate of hind plow to be of good length; (6) narrow share; (7) knife coulter and separate skimmer, also a nonswinging disc coulter secured to a single flat stalk and having combined a skimmer giving 2 or 3 in. vertical adjustment; (8) arch-backed beam, not dipping toward the ground, but carried parallel until almost at the point of draft; (9) provision for dipping the nose of either plow independent of the other; (10) good longitudinal distance between the bodies, up to 30 in. in 2-furrow plows; (11) not more than two wheels and a simple hind carrier for transport; (12) wheels to be capable of being lubricated without removal from axle; (13) rigid drawbar, giving liberal and fine lateral adjustment; (14) simple self-lifting arrangement, having the fewest possible moving parts; (15) provision for regulating depth of plowing otherwise than by lever and quadrant; and (16) no hexagonal nuts on any part of plow—all must be square.

The week of motor cultivation at Senlis, R. GREILSAMMER (*Jour. Agr. Prat., n. ser., 32 (1919), No. 39, pp. 789-792, figs. 4*).—The mechanical details of the different motor-plowing apparatus on demonstration at Senlis are described, it being shown that the French manufacturers are tending to replace slow-speed motors with light high-speed motors of greater flexibility and lower fuel consumption. There were more machines burning kerosene than gasoline, but none burning producer gas.

Mechanical cultivation in 1919, G. COUPAN (*Génie Civil, 75 (1919), Nos. 23, pp. 557-565; 24, pp. 593-599; 25, pp. 617-622; 26, pp. 645-648, figs. 48*).—This report describes the mechanical details of the different tractors, motor plows, and mechanical-plowing apparatus tested in France during 1919.

Cultural care of plantations, vines, and groves for silage, R. OPAZO G. (*Dir. Jen. Serv. Agr. [Chile] Bol. 49 (1919), pp. 35, figs. 15*).—Machinery and implements for the cultivation and care of silage crops are described and illustrated.

Farm implements and machinery in France and North Africa, H. L. GROVES (*U. S. Dept. Com., Bur. Foreign and Dom. Com., Spec. Agents Ser., No. 191 (1920), pp. 36*).—This is a report on the markets for farm implements in France and the French colonial territory in North Africa.

It is stated that in certain classes of implements, notably hay and grain harvesting machinery, manufacturers of the United States have dominated the trade for many years and have reasonable assurance of being able to maintain this position. The trade in some of the smaller types of implements, such as plows, harrows, cultivators, grain drills, straw cutters, and land rollers, and also in threshers and steam tractors, has hitherto gone largely to France and other European manufacturers. Changed conditions in the markets for raw materials and labor have furnished an opportunity for American exporters to compete on more favorable terms in the sale of these machines.

Useful data on reinforced-concrete buildings for the designer and estimator by the engineering staff of the Corrugated Bar Company, Inc. (*Buffalo, N. Y.: Corrugated Bar Co., Inc., 1919, pp. 216, figs. 174*).—This handbook contains data and diagrams on reinforced concrete for the use of the designer and estimator. It is intended to supplement textbooks on concrete design with the purpose of eliminating the manual labor involved in the repeated application of formulas and diagrams to the determination of the dimensions of a structure.

Attractive design for a country house, J. H. ADRIANZEN (*Building Age, 42 (1920), No. 4, p. 46, figs. 2*).—Plan drawings and brief specifications for a country house are given.

Stables, D. O. BERUMEN (*Rev. Agr. [Mex.]*, 5 (1919), No. 1, pp. 42-46, figs. 5).—Mexican practice in the arrangement and construction of horse stables is discussed.

Measurement of stacks to find weight of contents, A. MACPHERSON (*New Zeal. Jour. Agr.*, 20 (1920), No. 2, pp. 115-117, figs. 3).—Instructions for the measurement of hay stacks to determine their weight are given.

Scientific methods of sewage disposal, W. C. TUCKER (*Building Age*, 42 (1920), No. 4, pp. 33-36, figs. 5).—Descriptions are given of moderate cost installations suitable to the country home.

Sewage disposal in the private home, H. E. MILLER (*Health Bul.*, 35 (1920), No. 3, pp. 10-14, figs. 3).—The design and construction of small residential sewage disposal systems are discussed.

RURAL ECONOMICS.

Rent contracts in typical countries of the wheat belt, E. A. BOEGER (*U. S. Dept. Agr. Bul.* 850 (1920), pp. 13, fig. 1).—Material is presented here which was gathered in the spring of 1917 by visiting tenants on their farms in Barton County, Kans.; Clay County, Nebr.; Spink County, S. Dak.; Barnes County, N. Dak.; and Renville County, Minn. Six distinct systems found are described, and the comparative percentages of tenants who rent under each system in the different locations are tabulated. Certain minor factors concerned in renting farms are given consideration, such as obtaining hay and pasture land, pasturing wheat, the division of stalks and straw, distance to market, and value of land and buildings.

A preponderance of oral over written leases is noted and accounted for by the large percentage of parent landlords. It is also noted that tenants on farms for the first year were usually under written contract. The lease year varies in different localities, depending principally on the time of sowing and thrashing the main crop. From 60 to 86 per cent of the tenants in the localities visited preferred the long lease, and from 85 to 100 per cent preferred share to cash renting. In only two of the localities, Kansas and South Dakota, did a majority of the tenants think that they could become owners in their present localities within 15 years. From 85 to 96 per cent of the nonowners expect to own farms, if not in their present localities then in some place where land costs less. It is stated that tenancy in these regions will probably increase for some years yet.

The average size of the farms operated by tenants varied from 202 acres in the Minnesota area to 489 acres in the North Dakota area. The income from farms of this size is sufficient to encourage the owner to rent his land, while tenants find it increasingly difficult to attain the status of owner and will probably remain tenants for a longer period than has been the case in the past.

Agricultural war damages—a guide for their estimation (*Domages de Guerre Agricoles. Paris: Agr. Maison Rustique* [1919], pp. 63).—This handbook offers a scale by which losses in various crops, fertilizers, live stock, harness, tools, and certain raw materials incurred between 1914 and 1919 may be estimated. It is intended to serve as the basis for evaluating losses suffered and amount of reparation due.

Colonization projects, J. YAMANDI (*Rev. de Revistas [Buenos Aires]*, 2 (1919), No. 19, pp. 10-12).—In this article is outlined a tentative method of organizing a colonization company for Argentina, touching upon membership, means of acquiring capital, administration, buying and selling the land, and other details.

Selecting a farm, E. H. THOMSON (*U. S. Dept. Agr., Farmers' Bul. 1088* (1920), pp. 27, figs. 4).—The purpose of this bulletin is to suggest to those who have had limited experience in farming or who may contemplate moving into an unfamiliar locality, some of the points to be observed when selecting a farm. A blank form is appended summarizing the points emphasized, principally location; topography and soil; arrangement; water supply; social conditions; prospective rise in value; buying equipment, live stock, etc., with the farm; possibility of disposing of it; buying a farm and renting additional land; and renting a farm.

[**Report of farm management survey work**], A. LEITCH and J. C. NEALE (*Ann. Rpt. Ontario Agr. and Expt. Union, 41* (1919), pp. 46-49).—Tabulations of data from 1,400 farms representing for distinct areas and three types of farming in the Province of Ontario, dairying, beef-raising, and mixed farming, are given. In the first instance returns are arranged according to tillable area, capital, crop acres per man, and labor income, making comparisons between the dairying section of Oxford County and the beef-raising sections in Peel and Middlesex Counties. The first comparison indicates that the labor income is proportionate to the capital invested. The Oxford man buys a small farm because he must pay more per acre and must buy more live stock. The Peel County man buys a larger farm. Their labor incomes for the year will be approximately the same.

The second comparison indicates that the area actually under crop is much larger on the Oxford County dairy farm than on the Middlesex beef-raising farm, that with certain exceptions the number of acres of crops handled by each man is larger in Oxford than in Middlesex, these first two features involving a smaller labor income in the latter section, and that the capital invested is smaller on the beef farm than on the dairy farm of equal size.

Another tabulation is given showing a steady decrease in the labor income as the percentage of tillable land in pasture increases. Certain so-called odd-sized dairy farms are isolated from the data for Oxford County, and it is established that those of 61 to 75 tillable acres and of 111 to 135 tillable acres require a greater managerial ability on the part of the operator than do farms of any other size. The size of farm which seems to be nearest the ideal for dairying purposes is said to be the one having from 90 to 110 acres tillable.

Dairying turned the trick, J. C. McDOWELL (*Banker-Farmer, 7* (1920), No. 4-5, pp. 2-4, figs. 3).—This is an abstract of an article which has been noted from another source (*E. S. R., 41*, p. 677).

[**Study program by the American Association for Agricultural Legislation**], A. B. COX (*Amer. Assoc. Agr. Leg. Bul. 4* (1919), pp. 19).—Topics designed to stimulate study and training for leadership among advanced college students are outlined under the heads of food production and prices, land settlement study, education and improvement of rural life, marketing, taxation as it relates to agricultural, rural credits, economic studies in highway development, public grazing lands in the West, collective bargaining in agriculture, and farm labor problems in the United States. Subjects for debate and studies previously published are also noted.

[**Report of the Porto Rico commissioner of agriculture and labor**], M. CAMUÑAS (*War Dept. [U. S.] Ann. Rpt. Governor P. R., 19* (1919), pp. 685-713).—Included in this report are brief notes relating to agricultural associations, investigations relative to extending the Federal Farm Loan act to Porto Rico, and the economic and social condition of farm laborers.

Agricultural products [of Brazil], A. H. REDFIELD and H. WATKINS (*U. S. Dept. Com., Bur. Foreign and Dom. Com., Misc. Ser. No. 86* (1920), pp. 20-33).—This chapter in the study of economic conditions in Brazil during the war illus-

trates the diversification of agriculture which resulted from the cessation of allied importations of coffee and rubber. Notes are given on the recent increase in production and exportation of beans, rice, cassava, flour, wheat, sugar, cacao, meats and meat products, cotton, and coffee.

[**Agricultural France**] (*Rural Manhood*, 11 (1920), No. 4, pp. 131-133, 135-157, figs. 10).—Among the articles pertaining to various phases of French agricultural life included in a special France number of this magazine are Products of Agricultural France; The French Peasant; Women in Agriculture, surveying what France is doing in the matter of training women; Ancient Peasant Customs and Habits, which describes traits and traditions of family and neighborhood groups; and The Future of French Agriculture, noting some adjustments that are already being made, all by M. Augé-Laribé; The Peasant Mind in Rural Organization, by C. Gide; Agriculture in the Devastated Regions, by E. De Warren; and the Moral Renaissance of the Country, surveying efforts to establish rural community centers, by L. Compain.

[**Legislation and regulation affecting French agriculture**] (*Bul. Mens. Off. Renseig. Agr. [France]*, 18 (1919), Nos. 1, pp. 1-111; 2, pp. 131-310).—Laws and official decrees, resolutions, and documents issued by the French Minister of Agriculture of dates January to August, 1919, are published here.

Denmark—agriculture, commerce, finance (*New York: Brown Bros. & Co.*, 1920, pp. 32, pl. 1, figs. 39).—A description of Denmark's production of food-stuffs before the war and since is given in this pamphlet, together with accounts of the cooperative system as developed in connection with agriculture and of shipping and finance.

Reports of the National Congress for the Restoration of Agriculture and the Improvement of Rural Life (*Cong. Natl. Restauration Agr. et Embellissement Vie Rurale, Bruxelles, 1919; Compt. Rend., pp. 98; Raps., Sect. 1, pp. [4]+68; Sect. 2, pp. 78; Sect. 3, pp. 29; Sect. 4, pp. 171; Sect. 5, pp. 94*).—With the proceedings of this Belgian congress, noted editorially (*E. S. R.*, 42, p. 701), are published addresses and resolutions on reconstruction, agricultural education, rural hygiene and conveniences, rural charity and socialization, beautification of the countryside, and the agricultural labor situation. One paper by A. Delos gives statistics for recent decreases in the number of agricultural laborers and budgets showing wages and living expenses of agricultural laborers for a number of years in rural districts of Belgium.

The earliest agricultural organization in India and its methods, P. C. BASU (*Indian Jour. Econ.*, 2 (1919), No. 4, pp. 609-628).—This deals with the agricultural organization of the Aryans in India so far as that can be gathered from the earliest literature, the Rig Veda. It is shown that the system was complex and further developed than that of the Teuton or even the Briton.

Distribution of agricultural holdings, E. V. S. REDDY (*Indian Jour. Econ.*, 2 (1919), No. 4, pp. 522-538).—This is a discussion of the problem of preventing subdivision of holdings below limits which will be regarded as economic and bringing together scattered holdings, reviewing proposed legislation with this end in view, and noting difficulties arising out of conflicting systems of inheritance.

A study in village economics, V. G. KALE (*Indian Jour. Econ.*, 2 (1919), No. 4, pp. 462-476).—The author urges detailed investigation of prevailing economic conditions in Indian villages, pointing out that some work of this kind is already being done by revenue officials and others, that advantage should be taken of the existing official machinery to make the economic inquiries more comprehensive, and that the provincial governments need to conduct special inquiries into the material condition of rural areas. These studies have an economic importance for the people at large.

Land and labor in a Deccan village, H. H. MANN ET AL. (*London: Humphrey Milford, Oxford Univ. Press, 1917, pp. V+184, pls. 10*).—The village selected for the investigation reported here was chosen as being near enough to Poona to be accessible and yet as being largely out of the immediate influence of a large town, as being typical of a large tract in the districts of the Deccan where the "kharif," or rains crop, is the most important, and hence where the rains are more certain than they are farther east, and as being one where the influence of irrigation, whether from canals or wells, was all but negligible. The area of the village land comprises 1,065 acres. Certain physical characteristics, such as geographical features, soils, waters, and drainage, the land and its divisions and manner of holding, and the vegetation, principal crops, cultivation, and live stock, are described in some detail.

A chapter on the people of the village covers the characteristics of the population, labor supply, total village income, village expenditures and debts, and the standard of living. This examination shows three groups, one solvent, supporting itself from the land alone, one entirely supporting itself but by land income supplemented by that from outside labor, and a third insolvent. Estimates are made of the value of land, houses, live stock, and improvements. It is said that debts are a crushing load on the people.

Conclusions are drawn that since the coming of British rule the population of the village has increased, and along with it the subdivision of the land, but also that there are various indications that the standard of cultivation has deteriorated. It is becoming more and more necessary for villagers to seek employment outside the village. Appendixes give an analysis of river water at the village, certain decisions of the Inam Commission, and a list of herbaceous plants.

The rural life of Chotanagpur, P. C. BOSE (*Indian Jour. Econ., 2 (1919), No. 4, pp. 551-563*).—A descriptive account is given of village life in the division of Chotanagpur in the Province of Bihar and Orissa, covering housing, agriculture, and additional means of livelihood, classes or castes, village customs, and economic status of the villagers.

First investigations on the efficiency of agricultural labor in western India, H. H. MANN (*Indian Jour. Econ., 2 (1919), No. 4, pp. 456-461*).—The author briefly outlines the method by which he has arrived at figures for the average day's plowing accomplished by one man with plows of various types and on different soils. It is indicated that the plowman in America is 50 per cent more efficient than the Indian workman using equipment which he has at hand.

Cooperation in India, H. H. WOLFF (*London: W. Thacker & Co., 1919, pp. VII+352*).—Some of the peculiar difficulties of obtaining credit to peasant farmers and early attempts at establishing agricultural credit in India are discussed, citing frequently also the experience of the Agricultural Bank of Egypt with the reluctance of natives to take advantage of opportunities offered them. The introduction of cooperative credit in India and important results obtained during the last 25 years are described. Developments in various countries and certain European precedents, especially as to government subsidy and the antagonism between production and distribution, are noted as being justified or not in India.

The organization and working of the village society and its importance as the foundation of cooperative credit, as well as its affiliation with the larger national organization, are described. One chapter is devoted to non-agricultural credit, mainly in the form of clerks', employees', and small tradesmen's societies, and another to grain banks in comparison with which the Spanish "pósitos" are noted.

The true sphere of central banks, J. C. COYAJEE (*Bengal, Bihar, and Orissa Coop. Jour.*, 5 (1920), No. 4, pp. 232-241).—The author is opposed to an extension of the function of the central banks to control and propaganda in the cooperative credit system of India.

Short-time credit for farmers, W. R. CAMP (*Farm Jour.*, 44 (1920), No. 2, pp. 132, 133).—Certain salient points in the organization and operation of cooperative rural credit unions are set forth here, being illustrated with actual figures for the business of five such societies in North Carolina.

Short-time personal credit, J. YAMANDI (*Rev. de Revistas [Buenos Aires]*, 2 (1919), No. 17, pp. 19, 20).—The author sets forth farmers' needs of credit in general, indicates the expenses attached to mortgage credit obtained through private banking institutions, and urges the cooperative organization of small landholders for both long-time mortgage credit and short-time personal credit.

[Rural credit, cooperation, and insurance in the Philippines], A. HERNANDEZ [*Philippine*] *Bur. Agr. Rpt.* 1918, pp. 54-57, pl. 1).—Brief notes on the progress of projects previously noted (*E. S. R.*, 41, p. 793) are given here.

Problems of a rural juvenile court, J. W. LEE (*Colo. State Teachers Col. Bul. Ser.* 19, 1919, No. 7, pp. 52).—Characteristic geographic features and problems of Weld County, Colo., as they influence juvenile delinquency are described, and a general discussion is given to such problems as formal and informal probation, institutional treatment, and the functions of the juvenile court. Cases that have come to the attention of the juvenile department of the county court of Weld County are cited, especially in setting forth the means adopted for giving medical attention, the psychological clinic conducted in connection with the Colorado State Teachers' College, the field organization, and the correlation of court and school.

The banker's part in marketing, G. LIVINGSTON (*Banker-Farmer*, 7 (1920), No. 6, pp. 4-6, figs. 3).—The purpose of this article is to enlist the banker's interest in certain basic studies and activities of the Bureau of Markets of the U. S. Department of Agriculture, especially those relating to standardization of staple and perishable crops and of containers, the administration of the United States Warehouse Act, the market news service, and the food products inspection service, since these stabilize the basis of making loans and extending credit to producers.

The Market Reporter (*U. S. Dept. Agr., Market Rptr.*, 1 (1920), Nos. 18, pp. 273-288; 19, pp. 289-304; 20, pp. 305-320, fig. 1; 21, pp. 321-336).—These numbers continue weekly and monthly summaries of the movement, marketing, and prices of specified commodities, tabulated statistics with interpretative text in regard to important classes of agricultural products, and foreign market information.

Leading articles appearing in No. 18 note briefly the acreage, production, and prices of early tomatoes, and report an overstocked domestic market with limited export demand for condensed milk. In No. 19 are presented a summary of the April meat trade and notes on the shipments and prices of early strawberries in five years, 1916-1920, inclusive, and in No. 20, notes on the hide shortage and leather prices with a comparison of the American and German situations, together with an article on the oversupply of the British market with Australian mutton. No. 21 includes special articles on the scarcity and high prices of mill feeds, and the assistance rendered live-stock shippers by the Bureau of Markets of the U. S. Department of Agriculture, and reports a large supply of crimson clover seed.

Monthly Crop Reporter (*U. S. Dept. Agr., Mo. Crop Rptr.*, 6 (1920), No. 5, pp. 41-48, fig. 1).—This contains the usual estimates of acreage and production

and data relating to the farm and market value of important products, crop conditions, and the current United States crop summary. There are shown also statistics for the condition of farm animals May 1, and estimated losses during the year ended April 30, with yearly comparisons for the United States and changes in live stock on farms. Brief notes on the reduced potato and bean acreage indicated by May 1 reports and on leading breeds of live stock in the United States are included.

Agricultural statistics of Chile (*An. Estadis. Chile, 1917-18, Sect. VII, pp. [5]+133*).—Data previously noted (E. S. R., 40, p. 894) are continued for the later year.

[Agricultural statistics for Denmark] (*Statist. Aarbog Danmark, 24 (1919), pp. 40-64*).—In these pages are given statistics for later years, continuing information previously noted (E. S. R. 41, p. 94).

AGRICULTURAL EDUCATION.

[The reorganization of agricultural education in Belgium] (*Ann. Gembloux, 26 (1920), No. 2, pp. 90, 91*).—The text is given of a law of November 15, 1919, relating to agricultural education in Belgium, which takes the place of the act of April 4, 1890. It provides that agricultural education in Belgium shall comprise (1) two higher agricultural education institutions in which the language of instruction shall be French and Flemish, respectively, and including departments in agronomy, streams and forests, horticulture, agricultural industries, rural engineering, and colonial agriculture; (2) professional schools of agriculture and special schools of horticulture, floriculture, dairying, agricultural mechanics, agricultural housekeeping, etc.; (3) professional schools of elementary agriculture or of local special subjects; and (4) courses and lectures for the promotion of agricultural instruction and special subjects. Government aid may be given to schools offering agricultural courses or lectures, established by the communes or provinces or by both in accordance with the government program, submitting to official inspection, and, except in exceptional cases, attended by at least 15 pupils. A report on the status of agricultural education must be submitted every three years by the Government to the Legislative Chambers.

Education in French West Africa: Preapprenticeship and apprenticeship, G. HARDY (*Bul. Soc. Encour. Indus. Natl. [Paris], 131 (1919), No. 6, pp. 314-334, figs. 6*).—This is an account of the organization and some results of preapprenticeship and apprenticeship instruction of the natives in French West Africa by the director of education.

Preapprenticeship instruction is given in the village primary schools and in the elementary classes of urban schools. Its object is to teach general culture and useful living by developing the child's powers of observation and judgment and directing his mind along useful channels. In consequence of the adaptation of these courses to local needs these schools are differentiated as primary pastoral, agricultural, silvicultural, maritime, urban, or industrial schools, etc. Practical instruction is given daily, the agricultural work predominating because of the agricultural nature of this country. The prejudice of the natives against instruction in manual work has been overcome.

Apprenticeship instruction comprises professional schools, wholly specialized, and technical schools. There are eight such schools and two sections of agriculture in the experiment stations. A school of tropical agriculture and silviculture is soon to be established at Bingerville, Ivory Coast. These schools are residential schools and the Government furnishes students lodging, board,

and clothing. The time is about equally divided between practical and cultural instruction.

Instruction in home economics is organized along similar lines. The pre-apprenticeship instruction includes French, reading, writing, and arithmetic, and practical work in cooking, sewing, care of the clothes, domestic and infant hygiene, first aid, laundering, etc. The products of these activities, as well as of those for boys, are reserved to the pupils.

[**Report on agricultural forestry, and veterinary education in the Dutch East Indies**], W. G. BOORSMA, A. DE KONING, and H. C. H. DE BIE (*Jaarb. Dept. Landb., Nijv. en Handel Nederland, Indië, 1917, pp. 84-89, 142-151, 198-205*).—This is an account of the activities of the Department of Agriculture, Industry, and Commerce of the Dutch East Indies in 1917 in the promotion of agricultural and veterinary science instruction, comprising the work of the higher agricultural school at Buitenzorg, the secondary school of agriculture or cultivation school at Soekaboem (preparatory to the former), the veterinary school at Buitenzorg, and the information service for native agriculturists, including special agricultural schools for farmers' sons, agricultural instruction in academies for native teachers and in training schools for native officials, special courses and demonstrations for adults, etc. Very elementary agricultural instruction, including school gardening, is being experimentally introduced in the higher grades of some village public schools.

Agricultural instruction in Argentina, T. AMADEO (*Bul. Pan Amer. Union, 50 (1920), No. 4, pp. 420-430, figs. 11*).—This is an abbreviated version of an article previously noted from another source (*E. S. R., 42, p. 294*).

Vocational education under the Smith-Hughes law, 1919-20 (*Ala. Dept. Ed. Bul., 61 (1919-20), pp. 95, figs. 2*).—This bulletin contains an outline of the Alabama plan for vocational education for 1919-20; suggestions for making application for aid under the Smith-Hughes law; outlines of four-year courses in vocational agriculture and home economics for secondary schools, suggestive type short-unit courses in home economics for evening and part-time schools and classes, and teacher-training courses in vocational agriculture and home economics for white students; courses in vocational agriculture and home economics for colored schools, and courses for the training of colored teachers of vocational agriculture and home economics; and the texts of the Federal and State acts for vocational education.

It is provided that one-fourth of all Federal funds accruing to Alabama in any year shall be available for use in negro schools. The maximum amount of 20 per cent has been set aside for instruction in vocational home economics. Of the Federal funds for the training of vocational teachers 40 per cent shall be expended for agricultural subjects and 30 per cent for home economics subjects. Teacher-training work for white students in agriculture is being undertaken at the Alabama Polytechnic Institute, and in home economics at the Alabama Girls' Technical Institute at Montevallo. The course in agriculture extends over 4 years and requires 170 semester hours. The county high school in Auburn will serve for observation and practice teaching in agriculture. The course in home economics will be extended from 3 years of college work comprising 51 unit hours to 4 years' work with 68 unit hours, beginning with the fall of 1920. Tuskegee Normal and Industrial Institute has been designated for the training of teachers of vocational agriculture and home economics for negro schools. The agricultural course will comprise 2 years' work, and the 2-year home-economics course will be extended to 3 years beginning with the fall of 1920.

Outline of plans for vocational education in Colorado under the Smith-Hughes Act (*State Bd. Vocat. Ed. [Colo.], Vocat. Bul. 3 (1919), pp. 38*).—This bulletin contains the text of the State acts relating to vocational education in Colorado under the Smith-Hughes Act, and an outline of the plans for vocational education in 1919–20, including outlines of a 4-year course in vocational home economics, and of 4-year teacher-training courses in vocational agriculture and home economics. Of the funds available for teacher training, approximately 25 per cent will be used for agricultural and home economics subjects, respectively, 19 per cent for trade and industrial subjects, and the remainder held as a reservation to be used for either of the three lines as required.

The administration of the Smith-Hughes vocational act in Georgia for the second year [1918–19] (*Ga. Vocat. Bd. [Bul.] 9 [1919], pp. 52, figs. 20*).—This report consists of brief accounts on the progress of instruction in vocational agriculture and home economics in individual schools, together with statistical data on enrollment, activities of agricultural teachers, agricultural equipment, summaries of project work done in high-school vocational departments, and expenditures for vocational education for the fiscal year ended June 30, 1919.

Vocational education: Agriculture, home economics, and the trades and industries (*N. Dak. Vocat. Ed. Bul. 1 (1919–20), pp. 55*).—This bulletin outlines the minimum requirements and general regulations for all-day, part-time, and evening schools for 1919–20 in North Dakota under the Smith-Hughes Act. The North Dakota Agricultural College is recognized for teacher training in vocational agriculture and home economics and the University of North Dakota for teacher training in home economics. The course in agriculture extends over 4 years and consists of 216 unit hours, of which not more than 40 per cent must be given to technical and not more than 10 per cent to pedagogical subjects. The course in home economics covers 4 years, consisting of not less than 120 semester credit hours and including from 25 to 35 per cent of technical home economics subjects, from 20 to 25 per cent of related science and art subjects, from 10 to 15 per cent of professional subjects, and general subjects for the remaining time. The texts of the Federal and State vocational education acts are appended.

In order to insure a wider distribution of financial aid to schools, it is proposed, beginning in July, 1920, that those county agricultural and training schools and special agricultural high schools receiving State aid be excluded from receiving Federal funds. Such schools must meet the requirements for the fund in these plans and in the State high school manual. Outlines of 4-year type courses for all-day schools of vocational agriculture and home economics, type courses for evening and part-time schools and classes in home economics, and 4-year teacher-training courses in vocational agriculture and home economics are included.

Annual report, 1919 [of the Agricultural Extension Service of Manitoba] (*Manitoba Dept. Agr. and Immigr., Agr. Ext. Serv., 1 (1920), No. 3, pp. 56, figs. 6*).—This is the ninth annual report on the Agricultural Extension Service for the Province of Manitoba, comprising the work of agricultural societies, extension schools, institute meetings and chautauquas, motion-picture service, traveling libraries, exhibitions and demonstrations, women's institutes, boys' and girls' clubs, and agricultural representatives.

The consolidated rural school, edited by L. W. RAPEER (*New York: Charles Scribner's Sons, 1920, pp. XIII+545, pls. 32, figs. 24*).—This volume, it is stated, has been prepared through the cooperation of leading specialists in this field. It deals with national and rural consolidation, the American rural school—its

problems and needs, the school site, building, teacherage, curriculum, and teaching processes in the consolidated school, rural life needs and college entrance demands, and the country girl and the consolidated school; the relation of community organization, rural economics, school administration, and rural recreation to consolidation; the growth, methods and facts, and difficulties of consolidation; and the new consolidated school. The fundamental goals of each chapter are social, vital, vocational, avocational, civic, and moral efficiency. Each chapter includes a list of preliminary problems, problems in application and a brief bibliography. A bibliography on consolidation is also appended at the close of the book.

Requirements in vocational agriculture for Idaho schools (*Idaho Bul. Vocat. Ed.*, 2 (1920), No. 1, pp. 27).—This bulletin outlines the requirements as to general conditions, kinds of schools, plant and equipment, maintenance, time, courses of study, qualifications of teachers, etc., to be met by Idaho schools for Federal and State aid for instruction in vocational agriculture. A typical four-year course in vocational agriculture is outlined. A reprint of Bulletin 4, noted below, is appended.

Principles governing the granting of high school credits for agricultural work done off the school grounds (*Idaho Bul. Ed.*, 4 (1918), No. 5, pp. 4).—The principles adopted for the schools of Idaho are set forth. It is held that the theory of granting such credits rests upon the basis that such work contributes directly to a larger knowledge of the course of study being pursued. These principles, it is stated, will be satisfactory with very slight modifications, for the use of high schools approved for agricultural instruction under the Smith-Hughes Act.

Requirements in vocational home economics for Idaho schools, G. B. ELWELL (*Idaho Bul. Vocat. Ed.*, 2 (1920), No. 2, pp. 24).—In this bulletin are set forth the requirements to be met by Idaho schools for reimbursement from State and Federal funds for instruction in vocational home economics. A suggested list of home projects is included.

MISCELLANEOUS.

Annual Reports of the Department of Agriculture, 1919 (*U. S. Dept. Agr. Rpts. 1919*, pp. VIII+560, figs. 18).—This contains the reports of the Secretary and heads of bureaus and other administrative officers. The various reports are also issued as separates.

Annual Report of Nevada Station, 1919 (*Nevada Sta. Rpt. 1919*, pp. 44, figs. 4).—This contains the organization list, a report of the director on the work and publications of the station, departmental reports, the experimental work in which is for the most part abstracted elsewhere in this issue, and a financial statement for the fiscal year ended June 30, 1919.

NOTES.

Kentucky University and Station.—A conference on instruction in soils was held at the College of Agriculture, June 23 to 25. The subjects discussed included the nature of soils laboratory work and the possibility of adopting a first or basic course largely uniform both in its content of classroom and laboratory work in the various colleges.

The resignations are noted of O. G. Hankins, swine specialist; J. R. Dawson, dairy specialist in the extension division; and F. N. Barrett, leader in junior club work. R. H. Ridgell has been appointed chemist in the fertilizer department; Gerald Hoeft, D. V. M., assistant in veterinary science; and A. L. Darnell, dairy specialist in extension.

Maryland College and Station.—Richard Wellington, professor of vegetable gardening and vegetable breeding in the station, has returned to the New York State Station as associate in research in horticulture. The resignations are also noted of W. R. Ballard, pomologist; E. H. Parfitt, assistant chemist; C. C. Chen, assistant plant pathologist; and C. B. Nickels, assistant entomologist.

Appointments have been recently made of the following assistants: Geary Eppley in agronomy, J. R. Haag in soils, L. J. Poelma in animal pathology, and C. C. Hamilton in entomology.

Cornell University and Station.—W. H. Chandler, professor of pomology and station pomologist, has been appointed vice-director of research in the station. Other appointments include Byron E. Brooks as superintendent of dairy manufactures and R. B. Hinman as sheep extension expert, beginning August 1.

The resignation of H. E. Babcock as State leader of county agents to become secretary of the newly organized Cooperative Grange League Federation Exchange, Inc., has been followed by the appointment of Jay Coryell as State leader and Charles A. Taylor as assistant State leader. L. R. Simons, for the past four years with the States Relations Service, U. S. Department of Agriculture, has succeeded L. A. Toan as assistant State leader of farm bureaus.

The first annual Farmers' Field Days were held by the College of Agriculture and station from June 30 to July 2, with an estimated attendance of over 7,000. The main purpose was to show the experimental work conducted on the farm at a time when results could be more readily demonstrated. It is expected to make these field days supplemental to the annual Farmers' Week held in February.

Glista Ernestine, a Holstein cow bred at the college, has recently completed her sixth 7-day record of more than 30 lbs. of butter fat. She is said to be the only cow with such a record, and only two cows have made five 7-day records of more than 30 lbs. The record just completed was 34.24 lbs. of butter from 675 lbs. of milk. She freshened April 21 and during the last week in May was giving more than 100 lbs. of milk a day.

Oregon College and Station.—The registration of the School of Agriculture during the past year was almost 100 per cent greater than ever before. J. M. Clifford, secretary to the dean and director, has resigned to engage in commercial work.

Tennessee University.—The new agricultural building is expected to be ready for occupancy October 1.

The agriculture course has been remodeled. The first two years are to be devoted to required basic subjects, with opportunity for specialization during the last two years in animal husbandry, agronomy, dairying, horticulture, agricultural economics, and agricultural education.

American Association of Agricultural College Editors.—The eighth annual conference of this association was held at the Massachusetts Agricultural College June 30 and July 1 and 2. Sixteen States and the United States Department of Agriculture were represented. F. H. Jeter presided and delivered the annual presidential address, taking for his subject *The Business of Being an Editor*. In an address of welcome, J. D. Willard, State director of extension of Massachusetts, emphasized especially the importance of the editorial position and the recognition it should receive.

Among the subjects included in the program were: *What is the Function of the College News Service?* by M. G. Osborn of Louisiana; *The Human Interest Agricultural Story*, by R. W. Green of North Carolina; *Should Bulletins be Distributed Through Mailing Lists*, by A. L. T. Cummings of Maine and W. C. Palmer of North Dakota; and *Popular Appreciation of Scientific Work in Agriculture*, by W. H. Beal of the States Relations Service. The last-named stressed especially the fact that agricultural research is not now receiving recognition and support commensurate with its importance.

There were also addresses by Ray Stannard Baker on the publicity work of the peace conference at Paris, in which Mr. Baker participated as the representative of the United States; by J. A. Wood of Philadelphia, on *Advertising*; by F. A. Bassette of Springfield, Mass., on *Type and Type Faces*; and by Bristol Adams of New York, on *The Ethics of Publicity*.

A large part of the time of the conference was devoted to less formal discussion of special phases of the work of individual editors and institutions and to explanation, discussion, and judging the very interesting exhibits of publication and publicity work of several of the State colleges of agriculture. An outstanding feature of the conference was the lively interest manifested in the "human interest story" as a means of conveying agricultural information. The distribution of publications was another subject which aroused much interest. The question of holding sectional meetings of the association also received considerable discussion, and it was voted that the association would receive petitions for the formation of sectional branches.

The association adopted resolutions recommending that the extension work for country papers organized by the New York State College of Agriculture be called to the attention of the States Relations Service and to the State directors of extension with a view to including such work in the extension programs of other States. The attention of the various institutions was also called to the question of the status and duties of the college and station editor, for the purpose of indicating the desirability of "(1) placing the editorial work of the colleges on a project basis supported by budgeted funds, (2) recognizing the editor's service as on equal footing with that of the heads of other departments in the college, and (3) maintaining the editor's salary commensurate with the importance of his work and with the salaries of heads of other departments."

M. G. Osborn of Louisiana was elected president and M. V. Atwood of New York was reelected secretary and treasurer for the ensuing year. Columbia, Mo., was chosen as the next place of meeting.

EXPERIMENT STATION RECORD.

VOL. 43.

SEPTEMBER, 1920.

No. 4.

The project as a means of formulating and defining a scientific inquiry has rapidly gained ground and has come into quite general use. It is an evidence of clearer and more deliberate planning, and of more systematic, ordered effort. As such it is a distinct sign of advance.

Objection to the project system in experiment station work, quite marked at one time, has very largely died out, for it has proved to be a reasonable basis of operation in research as in engineering or industry, and to have marked advantages. It is found not to impose undue restraint on the freedom of investigation, but on the other hand to give stability and direction to it. It has proved to be a convenience to workers as well as administrative officers, and to be an essential in organized effort. Nothing has done more to give character and direction to the various types of station work, or to promote adequate preliminary study and planning.

It would have been well if the project system had come into use in the early days of the stations, when there was need in so many cases for clear thinking in regard to the laying out and conduct of experimental inquiry, and when with many inexperienced workers it was important to know both whither they were headed and when they had actually arrived. Such a system might have enabled the checking of some rambling efforts, the purpose and means for which were vague or inadequate, and thus have resulted in economy of the meagre funds. At all events, it would in some measure have avoided activities which turned out to be misdirected, and have hastened the day of more deliberate planning. It was because both the aim and the method were often indefinite or obscure that there was difficulty in following them or holding them within reasonable bounds. A false view of freedom, of the informality of research, and dependence on the inspiration of the moment, often made it difficult to formulate these activities, and was the main basis of objection to attempting to do so.

While the project system has now become an accomplished fact in station work, in its practical form it represents a considerable variety

of views as to what a project is or ought to be, and of the method of carrying it out. With some it is a definite, limited undertaking, aimed at a specific point; with others it represents a broad line or even a field of work; while with still others it is a less definite basis for the allotment of funds. Manifestly it is not a thing to be standardized, but on the other hand it ought clearly to conform to certain essentials as far as experience and good usage have disclosed them.

According to the dictionary, a project is an undertaking—something projected, designed, or intended to be accomplished; a purpose, a plan, a course of action marked out to attain a definite end.

As it has come to be employed in research, it is an ordered effort at the solution of a problem or the securing of exact information on a particular topic; but since in practice many of the existing projects are of long standing they represent a considerable variety of views in their nature and range, and embody some practices which it is desirable to avoid. It may be profitable to consider the more essential elements and attributes of the project, as applied to such conditions as obtain in an experiment station supported by the public and founded on certain expectations as to practical advantage.

Viewed from the standpoint of research especially, leaving aside the less formal or intensive types of effort, a project in agricultural inquiry is first of all a scientific undertaking. It aims to advance science and through it the art, and it is conducted in accordance with the method of science. It is subject to the same critical test and review that is applied to work in other branches of science. It implies accuracy and precision, and completeness as far as it goes.

Its purpose is "finding out and learning how"; it is "to seek out wisdom and the reason of things." Hence it must be dominated by the spirit of inquiry. A project in research will seek to understand the purport of the result—what does it mean, why is it so, and what does it help us to understand?

A research project deals with things that are fundamental—it may be a rule, a principle, a law, a relationship; something that applies generally or may be expected to follow under a given set of conditions. It does not stop with superficial observations or facts; it aims to disclose the underlying principle or condition of relationship. Instead of being satisfied with the purely empirical, it attempts to trace findings back to science or theory. It does not end with the gathering of observations and data, or those which are merely comparative, but it seeks to develop basic facts and to establish their universality. Experimental data and routine observations are means and not themselves the ends in research. They are designed for use and it is their use which makes them a part of re-

search. They are secured because of the end in view, and their determination is dominated by the purpose and the use they will serve in solving the questions at issue. Investigation has sometimes begun and ended with superficial facts and observations, the real meaning or significance of which has neither been disclosed nor adequately sought.

A research project is constructive in design; it aims to advance knowledge by considered steps, building up on what others have learned and profiting by their experience and results. It is sometimes necessary to verify the findings of others if there is reason to doubt them, but the purpose is to use the information in establishing a firmer foundation. The effort is not a mere repetition or imitation, but embodies something original in method or interpretation. It is not merely a demonstration that someone else was right or wrong. Originality in research implies going outside of what is known or practiced, and injecting something new in purpose or procedure. The scientific method of advancing knowledge is the substitution of detailed and verifiable results for broad, unproved generalities derived from practice or from inadequate experiment and speculation.

Original research concerns itself primarily with the things which are essential to the solution of the problem in question, rather than with matters which are trivial or commonplace in themselves. It is the basic fact that is being sought. Some points which are apparently small or insignificant often need to be studied because of their important bearings on the question at issue, while others which might be included are inconsequential and unimportant as far as the main purpose is concerned, and do not affect the safety of generalization. Once the central idea has been established, it may not be the part of research to pursue the subject in all its minor aspects or manifestations, for the making of such tests is largely a routine matter not calling for special ability, which may be left to others or to special occasion. The drawing of such lines calls for discrimination in outlining and conducting projects to maintain their fundamental and constructive character, and prevent drifting into relatively unimportant sidelines.

It will be evident therefore that a research project should be progressive in its conception and its conduct, proceeding in a systematic and orderly way from one essential point to another. It is not a conventionalized effort and it does not adhere to a stereotyped plan, but the method and plan will be progressive although the ultimate object remain permanent. These develop with the investigation, and the leader is constantly on the alert for new points of attack or means of securing enlightening suggestions. The watchword in research is advancement, and that is what determines its success.

The subject of a project should be concerned with something which it is deemed feasible to ascertain, and not merely something that it might be desirable to know. It is necessary to determine this feasibility at the outset as far as possible. Science proceeds on the basis that there is nothing which may not be known, but in specific cases the time may not be ripe for it. It may well be that more work on methods or technique, or a more adequate background of general information in science, is necessary before the particular question at issue can be successfully solved. This has been true in years past in regard to numerous agricultural topics, and has explained attempts which have been abortive or inconclusive. After the feasibility of a project has been reasonably tested and found lacking, or the plan not found competent to meet the needs of the case, it is natural that something should be done about it. Mere traversing of the same ground is unprofitable, and unless obstacles can be overcome progress can not be expected.

The theme or subject does not alone constitute a research project; it is the means to be employed and what is to be put into the effort that gives it life and promise. It is easy to formulate topics for research—subjects on which it would be desirable to have more positive light, but it is less easy to define the method of attack and the means which may be expected to afford this light. Unless it is possible to work out the plan tentatively in advance, the investigation will start in the dark, with the prospect of much groping and lost motion and possible miscarriage in the end.

It is because the project is a definitely planned and conceived effort that the statement of it is of great importance. It is the starting point, and it expresses the spirit and the nature of the undertaking. It shows the preparation which has been made for it, the originality of the effort, and in large measure determines the general character and probable effectiveness of the work under it.

In practice stress is more likely to be laid on making the subject and purpose of a project complete than in making the general procedure so. This is perhaps natural from the difficulty of anticipating the course which will be necessary, except in a general way, but it sometimes leads to broad projects which it is impractical to carry out or which lead to scattered effort.

Since a research project is not a fortuitous or circumstantial affair further than can be avoided, but is conceived in the best light available, it is evident that the project statement must be a carefully considered, deliberate product. In the haste to get to work this has not always been the case. No one would expect to start out upon a building project to cost \$50,000 or \$100,000, or an exploration of a new region to cover several years, without thorough study and planning. One who sets out to enter an unfamiliar region or to perform

a task of unusual character without first getting all possible light and making as adequate provision in advance as forethought could devise, would be thought lacking in wisdom and to risk partial failure if not disaster. Similarly in research, the review of the field, the study of the problem, and the development of adequate plans are necessary preparatory steps, the product of which is embodied in the project statement.

Constructive research involves originality, hence it must be based on a knowledge of what has been done and the actual status of the question, and upon this the necessary steps planned to advance or round out the subject in its scientific aspects. It is the point of departure in a line of inquiry.

It is self-evident from the nature of the case that a research project deals with something definite—a specific problem or a phase of it, the solution of which seems reasonably feasible and the plan adequate. Science is exact, and an attempt to add to it by research is naturally exact in purpose as well as in method. If something is being sought, presumably that something is well defined and lies clear in the mind of the one seeking it. The undertaking is entered upon with design. And because it has definite aim and attempts to establish some new scientific fact or relationship, it is necessarily restricted in scope.

This seems so fundamental and obvious that it is surprising how often it has been contravened in formulating projects for research. To find out something new in regard to Nature's laws or manifestations, or to establish something of permanent character not known before requires close application, and it is easy to make the mistake of being overambitious in laying out too large a theme or subject. To expect that sweeping discoveries of original nature may be made at one stroke or gradually disclosed by an aggregation of miscellaneous data over a broad general field is to misconceive the method of original inquiry and the manner by which the world's knowledge has grown. A limited undertaking evidences analytical ability in seeing into a subject or dissecting a question which in its entirety may represent a field or a many-sided problem, and it indicates a clear and definite purpose.

The worker who takes for a project a large question involving a broad field rarely sees clearly what is actually involved in it; he "fails to see the woods for the trees." His ambition or his sense of what it would be desirable to accomplish has become his guide, rather than a clear vision of the nature of the subject and how it must be approached and worked out step by step. In agriculture our problems are unusually complex, and they come to the station workers in their practical form, often representing aggregations of questions rather than specific and limited subjects of inquiry. Before they

can be solved there must be a knowledge of their component parts—of what constitutes them; and the analysis or dissection of them is often quite as intimately scientific as the synthetic stages in their solution. There is much need therefore for a careful definition of problems in agriculture as a preliminary to outlining research upon them.

As a research project is purposeful and is guided by a plan or hypothesis, it is diametrically opposed to the indiscriminate or indeterminate accumulation of data. This is a distinction that needs especially to be recognized at the present stage. In former years there was such a paucity of information as to what would follow a certain practice or a continued course of action that the rather routine gathering of data might give information which was original for the time and important in supplying a background for more specific plans. Many long continued observations and experiments of that type did not set out to test a theory or hypothesis, but mainly to see what would happen. This was especially true of a certain class of field experiments. The time was not ripe for soil studies as we now understand them, or for intimate inquiry into the relations of plant and environment. These commenced later; but the immediate purpose of such field work was largely to secure certain empirical facts which would be helpful to practice.

Following the example of the Rothamsted Experimental Station, whose system of plat experiments had become classic, many colleges and stations in this country early established similar field experiments, which were devoted to the accumulation of data according to a fixed plan. Much importance was attached to the continuity of such experiments without change, and as time went on the older series became venerated quite as much for their age, apparently, as for what they had proved or what the kind of effort applied to them was competent to prove. Although defects were in some cases detected in them which must be allowed for, and they were not supplying additional new facts, there was hesitation in modifying them or doing anything which would interfere with their historic course. Hence it happened that data continued to be accumulated from them long after such data were made the subject of critical study.

No one would wish to reflect upon the value for the time of these early efforts, but they need to be judged in the light of the period and the status of knowledge they represented. Criticism is more properly directed at their frequent neglect as a source of suggestion for more specific inquiry, and at the continuance of undue emphasis on the accumulation of data according to a conventional plan—of the periodical summary of comparative results rather than of the progressive study of them in the attempt to learn what they mean.

Such an accumulation of data is often vigorously defended by citing the case of the Rothamsted experiments, laying chief emphasis on their age and overlooking a distinctive feature that has characterized those experiments almost from the first. If those experiments had remained stereotyped, and if throughout their history they had not been marked by a type of inquiry which sought diligently the reason for the results and the relationships which they expressed, they would have been far less illustrious examples and would have wielded a much smaller influence.

It is well to remember that the work at Rothamsted has represented progressive stages of field experimentation. At first it was developing a method of plat experimentation; later it was a study of the balance of fertilizing ingredients in the soil, the taking up and the loss of elements, the residual value of manure and fertilizer, etc.; and this subsequently led to supplementing the work of the chemist by that of the bacteriologist, with significant findings. Still later various other types of soil study were taken up, the reciprocal relations of organic and inorganic elements of the soil, and other fundamental questions; and for years the recording of results on the field plats has been accompanied by a searching study of the meaning and the significance of the results. This has tended to make the station primarily an institute for soil technology, the largest of its kind in the world. While the original plan of certain experiments has been retained, the data from them have not been viewed as an end, but as a step and a means in investigation. The field work has gone hand in hand with intensive laboratory work, not alone analytical and routine, but research upon points suggested by the quantitative field data and their interpretation.

It is this spirit of inquiry accompanying the experiments through all the years and the advantage which has been taken of the opportunity afforded by them that has made them what they are. This fact needs to be adequately recognized in stressing the importance of long continued experiments. It is a great lesson from the Rothamsted work. The experimenter who sets out with no more definite plan or aim than to see what will happen through a long course of years, needs to take care that the effort does not degenerate into the mere routine gathering and summation of the results. Unless the element of inquiry is early injected into the undertaking and maintained, the work may actually represent a marking of time as far as research is concerned, a postponement of investigation which yearly becomes more remote. The data themselves need to be viewed in the light of furnishing material for investigation, the basis of possible facts and prospective subjects of research.

One important value of long continued experiments at the present stage lies in the questions they raise and the suggestions they offer for specific studies, and if they do not result in such studies as a real part of the plan, the experiments miss much of their research value and the effort may not attain its research character. Naturally such suggestions can not all be taken up simultaneously or in a single project. They represent a multitude of subjects in investigation, and the studied progress of such experiments ought to help increasingly in the analysis and differentiation of complex questions in soil fertility and crop response.

A project in research seeks an authoritative answer. Its purpose distinguishes it from routine effort. It is what a worker puts into his project, rather than the data he takes out from his experiments that determines its research value. As has been said, "neither logic without observation nor observation without logic can move one step in the formation of science." The mistaking of assembled facts and observations for the solution of a project, without the intensive search which the answer requires, may lead to the assumption that a discovery has been made when in reality it has been overlooked.

Every research project looks toward completion. It is a limited undertaking, and it is something to be accomplished. As it is not a field of work but deals with a definite topic, the expectation is that it will be completed in a longer or shorter time, dependent on its character, and that the completion will be recognized when the purpose has been accomplished. The work may lead to other investigations or other phases in the same general field; this is evidence of the progress it marks. But the effort should preferably be so organized that the end may be in sight and attainable in a reasonable time.

Apparently this has not always been given the attention it deserves. The terminal facilities of some projects seem to be poor. The inference is that either the workers do not recognize when they have arrived or are distrustful of their conclusions, for there is reluctance in bringing the project to a head and closing it out as far as that particular topic is concerned. Projects are continued without definite conclusions for many years, and are planned to be further continued without materially modifying the theory or plan or narrowing the range. Progress is accordingly slow, except that a large body of data is acquired, but light to guide further effort or to definitely clear up one point after another as steps in progress is not reflected in the course of procedure.

It is usually impossible and undesirable to place any time limit on a research project, for the rapidity of progress can not be foretold and unexpected difficulties or unusually suggestive results may de-

velop. But there is sometimes a tendency to cling to a project after the main point it set out to settle has been determined, or to digress from it to other points which tend to expand it indefinitely in time and scope. Some workers are prone to outline projects so broad and comprehensive that they will require years and possibly a lifetime for accomplishment. As an expression of a high ambition such projects may deserve approval, but as practicable undertakings they are often wide of the mark and are apt to represent a tendency toward diffusion rather than concentration.

One disadvantage of too large and time consuming projects is the uncertainty of the personnel and the chances of change to another location. Projects represent individual effort. Workers ordinarily select and state their own projects. They may be engaged for work in a particular field but they are less successfully assigned to established and incompleting investigations. When a change comes in the leadership of a long-time investigation there is difficulty in providing for its continuance, at least without considerable loss of efficiency and zeal. Such projects are therefore disadvantageous to the station unless they are so organized as to represent distinct phases or steps which may be completed in reasonable time, or which it may be feasible for another to carry forward.

On the other hand, unfinished studies can not always be transferred to another institution when a change of location is made, and hence the investigator may suffer loss of opportunity and of credit for what he has done. Large, comprehensive projects usually involve more extensive plant and operations, and greater expense in maintenance, while the progress from year to year is less definite. The station is thus burdened for an indefinite period with a heavy overhead which can not be reduced and which may prevent other work being taken up as it assumes importance; and the investigator himself may lose some of the incentive which comes from accomplishment, and may advance his reputation less rapidly than if the units of his effort were smaller.

This view is not opposed to large undertakings when properly organized, and it does not imply that a station should confine itself to simple things which can be quickly accomplished. Rather it suggests the advantage of analysis of large problems and of organization of the work under them so that they may progress step by step instead of attempting to advance simultaneously along a broad front.

The making of research projects requires study, quite as much as carrying them on. Much time and economy of effort may be gained by such study and examination at the outset, determining not only the methods of approach but the practicable units of effort. Many of the existing projects were made ten or fifteen years ago or even

longer, and their simplification might now be both feasible and profitable. Certain phases have undoubtedly been solved or their real nature determined, so that a redirection of the project is possible, giving it greater definiteness and more limited range. The study of such complex and long-continued projects as to their progress and promise will often start with the director's office, for action looking to the shaping of a live, practicable program is a part of good administration.

RECENT WORK IN AGRICULTURAL SCIENCE.

AGRICULTURAL CHEMISTRY—AGROTECHNY.

Chemical investigation of amylases and related enzymes, H. C. SHERMAN (*Carnegie Inst. Wash. Year Book*, 18 (1919), pp. 328-330).—This is the annual progress report of the author's investigations of amylases and related enzymes. In addition to the continuation of the studies referred to in the report of the previous year (E. S. R., 40, p. 608), an extended study has been begun of the effects of amino acids upon the enzymic hydrolysis of starch by different amylases. The results of this study as so far published have been noted from another source (E. S. R., 42, p. 203).

Determination of small quantities of iron, M. L. MATHIEU (*Bul. Assoc. Chim. Sucr. et Distill.*, 37 (1919), No. 6, pp. 205-208).—Sources of error in the usual colorimetric methods for the determination of small amounts of iron are noted, and a method is described which is said to avoid these errors.

The method as applied to wine must consist in evaporating 5 or 10 cc. of the sample in a platinum crucible and ashing at low red heat. The ash is taken up in 5 cc. of HCl (1:4), 10 cc. of a 1 per cent solution of KCNS is added, and the contents of the crucible are washed into a graduated tube and made up to 50 cc. This is checked with a similar tube to which is added from a burette a solution of pure ferric chlorid containing 0.0001 gm. in 1 cc. until the color is identical with that of the tube containing the sample.

The test is said to be sensitive between the limits of 0.01 and 0.2 mg. of iron in 10 cc.

Some factors influencing the quantitative determination of chlorids in soil, C. T. HIRST and J. E. GREAVES (*Soil Sci.*, 9 (1920), No. 1, pp. 41-51).—Experiments conducted at the Utah Experiment Station with a heavy black clay loam soil to study factors influencing the determination of chlorids in soils are reported. The work was based on the Mohr and Volhard methods.

It was found that equally satisfactory soil extracts from which the chlorids are to be determined are obtained either by the use of 2 gm. of alum or by the Pasteur-Chamberland filter. The extract obtained by use of the centrifuge gave higher results, due perhaps to the presence of proteins or other colloids in suspension. The quantity of chlorids obtained by the use of 5 parts of water to 1 part of soil was the same as with larger quantities of water. It was found that nothing is to be gained by agitating the soil and water for more than five minutes if the soil is finely divided and the solution vigorously shaken. The Mohr and Volhard methods gave low results in the presence of nitrates of the alkali and the alkali earths, and the Volhard method low results in the presence of carbonates of the alkali and alkali earths. The Mohr method gave high results in the presence of carbonates due to the precipitation of silver carbonate. The Volhard method gave more concordant and, as judged by the gravimetric method, more nearly exact results than the Mohr method. Ethyl alcohol caused the coagulation of silver chlorid as well as ether or boiling.

The best results were obtained by the following method: "One hundred gms. of finely pulverized soil was agitated in a mechanical shaker for five minutes and clarified either by the use of 2 gm. of alum or by the Pasteur-Chamberland filter; 20-cc. portions were pipetted into ground-glass-stoppered bottles and an excess of 0.1/N silver nitrate added; 10 cc. of 95 per cent ethyl alcohol was added, and the mixture shaken until the silver chlorid was coagulated and the supernatant solution was clear; 2 cc. of ferric sulphate solution containing 20 gm. of ferric sulphate to 500 cc. of water and 5 cc. of dilute nitric acid were added; the excess of silver nitrate was then titrated by the use of 0.1/N NH_4CNS ."

Concerning the effect of heat on the reaction between lime-water and acid soils, R. H. ROBINSON (*Soil Sci.*, 9 (1920), No. 2, pp. 151-157).—Results obtained by a study of the Veitch lime-water method for determining soil acidity, as conducted at the Oregon Experiment Station, are reported.

It was found that the lime requirement of the soil as shown by the lime-water method indicates a reaction that takes place under the conditions performed, and that the results will be affected by any variation of the following factors: (1) The physical or chemical properties of the soil, (2) probably by the ratio of amount of soil to quantity of solutions to be evaporated, (3) the temperature at which evaporation is made, (4) continued heating after the soil has been dehydrated, (5) the length of time during which treated and dried soil remains in contact with water, and (6) the source of heat, namely, steam bath, sand bath, hot plate, etc. Results will be comparative when the lime-water method is used if the determinations are conducted in exactly the same manner. The data are thought to emphasize the necessity of controlling all influencing factors if the lime-water method is used to observe changes in a soil by comparison of results obtained at different times.

Methods for the determination of borax in fertilizers and fertilizer materials, W. H. ROSS and R. B. DEEMER (*Amer. Fert.*, 52 (1920), No. 6, pp. 62-64).—This is a revision of the methods previously noted (*E. S. R.*, 42, p. 313), a few minor changes having been made as an outcome of further work on the subject.

Qualitative method for the detection of borax in mixed fertilizers, W. R. POPE and W. H. ROSS (*Amer. Fert.*, 52 (1920), No. 6, pp. 65, 66).—This qualitative method for detecting borax in mixed fertilizers, which has been developed at the Bureau of Soils, U. S. Department of Agriculture, is recommended particularly for use in eliminating fertilizer samples which contain distinctly less than 0.1 per cent of borax. The method is as follows:

Weigh 2 gm. of the powdered sample into a small flask, mix with 2 cc. of water and 48 cc. of 95 per cent alcohol, shake thoroughly, and filter. Transfer a 5 cc. portion of the filtrate to a small porcelain evaporating dish, add one drop of a 1 per cent solution of phenolphthalein in alcohol, and just enough approximately N/2 NaOH to make the solution alkaline, avoiding an excess. Evaporate to dryness on a steam bath, ignite below redness until the organic matter is fully carbonized, and treat the ignited residue with 0.5 cc. of approximately N/2 HCl and about 10 cc. of hot water. Filter if necessary into a small porcelain evaporating dish, wash two or three times with hot water, and bring the volume of the titrate to about 25 cc. Add to the solution 1 cc. of a 1 per cent solution of turmeric in alcohol, stir, and evaporate to dryness on a steam bath. A pink coloration which turns olive green on the addition of NaOH confirms the presence of borax. If this is matched against a standard solution of boric acid treated in the same way with the use of tincture of curcumin instead of turmeric, it is possible to determine whether the borax in the sample is more or less than 0.1 per cent.

A spectrophotometric study of the "salt effects" of phosphates upon the color of phenolsulfonphthalein salts and some biological applications, C. L. BRIGHTMAN, M. R. MEACHEM, and S. F. ACREE (*Jour. Bact.*, 5 (1920), No. 2, pp. 169-180, figs. 2).—The authors discuss the effect of the presence of certain salts upon the apparent values for H-ion concentration of solutions as determined by the hydrogen electrode and the sulfonphthalein indicators, and present data on the effect of phosphate solutions upon the colorimetric values of pH. A table is given of the corrections in pH which must be added to the observed colorimetric pH in order to give the true pH in solutions free from phosphates and salt effects and having the same indicator transformation.

"When measuring the limits of tolerance for hydrogen, or other ions, or molecules by organisms, care should be taken to state the concentration of chemicals and buffers used and possibly to free the published constants of these 'salt effects'."

Food inspection and analysis, A. E. LEACH, revised and enlarged by A. L. WINTON (*New York: John Wiley & Sons, Inc., 1920, 4. ed., rev. and enl., pp. XIX+1090, pls. 42, figs. 129*).—In the fourth edition of this volume (E. S. R., 29, p. 204) a large amount of new material has been added, including a final chapter by G. L. Wendt on the determination of acidity by the H-electrode. The lists of references at the end of the chapters, a feature of the previous editions, have been dropped and more attention has been given to footnote references.

The microscopical examination of flour, G. L. KEENAN and M. A. LYONS (*U. S. Dept. Agr. Bul. 839 (1920), pp. 32*).—The purpose of the investigation reported in this bulletin was to determine the possibilities in the use of microscopical methods for determining the offal content of flour of various commercial grades. The technique employed was as follows:

A 5-mg. portion of a composite sample of thoroughly mixed flour is carefully weighed out on accurate balances and the weighed portion transferred with a scalpel and camel's hair brush to the center of a microscopic slide ruled across the short diameter with lines about 0.5 mm. apart. About 3 or 4 drops of chloral hydrate solution is added to the flour from a 1-mm. bore pipette and the flour evenly distributed in the liquid by means of a preparation needle. A square cover glass is then applied and the slide carefully heated over the alcohol flame until the starch grains are dissolved, after which the slide is quickly transferred to the stage of the microscope, allowed to cool, and then counted for bran particles and hairs, these being taken as constituting the offal.

The investigation carried out by this method consisted of a preliminary study to determine the limits of error in the method due to the personal equation (including one analyst's variation in counting the same slides on different days and the variation between two analysts counting the same slide on the same day), daily variation due to the condition of light, slide variation due to limits of accurate weighing of the test portion of flour, and the variation in homogeneity of the bulk sample; an examination of the degree of purity of the various mill stocks entering into the composition of commercial flours; an examination of different commercial grades of flour; and an examination of experimental series of flour the composition of which was definitely known.

The preliminary study indicated that the personal equation causes slight differences in the count, the average variation of two analysts for the same sample being 20 for the bran particles and 18 for the count of hairs. Personal variation due to error of counting was estimated at between 12 and 17 points. The other factors tested were not considered to have appreciable influence on the count.

The experimental data obtained on the different flours showed a wide range in offal content, not only in the different grades but also among flours of the same commercial grade. The examination of mill stocks showed the offal content of the break-roll products to be high and that of middlings to be lower and to decrease the more thorough the purification process. The commercial grades of patent flours examined, ranging from 35 to 90 per cent extraction, gave an average total offal count of 57, straight flours of from 90 to 100 per cent an average offal count of 111, clear flours of from 5.5 to 52 per cent extraction an offal count of 273, and low-grade flours of from 2 to 10 per cent an offal count of 433.

The best grades of flour of the experimental series gave a slightly lower offal count than the corresponding grade of the commercial series, the two intermediate grades a lower offal count, and the lower grade flours about the same offal count as the corresponding commercial flours.

The inferences drawn from this study are that there is little uniformity in the matter of grading finished flours in different mills and that all mills do not composite finished flours in the same manner.

A bibliography of 22 titles is appended.

Invertin in pure honey, A. CAILLAS (*Compt. Rend. Acad. Sci. [Paris]*, 170 (1920), No. 10, pp. 589-592).—Invertin to the extent of 0.049 per cent was isolated from a sample of pure honey. Its presence is thought to explain why two analyses of honey made at widely separated intervals of time do not give the same results as to their content in sugar, the amount of sucrose sometimes decreasing from 8 per cent in fresh honey to from 2 to 3 per cent after some years. It is thought that the invertin enclosed in the honey continues its action until equilibrium is established and the products of the reaction arrest the action of the diastase.

Determination of invert sugar with the help of potassium thiocyanate and potassium iodid, G. BRUHNS (*Centbl. Zuckerindus.*, 27 (1919), Nos. 37, pp. 621, 622; 38, pp. 642, 643; 39, pp. 664-666; 44, pp. 767-771).—The author describes and discusses the details of a method for determining invert sugar which is said to be rapid, economical, and productive of as accurate results as the well-known methods heretofore used. The technique is as follows:

Ten cc. of a copper solution containing 69.28 gm. of finely crystallized CuSO_4 per liter and 10 cc. of alkaline tartrate solution containing 346 gm. of Rochelle salts and 100 gm. of NaOH per liter are mixed in an Erlenmeyer flask with 20 cc. of the sugar solution, which should contain not more than 4 gm. of sucrose. The mixture is kept at boiling temperature for two minutes by careful heating on a wire gauze, after which 50 cc. of water at room temperature is added, the mouth of the flask is covered with a small beaker, and the flask cooled in a stream of water.

To the cooled solution is then added 5 cc. of a solution containing 0.67 gm. of KCNS and 0.1 gm. of KI, the mixture is shaken, 10 cc. of 6 N/HCl or 6.5 N H_2SO_4 is added, and thiosulphate solution (34.4 gm. thiosulphate and 0.1 NaOH per liter) is run in rapidly from a burette until the original brown color on shaking temporarily turns gray. A little starch solution is then added, and the titration continued until the precipitate becomes light yellow and does not turn blue or gray on standing for five minutes. The amount of thiosulphate solution used is subtracted from the iodine titer of an equal amount of the same sugar solution determined without heating, and from this result the amount of invert sugar is calculated from a table of standard values.

Some vanillin oxidation products: Methods of analysis which exclude them, W. G. BOWERS and J. MOYER (*North Dakota Sta. Spec. Bul.*, 5 (1920), No. 16, pp. 518-520).—The authors discuss the behavior of vanillin with some of the

common oxidizing agents, and suggest a method of determining the true value of vanilla which is thought to be more accurate than the Official Method.

The method proposed involves the use of the clarifying agent¹ of Folin and Denis (E. S. R., 28, p. 807) and the coloring agent of Estes (E. S. R., 37, p. 12). The technique is as follows:

To 5 cc. of the vanilla extract in a 100 cc. flask are added 75 cc. of water and 4 cc. of lead acetate solution (containing 5 per cent basic and 5 per cent neutral lead acetate). The solution is made up to 100 cc., filtered, and 10 cc. of the filtrate placed in a 50 cc. flask. To this are added 15 or 20 cc. of water and 0.3 cc. of the Estes reagent (mercury dissolved in twice its weight of concentrated nitric acid and diluted with 25 times its weight of water). A 1 cc. portion of the 1 per cent standard vanillin is treated in the same manner, and both flasks are then placed in boiling water for 20 minutes, made up to volume, filtered if necessary, and compared in a colorimeter.

The solubility of raw cellulose in ammoniacal copper hydroxid and the utilization of this solubility for the valuation of feeding stuffs, F. MACH (*Landw. Vers. Sta.*, 91 (1918), No. 3-4, pp. 137-155).—This is a discussion of the value of the method described by the author and P. Lederle¹ for distinguishing between raw and hydrolyzed cellulose by treating the material with ammoniacal copper hydroxid and precipitating the dissolved cellulose with alcohol and acetic acid. In addition to the original use of the method, further applications are suggested such as the testing of new feeding stuffs; the quantitative determination of chaff-containing feeding stuffs; the study of the effect on feeding stuffs and foods of such influences as withering, storage, fermentation, etc.; the study of the relation between raw cellulose and nitrogen-free extract; and the examination of raw material for textile and paper manufacture.

Analytical applications of iodine reactions with nonsaturated substances.—The Hübl index and pseudo-indexes of essential oils, R. HUERRE (*Jour. Pharm. et Chim.*, 7. ser., 20 (1919), Nos. 7, pp. 216-224; 8, pp. 250-257; 9, pp. 273-281; abs. in *Chem. Abs.*, 14 (1920), No. 1, pp. 92).—It is pointed out that with essential oils the Hübl iodine number increases with the excess of iodine used, reaching a maximum at a definite optimum for excess which is 13 parts of iodine to 1 of oil of turpentine and 14:1 for oil of cedar. If Hübl's solution is used, the iodine number of an essential oil should consequently be defined as the maximum quantity of iodine which can be absorbed by 100 gm. of the oil in the presence of mercuric chlorid and of the optimum excess of the iodine.

As a substitute method, the author suggests the use of an alcoholic solution of iodine, which in contact with a solution of the essential oil in chloroform undergoes a loss of iodine determined by titration with thiosulphate. For the constant thus determined the name "pseudo-index for iodine" is suggested, and defined as the maximum amount of iodine which disappears in a two-hour contact with 100 gm. of the solution of the turpentine in alcohol when using the optimum excess of iodine.

A new method for detecting adulteration in butter and for estimating fats of the coconut group, G. V. B. GILMOUR (*Analyst*, 45 (1920), No. 526, pp. 2-7, fig. 1).—The chief difference between this method and those in general use consists in the treatment of the volatile acids. The neutral soaps representing the total volatile fatty acids obtained from the sample by the method described by Blichfeldt (E. S. R., 41, p. 412) are converted into the corresponding acids and separated into two groups depending upon their solubility or

¹Landw. Vers. Sta., 90 (1917), pp. 269-289.

insolubility in saturated brine. Tables are given showing the variations in insoluble and soluble volatile fatty acids in butter, coconut, palm kernel, and babassu^ofats, and in mixtures of different proportions of these fats.

The fat of Momordica seeds, C. E. CORFIELD and E. CAIRD (*Pharm. Jour.* [London], 4. ser., 50 (1920), No. 2935, pp. 43, 44; also in *Amer. Jour. Pharm.*, 92 (1920), No. 4, pp. 240-244).—A study is reported of the oil from the seeds of *Momordica cochinchinensis*, a cucurbitaceous plant indigenous to the Philippine Islands. As the composition of the oil was altered by heating it to 100° C., the method employed for extracting it consisted of pressing the coarsely powdered kernels at a temperature of about 40°, the heat being furnished by a steam coil around the press. The fat thus obtained was greenish brown in color and of an unpleasant and penetrating odor. The analytical constants obtained were as follows: Saponification number 185.2, acid number 1.9, iodine number 23.4, refractive index at 40° 1.496, ester value 183.3, melting point from 28° to 32°, and unsaponifiable matter a trace.

Before heating the fat showed certain characteristics of drying oils without the property of producing a varnish, while after heating it behaved as a semidrying oil. It is thought that it might be used with drying oil in the production of paints and varnishes.

[**Urine analysis**], W. A. FEARON (*Dublin Jour. Med. Sci.*, 4. ser., 1 (1920), pp. 28-32).—Laboratory notes on the following subjects are given:

I. *A modified Kjeldahl method for the estimation of nitrogen* (pp. 28, 29).—For Kjeldahl determinations of the nitrogen in urine and in foodstuffs such as protein digests and milk the author recommends in place of sulphuric acid alone as an oxidizing agent a mixture of sulphuric acid and phosphoric acid in the proportions of 100 cc. of the former to 200 gm. of the latter, together with 5 gm. of copper sulphate.

II. *The carbazol test for nitrites* (pp. 29-32).—This test for nitrites in urine or similar fluids consists in adding a very small amount of carbazol to a few cubic centimeters of strong sulphuric acid in a test tube, shaking well, and then adding a drop of urine or the substance to be tested. In the presence of nitrites, even to the extent of about one part in half a million, a deep green color develops.

III. *The detection of tryptophan in urine* (p. 32).—If urine containing tryptophan is treated with an excess of the Hopkins-Cole glyoxylic reagent and a drop of the mixture is added to strong sulphuric acid a deep green color is produced. The test is not given by indol or skatol.

Preservation of fruits and vegetables for home use, M. MACFARLANE (*Canada Expt. Farms Bul.* 93 (1919), pp. 32, figs. 20).—This bulletin, in addition to directions for canning and preserving fruits and vegetables by the various methods now in general use, including drying, contains the results of a comparison of the efficacy of the different methods in the case of specific vegetables and fruits as determined by the keeping qualities of the product. The results of these experiments, which were conducted at the Central Experiment Farm, Ottawa, in 1917 under the direction of L. Kirby, and in 1918 under the author's direction, are presented in tables which show at a glance the method to be recommended for that particular fruit or vegetable.

Processing and canning of ripe olives, W. V. CRUESS (*Fig and Olive Jour.*, 4 (1920), No. 11, pp. 9-11, 15).—This is a general treatment of the subject based in part upon investigations which have been previously noted from another source (*E. S. R.*, 42, p. 113).

Some bacteriological aspects of dehydration, S. C. PRESCOTT (*Jour. Bact.*, 5 (1920), No. 2, pp. 109-125).—In this address, delivered at the annual meeting of the Society of American Bacteriologists in Boston, December 29, 1919, the

author discusses briefly the utilization of dehydration in various countries and the results of previous investigations on some of the biological questions involved in this process of food preservation, and presents the results of bacteriological studies on the commercially dehydrated vegetables used by the U. S. Army during the recent war. These studies included determinations of the amounts of bacteria and molds on different kinds of vegetables and fruits, the effect of storage in various containers and under different conditions of temperature and humidity, and the effect of dehydration upon organisms commonly associated with food poisoning.

From the standpoint of numbers and types of bacteria, the commercially dehydrated products were found to have the same characteristics as raw fruits and vegetables except that the number of organisms was much less than on the fresh article. The predominating types of bacteria were those having their habitat in soil or water. Seven genera of molds were isolated, including two species of *Mucor*, two of *Penicillium*, and five of *Aspergillus*.

In the investigation of the effect of environment on the bacteriological character of the foods in different containers, four types of storage conditions were employed in which the humidity was at 100, 70, 50, and 95 per cent, with the corresponding temperatures 37° C., 20 to 25°, 37° and ordinary temperature, and 0°, respectively. Materials stored in tin and glass containers under all conditions of temperature and moisture remained practically constant in their content of moisture and molds, while the bacterial counts diminished either rapidly or slowly. Samples stored in paper containers, whether paraffin treated or not, under conditions of higher temperature and humidity showed a decided increase in moisture and in bacteria and mold count at the end of 6 weeks. Similar results were obtained in cold storage (0°, 95 per cent humidity), while at ordinary temperature and dry atmosphere a decrease in moisture and bacterial count resulted, the mold spores remaining practically constant. These results are considered to prove beyond doubt that paper or wood pulp containers of good quality may be safely used in temperate zones, but are not suitable for use in hot moist conditions.

Preliminary results obtained in a series of experiments in which vegetables were inoculated with pathogenic organisms associated with food poisoning and were then subjected to dehydration in the laboratory and in a commercial dehydrating plant indicate that these pathogenic organisms are, in general, destroyed by the process of dehydration, and consequently that the danger of poisoning from contamination of the vegetables before dehydration is slight.

Practical leather chemistry, A. HARVEY (*London: Crosby Lockwood & Son, 1920, pp. [8]+207, pl. 1, figs. 9*).—This laboratory manual, which has been designed particularly for chemistry students specializing in the leather industry, consists of methods of chemical analysis as applied to materials used in the tanning, dyeing, and finishing of leather.

The grasses of the Eastern Coast Belt available for the manufacture of paper, and the possibilities and prospects of paper making in the Union of South Africa, C. F. JURITZ (*[Union So. Africa, Min. Mines and Indus.], Indus. Bul. Ser., No. 7 (1919), pp. IV+115*).—This bulletin consists of reports of an investigation of the paper-making possibilities of various grasses of the Eastern Coast belt of South Africa and of the commercial prospects for such an industry. These are followed by appendixes consisting of an historical review of previous investigations along the same lines, notes on technical points in connection with paper making, brief descriptions of a large variety of raw materials in addition to grasses which have been suggested as suitable for the manufacture of paper, a discussion of the paper industry in various countries, and an extensive bibliography.

METEOROLOGY.

Report of the chief of the Weather Bureau, 1919 (*U. S. Dept. Agr., Weather Bur. Rpt. 1919, pp. 296, pls. 7*).—The work of the Weather Bureau during the year ended June 30, 1919, and the general weather conditions of each month of 1918, as well as the outstanding meteorological features of the year, are reviewed, and detailed tabular monthly and annual summaries of climatological data for 1918 are given as usual.

Recognizing that "weather is a dominant factor in the success or failure of agricultural or horticultural operations . . . special effort was made during the year to apply the information collected, through the vast organization of special and cooperative services of the Weather Bureau, to the important problem of food production in its various aspects." Special features of the report from the standpoint of agriculture are charts showing departure from normal temperature, total and departure from normal precipitation, and occurrence and distribution of injurious hailstorms during the crop season (March 1 to September 20, 1918).

"The most remarkable feature of the weather of 1918 was the prolonged period of marked cold over the central and eastern parts of the country, which, having set in during December, 1917, continued till about February 6, then ended abruptly. No other 2-month period averaging so cold appears in the temperature statistics of the central valleys, the Ohio drainage basin, the central South, or the Atlantic States. . . . In the middle and southern Plains there was rather severe heat for over two months, about June 10 to August 20, which aided the shortage of rainfall to produce serious harm to crops and pasturage. Ample and well-distributed moisture, with mainly mild weather, during the last few months of the year in districts where late crops and fall-sown grains are very important was decidedly favorable and showed a great contrast with the conditions in 1917."

Meteorological summaries (*Kentucky Sta. Rpt. 1918, pt. 1, pp. 69-71*).—Tables compiled from the records of the U. S. Weather Bureau Station at Lexington, Ky., summarize data for temperature, precipitation, humidity, wind, and cloudiness, 1872-1918.

Climatic conditions [on the Yuma Reclamation Project, 1918], R. E. BLAIR (*U. S. Dept. Agr., Dept. Circ. 75 (1920), pp. 10-13*).—Observations on precipitation, evaporation, wind movement, temperature, and killing frosts, 1910 to 1918, inclusive, at the Yuma Experiment Farm, are summarized and discussed.

The average temperature of 1918 was 69.35° F., as compared with a 9-year mean of 69.15°. The maximum temperature was 115°, the minimum 19°. The total precipitation was 3.57 in., as compared with a 9-year average of 4.11 in. The evaporation was 73.02 in., as compared with an average of 78.33 in. The frostless period was 261 days, from February 19 to November 7. The weather conditions of the year were generally favorable for all crops except cotton. This was injured by very sudden and extremely high temperatures in August, and by a freeze that occurred November 6.

Comparing observations at the experiment farm, which is representative of valley lands of the project, with records made at the Yuma office of the U. S. Weather Bureau, which are more nearly representative of conditions on the higher lands, it appears that "during the four months of ordinary frost—November, December, January, and February—the minimum temperatures at Yuma are generally from 5 to 8° higher than in the valley, while the maximum temperatures average about 1° less. Throughout the remaining eight months of

the year the minimum temperatures are from 8 to 10° higher on the mesas than in the valley, and the maximum temperatures are ordinarily 1 to 2° higher. . . . The total precipitation for the year, at the Yuma Weather Bureau station was only 2.9 in. [as compared with 3.57 in. at the experiment farm], which indicates the very local nature of the small rains in this region."

Method of constructing a diagram to show probable droughts, V. V. TCHIKOFF (*Engin. News-Rec.*, 83 (1919), No. 12, p. 554, fig. 1).—A table prepared from measurements of rainfall during 10-day periods from April to October, inclusive, for 32 years (1883 to 1914) at Kherson, Russia, is given, which shows the computed percentage probability of drought, that is, 10-day periods with not more than 5 mm. rainfall (termed dry), or not more than 10 mm. (termed unsatisfactory). A diagram is also given which is constructed from this table by letting "the abscissas represent the 10-day periods and the ordinates the number of cases with precipitation of less than 5 and 10 mm. The line parallel to the abscissa, through the points of 30 and 70 per cent, limits the dry and nondry periods. The line through the point of 50 per cent indicates the equal probability of dryness and nondryness." Dry periods are represented by shaded portions of the diagram.

The utilization of cirrus clouds in the forecasting of weather, G. REBOUL and L. DUNOYER (*Compt. Rend. Acad. Sci. [Paris]*, 170 (1920), No. 12, pp. 744-747; *abs. in Rev. Sci. [Paris]*, 58 (1920), No. 7, p. 219).—From a study of observations on cirrus clouds the authors conclude that in 70 per cent of the cases the appearance of such clouds betokens the approach of bad weather.

Tropical control of Australian rainfall, E. T. QUAYLE (*Commonwealth Bur. Met. Aust. Bul.* 15, pp. 24, pls. 12; *rev. in Nature [London]*, 105 (1920), No. 2631, pp. 152, 153).—This bulletin deals with "the influence of tropical conditions upon the development and rainfall production of storms in the temperate belt, and the increased range and accuracy of Australian rain forecasts made possible by taking this into account." The main feature of the author's theory is that high minimum temperatures in the tropical regions of Australia, which usually persist for a few weeks at a time, are due to cloudiness, extra humidity, or northeast winds, and that they cause "such a flow of air to the southern parts of the continent that the approaching cyclonic 'lows' are compelled to part with rain."

The value of weather records in fumigation, R. S. WOGLUM (*Cal. Citrogr.*, 5 (1920), No. 4, pp. 110, 111, figs. 2).—This article indicates briefly the various ways in which the efficiency of fumigation is influenced by temperature, humidity, pressure, wind, and the state of the sky, points out the need of weather observations with this purpose in view, and describes the necessary instrumental equipment for the use of practical orchardists.

SOILS—FERTILIZERS.

Soil studies (*North Dakota Sta. Bul.* 136 (1920), p. 18).—Studies conducted since 1900 on the relation of total and water-soluble magnesium for soils sampled at varying depths, in connection with soil fertility studies, and also to compare the acidity of soils continuously cropped in wheat with that of virgin soils or soils under rotation, showed that uniformity for all soils was found for nitrogen at a depth of from 18 to 24 in., for phosphorus at from 20 to 30 in., magnesium at from 6 to 12 in., and for calcium and carbon dioxide at a depth of from 30 to 36 in.

"Excepting in the virgin soil series the total magnesium is in excess of the total calcium to a depth of between 18 and 30 in., and water-soluble magnesium is greater than the water-soluble calcium in the wheat soils and practically the

same in the virgin soils beginning with the stratum 12 to 18 in. The data would seem to indicate that the water-soluble calcium and magnesium have been extracted to a depth of about 18 or 24 in., and that below that depth the calcium and magnesium have been made more soluble in water in the wheat soil compared with the virgin soil, possibly as a result of long cultivation."

The east German black soils (chernozem) with brief mention of east German brown soils, V. HOHENSTEIN (*Internatl. Mitt. Bodenk.*, 9 (1919), Nos. 1-2, pp. 1-31; 3-4, pp. 125-178, pl. 1, figs. 5).—An extensive study of the geology and physical and chemical properties of the black soils which cover an area of about 2,500 sq. km. (617,600 acres) in eastern Germany is reported.

These soils are coffee-brown to black-brown in color and average from 50 to 60 cm. in depth. For the most part the mother rock consists of pebble marl, clay marl, silica, and sand, and in some localities loess, and occasionally tertiary clay. The weathering of the black soil is gradual. The soils show the activities of earth worms and small burrowing animals. Where the mother rock contains lime, a heavy white carbonate stratum underlies the black soil, while the formation above is deficient in lime.

As compared with the other east German soils, these soils are said to have strikingly favorable chemical and physical properties, particularly with reference to their content of from 2 to 4 per cent of humus. Leaching is generally not extensive. The black soils are, therefore, considered the best adapted for wheat and sugar beets. It is the opinion that these black soils are not a product of the daily climate, but the result of an extreme climate similar to that of the steppes under grass and weeds.

The soils on the edge of the east German black soil region are mostly brown soils. They are strongly leached out forest soils, with extensive layers deficient in lime, and reddish brown subsoil having somewhat the character of podsol formations.

A list of 49 references to literature bearing on the subject is included.

Studies of red soils of "djati" forests, N. BEUMÉE-NIEUWLAND (*Boschbouwk. Tijdschr. Tectona*, 11 (1918), No. 3, pp. 187-205).—Analyses of 25 samples of red soils from djati forests of Java are reported and discussed, together with data from other sources on the fertility of these soils.

It is concluded, on the basis of a comparison of chemical analyses of poor and rich soils, that the presence of a large amount of nutritive constituents soluble in hydrochloric acid does not necessarily indicate a high state of fertility in djati soils. The analyses indicate this with reference to total fertility constituents, and in one case of apparent poverty in phosphoric acid better crops were produced than in a soil rich in phosphoric acid soluble in hydrochloric acid. The lowest figures for potash were associated with soils of lowest productivity. It is noted also that the lime content of these soils is low even in those which appear to be the most productive for djati. The physical properties of these soils, particularly hygroscopicity, are considered to have a great influence on their fertility with reference to the availability of nutritive constituents.

The physical properties of soils, B. A. KEEN (*Fruit, Flower, and Veg. Trades' Jour.* [London], 37 (1920), Nos. 7, p. 167; 8, pp. 195, 197; 9, p. 222; 10, p. 252; 11, p. 280; 12, p. 308).—This is a series of six lectures on the subject.

The soil viewed as a permanent depositary of moisture, I. R. FONTANA (*Univ. Tucumán, Ext. Agr. Bol.* 19 [1918], pp. 1, 2).—This is a popular discussion of physical and chemical factors governing the moisture content of soils.

Effect of initial moisture content on subsequent moisture movement in soil, G. ROBERTS (*Kentucky Sta. Rpt.* 1918, pt. 1, pp. 28, 29).—Experimental

work in progress, dealing with moisture movement in dry and wet sand and in soils of different initial moisture contents, has shown that with sand the movement is only from 1.3 to 1.7 times as great when wet as when dry, and that with soils there is very little greater movement in soil containing a small amount of initial free moisture than in soil previously air dry.

The daily march of temperature in the surface layer of the soil, R. SÜRING (*Veröffentl. Preuss. Met. Inst., 1919, No. 302, pp. 39, fig. 1*).—Observations with soil thermographs at depths of 10 and 20 cm. (3.9 to 7.9 in.) are recorded and discussed. The phase and amplitude of the daily march of temperature were found to be dependent first upon the air content of the soil, and second upon the moisture content.

Temperature of springs and of the soil (*Abs. in Met. Ztschr. [Brunswick] 36 (1919), No. 7-8, p. 231*).—This is a brief note on an article by C. Mezger, dealing with the normal temperature of springs, the influence of sea level and forests, relation of soil temperature to that of springs and the air and related subjects.

The value of lupines in the cultivation of poor light land, A. W. OLDERSHAW (*Jour. Min. Agr. [London], 26 (1920), No. 10, pp. 982-991, pls. 2*).—A report on experience on the growing of lupines in England, particularly for the improvement of poor light soil, is reviewed, it being shown that lupines grow with surprising luxuriance on poor blowing sand which will grow practically nothing but rye.

It was found in Suffolk that excellent crops of rye and frequently of oats can be grown on extremely poor, light, and somewhat acid soil after lupines which have been either folded green, plowed in, or harvested for seed. The crop value of the lupine itself is also discussed.

Legume inoculation, D. B. SWINGLE and G. B. NUTTING (*Montana Sta. Circ. 88 (1919), pp. 8, fig. 1*).—This circular deals with the practical phases of the inoculation of soils for the growing of leguminous crops, and includes a list of companies manufacturing cultures for legume inoculation.

Carbon dioxid and plant growth, F. BORNEMANN (*Deut. Landw. Presse, 47 (1920), Nos. 1, pp. 1, 2; 2, pp. 10, 11; 3, pp. 19, 20, figs. 6*).—The author reviews a number of his experiments to support his conclusion that the size of crop yields depends primarily upon the production of carbon dioxid by the soil. The experiments included the artificial introduction of carbon dioxid gas into the soil and the stimulation of carbon dioxid production in soil by the use of manure.

The results showed that large increases in leguminous crops were obtained by stimulation of carbon dioxid production in the soil. It is concluded that stable manure should always be used on leguminous crops, especially peas and beans.

Humin acids, J. MARCUSON (*Ztschr. Angew. Chem., 31 (1918), No. 99, Aufsatz., pp. 237, 238*).—A brief study of the pure chemistry of so-called humin acids from soils and brown coal is reported. It is stated that such acids, occurring mainly in moor and agricultural soils, peat, brown coal, and rotten wood, contain from 55 to 65 per cent carbon, from 3.7 to 4.6 per cent hydrogen, and about 4 per cent nitrogen, and the remainder consists mainly of oxygen with a little sulphur.

The farmer's part in bigger crops, R. W. TRULLINGER (*Amer. Farming, 15 (1920), No. 3, pp. 3, 14, 15, figs. 3*).—This is a brief popular article defining the general principles of seed-bed preparation and discussing the preparation of the soil for the more common field crops.

Fertility program for a 160-acre farm, C. E. THORNE (*Mo. Bul. Ohio Sta.*, 5 (1920), No. 4, pp. 99-106, fig. 1; also in *Amer. Fert.*, 52 (1920), No. 5, pp. 73-76).—The author reviews a number of rotation fertilizer experiments conducted by the station with the purpose of outlining a fertility program for a farm in Ohio.

Experiments on four quite different soils in various localities of the State, including fine silt loam and clay loam, are taken to justify the assumption that if the applications of fertilizers were increased to the average annual dressing of acid phosphate as used on these soils, viz, 80 lbs. per acre, or 50 lbs, more than is now used, the annual produce would be increased to a total annual value of \$34.50 per acre on the basis of average production figures for the State of Ohio for 10 years of \$29.50 per acre. In the case of a tenant it is considered fair for the landlord to pay half the cost of the fertilizer, the tenant performing all of the labor, as the experiments show that at least one-third of the effect of a fertilizer application is realized in following crops. The most effective chemical fertilizer in proportion to cost that was used in these experiments was on clay loam soil, and is equivalent to an annual dressing per acre of 53 lbs. of sodium nitrate, 160 lbs. of acid phosphate, and 13 lbs. of potassium chlorid. The average yield from this treatment has had an annual value of \$42 per acre.

Comparative experiments with barnyard manure applied at a rate equivalent to an annual dressing of 2½ tons per acre showed that the use of the manure brought the yield up to an annual value of \$48 per acre. When the same dressing of manure was reinforced with 107 lbs. of acid phosphate, the value of the annual yield rose to \$54.80, and when the reinforced manure was spread direct from the stable, the average yield had an annual value of \$57.80.

Corresponding data from tests on 10-acre fields are reported, and the profits of live-stock farming are discussed.

Soil fertility experiments (*North Dakota Sta. Bul. 136* (1920) pp. 9, 10).—Progress data from projects operating since 1912 and designed to determine systems of agriculture which will maintain soil fertility under Red River Valley conditions are reported. The trials consist of comparisons of live-stock farming systems with cash-crop farming systems. The only fertilizer that has returned a reasonable profit has been phosphorus on potatoes.

Facts concerning meadow fertility, M. A. BACHTEL (*Mo. Bul. Ohio Sta.*, 5 (1920), No. 4, pp. 121-124, fig. 1).—The effect of the proper use of fertilizers upon the fertility of meadow soils and subsoils is discussed.

“In view of the far-reaching influence of the quality of meadows it is interesting to note that both the character of herbage and its mineral composition may be influenced through fertilization of the soil.”

The nitrogen, phosphoric acid, and potash contents of oats and their relation to increased yields produced by fertilization, T. PFEIFFER, W. SIMMERMACHER, and A. RIPPEL (*Jour. Landw.*, 67 (1919), No. 1-2, pp. 1-57, figs. 6; *abs. in Zentbl. Agr. Chem.*, 49 (1920), No. 1, pp. 1-8).—Experiments on a sand soil with oats are reported, from which data were obtained on the yields resulting from increasing additions of the three main plant nutrients under different conditions, together with data on the content of the harvested plant materials in the nutritive constituents. Special attention was paid to the influence of excessive and moderate moisture additions and light.

In the nitrogen tests the percentage content of nitrogen in the dry matter of the plant increased with the size of the nitrogen addition. In several cases, however, the plants without nitrogen treatment contained more nitrogen than those receiving the smallest nitrogen addition. The higher nitrogen con-

tents usually accompanied the moderate water additions and this was increased by partially excluding light. However, the different conditions imposed produced no noteworthy variations in the nitrogen content of the dry matter.

In the phosphoric acid tests, in addition to full and moderate water additions and the exclusion of light, a full water addition was made, together with the addition of aluminum hydroxid and calcium carbonate. In contrast to the nitrogen tests there was relatively little increase in yield with increasing additions of available phosphoric acid. The phosphoric acid assimilation was smaller with the moderate water additions than with full water additions. The aluminum and lime decreased phosphoric acid assimilation.

Potash tests were also conducted but with contradictory results.

On the basis of these results the authors attempted to develop curves showing the relation between yield and analysis of crops as a basis for determining fertilizer requirements of soil, and give an intricate mathematical analysis of the subject with apparently more or less doubtful results upon which to base conclusions. They are of the opinion, however, that the data indicate that, for those points on the yield curves for which the values obtained by dividing the increase in yield by the yield are constant, the crops will show the same percentage contents of nutritive constituents.

Explanation of nitrogen loss in liquid manure, E. BLANCK (*Landw. Vers. Sta.*, 94 (1919), No. 5-6, pp. 285-291).—The author answers criticisms of his conclusions on the subject, and cites the results of numerous studies conducted by himself and others to show that nitrogen losses through the evaporation of ammonia begin when the total transformation of urea into ammonia is completed.

Does peat litter absorb water from damp air? TACKE (*Mitt. Ver. Förd. Moorkult. Deut. Reiche*, 34 (1916), No. 19, pp. 383-389).—Experiments are reported which showed that moss peat litter in finely divided condition absorbed very little moisture from very damp air in a room. Excessively moist peat litter under certain conditions lost moisture. Compressed balls of peat litter in relatively dry condition absorbed no appreciable amounts of moisture.

Theoretical study of nitrogen fixation by the electric arc, I-IV, C. P. STEINMETZ (*Chem. and Metall. Engin.*, 22 (1920), Nos. 7, pp. 299-304; 8, pp. 353-357; 9, pp. 411-416; 10, pp. 455-462, figs. 15).—This paper, in four parts, gives the results of an extensive theoretical study of the problem of electric arc nitrification.

Part 1 deals with the chemical dynamics of the nitrogen-oxygen reactions at the temperatures of the arc and during cooling, and includes equations of reaction velocity and temperature equilibrium. Tables of thermal nitrification constants, reaction periods, and velocities in air are also included. Part 2 deals with the effect of the rate of cooling upon the dissociation of NO and includes cooling curves. Part 3 deals with multiple arcs with intermediate cooling, and discusses cooling of the arc by adiabatic expansion and by molecular diffusion. Part 4 deals with the kinetic aspects of the nitrogen-oxygen reactions, taking up the effect of the arc in dissociating nitrogen, oxygen, and NO, the influence of molecular vibration speeds, the probability law, concentrations of NO, and principles of the electric arc.

Political and commercial control of the nitrogen resources of the world, I-III, C. G. GILBERT (*Chem. and Metall. Engin.*, 22 (1920), Nos. 10, pp. 443-448; 11, pp. 501-504; 12, pp. 557-559, figs. 5).—This paper is in three parts.

Part 1 gives a general review of the sources of nitrogen, including atmospheric, nitrate ore, organic, and carboniferous deposit sources, together with a description of the general aspects of the control of nitrogen resources in

normal and war times. Part 2 describes the commercial aspects of nitrogen resources, including natural by-product and fixation compounds and the recent developments and changes in the nitrogen industry practice. Part 3 is a review of the economic nitrogen industry outlook. A bibliography of recent literature on the nitrogen industry is included.

Plant ashes as a source of potash (*Bul. Imp. Inst. [London], 17 (1919), No. 3, pp. 281-289*).—Analyses of ashes of white chestnut, black wattle, and olive wood from East Africa indicate that the crude wood ashes "would form valuable manures for use in East Africa on account of the high percentage of potash, lime, and phosphoric acid which they contain. Owing to the high temperature at which the ashes were produced, they contain a considerable quantity of caustic lime which is of far more value for addition to the soil than calcium carbonate. . . . The olive-wood ash probably does not contain enough potash to be remuneratively extracted."

Analyses of blue gum-tree ash from Tasmania indicate its manurial value on account of its content of soluble potash salts and the lime and phosphoric acid contents of its insoluble constituents. The sodium carbonate content was rather high. The percentage of water-soluble potash was higher than in most plant ashes from mature woods.

Analyses of dry leaves, wood, and ashes from the African tragacanth showed that the wood and bark ash contains a greater percentage of soluble potash than the ash from the leaves. "The wood and bark of the African tragacanth evidently form a more valuable source of water-soluble potash than the leaves, but both materials compare favorably with the majority of plant products used as sources of potash."

Analyses of sunflower ashes are also discussed.

Basic slag v. acid phosphate, C. E. THORNE (*Mo. Bul. Ohio Sta., 5 (1920), No. 3, pp. 91-93*).—Experiments on silt loam and clay soils conducted since 1900 to compare basic slag with acid phosphate are reported.

On unlimed soil deficient in lime it was found that 1 ton of 17 per cent basic slag, containing 340 lbs. of phosphoric acid, increased crop yields by an amount not quite \$3 more than 1 ton of 14 per cent acid phosphate, containing 280 lbs. of available phosphoric acid, showing that a pound of phosphoric acid was less effective in basic slag than in acid phosphate. On the limed land in both cases a pound of phosphoric acid gave a larger gain in acid phosphate than in basic slag, but a ton of basic slag, with its 60 lbs. more phosphoric acid, produced \$2.54 more increase on clay soil than a ton of acid phosphate.

"The results do not justify the purchase of basic slag in preference to acid phosphate for use on average land, when the pound of total phosphoric acid in basic slag, limed included, costs more than the pound of available phosphoric acid in acid phosphate."

Basic slag v. acid phosphate, C. E. THORNE (*Mo. Bul. Ohio Sta., 5 (1920), No. 4, pp. 141-146*).—This is a revision of the above report in which additional data bearing on the subject are included to strengthen the conclusions.

Sulphur in plants and soils, A. M. PETER (*Kentucky Sta. Rpt. 1918, pt. 1, pp. 38, 39*).—Experiments on the composting of sulphur with soil, phosphate rock, and manure, using soil from the station farm, showed that nearly three-fourths of the phosphate added or already present in the soil was finally rendered soluble in ammonium citrate solution, although the action was slow in beginning and did not progress properly until after the addition of sulfifying organisms. These experiments are considered to indicate the practicability of this method for producing acid phosphate on the farm. Laboratory experiments with eight Kentucky soils of different types showed that sulphur added at the

rate of 500 parts to the million of soil was nearly all converted into sulphate in a month. There was little difference in the sulfofying power of the several soils, none of them exceeding the station farm soil in this property.

The question of lime fertilization, P. LIECHTI and E. TRUNINGER (*Landw. Jahrb. Schweiz*, 32 (1918), No. 5, pp. 573-588; *abs. in Zentbl. Agr. Chem.*, 49 (1920), No. 1, pp. 13-16).—In a second contribution to the subject (E. S. R., 37, p. 219), pot culture experiments with oats, red clover, and carrots on acid soil deficient in lime are reported, to determine the influence of the fineness and amount of lime. Calcium carbonate of five different degrees of fineness was used, having grain sizes of from less than 0.11 to 2 mm., and was added in amounts varying from 1,000 to 8,000 kg. per hectare (890 to 7,120 lbs. per acre.)

It was found that degree of fineness and amount of application of lime had only a slight influence in the case of oats. The coarse-grained lime in relatively large additions had a favorable influence on red clover and carrots, while the fine-grained lime had an injurious effect, especially on carrots. The depressing influence of fine-grained lime on the action of bone meal phosphoric acid decreased as the lime grains increased in size. Lime of 3 mm. size had no depressing influence. The influence of lime on the action of superphosphate phosphoric acid was determined more by the physiological behavior of the test crop than by the degree of fineness of the lime. Fine and coarse grained lime had about the same favorable influence on the nitrification of ammonium sulphate.

Action of lime on acid humiferous soil, S. ODÉN (*Meddel. Stat. Skogs-försöksanst.*, No. 13-14 (1916-17). pt. 2, pp. 1287-1301, figs. 9; *abs. in Internatl. Inst. Agr. [Rome], Internatl. Rev. Sci. and Pract. Agr.*, 10 (1919), No. 4, pp. 393, 394).—Investigations conducted in Sweden are reported from which it is believed that vegetation is not injured in soils by free humic acids but that the acid character of unlimed humiferous soil is due to absorbed organic acids. The xerophytic growth of peat-bog plants is attributed to lack of oxygen for the roots; accumulation of injurious excreta, such as oxalic and formic acids; and fixation of nutrient elements by humus and the consequent formation of mycorrhiza as a form of adaptation to the lack of nitrates.

It is further pointed out that the different conditions found in unsubmerged peat bogs are modified by liming, as the formation of calcium humate not only neutralizes the acid toxic substances but also sets free the fertilizing elements absorbed. On the other hand it is stated that calcium humates oxidize more easily than the corresponding humic acids. Liming on these soils had no influence on the water supply of plants.

Relation of pulverized limestone to crop production in North Carolina, J. L. BURGESS (*Bul. N. C. Dept. Agr.*, 39 (1918), No. 6, pp. 15).—This is a summary of available data relating to the use of pulverized limestone for agricultural purposes, with particular reference to North Carolina conditions.

Borax in fertilizers, S. D. CONNER and E. N. FERGUS (*Indiana Sta. Bul.* 239 (1920), pp. 3-15, fig. 4).—This bulletin reports investigations undertaken to determine under what conditions and in what amounts borax is injurious to crops, and to determine the relative value of German and American potash salts.

Laboratory and field experiments with corn on different soils of neutral and acid reaction showed that borax caused the greatest injury when the fertilizer in which it was contained was applied in the row. From $\frac{1}{2}$ up to 4 lbs. anhydrous borax per acre produced injury when drilled in the row with corn. Sixteen and 18 lbs. of borax per acre worked into the entire surface soil produced no injury to corn. Borax injury varied with the method of application, type of

soil, seasonal conditions, and the crop grown. Corn was injured by borax on sandy soil and much more than on clay and on acid soils more than on neutral soils. The decrease in corn yield caused by borax was in direct proportion to the decrease in stand. The borax caused its injury at germination time and in the early stages of growth. Rains either before or after using a fertilizer containing borax caused the borax to be diffused and fixed and the damage was less.

The only potash containing much borax came from Searles Lake, Cal. This potash gave good crop increases and caused no injury when applied broadcast.

Most American potash salts do not contain borax, and so far as tests have been made the indications are that they are equally as good as German potash salts. Six different forms of American potash salts from various sources were compared with three standard German potash salts on soils deficient in potash. The crop increases for 12 plats with American potash averaged 20.3 bu. of corn per acre. The crop increases for 12 plats with German potash averaged 20.4 bu. per acre.

Analyses of commercial fertilizers and ground bone; analyses of agricultural lime, C. S. CATHCART ET AL. (*New Jersey Stat. Bul.* 340 (1919), pp. 5-54).—This bulletin contains the results of actual and guaranteed analyses of 220 samples of fertilizers and fertilizer materials offered for sale in New Jersey during 1919, together with a discussion of the total fertilizer inspection in the State for the year.

Analyses are also included of 13 samples of burned limes, 9 limestones, and 4 lime by-products.

The Connecticut fertilizer law (*Connecticut State Sta. Bul. Inform.* 9 (1919), pp. 8).—The text and a brief explanation of important features of the Connecticut fertilizer inspection law of 1919 is given.

Fertilizer analyses, A. J. PATTEN ET AL. (*Michigan Sta. Bul.* 287 (1919), pp. 62).—This bulletin contains the results of actual and guaranteed analyses of 1,083 samples of fertilizers and fertilizer materials representing 342 brands offered for sale in Michigan during 1919. Of the samples analyzed 24.7 per cent were below the guaranty in one or more constituents, of which the greatest number were deficient in potash, followed in order by available phosphoric acid, nitrogen, and total phosphoric acid.

Registered brands of fertilizers and lime, J. W. KELLOGG (*Penn. Dept. Agr. Bul.* 338 (1920), pp. 48).—This bulletin reviews the text of the Pennsylvania fertilizer inspection law and contains a list of fertilizer manufacturers and brands of their fertilizers for which licenses to sell in Pennsylvania during 1920 were taken out prior to March 1, 1920.

AGRICULTURAL BOTANY.

Plant succession and plant distribution in South Africa, J. W. BEWS (*Ann. Bot. [London]*, 34 (1920), No. 134, pp. 287-297).—Willis's "age and area" law is discussed, and in general, accepted by the present author. He points out, however, that it will apply only to regions where conditions are fairly uniform, and that in South Africa, where climatic variations are extreme, its operation is greatly modified.

The effect of the frosts of the winter of 1916-17 on vegetation, E. A. BOWLES (*Jour. Roy. Hort. Soc.*, 43 (1919), No. 2-3, pp. 388-461).—The winter of 1916-17 is said to have been the most severe since that of 1894-95, and is considered to offer a fair test of the hardiness of plants. An account is given,

therefore, of the effects of the cold weather on various plants growing in the open air in different localities, which are named with an extensive list of plants concerned.

The effect of aeration on the roots of *Zea mays*, I, C. C. BEALS (*Proc. Ind. Acad. Sci.*, 1917, pp. 177-180, figs. 3).—This experiment, as briefly described, is considered to show the great importance of the presence of air in contact with the roots not only for the normal growth of plant tissue but also for obtaining the maximum plant growth.

The action of one crop on another, S. PICKERING (*Jour. Roy. Hort. Soc.*, 43 (1919), No. 2-3, pp. 372-380, pls. 5, fig. 1).—It is held that the toxicity of heated soils is due to the decomposition of the organic matter in the soil, and it is thought that a like decomposition must occur, though less readily, at ordinary atmospheric temperatures. As most of the organic matter in soil is a product of plant growth, it follows that more toxin will be produced by plants growing than where they are not, hence the toxic effect of one plant or another. The ultimate decomposition of the toxin into food material demonstrated by the results with heated soils also explains the increased fertility in a soil which has grown a surface crop as soon as that surface crop is removed and the production of toxin ceases.

What the toxic substance is has not yet been ascertained, but an examination is now in progress from the chemical point of view. Some of these experiments, as here noted, indicate that the toxin is either a substance which can be oxidized or a reducing body. It has been found that such a body is present to a certain extent in extracts from all soils, and that it is increased by growing a crop in the soil or still more by subjecting it to heat. The question is evidently one of great complexity.

The effect of centrifugal force on plants, F. M. ANDREWS (*Proc. Ind. Acad. Sci.*, 1917, p. 175).—*Edogonium ciliatum* was centrifuged, 1,500 gravities being employed. Apparently the protoplasm was not detrimentally affected.

Barium in plants and soils (Kentucky Sta. Rpt. 1918, pt. 1, p. 42).—A brief summary is given of the results of an investigation by J. S. McHargue, a full account of which has already been noted (*E. S. R.*, 40, p. 819).

Abnormal abundance of calcium oxalate in plants, N. PATSCHOVSKY (*Biol. Zentbl.*, 39 (1919), No. 11, pp. 481-489).—An account is given of studies regarding the presence in soluble form in plants of oxalates.

On the localization of anthocyanin in the spring leaves of some trees and shrubs in the temperate regions of Japan, T. ICHIMURA (*Bot. Mag. [Tokyo]*, 33 (1919), No. 385, pp. 12-15).—Tabulated results are given of observations regarding the presence of anthocyanin and its histological distribution.

In a majority of 69 species, anthocyanin is localized in the palisade layer. It is confined to the epidermis or leaf hairs in a few. It is noted that the lower epidermis and the lower hypodermal layer are richer in pigment than the upper ones in case of young leaves. The distribution of transitory anthocyanin in young leaves is also indicated.

A new chromogen, producing a blue pigment in *Galanthus nivalis*, T. TAMMES (*Rec. Trav. Bot. Neerland.*, 15 (1918), No. 1, pp. 1-16).—A chromogen is reported as producing an ultramarine blue coloring material under conditions of free oxygen access and temperature of 20 to 100° C. (68 to 212° F.) in all parts except bulb and roots of *G. nivalis* and other species of *Galanthus*.

The opening of anthers in Solanaceæ, I. NAMIKAWA (*Bot. Mag. [Tokyo]*, 33 (1919), No. 387, pp. 62-69, figs. 7).—This is an account of studies on the opening of anthers in *Lycopersicum esculentum*, *Schizanthus pinnatus*, *Capsicum annum*, *Solanum nigrum*, *S. dulcamara*, *S. tuberosum*, *S. melongena*, *Petunia violacea*, *Nicotiana alata grandiflora*, and *Physalis alkekengi*.

Studies on pollen, F. M. ANDREWS (*Proc. Ind. Acad. Sci.*, 1917, p. 163).—The author reports the general results of investigations as carried out on the behavior of pollen in 435 plants with respect to a culture medium of cane sugar. Of these, 110 showed no response as regards growth (although a wide range of percentages was employed), and the remainder showed a more or less pronounced growth.

Pollen development in Cinnamomum and the phylogenetic significance of pollen types, G. TÄCKHOLM and E. SÖDERBERG (*Arkiv. Bot.*, 15 (1917), No. 8, pp. 1-14, fig. 1).—This is a study by the authors of *Cinnamomum sieboldi*, which offers a new example of a dicotyledonous plant in which (as in most monocotyledons) the pollen grains develop by successive cell divisions, with a consideration of the phylogenetic significance of the facts observed.

The origination of variations in Anemone hepatica, S. GALANT (*Biol. Zentbl.*, 39 (1919), No. 12, pp. 529-535, figs. 2).—This contains statistical notes regarding certain flower variations in *A. hepatica*.

The genetics of flower coloration in Tropæolum majus, H. RASMUSON (*Bot. Notiser*, No. 5 (1918), pp. 253-260).—It is stated that the genotypic difference between plants of *T. majus* with dark yellow and such plants with light yellow flower color is due to a single factor, dark yellow being dominant. The difference between red and yellow flowered plants may be conditioned by a single factor.

Anatomical structure of wheat heads as related to their position on the stem and to the influence of external conditions, W. HEUSER (*Kühn Arch.*, 6 (1916), pt. 2, pp. 391-436, figs. 11).—In summer wheat, the heads show morphological and anatomical characters corresponding to stem position as described. They also show modifications corresponding to soil moisture and nutriment.

The fruit of Opuntia fulgida: A study of perennation and proliferation in the fruits of certain Cactaceæ, D. S. JOHNSON (*Carnegie Inst. Wash. Pub.* 269 (1918), pp. 62, pls. 13).—This paper embodies a discussion of the occurrence and significance of a number of striking peculiarities in the development and fate of the persistent, self-propagating fruits of certain *Opuntias*. It is concerned primarily with the perennation and vegetative propagation of the ovary of *O. fulgida*, chosen for special consideration because of its remarkable power of budding off secondary flowers from the primary ones and also of forming new flowers and vegetative shoots from the long-persistent fruits.

The fact that *O. fulgida* and other species have series of fruits showing various degrees of sterility, from those with scores of seeds to those that are entirely seedless, is not considered conclusive evidence that seed production is really on the way to complete extinction in these plants. Nor is the corollary that propagation by seeds is being replaced by the proliferation to new plants of fallen fruits regarded as very significant. On the contrary, the stem-like character of the fruits in this genus results in the persistence of many sterile ovaries, such as would, in many less fleshy angiosperms, wither and fall off soon after blooming, instead of maturing into seedless fruits as here noted.

Revision of Ichthyomethia, a genus of plants used for poisoning fish, S. F. BLAKE (*Jour. Wash. Acad. Sci.*, 9 (1919), No. 9, pp. 241-252).—The genus *Ichthyomethia*, here reviewed, is said to be of economic importance as furnishing a medicine, a fish poison, and a valuable timber.

The Uredinales of Delaware, H. S. JACKSON (*Proc. Ind. Acad. Sci.*, 1917, pp. 311-385).—This account of Delaware Uredinales is the result of a study of the rust flora of that State begun in 1906. The list contains 129 species, which are recorded on 232 different hosts.

The Ustilaginales of Indiana, H. S. JACKSON (*Proc. Ind. Acad. Sci.*, 1917, pp. 119-132).—The present list of Ustilaginales or smuts of Indiana, based primarily on material of the author's herbarium and that of the Purdue Experiment Station, includes a total of 47 species on about the same number of hosts.

Resistance of Mucor zygotes, M. NOTHNAGEL (*Proc. Ind. Acad. Sci.*, 1917, pp. 181-187).—In the fall of 1916, experiments were begun to test out the resistance of Mucor zygotes and spores to desiccation, to heat, and to different chemicals. The work and results are briefly detailed. The practical result of the work is that in attempting to kill Mucor, the surest way is to use moisture, not much heat being necessary in this case, whereas if moisture is not present a high temperature and long application will be required.

Reaction of culture media, H. A. NOYES (*Proc. Ind. Acad. Sci.*, 1917, pp. 149-162, fig. 1).—The purpose of this paper is to point out some factors in the making of culture media and in the controlling of reactions that are as important as the method by which the reaction is determined. Discussion is given of the so-called acidity due to crude methods of making media.

Bouillon cubes as a substitute for beef extract or meat in nutrient media, Z. N. WYANT (*Jour. Bact.*, 5 (1920), No. 2, pp. 189, 190).—From the results of comparative tests and from practical experience of nearly a year, the author recommends the use of ordinary bouillon cubes in general laboratory work where ordinary beef extract or meat media has been formerly used. The cubes are used in the proportion of 1 or 1.5 cubes per liter.

FIELD CROPS.

The work [with field crops] of the Yuma Reclamation Project Experiment Farm in 1918, R. E. BLAIR (*U. S. Dept. Agr., Dept. Circ. 75* (1920), pp. 26-42, 58, 59, 60, 61, figs. 4).—This work, including variety and culture tests with cotton, alfalfa, grain and forage sorghums, flax, field peas, velvet beans, horse beans, Giant Bermuda grass, potatoes, and sweet potatoes, was continued along the same general lines as previously noted (*E. S. R.*, 40, p. 433).

The yields in variety tests of cotton, conducted in 1916, 1917, and 1918, were compared with the yields of ratooned plats in 1918. The average yield of seed cotton per acre of 24 varieties under different tests was 1,626 lbs. from the planted crop in 1917 as compared with 1,543 lbs. from the ratooned crop in 1918. The planted crop in 1918 yielded an average of 1,531 lbs. of seed cotton per acre. The number of plants successfully ratooned in 1918 ranged from 34.7 per cent for Foster, a long-staple upland variety, to 85.4 per cent for the Yuma variety of Egyptian cotton. An experiment in planting Pima cotton on different dates in 1918 resulted in the best yield from the planting made March 16, and the next best yields from plantings made March 9 and March 23. The Pima and Durango varieties grown by the furrow-and-bed method produced somewhat larger yields than were secured from ordinary plantings. It is pointed out that under the furrow-and-bed method the feeding roots form only on one side of the plant and that this is probably the reason that the method is effective in reducing excessive growth in the cotton plant. Breeding work was continued, and specially encouraging results with a strain of upland cotton, designated as No. 18, are reported.

During the past two years the most promising varieties of grain sorghums tested at the station were compared with recently introduced varieties. Dwarf hegari was the only variety producing more grain than Dwarf milo, the standard variety for the region, and it ranked second in the growth of forage. The percentage of thrashed grain from air-dry head weights was among the

highest in the test and ranged about 5 per cent higher than that of either Dwarf milo or feterita. The yields of seven valuable varieties for the 6-year period ending with 1918 showed that Dwarf hegari, together with other leading sorts, gave much better yields on medium heavy soil than on light soil. Some of the best yields from April and May plantings represented two grain crops harvested from the same plats in one season. As the early crop is frequently largely lost through bird injury, a single crop planted either late in June or early in July is regarded as generally most profitable. Results of spacing tests in 1918 with Dwarf hegari grown in rows 42 in. apart were in favor of 6 to 8 in. between plants in the row. The best yields of a very good strain of Dwarf milo secured by 28 farmers in 1918 were reported from rows about 3 ft. apart with plants 14 to 24 in. apart in the row. The average planting date of fields producing good yields was from June 20 to July 15.

The average seed yields of different strains of flax for 1917 and 1918 ranged from 8.3 to 19.8 bu. per acre. Plantings made from December 15 to January 15 gave the best yields. The data in a rate of seeding test indicated that when flax is broadcasted for seed production from 30 to 40 lbs. of seed per acre is most desirable.

The Tangier pea, introduced from Turkestan, compared with other varieties produced at the rate of 4.44 tons of green material and 1.13 bu. of seed per acre. Osceola and Georgia velvet bean varieties yielded 193 lbs. and 266 lbs. of seed per acre, but did not prove to be satisfactory in forage production. Horse beans planted in November and harvested in May produced 2.49 tons of green material per acre, but the seed production was not sufficient to compare favorably with field peas as a soiling or pasturing crop. Of several varieties of forage sorghums Dwarf Java produced 16.6 tons of green forage per acre, and when left to mature seed gave a yield of 57.2 bu. per acre. Giant Bermuda grass (*Cynodon dactylon maritimus*) became well established and made a very good growth during a part of the year, but it did not prove more vigorous or productive than common Bermuda grass (*C. dactylon*).

Variety tests with potatoes at the farm have indicated that Irish Cobbler, White Rose, Red Triumph, and Early Ohio, in the order named, are the most suitable for the region. The 5-year average production of marketable potatoes for Irish Cobbler was 86.5 bu. per acre, but in 1918 White Rose ranked first with a yield of 168 bu. per acre. Irish Cobbler was found to be the best summer keeper of the varieties grown. White Vineless sweet potatoes, one of the most dependable varieties under the conditions of the farm, showed a 4-year average yield at the rate of 9.53 tons per acre.

[Field crops work at the Indiana Station] (*Indiana Sta. Rpt. 1919, pp. 61-64*).—The work with field crops during the year ended June 30, 1919, is briefly described.

The variety tests noted have been reported upon largely in an earlier publication (*E. S. R., 40, p. 735*). The results of studies in crop cultural methods were in favor of drilling soy beans solid at the rate of about 1 bu. per acre on relatively clean and mellow ground, and of planting $\frac{1}{2}$ bu. per acre in rows for cultivation on ground that is weedy or tends to crust and bake. The best yields of buckwheat were secured from seedings made late in July or early in August. Seeding at the rate of 7 pk. per acre proved preferable for Michigan Amber wheat. This variety outyielded the Marvelous or Stoner at all rates of seeding.

Sudan grass gave the best yields when seeded early in June and drilled solid at the rate of 32 lbs. per acre. Analyses of the cured hay showed 10.3 per cent of protein as against 5.4 per cent in sorghum hay and 8.2 per cent in Golden

millet hay grown on adjoining plats. The average hay yield for the last two years was 5,058 lbs. per acre, as compared with 8,220 lbs. for sorghum and 3,997 lbs. for Golden millet.

Among the results secured from improving field crops by breeding and selection, soy beans in the variety test plats produced numerous natural hybrids, showing that artificial hybridization is not necessary to produce new sorts. Corn selected continuously for 13 years from plants producing no suckers showed no advantage in yield and quality over corn not so selected and producing suckers freely. The results of cooperative pasture experiments indicate at this time that redtop, Kentucky blue grass, and sheep's fescue are the most promising grasses, and alsike clover and white clover the most promising leguminous plants for pasture purposes on the greater part of the uplands in southern Indiana.

Experiments in the failure of clover led to the conclusion that lime, organic matter, and fertilizers, especially acid phosphates, are important factors in restoring clover-sick land. In one experiment an application of wheat straw as organic matter resulted in a clover hay yield of 3,200 lbs. per acre the first year, as against an average of 1,440 lbs. on untreated land, while on land receiving lime 2,888 lbs. and on land treated with fertilizers 3,000 lbs. per acre were secured. In an experiment conducted for five years the clover hay yields on limed land averaged 3,404 lbs. as against 2,656 lbs. on untreated land in one test, and 3,516 lbs. as against 2,074 lbs. per acre in another. In a third experiment the yield of clover hay on untreated land was 1,350 lbs., with lime 2,660 lbs., and with both lime and phosphate 4,930 lbs.

[Report of the department of agronomy], G. ROBERTS (*Kentucky Sta. Rpt. 1918, pt. 1, pp. 22-28*).—The work for the calendar year 1918 was continued mainly as previously noted (*E. S. R., 39, p. 422*).

The status of the work on the soil experiment fields in various parts of the State is briefly described, and the results with tobacco on the Greenville field and with sweet clover on the Berea field are reported. The tobacco was grown in a 3-year rotation with wheat and clover, and the soil was either left untreated or received different combinations of 2 tons of limestone, 600 lbs. of acid phosphate and 150 lbs. of sulphate of potash per acre applied only to the tobacco crop, and 100 lbs. of nitrate of soda per acre used on the tobacco and wheat crops. The average yield of five tobacco crops given the complete application without limestone was 1,209 lbs.; limestone and acid phosphate 1,119 lbs.; the complete application with limestone 1,108 lbs.; and limestone, acid phosphate, and nitrate of soda, 1,047 lbs. per acre, as against 456 lbs. per acre without treatment. The best yield of clover, 4,313 lbs. per acre, the average of four crops, was secured with limestone and acid phosphate, and of wheat, 28.2 bu. per acre, the average of two crops, with limestone, acid phosphate, and nitrate of soda.

The sweet clover, on soil receiving lime and acid phosphate and seeded in the spring of 1916, produced 278 lbs. of marketable unhulled seed per acre. The straw was spread on the ground and plowed under in the fall. The succeeding corn crop in 1918 yielded 40 bu. per acre as compared with 20 bu. on untreated soil on which sweet clover would not grow.

The results of cultivation experiments with corn for eight years showed but little variation in the yield from the different methods of cultivation. No cultivation, with simply scraping off the weeds, gave 52 bu. per acre and from seven to eight cultivations 4 in. deep gave 55.2 bu. per acre, these being the lowest and highest yields, respectively, in the series of tests. When soy beans were drilled in the rows with the corn or in alternate rows the total value of the

grain was less than that from either crop planted alone. A hill of beans planted with a hill of corn or between hills reduced the yield of corn but little, and gave 4.3 bu. of soy beans and 34.9 bu. of corn per acre.

Tests with wheat for three years indicated that applying nitrate of soda when the wheat is seeded in the fall remained without effect, while top-dressing with the nitrate in the spring gave an increase in yield. Wheat drilled in rows 4 in. apart gave practically the same results as wheat drilled in rows 8 in. apart. In wheat breeding work pure-line selections from Jersey Fultz have given rise to a strain which yielded on an average for four years 38.2 bu. per acre as against 35.2 bu. for the original variety.

In experiments with hemp the crop on untreated soil yielded 939 lbs. of fiber per acre as an average for three years, while hemp on soil receiving from 100 to 150 lbs. of nitrate of soda per acre gave 1,300 lbs. of fiber. Hemp grown for three years in succession on land infested with wild onions apparently had nearly eradicated this weed at the close of the period.

In tobacco rotation experiments the best quality of leaf and the best yields were produced after grass sod. Manure used on grass sod did not seem to have reduced the quality appreciably, and leaf of fair quality was secured also in a rotation of corn, tobacco, wheat, and clover, and in one of alfalfa, corn, and tobacco. Poor yield and quality of leaf were secured where soy beans were grown in the 3-year rotations, as this crop seems to encourage the prevalence of root rot.

[**Work with field crops at the New Mexico Station in 1918-19**] (*New Mexico Sta. Rpt. 1919, pp. 27, 28, 34-36*).—Average yields of sugar beets of 13.25 tons from March plantings and 10.67 tons per acre from April plantings are reported. Artificial shading of some of the sugar beet plats did not prove beneficial.

The results of a cotton variety test have been noted from another source (E. S. R., 42, p. 829). Among alfalfa varieties a selection of Peruvian gave the best yield for the season. Irrigation, cultural, and variety tests with potatoes are also noted.

Agronomy experiments (*North Dakota Sta. Bul. 136 (1920), pp. 7-9, 11, 17, figs. 2*).—Rotation experiments and studies with flax and sweet clover in progress at the station during the period of the report are briefly described.

Tests of regional strains of sweet clover demonstrated the general excellence of North Dakota grown seed. The results of cereal varietal trials indicated the following as the leading sorts: Marquis hard red spring wheat, Kubanka amber durum spring wheat, Lincoln oats, Select Manchuria barley, and North Dakota 959 rye.

Dry farming in the plains area of Montana, G. W. MORGAN and A. E. SEAMANS (*Montana Sta. Circ. 89 (1920), pp. 22*).—This circular, describing the most successful cultural methods and rotations for ordinary field crops grown under dry land conditions in Montana east of the Rocky Mountains, is based largely on the results obtained in cooperation with the U. S. Department of Agriculture at the Judith Basin substation during the last nine years and at the Huntley substation during the last five years. Methods of producing crops on newly broken sod and on land previously cropped are described, and directions for growing spring wheat, winter wheat, oats, barley, corn, flax, and pasture, forage, and hay crops, including brome grass, winter rye, alfalfa, sweet clover, etc., under the conditions and requirements of the region are given. The varieties of the different crops which have given most reliable results are mentioned, and the average yields secured under different cultural practices and crop rotations are briefly reported.

A crop rotation for a hog farm, C. E. THORNE (*Mo. Bul. Ohio Sta.*, 5 (1920), No. 5, pp. 131-135, fig. 1).—This article points out the kind of crop production likely to meet the requirements on a hog farm, and discusses in this connection certain results obtained at the station, especially those with soy beans, as related to crop rotations adapted to hog raising.

At the Miami County experiment farm a four-year rotation with corn, soy beans, wheat, and clover has been in progress for nine years, and each crop has been grown every season. Part of the land received acid phosphate at the rate of 200 lbs. per acre each on corn and wheat and of 100 lbs. on soy beans. The average yields per acre of the plats receiving this treatment were as follows: Corn, 66.09 bu. grain and 2,917 lbs. stover; soy beans, 25.43 bu. grain and 2,813 lbs. straw; wheat, 27.45 bu. grain and 2,950 lbs. straw; and clover, 3,794 lbs. hay.

In another rotation running during this period with corn grown two years in succession, followed by oats and clover one year each, and receiving on part of the land 200 lbs. of acid phosphate on each corn crop and 100 lbs. on oats, the average yields on the treated land were as follows: Corn, first year, 52.9 bu. grain and 2,562 lbs. stover; second year, 45.94 bu. grain and 2,214 lbs. stover; oats, 57.98 bu. grain and 2,662 lbs. straw; and clover, 2,983 lbs. hay.

The percentage content of fertilizer constituents of corn stover and of the straw of wheat, oats, and soy beans as determined by analytical work at the Ohio Station, and the manurial value of the quantity of these constituents produced per acre, are shown in tables and discussed.

Short season hay crops, C. R. MEGEE (*Michigan Sta. Circ.* 42 (1920), p. 4).—This material has been noted from another source (*E. S. R.*, 42, p. 631).

Why does red clover fail? E. B. STOOKEY (*Washington Sta., West. Wash. Sta. Mo. Bul.*, 8 (1920), No. 2, pp. 18-20).—An article discussing seed and seeding, soil, insects and diseases, and other conditions influencing growth and development of the crop as factors in producing red clover failure.

Time of applying nitrate of soda to corn, E. F. CAUTHEN and J. T. WILLIAMSON (*Alabama Col. Sta. Bul.* 210 (1920), pp. 17-32).—The experiments reported were conducted at the station from 1910-1916, and in cooperation with farmers in various counties over the State from 1914-1919. The results of each series of tests are given in tables.

At the station, 120 lbs. of nitrate of soda per acre applied to corn 2½ ft. high gave an average increase in yield of 7.5 bu. per acre, the largest average increase for the five-year period as compared with results from making the same application at the time of thinning, when the plants were 3 to 4 ft. high, and when they were ready to tassel. Applying the same quantity of nitrate when the plants were 2½ ft. high and again when they were ready to tassel gave an average increase of 9.5 bu. per acre. This double application in a 3-year period gave an average increase of 11.9 bu. per acre, but when 240 lbs. of cottonseed meal was substituted for the first application of nitrate of soda the average increase was only 10 bu. per acre. In a 2-year test on poor sandy soil 120 lbs. of nitrate of soda per acre applied at planting time gave an average increase of 3.9 bu. and when used as a side dressing to corn 2½ ft. high an average increase of 9.3 bu. per acre.

In 11 experiments conducted in various counties, the use of 100 lbs. of nitrate of soda per acre, when the plants were 2½ ft. high, gave the largest average increase, 5.7 bu. per acre. When this application was not made until the plants were ready to tassel the average increase was only 3.1 bu. In these experiments 200 lbs. of nitrate of soda per acre, one-half applied when the

plants were 2½ ft. high and the other when they were ready to tassel, increased the average yield per acre by 6 bu.

Marketing hemp, J. R. HUMPHREY (*Kentucky Sta. Bul. 221 (1919)*, pp. 25-43, figs. 6).—This bulletin presents a historical review of the hemp industry in Kentucky, describes methods of preparing hemp for market, discusses marketing methods at home and abroad, points out the advantages of grading and of establishing market standards, notes the uses of hemp in the United States, and considers the export outlook and the future of the industry.

An experiment to determine the comparative advantages of cooperative sales of hemp between the farmer and the manufacturer was carried out in 1917. Farmers' associations were formed for grading, baling, and storing the fiber preparatory to selling the product. It developed that the mills did not favor direct buying on account of added expense, lack of information regarding the reliability of the shipper, and lack of faith in the samples submitted. To overcome these difficulties part of the hemp was sold on a commission basis through a single agent held responsible for the grading, selling, and collection. The experiment resulted in a profit to the participating farmers, and pointed out the possibility of profitable hemp marketing by proper stabilization of grades and standardization of processes of preparing fiber for market.

[Methods of marketing hemp], J. R. HUMPHREY (*Kentucky Sta. Rpt. 1918*, pt. 1, pp. 61-63).—A brief report on the work noted above.

Kudzu, C. V. PIPER (*U. S. Dept. Agr., Dept. Circ. 89 (1920)*, pp. 7, figs. 2).—A description of kudzu (*Pueraria thunbergiana*) is given, and the culture and uses of the plant for grazing, soiling, and hay are discussed.

Experiments with oats, F. A. WELTON (*Mo. Bul. Ohio Sta., 5 (1920)*, No. 3, pp. 79-84, figs. 2).—The data presented comprise earlier results previously noted (*E. S. R.*, 34, p. 631), together with those obtained up to and including 1919.

The average yields obtained in 10 years' work show that disking as compared with plowing gave slightly larger yields in both grain and straw on a silt loam soil on which the weeds were kept in check. The results of 16 years' experiments on the rate of seeding showed a gradual increase in yield up to and including the 10 pk. per acre rate, although from the use of 9, 10, and 11 pk. per acre the variation in net yield was less than 1 pk. A comparison of 4 in. with 8 in. between drill rows, conducted for five years and comprising 18 seeding tests, resulted in an average gain of 3.08 bu. of grain and 29 lbs. of straw per acre in favor of the 8-in. drilling.

Experiments with large and small seed and the use of unscreened seed, or of the grain as it came from the thrasher, were begun in 1909 and the selection of the seed from year to year was continuous. The three grades were sown at a uniform rate and at a varied rate to distribute as nearly as possible the same number of seeds per plat. The difference in the average yields for 10 years between large and small seed in the uniform and varied rates of seeding was 6.11 and 5.81 bu., respectively, but with the uniform rate of seeding the unscreened seed exceeded the large seed by 0.6 bu. per acre.

In the average results for 11 years in comparing North Dakota grown with Ohio grown seed there was a gain of 2.89 bu. in favor of the North Dakota seed, and the weight per bushel of each class was maintained. Variety tests in progress for 10 years showed a difference of 16.23 bu. per acre between the highest and the lowest yields. The varieties standing highest, given in order of their rank, were as follows: Ohio 6203, Silvermine, English Wonder, Ohio 6222, American Banner, Golden Rain, Sixty-day, Big Four, Lincoln, and Improved American.

Tests of barley, emmer, and spring rye in comparison with oats, to determine their relative value as spring crops, indicated that barley was the only one offering much competition to oats.

United States grades for Bermuda onions, H. E. TRUAX (*U. S. Dept. Agr., Dept. Circ. 97 (1920), pp. 4*).—The operation of grades for Texas Bermuda onions proposed in 1918 was observed for two seasons, and the changes suggested by the study are embodied in the new recommendations here presented.

United States grades for potatoes, H. E. TRUAX (*U. S. Dept. Agr., Dept. Circ. 96 (1920), pp. 4*).—The study of the use by the potato trade of standard grades recommended in 1917 suggested a few changes which are incorporated in the revision of the grades as here proposed.

Wild rice, F. FYLES (*Canada Expt. Farms Bul. 42, 2. ser. (1920), pp. 20, figs. 12*).—Descriptive and historical notes on the plant are given, together with directions for its cultivation, harvesting, and storing. The insects and diseases attacking the plant and the food value of the hulled grain are briefly discussed, and the results of germination studies are reported.

From August 19 to 21, 1911, seeds of wild rice, both green and brown colored, were gathered, some of which were sown immediately and others kept dry for three days and then sown in 3 in. of mud in quart glass jars filled with water. On May 8, 1912, it was found that the seeds kept dry for three days had germinated practically as well as those sown on the day of gathering, and that the green seeds kept dry did not give the same high percentage of germination as the fully matured brown seeds. In later tests seeds kept dry for two weeks after growth gave a germination of 72 per cent, and seeds in transit for eight days shipped in damp sphagnum moss and sown the ninth day after gathering gave 96 per cent. Some of the same seed taken out of the moss and kept dry for eight days gave 66 per cent.

In another test seeds shipped and kept dry for 12 days after gathering all germinated, while some of the same lot kept dry for two weeks, and others for three weeks, germinated 74 per cent and 66 per cent, respectively. Seed exposed to the sun for five hours after gathering and kept dry for two weeks gave a germination of 60 per cent, but when kept dry for three weeks of only 6 per cent.

At the Central Experimental Farm three lots of fully matured seeds gathered August 12, 1913, and kept dry for two days gave perfect germination. Of seeds gathered at Ottawa and sown 25 days later at Kew Gardens, England, 42 per cent germinated. The results of 24 other tests showed that of seeds kept dry for four weeks 45 per cent, for six weeks 14 per cent, and for seven weeks 1 per cent germinated.

Sorghum for sirup in Wisconsin, A. H. WRIGHT (*Wisconsin Sta. Bul. 311 (1920), pp. 3-30, figs. 17*).—This bulletin is a popular treatise on the culture of sorghum for sirup and its preparation for the mill. Historical and statistical data regarding the industry in Wisconsin are presented, certain improvements in handling and utilizing the crop are suggested, and directions for determining the amount of sirup obtainable from a given quantity of fresh juice are given.

Sweet potato fertilizer experiment, J. M. SCOTT (*Florida Sta. Bul. 156 (1920), pp. 59-63, fig. 1*).—A fertilizer experiment with sweet potatoes was conducted for the five years 1915-1919, on high pine sandy soil of average fertility used the six preceding years for a fertilizer experiment with Japanese cane. The plats were the same and were fertilized alike for the two crops. Triumph sweet potatoes planted each year during the last of May and the first week in June were grown after cotton in a rotation with corn and cotton. The plan

of fertilization and the average yield for the 5-year period are shown in the following table:

Fertilizers applied and the 5-year average yield per acre in an experiment with sweet potatoes, 1915-1919.

Plat.	Dried blood.	Sulphate of ammonia.	Muriate of potash.	Sulphate of potash.	Acid phosphate.	Ground limestone.	Average yield per acre.
	Lbs.	Lbs.	Lbs.	Lbs.	Lbs.	Lbs.	Bu.
1.....	112		84				151.8
2.....			84		224		166.8
3.....	112				224		65.0
4.....		72	84		224		200.4
5.....	112		84		224		204.0
6.....		72		84	224		173.4
7.....	112			84	224		185.8
8.....	112			84	224	2,000	186.7

The ground limestone was applied only in 1915, 1917, and 1919. Attention is called to the low yield on plat 3, which received no potash. Brief notes are given on the culture and importance of the crop in Florida.

United States grades for sweet potatoes, H. E. TRUAX (*U. S. Dept. Agr., Dept. Circ. 99 (1920), pp. 4*).—The grades here recommended by the department as a standard for grading and marketing sweet potatoes are based on tentative grade specifications proposed in 1918, as modified after use.

Summary of three years experiments on the tobacco station at Harrow, Ont., D. D. DIGGES (*Canada Expt. Farms Bul. 41, 2. ser. (1920), pp. 22*).—The work here reported included plant bed experiments; culture, fertilizer, and variety tests; and studies of methods of harvesting the crop and for the control of insects and diseases attacking tobacco. General directions with regard to various cultural phases also are given.

In the plant bed experiments glass covered cold beds as compared with canvas covered cold beds always produced plants ready for transplanting about two weeks earlier, and glass covered hot beds led all types of beds by about three days in the production of such plants. Fall steaming of the cold bed proved to be as effective as spring steaming for seedling production by the cold bed method. Plants were produced eight days earlier on steamed soil than on soil treated with chemicals, and from 8 to 18 days earlier than on untreated soil. Steaming for 30 minutes at 100 lbs. pressure appeared adequate for weed and disease eradication.

Four fall plowed plats of Burley tobacco of $\frac{3}{4}$ acre each, as compared with similar plats plowed in the spring, gave increases ranging from 67.6 lbs. to 298 lbs. of leaf per acre. In the spring the fall plowed plats were disked twice at different intervals, and the four remaining plats were plowed and disked once as a preparation for the crop. The results of transplanting tests indicated the following distances as preferable for the types of tobacco mentioned: Broadleaf Burley 44 by 28 in., Standup Burley 42 by 26 in., and Flue-cured $\frac{3}{8}$ by 24 in.

Fertilizer experiments were conducted with the Flue-cured and the Burley varieties of tobacco. It appeared from the results that on the heavier types of soils a complete fertilizer mixture consisting of 140 lbs. sulphate of ammonia, 500 lbs. acid phosphate, and 200 lbs. sulphate of potash per acre is likely to give the highest yield and the best quality of Flue-cured tobacco. The best fertilizer formula for Burley tobacco, as shown by the outcome of the tests, was 400 lbs. sulphate of ammonia, 400 lbs. acid phosphate, and 150 lbs. sulphate of potash per acre.

The most effective method for the control of the cutworm was spraying the plants before transplanting with a selection of 1.5 oz. of dry arsenate of lead per gallon of water. Plowing tobacco land after September 20 also reduced cutworm injury to a minimum. The horn worm was combated effectively by spraying with a solution of 6 lbs. of powdered arsenate of lead in 100 gal. of water, and after the plants are half-grown by dusting with powdered arsenate of lead mixed with an equal quantity of dry sifted wood ashes or air slaked lime.

Harvesting by the split stalk method was found to save labor, to expedite curing, and to produce a lighter colored leaf than when the crop was spudded or needed for comparison. The split stalk method consists in splitting the plant from the top to within 2 in. of the ground, cutting it off close to the ground, and allowing it to lie where it falls until it has wilted sufficiently to handle without breaking, when it is placed on laths and hauled to the barn. Scaffolding Burley tobacco in the field for about three days in fair weather favored a quicker and better cure, and saved time and barn space as compared with immediate hauling to the barn.

The Colorado pure seed law, W. W. ROBBINS (*Colorado Sta., Seed Lab. Bul., 1 (1919), No. 4, pp. 3-16, figs. 2*).—The text of the act of 1917 regulating the sale and importation of field and garden seeds is given, and 48 questions relating to the operation and enforcement of the law are answered.

Commercial agricultural seeds, 1919, C. D. WOODS (*Maine Sta. Off. Insp. 94 (1919), pp. 90-100*).—The text of the Maine law regulating the sale of agricultural seeds is given, and the results of the examination of samples of seeds in 1919 are reported. The weed seeds found in the seed samples examined are listed.

HORTICULTURE.

[**Report on horticultural investigations**], L. GREENE (*Indiana Sta. Rpt. 1919, pp. 45-51*).—The work for the year was continued along lines previously noted (E. S. R., 40, p. 738).

The trees in the orchard management plats suffered from the low temperatures of 1917-18. The Stayman apple sustained the greatest injury, while Jonathan and Grimes suffered very little. In the tillage and cover-crop plats, 17 per cent of the trees were severely injured. The next serious damage was in the straw mulch plat, while the sod plat and the plat on which grass mulch was supplemented with straw suffered least.

Summarizing the results upon the different plats for the tenth year of growth, tillage and straw mulch continue to take the lead in the matter of growth. One plat which was tilled for the first 5 years and then seeded to grass, has shown a decided "set-back," since it was seeded. Another plat which was in grass mulch for the first 5 years, and has since then received additional mulches of straw, has shown a decided improvement in tree growth. The work as a whole shows the desirability of adapting a method of orchard management that will conserve the soil moisture.

The tillage and straw mulch plats produced more than double the amount of fruit produced by any other plat. The tillage plat produced practically 10 times the amount of fruit produced under sod. In the spring of 1919, the tillage and straw mulch plats showed very much heavier bloom than the other plats, thereby confirming previous records as to the correlation between bearing habit and growth habit. Other studies made of leaf weights, of transpiration, and some other growth phenomena show the same general ranking of the different plats.

Complete fertilizer applied in excessive amounts up to the time the orchards reached bearing age did not show beneficial results. During the summer

of 1918, the fertilizer tended to stimulate production. On the tilled plat, fertilizer increased the yield about one-third, and on the grass plat more than four times. Where the fertilizer was applied, the rye cover-crop yielded at the rate of 3.6 tons per acre, while the unfertilized plat yielded only 1.8 tons of rye per acre.

A determination was made of the amounts of nitrates in the soil before and after fertilization. The first samples were procured the day before the fertilizer was applied. The grass plat contained the smallest amount of nitrates, suggesting that the grass uses the nitrates in its own growth. The largest amount of nitrates was present under the mulch. The second lot of samples, secured on May 15, showed that the fertilized plats carried from 2 to 10 times the amount of nitrates in the soil carried by the unfertilized plats. This was not true in the grass plats, where the increase was much less marked.

Judged by the results secured in 1918, pruning has continued to prove a dwarfing process, both to the root and top of apple trees. Heavy pruning reduces early bearing.

The results of cover-crop experiments confirm previous conclusions. Generally speaking, those cover-crops which have the greatest value in the orchard are those crops which produce the greatest bulk of vegetable matter to return to the soil.

In the stock and scion experiments with apples, considerable progress has been made in securing own-rooted trees. In the work at Bedford, nearly twice the number of trees had rooted from the scion the second year after planting than were rooted the first year.

The results of dusting experiments for the first season show that dusting was more expensive than spraying and was not so effective in the control of apple scab. Dusting controlled codling moth and curculio as well as did spraying. Ninety-five per cent of the cost of dusting was for material, while under spraying only 65 per cent was for material and 35 per cent for labor.

Fertilizer experiments are being conducted to determine whether nitrate of soda is ordinarily needed in Indiana orchards, and if so, when is the best time to apply it. Among the results thus far secured, leaf studies indicate that nitrate of soda increased both the green and dry weight of the leaves. Fertilized trees made more growth in three out of four cases. The terminal growth amounted to about one inch more than the check plats. The time at which the nitrate was applied, that is, several weeks before or several weeks after bloom, made very little difference so far as growth is concerned. Of 5 orchards under experiment in 1918, only one gave a consistent response to the use of nitrate. This orchard was the only one in sod and was on the poorest land in any of the plats. The trees in this orchard bore twice as much fruit as those not fertilized, thus indicating that on poor sod lands the fruit crop will be improved the first season by applications of nitrate, whereas in cultivated orchards the results the first season may be negative.

The work with vegetables in 1918 was largely with crops used by the cannery. Tomato seed was selected and distributed for the season of 1919 with satisfactory results. A variety test containing 14 different varieties and 30 strains of tomatoes was carried on. The yields in this test ranged from 1.3 tons to over 8 tons per acre. Different strains of the Greater Baltimore variety yielded from one and one-third to seven and two-thirds tons. In tomato fertilizer experiments conducted in 1918, acid phosphate applied at rates of 100 and 300 lbs. per acre gave average net increases of \$19.66 and \$32.18 per acre. Lime, 2,000 lbs. per acre, used with 100 lbs. acid phosphate reduced the net gain to \$6.38 per acre; used with 300 lbs. of acid phosphate, it reduced

the net gain from \$32.18 to \$16.62 per acre. Lime used alone also resulted in a loss.

A preliminary experiment conducted in onion seed production indicated that early planting is advisable where maximum yields are to be secured. Medium sized bulbs, 1.25 in. to 1.5 in. in diameter gave a greatly increased yield of seed over either the larger or smaller bulbs. It is questioned whether medium sized bulbs will always prove to be better yielders than larger bulbs, but on account of the high cost of larger bulbs the medium size is preferred.

Some work in the selection with sweet corn seed was started in 1918, and work was also started to determine the value of imported potato seed when compared with Indiana grown seed. The Indiana grown seed compared very favorably with and in most tests was better than imported seed stocks. The work will be continued.

[**Report on horticultural investigations**], N. R. ELLIOTT (*Kentucky Sta. Rpt. 1918, pp. 59, 60*).—A brief progress report on work conducted during the year 1918. In a variety test of strawberries, the Gibson, McAlpin, and St. Louis varieties showed remarkable hardiness to frost and extremely hot weather.

[**Report on horticultural work**] (*New Mexico Sta. Rpt. 1919, pp. 29-31*).—Brief statements are given of progress made during the fiscal year 1918-19 in various experiments with fruits and vegetables.

Horticultural notes from the county experiment farms of Ohio, F. H. BALLOU and I. P. LEWIS (*Mo. Bul. Ohio Sta., 5 (1920), No. 2, pp. 52-57, figs. 3*).—This comprises notes on the activities of several experiment farms now in operation in different Ohio counties. The notes deal primarily with the plans for pruning and fertilizing orchards.

[**Report on horticultural investigations at the Yuma Experiment Farm in 1918**], R. E. BLAIR (*U. S. Dept. Agr., Dept. Circ. 75 (1920), pp. 42-58, 59, 60, 61-74, figs. 18*).—A progress report on cultural and varietal experiments with dates, figs, various deciduous tree fruits, citrus fruits, nuts, vegetables, and ornamental trees and shrubs. Based on the work conducted for several years past, information is given relative to the adaptability of various vegetables, and special cultural practices which have been found satisfactory for different crops. Notes are also given on ornamental palms, evergreens and deciduous trees and shrubs, and vines and roses that are adapted for the Yuma region.

Spraying programs for the orchard and fruit garden (*Mo. Bul. Ohio Sta., 5 (1920), No. 3, pp. 67-78*).—A revision of the spraying programs previously noted (*E. S. R., 35, p. 36*), based on the experience and knowledge of spraying specialists of the Ohio Experiment Station, the College of Agriculture, and the State Department of Agriculture.

Insecticides and fungicides 1918 and 1919 (*Maine Sta. Off. Insp. 94 (1919), pp. 101-104*).—A statement of the requirements of the Maine law regulating the sale of fungicides and insecticides, together with a tabulation of insecticides and fungicides analyzed in 1918 and 1919.

A simple and pleasing vegetable support, F. MARKHAM (*Gard. Mag. [New York], 13 (1920), No. 3, p. 181, figs. 4*).—A system of horizontal and vertical staking for tomatoes, peas, and beans is here illustrated and described.

The refrigeration of fruit and vegetable shipments, A. W. MCKAY (*Proc. Fla. State Hort. Soc., 32 (1919), pp. 63-70*).—A contribution from the Bureau of Markets of the U. S. Department of Agriculture, in which the author summarizes some of the important results brought out in the department's investigations of refrigerator cars and refrigeration practices.

Selecting nursery stock, P. THAYER (*Mo. Bul. Ohio Sta., 5 (1920), No. 2, pp. 58-62, figs. 4*).—Practical suggestions are given on the selection of varieties and good grades of nursery stock.

Rodent protection for fruit trees (*Mo. Bul. Ohio Sta., 5 (1920), No. 4, pp. 125-127, figs. 2*).—Directions are given for the protection of fruit trees from mice and rabbits, and the method of bridge grafting girdled trees is described.

Dust spraying, H. A. GOSSARD (*Mo. Bul. Ohio Sta., 5 (1920), No. 5, pp. 147-153*).—Data are given on some comparative tests of dusting and spraying apples conducted during the three seasons 1916-1918. The results, although not conclusive, indicate in general that spraying is somewhat more efficient than dusting, but that dust may be advantageously substituted for some of the spray applications on large orchards where time and labor are important factors.

Culture and feeding of the apple orchard, F. H. BALLOU and I. P. LEWIS (*Mo. Bul. Ohio Sta., 5 (1920), No. 2, pp. 42-48, figs. 4*).—A comparison of fertilizers with grass mulch and with tillage in apple growing, based on the results of a 5-year experiment recently completed by the station.

In this experiment, which was begun in a practically abandoned Rome Beauty orchard 20 years old, the average cost of the tillage-cover-crop method of culture was \$17.09 per acre per year. This included annual plowing or disking, cultivation, seed, and seeding. Soy beans were used as the cover crop. The grass mulch method of culture cost only \$2.65 per acre per year. It consisted merely of two clippings of the grass during each growing season, and the necessary trimming, with a scythe, of small areas inaccessible to the mowing machine. The combined cost of the grass-mulch system of culture and of fertilization in connection with nitrate of soda and acid phosphate at the rate of 5 lbs. of each per tree or 200 lbs. per acre per year, even at prices prevailing during the war, was slightly less than the cost of the tillage-cover-crop plan without fertilization.

With the above rate of fertilization, the grass mulch plats gave an average gain of 22.2 bbls. of apples, or a net cash gain of \$71.48, per acre per year over the unfertilized tillage-cover-crop plats. When both the grass mulch plats and the tillage-cover-crop plats were given 5 lbs. of nitrate of soda and 5 lbs. of acid phosphate per tree, the grass mulch plats still gave a gain of 1.9 bbls., amounting to a cash gain of \$20.52 per acre per year, over similarly fertilized tillage-cover-crop plats.

Fertilization with nitrogenous plant food in the tillage-cover-crop plats gave a gain over no fertilization of 20.3 bbls., or a net cash gain of \$50.96, per acre per year. Unfertilized tillage-cover crop plats gave an average gain of 15.6 bbls., or a cash gain of \$35.48, per acre per year over the unfertilized grass mulch plats.

On the grass mulch plats fertilization with nitrogenous plant food gave a gain of 37.8 bbls., or a net cash gain of \$106.96, per acre per year over no fertilization on similar plats. The results were practically the same where the fertilizer was applied in circles under the outer extremities of the branches of the trees, or over the entire tree squares of ground. Distributing the fertilizer all over, however, had the added advantage of improving the growth of grass. This amounted to 1,650 lbs. per acre per year, sun-dry weight, as compared with the grass yield of unfertilized plats.

In a separate orchard of somewhat larger trees, wholly cared for by the grass mulch method, several combinations of chemical plant food were compared with no fertilization. The yields of apples per acre per year were for the unfertilized or check plats 36.7 bbls.; for a plat which received 5 lbs. each of nitrate of soda and acid phosphate, applied on a mulch of straw maintained in circular form under the outer extremities of the branches of the trees, 117.4 bbls.; for a plat fertilized with 2.5 lbs. of nitrate of soda and 5 lbs. of acid phosphate annually per tree, 93.4 bbls.; and for a plat fertilized annually with

10 lbs. each of nitrate of soda and acid phosphate per tree distributed evenly over the tree squares of ground, without a mulch, 118.1 bbls., or a gain of 1 bbl. per acre per year for the double quantity or all-over fertilization, as compared with the 5:5 and mulch formula. The costs of the 5:5 and mulch formula and the 10:10 all-over applications were practically the same. The principal benefit from the double application of fertilizer was the greatly increased growth of better grasses.

Plats fertilized with 10 lbs. each of tankage and bone, per tree per year, applied evenly over the tree squares, produced an average of 72.3 bbls. of apples per acre per year.

Pruning tests in young apple orchards, F. H. BALLOU and I. P. LEWIS (*Mo. Bul. Ohio Sta.*, 5 (1920), No. 3, pp. 85-90, figs. 6).—Comparative pruning tests were conducted in the Clermont County experiment farm orchard on young trees that had received three seasons' formative pruning, consisting of rather severely cutting back each year's growth of new shoots from one-third to one-half their length.

The results in general indicate that light pruning, whether during the dormant period or during the early summer, is more conducive to fruit bud formation and fruit production than heavy pruning. Nothing was gained by the supplementary practice of summer pinching or clipping of new shoots.

Trees that had received no pruning subsequent to the three seasons' formative pruning became a mass of crossed, inward-growing, tangled, crowding branches at seven years of age, but in a number of instances produced more fruit in their seventh year than the trees receiving any kind of pruning.

Thinning of apples, peaches, and plums, C. W. ELLENWOOD and P. THAYER (*Mo. Bul. Ohio Sta.*, 5 (1920), No. 5, pp. 136-140, figs. 4).—A discussion of thinning practices followed in seasons of heavy fruit setting, including a record of a thinning test conducted with Baldwin, Ben Davis, and Oldenburg apples, which is typical of results secured in thinning experiments conducted by the station.

A test of methods in pruning the Concord grape in the Chautauqua grape belt, F. E. GLADWIN (*New York State Sta. Bul.* 464 (1919), pp. 189-213, pls. 10).—This bulletin presents the results for the first 8 years of an experiment started at Fredonia, N. Y., in 1911 to determine which of the various methods commonly practiced in pruning are best for the Concord grape in the Chautauqua grape belt. The following methods were tried in the experiment: Single-stem, four-cane Kniffin; two-stem Kniffin; umbrella Kniffin; high renewal; horizontal arm; Chautauqua; and Munson.

The data secured during the past 8 years with these methods representing the drooping and upright types of training indicate that increased yields can not be expected by merely changing the method of training. The single-stem Kniffin, the umbrella Kniffin, the Munson, and the Chautauqua methods were about equally useful so far as yield is concerned for training the Concord. Under existing conditions, the high renewal and the two-stem Kniffin produced less and inferior fruit. Taking into consideration all the advantages and disadvantages of the various methods, together with the data covering the yields, wood production, and quality of the fruit, the author concludes that the single-stem Kniffin outranked any other method for training the Concord in the Chautauqua belt.

As measured by the yield, wood growth, and maturity of the fruit, there appeared to be no preference between early winter pruning and spring pruning. Spring pruning, however, does permit of a better selection of fruit canes after the severe temperatures of winter have passed.

Avocados, particularly Guatemalans, W. POPENOE (*Proc. Fla. State Hort. Soc.*, 32 (1919), pp. 88-104).—A contribution from the Office of Foreign Seed and Plant Introduction of the U. S. Department of Agriculture, in which the author briefly considers certain points dealing with the adaptation and culture of avocados in south Florida. The paper concludes with notes concerning the most promising varieties now being propagated in Florida.

Avocado varieties, E. D. VOSBURY (*Proc. Fla. State Hort. Soc.*, 32 (1919), pp. 105-109).—A contribution from the Bureau of Plant Industry, U. S. Department of Agriculture, in which the author sums up the experience in South Florida with different varieties of the West Indian, Guatemalan, and Mexican types of avocados.

Citrus fertilizer experiment: A résumé of ten years' work, S. E. COLLISON (*Proc. Fla. State Hort. Soc.*, 32 (1919), pp. 35-42, figs. 2).—A contribution from the Florida Experiment Station summarizing experiments reported in detail in Bulletin 154 of the station (E. S. R., 42, p. 837).

[Coffee, cacao, and tea in the French Colonies] (*Cong. Agr. Colon. [Paris]*, 1918, *Compt. Rend. Trav.*, vol. 3, pp. 7-72, 78-99, 265-288).—Under this general title are included the following reports and résumés of papers presented at the French Congress of Colonial Agriculture, May 21-25, 1918:

Coffee Culture in Madagascar, by Rollot (pp. 7-20); The Native Coffees of the Lower Oubangui-Congo, by Reste (pp. 21-27); Coffee in Indo-China, by Girard (pp. 28-33); Coffee Culture in China, by de La Pommeraye (pp. 34-39); Coffee in Guadeloupe, by Fawtier (pp. 40-43); The Diseases of Coffee in the French Colonies, by L. Beille (pp. 44-60); The Commercial Importance of Green Colored and Luster Coffee, by E. Sauvage (pp. 61-65); Monopoly of Coffee from the Colonial and Commercial Points of View, by P. Jobin (pp. 66-72); Cacao and its Possibility in Oceania, by Julien (pp. 78, 79); Cacao in Madagascar, by M. Robin (pp. 80-87); Note on the Cacao Station at Binger-ville Agricultural Station, Ivory Coast, by Leroide (pp. 88-92); The Metallic Impurities of Cacao, by G. Menier (pp. 93-95); The Budding of Cacao, by Bret (pp. 96-99); and a Contribution to the Study of Tea in Indo-China, by C. Shalot (pp. 265-288).

[Coffee in the Uganda Protectorate], L. HEWETT ET AL. (*Ann. Rpt. Dept. Agr. Uganda*, 1919, pp. 8, 11-14, 21, 23, 44).—Yield data are given for test plats of different varieties of coffee under observation on government plantations in the Uganda Protectorate.

State laws governing the protection and planting of street trees (*Michigan Sta. Circ. 41* (1920), pp. 8).—This circular comprises the text of the Michigan laws governing the protection and planting of trees along the streets and highways of the State.

What shade and ornamental trees shall we plant? W. E. BONTRAGER (*Mo. Bul. Ohio Sta.*, 5 (1920), No. 2, pp. 35-41, figs. 7).—A discussion of the selection of varieties, adaptation, planting, and care, with special reference to Ohio conditions.

Broad-leaved evergreens for Ohio planters, W. E. BONTRAGER (*Mo. Bul. Ohio Sta.*, 5 (1920), No. 4, pp. 111-113, fig. 1).—Suggestions are given on the use of native and other broad-leaved evergreens for ornamental purposes.

Gardens of celebrities and celebrated gardens in and around London, J. MACGREGOR (*London: Hutchinson & Co.*, 1918, pp. XII+326, pls. 26).—This work contains descriptions with illustrations in wafer color and pencil of 13 notable gardens in and around London.

FORESTRY.

Principles of a new philosophy of forestry, H. WEBER (*Grundlinien einer neuen Forstwirtschaftsphilosophie*. Tübingen: H. Laupp, 1919, pp. III+116, figs. 2).—A critical analysis of the science of forestry in part 1 of which consideration is given to the fundamental principles. Part 2 discusses the systematic arrangement, and part 3 the methodology of forestry science.

Elements of silviculture, I, II, F. E. G. D'ALVIELLA (*Éléments de Sylviculture*. Paris: Marcel Rivière, 1919, vols. 1, pp. XIV+383, pls. 2, figs. 84; 2, pp. 269, pl. 1, figs. 33).—An elementary treatise of silvicultural practice prepared with special reference to the reforestation of the devastated woodlands in Belgium. In the first section are given descriptions of coniferous and deciduous species adapted to that country. The succeeding sections discuss the tree in its relation to such natural agents as light, temperature, meteorological phenomena, climate, soil, etc.; preparation of woodland soils, nursery practices, and planting and cultural operations; and various causes of damage to woodlands, logging, exploitation, management, and trees in relation to the law.

A list of the principal works consulted is appended.

Economic aspects of State forests, W. COMPTON (*Chicago: Natl. Lumber Manfrs. Assoc., Bur. Econ., 1920, pp. 19*).—A paper delivered before the Tri-State Forestry Conference (Ohio, Indiana, Illinois) at Indianapolis, Ind., October 22, 1919.

Conservation: The form or the substance: Which? W. COMPTON (*Chicago: Natl. Lumber Manfrs. Assoc., Bur. Econ., 1919, pp. 24*).—A discussion of forest conservation more particularly from the lumbermen's point of view.

Forestry in the Douglas fir region, T. T. MUNGER (*Amer. Forestry, 26 (1920), No. 316, pp. 199-205, figs. 7*).—The author reviews the present status of lumbering in the Douglas fir region, and presents suggestions relative to a program for the reforestation of the cut-over lands.

Sixteenth annual report of the State forester [of Massachusetts], F. W. RANE (*Ann. Rpt. State Forester Mass., 16 (1919), pp. 61, pls. 5*).—This is the usual annual report relative to activities on the State forests and nurseries in Massachusetts, including accounts of general reforestation activities in the State and blister-rust, moth, and control work, together with recommendations relative to needed legislation.

Influence of sodium chlorid upon the physiological changes of living trees, W. RUDOLFS (*Soil Sci., 8 (1919), No. 5, pp. 397-425, figs. 15*).—This paper, a contribution from Rutgers College, reports experiments made upon 100 trees with sodium chlorid, applications to the soil ranging from 1 to 10 lbs. to individual trees.

"Some trees showed injury as early as 6 weeks after the application, while after 10 weeks a number of trees were seriously injured and some dying. The leaves of these trees turned brown and curled. An examination made at the height of the season showed some marked external changes. Smaller applications of salt apparently acted as a fertilizer. The trees treated with a small application were making a vigorous growth, the leaves becoming very large and thick, having a dark blue-green color and glossy surface. Others elongated their branches making the distance between the leaves unusually wide. The first signs of toxicity appeared usually at the edges of the leaves at the extreme end of the tracheids, or in the primary and secondary veins. The injury spread gradually until the leaves had a spotted, sickly appearance. After some time the leaves dried out with a rubberlike consistency. These leaves kept their flat and glossy surface and dropped from the branches. If the injury started at the

edges of the leaves, they gradually turned brown, curled, but remained on the trees. When the injury appeared in the veins first, a beautiful yellow-colored lace-work seemed to cover the underside of the leaves.

Quite frequently the trees made an effort to survive by sending forth tiny new branches from latent buds. These small branches in nearly all cases turned black-brown and dried out. Most of the trees which were given smaller applications made a secondary growth long before the untreated trees standing nearby.

"Of the trees experimented with, the maple is the most easily affected by sodium chlorid, followed by the birch and finally by the oaks. The rate of injury seemed to be dependent upon the height of the trees. The higher trees were more resistant than the lower ones of the same species. It is considered possible that the chlorin increases the acidity in the plant cell, accelerating or harming the vital activities according to the amount employed."

A list of 38 references to literature bearing on the subject is included.

Economic trees and their by-products, MRS. M. GRIEVE (*Chalfont St. Peter. Bucks: F. Newbery [1920], pp. 70*).—A concise account of over 70 species of trees that readily grow in Great Britain and which possess valuable by-products, now either neglected or entirely wasted in that country.

Black locust in Idaho, F. G. MILLER (*Idaho Sta. Circ. 11 (1920), pp. 4, fig. 1*).—This circular contains information relative to the range for planting black locust in Idaho, habits, rate of growth, and economic uses of black locust, together with methods of propagation, planting, and care.

Report on the culture of cinchona trees, G. PHILLIPE (*Rapport sur la Culture des Arbres à Quinquina. Lons-Le-Saunier: Lucien Declume, 1919, pp. 76*).—A report on investigations conducted in 1900 and 1901 on Ceylon, the British India, and Java, relative to the climatic and soil requirements of the cinchona tree and the cultural practices best suited to the maximum production of bark with high quinin content in the shortest time. Based upon this report, consideration is given to the possibility of growing cinchona trees in Annam, Madagascar, and Reunion.

[**Rubber in the French Colonies**] (*Cong. Agr. Colon. [Paris], 1918, Compt. Rend. Trav., vol. 3, pp. 316-443*).—Reports are given on the following papers delivered at the French Congress of Colonial Agriculture, May 21 to 25, 1918:

Wild and Plantation Rubber in the French Rubber Industry, by A. Dubosc (pp. 316-325); The Rubber Industry in Tropical Africa, by Y. Henry (pp. 326-339); The Status of Rubber on the Ivory Coast, by Bret (pp. 340-352); Rubber in Oubangui-Chari, by Baudon (pp. 353-373); The Rubber Extraction Industry in Brazil, by V. Cayla (pp. 374-401); and Rubber in Indo China, by O. Dupuy (pp. 402-436); the Yields from Hevea Rubber in Madagascar, by Luc (pp. 437-443); and *Hevea brasiliensis*: Methods of Tapping in "thirds" and the Manner of Applying it, by H. Fauconnier.

The report of the rubber section of the Congress concludes with a list of works published during the past 50 years on the planting and culture of rubber plants, the characteristics of latex, and raw rubber.

[**Rubber in the Uganda Protectorate**], L. HEWETT ET AL. (*Ann. Rpt. Dept. Agr. Uganda, 1919, pp. 8, 9, 14, 15, 21, 24, 30, 31*).—Data are given on cultural and tapping tests, chiefly with Hevea rubber trees on several government plantations in the Uganda Protectorate.

Lumber and its uses, R. S. KELLOGG (*New York: U. P. C. Book Co., Inc., [1919], 2. ed., rev. and enl., pp. 392, pls. 48, figs. 13*).—This is the second revised and enlarged edition of this book (E. S. R., 31, p. 840).

Cooperative marketing of woodland products, A. F. HAWES (*U. S. Dept. Agr., Farmers' Bul. 1100 (1920), pp. 15, figs. 6*).—This points out briefly what has been done in the cooperative marketing of other farm produce, and presents suggestions relative to the organization of farm products associations and methods adapted to the marketing of woodland products.

DISEASES OF PLANTS.

[**Report of the department of botany**] (*Indiana Sta. Rpt. 1919, pp. 19-25, figs. 4*).—The major investigations carried on by the department have been concerned with corn diseases, cereal rusts, and diseases of vegetables.

The work on corn diseases has been carried on to add information concerning certain ear, shank, and stem rots of corn in the hope of developing methods for avoiding losses from these diseases. The effect of the root-rot diseases on sweet corn is also being studied in cooperation with the horticultural department of the station. Physiological and chemical studies are in progress to determine the changes in composition of corn plants as induced by the different disease-producing organisms, the principal ones being species of *Gibberella*, *Fusarium*, *Rhizopus*, and *Pseudomonas*. The investigation includes field, greenhouse, and laboratory work on normal and abnormal physiology of the corn plant, chemical studies of the effect of the diseases on the composition of corn, and other important phases of the general problem.

The rust investigations have been mostly on the cereal leaf rusts, particularly relating to the species which causes the leaf rust of wheat. In connection with this work, the relation of leaf rust of wheat to a similar rust which is known to occur on 80 species of native grasses has been studied. Similar work is in progress with the leaf rusts of rye and barley.

Studies are reported in progress on *Septoria* leaf spot, mosaic, and *Fusarium* diseases of tomato, cabbage yellows, a malnutrition of onion apparently due to an excess of soluble salts in the surface soil, and tip burn and *Fusarium* wilt of potatoes, as well as a number of more common cucurbit diseases.

According to the report, a disease of wheat, identified by officials of the U. S. Department of Agriculture as probably the Australian "take-all" disease, was found in 3 counties in Indiana, and measures were taken to keep the trouble in check.

Some experiments have been inaugurated in cooperation with the department of horticulture of the station to study the effect of a dormant spray of strong lime-sulphur as a possible control measure for apple blotch. Laboratory tests showed that such applications would kill the spores of the fungus in exposed pycnidia, but not the mycelium in tissues of the bark. Field tests are in progress to determine the significance of these facts.

[**Notes on some plant diseases**] (*New Mexico Sta. Rpt. 1919, pp. 16, 17, 18*).—Brief notes are given on a number of plant disease projects which are being investigated at the station. These include chlorosis of trees, which was only temporarily checked by the use of iron sulphate solutions; also root-rot diseases of fruit trees and other plants; the *Fusarium* wilt of alfalfa; the occurrence of species of *Valsa* and *Cytospora* in connection with apple canker; and the presence in New Mexico of a disease of apple trees known as the Ozark Mountain measles. The last-named disease is thought to be connected in some way with the large amount of nitrates occurring in the soil.

Report of the phytopathological service [of the Dutch Pomological Union] (*Maandbl. Nederland. Pomol. Ver., 9 (1919), No. 9, pp. 140-142*).—A *Fusarium* disease in heads of summer wheat was controlled by the use of

copper sulphate or of hot water applied to the seed grain. A new tomato disease characterized by the appearance of brown sunken spots, followed by wilting and death, is ascribed to a species of *Ascochyta*. Stripe disease of barley was prevented by soaking the seed grains for from 12 to 16 hours in 0.5 per cent copper sulphate solution. Another successful method involves the employment of 200 gm. of copper sulphate in 2½ liters of water for each hectoliter of seed grain (about 2.5 oz. copper sulphate in 0.9 qt. of water per bushel of grain).

Gummosis, root rot, stem rot, and apoplexy in garden plants, L. SAVASTANO (*R. Staz. Sper. Agrumic. e Fruttic. Acireale, Bol. 28 (1917), pp. 4*).—The characters and treatments appropriate to the several diseases are briefly outlined.

Two destructive rusts ready to invade the United States, J. C. ARTHUR (*Science, n. ser., 51 (1920), No. 1314, pp. 246, 247*).—The author calls attention to two rust fungi which are said to possess possibilities of great harm, but which have not yet been reported in the United States.

One of these, *Uredo arachidis* or *Puccinia arachidis*, is said to be a serious menace to the peanut crop and has been reported in a number of places in South America and the West Indies. Experiments for its control with Bordeaux mixture were carried on in Montserrat, but without very much success.

The second rust to which attention is called is one on potatoes and tomatoes and is due to *P. pittieriana*. This rust is reported from Central and South America, where it is believed to be of considerable importance.

True and false silver leaf disease (*Gard. Chron., 3 ser., 66 (1919), No. 1712, p. 202*).—This is a condensation of the data presented by Bintner in his article previously noted (*E. S. R., 42, p. 150*).

Fumagine in cultivated trees and the lime-sulphur treatment, L. SAVASTANO (*R. Staz. Sper. Agrumic. e Fruttic. Acireale, Bol. 25 (1916), pp. 10*).—This includes accounts of experiments looking to the control of the fumagine due to the presence of certain fungi, the mycelium of which cause the smoky or sooty appearance but are otherwise harmless.

Lime-sulphur in winter, L. SAVASTANO (*R. Staz. Sper. Agrumic. e Fruttic. Acireale, Bol. 23 (1916), pp. 4*).—This bulletin deals with the necessity for simplifying the employment of lime-sulphur, the different types of this fungicide, and the necessary proportions, utensils, and manipulations.

Making lime-sulphur at home (*Brit. Columbia Dept. Agr., Hort. Branch Circ. 61 (1920), pp. 5*).—It is stated that at the present time the fungicide most extensively used in British Columbia is the so-called lime-sulphur solution. This is more commonly purchased in the form of the concentrate, a clear liquid of deep orange color requiring only the proper amount of water to make it ready for use. In view of a probable shortage of the commercial concentrate, directions are given for making it from the raw material, with estimates as regards cost and suggestions for storing.

Lime-sulphur as a substitute for Bordeaux mixture, L. SAVASTANO (*R. Staz. Sper. Agrumic. e Fruttic. Acireale, Bol. 22 (1916), pp. 4*).—This bulletin deals with lime-sulphur as adapted to employment against such diseases as *Fusicladium pirinum* and *F. dentriticum* on pome fruits; *Eoasacus deformans* and *E. pruni* on stone fruits; and *Cycloconium oleaginum* on olive.

Lime-sulphur wash [with saponin], E. S. SALMON and L. K. WORMALD (*Gard. Chron., 3. ser., 66 (1919), No. 1697, p. 4*).—Recent experimentation at the South Eastern Agricultural College, Wye, has shown that a small quantity (0.05 per cent) of saponin in solution added to lime-sulphur wash greatly improves the spreading quality and proportionately increases the protective capacity of the preparation. The use of the improved spray is said to secure

practically a continuous film of the sediment over the sprayed surface on drying, whereas ordinary lime-sulphur (when applied to gooseberries or to certain apple varieties) leaves the deposit in blotches or small patches even when carefully applied with a superior form of nozzle. A saponin solution of the strength indicated above is said to have been put on the market.

The use of soap to secure the necessary spreading has been shown to be precluded on account of chemical qualities.

Noxious action of emanations [from manufacturing plants], L. MANGIN (*Compt. Rend. Acad. Sci. [Paris]*, 168 (1919), No. 4, pp. 193-199, figs. 2).—An account is given of a study of the effects of emanations (finally synthesizing hydrochloric acid) from works producing a high explosive in large quantities during the war. These effects, as shown chiefly in conifers of several kinds, are discussed in relation to the production of injury, abnormality, or death in the plants affected.

Stinking smut of wheat [in Uruguay] (*Defensa Agr. [Uruguay]* Pub. 11, 1918, pp. 16, figs. 19).—This is a practical discussion of stinking smut (*Tilletia* sp.) of wheat, of various measures as used locally or recommended for its prevention, and of the cost of such preventive measures.

Take-all, Septoria, rust, and wheat mildew.—Practical methods of control, G. L. SUTTON (*West. Aust. Dept. Agr. Bul.* 69 (1920), pp. 27, figs. 10).—Take-all of wheat, here considered as due to *Ophiobolus graminis*, is said to attack wheat of all ages in patches aggregating in one instance as much as 75 per cent of 200 acres. The disease appears chiefly, though not exclusively, on wet, ill-drained lands, being characterized by a brown or dark discoloration of the stem and upper roots.

Though found in most of the wheat districts of Australia, it is not yet so important in West Australia as elsewhere. The spores, which live over in the soil from one season to the next, may be largely destroyed by such a fungicide as copper sulphate when small areas are dealt with. Alternate crops named as effective (if the ground is kept clean) are oats, rape, peas, and alfalfa. Rotation is advised and outlined.

Septoria or dry blight (*Septoria* sp.) is described as found on the leaves, stems, chaff, and grain. It first appeared in West Australia about 1905. Its appearance depends upon seasonal conditions which influence also, but independently, the seasonable or unseasonable flowering of the wheat, which should be planted later to avoid Septoria blight.

Red rust of wheat (*Puccinia graminis*) has been known in West Australia only during recent years, though recorded for New South Wales as early as 1825. It may cause in Australia a loss amounting to £5,000,000 in a single season. Barberry is not found in West Australia, but apparently it is not needed as an alternate host in other parts of Australia over which barberry is uncommon or unknown. The relations locally of conditions and varieties are discussed.

Asparagus root rot, L. GABOTTO (*Coltivatore*, 64 (1918), No. 35, pp. 735-737, fig. 1).—A root rot of asparagus is associated with a reticulum of fungal hyphæ, referred to *Rhizoctonia violacea*.

Mushroom root rot, H. P. BARSS (*Oreg. Grower*, 1 (1920), No. 11, pp. 2-4, figs. 3).—The information herein contained, primarily intended for comparatively inexperienced growers, deals with symptoms, varieties attacked by Armillaria root rot, and varieties found more or less resistant.

Disease of Chile pepper (*New Mexico Sta. Rpt.* 1919, pp. 14, 15).—A progress report is given of the study of the disease of Chile pepper, in which it is stated that an organism has been repeatedly isolated and inoculation experiments have shown that the isolated organism is the cause of the wilt disease. The fungus

is said to be a new species of *Fusarium*, for which the name *Fusarium annuum* is proposed. Investigations that have been in progress for some time have shown that there is a close correlation between the occurrence of the disease and the moisture content of the soil, and on this account it is recommended that in planting peppers light, well-drained soils should be selected, and irrigation should be practised only when necessary and not according to any fixed schedule.

Wart disease of potatoes [in England] (*Gard. Chron.*, 3. ser., 66 (1919), No. 1711, p. 190).—Sporadic cases of potato black wart having been reported from various points, a brief account is given for the benefit of growers of the infection, early and late stages, spreading, effects, and control of this disease. The only method known of raising clean crops in affected districts is by restricting cultivation to immune varieties, a number of which are now available.

Effect of fungi on the germination of sugar cane, C. W. EDGERTON and C. C. MORELAND (*Louisiana Stas. Bul.* 169 (1920), pp. 3-40, pls. 9, figs. 2).—The problem of the deterioration of sugar cane has been under investigation at the Louisiana Stations for a number of years, and the authors present the results of some of their experiments.

Sugar cane, it was found, does not germinate as well in Louisiana as in the Tropics, the average germination being only about 20 per cent. Among the factors instrumental in the deterioration of seed cane are certain parasitic fungi, among them *Colletotrichum falcatum*, *Melanconium sacchari*, *Gnomonia iliaui*, *Marasmius plicatus*, *Thielaviopsis paradoxa*, and species of *Fusarium* and *Scopularia*. The most serious injury to germination is said to be done by *C. falcatum*. *M. sacchari* is said to be abundant on deteriorating cane, but it does not seem to decrease the germination percentage. Some of the other species of fungi occur, but no evidence was obtained indicating that they directly reduce the germination.

The optimum temperature for the growth of the several fungi studied was about 27° C. (80.6° F.), and most of the forms make very slow growth at the normal temperature of the soil during the winter season. In order to prevent injury by these fungi, the authors carried on some experiments in treating seed cane with formaldehyde and corrosive sublimate, and while the tests are not considered conclusive, the results are believed to be encouraging. The best test gave an increase of 50 per cent in tonnage of cane where the seed was treated with corrosive sublimate.

A bibliography of the subject is appended.

The diseases of tomatoes, W. A. McCUBBIN (*Canada Expt. Farms Bul.* 35, 2. ser. (1918), pp. 16, pls. 3).—The author gives a key for the determination of the different diseases to which the tomato is subject, after which popular descriptions are given of the different diseases and so far as known methods for control are suggested.

Control of watermelon anthracnose by spraying, F. C. MEIER (*U. S. Dept. Agr., Dept. Circ.* 90 (1920), pp. 11, figs. 9).—The author gives a popular account of methods for control of watermelon anthracnose in which he recommends the use of Bordeaux mixture thoroughly applied to the plants. The spraying should be done on a bright, sunny day in order that the mixture may dry thoroughly, and if possible spraying when heavy bloom is on should be avoided. The use of more than 4 lbs. of copper sulphate to 50 gal. of water may result in serious burning of the foliage.

The control of apple blotch, F. H. BEACH (*Ohio Agr. Col. Ext. Bul.*, 15 (1919-20), No. 8, pp. 16, figs. 17).—Suggestions for the control of apple blotch and the results of highly successful demonstrations in control are given.

It is recommended that the trees should be sprayed four times with a 3:5:50 Bordeaux mixture, applied at intervals of 2, 4, 6, and 10 weeks after the petals have fallen. In order to spray the trees satisfactorily a working pressure from 200 to 300 lbs. per square inch is considered desirable. The author recommends the pruning and thinning out of the trees before spraying, and where the trees have been weakened by blotch to fertilize about the trees with about 5 lbs. of nitrate of soda when the blooms are in the pink.

The brown rot of stone fruits, W. A. McCUBBIN (*Penn. Dept. Agr. Bur. Plant Indus. Circ. 3* (1920), pp. 8, figs. 7).—It is estimated that brown rot causes 15 per cent loss annually to the peach crop in Pennsylvania, amounting to half a million dollars. The same rot in cherries causes an even greater loss. Plums also are affected and are protected by the same measures as are outlined for peaches.

Cure of brusone in the Japanese medlar, L. SAVASTANO (*R. Staz. Sper. Agrumic. e Fruttic. Acireale, Bol. 29* (1917), pp. 6, figs. 2).—An account is given of brusone due to *Fusarium pirinum* in the Japanese medlar, and of its successful treatment with lime-sulphur.

Further experiments against brusone of the Japanese medlar, L. SAVASTANO (*R. Staz. Sper. Agrumic. e Fruttic. Acireale, Bol. 33* (1918), pp. 2).—This is an account of experimentation continuing that noted above, employing lime-sulphur at different seasons and concentrations.

Cure of Oidium of peach, L. SAVASTANO (*R. Staz. Sper. Agrumic. e Fruttic. Acireale, Bol. 31* (1917), pp. 2).—Results are given of experiments in the south of Italy on the control of *Oidium leucoconium* of peach by means of a preventive application of lime-sulphur.

Diseases and insect pests of currants and gooseberries, A. FRANK (*Washington Sta., West. Wash. Sta. Mo. Bul., 8* (1920), No. 2, pp. 29-31, figs. 4).—Brief notes are given on fungus diseases and insect pests attacking currants and gooseberries, with suggestions for their control. In connection with the control of plant pests, the author calls attention to the different forms of lime-sulphur now upon the market and the necessity for following directions for the use of the different compounds.

Deformation of inflorescences of Theobroma cacao and T. bicolor, under the influence of Marasmius perniciosus, G. STAHEL (*Ann. Jard. Bot. Buitenzorg, 2. ser., 15* (1918), pt. 2, pp. 95-114, pls. 8).—An account is given of the malfomation known as Krülloten in *T. cacao* and *T. bicolor* associated with the presence of *M. perniciosus*.

History of citrus canker in Australia, with a brief account of the occurrence of the disease in the United States of America and South Africa, G. F. HILL (*Bul. North. Ter. [Aust.], No. 18* (1918), pp. 8, pls. 3).—Citrus canker (*Pseudomonas citri*), said to have been noted as occurring in Japan, China, Java, Singapore, five American States (Alabama, Florida, Louisiana, Mississippi, and Texas), the Northern Territory of Australia, and South Africa, is said to be controllable in the last-named region, owing to favoring climatic conditions, by the thorough and systematic use of Bordeaux mixture (4:4:50), but to require generally, in more humid regions elsewhere, complete extirpation by fire of infected trees. Condensed details and a bibliography are given regarding the history of the disease.

Methods of handling tree wounds, A. N. DUKE (*Citrus Indus., 1* (1920), No. 5, pp. 10, 15).—Principles and processes are discussed as applicable to the prevention of further injury to citrus and other trees resulting from wounds differing as to causation and situation. The general plans involved are thorough cleansing away where possible of dead or infected material and treat-

ment to prevent reinfection or spreading. A private crematory for dead materials is described.

Walnut diseases, C. CAMACHO (*Enfermedades del Nogal. Santiago, Chile: Serv. Pol. Sanit. Vegetal, 1917, pp. 13, figs. 4*).—Diseases of walnut here dealt with include bacteriosis (*Pseudomonas juglandis*), which may appear on any of the tender parts, as the annual branches, petioles, or young nuts; also melaxuma (*Dothiorella gregaria*). Control measures are outlined.

Diseases of Hevea brasiliensis in Uganda, W. SMALL (*Uganda Dept. Agr. Circ. 3 (1920), pp. 12*).—This publication, the first of a new series, treats of diseases of the Para rubber tree in Uganda so far as investigated to date. Symptoms of the diseases and recommendations for their treatment are given. The diseases are treated systematically as related to the root, stem, pod, and leaf of *H. brasiliensis*.

How to distinguish and combat the white pine blister rust, J. F. MARTIN, A. E. STENE, and R. A. SHEALS (*R. I. Bd. Agr., Ent. Dept. Bul., n. ser., No. 1 (1920), pp. 38, figs. 30*).—This account, written from a practical standpoint, deals with this disease as regards its identification and prevention and with insect injuries sometimes mistaken for white pine blister rust.

Insect and fungus pests of basket willows (*Bd. Agr. and Fisheries [London], Leaflet 301 (1918), pp. 11, pls. 4*).—A portion of this leaflet, devoted to fungus diseases, deals with willow rust and rust canker (*Melampsora* sp.) and willow canker (*Botryosphaeria gregaria*), with measures for their control.

Dry rot in timber, A. D. WEBSTER (*Gard. Chron., 3. ser., 66 (1919), No. 1697, p. 5*).—Noting the statement that half the wastage of timber in English coal mines is due to attacks by fungi, notably the so-called dry rot fungus *Merulius lacrymans*, the author details briefly attacks observed by himself. The protective measures suggested consist chiefly in the use of only dry, well-seasoned timber, exposure to sunlight, ventilation where possible, avoidance of the introduction of unsafe woods, and painting with carbolineum on the first indication of disease.

Investigations on the Narcissus disease, J. K. RAMSBOTTOM (*Jour. Roy. Hort. Soc., 43 (1918), No. 1, pp. 51-64, pls. 12*).—This is a more detailed account of work by the author on the Narcissus disease (*Tylenchus devastatrix*) than was given in the reports previously noted (*E. S. R., 38, p. 455; 43, p. 49*).

Nematodes (*Sacramento, Cal.: State Dept. Agr., Off. Pest Control, 1920, pp. 3, figs. 2*).—Statements are quoted regarding nematode injury to orchards through nursery stock and to potato crops through seed potatoes, also regarding the control of nematodes by selection of clean planting material.

The eelworm or nematode, a destructive plant pest (*Sacramento, Cal.: State Dept. Agr., Off. Pest Control, 1920, pp. 4, figs. 2*).—This pamphlet adds to the suggestions contained in that above noted a brief general account of the parasitism of *Heterodera radicum*.

ECONOMIC ZOOLOGY—ENTOMOLOGY.

Annual report of the Governor of Alaska on the Alaska Game Law, 1919 (*U. S. Dept. Agr., Dept. Circ. 88 (1919), pp. 18*).—This is the usual annual report on the administration of the Alaska game law. It includes estimates of game, including bears, caribou, moose, Arctic sheep, deer, goats, ptarmigan and grouse, migratory birds, and walrus; also, the fur-bearing and other animals, not classed as game animals, including wolves and coyotes, reindeer, and the musk-ox.

The cost of a squirrel and squirrel control, W. T. SHAW (*Washington Sta. Pop. Bul. 118 (1920), pp. 19, figs. 11*).—In determining the damage to winter

wheat caused by the Columbian ground squirrel (*Citellus columbianus columbianus*), individuals were placed in inclosed plats in which a good variety of wheat had been sowed on fallow Palouse wheat land. The several plats and their corresponding checks were harvested on July 30, the differences taken, and the damage carefully calculated.

It was found that during the 130 days of activity from March 22 to July 30 the male squirrel in yard 1 had destroyed 44 lbs. of wheat. A female squirrel, which gave birth to two young squirrels about May 19, was placed in a yard on April 14 and 51 lbs. of grain were destroyed by July 30. Computing the amount of destruction on the basis of a normal 130-day season, 1 young or 1 female brooding squirrel will destroy 51 lbs. of grain. In a third test in which a male squirrel was placed in a yard on May 15 to determine when the greatest damage was done to the crops, 56 lbs. of wheat were destroyed by July 30, showing that practically all the damage was done in 76 days of stem cutting and head destruction. The average destruction per squirrel in the experiments described was $50\frac{1}{2}$ lbs., which at a price of \$2.10 per bushel for hard winter wheat was worth \$1.76.

In an experiment in which a female, suckling four young, fairly mature squirrels, was given fresh white clover sod, it was found that she ate $\frac{1}{4}$ lb., or 17.2 per cent of her own weight per day. At this rate, 385 squirrels would consume the pasture of one cow in a day, or 96 squirrels would devour the pasture of one sheep in a day.

A brief summary is given of the life history of this species and the methods of control, including gassing, poisoning, and trapping, are described.

Facts about winter and summer robins in Ohio.—S. G. HARRY (*Mo. Bul. Ohio Sta.*, 5 (1920), No. 3, pp. 94-96).—This is a brief account of the American robin in which attention is called to the fact that there are northern and southern races. The forms found in Ohio during the winter months represent the more hardy or northern race. They are transients, the majority being Canadian birds. During the unusually severe winter of 1912, robins wintered in Ohio in large numbers, a flock of more than a thousand individuals having been observed from time to time throughout the winter. The fruit of the flowering dogwood (*Cornus florida*) is the staple winter food of the robin in the vicinity of Wooster.

[**Report of entomological work**] (*Indiana Sta. Rpt. 1919*, pp. 33-36).—From a systematic study of the life history of the codling moth, which was the most important work, the following tentative conclusions are drawn: "Between June 15 and August 15, the moths are constantly emerging but in no greater numbers at one time than at another. During hot weather the young larvæ may hatch in from 6 to 8 days from the time the moth emerges. Codling moths apparently do not mate on the wing. The larvæ may be poisoned after they have eaten under the skin of the apple. In order to keep apples free from codling moths, it is necessary to keep the surface of the apple covered with poisons from the time the blossoms fall till the last of August." These conclusions for the year 1919 are said to be practically in line with those obtained during the two years previous.

In investigations commenced the previous year for the purpose of determining the effect upon bees of arsenic compounds applied while fruit trees are in bloom, two bearing trees were screened in with wire screen and a colony of bees placed in each. Arsenicals were applied the trees, in one in a liquid and in the other in dust form. Observations were made from April 30 to May 15. Dead bees were gathered and counted at intervals, and the results showed a mortality of about 70 per cent for the sprayed tree and 46 per cent for the

dusted tree. Observations made upon several sprayed trees in bloom in the open show that the bees work the sprayed trees when they are at liberty and when there are unsprayed trees adjoining.

Studies of the life history of the Hessian fly in different sections of the State were continued during the year. Observations were made in several fields, and in no case was spring wheat infested as heavily as the winter wheat.

Observations and correspondence from various parts of the State showed that the joint-worm had done more injury to the wheat crop during the past summer than had the Hessian fly. In many fields from one-fourth to one-third of the yield of grain was destroyed.

The wheat midge was more numerous during the year than for many years, having been reported from more than half the counties in the State. Grasshoppers were so abundant in many sections of the State that whole fields of grain were practically destroyed or greatly injured. The army worm was more numerous and destructive in the State than at any time during the last 20 years. The distribution of the 17-year cicada which appeared during the year was much more irregular than has been the case with previous broods, but young fruit trees, especially those in sod, sustained serious injury from it in some communities.

Injurious insects of the garden (*New Mexico Sta. Rpt. 1919, pp. 16, 17*).—In tests made, it was found that kerosene emulsion used at the rate of 1:12 was more effective than blackleaf 40, 1:600, in controlling the cabbage aphid. A 2 per cent solution of lysol, with sticker consisting of commercial rosin fish oil, was very effective but too expensive from a commercial point of view. Tests were made of carbon bisulphid as a fumigant in controlling this insect, and the results seem to show that the method can be made practical. The fumigator used, which was 16 ft. long, 2.5 ft. wide, and 3.5 ft. high, is made to drag astride the cabbage rows.

Insect pests [at Yuma Experiment Farm in 1918], R. E. BLAIR (*U. S. Dept. Agr., Dept. Circ. 75 (1920), pp. 21, 22*).—The cotton aphid is said to have been the first pest that became generally detrimental and was found in great numbers until late in July. In some fields serious loss resulted through the heavy shedding of squares. The cotton bollworm, which was in great abundance during July and early August, was the greatest source of decrease, in some fields the loss caused by it being estimated at 70 per cent. Next in importance to the cotton bollworm came plant bugs as insect depredators. Other insects which are a source of injury to cotton but were of minor importance are cutworms (*Peridroma* sp.), wireworms (*Monocrepidius* sp.), the cotton leaf-perforator (*Bucculatrix thurberiella* Busck), the salt-marsh caterpillar, the red spider (*Tetranychus bimaculatus* Harvey), and grasshoppers. Mention is made of a number of other insect pests which sometimes injure crop plants in the region but were not seriously abundant during the year.

Dust v. spray for control of sour cherry pests in Pennsylvania, J. G. SANDERS and D. M. DELONG (*Jour. Econ. Ent., 13 (1920), No. 2, pp. 208-210*).—Control work against enemies of the sour cherry in Erie County, Pa., carried on during the summer of 1919, indicates that sulphur-arsenate of lead dust, 90:10, gives the best results on account of the rapidity and ease of application and the high efficiency in the control of curculio, slug, and leaf spot.

Important foreign insect pests collected on imported nursery stock in 1919, E. R. SASSER (*Jour. Econ. Ent., 13 (1920), No. 2, pp. 181-184*).—The more important findings of the year 1919 are noted.

Insect powder, C. C. McDONNELL, R. C. ROARK, and G. L. KEENAN (*U. S. Dept. Agr. Bul. 824 (1920), pp. 100, pls. 4*).—The sophistication and adulter-

ation of insect powder which have been largely practiced, much to the detriment of the industry, have led to the investigations here reported, made with a view to devising methods for the quantitative determination of such adulteration and for determining the reasonable allowances in the amounts of stems and acid-insoluble ash in insect powder. It is pointed out that the addition of the powdered stems of the plant has been the most serious form of adulteration practice, in some cases having been carried to the extent of complete substitution. The data presented, much of which is in tabular form, have been summarized by the authors as follows:

"The fact that flowers of certain species of *Pyrethrum* possess the property of killing various insects was known to the people of eastern Europe more than a century ago. Since that time this knowledge has gradually spread until insect powder is now a common household convenience. The powder owes its insecticidal activity to a mixture of acids and esters which first benumb and subsequently kill the insects brought into contact with it. While it is generally considered to be harmless to the higher animals, a number of cases where it has produced symptoms of a more or less serious nature are recorded.

"At present insect flowers are cultivated commercially in Dalmatia, Japan, Australia, Algeria, and California in the United States, the first three countries producing nearly all of the flowers that enter into international trade. The powder is made in each of these countries.

"In the enforcement of the Insecticide Act, insect powder has been found adulterated in a variety of ways. In some instances such substances as lead chromate, curcuma, and yellow ocher are added to give color. Other species of flowers, like the Hungarian or oxeye daisy, are substituted in whole or in part for the true insect flower, while almond shells, brick dust, hellebore, pepper, sawdust, starch, sumac, and the like have been found less frequently in samples examined. The ground stems of the *Pyrethrum* plant, however, probably constitute over 95 per cent of the adulterants used in insect powder at this time.

"Physiological, chemical, and microscopical methods which can be used satisfactorily in detecting adulteration with powdered stems have not as yet been perfected to such a degree as to make an accurate quantitative determination possible. However, from the data obtained in the examination of hundreds of samples of genuine insect powder, of the materials used for its sophistication, and of commercial samples, the results of which are reported in this bulletin, a formula given here has been developed by which it is possible to determine in an insect powder the approximate amount of added *Pyrethrum* stems present."

A bibliography of 299 titles is appended.

Poison baits for grasshoppers, W. P. FLINT (*Jour. Econ. Ent.*, 13 (1920), No. 2, pp. 232-237).—This is a brief report of work with poison baits in Illinois, where at least 75 per cent of the damage by grasshoppers occurs in fields of clover, alfalfa, soy beans, cowpeas, and other legumes.

Since legumes are distinctly attractive to grasshoppers, experiments were made with poison baits having a distinct legume odor. In experiments in which use was made of the inner bark of the black locust (*Robinia pseudacacia*), which possesses the strongest characteristic legume odor to be found in any plant, nearly as many grasshoppers were killed where it was used as with the molasses and lemons. A comparison made in 1918 and 1919 of the standard bran mash with the same amount of bran and Paris green mixed with water containing 3 lbs. of finely-ground green beans gave an average of 2 dead grasshoppers per square yard more in the areas treated with green beans. In tests in

1919 in which 3 lbs. of freshly ground clover were substituted for the ground green beans, about the same results were obtained. The results obtained in the poison bait experiments are summarized in tabular form.

Papers soaked in a solution of 1 gal. of molasses, 2 lbs. of sodium arsenite, and 32 gal. of water, failed to kill the grasshoppers, although they fed upon the papers in large numbers. Where Paris green (with salt) was substituted for the more largely water soluble poison, nearly four times as many grasshoppers were killed as where poison bran mash was used. Later visits to the field showed that the hoppers continued to feed upon the poisoned papers until they were almost entirely consumed. The results of two other tests conducted in the same manner showed a much higher number of grasshoppers killed in parts of the field where the poisoned papers were scattered than in those treated with the poison bran mash.

In a discussion of this paper which follows (p. 237), J. R. Parker refers to experiments made at the Montana Experiment Station with 12 different attractive substances in which amyl acetate was found most effective and salt alone practically as good as when both molasses and fruit juices were used.

A. Gibson reported having obtained results from salt in eastern Canada similar to those in Montana. Salt substituted for the molasses on fruit in the Kansas bait in 1915 reduced the cost from 21 to 7 cents per acre. One of the best formulas used in Canada consisted of 20 lbs. sawdust, 0.5 lb. Paris green, 0.25 lb. salt, and 3 gal. of water. As high as 720 grasshoppers to the square yard have been killed by the use of this mixture.

Organization for grasshopper control, G. A. DEAN and E. G. KELLY (*Jour. Econ. Ent.*, 13 (1920), No. 2, pp. 237-242).—This is a report of the work in Kansas.

The rosy aphid in relation to abnormal apple structures, P. J. PARROTT, H. E. HODGKISS, and F. Z. HARTZELL (*New York State Sta. Tech. Bul.* 66 (1919), pp. 3-29, pls. 8, figs. 6).—This is a report of investigations of the influence of *Aphis sorbi* Kalt. on the normal organization of apples, in continuation of reports of studies of the effect of its attacks on their development and conformation previously noted (E. S. R., 37, p. 561). The results of these studies have been summarized as follows:

"Apples attacked by the rosy aphid usually display suppression of the transverse and axial diameters. Inhibition of growth occurs to a greater extent with the transverse diameter. The injury varies in extent, even with fruits of the same cluster, and the amount of damage is largely determined by the earliness and intensity of attacks and the duration of period of infestation. Besides being reduced in size, affected apples are frequently poorly colored and are often not symmetrical in shape, one side being undeveloped, which causes the fruits to present a lopsided appearance.

"With apples showing extreme contortion one or more carpels on the side of greatest suppression in development frequently lack seeds or contain seeds that are inferior in size and weight to those of complementary cells. Seeds vary in number in normal and aphid-injured apples. Fruits not subjected to attacks by the insect surpass, on an average, aphid apples in number of seeds per apple. Injured apples show greater variability in seed content than do normal fruits. Apples under 30 mm. in transverse diameter are often sterile or have only a small number of seeds.

"Attacks by the rosy aphid tend to reduce the extent of dropping of fruits which possess empty carpels or have only few seeds. The existence of sterile or few-seeded apples on trees at the period of harvesting has the effect of lowering the mean number of seeds per apple and of increasing the variability of seed content.

"During 1916 apples had a greater range and a higher mean number of seeds per apple than fruits of the following year. This condition was noted with both normal and aphid apples, but with normal fruits the difference in variability was negligible. The average weight of seeds per apple was greater with normal fruits, and in comparison with aphid apples during the past two years the difference has been marked. The variability in weight of seeds was also much greater with injured fruits. In normal fruits the average weight of seeds per apple and the range in weight were greater in 1916 than in 1917.

"As judged by size, plumpness, and appearance of integument, both classes of fruits contained imperfect seeds. These were more abundant in aphid-injured fruits. As selected, normal apples weighed more than aphid apples. During 1916 they averaged 2.6 times the weight of aphid-injured fruits and during 1917 they were 3.2 times heavier. The coefficients of variability both seasons were considerably greater with the injured than with the normal fruits. Notwithstanding differences in average weight of seeds, normal apples weighed approximately the same for both seasons.

"Injuries by the aphid did not affect all structures of the apple to the same degree. The greatest percentage of decrease occurred in the weight of the individual fruits, with a smaller decrease in the weight of the seeds and the least decrease in the number of seeds. A comparison of variability in the several structures of normal apples showed that the variation in the number of seeds per apple is the most marked, followed by weight of seeds, while weight of fruits is the least variable. In aphid apples, however, the variability of each character is greatly increased over that found in normal apples, weight of seeds being highest, number of seeds intermediate, and weight of fruits least variable. The coefficients of correlation between weight of seeds and number of seeds per apple in aphid-injured and normal fruits both seasons were positive and high, but the regression coefficients of the two series each season did not differ to any great extent. There appears to be a closer relationship between fruit weight and seed weight in small apples than in large ones, but in none of the series is the relation between fruit weight and seed weight very marked.

"Severely malformed fruits sustained no reduction in the number of primary fibro-vascular structures. The strands on the side of greatest distortion generally showed suppressions in development and displacements with respect to distance from the vertical axis of the apple and the amount of space between the different elements. The ultimate branchlets did not display the dense plume-like appearance which is characteristic of normal, ripened fruit. Irregular developments in form and structural arrangements of fruits occur independent of the work of the rosy aphid. Attacks of such apples by the insect tend to aggravate the distortions."

The work of *Empoasca mali* on potato foliage, P. J. PARROTT and R. D. OLMSTEAD (*Jour. Econ. Ent.*, 13 (1920), No. 2, pp. 224-226).—The author reports upon 9 cage and 1 field experiment with *E. mali* at Geneva, N. Y.

In all the experiments, feeding by the insects produced at first small brownish areas of 0.25 in. or more in width at the tips and occasionally on the margins of the leaflets. The injury became more conspicuous as the season advanced, the brownish or burned areas increasing both in extent and numbers. The discoloration progressed from the tip toward the base of the leaf, and from the margins toward the midrib. As the tissues became desiccated the margins rolled up over the upper surface, leaving a small narrow strip of green tissue in the central area of the leaflet. In instances where such injuries were severe, all the leaflets curled and completely dried up, while the petioles often withered and dried so that any slight disturbance produced defoliation.

In the field tests made to determine the repellent effect of the usual spraying mixtures upon leaf hoppers, as compared with mixtures of heavier consistency, the heavy washes composed of china clay or lime were a little more effective than the other spraying mixtures. Because of serious damage to the foliage, the heavy lime wash was the least satisfactory of the various mixtures tested.

"Although the Bordeaux mixture alone or in combination with lead did not prove as effective a repellent as the sprays of heavier consistency, it should be emphasized that thorough spraying of all surfaces of the leaves of potato plants prevented serious damage by leaf hoppers. Furthermore, this spray withstood the washing effects of the rains much better than china clay or lime, the combination with lead proving somewhat superior to Bordeaux mixture alone."

What per cent of tipburn is caused by the potato leaf hopper? E. D. BALL and F. A. FENTON (*Jour. Econ. Ent.*, 13 (1920), No. 2, pp. 218-221, pl. 1).—This is a report of work carried on in Iowa during 1919 in an attempt to ascertain the relative proportion of different factors in causing tipburn.

Plants inclosed in cages continued to grow with green and healthy foliage when all the rest of the plants in the field were dead. In a test in which 50 males were placed in a wire gauze cylinder on a potato tip and 50 females in another, the females produced serious burning while the males produced none. A repetition of the experiment gave the same results. In an experiment in a shaded greenhouse burning developed on the leaves on which young nymphs were placed, although those that were free from nymphs remained green and normal.

Forms of the oyster-shell scale in Illinois, P. A. GLENN (*Jour. Econ. Ent.*, 13 (1920), No. 2, pp. 173-178).—Observations made during the last six years have led the author to recognize three forms of the oyster-shell scale as occurring in Illinois. The brown form which infests apples appears to be identical with the European species (*Lepidosaphes ulmi* L.) and has been successfully transferred to lilac, ash, and Cornus, but an attempt to transfer it to poplar was unsuccessful. This form is double-brooded, the first brood hatching between the first or second week in May at Urbana, the second brood during the latter part of July. It is usually very heavily parasitized.

The grayish-brown or banded form is the one that is generally and destructively abundant on poplar, ash, willow, lilac, cornus, and *Rosa rugosa* in Urbana and Champaign, and at numerous other places in the northern half of the State. American elm, soft and hard maple, ailanthus, and linden growing near heavily infested ash and poplar may become infested and seriously injured by the large number of young which are carried to them annually from the infested trees, but in other situations they do not become infested and it is doubtful whether the scale can maintain itself on them. This form can not live on apple, pear, peach, plum, hackberry, and horse chestnut. It is single-brooded and hatches at Urbana during the third or fourth week in May. This form is not parasitized.

The yellowish-brown form has been taken on Cornus, lilac, soft maple, and *R. rugosa* at Urbana. This form is double-brooded and is usually heavily parasitized. While little difference can be found in the structural characteristics of the three forms, the author finds that there is a striking and quite constant difference in the average number of circumgenital pores. The differences noted are summarized in tabular form.

Recent tests of materials to control San José scale, J. S. HOUSER (*Mo. Bul. Ohio Sta.*, 5 (1920), No. 2, pp. 49-51).—While during the past few years the San José scale has lost some of its virulence in some sections of Ohio, sections

are occasionally found in the State where it is gaining in virulency. Taking the State as a whole, however, the San José problem is not deemed nearly so important a factor as it was 10 or even 5 years ago.

During the season of 1919 spraying tests were conducted in an orchard of mixed peach and apple in northeastern Ohio in which trees averaged about 8 ft. in height and were badly infested with scale. In the plats in which Scalecide 1:15, Key Brand miscible oil 1:15, and Grasselli liquid lime-sulphur 1:7 were applied, almost perfect results were obtained, scarcely a single living scale being found. In plats in which barium sulphur 2.5 lbs. to 12 gal. of water, Niagara soluble sulphur compound, 3.5 lbs. to 15 gal. of water, Sherwin-Williams dry lime-sulphur 5 lbs. to 20 gal., and 5.5 lbs. to 20 gal. water were applied, little, if any difference in the degree of scale control could be detected. While it was possible to find occasionally a living scale, these materials gave commercial or practical control, since the small number of live scale found at the close of the breeding season was in no case sufficient to be of any material notice, particularly when it is generally conceded that annual spraying should be practiced after an orchard becomes scale infested. In a plat in which Derror improved tree fluid, 1 qt. to 25 gal. water was used, considerable quantities of living scale were to be noted at the end of the breeding season. In a plat in which Red Seal lye, 2 lbs. and 9 oz. to 12.5 gal. of water was applied, some scales succumbed to the treatment but the results were not satisfactory. "Live scale was abundant at the end of summer and the trees presented an unnatural appearance. The bark, while glistening in spots, due to the action of the caustic in removing the lichens and moldy growth, seemed drawn and taut. This material was unpleasant to apply because of its extreme causticity, which alone is almost sufficient reason to bar its use."

The alfalfa caterpillar, V. L. WILDERMUTH (*U. S. Dept. Agr., Farmers' Bul. 1094 (1920), pp. 16, figs. 14*).—The present paper supplements the information contained in the bulletin on the life history of this caterpillar previously noted (*E. S. R.*, 32, p. 57). It contains additional information relating to methods of controlling the pest by the management of irrigation water, as well as a brief account of its natural history, and is intended to meet the demands of ranchers and others for assistance in protecting their alfalfa.

Some features of the codling moth problem in the Ozarks, D. ISELY and A. J. ACKERMAN (*Jour. Econ. Ent.*, 13 (1920), No. 2, pp. 159-166).—This paper, based upon studies conducted at Bentonville, Ark., in 1918 and 1919, deals with the abundance, the variations in seasonal history, and the remedial measures necessary, particular attention being given to conditions differing from those reported by Jenne for 1907 and 1908 (*E. S. R.*, 21, p. 455). The experimental work in the control of this pest in the Ozarks thus far shows the necessity of making 6 to 7 spray applications, depending upon the season, and the desirability of a very fine mist in preference to a coarse spray.

Some experiences with the codling moth, T. J. HEADLEE (*Jour. Econ. Ent.*, 13 (1920), No. 2, pp. 166-173, figs. 2).—The author here discusses the New Jersey conditions and the control problems.

The spraying methods based upon studies made under conditions outside this part of the Atlantic Coastal Plain have in most cases proved insufficient to control the codling moth here when it occurs in maximum numbers. During the last two years the author has observed that about 9 out of 10 orchardmen in New Jersey fail to obtain a satisfactory control. The investigations of the year show that there are only two broods of codling moth in New Jersey; that the blossom fall spray does not appear to have the preeminent importance which it has been shown to have in previous studies elsewhere in the country; that

the sprays which come at the time the larvæ of the first and second broods are entering the apples are not only of much greater importance than has hitherto been attributed to them, but are absolutely necessary to satisfactory control when the codling moth is present in as great abundance as is now the case of New Jersey and probably Delaware; that that portion of the Atlantic Coastal Plain comprised in the southern half of New Jersey and probably Delaware varies sufficiently so to modify the habits of economic species of insect coming within its range as to render the studies made of them elsewhere in the country only partially applicable to coastal plain conditions; and that studies of countrywide economic species should be carried out on a regional basis under a plan which comprehends cooperation between State and between State and Government agencies.

[**Codling moth investigations**] (*New Mexico Sta. Rpt. 1919, pp. 31-33*).—A brief statement is made of the life history work. A summary of experimental spraying on apples, winter pears, and Bartlett pears is reported in tabular form.

A Connecticut corn field injured by *Crambus præfectellus* Zinck, W. E. BRITON (*Jour. Econ. Ent., 13 (1920), No. 2, pp. 222, 223*).—This is a brief account of the injury caused by *C. præfectellus* to a small field of corn a few miles from the center of New Haven. When only a few inches high, the plants began to look sickly and the outer leaves turned yellow, then shrivelled and died. The new leaves kept green for a time but the plant soon died. The injury was caused just at the surface of the ground where a cavity or hole had been eaten into one side of the stem, often to its center, there apparently being only one larva to each stalk. It is thought to be the first instance of serious injury having been caused by this insect.

An account of this injury by the author has been noted from another source (*E. S. R., 43, p. 251*).

A study of the oviposition of the corn earworm with relation to certain phases of the life economy and measures of control, J. W. McCOLLOCH (*Jour. Econ. Ent., 13 (1920), No. 2, pp. 242-255, fig. 1*).—This report is based upon studies in Kansas on different varieties of corn plants with relation to the date of planting and period of silking, made during the past six years. The work represents the daily number of eggs deposited on 128 individual plants and the silking period of 128 rows of corn.

“Three distinct broods of the corn earworm occur each year, the first brood of moths emerging early in June, the second brood about July 10, and the third brood about August 10. The maximum emergence occurs about two weeks after the first emergence. The first two broods are of little importance in comparison with the third brood.

“The date of silking is dependent on the variety rather than on the date of planting. While the plantings were made at intervals of two weeks, the dates of silking show a difference of less than a week for corn planted April 15, May 1, and May 15. The moths show a decided preference for the silks for oviposition. When these are not available, the upper surface of the leaves and the stalks are selected. Relatively few eggs are deposited on the lower surface of the leaves, the husk, or the tassel.

“There is a distinct relation between the date of planting and the number and location of the eggs. From the data presented, April 15 is too early to plant corn from the standpoint of oviposition, and June 1 is too late. The variety of corn, however, is to be considered in developing the optimum date to plant corn, since each variety exhibits certain variations which will have an influence on the number of eggs deposited on it. An analysis of the data indicates that from the standpoint of the number of eggs deposited, Boone County White can be

planted from April to May 1; Commercial White about May 1; and Kansas Sunflower and Hildreth from May 1 to May 15. Considering the results for the four varieties, May 1, under favorable conditions, is the optimum time to plant corn to escape the corn earworm.

"Considerable variation has been noted in the number of eggs deposited on the four varieties of corn. In 43.7 per cent of the plats grown in the six years, Boone County White has had the lowest number of eggs. Kansas Sunflower has had the fewest eggs in 28.3 per cent of the plats, Commercial White in 15.6 per cent, and Hildreth in 12.5 per cent.

"A similar variation was noted in the location of the eggs on the different varieties. There are a number of factors to be considered with relation to oviposition on varieties of corn, the principal ones being the time and period of silking, the time of maturing, and certain morphological characters of the plant."

The broods of the tobacco worms, H. GARMAN and H. H. JEWETT (*Kentucky Sta. Bul.* 225 (1920), pp. 3-24, figs. 4).—This bulletin deals with two species of Sphingidæ (1) the tobacco worm which is abundant in the North, and (2) the tomato worm most abundant in the South. The tomato worm is much more common during the majority of seasons in Kentucky, but is generally associated with small numbers of the tobacco worm in the fields, the two appearing locally and occasionally in nearly equal numbers.

The study of the two species, here reported, shows them to pass through their changes with the same number of annual broods, with practically the same time limit, in Kentucky tobacco fields. "Two definitely limited broods appear each year with a possible third very late brood, the latter maturing on the leaves of the tobacco stubble during long seasons, as indicated by numerous larvæ and occasional emerging adults observed long after crops were harvested. The first annual brood appears as young worms soon after the plants are transplanted from the beds and often in the beds after the cloth coverings are removed. A second brood of both species appears in early August, at which time there is a confusing condition resulting from an overlapping of first and second broods. The first brood requires about 45 days to complete its growth from egg to adult. The second brood requires about 23 days to complete its growth from egg to pupa, and passes the winter in the pupa stage in the soil of tobacco fields, emerging as adults the following June, with a total life period of about 326 days. Attention is directed to important fungus and insect parasites that cause wide fluctuations in the number of worms from season to season, sometimes causing what almost amounts to a suppression of the insects. An especially important parasite observed is a singular fungus (*Cordyceps*) attacking the pupa, of which an illustration is presented."

Ten years of the oriental moth, H. T. FERNALD (*Jour. Econ. Ent.*, 13 (1920), No. 2, pp. 210-212).—Scouting during the winter of 1916-17 showed that the territory in Massachusetts occupied by the oriental moth, though still very irregular in outline, was nearly four miles in length, and nearly three miles in width at its widest point, with an average width of nearly two miles. About 6 per cent of a collection of oriental moth cocoons made in the infested area in March, 1919, had been parasitized by a pupal parasite, *Chrysis shanghaiensis* Walk., imported in 1917 and 1918 from China.

A preliminary report on the use of sodium cyanid for the control of the peach tree borer (*Sanninoidea exitiosa* Say), A. PETERSON (*Jour. Econ. Ent.*, 13 (1920), No. 2, pp. 201-208, fig. 1).—This paper is based upon studies made at the New Jersey Stations during the past two seasons. Experiments with sodium cyanid were started by Blake and Connors in 1916, who found that

strengths up to and including 1 oz. to 1 gal. of water did not injure the trees. On the basis of their results, one peach grower in New Jersey, who has 3,000 6-year-old trees located on silt loam soil, has treated his orchard for 3 seasons with sodium cyanid, applying 0.75 oz. to 1 gal. of water to each tree in September or October. During the season of 1919, 1 oz. of dry sodium cyanid per tree was applied. As a result the orchard to-day is in excellent condition and the peach borers have been greatly reduced.

The author found that 1 oz. treatments (liquid or granular form) of sodium cyanid will kill from 75 to 90 per cent of the larvæ in 5- to 10-year-old trees. The granular or dry sodium cyanid is as efficient as the liquid (1 oz. to 1 gal. of water) and much easier to apply. One-half oz., and in many cases 0.75 oz., treatments for 5- to 10-year-old trees will not kill a sufficient number of larvæ to constitute a practical control. Vigorously growing peach trees 5 to 10 years of age have not been injured by 1 oz. treatments when the applications were made in May, June, September, or October. Also healthy trees 2 to 4 years of age have not been injured by 0.5 oz. treatments. In the liquid treatments a trough was dug about the tree 2 to 4 in. deep and the liquid was poured into the trough so that it came in contact with the tree. In the dry treatment, fine, granular sodium cyanid was used, sprinkled in the trough about the tree. The greater part of the sodium cyanid would be an inch or two away from the tree.

Chrysanthemum midge, C. A. WEIGEL and H. L. SANFORD (*U. S. Dept. Agr. Bul. 833 (1920), pp. 25, pls. 2, figs. 2*).—The chrysanthemum midge (*Diarthronomyia hypogaea* (F. Löw), a European insect, was first recorded from the United States by Felt in 1915 (E. S. R., 34, p. 251), since which time it has been reported as injurious from widely separated localities in this country and Canada. Its injury is caused by the larvæ, which upon hatching out from eggs deposited by the adult female on the surface of tender tips and new growth, bore their way into the tissues, thereby giving rise to galls on the leaf, stem, and flower head of the chrysanthemum plant. The galls are cone-shaped and generally project obliquely from the surface, the length of the gall when fully developed being about one-twelfth of an inch. When the leaf is affected, the galls usually occur on the upper surface, a slight swelling often being observed on the opposite or under side of the leaf.

The 1915 report of its occurrence in this country was based upon an infestation found by R. H. Pettit, of the Michigan Station, in large chrysanthemum houses at Adrian, Mich. Its occurrence at Ottawa, Canada, was reported by Gibson in 1916 (E. S. R., 38, p. 358), and Essig recorded its occurrence in California the same year (E. S. R., 36, p. 59), where it is thought to have occurred for 15 years.

The first severe infestation brought to the attention of the Bureau of Entomology was on chrysanthemums in greenhouses at Philadelphia in April, 1917, the entire stock having been infested, causing a total loss to the grower. During the same year, other florists reported a total loss of their stock of chrysanthemums valued at several thousand dollars. A survey conducted by the bureau in Indiana, Illinois, and Michigan during the months of November and December, 1918, in which greenhouses of 33 florists were visited, showed this section to be one of the centers from which the pest was being distributed over the United States, it having been found established in 8 of the 33 places visited.

While the species has been recorded from central and southern Europe as seriously injuring the common white or oxeye daisy (*Chrysanthemum leucanthemum*), as well as *C. corymbosum*, *C. atratum*, *C. japonicum*, and *C. myconis*, its dependations in North America are confined to practically all of the commercial chrysanthemums, both the single and pompon varieties. Attempts to

infest the Shasta daisy and the common field daisy in this country have thus far failed. Several varieties, all of which are the blended product of *C. indicum* and *C. morifolium*, both of which grow wild in China and Japan, are fairly free from injury.

While primarily a greenhouse pest, it was found by Gibson in August, 1915, occurring on both greenhouse and outdoor plants at Ottawa, Canada, and the authors have found it to infest hardy chrysanthemums growing out of doors all winter at Rosslyn, Va. A careful inspection of the entire stock at Rosslyn revealed the fact that the insects had wintered over on these plants in the immature stages, probably as either larvæ or pupæ within the galls.

The adults emerge after midnight, and egg-laying takes place early in the morning. The female shows a marked preference for the buds, or the tissues just unfolding from the buds, in oviposition. Observations show from 5 to 135 eggs to have been deposited at one time, with an average of 32. Five days were required for the incubation of the eggs during April and from 3 to 16 days in September, depending upon the temperature. From 4 to 14 days, with an average of 7 days, elapsed from the time the larva entered the tissue to the first sign of a swelling or gall. From 21 to 46 days with an average of 28 days passes from the time the larva first enters the tissue until the emergence of the adult. From 20 to 50 days were found by Britton (E. S. R., 41, p. 158) to be required for transformation within the gall. Data presented in tabular form which represent observations of 17 life history cages under Washington conditions, indicate that the total life cycle requires from 27 to 52 days, with an average of 35 days.

There is a constant overlapping of broods when the greatest numbers are present, namely in the spring and fall of each year. The aestivation period has been found to extend in Maryland, Virginia, and the District of Columbia from the early part of June to the latter part of August. "In the spring of 1917, 1918, and 1919, 3 distinct generations were observed. The first generation started about the middle of February, and the last adults of this generation emerged during the last few days of April. The second generation started about the middle of March, and the last adults issued around April 30. The third generation started the latter part of April and emerged during the early part of June. In the fall of 1918, when the occurrence increased again a similar grouping of generations was evident, the first beginning about the latter part of August, and the last adults emerging during the first days of October. A second generation started about the middle and latter part of September, maturing the first days of November. The third generation was observed beginning about the middle of October and the last adults emerged about November 25."

It has been reported to be attacked in California, by 2 parasites, namely, *Amblymerus* sp. and *Tetrastichus* sp. Experiments show that the egg stage may be controlled by spraying or dipping the cuttings or plants; that the adult can be killed easily at the time of emergence by consistent spraying; and that the adult is easily killed by fumigation, either with nicotin papers or hydrocyanic-acid gas. Experiments applicable to general propagation practices show conclusively that such measures offer a reasonable safeguard and protection against doubtful stock and infested material without injury to the plants.

"In case of a very light infestation, daily picking of gall-infested leaves will hold the pest in check, but should this practice prove ineffective, nightly fumigation for a period of 2 or 3 weeks may be resorted to. When a severe infestation is encountered the most heavily infested plants should be taken out immediately and burned. This should then be followed by either fumigation or spraying as outlined. Fumigate every night, with either nicotin papers

or hydrocyanic-acid gas, for a period of at least 6 weeks. This will kill all the adults that emerge during such a period and at the same time will prevent the further laying of eggs for future generations. The dosage need not be very heavy in either case. When nicotin papers are used one sheet to every 1,000 cu. ft. of space will suffice. If hydrocyanic-acid gas is employed, 0.125 to 0.25 oz. per 1,000 cu. ft. will kill all of the adults. The use of hydrocyanic-acid gas is not recommended unless in the hands of a competent fumigator, owing to its deadly poisonous effects. Too much emphasis can not be laid on the fact that the fumigation must be set off after 12 o'clock midnight, to be effective. It is preferable to start the generation between the hours of 12.30 a. m. and 2 a. m. Any fumigation done before midnight would be useless, for it has been pointed out that the adult does not emerge until after midnight. On the other hand, if it is started later than 2 a. m. many adults will have emerged and laid their eggs." Where fumigation is not advisable, spraying consistently for a period of 4 to 6 weeks, with a solution of 40 per cent nicotin sulphate extract diluted (1:800), and soap added at the rate of 0.5 to 1 oz. per gal. of solution is recommended.

The authors emphasize the importance of preventing any but clean plants and cuttings from being brought into commercial greenhouses where chrysanthemums are growing or to be grown.

An annotated list of 32 references to the literature is included.

The stable fly: How to prevent its annoyance and its losses to live stock, F. C. BISHOPP (*U. S. Dept. Agr., Farmers' Bul. 1097 (1920), pp. 21, figs. 11*).—This is a revision of Farmers' Bulletin 540, previously noted (*E. S. R., 29, p. 559*).

The green Japanese beetle problem, J. J. DAVIS (*Jour. Econ. Ent., 13 (1920), No. 21, pp. 185-194*).—This is a brief and concise résumé of the green Japanese beetle (*Popillia japonica* Newm.) problem, including its present status and plans for future work.

The green Japanese beetle quarantine, C. H. HADLEY (*Jour. Econ. Ent., 13 (1920), No. 2, pp. 198-201*).—This is a discussion of the quarantine work with *Popillia japonica*.

The strawberry rootworm injuring roses in greenhouses, C. A. WEIGEL and E. L. CHAMBERS (*Jour. Econ. Ent., 13 (1920), No. 2, pp. 226-232*).—Reports of injury to roses in greenhouses at Alexandria, Va., and Richmond, Ind., led to the investigation here reported. It was found at Alexandria on July 25 that the damage was caused mainly by the adults of *Paria cancellus* Fab., which were present in extremely large numbers, practically all the foilage being badly perforated and ragged.

"In addition, a large proportion of the new and young shoots had the wood badly scarred and girdled, giving it a very unsightly appearance. It was found that the adults had a marked preference for this new wood, of which there was an abundance at this particular part of the season, owing to the fact that the roses were being forced. Further examination showed that the larvæ had also been feeding on the roots earlier in the season. As a result of all of these injuries a gradual killing of the affected parts ensued, causing a stunted growth of the plants."

The infestation at Richmond was not as serious as that at Alexandria. It has since been found to occur in greenhouses in Washington, D. C., Summit, N. J., and Baltimore, Md. Experimental control work has shown that the use of hydrocyanic acid gas, at the rate of 2 oz. sodium cyanid per 1,000 cu. ft. of space, with an exposure of 2 hours, is a satisfactory method of controlling the adults.

Black grain-stem sawfly of Europe in the United States, A. B. GAHAN (*U. S. Dept. Agr. Bul. 834 (1920), pp. 18, pls. 2, fig. 1*).—This is a report upon *Trachelus tabidus* (Fab.), another exotic insect of considerable importance which has become established in the United States. The fact that it is now quite widely distributed in this country and is becoming a source of injury has led to the publication at this time of such information as is at hand.

This insect, which occurs in most of the countries of Europe and is of considerable economic importance, was first collected in this country at Riverton, N. J., some time prior to 1899, but it was not recognized as a European species until about 1910. Injury caused by it to wheat at Germantown, Md., was reported by Corey in 1914 under the name of *Cephus pygmaeus* L. Complaints of injury to wheat at Gaithersburg, Md., received by the Bureau of Entomology in 1918, led to the investigations by the author here reported. The records at hand are said to be sufficient to establish a probability that it already occurs over the greater part of Virginia, Maryland, Pennsylvania, New Jersey, and Delaware, and it is possible that West Virginia, eastern Ohio, southern New York, and even some of the New England States may be included within its range.

Thus far in America only wheat and rye are known to serve as food plants, but a number of others have been recorded in Europe. There are, as yet, only two instances of its occurrence in rye in this country, and in each case only single stalks in a field.

The only species occurring in America, so far as known, with which this species is likely to be confused are *C. cinctus* Norton and *C. pygmaeus* L. The larvæ of the three species are apt to be confused, since all three infest the small grain crops in practically the same manner, have similar biologies, and superficially resemble one another closely. A table is given by means of which the larvæ of the 3 species may be separated.

Observations indicate that its life history does not differ greatly from that of the western grass stem sawfly (*C. cinctus*), although the early stages have not yet been observed in this country. Collections of adults in the field indicate that egg-laying takes place from May 15 to June 10. The eggs are inserted in a slit made by the female in the stem some distance above the ground. The young larvæ burrow downward through the pith of the stem, hollowing it out to the base. They attain full growth about the time the grain is ripe, growth having been completed at the time investigations were commenced on July 22, and the larvæ having at that time apparently entered hibernation. At that time the hibernating larva was found at the extreme base of the stem of the wheat stalk. Before the burrow is completely closed, the stem is almost completely severed from the inside, at or near the surface of the ground. As a result, the first bending of the ripened straw, as by a strong wind, causes it to snap off and fall.

The hibernating period apparently extends from the time the wheat is ripe enough to cut until sometime the following spring when the larva changes to the pupa. Just when this change takes place has not been ascertained, but the pupal state is probably of short duration, as in the case of *C. cinctus*. The adults are found in the fields during the latter half of May and early June. The injury results in the falling of a large amount of grain which is missed by the binder. It was roughly estimated that in some of the worst cases the infestation amounted to 4 or 5 per cent, although in most of the fields the infestation was less than 4 per cent. Counts made by McConnell and Myers of infested stubble in experimental plats and wheat fields at Carlisle and Mount Holly Springs, Pa., showed variations from 4.36 per cent on one plat to 0.26 per cent on another, the average from all counts being 1.75 per cent. One effi-

cient parasite has been discovered in this country, a chalcidoid of the genus *Pleurotropis*, apparently undescribed.

Only suggestions can be made as to control measures, but they will doubtless be similar to those applicable against *C. cinctus* and *C. pygmaeus*. If, as now seems probable, this insect confines itself in this country to the small grain crops as host plants, crop rotation will prove an effective means of reducing damage from it.

An annotated list of 56 references to the literature cited is appended.

The clover and alfalfa seed chalcis-fly, T. D. URBAHNS (*U. S. Dept. Agr. Bul. 812 (1920), pp. 20, pls. 8, figs. 2*).—This pest, described by Howard in 1880 as *Eurytoma funebris* and for some years supposed to be a parasite of the clover flower midge, has been for many years a pest of clover and alfalfa seed in the Middle and Western States, as described in a popular account previously noted (*E. S. R.*, 32, p. 454). At the present time it is known to be present in practically every locality in the United States where either red clover or alfalfa seed is grown to any extent, and has been found in seed from Europe, Asia, and South Africa.

The habit of this species of feeding within the growing seeds of alfalfa and red clover is quite different from the general habits common to most of the other members of this group, many of which are parasitic in the larval stage upon various forms of insect life. Its injury consists entirely of the hollowing out of the developing seeds, the injury having been completed by the time the alfalfa seed pods and the clover heads have matured. The loss caused by it is to the growing of alfalfa or clover for a seed crop, it interfering in no way with the growing of either for forage purposes. The plants seeds of which are attacked are alfalfa, red clover, bur clover (*Medicago hispida* vars.), *M. falcata*, *M. ruthemia*, *M. tuncatana*, *M. tuberculata*, and *M. arabica*. The other common clovers, namely, white, alsike, yellow sweet, white sweet, and sour clover, apparently are not attacked. The loss caused frequently varies from 50 to 400 lbs. of seed per acre as a result of the destructive work of the pest, and there is frequently an additional loss caused by the planting of uncleaned seed and a loss of time and money in replanting.

The first adults appear in the spring, 4 or 5 weeks after warm weather has set in, the egg being usually placed just beneath the inner integument of the seed, sometimes between the cotyledons, and frequently within the semi-liquid contents of a cotyledon. At Pasadena, Cal., the period of incubation varied from 7 to 12 days in April; about 5 days were required in June. The larva never leaves the seed in which it is developing, and where two or more larvæ chance to be in the same seed, one or both usually perish before development is completed. Molts apparently occur indefinitely in the larval stage. Under the most favorable conditions, the larvæ complete development in 12 days, while in early spring the period was prolonged to 30 days. Aestivation occurs frequently in the larvæ during the months of July, August, and September. Favorable conditions may at any time cause transformation to the pupal stage, or aestivation may continue into hibernation. The transformation usually occurs at any time between March and July of the following season, though in exceptional cases the larval stage may be continued into the second year. The period of pupation in early spring requires an average of about 30 days, while the pupal period in midsummer is from 6 to 10 days. While some of the larvæ apparently go into hibernation as early as August, adults may be seen emerging from the infested seeds and seed pods in October and November.

The author's observations show that in southwestern Arizona this species may have as many as 4 generations in a single season. The minimum number

of generations in a single season may be less than one under very unfavorable conditions. Hibernation takes place in the larval stage within the infested seed, and the first larvæ enter hibernation as early as August. Diagrams are given which show the development of the species, and the comparative abundance of the stages during the different months of the year. The parthenogenetic habit is well established in the female of this species.

The practical methods of controlling the chalcis-fly in the alfalfa and clover seed fields are mostly cultural methods. Infestation and control measures are discussed under headings of burning over of fence lines, winter cultivation, irrigation of alfalfa seed fields, cutting early plants on waste areas, careful cutting of hay crops, pasturing before growing seed, allowing the seed crop to stand too long, second crop of seed, and pasturing infested fields.

Brief notes are given on the parasites which attack this species, including *Tetrastichus bruchophagi* Gahan, *Liodontomerus secundus* Gahan, *Eutelus bruchophagi* Gahan, *L. perplexus* Gahan, *Habrocytus mediscaginis* Gahan, *T. venustus* Gahan, *Trimcromicrus maculatus* Gahan, *L. insuctus* Gahan, and *Eupelmus* sp. Accounts of the more important parasites by the author have been previously noted (E. S. R., 40, p. 862). The larvæ of a midge of the genus *Lestodiplosis* have been found in infested alfalfa seeds, where they had apparently destroyed the larva of *B. funebris*.

FOODS—HUMAN NUTRITION.

Nutrition and physical efficiency, E. V. McCOLLUM (*Jour. Franklin Inst.*, 189 (1920), No. 4, pp. 421-440).—A popular lecture on the connection between the dietary habits of a nation or group of people and their physical efficiency and susceptibility to disease.

The essentials of chemical physiology, W. D. HALLIBURTON (*London: Longmans, Green, & Co.*, 1919, 10. ed., pp. XI+324, pl. 1, figs. 71).—This is the tenth revised edition of the work previously noted (E. S. R., 37, p. 501).

Food chemistry in 1915 and 1916, J. RÜHLE (*Ztschr. Angew. Chem.*, 29 (1916), Nos. 41, Aufsatz., pp. 209-212; 43, pp. 213-218; 30 (1917), Nos. 85, Aufsatz., pp. 253-258; 87, pp. 261-268; 89, pp. 271, 272; 91, p. 280).—These surveys of the literature of 1915 and 1916 on food chemistry follow the same general plan as the survey for 1917 previously noted (E. S. R., 42, p. 659).

[**Rabbit meat**], N. DEARBORN (*U. S. Dept. Agr., Farmers' Bul. 1090* (1920), pp. 22-27).—Data collected by the Office of Home Economics, States Relations Service, as to the composition and digestibility of rabbit meat are reported, together with recipes for its utilization.

Digestibility of raw corn, potato, and wheat starches, C. F. LANGWORTHY and H. J. DEUEL (*Jour. Biol. Chem.*, 42 (1920), No. 1, pp. 27-40).—Digestion experiments were conducted by the Office of Home Economics, States Relations Service, U. S. Department of Agriculture, to determine the digestibility of corn, potato, and wheat starches when consumed in the raw state. The starches were incorporated in a frozen pudding which was eaten with a basal ration of oranges and sugar. The experimental periods were of 3 days' or 9 meals' duration, 3 subjects being used in the corn starch experiments, 4 in the wheat starch, and 5 in a total of 7 potato starch experiments.

The average amount of raw starch eaten per man per day was 241 gm. of cornstarch, 194 of potato starch, and 188 of wheat starch, the average energy values for the same period being 2,760, 2,213, and 2,138 calories, respectively.

The raw corn and wheat starches were eaten with no discomfort and were completely assimilated, no trace of them being found in the feces. The ingestion of potato starch, however, resulted in the formation of much gas, with

attending discomfort. Large amounts of undigested starch were found in the feces and the coefficients of digestibility varied from 62.3 to 95.2 per cent.

The digestibility of the other constituents of the diet did not appear to be affected to any great extent by the large amounts of starch ingested.

The use of coarse grains for human food, C. E. SAUNDERS (*Canada Expt. Farms Bul.* 40, 2. ser. (1919), pp. 15).—In this bulletin the possibilities and advantages of adding to the human diet various articles of food prepared from the coarse ground grains, as well as peas and beans, are discussed, and tested recipes for preparing these articles are presented.

Value of red durum or D 5 wheat, T. SANDERSON (*North Dakota Sta. Spec. Bul.*, 5 (1920), No. 17, pp. 507-517).—Milling and baking tests of samples from crops grown from 1915 to 1919 are reported.

The data show that the red durum wheat when properly milled will produce a high percentage of flour that is high in absorption, being above the required standard of 53 per cent in every case with one exception, but low in volume, color, and texture. The difference between this type of wheat and the hard red spring or the other types of durum is so great that if it is produced in quantities it will be classed as feed and will sell on the market at a price on a par with emmer or speltz.

The food value of vegetables, F. STOKER (*Jour. Roy. Hort. Soc.*, 44 (1919), pp. 21-30).—The author discusses various factors which must be considered in estimating the relative value of different vegetables as sources of food. These include the actual nutrient value of the plant, its relative value in proportion to the area it occupies, the time it is in the ground, and the cultivation it requires. Various garden vegetables are discussed from this standpoint, and a formula is proposed by means of which the economic value, as applied in a gardening sense when the produce is not sold for profit, can be determined. This value is obtained by dividing the product of the calorific value and yield in pounds per rod by the product of the cost of the crop in shillings and the number of weeks the ground is occupied.

A table is given of the comparative values of some of the more common vegetables as determined by this formula.

Use of refined lactic acid in food products, G. DEFREN (*Chem. Age [New York]*, 2 (1920), No. 4, pp. 478, 479).—This is an enumeration of various uses of refined edible lactic acid. These include its use in low-alcohol beers made from regular beers to combine with amids and amino acids formed during the removal of alcohol, in soft drinks to replace citric and tartaric acids as acidulants, in the baking industry to form soluble proteins from the albuminous constituents of wheat flour, to serve as yeast nutrients and to replace cream of tartar in baking powders, in the candy industry as a substitute for cream of tartar in breaking the grain of cane sugar, in the production of jellies to raise the acidity of the fruit juices to the point at which pectin will jelly, in the manufacture of vinegar, in the canning of meat and fish products, and in the production of edible gelatin.

Experiments on the utilization of salep mannan, M. S. ROSE (*Jour. Biol. Chem.*, 42 (1920), No. 1, pp. 159-166).—The author, with the cooperation of L. McD. Browne, L. Gillett, E. Rothermel, and H. Coombs, has supplemented an earlier investigation of the utilization of salep mannan (*E. S. R.*, 25, p. 367) by further determinations of the coefficient of digestibility of the salep mannan, of its effect on nitrogen output, and of its fate in the diabetic organism in human subjects, and by an investigation of the possibility of its transformation into glycogen in rabbits.

The coefficients of digestibility were determined in feeding experiments with two healthy women, a diabetic boy, and a diabetic man. The results obtained,

together with the results of four experiments in the previous study, gave an average coefficient of digestibility of 97 per cent, the range being from 94 to 100 per cent.

In two experiments in which the nitrogen output was determined, noticeable increases in the fecal nitrogen and in the volume of the dry feces were obtained, amounting to 54 and 135 per cent for the former and 46 to 105 per cent for the latter.

Salep feeding did not result in glycosuria in one diabetic studied, nor did it arrest the production of β -hydroxybutyric acid in the other diabetic. No glycogen was stored in the livers of rabbits fed on salep mannan.

It is pointed out in conclusion that salep resembles inulin in its hydrolysis by fecal bacteria and in the readiness with which it disappears from the alimentary tract, as previously shown by the work of Okey (E. S. R., 41, p. 764), but differs from it in not forming gas so readily and in being less capable of glycogen formation in rabbits.

Vitamins. W. D. HALLIBURTON (*Scientia*, 27 (1920), No. 3, pp. 194-200).—This is a brief discussion of the nature and significance of the vitamins, with references to some of the recent contributions to the subject.

Fat-soluble vitamin.—VI, **The extractability of the fat-soluble vitamin from carrots, alfalfa, and yellow corn by fat solvents**, H. STEENBOCK and P. W. BOUTWELL (*Jour. Biol. Chem.*, 42 (1920), No. 1, pp. 131-152, figs. 4).—In continuation of the series of studies on the fat-soluble vitamin (E. S. R., 42, p. 556), attempts have been made to concentrate this vitamin by extraction with different solvents, including fats and fat solvents. The results, obtained in the usual feeding experiments with rats, may be summarized as follows:

The fat-soluble vitamin in carrots was not removed to any extent by saturation with corn oil and extraction with ether, and apparently not at all by similar saturation with lard. The vitamin was slightly soluble in ether, somewhat soluble in chloroform and carbon disulphid, and quite soluble in alcohol and benzene, although none of the extracts was sufficiently concentrated for practical purposes.

With alfalfa more satisfactory results were obtained with ether, benzene, and alcohol, sufficient fat-soluble vitamin being obtained in the ether extract to permit satisfactory growth when fed at a level equivalent to 20 per cent of alfalfa.

To further concentrate the extract containing fat-soluble vitamin, the authors employed with the alcohol extract from alfalfa meal the method commonly used for the separation of carotinoids. The extract was saponified with alcoholic potassium hydroxid and the mixture extracted repeatedly with ether until the yellow pigments were completely removed. The ether extracts after washing with water to remove alkali and salts were evaporated on the water bath to a small volume. This extract proved to be rich in fat-soluble vitamin. A further concentration of the vitamin was brought about by taking up a similar extract in a mixture of alcohol and petroleum ether and subjecting it to fractional extraction. The petroleum-ether carotin fraction was found to contain an abundance of the vitamin, while the alcohol xanthophyll fraction contained little or none of it. The efficiency of this method of fractionation has been demonstrated with different preparations.

The relative utilization by the animal organism of brewery yeast and mineral yeast as determined by experiments with dogs and sheep, W. VÖLTZ (*Wchnschr. Brau.*, 36 (1919), No. 7, pp. 43-45; *abs. in Chem. Abs.*, 14 (1920), No. 10, p. 1566).—A study of the comparative value of brewery yeast and yeast grown in solutions of sugar and inorganic salts, as determined by digestion experiments with dogs and sheep, is reported.

Tables are given of the composition of the two yeasts and of the coefficients of digestibility of the different constituents. The data reported indicate that the brewery yeast contains slightly more digestible matter than the so-called mineral yeast. Earlier experiments on the same subject have been previously noted (E. S. R., 35, p. 266).

What should be the basis of the control of dehydrated foods? S. C. PRESCOTT (*Amer. Jour. Pub. Health*, 10 (1920), No. 4, pp. 324-326).—This is a brief discussion of the standards adopted by the War Department for the manufacture and control of dehydrated foods.

[**Miscellaneous food and drug topics**] (*North Dakota Sta. Spec. Bul.*, 5 (1920), No. 16, pp. 475-522).—This number consists principally of a report by R. O. Baird of a sanitary survey of a number of North Dakota cities. Analyses by M. Jongenard, J. Moyer, and W. G. Bowers of several proprietary preparations and a modified method for determining vanillin by W. G. Bowers and J. Moyer noted on page 314 of this issue are also included.

Fargo and its grocery stores, E. F. LADD and F. C. HIMBER (*North Dakota Sta. Spec. Bul.*, 5 (1920), No. 18, pp. 535-550).—An economic study of the 50 grocery stores which supply Fargo's 25,000 population. The average operating expense was found to range from 9 to 52.23 per cent of the gross receipts averaging 16.72 per cent. The opinion is expressed that the number of stores is altogether too large for the population.

Brief notes regarding a patent medicine and the use of saccharin in the State are appended.

The diazo reaction of normal human urine and the dependence of the diazo value on the mode of nutrition, O. FÜRTH (*Biochem. Ztschr.*, 96 (1919), No. 4-6, pp. 269-296).—The diazo reaction of urine (the red coloration with diazobenzene sulphonic acid and sodium carbonate) is shown to be due to the formation of a urochromogen, resembling in its properties, but not identical with, histidin. The relative amount of the chromogen can be determined by comparison with the amount of histidin furnishing the same color reaction.

The so-called diazo value (reckoned as histidin monochlorid) of normal human urine was found to vary from 0.03 to 0.07 gm. in 100 cc. of the urine or from 0.3 to 0.6 gm. in a day's urine. Similar values were obtained in the urine of tuberculosis patients in a good state of nutrition as well as in the urine of noncachectic malaria cases. In cases of undernutrition with low protein, the lowered nitrogen balance was accompanied by a lowering of the absolute diazo value, but an increase in the relative value in some cases. A similar increase in the relative value or diazo quotient was observed in strongly cachectic individuals. This is thought to be an indication of the endogenous origin of the imidazol complex of the diazo chromogen.

The metabolism of a dwarf, F. B. TALBOT (*Jour. Amer. Med. Assoc.*, 74 (1920), No. 18, p. 1225).—The author reports a study of the metabolism of a 7-year old boy who weighed about 27 lbs. as against the normal for that age of a little over 48 lbs. and whose height was 36 in. as against the normal of 45 in.

The basal metabolism showed a total 24-hour metabolism of 780 calories as compared with an average of 900 calories for normal boys of the same age and 675 calories for normal boys of the same weight. Per unit of body surface, his metabolism was 12 per cent higher than normal boys of the same age and 11 per cent higher than normal boys of the same weight. With exercise the metabolism increased to a very marked extent, indicating possibly excessive activity of some gland of internal secretion for which no clinical sign was found.

The result of these metabolism studies indicates that a subject of this sort should receive as many calories as a normal boy of the same age, or considerably more per kilogram than normal boys of the same age or weight.

Card for recording epidemiology of botulism (*Pub. Health Rpts. [U. S.]*, 35 (1920), No. 15, pp. 894, 895).—This is a copy of a card which is being used in California in the epidemiological studies of botulism, and which is recommended to State and local health authorities as of value in recording data in the event of future outbreaks of the disease.

One side of the card is designed to give a complete record of the clinical data and epidemiology, while the reverse side provides for a compilation of data relative to analogous outbreaks in the domestic animals on the premises.

Action of secretin on metabolism, J. E. ABELOUS and L. C. SOULA (*Compt. Rend. Acad. Sci. [Paris]*, 170 (1920), No. 12, pp. 759-761).—A few experiments on dogs and cats are reported, from which the author concludes that secretin brings about a superactivity of metabolism as shown by an increase in the elimination of nitrogen and mineral matter in the urine and an increase in the respiratory quotient, together with a decrease in the glycogen content of the liver. This is explained on the ground that the secretin acts as a hormone charged with liberating the nutritive intracellular reserves to make way for the new reserves which constitute the products of digestion.

Scorbutic beading of the ribs, A. F. HESS and L. J. UNGER (*Amer. Jour. Diseases Children*, 19 (1920), No. 5, pp. 331-336).—From clinical observations and postmortem examinations conducted by the authors, and from the literature on scurvy and rickets, proof is advanced that beading of the ribs, the so-called rachitic rosary, is not the result of rickets alone but is one of the typical signs of scurvy and has also been noted in connection with beriberi and pellagra in children. The belief that this phenomenon is attributable solely to rickets is thought to be responsible for the misinterpretation of many cases of latent scurvy.

Craniotabes and beading of the ribs as signs of rachitis, H. SCHWARZ (*Amer. Jour. Diseases Children*, 19 (1920), No. 5, pp. 384, 385).—From clinical data on the presence of craniotabes and of beading in children of various nationalities in the first, third, sixth, ninth, and twelfth months of life, the author concludes that rickets can not be diagnosed on the basis either of an existing craniotabes or of beading of the ribs.

The effect of vitamin deficiency on various species of animals.—I, The production of xerophthalmia in the rabbit, V. E. NELSON and A. R. LAMB (*Amer. Jour. Physiol.*, 51 (1920), No. 3, pp. 530-535, figs. 4).—This is the first of a series of experiments which are being conducted at the Iowa Experiment Station to determine the effect of the lack of fat-soluble A on different species of animals.

Two rabbits fed a purified ration of casein, dextrin, salt mixture, lactose, wheat embryo, and alfalfa meal extracted with hot alcohol for 3 or 4 days to remove fat-soluble A developed xerophthalmia after 61 days, while a control rabbit on a similar diet plus butter fat showed no evidence of xerophthalmia and remained thrifty. One of the two animals suffering from xerophthalmia died, having refused to eat even fresh green lettuce. The other responded to the fresh vegetables and butter fat and rapidly recovered. A fourth rabbit, which after a month on the casein-dextrin ration was given a ration of oats, gelatin, dextrin, salts, agar, and extracted alfalfa, grew normally and showed no signs of xerophthalmia.

Modifications of the testicles of pigeons under the influence of a diet deprived of vitamins, P. PORTIER (*Compt. Rend. Acad. Sci. [Paris]*, 170 (1920), No. 12, pp. 755-757).—Examination of the testicles of pigeons fed on sterilized

grains indicated that the absence of vitamins produces important changes in the testicles, characterized by an arrest in the functioning of the gland and by phenomena of involution which are confined at first to a decrease, later to a complete arrest of spermatogenesis, and finally the resorption of spermatozoa and spermatids. This is thought to indicate a deficit in the sterilized food of a special form of nucleins.

Total dietary regulation in the treatment of diabetes, F. M. ALLEN, E. STILLMAN, and R. FITZ (*Monog. Rockefeller Inst. Med. Research, 1919, No. 11, pp. VI+646, pls. 69*).—This monograph constitutes one portion of a research "composed of three principal interdependent parts. One of these has compared clinical diabetes in its principal characteristics with that produced experimentally in various species of animals, and has shown that the latter, in the absence of spontaneous tendencies, is influenced by changes in the total metabolism and body weight, and not by carbohydrate ingestion alone. The second is the present clinical investigation, in which this principle has been applied to patients. The third is a pathological study, not yet finished, but included here in the form of a preliminary outline because of its important relation to the problems of treatment."

Following an introductory chapter dealing with the history of diabetes, the author's plan of dietetic treatment is described at length, clinical reports are given of 76 out of 100 cases of diabetes treated at the Hospital of the Rockefeller Institute by this method, and general conclusions are drawn as to the etiology and pathology of the disease and the effect of various factors upon its progress.

Experimental studies on diabetes.—I, Production and control of diabetes in the dog, F. M. ALLEN (*Jour. Expt. Med., 31 (1920), No. 4, pp. 363-402*).—The two papers presented are the first of the series comparing clinical diabetes with experimental diabetes in animals which constitutes a part of the research on diabetes noted above. The basis of the present studies has been a form of diabetes produced by removal of the greater part of the pancreas of animals but leaving a remnant about the duct secreting normally into the duodenum.

(1) *Gross anatomic relations of the pancreas and diabetes* (pp. 363-379).—In this paper are summarized the ordinary relations between body weight and pancreas weight in dogs and between the total pancreas and the size of the remnant with which diabetes occurs, the results of these observations serving as the working basis for succeeding experiments.

(2) *Effects of carbohydrate diets* (pp. 381-402).—This paper reports that the excessive carbohydrate diets of various kinds had the same effect upon partially dépancreatized dogs as upon human diabetic patients, resulting in rapid decline and death. In the early stage glucose was more effective than starch in producing diabetes. Whenever permanent diabetes was present starch brought on glycosuria more slowly than did sugar but just as surely, and the difference in time is thought to be due merely to the difference in the rate of absorption of the carbohydrate. No noticeable differences were noted between the assimilation of different starches, nor did there appear to be any marked lowering of the carbohydrate tolerance by proteins.

Antipyretics (*Arch. Int. Med., 24 (1919), No. 6, pp. 611-632, figs. 4*).—Three papers are presented which deal especially with clinical investigations of the respiratory exchange as influenced by antipyretic substances.

I. *The Benedict respiration chamber at the New Haven Hospital*, by H. G. Barbour (pp. 611-616).—This paper gives a general description of the respiration chamber at the New Haven Hospital, similar to but differing in certain

respects from the Benedict respiration chamber. One of the features of the cooling system is a thin flannel blanket which fits closely the entire chamber top and is wet thoroughly when the chamber is closed. It is kept cool by a sprinkling device consisting of a pail of ice water which drains into a perforated pipe running a few inches above the chamber. Results of check experiments with the respiration apparatus are presented and discussed.

II. *Acetylsalicylic acid and heat regulation in normal individuals*, by H. G. Barbour and M. M. Devenis (pp. 617-623).—The effect of aspirin on the heat regulation of normal subjects was studied by determining with the above apparatus the respiratory quotient and heat output of 5 normal subjects for several half-hour periods following the administration by mouth of 1 to 1.25 gm. of acetylsalicylic acid (aspirin).

In all cases the administration of aspirin was followed by an increase in the carbon dioxide output and heat production which reached its maximum during the fourth half-hour after administration. The average basal heat production of the 5 subjects of 37.8 calories per square meter per hour was increased to 40.3 calories. In spite of the increased metabolism the heat dissipation was not significantly altered. The respiratory quotient and the pulse rate were also not altered. There was no depression of metabolism in two experiments in which the subject was allowed to sleep after taking aspirin. This is thought to indicate that sleep is not a factor in the antipyretic action of the drug.

III. *Acetylsalicylic acid and heat regulation in fever cases*, by H. G. Barbour (pp. 624-632).—This paper reports the effects of aspirin given in the same amounts in fever cases.

The average heat elimination in six experiments on 4 subjects was 52.1 calories per square meter per hour following the administration of aspirin as compared with 37.7 for the control periods. In 1.5 hours the temperature changes averaged -0.81° C. as against an average rise of 0.18° on 4 control days. The fall in temperature was accompanied by a heat production of 38.8 calories as against 40.2 calories on the control days. The drug caused an average decrease in the pulse rate of 10 beats per minute.

"Sensitivity of febrile, temporarily afebrile, and convalescent subjects to antipyretics is not yet explained. These drugs do not 'stimulate' a 'depressed' heat-regulating mechanism, nor is sensitivity due to a lack of readily combustible material (dextrose); but the respiratory quotient of antipyretic sensitive individuals appears to be increased by doses of acetylsalicylic acid which do not affect the quotient of normal persons. Further studies of the carbohydrate metabolism may elucidate the question of sensitivity."

ANIMAL PRODUCTION.

Meat production, J. A. MURRAY (*Sci. Prog.* [London], 12 (1918), No. 48, pp. 665-671).—The author deals mostly with the distinction between fattening and growth, and presents two methods of estimating the chemical composition of the increase due to growth from analyses of lean and fat animals. By one method only the nonfatty increase is considered growth, the basis of reference being the fat-free weight of the lean animal, and by the other method the growth increase is assumed to have the same composition as the lean animal. The oxen, sheep, and pigs analyzed by Lawes and Gilbert¹ furnish the data

¹ Phil. Trans. Roy. Soc. London, 149 (1859), pp. 493-680; also issued in Rothamsted Memoirs, Quarto Ser., 3 (1890).

for the computations, although these investigators themselves refused to use their ox and sheep data directly for such a purpose on the ground that the particular lean and fat animals analyzed were not comparable.

Meat production, J. A. MURRAY (*Jour. Agr. Sci. [England]*, 9 (1919), No. 2, pp. 174-181, fig. 1).—The author summarizes the views developed in the paper noted above, and proposes that basal katabolism be computed on the basis of the fat-free body weight.

"It has been demonstrated that basal katabolism does not vary as the live weight or as the two-thirds power of the same when the variation in the latter is wholly or mainly due to alteration of condition; that it varies approximately as the two-thirds power of the live weight for animals in like condition is generally accepted. The basal katabolism in fat-free condition, therefore, suggests itself as the natural fundamental unit for estimation of maintenance requirements." Any determination of basal katabolism (B) derived from actual measurement is supposed to be related to the basal katabolism (b) of the same animal in fat-free condition by the formula

$$b = (1 - 1.247 f) B$$

where $100f$ is the percentage of fat in the body as estimated from the condition of the living animal at the time of the determination. The constant 1.247, which is considered of general application to ruminants, was derived by assuming that the steer studied by Armsby and Fries (*E. S. R.*, 38, p. 469) contained 20 per cent fat when in a medium condition and 35 per cent after fattening. On the further assumption that determinations of the fat-free basal katabolism of any two animals are to each other as the two-thirds powers of their fat-free body weights (no geometrical interpretation offered), it is found that the maintenance requirement of a very fat animal is much greater than that computed from the total live weight.

The nutritive value of feeding stuffs, J. A. MURRAY (*Sci. Prog. [London]*, 14 (1919), No. 54, pp. 319-326, figs. 2).—The author discusses the various accepted methods of comparing the nutritive values of feeds, notes that the maintenance starch equivalent of Wood and Halnan (*E. S. R.*, 41, p. 270) "is, in effect the discredited 'total digestible nutrients,' and not starch equivalent at all," declares in favor of energy values, summarizes his theory of basal katabolism (see preceding abstract), and suggests a geometrical method of comparing feeding stuffs in which the ratios of net energy to total (gross) energy and of nonavailable metabolizable energy to total energy are considered tangents of angles, the former being termed the productive index.

Net energy values and starch values, H. P. ARMSBY and J. A. FRIES (*Jour. Agr. Sci. [England]*, 9 (1919), No. 2, pp. 182-187).—This paper was written to remove misapprehensions as to the relationships between starch values, carbohydrate equivalents ("total" nutrients), metabolizable energy, and net energy.

"Kellner's starch values represent neither the digestible carbohydrates (actual or potential) contained in feeding stuffs nor the fuel value of the material which they supply to the tissues. What they seek to express in another form is precisely what we have expressed in our net energy values, viz, the extent to which the feed is able either to diminish or prevent loss of stored energy from the body (submaintenance and maintenance rations) or to bring about a storage of energy in new tissue (fattening, growth, etc.). Aside from experimental errors, there is no difference in principle between the two sets of values but merely a difference in the manner of expression." The attempt to express energy in terms of matter is considered "an unfortunate and an unnecessary concession to established usage."

The view that metabolizable energy represents maintenance value and net energy production value is deemed erroneous, for in practice only a part of the metabolizable energy is used for maintenance.

Digest and copy of revised feeding-stuffs law (*New Jersey Stat. Circ. 109* (1919), pp. 8).—A revision of Circular 10 (E. S. R., 28, p. 364) giving the text of the 1912 feeding-stuff law as amended in 1916 and 1919.

Feeds and their use: Inspection and analyses, J. D. TURNER, H. D. SPEARS, and A. M. PETER (*Kentucky Sta. Bul. 223* (1919), pp. 71-255).—The protein, fat, and fiber content of samples of the following materials are reported: Meat scrap, tankage, alfalfa meal, brewers' dried grain, distillers' dried grain, barley feed, barley mixed feed, coconut oil meal, dried beef pulp, shelled corn, corn chop, corn bran, corn feed meal, corn gluten feed, hominy feed, cottonseed meal (choice, prime, and good), cottonseed feed, linseed meal, rice bran, rye middlings, rye mixed feed, wheat bran, shorts, and middlings (with or without screenings), wheat mixed feed, red dog, and a variety of compounded grain feeds, proprietary stock feeds, calf meals, and poultry feeds.

Definitions of feeding stuffs and tables of average analyses derived from various sources are included.

The feeding value of seed beet straw, M. HOFFMANN (*Bl. Zuckerrübenbau, 23* (1916), No. 18, pp. 208-212).—The author reports the proximate composition of 19 samples of the stalks of seed-sugar beets and mangels, and cites the digestion coefficients determined by Eisenkolbe (E. S. R., 23, p. 175).

Is wild vetch seed a safe feed? R. A. GORTNER (*Breeder's Gaz., 77* (1920), No. 19, pp. 1230, 1232).—The author reports brief experiments at the Minnesota Experiment Station in which hogs were fed seeds of the wild vetch (*Vicia angustifolia*), a weed in wheat fields whose seeds accumulate in large quantities in Minnesota mills but are not generally utilized as feed since they are known to yield hydrocyanic acid. In the sample fed the hydrocyanic acid content was 0.0033 per cent.

Pigs having access to ground vetch seed in self feeders where corn feed meal, barley feed, and rye middlings were also supplied consumed 0.4 lb. per head per day (6.34 per cent of total ration). In other experiments, in which the vetch seed was fed mixed with other grains forming as much as 20 per cent of the ration, the hogs ate 1.5 lbs. per head daily with apparent relish and without any evidence of prussic acid poisoning. A buckwheat-vetch mixture was distasteful.

The vetch seed did not prove to be so valuable a feed as was expected from its chemical composition (crude protein 24.1 per cent, nitrogen-free extract 49.6 per cent). Hogs fed corn, shorts, and tankage (8:1:1) made a pound of gain on 4.05 lbs. of feed, while hogs fed a mixture in which vetch seed replaced two parts of corn required 5.16 lbs. of feed for equal gain. It is considered possible that vetch-seed protein is in some way deficient, since in one of the experiments hogs fed a grain mixture containing vetch seed consumed twice the proportion of tankage (self-fed) consumed by another lot not fed the vetch.

An 87-lb. lamb was fed various grain mixtures in which vetch seed comprised up to 50 per cent of the total without ill effects, but the author advises caution in feeding this material to ruminants.

[Feeding experiments with steers and swine], E. S. GOOD (*Kentucky Sta. Rpt. 1918, pt. 1, pp. 30-33*).—Continuation of previous work with steers and swine (E. S. R., 39, p. 474) is reported.

A further comparison of pasture *v.* barn for finishing steers confirmed previous conclusions that barn finishing produced larger and cheaper gains. More manure was also recovered from the animals fed in a barn.

Continued study of hogging-down soy beans indicated that turning hogs into a field of corn and soy beans was more profitable than feeding corn to hogs having the run of a soy-bean field.

Two experiments in feeding cantonment garbage to hogs indicated that corn meal or corn meal plus either tankage or soy bean meal was not a profitable addition to garbage.

[Range cattle experiments] (*New Mexico Sta. Rpt. 1919, pp. 39-42*).—In an experiment conducted in cooperation with the U.-S. Department of Agriculture, five 2-year-old grade Hereford heifers were wintered at the Tucumcari dry farm experiment station and received 20 lbs. of kafir silage and 3 lbs. of cow-pea hay per head daily besides the native range grasses. This proved to be more than a maintenance ration, and the calves averaged 11 lbs. heavier at birth than those of 5 other heifers wintered exclusively on such forage as the range provided.

As a preliminary to an experimental study of chamiso brush (*Atriplex canescens*) as maintenance feed for range cows, chemical analyses of leaves, seed pods, and entire plants are reported. The protein content of the leaves is 5.86 per cent (19 per cent on the dry basis), and the ash is also high.

Data are presented showing the influence of age and character of feed on the gain relative to body weight and on the finish of range steers during the fattening period. The finish was estimated from (1) dressing percentage, (2) proportion of visible fat in the bone-free cuts of ribs and loin, and (3) the proportion of ether-soluble matter in such cuts. The percentages of ether extract in the ribs show perhaps the most striking differences, and these data averaged by age classes and also the average gains are given below:

Influence of age and supplemental feed on gains and finish of alfalfa-fed steers.

Supplement to alfalfa.	Daily gain per 1,000 pounds live weight.				Ether extract in ribs (bone-free).			
	Calves.	Yearlings.	2-year-olds.	3-year-olds.	Calves.	Yearlings.	2-year-olds.	3-year-olds.
	<i>Lbs.</i>	<i>Lbs.</i>	<i>Lbs.</i>	<i>Lbs.</i>	<i>Per ct.</i>	<i>Per ct.</i>	<i>Per ct.</i>	<i>Per ct.</i>
None.....	3.97	2.59	2.48	1.06	15.91	20.00	20.09	36.79
Cottonseed meal.....	2.65	2.71	1.04	.84	17.96	21.69	33.11	34.49
Milo.....	2.70	2.21	2.25	1.52	35.42	41.18	37.53	34.08
Milo and cottonseed meal.....	2.91	2.62	24.89	40.61

[Cattle feeding experiments at North Dakota Station] (*North Dakota Sta. Bul. 136 (1920), pp. 11, 12, 16*).—Satisfactory use of barley in steer-fattening rations is noted, including one experiment where a high proportion of roughage was fed.

The third year's results are summarized of a pasture test with native range grasses begun in 1916 and conducted in cooperation with the U. S. Department of Agriculture. With 3 acres to a steer, pasturage was exhausted in 106 days and with 5 acres in 137 days. Steers given 7 and 10 acres per head, respectively, were carried throughout the grazing season.

In a study of protein requirements yearling steers were fed for 70 days on rations composed of oat straw, alfalfa hay, corn meal, and linseed meal. The proportions were such that 9.6 therms of net energy per 1,000 lbs. of live weight were furnished each animal, but the protein content varied. Two groups of 6

steers each received 0.98 lb. of protein per 1,000 lbs. of live weight and gained, respectively, at the rates of 0.87 and 1.01 lbs. per head daily. Two groups received double this protein allowance and the gains were 0.88 and 1.07 lbs., respectively.

Corn silage the keystone of economical cattle feeding, J. H. SKINNER and F. G. KING (*Indiana Sta. Bul.* 235 (1920), pp. 3-11, figs. 3).—The authors summarize the steer feeding trials with corn silage conducted at the station since the winter of 1906-7. The detailed results have been noted from earlier bulletins (E. S. R., 41, p. 68).

Calf feeding experiment (*Indiana Sta. Rpt.* 1919, pp. 26-28, figs. 3).—The continuation of experiments with Purdue (home-mixed) calf meal (E. S. R., 36, p. 565) is briefly reported. "The results secured from the use of Purdue calf meal in rearing young calves are convincing beyond a doubt that it is possible and practical to feed young calves, after they have reached the age of 10 to 15 days, without the use of milk."

Investigations on the color and markings of cattle, K. KUIPER, JR. (*Genetica [The Hague]*, 2 (1920), No. 2, pp. 137-161, figs. 5).—Results of experimental crosses between Dutch Belted cattle and black and white spotted cattle (Holstein markings), made by R. Houwink, are reported and discussed. The F₁s were self black. The offspring of an F₁ bull by spotted cows consisted of 27 belted, 24 self black, and 3 irregularly spotted individuals, and a calf that was either spotted or self. It is concluded that the factor for the belted pattern and the factor for self color are linked in such a way that they give the reduplication series 1:7:7:1.

The brindle color in cattle in relation to red, C. WRIEDT (*Jour. Genetics*, 9 (1919), No. 1, p. 83).—Some data on colors in the Telemark breed of cattle in Norway are cited to show that brindle is definitely dominant to red and is not, as suggested by Wilson (E. S. R., 21, p. 470), the heterozygote between black and red. Among Telemarks blacks are extremely rare while brindles are common, and the matings brindle×brindle and brindle×red produce only reds and brindles.

Notes on the inheritance of color and markings in pedigree Hereford cattle, F. PITT (*Jour. Genetics*, 9 (1920), No. 3, pp. 281-302, pls. 5).—The author has studied the pedigree records and an extensive series of photographs of a herd of Hereford cattle located in Shropshire, and presents data as to the inheritance of five pairs of allelomorphic characters, viz: (1) Excess white, recessive to normal Hereford marking, (2) dark (pigmented) neck dominant to the normal white neck, (3) "red eye" (ring of red-colored hairs around eye) dominant to the normal white, (4) "dirty nose" (pigmented rhinarium) dominant to clean nose, and (5) pale brown coat color dominant to the darker "claret" color.

Sheep feeding.—IX, Fattening western lambs, 1918-19, J. H. SKINNER and C. M. VESTAL (*Indiana Sta. Bul.* 234 (1919), pp. 3-16).—Seven lots of 25 lambs and 1 of 23 were fed for 3 months in the winter of 1918-19 partly in continuation of the work of the previous year (E. S. R., 41, p. 70) on limited corn rations and the use of hominy feed, and partly to determine whether oat straw and corn silage could be made as efficient a roughage as clover hay and corn silage by increasing the proportion of protein supplement fed with the grain.

The nature of the feeds offered and the chief results are tabulated below:

Results of feeding trials with 50-lb. lambs.

Lot.	Deviations from check lot in character of feeds.	Feeding period.	Daily gain per head.	Consumed per pound of gain.				Final weight per head.	Final valuation per pound.	Profit per head.
				Grain.	Cottonseed meal.	Silage.	Dry roughage.			
		<i>Days.</i>	<i>Lb.</i>	<i>Lbs.</i>	<i>Lb.</i>	<i>Lbs.</i>	<i>Lbs.</i>	<i>Lbs.</i>	<i>Cts.</i>	
7	Check lot (corn, clover hay).....	90	0.409	2.49	0.38	3.19	2.25	88.2	16.15	\$2.48
1	No corn first 50 days.....	108	.343	1.93	.64	5.28	2.39	88.3	15.75	2.03
2	Half feed of corn.....	109	.336	1.63	.65	5.48	2.81	88.1	15.75	2.01
3	No hay after tenth day.....	90	.318	3.04	.49	6.12	.33	80.2	15.50	1.43
4	No hay after tenth day; added cottonseed meal.....	90	.339	2.89	.70	5.54	.31	81.7	15.65	1.60
5	Oat straw replaced hay.....	90	.334	2.91	.45	5.41	1.67	82.2	15.80	1.95
6	Oat straw replaced hay; added cottonseed meal.....	90	.329	2.94	.70	5.47	1.70	81.1	15.90	1.69
8	Hominy feed replaced corn.....	90	.400	2.52	.38	3.05	2.25	87.0	16.10	1.67

¹ Nearly 0.3 lb. was clover hay.

The price schedule was as follows: Corn \$1.25 a bushel, hominy feed \$60, cottonseed meal \$67, corn silage \$7.50, clover hay \$25, and oat straw \$10 per ton. The initial cost of the lambs was 14.9 cts. a pound. The average initial weight per head was about 51.3 lbs. and varied but little from lot to lot.

Only a small amount of oat straw was eaten by lots 5 and 6, and the capacity of oat straw to correct the deficiencies of corn silage as sole roughage was not improved by changing the ratio of cottonseed meal and corn from 1:7 to 1:4. "With relatively cheap roughage and high-priced concentrates, the limited methods of feeding possess considerable merit. . . . But indications favor the liberal use of concentrates under average conditions." If hominy feed had been charged at \$45 a ton (the price of corn) the profit from lot 8 would have been \$2.35 per head.

Sheep feeding experiments at the Chapman Experiment Farm, G. L. SUTTON (*West. Aust. Dept. Agr. Bul. 70 (1920), pp. 8, figs. 2*).—Experiments were made in 1917, 1918, and 1919 to determine suitable home-grown rations for carrying sheep over the period of feed scarcity which normally occurs in Australia in April and May at the end of the dry season. Hoggets and nonpregnant ewes were maintained for several months in a thrifty condition on 1 lb. per head per day of chaffed wheat or chaffed oat hay. Pregnant ewes fed 0.6 lb. of whole oats and given access to wheat stubble came through satisfactorily.

The hay was chaffed after being well cured and the chemical composition of both kinds is reported. Comparisons were not made with uncut hay.

Pasturing alfalfa with hogs, R. E. BLAIR (*U. S. Dept. Agr., Dept. Circ. 75 (1920), pp. 74-76*).—The pasturing tests of 1916 and 1917 at the Yuma Reclamation Project Experiment Farm (E. S. R., 40, p. 472) were repeated in 1918 except that no pigs were available for the spring test. On July 29, eleven 38-lb. grade Duroc-Jersey shotes were turned on a 0.75 acre-plot of third-year Peruvian alfalfa and given a 2 per cent grain ration. During most of the time the supplemental grain was cracked milo, but for 28 days in the fall rolled barley was used without apparent effect on the gains. Three hogs were removed October 21 and the test closed November 25. After the 119 days of pasture the hogs averaged 96 lbs. in weight. They had gained the equivalent of 826.7 lbs. per acre and required 2.44 lbs. of grain per pound of gain. With pork at 7 cts. and grain at 1 ct. a pound, the prices previously used, the pasture gave a net

return of \$36.46 per acre. At current prices (pork 14 cts., grain 3 cts.) the net return was \$54.07.

[**Tornillo beans and cull Pinto beans for pigs**] (*New Mexico Sta. Rpt. 1919, pp. 38, 42, 43*).—It was found necessary to cook cull Pinto beans before feeding them to hogs. Corn and cull Pinto beans (1:1) did not produce the gains of corn and tankage (9:1), but the cost of gain was less.

In a preliminary trial it was found that a mixture of Tornillo beans and corn, 2:1, was too bulky for pigs, but that a 1:1 mixture was consumed readily enough. The gain was not so rapid as that on corn, and it is estimated that 3 lbs. of the beans were as effective as 1 lb. of corn. An analysis of a sample of Tornillo beans is reported. The fiber content was nearly 18 per cent and the fat less than 1 per cent.

Soy bean oil meal as a feed for swine, W. L. ROBISON (*Mo. Bul. Ohio Sta., 5 (1920), No. 4, pp. 115-120, figs. 3*).—Four feeding trials involving comparisons between soy bean oil meal and other protein concentrates as supplements to corn for fattening hogs are reported. The two most recent, one in dry lot and the other on rape pasture, are summarized below.

Two 17-week comparisons of soy bean oil meal with other supplements for fattening pigs.

Feeds offered.	Average initial weight.	Daily concentrate ration. ¹	Daily gain per head.	Consumed per pound of gain.		Cost of 1 lb. gain.	Returns on feed per day per head.
				Corn.	Supplement.		
In dry lot:	<i>Lbs.</i>	<i>Lbs.</i>	<i>Lbs.</i>	<i>Lbs.</i>	<i>Lb.</i>	<i>Cts.</i>	<i>Cts.</i>
Corn.....	66.8	3.05	0.50	5.86	16.1	-0.56
Corn, linseed meal (6:1).....	66.5	3.31	1.11	3.40	0.57	11.6	+3.75
Corn, soy bean oil meal (9:1).....	67.7	3.30	1.27	3.35	.37	10.9	5.21
On rape pasture:							
Corn.....	67.3	3.48	1.12	4.26	11.7	3.71
Corn, tankage (19:1).....	66.6	3.71	1.51	3.65	.19	11.1	5.90
Corn, soy bean oil meal (12:1).....	67.7	3.79	1.60	3.56	.30	11.1	6.21
Corn, ground soy beans (8:1).....	67.5	3.83	1.38	3.70	.46	12.0	4.11

¹ Per 100 lbs. live weight.

For the financial computations the following price schedule was used: Hogs 15 cts., corn 2.75 cts. a pound; tankage \$110, linseed meal \$80, soy bean oil meal \$90, ground soy beans \$80 a ton; no pasture charge.

The poor showing of ground soy beans in comparison with soy bean oil meal is confirmed by a 7-week dry-lot experiment made in 1916. Apparently the ground beans are unpalatable, since in another test also made in 1916 self-fed hogs consumed only a small amount of the material, not enough to balance the ration.

The consignment of soy bean oil meal fed in 1916 had the following percentage composition: Crude protein 49.2, fat 3.2, fiber 4.9, nitrogen-free extract 31, and ash 2.7.

The seasonal distribution of swine breeding, R. PEARL (*Sci. Mo., 7 (1918), No. 3, pp. 244-251, figs. 2*).—The author presents statistics indicating that hog slaughtering in the United States is distributed with fair uniformity throughout the year, whereas most pigs are born in the spring except in the southernmost States. The birth dates were determined from Poland China and Duroc-Jersey registration records.

Mendelian factors concerned with hair color in horses, J. H. W. T. REIMERS (*Cultura*, 29 (1917), Nos. 348, pp. 248-262; 350, pp. 339-354; 351, pp. 377-394; 352, pp. 404-416).—The author summarizes the results of previous investigations and presents new data derived from the East Friesian and Groningen stud books. Ten factors are recognized, although all are not involved in the matings tabulated. There appear to be complications in the inheritance of different shades of brown.

Poultry feeding [experiments] (*New Mexico Sta. Rpt. 1919*, pp. 21-24).—Five pens of 12 White Leghorn pullets were used in a study of cottonseed meal as a constituent of a bran and alfalfa meal mash. In 3 pens cottonseed meal formed, respectively, 50, 25, and 10 per cent of the mash and in the same order 37, 32, and 31 per cent of the total nutrients consumed were returned in the form of egg yolk and albumin. However, the check pen receiving no cottonseed meal or other protein supplement produced edible egg materials which weighed nearly 52 per cent of the nutrients consumed, while in the fifth pen where meat scrap formed 25 per cent of the mash (no cottonseed meal) the edible materials returned were 29 per cent of the nutrients consumed. Further work is planned to explain these results.

In a comparison of different whole grains fed with a mash of bran, alfalfa meal, and meat scrap (2:2:1) it was found that barley ranked first, milo second, wheat third, and corn fourth in number of eggs produced per hen (White Leghorn pullets) and that this order was reversed when eggs produced per pound of feed was considered.

In a third experiment, with Rhode Island Red pullets, a mash of ground Tornillo beans, bran, cottonseed meal, and meat scrap (2:1:1:1) was found to be as palatable and as efficient in egg production as a standard mash of bran, corn chop, alfalfa meal, and meat scrap (1:1:1:1).

Soil contamination [in poultry yards], H. E. URTON (*Brit. Columbia Dept. Agr., Circ. Bul. 26* (1920), pp. 3, fig. 1).—To avoid the transmission of parasites to young chickens through accumulated poultry manure, the author suggests a rotation system whereby the young stock is raised on a particular area only once in three years.

Rabbit raising, N. DEARBORN (*U. S. Dept. Agr., Farmers' Bul. 1090* (1920), pp. 34, figs. 22).—These pages include brief characterizations of the utility breeds of rabbits, notes on the breeding, feeding, management, and marketing of rabbits, directions for preparing rabbit skins, and suggestions for combating disease. A section on cooking rabbit meat is noted on page 365.

DAIRY FARMING—DAIRYING.

A study of Guernsey breeding, R. R. GRAVES (*Hoard's Dairyman*, 59 (1920), No. 17, pp. 1068, 1069, 1072, fig. 1).—This is a progress report on statistical studies of Guernsey advanced registry records, undertaken by the Dairy Division of the U. S. Department of Agriculture for the purpose of determining the hereditary qualities of the "best" sires of the breed.

Advanced registry testing, H. P. DAVIS (*Idaho Sta. Circ. 9* (1919), pp. 11).—A summary of breed requirements for advanced registry, with instructions for owners who desire tests made and for supervisors of tests.

Studies in the cost of milk production.—II, F. T. RIDDELL and A. C. ANDERSON (*Michigan Sta. Bul. 286* (1920), pp. 37, figs. 6).—As part of the series of cost of production studies in Michigan dairying centers, begun with Bulletin 277 (E. S. R., 37, p. 474), the authors report cost data collected near Howell, Livingston County, and near Webberville, Ingham County, during 3 and 2

years, respectively, beginning in March, 1916. Field agents employed by the station kept accounts on 25 farms each year in each locality. At Howell the records cover 1,240 and at Webberville 731 cow years. In both districts most of the milk was sold for condensing purposes. A preliminary report of the Livingston County data has been noted (E. S. R., 42, p. 377).

Costs were computed on the "cow" basis and the customary charge for managerial ability was included. The costs are averaged by months for each district, but not as in the earlier study itemized by farms. The annual production per cow was 7,211 lbs. at Howell and 6,047 lbs. at Webberville. In both localities, milk production was heavier in winter than in summer. The following table combines the data from both areas to determine the commodity cost of production:

Average amounts of feed and labor expended per 100 lbs. of milk.

Period.	Home grown grain.	Mill feed.	Hay.	Other dry roughage.	Silage.	Other succulence.	Pasture.	Bedding.	Operator's labor.	Hired labor.	Horse labor.	Corrective factor.
	Lbs.	Lbs.	Lbs.	Lbs.	Lbs.	Lbs.	Days.	Lbs.	Hours.	Hours.	Hours.	
Oct. 16-May 15.....	12.1	16.5	49.2	21.4	147.2	3.5	17.9	1.01	0.99	0.11	1.2183
May 16-Oct. 15.....	4.0	6.8	10.5	2.5	21.1	9.6	6.9	2.9	.96	1.00	1.4499
Entire year.....	9.4	13.3	36.3	15.1	105.1	5.5	2.4	12.9	.99	1.00	1.2750

The sum of the costs of the individual feed and labor items multiplied by the corrective factor gave the total cost of producing 100 lbs. of milk.

In both districts each year milk was marketed at a loss.

A comparison, with the standard plate method, of some rapid methods for bacteriologic analysis of milk, J. E. SIMMONS (*Jour. Infect. Diseases*, 24 (1919), No. 4, pp. 322-336, figs. 2).—The author, working at the Wisconsin Experiment Station, reports parallel analyses of 136 milk samples by five different methods, viz, the direct microscopic (Breed), standard agar plate, lactose plate, little plate (Frost), and methylene blue reduction test.

The standard plate, lactose plate, and little plate methods gave closely comparable results for milks containing less than 1,000,000 bacteria per cubic centimeter, while the direct microscopic method gave counts that were so variable (raw milk alone considered) that the method is deemed unreliable for the better grades of milk. For more richly seeded milk the lactose plate counts were about 50 per cent higher than the standard plate counts, the direct microscopic counts came very close to the standard counts, and the little plate counts were lower.

Some erratic variations occurred in the time in which different classes of milk reduced the methylene blue solution. However, when these were smoothed out by applying a moving average, a curve was obtained which closely approximated the results obtained by the culture methods. The time required for reduction was somewhat longer than that recorded by other observers, and it is suggested that a weaker solution would make the test still more rapid.

A clean milk supply, R. B. TENNENT (*Queensland Agr. Jour.*, 13 (1920), No. 4, pp. 151-161, figs. 6).—This is a general review of the problem of the bacteriological control of milk. Data secured at the Queensland Agricultural College are cited to show the desirability of moistening a cow's udder with a damp cloth just prior to milking. The adoption of refrigerator cars to transport market milk is recommended for Australia.

Color defects in butter, O. F. HUNZIKER (*N. Y. Produce Rev. and Amer. Creamery*, 47 (1919), Nos. 19, pp. 702, 704; 20, pp. 754, 756, 758, 760).—The author presents an extended summary of published experimental work on color defects in butter, drawing the following conclusions as to cause of color defects:

“Unevenness in color, mottles, waves, and streaks are due to uneven distribution of the small and large liquid drops in butter, the localized small droplets producing the opaque, ‘thick,’ dense, and whitish dapples and the large droplets producing the clearer and deeper yellow blotches. The localization of the small and large droplets is due to incomplete solution of the salt and uneven distribution and lack of emulsion of the brine, causing migration of water and brine in the butter at rest and consequent running together of the free water or brine into larger drops, which produce the clear, deep blotches, and the exposure of the localized fine droplets which show up as opaque, ‘thick,’ whitish dapples.”

VETERINARY MEDICINE.

Principal poisonous plants of Canada, F. FYLES (*Canada Expt. Farms Bul.* 39, 2. ser., 1920, pp. XI+112, pls. 8, figs. 94).—Brief descriptions given of the more important poisonous plants found in Canada are accompanied by illustrations, eight of the plates being in colors. The accounts include the common names of the plant, a description of it, its distribution, poisonous properties, symptoms, remedy, and means of control. A bibliography of two pages and a subject index are included.

St. John's wort and its effects on live stock, S. DODD (*Agr. Gaz. N. S. Wales*, 31 (1920), No. 4, pp. 265-272).—The experiments here briefly reported show that St. John's wort contains a principle, most abundant in the flowers and flowering stems, which, when the plant is consumed by an animal, becomes absorbed into the system and renders unpigmented or white skin peculiarly sensitive to sunlight, with the result that on exposure to the sun such skin is injured, as evidenced by the reaction. The reaction is much more than mere sunburn, especially as the condition is not seen in similar animals exposed to greater sunlight but not fed on this or other skin-sensitizing substances. In addition to the skin affection, St. John's wort appears to exert an effect upon the central nervous system, usually causing great mental depression but at times excitement, which sometimes becomes almost mania.

The biological relationships of ascarids, B. SCHWARTZ (*Jour. Parasitol.*, 6 (1920), No. 3, pp. 115-123).—This is a report of experiments undertaken with the view of determining whether *Ascaris lumbricoides* which occurs in man can be differentiated by means of immunological reactions from *A. lumbricoides* which occurs in the hog.

“The blood serum of rabbits immunized to salt-solution extract of *A. lumbricoides* (from swine) causes the formation of precipitates when added to salt solution extracts of various ascarids (*Ascaris*, *Belascaris*, *Toxascaris*, *Ascaridia*). The precipitin reaction as applied to extracts of these parasites is, therefore, a group reaction. By the use of proper dilutions, heavier and more rapidly-appearing precipitates are produced when rabbit serum immunized against *A. lumbricoides* is added to salt solution extracts of *A. lumbricoides* than when it is added to similar extracts of other ascarids. Extracts of species of the same genus (*A. lumbricoides* and *A. equorum*) show less difference in that respect than extracts of worms belonging to different genera (*Ascaris*, *Belascaris*, *Toxascaris*, *Ascaridia*). The results of the precipitin tests correspond, therefore, to the zoological relationships of these parasites.

“Extracts of *A. lumbricoides* from man do not appear to be distinguishable from extracts of *A. lumbricoides* from swine so far as the results of the pre-

cipitin test are concerned. Apparently, the forms from the two hosts are biochemically as well as morphologically indistinguishable. Small quantities of precipitating serum sufficient to cause the formation of precipitates in salt-solution extracts of ascarids failed to produce precipitates in similar extracts of unrelated nematodes (*Dictyocaulus*, *Strongylus*). The results obtained by means of the anaphylactic test appear to be in a general way in agreement with the results of the precipitin test, although a considerable degree of variation was noted as regards the reactions of guinea-pigs to injections of similar extracts. Definite conclusions from the experiments on anaphylaxis are not justified in view of the limited number of experiments."

On the resistance of *Ascaris* eggs, S. YOSHIDA (*Jour. Parasitol.*, 6 (1920), No. 3, pp. 132-139).—Data here presented have been substantially noted from another source (*E. S. R.*, 43, p. 80).

Studies on anthelmintics.—VIII, Some experiments with fluid extracts, M. C. HALL (*Jour. Amer. Vet. Med. Assoc.*, 57 (1920), No. 2, pp. 183-187).—This is a report of investigations conducted in continuation of those previously noted (*E. S. R.*, 42, p. 675). The results have been summarized as follows:

"The low taeniocidal value of fluid extract of kamala as compared with the high taeniocidal value of powdered kamala, and the low ascaricidal value of fluid extract of chenopodium as compared with the high ascaricidal value of oil of chenopodium, bear out the statement that fluid extracts are frequently unsuitable as anthelmintics. Fluid extract of spigelia and senna promises little of value as an anthelmintic, and this is in agreement with Foster's findings, published by Hall and Foster (1918) [*E. S. R.*, 38, p. 883]. Fluid extract of balsam poplar buds may prove to be effective against ascarids and uninjurious when taken in large doses, but large doses of this drug, with the precipitation of the resinous content on the buccal mucosa, are resented by dogs and would not be attractive to man. Fluid extract of caulophyllum did not receive sufficient test to draw conclusions on, but in the dose used it was not very effective."

Variations in the hydrogen-ion concentration in uninoculated culture medium, L. G. GRACE and F. HIGHBERGER (*Jour. Infect. Diseases*, 26 (1920), No. 5, pp. 457-462).—Daily determinations over a considerable period of time are reported of the pH values of 1 per cent glucose broth and of plain broth kept in test tubes and in flasks, in the incubator at 37° C., in the ice box, and at room temperature.

Both the plain broth and the glucose broth showed changing pH values, but the variations were not nearly so great in the plain as in the glucose broth, indicating that the resulting acid formed by the breaking up of the glucose is the chief factor responsible for the changes in H-ion concentration. The conclusion is drawn that as the question of optimum reaction for the growth of different organisms assumes greater importance it will become more important to take into account the variations in H-ion concentration occurring in a medium independent of the activities of bacteria and to determine the reaction of the medium just before it is inoculated.

The relation of the rate of absorption of antigen to the production of immunity, M. W. COOK (*Jour. Immunol.*, 5 (1920), No. 1, pp. 39-49).—The author refers to the fact established by various workers that previous treatment with an antigen confers upon an animal an increased power of absorption for that antigen, and to the work of Smith and Cook (*E. S. R.*, 38, p. 482) that absorption of antigen in immunized animals proceeds more rapidly than in sensitized or normal animals, and reports an investigation of the question as to whether the process of immunity production is in any way dependent

upon the changed absorption powers of the organism. The method employed was to introduce into the blood of rabbits, in connection with the usual immunizing process, an excess of Na ions or Ca ions, thereby increasing the power of absorption of the antigen (egg albumin) and subsequently to determine the antibody content of the animals.

It was found that the administration of electrolytes influenced very markedly the rate of absorption of antigen, and that variations in antibody content of the animals were parallel to the differences in the rates of absorption of the antigen. Similar experiments carried out on a series of animals immunized to typhoid bacilli showed that the production of agglutinins, opsonins, and precipitins varied with the rate of absorption of the antigen.

These results are thought to indicate that the condition of permeability of the cell with respect to its absorptive powers for the introduced antigen is a factor of considerable importance in the production of immunity.

On the so-called Neisser-Wechsberg inhibiting phenomenon in bactericidal immune sera. T. ТИЖОТТА (*Jour. Immunol.*, 5 (1920), No. 1, pp. 1-38, fig. 1).—Various theories which have been advanced to explain the Neisser-Wechsberg phenomenon of complement deviation are discussed and tested from the results of a series of experiments in which dysentery immune serum of rabbits was used on account of the frequency of the occurrence of the phenomenon in such sera. Among the points investigated were the dependence of the phenomenon on amboceptors and complements, its importance for the total bactericidal action of the immune serum, its variation during the immunization, and the question as to whether the phenomenon is due to already known antibodies or is brought about by unknown ones. The conclusions drawn from the investigation are as follows:

“The inhibiting phenomenon of Neisser and Wechsberg is of a specific nature. It is to be found in active as well as in inactive sera; it develops during the immunization and can be found in a very high degree in dysentery immune sera. In active sera from immunized animals, examined without the addition of foreign complement, the phenomenon presents itself as a complete abolition of the normal bactericidal action.

“The inhibition is due to antibodies that arise during the immunization or during the natural disease. These antibodies are not identical with the agglutinins, the bacteriolysins, or the precipitins. They must be considered as specific antibodies, which combine with dissolved antigen to form molecular complexes that have a marked tendency to absorb complement and to withdraw it from the bactericidal antibodies.

“The titer of inhibition is directly proportional to the employed dose of complement. With a small dose of the latter, smaller doses of inhibiting antibodies can be demonstrated than with a larger dose of complement.

“The inhibiting antibodies do not affect the bacteria themselves, nor can they be removed from the serum by absorption with an emulsion of the homologous bacilli. They can be demonstrated in sera that lack any bactericidal action.”

Experiments on immunization with pseudoblackleg pellets. T. P. HASLAM and O. M. FRANKLIN (*Jour. Infect. Diseases*, 26 (1920), No. 5, pp. 424-426).—This is a report of experiments undertaken at the Kansas Experiment Station to determine whether the commercial blackleg pellets, previously found by Franklin and Haslam to consist of an organism similar to but not identical with the true blackleg bacillus (*E. S. R.*, 36, p. 180), possess any ability to immunize calves against blackleg.

One group of calves was vaccinated with the commercial pseudoblackleg pellets and a second group with pellets of the same virulence prepared in the

laboratory from blackleg virus secured from naturally occurring cases of blackleg. After two vaccinations all calves were tested for immunity against blackleg virus. Of the 16 calves treated with pseudoblackleg commercial pellets 8 succumbed to a 1 gm. test dose of blackleg virus, and of 8 nontreated calves 4 succumbed. All of the 9 calves treated with true blackleg vaccine proved immune to the same test dose of the virus, thus proving that the pseudoblackleg commercial vaccines do not immunize calves against blackleg.

The limiting hydrogen-ion concentration of various types of pneumococci, H. M. JONES (*Jour. Infect. Diseases*, 26 (1920), No. 5, pp. 435-440, fig. 1).—A study of the factors influencing the H-ion concentration of various types of pneumococci, according to the methods previously noted (E. S. R., 41, p. 503), is reported with the following results:

"The final H-ion concentration produced by pneumococci of various types when grown in glucose broth varies, with different strains, between pH 5 and 5.6, being indistinguishable in this respect from various strains of *Streptococcus hemolyticus* of virulent type.

"The regularity with which these final H-ion concentration values can be reproduced depends largely on the initial reaction, ordinary glucose broth of pH 7 being useless for this purpose. None of the strains failed to grow, however, when the initial reaction was set at 7.6.

"This failure to grow in broth of pH 7 does not account for the often observed failure to secure growth of the pneumococcus when blood cultures are being made, since the addition of 2 per cent of whole blood renders the medium of pH 7 even superior to glucose broth of pH 7.6 in stimulating growth. A marked increase in tolerance toward the H-ion is also observed, as is also the case with *S. hemolyticus*."

Acid production by *Streptococcus viridans* in mediums of different hydrogen-ion concentration, L. G. GRACE and F. HIGHBERGER (*Jour. Infect. Diseases*, 26 (1920), No. 5, pp. 451-456).—A broth having an initial reaction of pH 6.8 was found to favor a more rapid growth of *S. viridans*, while a broth having a reaction more alkaline than pH 7.6 distinctly retarded growth. No appreciable difference in growth was obtained between the 5 per cent ascites, 0.2 per cent glucose, and 1 per cent glucose broth.

Observations on the recent epidemic of foot-and-mouth disease at the Royal College of Animal Husbandry at Reggio-Emilia, A. CUGNINI (*Indus. Latt. e Zootec.*, 17 (1919), Nos. 11, pp. 103, 104; 12, pp. 117, 118; 13, pp. 127, 128).—The author describes three outbreaks of foot-and-mouth disease occurring in October, 1918, and January and April, 1919, respectively, and presents data to show that although the disease passed from a benign to a severe form in the succeeding epidemics the animals which had recovered from an attack during an earlier epidemic proved, with few exceptions, to be immune to the later attacks.

The injection into the swine of an autolyzed anti-foot-and-mouth vaccine proved efficacious, the mortality during the later epidemic being greatly reduced. It is suggested that although the disease takes a somewhat different course in swine than in cattle the former are better adapted to experimental study of the disease from the standpoint of immunity, owing to their rapidity of reproduction which allows a study through several generations in a comparatively short time.

Ulcerative lymphangitis (*Rev. Gén. Méd. Vét.*, 28 (1919), No. 329, pp. 233-243; also in *Jour. Compar. Path. and Ther.*, 32 (1919), No. 2, pp. 127-132).—This is a summary of reports of investigations of ulcerative lymphangitis conducted by Boquet at the Alfort Veterinary School.

The prevention of goiter (big neck) and hairlessness of newborn domestic animals, J. W. KALKUS (*Washington Sta. Pop. Bul. 117 (1919), pp. 3-12, figs. 7*).—A popular account is given of the nature and cause of this affection, with recommendations for treatment based upon experiments conducted by the station since 1915, results secured by experiment stations and institutions of other States, and the results of the application of iodine treatment by practical stockmen.

In order to prevent this condition it is recommended that all pregnant animals in goitrous districts be treated by one of three methods described. The first consists of the internal administration of potassium iodide at the rate of 2 grains daily throughout the gestation period. The second consists of the application of tincture of iodine to the animal's skin, it being most easily applied by pouring the tincture of iodine on the animal's back once every two weeks, one teaspoonful being sufficient for mares and cows and half that amount for smaller animals. It is pointed out that the iodine should not be poured on the same spot each time, since it will blister the skin and cause the hair to fall out. The third method of application is that of subcutaneous injection of tincture of iodine, $\frac{1}{2}$ oz. of a 10 per cent solution for cows and mares, and $\frac{1}{4}$ oz. for smaller animals being administered every two weeks. In all cases treatment should begin as soon as possible after an animal has been bred.

Bovine malignant catarrhal fever, BRUINS (*Abs. in Vet. Rec., 32 (1919), No. 1632, pp. 167, 168*).—The author reports upon an outbreak in which seven animals died or were slaughtered, only one of which presented symptoms of excessive nervous excitement.

Coccidiosis in cattle, W. D. WAY and W. A. HAGAN (*Cornell Vet., 10 (1920), No. 1, pp. 17-27, pls. 5*).—A general account of this disease, together with brief reports of nine cases observed.

A disease in cattle due to crab grass (*Digitaria sanguinalis*), E. M. PICKENS, M. F. WELCH, and C. C. SHIVERS (*Cornell Vet., 10 (1920), No. 1, pp. 8-16*).—“An unusual disease affecting 78 head of cattle on five different farms has occurred in southern Maryland. The symptoms of this disease appear to coincide with those of buckwheat rash and clover disease. Limited feeding experiments were carried out with negative results. No evidence of fungi or other plant diseases were obtained. Crab grass (*D. sanguinalis*), the predominating forage in all the pastures, is thought to be the causative agent. The circumstantial evidence is sufficient to cause it to be looked upon with suspicion, at least until it is proved innocent.”

Transformation of the alveolar epithelium in verminous pneumonia in the sheep, J. M'FADYEAN (*Jour. Compar. Path. and Ther., 33 (1920), No. 1, pp. 1-10, figs. 9*).—This is a report of histopathological studies conducted by the author.

Intestinal worms in hogs and stomach worms in sheep, B. H. RANSOM (*Cornell Vet., 10 (1920), No. 2, pp. 66-74, pls. 3*).

[Report of the veterinary department] (*Indiana Sta. Rpt. 1919, pp. 68-72*).—This report deals largely with work on swine diseases.

In continuation of work on hog cholera previously noted (*E. S. R., 40, p. 783*), the results are reported of a series of experiments conducted for the purpose of determining the number of days that the hog cholera virus retains its virulence outside of the infected animal. Sterile earth contaminated with blood, urine, and feces from hogs having acute hog cholera was dried for varying periods of time and then mixed with feed and fed to susceptible hogs. Urine 18, 6, 5, and 4 days old proved to be nonvirulent; feces 18, 6, and 5 days old nonvirulent and 4 days old slightly virulent; blood 18 and 6 days old non-

virulent and 5 days old virulent. Stable flies did not transmit hog cholera virus.

A bacteriological study of hog cholera blood showed the presence of *Bacillus suispestifer* in 5 out of 8 cultures, atypical *B. suispestifer* in 2, and *B. paratyphosus* B in one culture. Of the 9 cultures isolated from the tissues of rabbits that had been inoculated with hog cholera blood, 5 proved to be *B. suispestifer*, 1 *B. paratyphosus* A, 2 *B. paratyphosus* B, and 1 *B. paratyphosus* B intermediate. A study of 200 cultures of bacteria isolated from hogs that had succumbed to so-called "mixed infection" indicated that *B. suispestifer* predominated in the body tissues and *B. coli* in the intestines. The inoculation of susceptible pigs with blood collected from sick hogs in 14 outbreaks which did not have the characteristic symptoms of hog cholera produced typical hog cholera in 7 cases. Four of the blood samples that were not pathogenic to hogs, rabbits, and guinea pigs were from hogs showing extreme hemorrhagic lesions on post mortem.

The section on swine diseases also includes brief reports of work on hemorrhagic septicemia, swine plague, and swine dysentery.

Experiments relating to hog cholera serum production are reported which indicate that virus blood from hogs killed 7 and 8 days after inoculation does not produce a more potent serum than that produced with virus blood from hogs killed from 4 to 6 days after inoculation. Elevation of body temperature (106 to 108° F.) is thought to be a safer guide in virus blood production than fatal symptoms or extreme cholera lesions. Negative results were obtained in attempts to correlate the presence of gas-producing bacteria in cholera blood virus with losses following hyperimmunization of hogs.

The report also includes a brief statement regarding the investigation of forage poisoning, and data on the laboratory diagnoses conducted by the department, and on the production and testing of hog cholera serum during the year.

Hog cholera (*North Dakota Sta. Bul. 136 (1920), p. 22*).—Experiments to determine the effect of the passage of hog cholera virus through foreign species of animals are reported. In the case of peccaries the virus remained active for susceptible pigs through four passages but after the fifth passage lost its virulence. With goats the virulence was destroyed after two passages and with rabbits after one. Neither peccaries, goats, nor rabbits contracted the disease, nor did the virus increase in potency in passage through these species.

Experiments to determine the minimal lethal dosage of virus for susceptible pigs indicated that quantities as small as 0.005 cc. and 0.0025 cc. of potent virus will produce the disease. In dialysis experiments the virus failed to dialyze in either 0.85 per cent NaCl solution or in distilled water.

Malignant edema in swine, F. PROESCHER and H. A. HOFFMAN (*Amer. Jour. Vet. Med., 15 (1920), No. 6, pp. 247-251, figs. 4*).—While this affection, due to *Bacillus œdematis maligni*, has seldom been recorded as occurring in swine, the authors' experience in Iowa indicates that it is more prevalent than is generally recognized.

The disease in swine appears to have usually been diagnosed as a form of septicemia of unknown origin. The authors have observed a considerable number of pigs at the Sioux City stockyards which succumbed to this disease immediately following serum simultaneous vaccination for hog cholera. A report of a similar loss from this affection is said to have been received from Nebraska, the diagnosis having been confirmed by bacteriological examination.

An account is given of an outbreak which occurred in a serum plant in which an antitoxin serum was produced by immunizing the pig with increasing doses of the toxin. The organism isolated was found to represent a new variety. This serum protected guinea pigs against a multiple fatal dose of the toxin.

The production of an antitoxic serum is thought to prove that the toxic substance contained in the muscle filtrate is a genuine toxin and not a definite chemical substance of an amin character.

Because of the enormous resistance of the spores of this organism to heat and to ordinary disinfectants, the usual methods for preparing the field of inoculation are ineffective. The authors have been unable to demonstrate the presence of this bacillus in hog cholera serum virus.

Scrapings made from the skin and bristles from the axillary region of a lot of pigs from the same district in Arkansas from which the affected pigs originated were examined and inoculations made of guinea pigs. An organism was recovered which was morphologically and culturally identical with the one obtained from pigs dying from malignant edema.

"The experimental investigations have shown that a highly potent serum can be produced by immunizing animals with the toxin of the malignant edema bacillus. At present we are not prepared to state the therapeutic value of such an antitoxic serum in foudroyant cases of malignant edema, but the situation might be handled by using an antitoxic serum as a prophylactic in herds where previous outbreaks have occurred. This antitoxic serum could be mixed with hog cholera serum and used in conjunction with the latter product. At present such a serum is not obtainable commercially. However, if the losses from malignant edema following simultaneous vaccination are increased to an alarming extent an antitoxic serum can easily be prepared in any quantity."

Swamp fever in horses (*North Dakota Sta. Bul. 136 (1920), p. 21*).—Brief reference is made to the administration of extracts of *Gastrophilus* in experiments under way. The injection of blood from an experimentally induced case of swamp fever into normal horses showed the horse to continue to be a carrier of the infection after 10 and 11 years, respectively.

RURAL ENGINEERING.

Study of relation of soil, water, and crop with respect to irrigation and dry farming supplemented by irrigation, 1916-18 (*New Mexico Sta. Rpt. 1919, pp. 26, 27*).—Three years' study on the movement and distribution of moisture in soil showed that 24 hours after irrigation the first foot of soil contained an average of 12 per cent moisture, with a diminishing amount toward the bottom. The percentage of moisture in the first foot 24 hours after irrigation was practically the same regardless of whether the land was fallowed or cropped. There was considerable irregularity in the downward movement of water after irrigation, both as to its rate of movement and amount held at various depths. Cropped plats receiving 5 in. of water at each irrigation, with a total of 55 or 60 in. per season, showed that practically none of the water percolated beyond the reach of plant roots. Cropped plats receiving 3 in. of water at each irrigation, with a total of 40 to 45 in. a season, showed that the maximum depth of penetration was about 4 ft. Fallow plats receiving 3 in. of water, with a total of 15 to 18 in. during the season, showed no percolation beyond 10 ft.; while 5-in. fallow plats receiving a total of 25 or 30 in. during the season showed considerable percolation beyond the depth of 10 ft.

Subsoil water in relation to tube wells, T. A. MILLER-BROWNLIE (*Indian and East. Engin., n. ser., 45 (1919), No. 6, pp. 191-193; abs. in Engin. and Contract., 53 (1920), No. 13, pp. 355, 356*).—It is stated that observation of a large number of tube-well installations has led to the conclusion that the engineers responsible for carrying out these works have never examined the conditions covering underground water supply. The object of this paper is to show that under normal conditions a permanent, fixed supply from tube

wells can be obtained, and that the ultimate head or depression necessary to obtain this supply can be calculated with fair accuracy. It is stated that the present method of estimating the various unknown quantities connected with tube-well water supplies appears to be based on entirely erroneous assumptions.

Observations made on the subsoils of the Punjab have shown that the slopes necessary to cause water motion have varied from 1 in 260 in moderately coarse sand to 1 in 175 in fairly fine sand. With flatter gradients in each type of sand there is no apparent motion. Capillary attraction interferes with the true flow. "Observations indicate that any lateral or forward motion of water, where the hydraulic gradients are slightly less than those mentioned, is so slow that for practical purposes it may be neglected, the actual velocity probably not exceeding a few inches per day. When water is flowing through sand the hydraulic gradient is a straight line as long as the sand is all of similar grade and density and all cross sections on the line of flow are of equal area."

Tabular data are given on the permanent depression head in tube-well installations, and the estimation of this factor is considered of the utmost importance.

Methods of irrigation and distribution of crops in irrigated areas, I-II (*Medios que se Utilizan para Suministrar el Riego a las Tierras y Distribución de los Cultivos en la Zona Regable*. [Madrid]: Min. Fomento, Dir. Gen. Agr., Minas y Montes, 1918, I, pp. VIII+732; II, pp. [1]+500, pls. 6, figs. 76).—This work, in two volumes, is a compilation by the Agricultural Consulting Board of Spain of a large amount of information on irrigation practice reported by the agricultural engineers of 40 Spanish provinces. It includes data on water supplies, conveyance and distribution of water, duty of water, irrigation structures, soil moisture and methods of irrigating different crops, and the results of numerous irrigation experiments with certain crops.

Public Roads (*U. S. Dept. Agr., Public Roads, 2* (1920), Nos. 21-22, pp. 48, figs. 9; 23, pp. 32, figs. 22).—These numbers of this periodical contain the following articles:

Nos. 21-22.—Relations of the States with the Bureau of Public Roads, by G. P. Coleman; Federal Control and Aid for Highways—Its Results, Merits, and Limitations, by T. H. MacDonald; Making Highways Ornamental and Useful, by J. A. Hazelwood; Design of Highway Drainage Structures, by C. Older; The Marking, Signing, and Making Safe of a State Highway System, by L. H. Neilsen; Maps of State Highway Systems for the Use of the Public, by M. W. Watson; The Alignment, Grade, Width, and Thickness in Design of Road Surfaces, by C. M. Upham; Highway Administration, by G. H. Biles; A National Program for Highway Research, by A. Marston; Shall Contract Bonds Be Eliminated? by W. G. Thompson; State Testing Engineers and Chemists Meet in Washington; Interesting Federal-aid Project; Graphical Progress Report in Federal-aid Road Construction; and December and January Federal Aid.

No. 23.—This number of this periodical contains the following articles: Mechanical Concrete Road Finisher, by H. G. McKelvey (see p. 388); A Convenient Method of Computing Cross Sections, by G. T. McNab (see p. 388); Substantial and Attractive Guard Rail on Oregon Road; Machinery Replaces Hand Labor on Minnesota Project, by G. C. Scales; Concrete Pressure against Forms, by E. B. Smith (see p. 388); Proper Consistency of Bituminous Materials in Highway Engineering, by P. Hubbard; Federal-aid Allowances—Project Statements Approved in February, 1920; and Tests of Road-building Rock in 1919.

Country roads, R. MARTÍN (*Univ. Tucumán, Ext. Agr. Bol. 35* [1919], pp. 12-17, figs. 3).—Features in the construction and maintenance of country roads in Argentina are briefly discussed.

A convenient method of computing cross sections, G. T. McNAB (*U. S. Dept. Agr., Public Roads, 2* (1920), No. 23, pp. 6-8, figs. 2).—A method of computing cross sections for highway earth works, based on the method of computing land areas by latitudes and double meridian distances, is described.

Mechanical concrete road finisher, H. G. McKELVEY (*U. S. Dept. Agr., Public Roads, 2* (1920), No. 23, pp. 3-5, figs. 3).—A road-finishing machine primarily devised for concrete roads is described and illustrated.

The machine, sustained on four flanged wheels, travels on the ordinary side forms used to confine the concrete or brick and is moved forward or backward under its own power, operating during the forward movement but usually running idle in the reverse direction. The power for both traction and operation is furnished by a 4-h. p. air-cooled gasoline engine protected by a housing. The three principal members of the machine are (1) a striking template with a metal edge adjustable to the crown of the pavement, (2) a tamper consisting of a heavy timber, kiln-dried and oil-soaked, and shod with a steel channel, and (3) a finishing belt attached to a supporting frame at the rear of the machine.

Concrete pressure against forms, E. B. SMITH (*U. S. Dept. Agr., Public Roads, 2* (1920), No. 23, pp. 15-20, figs. 11).—This is a progress report on tests being conducted by the Bureau of Public Roads, from which the following conclusions are drawn regarding the effect of the various factors influencing the design of concrete forms:

The maximum pressure exerted upon the forms increases as the rate of filling increases. At a slow rate of about 1 ft. per hour the pressure is approximately 1 lb. per square inch, but as the rate increases beyond this value the pressure increases approximately as the 0.3 power of the rate.

Field tests which were made in places where the distance between the form walls differed indicate that the maximum pressures obtained increase slightly with the mass of the concrete when the consistency is wet and sloppy. This conclusion probably does not hold in the case of dry mixes. Reinforcing just inside the form tends to slightly decrease the pressures, but probably this effect would be neglected in determining the final pressures for use in design.

The results show in general that the maximum pressure was increased as the consistency of the concrete was made drier within the limit of workability. In the case of wet or sloppy concrete this wedging action does not exist, as there is approximately a static fluid pressure. For low heads the dry concrete (when tamped as usual) will give the greater lateral pressure, but for heads of 4 ft. or more and within the time when initial set becomes an influencing factor the sloppy mixtures give the greater pressure. The average increase of pressure due to the effect of dry mixtures seems to be 0.3 lb. per square inch for each inch decrease in the standard slump test less than a 5 in. slump.

The richness of the mix also affects the maximum pressures obtained—the richer the mix the greater the maximum pressure—the average increase being 0.12 lb. per square inch for each per cent of increase in the ratio of the cement to the aggregate beyond 12 per cent. A decrease in the temperature of the concrete retards the set of the cement, and it is natural to suppose that this is the limiting factor in the maximum pressure obtained, since the pressure increases with the head until the cement takes a sufficient set to begin to support the overlying concrete.

An empirical formula giving the lateral pressures required for use in the design or the investigation of the strength of concrete forms, and taking into

account the above factors, is $P=H^{0.2}R^{0.3}\times 0.12C-0.3S$. In this formula, P =the resultant lateral pressure in pounds per square inch; R =the rate of fill in feet per hour; H =the head of concrete fill; C =the percentage by volume of cement in the combined fine and coarse aggregate; and S =the consistency in inches of slump.

The vertical pressure is obtained by adding $0.25H$ to the value of P as found above, except when the inside distance between the vertical sides of the form is greater than one-half of the depth of fill. Then the value should be taken as equal to the weight of the concrete. The value for H , the head of concrete, to be used in the formula, should not be greater than one-half the rate of fill, except where agitation is vigorous and continuous in a sloppy mix, when this ratio may be taken up to three-fourths.

Pressure of green concrete against forms, E. B. SMITH (*Concrete [Detroit, Mich.]*, 16 (1920), No. 3, pp. 158-161, figs. 5).—This is a less detailed report of the experiments noted above.

Determining bitumen content in bituminous concrete, R. M. GREEN (*Engin. News-Rec.*, 84 (1920), No. 18, pp. 871, 872).—On the basis of studies conducted at the Texas Agricultural and Mechanical College a method of proportioning the bitumen content in bituminous concrete is described, which takes into consideration surface area of aggregate, consistency of bituminous cement, absorption of aggregate, and specific gravity of aggregate.

Chemistry of materials of the machine and building industries, R. B. LEIGHOU (*New York: McGraw-Hill Book Co., Inc.*, 1917, pp. XV+449, figs. 75).—The object of this book is to supply information concerning the chemical properties of the materials commonly employed in building construction and equipment and in machinery construction and operation.

The following chapters are included: Water for steam generation; fuels; refractory materials for furnaces; iron and steel; the corrosion of iron and steel; the nonferrous metals; the nonferrous alloys; solder; foundry sands; building stones; lime and gypsum products; Portland cement; clay and clay products; paints, varnishes, stains, and fillers; lubricants; glue; rubber; electrical insulating materials; primary electric cells; secondary cells; and hydrometry.

Internal-combustion engine fuels, E. W. DEAN (*Jour. Soc. Automotive Engin.*, 6 (1920), No. 2, pp. 107-117, figs. 18).—The manufacture and testing of internal combustion fuels is described in some detail, with particular reference to their use in tractor engines.

Report of the Inter-Departmental Committee on various matters concerning the production and utilization of alcohol for power and traction purposes, B. REDWOOD (*London: Interdept. Com. Alcohol Motor Fuel*, 1919, pp. 8).—The results of an investigation into the use of alcohol for power and traction purposes are reported, and recommendations as to governmental action are given.

Tractor experience in Kentucky, W. D. NICHOLLS (*Kentucky Sta. Bul.* 222 (1919), pp. 47-68, figs. 4).—This bulletin reports the experience of tractor owners on 320 farms in Kentucky in 1918.

Seventy-one per cent of the tractor owners, on farms averaging 493 acres in size, reported a profitable investment. A unit of work with the tractor cost more on small farms than on large farms. The reports indicate that the smallest size of farm on which a tractor may be used economically is about 175 acres. The 3-plow size of tractor was recommended by a great majority of the owners reporting on this point. The average number of days of work reported was 49.5 per farm for 12 months. Adding to this the custom work done, the work averaged 55 days for the year. The average number of acres

of land plowed per day was 6.26 for the 2-plow tractor, 7.77 for the 3-plow, and 10.9 for those of the 4-plow size and larger. The use of the tractor enabled these farmers to reduce the number of work animals from an average of 10.6 to 8.7.

The amount of fuel used per acre for plowing with tractors of all sizes averaged 2.9 gals. and the amount of lubricating oil about 0.2 gal. per acre. The life of the tractors as estimated by 213 owners was 7.3 years. The cost per acre for plowing with a tractor is about \$1.70. This includes repairs, depreciation, interest, taxes, insurance, fuel, lubricants, and labor. Of 151 of these tractors used for cutting silage, all but 8 were reported as furnishing ample power for that purpose. Of the tractor owners doing custom work a majority expressed the opinion that it does not pay.

Notes on the tractor in the United States, O. PERES (*Brasil Agr.*, 4 (1919), Nos. 6, pp. 153-159; 7, pp. 188-193; 8, pp. 226-228, figs. 9).—In this paper, a contribution from the Georgia State College of Agriculture, practice in the design, operation, testing, and practical use of tractors in the United States is reviewed.

The tractor (*Topcka, Kans.: Capper Farm Press*, 3. ed., rev. and enl. [1920], pp. 56, figs. 39).—This is a general summary of data on the practical use of the tractor.

Tractor plowing speeds, O. B. ZIMMERMAN (*Jour. Soc. Automotive Engin.*, 6 (1920), No. 2, pp. 133-137, figs. 10).—Considerable data on tractor plowing speeds are summarized, with particular reference to the economic side of the question.

It is concluded that, placed upon a comparable basis and with reasonable assumptions supplementing the carefully prepared and conducted experiments used, the most economical plowing speeds are unquestionably below 3 miles per hour, the cost rising rapidly from about 2 miles per hour. "If plows are designed to meet higher speeds they can help only in reducing the greatly increased costs at the higher speeds, but they can not by any means veer the economical point above 3 miles per hour. The argument for better breaking up of the soil at the higher speeds is heavily paid for, and it is more economical to perform the operation of harrowing either separately or behind the plows than to try to accomplish it by rapid plowing. To attain the very best results with the plowing outfits, speed ratios of plow gearing and throttle should cover the ranges from $1\frac{1}{4}$ to 3 miles per hour. This would permit the most flexible ranges to meet the various soil resistances.

"It appears that in heavy land and in plowing up to 8 in. in depth with small tractors, greater acreage would be attained by the use of 10 or 12-in. instead of 14-in. plow bottoms. . . . A better adjustment of cutting width is also possible."

The time required to plow one acre is tabulated from tests with relation to the number of plows pulled, as follows: Heavy land, 2 plows 1.212 hours per acre, 3 plows 1.095 hours, 4 plows 1 hour, and 5 plows 0.926 hour; on light land, 2 plows 0.643 hour, 3 plows 0.563 hour, 4 plows 0.560 hour, 5 plows 0.462 hour, 6 plows 0.426 hour, and 7 plows 0.4 hour.

The installation of dust-collecting fans on thrashing machines for the prevention of explosions and fires and for grain cleaning, H. E. ROETHE, JR., and E. N. BATES (*U. S. Dept. Agr., Dept. Circ. 98* (1920), pp. 11, figs. 11).—This circular deals with the general features in the design, construction, and installation of fans for the collection of dust from thrashing machines to prevent dust explosions. A number of the most effective and satisfactory fans are illustrated and discussed.

"Extensive investigations and experiments have shown that to be most effective and satisfactory such equipment for thrashers should embody as many as possible of the following general points of design and construction: (1) A centrifugal type, steel-plate exhaust fan is most desirable. (2) A single-inlet-type fan has the advantage of offering the least obstruction to the deck. (3) The fan drive should be as direct as possible from the cylinder shaft. The fan pulley should be as large as practicable to prevent undue slippage of the belt. A minimum diameter of 4 in. is suggested. (4) A light running fan of simple but rigid construction, securely attached to the frame of the separator, answers the purpose best. (5) Ample exterior bearings should be provided, with no overhang of the shaft. (6) For medium sized machines, ranging from 26 to 46 in. to 32 by 54 in., the fan should have a peripheral speed of approximately 6,500 ft. per minute, with a capacity under field conditions of from 35 to 40 cu. ft. of air per second. These values would be slightly greater for the larger and slightly less for the smaller machines. . . . (7) The eye or inlet of the fan should be located opposite the fan pulley at the center of the casing. The discharge pipe should have an area at least as great as that of the inlet. . . . (8) The intake hood should be tapered and the intake should cover a deck area of not less than 600 sq. in. (9) The intake should be centered and placed at a forward position on the deck. On most machines this location would be over the beater. (10) If straw, grain, or other heavy material is thrown upward into the fan intake by the beater or cylinder of the separator, it will be necessary to place a deflection plate or baffle board, preferably metallic, under the intake at an angle of approximately 30° with the deck. (11) The absence of sharp, abrupt curves or bends in the intake and connecting parts is most important. . . . (12) The fan discharge should be conducted through a metal pipe to the rear of the separator, thence by a canvas tube into the base of the straw stack."

Concrete and steel fence posts, J. J. CRUMLEY (*Mo. Bul. Ohio Sta., 5 (1920), No. 4, pp. 107-110*).—Studies extending over two years of some 10,000 concrete and steel posts in service are briefly reported.

The concrete posts were round, rectangular, triangular, T-shaped, and flat on one side and round on the other. It was found that the type of reinforcement has a very important bearing on durability, its most important influence being on the tendency of the post to disintegrate. Thin flat strip and broad corrugated steel reinforcing were failures. Better results were obtained by the use of six No. 9 smooth wires. The results indicate that the reinforcement should be in compact form, either square or round, and should not be too close to the surface of the post. The two principal sources of weakness found in concrete posts were tendency to disintegrate and brittleness.

The steel posts were found to differ considerably from concrete in their period of use. "The fences examined seem to indicate that the quality of metal of which the posts are made is a greater factor in durability than the covering of paint, or even of zinc. Taking into account the various types of steel posts, the fences examined would place this material in a class about with white cedar. The examination of these 10,000 concrete and steel posts in actual service in fences seems to indicate that these two materials, especially the concrete, have fallen far below what was expected of them."

Preservative treatments for willow fence posts, R. E. BLAIR (*U. S. Dept. Agr., Dept. Circ. 75 (1920), pp. 76, 77*).—Experiments at the Yuma Reclamation Project Experiment Farm on the preservative treatment of 419 willow fence posts, not less than 5 in. at the smallest diameter, are reported, showing that placing the posts in commercial creosote maintained at a temperature of 200° F. for two hours gave the best results. The next best results were obtained by

placing the posts in a 3 per cent zinc chlorid solution for 2½ hours at a temperature of 200°. All the posts were serviceable for about four years and a very few were still serviceable at the end of seven years.

Time-saving equipment for handling growing chicks, G. R. SHoup (*Washington Sta., West. Wash. Sta. Mo. Bul.*, 8 (1920), No. 2, pp. 24-28, figs. 4).—Forced roost equipment, an outside feeding hopper, and automatically filled water troughs are described and illustrated.

Potable water for country houses (*Univ. Tucumán, Est. Agr. Bol.* 35 [1919], pp. 1-11, figs. 4).—This report deals with wells and springs and their contamination and protection, with reference to conditions and practice in Argentina. The use of cemented brick, cemented tile, and concrete well linings is recommended, with a concrete seal at the top in all cases.

Disinfection by boiling and chlorination is also briefly discussed.

RURAL ECONOMICS.

Factors affecting labor and miscellaneous costs of producing crops, C. W. MONTGOMERY (*Mo. Bul. Ohio Sta.*, 5 (1920), No. 5, pp. 154-158).—Account is rendered of man, horse, and tractor hours and miscellaneous costs, including seed, manure, green manure crops, lime, thrashing, twine, coal, etc., of producing crops without regard for investment in land, buildings, overhead charges, or depreciation. The costs shown as determined on the Northeastern Test Farm, Cuyahoga County, Ohio, may be summarized as follows:

Miscellaneous crop costs, Northeastern Test Farm, 1917-1919.

Year.	Total cost.					Cost per bushel.			Cost per ton.	
	Corn.	Oats.	Wheat.	Soy-bean hay.	Clover.	Corn.	Oats.	Wheat.	Soy-bean hay.	Clover.
1917.....	\$41.39	\$22.41	\$32.51	\$25.48	\$12.71	\$0.82	\$3.48	\$1.02	\$10.75	\$10.59
1918.....	53.34	28.45	41.34	28.17	18.22	1.32	.37	1.73	17.66	13.91
1919.....	65.61	30.32	51.43	39.24	22.48	1.03	.50	1.40	20.12	17.29

The 5-year average yield and value per acre for 3-year and 5-year rotations on the above farm, 1915-1919, are tabulated. Comparison is made of figures secured at other county experiment farms from which the conclusion is arrived at that the factors influencing the cost of producing a corn crop, leaving out the value of land, buildings, tools, and overhead charges are (1) the natural soil conditions, (2) getting a good seed bed, (3) getting a good stand, (4) weed infestation and disease infection, (5) weather conditions, and (6) price of labor and cost of soil amendments.

[Economic and crop conditions on the Yuma Reclamation Project in 1918], R. E. BLAIR (*U. S. Dept. Agr., Dept. Circ.* 75 (1920), pp. 3-10, 13-21, 23-25, 77, figs. 10).—In these pages of this report a summary is given of irrigation development on the Yuma Reclamation Project during the 7-year period from 1912 to 1919, inclusive, the items of comparison relating to the amount of water used, area irrigated, population, operation of farms, and value of crops.

It is noted that the number of farms being operated by tenants decreased from 66.2 per cent during 1917 to 40.9 per cent during 1918, this condition being probably due in part to the fact that the prospects for good prices induced many landowners to operate their own farms.

Cotton production was stimulated materially by prevailing high prices. The yields and farm values of all crops grown are recorded, and special reports are given relating to cotton, alfalfa, wheat and barley, miscellaneous crops, and live stock industries for the year.

Our basic industry, America's agricultural prosperity (*New York: Guaranty Trust Co. [1920], pp. 16, figs. 10*).—This is an adaptation with special reference to the importance of agriculture in the problem of extending credits to Europe of material noted from another source (E. S. R., 43, p. 92).

British crop production, E. J. RUSSELL (*Nature [London], 105 (1920), Nos. 2632, pp. 176-178; 2633, pp. 206-208*).—This article discusses the relative merits and costs of different types of farming in Great Britain, and presents data on the production and consumption of the more important crops of the country with a view to pointing out how the demands upon British agriculture may be met. The problem is considered as resolving itself into the development of a system of husbandry which suits the natural conditions equally as well as grass farming, and is also as productive of total wealth as arable crops. It is believed that in the future development of British agriculture combinations of crops best suited to particular conditions will be worked out, the yield and feeding value of each crop will be increased by the proper use of artificial fertilizers, and possibly also greater improvement will be achieved through plant breeding.

Italy's efforts to stimulate agricultural production, H. C. MACLEAN (*U. S. Dept. Com., Com. Rpts., No. 112 (1920), pp. 868-873*).—Statistics are given for Italy's total imports and exports and imports of cereals and flour, 1913-1918, showing the excess of imports over exports and the relative importance of cereals with regard to the trade balance; also for production and imports of grains in 1913, and of wheat from 1910-1919. Factors affecting agriculture and government measures to increase the grain acreage are discussed, including official measures for the importation of agricultural implements, encouragement of motor cultivation, requisitioning of fertilizers, facilitation of agricultural credit, and price fixing on wheat.

The future grain supply of Austria-Hungary, D. FARAGÓ (*Die Zukünftige Getreideversorgung Oesterreich-Ungarns. Belgrade: Govt., 1917, pp. 28*).—In this publication, issued in 1917, attention is directed to statistics of grain consumption in Austria-Hungary and the allotment of the grain crop to human needs, live stock feeding, and industrial purposes, respectively. It is urged that the use of commercial feeds and the curtailing of brewing and distilling industries are imperative in order to insure satisfaction of human needs. Government regulation of grain marketing is recommended, and what the author considers some outstanding policies for a program of control are outlined.

Economics of wheat production in South Africa, H. WOLFE (*So. African Jour. Indus., 3 (1920), No. 3, pp. 207-216*).—Economic factors that lay charges on South African wheat additional to world prices or to that of Australian wheat are discussed here, namely, the marginal productivity of the South African wheat land, the protective tariff on wheat, preferential railroad rates, and costs of transportation. It is maintained that the South African farmer is not to be recommended to increase wheat production under existing conditions of competition, transportation, labor, productivity of the land, and credit.

Farm allotments and farm laborers' allotments in the Delhi States land settlement (*Sacramento, Cal.: State Land Settlement Bd., 1920, pp. 8, pl. 1*).—In this pamphlet is offered information pertinent to the settlement of an area of about 8,000 acres in Merced County, Cal. A map is given showing a subdivisional plan of the first unit of a settlement.

Cooperative credit institutions in the United States, J. B. MORMAN (*Ann. Amer. Acad. Polit. and Soc. Sci., 87 (1920), No. 176, pp. 172-182*).—This discus-

sion includes urban and rural credit unions and Federal cooperative farm loan credit, the latter outlining briefly the Federal Farm Loan Act and describing Federal land banks and joint stock land banks as instruments for encouraging agriculture, promoting thrift, and extending credit.

The Federal farm loan system, A. C. WIPRUD (*St. Paul, Minn.: Virtue Printing Co., 1919, pp. 30*).—This paper presents particularly some of the cooperative aspects of the Federal farm loan system, its organization, the appraisal of farm land values, nature and benefits of loans, and method of financing.

Agricultural prices, H. A. WALLACE (*Des Moines, Iowa: Wallace Pub. Co., pp. 224, figs. 19*).—In Part I of this statistical study are found discussions of the price registering system on the Chicago Board of Trade, of three prominent agricultural price-making forces—cost of production, supply and demand, and strategic causes, and particularly of the ratio method of determining cost of production. The latter is applied to hog prices, illustrating the determination by corn-hog ratios of the production cost of pork and variations between this and the actual price in short-time periods, showing on the other hand the close agreement between actual price and supply and demand price. This method is also applied, although less in detail, to cattle prices, packer prices, and milk and crop prices. Chapters are included on consumers' ratios, technique and limitations of the ratio method, retail and wholesale prices, pork exports the barometer of corn belt prosperity, corn belt land values in relation to cost of producing corn, price stability and soil fertility, and measuring total crop production.

Part II covers the mathematical study of supply and demand in the hog market, predicting the future of hog prices, and limitations of the mathematical method. The author urges that farmers unite to insure to themselves a price representing ratio or cost of production by regulating the supply, educating consumers to seasonal vagaries and emergencies, and cooperating with capital and labor in order that fluctuations in supply and demand may be reduced to a minimum and excessive profit or loss on temporary situations eliminated. Education in price judging with the practical use of coefficients and lines of regression in determining prices from business conditions and the supply as well as adequate research in the statistical method in the agricultural world are also urged. In the appendix are given tabulations of agricultural prices for pre-war years as suggestive study material.

Government control over [food] prices, P. W. GARRETT ET AL. (*War Indus. Bd. [U. S.] Price Bul. 3 (1920), pp. 1-150, 565-639, figs. 15*).—These sections of a bulletin, which is one of a series previously noted (*E. S. R., 42, p. 191*), give a brief historical survey of the war-time rise of prices, together with conditions which threatened further increases, various agencies of price control, policies, and control systems. An analysis of license control is made with reference to distinct groups of foods under the main divisions of wheat, flour, and bread; sugar; live stock and meats; poultry and dairy products; oleomargarin; cotton seed and cottonseed products; canned and dried foods; rice and rice flour; coarse grains and feedstuffs; coffee; and the collateral commodities, ammonia, ice, and arsenic. The substance of all formal and informal regulations is also presented in compact form.

Farmers' Market Bulletin (*North Carolina Sta., Farmers' Market Bul., 7 (1920), No. 35, pp. 12, fig. 1*).—In this number is the usual list of products which farmers have for sale, together with an outline of a proposed plan for conducting cooperative wool auction sales, and a description of the food products inspection service of the Federal Bureau of Markets.

Acreege and live stock returns of England and Wales with summaries for the United Kingdom, R. J. THOMPSON (*Bd. Agr. and Fisheries [London], Agr. Statis., 54 (1919), No. 1, pp. 42*).—This report with statistical tables continues information previously noted (E. S. R., 40, p. 594).

[Agriculture in Japan], S. SATO (*Japan Year Book, 1919, pp. 536-556*).—Information regarding agriculture noted for earlier years (E. S. R., 41, p. 493) is continued in this chapter.

AGRICULTURAL EDUCATION.

[Report of the Executive Committee of the Association of Land-Grant Colleges], J. L. HILLS (*Assoc. Land-Grant Col. Bul. 1 (1920), pp. 8*).—This is the first of a series of bulletins to be issued following each meeting of the Executive Committee of the Association of Land-Grant Colleges, and deals with the meeting held at Washington, D. C., January 12 and 13, 1920. It takes up the present status of the engineering experiment station legislation, home economics experiment stations, a hearing before the House Committee on Agriculture touching the need of increased funds for research and an increase in the supplementary Smith-Lever extension funds, etc.

Extension, C. G. WOODBURY (*Indiana Sta. Rpt. 1919, pp. 37-43*).—This is a summarized report on the work of the extension department for the year ended June 30, 1919.

As demonstrating the value of cow-testing work, a comparison is included of the 10 highest and 10 lowest producers in one of the 10 cow-testing associations showing the following differences between good and poor cows, viz, an increase 6,700 lbs. of milk, 312 lbs. of fat, \$33.10 in the cost of feed, and \$138.73 profit above the feed cost. Tests by the home demonstration agent in cooperation with schools among children receiving different kinds of food showed that milk was necessary for the development of the children so that they might do the best work in school. With the aid of special garden supervisors and assistant county agents more than 640,000 home gardens covering an area of 100,000 acres and producing vegetables estimated at \$15,000,000 in value were grown in the State during the past year. Through county agents and individual farmers over 5,507 plans for farm buildings and other equipment were sent out, with a total of 12,023 blue prints. In the 5-acre corn-growing contest, enrolling 900 farmers, 4 farmers produced an average of 104.3 bushels per acre, 19 an average of 88.9 bushels per acre, and 51 an average of 79 bushels. A special wheat campaign conducted in the fall of 1918 in cooperation with the Indiana Committee on Food Production and Conservation resulted in an actual increase of 555,500 acres in the amount of wheat seeded last fall, more than a 22 per cent increase over the previous year.

Women's institutes (*Agr. Gaz. Canada, 7 (1920), No. 3, pp. 232-240*).—A series of brief statements is given describing the systems of organization and administration of women's institutes in the Provinces of Prince Edward Island, Nova Scotia, New Brunswick, Quebec, Ontario, Manitoba, Saskatchewan, and British Columbia, by the provincial officers in charge of this work. These systems are not uniform in the various Provinces, but the functions of the institutes and the work performed by them are practically the same in all parts of Canada. In all of the Provinces except British Columbia this work is assisted to some extent by funds provided under The Agricultural Instruction Act.

Training returned soldiers (*Agr. Gaz. Canada, 7 (1920), Nos. 2, p. 115; 3, pp. 213-215*).—This is a series of brief reports of the work in training returned soldiers at the experimental farms or stations at Agassiz and Summerland, B. C.; Kentville and Nappan, N. S.; Fredericton, N. B.; and Lennoxville, Que.

The work of the school of Piracicaba, F. T. DE SOUSA REIS (*Bol. Agr. [São Paulo]*, 20. ser., 1919, Nos. 6, pp. 179-190, figs. 4; 7, pp. 255-263, figs. 2).—This is a discussion of the developments in organization and instruction of the Luis de Queiroz School of Agriculture at Piracicaba, Brazil.

General science and vocational education, A. W. NOLAN (*School Sci. and Math.*, 20 (1920), No. 5, pp. 454-456).—In the author's opinion there are in all vocational work three phases of instruction to use in following out a curriculum, which may be called the "three r's" of vocational education, viz, rules, reasons, and related subjects. While, in a consideration of vocational methods to be used, the strictly vocational point of view would emphasize the rules of procedure not only learned but carried out to assure skill in the manipulative processes, vocational efficiency and progress require that the student pursue his training into the realm of reasons, principles, and related studies. It is here that general science may tie up at every point in vocational education, as a reference study, to give reasons, explain principles, and lead into related matter, for every manipulative process of all the vocations under the Smith-Hughes Act. The organization of general science subject matter, under this plan, is around the job and its processes. Besides this reference use of general science, it should be a required study in all vocational courses early in the course, either in the junior high school or in the first year of the four-year high school. It should precede or parallel the vocational courses as a separate subject for either one or two years. From an agricultural point of view, the author favors two years of general science paralleling the first two years of vocational agriculture.

The educational basis for junior extension work in agriculture and home economics, J. H. GREENE (*School News and Pract. Ed.*, 33 (1920), Nos. 8, pp. 474-476; 9, pp. 531-535).—The author considers briefly four aims set up tentatively as the educational goal of the Junior Farm and Home Bureau work, the interests between the goal and the child, and some of the details of devising plans and methods and outlining subject matter which will serve to connect these human nature traits or interests in the individual with the goal.

A war-modified course of study for the public schools of Colorado.—III, The world of nature and of man, M. C. C. BRADFORD ET AL. (*Denver, Colo.: Dept. Pub. Instr.*, 1918, vol. 3, pp. 179, figs. 15).—This contains outlines and suggestions for Grades 1-8, inclusive, in geography, nature study, and science; a preliminary outline for a two-year course in agriculture for rural schools; suggestions for garden work in the public schools; outlines of lessons in household arts in the elementary and secondary schools; and manual training and vocational education.

The school-book of farming, L. H. BAILEY (*New York: The Macmillan Co.*, 1920, pp. XI+388, pls. 12, figs. 147).—This text is intended for the elementary schools, homes, and clubs. Its object, as stated, is to develop a point of view on farming and country life in the minds of the young, to explain relationships of the parts, and to state the main reasons underlying the growing of the leading crops and the raising of farm animals. In addition to the topics on the leading farm and horticultural crops and the breeding and feeding of farm animals, including horses and mules, cattle, swine, sheep, and goats, the following topics are studied: The farm and the farmer, the land, the soil, the implements, the weather, the plant, the animal, the market, the community, cropping, poultry, bees and honey, the dairy, and the home. Each topic is followed by review questions, thought questions and inquiries, and special problems.

Illustrative material for teaching agriculture in the high school, D. L. REID (*Bd. Vocat. Ed. Ill. Bul.* 15 (1919), pp. 47, figs. 17).—This bulletin, which is intended for the use of teachers of vocational agriculture, suggests useful

illustrative material for the teaching of agriculture in the high school, and indicates the sources from which the material may be obtained.

Suggestions for a graded course in bird study, A. B. COMSTOCK (*Nature-Study Rev.*, 16 (1920), No. 4, pp. 147-158, fig. 1).—Suggestions are offered for the study of birds in Grades 1-8, inclusive.

MISCELLANEOUS.

Thirty-second Annual Report of Indiana Station, 1919 (*Indiana Sta. Rpt. 1919*, pp. 100, figs. 14).—This contains the organization list, reports of the director and heads of departments, the experimental features of which are for the most part abstracted elsewhere in this issue, lists of the organized lines of work, publications of the year, changes in staff, etc., and a financial statement for the Federal funds for the fiscal year ended June 30, 1919, and for the remaining funds for the fiscal year ended September 30, 1919.

Thirty-first Annual Report of Kentucky Station, 1918, Part 1 (*Kentucky Sta. Rpt. 1918*, pt. 1, pp. 71).—This contains the organization list, a financial statement as to the Federal funds for the fiscal year ended June 30, 1918, a report of the director on the work and publications of the year, departmental reports, and meteorological data. The experimental work reported is for the most part abstracted elsewhere in this issue.

Thirtieth Annual Report of New Mexico Station, 1919 (*New Mexico Sta. Rpt. 1919*, pp. 44).—This contains the organization list, a report of the director on the work and publications of the station, including reports of heads of departments, and a financial statement for the year ended June 30, 1919. The experimental work reported is for the most part abstracted elsewhere in this issue.

Report of the director for the years July 1, 1917, to June 30, 1919, P. F. TROWBRIDGE (*North Dakota Sta. Bul. 136* (1920), pp. 3-23, figs. 3).—This contains the organization list, a report of the director, and a financial statement for the years ended June 30, 1918, and June 30, 1919. The experimental work reported is for the most part abstracted elsewhere in this issue.

Thirty-eighth Annual Report of Ohio Station, 1919 (*Ohio Sta. Bul. 338* (1919), pp. XXXI+7, fig. 1).—This contains the organization list, a financial statement for the fiscal year ended June 30, 1919, and a report of the director summarizing the work and publications of the station during the year.

The work of the Yuma Reclamation Project Experiment Farm in 1918, R. E. BLAIR (*U. S. Dept. Agr., Dept. Circ. 75* (1920), pp. 77, figs. 33).—This report includes a summary of meteorological observations from 1910 to 1918, a review of agricultural conditions on the project, and a report of the work on the experimental farm during 1918. The experimental work reported is for the most part abstracted elsewhere in this issue.

Monthly Bulletin of the Ohio Experiment Station (*Mo. Bul. Ohio Sta.*, 5 (1920), Nos. 2, pp. 35-63, figs. 18; 3, pp. 67-96, figs. 7; 4, pp. 99-127, figs. 11; 5, pp. 131-159, figs. 6).—These numbers contain, in addition to several articles abstracted elsewhere in this issue and miscellaneous notes, the following:

No. 2.—Smudging to Prevent Frost, by W. J. Green.

Monthly Bulletin of the Western Washington Substation (*Washington Sta., West. Wash. Sta. Mo. Bul.*, 8 (1920), No. 2, pp. 17-32, figs. 9).—In addition to articles abstracted elsewhere in this issue, this number contains brief articles on the following subjects: Preparing the Farm-flock Wool Clip for Market, by C. M. Hubbard; Visceral Anatomy of the Domestic Fowl, W. T. Johnson; and Asparagus Culture, by J. L. Stahl.

NOTES.

Arizona University.—W. M. Cook has been appointed director of extension work beginning July 18, succeeding E. P. Taylor, resigned to accept a commercial position.

Hawaii Federal Station.—W. T. Pope, instructor in botany in the University of California, has been appointed horticulturist to succeed J. E. Higgins, who has accepted a position in the College of Agriculture of the University of the Philippines. John C. Ripperton of the Bureau of Soils, U. S. Department of Agriculture, was transferred to the position of assistant chemist June 25, succeeding K. A. Ching.

Purdue University and Station.—H. W. Gregory, assistant professor of dairying and associate in dairy manufactures, has been appointed chief in dairy husbandry vice O. E. Reed, whose resignation has been previously noted.

Iowa College.—Rev. Wm. I. Chamberlain, president of the college from 1886 to 1890, and subsequently a trustee of the Ohio State University and a member of the board of control of the Ohio Station, died July 1, at Hudson, Ohio, aged 83 years.

Louisiana University and Stations.—A tax levy was made by the last legislature on the natural resources of the State, which it is estimated will yield about \$3,000,000 per annum. A portion of this fund was allotted to the support of various State institutions, but the surplus, estimated at about \$1,000,000 at present, is for the development of the College of Agriculture.

The legislature also made an appropriation of \$10,000 for the establishment of a fruit and truck experiment station. This station is to be located in Tangipahoa Parish.

A tract of about 30 acres of land at Harahan, near New Orleans, has been purchased by the Sugar Planters Association, at a cost of about \$15,000. It is expected that this tract will eventually be deeded to the State for the use of the sugar station, now located at Audubon Park.

T. H. Jones has been appointed entomologist.

Minnesota University and Station.—The plan of conducting demonstration farms throughout the State, under the supervision of the extension service, has been abandoned, these problems now being covered by county agents and farm bureau activities.

Special spring and summer terms of the School of Agriculture have been held for disabled soldiers who are being reeducated under the auspices of the Federal Board for Vocational Education.

The resignations are noted of E. O. Hanson, assistant professor of dairy husbandry and supervisor of advanced registry testing; Edna R. Gray, instructor in home economics; C. J. Robertson, instructor in agricultural engineering at Morris; Frank Robotka, assistant in agricultural economics; Mildred Kimball, Gladys Grant, and Ethel Hedman, instructors in home economics at Morris; Lavinia Stinson, instructor in foods and cookery; T. B. McCulloch, supervisor of demonstration farms; A. M. Christensen, instructor in agronomy at Crookston; and V. R. Haber, research assistant in entomology.

Recent appointments include Milton H. Fohrman as assistant professor of dairy husbandry and superintendent of advanced registry testing; Arthur K. Anderson and Paul F. Sharp, instructors in agricultural biochemistry; Lucy A. Studley, assistant professor of home management; Laura MacArthur, Helen Rider, Edla Anderson, and Laura Randall, instructors in home economics; G. F. Puttick, Julian G. Leach, and J. L. Seal, instructors in plant pathology; T. S. Hansen and Leland deFlon, instructors in forestry; J. W. Wilbur and T. W. Gullickson, instructors in dairy husbandry; W. T. Tapley, assistant professor, and John W. Bushnell, instructor in horticulture; Martin W. Sandstrom, Walter Hoffman, A. H. Johnson, and Earl R. Norris, assistants in agricultural biochemistry; H. D. Barker and C. R. Hursh, assistants in plant pathology; and Norma Allen, instructor in home economics at Morris.

Mississippi Station.—J. F. O'Kelly, a 1919 graduate of the University of Arkansas, has been appointed fellow in plant breeding, specializing in the relations between soil types and length and strength of cotton fiber.

Missouri University.—P. H. Ross, assistant director and county agent leader, has been appointed director of the agricultural extension service, vice A. J. Meyer, resigned to become executive secretary of the Missouri Farm Bureau Federation.

New York State Station.—A conference of the directors of the New England stations was held at Geneva July 13 and 14.

A recent ruling by the State Civil Service Commission provides for certain changes in the titles of those engaged in scientific research at the station. Hereafter, all those engaged in research work will be designated as chief in research, associate in research, or assistant in research, according to their position. An appropriate qualifying word will be used to designate the particular line of investigation in which the individual is engaged, such as chief in research (bacteriology).

Two new positions were created by the last legislature, one that of museum preparator, and the other that of assistant editor and librarian. James S. Lawson was appointed July 1 as museum preparator. The primary object of the museum is to visualize the important results secured in investigations conducted at the station. A generous space for the museum was provided in the new administration building, and suitable cases for the exhibits have been obtained. Miss Laura G. Collison was appointed July 1 assistant editor and librarian.

Charles S. Wilson, State commissioner of agriculture and also president of the board of control of the station, resigned July 30 and has been succeeded by George E. Hogue. H. J. Conn, associate bacteriologist, has been appointed chief in research (bacteriology). M. T. Munn, assistant botanist, has been appointed associate botanist in charge of the seed testing work under the new State seed law.

North Carolina College.—S. G. Rubinow, assistant to the director of the extension service and assistant State club agent, has resigned to become secretary of the Oklahoma Cotton Growers' Association, a cooperative organization which is planning to market 300,000 bales of cotton in 1921.

Ohio State University and Station.—Dr. Carl W. Gay, professor of animal husbandry and chairman of the animal industry group at the University of Minnesota, has been appointed head of the department of animal husbandry, beginning August 1. Charles S. Plumb, head of the department for many years, will continue as professor of animal husbandry.

Dr. J. O. Halverson and E. B. Wells, associates in the department of nutrition in the station, have resigned, the former to accept a similar appointment

in the North Carolina Station, and have been succeeded by Charles H. Hunt, assistant chemist of the Washington Station, and Raymond F. Remlee.

Oklahoma Station.—M. A. Beeson has recalled his resignation announced some time ago and has been reappointed head of the department of agronomy, with Henry F. Murphy as assistant in agronomy. W. L. Blizzard has been appointed head of the department of animal husbandry, beginning July 1.

Oregon College.—Paul V. Maris, State leader of county agents, has been appointed director of extension. E. L. Westover, dairy extension specialist, has resigned to become western field representative of the American Guernsey Cattle Club.

Rhode Island Station.—Bertha M. Heath, assistant in animal breeding and pathology, is no longer connected with the station. F. P. Gross, jr., has been appointed assistant in chemistry.

Washington College and Station.—A destructive tornado passed over the college farm July 13. The All-Northwest Egg-Laying Contest building containing 100 entries was entirely demolished and 350 birds killed. The sheep barn and the bull barn were completely destroyed. The horse barn was blown down, and about one-fourth of the college poultry plant building was blown away. No serious injury was done to the experimental work in crops, although cereals and peas were badly lodged, and a 2.5-acre student apple orchard was entirely destroyed. The loss in buildings is estimated at more than \$50,000.

The U. S. Department of Agriculture and the Washington and Idaho stations are cooperating in a farm organization and cost of production survey of wheat farms in the Pullman-Moscow area of the Palouse wheat country. E. R. Johnson has been appointed research fellow in farm management in the Washington Station, beginning June 1.

J. P. Fairbank, head of the department of agricultural engineering, has resigned to enter commercial work, and was succeeded August 15 by L. J. Smith, head of the corresponding department at the Manitoba Agricultural College. T. J. Murray, associate professor of bacteriology and station bacteriologist, has accepted a similar position at the University of West Virginia.

H. H. Hill resigned as instructor in dairy manufactures March 15 to engage in commercial work and has been succeeded by C. A. Phillips. H. N. Colman, superintendent of official testing work, resigned April 1 and has been succeeded by Fred S. Martin. C. E. Howell, assistant professor of animal husbandry, has resigned to become manager of a large ranch in California. E. F. Gaines, cerealist in the station, has been granted a year's leave of absence for graduate study at Harvard University. J. H. Longwell has been appointed instructor in animal husbandry.

Ontario Agricultural College.—President G. C. Creelman has resigned to become agent-general for Ontario in London, beginning July 1, the business of this office consisting chiefly in directing prospective immigrants to Ontario's agricultural opportunities. J. B. Reynolds, president of the Manitoba Agricultural College, has been appointed to succeed him.

Meyer Memorial Medal.—A bequest of \$1,000 by the late Frank N. Meyer, agricultural explorer for the U. S. Department of Agriculture for 13 years until his death in China in 1918, has been devoted to the issuance of medals for distinctive service in plant introduction. The medals are to be awarded by the Council of the American Genetic Association, and the first was bestowed May 3 on Barbour Lathrop, associated with the work of the Office of Foreign Seed and Plant Introduction of the Bureau of Plant Industry since its establishment.

EXPERIMENT STATION RECORD.

VOL. 43.

OCTOBER, 1920.

No. 5.

Reports recently received in this country indicate that the first convention of the Canadian Society of Technical Agriculturists, held in Ottawa from June 2 to 4, was an event of considerable importance. The primary purpose of the meeting was to bring together and organize, in a single body, the various institutions and individuals engaged in the application of science to agriculture within the Dominion. This purpose was carried out by the completion of a permanent plan of organization, the enrollment of several hundred members, and the formulation of a preliminary program of work for the future. A new and potentially very useful agency for rural betterment was thus brought into being, distinctively Canadian in its membership and outlook, but of interest to all who are concerned with the development of agriculture and agricultural institutions in North America.

The initial steps for the formation of the society seem to have been taken about a year ago at a reunion of the agricultural graduates of McGill University. The feeling was expressed at this reunion that there was need of a closer cooperation between all workers in the agricultural profession in Canada. It was also felt that there should be a medium available for the discussion of topics of interest to agricultural education, research, and extension, and eventually for the dissemination of information by the establishment of a journal or other publications. Likewise it was thought that much could be accomplished in educating the public as to the need of technically trained men and of the adequate support of educational and research agencies.

Substantially the same objects were ultimately embodied in the constitution adopted at the Ottawa meeting. These objects are enumerated as follows: "To organize and unite all workers in scientific and technical agriculture, so that they may combine effort to promote the scientific and practical efficiency of the profession and to make the profession of increasing service to the agricultural industry; to maintain high standards in the profession; to encourage a national policy of agricultural research; to help to procure for scientific work in agriculture greater financial support and wider fields

of usefulness; to aid in securing and maintaining a closer cooperation among all workers engaged in the profession of agriculture in Canada, and the better coordination of their work; to aid in bringing about a closer coordination between the profession as an organized body and the various agricultural associations throughout Canada; to serve as a medium where progressive ideas for improvements in agricultural education, investigation, publicity, and extension work can be discussed, formulated, and recommended for adoption when deemed advisable; to aid in insuring the employment of technical men for technical positions; to issue publications in the interests of agricultural science."

Active membership in the society is restricted to Canadians who are graduates in agriculture from a university or college of recognized standing, to other graduates engaged in agricultural research, administration, education, extension, publicity demonstration, or other forms of scientific or managerial work, and under certain conditions to nongraduates engaged in some of these lines. Provision is also made for honorary membership, to which it is of interest to note citizens of foreign countries as well as of Canada are eligible, and for a body of not to exceed thirty fellows, this title being conferred by the society only for professional distinction.

In addition to the central body, both local and provincial subdivisions of the society are contemplated. In general, the local branches are to consist of at least twenty members, and units thereof will constitute the basis of delegate representation at conventions of the society. An annual convention is to be held each June, alternating between eastern and western Canada, and Winnipeg, Manitoba, has been selected as the meeting place in 1921.

Although the basis of membership is individual rather than institutional, it is stated that the roster already includes representatives of practically every agricultural activity in Canada. All of the seven principal agricultural colleges were represented at the meeting, and practically their entire staffs have been enrolled. The list also includes the Minister and Deputy Minister of Agriculture, representatives of the various provincial departments of agriculture, agricultural graduates engaged in farming, journalism, and other pursuits, superintendents of experiment farms, and many other lines of agricultural work. Of the initial membership of 435, about 60 per cent were from Ontario and Quebec, but ultimately a larger enrollment will doubtless be recruited from the more distant provinces.

The presidency of the society was bestowed upon President L. S. Klink of the University of British Columbia, with Professor H. Barton of Macdonald College as first vice president, and Mr. L. H. Newman, secretary of the Canadian Seed Growers' Association, as

honorary secretary-treasurer. Among the various standing and special committees may be mentioned those on research, headed by Dr. J. M. Swaine of the Entomological Branch, Canadian Department of Agriculture; marketing education, headed by Mr. H. S. Arkell, Dominion Commissioner of the Live Stock Branch; post graduate work, headed by Dr. M. Cumming of the Nova Scotia Agricultural College; and agricultural policies and technical appointments, both under the chairmanship of President J. B. Reynolds of the Ontario Agricultural College.

The society is expected to concern itself quite largely with agricultural policies affecting educational and research institutions. An idea of some of the more urgent matters already under consideration is afforded by the resolutions which were adopted. One of these looked toward a readjustment of the relationships between the federal and provincial departments of agriculture to the agricultural colleges with reference to the organization of research, experimentation, and plant breeding. Another resolution dealt with appointments and salaries, recommending the granting of larger powers to heads of departments and colleges in these directions. The revision of agricultural curricula to include comprehensive courses in marketing, business practices, and the economics of production was also advocated. Special committees were appointed to deal with each of these matters.

The publication by the society of a journal of scientific agriculture was definitely decided upon. It is hoped to establish this journal at an early date, issuing at least one number before the 1921 convention.

Relations with other agricultural societies and groups in Canada were also considered, and the honorary secretary-treasurer was instructed to endeavor to bring together, at the same time and place of meeting as the society, as many organizations working in the interests of agriculture as possible. Affiliation with these organizations is to be undertaken so far as practicable. In other words, it appears that the society may serve ultimately as a nucleus for a Canadian federation of agricultural organizations.

Aside from the business sessions, an interesting three-day program was presented of papers and addresses covering a wide range of subjects. The purposes and opportunities of the society naturally formed a leading topic which was discussed by several speakers. Dr. J. W. Robertson, who represented the Canadian Department of Agriculture at the Peace Conference, spoke on Technical Agriculturists in Relation to Agricultural Problems; Professor Barton considered the basic principles of the society; and Dean E. A. Howes of the University of Alberta took up Fields of Effort for Local Organizations.

Research was represented on the program by Dr. W. P. Thompson of the University of Saskatchewan, who discussed Scientific Research in Relation to Agricultural Problems, and Dr. A. B. Macallum, chairman of the Dominion Research Council, who took up the aims of the council in this direction. Study Courses at our Agricultural Colleges were considered by Dr. F. C. Harrison of Macdonald College, and Post Graduate Courses in Agriculture, by Dr. Cumming. Agricultural Extension Work was the subject of an address by Mr. George A. Putnam of the Ontario Department of Agriculture. Among other papers presented were those on Federal and Provincial Agricultural Policies by President Klinck; The Agricultural College in Relation to the Farmers' Movement, by Professor J. W. Crow of the Ontario Agricultural College; and The Basic Industry as Seen Through Urban Eyes, by Mr. Thomas Moore, president of the Trades and Labor Congress. The program was concluded by an inspiring address by President Reynolds, entitled A Vision for Canadian Agriculture.

A special feature of the meeting was a banquet at which the guest of honor was the Duke of Devonshire, Governor General of the Dominion. In an address of congratulation, His Excellency drew attention to the long career of usefulness of the Royal Agricultural Society of England, and prophesied far-reaching results from the "keenness and wholehearted desire which there is throughout the whole Dominion of Canada to make the very best use we can of the practical application of science to the needs and requirements of the country."

The Canadian Society of Technical Agriculturists thus appears to have been launched under very auspicious circumstances, and its subsequent development and progress will be followed with widespread interest. Notably in our own country, where representatives of the Canadian agricultural colleges and similar institutions have long been familiar and most welcome participants in scientific and educational gatherings, will the many expressions of good wishes already evoked by the formation of the society be cordially indorsed. The fact that it will occupy a field not precisely paralleled by any single organization in the United States, corresponding as it does in some functions to our Society for the Promotion of Agricultural Science, in others to the Association of Land Grant Colleges, and with many points of unique individuality, will further intensify interest in its practical workings.

Inquiries are occasionally received from users of the *Record* with reference to the feasibility of a revision of the system of classification of abstracts. Many of these inquiries advocate the reassignment of specific classes of abstracts from one to another of the

seventeen principal subject divisions. Not infrequently the suggestion is advanced that the usefulness of the *Record* could be increased, irrespective of the scheme of classification, by a more or less detailed system of cross-references or by some other device whereby the specialist could locate more rapidly, and preferably in a single place, all abstracts dealing with his immediate field of work.

These suggestions and all others advanced in a constructive spirit are, of course, most welcome. The fundamental object of an abstract journal is service, and the chief purpose of classification is obviously to save time. If, either by modification or radical revision, substantial improvements in the *Record* system seem attainable their prompt and careful consideration can be relied upon.

The question of the best system of classification is one which is nearly as old as the *Record* itself, and the present system is the result of considerable evolution. For the first two years of its existence, the *Record* confined its abstracts to the publications of the experiment stations and the U. S. Department of Agriculture, and in Volume 1 the only classification attempted was on an institutional basis. The same arrangement was followed in Volumes 2 and 3, but a combined subject list of abstracts was prepared with twenty-one subdivisions. Beginning with Volume 4, a topical arrangement was attempted for the station work, although abstracts of Department publications and those from foreign institutions were still segregated without formal classification. This plan continued until 1894, when the topical arrangement was extended to all abstracts. It may be of interest to note that Volume 6, the first in which the new plan was followed, contained 1,606 articles, occupying 773 pages, or somewhat less than one-fourth the number of articles and one-half the space available for Volumes 41 and 42, issued during the corresponding period ended June 30, 1920.

The plan adopted in Volume 6 included nineteen main divisions as follows: Chemistry, Botany, Bacteriology, Zoology, Meteorology, Water and Soils, Fertilizers, Field Crops, Horticulture, Forestry, Seeds and Weeds, Diseases of Plants, Entomology, Foods and Animal Production, Veterinary Science, Dairying, Technology, Agricultural Engineering, and Statistics. With relatively minor changes, such as the abolition of the separate sections on Bacteriology and Technology and the separation of Foods and Animal Production, this scheme remained in operation until Volume 17 in 1905, when substantially the present terminology and arrangement was substituted. Soils was then combined with Fertilizers, Seeds and Weeds with Field Crops, and Water with Meteorology, while new sections were begun in Rural Economics and Agricultural Education. Virtually the only changes since that time have been in the tentative

combination of Agrotechny with Dairying and its relocation in 1909 with Agricultural Chemistry, and the transfer in 1915 of Water from Meteorology to Rural Engineering.

The classification has thus been substantially stabilized for fifteen years, and as regards its basic principles and primary divisions for a much longer period. Since the *Record* is a permanent work of reference, this continuity probably constitutes one of the greatest assets of the system to-day. Despite its admitted imperfections readers have become accustomed to it, and its use is thus attended with a corresponding minimum of uncertainty and confusion.

The system has also demonstrated its practical workability to a remarkable degree. Despite the development of such subjects as agronomy, genetics, biometrics, farm management, and others since its adoption, its flexibility has been such as to find a place or places for all these branches within its limits. Whether a new system would prove equally inclusive could only be ascertained by actual trial.

The inclusiveness of the present system is, as a matter of fact, also one of its greatest objections. Consisting as it does in part of basic sciences such as Chemistry, Meteorology, Botany, and Economics, and in part of practical applications of these sciences as in Field Crops, Horticulture, Dairying, and the like, overlapping or conflict between these groups of subjects is well-nigh unavoidable. This conflict is intensified as modern scientific methods become more complex and the interrelationships of many lines of inquiry become more apparent. In practice, each section of the *Record* doubtless contains in nearly every issue articles of direct bearing and immediate interest to other sections. Exceptions might be expected of such apparently dissimilar sections as Forestry and Dairying, or Plant Diseases and Rural Engineering, yet studies of the utilization of the ranges on the National Forests for dairy farming or of the ravages of wood-destroying fungi on timber are examples of double appeal which readily suggest themselves. An economic study of the relative accuracy of forecasts of spring wheat yields from climatological data and crop estimates may be cited as a recent actual instance of the joint interest of economists and meteorologists in an abstract which might easily be overlooked by one group if inserted in the other section.

Situations such as these might be somewhat alleviated by the introduction of cross-references. This remedy is frequently adopted by abstract journals and has many obvious advantages. In the *Record*, however, a serious objection has been that of space limitations. Under the laws regulating Government printing, publica-

tions issued in editions of over 1,000 copies may not exceed 100 pages. So long as the number of issues remains as at present, therefore, not over 1,800 pages per year are available for abstracts, editorials, notes, and similar material. This space was proving barely sufficient for the adequate handling of material prior to the war, and the notable increase in new journals and the steadily growing output of many scientific institutions of late indicate that congestion of material is again a probability within a short time. It is believed that a system of cross-references sufficiently comprehensive to be of real value would require considerable space, obtainable only by a curtailment of the number or the fullness of the abstracts themselves.

This consideration is the more important since a better guide in most ways to the subject matter is afforded ultimately by the subject index, which of course disregards sectional lines. Efforts are made to issue this index as promptly as possible after the conclusion of a volume, so that the value of cross-references would be largely confined to the current issues. Even for these, however, the classified table of contents is perhaps a more reliable, if less convenient, aid than any system of cross-references which may by its seeming completeness delude the user into a false sense of security. Many busy readers of the *Record*, who are unable to scan each page in detail, find the comparatively few pages of the table of contents of appreciable assistance in indicating articles of interest.

Certain groups of specialists doubtless find regular perusal of several sections of the *Record* itself quite desirable. The plant breeder soon learns that in addition to the general articles in Agricultural Botany, he may locate some of his most useful material in the studies with wheat or corn in Field Crops, or with tomatoes or citrus fruits in Horticulture, and that a goodly number of current articles on heredity and biometrics will appear in Animal Production. The horticulturist and the agronomist will discover that the section of Agricultural Meteorology contains not only general articles and routine meteorological observations, but reports of frost protection work and other phenological studies of direct application in their respective lines. The rural economist may find cost studies of wheat, apples, beef, or milk grouped with articles dealing with other phases of their production in Field Crops, Horticulture, Animal Production, or Dairying. The poultry husbandman will have recourse to the section of Veterinary Medicine for work on poultry diseases and to that on Rural Engineering for poultry buildings and appliances. Perhaps most unexpected of all to many will be the revelation that textbooks are assembled irrespective of subject under Agricultural Education. Bacteriological articles are widely scat-

tered, dependent on their application, but the attempt many years ago to maintain a section of Bacteriology proved unworkable.

Reference should also be made in any discussion of classification to the fallibility of the classifier. As was pointed out in these columns when announcing the original topical arrangement, "it will readily be seen that the complex nature of many of the subjects treated makes their classification largely a matter of individual judgment." This statement is as true to-day as when written, and unfortunately is a large psychological factor whatever the system of classification.

From what has been said, it is evident that the *Record* groups should not be regarded as watertight compartments. They are rather to be looked upon as convenient units for the subdivision of the four hundred-odd abstracts which make up a number, much as an elaborate treatise is, for convenience, broken up into chapters. From this point of view the precise system of classification seems less important than the question of becoming as well acquainted as possible with the contents as a whole. So composite are the methods of attack in modern science that it is quite conceivable that the investigator may find his search for knowledge and inspiration abundantly rewarded when apparently far afield. This of course does not imply that classification is not important. On the contrary, its methods and details are worthy of close scrutiny and an unceasing effort to evolve the best system possible. Nor has the foregoing been written in any spirit of Bourbonism. The aim has been rather to point out some of the limitations inherent in any scheme of classification, and to emphasize the advantages to the teacher and investigator of as wide and comprehensive a survey of the current scientific literature as is practicable within the time at his disposal.

RECENT WORK IN AGRICULTURAL SCIENCE.

AGRICULTURAL CHEMISTRY—AGROTECHNY.

Annual reports on the progress of chemistry for 1919, edited by J. C. CAIN (*Ann. Rpts. Prog. Chem.* [London], 16 (1919), pp. IX+234, figs. 10).—This is the usual annual report (E. S. R., 41, p. 201) of progress in various branches of chemistry including, among others, sections on analytical chemistry by C. A. Mitchell, physiological chemistry by G. Barger, and agricultural chemistry and vegetable physiology by E. T. Russell.

Work of the chemist in the food industries, L. M. TOLMAN (*Chem. Age* [New York], 1 (1919), No. 6, pp. 241-245, fig. 1).—A brief summary of the development of chemical control in the manufacture of food.

Wood and chemistry, L. F. HAWLEY (*Chem. Age* [New York], 1 (1919), No. 6, pp. 247, 248, fig. 1).—This is a general discussion of the relation between wood and chemistry as shown in the manufacture of pulp and paper, wood preservation, wood distillation, the manufacture of methyl alcohol, ethyl alcohol, oxalic acid, tanning materials, etc.

Continuation and extension of work on vegetable proteins, T. B. OSBORNE and L. B. MENDEL (*Carnegie Inst. Wash. Year Book*, 18 (1919), pp. 352-360).—The progress report for 1919 in continuation of work previously noted (E. S. R., 43, p. 10) contains brief statements concerning investigations in progress and discussions of the significance of the results obtained in studies which have been previously noted from other sources.

The proteins of green leaves.—I, Spinach leaves, T. B. OSBORNE and A. J. WAKEMAN (*Jour. Biol. Chem.*, 42 (1920), No. 1, pp. 1-26).—The authors, with the cooperation of C. S. Leavenworth and O. L. Nolan, have investigated the proteins of spinach leaves by the following method:

The fresh green leaves were ground with water to break up the cell walls and set free the contents of the cells. By centrifuging or filtering through soft paper a green turbid extract was obtained in which only minute particles were visible under the microscope. The addition of about one-third volume of alcohol to this extract resulted in the formation of a voluminous green precipitate containing chlorophyll, phosphatids, and fats which were removed by extraction with alcohol and ether, leaving a residue consisting of about 20 per cent of the solids of the leaves and composed almost entirely of protein. This was found to be practically insoluble in aqueous alkaline solutions at room temperature, but soluble in boiling 60 per cent alcohol containing 0.3 per cent sodium hydroxid. On neutralizing this solution with acid the protein was precipitated in a form readily soluble in a slight excess of either acid or alkali, and containing about 15.25 per cent of nitrogen. This colloidal protein is thought to be a mixture of several individual proteins, possibly combined with carbohydrate-containing groups. The presence in it of nucleic acid has not been detected.

The filtrate from the original alcohol precipitate contained the water-soluble constituents of the cells, constituting about 50 per cent of the solids of the leaf and containing proteoses to the extent of 1.7 per cent, proteins coagulable by heat 1.4 per cent, and nonprotein organic substances 28 per cent of the total solids of the leaf, the balance consisting of mineral matter. The nonprotein

organic substances contained about 25 per cent of the total nitrogen of the leaves.

By applying similar methods to spinach leaves dried at low temperatures, results were obtained so nearly identical with those obtained from the green leaves as to indicate that the constituents of the cells were only slightly altered by drying.

"If, as seems probable, similar products can be made from other green leaves it ought to be possible to feed these as the sole source of nitrogen and thereby increase our knowledge of the nutritive value of a class of proteins about which at present we know almost nothing. Possibly we shall also be able to learn something of the nutritive value of the water-soluble constituents. A new field for investigation appears to be thus opening which promises to be fruitful."

Some proteins from the Georgia velvet bean, *Stizolobium deeringianum*, C. O. JOHNS and H. C. WATERMAN (*Jour. Biol. Chem.*, 42 (1920), No. 1, pp. 59-69).—An examination is reported of the proteins of the Georgia velvet bean (*S. deeringianum*), a sport of the Florida velvet bean, a study of the proteins of which has been previously noted (E. S. R., 39, p. 202).

The Georgia variety was found to contain about 23.6 per cent of protein. A yield of about 15 per cent of protein was obtained from the finely-ground seed by a 3 per cent solution of sodium chlorid, and by coagulation from the slightly acidified extract at the boiling temperature a yield of 13 per cent of mixed proteins was obtained. From the sodium chlorid extracts three types of proteins were separated: α -globulin precipitated by 0.4 saturation with ammonium sulphate, coagulable at 70 to 78° C., and containing 0.9 per cent of sulphur; β -globulin precipitated from the extract by 0.6 to 0.7 saturation with ammonium sulphate, coagulable at 90 to 100°, and containing 0.45 per cent of sulphur; and an albumin obtained by coagulation from aqueous extracts previously freed from globulin by prolonged dialysis, coagulable at 54 to 62°, and containing 1 per cent of sulphur. The α -globulin and the albumin gave strong tests for tryptophan with Hopkins and Cole's reagent, while the β -globulin gave no trace of this reaction. Attention is called to the fact that this is the first vegetable globulin which has been found to contain no tryptophan.

The percentages of the basic amino acids in the three proteins, as determined by the Van Slyke method, are given in the following table:

Percentage of the basic amino acids in the proteins from the Georgia velvet bean.

Amino acid.	α -Globulin.		β -Globulin.		Albumin.
	I.	II.	I.	II.	I.
	<i>Per cent.</i>	<i>Per cent.</i>	<i>Per cent.</i>	<i>Per cent.</i>	<i>Per cent.</i>
Cystin.....	1.03	1.04	0.91	0.87	1.92
Arginin.....	7.25	7.14	8.09	8.28	6.13
Histidin.....	1.34	1.14	3.32	3.43	0.82
Lysin.....	8.20	8.44	8.61	8.42	8.20

The simple carbohydrates and the glucosids, E. F. ARMSTRONG (*London: Longmans, Green & Co., 1919, 3. ed., pp. IX+239*).—In the preface of the third edition of this monograph on carbohydrates and glucosids (E. S. R., 28, p. 710) acknowledgment is made of the contributions of C. S. Hudson and associates, of the Bureau of Chemistry, U. S. Department of Agriculture, as follows:

"The relationship of optical rotatory power to structure in the case of the carbohydrates has long been a source of speculation, but because of the in-

different manner in which many of the carbohydrate derivatives had been characterized nothing definite had been achieved until recently. Owing to the painstaking work of Hudson and his school in America, we are now in possession of many of the necessary data, and the generalizations of this chemist have given a new and most promising aspect to this field."

[**Gossypol in cottonseed meal**], W. A. WITHERS (*North Carolina Sta. Rpt. 1919, pp. 40, 41*).—In continuation of the study of gossypol, the toxic principle of cotton seed, by Withers and Carruth (E. S. R., 38, p. 685), and by Carruth (E. S. R., 38, p. 801), the results of a further investigation of its chemical properties and the possibilities of its removal from cottonseed meal are reported.

No evidence was obtained that gossypol or D-gossypol is left in the meal after extraction with ethyl ether and then with anilin. The anilin-gossypol and the anilin-D-gossypol contained, respectively, 73.74 and 74.81 per cent of carbon, 5.76 and 6.12 per cent of hydrogen, and 3.85 and 3.89 per cent of nitrogen. Anilin-D-gossypol on heating to 140° C in the air gained 0.71 per cent in weight, while anilin-gossypol gained 1.96 per cent. These results are considered to furnish a further proof that the two substances are not identical.

Cottonseed hulls were found to contain 0.75 per cent and the meats 0.7 per cent of gossypol.

Benzidin, anilin, phenylhydrazin, *p*-nitroanilin, *p*-toluidin, and α -naphthylamin all produced precipitates with the gossypol present in crude cottonseed oil. These reagents and urea in alcoholic solution did not, however, form precipitates with pure gossypol or D-gossypol.

Free gossypol or D-gossypol in alcoholic solution formed precipitates with the alcohol-soluble proteins of either wheat flour or cottonseed meal. This is thought to explain partially why heating reduces the toxicity of cottonseed meal, on the assumption that the gossypol or D-gossypol protein compound is not readily digested by the animal.

In general, heating cottonseed meals to various temperatures in atmospheres of different gases and in the presence of various amounts of water decreased the gossypol but increased the D-gossypol content, although the results obtained have not been consistent in all cases.

Fermentation characteristics of certain pentose-destroying bacteria, E. B. FRED, W. H. PETERSON, and A. DAVENPORT (*Jour. Biol. Chem., 42 (1920), No. 1, pp. 175-189*).—Continuing the study of pentose-fermenting bacteria (E. S. R., 42, p. 709), the general fermentation characteristics of these bacteria have been studied by determining the change in reaction and the gas production in fermentation tubes containing a culture of the organism in yeast water and a 2 per cent solution of various carbon compounds including pentoses, hexoses, di-, tri-, and poly-saccharids, glucosids, polyatomic alcohols, and organic acids.

The average limits of growth in the yeast water medium were approximately pH 3.6 to 4 for xylose, glucose, galactose, fructose, sucrose, and lactose, and 4.3 for mannitol, which was decomposed more slowly. The results of acidity measurements and of the fermentation tube method gave no indication of the amount of carbohydrate consumed. It is thought that carbon compounds are broken down with the production of gas, largely CO₂, which does not accumulate in the closed end of the fermentation tube.

In regard to acid production arabinose and xylose decomposed rapidly, forming more than 20 per cent of normal acid consisting of practically equal amounts of acetic and lactic acids. Both xylose and arabinose were completely destroyed in less than 14 days. Rhamnose was not attacked. Glucose and galactose were decomposed in a similar manner but to a less extent, approximately 10 to 14

per cent of normal acid being formed in the proportion of about 5 parts of lactic to 1 part of acetic acid. The extent of fermentation was about the same with the two sugars, about one-half of the sugar being consumed in 15 days. Mannose fermented more slowly than glucose or galactose, and yielded nearly equal quantities of volatile and nonvolatile acid. Fructose disappeared completely in from 4 to 6 days with the formation of mannitol, volatile and nonvolatile acids, and CO_2 .

The disaccharids sucrose, maltose, and lactose were not completely fermented, sucrose being the most available and lactose the least. The products of reaction were chiefly volatile and nonvolatile acids, the latter predominating. Raffinose and melezitose were not fermented.

Mannitol was slowly broken down, yielding almost equal amounts of lactic and acetic acids. Glycerol and the glucosid salicin fermented slowly and esculin not at all. Starch, inulin, and cellulose were not fermented, while xylan was decomposed very slowly. Of the acids, succinic, tartaric, and citric were not attacked, while pyruvic, lactic, and malic were fermented.

Carbon as an adsorbent, R. E. LIESEGANG (*Chem. Ztg.*, 44 (1920), No. 13, pp. 89, 90).—This is a review of the literature on the use of carbon as an adsorbent from 1914 to 1919, inclusive. The references are arranged under the headings of the theory of adsorption with carbon, methods for testing adsorbing properties, preparation of carbons with strong adsorption properties, applications, and theoretical studies. A list of 44 references to the literature is included.

Vegetable decolorizing carbons, A. B. BRADLEY (*Jour. Soc. Chem. Indus.*, 38 (1919), No. 22, pp. 396T-398T).—A study of the effect of various factors on the percentage of color absorbed from solutions of raw Barbados and Mozambique sugars by the vegetable decolorizing carbon Norit is reported, with the following results:

The percentage of color removed was found to increase quite rapidly with a decrease in the size of the grain of the carbon up to a certain limit of size (about 94-mesh), after which the increased efficiency was relatively small. This is thought to indicate that the apparent difference in efficiency of different carbons may be partly due to the size of the carbon grain. Experiments undertaken to determine the effect of increasing percentage of decolorizing carbon on the amount of color removed from sugar solutions indicate that the greater part of the coloring matter can be removed by small amounts of the carbon, after which the finer, more soluble color particles can be removed to a considerable extent by boiling with colloidal substances, such as casein or gelatin.

For increasing temperatures up to 70°C . a marked increase in the percentage of sugar removed for each 10° was noted, after which the additional color absorbed was very small. Increasing concentration of the sugar solution up to a total sugar content of 40 per cent decreased the decolorizing efficiency quite rapidly, after which the loss of efficiency was not nearly so marked. An increase in the acidity of the sugar solution, whether due to organic or inorganic acids, was found to increase the decolorizing efficiency in a degree proportional to the degree of acidity.

The ash of calcium-containing soaps, E. LANTOS (*Chem. Ztg.*, 44 (1920), No. 5, p. 35).—Attention is called to the fact that if organic substances containing calcium are ashed to whiteness in the usual way the calcium is left in the form of the carbonate instead of the oxid. To overcome this, the author recommends adding a small amount of ammonium nitrate to the substance and heating before the blast lamp. The ashing is said to require a much shorter time and to convert completely the calcium into the oxid.

The quantitative determination of boric acid, P. JANNASCH and F. NOLL (*Jour. Prakt. Chem., n. ser., 99 (1919), No. 1-2, pp. 1-33, figs. 2*).—A method for the determination of B_2O_3 in salts and minerals is described which depends upon the fact that it is completely volatilized in the form of the methyl ester when distilled with methyl alcohol at from 60 to 90° C. The technique of the procedure as applied to the determination of boric acid in tourmalin is described in detail.

The determination of dicyandiamid in calcium cyanamid by Caro's method, G. HAGER and J. KERN (*Ztschr. Angew. Chem., 29 (1916), No. 63, Aufsatz., pp. 309-312*).—A critical study is reported of Caro's method of determining dicyandiamid in calcium cyanamid (E. S. R., 25, p. 24).

Two sources of error in the determination are pointed out. On warming the dicyandiamid-silver solution with potassium hydroxid double decomposition takes place, resulting in a loss of ammonia and nitrogen, and in the precipitation of large amounts of cyanamid with silver salts in ammoniacal solution more or less dicyandiamid is brought down at the same time. Both these sources of error tend to give too low results.

The determination of dicyandiamid in calcium cyanamid, A. STUTZER (*Ztschr. Angew. Chem., 29 (1916), No. 97, Aufsatz., pp. 417, 418*).—The author discusses the criticisms of Hager and Kern, noted above, in regard to Caro's method of determining dicyandiamid, and describes a modification of the method which is considered to eliminate these errors. The method consists essentially in dissolving the material in 94 per cent alcohol, using a portion of the solution to determine the total nitrogen soluble in alcohol, and the remainder to determine cyanamid by precipitation with a silver salt and ammonia and dicyandiamid by precipitation of the filtrate with sodium hydroxid.

The technique is described in detail.

The determination of dicyandiamid in calcium cyanamid, G. HAGER and J. KERN (*Ztschr. Angew. Chem., 30 (1917), No. 17, Aufsatz., pp. 53, 54*).—Attention is called to the method of determining calcium dicyandiamid in calcium cyanamid described by Brioux (E. S. R., 24, p. 323).

This consists essentially in determining both calcium cyanamid and dicyandiamid in an aliquot of the solution by precipitation with silver nitrate and potassium hydroxid, and in another portion of the solution determining the cyanamid by precipitation with silver nitrate and ammonia. The dicyandiamid is then determined by difference. The technique of the method is described, and results are reported which are considered to indicate the superiority of this method over Caro's method.

An examination of the method of Stutzer, noted above, is also reported. The authors conclude, however, that it is open to as many sources of error as Caro's method.

New extraction apparatus, E. BECCARD (*Chem. Ztg., 43 (1919), No. 113, p. 621, figs. 2; abs. in Chem. Abs., 14 (1920), No. 7, p. 869, fig. 1*).—Descriptions and illustrations are given of two forms of extraction apparatus in which the solvent is brought into contact with the substance to be extracted several times before siphoning, instead of once as in the ordinary extraction apparatus. One form of apparatus is suitable for extracting an aqueous solution with a solvent of lower specific gravity, and the other for solids or a solution with a solvent of higher specific gravity.

A photometric turbidimeter, W. G. BOWERS and J. MOYER (*Jour. Biol. Chem., 42 (1920), No. 1, pp. 191-198, figs. 2*).—In the apparatus which is described and illustrated the photometric oil spot is applied to the turbidimeter to balance intensities of illumination in measuring turbidities.

"The apparatus consists of a dark box 12.5 in. long, 4.5 in. wide, and 8 in. high, having a dark compartment at each end for the standard lights, next to these the small dark compartments for the cell of unknown substances on the one side and the standards on the other, a very small compartment in the middle for the paper with its oil spot, and the narrow mirrors which reflect the images of the spot through a small eyepiece directly in front." In using the instrument the unknown solution is put into the cell to the left, the lights are turned on, and wheels which control the standard ground glass discs are turned until the intensities of illumination are balanced. By comparing the reading thus obtained with a scale which has previously been worked out for the substance in question the turbidity can be calculated.

Some observations on colorimetric estimations with solutions containing two colored substances, K. G. FALK and H. M. NOYES (*Jour. Biol. Chem.*, 42 (1920), No. 1, pp. 109-130).—The authors report a study of the conditions involved in the colorimetric determination of reducing substances present in ordinary urine by the method developed by Benedict and Osterberg. Following a theoretical discussion of the significance of colorimetric determinations, a series of experiments is reported involving matching in the Duboscq colorimeter picrate against picrate, bichromate against bichromate, picramate against picramate, picramate against bichromate, picramate plus picrate against picramate plus picrate, and glucose-picrate product against picramate plus picrate.

The variations in results with differing concentrations and alkalinities indicate that the conditions under which accurate and comparative results may be obtained are very limited, especially with regard to the concentration of glucose which may be estimated accurately. "In order to be certain of quantitative results, the standard and unknown solutions, containing two colored substances, should be very nearly alike in composition and concentration. The errors introduced otherwise may be considerable."

A rapid method for the determination of carbon in organic mixtures, particularly urine, L. LESCOEUR and O. DUTRIEUX (*Compt. Rend. Soc. Biol. [Paris]*, 82 (1919), No. 34, pp. 1417, 1418).—The method consists essentially in fusing the material with sodium hydroxid and sodium nitrate and determining the amount of sodium carbonate formed. The fusion is conducted in a silver crucible provided with a cover and special outlet tube.

Rapid determination of carbon, M. L. LESCOEUR (*Jour. Pharm. et Chim.*, 7 ser., 21 (1920), No. 7, pp. 257-263).—Essentially noted above.

Fat determination in dehydrated potatoes, O. MATZDORFF and W. KÜHNE (*Chem. Ztg.*, 44 (1920), No. 15, p. 103).—Determinations of the fat content of various commercial products of dehydrated potatoes before and after hydrolysis of the starch are reported. While the results in general were higher after hydrolysis of the starch, one or two were lower. The authors conclude that the fat content is so low in dried potato preparations that accurate results can not be expected in this determination.

Examination of frozen egg products and interpretation of results, H. W. REDFIELD (*U. S. Dept. Agr. Bul.* 846 (1920), pp. 96, figs. 5).—This bulletin consists of outlines of standard methods found suitable by the Bureau of Chemistry for the chemical and bacteriological examination of frozen egg products to determine the presence of decomposed material, and a demonstration that the methods selected give concordant results in the hands of different analysts and in the examination of material of given quality from diverse sources. The determinations called for are total solids, ether extract, acidity of fat, ammonia nitrogen, reducing sugar, indol and skatol, and the enumeration of viable bacteria, total bacteria, and *Bacillus coli*. Parallel analyses by four or five

chemists and two bacteriologists were made on each of over 60 samples of varied grades prepared under supervision from known materials, the results being set forth in a series of tables. A weighed sum of the different determinations is proposed as a numerical criterion to determine whether or not a given sample is edible.

The determination of added water in meat products, R. LEDENT (*Ann. Falsif.*, 12 (1919), No. 133-134, pp. 356-367).—This is a criticism, based upon laboratory analyses, of the methods in use in France for determining moisture in meat products and of the official standards for detecting the presence of added water. The requirement that meat products shall not contain more than 75 per cent of moisture is considered too low, since meat which might enter into the composition of such products has been found to contain as much as 84 per cent of moisture.

The composition, action, and analysis of chemical yeasts, M. A. KLING, A. LASSIEUR, and L. VERNERD (*Ann. Falsif.*, 13 (1920), No. 135-136, pp. 9-17, fig. 1).—This is essentially a résumé of recent German literature on the composition of baking powder and methods for its analysis.

Chemical yeasts (baking powder), L. WEIL (*Ann. Falsif.*, 13 (1920), No. 135-136, pp. 17-21).—This is a general discussion of the ingredients of baking powder with suggestions as to limiting standards.

The analysis of milk, C. PORCHER (*Ann. Falsif.*, 13 (1920), No. 135-136, pp. 35-37).—The author calls attention to two possible sources of error in the analysis of milk. Data are given indicating that the addition of 1 cc. of formol to 50 cc. of milk does not alter the reducing power of the milk, while with increasing amounts of formol larger-reducing values are obtained for the same amount of milk. Data are also given showing appreciable differences in the weight of the same volume of milk when measured with pipettes having slow and rapid deliveries. This difference is accentuated with milk having a high percentage of fat.

A comparative study of some methods for determining the fat content of skim milk, T. J. MCINERNEY and H. C. TROY (*New York Cornell Sta. Bul.* 401 (1920), pp. 69-85).—A study is reported of the accuracy of the Babcock test for determining the percentage of fat in skim milk as compared with the Adams gravimetric, the Roese-Gottlieb, the Mojonnier, and the modified Leffman-Beam methods.

A preliminary study of the effect of various modifications of the Babcock test upon the yield of fat from skim milk indicated that by increasing the amount of acid, using excess speed, and centrifuging at a higher temperature for a long time the percentage of fat obtained is considerably higher than that obtained with the usual Babcock technique.

The results obtained with the Babcock method thus modified compared favorably with those obtained with the other methods tested. The authors consequently recommend the following modifications in the Babcock-test when it is to be used in determining the fat content of skim milk:

"At least 25 cc. of sulphuric acid should be used. If the size of the bottle permits, as much as 28 cc. may be used to advantage. The temperature of the testing machine should be at least 180° F. A centrifuge having a disk 15 in. in diameter, and strong enough to be run at a minimum speed of 1,800 revolutions a minute without danger of breaking, is recommended. The diameter of the disk is determined by measuring the distance between bases of the opposite cups when they are in a horizontal position. The milk should be centrifuged for 10, 2, and 1 minute periods, instead of for 5, 2, and 1 minute periods."

Microchemical method for the determination of sugar in body fluids, R. GOIFFON and F. NEPVEUX (*Compt. Rend. Soc. Biol. [Paris]*, 83 (1920), No. 5, pp. 121-123).—The colorimetric method described is said to be applicable to all body liquids susceptible of containing traces of sugar, to the intestinal contents, and to the study of amylolytic digestion.

It consists briefly in reducing a small volume of the liquid with Fehling's solution, dissolving the washed precipitate of cuprous oxid in a few drops of HCl, diluting with distilled water, adding a few drops of potassium ferrocyanid, and making up to a definite volume of 50 cc., after which the color of the colloidal solution is compared in a Dubosq colorimeter with a standard solution prepared in the same way.

Rapid methods for the determination of protein and sugar in urine, E. LENK (*Ztschr. Angew. Chem.*, 30 (1917), No. 13, Aufsatz., pp. 45-48).—The author states that the time required for an Elsbach determination of protein in urine can be shortened to about 10 minutes by the use of a small amount of powdered pumice stone, which causes rapid settling of the precipitate. A similar saving of time can be effected in the determination of reducing sugar by the addition of a magnesium salt.

Note on the methods of determining urea in the blood, A. SLOSSE (*Compt. Rend. Soc. Biol. [Paris]*, 82 (1919), No. 34, pp. 1402-1404).—Attention is called to some of the sources of error in the hypobromite method of determining the urea content of blood.

Technical application of hydrogen in hydrogenation or hardening of oils, H. L. BARNITZ (*Chem. and Metall. Engin.*, 22 (1920), No. 16; pp. 745-748, figs. 4).—This is a general discussion of the principles involved in the hydrogenation of oils, the commercial application of the method to industrial and edible oils, the technology of the process, and the apparatus employed.

Acidity and inversion: Observations from Hawaiian practice on the relation between them, R. C. PITCAIRN (*Facts About Sugar*, 10 (1920), No. 19, p. 370).—Attention is called, in cane sugar manufacture, to the danger of inversion and consequent loss of sugar while boiling low-grade products such as molasses or masseccutes. As a preventive the author suggests a regular system of acidity control, covering as completely as possible the various stages from mixed juice to final molasses.

The seeding method of graining sugar, H. E. ZITKOWSKI (*Trans. Amer. Inst. Chem. Engin.*, 11 (1918), pp. 81-87).—Previously noted from another source (*E. S. R.*, 40, p. 208).

The manufacture of alcohol from sulphite waste liquor, R. H. MCKEE (*Trans. Amer. Inst. Chem. Engin.*, 11 (1918), pp. 55-63).—This is a brief description of a patented method of manufacturing alcohol from sulphite waste liquor, which differs from previous methods in that the acid sulphite liquor is not neutralized before the addition of the yeast. To offset the loss of oxygen due to absorption by sulphur dioxid and sulphites in the acid solution, the oxygen requirement of the yeast is met by causing air to bubble through the solution during the fermentation period.

METEOROLOGY.

Periodicity in weather and crops (*Nature [London]*, 105 (1920), No. 2638, pp. 370, 371).—Brief reference is made to a lecture by Sir William Beveridge, director of the London School of Economics and Political Science, on what he claims to be a hitherto unrecognized periodicity in the weather and crops. On the basis of historic records of poor harvests, Indian famines, tropical droughts, and disastrous wet summers in higher latitudes, and also to a great

extent upon official statistics of food prices, the author endeavors to establish a weather period of $15\frac{1}{3}$ years during the past three centuries. He predicts unseasonable weather, bad harvests, and high prices, with possible famines, in one or more of the years 1924, 1925, and 1926.

Lunar and rainfall periods, E. MESNARD (*Compt. Rend. Acad. Sci. [Paris]*, 170 (1920), No. 4, pp. 242-245).—This article briefly reviews evidence tending to establish a certain correlation between meteorological phenomena, particularly rainfall, and lunar phases and motions.

[Influence of altitude and topography on temperature distribution in southern California], F. D. YOUNG (*Cal. Citrogr.*, 5 (1920), Nos. 5, pp. 136, 160, 161, figs. 3; 7, pp. 215, 231, figs. 4).—Studies near Pomona, Cal., on temperature distribution on a clear, calm night, over relatively level ground, on steep hillsides, at the bases of steep hills, and at different heights above the ground, are reported.

"It was noted that the temperature at some distance above the ground does not change much during such a night, while the air near the ground cools steadily, causing a considerable difference in temperature to develop between the air strata at the two levels before morning. The surface air, cooling steadily all night through conduction of its heat into the colder ground (which in turn is losing heat to the sky through radiation) continues to grow relatively denser and denser than the air at greater elevations. The greater density of this colder surface air operates to keep it in contact with the ground. Over sloping ground the force of gravity tends to cause this thin surface layer of cold air to move down the slope and to gather in depressions in somewhat the same manner as water. The flow of air and of water down the same slope differ, however, in that air is heated by compression as it moves to lower levels while water is not.

"From observations in the Pomona Valley it appears that there is little, if any, advantage to be gained by locating on the upper portion of a long, uniform slope with a fall of 150 ft. or less to the mile. In an orchard located even a short distance above the base of such a slope, the frost hazard is not likely to be greater than in a similar orchard near the summit of the slope. However, in even slight depressions of whatever shape or direction, on this slope, the frost hazard is likely to be considerably greater. The same is true of groves located directly at the base of the slope, where the ground begins to rise in the opposite direction."

Elevation above sea level was not an important factor under the conditions of these studies. "The rate of increase in temperature with altitude is likely to be greater after a warm day than after a cold day and to be greater on a night with low humidity than on a night when there is a great deal of moisture in the air.

"An interesting fact brought out in the observations on the steep hillside is that the highest average minimum temperature was found at the 225-ft. station, 50 ft. below the summit of the ridge; the minimum temperature at the summit was as high as that at the 225-ft. station on only one night during the season. The summit of the ridge is well rounded and the ground sloped away from the summit station in all directions. The steep slope began about 20 ft. from the thermometer shelter. As the same phenomenon has been observed by the writer on hills of varying height in other sections, it is probably safe to say that the frost hazard will be greater on a well-rounded or flat hilltop or ridge than for some distance below on the hillside, if the slope is fairly steep."

The effect of snow upon the growth of winter wheat, C. L. MEISINGER (*Science*, n. ser., 51 (1920), No. 1330, pp. 639, 640).—This is a brief review of

recent contributions to this subject, which seem to cast some doubt on the popular belief that a snow cover is a beneficial factor in the growth of winter wheat.

The economic value of Antarctic meteorology to agriculturists (*Internatl. Sugar Jour.*, 22 (1920), No. 257, pp. 264, 265).—It is stated in this article that "it is generally admitted that we must look to the polar regions for an explanation of the great variations from year to year in rainfall and temperature over the South Temperate Zone." The author maintains that even with the incomplete information now available "it has been possible to predict with comparative accuracy the probable seasonal rainfall of South America, the temperature of the South African Plateau, the intensity of the Indian monsoon, and the height of periodic floods, the forecasts being based on previous observations of atmospheric conditions in the sub-Antarctic and Antarctic regions. The probable conditions in Australia might also be anticipated if observatories were established in the Ross Sea area. With wireless communication not only weekly predictions of comparative accuracy but seasonal forecasts with practical certainty would be available."

General classification of climates by temperature, precipitation, and the character of the seasons, W. KÖPPEN (*Abs. in Internatl. Inst. Agr. [Rome], Internatl. Rev. Sci. and Pract. Agr.*, 10 (1919), No. 5, pp. 515-522).—This is a rather full abstract in English of an article briefly noted from the original (*E. S. R.*, 42, p. 212).

Climatic conditions [of the Huntley Reclamation Project Experiment Farm, 1918], D. HANSEN (*U. S. Dept. Agr., Dept. Circ. 86* (1920), pp. 5, 6).—The rainfall for the year at this farm, located near Osborn, Mont., was 13.46 in. as compared with an average of 14.19 in. for the past 8 years. "The winter precipitation was unusually high, so that the soil was well supplied with moisture at the beginning of the growing season. During the first part of the growing season the rainfall was slightly below normal. The frost-free period extended from May 21 to October 7, or 138 days, which was 10 days longer than the average for 8 years. Severe freezing occurred during the latter part of October and early in November, which occasioned some difficulty in harvesting sugar beets."

Tabular summaries of data for evaporation and wind velocity as well as for temperature, precipitation, and killing frosts, 1911-1918, are given.

Weather conditions [on the Newlands Reclamation Project, 1918], F. B. HEADLEY (*U. S. Dept. Agr., Dept. Circ. 80* (1920), pp. 5-8).—Observations at the Newlands Experiment Farm, near Fallon, Nev., from 1906 to 1918, inclusive, on precipitation, evaporation, wind velocity, cloudiness, temperature, and killing frosts are summarized, and a study of the effect of topography on temperature on the project is briefly reported.

The weather conditions during the growing season of 1918 were about normal, except that the frost-free period was 131 days, or 8 days longer than the average for 13 years. The total precipitation was 6.23 in., as compared with the 13-year average of 4.97 in. The evaporation during 1918 was 66.64 in., as compared with an 11-year average of 65.66 in. The temperature survey of the project during three years "shows that the higher altitudes have a decided advantage in the matter of minimum temperatures, the mean minimum averaging 4° F. and the absolute minimum 4.4° in favor of the high lands." The stations at which observations were made varied in elevation from 3,915 to 4,180 ft.

Minimum temperatures of 1918 in Paraguay, M. S. BERTONI (*An. Cient. Paraguay, Ser. II, 1919, No. 5, pp. 345-393*).—Observations at the Agricultural

Experiment Station of Puerto Bertoni, Paraguay, during 1918, showing the abnormal cold and its temporary and permanent effect upon plant and animal life, are discussed at considerable length.

SOILS—FERTILIZERS.

The data of geochemistry, F. W. CLARKE (*U. S. Geol. Survey Bul. 695* (1920), pp. 832).—This is the fourth edition, revised and enlarged, of this important work (E. S. R., 35, p. 16), dealing with the composition of the earth's crust, waters, and atmosphere. "To bring some of the data together, to formulate a few of the problems, and to present certain general conclusions in their modern form are the purposes of this memoir. It is not an exhaustive monograph upon geochemistry, but rather a critical summary of what is now known and a guide to the more important literature of the subject." It contains data of very great importance from the standpoint of agricultural science.

Soil survey of Cass County, Ind., C. C. BEALS (*Proc. Ind. Acad. Sci., 1918, pp. 186-204*).—This survey deals with the soils of an area of about 268,800 acres in north central Indiana. The topography varies from level to undulating and broken. The soils are classed as upland and alluvial soils. Including meadow and muck, 14 soil types of 5 series are discussed.

Analyses of one hundred soils in Allen County, Ind., R. H. CARR and V. R. PHARES (*Proc. Ind. Acad. Sci., 1918, pp. 151-159, figs. 4*).—Analyses of samples of 100 soils of the county are reported and discussed. The soils are of glacial origin, 70 per cent belonging to the Miami series and 18.5 per cent to the Clyde series.

It was found that there are many soils of this county quite high in organic matter, only 11 per cent containing below 4 per cent, while 45 per cent range from 4 to 7 per cent; 37 per cent range from 7 to 15 per cent; and 6 per cent are above that amount. They contain considerable nitrogen, but are somewhat deficient in phosphoric acid and very deficient in lime, 55 per cent being acid to litmus.

Report on Coastal Plain soils, particularly with reference to their nature, plant food requirements, and suitability for different crops, C. B. WILLIAMS, W. E. HEARN, W. F. PATE, J. K. PLUMMER, and E. C. BLAIR (*Bul. N. C. Dept. Agr., 39* (1918), No. 5, pp. 175, figs. 7).—This report contains the results of (1) a survey showing the location and extent of different soil types in the Coastal Plain section of North Carolina, (2) analyses of the soils to show their content of plant nutrients, and (3) field experiments to determine the fertilizer and cultural requirements of the more important types. The Coastal Plain region of North Carolina covers an area of about 11,814,700 acres, the topography of which varies from level, flat, to gently rolling and rolling. The natural drainage depends largely upon the topography. The soils are sedimentary in origin. The Norfolk series of soils is the most complete series in the State, and occupies from two-thirds to three-fourths of all the upland areas of the Coastal Plain region.

The analyses indicate that while there is considerable variation in the total amount of plant food contained in the different types, excepting the peats, mucks, and other soils containing large amounts of organic matter, these soils are particularly low in nitrogen and phosphoric acid. Potash was found to be contained in rather high amounts in most of the soils occurring in the Albemarle section of the State. Especially was this so with the soils in those counties occurring beyond Albemarle Sound. Lime is usually present in the Coastal Plain section of the State in only small amounts and in available forms.

"Generally speaking, with the exception of the soils high in organic matter, like the peats, mucks, and some of the soils of the Portsmouth series, nitrogen is the constituent that is most generally needed for the growing of profitable crops. Next in importance come potash, lime, and phosphoric acid. Even with soils containing small amounts of phosphoric acid, field experiments have not shown that this constituent is nearly so essential at the present time as would be indicated by the small amount present in the soils. It is quite evident, therefore, that this constituent, although contained in small amounts, is in a form or forms quite available under proper cultivation. . . . Coastal Plain soils, generally speaking, are deficient in organic matter. . . .

"The mineral soils nearly all show a slight degree of 'true acidity,' which can be overcome by much smaller applications of limestone or marl than the peats or mucks. Applications of 1 to 2 tons of high-grade limestone or marl on the sandy loams and loams will usually be sufficient to render the surface $6\frac{3}{4}$ in. sweet. Much larger amounts of lime carbonate are needed by the mucks; as high as 6 to 10 tons per acre will not completely reduce all of the acidity on some of this land. However, in general practice it is usually better to apply smaller amounts, 1 to 3 tons per acre more often, than to completely neutralize all acidity by one application."

Agricultural value and reclamation of Minnesota peat soils, F. J. ALWAY (*Minnesota Sta. Bul. 188 (1920), pp. 7-136, figs. 111*).—The purpose of this bulletin is to give a fair perspective of the agricultural possibility of the peat soils of Minnesota and the difficulties connected with their development. There are approximately 7,000,000 acres of peat soils in the State, occupying about one-eighth of its area. Tamarack and spruce occupy most of this land. Only a few thousand acres have been cultivated, usually with disappointing returns. "The future possibilities of these lands lie in their use for agriculture, forestry, and industrial purposes."

Drainage is the first essential step in the reclamation of these soils, followed by liming as an indispensable step, particularly on the low-lime peats. Potash and phosphate fertilizers are usually required also, although on Minnesota bogs those needing phosphate only have been most frequently encountered. Caution and moderation are advised with reference to the reclamation of these lands. It is pointed out that drainage alone will not make them productive, and large-scale reclamation should be preceded by systematic investigations and small-scale trials to establish the profitability of reclamation.

Experiments in the reclamation of alkali soil, F. B. HEADLEY (*U. S. Dept. Agr., Dept. Circ. 80 (1920), pp. 16-18*).—A series of 2-year rotations begun in 1917 on the Newlands (formerly the Truckee-Carson) Reclamation Project Experiment Farm near Fallon, Nev., to study the effect of manure in improving alkali soils have shown a gradual improvement, which is proceeding faster on soils receiving manure in the rotation.

Experiments begun in 1914, the treatments in which included the application of gypsum, sulphuric acid, manure, tile subdrainage, and green manuring with clover, showed that the yields of the soils treated with gypsum and sulphuric acid have been decidedly greater each year than those from untreated plats, but not large enough to be profitable.

The prevention of soil erosion.—I, Treating hillside ditches.—II, Checking overfalls, M. H. HOFFMAN and A. W. TURNER (*Iowa Agr. Col. Ext. Bul. 73 (1920), pp. [4], figs. 4; 74 (1920), pp. [4], figs. 5*).—This report is in two parts and deals with practice in checking and preventing soil erosion in Iowa.

Part I deals with the treatment of hillside ditches. It is stated that one of the best methods of preventing hillside wash in Iowa is the practice of

contour farming. The practice of leaving permanent strips of sod in hillside valleys is also strongly recommended. When hillside valleys are filled by plowing in, the use of obstructions made of short stakes and straw set in a crescent curved downstream is advisable.

Part II deals with the checking of overfalls. It is stated that practically all ditches in Iowa are caused by overfalls working back. "A successful method of preventing the overfall from working back is to ease the water from the higher to the lower level by putting in an obstruction of straw and brush staked down." The obstruction should come up almost as high as the top of the overfall. These obstructions are built by first setting one or more posts firmly in the ground in the bottom of the gully and within 2 ft. of the place where the water falls over. The number of posts to use varies with the size of the overfall, the best results being secured where they were put from $2\frac{1}{2}$ to 3 ft. apart around the bottom of the fall. The straw is packed around the posts and tight against the raw surface of the earth, being held in place by brush intertwined between the posts and well trampled down. The brush is held down by crosspieces nailed to the posts.

The lime requirement of soils according to the Veitch method, compared with the hydrogen-ion concentration of the soil extract, A. W. BLAIR and A. L. PRINCE (*Soil Sci.*, 9 (1920), No. 4, pp. 253-259, figs. 2).—Experiments conducted at the New Jersey Experiment Stations are reported, in which lime-requirement data secured by the Veitch method were compared with those indicated by the hydrogen-ion concentration of water extracts from loam soil.

For the samples tested there appeared to be a fairly close correlation between the hydrogen-ion concentration of the soil extract and the lime requirement as determined by the Veitch method. Certain inconsistencies appeared, which may be due to the inaccuracies of the Veitch method or to the lack of uniformity in the samples, or to the influence of buffer substances.

"With normal soils a determination of the hydrogen-ion concentration of the soil solution may give one some idea of the amount of lime water required by the Veitch method, and thus considerably shorten this method. Of the soils under consideration, those which have a hydrogen-ion concentration of about $\text{pH}=6.7$ or over are alkaline by the Veitch method. With further studies along this line it may be possible, with normal soils, to assign a fairly definite lime requirement to a given hydrogen-ion concentration, so that in many cases at least a determination of the hydrogen-ion concentration would make a lime-requirement determination unnecessary."

Reduction potentials of bacterial cultures and of water-logged soils, L. J. GILLESPIE (*Soil Sci.*, 9 (1920), No. 4, pp. 199-216, figs. 4).—In a contribution from the U. S. Department of Agriculture oxidation and reduction potentials are discussed as the intensity factor of oxidation and reduction.

Measurements of the reduction potentials of bacterial cultures or suspensions showed, when suitable precautions were taken, constant potentials for the facultative anaerobe *Bacillus coli* and for mixed cultures of soil microorganisms grown in a deep layer, the values for the reduction potentials being near the hydrogen-electrode potentials. Measurements with aerobes (*B. subtilis*, *B. mycoides*, and a third aerobe) showed progressively increasing reduction potentials with lapse of time, but in no case did the reduction potential approach the hydrogen-electrode potential as closely as 0.3 volt. It is thought that this difference between anaerobes and aerobes may hold in general, but the evidence is not conclusive.

When soils were treated with an excess of water they became highly reducing, as evidenced by their reduction potentials. At the same time their hydrogen-electrode potentials changed. In the cases noted the changes of hydrogen-ion

exponent indicated by the hydrogen-electrode potentials were very considerable, the soils becoming less intensely acid. Accompanying the development of reducing conditions was a production in most cases of a foul odor. Different soils differed in the rate at which they became highly reducing. The addition of dextrose to one soil favored the development of reducing conditions, the effect of 0.1 per cent of dextrose being very pronounced. It is thought that sourness of soils includes something beyond acidity, and that the residual unfavorable quality may be a high intensity of reduction. A discussion is given of the significance of reducing conditions and of reduction potentials in soil study.

Forty references to literature bearing on the subject are included.

Number of colonies for a satisfactory soil plate, H. A. NOYES and G. L. GROUNDS (*Proc. Ind. Acad. Sci.*, 1918, pp. 93-101, figs. 7).—Data from work conducted at Purdue University are reported, the results of which, together with results from other tests, are taken to indicate that 30 is near the optimum number of colonies for a petri plate 100 mm. in diameter. The averages of a sufficient number of plates carrying between 10 and 100 colonies are considered to be satisfactory for computing bacterial numbers.

The length of time to incubate petri plates, H. A. NOYES, E. VOIGT, and J. D. LUCKETT (*Proc. Ind. Acad. Sci.*, 1918, pp. 102-109).—The results of experimental work conducted at Purdue University are reported, which are taken to indicate that "counts made after 10 days' incubation at 20° C. of petri plates, made from bacterial dilutions of soil, give reliable results as to the bacterial content of the soil, providing the number of colonies present per plate is small enough for all organisms to develop into colonies. The rapidity with which bacteria develop into colonies has been shown to vary with the soil and to be influenced by soil temperature, moisture, and aeration. Much of the lack of confidence in results obtained by the plate method is due to having too many colonies present per plate and not allowing sufficient time of incubation of the petri plates."

The etching of marble by roots in the presence and absence of bacteria, E. B. FRED and A. R. C. HAAS (*Jour. Gen. Physiol.*, 1 (1919), No. 6, pp. 631-633, figs. 5; *abs. in Abs. Bact.*, 3 (1919), No. 6, p. 338).—Studies were made at the Wisconsin Experiment Station of the effect of soil bacteria upon the etching power of the roots of Canada field peas upon polished marble. These studies showed that the presence of the bacteria from field soils in pure culture increased the etching power of the roots.

The growth of higher plants in soils free of microorganisms, E. B. FRED (*Jour. Gen. Physiol.*, 1 (1919), No. 6, pp. 623-629, figs. 3; *abs. in Abs. Bact.*, 3 (1919), No. 6, p. 338).—In this paper, a contribution from the Wisconsin Experiment Station, the author calls attention to the advantages of growing plants under sterile conditions when studying the action of soil bacteria, and describes an improved apparatus for this purpose.

The seeds are sterilized by mercuric chlorid in partial vacuum. The plants are grown in a special pot fitted with a tall cylinder of pyrex glass, the upper end of which is covered with a pyrex beaker. A neck at the side of the pot, ordinarily plugged with cotton, provides a means of planting the seed and watering.

Bacteria in frozen soil, H. A. NOYES (*Proc. Ind. Acad. Sci.*, 1918, pp. 110-116, figs. 3).—The work of others bearing on the subject is reviewed and experiments conducted at Purdue University are reported, the results of which are taken to indicate that the number of bacteria present in soil is not increased when the soil is frozen.

Soil improvement for maize.—I, Manures and fertilizers, H. WENHOLZ (*Agr. Gaz. N. S. Wales*, 31 (1920), Nos. 1, pp. 29-35; 2, pp. 111-116; 3, pp.

177-183; 5, pp. 318-324).—Popular information is given on the treatment of maize soils for the maintenance of fertility, special attention being called to the proper application of manure, fertilizers, green manure crops, and cultivation.

Conservation of manure in the Province of Östergötland—as it is and as it should be, H. VON FEILITZEN (*Gödselvården i Östergötlands Lan—Sådan den Är och Sådan den Borde Vara. Göteborg [Sweden]: Göteborg Printing Co., 1920, pp. 77, figs. 30*).—Popular information is given on the value, conservation, and proper use of barnyard manure.

Engineering and sanitation for manure, J. M. DE SOROA (*Bol. Agr. Téc. y Econ., 12 (1920), No. 134, pp. 112-127, figs. 7*).—The design and construction of pits for the conservation of stable manure to meet conditions in Spain are described.

Conservation of liquid manure, GERLACH (*Mitt. Deut. Landw. Gesell., 33 (1918), No. 31, p. 441; also in Zentbl. Agr. Chem., 48 (1919), No. 5, pp. 187-190*).—Experiments on the conservation of liquid manure with peat litter, potash salts, gypsum, formalin, sodium sulphate, and superphosphate are reported.

The use of peat litter for this purpose was found to be especially desirable where the litter is cheap. Potash salts, when added to the extent of 10 per cent decreased the nitrogen loss from 64 to 67 per cent. Kainit gave the best results. Finely ground gypsum reduced the nitrogen loss from 53 to 63 per cent. The addition of 0.75 per cent of formalin, containing 30 per cent formaldehyde, to fresh liquid manure was sufficient to prevent the formation of gaseous nitrogenous compounds. When the acid-reacting salts, sodium bisulphate and superphosphate, were added to liquid manure in amounts sufficient to impart a permanent slightly acid reaction there was little or no loss of nitrogen. Owing to its general use as a fertilizer, superphosphate is considered the best material for this purpose.

What significance has peat litter for a better conservation of natural fertilizers, especially in view of the prevailing high prices of artificial fertilizers? H. VON FEILITZEN (*Vilken Betydelse Har Torvströet för ett Bättre Tillvaratagande av den Naturliga Gödseln, Särskilt med Hänsyn till Nuvarande Höga Priser på Konstgödsel medel? Örebro, [Sweden]: Örebro New Printing Co., 1917, pp. 20*).—This pamphlet deals principally with the use of peat litter for the conservation of liquid manure.

Green leaf manuring of dry paddy land, F. R. PARNELL (*Madras Agr. Dept. Yearbook, 1919, pp. 40-42*).—An experiment is reported in which the puddling of green manure in paddy soil was compared with plowing it into the dry land after harvest. It was found that the yield from the puddled plats was over 11 per cent greater than that from the dry plats, and the results on the plats individually and collectively were distinctly in favor of puddling the green manure before planting.

Effect of chemical fertilizers on the hydrogen-ion concentration of soils, F. W. MORSE (*Com. Fert., 20 (1920), No. 4, p. 84*).—Data on the fertilized plats at the Massachusetts Experiment Station are reported, showing that neutral salts with strong bases and strong acids, such as sodium nitrate, potassium chlorid, potassium sulphate, and calcium sulphate had little or no effect on the soil reaction in fertilized soil. Superphosphate composed of a strong base combined with a rather weak acid behaved in a similar way to the neutral salts. Ammonium sulphate, however, acted as a slightly ionized acid and calcium carbonate as a slightly ionized base. The values always remained within the limits given by these two compounds.

When agricultural lime was used with other chemical manures, the plats fertilized with sodium nitrate or gypsum kept the neutralizing effect of the calcium carbonate longer than the plats which had received potassium salts. The application of 2,000 lbs. per acre of slaked lime affected both the yield and the soil reaction for several years, but the lime finally disappeared, probably as a result of leaching and transformation. The latter apparently had less effect than the former.

Commercial fertilizer, T. R. HARNEY (*Sci. Amer. Mo.*, 1 (1920), No. 5, pp. 412-416, figs. 7).—A brief discussion is given of the functions of commercial fertilizers and methods of manufacture, with particular reference to soluble phosphates.

Investigation of a bacterial fertilizer from a superphosphate factory, GEILMANN (*Jour. Landw.*, 67 (1919), No. 4, pp. 209-227).—Analyses and vegetation and bacteriological studies of a so-called bacterial fertilizer are reported.

The analyses showed a certain content of potash, nitrogen, and phosphoric acid, but the main constituents were peat and calcium carbonate. The cropping studies showed that the fertilizer did not increase the nitrogen content of the soil, and had no effect as a nitrogenous fertilizer. The bacteriological tests showed no stimulation of bacterial activity, either in soil or nutritive solution, other than a small influence which is attributed to the calcium carbonate content.

Special [fertilizer] tests, C. B. WILLIAMS (*North Carolina Sta. Rpt.* 1919, pp. 28-32).—Studies on the effect of different fertilizer combinations on peat soils in progress at the Washington farm of the station have shown that liming is the first essential treatment after drainage. The use of 2 tons of calcium carbonate per acre gave better results than either 1 or 3 tons. Burnt lime so far has shown no superiority over raw ground limestone, and the data indicate that marl is not so efficient as other forms of lime. Phosphoric acid and potash alone and in combination have shown no benefit and have in some cases depressed crop yields. Nitrogen also appears to be of little value to this soil.

Experiments at the Pender farm, to determine the best fertilizer combination for corn, oats, vetch, and cotton in a 3-year rotation, have shown that nitrogen is the constituent most needed for better crops, and that phosphoric acid has given more increase when used with nitrogen than has potash with nitrogen. Basic slag has not given as good results as acid phosphate.

Tests at the Edgecombe farm on a 3-year rotation of corn, cotton, and peanuts, with a cover crop each year, have given average results showing that nitrogen and potash are the factors of first importance.

Tests at the Iredell farm on Cecil sandy loam soil gave conclusive evidence that the use of available forms of phosphoric acid and nitrogen are the main controlling factors in the improvement of crops. In the rotation tests the average results showed that corn every year and wheat every year with fertilizers are no more exhausting upon the fertility of the soil than a 2-year rotation of corn and wheat with fertilizers. By the use of legumes like red clover in the rotation a marked increase in the yields of both crops is secured. Inorganic forms of nitrogen were found to give better results on these soils than organic forms. There appeared to be no residual nitrogen in soils treated with organic forms of nitrogen. Potash used alone frequently depressed crop yields. Acid phosphate gave slightly better results with cotton than soft phosphate rock. Poor results were secured with red clover without the use of lime.

In tests at the Buncombe farm phosphoric acid, nitrogen, and lime seemed to be the controlling fertility factors on both bottom and upland soils. Where

acid phosphate and rock phosphate were used with stable manure and legumes, better results were generally obtained with the acid phosphate.

Tests at the Central farm showed a deficiency of vegetable matter in the soil. Nitrogen and phosphoric acid increased crop yields, but the use of potash with these fertilizers was found to be of little importance at present prices. It was found that a rotation simply of corn and cotton, without lime, using rye and crimson clover as winter cover crops had little improving effect on the soil.

Experiments with tobacco at the Reidsville farm showed the beneficial influence of potash, especially potassium chlorid. Ammonium nitrate from the Muscle Shoals Nitrate Plant was also found to give good results with tobacco. A 1-year test of basic ferric sulphate did not indicate any value for the growth of tobacco.

Fertilizer and crop tests in Java and the east coast of Sumatra.—**Report for the west monsoon, 1917-1918**, C. VAN ROSSEM (*Dept. Landb., Nijv. en Handel [Dutch East Indies], Meded. Alg. Proefsta. Landb., No. 3 (1919), pp. 123, figs. 12*).—A large number of different fertilizer experiments with rice, tea, and sugar cane conducted in Java and the west coast of Sumatra with different nitrogenous, phosphatic, and potassic fertilizers are reported, together with data on crop yields and revenues. Data on the residual action of different fertilizers are also included.

Effect upon profit of quantity of fertilizer used on cotton, C. B. WILLIAMS (*North Carolina Sta. Rpt. 1919, pp. 23, 24*).—The average results of long continued experiments at three of the station farms showed that, "other things being equal, the most profitable yields should be secured by materially increasing the yields per acre above what they are on an average at present and, if necessary to maintain a definite yield for the farm, reduce the acreage of the crop. In other words, where good farming is done, relatively large yields per acre are best. Not the largest yields, however, are always the most profitable ones."

The data indicate that on an average the best paying results above the cost of fertilizer were obtained from an application of 1,200 lbs. of complete fertilizer per acre. When the application was increased the profit was less.

Consumption of inorganic nitrogen in the United States, D. P. GAILLARD (*Chem. and Metall. Engin., 22 (1920), No. 17, pp. 783-786, fig. 1*).—A study of the consumption of inorganic nitrogen in agriculture, industry, and for military purposes is reported, the purpose being to forecast future consumption on the basis of conditions during the past 20 years.

It is shown that from 1899 to 1914 the consumption of fertilizer in this country practically tripled, an increase substantially equivalent to an increase each year of 7.5 per cent over the previous year. It is considered conservative to assume that this growth will continue at this prewar rate of 7.5 per cent per year at least until 1924. "This would give a total fertilizer consumption for 1924 of 10,500,000 tons. . . . The rate of growth from 1924 to 1930 has been assumed to continue uniformly at a somewhat slower rate, an increase little less than 800,000 tons a year, which gives for 1930 a total consumption of 15,200,000 tons."

In 1899, statistics indicate, about five-sixths of the nitrogen in mixed fertilizers, together with that used separately, came from organic nitrogenous materials; in 1904, about three-fourths; in 1909, slightly over half; in 1914, slightly under half; and in 1919, somewhat over a third. It is estimated that in 1924 this proportion will not be more than a fifth and in 1930 not more than a tenth, as in 1924 there will be available not more than 45,000 tons of nitrogen from

organic sources, about 60 per cent of the amount available in 1917, and in 1930 not more than 28,000 tons of nitrogen, about 40 per cent of the amount available in 1917. Inorganic nitrogen must, therefore, replace in 1924 about 40 per cent, and in 1930 over 60 per cent, of the organic nitrogen now being used.

Supply of inorganic nitrogen in the United States, D. P. GAILLARD (*Chem. and Metall. Engin.*, 22 (1920), No. 18, pp. 841-845, fig. 1).—This article considers the supply of inorganic nitrogen for agricultural, industrial, and military purposes to be expected in the years 1924 and 1930 from the coking of coal and the fixation of nitrogen, and summarizes data on this subject and on the subject of the probable consumption in these two years, as noted in the above report.

A chart is given showing the actual supply and consumption of inorganic nitrogen for each year since 1900 and the estimated supply and consumption for each year to 1930. "The chart shows how the expansion of nitrogen supply from coke ovens and gas works, even though abnormally stimulated by the war demand, will not furnish in the future half of the nitrogen used in this country, and unless this source of supply is supplemented as soon as possible by the operation of the Government fixed-nitrogen plants, and further supplemented by such development of the private fixed-nitrogen industry that there may be, this country will be even more dependent on imported nitrogen 10 years from now than it is at present. Not only will the country be less well prepared from a military point of view, but the American consumers, which include directly a very large proportion of the farmers of this country as well as many of the most fundamental chemical industries and indirectly the greater part of the population, will find it harder than ever to get an adequate supply of nitrogen at a cost within reason."

The German nitrogen syndicate, N. CARO (*Chem. Indus. [Berlin]*, 42 (1919), No. 13-14, pp. 149-153; also in *Chem. and Metall. Engin.*, 22 (1920), No. 15, pp. 686-688).—A discussion is given of Germany's capacity for nitrogen fixation before and after the war and her present apparent independence in that respect.

It is noted that while before the war Germany was obliged to import something like 100,000 tons of nitrogen a year in order to meet her agricultural and industrial requirements, she is now able to meet her greatly increased demands solely from domestic manufacture. The annual output, when plants under construction are completed, will be more than 500,000 tons of nitrogen, which will be divided as follows: Ammonia by the Haber process, 300,000 tons; ammonia from coke ovens, gas plants, and other by-products installations, 110,000 tons; and lime nitrogen, 100,000 tons. A description is given of government control of production, distribution, and prices.

Atmospheric nitrogen for fertilizers, R. O. E. DAVIS (*U. S. Dept. Agr. Yearbook*, 1919, pp. 115-121).—Sources of nitrogen and processes for the fixation of atmospheric nitrogen are discussed.

Calcium cyanamid and dicyandiamid as vegetation factors, E. LINTER (*Calcium Cyanamid und Dicyandiamid als Vegetationsfaktoren. Inaug. Diss., Königsb., Prussia, 1917; abs. in Zentbl. Agr. Chem.*, 48 (1919), No. 11, pp. 414-417; *Jour. Soc. Chem. Indus.*, 39 (1920), No. 4, p. 166A).—Studies of the suspected toxic action of dicyandiamid are reported, in which mixtures of dicyandiamid solution with different soils were kept for some days at 30° C. (86° F.) in the presence of carbon dioxide, the mixtures being shaken for seven hours each day.

No decomposition of the dicyandiamid occurred in sand or clay, and it is concluded that the toxic effect of the compound persisted until it was washed

out, this requiring longer in the heavy impervious soils than in the lighter ones. It is considered advisable, therefore, in applying calcium cyanamid to soils, to avoid any procedure which would tend to increase the formation of dicyandiamid, such as spreading on freshly plowed land in the autumn or top-dressing in the summer. On the other hand, soils, containing considerable humus are considered to be capable of absorbing dicyandiamid to such an extent that the poisonous action gradually disappears.

Ammonium nitrate, L. MALPEAUX (*Vic Agr. et Rurale*, 9 (1920), No. 17, pp. 294-296).—The author briefly reviews the results of work by himself and others on the use of ammonium nitrate as a fertilizer, and draws conclusions as to its practical use.

His experience demonstrated that the nitric nitrogen of ammonium nitrate is as effective as that of sodium nitrate, and its ammoniacal nitrogen is as effective as that of ammonium sulphate. With certain crops, such as beets, it was found that the use of ammonium nitrate gave results similar to those obtained when using a mixture of sodium nitrate and ammonium sulphate. Ammonium nitrate had a regular and sufficiently prolonged action on crops, and possessed the advantage of introducing no sodium into the soil. It is noted that the proper use of ammonium nitrate varies with the crop and the soil.

Relative efficiency of different carriers of nitrogenous materials, C. B. WILLIAMS (*North Carolina Sta. Rpt.* 1919, pp. 26, 27).—The average results of field experiments by the station are said to show that with regard to relative fertilizing value, the different common nitrogenous fertilizers stand in the following order: Sodium nitrate, ammonium sulphate, calcium cyanamid, dried blood, and cottonseed meal for cotton; and sodium nitrate, ammonium sulphate, calcium cyanamid, cottonseed meal, and dried blood for corn.

The effect of leaching on the availability of rock phosphate to corn, F. C. BAUER (*Soil Sci.*, 9 (1920), No. 4, pp. 235-251, figs. 4).—Investigations conducted at the Wisconsin Experiment Station are reported, the primary purpose of which was to test the effect of leaching on the availability of rock phosphate. The experiments were conducted in the greenhouse, using corn as the test crop.

It was found that leaching the soil increased the availability of rock phosphate to corn by removing the excess of soluble calcium bicarbonate and other soluble calcium salts. These results are in accord with the laws of mass action and chemical equilibrium. Ammonium nitrate had a marked influence on the solubility of rock phosphate to corn, due to its favorable effect on the solubility of calcium bicarbonate and its capacity to produce an acid medium either by acting as a physiologically acid salt or by becoming nitrified, but sodium nitrate had no appreciable influence. The soluble calcium leached from the pots treated with rock phosphate under the influence of sodium nitrate and ammonium nitrate was found to be in the ratio of 1:2.9. The growth ratio of corn under the same conditions was 1:2.5, showing, therefore, a rather definite relation between the calcium leached out in solution and plant growth. Leaching caused a decrease in the production of dry matter where acid phosphate was used. Ammonium nitrate with acid phosphate appeared to cause a physiological disturbance in the plants, especially with leaching. This was probably due to the insufficiency of basic material. The phosphorus content of the corn plants increased with increased growth. Leaching decreased the calcium and increased the nitrogen content of the plants. It also increased the water content as a result, undoubtedly, of the lessened concentration of soluble salts in the soil medium.

The fertilizing value of the reverted phosphoric acid in superphosphate, E. HASELHOFF (*Fühling's Landw. Ztg.*, 68 (1919), No. 23-24, pp. 450-460).—Experiments on the fertilizing value of reverted superphosphate are reported. These showed that the value of the reverted citrate-soluble phosphoric acid in superphosphate is less than 70 per cent of the water-soluble phosphoric acid. It is concluded that in general there is, under normal conditions of cultivation in mineral soils, no comparison between the two.

The potash salt beds of Dallol (Eritrea), M. GIUA (*Gaz. Chim. Ital.*, 48 (1918), II, No. 1-2, pp. 1-8).—The potash beds occurring in Italian Eritrea are described and analyses of 32 samples reported, showing a potassium chlorid content in 31 samples varying from 23 to 98.6 per cent. Some of the samples contained considerable sodium chlorid.

The status of lime in soil improvement, E. O. FIPPIN (*Jour. Amer. Soc. Agron.*, 12 (1920), No. 4, pp. 117-124).—A brief review of available information on the use of lime on soils is given, showing the lack of reliable data on such phases of the subject as the effect of lime upon soil, forms and fineness of lime, and relation of form of lime to the type of soil.

Home production of lime by the farmer, C. C. FLETCHER (*U. S. Dept. Agr. Yearbook, 1919*, pp. 335-341, figs. 5).—Information is given on the grinding or burning of limestone and other lime-containing materials for use on soil.

[Commercial fertilizer analyses], J. L. HILLS, C. H. JONES, G. F. ANDERSON, and L. H. FLINT (*Vermont Sta. Bul. 216* (1920), pp. 3-16).—A summary is given of the analyses of 356 samples of fertilizers and fertilizer materials representing 130 brands collected for inspection in Vermont during 1919.

It is stated that as a whole the fertilizers were not up to their usual grade, with particular reference to available nitrogen. Data are also included on the cost of fertilizers in the State during 1919, showing that nitrogen in commercial fertilizers cost between 53.4 and 97.6 cts. per lb. as against 30 cts., delivered, for nitrogen in Government nitrate.

Registration brands of fertilizer to August 1, 1918 (*Bul. N. C. Dept. Agr.*, 39 (1918), No. 7, pp. 93).—This bulletin contains a list of brands of fertilizers registered for sale in North Carolina up to August 1, 1918, together with guarantied analyses.

AGRICULTURAL BOTANY.

Hydration and growth, D. T. MACDOUGAL (*Carnegie Inst. Wash. Pub.* 297 (1920), pp. VI+176, figs. 52).—The purpose of the present work was to study growth upon the basis of a more inclusive conception than that usually implied in osmosis. The total absorbing capacity of a cell (as a mass of protoplasm) for water is regarded as being exercised in the process of hydration, the source of energy in growth and swelling being the unsatisfied attraction of molecules or particles or ions bearing an electrical charge. Substances made up in this manner may unite with definite proportions of water, which becomes part of a symmetrical chemical structure, the union being ordinarily termed hydration. In addition to this, however, it is known that such particles may adsorb and hold in combination additional molecules of water, an action especially characteristic of swelling in colloids, and the term hydration is used in the present work to include the entire range of such action.

In the method of study employed, biocolloids have been combined from pentosans and proteins in proportions simulating those occurring in plants. The total range of swelling of this material in thin plates has been measured by means of the auxograph, developed for this purpose, and the series of measure-

ments thus obtained have been paralleled with measurements of the unsatisfied hydration capacity of living cell masses and of dehydrated tissues. The acids and salts have been employed in concentrations mainly within the range of biological possibilities; that is, in cells in which complete or nearly complete dissociation has taken place.

The use of simple methods has served to reveal the general hydration relations of plant protoplasm and the influence of acidity and temperature upon growth and swelling; also to uncover the special effects of amido compounds upon hydration and their suggested possibilities in affecting growth. It is noted, however, that the exigencies of life may include conditions under which dehydration of the plasmatic colloids may reach such a degree that the nature of some of the sugars in growing cells may be affected. One of such changes is the conversion of polysaccharids with a low hydration coefficient to pentosans with a high hydration capacity, with the resulting succulency or xerophily of the tissue in which this occurs. An account in considerable detail is given of the work and its results.

The delicate balance between water loss and absorption as revealed by measurements of growing organs of all kinds is very striking. The rate at which water is received is generally so little in excess of the transpiration that a rise of 10 to 15° C. may extinguish the balance. At the same time such rise of temperature may also result in a lessened hydration capacity, so that by the action of the acids at the higher temperature water may be forced out of the colloidal complex.

It is considered evident that growth consists of two fundamental features—hydration of the colloidal material of the plasma, and the arrangement of additional material in colloidal structures with the entailed additional capacity for adsorbing water.

Hydration consists, in the first instance, of the union of molecules of water with the molecules of solid material in the colloidal masses, and it is this action which is entailed in the initial and almost instantaneous enlargement of dried sections when water is poured upon them. The manner in which hydration ensues, or rather the character of its process, will naturally depend upon the character of the cell colloids. Effects which are described are modified or reversed in colloidal material which consists more largely of carbohydrate material. The solubility of protoplasm will depend upon the presence of substances which are indicated.

The ideal capacity for hydration and growth of any mass of protoplasm would be a resultant of the composition and proportions of its organic material and of the relation of the phases in which they occur. The theoretical maximum of a carbohydrate-protein system is invariably modified by the nutrient salts adsorbed in its structure and by the products of unceasing metabolic changes, especially the transformations which carry compounds through a stage in which acids are formed. These features, as influenced by temperature, determine the rate, daily course, and total expansion in growth. In addition, a certain amount of material is lost in the form of carbon dioxide, and the surface loss of water may on occasion be greater than the amount passing into the growing cell masses. The above-mentioned processes and agencies affect the rate, course, and amount of growth.

The components and colloidal behavior of protoplasm, D. T. MACDOUGAL and H. A. SPOEHR (*Abs. in Science, n. ser., 51 (1920), No. 1328, pp. 595, 596*).—The authors give summarized accounts of their investigations on biocolloids, some of their previous conclusions having been noted (*E. S. R., 40, p. 28; 41, p. 221; and 42, p. 433*).

The fixation of free nitrogen by green plants, F. B. WANN (*Science, n. ser., 51 (1920), No. 1314, pp. 247, 248*).—Attention is called to differences of opinion regarding the ability of chlorophyll-containing plants to utilize the uncombined nitrogen of the air. Experiments were carried on in the New York State College of Agriculture laboratory with seven species of grass-green algæ, and with the exception of one (*Protococcus* sp.), all were isolated from the soil and used in pure cultures.

The cultures were grown in Kjeldahl flasks containing 150 gm. of a mineral nutrient agar. The full nutrient solution contained 0.5 gm. ammonium nitrate per liter, and in the various series of the experiments this source of nitrogen was replaced by ammonium sulphate, calcium nitrate, asparagin, glycooll, and urea. In all cultures, approximately equal quantities of nitrogen were used with and without 1 per cent glucose. In the cultures receiving ammonium nitrate, calcium nitrate, and ammonium sulphate, mannite was also used.

At the end of the growing period, which was from five to seven months, the cultures were analyzed for total nitrogen, and it was found that in the urea, glycooll, asparagin, and ammonium sulphate series no marked increase or decrease of nitrogen occurred in the presence of either glucose or mannite. Marked increases were found, however, in both ammonium nitrate and calcium nitrate media in the presence of glucose, the increase in total nitrogen ranging from 17 to 55 per cent. Where mannite replaced glucose in nitrate media there was no indication of fixation and in the absence of both glucose and mannite there was only a slight increase over the checks. Fixation was not confined to any one of the species, all seven showing the ability to use free nitrogen. The amount of fixation, however, varied with the different species and seemed to be related to the intensity of growth.

In experiments carried on in 1919, there is said to have been a denitrification of one species when grown on nitrate media in the presence of mannite. However, the same species in the presence of glucose increased the total nitrogen content of the culture. There was also a slight indication of denitrification with this species on nitrate media in the absence of both glucose and mannite.

Nitrophile plant formations around manure heaps, J. FRÖDIN (*Bot. Notiser, No. 6 (1919), pp. 271-277*).—This is an account of the belts of vegetation growing in the vicinity of manure heaps, with some account of the relations thereto of nitrogenous compounds.

The production of fat in plants, T. BOKORNY (*Bot. Centbl., Beihefte, 35 (1917), 1. Abt., No. 1, pp. 171-181*).—An account is given of the determination of the production of fat in plants, particularly yeast in the presence of nutrients.

Carbon-nitrogen ratio in relation to plant metabolism, A. M. GURJAR (*Abs. in Science, n. ser., 51 (1920), No. 1318, pp. 351, 352*).—According to the author, the supply of nitrogen determines the relative proportion of carbohydrates and proteins in the tomato plant. Changes in these proportions are accompanied by marked changes in the metabolism of the plant. Although the carbon-nitrogen ratio may be as high as 19 and as low as 2, fruiting was found to take place only between the ratios of 4 and 6. Respiration was influenced directly and photosynthesis inversely with the carbon-nitrogen ratio. In nitrogen starved plants, catalase activity was not parallel to respiration but varied inversely with it. Under etiolation, the high carbohydrate plants were reduced to protoplasmic respiration sooner than the low carbohydrate plants, which is said to mean that the enzym system of the former fails to make available the starch reserve. The observations on tomatoes, which were confirmed by similar data obtained with turnips and radishes, are said to emphasize the importance of determining the proper carbon-nitrogen ratio for all economic plants.

Plant growth, G. D. BUCKNER (*Abs. in Science, n. ser.*, 52 (1920), No. 1332, p. 44).—A comparative study was made of the translocation of the ash, phosphorus, calcium, and magnesium from the cotyledons of germinating garden beans (*Phaseolus vulgaris*) when grown in distilled water culture and in garden soil. In the distilled water culture 55 per cent of the original ash, 57 per cent of the phosphorus, 25 per cent of the calcium, and 59 per cent of the magnesium were translocated to the seedling. In seedlings grown in garden soil, the corresponding percentages utilized by the seedling were 91, 92, 78, and 83. Attention is called to the abnormal condition caused by the distilled water culture, and to the fact that less calcium was removed from the cotyledons by the growing seedling due to the insoluble form in the cotyledons and its structural function.

Mineral constituents of the paired seeds of cocklebur, J. S. McHARGUE (*Abs. in Science, n. ser.*, 52 (1920), No. 1332, p. 43).—Contrary to the opinion of other investigators, the author found that, if well developed, both seeds would germinate at approximately the same time if removed from the burs and planted in moist sand. If allowed to remain in the burs, only one seed germinates until the bur disintegrates and decays when the second seed will germinate. The mineral constituents of the two seeds were found to be practically the same. The large seeds averaged about 65 mg. in weight, the small seeds about 45 mg. The large seeds are said to produce the largest seedlings. This is accounted for by the fact that the large seed contains much more plant food than the small one.

The ash of dune plants, W. D. RICHARDSON (*Science, n. ser.*, 51 (1920), No. 1326, pp. 546-551).—The author has made a study of the ash of plants grown on sand dunes of almost clear silicate near Gary and Michigan City, Ind. The species investigated were the sand cherry (*Prunus pumila*), artemisia (*Artemisia caudata*), black oak (*Quercus coccinea tinctoria*), the three grasses Calamovilfa, Ammophila, and Andropogon, and the scouring rush (*Equisetum hyemale intermedium*).

From the analyses it appears that dune plants obtain and concentrate in their tissues the same mineral constituents commonly found in plants growing on common soils, and these are accumulated in approximately the same relative proportion. The author pays considerable attention to the rôle of silicon in the plants, and concludes that it is improbable that the plant organism would absorb and store up such a substance, which could have no real use in its life cycle.

[Illumination and growth], V. RIVERA (*I Problemi Agrari del Mezzogiorno. Rome: Mem. R. Staz. Patol. Veg. Roma, 1919, pp. 18*).—A preliminary study of the effect of illumination, varied as regards duration and intensity, is considered as on the whole supporting the view that the accumulation of carbohydrate is in relation to the number of hours during which the plant has the sunlight and not to the intensity of illumination.

The influence of light on some water plants, B. SCHLOSS-WEILL (*Bot. Centbl., Beihefte, 35 (1917), 1. Abt., No. 1, pp. 1-59, figs. 22*).—This is an account of the behavior of Ceratophyllum in darkness and the influence of external factors, with explanations and comparisons with other water plants.

Respiration, W. J. V. OSTERHOUT (*Abs. in Science, n. ser.*, 51 (1920), No. 1328, p. 596).—Attention is called to a simple method of measuring respiration in plants, an account of which has already been given (*E. S. R.*, 41, p. 524).

Climatic control in relation to plant growth, W. E. TOTTINGHAM (*Abs. in Science, n. ser.*, 51 (1920), No. 1318, p. 352).—A brief description is given of a small plant culture chamber for climatic control within a greenhouse.

Observations and interpretations regarding frost injury in West Prussia in the winter of 1916-17, E. WOCKE (*Mitt. Deut. Dendrol. Gesell., 28*

(1919), pp. 207-212).—An account giving condensed details is presented of injury done to different plants during the winter 1916-17 by the unaccustomed conditions.

Studies on frost injury to cereals and legumes, H. FISCHER (*Jahresber. Ver. Angew. Bot.*, 13 (1915), No. 2, pp. 92-141).—Extensive tabulations are given of observations regarding effects of cold on different portions of cereals and legumes, some of which sustained remarkably low temperatures.

The significance of the manner of thawing for the preservation of frozen plants, Å. ÅKERMAN (*Bot. Notiser*, No. 2 (1919), pp. 49-64, figs. 2; No. 3 (1919), pp. 105-126).—The author concludes from the work here indicated as done with different plants that the manner of thawing (rapid or slow) in case of a frozen plant is not always without significance as regards the final effect upon the life of the plant. Many plants have been found that were injured more by rapid thawing in lukewarm water than by slow thawing in air. This holds, however, only when plants were subjected to moderate temperature. If the plants were subjected to a certain low temperature (which was found to differ for different plants and for the same plant in different external conditions), the manner (rate) of thawing had no significance for that plant, for the reason that it already had been killed in freezing. Although it appears that in case of plants frozen easily (near the freezing point of water) rapid thawing may be as little harmful as slow thawing, in general rapid thawing must be regarded as distinctly the more injurious to the plant. A very large amount of heat suddenly presented to a frozen part of a plant may be significant in case of many plants investigated, but in case of less heat little difference may be noted between rapid and slow thawing.

Effect of seasonal conditions and soil treatment on bacteria and molds in soil, P. E. BROWN and W. V. HALVERSEN (*Iowa Sta. Research Bul.* 56 (1919), pp. 251-278, figs. 7).—A report is made on a study of the relative numbers of bacteria and molds in variously treated soils throughout the entire season. Samples were taken from six plats at 10 to 12-day intervals throughout the year, the plats being located in the station series where soil investigations were in progress.

The organisms were grown on three different media and the numbers developing determined. It was found that the bacteria decreased in the late fall with a drop in temperature until the soil became frozen, when the number of bacteria rose with decreased temperatures and fell with higher temperatures regardless of the moisture content. Upon the thawing of the soil, the number of bacteria decreased. With increasing temperature, however, an increase in bacteria occurred which reached the maximum on all the cultivated plats on June 19, and on the continuous timothy plat on April 12. Two maximum counts were observed during the year, February 12 and June 19, with intervening minimum counts.

It was found that during the summer and early fall the bacteria did not develop parallel with either moisture or temperature, and during much of the year other undetermined factors seemed to control bacterial development. The treatment of the different plats is said to have led to some unexpected effects. Applications of peat depressed the bacterial growth, while manure and clover increased their number. The continuous timothy plat showed the largest number of bacteria, but this is thought to have been due probably to the topography of the plat.

In regard to the molds, the numbers present in the soils were found to fluctuate from one sampling to the next, but their number was apparently unaffected by moisture, temperature, or soil treatment. There was apparently no relation between the bacteria and the molds present in the soil.

Factors influencing the invertase activity of mold spores in sugar, N. KOPELOFF and S. BYALL (*Abs. in Science, n. ser., 51 (1920), No. 1318, p. 351*).—A brief account is given of investigations carried on by the authors on the invertase activity of mold spores, a more detailed account of which has already been noted (*E. S. R., 42, p. 803*).

A suggestion as to the flagellation of the organisms causing legume nodules, H. J. CONN and R. S. BREED (*Science, n. ser., 51 (1920), No. 1320, pp. 391, 392*).—Attention is called to the statement of Hansen (*E. S. R., 42, p. 434*) that the organism occurring in the root tubercles of the soy bean is monotrichic, while Wilson (*E. S. R., 36, p. 848*) has reported it as peritrichic. It is stated by the authors that in Hansen's investigations the cultures were but a few days old, while those of Wilson were 28 days old before staining. This is said to raise the question whether the cowpea and soy bean organisms may not be monotrichic in young cultures and peritrichic when they are older.

Studies in variegation, I. W. BATESON (*Jour. Genetics, 8 (1919), No. 2, pp. 93-98, pls. 3, fig. 1*).—Variegation due to absence or deficiency of chlorophyll has been for some time a special object for study at the John Innes Horticultural Institution, the interest being based on the circumstance that in variegated plants an opportunity is given of witnessing somatic distribution of a character, deficiency of chlorophyll, already known to be in many plants a Mendelian recessive. The examples described in this paper illustrate miscellaneous features in the special kind of segregation indicated in the opening paragraph of the paper. The phenomena are considered as of importance aside from any question of their wider application.

The first section of this work deals with reversal in periclinal chimeras as illustrated in different plants, notably *Pelargonium*, *Coprosma baueri*, and *Euonymus japonicus latifolius variegata*. The occurrence of reversal, and of areas wholly green or wholly white, is considered as a result of some instability arising in the growing point, regarding which certain suggestions are offered.

In consequence of somatic reversal, the genetic properties of the plant are completely changed. The implications are briefly discussed.

On the non-Mendelian inheritance in variegated plants, O. WINGE (*Compt. Rend. Lab. Carlsberg, 14 (1919), No. 3, pp. 1-21, figs. 4*).—The author details experimentation carried out during 1911-1916 as to heredity in *Humulus japonicus albomaculata*, in which the albomaculata character was transmitted only through the mother. Variegated female plants gave throughout (1,500 plants) only variegated descendants (never entirely green nor entirely white), regardless of the characters in the father plants.

For entirely yellow varieties (incapable of indefinite existence) the author proposes the term *citrina*; for entirely white ones (equally incapable) the term *albina*. It is thought that the quality in variegated plant forms which segregates *albina* and self-colored green forms probably originates in the chromatophores themselves, that quality in those producing only variegated offspring arising from peculiarities in the plasm.

Suggestions are offered as to hypotheses, which are followed up with a discussion of the real nature of the hereditary conditions here involved.

Variation in *Abutilon theophrasti*, C. A. SHULL (*Abs. in Science, n. ser., 52 (1920), No. 1832, p. 41*).—The author gives a brief account of investigation on the variability in the number of carpels in the ovaries of *A. theophrasti*. The range of variability is said to be from 10 to 17 with the mode usually on 14 or 15. Only three specimens out of about 8,000 examined had 17 carpels to the ovary.

A third duplication of generic factors in shepherd's purse, G. H. SHULL (*Abs. in Science, n. ser., 51 (1920), No. 1328, p. 596*).—In continuation of the author's study on generic factors of shepherd's purse (*E. S. R.*, 41, p. 134), a report is given of a third generation of a cross between a wild biotype of the common shepherd's purse (*Bursa bursa-pastoris*) from Wales and the allied species *B. heegeri*. In this cross there appeared a small number of plants of unique type, having a more coriaceous texture than either of the plants involved in the cross. This type has been designated as coriacea, and it appeared in the F_3 family in almost exactly the ratio of 1:15.

Subsequent breeding experiments have shown that this type breeds true when selfed and have also confirmed the interpretation of this as a third case of duplication of factors in this species.

FIELD CROPS.

[Work with field crops at the North Carolina Station in 1918-19], C. B. WILLIAMS (*North Carolina Sta. Rpt. 1919, pp. 32-39*).—The different lines of work with tobacco conducted at the Granville farm are briefly noted. The results of general fertilizer tests are reported as indicating that acid phosphate is the best source of phosphoric acid for flue-cured tobacco, as bone meal and basic slag retard maturity. The use of 36 to 40 lbs. of potash per acre even at the very high cost of the material showed a profit, but larger quantities were not so profitable. Good tobacco was grown also with the use of barnyard manure and hardwood ashes, as well as with tobacco stems and phosphoric acid. It was found that by closer planting with intensive fertilization the yield could be doubled practically and the quality maintained. Experiments in harvesting by priming the leaves and cutting the stalks have been noted heretofore (*E. S. R.*, 38, p. 37). Six years' work has shown definitely the advantage of priming over cutting. It is stated that tobacco seed beds can be maintained indefinitely provided the beds are properly sterilized each year.

In cotton-breeding experiments during the past two years the highest yielding strain on the average produced 146 per cent more seed cotton than was secured from the lowest yielding strain. Other similar average variations reported are 59 per cent more seed cotton per boll, 33½ per cent greater length of lint, and 17 per cent greater percentage of lint to seed. When cotton plants from Mississippi and North Carolina grown seed from the same pure strain were grown in comparison, the plants from the Mississippi seed showed slightly heavier yields, a little longer staple, and somewhat earlier maturity.

In connection with crop improvement work the following varieties and strains are regarded as valuable for distribution: Biggs Seven-ear corn; Haberlandt No. 38, Virginia No. 11, and Mammoth Yellow-No. 101 soy beans; King No. 29 and Mexican Big Boll cotton; Leap Prolific No. 12 wheat; and Abruzzi rye. The breeding of soy beans for high oil content resulted in strains producing higher percentages of oil, but thus far these have been the poorest yielders, and the largest quantity of oil per acre has been found to come from those strains which yield the largest quantity of seed.

Cooperative experiments with the U. S. Department of Agriculture in seeding wheat and oats at different rates and on different dates are briefly described. In all plantings with wheat up to December 1 the 60-lb. seedings gave the best yields. The highest yields of grain at the Iredell farm were secured from seeding oats at the rate of 30 lbs. per acre on October 1 and November 1, of 60 lbs. on October 15, and 120 lbs. on November 15. The best yield of straw was secured from the seeding made November 1. At the Edgecomb farm the

highest yields of oats were obtained from the 60-lb. seeding made October 1, 30 lbs. October 15, 90 lbs. November 1, and 120 lbs. per acre November 15. The seeding made November 15 showed the largest amount of winterkilling and the one made October 15 the least damage from this cause.

The agricultural conditions and work with field crops of the Huntley Reclamation Project Experiment Farm in 1918, D. HANSEN (*U. S. Dept. Agr., Dept. Circ. 86 (1920), pp. 1-4, 6-18, figs. 3.*)—The crop conditions of the project are described, the acreage, yields, and farm values of crops produced there, and the number of live stock are given in tables, the lines of work of the experiment farm, located near Osborn, Mont., are briefly noted, and the results of field-crop experiments in 1918 are reported in continuation of earlier work (*E. S. R., 39, p. 834*).

The plans of the rotation experiments in progress are outlined, and the yields of the various crops in the different rotations are tabulated. The results of these tests from 1912-1918, inclusive, are regarded as indicating that alfalfa seeded in the fall in oat stubble gives better yields than when seeded the following spring, and that sugar beets make the greatest yields in a rotation in which one of the crops is manured or when following a cultivated crop. Potatoes and oats produced best when grown in a rotation including alfalfa or a manured crop. The best average yield of wheat was obtained in a two-year rotation with sugar beets. For the past six years flax in rotation gave more than double the yield of flax under continuous cropping.

In a test of sunflowers for silage in 1918 the highest yield, 37.62 tons per acre, was obtained from rows 20 in. apart with plants 3 in. apart in the row. Of three varieties of corn Northwestern Dent gave the best yield, a total of 10,439 lbs. of corn and stover per acre.

Clover-seed production was found profitable only when the first crop was left for seed. Of five varieties of barley in 1918 on land broken up from the native sod the year before Trebi ranked first in yield with 70.5 bu. per acre, being followed by White Smyrna and Chevalier with 62 and 61.5 bu., respectively.

Brief notes on winter injury of apples, plums, and cherries are also given.

The agricultural conditions and work with field crops in 1918 of the Newlands Reclamation Project Experiment Farm, F. B. HEADLEY (*U. S. Dept. Agr., Dept. Circ. 80 (1920), pp. 1-5, 8-14, fig. 1.*)—In a discussion of the agricultural conditions of Newlands (formerly the Truckee-Carson) Reclamation Project the average values of farm products per acre and the acreage, yields, and production of leading crops for 1912-1918, inclusive, and the acreage, yields, and farm values of the 1918 crops and the number and value of the live stock in 1918 are tabulated. The character of the work in progress at the project experiment farm near Fallon, Nev., is described, and the results of varietal and cultural tests are reported in continuation of previous work. (*E. S. R., 40, p. 31.*)

According to the results of varietal tests in 1918 and in preceding years, Coast barley, Australian White Flint, Wimples Yellow Dent, and Minnesota No. 13 corn, and Little Club wheat seemed best adapted to the conditions of the project. In 1918, Blue Visitor, among eight varieties of potatoes, ranked first in yield. In time of planting tests in 1918, the highest average yield was secured from planting April 23 as compared with planting April 17 and 30 and May 7, 14, and 21. Selected seed potatoes yielded nearly 50 per cent more than regular stock. Eelworm-infested seed tubers, as a whole, did not germinate or yield so well as noninfested seed. Flax, buckwheat, and Sudan grass gave promising yields in 1918.

Maintenance of pastures and meadows, E. B. STOOKEY (*Washington Sta., West. Wash. Sta. Mo. Bul.*, 8 (1920), No. 3, pp. 36-39).—The mowing, cultivation, reseeding, fertilization, and use of pastures and meadows is briefly discussed, and the annual results secured from 1913-1919 on an experiment field sown with grasses and clovers are noted. The field at the close of the period was practically free from moss, and had very few weeds and a very good stand of grasses and clovers, which made satisfactory growth. The plants proving specially valuable and persistent were Italian rye grass, orchard grass, tall oat grass, Kentucky blue grass, redtop, meadow fescue, white clover, alsike clover, and red clover.

Legume inoculation, A. F. VASS (*Wyoming Sta. Circ.* 15 (1920), pp. 4).—A popular discussion of the purpose and value of inoculating soils for the culture of leguminous crops, together with a description of methods of inoculation.

Varieties of cotton, 1919, M. NELSON and E. A. HODSON (*Arkansas Sta. Bul.* 166 (1920), pp. 3-8).—The yields secured in 1919 in cooperative tests with standard varieties of cotton in different localities are tabulated. The tests comprised three with 25 varieties, four with eight varieties, and one with different strains of a number of standard sorts. The results of only two of the tests with 25 varieties are reported. In addition to yield the percentage, length and value per acre of lint, and the approximate relative value of staples in December, 1919, are also given. The highest yield in all tests, 2,664 lbs. of seed cotton, furnishing 900 lbs. of lint per acre, was recorded for Rublee, with a length of lint of $1\frac{1}{8}$ in., and the highest value of lint, \$447.72 per acre, for Foster, with a staple of $1\frac{1}{4}$ in. The results with these varieties were obtained in the same test.

Special cotton growing contest, C. D. GIROLA (*Pub. Mus. Agr. [Soc. Rural Argentina]*, No. 16 (1919), pp. 9, figs. 4).—The conditions of a cotton growing contest conducted in 1918-19 are given, and the results secured by 28 contestants in seven different provinces are reported. The varieties grown were Chaco, Catamarca, Tanguis, Egyptian, Peruvian, Texas Wood, Simpkins, and Sea Island. The yields secured ranged from about 210 lbs. to 2,230 lbs. of seed cotton per acre.

Flax culture in the Argentine Republic, C. D. GIROLA (*Pub. Mus. Agr. [Soc. Rural Argentina]*, No. 17 (1920), pp. 20, pl. 1, figs. 8).—A description is given of flax culture for seed in Argentina including cultural practices, varieties, weeds, diseases, and the uses of flax seed and its products, and the results are reported of a contest in flax seed culture in 1918-19 instituted by the Agricultural Museum of the Argentinian Agricultural Society. The yields in the contest ranged from 12.66 to 31.83 bu. per acre.

Prevention of sprouting and greening of potatoes by properly lighting, ventilating, and cooling the storage rooms, G. SCHNEIDER (*Deut. Landw. Presse*, 45 (1918), No. 51, pp. 315, 316, figs. 12).—The results of storage experiments with potatoes, including tests of storing tubers in the dark, in daylight, and under light of different colors such as red, blue, yellow, and green are reported.

The conclusion is drawn that the best lighting of potatoes in storage is subdued daylight, which may be secured by painting the windows with lime or covering them with white or gray paper. These lighting conditions, it is stated, will reduce the tendency to sprout and prevent greening. Yellow, blue, or red light was found as effective as subdued daylight, but dark green light did not give the desired effect. Storage in the absence of light, especially in spring and summer, aided the development of sprouts and is, therefore, not recommended.

Three centuries of tobacco, G. K. HOLMES (*U. S. Dept. Agr. Yearbook 1919*, pp. 151-175).—This article reviews the history of tobacco culture in the United States, and presents statistical data regarding the various factors entering into total production and aggregate values. Among the different topics discussed are exports, imports, the national net surplus, the tobacco trade with the Philippine Islands and Porto Rico, the yearly carry-over, consumption, import duties, internal revenue rates, Government income from tobacco, and the magnitude of the tobacco manufacturing industry.

Farm practices in growing wheat, J. H. ARNOLD and R. R. SPAFFORD (*U. S. Dept. Agr. Yearbook 1919*, pp. 123-150, figs. 28).—This article is a geographical presentation and description of wheat growing operations, including preparation of seed bed and sowing, harvesting, thrashing, and marketing as practiced in the United States. The regions in which the different practices are followed are indicated on outline maps, and the significance of factors underlying these practices is briefly pointed out.

Description of Argentine and introduced varieties of wheat, C. D. GIROLA (*Bol. Min. Agr. [Argentina]*, 24 (1919), No. 1, pp. 71-137, figs. 17).—The following varieties of soft wheats are described with reference to characters, cultural requirements, yielding capacity, disease resistance, and general value: Australian, French, Tuzela, Ulku, Pedigree No. 169, Fife, Marquis, Turkey Red, Saldomé, Hungarian, Richela barbudo, Italian, Rieti, Japanese, Bearded Russian, Barleta, Chubut, Piamontés, Paduano, and Costa di Bari.

What the farmer should expect from the seedsman, E. BROWN (*U. S. Dept. Agr. Yearbook 1919*, pp. 343-346).—This article considers the seed business from the standpoint of its relation to agriculture, and emphasizes especially the information regarding seed to which the farmer is entitled when he makes his purchases. It is stated that the farmer should know the origin of the seed, how much of it is of the kind it is represented to be, the proportion of it which may be expected to grow under normal conditions, and the proportion of weed seeds present.

Agricultural seed inspection, J. L. HILLS, C. H. JONES, G. F. ANDERSON, and L. H. FLINT (*Vermont Sta. Bul. 216* (1920), pp. 26-32).—Tables are given showing the purity guaranty, the percentage of germination, and the number of weed seeds per pound of about 200 samples of agricultural seed gathered from local dealers over the State.

HORTICULTURE.

[Report of horticultural investigations in 1918 on the Newlands Reclamation Project Experiment Farm], F. B. HEADLEY (*U. S. Dept. Agr., Dept. Circ. 80* (1920), pp. 15, 16).—Data are given showing the results at the experimental farm on this project (formerly the Truckee-Carson Reclamation Project) of variety tests of sweet corn and string beans, together with data showing the blossoming period of apple, pear, and plum varieties during the three years, 1916 to 1918, inclusive.

Methods of growing the morels, K. FALCK (*Ztschr. Forst. u. Jagdw.*, 52 (1920), No. 5, pp. 312-323).—An extract from the author's paper, which appeared in the April (1920) number of "*Pflanz- und Kräuterfreund*" Heilbronn. It comprises a study of methods of growing morel mushrooms under forest conditions.

On the fruiting relations of the tomato, F. HERRMANN (*Gartenflora*, 69 (1920), Nos. 3-4, pp. 53-55, figs. 2).—Some pollination tests conducted by the author demonstrated the superiority of artificial and cross-pollination as compared with self-pollination in the tomato.

The problems of Italian arboriculture, G. BRIGANTI (*I Problemi Dell' Arboricoltura Italiana*. Bologna: Nicola Zanichelli, 1919, pp. 107).—Brief critical surveys of the fruit and nut industries of Italy, with suggestions for their betterment and extension. A bibliography of related literature is included.

The resistance of vines to winter, P. DIFFLOTH (*Vie Agr. et Rurale*, 16 (1920), No. 21, pp. 356-359, figs. 3).—A partial review of our knowledge relative to factors influencing the resistance of fruit trees and vines to cold.

List of fruits recommended by the District Horticultural Societies for the territory embraced in their districts (*Trans. Ill. Hort. Soc., n. ser., 53* (1919), pp. 25-28).—Variety lists are given of orchard and small fruits recommended for planting in northern, central, and southern Illinois.

The control of diseases and insect pests of fruit trees (*Dir. Jen. Serv. Agr. [Chile]*, Bol. 41 (1919), pp. 8, figs. 4).—Directions are given for the control of some of the more important diseases and insects attacking fruit trees in Cuba.

Orchard management, W. S. BLAIR (*Ann. Rpt. Fruit Growers' Assoc. Nova Scotia*, 56 (1920), pp. 43-50).—A contribution from the Nova Scotia Experimental Station, at Kentville, in which the author outlines the management of a closely planted commercial apple orchard set out in 1912, and gives the yield in 1919 of different varieties in the orchard. The trees were set out at a distance of 20 by 20 ft. An orchard fertilizer test conducted on pure sandy land at Berwick, N. S., is also briefly noted.

The commercial varieties of apples of Canada and the United States, W. T. MACOUN (*Ann. Rpt. Fruit Growers' Assoc. Ontario*, 51 (1919), pp. 11-22).—A contribution from the Canadian Department of Agriculture discussing varieties of apples adapted for culture in different sections of the United States and Canada, and giving a list of summer, autumn, and winter varieties recommended for different districts of Ontario.

The histories of some of our well-known pears, C. H. HOOPER (*Fruit, Flower, and Veg. Trades' Jour. [London]*, 37 (1920), No. 25, pp. 675, 677).—Brief notes on the origin of a number of well-known pears, compiled from various sources.

Some principles of peach growing, H. P. GOULD (*Trans. Ill. Hort. Soc., n. ser., 53* (1919), pp. 96-115).—A paper with discussion following, in which the author presents some of the fundamental principles of peach growing as distinct from rule-of-thumb practices and methods.

Good new not well-known varieties of small fruits, M. B. DAVIS (*Ann. Rpt. Fruit Growers' Assoc. Ontario*, 51 (1919), pp. 53-56).—A contribution from the Central Experimental Farm, Ottawa, comprising brief descriptions of a few varieties of strawberries, raspberries, grapes, and currants that have shown a good record of performance at the farm.

Black currant varieties: A method of classification, R. G. HATTON (*Jour. Pomol.*, 1 (1920), Nos. 2, pp. 65-80, pls. 8, figs. 2; 3, pp. 145-154, pls. 8, figs. 2).—A contribution from the Fruit Experiment Station at East Malling, England, comprising a classification of the black currant varieties. The classification is based on a study of some 60 different collections of black currants from nearly as many sources, and was made preliminary to a study of the economic value of the different varieties.

A mutating blackberry-dewberry hybrid, L. R. DETJEN (*Jour. Heredity*, 11 (1920), No. 2, pp. 92-94, figs. 4).—The author discovered in the summer of 1915 a cut-leaved plant arising as a bud mutation from what appears to be a wild, natural, blackberry-dewberry hybrid. The plant as discovered is here

illustrated, together with illustrations of resulting plants which show both intermediate and extreme atavistic types.

Are our raspberries derived from American or European species? G. M. DARROW (*Jour. Heredity*, 9 (1920), No. 4, pp. 179-184, figs. 4).—A contribution from the Bureau of Plant Industry, U. S. Department of Agriculture, in which the author presents some evidence to show that the European red raspberry (*Rubus idæus*) has played a more important part in the development of cultivated red raspberries in America than is commonly supposed to be the case.

Some results of fig breeding by the U. S. Department of Agriculture, G. P. RIXFORD (*Fig and Olive Jour.*, 4 (1920), No. 10, pp. 12, 13).—Brief popular descriptions are given of several fig seedlings developed from the breeding work of the Department.

Some causes of the souring and splitting of figs, I. J. CONDIT (*Fig and Olive Jour.*, 3 (1919), No. 9, pp. 13-16).—The theory that overcapricification of the Smyrna fig causes splitting has not been substantiated by investigations of the author in various orchards. An account is given of a series of observations to determine the relation between the number of fertile seeds in figs and their tendency to split. The figures as tabulated show the split figs contain a larger proportion of seeds than the others. Discussion is given of other possible causes. The conclusion reached is that the splitting of figs is probably due to abnormal water relations in the fruit and leaves brought on by irregular moisture in the soil or atmosphere. The splitting of the Smyrna fig due to atmospheric conditions can hardly be remedied, unless nonsplitting types can be developed.

Souring of figs is also discussed in connection with such probable causes as insects and variety.

Statistics on olive production during the year 1919 (*Estadística de la Producción Olivarera en le Año 1919. Madrid: Govt., 1920, pp. 6*).—A statistical report on the olive acreage and the production of olives and olive oil in the various regions and Provinces of Spain in 1919.

Cooperative improvement of citrus varieties, A. D. SHAMEL (*U. S. Dept. Agr. Yearbook 1919, pp. 249-275, figs. 16*).—A contribution from the Office of Horticultural and Pomological Investigations of the Bureau of Plant Industry comprising a popular résumé of the author's investigations dealing with the bud selection in citrus fruits (*E. S. R.*, 39, pp. 447, 448, 845). It includes a description of the methods employed in keeping individual-tree records, and an account of the cooperative work of the California Fruit Growers' Exchange in securing and distributing bud wood from superior parent trees.

Results of individual tree performance record studies with pruned and unpruned Marsh grapefruit trees, A. D. SHAMEL (*Cal. Citrogr.*, 5 (1920), No. 8, pp. 248, 268, 269, figs. 4).—In this paper the author presents some data showing the behavior of pruned and unpruned Marsh grapefruit trees on the same ranch and under similar conditions to those existing in the case of the Washington navel orange (*E. S. R.*, 41, p. 241) and the Eureka lemon tree studies (*E. S. R.*, 43, p. 239).

The grapefruit trees in this experiment were what is commonly termed of full bearing age, healthy, of a uniform strain, and producing desirable crops of fruit. The comparative yield of the pruned trees has been consistently less than that for the unpruned trees. During the course of the experiment, the pruned trees produced on the average approximately 18 per cent less fruit than the unpruned trees. The most severely pruned trees have produced the least fruit. What slight difference there was between the grades of fruit

from the pruned and unpruned trees was in favor of the unpruned trees, which produced a few more first grade fruit. These results indicate that with grapefruit trees of bearing age, severe pruning should be avoided unless it is definitely known that such pruning is necessary and likely to prove beneficial rather than detrimental to crop production.

Origin of a grapefruit variety having pink-colored fruits, A. D. SHAMEL (*Jour. Heredity*, 9 (1920), No. 4, pp. 156-159, figs. 5).—The author illustrates and briefly summarizes the history of the pink-fleshed Foster variety of grapefruit originating in Florida, and illustrates and describes a pink-fleshed grapefruit which originated as a bud sport in a Marsh grapefruit tree near Riverside, Cal.

Citrus-fruit improvement: A study of bud variation in the Eureka lemon, A. D. SHAMEL, L. B. SCOTT, C. S. POMEROY, and C. L. DYER (*U. S. Dept. Agr. Bul. 813* (1920), pp. 88, pls. 7, figs. 22).—This is the fourth of a series of publications summarizing the citrus fruit-improvement investigations of this Department (E. S. R., 39, p. 845). A detailed account is given of bud variations in the Eureka lemon as determined by means of individual tree performance records and observations.

As in the previous studies with the orange and grapefruit, it was found that both desirable and undesirable strains of Eureka lemon have been introduced into the groves through the unintentional propagation of bud variations. Eight strains were studied and are described. The performance of typical individual trees is recorded, and the importance of selecting only fruit-bearing wood from superior parent trees for propagation or for top-working is again emphasized.

Citrus-fruit improvement: A study of bud variation in the Lisbon lemon, A. D. SHAMEL, L. B. SCOTT, C. S. POMEROY, and C. L. DYER (*U. S. Dept. Agr. Bul. 815* (1920), pp. 70, pls. 8, figs. 14).—This is the fifth of the series of publications summarizing the citrus-fruit improvement investigations of this Department, and treats in a manner similar to that noted above for the Eureka lemon, a study of bud variation in the Lisbon lemon. The results secured in this study are in conformance with those noted for the Eureka lemon.

Frost protection in lemon orchards, A. D. SHAMEL, L. B. SCOTT, and C. S. POMEROY (*U. S. Dept. Agr. Bul. 821* (1920), pp. 30, pls. 3, figs. 15).—This bulletin presents detailed records of the proportion of merchantable and frozen fruits produced in 5 heated and 5 nonheated acre plats of Eureka and Lisbon lemons during the calendar year 1913, and in 2 comparative plats during the calendar year 1914 in the Corona, Cal., lemon district.

The data show that in orchards which were protected with an adequate supply of heaters during the cold weather of 1912-13 a large percentage of merchantable fruit was saved and harvested throughout the year. In unheated orchards a large proportion of the lemons picked during the first 6 months following the freeze were frozen or unmerchantable, and the trees did not return to normal production until a year had elapsed.

Nonheated orchards which had received good care prior to the freeze of 1913 and also during that year had returned to normal production by the beginning of 1914, and the heating during the cold period in 1913 had practically no effect on the second season's crop. In unprotected orchards, under comparative conditions, a greater amount of injury was found in the Eureka than in the Lisbon variety. These differences were attributed to the denser foliage of the Lisbon variety rather than to any considerable difference in the hardiness of the two varieties.

From these investigations it appears that the main effect of protecting trees during one season of low temperatures is in the saving of the crop for the

current year, and that as a rule where the trees are in vigorous condition and receive good cultural treatment they will return to normal production at the end of one year.

A review of the coconut investigations at the College of Agriculture, R. B. ESPINO (*Philippine Agr.*, 8 (1919), No. 5, pp. 161-178).—A review of the results obtained from observations and experiments on the coconut carried out at the College of Agriculture, Los Banos, P. I. The results are discussed under the following headings: Study of varieties, the coconut and environment, chemistry of the coconut, cultural experiments, and diseases and pests. A list of cited literature and of present and contemplated coconut projects is appended.

Pecan varieties, grades, standards, and packages, C. A. REED (*Amer. Nut Jour.*, 12 (1920), No. 6, pp. 82, 93).—A popular discussion of pecan varieties and methods of preparing the nuts for the market.

Sweet peas and antirrhinums: How to grow them to perfection, W. CUTHBERTSON (*London: James Clark & Co., 1919, 2. ed., rev., pp. 119, figs. 28*).—A small, practical treatise on the culture of sweet peas out of doors and under glass, including also information relative to the best varieties for different purposes, cutting and arranging, raising new varieties, diseases, and insect troubles. A section of the book is also devoted to the different classes, varieties, and culture of antirrhinums.

Native plants suitable for the gardens of Missouri and adjoining States.—V, Native perennials for the hardy border (*Missouri Bot. Gard. Bul.*, 8 (1920), No. 6, pp. 69-79).—A contribution from the Missouri Botanical Garden, comprising a tabular list of hardy perennials, for the most part native, but containing a few introduced species, that are adapted for planting in Missouri and adjoining States. The data for each plant include the botanical and common name, approximate height, color of flowers, and the approximate time of bloom.

Flowering trees and shrubs, T. R. SIM (*Johannesburg, So. Africa: The Specialty Press, Ltd., 1919, pp. 200, pl. 1, figs. 145*).—Descriptive accounts are given of flowering trees and shrubs that are in common use in South Africa and are easily obtainable. Information is also given relative to the selection of trees and shrubs for various purposes, as well as their propagation, culture, and care.

Lawn grasses for South China, H. B. GRAYBILL (*Canton Christian Col. Bul.* 25 (1920), pp. 6, pls. 6).—A contribution from the Canton Christian College, comprising notes on lawn making and grasses suitable for lawns in South China.

FORESTRY.

Cooperation between the Federal Government and the States, J. G. PETERS (*Jour. Forestry*, 18 (1920), No. 5, pp. 477-485).—In this paper the author discusses various forest activities in which it is believed cooperative effort between the Government and the States is essential to secure results commensurate with the needs of the country.

The Tri-State Forestry Conference, Ohio, Illinois, Indiana (*Ind. Dept. Conserv., Pub. No. 10* (1920), pp. 103).—This comprises a report of the papers and discussions on forestry problems at the Tri-State Forestry Conference held at Indianapolis, Ind., October 22 and 23, 1919.

Plan of relation of forest regulation to forest communities, M. H. WOLFF (*Jour. Forestry*, 18 (1920), No. 5, pp. 486-497).—A discussion of some of the principles on which regulation on the Coeur d'Alene National Forest is based,

with special reference to the development of working plans favoring the establishment and maintenance of forest communities.

The open road through the Nation's forests, J. L. COBBS, JR. (*U. S. Dept. Agr. Yearbook 1919*, pp. 177-188, figs. 12).—A contribution from the Forest Service depicting the work accomplished in the construction and improvement of roads through the National Forests in the West.

Recreation in the forests, A. H. CARHART (*Amer. Forestry*, 26 (1920), No. 317, pp. 268-272, figs. 10).—A popular discussion of recreation in relation to other utilities of the National Forests.

California forests and forestry, T. D. WOODBURY (*Amer. Forestry*, 26 (1920), No. 317, pp. 262-267, figs. 8).—A popular description of some of the outstanding features of California forests and forest practices, with suggestions relative to better regulation and control of lumbering operations.

[**Forestry in Saskatchewan**] (In *The Province of Saskatchewan, Canada: Its development and opportunities*. Canada Dept. Int., Nat. Resources Intel. Branch, 1919, pp. 99-111, figs. 3).—A brief descriptive account of the forests and forest activities, together with a discussion of the possibilities of forestry in Saskatchewan.

The management of English woodlands, W. F. BEDDOES (*London: Simpkin, Marshall, Hamilton, Kent & Co., Ltd.*, 1919, pp. XIX+172, fig. 1).—A treatise on woodland management, the succeeding chapters of which discuss planting, thinning, mixed and pure woods, notes on particular trees, planting for shelter, finance, systematic forestry, afforestation, measurement, and public burdens.

Early English forest regulations, J. D. GUTHRIE (*Jour. Forestry*, 18 (1920), No. 5, pp. 530-541).—In this article the author has grouped roughly the forest activities of early England into lines of work used in the Forest Service of the U. S. Department of Agriculture. These activities are discussed under the general headings of personnel and administration, silviculture, and grazing.

Fire protection in Portugal, T. S. WOOLSEY (*Jour. Forestry*, 18 (1920), No. 5, pp. 542, 543).—A brief note on forest fire laws and protective measures in Portugal, based on data secured by the U. S. Department of State.

The forest situation in France, R. C. HALL (*Jour. Forestry*, 18 (1920), No. 5, pp. 522-529).—The author points out the benefits derived from the past forest policy in France during the world war, and briefly reviews the present forest situation in that country.

The rational practice of silviculture, P. B. DE FONTENY (*Pratique Raisonnée de la Sylviculture*. Paris: Berger-Levrault, 1919, pp. XIV+310, figs. 5).—A general treatise on the economic phases of silviculture, the succeeding parts of which deal with the application of economic principles to silviculture, estimation and exploitability, damages, and silvicultural mathematics, formulas, and tables.

Silvicultural practice in copice-under-standard forests of eastern France, J. KITTREDGE (*Jour. Forestry*, 18 (1920), No. 5, pp. 512-521).—Notes on silvicultural practice in eastern France based on personal observation.

Some silvicultural problems in Pennsylvania, J. S. ILLICK (*Jour. Forestry*, 18 (1920), No. 5, pp. 502-511).—A discussion of certain problems relating to the establishment and development of forest plantations in Pennsylvania.

Decree and instructions relating to Eucalyptus culture (*Decreto e Instruções Sobre a Cultura do Eucalyptus*. Rio de Janeiro: Min. Agr., Indus., e Com. [Brazil], 1919, 3. ed., pp. 12).—This document contains the decree issued by the President of Brazil on March 6, 1918, providing measures for the consideration of intensifying the culture of forest species, with special reference to the Eucalypts. Information is also given relative to the soil

requirements and uses of different species of the genus, together with brief notes on methods of planting, culture and care, enemies, cost of plantations, and returns.

Jack pine, W. D. STERRETT (*U. S. Dept. Agr. Bul. 820 (1920), pp. 47, pls. 17, figs. 3*).—An account of the jack pine with reference to its distinguishing characteristics, range, forest types, soil, moisture, and light requirements, form and development, reproduction, susceptibility to injury, timber supply, characteristics of the wood, utilization, stumpage values, and management. Appended to the bulletin, are considerable diameter, volume, and yield data relating to the jack pine.

Philippine palms and palm products, W. H. BROWN and E. D. MERRILL (*[Philippine] Bur. Forestry Bul. 18 (1919), pp. 129, pl. 1, figs. 50*).—This bulletin contains popular descriptive accounts of the Philippine palms and their products, including also a key to the genera, conspecti of the species of the various genera, and references to cited literature.

Identification of the economic woods of the United States, S. J. RECORD (*New York: John Wiley & Sons, Inc., 1919, 2. ed. rev. and enl., pp. IX+157, pls. 6, figs. 15*).—In the present edition of this work (*E. S. R., 27, p. 541*), the key to the economic woods has been entirely rewritten and rearranged. Several new woods are included, and more of the common names are given. Reference lists and bibliographies have been brought up to date, and recent data dealing with structural and physical properties of woods and wood structure are appended.

Seventy-eight Preanger wood species, H. BEEKMAN (*Dept. Landb., Nijv. en Handel [Dutch East Indies], Meded. Proefsta. Boschw., No. 5 (1920), pp. 186, pls. 60*).—A descriptive account, together with photographic illustrations and a determination table, is given of the wood of 78 species of trees growing in Preanger, Java. Each wood is considered with reference to its general and microscopical characters and appearance, the color of its extract, and its burning properties.

A proposed standardization of the checking of volume tables, D. BRUCE (*Jour. Forestry, 18 (1920), No. 5, pp. 544-548, fig. 1*).—A contribution from the University of Washington. The author here proposes that two tests should be made of every volume table against its fundamental data and the results thereof published with the table itself. The first of these tests is a comparison of the aggregate true volume of the basic trees with that given therefor by the table, and the second is a computation of the average deviation of the individual tree volume from it.

The height and diameter basis for volume tables, D. BRUCE (*Jour. Forestry, 18 (1920), No. 5, pp. 549-557*).—A contribution from the University of California. The author discusses the use of height and diameter measures for the construction of volume tables, and concludes that for western conifers, at least, the proper program is to prepare volume tables on the basis of diameter breast high and either total height or merchantable height to a fixed top cutting limit in accordance with the use to which they are to be put, omitting the addition of the third factor of form until it has been proved needed.

DISEASES OF PLANTS.

The Advisory Board of American Plant Pathologists, G. R. LYMAN (*Phytopathology, 9 (1919), No. 5, pp. 201-206*).—The origin and function of the Advisory Board of American Plant Pathologists is described and a list given of the members appointed in 1919.

The differential staining of plant pathogen and host, B. T. DICKSON (*Science, n. ser.*, 52 (1920), No. 1333, pp. 63, 64).—A description is given of a method of staining by which a clear differentiation is brought out of the fungus and its host plant.

The "iceless refrigerator" as an inoculation chamber, N. R. HUNT (*Phytopathology*, 9 (1919), No. 5, pp. 211, 212, pl. 1).—The author describes the use of the iceless refrigerator as an inoculation chamber, and states that various members of the Office of Forest Pathology, Bureau of Plant Industry, U. S. Department of Agriculture, have successfully used this apparatus for inoculations with various species of *Coleosporium* and *Cronartium*.

The rôle of bacteria in plant diseases, E. M. DOIDGE (*So. African Jour. Sci.*, 16 (1919), No. 2, pp. 65-92).—Besides a systematic treatment of the historical development of opinion and knowledge regarding the bacterial causation of plant diseases, this address deals separately with symbiosis, organisms pathological to plants, agents of transmission, factors favoring infection, its occurrence, latency period, and symptomatology, and pathological plant anatomy. Important or typical plant diseases are discussed separately. A long list of related literature is appended.

Giant crown galls from the Florida Everglades, B. T. GALLOWAY (*Phytopathology*, 9 (1919), No. 5, pp. 207, 208, pl. 1).—A description is given of unusually large galls or swellings on *Hippocratea volubilis* and *Ficus aurea*. From the galls the crown gall organism (*Bacterium tumefaciens*) has been successfully isolated.

Puccinia subnitens and its æcial hosts, II, E. BETHEL (*Phytopathology*, 9 (1919), No. 5, pp. 193-201).—In continuation of a previous publication (E. S. R., 38, p. 249), in which the author reported on the hosts of this rust, additional studies are given which indicate that *P. subnitens* is known to occur on 84 host species, in 52 genera belonging to 19 families of plants. Attention is called to the variability of the æcia on different hosts and often on the same plant. The extreme variability of many of the *Æcidiums* which have been described for *P. subnitens* is believed to indicate that there are several unattached species which should be referred to this rust.

Puccinia malvacearum and the mycoplasma theory, M. A. BAILEY (*Ann. Bot. [London]*, 34 (1920), No. 134, pp. 173-200, figs. 2).—This work was started in order to throw further light on the grounds for or against the various views regarding the mycoplasma theory, as herein outlined with discussion in connection with the work of Eriksson and others. A critical discussion is given of the conditions surrounding the hollyhock seeds and young seedlings as regards the possibility of infection of the seeds by *P. malvacearum*.

The chemical composition of Bordeaux mixture, A. WÖBER (*Ztschr. Pflanzenkrankh.*, 29 (1919), No. 3-4, pp. 94-104).—This deals with what is known or thought regarding the acid, the neutral, and the alkaline phase of Bordeaux mixture. The last named is regarded as the most durable and reliable as a fungicide for use on foliage.

Mycology and plant pathology [India, 1918-19] (*Rpt. Prog. Agr. India, 1918-19*, pp. 63-70).—The progress of the year is briefly reviewed, including work with rice ufra (*Tylenchus angustus*) and blast (*Piricularia oryzae*); jute black band (*Diplodia corchori*) and a sclerotial fungus, *Rhizoctonia solani*; sugar cane smut (*Ustilago sacchari*), red rot, and two sclerotial diseases of minor importance; chilli pepper die-back (*Vermicularia capsici*), the blossom and twig rot due to *Choanephora cucurbitarum* being absent this year, presumably on account of the dry season; pigeon pea wilt (*Fusarium udum*); diseases of Rangoon beans (*Phaseolus lunatus*), (*Sclerotinia* sp.?) ; tea stem disease (*Nectria cinnabarina*), and black rot (*Hypochnus* sp.); coffee leaf

disease (*Hemileia vastatrix*); Para rubber diseases (*Phytophthora meadii* and brown bast); palmyra bud rot (*Pythium palmivorum*); areca palm mahali disease (*Phytophthora arecæ*); and miscellaneous disorders, which as briefly discussed include a disease of ginger, tobacco, and papayá due to a fungus which is here designated as *Pythium butleri* n. sp.

Spraying with lime sulphur, Burgundy mixture and Berger's lime proved efficacious in controlling peach leaf curl (*Exoascus deformans*) in Peshawar and Kumaon. In Bombay a vine mildew was controlled with a spray made up of 3 lbs. copper sulphate, 2 lbs. lime, and 2½ lbs. soft soap with water added to make 25 gal. The copper sulphate seed treatment of jowar against smut has proved to be thoroughly successful in Bombay, Madras, and the Central Provinces.

Mycological investigations in progress at Pusa deal with diseases of fruit trees in Kumaon, tokra of tobacco, and Helminthosporium species found on cultivated cereals and sugar cane at Pusa.

Wheat smuts and their prevention, with notes on other cereal smuts and ear cockle, G. L. SUTTON (*West. Aust. Dept. Agr. Bul. 71 (1920), pp. 44, figs. 27*).—Wheat in Australia is attacked by flag smut or black rust (*Urocystis tritici*), loose or flying smut (*Ustilago tritici*) and ball (stinking) smut or bunt (*Tilletia levis, T. tritici*), all of which are confined to this host. A descriptive account is given regarding each of these smuts, as also regarding barley naked smut (*Ustilago nuda*) and covered smut (*U. hordei*), oat loose smut (*U. avenæ*), rye stem smut (*Urocystis occulta*), and wheat ear cockle (*Tylenchus tritici, T. scandens*).

The microflora of normal and of moldy wheat, O. MORGENTHAUER (*Landw. Jahrb. Schweiz, 32 (1918), No. 5, pp. 551-572, figs. 2*).—This is a study of the presence and constituents of the microflora of musty wheat, of the introduction, distribution, and effects of the organisms, and of some practical measures in this connection. No fungi were present in the plated healthy grain examined, the content as regards other organisms being chiefly *Bacterium herbicola*, which was abundant.

Moldy grain, on the contrary, contains fewer bacteria but an abundance of cocci and fungi, *Penicillium* spp. predominating among the latter. It is not known which organisms originate the characteristic musty odor. The fungi appear to be wound parasites. Upon this fact are based mainly the few practical considerations which are outlined.

Foot-rot of wheat, F. L. STEVENS (*Science, n. ser., 51 (1920), No. 1325, pp. 517, 518*).—In a previous publication (*E. S. R., 42, p. 244*) attention was called to the occurrence of foot-rot of wheat in Madison County, Ill. Since that time additional studies have been made of this disease, which from the first was considered as due to a certain fungus that was universally present and gave positive results in inoculation with pure cultures. This fungus has been isolated by transfer, and no other species of fungus or other parasite was constantly present or present in any large percentage of the cases. The disease lesions were always of the same character, and wheat stems placed in conditions of suitable humidity became covered with spores of the fungus. When inoculated with pure cultures, wheat seedlings in moist chambers produced a condition of disease indistinguishable from foot-rot as occurring in the field. Wheat planted in soil, pots, or benches containing inoculum of the fungus developed typical foot-rot; when planted in infested soil in the greenhouse it developed a typical form of disease; and when placed in a moist chamber it bore the same fungus that was constantly associated with the disease in the field.

Studies of the organism have led to the determination that the foot-rot as known in Illinois is due to a species of *Helminthosporium*, and it is stated that this cereal disease, while of the general type of foot-rot known in Europe, Australia, and elsewhere, is caused by an organism not heretofore designated as a cause of foot-rot in any of the publications on this disease in other countries. The author claims that the foot-rot of wheat in Illinois should be recognized as a disease quite distinct from all others of similar type that have been previously described. From his experiments it appeared that the fungus is soil-borne, and it is considered probable that it is also seed-borne. Further studies on the morphological and histological features and the relation of the fungus to other species common to cereals are to be published later.

A disorder of cotton plants in China; Club leaf or cyrtosis, O. F. COOK (*Jour. Heredity*, 11 (1920), No. 3, pp. 99-110, figs. 10).—This is an account of an abnormality said to be peculiar to certain sections, constituting one of the principal limiting factors as regards cotton production in the central Yangtze Valley. Although no diseased spots or other localized injuries of the sorts usually caused by fungi, bacteria, or insect parasites could be demonstrated, the plants showed dwarfing, distortion, discoloration, anomalous branching, and other forms of abnormality, with corresponding reduction of crop yields. The disorder shows analogy and resemblance to the leaf curl caused elsewhere by plant lice.

The degree of the disorder appears to be related to variety and also to external conditions, though plants standing side by side may show very different degrees of the trouble. In severe cases all of the floral buds are aborted so that no more fruit is produced. Late plantings suffer worse in this respect. Hot weather favors early development of the trouble. Humidity and shade may be measurably protective. In club leaf, many branches develop that normally remain dormant. Shortening of internodes is another feature. The reduction and distortion of the leaves is one of the most prominent symptoms. Discoloration varies with varieties and conditions. An angular mottling of the leaf is a regular feature. Detailed discussion is given of the possibilities as regards control, including selection for resistance and reduction of insect parasites.

On forms of the hop (*Humulus lupulus*) resistant to mildew (*Sphaerotheca humuli*), II, E. S. SALMON (*Jour. Genetics*, 8 (1919), No. 2, pp. 83-91).—In the article previously noted (E. S. R., 39, p. 147) it was stated that plants resistant or immune to hop mildew (*S. humuli*) separate into two groups, containing, respectively, individual seedlings of the wild hop (*H. lupulus*) raised from seed obtained from Vittorio, Italy, and a female variety of a type having yellow leaves and being known as the golden hop. The present article describes further experimentation carried out during 1917 with these and other plants.

It is stated that individual seedlings of the wild hop grown in a greenhouse may be immune as regards leaf and stem to the attacks of the mildew. This immunity has been shown by the same seedlings throughout the growing season for two consecutive years. Such seedlings, however, when planted out in the hop garden may show susceptibility late in the growing season as regards the leaf and strobile. The immune plant in the greenhouse may also show strictly local susceptibility without loss of general immunity. The yellow-leaved female variety of *H. lupulus* is immune to *S. humuli*, while the yellow-leaved male variety is susceptible to this fungus.

Failure of lettuce to head, A. J. OLNEY and W. D. VALLEAU (*Abs. in Science*, n. ser., 52 (1920), No. 1332, p. 41).—According to the authors, the various physiological troubles associated with the failure of greenhouse lettuce

to head, including those known as rosette, tip burn, black heart, etc., have been found to be associated with a root rot apparently due to *Fusarium* sp. Soil sterilization by use of steam or formaldehyde gave only partial control, and this is thought to be due probably to incomplete sterilization of the lower layers of the soil.

Potato spraying trial [Long Ashton] (*Gard. Chron.*, 3. ser., 66 (1919), No. 1715, p. 233).—The report for 1918 of the Agricultural and Horticultural Research Station, Long Ashton, England, gives information regarding the results of spraying potatoes with copper fungicides. No protection is afforded by spraying unless the materials adhere to the leaf surface.

Fusarium wilt of potato in the Hudson River Valley, New York. R. J. HASKELL (*Phytopathology*, 9 (1919), No. 6, pp. 223-260, pls. 3).—Field and laboratory studies are reported on a disease of the potato that assumed serious proportions in the Hudson River Valley, New York, in 1914. The symptoms of the disease are practically the same as described by other writers for *Fusarium* wilt except that the tubers commonly exhibited a condition in which the vascular system near the stem end was browned without the causal organism being present. Experiments showed that *Fusarium oxysporum* was the primary cause of the disease, and an effort was made to discover the possible reasons for a necrosis of the tuber in the absence of any organism. It is thought that the apparently nonparasitic affection of the tuber accompanying *Fusarium* wilt may be explained on the basis of the presence of toxins.

Studies were made of the temperature relations of the fungus, and a distinct correlation was found between the amount of disease and factors influencing the soil temperature, such as altitude, exposure of fields, and shading of the plants. The most practical solution of the problem is believed to be the planting of early potatoes very early in the season, so that the crop will be matured before temperature conditions become favorable for the *Fusarium* wilt.

Experiments with lime, acid phosphate, and soil fungicides on land infested with root rot disease of tobacco. G. C. ROUTT (*Abs. in Science*, n. ser., 52 (1920), No. 1332, p. 44).—Experiments are reported in which an attempt was made to control root rot disease by applications of lime, acid phosphate, mixtures of lime and sulphur, dilute sulphuric acid, land plaster, copper sulphate, potassium polysulphid, gas lime, ferrous sulphate, and formaldehyde, but the results obtained led to the conclusion that the disease could not be controlled in this way.

A disease of tomato and other plants caused by a new species of *Phytophthora*. G. H. PETHYBRIDGE and H. A. LAFFERTY (*Sci. Proc. Roy. Dublin Soc.*, n. ser., 15 (1919), No. 35, pp. 487-505, pls. 3).—A disease attacked in 1916 nearly 50 per cent of young tomatoes in a Dublin nursery and appeared recently at other points in Ireland, perhaps also in England. The attacking fungus is considered as a new species, which is described under the name *Phytophthora cryptogea*. A closely similar disease noted in *Petunia* yielded a fungus which after being grown in pure cultures proved to be pathogenic to this and other plants. The disease harbors in the soil, working upward in the plant to the ground level and causing a basal rot. Methods of control are outlined.

A comparison of the late blights of tomato and potato. N. J. GIDDINGS and A. BERG (*Phytopathology*, 9 (1919), No. 5, pp. 209, 210, pl. 1).—A preliminary report is given of investigations which are believed to indicate that the *Phytophthora* on the tomato is somewhat different biologically from that usually found on the potato. The authors have been studying this problem for some time, and during 1918-19 several series of inoculations were made on tomatoes and potatoes with three strains of *Phytophthora infestans*, one of which was

secured from diseased tomato fruits in West Virginia; the second from diseased potatoes in West Virginia; the third from diseased potatoes in Maine. Thirty tomato plants were used in each experiment, and it was found that plants inoculated with the strain of the organism from tomatoes showed pronounced wilting of the younger growths and several stem lesions, while the plants inoculated with the strains isolated from potatoes showed no evidence of wilting or of stem lesions but did have numerous spots on the lower leaves. The differences are said to have become more marked daily until all plants inoculated from the tomato were dead, while those inoculated from the strains of the potato grew nicely and shed their lower leaves so that no evidence of infection remained.

Cultures isolated from the potato when inoculated upon tomato produced leaf spots, but did not produce the scalded, wilted appearance that is always considered characteristic of the late blight, while the cultures isolated from the tomato produced typical late blight symptoms on the tomato.

"Crinkle" on Northwestern Greening, R. H. ROBERTS (*Phytopathology*, 9 (1919), No. 6, pp. 261-263, pls. 2).—An account is given of an unusual injury on Northwestern Greening apples in Wisconsin in 1918. The trouble is considered apparently the same as the physiological crinkle reported by McAlpine (E. S. R., 31, p. 244). Limited observations are believed to indicate that the cause of this disease is comparable to that of the injury mentioned by Brooks and Fisher (E. S. R., 36, p. 50). It was not determined when the browning or injury began, but it was presumed to be associated with the extreme drought conditions which prevailed during the season.

Reversion in black currants (*Gard. Chron.*, 3. ser., 66 (1919), No. 1715, p. 233).—This work of Lees has already been noted (E. S. R., 42, p. 150).

Diseases of orange and other citrus plants, J. R. JOHNSTON and S. C. BRUNER (*Estac. Expt. Agron. Cuba Bol.* 38 (1918), pp. 7-54, pls. 15).—This body of information regarding the character, causation, results, and control of diseases affecting citrus plants in Cuba is intended to bring this general subject so far as possible up to the date of its publication.

Forest botany [and pathology], R. S. HOLE (*Rpt. Forest Research Inst. [Dehra Dun], 1917-18*, pp. 2-4).—Studies continued during the year regarding the amount of oxygen and carbon dioxide present in badly aerated soils and the relation of these gases to inferior root development in sal (*Shorea robusta*) gave reason to believe that the trouble is correlated with a deficiency of oxygen and an accumulation of carbon dioxide, possibly also of other substances. Absence of reproduction by sal in certain forests appears to be due chiefly to denudation and drying of the soil.

The gradual weakening of ulla grass (*Anthistiria gigantea*) observed in areas protected from fire is believed to be due to an accumulation of dead leaves and culms and the consequent suppression of the young shoots. A system of annual cropping prevents this trouble.

Spike disease of sandal was studied in the field. Experiments were inaugurated to test the effects of prolonged action of such factors as deficiency of an essential nutrient substance, acid soil, deficiency of water, interference with translocation of organic food, and fungi, and in general the relation between such factors (when acting continuously or rapidly) and the occurrence of starch in the parts above ground.

Black canker of chestnut, L. PETRI (*Ann. R. Ist. Super. Forestale Naz. Firenze*, 3 (1917-18), pp. 151-185, pl. 1, figs. 8).—This is a morphological and biological study of the black canker of chestnut and of its association with fungi, notably *Blepharospora cambivora* and *Coryneum perniciosum*. The

mycelium which apparently determines the death of the cambium and is regarded as the specific agent of the disease is referred to the Saprolegninae. Conclusions are reported in some detail.

Observations on gummosis of elm, L. PETRI (*Ann. R. Ist. Super. Forestale Naz. Firenze*, 3 (1917-18), pp. 75-92, figs. 4).—A gumming disease of elm is dealt with in some detail in connection with similar or related diseases of this and of various other trees as regards causation and bearings of such diseases.

A Thelephoraceæ on oak, C. MASSA (*Ann. R. Ist. Super. Forestale Naz. Firenze*, 3 (1917-18), pp. 1-31, pls. 2, figs. 5).—A Thelephoraceæ (*Stereum gausapatum*) is described in connection with injuries done thereby to oaks at points in Italy.

Peridermium pini and its transmission from pine to pine, H. KLEBAHN (*Flora [Jena]*, n. ser., 11-12 (1918), pp. 194-207, pls. 2, fig. 1).—The author, inoculating young pines directly with *P. pini*, was able to find infection in about 30 per cent of the cases. He considers this a confirmation of the conclusions previously announced by Haack (*E. S. R.*, 31, p. 153).

A supposedly parasitic disease of poplar, L. PETRI (*Ann. R. Ist. Super. Forestale Naz. Firenze*, 4 (1918-19), pp. 95-104, figs. 5).—Investigation of an intracellular fungus in poplar having negatived the question of its identity with *Blepharospora cambivora*, the cause of black canker of chestnut, the author gives a review of related or somewhat similar phenomena as reported by other investigators, and as bearing upon the question of a possible symbiotic relation between fungus and host.

Transference of nematodes from place to place for economic purposes, N. A. COBB (*Science*, n. ser., 51 (1920), No. 1330, pp. 640, 641).—Attention is called to the possibility of combating injurious nematodes through the presence of other species which feed upon the parasitic ones. It is considered that many of the practices evolved in the transfer of beneficial insects can, with appropriate modification, be applied to the transference of nematodes.

ECONOMIC ZOOLOGY—ENTOMOLOGY.

Trapping on the farm, N. DEARBORN (*U. S. Dept. Agr. Yearbook 1919*, pp. 451-484, figs. 30).—The author describes the manner in which pests on the farm may be turned into profit and the ways in which they may be trapped. Descriptions are given of the various kinds of traps and the ways in which they may be set. Information on the preparation of skins is included.

The Migratory Bird Treaty (*U. S. Dept. Agr., Dept. Circ. 102* (1920), pp. 4).—The decision of the Supreme Court of the United States sustaining the constitutionality of the Migratory Bird Treaty and Act of Congress of July 3, 1918, to carry it into effect, is here presented.

The writings of the late C. Gordon Hewitt, compiled by C. B. HUTCHINGS (*Canad. Ent.*, 52 (1920), No. 5, pp. 100-105).—The writings of the late government entomologist of Canada (*E. S. R.*, 42, p. 699) are here listed.

Report of the division of entomology, F. SHERMAN (*North Carolina Sta. Rpt. 1919*, pp. 54-58).—In control work with cabbage worm, it was found that weekly dusting with arsenate of lead and air-slaked lime in the proportion of 1:8 is a satisfactory means of control. It was found that an expenditure of about \$6 per acre in this work brings an increased return varying from \$50 to \$175 per acre in value of product, according to the market. In check plats not dusted, 28 per cent of the plats matured heads, whereas upon plats dusted weekly 75 per cent matured heads.

There was a severe outbreak of the green clover worm (*Plathypena scabra* Fabr.) on soy beans in July and August involving thousands of acres, the injury having been greatest in the eastern half of the State.

Reference is also made to potato spraying, work with the larger corn stalk-borer, with the black corn weevil, the insect survey, army worms, and invasion of the State by the cotton boll weevil.

[**Work with insects and their control in Antigua**] (*Imp. Dept. Agr. West Indies, Rpt. Agr. Dept. Antigua, 1918-19, pp. 15-18*).—This report relates to insect enemies of sugar cane, cotton, limes, sweet potatoes, and onions.

Enemies of maize in Uruguay (*Defensa Agr. [Uruguay] Pub. 10, 1918, pp. 14, pls. 4*).—Insect pests here considered include the granary weevil, *Diloboderus abderus*, the fall army worm, etc.

Pink bollworm and cotton stem weevil and their attacks upon Cambodia cotton (*Trop. Agr. [Ceylon], 53 (1919), No. 3, pp. 197-199*).—It is said that the increased price of cotton during the war has induced growers of Cambodia cotton to leave their crop in the ground for two or even three years instead of practicing the usual rotation of crops. As a result the pink bollworm has increased enormously, in some fields over 80 per cent of the cotton bolls being found infested. The cotton stem weevil (*Pempheres affinis*) is also a dangerous menace to the cotton industry of South India, 70 and even 100 per cent of the cotton in some fields being attacked. In order to combat these pests the Pest Act was passed, which requires clearing the land of cotton for a definite period of the year and pulling up and destroying their food plants over wide areas.

[**Economic forest insects in Dutch East Indies** (*Dept. Landb., Nijv. en Handel [Dutch East Indies], Meded. Proefsta. Boschw., No. 4 (1919), pp. 1-30, 55-81, pls. 16*).—Papers here presented are on The Large Teak Borer (*Duomitus ceramicus* Wlk.) (pp. 2-17), and The Teak Termite (*Calotermes tectona* Damm.) (pp. 21-30), both by H. Beekman; and The Red Coffee Borer (*Zeusera coffea* Nietner) in Forestry (pp. 55-65), The Red Stem Borer (*Z. postexicisa* Hamps.) (pp. 69-71), and Injury by the China Girdler (*Phassus (?) damoore* Moore) in Silviculture (pp. 75-81), all by L. G. E. Kalshoven.

A coordination of our knowledge of insect transmission in plant and animal diseases, F. V. RAND and W. D. PIERCE (*Phytopathology, 10 (1920), No. 4, pp. 189-231*).—This is a general discussion of the subject in connection with a bibliography of 178 titles.

Termites and termitophiles, E. WARREN (*So. African Jour. Sci., 16 (1919), No. 2, pp. 93-112, pls. 3*).—This is a comparative study of the modifications of structure and habit occurring in the various foreign organisms living as guests or parasites in the nests of termites. The subject is dealt with under the headings of distribution of termites in space and time, the termitophilous habit, comparison of the termitophile faunas of the various regions, and comparison of the termite faunas of the various regions.

Concerning the distribution of North American Cicadellidæ (Hemip.), G. W. BARBER (*Canad. Ent., 52 (1920), No. 5, pp. 116-118*).

Leaf hopper investigations on Hawaii, C. E. PEMBERTON (*Abs. in Rev. Appl. Ent., 8 (1920), Ser. A., No. 1, pp. 19-21*).—This is a preliminary report of investigations made of the sugar cane leaf hopper (*Perkinsiella saccharicida*) in Hawaii during June and July.

The jumping plant lice of the Palæotropics and the South Pacific Islands (Family Psyllidæ, or Chermidæ, Homoptera), D. L. CRAWFORD (*Philippine Jour. Sci., 15 (1919), No. 2, pp. 139-205, pls. 3, figs. 3*).—This paper includes keys to the subfamily, genera, and species. Three genera are erected

and 37 species described as new. *Psylla isitis* Buckton is a pest on indigo and *Euphalerus citri* (Kuwayama) on citrus trees.

Potato spraying experiments on the control of the pink and green aphid (*Macrosiphum solanifolii* Ashmead), Part I, L. B. SMITH (*Virginia Truck Sta. Bul. 29* (1919), pp. 101-118, fig. 1).—This is a report of control work with the pink and green aphid begun in 1915 and conducted each year since that time. An account of this pest by the author has previously been noted (E. S. R., 41, p. 662).

"The losses from this insect have been in the past more severe on the Eastern Shore peninsula than in the Norfolk section. Much of the data herein recorded is based on experiments conducted in 1917.

"The spring crop of potatoes are usually infested within 2 or 3 weeks after they come through the ground. The effect of the aphids feeding is first noticeable as a curling of the leaves, which is later followed by their turning yellow and dropping to the ground. The infested areas within a field are easily distinguishable by the yellow and withered appearance of the plants. The effect of the injuries when the plants are not killed is to delay the development of the tubers.

"Nicotin sulphate and fish oil soap were the materials used to combat the aphids. . . . Nicotin sulphate was also used in combination with Bordeaux mixture and arsenicals. . . . The formula recommended is as follows: Nicotin sulphate, 8½ oz.; fish oil soap, 5 lbs.; and water, 50 gal.

"If it is desired to use a combination spray, add 8 to 10 oz. of nicotin sulphate to the 50 gal. of mixture as prepared for use against the potato beetle. Do not mix the nicotin in the same spray with Paris green. When the Bordeaux-nicotin combination is used, two or more sprayings should be made about 8 to 10 days apart, and the first one to come when the plants are 5 or 6 weeks old. Sprayings with the nicotin and soap may be withheld somewhat longer but in no case until serious injury has resulted to the plants. It is better to spray too early than too late. If the first application does not entirely destroy the aphids, a second application must be made one week later.

"The governing factor of the results obtained in spraying for the control of plant lice is the thoroughness of application. No benefits are derived unless a large proportion of the insects are directly hit by the spray. To accomplish this purpose, it is essential that the machinery is suitable and in the best possible mechanical condition by the time the spraying season commences. A hard driving spray is best for use against these insects on potatoes, and a machine which will develop and maintain at least 150 and preferably 200 lbs. is the most economical to use."

Sugar-beet root-lice control, D. HANSEN (*U. S. Dept. Agr., Dept. Circ. 86* (1920), pp. 16, 17).—This is a brief report of work with the sugar-beet louse, conducted in cooperation with the Montana Experiment Station, and is in continuation of that previously noted (E. S. R., 39, p. 863). In the work in 1918, 16 plats in the field used in 1916, 1917, were irrigated 2, 3, 4, and 5 times, respectively. The results, which are reported in tabular form, indicate that the amount of infestation on any of the plats, regardless of the number of irrigations, was very small and perhaps not sufficient in any case to affect the yield. This was the case also in other fields that were observed, and was apparently due to climatic conditions that at some time during the season were unfavorable for the development of the root louse.

Spraying walnut aphid, E. BRAUNTON (*Cal. Cult.*, 54 (1920), No. 20, p. 812, fig. 1).—The nicotin dust spray is said to have proved quite effective during 1919 against the green apple aphid, melon aphid, peach thrips, and onion thrips, as well as against the walnut aphid.

A synopsis of the Aphididæ of California, A. F. SWAIN (*Univ. Cal. Pubs. Ent.*, 3 (1919) No. 1, pp. 221, figs. 317).—The author recognizes 182 species, representing 48 genera of aphids, as occurring in California. All the present records of California species are brought together. Tables are given for the separation of the subfamilies, tribes, genera, and species. Keys to the Genera and Tribes of Aphididæ, by P. van der Goot (pp. 154-158), and a Host Plant List of California Aphididæ (pp. 159-177) are appended. An index to genera and species is included.

Notes on oriental Aphididæ, P. VAN DER GOOT (*Tijdschr. Ent.*, 61 (1918), No. 3-4, pp. 112-127, figs. 5).—This is a contribution to the knowledge of the geographical distribution of aphids, in which the author reports upon the results of limited collections made at Singapore and Hongkong. Ten species were collected at Singapore, of which 3 are described as new, and 8 at Hongkong, of which 1 is described as new.

Cypress bark scale, F. B. HERBERT (*U. S. Dept. Agr. Bul.* 838 (1920), pp. 22, pls. 6, figs. 5).—The cypress bark scale (*Ehrhornia cupressi* Ehr.) infests a large percentage of the Monterey cypress trees in California. Monterey cypress is one of the most popular shade and ornamental trees in California, where it is planted separately or in hedgerows and often trimmed to formal shapes. Its attack caused a great deal of injury, particularly to the thickly planted hedgerows and windbreaks, and in the San Francisco Bay region, it ranks first among the pests of the Monterey cypress.

"It was found in the course of a thorough investigation that the scale insect was not a native of the Monterey cypress, but of the incense cedar which occurs in the mountains of California, Nevada, and southern Oregon. From this host it has probably spread to the Monterey cypress by the transportation of incense cedar seedlings or rustic timber to the regions infested. The characteristic injury caused by this insect begins to show on 1 or 2 limbs and slowly spreads to the rest of the tree. The foliage turns first yellow, then red or brown, giving the tree a very dilapidated appearance. After a few years the whole tree dies. The food plants of the cypress bark scale are Monterey cypress, Arizona cypress, Guadalupe cypress, and incense cedar.

"The larvæ are small oval bodies, pale yellow in color, which are active for a short time after hatching. They attach themselves in crevices of the bark and are soon enveloped in a white cottony secretion. As they reach maturity they become reddish brown in color and nearly spherical in shape.

"Oviposition begins in the spring and lasts throughout the summer. The eggs hatch into larvæ in less than an hour and soon attach themselves. The females reach maturity in the fall and hibernate over the winter, starting oviposition in the spring. The males appear in the late fall or early winter to mate and die. There are several insects which prey upon the cypress bark scale, none of which, however, is abundant enough to control the scale insect. Consequently remedial measures have to be adopted. A 12.5 per cent solution of a high-gravity miscible oil is the spray recommended. To obtain complete control it is necessary to spray twice in the early fall, once in August, and once in the latter part of September."

Coccidæ from the island of São Thome, A. F. DE SEABRA and P. VAYSSIÈRE (*Bul. Soc. Ent. France*, No. 10 (1918), pp. 162-164; *abs. in Internatl. Inst. Agr. [Rome]*, *Internatl. Rev. Sci. and Pract. Agr.*, 10 (1919), No. 3, pp. 360, 361).—This is an annotated list of 14 species occurring in São Thome, Africa.

Contributions toward a monograph of the sucking lice, G. F. FERRIS (*Leland Stanford Jr. Univ. Pubs., Univ. Ser.*, 1919, No. 1, pp. 51, figs. 32).—This paper, the first of a series to be published, deals with the genera *En-*

derleinellus and Microphthirus n. g. The author recognizes 19 species of Enderleinellus, of which 13 are described as new and one as belonging to the genus Microphthirus.

Experiments on the destruction of lice and nits (*Brit. Med. Jour.*, No. 3074 (1919), pp. 703-705).—The first part of the paper, by A. Bacot and G. Talbot, deals with the survival period of lice and nits (*Pediculus humanus*) when submerged in tap water and water containing 1 per cent of salt at various temperatures. The results obtained show that no reliance can be placed on the simple soaking of verminous textiles in water even for so long a period as 24 hours unless the temperature of the water is about 90° F. Four per cent of the nits hatched after 22 hours in salt water at 91°, but none in tap water. No apparent advantage is gained by the addition of salt, plain tap water giving results just as good and in some cases better.

The second part of the paper, by A. Bacot and L. Lloyd, relates to experiments concerning the destruction of active lice (*P. humanus*) by solutions of cresol soap emulsion and lysol, and of lice and nits with kerosene, with a view to the use of these remedies for the treatment of verminous heads. While the lice are able to survive immersion in fluids at temperatures somewhat below that which they experience on man, when immersed in a 2 per cent solution of lysol at 100 to 104° for 30 minutes they are destroyed. Where it is not possible to use heated solutions, the complete disinfestation of garments or bedding may still be achieved with cold solutions, provided their strength is not less than 1.5 per cent with an immersion period of 1 hour and that the solution remaining on the fabric after dipping be allowed to dry in.

Lice and nits were immersed in kerosene at a temperature of 68° for a period of 5 minutes. Most of the lice made active movements while immersed, and one or two made slight movements immediately after removal. The fatality of active lice following immersion is thought to be due to the oil on the surface of the insect or the object to which it clings obtaining entrance to its body after removal from the fluid rather than during the short period of immersion.

The Achemon sphinx moth (*Pholus achemon Drury*), R. L. NOUGARET (*Mo. Bul. Dept. Agr. Cal.*, 8 (1919), No. 10, pp. 560-584, figs. 18).—This moth occurs throughout the United States, but is of economic importance only in the vine-growing districts of California. It is most abundant in the warmer centrally located valley of the San Joaquin, where local sporadic outbreaks occur from time to time. At times it becomes a pest of considerable importance because of serious crop losses due to complete defoliation of the vine through skeletonizing of the leaves. The sudden arrest in the vegetative functions of the plant caused by defoliation reacts upon the development of the fruit, which, if small and quite green, will shrivel and more often drop from the stems, a total loss of the crop resulting. If the fruit has reached a point where the berries have begun to ripen, the maturing progress of the grapes is arrested until a new growth of leaves, which continue once more the transformation of the sap for the benefit of the fruit. In the meantime the berries have softened somewhat, they are not so firm in texture as a normal ripening would produce, and they do not attain so perfect a state of maturity.

The eggs are deposited singly on the upper surface of fully developed leaves. No reliable data on the period of incubation have as yet been obtained. The three larval instars last for an average of 7.6, 7.2, and 14.6 days, respectively. An average of 30 days is required from hatching until pupation and an average of 54 days from hatching until the emergence of the adult. The larva is commonly parasitized by the tachinid fly *Sturmia distincta* Wied.

As a control measure the author recommends the use of arsenate of lead paste 11 lbs., atomic sulphur 24 lbs., ground glue 1 lb., blackleaf 40 1.5 pints, and water 200 gal. The application of this spray results in first and second instar larvæ being killed by contact without further injury, while the older larvæ are destroyed by the arsenical. The combination of arsenate of lead, atomic sulphur, and glue produces a good adhesive coating which provokes a longer contact of the blackleaf 40 with the worm and causes death, when otherwise the nicotin, volatilizing more rapidly, would not do so.

The glasshouse tomato moth and its control, L. LOYD (*Fruit, Flower, and Veg. Trades' Jour.* [London], 36 (1919), No. 26, pp. 717, 718; 37 (1920), Nos. 1, p. 9; 2, p. 87).—This is a summary of information on *Hadena oleracea*, which is a source of loss in greenhouses in the Lea Valley amounting to £5 to £10 or more per acre where special remedial measures have not been adopted. The use of arsenate of lead paste at the rate of 6 lbs. to 100 gal. water, to which 2 oz. saponin has been added, is recommended. It is essential that the spray be applied just after transplanting and repeating about four weeks before the first fruit is picked. Caterpillars that appear when the plants can not be sprayed should be trapped, directions for which are given. The moths should be trapped throughout the season.

Control of the grape-berry moth in northern Ohio, H. G. INGERSON and G. A. RUNNER (*U. S. Dept. Agr. Bul.* 837 (1920), pp. 26, pls. 4, fig. 1).—This is a report on extensive experiments in cooperation with the Ohio Experiment Station conducted in northern Ohio during the seasons of 1916, 1917, and 1918. This moth has been a more general pest in northern Ohio than in other commercial grape sections because of the following conditions: (1) Production of the late maturing Catawba variety, (2) cultural methods favorable to successful wintering of the insect, (3) harvesting methods which leave the insect in the vineyards, and (4) a grape training system which prevents spray materials from reaching the clusters when applied with set nozzles.

The work has shown that a combination of first and second spray applications is adequate for control on the principal varieties of grapes grown in northern Ohio, and when carefully applied leaves the fruit suitable for the basket market. "A combination of arsenate of lead powder 1.5 lbs. to 50 gal. and resin fish oil soap 1 lb. to 50 gal., in Bordeaux mixture or with stone lime 2 lbs. to 50 gal., may be used for spraying Concords and Catawbas. Copper sulphate should not be used in the above mixture for Ives variety. Arsenate of calcium, commercial powder, proved almost as efficient as arsenate of lead for grape-berry moth control. Dust mixtures do not adhere to the grape berries as well as liquid sprays, but may be used on small home grape arbors if applied frequently. The grapes will be practically free from spray residue if the schedule recommended is used according to directions. The trailer method only was used, and a trailer provided with a short rod and two angle nozzles proved most satisfactory in most vineyards."

The fight against the pink bollworm in the United States, W. D. HUNTER (*U. S. Dept. Agr. Yearbook* 1919, pp. 355-368, figs. 5).—This is a brief popular summary of the work carried on against the pink bollworm in this country, a more extended account of which by the author has been previously noted (*E. S. R.*, 39, p. 764).

Antagonism of cattle and man in the blood nutrition of *Anopheles maculipennis*.—The antimalarial rôle of domestic cattle, E. ROUBAUD (*Compt. Rend. Acad. Sci.* [Paris], 169 (1919), No. 10, pp. 483-486).—The author reports observations on the food habits of *A. maculipennis*, the principal transmitter of malaria in Europe. Comparative observations made in the Vendéen fens, the Loire-Inferieure, and the vicinity of Paris indicate that the problem

of malaria eradication in France is connected in large part with the protection furnished by cattle. It appears that domestic cattle play an anti-malarial rôle of first importance, since the great majority of *Anopheles* feed upon them, and thus lessen accordingly their attack upon man.

The animals attacked in order of preference are the porcine, bovine and equine, goat and sheep, rabbit, and dog.

The apple maggot in New York, G. W. HERRICK (*New York Cornell Sta. Bul. 402 (1920), pp. 89-101, figs. 7*).—This insect is widely distributed in New York State and apparently increasing in importance as an injurious pest. The greatest commercial loss appears to be caused in the Hudson River Valley, in the Champlain district, and along the eastern end of Lake Ontario. The author has found that the varieties more commonly attacked in New York are Early Harvest, Red Astrachan, Maiden Blush, Primate, Alexander, Pumpkin Sweet, Tolman Sweet, Fameuse, McIntosh, Rhode Island Greening, Oldenburg, Northern Spy, Baldwin, and Tompkins King.

"Experiments begun in this country in 1910 and carried through subsequent years have shown that the apple maggot can be effectively controlled by spraying infested trees with arsenate of lead paste at the rate of 5 lbs. to 100 gal. of water. In general two applications should be made, the first during the last days of June or the very first days of July and the second about two weeks thereafter. The spraying should be done rather thoroughly, although there appears to be no need of coating the trees as completely as one would when spraying for the codling moth, for example. The applications can be made more quickly and with less material than in usual spraying operations. All trees on the farm, especially those about the house and barn, should be sprayed to prevent the maggot from breeding undisturbed on such trees. If there is an infested orchard near by, the owner should be induced if possible to spray it as a matter of protection. It seems probable from the experience of practical fruit growers that after the maggot has once been brought under control the ordinary codling moth sprays given after the petals fall and again 3 weeks later would suffice to control the flies."

The melon fly: Its control in Hawaii by a parasite introduced from India, D. T. FULLAWAY (*Hawaii. Forester and Agr., 17 (1920), No. 4, pp. 101-105*).—This is a brief account of the introduction of the Indian parasite *Opius fletcheri* of *Bactrocera cucurbitæ* into Hawaii in 1915, where at the present time 50 per cent of the melon fly infesting fruit is destroyed by it.

The bean ladybird, F. H. CHITTENDEN and H. O. MARSH (*U. S. Dept. Agr. Bul. 843 (1920), pp. 24, pls. 6, figs. 8*).—This is a report of investigations of *Epilachna corrupta* Muls., the life history investigations of which were conducted by the late junior author at Rocky Ford, Colo., from 1914-17. Some field operations were also conducted at Pueblo, Fort Collins, and Colorado Springs, Colo., and at Maxwell and French, N. Mex. A Farmers' Bulletin on this insect by the senior author has previously been noted (*E. S. R., 42, p. 252*), as has also a report of investigations of this pest in New Mexico by Merrill (*E. S. R., 37, p. 465*).

The authors find that the life cycle may be passed in the summer from 22 to 30 days; the eggs hatch in from 4 to 9 days; the larval period is between 15 and 21 days; and the pupal period varies from 3 to 6 days. Two generations are produced annually.

Insect enemies do not appear to be particularly effective in controlling this beetle. There are 3 species of ladybird beetle, namely *Hippodamia convergens* De G., *H. 5-signata* Kby., and *Coccinella transversoguttata* Fab., known to destroy the eggs, and next to cold are the most effective known factors in its

natural control. Control work with arsenicals indicates that lead arsenate acts largely as a repellent rather than an insecticide. Experiments reported in which lead arsenate, zinc arsenite, and Paris green were used led to the recommendation that arsenite of zinc be applied at the rate of 1 lb. to 40 gal. of water, or $1\frac{1}{2}$ lbs. to 50 gal. of water, or lead arsenate 1 or 2 lbs. to 50 gal. of water.

A list is given of 23 references to literature. A brief account of the bean ladybird in Colorado in 1919, by A. E. Mallory (pp. 21-24), follows.

Smaller pear borer (*Laspeyresia molesta* Busck), NISHI-HIME-SHINKU (*Abs. in Rev. Appl. Ent.* 8 (1920), *Ser. A, No. 1*, pp. 23, 24).—This pest, known in the United States as the oriental peach moth, is one of the most destructive insects in Japan, occurring in nearly all of the Provinces of the Empire. Where it is most numerous in that country, from 80 to 90 per cent of the pear crop may be destroyed by it. There are 4 or 5 generations per year, the time of appearance varying with the climate of the locality.

On hybrids of *Batocera albofasciata* and *B. gigas*, K. W. DAMMERMAN (*Tijdschr. Ent.*, 62 (1919), *No. 3-4*, pp. 157-160).—Breeding experiments by the author show that deviating forms are actually hybrids of *B. albofasciata* and *B. gigas*. It appears that so long as these species are free to select, the hybrids will only occasionally occur.

Root-bark channeller of citrus (*Decilaus citriperda* Tryon), H. TRYON (*Queensland Agr. Jour.*, 13 (1920), *No. 2*, pp. 71-82, *figs. 14*).—Injury to the orange by a cryptorhynchid beetle here described as new was first observed in Queensland in 1908, but not until 1917 was its noteworthy harmfulness brought to attention. In the latter year certain trees at Montville exhibited a lack of vigor suggestive of die-back but without the shedding of foliage. Examination of their root system showed that those roots at or near the surface were apparently dead or nearly so, having been attacked by borers. Soon afterwards the occurrence of this pest was observed at Mapleton.

Technical descriptions are given of this beetle and an account of its habits, injury caused, and the present status of control work. The eggs are deposited in small depressions or holes gnawed in the bark, one egg in each. Upon hatching out, the larva at once commences to mine, but apparently in no fixed direction. Pupation takes place in wide channels within the root bark tissue. There are thought to be at least two broods, adults emerging in the spring (September) and again in December-January.

Thus far experiments have not resulted in the discovery of any remedial measures that can be relied upon for successful results.

The powder-post beetle and its parasite, W. W. FROGGATT (*Agr. Gaz. N. S. Wales*, 31 (1920), *No. 4*, pp. 273-276, *figs. 2*).—This is a brief account of *Lyctus brunneus*, which was found in 1919 to be attacked by an undetermined braconid parasite.

Further experiments with poisoned bait on maize lands, R. W. JACK (*Rhodesia Agr. Jour.*, 17 (1920), *No. 2*, pp. 130-136).—This is a brief report of tests made with snout beetles (*Tanymecus*) and the surface beetles (*Gonocephalum*).

Poison boll weevils, F. C. WARD (*Ga. Col. Agr. Bul.* 196 (1920), pp. 12, *figs. 2*).—This presents the results of several demonstrations in poisoning the boll weevil made in Georgia during the summer of 1919. Details are given of the work carried on on six farms, four of which showed profits, respectively, of \$1.31, \$4.53, \$18.87, and \$23.31, and two showed losses of \$3.17 and \$6.05 per acre. The data presented have been summarized by the author as follows:

"The use of calcium arsenate for controlling the boll weevil is profitable if it is used under proper conditions. It will be more profitable when used on

high-yielding areas. Only a high grade of calcium arsenate containing not less than 42 per cent of arsenic pentoxid and not more than 0.75 per cent water soluble arsenic should be used. It should never be used as a liquid spray, but should be dusted on the cotton. It should be applied at night or in early morning when the plants are moist with dew.

"Hand picking of weevils and squares will be more profitable than poisoning until the damage is 10 per cent, which will be about the last of June or the middle of July. Poison every week so that all new leaves and squares will be covered, and poison after each heavy rain that washes off the poison. Be economical with poison, for cost of material is the greatest item of expense. Use power machines if possible, for they use less material and cover the plants more thoroughly. Poisoning alone without other control measures is not sufficient."

Alfalfa weevil and control methods, C. WAKELAND (*Univ. Idaho Ext. Circ.* 23 (1920), pp. 4).—This is a popular summary of information.

The banana weevil (*Cosmopolites sordida* Chev.), H. TRYON (*Queensland Agr. Jour.*, 13 (1920), No. 4, pp. 165-168, fig. 1).—This paper includes descriptions of the several stages of the weevil, an account of its habits, and the detection of its occurrence. Remedies suggested, by A. H. Benson, are appended.

Beekeeping for the Oregon farmer, A. L. LOVETT (*Oreg. Agr. Col. Ext. Bul.* 282 (1919), pp. 24, figs. 12).—This is a practical summary of information.

Notes on the bionomics, embryology, and anatomy of certain Hymenoptera Parasitica, especially of *Microgaster connexus* (Nees), J. B. GATENBY (*Jour. Linn. Soc. [London], Zool.*, 33 (1919), No. 224, pp. 387-416, pls. 3, figs. 15).—The data here presented have been summarized by the author as follows:

"Notes are given on the bionomics of certain Chalcididæ, Braconidæ, Proctotrypidæ, and Cynipidæ, especially of *M. connexus*, *Mesochorus pallidus*, and *Aphidius* sp. *M. connexus* (Nees) is a Braconid parasite on the larvæ of the moth *Porthesia similis*. *M. pallidus* (Brisch.) is a hyperparasite on the larvæ of *Microgaster* which live inside the larvæ of the moth *P. similis*. Notes and descriptions of part of the life-history of *Apanteles glomeratus*, allied to *M. connexus*, are also given."

Microgaster lays from 16 to 50 eggs inside the body of small larvæ of *P. similis*. In rare cases very few eggs are laid, while in other examples 60 larvæ were bred from one parasitized moth caterpillar. The average number is about 30. The anatomy of the larvæ is described.

"The hyperparasite has been shown to oviposit while the larval *Microgaster* is from one-third to one-half full size. Certain facts with regard to the habits of the hyperparasite (*Mesochorus*) are given.

"Notes are given on parasitism and hyperparasitism among Aphidæ. Figures of four insects bred from aphids, and belonging to different families, are given. The presence of a peculiar embryonic membrane in *Aphidius* sp., parasitic on *Aphis pomi*, is described, and its use pointed out. The subject of entomophagus parasitism in Hymenoptera is fully discussed from the point of view of *Microgasteridæ* and *Aphididæ*."

Notes on certain entozoa of rats and mice, together with a catalogue of the internal parasites recorded as occurring in rodents in Australia, T. H. JOHNSTON (*Proc. Roy. Soc. Queensland*, 30 (1918), pp. 53-78, fig. 1).—A bibliography of 57 references to the literature is included in this paper.

FOODS—HUMAN NUTRITION.

An investigation of the methods employed for cooking vegetables, with special reference to the losses incurred.—II, **Green vegetables**, H. MASTERS and P. GARBUTT (*Biochem. Jour.*, 14 (1920), No. 2, pp. 75-90).—In continuation of the investigation previously noted (*E. S. R.*, 40, p. 360), similar studies were made with green vegetables, principally cabbage, spring greens, and Brussels sprouts. In addition to considering the losses on cooking and the time of cooking, a study was made of the color changes in the green vegetables on cooking and the extent to which it is possible to preserve the original green color.

The changes in color were shown to be due chiefly to the action on the chlorophyll of the hydrogen sulphid and volatile organic acids liberated during cooking. The common practice of helping to preserve the original green color of the vegetables by cooking in a considerable volume of rapidly boiling water in an open vessel or by adding a small amount of alkali, usually sodium bicarbonate, to the cooking water is thought to result in a loss of these acids, in the first method on account of their volatility and in the second through neutralization. The use of a relatively large volume of water also tends to dilute the acids formed and render them less capable of action on the chlorophyll.

A comparison of the different methods of cooking green vegetables showed that the addition of a small amount of alkali decreased the time required for cooking and slightly decreased the losses. The addition of salt appeared to have no effect on the time of cooking or losses incurred.

The losses of solid and mineral matter were less when the vegetables were steamed or cooked in covered vessels with a small amount of water, but the color of the final product was not so good and the time required was much longer. To obviate these difficulties the use is recommended of a small amount of sodium bicarbonate in boiling, and of ammonium carbonate in steaming vegetables. An excess of either of these salts should be avoided.

Lupins in human nutrition, A. FUNARO and L. MUSANTE (*Atti R. Accad. Econ. Agr. Georg. Firenze*, 5. ser., 15 (1918), No. 1-4, pp. 68-78).—Analyses of flour prepared from the common lupin before and after the extraction of the alkaloidal principles by alcohol acidified with hydrochloric acid are reported. These indicate a slight increase in fat, protein, cellulose, and pentosans and a decrease in other carbohydrates and in mineral matter. The high percentage of soluble proteins in lupin flour is thought to make it a valuable part-substitute for wheat flour, 15 parts of the lupin flour to 85 of the wheat flour being suggested as satisfactory proportions.

Condensed nuoc-mam, ROSÉ (*Bul. Écon. Indochine*, n. ser., 22 (1919), No. 134, pp. 75-82).—Nuoc-mam, the Indochinese fish sauce previously noted (*E. S. R.*, 41, p. 66), has been successfully condensed for transportation and use by the Indochinese soldiers in France. The process of condensation and the composition, properties, and use of the condensed product are described briefly.

The formation of ferrous sulphid in eggs during cooking, C. K. TINKLER and M. C. SOAR (*Biochem. Jour.*, 14 (1920), No. 2, pp. 114-119).—Experimental evidence is given that the greenish black coloration observed on the surface of the yolk of "hard boiled" eggs which have been cooled slowly is due to the formation of ferrous sulphid from the iron in the egg yolk and hydrogen sulphid formed in the egg white by slow decomposition of a sulphur compound. The absence of this color on the yolk of a "hard-boiled" egg which is placed in cold water immediately after cooling is thought to be due to the checking of the decomposition.

Food poisoning, W. L. DODD (*Amer. Food Jour.*, 15 (1920), No. 5, pp. 20-22, 32).—A general discussion.

German nutrition, 1914-1919, C. C. MASON (*Bul. Johns Hopkins Hosp.*, 31 (1920), No. 349, pp. 66-79, figs. 7).—This is a discussion of the policies adopted by Germany in regard to the food situation during the war and the lessons that should be drawn from the failure of the German system of rationing. Attention is called to the essential differences between food control as practiced by England and the food rationing of Germany.

"Food control can be a success. mass rationing will always be a failure. By food control, as the term is now used, is meant a control of those activities which tend to dissipate the energy contained in food and a more complete conservation of the same. Broadly speaking, any activity which tends to raise the price of any article of food above its normal level tends to destroy the usefulness of the food and in that way works against the greatest public good. Under this type of activity we can class such things as useless transportation, too many middlemen, or withholding food from the market in order to maintain a price. Inasmuch as such procedures tend to keep the food out of the hands of the consumer they work against fullest conservation of national resources. Along the lines of positive control there is a great deal of work to be done on the stock question, the relationship which must exist between the number of people and the amount of live stock to be maintained. This problem alone played a quite important part in the German food question all during the war. Then the control of live stock is intimately wrapped up with the question of the milling of flours, the choice of grains to be milled, the percentage to which they shall be made of the millings."

From the experiences of England and Germany in relation to the problem of mass feeding under conditions of famine, blockade, or siege, the author draws the following conclusions:

"Food control, i. e., food conservation, must be practiced by every person.

"Live stock must be reduced to a level compatible with the grain supply.

"The people must subsist on a larger percentage of vegetable products, increasing the amount of land used for such crops as rapidly as such land is freed from the support of live stock. Bread will form the staple of diet, so the milling of the flour must be carried out in the most efficient manner, taking into consideration the actual nutriment to be given to humans and to stock.

"Rationing must be limited to those articles which are luxuries; necessities, i. e., bread, meat, potatoes, etc., must be permitted to circulate freely. (In case of actual siege or practically closed blockade it may become necessary to enforce stringent rationing.) The psychological aspects must never be overlooked."

Tables and charts of statistical data illustrative of food conditions in Germany during the war are included.

The chemical isolation of vitamins, C. N. MYERS and C. VOEGTLIN (*Jour. Biol. Chem.*, 42 (1920), No. 1, pp. 199-205).—The authors describe the preparation of active antineuritic material from autolyzed and from dried brewers' yeast.

The technique of the preparation of the extract from autolyzed yeast is as follows: Bottom yeast, obtained fresh from the brewery, was pressed into a cake and then placed in a hot room (40° C.) in alcohol barrels with 200 cc. of chloroform for 100 lbs. of yeast. In about 36 hours autolysis was complete, and the liquid was run through a filter press. The filtrate was then treated with concentrated HCl in the proportion of 40 cc. of acid to 1 liter of filtrate. The precipitate thus formed was filtered off, and the clear filtrate shaken with one-fourth its volume of olive oil until an emulsion was formed. After standing until two distinct layers were formed the oil layer was separated, filtered to remove sediment, taken up with from 8 to 10 volumes of ether,

extracted with 0.1 per cent HCl, and the extract concentrated in vacuo. This extract, which gave a heavy precipitate with phosphotungstic acid, an insoluble precipitate with picric acid, and a negative biuret test, was found to relieve the polyneuritic symptoms of pigeons.

The method of preparing an active material from dried yeast was as follows: The yeast, dried in a current of air at ordinary temperature, was ground to a fine powder and extracted with 95 per cent methyl alcohol (2 cc. of alcohol to each gram of yeast), 1 cc. of concentrated HCl being used for each liter of alcohol. The soluble part was filtered off by suction, and the residue again extracted as before, the two extracts were combined, the alcohol removed in vacuo at 35°, and the wax-like residue repeatedly extracted with small volumes of ether and 0.1 per cent HCl. This extract, when further purified by the use of the Funk silver method and the mercuric sulphate procedure, yielded an apparently crystalline substance which became inactive on drying. The material gave a heavy precipitate with phosphotungstic acid slightly soluble in excess, a negative biuret test, and no precipitate with picric acid. It was highly active on polyneuritic pigeons. This method of isolation eliminates from the active material purins, histidins, proteins, and albumoses.

The antiscorbutic properties of concentrated fruit juices, A. HARDEN and R. ROBISON (*Biochem. Jour.*, 14 (1920), No. 2, pp. 171-177).—Samples of dried orange juice, the preparation and properties of which have been previously noted (*E. S. R.*, 41, p. 470), were examined for antiscorbutic potency after having been stored in a desiccator at room temperature for nearly two years. Complete protection from scurvy was afforded guinea pigs weighing about 300 gm. by a daily ration of 0.5 gm. of the dried orange juice, equivalent to about 4.5 cc. of the raw juice.

Preliminary experiments are reported on large scale evaporation of the orange juice to determine the practicability of preparing a highly active product on a commercial scale. These experiments were discontinued after the publication by Givens and McClugage of successful results along similar lines (*E. S. R.*, 41, p. 560).

“The preparation on a commercial scale of such a dried orange juice appears to be quite practicable, and should prove of considerable value where an antiscorbutic material is required in a highly concentrated and stable form.”

The antineuritic and growth stimulating properties of orange juice, A. H. BYFIELD, A. L. DANIELS, and R. LOUGHLIN (*Amer. Jour. Diseases Children*, 19 (1920), No. 5, pp. 349-358, figs. 5).—The antineuritic and growth-promoting properties of orange juice were studied by a series of observations carried out on babies under the same conditions as those reported in the study by Daniels et al. of the rôle of the antineuritic vitamin in infant feeding (*E. S. R.*, 42, p. 256).

By increasing the amount of orange juice from the 15 cc. usually given as a daily antiscorbutic dose to 45 cc. a marked stimulation in growth resulted in every case, the results being comparable with those obtained in the earlier study with the use of wheat embryo extract as a source of the antineuritic vitamin. Orange juice filtered after being shaken with kaolin caused no gain in weight when fed in daily doses of 45 cc. When an equal quantity of untreated orange juice was given there was an immediate gain in weight, thus showing that the growth-promoting substance was removed by the kaolin. Similar results were obtained in experiments with rats. That the growth-promoting factor was not identical with the antiscorbutic factor was proved by the growth of rats receiving orange juice which had been boiled for five

minutes with an excess of a 2 per cent solution of sodium hydroxid to destroy the antiscorbutic vitamin.

Untreated orange juice in daily doses of 10 cc. was found to have a curative effect on polyneuritic pigeons, while kaolin-treated juice was without effect. Guinea pigs in which scurvy had been produced by a prolonged diet of oats and superheated milk were cured by the addition of 5 cc. per day of the filtrate of kaolin-treated juice.

From these observations the authors conclude that orange juice contains a relatively large amount of the antineuritic vitamin, which is apparently responsible for the growth-stimulating influence of the juice. Attention is called to the evidence in the literature of the coexistence of the antineuritic and antiscorbutic vitamins in other foods, including the tomato, banana, cabbage, potato, and turnip, and of the pathologic similarities of beriberi and scurvy. "The 'pathologic affinities' of beriberi and of scurvy may possibly be explained by the fact that the antineuritic content of the commonly used antiscorbutics has not been considered."

The antiscorbutic requirements of the monkey, A. HARDEN and S. S. ZILVA (*Biochem. Jour.*, 14 (1920), No. 2, pp. 131-134).—Supplementing earlier work on scurvy in monkeys (E. S. R., 41, p. 860), the authors have determined the minimum dose of orange juice for these animals.

Experiments with five monkeys are reported which indicate that the daily minimum protective dose of fresh orange juice for monkeys lies between 1 and 2 cc., while higher doses of 2 to 5 cc. proved an adequate prophylactic. "A monkey, therefore, of 2 or 3 kg. is protected from scurvy by about the same quantity of orange juice as a guinea pig weighing 300 to 400 gm. It is interesting to note that, while the minimum dose of antiscorbutic required by the two animals to protect them from scurvy is of the same order, the time taken for the development of the disease is very different, being about two months for a monkey and three weeks for a guinea pig. This suggests that the monkey possesses a higher store of the antiscorbutic factor than the guinea pig, while their daily requirements for metabolism are equal."

The production in monkeys of symptoms closely resembling those of pellagra, by prolonged feeding on a diet of low protein content. H. CHICK and E. M. HUME (*Biochem. Jour.*, 14 (1920), No. 2, pp. 135-146, pl. 1, fig. 1).—This paper gives an account of preliminary experiments in an attempt to produce experimental pellagra in monkeys by a diet of which the protein was deficient in tryptophan and lysin, all other requirements being satisfied. The accessory food factors were supplied by daily rations of from 10 to 20 gm. of butter as a source of fat-soluble A, 2 gm. of marmite for water-soluble B, and 10 cc. of fresh orange juice for the antiscorbutic factor. The rest of the diet consisted of sugar, corn flour, salt, and corn gluten, together with a small daily ration of apple or banana.

The corn gluten was fed in different proportions. Two of the three monkeys used began to lose weight on a ration containing sufficient gluten to give a total protein content of 23 gm., of which 15.6 gm. was zein. The third monkey did not begin to lose weight until the corn gluten was reduced until it furnished only 15 gm. of total protein, of which 10 gm. was zein.

The first two animals began to show a faint erythema on the face on the fifty-first and thirty-third days, respectively. This erythema, which was of a papillo-macular type, continued intermittently but progressively for the rest of the experiment. The third animal developed faint erythema soon after being put on the low protein diet. This gradually increased until the skin lesions closely resembled those of pellagra, being bilaterally symmetrical and

heightened by direct sunlight. This animal also developed localized edema of the face.

Attempts to cure with tryptophan and with caseinogen failed with the first animal. The second animal was treated successively with tryptophan, a mixture of lysin, arginin, and histidin, and caseinogen, but while life was prolonged little improvement was noted until a normal diet was used. To this the animal responded very quickly. The third animal was apparently cured very promptly by the administration of from 5 to 10 gm. of caseinogen.

The authors point out that as the exact amount of food consumed could not be determined it is not possible to ascertain how far the pellagra-like symptoms and wasting were due to an inadequate supply of tryptophan, of lysin, or of both, or possibly of some other unappreciated constituent of the protein.

Beriberi and deficiency diseases, A. SCALA (*Ann. Ig. [Rome]*, 29 (1919), Nos. 4, pp. 215-230; 5, pp. 286-301).—The author presents a critical discussion of the literature of deficiency diseases, from which he advances the hypothesis that they originate in a deficient mineral nutrition either in the lack of certain acids or bases or of complexes by means of which they are transported.

In scurvy the inorganic substance which is lacking is thought to be the phosphates of the earth metals, which exist in food materials in combination with organic material in the form of complexes, easily decomposed by heat and by desiccation. The destruction of these complexes tends to bring about a state of acidosis and prevents the transportation of calcium phosphate, etc., to the bones.

In beriberi the alkaline phosphates are unable to reach the central nervous system through the destruction of the organic complexes containing them and the development of a form of acidosis. The fact that various mineral substances when added to a beriberi-producing diet fail to bring about appreciable benefit is explained on the ground of inability to reproduce the exact complexes found in the original food material.

Dietetic experiments with frogs, A. HARDEN and S. S. ZILVA (*Biochem. Jour.*, 14 (1920), No. 2, pp. 263-266).—The results of a series of experiments in which mature frogs were fed synthetic rations deficient in one or more of the three known accessory food factors indicate that water-soluble B is necessary for the continued existence of adult frogs, while the effect of absence of fat-soluble A is not shown definitely for six months, and absence of the anti-scorbutic vitamin apparently produces no definite effect.

Experiments with tadpoles similar to those reported by Emmett and Allen (*E. S. R.*, 41, p. 468) are also noted, but as the results obtained were not considered entirely satisfactory they are not described in detail.

Artificial infant feeding, M. OSTHEIMER (*Amer. Jour. Diseases Children*, 19 (1920), No. 5, pp. 386, 387).—This is an outline of the customary practice in infant feeding in the children's dispensary of the University of Pennsylvania hospital. The principle employed is a rapid increase in the quantity and quality of the cow's milk mixtures until whole milk is reached between 8 and 12 months of age, and the use of semisolid food as soon as the infant has four or more opposing teeth.

It is pointed out that this diet is in marked contrast to the simple old-fashioned diet still advocated by Morse (*E. S. R.*, 42, p. 555).

A note on the effect of purgation on the creatinin content of urine, D. BURNS (*Biochem. Jour.*, 14 (1920), No. 2, pp. 94-97).—The author refers to the work of Anderson and Bosworth (*E. S. R.*, 36, p. 365) indicating that the administration of inositol to man results in diarrhea and an increased excretion of creatinin, and reports similar results obtained by Burns and Orr

following the copious ingestion of water. To determine whether this increase in creatinin was the result of purging, digestion experiments on two human subjects were conducted in which purgation was effected by the use of Rochelle salts. This also resulted in an increase in the amount of creatinin eliminated. Administration of an alkali which does not induce purgation (NaHCO_3) caused no appreciable alteration in the creatinin output, while the administration of an acid purgative (NaH_2PO_4) led to a slight decrease in creatinin excretion.

New contributions to the knowledge of the residual nitrogen in the blood, criticism of methods, and their value and use in clinical pathology, J. FEIGL (*Arch. Expt. Path. u. Pharmakol.*, 83 (1918), Nos. 3-4, pp. 168-203, 257-298; 5-6, pp. 299-365, figs. 2).—This is a series of studies of the residual nitrogen of blood under the following headings:

The total nonprotein nitrogen in varying physiological conditions and at different ages (pp. 168-189); the structure of the total nonprotein nitrogen with special regard to the urea content under different conditions (pp. 190-203); the structure of the total nonprotein nitrogen under varying physiological states in relation to old age calculated from the ratio of urea to total residual nitrogen (pp. 257-270); creatinin, creatin, and uric acid and the participation of these materials in the building up of the residual nitrogen in the blood of fasting subjects (pp. 271-298); amino acid nitrogen (pp. 299-316); the blood picture of the nonprotein nitrogen under varying conditions as shown by the selected analyses for the highest, mean, and lowest results, and the fasting blood of old age (pp. 317-334); and a summary of the above studies with practical conclusions (pp. 335-365).

The CO_2 ordinate of a dock laborer (Tom King) during six days' work (winter hours 7.30 a. m. to 12; 1 p. m. to 4.30), A. D. WALLER (*Jour. Physiol.*, 52 (1918-19), No. 1-6, pp. LIX, LX, fig. 1).—The hourly CO_2 values are given for the week's work of a dock laborer who was part of the time on piecework and part on miscellaneous time-work.

Averaging from the last three hours of the two complete piecework days and the same period of the two complete time-work days and allowing 4 cc. per second as the resting CO_2 , the average values of the net physiological cost were 20.2 cc. of CO_2 per second for piecework and 13.4 cc. for time-work. At 5.91 calories per cubic centimeter these figures represented expenditures of 430 and 284 calories per hour, respectively.

The physiological cost of tailor's work measured by CO_2 and expressed in calories, A. D. WALLER and G. DE DECKER (*Jour. Physiol.*, 53 (1920), No. 5, pp. LXXIII, LXXIV).—Similar measurements to the ones noted above were taken of the CO_2 output of tailors and tailoresses during their ordinary piece work. The observations were taken every hour upon 4 men and 2 women for 17 and 7 complete days, respectively, the men working 10 hours and the women 7.5 hours per day. The work consisted of sewing by hand and by machine, and pressing by irons weighing 30 and 10 lbs., respectively.

The average results expressed in calories per square meter per hour were 32.4 ± 1.5 and 36.6 ± 2.3 . These results are compared with those obtained with the dock laborer as noted above. Calculated in the same way the net output of the dock laborer during 2 days of maximal work was at the rate of 170 calories per square meter per hour, while the net average cost per man per day for the whole week of mixed work was 2,176 calories for the dock laborer as compared with the tailors' net average per man per day of 8 hours of 463 calories.

ANIMAL PRODUCTION.

Harnessing heredity to improve the Nation's live stock, D. S. BURCH (*U. S. Dept. Agr. Yearbook 1919*, pp. 347-354, figs. 3).—A report of early results from the "better sires—better stock" campaign of the Bureau of Animal Industry (E. S. R., 42, p. 866.)

Selling purebred stock to South America, D. HARRELL and H. P. MORGAN (*U. S. Dept. Agr. Yearbook 1919*, pp. 369-380, figs. 5).—This article considers Brazil, Paraguay, Uruguay, and Argentina as possible importers of purebred stock, particularly cattle, from the United States. Sale prices at the Palermo (Argentina) live stock show of 1919 are tabulated.

Live stock conditions in Europe, T. WRIGHT and G. A. BELL (*U. S. Dept. Agr. Yearbook 1919*, pp. 407-424, figs. 6).—The authors record observations made in 1919 on the live stock conditions in France, Belgium, Switzerland, Italy, Holland, and Great Britain, and present a table of available census data showing the effect of the war on the number of cattle, swine, and sheep in these and other countries. There was a noticeable shortage of swine in all the European countries visited, but in general the decreases in other classes of live stock were not as marked as the authors had expected. There were evidences of careful culling of herds and flocks on the part of many farmers and of a widespread interest in purebred stock. Immediate importations of stock on an extensive scale from outside countries is not anticipated.

Federal supervision of live stock markets, L. D. HALL (*U. S. Dept. Agr. Yearbook 1919*, pp. 239-248, figs. 4).—An account of the operation of the wartime licensing system for stockyards and of the policies of the Bureau of Markets in administering the system.

Live stock drought relief work in 1919, G. M. ROMMEL (*U. S. Dept. Agr. Yearbook 1919*, pp. 391-405, figs. 12).—This is an account of the measures taken by the Department of Agriculture and cooperating agencies in the summer of 1919 to secure the rapid transfer of cattle and sheep from the drought-stricken ranges of Montana, Wyoming, and neighboring States to good grazing areas in the Great Lakes region and in Texas. The successful accomplishment of the task is considered a triumph for cooperative effort.

Feeding stuffs inspection, J. L. HILLS, C. H. JONES, G. F. ANDERSON, and L. H. FLINT (*Vermont Sta. Bul. 216 (1920)*, pp. 16-26).—This report on the 1919 feeding stuffs inspection consists mainly of lists of brands which did and did not conform to guaranty in respect to protein content. A table gives the observed ranges in protein content of the following materials: Cottonseed meal, linseed meal, gluten feed, hominy feed, corn meal, brewers' dried grains, dried beet pulp, peanut feed, velvet bean meal, wheat bran, wheat middlings, wheat mixed feed, red dog, wheat screenings, ground oats, oat hulls, and various kinds of compounded and proprietary feeds.

Sweet-clover seed screenings not injurious to sheep, C. D. MARSH and G. C. ROE (*U. S. Dept. Agr., Dept. Circ. 87 (1920)*, pp. 7).—Four sheep, weighing from 81 to 99 lbs., were fed for 7 or 8 days on a ration (from 1 to about 2 lbs.) of screenings composed mainly of immature seeds of the white sweet clover. They lost in weight somewhat, but later two of them were maintained satisfactorily during nearly 7 weeks of pasture on a 0.75-lb. ration of screenings, making about the same gain as the other two, which received bran as a supplement to pasture. In another experiment two sheep gained in weight during a month's feeding on alfalfa hay and screenings.

In no case was any injurious result noted and the authors, therefore, are unable to confirm reports that sweet-clover seeds may be poisonous to sheep.

Pasturing sheep [at the Huntley Reclamation Project Experiment Farm], D. HANSEN (*U. S. Dept. Agr., Dept. Circ. 86 (1920), p. 32*).—The sheep pasturing test conducted in 1917 (*E. S. R., 39, p. 879*) was repeated in 1918. From April 24 to September 9 the six ewes on the four quarter-acre plats made a total gain of 66 lbs. and their lambs gained 314 lbs. Ten ewes were carried from September 10 to October 21 without increase in weight, although they remained in good condition.

Swine experiments [at North Carolina Station], D. T. GRAY (*North Carolina Sta. Rpt. 1919, pp. 43-47*).—Results of several experiments conducted by E. Hostetler are briefly reported, including those on mineral mixtures noted below.

In a 119-day test begun April 23, 1919, a lot of hogs fed corn and fish meal (9:1) made a daily gain of 1 lb. per head, while the check lot fed corn and tankage (9:1) averaged 0.95 lb. per head.

Two grazing experiments were made in connection with soft pork investigations. In the first test (57 days beginning October 10, 1918) a lot fed corn and shorts (2:1) without pasture made a daily gain of 0.32 lb. per head, a lot on soy bean pasture plus the same grain mixture gained at the rate of 0.46 lb., a third lot on soy bean pasture without supplement gained 0.41 lb. per day, and a fourth lot on peanut pasture without supplement gained 0.62 lb. The pastures were in poor condition. In the second test (52 days beginning October 28, 1918) the same grain mixture was used and the lots on pasture received a half feed of grain. Pigs not on pasture gained 0.46 lb. per head daily, those on soy bean pasture gained 0.46 lb., and those on peanut pasture 0.9 lb. Samples of lard were collected from the pigs in both tests, but the chemical analyses had not been completed.

"In our work meat cured from hogs which never had peanut or soy-bean pasture shrank 19.4 per cent; cured meat from hogs which were grazed upon soy beans shrank 20.6 per cent; meat made from hogs fattened upon peanut pastures shrank during the curing process 16.9 per cent." The claim of packers that hogs fed on soy bean and peanut pastures shrink much more in curing than those fattened on corn alone is, therefore, considered untenable. It is also noted that a proprietary "liquid smoke" produced substantially the same shrinkage in an experimental test as hickory smoke.

Two other grazing experiments were conducted, the grain mixture in all cases being corn and shorts (2:1). In a 48-day test beginning March 23, 1919, one lot on bur clover (17 to an acre) were given an average ration of 1.03 lbs. of grain per head, while the check lot not on pasture consumed 1.89 lbs. per head daily. The gains per head were the same in both cases, viz, 0.17 lb. per day. In a 112-day test beginning May 27, a lot on a permanent Bermuda grass pasture consumed an average ration of 2.46 lbs. of grain and the check lot (not on pasture) 2.94 lbs. The daily gains per head were, respectively, 0.41 and 0.42 lb.

[Swine feeding at the Huntley Reclamation Project Experiment Farm in 1918], D. HANSEN (*U. S. Dept. Agr., Dept. Circ. 86 (1920), pp. 18-25, fig. 1*).—Records of the utilization by hogs of the crops in irrigated rotations in 1918 and the results of several swine feeding experiments are reported. Both series of investigations followed in general the plans outlined for the preceding years (*E. S. R., 39, p. 378*). The past results in the crop-utilization tests are also tabulated.

A quarter-acre plat of alfalfa in each of two rotations (numbered 67 and 69) furnished pasture for 5 fall pigs and 8 spring pigs in succession for a total of 148 days, the pigs being fed a 2 per cent corn ration. The gains

per acre were 2,360 lbs. in rotation 67 and 2,248 lbs. in 69, and the daily gains per head were 0.66 and 0.63 lb., respectively. In the first case 2.72 and in the second 2.85 lbs. of grain were consumed per pound of gain.

In the hogging-off tests with the spring pigs after the pasture season a quarter acre of mature corn in rotation 67 supported 4 pigs for 27 days in the late fall, producing pork at the rate of 26.8 lbs. per acre per day. On the basis of an estimated yield of 65 bu. of corn to an acre, 5.1 lbs. of grain were consumed per pound of gain. In rotation 69 a quarter acre of corn that had been seeded to rape in July supported 4 pigs from the alfalfa pasture for 35 days in the fall and produced pork at the rate of 23.1 lbs. per acre per day. The estimated yield of corn was 55 bu. an acre and on this basis 3.8 lbs. of grain were consumed per pound of gain. "Comparing the average results for seven years of hogging-off corn without rape with the average of three years of hogging-off corn and rape, there seems to be no increase in gain in favor of the rape."

The feeding experiments were conducted in cooperation with the Montana Experiment Station, the hogs used being Duroc-Jerseys. The following table summarizes the results with the spring pigs:

Results of a 71-day test of alfalfa pasture with spring pigs, followed by a dry-lot finishing period on a full feed of corn and alfalfa hay.

Lot number.	Corn ration on pasture.	Pigs per acre.	Initial weight per head.	Gain on pasture.		Weight, end of pasture.	Finishing period.	Gain in dry lot.		Grain per pound of gain	
				Per day per head.	Per acre.			Per day per head.	Total per head.	Pasture period.	Finishing period.
			Lbs.	Lbs.	Lbs.	Lbs.	Days.	Lbs.	Lbs.	Lbs.	Lbs.
1	None.....	18	38	0.11	144	46	184	0.70	124	5.49
2	1 per cent.....	28	37	.20	400	51	184	.71	121	6.12
3	2 per cent.....	32	38	.38	864	65	150	.94	132	5.67
4	do.....	32	37	.37	832	63	2.90
5	3 per cent.....	36	39	.62	1,592	83	114	1.11	127	4.70
6	Self-fed.....	36	38	1.08	2,760	115	114	.93	91	5.89

¹ Pasture divided.

Lot 3 was also used as a check lot for a similar group of pigs pastured on a divided plat of Turkestan alfalfa. The latter pigs made an average daily gain of 0.32 lb. per head (a total gain of 732 lbs. an acre for the 71 days) and required 3.31 lbs. of corn (2 per cent ration) to produce a pound of gain. Preliminary observations had indicated that hogs prefer Turkestan to common alfalfa.

No data from pasture tests with fall pigs are reported. Four lots, each comprising 10 or 11 fall pigs that had been on alfalfa pasture, were used in a comparative study of alfalfa hay, tankage, and skim milk as supplements to corn in dry-lot finishing. The test lasted 16 days in July and August. The lot fed skim milk made the best gain (3.25 lbs. per head daily) and consumed 2.8 lbs. of corn per pound of gain. The tankage-fed lot required 3.32 lbs. of corn for equal gain, the alfalfa-fed lot 3.88 lbs., and the no-supplement lot 4.01 lbs.

Two lots of six 80-lb. hogs were used in a test of hogging-off corn, one lot having free access to alfalfa hay, the other receiving no feed beyond that growing in the cornfield. The results are considered distinctly in favor of the alfalfa feeding, as there was a difference of about 1.5 lbs. in the amounts of corn required for a pound of gain.

In tests with 15 brood sows divided into 3 lots and kept on alfalfa pasture during July and August the lots fed corn or corn and tankage as supplements gained in weight, while the lot receiving no added grain lost in weight.

The value of mineral and medicinal mixtures for hogs, D. T. GRAY and E. HOSTETLER (*Bul. N. C. Dept. Agr.*, 41 (1920), No. 6, pp. 14; also in *Swine World*, 7 (1920), No. 24, pp. 20-23).—Two hog feeding experiments at the North Carolina Experiment Station are reported. The pigs were all unthrifty and showed the characteristic physical evidences of worm infection. In both tests some were given a proprietary "hog remedy" administered according to the manufacturer's directions, some were fed a mixture of crushed charcoal, slaked lime, common salt, sulphur, and copperas (10:5:4:2:3) and the others received no addition to their grain ration. The grain mixture consisted of shelled corn, wheat shorts, and peanut meal (2:1:1), with the peanut meal omitted during the initial two weeks of each test. Feeding was entirely in the dry lot.

Three lots of five 52-lb. pigs were used in the first test, which began in December, 1918, and lasted 88 days. Lot 1 (grain alone) made a daily gain of 0.47 lb. per head and consumed 7.3 lbs. of feed per pound of gain. Lots 2 and 3 received only the amounts of grain consumed by lot 1, although it was discovered that they had appetite for more. The daily gain per head in lot 2 (charcoal mixture) was 0.63 lb. and in lot 3 (hog remedy), 0.71 lb. The feed requirement for a pound of gain was substantially the same in each, viz, 4.8 lbs.

The second experiment was begun in June, 1919, and continued 142 days. There were 5 lots of five 37-lb. pigs, lots 1 to 3 duplicating the corresponding lots of the first experiment in treatment and uniformity of grain ration. The daily gains per head in these lots were, respectively, 0.33, 0.43, and 0.42 lb., and the feed consumption per pound of gain 6.6, 5.1, and 5.3 lbs. Lots 4 and 5 received all the grain they would eat. Lot 4 (charcoal mixture) gained 1 lb. per day per head and required 4.6 lbs. of grain for a pound of gain. The rate of gain in lot 5 (hog remedy) was 1.15 lbs., and 4.8 lbs. of feed were required for a pound of gain.

Autopsies were made of all hogs at slaughter, and a table gives the numbers of kidney worms, intestinal worms, and liver abscesses found in each animal, and also similar data for check animals slaughtered at the beginning of the tests. The pigs fed the charcoal mixture or the hog remedy were relatively free from worms and abscesses.

Experimental work [with poultry], D. T. GRAY (*North Carolina Sta. Rpt.* 1919, pp. 48-52).—Progress reports on various poultry experiments conducted by B. F. Kaupp in 1918-19 are presented. Results not noted from other sources are as follows:

In a grading experiment the original flock (lot 1) had an annual production of 89 eggs per bird. Their offspring by common cockerels (lot 2) had a 3-year average of 92 eggs per bird per year, while offspring by good White Leghorn cockerels (lot 3) had a 2-year average of 135 eggs per year. Brothers of pullets in lot 3 mated to pullets in flock 2 produced offspring which laid an average of 112 eggs the first year.

In an uncompleted study of growth as influenced by source of protein it was found that the most rapid early growth and the least deaths occurred when blood meal was fed to the chicks, and that the greatest weight at 16 weeks was attained when buttermilk was fed. The other protein supplements tested were meat scrap, tankage, soy bean meal, and peanut meal. In other experiments velvet bean feed was found to be an unsatisfactory supplement, due it is thought, to injurious material in the pod.

Two studies of sour skim milk in chick rations are in progress. At the Iredell substation the average chick fed corn meal, oats, soy bean meal, and meat scrap weighed 0.7 lb. at 8 weeks and 2.9 lbs. at 16 weeks, while the chicks fed the same mixture plus skim milk, averaged 1.32 lbs. at 8 weeks and 3.7 lbs. at 16 weeks. In a similar comparison at the Edgecombe substation the basic feed consisted of corn meal and peanut meal. The lot not fed milk averaged 0.87 and 2.07 lbs. at the respective standard ages, and the lot given the skim milk averaged 0.91 and 3.45 lbs.

The Bergen County international egg-laying and breeding contest, H. R. LEWIS (*New Jersey Stas., Hints to Poultrymen, 8 (1920), No. 9, pp. 4*).—This is an announcement of a 3-year contest at Westwood, Bergen County, N. J., and a statement of the contest rules.

“The new contest which will start November 1, 1920, will introduce an entirely new and distinct feature in poultry work, namely, the registration and advanced registration of poultry, and the maintenance of flock books, which will show pedigrees and performances of all birds qualifying for registration.”

Common sense in poultry keeping, R. R. SLOCUM (*U. S. Dept. Agr. Year-book 1919, pp. 307-317, figs. 17*).—The author takes the view that success with farm poultry depends primarily on good judgment, and that elaborate rules and complicated methods are not necessary.

DAIRY FARMING—DAIRYING.

Mixed-grass pastures for cows, D. HANSEN and B. L. COLLINS (*U. S. Dept. Agr., Dept. Circ. 86 (1920), pp. 25-32, fig. 1*).—These pages summarize the results during the first year (1918) of a comparative test of three different irrigated mixed-grass pastures for dairy cows at the Huntley (Mont.) Reclamation Project Experiment Farm. Mixture No. 1 consisted of awnless brome grass, orchard grass, tall fescue, perennial rye grass, Kentucky blue grass, white clover, and alsike clover. No. 2 differed from this by the omission of the clovers, while brome grass and rye grass were omitted from No. 3, in both cases without change in the rate of seeding of the remaining constituents. Two one-acre plats had been seeded to each mixture in 1916, the Kentucky blue grass being seeded in 1917. On May 22, 1918, three Holstein cows were turned on each mixture. They were alternated from one plat to the other during the season, with occasional days off pasture, when the cows were fed alfalfa hay. On June 10 a grade cow (dry) was added to each lot, and beginning August 28 the animals were removed at night. The Holstein cows were in different stages of lactation, and of those assigned to mixtures 1 and 3, one cow in each case was dry throughout. Complete milk records were kept, and fat analyses and lactometer readings were made each week. The following table summarizes the results, reduced to an acre basis:

Comparison of grass mixtures as pasture for milch cows, 1918. (Acre basis.)

Grass mixture, number.	Pas-ture period.	Cow days on pas-ture.	Cow days off pas-ture.	Alfalfa hay fed.	Hay har-vested.	Cow days in milk.	Whole milk pro-duced.	Butter fat pro-duced.	Skim milk pro-duced.	Total milk solids.	Net in-come.
	<i>Days.</i>			<i>Lbs.</i>	<i>Lbs.</i>		<i>Lbs.</i>	<i>Lbs.</i>	<i>Lbs.</i>	<i>Lbs.</i>	
1.....	135	234.5	9.5	1,475	2,674	159.5	3,016	105	2,666	353	\$67.26
2.....	125	219.5	4.5	1,115	2,140	201.0	4,042	130	3,609	463	79.60
3.....	135	239.0	5.0	1,530	1,278	85.0	2,588	84	2,308	278	46.44

The net income represents the sum of the market values of the butter fat, skim milk, and cut hay, less the value of the alfalfa hay fed. Hay in both cases was charged at \$15 a ton.

The weights of the cows are also recorded. In general, there was an increase in weight.

Calves make biggest gain on heavy skim milk ration (*U. S. Dept. Agr., Weekly News Letter*, 7 (1920), No. 44-45, p. 8; also in *Hoard's Dairyman*, 59 (1920), No. 25, p. 1479).—A brief summary of calf feeding experiments conducted by the Dairy Division at the Beltsville (Md.) Experiment Farm is presented. Four groups of 4 calves each were fed on skim milk exclusively for 70 days beginning at the age of 15 days. The daily milk ration of groups 1, 2, and 3 equalled, respectively, one-seventh, one-sixth, and one-fifth of the body weight or 13.5, 17, and 21 lbs. per head. Group 1 made an average daily gain of 0.95 lb. per head, group 2 1.09 lbs., and group 3 1.26 lbs., but the milk requirements per pound of gain were, respectively, 14.4, 15.6, and 17 lbs. The fourth group, which received a full feed of milk (averaging 24.2 lbs. per head daily), made a daily gain of 1.48 lbs. and consumed 16.6 lbs. per pound of gain.

Cost of milk production, D. T. GRAY (*North Carolina Sta. Rpt. 1919*, pp. 53, 54).—A brief report is made of a study by S. Combs of the cost of milk production in "more than a dozen herds" near Greensboro, N. C. The average amounts of feed and labor used per 100 lbs. of milk were as follows: Concentrates 52.9 lbs., dry roughage 56.8 lbs., succulent feed 132.4 lbs., man labor 3.4 hours, and horse labor 1.8 hours. In addition there was a charge of 11.2 cts. for pasture, and the excess of miscellaneous charges over credits was 3.7 cts.

A comparison of fat tests in milk as determined by a cow-testing association and by a creamery, H. C. TROY (*New York Cornell Sta. Bul. 400* (1920), pp. 3-66, figs. 2).—The bulk of this publication consists of tables in which the production records of 22 herds each month as estimated by a cow-testing association from two successive milkings are exhibited in parallel columns with the semimonthly production as determined by the milk delivered to the college creamery. There were 32 records where the herds were tested for 12 consecutive months and 21 records for lesser periods.

The weighed average of the fat percentages of all the records was 4.51 in the case of the association tests and 4.49 in the case of the creamery tests. It was found that the two tests agreed very well in individual herds if production for a whole year is considered, but there were a number of marked discrepancies in the shorter records.

Phosphorus in butter, J. T. CUSICK (*New York Cornell Sta. Mem.*, 30 (1920), pp. 159-187).—Two duplicate series of experimental butters were made from uniform lots of sweet cream treated in the following ways: (1) Ripened with lactic starter and churned raw, (2) churned raw without starter, (3) pasteurized after the addition of enough lactic acid to make the acidity 0.38 per cent, (4) self-ripened to an acidity of 0.35 per cent and churned raw, (5) made 0.35 per cent acid by the addition of lactic acid and churned raw, (6) pasteurized without starter, and (7) ripened with starter after pasteurization. Both salted and unsalted samples of butter were made up from each portion of cream. Analyses of these samples a few days after churning indicated that pasteurization had rendered certain of the organic phosphorus compounds of the protein residue more soluble so that they were lost in churning. In both the pasteurized and unpasteurized samples more phosphorus was lost in churning from ripened than from unripened cream.

When the samples were again analyzed after 15 months' storage it was found that most of the soluble organic phosphorus had been transformed into inorganic

phosphorus. The ripened samples without regard to pasteurization tended to retain more soluble organic phosphorus than the others. The presence of salt hastened the breakdown of the organic compounds.

Several variously handled portions of cream were inoculated with Hammer's *Bacterium ichthyosmii* (E. S. R., 37, p. 686) and then churned. Butter from cream so treated that there was a noticeable decomposition of the soluble organic phosphorus compounds (i. e. lecithin, chiefly) developed fishy flavors during storage. It is supposed that trimethylamin is formed under these circumstances. Somewhat similar experiments by Supplee have been noted (E. S. R., 42, p. 564).

In another experimental churning it was determined that about two-thirds of the total phosphorus of the cream is retained in the buttermilk, and only about 25 per cent is carried over into the butter, the difference being accounted for by the phosphorus dissolved in wash waters and salt exudates.

Besides casein the protein residue of butter was found to include the alcohol-soluble protein found in milk by Osborne and Wakeman (E. S. R., 38, p. 611).

VETERINARY MEDICINE.

New and nonofficial remedies, 1920 (*Chicago: Amer. Med. Assoc., 1920, pp. 396+XXXI*).—In the preface of the 1920 edition of this book, the previous editions of which have been noted (E. S. R., 41, p. 781), particular attention is called to the general article on lactic-acid producing organisms and preparations, which has been rewritten by a special committee, and to the statement in the article on serums and vaccines concerning the dating of biological products, which has been rewritten in accordance with the recent Federal regulations for governing the sale of biologic products.

In addition to the customary omissions, additions, and revisions, a change from previous editions has been made in the establishment of a department of articles described but not accepted, in which are listed "proprietary preparations which have therapeutic value but which are so exploited as to be unadmissible to New and Nonofficial Remedies."

Poisonous plants and the Department of Agriculture, C. W. MARSH (*Producer, 1 (1920), No. 12, pp. 7-11, figs. 4*).—A brief popular account of work with poisonous plants.

The whorled milkweed (*Asclepias galioides*) as a poisonous plant, C. D. MARSH, A. B. CLAWSON, J. F. COUCH, and W. W. EGGLESTON (*U. S. Dept. Agr. Bul. 800 (1920), pp. 40, pls. 9, figs. 4*).—The first part (pp. 1-8) of this bulletin consists of an account of the status of knowledge of this plant; the second part (pp. 8-25) gives the details of experimental work. The data presented are summarized by the author as follows:

"The whorled milkweed growing in Colorado, Utah, New Mexico, and Arizona has been proved to be exceedingly poisonous. The weed has been identified botanically as *A. galioides*. In previous publications it has been cited as *A. verticillata*. The plant is poisonous to horses, cattle, and sheep, but most of the reported losses have been of sheep. The most marked symptoms are the violent spasms. The autopsies and microscopical examinations show congestion of the peripheral blood vessels, the congestion being especially marked in some glands, the lungs, and the central nervous system. The chemical examination of the plant, while incomplete, has demonstrated the existence of definite toxic compounds, part of which are glucosidal in nature. The plant contains also a minute quantity of nontoxic alkaloid. There is no medicinal remedy which gives satisfactory results. Reliance must be placed on the destruction of the

plant and such care of stock as will prevent hungry animals from coming into contact with masses of the weed."

An account of this plant and eradication work with it by W. L. May at the Colorado Experiment Station has previously been noted (E. S. R., 43, p. 141).

The whorled milkweed, a plant poisonous to live stock, C. D. MARSH (U. S. Dept. Agr., Dept. Circ. 101 (1920), pp. 2, fig. 1).—This circular calls attention to the poisonous effect of this plant upon live stock, a detailed account of which is noted above.

The poisoning of horses by the common bracken, S. HADWEN and E. A. BRUCE (Vet. Jour., 76 (1920), No. 537, pp. 98-109, figs. 2).—The authors report upon observations of the affection caused by *Pteris aquilina*, locally known as staggers, which has been prevalent on the Pacific slope of British Columbia for many years. The mortality among horses in the Fraser Valley and on Vancouver Island was very heavy during the hard winter of 1915-16. Feeding experiments with four animals are summarized as follows:

"Of the four animals that developed the disease, one showed symptoms on the twenty-fourth day and was dying on the thirty-fifth day. . . . The second horse did not show marked symptoms until the thirty-eighth day, and was dying on the forty-sixth day, when it was killed. The length of time it took the second horse to develop symptoms as compared with the first was no doubt due to the fact that for about 12 days properly dried bracken could not be procured, and also to the mistaken kindness of a careless attendant who was caught giving the animal green clover. The third horse, which had served as control in the two preceding experiments, was fed on hay exactly as received from a local source. The hay carried 29 per cent bracken and caused the death of the animal in 36 days. The fourth experiment was somewhat different to the others; this animal was fed 4.4 lbs. of fern per day for three weeks, and was then reduced to 2.4 lbs. per day for a further three weeks with no apparent ill resulting. Upon increasing the daily feed of fern to 6.9 lbs., definite symptoms of the disease were noticed on the twenty-ninth day after this increase, and the animal was killed on the thirty-fifth day. Judging from the foregoing, it can be assumed that an addition to the daily diet of about 6 lbs. of dried bracken will kill a horse in about one month."

Review of the literature of the past five years on anaphylaxis and related phenomena, A. R. CUNNINGHAM (Amer. Jour. Diseases Children, 19 (1920), No. 5, pp. 392-412).—This is an extensive review of recent literature on anaphylaxis and related phenomena with 87 references to the literature.

Progress in eradicating contagious animal diseases, J. R. MOHLER (U. S. Dept. Agr. Yearbook 1919, pp. 69-78, figs. 8).—This is a review of the progress made in eradicating diseases of live stock. The results accomplished are graphically illustrated by means of charts in the cases of contagious pleuropneumonia, cattle scabies, sheep scabies, bovine tuberculosis in the District of Columbia, cooperative tuberculosis eradication in the United States, cattle ticks, and foot and mouth disease, and the extent of hog cholera losses.

Blackleg, J. W. BENNER (Cornell Vet., 10 (1920), No. 2, pp. 121-132).—This is a discussion of the occurrence, limiting conditions, symptoms, and methods of control of blackleg. The older methods of immunization against blackleg are reviewed briefly and the newer methods discussed more fully. A list of 21 references is appended.

The application of the lipoid fixation reaction to the diagnosis of glanders, E. MEINICKE and E. NEUMANN (Ztschr. Veterinärk., 30 (1918), No. 6, pp. 265-270, fig. 1).—In continuation of the study of the lipoid fixation reaction for glanders previously noted (E. S. R., 43, p. 277), the authors suggest

and explain the use of an extract of colon bacilli as a control antigen, and report the results of the application of the test in the examination of a number of horses on two army transports.

Of 50 horses proved on autopsy to be glandered, 4 had given positive lipid fixation tests immediately, but responded at first negatively to the complement fixation and agglutination tests. Three other horses which had given negative results with the complement and agglutination tests reacted weakly positive to the lipid fixation test, and proved on autopsy to have pulmonary glanders.

Investigations on specific ophthalmia, in continuation of the observations made whilst in the abattoir, Paris (December 7, 1918), T. DALLING (*Vet. Jour.*, 75 (1919), No. 523, pp. 16-24).—The author reports upon studies of sections of optic nerves from animals affected with specific ophthalmia, made with a view to ascertaining whether or not any structural changes could be observed.

In smears made of the nerve matter, he found an organism present which was easily demonstrated, to which he refers as the "nerve bacillus." Pure cultures of this organism were obtained. Examinations were then made of 8 animals affected with the disease, obtained from Havre butchers, and typical growths were obtained from each of the 16 nerves.

The organism appears as a cocco-bacillus with rounded ends, 1 to 2 mm. in length by $\frac{1}{2}$ to 1 mm. in breadth. Pairs are very often seen end to end. It is motile, and stains well with any of the anilin dyes, is not acid fast, but is strongly gram negative. It grows both aerobically and anaerobically, but best as an aerobe and on practically all ordinary culture media.

Numerous inoculation experiments have been made on both horses and laboratory animals with various results. Since young cultures have practically no effect and the old have, the author considers it reasonable to assume that the organism must be present in considerable numbers before any evil effects are seen. Animals suffering from the disease and those cured had developed agglutinin in their blood which was capable of acting on the "nerve bacillus," indicating that this organism is at least one of the causes.

A study of the bacterial flora of the conjunctival sac of the horse, at the Central Veterinary Research Institutè, Aldershot, R. H. KNOWLES (*Jour. Compar. Path. and Ther.*, 33 (1920), No. 1, pp. 13-22, figs. 4).—A comparison made of the cultural findings of normal eyes with those of eyes affected with recurrent ophthalmia shows that the principal differences occur in the case of the two diphtheroid forms (of which the first is the *Bacillus xerosis*), which make up as high as 31 and 11.9 per cent, respectively, in normal eyes and 80 and 30 per cent in the eyes of affected animals.

"These are the most numerous organisms in the normal eyes, and they also show the greatest increase in number during an attack of recurrent ophthalmia. On the other hand, the other two varieties of organisms commonly present, viz, *Staphylococcus albus* and *Streptothrix*, show a slight decrease. It is this frequent occurrence of the *B. xerosis* which has from time to time led observers to assign a pathogenic rôle to it. All strains of these diphtheroids have, however, proved to be avirulent, and it must be concluded that the inflammatory phenomena associated with pathological conditions of the eye in some manner specially favor the growth of the organisms."

A trypanosome associated with a fatal disease in the carabao, F. G. HAUGHWOUT and S. YOUNGBERG (*Philippine Jour. Sci.*, 16 (1920), No. 1, pp. 77-87, figs. 2, pls. 3).—This is a report of studies of a trypanosome found in the blood of a male carabao at the rinderpest immunizing station at Fernando, Pampanga Province, P. I. While this form in many ways resembles *Trypanosoma*

theileri, the preparations at hand do not permit the author to place it definitely as that species.

The toll of tuberculosis in live stock, J. A. KIERNAN and L. B. ERNEST (*U. S. Dept. Agr. Yearbook 1919*, pp. 277-288, figs. 3).—The importance of eradicating tuberculosis in live stock is pointed out and the accredited-herd plan briefly considered. The benefits to be derived from tuberculosis-free herds are emphasized.

Methods of eradication of bovine tuberculosis, J. G. WILLS (*Cornell Vet.*, 10 (1920), No. 2, pp. 79-82).—The author discusses the advantages and disadvantages of various systems in operation for the eradication of bovine tuberculosis. These include the Bang, Ostertag, Manchester, physical examination, State control, and accredited herd methods. The accredited herd plan, while possessing certain disadvantages, is considered by the author to be the most attractive method so far devised.

The accredited herd plan for the control of bovine tuberculosis, H. B. LEONARD (*Cornell Vet.*, 10 (1920), No. 2, pp. 75-79).—A brief discussion of the scope, operation, and value of the accredited herd plan for the control of bovine tuberculosis.

Vaccination against typhoid fever by ingestion, A. BESREDKA (*Ann. Inst. Pasteur*, 33 (1919), No. 12, pp. 882-903).—This is a report of the author's experiments on the vaccination of rabbits against typhoid fever by the ingestion of heated cultures of the organism, preceded by the ingestion of bile. A preliminary note on the same subject has been previously noted from another source (*E. S. R.*, 40, p. 83).

The immunity acquired in this way is said to appear with great rapidity and to be much more lasting than that obtained by subcutaneous vaccination, corresponding more closely to the immunity acquired by an attack of the disease.

A fatal unidentified cattle disease in New York State, J. K. BOSSHART and W. A. HAGAN (*Cornell Vet.*, 10 (1920), No. 2, pp. 102-113).—The authors here deal with a peculiar disease among cattle which has caused considerable loss each fall in New York for the past three years, 11 cases having been observed in 1917, 17 in 1918, and 73 in 1919. These cases have been reported with the provisional diagnosis of hemorrhagic septicemia, but at no time have findings been made in the laboratory which would substantiate this diagnosis.

In part 1 (pp. 102-105) J. K. Bosshart reports upon the clinical manifestations, and in part 2 (pp. 105-113) W. A. Hagan deals with the pathology and studies in attempts at making a diagnosis.

Orchard horse disease, J. W. KALKUS (*Amer. Jour. Vet. Med.*, 15 (1920), No. 4, pp. 139-144, figs. 8).—This is a report of investigations made by the Washington Experiment Station of a disease that has been causing considerable loss of horses in certain sections of the State, where it occurs in enzootic form in the irrigated apple orchard districts. The disease is known locally by various names, such as orchard horse disease, orchard poisoning, alfalfad horses, arsenate of lead poisoning, thick-winded horses, etc. The affection appears to have been little known prior to the last three years, within which time it has increased to an alarming extent. It is now claimed by many that it is practically impossible to keep a horse for any great length of time on an irrigated orchard tract, where orchard-grown hay is fed, without the animal contracting the disease.

In general, the symptoms are either acute or chronic. In the acute form the disease manifests itself suddenly and resembles very much a typical case of respiratory influenza. There is usually an elevation of temperature varying from 102° to 104.5° F., but in the majority of cases, the temperature does not rise higher than 103°. The pulse is accelerated, 60 to 80 beats per minute,

regular but weak, and sometimes thready. Respirations are correspondingly increased, 12 to 20 per minute. A few hours prior to these initial symptoms, some animals show marked indications of abdominal pain as evidenced by pawing, lying down, and sometimes rolling, but this is usually of short duration: In all cases there is loss of appetite, and the horse becomes dull and listless and invariably coughs.

The visible mucous membranes may at first show a decided congestion, sometimes accompanied by watering of the eyes. Later there may be decided icterus or paleness of the mucous membranes. In most instances there is a mucous or greenish colored discharge from the nostrils. The discoloration is apparently due to admixture of food, as a result of paralysis of the pharynx.

Affected animals rapidly lose flesh, become emaciated, and their coats become rough and starring. Decided weakness is manifested by disinclination to move and unsteadiness when walking. The trouble is frequently complicated by pneumonic changes, and in such instances there is always a foul odor from the breath. The majority of the acute cases die after six or seven days' illness. A few of the less severe cases make a partial recovery, but it usually terminates in the chronic form after an illness of three weeks or more.

About 50 per cent of all cases of orchard horse disease, according to the records of one veterinarian, are of the chronic type. Such animals are usually in good physical condition and when at rest appear normal, but when exercised, they show symptoms of difficult breathing during inspiration, accompanied by a roaring sound which is due to a paralysis of the vocal cords. In most cases, the condition is so severe that it is impossible to trot or walk any great distance without causing distress. The working of such an animal is practically impossible. "Some chronic cases are apparently a sequel to the acute form of the disease, while others develop so gradually as to escape notice until roaring is noted. Some cases show a slight nasal mucous discharge and a chronic cough which may persist for months. This condition is especially prevalent in the early stages, but may later disappear."

The principal lesions in the acute cases consist of acute inflammation of the pharynx and larynx, pneumonia, and pleurisy. The mucous membranes of the nasal passages, except for icterus or paleness, are normal, while all other organs seem free from inflammatory disturbances. In one chronic case, the chief lesion was paralysis of the left vocal cord and marked atrophy of the muscles controlling it. "The liver showed a few attached shreds of fibrin on the surface; the spleen showed a sprinkling of petechial hemorrhages; a few small subserous hemorrhages were present on the heart over the left ventricle near the apex. There was evidence of inflammatory disturbance in the respiratory tract, and all visceral organs were apparently normal. This animal had never shown acute symptoms and had shown the roaring symptoms only about two weeks prior to the time that he was killed for autopsy."

Medicinal treatment seems to be of little value. The prognosis in all acute cases is very grave, no authentic case of complete recovery having been reported. "Affected horses which do not succumb in the acute stage gradually get better, and after a duration of three to six weeks the disease assumes the chronic form accompanied by roaring. Veterinarians at Wenatchee, Wash., who have operated for roaring upon about 100 chronic cases, have had about 80 per cent of the subjects become serviceably sound. About half of this number make a perfect recovery."

Practical points in hog cholera control, T. P. WHITE (*U. S. Dept. Agr. Yearbook 1919, pp. 197-204, figs. 2*).—This is a popular account of the control work with hog cholera.

Epidemiology of blackhead in turkeys under approximately natural conditions, T. SMITH and H. W. GRAYBILL (*Jour. Expt. Med.*, 31 (1920), No. 5, pp. 633-645).—This is a report of field experiments made in continuation of those conducted during the warm season of 1916, previously noted (E. S. R., 37, p. 383).

“The foregoing experiments in outdoor, unprotected inclosures demonstrate the difficulties surrounding the rearing of turkeys. These are discussed from another viewpoint below.

“The occasional presence of coccidia, the presence of *Heterakis papillosa* in the ceca, the occurrence of cases of aspergillosis and of chickenpox in incubator-bred birds which did not come in contact with other domesticated birds, except in a few cases with incubator-bred chickens, show clearly that turkeys are picking up from the ground material deposited by other birds. The agent of blackhead must come from the same sources.

“The field experiments show a steadily increasing concentration of the infection from 1917 to 1919, even though the ground had been plowed and seeded before use. As a result, the various groups of turkeys became infected to a greater degree. The growth in the intensity of the disease may be in part ascribed to an accumulation on the soil of infectious agents during any given season after they had been introduced, but it is hardly acceptable as an explanation from season to season, when the soil was either virgin, as regards poultry yards, or plowed deep and seeded before use. A more rational hypothesis is the gradual attraction of birds in larger numbers and greater variety on account of the food supply in the turkey inclosures and the more intensive cultivation of the land surrounding the laboratory and animal buildings since the beginning of the experiments in 1917.

“The intensity of the outbreaks due to the confining of young turkeys with birds over a year old which had been infected during the preceding year, or on grounds previously occupied by them, was in all instances much greater than in the spontaneous outbreaks. The cases amounted to nearly 100 per cent of the exposed. On the other hand, the number of cases in the control flocks varied and was very low in some groups. It could have been kept down if the sick birds had been promptly removed and not permitted to recover on the same ground. However, the object of the experiment was not to suppress the disease, but to see to what extent it would develop.

“It is self-evident that the results obtained apply strictly only to that part of the country where the experiments were made. We have at present no means of knowing whether the sources of infection would become more numerous and concentrated with a higher mean annual temperature, or the reverse. Only by using incubator turkeys exclusively for such tests and eliminating the older turkeys and domesticated birds as carriers can the miscellaneous, at present not controllable sources of the agents of this disease in different localities and the chances of successful rearing, be determined.”

Production of fatal blackhead in turkeys by feeding embryonated eggs of *Heterakis papillosa*, H. W. GRAYBILL and T. SMITH (*Jour. Expt. Med.*, 31 (1920), No. 5, pp. 647-655).—“In four experiments, three with young incubator turkeys and one with young incubator chickens, in which the feces of old turkeys from an infectious flock, kept at room temperature up to 5, 8, and 10 days, were fed, no infection resulted. In an experiment in which two of four young incubator turkeys used in one of the above experiments were fed embryonated eggs of *H. papillosa* and feces of turkeys from an infectious flock both contracted blackhead. Two controls remained well. Later they were fed embryonated eggs of *H. papillosa* and both contracted blackhead. In

another experiment, three incubator turkeys received embryonated eggs plus turkey feces from an infectious flock. All contracted blackhead. Three received embryonated eggs alone; all contracted blackhead. Three received turkey feces only; none contracted blackhead. Three controls received nothing; one showed blackhead lesions at the autopsy.

"In a final experiment three turkeys were fed cultures of feces from the ceca of diseased turkeys, three were fed cultures of feces of old turkeys from an infected flock, and three controls were fed nothing. None contracted blackhead. The cultures of feces were prepared precisely as were the earlier ones containing *Heterakis* eggs, but without the latter. From these experiments, it becomes evident that blackhead may be produced in healthy incubator-raised turkeys, reared in the open in an environment where blackhead occurs, but out of direct contact with old turkeys and other poultry, by feeding cultures of embryonated eggs of *H. papillosa*, prepared by cutting up the worms in isotonic salt solution and incubating the suspension at room temperature.

"The production of acute blackhead by feeding embryonated eggs to turkeys in whose ceca adults of *H. papillosa* are already present seems incomprehensible at first thought. A tentative explanation to be offered is that the worms when invading the ceca in large numbers break down the resistance of the bird, which is able to protect itself against a few. This may account for the very irregular occurrence of cases in contact with older recovered birds on infected grounds. The rôle of *Heterakis* as a preliminary agent may also account for the continuing high mortality in turkeys in which the disease has been operating for so many generations to eliminate the most susceptible. It now seems highly probable that the turkey has become relatively resistant to the invasion of the protozoan parasite acting alone, and that such invasion may require other agencies. Whether *H. papillosa* is the only, or at any rate the chief accessory agent or whether there are others, living or inert, which when ingested by the turkey assist in preparing the way for the destructive invasion of the walls of the ceca and the liver by *Amœba meleagridis* is a question now open to solution by experimentation. The relation of common poultry to outbreaks of blackhead may be accounted for, at least in part, by the fact that they are hosts of *H. papillosa*. How frequently they also carry *A. meleagridis* remains to be determined."

The flagellate character and reclassification of the parasite producing "blackhead" in turkeys.—*Histomonas* (n. g.) *meleagridis* (Smith), E. E. TYZZER (*Jour. Parasitol.*, 6 (1920), No. 3, pp. 124-131, pl. 1).—The early studies of the author led to the suggestion of the flagellate character of this parasite (E. S. R., 41, p. 685). Subsequent observations are here recorded, showing that this organism may under certain conditions exhibit characteristic flagellate motility. The proof that it is not an amœba makes necessary its reclassification, for which the generic name *Histomonas* is proposed and is characterized as follows:

"*Histomonas* n. g., plemorphic, parasitic Tetramitidæ with amœba-like phases of development within tissues of host. The kinetic structures associated with blepharoplast, intraprotoplasmic during amœba-like phase. Nuclear division trichomonad in type with well-developed parademesome."

RURAL ENGINEERING.

Irrigation, M. F. DE MAGALHÃES (*Escola Agr. "Luis de Queiroz," Piracicaba, Brazil, Bol. 5* (1920), pp. 38, figs. 25).—Irrigation practice in some of the southern States in both arid and humid regions is reviewed, and analogies drawn with conditions in Brazil.

Report of the Water Conservation and Irrigation Commission for the year ended June 30, 1919 (*N. S. Wales, Rpt. Water Conserv. and Irrig. Comn., 1919, pp. 34*).—Data on the works and expenditures of the Water Conservation and Irrigation Commission of New South Wales for the year ended June 30, 1919, are reported, covering irrigation areas established and controlled by the State, proposed irrigation areas, private and State water conservation works, and artesian and shallow well boring.

Administration report for the [fiscal] year 1918–1919, W. J. J. HOWLEY and K. R. S. RAU (*Madras Pres. [India], Irrig. Branch, Admin. Rpt. 1918–19, pt. 2, pp. VIII+206, pl. 1*).—The expenditures on and revenues derived from Government irrigation works in the Madras Presidency for the year 1918–1919 are reported in detail.

Another diagram for solving the Manning hydraulic formula, R. D. GOODRICH (*Engin. News-Rec., 83 (1919), No. 14, pp. 648, 649, fig. 1*).—A metric logarithmic diagram for solving the Manning hydraulic formula is given, which was used in the hydraulic computations involved in the investigation of river and flood channels preliminary to the design of the system for the regulation of the rivers of the Province of Chili, China.

It is noted that for hydraulic radii between 0.4 and 3 meters, with slopes from 0.0001 to 0.01, this diagram will give practically the same results for all values of n as diagrams for the Kutter formula. It will also check very closely for flatter slopes when n does not exceed 0.015, and may therefore be useful in the design of sewers, aqueducts, or irrigation flumes.

Computation of the coefficient of discharge of Venturi meters, W. S. PARDOE (*Engin. News-Rec., 83 (1919), No. 13, pp. 606–608, figs. 6*).—The results of tests conducted at the University of Pennsylvania on meters ranging in diameter from 0.625 and 0.405 in. to 16 and 8 in. are reported.

It is believed that the most important constructional feature of Venturi meters is a perfect brass or noncorrosive throat piece with proper piezometer connections and a constant ratio of length to diameter of throat, preferably one-half. The graphic data reported indicate that coefficients may be computed to within 0.5 per cent of experimental values.

Duty of water when irrigating by pumping, J. NARAYANAMURTI (*Madras Agr. Dept. Yearbook, 1919, pp. 55–68*).—Considerable data on duty of water on the black alluvial soils of the Kistna Delta when irrigating by pumping are summarized, it being shown that, roughly speaking, the number of acres that can be cultivated by a pump is equivalent to its discharge in gallons per minute divided by 10.

Flooding and furrow irrigation in Coimbatore, R. C. WOOD and K. RAGHAVA ACHARYA (*Madras Agr. Dept. Yearbook, 1919, pp. 42–54*).—Experiments with well-water irrigation under conditions of considerable heat and evaporation are reported, showing that a given quantity of water, provided it is not excessive, can be applied to a crop more economically by running it along furrows than by flooding beds or checks. However, the actual quantity of water that can be applied at a single irrigation is less with the furrow system than with the flooding system, and if a crop requires a heavy irrigation it is better to flood, because the quantity of water needed can only be given by numerous small waterings with the furrow system, with the attendant loss by evaporation and waste of labor.

For conditions at Coimbatore it is concluded that the system can be recommended for ragi grown in the monsoon, but not for wheat or sorghum.

Reclamation and irrigation combined, A. PRIVAT (*An. Soc. Rural Argentina, 52 (1918), Nos. 7, pp. 409–422; 8, pp. 483–495, figs. 51*).—An extensive sys-

tem of combined drainage and irrigation of swamp land in Argentina is described and experience in the design and development of the different engineering features discussed in some detail, with drawings of different structures. Drainage is accomplished both by tile and open drains, and the drainage water is partially utilized for irrigation by pumping from open drainage canals and storage reservoirs.

The flow of water in dredged drainage ditches, C. E. RAMSER (*U. S. Dept. Agr. Bul. 832 (1920), pp. 60, pls. 20, figs. 13*).—This bulletin reports and summarizes a series of experiments to determine the values of the roughness coefficient n in Kutter's formula which will properly apply to the various conditions of dredged drainage channels. The experiments were conducted in Lee and Bolivar Counties, Miss., western Tennessee, western Iowa, southern North Carolina, and eastern Florida.

It was found that a deposit of slick, slimy silt on the sides and bottom of a channel and the clearing out of perennial growth reduce frictional resistance to flow and increase the capacity. The growth of grass and weeds and the accumulation of drift trees, logs, and other obstructions in the channel greatly decrease the capacity. After a certain amount of erosion has taken place in a channel, further erosion does not necessarily increase the roughness of the perimeter.

The roughness coefficient n was found to be appreciably higher for a roughly dredged channel than for a smoothly dredged one, and abrupt variations in cross section are active in reducing the hydraulic efficiency of a channel. Ordinarily a dredged channel quickly deteriorates in hydraulic efficiency unless systematically maintained.

The conclusion is drawn that generally in designing a proposed dredged channel a value of n of 0.03 should be used if the channel is to be smoothly dredged and of 0.035 if roughly dredged. If these values are used, the channels should be carefully maintained, and if not to be so maintained a value of n should be selected in accordance with the worst anticipated conditions for the channel. In computing the capacity of an existing channel the value of n chosen should, whenever possible, be based upon a comparison of the conditions in the existing channel with the conditions of channels for which values of n have been determined.

Community tile drainage construction, J. R. HASWELL (*U. S. Dept. Agr. Yearbook 1919, pp. 79-93, figs. 10*).—Several small community tile drainage organizations are briefly described, and data are given on operation, especially with ditching machinery.

Information on the divining rod, MARAGE (*Rev. Sci. [Paris], 58 (1920), No. 3, pp. 72-80, figs. 4*).—A number of experiments on the use of the divining rod for locating underground water supplies are described, the author apparently being a believer in this method of discovering underground water.

Importance of hygienic inspection of wells in securing a supply of pure potable water, L. KROEBER (*Schweiz. Apoth. Ztg., 55 (1917), Nos. 19, pp. 274-277; 20, pp. 287-290*).—On the basis of his studies the author expresses the opinion that chemical examination alone is not sufficient, but that the analyst must secure the sample personally and examine the surrounding conditions, with particular reference to closets and accumulations of kitchen wastes.

Methods of chemical examination for chlorin contamination are briefly outlined.

The purification of moorland water supplies, E. G. BLAKE (*Sci. Prog. [London], 14 (1920), No. 56, pp. 659-664*).—Information is given on the installation of moorland water supply systems for rural use in England, with

particular reference to purifying equipment for the removal of acidity and the consequent protection of metal parts of the system against excessive corrosion. It is stated that ordinarily the litmus test will serve to detect the least trace of acidity in such waters. Primary treatment with a chalk filter followed by sand filtration is recommended.

The sterilization of water by means of ultra-violet rays, W. L. DECKER (*Chem. and Metall. Engin.*, 22 (1920), No. 14, pp. 639-645, figs. 10).—The records of work conducted on the adaptation of ultra-violet ray treatment to small isolated plant water supplies are reported, and the entire theory of the process discussed in some detail.

“Water, if clear, is practically as transparent as air to ultra-violet rays. In many cases, however, it must first be filtered to free it from suspended matter and, if possible, also from colloidal matter, which would otherwise retard the passage of the rays. Careful observation of well-filtered water, however, nearly always reveals the presence of a small amount of suspended matter of a large enough size to allow microbes to be protected against the rays. To sterilize such water with safety it was found advantageous to agitate it while passing through the illuminated zone and to expose it several times to the light of the same lamp. This stirring up is best accomplished by a proper arrangement of baffles.”

It is noted that in the majority of analyses the water after passing through the filters showed the presence of *Bacillus coli*. The sterilized water showed that the violet-ray sterilizer functioned properly in killing all the *B. coli* germs that were left after passing the filter.

“An interesting development of the violet-ray apparatus is that the amount of water that can be treated does not vary in arithmetical progression with the number of units used.” Recent tests have also developed the fact that water treated with ultra-violet rays has a residual effect. When to a sample of water that had been sterilized fresh bacteria were added, it was found that in an hour’s time 90 per cent of these added bacteria had succumbed.

Copper sulphate treatment to counteract algæ growths in large reservoirs (*Engin. and Contract.*, 53 (1920), No. 15, pp. 432, 433).—An account is given of recent experiments intended to free the Catskill water supply for the city of New York from Asterionella. It was found that a continuous supply of copper sulphate amounting to 625 lbs. daily in a flow of 380,000,000 gal. substantially reduces the number of the microscopic organisms, the resulting cost being about 13 cts. per million gallons.

Running water in the farm home, C. A. NORMAN (*Purdue Agr. Ext. Bul.* 91 (1920), pp. 12, figs. 7).—Brief popular information is given on systems for farm water supply and sewage disposal. The water-supply systems include the gravity, hydropneumatic, and pneumatic systems, the last of which has been subject to considerable attack during the past from various sources.

In the brief discussion of sewage disposal the statement is made that “the septic tank provides a means for liquidifying and purifying sewage.”

Treatment of beet sugar plant sewage, L. PEARSE and S. A. GREELEY (*Amer. Jour. Pub. Health*, 10 (1920), No. 4, pp. 312-320, figs. 3).—A summary of data on the subject, together with results of two years’ experiments upon beet sugar plant waste disposal, are reported.

It was found that fine screening and sedimentation are necessary for any type of treatment plant. The effluent of the settling tanks can be treated on sprinkling filters. It is concluded that sprinkling filters for the crude concentrated sewage can be dosed at about 200,000 gal. per acre per 24 hours, and sand filters at about 75,000 gal. per acre per 24 hours. Should the

concentrated sewage be mixed with an equal volume of beet-carrying water, the data indicate that a settled effluent could be treated on sand filters dosed at the rate of 100,000 gal. per acre per 24 hours.

"These rates of filtration result in quite costly installations, and every effort should be made to keep the cost down by utilizing local conditions of stream flow and soil to the utmost. These results are not wholly conclusive, but indicate the great difficulty of treating beet sugar plant sewage."

Utilization of war explosives in industry and agriculture, G. GARIBOLDI (*Gior. Chim. Indus.*, 2 (1920), No. 1, pp. 10-22, figs. 9).—Data are reported on experiments conducted in different parts of Italy on the use of ballistite, T. N. T., and picric acid for the blasting of rocks and especially for soil blasting.

The ballistite appears to be a lower velocity explosive than T. N. T. or picric acid and is better adapted for damp soil blasting, while the T. N. T. and picric acid are better adapted for dry, hard soil and rock blasting. The ballistite is apparently not sensitive to moisture, and may be exploded under water as effectively as an equal amount of dynamite. In dry, hard, rocky soils the picric acid demonstrated its superiority to the other two explosives. However, picric acid and T. N. T. were found to be effective in humid soils also.

Utilization of dynamite in agriculture, F. A. KUHN (*Hacienda*, 14 (1919), No. 11, pp. 322-329, figs. 14).—Practical data on the use of dynamite for stump removal, ditch digging, subsoiling, tree planting, and rock blasting are given.

Forced v. delayed systems of clearing stump land, M. J. THOMPSON (*Minnesota Sta. Bul.* 189 (1920), pp. 5-24, figs. 16).—This bulletin supplements Bulletin 163 of the station (E. S. R., 36, p. 785), reporting the progress of stump-clearing experiments on tract 3, and includes miscellaneous data related to the general subject of land clearing.

Tract 3 was sown in the spring of 1914 to clover and grass at the rate of about 2 lbs. alsike clover, $\frac{1}{2}$ lb. red clover, and 2 $\frac{1}{2}$ lbs. mixed grasses per acre. The land was prepared before and after seeding by stirring with one section of a spring-toothed harrow drawn by one horse, and covering as much ground as possible between the stumps. It was lightly pastured during the season of 1914 and pastured through the seasons of 1915-1918. Removal of stumps was begun in 1918, and stumping and plowing was completed in 1919. Two-thirds of the stumps were pulled by horsepower direct without dynamite or machine. The stumps not thus pulled averaged 13.17 in. in base diameter. The value of dynamite and accessories thus displaced averaged about \$25 per acre.

The cost of clearing ripe stumps per acre using dynamite was \$55.31 in 1918 as compared to \$51.64 with green stumps in 1914. This was an increase of 7.1 per cent, due to increased costs of labor and material, as on the basis of costs in 1914 the 1918 cost of clearing ripe stumps would have been \$37.72, or 36.7 per cent less than the 1914 cost of green blasting. The cost of clearing an acre of ripe stumps in 1918 using the stump-puller was \$44.08, a saving of \$14.96, or 33.9 per cent, on the cost of removing an acre of green stumps by machine power in 1914. On the basis of 1914 costs of labor and material, the 1918 cost would have been \$31.81, and the saving 46 per cent.

Stump-puller clearing cost more than dynamite clearing in 1914, but in clearing ripe stumps in 1917 it was lower than all other prices for either year. It cost as much to blast, pull, and pile one large decayed stump as to pull and pile 10 small ones by horsepower. It cost as much to pull and pile one stump by machine power as it did to pull and pile three by horsepower.

In 1915 clearing operation receipts exceeded costs of clearing up to the stump stage, with a surplus credit of pole and slab wood, and sawdust for bed-

ding. In land clearing work in 1917, 30 per cent dynamite proved more effective than 20 per cent.

"The delayed system of clearing on tract 3 was superior to green clearing on tract 1 in three respects: (1) There was a saving of one-third or more in cost per acre. (2) There was a certain annual pasture crop harvested by the cattle while the crops from tracts 1 and 2 were low in volume and high in cost of production. (3) The quality of the land was improved by the decaying vegetation and thickening sod, the land more easily plowed, and a better and cheaper seed bed produced."

Terracing of fields (*Univ. Tucumán, Ext. Agr. Bol. 36 [1919], pp. 1-10, figs. 5*).—Features of land terracing to prevent soil erosion, as practiced in Argentina, are discussed.

Modern road construction, A. T. BYRNE (*Chicago: Amer. Tech. Soc., 1919, pp. [8]+187+6, figs. 110*).—This is a practical treatise on the engineering problems of road building, and includes a compilation of specifications for modern highways and city streets and boulevards.

The following subjects relating to country roads and boulevards are dealt with: Resistance to movement of vehicles, location of roads, preliminary road construction methods, and maintenance and improvement of roads.

Modern roads, H. P. BOULNOIS (*London: Edward Arnold, 1919, pp. VII+302, pls. 13, figs. 6*).—This book is intended for a comprehensive treatise on the subject, covering modern improvements and methods as far as possible, with particular reference to British practice. No cost data are given.

The following chapters are included: Traffic, water-bound macadamized roads, tar treatment of road surfaces, bituminous roads, bituminous carpets, waves and corrugations, paved streets, concrete roads, and slippery streets. Two appendixes are also included, namely, conference of road users on traffic regulations and Royal Automobile Club—traffic rules.

County highway data (*Pub. Works, 48 (1920), No. 12, pp. 276-287*).—Data obtained by questionnaire from county engineers and officials representing between 300 and 400 counties in the various States are reported, showing county highway work done during 1919 and practice as to road shoulders, resurfacing of county highways, and maintenance of water-bound macadam county highways.

Annual report of the highway commissioner to the governor for the term beginning October 1, 1918, and ended June 30, 1919, C. J. BENNETT (*Conn. Highway Commr. Ann. Rpt., 1919, pp. 84+27, pls. 6*).—The work and expenditures of the Connecticut State Highway Department for this term are reported.

[Thirteenth annual report of the Board of County Road Commissioners of Wayne County, Mich., 1918-19], E. N. HINES ET AL. (*Ann. Rpt. Bd. Road Commrs. Wayne Co., Mich., 13 (1919), pp. 93, pl. 1, figs. 89*).—This report deals with the work and expenditures on road design and construction in Wayne County, Mich., for the year ended September 30, 1919, the striking feature of the work being the notable development in concrete road construction.

Road problems in the Ozarks, E. G. HARRIS (*Bul. School Mines and Metall., Univ. Missouri, 11 (1919), No. 3, pp. 70, figs. 7*).—This is a revision of a bulletin of the same title issued in 1917 (*E. S. R., 37, p. 695*) before the authorization of State aid for road building.

It is stated that in the Ozark region the present bad location of many of the roads constitutes the chief reason why improvement is impossible, or possible only at great and continuous expense. "In the Ozarks, outside the mining districts, no other material than gravel (including "hardpan") should be considered for road surfacing. The order of improvements should be relocation,

crowning and ditching, construction of culverts and small bridges, graveling where most needed, and last, the construction of the larger bridges. The culverts and small bridges should be of concrete of simple design requiring the minimum steel, carpenter work, and lumber."

Road-building materials in Texas, J. P. NASH, C. L. BAKER, E. L. PORCH, JR., and R. G. TYLER (*Univ. Tex. Bul.* 1839 (1918), pp. 159, pls. 8).—This report contains information on the nature, distribution, and extent of the road-building materials of the different counties of Texas, and includes data on mechanical and physical properties and the different types and methods of testing.

The most prevalent road-building material in the State is gravel, but there is also an abundance of limestone over a considerable area. In certain restricted areas there is an abundance of granite suitable for the making of granite blocks. Sand and clay suitable for sand-clay road construction occur in a number of localities. Along the coast and paralleling it as far inland as 100 miles, there are practically no natural deposits of satisfactory road materials, so that the matter of constructing first-class highways in this country is a question of importing materials. The most accessible material is the shell, dredged from the Gulf.

Aggregate proportions for equal strength concrete, A. N. JOHNSON (*Engin. News-Rec.*, 84 (1920), No. 20, pp. 964-966).—Tabular data are given for 135 combinations of fine and coarse aggregates producing equal strength concrete, based on the fineness-modulus theory of proportioning concrete for actual field use in concrete highway construction.

Concrete beam tests, Northport unit, North Platte Project, W. H. FISHER (*Reclam. Rec. [U. S.]*, 11 (1920), No. 4, pp. 175-178).—Field tests of reinforced concrete beams, made to determine the advisability of using local gravel as a concrete aggregate for irrigation, canal, and lateral features, are reported. The gravel used contained about 20 per cent of sandstone pebbles.

"On nearly all these tests, the failure was in the mortar or mortar bond on gravel except in those tests showing an ultimate stress near 2,000 lbs. per square inch, where a few of the sandstone pebbles . . . were sheared. This shows that as far as quality of coarse aggregate is concerned suitable concrete would be made from this gravel for any and all required structures. All beams that failed at the lower unit concrete stresses . . . seemed to carry a larger percentage of the coarsest aggregate than those which failed at the higher stresses."

There was also a marked increase of strength, varying from 40 to 55 per cent, in those beams which were covered with sand while curing as compared to those of the same age and mix which were left exposed to the weather. The 1:2½:5 beams covered while curing for both 30 and 90 day tests were stronger than the 1:2:4 beams of the same age that were not covered while curing.

Concrete mixtures in alkali soils, C. J. MACKENZIE (*Jour. Engin. Inst. Canada*, 3 (1920), No. 4, pp. 176-181, figs. 5).—A historical review of the subject is given, and the details of experiments being conducted in Saskatchewan are outlined, the results of which are to be reported later. These consist of a series of actual field tests of concrete in the form and under conditions found in practice, observations of structures in course of construction in troublesome areas, and chemical and physical laboratory tests.

Cement joints economical in cast-iron gas pipes (*Pub. Works*, 48 (1920), No. 10, p. 214).—This is a review of a paper by W. M. Henderson presented at a meeting of the Pacific Coast Gas Association, in which data from two years' work in laying large quantities of cast-iron pipe 4 to 30 in. in diameter are presented. The conclusion is drawn that the cost of cement mortar in hub

and spigot joints is only from 25 to 50 per cent of the cost when they are calked with lead.

The mechanical properties of West African "pooli" timber (*Bul. Imp. Inst.* [London], 17 (1919), No. 3, pp. 277-280).—Tests of the compressive, shearing, and cross bending strengths of four samples of so-called pooli timber derived from *Cordia platythyrsa* and found in Sierra Leone and in the Gaboon, Nigeria, and Cameroons showed that it equalled the average coniferous timbers used in the United Kingdom in compressive strength and exceeded them in bending and shearing strengths. The weight per cubic foot varied considerably but was about the same as that of white pine.

Lubrication of internal-combustion engines, W. F. OSBORNE (*Power*, 51 (1920), No. 15, pp. 590-593).—Beginning with a discussion of the action of lubricants during each stroke, this article takes up in detail the various construction and operating conditions which affect the choice of oil for internal-combustion engines. A list of lubricating troubles is given, together with the causes of each.

Low-grade fuel requires new valve adjustment, J. P. MAHONEY (*Agrimotor*, 3 (1920), No. 7, p. 13).—The results of experiments on valve adjustments of gas engines required on account of the present low-grade fuels on the market indicate that tappet clearances should be increased to prevent valves from being held open when the engine is hot. Valve tappet clearances are advocated as follows: "For engines from 3½-in. bore by 5½-in. stroke to 4¼-in. bore by 5½-in. stroke—intake valves 0.008 in.; exhaust valves 0.012 in. For engines from 4¼-in. bore by 6-in. stroke to 5-in. bore by 6½-in. stroke—intake valves 0.01 in.; exhaust valves 0.016 in. Never less but rather more than these clearances should be given."

Report of the Departmental Committee on Agricultural Machinery, together with appendix and summaries of evidence (London: *Min. Agr. and Fisheries*, 1920, pp. II+75; *abs. in Impl. and Mach. Rev.*, 45 (1920), No. 540, pp. 1787-1790).—This is the report of a committee of eight appointed to arrange for the testing, adaptation, and improvement of machines likely to prove of value to agriculture; to examine inventions and new devices; and to advise as to the further steps which should be taken in England to promote the development of agricultural machinery.

Among the recommendations of the committee are included sections for research, standardization, testing, popular information, education, and advice and propaganda on agricultural machinery. It is to be noted that the recommendations of this committee propose to consolidate functions on the development of agricultural machinery in England which are widely scattered amongst engineering societies and State and Federal institutions in the United States.

Handy charts for belts (*Tractor and Gas Engine Rev.*, 13 (1920), No. 4, p. 18, fig. 1).—A chart is presented giving data on the transmission of horsepower by different types and widths of belts at varying speeds.

How to use the post drill press, G. H. RADEBAUGH (*Power Farming*, 29 (1920), No. 5, pp. 14, 15, 18, 20, figs. 22).—The proper use of the post drill press is described and profusely illustrated, with particular reference to the repair of broken farm machinery.

The horse-power problem on the farm, O. A. JUVE (*U. S. Dept. Agr. Year-book 1919*, pp. 485-495, pl. 1, figs. 7).—A discussion of the choice of farm power with particular reference to the use of horse power is given. This is based upon results obtained with horse power on a number of representative farms.

It is shown that there are large variations in the number of horses used even for the same operation in different sections of the country. Other factors

are discussed showing the complexity of the problem, particularly when it is desired to substitute intelligently mechanical power for horse power.

The present position of mechanical road traction, C. G. CONRADI (*Jour. Inst. Mech. Engin.* [London], No. 9 (1919), II, pp. 661-701, pls. 8, figs. 24; also in *Engineering* [London], 108 (1919), Nos. 2813, pp. 714-718; 2814, pp. 764-768, figs. 53; abs. in *Electrician* [London], 83 (1919), No. 24, pp. 682-687, figs. 8; *Sci. Abs., Sect. B—Elect. Engin.*, 23 (1920), No. 267, pp. 121, 122).—Descriptions are given of the different kinds of vehicles used in England for mechanical transportation, together with considerable data on operating experience.

It is concluded that animal traction and electric vehicles are the most applicable for frequent-stop delivery, steam for heavy hauls at moderate speeds over comparatively long distances, gas motor vehicles for work involving few stops and high speeds, and electric tractors for heavy haulage. Electric vehicles were found to possess a maximum degree of reliability of 95 per cent, gas motor vehicles 90 per cent, and steam 85 per cent. Spur gears, especially internal gears, are recommended for reduction gearing.

Tests of an electric vehicle running with the differential gear locked and free are also reported. It was found that when the differential gear was locked the power required was from 7 to 12 per cent higher, according to the load, and the wear on the tires was greater.

Farm tramways (*Min. Agr. and Fisheries* [London], Leaflet 341 (1920), pp. 4, figs. 3).—This leaflet briefly describes British practice in regard to farm tramways, many of which are said to be laid down in parts of England where the land is flat.

Protection of the tractor against freezing, G. PASSELÈGUE (*Jour. Agr. Prat., n. ser.*, 33 (1920), No. 4, pp. 72, 73, fig. 1).—An apparatus is described which is to be attached to the radiator of a farm tractor as a protection against freezing. The apparatus is so constructed that water from the radiator obtains access to it, this water freezing before the water in the radiator as the temperature decreases. The freezing of the water in the apparatus causes the draining of the radiator of the tractor.

Reclaiming swamp land with tractors, W. ASHBY (*Power Farming*, 29 (1920), No. 5, pp. 9, 10, figs. 3).—A year's experience in the reclamation of a ditch-drained swamp in St. Louis County, Minn., by tractors is recorded.

Five tractors were used as follows: Two 45-h. p. tracklaying machines with 30-in. tracks, one 75-h. p. tracklaying machine with 24-in. tracks, one 20-h. p. tracklaying machine with 6½-in. tracks, and one 22 h. p. wheel tractor. These machines all did good work in breaking on hard ground, but in the softer parts of the swamp the 45-h. p. machines with 30-in. tracks were the only ones which could be depended upon. Tabular data show that the weight of the 45-h. p. tractors per square inch of ground contact was 3.17 lbs., while that of the 75-h. p. machine was 5.48 lbs. and the 20-h. p. machine 3.85 lbs. The two latter machines slid the tracks on soft ground. It is noted that the three large tractors working an average of only a little more than two months apiece broke 1,350 acres of wild land, disked 1,200 acres, and completed the seed-bed preparation of 350 acres.

Experiments on the mechanical cultivation of rice in Cochin China, M. LABASTE, M. P. M. LEGRAS, and P. MORANGE (*Bul. Agr. Inst. Sci. Saigon* [Cochin China], 1 (1919), No. 1, pp. 4-12; abs. in *Internatl. Inst. Agr.* [Rome], *Internatl. Rev. Sci. and Pract. Agr.*, 10 (1919), No. 4, pp. 466-468).—Cultivation experiments in rice fields and on red soils growing Hevea are reported, in which a 45-h. p. caterpillar tractor was used drawing two 4-furrow gang plows with wooden frames and a Norwegian harrow with a metal frame.

The tractor was easy to drive and maneuver, but could not work in the rice fields as it sunk too deeply into the soft soil. As a result of three months' experiments it is recommended that the chain tracks be widened from 27.3 in. to from 33 to 35 in. and fitted with strakes projecting about 3 in. at right angles to the tracks to prevent slipping. The tractor should also be supplied with a carbureter to enable it to burn paraffin, an electric lighting apparatus to permit night work, and a special pulley for driving farm machinery. It is noted that the hitch point between the tractor and plows was too low, causing the first two shares to work too deeply.

The plows were unsuitable for rice field work, the shares being too close together longitudinally and too large and heavy. The system of lifting with levers and toothed sectors should be replaced by a system with a wheel and vertical endless screw. The shares should be at least 35 in. apart in horizontal alignment. The trailing wheels should be replaced by very large and very light drums.

Retaining walls—their design and construction, G. PAASWELL (*New York and London: McGraw-Hill Book Co., Inc., pp. X+275, pls. 9, figs. 135*).—The first chapter of this book presents the existing theories of lateral earth pressure and attempts to codify such theories, evolving a simple but well founded expression for the thrust. In following chapters it is attempted to continue this codification throughout the theories of retaining-wall design so that a direct and continuous analysis may be made of a wall from the preliminary selection of the type to the finished section.

Part 2 of this book deals with construction, including a full presentation of the modern development of concreting, with frequent extracts from some of the recent important reports of laboratory investigators. A feature of this section is data on the principles of proper construction plant selection.

A final section contains specifications and an extensive bibliography.

Securing a dry cellar, G. M. WARREN (*U. S. Dept. Agr. Yearbook 1919, pp. 425-449, figs. 21*).—Practical information is given on the damp-proofing of cellars and cellar walls, both during and after construction.

Silo construction, C. K. SHEDD and W. A. FOSTER (*Dir. Jen. Serv. Agr. [Chile] Bol. 50 (1919), pp. 66, figs. 45*).—This material has been previously noted as Bulletin 189 of the Iowa Station (E. S. R., 41, p. 691).

Practical hog houses for Indiana, C. A. NORMAN and J. W. SCHWAB (*Purdue Agr. Ext. Bul. 76, rev. ed., (1920), pp. 8, figs. 13*).—This is a revised edition of this bulletin, previously noted (E. S. R., 41, p. 586).

How to make and use a self-feeder for hogs, J. W. SCHWAB and C. A. NORMAN (*Purdue Agr. Ext. Bul. 90 (1920), pp. 8, figs. 4*).—A hog self-feeder found to be suitable for Indiana conditions is described and illustrated, and a bill of materials is included. The outstanding features of this design are (1) vertical sides, insuring the contents feeding down properly, (2) covered troughs, which keep out chickens and weather, (3) divider boards inside the feeder, set at a 45° angle and extending out into the troughs a little past the side wall of the feeder, (4) one side of the roof and the comb boards nailed securely with the other side in two sections, and (5) an adjustable feed opening.

How to build a self-feeder for hogs, C. P. THOMPSON (*Kans. Agr. Col. Ext. X Form No. 24 (1918), pp. [2], figs. 3*).—Photographs and drawings of a self-feeder for hogs are given.

Self-feeders for hogs, G. BOHSTEDT (*Chester White Jour., 10 (1920), No. 12, pp. 18-20, figs. 3*).—Self-feeders for hogs adapted to Wisconsin conditions are described and detailed drawings and bills of material included.

Electric light and power in the farm home, A. M. DANIELS (*U. S. Dept. Agr. Yearbook 1919*, pp. 223-238, figs. 10).—Information is given on the uses of electric light and power on the farm and the installation of wiring systems.

The design of hot water heating systems, I-II, W. EHRLICH (*Building Age*, 42 (1920), Nos. 1, pp. 33-35; 3, pp. 30-33, figs. 3).—Practical methods for proportioning the radiators and sizing the mains and branches to insure successful installation are presented.

Air conditioning in private houses, K. G. SMITH (*Iowa Agr. Col. Off. Pub.*, 18 (1919), No. 22, pp. 7, fig. 1).—Information is given on methods of supplying moisture to the air in houses in winter. It is stated that the humidity of the air in a dwelling house should not be less than 30 per cent.

“If the temperature is zero and the outdoor humidity at the average of 70 per cent, it requires about 1 gal. of water every 12 hours to properly moisten the air required by one person when it is warmed to a room temperature of 70° F. The moisture must be supplied to the air in the form of vapor or steam. To evaporate water with sufficient rapidity to supply this moisture requires either a large surface, a high temperature, or both. Pans which hang on the back of a radiator do not have a large surface and are not highly heated, hence they are not very effective. A small tube attached direct to the radiator and discharging steam into the room is also used. This supplies vapor faster than the pans, providing there is steam pressure. . . .

“One of the most effective pans made has a water space in the middle and a wick to give a large evaporating surface. . . . Pans may be made somewhat more effective by placing sheets of blotting paper or asbestos beneath them and punching a needle hole in the bottom of the pan. The paper absorbs the water and increases the evaporating surface.”

Warm-air furnace water-pan equipment is also described.

RURAL ECONOMICS.

The agriculture of Ohio (*Ohio Sta. Bul. 326 (1918)*, pp. 5-441, figs. 163).—Following a preface (pp. 5, 6) by C. E. Thorne, Part I of this bulletin consists of A History of the Agriculture of Ohio by W. A. Lloyd (pp. 7-86). In outline, its development is said to begin with an era of preparation, including the period of the aborigines from earliest times to 1788, and that of the pioneers extending down to 1832, and to pass through an epoch of formation in which were the periods of extension, 1832-1865, and of development, 1865-1900, to an epoch of stabilization with its periods of reorganization and of cooperation.

Part II (87-246), by J. I. Falconer, is a detailed statistical study of Ohio Agriculture from 1850 to 1910, covering the development of live stock industries and farm crops in Ohio, the use of fertilizers, size and tenancy of farms, and the development of land values and prices, as well as of railroads, cities and rural population, farm machinery, and the various agricultural regions.

Part III gives statistics of Crop Production by Counties in Ohio since 1850 (pp. 247-427), by C. E. Thorne, followed by an abridged description of the Principal Soil Types of Ohio (pp. 428-437), previously noted (*E. S. R.*, 34, p. 322).

Minutes of the farmers' club of Pennsylvania, E. B. MORRIS (*Philadelphia: J. B. Lippincott Co., 1920*, pp. XII+361).—Notes relating to this organization that appeared in the local paper at intervals between November, 1849, and July, 1859, as well as minutes of the meetings up to and including December, 1919, are published here.

Lessons from the history of the public domain, C. TALLMAN (*In Soldier Settlements in the South. Savannah, Ga.: South. Land Cong. Proc., 1918*, pp.

39-58).—Three periods in the history of land settlement in United States are designated as the period of sale, period of development and home building, and the period of research and conservation, and a fourth and latest one called the period of cooperation is suggested. It is stated that the chief fertile public lands are no longer available in the West, and that the course of settlement and agricultural development may well be directed toward the South and East.

Land settlement in Denmark, J. G. STEWART (*Jour. Min. Agr. [London]*, 26 (1920), No. 11, pp. 1061-1080, figs. 2).—In this article is described the way in which Denmark fulfills the conditions deemed essential to a successful scheme of land settlement, providing small holders with adequate capital, practical experience, and sound general education. It is concluded that a small holder in Denmark may make a comfortable living from about 11 acres provided he employs no extra labor; also, that the Danish small holder is slightly better equipped than the average in England and is more inclined toward cooperative methods.

The development of peasant land holding in a commune of Berry, P. CAZIOT (*Jour. Agr. Prat., n. ser.*, 32 (1919), Nos. 37, pp. 745-747; 39, pp. 785, 786).—Some statistics are given to show the increase in number of small peasant holdings at a certain commune in the north of Sancerrois, France, between 1835 and 1919, and to show the breaking up of large estates into medium and small peasant holdings cultivated by the owner. The author considers this development an important one for France both from the social and economic points of view.

Rural economy in the Province of Santiago del Estero, M. T. GÓMEZ (*Bol. Min. Agr. [Argentina]*, 25 (1920), No. 1, pp. 55-80).—This province in north central Argentina is described from the point of view of potential agricultural production, depending principally upon irrigation, colonization, and the remedying of the present evil of absentee land ownership. Fundamental detailed accounts of costs of producing alfalfa, corn, and wheat on 12 different ranches are given. In noting the increase in price of agricultural products, attention is paid to transportation charges and particularly to the cost of charcoal and wood used for fuel by the railroad companies in this region.

A review of Philippine agriculture and Philippine trade opportunities in the United States, P. J. WESTER (*Philippine Agr. Rev.*, 13 (1920), No. 1, pp. 5-24, pls. 10).—This paper reviews the agricultural progress of the Philippines in the last nine years, noting the introduction or development of specific important crops and live stock, the production, export trade, and possibilities for the future as depending upon the influx of capital, particularly from the United States.

[Zamboanga Province and the Sulu Archipelago: Natural resources and opportunities for agricultural development], P. J. WESTER (*Philippine Agr. Rev.*, 13 (1920), No. 1, pp. 25-56, pls. 12).—Two descriptive articles are included in these pages relating to the agricultural industries of two regions of the Philippines.

The development of English agriculture and rural life, A. W. and M. K. ASHBY (*London: Natl. Home Reading Union [1918]*, pp. 32).—A discussion is given of the changes in Government agricultural policy brought about by the war and the early attempts at education, inducement, and compulsion to increase food production leading up to the Corn Production Act of 1917, with a brief historical résumé of social problems arising out of England's agricultural system, mainly since 1865, also of the development of agricultural education and the cooperative and rural housing and town planning movements. There follows a consideration of the general problem of village society, organization of

the agricultural laborer, personal prospects for the laborer, rural housing, education, village clubs, and demands for the future.

The rural problem, GORBEA (*Inform. Agr. [Madrid], 10 (1920), No. 209, pp. 1-4*).—Grievances of farmers over high railroad freight charges throughout Spain and the deleterious effect of high land and ocean transportation rates on national production are discussed. Resolutions approved by the Farmers' Association of Spain are given, favoring temporary Government supervision and subsidy for existing railroads and the construction of new lines.

Service rendered by the executive committee on national production, J. G. P. LIMA (*Servicos Prestados pela Delegação Executiva da Produção Nacional. Rio de Janeiro: Min. Agr., Indus., e Com. [Brazil], 1918, pp. 58*).—This report gives an account of the work of the executive committee on national production in Brazil from January to November, 1918, including distribution of agricultural seeds, fertilizers, insecticides and machinery, publication and distribution of agricultural propaganda, the work of traveling teachers, and setting a minimum price on wheat.

Agriculture and cooperation, J. MATHAI (*Bengal, Bihar, and Orissa Coop. Jour., 5 (1920), No. 5, pp. 326-331*).—This paper notes briefly a conference between the agricultural and cooperative departments of the Government in India in 1917 relative to the improvement of agriculture by the coordination of the functions of the two. Attention is directed to the advantages of joint purchase and sale, noncredit cooperation, improvement of transportation facilities, and the making of local cooperative unions natural self-governing units in the cooperative system of India.

Report of the Irish Agricultural Organization Society, Ltd. (Rpt. Irish Agr. Organ. Soc., 1919, pp. 127).—This report continues essentially information previously noted (*E. S. R., 41, p. 491*).

The flax industry of Russia and the Central Association of Flax Growers, G. A. MARTUSHIN (*New York: The Amer. Com. of Russian Cooperative Unions, 1919, pp. 22, pl. 1, figs. 9*).—This pamphlet is intended as a means of making available information as to the present situation of the flax industry in Russia, including the effect of the political situation upon cooperative production.

The farmers' purchase power, how organized, J. M. MEHL (*U. S. Dept. Agr. Yearbook 1919, pp. 381-390, fig. 1*).—This is a discussion of the organization and control of the farmers' purchasing power through cooperative buying of farm supplies for which warehousing, sales, and unnecessary service expenses can be eliminated and purchases standardized. Incorporated associations and unincorporated buying clubs are outlined, together with a plan of operation covering capital requirements and method of conduct. A combination order and payment form is suggested.

Collective bargaining in agriculture, J. E. BOYLE (*Amer. Assoc. Agr. Leg. Bul. 6 (1920), pp. 35-57*).—These pages embody the author's paper and an ensuing discussion of it. The author notes some manifestations of the principle of collective bargaining in the field of organized labor. Regarding this from the agricultural point of view, he differentiates between cooperative buying and collective bargaining. Collective bargaining in agriculture is defined as an agreement by a group of farmers concerning the selling price of a product, the supply of which they produce and control. The development of this theory in the farmer's consciousness is attributed to the instinct for a voice in the control of economic conditions, complaint against price fluctuation and speculation, and desire for certainty of profits.

Certain limitations and dangers, as for example, limitation of output, and two instances of the exercise of the principle in the sale of certified seed corn

on Long Island and of whole milk by producers supplying New York City, are described.

The division of farm income between landlord and tenant, J. D. BLACK (*Amer. Assoc. Agr. Leg. Bul.* 6 (1920), pp. 6-21).—The operation of demand and supply in rent determination is discussed. The objection is offered that competition is not free, owing to economic friction as a result of the inflexibility of the farm business, circumstances tending to keep the right tenant from getting on the right farm, the bargaining skill of the landlord or tenant, and custom, also that monopoly power is possible. It is said, however, that true economic rents probably more nearly prevail in the cornbelt than elsewhere.

A table is included, illustrating the margin of variation between economic rents and land valuation on 396 cash-rented farms in southwestern Wisconsin, and figures are quoted from Minnesota (*E. S. R.*, 41, p. 93) and Iowa (*E. S. R.*, 34, p. 193) studies in the same connection. It is claimed that in the absence of statistical method, which in itself presents certain difficulties, cash-rent rates will be best determined by prospective net incomes, competition, and bargaining rather than by land values.

Two final suggestions offered for the determination of share rental are (1) to follow the custom of the community as far as possible and when not possible to make allowance for it in some other part of the lease, and (2) to count the tenant's labor and management, family labor and hired labor, interest, taxes, depreciation, and upkeep on his equipment as equal to the landlord's management, interest, taxes, upkeep, and depreciation on real estate and equipment, other expenses to be divided half and half, estimating their amounts in advance or settling afterwards.

Agriculture and prices, J. D. WILLARD (*Jour. Farm Econ.*, 2 (1920), No. 2, pp. 70-82).—An account is given of problems of price levels under peace-time conditions, using as an illustration difficulties of price fixing in the New England milk industry before and during the war. Difficulties of competition with city buyers between farmers' plants, of buyers' control over shipping facilities, with so-called agricultural bankrupts, and over the growing public opinion unfavorable to the privilege of collective bargaining are noted in the discussion of farmers' cooperative ownership of producing and distributing plants. The author endorses cost of production studies for educational purposes, but maintains that accurate determination of agricultural costs is impossible, marginal costs being therefore necessarily the basis of price fixing.

[**Statement of the United States Wheat Director at the Trade Conference**], J. H. BARNES (*Chicago: Trade Conf.*, 1920, pp. 11).—This outlines briefly the protection to the producer afforded by Government price regulation.

Influence of depreciation of exchange on agricultural production, A. E. TAYLOR (*U. S. Dept. Agr. Yearbook 1919*, pp. 189-196).—Unrest of European peasants and uncertainty on the part of producers in both importing and exporting regions as to the agricultural program for the spring of 1920 is attributed to the instability of exchange. The problem of purchasing wheat on credit is said to be urgent alike to buying and selling nations. Three factors, (1) the depreciation of currency, to which the price of the imported article is directly (or more than directly) proportional, (2) the elevated prices of domestic commodities, and (3) the wage level of the workers, complicate the situation.

It is noted that Europeans are demanding payment in commodities in preference to gold, and that everywhere there is a necessity of return to normal agricultural practices.

Some fundamental problems in marketing farm products, G. LIVINGSTON (*Jour. Farm Econ.*, 2 (1920), No. 2, pp. 83-86).—Reasons are given for a

specialized study of various fields in marketing, and the importance to producers of the collection and dissemination of market information, farmers' marketing organizations, standard grades for farm products, and wise legislation in regard to marketing practices.

Report of division of markets and rural organization in North Carolina, W. R. CAMP (*North Carolina Sta. Rpt. 1919*, pp. 66-85).—This report gives recommendations for the better storing and marketing of farmers' cotton, based on information gained by means of warehouse surveys, also findings of market surveys in regard to grain and soy beans, peanuts, sweet potatoes, fruits and vegetables, hogs, beef cattle, and sheep and wool. The adoption of revised State warehouse regulations is noted, and service work of the division in promoting warehouse and marketing organizations, the formation, incorporation, and supervision of credit unions, classing cotton, grading and inspecting potatoes, and marketing farm products is reported upon.

Marketing and purchasing demonstrations in the South, B. KNAPP (*U. S. Dept. Agr. Yearbook 1919*, pp. 205-222, fig. 1).—The place and aim of marketing and purchasing demonstrations by county agents in the South are described. Specific examples of the organization of farmers in Mississippi, Alabama, and Texas, undertaken by county agents in consultation with marketing specialists in order to demonstrate the advantages of cooperative marketing, are noted.

How to use market stations, G. B. FISKE (*U. S. Dept. Agr. Yearbook 1919*, pp. 94-114, figs. 10).—A detailed explanation is offered of the help and information offered by the Bureau of Markets in the way of market quotations, reports, and interpretation of market courses.

Why produce inspection pays, H. E. KRAMER and G. B. FISKE (*U. S. Dept. Agr. Yearbook 1919*, pp. 319-334, figs. 7).—The food products inspection service of the Bureau of Markets is described as a trade insurance in furnishing reliable disinterested reports valuable to both receivers and shippers on the quantity, quality, grade, and condition of interstate shipments. The growth of Federal inspection since November, 1917, is illustrated, and inspection markets are listed and located.

The Market Reporter (*U. S. Dept. Agr., Market Rptr., 1 (1920), Nos. 22, pp. 337-352; 23, pp. 353-368, fig. 1; 24, pp. 353-368; 25, pp. 385-400; 26, pp. 401-416*).—These numbers contain weekly and monthly summaries of the movement, marketing, and prices of specified commodities, tabulated statistics with interpretative text relating to market situations for important classes of agricultural products, and foreign market information.

Among leading articles published here there appears one by E. T. Meredith, calling attention to agriculture's part in foreign trade and to the fund of information in regard to agricultural exports and imports gathered by the Bureau of Markets of the U. S. Department of Agriculture. The importance of our foreign trade is urged. In No. 24 appears the first of a series of articles, which will review receipts and unloads during the past four calendar years of certain fruits and vegetables at a number of large city markets, this one relating particularly to Cincinnati. In No. 25 there is a brief article on the importance of the dairy industry in 1919.

Prewar crop estimates in Germany, A. E. TAYLOR (*U. S. Dept. Agr. Yearbook 1919*, pp. 61-68, fig. 1).—Specific evidence is presented to show that the German official prewar crop estimates have been exaggerated, the discussion being confined to bread grains and potatoes. Between 1893 and 1898, when communal reports were discontinued, the reports of State agricultural experts ran 12 to 20 per cent higher than those of local authorities. Following the discovery of large discrepancies between the estimates and an actual inventory,

in 1915 reports by communal authorities just before and just after the harvest were instituted and investigations by the Imperial Grain Department have vindicated the reporting system discredited by the agrarian party.

Forecasting the crops of the Dakotas, H. L. MOORE (*Polit. Sci. Quart.*, 35 (1920), No. 2, pp. 204-235, figs. 8).—The theories are advanced in this paper that yields of spring wheat in North Dakota may be more accurately forecasted from the accumulated weather changes than the Government officials forecast them from data supplied by agents in the field; that accumulated changes, particularly the rainfall of the critical growth season of crops, tend to follow a compound cycle of 8 and 11 years; and that the wheat, oats, and barley crops tend to follow the same constituent cycles.

Examining the official method of crop forecasting, it is concluded that in eight out of nine cases in the Dakotas the forecasts from the weather are more accurate than the official forecast from the condition of the crops. The advantage of the forecasts from the weather is greater for the early months than for the later months, that is, that the margin between the two forecasts is narrowed with the approach of the harvest. In the one case in which the forecast by which the official method is better, the report is made only about two weeks before the harvest.

Findings of this and of earlier studies, one of which has been previously noted (E. S. R., 41, p. 892), would indicate that the compound cycles of 8 and 4 years in the annual rainfall of the Ohio Valley, the May and June rainfall in the Dakotas, the yield of cotton in the United States, and the yield of wheat, oats, and barley in the Dakotas, in the United States, in the United Kingdom, and in France are, as far as concerns the dates of their maxima and minima, practically synchronous.

Monthly Crop Reporter (*U. S. Dept. Agr., Mo. Crop Rptr.*, 6 (1920), No. 6, pp. 49-60, figs. 4).—This contains the usual estimate of acreage and production, and data relating to the farm and market value of important products and crop conditions, together with the current United States crop summary.

There are included estimates by States representing the proportion of the total number of hogs and cattle in the United States belonging to the breeds named, a chart showing regions where long staple cotton is grown, also tabulations of the percentage of the principal spring wheat varieties in the total crop, and of the percentage of the total year's farm work done each month in the year.

[**Population and agriculture in South Dakota**], S. S. VISHNER (*S. Dak. Geol. and Nat. Hist. Survey Bul.* 8 (1918), pp. 109-124, figs. 6).—Statistical data relating to population and notes on the farming and stock-raising industries of the State and irrigation projects, with figures on crop acreage and yield, are given.

Returns of produce of crops in England and Wales with summaries for the United Kingdom (*Bd. Agr. and Fisheries [London], Agr. Statist.*, 54 (1919), No. 2, pp. 43-69).—This report continues information previously noted (E. S. R., 41, p. 892).

[**Land tenure and settlement: Agriculture in New Zealand, 1919**], J. W. BUTCHER (*New Zeal. Off. Yearbook 1919*, pp. 498-565, figs. 2).—Statistical information, previously noted (E. S. R., 42, p. 90), is continued for the later year.

[**Agricultural production in New Zealand**], J. W. BUTCHER (*Statist. New Zeal.*, 3 (1918), pp. 1-70).—These pages continue information previously noted (E. S. R., 41, p. 493).

Area, classification of area, area under crops, live stock, land revenue assessment, and transfers of land in certain Indian States, G. F. SHIRRAS

(*Agr. Statis. India, 33 (1916-17), II, pp. III+V+116, pl. 1*).—This volume continues statistics previously noted (E. S. R., 41, p. 595).

Area, classification of area, area under crops, live stock, land revenue assessment, and transfers of land in British India, D. N. GHOSH (*Agr. Statis. India, 34 (1917-18), I, pp. IV+X+321, pls. 6*).—This volume continues statistics previously noted (E. S. R., 41, p. 595).

[Agricultural statistics of British India for the years 1916-17, 1917-18], G. F. SHIRRAS (*Brit. India Agr. Statis., Summary Tables, 1916-17, pp. 2-10; 1917-18, pp. 12*).—These reports continue data previously noted (E. S. R., 37, p. 891).

Estimates of area and yield of principal crops in India, 1918-19 (*Dept. Statis. India, Est. Area and Yield Princ. Crops India, 1918-19, pp. [3]+31, figs. 9*).—Tabulated estimates of yields by provinces, together with a general introductory note continue information previously noted (E. S. R., 41, p. 893).

AGRICULTURAL EDUCATION.

The project method in education, M. E. BRANCH (*Boston: Richard G. Badger, 1919, pp. 282*).—This book, which is intended primarily for the use of teachers, deals with the nature of the project method, its relation to instincts, and its social basis; the evolution of the project as an educational concept; the significance of motivation; teaching and learning by projects; the project question, exercise, and problem; manual or physical projects; mental projects not involving manual activities; the project method in history and geography; the reorganization of the course of study; and the preparation of the teacher. Problem questions and lists of references are included.

The time emphasis in vocational agriculture, J. W. DAY (*School and Soc., 11 (1920), No. 268, pp. 200-202*).—Attention is called to two factors on the basis of which the allotment of time in vocational agriculture has frequently been made, viz, the allotment made by the author of a textbook and that based on the preparation and previous experience of the instructor himself. The author holds, however, that the main factor to be recognized in determining the time emphasis is the farm practice of the community itself. Exception to this principle, however, may be made in the case of a crop that is practically unknown in the community but which is peculiarly adapted to it. The attention given to any one phase of agriculture will also necessarily be affected by its relative complexity and by the previous knowledge of the students in regard to it, the interest of the students, their ability to grasp the subject, etc. While this method, at first thought, might seem to result in a narrow type of training by preparing the individual for farming in only one particular locality, it is held that the majority of the students will actually farm in the neighborhood in which they receive their training, and that even those who move to other sections will there derive more benefit from their definite and practical course of instruction than would be the case if they had been given a vague and theoretical smattering of all the agricultural practices of the nation.

The reorganization of the country school, A. DILLE (*U. S. Dept. Agr. Yearbook 1919, pp. 289-306, figs. 5*).—The author discusses the reorganization of the rural schools along educational and administrative lines to meet the needs of present and future conditions of rural life.

The necessary educational redirection of the school, it is suggested, would involve the teaching of the basic subjects that belong to all culture, and in addition the subjects that give to the pupil the knowledge, the attitude, and the technique belonging to the life on the farm, such as agriculture, home economics, and farm shopwork. This broadening of the curriculum presupposes

better physical equipment. In general every school building that accommodates 100 or more pupils, it is held, should provide a suitable auditorium with a stage, a good stereopticon, and, if possible, a moving-picture machine; a home-economics laboratory with a lunch room adjoining; a gymnasium with shower baths and lavatories; a well-equipped laboratory and classrooms for science and agriculture; and a well-equipped room for farm shopwork.

Attention is called to certain serious deficiencies of the rural school, viz, the absence of real professional supervision, insufficient revenue, and the untrained teacher. Consolidation is advocated as the best means of securing effective reorganization to remedy these defects.

The future of agricultural education [in England and Wales], LORD LEE OF FAREHAM (*Fruit, Flower, and Veg. Trades' Jour.* [London], 37 (1920), No. 5, pp. 109, 110).—In this summary of a recent address by the Minister of Agriculture and Fisheries, outlining the plans that the ministry proposes to follow in its effort to extend the advantages of agricultural education and spread the results of agricultural research throughout England and Wales, it is stated that a policy of decentralization will be followed and every use made of existing institutions. The principal effort of the ministry will be in the direction of coordinating and stimulating local effort. The work of land settlement, it is stated, has been given over to the county councils, and agricultural education is to be extended also to ex-service men settled on the land.

The Ministry of Education is in close and sympathetic union with the Ministry of Agriculture, and has asked only for adequate representation on the agricultural subcommittees if these are chosen by the counties to be the medium of educational administration. It is left to the counties to decide as to whether their educational committee or their county agricultural committee is best fitted to further the cause of agricultural education.

In 42 counties agricultural organizers have been appointed, and special instructors in horticulture, dairying, and poultry raising are contemplated. The policy of the ministry is also toward the establishment of demonstration farms, arable dairy farms, and demonstration plats for grassland improvement. Great importance is attached to farm institutes, which are defined as agricultural schools with agricultural courses for farmers' sons who have completed their school education and are about to go upon the land, together with summer and other special courses for women and others.

Vocational agriculture for Idaho high schools, C. B. WILSON (*Idaho Bul. Vocat. Ed.*, 1 (1919), No. 1, pp. 50).—This bulletin contains the requirements, together with suggestions, with reference to agricultural instruction under the State plan for vocational education in Idaho. A suggested course of study is outlined, including general plant production in the first year, general animal husbandry in the second year, farm machinery, motors, tractors, and concrete construction in the third year, and farm management, farm accounting, marketing, and problems of rural economics in the fourth year, with comments. A detailed outline of the first and second year courses, including suggested field and laboratory exercises and practicums, projects, a pupil's project plan and study outline, and references to the literature; suggestions with reference to the agricultural room; and lists of apparatus and materials for the laboratory and of publications for the library are included.

State-aided high school departments of homemaking (*Univ. State N. Y. Bul.* 698 (1919), pp. 11).—This bulletin sets forth the requirements of the education law as amended to May 10, 1919, relating to State-aided high school departments of home economics. A suggested curriculum for a high school course in home economics is included.

Administration of independent day household arts schools (State-aided vocational schools) (*Bul. Bd. Ed. Mass., No. 9 (1918), pp. 38, figs. 2*).—This bulletin describes the present aims, courses of study, methods of instruction including home project work, types of cards for the individual record of the pupil, and promotion and graduation of pupils of the independent day household arts schools (State-aided vocational schools) in Massachusetts.

The training of children as a part of laboratory work in home management, E. VERMILVE (*Jour. Home Econ., 12 (1920), No. 1, pp. 28-34*).—The author describes a project in the training of children undertaken as a part of the laboratory work in home-management instruction in the spring and summer quarters of 1918-19 at the University of Minnesota. The division of home economics of the university conducts two home-management houses, in each of which a child aged 13 and 21 months, respectively, was taken, and its entire care placed in the hands of the students under the supervision of the instructor. The object of the work was to show that laboratory work in the care of children can be fitted into a college program, to demonstrate methods of child care, both physical and mental, which are known to result in the well-being and development of the child, and to work out some management problems involved in the care of children. It was concluded that the work was of decided benefit to both students and children. The most desirable age for the babies is open to discussion. In the author's knowledge there are at present 18 colleges and universities in this country offering laboratory work in home management, but the care and training of children has so far been omitted.

Suggested outline course of study in animal husbandry for high schools, T. B. MEADOWS (*Vocat. Dir. Pub. Ed. [Miss.], Memo D (1919), pp. 31*).—The author presents 20 lessons in animal husbandry; suggestive lesson plans indicating the topic and aim of the lesson, the class assignment, the method of procedure with the subject matter, and the practical work, in order to use the 90-minute period for agricultural instruction to the best advantage; topical outlines; a suggested outline for a brief course in dairying; lessons and list of references on bees; and a list of suggested reference texts in animal husbandry.

Animal husbandry, J. L. TORMEY and R. C. LAWRY (*New York: Amer. Book Co., 1920, pp. 351, figs. 121*).—This text, designed for the use of teachers of vocational agriculture, is devoted to a study of the fundamental principles and the art of breeding, feeding, and caring for live stock, including horses, cattle, sheep, swine, and poultry. Practical exercises and suggestive home projects are included.

The fundamentals of live stock judging and selection, R. S. CURTIS (*Philadelphia: Lea & Sebigier, 1920, 2. ed., pp. XII+17-464, figs. 190*).—In this second edition of this text, previously noted (*E. S. R., 33, p. 870*), only a few minor changes and additions have been made.

The essentials of poultry raising, B. F. KAUPP (*Richmond, Va.: B. F. Johnson Pub. Co., 1920, pp. 136, figs. 34*).—This text on the essentials of poultry raising has been written for vocational agricultural schools. Suggestions for projects, laboratory exercises and skills, and review questions are included.

Lessons in cookery.—**Books II, Diet for adults; III, Diet for children**, F. E. STEWART (*Chicago: Rand McNally & Co., 1919, pp. VIII+257, pl. 1, figs. 6; VII+223, pls. 2, figs. 49*).—Book II of this series (*E. S. R., 40, p. 693*), is divided into two main sections dealing with hearty and light diets, respectively, for normal adults, the typical recipes and menus given being based on the approximate fuel values of the foods. It is aimed to make the calorie a term of practical meaning for the student and housekeeper. Special opportunity is

offered for correlating dietetics with such sciences as physics, chemistry, and bacteriology.

Book III presents a consideration of certain basic principles and a collection of typical recipes and menus for use in children's diets for definite ages, arranged in sequence from birth through high-school age. The author, who believes in individual rather than group work, has endeavored to construct and classify the typical recipes according to certain organizing principles, the chief of which are evolution and food value. The book, consisting of 40 cooking lessons, is intended primarily for the high-school student of home economics and covers a semester's work. Suggestions for definite lessons and optional work, chiefly chart and experimental problems, for recitation or home work are included.

Putting over budget lessons, J. G. CATION (*Jour. Home Econ.*, 11 (1919), No. 11, pp. 484-487).—A summary is given of eight lessons taught by the author at a farm camp held in connection with a Chautauqua to show one way in which clothing lessons may be linked up with budget work. In the author's opinion, account keeping should be included in the first year of the home economics course, as many girls do not attend a second year.

Girls' clothing contest—Texas high schools, L. PEEK (*Dept. Ed. Tex. Bul.* 109 (1919), pp. 13).—Plans for a 1919-20 girls' clothing contest are presented for consideration of Texas high schools. The aims of the contest are to raise the standards of dress among girls of high-school age; to place the domestic-art work on a more practical, consistent, and artistic basis; to increase interest in the art of good dressing; and to encourage the subordination of clothing to the efficiency, satisfaction, happiness, and health of the individual.

Suggestions for a demonstration on the selection of clothing, Z. E. BIGELOW (*Jour. Home Econ.*, 12 (1920), No. 2, pp. 69-72).—The author outlines a suggestive plan for a demonstration lesson in the selection of clothing. The plan has resulted from the experience of several teachers and is deemed suitable for use with groups of any age.

A course in home mechanics, T. R. FOULKES (*Manual Training Mag.*, 21 (1920), No. 8, pp. 269-272, fig. 1).—The author describes a one-semester course in home mechanics offered as an elective course to be carried on concurrently with the regular work in manual training in the high school of Sun Prairie, Wis. This course was found of great practical value to the pupil, stimulated public interest in the department, and solved the problem of discipline in the manual-training department.

Household physics, A. M. BUTLER (*Boston: Whitcomb & Barrows, 1919, pp. VIII+382, pls. 2, figs. 361*).—This text deals with the principles and applications of those phases of physics which enter into the daily household life, such as heat, light, sound, magnetism and electricity, mechanics, and plumbing. The material in the text is sufficient to allow considerable latitude in the selection of work for a year's course.

Supplemental problems in arithmetic for use in rural schools, R. M. KILLION (*Los Angeles City School Dist. School Pub.* 4 (1919), 3. ed., rev., pp. 54).—The object of the problems comprising this bulletin is to demonstrate how the fundamental processes in arithmetic may be applied in a practical way to the contingencies of everyday life in rural and suburban communities. They are intended for grades 3 to 8, inclusive, and are based on data which are believed to be representative of actual conditions.

Training for rural service, P. L. VOGT (*Amer. Jour. Sociol.*, 25 (1920), No. 5, pp. 562-567).—The author calls attention to the demand for trained leadership as shown in the call for county agricultural agents, rural nurses, workers in home betterment, county social service leaders, and ministers interested in

rural life. A curriculum, recommended by the Committee on Training for Rural Leadership of the National Country Life Association, and consisting of a minimum number of courses to be included in the undergraduate work of those preparing for rural service, is presented. The subjects include general economics, general sociology, rural economics, rural sociology, rural leadership, rural clinic, religious education, farm practice (for city youth), history of religion, public speaking, English, public health, hygiene, journalism, rural politics, psychology, and the Bible. Courses should also be selected in esthetics, landscape gardening, art, music, home service, etc. It is stated that special work along the lines recommended by this committee was begun at the opening of the present college year at eight sectarian institutions and in connection with the agricultural colleges at the universities of Illinois, Wisconsin, and Minnesota.

MISCELLANEOUS.

Yearbook of the Department of Agriculture, 1919 (*U. S. Dept. Agr. Yearbook 1919*, pp. 790, pl. 1, figs. 237).—This contains the report of the Secretary of Agriculture; 29 special articles abstracted elsewhere in this issue; an appendix containing a directory of the agricultural colleges and experiment stations, the State officials in charge of agricultural and extension work, and National and State live stock associations; and the usual statistics of the principal crops, farm animals and their products, the Federal meat inspection, imports and exports of agricultural products, crop summaries, estimated value of farm products, world production and export trade in important crops, miscellaneous information relating to various crops and to live stock, movement of farm produce, prices paid by farmers for miscellaneous articles, information pertaining to farm labor, farm and labor incomes, value of plow land by States, sectional meat consumption in the United States, railway freight tonnage for 1915-18, farm tractors in the United States, wagon and motor-truck hauls from farms to shipping points, rural and agricultural populations and area of agricultural land by countries, and area and utilization of the National Forests.

Forty-second Annual Report of North Carolina Station, 1919 (*North Carolina Sta. Rpt. 1919*, pp. [265], pls. 13, figs. 45).—This contains the organization list, a report of the director and heads of departments, a financial statement for the year ended June 30, 1919, and reprints of Bulletins 239 and 241, and Technical Bulletins 15 and 16, which have already been noted. The experimental work is for the most part abstracted elsewhere in this issue.

Monthly bulletin of the Western Washington Substation (*Washington Sta., West. Wash. Sta. Mo. Bul.*, 8 (1920), No. 3, pp. 33-48).—In addition to an article abstracted on page 436 of this issue, this number contains brief articles on the following subjects: Gardening Is Real Work, by J. L. Stahl; Culling the Commercial Flock, by Mr. and Mrs. G. R. Shoup; Insect Pests of the Home Garden and Their Control, by A. Frank; and Notes on Bee Management, by J. W. Ware.

Publications available for free distribution (*Idaho Sta. Circ. 13* (1920), pp. 2).

[List of available publications of the Oklahoma Station] (*Oklahoma Sta. Circ. 46* (1919), p. 1).

The research spirit in scientific institutions, B-YOUNGBLOOD (*Texas Sta. Circ. 21* (1920), pp. 3, 4).—A brief discussion of the research spirit and of some of the more common criticisms applied to scientific workers.

NOTES.

Georgia College.—The summer school held from June 22 to August 1 included 125 wounded soldiers receiving retraining, 60 men in the cotton grading school to prepare students to take charge of warehouses bonded under Federal laws, 60 men and women in college courses, and 100 men and women in normal training work. Two short courses lasting one week each were also held, one beginning August 10 for fertilizer salesmen on fertilizers and soil conditions, and the other beginning August 2 for the 275 winners of the boys' and girls' clubs scholarships. A series of farm bureau meetings under the auspices of the extension division opened at the college August 3.

P. W. Chapman has been appointed supervisor of vocational education for the State with headquarters at Athens, succeeding Robert D. Maltby, who has been transferred to the Federal Board for Vocational Education.

Dr. A. G. G. Richardson, formerly professor of veterinary pathology at the Ohio State University, has been appointed head of the veterinary division.

Idaho Station.—Emery M. Roller has been appointed assistant in agricultural chemistry.

Kansas College and Station.—B. S. Wilson, for several years in charge of crops exhibit work and assistant in cooperative experiments, has resigned to engage in farming. C. F. Huffman, instructor in dairy husbandry, has resigned to take up commercial work and has been succeeded by R. B. Becker. George Maxey has been appointed assistant professor of dairy husbandry and will have charge of dairy manufactures.

Kentucky Station.—A. L. Darnell, extension dairy specialist, has resigned. Recent appointments include in the station Jack Dorr as inspector of creameries and Ethel M. Snyder as laboratory assistant in veterinary science; and as field agents in extension work, R. C. Miller and W. J. Harris in animal husbandry, J. R. Smyth and J. H. Bardsley in poultry, and Dana G. Card in marketing.

Maine Station.—Royden L. Hammond, seed analyst, has resigned to accept a similar position about October 15 with the Delaware State Laboratory.

Massachusetts College.—J. C. McNutt has resigned as head of the department of animal husbandry to become eastern representative of the American Shorthorn Breeders' Association, with headquarters at Amherst. R. B. Cooley, extension assistant professor of animal husbandry, has resigned to become assistant professor of animal husbandry at Purdue University. Lawrence R. Grose, instructor in forestry in Bates College, has been appointed professor of forestry vice William D. Clark, resigned.

Minnesota University and Station.—R. J. Garber, assistant professor of plant breeding, has accepted an appointment as associate professor of agronomy and associate agronomist in the West Virginia University and Station. Holbrook Working has been appointed assistant professor of agricultural economics.

Missouri University and Station.—The university was unusually well represented this year at the State fair. Over 150 graduates and former students of the College of Agriculture exhibited live stock or other agricultural products or in other ways participated in the fair. The university made a comprehensive exhibit of the facilities for training students, and a station exhibit of the results of its work attracted a great deal of attention.

A home economics building of modern design is to be erected immediately.

E. H. Hughes, superintendent of short courses and assistant to the dean and director, has accepted a position as professor of animal husbandry at the University of California. Samuel Brody has been appointed professor of dairy chemistry, chiefly for research work in connection with the Adams project on factors influencing the composition of milk. J. C. Wooley, professor of agricultural engineering at the Idaho University and Station, has been appointed professor of agricultural engineering vice E. W. Lehmann, resigned.

Montana College and Station.—C. N. Arnett has returned as head of the animal husbandry department, beginning July 1. H. E. Selby, instructor in farm management at the Oregon College, has been appointed assistant in farm management investigations in the station.

Nebraska University and Station.—The resignations on September 1 are noted of John W. Calvin as professor of chemistry and associate chemist in the station to become chemist in the experiment station of the Dominican Republic; P. L. Gaddis as professor of agronomy and station agronomist to take charge of a farm in Custer County; and C. K. Shedd as professor of agricultural engineering to engage in commercial work.

Nevada Station.—The station is endeavoring to develop suitable pasturage or other feeds to enable the holding of immature lambs for four to six weeks later in the fall. At present these lambs are marketed in September when driven out of the mountains by early snows, although those reared in eastern Nevada are still too young for slaughter. Studies of desirable mixtures of grains and clover for pasturage and other pasturage problems are also under way.

New Hampshire College and Station.—*Science* notes the appointment of Dr. H. R. Kraybill of the Office of Horticultural and Pomological Investigations, Bureau of Plant Industry, U. S. Department of Agriculture, as professor of agricultural chemistry and head of the department. J. H. Gourley, professor of horticulture and vice director and horticulturist in the station, has resigned to become head of the horticultural department of the University of West Virginia.

New York State Station.—Harold L. Winston, assistant chemist, resigned August 1 to accept a commercial position. Guy F. MacLeod has been appointed assistant in research (entomology), beginning July 1.

Oklahoma College and Station.—The resignations September 1 are reported of Dean H. W. Moorhouse of the School of Commerce and Marketing, and of W. C. Rapp, assistant horticulturist, the latter becoming assistant horticulturist at the University of Arkansas. C. E. Sanborn, professor of entomology and entomologist, is to spend the coming year in California on special entomological investigations.

Pennsylvania College and Institute of Animal Nutrition.—The college has recently received from the Rockefeller Institute for Medical Research a grant of \$5,000 for the current fiscal year in aid of the researches in animal nutrition which have been carried on for the past twenty years by the Institute of Animal Nutrition. W. J. Sweeney has resigned as assistant in animal nutrition to take effect September 1, and has been succeeded by R. M. Meredith, a 1920 graduate of the college.

Recent resignations in the college department of agronomy include Dr. D. S. Fox, assistant professor of farm management, to become farm adviser in San Bernardino, Calif.; D. C. Wimer, assistant professor of soil technology, to accept a position in soil technology at the University of Illinois; and F. G. Bamer, assistant in agronomy, to engage in commercial work.

Utah College and Station.—A new 20-acre irrigated experimental farm has been established at Farmington in Davis County. The county furnishes the

land and \$1,000 a year toward operating expenses for such period as the station sees fit to carry on experimental work there. The farm will be devoted to general agricultural investigations. A. L. Wilson has been appointed superintendent.

W. W. Henderson, professor of zoology and entomology and State entomologist, has resigned to become president of the Brigham Young College. Herbert J. Pack has been appointed instructor in zoology and assistant entomologist, vice Charles J. Sorenson resigned to engage in commercial work.

Vermont University.—Guy W. Bailey, acting president, has been appointed president.

Virginia College and Station.—J. C. Hart, associate agronomist in the station, has been transferred to the extension division, assuming the duties of agronomist therein July 1.

Washington Station.—Otto McCreary, assistant chemist in the New York State Station, has been appointed assistant chemist beginning September 1, and W. I. Nightingale, assistant bacteriologist.

New Journals.—The first issue has recently been received of *World Agriculture*, which is being published at Amherst, Mass., as the official organ of the American E. F. Farmers' Club and the World Agriculture Society, as previously announced (E. S. R., 41, p. 107). The initial number is that of October-December, 1919, and the second that of June, 1920, but quarterly publication is contemplated.

The purposes of the magazine are announced as follows: To further a sympathetic understanding among all nations in matters relating to the production, distribution, and consumption of the products of the soil; to encourage study of the principles which should control the agricultural policies of the world to the end that every individual may do his full duty and may enjoy his rightful share of the results; to aid in the application of these principles through the dissemination of information, the exchange of students and teachers between educational institutions, and the rendering of practical assistance in the agricultural regions devastated by the world war and wherever such assistance is needed; to promote the correlation on world lines of all agencies concerned in rural improvement, technical, scientific, economic, and social, and a greater appreciation of the possibilities of the country for the development of the highest types of individual and social life.

In addition to the World Agriculture Society the journal expects to print official items regarding the International Institute of Agriculture, the American E. F. Farmers' Club, American Country Life Association, the International Live Stock Breeders' Association, the Beaune Committee on World Cooperation in Agriculture and Country Life, the International Association of Agricultural Missions, the Agricultural Club of the North Carolina College, and the Agricultural Society of France. The June issue contains the officers of these organizations; reports of the Beaune conference of 1919, and the Belgian national conference, and of the International Association of Agricultural Missions of 1920; a memorandum presented to the Peace Conference on World Agricultural Principles by President K. L. Butterfield of the Massachusetts Agricultural College; a tribute to the late David Lubin; Some Impressions of French Agriculture by Capt. E. N. Wentworth, Assistant Director of the College of Agriculture, American E. F. University; the State Society of Agricultural Teaching in France, by G. Wery, Director of the National Institute of Agronomy; several shorter articles relative to the reconstruction of French agriculture; and other topics.

Hereditas, a journal of genetics, is being published by the Mendelian Society of Lund, Sweden. The publication committee is headed by Dr. H.

Nilsson-Ehle, with Robert Larsson as editor. It is to be devoted to original contributions on heredity, printed in German, French, or English. The initial number comprises the following: The Resistance against *Heterodera schachtii* of Certain Barleys, its Transmission and Significance in Practice, by H. Nilsson-Ehle; Hereditary Transmission of Genotypical Deaf-mutism, by H. Lundborg; The Increased Rate of Growth of Pollen Tubes and the Deviation from the Mendelian Ratio in *Oenothera lamarckiana*, by N. Heribert-Nilsson; The Inheritance of Flower Color in *Pisum*, by H. Tedin; A Family with Hereditary (Genotypical) Tremor, by E. Bergman; A Few Genetic Experiments with *Papaver rhœas* and *P. lœvigatum*, by H. Rasmusson; Spelt-like Bud-sports in Common Wheat, by Å. Åkerman; and Mendelian Chlorophyll Factors in *Allium cepa*, by J. Rasmusson.

Zentralblatt für die gesamte Landwirtschaft is being published at Liepsic under the editorship of Prof. Dr. Richard von der Heide and Robert Lewin, with a corps of about 65 abstractors. A general abstract journal is contemplated, to be issued monthly and with from 64 to 80 pages. The initial number contains 86 abstracts, all of German articles, classified into sections of meteorology and climatology, mineralogy and geology, physics and physical chemistry, agricultural soils and soil chemistry, fertilizers, plant chemistry, plant physiology, plant breeding, plant production, plant diseases, moor culture, forestry, plant products and their utilization, agricultural technology, animal physiology, digestibility of feeding stuffs, fresh water biology, and dairying. An author and subject index is to be included in each issue.

Metron, a new international statistical journal, is being published at Padua, Italy, with Prof. Corrado Gini of the University of Padua as editor, and an international editorial board on which Dr. Raymond Pearl represents the United States. It is a quarterly journal intended for contributions to the theory or practice of statistics of original value and likely to interest students of statistics. Each number will also have analyses of statistical work.

Giornale di chimica industriale is being published by the Society of Chemical Industry of Milan as the official organ of that society and that at Turin. The initial number contains several original articles, including the following: Factors of Success in the Dry Distillation of Wood, by E. Molinari; The Cellulose Industry, by C. Levi; The Problem of Industrial Fuels, by D. Meneghini; together with shorter notes, proceedings of the societies, etc.

Boletín del Laboratorio Municipal de Guayaquil is being published quarterly at Guayaquil, Ecuador. The initial number contains articles by Drs. G. S. Ponce and José R. Palma on the Necessity of Milk Control and Bacteriological Examinations in Relation to Infant Mortality; by Dr. G. A. Fassio entitled The Campaign Against Ankylostomiasis; by Drs. Ponce and Palma on Adulteration of Seeds of Vetch; by Dr. C. D. Andrade on Nutrition; and by Dr. L. E. Tamayo on the Analysis of Wines from the Native Fruits.

Revista Ganadera is being published semi-monthly by the Argentine Short-horn and Aberdeen Angus Associations and others interested in animal husbandry. The initial number contains brief accounts of these associations and the Rural Society of Argentina, notes as to recent importations of pure bred stock, various short articles, news notes, etc.

ADDITIONAL COPIES

OF THIS PUBLICATION MAY BE PROCURED FROM
THE SUPERINTENDENT OF DOCUMENTS
GOVERNMENT PRINTING OFFICE
WASHINGTON, D. C.

AT

15 CENTS PER COPY
SUBSCRIPTION PRICE, \$1.00 PER YEAR

▽

EXPERIMENT STATION RECORD.

VOL. 43.

ABSTRACT NUMBER.

No. 6.

RECENT WORK IN AGRICULTURAL SCIENCE.

AGRICULTURAL CHEMISTRY—AGROTECHNY.

Effect of premature freezing on composition of wheat, M. J. BLISH (*Jour. Agr. Research [U. S.]*, 19 (1920), No. 4, pp. 181-188).—This paper, from the Montana Experiment Station, presents the results of an investigation of the effects of premature freezing on the more important chemical constituents of the wheat kernel, particularly the nitrogen compounds from which the gluten is formed.

In order to obtain samples of sound and frozen wheat of the same varieties and grown as nearly as possible under the same conditions, plats were seeded at intervals of a week for about two months, the wheat in all the plats being cut shortly after maturity or immediately after the first killing frost. A series of samples was obtained in 1917 and 1918. The wheat from the 1917 series was brought to the granary shortly after cutting, thrashed when dry enough to permit, and stored in a room where the temperature was abnormally high. The wheat from the 1918 series was allowed to remain in the field through the winter, after being cut and shocked, the grain being thus subjected to severe weathering. The chemical analyses of the grain from the two series indicated a very appreciable effect on the biological properties aside from the effects of freezing. This was noted principally in a higher α -amino and amid nitrogen content in mature samples of the 1918 series than in corresponding samples of the 1917 series.

The frozen wheat in each series was found to contain larger amounts of nonprotein nitrogen, reducing sugars, and acid-reacting constituents than the sound wheat of the same series. The α -amino acid fraction of the nonprotein nitrogen was also considerably higher in the frozen than in the sound wheat. In the most severely frozen sample of the 1917 series nine times as much of the total nitrogen of the wheat was in the α -amino form as in the sample which matured earliest.

The effect of these factors on the milling and bread-making value of wheat is to be considered in a later publication.

Influence of fermentation on the starch content of experimental silage, A. W. DOX and L. YODER (*Jour. Agr. Research [U. S.]*, 19 (1920), No. 4, pp. 173-179).—This contribution from the Iowa Experiment Station supplements previous studies on the chemical changes occurring during the fermentation of corn silage (E. S. R., 29, p. 712) by an investigation of possible changes occurring in the starch of the corn during fermentation. Normal experimental corn silage at various stages of fermentation was examined for total acidity, alcohol, total sugar, and starch. Qualitative tests were also made for soluble starch and dextrins. The results obtained are summarized as follows:

"Changes in total acidity, alcohol, and sugar are entirely independent of the starch content of the ensiled corn and of the silage produced from it. The first intermediate products resulting from the decomposition of starch are not present in demonstrable quantities. The starch content remains constant throughout the fermentation process. The starch granules remain intact, undergoing no physical change that can be detected by microscopic examination."

The composition of oil of chenopodium from various sources, E. K. NELSON (*Jour. Amer. Chem. Soc.*, 42 (1920), No. 6, pp. 1204-1208).—This is the report of an examination at the Bureau of Chemistry, U. S. Department of Agriculture, of samples of native oil of chenopodium.

Of 7 authentic samples collected from different distilling plants all complied with the requirements of the U. S. Pharmacopœia and contained from 60 to 77 per cent of the active constituent ascaridol. The oil distilled from wild plants collected in Florida was found to contain less ascaridol than the oil distilled from cultivated plants in Maryland.

The chemical composition of cottonseed oil, G. S. JAMESON and W. F. BAUGHMAN (*Jour. Amer. Chem. Soc.*, 42 (1920), No. 6, pp. 1197-1204).—An analysis is reported from the Bureau of Chemistry, U. S. Department of Agriculture, of a sample of cottonseed oil cold pressed by means of an oil expeller from Sea Island cotton seed.

The lead salt ether method gave a yield of 23 per cent of saturated acids and 72.5 per cent of unsaturated acids. The iodine number (Hanus) of the unsaturated acids was 142.2, the saponification number 199.4, and the mean molecular weight 281.3. The percentage composition of the oil calculated as glycerids was as follows: Myristic acid 0.34, palmitic acid 20.04, stearic acid 1.98, arachidic acid 0.58, oleic acid 0.53, and linolic acid 0.64 per cent.

Oil of *Rubieva multifida*, E. K. NELSON (*Jour. Amer. Chem. Soc.*, 42 (1920), No. 6, p. 1286).—An analysis is reported of the essential oil of *R. multifida*.

Preparation of peptone (*Rpt. Bombay Bact. Lab. 1918*, pp. 9, 10).—A satisfactory substitute for Witte's peptone has been prepared by M. B. Soparkar as follows:

Casein obtained from skim milk is digested for a few days at 40° C. with proteolytic enzymes derived from the pancreatic glands of goats. Further digestion is then prevented by boiling, and the resulting extract, consisting of a mixture of proteoses, peptones, polypeptids, and amino acids, is evaporated to dryness and pulverized.

The products of the "acetone: *n*-butyl alcohol" fermentation of carbohydrate material, with special reference to some of the intermediate substances produced, J. REILLY, W. J. HICKINBOTTOM, F. R. HENLEY, and A. C. THAYSEN (*Biochem. Jour.*, 14 (1920), No. 2, pp. 229-251, figs. 2).—This is a report of a quantitative examination of the intermediate substances and end-products of the acetone-butyl alcohol fermentation of carbohydrate material (6.5 per cent maize mash) under varying conditions. The results obtained are summarized as follows:

"In the fermented mash, acetic and butyric acids are present in varying proportions. During the progress of the fermentation the ratio of butyric acid to acetic acid increases with the increase in the acidity of the mash, reaching a maximum when the acidity is at its highest. With the production of 'oil' the ratio of butyric acid to acetic acid diminishes until the mash contains an excess of acetic acid. If the acidity is neutralized by the addition of calcium carbonate, the calcium salts of the acids present in the mash replace the acetone and *n*-butyl alcohol, and these latter are produced in almost negligible amount. In the presence of calcium carbonate, however, the fermentation proceeds as far as the point corresponding to the maximum acidity in a normal fermentation.

It is extremely probable that acetic and butyric acids are not the only acids present. The type of infection most frequently observed in the fermenting mash produces lactic acid. When the mash is infected in this way, the amount of volatile acid accounted for by the Duclaux estimation is lower than in the case of a normal fermentation.

"When acetic acid is added to the fermenting mash, an increased yield of acetone is obtained, the yield of *n*-butyl alcohol being unchanged. Propionic and butyric acids when added appear to be converted into the corresponding alcohols. An increased yield of acetone has been obtained by the addition of aceto-acetic ester."

The properties of a specially prepared enzymic extract, polyzime, comparing its starch liquefying power with malt diastase, J. TAKAMINE, JR. and K. OSHIMA (*Jour. Amer. Chem. Soc.*, 42 (1920), No. 6, pp. 1261-1265).—A comparison of the properties of polyzime, a commercial enzymic extract of *Aspergillus oryzae*, with those of standard malt is reported, together with a chemical analysis of polyzime. The amyloclastic power was determined by the Wohlgemuth method (E. S. R., 20, p. 208) and the saccharogenic power by the Lintner method.

The optimum temperature of starch liquefaction by both polyzime and malt extract was 55° C. for a digestion period of from 30 minutes to 2 hours and 40° for 24 hours. The optimum reaction of the solution in both cases was neutral or faintly acid.

The amyloclastic power of polyzime proved to be from three to five times as great as that of malt extract, while the saccharogenic power was considerably less. The diastatic power of polyzime showed no decrease at temperatures below 40° but a progressive increase with increasing temperatures above 40°.

An improved comparator, L. H. COOLEGE (*Jour. Indus. and Engin. Chem.*, 12 (1920), No. 5, pp. 499, 500, figs. 2).—This is a modification of the comparator of Hurwitz, Meyer, and Ostenberg.¹

Two sliding test-tube racks each containing six tubes are so arranged in the comparator that the one carrying the standard tubes can be slid back and forth until a tube is found that compares in color with the first unknown in the second rack. The second rack is then moved along one place and the reading of the second unknown found in the same way. The readings may be made by using light directly transmitted, or the comparator may be tilted so that light is reflected from a white surface through the tubes.

This modified apparatus is said to make it possible to compare in a short time a large number of unknowns with the standard tubes.

The combination of fractionation with spectrophotometry in proximate organic analysis, W. E. MATHEWSON (*Jour. Amer. Chem. Soc.*, 42 (1920), No. 6, pp. 1277-1279).—This contribution from the Bureau of Chemistry, U. S. Department of Agriculture, consists of a brief description of a procedure for the estimation of small amounts of organic compounds by converting them into colored derivatives, separating them from the excess of the reagents and from any other colored substances present by fractionation with immiscible solvents, and finally estimating them by the spectrophotometric method.

A few experiments illustrating the method are described.

A method for the determination of bromin, F. WÜNSCHE (*Arch. Expt. Path. u. Pharmakol.*, 84 (1919), No. 6, pp. 328-338, fig. 1).—The method described, which is said to be applicable to the determination of small amounts of bromin in organic substances, consists in oxidizing the substance first with

¹ Johns Hopkins Hosp., Bul. 27(1916), p. 16.

sodium peroxid to convert the organically combined bromin into bromids and then in sulphuric acid solution with potassium permanganate to liberate the bromin.

The bromin set free is led into a flask containing a definite volume of a 0.1 per cent fuchsin solution decolorized by sulphurous acid. The amount of bromin is determined by matching the violet color produced in the reagent with standards of gentian violet, methylene blue, or fuchsin.

It is stated that with this method 0.2 mg. of bromin in 50 gm. of animal organs can be estimated with accuracy.

Note on the solubility of benzidin sulphate in water, C. S. BRISSEY and A. W. CHRISTIE (*Jour. Indus. and Engin. Chem.*, 12 (1920), No. 5, pp. 485, 486).—The solubility of benzidin sulphate at different temperatures has been determined by agitating an excess of the purified salt with distilled water in a constant temperature thermostat, and either evaporating a measured volume of 100 or 200 cc. to dryness in a platinum dish on the steam bath, drying at 100° C., cooling in a desiccator, and weighing, or by titrating a measured volume of the solution with N/20 potassium permanganate after the addition of 5 per cent of sulphuric acid.

The two methods gave concordant results at all temperatures except 80°, the solubility increasing from 0.049 and 0.048 gm. per liter at 0° C. to 0.141 and 0.149 gm. at 50° as determined by the gravimetric and volumetric methods, respectively. These results are thought to indicate the necessity of using a minimum amount of cold water in washing the benzidin sulphate in quantitative determinations of sulphate.

Chemical soil analysis, F. MÜNTER (*Landw. Vers. Sta.*, 94 (1919), No. 3-4, pp. 181-189).—This is a study of the efficacy of various concentrations of hydrochloric acid at different temperatures as solvents for silica, iron, aluminum, potash, and phosphoric acid in soils.

The best results in general were obtained with the digestion of the soils in the cold with concentrated HCl (25 to 30 per cent). Hot concentrated HCl gave slightly better results for potash and phosphoric acid.

As a general method of extraction the author recommends that 300 gm. of the sample be mixed with 900 cc. of concentrated HCl and shaken occasionally for 48 hours. The solution is then decanted and filtered and 300 cc. of the filtrate evaporated with ammonium chlorid on a water bath.

A protein color reaction, S. EDLBACHER (*Hoppe-Seyler's Ztschr. Physiol. Chem.*, 105 (1919), No. 5-6, pp. 240, 241).—On shaking a protein solution with sodium hydroxid and dimethyl sulphate until the latter is decomposed, and then adding concentrated sulphuric acid to form a layer at the bottom of the tube, a bluish red color zone is said to form at the juncture of the two liquids. The color is caused by tryptophan and resembles somewhat the glyoxylic reaction for tryptophan. The test is considered to be more delicate than the bromin test for free tryptophan.

The esterification of alpha amino acids, H. A. SHONLE and H. H. MITCHELL (*Jour. Amer. Chem. Soc.*, 42 (1920), No. 6, pp. 1265-1277).—The authors discuss the methods which have so far been used in following the rate of esterification in the analysis of proteins, and describe experimental work leading to a satisfactory modification of the titrimetric method which involves the use of the Sørensen formaldehyde titration of amino acids.

In the method as finally adopted, the free amino acid acidity in samples withdrawn from the esterification flask is titrated together with the free mineral acid acidity after the destruction of the amino groups and ammonium salts with formaldehyde. The determination of the free and combined HCl (the only mineral acid present) is obtained by a Volhard chlorin titration, and the

difference between these two titrations represents the free amino acid acidity. The total amino acid acidity is determined by a similar procedure with an aliquot of the sample after saponification with dilute HCl. From these two results the unesterified amino acid is calculated by difference.

In the case of highly colored mixtures, decolorization should first be effected by the addition of aluminum sulphate to the hydrolyzate made alkaline with barium hydroxid and subsequently filtered.

The results are given of the application of this method to mixtures of amino acids from casein, vignin, gelatin, and vegetable albumin, to mixtures rich in diamino acids, and to individual amino acids. In a single esterification alanin was esterified 96, lysin 82, and glutamic acid 85 per cent. In the case of mixtures of amino acids a single esterification yielded as high as 90 per cent of the amino acid acidity.

A method for the determination of cystin, Y. OKUDA (*Jour. Col. Agr., Imp. Univ. Tokyo*, 7 (1919), No. 1, pp. 69-76).—In the method described, 10 cc. of a 20 per cent NaOH solution is added to 10 cc. of a 5 to 10 per cent HCl solution of cystin. The solution is then titrated with a solution of potassium bromate containing 8.35 gm. KBrO_3 in one liter of water until the faint yellow color produced remains for one minute.

The presence of histidin, which also absorbs bromin, is said not to interfere with the reaction, as the velocity of the reaction of cystin for bromin is much higher than that of histidin. In the presence of tyrosin the bromate titration corresponds to the sum of tyrosin and cystin. This necessitates either a separate determination of the tyrosin or of the cystin by one of the customary methods.

Some observations on the color changes of the diphenylamin reaction, E. M. HARVEY (*Jour. Amer. Chem. Soc.*, 42 (1920), No. 6, pp. 1245-1247, fig. 1).—The author reports a study at the Oregon Experiment Station of factors influencing the production and intensity of the coloration of the diphenylamin reaction as a microchemical test for nitrates in plant tissues.

The concentration of the sulphuric acid was found to be the most important factor, three distinct color changes resulting from a gradual increase in concentration. The amounts of diphenylamin and of nitrate which could be used without altering the reaction varied within rather wide limits. Variable temperatures between 20° and 50° appeared to have very little effect except on the time required for the development of maximum coloration. A consideration of these and other less important factors has led to the suggestion of slight modifications in the usual formulas, as follows:

The modified reagent is made up of 0.05 gm. of diphenylamin, 7.5 cc. of 95 to 96 per cent H_2SO_4 , and 2.5 cc. of a 10 per cent aqueous solution of potassium chlorid. This salt is substituted for hydrochloric acid on account of its forming less free HCl during the mixing. This reagent is applied directly to a thin section of the tissue on a glass plate or microscope slide.

Determination of lactose in altered milk, E. HILDT (*Ann. Falsif.*, 13 (1920), No. 135-136, pp. 21-25).—Previously noted from another source (*E. S. R.*, 43, p. 14).

Butyl alcohol as a medium for the determination of saponification numbers, A. M. PARDEE, R. L. HASCHÉ, and E. E. REID (*Jour. Indus. and Engin. Chem.*, 12 (1920), No. 5, pp. 481, 482).—The results are reported of duplicate determinations of the saponification numbers of various fats, oils, and waxes with ethyl and butyl alcohols as fat solvents. The data corroborate the conclusions of Pardee and Reid previously noted (*E. S. R.*, 42, p. 502) that butyl alcohol is superior to ethyl alcohol as a medium for quantitative saponification.

A method for the determination of taurin in muscles, Y. OKUDA and K. SANADA (*Jour. Col. Agr., Imp. Univ. Tokyo*, 7 (1919), No. 1, pp. 77-80).—The method consists in first removing other sulphur compounds such as proteins, sulphates, and, if necessary, cystin, from a water extract of the material by successive treatment with acetic acid, basic lead acetate, sulphuric acid, phosphotungstic acid (if cystin is present), barium hydroxid, and ammonium carbonate. In the final filtrate the sulphur is determined as barium sulphate and the amount of taurin calculated by multiplying the weight of the sulphate in grams by 0.5358.

Determinations by this method are reported of the taurin content of the muscles of certain varieties of fish, Mollusca, and Crustacea. Taurin was found in varying amounts in all the muscles examined, the largest amounts being found in Mollusca.

The distribution of certain chemical constants of wood over its proximate constituents, W. H. DORE (*Jour. Indus. and Engin. Chem.*, 12 (1920), No. 5, pp. 472-476, fig. 1).—In continuation of the study at the California Experiment Station of the proximate analysis of wood (E. S. R., 42, p. 614), experiments have been conducted to determine the distribution of furfural-yielding, acetic-yielding, and methoxy groups over the two chief proximate groups cellulose and lignin, the experiments being confined to redwood sawdust.

It was found that about half of the furfural-yielding groups are associated with the cellulose, but only a small amount with the lignin. The true pentosans are hydrolyzed and removed during chlorination.

The acetic-yielding groups were found to be partly associated with the cellulose and slightly with the lignin, while a small amount is apparently detached from either. The methoxy groups are wholly associated with the lignin and may be partially split off from it by acid hydrolysis.

"In the summative analysis of coniferous woods, all of the acetic-yielding and methoxy groups and part of the furfural-yielding groups may be disregarded as already accounted for in the cellulose and lignin. The furfural-yielding substances contained in the chlorination washings and representing hydrolyzed pentosans should be estimated."

The proximate analysis of coniferous woods, W. H. DORE (*Jour. Indus. and Engin. Chem.*, 12 (1920), No. 5, pp. 476-479).—This paper considers in detail certain modifications of the method proposed by the author for the proximate analysis of wood (E. S. R., 41, p. 14), considered advisable as the result of the study noted above and a previous contribution (E. S. R., 42, p. 614). Revised methods are given for the estimation in coniferous woods of the following constituents: Loss on drying, benzene extract, alcohol extract, cellulose, lignin, soluble pentosans, mannan, and galactan.

Complete analyses of redwood, yellow pine, and sugar pine by these methods are reported, in all of which a summation of slightly over 100 per cent was obtained. The results are thought to indicate that overlapping of the proximate groups has been largely avoided, and that the method accounts for all important constituents.

The true tanning value of vegetable tanning materials, J. A. WILSON and E. J. KERN (*Jour. Indus. and Engin. Chem.*, 12 (1920), No. 5, pp. 465-469, figs. 3; also in *Jour. Amer. Leather Chem. Assoc.*, 15 (1920), No. 5, pp. 295-308, figs. 3).—A new method of determining the true tanning value of vegetable tanning materials is described which is considered by the author to be much more accurate than the official method of the American Leather Chemists Association.

The method differs from the official method in that after shaking the solution of the tanning material with hide powder, the tanned powder is not discarded but is washed free from soluble matter, dried, and analyzed for tannin as in

the regular procedure for vegetable-tanned leathers. The technique of the method is described in detail, and the comparative results are reported of analyses of eight tanning materials by this and the official method.

The iodometric estimation of sugars, H. M. JUDD (*Biochem. Jour.*, 14 (1920), No. 2, pp. 255-262).—A critical examination is reported of various modifications of the iodometric method for the estimation of sugars, including those of Bougault (*E. S. R.*, 37, p. 714), Colin and Lièvin (*E. S. R.*, 40, p. 114), and Willstätter and Schudel (*E. S. R.*, 40, p. 312).

While none of these methods gave quantitative results, it was found that with either the method of Colin and Lièvin or that of Willstätter and Schudel a definite weight of iodine always reacted with a given weight of glucose independently of the amount of alkali or other sugars present in the solution. This was also found to be true of fructose and of other sugars, each having its own characteristic iodine value. Sucrose was not oxidized under the conditions of the experiment, while lactose and maltose were both oxidized, lactose requiring twice as much iodine as maltose.

"It is therefore possible, using either of the above methods, to calculate from the copper-reducing power of a solution containing glucose and fructose, and from its action on iodine in alkaline solution, the amount of each sugar present in the solution."

Effect of varying the amount of inoculum and concentration on the deterioration of sugar by molds, N. KOPELOFF (*Jour. Indus. and Engin. Chem.*, 12 (1920), No. 5, pp. 455-457).—This is a report of a further investigation at the Louisiana Sugar Experiment Station of the influence of the amount of inoculum and concentration on the deterioration of sugar by molds, the method of procedure being the same as that outlined in the previous report (*E. S. R.*, 42, p. 803) with the exception that the incubation period was extended to 5.5 months.

The results previously reported were entirely corroborated. An increase in deterioration of the sugar resulted from an increase in number of mold spores and from a decrease in concentration of the films surrounding the sugar crystals. From the data obtained, a table has been constructed showing the deterioration which may be expected from a definite number of molds in sugars of known moisture ratio. This indicates that at moisture ratios $\left(\frac{\text{moisture}}{100\text{-polarization}}\right)$ of less than 0.18, there is little if any, deterioration with a mold infection of less than 5,000 spores per gram. A larger number of spores will cause deterioration. At moisture ratios above 0.18 deterioration occurs with 100 or more spores per gram.

Some temperature experiments in clarification, H. S. WALKER (*Internatl. Sugar Jour.*, 21 (1919), No. 252, pp. 611-613).—Experiments are reported which indicate that the loss in purity in limed and heated cane sugar juices kept in well insulated settling tanks can be avoided by lowering the initial temperature of the tanks to 180° F. Formalin was found to be of no value in preventing loss in purity. It is estimated that the yearly loss in purity from clarification at too high temperatures is fairly serious, and should be prevented by conducting the clarification at as low a temperature as possible and reheating the clarified juice just before it enters the evaporator.

Molasses as an index of inversion in manufacture, F. I. SCARD (*Internatl. Sugar Jour.*, 21 (1919), No. 252, pp. 604, 605).—To determine the amount of inversion occurring in the process of cane sugar manufacture, the author recommends the following method:

"Take a known quantity of molasses, clarify by means of the ordinary (not the basic) lead acetate, and sulphate of soda, and make up to known bulk.

Estimate the reducing sugar present by means of Pavy's copper method. Then invert a portion by boiling briskly with 1 to 2 per cent hydrochloric acid for two or three minutes, make up to known bulk, and titrate with Pavy. The difference between the two results multiplied by 0.95 gives the amount of sucrose present. Now polarize this mixture, still using the ordinary acetate of lead and sodium sulphate, with alumina if necessary. If the sucrose indicated in the polariscope agrees with that found by the chemical process there has been no inversion. If it is perceptibly less, there has been. Roughly, one part of invert sugar obscures three parts of sucrose; but as the rotatory power of the invert sugar varies with the temperature, the figure corresponding to the laboratory temperature should be taken."

Investigations on the formation and exhaustibility of molasses, T. VAN DER LINDEN (*Meded. Proefsta. Java-Suikerindus., Chem. Ser. No. 4 (1919), pp. 50, pls. 7, figs. 3; also in Arch. Suikerindus. Nederland. Indië, 27 (1919), No. 31, pp. 1511-1559, pls. 7, figs. 3; abs. in Chem. Abs., 14 (1920), No. 6, pp. 859, 860*).—To determine the nature of Java molasses six samples from the defecation, carbonation, and sulphitation processes were mixed with an excess of sucrose crystals and shaken at different temperatures until equilibrium was reached, after which the molasses was filtered out and the purity determined. An examination of the curves plotted for the purity at different temperatures failed to show whether the molasses was an undercooled eutectic mixture or a saturated solution of sucrose in nonsucrose.

In experiments carried out to determine under what condition molasses can be exhausted most completely, the best results were generally obtained when the water content was about 14 to 16 per cent and the temperature about 30° C. (86° F.). Molasses of low purity was usually obtained when the ratio of glucose to ash was high. A high content of gums and of SO₄ and Cl ions was found to interfere with the exhaustibility of the molasses. The curves indicating the relation between the sucrose and nonsucrose offered evidence that molasses is a saturated solution of sucrose in nonsucrose.

Grain in molasses, H. KALSHOVEN (*Meded. Proefsta. Java-Suikerindus., Chem. Ser. No. 5 (1919), pp. 5+2, figs. 3; also in Arch. Suikerindus. Nederland. Indië, 27 (1919), No. 31, pp. 1560-1564, figs. 3*).—Attention is called to the fact that molasses is apt to contain very fine grain which can not be removed by filtration or other means.

A method of determining the amount of such grain in a given molasses and the purity of the molasses is described. This method involves determining the real sucrose content of the ordinary grain-containing molasses and the refractometer Brix values of both the grain-containing molasses and the same molasses in which the grains have been dissolved by dilution with water. Formulas are given for the necessary calculations.

By the use of this method with molasses at different states of exhaustion, it was found that up to a certain point the purity decreased regularly with decreasing water content. This is thought to corroborate the view of Van der Linden, noted above, that molasses is really a saturated solution of sucrose in nonsucrose.

Correction, H. KALSHOVEN (*Arch. Suikerindus. Nederland. Indië, 27 (1919), No. 33, pp. 1663, 1664*).—A modified formula is given for determining the fine grain in molasses without determining the total solids by drying.

Grain in molasses.—II, H. KALSHOVEN (*Meded. Proefsta. Java-Suikerindus., Chem. Ser. No. 6 (1919), pp. 7, pl. 1; also in Arch. Suikerindus. Nederland. Indië, 27 (1919), No. 42, pp. 1967-1973, pl. 1; abs. in Chem. Abs., 14 (1920), No. 6, p. 860*).—The author reports an application of the method noted above to 80 samples of Java molasses prepared by different methods. The grain

contents varied from 0 to 17.7 per cent. Samples of molasses made by the sack sugar method were practically free from grain, while all others contained an appreciable amount varying with the Brix reading.

The formation of very fine grain is thought to be due to high temperatures of purging or to retardation of the crystallization through failure of the massecuite to reach equilibrium at the purging temperature. Good results as to freedom from grain may be obtained by boiling to a moderately high Brix and slow cooling or by boiling to a high Brix and adding water while cooling. From the standpoint of exhaustibility of the molasses the carbonation process is thought to give the best results.

Sugar grain in final molasses, W. H. T. HARLOFF (*Internatl. Sugar Jour.*, 21 (1919), No. 252, pp. 608-610).—The author summarizes the studies of Kalshoven noted above and discusses their practical bearing on sugar manufacture.

The water content of true final cane molasses, H. C. P. GEERLIGS (*Internatl. Sugar Jour.*, 22 (1920), No. 253, pp. 34-40).—This is a summary and discussion of the reports of Van der Linden and of Kalshoven noted above and of some of the earlier work of the author (E. S. R., 39, p. 415). In conclusion the author suggests that in the modern practice of sugar manufacture the yield is sometimes sacrificed to the desire for rapid output.

METEOROLOGY.

Modifying factors in effective temperature, or, a principle of modified thermal influence on organisms, A. D. HOPKINS (*U. S. Mo. Weather Rev.*, 48 (1920), No. 4, pp. 214, 215; *abs. in Bul. Amer. Met. Soc.*, 1 (1920), No. 5, p. 54).—Supplementing articles previously noted (E. S. R., 39, p. 317, 41, p. 16), the author discusses briefly "the effectiveness of applying the bioclimatic law of altitude, latitude, and longitude to determining for any locality the proper time for applying remedies to control insects, or to plant crops. This law, which postulates that periodic events progress 1° of latitude, 400 ft. of altitude, and 5° of longitude every 4 days, northward, upward, and eastward in spring, and southward, downward, and westward in autumn, needs considerable regional correction in parts of the United States. These corrections are retarding in general for lowland regions and accelerating for highland regions as a general rule in spring."

The influence of snow on the development of vegetation in spring, P. JACQUES (*Nature [Paris]*, 48 (1920), No. 2399, pp. 179, 180, fig. 1; *abs. in U. S. Mo. Weather Rev.*, 48 (1920), No. 4, p. 222).—Observations at Mont Aigoual, Cevennes, France, "with dry thermometers at depths of 0.1 meter and 0.2 meter, respectively, in the snow and also at a height of 0.2 meter above the surface of the snow," are reported which show "that there is no variation of the mean temperature of the thermal blanket at a depth of 0.2 meter during the months of February and March; that at 0.1 meter it is 0.2° C., and that at 0.2 meter above the snow it is 2.1°. In April there is no variation during the first and third decades, and it is almost constant during the second decade. The temperature of the air, on the other hand, was decidedly variable during all of these periods."

It is estimated that the 1,621.7 mm. of snow that fell at Mont Aigoual from December to May, inclusive, supplied 43.736 kg. of nitrogen per hectare (about 38.9 lbs. per acre).

The agricultural significance of sunshine as illustrated in California, A. H. PALMER (*U. S. Mo. Weather Rev.*, 48 (1920), No. 3, pp. 151-154, pls. 2).—The function of sunshine in plant growth is briefly discussed, but more specific consideration is given to the wide variation in sunshine conditions in California

and their suitability to fruit and vegetable growing, sun-curing of fruits, dehydration of vegetables, and production of flower and vegetable seeds.

Carbon dioxide and plants, II, E. REINAU (*Chem. Ztg.*, 43 (1919), Nos. 88, pp. 449-451; 91, pp. 469-472; 94, pp. 489-491; 97, pp. 509-512; 99, pp. 524, 525; *abs. in Jour. Chem. Soc. [London]*, 118 (1920), No. 687, I, pp. 128, 129).—Continuing earlier work,¹ an account of which has been noted from another source (E. S. R., 31, p. 235), a critical review is given of the available data concerning the amount of carbon dioxide in the air, its fluctuations, and its relation to plant growth under natural climatic conditions.

A mathematical expression is developed which takes into consideration the effect of both water and carbon dioxide on the growth of plants under such conditions. "The differences in concentration of these substances within and without the plant are regarded as differences of tension, the value of which appears to depend mainly on temperature and atmospheric humidity. Under climatic conditions, the amount of assimilation by green plants is not proportional to the absolute carbon dioxide content of the air but to the difference in tension. The internal pressure of carbon dioxide depends on the temperature, with rise of which it increases, and also on the illumination, with increase of which it falls. . . . The actual value of the carbon dioxide tension difference depends on the capacity of the air to receive water vapor, and therefore indirectly on the temperature, and this is explained by the close connection which exists between the utilization of the carbon, water, and salts within the plant."

The author believes that "the carbon dioxide content of the atmosphere is regulated by the activity of terrestrial green plants and of the sea on the one hand, and by that of humus (edaphon) on the other; this is rendered probable by the extreme sensitiveness of plants to alteration in the tension of carbon dioxide and by the fact that the action of green plants and edaphon is so nicely balanced that the actual quantity of carbon dioxide in the atmosphere is the expression of the dynamic equilibrium of the results of these two factors. Consequently, the absolute carbon dioxide content of the atmosphere is not a measure of the amount of carbon dioxide available for vegetation, but represents the proportion which can not be lessened by plants under average conditions. It is conceivable that cases could arise in the open in which the plant suffers from too little carbon dioxide; the agricultural aspect of this possibility and the means of preventing it are discussed in the original paper, as is also the beneficent effect of an increased concentration of carbon dioxide on diseased plants."

The influence of crop rotation, green manuring, and the use of manures on the carbon dioxide balance in soils is discussed as compared with that of the continuous growth of cereals. The need of study on the relation of the character of the humus, temperature, moisture, and bacterial action, to the production of carbon dioxide in the soil is emphasized. The author attempts to explain why an increase of carbon dioxide in the air surrounding plants promotes flowering and enables them to overcome injuries and diseases more successfully.

Monthly Weather Review (*U. S. Mo. Weather Rev.*, 48 (1920), Nos. 3, pp. 127-190, pls. 19, figs. 22; 4, pp. 191-249, pls. 17, figs. 12).—In addition to detailed summaries of meteorological, climatological, and seismological data and weather conditions for March and April, 1920, and bibliographical information, reprints, reviews, abstracts, and minor notes, these numbers contain the following contributions:

¹ *Chem. Ztg.*, 38 (1914), No. 51, pp. 545-547.

No. 3.—Relation of Changes in Storm Tides on the Coast of the Gulf of Mexico to the Center and Movement of Hurricanes (illus.), by I. M. Cline; Discrepancies between Ångström and Smithsonian Instruments, by C. G. Abbot; Forecasting the Weather on Short-period Solar Variations, by C. F. Marvin; The Agricultural Significance of Sunshine as Illustrated in California (illus.), by A. H. Palmer (see p. 509); Project for Local Forecast Studies, by R. H. Weightman; Mackerel Sky as a Prognostic of Precipitation, by H. H. Martin; The Drought in California, by A. H. Palmer; "Snowball" Hail at Topeka, Kans., March 3, 1920, by S. D. Flora; and Hailstorm of March 3, 1920, at Broken Arrow, Okla., by J. W. Arnold.

No. 4.—The Thirteen Tornadoes of March 28, 1920 (illus.); The Four Tornadoes of April 20, 1920 (illus.); Tornado in Union County, N. C., April 12, 1920, by G. S. Lindgren; Tornadoes in Northeastern Oklahoma, May 2, 1920; by J. A. Reihle; The Hailstorm of April 8, 1920, in Washington County, Ala., by P. H. Smyth; Cloudiness in New York State (illus.), by E. S. Clowes; Modifying Factors in Effective Temperature, or, a Principle of Modified Thermal Influence on Organisms, by A. D. Hopkins (see p. 509); Climatic Conditions in a Greenhouse as Measured by Plant Growth, by E. S. Johnston; The Distribution of Maximum Floods—Discussion; and Some Meteorological Observations of a Bombing Pilot in France, by T. R. Reed.

Climatological data for the United States by sections (*U. S. Dept. Agr., Weather Bur. Climat. Data, 6 (1919), Nos. 11, pp. [222], pls. 2, figs. 4; 12, pp. [228], pls. 3, figs. 3*).—These volumes contain brief summaries and detailed tabular statements of climatological data for each State for November and December, 1919, respectively.

Meteorological observations at the Massachusetts Agricultural Experiment Station, J. E. OSTRANDER, G. S. SMITH, and G. E. LINDSKOG (*Massachusetts Sta. Met. Buls. 377-378 (1920), pp. 4 each*).—Summaries of observations at Amherst, Mass., on pressure, temperature, humidity, precipitation, wind, sunshine, cloudiness, and casual phenomena during May and June, 1920, are presented. The data are briefly discussed in general notes on the weather of each month.

Meteorology, W. FREAR, H. D. EDMISTON, and C. A. KERN (*Pennsylvania Sta. Rpt. 1916, pp. 487-529, 579-600*).—The usual observations on pressure, temperature, precipitation, cloudiness, and frostless period at State College, Pa., are summarized for 1915 as in previous reports (*E. S. R., 38, p. 13*). There are also special summaries on the following topics: The daily course of temperature; excessive temperature changes for short periods; sunshine records; distribution of precipitation during the growing season, 1915; wind velocity records, 1915; and wind direction.

SOILS—FERTILIZERS.

Soil survey of Shelby County, Ala., J. F. STROUD, H. C. SMITH, and J. H. AGEЕ (*U. S. Dept. Agr., Adv. Sheets Field Oper. Bur. Soils, 1917, pp. 60, fig. 1, map 1*).—This survey, made in cooperation with the State of Alabama, deals with the soils of an area of 513,920 acres situated just north of the center of Alabama. The topography ranges from mountainous and rough to rolling and flat.

The soils fall naturally into four soil provinces. The most extensive is the Appalachian Mountain province. The second division in point of area and the first in agricultural importance is the Limestone Valleys and Uplands province. The other two provinces in order of area are the River Flood Plains and Coastal Plains provinces.

Including rough broken land, rough stony land, and mine pit and dump, 38 soil types of 18 series are mapped, of which rough broken land is the most extensive single type, while Montevallo gravelly loam is the most extensive classified type. It is stated that all the upland soils, which include 13 series, are in need of liming, deeper plowing, vegetable matter, and steps for the prevention of erosion.

Soil survey of the Ventura area, Calif., J. W. NELSON, W. C. DEAN, A. E. KOCHER, E. B. WATSON, and E. J. CARPENTER (*U. S. Dept. Agr., Adv. Sheets Field Oper. Bur. Soils, 1917, pp. 87, pls. 3, fig. 1, map 1*).—This survey, made in cooperation with the California Experiment Station, deals with the soils of an area of 768,000 acres lying along the coast in southwestern California and including most of the southern half of Ventura County and a small area in the western part of Los Angeles County. The surface features of the area vary greatly and include many narrow valleys and broad alluvial deltas, with numerous hilly and mountainous elevations.

The soils are divided with reference to origin into residual, recent alluvial, and old valley-filling soils, the recent alluvial soils being the most extensive. Including rough, broken, and stony land, riverwash, tidal marsh, and coastal beach and dunesand, 32 soil types of 11 series are mapped, of which the rough broken and stony land covers 56.7 per cent of the area, while Yolo fine sandy loam covering 7.1 per cent of the area is the most extensive classified type.

It is stated that irrigation is not absolutely necessary for the production of crops in the area, except citrus fruits, but is a material aid. Alkali is present in the soil over much of the Oxnard Plain and also occurs in the west end of Simi Valley, in small bodies in the towns of Saticoy and Ventura, and in the region southwest of Montalvo. It is always associated with a high-water table, and varies in concentration from mere traces to quantities greater than 1 per cent for the surface 6 ft. Sulphate of sodium predominates in the more inland areas, and sodium chlorid prevails near the seacoast. Black alkali apparently is not present. Drainage to lower the water table and surface flooding to wash out the alkali are necessary in reclaiming land containing the larger concentrations of alkali.

Soil survey of Yamhill County, Oreg., A. E. KOCHER, E. J. CARPENTER, C. V. RUZEK, and J. E. COOTER (*U. S. Dept. Agr., Adv. Sheets Field Oper. Bur. Soils, 1917, pp. 66, pls. 5, fig. 1, map 1*).—This survey, made in cooperation with the Oregon Experiment Station, deals with the soils of an area of 445,440 acres in northwestern Oregon which lies in the Pacific Coast soil region. The northwestern two-thirds of the county lies on the east slope of the Coast Range and the rest in the Willamette Valley. A large part of the hills is sufficiently smooth for cultivation. Except in a few areas in the valleys, drainage is well established.

The soils of the area are of residual and sedimentary origin. Including rough stony land, muck and peat, and riverwash, 32 soil types of 15 series are mapped, of which the Aiken clay loam and the Melbourne clay are the most extensive individual types, covering 18.9 and 11.5 per cent of the area, respectively.

Soil survey of Lubbock County, Tex., J. O. VEATCH and H. G. LEWIS (*U. S. Dept. Agr., Adv. Sheets Field Oper. Bur. Soils, 1917, pp. 32, pls. 2, fig. 1, map 1*).—This survey deals with the soils of an area of 555,520 acres in central-western Texas situated in the Llano Estacado division of the High Plains region. The topography in general is that of a nearly level plain. The climate is semiarid.

The soils are mainly residual in origin. Fine sandy loams and clay loams predominate, the two classes of soils having about the same total area and

together covering about 90 per cent of the county. Including steep broken land, 12 soil types of 5 series are mapped, of which the Amarillo fine sandy loam and clay loam cover 39.1 and 29.1 per cent of the area, respectively, while the Richfield clay loam covers 17.6 per cent.

Soil survey of Accomac and Northampton Counties, Va., E. H. STEVENS (*U. S. Dept. Agr., Adv. Sheets Field Oper. Bur. Soils, 1917, pp. 62, pls. 4, fig. 1, map 1*).—This survey deals with the soils of an area of 436,480 acres lying in the Coastal Plain region and comprising two counties in extreme eastern Virginia, the topography of which is prevalingly level, varying from low flat foreland country to gently undulating upland plain. Drainage is fairly good in the uplands and the forelands of Northampton County are well drained, as well as the almost entire seaward side of the area.

Including tidal marsh, coastal beach, swamp, and dunesand, 17 soil types of 5 series are mapped, of which the Sassafras sandy loam and fine sandy loam are the most important classified types.

The importance of geology for the study of agricultural and forest soils, H. NIKLAS (*Naturw. Ztschr. Forst u. Landw., 18 (1920), No. 1-2, pp. 22-35*).—Geological and soil surveys of Bavaria are briefly described, and an argument is presented for a soil survey of Germany.

Agronomic study of the soils of Morocco, M. and L. RIGOTARD (*Ann. Sci. Agron. Franç. et Étrangère, 4. ser., 6 (1917), No. 4-6, pp. 197-215, figs. 2*).—Analyses of samples representative of the soils of the different parts of Morocco are reported and discussed with reference to their mechanical and chemical composition and relative fertility.

The soils vary widely in both mechanical and chemical composition, particularly with reference to the latter. Some soils are deficient in all the main fertility constituents, some in only one or two, and some are well supplied with all. It is noted that the soils contain a relatively high proportion of either fine or coarse sand, or both, and in some cases considerable clay, especially in the region between Rabat and Fez. In the Chaouia region the soils are a little better supplied with organic matter. The principal chemical deficiencies are apparently phosphoric acid and nitrogen.

Relations between soil reaction, the appearance of plant diseases, and the development of certain plants, A. STUTZER (*Fühling's Landw. Ztg., 66 (1917), No. 5-6, pp. 130-132*).—Observations at different places and times are cited as showing a close relation between soil reaction and the health and growth of plants.

The influence of soil and fertilization on diseases of plants, P. EHRENBURG (*Fühling's Landw. Ztg., 68 (1919), No. 21-22, pp. 401-412*).—This is a lecture given at the University of Göttingen on the injurious influence of soils in different conditions on plants, and on the direct and indirect injurious influence of fertilizers on plants. Attention is drawn to the action of acid, raw, and sick soils, and of soils which have become physically and chemically unfit through the action of different fertilizers.

Some investigations on the restoration to productivity of soils in the vicinity of zinc roasters, F. T. ULLRICH and W. C. TREWARTHA (*Bul. State Norm. School, Platteville, Wis., 17 [1919], No. 3, pp. 21, figs. 9*).—Pot and field experiments with oats and corn, conducted in the lead and zinc regions of southwestern Wisconsin and northwestern Illinois to determine means for the reclamation of soils thought to be injured by the gases from zinc roasters, are reported.

The conclusion is drawn that among the elements to be added to this soil to bring the best response in crop growth are calcium, phosphorus, and nitrogen. The jar cultures indicated that potassium is a corrective, but the

field demonstration with oats and the one with corn indicated that its addition is not essential to get maximum results. The response from the addition of phosphorus is explained in two ways, namely, that the extreme acidity of the soil caused the loss of the original phosphorus through leaching, and that the original phosphorus is still present in the soil, but is combined with other elements to form compounds in which it is unavailable. The increase in growth from the treatment with a nitrogen fertilizer is explained by the fact that a soil which remains barren of vegetation for a number of years loses its nitrogen through leaching. The effect of lime alone in recreation of the soil was much more noticeable with oats than with corn.

The preliminary field tests showed that alsike clover becomes more readily established than red clover. Jar culture tests indicated that the soil can not be reclaimed by deep tillage. Field observations during the summer of 1919 indicated that not all of the damage to growing crops occurs after the contamination of the soil, but is due to poisonous gases when they come in contact with the green tissues of the plants. Of the common crops, barley is the most sensitive.

The effect of nitrogen-fixing organisms and nucleic acid derivatives on plant growth. W. B. BOTTOMLEY (*Proc. Roy. Soc. [London], Ser. B, 91 (1920), No. B 636, pp. 83-95; abs. in Jour. Soc. Chem. Indus., 39 (1920), No. 5, p. 200A*).—Continuing experiments previously noted (*E. S. R., 33, p. 124; 37, p. 719*) on the influence of a water extract of bacterized peat on plants in water cultures, experiments are reported on the influence of the individual constituents of the bacterized peat extract on the growth of *Lemna minor*.

A pure growth of *Azotobacter chroococcum* was sterilized in the autoclave in the presence of water and added in small known amounts to the *L. minor* plants in nutritive solution. There was an increase in rate of growth and in dry weight of the crop in six weeks over untreated plants. Similar results were obtained with *Bacillus radicicola*. An extract of the crude nucleic acid derivatives and of the adenin-uracil fraction from raw peat also stimulated growth.

When the extract of the crude nucleic acid derivatives was added along with the growth of *A. chroococcum* to the same plants the increase in growth exceeded that of the total produced by the two substances added separately. "It would therefore appear that the growth-promoting substances in these two liquids are dissimilar in their action upon the plant, and that they are in some manner complementary to one another."

It was further found that "the ash of the nucleic acid derivatives and the *Azotobacter* had evidently not the slightest effect on the growth of *L. minor*, and the beneficial results following the addition of these materials can only be attributed to their organic constituents."

The influence of nitrates on the growth of *Azotobacter*, T. L. HILLS (*Pennsylvania Sta. Rpt. 1916, pp. 311-317*).—Soil and liquid cultures containing small amounts of potassium, sodium, and calcium nitrates were found to cause an increase in numbers of *Azotobacter* in pure culture over control cultures containing no nitrate.

It was found that an increasing concentration of the nitrates continued to favor *Azotobacter* growth up to a certain limit, viz, 1 per cent in the case of potassium nitrate and 0.5 per cent in the case of sodium nitrate and calcium nitrate. Higher concentrations than these retarded the growth, and a limit was reached at which *Azotobacter* growth ceased altogether. Calcium nitrate was apparently the most toxic.

These results are thought to have a bearing on the niter spot theories advanced by the Colorado and Utah Experiment Stations. "That these 'niter

spots' may be due to a concentration of salts caused by the evaporation of a ground water seems more likely."

Velocity of nitrification in soils of the general fertilizer series, G. C. GIVEN and G. J. KUHLMANN, JR. (*Pennsylvania Sta. Rpt. 1916, pp. 445-451, fig. 1*).—Nitrification studies of soils of the general fertilizer series at the station, using ammonium sulphate, showed that nitrification proceeded more rapidly and to a greater extent in a soil well supplied with lime, was only somewhat retarded in an acid soil, and was benefited by soil organic matter. There was little correlation between nitrification and the yield of the rotation crops used, except perhaps in the case of the corn crop. It is thought that cases of excessive deficiency in plant nutrients may be revealed by a nitrification test.

The coagulation of clay and the protective action of humus acids, S. ODÉN (*Jour. Landw., 67 (1919), No. 3, pp. 177-208, figs. 6*).—Experiments on the coagulation of clay and clay suspensions by electrolytes and the protective action of humus against such coagulation are reported. It is concluded that humus has a protective action against the coagulation of clay by electrolytes, the nature of which, however, is as yet unknown.

Further studies on the freezing-point lowering of soils and plants, M. M. MCCOOL and C. E. MILLAR (*Soil Sci., 9 (1920), No. 4, pp. 217-233, figs. 5*).—In a repetition of certain phases and continuation of other phases of experiments, previously noted (*E. S. R., 37, p. 116*) as conducted at the Michigan Experiment Station, the amount of water that froze readily, or at -1.5° C. (29.3° F.) and at lower temperatures in the leaves of several crops, was determined. Wide variations in the amount of water that easily froze in the plants studied were found, the greatest taking place in those having low freezing-point depressions. The differences were much less striking when lower temperatures were employed, although larger amounts of water were found to freeze. However, subjection to very low temperature (-15°) resulted in the freezing of no more water at -4° when subsequent determinations were made at that temperature.

The concentration of the cell sap of the roots of the plants used in these investigations was influenced quite decidedly by the concentration of the soil solution in which the plants were grown. The effect of the concentration of the soil solution was not so marked on the concentration of the cell sap of the leaves. These results substantiate the conclusions drawn from the previous work. Marked increases in the concentration of the soil solution induced by the addition of full nutrient solutions of varying strength, the water content of the soil remaining constant, did not measurably alter the amounts of water that froze at -2.5 and -4° , respectively.

Corn and barley plants grown in soils of high, medium, and low water content possessed more easily freezable water when grown in the soil of higher water content. When the water content varied and the concentration of the soil solution was maintained practically constant by the addition of a nutrient solution, more water froze at -2.5° in the leaves of the plants grown in the soils of low water content. There was very little difference in the amount of water that froze at -4° . These results are somewhat at variance with the results obtained when both the water content of the soil and the concentration of the soil solution varied.

Hydrogen-ion concentration measurements of soils in connection with their "lime requirements," J. S. JOFFE (*Soil Sci., 9 (1920), No. 4, pp. 261-266, figs. 2*).—Experiments conducted at the New Jersey Experiment Stations are reported, in which an attempt was made to establish a correlation between the lime requirement of sandy soils as determined by the Veitch method and the curve of hydrogen-ion concentration values resulting from lime-water treatment.

The results indicate that "in the case of sandy soil with little organic matter, an adjustment of the reaction to neutrality, or any point desired, may be accomplished very conveniently by the hydrogen-ion concentration method." It is thought that this study "points toward a method for the determination and adjustment of the soil reaction in sandy soils and possibly even in soils with a high organic matter content."

The relative absorption by soil of sodium carbonate and sodium chlorid, T. H. KEARNEY (*Soil Sci.*, 9 (1920), No. 4, pp. 267-273, fig. 1).—Experiments on the absorption of sodium carbonate and sodium chlorid by sand soil, conducted by the U. S. Department of Agriculture, are reported, in which the usefulness of the electrical-resistance method of determining differences in the absorption of different salts by a soil was tested. Solutions of sodium carbonate and sodium chlorid, of concentrations ranging from 0.05 to 1 per cent, were added to air-dry sand in sufficient quantity to supersaturate it slightly.

It was found that when equal volumes of solutions of equal concentration of sodium carbonate and of sodium chlorid are added to sand and the solution and soil are allowed to remain in contact during several hours the electrical resistance of the sand to which sodium carbonate has been added is much the higher. Since the greater resistance in the case of sodium carbonate must be due to proportionately greater withdrawal of the solute by the sand, it follows that plants growing in soils to which equal quantities of the two salts have been added are in contact with soil solutions of very unequal concentration.

The results of the experiment indicate that the electrical bridge affords a convenient means for determining the degree to which different salts are withdrawn from a solution which has been added to a soil. In the case of sodium carbonate and sodium chlorid, equivalent solutions of which (at the concentrations ordinarily encountered in alkali soils) do not differ greatly in electrical resistance, the bridge method permits direct comparison of the concentration of the solution in soils to which these salts have been added.

The injurious effects of potash and sodium salts on the soil structure and their causes, O. NOLTE (*Jour. Landw.*, 67 (1919), No. 4, pp. 267-272, fig. 1).—The author reviews his own work and that of others on the subject, and describes the equipment used in his studies. He found that an alkaline salt caused an increase in soil density and that an acid salt increased soil permeability. A neutral salt slightly increased soil permeability, but this gradually decreased.

Effect of calcium sulphate on the solubility of soils, M. M. McCool and C. E. MILLAR (*Jour. Agr. Research [U. S.]*, 19 (1920), No. 2, pp. 47-54).—In the study here reported, which is a contribution from the Michigan Agricultural Experiment Station, "six different soils were treated with a saturated solution of calcium sulphate. In one series of experiments the mass was transferred to filter paper, permitted to drain, and then transferred to containers and the rate of formation of soluble substances determined by means of the freezing-point method. The treatment was found to have increased the solubility of the soil to an appreciable extent.

"In another series the amount of soluble material was reduced to a minimum by washing with distilled water, and the residuary effects of the treatment on the solubility were likewise determined. The calcium-sulphate treatment was found to have resulted in a very large increase in the rate of formation of soluble substances. The effects were great even when the soils were washed the second time. Obviously the treatment results in changes in the composition of the soil mass—in other words, a soil of different properties is formed. It seems that it is possible to alter the composition of the soil solution, and that whether such change will have any effect on plant growth or not or whether

the effect will be favorable or unfavorable will depend upon the nature of the soil and of the substances added. Moreover, it is probable that this phase of the subject has not received sufficient attention in connection with our field experiments.

"Two soils of somewhat different texture and organic content were treated with a saturated solution of calcium sulphate, a $N/10$ solution of calcium phosphate, and a combination of the two. The soils were washed and the rate of formation of soluble salts was determined. The calcium sulphate markedly increased the solubility in each soil, while the calcium phosphate decreased the rate of formation of soluble substances. When calcium phosphate was used in conjunction with calcium sulphate it counteracted the effects of the latter to some extent.

"If the carbon dioxide produced, as determined by the methods used, is taken as a measurement of the biological activities, the increase in the rate of formation of soluble substances brought about by the calcium-sulphate treatment is due mainly to other causes."

Sulphur in relation to soil fertility, R. STEWART (*Illinois Sta. Bul. 227* (1920), pp. 99-108).—The available data on the value of sulphur as a fertilizer are summarized, leading to the conclusion that there is no basis for the belief that it is necessary to add sulphur to soil in a permanent system of soil fertility.

Experiments extending over a period of years are reviewed, showing that under Illinois conditions sulphur is not a factor on brown silt loam soil in the production of such common farm crops as corn, oats, wheat, clover, and alfalfa. It is further shown that the sulphur supply of the soil is automatically replenished from the atmosphere, and it is concluded that the relation of sulphur to soil fertility is not in any sense similar to that of phosphorus, but is more similar to that of carbon on the basis that both sulphur and carbon are supplied to crops from the atmosphere.

Effect of manure-sulphur composts upon the availability of the potassium of greensand, A. G. McCALL and A. M. SMITH (*Jour. Agr. Research* [U. S.], 19 (1920), No. 6, pp. 239-256, fig. 1).—Studies conducted at the Maryland Experiment Station on the effect of composting greensand with sulphur, manure, and other materials, with a view to making the potassium in the greensand available through sulfonation, are reported.

Two greensands, one containing 5.88 per cent and the other 1.42 per cent of potassium, were used. It was found that in composts consisting of greensand, manure, and soil in different proportions an appreciable amount of the potassium of the greensand was made water soluble through sulfonation. The composts containing the largest proportion of manure developed the highest degree of acidity, oxidized the greatest amount of sulphur, and produced the largest quantity of water-soluble potassium, while those in which soil was substituted for a part of the manure developed less acidity, oxidized less sulphur, and produced a smaller amount of soluble potassium. When all the manure was replaced by soil the rate of sulfonation was so slow that at the end of 23 weeks only a very small amount of acidity had developed and very little potassium had been made soluble. When no organic matter was added, the amounts of acidity and soluble sulphates were no greater than might be accounted for by the natural oxidation of the sulphur.

The addition of small amounts of ferrous and aluminum sulphates failed to stimulate sulfonation. Calcium carbonate added to the sulphur-manure-soil compost produced a stimulating effect during the early part of the period, but failed to increase the acidity, soluble sulphates, or potassium above the maximum reached by the corresponding compost in which no calcium carbonate was

used. More water-soluble potassium was formed in the composts containing the high-potassium greensand, but a larger percentage of the total potassium present was liberated in the composts containing the low-potassium greensand. In the composts containing manure, the total amounts of potassium recovered in the water extracts varied from 9.1 per cent to a maximum of 41.3 per cent of the total initial amount present.

Farmyard manure: Its making and use, E. J. RUSSELL (*Jour. Farmers' Club* [London], 1920, pt. 5, pp. 89-106).—This is a popular dissertation on the subject.

Plant analyses and the fertilizer requirements of soil, MÜNTER (*Jour. Landw.*, 67 (1919), No. 4, pp. 229-266).—The results of fertilizer and rotation experiments begun in 1902 with beets, barley, potatoes, and wheat on a loess loam soil are reported.

Final results were obtained with wheat only. It was found that potash and phosphoric acid fertilization increased the silica content of wheat straw, and nitrogen fertilization reduced it. Potash and phosphoric acid fertilization reduced the nitrogen, lime, and magnesia contents of the straw, and nitrogen fertilization increased them. Potash slightly reduced the nitrogen content of the grain, and phosphoric acid strongly depressed it. A chemical analysis of the wheat plant from fertilized soil gave no sure indication of the fertility condition of the soil.

It was further found that in good cropping years nitrogen had the greatest influence on crop growth, and in poor years potash had the greatest influence. Phosphoric acid acted indifferently in this respect. Fertilization with an excess of nitrogen, potash, or phosphoric acid was mainly evident in the straw. The weather conditions of a year exercised a strong influence on the assimilation of nutrients by wheat, and the relative percentage of nutrient content was more strongly influenced in individual years by the weather than by fertilization.

It is believed that the nitrogen requirements of the soil used are indicated by the contents of nitrogen, lime, and magnesium in the wheat plant. When the sum of these three for 1 hectare exceeds 90 kg. in the grain and straw, 60 kg. in the grain alone, or 30 kg. in the straw alone, there is sufficient nitrogen present in the soil. If, after subtracting the sum of these three, the figures for the potash percentage are positive, there is sufficient soil potash, but if negative the soil is deficient in potash.

The wheat plants on plats receiving no fertilization and complete fertilization showed generally the same percentage content of nitrogen and phosphoric acid, while the potash content of the straw was higher on the completely fertilized plats. A comparison of analyses of plants from unfertilized and completely fertilized plats gave no indication of the fertilizer requirements of the soil.

It is concluded that the fertilizer requirements of a soil are best indicated when studied by growing and analyzing plants under two excess fertilizations, namely, nitrogen and phosphoric acid plus potash. If the nitrogen : potash ratio is narrower than 1 : 2 there is a potash deficiency. If the nitrogen : phosphoric acid ratio on the nitrogen plats is wider than 100 : 35 there is a phosphoric acid deficiency. If the ratio of nitrogen to phosphoric acid on the phosphoric acid potash plats is narrower than 100 : 60, or if the silica : nitrogen ratio is greater than 100 : 6 there is a nitrogen deficiency. If the percentage of nitrogen found in the wheat straw from the nitrogen plat is placed at 100 there is sufficient nitrogen present in the soil of the phosphoric acid potash plat provided the ratio of the two nitrogen percentages is narrower than 100 : 60.

The content of phosphoric acid in the oats plant and its relation to the increased yield produced by fertilization, E. A. MITSCHERLICH (*Jour. Landw.*,

67 (1919), No. 3, pp. 171-176, fig. 1).—Experimental results are reported, and an intricate mathematical discussion is given in an apparently unsuccessful effort to establish a definite law showing the relation between the content of the oats plant in phosphoric acid and fertilization as a means for determining the absolute phosphate requirement of soil.

Field tests on the action of fertilizers on soil aldehydes, J. J. SKINNER and C. F. NOLL (*Pennsylvania Sta. Rpt. 1916*, pp. 69-85, pls. 8, fig. 1).—This article has been previously noted from another source (E. S. R., 36, p. 424).

Separation of dust from lime nitrogen, N. CARO (*Chem. Ztg.*, 44 (1920), No. 8, pp. 53-56; *abs. in Jour. Soc. Chem. Indus.*, 39 (1920), No. 5, pp. 200A, 201A).—Different methods for reducing the dustiness of lime nitrogen to a minimum are discussed, it being concluded that treatment with a neutral oil has given the best results. On account of the high cost of such treatment and the fact that the causticity of the lime nitrogen is not affected, it is considered desirable to find some treatment which will neutralize the caustic action without reducing the fertilizing value of the lime nitrogen.

Improvement of lime nitrogen, J. BAUMANN (*Chem. Ztg.*, 44 (1920), No. 23, pp. 158, 159).—Some of the disadvantages of crude calcium cyanamid as a fertilizer are reviewed, and it is proposed to obtain the nitrogen of this fertilizer in a more suitable form by combining the cyanamid and ammonia-soda processes. The ammonia for the process is to be obtained from calcium cyanamid, and the liquors from the sodium bicarbonate, which contain ammonium chlorid and sodium chlorid, are to be evaporated to crystallize out the ammonium chlorid. The ammonia is thus recovered as chlorid for use as a fertilizer, and the lime which would have been used for regeneration of the ammonia is used for the manufacture of cyanamid. It is estimated that considerable saving can be effected by the proposed combination of the two processes. Alternate processes are also suggested.

Lime nitrogen as a top-dressing, J. KUHN (*Deut. Landw. Presse*, 47 (1920), Nos. 5, p. 35; 6, pp. 42, 43; 7, pp. 50, 51).—Experiments to determine the possibility of using lime nitrogen as a top-dressing are reviewed and summarized.

The largest practical applications were relatively small. Frequently larger applications were found not to be injurious, but a warning is sounded against such applications in practice because there was considerable variation in the injurious action of the lime nitrogen in individual cases. Such injurious action was closely related to the content of dicyandiamid.

The national aspects of the case for increasing the supplies of basic slag, T. MIDDLETON (*Jour. Min. Agr. [London]*, 27 (1920), No. 3, pp. 241-249).—The value of basic slag as a means of improving pastures, thus increasing meat production and at the same time making it possible to increase the tilled area in case of a national emergency, is especially emphasized in this article.

The separation of feldspar for the technical production of potash, B. NEUMANN and F. DRAISBACH (*Ztschr. Angew. Chem.*, 29 (1916), Nos. 65, *Aufsatz.*, pp. 313, 319; 67, pp. 326-331, figs. 3).—The authors describe the different American sources of potash and give a list of processes for the separation of potash from feldspar.

Tests of a number of the different processes are reported, leading to the conclusion that better results are produced by roasting than by treatment in the autoclave. In the roasting experiments the best results were obtained by the use of lime and magnesium chlorid or calcium chlorid. The latter treatment especially resulted in a complete separation of the potash from the feldspar.

The use of lime on the soil, E. O. FIPPIN (*Cornell Reading Course for the Farm No. 148* (1919), pp. 31-92, figs. 36).—This is a popular bulletin based on New York conditions, the main purposes of which are "to explain some of the

reasons for the need of lime in soils; to point out the indications of that need and its distribution over the State; to explain the different forms of lime that may be used, and to point out their limitations and advantages; to give some directions for the use of lime; and finally to present briefly data showing the value of lime as a means of soil improvement as revealed in experiment station tests and in farm demonstrations."

Limestone resources of Pennsylvania, F. J. HOLBEN and W. FREAR (*Pennsylvania Sta. Rpt. 1916*, pp. 423-444).—This is a supplementary report (E. S. R., 38, p. 22) containing descriptions by counties and analyses of 152 samples of limestones occurring on Pennsylvania lands and received from landowners who desired information as to their agricultural value.

Analyses of 23 samples of commercial ground limestone, burnt and hydrated lime, and limestone by-products are also included.

Lime report 1919, J. W. KELLOGG (*Penn. Dept. Agr. Bul. 336 (1920)*, pp. 37).—This bulletin reports the results of actual and guaranteed analyses of 187 samples of lime products for agricultural uses, representing 66 brands registered for sale in Pennsylvania during 1919. In addition, the text of the State lime-inspection law is given, together with discussions of important features.

By-products from sewage sludge, I. S. WESTON (*Amer. Jour. Pub. Health, 10 (1920), No. 5*, pp. 405-409).—In a review of data on the subject it is pointed out that the most promising of the sludges from the standpoint of the recovery of by-products are those of the activated sludge and the Miles acid processes.

"The cost of aeration and acid treatment are not far apart, and the more valuable Miles process sludge contains less water and is much more stable than the bulkier and partially defatted activated sludge. Repeated experiments have shown that many American sewages contain enough fats and fertilizer constituents to make the problem of their recovery worth consideration. This is as far as the art has progressed in this country, but in England . . . certain cities using the Miles process recovered grease and fertilizer at a profit. Furthermore, a drier has been brought out which promises success with American sewages, and Dorr has suggested a method for avoiding the process of dewatering sludge to a point where it can be handled in a heated drier. This brings the process to a point where a large scale experiment is necessary. In this experiment various processes for making sludge and for handling the same should be tried side by side, and devices like the Dorr thickener and the B. T. W. drier should be valued."

Can the farmer mix his own fertilizers? F. W. TAYLOR (*New Hampshire Sta. Circ. 21 (1920)*, pp. 3-8).—Analyses of 21 samples of home-mixed fertilizers obtained from farmers in New Hampshire are reported and discussed.

It was found that the average of the nitrogen determinations of the 21 samples was within 0.06 per cent of the amount calculated. The average percentage of phosphoric acid was 2.34, and of potash 0.97 per cent higher than that calculated.

It is stated that variations almost as wide as these were found in 34 samples of complete factory-mixed fertilizers. The rather wide discrepancies in the phosphoric acid figures are attributed to the assumption that there was a smaller content of available phosphoric acid in the mixing ingredients than actually existed. It is considered true that the farmer can mix his own fertilizers fairly well.

Report of analyses of samples of commercial fertilizers collected by the Commissioner of Agriculture during 1919 (*New York State Sta. Bul. 467 (1919)*, pp. 61-112).—This bulletin presents the results of actual and guaranteed

analyses of 588 samples of fertilizers and fertilizer materials collected in New York during 1919.

Fertilizers: Notes on spring fertilizer inspection (*Va. Dept. Agr. and Immigr. Bul. 152 (1920), pp. 18-27*).—Analyses of 62 samples of fertilizers and fertilizer materials offered for sale in Virginia during the spring of 1920, and which were either badly or slightly deficient in one or more plant-food constituents, are reported, together with a list of some 270 brands which were found to meet the guaranty in all respects.

Analyses of four samples of burnt lime, three samples of unburnt lime, and one sample of lime and potash are also reported.

AGRICULTURAL BOTANY.

The causes and course of organic evolution: A study in bioenergies, J. M. MACFARLANE (*New York: The Macmillan Co., 1918, pp. 875, pls. 5, figs. 25*).—The author synthesizes herein the results of study carried on during a long period in many fields, together embracing the whole range of biotic activity. He emphasizes the facts and bearings of evolution in its different forms throughout the course of plant and animal life. Energy, continuity, and evolution together form the keynote of this volume. A long list of related literature is given.

Visibility of Mendelian splitting in pollen of *Oenothera* hybrids, O. RENNERT (*Ber. Deut. Bot. Gesell., 37 (1919), No. 2, pp. 129-135, figs. 2*).—Pollen grains of the hybrid *Oenothera (lamarckiana* × *muricata*) *gracilis* show even under low magnification a clear differentiation as regards size of the pollen grains and form of granulations therein.

***Oenothera lamarckiana* mutant simplex**, H. DE VRIES (*Ber. Deut. Bot. Gesell., 37 (1919), No. 1, pp. 65-73*).—A mutation appearing in 1906 and named *O. lamarckiana simplex* is here discussed in its relations with other forms.

Further experimental studies on self-incompatibility in hermaphrodite plants, A. B. STOUT (*Jour. Genetics, 9 (1920), No. 2, pp. 85-129, pls. 2*).—This report represents an extension of experimental studies previously noted (*E. S. R., 40, p. 427*), continuing to yield evidence that compatible and incompatible relations of the sex organs (including germ cells) in the fertilization of hermaphrodites are highly fluctuating in the progeny of single cross- or self-fertilized descent. There are all grades in the degree to which both self-compatibility and cross-compatibility may appear, and even the reciprocal matings of two hermaphrodites may give opposite results.

It is assumed that within the species both self- and cross-compatibility constitute the rule, representing the primitive condition. Incompatibilities are special cases. Cross-sterility within a species is a relatively rare phenomenon, often accomplished by such morphological modifications in the sex organs as dimorphism. Self-incompatibility is more common and appears to have a value in connection with natural selection. It appears from its wide distribution to have arisen often independently, and it is argued that it may be of fundamental significance.

The evidence is considered to favor the view that self-compatibility is a progressive character. Intensive study of fertility of feebly self-compatible individuals yields positive evidence as to how self-sterility has arisen in species originally self-fertile. The marked fluctuation of the character in practically all self-sterile species is regarded as specially significant. More recent studies than those above noted are said to have yielded additional support to the general conclusions that follow.

In all self-compatible species investigated, except *Raphanus sativus* and *Linum grandiflorum*, self-incompatibility and self-compatibility are highly variable. The variations are mostly indiscriminate, though there are cases of marked correlation with conditions as regards age or vegetative vigor during the period of bloom. In some cases at least embryo abortion appears to be due to physiological incompatibility. Repeated selection does not eliminate the extreme fluctuations, though tending toward the establishment and maintenance of highly self-fertile races. Continued self-fertilization in chicory has not decreased self-compatibility or vegetative vigor. It is stated that all results favor the view that incompatibilities arise primarily in the ontogenetic processes of physiological differentiation of sex organs, and are not determined by either individual stuffs or line stuffs of definite hereditary value. As far as general constitution is concerned, similarity in parents favors fertility. Apparently, successful fertilization depends fundamentally on similarity.

Probable bearings of data and conclusions reported by investigators are indicated, and new data as obtained with different plants are presented in detail with interpretations.

Both self-fertility and cross-fertility within a species are considered original and primitive conditions as compared with self-incompatibility and cross-incompatibility. Self-fertility is more primitive than cross-fertility. In hermaphrodites incompatibilities have arisen and are arising in species through fluctuating variation in the physiological differentiation of the sex organs. The evidence supporting the general conclusion in this paragraph is outlined with interpretative discussion.

Sexuality is regarded as a cyclic recurring condition which makes possible the fusion of cells and nuclei and the pairing of chromosomes. The incompatibilities exhibited in processes of fertilization are due to physiological properties that are acquired during sex differentiation. The behavior of both self- and cross-incompatibilities affords no proof that unlikeness in sex organs favors the union of gametes or that some element of similarity leads to incompatibility.

A study of *Allocarya*, C. V. PIPER (*U. S. Natl. Mus., Contrib. U. S. Nat. Herbarium*, 22 (1920), pt. 2, pp. VII+79-113).—Results are given of a study of *Allocarya*, a genus of boraginaceous plants, chiefly of the western United States.

Revisions of North American grasses, A. S. HITCHCOCK and A. CHASE (*U. S. Natl. Mus., Contrib. U. S. Nat. Herbarium*, 22 (1920), pt. 1, pp. X+77, pls. 24, figs. 20).—The authors describe species recognized under the genera *Ichnanthus*, *Lasiacis*, *Brachiaria*, and *Cenchrus*.

The diecious nature of buffalo grass, J. H. SCHAFFNER (*Bul. Torrey Bot. Club*, 47 (1920), No. 3, pp. 119-124).—A study in 1919 at Morganville, Kans., of buffalo grass (*Bulbilis dactyloides*) gave no support to the view expressed by certain investigators that a monocious form exists, though certain possibilities are indicated.

It is stated that this grass is holding its own very well under civilized conditions, and toward its eastern limit is spreading in pastures and abandoned fields, because its strongest competitors (*Andropogon scoparius* and *A. furcatus*) are much more subject to destruction through grazing and trampling of live stock.

Composition and density of the native vegetation in the vicinity of the Northern Great Plains Field Station, J. T. SARVIS (*Jour. Agr. Research [U. S.]*, 19 (1920), No. 2, pp. 63-72, pls. 3, figs. 2).—In a contribution from the Bureau of Plant Industry, U. S. Department of Agriculture, the author reports on cooperative experiments with the North Dakota Experiment Station, con-

ducted with a view of determining the carrying capacity of the range in that section and working out a grazing system adapted to conditions in the Great Plains.

The vegetation in the area studied was found to be composed of a large number of species, only a few of which produce a considerable amount of the total forage. The dominating species were found to be *Bouteloua gracilis* and *Stipa comata*. The density of the vegetation was determined by the thickness of the plants upon the ground surface and not by foliage growth. The total basal cover of all species in the Mandan region was approximately 60 per cent of the ground surface, *B. gracilis* having a basal covering of about 20 per cent and *S. comata* nearly 10 per cent of the surface. Clipping data taken on different day periods showed that *B. gracilis* produced 40 to 50 per cent and *S. comata* from 15 to 20 per cent of the total forage.

Upland societies of Petoskey-Walloon Lake region, H. D. CLAYBERG (*Bot. Gaz.*, 69 (1920), No. 1, pp. 28-53, fig. 1).—These notes, embodying the results of observations during some years, state that the sapling age in the area studied shows the maximum increase in size for a given decrease in the number per unit area, so that competition between trees of equal age is keenest at this age. The name *synfolium* is coined for the foliage layer, and the development and ecological significance of this layer are analyzed.

Throughout this region the response of the plant societies to interference and changed environment has been adaptive, in so far as their constitution allowed. It is claimed that such natural societies as the blackberry are fitted to survive in partly wild areas, while others can invade the fields in competition with the crops. Characters favorable to survival are quick entry, speed of vertical growth, quickness of fruiting after germination, quantity of seed production, and efficiency of distribution.

The phenological influence of the sea, G. RITTER (*Bot. Centbl., Beihefte*, 36 (1919), 1. Abt., No. 1, pp. 78-132).—An extended account is given of studies on influences affecting plants as related to bodies of water, with a discussion of the significance of the observations.

Experimental cultures of garden salad plants in seashore situations, L. DANIEL (*Compt. Rend. Acad. Sci. [Paris]*, 168 (1919), No. 2, pp. 116-118).—A study of salad plants grown on exposed seashores is said to have emphasized the predominating part played by water in such situations.

The effects of gases on plants, C. WEHMER (*Ber. Deut. Bot. Gesell.*, 35 (1917), Nos. 3, pp. 318-332, figs. 4; 4, pp. 403-410, figs. 3).—Details are given of studies regarding the effects of different gases on various trees and garden plants.

The influence of fluorin on plants, A. GAUTIER and P. CLAUSMANN (*Compt. Rend. Acad. Sci. [Paris]*, 168 (1919), No. 20, pp. 976-982).—Details are given of preliminary tests on 14 species in widely separated families in regard to the presence and influence of fluorin compounds.

The influence of the concentration of the nutritive medium on some plants, L. GURLITT (*Bot. Centbl., Beihefte*, 35 (1918), 1. Abt., No. 2, pp. 279-341, figs. 34).—Studies on mosses and higher plants are noted, with the effects of different concentrations of nutritive media on their development.

Effects of acids and the formation of soluble starches by mold fungi, F. BOAS (*Bot. Centbl., Beihefte*, 36 (1919), 1. Abt., No. 1, pp. 135-185, figs. 5).—This is a detailed account of work which the author carried out during the years 1913-1917 with *Aspergillus niger*.

A new fungus destroying complex polysaccharids, A. EPSTEIN (*Bul. Soc. Bot. Genève*, 2. ser., 11 (1919), No. 5-9, pp. 191-198).—The author obtained in

1917 and studied an organism which has the property, among others indicated, of destroying certain complex polysaccharids. The organism is considered a new species and named *Pseudomonas polysaccharidarum*.

The breeding of fungi on highly concentrated cane sugar solutions and the question of chondriomes, N. BEZSSONOF (*Ber. Deut. Bot. Gesell.*, 37 (1919), No. 2, pp. 136-148, pl. 1).—An account of studies on several fungi concludes with the statement that rearing mold fungi on strong sugar solutions tends to the development of sexuality. Discussion is also given of the characters and significance of the chondriomes and various related structures.

Conidia-forming materials, F. BOAS (*Ber. Deut. Bot. Gesell.*, 37 (1919), No. 1, pp. 57-62).—This is a brief study of the relation between the components of the substratum and conidia formation as regards rapidity and amount, in case principally of *Aspergillus niger* and *A. glaucus*. The degree of dissociation appears to be significant in this connection.

The sexuality of *Phycomyces nitens*, G. ORBAN (*Bot. Centbl., Beihefte*, 36 (1919), 1. Abt., No. 1, pp. 1-59, pls. 2, figs. 20).—It is stated that *P. nitens* presents a plus and a minus strain, the mycelium being distinguishable through differences in such characters as germination period, growth, and starch production.

Auto-toxicity in *Aspergillus niger*, F. BOAS (*Ber. Deut. Bot. Gesell.*, 37 (1919), No. 1, pp. 63-65).—Noting manifestations of auto-toxicity in *A. niger* grown on a suitable substratum, the author observes that other fungi, as *Botrytis cinerea* and *Oidium* under comparable conditions, gave negative results.

Studies on plant colloids.—VIII, Cellulose dextrans, M. SAMEC and J. MATULA (*Kolloidchem. Beihefte*, 11 (1919), No. 1-2, pp. 37-73, figs. 3).—An account is given of a study of several cellulose dextrans as regards their physico-chemical characters, also of the influence of diastase on these bodies, the results being presented in tabular form with discussion.

Demonstration of lipoids in plant cells, F. CZAPEK (*Ber. Deut. Bot. Gesell.*, 37 (1919), No. 5, pp. 207-216).—A discussion is given of methods for the demonstration of lipoids in plant cells and of work done with different plants.

The passage of undissolved substance from the cell nucleus, M. VON DER-SCHAU (*Arch. Zellforsch.*, 14 (1915), No. 2, pp. 255-277, pls. 2).—This is a synthetic account, with discussion, of studies on the nature and behavior of certain nuclear bodies and substances in different plants.

Size and function of cell nuclei, particularly with reference to classification, E. KLIENEBERGER (*Bot. Centbl., Beihefte*, 35 (1918), 1. Abt. No. 2, pp. 219-278, pl. 1, figs. 3).—As a result of the studies here noted, it is claimed that both the size and structure of the cell nuclei are significant in the detection of close relations among plants.

Effect of reaction of solution on germination of seeds and on growth of seedlings, R. M. SALTER and T. C. McILVAINE (*Jour. Agr. Research [U. S.]*, 19 (1920), No. 2, pp. 73-96, pl. 1, figs. 5).—A study was made at the West Virginia Experiment Station to determine the effects of reaction as made by H-ion concentration upon the growth of the seedlings of wheat, soy beans, corn, and alfalfa in solution culture and upon the germination of the seeds of wheat, soy beans, corn, alfalfa, and red clover.

Citric acid was found unsuitable for adjusting the reaction of culture solutions for such work, but a satisfactory method was found in the addition of a uniform amount of orthophosphoric acid to all cultures and increasing the amounts of sodium hydroxid to successive cultures. Maximum H-ion concentrations for the growth of seedling were determined. The hydroxyl-ion was found apparently more harmful than the H-ion in equivalent concentrations. Measurements of reaction of solutions before and after the growth of wheat

seedlings showed a general tendency of the plant to adjust the reaction to a point slightly below neutrality. Germination of the seed was found less sensitive to an acid reaction in wheat, corn, soy bean, and alfalfa than was the subsequent growth of the seedling. The reaction of different concentrations toward germination is shown.

Growth curves, A. RIPPEL (*Ber. Deut. Bot. Gesell.*, 37 (1919), No. 3, pp. 169-175, fig. 1).—It is thought safe to conclude that growing protoplasm passes through a period of activity specific for both organ and individual. The course of this is determined by physico-chemical laws and is of the same order as an autocatalytic reaction, being influenced only collaterally and quantitatively by external factors.

Regeneration of tendril tips and contact sensitivity in twining plants, B. LÖFFLER (*Ber. Deut. Bot. Gesell.*, 37 (1919), No. 1, pp. 6-24, figs. 8).—The results are indicated of studies on such plants as *Phaseolus multiflorus*, *P. vulgaris*, *P. tunkinensis*, *Humulus lupulus*, *Dioscorea sativa*, and *Hexacentris mysorensis*, as regards the effects on growth and movement of various factors which are indicated.

[**The function of latex vessels**], C. SIMON (*Bot. Centbl., Beihefte*, 35 (1918), 1. Abt., No. 2, pp. 183-218).—Studies on species of *Papaver* and *Euphorbia* as described are said to show that certain coloring matters are abundantly deposited in the latex vessels, though these vessels may remain uncolored in spite of the high coloring produced in neighboring tissues. The latex tubes are probably not to be regarded as organs of transference.

Recent notes on the nutritive layer of the pollen, MASCRÉ (*Compt. Rend. Acad. Sci. [Paris]*, 168 (1919), No. 24, pp. 1214-1216).—Studies previously reported (*E. S. R.*, 42, p. 819) are said to have been confirmed by studies on *Datura stramonium* and *D. tatula*, the order of the occurrence of the phenomena being the same in each case. Observations on other species are noted. The existence of chondriomes was established for all the genera studied. Starch was always present, in the form of very small grains. Fats were abundant in certain species named. Tannoid and alkaloid bodies (both presumably waste materials) were present in the nutritive layer of the pollen grains of certain species.

Two crystalline phospho-organic salts in green plants, S. POSTERNAK (*Compt. Rend. Acad. Sci. [Paris]*, 168 (1919), No. 24, pp. 1216-1219, fig. 1).—The author gives a descriptive account of the preparation of two crystalline phospho-organic salts for use in connection with the study of phospho-organic reserves in green plants.

The formation of soluble starch in elective nitrogen metabolism, F. BOAS (*Ber. Deut. Bot. Gesell.*, 37 (1919), No. 1, pp. 50-56).—The general significant difference between ammonium chlorid and other nitrogen yielding compounds (tested with *Aspergillus niger*) is that the latter are less readily dissociated. The significance of certain implications in this connection is discussed.

Studies on the assimilation of carbon dioxid, R. WILLSTÄTTER and A. STOLL (*Untersuchungen über die Assimilation der Kohlensäure. Berlin: Julius Springer, 1918, pp. VIII+448, pl. 1, figs. 16*).—This collection, comprising contributions on assimilation by plants of carbon dioxid, is in seven main sections, dealing respectively with the constancy of chlorophyll content during assimilation; the relation between assimilatory performance by the leaves and their chlorophyll content; absorption of carbon dioxid through unilluminated leaves; the behavior of chlorophyll toward carbon dioxid; the constancy of assimilatory coefficients during increased assimilation; the dependency of assimilation upon the presence of small amounts of oxygen; and studies on intermediate stages in assimilation.

The authors state in the general conclusion to this work that the yellow pigment was not found to function either in assimilation or in respiration. Chlorophyll, on the contrary, unites with its ordinary and apparent function, another which is more difficult to detect and which is related to its capability to react chemically. This pigment is decomposed in connection with a reaction of carbon dioxid in the presence of magnesium, an intermediate product being a dissociable carbon dioxid compound. A theory of assimilation is outlined with supporting conclusions.

Willstätter and Stoll's recent work on assimilation by plants, H. BORUTAU (*Umschau*, 22 (1918), No. 9, pp. 100-102).—This is a review of some features (largely chemical) of recent work by Willstätter and Stoll, as embodied in the volume above noted.

The water absorption region of roots, H. COUPIN (*Compt. Rend. Acad. Sci. [Paris]*, 168 (1919), No. 20, pp. 1005-1008).—Pursuing studies as previously indicated (E. S. R., 42, p. 819), the author found that no advantage was gained by immersion of more than the tip of a root in water. He claims that water in the plants tested is absorbed exclusively by the root tip, the root hairs not functioning in this regard.

The response of plants to wireless stimulation, J. C. BOSE (*Nature [London]*, 104 (1919), No. 2609, pp. 172-174, figs. 2).—The author states that investigations regarding the influence on plants of ultra-violet and infra-red spectral wave lengths have shown that the very short electric waves retard growth, producing responsive movements in *Mimosa* when in a highly sensitive condition. A definite mechanical and electric response to wireless impulse was obtained with all plants tested. The arrangement employed is briefly described as to the production and effect both of strong and of weak stimuli. It is claimed that the perceptive range of plants is very great, and that they not only perceive but respond to the different wave lengths of the vast ethereal spectrum.

The influence of colored lights on the coloration of Cyanophyceæ, K. BORESCH (*Ber. Deut. Bot. Gesell.*, 37 (1919), No. 1, pp. 25-39).—The capability of certain Cyanophyceæ to modify the color of incident light by assuming a complementary color was demonstrated for *Phormidium foveolarum*. This is discussed in regard to its probable significance.

The fate of chlorophyll in plants in autumn, R. KOLKOWITZ (*Ber. Deut. Bot. Gesell.*, 37 (1919), No. 1, pp. 2-5).—Observations are noted as made on changes affecting chlorophyll in plants, covering a wide range as regards systematic arrangement.

FIELD CROPS.

Practical universality of field heterogeneity as a factor influencing plat yields, J. A. HARRIS (*Jour. Agr. Research [U. S.]*, 19 (1920), No. 7, pp. 279-314).—This paper presents the results of studies with reference to the use of the modern higher statistical methods in the analysis of data from plat tests in field experiments. The particular phase of the problem dealt with is the lack of uniformity of the experimental field. Data secured by other investigators are reviewed, a bibliography of 22 references to the literature cited is given, and the results of the author's own studies are presented in tables and discussed.

Heterogeneity is defined as differences in capacity for crop production throughout the field of such a magnitude as to influence in like manner, but not necessarily to like degree, the yield of adjacent small plats, and it is pointed out that this factor is measured by a coefficient which shows the degree of correlations between the yields of associated ultimate plats, grouped in combination plats. The determination of this coefficient for a relatively large series of experimental fields, widely distributed throughout the world and planted to a

considerable variety of crops, is shown as having brought out that in every field the irregularities of the substratum were sufficient to influence the experimental results.

The coefficients for water content and for chemical composition of the soil were found to be of about the same order as those determined for crop yields, and the belief is expressed that the heterogeneity of experimental fields in their capacity for crop production is directly due to these and other physical and chemical factors. The existence of significant heterogeneity in fields passed by agricultural experts as satisfactorily uniform is regarded as illustrating the inadequacy of personal judgment concerning the uniformity in physical characters or in crop-producing capacity of fields under consideration for experimental work.

[The relation of size, shape, and number of replications of plats to probable error in field experimentation], J. W. DAY (*Jour. Amer. Soc. Agron.*, 12 (1920), No. 3, pp. 100-105).—Studies of the grain and straw yields of 3,100 5-ft. row segments of a wheat plat at the Shelbina field of the Missouri Experiment Station, made to determine the relation of size, shape, and number of replications of plats to probable error in field experimentation, are discussed. Detailed notes with standard deviations and coefficients of variability are presented in tabular form.

Summarizing the results, it is stated that increasing the size of the plat to at least $\frac{1}{20}$ acre or more reduced variation. Single plats, long and narrow in form and extending in the direction of greatest variation, gave more accurate results than those of other shapes, but plats, square or nearly square, were preferable to long, narrow plats with the greatest dimensions in the direction of least variation. Results from single plats were usually not sufficiently accurate to determine small differences between varieties or fertilizer and cultural treatments.

The use of a unit of comparison composed of systematically distributed parts gave results much less variable than those obtained from an equal area in a single plat. When the number of replications remained constant but the size of the plat was increased, variation was reduced. From the viewpoint of shape, the most effective replicated block was one that was long and narrow with its greatest dimension in the direction of greatest variation.

The uselessness of hill selection under conditions where rapid degeneration or "running out" is prevalent, R. WELLINGTON (*Proc. Amer. Soc. Hort. Sci.*, 16 (1919), pp. 175-179).—Hill selection experiments at the Minnesota Experiment Station, where potato varieties had been degenerating or "running out" very rapidly for many years, are described. It is stated that efforts made to select strains resistant to degeneration ended in total failure. High and low-yielding hills and tubers possessing so-called desirable and undesirable characters followed the same course, low-yielding hills often giving the better results.

Annual hay and forage crops, L. R. WALDRON and F. W. CHRISTENSEN (*N. Dak. Agr. Col. Ext. Circ.* 37 (1920), pp. 8, fig. 1).—Millet, Sudan grass, corn, oats, barley, Canadian field peas, sunflowers, sweet clover, rape, and Russian thistle are among the crops considered for use as hay and forage. Brief notes are presented on varieties, culture, yields, and utilization of the crops listed.

Harvest report [Roseworthy Agricultural College], 1919-20, W. J. COLEBATCH (*Jour. Dept. Agr. So. Aust.*, 23 (1920), Nos. 8, pp. 659-671; 9, pp. 738-753).—This continues work previously noted (*E. S. R.*, 41, p. 639) reporting considerable meteorological and crop data for the season 1919-20. Average acre yields on the college farm for 1919 were as follows: Berseem clover 28.4 tons, silage from wheat, barley, and oats 1.95 tons, wheat 9 bu. 22 lbs., barley 17 bu.

15 lbs., oats 10 bu. 17 lbs., and rye 14 bu. 7 lbs. Additional data show yields of variety tests of wheat, barley, oats, and rye, with studies of wheat selections and hybrids.

Report on variety tests, 1914, F. MERKEL (*Arb. Deut. Landw. Gesell.*, No. 298 (1919), pp. XIV+300).—In continuance of previous work, the author presents data on numerous variety tests with oats, spring and winter wheat, winter rye, field beets, sugar beets, field peas, and field beans conducted throughout Germany during 1914.

[Report on field crops work in South Australia, 1919-20], W. J. SPARFORD ET AL. (*Jour. Dept. Agr. So. Aust.*, 23 (1920), Nos. 6, pp. 493-502; 7, pp. 593-602; 8, pp. 762-686; 9, pp. 754-756).—Variety, cultural, and fertilizer tests with wheat conducted at Hammond, Butler, Wilkawatt, and Yeelanna are reported in continuation of work previously noted (*E. S. R.*, 41, p. 529). Results of variety, fertilizer, and cultural tests with wheat, and variety tests with oats and barley at Minnipa, work with rotations and root crops at Penola, and flax tests at Moorak, Kybolite, and Turretsfield are also given.

The important legumes.—II, Soy beans, common beans, chick-peas, vetches, bitter vetch, and chickling vetch, C. FRUWIRTH (*Landw. Heft.*, No. 30-31 (1918), pp. 76, pls. 4, figs. 13).—This is the second part of a publication previously noted (*E. S. R.*, 36, p. 635), and continues the description of leguminous crops together with a discussion of their food uses and agricultural values. Detailed descriptions with lists of local varieties are given of the following: Common bean (*Phaseolus vulgaris*), scarlet runner (*P. coccineus* or *P. multiflorus*), one-flowered vetch (*Vicia monantha*), bitter vetch (*V. ervilia*), soy bean (*Soja max*), chick-pea (*Cicer arietinum*), and chickling vetch (*Lathyrus sativus*). Brief notes are also presented on the outstanding points of the imported legumes less commonly cultivated.

The development of the Peruvian alfalfa industry in the United States, H. L. WESTOVER (*U. S. Dept. Agr., Dept. Circ.* 93 (1920), pp. 8, figs. 2).—The history of the introduction of Peruvian alfalfa into the United States is reviewed, and the development of the culture of this crop in this country is described. The distinguishing characters of the plant are pointed out, and its value for certain sections, particularly in some of the Southwestern States and along the Pacific Coast, is discussed. The author differentiates between the true Peruvian alfalfa, introduced in 1903 under S. P. I. No. 9303, and "smooth-leaved Peruvian" procured from Peru in 1908 under S. P. I. No. 22834, characterized by fewer hairs on the stems and leaves and by slower and shorter growth.

[Proceedings of the New Jersey Alfalfa Association] (*N. J. Dept. Agr. Bul.* 24 (1920), pp. 339-369).—A report of the annual meeting of the association held at Trenton in January, 1920. The following papers were presented: Methods of Seeding Alfalfa and Crops Following Alfalfa in the Rotation, by N. Schmitz; Alfalfa—My Experience in Growing It and Crops of Corn and Potatoes After It, by D. D. Solomon; and Practical Methods of Harvesting and Curing Alfalfa Hay, by W. L. Minch.

Bahia grass, J. M. SCOTT (*Jour. Amer. Soc. Agron.*, 12 (1920), No. 3, pp. 112, 113).—Bahia grass (*Paspalum notatum*), recently introduced into Florida, has been shown in tests at the station to possess ability to spread and make a good sod while being subjected to heavy pasturing. This grass is said to be indigenous to South America and northward to Mexico, and to have been introduced into this country by the U. S. Department of Agriculture in 1913.

A remarkable fodder plant: Shearman's clover (*Trifolium fragiferum* var.), E. BREAKWELL (*Agr. Gaz. N. S. Wales*, 31 (1920), No. 4, pp. 245-250, figs. 4).—An account of the origin, habits of growth, methods of propagation, and comparative analyses of Shearman's clover, a promising new fodder plant re-

cently brought to light in New South Wales, is given. This plant is said to be closely allied to strawberry clover (*T. fragiferum*), but sufficiently individual to be classified as a distinct variety.

Selection in self-fertilized lines as the basis for corn improvement, D. F. JONES (*Jour. Amer. Soc. Agron.*, 12 (1920), No. 3, pp. 77-100, pls. 5, figs. 3).—In this paper, a contribution from the Connecticut Experiment Station, the author reviews the progress of maize breeding, specially discussing the pedigree record system, the ear-to-row method, significance of inbreeding, results of self-fertilization, and the value of inbred strains. He urges the application of selection in self-fertilized lines to corn breeding and outlines a tentative plan of procedure.

A teosinte-maize hybrid, G. N. COLLINS and J. H. KEMPTON (*Jour. Agr. Research [U. S.]*, 19 (1920), No. 1, pp. 1-38, pls. 7, figs. 33).—This paper, a contribution from the Bureau of Plant Industry, U. S. Department of Agriculture, describes the behavior of a number of the more sharply contrasted characters in the second generation of a hybrid between Florida teosinte and Tom Thumb pop corn in an attempt to determine more definitely the relation of teosinte to the origin of maize.

Six F_1 plants were grown from hybrids secured in a greenhouse by using teosinte plants as the female parents. From the self-fertilized seed of one of these, 127 F_2 plants were produced. Field measurement of characters, including dates of flowering and size and number of the several organs, were transferred to punched cards, each card representing an individual plant. Practically all calculations were made by the use of electric sorting and tabulating machines, the distribution and means being obtained by sorting with respect to each character and counting the cards in each class with the tabulator. The use of mechanical tabulating machines in calculation of correlations is explained in detail. The data on the characters are presented in tabular form and the frequency distribution by numerous figures.

Many of the 33 characters recorded and correlations considered fell into groups, the members of which seemed to be mutually related, either physically or physiologically. Eight such groups, including height, nodes above, tassel, male branch, alicole, nodes silking, prophyllary, and number of rows are recognized, comprising in all 26 characters. Among the 7 remaining characters considered as independent, physiological relations, if existing, were more obscure.

The observations made can be summarized as follows: The F_2 plants, like the F_1 plants, showed characters largely intermediate between those of the parents. The distribution of 33 of the recorded differentiating characters with one or two exceptions showed little or no evidence of alternative or Mendelian inheritance. With respect to individual characters the extreme variants approached, and sometimes exceeded, those of the parents, but none possessed any large number of characters of either maize or teosinte.

The greatest freedom of recombination was shown, all combinations of characters appearing that might be expected from so few individuals. The many instances of coherence or partial coupling were nearly equaled by instances where characters derived from different parents showed a tendency to combine more frequently than would be expected as the result of chance. However, it was found impossible to distinguish primary from secondary correlations.

Although no incompatible combinations appeared, there were no completely independent characters. Every character recorded showed significant correlation with one or two others, which in turn were correlated with still others, resulting in the interrelation of all characters and the formation of a single

group. All characters may be arranged in such a way that they form a single group in which there is no coefficient of correlation lower than ± 0.31 .

The arrangement of the spikelets in the pistillate inflorescence showed the nearest approach to Mendelian inheritance. In maize the female spikelets are borne in pairs (double female alicoles); in teosinte they occur singly (single female alicoles). While dominance of the maize character was complete in the first generation, this did not hold true in the second generation, many plants possessing both single and double female alicoles; but the number of individuals in which double female alicoles predominated was approximately three times the number possessing more single female alicoles.

The characters of the pistillate inflorescence were found to be subdivided in transmission to a remarkable degree. The maize ear, instead of behaving as a unit was subdivided into a large number of separately inherited units, such as number of rows, closely crowded seeds, and shortened peduncles, all of which were inherited more or less independently. Number of rows was still further resolved into paired or single spikelets and the number of rows of alicoles in which they were borne. A surprisingly large number of plants combined the abundant production of suckers characteristic of the teosinte parent with the sturdy, upright character of maize, resulting in very leafy, compact plants of a desirable forage type.

Lint frequency in cotton with a method for determination, E. A. HODSON (*Arkansas Sta. Bul. 168 (1920), pp. 3-11*).—This bulletin defines the term lint frequency, briefly reviews literature bearing on the subject, describes in detail the method followed in determining this factor for 25 varieties of cotton, and reports in tabular form the averages of the data so secured for 10 selected plants for each of the varieties. The rank of the 25 varieties in lint frequency, index, percentage, and length is also given in a table.

Lint frequency is defined as "the weight in grams of the fiber of uniform length produced per square centimeter of seed surface," and the lint index as "the average amount of lint produced on one seed without regard to the size of the seed." It is pointed out that the quantity of lint produced on a cotton seed depends upon the frequency and the length of the lint hairs and upon the area of the surface. High lint frequency was found closely correlated with short lint, and attention is called to the fact that it is necessary, therefore, in making selections for high lint frequency to consider length and percentage of lint. Boykin, which ranked first in lint frequency, second in lint index, and second in lint percentage, stood twenty-fifth in length of lint, while Dix-Affi, ranking twenty-fifth in lint frequency, lint index, and lint percentage stood first in length of lint.

Correlations of certain characters in cotton, E. A. HODSON (*Arkansas Sta. Bul. 169 (1920), pp. 3-15, figs. 3*).—Correlations were determined for number of base limbs with number of fruiting branches, number of bolls per plant, and height of plant; for number of fruiting branches with height of plant and number of bolls per plant; and of length of fruiting period and other characters studied. Based on the data from material studied, the correlation coefficients for these and other characters, including length of lint and percentage of lint, weight of boll, and weight of seed; weight of seed and weight of boll; and percentage of lint and weight per boll are reported.

The results indicated that the number of base limbs per plant depends upon the variety and the environment, without being significantly correlated with any physical character. The number of fruiting branches per plant was found closely correlated with the height of the plant, which is in turn dependent upon the environment and the variety. A very low correlation was found to

exist between the number of fruiting branches per plant and the number of bolls per plant, and it was observed that when the environment favors the production of a larger number of fruiting branches than the mean for the variety there was not a corresponding increase in number of bolls per plant. The correlation between the length of the fruiting period and other physical characters was shown not to be nearly so close as usually supposed. The data further indicated that the percentage of lint was negatively correlated with weight of seed and length of lint, and the highest correlation was found to occur between weight of boll and weight of seed.

Upland long staple cotton in Arkansas, E. A. HODSON (*Arkansas Sta. Circ.* 49 (1920), pp. 4, fig. 1).—A brief discussion is presented of the importance and value of producing upland long staple cotton in Arkansas, and the areas of the State adapted to the production of staples $1\frac{1}{8}$ in. and longer, 1 to $1\frac{1}{4}$ in., and about 1 in. and less are pointed out. The length, percentage, and yield of lint of Foster and Webber, two upland long staple varieties, are compared with those of Triumph, a variety of short staple.

The cultivation of cotton in the Ottoman Empire (*U. S. Dept. Com., Bur. Foreign and Dom. Com., Com. Rpts. No. 72* (1920), pp. 1725-1727).—A brief report of the methods of cultivation and the chief producing regions of the crop in Asiatic Turkey.

Correlation between depth of eyes and degeneration among potatoes, O. B. WHIPPLE (*Proc. Amer. Soc. Hort. Sci.*, 16 (1919), pp. 181-183).—After three years' work at the Montana Experiment Station with a deep-eyed potato variety in an endeavor to improve the commercial value by selecting to a shallower-eyed type, the yielding power was greatly reduced, and careful field counts showed 90 per cent of the plants to possess degenerate tendencies. Studies of hills and tuber characteristics in seed plats planted in 1919 on a tuber-unit plan and classified as normal-vigorous, intermediate, and degenerate, showed conclusively that shallowness of eye was correlated with degeneracy. In practically all varieties, the most perfect tubers as regards size, form, and depth of eye, came from intermediate plants, while in advanced degenerate types the depression about the eye was often entirely absent.

Thinning as a possible substitute for seed pieces of uniform size in potato tests, O. B. WHIPPLE (*Proc. Amer. Soc. Hort. Sci.*, 16 (1919), pp. 179-181).—Tests at the Montana Experiment Station to determine the value of thinning as a substitute for seed pieces of uniform size are described. All hills were thinned to a single stem as soon as the plants were large enough to pull. Plats planted with seed pieces averaging 1.04 oz. gave average yields of 20,575 lbs. of marketable tubers per acre, while those planted with seed pieces weighing 0.33 oz. yielded 19,447 lbs. per acre. On other plats 1.3 oz. seed pieces yielded 17,867 lbs. compared with 16,097 lbs. from 0.33 oz. seed. Field counts before thinning showed plats planted with 1.3, 1.04, and 0.33 oz. seed to average 2.27, 2.22, and 1.47 stems per hill, respectively. Results, though not conclusive, show that variations in yield following planting of large and small seed pieces are largely a matter of stand, i. e., the number of plants produced per seed piece planted.

[**Proceedings of the New Jersey State Potato Association**] (*N. J. Dept. Agr. Bul.* 24 (1920), pp. 257-319).—This comprises a report of the annual meeting of the association held at Trenton in January, 1920. The following papers were presented:

One of the Controllable Factors in Potato Growing, With Special Reference to Losses From Poor Seed, by H. R. Talmage; The American Giant Situation in Washington County (N. Y.), by J. M. Hurley; Lessons Learned From Seed Inspection Last Season, by M. T. Cook; Seed Certification in New Jersey, by

W. L. Minch; Potato Scab Control, by W. H. Martin; Maine Methods of Seed Production, by E. Edmunds; The Cost of Producing Potatoes in New Jersey, by F. App; Results of Fertilizer Experiments, by J. G. Lipman; and Insect Problems, by T. J. Headlee.

Rice cultivation in British Guiana, F. A. STOCKDALE (*Jour. Bd. Agr. Brit. Guiana*, 12 (1919), No. 4, pp. 234-250).—The history and present status of rice culture in the colony are reviewed, and information given regarding varieties, cultural methods, harvest practices, and crop pests. Suggestions are offered for the improvement of the crop by seed selection.

The rice bean (*Phaseolus calcaratus*), A. H. HAYWOOD (*Agr. Gaz. N. S. Wales*, 31 (1920), No. 4, pp. 289, 290, fig. 1).—The rice bean (*P. calcaratus*), said to be identical with the Jerusalem pea, (*P. trinervis*), is briefly described, and its use as a green mulch for bananas on the North Coast in New South Wales is recommended.

Sweet sorghum variety demonstrations, 1919, M. W. HENSEL (*N. C. Agr. Col. Ext. Circ.* 102 (1920), pp. 3-14, figs. 4).—Adaptation studies of sweet sorghum varieties in several localities of North Carolina, carried on in cooperation with the U. S. Department of Agriculture, are reported for 1919. Japanese Seeded Ribbon (Honey) was first in average yield with 370.6 gal. of sirup per acre, followed by Red Amber with 319 gal. and Sugar Drip with 218 gal. These varieties required, respectively, 150, 143, and 133 days to mature. Long season strains were found to be more profitable than early maturing varieties where the period between killing frosts exceeded 120 days. The crop harvested when the seed was in the dough or late milk stage produced a sirup superior to that cut when even slightly overripe.

Isolation of seed sugar beets, G. GAUDOT (*Jour. Agr. Pract., n. ser.*, 33 (1920), No. 20, pp. 364, 365, fig. 1).—A device is described for protecting seed sugar beet selections from adventitious pollen, consisting of a hood of thin cloth or gauze upheld by a strong stake driven into the soil close to the beet root. The sides are extended by a frame of hoops and the bottom fastened to a band of galvanized iron half buried in the ground surrounding the beet. A flap which can be opened at will permits access to the interior. To facilitate fertilization the frame is frequently agitated. Seed production is said to be less abundant than when exposed to the open air, but the desired result is obtained.

The beet sugar industry [in Victoria], W. L. WILLIAMS (*Jour. Dept. Agr. Victoria*, 17 (1919), No. 12, pp. 722-729; 18 (1920), Nos. 1, pp. 15-24, figs. 7; 2, pp. 65-74, figs. 4).—A popular discussion of the development of the beet sugar industry in Victoria, together with information on cultural methods, seed production, sugar manufacture and by-products, cost data, and analyses.

The question of fertilization [of sugar cane], A. VAN ELK (*Arch. Suiker-indus. Nederland. Indië*, 27 (1919), No. 30, pp. 1477-1482).—Experiments with sugar cane are reported, comparing with ammonium sulphate, green manure, ammonium sulphate alone, and with peanut cake.

In the first comparison the yields obtained were about equal, but fertilization with the use of green manure was the cheaper. In the second comparison better results were obtained with the green manure combination. It is concluded that green manure may be profitably used to replace concentrated nitrogenous fertilizer, especially on light soils. It was also found that the nitrogen in the peanut cake was only about half as effective as that in ammonium sulphate.

Rice straw as a mulch for sugar cane, J. B. HARRISON and R. WARD (*Jour. Bd. Agr. Brit. Guiana*, 12 (1919), No. 4, pp. 251-258).—This reports fertilizer experiments with sugar cane in British Guiana in continuation of work previously noted (E. S. R., 40, p. 633).

The average 1919 yields of ratoon crops of the varieties D 625, D 118, and D 145 were 19, 17.1, and 15.6 tons of cane per acre, respectively. Where the three varieties received dressings of 200, 300, 400, and 500 lbs. of sulphate of ammonia and 375 lbs. of nitrate of soda, the acre yields amounted to 15.5, 18.8, 22.8, 22.8, and 15.3 tons of cane respectively, as compared with 11.6 tons for the unfertilized check. Applications of rice straw at the rate of 25,000 lbs. per acre resulted in an average yield of 19.5 tons as compared with 15 tons without the mulch. Without rice straw the same varieties gave average yields of 9 tons of cane per acre without fertilizer, 9 with potash alone, 18 with sulphate of ammonia alone, 15.7 with potash and sulphate of ammonia, and 18.3 with potash and nitrate of soda. With applications of rice straw the yields of the variously treated plats amounted to 12.5, 16.1, 21.3, 19.6, and 22.5 tons respectively. The beneficial effects of rice straw are considered to be due to direct manurial action, improvement of tilth, and the inhibition of weed development, especially those of the order Graminæ.

Tobacco experiments [1915], W. FREAR, O. OLSON, and H. R. KRAYBILL (*Pennsylvania Sta. Rpt. 1916, pp. 455-480, pls. 5, figs. 2*).—Continuing work previously noted (*E. S. R.*, 38, p. 36), further improvement of Pennsylvania Seedleaf (Broadleaf), varieties of cigar tobacco by selection, fertilizer experiments, adaptation studies on Clinton and Lycoming County soils, spacing and topping experiments, and seedbed studies are reported for 1915. The work was in cooperation with the Bureau of Plant Industry, U. S. Department of Agriculture. Tabulated data are presented on plant measurements, yields, and leaf quality.

Unfavorable weather conditions depressed the average acre yields of the seed-leaf selections in 1915 to but 69 per cent of those of the previous year. The average yields of three single line selections of each strain were as follows: Slaughter, 1,905 lbs.; Hostetter, 1,498 lbs.; Espenshade, 1,715 lbs.; Cooper, 1,521 lbs.; and Hoffman, 1,455 lbs.; with extreme differences in yields between the different selections of each strain of 370, 275, 365, 370, and 276 lbs. The differences in type yields shown by the average for the five strains were 327.6 lbs. in 1915 as compared with 294.3 lbs. in 1914, the differences for Slaughter and Hostetter being reduced, increased for Espenshade and Cooper, and but little changed for Hoffman. Analyses of the relative type yields are held to show the varieties most productive in 1914 retained their superiority in the unfavorable conditions of 1915. Cigar tests of the leaf produced by the different strains studied resulted in scores ranging from 79 to 80.25 for Slaughter, 73.25 to 74.25 for Hostetter, 72.25 to 74.5 for Espenshade, 74.6 to 75.25 for Cooper, and 68.25 to 70.25 for Hoffman. It was observed that in the same strain the types varied but little, save in fire-holding capacity, while the strains themselves differed considerably in aroma and flavor.

The Lancaster County fertilizer experiments comparing the use of manure alone and manure fortified with acid phosphate, sulphate of potash, and cotton seed meal in different combinations, resulted in average yields of 754 lbs. per acre for the untreated plat and 1,389 lbs. for manure alone. The maximum yield, 1,749 lbs. per acre, was secured from a treatment consisting of manure, cottonseed meal, dissolved bone, and sulphate of potash. Each addition to the manure produced a decided increase in yield, although the greater amounts of potash and nitrogen did not prove profitable. In general, all additions of manure dressing distinctly improved leaf quality.

In 1915 tests of adaptation of binder and wrapper types on the Clinton-Lycoming sandy soils, two strains of the wrapper type, Ohio Hybrid and Halliday Hybrid, were harvested by priming, producing 2,880 and 1,591 lbs. per acre, respectively. Harvested and cured on the stalks, Ohio Hybrid yielded 600

lbs. less. and Halliday 209 lbs. less. Of the 18 strains harvested on the stalk, Ohio Hybrid was first with a yield of 2,280 lbs. per acre and Slaughter second with 1,904 lbs. The gain in cured weight by primed crops is considered to be due to greater average maturity and the smaller decomposition and loss in the curing of the primed leaf and is usually small. When judged for quality by cigar-burning tests, Halliday Hybrid was first with 70.3, followed by Cuban with 68 and Connecticut Broadleaf with 66.3 points. The wrapper quality of these tobaccos grown in the field was far inferior to that of shade-grown Sumatra and Connecticut Havana leaf, on whose characters the scoring was based.

The continuation of spacing and topping experiments with two Broadleaf and two Havana strains was noted. The close-spaced plants were in rows 36 in. apart as contrasted with 42 in. as the normal. The high topping left about four more leaves on the plant than the low topping. The close-planted rows made average acre yields of 1,200 lbs. of cured stripped tobacco, including primed leaves, for the high topped, and 939 lbs. for low topped. In the normal-planted rows the high-topped plants produced 1,388 lbs. and the low topped 901 lbs. Although high topping and normal spacing resulted in the largest yields in every case, the effect of the difference in topping was much greater than that of the distance between rows.

Steam sterilization of the seed beds was omitted in 1915. The profuse weed development and the large insect infestation led the experimenter to conclude that annual sterilization is necessary.

Further study of tobacco burning quality.—The grain of the tobacco leaf, C. S. RIDGWAY (*Pennsylvania Sta. Rpt. 1916, pp. 481-485*).—"Grain" is defined as the small pimply projections found on the upper or outer surface of fully cured and sweated cigar tobacco of good quality. These grains are not visible on the green leaf, but first appear a few days after curing has begun and the leaves have turned from yellow to brown. They do not appear in fire-cured tobacco. Grains occur chiefly in the palisade cells of the upper epidermis in the web of the leaf and near the small veins, revealing themselves under the microscope as crystalline aggregates associated with a large portion of the leaf coloring matter.

The grains which can be mechanically separated from the cured leaf by the use of a rubber pestle, sieve, and other means are composed of a mixture of salts, chiefly of lime and magnesia, with organic acids, largely citric and malic.

Burn tests of Red Lion tobacco in 1914 showed good burning tobacco to score an average of 18 points for burn and 10.4 for grain. Poor burning tobacco gave an average burn score of 13 with 5 for grain. This data is considered as showing distinct relationship between grain development and burning quality. The author explains the good burning quality of leaf with well developed grain by assuming the substances retarding the burn to be gathered into the grain from surrounding tissue, which is left in condition to burn freely.

Speltlike bud-sports in common wheat, Å. ÅKERMAN (*Hereditas, 1 (1920), No. 1, pp. 116-127, figs. 6*).—This is a preliminary account of the behavior of a number of speltoid chimæras found in the trial wheat plats at Svalöf.

Speltoids are regarded as "loss-mutants" arising spontaneously both in old pedigrees and among cross descendants. They are generally heterozygotic, and are characterized by short outer glumes abruptly cut off at the top as in *Triticum spelta*, with longer straws, longer and more lax spikes, and a later maturity than the mother variety. The chimæras were plants in which part of a spike had the character of a speltoid heterozygote, while the other part had the normal type. Concerning the origin of chimæras, the author assumes "that the plants originally were of normal type, and that the speltoid component arose

through a mutation in a cell of the growing point so that one of the two factors (SS) necessary for normal development was changed or 'fell away,' resulting in a change in the genetical constitution."

Dockage under the Federal wheat grades, R. H. BROWN (*U. S. Dept. Agr., Farmers' Bul. 1118 (1920), pp. 26, figs. 10*).—Dockage is described, directions for distinguishing dockage and foreign material other than dockage are given, and the method of determining dockage is outlined in detail. Notes are given also on test weight determinations on dockage-free wheat, grading dockage-free samples, and on practical methods of handling dockage. The grade requirements of the official grain standards of the United States for wheat are given in abridged form.

Spraying lawns with iron sulphate to eradicate dandelions, M. T. MUNN (*New York State Sta. Bul. 466 (1919), pp. 21-59, pls. 6, figs. 2; abr. ed., pp. 8, fig. 1*).—After reviewing earlier and contemporary investigations along this line, the author reports a series of experiments from 1911 to 1919, including the effect of iron sulphate solution on the dandelion, other lawn weeds, grasses, and clovers; a comparison of spraying with other methods of eradication; the toxic action of iron sulphate; and the relation of weather conditions to the extent of injury to grasses and weeds. A bibliography is appended.

Seed from flowers castrated and bagged, castrated and not bagged, and untreated germinated 21, 56, and 71 per cent, respectively, indicating that parthenogenesis occurs in *T. officinale*. Germination tests of dandelion seeds collected from lawns showed that some of the seeds were matured sufficiently to germinate as soon as they began to leave the plant, the percentage of germination increasing directly in proportion to the degree of maturity.

The experiments demonstrate that dandelions may be eradicated from lawns, at relatively slight expense and without material injury to the grass, by proper spraying with an iron sulphate solution. From four to five applications are required, first, just before the blooming period, one or two others following at intervals of three or four weeks, and finally one or two in late summer or fall. With proper management and the application of grass seed and fertilizers in the spring and fall of each year, spraying is necessary only about every third year to keep a lawn practically free from dandelions.

The cutting-out method of fighting dandelions is held to be laborious and ineffective unless the greater part of the root is removed. Infrequent shallow cutting is worse than none at all, as each cut off root promptly sends up one or more new plants.

HORTICULTURE.

Breeding methods with horticultural plants, J. W. CROW (*Proc. Amer. Soc. Hort. Sci., 16 (1919), pp. 19-24*).—A contribution from the Ontario Agricultural College. The author presents a plant breeders' classification of important horticultural plants, with special reference to their method of reproduction, and discusses the principles of plant breeding as applied to the isolation of mutations and recombinations of characters by crossing.

The term "isolation" is preferred to "selection" as better expressing the fundamental idea of most improvement work. It is pointed out that "selection" as used by Darwin implied a gradual change of a cumulative nature in each succeeding generation. "Isolation," on the other hand, consists in the segregation of a type or line of heredity which was there all the time and which is only brought to light through being segregated, as in the simple plant progeny test.

Experiences in plant hybridization, H. NESS (*Proc. Amer. Soc. Hort. Sci., 16 (1919), pp. 52-60*).—A contribution from the Texas Experiment Station, giving a résumé of the author's investigations with the genera *Rubus* and *Quercus*.

Although certain hybrids have been secured between cultivated blackberries and dewberries through the F_2 generation, further progress has been unsuccessful either from complete or partial sterility or because the hybrids showed confused characters and no promise of improvement for economic purposes. By hybridizing seedlings of the Louisiana dewberry (*Rubus rubisetus*) with the Brilliant and Loudon red raspberries as male parents, almost complete sterility in F_1 was overcome to some extent in F_2 by the occurrence among the raspberry dominants of 5 plants setting perfect fruits and promising a good crop on each plant. The F_1 mother plants were not screened from foreign pollen, hence their true origin is in doubt, but in general appearance the F_2 descendants vary no more from each other or from their F_2 mother plants than the expected variation in the descendants of a true species. Four plants of F_2 finally selected as elites produced fruit from the middle of May to the middle of August. The fruit differs from both the blackberry and the raspberry in the mode of disjoining from the pedicel. Disjointing takes place at the base of the calyx, which is attached to the fruit, there being no definite node. No positive variation in this character has given opportunity for selection.

The most important fact developed by this work is that the fertility appearing in these few raspberry dominant plants in F_2 has become hereditary and has made it possible to extend the hybridization work. Both the F_2 and F_3 generations have been crossed with foreign pollen with excellent results.

The author has grown F_2 hybrids of *Quercus lyrata* × *virginiana* (E. S. R., 40, p. 47), has secured F_1 seedlings of *Q. bicolor* × *virginiana*, and has thus far succeeded in germinating acorns from post oak × live oak, and water oak × live oak crosses. An important fact brought out in this work is that the various individuals of a species vary widely in their affinity for foreign pollen. Individuals selected for desirable characters may prove sterile, whereas individuals that would ordinarily be discarded may show good affinity for foreign pollen.

Results of bud selection investigations at the Missouri and Oregon Experiment Stations, and their interpretation, V. R. GARDNER (*Proc. Amer. Soc. Hort. Sci.*, 16 (1919), pp. 66-70).—Continuous bud selection of high and low yielding strains of the Ben Davis apple and of strawberries at the Missouri Experiment Station has confirmed previous results as to the failure to transmit high yield through bud selection (E. S. R., 33, p. 236).

Most of the bud selection work with strawberries at the Oregon Experiment Station has given similar results. In one case, however, light and heavy runner productiveness was transmitted. In another case, although the offspring of the high-yielding plant did not attain the high yield of the parent, they did maintain a normal average yield for the variety, whereas the yield from the offspring of the low-yielding parent averaged less than half of the normal yield for the entire stock of plants of this variety. This indicates that bud selection may prove of value in eliminating infertile or semibarren strains.

Observations made on some of the station seedlings indicate that certain promising variations may run out or degenerate quickly through bud or runner propagation, whereas other varieties under the same conditions show no tendency to undergo such changes.

Important lessons from [vegetable] experiments completed or in progress, M. G. KAINS (*Pennsylvania Sta. Rpt. 1916, p. 63*).—Brief statements of facts brought out in the vegetable studies at the station are presented.

The variety tests of cabbage and vegetables have shown that many so-called varieties are synonymous, and are in many instances old varieties renamed. A study of the root development of cabbage seedlings has shown that a large amount of sand is desirable in the seed bed, as it promotes the development

of the root system and retards the overdevelopment of the tops. In the breeding work with late cabbage, several strains of the Danish Ballhead variety have been developed which are superior in uniformity and yield to commercial strains.

In a breeding experiment with tomatoes where Yellow Pear was crossed on Enormous the pure types have been isolated, together with other combinations that appear to breed true. It has also been observed that the habit of the plant as regards branching behaves as a unit character. A study of eight varieties of rhubarb showed that the varieties are not uniform, either in character of plant or acidity. The results of work with asparagus are noted below.

Experiments with asparagus, C. E. MYERS (*Pennsylvania Sta. Rpt. 1916*, pp. 557-578, figs. 2).—The detailed results are given of a test of six commercial varieties of asparagus conducted during the period 1908-1915, inclusive, together with the results of a test of the value of subsoiling and preliminary heavy manuring at the time the crowns are set in the field.

During the course of the experiment very little difference was found between the six varieties as far as varietal characters are concerned. It was impossible to identify one variety from another because of the constancy of any well-defined characters. In all instances, 1-year-old crowns proved to be superior to 2-year-old crowns. The experiment has shown the importance of grading the crowns at the time of planting and of eliminating the undersized crowns. During a 5-year period of cutting, there was an average difference of approximately \$125 per acre between size one and size three crowns.

The results obtained in the fertilizer test indicate that it does not pay to apply either yard manure or commercial fertilizers in large amounts in the trench when planting asparagus.

A fertilizer experiment with asparagus, W. P. BROOKS and F. W. MORSE (*Massachusetts Sta. Bul. 194 (1919)*, pp. 227-257, pl. 1, figs. 3).—Continuing previous reports (E. S. R., 36, p. 839), a detailed account is given of a fertilizer experiment with asparagus that was conducted for a period of nine years in Concord, Mass., on coarse sandy loam which was typical of the soils used for asparagus culture. Seven crops of young stalks were produced during the experiment, and the yield steadily increased each year until the sixth, which was the crop of maximum size on nearly every plat. Following the second crop an attack of rust from an adjacent field swept over about half of the plats. The plats nearest the source of the attack were reduced in yield the next season nearly 20 per cent, and were permanently injured. The remainder of the plats apparently recovered before the maximum yield of the sixth crop.

As summarized by the junior author, of the chemical fertilizers used a mixture of 466 lbs. nitrate of soda, 300 lbs. of acid phosphate, and 260 lbs. muriate of potash per acre produced the best yields. Manure at the rate of 10 tons per acre produced nearly as good results as the chemicals, while combinations of manure with chemicals and with nitrate of soda were no better than manure or chemicals used separately. When nitrate of soda was added to manure it was most efficient when applied in two portions, one in the spring and one in the summer. Nitrate of soda applied with acid phosphate and muriate of potash was slightly more effective when applied in summer in four years out of seven. Muriate of potash proved to be the most satisfactory potash compound used. There was no apparent cumulative effect produced by the annual use of manure, and the asparagus tops harrowed into the soil each year seemed to supply sufficient organic matter for the efficient use of chemicals.

Among the conclusions submitted by the senior author, the variety of asparagus and the location of the bed with reference to badly infected beds influenced susceptibility to rust and probability of bad attacks to a greater extent than

variations in manurial or fertilizer treatments. A number of the varieties produced by Norton in the cooperative breeding experiments conducted in Concord appear to have to an exceptional degree the character of relative immunity from rust (E. S. R., 40, p. 538). The season of application of nitrate of soda appears to influence the susceptibility of asparagus to rust, which is reduced by the application of at least a portion of the nitrate of soda at the close of the cutting season. The character of the season, especially the amount and distribution of rainfall, appears to affect the probability of a serious attack of rust to a considerable degree, such attacks being more common in dry seasons than in those characterized by normal or abundant and well-distributed rainfall.

In commercial asparagus growing as usually carried on in Massachusetts, it is a common practice to apply what appear to be excessive quantities of fertilizers. Applications of 460 lbs. of nitrate of soda, 300 lbs. of acid phosphate, and 260 lbs. of muriate of potash per acre appear to be as large quantities of these elements as could be utilized by the crop. Nitrate of soda at the rate of about 400 lbs. per acre in connection with manure at the rate of 10 tons per acre increased the crop, and appears to be the maximum amount which proved beneficial. The application of either acid phosphate or muriate of potash with manure at the rate of 10 tons per acre appears not to have increased the crop. Generally speaking, chemical fertilizers upon this sandy soil give as good results as manure. The season of application of nitrate of soda does not appear to affect the relative yield of commercial asparagus in successive 10-day periods throughout the season. In other words, the cut of commercial asparagus during the early part of the season is not increased by either small or large applications of nitrate made as early as the soil can be worked. The lack of benefit from humus furnished by the manure is explained in part by the practice of working the tops grown subsequent to the cutting season into the soil and in part to the yearly replacement and decay of a portion of the asparagus roots, thus adding to the organic matter of the soil.

[Report on pomological investigations], J. P. STEWART and W. C. GILLESPIE (*Pennsylvania Sta. Rpt. 1916, pp. 52-56*).—A progress report on projects under way in 1916.

Experiments on the fertilization of apple orchards have been summed up for a 10-year period in a subsequent bulletin of the station (E. S. R., 39, p. 445). Summing up to date the results on cultural methods and cover crops in apple orchards (E. S. R., 35, p. 644), it is concluded that in the absence of fertilization, the mulch method gives the largest growth and most fruit in young orchards, while the tillage and cover-crop method has done slightly better in mature orchards. In the presence of fertilization, there was usually comparatively little difference between tillage, tillage and cover crops, and sod mulch. Even sod, plus proper fertilization, has not been far behind. The greater efficiency of the mulch on the younger trees appears to be connected with its greater moisture-conserving effects.

Among the annual cover crops, hairy vetch, soy beans, millet, medium red clover, and the combination of oats and Canada peas have shown the best results. The addition of cover crops, however, appears to be of little value, excepting possibly in seasons of abundant rainfall. The use of tilled intercrops, with appropriate fertilization and with a subsequent winter cover of rye, or rye and vetch, has proved very satisfactory in the development of young orchards, and has resulted in no apparent injury during the first eight years. Potatoes have done specially well in this connection.

Nearly all of the experiments show a marked correlation between yield and growth under all normal conditions. It is only when one of these characters

develops to an abnormal extent that it results in any appreciable interference with the other; hence, it is pointed out that the fruit on young trees need not be removed, but should merely be thinned to the proper amount for the trees to carry. There was also a marked correlation between cultural methods and the color and size of the resulting fruits. The sod fruit was regularly highest in color, and the mulched fruit generally averaged largest. In general, however, the chief influences affecting color are sunlight and maturity, and the principal one affecting size is the amount of moisture available to each fruit.

Experiments on the influence of selection, stock, and heredity in apples have thus far shown marked individuality in tree yield. The possibility of perpetuating the differences observed through scion selection is now being studied.

Certain of the fertilizer experiments with peaches have shown very marked effects, with nitrogen apparently most important, phosphorus next, and potash last. A combination of all three materials has given the best results.

The project in spray materials and spraying was largely completed. Generally speaking, the recommendations for the use of lime-sulphur spray conform to those in Bulletin 115 of the station (E. S. R., 27, p. 242), except that about one-third more water is recommended, making the formula 45 lbs. of lime and 90 lbs. of sulphur to 60 gal. of final product. This change materially reduces the coarse sediment. Recent studies in spray injury on peaches indicate the importance of avoiding, during the growing season, any material containing sodium, potash, or similar materials in combination with any kind of arsenical. The new barium-sulphur compound is rather similar in its action to the soda or potash compounds, although to a reduced extent. It is deemed unsafe for summer use on peaches in combination with any of the present arsenicals.

Concerning the shedding of flowers and fruits and other abscission phenomena in apples and pears. A. J. HEINICKE (*Proc. Amer. Soc. Hort. Sci.*, 16 (1919), pp. 76-83).—A contribution from Cornell University, presenting some of the results of observations and experiments conducted in connection with a study of factors influencing the set of fruits. The author describes the separation zone in apples and pears, some characteristics of fruit doomed to fall, conditions or treatments that induce or hasten abscission, and conditions or treatments that delay or prevent abscission.

It is concluded that although investigations thus far conducted along this line do not afford an entirely satisfactory explanation of the behavior of the cells in the abscission zone, undoubtedly the causes that stimulate or excite the peculiar changes in this region are associated with variations in nutrition and water supply. Effective fertilization is only one of several possible means of causing a set of fruit. Self-fruitfulness may be associated with the fact that the cells at the base of the pedicels of the flowers on self-fertile varieties are not so easily stimulated into abscission activity as similar cells of self-barren trees.

Some characteristics of open-pollinated seedlings of the Malinda apple. M. J. DORSEY (*Proc. Amer. Soc. Hort. Sci.*, 16 (1919), pp. 36-42).—A contribution from the Minnesota Agricultural Experiment Station. Observations were made on seedlings of Malinda open pollinated in an orchard of desirable varieties.

Briefly summarized, the author found that the inferior types can be detected and discarded before fruiting by the appearance of leaf, thorns, and branches. The time of coming into fruiting varied greatly. Some fruited at the third and fourth year, and about one-fifth had not fruited at the twelfth year. Less

than 8 per cent of the seedlings had superior fruit. Long keeping selections of promise do not exceed a dozen. Some of the superior quality seedlings are hardier than the standard varieties commonly grown in Minnesota.

The occurrence of so many wild and inferior types as the result of open pollination with superior varieties suggests that genetically the best varieties of *Pyrus malus* are heterozygous for a large number of characters, and that a comparable number of wild and inferior types will be found even in controlled crosses with the same varieties.

Scion root production by apple trees in the nursery, J. G. MOORE (*Proc. Amer. Soc. Hort. Sci.*, 16 (1919), pp. 84-88).—A contribution from the University of Wisconsin, reporting observations made of the behavior of grafts of various varieties commonly grown in Wisconsin as regards scion root production. The trees observed have been largely three year old nursery trees dug during the years 1914-1918, inclusive.

There were wide differences between the ability of different varieties to produce scion roots. Generally speaking, varieties showing a relatively large number of trees producing scion roots also show a relatively large number of trees with "strong scion roots;" but with most varieties, even after three years in the nursery, the number of trees having sufficient scion roots to support the tree is very small.

In addition to the varietal difference, the factors favoring scion root production are an abundance of soil moisture, deep planting of the scions, and probably the character of the union. Observations made indicate that when poor scion unions occur, scion root production is encouraged.

Progress in apple breeding for the Canadian prairies, W. T. MACOUN and M. B. DAVIS (*Proc. Amer. Soc. Hort. Sci.*, 16 (1919), pp. 13-18).—A contribution from the Central Experimental Farm, Ottawa, briefly reporting the present status of the breeding work started by Saunders in 1894 (E. S. R., 25, p. 643).

Crosses between the hardy Siberian crab apple (*Pyrus baccata*) and several commercial varieties used as male parents have resulted in only two small sized varieties of fair quality, the Columbia and Osman, both having Russian varieties as male parents that have proved to be sufficiently hardy for the most exposed and trying places in the prairies. It is suggested that these varieties may yet play an important part in the development of hardy apples for the prairies.

In 1904 crosses were made on the most promising F_1 seedlings, using 18 varieties of apples, with the view of retaining the character of hardness and improving the size of the apples. Several of these second crosses have fruited at the experimental station at Morden, Manitoba. It is hoped that some of them will be considerably hardier than the Russian apples and will extend the area over which apples can be grown. McIntosh has proved to be a valuable parent in imparting quality and color to F_1 crosses and has also exerted some influence in increasing size.

The results in general indicate that if a high-class progeny is desired at least one of the parents should possess the desired character developed to the highest possible degree of perfection. It is concluded that there must be more blood of the *P. baccata* put into even the hardest Russian apples to obtain varieties that will withstand the severe tests on the Canadian prairies. Work is to be continued, using *P. baccata* as the male parent rather than the female, with the view of procuring at least a few hardy varieties of marketable size among the F_1 seedlings.

Some notes on the inheritance of unit characters in the peach, C. H. CONNORS (*Proc. Amer. Soc. Hort. Sci.*, 16 (1919), pp. 24-36).—A contribution from the New Jersey Experiment Stations, discussing character inheritance in the

first crop of fruit from the F_1 seedlings of crosses among commercial varieties of peaches. The data are presented at this stage primarily for the benefit of other workers along the same line rather than to formulate definite conclusions. The general results are summarized as follows:

"Elberta carries white flesh as a recessive character to the extent of about one-third. It seems prepotent with respect to ripening period. Its character for quality is only mediocre. Belle is strongly white, but seems to carry a 25 per cent character for yellow. It is prepotent with respect to vigor and quality and carries a factor for clinginess of about 25 per cent. Early Crawford is almost pure yellow. Its character for quality seems dominant, as does its character for freestone. Greensboro seems to be pure white, is clingstone, but carries a small factor for freestone. White on yellow gives increased vigor. White seems to be dominant over pure yellow in the F_1 generation."

In addition to the correlation of green calyx cup with white fleshed fruit and of orange calyx cup with yellow fleshed fruit, as noted by Hedrick (E. S. R., 29, p. 424), the author observed an intermediate type in which the calyx cup is yellowish buff and the fruit white fleshed, but the variety carries a character for yellow flesh, as was the case with Belle. A correlation was also observed between the dark green leaves and white fleshed fruit and between normally yellowish leaves and yellow fleshed fruit. In this connection, however, the leaf veins should also be examined. When the midrib and veins of the leaves have a yellowish cast the fruit is yellow, and when the midribs and veins are a pale green or whitish the fruit will be white.

Inter species pollination of plums, A. H. HENDRICKSON (*Proc. Amer. Soc. Hort. Sci.*, 16 (1919), pp. 50-52).—A contribution from the University of California. The data given deal with the interpollination of two varieties of *Prunus domestica* (Reine Claude and German Prune), and one variety each of *P. triflora* (Burbank) and *P. insititia* (Shropshire). The observations were conducted in the orchard at Cornell University during the spring of 1919.

As far as the varieties tested were concerned, there was no evidence of sterility existing between *P. triflora* and *P. domestica* or between *P. domestica* and *P. insititia*. Burbank and German Prune gave evidence of being self-sterile; Reine Claude and Shropshire were evidently self-fertile; Burbank and Reine Claude were interfertile; and likewise Reine Claude, German Prune, and Shropshire were interfertile.

Report of three years' results in plum pollination in Oregon, R. E. MARSHALL (*Proc. Amer. Soc. Hort. Sci.*, 16 (1919), pp. 42-49, pls. 2).—A contribution from the Oregon Agricultural College. Tabular data are given and discussed, showing the results of self-pollination of plums, cross-pollination with varieties of *Prunus domestica*, and interspecies pollination.

Among the results noted, pollen of the varieties of *P. domestica* and of *P. triflora* appeared to germinate best in a solution of 5 per cent of cane sugar and 2 per cent gelatin. With a normal bloom, generally speaking, one flower in 5 should set to produce a full crop, although in some cases, one flower in 20 is sufficient. Thirteen out of 23 varieties tested were evidently self-sterile, but the varieties of *P. domestica* may be considered interfruitful. Blue Damson was decidedly self-fruitful, and Italian and Petite partially so. These two varieties are good pollenizers for practically all varieties of *P. domestica* tested. The important point, however, is to interplant varieties that bloom at the same time.

Some varieties are actually commercially profitable where no pollenizers are used. In such varieties as Bavay, Blue Damson, Giant, Green Gage, Pond, Quackenboss, Red Magnum Bonum, Tennant, and Tragedy the fruit may mature regardless of complete seed development. There appeared to be no

direct relation between the variety of pollen used and the ratio which exists between plump or well-developed seeds and mature fruit. This ratio is fairly constant for the variety regardless of the kind of pollen applied.

There was evidently no relation existing between the degree of fruitfulness of reciprocal crosses. The same results in crossing were secured whether the varieties of a given species were closely related or nonrelated. The species of *P. domestica* and *P. triflora* may be considered intersterile for all practical purposes.

Bud selection investigation with citrus fruits, A. D. SHAMEL (*Proc. Amer. Soc. Hort. Sci.*, 16 (1919), pp. 70-76).—A contribution from the Bureau of Plant Industry of the U. S. Department of Agriculture, comprising a general summary of the author's work with citrus fruits. See also a previous note (*E. S. R.*, 43, p. 439).

FORESTRY.

A handbook of forestry, A. D. WEBSTER (*London: William Rider & Sons, Ltd.*, pp. VIII+216, figs. 6).—A small handbook of concise notes, rules, and tables, relative to trees and their timber.

The forest manual, 1919 (*Augusta: Maine Forestry Dept.*, 1919, pp. 93).—This manual presents information relative to the organization of the Maine Forestry Department, instructions to fire wardens, the forest-fire laws applicable to the Maine Forestry District, and the forest laws applicable to the State at large.

Report of the director of forestry for the fiscal year ended March 31, 1919, R. H. CAMPBELL ET AL. (*Dept. Int. Canada, Rpt. Dir. Forestry, 1919*, pp. 52, figs. 14).—The report includes a review of the several lines of work conducted by the forestry branch of the Canadian Department of the Interior, and detailed reports of the work of the tree-planting division and on the forest reserves in Manitoba, Saskatchewan, Alberta, and British Columbia, together with the report of the forest-products laboratories of Canada.

Report on forest administration for the year 1918, E. CUBITT (*Fed. Malay States, Forest Admin. Rpt. 1918*, pp. 43).—The routine report on the administration and management of the State forests, including tabular data on forest areas, forest surveys, work of reproduction and improvement, yields of major and minor forest products, revenues, expenditures, etc. A list of the trees mentioned in the report is also appended, showing the vernacular or English name, the botanical name, and the uses of each tree.

Department of forestry: State forestry. Report for the year ended 31st March, 1919, E. P. TURNER ET AL. (*New Zeal. Dept. Lands and Survey, Ann. Rpt. Forestry Branch, 1918*, pp. 43).—A report on the administration and management of the indigenous forests, State nurseries, and plantations, including also reports upon afforestation operations in the North and South Islands and extracts from reports by conservators of State forests, together with data on revenues and expenditures, imports and exports of timber, yield in sawed timber, the present forest areas, etc.

The next steps in the forestry program, F. L. MOORE ET AL. ([*New York*]: *Rpt. Com. Forest Conserv., Amer. Paper and Pulp Assoc.*, 1920, pp. 8).—This comprises a report of the committee on forest conservation of the American Paper and Pulp Association at the annual meeting, April 15, 1920.

The forestry situation in Illinois, R. S. MILLER (*Trans. Ill. Hort. Soc.*, n. ser., 53 (1919), pp. 68-75).—The author briefly summarizes the activities of the State Forester since the creation of this office on July 1, 1919, outlines a tentative forestry program, and briefly summarizes the present forestry situation in Illinois.

Why Massachusetts should have State forests (*Mass. Forestry Assoc. Bul.* 125 (1919), pp. 23, figs. 18).—This bulletin, issued by the Massachusetts Forestry Association, presents some of the chief arguments for the reclamation of wild and idle land by the Commonwealth as publicly owned forests.

Forests as a farm crop, E. T. MEREDITH (*Amer. Forestry*, 26 (1920), No. 318, pp. 337, 338, 342).—A popular discussion of the economic importance of farm woodlands and a plea for their more rational management.

Roadside trees, H. R. FRANCIS (*N. Y. State Col. Forestry, Syracuse Univ., Circ.* 17 (1919), pp. 16, figs. 13).—This circular discusses existing roadside tree conditions in New York State, points out the values to be derived from roadside trees, and presents recommendations relative to their future management.

The self-contained forest estate in the Himalayas, J. W. A. GRIEVE (*Indian Forester*, 46 (1920), No. 6, pp. 273-279).—In the present article, the author presents suggestions based on experience gained in other Provinces relative to the development of a practical working scheme for the more economic use of the land in the Himalayas.

How fires destroy our forests, J. V. HOFMANN (*Amer. Forestry*, 26 (1920), No. 318, pp. 329-336, figs. 17).—A popular description of different types of forest fires and the nature of the injuries resulting from them.

The use of aircraft in forestry, E. WILSON (*Amer. Forestry*, 26 (1920), No. 318, p. 326-328, figs. 3).—A popular account of the utilization of aircraft in Canada in the work of forest fire protection and in making photographic maps of the forests.

The land of beautiful water (*U. S. Dept. Agr., Dept. Circ.* 91 (1920), pp. 14, pl. 1, figs. 7).—An account of the recreational features of the Chelan National Forest in the north central part of the State of Washington.

The forest flora of New South Wales, J. H. MAIDEN (*Sydney, N. S. Wales: Govt.*, vol. 7 (1917), pt. 1, pp. 1-37, pls. 7; 1918, pt. 2, pp. 39-75, pls. 19; 1920, pt. 3, pp. 77-121, pls. 10).—This comprises the first three parts of the seventh of a series of volumes on the forest flora of New South Wales (E. S. R., 39, p. 145). In the present parts 14 species are described, each species being considered with reference to its botanical characteristics, common and scientific nomenclature, size, habitat, economic products, and propagation.

In part 1 are appended some notes on seeds and fruits of more or less interest to the forester. Part 2 includes notes on adventitious roots, such as stilt-roots, lenticels, pneumatophores, and swamp plants. In part 3 is appended information relative to mannas and sugary substances on plants other than Eucalyptus, botanical, zoological, and chemical notes on Eucalyptus manna, and watery liquids from Eucalyptus trees.

A critical revision of the genus Eucalyptus, J. H. MAIDEN (*Sydney, N. S. Wales: Govt.*, vol. 4 (1917-1920), pts. 1-10, pp. 1-343, pls. 40).—In conformity with the previous volumes of this revision (E. S. R., 39, p. 146), the present volumes contain detailed descriptions of some 64 species of Eucalyptus, including supplementary notes.

Natural reproduction of sal in Singhbhum, F. K. MAKINS (*Indian Forester*, 46 (1920), No. 6, pp. 292-296, pls. 3).—This comprises notes on the reproduction of sal (*Shorea robusta*) in the Porahat Division of the Singhbhum forests. The notes are presented as a guide to further investigations.

Length of time taken by sal seedlings to establish themselves, W. A. BAILEY (*Indian Forester*, 46 (1920), No. 6, pp. 307-309).—Observations made on the growth of sal seedlings indicate that the seedlings establish themselves much quicker and more satisfactorily under regular cleanings and when protected by fencing.

History of Spruce Production Division: United States Army and United States Spruce Production Corporation (Portland, Oreg.: U. S. Army and U. S. Spruce Prod. Corporation [1918], pp. IX+127, pls. 32, figs. 11).—A historical account of the activities of the Spruce Production Division in the exploitation of spruce forests and the preparation of aircraft lumber for the United States and the Allies during the world war.

DISEASES OF PLANTS.

Sexual fusions and development of the sexual organs in the Peridermiums, J. F. ADAMS (*Pennsylvania Sta. Bul.* 160 (1919), pp. 31-77, figs. 13).—Results are given of a study on the sexual cell fusions and development of the æcidium in five species of Peridermiums, *Peridermium comptoniæ*, *P. pyriforme*, *P. aciculum*, *P. peckii*, and *P. balsameum*.

Infection studies with graft hybrids, H. KLEBAHN (*Flora [Jena], n. ser.*, 11-12 (1918), pp. 418-430, figs. 9).—This work includes experimentation with a number of graft hybrids as to the behavior of the constituents as such (whether outer or inner) towards infection. Notes are given of tests involving the fungi *Septoria lycopersici* and *Cladosporium fulvum*, and the chimeras *Solanum tubigenae*, *S. koelreuterianum*, *S. proteus*, and *S. gaertnerianum*, besides other plants.

A general conclusion reached is that the chimeras are not protected against infection when the susceptible member is covered only with the epidermis of the nonsusceptible component.

Copper sprays, L. RAVAZ (*Prog. Agr. et Vit. (Ed. l'Est-Centre)*, 40 (1919), Nos. 16, pp. 361-370; 18, pp. 409-416, figs. 5).—The first section of this contribution deals with Burgundy, the second with Bordeaux mixture, the preparation, properties, employment, and values of these fungicides being systematically discussed.

Lime-sulphur sprays, VERMOREL and DANTONY (*Prog. Agr. et Vit. (Ed. l'Est-Centre)*, 40 (1919), Nos. 15, pp. 343-345; 17, pp. 393-398; 18, pp. 420-424; 20, pp. 469-473).—This series deals with matters related to the chemical composition of lime sulphur; the action of sulphur on lime in the mixture and the compounds formed as determined by temperature, time, proportion, dilution, and the presence of magnesia; analyses to determine the different constituents and their proportions and changes therein; the action of oxygen; and the mode of operation of the lime-sulphur mixture. The results of tests are tabulated with discussion.

Notes on New York plant diseases, II, F. C. STEWART (*New York State Sta. Bul.* 463, pop. ed., (1919), pp. 9, pls. 2, fig. 1).—This is a popular edition of the bulletin previously noted (E. S. R., 42, p. 349).

Diseases of economic plants in Porto Rico, J. A. STEVENSON (*Rev. Agr. Puerto Rico*, 2 (1918), No. 1, pp. 19-27; 2 (1919), No. 2, pp. 23-33).—This is a list, partly descriptive, of the fungus and other diseases attacking economic plants in Porto Rico.

Diseases of cotton, quince, and apple (*Bol. Agr. [Sao Paulo]*, 20. ser., No. 4 (1919), pp. 90, 91).—Quince is attacked by *Glæosporium cydoniæ* and *Cercospora tomenticola*, and apple by *G. fructigenum*, causing injuries which are described. These diseases may be controlled by Bordeaux mixture at a strength of 1 per cent for both copper and lime constituents. Cotton is attacked as to its leaves by *Cercospora* sp. and *Ramularia aërea*.

New [plant] diseases, T. A. C. SCHOEVEERS (*Tijdschr. Plantenziekten*, 25 (1919), Nos. 2, pp. 95-98; 3, pp. 126-128).—Brief discussion is given of diseases, supposedly new, of spinach, tomato, aster, wallflower, petunia, and *Gilia tricolor*.

Production of conidia in *Gibberella saubinetii*, J. G. DICKSON and H. JOHANN (*Jour. Agr. Research [U. S.]*, 19 (1920), No. 5, pp. 235-237, fig. 1).—Results are given of a cooperative investigation of the Wisconsin Experiment Station and the Bureau of Plant Industry, U. S. Department of Agriculture, on the development of the scab fungus (*G. saubinetii*) which attacks wheat, corn, rye, barley, and oats.

It was found that repeated crops of conidia of *G. saubinetii* can be produced in abundance in short periods of time from ascospores, sporodochial conidia, vegetative conidia, or mycelium when favorable moisture and temperature conditions obtain. This ability of the wheat scab organism to produce virulent spores in abundance in short periods of time is considered to have an important bearing upon the development of wheat scab epidemics.

Philippine downy mildew of maize, W. H. WESTON, JR. (*Jour. Agr. Research [U. S.]*, 19 (1920), No. 3, pp. 97-122, pls. 12, figs. 3).—The author has investigated for the Bureau of Plant Industry, U. S. Department of Agriculture, the downy mildew of maize, which has been known to occur in the Philippine Islands for a number of years. The present paper gives results of his study on the distribution, severity, and characteristics of the disease, and the nature and relationships of the causal fungus.

The disease is said to be extremely destructive, and representative varieties of all kinds of maize were found highly susceptible. Teosinte and maize-teosinte hybrids and sorghums were attacked, but with less virulence. The symptoms of the disease may appear from the time plants are seedlings with only three or four leaves to the time when the tassels and silk are fully developed. In general, infected plants showed a yellowing of the leaves in more or less restricted striped areas, a whitish down due to the abundance of conidiophores, principally on the leaves, abnormal growth of vegetative parts, and abortive development of the ears, resulting in partial or complete sterility.

The causal fungus is said to be *Sclerospora philippinensis*, which is described as a new species, and its relationship with other species known to attack maize is pointed out. The fungus produces conidiophores in great abundance, but only at night when a thin layer of dew or rain is on the leaf surface. No oospores or other resting bodies have yet been found to be produced by this species. The author reports having found the oospore stage of a *Sclerospora* on *Saccharum spontaneum*, a common wild grass in the Philippines, but whether this is connected with the conidial stage on maize is yet to be determined.

Halo blight of oats, C. ELLIOTT (*Jour. Agr. Research [U. S.]*, 19 (1920), No. 4, pp. 139-172, pls. 11, fig. 1).—A description and discussion of a bacterial disease of oats which has been the subject of investigation by the author are given in a contribution from the Bureau of Plant Industry, U. S. Department of Agriculture.

This disease was unusually severe in its attack on oats in Wisconsin during 1918, and reports of a similar disease were received from southern Minnesota, Iowa, northern Illinois, and Indiana. The disease is characterized by halo-like margins of chlorotic tissue about a center of dead tissue. Isolations made from these lesions have constantly given a typical white organism, which has been studied and the disease produced by artificial infections. The organism is believed to live over the winter on the seed, producing primary lesions on the first leaves of seedlings, and from these the organism is carried to other leaves by winds and rain. In natural infections, halo blight has been observed only on oats and rye, but artificial inoculations showed that the organism may be slightly pathogenic on wheat, rye, and barley. The halo blight is considered due to *Bacterium coronafaciens* n. sp., a technical description of which is given.

Rust in seed wheat and its relation to seedling infection, C. W. HUNGERFORD (*Jour. Agr. Research [U. S.]*, 19 (1920), No. 6, pp. 257-278, pls. 11, fig. 1).—The author reports in a contribution from the Bureau of Plant Industry, U. S. Department of Agriculture, the occurrence of uredinia and telia of *Puccinia graminis tritici* embedded in the pericarp on the hilar end of wheat kernels and sometimes along the ventral groove as far up as the middle of the kernel. Only a small percentage of infection was found by examination of hundreds of samples of wheat from the crops of 1915 and 1916. Infection is believed to spread to the kernel from original infection occurring on the rachis, rachilla, or glumes. The germinating power of the seed was not impaired by the rust infection. When rusted kernels of wheat were sown in the field, the rust infection that occurred on the resulting plants was no earlier or more severe than that occurring on plants grown in adjacent plots sown with clean seed or rust-infected seed treated with the modified hot water treatment.

A study was made in the pathological greenhouse at the University of Wisconsin of more than 2,500 plants grown from rusted seed and no infection appeared at any time. No spread of infection from the pericarp to the young plant was found, although the infected seed were germinated under various conditions, simulating as nearly as possible natural conditions in the field. The author claims that the results of his experimental work indicate that stem rust is not transmitted from one wheat crop to the next by means of infected seed grain.

Barberry eradication, A. N. HUME and H. C. GILBERT (*S. Dak. Agr. Col. Ext. Circ. 33* (1920), pp. 24, figs. 12).—This circular is a report on the work of barberry eradication during the two years in which it has been carried on, with notes on the black stem rust, the statements and figures given being for South Dakota unless otherwise stated. The work is cooperative between the U. S. Department of Agriculture, Office of Cereal Investigations, and the South Dakota College. An account is given of grain rusts in South Dakota, particularly black stem rust (*Puccinia graminis tritici*), which overwinters in the black spore stage and infects the barberry.

The work done against barberry is outlined or tabulated with discussion. It is thought that four years or more will be required to complete the eradication of black stem wheat rust from South Dakota.

The barberry and its relation to the stem rust of wheat in Indiana, F. J. PIPAL (*Proc. Ind. Acad. Sci.*, 1918, pp. 63-70, figs. 2).—An account is given of the relation of wheat rust incidence to barberry in Indiana.

Gleosporium lindemuthianum in the Princess bean, A. M. SPRENGER (*Tijdschr. Plantenziekten*, 24 (1918), No. 6, Bijbl., p. 20).—Brief discussion is given of Bordeaux mixture and formaldehyde as a defense against *G. lindemuthianum* attacking Princess bean. This bean is apparently identical with a variety of *Phaseolus vulgaris* mentioned in connection with the same disease and fungicides by Schenk (*E. S. R.*, 39, p. 249.)

Crucifer diseases, J. R. BOS (*Tijdschr. Plantenziekten*, 24 (1918), No. 6, Bijbl., pp. 26-35, figs. 3).—Discussion is given of finger-and-toe of crucifers, which is believed by the author to be carried in the soil and not on the seed.

The effects of potato leaf roll, C. S. WENNINK (*Tijdschr. Plantenziekten*, 24 (1918), No. 6, Bijbl., pp. 1-4, figs. 5).—This shows the deterioration of tuber output by potatoes affected with leaf roll.

Transmission of the mosaic disease of Irish potatoes, E. S. SCHULTZ and D. FOLSOM (*Jour. Agr. Research [U. S.]*, 19 (1920), No. 7, pp. 315-338, pls. 8).—In continuation of a previous report (*E. S. R.*, 42, p. 47), the authors give further data regarding experiments carried on cooperatively between the Bureau of Plant Industry, U. S. Department of Agriculture and the Maine Experiment

Station on the mosaic disease of Irish potatoes. Transmission of the potato mosaic was found to take place by means of tubers, grafting, the transfer of plant juice, and aphids under various conditions. Infection was also obtained with intervarietal transfer of juice. Transmission was attempted, but without success so far as could be ascertained in the same season, by means of flea beetles, Colorado potato beetles, the seed-cutting knife, and contact of seed pieces, of roots, and of vines.

Preliminary observations are believed to indicate that infection does not result from growth in soil that produced mosaic plants the previous season. It seems impossible either for infected plants to recover, or if diseased stock is not far away and insect carriers exist, to assure the maintenance of health of susceptible varieties by roguing plats or by selection of hills, tubers, or seed pieces. Isolation of plants by means of insect cages, as well as growing potatoes in greenhouses in which insects were excluded, maintained stocks free of disease. This is believed to indicate that the control of aphids and possibly some other kinds of insects is the most important means of checking the spread of potato mosaic among susceptible varieties.

The source of the primary field outbreak of potato late blight, J. ERIKSSON (*Arkiv. Bot.*, 14 (1916), No. 4, Art. 20, pp. 1-72, pls. 6, figs. 5).—The author here deals with the development of potato late blight (*Phytophthora infestans*) in considerable detail, somewhat as in a report previously noted (E. S. R., 39, p. 650).

Wilt diseases [of potato], H. A. A. VAN DER LEK (*Tijdschr. Plantenziekten*, 24 (1918), No. 6, pp. 205-219, pl. 1; 25 (1919), No. 1, pp. 17-52, pls. 2).—This is a review of wilt diseases of potato with particular reference to that caused by *Verticillium alboatrum*, which is discussed in connection with lists of its hosts in Europe and America, its effects on potato, its distribution, and its control.

Treatment of seed potatoes, D. C. GEORGE (*Ariz. Conn. Agr. and Hort. Ann. Rpt.*, 9 (1917), pp. 67, 68, pl. 1).—The most important potato diseases in Arizona are said to be Rhizoctonia and scab, which are compared to show resemblances and differences. They are controlled by the same sort of seed treatment, namely, 1 per cent corrosive sublimate solution. Formaldehyde is effective against scab, but not very satisfactory against Rhizoctonia.

Effects of Bordeaux mixture on potato plants, J. R. BOS (*Tijdschr. Plantenziekten*, 25 (1919), No. 2, pp. 77-94).—Aside from any control exerted as regards *Phytophthora infestans*, Bordeaux mixture has a decided beneficial effect on the plant itself. This the author is inclined (as the result of work to be continued) to attribute to the protection afforded to the plant against overinsolation and to consequent increase of assimilation, as well as to the longer period of growth in sprayed plants.

Spinach blight and its transmission by insects, L. B. SMITH (*Rpt. State Ent. and Plant Path. Va.*, 11 (1916-17), pp. 40-58, figs. 6).—A more extended account of this disease, as given by the author and McClintock, has been noted from another source (E. S. R., 39, p. 550).

Artificial and insect transmission of sugar cane mosaic, E. W. BRANDES (*Jour. Agr. Research [U. S.]*, 19 (1920), No. 3, pp. 131-138).—In a contribution from the Bureau of Plant Industry, U. S. Department of Agriculture, the author gives an account of experiments conducted to determine if possible the means of transmission of the mosaic or mottling disease of sugar cane.

Some healthy plants were grown near but not touching diseased ones. Insect visits were permitted, with the result that evidence of mosaic appeared on the sound plants after a period of approximately a month. Plants screened against insects remained healthy. Sorghums and various grasses were also found to be affected by the disease. The corn aphid (*Aphis maidis*)

seems to be a carrier of the infection. Inoculation experiments were conducted in which juice from diseased plants was transmitted to sound cane and the diseased condition produced. It is considered that the cell sap of diseased plants is infectious when introduced in the proper manner, and that the disease can be transmitted by insects. Just what insects are responsible for dissemination in the cane regions remains to be proved.

[**Matizado or mosaic of sugar cane**], F. S. EARLE (*Rev. Agr. Puerto Rico*, 2 (1918), No. 1, pp. 5-10).—A résumé is given of what is known regarding the characters and effects of sugar-cane mosaic, now widely distributed in this region.

Matizado of sugar cane, J. A. STEVENSON (*Rev. Agr. Puerto Rico*, 2 (1918), No. 1, pp. 51, 52; 2 (1919), No. 2, pp. 11, 12).—Matizado of sugar cane is said to be caused by a virus or an ultramicroscopic organism which may be transmitted by insects or other means. Certain varieties appear to be somewhat resistant. Control measures recommended include seed selection, destruction of infective material, and breeding of resistant varieties.

[**Sieve tube disease of sugar cane**], P. VAN HARREVELD (*Arch. Suikerindus. Nederland. Indië*, 26 (1918), No. 9, pp. 333-346; also in *Meded. Proefsta. Java-Suikerindus., Landbouwk. Ser., No. 4* (1918), pp. 333-346).—This is largely a discussion of recent study and opinion regarding sieve tube disease of sugar cane, and regarding its probable causation by *Bacillus vascularum*.

[**The causation and prevention of sieve tube disease**], P. VAN HARREVELD (*Arch. Suikerindus. Nederland. Indië*, 26 (1918), No. 13, pp. 527-531).—It is claimed that sieve tube disease has been shown by C. A. H. von Wolzogen Kühr to be due to *Bacillus vascularum*, and that the chief protective measures at present available are preventive, such as control of importation of planting material.

Mosaic of tobacco, J. A. STEVENSON (*Rev. Agr. Puerto Rico*, 2 (1918), No. 1, pp. 39-44).—This brief account dealing with the symptoms, causation, prevention, and other modes of control of tobacco mosaic states that the disease (apparently due to an ultramicroscopic organism) is transmitted by insects, by contact of implements and clothes, and by other agencies.

Notes on some tomato diseases, C. R. ORTON and W. H. MCKINNEY, JR. (*Pennsylvania Sta. Rpt. 1916*, pp. 285-291, pls. 4).—Accounts are given of a number of tomato diseases observed by the authors during their three years' study of the disease known as winter blight that occurs in greenhouses. The purpose of the present publication is to call attention to these diseases and to control measures which may be of value to growers.

Among abnormal conditions reported upon is one designated as bull plants. These are distinguished by faster growth, greater height, the leaves being much larger than in normal tomato plants and the foliage usually darker green. These plants have not been observed to bloom and in all their study no fruit was produced by them. The removal of the plants as soon as they are noticed is recommended.

A second disease reported upon is the curly top or rosette. Plants affected by this disease are usually not detected until they are a foot or more in height. At this time the stalks appear thicker and there is a strong tendency for the leaves to be clustered at the top of the stalk. The leaves are numerous and smaller, being noticeably shorter, thicker, and conspicuously curled. Diseased plants are said to blossom rarely and were never observed to set fruit. An examination of the root system for parasites was made, but none were found. Plants affected by curly top are said to be as susceptible as normal plants to mosaic.

Another disease described is designated as sleepy disease. This is due to the fungus *Fusarium lycopersici*. The disease appears about the time the plants are setting their last fruits. For control of this disease the authors recommend the replacement of the soil in the beds with a new soil in which tomatoes have not been recently grown or the sterilization of the old soil before the new crop is transplanted. When the disease appears in the bed, destroying the affected plants and sterilizing the soil with ammoniacal copper carbonate solution are recommended.

Notes are also given of stigmomose, which is attributed to the action of aphids, and bacterial wilt which is caused by *Bacterium solanacearum*. For the control of these diseases the use of nicotine sulphate for eradication of aphids, and for the bacterial wilt care in transplanting plants so as not to injure the roots, is advised.

A diseased condition which is called white leaf curl is described, and in certain stages is said to be similar to the leaf roll of potatoes. This disease was particularly prevalent on the variety Lorillard grown in greenhouses. The first appearance of the disease is indicated in the upper part of the plant, where the main leaves become affected. They present a grayish white color on the upper and lower sides of the leaves as well as on the stem. The leaflets become pointed or narrowed, giving something of the appearance of one of the stages of mosaic. This disease is believed to spread in much the same way as true mosaic, and is considered to be contagious. Methods of control are the same as those practiced for mosaic, which include the handling of the plants as little as possible, the careful removal of suckers, and control of white fly, green aphid, and other evident carriers.

Brief notes are given of edema of tomatoes, which is thought to be similar to if not identical with that described by Atkinson (E. S. R., 5, p. 55). For the prevention of this disease, control of the water supply, ventilation, and heating are recommended.

Control of apple powdery mildew, D. F. FISHER (*U. S. Dept. Agr., Farmers' Bul. 1120 (1920), pp. 14, figs. 8*).—A popular account is given of the apple powdery mildew (*Podosphaera leucotricha*), a serious disease of nursery stock throughout the United States, and also an important orchard disease in the apple growing districts west of the Rocky Mountains, especially in the Pacific Coast States.

For the control of the disease the use of lime sulphur or finely divided sulphur is recommended. In regions where burning is liable to follow the application of lime sulphur or sulphur, later sprayings with Bordeaux mixture are advised.

Powdery mildew experiments, H. E. WATERBURY (*Ann. Rpt. Dist. Hort. Insp. Yakima County, Wash., 1917, p. 49*).—The conclusions drawn from these experiments on powdery mildew are that the expense of a third spraying is justified by the results in an orchard where infection is pronounced. Iron sulphid appears to be slightly more effective than atomic sulphur. Climatic conditions in 1917 were much less favorable to mildew than in 1916. It is thought that in a normal or abnormally moist season repeated sprayings would be of greater value.

The value of industrial fungicides in relation with mildew, SAUZÉAT (*Prog. Agr. et Vit. (Ed. l'Est-Centre), 40 (1919), No. 20, pp. 467, 468*).—Commercial fungicides are recommended as regards adherence, simplicity of preparation, and uniformity and reliability as regards composition.

Transmissibility of false mildew by seed, R. LAUBERT (*Gartenflora, 68 (1919), No. 13-14, pp. 175, 176*).—Having raised the question in work previously

noted (E. S. R., 42, p. 350) regarding the overwintering of Peronosporaceæ by means of spores in or on seeds, the author made some observations during 1919, which as here noted are considered to show that so far as *Peronospora parasitica* and *P. alsinearum* are concerned, seed three years old are safe as to infection of the young plants.

The comparative efficacy of ordinary and casein Bordeaux mixture for the preservation of grapes, VERMOREL and DANTONY (*Compt. Rend. Acad. Sci. [Paris]*, 169 (1919), No. 9, pp. 439, 440).—From work briefly described, it is concluded that casein is an important addition to Bordeaux mixture, increasing the spreading and uniformity of distribution over all the surface of the organs treated. The copper compounds remain in place in spite of rains without loss of solubility.

Avocado diseases, H. E. STEVENS (*Proc. Fla. State Hort. Soc.*, 31 (1918), pp. 67-73).—Among the troublesome fungus diseases of avocado in different countries, rusty blight, root rot, and anthracnose are regarded as the most serious. The first two named are not known to occur in Florida, but injury has been caused by anthracnose or closely related diseases. Leaves and fruit are attacked by a fungus supposed to be a *Glœosporium*. A *Colletotrichum* is often found on diseased leaves and fruit spots. This is controlled by timely use of Bordeaux mixture.

Of two apparently new and undescribed diseases, one is a fruit spot. The other, primarily a disease of young tender foliage and named avocado scab, has been proved by a series of experiments to be caused by the same fungus as that producing citrus scab (*Cladosporium citri*).

Some disease problems of the season, H. E. STEVENS (*Proc. Fla. State Hort. Soc.*, 30 (1917), pp. 37-43).—This includes discussion of the direct and indirect effects of cold on citrus trees and their performance; also of citrus scab (*Cladosporium citri*), melanose (*Phomopsis citri*), and withertip (*Colletotrichum glœosporioides*).

Spraying for citrus diseases: Its usefulness and its limitations, R. R. FULTON (*Proc. Fla. State Hort. Soc.*, 30 (1917), pp. 60-65).—A brief review is given of the possibilities and limitations of methods indicated for control of such citrus diseases as scab, melanose, and withertip or anthracnose.

Report of citrus canker committee, D. C. GILLET ET AL. (*Proc. Fla. State Hort. Soc.*, 30 (1917), pp. 51-59).—An account is given of measures and related activities looking to eradication of citrus canker in Florida.

Citrus canker condition, F. STIRLING (*Proc. Fla. State Hort. Soc.*, 30 (1917), pp. 48-50).—A brief account is given of the work looking to the eradication of citrus canker since May, 1914, when it was definitely known that the disease was present in Florida.

Citrus canker eradication, N. D. ZUBER (*Ann. Rpt. Commr. Agr. Tex.*, 11 (1918), pp. 47-49).—In this portion of the orchard and nursery inspection report, it is stated that citrus canker eradication work has been carried on actively in collaboration with the Bureau of Plant Industry, U. S. Department of Agriculture. The State is divided into 11 districts, bordering largely on the Gulf, and inspections of citrus trees are made at intervals of two to six months according to location. Statistics are given of the work during the fiscal year.

Pear blight control work has also been continued, and statistics are given of these activities.

Behavior of the citrus canker organism in the soil, H. A. LEE (*Jour. Agr. Research [U. S.]*, 19 (1920), No. 5, pp. 189-206, pls. 2).—In an investigation carried on under the auspices of the Bureau of Plant Industry, U. S. Depart-

ment of Agriculture, the author has obtained experimental evidence to show that *Pseudomonas citri* disappears from unsterilized soil in tubes and boxes usually within six days after they are inoculated. *P. citri* inoculated in sterilized soil increases and multiplies. The disappearance of *P. citri* in unsterilized soil is believed to be attributable to the antagonistic effect of other soil organisms. Under orchard conditions the canker organism was found to disappear even more readily than in soil confined in boxes or culture tubes. Seeds planted in pots of soil naturally infected with the canker organism and in pots artificially inoculated developed normally without any canker, indicating that the canker bacteria had in some way been killed in the normal soils. Buried leaves and mature wood and roots are believed to be possible sources of holding over the canker organism.

Decline of *Pseudomonas citri* in the soil, H. R. FULTON (*Jour. Agr. Research* [U. S.], 19 (1920), No. 5, pp. 207-223).—In a contribution from the Bureau of Plant Industry, U. S. Department of Agriculture, results are given of an investigation to determine whether or not the citrus canker organism (*P. citri*) is capable of persisting in the soil to such an extent as to make the soil an important medium in holding over or disseminating the organism.

Tests on many types of soils showed a rapid decline of *P. citri* in all. This decline was retarded slightly by rendering the soil alkaline with lime water or by lowering its temperature, and more decidedly by withholding water or by previous sterilization with steam. Extremely long persistence in small numbers was noted in soil held in air-dry condition. *P. citri* was found to penetrate the soil to depths ordinarily cultivated, but the normal decline seemed to occur at such depth. In water the decline was more rapid than in soil, but previous sterilization of water had a decided effect in prolonging resistance. Certain bacteria commonly found in soils are said to have a marked deleterious effect on *P. citri* in artificial culture media, and the presence of such organisms in soil is believed to be concerned in producing a decline of *P. citri*. Young roots of grapefruit seedlings did not seem to be readily infected except through wounds.

Control of root knot by calcium cyanamid, J. R. WATSON (*Proc. Fla. State Hort. Soc.*, 30 (1917), pp. 27-34).—A more extended account of these experiments has been noted (E. S. R., 37, p. 453).

Scaly bark, a disease of citrus trees, C. D. KIME (*Proc. Fla. State Hort. Soc.*, 31 (1918), pp. 86-89).—Citrus scaly bark (*Cladosporium herbarum citricolum*) outbreaks are said to have been reported for 11 counties, representing many prominent citrus sections of Florida. An account is given of the outbreaks, effects, and efforts at control.

Coconut bud rot, J. A. STEVENSON (*Rev. Agr. Puerto Rico*, 2 (1918), No. 1, pp. 49, 50).—A rapidly progressing bud rot of coconut is said to be caused by *Bacillus coli*.

Correspondence relating to coconut diseases occurring in Grenada ([*Imp. Dept. Agr. West Indies*] [*Pamphlet*], 1918, pp. 6).—The chief particulars in this correspondence regarding coconut diseases are furnished by W. Nowell, who reports on a visit to Grenada in October, 1918, to investigate diseases of coconut.

Besides bud rot, three other local diseases are distinguished, namely, little leaf disease, root disease, and a condition of debility associated with water-logging, severe root competition, or soil exhaustion. These are discussed in connection with remedial measures. Nematodes are found in connection with the root disease here noted, and with the disease locally called bluggoes.

A stem disease of tea caused by *Nectria cinnabarina*, A. C. TUNSTALL (*Calcutta: Criterion Ptg. Works, 1918, pp. 6, pls. 4*).—It has been found that tea bushes showing a poor condition were attacked by a fungus, supposedly a variant form of *N. cinnabarina*.

Rusts on conifers in Pennsylvania, J. F. ADAMS (*Pennsylvania Sta. Bul. 160 (1919), pp. 3-30, figs. 10*).—The results are given of observations and collections made in various parts of the State, for the most part in the vicinity of State College, on the rusts of conifers, 27 species being reported.

White pine blister rust, W. R. BROWN ET AL. (*Bien. Rpt. Forestry Comm. N. H., 1917-18, pp. 36-47, pls. 2*).—This gives an account of the nature, introduction, spread, and attempts at eradication of the white pine blister rust.

It is believed that an area once thoroughly worked will not need to be reworked more than two or three times in order to make it safe from blister rust in a commercial sense.

The white pine blister rust, G. C. CUNNINGHAM (*Ann. Rpt. Crown Land Dept. New Brunswick, 57 (1917), pp. 103-106, pls. 4*).—White pine blister rust (*Peridermium strobi*) has not yet been observed in New Brunswick, but only a partial survey in a few sections has been made.

Experimental production of bacterial tumors on pine, J. DUFRÉNOY (*Compt. Rend. Acad. Sci. [Paris], 169 (1919), No. 12, pp. 545-547*).—Piercing in July, 1918, cambium of sound plants two years old with a needle previously inserted into a tumor, the author obtained cankers in October, 1918, and in July, 1919, resinous tumors. The agent appears to be a Gram-positive coccus (usually intracellular) which is discussed.

Bacterial canker of poplar, R. RÉGNIER (*Compt. Rend. Acad. Sci. [Paris], 169 (1919), No. 2, pp. 85-88*).—Giving the result of observations, dating back as far as 1913, on a canker of poplar (*Micrococcus populi*), which has become a veritable scourge in the Oise and neighboring valleys of France, the author arbitrarily divides the evolution of the canker into five stages which are outlined. Treatments (which are preventive only) include selection of planting material and if possible its disinfection, selection of localities free from infection, destruction by fire of all diseased materials or the utilization of trunks affected with canker, and the destruction of all parasites of poplar. The canker attacks indifferently the branches and stem of young plants and the trunks of much older plants.

Brown bast, T. PETCH (*Dept. Agr. Ceylon Leaflet 12 (1919), pp. 2*).—This is a condensed account of brown bast of rubber trees as studied in Ceylon. Outlines of three methods of treatment are given, each aiming at the removal or destruction of the diseased cortex to such a depth that any diseased tissue is destroyed and the formation of nodules prevented. These methods are distinguished respectively as stripping, scraping, and tarring, the last two involving the application of Brunolinum plantarium. This is applied at 20 to 50 per cent strength according to the widely varying susceptibility of the trees.

The biology of Polyporus pargamenus, A. S. RHOADS (*N. Y. State Col. Forestry, Syracuse Univ., Tech. Pub. 11 (1918), pp. 197, pls. 31, figs. 6*).—*P. pargamenus*, one of the most common wood destroying fungi, causes sap rot of most of the species of dicotyledonous trees occurring throughout the wide range of this fungus. It is usually saprophytic, attacking particularly felled wood with the bark still on, although it frequently becomes a wound parasite, particularly on trees injured by fire.

The species appears to consist of a number of intergrading forms, often becoming sufficiently distinct to constitute varietal forms or subspecies. It is advocated that these varietal forms be recognized, particularly for the convenience of the critical worker.

The decay of wood by *P. pargamenus* consists of a series of chemical and physical changes brought about by the reduction of the woody substance by enzym secretions. The dissolution of the cell walls is attributed to the fact that they, as a potential source of food, are valueless to the fungus until broken down and reduced to a condition suitable for translocation and assimilation. The enzymatic digestion and consequent decay of wood is accomplished mainly by the exceedingly minute fungal hyphæ, the ultimate branches of the mycelial system.

Decay by this species is characterized by its habitual tendency to produce a minute pocket type which becomes a conspicuous feature in the later stages of the disease. The first chemical change brought about by the action of the fungus is that of delignification.

The results obtained from the study of the decay caused by this fungus establish the fact that the minor variations in the decay of different woods are much more dependent upon the dissimilar structures of the respective woods than has been generally supposed. Anatomical and microchemical observations on the decay of the five woods studied indicate that the vegetative mycelium of *P. pargamenus* secretes diastatic, proteolytic, and cytohydrolytic enzymes, among the latter being pectinase, cellulase, and ligninase.

The practice of allowing fires to run through hardwood forests furnishes favorable conditions for the entrance into wounds of this and other sap rotting fungi.

The incubation period of *P. pargamenus* under conditions studied was less than 15 months and appears to be more nearly 12 months. In case of artificial cultures the length of the entire life cycle varied from 4 months in agar plate cultures to 18 months in cultures on blocks of wood.

ECONOMIC ZOOLOGY—ENTOMOLOGY.

Field experiments on the chemotropic responses of insects, A. D. IMMS and M. A. HUSAIN (*Ann. Appl. Biol.*, 6 (1920), No. 4, pp. 269-292, fig. 1).—The most noteworthy features of the experiments here reported have been summarized as follows:

"The experiments were conducted during July and August, 1918, and for the most part during wet and apparently unfavorable climatic conditions. The insects attracted consisted almost exclusively of Diptera. With the exception of one or two examples of *Vespa vulgaris*, no Hymenoptera responded. Rynchota, Coleoptera, and Neuroptera (sen. lat.) were unrepresented. A small number of Noctuid Lepidoptera entered the traps, but for the purpose of conducting experiments with such relatively large insects as many Lepidoptera it would be necessary to alter slightly the construction of the traps used in order to allow of greater facilities for ingress.

"Beer, cane molasses, and mixtures of these two substances are powerful chemotropic agents for various Diptera. Ethyl alcohol, in various concentrations, exhibited little or no chemotropic properties, but with the addition of small amounts of butyric, valerianic, or acetic acids it exercised a powerful stimulus. Aqueous solutions of the above acids were not attractive, the respective esters probably being the attractive agents in each case. The remaining substances utilized in these experiments were found to exhibit little or no positive chemotropic properties.

"Out of considerably over 3,000 Diptera attracted during the course of these observations, by far the greater number pertained to one or other of the five families Rhyphidæ, Mycetophilidæ, Sepsidæ, Muscidæ, and Anthomyidæ. As a general rule members of both sexes of a species were attracted irrespective of

the chemotropic agent employed. In the majority of instances males predominated over females, but in no case where the number of individuals of a species attracted exceeded 20 was the disproportion greater than 2.9 to 1 female. *Rhyphus punctatus*, *Hylemyia strigosa* and *Calliphora erythrocephala* were the dominant species attracted."

A bibliography of 36 titles is included.

[Insect control work in Texas] (*Ann. Rpt. Commr. Agr. Tex.*, 11 (1918), pp. 50-53, 63-79).—Brief accounts are given of the Argentine ant eradication campaign and work with the cottony cushion scale, by N. D. Zuber, and a detailed report of work against the pink bollworm, by E. E. School (pp. 63-79).

Insect pests [in the West Indies in 1918] (*West Indian Bul.*, 18 (1920), No. 1-2, pp. 39-58).—This is a report upon the occurrence of insect pests in the West Indies during 1918, the subject being dealt with under the headings of crops attacked.

Experiments on borer control, J. P. STEWART (*Pennsylvania Sta. Rpt. 1916*, pp. 56, 57).—In control work with borers, some 20 different kinds of materials were tested as coatings for the bases of tree trunks to prevent the attacks of borers and other enemies. This work was started on apples in 1909 in an experimental orchard at the college, and was extended to peaches in 1910 in an orchard near Bellefonte.

Thus far, the work has shown that "the following materials are either worthless or unfit for use on apple or peach: Whitewash, slater's cement, rubber roofing cement, water-gas tar, refined water-gas tar, Barrett coal tar, heavy creosoting oil, and dead oil. The whitewash is safe and probably useful while it lasts, but it flakes off much too quickly, especially on young trees which are swayed by the wind. The various tars make good and effective coatings, but they have proved decidedly injurious both on the apple and the peach, although it has sometimes required three or four seasons for the injury to appear. The latter fact probably accounts for some of the favorable recommendations that have appeared concerning tar applications in the past.

"Of the other materials under test, white lead and oil had proved distinctly injurious to the peach, but we have applied it annually on apples for seven years with no apparent injury except for the development of some abnormal roughening on the bark. This paint also has made an apparently effective coating against apple borers and is easily maintained. Raw linseed oil is used, without any turpentine or any other additional material. In general, however, lime-sulphur is likely to be safer and fully as efficient, if renewed often enough."

The other materials that are still under test on apples and peaches and appear to be the most promising are *Avenarius carbolineum*; dense lime sulphur; and the various asphaltum compounds. "The gas tar, the Borene paste, and the lead and oil paint have all given very severe injury on the peach, and also, rather unexpectedly to us, the lime-sulphur sludge has apparently resulted in some injury on this fruit during the past year."

Fruit tree borers and their control, W. C. GILLESPIE (*Pennsylvania Sta. Rpt. 1916*, pp. 533-553, pls. 4).—Summarized accounts are given of the more important borers attacking fruit trees, including control measures. In experiments with the peach tree borer, one of which was conducted at Tarentum and another at State College, one season's test indicates that the asphaltum compounds, the dense lime-sulphur solutions, and the *Avenarius carbolineum* are the most promising.

The effects of the freeze of February 2-4, 1917, on the insect pests and mites on citrus, W. W. YOTHERS (*Fla. Buggist*, 1 (1917), No. 3, pp. 30-35, 38-40).—In discussing the effects of the freeze of February 2-4, 1917, upon citrus

pests in Florida, the author divides the State into zones based upon temperature records of the U. S. Weather Bureau.

In the first zone, comprising the citrus producing counties of Putnam, Volusia, and Marion, with parts of Lake and Orange in which the temperature varied from 15 to 20° F., there was practically complete defoliation of all citrus trees, many grapefruit trees were killed to the ground, and oranges were killed back to within 4 to 8 ft. of the ground. In the second, or next warmer zone, comprising the remainder of the counties of Lake and Orange, and the counties of Osceola, Polk, De Sota, Manatee, and Lee, in which the minimum temperature varied from 20 to 25° F., the percentage of bearing wood killed varied from 20 to 40 with oranges and 25 to 50 with grapefruit. In this zone, there was about 90 to 95 per cent defoliation of orange trees except in a few protected places, and the grapefruit trees were completely defoliated. In the third, or warmest zone, comprising the counties of Pinellas, Dade, Palm Beach, St. Lucie, and part of Brevard in which the minimum temperature varied from 25 to 30°, the percentage of bearing wood killed varied from 0 to 15 for oranges and from 0 to 20 for grapefruit. In this third zone, defoliation was not sufficient to influence the number of white flies to a degree to be of economic importance.

While the citrus white fly survives on privet in the temperatures of North Carolina, and the recent cold wave did not injure this species in Florida, the defoliation of the citrus trees resulted in reducing the number in many places and localities to the point of almost complete extermination, particularly in zone 1. The cloudy-winged white fly, which infests only citrus and is found largely on grapefruit, was destroyed only in proportion to the extent of the defoliation. The purple scale was almost exterminated in the counties of zone 1, but the eggs were not frozen sufficiently to keep them from hatching. It also received a complete setback in zone 2, but not to the extent it did in zone 1. In zone 3, the number was greatly reduced but not sufficiently to make spraying unnecessary. The red scale on camphor (*Chrysomphalus aonidium* L.) was injured in nearly all stages except the egg by the frost, and not more than one insect in 10,000 or more survived. The rust mite (*Eriophyes oleivorus* Ashm.) was partially frozen and partially killed because the foliage was shed. It was nearly exterminated in zone 1, severely set back in zone 2, and though greatly reduced in number in zone 3 not sufficiently to be of much economic importance. The adults of the purple mite (*Tetranychus citri* McGr.) did not appear to have been hurt. The eggs, however, are thought to have been affected, since the pest has not been very abundant since the freeze.

A brief account is also given of the effect of the freeze on the pests of other plants than citrus. The spider mite *Tenuipalpus bioculatus* McGr. was but slightly injured by the cold, while *Tetranychus yothersi* McGr. on camphor appeared to have been seriously affected.

Work on citrus insect pests [in Porto Rico] (War Dept. [U. S.], Ann. Rpt. Governor P. R., 19 (1919), p. 695).—A number of insects that have not previously been recorded from Porto Rico have been found breeding upon citrus foliage, as follows: The star scale (*Vinsonia stellifera* [Westw.]), a common pest of mango, coconut, and pomarosa at Rio Piedras, also observed on cattleya orchids; *Ormenis pygmaea* Fab., which heavily infests citrus sprouts, particularly in June, and breeds abundantly upon the wild bushes *Cordia corymbosa* and *C. cylindrostachya*, also upon young coffee foliage and the passion fruit vine; an undetermined orange-brown thrips; two mealy bugs, one very close to *Pseudococcus longispinus*, the other apparently the citrophilus scale; a bag worm; and a larva of an undetermined arcteid moth.

An examination of the orchard in April showed many terminal leaves to have been curled and distorted by the black citrus aphid, which was highly parasitized. The citrus leaf roller (*Eantis thraso* Hubn.) was abundant in May. A fulgid leaf hopper (*Bothriocera* sp.) was common on grapefruit twigs.

The insects of the evening primroses in New Jersey, E. L. DICKERSON and H. B. WEISS (*Jour. N. Y. Ent. Soc.*, 28 (1920), No. 1, pp. 32-74, pls. 3).—This is a report of observations of the evening primroses (*Oenothera* spp.) in various parts of New Jersey.

Insect and fungus pests of basket willows (*Bd. Agr. and Fisheries* [London], *Leaflet 301* (1918), pp. 11, pls. 4).—Brief accounts are given of the more important enemies of basket willows in England and means for their control.

Insects attacking farm animals, G. MAHEUX (*Min. Agr. Prov. Quebec, Bul.* 67 (1920), pp. 29, figs. 29).—This is a popular account.

The colonizing reproductive adults of termites, T. E. SNYDER (*Proc. Ent. Soc. Wash.*, 22 (1920), No. 6, pp. 109-150).

Zoraptera not an apterous order, A. N. CAUDELL (*Proc. Ent. Soc. Wash.*, 22 (1920), No. 5, pp. 84-97, figs. 5).

The paddy bug (*Leptocorisa varicornis* F.), J. C. HUTSON (*Trop. Agr. [Ceylon]*, 54 (1920), No. 6, pp. 363-366, fig. 1).—This is a summary of information on the most serious insect enemy of paddy in Ceylon.

On the biology of *Aphis avenæ* Fab. in the Southeast, with causes conducive to the unusual abundance of this species as well as *Toxoptera graminum* Rond. during certain seasons, P. LUGINBILL (*Ann. Rpt. Commr. Agr., Com. and Indus., S. C.*, 16 (1919), pp. 219-229, figs. 4).—This is a report of studies conducted in the vicinity of Columbia, S. C., with a view to determining the number of generations occurring annually, whether or not oviparous forms appeared at any time during the year, comparative length of life of the individuals constituting the generations, and the number of young produced by each individual. The investigations were conducted in connection with those of *T. graminum* previously noted (E. S. R., 39, p. 559).

The methods of study employed and the feeding habits of *A. avenæ* as compared with *T. graminum* are first considered. The life history studies have shown that the average length of life of the individuals born during the summer months is about 22 days, increasing to 25 days for those born during the fall months and 75 days for those born during the winter months. The average number of young for an individual during the summer months is about 33 days, and for the winter months 38 days. The time elapsed between the birth of the individuals and the commencement of reproduction varied very greatly. Reproduction may follow within 24 hours after the last molt has occurred, while during the winter a maximum of 36 days and a minimum of 15 days were obtained. Approximately 24 generations for the calendar year were obtained for the latitude of Columbia, no oviparous form appearing in this series.

The influences conducive to the unusual abundance of aphids during certain seasons in the Southeast are discussed at some length. Graphs are given which show the comparative length of life of individuals, the comparative number of young, period in days between birth and beginning of reproduction, mean temperatures from September to March, and minimum temperatures from September to March.

An infestation of the white-pine aphid, H. B. PIERSON (*Psyche*, 27 (1920), No. 2-3, pp. 62, 63).—The author records an infestation at Petersham, Mass., of white pine 40 to 50 years old by *Lachnus strobi* Fitch, in which infested trees averaging about 14 in. in diameter succumbed to the attack.

Control of the citrophilus mealy bug, R. S. WOGLUM and A. D. BORDEN (*Cal. Citrogr.*, 5 (1920), No. 7, pp. 214, 230, fig. 1).—This account is based upon investigations by agents of the Bureau of Entomology of the U. S. Department of Agriculture, which resulted in effective control measures for the common or citrus mealy bug that were universally adopted by the growers during the season of 1919. The investigations by the senior author of the citrus mealy bug (*Pseudococcus citri*) resulted in the discovery that it could be successfully controlled by 4 important predators (*Symphorobius* 2 spp., *Hyperaspis* sp., and *Cryptolæmus* sp.) provided ants, particularly the Argentine ant, were eliminated from the infested territory.

The control of the Argentine ant by use of poisoned syrup having been accomplished (E. S. R., 41, p. 166), it was found that *Cryptolæmus* was the only one of the 4 predators which fed freely on the citrophilus mealy bug (*P. gahani*), but that other important predators of this pest were the *Leucopis* sp. and *Scymnus* sp. The combined efforts of these species failed, however, to control severe infestations, although quite efficient in lighter infestations. Spraying with the insecticides effective against the citrus mealy bug did not prove satisfactory, and fumigation proved to be a failure.

Studies of the citrophilus mealy bug revealed a spring migration of the mature females to the trunk and rough places on the main branches, where they deposit the egg masses for the succeeding generation. This led to the use of burlap bands on the trunks, applied not later than April 1, as an additional inducement for the insect to oviposit there. The trunks and lower main branches were subsequently sprayed with an effective insecticide (soap powder, 40 lbs.; distillate crude, 28 per cent, 30 per cent Baumé, 10 gal.; water to make 200 gal.) before the eggs hatched. In this way a 2-acre demonstration plat was cleaned up. The methods which resulted in the freeing of this orchard of ants and control of the mealy bug within a year's time at a cost of less than 10 cts. per tree are briefly described by the author under the headings of Argentine ant control, banding with burlap, trunk treatment, and natural enemies.

A new species of Aleyrodidæ found on azalea, A. C. BAKER and M. L. MOLES (*Proc. Ent. Soc. Wash.*, 22 (1920), No. 5, pp. 81-83, figs. 10).—Under the name *Aleyrodæ azaleæ*, the author describes a new species frequently found on foreign shipments of azalea from Belgium and Holland. It was also taken in November, 1919, from plants shipped from Japan.

Is sericulture an American possibility? R. H. TINGLEY (*Textile World Jour.*, 58 (1920), No. 5, pp. 31, 81, fig. 1).—This is an account of work with mulberry and osage orange trees and with food preparation based upon work by V. K. Osigian in Louisiana and Texas.

The semitropical army worm, E. W. BERGER (*Quart. Bul. State Plant Bd. Fla.*, 4 (1920), No. 2, pp. 17-34, fig. 1).—This is an account of *Prodeina* [seu *Xylomiges*] *eridania* Cramer, a serious enemy of the castor bean, which crop was grown in large quantities in Florida in 1918. Serious outbreaks of this pest occurred that year in central and southern Florida, it having been first reported from Vero on July 18. An account is given of its biology and control, reference being made to a bulletin on the pest by Chittenden and Russell previously noted (E. S. R., 20, p. 953).

All parts of the castor plant are eaten by the worm, the leaves being preferred, the young fruit spikes next, and then the leaf petioles and the tips of the plants. Next to the castor-bean plant, cotton, of the cultivated plants, is probably preferred as a food plant. The immature cotton bolls were attacked even when plenty of foliage was present, and the bark near the base was also eaten.

Other cultivated plants observed to be attacked by the worms in order of preference were sweet potato, sunflower, Irish potato, velvet potato, okra, egg-plant, pepper, oleander, beggarweed, avocado, peanuts, watermelon, cowpeas, and citrus. The noncultivated plants observed to be eaten were careless weed, pokeweed, willow, morning-glory, bloodroot, *Sonchus* sp., and *Rumex* sp.

Control measures include picking the leaves with young broods or egg masses, dusting with arsenicals, spraying with arsenicals, and using poisoned baits.

A brief statement by J. R. Watson, of the Florida Experiment Station, of experience with *P. eridania* caterpillars on castor beans in 1918 is appended (pp. 33, 34).

A honey-feeding larva, W. COCKLE (*Amer. Bee Jour.*, 60 (1920), No. 7, pp. 234, 235).—The feeding of *Vitula serratilineella* upon honey in partially filled cells at Kaslo, B. C., is reported upon.

Experiments on the control of the oriental fruit moth (*Laspeyresia molesta* Busck), L. A. STEARNS (*Quart. Bul. Va. State Crop Pest Comm.*, 2 (1920), No. 1, pp. 3-16, figs. 3).—The author here reports upon twig cutting and insecticide experiments for the control of this pest, which now occurs in Virginia to a distance of 20 odd miles south and west of the Potomac River in Alexandria and Fairfax Counties. The experiments reported have led the author to suggest the following control measures:

"(1) The removal and the destruction by burning or otherwise of all infested twigs of nursery stock and young orchard trees. This measure would be of most value in the spring. At that time the terminals are infested by small numbers of overwintering and first brood larvæ, whose destruction will decrease considerably the size of the summer broods causing widespread injury. (2) The cutting back severely or 'dehorning' each year of a few trees in a single section of an infested orchard. The resulting fresh growth on these 'trap trees' should attract the moth, and the succulent shoots would serve as a feeding ground during the spring and early summer for the worms. These trees may be examined frequently, and the infested twigs removed and destroyed. In bearing orchards fruit infestation might be decreased materially in this way. (3) Applications of nicotine sulphate, 40 per cent, blackleaf 40 diluted 1 part to 800 parts of water about May 17, June 26, and August 28. Life history studies in 1918 and 1919 have shown that the heaviest deposits of eggs are present on the foliage at these dates. (4) Clean culture, which would include the removal and destruction by plowing under or burning of all refuse (leaves, grass, weeds, and especially decaying and mummied fruit) about the tree trunks in which the larvæ find suitable quarters to cocoon for hibernation."

Codling moth control v. extermination, P. S. DARLINGTON (*Better Fruit*, 14 (1920), No. 7, pp. 27, 28, 30).—This is a discussion of the subject as related to the problem in the State of Washington.

A study of the malarial mosquitoes of southern Illinois.—I, Operations of 1918 and 1919, S. C. CHANDLER (*Ill. Dept. Registr. and Ed., Div. Nat. Hist. Survey Bul.*, 13 (1920), Art. 11, pp. 307-328, pls. 9, figs. 3).—This is a detailed account of work conducted by the author.

The house fly: Carrier of disease, L. O. HOWARD (*Columbus, Ohio: State Bd. of Health, 1918, pp. 16, figs. 11*).—This is a popular account in which the importance of the house fly as a disseminator of disease germs is pointed out, its life history and means of control being briefly described.

The green Japanese beetle, J. J. DAVIS (*N. J. Dept. Agr. Circ.* 30 (1920), pp. 3-33, pl. 1, figs. 20).—This is a summary of information on *Popillia japonica* Newm., its economic importance, occurrence and spread in this country, host plants, life history and habits, insects likely to be mistaken in the adult and

larval stages, means of control under way, prevention of injury, natural enemies, etc.

"The Japanese beetle was introduced into Burlington County, N. J., from Japan in soil about the roots of plants previous to 1916. It is now known to occur in the United States only in Burlington and Camden Counties in New Jersey. The insect has shown that it can increase at a menacing rate and may become a dangerous pest to a variety of crops, and it will probably be a heavy charge on agricultural production unless checked by artificial or natural means.

"It has a one-year life cycle, wintering in the ground as a grub and occurring as a beetle above ground for several months during the summer and fall. The beetles feed on a great variety of weeds and cultivated crops, skeletonizing the foliage and riddling the flowers. The eggs are laid and the grubs flourish in low ground that is rich in humus and preferably covered with grass or other vegetation. Roadsides, fence rows, headlands, and creeks, grown up with grass and weeds, are favorite breeding grounds for the Japanese beetles, as well as many other pests, and are therefore a nuisance of the worst type. Cooperation of all residents of the area now infested, and that surrounding, in eliminating headlands and fence rows and destroying the wild vegetation along creeks and roadways, is urged. Also, individuals are asked to cooperate so far as practicable in the cropping and cultivation of fields . . . and in the collection and destruction of the beetles. The work of controlling the Japanese beetle as planned consists in the prevention of spread by barriers and quarantine measures, the discovery of practical control measures, and the introduction of natural enemies from Japan."

The control of the strawberry leaf beetle (*Typophorus canellus* Fabr.), E. N. COBY and W. C. TRAVERS (*Maryland Sta. Bul.* 236 (1920), pp. 133-136, fig. 1).—This beetle, the larva of which is known as the strawberry root worm, has during the past three years severely injured strawberry plants in some sections of Somerset County, Md., in many cases entire beds having been destroyed by it. This has led to control experiments, which have shown that both arsenate of lead and arsenate of lime are effective in reducing the insect depredations to a marked degree. The authors recommend that either a mixture of 85 per cent hydrated lime with 15 per cent of arsenate of lime or 15 per cent of arsenate of lead, or a mixture containing 65 per cent hydrated lime, 20 per cent ground Bordeaux, and 15 per cent of either arsenate of lead or lime be applied. "The first application should be made on or about the first of July and be followed by a second application in three weeks, if no heavy rains intervene. All the applications should be repeated if followed in the course of several days by heavy rains. The plants should be watched carefully and if the injury continues, added applications may be necessary."

Does experimenting with native predatory insects pay? E. G. WOOD (*Better Fruit*, 14 (1919), No. 5, pp. 6, 7, figs. 3).—This is a brief account of the collection and storing of ladybird beetles found in the orchards of Walla Walla County, Wash., reference to which has been previously made from another source (E. S. R., 41, p. 666).

The work has led to the conclusion that September or October is the best time to collect the beetle, though it might be possible to collect them during a period of about 10 days in April. The best method of storing is in small boxes with dry excelsior, about 3 lbs. in each box, the boxes being screened on two sides and kept in cold storage at 40° F. By this method, 98 per cent can be brought through the winter in good condition.

Common storage or outdoor storage is fairly satisfactory if the beetles are liberated about the first of April. They should be liberated early enough in the spring so that the eggs will be hatching before the aphid begins multiplying

rapidly. Although there may be several other important reasons why there were so few aphids in 1919, the ladybird beetles were undoubtedly a large factor in keeping them in control. The author concludes that the practice of storing ladybird beetles and liberating them in the spring should be continued and more data collected to prove that they control the aphids.

Direct sunlight as a factor in forest insect control, F. C. CRAIGHEAD (*Proc. Ent. Soc. Wash.*, 22 (1920), No. 5, pp. 106-108).—Experiments conducted show that borers attacking logs are killed by exposure of the logs to sunlight. Control was obtained by turning the logs weekly during June, July, and August.

Banana root-borer, G. F. MOZNETTE (*Jour. Agr. Research [U. S.]*, 19 (1920), No. 1, pp. 39-46, pls. 4, fig. 1).—The existence of *Cosmopolites sordidus* Germar in Florida was brought to the author's attention in December, 1917, by the receipt of specimens from a grower near Larkins, in Dade County, where they were causing serious damage to banana plants. Eradication and inspection work by the Florida State Plant Board was begun at once, and a national quarantine was placed on this species April 1, 1918. It was found that the infested plantings at Larkins had been made four years previous to the discovery of the weevils with plants originating in a nursery in southern Florida. This led to investigations which showed the presence of the weevils at the nursery, and every effort was made to exterminate them. While it could not be determined how the pest found its way into Florida, it is thought to have come in with sprouts or young plants introduced for propagation. This species confines itself almost entirely to the banana, attacking all varieties, but has been reported to attack sugar cane. It is quite widely distributed in the Tropics, occurring in the West Indies, Brazil, the Philippines, Fiji, India, Java, Ceylon, New Guinea, China, Borneo, Sumatra, Queensland, the Straits Settlements, etc.

The young suckers attacked by the borers wither and die in a short space of time, due to the feeding and tunneling of the larvæ between the lateral roots and the bulb, thus cutting off the flow of sap to the plant. The adult weevils are found in the soil about the root and also under loose fiber surrounding the base of the stem, at the crown. They congregate in the cavities caused by the larvæ at the base of the bulb of the plant. Technical descriptions of the several stages of this species by W. D. Pierce are incorporated. The eggs are deposited in the tissues, usually in the small compartments in the sheaths or stem but occasionally being laid loosely in the slightly decayed leaf sheaths close to the healthy fleshy banana bulb, from which place they enter the bulb. The incubation period of the egg was found to be from 5 to 7 days. On hatching out, the larvæ eat their way into the body of the bulb or the trunk. The work of the larvæ is particularly destructive, since they girdle the plant in the immediate vicinity of the lateral roots put out from the bulb of the plant, thus cutting off the passage of the sap. They may be found tunneling into the main trunk as far as the heartwood, usually working below ground, but in a few instances have been found in the trunk as high as 2 ft. above ground. The larval stage was found to extend over a period of from 15 to 20 days. While not observed by the author, the pupal period was found by Jepson in Fiji to extend from 5 to 8 days. The pest is a difficult one to control, and where plants are found infested in Florida and elsewhere in the United States, they should be destroyed immediately and traps laid by using strips of healthy banana trunks.

The banana weevil (*Cosmopolites sordidus* Chevrr.), H. TRYON (*Queensland Agr. Jour.*, 13 (1920), No. 5, pp. 222, 223).—This is a continuation of the

article previously noted (E. S. R., 43, p. 457), in which methods of repression are dealt with.

The cowpea weevil, F. B. PADDOCK and H. J. REINHARD (*Texas Sta. Bul.* 256 (1919), pp. 9-92, pls. 6, figs. 3).—This is a review of the present status of knowledge of *Bruchus quadrimaculatus* Fabr., together with a detailed report of investigations conducted at the station, many of which data are presented in tabular form. This is the most common species of weevil infesting cowpeas in Texas, occurring in all localities where the cowpea is grown. The climatic conditions of the State are said to be specially favorable for the development of this insect. All varieties of cowpeas grown in the State are subject to the attack, no preference being shown for any particular variety.

"Under favorable conditions the life cycle from egg deposition to emergence of the adult may be completed in less than 3 weeks. The weevil is very prolific. An average of 106 eggs has been produced by females during the warm season. Temperature has a positive influence on the rate of oviposition and the length of the various stages of the weevil. In stored seed, breeding is practically continuous throughout the year. Most weevils undoubtedly hibernate in stored seed. Nine generations of weevils occur in a year at College Station."

Three natural enemies of the immature stages of the weevil were found: A predacious mite, a chalcidoid parasite of the larva (*Bruchobius laticeps* Ashmead), and an egg parasite (*Uscana semifumipennis* Girault). "The weevil, however, is not sufficiently checked by its natural enemies, and remedial and artificial control measures must be employed. Proper harvesting will greatly reduce the initial infestation of the field. To prevent seed from becoming reinfested, it must be stored in tight bins or containers. The weevil can be destroyed in any stage by heating the infested seed to a temperature of 146° F. for an exposure of 15 minutes, which will not affect the germination of the seed. Fumigation with carbon bisulphid is an effective means of destroying the cowpea weevil and, used at the rate of 4 lbs. for 1,000 cu. ft. of space with a 24-hour exposure, it will kill the insect in all of its stages. Fumigated and 'processed' or heated seed is always subject to reinfestation by the weevil."

A bibliography of 34 titles, together with a list of 13 references to the literature cited, are included.

Boll weevil controllable by poisoning cotton, W. E. HINDS (*Ala. Polytech. Inst. Ext. Serv. Circ.* 38 (1920), pp. 16, figs. 6).—This discussion of control work with the boll weevil by dusting cotton with calcium arsenate includes a report of demonstration control work conducted by the station entomologist in 1919.

In 9 plats in four localities in which power dusting work was completed results which seemed to be reliable were obtained on 120.78 acres. The average yield per acre of seed cotton on this area was 903.5 lbs., representing a gain over the yield on the check areas of 247.5 lbs. per acre, or an increase of 38 per cent. The total cost for treatment for the entire area was \$1,130.63, or an average of \$9.36 per acre for this part of the entire dusted area. The total net profit for the entire area amounted to \$2,775.79, which is an average of \$22.82 per acre net profit from the dusting work with power machines.

In 3 hand-dusted plats with a total of 4.7 acres, from which complete records were obtained, there was an average yield of 668 lbs. per acre, or an increase of 222.3 lbs. per acre over the yield of check plats. The total gain from the dusting on the 4.7 acres was 1,044.75 lbs., worth \$135.82. The total cost for treating the 4.7 acres was \$44.13, leaving a total net profit for that area amounting to \$91.69. This is an average net profit of \$19.51 per acre.

The percentages of increase in a series of 9 fields ranged from 6 to 150 per cent. "In an average of the 5 highest yielding fields, the yield was 1,066 lbs.

of seed cotton per acre, or better than two-thirds of a bale. Here the gain over untreated check plats amounted to 273.6 lbs., or an increase of nearly 35 per cent over checks, and the net profit was \$25.23 per acre. In the 4 lowest-yielding, power-dusted plats, with an average of 361 lbs., or one-fourth bale, the gain over the checks was 160 lbs. or 80 per cent, and the net profit averaged \$14.72 per acre. The cost for treatment with highest-yielding cotton averaged \$10.35 per acre, while with the low yielding it was \$6.08 per acre. In all the power-dusting demonstrations of 1919, with an average yield of three-fifths bale per acre, the dusting increased yields by an average of nearly 40 per cent over the check plats. This rate of increase would pay a small profit, at the average cost of treatment in 1919, on fields yielding as low as one-fifth bale per acre. However, until we have the results from many more demonstrations than we have at the present time, we feel that we can not advise dusting generally except where there is a 'prospect' of more than one-third bale per acre.

"The average cost per acre for each application in power dusting was \$2.13, while in hand-dusting work it was \$1.70, at the prices prevailing for labor and materials in 1919. From four to six applications at weekly intervals were necessary for effective weevil control in most cases. Better results may be possible with shorter intervals. Excessive rainfall interfered seriously with the effectiveness of the earlier applications made in 1919, but did not prevent profitable results from the work of the season as a whole. When weevil control is fairly effective through drought and heat, as in 1918, cotton dusting is not likely to prove sufficiently profitable to justify the expenditure. Dusting is most advisable ordinarily to repress a heavy, threatened infestation in productive cotton."

The hand-dust gun, gas-engine driven dusters, and the wheel-traction duster, together with a lighting system for night work, are considered.

Poisoning boll weevils, J. B. WATKINS (*Farm and Ranch*, 39 (1920), No. 30, p. 8).—This paper gives an account of the dusting method now in use in controlling the boll weevil and the results of tests conducted in Texas, plats having been selected in localities extending from Karnes City to Fort Worth.

On a plat of 35 acres at Austin where poison was used between June 19 and July 9 there was a decrease in the infestation from 82 to 7 per cent. A decrease in infestation on check plats from 78 to 50 per cent is thought to have been due to the fact that some of the poison drifted from the poisoned plat. At the station at Karnes City there was a reduction from 72 per cent to 4 per cent after two applications had been made. At San Marcos there was a reduction from 73 per cent to 29 per cent after two applications which were followed by rain. The poisoned plat was full of blooms and bolls, but where it had not been poisoned there are few blooms and no bolls.

In these tests the counting was done by three men in order to eliminate the personal factor. The arsenical was applied with hand dust guns. This is said to have given the same effect as a four-row machine, having produced a cloud of dust that hung in the rows for 30 minutes or more when the weather conditions were favorable.

The cotton boll weevil, F. SHERMAN (*N. C. Agr. Ext. Serv. Circ. 104* (1920), pp. 20, figs. 8).—This is a summary of information on the cotton boll weevil, including the history of its invasion of North Carolina, means for combating it, etc.

A new tropical weevil from Florida and Cuba, H. S. BARBER (*Proc. Ent. Soc. Wash.*, 22 (1920), No. 6, pp. 150-152, pl. 1).—Under the name *Metamasius mosieri* the author describes a new species collected on Paradise Key, Fla., and Santa Clara Province, Cuba, which is supposed to breed in certain epiphytal plants of the tree tops in the jungle-like "hammocks."

Notes on the dicky rice weevil (*Prosayleus phytolymus* Oliff), L. GAL-LARD (*Agr. Gaz. N. S. Wales, 31 (1920), No. 4, pp. 280-284, figs. 11*).—Attempts to find the larvæ of this weevil have previously failed notwithstanding the fact that it has been a serious pest in the orchards and nurseries of New South Wales for the past 15 years. The author here reports upon the finding of larvæ and pupæ at a depth of 9 to 12 in. in the soil.

The adults emerge in the spring, attack the young shoots, and in many cases eat out the crown, while in others they so damage the shoot that its growth is stunted and deformed. The young leaves are eaten half away around the edges and the outer surface is chafed in patches almost all over the leaves. The older leaves when attacked are eaten all around the edges, leaving them irregular and scalloped. The young fruit is also attacked, the outer surface being nibbled off in irregular patches and lines. Young trees which have been eaten badly never make much growth and often stand in the nursery for two years without making more than a foot of young wood. The chafing of the roots by the larvæ is responsible for much of the injury and is almost identical with that of the apple root borer. There appear to be two broods each year.

Transferring of bees, F. E. MILLEN (*Ontario Dept. Agr. Circ. 27 (1920), pp. 12, figs. 12*).—This is a popular account.

FOODS—HUMAN NUTRITION.

The chemistry of foodstuffs in 1917 and 1918, H. KUTTENHEULER (*Chem. Ztg., 43 (1919), Nos. 145, pp. 841-843; 147, pp. 853-856; 149, pp. 869, 870; 152, pp. 889, 890*).—This is an extensive review of the literature on food chemistry published in 1917 and 1918. Following a general survey of the literature on food substitutes the subject matter is grouped under the headings of methods; meat, meat products, and substitutes; egg and egg preservatives; edible fats and oils; cereals, flour, and pastry; vegetables; vinegar and spices; honey, sugar, and confectionery; coffee, cocoa, and tea; fruit and fruit products; grape and fruit wines; and commodities. A list of 373 references to the literature is included.

On the chemistry of "chiai" flesh, Y. OKUDA (*Jour. Col. Agr., Imp. Univ. Tokyo, 7 (1919), No. 1, pp. 1-28, fig. 1*).—A chemical study is reported of "chiai," the blood-colored flesh in the lateral muscle of the fish. The studies include determinations of the general constituents, extractives, distribution of amino acids, and purin bases.

In comparison with the ordinary flesh of the same fish, the chiai was found to contain more ether extract and less carbohydrates, soluble matter, creatin, and total nitrogen. The content of phosphorus in lipoid form was higher and in inosinic acid form lower in chiai than in ordinary flesh. The former contained more hemoglobin and taurin.

Corn oil successful substitute for ghee, A. E. SOUTHARD (*U. S. Dept. Com., Bur. Foreign and Dom. Com., Com. Rpts., No. 115 (1920), pp. 946, 947*).—The author reports that American corn oil has been introduced to the trade of the Aden-Red Sea commercial district of Arabia as a substitute for ghee, or clarified butter. The corn oil is said to be similar in taste and flavor to the ordinary ghee and to offer promising possibilities as a substitute.

Pearl barley: Its manufacture and composition, J. A. LECLERC and C. D. GABBY (*Jour. Indus. and Engin. Chem., 12 (1920), No. 5, pp. 451-455, figs. 5*).—This contribution from the Bureau of Chemistry, U. S. Department of Agriculture, consists of a description of the process of manufacture of pearl barley, and the results of analyses of the original barley and the products of pearling obtained from five or six pearling operations.

These analyses show that the first two operations of pearling result in pot barley, bringing about the removal of most of the husk and carrying with it the greater part of the fiber and silica. The composition of the pot barley as compared with the original barley shows a loss of 22 per cent of the total material, 25 per cent of the protein, 41 per cent of the fat, and 50 per cent of the mineral constituents. In continuing the operations to produce the pearl barley, the loss in different constituents was as follows: Sixty-five per cent of the barley material, 74 per cent of the protein, from 80 to 85 per cent of the fat, P_2O_5 , K_2O , CaO , and MgO ; and from 97 to 98 per cent of the fiber and SO_2 .

Attention is called to the great waste of available food material involved in carrying the pearling beyond the pot-barley stage. "Assuming that 5,000,000 bu. of barley are being pearled yearly, 52,000 tons of barley material, consisting of over 1,000 tons each of fat and mineral ingredients and 6,700 tons of protein are removed."

Digestibility of steam-cooked soy beans and peanuts, A. D. HOLMES (*Jour. Amer. Med. Assoc.*, 74 (1920), No. 12, pp. 798-801).—When fed to healthy young men, steam-cooked soy beans and peanuts were both found to be well utilized, the carbohydrates in the entire diet in which the legumes formed a prominent part being 97 per cent digested in the case of the soy beans and 99 per cent in the case of the peanuts. The average digestibility of the soy bean protein was 79.9 per cent and of the peanut protein 92.8 per cent.

The fact that large quantities of soy beans and peanuts were consumed daily for three successive days without causing any physiological disturbances indicates that these foods cooked for two hours by steam at 15 lbs. pressure are well tolerated by the human body. It is concluded that soy beans and peanuts are specially valuable for human food as compared with other legumes which have been studied with the same thoroughness.

The drying of bananas, W. BURNS and P. G. JOSHI (*Agr. Jour. India*, 15 (1920), No. 2, pp. 166-173, figs. 3).—The authors have succeeded in drying bananas in India by exposing them to the sun under glass in an apparatus shaped somewhat like a museum case. The peeled bananas require from four to six days to dry thoroughly. It is said that from 20 to 30 moderate-sized bananas makes 1 lb. of dried material, which has good keeping qualities and can be eaten raw or used in the making of jam or various Indian food dishes.

Industrial medicine and surgery: [Food in industrial plants], H. E. MOCK (*Philadelphia: W. B. Saunders Co.*, 1919, pp. 846, figs. 210).—Industrial health service, prevention of disease, industrial medicine, industrial surgery, compensation, insurance, medicolegal phases, and reconstruction are discussed. The first-mentioned section contains a chapter on food, in which the need for attention to food for employees is insisted upon and ways are suggested whereby the physician or medical staff of the enterprise may be of assistance. The need for proper places where employees may eat the food brought with them, the advantages of a restaurant or eating place, and similar matters are discussed. If a restaurant is maintained, it is pointed out there should be periodical medical examinations of all employees and sanitary inspection of storerooms, dining rooms, etc., while food should be frequently inspected. The milk and ice cream should be bacteriologically examined, and every effort made to see that nourishing, well-prepared food is served. A score card for the frequent inspection of the restaurant is suggested. Some information is also given regarding plans followed in industry.

Studies on adaptation of man to high altitudes, I-V, E. S. SUNDSTROEM (*Univ. Cal. Pubs. Physiol.*, 5 (1919), Nos. 5, pp. 71-86; 6, pp. 87-104; 7, pp. 105-112; 8, pp. 113-120; 9, pp. 121-132).—This is a series of papers dealing with different phases of the adaptation of two persons (the author and his wife) in

several successive sojourns in high altitudes under conditions as nearly uniform as possible. The three high altitude stations were Leadville, Colo., 3,100, the shore of Fallen Leaf Lake, of the Sierra Nevada Mountains, 1,900, and Pike's Peak, 3,100 meters above sea level. The diets in all of the experiments were uniform, and the composition was determined by the composite sample method.

I. *Effect of high altitudes on pulse, body temperature, blood pressure, respiration rate, output of urine, and loss of energy in feces* (pp. 71-86).—The results of this study may be summarized as follows:

At elevations below 3,000 meters the quickening effect of the altitude on the pulse rate was inconstant, while above 3,000 meters the pulse rate was accelerated, particularly at first. After descending to low altitudes subnormal pulse rates were observed.

The body temperature was not appreciably affected at altitudes up to 3,000 meters, while above that altitude the temperature was increased. Mountain sickness was not accompanied by rise of temperature.

The systolic blood pressure was increased at altitudes of from 3,100 to 4,300 meters.

The volume of urine was decreased in the two to four first days at high elevations, but later an increase in volume took place. The assimilation of energy was not altered at high elevations.

II. *Effect of high altitudes on protein metabolism* (pp. 87-104).—In four experiments in high altitudes on a uniform low protein diet great variations were observed in the protein metabolism. At an altitude of 1,900 meters a slight retention of nitrogen was observed in the subject who had not previously lived at high elevations, but no appreciable effect on the protein metabolism was noted in the other subject. In the first period at 3,100 meters, the nitrogen and sulphur balances were negative, while the phosphorus balance was positive. In the second period, at the same elevation, an initial increase of the protein catabolism was followed by a tendency to retain nitrogen and sulphur. The phosphorus balance was close to equilibrium. At an elevation of 4,300 meters the nitrogen and phosphorus balances were close to equilibrium, the sulphur balance slightly negative. The calcium balance was negative in all but the period at 4,300 meters, when it was slightly positive.

III. *Effect of high altitudes on iron metabolism* (pp. 105-112).—"On a uniform diet, with a normal iron content, the iron balance did not alter at an elevation of 3,100 meters, although the erythropoetic organs were stimulated to greater activity. On a uniform diet, rich in organic iron compounds, the retention of iron at an elevation of 1,900 meters did not exceed the iron retention observed in low altitude. On a uniform diet of normal iron content to which iron acetate was added a great elimination of iron occurred at elevations of 3,100 and 4,300 meters. As the number of erythrocytes simultaneously decreased, it is suggested that the heavy output of iron was caused by the hemolysis of red blood corpuscles."

IV. *Effect of high altitudes on the carbon dioxide content and on the hydrogen-ion concentration of the blood* (pp. 113-120).—"The indirect determination by other observers of the CO₂ content of the blood in high altitudes from observation on the alveolar CO₂ tension, showing a proportional decrease with decreasing atmospheric pressure, have been confirmed at elevations of 3,100 meters and 4,300 meters by direct determinations of the CO₂ content of the blood.

"Alterations of the hydrogen-ion concentration of the blood have been observed in high altitudes. A slight acidosis was found when an apparently successful acclimatization was going on. A slight alkalosis was present in a case of mountain sickness.

"It is suggested that the acidosis may be beneficial, because it accelerates the reduction of the blood in the capillaries and thus facilitates the respiratory function of the blood. It is further suggested that an alkalosis of the blood may cause mountain sickness or contribute to the pathology of that condition by retarding the blood reduction."

V. *Effect of high altitudes on salt metabolism, with special reference to the mechanism of maintaining the acid-base equilibrium of the body* (pp. 121-132).—By computing the intake and output of acids and bases on a uniform diet in terms of N/10 solutions, an increase of the base output was observed at an elevation of 3,100 meters. This excess elimination of bases was in the form of fixed alkalis. In a case of mountain sickness at an altitude of 4,300 meters, the increase of base excretion was delayed.

It is suggested that the excessive base output was partly due to the elimination of bicarbonates and partly to salts of strong fatty acids, the increase in base excretion being the main mechanism in restoring the reaction of the blood disturbed by the loss of CO₂.

Dried milk powder in infant feeding, W. H. PRICE (*Pub. Health Rpts.*, [U. S.], 35 (1920), No. 14, pp. 809-828).—Safety, usefulness, and comparative value of dried milk powder in infant feeding are discussed in this preliminary report of investigations carried on by the U. S. Public Health Service cooperating with the Boston Baby Hygiene Association, the Boston Health Department, and other agencies.

Three groups of infants were fed under comparable conditions: The first with grade A milk, which contained 4 per cent of fat, 4.8 per cent of sugar, and 3.18 per cent of protein; group 2 with modifications prepared from whole milk powder, dispensed by nurses and reconstituted in the homes according to directions, containing 4 per cent of fat, 5.7 per cent of sugar, and 3.71 per cent of protein; and group 3 with modifications prepared from milk which was reconstructed from unsalted butter and skimmed milk powder, containing 4 per cent of fat, 5.1 per cent of sugar, and 3.1 per cent of protein. "Some difficulty was experienced in obtaining a perfect emulsion of the unsalted butter and powdered skimmed milk. A thin float of fat appeared on the surface of the milk in the necks of the bottles in which the milk was delivered, and this difficulty was never entirely overcome. This loss of fat was compensated for, however, so that the remaining emulsion contained the required 4 per cent, and the float was removed and discarded. It is believed that the ingredients and the machine used in this study are capable of producing better results than we obtained, but it is doubtful if better results are likely to be obtained in commercial practice at the present time."

Experimental data reported are summarized in the table which follows:

Results of feeding experiments comparing dried milk powders with whole milk in infant feeding.

Group.	Kind of milk.	Number of babies.	Average initial age.		Average initial weight.		Duration of feeding.		Average daily gain.
			Months.	Days.	Lbs.	Oz.	Days.	Oz.	
1	Grade A.....	27	3	20.5	10	14.2	66.8		0.63
2	Whole milk powder.....	30	3	20.0	10	6.8	71.1		.90
3	Skim milk powder and unsalted butter.....	14	4	12	4.2	69.1		.82

As regards safety, "such laboratory analyses as were made indicate that the dry milk powders and their remade products used in this study are safe for infant feeding."

With respect to usefulness, the conclusion is that "while gain in weight alone is not sufficient evidence on which to base final conclusions relative to the adequacy of a food for infant feeding, and while it may prove that excess gain over that which has been considered normal may not be desirable, the foregoing figures seem to indicate that the whole milk powder and the skimmed milk powder and unsalted butter employed in this study are useful in infant feeding, and further—and especially in the case of the whole milk powder, and in the case of babies who are undernourished and who digest natural milk badly—these remade milks may have points of distinct advantage in infant feeding. The figures also warrant the conclusion that reconstituted, reconstructed, and natural milks differ in their effects when fed to infants; and that reconstituted and reconstructed milks should be labeled and sold for what they are, and that they should not be substituted and sold for natural milk in a manner to deceive the purchaser. The figures further confirm the previous conclusion of the safety of the brand of remade milk used in infant feeding."

Data as to the comparative value of reconstituted, reconstructed, and natural milk in infant feeding with special reference to the influence of the different milks on the babies' general development, activity, teething, and disposition "strengthen the conclusions already drawn—viz, that reconstituted and reconstructed milks of the brand employed are safe and useful for infant feeding, and that in certain respects, particularly in the case of reconstituted milk and in the cases of babies who digest natural milk badly, they may have points of distinct advantage. The opinions of the nurses further strengthen the conclusion previously arrived at that reconstituted, reconstructed, and natural milks differ in their effects when fed to infants.

"The facilities available for this study permitted the use of only one brand of dried milk powder. Therefore no conclusions are drawn relative to the safety, usefulness, advantages, or disadvantages of other brands."

The application of butter-flour feeding to infant feeding, H. KLEIN-SCHMIDT (*Berlin. Klin. Wchnschr.*, 56 (1919), No. 29, pp. 673-675).—This is a discussion of the merits of the butter-flour preparation described by Türk (E. S. R., 42, p. 255) as a substitute for milk in infant feeding. The author recommends the preparation for infants above the age of 13 days and body weight of 2,000 gm. (4.4 lbs.), the proportions of butter and flour varying with the age of the child. It is considered particularly desirable for infants suffering from severe inanition, infection, and constitutional abnormality, but is not recommended in cases of disorders of the alimentary tract.

Accessory food factors in infant feeding (*Lancet [London]*, 1920, I, No. 11, pp. 604-607).—Essentially noted from another source (E. S. R., 43, p. 166).

Effect of heat on the antiscorbutic accessory factor of vegetable and fruit juices, E. M. DELF (*Biochem. Jour.*, 14 (1920), No. 2, pp. 211-228, figs. 4).—Experiments are described in which the juice of fresh cabbages, swedes, and oranges was fed to young guinea pigs as the sole antiscorbutic factor in a basal ration of oats and bran ad libitum and from 60 to 90 cc. autoclaved milk daily. This rather liberal milk ration was adopted as producing healthier animals while not affecting appreciably the onset of scurvy.

The minimal daily dose of the raw juice for the adequate protection of young guinea pigs was about 1 cc. of cabbage, 2.5 cc. swede, and 1.5 cc. orange juice, respectively. On heating the juices to 100° C. for an hour the orange juice did not show any marked deterioration of antiscorbutic properties, while it required twice the dose of the raw juice in the case of the swede and at least 7.5 times the amount of the raw juice of the cabbage to give the necessary protection. Only at 130° was any definite deterioration in the orange juice detected, about twice as much being required as of the raw juice. The dif-

ferences in stability to heat of the three juices did not appear to be due to their H-ion concentration.

The growth curves recorded in these experiments furnish evidence that growth is affected by the limitation of the antiscorbutic factor in the diet apart from the appearance of definite symptoms of scurvy and apart from deficiency in the growth-promoting vitamins.

The stability of the swede and orange juice at temperatures above 100° is thought by the author to be due possibly to the absence of air during the process of heating in the autoclave. "This may well affect the rate of destruction, either directly by retarding oxidation or indirectly by the production of stabilizing bodies. The rather surprising stability at 130° in the absence of air suggests that there may be advantage in adopting methods of canning fruit or vegetables at temperatures above boiling point for as short a time as possible to insure sterility. Further investigations into the value of canned products would appear to be desirable."

Orbital hemorrhage with proptosis in experimental scurvy, S. S. ZILVA and G. F. STILL (*Lancet [London]*, 1920, I, No. 19, p. 1008).—The authors report a case of exophthalmos and hemorrhage of the eyelids in a monkey which had been fed for about two months on a scorbutic diet. Recovery was rapid on the administration of double strength decitrated lemon juice as an antiscorbutic. Attention is called to the fact that the exophthalmos affected the left eye, which is in agreement with the special tendency to a similar left-eye infection in scorbutic infants.

The apparent influence of a diet of carbohydrates on the pancreas remnant of partially pancreatectomized dogs, V. W. JENSEN and A. J. CARLSON (*Amer. Jour. Physiol.*, 51 (1920), No. 3, pp. 423-429).—From experiments undertaken with the view of determining more definitely whether a carbohydrate diet prevents pancreatic hypertrophy or induces pancreatic degeneration after partial pancreatectomy, the authors conclude that while their results, in general, support the view that a liberal carbohydrate diet tends to change diabetes levis into diabetes gravis after partial pancreatectomy in dogs, the question can be definitely settled by the statistical method only, using a large number of animals.

The view that the impairment of the pancreas in diabetes is a direct result of physiological overstrain is considered untenable in view of the indications from human and comparative physiology that starvation within limits tends to rejuvenate tissues in general.

Hydrolysis of the muscle proteins of *Loligo breckeri*, *Palinurus japonicus*, and *Paralithodes camtschatica*, Y. OKUDA, S. UEMATSU, K. SAKATA, and K. FUJIKAWA (*Jour. Col. Agr., Imp. Univ. Tokyo*, 7 (1919), No. 1, pp. 39-54).—Determinations are reported of the hydrolysis products of the muscle proteins of *L. breckeri*, a mollusk and of *Palinurus japonicus* and *Paralithodes camtschatica*, two Crustacea.

The results of these studies, together with those of previous studies by the senior author and collaborators and similar studies from the literature, are summarized in a table which makes possible a comparison of the hydrolysis products of mammals, birds, fish, Crustacea, and Mollusca.

It is pointed out that while there are differences in the amounts of the hydrolytic products of the various muscle proteins, these differences are more marked in the case of the amino acids which can be synthesized in the animal body than of the physiologically more important amino acids which can not be synthesized. The quantity of lysin tended to be slightly larger and the arginin smaller in the muscle proteins of the vertebrates than in those of the invertebrates.

Hydrolysis of the muscle proteins of the whale and the cod, Y. OKUDA, T. OKIMOTO, and T. YADA (*Jour. Col. Agr., Imp. Univ. Tokyo*, 7 (1919), No. 1, pp. 29-37).—Continuing the comparison of the composition of the muscle substances of aquatic animals (E. S. R., 40, p. 171), analyses are reported of the hydrolysis products of the muscle proteins of the whale and the cod.

Further data concerning the alleged relation of catalase to animal oxidations, R. L. STEHLE and A. C. McCARTY (*Jour. Biol. Chem.*, 42 (1920), No. 2, pp. 269-272).—Further evidence in support of the previous suggestion (E. S. R., 42, p. 259) that fluctuations in catalase content of the blood are due to fluctuations in the number of red blood cells and not to variations in metabolism as alleged by Burge (E. S. R., 40, p. 766) is presented in a series of experiments in which measurements were made of the CO₂ production and hemoglobin and catalase contents of rabbit and cat blood drawn to correspond as nearly as possible to successive periods of normal and high metabolism, the latter produced by rapid cooling of the body.

The results of these experiments are considered to demonstrate conclusively that there may be great variations in the rate of animal metabolism without any corresponding change in the catalase content of the blood.

ANIMAL PRODUCTION.

Studies in the preservation of corn silage, S. I. BECHDEL (*Pennsylvania Sta. Rpt. 1916*, pp. 323-348).—Investigations of the normal fermentation temperatures of corn silage and the influence of the material used in constructing the silo on the composition and quality of the silage are reported. Five silos were used, two of the patent wood-stave type and one each of concrete block (solid wall), hollow-tile block, and monolithic concrete.

The maximum temperature attained was slightly in excess of 80° F. and was approximately the same with all types. Since the quality of silage was excellent in all cases it is concluded that higher temperatures are unnecessary.

Thirteen comparisons all indicated that the total acidity of silage near the center of the silo is greater than that of samples collected near the walls. In the later case there was also proportionally more acetic and less lactic acid, a difference attributed to less firm packing close to the walls.

The proportion of lactic acid developed in the stave silos was higher than in the concrete types, but otherwise there were no characteristic differences in chemical composition between the silages made in the different silos.

A contribution to the bacteriology of silage, J. M. SHERMAN (*Pennsylvania Sta. Rpt. 1916*, pp. 295-300).—Previously noted from another source (E. S. R., 35, p. 769; 36, p. 611).

On the hydrolysis of straw, [F.] HONCAMP (*Landw. Vers. Sta.*, 95 (1919), No. 1-3, pp. 69-89).—This paper, read at a meeting of the Association of Agricultural Experiment Stations in Germany, consists of a general summary of methods used in hydrolyzing straw for feeding purposes and preliminary reports of some digestion trials with sheep. Remarks by other speakers follow the main paper.

It is concluded that hydrolysis under pressure results in greater loss of organic matter than cooking in open vessels. Hydrolysis with sodium hydroxide produced substantial increases in digestibility of rye straw, barley straw, and oat straw, but only slight increases in the case of pea straw, seed beet straw, and rape straw.

Steer feeding experiments, W. H. TOMHAVE and P. GERLAUGH (*Pennsylvania Sta. Rpt. 1916*, 219-251, pls. 8).—This paper is divided into three parts. The experimental results reported in part 1 dealt with the place of silage in

the fattening ration and formed the 1915-16 results in a 3-year summary noted from Bulletin 145 (E. S. R., 37, p. 365).

Part 2 gives the results from 2 lots of 6 promising 980-lb. steers fed 140 days beginning November 17, 1915. Lot 2, which received corn, cottonseed meal, corn silage, and mixed hay, made an average daily gain of 2.17 lbs. per head. Lot 1, which received the same ration as lot 2, except that 5 lbs. of molasses was substituted for 5 lbs. of corn, made a daily gain of 2.36 lbs., but did not show as much finish as lot 1.

In part 3 it is reported that a group of 12 thin steers were carried through the winter in good condition on corn stover, mixed hay, and a ration of 2.5 lbs. of cottonseed meal per 1,000 lbs. live weight. On March 15 ear corn was added to the ration and on May 18 the steers were put on blue-grass pasture, supplemented with corn and cottonseed meal, for an 8-weeks' finishing period. The average daily gain up to March 15 was 0.78 lb. per head and after that date 1.83 lbs.

Individual weights and feeding records are given in the reports of all three experiments.

Records of body measurements of steers, B. O. SEVERSON and P. GERLAUGH (*Pennsylvania Sta. Rpt. 1916*, pp. 251-282).—Tables are presented similar to those previously noted (E. S. R., 38, p. 69) giving the individual body measurements (23 dimensions) of the 84 steers used in the experiments noted above, both at the beginning and at the end of the feeding periods.

Ground soy beans for fattening cattle, F. G. KING (*Indiana Sta. Bul. 237 (1920)*, pp. 3-6).—A summary of three comparisons between ground soy beans and cottonseed meal as supplements to corn for fattening steers is presented. The detailed results have been noted from Bulletins 167, 178, and 183 (E. S. R., 35, p. 475). The cattle did not relish the ground soy beans as a daily feed for more than a limited period (say 100 days), but when palatable this feed was as efficient as cottonseed meal. The chemical analyses of the samples of soy beans and cottonseed meal are also averaged. No oil was extracted from the soy beans and they had an average fat content of nearly 19 per cent. It is predicted that soy-bean oil meal would prove a still more satisfactory feed.

Problems of sheep breeding, I, F. AEREBOE ET AL. (*Arb. Deut. Landw. Gesell., No. 293 (1918)*, pp. 190, pl. 1).—This publication includes the following papers: Types of Sheep Farming, by Aereboe; Breeding, by Brödermann; Sheep Pastures, by Ulrichs; The Condition of Teeth in Relation to the Age of Sheep, by Ulrichs; Profitableness of Sheep Raising, by [G.] Stieger; Sheep Diseases, by [R.] von Ostertag, and Sheep Barns, by [A.] Blume.

Maintenance rations for breeding flocks of mutton and wool types of sheep, O. B. SEVERSON (*Pennsylvania Sta. Rpt. 1916*, pp. 113-218, pls. 25).—This is the complete report of experiments noted from Bulletin 144 (E. S. R., 36, p. 667). Individual weights, and feeding, lambing, and wool records are tabulated in detail.

The accounts of a Hampshire flock in 1918-19, D. HALL (*Jour. Min. Agr. [London]*, 27 (1920), No. 2, pp. 126-132, fig. 1).—The author summarizes a year's financial records of a flock of 281 Hampshire ewes belonging to the Lord Wandsworth Institution, the attempt being made to separate the costs of pedigree sheep raising from the costs of the other farm enterprises.

It was found that the British Government's price-fixing policies whereby no premium was allowed for spring lamb made sheep raising on arable land very unprofitable. "The accounts further illustrate the unremunerative character of pedigree stock breeding in the early years before the name of the herd or flock has been made. The quality of the produce may be undeniable, but a

place in the charmed circle of big prices depends very much upon the personal skill and advertising art of the owner."

A map is presented showing the decline in sheep breeding in different parts of England.

Further studies on the influence of humidity upon the strength and elasticity of wool fiber, J. I. HARDY (*Jour. Agr. Research [U. S.]*, 19 (1920), No. 2, pp. 55-62, figs. 4).—Additional determinations of the mechanical properties of wool fiber at the Wyoming Experiment Station are reported in continuation of work previously noted (E. S. R., 39, p. 774). Most of the observations were made on a set of four samples of different average diameters at five relative humidities, viz, 40, 50, 60, 70, and 80 per cent. Observations on one of the samples was made at 100 per cent humidity.

The ultimate strength of both scoured and unscoured wool per unit of cross-section area decreased irregularly as the humidity changed from 40 to 80 per cent. The strength of unscoured wool then increased as the saturation point was reached, while the strength of scoured wool remained substantially unchanged. The elastic limit increased steadily until it reached a maximum at 80 per cent humidity and then declined abruptly.

Particularly in the case of the finer wools, the ultimate strength seemed to vary as the diameter of a fiber, and not as the cross-section area (square of the diameter).

Regulations of the Secretary of Agriculture under the United States Warehouse Act of August 11, 1916, as amended July 24, 1919.—Regulations for wool warehouses (*U. S. Dept. Agr., Off. Sec. Circ. 150 (1920)*, pp. 31).—This publication includes the text of the United States Warehouse Act and the regulations for wool warehouses promulgated June 18, 1920.

Variations in farrow, with special reference to the birth weight of pigs, W. J. CARMICHAEL and J. B. RICE (*Illinois Sta. Bul. 226 (1920)*, pp. 67-95, fig. 1).—The authors tabulate and discuss a large amount of data extracted from the farrowing records of the university herd of swine from 1903 to 1916. Many of the tables have the form of frequency distributions and correlation tables, but averages and percentages are the only statistical determinations attempted.

The following table summarizes such of the records as are grouped by breeds, omitting the two litters of Hampshires:

Relation of breed of hogs to gestation period, fertility, and birth weights.

Breed.	Average age of sow.	Number of gestation records.	Gestation period.			Pigs per litter.	Average weight of litter.	Average weight of pig.
			Average.	Shortest.	Longest.			
	<i>Years.</i>		<i>Days.</i>	<i>Days.</i>	<i>Days.</i>		<i>Pounds.</i>	<i>Pounds.</i>
Berkshire.....	2.42	293	115.4	98	124	7.42	19.3	2.61
Chester White.....	2.52	30	113.0	106	119	9.59	24.8	2.59
Duroc-Jersey.....	2.04	62	113.1	102	118	8.74	19.7	2.25
Poland China.....	2.34	48	114.6	107	118	6.57	16.5	2.50
Tamworth.....	2.28	32	113.8	110	123	9.43	24.4	2.58
Large Yorkshire.....	2.85	30	113.2	107	117	11.58	30.1	2.60

In the treatment of the mutual relationships of length of gestation, age of sow, size of litter, birth weight, order of farrowing, sex ratio, and still births, the records of all breeds and a few crossbred litters are combined.

The average gestation period was 114.58 days. The length of gestation seemed not to be influenced by the age of the sow. Litter size was not affected by length of gestation, but sows under two years of age produced litters

averaging 7.5 pigs, while litters from older sows averaged 8.6 pigs. The pigs farrowed by young sows averaged 2.44 lbs. in weight, and those from older sows 2.61 lbs. Where successive litters were secured from the same sow there was, in general, an increase in the number of pigs per litter and in the weight of individual pigs up to the fourth litter. Older sows farrowed a higher proportion of dead or immature pigs than the younger sows.

Among 5,657 pigs whose sex was recorded, 51.9 per cent were males. Of pigs born dead, about 56 per cent were males. In 261 litters where the order of birth was observed, males formed 59.4 per cent of the pigs farrowed first and 51 per cent of those farrowed last.

Variation of individual pigs in economy of gain, R. C. ASHBY and A. W. MALCOMSON (*Jour. Agr. Research [U. S.], 19 (1920), No. 5, pp. 225-234*).—This paper gives the complete details of an investigation at the Minnesota Experiment Station, previously noted from preliminary reports (*E. S. R., 41, p. 772*). When the pigs in each group were arranged in order of daily gain, and in order of economy of gain, it was found that more than 60 per cent of the fastest growing pigs were also distinctly economical producers, but when all the 63 pigs were considered the coefficient of correlation between rate and economy of gain (each measured as percentage of group mean) was distinctly negative (-0.452 ± 0.068).

Dry lot v. pasture crop for growing pigs with a self-feeder, H. H. HAVNER and P. GERLAUGH (*Pennsylvania Sta. Rpt. 1916, pp. 109-111, pls. 4, fig. 1*).—A comparison between dry lot and pasture for feeding 40-lb. pigs is reported, differing from the two similar comparisons previously noted (*E. S. R., 38, p. 69*) in that the animals had free choice of the feeds offered (corn meal and tankage). The pasture was oats and peas for 5 weeks, and then rape for 14 weeks.

Considering the entire 19 weeks, the 18 pigs not on pasture made an average daily gain of 0.77 lb. per head while the 20 in the pasture group gained 1.04 lbs. per head daily. The costs of the feeds are recorded but not the amounts consumed. Gains were produced more cheaply by the pasture group. During the first 5 weeks corn and tankage were selected by the dry lot in the proportion 6.9:1 and by the pasture group in the proportion 16.1:1. The total consumption for the 19 weeks showed the proportions to be 9.1:1 and 21.6:1, respectively.

Maintaining brood sows, H. H. HAVNER and M. F. GRIMES (*Pennsylvania Sta. Rpt. 1916, pp. 89-106*).—A summary of an experiment conducted in the winter of 1914-15 and the complete data (individual weights, feeding records, costs, etc.) of a duplicate experiment the following year are presented.

Four lots of 5 sows were used each year, several breeds being represented in each lot. The following feeds were offered the respective lots before farrowing (1) Alfalfa hay, plus a little corn at the beginning; (2) alfalfa hay with corn throughout; (3) corn and tankage, 10:1; and (4) corn meal, ground oats, and wheat middlings 1:1:1. After farrowing all received the same feed mixture, viz, corn meal, middlings, bran, and tankage, 4:3:1:1, the bran being omitted after 3 weeks.

In each year the lot fed mainly on alfalfa lost in weight and were in poor condition at farrowing, while the other lots all gained. During the nursing period the alfalfa-fed sows consumed more feed than the other lots, and therefore the cost of carrying these sows from the beginning of pregnancy to the end of the weaning period was not lower than the costs in the case of lots 2 and 3. The mixture fed lot 4 prior to parturition is deemed too expensive, since better and more economical results were secured with lots 2 and 3.

In 1914-15 lot 1 averaged 4.5 pigs per litter, lot 2 produced 6, and lots 3 and 4, 7.3 each. The corresponding figures for 1915-16 were 7.4, 7.8, 10.2, and 4.5.

Lot 2 produced the heaviest pigs and lot 4 the lightest in the first experiment, and lot 4 the heaviest and lot 1 the lightest in the second experiment.

Swine feeding experiments with oil cakes and other feeding stuffs, MÜLLER (*Ztschr. Landw. Kammer Braunschweig*, 89 (1920), No. 3, pp. 33, 34; also in *Deut. Landw. Tierzucht*, 24 (1920), No. 17, pp. 173, 174).—Ten lots of four 50-kg. hogs were fed for one or two 4-week periods. Six lots received rye bran and an oil cake meal (1:2), 3 lots a fish meal as 20 per cent of the concentrate ration, and the remaining lot a commercial hog feed. The daily concentrate ration was 1.5 kg. per head, and all hogs had free access to fresh mangels.

The lot fed codfish meal and corn feed meal made a total gain of 910 kg. in 8 weeks. The lot fed herring meal and rye bran gained 844 kg. and that fed codfish meal and rye bran 665 kg. These were the best gains. The gains in the 4 cake-fed lots that were continued 8 weeks varied from 635 to 422 kg., with rape seed oil meal producing the most and peanut oil meal the least gains, while palm kernel oil cake (coarsely ground) and coconut oil meal were intermediate in value. Lots fed corn oil meal and ground soy beans were continued only 4 weeks. In this period the latter feed produced nearly the same gain as rape seed cake, while the former produced only 247 kg., which was the same as the palm nut meal.

American mules as substitutes for draft horses and work oxen (*Nachr. Deut. Landw. Gesell. Österr., n. ser.*, 4 (1920), No. 1, pp. 7, 8).—This is an editorial discussion advocating the importation of mules from the United States to be used as work animals on farms in German Austria and Czecho-Slovakia. It is stated that practically all the horses and oxen have been slaughtered for food, and that nearby countries have no work horses for export.

The hardness and longevity of mules and their economical use of feed are emphasized.

Utilize the mule for farm work, H. CIROTTEAU (*Vie Campagne*, 16 (1919), No. 197, p. 275).—The author suggests the use of mules instead of horses as work oxen on French farms.

The study of some feed mixtures with reference to their potential acidity and their potential alkalinity, I, B. F. KAUPP and J. E. IVEY (*Jour. Amer. Assoc. Instr. and Invest. Poultry Husb.*, 6 (1920), No. 6, pp. 57-60, 62, 63).—The authors extend the table of mineral analyses of poultry feeds given in a previous paper from the North Carolina Experiment Station (E. S. R., 39, p. 577), note the potential acidity or alkalinity of 34 feeds, and report some feeding experiments.

All the cereal products examined (except wheat middlings) were potentially acid, while legume feeds, green feeds, animal products (except whole eggs), and dried fish), limestone grit, and oyster shell were alkaline.

In the feeding experiments the scratch feed consisting of corn and oats was acid in reaction, while the mash compound of middlings, corn meal, oats, and a protein supplement was alkaline. The protein supplements tested were buttermilks, meat-and-bone meal, tankage, blood meal, soy-bean oil meal, and peanut feed. A table gives the relative amounts of grain and mash consumed by each of the six lots of chicks in the first three 8-week periods after hatching, the protein calories in the feed, the relative growth attained in each period, and the amount of feed required per unit of gain. No marked differences in growth-producing capacity are evident between acid and base rations, although it is not certain that any of the rations were markedly acid, since no record was kept of the consumption of grit. The chicks were Single Comb White Leghorns, and the ones fed animal by-products began to lay toward the end of the third period. Relatively more mash was consumed as laying began.

Studies relating to calcium metabolism, W. P. WHEELER (*New York State Sta. Bul.* 468 (1919), pp. 3-43).—The author reports seven series of experiments with chickens and ducks conducted at intervals over a term of years, one series dating back to 1897. The birds employed in the respective series were young hens, chicks, laying hens, young ducks, ducklings, mature nonlaying ducks, and laying ducks. The basal rations fed to all the birds were low in calcium, the feeds being selected from the following materials: Cracked corn, corn meal, corn gluten meal, starch, rice, rice flour, wheat flour, wheat gluten, apples (without seeds), beef fat, bone-free meat scrap, blood meal, gelatin, and common salt. During part of the tests with mature hens the yolks and whites of eggs and sour milk whey were also fed. White quartz glass sand covered the floor, and rain water was provided for drinking purposes. In addition to the basal ration the three lots in each series received, respectively, magnesium, strontium, and calcium carbonate, and in some cases also the corresponding phosphates. Usually a lot consisted of six birds. They were killed at intervals after several weeks to a year's feeding. Tables present the skeletal weights of the slaughtered birds and mineral analyses of the axial and appendicular skeletons and the shells of such eggs as were laid.

No instance was found where magnesium served to any significant extent in place of calcium to form egg shells directly or to replace the calcium withdrawn from the skeleton for egg production. Strontium, on the other hand, although normally not a constituent of the body or of ordinary feeds, did serve in place of calcium in egg shells and bones.

"Whenever rations deficient in calcium but carrying abundant supplies of magnesium were fed to the common fowl and the duck, there soon followed a noticeable shortage of calcium and of total mineral matter in the bones. With mature birds whenever calcium was withdrawn from the skeleton it was usually taken in larger proportion from the softer bones [axial skeleton].

"When strontium salts were fed with low calcium rations for several weeks or months to mature fowls, these birds always had heavier bones with more mineral matter in them than did similar birds fed corresponding calcium or magnesium salts. Where strontium replaced calcium in the bones of mature birds, the ratio of replacement in every instance was higher in the softer bones." In some cases after prolonged strontium feeding more strontium than calcium was found in the feathers.

Of the two species, the common fowl showed the greater tolerance for strontium and the duck a greater tolerance for magnesium. Ducks fed strontium were noticeably deficient in body fat. More eggs were secured from hens fed strontium than from those fed magnesium, while only very few eggs were laid by strontium-fed ducks. Scarcity of calcium reduced egg laying markedly in both the fowl and the duck.

Something about calcium in the body, W. P. WHEELER (*New York State Sta. Bul.* 468, pop. ed. (1919), pp. 3-11).—A popular edition of the above, emphasizing particularly the applications to human and animal nutrition.

Capons v. cockerels.—A comparison of their rate of growth and feed consumption, R. H. WAITE (*Maryland Sta. Bul.* 235 (1920), pp. 119-132, figs. 9).—This bulletin reports the growth and feeding records of two lots of 21 White Plymouth Rock cockerels hatched March 28, 1919, from the age of two months, when one lot were caponized, until the following February, when both were marketed. During the growing period the birds were given corn and wheat and a dry mash of bran, middlings, and beef scrap (10:10:3) plus bone meal and salt. During a 3-week fattening period, begun January 17, yellow corn and a wet mash of cornmeal, middlings, beef scrap, and alfalfa meal (10:5:2:3), and salt were offered.

In the 33-week growing period the cockerels increased in weight from 1.13 to 6.73 lbs. per bird, while the capons increased from 1.1 to 7.42 lbs. The capons did not begin their faster growth until October. During the fattening period the cockerels gained only 0.06 lb. per head while the capons put on an average of 0.34 lb. The cockerels consumed 10.95 lbs. of feed per pound of grain and the capons 9.5 lbs.

The capons dressed out with a loss of 6 per cent in weight and the live cockerels shrank 2.6 per cent during shipment to Baltimore. With feed at 3.5 cts., capons at 55 cts. and live cockerels at 34 cts. a pound, there was an average loss of 45 cts. per head on the cockerels and an average profit of \$1.24 on the capons.

The author deplors the erroneous statements to be found in some poultry books that capons grow much larger than cockerels.

Broodiness: Its influence and control, R. R. HANNAS (*New Jersey Stas., Hints to Poultrymen*, 8 (1920), No. 10, pp. 4).—The economic loss due to broodiness is illustrated by data secured at the first Vineland egg-laying contest. Some control measures are suggested.

The effect of age of eggs on their hatching quality, R. H. WAITE (*Maryland Sta. Bul.* 233 (1919), pp. 87-101, figs. 8).—Observations are recorded of the hatching percentages of a total of 26,415 eggs grouped according to the length of time (up to 28 days) between laying and the beginning of incubation.

It is concluded that "the deterioration in hatching quality of eggs with age is slight up to the sixth or seventh day, but after this period the rate of deterioration is very much accelerated and varies almost directly with the age." Eggs set on the day laid hatched at least as well as those held for a few days. No differences were observed between Leghorn and White Plymouth Rock eggs.

Data are also presented showing that the practice of turning eggs prior to incubation is unnecessary if not harmful.

A list of breeders of standard bred poultry in Montana (*Montana Sta. Spec. Circs.*, 6 (1918), pp. 19; 7 (1920), pp. 16).—These lists are classified by breeds.

Standard of perfection for rabbits, cavies, mice, rats, skin and fur bearing animals (*Cleveland: Henry M. Adolph*, 1920, pp. 52, figs. 2).—This is a formulation of exhibition standards for varieties of rabbits and guinea pigs recognized by the National Breeders and Fanciers Association of America, together with briefer notes on mice, rats, and skunks.

DAIRY FARMING—DAIRYING.

Breeding experiments with dairy cattle, W. M. REGAN (*N. J. Dept. Agr. Bul.* 24 (1920), pp. 323-326).—The author outlines briefly the plans of two breeding experiments being started by the New Jersey Experiment Stations, one of which involves crosses between Jerseys and Holsteins and the other a study of inbreeding in Holsteins.

Calf rearing, J. L. BRUCE (*New Zeal. Jour. Agr.*, 20 (1920), No. 5, pp. 289-298, figs. 10).—Two 17-week feeding experiments are reported, each involving 4 lots of 4 calves less than one week old at the start. Except in one lot the ration during the first 2 weeks consisted of whole milk exclusively (8 lbs. per head daily). Various amounts of skim milk and home-grown concentrates were fed during the rest of the period, and the calves had access to pasture. There were no deaths.

In the first experiment, conducted at the Ruakura Farm of Instruction, Hamilton, the initial weights varied from 301 to 303 lbs. per lot. In the case of 3 lots skim milk feeding (15 lbs. per head daily) continued throughout the final

15 weeks with the following results: (1) Daily gain per head of 1.61 lbs. when the daily grain ration was boiled whole linseed 8 oz. and flour 2 oz.; (2) gain of 1.54 lbs. on 8 oz. of oat meal and 4 oz. of crushed linseed, and (3) gain of 1.77 lbs. on 9 oz. of crushed linseed. The fourth lot received a grain ration of linseed meal 7.5 oz. and "bean meal" 12 oz. but was given skim milk (8 lbs. daily) during the third and fourth weeks only. The daily gain was 1.36 lbs. per head.

At the Central Development Farm, Weraroa, where the second test was conducted, the initial weights varied from 261 to 280 lbs. per lot. Only one lot received skim milk (16 lbs. per head daily) throughout the last 15 weeks. Linseed was also fed to this lot (4 oz. per day boiled to a jelly in water), and the average daily gain was 1.6 lbs. Two lots were fed exclusively on skim milk (16 lbs.) during the third and fourth week, and during the final 13 weeks received in one case 1 lb. of crushed oats and in the other 3 oz. of linseed meal and 4 oz. of flour. The daily gains per head were, respectively, 1.7 and 1.5 lbs. The fourth lot received 8.5 lbs. whole milk per head during the first week of the test, 16 lbs. of skim milk during the second week, and an aqueous infusion of "bean meal" (8 oz.) and linseed meal (6 oz.) without milk during the last 15 weeks. The daily gain was 2.3 lbs. per head.

Suggestions regarding dairying in northwestern Kansas, J. B. FITCH and J. J. BAYLES (*Kansas Sta. Circ. 81 (1920), pp. 16, figs. 6*).—As an example of dairy farming in northwestern Kansas, some results secured at the Colby sub-station with a small herd of grade Ayrshires are outlined. The use of the pit silo is considered an important item in successful dairying in this region.

The decline of alpine dairy farming in Switzerland, Austria, and Bavaria, with particular reference to the Bavarian Allgäu, T. SPANN (*Landw. Jahrb. Bayern, 9 (1919), No. 9-10, pp. 505-583*).—This is a study of the economic conditions which in recent decades have tended to keep milking stock in the valleys during the mountain pasture season, the elevated pastures being used chiefly for heifers and dry cows. A live-stock census of the Allgäuer Alps of Bavaria is included.

A study of the dairy herd records of the Pennsylvania Experiment Station, A. L. BEAM (*Pennsylvania Sta. Rpt. 1916, pp. 353-391, figs. 3*).—This consists of tabulated statistics (with discussions) of milk and fat production in a grade Guernsey herd of which records have been kept since 1890. "No selection has been practiced, every heifer calf being raised and kept in the herd regardless of its conformation and producing ability." The records are arranged so that the production of an individual in successive lactations can be studied conveniently.

The annual milk yields of a cow were found to increase through the first six lactations and then decrease slowly. The average individual produced 76 per cent of her maximum milk yield as a two-year old, 83 per cent as a three-year old, and 86 per cent at the age of four years. The fat percentage was highest in the second lactation.

"In studying the records of 81 cows which are included in these tables, it was found that had these cows been culled upon the basis of their two-year-old records in only two cases would good cows have been sacrificed."

Of the seven herd sires employed, two failed to increase the average milk production of their daughters over that of the dams.

Advanced-registry testing of dairy cows, F. W. WOLL and P. I. DOUGHERTY (*California Sta. Circ. 218 (1920), pp. 15, figs. 6*).—This circular describes the conditions under which advanced-registry testing is conducted in California. Some of the records secured are cited.

A study of forced feeding and methods used in advanced registry feeding, H. O. HENDERSON (*Pennsylvania Sta. Rpt. 1916, pp. 393-419*).—The author tabulates the protein and energy in the feed consumed by cows undergoing advanced registry (year) tests, considering 10 Guernsey, 6 Ayrshire, and 3 Jersey records made at the Pennsylvania Experiment Station, and 1 Holstein record (Missouri Chief Josephine) made at the Missouri Station. The consumptions are compared with the requirements on the Armsby standard.

“With the Guernsey group it required on the average 21.91 per cent more protein and 14.63 per cent more energy to produce a pound of milk, and 20.21 per cent more protein and 14.94 per cent more energy to produce a pound of butter fat under forced feeding than under standard feeding. With the Ayrshire group this was even more apparent. Here it required on the average 39.58 per cent more protein and 27.27 per cent more energy to produce a pound of milk, and 39.68 per cent more protein and 25.67 per cent more energy to produce a pound of fat. . . . The Jersey group averaged almost the same as the Guerneys, and Missouri Chief Josephine was somewhat lower than any, averaging only 6.02 per cent more protein and 20.80 per cent more energy to produce a pound of milk and 21.45 per cent more protein and 12.08 per cent more energy to produce a pound of fat when forced than if fed according to the standard.

“The average for the 20 cows, which is probably not far from the amounts which should be fed to cows when running on advanced registry test was 27.23 per cent more protein and 16.94 per cent more energy to produce a pound of milk and 25.88 per cent more protein and 16.46 per cent more energy to produce a pound of fat under forced feeding than under standard feeding.”

Experimental tests with a number of reputed galactogogues are also reported. Each test was made with 10 (in one case 9) cows. Cows of similar productivity were paired off and fed (or otherwise treated) simultaneously or by the reversal method during two periods of short duration (2 days or 1 week). Results with feeding gentian and nux vomica, injecting pilocarpin hydrochlorid, applying alcohol to the udder prior to milking, and changes in the character of the grain ration were negative or inconclusive. Feeding sodium bicarbonate (2 oz. per day) produced slight but consistent increases in the amounts of milk. Feeding of malt extract, which was relished by the cows, increased the milk in the case of 7 of the 10 cows and increased the amount of fat in 9 cases. Ginger fed at the rate of 2 oz. per day was not particularly palatable, but the percentage of fat was increased (varying from 0.011 to 0.334) in all 10 cases, and in 7 cases the amount of fat was increased. Withholding water for two days tended to decrease the amounts of milk and fat. These positive results are deemed suggestive rather than conclusive.

Effects of drugs on milk and fat production, F. A. HAYS and M. G. THOMAS (*Jour. Agr. Research [U. S.], 19 (1920), No. 3, pp. 123-130, figs. 8*).—The galactogogic properties of the following substances were tested at the Delaware Experiment Station: Air-slaked lime, Fowler's solution of arsenic, gentian, physostigmin (eserin) sulphate, sodium bicarbonate, ginger, and two tonic mixtures, one composed of linseed meal, saltpeter, epsom salts, gentian, fenugreek, charcoal, and sulphur, and the other of black sulphid of antimony, sulphur, fennel, caraway, juniper berries, and common salt. The physostigmin was injected hypodermically and the others were given with the feed at the rate of 2 oz. per day. Each was administered to four cows during a 5-day period.

There was some evidence that the air-slaked lime increased the amount of milk significantly, and perhaps the amount of fat. Results with the other substances were entirely negative.

An economic method of determining the average percentage of fat in a cow's milk for a lactation period, E. J. SHEEHY (*Sci. Proc. Roy. Dublin Soc., n. ser., 15 (1919), No. 40, pp. 546-573, pl. 1, figs. 6*).—The author tabulates the individual morning and evening milk yields and fat percentages of 11 cows for 40 consecutive days and similar daily data for one cow during nearly 9 months, the object being to find a method of estimating the fat yield of a lactation from systematic weighings of milk and a limited number of fat analyses. It is concluded that analyses on 4 successive days during the middle of lactation (particularly the fifth and sixth months) provide an average fat percentage which in general differs from the true lactation average by less than 10 per cent. Samples for analysis are not to be collected within several weeks of change to or from pasture.

The comparative variation of the constituent substances of cows' milk, E. J. SHEEHY (*Sci. Proc. Roy. Dublin Soc., n. ser., 15 (1919), No. 41, pp. 574-584, figs. 4*).—The author tabulates the morning and evening milk and fat yields of a cow during 82 consecutive days and the fat percentage and lactometer reading of each milking, and by Richmond's formula estimates the total solids, solids-not-fat, and water content of each sample. From inspection of these data in tabular and graphical form it is concluded that the fat is the most variable constituent.

"A lactating cow produces water and solids-not-fat in proportions which are practically constant and produces fat in proportions which bear no constant ratio to the total milk, thus indicating that fat production is influenced by factors which are not identical with those influencing the production of the other constituents of the milk."

Conditions causing variation in the reaction of freshly drawn milk, L. L. VAN SLYKE and J. C. BAKER (*New York State Sta. Tech. Bul. 70 (1919), pp. 9; also in Jour. Biol. Chem., 40 (1919), No. 2, pp. 345-355*).—In 308 samples of cow's milk, each representing the foremilk from one quarter of the udder, the H-ion concentration varied from pH=6.5 to pH=7.2. In 83 per cent of the samples pH was less than 6.76. In two sets of samples, collected from the separate teats of 20 cows, some erratic variations in the reaction of milk from the different quarters of the udder of the same cow were observed. In the first set the 4 samples were approximately uniform in the case of 4 animals, and in the second set (not presented in detail) they were uniform in 10 individuals. In one case milk from the right front quarter belonged in the most acid group of samples, while that from the right hind quarter was the only definitely alkaline sample of the 80 tested.

Chemical analyses were made of 15 samples of known pH values, and leucocyte and streptococcus counts were made of the 10 having the lowest H-ion concentration. In general, with a decrease of acidity there was a definite tendency toward a decrease in specific gravity and in the percentages of fat, total solids, solids-not-fat, casein, and sugar; and an increase in noncasein protein, ash, and chlorin. The samples of high leucocyte content were alkaline except where acid-producing streptococci were present.

Because of this relationship between leucocytes and low acidity, which was confirmed by observations on milk known to have been derived from diseased udders, the hypothesis was formulated that the lowered acidity resulted from the direct passage of blood serum into the alveoli through lesions caused by bacterial action. However, careful tests for glucose in the milk serum were negative, and it is concluded that at least the blood sugars underwent transformation in the udder.

Reaction of milk in relation to the presence of blood cells and of specific bacterial infections of the udder, J. C. BAKER and R. S. BREED

(*Jour. Biol. Chem.*, 43 (1920), No. 1, pp. 221-235).—Observations were made of the acidity and the leucocyte and streptococcus content of 124 samples of milk, as a further test of the above-noted hypothesis of Van Slyke and Baker.

"From the new data here given, and from histological and physiological considerations, it appears that a more exact statement of the case would be that the infection causes the entrance of a serous exudate derived by the gland cells directly from the lymph rather than from blood. This serous exudate is neither exactly like blood serum nor milk. When the infection has proceeded to the place that actual rupture of the vessels occurs, then unchanged lymph and blood would enter. The modifications in the secretions may be due to a weakening of the secretory activity of the cells, or the exudate may have a definite protective function against the bacterial infection, or both conditions may hold simultaneously." Desquamation of the glandular epithelium accompanies the secretory changes.

Carbonic acid and carbonates in cow's milk, L. L. VAN SLYKE and J. C. BAKER (*New York State Sta. Tech. Bul.* 69 (1919), pp. 9; also in *Jour. Biol. Chem.*, 40 (1919), No. 2, pp. 335-344).—The carbon dioxide content of 25 samples of milk drawn from separate quarters of the udder varied from 7 to 86 per cent by volume, the usual determination being about 10 per cent. The H-ion concentration decreased in general with increase in CO₂. When milk was pasteurized the CO₂ was decreased, but the H-ion concentration remained unchanged.

It is estimated that CO₂ exists in milk as H₂CO₃ and as NaHCO₃ (or other bicarbonate) approximately in the proportion 1:2. The CO₂ tension in milk seems to be the same as in other body fluids.

In making the CO₂ determinations the authors used the method of D. D. Van Slyke (*E. S. R.*, 37, p. 804). A 20 per cent solution of lactic acid was used in place of sulphuric acid to separate CO₂ from the carbonates. The lower CO₂ content of milk reported by previous workers is attributed to the faulty use of the ordinary vacuum exhaustion method which, it was found, failed to remove the CO₂ unless the milk was kept spread out in a thin film by constant agitation.

Bacteriological methods for determining the quality of milk, II.—The advantages of a carbohydrate medium in the routine bacterial examination of milk, J. M. SHERMAN (*Pennsylvania Sta. Rpt.* 1916, pp. 301-310, pls. 2, figs. 3).—This continuation of work noted in the previous report (*E. S. R.*, 38, p. 74) has been abstracted from another source (*E. S. R.*, 36, p. 875).

The determination of the keeping quality of milk, J. C. BAKER and L. L. VAN SLYKE (*New York State Sta. Tech. Bul.* 72 (1919), pp. 8).—Previously noted from another source (*E. S. R.*, 42, p. 209).

A method for the preliminary detection of abnormal milks, J. C. BAKER and L. L. VAN SLYKE (*New York State Sta. Tech. Bul.* 71 (1919), pp. 3-14).—Previously noted from another source (*E. S. R.*, 42, p. 209).

An epidemic of ropy milk, H. A. HARDING and M. J. PRUCHA (*Illinois Sta. Bul.* 228 (1920), pp. 111-124, fig. 1).—This bulletin, which is written in a popular style, consists of a discussion of the cause of ropy milk and an account of the methods adopted to cope with a severe outbreak of the infection among the patrons of a large milk plant. Thorough pasteurization (holding at 140° F. for 30 minutes) and the prevention of reinoculation by careful sterilization of cooling tanks, milk pumps, piping, bottle fillers, and bottles, put an end to complaints from customers. "Ropy milk germs" were found in the water supply of at least one farm, and on two occasions in material removed from the udders and flanks of cows.

Manual for the dairy-plant worker, L. MORELLI and A. BIANCHI (*Manuale del Casaro. Milan: Ulrico Hoepli, 1918, 2. ed., pp. XVI+259, pl. 1, figs. 128*).—This manual for managers and technical workers in milk plants, creameries, and cheese factories covers in brief space the handling of market milk and the manufacture of butter and cheese, and devotes considerable attention to the problems of the cooperative dairy.

Advertising.—A factor in merchandising dairy products (*U. S. Dept. Agr., Bur. Markets, Fluid Milk Market Rpt., 1920, May, Sup., pp. 2; also in N. Y. Produce Rev. and Amer. Creamery, 50 (1920), No. 8, pp. 528, 530-532*).—This article includes a brief report of a survey by the Bureau of Markets of the publicity methods employed by milk dealers, and some suggestions for appropriate advertising copy emphasizing the food value of milk.

The 1917 expenditures for advertising were only about 0.3 per cent of the gross sales, and the 1919 expenditures 0.4 per cent. There was no general agreement as to the most effective kind of advertising, but about a quarter of the expenditure went for space in local newspapers. Instances of cooperative educational campaigns are cited.

VETERINARY MEDICINE.

Parasites and parasitosis of the domestic animals, B. M. UNDERHILL (*New York: The Macmillan Co., 1920, pp. XIX+379, figs. 184*).—This work on the zoology and control of animal parasites and the pathogenesis and treatment of parasitic diseases is intended for use by the student and practitioner. It consists of three parts, part 1 (pp. 1-153) dealing with the external parasites; part 2 (pp. 155-310) with the internal parasites; and part 3 (pp. 311-352) with the pathogenic protozoa. A glossary and a subject index follow.

Forage poisoning: Character of causative agent, mode of infection, means of prevention, and specific treatment, R. GRAHAM (*Univ. Ill., Col. Agr. Ext. Circ. 38 (1920), pp. 16, figs. 11*).—This is a popular summary of information.

Pyotherapy, HARTNACK (*Berlin. Tierärztl. Wehnschr., 35 (1919), No. 34, pp. 305-308*).—This is a review of recent literature on pyotherapy under the following headings: History of pyotherapy, preparation, action, dosage and application of pyovaccines, surgical treatment, and success of pyotherapy. A list of 22 references to the literature is appended.

Useful drugs (*Chicago: Amer. Med. Assoc., 1920, 4. ed., pp. 176*).—This is the fourth edition of the handbook prepared under the direction and supervision of the council on pharmacy and chemistry of the American Medical Association to supply the demand for a less extensive materia medica. It consists of a list of the more common useful drugs, with a brief discussion of their action, usage, and dosage. Among the changes in the present revision is the adoption of nonproprietary names such as arsphenamin "in place of the monopolistic and nondescriptive proprietary titles."

Culture media from fish, E. HARDE and A. HAUSER (*Compt. Rend. Soc. Biol. [Paris], 82 (1919), No. 31, pp. 1259, 1260*).—The authors have prepared a culture medium from the common whiting by boiling 500 gm. of the fish for 20 minutes in a liter of water, filtering on paper, and sterilizing the filtrate at 120° C. for 20 minutes, after which it can be used in place of meat extract in the preparation of agar or gelatin media. Another culture medium has been made by adding a small piece of the fish to 8 cc. of water in an ordinary tube and sterilizing for 20 minutes.

Preliminary studies have shown the two media to be very satisfactory for the growth of pneumococcus, streptococcus, etc.

The agglutinability of attenuated microorganisms, P. FABRY (*Compt. Rend. Soc. Biol. [Paris]*, 83 (1920), No. 7, pp. 201, 202).—On cultivating *Bacillus typhosus* in culture media containing increasing proportions of phenol, increasing agglutinating powers were obtained with decreasing strength of the organism.

The presence and importance of coagglutinins in immune sera, C. SARTI (*Ann. Ig. [Rome]*, 29 (1919), No. 6, pp. 349-358).—This is a report of a study of the phenomenon of coagglutinin formation in dogs immunized against various organisms.

In the course of immunization against typhoid and paratyphoid A and B of normal dogs, the sera of which originally contained no agglutinins against the various organisms used, not only were agglutinins formed for the specific organisms, but the sera acquired agglutinating power against organisms of a different species from that serving as antigen. Weak agglutinating power for the specific organism corresponded with weak secondary agglutinating properties, which became stronger with stronger specific agglutinating power. The strength of the secondary agglutinins was not, however, in strict proportion to that of the primary, and differed with the various antigens employed. Both the primary and secondary agglutinins in dogs were located principally but not exclusively in the pseudoglobulin fraction of the serum.

The administration of sera by the respiratory tract, A. BESREDKA (*Ann. Inst. Pasteur*, 34 (1920), No. 1, pp. 51-54).—In the course of the author's researches on anaphylaxis and immunity the effect of the administration of sera by the respiratory tract has been studied on guinea pigs and rabbits.

It was found that the respiratory tract is capable of absorbing large quantities of serum which causes no anaphylactic shock in normal animals but provokes anaphylaxis in sensitized animals. If the consistency of the serum approaches the solid state anaphylactic accidents are more easily avoided.

The method is recommended on account of the rapidity of absorption, absence of danger of anaphylaxis, and simplicity of operative technique.

Serological groupings of *Vibrio septique* and their relation to the production of toxin, M. ROBERTSON (*Jour. Path. and Bact.*, 23 (1920), No. 2, pp. 153-170, pls. 2).—An examination of 23 strains of *V. septique* for agglutinating properties indicated that there are at least three serological types. The presence of slight impurities in the cultures usually rendered them unagglutinable.

The production of a soluble toxin was demonstrated for 11 strains tested for this property, equally potent toxin being obtained from old laboratory strains and from those recently isolated from acute cases of gas gangrene. The toxin injected intravenously into rabbits in doses of from 0.1 to 1 cc., according to the potency, produced death in from 3 to 10 minutes with symptoms of respiratory disturbance, paralysis, and convulsions. Monotypical antitoxins neutralized the toxins from cultures belonging to each of the three types. A serum made with the toxin from two strains belonging to the same type protected guinea pigs against infection with living cultures of *V. septique* belonging to the three agglutination types and to a fourth strain which at present stands in a group by itself.

Attention is called to the account by Meyer (E. S. R., 34, p. 479) of an outbreak of so-called symptomatic anthrax in hogs due to an organism with the properties of *V. septique*. An examination of two strains of *Bacillus chauvavi* showed that they differed in agglutinating properties and in cultural and morphological characters from all three types of *V. septique*.

A study of *Bacillus pyogenes*, J. H. BROWN and M. L. ORCUTT (*Jour. Expt. Med.*, 32 (1920), No. 2, pp. 219-248, pls. 3, figs. 4).—" *B. pyogenes* is probably

quite common in this country, as it is known to be in Europe. A careful study of 12 strains from cattle and one from a hog has disclosed the following characteristics, which have not been reported or have been in dispute:

"*B. pyogenes* is gram-positive and pleomorphic, producing forms ranging from short chains of streptococoid elements to branching filaments. It is hemolytic, producing the beta type of hemolysis in blood agar. It is not hemoglobinophilic, though its growth is greatly favored by some higher protein material, such as egg albumin, serum, or blood. It ferments xylose in addition to the substances previously reported. The coagulation of milk by *B. pyogenes* is primarily an enzym coagulation, and the subsequent digestion of the curd takes place in an acid medium. The intravenous injection of rabbits was invariably fatal. The lesions most commonly developed were those of the bones. Paralysis was frequently produced, and in each case was caused by lesions in the vertebræ exerting pressure against the ventral columns of the spinal cord. Muscle abscesses were also frequently produced. The authors regard the organism as belonging to the Corynebacteria rather than to the influenza group."

A bibliography of 34 titles is included.

African coast fever, L. E. W. BEVAN (*Rhodesia Agr. Jour.*, 17 (1920), No. 2, pp. 118-129, pls. 7, figs. 8).—This revision of the account previously noted (E. S. R., 34, p. 879) includes colored plates showing the life history of the brown tick (*Rhipicephalus appendiculatus*). In addition to the brown tick, which is the chief offender, the disease is transmitted by *R. evertsi*, *R. simus*, *R. capensis*, and *R. nitens*.

Vaccination and serum prophylaxis for anthrax in the province of Milan during 1918-19, L. COMINOTTI (*Clin. Vet. [Milan], Rass. Polizia Sanit. e Ig.*, 42 (1920), No. 15-16, pp. 499-503).—In the province of Milan 3,740 cattle were vaccinated for anthrax during 1918-19, and of these 580 were revaccinated five months after the first inoculation. In cases of no particular urgency simple vaccination was employed, while in cases of immediate urgency serum therapy was practiced, followed later by serum or simple vaccination.

In administering the serum 20 cc. was injected subcutaneously at frequent intervals, the temperature of the animals being taken twice daily. When the temperature of the animal rose to from 41 to 42° 200 cc. of the serum was given once intravenously. This was usually followed in a few hours by a drop in the temperature. Eight days after the first injection of the serum the animals were vaccinated in the ordinary manner, the vaccination being repeated on the twelfth day with a double dose (5 cc.).

The author advocates a systematic vaccination by triple inoculations four months apart of vaccines of increasing virulence in order to establish immunity against severe forms of natural contagion. It is stated that there have been no losses from anthrax in the province of Milan since this practice has been adopted.

Anthrax in cattle subjected to the inoculation of antianthrax serum or to antianthrax serum vaccination, L. COMINOTTI (*Clin. Vet. [Milan], Rass. Polizia Sanit. e Ig.*, 43 (1920), No. 3, pp. 96-103).—Attention is called to an atypical form of anthrax noted in animals which have succumbed as the result of the application of too small a dose of antianthrax serum. On autopsy such animals present a different appearance from usual cases of anthrax, in that the blood and spleen may contain no anthrax bacilli. In such cases the kidneys and the tissues should be examined for the organism and for lesions due to infiltration. Cattle slaughtered on the first symptoms of anthrax may present a similar atypical appearance and the spleen pulp react negatively on bacterio-

logical examination. In such cases it is necessary to make use of animal inoculation to establish an accurate diagnosis.

The detection of anthrax precipitinogen in the hide of a cow having an atypical case of glanders. W. PFEILER and E. HOLTZHAUER (*Berlin. Tierärztl. Wchnschr.*, 35 (1919), No. 5, pp. 37, 38).—The post-mortem examination of a cow supposed to be the cause of anthrax infection in the man who slaughtered it gave negative results as to bacteriological findings, pathological changes in the various organs with the exception of a hyperplastic tumor on the spleen, and the precipitin test with the under skin. The precipitin test with the corium and outer skin, including the hair, gave positive results.

The authors are of the opinion that in an animal which has been thoroughly bled few precipitins are present in the under part of the skin, but that in the corium the network of fine blood vessels and capillaries is not so readily emptied of blood and consequently contains more antigens.

Note on the diagnosis of glanders. R. VAN SACEGHEM (*Compt. Rend. Soc. Biol. [Paris]*, 83 (1920), No. 10, pp. 305-307).—The author discusses briefly the limitations of the various methods in use for the diagnosis of glanders, and proposes a method based upon the observation that all cases of glanders, whether acute or chronic, are accompanied by a very marked leucocytosis which is constant whatever the temperature of the animal. The determination of the leucocytic formula is thought to be of great usefulness in the diagnosis of pulmonary glanders in which there is no nasal localization and where the mallein reaction would give only uncertain indications. The test is, however, of value only in cases in which there exists no concomitant disease.

Infection, sensitization, and immunity in epizootic lymphangitis. A. BOQUET and L. NÈGRE (*Ann. Inst. Pasteur*, 33 (1919), No. 10, pp. 678-712).—This is a detailed report and discussion of the authors' investigations on epizootic lymphangitis, a briefer report of which has been previously noted from another source (*E. S. R.*, 40, p. 885). An extensive bibliography is appended.

Preservation of fixed virus. J. G. NASSY and F. W. WINCKEL (*Arch. Schiff's u. Tropen Hyg.*, 22 (1918), No. 24, pp. 438-441).—As the result of an examination of the glycerin and drying methods for the preservation of rabies virus, the authors recommend the drying process (vacuum dehydration over sulphuric acid) as furnishing the most stable product.

The glycerinated product, although kept in the ice box, lost its virulence after three months, while the dried product retained its virulence for a longer time even when kept at room temperature. At higher temperatures (22°) neither product was stable except when kept in the ice box.

Rinderpest. L. TEPPAZ (*Rec. Méd. Vét.*, 95 (1919), No. 21, pp. 642-644).—From observations of rinderpest in Sénégal, the author concludes that the survivors of rinderpest apparently confer a certain degree of immunity to their offspring, as shown by the fact that the latter contract only a relatively mild form of the disease with low mortality. The gradual disappearance of the disease from a locality is attributed to the acquired and transmissible immunity. Brief accounts are given of observations supporting this claim.

The question of the solubility of tubercle bacilli in specific immune substances. BAATZ (*Centbl. Bakt. [etc.]*, 1. Abt., Orig., 84 (1920), No. 2, pp. 81-88).—The author has repeated the experiments of Kraus and Hofer previously noted (*E. S. R.*, 28, p. 283), as the result of which the claim was made that subjects infected with tuberculosis produce specific bacteriolysins for tubercle bacilli.

The present experiments were also conducted on guinea pigs, the principal difference in technique being a more careful measurement of the number of

tubercle bacilli injected by the use of a standard suspension in salt solution. The injections were made subcutaneously instead of intramuscularly.

From the results reported, the conclusions are drawn that a specific solution of tubercle bacilli in a tuberculous organism does not take place, that the biological method for the differentiation of acid-fast bacteria is not reliable, and that the importance of bacteriolysis in tuberculosis immunity has not yet been proved.

Benzyl alcohol in experimental tuberculosis (in vitro), J. JACOBSON (*Compt. Rend. Soc. Biol. [Paris]*, 82 (1919), No. 31, pp. 1264-1266).—The author reports that benzyl alcohol has the power of dissolving tubercle bacilli and of rendering them less easily stained by fuchsin. Subcutaneous injection of 0.02 gm. of benzyl alcohol into tuberculous rabbits was found to cause no local or general reaction.

Chemotherapy of tuberculosis with potassium cuprocyanid, C. HOLLANDE and J. GATÉ (*Compt. Rend. Soc. Biol. [Paris]*, 83 (1920), No. 7, pp. 178-180).—Potassium cuprocyanid has been found to have properties similar to those of the cyanopurpl of Koga (*E. S. R.*, 36, p. 278). In weak doses it has no bactericidal action on the tubercle bacillus. In the experimental tuberculosis of guinea pigs, it first causes congestion around the lesion and then a tendency to form granular tissue.

The present status of tuberculosis treatment with partial antigens of Deycke-Much, K. KLARE (*Internatl. Centbl. Gesam. Tuberkulose Forsch.*, 14 (1920), No. 1, pp. 4-16).—A review of the literature from 1907 to 1919, including 119 references.

Infectious abortion in cattle.—II. Specific measures of control and ultimate eradication, G. C. WHITE and L. F. RETTGER (*Connecticut Storrs Sta. Bul.* 103 (1919), pp. 139-150, figs. 5).—This second contribution to the subject (*E. S. R.*, 39, p. 491) discusses the rôle of the bull as a carrier of the infection and the manner of control by disinfection. The authors recommend the use of a 1 per cent solution of cresol. The sheath should be disinfected by use of a continuous flow suction and injection pump with rubber tube attached.

The control of contagious bovine pleuropneumonia in French SÉNÉGAL, L. TEPPAZ (*Rec. Méd. Vét.*, 95 (1919), No. 21, pp. 614-617; *abs. in Trop. Vet. Bul.*, 8 (1920), No. 1, pp. 57, 58).—The method employed in SÉNÉGAL for combating pleuropneumonia in cattle consists in vaccinating all of the cattle in infected herds with material from the lungs of an affected animal slaughtered for the purpose or which had died within six hours. The inoculations are made at the tip of the tail or on the forehead, three incisions being made.

It is reported that 15,400 cattle were thus vaccinated in 1918, and 6,817 during the first half of 1919.

Malignant catarrhal fever of cattle in Kansas, L. W. GOSS (*Vet. Notes*, 13 (1920), No. 2, pp. 29-31).—The author records the occurrence of this disease on several farms in Kansas. In one herd of 30 grown animals, all of which were affected, 5 succumbed and 1 aborted. None of the calves was affected. In none of the herds was there any indication that the disease was transmitted from one animal to another. In two places the opportunity for transmission was excellent, if it is a transmissible disease. In most of the herds it seemed that the onset was sudden and the recovery slow. After the trouble developed, the feeds were changed and there was no recurrence.

A note on the treatment of surra in camels by intravenous injections of tartar emetic, H. E. CROSS (*Agr. Research Inst. Pusa Bul.* 95 (1920), pp. 6).—Experiments reported led to the conclusion that a number of camels were cured, and that tartar emetic gives promise of success in the treatment of surra.

Clinical researches upon equine infectious anemia, E. FRÖHNER (*Monatsh. Prakt. Tierheilk.*, 29 (1919), No. 9-10, pp. 385-405; *abs. in Vet. Rec.*, 32 (1920), No. 1660, p. 510, pl. 1, fig. 1).—The epizootic which appeared in 1917-18 in Posen, Silesia, and East Prussia constituted a septicemia sui generis, which is transmissible to healthy horses through the injection of blood and which may be considered as infectious anemia. Its etiology remains unknown, and it is also uncertain whether there is an identity between the disease observed on the eastern frontier and the western German frontier with the anemia observed in France, America, and Japan. According to the experiences on the eastern frontier, in America, and in Japan, it seems probable that infection is caused by the puncture of insects (Stomoxids, Tabanids). On the western frontier, however, the disease seemed to be a contagion in the stable, due to a filterable virus. Moreover, from the negative results of attempts at infection by contact, and from some diversity in the symptoms, it may be supposed that the disease in the West is not identical with that found on the eastern frontier.

Equine anemia appears to have no relation with pernicious anemia of man (absence of poikilocytosis and of erythrocytosis). The diagnosis presented great difficulty, the principal clinical symptoms of anemic mucous membranes and fever often being absent. No constant characteristic hematological appearances existed, only anisocytosis and lymphocytosis being found. Exact examinations of the blood were not possible in practice, and thus the anatomo-pathological results were often negative, especially in chronic cases. The only certain means of diagnosis is the injection of blood into healthy horses. The differential diagnosis is very difficult, because generally not a few secondary anemias are comprised under the name of infectious anemia. The author concludes that in view of the difficulties of the clinical and anatomo-pathological diagnosis, and our very limited knowledge of the etiology and pathogenesis of the disease, its compulsory notification is not advisable for the present.

A contribution to the study of habronemiasis: A clinical, pathological, and experimental investigation of a granulomatous condition of the horse, habronemic granuloma, L. B. BULL (*Roy. Soc. So. Aust. Trans.*, 43 (1919), pp. 85-141, pls. 3; *abs. in Rev. Appl. Ent.*, 8 (1920), Ser. B, No. 3, pp. 51, 52).—The evidence is said to indicate that the house fly acts as the intermediate host of certain species of *Habronema*, the larvæ of which cause a granulomatous condition generally affecting the external mucous membranes of the horse in South Australia. When deposited on the external mucous membrane the larvæ are apparently able to penetrate to the submucosa. An account is given of the life histories of *Habronema muscæ*, *H. megastoma*, and *H. microstoma*.

The prophylaxis of joint evil in foals, W. SCOTT (*Vet. Rec.*, 32 (1920), No. 1648, pp. 373-375).—This is a report of the observations of the author and three other practitioners regarding the prophylactic treatment of joint-ill by the following method:

"Active immunization of the pregnant mother, invariably at or as near as possible the ninth month, with a polyvalent vaccine composed of streptococci and staphylococci and *Bacillus coli*.

"Passive immunization of the foal at birth with antistreptococcal plus antistaphylococcal plus anticolic sera, by subcutaneous and intra-umbilical injections."

Three injections of the pregnant mare with the vaccine and two injections of the foal (at 10 days' interval) with hyperimmune sera are recommended as the only safe means of acquiring immunity.

Infectious abortion disease of swine, J. TRAUM (*Swine World*, 8 (1920), No. 1, pp. 208, 209, 211, 212, figs. 3).—This is a practical discussion of this dis-

ease in swine, based upon the results of work at the California Experiment Station.

In the outbreaks investigated, the author and Hayes have found a microorganism, indistinguishable from *Bacillus abortus* Bang, to be responsible for disease in swine in California. This organism has been consistently found in the afterbirth and vaginal discharges of the sow and in organs and body fluids of the aborted pigs, in most cases to the exclusion of all other bacteria. Abortion infections in sows have also been caused by the injection and feeding of this organism.

Infectious abortion of swine, L. P. DOYLE and R. S. SPRAY (*Jour. Infect. Diseases*, 27 (1920), No. 2, pp. 165-168).—This report of investigations at the Indiana Experiment Station is summarized as follows:

"The history of eight herds indicates that infectious abortion of swine is a serious and increasingly important source of loss to the swine industry. Inoculation of two guinea pigs with triturated afterbirth from an aborting sow resulted in an infection, as demonstrated by the development of agglutinins and typical lesions. At the time of inoculation the blood of the two guinea pigs did not agglutinate a *Bacillus abortus* (Bang) antigen. Four weeks after inoculation the blood agglutinated this antigen completely in all dilutions up to and including 1:500. An organism was isolated from the liver and spleen of both guinea pigs, which, except for slight cultural peculiarities, is indistinguishable morphologically, culturally, or agglutinatively from typical *B. abortus*.

"Rabbit antiserum for four cattle strains and for this swine strain gave cross-agglutination to the same titer as with the homologous antigens. Antigen of the swine strain completely absorbed agglutinins from antiserum for each of the four cattle strains. Antigen of the four cattle strains each completely absorbed agglutinins from antiserum for the swine strain."

Success with "galloserin" for fowl cholera in Rumania, JAHN (*Berlin. Tierärztl. Wchnschr.*, 35 (1919), No. 30, p. 260).—Successful results are reported in the use of a commercial vaccine "galloserin" both as a preventive and curative measure for fowl cholera. Of a total of 2,062 sick and well fowls thus vaccinated by the author, less than 1 per cent succumbed later, and of these only the weakest and sickest.

Blackhead in chickens and its experimental production by feeding embryonated eggs of *Heterakis papillosa*, T. SMITH and H. W. GRAYBILL (*Jour. Expt. Med.*, 32 (1920), No. 2, pp. 143-152).—This report of work in continuation of that previously noted (*E. S. R.*, 43, p. 475) has led to the following conclusions:

"Feeding embryonated eggs of *H. papillosa* to brooder chickens led to a disease of both ceca, characterized by the presence of a core consisting of fecal matter, coagulated blood, and emigrated cells from the mucosa. The walls of the ceca were thickened as a result of cell invasion and multiplication, invasion and multiplication of *Amœba meleagridis* or allied parasites, and more rarely hemorrhage and edema. The respective parts played by *H. papillosa* and the protozoa in starting the lesions and the source of the protozoa remain to be defined. The invasion of the liver by the protozoa was insignificant."

Earthworms: The important factor in the transmission of gapes in chickens, R. H. WAITE (*Maryland Sta. Bul.* 234 (1920), pp. 103-118, figs. 6).—This bulletin consists of an extensive review of the literature, together with a report of experiments conducted at the Maryland Experiment Station.

The experiments are believed to establish the fact that earthworms are the important factor in the transmission of gapes, as contended by Walker,¹ rather

¹Bul. Buffalo Soc. Nat. Sci., 5 (1886), No. 2, pp. 47-71.

than being of only secondary importance as assumed by Salmon.¹ Such conclusion is based upon the fact that "100 per cent infection was obtained in all chicks fed earthworms taken direct from the original infected soil. No chick contracted gapes from gape-infected chicks of the same age even when closely confined with them. Neither of the two chicks fed gape worms taken from chicks which died from the disease became infected. None of the 24 chicks allowed to partake freely of earth direct from the infected yard contracted the disease. While Megnin,² Walker, Salmon, Ransom,³ and others showed it possible to produce gapes in chicks by feeding them gape worm embryos hatched in water, it seems improbable that under practical conditions such contaminated water would be available to the chicks except in rare instances. It is shown conclusively that earthworms are capable of playing an important part in carrying gapes over from one season to another. Adult fowls were infected with gapes by feeding them earthworms from the infected chick run. It is pointed out that the important method of treatment is to prevent the disease by keeping the young chicks from obtaining infected earthworms. This can usually be done by growing the chicks on new land or confining them when the ground is wet with rain or dew, at which time earthworms are at the surface."

The chicken sticktight flea (*Sarcopsylla gallinacea* Westw.), C. E. SANBORN (*Oklahoma Sta. Bul. 130 (1920), pp. 3-8, figs. 4*).—This is a popular summary of information. The author recommends the use of a 5 to 10 per cent mixture of kreso in vaseline or lard; or a mixture of carbolic acid, 1 part and vaseline 5 parts; or 1 part of kerosene to 2 parts of lard, applied to the infested parts. Four parts of zenolium in 100 parts of water, sprayed in the poultry houses and yards, is said to be quite effective.

RURAL ENGINEERING.

Agricultural associations for irrigation of soil according to Italian practice, E. P. CASELLI (*Bul. Inst. Égypte, 1 (1919), pp. 71-85*).—The legal and economic phases of irrigation practice in Italy are discussed, with particular reference to the organization and operation of irrigation associations or districts.

Precast concrete slabs for small irrigation structures, R. W. OLMSTED (*Engin. News-Rec., 84 (1920), No. 24, pp. 1167, 1168, figs. 5*).—Precast concrete slabs for small irrigation structures are described, and experience on their use on several California irrigation projects is discussed. They are used especially for gates, checks, and drops, and no nails or bolts are used in assembly. The bond between slabs is obtained by beveled lugs on the ends and sides, which fit into corresponding recesses in the adjoining slabs. Beams are used as spreaders. The structures are designed so that joints between slabs will come where the bending moment is least, thus requiring the lugs to resist shear only.

The reinforcing consists of 6 by 6 in. galvanized No. 6 wire mesh. At current prices the cost is about the same as it would be for redwood lumber, and it is stated that the saving in cost of the precast gate over the cost of monolithic structures varies from 25 to 40 per cent. The amount of concrete per slab gate is only from one-third to one-half of the monolithic structure.

Factors affecting the use of water in irrigation, E. A. MORITZ (*Engin. News-Rec., 84 (1920), No. 24, pp. 1150-1155*).—This paper, a contribution from

¹ Rept. U. S. Dept. Agr., 1885, pp. 274-277.

² Rept. U. S. Dept. Agr., 1884, pp. 281-296.

³ Ann. Rept. Sec., U. S. Dept. Agr., 1917, p. 122.

the U. S. Reclamation Service, discusses the scientific and practical aspects of irrigation water utilization in connection with the presentation of data on the use of water for the seven seasons from 1912 to 1918, inclusive, by 22 irrigation projects.

The soil, climate, and class of crops are considered to be the three fundamental factors upon which the probable water requirements must be based in the design of irrigation systems. It is pointed out that alfalfa is the backbone of irrigation agriculture. Combining all the projects, the percentage of area devoted to forage crops, mostly alfalfa, is 56, indicating that other crops are of more or less incidental importance from a broad viewpoint. Furthermore, the data show that for purposes of design of the principal canals and structures and determination of storage requirements, a knowledge of the quantity of water required each month is of prime importance.

Data on seepage losses from canals indicate that concrete lining is the most practicable and satisfactory. "It is very costly, especially the lining of old canals which have a greater cross section than is needed for the smoother concrete surface, but its results are certain and permanent, especially in the milder climates, and for this reason lining with concrete is now recognized as the standard method of preventing seepage losses. Even concrete lining, however, does not prevent losses entirely." It is concluded that 25 per cent is about the minimum loss that can be safely assumed under favorable conditions, and that 50 per cent is sufficiently high under unfavorable conditions.

Use of water from Kings River, Calif., 1918, H. BARNES (*Calif. Dept. Engin. Bul. 7 (1920), pp. 119, pls. 13, figs. 2*).—This report presents the results of a field study of the use of water for irrigation from Kings River during 1918, conducted under a cooperative agreement between the Bureau of Public Roads of the U. S. Department of Agriculture and the California State Department of Engineering. In addition, methods of water delivery, organization of companies for water distribution, and essential conditions affecting the use of water, including water contracts, water rates, and the physical characteristics of the various systems are dealt with.

The data show a total of 40 diversions with a capacity of practically 10,450 second ft. The area served is 840,000 acres, of which 553,000 acres are estimated to be irrigated.

Of the organizations diverting water, 15 are upon a cooperative basis and 6 sell or have sold contract water rights. The cost of water from contract companies varies from 60 cts. to \$1 per acre per year and from the cooperative organizations from 10 cts. to \$1 per acre. It is noted that the average gross duty of water represented by diversions to the capacity of 10,450 second ft. upon the total 840,000 acres under ditch is in the ratio of 1 second ft. to 80.4 acres.

The two most prominent features of the situation on Kings River are said to be the need for public supervision of diversions on the basis of a clearly defined list of priorities, and a more systematic and more economical administration of the distribution of water to irrigators.

Comparative study of the potable waters of the canton of Ticino from the chemical and microbiological viewpoints, A. VERDA (*Helvetica Chim. Acta, 3 (1920), No. 1, pp. 3-22*).—Considerable data on the geology and the chemical and biological composition of the potable waters of the canton of Ticino in Switzerland are given.

Regarding chemical composition, it is noted that the waters in general have a low mineral content and are relatively poor in lime. A common characteristic of the majority of these waters is the absence of nitrates and the presence of ammonia in water which is relatively impure. As a whole, the waters are

relatively free from nitrates and nitrites, and those from limestone regions usually have a chlorid content less than 10 mg. per liter. It is further noted that these waters have a low microbiological content, corresponding to a generally low organic matter content.

Inspection of drain tile for the U. S. Reclamation Service, W. L. DRAGER (*Reclam. Rec. [U. S.], 11 (1920), No. 5, pp. 229-231, figs. 2*).—Data are reported showing the inconsistency in the variation in both thickness and breaking strength of drain tile from different kilns. These data are taken to indicate that the most satisfactory method of determining the crushing strength of a class of tile is to actually test samples rather than depend upon thickness indications. Absorption tests gave fairly consistent results, indicating a maximum allowable absorption for the clay used of about 4 per cent.

Excerpts from the U. S. Reclamation Service specifications for drain tile are given, together with a description of the testing methods and apparatus used. A summary of over 800 tests is also given.

Farm drainage machinery, J. G. MERRISON (*Jour. Min. Agr. [London], 26 (1920), No. 11, pp. 1080-1088, pls. 7, figs. 4*).—This article describes and illustrates various classes and types of machines successfully employed in England and elsewhere in the construction of farm drains, including particularly plows and scoops, wheel and endless-chain excavators, steam tackle, and scraper excavators.

Earthwork and its cost, H. P. GILLETTE (*New York and London: McGraw-Hill Book Co., Inc., 1920, 3. ed., pp. XVI+1346, figs. 58*).—This is the third revised edition of this handbook. It contains a large amount of practical working data on earthworks, methods of fill and excavation, machinery and equipment, and cost data.

The following chapters are included: Properties of earth; measurement, classification, and cost estimating; boring and sounding; clearing and grubbing; loosening and shoveling earth; spreading, trimming, and rolling earth; hauling in barrows, carts, wagons, and trucks; methods and costs with elevating graders and wagon loaders; methods and costs with scrapers and graders; methods and costs with cars; methods and costs with steam and electric shovels; methods and costs with grab buckets and dump buckets; methods and costs with cableways and conveyors; methods and costs with drag-line scrapers; methods and costs of dredging; methods and costs of trenching; ditches and canals; hydraulic excavation and sluicing; road and railroad embankments; design and construction of earth dams; dikes and levees; and slips and slides.

Measuring upward pressure under a masonry dam, E. W. LANE and E. L. CHANDLER (*Engin. News-Rec., 84 (1920), No. 21, pp. 1014-1016, figs. 4*).—Piezometric measurements of the upward pressure under a masonry dam on a porous foundation, consisting of sand and gravel and a slight intermixture of clay, showed that gas was accumulating in considerable quantities beneath the dam. The dam, because of its shape, acted as a gas holder and the gas increased the upward pressure. It was found in general that a considerable drop in pressure was caused by the upstream sheet-piling and a lesser one by the downstream piling.

“From these experiments it seems evident that although sheet-piling and cut-off walls are of value in reducing upward pressures, their effect is not necessarily in accordance with the line of creep theory. The results obtained are probably not representative of conditions existing immediately after the closure of the dam, and it is therefore concluded that the greatest danger exists when the head against such a structure is first accumulated. The upward pressure may soon be reduced to an unimportant factor, the length of time required to bring about the change being dependent upon the rapidity with which silt is

deposited over the bottom. It is also evident that the formation of gas under a dam is a potential source of danger if the shape of the structure is such as to confine the gas."

Concrete consistency measured by the flow table, G. M. WILLIAMS (*Engin. News-Rec.*, 84 (1920), No. 22, pp. 1044-1046, figs. 4).—The so-called flow table devised at the U. S. Bureau of Standards for measuring the flowability and workability of concrete is described and tests reported.

The apparatus consists of a metal covered table top which can be raised vertically by means of a cam working at the end of a vertical post to which the top is attached. The height of drop can be adjusted by means of a bolt at the lower end of the shaft. A mass of concrete or mortar is molded at the center of the table in a sheet metal mold which has the shape of a hollow frustum of a cone. For aggregates up to 2 in. maximum size this cone has a height of 6 in. and upper and lower diameters of 8 and 12 in. For smaller aggregates when made up in small quantities, a cone having a height of 3 in. and upper and lower diameters of 4 and 6 in. is used. The mass of concrete is tamped just sufficiently to completely fill the form, the form withdrawn, and the table top dropped 15 times through a distance of $\frac{1}{2}$ in. The mass flattens and usually spreads concentrically. Two diameters at right angles to each other are measured, the long and short if difference is apparent, by means of a self-reading caliper which is so graduated that the sum of the two readings is the value for flowability, which may also be calculated by dividing the new diameter by the old and multiplying by 100.

Five separate batches of 1:2 $\frac{1}{2}$:3 $\frac{1}{2}$ concrete were prepared with percentages of mixing water ranging from 7 to 11. Seven per cent resulted in a concrete too dry for ordinary construction work, 9 per cent in a concrete which flowed sluggishly in a steel chute which had an angle of 21°, 10 per cent furnished as wet and fluid concrete as is ever needed in practice, and 11 per cent a sloppy, segregating concrete difficult to properly sample. The added water in excess of 10 per cent resulted in practically no increase in flowability as measured by both the flow table and the steel chute.

The advantages of the flow table over the slump method are stated as follows: The flow table accurately measures flowability or consistency of concrete, mortar, cement, or lime pastes for all consistencies varying from dry masses, which have only a slight tendency to flow or change their shape when acted upon by external forces, to those consistencies which are so fluid that the water and laitance will flow away from the coarse aggregate. The relation between flowability and quantity of mixing water is practically a straight line relation for all workable and usable mixtures and consistencies. The stiffening of a mass of concrete due to absorption of water by the aggregate, evaporation, or setting of the cement is indicated by reduction of flow of the mass on the flow table.

Tests of solid and laminated wood sheet-piles (*Engin. News-Rec.*, 84 (1920), No. 25, pp. 1201, 1202, figs. 3).—Studies conducted at Cornell University on the relative transverse strength and stiffness of solid and compound or laminated wooden sheet-piles under bending loads, and on the efficiency of three types of fastenings, are reported. The data indicate the distinct superiority of the solid over compound or laminated piles.

The phenomena of drying wood, H. D. TIEMANN (*Jour. Franklin Inst.*, 188 (1919), No. 1, pp. 27-50, figs. 8).—An analysis is given of the internal stresses which occur in wood during the progress of drying from the green condition, together with a brief discussion of the physical properties which affect these stresses.

Phenomena of drying wood, H. D. TIEMANN (*Jour. Franklin Inst.*, 189 (1920), No. 5, pp. 645-648, fig. 1).—In a second article on the subject, an outline is given of the various facts known as to the manner in which a block of wood dries out, in which the various properties of the wood which affect drying are considered. An analysis of the stresses brought about during the progress of drying and of casehardening is given and illustrated by photographs of actual wooden discs cut from casehardened maple and oak boards.

Public Roads (*U. S. Dept. Agr., Public Roads*, 2 (1920), No. 24, pp. 32, figs. 26).—This number of this periodical contains the following articles: Housing and Equipment of Army Trucks by the States; Handling Federal Equipment After its Receipt by States, by R. J. Windrow; Distribution of Surplus War Materials for Road Building, by H. L. Bowlby; Subgrade Investigations Begun by Bureau of Public Roads; and Federal-aid Allowances in March, 1920.

Report of the commissioner of highways of Minnesota, C. M. BABCOCK (*Minn. Commr. Highways Rpt.*, 1918-19, pp. [42]).—The work and expenditures on roads and bridges of the Minnesota Highway Department for the years 1918 and 1919 are reported.

Tenth biennial report of the State highway commissioner of the State of Vermont for the two years ended June 30, 1918, S. B. BATES (*Vt. Highway Commr. Bien. Rpt.*, 1918, pp. 36).—This report gives the text of the law relative to the highway funds expended under the supervision of the Vermont Highway Department, a detailed tabulated statement of expenditures on road and bridge work for the calendar years 1916 and 1917, and a statement of expenditures under special appropriations and special provisions of the law for the biennial term ended June 30, 1918.

Power applied to agriculture, compiled by W. S. H. CLEGHORNE (*So. African Jour. Indus.*, 3 (1920), No. 3, pp. 247-255).—Working data on the use of hand pumps, animal power, heat motors, and other sources of power on the farm are given.

Valve springs for internal combustion engines.—Data for determining dimensions, E. R. MATHOT (*Gas Engine*, 22 (1920), No. 7, pp. 206-208, figs. 2).—Formulas and tabular data for determining the dimensions of both compression and tension type valve springs for internal combustion engines are given.

Motor fuel from waste molasses (*Sugar [New York]*, 22 (1920), No. 6, pp. 335-337).—Hawaiian practice in the manufacture and utilization of motor fuel from waste molasses in the form of denatured alcohol is reviewed.

It is stated that in general a yield of 1 gal. of 93 per cent alcohol can be obtained from 3 gals. of average Hawaiian molasses. The alcohol is denatured by treatment with about 5 per cent of sulphuric ether, 2 per cent of kerosene, and 1 per cent of pyridin. In order to obtain higher volatility and greater flexibility of mixture with air, the denatured alcohol is treated with about 40 per cent ether. The motor alcohol then has the following approximate composition: Alcohol 55.55 per cent, ether 42.78, kerosene 1.11, and pyridin 0.56 per cent. The ether is obtained by distillation of the denatured alcohol with sulphuric acid. About 1½ gals. of alcohol are required for each gallon of ether. The pyridin is used to neutralize the acetic acid and corrosive aldehydes formed by the combustion of ether and alcohol.

It is stated that the annual Hawaiian production of molasses is some 135,000 tons, from each ton of which may be produced approximately 67 gals. of 95 per cent alcohol.

Tests in stationary, marine, automobile, truck, and tractor engines are reported to have been successful, indicating great power, speed, and flexibility, combined with smoothness of operation, low heat, and ease of starting.

Analysis of fundamental factors affecting tractor design, O. B. ZIMMERMAN (*Jour. Soc. Automotive Engin.*, 7 (1920), No. 1, pp. 7-12, figs. 15).—An analysis is given of the relation between weight, total and available drawbar pull, plowing speeds, soil resistance, rolling resistance, and slope in their effect upon the design of a tractor.

Considerable graphic data are presented, which show that the higher the speed the less is the flexibility of the tractor as regards operation on rolling or level land and available drawbar pull. It is shown that the possible accomplishment in acreage for a given theoretical expenditure of energy is in favor of low speeds, and the advantage of giving considerable attention to reducing the rolling resistance on loose or moist soils by every practical means is considered obvious. It is noted that while the resistance of the soil to the plow is noticeably less in loose land, the surface conditions cause the rolling resistance to be greater and the two factors to a certain extent compensate.

The data further show that "even allowing the full value in fractional plows pulled at all speeds, and even though discount be made for the rolling resistance in the lighter lands, so long as a footing is permitted the advantage lies with moderate and low speeds of plowing."

Modern farm buildings, A. HOPKINS (*New York: Robert M. McBride & Co.*, 1920, 3. ed., rev. and enl., pp. 237, pls. 62, figs. 85).—This is the third revised and enlarged edition of this book (*E. S. R.*, 31, p. 291; 37, p. 90), containing chapters on the cow barn, dairy, garage, and other farm buildings, and including plans of farm barns in existence. A final chapter deals with materials of construction.

Protecting buildings against the white ant, T. E. SNYDER (*Engin. News-Rec.*, 84 (1920), No. 23, pp. 1110-1112, figs. 6).—In a contribution from the Bureau of Entomology of the U. S. Department of Agriculture, information is given on the protection of structures, both rural and urban, against termites.

It is stated that all untreated wood should be completely isolated from the soil, and that in the case of termite-infested frame buildings when once the infested beams are disconnected from the earth the insects will soon dry up and die. It is recommended that in order to prevent the insects from reaching the woodwork of buildings from their nests in the soil, the foundations be entirely of stone, brick, or concrete, including the pillars in basements and cellars.

Tests to determine the efficiency of coal stoves, J. R. ALLEN and F. B. ROWLEY (*Jour. Amer. Soc. Heating and Ventilating Engin.*, 26 (1920), No. 1, pp. 119-126, figs. 4).—Tests conducted at the University of Minnesota on base-burner coal stoves are reported.

The results indicate that the best stoves are usually those which have the smallest lengths of cracks and seams. It is noted that in some stoves there are so many cracks and seams that it is almost impossible to make them reasonably air-tight.

In one test the carbon dioxid was high, showing high efficiency of combustion, and in a second test the carbon dioxid was low, showing a poor state of combustion, but the actual total efficiency in the two cases was about the same. This is accounted for by the difference in the stack temperature in the two cases. In the case where the carbon dioxid was high the stack temperature was high, so that the benefit of the better combustion was offset by the loss at the stack. In test No. 2 the carbon dioxid and the stack temperature were low, and while there was poor combustion it was offset by less loss at the stack.

RURAL ECONOMICS.

Animal foodstuffs, E. W. SHANAHAN (*New York: E. P. Dutton & Co., 1920, pp. 331*).—This study in economic geography and agricultural economics is one of a series, edited by the Director of the London School of Economics and Political Science, relating to the supplies of animal foodstuffs. From the standpoint of the production of animal foodstuffs or the raw materials for the same, the countries of the world are said to fall into four groups, the surplus-producing, tropical, elaborating commercial, and deficient industrial, and it is noted that the consuming population of the world lies almost entirely in three of the above-mentioned groups, the surplus-producing, elaborating commercial, and deficient industrial. These various regions are described in detail. Such topics as the supplies of capital, agricultural machinery in relation to the production of animal foodstuffs, uses of land competitive with animal industries, and cost price and costs of production are discussed with reference to animal industry as the key to permanent intensive agriculture.

Conclusions are reached that there has been a relative decline in the output of animal produce and that costs of production tend at the present to increase, yet there is progress in the direction of intensification and the shortage of animal foodstuffs may be of short duration, perhaps to be followed within a decade or so by a period of comparative abundance for the consuming population of the world.

The latter part of the study is devoted, particularly, to the production and consumption within the British Empire and some effects of the war upon it.

The cost of producing wheat in Kansas, crop of 1919, J. C. MOHLER (*Kans. Bd. Agr. Quart. Rpt., 38 (1919), No. 151, pp. 31, figs. 7*).—This is a summary of statements from 2,057 Kansas wheat growers, collected by the State Board of Agriculture in December, 1919, by means of a questionnaire carrying 245 questions on the cost of producing wheat. These growers represent every county in the State and both landowners and tenants.

The cost per acre is stated to have been less affected by the yield than the cost per bushel. For the State as a whole a loss of 43 cts. an acre is shown for the crop of 1919, but in the main wheat belt (central Kansas) the loss reached \$1.52 an acre. Of the total wheat acreage in the State, 76 per cent showed a loss and 24 per cent a gain. It is said, however, that these amounts do not show the full extent of the loss because in the calculations nothing was charged for the loss of fertility by the soil, the lack of compensation for over-time work, and the lack of proper employment for a portion of the year.

Tabulations are given, showing the number of acres, production, and value of winter and spring wheat for the year 1919, and detailed statements of the cost of producing an acre of wheat are included for the entire State, the eastern, central, and western divisions, and the northern and southern sections of each of the latter.

Farm tenancy and rural credits (*Ill. Leg. Ref. Bur., Constitutional Conv. Bul. 13 (1919), pp. 1079-1123*).—A compilation of information relating to farm tenancy and absentee landlordism in Illinois and elsewhere, also to first-mortgage systems, Federal farm loans, numerous State rural-credit systems, second mortgages, and short-time credits is offered for the consideration of the Illinois Constitutional Convention in drawing up constitutional changes with respect to farm tenancy, loans, and land taxation.

Studies of land values in Iowa, O. G. LLOYD (*Iowa Agr., 20 (1919), No. 9, pp. 361-363; also in Jour. Farm Econ., 2 (1920), No. 3, pp. 136-140*).—Census data and figures from surveys and other reports with reference to several Iowa counties are tabulated to show the advance in the price of land from

1850 to August 15, 1919, the price per acre, total value, and payments on farms for the years 1917 and 1919, the time and rate of interest for the same years, a correlation of the prices of crops and live stock with the price of land, 1915-1919, inclusive, the labor income and landlord's percentage on the investment on Iowa farms, and the net worth of 204 farmers who reported in 1914. The data presented indicate that buyers of land were thinking in terms of the prices of farm products current at the time, and that regardless of the land paying its way they could afford to pay the price for other reasons.

In addition answers returned from a questionnaire inquiring the reasons for the advance in the price of land are given, the five principal causes shown being speculation, prices of food products, high returns, the increasing value of the farm home as an institution, and the security of the investment.

Sale and rental value of agricultural land in Sweden before the outbreak of the war and the rise in price of the same up to the beginning of 1918, L. NANNESEN (*K. Landtbr. Akad. Handl. och Tidskr.*, 58 (1919), No. 3, pp. 178-186).—Data returned on a questionnaire, distributed by the economics division of the National Agricultural Bureau of Sweden, are summarized and compared. Answers are given as to land values from the point of view of soil types, size of holdings, location, and transportation facilities.

Interim report to the Board of Agriculture for Scotland on the economics of small farms and small holdings in Scotland, H. M. CONACHER and W. R. SCOTT (*Edinburgh: Scot. Bd. Agr.*, 1919, pp. 98).—Report is made of an inquiry to ascertain the facilities needed in order to enable small farmers and small holders to obtain more capital for their undertakings or steps to be taken to cheapen expenses of production, as well as to study the experiences of existing holders with a view to future settlement on new holdings. Various types of holdings in noncrofting and crofting districts are described. Questions were asked regarding the value of stock, capital required, average stock required, and financial returns of typical small holdings.

Cooperation in many lands, L. SMITH-GORDON and C. O'BRIEN (*Manchester, [England]: The Cooperative Union, Ltd.*, 1919, vol. 1, pp. II+272).—Early chapters of this volume are concerned with the principles and organization of the cooperative movement and theories of the relation between producers and consumers. The history of consumers' and producers' cooperation in various countries is outlined. Societies are described and classified according to activities, with technical details of organization, conduct of meetings, functions of committees, finance, and economic, political, and educational policy.

The appendix gives a brief review of the legislation of various countries relating to cooperation, together with a bibliography.

The cooperative movement in Nebraska, M. H. WESEEN (*Jour. Polit. Econ.*, 28 (1920), No. 6, pp. 477-498).—Reviewing the history of the movement, it is stated that the first farmers' organization in Nebraska to embody cooperative principles in its by-laws was started in 1904. Since that time the number and functions of such groups have increased rapidly until there are in the State at present about 400 genuinely cooperative elevators, 170 farmers' union companies shipping live stock, and 100 cooperative stores handling merchandise. The number and amount of business of mutual insurance companies and miscellaneous and unique associations are noted. Account is given of difficulties in the way of competitive pressure, the struggles of cooperators to secure representation on the Grain Exchange, and the obstacle of being classified as corporations subject to the constitutional provision allowing stockholders the right to vote according to number of shares.

An act incorporated into the laws of 1919 obviates the last-named difficulty. Another act in 1919 authorizing cooperative credit associations is outlined.

The law of Nebraska is said to be somewhat less liberal than that of certain other States with which it is here compared. A prosperous future is forecasted for cooperative societies of all kinds in Nebraska.

A brief list of good publications on the rural community (*Mass. Agr. Col., Ext. Circ. 36 (1920), pp. [4]*).—A brief suggestive bibliography is given.

Farm life studies and their relation to home economics work, C. J. GALPIN (*Jour. Home Econ., 12 (1920), No. 4, pp. 159-161*).—This is a brief outline of one of the research projects in farm-life studies in the Office of Farm Management of the U. S. Department of Agriculture, which is concerned with social situations, farm home life, the spiritual rôle of the woman in the farm home, the use of leisure time, and other related questions.

The Market Reporter (*U. S. Dept. Agr., Market Rptr., 2 (1920), Nos. 1, pp. 16; 2, pp. 17-32, figs. 2; 3, pp. 33-48, fig. 1*).—The usual weekly and monthly summaries of information regarding movement, marketing, and prices of specified commodities, and important classes of agricultural products and foreign markets are continued in these numbers.

Special articles appearing in No. 1 relate to the fruit and vegetable market at Kansas City and potato shipments at the principal markets for 1919. In No. 2 there is one indicating that American exports of food have doubled in the last five years, comparing the trend of food exports before and during the war and noting the outlook in foreign countries. Diagrams present the export trade in three periods, the decade from 1900 to 1909, the 5-year prewar period, 1910 to 1914, and the war period from 1915 through 1919. It is concluded that there need be no alarm as to the ability of the United States to hold its own in foreign trade in agricultural products. In the same number are articles on the peach as a popular short-season fruit, the market for hides, and the effect of car shortage on the grain market. No. 3 contains leading articles on beef and cattle prices, the advance in evaporated and condensed milk prices, and the onion market in the principal cities.

Farmers' Market Bulletin (*North Carolina Sta., Farmers' Market Bul., 7 (1920), No. 36, pp. 10*).—This number contains a brief note on cooperative wool sales and the usual list of products which farmers have for sale.

Economic notes on Brazil (*Rio de Janeiro: Min. Agr. Indus. and Com., 1919, 3. ed., pp. 103*).—This is a revision of a report previously noted (*E. S. R., 38, p. 393*), in which statistical data is continued down through 1917.

Area and yields of agriculture in the Republic of Austria for the year 1918, with comparisons (*Anbauflächen und Ernteergebnisse im Gebiete der Republik Österreich im Jahre 1918, Verglichen mit den auf dieses Gebiet Bezogenen einschlägigen Daten des Jahres 1917 und des Letzten Normaljahres (1913)*). [*Austria: Govt., 1919, pp. 25*].—Tabulated statistics for 1918 with comparisons for 1917 and 1913, as collected by the Austrian Commission of Agriculture and Forestry, are given.

AGRICULTURAL EDUCATION.

Vocational education, S. A. BAKER (*Missouri Pub. Schools Rpt., 70 (1919), pp. 26-30*).—This is a report on the program, organization, and status of vocational education in Missouri for the year ended June 30, 1919. Instruction in vocational agriculture was introduced into 38 high schools and instruction in vocational home economics into 32 high schools. The State university has well-organized plans for the training of teachers of agriculture, home economics, and of trade and industrial subjects.

Vocational education [in Florida], S. PHILLIPS (*Fla. Supt. Pub. Instr. Bien. Rpt., 1916-1918, pp. 771-780*).—This is a report of the Florida State Board for Vocational Education for the years 1917-18 and 1918-19.

Only four schools were able to secure teachers and to use the agricultural funds for 1917-18, and only three schools were aided for vocational home economics. In 1918-19 ten schools had vocational agricultural classes, and five schools were conducting vocational home economics work.

The University of Florida has been designated for the training of teachers of vocational agriculture and industrial subjects, and the Florida State College for Women for the training of teachers of vocational home economics.

Vocational education in Nebraska under the Smith-Hughes Act, W. H. CLEMMONS (*Nebr. Supt. Pub. Instr. Bien. Rpt., 25 (1917-1919), pp. 46-51*).—In 1917-18 only 2 high school agricultural departments and 1 home economics department were aided financially under the Smith-Hughes Act. Considerable progress was made in the training of teachers for this work in the University of Nebraska. A survey of the home economics instruction was made in 39 schools of the State. Financial statements and lists of schools approved for agriculture, home economics, and the trades and industries are given.

Vocational schools for girls in New Jersey, I. P. O'LEARY (*Trenton, N. J.: N. J. Dept. Pub. Instr., 1917, pp. 24*).—The purpose of this bulletin is to suggest improvements in the organization in all-day vocational household arts schools in New Jersey. It discusses the aim of vocational household arts instruction; consideration in the curriculum of certain economic and social changes affecting the woman in the home; the development of standards of work; the organization of trade departments in these schools; the distinction between the teaching of elementary sewing and of dressmaking; the fundamental difference between instruction in trade and vocational household arts dressmaking and millinery; cooking; and cooperation between the school and the home.

Vocational education, C. E. CAVETT (*N. Dak. Bd. Admin. Ann. Rpt., 1 (1919), pp. 45-49*).—In this résumé the State director of vocational education briefly outlines the vocational education work accomplished in North Dakota in 1917-1919 and the plan for 1919-20, and offers recommendations for the continuation of the work.

Since August, 1919, this work, which previously had been directed by a committee on vocational education of the State board of education, has been under the direction of the State board of administration created July 26, 1919. In North Dakota, it is stated, only 30 per cent of the farm pupils have been completing the eighth grade and 4 per cent the high school. It is recommended that the proper balance should be sought among the scholastic, esthetic, and vocational phases of education. Further, that the work in manual training, agriculture, and domestic science should be reorganized and placed upon a truly educational basis.

Vocational education in New Mexico (*N. Mex. Bd. Ed. Vocat. Bul. 4 (1920), pp. 52*).—These are the revised plans for vocational education in New Mexico for 1919-20 under the Smith-Hughes Act.

The teacher-training course in vocational agriculture extends through 4 years, or 216 unit hours, not more than 40 per cent of which can be given to technical and not more than 10 per cent to pedagogical subjects. A plan of combined supervision and improvement in service and itinerant teacher training in agriculture is outlined.

The New Mexico College of Agriculture and Mechanic Arts has been designated for teacher training in vocational home economics. The course extends through 4 years, or 216 unit hours, including a minimum of technical or home economics subjects of 25 per cent, related sciences and art 20 per cent, professional subjects 12.5 per cent, and general 28 per cent.

Four-year courses in vocational agriculture and home economics and 4-year teacher-training courses in vocational agriculture and home economics are outlined.

Report of the State supervisor of agricultural instruction, V. PETERSON (*S. C. Supt. Ed. Ann. Rpt.*, 50 (1918), pp. 45-78).—This is a report on the organization and administration of agricultural instruction in South Carolina for the year ended June 30, 1918, under the State and Smith-Hughes laws.

The first State plan under the Smith-Hughes Act was approved November 9, 1917, and 13 groups of schools were subsidized during the fiscal year, with an enrollment of 290 pupils in agriculture. A total of about 385 acres of field and garden crops were produced by these pupils.

Teacher-training work in vocational agriculture was begun during the year at Clemson College, and a comprehensive vocational course was introduced at the Winthrop Normal and Industrial College. A special report on agricultural instruction in Darlington County, reports from the teachers of agriculture, and some of the provisions of the State plans for vocational agriculture for 1918-19 are included.

Vocational agriculture in Virginia, H. HART (*Bul. State Bd. Ed. [Va.]*, 2 (1919), No. 1, pp. 48-58, figs. 2).—This report by the State superintendent of public instruction contains a statement of the status of vocational agriculture in secondary schools in Virginia at the time of the acceptance by the State of the provisions of the Smith-Hughes Act, the statistical report of the State supervisor of agriculture with reference to attendance, equipment, etc., of vocational schools for the year ended June 30, 1918, and a report on the work of the supervising industrial teachers for colored schools.

Annual report of the public high schools of Virginia for the school year 1917-18, S. P. DUKE (*Bul. State Bd. Ed. [Va.]*, 1 (1918), No. 1, pp. 79, figs. 13).—This report deals with constructive suggestions bearing upon high school organization, supervision, and instruction, including a plan for the reorganization of instruction in agriculture in rural high schools other than Smith-Hughes schools in counties with agricultural demonstration agents.

Under this plan agriculture with laboratory instruction is recommended as one unit in science for all rural high schools. The subject will be given in the second year or the ninth grade of the course. The year's work will include a general course in agriculture in the first or fall term. At the end of this term or sooner four projects will be selected for the class, to be worked out by the pupils during the term and the summer vacation on the home farm or garden. A minimum of one month, or 20 lessons is to be devoted to instruction and laboratory work for each of the four projects, and each boy is required to devote approximately 120 hours to the completion of his project out of school hours. In order to provide better classroom instruction in agriculture, the county demonstration agent in agriculture will visit the high school during the second term to give instruction in the technical phases of project work that can not be handled by the regular teacher. A series of ten or more bulletins containing a series of outlined lessons and projects to be used as text material for the project work and class instruction during the spring term is to be prepared by the extension department of the Virginia Polytechnic Institute. On the successful completion and approval of the project, one unit of high school credit will be awarded in addition to the one unit credit for the regular agricultural work.

Attention is called to an experiment in the solution of problems of organization and administration of the small two-year high school found almost exclusively in strictly rural districts, and which may be called the rural junior high school. In order to make sure that the type of rural junior high schools

selected for future development is the type needed, several demonstration schools were organized for 1918-19, the standard requirements for which include that the school shall be organized on a departmental basis and shall embrace the seventh, eighth, and ninth grades. The course of study shall include general science in the seventh and eighth grades and manual arts and agriculture in the ninth grade for boys, and home making, including cooking, sewing, home sanitation, and decoration, etc., for girls. Suitable rooms and laboratory equipment for these subjects are to be provided. The teachers must be normal school or college graduates qualified to teach these subjects.

Wisconsin laws relating to vocational education (*Wis. Bd. Vocat. Ed. Bul. 3 (1919), pp. 20*).—The text of the laws governing vocational education in Wisconsin are given.

Social surveys of rural school districts: How made and how utilized, C. J. GALPIN, G. W. DAVIES, and G. WYMAN-STONE (*Wis. Agr. Col. Ext. Circ. 122 (1920), pp. 24, figs. 15*).—Directions are given for making a social survey of the rural school district and for using it in the school.

School house and shops for Arkansas schools of vocational agriculture (*[Univ. Ark., Col. Engin. [Pub.], 1919], pp. 8, figs. 3*).—This circular gives a description of a schoolhouse arranged for a class of 30 students working in 2 sections in a course in vocational agriculture. Views of front and side elevations, the floor plan, and a bill of material are included.

Agriculture: Tentative course of study for schools of Montana, M. J. ABBEY (*Helena, Mont.: [Supt. Pub. Instr.], 1917, pp. 39*).—The author outlines courses in agriculture for the seventh and eighth grades in city schools, or for odd and even years in rural schools where the seventh and eighth grades are combined. Instructions on methods of teaching are included.

Nature study, geography, and agriculture, A. W. BLANTON (*Dept. Ed. Tex. Bul. 105 (1919), pp. 48-58*).—This is an outline of work, in seasonal sequence, in nature study for the first and second grades and in geography for grades 3 to 6, inclusive, with suggestions for teaching agriculture in the seventh grade of the public schools of Texas.

Reconstruction in the domestic science kitchen, H. C. GOODSPEED (*Madison, Wis.: Dept. Pub. Instr., 1919, pp. 8, figs. 4*).—The author points out (1) the disadvantages of the hollow square plan of desks in the domestic science kitchen, as found in the majority of public schools, and (2) the advantages of the group or unit arrangement, each unit accommodating four girls.

MISCELLANEOUS.

The impartiality of research, L. H. BAILEY (*Proc. Amer. Soc. Hort. Sci., 16 (1919), pp. 197-203*).—An abstract of an address before a joint meeting of the Botanical Society of America, the American Phytopathological Society, and the American Society for Horticultural Science.

Director's report for 1919, W. H. JORDAN (*New York State Sta. Bul. 470 (1919), pp. 28*).—This contains the organization list and a review of the work and publications of the station during the year.

Annual Report of Pennsylvania Station, 1916 (*Pennsylvania Sta. Rpt. 1916, pp. 603, pls. 60, figs. 14*).—This contains the organization list, a financial statement for the fiscal year ended June 30, 1916, a report of the director on the work and publications of the station during the year, departmental reports, and many special articles abstracted elsewhere in this issue.

NOTES.

California University.—Under the will of the late James Horgan, an income of about \$2,000 a year is to be available for the promotion and development of agriculture, especially at the University Farm at Davis.

Florida University and Station.—The resignations, September 1, are noted of H. E. Stevens as plant pathologist to become county agent in Lee County; and C. D. Sherbakoff, truck pathologist, to take up work with the Tennessee Station.

Georgia College.—With the cooperation of the Central of Georgia Railroad, representatives of the college conducted about 200 farmers on a trip through the cattle-producing sections of the Middle West during the latter part of August. Many noted herds, several agricultural colleges, and the Chicago stockyards were visited. During the last week in September, two trains carrying several hundred farmers of south Georgia were conducted through North and South Carolina to give an idea of how tobacco is cured and prepared for market. There are now many new tobacco farmers in Georgia, the crop having increased from 3,500,000 to 20,000,000 lbs. in three years.

Headquarters for the State Farm Bureau Federation have been established at the college, and a State-wide membership campaign for 100,000 members has been begun. The organization work is being carried out with farmers as organizers, but the college through its district and county agents is supporting the movement.

The college opened September 15 with an enrollment of over 500 students. This is the largest in the history of the institution and greater than the entire student body attending the university ten years ago.

Kansas College and Station.—The department of agronomy in cooperation with the State Crop Improvement Association has inspected this year about 600 fields of Kanred wheat grown for seed. These fields aggregate about 15,000 acres. The total acreage in Kanred wheat in the State during the past season was about 500,000 acres.

During the past summer five new silos have been added to the equipment of the main station. This brings the number of silos at the station to fourteen, with a total capacity of 1,300 tons.

R. M. Green, assistant professor of farm management at the Missouri University and Station, has been appointed associate professor of agricultural economics and will have charge of the investigational and teaching work in marketing. Morris Evans has been appointed instructor in agricultural economics.

Minnesota University and Station.—Fred Griffee has been appointed assistant professor of agronomy in the College of Agriculture and assistant in plant breeding in the station.

Pennsylvania College and Station.—The resignations are noted of D. S. Fox, assistant professor of agronomy, on July 1; W. S. Taylor, professor of agricultural education, on August 15; and F. T. Struck, associate professor of agricultural education, on September 1. Recent appointments include Carl G. Vinson as professor of pomology extension, beginning September 1; Henry W. Popp as instructor in botany; and Donald Gray as assistant in poultry husbandry extension.

Porto Rico Federal Station.—W. A. Mace, agricultural technologist, has resigned to accept a commercial position in Havana, Cuba. J. P. Griffith, plant breeder, has resigned to take up further studies.

Rhode Island College.—The horticultural building was completely destroyed by fire August 22, causing a loss estimated at \$6,000. The greenhouses and other adjoining buildings were saved.

Virginia Truck Station.—Fred W. Geise, assistant physiologist in the Bureau of Plant Industry, U. S. Department of Agriculture, has been appointed associate pathologist and entered upon his new duties August 15.

Wisconsin University.—P. W. Boutwell, assistant professor of agricultural chemistry, has resigned to become associate professor of chemistry at Beloit College.

National Demonstration Farm in Great Britain.—The British Ministry of Agriculture and Fisheries purchased in 1919 an estate of over 1,500 acres of typical heath land at Methwold in Norfolk. This estate is to be developed as a national demonstration farm, chiefly to show what can be done with poor heath land by the adoption of good husbandry methods. About 200 acres have already been reclaimed, and at the present time, 1,043 acres are under cultivation, 43 acres are in grass, and the remainder in waste heath. Liming and the incorporation of organic matter are the chief processes to be utilized.

Tobacco growing on a comparatively large scale is to be attempted on the farm, as are also stock raising, poultry keeping, and swine husbandry on the open air system.

Central Agricultural Council in Denmark.—The various technical and cooperative organizations concerned with Danish agriculture have recently organized a Central Agricultural Council, known as the Landbrugsraadet, to promote their general interests. In addition to duties of a purely economic nature, this new institution also intends to disseminate information about foreign agriculture, especially that of a statistical nature, partly by furnishing prominent farmers directly with this data and partly through instructive articles in Danish agricultural periodicals.

Agricultural Conditions in Greece.—A recent number of *Breeders' Gazette* contains an article by Dr. Geo. Bouyoucos, of the Michigan College and Station, regarding agricultural conditions found in Greece by the Agricultural Commission to that country headed by the late Dr. Cyril G. Hopkins.

Soil analyses indicated abundant amounts of potash and magnesium in practically all the soils, and lime was lacking in only a few cases. Nitrogen and phosphorus, however, were present in insufficient amounts in nearly all the soils of Greece, and especially those of the long cropped lowlands and plains. This deficiency is so serious that much of the land has become extremely unproductive, many plains soils often not returning the seed sown. Cultural methods are also for the most part quite primitive.

About 200,000 copies of a booklet prepared by Dr. Hopkins were distributed among the farmers, advocating especially an increased use of phosphates and the growth of legumes instead of fallowing. Recommendations were also made to the Government for establishing a high grade agricultural college and experiment station in connection with the University of Greece, the teaching of agriculture in the high schools, a comprehensive soil survey, and the maintenance of soil test fields. The obtaining by the Government of supplies of acid phosphate and finely ground raw rock phosphate for sale at reasonable prices was also advocated.

EXPERIMENT STATION RECORD.

VOL. 43.

NOVEMBER, 1920.

No. 7.

A great man is a product of opportunity, but not wholly of circumstance. He waits not for opportunity to come to him but himself helps to make it, and a part of his genius is his ability to see an opening and to broaden it so that he may have the chance to carry forward his aims and purposes.

This was characteristic of James Wilson, late Secretary of Agriculture. He believed in agriculture as an enlightened occupation, and in the force of science to advance it to the standing and the efficient position it must ultimately occupy in the Nation's life. He worked in a period when changes were beginning to come rapidly, and he took advantage of this to broaden the opportunity for accomplishing the things he believed in and to build up an enlightened public sentiment in support of it. He made agriculture recognized as it had not been before. He gave it a larger place in the public mind and in constructive legislation; and perhaps greatest of all, he developed a broad public consciousness of the need for aid to the farming industry and confidence in technical investigation to render such aid. With the other influences at work, he inculcated the idea of "scientific farming", and gave the illustrations of it a spectacular interest. He not only saw clearly himself, but he made the country see what an adequate Federal department of agriculture might do for the benefit of the industry and those living under it.

There was a psychological aspect to his career which helped at the outset and was borne out by events. The farmers believed in him. He was a man of their own kind, who had lived their life and had to cope with difficulties like theirs. He understood them and they understood him, and it made a strong bond of sympathy.

The sixteen years of Secretary Wilson's administration, from 1897 to 1913, is a record of unprecedented advance and accomplishment. It marked a period of phenomenal development in organization, in scope of work, and in direct usefulness, as well as in public confidence and support. When the various features are reviewed which were epochal or have brought the Department into special prominence, it is surprising to find how many of them pertain to his time. This fact shows his grasp of the situation, his constructive ability

in enlarging the field of effort, and his broadmindedness in reference to new proposals for work or action.

The influence of such an administrative officer is not measured by length of service nor alone by what he himself does, but by what he enables and stimulates others to do. He was a great directing and controlling influence. He was a striking example of the practical man administering scientific inquiry and developing it in many lines. He was not confused or overawed by it. On the contrary, he had a clear understanding of its requirements as well as its results, and he was not troubled if it led into strictly technical channels for the time being, provided the problem was not lost sight of. This he saw to with a native shrewdness which helped to keep the feet of the most technical workers on the ground. He maintained an intimate contact with the varied lines of activity throughout the Department, and dealt directly with them through personal conference with those in charge. His capacity for detail was remarkable.

A common measure of growth in such an institution is the increase in funds, in personnel, in facilities for doing things and for placing them before the people. In the year in which Secretary Wilson came to the Department the combined appropriation was approximately three and a quarter million dollars, of which close to a million was for the State experiment stations, the distribution of seeds, and for special publications ordered by Congress. By 1905 the appropriation had nearly doubled, and two years later it had quadrupled. In consequence of new functions and the general expansion of work, the appropriation had reached more than twenty million dollars by 1911, and for 1913, the closing year of his administration, the total was \$24,743,044.81.

The working force of the Department numbered less than twenty-five hundred persons in 1907, and in his last year it was nearly fourteen thousand. This expansion was due in part to regulatory duties imposed by new laws and the management of the National Forests, but it represented a very large growth in the forces concerned with research and measures for the improvement of agricultural practice. In the period covered the number of employees of the Weather Bureau practically doubled, that of the Bureau of Animal Industry quadrupled, the Bureau of Chemistry increased from twenty to over five hundred, and the Forest Service from only fourteen to more than four thousand, while the personnel represented in what became the Bureau of Plant Industry grew from 127 to 2,128, and that of the Bureau of Entomology from 21 to 339.

Another measure of growth is supplied by the record of the Department's publications and the demand for them. The printing fund increased from \$116,888 in 1897 to \$470,000 at the end of the

period under consideration. The number of publications issued was enlarged from a little over four hundred to more than two thousand a year, and the aggregate edition from six and one-half million copies to nearly thirty-five million. That this increase was accompanied by a corresponding growth in the call for them is shown by the fact that in 1897 the requests for publications barely exceeded five hundred letters a week, while sixteen years later such weekly applications averaged more than fifty-two thousand. This reflects the extension of the Department's contact with the farmers and other readers of the country.

A measure for which Secretary Wilson labored with much zeal was the provision of a building plan to afford adequate facilities for the Department. A beginning in that direction was realized in 1902, in the appropriation of two and one-half million dollars with which two units of a prospective building were erected. Several large laboratories and other buildings for the Department's special use were also put up by private owners, to meet the need of its rapid growth. The Arlington farm tract, an area of about 400 acres, was transferred to the Department from the War Department in 1900, and improved and developed as a field laboratory; and another farm was purchased and equipped for experiments in animal husbandry and dairying, thus greatly strengthening the facilities in these directions.

These changes give a conception of the material growth of the Department in his time, and suggest the enlarged scope of its activities. They came as a result of increased demands upon the Department and its initiative in attacking new lines of effort, and they were made possible by the convincing manner in which the requirements and benefits were presented. They could not have come with any such rapidity if they had not been supported by public sentiment and confidence. That this was justified is evidenced by lack of charges of extravagance or the feeling that more was being asked for than could be warranted. It is a striking fact that apparently nothing could have held back this growth after Secretary Wilson had got his plans well under way and convinced the farming people of his ability to lead. It shows the hold he had secured. They felt that at last agriculture was coming into its own, and they demanded support for their Department. That agriculture was prospering and growing in productivity is indicated by the combined value of farm products, which at the beginning of this sixteen-year period was four billion dollars and at its end over nine and one-half billions.

Naturally the tremendous enlargement and multiplication of the Department's activities necessitated changes in organization to make it more effective. Secretary Wilson found only two bureaus in operation when he came, the Weather Bureau and the Bureau of Ani-

mal Industry. In addition there were ten subject matter divisions and the Office of Experiment Stations. The plant industry work was divided among several independent divisions, giving a lack of coherence in related lines of effort. Ultimately these divisions were brought together in a large Bureau of Plant Industry, whose scope was rapidly expanded to meet advancing needs. Six of the other divisions were raised to the grade of bureau as their lines became more numerous, and special laboratories, offices and boards were provided to care for new features.

Thus, farm management as a special branch of agriculture was originated, and an office established. Animal husbandry was organized as a separate branch of the Bureau of Animal Industry, and work in horse breeding, among other lines, commenced in several parts of the country. Provision was made for systematic studies in irrigation and drainage, with special officers in charge. Agricultural extension was started under the name of the Farmers' Cooperative Demonstration Work, especially as a result of the advent of the cotton boll weevil and the necessity of more diversified farming in meeting its ravages. An insecticide and fungicide board, and a Federal horticultural board were organized, with laboratories and specialists to meet their needs.

A new feature developed soon after the Secretary came to the Department was organized effort at plant introduction and the sending of explorers to different countries of the world in search of crops and strains adapted to the agriculture of the United States. Attention was given to such crops as the cereals, rice, alfalfa, the date palm, forage plants, etc. Among these, the success in introducing durum wheat into the northwestern semi-arid regions, where it has become one of the great staples, may be specially mentioned. Plans for a systematic survey of the soils of the country were put into effect in 1900, the work being done to considerable extent in cooperation with the States. In response to the growing interest in better roads and the realization of their importance to agriculture, this line of effort was greatly enlarged and strengthened, and the way prepared for a nation-wide development which came a little later.

The beet sugar industry in this country practically grew up during Secretary Wilson's administration, and largely through activities under his direction. The more extensive production by the United States of its own sugar supply was one of his early dreams, and he soon set in motion an extensive campaign, in cooperation with local agencies, to determine the localities most favorable for the growth of the beet. Every phase of the production of this crop was given extensive study, including not only the culture and handling of the crop, but the control of disease and insect pests, the raising of Ameri-

can sugar beet seed, and the utilization of by-products for feed. At the conclusion of his term there were sixty-six factories operating in seventeen States, which handled over five million tons of beets and produced close to seven hundred thousand tons of sugar. The industry had thus become firmly established as a branch of agriculture and one of the chief supports of farming under irrigation.

Texas fever had long been a heavy handicap to cattle raising in the South, resulting in an estimated annual loss of from sixty to a hundred million dollars. The Department undertook to rid the country of this disease by the eradication of the tick known to be the carrier and disseminator of it. While at first regarded by many as an impossibility, and admittedly an enormous task, it soon proved to be both possible and practicable, and has resulted in freeing a large portion of the South from quarantine, enabling the introduction of improved stock and proving a great stimulus to the cattle industry.

An extensive campaign for the eradication of bovine tuberculosis from dairy herds was also inaugurated, which has resulted in a marked reduction in the prevalence of this disease in cattle maintained under Department supervision, and has contributed greatly to the safety of city milk supplies. The vigor and dispatch with which two outbreaks of foot and mouth disease of foreign origin were stamped out demonstrated the ability to successfully meet an unusual emergency. Attempts to bring the scourge of hog cholera under control had the Secretary's active interest, and when the efforts of the Bureau of Animal Industry culminated in the discovery of the direct cause and the production of a protective serum, he felt that a great step had been taken in safeguarding that important branch of agriculture.

The Adams Act, supplementing the original Federal appropriation to the State experiment stations, had the cordial support of the Department, and following its passage and the decision that it did not carry any appropriation, the Secretary's success in securing an addition to the agricultural appropriation bill construing the act enabled it to be put into effect without delay.

The interest of the Department was likewise extended to the agriculture of Alaska and the insular possessions, and plans matured for supplying aid to them similar to that afforded by the State experiment stations. The year following Secretary Wilson's appointment authority was secured for agricultural explorations in Alaska which resulted in the establishment of stations there, and this was followed successively by the provision of stations in Hawaii, Porto Rico, and Guam, to be conducted under the direct management of the Department. This step was significant not only in the importance it had for the agriculture of those localities, but because of the new attitude it marked toward those possessions.

One of the most remarkable lines of development with which the Secretary's administration was identified was in relation to forestry. At the beginning of his term, forestry in this country was still in the dark ages. Its general practice seemed exceedingly remote. Wasteful destruction of a great primary resource went on unchecked. Forestry was largely a sentiment and not a reality, and there was small conception of its intimate relation to public welfare so soon to develop. There were less than ten professional foresters in the whole United States. Neither a science nor a literature of American forestry was in existence, nor could an education in the subject be secured in this country. The forest reserves totaled nearly forty million acres, but there was no provision for their use and there was insistent demand that they be returned to the public domain.

The key to the situation was supplied when the practice of forest conservation was shown to involve not barriers against utilization, but the development of these resources through wisely regulated use. Such regulated use of National Forest resources, and the measures inaugurated by the Department in executing this policy, provided the main foundation on which rests the present system of administering the forests for the benefit and profit of the country. As a result of the working out and putting into successful operation of a definite forest policy, opposition was quieted, the area of National Forests was increased to over 185,000,000 acres by June, 1912, and these vast tracts had become not a burden but a source of national wealth. It has been well said that "as a great constructive accomplishment, the National Forests and the administrative system under which they are made to serve their rightful part in our national economy deserve to rank and will rank among the notable triumphs of this generation."

The period of Secretary Wilson's administration, was notable for the passage by Congress of a number of important and far-reaching measures designed for the protection of the health and welfare of the people of the country. These measures were the culmination of investigation and efforts of the Department which exposed conditions requiring legislation and provided publicity for the development of support for such action.

The long continued efforts to secure a national pure food law resulted in 1906 in the passage of the Food and Drugs Act, which with the organization of means for its enforcement comprised one of the large constructive measures of the administration. The Meat Inspection Law of 1906 followed the Department's labors for years to secure the enactment of a law which would authorize rigid inspection of all meat and meat food products intended for interstate and foreign commerce. This act, with a permanent annual appropriation of three million dollars, enabled the safeguarding of this class of

food materials and the maintenance of sanitary conditions at a high standard in the establishments where they are prepared.

Other measures which may be mentioned in this connection are the Insecticide and Fungicide Act, intended to suppress interstate commerce in adulterated and misbranded materials; the act of 1905 for the suppression of contagious diseases of live stock through quarantine measures; the Plant Quarantine Act to prevent the importation of nursery stock infested with injurious insects or plant diseases, and combat the spread of insects and diseases from one State to another; and the Lacey Act, regulating the importation of destructive animals and controlling commerce between the States in game killed in violation of State laws. These and other regulatory measures greatly increased the duties and the responsibilities of the Department, and further extended its activities throughout the country.

The Commission on Country Life, while not a direct outgrowth of Secretary Wilson's suggestion, received his hearty support and cooperation, for he believed the problems of the farm and of country living were fundamental and that the attempt to secure a closer insight into the situation was an important step. He appreciated the benefits which had resulted from the propaganda and the stimulation of thought it aroused in this new direction.

The above are some of the changes which occurred, the measures inaugurated, and the things accomplished in this remarkable period. While far from a complete review it will serve to show the scope and the magnitude of development of the national Department of Agriculture under wise, progressive leadership. Probably no executive ever gave himself more thoroughly and whole heartedly to the task before him. He took the deepest interest and pride in the activities of the Department and in its growth and influence. He understood the farming people and how to serve them. He looked upon the whole Nation as his field, and his interest was confined to no section and to no particular branch of the industry. It was said of him on the floor of Congress that "Secretary Wilson has never known party or sectional lines," and some of his most ardent support and commendation came from those of opposite political faith.

It was not that his period of service exceeded that of any previous cabinet officer, covering four successive presidential terms, or that he had come to this high position from the soil through experience in public life and in his State agricultural college and experiment station, that gave him claim to fame, but it was the great constructive advancement he brought about through a national interest for the just recognition of the farming industry. It was a product of this unprecedented term and the preparation which had preceded it—a vigorous rising to opportunity when it opened.

His last annual report, prepared in the closing year of his term, is a fitting record of the career of one of the most notable figures in American agriculture. As he there wrote, the Department during sixteen years "has progressed from the kindergarten through the primary, middle, and upper grades of development until now it has a thousand tongues that speak with authority. Its teachings, its discoveries, and its improvements are permeating the national agricultural life. The forces that are at work must cause ever increasing results." After paying generous tribute to those who had worked with him and helped to make his success, he concluded with this simple benediction: "Men grow old in service and in years, and cease their labor, but the results of their labor and the children of their brains will live on; and may whatever of worth that is in these be ever blooming."

This closing chapter was written in his seventy-eighth year, nearly eight years before his call came. The interval had reflected his prophecy and his wish. It had shown how well he had builded.

The resolutions passed by the Department workers when the news of his death came express the homage and the affection in which he was held. As there recorded, "his patriotic devotion to the interests of all the people, his broad vision and his practical wisdom place him high among those who have deserved well of their country. Beloved as a friend, admired and respected as an officer, his example as a man and a statesman is one to which all Americans may turn for inspirator and emulation."

RECENT WORK IN AGRICULTURAL SCIENCE.

AGRICULTURAL CHEMISTRY—AGROTECHNY.

Industrial chemistry: A manual for the student and manufacturer, edited by A. ROGERS (*New York: D. Van Nostrand Co., 1920, 3. ed., rev. and enl., pp. XXIII+1232, pls. 2, figs. 375*).—The third revised and enlarged edition of this manual, the first edition of which has been previously noted (*E. S. R.*, 29, p. 107), contains chapters by the editor and various collaborators on the fundamental principles of modern American methods and processes on the following subjects:

General processes; water for industrial purposes; fuels; sulphuric acid; nitric acid; salt and hydrochloric acid; elements and compounds; chlorine and allied products; electrochemical industries; lime, cement, and plaster; clay, bricks, and pottery; glass; white lead; zinc oxide; pigments and paint oils; mixed paints; the metallurgy of iron and steel; fertilizers; commercial organic chemicals; illuminating gas; coal tar and its distillation products; the petroleum industry; the destructive distillation of wood; oils, fats, and waxes; linseed oil; hydrogenation of oils; lubricating oils; soaps and soap powder; glycerin; laundering; essential oils, synthetic perfumes, and flavoring materials; turpentine and rosin; resins, oleo-resins, gum-resins, and gums; shellac; rubber and allied gums; varnish; sugar; starch, glucose, dextrin, and gluten; brewing and malting; wine making; distilled liquors; textiles; dyestuffs and their application; the art of paper making; cellulose industries; explosives; leather; glue and gelatin; casein; practical applications of colloid chemical principles; dehydrated, dried, and evaporated foods, and condensed foods; and baking.

Treatise on general and industrial inorganic chemistry, E. MOLINARI, trans. by T. H. POPE (*Philadelphia: P. Blackiston's Son & Co., 1920, 2. ed., pp. XIX+876, pls. 2, figs. 328*).—The second English edition of this work, the first English edition of which by E. Feilmann has been previously noted (*E. S. R.*, 30, p. 309), is the translation of the fourth revised and amplified Italian edition.

Colloidal chemistry and food chemistry, W. OSTWALD (*Chem. Ztg.*, 43 (1919), Nos. 143, pp. 829-831; 146, pp. 849, 850).—This is a discussion of the application of colloidal chemistry to various problems of food chemistry, with particular reference to the chemistry of milk, meat, and bread.

Practicum of medical chemistry, S. FRÄNKEL (*Praktikum der Medizinischen Chemie. Berlin: Urban & Schwarzenberg, 1918, pp. VII+448, pls. 2, figs. 38*).—According to the preface this volume is designed to furnish practical information to physicians who desire to acquire more than a superficial knowledge of pure and applied medical chemistry. It contains methods of qualitative and quantitative inorganic analysis, representative methods for organic syntheses and quantitative organic analysis, and methods of physiological and pathological chemistry, particularly in its medico-legal phases. The methods selected are those requiring the least manipulation and a minimum of laboratory equipment.

Chemistry of human foods and condiments.—Vol. III, **Foods, condiments, and commodities: Pts. 2, animal and plant food; 3, condiments,**

water, air, commodities, patent medicines, and similar materials, J. KÖNIG (*Chemie der Menschlichen Nahrungs- und Genussmittel*. 2, *Die Tierischen und Pflanzlichen Nahrungsmittel*. 3, *Die Genussmittel, Wasser, Luft, Gebrauchsgegenstände, Geheimmittel, und Ähnliche Mittel*. Berlin: Julius Springer, 1914, vol. 3, pt. 2, 4. rev. ed., pp. XXXV-972, figs. 260; 1918, vol. 3, pt. 3, 4. rev. ed., pp. XX+1120, figs. 337).—These numbers complete the revision of the third volume of this extensive treatise on food chemistry. The preceding volumes and the first part of the present volume have been previously noted (E. S. R., 22, p. 508).

The hydrocyanic acid content of Phaseolus lunatus, H. LÜHRIG (*Chem. Ztg.*, 44 (1920), No. 24, pp. 166, 167).—The author reports the results of an examination of the methods recommended by Guignard (E. S. R., 20, p. 1161) for the estimation of hydrocyanic acid in beans. A study of the influence of various factors on the determination has led to the recommendation of the following technique for the rapid examination of the beans:

To 50 gm. of the finely chopped sample are added 200 cc. of water and from 0.3 to 0.5 gm. of emulsin. After standing for 24 hours, preferably in the incubator, the solution is acidified with tartaric acid and distilled into dilute silver nitrate solution. The amount of the grayish white flocculent precipitate which forms is a measure of the HCN present.

Another portion, consisting of 100 gm. of uncrushed beans, is treated with 0.3 to 0.5 gm. emulsin, soaked in water over night, and the water poured off. The beans are then cooked for three or four hours, renewing the water twice, tartaric acid is added, and the mixture is distilled until 100 cc. of the distillate has been collected. Ammonium sulphid is added, and the solution is evaporated to dryness. On the addition of hydrochloric acid and iron chlorid the formation of ferric thiocyanate denotes the presence of HCN.

Soy bean oil, W. H. Low (*Jour. Indus. and Engin. Chem.*, 12 (1920), No. 6, pp. 572, 573, fig. 1).—An examination of filtered soy bean oil for total fatty acids, unsaponifiable matter, glycerol (by calculation), and the iodine number is reported with the following results:

Unsaponifiable matter 1.16 per cent, total pure fatty acids 94.966 per cent, glycerol 10.37 per cent, and iodine number (Wijs) 138.45 and 137.39.

Notes on soy bean urease, A. W. Dox (*Amer. Jour. Pharm.*, 92 (1920), No. 3, pp. 153-157).—Determinations are reported of the urease content of a number of soy beans of different varieties, which varied in protein content and in germinating power. While some difference existed in the urease activity of the different varieties of the soy beans, this difference appeared to bear no relation to the germinating power of the seed or to its protein content.

The fermentation of glucose, galactose, and mannose by Lactobacillus pentoaceticus n. sp., W. H. PETERSON and E. B. FRED (*Jour. Biol. Chem.*, 42 (1920), No. 2, pp. 273-287).—The authors, with the cooperation of J. A. Anderson, have continued the investigation of the pentose-fermenting bacteria previously noted (E. S. R., 43, p. 411) by a study of the fermentation of glucose, galactose, and mannose.

The products of the fermentation of these aldo-hexoses by *L. pentoaceticus* were lactic acid, ethyl alcohol, carbon dioxide, and small quantities of acetic acid, the latter resulting from a secondary fermentation of lactic acid. Glucose and galactose were fermented at approximately the same rate and to the same extent, from 20 to 30 per cent remaining unfermented after 30 to 40 days. Mannose was more slowly attacked and less of the sugar was consumed, from 50 to 70 per cent remaining unfermented.

The production of ethyl alcohol as one of the major products from glucose and of acetic acid from fructose is thought to be due to the difference in stereo-

isomerism between an aldose and a ketose, resulting in different conditions of oxidation and reduction operating on the intermediate products of the fermentation. The difficulty with which mannose is fermented is also thought to be due to its configuration.

The influence of hydrogen-ion concentration on the inactivation of pepsin solutions, J. H. NORTHRUP (*Jour. Gen. Physiol.*, 2 (1920), No. 5, pp. 465-470, figs. 2).—In continuation of the studies on pepsin previously noted (E. S. R., 42, p. 204) the results are reported of a study of the effect of the H-ion concentration, the anion of the acids, and the purity of enzym solution on the activation of pepsin in solution.

It was found that pepsin in solution at 38° C. was most stable at an H-ion concentration of about pH 5: Increasing the H-ion concentration above this value caused a slow increase, and decreasing it a very rapid decrease in the rate of destruction of the enzym.

The purity of the enzym solution and the anion of the acid used appeared to have no marked effect on the rate of destruction of the enzym or on the zone of H-ion concentration in which it was most stable.

“The existence of an optimum range of H-ion concentration for the digestion of proteins by pepsin can not be explained by the destruction of the enzym by either too weak or too strong acid.”

The effect of the concentration of enzym on the rate of digestion of proteins by pepsin, J. H. NORTHRUP (*Jour. Gen. Physiol.*, 2 (1920), No. 5, pp. 471-498, figs. 5).—This paper discusses the kinetics of enzym action as applied to the rate of digestion of proteins by pepsin under different conditions determined, according to the method previously noted (E. S. R., 42, p. 204), by means of changes in the conductivity of an egg albumin solution to which the pepsin had been added. The conclusions drawn from this study may be summarized as follows:

In certain cases the rate of digestion of proteins by pepsin is not proportional to the total concentration of the pepsin. It is suggested that this is due to the fact that the enzym in solution is in equilibrium with another substance (called peptone for convenience) according to the law of mass action. Pepsin inactivated with alkali apparently enters the equilibrium to the same extent as active pepsin in spite of the fact that it has lost its power to hydrolyze protein. If the concentration of peptone is large with respect to pepsin and the concentration of substrate relatively constant, the relative change in the amount of active pepsin is inversely proportional to the concentration of the pepsin.

An integral equation has been obtained which holds for the entire course of the digestion (except for the first few minutes) with varying enzym concentration.

The nature of enzym action, W. M. BAYLISS (*New York and London: Longmans, Green & Co.*, 1919, 4. rev. ed., pp. VIII+190, figs. 9).—This is the fourth revised edition of this well-known monograph (E. S. R., 32, p. 19).

A weight burette for gas analysis, E. R. WEAVER and P. G. LEDIG (*Jour. Amer. Chem. Soc.*, 42 (1920), No. 6, pp. 1177-1185, figs. 2).—“An apparatus for conveniently determining small quantities of gas by weighing the confining liquid displaced is described, and its percentage accuracy is shown to be comparable with the general accuracy of good titrimetric measurements.”

A modified form of the Smith fermentation tube, A. V. FULLER (*Jour. Indus. and Engin. Chem.*, 12 (1920), No. 6, p. 595, fig. 1).—In the modified fermentation tube described the bulb, instead of being symmetrical, is made trough shaped on its under side. This is considered to facilitate the falling of growth to the lowest part of the gas tube proper, with the result that as the

gas is liberated it rises vertically in the closed arm without appreciable loss through the bulb. The introduction of a small quantity of rather coarse, acid-washed sand into the depression is suggested as aiding materially the liberation of the gas.

It is stated that with the same inoculum the volume of gas liberated within a given time is about three times as great with the modified tube as with the ordinary Smith type.

Electrodes of platinized glass for electrolytic determinations, G. MEILLÈRE (*Jour. Pharm. et Chim.*, 7. ser., 21 (1920), No. 8, pp. 311-313).—The author suggests the substitution of platinized glass in place of platinum for electrodes.

The glass is platinized by covering it with a thin coating of platinum chlorid in oil of turpentine or some other essential oil to which methyl alcohol has been added to render the mixture more fluid. On heating, the platinum chlorid is reduced to metallic platinum, forming a thin coating on the glass.

Acidity and acidimetry of soils.—II, Investigation of acid soils by means of the hydrogen electrode, H. G. KNIGHT (*Jour. Indus. and Engin. Chem.*, 12 (1920), No. 5, pp. 457-464, figs. 8).—In continuation of the investigation pre-

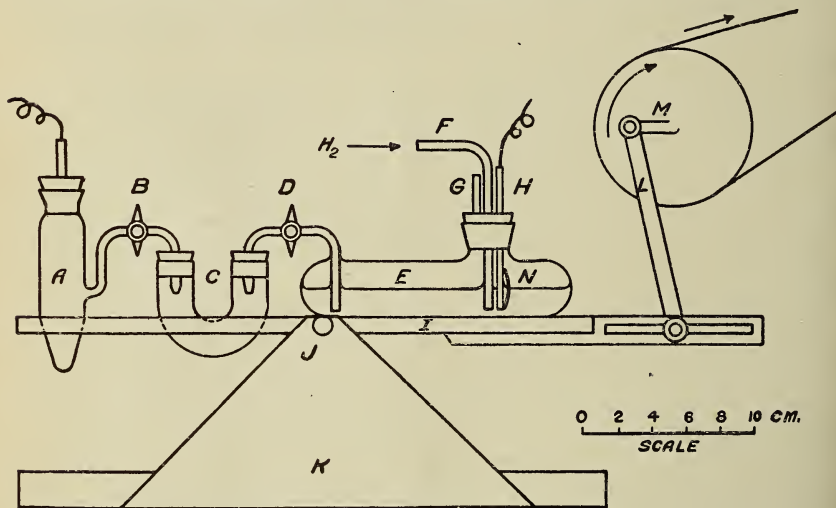

FIG. 1.—New hydrogen electrode cell for continuous agitation.

viously noted (E. S. R., 43, p. 12), the author presents the results of a study of (1) the speed of reactions between neutral salt solutions and soils, (2) the speed of reactions in the presence of a base, (3) the change in H-ion concentration with change of amount of base and with time, and (4) the change in conductivity of soil solutions.

A special gas cell which could be agitated continuously was designed for the work. The essential features of the apparatus as shown in the accompanying diagram (fig. 1) are as follows:

The calomel electrode A is connected by means of the stopcock B with a U-tube C filled with N KOH, which in turn is connected with the hydrogen gas cell by the tube D. The gas cell E is cylindrical in shape, 3.3 by 16 cm., with rounded ends. The hydrogen enters through the tube F, which extends nearly to the bottom of the cell. A short outlet tube G and the electrical connection H also pass through the same rubber stopper. The apparatus is placed on a tilting table I hinged at the point J to the base K. The

table is rocked by means of the adjustable arm L and crank M attached by gears and pulleys to a constant source of power. The electrode N is a rectangular piece of sheet platinum 1.2 by 2.4 cm., with pieces of platinum wire welded to each end, and is prepared by plating as a cathode in a 1 per cent solution of platinic chlorid containing a small amount of lead acetate to cause the platinum block to adhere.

In operation the cell is partly filled with soil and solution, the table oscillated, and hydrogen run in for four or five minutes, the tube G is closed and rocking at a rate of 72 complete oscillations per minute through an angle of 6 to 7° continued for four minutes, hydrogen is again run in for four minutes, and finally the tube G is again closed, the stopcock B opened, and readings are taken immediately.

The results of the investigation of several widely differing soils under the conditions noted above are summarized as follows:

"When an acid soil is added to a neutral salt solution the H-ion concentration of the solution reaches a maximum almost immediately if the soil is wet thoroughly by the solution, but secondary reactions later cause a decrease in H-ion concentration of the solution.

"When an acid soil is added to a neutral salt solution containing a free base the base is neutralized rapidly, as indicated by the change in H-ion concentration of the solution, following closely the law for equilibrium reactions, but the H-ion concentration of the solution continues to rise for an unknown period. There is no sharp break in the progress of base absorption by an acid soil which will warrant any arbitrary division, such as active and latent acidity, or immediate and eventual lime requirement.

"The changes in $\log C^H$ approach nearly straight line functions with progressive addition of base in the presence of a neutral salt solution. Different indicators will give differences in lime requirement for soils depending upon the slope of the $\log C^H$ curve. The greatest differences may be expected with soils high in organic matter. . . .

"When a base is added to an acid soil comparatively insoluble products are formed. Calcium produces a product less soluble than does potassium. The specific conductance of a water solution of an acid soil to which a base has been added increases with each addition of base, but the increase is greater with potassium than with calcium hydroxid, which is far too great to be accounted for by the difference in conductivity of potassium and calcium. Calcium and potassium hydroxids have practically equivalent power to neutralize the acid of an acid soil. The specific conductivity of a pure water solution containing a base in contact with an acid soil decreases with time. An acid soil shows high reserve acidity. The reaction between a water solution of a base and an acid soil is much slower than in the presence of a neutral salt. The absorption of bases by acid soils is due largely to relatively insoluble acids."

Determination of borax in fertilizers and crude stock, C. H. JONES and G. F. ANDERSON (*Amer. Fert.*, 52 (1920), No. 8, pp. 57, 58).—The authors, at the Vermont Experiment Station, describe a method for the determination of borax in fertilizers. This method is similar in principle to the method described by Ross and Deemer (*E. S. R.*, 42, p. 313), but differs from it in certain details, particularly in that the evaporation, ashing, and subsequent titration are on 1 gm. of material and that $N/50$ alkali is used in the titration in place of a $N/10$ solution. These changes are considered to render the determination more rapid and more accurate.

Turbidity standard of water analysis, P. V. WELLS (*U. S. Dept. Com., Bur. Standards Sci. Paper 367* (1920), pp. 693-721, pl. 1, figs. 2).—This paper reports

the results of a study of the present standard of turbidity in water analysis as determined by comparing samples of standard turbidity used by different State and municipal water laboratories in a special turbidimeter, the construction and operation of which are described in detail.

This study has shown the present standard of turbidity to be inaccurate, the variations from the average amounting in some cases to over 50 per cent. It is thought that these variations could be eliminated by having all the standards prepared by the Bureau of Standards, and the possibility is suggested of preparing standard samples of dry powdered silica sufficiently uniform in size of particle to use directly by suspension in the appropriate amount of distilled water.

Critical study of methods for the detection of methyl alcohol, A. O. GETTLER (*Jour. Biol. Chem.*, 42 (1920), No. 2, pp. 311-328).—An extensive review of the literature on methyl alcohol is reported, together with a critical study of 58 selected tests as applied to over 250 liquors and 700 human organs. As a result of this study typical procedures for the detection of methyl alcohol in liquors and tissues, involving a number of color reactions and a few crystal-producing tests, are described in detail. A bibliography of 123 titles is appended.

The diazometric determination of phenol, and certain of its homologs, R. M. CHAPIN (*Jour. Indus. and Engin. Chem.*, 12 (1920), No. 6, pp. 568-570).—The author, from the Bureau of Animal Industry, U. S. Department of Agriculture, reports a study of the possibility of applying the diazometric method to determine the strength of cresylic solutions used in official disinfecting operations.

The method depends upon the quantitative coupling of phenols with diazonium salts to form insoluble hydroxyazo compounds, as in the equation

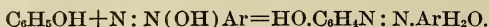

The conditions found to be essential for accurate results with the lower monohydric phenols of the benzene series consisted principally in working with as concentrated solutions as practicable and using as a buffer, to maintain the lowest possible concentration of H-ion without notable formation of isodiazo compounds, basic lead acetate in the presence of sodium acetate. The technique of the procedure is described in detail with the precautions that must be observed to secure accurate results.

Preliminary experiments upon the use of this method as a field test for cresol solutions used as animal dips are reported to be encouraging. "The results are not affected by the soap present in such solutions, while the basic lead acetate employed appears to precipitate and render innocuous organic matter derived from the animals (hogs)."

A quantitative method for determination of vitamin, R. J. WILLIAMS (*Jour. Biol. Chem.*, 42 (1920), No. 2, pp. 259-265, fig. 1).—The method described differs from the one previously suggested (E. S. R., 41, p. 670) in that instead of measuring the growth of single yeast cells, the growth of a large number of cells, under defined conditions is measured by a gravimetric determination which is said to give more accurate results than the single cell method.

The results obtained are expressed as the "vitamin number" which is defined as the "number of milligrams of yeast produced by the addition of its extract minus that produced in a control solution, under given conditions and within certain limits, computed to 1 gm. of the original material tested."

Certain precautions that must be taken in both the single cell and gravimetric methods are outlined, and some of the facts discovered in the application of both procedures are discussed. It was found that a solution containing ammonium sulphate and asparagin was not improved as a nutrient medium for

yeast by the addition of a mixture of amino acids, but was improved by the addition of small amounts of the antineuritic vitamin.

Modification of the Van Slyke method for determining arginin, A. E. KOEHLER (*Jour. Biol. Chem.*, 42 (1920), No. 2, pp. 267, 268, fig. 1).—An apparatus designed to eliminate bumping in the ordinary determination of arginin by the Van Slyke method is described and illustrated.

A tube leading from the top of the reflux condenser connected with the digestion flask extends nearly to the bottom of a wash bottle containing 30 cc. of N/14 acid. This bottle is connected by means of a long tube to a suction pump. Air, purified by passing through a wash bottle connected with the digestion flask, is drawn slowly through the apparatus, carrying with it into the standard acid the ammonia liberated during the boiling.

The graphical representation of analytical results, especially for the analysis of flours, F. MARION (*Ann. Chim. Analyt.*, 2. ser., 2 (1920), No. 4, pp. 107-109, fig. 1).—The author suggests a graphical method of indicating the quality of any particular flour from the results obtained in the customary analytical determinations of moisture, dry gluten, hydrated gluten, fat, mineral matter, and acidity. The results of these determinations are plotted on six axes intersecting at one point to form equal angles. The scale for each determination is so chosen as to make with a flour of the first quality a regular hexagon on the joining of the points representing the six determinations. In any given flour a point lying within the regular hexagon indicates an inferiority in that particular constituent, while every point situated outside the hexagon is a sign of superior quality.

How to know your flours, G. L. TELLER (*Amer. Food Jour.*, 15 (1920), No. 6, pp. 7-9, 19).—This is a general discussion of methods for determining the quality, grade, and market value of flour.

The keeping quality of milk as judged by the colorimetric H-ion determination, L. H. COOLEGGE and R. W. WYANT (*Jour. Dairy Sci.*, 3 (1920), No. 2, pp. 156-166).—This is the detailed report, with experimental data, of the investigation leading to the development of the method previously noted (E. S. R., 42, p. 613) for judging the keeping quality of milk by colorimetric H-ion determination. A provisional scheme is included for using the pH values in assigning to any milk a score indicative of its suitability either for market milk or for manufacturing purposes.

A method for manganese quantitation in biological material together with data on the manganese content of human blood and tissues, C. K. REIMAN and A. S. MINOT (*Jour. Biol. Chem.*, 42 (1920), No. 2, pp. 329-345).—The method described is essentially a modification of the method of Bertrand previously noted (E. S. R., 27, p. 670), the principal differences consisting in ashing the material in quartz beakers instead of platinum and in taking up the ash with an acid sulphate fusion instead of dissolving it in hydrochloric and sulphuric acids at low temperatures.

The technique of the procedure is described in detail, and results are given of a series of determinations of the manganese content of human blood and of human tissues from a limited number of autopsies.

The manganese content of the blood samples examined varied from 0.004 to 0.025 mg. per 100 gm. of blood, these results being considerably higher than those reported by Bertrand. No abnormality in manganese content was shown in the few pathological cases, including anemia, examined. Manganese was found in all the tissues analyzed, the liver showing the largest amount, the average of 13 analyses being 0.17 mg. per 100 gm. of wet tissue.

The determination of sugars by inversion, M. HILDT (*Ann. Chim. Analyt.*, 2. ser., 2 (1920), No. 4, pp. 103-106).—This is a brief survey of the literature on

the application of the principle of inversion or hydrolysis to the determination of different sugars.

The deterioration of Cuban raw sugars in storage, N. KOPELOFF and H. Z. E. PERKINS (*Jour. Indus. and Engin. Chem.*, 12 (1920), No. 6, pp. 555-558).—Samples representative of the middle and of the surface contents of a number of bags of Cuban raw sugar were analyzed chemically and bacteriologically at the beginning of the storage period and again at the end of 1 and 5.5 months in one series, and 1, 4.25, and 5.5 months in another series, the bags of sugar being kept under approximately normal storage conditions. The results obtained are summarized as follows:

“Cuban raw sugars (with moisture ratios varying from 0.22 to 0.49) were stored under normal conditions for 5.5 months and analyzed chemically and bacteriologically. There was a loss in polarization at the end of this period, as well as at the end of one month, which was generally accompanied by a gain in reducing sugars. There was a gain in moisture content and reduction in the factor of safety.

“There was a decided increase in total number of microorganisms after one month, which could be correlated within certain limitations with deterioration. When there was a large initial infection, deterioration was rapid. In general there were more microorganisms in the middle of the bag than at the surface. The percentage of molds increased over the longer incubation period, but often failed to increase in one month.

“A correlation between the number of microorganisms and the moisture ratio is indicated which appears to make it possible to predict the keeping quality of a sugar.

“Bags designated as wet, stained, or having sugar light in color deteriorated more rapidly than when drier, unstained, or dark in color. In bags of sugar which are deteriorating rapidly the surface deterioration is greatest, while in less rapid deterioration the middle of the bag seems to undergo greater decomposition.

“Deterioration was proportionately greater over a longer incubation period than in one month.”

Sauerkraut production controlled by heat, with the report of an experiment, E. LE FEVRE (*Canner*, 50 (1920), No. 10, pp. 161, 162).—This paper, presented at the annual meeting of the National Canner's Association at Cleveland, on January 27, 1920, presents the results of an investigation conducted by the Bureau of Chemistry, U. S. Department of Agriculture, on the control of sauerkraut production by heat. From experiments conducted under factory conditions the following conclusions were drawn:

“The essential factor in securing a rapid fermentation of cabbage is the proper degree of heat which, as determined by the optimum requirement of the organisms concerned in this process, is approximately 30° C. (86° F.).

“The heating of cabbage with a view to promoting its fermentation should be done just before it enters the tank, and this can be very effectively accomplished, with a minimum of expense, by the direct application of jets of steam to the shredded cabbage. The addition of a culture of lactic acid bacteria aids in the fermentation of cabbage, but not to the extent that it can be considered of great practical importance. As far as shortening the period of fermentation is concerned, the proper use of heat leaves little to be desired.”

Jelly, C. H. CAMPBELL (*Jour. Indus. and Engin. Chem.*, 12 (1920), No. 6, pp. 558, 559).—An experimental study is reported of the proportions of acid, pectin, and sugar necessary to obtain jelly of the best quality.

An excess of pectin was found to produce a firm, tough jelly. A pectin content of 1.25 per cent is recommended for commercial jelly, and from 0.75

to 1 per cent for a more delicate product resembling homemade jelly. The limiting, optimum, and maximum values for acidity (calculated as sulphuric acid) were found to be 0.27, 0.3, and 0.5 per cent, respectively.

With an apple juice of 0.43 per cent acidity and 1.25 per cent pectin content, jelly with the best texture for commercial purposes was obtained with a sugar content of 5 lbs. per gallon of juice, although the flavor of the lot containing 6 lbs. per gallon was somewhat better. It was also found that a jelly of satisfactory texture and quality can be made from apple juice by using 1 lb. of sugar per gallon for every degree of the Brix hydrometer reading.

As a quantitative method of determining pectin the author uses 10 cc. of filtered juice and 180 cc. of alcohol, adding the juice drop by drop from a pipette with frequent stirring. The precipitate is either filtered directly on a weighed Gooch crucible, dried, and weighed, or is filtered, dissolved in boiling distilled water, evaporated to dryness, heated two hours at 70° C. in vacuo, weighed, ashed, and reweighed. By observing the precipitation of the pectin as the juice is slowly run into the alcohol in the above proportions, an indication of the amount of pectin may be obtained, the precipitate forming a cohesive gummy mass with over 1 per cent of pectin and only a flocculation if the amount is less.

The chemistry of leather, L. EGLÈNE (*La Chimie du Cuir*. Paris: H. Dunod and E. Pinat, 1919, pp. XV+136, figs. 9).—This book treats of the chemical changes involved in the preparation of hides for tanning, in the tanning process proper, and in the finishing of the leather. The general processes involved in the making of leather are outlined in a preface by G. Jossier.

The chemistry of wood, I. B. WAESER (*Ztschr. Angew. Chem.*, 33 (1920), No. 30, Aufsatz., pp. 85-89).—This is a brief summary of recent studies on the chemistry of wood. A list of 110 literature references is included.

The proximate composition of Korean hemp and ramie, Y. UYEDA (*Jour. Indus. and Engin. Chem.*, 12 (1920), No. 6, pp. 573-576).—This paper, from the California Experiment Station, is the first of a series of reports on Korean bast fibers from the standpoint of textile chemical research. The methods proposed by Dore (E. S. R., 41, p. 14) for the proximate analysis of wood were applied with slight modifications to the analysis of samples of Korean hemp (*Cannabis sativa*) and of ramie (*Bahmeria nivea*), both of which were retted and scutched. The results obtained are given in the following table:

Proximate analysis of Korean hemp and ramie.

Sample.	Loss on drying.	Benzene extract.	Alcohol extract.	Water soluble material.	Material soluble in 1 per cent NaOH.	Cellulose.	Lignin.
	<i>Per cent.</i>	<i>Per cent.</i>	<i>Per cent.</i>	<i>Per cent.</i>	<i>Per cent.</i>	<i>Per cent.</i>	<i>Per cent.</i>
Hemp.....	8.83	1.92	1.20	4.50	18.53	62.42	3.32
Ramie.....	10.50	.86	.75	3.79	17.27	65.88	.66

Three new sources of fuel alcohol (*Automotive Indus., Auto.*, 42 (1920), No. 2, pp. 80-83; also in *Sci. Amer. Mo.*, 1 (1920), No. 6, pp. 531-534).—This article consists principally of a translation of technical appendixes to a German war-time law concerning alcohol manufacture. These appendixes describe a process for manufacturing alcohol based on the use of molasses, a process utilizing the sulphite liquor of plants for the purification of wood pulp, a process consisting in saccharifying wood and fermenting the sugar thus pro-

duced, and a process of generating alcohol from calcium carbide. The last-named consists of decomposing the carbide with water, forming acetylene. This is introduced into a heated diluted acid in the presence of a mercury compound, forming acetaldehyde. This in turn, by a process of hydrogenation with metallic nickel, is converted into alcohol.

The economic values to Germany of the different processes are also discussed.

METEOROLOGY.

The blue sky and the optical properties of air, LORD RAYLEIGH (*Nature* [London], 105 (1920), No. 2645, pp. 584-588).—The author concludes from visual examination with a Nicol's prism and by means of photography that the polarization of the daylight sky was almost complete, due to scattering of the light by small particles in the air. Observation with a Savart polariscope did not show a like polarization of the night sky, indicating a different origin of the night light. Ozone appeared to have no relation to the blue color of the sky. Experiments are reported which led to the conclusion that there is high up in the atmosphere an absorbent layer of ozone that "acts as a screen to protect us from the ultra-violet rays of the sun, which without such a protection would probably be fatal to our eyesight."

The aeroplane and hail, G.-M. STANOÏÉVITCH (*Compt. Rend. Acad. Sci. [Paris]*, 170 (1920), No. 26, pp. 1590-1592; *abs. in Rev. Sci. [Paris]*, 58 (1920), No. 13, p. 414).—The author proposes the use of aeroplanes to upset atmospheric conditions favorable to hail, on the theory that the motion of the propellers is sufficient to destroy the characteristic calm which precedes the fall of hail.

California precipitation, A. H. PALMER (*Jour. Electricity*, 44 (1920), No. 12, pp. 607-610; 45 (1920), No. 1, pp. 25-27, figs. 5).—This article, by the local representative of the U. S. Weather Bureau, summarizes and discusses the available data of precipitation in California, but deals particularly with the snowfall in the mountains and its relation to the flow of streams, with special reference to estimating its value for hydroelectric power and irrigation. The available data for snowfall and run-off are summarized in tables and diagrams.

A marked deficiency of run-off during the present season, 1919-20, as the cumulative effect of four consecutive seasons of deficient precipitation was noted, indicating that central California faced a serious shortage of water during the summer of 1920. Timely warnings were therefore given to the agricultural interests to plant only such crops as require a minimum of irrigation water, and the utmost conservation of water was urged until the next rainy season. As a result the acreage of rice especially was reduced.

The climate [of South Dakota], S. S. VISHNER (*S. Dak. Geol. and Nat. Hist. Survey Bul.* 8 (1918), pp. 50-67, figs. 7).—This article summarizes briefly the more important available data regarding the general characteristics of the climate of the State and the factors determining it, winds, temperature, length of day, humidity, evaporation, cloudiness, precipitation, variability of the weather, and supposed changes of climate.

"The climate is invigorating. Clear skies and stimulating breezes prevail. Though great ranges of temperature occur, the dryness of the atmosphere helps to keep the sensible temperatures more nearly uniform. The summer season is usually long and warm enough for raising corn. The normal annual precipitation is sufficient for the crops grown. The seasonal distribution of precipitation is very favorable, since slightly more than three-quarters normally fall during the six months, April-October 1. The autumns and winters have relatively little precipitation, to which fact is due the naturally-cured hay fur-

nished by the native grasses. . . . The 'openness' of the winters encourages grazing. . . .

"The chief climatic handicaps are (1) irregularity in the amount and distribution of precipitation, and (2) unseasonable low temperatures in the growing season. Periods of drought are common, but the southeastern quarter of the State never has had a general failure of both the corn and small grain crops. In the western part of the State especially, the normal amount of rain in some years may fall in such short, heavy showers that most of it runs off and thus is of little benefit to the crops. Late killing frosts in the spring are not infrequent and are a menace to fruit growing and occasionally injurious to corn. Early autumn frosts occasionally damage corn and flax crops especially in the northern sections. . . .

"The mean annual temperature of the State is about 45° F., for the eastern half about 44.5°, and for the western half about 45.6°. The northern counties have an annual mean about 5° lower than the southern countries. . . . Maxima temperatures of over 100° have been recorded for most of the stations outside the Black Hills, and minima temperatures below -40° having been recorded from most of the long-established stations except those in the Black Hills region. The extremes for the State are 115 and -50°, a range of 165°. Several stations have recorded an annual range of more than 150°. . . .

"The interval between the last killing frost in the spring and the first in the autumn—the crop-growing season—averages nearly 130 days. For the northern half of the State it is nearer 120 days, and for the southeastern quarter it is 140 days. The northern border has the shortest season (115 days) and the lower Missouri Valley the longest (150 days). The frost-free period around the base of the Black Hills and on the slopes of some of the buttes where there is good air drainage is a week or two longer than the average for the State. . . .

"Because of the low relative humidity, high summer temperatures, and persistent wind, the rate of evaporation is high. Experiments have shown that in most parts of the State evaporation from a water surface would amount to about 40 in. annually. In the northeast corner, however, it would be only 30 in. and in the southwest corner over 50 in. . . .

"The average annual precipitation in South Dakota is approximately 20 in., in the eastern half about 22.3, in the western half about 17 in. In the former 83 per cent, and in the latter 81 per cent, usually is received between March 1 and September 30. The amount of rainfall decreases toward the west and north. Because of the increased altitude, the central portions of the Black Hills receive more precipitation, especially snow, than do the surrounding plains."

The evidence does not indicate that the climate of the State is changing.

Tornadoes occur, especially in the southeastern part of the State, but are very irregular in distribution, and the area affected is very restricted. The blizzard, which has given the State a reputation for severe winters, is much less frequent than is generally supposed by nonresidents, "and as a result of the conditions attending the settlement of the rural districts, the construction of more commodious and more substantial farm buildings, fencing, and the more complete preparation for winter, such storms should be much less injurious than formerly. . . .

"It is not unlikely that the extension of the tilled area has reduced the injury inflicted on any given locality by hot winds. . . . Nevertheless, winds which are very drying still occur, and if their occurrence coincides with a period of deficient soil moisture, vegetation suffers severely, especially sorts

which are unable to absorb water approximately as rapidly as it is transpired. Some crop is ruined in some parts of the State nearly every year by a hot wind at a critical time." Northwest winds prevail during the colder six months and southeast winds during the warmer six months. As a rule the winds are of moderate velocity, the average being about 10 miles an hour and very persistent. On this account they "favor the use of windmills, which have become very numerous except where artesian flows may be obtained readily."

Climate [of Saskatchewan], F. H. KITTO (*In The Province of Saskatchewan, Canada: Its Development and Opportunities. Canada: Dept. Int., Nat. Resources Intel. Branch, 1919, pp. 56, 58-62*).—The characteristic features of the climate of this region are briefly described, and detailed data for temperature, precipitation, hail, and frost in 1916 are given in tables.

It is stated in general that the climate is characterized by clear, dry, very cold winters, and summers of high day temperatures and an abundance of sunshine. "A very noticeable feature of the climate is the rapidity with which winter gives way to spring or even summer weather. A sudden rising of the temperature, with bright sun and soft breezes, and in an incredibly short time the light mantle of snow has disappeared. Without waiting for the frost 'to come out of the ground' the waters from the melted snow disappear, the ground surface dries up as fast as it thaws out, and in a few days the dust is flying again. Seeding operations soon follow, and the transition has taken place usually without the proverbial 'March winds and April showers' and all their discomforts.

"As a rule the snow disappears during March or very early in April. Seeding operations usually commence about the first week of April. During the past ten years the average date of the commencement of seeding operations was April 8, and the average date at which seeding operations were general was April 18.

"Harvest begins early in August and is usually well under way by the middle of that month. Early frosts and fall weather may be looked for in September. The most pleasant months of the year, however, are usually September and October. Wintry weather is due any time after the first of November, though open falls till the first of December are not uncommon. Thus, it will be seen that the summers on the prairie are unusually long, and the winters, though cold, are shorter and brighter than those of eastern districts with more moderate temperatures."

Climates of the British Empire suitable for the cultivation of cotton, C. E. P. BROOKS (*Met. Mag. [London], 55 (1920), No. 651, pp. 37-39; abs. in Nature [London], 105 (1920), No. 2637, p. 338*).—The temperature and rainfall of parts of the British Empire considered adapted to the cultivation of cotton are briefly discussed and compared with similar data for the cotton-growing region of the United States.

It is stated that the essential features of a cotton-growing climate are as follows: "(1) The mean annual temperature should not be below 60° F. (2) The mean temperature of the warmest month should exceed 80° or the mean of the three warmest months should exceed 77° to get the best results; this condition, however, is not so important as the first. (3) The interval between killing frosts (or droughts) should be at least 200 days. (4) The annual rainfall should not exceed about 60 in. for good crops, though cotton of a poorer quality can be grown in much wetter climates. Unless irrigation is possible the annual fall should not be less than 23 in. (5) There must be plenty of bright sunshine. A dull and humid atmosphere is particularly unfavorable to the cotton plant.

“In the cotton belt of the United States the rainfall lies in almost all parts between 23 and 60 in. The mean annual temperature nowhere falls below 60°, and the warmest month always just exceeds 80°. In the British Empire these conditions are found in their entirety in parts of India and in the West Indies, which are already important cotton-producing countries.” Other colonies whose annual rainfall lies within the specified limits and which are considered in some detail with reference to their suitability for cotton growing are Uganda, Nyasaland, Gambia, the Sudan, Nigeria, Gold Coast, Rhodesia, British East Africa, the Union of South Africa, Australia, and New Guinea.

The weather of the past agricultural year, F. J. BRODIE (*Jour. Roy. Agr. Soc. England*, 80 (1919), pp. 201–212).—The weather conditions, particularly rainfall, temperature, and sunshine, in Great Britain during the winter of 1918–19 and the year 1919 are briefly summarized as in previous reports.

Swedish meteorological observations, 1917 (*Met. Iakttag. Sverige (Observ. Mét. Suéd.)*, *Met. Centralanst.*, 59 (1917), pp. XIV+183; 59 *Bihang* (1917), pp. [3]+50, pls. 6, figs. 21).—These are the detailed reports of the Central Meteorological Institute of Sweden for 1917, with an appendix containing a special report on frequency of hail in Sweden, 1865–1917.

SOILS—FERTILIZERS.

The soil, A. D. HALL (*London: John Murray, 3. ed., rev. and enl., 1920, pp. XV+352, pls. 4, figs. 14*).—This is the third revised and enlarged edition of this book (*E. S. R.*, 20, p. 1113).

The developments and modifications in theories relating to soils from 11 years' research have materially modified and enlarged the book, particularly with reference to the knowledge of soil organisms and their functions and the structure of clay and the soil reactions influenced by clay, as indicated by the present conception of colloids.

A student's book on soils and manures, E. J. RUSSELL (*Cambridge [England]: Univ. Press, 1919, 2. ed., rev. and enl., pp. XII+240, figs. 45*).—This is the second edition of this book (*E. S. R.*, 34, p. 716), in which the author has incorporated a number of changes in the section on fertilizers and manures in order to bring in new material and new points of view which have been developed by war-time conditions in England.

Methods for the physical analysis of soil, P. KOETTGEN (*Internatl. Mitt. Bodenk.*, 7 (1917), No. 5–6, pp. 205–246).—Considerable experimental work on different methods for the physical analysis of soils is reported, on the basis of which the author developed a process of mechanical separation of soils into groups according to grain size, chiefly by sieving, weighing, sedimentation, and centrifuging. Groups of grain sizes are determined from greater than 1 mm. to less than 1 μ , the latter being apparently the most difficult.

Mechanical and chemical analyses of part of the agronomic station at La Jaille, C. T. ALLDER (*Guadeloupe Rap. Sta. Agron.*, 1 (1918–19), pp. 35–37).—Mechanical analyses of samples of soil from the station show a high percentage of fine sand, silt, and clay. On this basis the soils of the locality are classed as fine sandy clay. The subsoil is of the same mechanical composition.

Chemical analyses show that these soils are poor in lime and other alkaline materials, but contain no soluble free acids. The total contents of potash and phosphoric acid are not high, and the available content approaches the minimum permissible. There is a 3 per cent content of organic matter, and the nitrogen content is also high.

The soils of the Detroit area, M. M. McCool and G. M. GRANTHAM (*Michigan Sta. Quart. Bul.*, 2 (1920), No. 4, pp. 192-195, fig. 1).—Data on the lake bed soils of an area of 987,520 acres in eastern Michigan are reported.

The surface features of the area consist of sand drift, level to undulating lands, old deltas, gravelly ridges, and river flood plains and terraces. The Clyde clay loam, which comprises the black swamp region, is the most extensive type. It is well supplied with nitrogen and has an average content of phosphorus and potash but requires drainage. The Clyde silt loam comprises about 30 per cent of the area. It is well supplied with nitrogen and potash but requires phosphorus and drainage. The Dunkirk sandy loam covers about 15 per cent of the area.

The soils of northern Wisconsin, A. R. WHITSON, T. J. DUNNEWALD, and C. THOMPSON (*Wisconsin Sta. Bul.* 306 (1919), pp. 45, pls. 4, figs. 3).—This is a survey, made in cooperation with the Wisconsin Geological and Natural History Survey and the Bureau of Soils of the U. S. Department of Agriculture, of the soils of upper Wisconsin, particularly of an area of about 8,500,000 acres of farm land and 2,000,000 acres of pasture and forest which are yet unoccupied.

There are 10 principal soil types in this region, including sands, light sandy loams, heavy sandy loams, silt loam with a well-drained subsoil, silt loam with heavy subsoil, silt loam on limestone, heavy red clay, poorly drained soils, peat and muck, and rough or very stony soils. Heavy sandy loam is said to be the most common soil and one of the most valuable in the area, followed by silt loam in acreage. The silt loam with a heavy subsoil is said to be one of the most uniform in the region. Considerable information is included on the crops best adapted to the different soil types.

Survey of soil conditions in Bavaria, H. NIKLAS (*Forstw. Centbl.*, n. ser., 42 (1920), No. 4, pp. 123-135).—The author groups the soils of Bavaria into 7 relief zones according to their texture and cropping adaptabilities as follows: Zone 1, prevaillingly heavy soils adapted to wheat and meadow culture; zone 2, heavy soils adapted mainly to barley culture; zone 3, medium soils adapted to barley culture; zone 4, in which neither heavy nor light soils prevail, adapted to general cropping of all kinds; zone 5, in which neither light nor medium soils prevail, adapted to oats and rye and some barley culture; zone 6, prevaillingly light soils adapted to rye and oats culture; and zone 7, containing soils of all kinds which are adapted to meadow culture, mainly owing to the influence of climatic conditions, rainfall especially. These zones cover the area as follows: Zone 1, 13 per cent; 2, 12 per cent; 3, 14 per cent; 4 and 5, 17 per cent; 6, 31 per cent; and 7, 13 per cent.

A comparative study of cropped and virgin soils, C. E. MILLAR (*Michigan Sta. Quart. Bul.*, 2 (1920), No. 4, pp. 195, 196).—An extension of experiments previously reported (*E. S. R.*, 41, p. 420) to include soils from many sections of Michigan confirms the conclusions of the previous report.

Further studies to determine the nature of the material going into solution showed a larger total residue for the virgin than for the depleted soils. A large part of this residue was volatile, and while all the extracts showed large quantities of organic matter there are considerable quantities of carbonates present in the extracts which would be decomposed on ignition. More calcium was extracted from virgin than from cropped soils. These experiments are being continued.

Testing soils for acidity, E. TRUOG (*Wisconsin Sta. Bul.* 312 (1920), pp. 24, pl. 1, figs. 12).—Popular information is given on soil acidity and lime require-

ment of soils, and instructions as to the practical use of the lead acetate test for soil acidity are outlined.

Report of the director of soil and fertilizer investigation, E. M. TAYLOR (*Ann. Rpt. Dept. Agr., New Brunswick, 1919, pp. 188-191*).—Data are reported on the lime requirements of representative samples of soils from various parts of the Province of New Brunswick, the conspicuous feature of which is the apparent degree of acidity of these soils. Data on the lime resources of the Province and the use of lime are also included.

Reactions of experimental soils and the lime requirements of the soils of Malmöhus, Sweden, L. FORSBERG (*Malmö. Läns. Hushåll. Sällsk. Körtlsskr., 1919, No. 4, pp. 458-463*).—Data on the reactions of representative sand and clay soils from the Province of Malmöhus, determined each successive year for 11 years, showed 45 per cent of the sand soils to be acid, 13 per cent neutral, and 42 per cent alkaline in reaction. Of the clay soils, 30 per cent were acid, 13 per cent neutral, and 57 per cent alkaline. These results are taken to indicate the advisability of testing all sand and clay soils for acidity, and the litmus test is recommended for this purpose. Marling of these soils, while successful, was found to be expensive, and the use of commercial ground limestone is recommended for reducing the acidity.

The development of roots and the lime content of soil, TACKE (*Fühling's Landw. Ztg., 69 (1920), No. 3-4, pp. 58, 59*).—Commenting on the report by Osvald, noted below, different experiments are reviewed to show that the roots of crops penetrate into upland moor soils only to the depth at which they contain sufficient basic material to neutralize the free humus acids.

Investigations on the effect of ground water level on the rooting of meadow plants on moor soils, H. OSVALD (*Fühling's Landw. Ztg., 68 (1919), Nos. 17-18, pp. 321-340; 19-20, pp. 370-386, figs. 4*).—Five years' experiments on the influence of varying the ground water level in a well-decomposed sandy lowland moor peat soil and in a little decomposed sandy upland peat soil, on the yield and manner of rooting of nine different types of grasses and clovers, are reported.

The kind of soil was of the utmost importance relative to the influence of soil water on the spreading of grass roots in the different soil layers. This is caused by the greater or lesser capillary power of the soil and its ability to retain rain water. With reference to the retention of rain water the sphagnum moor soils were equal to the coarser forest moor soils, but could not be compared with them as regards capillarity.

It is concluded, therefore, that moor soil should not be too intensively drained owing to the danger of lowering the ground water level below the rooting area of plants, thereby causing them to suffer from drought. The sphagnum moor soils, on account of their general condition, should contain much more moisture than the lowland moor soils. It was found in this connection that crops on upland moor soils suffered more from drought than crops on excessively drained lowland moor soils. The rolling of upland moor soils to compact the upper layers of soil and render them more retentive of moisture is recommended. Methods are also discussed for the preparation of root systems for study.

A list of 52 references to literature bearing on the subject is included.

The extent, geographic condition, quality, and utilization of the moors of Courland, J. DREYER (*Veröffentl. Geogr. Inst. Albertus Univ., Königsb., No. 1 (1919), pp. [VI]+261, pl. 1, figs. 4*).—The results of a year's study of the geography, physical and chemical composition, extent, and possibilities for utilization of the moor soils of Russian Courland are reported, particular reference being made to their agricultural value,

These moors are upland and flats, and the area of individual moors varies very little, rarely being over 2,500 acres. The depth of the moor soil averages between 2 and 4 meters and seldom exceeds 6 meters. The soil is rather well decomposed but is poorly drained. The ash content is relatively low, and the content of plant nutrients is about the same as that of the north German moor soils. Analyses show the nitrogen content to exceed that of almost all other soil types, and the lime content is relatively high. The soils are generally deficient in phosphoric acid and potash.

Brak in its relation to irrigation, A. STEAD (*Union So. Africa, Dept. Agr. Jour.*, 1 (1920), No. 1, pp. 13-25, figs. 7).—This is a popular article on the nature, occurrence, and action on soil and crops of so-called brak, or alkali, with particular reference to South African conditions, and methods for its removal are described.

It is stated that brak occurs in South Africa in both dry and humid regions. Removal by proper drainage is recommended. Deep plowing and the maintenance of a surface mulch to prevent evaporation are considered essential to success in cultivating brak soils. "Brak waters may be used for irrigation under special conditions, but the use of water which contains sodium carbonate is not to be recommended for the finer types of soil, especially if the water is muddy. The action of the sodium carbonate, in addition to its effect on the crop, is to render the soil impermeable and to depreciate its tillage qualities."

Notes on practical salt land reclamation, G. S. HENDERSON (*Agr. Research Inst. Pusa Bul. 91* (1920), pp. [1]+16, pls. 2, figs. 2).—This bulletin describes the alkali soils of the Province of Sind and alkali soil reclamation as practiced in Egypt and India.

It is stated that the three predominating alkali types in Sind soils are chlorid, sulphate, and carbonate of sodium.

It is concluded that methods of alkali land reclamation successfully adopted in Egypt are suitable for northwest India, the only effective method being that of washing the salt into the subsoil. Surface washing and running the salt-impregnated water off periodically is a wasteful and unsatisfactory method except under very special circumstances. Careful leveling is essential. After washing, the physical texture of the soil must be improved by suitable cropping, which is done in practice most easily by feeding cattle on the land on leguminous fodder crops.

Soil-sorption, E. RAMANN and A. SPENGLER (*Landw. Vers. Sta.*, 92 (1918), pp. 127-146; *abs. in Jour. Chem. Soc. [London]*, 116 (1919), No. 686, I, p. 615; *Jour. Soc. Chem. Indus.*, 39 (1920), No. 2, p. 74A).—Experiments are reported in which an artificial zeolite, consisting of permutite and hydrated aluminum alkali silicate, was treated with solutions of neutral potassium, ammonium, calcium, and sodium salts.

It was found that the interchange of bases had the character of a chemical exchange, and no signs of physical adsorption could be detected. Potassium and ammonium were mutually replaceable and displaced sodium and calcium completely from the zeolite. The displacement of potassium and ammonium by sodium and calcium was incomplete. The ratios between the bases in the solutions and in the zeolite were different. Bases present in small proportions in the solution were combined by the zeolite in relatively greater amounts. Within wide limits the absolute concentrations of the salts in the solution were without appreciable influence on the composition of the zeolite, this being the case even with mixtures of calcium salts and salts of univalent metals.

Solid phases obtained by the evaporation of certain soil extracts, M. S. ANDERSON and W. H. FRY (*Jour. Indus. and Engin. Chem.*, 12 (1920), No. 7, pp.

663-669).—Experiments conducted by the Bureau of Soils of the U. S. Department of Agriculture to determine the nature of the salts which are crystallizable from soil extracts and to determine, if possible, the variations in these in different types of soil are reported.

It was found that salts deposited on the evaporation of the water extract of soils are much more complicated in character than is indicated by a simple statement of the ions existing in solution. There is a marked general similarity between the salts so obtained and those obtained by both natural and artificial evaporation of sea water. It is considered probable that the complex salts obtained from soil extracts may be present in the soils only in solution in soil moisture and never in the solid phase.

A bibliography is appended.

The distribution in the soil of currents emitted by electric traction lines, GIROUSSE (*Compt. Rend. Acad. Sci. [Paris], 170 (1920), No. 14, pp. 841-843*).—A mathematical discussion is given of the distribution and intensity of electrical currents leaking from electric traction lines into the neighboring soils. Formulas are derived, based on the electrical resistance of the soil, the amperage and voltage of the electrical current, and other factors.

The potential biochemical activity of the spores of soil bacteria, J. R. NELLER (*Soil Sci., 9 (1920), No. 5, pp. 329-340, fig. 1*).—Studies at the New Jersey Experiment Stations are reported, in which laboratory tests were conducted with infusions from the five successive layers of the upper 64 cm. of gravelly loam and shale loam soils, which were heated to 85° C. for 10 minutes, and the carbon dioxid production, ammonia accumulation, and bacterial numbers were compared with a similar treatment with unheated infusions.

In the surface soil of the finer textured loam 5.8 per cent, and of the coarser loam 8.7 per cent of the original bacterial count, survived a temperature of 85° for 10 minutes. The relative numbers surviving in the subsoils were much less, being 2.7 and 1.6 per cent, respectively. Very few fungus colonies and no actinomycetes or chromogenic types were observed in the plates inoculated with heated infusions.

For a 7-day period the average ammonia accumulation resulting from inoculating with heated infusions was 46.6 per cent of that with unheated infusions obtained from gravelly loam and 39 per cent when infusions from shale loam were used. For a 10-day period the carbon dioxid produced by inoculating with heated infusions of *Bacillus subtilis* was about the same whether the infusion had been heated for 5, 10, or 15 minutes, and averaged 73.6 per cent of the amount produced by unheated infusions. For a 7-day period the average carbon dioxid production resulting from the use of heated infusions of shale loam was 77 per cent of that obtained with unheated infusions. The corresponding value for gravelly loam was 76.2 per cent. The accumulation of ammonia and the production of carbon dioxid resulting from inoculating a sterile soil with heated infusions correlated with each other in showing that the bacterial spores of the soil are capable of energetic activity when supplied with sufficient food and moisture.

Symbiotic nitrogen fixation as influenced by the nitrogen in the soil, W. A. ALBRECHT (*Soil Sci., 9 (1920), No. 5, pp. 275-327, figs. 7*).—Following an extensive review of the works of others bearing on the subject, studies conducted at the University of Illinois are reported on the relation of symbiotic nitrogen fixation to the nitrogen content of soils, particularly the total nitrogen as obtained by soil analysis.

Variations in the mineral and organic nitrogen content of the soil were brought about by adding sodium nitrate, and by incorporating organic matter

in the form of clover tops in a soil containing only 625 lbs. of nitrogen per 2,000,000 lbs. of soil. One crop of soy beans and two crops of cowpeas were grown. Some of the original soil was used each time for the treatment with nitrates, but the same soils were used throughout the three crops for the treatment with organic matter.

The results indicate that nitrogen fixation will take place in a soil containing large amounts of nitrogen in the form of either nitrates or organic matter. No injurious effects on nitrogen fixation were caused by nitrates in this experiment, and it is concluded that if such ever occur under similar conditions, the application of nitrates must be many times larger than is ever applied in agricultural practice. It was found that nodules are produced when large amounts of organic nitrogen are present in the soil, and good legume growth results even when sufficient organic matter is present to give large losses of volatile nitrogen from the soils. The addition of some organic matter may increase the amount of nitrogen fixed by cowpeas. In soils containing varying amounts of total nitrogen, as much fixation of nitrogen by cowpeas may be expected in one with 3,000 lbs. of total nitrogen as in one with lesser amounts. According to the data, variations in the amount of total nitrogen in a soil failed to exert any varying influence on the amount of nitrogen fixed.

Some of the effects of the war upon fertilizers, L. L. VAN SLYKE (*New York State Sta. Bul. 471 (1920), pp. 10*).—A study is given of data regarding commercial fertilizers collected in the State of New York during the years 1914-1919, showing that the number of complete fertilizers decreased each year from 614 in 1914 to 171 in 1919.

Mixtures of phosphoric acid and potash had practically disappeared by 1916, while mixtures of nitrogen and phosphoric acid appeared in relatively large numbers in 1916 and the following years. Acid phosphate brands increased, sodium nitrate, bone, blood, and tankage decreased, and potash salts entirely disappeared.

The average percentage of nitrogen in complete fertilizers decreased appreciably after 1915, while that of potash decreased greatly after 1914 and still more after 1916. The average percentage of available phosphoric acid increased considerably after 1914, but with some variation from year to year. The total percentage of available plant nutrients decreased continually after 1914.

The average retail cost of 1 lb. of plant nutrient material in complete fertilizers increased continuously from 8.8 cts. in 1914 to 33.1 cts. in 1919. The retail cost of plant nutrient material in acid phosphate, sodium nitrate, bone, dried animal manures, etc., increased, but not so much relatively as in the case of complete mixed fertilizers.

High-grade fertilizers most economical, A. J. PATTEN (*Michigan Sta. Quart. Bul., 2 (1920), No. 4, pp. 179-181*).—Practical information is given on the subject showing that, owing to the overhead expense of mixing and manufacture, it is advisable to purchase high-grade fertilizers. It is pointed out that as the actual value of the fertilizer increases the overhead percentage of cost decreases.

Fertilizer work, W. G. TAGGART (*Louisiana Stas. Rpt. 1919, pp. 23, 24*).—Fertilizer experiments with sugar cane showed the good effects of green manuring with clover together with applications of acid phosphate. Better results were obtained with 500 lbs. of acid phosphate than with 250 lbs. when an equal amount of nitrogenous fertilizer was used. Better results were obtained on stubble than on plant cane.

In tests of nitrogenous fertilizers, cyanamid gave yields of 18.52 tons of cane per acre, sodium nitrate 18.62, ammonium sulphate 17.63, tankage 19.62, an unusual sample of cottonseed meal 17.19, and ammonium nitrate 17.18 tons.

Soil fertility investigations, M. J. THOMPSON (*Minnesota Sta., Rpt. Duluth Substa., 1918-19, pp. 14-22*).—Phosphate-manure fertilizer experiments with potatoes, rutabagas, and oats begun in 1916 showed that with potatoes manure was the most effective when in combination with either rock or acid phosphate. Neither kind of phosphate was of value unless combined with manure. Acid phosphate gave the best results with rutabagas. Both manure and phosphate slightly improved the oats grain crop. In the following hay crop the phosphates were without any distinct effect.

Experiments with the same crops using clover as green manure, and with a rotation of barley, oats, potatoes, and rutabagas on a virgin forest soil without clover or manure, are also reported.

In rate of manuring experiments with the same crops very little effect was noticeable from manure applications on potatoes and rutabagas on new soil. The grain crop showed a distinct but small reaction to the manure treatment.

Field experiments on the availability of nitrogenous fertilizers, 1908-1917, J. G. LIPMAN and A. W. BLAIR (*Soil Sci., 9 (1920), No. 5, pp. 371-392*).—Field experiments conducted at the New Jersey Experiment Stations are reported, which were started in 1908 for the purpose of studying the relative availability of different nitrogenous fertilizer materials. The plan was developed somewhat along the line followed for the well-known cylinder experiments which were started 10 years earlier, and a brief summary of the second five years' work so far as it relates to the lime treatment has been previously noted (*E. S. R., 43, p. 128*).

The present report is limited to data on the relative availability of the nitrogenous materials and of nitrogen losses under a 5-year rotation of corn, oats, wheat, and two years of timothy. With slight exceptions, the mineral nitrogenous materials increased the yields, and the average yields of dry matter and percentage of nitrogen recovered were greater than with organic materials. Sodium nitrate gave the largest yields of dry matter and the highest percentage of nitrogen recovered on the unlimed soils, and ammonium sulphate gave the highest results on the limed soils. Of the organic materials, dried fish gave the best results on unlimed soils and dried blood the best on limed soils. Farm manure and farm manure with sodium nitrate gave the largest total yields, but on account of the large excess of nitrogen supplied by these materials the increases are not considered profitable when compared with those from commercial materials. The supply of nitrogen and carbon was best maintained on those plats which received the farm manure and the farm manure plus sodium nitrate.

Industrial gases, H. C. GREENWOOD (*London: Baillière, Tindall & Cox, 1920, pp. XVII+371, figs. 23*).—In this volume, one of a series dealing with the chemical industries and edited by S. Rideal, a section is included on nitrogen and its manufacture and nitrogen fixation processes.

Nitrogen fixation by the Haber method, C. H. JONES (*Chem. and Metall. Engin., 22 (1920), No. 23, pp. 1071-1075, figs. 6*).—The theoretical consideration of the process of nitrogen fixation by the Haber method is given, together with data on the design of apparatus and existing plants, including the U. S. Nitrate Plant No. 1.

It is concluded that the Haber method is the coming process for nitrogen fixation because of the lower cost of manufacture combined with the purity of

the product. However, the cyanamid process is considered to be the only practicable and commercial method established in the United States at the present time for the direct fixation of atmospheric nitrogen. It is further concluded that if the industry employing the Haber method should be developed to keep pace with other nations the research in the process should be carried on by the Government.

Nitrate of lime: Its manufacture and use, G. A. COWIE (*Jour. Min. Agr. [London]*, 27 (1920), No. 1, pp. 43-48).—Information on the manufacture and use of nitrate of lime is given, and data from experiments with different crops on various soils are reported. In most cases nitrate of lime gave results equal to those produced by sodium nitrate and ammonium sulphate, and on soils deficient in lime it gave better results.

Study on cyanamid and its transformation into ammonium sulphate, NITRICUS (*Rev. Prod. Chim. [Paris]*, 22 (1919), No. 22, pp. 587-592; 23 (1920), Nos. 1, pp. 1, 3-6; 4, pp. 89-92, figs. 14).—This article reports a physico-chemical study of the formation of calcium cyanamid and related matters, and reviews data on its fertilizing value indicating that it is a fairly efficient nitrogenous fertilizer when compared with ammonium sulphate. It should be mixed with other fertilizer materials only in small quantities, and it is best used broadcast before seeding time, preferably in the fall.

A further study is reported on the polymerization of cyanamid and the preparation of ammonia and finally of ammonium sulphate by the use of sulphuric acid. Data are also reviewed on the fertilizing value of ammonium sulphate.

Fertilizer experiments with deteriorated lime nitrogen, M. POPP (*Mitt. Deut. Landw. Gesell.*, 34 (1919), No. 12, pp. 169-171; *abs. in Zentbl. Agr. Chem.*, 49 (1920), No. 3, pp. 88-93).—Experiments are reported which showed that lime nitrogen kept perfectly dry will within a year's time undergo decomposition resulting in the transformation of about a third of the total nitrogen into the form of dicyandiamid.

Pot experiments with tomatoes showed the injurious action of the deteriorated lime nitrogen, even though it was applied eight days before setting out the plants and not as a top-dressing. The injurious action of the deteriorated lime nitrogen was considerably decreased by mixing it with from 3 to 4 per cent of so-called humus carbolineum, which also increased the utilization of the nitrogen of the lime nitrogen to a marked degree.

It is concluded that the farmer in purchasing lime nitrogen should be assured that it is free from materials injurious to plants.

The prevention of volatilization of ammonia nitrogen by calcium chlorid, A. STUTZER (*Fühling's Landw. Ztg.*, 69 (1920), No. 3-4, pp. 73, 74).—In a second contribution to the subject (*E. S. R.*, 42, p. 22), the author reports further experiments with calcium chlorid added to ammonium carbonate in amounts calculated on the water-free basis, showing that calcium chlorid is very effective in fixing the ammonia and much more so than previously reported. Considerable value is attached to its use with liquid manure.

The solubility of mono- and diammonium phosphate, G. H. BUCHANAN and G. B. WINNER (*Jour. Indus. and Engin. Chem.*, 12 (1920), No. 5, pp. 448-451, figs. 3).—Data and curves from solubility determinations made on the two commercially important ammonium phosphates are reported. The following solubility equations are derived, representing the grams of the salt dissolved in 100 gm. of the saturated solution between the temperature limits given: Solubility monoammonium phosphate from 5 to 90° C.= $18+0.455t$; solubility diammonium phosphate from 10 to 70°= $36.5+0.213t$.

The production of phosphoric acid by smelting phosphate rock in a fuel-fed furnace, W. H. WAGGAMAN and T. B. TURLEY (*Jour. Indus. and Engin. Chem.*, 12 (1920), No. 7, pp. 646-650, figs. 3).—The results of preliminary experiments on the production of phosphoric acid by smelting phosphate rock in a fuel-fed furnace, conducted by the Bureau of Soils of the U. S. Department of Agriculture, are reported.

Preliminary work in the laboratory showed that the nearly complete evolution of phosphoric acid from a charge of calcium phosphate, carbon, and quartz flour was perfectly feasible if reducing conditions were maintained until a fusible slag was produced and a temperature of approximately 1,500° C. was continued throughout the operation. The addition of small amounts of alumina to the charge seemed to aid the fusion somewhat.

Further experiments on a larger scale, in which a fire-brick furnace fitted with two oil burners was used, showed that in order to make the process economically practicable the full calorific power of the fuel must be utilized, which can be done only by heating the charge directly in the flame. The plan of spraying the phosphatic charge into the furnace along with the fuel was also tested, but the vast bulk of material was carried out of the furnace along with the gases of combustion and lost.

Tests on briquetting the phosphate charge showed that a charge containing from 20 to 25 per cent of finely divided material classed as clay can be formed into very satisfactory briquettes. The furnace was modified so that a portion of the flames and hot gases of combustion from the oil burners would play up through the central shaft and thus heat the charge of briquettes directly. While the results obtained with this furnace were not entirely satisfactory, it appeared that by exposing the charge to a high temperature for a sufficient length of time nearly complete evolution of the phosphoric acid can be brought about. This process is said to show a considerable economic advantage over the ordinary method of obtaining soluble phosphoric acid.

Making phosphate available with bisulphate, B. NEUMANN and K. KLEYLEIN (*Ztschr. Angew. Chem.*, 33 (1920), No. 26-27, *Aufsatz.*, pp. 74-77, figs. 3).—Laboratory experiments are reported on the substitution of sodium bisulphate for a part of the sulphuric acid in the process of treating raw phosphate for the production of superphosphate. It was found when working with sulphuric acid of different concentrations that the concentration of the acid was increased by additions of bisulphate up to 47.5° Baumé, beyond which the concentration was decreased. The bisulphate was found to be a practical substitute only when working with an acid of 30° Baumé or lower.

Phosphorite, superphosphate, and tetrphosphate, A. QUARTAROLI (*Staz. Sper. Agr. Ital.*, 52 (1919), No. 7-9, pp. 416-435).—The author reviews the results of work by others, and reports studies to show that tetrphosphate does not have a higher content of easily soluble phosphate than ordinary rock phosphate.

Phosphoric acid utilization, with special reference to conditions in Bavaria, H. FISCHER (*Landw. Jahrb. Bayern*, 9 (1919), No. 3, pp. 161-169).—The author reviews a number of studies by himself and others on the ways in which phosphoric acid is placed in available condition in soils, particularly those of Bavaria.

He takes up especially the unlocking of soil phosphates by soil acids, chemical action and mass action of soil amendments, and heat and soil bacteria. With reference to the action of soil amendments, it is believed that liming has a favorable effect upon the solubility of soil phosphates owing to its precipitating action on solutions of iron salts. This is thought to explain the relatively

large amounts of available phosphorus in certain of the Bavarian soils which are rich in lime.

It is also concluded that the action of heat and soil bacteria on the production of carbon dioxide in soils has a marked effect upon the availability of soil phosphates, and the use of organic matter as an aid in this action is therefore recommended.

Raw rock phosphate v. acid phosphate, G. D. CAIN (*Louisiana Stas. Rpt. 1919, p. 31*).—Experiments on a 3-year rotation are reported showing that raw rock phosphate applied to corn at the rate of 2,700 lbs. per acre every third year gave slightly better results than 16 per cent acid phosphate applied at the rate of 300 lbs. per acre. Opposite results were obtained with cotton.

Potash from kelp.—II, **The experimental distillation of kelp at low temperatures**, G. C. SPENCER (*Jour. Indus. and Engin. Chem., 12 (1920), No. 7, pp. 682-684, fig. 1*).—In a second contribution (*E. S. R., 41, p. 508*), studies of the experimental destructive distillation of dried kelp, to determine whether or not under carefully controlled conditions any relationship could be established between the temperature at which distillation was taking place and the nature of the distillation products, are reported.

Sixteen distillations of dried kelp were made in an oil-jacketed wood retort at temperatures not exceeding 320° C. These yielded aqueous liquor, tar, and a noninflammable gas. The residual charcoal was insufficiently heated either for a good extraction of potash or for use as a filtering medium. This work has demonstrated the necessity for distilling kelp at a much higher temperature.

Experiments with sodium chlorid and potassium salts, H. R. CHRISTENSEN (*Tidskr. Planteavl, 26 (1920), No. 5, pp. 737-823*).—The results of the works of others bearing on the subject are briefly reviewed, and experiments conducted at the Danish state experiment stations on the fertilizing influence of sodium chlorid and potassium salts on such root crops as mangolds, swedes, and potatoes, are reported.

The results indicate that under certain conditions sodium chlorid has a very stimulating effect on the production of dry matter in crops, but this was evident only in the case of mangolds for Danish crops. Raw Stassfurt salts, kainit for instance, consistently replaced sodium chlorid in this respect.

It is concluded that the more extensive use of low-grade potash salts is justified and also the use of sodium chlorid. It is the opinion that the use of these salts, sodium chlorid in particular, tends to offset the injurious effect of summer droughts on the growth of mangolds. Sodium chlorid as a rule had no effect on swedes, and there was no difference between the results obtained with high and low grade potash fertilizers. High-grade potash salts were preferable for potatoes, however. Kainit and sodium chlorid often had a directly negative influence upon potatoes, as indicated by small production and low quality.

Lime in 1918, G. F. LOUGHLIN and H. INSLEY (*U. S. Geol. Survey, Min. Resources U. S., 1918, pt. 2, pp. 813-856, pls. 3, figs. 3*).—Considerable statistical data on the production, sale, and use of lime for different purposes, including agriculture, in the United States during 1918 are reported graphically and otherwise.

The total quantity of lime sold in 1918 was 3,206,016 short tons, valued at \$26,808,909—a decrease in quantity of 580,348 tons, or 15 per cent, but an increase in value of \$3,001,032, or 13 per cent, compared with the production in 1917. The average price per ton of lime increased from \$6.29 in 1917 to \$8.36 in 1918. This was an increase of 33 per cent over the price for 1917 and of 113 per cent over the price for 1914. The greatest increase in price

was in Florida, where the average price per ton rose from \$5.74 in 1917 to \$13.58 in 1918. The average price per ton in Wyoming was \$18.75, the highest price in any State.

Twelve per cent of the total quantity of lime sold in 1918 was used for agriculture. This amounted to 391,047 tons, valued at \$2,698,848, a decrease of 20 per cent in quantity compared with the output of 1917, but an increase of 9 per cent in value. Agricultural lime was produced in 27 States and in Porto Rico in 1918. Pennsylvania led with a production of 200,073 tons, about 25 per cent of the total output of the State. The other leading States in order of production were Maryland, Ohio, Virginia, and West Virginia. New Jersey's very small production was all used for agricultural purposes, and of Maryland's production 64 per cent was used in agriculture. The average price per ton of lime used in agriculture (\$6.90) increased \$1.83 over the price for 1917. Agricultural lime included 3,304 tons of lime, valued at \$30,328, reported as sold for use in prepared fertilizer, and 1,989 tons, valued at \$6,750, sold combined with wood ashes.

Of the total marl produced, 57,821 short tons, valued at \$148,873, or \$2.57 per ton, was fresh-water marl, consisting mainly of small shells of fresh-water animals.

The value of late glacial drift from the Province of Bohus as liming material for peat soils poor in lime, H. VON FEELTZEN and E. NYSTRÖM (*Svenska Mosskulturför. Tidskr.*, 34 (1920), No. 2, pp. 115-124, figs. 5).—Experiments on peat soils poor in lime growing red clover to compare coarse and finely ground glacial drift with ground limestone as sources of lime are reported. These materials were added in amounts equivalent to 1,000, 2,000, and 4,000 kg. of calcium oxid per hectare (890, 1,780, and 3,560 lbs. per acre).

The finely ground glacial drift gave results comparable to those given by the ground limestone, and in some cases gave better results. The finely ground drift gave much better results than the coarse drift, and in the smallest applications was better than the largest applications of the coarse material. Comparisons of the solubilities of the glacial drift and of ground limestone in water saturated with carbon dioxide made by H. Christensen showed that the coarse drift material was slowly soluble as compared to the fine drift, and that the fine drift was in all cases equal in solubility to the ground limestone.

It is concluded that this glacial drift is equal to high-grade limestone as a carrier of lime, but that it must be finely ground.

Analyses of fertilizer by the department of agriculture for 1919 (*Va. Dept. Agr. and Immigr. Bul.* 149 (1920), pp. 8-11).—Analyses of 66 samples of fertilizers and fertilizer materials, collected for inspection in Virginia during the fall of 1919 and found to be deficient in one or more constituents, are reported.

[Fertilizer inspection work for the spring of 1920] (*Va. Dept. Agr. and Immigr. Bul.* 153 (1920), pp. 14-27).—Actual and guaranteed analyses of 71 samples of fertilizers and fertilizer materials offered for sale in Virginia during the spring of 1920 are reported, all of which were deficient in some respect. In addition, a list is given of 235 samples of fertilizers which met the guaranty. Analyses of 7 samples of burnt lime, 13 samples of unburnt lime, and 3 samples of lime and potash are also reported.

The fertilizer control law and how to comply with it, E. G. PROULX (*Indiana Sta. Circ.* 96 (1920), pp. 8, fig. 1).—The purpose of this circular is to furnish information concerning the law regulating the sale and inspection of commercial fertilizers in Indiana, as passed by the legislature in 1881 and amended in 1889 and 1901. The full text of the law is given, together with a description of the method of administering it.

AGRICULTURAL BOTANY.

The problems of experimental heredity, L. BLARINGHEM (*Les Problèmes de l'Hérédité Expérimentale*. Paris: Ernest Flammarion, 1919, pp. 317, figs. 20).—The material in the three main divisions of this book (which deals with heredity more extensively on the botanical side), namely, normal heredity, hybrids between species, and crossings of varieties, is further subdivided into chapters. These deal, respectively, with pure lines; the biometric laws of fluctuating heredity; mixed heredity; mosaic or Naudinic heredity; unilateral heredity; the duration and heterogeneity of tissues in hybrids; the laws of alternate or Mendelian heredity; characters of varieties and their hereditary transmission; and the hypotheses of Mendel and Mendelian polyhybrids.

The genetics of *Campanule carpatica*, C. PELLEW (*Gard. Chron.*, 3. ser., 66 (1919), No. 1715, p. 238, figs. 3).—The author here presents in condensed form, with comments, the account previously noted (*E. S. R.*, 39, p. 123).

On the relation between number of chromosomes and number of types, in *Lathyrus* especially, Ö. WINGE (*Jour. Genetics*, 8 (1919), No. 2, pp. 133-138, pl. 1).—The author gives details of a study of the chromosome number in *Lathyrus odoratus* and *L. latifolius*, in both of which this number was seven. This low chromosome number is considered to favor the use of *Lathyrus* in genetic experiments.

Double flowers and sex-linkage in *Begonia*, W. BATESON and I. SUTTON (*Jour. Genetics* 8 (1919), No. 3, pp. 199-207, pl. 1).—This is a brief account of a discovery made when *Begonia davisii*, originally a wild plant from Peru, was brought into a series of experiments then in progress. It was used (on account of its being a genuine (wild) species breeding true on self-fertilization) as a single for crossing with doubles. When these crosses were made it was found that any double fertilized with pollen of *B. davisii* gives only double-flowered offspring (being thus double-bearing, but on the male side only, since the same plant fertilized with its own pollen gives singles only). Tested, however, with the pollen of a double it gave a result which has not been satisfactorily interpreted, as here detailed with discussion. The conclusion reached that the male side of this wild species must be genetically all double is considered noteworthy.

The presence of iodine in plants, E. WINTERSTEIN (*Ztschr. Phys. Chem.*, 104 (1918), No. 1, pp. 54-58).—A long list of plants was examined for iodine, which was found in *Beta vulgaris*, *Solanum tuberosum*, *Apium graveolens*, *Lactuca sativa*, and *Daucus carota*.

The behavior of some organic substances in plants, X, G. CIAMICIAN and C. RAVENNA (*Gaz. Chim. Ital.*, 48 (1918), I, No. 4-6, pp. 253-304, figs. 7).—This communication, which is one of a series previously noted (*E. S. R.*, 39, p. 526), is in three parts. The first deals with the action of some substances on germination and development; the second with oxidation in the plant; and the third with the elimination of certain substances by the aerial organs of plants.

Rutin, the flavone pigment of *Eschscholtzia californica*, C. E. SANDO and H. H. BARTLETT (*Jour. Biol. Chem.*, 41 (1920), No. 4, pp. 495-501, pls. 2).—*E. californica*, containing in its petals nearly 5 per cent of rutin (quercetin glucosyl-rhamnosid) and showing a color range from golden yellow to white, and from white to rose, was chosen as affording specially suitable material for the study of the physiological and genetic relationships of the flavonol and anthocyanin pigments. The preliminary work here outlined dealt chiefly with the preparation, properties, and distribution of rutin, the identification of quercetin, and the determination of the sugars resulting from hydrolysis. It is considered that

the share of the geneticist in the final elucidation of the pigment situation must be to provide the chemist with materials of known factorial composition.

Comparative studies on the carotin and xanthophyll content of green and autumn yellow leaves, E. GOERRIG (*Bot. Centbl., Beihefte*, 35 (1918), 1. *Abt.*, No. 2, pp. 342-394).—It is stated that carotin and xanthophyll participate in the necrobiotic phase of autumn leaf coloring, the latter pigment at least doubling the former as regards quality but the ratio varying with the species. It is thought that quantitative genetic relations do not hold between the green and the yellow colorants of the chloroplasts. Carotin and xanthophyll differ greatly as regards such characters as sensitivity to light and temperature.

Exudation of water by *Colocasia antiquorum*, M. G. FLOOD (*Sci. Proc. Roy. Dublin Soc., n. ser.*, 15 (1919), No. 36, pp. 506-512, pls. 2, fig. 1).—Experimentation is described which is considered to show that there is no special tissue in the leaf tip of *C. antiquorum* serving as a gland or epithem for the secretion given up by the leaves. No membrane for filtering the water was found to intervene between the water channels and the depression in the leaf. Transfer arrangements in the plant would indicate that cells lower down may secrete and filter the water. No special cells for such work outside the root have been demonstrated.

On some factors affecting the concentration of electrolytes in the leaf sap of *Syringa vulgaris*, T. G. MASON (*Sci. Proc. Roy. Dublin Soc., n. ser.*, 15 (1919), No. 46, pp. 651-666).—An account is given of attempts to work out a plan for making corrections for the viscosity of sap in the determination of concentrations of electrolytes in plant cells by means of conductivity observations. The osmotic pressure of the cell is frequently due mainly to electrolytes, but the presence of solutes which are neither electrolytes nor sugars is not excluded. Considerable fluctuations have been indicated in the concentrations of electrolytes in the leaf sap of *S. vulgaris* growing in different localities. There is a tendency for the concentration of electrolytes to vary inversely with that of nonelectrolytes. It is suggested that these fluctuations may be associated with the rate of carbon assimilation, which determines the rate at which electrolytes are removed from solution in metabolism.

The existence of daily growth rings in the cell wall of cotton hairs, W. L. BALLS (*Proc. Roy. Soc. [London], Ser. B*, 90 (1919), No. B 634, pp. 542-555, pls. 3, figs. 4; *abs. in Gard. Chron., 3. ser.*, 66 (1919), No. 1715, p. 234).—As a result of studies outlined, the author considers it well established that the primary wall of the seed hairs in cotton contains very small amounts of cellulose; that the secondary thickening of the wall proceeds intermittently under normal Egyptian field crop conditions, being arrested each afternoon; that the cellulose of each hair is arranged in 25 growth rings, each being the result of one day's growth with the exception of that of the primary wall; and that the so-called fuzz hairs are analogous with the lint hairs, though they have coarser and plainer growth rings.

Outside the cellulose of the primary wall the hairs are covered by a cuticle, bearing wax, which is structurally and historically identical with the cuticle of the testa while structurally and chemically distinct from the cellulose. The secondary wall, but not the primary, is traversed obliquely to the hair axis by simple pits (rarely visible except in the living hair), which cause the twisting and convolutions of the hair after death (which are described).

The method employed utilizes a simple but special sort of ultramicroscopy, the growth rings being but about 0.4μ in thickness.

The layers are due to arrest of growth each afternoon during the hot days, in which the lint grows in thickness after forming, by growth in length, the

one thin primary layer. These are, therefore, rings of nightly growth. Certain abnormal appearances indicate that the cellulose wall may grow for a time without being in full contact with the ectoplasm.

Artificial budding of roots, H. MOLISCH (*Sitzber. K. Akad. Wiss. [Vienna], Math. Naturw. Kl., 126 (1917), I, No. 1, pp. 3-13, pls. 2; abs. in Internatl. Inst. Agr. [Rome], Internatl. Rev. Sci. and Pract. Agr., 9 (1918), No. 11, pp. 1302, 1303; also in Gard. Chron., 3. ser., 66 (1919), No. 1714, pp. 227, 228*).—The question regarding a winter resting period for the subterranean, corresponding to that of aerial, parts was investigated. The author employed for this purpose freshly cut branches one to three years old of *Salix*, *Populus*, *Philadelphus coronarius*, and *Viburnum opulus*, all of which produce readily adventitious roots. These plants were subjected during September to November to forcing by such agents as hot water and smoke of tobacco and paper, exposed for an hour or two to the open air, and placed in a greenhouse at 12° to 20° C. or in a thermostat at 25° (77° F.).

The tobacco smoke exposure during 24 hours caused earlier leaf fall and also caused adventitious roots to appear a few weeks later, as in case of exposure to paper smoke for 48 hours and to warm water (30°) for 12 hours. Controls showed a few or no adventitious roots.

The conclusion reached is that during a certain period the roots tend to rest from their functions. This period does not always depend upon the existence of unfavorable factors, but is very often independent.

Old age in perennial plants, [H. M. BENEDICT] (*Gard. Chron., 3. ser., 66 (1919), No. 1711, p. 190*).—To the contribution previously noted (E. S. R., 34, p. 222) is added here a brief notice of observation and opinion by others bearing on the subject.

Studies in the metabolism of actinomycetes.—III, Nitrogen metabolism, S. A. WAKSMAN (*Jour. Bact., 5 (1920), No. 1, pp. 1-30*).—Experiments conducted at the New Jersey Experiment Stations on the utilization of different nitrogenous compounds by actinomycetes and the transformation of the substances due to the action of these soil organisms are reported.

It was found that the actinomycetes do not fix atmospheric nitrogen, although some colonies will develop on routine nitrogen-free media. Most species were able to reduce nitrates to nitrites with the proper source of carbon, a few species were able to reduce nitrates to nitrites actively with nearly all sources of carbon studied, and a few others gave no reduction or only traces with nearly all sources of carbon.

The proteins and amino acids studied were found to form the best sources of nitrogen for this group of organisms. Amids were used only to a very small extent. Nitrates were used fairly well in the presence of the proper source of carbon. Nitrites present in small quantities in the medium were utilized well by most species, particularly by those that reduced nitrates actively. Ammonium salts formed the poorest sources of nitrogen with glycerol as a source of carbon; with glucose as a source of carbon, both amids and ammonium salts were utilized well as sources of nitrogen, if the reaction of the medium did not tend to become too acid.

Most actinomycetes split proteins actively, as indicated by an increase of the amino-nitrogen content of the medium. The organisms that produced only a small amount of growth split proteins only to a very limited extent, and used up only small quantities of the amino acids. The production of ammonia from proteins and amino acids is not characteristic of this group, although, on continued incubation, considerable quantities of ammonia may accumulate in the medium, as indicated by the growth of the organisms in milk or on pure proteins added to sterilized soil. Many species produced soluble yellow, brown to dark

brown pigments in media containing proteins and amino acids, the production of a brown pigment being due, in most cases, not to a tyrosinase reaction. Only some strains of *Actinomyces scabies* and a few other chromogenous species were able to produce a soluble brown pigment from tyrosin; most of the species that produced brown pigments on protein media, even if they did not give the tyrosinase reaction, produced an oxidase.

"For comparative cultural purposes a definite incubation period is very important, since two organisms will show a different relationship in their metabolism (splitting of milk in this case) at different periods of incubation. With the prolongation of the period of incubation the difference in the quantity of the products obtained from the splitting of milk will greatly decrease and may, in some cases, almost disappear."

Studies in the metabolism of actinomycetes.—IV, Changes in reaction as a result of the growth of actinomycetes upon culture media, S. A. WAKSMAN and J. S. JOFFE (*Jour. Bact.*, 5 (1920), No. 1, pp. 31-48).—Investigations conducted at the New Jersey Experiment Stations are reported, which dealt with the changes in reaction of the culture medium as affected by the growth of actinomycetes, as well as the effect of the initial reaction of the medium upon the growth of these soil organisms.

It was found that the actinomycetes are not able to produce any appreciable quantities of acid from the carbohydrates studied, the changes in the reaction of the medium being due to the source of nitrogen. With different sources of carbon and sodium nitrate as a source of nitrogen, the reaction of the medium tended to become alkaline. When sodium nitrate was replaced by sodium nitrite those organisms that were able to grow on the latter source of nitrogen changed the reaction of the medium to acid rather than to alkaline. When ammonium salts of strong acids were present as the only source of nitrogen, the medium tended to become distinctly acid, due to the fact that the cation was used up by the organism and the anion was left in the medium. With proteins and amino acids it was found that the reaction may be unchanged or may become acid or alkaline, depending on the species, source of carbon, and original hydrogen-ion concentration of the medium. Certain species seemed to change the reaction of the protein and amino acid media always to alkaline, others always to acid. Leucin as the only source of nitrogen nearly always favored a distinct acidity of the medium. The presence of an available carbohydrate in a protein medium seemed to favor an acid reaction. With media of different hydrogen-ion concentrations the reaction tended to an optimum; the more acid media tended to become less acid and the more alkaline media above the optimum less alkaline.

Plant hygiene, G. C. GOUGH (*Gard. Chron.*, 3. ser., 67 (1920), Nos. 1726, pp. 40, 41; 1727, p. 54).—Illustrative matter on plant hygiene is cited as furnished by several investigators.

Inventory of seeds and plants imported by the Office of Foreign Seed and Plant Introduction during the period from April 1 to June 30, 1916 (*U. S. Dept. Agr., Bur. Plant Indus. Inventory No. 47 (1920), pp. 96, pls. 5).*—Notes are given on about 600 lots of seeds and plants imported for trial in this country.

FIELD CROPS.

[Report of field crops work in Louisiana, 1919], A. F. KIDDER, W. G. TAGGART, and G. D. CAIN (*Louisiana Stas. Rpt. 1919, pp. 14, 15, 22, 23, 31-34).*—This continues work previously noted (*E. S. R.*, 39, p. 528).

In experiments at Baton Rouge yields indicated that velvet beans planted in the row with corn produced more than when planted in every other row or

one row of beans and two rows of corn. Where velvet beans were planted in the row with the hills of corn four feet apart each way and one-half the corn was tied similarly to tying for fodder cutting, no difference in yields of corn and beans was noted. The increase of yield of velvet beans obtained by substituting castor beans for corn was not enough to overcome the yield of both corn and beans and did not justify the extra expense of eliminating the castor bean stalks.

In variety tests at the Sugar Experiment Station, L-511 equaled the production of the older canes and possessed a sugar content of juice of 14.25 as compared with about 11.5 for D-74 and Purple. L-511 seemed to suffer less from the mosaic disease than older varieties in the State.

Alexander Mexican June, Surcropper, and Ferguson Yellow Dent with respective yields of 28.2, 28.2, and 25.5 bu. per acre were first in corn variety tests at Calhoun. In percentage of grain, the leading varieties were Calhoun Red Cob (North Louisiana Substation) with 88.22, Hastings Prolific with 86.11, and Calhoun Red Cob (Supple) with 86.05.

The highest yielding cotton varieties were Trice, with 441 lbs. of seed cotton per acre, and Wanamaker-Cleveland and Cleveland with 399 lbs. each. The lint percentages were 27.5, 35, and 31.75, respectively.

Experiments were also conducted with cowpeas, forage crops, and potatoes. Of 15 cowpea varieties, Red Ripper and New Revenue were the heaviest producers, yielding 11.5 and 11.37 bu. per acre, respectively. Japanese Honey sorghum was first in the 1919 forage crop tests with a yield of 16.73 tons of green material per acre, followed by Texas Seeded Ribbon cane with 15.47 tons, and Sumac with 13.2 tons.

In potato tests, northern grown Triumph seed from different sources produced yields ranging from 5.8 to 63.5 per cent in excess of the Louisiana grown seed.

[Report of field crops work at the Duluth Substation, 1918-19], M. J. THOMPSON (*Minnesota Sta., Rpt. Duluth Substa., 1918-19, pp. 6-13, figs. 3*).— This reports the progress of experiments conducted during 1918 and 1919. The portion dealing with work in 1918 has been previously noted (*E. S. R., 42, p. 825*).

In 1919 tests of wheat varieties, Mindum, Kubanka, and Marquis gave average yields of 26.73, 20.37, and 18.79 bu. per acre, respectively. Iowa 60-day, with a yield of 54.31 bu. per acre, Victory with 50.11 bu., and Swedish Select with 48.83 bu. were first in oat variety tests. Svansota, with an average yield of 53.76 bu. per acre, was first among the barley varieties tested; Lion Manchuria second with 49.94 bu.; and Imp. Manchuria third with 47.07 bu. Spring rye averaged 32 bu. per acre. Of three bean varieties tested Snowflake yielded highest, producing 33.2 bu. per acre.

Yields in the roughage plats were poorer than that of grass in other fields. The most productive of the varieties grown for hay were Golden millet with 8,111 lbs. per acre, Hungarian millet with 5,486 lbs., Siberian millet with 5,293 lbs., and alsike clover with 5,228 lbs. Of the crops tested for silage production, sunflowers and sorghum were first with acre yields of 36,666 lbs. and 31,153 lbs., respectively.

Observations on new place effect experiments with potatoes indicated that first season seed from native stocks produced larger yields than seed from regions farther south, but the second year seed, removed by one season from southern Minnesota, showed a relative increase in yield and uniformity of type, apparently adjusting itself to the new conditions. Burbank potatoes were first in the variety tests with a 2-year average yield of 300 bu. per acre, followed by Green Mountain and Russet, yielding, respectively, 283 and 262 bu.

Seed potatoes treated with corrosive sublimate, formalin, and copper sulphate produced average yields of 338, 331, and 248 bu. per acre, respectively, as compared with 368.6 bu. from the untreated check. It was noted that yields seemed to be depressed by the seed treatment, especially in the case of copper sulphate.

Potatoes given level cultivation yielded in 1919 365.6 bu. per acre as compared with 339 bu. from ridged cultivation. The vine growth was much heavier on the level cultivated plats.

[**Report of field crops work in Nebraska**] (*Nebraska Sta. Rpt. 1919, pp. 25, 27, 28*).—This reports briefly on work conducted during 1919 on the North Platte, Scottsbluff, and Valentine substations.

Nebraska Hybrid No. 28, with a yield of 25.6 bu. per acre, was the highest in winter wheat tests at the North Platte substation. Among spring wheat varieties the durum wheats produced an average of 15.4 bu. per acre, while common varieties averaged but 9.4 bu. Winter wheat gave an increase of 23 per cent over spring wheat. After summer tillage, winter wheat yielded 24.1 bu. per acre and following corn 16.7 bu. Irrigated fields produced acre yields of 11 tons of silage and 37.5 bu. of winter wheat, as compared with 5.1 tons and 23.3 bu., respectively, without irrigation.

Observations on irrigated crop rotations at Scottsbluff coincided with those noted previously (*E. S. R., 41, p. 433*). Sugar beets thinned on June 1, 10, and 20, produced average yields amounting to 18.8, 17.5, and 14.5 tons per acre, respectively. These and previous results are held to show conclusively that delayed thinning causes a marked decrease in yield. On the cultural test plats oats made an average yield of 64.2 bu. per acre, and barley 59.7 bu. Trebi barley has proved very satisfactory for irrigated land, doubling the yield of common barley. Sweet clover continued to give good results, producing more pasture per acre than any combination of grasses used.

[**Report of field crops work in Nigeria in 1917**], K. T. RAE and T. THORNTON (*Ann. Rpt. Agr. Dept., North. Provs., Nigeria, 1917, pp. 8-17*).—In continuation of similar work previously noted (*E. S. R., 40, p. 230*), this reports the results of limited variety tests with cotton, peanuts, and sorghum; breeding work with corn, peanuts, sorghum, and sweet potatoes; cultural tests with tobacco; and fertilizer experiments with sweet potatoes.

[**Report of field crops work in Nigeria, 1918**], T. THORNTON and V. A. RENWICK (*Ann. Rpt. Agr. Dept., North. Provs., Nigeria, 1918, pp. 14-23*).—This reports the progress of variety tests with cotton, peanuts, and sorghum; selection work with corn and sorghum; cultural tests with tobacco; and fertilizer tests with sweet potatoes. Results of plantings of miscellaneous cover, forage, cereal, and root crops, and dye plants are also recorded.

Cotton was not deemed a success in the Ilorin area. Experiments with tobacco at this point led to the conclusion that the color of the cured leaf was closely associated with the climatic conditions prevailing during the curing process. A dark color was secured during the wet season or in a humid atmosphere, while dry weather, especially when accompanied by the wind known as the harmattan, produced a bright color in the cured leaf.

Growing irrigated grain in southern Idaho, L. C. AICHER (*U. S. Dept. Agr., Farmers' Bul. 1103 (1920), pp. 28, figs. 13*).—This publication, intended primarily for settlers on the irrigated lands of the Snake River Basin in southern Idaho, describes the soils and climate of the region, and discusses field practices and cultural methods that have produced the best returns from cereals grown under irrigation. Information is also presented on harvesting and thrashing small grain, and on the principal varieties of wheat, oats, and barley cultivated.

The author includes results of varietal experiments with cereals, conducted from 1913 to 1918 at the Aberdeen substation in cooperation with the Idaho Experiment Station and noted previously (E. S. R., 41, p. 226).

Improvement of Rhodesian pastures, H. G. MUNDY (*Rhodesia Agr. Jour.*, 17 (1920), No. 2, pp. 113-117, pls. 4).—Numerous trials of exotic pasture plants and grasses, representative of almost every part of the world, are said to have been without success, the primary cause of failure being the long dry season of Rhodesia. Native African grasses giving promise in this region, namely, Sudan grass, Napier grass, Guinea grass, teff grass (*Eragrostis abyssinica*), kikuyu grass (*Pennisetum longistylum*), Rhodesian tussock grass (*Setaria*, sp.), molasses grass (*Melinis minutiflora*), Penhalonga grass, and Rhodesian buffel grass (*Panicum*, sp.), are described briefly.

Culture tests with root crops, 1917-1919, L. HELWIG (*Tidsskr. Planteavl*, 26 (1920), No. 5, pp. 824-880, fig. 1).—Cooperative culture tests in 10 localities in different parts of Denmark were conducted with beets, turnips, and carrots as forage crops. The varieties under test were compared on the basis of dry matter production.

In the test with field beets Eckendorfer ranked under Barres field beet and several strains of sugar beets in average dry matter production. Among the varieties of yellow turnips Yellow Tankard gave good results, while among the varieties of white turnips White Tankard stood high in dry matter content. Yellow carrots ranked above red carrots in dry matter production. Of different varieties of turnips grown on land infested with cabbage diseases, May turnips proved most resistant.

Oil seed plants, H. WACKER (*Landw. Hefte*, No. 32-33 (1917), pp. 66, figs. 20).—A treatise on the production of fats and oils from oil seed plants, with statistics on the importation and extent of culture of the plants in Germany. Brief descriptions of rape, turnip, false flax, white and black mustard, radish, poppy, sunflower, flax, and hemp are included, together with lists of varieties, cultural methods, and comparative analyses.

Seed studies: Red clover with special reference to the country of origin of the seed, R. G. STAPLEDON (*Jour. Agr. Sci. [England]*, 10 (1920), No. 1, pp. 90-120).—This article reports a series of studies of red clover seed derived from British, Canadian, Chilean, French, and Italian sources. Detailed notes on the grain weight, color characteristics, germination, and diagnostic weed seeds are included in tabular form. The author suggests a nationality test of red clover seed based on differences in the foregoing qualities.

The corn crops, E. G. MONTGOMERY (*New York: The Macmillan Co.*, 1920, rev. ed., pp. XVII+347, pl. 1, figs. 120).—This is a revised edition of a work previously noted (E. S. R., 30, p. 635).

Guam corn, G. BRIGGS (*Jour. Amer. Soc. Agron.*, 12 (1920), No. 5, pp. 149-157).—This paper, a contribution from the Guam Experiment Station, discusses the origin of the one type of maize grown on the island, and describes in detail the habits of growth, stalks, and ear characteristics.

From all data available the author estimated that about 243 years had elapsed since corn was first planted in Guam, and inasmuch as the natives have made a common practice of saving the seed of a crop for the next planting, the current crop was held to be attaining its 486th cycle. The cultural practices, together with the food and corn nomenclature in vogue, suggested a Mexican origin. No introduction from the United States or tropical countries has proved so well adapted to tropical conditions or the local environment as the Guam corn.

Forage for the cotton belt, S. M. TRACY (*U. S. Dept. Agr., Farmers' Bul.* 1125 (1920), pp. 63, figs. 9).—This is a revision and enlargement of Farmers' Bulletin 509, previously noted (E. S. R., 28, p. 40).

Interim report to the Board of Trade of the Empire Flax Growing Committee on the general situation and immediate prospects of supply in April, 1919 (London: [Gt. Brit.] Bd. Trade, *Empire Flax Growing Com., Interim Rpt., 1919 pp. 11*).—This comprises a brief report on the present status and future possibilities of flax culture in the United Kingdom and the British Empire.

Experiments with Kherson and Sixty-Day oats, C. W. WARBURTON and T. R. STANTON (*U. S. Dept. Agr. Bul. 823 (1920), pp. 72, figs. 15*).—This bulletin is a compilation of results from oat variety experiments, including Kherson and Sixty-Day, conducted by this Department and the State experiment stations, independently and in cooperation for periods ranging from 4 to 14 years and covering a wide scope of soils and climatic conditions. The histories and descriptions of the two varieties are included, together with brief statements on yields of straw, weights per bushel, percentage of hull, and improvement work. The yield data from the different stations are tabulated in both detailed and summarized form, and with the aid of numerous diagrams are fully discussed. In conclusion, the authors designate the varieties and types that have proved best for each section of the country. A list of 51 titles, comprising literature cited, is appended.

A general consideration of the results noted led to the conclusion that the early varieties, Kherson and Sixty-Day, yielded well in most of the spring-oat sections of the United States. The summary of average results indicates that at more than 50 per cent of the stations under a wide range of climatic conditions, early varieties have outyielded midseason and late varieties. Kherson and Sixty-Day are said to have given the best results in the warmer humid, subhumid, and semiarid sections. Late varieties were superior in yield to those of the midseason group at only a few stations.

Oats in Michigan, J. F. COX (*Michigan Sta. Spec. Bul. 101 (1920), pp. 10, figs. 4*).—This is a popular description of cultural methods and field practices deemed best for growing oats in the State, together with notes on varieties, seed treatment, and rotations.

Seed potato preparation, R. P. HIBBARD (*Michigan Sta. Quart. Bul. 2 (1920), No. 4, pp. 176-179, fig. 1*).—Comparisons of the different parts of the potato showed that the stem-end pieces bore as vigorous sprouts when separated from the seed ends as the seed ends themselves, and no one section proved to be uniformly better than another. Tests indicated that two eyes or more gave perfect germination, and that the practice of planting small tubers of proper weight and cutting the larger ones to suitable size is sound from both physiological and commercial viewpoints.

Soy beans, C. R. MEGEE (*Michigan Sta. Spec. Bul. 100 (1920), pp. 11, figs. 5*).—The author recommends the culture of the soy bean for hay, silage, and green manure, and describes methods of planting and harvesting applicable to the various uses. He reports a variety test of soy beans in 1919 in which the highest acre yields were made by Manchu, Ito San, Early Brown, and Black Eyebrow, with 5,107, 4,931, 4,760, and 4,688 lbs. of air dry hay, respectively. These varieties are considered among the best for Michigan conditions.

Sudan grass, H. N. VINALL (*U. S. Dept. Agr., Farmers' Bul. 1126 (1920), pp. 30, figs. 11*).—The origin and adaptation of Sudan grass are discussed, and field practices in growing the crop for hay, silage, pasture, and seed production are described. Practical suggestions for its utilization, together with comparative analyses and information on the control of diseases and pests, are included.

Sweet clover seed, H. S. COE and J. N. MARTIN (*U. S. Dept. Agr. Bul. 844* (1920), pp. 39, pls. 5, figs. 6).—This bulletin comprises two parts, as follows:

Part 1. *Pollination studies of seed production* (pp. 1-25).—This section is concerned primarily with the factors underlying failure of sweet clover to produce a normal seed yield through shedding of immature pods and lack of pollination. The author reviews previous work on the same problem and describes the structure and development of the flower and floral organs of sweet clover. The results of studies of the insects most active in pollination, sources of pollen necessary for fertilization, conditions of pollination required for fertilization, and the relation of environmental conditions to shedding of immature pods may be summarized as follows:

Very little tendency toward sterility of ovules was observed in *Melilotus alba* and *M. officinalis*. Self-pollination appeared to be as effective as cross-pollination in *M. alba* so far as the vigor of the pollen tubes and the rate of embryonic development were concerned. The average dimensions of the pollen of *M. alba* and *M. officinalis* were found to be 26 by 32 μ and 24 by 30 μ , respectively. A high atmospheric humidity did not seem to check the germination of pollen. This also held true with an excess of water in the stigmas resulting from an abundance of soil moisture.

Flowers fertilized with pollen transferred from another plant produced a higher percentage of pods than when selfed or pollinated with pollen from other flowers on the same raceme. Pollen transferred from one flower to another on the same raceme proved more effective than when the pollen produced was used to fertilize its own stigma. Self-pollination was effective, but occurred spontaneously to a very small extent.

Night-flying insects were not found to be an important factor in production of sweet clover seed. Although results showed small insects to pollinate sweet clover flowers freely, it was doubted whether these insects would be numerous enough to pollinate sufficient flowers in a large field for profitable seed production. The honeybee was the most efficient insect pollinator of this plant, and in many sections is believed responsible for the pollination of more than half of the flowers. Insects more frequently visited flowers that were directly exposed and readily accessible. Clear weather with vigorous insect activity was accompanied by a greater effective pollination than cloudy or rainy weather, when but few insects visited the flowers.

Deficiency in soil moisture was an important factor in reducing seed production. However, an appreciable increase in the water supply by rains or other sources decidedly checked the fall of flowers and immature pods from this cause.

Part 2. *Structure and chemical nature of the seed coat and its relation to impermeable seeds of sweet clover* (pp. 26-35).—A historical summary of the contributions of earlier investigators to the knowledge of the structure of legume seed coats and the cause of impermeability in seeds is presented. The authors outline the methods of procedure followed and material used in a series of microscopic and microchemical studies of the seed coat of *M. alba* and *M. officinalis*, and describe in detail their observations on the structure and chemical composition of the seed coat, the seed coat in relation to absorption of water, a comparison of permeable and impermeable seeds, and the action of sulphuric acid on the coats of impermeable seed.

A list of 44 titles, comprising the literature cited, is appended.

Essays on wheat, A. H. R. BULLER (*New York: The Macmillan Co., 1919*, pp. XV+339, pls. 45, figs. 6).—This book comprises a short history of wheat culture in Manitoba and a discussion of the industry in western Canada, including culture, marketing, and transportation. The origin and development of Marquis

wheat is treated at length, and descriptions of the Red Bobs and Kitchener varieties, together with notes on the wild wheats of Palestine, are included.

Wheat investigations.—I, Pure lines, J. ZINN (*Maine Sta. Bul. 285 (1920), pp. 48, pls. 3, figs. 12*).—An account of the origin and development of a number of pure lines of wheat by the method of selection is presented. The relation of environment to the chemical composition and quality of wheat is discussed, and the soils, climate, and characteristics of the wheats of Aroostook County are described. The author also makes observations on the adaptation of pure strains from Minnesota to the environment of northern Maine.

Several hundred wheat spikes representing the four chief groups of hard spring wheat grown in Aroostook County were planted in 1915, and by 1917 selection had reduced this number to 44 pure lines and to 6 lines of the 7 Minnesota strains introduced in 1916. A complete chemical analysis of 37 lines and baking tests of 31 wheat lines made in the spring of 1919 led the breeder to reject all but 12 Aroostook lines and 4 Minnesota lines for the 1919 crop.

Observations on the different tests may be summarized as follows: Under the same environmental conditions pure lines of wheat showed distinct differences in physical and chemical characteristics and in the bread value of their grain. The average weight of 1,000 kernels of all lines was found to be 35.314 gm., with the weights for individual strains within a variety ranging from 26.541 to 44.789 gm. and deviating in marked degree from the average of their respective parent varieties. It appeared that strains with the highest weight per 1,000 kernels produced the greatest percentage of yellow berries and yielded flour of poor baking quality. Environmental conditions in Aroostook County are believed to have elevated the originally low kernel weight of the Minnesota seed to the level of that of Aroostook strains in a single season.

Limited yield data indicated that each variety furnished high and low yielding strains, with greater differences in yield between the lines of the same variety than between varieties themselves.

A comparison of the protein content of the pure lines in 1917 and 1918 revealed a tendency for varieties, as well as strains, to retain their relative rank with respect to this quality from year to year. The coefficient of correlation between the protein content of the pure strains in the years noted was found to be 0.381 ± 0.092 . The Aroostook-grown Minnesota bread wheats tended to retain their high protein content in this respect, averaging higher than the Aroostook pure lines. Among the durum strains deterioration was very rapid. Speltz Marz and Hedge Row were the highest of the Minnesota introductions in protein content; after one season's growth in Aroostook, these lines showed the lowest protein percentage of all 99 strains analyzed. The low protein content is said to have been accompanied by a very high percentage of yellow berries.

Preston strains contained the highest percentage of gluten, followed by the Minnesota, Red Fife, Canada Red, Bluestem, and Marquis lines in the order named. With respect to quality of gluten, Red Fife and Bluestem strains were found to be superior to strains of Preston and Marquis. The Minnesota strains, with the exception of durum and Marquis wheat, yielded a strong elastic gluten of good quality.

Baking tests brought out very marked variations in the flour strength of the different pure lines, the volume of bread loaf baked from 340 gm. of flour ranging from 1,518 to 2,221 cc. The bread baked from the flour of a number of strains possessed excellent baking and eating quality. Data from the

baking and other tests indicate to the author that strains of wheat of good quality can be isolated and successfully grown under Aroostook conditions.

[**The necessity for increased wheat production in Victoria**] (*Jour. Dept. Agr. Victoria*, 18 (1920), No. 4, pp. 193-253, pl. 1, figs. 21).—This includes the following articles on wheat culture in Victoria: Increasing Primary Production, by D. S. Oman; 1920 Wheat Campaign, Wheat and Its Cultivation, and Increased Wheat Production, by A. E. V. Richardson; Post-war Reconstruction—How the Farmer May Help, and Crop Competitions in the Wimmera—Rupanyup District, by H. A. Mullett; Flag Smut, by C. C. Brittlebank; and Results of Field Tests in the Wheat Belt, by A. E. V. Richardson and H. A. Mullett.

The bread value of wheat, T. SANDERSON (*North Dakota Sta. Bul.* 137 (1920), pp. 3-45).—The data in this bulletin are presented to show "that the application of the Federal standards for wheat does not reflect the true value of the different subclasses or grades into which it divides wheat." The author suggests a system for determining the value of wheat based on the milling and baking factors of quality, and gives in tabular form the results of numerous milling and baking tests by grades and subclasses for samples from the crops 1916 to 1919, inclusive. Previous work along the same line has been noted (E. S. R., 39, p. 871; 40, p. 145).

Equitable wheat grading is discussed in a brief foreword by E. F. Ladd.

A modified Boerner sampler, E. G. BOERNER and E. H. ROPES (*U. S. Dept. Agr. Bul.* 857 (1920), pp. 8, figs. 5).—This describes modifications of a device for sampling grain, seeds, and other material, previously noted (E. S. R., 33, p. 836).

Report on the proposed electrolytic treatment of seeds (Wolfryn process) before sowing, E. J. RUSSELL (*Jour. Min. Agr.* [London], 26 (1920), No. 10, pp. 971-981).—Treatment of barley, oats, and wheat by a process consisting of soaking the seed in a solution of from 2.5 to 5 per cent sodium chlorid or 5 per cent calcium chlorid, submitting while still in solution to an electric current of 8 watts per gallon of solution, and drying at 110° F., failed to produce consistent increases in yields under the controlled conditions of the Rothamsted Experiment Station. Because of the uncertainty involved the process was held to be of doubtful value to the farmer.

[**Report of the Official Seed Testing Station of England and Wales**] (*Jour. Min. Agr.* [London], 26 (1919), No. 9, pp. 868-880, figs. 2).—This comprises the second annual report of the station, dealing with the purity and germination of 23,604 samples of seed received during the year ended July 31, 1919.

HORTICULTURE.

Cooperation in and coordination of investigational work in horticulture, L. C. CORBETT (*Proc. Amer. Soc. Hort. Sci.*, 16 (1919), pp. 145-148).—A plea for more thorough cooperation between the States and between the States and Federal investigators in the planning and execution of horticultural problems of national importance.

Methods of approach to horticultural problems, H. D. HOOKER, JR. (*Proc. Amer. Soc. Hort. Sci.*, 16 (1919), pp. 140-145).—This is a contribution from the University of Missouri.

The author calls attention to the diversity of opinions held by our leading horticulturists concerning many fundamental questions of orchard management. This condition, it is believed, is largely due to a lack of knowledge of the physiological action of various treatments on the organism itself. Hence the importance of collecting data concerning the fundamental physiological condition

and chemical composition of our fruit-bearing plants and ascertaining the approximate limits within which variation may occur without producing a decrease in the quality and quantity of fruit. With such knowledge at hand it will be easier to prescribe treatments that will be effective in producing desired results.

Some indirect methods in extension horticulture, H. A. CARDINELL (*Proc. Amer. Soc. Hort. Sci.*, 16 (1919), pp. 166-171).—A contribution from the University of Missouri. The author discusses several extension problems in horticulture and methods by which they are being attacked in Missouri.

The county horticultural agent, A. R. JENKS (*Proc. Amer. Soc. Hort. Sci.*, 16 (1919), pp. 163-166).—A discussion of the functions of the county horticultural agent, including an outline of fruit, vegetable, and marketing projects developed by the farmers in Middlesex County, Mass., that were under way during 1919.

The development of practical horticulture and its relation to the farm bureau movement, C. E. DURST (*Proc. Amer. Soc. Hort. Sci.*, 16 (1919), pp. 155-162).—In this paper the author suggests methods of preparing and presenting horticultural information, with special reference to its utilization by county agents in farm bureau work.

Observations on French horticulture, S. W. FLETCHER (*Proc. Amer. Soc. Hort. Sci.*, 16 (1919), pp. 136-140).—A contribution from the Pennsylvania State College comprising a brief descriptive account of horticultural industries and conditions in France.

The need of vegetable investigations, J. W. LLOYD (*Proc. Amer. Soc. Hort. Sci.*, 16 (1919), pp. 171-175).—A contribution from the University of Illinois. The author briefly classifies the various vegetable investigations that have been conducted during recent years, and points out lines of work which are much in need of investigation at the present time.

Nature of hardening in vegetable plants, J. T. ROSA, JR. (*Proc. Amer. Soc. Hort. Sci.*, 16 (1919), pp. 190-197, figs. 3).—A contribution from the University of Missouri.

In work begun in 1917, several methods were utilized to check the growth of plants in the greenhouse, and observations were made on the nature of the changes taking place. The work was conducted chiefly with tomatoes, leaf lettuce, and cabbage. The methods used included partial withholding of moisture for several weeks; growing plants on poor sandy soil; growing plants in poor soils and partial withholding of moisture combined; checking growth by allowing plants to become rootbound in small pots; applications of M/10 solutions of various salt solutions which inhibit growth; and exposing greenhouse grown plants to relatively low temperatures in a coldframe. The results secured are presented in tabular form and briefly discussed.

With all of the above methods, the final effects as to hardness to cold were about the same as exposure to low temperatures in a coldframe. The outstanding effect of these treatments upon the plant was slowing the rate of growth. Other changes accompanying the checking process were an increase in dry matter, greater depression of the freezing point of the sap, and an accumulation of sugar, starch, and polysaccharids. In addition, it seems that there may be smaller cells in hardened plant tissues.

Fertilizer v. manure for continuous vegetable growing, B. L. HARTWELL and S. C. DAMON (*Rhode Island Sta. Bul.* 182 (1920), pp. 3-11).—A progress report on the market garden experiment started at the station by F. W. Card in 1904, in which stable manure has been compared with chemical fertilizers for continuous vegetable growing (*E. S. R.*, 20, p. 144).

Ten cords of manure per acre have been compared annually for 16 consecutive years with fertilizer containing an average of 96 lbs. of nitrogen, 170 lbs. of phosphoric acid, and 150 lbs. of potassium oxid, which is about the equivalent of 2,500 lbs. 5:6:6 fertilizer. The soil has been tilled each year and various garden crops grown fairly intensively most of the time, although some attention has been given to cover crops for green manuring.

After the first few years the crops have generally grown better with the manure than with the fertilizer. It is suggested that this may be due to the smaller amount of nitrogen applied in the fertilizer as compared with that applied in the manure. At the end of the first decade there was about 800 lbs. more nitrogen in an acre-foot of the manure area than of the fertilizer area, whereas the amounts of the other fertilizer elements were more nearly alike. In continuing the work it is intended to apply considerable nitrogen compounds during the growing season in an attempt to offset any advantage which may have been derived from the larger residue of nitrogen in the manure plot. It is pointed out that in case this treatment does not equalize the production between the manure and fertilizer plots, indirect evidence will have been obtained that the additional humus-forming material in the manure was in some way responsible for its greater efficiency.

The farm garden, F. E. McCALL (*Proc. Amer. Soc. Hort. Sci.*, 16 (1919), pp. 188-190).—A contribution from the South Dakota Agricultural College giving the results of cooperative farm garden demonstrations conducted on 12 farms.

Keeping qualities of Hubbard squash, G. W. HOOD (*Proc. Amer. Soc. Hort. Sci.*, 16 (1919), pp. 186-188).—A contribution from the University of Nebraska giving the results of a storage test with Hubbard squash.

With squash stored at a temperature averaging 40 to 50° F., and for a period beginning November 1 and ending March 31, there was an average of 20 per cent loss in weight. The loss from individual squashes ranged from as low as 9 per cent to as high as 40 per cent. The loss in weight materially increased with the length of storage. The test indicates that storage may be continued too long to be profitable, and under certain local conditions as to price and market it may not pay to store at all.

Varietal variations as seen in similar methods of training tomatoes, G. W. HOOD (*Proc. Amer. Soc. Hort. Sci.*, 16 (1919), pp. 183-185).—A contribution from the University of Nebraska, in which the author presents evidence, from pruning and training experiments with three varieties of tomatoes, tending to show that under field conditions the slightly greater amount of earlier fruit produced by pruning and staking does not pay for the labor involved.

[Report on fruits, shrubs, and flowers at the North Platte Substation] (*Nebraska Sta. Rpt. 1919*, p. 26).—Of the fruits being tested at the substation, cherries and plums yield abundantly, and there is some promise that apples may be grown successfully for home use where the soil is properly tilled and modern methods of spraying followed. Small fruits, such as currants, gooseberries, and strawberries do well, but strawberries must be irrigated to secure annual crops. Among the hardy shrubs that are entirely successful are spirea Van Houttei, tartarian and other honeysuckles, mock orange, lilac, Siberian pea tree, buckthorn, cut leaf sumac, golden elder, tamarisk, and others. The tulip, peony, hollyhock, and dahlia are among the most easily raised flowers.

Some results as to the response of fruit trees to pruning, W. H. CHANDLER (*Proc. Amer. Soc. Hort. Sci.*, 16 (1919), pp. 88-101).—A contribution from Cornell University, comprising a discussion of results secured with young fruit trees.

From the evidence at hand, the author is of the opinion that the increased vigor of new growth in the vicinity of the cut following dormant pruning, and

usually following summer pruning, is due to the increased water supply or the mineral nutrient supply, especially nitrogen, afforded the remaining shoots, thereby enabling a more complete use of carbohydrates, as observed by Kraus and Kraybill in their work with tomatoes (*E. S. R.*, 40, p. 40). The evidence secured tends to show, however, that this more complete utilization of carbohydrates for top growth takes place at the expense of root development; hence, unless the pruning is repeated, there will come a time when the reduced transpiration due to previous pruning will be balanced by reduced root growth, and increased vigor will cease to be evident.

All types of pruning have a dwarfing effect and tend to reduce fruit production on young trees, primarily because of the reduction in the size of the tree. With species bearing fruit from spurs, the reduction in yield is greater than for species bearing fruit on laterals or one-year twigs. Thus far pruning has not affected the yield through any marked stimulating effect on fruit-bud formation or twig growth.

The status of orchard fertilization experimentation, W. H. ALDERMAN (*Proc. Amer. Soc. Hort. Sci.*, 16 (1919), pp. 109-113).—A contribution from the Minnesota Experiment Station briefly summing up the results of various investigators relative to orchard fertilization.

Methods of interpreting results in orchard fertilizer experiments, R. D. ANTHONY (*Proc. Amer. Soc. Hort. Sci.*, 16 (1919), pp. 113-117).—A contribution from the Pennsylvania Experiment Station discussing methods of interpreting fertilizer results which the author has found of value in his own work.

Observations on characters of forms of Malus, C. S. CRANDALL (*Proc. Amer. Soc. Hort. Sci.*, 16 (1919), pp. 131-135).—A contribution from the University of Illinois comprising a general discussion of character variations observed in F₁ seedlings of apple crosses.

The apple cross Tolman × Malus Toringo, C. S. CRANDALL (*Proc. Amer. Soc. Hort. Sci.*, 16 (1919), pp. 60-66).—A contribution from the University of Illinois in which are considered a group of apple seedlings resulting from a cross of Tolman, a well-known standard variety, as the pistillate parent and a dwarf form of Malus Toringo (*Pyrus sieboldii*) as the pollen parent.

The outstanding fact regarding this group of seedlings is the extent of the domination of the dwarf, small-fruited male parent and the corresponding suppression of resemblance to the mother plant. Those characters that occupy intermediate positions between the parents are not median, except as to flower expansion, but are much nearer the male than the female plant.

Self-sterility and cross-sterility in the apple, J. W. GOWEN (*Maine Sta. Bul.* 287 (1920), pp. 61-88).—This bulletin presents and discusses data showing the effect of self- and of cross-pollination on the yield of marketable fruit with 16 varieties of apples, and also summarizes similar data secured from a large number of varieties by various investigators. A list of consulted literature is given, and additional data showing the size of apples, together with the number of good and poor seed secured from the selfing and crossing of varieties, are appended.

The results of the investigation as a whole show that most varieties of apples are more or less self-sterile in the case of varieties that are to some extent self-sterile. No difference is noted in the fruit set when a variety is self-pollinated, when it is pollinated with the pollen from different flowers on the same tree, or when it is pollinated with pollen from different trees of the same variety. Summing up the investigations dealing with sterility in apples, out of 119 varieties only 42 set fruit, and only 15 of these had a set of fruit which was even moderately commercially profitable. Most varieties are capable of ready cross-fertilization with the pollen of other varieties. Over three-

fourths of those varieties pollinated with pollen of other varieties set fruit satisfactorily. Hence, it is concluded that every apple grower should provide suitable varieties for pollinators if large, dependable crops are to be secured. The results secured in this investigation indicate that it is necessary to test a variety for cross compatibility before any conclusion can be drawn for the variety.

When cross-pollination is effected, the size, color, and quality of the fruit remain practically the same as the standard for the mother parent. The number of good seeds in the crossed apples is greater than in those which are selfed. External causes of self-sterility, such as weather, spraying, insects, and disease, are somewhat within the control of the grower. The chief internal cause of sterility is the slowness of growth of the pollen tube in the selfed style as against that in the crossed style.

Comparison of fall, winter, and spring pruning of apple trees in Minnesota, W. G. BRIERLEY (*Proc. Amer. Soc. Hort. Sci.*, 16 (1919), pp. 102-104).—A contribution from the Minnesota Experiment Station, giving the results of pruning experiments conducted during the seasons of 1913-17, inclusive, and confirming a previous report on this work to the effect that apple trees in Minnesota may be pruned safely at convenient times during the fall, winter, and spring (E. S. R., 39, p. 347).

The maturity of shoots and the healing of wounds, as well as the amount of winter injury, was practically the same for all pruning seasons tested. Likewise there was no detrimental effect upon growth chargeable to pruning in the late fall or in the winter under normal conditions.

Some influences of thinning, pollination, and fruit spur growth on the yearly performance record of fruit spurs and on the size of fruit produced, E. C. AUCHTER (*Proc. Amer. Soc. Hort. Sci.*, 16 (1919), pp. 118-131).—This bulletin presents results secured since 1916 of thinning experiments with apples started at the West Virginia Experiment Station in 1912 (E. S. R., 37, p. 448), and summarizes the results of the investigations to date.

It is concluded that fruit thinning does not affect the annual bearing of apple trees. In cases where the trees are bearing a good crop of fruit, thinning increases the size of the individual apples and the total quantity of marketable fruit for the current season. This influence is lessened or lost altogether when trees are bearing light crops.

Spurs on certain varieties of apples bloom more regularly than those of other varieties, but do not necessarily bear fruit more regularly. Generally speaking, spurs which set fruit one year do not blossom the next year. Spurs which blossom one year but do not set fruit may or may not blossom the next year. Spurs which blossom two years in succession make a greater yearly growth, have more leaves, and a greater total leaf area in the year preceding the second successive blooming year. Thus it appears that growth and vigor to a certain degree do not oppose but rather encourage fruitfulness. The results indicate that a variety is an annual bearer because either a certain percentage of the total spurs on such a variety does not bloom in the heavy crop year and, therefore, blooms and sets fruit the next year, or if all the spurs do bloom a certain percentage of the spurs does not set and thus more readily blooms and sets the next year. It appears that a large proportion of the spurs on the biennial bearers not only bloom but also set fruit in the crop year. Such spurs do not readily bloom the next year.

Certain varieties which produce fruit yearly form fruit buds terminally and laterally on one-year-old growths to such an extent that the production of fruit from these sources is often enough to class a variety as an annual bearer without reference to its fruit spurs. From the results thus far secured, the

whole problem of biennial and annual bearing appears to be affected to a degree by the sterility and pollination problem and is not one of growth and nutrition only.

There appears to be a good correlation between the weight of the individual apples produced on a tree and the weight of seeds in each fruit. Since the number of good seeds and weight of seeds are correlated, it is suggested that the correlation would probably hold between weight of fruit and number of good seeds. Such factors as temperature, wind, sunshine, etc., exert a marked influence through their effect on the length of the blooming period, light and bee activity, on the number of good seeds, and the weight of seeds in individual apples on a tree. With the same crops per tree and with cultural practices favorable to good vigorous spur growth, the size of the individual apples of a tree should be larger in those seasons which have good weather at pollination time. Although the correlation between weight of seeds and weight of individual apples holds true for any particular season, a large crop per tree in any particular season is conducive to smaller fruit.

Growth and yield of apple trees, N. L. PARTRIDGE (*Proc. Amer. Soc. Hort. Sci.*, 16 (1919), pp. 104-109, figs. 8).—A contribution from the Delaware Experiment Station comprising a preliminary report on some of the results secured in the station's experimental apple orchard.

The orchard in question has now completed its tenth season's growth and has produced fruit in six seasons. Curves are given showing the growth and yield of the Jonathan, Yellow Transparent, and Stayman Winesap trees during the seasons of 1917-19, inclusive, together with the growth and yield of some individual Stayman Winesap trees. Observations thus far made indicate that the trees have fallen into three natural classes: Those which have a tendency to bear heavier in the odd year than in the even; those which have a tendency to bear more in the even year than in the odd; and those which have, generally speaking, made a consistent increase in yield each year but with no consistent biennial tendency indicated.

The growth made the previous year is more significant in relation to the current year's yield than is the growth made during the current year. In other words, there appears to be an alternate habit of growth as well as an alternate habit of bearing in the trees.

Orchard rejuvenation in southeastern Ohio, F. H. BALLOU and I. P. LEWIS (*Ohio Sta. Bul.* 339 (1920), pp. 3-42, figs. 20).—This comprises the final report on the station's orchard rejuvenation work in southeastern Ohio (E. S. R., 36, p. 40). It deals particularly with the results secured during a 5-year period in two experimental orchards.

The work in one of these orchards comprised a comparison of the grass-mulch and tillage-cover crop methods of culture combined with a test of complete and incomplete fertilization. The cost of cultural work in the grass-mulch section averaged \$2.65 per acre per year as compared with \$17.09 per acre per year in the tillage-cover crop section. Under uniform fertilization throughout both sections the grass-mulch system gave an average gain of 1.9 bbls. of apples or a cash gain of \$20.52 per acre per year over the tillage-cover crop system. Unfertilized plats under tillage and cover cropping gave an average gain of 15.6 bbls. of apples, or a cash gain of \$35.48 over the unfertilized plats in the grass-mulch section. It is pointed out that these latter plats remained in their former state of neglect with the exception of spraying. Grass-mulch culture plus fertilization with quickly available nitrogenous plant food gave an average gain of 22.2 bbls. of apples, or a net cash gain of \$71.48 per acre per year over the tillage-cover crop system without fertilization. The cost of the grass-mulch method of orchard culture, plus fertiliza-

tion with a nitrate-phosphate-potash formula 5:5:2.5 lbs. per tree per year, is practically the same as that of the tillage-cover crop system without fertilization. Under the tillage-cover crop system fertilization with nitrogenous plant food gave a gain of 20.3 bbls. of apples, or a net cash gain of \$50.96 per acre per year over no fertilization under the same cultural conditions. Under the grass-mulch method of culture, fertilization with nitrogenous plant food gave a gain of 37.8 bbls. of apples, or a net cash gain of \$106.96 per acre per year over no fertilization in the same section.

Apples grown under the grass-mulch plan of culture were slightly smaller but were finer in texture, firmer, higher in color, and superior in keeping qualities to those produced under tillage. Also, the orchard work was performed with cleanliness and comfort at all seasons of the year in the grass-mulch section.

There was little difference in results as to fruit production whether the fertilizer was applied in circles beneath the outer extremities of the branches of trees or over the entire tree squares of ground. The advantage of applying the fertilizer all over the tree square, aside from increasing fruit production, is that the vegetation of the orchard ground is increased, affording a greater quantity of mulch material. This increase amounted to 1,650 lbs. per acre per year, sun-dry weight, as compared with the yield of unfertilized plats. The nitrate-phosphate-potash formula 5:5:2.5 lbs. per tree per year applied over tree squares promptly developed, without seeding, a dense soil covering of grasses and red and white clover where previously only mixed weeds, poverty grass, and sedge prevailed. Broom sedge, by the annual nitrate-phosphate treatment, was practically eliminated from the fertilized plats. Generally speaking, pruning, spraying, and fertilization transformed this orchard from a disappointing farm encumbrance to a fruitful, vigorous, profitable plantation.

The work on the other experimental orchard has been confined to orchard rejuvenation by means of the grass-mulch system of culture combined with a fertilization test and the necessary pruning and spraying. The results secured confirm previous conclusions as to the importance of quickly available nitrogen in successful orchard fertilization on thin, poor, upland soils of southern Ohio. Phosphorus has also proved beneficial, but potash has given little or no returns.

Annual applications of 5 lbs. per tree per year each of nitrate of soda and acid phosphate used in connection with a mulch of straw maintained by annual or biennial applications of one bale per tree gave practically the same results as the use of 10 lbs. per tree per year each of nitrate and phosphate applied evenly over the tree squares without a mulch from outside sources. The greater amount of fertilization, however, gave a gain of 2,066 lbs. per acre per year, sun-dry weight, of grasses for mulch, as compared with the yield of inferior grasses and weeds in the unfertilized plat. Annual applications of a 5:5:2.5 lbs. per tree, nitrate-phosphate-potash mixture, used in conjunction with a mulch of straw, gave a gain of 24 bbls. of apples per acre per year over a 2.5:5:2.5 lbs. per tree formula of the same fertilizers.

On soil that is not deficient in organic or vegetable matter, a liberal mulch of straw alone will assist in producing effects similar to those following the application of a moderately prompt-acting nitrogenous plant food, as such a mulch affords conditions under which there occurs a hastened liberation of nitrates from the organic matter in the soil. On thin, poor, compact soils, the chief office of a mulch of straw or similar material is its helpfulness in conservation of soil moisture. Under poor soil conditions where prompt results are sought, mineral compounds of nitrogen and phosphorus are much more available than animal compounds. With the tillage-cover crop system of orchard culture

where the fertilizer is incorporated with the soil, tankage and bone are deemed ideal.

The omission of nitrate after heavy initial use of the same in orchard fertilization will soon result in a material reduction in the vigor of the trees and yield of the fruit as compared with plats upon which nitrogenous applications are continued. In connection with the laying out of such experiments, it is pointed out that beginning with trees 15 to 20 years of age, even if these be stunted and small for their age at the outset, it is doubtful whether quickly available nitrogenous fertilization can be conducted longer than from 3 to 5 years without serious "cross-feeding" by trees of different fertilized plats unless the plats in each case be separated by an untreated or neutral row. The results in this orchard also have demonstrated the combined value of pruning, spraying, fertilization, and mulching in rejuvenating unprofitable apple orchards.

Increasing the production of the bearing apple orchard, C. P. HALLIGAN (*Michigan Sta. Circ. 43 (1920), pp. 18, figs. 7*).—This circular contains practical suggestions on orchard management.

Cost of producing apples in five counties in western New York, 1910-1915, G. H. MILLER (*U. S. Dept. Agr. Bul. 851 (1920), pp. 47, figs. 16*).—A contribution from the Office of Farm Management of this Department, this bulletin treats of the relation the orchard bears to the culture of other fruits and farm crops in the region under investigation, of the orchard practices followed by the more successful growers, the effect of these practices on yields, the returns derived from different systems of orchard management, and the cost of maintaining orchards under each system. Detailed information is presented as to the time required to perform each operation, the necessary equipment, the size of the orchard, the age of the trees, yield of fruit, and other related factors.

Two hundred and eighteen bearing apple orchards averaging 40 years of age were included in the study. The average acreage per farm studied was 118.65; of bearing apple orchard, 14; other fruit, 20.44; and general crops, 73.76. The average yield per acre was 84.1 bbls. (exclusive of culls), and the average number of trees per acre 35. The average investment per farm was \$25,424, and the average investment per acre of bearing apple orchard was \$514. The total net cost of production per barrel was \$1.41, divided as follows: Maintenance 20.24 per cent, handling 10.15, material 41.31, and fixed charges 28.30 per cent.

Nut trees, A. K. CHITTENDEN (*Michigan Sta. Quart. Bul. 2 (1920), No. 4, pp. 185, 186*).—Brief suggestions are given on the culture of nut trees in Michigan.

Useful wild plants of the United States and Canada, C. F. SAUNDERS (*New York: Robert M. McBride & Co., 1920, pp. 12+275, pls. 16, figs. 73*).—A popular account of the uses of various wild plants. The successive chapters discuss wild plants with edible tubers, bulbs, or roots, wild seeds of food value and how they have been utilized, the acorn as human food and some other wild nuts, some little-regarded wild fruits and berries, wild plants with edible stems and leaves, beverage plants of field and wood, vegetable substitutes for soap, some medicinal wildings worth knowing, and miscellaneous uses of wild plants. The work concludes with a cautionary chapter on certain poisonous plants. A regional index is also given.

FORESTRY.

Timber depletion and the answer (*U. S. Dept. Agr., Dept. Circ. 112 (1920), pp. 16*).—A summary of the report on timber depletion and related subjects prepared by the Forest Service of this Department in response to Senate

Resolution 311. It presents the main factors as to timber depletion in the United States, and suggests needed national legislation dealing with the cooperation with States in fire protection and forest renewal, the extension and consolidation of Federal forest holdings, the reforestation of denuded Federal lands, a study of forest taxation and insurance, the survey and classification of forest resources, and current appropriations for forest research. State legislation relating to fire prevention and reforestation of private lands, State and municipal forests, and taxation of forest lands is also recommended.

Tree windbreaks as a farm asset, C. G. BATES (*Canad. Forestry Jour.*, 16 (1920), No. 6, pp. 280-284, figs. 4).—This article deals particularly with the economic importance of windbreaks to the prairie farm.

Forest and shade trees for planting in Idaho, F. G. MILLER (*Idaho Sta. Circ. 10* (1920), pp. 4, figs. 3).—This comprises a list of trees offered for sale for planting in the State by the School of Forestry of the University of Idaho, together with brief suggestions for selecting, planting, and caring for trees.

[**Forestry at the North Platte Substation**] (*Nebraska Sta. Rpt. 1919*, pp. 25, 26).—A brief statement relative to the condition in 1919 of various trees being tested on the substation grounds.

The white elm, honey locust, hackberry, and Russian olive have proven to be the best of the more permanent deciduous hardy trees. The conifers, generally speaking, are difficult to start, but the bull pine, jack pine, Black Hills spruce, as well as other varieties, have made a reasonably rapid growth and give promise of great value for windbrakes and ornamentation. The cottonwood and box elder are also desirable for planting on account of their hardiness and fast growth. The wild buffalo berry grows at a fair rate and makes a very effective windbreak.

Conifers and their characteristics, C. COLTMAN-ROGERS (*London: John Murray, 1920*, pp. XIII+333, pls. 4, figs. 7).—Popular descriptive accounts are given of the various conifers, together with identification tables and a glossary of botanical terms.

The establishment of a Douglas fir forest, J. V. HOFMANN (*Ecology*, 1 (1920), No. 1, pp. 49-53, fig. 1).—A contribution from the Forest Service of the U. S. Department of Agriculture, continuing a previous paper dealing with a reproduction of Douglas fir (*E. S. R.*, 38, p. 145).

The author concludes that the measurable characteristics of the Douglas fir, which give it such a prominent place in cedar and hemlock forests, are as follows: The production of heavy crops of seed, which is stored in the forest floor by the indigenous rodents; the ability of the seed to retain its viability while thus stored and to live through forest fires; early and quick germination of the seed under favorable conditions; and a rapid development of a long radical. The unfavorable factor is the inability of the Douglas fir to withstand shade, which results in its elimination from the under story of the forest and consequently from the climax forest. It is pointed out that these factors are within the control of man, and must be regulated in order to keep the Pacific Northwest region under continuous natural production of this species.

American pulpwoods: The suitability of various species of American woods for pulp and paper production, O. KRESS, S. D. WELLS, and V. P. EDWARDES (*Paper*, 24 (1919), No. 21, pp. 15-23).—The data presented in this paper are based upon investigations at the Forest Products Laboratory of the U. S. Department of Agriculture, extending over a period of more than 10 years, relative to the pulp and paper value of various species. The wood of each species is considered with reference to its weight per cubic foot, fiber length, range, com-

mon names, and the quantity, character, and value of the pulp produced by different processes, such as the sulphite, sulphate, soda, and mechanical methods.

Log piles: Their hazards and protection. Growth of fungus and quality of pulp, F. J. HOXIE (*Quart. Natl. Fire Protect. Assoc.*, 14 (1920), No. 1, pp. 81-94, figs. 9).—A discussion of the fire hazard in log piles and methods of handling log piles in order to minimize the fire hazard, with brief notes on various fungi attacking pulpwood.

Practical treatise on silviculture, forest exploitation, and afforestation, L. CHANCEREL (*Traité Pratique de Sylviculture, Exploitation Forestière et Boisement. Paris: Gauthier-Villars & Co., 1920, pp. 367, figs. 87*).—A concise treatment of the principles of silviculture, exploitation, and afforestation.

The introductory chapter discusses the economic effect of forests, as well as their action on the soil, rain and stream flow, temperature, humidity, and health and their esthetic rôle. Consideration is then given to the general principles of silviculture and the several silvicultural systems, the exploitation of special products, the technology of lumbering, millwork, and transportation, the defects and diseases of wood, the natural and artificial processes of wood conservation, the technology of various forest products, forest management, timber estimation, sales, valuation, forest usufruct, the methods of afforestation, and forest protection.

The sand dunes of the Lincolnshire coast, W. P. GREENFIELD (*Quart. Jour. Forestry*, 14 (1920), No. 3, pp. 176-184).—A short discussion of methods of afforesting these sand dunes.

Why and how the exploitation of the colonial forests should be developed, F. ROUGET (*Pourquoi et Comment il faut Développer l'Exploitation des Bois Coloniaux. Paris: Emile LaRose, 1919, pp. IV+119*).—Part one of this paper discusses the importance and value of the French colonial forest domain as a source of supply for the mother country, the importation of foreign woods into France, and the value of various colonial woods. The succeeding parts deal with the capacity of production in the several French colonies, the important problems bearing on the exploitation of colonial woods, and methods of developing exploitation.

Forestry in Morocco, C. C. HOOD and M. I. BACON (*Quart. Jour. Forestry*, 14 (1920), No. 3, pp. 165-169).—A short account of the existing forests, together with a brief survey of forestry work established by the French Department of Waters and Forests.

New Zealand forestry.—I, Kauri forests and forests of the North and forest management, D. E. HUTCHINS (*Wellington, New Zealand: Dept. Forestry, 1919, pp. XII+200, pls. 22, figs. 2*).—A detailed report on the Kauri forests and on forest conditions generally in northern New Zealand, with recommendations relative to the future management of these forests.

Annual progress report on forest administration in the Presidency of Bengal for the year 1918-19, H. A. FARRINGTON (*Rpt. Forest Admin. Bengal, 1918-19, pp. II+51+4, pl. 1*).—The usual progress report relative to the administration and management of the State forests in Bengal, including appended data relative to forests areas, surveys, progress in working plans, forest fires, silvicultural operations, yield in major and minor forest products, revenues, expenditures, etc.

The State reserves of Maryland, "A playground for the public," J. G. DORRANCE (*Baltimore: Md. Bd. Forestry, 1919, pp. 22, pls. 4, figs. 2*).—A descriptive account of the State reserves and parks in Maryland, with special reference to their recreation facilities.

DISEASES OF PLANTS.

Notes on plant diseases in 1917, D. C. GEORGE (*Ariz. Comn. Agr. and Hort. Ann. Rpt.*, 9 (1917), pp. 62-66, fig. 1).—Alfalfa leaf spot (*Cercospora medicaginis*) was general in the latter part of the season 1917. Bean bacterial blight (*Pseudomonas phaseoli*) appeared on beans raised on the experimental dry farm at Prescott from seed obtained in eastern States. Cotton angular leaf spot (*Bacterium malvacearum*) shows three forms which are described. Alternaria leaf spot (*Alternaria* sp.) was abundant late in the season. Texas cotton root rot (*Ozonium omnivorum*) is said to be the most serious disease of cotton in Arizona. In connection with a study of this disease, observations were made on the so-called conidial stage known as *Phymatotrichum omnivorum*.

Potato black scurf (*Rhizoctonia* spp.) appeared on 65 per cent of potatoes exhibited at the State Fair of 1917. Scab was also prevalent in some potato-growing districts. Dodder is reported as parasitic on citrus and olive. Gummosis of stone fruit trees is said to have been quite prevalent throughout the State.

Report on the occurrence of insect and fungus pests on plants in England and Wales in the year 1917, T. H. MIDDLETON (*Bd. Agr. and Fisheries [London], Misc. Pub. 21* (1918), pp. 32).—A general account dealing with conditions during 1917 is followed by a special account regarding insects and fungi as related to cereals, potatoes, roots, legumes, pasture and forage crops, vegetables, and fruit.

The development of some plant diseases during dry weather, J. CAPUS (*Rev. Vitic.*, 49 (1918), No. 1258, pp. 82, 83).—This deals with the influence of dry weather on grape black rot, a disease of plane tree caused by *Gnomonia vcneta*, and wheat rust.

Report on work done for the Province of Bengal by the Mycological Section, Agricultural Research Institute, Pusa, during the year ending 31st March, 1918, E. J. BUTLER (*Ann. Rpts. Expert Off. Dept. Agr., Bengal, 1918*, pp. 92-94).—Ufra disease of rice appears to be sometimes conveyed by seed from an infected crop. Laboratory work at Pusa shows that the nematode *Tylenchus angustus* moves freely on glass slides at a relative humidity of 95 (temperature 87 to 90° F.) but not at all at 90, the maximum point being about 93. On the plant the lower limit is between 75 and 90. The influence of nourishment on the nematode is discussed. Starvation is a most important factor, increasing the tendency of the nematodes to wander. This comes into play as the crop ripens, since the nematodes feed only on the unripe plant. Ripening infected Aus paddy must, therefore, be a source of great danger to the neighboring Aman crop. Studies of the effects of the practice of burning the stubble showed inconclusive results.

Soft rot of ginger has been shown to be due to *Pythium gracile*, which also causes a serious stem disease of papaya and attacks tobacco seedlings.

Black band disease of jute (*Corchorus capsularis*) is ascribed to a fungus supposed to be identical with that known as *Diplodia corchori*. Since 1910 this organism has been known to occur on jute, but until 1917 it was thought to be only an occasional parasite.

Sal root rot inoculations on young trees at Dehra Dun have not yielded results. A further series of infections has been started.

Plant pathology [Nigeria], W. H. JOHNSON (*Ann. Rpt. Agr. Dept. South. Provs., Nigeria, 1918*, pp. 18, 19).—In this portion of a more extended report, several cases are noted in which oil palms were killed by *Fomes lucidus*. A fungus attacking yams in the Okigwi district was determined as *Bagnisiopsis*

dioscoreæ n. sp. Bacterial bud rot of coconut in the Awka district was brought under control during 1917. Roots of Para rubber trees bearing large galls were found to be attacked by a parasitic plant, probably *Thonningia sanguinea*.

Specialization in *Peronospora calotheca*, E. GÄUMANN (*Svensk Bot. Tidskr.*, 12 (1918), No. 4, pp. 433-445, figs. 2).—Four new *Peronosporas* are recognized as found on different parts of *Galium* spp., namely, *P. aparines*, *P. borealis*, *P. galii veri*, and *P. silvatica*.

Seed corn infection with *Fusarium moniliforme* and its relation to the root and stalk rots, W. D. VALLEAU (*Kentucky Sta. Bul.* 226 (1920), pp. 27-51, fig. 1).—The author presents data regarding the extent of infection of seed corn grown in various parts of Kentucky and several other States, and its possible bearing on the high percentage of root and stalk rot infection found in the field.

Field examinations at Lexington have shown infection with the root and stalk rots to an extent of nearly 100 per cent. Studies of considerable numbers of ears of seed corn from a number of States showed infection with *F. moniliforme*, and no ears examined from the districts from which the corn was obtained were found free from infection.

The occurrence of pink crowns or stripes on normally white kernels is said to be an indication of infection with *F. moniliforme*, and the development of reddish or black discolorations of the seed coats of corn during or after germination is an indication of the presence of the same fungus, while the absence of discoloration is not considered conclusive evidence of freedom from infection. As a result of careful examination of more than 60 ears, the presence of any infected grain is believed to indicate that all the kernels are infected. *F. moniliforme* is said to be an active parasite and capable of causing root and stalk rots of corn under laboratory and field conditions.

The seed germinator method of selecting disease-free seed is reported as not proving practical with the seed studied as a means of eliminating diseased ears.

Because of the high degree of infection of seed corn with *F. moniliforme* over much of the corn belt, it is considered probably the most common cause of root and stalk rots of corn. The author claims that *Gibberella* sp. may or may not be present in a field badly infected with the root and stalk rots. *F. moniliforme* is said to be the more active parasite when it and *Gibberella* sp. are associated on rotting stalks of corn.

Biologic forms of *Puccinia coronata* on oats, G. R. HOERNER (*Phytopathology*, 9 (1919), No. 8, pp. 309-314, pls. 2).—In a study of the infection capabilities of *P. coronata*, the author inoculated 55 species of cereals and grasses with rust cultures obtained from oats in four widely separated States. The behavior of the oat plants suggested the possibility of biologic forms of the crown rust, and further inoculation experiments were undertaken using rust material from 30 different localities. Judging from the behavior of the varieties of oats, the author concludes that there are at least four biologic strains of the crown rust. The results of his experiments are considered significant, as they may throw some light on epidemiology studies and perhaps materially affect the problem of breeding oat varieties for resistance to crown rust.

Relation of the barberry to stem rust in Iowa, I. E. MELHUS, L. W. DURRELL, and R. S. KIRBY (*Iowa Sta. Research Bul.* 57 (1920), pp. 283-325, figs. 21).—The authors give accounts of data and observations on the manner of infection of the alternate host, the susceptibility of the young and older leaves and different varieties and species of the genus *Berberis*, the incubation period, and the influence of climatic factors on aëdiospore production of *Puccinia graminis*.

In the teleutospore germination studies reported, *P. graminis* on quack grass, wheat, and volunteer oats germinated best when allowed to remain attached to the straw. A relative humidity of at least 95.6 per cent is required for teleutospore germination and sporidia production, the sporidia production taking place at temperatures between 5 and 25° C., but most profusely at 20°. The teleutospores were found to germinate in the open following a rain, and those developed on volunteer grain in the late fall germinate more readily than those maturing in summer or early fall.

In studying infection, sporidia were placed on barberry leaves under greenhouse conditions and infections secured with the production of mature æcidiospores in 12 days. When the barberry leaves had become green and crisp infection apparently did not take place, due possibly to the increased thickness of the cuticle and walls of the epidermal cells. Both surfaces of the barberry leaves are susceptible to infection, although the stomata occur only on the lower surface. The germ tubes of the sporidia enter directly through the cuticle and epidermis.

A survey was undertaken to locate European barberry bushes in Iowa, and although incomplete, 132,673 bushes were found on private and public grounds in 300 cities, towns, and surrounding country of the State. The barberry was found to have escaped from cultivation in several localities, but in no case was the plant far from the original planting, the farthest distance observed being about one mile.

The authors have traced a number of local epidemics of rust, not only on wild grasses, but also oats, wheat, barley, etc., and found that the rust spreads in concentric zones in the direction of the prevailing wind. Infection centers vary from 5 to 320 rods in diameter. When near barberry bushes infected with æcidia, stem rust was found on *Hordeum jubatum*, *Agrostis alba*, *Agropyron repens*, and *A. tenerum*. On account of their universal presence and long growing period, the authors consider these wild grasses important factors in starting and aiding the spread of local epidemics of stem rust.

Blackleg disease of cabbages, T. G. B. OSBORN (*Jour. Dept. Agr. So. Aust.*, 23 (1919), No. 2, pp. 107-110, fig. 1).—Observations made at Summertown on plants grown in South Australia are said to be in full agreement with those of Henderson (E. S. R., 40, p. 846), regarding the causation, character, and course of the cabbage blackleg disease due to *Phoma lingam*.

Seed transmission of cucurbit mosaic by the wild cucumber, S. P. DOLLITTLE and W. W. GILBERT (*Phytopathology*, 9 (1919), No. 8, pp. 326, 327).—In a previous article (E. S. R., 39, p. 853) the authors reported the occurrence of the cucurbit mosaic on the wild cucumber (*Micrampelis (Echinocystis) lobata*). In order to determine the possibility of this plant acting as an overwintering host, seed was collected from wild cucumber plants and tested under greenhouse conditions. It seems possible that a certain percentage of the seed from mosaic plants of the wild cucumber may produce diseased plants the following season. In this way the first mosaic centers could be established, from which the disease is later carried to cultivated cucumbers by the striped cucumber beetles or other insects.

Onion smut, R. E. VAUGHAN (*Canner*, 51 (1920), No. 4, pp. 51, 52, fig. 1).—Formaldehyde solution, prepared as outlined and applied as a drip with the seed at planting time, is said to have given satisfactory control of onion smut (*Urocystis cepulae*) under Wisconsin conditions. Treatment of 11 acres at Racine, Wis., in 1917, at an expense of \$55 increased returns more than \$3,000.

Studies on the viability of the potato blackleg organism, G. B. RAMSEY (*Phytopathology*, 9 (1919), No. 7, pp. 285-288).—In order to secure data regard-

ing the ability of the blackleg organism to withstand low temperatures within infected tubers, the author inoculated healthy, disinfected potato tubers with cultures of a strain of *Bacillus atrosepticus*. The tubers were then placed in a moist chamber and allowed to remain at room temperature for 48 hours, at which time all showed a marked rot at the point of inoculation. The potatoes were then packed in ice and placed in a refrigerator, where they were kept at 0° C. during the entire experiment. The tubers were examined at frequent intervals and later planted in sterilized soil in the greenhouse. After the tubers had been on the ice for 168 hours, the plate cultures showed that the number and activity of the bacteria had decreased considerably. At the end of 11 days there was still some bacterial growth, but it was reduced to a minimum. Tubers were planted and two germinated and sent up sprouts which attained a height of about 2 in., when they died down immediately with blackleg.

The results of this experiment are believed to show that infected tubers which remain buried in fields at digging time decay to such an extent that they are unable to germinate, or if they do germinate, the sprouts are killed by the organism. This is believed to explain why blackleg is never found in volunteer plants in Maine.

Studies were made of soil in order to determine whether the organism would persist, but of the strains obtained from the soil which had overwintered in the field, not one was found capable of producing blackleg rot. An attempt was also made to inoculate plants by a watering method. The watering treatment was begun when the plants were about 4 in. high and continued each week for seven successive weeks. This experiment was duplicated in 1917. The tubers of all plants growing during the season were found free from rot at harvest time. The author's experiments are considered to show that unless the seed piece is infected at planting time there is little chance that the plants will contract the disease, even though the causal organism is washed about the stem and root system.

The potato leaf hopper and the hopper burn, E. D. BALL (*Phytopathology*, 9 (1919), No. 7, pp. 291-293).—Severe burning of potato foliage in 1918 is reported as extending from Montana and Kansas to New York and New Jersey. The author's attention was called to the condition in Wisconsin, and an examination of plants disclosed the fact that the partly burned leaves had one or more nymphs of the potato leaf hopper (*Empoasca mali*) on the under side, while the younger leaves, still green, showed no trace of them.

The potato leaf hopper is said to fly to potato fields soon after the plants appear, and to lay its eggs in the midribs or leaf stems of the partly grown leaves. Cage experiments in which a large number of adult leaf hoppers were placed on a half-grown plant produced a bad burning and rolling of the leaves in three days. Early planted potatoes were found to be most seriously injured, because the leaf hoppers were then flying in greatest abundance. Those planted a few weeks later, after most of the eggs had been deposited, were practically free from injury until the second brood appeared late in July or August.

The author considers hopper burn as a specific disease, caused by a single species of leaf hopper. Spraying with Bordeaux mixture is said to act as a partial repellent of leaf hoppers, but the most effective treatment was obtained by use of Blackleaf 40, not weaker than 1:800 with 5 parts of soap added to it.

Nomenclature of the potato scab organism, H. H. MCKINNEY (*Phytopathology*, 9 (1919), No. 8, pp. 327-329).—Attention is called to the work of a number of authors, showing that *Actinomyces chromogenus* is not a definite species but a group of organisms differing in physiology and morphology. On this

account the author is led to believe that the name of the potato scab organism should be *A. scabies* and not *A. chromogenus*.

A new stem rot and wilt of tomatoes, R. E. STONE (*Phytopathology*, 9 (1919), No. 7, pp. 296-298, figs. 2).—The author reports the occurrence of stem rot and wilt of tomatoes growing in the greenhouses at the Massachusetts Experiment Station in January, 1919. By February 20, fully 50 per cent of the diseased plants had wilted. The first symptom of the disease was the appearance of gray, slightly sunken spots on the stems, often beginning about an old leaf scar as a center. The lesions enlarge slowly until the stem is girdled and the upper part of the plant wilted. The causal organism was found to be a species of *Botrytis*, and inoculation experiments were successfully performed, using pure cultures of the organism. Since infection took place only under exceptionally humid conditions, it is thought that proper ventilation of greenhouses will control this disease.

Effect of spraying on early ripening of tomato fruit, F. J. PRITCHARD and W. B. CLARK (*Phytopathology*, 9 (1919), No. 7, pp. 289-291, fig. 1).—A summary is given of spraying experiments carried on in cooperation with the U. S. Department of Agriculture and the experiment stations of Maryland, New Jersey, Indiana, and Virginia, which are held to indicate that spraying does not materially affect the early ripening of tomato fruit. The average yield of early fruit from the 14 fields which were sprayed was somewhat higher from the sprayed plats than from the unsprayed ones.

Concerning spoilage of vegetables in transit and storage, F. C. MEIER (*N. Y. State Dept. Farms and Markets, Foods and Markets*, 2 (1920), No. 18, pp. 22-25).—This discussion, regarding causes of vegetable diseases (deviations from the normal condition of function or tissue) and regarding the problems of vegetable distribution stressed the qualifications for trained buyers and the need for information that would prevent unnecessary waste of necessities.

Diseases of fruit and causes of deterioration in transit, O. F. BURGER (*N. Y. State Dept. Farms and Markets, Foods and Markets*, 2 (1920), No. 18, pp. 12-15).—Discussing diseases and causes of deterioration in fruit mainly as becoming effective during its transportation to market, the author considers those which are apparent when gathered, those which spread in transit due partly at least to improper conditions, and those which will remain harmless for a considerable time if kept at proper temperatures, usually not over 45 or 50° F.

Fruit diseases and pests, A. C. ALLEN (*Bien. Rpt. Bd. Hort. Oregon*, 14 (1917), pp. 18-21).—Fire blight, though prevalent in Jackson and Josephine Counties, Oreg., for several years, has always been kept under control. Infection in the severe outbreak of 1916 was not confined to pears, but was exceptionally severe on both Spitzenberg and Newtown apples. Weather conditions favored the blight during the spring. Sulphur in connection with root cleaning appeared to lessen infection when applied as an insect repellent. Oil sprays as repellants are also to be tested out.

Scab control activities in Jackson County gave gratifying results during 1916. Prune brown rot caused enormous losses in Douglas County, running as high as 50 per cent in 1915. Winter injury was worse in 1916 than for several years preceding. Mildew was severe in some places.

Winter injury among fruit trees, J. A. NELSON (*Ann. Rpt. Fruit Growers' Assoc. Ontario*, 50 (1918), pp. 41-48).—It is stated that the winter of 1917-18 was exceptionally severe as regards injury to fruit plantations in all parts of Ontario, thousands of trees being killed and hundreds of thousands being more or less damaged. This discussion deals with the forms and factors in-

volved and measures promising a degree of protection against a recurrence of the trouble.

Winter injury to fruit trees in Canada, 1917-18, W. T. MACOUN (*Ann. Rpt. Pomol. and Fruit Growing Soc. Quebec, 1918, pp. 31-34*).—This information has been noted from another source (E. S. R., 40, p. 835).

Secretary's report on winter injury, P. REID (*Ann. Rpt. Pomol. and Fruit Growing Soc. Quebec, 1918, pp. 34-46*).—As contrasted with trunk and bark injury at Ottawa as reported by Macoun in the paper above noted, the secretary called attention to a considerable injury from root killing as noted in inspection tours of the Province of Quebec following the unusual winter weather of 1917-18.

Winter injury [to orchards], W. T. MACOUN (*Rap. Ann. Soc. Pomol. Cult. Fruitière, Prov. Quebec, 1918, pp. 45-52*).—An account in some detail with discussion is given of the injury referred to in the communications above noted.

Protection of grape against parasites by cultural methods, J. CAPUS (*Rev. Vitic., 48 (1918), Nos. 1248, pp. 340-344; 1250, pp. 374-378*).—This account deals with *Oïdium* and two rots of grape, besides animal parasites.

The action of sulphur on grape *Oïdium*, J. CAPUS (*Rev. Vitic., 49 (1918), No. 1258, pp. 81, 82*).—It is concluded from observations cited that sulphur is not a dependable control for *Oïdium* during all sorts of weather in any degree comparable to the effects of the standard copper fungicides.

Grape downy mildew in Vienne, 1918, LABERGERIE (*Rev. Vitic., 49 (1918), No. 1262, pp. 145, 146*).—This is a discussion of plant disease conditions as related to the shortage of labor in 1918.

Grape downy mildew and overflows, 1918, J. CAPUS (*Rev. Vitic., 49 (1918), No. 1254, pp. 21-23*).—This deals with the probable relations between grape downy mildew and unusually dry weather or floods as noted in the summer of 1918.

Pruning against grape downy mildew, R. SALOMON (*Rev. Vitic., 48 (1918), No. 1237, pp. 170-172*).—Choice of stocks should be limited to those well adapted as regards climate and soil, and resistant naturally to diseases. Growth should be so controlled that copper sprays may readily reach all parts which are susceptible to downy mildew.

Treatment of grape downy mildew and black rot, J. CAPUS (*Rev. Vitic., 48 (1918), No. 1244, pp. 273-279*).—This discussion includes the theory and practice of treatments for downy mildew and black rot as regards the time, period, or number of treatments and the composition of sprays. The concentrations recommended include 2 per cent of copper for both Bordeaux and Burgundy mixture, with lime or soda at 1 per cent or higher.

Time and dosage for the last downy mildew treatment, J. CAPUS (*Rev. Vitic., 49 (1918), No. 1257, pp. 70, 71*).—It is stated that circumstances outlined determine the dosage and time of the concluding treatment for grape downy mildew.

The action of rain on sprays, J. CAPUS (*Rev. Vitic., 48 (1918), No. 1231, pp. 65-71*).—Discussion of experience during several years related to the question as to the advisability of spraying just before, during, or just after a rain, leads to the conclusion that the best time to spray is just before the incidence of the spores, which in spring (April-May) is during a period of precipitation. In June and July, the spray should be used in the period elapsing between the first appearance of mildew and the rain which determines the contamination. In case this plan is followed, sprays of long duration are not particularly needed, though such sprays are required when treatments are made in times not favorable to control and particularly in case of the last treatment for the season.

Phyllosticta leaf spot and damping-off of snapdragons, E. F. GUBA and P. J. ANDERSON (*Phytopathology*, 9 (1919), No. 8, pp. 315-325, figs. 8).—During the summer of 1918 a leaf spot of cultivated snapdragon was observed at the Massachusetts Agricultural College, the spots being much larger and quite different from those produced by the anthracnose fungus (*Colletotrichum antirrhini*). A study was made of the disease, which was found to be due to a species of *Phyllosticta*, previously reported as occurring in Europe. The cultural characters of the organism and the results of infection experiments are described at length.

Experiments were conducted which indicate that all types of the disease, with the exception of damping-off, may be controlled by spraying with Bordeaux mixture 4:4:50. In checking the disease, it is said to be essential that the air and soil be kept as dry as is consistent with the good growth of the plants.

The chestnut bark disease and the chestnut market in Massachusetts, F. W. RANE (*Boston: State*, 1916, pp. 30, pls. 4, fig. 1).—An account is given of the history of the chestnut bark disease (particularly in its relation to the chestnut market in Massachusetts), its distribution in the State, detection and control of the disease, and economic utilization of the trees affected.

White pine blister rust in New Hampshire (*N. H. State Forestry Dept. Circ. 10* (1920), pp. 4).—This circular is issued in cooperation with the Bureau of Plant Industry, U. S. Department of Agriculture.

It is stated that the white pine blister rust is generally distributed throughout the pine regions of New Hampshire, large areas of infected pines being found each year in towns not previously examined. The history and distribution of the disease is outlined. Accounts are given of field work in 1917, 1918, and 1919, and of the expenses by towns during 1918 and 1919, with a summary of work related to control of blister rust.

Report on the white pine blister rust, State of Rhode Island, 1919, in cooperation with the Bureau of Plant Industry, U. S. Department of Agriculture, R. A. SHEALS (*Ann. Rpt. Bd. Agr. R. I.*, 34 (1919), pp. 13-32).—White pine blister rust was first discovered in Rhode Island in 1912, a single diseased pine being found in a nursery among seedlings imported from Europe. The entire shipment was destroyed, and scouting of nurseries and pine plantations failed to show any blister rust infections. In 1916, a diseased pine was found on the Island of Newport, and scattered *Ribes* infections were located in practically every town in the State. An eradication area was established and afterwards enlarged. Details are given of systematic attempts to eradicate the disease.

The preliminary scouting method as here employed is regarded as practical and successful, except in areas where *Ribes* is abundant, such areas being very suitable to the close formation crew method. The plans for 1920 are outlined.

Fungoid diseases of rubber in southern India, W. MACRAE (*Planters' Chron.*, 13 (1918), No. 23, pp. 395-401).—In this address, delivered at the Rubber Planters' Conference at Cochin, it was stated that under conditions very favorable to infection *Phytophthora faberi* (the fungus causing cacao pod rot and stem canker, also claimed to cause fruit rot, leaf fall, and bark rot of *Hevea* in Ceylon) more readily infected fruits in the author's experiments than did the form considered by him as a different species and tentatively designated as *P. meadii*. The probable identity and dissemination of the fungus are discussed in connection with preventive measures.

Attention was given also to bark rot and measures to prevent or lessen damage from this source. Izal is a powerful fungicide so far as this disease is concerned and can be used in dilute solutions, though 5 per cent is the concentration commonly used during the monsoon. Other applications for the tapping rot are discussed.

General preventive measures are indicated, as ventilation by cutting out and pruning in case of closely planted estates.

An account is given briefly of attempts to present short courses for the training of young planters in dealing with plant diseases in this region.

Brown bast of *Hevea brasiliensis*, R. D. RANDS (*Arch. Rubbercult. Nederland. Indië*, 3 (1919), No. 3, pp. 156, 157; *Eng. ed.*, pp. 158, 159).—In a preliminary communication including a short list of related publications, it is claimed that brown bast presents a condition of severe gum formation apparently arising as a reaction of the tree against the injurious form of tapping employed.

The cause of brown bast in *Hevea brasiliensis*, W. BOBILIOFF (*Arch. Rubbercult. Nederland. Indië*, 3 (1919), No. 4, pp. 172-178).—The cause of brown bast is declared to be physiological. It is characterized by the formation of a brown degenerate substance in the intercellular spaces and middle lamellæ of the cortical cells. This substance gives the principal reactions for lignin. It has not yet been proved that this substance is gum. Other characteristics are the formation of burs and abnormalities of the stone cells. The severity of the disease probably depends upon the general physiological condition of the trees.

A method of steam sterilization of soil for controlling nematodes, L. E. MELCHERS (*Phytopathology*, 9 (1919), No. 7, pp. 294-296).—A description is given of a method used in 15 greenhouses at Hutchinson, Kans., in which low-pressure steam was utilized for the control of nematodes (*Heterodera radicola*).

ECONOMIC ZOOLOGY—ENTOMOLOGY.

Birds beneficial to agriculture, F. W. FROHAWK (*Brit. Mus. (Nat. Hist.), Econ. Ser.*, No. 9 (1919), pp. VI+47, pls. 22).—This consists of brief popular accounts of the beneficial species occurring in Great Britain.

Description of a new clapper rail from Florida, H. C. OBERHOLSER (*Proc. Biol. Soc. Wash.*, 33 (1920), pp. 33, 34).

Insects of economic importance, G. W. HERRICK (*New York: The Macmillan Co.*, 1920, rev. ed., pp. [6]+172).—This is a revised edition of the author's lectures in economic entomology, previously noted (*E. S. R.*, 34, p. 651).

Entomological work, W. G. TAGGART (*Louisiana Stas. Rpt. 1919*, pp. 24-26).—This report relates to investigations of the sugar cane moth borer in cooperation with the Bureau of Entomology, U. S. Department of Agriculture, a bulletin relating to which has been noted (*E. S. R.*, 41, p. 60). Reference is made particularly to the introduction of the tachinid fly parasite from Cuba, and its establishment in Louisiana.

Fungus insects and their hosts, H. B. WEISS and E. WEST (*Proc. Biol. Soc. Wash.*, 33 (1920), pp. 19, pl. 1).—This paper, which lists the fungus hosts of insects, includes both insect and host lists.

[Insect enemies of the loganberry], W. S. BROWN (*Better Fruit*, 14 (1920), No. 10, p. 34).—The raspberry cane maggot, the leaf hopper, and the raspberry root borer are said to cause the most injury to the loganberry in Oregon.

Text-book of protozoology, F. DOFLEIN (*Lehrbuch der Protozoenkunde. Jena: Gustav Fischer, 1916*, 4. ed., enl., pp. XV+1192, figs. 1201).—A new and enlarged edition of the work previously noted (*E. S. R.*, 27, p. 356).

Biological control of mealybugs in California, H. S. SMITH and H. M. ARMITAGE (*Mo. Bul. Dept. Agr. Calif.*, 9 (1920), No. 4, pp. 104-158, pl. 1, figs. 34).—This is an account of the mealybugs attacking citrus in California (pp. 107-113), their natural enemies (pp. 114-118), the biological method (pp. 119-122), practical application of biological control (pp. 123-145), branch in-

sectaries (pp. 146-149), buildings and equipment (pp. 150-155), and demonstration work (pp. 156-158). The pests considered are the citrus mealybug (*Pseudococcus citri*), citrophilus mealybug (*P. gahani*), Baker mealybug (*P. maritimus* (*bakeri*)), and the Japanese mealybug (*P. krauhniae* Kuwana). Their natural enemies of particular importance are the lady bird beetle *Cryptolæmus montrouzieri* and the Sicilian parasite *Tanaomastix abnormis* Gir.

Of the four species of mealybug, *P. citri* has been the longest established within the State and seems particularly adapted to the coastal regions, though it has been found to thrive exceedingly well at certain seasons of the year in the hotter interior valleys. *P. gahani* has spread quite extensively since its original infestation at Uplands, San Bernardino County, in 1914, and is now found quite widespread near Riverside, Riverside County; in Pasadena, South Pasadena, Alhambra, and the city of Los Angeles in Los Angeles County; and has been reported from Fillmore in Ventura County. It is thought that due to the fact that it has only one main generation it can not become quite so serious as the citrus mealybug, which has two or more definite generations.

P. maritimus has been found throughout the southern part of the State since 1898, at which time it occurred quite generally on citrus in Orange County, and has since been taken on citrus in nearly every county in the south. It has seldom reached a stage where it has been necessary to consider control, having for the most part been suppressed by native natural enemies. *P. krauhniae*, which occurs in the Ojai Valley in Ventura County, and was for a number of years considered to be the citrus mealybug, was discovered in 1918 to be the Japanese mealybug.

The Lecania of Michigan, R. H. PETTIT and E. McDANIEL (*Michigan Sta. Tech. Bul.* 48 (1920), pp. 35, figs. 23).—Thirteen species and one variety are described, of which *Lecanium* (*Toumeyella*) *numismaticum* from Scotch pine and *L. (Toumeyella) corrugatum neglectum* from pitch pine are described as new.

It is pointed out that the only characters apparently thus far discovered for separating the forms of *Lecanium* into species lack stability, and this accounts for the multitude of species recorded. Forms of what the authors considered *L. corni* are distributed over a multitude of host plants and seem to thrive under various climatic conditions. They vary in size, shape, color, and somewhat in derm markings, characters of the anal plates, and in the antennal characters, and the appearance of the derm seems to be influenced strongly by the age of the subject, by the method of its preparation, and by the time of boiling. The preparation of a key has been deferred until a later date.

A new Myzocallis (Aphididæ: Homoptera), W. M. DAVIDSON (*Canad. Ent.*, 52 (1920), No. 8, pp. 176, 177, fig. 1).—*M. alhambra* taken from *Quercus engelmanni* at Alhambra, Cal., in 1919 is described as new.

Some poultrey lice and mites found in Colorado, C. G. BABCOCK (*Colo. Agr. Col. Ext. Bul.*, 1. ser., No. 165A, (1920), pp. 3-14, figs. 4).—This is a popular account.

Dusting and the spray gun in calyx worm control, L. CHILDS (*Better Fruit*, 14 (1920), No. 10, pp. 7, 8, 38, figs. 2).—This report is based upon investigations made by the entomologist of the Hood River Experiment Station.

The European corn borer again, R. H. PETTIT (*Michigan Sta. Quart. Bul.*, 2 (1920), No. 4, p. 183).—This note calls attention to the fact that shipment of broom-corn stock from abroad and from infested regions is a prolific source of infestation of the European corn borer. It has been found that broom corn from Europe has been shipped to several localities in Michigan, and it is

urged that special efforts be made to determine the possible presence of this pest.

The European corn borer and some similar native insects, W. P. FLINT and J. R. MALLOCH (*Ill. Dept. Registr. and Ed., Div. Nat. Hist. Survey Bul., 13 (1920), Art. 10, pp. 287-305, figs. 45*).—A summarized account is first given of *Pyrausta nubilalis* Hübner. This is followed by a discussion of other insects likely to be mistaken for the European corn borer, including the distinguishing characters of the corn-borer group (*P. nubilalis*, *P. penitalis*, and *P. obumbratalis*). The author concludes that the smartweed borer, which is very common in Illinois and has been described by Heinrich as *P. ainsliei*, represents *P. obumbratalis* Led. A form taken in a field of sweet corn at Bloomington, Ill., the immature stages and food plant of which are at present unknown, is described as *P. caffreii* n. sp.

Proceedings of the conference on the European corn borer (*N. Y. Dept. Farms and Markets, Div. Agr. Bul. 123 (1919), pp. 74, pls. 11*).—Papers presented at the conference held at Albany August 28, and at Boston August 29, 1919, include the following: The European Corn Borer, by C. S. Wilson (pp. 7-10); The European Corn Borer in America, by L. O. Howard (pp. 10-15); Danger to the Corn Industry of this Country, if the European Corn Borer Is Not Exterminated, by C. Adkins (pp. 15-20); The Life History of the European Corn Borer and a Summary of the Possibilities of Exterminating the Pest in New York, by E. P. Felt (pp. 20-27); Information Relative to the Control of the European Corn Borer in New York, by G. G. Atwood (pp. 27-32); Summary of the Situation in Massachusetts as it Relates to the European Corn Borer, by W. Wheeler (pp. 33-35); Report on the Work of the American Pest Committee, by H. A. Reynolds (pp. 36, 37); Facts Revealed in Two Years' Work with the European Corn Borer in Massachusetts, by D. J. Caffrey (pp. 37-49); and the Corn Borer from the Standpoint of Quarantine and General Control, by C. L. Marlatt (pp. 60-67).

Monograph of the fungus gnats of the Canary Islands, E. S. ABREU (*Mem. R. Acad. Cien. y Artes Barcelona, 3. ser., 16 (1920), No. 1, pp. 154, pls. 2*).—This is a monograph of the Mycetophilidæ.

The violet cecidomyiid (Perrisia affinis Kieffer), P. VAYSSIÈRE (*Bul. Soc. Path. Veg. France, 7 (1920), No. 1, pp. 31-33*).—A brief account of this pest, which is a source of serious injury in the region of Hyères.

The Hessian fly in Indiana, W. H. LARRIMER (*Indiana Sta. Circ. 95 (1920), pp. 8, figs. 5*).—This is a brief popular account which includes a double page figure showing the development of the Hessian fly from egg to adult twice during the year.

Some observations on Pipunculus flies which parasitize the cane leaf hopper at Pahala, Hawaii, February 11, April 25, 1918, F. X. WILLIAMS (*Proc. Hawaii. Ent. Soc., 4 (1919), No. 1, pp. 68-71, fig. 1*).—Observations of the habits of several species which have transferred their attention from native leaf hoppers to the sugar cane leaf hopper (*Perkinsiella saccharicida* Kirk.) are recorded.

Some additional notes on Bruchidæ and their parasites in the Hawaiian Islands, J. C. BRIDWELL (*Proc. Hawaii. Ent. Soc., 4 (1919), No. 1, pp. 15-20; abs. in Rev. Appl. Ent., 7 (1919), Ser. A, No. 10, pp. 434, 435*).—These notes supplement the paper previously noted (E. S. R., 40, p. 266).

The A B C and X Y Z of bee culture, A. I. and E. R. ROOT (*Medina, Ohio: The A. I. Root Co., 1920, rev. and enl. ed., pp. 8+856, pl. 1, figs. 800*).—This is a new edition of the work previously noted (E. S. R., 37, p. 568).

Fortieth annual report of the Beekeepers' Association of the Province of Ontario, 1919 (*Ontario Bee-Keepers' Assoc., Ann. Rpt. 1919, pp. 72*).—Among the papers presented are the following: Spraying and Its Relation to Bees, by L. Caesar (pp. 25–28); Stimulative Feeding, by H. W. Jones (pp. 37–43); Experimental Work in Beekeeping, by C. B. Gooderham (pp. 43–48); etc.

Descriptions of new genera and species of Hawaiian Encyrtidæ (Hymenoptera), P. H. TIMBERLAKE (*Proc. Hawaii. Ent. Soc., 4 (1919), No. 1, pp. 197–231*).—Among the species here described that are of economic importance are the following: *Anagyrus nigricornis* reared from *Pseudococcus lounsburyi* Brain, *P. longispinus* (Targ.), *P. montanus* Ehr., *P. gallicola* Ehr., and *Ripersia palmarum* Ehr.; *Xanthoencyrtus fullawayi* reared from *P. saccharifolii* (Green), and *Pseudococcobius terryi* (Fulla.); *Pauridia* (n. g.) *peregrina* reared from *P. krauhnia* (Kuwana), and *Cassia fistula* (Ehr.); *Encyrtus barbatus* reared from *Saissetia hemisphærica* (Targ.), and *S. nigra* (Niet.); *Quaylea* (n. g.) *aliena* reared from *Scutellista cyanea* Motsch. from *Asterolecanium* sp. on bamboo, *A. pustulans* (Cock.), and *Coccus viridis* (Green); *Aphycomorpha araucariae* reared from *Eriococcus araucariae* Mask.; and *Anicetus annulatus* reared from *Encalymnatus tessellatus* (Swezey).

Descriptions of new species of Hymenopterous parasites of muscoid diptera with notes on their habits, J. C. BRIDWELL (*Proc. Hawaii. Ent. Soc., 4 (1919), No. 1, pp. 166–179*).—Nine species of Hymenopterous parasites are described as new.

Some observations on the leaf-hopper wasp, *Nesomimesa hawaiiensis* Perkins, at Pahala, Hawaii, February 11, April 25, 1918, F. X. WILLIAMS (*Proc. Hawaii. Ent. Soc., 4 (1919), No. 1, pp. 63–68, figs. 3*).—A report of observations of the habits of this enemy of the sugar cane leaf-hopper.

Epyris extraneus Bridwell (Bethyridæ), a fossorial wasp that preys on the larva of the Tenebrionid beetle, *Gonocephalum seriatum* (Boisduval), F. X. WILLIAMS (*Proc. Hawaii. Ent. Soc., 4 (1919), No. 1, pp. 55–63, figs. 8*).—The author has succeeded in rearing this parasite from egg to adult and reports upon its life history and habits.

FOODS—HUMAN NUTRITION.

Effects of enforcement of the National Food and Drug Law of June 30, 1906, J. FOUST (*Amer. Food Jour., 15 (1920), No. 6, p. 26*).—This is a brief discussion of the benefits resulting from the enforcement of the Federal Food and Drugs Act of 1906 and of some of the weak points in the law.

Drugs and foods, C. D. WOODS (*Maine Sta. Off. Insp. 95 (1920), pp. 28*).—This publication consists of the reports of analyses of samples of drugs and foods sent to the station for examination during 1919.

For the purpose of comparison of clams on sale with specimens handled under known conditions and from salt and brackish water, specimens were collected and examined for percentage of liquids and solids under varying conditions. Tables are given showing the composition of clams opened raw, compared with clams from the same source but dipped for two minutes in boiling salt water or in boiling fresh water before opening, also of clams dried without washing in fresh water as compared with samples washed in fresh water after shucking.

From these analyses the conclusion was drawn that good, fresh-opened, well-drained clams should carry not more than 10 per cent of liquids and not less than 17 per cent of solids. Judged by these standards, the practice of watering clams by placing them in brackish water is apparently quite common.

A pink yeast causing spoilage in oysters, A. C. HUNTER (*Amer. Food Jour.*, 15 (1920), No. 6, pp. 16-19).—Essentially noted from another source (*E. S. R.*, 42, p. 860).

Some considerations concerning the salting of fish, D. K. TRESSLER (*U. S. Dept. Com., Bur. Fisheries Doc. 884* (1920), pp. 55, figs. 8).—This publication consists of a survey of present commercial methods of salting fish, and the results of an experimental study of the influences of various factors upon the quality of the final product. The general conclusions drawn are as follows:

Calcium and magnesium salts and sulphates as impurities in common salt retard the penetration of salt into fish, and consequently cause fish to spoil during salting at a lower temperature than salts not containing these impurities. Fish packed in dry salt have better keeping qualities than fish salted in brine.

The predominant factors in controlling the qualities of the salt fish are thorough cleaning of the fish and the use of perfectly fresh fish.

School lunches at Columbus, Ind. (*Mo. Bul. Ind. State Bd. Health*, 23 (1920), No. 4, p. 43).—A school lunch project is described which was found to be very successful. Parents were requested to pledge 15 cts. a week for milk and to prepare each morning a large bread and butter sandwich to be properly wrapped and brought to school by the child. The school in return agreed to provide a half pint of milk per child per day. The luncheons were eaten before the mid-morning recess. At the end of the first month after this luncheon plan was put into effect the children participating showed an average gain of 12.2 oz. and at the end of the second month of 16.3 oz. As pointed out, this is equivalent to the expected gain in weight for normal children.

Cafeterias for industrial plants (*Hotel Mo.*, 28 (1920), No. 327, p. 19).—Some information regarding the value of cafeterias from the industrial standpoint is summarized.

Dietitian supervises employees' meals, E. BECKER (*Hotel Mo.*, 28 (1920), No. 327, pp. 22-24).—In an address at Hotel Men's Show, Chicago, the author described methods of supervising employees' meals in a very large hotel in New York.

Restaurant economics in England (*Hotel Mo.*, 28 (1920), No. 327, p. 54).—Brief statements are made regarding some practices which have been introduced for reasons of economy.

The metabolism of sulphur.—III, The relation between the cystin content of proteins and their efficiency in the maintenance of nitrogenous equilibrium in dogs, H. B. LEWIS (*Jour. Biol. Chem.*, 42 (1920), No. 2, pp. 289-296).—The investigation previously noted (*E. S. R.*, 38, p. 570) has been extended to include proteins of known sulphur and cystin content in order to determine to what extent the minimum of these proteins is determined by their cystin content. The relative efficiency of serum albumin, casein, and casein plus cystin in the nutrition of dogs was determined by a comparison of the nitrogen balances of the different experimental periods.

With a low protein intake, serum albumin proved more effective in maintaining nitrogen equilibrium than did casein. Casein supplemented by cystin proved, however, to be as efficient as serum albumin. These results are thought to furnish additional evidence that cystin is essential for maintenance as well as growth.

Accessory food factors (vitamins) in the feeding of infants, E. MEL-LANBY (*Lancet* [London], 1920, I, No. 16, pp. 856-862, figs. 14).—This paper, which consists of the opening remarks at the discussion on the influence of vitamins in infant nutrition previously noted (*E. S. R.*, 43, p. 166), deals chiefly

with the relation between fat-soluble A and the antirachitic factor, the relation of the latter to age and to the energy-bearing portions of the diet, and the effect of exercise, unhygienic surroundings, etc. on the development of rickets.

The discussion of these topics supplements earlier work of the author (E. S. R., 41, p. 364). Attention is called to the difference in distribution of the fat-soluble factor and the antirachitic accessory factor in vegetable fats, and to the importance of the fat-soluble factor for the growth of rats and its probable unimportance in the growth per se of puppies and children. The suggestion is made that both of these differences can probably be explained by variations in the general and intermediate metabolism of these animals, but that care should be taken not to confuse the two types of work, namely, the growth experiments on rats and the rickets experiments on puppies.

Other points brought out in the discussion are that the younger the animal the more necessary is the antirachitic accessory factor in the diet until some essential process or secretion has developed which effectually prevents the development of rickets whatever the diet; that an increase in the protein of the diet aids the antirachitic vitamin so that less of it will suffice to keep the growth normal, while an increase in carbohydrate, especially when it results in the storage of fat, appears to render additional antirachitic vitamin imperative; and that exercise is not the prime factor in the etiology of rickets but is a secondary factor in the prevention of the disease in being a stimulant to the general metabolism.

Vitamin studies.—V, The antiscorbutic properties of raw beef, R. A. DUTCHER, E. M. PIERSON, and A. BIESTER (*Jour. Biol. Chem.*, 42 (1920), No. 2, pp. 301-310).—This paper, in continuation of the vitamin studies previously noted (E. S. R., 41, p. 766), consists of the detailed report of a study of the antiscorbutic properties of raw lean beef. The conclusion that this material is lacking in antiscorbutic properties has been noted in a preliminary report from another source (E. S. R., 41, p. 861).

The pathogenesis of deficiency disease, R. McCARRISON (*Indian Jour. Med. Research*, 7 (1919), No. 2, pp. 269-345, pls. 29, figs. 2).—In continuation of the investigation previously noted (E. S. R., 42, p. 463), five papers are presented.

V. Histopathology (pp. 269-278).—This paper deals with the histological changes observed in the spleen, liver, pancreas, kidneys, pituitary body, and thyroids of pigeons fed exclusively on a diet of autoclaved milled rice, the study being a continuation of the one previously reported in which histological changes in the intestines and testicles of pigeons so fed were noted.

In general the histopathological changes found in the various organs were of two kinds, necrobiosis and congestion. In the thymus, spleen, and testicles the disappearance of tissue cells was the more prominent change. In the intestines, liver, pancreas, and kidneys congestion, with hemorrhagic infiltration, was often the more prominent feature. In the thyroids and the glandular part of the pituitary both features were present, but usually in mild degree.

Arranged in the order of severity in which these changes occurred, it is shown that "the organs which suffer most are those which are least essential to the life of the individual. Next in order are the organs of digestion and assimilation, then the organs of excretion, and, lastly, the organs of internal secretion. That the central nervous system suffers least, from the point of view of organic lesions, is shown by the rapidity with which the nervous symptoms due to the deficient diet can be controlled or abated by the administration of vitaminic substances. It seems probable that the cellular elements of the organs least essential to the life of the individual are utilized to

provide accessory food factors and other nutritive materials for the cells of higher function."

VI. *The influence of a scorbutic diet on the bladder* (pp. 279-282).—The effects of a scorbutic diet on the bladder were studied in five guinea pigs fed on crushed oats and autoclaved milk, while the controls were fed on the same diet, with an abundance of green vegetables.

The animals fed on the scorbutic diet died within periods varying from 19 to 29 days. One only developed clinical signs of scurvy, and in two only were naked-eye evidences of a scorbutic state obvious at autopsy. In all, histological examination showed the presence of hemorrhagic infiltration of the adrenals, the kidneys, the liver, and the intestines. The heart's blood of the animal exhibiting clinical evidences of scurvy yielded a coliform organism on culture. The adrenalin content of the suprarenal glands in this animal was very low.

Evidences of derangement of the bladder were noted as follows: Hematuria was observed in the animal showing clinical evidences of scurvy. In all cases on autopsy the bladder proved to be empty and tightly contracted. The histological changes consisted in congestion of all coats with hemorrhagic infiltration of the mucous membrane and degenerative changes in the epithelium of the mucous membrane. These consisted in swelling of the epithelial cells and their nuclei and desquamation of degenerated cells.

"Considered from the clinical point of view, these findings afford an explanation of the comparatively frequent occurrence of hematuria in human scurvy. They indicate that this symptom, which is usually a late manifestation of the scorbutic state in man, is the clinical evidence of an extreme degree of congestive and degenerative change in the mucous coat and epithelial lining of the bladder. They indicate also that congestive states of the bladder may occur in guinea pigs, fed on a scorbutic diet, which exhibit no obvious clinical evidences of scurvy during life and little or no naked-eye pathological evidences of this malady after death.

"Congestion of the bladder without clinical evidences of hematuria may, then, be regarded as a prescorbutic process in guinea pigs. This being so, a point of practical importance to the physician is to ascertain, by clinical and therapeutical observation, whether congestion of the bladder may not be so produced in man, and if so whether certain abnormalities of micturition may not sometimes be evidences of a prescorbutic state in human beings, especially in children."

VII. *The effects of autoclaved rice dietaries on the gastro-intestinal tract of monkeys* (pp. 283-307).—The object of the investigation described in this paper was the production of beriberi in monkeys by means of dietaries of autoclaved rice, but as the animals, after several days, refused to eat, the study finally resolved itself into observations of the effects of malnutrition. Two diets were used, one consisting of autoclaved rice alone and the other of autoclaved rice and butter. The animals fed on autoclaved rice alone died in an average of 23.4 days, while those receiving butter died in an average of 15 days. The clinical, pathological, bacteriological, and histological evidences of the resulting gastro-intestinal disease are discussed in full and summarized as follows:

"Congestive, necrotic, and inflammatory changes in the mucous membrane of the entire tract. Degenerative changes in the neuro-muscular mechanism of the entire tract, leading to dilatation of the stomach, ballooning of areas of the small and large bowel, and probably also to the intussusceptions which so frequently occur.

"Pronounced necrotic changes in the secretory elements of the entire gastro-intestinal tract—of the gastric glands, the pyloric glands, the glands of Brunner,

the glands of Lieberkühn, and of the mucous glands of the colon. These changes are such as must cause grave derangement of the digestive and assimilative processes.

"Intense toxic absorption from the diseased bowel as evidenced by the changes in the colonic mesenteric glands.

"Impairment of the protective resources of the entire gastro-intestinal mucosa against infecting agents, leading to infection of the mucous membrane by 'pathogenic saprophytes' and by ingested pathogenic organisms. These infections give rise to gastritis, enteritis, colitis, and frequently to hemic infections. The occurrence of dysentery in these circumstances is a most significant finding.

"In the present experiment the gastro-intestinal lesions described were initiated by dietaries too rich in carbohydrates and too poor in other essential attributes of a perfectly balanced ration. With this combination the physician is familiar in the dietaries of human beings. It may be expected, then, that gastro-intestinal lesions of like kind, if not of like degree, will result in man from the continued use of such dietaries."

VIII. *The general effects of deficient dietaries on monkeys* (pp. 308-341).—In this paper are summarized the general effects on monkeys of the dietaries used in the preceding study, representing, in the case of the autoclaved rice, a dietary deficient in suitable protein, in fat, and in accessory food factors of all three classes and excessively rich in starch, and in the case of the autoclaved rice and butter, one deficient in suitable protein and in accessory food factors of the B and C classes, and excessively rich in starch and fat. In addition, a series of monkeys was fed a diet of autoclaved food (rice, wheat bread, milk, and peanuts) to which a small ration of fresh onion was added. This diet was deficient in accessory food factors of the A and B classes. A fourth series was fed on the last-mentioned diet plus butter, this representing a diet deficient only in accessory food factors of the B class and excessively rich in fats.

The average lengths of time in which the monkeys survived on the various diets were as follows: Autoclaved rice, 23.4 days; autoclaved rice and butter, 15; autoclaved food and fresh onion, 70; and autoclaved food, onion, and butter, 100 days.

The total loss of weight in monkeys on all four diets was from 25 to 32 per cent of the original weight of the animal, the loss being most rapid on the diet of autoclaved rice and butter.

The clinical symptoms were similar in all four cases, but appeared later in monkeys whose food was more perfectly balanced as to protein and carbohydrate. Symptoms referable to the nervous system were less prominent and appeared later than those of the digestive system.

The changes taking place in the weight of the organs were in general the same in kind as those previously reported for pigeons, although differing somewhat in degree. The atrophy of the testicles and spleen was less than in the case of the pigeons. The lungs of the monkeys showed a marked reduction in weight, while those of the pigeons showed an increase on the autoclaved rice and butter diet.

The main pathological states observed, aside from the enlargement or atrophy of the organs, consisted of dilatation of the stomach, gastritis, duodenitis, enteritis, ballooning of the small intestines, intussusception, colitis, atrophy of the muscular coats of the bowel, complete loss of fat from the omentum, and enlargement of the abdominal lymphatic glands.

The general conclusions applicable to human nutrition are as follows:

"Dietaries which are deficient in vitamins and in protein, and at the same time excessively rich in starch or in fat or in both, are potent sources of

disease and especially of gastro-intestinal disease. An excess of fat, in association with deficiency of B-vitamin and protein and superabundance of starch, is peculiarly harmful to the organism. Certain dietetic deficiencies greatly favor the invasion of the blood and tissues by bacteria; especially is this the case when deficiency of vitamins and protein is associated with an excessive intake of starch."

IX. *On the occurrence of recently developed cancer of the stomach in a monkey fed on food deficient in vitamins* (pp. 342-345).—The accidental discovery of a recently developed carcinoma of the pylorus in one of the monkeys fed a diet deficient in B-vitamin is reported as indicating the possible influence of vitaminic deficiency on the onset of cancer of the stomach.

Deficiency diseases in Vienna (*Brit. Med. Jour.*, No. 3092 (1920), pp. 477, 478).—This is an editorial discussion of the work of the mission sent to Vienna by the Accessory Food Factors Committee, appointed by the Lister Institute and the Medical Research Committee (England) to investigate the prevalence of scurvy, rickets, and other disorders attributable to malnutrition, and to determine the value of methods of curing these diseases which have been found effective in animal experimentation.

The study of an outbreak of infantile scurvy indicated that in the case of bottle-fed infants the repeated heating of the milk was probably the cause of the outbreak, while in breast-fed infants the fault lay in the defective diet of the mothers. Raw swede juice, orange juice, and neutralized lemon juice proved effective antiscorbutics for the bottle-fed infants. To counteract rickets and scurvy in the bottle-fed, the mothers have been provided with a daily ration of 50 gm. of butter and 30 gm. of raw swedes.

An investigation of the causal factors of osteomalacia has led to the belief that it is caused by a deficiency in the fat-soluble accessory factor.

The relation of undernutrition to osteoporosis and osteomalacia, ALWENS (*München. Med. Wchnschr.*, 66 (1919), No. 38, pp. 1071-1075, figs. 2).—The author describes in considerable detail 16 cases of illness of the bone system occurring in Frankfort as a result of prolonged undernourishment on a protein-, calcium-, and phosphorus-poor diet. The disease attacked principally women of the middle class in the climacteric and postclimacteric periods, although a few cases occurred in young women and men.

The majority of cases presented a true picture of osteoporosis, while a few were typical cases of osteomalacia. For therapeutic treatment the author recommends a liberal diet rich in protein, calcium, and phosphorus supplemented by daily doses of 0.5 mg. of phosphorus in cod liver oil. In the case of true osteoporosis strontium lactate is recommended.

[**Pellagra**] (*Pub. Health Serv. U. S., Hyg. Lab. Bul. 116* (1920), pp. 100).—This bulletin consists of four papers on pellagra, as follows:

I. *The influences of vitamins on the course of pellagra*, by C. Voegtlin, M. H. Neill, and A. Hunter (pp. 7-35).—To determine if possible whether the beneficial effects on pellagra of fresh meat, eggs, and milk are due to their content of vitamins, 13 selected cases of pellagra were treated with various vitaminic preparations in connection with a vitamin-deficient diet, approximately that on which the patient contracted the disease. The vitamin preparations consisted of protein-free extracts from liver and thymus glands and from yeast and rice polishings. The technique of their preparation is described in detail. The liver and thymus extracts, while containing a greater variety of accessory substances than did the extracts from yeast and rice polishings, were poorer in antineuritic substances as shown by their relative efficacy in the prevention and cure of avian polyneuritis.

The case reports presented showed that the administration to cases of pellagra of the preparations from yeast and rice polishings, over a considerable period of time and in large amounts, in general failed to modify the course of the disease, while the administration of the liver and thymus preparations was followed by a rapid improvement in the condition of the patients apparently comparable to that produced by a diet rich in fresh animal proteins.

"The evidence presented clearly indicates that the dietary defect responsible for pellagra is distinctly (qualitatively) different from and perhaps more complex than the one causing fowl polyneuritis and human beriberi."

II. *The chemical composition of the blood of pellagrins*, by R. C. Lewis (pp. 37-44).—Quantitative chemical analyses of the blood of a number of pellagrins for total nonprotein nitrogen, urea, sugar, chlorids, sodium, potassium, calcium, and magnesium are reported. With the exception of low total nonprotein nitrogen and urea figures for one group of patients on a comparatively low protein diet, no variations from the normal were found.

III. *The amino acid fractions and hippuric acid in the urine of pellagrins*, by J. R. Murlin (pp. 45-72).—The author discusses several conditions suggestive of possible metabolic alterations which are characteristic of pellagra, and points out that imperfect gastric digestion, which is characteristic of a large number of cases of pellagra, might lead to imperfect assimilation of protein material with the formation of toxic products such as the precursors of hippuric acid. The experimental work reported consisted of the quantitative analysis of the urines of pellagrous patients on low and high protein diets for amino acids, peptid-bound nitrogen, and hippuric acid.

Taking as normal the limits arrived at from a study of the literature, all of the results obtained were considered normal with the exception of hippuric acid the amount of which, especially as excreted by pellagrins on a corn-vegetable diet, was from two to three times the quantity excreted by normal men on a general mixed diet. "The question may be raised whether this does not denote an intestinal condition capable of producing toxins which may have far-reaching somatic effects."

IV. *The occurrence of pellagra in nursing infants, with observations on the chemical composition of the human milk from pellagrous mothers*, by C. Voegtlin and R. H. Harris (pp. 73-100).—The literature on the occurrence of pellagra in nursing infants is reviewed, a report is given of pellagra in a nursing infant of a nonpellagrous mother, analyses are given of the milk obtained from pellagrins, and several possible explanations for the occurrence of pellagra in breast-fed infants are suggested.

The chemical analysis of the milk from five cases of uncomplicated pellagra showed no striking abnormalities. Lactose, fat, total nitrogen, and total solids were below the average but within normal limits; the total ash and phosphoric anhydrid were normal; chlorin and sodium were higher than normal; and calcium, magnesium, and potassium were slightly below the normal. No observations were made on the vitamin content of the milk. The vitamin theory is, however, considered to be the most plausible explanation of the occurrence of pellagra in breast-fed infants.

ANIMAL PRODUCTION.

The tabulation of factorial values, C. ZELENY (*Amer. Nat.*, 54 (1920), No. 633, pp. 358-362, figs. 2).—The author suggests a statistical device for use in the study of the inheritance of quantitative characters where factors produce changes in an organ in proportion to its size. Class ranges are not kept uniform but are made to include a uniform number of factorial units, i. e., the class

ranges are directly proportional to class means. In this way the original unsymmetrical frequency distribution becomes approximately symmetrical. Standard deviations of percentage frequencies "are used directly as coefficients of variation."

The data cited are counts of the number of facets in the eyes of the bar-eyed mutant of *Drosophila melanogaster*.

The inheritance of congenital cataract in cattle, J. A. DETLEFSEN and W. W. YAPP (*Amer. Nat.*, 54 (1920), No. 632, pp. 277-280).—A registered Holstein-Friesian bull had 93 normal offspring by a number of unrelated cows. Thirty-two of the daughters were mated to a son and produced 63 calves, of which 8 showed well-defined congenital cataracts of the stellate type. It is concluded that congenital cataract in cattle is a simple Mendelian recessive.

Hereditary cataract in calves, C. P. SMALL (*Amer. Jour. Ophthalmology*, 3. ser., 2 (1919), No. 9, pp. 681, 682).—The author reports clinical observations made at the Illinois Experiment Station on four of the blind calves noted above, and on one calf got by the original sire out of one of his daughters. The latter calf, which was 4 months old, had a soft cataract, while the others, ranging in age from 6 to 23 months, had mature cataracts in both eyes.

"Small chalky dots of further degeneration in the lens substance were seen in most of the cases. . . . In several of the eyes the lenses, apparently undeveloped in size, were seen throughout their entire circumferences, giving the appearance of a glass marble suspended in the clear vitreous. The other ocular conditions were practically identical in all the animals. Intraocular tension, so far as could be judged, was normal. There was no ciliary nor conjunctival congestion. Light perception and a good degree of light projection was found in all cases. The pupils responded readily to light." Full mydriasis was obtained in one hour with atropin and homatropin.

The inheritance of coat color in Great Danes, C. C. LITTLE and E. E. JONES (*Jour. Heredity*, 10 (1919), No. 7, pp. 309-320, fig. 1).—The authors summarize breeding records of Great Danes in the American Kennel Club studbooks.

Solid black, brindle, and fawn are interpreted, respectively, as complete extension, partial extension, and restriction of black, and form a set of three allelomorphs. These colors are also dominant to the corresponding dilute conditions, the genes for intensity and dilution being allelomorphic. Harlequin spotting (dominant) and solid color also form a pair of allelomorphs. The appearance of small white spots on the chest and feet of the progeny of solid-colored animals is thought to be due to a recessive gene for piebald spotting.

It is pointed out that dogs, despite their slow breeding and large size, represent the best material among mammals for a relatively complete genetical analysis. There are more color varieties, structural differences, and size differences than in any other domesticated mammal, crossbreds are fertile, and artificial insemination has been practiced successfully. The work of Malone (*E. S. R.*, 43, p. 269) showed that the number of chromosome pairs was not large and indicated the possibility of sex-linked inheritance.

A note on the origin of piebald spotting in dogs, C. C. LITTLE (*Jour. Heredity*, 11 (1920), No. 1, pp. 12-15, fig. 1).—Two cases are reported of the occurrence of white spotted pups in litters produced by solid-colored dogs belonging to typically solid-colored breeds, Scottish Terrier in one case, Airedale in the other. In each instance the parents were somewhat related, and it is suggested that by mutation an ancestor common to both parents became heterozygous instead of homozygous for solid color. The white marks were very conspicuous and could not have arisen by selection.

Is there linkage between the genes for yellow and for black in mice? C. C. LITTLE (*Amer. Nat.*, 54 (1920), No. 632, pp. 267-270).—The author con-

siders it probable that the peculiar ratios observed by Dunn (E. S. R., 42, p. 762) were chance deviations from ordinary no-linkage ratios, but points out that a lethal factor might be invoked to explain the results.

Experiments on sex determination, S. M. COPEMAN (*Proc. Zool. Soc. London*, 1919, III-IV, pp. 433-435).—To test the theory that in mammals the gonads on one side of the body give rise to male-producing gametes and those on the other side to female-producing gametes, the author made various matings of semicastrated and semispayed rabbits. The operations were without influence on the sex ratios among the progeny. The experimental data are not reported.

Studies on the cells of cattle with special reference to spermatogenesis, oögonia, and sex determination, J. E. WODSEDALEK (*Biol. Bul. Mar. Biol. Lab. Woods Hole*, 38 (1920), No. 5, pp. 290-316, pls. 5, fig. 1).—This is a contribution from the Idaho Experiment Station.

The author's counts gave quite uniformly 37 chromosomes in the spermatogonia of adult bulls and in the somatic tissues of male fetuses. The unpaired (sex) chromosome is larger than the ordinary chromosomes and passes undivided to one pole at the first spermatocyte (reduction) division. Measurements of mature spermatozoa indicated a rather definite dimorphism in head length, the larger type presumably containing the sex chromosome. Two sex chromosomes were observed in the oögonia of female embryos.

The spermatogenesis of domestic mammals, I, II, K. MASUI (*Jour. Col. Agr., Imp. Univ. Tokyo*, 3 (1919), No. 6, pp. 357-403, pls. 6, figs. 3).—Two papers are presented dealing, respectively, with the horse and the bull. Besides the chromosome relationships, the mitochondria, idiosomes, and other cytoplasmic inclusions are described. The materials from which the preparations were made were secured in Japan.

I. *The spermatogenesis of the horse* (pp. 357-373).—The somatic number of chromosomes is found to be 37. The odd chromosome appears as a chromosome nucleolus in resting and growth stages, and passes undivided to one pole at the first spermatocyte (reduction) division.

II. *The spermatogenesis of cattle* (pp. 377-398).—The number of chromosomes counted in spermatogonial divisions was 33. The odd chromosome stained as a chromosome nucleolus, and could be traced throughout the growth stage. It remained undivided at the first spermatocyte (reduction) division.

"In the testes of embryos and quite young animals the spermatogonia are divided by amitosis, and in such young individuals amitosis occurs more frequently than mitosis. Judging from their nuclear organizations and other structures, it is evident that the cells produced by amitosis are degenerating, being used as nutritive materials by the germ cells."

On cellulose digestion in vitro for the purpose of estimating the digestibility of feeds containing cellulose, P. WAENTIG and W. GIERISCH (*Hoppe-Seyler's Ztschr. Physiol. Chem.*, 107 (1919), No. 4-5, pp. 213-224).—The authors have studied the ability of the microflora of fluid from the cecum, colon, and feces of the horse to digest cellulose by comparing the digestive action in vitro of fresh untreated fluid with that of sterile fluid. Neither untreated pine wood meal nor hydrolyzed pine needles was digested by the bacteria, nor to any extent by experimental animals (species not stated). On the other hand sulphite paper pulp, rye straw meal, and rye straw pulp were digested in varying degrees in vitro and by animals. Unless there are marked differences between feeding stuffs in the extent to which their crude fiber is utilized by animals, the in vitro method does not seem to grade them accurately.

Kudzu feeding experiments, A. F. KIDDER (*Louisiana Stas. Rpt.* 1919, pp. 15, 16).—Three Hereford cows were maintained on an acre plat of kudzu for

30 days, a small amount of corn being fed to counteract any laxative effect. The cows rejected the tougher vines. "Probably the best way to pasture the plant would be to start in early spring when the first growth begins, and graze enough to prevent development of any large woody vines, the young shoots being very tender and well liked by the cattle."

It was also found that the chopped kudzu vines compared favorably with corn or soy beans as a soiling crop for dairy cows.

Pasture trials, M. J. THOMPSON (*Minnesota Sta., Rpt. Duluth Substa., 1918-19, pp. 22-24*).—Continuing work previously noted (E. S. R., 39, p. 474), progress reports on the use of cut-over stump land and pasture are presented.

In 1918 the fourth and final test of a project to study the butter fat producing value of the pasture was conducted. Three cows grazed five acres for 3.9 months, day and night, and produced 336.4 lbs. of butter fat valued at \$153.06. About 140 lbs. of grain valued at \$26.60 were fed. There was an average gain in weight of 43 lbs. per head.

In 1918 six heifers gained 175 lbs. per head during a pasture season of 129 days, and in 1919 eight heifers averaged 172 lbs. gain in 146 days. In 1918 and 1919 six horses were on pasture from June to September except during their working hours. In 1918 they increased somewhat in weight and in 1919 maintained their weight. Substantial saving in hay and labor by this method of management is noted.

Broom millet seed as feed for stock, H. WENHOLZ (*Agr. Gaz. N. S. Wales, 31 (1920), No. 5, pp. 305-307*).—The author reports that the grain shortage in New South Wales following a recent drought has resulted in the extensive use of broom corn ("broom millet") seed as a feed for live stock, particularly poultry. The seeds are fed whole to chickens and sheep, ground for horses and cattle, and soaked in water or skim milk for hogs. The seeds must be stored in a well ventilated barn to prevent heating.

Fish meal as stock food (*Live Stock Jour. [London], 92 (1920), No. 2414, pp. 56, 57*).—Cases are cited of the successful use of fish meal in calf feeding at Kilmarnock (E. S. R., 41, p. 572) and elsewhere. It is stated that British manufacturers have agreed to put on the market a "white fish meal" having a minimum of 55 per cent protein and a maximum of 5 per cent oil. It will contain not more than 4 per cent salt nor less than 16 per cent of lime phosphate.

Sugar in oat straw and cattle foods, S. H. COLLINS and A. SPILLER (*Jour. Soc. Chem. Indus., 39 (1920), No. 5, p. 66T*).—The authors report that oat straw cut green may have a sugar content in excess of 6 per cent (mostly invert sugar), while fully mature straw contains practically no sugar. Peanut cake contained 8.46 per cent of sugar and palm kernel cake 3.05 per cent; in neither case was there more than a trace of invert sugar. A knowledge of the sugar content of feeds is considered important, so that results secured with ordinary feeds rich in sugar will not be ascribed to the sugar in any condimental feeds that may also have been fed.

Feeds with public formulas, E. S. SAVAGE (*Cornell Countryman, 16 (1919), No. 2, pp. 71-73, 90, 92, 94, 96, fig. 1*).—At the time of writing there were being sold three ready-mixed dairy feeds compounded according to nonsecret formulas furnished by the New York State College of Agriculture, and formulas had been suggested for two other feeds not yet marketed. The State Grange and the Dairymen's League were active in initiating the project.

Analyses of commercial feeding stuffs and registrations for 1920, C. S. CATHCART (*New Jersey Stat. Bul. 342 (1920), pp. 5-62*).—The report is made on 826 samples of feeding stuffs collected under the State law in 1919. Data as

to the moisture, protein, fat, and fiber content of the following products are given: Alfalfa meal, brewers' dried grains, yeast dried grains, malt sprouts, buckwheat feed, buckwheat middlings, buckwheat offal, cocoa bean shell meal, coconut oil meal, cottonseed feed, cottonseed meal, corn oil meal, corn feed meal, corn gluten feed, corn gluten meal, corn and cob meal, hominy feed, dried beet pulp, linseed meal, oat hulls, rye bran, rye middlings, wheat bran, wheat middlings, red dog, wheat mixed feed, and various proprietary mixed feeds, calf meals, and poultry feeds. The moisture, protein, fat, and phosphoric acid in samples of meat scrap, fish scrap, digester tankage, and bone meal are also reported. The sample of cocoa bean shell meal analyzed contained about 15 per cent protein, 8 per cent fat, and 14 per cent fiber.

The prices of 20 feeding stuffs in 1920 and in the four preceding years are tabulated.

Inspection of commercial feeds, P. H. WESSELS (*Rhode Island Sta. Ann. Feed Circ.*, 1920, pp. 3-11).—This is a report on the protein and fat content of samples of feeding stuffs collected in 1919. The materials include cottonseed meal and feed, corn gluten feed, hominy feed, brewers' and other dried grains, wheat bran, wheat bran with screenings, wheat middlings, wheat shorts, oat hulls, rye feed, and various proprietary stock, calf, and poultry feeds.

Proceedings of the twenty-third annual convention of the American National Live Stock Association (*Amer. Natl. Live Stock Assoc. Proc.*, 23 (1920), pp. 191, pls. 10).—This publication contains the addresses made during the Spokane meeting in January, 1920, together with the committee reports presented and the texts of resolutions adopted. Proposed legislation regulating the meat-packing industry and the apportionment of grazing lands were the main topics discussed.

Loss of weight by live stock during transportation, KUPPELMAYR (*Ztschr. Fleisch u. Milchhyg.*, 30 (1919), Nos. 5, pp. 65-68; 6, pp. 81-85).—The author cites numerous data as to the shrinkage of cattle and sheep sent to market for slaughter, showing particularly the relation of shrinkage to duration of the trip.

Cattle feeding [at North Platte Substation] (*Nebraska Sta. Rpt.*, 1919, p. 26).—A group of 25 2-year-old grade Hereford steers maintained their weight for 80 days in winter on a ration of 15 lbs. of wheat straw and 1 lb. of cottonseed cake.

Value of elevator screenings in the ration, E. S. HAYTER (*Canada Expt. Farms, Seasonable Hints No. 17* (1920), pp. 11, 12).—A lot of eight steers fed elevator screenings during a fattening period of 114 days at the Morden, Manitoba, Experimental Station made an average daily gain of 1.77 lbs. per head, while a similar lot fed the same amount of oat chop gained 1.38 lbs. Each lot received equal amounts of corn silage, hay, and oat straw. The screenings contained high percentages of shrunken and broken wheat kernels and wild buckwheat seeds.

A defect of hair and teeth in cattle, probably hereditary, L. J. COLE (*Jour. Heredity*, 10 (1919), No. 7, pp. 303-306, figs. 5).—Three calves, all sired by the one Holstein bull, showed, respectively, two, three, and four incisors that were small in size and in one case conical in form. When young these calves and two others (whose teeth were not examined) sired by the same bull had very short hair on the neck and parts of the head. The bull, when examined at 3 years of age, had only five incisors, three on the left and two on the right side, all small in size. The dams are thought to have been normal, and a number of normal calves were sired by the bull.

It was recalled that the bull, when a year old, became very thin on pasture which kept other cattle in good condition.

Cattle in the [South African] Union.—The trade in beef (*Union So. Africa, Dept. Agr. Jour.*, 1 (1920), No. 3, pp. 278-280).—Statistics of the number of cattle in the four Provinces of the Union of South Africa, and the imports and exports of beef since 1903 are presented. Since 1915 imports have been negligible, while exports have greatly increased.

Managing sheep on North Dakota farms, W. F. LA GRANGE (*N. Dak. Agr. Col. Ext. Circ.* 35 (1920), pp. 23, figs. 14).—The purchase of stock, sale contracts, feeding for market, breeding and the care of pregnant ewes, wintering the flock, and pastures are discussed. There is a section on sheep diseases and parasites by D. McMahan.

A suggested plan for marketing Kentucky wool, J. R. HUMPHREY (*Ky. Agr. Col. Ext. Circ.* 79 (1920), pp. 11, fig. 1).—Wool auctions, regional or State, are advocated in place of county pools.

[Hog grazing in Louisiana], A. F. KIDDER and G. D. CAIN (*Louisiana Stas. Rpt.* 1919, pp. 16, 34).—At Baton Rouge the following results were obtained in a practical hogging-off test in 1919: (1) A 2-acre plat of corn and peas (estimated yield, 28 bu. corn and 5.5 bu. peas per acre) produced 620 lbs. of pork; (2) a 2.75-acre plat of sweet potatoes (55 bu. per acre) and 4.25 acres of corn (9.5 bu.) and soy beans (5 bu.) produced 1,423 lbs. of pork; and (3) a 2-acre plat of sweet potatoes (140 bu.) and 3.25 acres of soy beans (8 bu.) plus 12 bu. of corn produced 1,617 lbs. of pork. There were 35 hogs used and the feeding period lasted 83 days.

At the North Louisiana Substation, a group of 52 shotes and pigs gained 350 lbs. in a week on a 1.5-acre plat of cowpeas. A group of 50 shotes and pigs gained 700 lbs. in 24 days on 4.45 acres of corn yielding 25 bu. per acre.

[Hog feeding trials at the Scottsbluff Substation] (*Nebraska Sta. Rpt.* 1919, pp. 29, 30).—A lot of 10 shotes on a full feed of corn and with access to an acre of undivided alfalfa pasture gained 1,452 lbs. in 90 days, consuming 3.7 lbs. of corn per pound of gain. A second and third lot received a 2 per cent corn ration for the first 60 days, a heavier ration (increasing to 3 per cent) the next 30 days, and a full feed of corn the last 30 days. Lot 2 had access to an undivided plat of alfalfa and made a total gain of 1,133 lbs. during the 120 days. Lot 3 had access to a divided half acre plat of alfalfa and gained 1,168 lbs. in 120 days. Lots 2 and 3 required, respectively, 3.85 and 3.92 lbs. of corn for a pound of gain.

In a 2-year experiment it was found that shotes on Turkestan alfalfa consumed 3.06 lbs. of corn per pound of gain, while those on common alfalfa consumed only 2.91 lbs. Total gains were also less on the Turkestan plats, and it is concluded that the use of this variety for hog pastures is not economical although hogs show a decided preference for it. Similar results have recently been reported from the Huntley (Montana) Reclamation Project Experiment Farm (E. S. R., 43, p. 465).

A third experiment was a comparison of methods of preparing barley for pigs on alfalfa pasture. It took 3.29 lbs. of soaked whole barley or 2.77 lbs. of ground barley to produce a pound of gain.

Buying hog feeds cooperatively, R. C. ASHBY (*Swine World*, 8 (1920), No. 1, pp. 87, 88).—A summary of the cooperative purchases of hog feeds in 16 States. In some cases the buying was done through farm bureaus.

The Chinese hog and Poland Chinas, H. H. YAO (*Swine World*, 8 (1920), No. 1, pp. 63, 64).—The author presents a few notes on hog raising in China and predicts a demand for imported Poland China boars to grade up the native black hogs. Chinese hogs are not fattened previous to slaughter, partly because little grain is available for feeding purposes and partly because the public seem to prefer lean meat.

Kansas State Live Stock Registry Board, F. W. BELL (*Kansas Sta. Insp. Circ. 11 (1919), pp. 127*).—This publication contains a list of all the stallions licensed in Kansas during the calendar year 1919, the text of the State law requiring registration and licensing, a statistical discussion showing that in 1910 when the registration law went into effect only 40.8 per cent of the licensed stallions were pure bred whereas in 1919 the percentage was 67.4, and the proceedings of the annual meeting of the Kansas Horse Breeders' Association. The latter includes an address by G. M. Rommel, on The Horse Situation as I saw it in Europe (p. 10). European demand for American horses is prophesied.

[Sunflower silage and frozen fish for] poultry, M. J. THOMPSON (*Minnesota Sta., Rpt. Duluth Substa., 1918-19, p. 24, fig. 1*).—It is reported that sunflower silage forms a good winter substitute for green feed in poultry feeding. The sunflowers were ensiled in barrels, each holding about 350 lbs. Frozen fish was also fed successfully during the winter in place of meat scrap.

The value of soy bean meal as a feed for chicks, B. F. KAUPP (*Poultry Item, 21 (1919), No. 9, pp. 6, 7*).—The growth, feed consumption, and mortality records of nine broods of Buff Plymouth Rock chicks hatched at different dates in 1916 and fed a mash of soy-bean meal and sweet skim milk are reported. These chicks average 1.3 lbs. in weight at eight weeks, while two broods fed rolled oats and sweet skim milk average 1.15 lbs. It is concluded that soy bean meal can replace rolled oats in chick feeding.

Some practical data on the amount of feed required to produce a dozen eggs by hens of different breeds, B. F. KAUPP (*Poultry Item, 22 (1919), No. 2, pp. 5-7*).—The author averages by variety and year the annual feed consumption and egg production in 1915-16 to 1918-19 of flocks of Silver Campines, Wyandotte (3 varieties), Plymouth Rock (3 varieties), Buff Orpington, Black Spanish, Mottled Houdan, and White Leghorn hens at the North Carolina Experiment Station and gives one year's results with Rhode Island Reds. Averaging all the data it was found that 544 Campines and Leghorns consumed 74 lbs. of feed per hen per year and produced a dozen eggs on 9.8 lbs. of feed. The annual average consumption of the 414 birds of the large breeds was 67.6 lbs. and a dozen eggs were produced for every 12.1 lbs. of feed.

Breeding for egg production, C. H. BURGESS (*Michigan Sta. Quart. Bul., 2 (1920), No. 4, pp. 190-192, fig. 1*).—Improvement in winter egg production in three generations of selected Barred Plymouth Rocks and Single Comb White Leghorns is reported.

Egg-laying tests at Hawkesbury Agricultural College, eighteenth year's results, 1919-20, F. H. HARVEY and J. HADLINGTON (*Agr. Gaz. N. S. Wales, 31 (1920), No. 5, pp. 353-368, figs. 6; also in Dept. Agr. N. S. Wales, Farmer's Bul. 131 (1920), pp. 26, figs. 6*).—This is a discussion of the New South Wales contest concluded March 31, 1920. Monthly individual egg records are tabulated of 540 pullets. The testing of second-year hens, a feature of the previous contests (*E. S. R., 42, p. 874*), was abandoned, and the space thus made available was used to house a new section composed of standard-bred pullets, i. e., pullets bred by persons who had won prizes by exhibiting the breeds which they entered in the contest. The egg records of these pullets are considered very satisfactory.

Studies on the inheritance of egg-weight.—I, Normal distribution of egg-weight, P. HADLEY and D. W. CALDWELL (*Rhode Island Sta. Bul. 181 (1920), pp. 5-64, pl. 1, figs. 41*).—This bulletin deals primarily with the weights of the individual eggs laid year after year by an unselected flock of 39 White Plymouth Rock hens hatched in May, 1910. Two hens survived to lay in their eighth year. Incidental use is also made of some data secured from descendants of the flock.

There was a distinct tendency for each hen to lay eggs of characteristic size. The frequency curves of the weights of the eggs of individual birds were, in general, unimodal and are considered fairly symmetrical. A careful investigation was made of the variability of the first year records in order to determine the relationship between the standard deviations and the means. Standard deviations were positively correlated with the means and covered a wide range. The coefficients of variability covered a narrow range and their correlation with the means was substantially zero. Under the circumstances, therefore, the coefficient of variability was used throughout as a measure of variation.

The changes in the weights of eggs of the individual hen throughout the year were found to be fairly consistent. In the pullet year the eggs at first were small, but they gradually increased in size, reaching a maximum in April. They then decreased again, but later reached a second maximum in September. Seasonal changes in later years were similar to these, although the maxima became less marked in the course of time.

No certain relationship was found between body weights of the birds and the average weight or total weight of the eggs.

It is planned to deal with the relationship between egg weight and number of eggs in a subsequent publication of this series, but a practical application of the relationship between the spring and autumn maxima and the number of eggs has been noted from preliminary papers (E. S. R., 42, p. 770).

Methods of pedigree breeding at the Government Poultry Farm, R. R. SLOCUM (*Amer. Poultry Advocate*, 28 (1920), No. 8, pp. 435-437, figs. 8).—The pedigree hatching baskets and the chick-banding system in use at the U. S. Experimental Farm, Beltsville, Md., are described. The chick bands employed are No. 2 open pigeon bands. These are stamped in duplicate, one for each leg, and are transferred to the wings as permanent records after three weeks.

Culling equipment, MR. and MRS. G. R. SHOUP (*Washington Sta., West Wash. Sta. Mo. Bul.*, 8 (1920), No. 4, pp. 54-58, figs. 2).—The authors describe a sorting crate, herding screens, catching hook, catching net, and a drop curtain for the roosting closet—devices useful in catching chickens for culling, transfer to other quarters, etc.

The sorting crate (4 by 2 by 1.5 ft.) is composed of slats and wire netting, and one end forms a sliding door. The open end is applied to the hen opening of the poultry house, and the birds are driven in with the aid of the wire herding screens.

The relative position of yolks in eggs not turned for a period of three weeks, B. F. KAUPP (*Jour. Amer. Assoc. Instr. and Invest. Poultry Husb.*, 6 (1919), No. 3, pp. 22, 23, pl. 1; also in *Poultry Item*, 22 (1920), No. 6, pp. 9, 10, figs. 2).—The author reports the observation that the blastoderm does not adhere to the shell membrane when an egg is kept in a constant position for 20 days, and cites fertility and hatching tests with 700 eggs which indicate that the turning of eggs held for incubation is without definite influence on the percentage of dead germs.

The rate of growth of Single Comb White Leghorn chicks, B. F. KAUPP (*Jour. Amer. Assoc. Instr. and Invest. Poultry Husb.*, 5 (1919), No. 8, pp. 60-62).—The author repeats the growth data given in a previous paper (E. S. R., 39, p. 577), and discusses them with respect to the amounts of feed required per unit gain each week for the first eight weeks.

Poultry [experiments at the Nebraska Station] (*Nebraska Sta. Rpt. 1919*, pp. 11-13).—Progress reports are presented of (1) selection experiments to improve egg production and early maturity of pullets; (2) studies of the conditions influencing maturity, and (3) a study of the physical and chemical characteristics of feeds with reference to their palatability.

Maturity is measured by the age at which the first egg is laid. Breed averages for this age were determined as follows: Single Comb White Leghorn 205.5 days, Barded Plymouth Rock 239.2 days, and Single Comb Rhode Island Red 250 days.

Samples of cornmeal modified in flavor by the addition of different substances (water, acetic acid, sugar, epsom salts, or common salt) were offered to hens that had received no feed for 24 hours, and the amount of each consumed during a brief feeding period was observed. Consumption was found to be independent of the flavor to the human palate. The physical consistency, however, was found to be of importance in determining palatability. Neither moist ground rye nor moist wheat bran was particularly palatable to poultry, but a mixture of the two was consumed readily and this is attributed to a change in the physical condition. Whole rye was much less palatable than moist ground rye.

Poultry culture in Maine, past, present, and future, G. P. COFFIN ([*Maine*] *Dept. Agr. Bul.*, 19 (1920), No. 1, pp. 4-18, fig. 1).—The author presents a survey of current poultry practices in Maine, with historical notes.

Canadian farm poultry, M. A. JULI ([*Ste. Anne de Bellevue, Quebec*]: *Macdonald College*, 1920, pp. 94, figs. 97).—This manual deals with the breeding, feeding, housing, incubation, marketing, and sanitation problems of the farmer who produces eggs and dressed poultry. Plans for various types of poultry houses are given.

Export of South African eggs and poultry, year 1919, W. O. JOHN (*Union So. Africa, Dept. Agr. Jour.*, 1 (1920), No. 3, pp. 258-260).—Statistics of the eggs and poultry exported to Great Britain and to various African States from the Union of South Africa in 1919 are tabulated. This is the first year that poultry has been exported on a commercial scale.

Concerning rabbits, F. W. ARMS (*Washington Sta., West Wash. Sta. Mo. Bul.*, 8 (1920), No. 4, pp. 61-64).—The author reports practical feeding experiments with weanling rabbits (grades of the Flemish Giant and New Zealand Red breeds), and outlines the feeding routine followed at the station rabbitry.

When a wet mash of bran, ground barley, alfalfa meal, and linseed meal (2:3:4:1) was fed, or a variant of this in which 2 parts of beet pulp replaced 2 parts of alfalfa meal, the gains were slow and expensive, due largely, it is thought, to the absence of dry roughage. Each mixture was fed to 6 rabbits for 55 days, and about 5 lbs. of the first mixture was required for a pound of gain.

In another comparison, lasting 40 days, one lot of 6 animals gained 45.5 lbs. on 105 lbs. of a mixture of beet pulp, bran, and corn meal (1:1:1), and 47 lbs. of dry alfalfa meal, while a similar lot gained 49 lbs. on 120 lbs. of beet pulp, bran, and oats (2:3:2), and 65 lbs. of alfalfa hay. In each case the animals had all the alfalfa they would eat.

In 36 days 17 3-lb. rabbits gained 42.75 lbs. on 129 lbs. of a mash of alfalfa meal, beet pulp, oats, bran, and corn meal (1:1:2:2:1), and 67 lbs. of alfalfa hay. The first three ingredients of the mixture were soaked over night and added to the bran and corn before feeding.

DAIRY FARMING—DAIRYING.

Studies in milk secretion.—V, On the variations and correlations of milk secretion with age, J. W. GOWEN (*Genetics*, 5 (1920), No. 2, pp. 111-188, figs. 9).—This is a biometrical study of the total milk yields in the first eight months of each lactation of the cows in a Jersey herd where the production records date back to 1897. The foundation stock were Island cattle, and the

herd, which is located in western Virginia, has been under a uniform system of management and apparently selection on a basis of yield has not been extensively practiced. Records of 1,741 lactations were used in the study.

The data showing the change in production with age were fitted by the method of least squares to an equation of the type previously used by Pearl and his collaborators for similar data, the equation in this case being

$$y = 3387.912 - 99.883x - 0.487x^2 + 2896.219 \log_{10}x$$

where y is the 8-months milk yield in pounds and the age in years equals $1.25 + 0.5x$. According to this formula the age of maximum yield is 7 years 2.4 months. Since similar equations have been used successfully to describe growth changes, it is suggested that the change in milk yield with age is due to growth of the udder.

Pearson's generalized probability curves were fitted to the frequency distribution of each age. Eight of the nine curves belonged to types I or II, and since they were not markedly unsymmetrical it was found that the distribution could also be satisfactorily graduated by the normal curve—a result which justifies the procedure of Rietz (*E. S. R.*, 22, p. 278) in estimating the "tail frequencies" of advanced registry data (i. e., the records eliminated through the requirement of minimum production for entry) by means of the normal curve.

The last sections of the paper deal with the mutual correlations of the different lactation records of a cow and also the correlation between particular lactation records and the total of the first five lactations. The general results have been noted from the author's abstract in *Maine Station Bulletin* 283 (*E. S. R.*, 43, p. 174).

The variation of milk secretion with age in Jersey cattle, J. W. GOWEN (*Maine Sta. Bul.* 286 (1920), pp. 49-60).—This is an abstract of the preceding publication with the exception of the material in the last sections.

Rules for testing dairy cows for advanced registration, J. B. FITCH and F. W. ATKESON (*Kansas Sta. Circ.* 82 (1920), pp. 12, fig. 1).—Includes breed regulations and rules for supervisors.

Sunflower silage (*Michigan Sta. Quart. Bul.*, 2 (1920), No. 4, pp. 163, 164).—Sunflowers chopped and put in a silo with corn silage above and below were fed the following winter to dairy cows. During a week of sunflower silage feeding, the milk produced by 24 cows was 11.65 per cent lower than the yield in the previous week when corn silage was fed. There was some recovery in the third week when both kinds of silage were fed in equal amounts, but a return almost to the sunflower silage level in the fourth week when corn silage alone was fed. "In this feeding trial sunflower silage compared very unfavorably with corn silage. However, the drop in milk flow when the cows were changed from the mixed corn and sunflower silage to clear corn silage would indicate that the mixture may be preferable to straight corn silage, and work along this line will be continued during the coming season."

Wild sunflowers for silage, J. B. FITCH (*Breeder's Gaz.*, 78 (1920), No. 7, p. 254).—Wild sunflowers in full bloom were cut at the Kansas Experiment Station and "put into a silo between layers of corn silage." The material was fed to dairy cows in place of corn silage, but they ate it sparingly, declined in milk, and lost in weight. Part, at least, of the poor success is attributed to the late cutting.

Silage crops [at the Scottsbluff Substation] (*Nebraska Sta. Rpt.* 1919, p. 28).—It is stated that a comparison between corn and sunflowers as silage crops is under way. "The silage made from sunflowers is less desirable than that made from corn. Dairy cows eat this silage fairly well, however, and their milk flow seems to hold up nearly as well as on corn silage."

A study of the factors involved in producing milk in North Carolina, S. COMBS and J. B. BAIN (*N. C. Dept. Agr. Bul., 41 (1920), No. 5, pp. 30, figs. 2*).—This is a study of the cost of producing market milk for small cities in Guilford and Forsyth Counties, conducted by the North Carolina Experiment Station in cooperation with the Dairy Division of the U. S. Department of Agriculture. The survey was begun in August, 1915, and lasted two years. Field agents paid monthly visits to 13 farms the first year and 14 farms the second. The records cover 557 cow years. The average production per cow was 4,908 lbs. of milk the first year and 4,922 lbs. the second. The following table summarizes the main results for the two years:

Miscellaneous expenditures and amounts of feed and labor required for milk production in North Carolina.

Basis of computation and season.	Mill feed.	Home-grown grain.	Le-gume hay.	Other hay.	Stover and fodder.	Silage, etc.	Human labor.	Horse labor.	Bed-ding and pas-ture costs.	Mis-cellan-eous costs. ¹	Cred-its for calf and ma-nure.
Per cow:	<i>Lbs.</i>	<i>Lbs.</i>	<i>Lbs.</i>	<i>Lbs.</i>	<i>Lbs.</i>	<i>Lbs.</i>	<i>Hrs.</i>	<i>Hrs.</i>	<i>\$</i>	<i>\$</i>	<i>\$</i>
November to April	1,394	40	494	1,275	176	4,499	173.2	44.0	\$0.48	\$13.30	\$11.48
May to October....	1,161	19	189	344	366	2,121	163.1	42.7	4.99	12.07	8.57
Entire year.....	2,555	59	683	1,619	542	6,620	336.3	86.7	5.47	25.37	20.05
Per 100 lbs. milk:	<i>Lbs.</i>	<i>Lbs.</i>	<i>Lbs.</i>	<i>Lbs.</i>	<i>Lbs.</i>	<i>Lbs.</i>	<i>Hrs.</i>	<i>Hrs.</i>	<i>Cts.</i>	<i>Cts.</i>	<i>Cts.</i>
November to April	56.2	1.6	19.9	51.5	7.1	181.5	7.0	1.8	2.0	53.7	46.3
May to October....	47.6	.8	7.8	13.9	15.2	87.0	6.7	1.8	20.5	49.5	35.2

¹ Excluding changes in inventory values of cows.

The cost of feed and pasture totaled 54.8 per cent of the gross cost, labor 28.6 per cent, and miscellaneous charges (including bedding) 16.6 per cent. Credits formed 12.2 per cent of the gross cost and appreciation in value of cows 3.4 per cent. A managerial charge is not included in this computation. In the winter 50.3 and in the summer 46.7 per cent of the labor used was employed for milk production; the rest was used for cooling, bottling, and distributing the milk. About 18 per cent of the labor was done by women and children winter and summer.

The feed and labor requirements per 100 lbs. of milk on a year basis, noted from a preliminary report (*E. S. R., 43, p. 469*), are not repeated in the final publication.

Requirements and cost of producing market milk in northwestern Indiana, J. B. BAIN and R. J. POSSON (*U. S. Dept. Agr. Bul. 858 (1920), pp. 31, figs. 8*).—This study of the cost of producing milk in Porter County, Ind., for the Chicago market extended over the same period as the North Carolina study noted above and was conducted according to the same general plan, the Dairy Division cooperating with the agricultural extension service of Purdue University.

In 1915-16 records were secured from 334 cows in 16 herds with an average production of 6,877 lbs. of milk. In the following year there were records of 404 cows in 21 herds and the average production was 6,987 lbs. The butter-fat test averaged about 3.7 per cent. There was about the same proportion of dry cows (12 or 13 per cent) in summer and winter. The calf crop was 87 per cent a year divided equally between winter and summer.

The table following gives the main results and shows the influence of season of year.

Miscellaneous expenditures and amounts of feed and labor required for milk production in Indiana.

Basis of computation and season.	Mill feed.	Home-grown grain.	Legume hay.	Other hay.	Stover and fodder.	Silage, etc.	Human labor.	Horse labor.	Bedding and pasture costs.	Miscellaneous costs. ¹	Credits for calf and manure.
Per cow:	<i>Lbs.</i>	<i>Lbs.</i>	<i>Lbs.</i>	<i>Lbs.</i>	<i>Lbs.</i>	<i>Lbs.</i>	<i>Hrs.</i>	<i>Hrs.</i>			
November to April	707	659	887	862	616	5,224	90.1	8.9	\$1.31	\$13.07	\$21.44
May to October....	491	187	536	278	116	2,042	74.4	7.4	10.49	12.79	6.99
Entire year.....	1,198	848	1,424	1,143	734	7,276	164.5	16.2	11.80	25.91	28.43
Per 100 lbs. milk:	<i>Lbs.</i>	<i>Lbs.</i>	<i>Lbs.</i>	<i>Lbs.</i>	<i>Lbs.</i>	<i>Lbs.</i>	<i>Hrs.</i>	<i>Hrs.</i>	<i>Cts.</i>	<i>Cts.</i>	<i>Cts.</i>
November to April	20.0	18.6	25.1	24.3	17.4	147.6	2.5	0.3	3.7	36.8	60.5
May to October....	14.5	5.5	15.8	8.2	3.4	60.1	2.2	.2	30.8	37.5	20.6

¹ Excluding changes in inventory values of cows.

The figures for bedding and pasture costs and the credits given in the table are the averages of the two years as reported by the authors, and were computed to provide more direct comparison with the North Carolina data. The bedding charges apply exclusively to the winter season and the pasture charges to the summer.

On a year basis the percentage distribution of the items in the gross cost was as follows: Feed 49.4, pasture 8.2, labor 19.5, miscellaneous 21.6, and depreciation on cows 1.3. No charge was made for managerial ability. The allowance for calves was 6.8, and for manure 15.5 per cent of the gross cost plus depreciation. In the winters 80 per cent, and in the summers 76.5 per cent of the labor was used for production of milk, as distinct from handling and hauling. Women and children performed 15 per cent of the total labor in the winter, and over 19 per cent in the summer.

The production of clean milk and cream for industrial purposes, J. POSTMA (*Loleta, Calif.: Author, 1920, pp. 55, figs. 9*).—This booklet is designed as a nontechnical guide for dairymen and milkers in the production of clean milk and cream. It emphasizes particularly the necessity of a high grade of raw product in dairy manufacturing, and gives directions for the proper use and care of appliances on the farm.

Milking machines: V, The production of high grade milk with milking machines under farm conditions, J. W. BRIGHT (*New York State Sta. Bul. 472 (1920), pp. 27, pls. 4, figs. 6*).—The author describes the degree of success attained with milking machines on three farms furnishing milk to Geneva, the city's milk supply being under the control of the station staff. Milk from two of the farms was unsatisfactory from a sanitary standpoint, and visits to the farms revealed in one case, imperfect cleaning of the metal parts of the milker, and in the other, poor sterilization of the teat cups and rubber parts, and inadequate cooling of the milk. When these faults were corrected a good grade of milk was produced. On the third farm the dairyman, upon installing a machine, adapted the station's cleaning methods to his own conditions so successfully that he has maintained an almost perfect record for producing milk of low germ content.

The previous studies in this series have been noted (E. S. R., 41, p. 277).

Observations on milking machine, M. J. THOMPSON (*Minnesota Sta. Rpt., Duluth Substa., 1918-19, p. 25*).—Records are cited showing increased yields of milk after the installation of a milking machine at the Duluth Substation.

The straining cloth and bacterial contamination of milk, R. R. ASHWORTH and W. F. LANDON (*Milk Dealer, 9 (1920), No. 7, p. 50*).—Cloths in use for

straining milk sent to the District of Columbia were collected after the usual farm cleaning and examined bacteriologically. Counts of total bacteria ranged from 6,000 to 430,000,000 per 0.01 sq. ft. Colon organisms and streptococci were numerous in many cases.

Number of bacteria on the lips of milk bottles and their significance, R. S. DEARSTYNE and C. L. EWING (*Amer. Jour. Pub. Health*, 10 (1920), No. 6, pp. 533-535).—Counts are recorded of the number of bacteria collected (by swabbing) from the rims of 50 bottles of pasteurized milk delivered to consumers in Baltimore, Md., and 50 bottles of raw milk delivered in Alexandria, Va. Half the Baltimore samples bore over 5,000 bacteria, and half those from Alexandria over 50,000 bacteria. The hands of deliverymen, dust from the air, flies, cats, and dogs are listed as sources of contamination.

The accuracy of bacterial counts from milk samples, R. S. BREED and W. A. STOCKING, JR. (*New York State Sta. Tech. Bul.* 75 (1920), pp. 3-97).—Three series of parallel bacteriological analyses of milk samples by workers at Geneva and Ithaca are reported. Results from two of the series have been noted from a preliminary report (*E. S. R.*, 38, p. 579). In the third series, which was mainly a repetition of the second (the samples being inoculated with a colon organism), a still greater uniformity was secured both in the plate counts and in the direct counts with a microscope.

There was a close agreement between the microscope counts of isolated groups (clumps) of one or more organisms and the agar plate counts. "The average number of individuals in the clumps of bacteria present commonly varied between two and six, but at times (when streptococci were present) greatly exceeded these numbers. As the data indicate that the clumps are only very poorly broken apart in the processes ordinarily used in preparing dilution waters, the plate counts did not represent the full number of bacteria present."

The lactic acid bacteria, S. O. JENSEN (*K. Danske Vidensk. Selsk. Skr., Naturvidensk. og Math. Afd.*, 8. ser., 5 (1919), No. 2, pp. 81-196, pls. 51).—This is an elaborate monograph (written in English) on the lactic acid bacteria, emphasizing particularly the cultural features and the sources of energy and nutriment utilized by the species considered. It is based on 10 years' work and the cultivation of 330 strains isolated from dairy products, animal feces, and plant materials.

The lactic acid bacteria are considered a natural group composed of immotile, sporeless, Gram-positive, rod- and sphere-forms, which are lacking in catalase and which in fermenting sugar form chiefly lactic acid. Whether the lactic acid is dextrorotatory or laevorotatory is found to be an important diagnostic character, since the optical properties are not influenced by the kind of sugar fermented. Five genera (*Thermobacterium*, *Streptobacterium*, *Betabacterium*, *Streptococcus*, and *Betacoccus*) comprising 22 species are recognized as true lactic acid bacteria, and two genera (*Microbacterium* and *Tetracoccus*) are regarded as closely related. Except for *Streptococcus*, which is redefined, these generic names are new. A number of changes in the designation of species are also introduced.

The true lactic acid bacteria are incapable of breaking down uncombined amino acids, and relatively few have marked proteolytic action. "The cocci which split up casein decompose it gradually through peptones to amino acids; the casein-splitting rod forms, however, peel off the mono-amino acids from the casein molecule without previous formation of peptone. From the peptones, the lactic acid bacteria appear to form a quantity of polypeptids, which are not precipitated by phosphotungstic acid."

When cultivated in milk many of the lactic acid bacteria were observed to produce slime, particularly at low temperatures, through the swelling up of the more or less distinct capsules surrounding the cells at certain stages of the culture. *Streptococcus cremoris* (new name), the distinctive organism in starters used in butter making, also produced ropy milk. The best strains of *S. cremoris* for butter making seem to have the least power of fermenting saccharose, maltose, and dextrin.

Some results with experimental cheeses made from practically germ-free milk inoculated with pure cultures of lactic acid bacteria are briefly reported. In all cases putrefactive fermentations were greatly reduced. *Streptobacterium casei* (= *Bacterium casei* a) was the most satisfactory when high temperatures are not used in the process of manufacture, with *Streptococcus lactis* (= *S. lactions*) and *S. cremoris* next in value. *Tetracoccus liquefaciens* (= *Micrococcus casei liquefaciens*) made the cheese rather soft and imparted a flavor resembling "Danish Swiss" or "Russian Steppe" cheese. For cooked cheese, previous results indicating the value of *Thermobacterium helveticum* (= *Bacterium casei* e) are confirmed. The thermobacteria are characterized by ability to withstand heat.

Relation between lactic acid production and bacterial growth in the souring of milk, J. C. BAKER, J. D. BREW, and H. J. CONN (*New York State Sta. Tech. Bul.* 74 (1919), pp. 24, figs. 5).—Two samples from the same cow of pasteurized skim milk low in bacteria were each inoculated with a different culture of *Streptococcus lacticus* and incubated at 25° C. Determinations of acidity and number of bacteria were made at hourly or half-hourly intervals through 10 hours, beginning 15 hours after inoculation. Less systematic observations were made at later periods, and some supplementary data were secured from other cultures.

In one case the expected increase in number of bacteria (a doubling every generation) was approximately realized, but in the other case the rate of multiplication was much slower and remained fairly constant throughout the period of systematic observation. This behavior is attributed to the attenuated nature of the original culture (an old butter starter); the milk was not curdled in 24 hours, and it is thought that many of the organisms had lost the power of growth.

In each case the amount of acid produced was approximately proportional to the number of bacteria present. In a vigorous culture an individual cell produced between 5×10^{-10} and 10×10^{-10} mg. of lactic acid per hour. The much higher average figure (18×10^{-10}) given by Rahn (*E. S. R.*, 26, p. 708) is deemed subject to correction, since it is based on plate counts. The authors' deductions are drawn entirely from direct microscope counts, although plate counts were made for comparison. The former averaged 1.8 times the latter, and the latter were approximately equal to the estimated number of isolated groups counted by the microscope.

At the time of curdling, the milks contained several billion bacteria per cubic centimeter. The rate of multiplication became slower after coagulation and acid formation declined.

Determination of keeping quality of milk, L. H. COOLEGE (*Michigan Sta. Quart. Bul.*, 2 (1920), No. 4, pp. 168, 169).—The author cites data illustrating the value of the milk scoring method of Coolege and Wyant (noted on p. 615) in estimating the keeping quality of milk samples.

The question of city milk distribution, F. L. THOMSEN (*Hoard's Dairyman*, 59 (1920), No. 8, pp. 453, 467-470, figs. 3).—Eleven plans for the distribution of milk in cities are outlined.

City milk plants: Construction and arrangement, E. KELLY and C. E. CLEMENT (*U. S. Dept. Agr. Bul. 849 (1920), pp. 35, figs. 15*).—The authors present a series of suggestions for the location of milk plants, the construction of the building, and the internal arrangements, and cite illustrative data secured from milk plants throughout the country as to the economy in labor, time, and space of different layouts and operating schemes. Considerable emphasis is placed on sanitary requirements.

It was not found economical to have wagons or trucks enter the building to deliver incoming milk, to be loaded with bottles, or to return empty bottles, and outside sheltered platforms for these purposes are recommended. The bottled milk may advantageously be transferred from the storage room to the exterior through chutes. Usually a considerable saving of time and labor occurs when incoming milk is dumped and then pumped to the receiving tank instead of being raised by conveyors or elevators.

A cooperative milk delivery plant, E. BROWN (*Hoard's Dairyman, 60 (1920), No. 4, pp. 109, 119, figs. 2*).—An account of a cooperative milk plant organized in 1918 by farmers delivering milk to Greenville, Pa.

Cooperative creameries in Minnesota, N. RADDER (*Hoard's Dairyman, 59 (1920), No. 8, p. 478*).—The author cites the data published in Bulletin 184 of the Minnesota Experiment Station (E. S. R., 42, p. 391), showing the success in 1917 of cooperative creameries in comparison with proprietary and centralizer creameries, and quotes a statement by A. J. McGuire indicating greatly increased business since then by the cooperative concerns, of which there were 630 in operation in the State in 1919.

The permit system of cream buying, revised by H. M. JONES, L. D. BUSHNELL, and J. B. FITCH (*Kansas Sta. Insp. Circ. 9 (1919), pp. 7-57, figs. 24*).—This is a revised edition of Bulletin 184 (E. S. R., 29, p. 879). A section on cream grading has been added, and that dealing with bacteriology has been extensively modified.

Sixth annual report of the creamery license division for the year ending March 31, 1920, O. E. REED and T. H. BROUGHTON (*Indiana, Sta. Circ. 97 (1920), pp. 3-16, figs. 2*).—This report differs from preceding ones (E. S. R., 41, p. 777) in the omission of the names of testers licensed, and the condensing of the list of licensed manufacturing plants. The statistical data are revised to include the year 1919.

Preservation of butter for long periods by means of dehydrated butter fat, T. PAUL (*Landw. Jahrb. Bayern, 7 (1917), No. 1, pp. 83-87*).—A method of dehydrating butter with sodium chlorid, previously noted (E. S. R., 39, p. 282), is outlined. The simplicity of the process and its utility on small dairy farms are emphasized.

Leaky butter, E. H. FARRINGTON (*N. Y. Prod. Rev. and Amer. Creamery, 47 (1919), No. 25, pp. 988, 990, 992, 993*).—This paper, read at a meeting of the Wisconsin Buttermakers' Association, includes some detailed experimental data as to the causes of leakiness secured at the Wisconsin Experiment Station and not otherwise reported. Conclusions drawn from this investigation have been noted (E. S. R., 42, p. 377).

[**British cheese making**] (*Min. Agr. and Fisheries [London], Leaflet, 1920, Nos. 336, pp. 6; 337, pp. 4; 338, pp. 4; 339, pp. 4; 340, pp. 4*).—Leaflet 336 consists of general instructions for cheese makers, and the others give directions for making Cheddar, Caerphilly, Lancashire, and Cheshire cheese, respectively.

VETERINARY MEDICINE.

Veterinary materia medica and therapeutics, K. WINSLOW (*Chicago: Amer. Vet. Pub. Co., 1919, 8. ed., rev., pp. 640, figs. 22.*)—This edition of the work previously noted (*E. S. R., 36, p. 675*), which is bound in flexible leather, has been wholly revised and reprinted. It is in accord with the ninth edition of the U. S. Pharmacopœia (*E. S. R., 36, p. 378*), and contains a section on biological therapy by A. Eichhorn (*pp. 525-563*). The matter on anthelmintics has been revised by M. C. Hall.

Veterinary education and research in South Africa, A. THEILER (*Union So. Africa, Dept. Agr. Bul. 5 (1920), pp. 6; also in Vet. Jour., 76 (1920), No. 543, pp. 326-331.*)—This is an address delivered by the Director of Veterinary Education and Research at Pretoria, on April 9, 1920, on behalf of the newly founded veterinary faculty of Transvaal University College.

Report of the New York State Veterinary College for the year 1918-19 (*Rpt. N. Y. State Vet. Col., 1918-19, pp. 222, pls. 17, figs. 15.*)—Papers presented in this report include the following: Researches in Regard to Immunizing Young Pigs, by R. R. Birch (*pp. 73-90*); Researches in the Disease of Breeding Cattle, with Observations upon the Diseases Interfering with Reproduction in Sheep and Swine, by W. L. Williams and C. M. Carpenter (*pp. 91-92*); A Standard for Measuring the Reproductive and Dairy Efficiency of Cattle (*pp. 92-101*); The Experimental Evidence of the Power of *Bacillus abortus* of Bang to Cause Abortion (*pp. 101-109*); The Nature of Contagious, Infectious, or Epizootic Abortion in Cattle (*pp. 110-115*); Cervicitis (*pp. 116-121*), Death and Maceration of Fetuses of Swine (*pp. 122-124*), and Diseases of the Genital Organs of Sheep Associated with Abortion (*pp. 125-128*), all by W. L. Williams; Differential Features between Melanosis and Melanosarcoma, by S. A. Goldberg (*pp. 158-182*); Experiments on the Intradermal Test for *Bacterium pullorum*, by M. Scherago and J. P. Benson (*pp. 183-191*); and the Bovine Tuberculosis Problem, by V. A. Moore (*pp. 192-217*).

Proceedings of the Wisconsin Veterinary Medical Association, edited by F. B. HADLEY (*Proc. Wis. Vet. Med. Assoc., 5 (1920), pp. 129, figs. 2.*)—Among the papers here presented are the following: Hog Cholera v. Hemorrhagic Septicemia, by J. T. Purcell (*pp. 52-57*); Practical Hints for Vaccinating in the Field, by L. B. Huff (*pp. 50-60*); Necrophorus Infection of Swine, by B. A. Beach (*pp. 61-63*); Collecting and Shipping Veterinary Specimens for Laboratory Examination, by F. B. Hadley (*pp. 64-79*); Sterility of Cows and its Treatment, by H. Lothe (*pp. 86-101*); The Intradermal Test and Tuberculosis Eradication, by O. H. Eliason (*pp. 106-111*); and Accredited Herd Testing, by J. S. Healy (*pp. 111-117*).

Experiments with iodine-neol preparations, DORNIS (*Ztschr. Veterinärk., 32 (1920), No. 2, pp. 27, 28.*)—A substitute for iodine as a disinfectant is described consisting of a solution of one part of free iodine and three parts of a compound of iodine with ricinoleic acid. This mixture is insoluble in water, difficultly soluble in alcohol, and readily soluble in ether-alcohol, ether, chloroform, carbon disulphid, and essential and fatty oils. The iodine-neol is dispensed either as a powder, in a sterilized bolus with talc, as a tincture in ether-alcohol, or incorporated in a soap salve.

The author has demonstrated the value of the iodine-neol bolus in wounds for which an open dressing is indicated. As an antiseptic under permanent dressings, as in the case of hoof operations, the tincture is preferred. The latter in concentrated form is recommended as a mild caustic, and, diluted with one or two parts of alcohol, as a disinfectant for infected wounds of all kinds.

It is also recommended for skin disinfection before operations and in the treatment of skin diseases of parasitic and nonparasitic nature.

The use of normal horse serum inoculation in the treatment of sepsis, E. EMBYS-ROBERTS (*Jour. Roy. Army Med. Corps*, 34 (1920), No. 4, pp. 321-334, figs. 4).—A number of case reports are given indicating the value of subcutaneous or intramuscular injections of normal horse serum in the treatment of human septic wounds. In discussing the nature of the underlying factor or factors responsible for the encouraging results following this treatment, the hypothesis is suggested that the inoculation of the serum results in an increased production of complement or complementogen, which is immediately used up in some process resulting in the improved condition of the patient.

On the toxin for leucocytes produced by streptococci (Streptoleucocidin), Y. NAKAYAMA (*Jour. Infect. Diseases*, 27 (1920), No. 1, pp. 86-100).—"Streptococci, like certain other bacteria, produce a toxic substance—apparently a toxin—that destroys leucocytes. In serum-broth medium the largest amount of streptoleucocidin is produced in from 10 to 24 hours; after that the production falls. The largest amount of leucocidin was obtained in broth with goat serum and horse serum, the next largest amount with rabbit serum, while guinea pig serum gave the least. There is a definite relation between the volume of production and virulence—virulent streptococci produce more leucocidin by far than avirulent, which may produce none at all.

"Streptoleucocidin is rendered inactive when heated to from 58 to 60° C. for 30 minutes, and it is an unstable substance. Once rendered inactive it can not be made active again by the addition of small quantities of fresh leucocidal culture fluid. The leucocidin and leucocytes unite at room temperature as well as in the ice box.

"Normal serum and leucocytic extract possess antileucocidal action; this antiaction is lost when the fluids are heated at 70° C. for 30 minutes. It seems difficult to produce antileucocidal effects by immunizing rabbits with streptococci, but easier by injecting leucocidal culture fluids. Antileucocidal immune serum not only exercises antileucocidal action against homologous and heterologous streptoleucocidin, but also possesses strong opsonic powers, rendering virulent streptococci, homologous as well as heterologous, easily phagocytatable. Streptoleucocidin appears to be distinct from streptolysin, and anti-streptoleucocidin does not neutralize staphyloleucocidin."

Some observations on the constitution of the complements of different animals, T. J. MACKIE (*Jour. Immunol.*, 5 (1920), No. 4, pp. 379-389).—"These experiments elicit striking differences in the constitution of the complements of different animals apart from their relative activity with hemolytic immune body and venom. In the case of human and rabbit's serum acting on ox red blood corpuscles, plus immune body venom, the complement is entirely associated with the globulins of the serum, while in the case of guinea pig's serum, which represents with these hemolytic systems a much more powerful complement, the albumin fraction is also an essential constituent of the complement. Whether the potency of a complement depends on the presence of constituents associated with the serum albumin is a matter for further investigation. In the case of human and rabbit's sera, however, acting with venom, the effect of the globulin is 'masked' in the whole serum by the albumin, while in the case of guinea pig's serum the albumin also contributes to the full action of the serum along with the globulin. It has also been shown how the albumin of human and rabbit's serum may inhibit the action of guinea pig's serum globulin. In the case of horse's serum, the activating effect with venom is due not only to

a complement body represented by the globulin but also to the lecithin contained in the albumin fraction."

Anaplasms and anaplasmosis (*Vet. Rev.*, 4 (1920), No. 2, pp. 160-164).—Six recent papers on the subject are here reviewed.

Blackleg infection by ingestion, V. RONCA (*Clin. Vet. [Milan], Rass. Polizia Sanit. e Ig.*, 43 (1920), No. 7-9, pp. 195-210).—This is the report of a series of experiments undertaken to determine the possibility of blackleg infection through ingestion of the causative organism, with a view to ascertaining the possible dangers of blackleg infection through feeding in infected pastures. The investigation included a series of experiments in vitro to determine the effect of the digestive juices on the virus and in vivo to determine the action of the virus when introduced into the gastro-intestinal tract.

The digestive juices (gastric, intestinal, pancreatic, and bile) of cows, swine, guinea pigs, asses, and dogs had no effect in vitro on the virulence of the bacilli and spores of blackleg.

Experimental blackleg infection of guinea pigs was successful only with the use of massive doses of high virulence. By direct introduction into the intestines of a solution of lactic acid followed by blackleg virus the disease was easily produced. The organisms thus introduced, entering into the circulation, became localized by preference in the testicles, which showed the characteristic changes of the infective process.

The author concludes that under certain favorable conditions blackleg infection may be brought about by ingestion of the virus, which, unaltered by passage through the stomach, may gain access to the circulation through some vulnerable point in the intestinal cell walls.

Epizootic lymphangitis (*Vet. Rev.*, 4 (1920), No. 2, pp. 149-151).—This is a review of four recent papers on the subject.

A new immunity reaction, E. MEINICKE (*Deut. Med. Wchnschr.*, 45 (1919), No. 30, pp. 821, 822).—This is a brief description of the lipid-fixation reaction for glanders previously noted. (*E. S. R.*, 43, p. 278).

Bacilli of the hog cholera group (*Bacillus cholerae suis*) in man, C. TENBROECK (*Jour. Expt. Med.*, 32 (1920), No. 1, pp. 33-40).—This report of investigations by the Department of Animal Pathology of the Rockefeller Institute for Medical Research at Princeton, N. J., has been summarized as follows:

"The organisms isolated by Hirschfeld from febrile cases resembling paratyphoid fever and named Paratyphoid C can be placed in the hog cholera bacillus group by their agglutination absorption properties though they are not typical culturally. When fed to a pig a febrile disease resulted from which the animal recovered. After injection of hog cholera virus the organisms fed were found generally distributed, and some of them had lost cultural characters so that they are brought into the class of typical hog cholera bacilli except for their low virulence for rabbits. While hog cholera bacilli have many opportunities to infect man, they either are not able to grow in the human body or, what is less likely, they do grow and lose the characters that distinguish them."

Vaccination against sheep pox with sensitized virus in the department of Bouches-du-Rhône (France), E. CANABY (*Rec. Méd. Vét.*, 95 (1919), No. 14, pp. 243-248; *abs. in Trop. Vet. Bul.*, 8 (1920), No. 1, pp. 61, 62).—Statistics are given from the author's experience indicating the success of the method of Bridré and Boquet (*E. S. R.*, 29, p. 680) of vaccination against sheep pox with sensitized virus.

Etiological studies in tuberculosis, L. BROWN, S. A. PETROFF, and G. PESQUERA (*Amer. Rev. Tuberculosis*, 3 (1919), No. 10, pp. 621-630).—In these studies

an examination has been made of possible avenues of transmission of the tubercle bacillus as determined by microscopic examination of culture media inoculated from the material under examination, and by tuberculous infection in guinea pigs inoculated with the same cultures.

Negative results were obtained with cultures from the dust of rooms in which tuberculous patients were living, the mouthpiece of a telephone used in common by the patients at a tuberculosis sanitarium, washings from contaminated hands and door knobs, and food contaminated by infected flies. Positive results were obtained from unwashed eating utensils and from previously sterile dishes kissed by tuberculous patients.

The bacteriological characteristics of tubercle bacilli from different kinds of human tuberculosis, A. S. GRIFFITH (*Jour. Path. and Bact.*, 23 (1920), No. 2, pp. 129-152).—This report gives the results of further investigations of the types of tubercle bacilli in human tuberculosis, in continuation of studies some of which have been previously noted (*E. S. R.*, 37, p. 378). The cases examined include tuberculous meningitis, pulmonary tuberculosis, miscellaneous cases, and scrofuloderma. The main objects of the investigation were to determine the relative proportions of the human and bovine types of tubercle bacilli in different kinds of human tuberculosis, and the frequency of occurrence and the distribution in the human body of various strains of tubercle bacilli.

Of the 12 cases of tuberculous meningitis examined, 10 were caused by the human type and 2 by the bovine type of tubercle bacilli. The cow's milk which was being supplied to one of the bovine cases proved to contain virulent bovine tubercle bacilli identical with the strain from the meningitis of the child.

Of the organisms isolated from 17 cases of pulmonary tuberculosis 16 proved to be of the human type and 1 of a variety of tubercle bacilli recently found in various kinds of human tuberculosis and differing in certain respects from both standard bovine and human tubercle bacilli.

The miscellaneous cases included 3 of bone and joint and 8 of glandular tuberculosis, and 1 of intramuscular abscess. The organisms isolated from 9 of these cases were of the human type and 3 of the bovine type. Of the latter cases, one is considered of interest as being "the first case in which the bovine type of tubercle bacillus has been demonstrated to be the cause of human tuberculosis which was apparently primary in the bronchial glands."

Of 52 cases of scrofuloderma from which tubercle bacilli were obtained, 32 yielded cultures of the human type and 20 of the bovine type. Of 30 human strains examined culturally 26 showed standard and 4 attenuated virulence. Of the bovine strains 19 cultures from 16 cases showed standard virulence, and 6 cultures from 4 cases attenuated virulence.

The 6 lupus cases examined furnished 3 cultures of the bovine type and 3 of the human type, all of attenuated virulence. In this connection it is pointed out that there is apparently a close relationship between attenuation of tubercle bacilli and nearness of the tuberculosis lesion to the surface of the body.

The information so far collected on the types of human tuberculosis is summarized in tables. Of a total number of 1,068 cases, 803 were of the human, 194 bovine, and 5 mixed types of standard virulence. Atypical cases included 21 of the human type considered atypical in cultural characteristics, 23 of the human type atypical in virulence, and 22 of the bovine type atypical in virulence. The total percentage of bovine infections was 20.7. Classified according to age the percentages of bovine infection were as follows: From 0 to 5 years, 37.55 per cent of 221 cases; 5 to 10 years, 29.55 per cent of 312 cases; 10 to 16 years, 14.66 per cent of 150 cases; and 16 years and upward, 6.25 per cent of 384 cases.

The complement fixation test for tuberculosis, H. O. VON WEDEL (*Jour. Immunol.*, 5 (1920), No. 2, pp. 159-225).—This is the report of an extensive investigation of the complement fixation reaction to determine its value as a routine diagnostic test for tuberculosis. The report includes a review of the literature, a description of the technique employed in the study, and the results of the study of the influence of various factors upon the test. These may be summarized as follows:

The 1-hour fixation period in the water bath at 37° C. appeared to be the optimum time and temperature for the test. Untested pooled complement from 6 or more guinea pigs gave satisfactory results, while if but one guinea pig was used special testing was required. Natural sheep hemolysin was markedly thermolabile, but did not depreciate very rapidly due to aging provided the serum was kept sterile.

Heating tubercle bacillus antigen at 100° for three hours did not seem to impair its antigenic value. The addition of 25 per cent alcohol or 0.5 per cent phenol to the finished antigen tended to make it more or less anticomplementary. The best method for preparing the antigen seemed to be by killing the bacilli with alcohol and sterilizing in small corked vials for one hour on two or three successive days to kill all contaminating spores and bacteria.

"The increase in the strength of the fixation and the increase in the percentage of positive findings after preserving the patient's sera for seven days in the ice chest is due, probably, to one or more of the following reasons: The formation of thermostable antilynsins in the kept sera, loss of natural antisheep amboceptor due to aging, loss of natural antisheep amboceptor due to reheating, and other unknown nonspecific causes. This change in sera after preserving in the ice chest for one week is apparently nonspecific. . . .

"About 70 per cent of all types of tuberculosis patients except those clinically healed or inactive gave positive fixation results on repeated tests. Normal nontuberculous cases gave almost no positive results on repeated tests. Moderately and far advanced cases in good condition showing constitutional symptoms gave an average of 85.2 per cent positive fixations for all six series.

"The complement fixation reaction will not be very valuable, as an aid in diagnosis, to the tuberculosis specialist except as a confirmatory test. However, a positive fixation reaction will be of very great value to the general practitioner not only as a confirmatory test but also as an aid in diagnosis and prognosis."

The transmission of human tuberculosis to fowls, M. C. BARILE (*Rec. Méd. Vét.*, 96 (1920), No. 4-6, pp. 66-69).—Attention is called to the conflicting views regarding the possibility of the transmission of the tuberculosis of mammals to fowls, and observations are reported which incline the author to the belief that human tuberculosis can be transmitted to fowls through ingestion of sputum.

Vaccination of cattle against hemoglobinuria, PRÖSCHOLDT (*Berlin. Tierärztl. Wchnschr.*, 36 (1920), No. 12-13, pp. 133-135).—This is a brief discussion, based on the author's experiences of the value of vaccination against hemoglobinuria. The following recommendations are made:

The vaccination should be done in the spring before the cattle go to pasture. Animals which are already suffering from hemoglobinuria should not be vaccinated. Great care should be taken in the vaccination of older animals for the first time. Vaccination of these animals is not without risk, yet the sickness following such vaccination is not so serious as the disease itself, which they are likely to contract in infected pastures. Vaccination is harmless for healthy

calves and heifers as well as for older cattle that have been previously vaccinated. The best results are obtained by yearly vaccination of calves, heifers, and previously vaccinated cattle. Following vaccination the animals should be kept in their stall for 20 days and given easily digestible feed.

Syngamus laryngeus in cattle and buffaloes in India, A. L. SHEATHER and A. W. SHILSTON (*Agr. Research Inst. Pusa Bul. 92 (1920), pp. [2]+8, pls. 8*).—This paper is based upon the examination of 100 individuals obtained from nearly 200 buffaloes, 100 plains cattle, and 500 hill bulls. Parasites were found in about 13 per cent of the buffaloes and hill bulls and about 15 per cent of the plains cattle.

Abortion and wasting disease in goats, I. F. HUDDLESON (*Michigan Sta. Quart. Bul., 2 (1920), No. 4, pp. 169, 170*).—An affection enzootic in Angora goats in the northern part of Michigan was recently brought to the station's attention. The disease appears to manifest itself by two separate and distinct symptoms, the casting of the developing kid prematurely and a wasting which always terminates fatally.

A flock of goats, 169 in number, which had been shipped from the southwestern part of the United States arrived in Michigan in the month of November in a partly starved condition. Although placed on a well-balanced ration, the casting of the young prematurely began soon after their arrival, at the rate of one to four a day for the flock. Examinations were made of several fetuses for the presence of the abortion bacillus with negative results. It is thought possible that the change in climate may be a causative factor. The wasting disease is thought to be takosis, caused by *Micrococcus caprinus*.

Hog lice and hog mange: Methods of control and eradication, M. IMES (*U. S. Dept. Agr., Farmers' Bul. 1085 (1920), pp. 28, figs. 12*).—Popular accounts are given of the hog louse (*Hæmatopinus suis*) and the mange mites (*Sarcoptes scabiei suis* and *Demodex folliculorum suis*) and means for their control. Plans for the construction of hog wallows and dipping plants are included.

Pseudomonas pyocyaneus as a factor in pneumonia of swine, R. R. BIRCH and J. W. BENNER (*Cornell Vet., 10 (1920), No. 3, pp. 176-189*).—The author reports upon investigations of an outbreak of swine pneumonia in which *Bacillus pyocyaneus* played an active part, especially in the latter stages. Fifteen cases are reported upon. Necrotic areas were found in the lungs of all the cases which died with pneumonia in this outbreak, and *B. pyocyaneus* was found in large numbers in these areas and in the tissues around them. This was also the case in numerous hog lungs received from various parts of the State for diagnosis.

"We have seen this form of pneumonia affecting young and old hogs, hog cholera susceptibles, immunes, and hyperimmunes. The disease may develop slowly or quickly. Cough, dyspnea, and thumping are prominent symptoms. Hyperimmunization seems to be a predisposing cause, as does a dusty earth floor. The disease traveled slowly but persistently, and was controlled effectively by isolating the sick and by placing the well animals on disinfected and dampened concrete floors, thus protecting them almost entirely from dust.

"Experimentally the disease could not be produced in healthy animals in typical form, either by feeding, inhalation, or subcutaneous or intravenous injections, nor did healthy animals penned with the sick in quarters free from dust contract it. Some primary devitalizing influence seems to be a prerequisite. Salt solution suspension of *B. pyocyaneus* grown on slant agar, injected intravenously in large doses (20 cc.), later in smaller doses (3 cc.) to young shoats, produced immediate distress, from which the animals rallied temporarily only to die of septicemia a few hours later. Still smaller doses (0.5, 1, and 2 cc.) produced a slight temporary distress followed usually by recovery, but in

one case paralysis of the hind legs developed. Bouillon cultures of the organism administered intravenously in large doses produced paralysis but failed to produce death.

"We have observed this form of pneumonia in the field associated with hog cholera, with lung worm infestation, and following exposure incident to shipping or prolonged exposure in dusty yards, and in spite of the fact that we failed experimentally to transmit the disease in typical form by artificial means, our observations lead us to believe that *B. pyocyaneus*, when once it gains a foothold in the lung tissue, plays an active and important part in destroying hogs that otherwise would recover. Bacterins made from the strains of the organism found active in this outbreak administered frequently in large doses seemed to have some curative value, but immediate and sure results following their administration were not the rule."

Digestive organs of the chicken, W. T. JOHNSON (*Washington Sta., West. Wash. Sta. Mo. Bul.*, 8 (1920), No. 4, pp. 58-61, fig. 1).—This is a popular account.

RURAL ENGINEERING.

Notes on agricultural hydraulics in Cochin China, J. BÉNABENQ (*Bul. Agr. Inst. Sci. Saigon [Cochin China]*, 2 (1920), No. 5, pp. 129-138, figs. 6).—Data on tides in river basins and streams in the rice-growing districts of Cochin China are reported, and it is shown how advantage may be taken of the tides in the management of irrigation and drainage canals for rice irrigation. The tide is apparently sufficient to permit the use of one canal for both irrigation and drainage.

Report of the drainage demonstrator, J. Woods (*Ann. Rpt. Dept. Agr., New Brunswick, 1919*, pp. 51-54).—Tests of the crushing resistance of clay and cement drain tiles from 3 to 6 in. in diameter showed that for all sizes the clay tiles were at least twice as strong. Tests of 15 lots of 3-in. concrete tiles made of sand cement mixtures varying from 3:1 to 7:1 showed corresponding crushing strengths of 754.6 lbs. and 234 lbs. Tests of 4-, 5-, and 6-in. tile made of a 4:1 sand cement mixture showed a decrease in strength as the diameter increased. Dry mixtures gave better average results as regards crushing strength than wet mixtures. This was also true with clay tile.

Notes on drainage, A. J. BROOKS (*[Imp. Dept. Agr. West Indies], Agr. Dept. St. Lucia Leaflet 14 (1918)*, pp. 8).—The general principles of soil drainage are outlined with particular reference to conditions in St. Lucia.

Public Roads (*U. S. Dept. Agr., Public Roads, 3 (1920), No. 25*, pp. 32, figs. 11).—This number of this periodical contains the following articles: Bituminous Surface Treated Macadam and Gravel Roads, by J. F. Witt; Winter Road Work in the Dakotas, Minnesota, and Wisconsin a Success, by E. G. Edwards; 7,565,446 Motor Vehicles in United States—Registrations, Licenses, and Revenues in the United States during the Calendar Year 1919, by A. P. Anderson; Federal Control of Bridges over our Navigable Streams, by G. B. Pillsbury; The "Asphalt Content" of Road Oils, by B. A. Anderton and D. G. Taylor (see below); Galvanized Culverts, by L. G. Carmick (see p. 690); and Federal Aid Allowances: Project Statements Approved in April, 1920.

The "asphalt content" of road oils, B. A. ANDERTON and D. G. TAYLOR (*U. S. Dept. Agr., Public Roads, 3 (1920), No. 25*, pp. 23-25, fig. 1).—Experiments to determine the value of the grading of asphaltic road oils, on the basis of the percentage of asphalt contained in them, led to the conclusion that the percentage of asphalt gives no additional information on the suitability of a road oil for a given purpose which is not adequately shown by the results of other tests, better understood and at the present time well standardized.

Galvanized culverts, L. G. CARMICK (*U. S. Dept. Agr., Public Roads, 3 (1920), No. 25, pp. 26-29, fig. 1*).—Experiments on the value of the method of testing the galvanizing of metal culverts by chemical analysis of one or two small pieces cut at random from the culverts are reported.

It was found that there is a great lack of uniformity in the coating on the different parts of a sheet, which may amount to as much as 50 per cent of the average for the sheet. This is taken to indicate that little reliance can be placed on the results from tests of one or two small pieces. In order to secure an adequate idea of the spelter coating on a shipment of culverts it is considered necessary to take quite a large number of samples.

Comparative tests of the hydrochloric acid-antimony chlorid and the lead acetate methods of testing for spelter coating showed that when the acid method was used with 1-minute immersions the results were much too high. When the time was reduced to 30 seconds, the results were remarkably accurate, more so than those given by the acetate method.

Economics of the farm tractor, C. E. ALLRED (*Tenn. Farmer, 13 (1920), No. 7, pp. 143, 144, 146, 148, 156, 158, 160, fig. 1*).—Average data based upon reports of tractor owners in Tennessee are summarized. With reference to the relation of size of farm to the size of tractor, it is estimated on the basis of the number of 14-in. plows pulled that for 200-acre farms a 3-plow tractor is the most desirable, and for farms of from 201 to 750 acres of crops, the 4-plow outfit is the best. Other economic factors are considered.

Influence of the tractor on use of horses, L. A. REYNOLDSON (*U. S. Dept. Agr., Farmers' Bul. 1093 (1920), pp. 26, figs. 7*).—This reports the results of the personal experience of 191 tractor owners in seven corn belt States on farms varying in size from 80 to 1,640 acres.

Of the 141 farms upon which tractors had been in operation for a year or more the greater number ranged in size from 141 to 220 acres and from 221 to 300 acres. Five large tractors were found ranging in size from 8 to 12 plows and in age from 8 to 12 years. All other tractors ranged in size from 2 to 6 plows.

It was found that the number of horses disposed of on 141 farms averaging 346.5 acres, on which tractors had been used for a year or more, was 2.5 per farm. The average number of tillable acres per horse increased from 26.5 to 38.5 after the purchase of the tractor. Nine operators out of 191 displaced horses entirely on plowing, disking, and harrowing. Only 16 operators allowed their horses to stand idle while the tractor was in use. The number of horses displaced by the tractors on these farms was governed by the number it was necessary to retain for corn cultivation and other work current at the same time which the tractor could not do. The horses remaining on these farms are doing about 75 per cent of the tractive work and tractors the remainder.

The tractor was used for an average of 29 10-hour days per year on the home farm, no record of the amount of custom work done being obtained. A 3-plow tractor on these farms did the work of 8.5 horses in plowing, disking, harrowing, and harvesting. After purchasing the tractor the average size of the farms was increased by 22 acres, or 6½ per cent.

Report of motor tractor plowing trials at the Elsenburg School of Agriculture (*Union So. Africa Dept. Agr., Local Ser. No. 86 (1918), pp. 16, pls. 10*).—Trials to determine the efficiency of four American tractors and one Swedish tractor for plowing are reported. Each tractor was required to plow 12 acres of hillside stubble land consisting of coarse sandy loam to a depth of at least 5 in., and 6 acres of virgin sandy vlei land to a minimum depth of 7 in.

The Swedish machine weighed 9,000 lbs. net, while the American machines varied in weight between 2,800 and 5,000 lbs. The Swedish machine had a

single cylinder, two-stroke cycle, crude oil engine. The American machines had 1, 2, and 4 cylinder engines all of the four-stroke cycle type.

The Swedish machine plowed three furrows on the hillside and only two in the vlei soil. The plows did not scour owing to the unsuitability of the Swedish steel, which was inferior to the American steel in this respect. Considerable difficulty was experienced due to slipping on the hillside. This machine could not cross ditches which were easily crossed by the American machines, as the engine and plows were mounted on one rigid frame. Aside from these difficulties, this tractor did good work on both soils but operated somewhat slowly.

Two of the American machines gave poor results, and two gave excellent results. One tractor with 22 h. p. engine plowed both hillside and vlei with great speed and thoroughness and with a minimum loss of time due to trouble. A feature of this machine was its low fuel consumption and ability to operate in wet soil. It is noted that the Swedish machine plowed both soils at the smallest cost per acre, this being due to a smaller total cost for fuel, water, and lubricant.

The establishing of different seeding widths with a seeding machine, D. RUDOLFF (*Nachr. Deut. Landw. Gesell. Österr., n. ser., 3 (1919), No. 41, pp. 347-351, figs. 4*).—A mathematical analysis of seeder operation and construction is given, the purpose being to derive an equation for the adjustment of the seeder shares and wheels.

Silo selection, F. E. FOGLE (*Michigan Sta. Quart. Bul., 2 (1920), No. 4, pp. 186-190*).—The important features of different types of silos are discussed.

How to build caves and storages for vegetables (*Vie Campagne, 16 (1919), No. 196, pp. 242-246, figs. 24*).—Information on French practice in the construction of underground storage rooms for vegetables is given, together with a number of sectional drawings of typical structures.

Disposal of sewage in the Tropics by means of septic tanks and soil purification, C. A. E. VAN LEEUWEN (*Meded. en Rap., Dept. Burgerl. Openb. Werken Nederland. Indië, Afd. G, 1919, III, pp. 18, pls. 6*).—Tropical practice in the disposal of sewage by small installations is described, and studies of soil and the action in septic tanks are reported.

It was found that the cholera bacillus was killed after remaining three days in a septic tank, but that the typhoid bacillus was not. Experience with small septic tanks and sand and stone filters in Dutch East India is reviewed, and drawings of three sewage disposal systems to care for 15, 50, and 100 people are included, the design of which is based upon the disposal of about 25 liters (6.6 gal.) of sewage per capita per day.

Injury (narcosis) of a sewage purification plant by industrial sewage, KAMMANN and KEIM (*Gesndhts. Ingen., 43 (1920), No. 10, pp. 109-112, fig. 1*).—Laboratory studies of filters, especially soil filters and sewage irrigation areas, showed that sewage effluent containing only slight amounts of ethylene trichlorid will seriously impair the effectiveness of sewage filters, owing to the resulting paralysis of bacterial life, especially in the soil filter areas.

RURAL ECONOMICS.

An economic study of small farms near Washington, D. C., W. C. FUNK (*U. S. Dept. Agr. Bul. 848 (1920), pp. 19, pl. 1, figs. 6*).—Results are here presented which were derived from a study of the organization of 152 small farms in the vicinity of Washington, D. C., most of which were located in Prince Georges County, Md., or Fairfax County, Va. The data, tabulated and graphically illustrated, relate to the average distribution of crop area, a summary of the farm business, distribution according to tillable area of farm receipts, expenses, capital, and labor income, and relation of tenure to type of farming and profits.

Over 50 per cent of the total crop area of the farms visited was devoted to vegetables and fruits, and 90 per cent of the receipts were from this source. The following table indicates the average labor incomes realized in the crop year 1916:

Labor incomes on small farms near Washington, D. C.

Number of farms.	Farm area.	Tillable area.	Labor income.	Number of farms.	Farm area.	Tillable area.	Labor income.
45	Acres. 11	Acres. 6	\$131	29	Acres. 39	Acres. 23	\$668
57	21	13	223	21	57	35	1,147

In most instances 5 per cent of the land value exceeds the renting value. The landlords of the rented farms realized an average of only 2.9 per cent on the investment. Twenty to thirty per cent of the crop area is double cropped. The farm produce is disposed of by hauling it to the city and selling it either at the public market stands (wholesale or retail) or through commission men.

Twenty-four farms, or 16 per cent of those studied, were operated by tenants. Twenty of the tenants paid a cash rent and the other four gave a share of the crops as rent. Thirty-six owners rented additional land and, in general, increased their profits thereby.

The organization and management of farms in northwestern Pennsylvania, E. D. STRAIT and H. M. DIXON (*U. S. Dept. Agr. Bul. 853 (1920), pp. 32, pl. 1, figs. 8*).—A detailed analysis of 422 farms within a radius of 10 miles of Grove City, Pa., was made in the summer of 1917 for the purpose of gathering information as to farm organization in this area, which is representative of numerous similar areas in western Pennsylvania, southwestern New York, eastern Ohio, and parts of West Virginia. This study covers the farm year 1916.

General live-stock and crop farming is gradually being superseded by the dairy type, owing largely to the establishment of a creamery at Grove City. Forty-six per cent of the farms studied might be classified as dairy farms. The 422 farms studied averaged 101 acres in size, 60 per cent of the land being tillable and the remainder being used mostly for pasture. The average value of real estate was \$57 per acre. The average capital invested in the dairy farms was \$8,112 and in the general farms \$7,252. A working capital of \$1,994 was required to operate the average dairy farm and \$1,746 to operate the average general farm. For the year 1916 the average labor income of 159 dairy farms was \$279 and of 190 general farms, \$291.

Two charts are given, one showing labor income, receipts, and expenses for the 349 farms arranged according to total acreage, the other the distribution of the farmer's gross income in which the 349 farms were arranged in 4 size-groups. The latter indicates that on the larger farms, if the farmer is free from debt, the amount available for family living is large, even though there is little or no labor income.

Data relating to production per farm; distribution of farm area, capital, receipts, crop area, and live stock; expenses; size of farm, organization, and profits; live stock and live-stock products produced and sold; crop yields; maintenance of soil fertility; income from sources outside the farm; and land tenure are tabulated and discussed.

Some salient features in farm organization, W. F. HANDSCHIN (*Jour. Farm Econ., 2 (1920), No. 3, pp. 141-154*).—This discussion covers the selection of the crops and the proportions in which they are to be grown, as based upon the necessity for soil maintenance, the relative profitableness of the various

crops in rotation, the most advantageous utilization of the man and horse labor required, and insurance against crop failures and market fluctuations. It includes also the production of live stock as a part of the farm scheme. Various types and systems of farming are considered, and it is concluded that still more investigational work needs to be done to make possible further really scientific procedure in farm organization.

Problems of the farm manager, E. MAYLAND (*Jour. Farm Econ.*, 2 (1920), No. 3, pp. 155-162).—The major farm management problems are outlined as being the selection of the farm, distribution of the investment, farm outlay, selection of enterprises, distribution of adjustment of enterprises, and the labor schedule. Each of these problems is discussed in outline, mainly from the point of view of conditions existing in North Dakota, including that of the chances for success of settlers buying land from a certain land company selling under what is known as a "crop, stock, and insurance contract." Under this contract the buyer makes a small initial payment of about 20 per cent of the purchase price of the farm, and he is allowed ten years in which to complete the remaining payments by each year turning over to the company one-half of the proceeds from the sale of crops and live stock and live-stock products. This sum is applied, first, in payment of the interest, and, second, in reduction of the principal until paid. The insurance feature provides that the buyer must insure his life to the company as beneficiary during the period of the contract for an amount equal to his indebtedness.

Valuation of farm crops, P. A. BOVING (*Agr. Jour. [Brit. Columbia]*, 5 (1920), Nos. 4, pp. 120, 121; 5, pp. 136, 137).—The author applies the feed unit system to crop valuation in calculating relative acre yields and in examining the market value of various feeds, the feed unit constituting 1 lb. of wheat or its equivalent in other feeds. A table is given, showing the average number of pounds of some of the more common feeds which have proved to be equivalent to one feed unit, the average number of feed units in 1 lb. of feed, and the average percentage of digestible protein and of amids in the respective feeds. Tabulations are also given for the yield and crop value from one acre of land, the available cattle feed on a good 100-acre farm, the valuation of pasture, and the cost per feed unit of different feeds.

Population, E. M. EAST (*Sci. Mo.*, 10 (1920), No. 6, pp. 603-624).—In this address, delivered before the American Society of Naturalists December 30, 1919, it is asserted that in the United States, taken as illustrating the economic and biological consequences of population pressure, the actual population is lagging behind the predicted population, and that the law of diminishing returns is even now in operation in regard to natural resources and agriculture.

"Novel methods of culture, more efficient machinery, new and better yielding varieties are but means of exploiting a limited reserve of soil fertility at a higher rate. . . . After the expenditure of vast sums, after the completion of tremendous tasks of engineering, we can add barely 35 per cent to our present farm area."

It is said that absolute costs per unit of man power and monetary unit are mounting and will continue to mount because of the diminishing returns imposed by a system of agriculture on soil, the present productiveness of which can only be kept up by increasing amounts of artificial fertilizers, and because of competition with new land farming.

Examination is made of data which show that agricultural production is not keeping pace with the population, a slight decline in the per capita production occurring between 1880 and 1890. It is said that a shift from cities to farms must come in the next half century, and that coincident with it will be a simplification of the standard of living.

The problem of the United States in regard to its increasing population is involved with the rapid immigration by southern European peoples and the potentiality of ethnic mixtures for strength or weakness to a race and to a civilization. It is urged that a restriction of immigration, education, equitable readjustment in many of our economic customs, and rational marriage selection and birth rate are necessary to meet the problem of population for the future.

Our national food supply: Limits of self-support, D. HALL (*Jour. Min. Agr. [London]*, 27 (1920), No. 2, pp. 133-137).—It is indicated from a table for the produce from an acre of arable land as compared with the prewar consumption of a unit of the population of the United Kingdom that theoretically an acre of arable land, assuming present average yields, could maintain one person for a year. Certain limiting factors which, however, prevent the maintenance at home of the population of the United Kingdom are outlined. The stand is taken that higher prices for agricultural products will follow a diminution in the total world supply, owing to the withdrawal of labor from agriculture, and that the great bulk of the population will be compelled to increase its consumption of bread, potatoes, vegetables, milk products, and pork.

Cooperation in Denmark, L. SMITH-GORDON and C. O'BRIEN (*Manchester, England: The Cooperative Union, Ltd., 1919, pp. 74*).—This is another of the international cooperative series (E. S. R., 43, p. 595), and contains a description of the origin, growth, organization, and results of cooperation in Denmark. The chapters take up early conditions in Denmark, the dairying industry, cooperative credit societies, the distributive movement, types of agricultural societies, and some results of cooperation. A brief bibliography is appended.

The quit-rent system in the American colonies, B. W. BOND, JR. (*New Haven: Yale Univ. Press, 1919, pp. 492*).—This is a detailed historical study of the introduction, character, spread, and significance of proprietary and royal quit-rents in the British colonies in North America. An introduction briefly noting the character and importance in American history of this remnant of feudalism has been written by C. A. Andrews, and a bibliography of sources, both printed material and manuscript, of a general nature and relating to individual colonies, is included.

The child-welfare special (*U. S. Dept. Labor, Children's Bur. Pub. 69 (1920), pp. 19, pls. 8*).—The special arrangement and equipment of a truck used by the Children's Bureau as a traveling clinic, and the personnel, methods, and findings of this means of teaching child-welfare in rural districts, are described. It is said that widespread and interested response was met with on the initial field trip, and that this method with certain adaptations is to be recommended for effectively reaching rural inhabitants.

Monthly Crop Reporter (*U. S. Dept. Agr., Mo. Crop Rptr., 6 (1920), No. 7, pp. 61-76, figs. 6*).—This number contains the usual monthly estimates of acreage and production and brief articles, notes, and tabular data as to stocks, farm and market prices, and the marketing of important agricultural products. Among special reports are included one with a chart and tabulations, representing the present narrow price relations between hogs and corn, and an article on the wages of farm laborers in Bessarabia.

The Market Reporter (*U. S. Dept. Agr., Market Rptr., 2 (1920), Nos. 4, pp. 49-64, figs. 2; 5, pp. 65-80; 6, pp. 81-96, fig. 1*).—In these numbers are continued the usual weekly and monthly summaries of movement, marketing, and prices of specified commodities, and important classes of agricultural products, together with information on foreign markets.

In No. 4, there are special articles on the satisfactory market position of the American type of grapes and grape products and of alfalfa meal production in recent years; a review of cold storage stocks; and a summary of the production,

trade, and prices of wool during the past 10 years. No. 5 includes articles on melon shipments for July, the crimson clover seed harvested and imported, and the produce market at Chicago. The leading articles in No. 6 relate to fresh meat prices during July, honey prices for July, and the grain situation in south-eastern Europe, 1919-20.

AGRICULTURAL EDUCATION.

Proceedings of the high school conference of November 20, 21, and 22, 1919 (*Univ. Ill. Bul.*, 17 (1919), No. 13, pp. 313).—These proceedings include among others the following reports and addresses relating to instruction in agriculture and home economics: Report of the Working of the Smith-Hughes Law in Illinois, by A. W. Nolan; The Point of View of the Teacher of Vocational Agriculture (abstract), by G. A. Works; Report of Progress in Vocational Agriculture in Illinois, by J. E. Hill, noted below; Equipping the School Plant for Vocational Agriculture, by C. C. Turner; Connecting the Agriculture of the High School with the Farm Interests of the Community, by E. B. Henderson; An Experiment on Profit from City Bred Pigs, by R. W. Sutherland; The High School Agricultural Teacher and Junior Extension Work, by J. H. Greene; and The Budget as a Basis for the Clothing Work, by H. C. Goodspeed.

Report of progress in vocational agriculture in Illinois, J. E. HILL (*Univ. Ill. Bul.*, 17 (1919), No. 13, pp. 94-97).—This report shows that the number of schools teaching vocational agriculture in Illinois increased from 15 in 1918 to 70 in 1920, and the number of students in these courses from 323 to 1,618.

The major part of the report is devoted to a discussion of the degree of success of the project method in the training of boys to be practical farmers in those communities now teaching vocational agriculture, based on the results of a questionnaire sent to all the teachers of vocational agriculture in the State. As regards the opinion of farmers concerning the home project and supervised farm practice, of 35 replies received, 25 state that the communities are in favor of the work as it is being taught in the Smith-Hughes high schools. Two indicated that the communities were opposed to this method of agricultural instruction. With reference to the project that proved most interesting and profitable among the boys, 28 out of 33 replies named live stock and 19 of these the raising of hogs. Live stock, dairying, hogs, alfalfa, soil improvement, corn, or any other project where the boy solves his own problems and meets competition, farm practice, and account books, were some of the projects which 22 teachers thought gave the boys good training for efficient farming. The greatest difficulties in teaching vocational agriculture mentioned by the teachers are summarized by the author, with suggested solutions.

Vocational education (1917-18) (*Ind. Dept. Pub. Instr. Rpt.*, 1918, pp. 25-38).—This is a report on vocational education in Indiana for 1917-18, including statistical data. Important provisions of the Indiana vocational education law enacted in 1913 are given.

In 1917-18 forty-eight schools were approved for instruction in vocational agriculture as compared with 7 in 1914-15. The number of schools approved for vocational home economics increased from 18 in 1914-15 to 36 in 1917-18. Evening classes were conducted in 21 cities and towns with a total enrollment of 6,200 women. Short unit courses were outlined and so planned that a limited number of lessons in each subject satisfied a specific need of a particular group. More than 60,000 young people in the State received instruction and direction in supervised practice on the farm.

Vocational education, McH. RHOADS (*Ky. Supt. Pub. Instr. Bien. Rpt.*, 1917-1919, pp. 171-184).—This is the report of the State Director of Vocational Education for the year ended June 30, 1918, giving a brief account of the

beginning of the Smith-Hughes vocational work and its progress in the year ended June 30, 1919. The funds available for teacher training under the Smith-Hughes Act were apportioned on the basis of 75 per cent for the University of Kentucky for the training of white teachers and 25 per cent for the Kentucky Normal and Industrial Institute for the training of colored teachers.

Vocational education in the State of Maine, 1917-18, A. O. THOMAS (*Maine Supt. Pub. Schools Rpt., 1918, pp. 12-16*).—This is a report on the promotion of vocational education in Maine in 1917-18 under the Smith-Hughes Act. The training of teachers of vocational agriculture was conducted at the University of Maine, and the training of teachers of vocational home economics at the State Normal and Training School at Farmington. Four teachers completed the work in agriculture and received certificates and 10 completed the 4-year course required for home economics teachers.

Annual report of the State Board for Vocational Education for 1918-19 and plans for 1919-20 (*N. C. Bd. Vocat. Ed. Bul. 3 (1919), pp. 60*).—According to this report the North Carolina State College of Agriculture and Engineering graduated 7 students from the department of vocational education. Nine more completed the 1918 six weeks' summer course and 14 the 1919 summer course at this college. The North Carolina College for Women graduated 10 students from the department of teacher training in vocational home economics.

In accordance with the vocational education act passed by the general assembly of 1919 the governor appointed a new State Board for Vocational Education, with the State Superintendent of Public Instruction as chairman. Statistical data with reference to schools, students, teachers, receipts and expenditures, etc., and the State laws relating to vocational education under the Smith-Hughes Act are included.

For 1919-20 it was planned to devote 40 per cent of the teacher-training fund to agricultural subjects and 35 per cent to home economics subjects. It is provided that from 35 to 45 per cent of the time of the 4-year teacher-training course in vocational agriculture for white students shall be given to technical subjects, from 25 to 35 per cent to science, from 20 to 25 per cent to nontechnical and military subjects, and from 10 to 15 per cent to professional subjects. A suggested 4-year course (grades 8 to 11, inclusive) for vocational schools of agriculture for white students, a 4-year course in agriculture for colored schools (grades 6 to 9, inclusive), subjects for type courses for evening classes in home economics, including a budget course in the care and repair of clothing, type courses for part-time classes, including a short unit on the budget, 2-year type courses for all-day home economics schools, 4-year teacher-training courses in vocational agriculture for white students and for colored students, a 4-year teacher-training course in vocational home economics for white students, and a 2-year course for colored students are included.

Course of study, Missouri high schools, 1919 (*Jefferson City, Mo.:* State Dept. Ed., [1919], rev., pp. 192, figs. 3).—This State course of study includes outlines of a one-unit course in agriculture and a two-unit course in home economics, cooking, and sewing for the high schools of Missouri which can not provide the vocational agriculture or home economics under the Smith-Hughes Act; suggested lists of equipment and library reference books for agriculture and home economics, and a synopsis of conditions under which State aid for high schools may be obtained and State legislation for the promotion of vocational education, 1917. The subjects of the agricultural course include farm and garden crops, soils, animal husbandry, farm management, and ornamental gardening. The most important portion of the two-unit home economics course may be selected for a one-unit course, or each unit may be offered individually.

Standard program of studies for the secondary schools of New Hampshire (*Concord, N. H.: Dept. Ed., 1919, 3. ed., pp. 279, figs. 9*).—This State program of studies for the secondary schools of New Hampshire organized on the six-six plan, includes, among others, outlines of curricula and courses in (1) academic and liberal domestic arts, including cooking, canning, and sewing in the first and second years, household appliances in the third, nursing and physiology in the fourth, household organization in the fifth, and household management in the sixth; and (2) in Smith-Hughes agriculture, including soils and horticulture in the third year, field crops in the fourth, animal husbandry and farm engineering and tools in the fifth, and farm organization and management and roads and forestry in the sixth year.

Agriculture (*In Course of Study for High Schools.—V, Science. Topeka, Kans.: State Bd. Ed., 1919, rev., pp. 17-26*).—A one-unit course in agriculture for Kansas high schools, based on the State text, Waters' Essentials of Agriculture, is outlined in seasonal sequence. It is the normal training course for the preparation of students to teach agriculture in the grades. It is also a general cultural course, and for many it serves as a sort of introductory science course. Suggestions for laboratory work and equipment and for agricultural reference books are included.

Agriculture (*In Course of Study for Rural and Graded Schools, 1917. Topeka, Kans.: State Bd. Ed., 1919, rev., pp. 202-220*).—This outline of work in agriculture for the eighth grade is based on the textbook in agriculture published by the State school commission. It divides the work of the text into seven parts for as many months.

Everyday chemistry, A. VIVIAN (*New York: Amer. Book Co., 1920, pp. 560, figs. 246*).—This text on the science and art of chemistry as applied to everyday life is intended for high school use, and comprises three parts, viz, (1) inorganic chemistry, (2) organic and applied chemistry with special emphasis on household chemistry, and (3) soils and fertilizers. Introductory instructions in laboratory manipulations, exercises in connection with each chapter, and lists of chemicals and apparatus needed for a class of 12 are included.

Types and market classes of live stock, H. W. VAUGHAN (*Columbus, Ohio: R. G. Adams & Co., 1919, 5. ed., rev., pp. 503, pl. 1, figs. 167*).—Besides revising the material in the original edition (*E. S. R., 37, p. 194*), the author has added chapters on packing house by-products from cattle, the selection of feeder steers, and sheep markets and market classification.

Judging live stock, J. A. CRAIG (*Des Moines, Iowa: Estate of Author, 1920, 27. ed., rev., pp. [4]+187, pls. 111*).—This is the twenty-seventh revised edition of this text which was first issued in 1901. It gives instructions for judging horses, cattle, sheep, and swine.

Educational gardening, R. HOGG (*London: A. Brown & Sons, Ltd. [1919], pp. VIII+[3]+159, figs. 64*).—This book is intended as a guide to teachers, pupils, and others desiring a knowledge of practical gardening. It contains instructions, together with the necessary facts and principles, for laying out a garden, cropping, fertilizing, conducting pot and germination experiments, and growing potatoes and other vegetables, fruits, and flowers, manual work for the winter, beekeeping, drawing, and a garden calendar.

Home economics, B. DAVIS (*In State Manual of the Courses of Study for the High Schools of Oregon, 1919-21. Salem, Ore.: Dept. Ed., 1919, pp. 96-113*).—A suggestive four-year course in home economics is outlined so that each semester's work represents a complete half unit. Subject matter, technical work, and correlations are indicated. The subjects include cookery, camp cookery, cafeteria cookery, dietetics, care of the house, house management, home nursing, sewing, dressmaking, and millinery.

A bibliography of agricultural books for the high school library, C. COLVIN (*Bd. Vocat. Ed. Ill. Bul. 16 (1919), pp. 31*).—It is stated that this suggested list of books, which has been prepared in cooperation with the various departments of the College of Agriculture of the University of Illinois, is to be adopted for use in all departments of vocational agriculture in Illinois. The books are listed under the main divisions of agriculture, agricultural arithmetic, agricultural education, agronomy, animal husbandry, apiculture, dairying and dairy cattle, economic entomology, farm accounting and farm management, forestry, horticulture, related sciences, rural life, and miscellaneous. Each book bears a number as well as a letter designating the division.

Motion pictures of the U. S. Department of Agriculture, F. W. PERKINS and G. R. GOERGENS (*U. S. Dept. Agr., Dept. Circ. 114 (1920), pp. 22, figs. 12*).—This circular contains a list of motion-picture films, including 460 reels, or more than 460,000 feet of film, on 112 agricultural subjects, available for distribution. A brief statement of the uses that are being made of these motion pictures, together with information concerning their distribution, exhibition, handling, and purchase, is included.

MISCELLANEOUS.

Thirty-first Annual Report of Louisiana Stations, 1919, W. R. DODSON (*Louisiana Stas. Rpt. 1919, pp. 38*).—This contains the organization list, a financial statement regarding the Federal funds for the fiscal year ended June 30, 1919, and the State funds for the fiscal year ended November 30, 1919, and corresponding financial statements for the preceding fiscal year; and a report by the director, including brief departmental reports. The experimental work reported is for the most part abstracted elsewhere in this issue.

Report of Northeast Demonstration Farm and Experiment Station, Duluth, 1918-19, M. J. THOMPSON (*Minnesota Sta., Rpt. Duluth Substa., 1918-19, pp. 28, figs. 4*).—The experimental work reported is for the most part abstracted elsewhere in this issue.

Thirty-third Annual Report of Nebraska Station, 1919 (*Nebraska Sta. Rpt. 1919, pp. 49*).—This contains the organization list, a report of the work of the year, a report of the extension service of the college of agriculture, and a financial statement for the fiscal year ended June 30, 1919. The experimental work reported is for the most part abstracted elsewhere in this issue. The text of the State Farm Bureau Law is included.

Quarterly bulletin of the Michigan Experiment Station, edited by R. S. SHAW and H. W. NORTON, JR. (*Michigan Sta. Quart. Bul., 2 (1920), No. 4, pp. 157-199, figs. 9*).—In addition to articles abstracted elsewhere in this issue, this number contains the following: Experiment Station Publications; The Experiment Station Mailing List; The Detroit Commission Plan of City Milk Administration; Animal Husbandry Exhibit, by G. A. Brown; Farm Vinegar Making, by Z. N. Wyant; Soy Bean Inoculation, by R. M. Snyder; Treatment of Seed Potatoes, by G. H. Coons; Dairy Exhibit, by S. J. Brownell; The Farm Crops Exhibit, by J. F. Cox; and List of Available Bulletins.

Monthly bulletin of the Western Washington Substation (*Washington Sta., West. Wash. Sta. Mo. Bul., 8 (1920), No. 4, pp. 49-64, figs. 3*).—In addition to articles abstracted elsewhere in this issue, this number contains brief articles on the following subjects: Saving Money on Feed, by K. B. Musser, and Tree Fruits for Canning, by J. L. Stahl.

Organization of investigation in agriculture, E. W. ALLEN (*Jour. Dairy Sci., 3 (1920), No. 3, pp. 169-179*).—This paper has been noted editorially (*E. S. R., 42, p. 305*).

NOTES.

California University and Station.—The appointment by President Wilson is announced of Dean T. F. Hunt, now on sabbatical leave in Europe, as the member from the United States on the permanent committee of the International Institute of Agriculture at Rome. This position has been vacant since the death of the late David Lubin, to whose suggestion the founding of the Institute is accredited.

The division of entomology has been reorganized as the division of entomology and parasitology. W. B. Herms has been appointed head of the division, continuing his activities in parasitology, practical medical entomology, and ecology. The division is made up of three groups, viz, general entomology and taxonomy, agricultural entomology, and parasitology in relation to animal industries, in charge, respectively, of E. C. Van Dyke, E. O. Essig, and S. B. Freeborn.

Carroll E. Howell, assistant professor of animal husbandry at the Washington College, has been appointed to a corresponding position in the division of animal husbandry; and Walter E. Tomson, field agent in dairying at the Montana College, has been appointed associate in animal husbandry. Ralph V. Wright has been appointed specialist in agricultural extension.

Idaho University and Station.—The department of soils has been discontinued, the chemical phases of the work being combined with the department of agricultural chemistry and those relating to crops with other crop work to form a new department of agronomy. R. K. Bonnet, formerly professor of farm crops, has been appointed professor of agronomy, with G. R. McDole, of the University of Minnesota as associate professor, H. W. Hulbert as assistant professor, and F. L. Burkhart as field superintendent. Station work in soil physics and instruction in soils except soil chemistry will be in charge of Prof. McDole, and a soil chemist is expected to be appointed for research along that line.

Recent appointments include Dr. Charles O. Williamson of the Veterinary College of Ohio State University as instructor in veterinary science vice Dr. W. R. Kidwell, who has accepted a position with the State department of agriculture; R. E. Gongwer of the Huntley (Mont.) Substation of the Bureau of Plant Industry, U. S. Department of Agriculture, as assistant professor of animal husbandry; Sherman Dickinson, instructor in agricultural education at the University of Minnesota, as associate professor; H. W. Hulbert as assistant and professor of agricultural education vice C. B. Wilson, who has accepted a position at the Washington College; and Roy B. Gray as professor of agricultural engineering and head of the department vice John C. Wooley, whose resignation has been previously noted.

Kansas College.—J. D. Parsons, assistant professor of farm engineering, resigned August 1 to become assistant professor of farm engineering at the University of Nebraska. R. H. Driftmier, a 1920 graduate of the Iowa College, has been appointed instructor in farm engineering.

Louisiana Stations.—Dr. Nicholas Kopeloff has resigned as bacteriologist of the Sugar Station to become associate in bacteriology at the Psychiatric Institute of the New York State Hospital.

Massachusetts College and Station.—New buildings include Abigail Adams House, a women's dormitory housing about 100 students, a cavalry barn to accommodate the cavalry unit to be established at the college by the War Department, and a horticultural manufactures laboratory building.

The entering class numbers about 125, with a similar enrollment of the two-year course in practical agriculture. R. W. Neal, associate professor of rural journalism, has resigned to engage in commercial work. H. P. Cooper and Fred G. Merkel have also resigned, the former to accept a position at Cornell University and the latter to become assistant professor of soil technology at the Pennsylvania College.

F. M. Salisbury of the Medina (Ohio) County Farm Bureau has been appointed head of the department of animal husbandry vice J. C. McNutt, whose resignation has been previously noted. Other appointments include Miss Lorain P. Jefferson as assistant research professor in agricultural economics, W. F. Robertson as instructor in horticultural manufactures, Raymond W. Swift as analyst in the department of plant and animal chemistry in the station vice A. M. Clarke resigned, and Harlan N. Worthley as investigator in entomology.

Mississippi College and Station.—C. B. Anders, associate agronomist, has been appointed to take charge of the new substation to be established at Raymond. F. B. Richardson, extension horticulturist, has accepted a position as horticulturist for the South Mississippi Substation at Poplarville.

Nebraska University and Station.—Ray W. Carpenter, assistant extension agricultural engineer, resigned September 15 to become professor of agricultural engineering in the University of Maryland. Fred R. Nohavee has been appointed acting manager of tractor tests beginning September 1, vice C. K. Shedd, resigned, and Lew Wallace, engineer in tractor testing beginning October 1, vice F. L. Orr, resigned. Other appointments effective September 1 include W. W. Derrick as instructor in animal husbandry; F. D. McClure as instructor in rural economics; and L. V. Skidmore, D. V. M., as instructor in plant pathology.

Nevada University and Station.—Dr. Robert Stewart, professor of soil fertility at the University of Illinois, has resigned to become dean of the college of agriculture. Dr. Lyman R. Vawter, associate professor of veterinary medicine at the Georgia College, has succeeded Dr. Lewis H. Wright as station pathologist. N. F. Petersen of the station department of range management resigned September 1 to accept a position with the Wayne (Nebr.) Normal School.

New York State Station.—Otto McCreary, assistant chemist, resigned September 1 to accept a similar position with the Washington Station. Elizabeth F. Hopkins has been appointed assistant botanist for seed testing work.

Pennsylvania College and Station.—D. C. Wimer, assistant professor of soil technology, resigned September 15. Recent appointments include W. A. Broyles of the Texas College as professor of agricultural education, J. L. E. McCord as assistant professor of farm management and rural economics, W. H. Martin as instructor in dairy husbandry, and Paul L. Fatout as assistant in animal husbandry.

Ohio Station.—The departments of animal husbandry and nutrition have been formally abolished as of August 1, vacating all positions therein. A new department of animal nutrition has been established with the following personnel: E. B. Forbes chief, J. W. Hammond associate, and C. H. Hunt, J. A. Schulz, R. F. Remler, A. R. Winters, W. J. Buss, and W. L. Robison assistants.

Rhode Island College and Station.—Dr. Philip Hadley, professor of bacteriology and biologist, has been appointed to the faculty of the department of bacteriology and hygiene of the school of medicine, University of Michigan.

South Dakota College.—Dr. Arthur T. Evans, professor of botany at Huron College, has been appointed associate professor of agronomy.

EXPERIMENT STATION RECORD.

VOL. 43.

DECEMBER, 1920.

No. 8.

For various reasons, the 1920 convention of the Association of Land-grant Colleges was awaited with unusual interest and some forebodings. Although it was the thirty-fourth annual convention of this body in point of continuity, it was the first to be scheduled since the adoption of the revised constitution, carrying with it a new name and a considerably altered form of organization and manner of procedure. Under these circumstances there was naturally some speculation as to the practical workings of the changes which had been effected, and more or less uncertainty had been expressed regarding the prospective attitude and policies of the association in its reconstructed form. Most of the difficulties which had been apprehended, however, failed to materialize, and the final outcome may be characterized as unexpectedly successful and encouraging.

In response to an invitation extended several years ago by the Massachusetts Agricultural College, the convention was arranged to constitute a part of the series of important meetings centering around that institution during the present academic year, which represents the fiftieth anniversary of the graduation of its first class of students. For the better accommodation of the delegates, however, convention headquarters were established in Springfield and the business sessions were held in that city, with a visit to the college on the final day. This arrangement was substantially that followed at the only previous meeting of the association in New England, that at New Haven and Middletown, Conn., twenty years before.

The convention was held from October 19 to October 22 and as usual was preceded by gatherings of several other bodies. Its initial session coincided with the termination of the third annual conference of the American Country Life Association, which had opened its proceedings October 16 in a joint session at Amherst with the American Civic Association. The American Society of Agronomy, the Society for the Promotion of Agricultural Science, and the Association for the Advancement of Agricultural Teaching also met in Springfield, October 18 and 19. Goodly numbers, excellent programs, and well-sustained interest were the rule in these bodies, and their sessions doubtless enhanced the number and representative character of those participating in the convention itself. Exact

figures as to the aggregate attendance were not obtainable, but probably at least five hundred persons were present for a greater or lesser part of the proceedings.

The association met earlier in the week than usual, commencing on Tuesday evening and concluding its public sessions on the following Thursday afternoon. This change was necessitated partly by the Amherst excursion of Friday and partly by the arrangement for Thursday evening of a "farm festival and beefsteak barbecue" on the Eastern States Exposition Grounds under the auspices of the exposition authorities. Some congestion followed the resulting reduction in the time available for meetings, despite many evidences of skillful planning in the framing of the program. On the other hand, the convention was exceptionally free from extraneous distractions, and has seldom been excelled in sustained interest and close attention to the work before it.

The excursion to the Massachusetts Agricultural College was favored by ideal weather conditions, and an exceptional opportunity was afforded to see something of the specialized agriculture of the Connecticut Valley as well as for a brief tour of inspection of the oldest and largest of the New England colleges of agriculture. No formal exercises were held at the college other than an illustrated lecture by Prof. F. A. Waugh on the college campus and grounds. This was chiefly from the point of view of the landscape engineer, as a practical demonstration of some of the possibilities in the development of an institution of this type. Great interest was aroused in the results which had already been accomplished, and there was general regret at the limited time available for the stay at the institution.

The revised constitution of the association provides for general sessions, sectional meetings, and business sessions of the executive body. Two evenings and an afternoon were assigned to the general sessions and an equivalent amount of time was allotted to the various sections, while the executive body had available two late afternoon periods and the final evening.

Two of the three sections, home economics and engineering, attempted no subdivision of work and thus had at their disposal fully as much time as in previous years. The section on agriculture, however, subdivided into groups of resident teaching, experiment station work, and extension service, these meeting simultaneously for morning and afternoon sessions on the second day, while the final period on the morning of the third day was utilized for a session of the entire section. This arrangement afforded an opportunity for a common meeting ground of all agricultural workers, and received many favorable expressions of opinion as well devised to secure united action and promote institutional homogeneity. With a view

to extending its benefits, a proposal was adopted to change the subdivision of time between the section and subsections at subsequent conventions, allotting more time to general sessions for the section as a whole.

The executive body, which it will be recalled consists of the presidents or corresponding executive officers of the constituent institutions and is now the legislative branch of the association, met in strictly executive session. Some thirty institutions, or about three-fifths of the total membership, were represented in its deliberations. In convention with most of its decisions, although these of course of the general sessions, no opportunity was available to acquaint the convention with most of its decisions; although these of course officially determined the policies of the association. Announcement was made that a statement of action taken would be issued as soon as possible.

The presidency of the association for the ensuing year was bestowed upon Dean H. L. Russell of Wisconsin, who was succeeded on the executive committee by Dean F. B. Mumford of Missouri. President Howard Edwards of Rhode Island was elected vice president, and Dean J. L. Hills of Vermont was continued as secretary-treasurer. Few changes were made in the personnel of the various standing committees, except that the committee on graduate study was abolished. A complete list of the officers and committees may be found elsewhere in this issue.

Aside from the transfer of legislative business to the executive body and the presentation of committee reports in full to the sections or subsections, the general sessions closely resembled those of former years. The chief matters taken up in them were the addresses of the president, Chancellor Avery of Nebraska, the Secretary of Agriculture, and two other invited guests, and a discussion by Col. F. J. Morrow of the War Department of some of the problems relating to military instruction in the land grant colleges. The various committee reports were presented in abstract, and a forceful statement from the experiment station subsection set forth the need of increased funds for the stations.

The presidential address of Chancellor Avery was entitled *Our Present College Problems*, and dealt broadly with conditions essential to the maintenance and development of the land-grant institutions in a position of leadership among the great middle classes. As one of the most pressing problems, Chancellor Avery dwelt particularly upon the experiment stations, pointing out some of the reasons why their work is languishing and describing the situation as in danger of "drifting toward sterile times in thought and progress."

Much prominence was also accorded the fostering of research in the address of Secretary Meredith, who expressed himself in part as follows: "We must be frank enough with ourselves to recognize the fact that fundamental research has not gone forward as rapidly as our best interests demand, and it seems to me that the time has come for us—the colleges and stations and the Department—to see that it is given and retains the proper place in our respective organizations. I am sure that nowhere has the importance of research been consciously minimized, but in the exigencies of war and its aftermath, a situation has come about which, I think you will agree, amounts to neglect of this basis of agricultural progress."

Secretary Meredith went on to enumerate many specific lines of inquiry demanding attention, citing the economic problems in farm management, marketing, and distribution, land utilization and agricultural cooperation, methods for converting perishable and surplus farm products into more stable commodities, the better utilization of farm by-products, farm machinery and farm power, farm forestry, and agricultural meteorology. He advocated more adequate courses in the colleges to prepare workers along these lines as well as in the better established fields, stating that "unless we are to permit an insidious undermining of the whole structure that we have reared through six decades of tireless work, we must have a larger number of thoroughly trained and experienced investigators to give their time exclusively to research," and he strongly urged that the salary standards and opportunities should be made such as "to attract and hold the ablest and most farseeing scientific men in America." One of the fundamental reasons for institutional inability to pay adequate compensation he believed to be a lack of understanding on the part of the public of the importance of research work, and he advocated greater efforts to correct this condition by demonstration "to the people in the cities, as well as those in the rural districts, that the funds devoted to agriculture are not used in the interest of the farmer alone but in the interest of the consumer as well."

The address of the Secretary also emphasized the need of close cooperation between the agricultural colleges and the Department of Agriculture. As one means to this end he announced a recommendation to Congress for the appointment within the Department of a director of scientific work, who would be a permanent official and who would devote himself to the development and coordination of the research work of its various branches and to fostering the further correlation of these activities with those of the appropriate State agricultural agencies. The exchange of scientific workers by the Department and the colleges was also suggested.

One of the most notable papers of the convention was that of Dr. A. E. Taylor of the University of Pennsylvania and associated with

the Federal Department throughout the war. Dr. Taylor presented an exhaustive analysis of the world's wheat supply and prices, showing in detail the immensity and complexity of the postwar influences affecting this staple crop, that the price of wheat is by no means a local or even a national matter but world-wide in its ramifications, depending not only upon production but upon transportation facilities, national and international credit and exchange, and many other factors. The paper was recognized as a distinct contribution of such value to economic and extension workers and others that the executive committee of the association was requested to arrange for its early publication.

Of quite different scope, but also of wide appeal, was the address of Dean W. W. Charters of the Carnegie Institute of Technology on the improvement of college teaching. In this address Dean Charters compared the pedagogic value of the fundamental and applied sciences, arguing for a greater use of the latter as cultural material. He also explained the project method for various subjects, and advocated a greater employment of this method in college teaching.

This address proved to be the forerunner of several on the same general subject in the subsection of resident instruction and elsewhere. The subsection devoted one of its sessions to a symposium on the content of a four-year college curriculum in agriculture, at which Dean Eugene Davenport of Illinois discussed required fundamental courses in science, English, etc.; Prof. H. F. Cotterman of Maryland, the required courses in agricultural subjects; and President W. M. Jardine of Kansas, the amount and character of the elective courses. Another session dealt largely with means of improving the methods of teachers already in service. Dean R. L. Watts of Pennsylvania aroused much interest by an account of the beneficial results obtained from a course of lectures by an expert in pedagogy on the principles of teaching, attended voluntarily by ninety-five per cent of his staff. Mention should also be made of an afternoon symposium of the American Society of Agronomy, at which both content and method of teaching were considered.

The standing committee on instruction in agriculture, home economics, and mechanic arts presented a preliminary report on a comprehensive inquiry into the improvement of college teaching in vocational subjects. On the basis of over eight hundred replies received from questionnaires sent to college presidents and teachers of agriculture, home economics, and mechanic arts, the committee found that, while there is some variation among the various subjects, only fourteen per cent of instructors, thirty-eight per cent of assistant professors, and forty-seven per cent of professors now have a

second degree, while less than nine per cent of the college teachers of agriculture possess a doctor's degree. In the opinion of the committee, higher academic standards are essential and the present unsatisfactory conditions should be regarded as temporary. It was urged that appointments to instructorships in particular should be more carefully considered, the position being regarded as one of trial and of opportunity for graduate study and general development, and without obligation to the institution as regards permanent employment or higher rank.

Certain other aspects of the situation, however, were regarded as more encouraging. Nearly half of the teachers replying had studied one or more subjects in education, and greater insistence now seems to be placed on such training. A marked tendency to reduce the number of subjects carried by a teacher was also noted, almost sixty per cent now confining their work to a single subject.

A paper by Mr. L. S. Hawkins of the Federal Board for Vocational Education, before the section on agriculture, emphasized the opportunity and responsibility of the land-grant colleges in preparing teachers for vocational and secondary agriculture. He pointed out that this service, while relatively expensive in proportion to the number of students enrolled, is none the less of great importance, and has numerous advantages for the colleges themselves as they are thereby brought more closely in touch through their graduates with the farm boys and girls from whom much of their student body is recruited.

The committee on college organization and policy reported a need of greater publicity regarding opportunities for agricultural graduates. It voiced a belief that agricultural vocations are not now attracting young men as are many other vocations, although offering many attractive opportunities for leadership, fair financial returns, and a real career. Each agricultural college was, therefore, urged to gather, interpret, and disseminate precise facts as to openings available in agricultural work, and a tentative classification of such openings was submitted. It was also suggested that the colleges might cooperate more effectually along regional and national lines in the training of specialists and other ways.

The subsection on extension service concerned itself largely with the relation of extension work to the new farm bureau movement and to such business enterprises as buying and selling organizations of farmers. The entire subject of marketing relations was thoroughly considered, and a committee of extension directors was appointed to join a similar committee from the American Farm Economics Association and confer with the Federal Department of Agriculture following the December meetings of that association in an attempt to formulate a comprehensive program on marketing work.

As at the 1919 meeting in Chicago, interest in research may again be said to have been the keynote of the convention. Reference has already been made to the strong indorsements of Chancellor Avery and Secretary Meredith, but these were only typical of what was in the minds of the speakers and members generally. Seldom, if ever, has the realization of its fundamental importance to the entire structure of agricultural advancement been more in evidence, especially among those whose immediate work is along administrative, instructional, and extension lines.

This interest was reflected in the consistently large attendance at the meetings of the subsection on experiment station work. This subsection devoted one of its sessions to the consideration of the general outlook for the stations and means of enlisting popular support for their work. The second session included a paper on institutional co-operation in research, and the reports of the various standing committees. There was also an exhibit of methods of keeping records in experimental work, assembled and arranged by Director Watts and containing material collected from a considerable number of the stations.

The subsection opened its program with a review of the effects of the war on research in agriculture, presented by Dr. E. W. Allen, Chief of the Office of Experiment Stations. This review dealt primarily with the effect on the experiment stations as typical research agencies. As regards personnel, it showed a turnover in the stations for the period from 1914 to 1919 of over eighty per cent, a net decline of two hundred fifty persons in the combined-station staffs, and a withdrawal from station work of no less than three hundred seventy department heads and leaders of special lines. These changes, together with the difficulty in filling vacancies with thoroughly trained men, were shown to have resulted in many cases in a trend toward a lower grade of inquiry, a performance of the simpler routine features with an omission of the constructive inquiry essential in original research, and a more elementary outlining of new research projects.

Evidences were also shown that under the lack of special incentive fewer men are preparing for research as a career. Other untoward developments have been the employment of fewer assistants with consequent greater performance of routine duties by project leaders, the loss of experienced directors, the increasing tendency to "double up" the directorship with other positions, and the diversion of the attention of administrative officers in general to other urgent lines.

Efforts to retrieve such conditions were declared to be impeded by the stationary conditions of station resources in the face of ascending operating costs, and the enlarged demands upon the staffs for teaching and extension duties. Instances were cited of a few States in

which improvement had already been effected, but it was pointed out that the stations as a group "have reached the limit of their ability to maintain a satisfactory output and to keep step with the advance in the demands for teaching and extension. New problems are crowding for solution. They ought to be solved in a more definite and permanent way. This means an enlargement of the body of advanced research. Provision for it will require not only means but men adequately prepared for it. It will require guidance of the most capable character, and the strengthening of the station organization to prepare it to use larger funds."

This summary of existing conditions was followed by a further consideration of the situation by Director Burnett of Nebraska, in whose paper a plan for increased Federal aid was outlined. This plan was the subject of considerable discussion, receiving the indorsement of the subsection. Subsequently, following a vigorous presentation of the matter by Dean A. R. Mann of Cornell University, the general session of the convention itself recorded its approval.

Some methods of conducting State campaigns for station funds were suggested by Director F. S. Harris of Utah and Vice Director W. H. Chandler of Cornell University. The former took up some of the findings from a questionnaire sent out to the station directors, and the latter explained in some detail the successful results obtained in New York through enlistment of various farmers' organizations.

The practical importance of getting the stations into closer touch with their constituency was further set forth in a paper by Director F. D. Farrell of Kansas. Such details as prompt and accurate replies to inquiries, courteous consideration of all visitors, holding meetings on the station grounds, a wider use of newspapers in setting forth station accomplishments, and exhibits at fairs, as well as the maintenance of a just proportion of work between the fundamental and practical, were deemed useful in overcoming popular misconceptions, sometimes encountered, of the station as institutions isolated and aloof from the farmers and practical affairs.

Cooperation in research was again a familiar theme of discussion. A review of previous efforts in this direction by the stations and various societies was presented by Director P. F. Trowbridge of North Dakota, illustrating the progress attained in the development of this idea of a more intimate association of workers in advancing research on subjects of common interest. A number of concrete suggestions for the future were advanced in the report of the joint committee on projects and correlation, which gave special emphasis to the question of group conferences, both regional and topical. The advantages and drawbacks of such conferences were discussed quite fully by several speakers, with some differences of opinion as to their general feasibility, but the suggestion of the committee that

it be authorized to arrange for group conferences for specific undertakings upon request and with the approval of the administrative officers concerned was accepted. Suggestions were also made looking to conference with the National Research Council, a fuller description of projects in the Program of Work of the U. S. Department of Agriculture, and the preparation and distribution by the States Relations Service of a compilation of the projects of the stations.

Problems connected with the publication of the results of station work formed the subject of the report of the committee on experiment station organization and policy and also of the committee on publication of research. The former committee referred to the possible waste in distributing station publications through the use of general mailing lists. The importance of conserving printing funds, especially under present conditions, was emphasized; but it was indicated that substituting a system of individual requests would also be open to some objections. Among these were mentioned the long continued period through which the custom of automatic distribution had been in effect, the possible loss of a direct contact with the public, and the doubt as to whether the financial saving through smaller editions might not in many cases be offset by the higher cost of clerical labor in handling individual requests. At the same time the committee recommended a study by each institution of the general situation, with consideration of the advisability of classified mailing lists, the possibilities of a wider use of the rural press in disseminating the new findings of publications, the use of brief postcard announcements, and the ascertaining from farmers themselves whether the request system would meet their needs. It was also pointed out that considerable economy in publications could frequently be effected in other ways, such as careful editing and the use of brief "abstract editions."

The wider use of channels outside the station publications was deemed imperative by the joint committee on publication of research. The report of this committee cited the inadequacy of station funds for this purpose and advocated the strengthening of scientific journals, stating that these should be encouraged to become more broadly national and international. One remedy for the increasing congestion was held to be the restoration of the *Journal of Agricultural Research* to its prewar size. Subsequently the attention of the association was directed to the present legislative status of the *Journal*, whereby its continuance in common with that of other Government periodicals is dependent upon a specific authorization of Congress, and a motion was adopted affirming the interest of the association in permanent provision for both the *Journal* and *Experiment Station Record*.

Another important paper dealing with research was presented before the combined section of agriculture. This was prepared by Dr. H. J. Webber, formerly director of the California Station, and was entitled *The Methods and Problems of Agricultural Investigation*. This paper set forth with characteristic frankness and clarity the author's views of how agricultural research may best be strengthened. Among the needs, he cited that of a more discriminating selection of problems by investigators with greater pains to make sure of their ultimate practical utility. He also urged a careful review of the work by the director and more constructive leadership, pointing out that an essential qualification for this is permanency of tenure. At the same time he decried autocracy in administration and opposed a tendency to build up large departments, insisting that men should be selected for specific projects and that the true investigator needed little but "a problem, a Man Friday, and freedom." Better training of investigators, greater use of graduate students, continuity of policy, and more team work and cooperation, but with scrupulous guarding of the rights of the individual worker, were also thought to be desirable.

Closer relations between stations and with the Federal Department were favored by Doctor Webber, and as a means to this end he proposed the organization of the stations as State bureaus of the Department, with joint maintenance and with the station director responsible to both the Department and the institution, and in local charge of all their experimental work within the State. Great interest was manifested in the paper, and although there was by no means complete agreement with Doctor Webber's suggestions, its constructive spirit and breadth of view were generally recognized. After some discussion, in order to give opportunity for its further consideration, the committee on experiment station organization and policy was directed to make the matters presented its topic for study during the ensuing year.

Summarizing the proceedings as a whole the 1920 convention afforded, first of all, a practical opportunity to try out the new plan of organization, revealing both advantages and disadvantages likely to arise under its operation. Despite some congestion and curtailments a well-balanced and enlightening program was presented, and it received the close attention of the large attendance of delegates and visitors. Many important matters received consideration, and the association once more showed itself progressive in its sympathies and outlook. From the point of view of the readers of the *Record*, the large attention given to research and the unqualified indorsement at the public sessions of an enlarged program for its development was one of the outstanding features of the meeting.

RECENT WORK IN AGRICULTURAL SCIENCE.

AGRICULTURAL CHEMISTRY—AGROTECHNY.

The odorous constituents of apples.—Emanation of acetaldehyde from the ripe fruit, F. B. POWER and V. K. CHESNUT (*Jour. Amer. Chem. Soc.*, 42 (1920), No. 7, pp. 1509-1526).—A detailed investigation of the chemical nature of the odorous constituents of apples is reported from the Bureau of Chemistry, U. S. Department of Agriculture. The varieties of apples used in the investigation included the Ben Davis, Springdale, and a variety of crab apples known as the Golden Beauty.

The preliminary extraction of the odorous constituents was effected by prolonged distillation with steam of fresh parings from the apples and repeated cohobation of the aqueous distillate in a current of steam until the distillate was concentrated to about one-hundredth of its original volume. A detailed chemical study of this distillate and of the aqueous liquids remaining from the concentration of the original distillate led to the following conclusions:

“The odorous constituents of apples have been found to consist essentially of the amyl esters of formic, acetic, and caproic acids, with a very small amount of the caprylic ester and a considerable proportion of acetaldehyde. In considering the relative amounts of the respective alcohols and acids it seems probable that the latter are also present to some extent in the free state.

“It has been shown that acetaldehyde is a product of the vital activities of the fruit, and that it occurs in the exhalations of ripe apples. This observation is deemed of considerable biological importance, especially as it has hitherto been assumed that the lower aliphatic aldehydes are first formed during the process of steam distillation. It is, for example, quite probable that the exhalation of acetaldehyde may prove to be one of the factors involved in the production of so-called ‘apple-scald,’ an affection to which some apples are subject when stored without free circulation of air.

“The aqueous distillate from fresh apple parings has been found to contain, in addition to the above-mentioned substances, exceedingly small amounts of methyl and ethyl alcohols and also a small amount of furfural. Inasmuch as the last compound is doubtless produced by chemical changes in the material during its distillation, it can not be regarded as one of the odorous constituents of the apple.

“The essential oil, as extracted by means of ether from a concentrated distillate of either ordinary apple parings or those of the crab apple, is at ordinary temperatures a yellowish, somewhat viscid liquid, becoming much darker on keeping. When slightly cooled it forms a concrete mass, due to the separation of small acicular crystals which consist of a paraffin hydrocarbon. It possesses in a high degree the characteristic, fragrant odor of fresh apples. Besides the esters mentioned, it has been found to contain, by specific tests, small amounts of acetaldehyde and furfural. The yield of oil from the parings of the Ben Davis apple was 0.0035 per cent, and that from the more odorous crab apple 0.0043 per cent, which corresponds to about 0.0007 and 0.0013 per cent, respectively, of the entire ripe fruit.

"Although amyl valerate is generally designated in chemical literature as 'apple oil,' it is quite certain that this compound has never been identified as a constituent of apples, and in the course of this investigation no evidence could be obtained of its presence. On the other hand, it has been shown that the characteristic, fragrant odor of ripe apples is due to a mixture of the previously enumerated substances, which may exist in varying proportions in the numerous varieties of the fruit, thus giving rise to slight differences of odor."

The enzymes of milk and their relations to abnormal flavors, L. S. PALMER (*Missouri Sta. Bul.* 172 (1920), pp. 20, 21).—In the search for a suitable antiseptic to use in lipase studies with milk and for a satisfactory method for determining lipase activity of milk, particularly successful results were secured by the use of artificial milk prepared by emulsifying butter fat with gum arabic and diluting the emulsion with water, the resulting preparation being free from lactose, proteins, and inorganic phosphates present in real milk.

A study of the action of various antiseptics toward the activity of pancreatic lipase upon this artificial milk indicated that formaldehyde would be the best antiseptic to use for lipase studies, concentrations as high as 1 per cent having no retarding effect, and concentrations of 0.1 and 0.05 per cent having a slight accelerating effect upon lipase activity.

In determining the total fatty acids liberated from milk fat by lipase, the best results were obtained by adding 4 volumes of a mixture of acetone and ether (2:1) and titrating with $N/10$ alcoholic KOH, using phenolphthalein as indicator.

"The work has not progressed to the point where it can be stated with assurance whether or not lipase is a normal constituent of milk. Further indications were secured, however, that the bitter milk, which frequently characterizes the close of the lactation period of single cows, is due to the action of lipase on the milk fat."

The production of hydrochloric acid from chlorin and water, H. D. GIBBS (*Jour. Indus. and Engin. Chem.*, 12 (1920), No. 6, pp. 538-541, figs. 3).—This is a brief report from the Bureau of Chemistry, U. S. Department of Agriculture, of an investigation of the possibility of the economic conversion of chlorin into hydrochloric acid. A reversal of the Deacon process is considered to be of possible commercial application with charcoal as a catalyzer. A reaction between chlorin water and charcoal takes place between 0 and 130° C., the most important factors influencing the speed of the reaction being the character of the charcoal, the temperature, and the relation between the concentration of the water and the chlorin.

Seed-culture methods in the production of acetone and butyl alcohol by a fermentation process, H. B. SPEAKMAN (*Jour. Indus. and Engin. Chem.*, 12 (1920), No. 6, pp. 581-587, figs. 8).—This paper describes in detail the apparatus and methods used in the large-scale production of pure seed cultures for the manufacture of acetone and butyl alcohol by the fermentation process previously noted (*E. S. R.*, 41, p. 415).

A simple alcohol testing device, S. WALDBOTT (*Jour. Indus. and Engin. Chem.*, 12 (1920), No. 7, p. 690, fig. 1).—The apparatus described consists of a copper flask surmounted by a simple fractionating device filled with glass beads and terminating in a bent glass exit tube. Fifty cc. of the liquid to be tested is placed in the flask and heated to boiling and the vapor ignited as it issues from the exit tube. It is stated that if the liquid contains as much as 3 per cent of alcohol a semiluminous blue flame, about 3 in. long, will continue to burn for from 120 to 150 seconds, while, if the alcohol content is only about 0.5 per cent, a flame of the same length lasts for about 20 to 25 seconds under the same conditions of heating the flask.

Acidity and acidimetry of soils, III, IV, H. G. KNIGHT (*Jour. Indus. and Engin. Chem.*, 12 (1920), No. 6, pp. 559-562).—Continuing the investigation previously noted (*E. S. R.*, 43, p. 612), two papers are presented.

III. *Comparison of methods for determining lime requirements of soils with hydrogen electrode* (pp. 559, 560).—In this study 15 samples of soils, the lime requirements of which as determined by the Veitch, Hopkins, Hutchinson-MacLennan, MacIntire, and vacuum methods had been reported by Ames and Schollenberger,¹ were used for H-ion concentration determinations according to the method described in the previous paper, using $N/2$ KCl solution containing various predetermined amounts of lime. By interpolating the results obtained as straight line functions to determine the amount of lime necessary to lower the H-ion concentration to 10^{-7} with a 0.69 volt potential, a comparison was made with the results reported by Ames and Schollenberger.

From a study of these data the authors conclude that the vacuum method approaches nearer to the lime requirements as shown by the hydrogen electrode than do any of the other methods, although the results are uniformly higher. "It is quite evident that the above methods, with the possible exception of the vacuum method, do not indicate the amount of lime necessary to completely neutralize a soil, especially in the presence of neutral salts, except for a limited period."

IV. *Proposed method for determination of lime requirements of soils* (pp. 560-562).—In this paper certain disadvantages of the hydrogen electrode method for the practical determination of the lime requirements of soils are pointed out, and a method is proposed which is said to approximate the results obtained with the hydrogen electrode but to be much more rapid and less expensive.

The proposed method is essentially a modification of Tacke's method previously noted (*E. S. R.*, 9, p. 32). A weighed quantity of the soil (from 5 to 10 gm.) is mixed with an excess of precipitated calcium carbonate in a 125 cc. Erlenmeyer flask. This is attached to a Parr apparatus, 25 cc. of normal salt solution is added, and the mixture is boiled for a fixed period, after which the carbon dioxide evolved is determined by Pettit's modification of the Parr method (*E. S. R.*, 16, p. 638). The method was found to give varying results, depending upon the time of boiling. A 10-minute period is recommended, although the reaction is probably not complete even at the end of that time.

"It is quite evident that any of the proposed methods gives comparative results only. The true lime hunger as it relates to cropping is after all the matter that we are most interested in determining, and this, it seems, with the present state of our knowledge must be determined by field experiments."

By subtracting the acidity values found in acid soils from those found in the limed soils from corresponding half plats, the residual reduction in acidity due to previous applications equivalent to 5,700 lbs. of calcium carbonate was determined.

"As an average of the results from seven plats which afford data for this measurement the reduction in acidity is 2,864 lbs. by the Hopkins method, 2,674 by the vacuum method, and 2,388 by the hydrogen electrode, while the MacIntire, Hutchinson, and modified Tacke methods show reductions of 1,243, 1,279, and 1,375 lbs., respectively. That any method will show a greater reduction in acidity than actually occurs and remains at the time of sampling seems extremely doubtful.

"As suggested above, the vacuum method appears to furnish the most trustworthy measure of the total lime requirement, and it also seems safe to assume that the hydrogen electrode will give results in substantial agreement with the

¹ *Jour. Indus. and Engin. Chem.*, 8 (1916), pp. 243-246.

vacuum method if sufficient time is allowed. If these methods are accepted as standards, then the Hopkins method seems to give correct results when used to measure the reduction in soil acidity by applications of lime. It may also measure with accuracy the most immediate lime need, although it does not measure the total power of a soil to decompose carbonates.

"If we assume that the reduction in acidity should be approximately the same for all limed plats, the Hopkins method and the hydrogen electrode show the highest percentage consistency."

Determination of nitrate nitrogen in nitrates and fertilizers, H. C. MOORE (*Jour. Indus. and Engin. Chem.*, 12 (1920), No. 7, pp. 669-673).—The author outlines briefly the methods commonly employed for the determination of nitrate nitrogen in nitrates and fertilizers, and describes a modified Kjeldahl-Gunning method which, if correctly applied, is said to yield extremely accurate results. The method is based upon the following reactions:

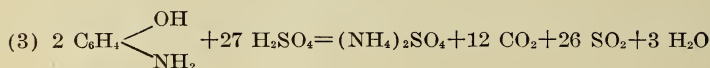
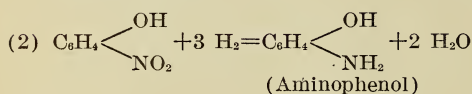
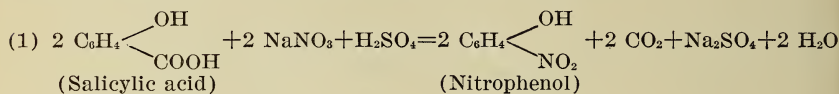

The reduction of the nitrophenol may be brought about either with the use of "hypo" or zinc dust, although the author prefers the former. The technique of the method as applied to nitrates is as follows:

Fifty cc. of salicyl-sulphonic acid, prepared by making up 40 gm. of salicylic acid to one liter with concentrated H_2SO_4 , is slowly added to 0.8517 gm. of NaNO_3 in a Pyrex Kjeldahl flask, and the flask warmed over low heat or in boiling water or steam bath, shaking frequently until the solution is complete. Five gm. of "hypo" is added and the heating continued until frothing ceases (about 5 minutes), after which 10 gm. of sodium or potassium sulphate and 1 gm. of mercury are added, and the digestion continued with rapid boiling for one hour after the solution has become clear. The solution is then diluted with water to about 400 cc., a small piece of granulated zinc and from 70 to 80 cc. of caustic soda (made by dissolving 30 lbs. of commercial soda in 2.5 gal. of water) containing 2 gm. of fused sodium sulphid are added, and the ammonia is distilled into 21 cc. of $\text{N}/2\text{H}_2\text{SO}_4$ diluted to 125 or 150 cc. with water containing 3 drops of alizarin sulphonate. The distillation is continued for about 45 minutes, or until about 150 or 200 cc. of the distillate is collected. Blanks should be run with all reagents and the correction thus obtained applied.

Essentially the same technique is employed in the case of fertilizers, using 1.7034 gm. of the sample, 35 cc. of salicyl-sulphonic acid, 5 gm. of "hypo," 5 gm. of potassium or sodium sulphate, 0.5 gm. of mercury, and 1 gm. of sodium sulphid.

The results are summarized of a large number of determinations on nitrate samples and mixed fertilizers and of a comparison of this method with the West Coast or refraction method.

The Hess-Ives tint-photometer and its use with raw sugars, G. P. MEADE and J. B. HARRIS (*Jour. Indus. and Engin. Chem.*, 12 (1920), No. 7, pp. 686-688, fig. 1).—The authors discuss the Hess-Ives tint-photometer and the diffi-

culty in interpreting the scale readings in terms of color concentration. From a series of readings on various strength solutions of the same raw sugar, it was found that the readings in any series (considered as decimal fractions) run in powers of the first reading of the series if multiples of a unit of material be used. This is due to the mechanical make-up of the instrument and holds whatever color screen or kind of material is used.

This relationship between the scale readings and the amount of material taken can be expressed by the equation $y = Kx^n$, where y = any scale reading, K = the scale reading for one unit of the material, and x^n = the number of units of material which will give the scale reading y . By means of this equation the color of two materials may be compared if the scale readings for equal quantities are known, or all scale readings may be compared to a standard. A table has also been calculated which gives the units of color corresponding to each scale reading from 100 to 1. This may be used for the rapid determination of the color of raw sugars as follows:

Twenty gm. of the sugar is dissolved in distilled water, made up to 100 cc., filtered through paper in which is placed 2 or 3 teaspoonfuls of kieselguhr, and refiltered until the solution is clear. Twenty-five cc. of this solution is transferred to the observation cell on the right of the instrument, and an equal amount of distilled water is placed in the left hand cell. The solution is read through each of the 3 screens, the readings are recorded, and the corresponding color units read from the table. The color of the sugar is calculated by adding the color units thus obtained and dividing by 3. Typical results of color determinations on raw and refinery sugars are reported.

Fruit evaporation and by-products, O. M. MORRIS (*Washington Sta. Bul. 155 (1920), pp. 33, 34*).—Preliminary work on fruit evaporation and by-products has indicated that dipping the fruit in a solution before drying is of no particular advantage. Added circulation with a fan was found to increase greatly the rate of drying without increasing the quantity of heat generated. Tests made with apple sirup to determine whether the boiling point can be used as a test for the keeping qualities of the material indicated that at the elevation of Pullman, 2,500 ft., sirup concentrated to a boiling point of 103° C. was not uniformly satisfactory, but that when concentrated to a boiling point of 105° the sirup kept perfectly.

The evaporation of grapes, W. V. CRUICK, A. W. CHRISTIE, and F. C. H. FLOSSFEDER (*California Sta. Bul. 322 (1920), pp. 421-471, figs. 12*).—In this bulletin are presented the results of an investigation of different methods of constructing and operating evaporators for the drying of raisin grapes, wine grapes, cull table grapes, and second-crop Muscats.

Following a brief discussion of the principles of evaporation, a detailed description is given of an evaporator of the horizontal tunnel, air-blast type and of 6 tons of fresh fruit capacity which was constructed on the university farm in 1919 and used for the experimental work here reported. The discussion of the evaporator includes a list of materials and cost of construction, a description with accompanying diagrams of the original evaporator, an explanation of the course followed by the grapes at the evaporator, suggested revisions in the plan of the evaporator resulting from the experience gained in its use, and estimates of the cost of operation of such an evaporator.

The experimental work reported upon includes studies of the effect of dipping grapes in hot lye solution before drying; the relative merits of drying fruit in the sun and in evaporators; the effect of sulphuring and of temperature on the quality and rate of drying; a comparison of the efficiency of trays, burners, fans, and fuel of different types; a study of permissible ranges of moisture

content of evaporated grapes; and experiments on stemming, seeding, and packing evaporated grapes.

Dipping the grapes in a dilute boiling lye solution was found approximately to double the rate of drying, the strength of the solution required depending upon the variety of grape. Most wine-grape varieties and Muscat grapes required a 2 or 3 per cent solution, while Tokays and Thompson Seedless required only a 0.5 per cent solution. Sulphuring for a short period was found to shorten the period of drying, to improve the color of the grapes, and to produce a slightly larger yield. No constant difference in yield was obtained in sun-drying and in evaporation. The color and flavor of the juice of sun-dried grapes obtained by soaking in water was inferior to that obtained from evaporated grapes.

The rate of drying was greatly increased by an increase in the temperature of the air used in drying. The temperature of 165° F. is recommended for general practice. Recirculation of a large proportion of the exhaust air was found to reduce fuel consumption without reducing the rate of drying, and also to prevent the overdrying of the fruit and permit regulation of the moisture content of the dried product. The limit of safety in keeping quality of the moisture content of dried grapes was between 25 and 30 per cent. With a moisture content of 20 per cent the finished product was of the most desirable texture. By allowing the dried product to stand in sweat boxes or bins for a number of days equalization in moisture content resulted.

Dried grapes can be stemmed satisfactorily when dried to about 10 per cent moisture and stemmed within a few hours after drying. Dried wine grapes were seeded successfully, although with considerable loss.

In conclusion, attention is called to the indiscriminate use of various terms to designate fruits and vegetables from which most of the water has been removed. A committee appointed to consider the question has made the following recommendation:

"(a) The same nomenclature shall be applied to fruits and vegetables.

"(b) The term 'dried' is applied to all fruits and vegetables preserved by the removal of moisture, irrespective of the method of removal.

"(c) There are but two classes of dried fruits and vegetables, namely, those dried principally by solar heat and those dried principally by artificial heat.

"(d) The class dried principally by solar heat shall be designated 'sun dried,' by which is meant the removal of moisture by solar heat without control of temperature, humidity, or air flow.

"(e) The class dried principally by artificial heat shall be designated either 'evaporated' or 'dehydrated.' The committee finds at this time no sufficient reasons for distinguishing between 'evaporated' and 'dehydrated'."

Commercial production of grape sirup, W. V. CRUESS (*California Sta. Bul.* 321 (1920), pp. 401-416, figs. 5).—This publication supplements the information on the manufacture of grape sirup given in Bulletin 303, previously noted (*E. S. R.*, 40, p. 414). Of several different types of sirup which have been produced, the three which appear to be most promising are (1) "a sirup of deep violet-red color and rich berry-like flavor, made in vacuum pans of standard design; (2) a sirup, red or white as desired, made by concentrating fresh Muscat or other highly flavored juice by the freezing process and blending this with a sirup of high sugar content made by the vacuum-pan process; (3) a red or white sirup made in a proprietary patented vacuum pan so designed that part of the natural grape flavor is condensed and returned to the sirup."

The manufacture of the first type of sirup, which is considered to give the best results from a commercial standpoint at present, is described in detail,

including the necessary equipment, varieties of grapes, and the different processes involved. Diagrams are included of different types of vacuum pans with dry and wet vacuum-pump connections.

The second method, which is described briefly, is an application of the process developed by Gore (E. S. R., 33, p. 316). This consists essentially of freezing the fresh juice and separating the sirup from the ice by centrifugal force. As the sirup obtained from grape juice by this process is not sweet enough for general use, it has been found necessary to blend with it a sirup of 70 to 75° Balling made in an ordinary vacuum pan. The resulting sirup is said to retain more of the fresh grape flavor than a sirup made entirely by the vacuum process.

It is suggested that grape sirup manufacture can be undertaken profitably by large wineries, milk canneries, and breweries. Attention is called to the importance of the character of the lining of the vacuum pans. As analyses have shown that small amounts of copper may be dissolved in the juice during concentration, it is considered advisable to use monel metal or glass-lined vacuum pans.

Unfermented fruit juices, W. V. CRUESS (*California Sta. Circ. 220 (1920)*, pp. 32, figs. 18).—This circular consists of a compilation of information from various sources on the home and commercial manufacture of unfermented fruit juices. The general principles involved are discussed briefly and the most common forms of equipment for fruit-juice manufacture are described and illustrated by photographs and diagrams, including a diagram of a home-made fruit-juice press, which is also suitable for pressing olives for oil.

The manufacture of grape juice is described in detail, and estimates are given of costs and returns on grape juice based upon the results of experiments at the university farm. Brief directions are also given for the manufacture of unfermented apple, loganberry, pomegranate, and citrus fruit juices.

Tar-still operation in hardwood distillation plants, L. F. HAWLEY and H. N. CALDERWOOD, JR. (*Jour. Indus. and Engin. Chem.*, 12 (1920), No. 7, pp. 684, 685).

METEOROLOGY.

Relation between the annual precipitation and the number of head of stock grazed per square mile, J. W. SMITH (*U. S. Mo. Weather Rev.*, 48 (1920), No. 6, pp. 311-317; *abs. in Bul. Amer. Met. Soc.*, 1 (1920), No. 5, p. 55).—A review of the available data indicates that wherever grazing is carried on throughout the year it is possible to establish a close ratio between annual rainfall and the number of head of stock that can be grazed per square mile. "In New South Wales, for example, where the rainfall is between 20 and 30 in., 250 sheep are grazed to the square mile; where it is between 10 and 20 in., 100 sheep; and where under 10 in., only 40 sheep to the square mile."

"In the Great Plains States the relation between the annual precipitation and the number of head of stock that can be grazed per square mile can be fairly well established, the possible number decreasing with fair uniformity from east to west with the decreasing annual rainfall. The number grazed in Oklahoma and Texas is close to 50 per square mile where the rainfall is between 25 and 35 in. and about 40 where the rainfall is from 15 to 25 in.

"In the Great Plains States north of Oklahoma, where feeding is necessary during the wintertime and where the rate of evaporation is less in the summer months, the grazing rate averages close to 20 where the rainfall is between 10 and 15 in., nearly 40 where it is from 15 to 20 in., and nearly 80 where it is 20 to 25 in. The ratio rises at a faster rate with heavier rainfall.

"In all the Rocky Mountain region it becomes more difficult to establish a ratio between the annual precipitation and rate of grazing because of seasonal distribution of precipitation, temperature variations, the topography, soil, evaporation, snow cover, nature of the vegetation, and differences in the length of the grazing period. In the central and upper Rockies the grazing rate is slightly greater with small rainfall amounts than farther east, because of the shorter grazing period, but less than in the Great Plains with heavier precipitation, because of the relatively less grazing areas in the higher mountains, where the greatest precipitation occurs."

Agricultural meteorology, J. W. SMITH (*U. S. Mo. Weather Rev.*, 48 (1920), No. 5, pp. 281-283).—The historical development of agricultural meteorology or, as it may be broadly termed, meteorology in its relation to agriculture, is briefly reviewed, the present work of the Division of Agricultural Meteorology in the U. S. Weather Bureau is described, and future lines of development of such work are discussed. The more important contributions to the subject are indicated and a bibliography is given.

The bioclimatic law, A. D. HOPKINS (*Jour. Wash. Acad. Sci.*, 10 (1920), No. 2, pp. 34-40; *abs. in U. S. Mo. Weather Rev.*, 48 (1920), No. 6, p. 355).—This is a brief exposition of the bioclimatic law which has been more fully explained, particularly in its relation to various phenological events, in articles noted (*E. S. R.*, 43, p. 509).

Intensity of nocturnal radiation at high altitudes, A. BOUTARIC (*Compt. Rend. Acad. Sci. [Paris]*, 170 (1920), No. 20, pp. 1195, 1196; *abs. in U. S. Mo. Weather Rev.*, 48 (1920), No. 5, p. 284; *Rev. Sci. [Paris]*, 58 (1920), No. 11, p. 348).—Observations on Pic du Midi at an elevation of 2,859 meters, and at Montpellier, practically at sea level, are cited to show that the intensity of nocturnal radiation is independent of altitude when the temperature and vapor pressure are the same.

Monthly Weather Review (*U. S. Mo. Weather Rev.*, 48 (1920), Nos. 5, pp. 251-310, pls. 16, figs. 20; 6, pp. 311-377, pls. 13, figs. 43).—In addition to detailed summaries of meteorological, climatological, and seismological data and weather conditions for May and June, 1920, and bibliographical information, reprints, reviews, abstracts, and minor notes, these numbers contain the following contributions:

No. 5.—Preliminary Steps in the Making of Free-air Pressure and Wind Charts (illus.), by C. L. Meisinger; Detection of Storms and Their Travel by Radio Equipment, by C. N. Keyser; Aerological Observations in the West Indies; The Measurement of Temperature, With Some Remarks on other Physical Measurements, and Applications to Meteorology, by E. W. Woolard; Shading Instrument Shelters (illus.), by S. D. Flora; The Standard Atmosphere, by W. R. Gregg; Intervals Between Beginning of Rainfall in West and Central France; The Most Intense Rainfall on Record, by B. C. Kadel; Sunshine and Cloudiness in the Canal Zone (illus.), by H. G. Cornthwaite; Humidity and Hot Weather, by H. G. Cornthwaite; Note on Dr. Griffith Taylor's Climograph Charts; and Agricultural Meteorology, by J. W. Smith (see above).

No. 6.—Relation Between the Annual Precipitation and the Number of Head of Stock Grazed Per Square Mile, by J. W. Smith (see p. 717); New Aerological Apparatus (illus.), by S. P. Fergusson; A General Theory of Halos (illus.), by C. S. Hastings; Beautiful Halo Display Observed at Ellendale, N. Dak. (illus.), by F. J. Bavendick; The Boulder Halo of January 10, 1918 (illus.), by E. W. Woolard; The Grand Junction Halo of March 2, 1906 (illus.), by E. W. Woolard; Outline Showing the Formation of the Elements of a Halo Complex, by E. W. Woolard; Iridescent Clouds, by C. F. Brooks; Some Observations on a Free-

Balloon Flight Made from Aberdeen Proving Ground, Md., June 3, 1920, by D. McNeal; Daytime Wind Turbulence in a Mountain Valley (illus.), by B. M. Varney; A Fog Phenomenon of San Francisco Bay (illus.), by B. M. Varney; Measurements of Solar Radiation at Madison, Wis., with the Callendar Pyrheliometer (illus.), by E. R. Miller; Some Characteristics of the Callendar Pyrheliometer (illus.), by E. R. Miller; Suggestions Concerning Dr. C. G. Abbot's Program for Four World Observatories for the Observation of Extraterrestrial Solar Radiation (illus.), by C. Dorno; A Waterspout in the Adirondacks; Tornado in Union County, N. C., June 20, 1920, by G. S. Lindgren; Tornado in Southeastern Wyoming, June 24, 1920; and Cold Shore Water Owing to Off-Shore Winds, by C. F. Brooks.

Meteorological observations at the Massachusetts Agricultural Experiment Station, J. E. OSTRANDER and G. E. LINDSKOG (*Massachusetts Sta. Met. Buls.* 379-380 (1920), pp. 4 each).—Summaries of observations at Amherst, Mass., on pressure, temperature, humidity, precipitation, wind, sunshine, cloudiness, and casual phenomena during July and August, 1920, are presented. The data are briefly discussed in general notes on the weather of each month.

SOILS—FERTILIZERS.

Productive soils, W. W. WEIR (*Philadelphia and London: J. B. Lippincott Co., (1920), pp. XVI+398, pls. 2, figs. 233*).—It is the purpose of this book to give definite, practical, and complete information concerning soils and profitable crop production. It is divided into the following sections: Soils, their origin and classification; soils from a chemical point of view; soil and plant relations; crop production; factors determining soil fertility; crop production affected by systems of cropping; application of principles to management of special soils; principles of soil fertility applied to the farm as a whole; and other points on soil management.

Agricultural geology, F. V. EMERSON (*New York: John Wiley & Sons, Inc., 1920, pp. XVIII+319, figs. 271*).—This book deals primarily with the origin of soils, and, to a less extent, with the origin of mineral fertilizers. It contains the following chapters: Minerals; rocks; weathering; residual soils from various rocks; wind work and eolian soils; ground water; streams and their work, alluvial soils; classes of alluvial deposits; soil creep, colluvial soils; glaciers and glaciation, glacial soils; lakes and swamps, lacustrine and cumulose soils, lakes, lacustrine soils; oceans; mineral fertilizers; soil regions of the United States; and historical geology.

**Soil survey of Kent County, Del., J. E. DUNN, J. M. SNYDER, and E. HOF-
FECKER** (*U. S. Dept. Agr., Adv. Sheets Field Oper. Bur. Soils, 1918, pp. 32, fig. 1, map 1*).—This survey, made in cooperation with the Delaware Experiment Station, deals with the soils of an area of 380,160 acres in central Delaware, which lies in the Atlantic Coastal Plain, and has a flat to slightly undulating topography. As a whole, the drainage of the eastern and western parts is poor, while that of the central belt is good.

The soils are of sedimentary origin. Including tidal marsh, swamp, meadow, and coastal beach, 17 soil types of 4 series are mapped, of which the Sassafras sandy loam covers 28.9 per cent, the Elkton sandy loam 13.5 per cent, and tidal marsh 12 per cent of the area. The Sassafras series covers about half of the entire area.

Soil survey of St. Johns County, Fla., A. E. TAYLOR, G. B. JONES, E. C. HALL, and C. N. MOONEY (*U. S. Dept. Agr., Adv. Sheets Field Oper. Bur. Soils, 1917, pp. 37, pls. 3, fig. 1, map 1*).—This survey deals with the soils of an area of 388,480 acres in northeastern Florida, the surface of which consists of an

almost level area, broken along the coast and to a lesser degree along streams by low ridges. The topography ranges from shallow undrained basins through flat, poorly drained areas to excessively drained ridges. The soils vary from loose sands to heavy clays and peaty muck, but fine sands predominate. The soils are of residual, alluvial, and cumulose origin, including swamp, tidal marsh, peaty muck, and coastal beach. Sixteen soil types of 10 series are mapped, of which the St. Johns, Bladen, and Leon fine sands are the three predominating types.

Soil survey of La Salle Parish, La., C. LOUNSBURY and R. F. ROGERS (*U. S. Dept. Agr., Adv. Sheets Field Oper. Bur. Soils, 1918, pp. 42, pls. 2, fig. 1, map 1*).—This survey deals with the soils from an area of 394,880 acres in north-central Louisiana, which comprises a gently rolling to rolling region in the central part, a relatively low, undulating flatwoods region in the northwestern part, and low alluvial belts subject to inundation in the southern part. The area lies within the Gulf Coastal Plain and for the most part the uplands are well drained. A few level areas have no well defined drainage courses and are swampy. The upland soils are of sedimentary origin. Twenty-six soil types of 15 series are mapped, of which the Montrose silty clay loam, the Orangeburg fine sandy loam, and the Sharkey clay are the most extensive individual types.

Soil survey of Madison County, Miss., W. E. THARP, E. H. SMIES, and G. W. MUSGRAVE (*U. S. Dept. Agr., Adv. Sheets Field Oper. Bur. Soils, 1917, pp. 37, pl. 1, fig. 1, map 1*).—This survey, made in cooperation with the State of Mississippi, deals with the soils of an area of 404,000 acres in central Mississippi.

The central and southern parts of the county are undulating to rolling, while the northern and northeastern parts are more or less hilly. Most of the uplands, second bottoms, and the small branch bottoms are cleared, while the overflow lands of the larger streams are forested. Nearly all of the county is drained by the Big Black River.

The soils are mainly silts and silty clay loams free from stones and gravel. The prevailing surface formation is loess. Thirteen soil types of 9 series are mapped, of which the Grenada silt loam and the Vicksburg silt loam cover 43.4 and 12 per cent of the area, respectively.

Soil survey of Webster County, W. Va., C. N. MOONEY (*U. S. Dept. Agr., Adv. Sheets Field Oper. Bur. Soils, 1918, pp. 24, fig. 1, map 1*).—This survey, made in cooperation with the West Virginia geological survey, deals with the soils of an area of 357,120 acres in central West Virginia, lying in the Allegheny Plateau section of the Appalachian Province. The topography is mountainous. The soils are of residual and alluvial origin. Including rough stony land, seven soil types of five series are mapped, of which De Kalb stony silt loam covers 66.4 and rough stony land 21.9 per cent of the area.

Agricultural characteristics of the cultivated soils of the coast of Peru, J. A. DE LAVALLE (*Inform. y Mem. Soc. Ingen. Perú, 20 (1918), Nos. 4, pp. 129-143; 5, pp. 172-189; 6, pp. 264-275; 7, pp. 307-320*).—This report deals with the geology and physical and chemical properties of the cultivated soils of the coastal districts of Peru, and includes 30 tables of analyses.

Soils of practically all types as regards physical properties are found in the region. The important types are clays, clay sands, sandy soils, alkali soils, and so-called humus soils. The alkali soils occur mainly in the lower valleys due to inadequate drainage. The character of the subsoil is very variable. Most of the coastal soils are rich in nitrogen which, however, occurs largely in unavailable organic forms. The soils are also generally well supplied with phosphoric acid, but are deficient in available potash and lime.

Analyses of soils of Eritrea, A. CAUDA (*Agr. Colon. [Italy], 14 (1920), No. 5, pp. 226-228*).—Analyses of samples of a number of different soils from Eritrea are reported and discussed, showing that the matter soluble in concentrated hydrochloric acid varies from a minimum of 97.51 to a maximum of 104.76 gm. per thousand of fine soil. Calcium oxid comprised from 0.76 to 23 per cent of the soluble matter, potash from 1.58 to 7.93 per cent, phosphoric acid from 0.38 to 2.68 per cent, and total nitrogen from 0.37 to 1.96 per cent.

It is concluded that the average chemical composition of these soils corresponds to good Italian field soils.

Sandy soils, W. J. SPAFFORD (*Jour. Dept. Agr. So. Aust., 23 (1920), No. 10, pp. 829-838*).—The results of experiments on the improvement of sandy soils in South Australia are reviewed, it being shown that the most profitable handling of these soils after the bulk of their organic matter content has become exhausted consists of pasturing with very infrequent cropping.

For the purpose of carrying much live stock, lucern is said to be the most useful crop used in a rotation of fallow, wheat with lucern, and lucern alone for three successive years. On sandy soil it was found that from one course of such a rotation from 1914 to 1918 the returns were nearly four times as much per acre per year as for wheat or bare fallow similarly fertilized. Where such soils are to be cropped, owing to insufficient water supply for live stock, the land should be plowed early and heavily fertilized.

Soils (Missouri Sta. Bul. 172 (1920), pp. 37-44, fig. 1).—Experiments conducted by M. F. Miller, R. H. Hudelson, and F. L. Duley, on the relative values of different forms of phosphorus upon the soil at the station, showed that calcined phosphate gave the best results, followed in order by acid phosphate, basic slag, rock phosphate, and bone meal.

Experiments conducted by W. A. Albrecht on the fertilizing value of bat guano obtained from caves in the southern half of the State showed it to be equal to dried blood and tankage in ammonia production in soil and superior to tankage in nitrate production, but not the equal of blood. In pot cultures with oats, guano supplying 100 lbs. of nitrogen per acre gave results equivalent to those from dried blood and tankage added at twice that rate or ammonium sulphate at the same rate. Studies on the longevity of *Pseudomonas radiccicola* by Albrecht showed that even though the soil which had grown legumes was dried in the sun and stored for from 6 to 12 months, there were enough active bacteria present to produce as good an inoculation as soil which was dried in the dark or left out of doors.

Experiments conducted by Miller and Duley on the effect of weathering and storage upon the composition of mule manure are reported. One ton of the manure was stored in a galvanized iron pan 10 ft. square and 6 in. deep, another ton was placed in a similar pan provided with drainage, and a third ton on the ground in a conical pile. After five months' exposure to the weather the manures stored in the pan without drainage and in the conical pile lost about one-third of their dry matter, while that in the pan having drainage lost 45 per cent. The nitrogen loss from the conical pile was slightly less than from the undrained pan, but the loss of potash was nearly five times as great. The greatest loss of potash was from the drained pan, but the nitrogen loss was small.

The results of two years' experiments by Miller and Duley on run-off and absorption of rain water showed that land plowed 8 in. deep lost nearly two and one-half times as much soil as land having no cultivation. Land plowed 4 in. deep lost nearly as much as that plowed 8 in. deep. Sod land was most efficient in preventing erosion and absorbed a greater percentage of the rain-

fall than any of the other soils. Land continuously cropped to wheat was almost as efficient in this respect as sod land, but lost considerable soil when the land was first broken. Land having rotations of corn, wheat, and clover lost very little soil except during the time it was growing corn. Land continuously cropped to corn lost about the same amount of soil as uncultivated land and less than half as much as that plowed to the same depth and having no crop.

Two years' studies on nitrate production in soil by Albrecht showed that the most significant influence of crops was that of removing the nitrates. Plowing had a very significant effect toward increasing nitrates, although cultivation of the surface soil reduced the nitrate content in the upper 7 in. of soil. Mulching had a marked depressing effect upon nitrate accumulation. The moisture and nitrate contents were negatively correlated. Long-continued rains removed the nitrates, especially in tilled soils, while downpours did not have as serious effects. High concentrations of nitrates were reached in fallow soil.

Experiments conducted by Miller and Duley to determine the best systems of soil management for the most important soil types in Missouri showed that the three materials giving most consistent and economical returns are manure, soluble phosphates, and limestone. On certain thin Ozark soils bone meal showed a decided advantage over acid phosphate in its residual effect upon clover. Raw rock phosphate scarcely paid the cost of application.

Relation between fertilization and soil compression on the one hand and germination in soil on the other, W. KOSTERZ (*Nachr. Deut. Landw. Gesell. Österr., n. ser., 3 (1919), No. 28, pp. 231-235*).—Experiments on fertilization, soil cultivation, and crop rotation on some of the more arid soils of Turkey are reported and discussed, particular attention being paid to the action of barnyard manure and rolling of the soil on soil moisture.

It was found that on such soils barnyard manure and rolling to compact the soil had a marked effect in increasing the soil moisture content. The disadvantage of extensive soil preparation in the spring was also brought out. The use of barnyard manure and rolling of the soil also had similar stimulating effects on the germination of certain crops, especially corn.

Soil moisture studies, F. J. SIEVERS (*Washington Sta. Bul. 155 (1920), pp. 39, 40*).—Studies of soil moisture in soils under wheat and in fallow showed that in the fallowed soils there were decided variations in moisture and nitrate content as affected by different times and methods of tillage. The greatest quantity of available nitrogen was developed under those conditions where the tillage practiced retained the highest percentage of moisture in the surface foot of soil for the greatest length of time during the warm portion of the year.

Evidence was obtained that nitrogen is one of the chief limiting factors in wheat production. The best results on spring wheat were obtained when the fertilizer was applied to the soil in the fall, while on winter wheat the best results were obtained when the application was made in the spring. The depressing effect of straw applications was in part overcome by supplementing with a nitrogen fertilizer.

Data on the effect of moisture and nitrate on the wheat plant are also summarized. It was found that nitrification takes place very slowly in Palouse silt loam soil when the moisture content is below 15 per cent.

Capillary movement of soil moisture, W. W. McLAUGHLIN (*U. S. Dept. Agr. Bul. 835, pp. 70, figs. 10*).—Experiments are reported, the purpose of which was to obtain specific data as to the capillary movement of moisture in arid soils. The experiments embodied a study of the rate and extent of capillary movement of moisture in columns of various types of soil where capillarity was assisted by gravity, where it acted against gravity, and where gravity as a

factor was eliminated. The columns in which gravity assisted capillarity were inclined downward at various angles from the horizontal, the columns in which gravity acted against capillarity were inclined upward at various angles from the horizontal, and the columns in which the effect of gravity was eliminated as far as possible were set horizontal.

The movement of moisture in vertical columns from free waters was found to be very rapid for the first few hours of the experiment, after which there was a marked decrease until about the fifth day when the rate became more uniform, growing slightly slower day by day. The rate of movement in the light soils was more rapid for the first few hours and then slowed down much more quickly than in the heavy soils. The heavy soils maintained a relatively more uniform variation than the light soils. There was a variation of nearly 250 per cent in the total distance moved in a period of 30 days. In general, the lighter the soil the shorter the distance the moisture moved upward in a long period of time. Except in the light soils of the sandy type, the quantity of water required to move the moisture the first inch was about the same or a little less than that required to move it the last inch on a 30-day basis. The decrease in the percentage of moisture in these columns from the water surface to the upper extremity of the wetted area was not uniform.

The movement of moisture in horizontal columns was in general the same as in vertical columns, the chief difference being one of degree. The data indicated the extensive and long-continued capillary action in a horizontal direction in the light soils. All of the columns showed a gradual decrease in the percentage of moisture from the tank end to the outward extremity of the wetted area.

In columns inclined downward from the horizontal, the movement of moisture and the amount of water used were greater than for the horizontal columns or those inclined upward from the horizontal. After the first day or two the type of soil used in the columns was found to be of greater importance in limiting the extent of the movement of moisture. Porosity was not the only factor, but the so-called transporting power of the soil was of prime importance. The heavy and less porous soils showed a relatively greater percentage of moisture movement the first day or two and a relatively slower rate of movement the last few days than the light and more porous soils, which showed a more uniform and extended moisture movement. Evaporation did not appear to have varied the quantity of water used to any extent. In a general way, the greater the moisture equivalent of a soil the greater was the quantity of water required to advance the moisture 1 in. It was observed that for soils of the heavy type for some time after the beginning of the experiment less water was required per inch than for the following day, but after about the thirtieth day there was a very rapid increase in the water requirements. In some cases the water requirement per inch at the end of the fortieth day was about double the requirement for the first day, but in the heavy soils this was not so pronounced.

In columns inclined upward from the horizontal at an angle of 15° , there was less moisture movement and less water used than in the horizontal columns and more than in the vertical columns. The distribution of moisture in these columns did not differ materially from the distribution in the vertical columns.

Data on the effect of gravity on the movement of soil moisture by capillarity showed that even on the first day inclination is a marked factor in the extent of the movement of soil moisture. At the end of the thirtieth day the column inclined upward at 45° indicated only one-half, and the column inclined upward at 30° , about two-thirds as extensive a movement of soil moisture as the horizontal column. The extent of soil moisture movement in the horizontal column, the columns inclined upward at 30° and 45° , and the vertical one was in the order

given, with the greatest movement in the horizontal column. As the columns receded from the vertical, the rate of movement day by day was more uniform and more constant.

In considering the quantity of water used by the several columns, from the vertical upward to the 45° downward from the horizontal, it was found that the inclination of the columns was a most potent factor in determining the quantity of water removed from the tanks. The columns inclined upward used a relatively large quantity of water during the first two or three days and after that time a relatively small quantity. A somewhat larger quantity of water was used in the columns inclined downward from a horizontal during the first three or four days than thereafter. As the inclination receded from the vertical, the quantity of water required per inch of movement was less.

A comparison of results obtained from columns opened to evaporation and from covered columns showed them to be essentially similar, the main difference being one of degree.

Data are reported establishing the existence of the capillary siphon in soil, and it is thought that capillary siphons may not be uncommon in nature and may cause the swamping of lands. Further data are given on capillary movement of moisture from a wet to a dry soil and on the effect of temperature on soil moisture conditions.

The data obtained are reduced to empirical formulas, and a bibliography is appended.

The present status of alkali, W. P. KELLEY (*California Sta. Circ. 219 (1920), pp. 10*).—This is an address delivered at the annual conference of farm advisors at Berkeley, Calif., on March 25, 1920.

The alkali problem resolves itself into the two following simple matters: (1) Preventing the accumulation of an excess of salts in the soil by the elimination of saline irrigation water and keeping the water table below the capillary reach of the soil surface, and (2) leaching the excess of salts out of the soil after they have accumulated. Drainage accompanied by flooding is considered to be a reasonably successful means of removing white alkali from soils. If large amounts of black alkali are present, ordinary drainage will probably not restore the land to a productive condition unless the alkali is first neutralized. Where only comparatively small amounts of black alkali are present, the soils can often be successfully reclaimed by drainage, provided an application of gypsum is also made.

Alkali studies, A. E. VINSON and C. N. CATLIN (*Arizona Sta. Rpt. 1918, pp. 346-348*).—Studies on the use of chemicals, particularly gypsum, for the improvement of alkali soils showed that when a percolation test was made comparing untreated soil with samples to which the theoretical amount and half that amount of gypsum were added, the second half of the gypsum applied had two or three times the effect of the first half in promoting percolation. Laboratory studies showed that light or insufficient applications of gypsum are unprofitable. The effect of gypsum on the rate of percolation in 10-in. pots on soils containing black alkali showed a saving in humus and all plant foods with the exception of potassium.

Resistance of crops to alkali, A. E. VINSON and C. N. CATLIN (*Arizona Sta. Rpt. 1918, pp. 342-345*).—A series of soil analyses illustrating the resistance of cotton, milo, barley, tepary beans, asparagus, feterita, and alfalfa, to alkali under field conditions are reported. In general, 0.1 per cent seems to be the limiting amount of black alkali for these crops.

Nitrification in Texas soils, G. S. FRAPS (*Texas Sta. Bul. 259 (1920), pp. 5-37, figs. 2*).—This bulletin reports studies on the relation of nitrate production in Texas soils to various factors which influence soil fertility. Nitrification

was carried on with 500-gm. portions of the soil in percolators, and the nitrates were extracted at intervals of four weeks.

It was found that usually maximum nitrification took place during the first four weeks, but in some cases it was delayed to the second and even third period, and in some soils nitrification did not occur for a year or more. When nitrification was carried on for several years, a second maximum occurred during the second summer and a third during the third summer, but these were much smaller than the first maximum. The average quantity of nitrates produced increased with the total nitrogen of the soil. With the exception of soils containing less than 0.02 per cent of nitrogen, the percentages of organic nitrogen converted into nitrate were on an average fairly constant.

There were wide variations in the amounts of nitrates produced by individual soils. The addition of 1 per cent calcium carbonate caused most of the soils which failed to nitrify without such addition to do so within the first four weeks. Acid soils nitrified slightly less on an average than nonacid soils with a low lime content. Some acid soils did not nitrify at all, while others showed high nitrification. No other relation could be traced between the amount of nitrification and the chemical composition of the soil.

The nitrification in subsoils averaged nearly the same as that in surface soils. Subsoils having a low nitrification were usually low in lime and over half of them were acid, while of those having a high nitrification several were acid. The addition of phosphate or potash increased nitrification in several of the soils, the phosphate being the more effective.

The nitrifying capacity of 29 soils was found to vary from 2 to 232. Of these, 8 had a nitrifying capacity of less than 25 and 3 had a capacity of more than 100.

The addition of manure to the soil resulted in a decrease in the amount of nitrates in the percolate. There was no agreement between the nitrifying capacity of the soil and the nitrification of the manure.

Supply of nitrogen in the soil, J. W. AMES (*Mo. Bul. Ohio Sta., 5 (1920), No. 6, pp. 174-177*).—Studies of the effect of cultivation and fertilization on the nitrogen content of certain soils at the station are reported.

On a soil which was unfertilized and unlimed and constantly cropped for 18 years it was found that the decrease in nitrogen content averaged 20 lbs. per acre annually. On another soil, which was cropped with a 3-year rotation of potatoes, wheat, and clover for 18 years, the decrease in nitrogen content was about 40 lbs. per acre.

Analyses of pasture soils which had been cropped and cultivated for 20 years showed a total decrease in nitrogen content for the period of 1,000 lbs. per acre. Adjacent soil which was in grass during the 20-year period showed an increase of 600 lbs. per acre.

On soil continuously cropped for 16 years to corn, oats, and wheat it was found that the largest decrease occurred in the corn plats and the smallest decrease in the wheat plats. The supply of nitrogen in limed soils did not decrease as much as that in unlimed soils, whether fertilized or not.

The hysteresis of aqueous solutions of humus soils, H. PUCHNER (*Kolloid Ztschr., 25 (1919), No. 5, pp. 196-207, figs. 12*).—Studies with peat are reported, which showed that a clear dark yellow solution may be obtained by digesting it with cold water. During the solution a faintly acid, somewhat aromatic odor was noticeable. The solution obtained had an acid reaction, and on being kept for several days a slimy brown substance was deposited, after which the clear solution became alkaline. The residue from the incineration of the deposit contained alumina, ferric and manganese oxids, lime, and magnesium sulphates,

silicates, and phosphates. Microscopic examinations of the solution and deposit, immediately after preparation and after certain intervals, showed the formation of crystals with time. The clear solution after sedimentation was found to contain gels of alumina, ferric hydroxid, and silicic acid.

The conclusion is drawn that the peat used contains either organic acids or related compounds, which are easily evaporated with steam, are readily soluble in hot water, and not so soluble in cold water.

Crop residue work in jars, F. J. SIEVERS (*Washington Sta. Bul. 155 (1920)*, pp. 40, 41).—Data are summarized which point to the fact that the difficulty of increasing the organic matter in Palouse silt loam soil becomes increasingly greater as the natural supply in the soil becomes more and more depleted.

The effect of straw on the soil, T. J. MURRAY (*Washington Sta. Bul. 155 (1920)*, pp. 12, 13).—It was found that the addition of straw in amounts of from 0.1 to 0.7 per cent actually stimulated the formation of nitrates in soil, but when added in greater quantities there was a loss of nitrates in every case. Total nitrogen determinations showed that although there was a loss in nitrates and a decrease in nitrate formation, there was never any loss in total nitrogen.

Bacterial counts made on the soil showed that as the straw increased the number of bacteria increase. Further studies showed that the addition of cellulose to soil had no inhibiting effect on the nitrifying bacteria.

The maintenance of soil fertility in Hamilton County, Ohio, C. E. THORNE (*Mo. Bul. Ohio Sta., 5 (1920)*, No. 6, pp. 170-173).—Experiments on benefits derived from fertilizers and limestone on a 4-year rotation of corn, soy beans, wheat, and clover are reported.

The financial estimate was based on corn at \$1 per bushel, soy beans at \$3, wheat at \$2, and hay at \$20 per ton, and the cost of treatment on the basis of 16 per cent acid phosphate at \$30 per ton, sodium nitrate at 6 cts. per pound, potassium chlorid at 7.5 cts. per pound, manure at \$1 per ton, and ground limestone at \$5 per ton. It was found that on this soil potassium may be nearly as important as phosphorus. The test throughout indicated that the two leguminous crops, soy beans and clover, were able to furnish all the nitrogen required by the corn and wheat, and that the effect of manure was due to the phosphorus and potassium carried.

Where yard manure was substituted for chemicals, there was a drop in yield which is explained by the smaller quantity and lower availability of phosphorus in the yard manure. The reinforcement of this manure with phosphorus produced a further increase in yield, but not sufficient to cover the cost of the phosphorus. The addition of limestone to the manure caused a very decided increase in yield. Two tons of untreated shed manure on one plat produced a slightly larger increase than \$14.25 worth of phosphorus and chemicals on another plat. Two tons of powdered limestone applied every fourth year apparently increased the 4-year yield.

Investigational work with fertilizers, F. T. SHUTT (*Canada Expt. Farms Rpt. 1919*, pp. 47-49, 50).—Progress results of the complete fertilizer series of experiments indicate the following salient features: (1) The very striking lack of productiveness on the permanent check plat which for more than five years received neither manure nor fertilizers, (2) the uniformly low standing of the checks which received only the initial light dressing of manure and no fertilizer, (3) the beneficial influence of additional manure when used in conjunction with fertilizers, (4) the distinctly lower yields produced from heavy applications of manure alone as compared with those from the practice of supplementing smaller quantities of manure with fertilizers, (5) the probability

that on certain soils treated to liberal amounts of sodium nitrate and superphosphate, potash in the fertilizer is less essential than where nitrate and phosphate are sparingly applied, (6) the superiority in the first season of sodium nitrate as the sole source of nitrogen as compared with ammonium sulphate and certain organic sources of nitrogen, constituting the whole or part of the nitrogenous component of the fertilizer, and (7) the evident greater influence at this stage of the more readily available forms of nitrogen and phosphoric acid in comparison with those contained in organic substances.

Studies on sources of nitrogen showed that dried blood failed to give any increase in the potato crop, while sodium nitrate, calcium nitrate, and ammonium sulphate produced increases of from 30 to 50 bu. Whale guano did not appreciably increase the yield of mangels and corn.

Liming experiments showed the value of ground limestone when used in conjunction with fertilizers and manure. Three years' results from an experiment in which burned lime and ground limestone were used in varying quantities, with and without manure, showed that burned lime was about 12 per cent more effective than the ground limestone equivalent.

Analyses of limestones and miscellaneous fertilizer materials are reported.

Fertilizers, G. A. LANGALIER (*Canada Expt. Farms Rpt. 1919, pp. 121, 122*).—A comparison of sodium nitrate with ammonium sulphate on a 3-year rotation of potatoes, oats, and clover in the presence of a sufficiency of phosphorus and potash showed that the potato crop was 36 per cent and the oats crop 1 per cent greater when sodium nitrate was used, while with clover sodium nitrate and ammonium sulphate gave about equal results.

A comparison of superphosphate, basic slag, and bone meal on a 3-year rotation of potatoes, oats, and clover in the presence of a sufficiency of nitrogen and potash showed that if 100 is taken as the crop obtained from superphosphate, the crops obtained with the use of basic slag and bone meal were, respectively, 56 and 47 for potatoes, 100 and 113 for oats, and 110 and 115 for clover hay.

Experiments on the fertilizing value of ground seaweed on a rotation of potatoes, oats, and clover showed that as a source of potassium, if 100 is taken as the crop obtained by 1,500 lbs. of ground seaweed, the crops obtained with the use of 100 lbs. of muriate of potash were 128 for potatoes, 90 for oats, and 124 for clover hay.

A comparison of burned lime with ground limestone on a clayey loam soil of better than average fertility with a 3-year rotation of oats, clover, and timothy showed that if 100 is taken as the crop obtained with the use of ground limestone, the crops obtained with the use of burned lime were 102 for oats, 113 for oat straw, 106 for clover hay, and 116 for timothy hay, about the same quantities of calcium oxid being applied in both cases. When 15 tons of manure were added to both, and 100 taken as the crop obtained with the use of ground limestone, the crops obtained with the use of burned lime were 120 for oats, 91 for oat straw, 107 for clover hay, and 95 for timothy hay.

Fertilizer formulas for Georgia soils, J. N. HARPER (*Ga. Dept. Agr., Quart. Bul. 82 (1920), pp. 9-15*).—A list of formulas applying to general conditions and farm practices is recommended for the different prevailing soil types of Georgia.

The preparation of mixed fertilizers for agriculture, F. A. LÓPEZ DOMÍNGUEZ (*Porto Rico Dept. Agr. and Labor Sta. Circ. 19 (1919), [Spanish Ed.], pp. 27*).—This is a popular publication for Porto Rico farmers, containing information on the selection and mixing of fertilizers and outlining the functions of and plans for assistance by the station in this connection. General information on fertilizer and fertilizer materials is also given.

Chemical fertilizers in Italian agriculture, BORGHESANI (*Vie Agr. et Ruralc*, 9 (1920), No. 27, pp. 14-19, figs. 9).—A general review is given of the fertilizer resources of Italy and of the consumption and practical use of different types.

Sodium nitrate, ammonium sulphate, and calcium cyanamid are the three most important nitrogenous fertilizers used. Superphosphate and Thomas slag are the most important phosphatic fertilizers, although some bone meal and guano are used. It is stated that an immense reserve of potash exists in Italy in the different natural resources, of which the mineral leucite is considered to be an important source.

The nutrient content of water supply and its utilization, H. FISCHER (*Naturw. Ztschr. Forst u. Landw.*, 18 (1920), No. 3-4, pp. 66-83).—Analyses of lake, river, and pond waters of Germany are reported and discussed, with particular reference to their content in potash, phosphoric acid, nitrogen, and lime.

The fertilizing value of rain and snow, F. T. SHUTT (*Canada Expt. Farms Rpt.* 1919, p. 51).—A summary of the analyses of 81 samples of rain and 29 samples of snow, representing a total precipitation of 35.59 in. for the year, indicate that the total nitrogen supplied thereby was 5.845 lbs. per acre.

The nitrate industry of Chile (*U. S. Dept., Com., Bur. Foreign and Dom. Com., Com. Rpts. No. 122* (1920), pp. 1093-1103).—This is a report on the general features of the mining and refining of Chilean nitrate, together with a discussion of business organization and finances.

It is stated that two grades of nitrates are now produced, namely, a 95 per cent nitrate, which is used for fertilizer purposes, and a 96 per cent nitrate, used for manufacturing purposes. Imports of sodium nitrate into the United States for the year 1919 were 407,459 long tons. Apparently a relatively small proportion of the nitrate imported into the United States from Chile is used for fertilizer purposes.

Potash, an American war industry, T. G. PALMER (*Washington: Author*, 1919, pp. 20).—Considerable general information on the development and present status of the American potash industries and on the past history of the German potash industry, particularly during the war years, is given. The present is considered to be the most critical period in the history of the newly developed American potash industry. The great bulk of present American potash production is said to be based upon inflated war prices and can not be profitably continued if prices drop materially.

A list of producers of potash reporting to the U. S. Geological Survey in 1918 is included.

Potash deposits in Spain, H. S. GALE (*U. S. Geol. Survey Bul.* 715-A (1920), pp. 16, pls. 3, figs. 3).—This is a report of a general survey of the potash deposits in Spain. The main area is about 75 miles long, and consists of an irregular belt with a maximum width of between 15 and 18 miles.

The principal discoveries of potash have been made in the immediate vicinity of the villages of Cardona and Suria. It is stated that evidence of the existence of potash in the Cardona deposit is not very definite, probably because of the lack of adequate investigation. The existence of potash in considerable amounts has been demonstrated in the Suria deposits. In this deposit there are in general two beds of carnallite and a lower bed of sylvinite. The carnallite zone, containing workable beds 3 meters or more in thickness, averages 12 per cent of potash, and the sylvinite, in beds of 2 meters or more in thickness, is reported to average at least 20 per cent of potash. The Suria area covers about 8,648 acres, and an estimate places the potential production at about 200,000,000 tons of pure potash.

The general geology and ownership of the deposits are discussed.

Limestone and fertilizer experiments, W. S. BLAIR (*Canada Expt. Farms Rpt. 1919, p. 91*).—Tests at Kentville, N. S., of the agricultural value of ground raw limestone on clover in $\frac{1}{2}$ -acre plats showed that 2 tons of limestone supplemented by $\frac{1}{2}$ ton of slag produced a considerably greater average increase in the hay crop than $\frac{1}{2}$ ton of slag alone and a slightly greater increase than 2 tons of limestone alone.

Tests with wheat showed a striking increase in both straw and grain when the wheat was both limed and fertilized. Liming alone gave greater increased yields than fertilizing alone.

Does burnt lime destroy organic matter? E. O. FIPPIN (*Natl. Lime Assoc., Trade Bul. 107 (1920), pp. 4, fig. 1*).—Data from different State agricultural experiment stations are reviewed to show that burnt forms of lime do not have a direct destructive effect upon soil organic matter or humus, and that their use is permissible and desirable.

Agricultural lime, M. F. MILLER and H. H. KRUSEKOPF (*Missouri Sta. Bul. 171 (1920), pp. 24, figs. 8*).—This is a revision of Bulletin 146 (E. S. R., 37, p. 428).

Fertilizer control in 1918, C. O. SWANSON, W. L. LATSHAW, and L. T. ANDEREGG (*Kansas Sta. Insp. Circ. 10 (1919), pp. 9*).—This circular contains the results of actual and guaranteed analyses of 49 samples of fertilizers and fertilizer materials collected for inspection in Kansas during the spring and fall of 1918, together with a list of fertilizer dealers registered in the State.

AGRICULTURAL BOTANY.

Genera and supergenera, A. S. HITCHCOCK (*Science, n. ser., 52 (1920), No. 1335, pp. 107, 108*).—The author discusses some of the problems that arise from the strict adoption of Linnæan genera of grasses.

Species formation from the phylogenetic and group standpoint, H. DE VRIES (*Flora [Jena], n. ser., 11-12 (1918), pp. 208-226*).—This is a discussion of facts observed and deductions therefrom in connection with the appearance and behavior of mutants and mutating forms, most of which have been dealt with in previous communications.

Heredity in *Oenothera*, O. RENNER (*Flora [Jena], n. ser., 11-12 (1918), pp. 641-667, figs. 18*).—The author notes various findings and conclusions as resulting from crossings among *Oenothera* spp. and among their descendants.

Floral variations in the ox-eye daisy, L. BLARINGHEM (*Compt. Rend. Acad. Sci. [Paris], 169 (1919), No. 4, pp. 193-195*).—Floral variations in the ox-eye daisy, *Leucanthemum vulgare* (*Chrysanthemum leucanthemum*), under conditions very favorable to vegetative development are outlined as noted in some individuals.

On the periodicity of *Hyacinthus orientalis*, A. H. BLAAUW (*Meded. Landbouwhoogsch. [Wageningen], 18 (1920), No. 1, pp. 1-82, pls. 5, figs. 10; also in Lab. Pflanzenphysiol., 3 (1920), pp. 1-82, pls. 5, figs. 10*).—This is a summary of a study on the life history of the new bud of *H. orientalis*, beginning in summer and continuing over nearly two years, also of the influence of various factors on flower formation.

Variation in tree foliage, E. KÜSTER (*Mitt. Deut. Dendrol. Gesell., 28 (1919), pp. 85-88, figs. 8*).—This is an account of observed forms and effects as regards decoloration or discoloration in trees, among which in this regard the maples are conspicuous.

Nitrogen metabolism and yellowing in leaves of *Tropæolum majus*, A. MEYER (*Flora [Jena], n. ser., 11-12 (1918), pp. 85-127, figs. 17*).—This deals with the color changes occurring in the life course of leaves of normal plants, the

microscopic xanthoprotein reaction and coloration in living leaves, microscopic investigation of palisade cells in *T. majus*, the formation of nitrogenous materials in chloroplasts, and the influence of different factors in leaf coloration. Exact conclusions await further determinations.

Orientation movements of buds, blooms, and fruits, M. MÖBIUS (*Flora [Jena]*, n. ser., 11-12 (1918), pp. 396-417, figs. 11).—This is a study of orientation of plant parts and the supposed causes and significance.

The microchemical demonstration and the distribution of dissolved oxalates in plants, H. MOLISCH (*Flora [Jena]*, n. ser., 11-12 (1918), pp. 60-70, pl. 1).—Presenting data more specialized than in the contribution previously noted (E. S. R., 30, p. 310) and in tabular form with discussion for a long list of widely divergent plants said to contain demonstrable oxalates in their different parts, the author states that oxalates are found in a large number of phanerogams, a few families containing species yielding very abundant oxalates. While relationship between members of a family may show a relation to the content of oxalates this is not always the case, as even within the same family great differences may exist as regards oxalate content.

The absorption of minerals by root tips, COUPIN (*Compt. Rend. Acad. Sci. [Paris]*, 169 (1919), No. 5, pp. 242-245).—Carrying forward work previously noted (E. S. R., 43, p. 526), the author has shown that root tips absorb mineral salts from solutions, and that such nutrient salts are copiously utilized for the upbuilding of the plants to which they are thus furnished.

Influence of certain conditions on the utilization of glucose and levulose by *Sterigmatocystis nigra*, M. MOLLIARD (*Compt. Rend. Acad. Sci. [Paris]*, 167 (1918), No. 26, pp. 1043-1046).—The author presents data bearing upon the variant utilization ratio of glucose and levulose by *S. nigra* under modification of conditions which are described. Any difference in the diffusion rates of these sugars does not appear to be a factor here. Utilization appears to be a function of mycelial development. In the cases here considered cellular multiplication is greatly decreased. This is considered as an additional reason to believe that levulose plays the principal rôle in the upbuilding of vegetable tissues.

The fermentation by some yeasts of nectar from winter plants, K. SCHOELLHORN (*Bul. Soc. Bot. Genève*, 2. ser., 11 (1919), No. 5-9, pp. 154-190, figs. 32).—Particulars are given regarding the characters and fermentation of nectar from different plants.

Ultraviolet rays and the sugar cane, pineapple, and banana industries, T. TSUJI (*La. Planter*, 60 (1918), No. 26, pp. 413, 414; also in *Gard. Chron.*, 3. ser., 66 (1919), No. 1719, p. 283).—The author, studying the action of the ultraviolet rays on chlorophyll in sugar cane, found that germinated and intact canes cultivated in moist soil with exclusion of light at 22° C (71.6° F) grew but remained etiolated for 30 days. After this period, one half of these plants were exposed to direct sunlight, the other half to the ultraviolet rays of a quartz mercury vapor lamp of 110 volts and 4 amperes for 2.5 hours. The former plants remained yellow, while the latter assumed a deep green coloration.

Of three rows of sugar cane, one was so shaded with colored glass as to decrease by 50 per cent the ultraviolet rays of the sun; the plants of the second were exposed to open sunlight; those of the third were exposed to the ultraviolet rays of the sun and of a weak mercury lamp. Fertilization was the same in each case. After some months of growth, the plants of the first row had gained 1.25 lbs., those of the second, 2.8 lbs., and those of the third, 3.33 lbs. These results, and the fact that the period of growth to maturity was reduced from 20 to 11 months, suggest the practicability of using ultraviolet rays for increasing cane crop yields and decreasing the time required per crop in Hawaii.

It is claimed that the action of ultraviolet rays on carbon dioxide and hydrogen in the nascent state in the presence of potassium hydroxide determines a photosynthesis. The formaldehyde thus produced is condensed to sugar under the influence of the rays, and carbon dioxide and water vapor are also combined to form sugar and other carbohydrates. The canes in the second row above mentioned had 30 per cent and those in the third row 38 per cent more sugar than those in the first row.

The influence of ultraviolet rays in producing sulphuric acid from sulphur dioxide, oxygen, and water is mentioned in connection with suggested possibilities.

Ultraviolet rays with carefully controlled daily exposure lasting for 40 minutes were found to ripen pineapples more completely and satisfactorily than was usual for these fruits.

Etiolated banana leaves developed in 5 hours a deep green color. Banana leaves and stalks exposed to ultraviolet rays after being cut and kept in water remained perfectly fresh for two weeks, at least twice as long as those kept in diffused daylight. This is thought to indicate a means of preserving and ripening with improvement bananas for shipment to distant points.

The problem is how to produce and employ practicable apparatus for the application of the shorter ultraviolet rays to sugar cane, pineapple, and banana culture.

Light and heat radiation as ecological factors, O. DRUDE (*Flora [Jena]*, n. ser., 11-12 (1918), pp. 227-267, figs. 2).—This deals chiefly with the beneficial or injurious effects of solar radiation in relation with plant distribution.

Some aspects of the plant ecology of certain Kansas sand hills, F. W. EMERSON (*Abs. in Science*, n. ser., 52 (1920), No. 1334, pp. 87, 88).—A brief account is given of studies of sand hills along the Arkansas River between Wichita and Hutchinson, Kans. The natural vegetation has held sand wherever allowed to remain, but burning, close grazing, and farming have removed the natural vegetation from considerable areas, making them useless and threatening other areas with a cover of blowing sand. The types and characteristics of the plants of the region are noted.

The Chloridææ of Argentina, L. R. PARODI (*Univ. Nac. Buenos Aires, Rev. Facult. Agron. y Vet.*, 2 (1919), No. 3, pp. 233-335, figs. 25).—This is a record of studies made on living or herbarium plants in Argentina pertaining to the Chloridææ. About 15 genera and 60 species are here listed in connection with their distribution among the areas here designated as subtropical, great river, pampas, montane, and Patagonian formations.

Two Russian Gymnosporangiums, J. ERIKSSON (*Arkiv. Bot.*, 15 (1919), No. 20, pp. 1-23, pls. 3).—Of two fungi attacking branches of *Juniperus oxycedrus*, one was, after an investigation, assigned to *Gymnosporangium oxycedri*. The second is described as a new species under the name *G. tauricum*.

The Uredinales of Indiana, [I], II, H. S. JACKSON (*Proc. Ind. Acad. Sci.*, 1915, pp. 429-475; 1917, pp. 133-137).—The first of these articles includes an account of work done and lists previously published by others in connection with Uredinales in Indiana, also Nos. 1-141 of the author's collections. The second article includes Nos. 142-155.

Anatomical study of fungus symbiosis in *Casuarina equisetifolia* with notes on the problem of mycorrhiza, H. MIEHE (*Flora [Jena]*, n. ser., 11-12 (1918), pp. 431-449, pl. 1, figs. 2).—Observations and deductions are noted in connection with a study of a mycorrhizal fungus associated with *C. equisetifolia* in the strand flora at points in the East Indies.

Some abnormalities in plant structure, M. S. MARKLE (*Proc. Ind. Acad. Sci.*, 1918, pp. 117-124, figs. 9).—Brief descriptions are given of cell abnormalities observed in plants named.

Banding and forking in roots, H. SCHENCK (*Flora [Jena]*, n. ser., 11-12 (1918), pp. 503-525, figs. 10).—Examples cited are taken to indicate that, in connection with most plant organs or parts, roots lack definiteness and fixity of form when tested under unusual conditions as regards environment.

Anatomical modifications of roots by mechanical action, E. BLOCH (*Compt. Rend. Acad. Sci. [Paris]*, 169 (1919), No. 4, pp. 195-197).—Studies briefly described as carried out with plants named show that it is possible to reproduce experimentally not only certain asymmetric structures observed in plants as occasionally subject to unusual natural stresses, but also anatomical modifications resulting in certain cases from the influence of the medium.

Wound cork formation in the potato in relation to seed piece decay, M. SHAPOVALOV and H. A. EDSON (*Phytopathology*, 9 (1919), No. 11, pp. 483-496, figs. 3).—Experiments are reported in which Irish Cobbler, Green Mountain, and Bliss Triumph potatoes were investigated to determine whether the sprouting of the tuber, dusting it with sulphur, or entrance of decay has any bearing on the formation of wound cork.

It was found that sprouting did not affect the ability of the potato to form wound cork over a wound surface, but drying of the tissues, as when potatoes were stored in a warm room, checked this ability. Sulphur applied to cut seed pieces was neither beneficial nor detrimental to cork formation. The presence of decay in the central surface of the cut seed pieces appeared to be correlated with the healing proclivity of the central portion as compared with that of the more resistant peripheral areas. The resistance of the seed piece to attacks was found to diminish in direct proportion to the water loss, and a shriveled tuber is unable to initiate cell division until it has imbibed the necessary amount of moisture from the soil. Consequently destructive activities of microorganisms develop so rapidly that the formation of the protective layer under the infected lesions is often checked and the seed piece fails to grow entirely or produces only feeble shoots.

Root cork in plants of highly heated soils, L. DIELS (*Flora [Jena]*, n. ser., 11-12 (1918), pp. 490-502, figs. 3).—Notes are given of a partial study of the ecological significance of root cork of plants under certain trying conditions as regards environment.

The penetrability of foliage leaves for gases, F. W. NEGER (*Flora [Jena]*, n. ser., 11-12 (1918), pp. 152-161 figs. 3).—Placing leaves in one or the other of the two classes homobaric or heterobaric according as they possess comparatively free or practically no communication between their intrafoliar spaces, the author lists as homobaric all conifers and some other plants and as heterobaric a number of other plants. The significance of the two plans is discussed.

Kerosene injury to shade trees, R. E. STONE (*Phytopathology*, 9 (1919), No. 10, pp. 476, 477).—An examination was made of a number of shade trees, particularly maple, which had died, and it was found that the bark, cambium, and sap wood had been killed in a zone 3 in. wide at a height of about 4 ft. from the ground. An investigation showed that about three years before the appearance of the disease the trees were banded with cotton wool soaked in kerosene to prevent the climbing of tussock moths. The excess of kerosene was allowed to run down the trunk, and from the form and position of the dead areas it is considered that kerosene had been the destructive agent.

The influence of winter weather on forest trees, H. HÖFKER (*Mitt. Dcut. Dendrol. Gesell.*, 28 (1919), pp. 196-207).—An account is given with discussion

of conifers and deciduous trees listed separately as injured or killed during cold weather, particularly that of the winter of 1916-17.

A simplified nonabsorbing mounting for porous porcelain atmometers, B. E. LIVINGSTON and F. THONE (*Science, n. ser.*, 52 (1920), No. 1334, pp. 85-87).—A description is given of a simplified form of mounting for atmometers which it is believed will prove of value in obtaining records during rainy weather.

FIELD CROPS.

[**Report of field crops work in Arizona**], G. E. THOMPSON and F. J. CRIDER (*Arizona Sta. Rpt. 1918, pp. 287-295, 300, 301, 310, 311, figs. 3*).—This reports the progress of work along lines similar to those previously noted (E. S. R., 41, p. 331).

Careful observation on the growth and yields of 17 varieties of each indicated that soy beans were decidedly inferior to cowpeas for conditions at the Salt River Valley farm. The soy beans shriveled badly and were of inferior quality. Soy bean varieties giving most promise were Biloxi, a late upright sort; Wilson No. 5, a medium maturing variety; and the small early Ito San. Promising cowpea varieties included Groit, Brabham, Red Ripper, and Two Crop Clay. It is stated that results show that cowpeas can be used successfully as a green manure crop after wheat.

In a limited test of fall-sown field peas, Warsaur led in seed yield and vine growth. Studies of four velvet bean varieties planted June 14 showed the Osceola to be of promise and suggested that earlier planting was necessary. Although tepary proved best in tests of table beans, the results were held far from satisfactory on account of damage from the lesser cornstalk borer. This insect destroyed practically every variety of beans on the farm, attacking cowpeas and sorghums to a lesser degree.

Corn proved unsatisfactory in the Salt River Valley, with the best yield coming from selected strains of Mexican June. This year's work, in confirmation of previous results, was held to indicate that sorghum varieties properly handled are more profitable than corn in this section.

Milo, hegari, and kafir with yields of 72, 65, and 40 bu. per acre led the sorghum varieties in grain production. It was observed that darso was inferior to the other sorghums from both grain and fodder standpoints.

In wheat variety tests Early Baart averaged 45 bu. per acre, followed by Red Turkey. Club wheat and Sonora made good yields, but the grain quality was inferior to that of Early Baart. Texas Red oats with yields ranging from 90 to 95 bu. per acre and common 6-rowed barley averaging 66 bu. were the highest in their respective tests. Rye was less valuable than either oats or barley, and buckwheat was considered a complete failure.

Volunteer cotton proved decidedly unprofitable, producing many rotten or moldy bolls with weak, short fiber and a low lint percentage.

Seasonal conditions at the Prescott dry farm during 1918 were less favorable than for a number of years preceding. Creditable silage yields totaling 125 tons were secured from Club Top sorghum, darso, kafir, milo, and corn. The grain yields of all were very light. Potatoes and Canada field peas were failures, and sweet clover failed to make a satisfactory stand. Two cuttings of Sudan grass hay were made, and about 450 lbs. of seed per acre were harvested.

At the Sulphur Springs Valley dry farm, the results of the nonirrigated crops were said to be of small value on account of the extremely dry weather. Mexican June corn produced 3,300 lbs. of silage per acre without irrigation, but

did not pay for the time and labor expended. With supplemental irrigation, kafir, Freed sorghum, Sudan grass, cowpeas, and sweet clover made reasonable yields.

Hegari and milo gave excellent grain yields in limited sorghum tests at Yuma. Honey Drip, the best of the sweet sorghums, made a very heavy growth of forage. Flax and tepary beans were of considerable promise, while buckwheat varieties, root crops, and vetch did not prove satisfactory.

Acre yields of potatoes at Yuma were 10,976 lbs. for White Rose, 10,192 lbs. for Irish Cobbler, and 9,800 lbs. for Triumph. In a comparison of storage methods, the practice of spreading potatoes out thinly in ventilated bins proved equally effective as storage in a ventilated dugout, both methods preserving a high percentage of sound potatoes. In case of potatoes coated with paraffin, all were rotted at the end of four weeks. This was held to emphasize the detrimental effect of excluding air and the value of thorough ventilation during storage.

Japanese kudzu vine (*Pueraria hirsuta*) made a vigorous growth in the introduction garden at Tucson, some of the vines attaining a length of 50 ft. in a season. Its culture as a forage crop, along irrigation ditches or in areas not readily accessible to cultivation, is recommended.

[Report of plant breeding work in Arizona], W. E. BRYAN and C. O. BOND (*Arizona Sta. Rpt. 1918, pp. 314-321*).—This reports the continuation of work previously noted (E. S. R., 41, p. 332).

In the wheat breeding plats at Yuma, several hybrids produced from 50 to 60 bu. per acre, about 20 bu. more than Early Baart. The quality of the high yielders was fair, but neither grain nor plants were deemed to be sufficiently uniform for bread wheat plantings, and required further selection. Selection 39A-5 with 45.7 bu. per acre outyielded Early Baart by approximately 10 bu. in trials of pure selections at the Salt River Valley farm. This variety, as well as all others tested, proved inferior to Early Baart in comparative baking tests.

Studies of the heat resistance of individual selections of alfalfa at Tucson indicated that practically all plants were reduced in yield as the summer advanced. The yield of the fourth cutting was said to be less than one-fourth that of the first cutting in practically every case. A French variety was the highest summer yielder of all alfalfas tested in field plats at the Salt River Valley farm, producing 9,098 lbs. per acre as compared with 7,128 lbs. for Algerian and 6,649 lbs. for Peruvian. Although the French variety gave a more vigorous summer growth, it was not expected to flourish in the winter as well as the Peruvian.

Thirty-four milo heads selected from plants producing neither suckers or branches, but with single upright heads, were planted in individual rows at the Mesa farm. Of the 5,270 plants in the 34 rows, 80 were found coming true to the single head type, and about one-half of the heads of these plants were upright. Some of the plants appeared to be pure for the type selected, while others were the result of abnormal field conditions.

Breeding work with beans is also briefly noted.

[Field crops work on the Canada Experimental Farms in 1918], J. H. GRISDALE ET AL. (*Canada Expt. Farms Rpt. 1919, pp. 9-13, 24-27, 29, 30, 37-42, 44, 45, 49, 52-55, 60, 61-63, 65-79, 84, 90, 91, 92, 96-98, 102-104, 116-121, 129, 130, 136, 137, 142, 143, 148-150, 152, 153, 155, 156, 159-161, 165, 166, 169, 170, 172, 173, 181-185, 189, 190, 193-195*).—This reports variety, fertilizer and cultural tests, and breeding work with cereals, forage crops, root crops, potatoes, and tobacco in continuation of similar work previously noted (E. S. R., 41, p. 528).

Variety tests with winter and spring wheat, oats, barley, field peas, flax for seed and fiber, winter and spring rye, vetch, corn for grain and silage, root crops for seed and forage, clovers, alfalfa, and miscellaneous legumes and grasses for hay were conducted at the stations, substations, and farms in the Provinces of Ontario, Prince Edward Island, Nova Scotia, New Brunswick, Quebec, Manitoba, Saskatchewan, Alberta, and British Columbia. Rotations and cultural, fertilizer, and rate-of-seeding tests, together with extensive studies of the cost of production of various field crops were carried on in the same localities. Retting and scutching tests with flax, breaking tests with prairie flax straw, and a study of flax pulling machines are noted in addition to the use of a system of fiber grading.

Variety, cultural, and fertilizer tests with tobacco; a survey of tobacco soils; and studies of seed production, harvesting, curing, bed management, and the control of mosaic disease and root rot, conducted in the Provinces of Ontario and Quebec, are described as heretofore. Fall plowing at Harrow (Ontario) proved distinctly better for tobacco than spring plowing, utilizing both animal and man labor to better advantage and destroying insect pests. Seed beds covered with glass and semihotbeds were deemed decidedly superior to all other types. The practice of splitting stems at harvest time is said to have made a gain of 15 days in the curing period and resulted in a brighter colored product.

The work with root crops included variety and fertilizer tests, selection work, analyses, and seed production of mangels, turnips, and carrots, as well as variety tests and sugar content studies of sugar beets. In the experiments in mangel seed production, the greatest yields were obtained from plats receiving 200 lbs. of nitrate of soda and 500 lbs. of superphosphate per acre. A decrease of 19 per cent in yield followed the reduction of the nitrate of soda to 100 lbs. per acre, nitrogen having proved to be the limiting factor. The omission of potash failed to depress the yield. In the work at the Central Experiment Farm at Ottawa, the application of 20 tons of manure per acre increased the seed yield decidedly, whether applied alone or with chemical fertilizers; close planting tended to increase the seed yield, whether full-grown or small roots were used as seed roots; and the results in general indicated that the heaviest yields of seed were secured from full-grown roots planted as early in the spring as possible.

Storage experiments with turnip stecklings indicated that they may be most safely and economically stored on shelves 12 to 15 in. deep in a well-ventilated cellar, where the temperature is held below 35° F. In tests of mangel seed at the Cape Rouge (Quebec) Station, soaking seemed to be the only means of improving the germination, and it had but little influence.

[**Report of field crops work in Missouri, 1918-19**], W. C. ETHERIDGE, C. A. HELM, E. M. McDONALD, and L. J. STADLER (*Missouri Sta. Bul.* 172 (1920), pp. 26-31, fig. 1).—Variety, cultural, and fertilizer trials with various field crops conducted in continuation of similar work already reported (E. S. R., 41, p. 636) are described.

In tests of 31 varieties and selected strains of soy beans at Columbia, Taha, Ebony, and Sable were highest in seed production, with acre yields of 21.94, 19.69, and 18.97 bu., respectively. Taha, Chiquita, and Buster Brown, yielding 4.16, 3.87, and 3.49 tons per acre, respectively, were first in hay production. At Warrensburg, Mikado with 6.82 bu. and Morse with 5.86 bu. per acre led in seed yields, while Chiquita with 3.42 tons, followed by Mikado with 2.55 tons, produced the most hay. Virginia and Black Beauty with 4.46 and 4.10 bu. of seed were first at Marysville, while Wilson with 4.02 bu. and Morse with 2.68 bu. led at Kirksville. Comparisons of different rates of seeding and different

spacing of rows indicated that from 15 to 20 lbs. of seed per acre in rows the width of ordinary corn rows would give maximum yields of both seed and hay.

Tests of 10 cowpea varieties showed the leaders in seed production to be Groit with 13.77 bu., New Era with 12.69 bu., and Cream with 11.77 bu. Brabham, Groit, and Black led in hay yields, producing 3.86, 3.61, and 3.6 tons per acre, respectively. An average of the hay and seed production of the six leading soy bean varieties was 18.96 bu. of seed and 3.47 tons of hay compared with 10.89 bu. of seed and 3.54 tons of hay for the six best cowpea varieties. The hay yields were equally abundant, but the superior seed production made soy-bean hay more valuable pound for pound than cowpea hay.

A mixture of Amber sorghum and soy beans produced the highest yield of the summer-sown forages with 2.88 tons of cured hay at Columbia and 3.3 tons at Warrensburg. Canada field peas with oats was the best of spring-sown forages, yielding 1.86 tons of hay at Warrensburg and 1.51 tons at Columbia. A mixture of rye and vetch proved best at Columbia as a fall-sown forage.

Sudan grass sown at the rate of 5 lbs. per acre in 3-ft. rows gave a total yield of 10.2 tons per acre in three cuttings, while sowings at the rate of 25 lbs. in 8-in. drills, produced 9.3 tons. The yield was lower in the latter case, but the hay was finer in quality because of the smaller stems. A summer-sown crop planted July 10 at Columbia and July 12 at Warrensburg yielded 1.6 tons and 1.1 tons per acre, respectively, from a single cutting.

Leading varieties of wheat in tests conducted at Warrensburg included Jones Red Wave, with a yield of 24.4 bu. per acre, Michigan Wonder with 21.6 bu., and Fulcaster 15 with 20.9 bu. A difference of 13.2 bu. was observed between the acre yields of the highest and lowest yielding varieties. In wheat-breeding investigations at Columbia it was noted that the Fulcaster Selection 8-Y during the years 1914 to 1918 yielded a yearly average of 6.1 bu. more to the acre than the commercial parent variety.

Oat tests showed Texas Red and Burt, medium early varieties, to be outstanding, yielding at Warrensburg 10.9 and 17 bu. and at Marysville 60.8 and 53.2 bu., respectively. Winter oats did not survive the winter at Columbia, and this experience, together with previous failures, led to the conclusion that this crop was of slight value in the State.

Severe drought caused a practical failure of the corn crop at both Marysville and Warrensburg. The most significant result in the culture experiments was secured from frequent shallow scraping of the surface. At Warrensburg this practice produced 8.44 bu., compared with 4.97 bu. with deep cultivation of corn surface planted in both tests. Studies of intertilled soy beans showed that a material growth of beans, by whatever means combined with corn, produced a decided reduction in the corn yield, but when the beans were planted late they made but little growth, with no effect on the yields of corn.

The big-bolled cotton varieties outyielded the small-bolled type in the south-east Missouri lowlands, Mebane Triumph and Cleveland producing 395 and 374 lbs. of lint, respectively, as compared with 324 lbs. for Simpkins and 319 lbs. for King. In cotton fertilizer tests the maximum yield, 436 lbs. of lint per acre, was obtained from a treatment of 300 lbs. of acid phosphate and 35 lbs. potassium chlorid, compared with 390 lbs. for the unfertilized check.

Spring barley made average yields of 20.6 bu. per acre at Columbia and 37 bu. at Marysville, with the Oderbrucker variety leading in both sections. This crop is held to be fairly safe in north Missouri, but is not recommended for the central and southern parts of the State.

[Report of work with field crops in Washington], G. A. OLSON, E. G. SCHAFER, M. A. MCCALL, and C. E. HILL (*Washington Sta. Bul. 155 (1920)*, pp.

16, 17, 26-29, 46-49).—The progress of work along the same general lines as noted heretofore (E. S. R., 40, p. 730) is reported for the year ended June 30, 1919.

Winter wheat varieties tested during a 5-year period showed extreme ranges from 2.15 to 2.9 per cent in nitrogen content, while the average annual variation of farmers' samples ranged from 1.5 to 2.32 per cent. During a 4-year period with spring wheats, an extreme range from 2.23 to 3.13 per cent of nitrogen was noted; the farmers' samples from the same locality having a variation of from 1.73 to 2.5 per cent of nitrogen. The data showed tendencies of a large annual precipitation to favor higher nitrogen percentages in winter wheat; lower annual precipitation to be conducive to higher percentage in spring wheat; and good tillage to favor a higher nitrogen content generally.

Ruddy, Hybrid 128, Turkey Red, and Bluestem were outstanding in the wheat variety tests, with respective average yields for 1918 of 22.07, 23.09, 25.45, and 22.89 bu. per acre, and for the period 1914-1918, 44.2, 39.6, 37.3, and 38.9 bu. per acre. Because of the inferior milling quality of Ruddy, Hybrid 128 was considered to be a more desirable wheat, especially for the Palouse region. The oat varieties, Banner and Abundance, and two coast spring barleys, California and Beldi, produced the highest yields both in 1918 and for the average of the 5-year period 1914-1918. Wisconsin, a winter barley, led in yields in 1918. The early, small-seeded varieties of field peas produced a larger yield than the late varieties, Bangalia making an average of 29.7 bu. per acre for a 7-year period. Carrots, with 28.3 tons per acre, made a larger return than any other root crop.

The use of a nurse crop of wheat or barley in starting alfalfa resulted in a greater total yield of hay the first year after seeding, but the chances of securing a stand and subsequent growth of alfalfa and red clover were reduced.

Cultivation was found to increase the yield of winter wheat 6.8 per cent and spring wheat 2.7 per cent in 1918; for a 4-year period an average increase of 15.1 per cent for winter wheat and a decrease of 2.8 per cent in spring wheat yields were noted. Wheat seeded in rows 18, 12, and 6 in. apart yielded in the increasing order named.

A study of inheritance of varietal characters indicated that there are multiple factors for smut resistance in different wheat varieties, which are inheritable independently and with cumulative effect. It was noted that beards were recessive to awnlessness in a simple Medelian ratio, except where either Turkey or Red Russian was one of the parents, in which case there were but one-half as many bearded segregates as in other crosses. In several crosses of winter and spring wheats and spring barley, the F_1 ripened late and the F_2 gave a 1:2:1 ratio of normal spring plants, plants ripening late, and plants that did not head out. The plants that ripened late were proved to be heterozygous for the winter habit. When crossed with certain other normal varieties, Marquis, Baart, and Kubanka all produced a certain percentage of dwarf plants. Dwarfness seemed to be associated with late ripening and was thought probably linked in some degree to winter habit.

In a season said to be extremely unfavorable for crop production at the Adams Substation, Turkey Red (Washington 326) proved most drought resistant and was best in yield and quality in tests conducted in cooperation with the U. S. Department of Agriculture. Early Baart (Washington 618) was best among spring wheats, yielding 35 per cent better than Bluestem. Field peas did not compare favorably with wheat, making but 5.3 bu. per acre as compared with 6.8 bu. from the best winter wheat variety. In a depth-of-seeding test for winter wheat, depths of 1, 2.5, and 4 in. gave respective stands of 237,000,

157,000, and 171,000 plants per acre. Because of the lack of moisture the lighter stands gave slightly greater yields, but the difference in stand secured indicated the desirability of shallow seeding.

In small grain investigations at the Waterville Substation, beardless varieties yielding the most grain were found to be the best for forage. Highest yields of hay were secured when harvested in the dough stage. Fall seeding gave better results than spring seeding. The practice of harrowing winter wheat in the spring did not appear to increase yields at the station. When grown in cultivated rows, spring wheat is said to have yielded higher than when drilled in the usual way. Field peas sown May 3 yielded 50 per cent less than when sown April 5, emphasizing the necessity of early planting to obtain best results.

Fall seeded farm crops, E. B. STOOKEY (*Washington Sta., West. Wash. Sta. Mo. Bul.*, 8 (1920), No. 5, pp. 68-70).—This briefly discusses the practices deemed best for fall planting of wheat, rye, winter oats, vetches, grasses, clovers, and crop mixtures in western Washington, and indicates the most profitable varieties and rates of seeding.

Forage crops for the nonirrigated lands of Idaho, R. K. BONNETT (*Idaho Sta. Bul.* 120 (1920), pp. 23, figs. 5).—Brief notes on the perennial grasses, legumes, and grass mixtures suitable to the drier regions of Idaho are presented, in addition to instructions regarding the preparation, seeding, and use of nurse crops. The success of forage crops on the nonirrigated lands is said to be determined largely by the cultural practices followed in the preparation of the seed bed and in seeding. Comparative yields of various grass mixtures, sweet clover, alfalfa, and Sudan grass at different rates and methods of seeding are given in tabular form.

Soil moisture movement in relation to growth of alfalfa, C. A. THOMPSON and E. L. BARROWS (*New Mexico Sta. Bul.* 123 (1920), pp. 38, figs. 18).—Supplementing work previously noted (E. S. R., 33, p. 229), this report studies on the movement and distribution of soil moisture in connection with the depth of application of irrigation water and cultural treatment of the soil. Climatic, meteorological, and yield data, as well as plant-root measurements, are presented in tabular and diagrammatic form and are fully discussed. The results obtained may be summarized as follows:

Yields of alfalfa were found to increase in proportion to the total depth of water applied regardless of soil depth, while the yield per acre-inch of water decreased with an increase in the amount of water added. Besides requiring larger amounts of water to maintain a given percentage of moisture, plats cultivated after irrigation showed smaller average yields and smaller yields per acre-inch of water than uncultivated plats. The duty of water decreased as the amount applied was amplified, and increased as the depth of soil over gravel increased.

It was noted that water did not percolate below the reach of plant roots on cropped plats receiving an average annual application of 55 in. Percolation was observed below 10 ft. on fallow plats receiving from 25 to 30 in. of water annually, but not on fallow plats receiving annual applications of from 15 to 20 in. But slight variation was found in the moisture content of the soil below 4 ft. on cropped plats receiving 3 in. of water at each application. Evaporation from fallow plats during the growing season was about 20 in.

Alfalfa (*U. S. Dept. Agr., Dept. Circ.* 115 (1920), pp. 6).—This describes cultural methods and field practices deemed best for growing the crop on soils not of limestone origin.

Corn experiments at the Judith Basin Substation, W. P. BAIRD (*Montana Sta. Bul.* 132 (1919), pp. 24, figs. 10).—Experiments conducted in cooperation

with the Bureau of Plant Industry of the U. S. Department of Agriculture from 1908-1918, including observations on yields of fodder from corn in rotations and under various systems of tillage, are reported, together with studies of the effect of corn on the yields of succeeding crops, and a comparison of disking *v.* plowing corn stubble. Meteorological data and crop yields are presented in tabular and diagrammatic form. The results obtained and conclusions reached may be summarized as follows:

Although no corn could be found that matured a grain crop in the short season, Northwestern Dent and several other varieties produced a fine quality of fodder mature enough for feeding either dry or as silage. The 10-year average yield for corn in rotations was 5,071 lbs., as compared with 2,530 lbs. for alfalfa, 2,128 lbs. for red clover, and 1,953 lbs. for brome grass. Corn made higher yields following corn than after summer fallow or small grain, but the advantages of a rotation were held to make this preferable to continuous cropping.

Subsoiling produced the highest average fodder yield, but the increase over shallow plowing was not deemed sufficient to pay for the increased cost of production. Plowing gave higher yields than listing, which was not considered to be adapted to the soils in Judith Basin. Summer fallowing before corn, like dynamiting, did not justify the practice with increased yields. Stable manure applied to corn plats before spring plowing at the rate of 10 tons per acre increased the average yields of fodder about 1,000 lbs. per acre.

In all cases yields of oats, spring wheat, and barley averaged higher after corn than after small grain crops, and as high, or nearly as high, as when following summer fallow. Spring wheat, oats, and flax all gave slightly higher yields on disked than on plowed corn land.

Results of seven years' pedigree selection in Trice cotton, E. A. HODSON (*Arkansas Sta. Bul. 171 (1920), pp. 3-27, pls. 4, figs. 4*).—Data describing in detail the progeny of a number of selections of Trice cotton of both semicluster and Peterkin type are represented. In addition to pedigree charts, frequency distributions, and correlations for the separate characters studied, detailed notes on the type, fruiting habits, and yields of the selected plants are included in tabular form.

Illustrating the variability in desirable plants, the author notes that the selections varied from 30 to 65 in. in height; had from 0 to 6 base limbs, 6 to 25 fruiting branches, and 10 to 85 bolls per plant; and bore bolls varying from 50 to 110 per pound. The lint of the selected plants varied from 18 to 27 mm., while the mean length ranged from 22.05 mm. in 1911 to 25.27 mm. in 1914. In a study of the length of lint in progeny the average of the 10 longest lint selections in 1914 was 25.79 mm., while the average of the 10 shortest lint selections was 23.56 mm. The progeny of the short lint selections gave longer lint than the progeny of the long lint selections in 1915, but shorter in 1917 and 1918.

A study of the descriptions of selected plants indicated to the author that that type of plant was not to be considered as an index to the potential productivity, and that there was no measurable difference between the parents of the most productive and those of the least productive plats.

Experiments in the size of the seed piece and other factors in the production of potatoes under irrigation in southern Idaho, L. C. AICHER (*Idaho Sta. Bul. 121 (1920), pp. 3-16, figs. 8*).—This reports potato experiments conducted at the Aberdeen Substation embracing comparisons of whole seed *v.* cut seed, and irrigated *v.* dry-land seed stock for irrigated land, in addition

to the determination of the most productive size of seed piece and the best spacing within the row. The observations may be summarized as follows:

Plants from whole tubers sprouted and emerged more quickly than those from cut tubers, and sets from whole potatoes produced a more luxuriant vine growth than cut tuber sets, the plant vigor increasing in proportion to the size of the set. The average loss of stand ranged from less than 1 per cent for whole and halved tubers to 12 per cent with quartered tubers. The number of stalks per hill increased directly as the size of the set increased. It was noted that the earlier sprouting bud-eye of the Idaho Rural potato did not grow to the exclusion of the growth of the other eyes.

Although whole tubers produced 15.4 per cent greater total yield than cut seed, the cut tubers yielded 18 per cent more marketable potatoes per acre, the percentage of marketable stock increasing as the size of set decreased. The larger sets produced greater numbers of tubers but with a smaller average weight per tuber. When yield and amount of seed used were considered, the 3 oz.-halved and 4 oz.-quartered seed rendered the most economical returns.

Results of spacing studies indicated that the largest percentage of marketable tubers, together with the greatest weight per tuber, were obtained from the greater distances between hills in the row. On good alfalfa land, plantings from 24 to 28 in. in the row gave the best yields, while spacing 16 in. or less did not prove to be economical. On the other hand, the most profitable yields for seed-stock purposes were obtained from 8 to 12 in. spacing in the row, as the close plantings reduced the size of the tubers and produced large numbers of potatoes of seed size. The main essentials in seed-stock selection are held to be health and trueness to type and variety, regardless of whether grown on irrigated or dry land.

Late-planted potatoes produce good seed, J. B. KEIL (*Mo. Bul. Ohio Sta., 5 (1920), No. 6, p. 179*).—The practice of planting potatoes during the last week in June is recommended, as the plants set tubers early in September or October, generally receive more rainfall, return higher yields, and produce more seed of good vitality than early potatoes which set their crop in August. Seed for this planting is frequently prepared by sun-sprouting, a procedure consisting essentially of removing the long sprouts from the stored potatoes and spreading the tubers out on a floor exposed to light until planting time. It is said that only small green sprouts develop under this treatment, and that the potatoes grow very rapidly after planting.

Growing late potatoes, J. T. ROSA, JR. (*Missouri Sta. Circ. 95 (1920), pp. 4*).—Brief popular instructions on the culture of the fall crop in Missouri, including notes on seed, preparation of land, and pests.

HORTICULTURE.

[Report of the horticulturist], F. J. CRIDER (*Arizona Sta. Rpt. 1918, pp. 303-310, 311-313*).—The condition of the date orchards at Tempe and Yuma is briefly noted, and varietal yields for the 1917 season are tabulated. Studies in the culture and management of date orchards and of cultural methods with citrus fruits here outlined were begun in 1918.

The method of propagating dates in a propagating house covered with canvas and with no ventilation (*E. S. R., 36, p. 142*) gave poor results in 1917, but was giving much better results in 1918 than propagation in the open after the propagating house had been removed from a location where the soil is heavy and poorly drained to a location where the soil is sandy and well drained. A careful examination in the latter part of November showed that out of 237 off-shoots placed in the house, only 37 failed to show evidence of growth. Several indi-

viduals had developed good root systems, whereas suckers on the outside of the house, although alive, showed no signs of root formation.

Attention was given during the year to the maintenance of an all-the-year family garden at Yuma and on the university grounds at Tucson. The results thus far secured indicate that with good cultivation and ample irrigation an ample variety of vegetables can be produced in the home garden during the fall and winter months. Such plants as the tomato, eggplant, pepper, okra, carrot, and the garden cowpeas were made to produce during the hottest portion of the summer. Work is being conducted to determine the value of spinach as a commercial crop for southern Arizona.

[Report on horticultural work for the year ended March 31, 1919], W. T. MACOUN ET AL. (*Canada Expt. Farms Rpt. 1919*, pp. 14, 28, 29, 31, 93, 98, 122, 123, 130, 131, 140, 143, 144, 156, 157, 161, 170, 171).—In continuation of previous reports (E. S. R., 41, p. 538), the horticultural work at the Central Farm is briefly reviewed, and notes are given on cultural and variety tests of fruits, vegetables, and ornamentals at the branch farms and stations.

Horticultural statutes of the State of California corrected to November 1, 1919 (*Sacramento, Cal.: State Dept. of Agr., 1919*, pp. 174, pl. 1).—The text is given of California statutes and quarantine orders relating to horticulture.

Rules and regulations governing (1) entry for immediate export, (2) entry for immediate transportation and exportation in bond, and (3) safeguarding the arrival at a port where entry or landing is not intended of prohibited plants and plant products (*Washington: U. S. Dept. Agr., Fed. Hort. Bd., Rules and Regulations, 1920*, pp. 6).—This comprises rules and regulations of the Federal Horticultural Board, effective on and after August 1, 1920, dealing with the importation of plants and plant products.

The Christ-Lucas garden book, F. LUCAS (*Christ-Lucas Gartenbuch. Stuttgart: Eugen Ulmer, [1920], 21. ed., rev., pp. XII-468, pls. 2, figs. 286*).—A general guide to the laying out and management of house gardens and the culture and care of flowers, ornamental plants, vegetables, fruit trees, and grapes, including the care of house flowers. The appendix contains a seasonal working calendar.

The busy woman's garden book, I. D. BENNET (*Boston: Small, Maynard & Co., 1920*, pp. XIV+334, pls. 6).—A popular treatise on vegetable and ornamental gardening.

Vegetable gardening in Georgia, T. H. MCHATTON, J. W. FIROR, and E. RAGSDALE (*Ga. State Col. Agr. Bul. 180 (1920)*, pp. 32, figs. 5).—A treatise on home vegetable gardening, briefly discussing general principles and giving concise cultural directions for growing all of the common vegetables, together with a planting table.

Transplanting investigations with vegetables, J. T. ROSA, JR. (*Missouri Sta. Bul. 172 (1920, p. 34)*).—It has been found that the conditions of hardness in plants can be brought about as effectively by withholding moisture or by decreasing the supply of available plant food as by exposure to low temperature. See also a previous note (E. S. R., 43, p. 643).

Recent investigational work with the tomato, R. WELLINGTON (*Trans. Peninsula Hort. Soc. [Del.], 9 (1920), No. 3, pp. 73-76*).—A contribution from the Maryland Agricultural College. The author discusses the superiority of F₁ tomato seed, cites the results of various investigators substantiating the value of F₁ seed, and presents data along this line secured at the Minnesota Experiment Station during the years 1911-18, inclusive.

During this 8-year period, F₁ seed of dwarf-standard crosses averaged nearly 4 lbs. of fruit per plant more than the plants of the standard parents. In most cases F₁ seed of standard-standard crosses have outyielded the average of the

parents, although not always the high yielding parent. Qualities other than yield that are present in the crosses are marked increase in number of fruits, smoothness, and earliness.

The results secured for individual years from different strains indicate that single-year tests have little value. The high and low yielding strains of 1915, a wet, cold year, reversed their position in 1916, a hot, dry season.

The author states that the wilt-resistant strains of tomatoes originated by the U. S. Department of Agriculture in cooperation with the Maryland College and Station have given excellent results. Attention is called to the fact that these wilt-resistant strains are not immune to other tomato diseases like the black shank, leaf blight, etc.

Profitable tomato fertilizers, J. T. ROSA, JR. (*Missouri Sta. Bul. 169 (1920)*, pp. 12, figs. 2).—The results are given of commercial fertilizer tests conducted in cooperation with 10 growers, 7 of whom were located on typical Ozark soils. Different commercial fertilizers and mixtures were compared with stable manure as affecting the yield and time of maturity of the tomato crop.

Both complete fertilizer and a mixed fertilizer containing no potash produced a marked increase in yields. The percentage of increase was greater on the poorer soils. Acid phosphate alone produced a good increase in yield, but nitrate of soda alone and sulphate of potash alone did not give a large increase, and in some cases decreased the yield through plant injury.

Stable manure and poultry manure were excellent fertilizers for tomatoes, but did not stimulate early maturity so well as the 4.6:8:7 and 5:8:0 commercial fertilizers. Both the mixed fertilizers and acid phosphate alone gave a striking increase in the amount of early fruit, the plants reaching quantity production four weeks earlier than on the unfertilized check plats.

In view of these tests, the use of at least 250 lbs. per acre of a commercial fertilizer analyzing 3 or 4 per cent nitrogen and 10 to 12 per cent phosphorus is recommended.

Fruits, trees, and shrubs for Iowa planting, S. A. BEACH (*Iowa State Col. Agr. Ext. Bul. 27 (1918)*, pp. 4).—This comprises a variety list of orchard and small fruits, trees, and ornamental shrubs suitable for planting in different parts of Iowa.

Fruit-breeding investigations, B. T. P. BARKER and G. T. SPINKS (*Univ. Bristol, Ann. Rpt. Agr. and Hort. Research Sta., 1919*, pp. 76-84).—A progress report on breeding investigations with apples, plums; cherries, currants, gooseberries, raspberries, and strawberries, being conducted at Long Ashton, Bristol (E. S. R., 37, p. 646), including notes on crosses thus far made.

Factors governing fruit bud formation, B. T. P. BARKER and A. H. LEES. (*Univ. Bristol, Ann. Rpt. Agr. and Hort. Research Sta., 1919*, pp. 85-98).—Continuing a previous paper dealing especially with the influence of pruning on fruit bud formation (E. S. R., 37, p. 646), the authors here present the results of observations on the normal growth of apples and pears, and also discuss the effect of notching and ringing on apple trees.

It is concluded that the normal growth of buds from a last year's shoot is influenced by the following factors: Temperature, inhibition of some substance from the first bud to grow that flows backward and checks all the other buds (here called the "Loeb effect"), bud strength, root action, and variety influence.

Ringing experiments were conducted in May, June, and July. The results indicate that ringing causes stimulation of dormant buds on bare wood below, and that the stimulation acts as long as callus has failed to bridge the wound. The later the rings are made, the less will dormant buds be stimulated. Ringing in July is dangerous, owing to the risk of canker.

Notching above a bud resulted in nearly every case in more growth for the bud affected than for similar buds situated on untreated twigs. Notching below a bud in every case prevented growth and kept the bud dormant. Where notches were made alternately above and below, from base to apex on one-year-old twigs, with the exception of the terminal buds which grew into wood shoots, every bud with a notch underneath remained dormant, and every bud with a notch above grew into a very short wood spur. In either case, the effect of notching only extended to the bud adjacent to the notch.

Temperatures which will damage or kill fruit buds, F. L. WEST and N. E. EDLEFSEN (*Better Fruit*, 14 (1920), No. 10, pp. 13, 14, fig. 1).—A contribution from the Utah Experiment Station, comprising a popular summary of the authors' previously noted investigation (E. S. R., 37, p. 344).

The espalier and fancy fruit, J. BOTTNER (*Spalier und Edelobst. Frankfort on the Oder: Trowitzsch & Son, 1919, 3. ed., pp. IV+324, figs. 330*).—A small treatise on the planting, pruning, and care of fruit trees trained to special forms.

Report of dusting investigations, W. C. TRAVERS (*Trans. Peninsula Hort. Soc. [Del.]*, 9 (1920), No. 3, pp. 39-44).—A contribution from the Maryland Agricultural College. Cooperative dusting experiments were conducted in 1919 on the Eastern Shore of Maryland, using a dust mixture consisting of 85 per cent sulphur and 15 per cent lead arsenate in dusting apples, peaches, and strawberries.

As compared with lime-sulphur spray, dusting was fairly satisfactory in controlling insects, but was far from satisfactory in controlling apple diseases. It failed to control peach scab and curculio, but was successful in controlling brown rot. The dust killed the curculio, but not until after they had punctured the fruit. The cost of dusting was greater than for spraying, both with apples and peaches.

Dusting experiments conducted for the control of the strawberry weevil were highly successful and profitable. The 85 per cent sulphur and 15 per cent lead arsenate mixture gave the best results in this work.

The control of the codling moth and apple scab in Delaware, B. R. LEACH and J. W. ROBERTS (*Trans. Peninsula Hort. Soc. [Del.]*, 1920, pp. 14-22).—This report gives the results of experimental work conducted in 1919 by the Bureaus of Entomology and Plant Industry, U. S. Department of Agriculture, in cooperation with the Delaware Experiment Station.

A comparative test of dusting and spraying indicated that the dusting of apples is not advisable in Delaware, since the dust does not control the codling moth or apple scab as efficiently as the spray. The combination of calcium arsenate and lime sulphur used as a spray controlled the codling moth as well as the arsenate of lead and lime sulphur. In case calcium arsenate is used, however, hydrated lime should be added to avoid injury to the foliage. The spray gun compared favorably with the spray rod in the control of the codling moth, and if operated properly good results can be secured by its use. A spraying schedule, which it is believed is best suited for the control of the codling moth and apple scab in Delaware, is given.

[Report of the] division of horticulture, O. M. MORRIS (*Washington Sta. Bul.* 155 (1920), pp. 30-33).—Brief statements are made of progress in various horticultural projects.

Observations thus far made on the relation of the pollination and proper fertilization of apple blossoms to June drop indicate that inefficient fertilization is a prime cause of June drop.

Data secured in orchard cover crop investigations indicate that permanent cover crops such as alfalfa and clover may be established in orchards without checking the growth and production of the trees, provided a sufficient water

supply is available and fertilizers containing high nitrate contents are added at the time or prior to the date of seeding of the cover crop. The use of fertilizers in run-down prune orchards has shown nitrate fertilizers to be the only ones that have made any distinct improvement in the orchards studied.

- In apple storage tests conducted in the winter of 1918-19 the fruit produced in the warmer parts of valleys went down in storage before the material of the same valley secured from the cooler and more elevated sections.

Some orchard problems, C. A. McCUE (*Trans. Peninsula Hort. Soc. [Del.]*, 9 (1920), No. 3, pp. 48-51).—A contribution from the Delaware Agricultural College, comprising recommendations relative to orchard fertilization and outlining a test fertilizer experiment to be used by the grower in seeking to determine the fertilizer needs of his orchard.

Results of pollination studies at Idaho University, C. C. VINCENT (*Better Fruit*, 14 (1920), No. 8, pp. 11-13, 15, figs. 3).—Data are given on pollination studies conducted with a large number of varieties of apples for several years. Results in general indicate that, although a few varieties were self-fertile, most varieties are from a practical standpoint self-sterile and should be interplanted with suitable pollenizing varieties.

Thirty years' experience in application of bud selection in the fruit industry, G. T. POWELL (*Calif. Citrogr.*, 5 (1920), No. 11, pp. 344, 364-366, figs. 4).—A paper read before the California nurserymen at San Francisco, in which the author briefly reviews his experiences in the propagation of apples from selected buds.

Life histories of some well-known apples, C. H. HOOPER (*Fruit, Flower, and Veg. Trades' Jour. [London]*, 38 (1920), No. 2, pp. 35-37).—A compilation of information relative to the origin, value of the fruit, fruiting period, and sterility or fertility of a large number of apples grown in Great Britain.

Varieties of apples adapted for Ohio culture, W. J. GREEN, P. THAYER, and J. B. KEIL (*Mo. Bul. Ohio Sta.*, 5 (1920), No. 6, pp. 180-186).—This comprises excerpts from Bulletin 290 of the station (E. S. R., 35, p. 40). It discusses in particular the adaptability of the Baldwin, Ben Davis, and Northern Spy varieties to Ohio conditions.

Experimental results in pruning apple trees, E. C. AUCHTER (*Rpt. Md. Agr. Soc.*, 4 (1919), pp. 116-128; also in *Trans. Peninsula Hort. Soc. [Del.]*, 9 (1920), No. 3, pp. 23-30).—A contribution from the Maryland Agricultural College. The author summarizes pruning experiments previously conducted at the West Virginia Station (E. S. R., 36, p. 535), and briefly discusses the application of the results to Maryland conditions.

Notes on the origin of some of our cherries, C. H. HOOPER (*Fruit, Flower, and Veg. Trades' Jour. [London]*, 38 (1920), No. 3, pp. 63, 64).—A compilation of information relative to the origin, blossoming, and harvest periods, sterility or fertility of the blossoms, and distinguishing characteristics of a large number of cherries grown in Great Britain, including also notes on a few American varieties.

The histories of the plums we grow, C. H. HOOPER (*Fruit, Flower, and Veg. Trades' Jour. [London]*, 37 (1920), No. 24, pp. 647, 648).—This comprises compiled information relative to the origin and sterility or fertility of varieties of plums grown in England.

Prune growing in western Washington, O. M. MORRIS (*Washington Sta. Pop. Bul.* 120 (1920), p. 21, figs. 7).—Practical suggestions are given on prune growing, the information being gained by a survey and also through cooperative experimental work, including fertilizer tests. Consideration is given to varieties, pruning, cultivation, fertilizers, and the cause of crop failures.

Crop failures have been traced to three very general causes acting together or separately. These are unfavorable weather at the blossoming season, brown rot in seasons of rainy weather during the blossoming season, and lack of vigor in the trees due to improper cultural practices.

The value of the different roots as stocks, W. L. HOWARD (*Better Fruit*, 14 (1920), No. 10, pp. 19, 20).—A contribution from the California Deciduous Fruit Station briefly discussing the value of different roots as stocks for prunes and pears.

Experimental fields in calcareous soil, A. TACUSSEL and E. ZACHAREWICZ (*Rev. Vitic.*, 52 (1920), No. 1350, pp. 333-335).—A summary of the results secured during a period of 28 years in testing varieties of grapes suitable for soils high in lime content, including lists of varieties that have done well, those that have made vigorous growth, and those that have made very vigorous growth.

The hybrid direct bearers in the valley of the Drome in 1919, A. DESMOULINS and V. VILLARD (*Prog. Agr. et Vitic. (Ed. l'Est-Centre)*, 72 (1920), Nos. 29, pp. 61-65; 30, pp. 83-85; 31, pp. 114-116; 32, pp. 133-137).—In continuation of previous data (E. S. R., 40, p. 838) observations are given for the twentieth year relative to the behavior of a large number of hybrid direct-bearing grapes, with reference to their resistance to disease, adaptation to various soil conditions, production, etc.

The cultivation of the areca palm in Mysore, L. C. COLEMAN and M. K. VENKATA (*Dept. Agr. Mysore, Gen. Ser. Bul. 10* (1918), pp. [3]+32, pls. 7, fig. 1).—A detailed account is given of the culture, harvesting, and preparation of areca nuts for the market, including information relative to the diseases and pests of the areca nut and the economic uses of the various parts of the areca palm. Suggestions are also given relative to measures for improving the industry.

Date processing and marketing, A. E. VINSON (*Arizona Sta. Rpt. 1918*, pp. 348, 349).—Based on the results of the station's date investigations during the past 13 years, the author concludes that the date industry in Arizona, properly managed, can be recommended to the investing public. The station has proved at least some of the varieties that are successful in Arizona, and climatic difficulties have been overcome to the extent that losses due to this cause are almost negligible. A market has been made that will take the output of a large acreage at profitable prices. Fresh soft dates, such as Hayany, Rhars, Tadala, and similar varieties, promise to become a staple food as soon as they can be supplied in quantities and may be carried for months in dry cold storage without serious deterioration in quality. Culls and stock that may not be fit for the fresh date trade can be processed quickly for ordinary commercial dry dates.

The cultivation of oranges and allied fruits in the Bombay Presidency, H. P. PARANJPE (*Dept. Agr. Bombay Bul. 95* (1919), pp. [II]+23).—This bulletin describes the methods of growing citrus trees that have been found to yield the best results in the Bombay Presidency.

Notes on the production and quality of local teas, G. G. AUCHINLECK (*Mauritius Dept. Agr., Gen. Ser., Bul. 13* (1918), [English Ed.], pp. 15).—This bulletin contains notes on the production of tea in Mauritius, together with the analyses of a number of local teas and some observations on the processes concerned in tea manufacture.

The cultivation of yerba mate, C. D. GIROLA (*Pub. Mus. Agr. [Soc. Rural Argentina]*, No. 14 (1919), pp. 30, figs. 14).—This publication discusses the gathering of the leaves and shoots, the yield of material either green, cured, or ground, the cost of establishing plantations, and the cost of production and farm value of yerba mate (*Ilex paraguariensis*) in Argentina.

Filbert culture in the Northwest, G. A. DORRIS (*West. Walnut Assoc. Ann. Rpt.*, 2 (1919), pp. 22-28).—Suggestions on filbert culture based on the author's long-continued personal experience.

Filbert culture in the county of Kent, England, A. A. QUARNBERG (*West. Walnut Assoc. Ann. Rpt.*, 2 (1919), pp. 28-32, figs. 2).—The methods practiced and the results obtained in the culture of the filbert in Kent are briefly described.

Propagating pecans by budding and grafting, J. A. EVANS (*Tex. Agr. Col. Ext. Bul. B-55* (1920), pp. 3-31, figs. 14).—A discussion of various methods of budding and grafting pecan trees.

The walnut plantations at Point Platon, A. JOLY DE LOTBINIÈRE (*Canad. Forestry Jour.*, 16 (1920), No. 7, pp. 325-329, figs. 4).—Notes are given on the present condition of three black walnut groves that were planted by the author's grandfather 37 years ago at Point Platon, Quebec.

Trees were planted on three different sites, a cultivated soil protected on all sides from the wind, an alluvial soil protected from the wind on one side only, and on an exposed boulder clay soil. The results in general indicate that protection from the wind is the keynote to success in planting the black walnut in a cold climate, providing the trees are planted on a good soil and are given a fair start. Walnut trees growing in the open required 9 years to grow an inch in diameter, as compared with 5 years for protected walnut trees and 6 years for paper birch, chestnut, and oak.

Pacific Coast lilies and their culture, C. PURDY (*Jour. Internat. Gard. Club*, 3 (1919), No. 4, pp. 497-532, pl. 1, figs. 9).—Descriptions are given of the lily species growing on the Pacific coast, including suggestions relative to their specific cultural requirements.

Medicinal plants, C. D. GIROLA (*Bol. Min. Agr. [Argentina]*, 25 (1920), No. 1, pp. 3-46).—The author reviews the status of medicinal plant culture in Argentina, and discusses the possibility of cultivating foreign species and the progress made with indigenous plants having medicinal properties. Lists are given of the more important species grown for medicinal and allied purposes, and statistics on the importation of the principal drug plants or their products are tabulated. A list is also given of drug plants considered possible or desirable of cultivation in Argentina.

Medicinal plants in the Department of Gard, C. FLAHAULT ET AL. (*Les Plantes Médicinales dans le Département du Gard. Nîmes: Interministerial Com. Medicinal Plants and Essences*, 1920, pp. 48, fig. 1).—A report on the medicinal and essence plants in Gard, France, with reference to their general distribution, methods of collecting, and the distribution and characteristics of valuable species. A plant collector's calendar, together with notes on the essence industry in Gard and oil of cade, is also included.

Cultivation of saffron in Macedonia, F. H. BAXTER (*U. S. Dept. Com., Bur. Foreign and Dom. Com. Rpts. No. 194* (1920), pp. 844, 845).—A brief consular report discussing methods of growing the saffron plant (*Crocus sativus*), characteristics of the plant, gathering the crop, and preparing saffron for market.

Protection for shade trees, E. SECREST (*Mo. Bul. Ohio Sta.*, 5 (1920), No. 6, pp. 162-169, figs. 9).—A popular discussion of methods of protecting shade trees from mechanical injuries, earth fills, etc.

FORESTRY.

The United States forest policy, J. ISE (*New Haven: Yale Univ. Press*, 1920, pp. 395, figs. 4).—A contribution from Yale University comprising a historical study of the forest policy of the United States.

The introductory chapter deals with the period prior to 1878, when the Free Timber and the Timber and Stone Acts were passed. The subsequent chapters discuss the period leading up to the establishment of forest reserves and their administration and protection, conservation activity, anticonservation activity, the forest reserves in the Appalachian and White Mountains, the unreserved timber land since the passage of the Forest Reserve Act, the hostility to National Forests in recent years, the work of the Forest Service, and the results of our forest policy.

Vacation on the White Mountain National Forest (*U. S. Dept. Agr., Dept. Circ. 100 (1920), pp. 24, figs. 16*).—An account of the recreational features of this forest, including instructions to campers.

Mountain outings on the Rainier National Forest (*U. S. Dept. Agr., Dept. Circ. 103 (1920) pp. 28, pl. 1, figs. 16*).—An account similar to the above.

Fishing, hunting, and camping on the Cascade National Forest (*U. S. Dept. Agr., Dept. Circ. 104 (1920), pp. 22, pls. 2, figs. 14*).—An account similar to the above.

Ninth annual report of the State forester to the governor for the year ending December 31, 1919, F. A. ELLIOTT (*Ann. Rpt. State Forester Oreg., 9 (1919), pp. 57, figs. 13*).—The report deals largely with forest fire protective work for the season.

Texas forest facts, E. O. SIECKE (*Texas: State, 1918, pp. 16*).—A brief review of timber resources and the status of forestry work in Texas.

Hawaii's tapestry forests, V. MACCAUGHEY (*Bot. Gaz., 70 (1920), No. 2, pp. 137-147, figs. 6*).—A descriptive account of those portions of the rain forest on the Hawaiian mountains that cling to very steep slopes, together with a list of species included in these formations.

Forests and forestry in British Columbia, T. D. PATTULLO, G. R. NADEN, and M. A. GRAINGER (*Victoria, B. C.: Govt., 1920, pp. 35, pls. 2, figs. 6*).—This report embraces the replies to the questionnaire sent out by the British Forestry Commission. The information given deals with the topography, geology, soils, and climate of the country, forest types and trees, forest areas, important timber trees, forest ownership, relationship of the State to the forests, the forest authority, forestry activities of municipalities, etc., forestry or utilization associations, educational, research, and experimental work, annual increment and utilization of home-grown timber, forest industries, and statistics of exports and imports of timber.

The history of Irish forests and forestry, G. ROBINSON (*Irish Gard., 15 (1920), Nos. 173, pp. 104-106, fig. 1; 174, pp. 116-121, fig. 1*).—A paper read before the Irish Forestry Society, May 27, 1920.

The woods and forest institutions in the new Province, A. SERPIERI ET AL. (*R. Ist. Super. Forestale Naz. Firenze [Pub.], No. 4 (1920), pp. VI+283, figs. 15*).—An account is given of the forests, the organization of the forest service, general forest legislation, the administration of State, communal, and private forests, the control of torrents, reforestation of poor soils, and agricultural operations in the province returned by Austria to Italy after the World War. The text of various laws dealing with forestry in this province is appended.

Department of forestry: State forestry report for the year ended March 31, 1919, E. P. TURNER ET AL. (*New Zeal. Dept. Forestry, State Forestry, Ann. Rpt. 1919, pp. 43*).—This comprises an annual report relative to the administration and management of the indigenous forests, as well as the State nurseries and plantations. Information relative to legislation, finances, and trade and forest areas is included. Appended to the report are reports upon afforestation operations in the North and South Islands, together with extracts from reports by the conservators of State forests.

Administration report of the forest circles in the Bombay Presidency, including Sind, for the year 1918-19 (*Admin. Rpt. Forest Circles Bombay, 1918-19, pp. 133+3*).—A report of administration and management of the State forests in Bombay and Sind for the fiscal year 1918-19. Data relative to forest areas, forest surveys, working plans, forest protection, miscellaneous work, yields in major and minor forest products, revenues, expenditures, etc., are appended.

Forestry in Netherlands India, VAN ASBECK (*Jaarv. Dept. Landb., Nijv. en Handel Nederland. Indië, 1918, pp. 241-263*).—A progress report on the administration and management of the forests, including rubber plantations, in Netherlands India for the year 1918.

Twelfth annual report of the Washington Forest Fire Association, 1919 (*Wash. Forest Fire Assoc. Ann. Rpt., 12 (1919), pp. 27*).—A report on the activities of the State Forest Fire Association, with tabular data showing the burned area and losses for the season of 1919.

Fire warden's handbook (*Oregon: State Bd. Forestry, 1919, rev., pp. 51*).—This handbook briefly indicates the forest policy of the State, and supplies the information needed by the State fire wardens in the discharge of their duties. The full text is given of the forest laws, together with opinions of the Attorney General in digest form relative to several important sections.

Forest aerial photographs, L. A. NIX (*N. Y. Forestry, 7 (1920), No. 3, pp. 8-11, figs. 2*).—This article briefly reveals some of the facts regarding the interpretation of aerial photographs, with special reference to their use in forest mapping.

Collection of data as to the rate of growth of timber (*[Gt. Brit.] Forestry Comm. Bul. 1 (1919), pp. 16, pl. 1*).—This bulletin contains instructions to statistical field parties and to parties collecting timber samples for testing purposes, together with forms used in the work.

Rate of growth of conifers in the British Isles, W. H. GUILLEBAUD, H. M. STEVAN, and R. E. MARSDEN (*Gt. Brit. Forestry Comm. Bul. 3 (1919), pp. 86, pl. 8*).—This bulletin presents the results of a survey of the development of coniferous trees grown under silvicultural conditions in the British Isles. The first three chapters deal with the general methods employed in the field and in working up the collected data into yield data for the principal species. In the succeeding chapters, the data secured are submitted to statistical analysis with a view of determining the effect of locality upon the growth of larch, Scots pine, and spruce. In the concluding chapter, the evidence secured as to the prevalence of canker in larch, crown damage in Scots pine, and heartrot in larch, Scots pine, and spruce is briefly discussed.

Results of the timber census, A. B. RECKNAGEL (*N. Y. Forestry, 7 (1920), No. 3 pp. 3-5, pl. 1*).—A tabular estimate is given of standing timber of various species in the State of New York according to the 10 forest districts in 1918-19. The data given and discussed are based on a war-time census by the New York State Conservation Commission in cooperation with the Forest Service of the U. S. Department of Agriculture, The Society of American Foresters, and State agencies.

Rubber and coffee selection, W. BALLY (*Meded. Proefsta. Midden-Java, No. 33 (1920), pp. I-XII*).—A lecture delivered before assemblies at the Solo and Semarang Experiment Stations. It discusses methods employed in conducting selection work with rubber and coffee.

On tapping systems, W. BALLY (*Meded. Proefsta. Midden-Java, No. 34 (1920), pp. 7-13*).—A discourse on methods of conducting rubber tapping experiments presented at the General Assembly of the Central Java Experiment Station, Semarang, May 17, 1920.

DISEASES OF PLANTS.

Plant disease studies, J. J. THORNER (*Arizona Sta. Rpt. 1918, pp. 301, 302*).—A serious disease of pepper, somewhat resembling tomato wilt, appeared at Tubac and near Tucson. A serious disease of cottonwood and poplar trees, caused by *Cytospora chrysosperma*, has been found in Flagstaff, Williams, Prescott, Douglas, Nogales, Continental, and Tucson. It causes on the bark of the large branches sunken, dead, and blackened areas, having a pronounced odor. These areas give rise later to the fruiting bodies, which can also be seen in the fissures formed on the older bark. Affected trees live two or three years, spreading the disease. Native cottonwoods, of which several species thrive at various altitudes in Arizona, are more resistant to this disease than is the Carolina poplar.

A study of certain fusarial diseases of plants, W. E. MANEVAL and H. JOHANN (*Missouri Sta. Bul. 172 (1920), pp. 19, 20*).—Isolations were made from corn received from Missouri and from scabby wheat from Missouri, Iowa, and Minnesota, and 40 different strains were kept growing in pure cultures. Other organisms isolated and studied included *Gibberella saubinetii* and *Diplodia*. Scabby wheat grains were studied as to means of disinfection, including formaldehyde, mercuric chlorid, copper sulphate, calcium hypochlorite, and hot water.

It was found possible to kill a large percentage of the scab organisms in infected wheat seed by means of hot-water treatment. Shriveled grains from scabby heads are not necessarily infected, this condition possibly being due to the failure of food supply during growth.

The optimum temperature for vegetative growth of *Diplodia* is between 30 and 35° C. (86 to 95° F.), that for the rest of the organisms studied from 25 to 28° C. *G. saubinetii* will kill corn seedlings grown under sterile conditions in the laboratory at room temperature.

Division of plant pathology, F. D. HEALD (*Washington Sta. Bul. 155 (1920), pp. 34-38*).—The wheat smut work as here outlined has shown that a standard formaldehyde solution kept in an open barrel and used continuously during three months will not lose its effectiveness or injure the seed. Shallow planting gives less smut than deep planting, and trenching less than level planting. Wide spacing, which lessens smut in resistant varieties, has little effect on susceptible varieties. More than 40,000 spores per grain are required to produce maximum smutting. The apparent existence of a minimum spore load, which gives a small percentage, if any, smut, with other data obtained, point to a multiple infection rather than infection from a single spore. The sack and the open-tank method gave equally good protection, but the Haskell method was not effective. None of the 116 varieties of winter wheat tested was free from smut, though certain strains of Turkey continued to show minimum infection. Of 86 spring varieties tested, 6 remained free from smut. Regional strains of a variety show wide variations in degree of smut attacks.

The *Rhizoctonia* disease work has been confined largely to experiments with tomatoes and potatoes. The former gave 90 per cent of blight following inoculation with pure cultures of *Rhizoctonia*, as compared with 58 per cent in the uninoculated plants. Inoculation with potato peels did not increase the blight. The experiments on potato infected with *Rhizoctonia* showed that the corrosive sublimate treatment of seed retards germination and lowers yield in cases of sprouted seed stock, but it increases the percentage of clean tubers. Seed selected as visibly clean and planted without treatment gave higher yields of table stock than was given by infected seed treated only after sprouting. Clean treated seed gave a lower yield but a larger percentage of clean tubers

than infected untreated seed. No fertilizers increased the percentage of clean tubers from untreated (visibly) clean seed, though with untreated infected seed a small percentage of increase of clean tubers was obtained over the unfertilized plats, sulphur being most effective in this respect. Bordeaux spray increased neither yield nor clean tubers. Rhizoctonia disease was found on a number of hosts not previously reported. Cases cited are the dying out of strawberry beds, particularly in western Washington, and a severe attack on onions, previously supposed to be immune to Rhizoctonia.

In experiments with oat smut, the dry method gave better results than were given by the sack, sprinkle, and dry or Haskell methods. The percentage of smut varied with the time of planting, ranging upward to a maximum from the earliest and then showing a fluctuating decline. Both varietal and regional resistance to disease are noted.

Review of diseases of cultivated plants in 1918; C. FERDINANDSEN and S. ROSTRUP (*Tidsskr. Planteavl*, 26 (1919), No. 4, pp. 683-733, fig. 1).—This review includes both diseases and insect enemies of field and garden plants, covering a wide systematic range.

Destruction of zoöspores of plant disease organisms by natural enemies, R. B. HARVEY (*Science*, n. ser., 52 (1920), No. 1334, p. 84).—The author reports observing, while making photomicrographs of the liberation of zoöspores from the sporangia of *Physoderma zea maydis*, the destruction of the zoöspores by certain animalcules which are commonly found in decaying vegetable matter. One infusorian (*Keronia* sp.) was observed to devour a perfect stream of the zoöspores of *Physoderma*, at the same time increasing in size until it became gorged almost beyond recognition. The author thinks it would be desirable to determine just how important such animalcules are as natural enemies of those plant diseases which are disseminated by zoöspores.

Emission and germination of spores by *Leptosphaeria herpotrichoides*, E. FOEX (*Bul. Soc. Path. Vég. France*, 6 (1919), No. 3, pp. 43, 57-61).—Particulars are given of the behavior of ascospores under conditions indicated.

Biological studies on *Botrytis cinerea*, M. BÜSGEN (*Flora [Jena]*, n. ser., 11-12 (1918), pp. 606-620).—This account includes lists of plants found to be susceptible or immune to *B. cinerea*.

The supposed parasitism of *Coprinus radians*, P. M. BIERS (*Bul. Soc. Path. Vég. France*, 6 (1919), No. 3, pp. 63, 72-74).—Evidence is discussed regarding the alleged parasitism of *C. radians*, the perfect form of *Ozonium auricomum*.

The probable parasitism of *Coprinus*, P. M. BIERS (*Bul. Soc. Path. Vég. France*, 6 (1919), No. 6, pp. 151, 159, 160).—A case is mentioned of apparent parasitism of *Broussonetia* by a *Coprinus*, probably *C. domesticus*.

Foot disease of wheat, E. FOEX (*Bul. Soc. Path. Vég. France*, 6 (1919), No. 3, pp. 43, 52-56).—An account is given of observations made during 1913-14 in the Paris basin on foot or stalk disease of wheat. It is stated that cereals in this region are attacked frequently by *Leptosphaeria herpotrichoides*, more rarely by *Ophiobolus graminis*. Both are here discussed. Addition of sodium nitrate to the soil in spring is thought to aid in combating cereal stalk disease.

Glume spot of wheat, J. H. GRISDALE (*Canada Expt. Farms Rpt.* 1919, p. 60).—An investigation has been made of the glume spot of wheat due to *Septoria glumarum*, in which experiments on the date of planting, source and quality of seed, variety, seed treatment, and soil treatment were made. While the results were inconclusive, they are believed to emphasize the importance of early planting and the use of good seed in localities where the disease is likely to occur.

Partial smutting of wheat heads, E. FOEX (*Bul. Soc. Path. Vég. France*, 6 (1919), No. 5, pp. 100, 105, 106).—An account with discussion is given of the

partial smutting of a head of wheat. Three grains of this head, sown in 1919, gave several stalks bearing heads free from smut (*Ustilago tritici*).

A disease of barley and oats, E. FOËX (*Bul. Soc. Path. Veg. France*, 6 (1919), No. 6, pp. 116, 118-124).—A disease affecting both barley and oats is said to be caused by a *Fusarium* analogous to *F. rubiginosum*. It shows itself like foot rot at the base of the stalk, but its mycelium is black, not brown.

The wheat nematode, *Tylenchus tritici*, attacking rye, oats, spelt, and emmer, L. P. BYAES, A. G. JOHNSON, and R. W. LEUKEL (*Phytopathology*, 9 (1919), No. 7, pp. 283, 284, pl. 1).—In continuing investigations on the eelworm disease of wheat caused by *T. tritici* (E. S. R., 40, p. 849), an experimental plot was planted in the fall of 1918 to rye, barley, oats, spelt, and emmer, as well as a number of varieties of wheat. In seeding the crops, viable wheat nematodes, in some cases free in water and in other cases normally inclosed in the galls, were sprinkled or strewn with the seed when sown. The plot was kept under continuous observation, and abundant infections were noted on the wheat varieties, although there was some variation in regard to different varieties. There were also abundant infections on rye, and definite infection on oats, spelt, and emmer, but no infection has yet been noted by the authors on barley. This is believed to be the first record of the occurrence of nematodes on spelt and emmer in the United States.

Market pathology and market diseases of vegetables, G. K. K. LINK and M. W. GARDNER (*Phytopathology*, 9 (1919), No. 11, pp. 497-520).—The authors discuss the present status of market pathology and investigations describing types of market diseases of vegetables, in which four types are recognized, slimy soft rots due to bacteria, watery soft rots caused by *Sclerotinia libertiana*, Rhizopus rot, and gray mold rot. The diseases observed on different market crops are described according to the host plants.

Transmission of the virus of bean mosaic in seed and observations on thermal death point of seed and virus, D. REDDICK and V. B. STEWART (*Phytopathology*, 9 (1919), No. 10, pp. 445-450).—In a previous publication (E. S. R., 41, p. 155) the authors reported that the virus of bean mosaic is transmitted by the seed, and in the present publication some of the evidence upon which the statement was based is recorded. Suspected seeds were disinfected and after treatment planted, and fully 50 per cent showed signs of mosaic disease. Other varieties which are usually more susceptible to the disease were tested with the same results. Heat as a possible means of controlling the disease was tried, but it was found that both when used with dry seed or moist the death point of the seed is as low as that of the agent causing mosaic.

Cotyledon infection of cabbage seedlings by *Pseudomonas campestris*, C. DRECHSLER (*Phytopathology*, 9 (1919), No. 7, pp. 275-282, figs. 6).—This is a detailed account of work previously noted (E. S. R., 33, p. 346), in which it is demonstrated that infection of cabbage seedlings may take place through the stomata occurring on the cotyledons.

Is the common potato scab controllable by a mere rotation of crops? M. SHAPOVALOV (*Phytopathology*, 9 (1919), No. 9, pp. 422-424, fig. 1).—An inoculation with a strongly pathogenic strain of *Actinomyces scabies* on sterilized filter paper in test tubes and flasks containing a synthetic solution showed good growth after the expiration of two years. This indicates that this organism is able to exist for years on a comparatively moderate amount of cellulose material in the absence of a regular nutrient stratum or the host tissues, and it is believed that attempts to eradicate the scab fungus by rotation of crops will be unsuccessful.

Susceptibility of various plants to curly top of sugar beet, E. CARNSNER (*Phytopathology*, 9 (1919), No. 9, pp. 413-421, figs. 7).—On account of the importance of the curly top disease of sugar beets, a study was made to determine how the virus or disease-causing factor overwinters. A large number of plants were studied, 14 species of plants, representing 8 families, being proved to be susceptible, and 24 species of 17 families, nonsusceptible. From the standpoint of overwintering it is thought that the red-stem filaree (*Erodium cicutarium*) is probably the most important. This plant is widely distributed in the West and is specially abundant in the foothills of California.

In connection with this investigation an attempt was made to determine how long virulent leaf hoppers retain their ability to communicate the disease after they have been removed from susceptible plants. In one instance a lot of leaf hoppers kept on *Atriplex polycarpa*, a nonsusceptible species, retained their virulence for 58 days, and on *Rumex crispus* (also nonsusceptible) for 111 days.

The surface rot of sweet potatoes, L. L. HARTER and J. L. WEIMER (*Phytopathology*, 9 (1919), No. 10, pp. 465-470, pl. 1).—During a study of diseases of sweet potatoes, one to which the name surface rot is given has been under observation. This is generally recognized as a storage trouble, and is characterized by nearly circular brownish sunken spots, usually several in number, varying in size according to age, and attaining a maximum diameter of about $\frac{3}{4}$ in. Three well-marked stages are noted, the first, which consists in the formation of spots, the second, a shrinkage of the potato, and the third, the drying up of the potato, making it useless for food. The latter stage is usually most pronounced during the latter part of the storage period.

Surface rot is said to have characteristics in common with black rot caused by *Spharionema fimbriatum*, but is sufficiently distinct to be readily distinguished. Isolations were made from sweet potatoes which showed the constant presence of *Fusarium oxysporum*. Inoculation experiments were repeated several times with this organism, and a typical diseased condition obtained. Infection is considered to take place at digging time or a little before it, or in the early storage period. For control the authors recommend, wherever possible, the harvesting during dry weather and allowing the potatoes to dry in the sun for a few hours. Conditions in the storage house should be dry and warm when the potatoes are put in, so that curing will begin promptly.

Heterosporium leaf spot of timothy, C. T. GREGORY (*Phytopathology*, 9 (1919), No. 12, pp. 576-580, figs. 2).—A description is given of a leaf spot of timothy due to *Heterosporium phlei* n. sp. The disease is said to have been found throughout New York, and is thought to probably occur in all timothy growing regions.

A mode of treatment for chlorosis [in trees], G. ARNAUD (*Bul. Soc. Path. Vég. France*, 6 (1919), No. 6, pp. 117, 137-146, figs. 2).—This method has been noted from another source (E. S. R., 42, p. 647).

Spraying and dusting [apples], C. F. PETCH (*Ann. Rpt. Pomol. and Fruit Growing Soc. Quebec*, 1918, pp. 27-29).—A condensed account is given of this address, which dealt with the work and results of comparative tests with dust (45 per cent talc, 45 per cent sulphur, and 10 per cent lead arsenate) and lime-sulphur spray (1.01 to 1.006). Both of these treatments gave practically perfect fruit under conditions of close planting, regarded as greatly favoring the spread of apple scab. Combined or varied treatments were not encouraged on account of cost and the satisfactory results obtained from the treatments indicated above.

Second year's success with dusting [apple trees], R. COSSETTE (*Ann. Rpt. Pomol. and Fruit Growing Soc. Quebec*, 1918, pp. 1-7).—The progress of the second year's experimentation with sulphur dust is considered to indicate

the success and reliability of this treatment as a fungicide, which in this respect is compared with lime sulphur. General discussion brought out the results of the experience of others with sulphur as used alone and in connection with insecticides.

A disease of pear, E. FOEX (*Bul. Soc. Path. Veg. France*, 6 (1919), No. 5, pp. 100, 102-104).—Brief notes are given of pear twig blight ascribed to *Diplodia griffoni*. Remedial measures include removal of affected wood and a winter copper spray at 3 to 4 per cent, repeated at a strength of 1 per cent two or three times after blooming.

Pear rust (*Roestelia cancellata*) and *Juniperus sabina*, F. CHASSIGNOL (*Bul. Soc. Path. Veg. France*, 6 (1919), No. 6, pp. 116, 133).—Brief reference is made to a case of apparent partial immunity in a pear tree of unknown variety to pear rust from *J. sabina*.

***Dendrophoma* leaf blight of strawberry, H. W. ANDERSON** (*Illinois Sta. Bul.* 229 (1920), pp. 127-136, figs. 3).—The author reports the occurrence during the summer of 1919 of a serious leaf blight of strawberry in several localities of Illinois and Indiana. At first it was thought to be an advanced stage of the ordinary leaf spot, but a detailed study showed that the disease had entirely different symptoms. The lesions of the leaf blight in question, even in an early stage, are said to be much larger than the mature lesions of the ordinary leaf spot. In an advanced stage, the most common condition is a V-shaped dead area extending from the midrib or one of the larger veins to the tip or side of the leaflet. The young spots are uniformly reddish-purple when they first appear and are almost circular in outline. As they enlarge the central area dies and becomes brown. In 1919 the diseased areas were observed as early as June, but it was not known how much earlier they may appear.

In a study to determine the cause of this leaf blight, the author isolated a fungus, the morphology and life history of which are described. The disease is said to be due to *Dendrophoma obscurans* n. sp., a technical description of which is given. No experiments for the control of the leaf blight have been attempted, but it is believed that the practice of mowing the leaves of the old vines and cultivating after harvest will reduce the amount of trouble from this source.

A rose graft disease, I. H. VOGEL (*Phytopathology*, 9 (1919), No. 9, pp. 403-412, figs. 6).—A study is reported of a disease of rose grafts said to occur in rather severe form at Council Bluffs, Iowa, in 1917. It was particularly destructive to certain varieties which are popular with rose growers.

A characteristic symptom is the occurrence of lesions on the scion at or just above the union, which results in the sudden wilting and death of young rose grafts. The lesions usually encircle the scion within a few days so that the death of the graft is sudden. Study of the disease showed that it was due to *Coniothyrium rosarum*. Marked resistance is shown by some varieties, while others are specially susceptible to the fungus. The most satisfactory method of control is believed to be the growing of resistant varieties. Where this is not possible, care should be exercised in the selection of scions, which should not be taken from rose houses in which the disease is known to exist.

Tuberosities of chestnut and canker of rose, E. FOEX (*Bul. Soc. Path. Veg. France*, 6 (1919), No. 3, pp. 63, 68-71).—An account is given of outgrowths of *Castanea vulgaris* and of rose canker, associated with a fungus differing somewhat as to dimensions from *Coniothyrium fuckelii*.

Winter injury to ornamental trees and shrubs, F. S. BUCK (*Ann. Rpt. Pomol. and Fruit Growing Soc. Quebec*, 1918, pp. 47-53).—The winter of 1917-18 was exceptionally cold and dry for long periods and was correspondingly abnor-

mal as regards winterkilling and injury to trees and shrubs of all classes. The dry condition of the atmosphere was associated with a remarkable dryness and brittleness of the leaves. Other factors are briefly considered. Lists are given of trees and shrubs grouped according to the amount of injury they sustained.

Phyllactinia corylea on oak leaves, E. FOEX (*Bul. Soc. Path. Veg. France*, 6 (1919), No. 6, pp. 151, 161-166).—From evidence here presented it is concluded that some oaks in the forest near Lyons are attacked by both *P. corylea* and *Microsphaera quercina*.

Parasites of plane trees in Nice, 1918, J. COTTE (*Bul. Soc. Path. Veg. France*, 6 (1919), No. 3, pp. 63, 65-67).—In addition to certain animal parasites, *Gnomonia veneta* (*Glaosporium nervisequum*) was noted as possibly connected with *Nectria cinnabarina* in a disease indicated of plane trees.

A walnut shell disease, R. MIRANDE (*Bul. Soc. Path. Veg. France*, 6 (1919), No. 6, pp. 117, 134-136, pl. 1).—Lesions, of considerable size in some cases, near the apical portions of the shell in case of walnuts showed no sign of microorganisms, and are considered as exemplifying failure in the process of lignification, possible causes of which are suggested.

White pine blister rust, J. H. GRISDALE (*Canada Expt. Farms Rpt. 1919*, pp. 57, 58).—The author reports the results of scouting investigations to determine the extent to which the white pine blister rust exists outside of Ontario and Quebec. No disease was found in British Columbia, Manitoba, Saskatchewan, Northern Ontario, and New Brunswick. The results seemed to indicate that the disease is still confined to southern Ontario and Quebec. A number of experimental control areas have been established to determine the possibility of preventing the occurrence of the blister rust in pine woodlots, and observations have shown that infection will not readily cross a distance of 500 yds. An attempt was made to determine the amount of damage done to pines by a survey of a number of woodlots, and out of 11,279 trees in 22 woodlots in the Niagara Peninsula, only 2.3 per cent were found infected. On account of the comparatively small amount of infection found, it is hoped that under favorable conditions the losses from the disease may be kept so low that the growing of white pine on a commercial basis will be possible. The factors concerned in the infection of pines are held to be nearness of cultivated Ribes, especially black currants, the number of wild currants present, and moisture of the situation.

Some experiments were carried on to determine the effect of ultraviolet light and sunlight on the aecidiospores and uredospores of the blister rust fungus. It was found that exposure for 2½ minutes to ultraviolet light was fatal to the germinating capacity of the spores, but that when exposed to sunlight under glass they survived exposures as long as 5 hours. A determination was made on the rate of fall of aecidiospores of the rust fungus, and it was found that in still air the aecidiospores dropped a distance of 8 ft. in a little over 7 minutes. This rate of motion is considered important as indicating the rapidity by which the spores can be carried by wind to a considerable distance.

Observations on the relation of insects to the dissemination of Cronartium ribicola, W. H. SNELL (*Phytopathology*, 9 (1919), No. 10, pp. 451-464).—Results are given of cooperative investigations carried out with the Bureau of Plant Industry and the Bureau of Entomology, U. S. Department of Agriculture, on the relation of spread of insects to the spread of plant diseases. A large number of species of insects, chiefly beetles, were found on or near blister rust lesions of the white pine, bearing aeciospores in varying quantities. One beetle (*Serica sericea*) was collected feeding upon a red currant bush and bore aeciospores on its body. Many species of insects were found to bear urediniospores from infected leaves, some in large quantities. Inoculations

prove that insects may spread the uredinospore stage from bush to bush. It is believed that while the spread of *C. ribicola* from pine to Ribes or vice versa may be infrequent or accidental, the spread of the uredinial stage upon Ribes probably occurs with considerable regularity.

Pine rust control, H. HESSELMAN (*Statens Skogsförsöksanst., Flygbl. 15 (1919), pp. 8, figs. 4*).—This deals with the question of controlling pine rust (*Peridermium pini*) under different conditions and on pines of widely varying ages.

A brief report of the proceedings and recommendations of the International White Pine Blister Rust Conference for Western North America, 1919 (*Corvallis, Oreg.: Amer. Plant Pathologists Ad. Bd. Rpt., 1919, pp. 4*).—This account with discussion of the work of this conference, which was held in Portland, Oreg., April 23 and 24, 1919, under the auspices of the Advisory Board of American Plant Pathologists, includes the recommendations adopted.

An outbreak of Trametes pini in a forest of maritime pine, F. GUINIEB (*Bul. Soc. Path. Veg. France, 6 (1919), No. 3, pp. 42, 48-51*).—An account is given of widespread attack on maritime pine (*Pinus pinaster*) by *T. pini*, in parts of France.

ECONOMIC ZOOLOGY—ENTOMOLOGY.

Insecticide investigations, A. L. LOVETT (*Oregon Sta. Bul. 169 (1920), pp. 55, figs. 6*).—This is a report on the progress of an investigation of insecticides under way at the Oregon Experiment Station, which was commenced in 1914 and has been in part previously noted (*E. S. R., 37, p. 759*). The work has shown that the acid salt, or lead hydrogen arsenate, has a higher killing efficiency at a given dilution than either the neutral salt (basic lead arsenate) or calcium arsenate.

"All the arsenic devoured by caterpillars feeding upon sprayed foliage is not assimilated, a portion passing through the digestive tract in the excrement. The proportion assimilated is higher where an acid arsenate is employed. This accounts for the higher killing efficiency of the acid lead arsenate. . . .

"It requires approximately 0.1595 mg. of arsenic pentoxid to kill 1,000 small tent caterpillars, and approximately 1.84 mg. of arsenic pentoxid to kill 1,000 nearly mature tent caterpillars, irrespective of the particular arsenate used as a spray. A dilution of 1:400 of lead hydrogen arsenate proved a satisfactory killing dosage for the very small caterpillars."

"Under laboratory control conditions a dilution of 1 lb. of the acid lead arsenate to 400 gal. of water proved an effective killing solution for very small tent caterpillars. It is reasonable to assume that newly hatched codling-moth larvæ are no less susceptible to poison.

"The commercial lead arsenates on the market, unless specifically prepared and labeled otherwise, are nearly pure acid lead arsenate. The powdered lead arsenates are physically superior to the paste forms and are generally the advisable form to use. Particularly is this true if one is not near the point of manufacture, so as to insure a freshly made paste which has had no opportunity to dry out or freeze. Allowing for the natural factors which render ideal control conditions impossible in commercial orchard spraying, the apparent discrepancy between the theoretical killing dosage of arsenate and the standard dosage in vogue is due in part to physical defects: (a) In the methods of application of spray; (b) in the spray solution; (c) in the spray material. Commercial lead arsenates are in general a standard product. They vary but slightly in the percentage of arsenic carried or in the low percentage of soluble arsenic present.

"In their physical properties there is considerable variation. By improving the physical properties of the spray solution we are enabled to improve the efficiency of the spray: (a) By increasing the wetting and covering power of the spray solution; (b) by increasing its adhesiveness. . . . The spray solution, without the addition of a spreader, as normally applied to the waxy surface of an apple finally rests as an irregular, blotchy coating of uneven thickness and with interspaces but poorly coated or free from spray. The spray solution, with a spreader, applied to the surface of the apple, finally rests as a smooth, even, inconspicuous covering, affording practically an equal and perfect protection for every surface. Materials showing value as spreaders in the poison spray solution, given in the order of their merit, based on compatibility, efficiency, availability, cost and ease of preparation, are caseinate, glue, gelatin, soap bark, and oil emulsion. In preliminary experiments conducted thus far these spreaders are not improved by the addition of phosphates and sulphates. Methods have been developed for testing the comparative wetting values of spreaders for the surface of the apple fruit by means of capillary tubes.

"The improvement of the physical condition of any one of the three factors, method of application, the spray solution, and the spray material, decreases the relative importance of defects in the other two. The physical properties of the spray material and of the spray solution are inversely proportional to the power and agitator effectiveness of the outfit. Where the agitator is faulty or mediocre, where the pressure capacity is limited, or the spray nozzle defective, the efficiency value of improved solution and materials rapidly increases in importance. The importance of the capacity of the outfit and physical qualities of the material are inversely proportional to the wetting, covering, and adhesive properties of the spray solution. The importance of the physical solution and capacity of outfit is inversely proportional to the fineness, uniformity of division, powers of suspension, and adhesiveness of the spray material. Where the physical qualities of all three are developed to the highest possible standard we should, in the hands of a careful manipulator, approach the ideal protective covering sought for in a spray application. A fine, misty spray applied in the calyx application for codling-moth control is equal in effectiveness to a driving spray.

"The total calyx worms in the commercial orchard in Oregon is usually less than 50 per cent of the total worm infestation. In commercial orchards in Oregon where a spray program is practiced, the worm infestation is normally light until late summer. Data accumulated for a series of years shows that it is the late summer brood of moths, giving rise to the worms which infest the fruit during late August and early September, causing the costly 'September sting,' that is responsible for our heavy losses from wormy fruit. To attach undue importance to the calyx application has not been found warranted in our experiments. All applications are essentially of equal merit, and conscientious effort in their application is desirable. The last summer application is particularly significant because of the difficulty in timing it properly.

"The calcium arsenates have a high killing efficiency as a poison spray for chewing insects. They are not so stable as are the corresponding lead salts, and for use in commercial orchard spraying, under western Oregon conditions, it is advisable to have an excess of lime present in the solution. Methods of manufacture have not been standardized, and commercial brands of calcium arsenate vary greatly in their chemical and physical properties. There is at present probably no adequate reason for a wholesale abandonment of the lead in favor of the calcium arsenate for orchard work.

"Nicotin sulphate is a powerful repellent for tent caterpillars. They will not ordinarily feed from choice on foliage sprayed with it. Where feeding does

take place, the action of the nicotin is apparently rapid and sure. Foliage in small bits sprayed with comparatively weak solutions, where devoured, kills almost instantly. Nicotin sulphate is an effective ovicide for codling-moth eggs. The addition of soap renders it practically perfect in this regard. As a substitute for the standard arsenical sprays for codling-moth control, efficiency and cost considered, nicotin sulphate does not show qualities to recommend its general adoption. The use of nicotin and sulphate as a supplement to and in certain combinations with the standard arsenate sprays may, under certain conditions, prove highly practical: (a) As a substitute for the arsenate spray in the July application where a serious summer reinfestation of aphids is present; (b) in combination with the last summer application of arsenate (plus a spreader) as a further insurance against the 'September sting.'

Entomology, A. W. MORRILL (*Arizona Sta. Rpt. 1918*, pp. 335-338).—Tests made of the effect of 40 combinations of poison baits for the differential grasshopper during 1918 in continuation of experiments of 1917, previously noted (E. S. R., 41, p. 355), have led to the following tentative conclusions:

"Half and half and 60-40 per cent wheat bran and sawdust mixtures are fully as good as all bran. Barley middlings is not entirely satisfactory as a substitute for wheat bran, although it usually gives fairly good results when used in half and half mixtures with sawdust. Dry horse manure is not a satisfactory substitute for wheat bran, although it is not without merit for use in emergencies. A mixture composed of wheat and corn bran (not over 50 per cent of the latter) is as good as straight wheat bran. Cantaloups are fully equal to lemons as ingredients of poisoned baits. Molasses does not add to the value of the bait. London purple as the poisonous ingredient in baits is inferior to Paris green."

Corn bran alone appeared to be inferior to barley middlings and sawdust, but the conditions in the tests were such that even tentative conclusions could not be drawn. In tests in which molasses was omitted from the bait the effectiveness did not appear to be reduced. In a test made of the bran, Paris green, and water combination in the fall of 1918 it appeared to give perfect results in combating the common alfalfa pest *Feltia annexa* Tr.

In the course of investigations of grasshoppers and square daubers (*Lygus elisus hesperus* Knight and *L. pratensis oblineatus* Say), it was found where alfalfa fields adjoined cotton fields the cutting and raking of alfalfa should be started on the sides and continued toward the center. In this way these pests are concentrated near the center of the field and can be destroyed by the use of a comparatively heavy application of poison bait or by means of a hopper-dozer. In one test daubers were captured at the rate of more than 7,000 per acre at an expense not to exceed 25 cts. per acre.

Entomology, L. HASEMAN and K. C. SULLIVAN (*Missouri Sta. Bul. 172* (1920), pp. 24-26, fig. 1).—In work during the year with the bollworm on corn at Columbia, in which three varieties of sweet corn, one of pop corn, and five of field corn were used, dusts were applied twice, as were two sprays of different strengths. The results indicate that it is cheaper to dust than to spray, and there was much less damage to the treated than to the untreated corn, though neither dusting nor spraying entirely kept the worm from working.

In control work with insect pests of melon and related crops, 2 lbs. of arsenate of lead in 50 gal. of water gave good results when applied early against the striped cucumber beetle. In control work with the squash bug, nicotin sulphate gave the best results.

A Bordeaux nozzle and an angled disc nozzle were used in control work with the codling moth, in which arsenate of lead was applied at varying pressures of 200, 145, and 85 lbs. At these respective pressures 11.01, 8.8, and 2.31

per cent of end-worms occurred where the Bordeaux nozzle was used and 8.74, 3.09, and 1.89 per cent of end-worms with the disc nozzle.

It is stated that the San José scale, which has been the most important nursery stock pest in Missouri, has been practically eradicated from the nurseries of the State, only two having been found infested during 1918-19.

Seventeenth annual report of the State entomologist of Montana, R. A. COOLEY (*Montana Sta. Bul. 133 (1919), pp. 15, fig. 1*).—The first part of this report consists of brief notes on the insect pests of 1919. This is followed by brief discussions of the outstanding entomological problems of the present time, in which the importance of the pale western cutworm (*Porosagrotis orthogonia* Morr.), grasshoppers, the sugar beet webworm, alfalfa weevil, foul brood of bees, codling moth, leaf roller of the apple, and flea beetles are considered. It is deemed impossible at the time of writing to say whether the leaf roller which appeared in injurious numbers on apple trees in the Bitter Root Valley in 1919 was the fruit tree leaf roller (*Archips argyrospila* Walker) or the oblique-banded leaf roller (*A. rosaceana* Harris).

Insect pests of field crops, L. HASEMAN (*Missouri Sta. Bul. 170 (1920), pp. 39, figs. 37*).—This is a reprint of Bulletin 134, previously noted (E. S. R., 33, p. 555), in which a few sections have been revised.

The chinch bug in Montana, J. R. PARKER (*Jour. Econ. Ent., 13 (1920), No. 3, pp. 318-322*).—A report of observations of this pest in Montana, the first record of the occurrence of which in that State was obtained on May 23, 1911. The author's observations indicate that in Montana the chinch bug changes its usual habit and hibernates as a well-advanced nymph.

Watch for chinch bugs.—Method of constructing dust and tar barriers in farm fields, H. A. GOSSARD (*Mo. Bul. Ohio Sta., 5 (1920), No. 6, pp. 178, 179*).—The author describes the construction of barriers for the prevention of chinch bug migration and calls attention to the profitable use of crops immune to their attacks.

Generic classification of the hemipterous family Aphididæ, A. C. BAKER (*U. S. Dept. Agr. Bul. 826 (1920), pp. 109, pls. 16, fig. 1*).—This, the first of a series of papers treating of the Aphididæ, deals with the classification of the genera. The phylogeny of the Aphididæ is first discussed in connection with a diagram. A key is presented for the separation of the four subfamilies, Eriosomatinae, Mindarinae, Hormaphidinae, and Aphidinae. The classification of these subfamilies is then taken up, keys being presented, to the tribes, subtribes, and genera. New genera erected include the following: Protrama, Neotrama, Tamalia, Neosmydobius, Patchia (represented by *P. virginiana* n. sp.), Neothomasia (n. n.), Sanbornia (represented by *S. juniperi* Pergande, n. sp.), Anomalaphis (represented by *A. comperei* Pergande, n. sp.), Rhopalosiphoninus, and Pachypappelia (n. n.). Reference is made to several genera not placed and an index to the genera is included.

The cotton or melon louse: Life history studies, F. B. PADDOCK (*Texas Sta. Bul. 257 (1919), pp. 7-54, pls. 4, figs. 3*).—This is a detailed report of biological studies of the cotton or melon aphid commenced in March, 1916, much of the data being presented in tabular form.

"In Texas the normal form of reproduction is asexual throughout the entire year. The alternate host plants in this State have not been determined. Fifty-one generations completed their life cycle in a period of exactly 12 months. The average reproduction period was 21.4 days, and the average young produced was 84.4. The migration tests indicate that the lice do not migrate from cotton to the cucurbits or the reverse. Ants were found associated with the lice at all times, but no definite relation was established.

"The plant louse is reduced by natural factors of control. One species of parasite, three species of ladybird beetles, and two species of syrphid flies were observed to prey on this louse."

A bibliography of 5 pages is appended.

The European corn borer, L. HASEMAN (*Missouri Sta. Circ. 94* (1920), pp. 4, fig. 1).—Attention is called to the occurrence of *Pyrausta nubilalis* in this country, with a brief account of its injury, general appearance, life history, methods of control, and quarantines against it.

The green clover worm (*Plathypena scabra* Fabr.) as a pest on soy beans, F. SHERMAN (*Jour. Econ. Ent.*, 13 (1920), No. 3, pp. 295-303).—This is a report of studies made during the course of an outbreak of *P. scabra* in North Carolina during August, 1919.

The first report of the destruction of leaves of soy beans by this pest came to the author from a farm agent of an eastern county on July 29, 1919. Following that date reports of injury were received in large numbers. Within 10 days the injury caused was at its height, and two weeks later it was on the decline and some fields were recovering. The outbreak was universal throughout the eastern half of the State, tens of thousands of acres of soy beans being so defoliated that the lacework of dried leaf veins gave a hazy, cobwebby appearance to whole fields. In the most severe cases all the foliage was eaten, but normally the attack was most severe on the younger of the grown leaves in the upper part of the plant, leaving the growing bud and the older lower leaves.

The author found that 51 days are required for completion of the life cycle, as follows: Egg, 5 days; hatching to spinning of cocoon, 25 days; larva in cocoon, 2 days; true pupal stage, 11 days; emergence to mating, 1 day; and mating to laying of eggs, 7 days.

The egg-parasite *Trichogramma pretiosa* was found to be the most important enemy, approximately 50 per cent of the eggs being parasitized by it. The tachinid *Phorocera claripennis* Macq. was the second in importance as a parasite. Other parasites reared include *Exorista boarmiae* Coq., *Frontina aletiae* Riley, *Euphorocera floridensis* Tns., *Anthrax lateralis* Say., *Sarcophaga cimbicis* Tns., and a campoplegine, probably representing a new genus and new species.

In work with control measures powdered arsenate of lead at the rate of 1 to 8 lbs. of lime was effective and safe to the plant. Its use is deemed practicable in large areas of soy beans, particularly when grown in rows. It is not too costly and pays a good profit on its use, especially if applied before the injury reaches its maximum. It is stated that a very careful farmer whose field was under observation tried arsenate alone successfully as a test, a very light application having been made. It was found that there was little danger from the use of hay treated in this way, the material gradually disappearing from the leaves.

Farmers' Bulletin 982, by Hill, on this insect, particularly as an enemy of alfalfa, has been noted (E. S. R., 39, p. 865).

Green clover worm as a pest of soy beans, with special reference to the outbreak in 1919, F. SHERMAN and R. W. LEIBY (*N. C. Agr. Ext. Serv. Circ. 105* (1920), pp. 14, figs. 5).—This is an account of *Plathypena scabra* Fabr., an account of which, from another source, is noted above.

Experiments for the control of cabbage root maggot, W. T. MACOUN (*Canada Expt. Farms Rpt. 1919*, pp. 30, 31).—Experiments conducted at the Central Experimental Farm in 1918 indicate that corrosive sublimate and oakum are two very promising remedies for the cabbage root maggot. The corrosive sublimate was used at the rate of 1 oz. to 10 gal. of water, applied four times at intervals of a week beginning immediately after the plants were

set out, about a teacupful being poured around each plant. In using the oakum a small amount was pressed about the base of the plant. The tar-felt disk, which has in the past been found the best preventive, gave a slightly larger number of heads in 1918, but the other methods were easier to follow. From 60 plants set out on May 25 for each method, 52 marketable heads were obtained from the oakum plat, 54 from the tar-felt paper disk plat, 47 from the corrosive sublimate plat, and 21 from the unprotected plat.

The life histories of some Kansas Lachnosterna, W. P. HAYES (*Jour. Econ. Ent.*, 13 (1920), No. 3, pp. 303-318, figs. 2).—"The life histories of seven species of Lachnosterna, found in the vicinity of Manhattan, Kans., are herein considered. Five of these, *L. crassissima*, *L. rubiginosa*, *L. futilis*, *L. rugosa*, and *L. implicata*, in the order named, are the most abundant in this locality. The other two, *L. vehemens* and *L. submucida*, ranked eighth and sixteenth, respectively. Their flight periods begin about April 18 and may last, as in the case of *L. submucida*, until August 17.

"The egg stages were found to average from slightly over 14 to 29.8 days. The larval period varied, 2 and 3 year life cycles occurring for the five important species. Only a 3-year cycle was observed in the case of *L. vehemens*, and grubs now living in rearing cages indicate a 3-year cycle for *L. submucida* besides the 2-year cycle discussed. The prepupal stage averaged from 6.6 to 9 days for the different species, and the mean pupal stage varied from 21.9 to 30.5 days. The averages of the 2 and 3 year life cycles for the different species were 478.3 and 807.7 days for *L. crassissima*, 475.9 and 805.3 for *L. rubiginosa*, 462 and 827 for *L. futilis*, 461.3 and 813.9 for *L. rugosa*, 411.7 and 750.7 for *L. implicata*, and 845 days for *L. vehemens*. *L. submucida* pupates in the spring instead of the fall, and thus a 2-year cycle is produced which nearly equals the period of development of the 3-year individuals. The average period for the species was slightly over 711 days.

"A list of food plants of the adults and situations apparently preferable to the grubs are given, as is also a list of natural enemies found or reared during this study."

Roundheaded apple tree borer: Its life history and control, F. E. BROOKS (*U. S. Dept. Agr. Bul.* 847 (1920), pp. 42, pls. 9, figs. 7).—This is a report of investigations conducted from 1911 to 1918 at a field station at French Creek, W. Va., also at Elkins, Pickens; Weston, and Great Cacapon, W. Va., Demorest, Ga.; Biltmore, N. C.; Winthrop, Me., and Munising, Mich. This borer is a native American insect which has been recognized as a serious pest of the apple, pear, and quince since the early days of orcharding in this country, occurring as it does in the United States and Canada over most of the apple-growing east of the Rocky Mountains.

"In addition to the cultivated fruits named, it breeds also in such wild trees as wild crab, hawthorn, mountain ash, and service. These native trees growing in woods or neglected fields often serve as centers in which the adults develop, and from which they fly to near-by orchards to deposit their eggs. In the woods and in orchards the insect is inclined to colonize, families or communities living in the trees of somewhat restricted localities. Often infestation in an orchard or in native woods will be confined for years to rather definite areas or spots. This habit is due largely to the inclination of the adult female to deposit her eggs near the place where she developed. . . .

"About 95 per cent of the eggs from which the borers hatch are deposited in the bark within a few inches of the ground. The incubation period is about 16 days. The borers feed in the bark and wood for from one to four years and finally pupate at the end of an ascending gallery which extends up the trunk from a few inches to approximately 2 ft. above the ground. The burrows made

in the bark and wood are broad and irregular in form. Often several borers work close together, as many as 25 or 30 having been found in a single tree. Infested trees become sickly in appearance. They are inclined to bloom freely and set heavy crops of fruit, but often die in an attempt to bring the crop to maturity. Young trees suffer most, but trees of all ages are attacked. Trees of an orchard standing near woods are more likely to be injured by borers than those more distant from the woods.

"In depositing her eggs, the female beetle makes a slit in the bark with her mandibles and then inserts her ovipositor and places the eggs between the bark and wood or between layers of the bark. About 9 or 10 minutes are required for the deposition of a single egg. Usually from 2 to 5 eggs are laid at a time. Probably all eggs are deposited by day, and the female in ovipositing shows a slight preference for the sunny or exposed side of the trunk, 65 per cent of the eggs being found in one case on the exposed side of the tree. In the latitude of West Virginia, the average number of eggs deposited by a single female is apparently from 20 to 30. Oviposition in a given locality extends over a period of from 50 to 60 days.

"The larvæ begin to feed immediately after hatching and usually grow rapidly the first season. Feeding is continued until cold weather, and is resumed again in the spring shortly before the blossoming time of the apple. The larva may spend from one to four years in the tree, this stage being of longer duration in the North than in the South. At French Creek, W. Va., 85 per cent of the larvæ remained in the trees two years before pupation, and 12 per cent three years. At Winthrop, Me., 25 per cent remained in the tree three years and 75 per cent four years.

"The pupal stage lasts about 20 days, and the period is about coincident with the blossoming time of apple. After changing to beetles, the insects remain in the pupal chamber for from 5 to 10 days and then gnaw a circular hole through the bark at the upper end of the chamber and escape. The beetles appear in the South earlier than in the North. Between Demorest, Ga., and Munising, Mich., there was a difference of 75 days in the dates of the emergence of the first beetles. At French Creek, W. Va., beetles issued from the wood during the two different years over a period of 30 days. Other years the period was shorter. May 12 was the earliest date for the appearance of a beetle in any year at French Creek, and June 23 was the latest date. A few beetles lived 60 days after issuing.

"Pairing may take place at once or may be delayed 10 days after emergence. Eggs are laid soon after pairing. In an apple orchard containing 310 King, 341 Grimes, and 341 York Imperial trees, the Grimes were most severely attacked in four out of five years, nearly 50 per cent of all the eggs being laid in Grimes trees. This could be accounted for in no other way than that the borers showed a preference for this variety. Experiments showed that the female beetles during oviposition are capable of flying to a considerable distance, but that they prefer to place their eggs in trees near the place where they themselves have developed. By preventing the development of adults in the orchard trees and in other trees growing within from 300 to 600 ft. of the orchard, subsequent infestation was reduced 73.6 per cent.

"The borers have few insect enemies, but woodpeckers play an important part in holding them in check. The downy woodpecker was observed removing borers from trees.

"No easier and cheaper way of controlling borers was found than the old method of worming trees. The worming should be done as soon as possible after the last eggs of the season have hatched, and should be repeated in the spring

following the blossoming time of apple trees. Worming can be done most effectively by two men working together on opposite sides of the tree. In this practice emphasis is placed on the importance of removing all breeding centers within or adjacent to the orchard.

"Paints and various other kinds of tree protectors were used to prevent the adult females from ovipositing in the bark. Nothing of this nature was found that surpassed common white-lead paint in cheapness, ease of application, and effectiveness in controlling the borers. Young apple trees painted once annually for from four to six years showed no injury, and the treatment gave a control efficiency of 74.3 per cent.

"Various attempts to kill borers were made by applying to the bark of infested trees penetrating liquids of a poisonous or irritating nature. Nicotin sulphate, kerosene, kerosene emulsion, sodium arsenate in a miscible-oil carrier, and linseed oil were among the materials tested. None of these was effective on large borers that had penetrated deep into the tree, but most of them killed a considerable percentage of young borers that were still feeding in shallow burrows.

"The beetles feed rather freely upon leaves and the bark of twigs. Tests made indicate that it is possible to kill the beetles by spraying with arsenicals. Sprays for this purpose should be applied to young orchards within 10 days after apple blossoms have disappeared. In bearing orchards what is known as the first codling-moth spray will be effective also against the adults of the roundheaded apple tree borer."

Notes on the habits of *Calendra pertinax* Olivier, A. F. SATTERTHWAIT (*Jour. Econ. Ent.*, 13 (1920), No. 3, pp. 280-295, pls. 2).—This is an account of one of the common and most widely distributed billbugs, which breeds normally in the common cat-tail (*Typha latifolia* L.) and calamus or sweet flag (*Acorus calamus* L.). It is of economic importance due to its attacking corn. The material studied was collected at Flushing, N. Y., and in Maryland, Indiana, and Missouri.

The cornpith weevil (*Centrinus penicellus* Host.), G. G. AINSLIE (*Jour. Econ. Ent.*, 13 (1920), No. 3, pp. 271-280, figs. 3).—This is an account of the main facts in the life history of a corn-attacking weevil, first noted in Tennessee in 1911, which has not as yet become of economic importance. It bores in the upper two or three nodes of cornstalks. Winter is passed in the larval stage in the earth, the first beetles making their appearance about July 1 and increasing greatly in numbers until early August. In corn the eggs are deposited in the main stem either in or immediately below the tassel. The larvæ feed through the rest of the summer, reaching their growth and leaving the cornstalk for the earth about October 1, there being but one generation a year. While corn is the main and most common food plant, the larvæ have been found in the stems of *Panicum crusgalli* and *P. dichotomiflorum*.

A description of last instar larva by A. G. Boving is included.

Report of the apiarist, F. W. L. SLADEN ET AL. (*Canada Expt. Farms Rpt.* 1919, pp. 42, 43, 90, 96, 102, 116, 129, 164, 169, 172, 181, 189, 193).—In addition to the report of the apiarist (pp. 42, 43), brief accounts are given of the condition and production of the colonies at the several experimental farms. A table summarizing the average weight of honey produced per colony in the spring of 1918 and the average annual production in the past six years is given in the apiarist's report.

Progress is said to have been made in the attempt to breed a nonswarming variety of bee. In tests made of different kinds of winter stores for bees at Ottawa in 1918-19, the best results were obtained from the regular stores

supplemented with a liberal amount of sirup made from refined sugar. Eight colonies on such stores that were wintered outside, packed in planer shavings in two cases, taking four colonies each, standing in the sheltered apiary, wintered somewhat better than four colonies on similar stores in the cellar. "In one of the cases, which had from 5 to 6 in. of side packing, the bees wintered no better than in the other which had only 2.5 to 3 in., and the loss of weight of the outside wintered bees between October 11, 1918, and April 23, 1919, was slightly less (average loss 24 lbs.) than that of the colonies wintered in the cellar (average loss 27.5 lbs.)."

At the experimental station at Cap Rouge, Que., where a comparison was made by G. H. Langelier of different stores for wintering, it was found that bees fed early-gathered honey lost 22 lbs., those fed early-gathered honey and sugar sirup lost 18 lbs., and those fed only sugar sirup lost 11 lbs. There was but little difference in the condition of the bees apparent in the spring.

Beekeeping in Arkansas, W. J. BAERG (*Arkansas Sta. Bul. 170 (1920)*, pp. 3-32, figs. 4).—This is a popular summary of information on beekeeping, particularly as applied to conditions in Arkansas.

Solenopsis molesta Say (Hym.): A biological study, W. P. HAYES (*Kansas Sta. Tech. Bul. 7 (1920)*, pp. 3-55, figs. 11).—The destruction of thousands of acres of planted seed, principally kafir, in eastern and south central Kansas during the past six or seven years by this ant has led to the investigation here reported, a preliminary account of which has been noted (*E. S. R.*, 35, p. 662). It has caused this destruction of planted sorghum seed by eating into the seed, undoubtedly for the purpose of extracting the oils.

"The synonymy and taxonomy of the species have been greatly confused. All American citations to *S. fugax*, *S. debilis*, and *Myrmica molesta* refer to *S. molesta* Say. The species is not only of economic importance as a field pest but is well known in some regions as a household pest. It is widely distributed over the United States. Rearing methods are difficult. In general, the life history is much the same as other ants. The minimum length of the egg, larval, semipupal, and pupal stages was found to be 16, 21, 2, and 13 days, respectively, or a total minimum time for development of 52 days. The data thus far show four general methods of procedure to control the ant in fields where damage to sorghums is being done; namely, fall plowing, early planting (before May 10), surface planting, and the use of repellents on the seed. The first three are consistent with good farming methods. As yet no satisfactory repellent has been found. Those which are of such a character as to be wholly repellent are detrimental to the germination of the seed, and vice versa."

A bibliography of 79 titles is included.

FOODS—HUMAN NUTRITION.

Studies in nutrition.—IV, The nutritive value of peanut flour as a supplement to wheat flour, C. O. JOHNS and A. J. FINKS (*Jour. Biol. Chem.*, 42 (1920), No. 3, pp. 569-579, figs. 6).—In this paper, which continues the series previously noted (*E. S. R.*, 42, p. 756), the results are reported of an investigation of the value of peanut flour as a supplement to wheat flour.

Rats were fed diets composed of 80 parts of dried bread, 16 parts of butter fat, and 4 parts of salt mixture. The varieties of bread tested included one made from so-called "war flour" of 74 per cent extraction, one from a specially prepared "straight" flour, one from 75 parts wheat flour and 25 parts peanut flour, and one from 85 parts wheat flour and 15 parts peanut flour. The diets were calculated to furnish, respectively, 10, 10, 16.3 to 16.8, and 14

per cent of protein. By replacing some of the 25 per cent peanut bread by starch, a diet including the peanut-flour bread and furnishing only 10 per cent protein was obtained.

The rats fed on the diet containing bread from the war flour grew at approximately one-third to two-thirds of the normal rate. Those fed on the straight flour bread diet grew at a somewhat better though not normal rate. Normal growth was obtained with rats fed on a diet of which 12 per cent of purified casein replaced an equivalent amount of bread, thus indicating that the previous failure was not due to a lack of water-soluble vitamin.

The animals fed on diets containing 25 per cent peanut bread and furnishing from 16.3 to 16.8 per cent of protein grew normally, as did those on the diet furnishing 10 per cent of protein. In the latter case there was slight retardation of growth at first. Growth at nearly the normal rate was also obtained with the 15 per cent peanut bread.

The efficiencies of the proteins in the different breads, calculated according to the method described by Osborne, Mendel, and Ferry (*E. S. R.*, 40, p. 765), for 4 weeks' periods in the case of the 25 per cent peanut bread furnishing 16.8 and 10 per cent of protein and the wheat bread (war flour) furnishing 10 per cent of protein were 1.42, 3.14, and 1.04 gm., respectively. Corresponding values for a 10 weeks' period were 0.97, 1.91, and 0.99 gm. While these results are only approximate, they are considered to indicate the value of peanut flour as a supplement to wheat flour in bread making.

Baking qualities of flour. G. A. OLSON (*Washington Sta. Bul.* 155 (1920), pp. 15, 16).—This is a progress report of investigations relating to the baking qualities of flour, the determinations undertaken including a study of the nitrogen content, specific conductivity, and viscosity of the carbon dioxide-free distilled water extract, 50 per cent alcoholic extract and 70 per cent alcoholic extract of the flours examined, and the specific conductivity and viscosity of the mineral matter contained in the various extracts. The glutes were examined for hydration capacity, nitrogen, ash, expansibility, and acid hydrolysis. The specific conductivity was also determined of organic and inorganic acids in which the glutes were immersed for different intervals of time.

The specific conductivities of the water extract of the flours were of the same order as that of the alcoholic extracts. The specific conductivity was highest in the case of the 70 per cent alcoholic extract and lowest in the water extract. In general, the viscosity of the extracts varied in the same order as the specific conductivity.

The volume per gram of expanded gluten when immersed in $N/100$ sulphuric acid varied directly as the conductivity, while corresponding volumes of gluten immersed in $N/100$ lactic and citric acids varied inversely with the conductivity. The purity of the glutes was inversely proportional to the expansion per gram of baked gluten, and was proportional to the amount of amino nitrogen in the gluten. The percentage of dry gluten and the ratio of the water-soluble nitrogen of the flour to the amino nitrogen of the gluten were inversely proportional to the purity of the gluten.

[**Miscellaneous food analyses**], A. E. VINSON and C. N. CATLIN (*Arizona Sta. Rpt.* 1918, pp. 345, 346).—Analyses of barley flour are reported, as well as findings with samples of corn meal and cocoa suspected of containing ground glass.

Note on the fat-soluble growth-promoting substance in lard and cottonseed oil. A. L. DANIELS and R. LOUGHLIN (*Jour. Biol. Chem.*, 42 (1920), No. 3, pp. 359–362, figs. 3).—Evidence is furnished that commercial lard and cottonseed oil contain appreciable amounts of fat-soluble vitamin, demonstrable, however, only when fairly large amounts are fed.

Rats were fed a ration consisting of 18 per cent of casein, 28 per cent of fat (cottonseed oil or lard), 7 per cent of salt mixture, 47 per cent of cornstarch, and the water-alcohol extract of 9 gm. of wheat embryo. To insure absence of the fat-soluble vitamin, except as it might occur in the lard or cottonseed oil, the casein and wheat embryo had been previously extracted for 48 hours with ether in a Soxhlet apparatus. On this ration all of the animals grew normally. The females in both the lard and cottonseed groups reproduced, and the young in both groups were successfully reared on the same diets.

In another series of experiments in which the rations were the same except that 53 per cent of starch and 21 per cent of fats were used in place of 47 and 28 per cent, respectively, normal growth gains took place with the lard ration for about 2 months, when the weight became stationary. With the lower cottonseed-oil ration growth was normal for only about 6 weeks, when a gradual decline in weight took place.

"Since the relation between the fat-soluble vitamin and rickets is undergoing experimental scrutiny, our findings may be of interest in this connection. It is possible that recent workers who have been using the vegetable oils, more particularly cottonseed, in the study of rickets, with the thought that these are quite free from the fat-soluble complex may have been furnishing enough of the vitamin to meet the requirements of growth, especially if the experimental periods were of comparatively short duration."

The occurrence of water-soluble vitamin in some common fruits, T. B. OSBORNE and L. B. MENDEL (*Jour. Biol. Chem.*, 42 (1920), No. 3, pp. 465-489, figs. 9).—The presence of water-soluble B in various fruits was tested by feeding experiments with white rats. A standard ration consisting of meat residue 19.6, salt mixture 4, starch 52.4, butter fat 9, and lard 15 per cent was fed ad libitum, and a measured amount of fresh fruit, fruit juices, and dried fruit furnished daily, apart from the rest of the ration. The results obtained may be summarized as follows:

Fresh orange juice, prepared by squeezing the skinned oranges, was found to contain sufficient water-soluble B to promote growth in rats at about the same rate as do corresponding volumes of milk, as shown by the fact that satisfactory growth was obtained with a daily dose of 10 cc. while smaller amounts proved insufficient. Orange juice, desiccated by concentration in vacuo and dried in a current of air, was of equal value when fed in quantities equivalent to the fresh juice. The fresh inner peel of the orange, when relished by the rats, promoted normal growth fed in daily doses of 5 gm.

Lemon juice and grapefruit juice, desiccated in the same way as the orange juice, proved equally potent. Commercial grape juice in 10 cc. daily doses proved insufficient although containing some of the water-soluble B. Fresh apples and pears also contained some of the vitamin but in very small quantities, 10 gm. of the fresh fruit proving far less potent than 2 gm. of dried brewer's yeast. Fresh prunes were apparently much richer than apples or pears in water-soluble B (rapid growth resulting with 5 gm. daily doses).

Preliminary experiments indicate that there is very little if any of the fat-soluble A in the juice of lemon or grapefruit, but that it is present to some extent in orange juice.

"The experiments with fruits place the dietary value of these foods, hitherto recommended because of their salt content, their laxative properties, or their antiscorbutic potency, in a new light as sources of water-soluble vitamin."

Antiscorbutic property of vegetables.—II, An experimental study of raw and dried potatoes, M. H. GIVENS and H. B. McCLUGAGE (*Jour. Biol. Chem.*, 42 (1920), No. 3, pp. 491-515, pls. 4, figs. 13).—In continuation of the investiga-

tion previously noted (E. S. R., 40, p. 762), data are reported concerning the antiscorbutic value of potatoes, raw and cooked, fresh and dried. The general procedure and methods were the same as described in the first paper. Young guinea pigs were fed a basal scurvy-producing diet of heated soy bean flour, milk, yeast, paper pulp, calcium lactate, and salt, and to this was added 10 gm. daily of fresh potatoes or its equivalent in the dried or cooked product. The experimental results are presented in graphic form in the usual growth curves, together with supplemental feeding curves indicating the amount of the basal diet and of the supplemental diet (potatoes) consumed daily.

A daily supplement of 10 gm. of raw white potato was sufficient to protect the growing guinea pigs from scurvy for the duration of the experiment, 129 days. While the minimal protective amount of raw potato was not determined, indications are that slightly less than 10 gm. daily is about the lower limit of safety. Cooking the potatoes in water at 100° C. for 15 minutes caused only a slight reduction in antiscorbutic value, while cooking for an hour at the same temperature reduced the vitamin content to such an extent that the disease could not be arrested by feeding 15 gm. daily of the product. Scurvy was checked in two animals by feeding 10 gm. of potatoes cooked in 1 cc. of 0.5 per cent citric acid for 1 hour.

With potatoes dried at 35 to 40° death from scurvy was slightly delayed by an amount (2.5 gm.) equivalent to 10 gm. of the fresh product, while with double the amount life was prolonged still further. One out of four animals on a daily dose of 2.5 gm. dried at 55 to 60°, and one out of three animals on the same amount dried at 75 to 80°, showed signs of scurvy at death. On heating at 100° for 1 hour the products dried at these temperatures, no protection was secured in any case.

Potatoes baked in the skins for from 45 to 55 minutes at 204° and then scooped out and dried at 35 to 40° protected against scurvy in 2.5 gm. daily portions. The potato skins had no protective action. Potatoes steamed for 4 minutes, dried at 55 to 60° and cooked for 15 minutes at 100°, offered no protection even when the dose was doubled. Potatoes soaked over night in dilute acetic acid, dried at 55 to 60°, and then cooked for 15 minutes at 100° gave no protection. Similar results were obtained with a like treatment with dilute hydrochloric acid.

In discussing these results, the authors suggest the possibility that the factors involved in the destruction of the antiscorbutic vitamin are not only the degree of heat and the duration of the heating but also the enzym content and the reaction of the food being dried. By employing a high temperature for a short time, as in the case of baked potatoes, the enzymes are destroyed, while at any temperature below 80° the enzymes are still functioning and probably play an important rôle in the destruction of the antiscorbutic vitamin.

Influence of diet on the antiscorbutic potency of milk, E. B. HART, H. STEENBOCK, and N. R. ELLIS (*Jour. Biol. Chem.*, 42 (1920), No. 3, pp. 383-396, pl. 1, figs. 15).—This paper reports the result of an investigation of the dietary relation to the antiscorbutic vitamin concentration in cow's milk.

The varieties of milk tested included dry feed milk, obtained from a herd of 18 cows which had never been fed any fresh vegetable tissues but only air-dried roughages and grains; summer pasture milk from cows which during part of the day grazed on a timothy, blue grass, clover pasture; and winter produced milk from cows fed on dried grains and hays, supplemented in one case by a corn silage made from corn that had well matured and partly dried but had not been frozen, and in another case by a small amount of silage and a considerable amount of hybrid sugar mangels. Each variety of milk was tested for its antiscorbutic vitamin content by feeding it to guinea pigs in

amounts varying from 15 to 50 cc. per animal in the case of the summer pasture milk and from 15 to 100 cc. in the case of the dry feed milks, the milk in each case serving as a supplement to a basal scurvy-producing ration of heated ground alfalfa hay, rolled oats, and common salt.

A daily consumption of 15 cc. of summer pasture milk afforded protection against scurvy for 20 weeks to one guinea pig but did not protect two others in the same group. On increasing the amount to 30 cc. two animals out of three were protected, the third developing scurvy in 8 weeks. Full protection was secured by the daily consumption of 50 cc. of the milk.

In the case of the dry feed milk 15 cc. and 30 cc. daily completely failed to prevent scurvy, 50 cc. delayed the onset but did not afford entire protection, and 75 cc. furnished complete protection. The fact that protection against scurvy was ultimately secured with the dry feed milk indicates that the materials fed, although dried and at least a year old, still had some antiscorbutic potency.

Both varieties of the winter produced milk proved only slightly richer in the antiscorbutic vitamin than the dry feed milk, complete protection not being secured until 75 cc. of milk daily had been added to the basal ration. The sugar mangel milk was a slightly better source for this vitamin than the silage milk.

The investigation as a whole is considered to afford conclusive proof that the diet of the milk-producing animal is a factor in the relative antiscorbutic potency of the milks produced.

The use of fermented milk and milk diets to control intestinal putrefaction, R. C. FISHER (*Connecticut Storrs Sta. Bul. 104 (1919), pp. 153-175*).—Results are reported of experiments carried on in the dairy laboratory of the Ohio State University in 1917 and 1918 to determine the influence of fermented milks and of whole-milk diets in the control of intestinal putrefaction. The preparation of the special milks and other details of the experiments are described in full.

While the work touches upon a number of important points, the special questions considered were the production of lactic acid by *Bacillus bulgaricus* and its germicidal effect in milk; the use of fermented milk, sweet whole milk, and *B. bifidus*, *B. acidophilus*, and *B. bulgaricus* (without milk) in controlling intestinal putrefaction; also the effect of lactose feeding on the intestinal flora and on intestinal putrefaction.

The several experiments were of 28 days' duration and all of the six subjects continued to the end except in the first experiment. Observations were made of the nature of the intestinal flora and records kept of bowel movements and of the general welfare as indicated by gain or loss of weight. Urine and feces were examined during and after the experiments for indol, skatol, and indican. Quotations from the author's summary follow:

"*B. bulgaricus* and *B. bifidus* supplied to the diet in the form of watery suspensions only temporarily affect the intestinal flora. They do not cause any marked decrease in the production of intestinal decomposition products. Their implantation without milk in the intestinal tract is very doubtful. The series of experiments seems to show that milk is necessary to establish *B. bifidus* and *B. acidophilus* in the intestinal tract. The benefit derived from the use of fermented milk, therefore, must be credited to the milk diet. The characteristic change of the intestinal flora to the *bifidus* and *acidophilus* types is in some way associated with the use of considerable quantities of milk. . . .

"The feeding of lactose changes the intestinal flora from a Gram-negative to one in which considerable numbers of Gram-positive organisms of the *B.*

bifidus and *acidophilus* types are present. This in connection with a slight decrease in decomposition products seems to point out that lactose is an important factor as a controlling agent in intestinal putrefaction. The best results, however, are obtained by using a milk diet in the form of fermented milk or sweet whole milk.

"One of the most striking facts to be noticed in the series of experiments is the characteristic change in the intestinal flora coupled with decreased intestinal putrefaction whenever milk constituted a large part of the diet. In these cases the intestinal flora changed from the usually Gram-negative coli type to one in which the Gram-positive aciduric *B. acidophilus* was prominent. In all instances where milk made up the principal part of the diet there was a marked decrease in the decomposition products.

"The first experiment deals with the germicidal effect of lactic acid in milk. Pathogenic bacteria introduced into milk cultures containing 1 per cent of lactic acid were effectively checked and destroyed. This proves that lactic acid has decided germicidal properties, and may prevent the infection of fermented milk with harmful organisms. The results of the other experiments, however, seem to indicate that this germicidal action of lactic acid does not extend to the control of the organisms already in the intestine.

"The results from the use of *B. bulgaricus* milk in connection with a regular diet were very gratifying. Intestinal putrefaction decreased markedly when at least 2 qts. of *bulgaricus* milk were used and the other food reduced proportionately. There was a general gain in weight, and those suffering from constipation were very much relieved. Of special interest is the change in the intestinal flow. Notwithstanding the fact that very large numbers of *B. bulgaricus* were ingested with the milk, only a few could be recovered from the feces. *B. bulgaricus* is therefore not a natural inhabitant of the human intestinal tract. The very closely related *B. acidophilus* could be found in large numbers, but only after about 8 or 10 days' use of the *bulgaricus* milk. When milk was discontinued the *B. acidophilus* gradually disappeared, and the flora again showed large numbers of the Gram-negative organisms.

"The same held true with the whole sweet-milk experiment, which gave practically as good results as *bulgaricus* milk. This fact becomes still more significant when it is considered that *B. acidophilus* became a common inhabitant of the intestinal tract without the ingestion of the organism itself. This would indicate that *B. acidophilus* is naturally an intestinal organism, and that its presence or absence is dependent upon the nature of the food consumed. The diet or nature of the food, then, is the controlling factor. The character of the intestinal flora is dependent on, and alters with, the type of the food. The ingestion, then, of large numbers of certain bacteria without the proper diet can be of little permanent value. This fact was brought out by the experiment in which watery suspensions of *B. bulgaricus*, *B. acidophilus*, and *B. bifidus* were consumed. The intestinal flora throughout the experiment showed large numbers of the Gram-negative types, and there was no appreciable decrease in the decomposition products.

"The use of lactose in bringing about decreased intestinal putrefaction gave fair results, but they can not compare with the remarkable results obtained by the use of *bulgaricus* or sweet milk. The beneficial effect of milk in the successful treatment of various intestinal diseases, as typhoid fever, has for some time been known to the medical profession, but not until recently has it been realized that the explanation lay in its ability to change the intestinal flora from the putrefactive type to the Gram-positive aciduric *B. acidophilus* group, the pres-

ence of which is associated with a minimum amount of putrefaction and the general well-being of the individual. Whether *bulgaricus* milk or fresh sweet milk is preferable depends upon the conditions. If the subject is constipated the *bulgaricus* milk may prove very helpful. On the other hand, some individuals apparently do not tolerate acid milk, and in such cases the sweet milk would be best. Approximately 3 to 4 qts. should be used daily, in half-pint quantities taken every hour or two. Other foods should be reduced proportionately, and in certain cases it may prove advisable to leave them out entirely and increase the milk to 4 or even 6 qts., depending on the needs of the patient.

"There may be conditions when it is advisable to have in the intestines at once large numbers of the *B. acidophilus*. It seems that a fermented milk prepared with *B. acidophilus* would be admirably suited for such needs. Instead of using the *bulgaricus* culture an *acidophilus* culture could be used, thus providing both the essential factors, milk and the large numbers of the desirable organism which is a natural inhabitant of the intestinal tract."

Studies on the transformation of the intestinal flora, with special reference to the implantation of *Bacillus acidophilus*.—I, Feeding experiments with albino rats, H. A. CHEPLIN and L. F. RETTGER (*Proc. Nat. Acad. Sci.*, 6 (1920), No. 7, pp. 423-426).—This is a brief report of experimental work with white rats in attempts to alter the intestinal flora by the feeding of different sugars and by the direct implantation of *B. acidophilus* and *B. bulgaricus*.

The addition to the basal diet of bread and meat of 2 gm. daily of lactose or dextrin caused a very pronounced transformation in the intestinal flora of the rats, *B. acidophilus* displacing practically all the other bacterial types. The addition of 1 gm. of lactose or dextrin brought about a partial transformation never exceeding 50 per cent. Maltose, sucrose, and glucose did not alter the types of bacteria present. It is pointed out that these results are in agreement with those of Hull and Rettger previously noted (*E. S. R.*, 36, p. 664).

The addition of 1 cc. of *B. acidophilus* suspension of 1 gm. to lactose or dextrin, or the administration of 2 cc. daily of *B. acidophilus* culture without the carbohydrates, produced the same effect as the feeding of 2 gm. of lactose or dextrin. Repeated attempts to establish *B. bulgaricus* in the alimentary canal of rats through the administration of as much as 5 cc. of suspension of the organism were entirely unsuccessful.

In discussing the bearing of these findings on the Metchnikoff sour milk therapy, attention is called to the fact that milk, when given in sufficient amounts, causes rapid development of *B. acidophilus* in the intestine, resulting at times in the complete suppression of other forms of bacteria. The suggestion is made that what Metchnikoff and his pupils regarded as *B. bulgaricus* in the feces of animals and of human subjects was really *B. acidophilus*.

"The feeding of *B. bulgaricus* without due regard to the use of milk can have little or no importance attached to it. The beneficial results which have been attributed to yogurt and other oriental sour-milk products have in all probability been due to the milk as such rather than to the acid-producing bacteria contained in these products."

Evidence indicating a synthesis of cholesterol by infants, J. L. GAMBLE and K. D. BLACKFAN (*Jour. Biol. Chem.*, 42 (1920), No. 3, pp. 401-409).—Determinations of the cholesterol intake and excretion of four infants over periods of three days showed in all cases a much larger excretion than intake, thus indicating a synthesis of cholesterol within the organism.

The method of determining cholesterol in the milk consisted essentially in saponifying the sample with potassium hydroxid and separating the nonsaponi-

fiable matter from the soaps by shaking out with dilute alcohol and petroleum ether. In determining cholesterol in the feces, a large sample of the dried feces was extracted with boiling alcohol and ether (3:1) for 1 hour under a reflux condenser. An aliquot was then saponified as in the case of the milk. This method proved more reliable than the direct method of Denis and Minot previously noted (E. S. R., 40, p. 11).

ANIMAL PRODUCTION.

Types and breeds of farm animals, C. S. PLUMB (*Boston and London: Ginn & Co., 1920, rev. ed., pp. VIII+820, pl. 1, figs. 366*).—With practically every chapter revised and enlarged, and with citations of recent milk, butter-fat, speed, and sale-ring records, this second edition retains the characteristics which at once made the first (E. S. R., 18, p. 762) a standard treatise. Chapters on Dexter cattle, Corriedale and Karakul sheep, and Large Black and Mule-Foot hogs have been introduced, and several nearly defunct breeds have been dropped.

On the functional correlation of the hypophysis and the thyroid, J. A. LARSON (*Amer. Jour. Physiol., 49 (1919), No. 1, pp. 55-89*).—The similarity between the thyroid and the hypophysis cerebri (pituitary body) in structure and influence on growth and metabolic processes led the author to feed fresh anterior lobe of the hypophysis of the ox to a series of rats from which the thyroids and parathyroids had been removed. These rats grew much better and lived much longer than the control series of thyroidectomized rats fed fresh beef liver.

There is an extensive literature review of the functions of the two glands and the chemical nature of their secretions.

Further evidence on the functional correlation of the hypophysis and the thyroid, J. A. LARSON (*Amer. Jour. Physiol., 53 (1920), No. 1, pp. 89-100*).—The experiments reported in the preceding paper were extended with similar results. In addition it was found that the feeding of anterior lobe accelerated the growth of normal rats also, but to a lesser extent. It is concluded, therefore, that some of the results from feeding the hypophysis to rats lacking thyroids might be attributed to the general beneficial action of the pituitary, but that part of the effect, at least, was due to the utilization of some substance in the hypophysis as a substitute for the missing thyroid secretion.

Ratio of sires and dams (*U. S. Dept. Agr., Weekly News Letter, 8 (1920), No. 8, p. 8*).—From data collected in the course of the "better sires, better stock" campaign, the following ratios of male to female breeding stock were found in the different classes of farm animals: Cattle 1:18.9, horses 1:16.9, swine 1:11.5; sheep 1:37, goats 1:26.6, chickens 1:23.3, and other domestic birds 1:8.5.

Silage investigations, A. C. RAGSDALE and M. H. FORHMAN (*Missouri Sta. Bul. 172 (1920), pp. 22-24*).—The authors report success in ensiling shock corn, ear corn too soft for cribbing, and cornstalks without ears.

Studies on the digestibility of sunflower silage, W. E. JOSEPH and M. J. BLISH (*Montana Sta. Bul. 134 (1920), p. 8*).—Digestion trials were made with 3 steers during three 20-day periods. Clover hay alone was fed during the first period, clover hay and sunflower silage (1:3) in the second, and sunflower silage alone in the third. The silage was made from Mammoth Russian sunflowers harvested at the time 20 per cent of the plants were in bloom. The table following summarizes the results.

Composition and digestibility of clover hay and sunflower silage fed to steers.

Period.	Feed.	Composition (dry basis).					Digestibility.				
		Crude protein.	Ether extract.	Crude fiber.	N-free extract.	Ash.	Dry matter.	Crude protein.	Ether extract.	Crude fiber.	N-free extract.
		<i>Per ct.</i>	<i>Per ct.</i>	<i>Per ct.</i>	<i>Per ct.</i>	<i>Per ct.</i>	<i>Per ct.</i>	<i>Per ct.</i>	<i>Per ct.</i>	<i>Per ct.</i>	<i>Per ct.</i>
1	Clover hay.....	13.77	1.63	31.70	47.89	4.95	60.65	63.28	37.75	51.79	71.66
	Clover hay.....	13.19	1.65	30.65	47.76	6.73	63.23	60.72	46.49	50.73	73.14
2	Sunflower silage.....	9.60	2.47	30.67	48.65	8.60	60.35	55.23	77.62	40.81	71.48
3	Sunflower silage.....	9.82	2.40	32.66	48.69	6.41	57.27	59.88	70.63	42.16	69.75

It is concluded that the digestibility of the sunflower silage is approximately the same whether fed alone or in conjunction with clover hay, and that the coefficients of digestibility of sunflower silage resemble those of silage made of immature corn.

[Steer feeding experiments in Canada] (*Canada Expt. Farms Rpt. 1919*, pp. 82, 89, 95, 96, 142, 155).—It is stated by J. A. Clark (p. 82) that tests at Charlottetown, P. E. I., indicate that blood meal is not an economical supplement in steer feeding.

In a comparison of heavy and light steers fed identical rations at the Kentville, N. S., Experimental Station, reported by W. S. Blair (p. 89), it was found that a lot of 12 steers, averaging 1,007 lbs. in weight, made an average daily gain of 1.095 lbs. per head during the 168 days of the feeding trial, while 12 lighter steers, averaging 785 lbs. in weight, gained at the rate of 1.378 lbs. per day.

Two years' results at Nappan, N. S., are reported by W. W. Baird (pp. 95, 96). In 1917-18, 34 beef steers, fed roots and grain in an open shed, made an average daily gain of 1.58 lbs. per head. Three smaller groups (totaling 8 steers) were kept loose in box stalls and fed similarly or with silage added or substituted for roots; the daily gains varied from 2.4 to 2.67 lbs. per steer. In 1918-19, three lots of 8 steers each were fed on roots and grain. A lot of good beef type (averaging 1,067 lbs. at the start) housed loose in a box stall made a daily gain of 1.62 lbs. per steer. A lot of poorer beef type (averaging 931 lbs. in weight) gained at the rate of 1.87 lbs. The third lot, which was of mixed Shorthorn and dairy breeds (weighing 1,014 lbs. per head), was tied in a barn and made an average daily gain of 1.875 lbs.

In tests at Morden, Man., reported by E. M. Straight (p. 142), it was found that 15 steers fed in a barn for 151 days made a total gain per steer of 194 lbs. and that a similar group fed in an open front board shed gained 151 lbs.

At Rosthern, Sask., it was found by W. A. Munro (p. 155) that a lot of 23 steers fed oat and barley chop and hay made a total gain of 263 lbs., whereas a similar lot fed the same ration plus 10 lbs. of turnips made a gain of 295 lbs.

The occurrence of red calves in black breeds of cattle, L. J. COLE and S. V. H. JONES (*Wisconsin Sta. Bul. 313 (1920)*, pp. 36, figs. 4).—The authors show from historical records that red or red and white animals formed part of the foundation stocks of the Aberdeen-Angus, Galloway, and Holstein-Friesian breeds. Since black is a simple Mendelian dominant to red, the occasional production of red calves by registered animals of the black breeds is not surprising and should not be considered a necessary or even a probable indication of recent crossbreeding, and the good name of a breeder should not be impugned because of such an occurrence. It is pointed out that both parents are equally

responsible for red calves, and that the common practice of blaming one or the other must be abandoned.

Feeding tests [with sheep], W. H. FAIRFIELD (*Canada Expt. Farms. Rpt. 1919, p. 164*).—In a comparison between barley and oats (1:1) and screenings for lamb feeding at Lethbridge, Alta., it was found that 1.06 lbs. of screenings was approximately equal in value to a pound of the mixed grain.

[Pea straw for feeding sheep], H. HACKEDORN (*Washington Sta. Bul. 155 (1920), pp. 8-10*).—A lot of 6 lambs fed an average ration of 3.49 lbs. of pea straw gained 30.8 lbs. per head in 120 days, beginning December 18, 1918, and produced fleeces averaging 10.17 lbs. A similar lot fed an average ration of 3.42 lbs. of alfalfa hay gained 43.7 lbs. per head during the same period and produced fleeces weighing 10.41 lbs. Each of the lambs in both lots received 1 lb. of grain per day. The lower price of the pea straw made it a more profitable roughage than the alfalfa.

During an average winter period of 80 days, pregnant ewes receiving pea straw and grain required 0.16 lb. more grain per day than ewes on a standard ration of alfalfa hay and 0.5 lb. of grain. After lambing, a group of 7 ewes and 9 lambs were continued on each of the roughages, the amount of grain being varied to secure an equal growth in both groups of lambs. During the first 60 days of the suckling period the alfalfa hay lot consumed 1.9 lbs. of grain per ewe daily, while the pea straw lot consumed 2.93 lbs.

[Feeding experiments with hogs], R. H. WILLIAMS and W. S. CUNNINGHAM (*Arizona Sta. Rpt. 1918, pp. 325-328*).—Experiments are reported to show that garbage is an economical feed for hogs, and that well-fed hogs grow better than those given only ordinary care.

[Swine feeding investigations], L. A. WEAVER (*Missouri Sta. Bul. 172 (1920), pp. 16-19*).—Brief progress reports are made of several swine feeding projects.

Hominy feed v. corn for fattening swine on forage (pp. 16, 17).—During an 86-day period on bluegrass pasture, a lot of 10 pigs fed hominy feed, shorts, and tankage (9:2:1) made an average daily gain of 0.9 lb. per head and consumed 4.77 lbs. of feed per pound of gain. A similar lot on the same pasture, and fed ground corn, shorts, and tankage (9:2:1), gained 0.97 lb. per head daily and required 4.58 lbs. of feed per pound of gain. Hogs receiving the hominy-feed mixture and grazed on alfalfa or rape also made satisfactory gains.

Semisolid buttermilk v. tankage as a protein supplement in rations for fattening swine (pp. 17, 18).—Forty fall pigs, divided into 4 lots, were fed for 49 days beginning March 11, 1919. Lot 1 received corn, shorts, and tankage (9:2:1), made an average daily gain of 1.93 lbs., and required 4.1 lbs. of feed per pound of gain. Lot 2 received corn, shorts, and semisolid buttermilk (9:2:1.5), made an average daily gain of 1.94 lbs., and required 4.24 lbs. of feed per pound of gain. Lots 3 and 4 were fed like lots 1 and 2, respectively, with barley substituted for corn. Lot 3 made an average daily gain of 1.85 lbs. per head and required 4.27 lbs. of feed per pound of gain. Lot 4 made an average daily gain of 1.87 lbs. and required 4.34 lbs. of feed per pound of gain. It is concluded that 1.5 lbs. of semisolid buttermilk may be used to replace a pound of tankage without substantial influence on the rate or economy of gain.

Barley v. corn for fattening swine (p. 18).—From the results of the preceding experiment it is concluded that barley is slightly inferior to corn for swine feeding.

Fishmeal v. tankage as a supplement to corn in rations for fattening swine (pp. 18, 19).—A lot of 10 spring pigs, fed for 49 days, beginning September 21, 1918, on corn, shorts, and fishmeal (9:2:1), made an average daily gain of

1.76 lbs. per head and required 4.41 lbs. of feed per pound of gain. A check lot fed tankage in place of fishmeal made an average daily gain of 1.45 lbs. and required 5.17 lbs. of feed per pound of gain.

[**Swine feeding experiments in Canada**] (*Canada Expt. Farms Rpt. 1919*, pp. 21, 22, 148, 159, 164, 168, 169).—These pages contain brief summaries of swine feeding experiments, including those given more in detail in the three publications noted below.

Pasture experiments with swine at the Central Experimental Farm are reported by E. S. Archibald (pp. 21, 22). A lot of 29 pigs on one acre of clover pasture selected concentrates from a self-feeder in the following proportions: Corn 62.2, shorts 18.8, screenings 11.4, and tankage 5.6 per cent. The clover pasture had greater carrying capacity than either rape or barley and produced gains more cheaply than the latter. A group of 19 sows on one acre of rape pasture received only a small amount of grain for 69 days. The litters produced in this time averaged 8.9 pigs each, and of these 70 per cent were raised. Fifteen of the sows were continued for a month longer on rape, but received a ration of 2.3 lbs. of grain. The litters averaged 7 pigs, and all were raised. Ten sows fed in a dry lot on bran and shorts (1:1) during these 99 days produced 12 pigs per litter but raised only 45 per cent.

Tests with Berkshire pigs at Scott, Sask., reported by M. J. Tinline (p. 159), indicated a daily gain per head of 1.98 lbs. for self-fed lots and 1.32 lbs. for hand-fed lots. The grain required for a pound of gain was 4.46 and 5.27 lbs., respectively.

Tests at Lethbridge, Alta., reported by W. H. Fairfield (p. 164), showed that 25 grade Berkshire pigs on 4.9 acres of field peas made a gain of 260 lbs. per acre from August 1 to November 4.

Value of hog pastures in pork production, B. C. MILNE (*Live Stock Jour. [London]*, 92 (1920), No. 2415, p. 80).—From 2 to 5 years' work with different pasture crops at the Lacombe, Alta., Experimental Station are summarized. The following average amounts (in pounds) of supplemental grain were required to produce a pound of pork on the different pastures: Barley 3.69, wheat 4.27, oats 4.38, alfalfa 4.64, rape 4.71; and sweet clover 5.68. A pound of gain in dry-lot feeding was produced by 4.93 lbs. of grain. Sweet clover was not eaten readily by young pigs and thus made rank growth. That this pasture was less economical than dry-lot feeding is attributed in part to the greater activity of the pigs.

Oats provided the most pasture, carrying fully 1,000 lbs. more pork per acre than barley.

The cost of producing pork, G. H. HUTTON (*Farmer's Advocate and Home Jour.*, 54 (1919), No. 1378, p. 277, figs. 4).—Average results are reported of three years' tests at the Lacombe, Alta., Experimental Farm to determine the relative economy of three breeds of swine in producing pork. Pigs in the first test (winter of 1916) were fed in the dry lot on oats, barley, and tankage. The 1917 pigs were fed shorts and tankage and had access to timothy and alsike clover pasture. The 1918 pigs were on a rape pasture and received grade A screenings and tankage.

The Yorkshire pigs required 4.09 lbs. of concentrates for a pound of gain, the Duroc-Jerseys 4.69 lbs., and the Berkshires 4.71 lbs. The dressing percentages (based on weights before shipping) in 1917 and 1918 averaged 74.62 for the Yorkshires, 74.47 for the Duroc-Jerseys, and 72.05 for the Berkshires. The Yorkshire sows averaged 10.8 pigs per litter and raised 7 to weaning, the Berkshires averaged 9.1 at birth and raised 6.4, and the Duroc-Jerseys averaged 8.4 and raised 7.4.

The value of re-cleaned screenings, W. C. McKILICAN (*Saskatchewan Farmer*, 9 (1919), No. 6, p. 17).—This is a report from the Brandon, Man., Experimental Farm of the results of a 49-day comparison between barley chop and re-cleaned screenings for feeding 125-lb. shotes. The screenings were of the sort formerly known as "grade A," and now called "standard stock food." They consisted chiefly of broken and shrunken wheat and wild buckwheat, with small amounts of oats and flaxseed.

The tests began December 3, 1918, and 12 lots of 10 hogs each were employed, each grain mixture tested being fed to 2 lots. A small amount of tankage was fed to each lot, and the grain mixtures were given according to appetite. The amounts of the respective grain mixtures consumed per pound of gain were as follows: Barley alone, 4.53 lbs.; screenings alone, 4.43 lbs.; barley and red dog (3:1), 4.32 lbs.; screenings and red dog (3:1), 4.51 lbs.; barley and shorts (3:1), 4.54 lbs.; and screenings and shorts (3:1), 4.66 lbs. The gains were quite uniform from lot to lot, and it is concluded that the screenings were fully equal to barley for finishing hogs.

Barley v. corn for breeding gilts, J. M. EVVARD and R. DUNN (*Swine World*, 8 (1920), No. 3, pp. 26, 27; also in *Duroc Bul. and Live Stock Farmer*, 16 (1920), No. 20, pp. 50, 52).—Five lots of 130-lb. pregnant gilts were fed for about five months at the Iowa Experiment Station beginning November 14, 1918. The check lot received shelled corn (averaging 3.68 lbs. per head daily), tankage (0.2 lb.), and ground alfalfa (0.2 lb.), and made a daily gain of 0.77 lb. per head. Barley prepared in one of four ways replaced the corn in the rations of the other lots, the amount of barley being adjusted to secure, so far as possible, the same gain as the check lot. From the feed consumption and gains it was computed that for wintering gilts 1 lb. of corn is equal in value to 1.05 lbs. dry ground barley, 1.13 lbs. soaked ground barley, 1.24 lbs. dry whole barley, or 1.25 lbs. soaked whole barley.

Barley for fattening pigs, F. B. MORRISON and G. BOHSTEDT (*Wis. Farmers' Insts. Bul.* 32 (1919), pp. 96-103, figs. 2; also in *Hoard's Dairyman*, 57 (1919), No. 15, pp. 773, 776, figs. 3).—A feeding experiment with 10 lots of hogs averaging 128.8 lbs. in weight was begun at the Wisconsin Experiment Station February 14, 1919. Lot 1 consisted of 10 shotes, the others of 5. The feeding methods compared and the main results are indicated in the following table:

Comparisons of supplements to barley for fattening 130-pound hogs and of methods of preparing barley.

Lot No.	Character of feeds. (Each self-fed unless indicated. Barley ground except in lot 5.)	Average ration.		Daily gain per head.	Time required to reach 225-pound weight.	Feed per pound of gain.		Feed cost of pound of gain.	
		Grain.	Supplement.			Grain.	Supplement.	Farm price.	Purchase price.
		Lbs.	Lbs.	Lbs.	Days.	Lbs.	Lbs.	Cts.	Cts.
1	Shelled corn, tankage.....	7.5	0.72	2.14	45.0	3.50	0.34	9.92	10.55
2	Barley, tankage.....	7.7	.54	1.95	49.5	3.95	.28	8.83	9.50
3	Barley (hand fed), tankage.....	7.4	.39	1.81	53.0	4.09	.22	8.74	9.44
4	Soaked barley (hand fed), tankage (hand fed).....	7.4	.37	1.97	49.0	3.77	.19	8.00	8.64
5	Soaked whole barley (hand fed), tankage (hand fed).....	6.6	.37	1.13	5.82	.33	12.02	13.01
6	Barley, shorts.....	5.6	.76	1.27	4.39	.60	9.44	10.18
7	Barley, linseed meal.....	5.5	.43	1.22	4.52	.35	9.57	10.34
8	Barley, skim milk (hand fed).....	7.2	7.70	2.10	46.0	3.45	3.66	8.72	9.31
9	Barley, whey (hand fed).....	8.4	15.90	2.53	38.0	3.31	6.29	8.14	8.70
10	Barley, whey (hand fed), linseed meal (hand fed).....	7.4	(¹)	2.33	41.5	3.16	(²)	8.21	8.75

¹ Whey, 15.4; linseed meal, 0.17 pounds,

² Whey, 6.64; linseed meal, 0.07 pounds,

The two price schedules differ in the charge for grain. Average Milwaukee prices (corn, \$1.38; barley, 92 cts. a bushel) were used for the "purchase" price and the "farm" price was taken as 10 cts. lower for corn and 8 cts. lower for barley. A charge of 5 cts. a bushel was added for grinding barley. The prices per ton of the purchased supplements were: Tankage, \$110; shorts (standard middlings), \$44; and linseed meal, \$67.50. Half the farm price of a bushel of corn was taken as the price of 100 lbs. of skim milk. Whey was charged at half the price of skim milk.

The outstanding feature of the experiment, in the authors' opinion, was the marked success with barley and whey, a ration low in protein. Dry ground barley is considered an excellent substitute for corn in swine fattening.

Soft pork studies, J. M. SCOTT (*Florida Sta. Bul.* 157 (1920), pp. 67-75).—This is mainly an announcement of the successful sampling of the fat of living hogs in order to determine the changes in melting point during the progress of a feeding experiment. The fat is removed from a 2-in. incision in the ham and the opening is closed with a few stitches. The site of the incision is disinfected before and after the operation. This procedure was found not to interfere with growth.

The protocol of a preliminary experiment is presented to illustrate the uses of the method. Nine hogs were fed during two 44-day periods and the initial melting points varied from 35.5 to 40.5° C. The three hogs with fat of highest melting point received peanuts alone during the first period and a mixture of corn, shorts, peanut feed, and skim milk during the second period. By the end of the first period the melting points had declined about 4°, and at the end of the second period they had returned almost to their original state. The three hogs with fat of the lowest melting points received a mixed feed throughout and the melting points steadily increased. Of the remaining hogs, two showed decrease in melting points during the second feeding when on peanuts alone, and one showed increase. The detection of individual idiosyncrasies of this sort is considered one of the advantages of the sampling method.

[**Feeding records of Canadian horses**] (*Canada Expt. Farms Rpt.* 1919, pp. 106, 107, 112, 113).—The year's feeding records of a Percheron colt and a Percheron filly at Ste. Anne de la Pocatiere, Que., are recorded by J. Begin (pp. 106, 107). These are continuations of the records noted in the preceding report (E. S. R., 41, p. 570).

Feeding records at Cap Rouge, Que., Experimental Station are reported by G. A. Langelier (pp. 112, 113). They include a colt and 4 fillies up to the age at which they were broken to harness and also the records of 2 working horses.

Feeding work horses on corn silage, R. H. WILLIAMS and W. S. CUNNINGHAM (*Arizona Sta. Rpt.* 1918, pp. 328, 329).—It is reported that horses at the Prescott dry farm consumed from 32.5 to 122.5 lbs. of corn silage per head daily during the summer. The average daily consumption was nearly 75 lbs. per head. No injurious results were noted.

Oat straw as winter roughness for farm work horses, E. A. TROWBRIDGE (*Missouri Sta. Bul.* 172 (1920), pp. 15, 16, figs. 2).—Twelve horses doing winter farm work were maintained for 70 days in satisfactory condition on oat straw and a grain ration composed of corn, oats, and bran (2:2:1) plus a little linseed meal.

Marine algæ as feed for work horses, LAPICQUE and BROCC-ROUSSEU (*Compt. Rend. Acad. Sci. [Paris]*, 170 (1920), No. 26, pp. 1601-1603).—*Laminaria flexicaulis*, a seed weed, was found to be a satisfactory substitute for oats in horse feeding. Much of the salt was removed before use.

[Poultry experiments in Canada] (*Canada Expt. Farms Rpt. 1919, pp. 34, 35, 114, 115, 180*).—A report by F. C. Elford of the work at Lethbridge, Alta. (pp. 34, 35), includes the following determinations of breed averages for percentages of fertile eggs: Barred Plymouth Rocks 77.9, White Wyandottes 57.5, White Leghorns 88, and Rhode Island Reds 80.8. The number of eggs set per hatched chick were, respectively, 2.8, 3.1, 2.1, and 3. In comparing hens and pullets it was found that 73.7 per cent of the hens' eggs were fertile, and that 2.4 eggs were required to secure one chick. Of the pullet eggs 79.8 were fertile and 2.9 eggs were required for a chick. In a comparison of hatching dates of Barred Plymouth Rock pullets it was found that a pen hatched April 21 produced more eggs from November to March than pullets hatched either in March or in May.

In feeding experiments at Cap Rouge, Que., reported by G. A. Langelier (pp. 114, 115), it was found that, as measured by egg production of pullets in the winter, skim milk is superior to beef scrap and dried clover leaves better than swede turnips. Snow can, in case of necessity, be used in place of water.

At Invermere, B. C., it is reported by G. E. Parham (p. 180) that the average Barred Plymouth Rock pullet consumed 84.2 lbs. of feed per year, or 7.5 lbs. per dozen eggs. It was also found that Barred Plymouth Rock chicks at the age of 10 weeks had consumed 5.5 lbs. of feed each and that at 20 weeks they had consumed 19.75 lbs.

Value of sour milk, beef scrap, cottonseed meal, gluten meal, and oil meal in rations for egg production, H. L. KEMPSTER (*Missouri Sta. Bul. 172 (1920), pp. 36, 37*).—In two experiments meat scrap, or cottonseed meal, or both, were added in varying proportions to the mash fed to White Leghorn hens. In general the hens produced eggs most economically when a quarter or a third of the mash was composed of meat scrap. Cottonseed meal did not increase the efficiency of the ration and when fed alone was very uneconomical.

Gluten meal and linseed meal were not specifically mentioned as part of the rations of any pen.

How to select good layers, F. E. MUSSEHL (*Nebraska Sta. Circ. 12 (1920), pp. 8, figs. 5*).—The author describes the physical characteristics that are supposed to indicate laying capacity in hens.

Absence of xenia in ostrich eggs, J. E. DUERDEN (*Jour. Heredity, 9 (1918), No. 6, pp. 243-245, fig. 1*).—The egg of the North African ostrich (*Struthio camelus*) is almost round and the surface is smooth, while the egg of the South African species (*S. australis*) is definitely oval and the respiratory pits are large and conspicuous. In the author's experiments, when the hen of one species was mated to the cock of the other, the hen invariably laid eggs characteristic of her species.

DAIRY FARMING—DAIRYING.

Influence of nutrition of heifers and the age of breeding upon their subsequent development, A. C. RAGSDALE and W. W. SWETT (*Missouri Sta. Bul. 172 (1920), pp. 21, 22*).—Studies on the protein requirements for growth (E. S. R., 41, p. 676) were continued with 12 heifers. It is noted that neither Holsteins nor Jerseys made normal gains on an 8 per cent protein plane, and that on a 35 per cent plane the gains of the Jerseys were only slightly above normal, while the Holstein gains were greatly in excess of normal. From these and the earlier results it is concluded that "the Jerseys can not make normal gains on a ration, which, figured on the same basis, is adequate for Holsteins."

Experimental feeding [of dairy stock], G. A. LANGELIER (*Canada Expt. Farms Rpt. 1919, pp. 110, 111*).—Continuing work previously noted at Cap

Rouge, Que. (E. S. R., 41, p. 572), the author reports that the average feed consumed by heifers until calving time (about 26 months) was 692 lbs. whole milk, 5,993 lbs. skim milk, 736 lbs. grain, 2,902 lbs. hay, 177 lbs. green feed, 4,326 lbs. roots, and 5,660 lbs. silage, together with 97 days of pasture.

Dairy cow feeding experiments, L. FOSTER and J. R. MEEKS (*New Mexico Sta. Bul.* 122 (1920), pp. 40, fig. 1).—The first part of this bulletin deals with the comparison between alfalfa hay alone and alfalfa hay plus corn silage as feeds for dairy cows. The results of a previously reported experiment are reprinted from Bulletin 98 (E. S. R., 33, p. 872), and two additional experiments are reported. These were conducted from January to May in 1916 and 1917. Two groups of cows were used in each, and these were fed during four 25-day periods by the reversal method.

“Taking the average of the two experiments, the addition of a 30-lb. ration of corn silage to an alfalfa hay and grain ration made a saving of 30 per cent of the hay, but it did not reduce the cost of the ration. It required three tons of silage to replace one ton of alfalfa hay. Considering the hay at \$10 per ton and the silage at \$3.50 per ton, there was little difference in the cost of the two rations; but the milk product of the alfalfa ration was 4 per cent greater than that of the silage, and the butter 2.4 per cent greater.”

The second part of the bulletin deals with the comparison between beet pulp and corn silage for dairy cows and is a detailed report of an experiment previously noted from the 1915 report of the station (E. S. R., 34, p. 774).

Growth of green crops on arable land for dairy cows, R. G. WHITE (In *Rpts. on Expts. 1917-1919, Univ. Col. No. Wales, Bangor, Dept. Agr., pp. 41-51*).—Preliminary experiments to determine a soiling system suited to conditions in North Wales are reported. “By sowing suitable mixtures of oats and peas or vetches, a succession of very useful green food to supplement the failing pastures, and to take the place of purchased cake, etc., can be secured in July and August.”

Cottonseed cake for dairy cows, R. H. WILLIAMS and W. S. CUNNINGHAM (*Arizona Sta. Rpt.* 1918, pp. 330-333).—Three lots of 3 or 4 cows each were fed by the reversal method during three 28-day periods on the following rations: (1) Alfalfa hay 15 lbs., corn silage 40 lbs.; (2) alfalfa hay 22 lbs., cottonseed cake 4 lbs.; and (3) alfalfa hay 11 lbs., silage 40 lbs., and cottonseed cake 3 lbs. Ration 2 produced 459.7 lbs. of milk and 26.8 lbs. of fat more than ration 1, and 590.8 lbs. of milk and 20.2 lbs. of fat more than ration 3. It is concluded that it was the alfalfa hay rather than the cottonseed cake of ration 2 which increased the production.

The use of poppy seed cake as a cattle food and its effect on yield of milk and composition of the butter fat, H. E. ANNETT and JATINDRA NATH SEN (*Jour. Agr. Sci. [England]*, 9 (1919), No. 4, pp. 416-429, figs. 7).—Feeding experiments with one cow and two Murrai buffaloes in India indicated that the substitution of poppy seed oil cake for mustard seed cake is without influence on the yield of milk, the percentage of fat, the relative proportions of volatile and nonvolatile fatty acids in the fat (Reichert-Meissl and Polenske numbers), the saponification value of the fat, or the butyro-refractometer readings. The reputed effects of poppy seed cake in producing drowsiness and watery milk were not observed. The cow received 2 lbs., and each buffalo 3 lbs., of the poppy seed cake per day for 44 days.

Jerseys as economical producers of milk, H. CORNER (*Jour. Brit. Dairy Farmers' Assoc.*, 32 (1920), pp. 18-29, figs. 2).—The author cites milk production records of British Jerseys, and states that he has made computations indicating high yields per unit of feed consumed.

Official testing of dairy cattle, A. C. RAGSDALE and C. W. TURNER (*Missouri Sta. Circ. 96 (1920), pp. 12, figs. 5*).—This publication discusses the value of official tests, summarizes the breed requirements for advanced registry, gives rules for the supervision of official tests, and suggests methods of fitting cows for the test.

Daily variations in milk test, W. M. SINGLETON (*New Zeal. Jour. Agr., 20 (1920), No. 6, pp. 346-349*).—A few data are cited from the certificate-of-record work of the New Zealand Department of Agriculture.

The influence of the condition at parturition on the composition of milk and butter fat, L. S. PALMER (*Missouri Sta. Bul. 172 (1920), p. 21*).—The cow used in making previous observations of this series (E. S. R., 41, p. 677) calved in good condition in July, 1918, and was kept on a high protein plane for about two months. The treatment failed to increase the fat and protein content of the milk, despite the fact that a poor condition at parturition and a low protein plane had in previous years seemed to depress the fat and protein content of the milk. It is concluded that the abnormally low protein and fat content of this cow's milk is independent of the condition at calving and the plane of nutrition. It has been decided, therefore, to abandon the observations on this animal.

On the destruction of bacteria in milk by electricity, J. M. BEATTIE and F. C. LEWIS (*Natl. Health Ins., Med. Research Com. [Gt. Brit.], Spec. Rpt. Ser., No. 49 (1920), pp. 32, figs. 8*).—The authors report observations indicating the destruction of colon and tubercle organisms and most of the other bacteria in milk subjected to an alternating electric current. Most of the results were published in preliminary papers (E. S. R., 35, pp. 176, 378).

The essential feature of the apparatus used is a horizontal "lethal tube" of glass, through which the milk flows continuously, passing three copper electrodes, one in the middle, and one at each end. The proper current and voltage is a function of the length and diameter of the lethal tube and the rate of milk flow in a way not clearly formulated, but it is apparently expected that these relationships will be determined empirically for each machine of different dimensions and capacity. Since approximate sterilization of milk was secured after 16 seconds exposure to the current, during which the temperature was above 55° C. (131° F.) for the last 4 seconds only, the end temperature being 64°, it is concluded that the bactericidal effect is due directly to the current and not to the heat generated. However, it is mentioned that unpublished results with a similar apparatus led Sir Oliver Lodge and R. F. C. Leith to doubt this conclusion, and, to judge from the introductory note, the Medical Research Committee shares this skepticism. See also the recent work of Anderson and Finkelstein (E. S. R., 42, p. 875).

Suggestions regarding the control of municipal milk supplies, H. A. HARDING and M. J. PRUCHA (*Jour. Dairy Sci., 3 (1920), No. 2, pp. 107-121*).—The central idea in this discussion is essentially that in Harding's paper on simplified milk inspection (E. S. R., 41, p. 775), but the suggestions are less concrete.

"The consuming public desires a milk which is safe, rich, clean, and sweet. Any system of control which they understand is striving to provide them with such an article tends to enlist their support. Most workers in milk improvement will insist that these are precisely the objects which they have had constantly in view. However, so long as their private and public statements are directed primarily toward minimum legal limits of composition, barn scores, and bacterial counts, it is a fair question as to how much the public is to be blamed for not appreciating the connection between such things and the characteristics of a milk supply in which the public is interested."

The trend of the dairy industry in Canada, J. A. RUDDICK ET AL. (*Agr. Gaz. Canada*, 7 (1920), No. 4, pp. 311-313, 318-325).—These pages contain a series of brief statistical articles dealing with the manufacture of dairy products in 1919 and preceding years in the Dominion as a whole, and in Prince Edward Island, Nova Scotia, New Brunswick, Ontario, Manitoba, Saskatchewan, and Alberta.

The milk industry, [R.] S. WILLIAMS (*Jour. Farmers' Club [London]*, 1919, May, pp. 59-73).—Some account is given of the policies, work, and handicaps of the Research Institute of Dairying established in 1913 at University College, Reading, and also notes on the activities of the Associated Milk Producers' Council, an organization of dairy farmers whose main purpose appears to be self-instruction in the sanitary aspects of milk production. The paper is followed by a general discussion.

Dairy farming in Switzerland in 1919, J. LONG (*Jour. Brit. Dairy Farmers' Assoc.*, 32 (1920), pp. 30-42).—Observations made in Switzerland in 1919 and previous years are recorded.

"Dairy farming in Switzerland is successful chiefly on account of the abundance of grass which the cultivated lands provide for stall feeding in summer and for the production of hay for use in winter." The excellence of the soiling crops is attributed mainly to the system of seed control which the author has discussed elsewhere (E. S. R., 29, p. 337).

The butter industry, O. F. HUNZIKER (*LaGrange, Ill.: Author, 1920, pp. 671, figs. 115*).—One of the purposes of this volume is to acquaint investigators with "the real problems of the butter industry." The topics discussed include the history of the butter industry, creamery organization, the buying of milk and cream, cream separators, and the grading, sampling, neutralization, pasteurization, and ripening of cream; churning, washing, salting, working, packing, marketing, storing, and scoring the butter; the overrun, butter defects, whey butter, and renovated butter; the chemical, physical, and biological properties of butter and butter standards and definitions.

Mottles in butter—their causes and prevention, O. F. HUNZIKER and D. F. HOSMAN (*Jour. Dairy Sci.*, 3 (1920), No. 2, pp. 77-106, figs. 19).—The authors report gross and microscopic observations on butters made in a series of experimental churnings.

Mottles appeared only in salted butter that was improperly worked. The deep yellow patches in mottled butter contained relatively large and relatively few water droplets, whereas the white dapples contained a multitude of minute droplets. It is concluded that the presence of salt disturbs the water-in-fat emulsion and that uniformity in the emulsion is restored by the process of working.

"In order to prevent mottles, butter must be worked sufficiently to accomplish this fusion and reemulsification of water and brine. This point is usually reached when the butter has been reduced, by working, to a plastic, tough, and waxy body. The working must be uniform throughout the churn; overloaded workers and workers improperly set, loose, or slipping, will not work butter evenly and are prone to produce mottled and wavy butter."

The cause and control of "buttons" in sweetened condensed milk, L. A. ROGERS, A. O. DAHLBERG, and A. C. EVANS (*Jour. Dairy Sci.*, 3 (1920), No. 2, pp. 122-133, figs. 6).—The authors report observations, made in the laboratories of the Dairy Division of the U. S. Department of Agriculture, indicating that the hard reddish-brown lumps of curd occurring on sweetened condensed milk and known as buttons are caused by the enzymes produced by *Aspergillus repens* and possibly other molds. Contamination probably occurs after the milk leaves the condensing pans. Sealing the cans under a 20-in. vacuum was found to be an effective means of control, as the molds require oxygen for growth.

[The churning and whipping of cream, and fillers for ice cream], E. G. WOODWARD (*Washington Sta. Bul.* 155 (1920), pp. 20, 21).—Brief progress reports are presented showing (1) that pasteurization may prevent the frothing of cream and the resulting difficulty in churning; (2) that cream containing 30 per cent fat may be whipped more readily than cream either richer or poorer in fat; (3) that the addition of sugar or condensed milk to cream increases the whipping capacity; and (4) that gelatin is a more desirable filler for ice cream than commercial ice cream powder, gum tragacanth, or cornstarch.

VETERINARY MEDICINE.

Proceedings of the thirty-seventh annual convention of the Pennsylvania State Veterinary Medical Association (*Penn. State Vet. Med. Assoc. Proc.*, 37 (1920), pp. 104).—Papers here presented are as follows: Some Observations Made in General Practice, H. E. Bender (pp. 7-13); Ruminatorics in Impaction and Atony of the Rumen, by L. A. Klein (pp. 13-23); Federal Meat Inspection: How Obtained and How Conducted, by C. S. Rockwell (pp. 23-29); Scope and Policy of the [Pennsylvania] Bureau of Animal Industry, by T. E. Munce (pp. 35-44); Sterility and Abortion Work, by C. Way (pp. 50-62); Success of the Present Methods of Treatment for Abortion and Sterility, by S. E. Young (pp. 62-65); Tuberculosis Control in Pennsylvania, by S. E. Bruner (pp. 65-71); Differential Diagnosis of Hog Cholera, by E. A. Cahill (pp. 71-76); Hog Cholera, With Special Reference to Differential Diagnosis, by A. Eichhorn (pp. 77-84); and Hog Cholera Control, by R. M. Staley (pp. 84-89).

Eighth annual report of the commissioner of animal industry for the year ending November 30, 1919, L. H. HOWARD (*Ann. Rpt. Commr. Anim. Indus.* [Mass.], 8 (1919), pp. 57, figs. 4).—This report deals in particular with the occurrence of infectious diseases of live stock and control work therewith.

Report of the chief veterinary surgeon for the year 1919, J. M. SINCLAIR (*South. Rhodesia, Chief Vet. Surg. Rpt.* 1919, pp. 8).—This deals with the occurrence of and control work with the more important infectious diseases of live stock in Southern Rhodesia during the year.

Report of the veterinary bacteriologist [for the year 1919], L. E. W. BEVAN (*South. Rhodesia, Chief Vet. Surg. Rpt.* 1919, pp. 9-17).—A brief report of the more important work of the year.

Anaphylaxis and allied phenomena in relation to disease, T. H. BOUGHTON (*Jour. Lab. and Clin. Med.*, 5 (1920), No. 9, pp. 597-608).—This is a review of the literature on the subject under the headings of theories, passive anaphylaxis, antianaphylaxis, bacterial anaphylaxis, related phenomena, and clinical considerations. A list of 118 literature references is appended.

Precise titration of complement, S. C. BROOKS (*Jour. Med. Research*, 41 (1920), No. 4, pp. 399-409, figs. 2).—The author describes a method by which it is said to be possible to titrate complement with a probable error of about 1 per cent in the relative efficiency of two or more samples. The most important modifications of the usual technique are as follows:

(1) Substitution of a physiologically balanced solution especially adapted to the red blood cells employed in place of the normal salt solution for use in studying the hemolysis of sheep's erythrocytes. The solution used consisted of sodium chlorid 80 gm., potassium chlorid 2 gm., calcium chlorid (6 H₂O) 2 gm., sodium bicarbonate (anhydrous) 10 gm., sodium phosphate, monobasic (H₂O) 0.5 gm., and distilled water 10 liters. This solution is of such a composition that the various cations are present in the same proportions and total concentrations as in sheep serum, and the proportion of bicarbonate to phosphate is such as to maintain in the solution an H-ion concentration (pH=7.6) like that of

normal blood. The use of such a balanced solution in place of normal salt solution is said to result in a marked reduction of the hemolysis produced in the controls.

(2) Determinations of the proportion of cells hemolyzed in each mixture rather than of the number of cells. This is done by estimating the color of the decantate from each tube after the partially hemolyzed mixture is centrifugalized relative to that of the solution obtained by hemolyzing the residual cells of the same tube in a volume of distilled water equal to that of the original hemolytic mixture. The standard solution used in known dilutions for comparison is made by diluting 1 cc. of a 5 per cent suspension of cells with 24 cc. of distilled water. The comparison is best made in a darkened room, using Nessler tubes which are held in front of a diffusely illuminated slit.

(3) Interpretation of the results of titration by determining the relative amounts of complements necessary to cause given degrees of hemolysis in a definite length of time. The end points selected are 80, 60, 40, and 20 per cent hemolysis. By plotting concentrations of complement as abscissas and the corresponding grades of hemolysis as ordinates, smooth curves are obtained from which the efficiency of different samples of complement may be determined accurately if corrections are made for color contributed to the decantate by the complement itself, for hemolysis occurring in the absence of complement, and for the drop of decantate left with the sediment of the cells.

"It is hoped that the presentation of this method for the precise titration of complement may serve as an incentive to quantitative studies of complement, for we must admit that the qualitative work of a generation of students has furnished but slight foundation for a valid theory by which to account for the complementing power of serum."

The regeneration of complement after radiation or heating, S. C. BROOKS (*Jour. Med. Research*, 41 (1920), No. 4, pp. 411-424, figs. 7).—With the use of the titration method described above, a comparison was made between the behavior of samples of complement which had been partially inactivated by heat and that of similar samples partially inactivated by ultraviolet light. The complement used was fresh guinea pig serum diluted in a modified Ringer's solution. Normal and treated samples of this complement in varying dilutions were tested against sheep's red blood cells sensitized with from 2 to 3 units of amboceptor (rabbit's antisherp serum). The results of this investigation are summarized as follows:

"After partial photoinactivation, complement deteriorates slowly at 7° and more rapidly at 37° C. The rate of deterioration is the same as that of normal complement.

"After partial thermoinactivation, complement recovers a portion of its lost hemolytic power, the recovery taking place more rapidly at 37° than at 7° C. This recovery or regeneration may restore at least one-third of the lost hemolytic power.

"It is suggested that the regeneration may be attributable to the presence of a parent substance which is less sensitive to high temperatures than the hemolytic principle, but equally sensitive to radiation."

Researches on agglutination.—Continued action of an electric current on agglutinating sera, P. ZANNELLI (*Ann. Ig. [Rome]*, 30 (1920), No. 7, pp. 405-407).—To study the action of the electric current on agglutinating sera, typhoid, paratyphoid A, paratyphoid B, and cholera agglutinating sera were exposed in U tubes to an electric current of 8 volts and 0.0005 ampere for a period of two hours. At the end of this time that portion of the serum in the branch of the tube corresponding to the cathode was turbid with a strongly

alkaline reaction, while that in the other side appeared gelatinous and gave an acid reaction. Tested separately, both portions of the serum reacted negatively to agglutination tests, but when brought together again exhibited the original agglutinating power. The author is of the opinion that the action of the electric current causes the division of the agglutinins into two parts, each of which has no agglutinating power.

Effects of enzymes in serum on carbohydrates and their relation to bacteriological technique, C. TENBROECK (*Jour. Expt. Med.*, 32 (1920), No. 3, pp. 345-349).—"It has been shown that enzymes in serum will change maltose, dextrin, and starch so that they will react as dextrose in media. These enzymes are destroyed by heating to 60° C. [140° F.] for 15 minutes, but they are present in sera that have been refrigerated for as long as 18 months. The practice of using carbohydrate media containing unheated serum should be discouraged, and if it is used the possibility that the carbohydrate may be changed by the enzymes present must be considered."

A nephelometric method of estimating the number of organisms in a vaccine, G. C. DUNHAM (*Jour. Immunol.*, 5 (1920), No. 4, pp. 337-343, fig. 1).—A method of estimating the number of organisms in a vaccine is described in which the turbidity of the suspension is measured by means of a Kober nephelometer, the standard consisting of suspensions of killed bacteria in normal salt solution. The method is considered to be as accurate as the microscopical count and to require less time and labor.

Chemical and pharmacological examination of the woody aster, O. A. BEATH (*Wyoming Sta. Bul.* 123 (1920), pp. 39-66, figs. 9).—Following a description of the symptoms of poisoning in sheep caused by the woody aster (*Xylorrhiza parryi*), and a review of the literature on the poisonous nature of the aster, a detailed report is given of an investigation of the chemical nature and pharmacological effects of the poison.

Fresh material was collected at three distinct periods of growth, when immature, flowering, and seeding. The immature plants yielded a definite toxic crystalline substance when subjected to the following treatment: The powdered, air-dried material was extracted with lukewarm water, the extract filtered, concentrated to the consistency of thin sirup, and treated with a slight excess of basic lead acetate. The resulting precipitate was filtered, suspended in water, and treated with hydrogen sulphid to remove the lead. The process was repeated with the resulting solution until the final precipitate was nearly white. The aqueous concentrate from the lead treatment was digested with an excess of hot 70 per cent alcohol, cooled and filtered, and the concentrated filtrate re-treated with 80 per cent alcohol. After cooling in the ice box an excess of ether was added and the mixture allowed to stand from 24 to 36 hours. The clear liquid was removed from the sediment by decantation, concentrated, and re-treated with anhydrous ether. The sediment formed was added to the first fraction and the mixture treated with enough water to form a paste. This was mixed thoroughly with 90 per cent alcohol, filtered, and the filtrate evaporated over sulphuric acid and lime. The crystalline deposit which was obtained proved to be the toxic material of the immature aster. It was also isolated in the crude state from the immature plant by extraction with 90 per cent alcohol and precipitation with either water or absolute alcohol. The total yield of the purified product by any of these methods averaged approximately 1 per cent of the dried plant material.

Similar treatment of the seeding plants resulted in the isolation of a toxic crystalline product which proved to be readily soluble in ether, although it could not be extracted from the original plant with ether. The active principle was present in the seeding plant in very small quantities.

The flowering plants, on extraction with 90 per cent alcohol and subsequent treatment with absolute alcohol and ether, yielded an amorphous poison which was insoluble in water and ether but soluble in alcohol. The yield was about 0.25 per cent of the air-dried plant. Small quantities of the water-soluble and ether-soluble substances, as isolated from the immature and seeding plants, were also obtained. The author is of the opinion that the amorphous substance is the mother substance of the ether-soluble crystalline toxic compound obtained from the seeding plants.

The water-soluble, amorphous, and ether-soluble poisons were subjected to physical, chemical, and toxicity tests, the general results of which are reported briefly. No definite conclusions have been drawn concerning their composition. The water-soluble form, while giving an acid reaction in solution, is apparently not a typical organic acid. No relationship has been found to exist between it and alkaloids or glucosids. It is thought to contain potassium as well as carbon, hydrogen, oxygen, and nitrogen. The amorphous and ether-soluble forms contain no inorganic element. The former is less acid and the latter more strongly acid than the water-soluble form.

In the toxicity experiments with guinea pigs and rabbits the ether-soluble compound had a marked coagulating effect upon the blood, while no such effect was observed with the two other forms. All three showed strong toxic action when injected intravenously, the action being less marked in each case if the material was neutralized with sodium bicarbonate before administration. The toxicity of the poison obtained from the seeding plants appeared to be considerably greater than that of the other forms. The plant is, however, considered to be more poisonous during its initial development "because of the quantity of poison and the avidity with which it is absorbed. The presence of moisture undoubtedly influences its toxic action. Under normal conditions of growth the aster at no time loses its toxic activity. (Field observations and laboratory tests fully substantiate this statement.) It is, therefore, a dangerous plant throughout its existence."

No specific treatment has as yet been recommended, although from the laboratory tests a mild alkali would appear to be indicated.

The chemical examination of the silvery lupine, O. A. BEATH (Wyoming Sta. Bul. 125 (1920), pp. 99-114, figs. 5).—This is a preliminary report of a study of the silvery lupine, *Lupinus argenteus*, along the same general lines as that of the woody aster noted above. Losses from lupine poisoning occur chiefly among sheep, although cattle are occasionally poisoned. It is stated that more sheep are poisoned by lupine in Wyoming than by any other one poisonous plant.

The experimental work reported includes toxicity experiments upon rabbits with the alkaloidal extracts of various parts of the plant, determinations of the relative amounts of alkaloid present at different periods of growth of the plant, proximate analyses of a mixed sample of flowers and green fruit, the isolation and purification of the alkaloids from a composite sample of the plant, and a study of the properties of the free bases, including their pharmacological effects. The results of the study, so far as they can be summarized, are as follows:

Two analyses of a representative sample of flowers and green fruit gave the following results: Alcoholic extract (100°), 22.52 and 22.28 per cent; ligroin (25-40°) extract (93°), 1.92 and 2.09 per cent; starch by acid hydrolysis, none; reducing sugars, 2.53 and 2.62 per cent; sucrose, 0.86 and 0.66 per cent; pentosans, 10.06 and 10.28 per cent; alkaloids total, 0.517 and 0.459 per cent; and resin, 4.4 and 4.6 per cent.

The toxicity of the alkaloids from different parts of the plant, as determined by intravenous injections into rabbits, appeared to decrease in the following order: Green leaves, green pods, flowers, ripe seeds, green seeds, and mature pods. The percentage of crude alkaloids estimated as lupanin appeared to decrease in the order of green fruit, ripe seeds, early seeds, ripe pods, green leaves, and flowers. These findings, together with the reports of poisoning on the range, are considered to "substantiate the fact that *L. argenteus* is a dangerous plant from the first appearance of the pods until the seeds have been expelled from them. . . . The author believes that too much emphasis has been placed upon poisoning from the ripe seeds."

On purification two alkaloids were isolated from a composite sample, one a water-soluble crystalline substance with an extremely bitter taste, and the other a brown oily liquid with strongly alkaline reaction and bitter taste, and evidently more highly toxic than the other.

"The results of chemical and pharmacological investigations of *L. argenteus* are far from complete. A detailed study is being made not only of the alkaloidal constituents but of the resins, volatile oil, etc., as well, and this will be made the subject of a station publication during the coming year."

Contagious abortion investigations, J. W. CONNAWAY, A. J. DURANT, and H. G. NEWMAN (*Missouri Sta. Bul.* 172 (1920), pp. 44, 45).—Serological tests, including retests, made during the year on 1,260 blood samples from 51 herds comprising 587 animals, showed infection in 35 herds, with 171 positive reactors.

To determine through what channels *Bacillus abortus* Bang can invade the pregnant uterus, artificial infection with cultures of the organism was attempted in several pairs of heifers by ingestion, by injection into the udder through the teats after inserting a sterile milk tube, by injection into the vagina, by subcutaneous injection with a saline suspension of the culture, and by contact with heifers which had aborted after having been fed cultures of the organism. All of the animals in the experiment developed positive reactions to the blood tests for abortion disease and have remained reactors. All of the living calves showed a positive reaction to the test at birth, but ceased to react later. Milk from the lactating heifers gave a positive reaction.

To determine the specificity of *B. abortus* Bang, six pregnant sows were inoculated with cultures of the organism of bovine origin, one by intramuscular, one by intravenous, two by intra-axillary, and two by vaginal injection. Of the first four 2 aborted. One, which was a positive reactor, gave birth to six healthy living pigs and one dead one, and had four runty pigs. The two given vaginal injections did not abort nor show any reaction to the abortion test.

A review of several publications on infectious abortion disease, E. C. SCHROEDER (*Jour. Amer. Vet. Med. Assoc.*, 57 (1920), No. 3, pp. 270-281).—This paper, presented at the annual meeting of the American Veterinary Medical Association at New Orleans in November, 1919, consists of a review and discussion of several recent articles on abortion disease, most of which have been previously noted from the original sources.

Goitre and associated conditions in domestic animals, J. W. KALKUS (*Washington Sta. Bul.* 155 (1920), pp. 43-46).—In continuation of work conducted since 1915 at the temporary station in the Methow Valley, a popular bulletin on which has been noted (E. S. R., 43, p. 384), experiments consisted chiefly in further determination of the value of iodine in the prevention of goitre and hairlessness. Since tincture of iodine applied to the skin had given as good results as any other form of administration, it was resorted to entirely during the season 1918-19. Treatment of angora does with 1 cc. of tincture of iodine, which was poured on the skin every two weeks throughout pregnancy,

gave uniform and satisfactory results, no indication of goitre or hairlessness being evident in the young.

Field experiments carried on in cooperation with stock owners indicate that even smaller doses of iodine and less frequent application will produce the desired effect. The iodine administered to the does during one gestation period appears to have a decided influence in preventing goitre in the young during the subsequent period, but there is a great variation in individuals, and the results obtained indicate that it is unsafe to depend on previous treatment as a prevention of goitre.

It is stated that iodine has been administered experimentally during the past two seasons to sheep in the same way as to goats. In every instance where iodine was administered to ewes during pregnancy, the young showed no indication of goitre or hairlessness. The same results were obtained by practical stockmen who used the treatment according to directions.

In the experimental work with swine carried on for the purpose of determining the cause of goitre, results were so variable that no definite conclusions could be drawn. In cooperative field tests with 24 practical stockmen during the year in which 11 mares, 137 cows, 66 ewes, and 24 sows, treated with iodine, dropped young, no indication of goitre or hairlessness was found in any of the offspring.

A group of paratyphoid bacilli from animals closely resembling those found in man, C. TENBROECK (*Jour. Expt. Med.*, 32 (1920), No. 1, pp. 19-31).—“In addition to the paratyphoid bacilli already named there exists a group which occurs in a variety of animals and which culturally is the same as *Bacillus schottmülleri*. As a rule this group can be separated from the latter by the type of clumps formed when bouillon cultures are used as antigens, while other antigens and complement fixation tests have failed to differentiate it.

“Agglutination absorption tests sharply separate the animal from the human paratyphoids. No differences have been detected between organisms of this group derived from a number of animals and a common name for them is desirable, but for the present it seems better to call them calf-, swine-, mouse-, etc., typhus, according to the animal from which they were isolated. Evidence exists in the literature that these organisms have been associated with food infections in man, particularly with what have been called paratyphoid B infections, but this function, as well as the part they play in animal diseases, is a subject for further study.

“Well-defined groups of paratyphoid such as *B. cholerae suis*, the Voldagen bacillus, *B. abortus equi*, and *B. enteritidis* are found in animals in addition to the organisms considered in this paper, and every attempt should be made to range newly isolated organisms in one or the other of these well-recognized groups. One of the objects in continuing this work was to find a method of differentiating these animal from the human paratyphoids less complicated than agglutination absorption. This object was not realized; the two groups are very similar, and agglutination absorption seems to be the only means of classifying them.”

Studies on *Bacillus murisepticus*, or the Rotlauf bacillus, isolated from swine in the United States, C. TENBROECK (*Jour. Expt. Med.*, 32 (1920), No. 3, pp. 331-343, pl. 1).—“In the United States, organisms which culturally are mouse septicemia or swine erysipelas bacilli have been isolated from the tonsils of 5 of 16 pigs examined. These pigs all had hog cholera, but it is probable that the bacilli were in the tonsils before they were infected with hog cholera, and there is no evidence that they played any part in the disease. The distribution

of the infection seemed to be restricted, as most of the pigs from which the bacilli were obtained came from one litter. As we do not have clinical rotlauf or swine erysipelas in this country, as these organisms in Europe have been found in a large percentage of apparently normal swine, and as the disease is produced with difficulty by the injection of cultures, the question may be raised whether they are not secondary invaders rather than the primary cause of the disease with which they have been associated, or else whether the resistance of swine on the European continent does not differ from that of our breeds as a result of differences in foods. It is possible that the mouse septi-cemia bacilli found in this country may differ culturally from those present in animals with swine erysipelas. With this in mind, the carbohydrate reactions, as well as other cultural characters not necessary for the identification of the bacilli isolated, have been studied.

"The disease produced by the injection of these bacilli into mice and pigeons has been studied and shown to be largely an intracellular process. The organisms are taken up by the endothelial cells lining the veins and capillaries; there they multiply and soon kill the cells. It has also been shown that the only type of cell in the blood stream which contains bacteria is the endothelial leucocyte, and the probabilities are that the free phagocytes have been detached from the lining of the vessels. The disease is acute, and the indications are that in the cells the bacilli find a favorable medium for their growth. While phagocytosis may, in general be an immune reaction, in this case it appears to favor the parasite rather than the host."

Diagnosis of contagious bovine pleuropneumonia by means of the complement-deviation test. TITZE and GIESE (*Berlin. Tierärztl. Wchnschr.*, 35 (1919), No. 32, pp. 281, 282; *abs. in Trop. Vet. Bul.* 8 (1920), No. 1, pp. 55-57).—The authors describe in detail the technique which they employ in the complement deviation test for the contagious bovine pleuropneumonia, and present statistical data indicating that reliable results are obtained by means of this test.

Of 140 blood tests conducted by this method on suspicious cattle, 51 gave positive and 89 negative results. Of the 51 positive cases 47 proved on slaughter to be affected with the disease while 4 showed no macroscopic lesions. None of the 89 negative cases showed any macroscopic lesions of the disease in question, but gave evidence of other diseases, including 47 cases of tuberculosis.

Sarcocystis tenella, the muscle parasite of the sheep, J. W. SCOTT and E. C. O'ROKE (*Wyoming Sta. Bul.* 124 (1920), pp. 69-94).—This report of investigations includes a summary of the present status of knowledge of *S. tenella*, a progress report of which by the author has been previously noted (*E. S. R.*, 41, p. 379). It was found that infection takes place independent of the presence or absence of insects, and the feeding of hundreds of the particular insects that appeared to be the only possible carriers of the infection produced no effect on the results.

"Infection occurred in the absence of any carnivorous animal. Hence, the suggestion by Minchin and later by Crawley appears likewise untenable. Though contamination of some of the dry feed with mouse feces can not be excluded, the comparative results obtained indicate that this had nothing whatever to do with infection. Both the percentage and degree of infection are greater in wet pastures than in dry pastures, and greater than in dry lots where grain and hay are fed. Restricted range tends to increase infection; this holds true whether lambs are grazed in pasture or fed dry feed in a dry lot or confined to a screen cage. The infection of lambs 16, 59, and 91, raised by hand, is best accounted for on the theory that they were infected by an

intestinal stage derived from lamb 27. The heavy degree of infection of three out of four of these lambs and the medium infection of the other indicates that they were probably reinfected from their own feces. All the above conditions of infection, in all of the experiments described, conform best to the theory of an infective intestinal stage. While not directly proved, there appears to be no reasonable doubt about accepting this hypothesis as an adequate explanation of a part of the life cycle of *S. tenella*.

"Control measures are suggested based on the theory that infection results from eating food contaminated with infective feces.

Hog cholera, R. R. BIRCH (*Cornell Reading Course for the Farm, No. 150 (1919)*, pp. 117-136, figs. 6).—The essential facts concerning hog cholera and measures for its control are presented in nontechnical terms.

Infectious anemia of the horse, LÜHRS (*Ztschr. Veterinärk., 31 (1919)*, Nos. 10-11, pp. 369-440; 12, pp. 450-464, figs. 5).—The author finds the virus of this affection to be filterable, difficult to destroy by disinfectants, and resistant to drying. It is destroyed at a temperature of 60° C. (140° F.).

A campaign against dangerous poultry parasites, W. C. THOMPSON (*New Jersey Stas., Hints to Poultrymen, 8 (1920), No. 11, pp. 4*).—This pamphlet calls attention to the importance of certain parasitic insects and helminths as enemies of poultry, and means for their control. Round worms, tape worms, gape worms, lice, and mites are briefly considered.

RURAL ENGINEERING.

Agricultural engineering (*Missouri Sta. Bul. 172 (1920), pp. 13, 14*).—Investigations conducted by E. W. Lehmann, on the draft of a 6-shovel cultivator in a variable sand and clay loam soil growing soy beans, showed that up grade on clay loam soil the draft was about 470 lbs., about 400 lbs. up grade on sandy loam soil, and 375 lbs. down grade on sandy loam.

An investigation of sanitary conditions on 50 farms by E. W. Lehmann and C. C. Taylor showed that of 48 samples of water taken from cisterns, springs, and shallow wells, practically all were contaminated.

Report of the hydrometric survey of British Columbia for climatic years 1916-17 and 1917-18, R. G. SWAN (*Canada Dept. Int., Water Power Branch, Water Resources Paper No. 23 (1919), pp. 328, pl. 1, fig. 1*).—This report presents the results of measurements of flow made on streams in the Pacific coast, Fraser River, Thompson River, and Columbia River Basins, and in miscellaneous smaller drainage basins during the climatic years 1916-17 and 1917-18.

Spillways for reservoirs and canals, A. T. MITCHELSON (*U. S. Dept. Agr. Bul. 831 (1920), pp. 40, pls. 15, figs. 14*).—This is a summary of information on the subject, in which the author briefly points out the advantages of the siphon spillway when it is desired to facilitate the escape of high flood crests, and at the same time to conserve crest length and cost of construction and maintenance, by eliminating the use of mechanical or other energy necessary to operate partially or completely automatic spillways of other types. It is stated that the siphon is the only absolutely foolproof method of maintaining adequate spillway capacity without the addition of moving parts. Data on design are included.

Tests of the over-all efficiency on working models of siphon spillways are described. It was found that the theoretical and actual loss of head in the various parts of the structure was not consistent for the various tests nor for the different models, but was of sufficient accuracy to warrant the use of stand-

ard formulas. The standard formula for the loss at entrance head $0.5H_v$ for the type of opening for which the formula was developed ran both high and low in the tests, and may be considered as holding good as an average, so far as any developments in the laboratory results are concerned. Friction loss in the structure was indicated as being negligible in the larger sections of the tube and was heaviest at the throat or contracted section. It was so small as to be neglected in the results. The varied shapes of the discharge lip did not seem to affect the total efficiency, and since all the models were of uniform design at the intake end, nothing developed in the tests at that point or in the bends from which to draw conclusions.

The total efficiency for the various models for different air-inlet conditions ran 0.84, 0.98, and 0.983 for the three sets of tests when grouped and averaged. Similar tests on larger models, without the introduction of varying air-inlet conditions, ran from 0.644 to 0.805, and in a number of other siphons in this country and Europe coefficients of discharge ranging from 0.7 to 0.82 have been found.

With reference to the relation between the depth of submergence of the discharge lip and the depth of water over the throat to bring the siphon into action under different conditions of air inlet, the tests indicated a tendency to develop a back pressure in the crown between the rise of the water surface at the inlet and the suppressed effort of the air to escape under the discharge lip when the seal was complete. The placing of air inlets and the submergence of the outlet end were found to be so closely related that the points are difficult of separation.

Data from other sources are also summarized.

Irrigation investigations, G. E. P. SMITH (*Arizona Sta. Rpt. 1918, pp. 351-358, figs. 2*).—Irrigation investigations at the station for the year are summarized, including data on the status of irrigation water supplies, pump irrigation, cement pipe for irrigation pipe lines, and tractor power on farms.

It is noted that in trials of reinforced cement pipe in all cases the reinforced pipe were found to be weaker than plain pipe.

Seepage and waste water losses on Wapato Irrigation Project, L. W. HOLT (*Engin. News-Rec., 85 (1920), No. 8, pp. 365, 366, fig. 1*).—Measurements of the flow from the discharge system of the Wapato Irrigation Project in Washington are reported, which show that, as an average for the six years from 1913 to 1919, about 60 per cent of the applied water reached the main drainage ditch. On an average 3.7 acre-feet of the 6.1 acre-feet applied to each acre were lost by deep percolation and through waste-water ditches, and at least 90 per cent of the total loss was by deep percolation.

Flood problems of Calaveras River, H. BARNES (*Sacramento: Calif. Dept. Engin., 1919, pp. 57, pls. 2, figs. 15*).—This is a preliminary report on flood control of the Calaveras River, with particular reference to the protection of agricultural lands against overflow. It contains maps and data of a preliminary survey. A comparison of a by-pass plan of flood control with that of utilizing a reservoir indicated the latter plan to be the more feasible.

The flow of water in drain tile, D. L. YARNELL and S. M. WOODWARD (*U. S. Dept. Agr. Bul. 854 (1920), pp. 50, pls. 13, figs. 5*).—This is a progress report of an investigation being conducted on the carrying capacity of tile drains as conduits. The results of 824 separate tests are reported on commercial sizes of clay and concrete tile varying from 4 to 12 in. in inside diameter. The capacity at different depths of flow was also determined. For comparison, 69 tests were made on 10 and 12-in. tile so laid as to closely approximate poorly laid drains found in the field.

It was found that the value of the coefficient of roughness n in the Kutter formula, as obtained by experiments in a drain or pipe at any depth of flow less than full, does not necessarily apply to that drain or pipe when flowing full. It was also found that the Chezy formula gives the same velocity of flow in a pipe flowing one-half full as in one flowing full with the grade constant. The experimental data obtained seemed to disprove this theory, and showed that the exponent of the slope s is practically 0.5, and that the exponent of the mean hydraulic radius R is two-thirds. From these data a new formula is presented for computing the flow in drain tile, as follows: $V=138 R^{\frac{2}{3}} s^{\frac{1}{2}}$, in which V =the velocity, R =the mean hydraulic radius, and s =the slope.

A diagram is given showing discharge capacities based upon this formula covering tile sizes from 4 to 48 in. and grades from 0.04 to 3 per cent. A detailed description of the equipment and methods used is given, together with tabulated data from the experimental work. The data are also graphically reported and the method of developing curves is explained.

The Tempe drainage ditch, A. E. VINSON and C. N. CATLIN (*Arizona Sta. Rpt. 1918, p. 346*).—Continuing work previously noted (*E. S. R.*, 39, p. 793; 41, p. 379), analyses of the waters discharged from the Tempe drainage ditch for the year 1918 are reported.

The effect of alkali upon Portland cement, II, K. STEIK (*Wyoming Sta. Bul. 122 (1919), pp. 38, figs. 23*).—This is the second and final report on the subject (*E. S. R.*, 37, p. 788) in which a neat cement and cement and sand mortars varying in strength from 1:1 to 1:5 were subjected to the action of different alkali solutions singly and in different combinations for time periods up to 84 months.

It was found that the chief reacting substance in the cement is lime in the form of calcium hydroxid. Cement put in solutions of alkali salts was found to set as well as in water. Sodium hydroxid and magnesium hydroxid were formed respectively in solutions of sodium sulphate and magnesium sulphate. A solution of magnesium chlorid had the greatest disintegrating effect, due to the action of hydrochloric acid produced by the hydrolysis of this salt. A sodium sulphate solution was more harmful than a magnesium sulphate solution, other conditions being equal.

The presence of sodium chlorid in solutions of sulphates of sodium and magnesium increased their harmful effect on cement. A 5 per cent solution of sodium sulphate had a stronger effect than either the 1 per cent or 10 per cent solutions. The presence of sodium carbonate in solutions of the other salts retarded the disintegrating effects. Compression strength and tensile strength were not affected in the same degree. Tensile strength decreased more rapidly in all solutions, even when compression strength increased. Solutions of calcium sulphate had no bad effects. Water-proofing paints offered protection only for short periods.

A so-called iron cement resisted the action of sodium carbonate-sulphate-chlorid solution. The other cements tried had somewhat lower tensile strengths. It is concluded that the mixing of cement in weak solutions of sulphuric acid, disodium phosphate, magnesium fluorid, and oxalic acid is of advantage and increases the alkali-resisting qualities.

Test of timber posts with warp and seasoning cracks, T. W. GREENE (*Engin. News-Rec.*, 85 (1920), No. 8, pp. 342, 343, fig. 1).—Tests at the U. S. Bureau of Standards of four columns of Virginia pine 4 in. by 8 in. by 8½ ft. in length showed that seasoning cracking alone does not appreciably affect the strength of straight columns where the plane of cleavage is parallel to the plane of least dimension. However, any bending or warping produced by seasoning considerably weakens the column.

Public Roads (*U. S. Dept. Agr., Public Roads, 3 (1920), No. 26, pp. 36, figs. 32*).—This number of this periodical contains the following articles: Four Years of Road Building under the Federal-aid Act, by T. H. MacDonald; Federal Road Building in the National Forests of the West, by L. I. Hewes; The Selection and Comparison of Federal-aid Road Types, by E. W. James; and Federal-aid Allowances: Project Statements Approved and Agreements Executed in May, 1920.

The development of an economic theory of highway transportation, R. C. BARNETT (*Engin. and Contract., 54 (1920), No. 9, pp. 201-205, figs. 6*).—The author attempts to set forth the basis for the development of an economic theory of highway transportation, and derives certain formulas to show the relation between costs of roadway, motive power, and vehicle elements.

Reinforcing concrete pavements on California highways (*Engin. News-Rec., 84 (1920), No. 26, p. 1255, fig. 1*).—The progress results of experiments being conducted by the California Highway Commission show that on the theory that the primary function of concrete pavement reinforcement is to provide a bond across the longitudinal cracks, the preferred plan is to use $\frac{3}{8}$ -in. twisted bars placed transversely on 18-in. centers. This size and spacing was found to meet most nearly the requirement of maximum bond across such cracks for the minimum outlay in steel.

More recent experiments have resulted in the addition of a longitudinal run of $\frac{3}{8}$ -in. bars along each edge of the pavement. On the basis of reinforcing steel at 5 cts. per pound, delivered, this reinforcing cost \$1,770 per mile.

Selection and cost of farm machinery, F. M. WHITE (*Rpt. Md. Agr. Soc., 4 (1919), pp. 285-292*).—General information on the subject is given.

Proper treatment of transmission belts, E. J. BLACK (*Cement and Engin. News, 32 (1920), No. 7, pp. 26-28, figs. 2*).—It is pointed out that improper lacing is probably the most common mistake made by users of belts, and what is regarded as the correct method is explained in detail. A table is included for finding the horsepower of a belt.

Official gasoline analyses, 1920, R. E. ROSE and E. T. CASLER (*Fla. Quart. Bul. Agr. Dept., 30 (1920), No. 3, pp. 90-116*).—This section of this bulletin contains the results of official analyses of 331 samples of gasoline collected for inspection in Florida during the second quarter of 1920.

Official kerosene analyses, 1920, R. E. ROSE and E. T. CASLER (*Fla. Quart. Bul. Agr. Dept., 30 (1920), No. 3, pp. 117-126*).—This section of this bulletin contains the results of official analyses of 109 samples of kerosene collected for inspection in Florida during the second quarter of 1920.

White coal, A. TURPAIN (*Vers la Houille Blanche. Paris: H. Dunod & E. Pinat, 1919, pp. XI+76*).—This publication deals with the development and use of electrical power in France, particularly for farm purposes, and gives the results of considerable study of the water-power resources in France.

How to let in the sunshine, W. G. KAISER (*Farm Mechanics, 3 (1920), No. 1, pp. 22-25, figs. 8*).—Data on the design of hog houses are given, including cross sectional drawings of several types. It is shown that the horizontal distance as measured from a point on the floor directly below the windows to the north wall is an important factor to be considered when determining the proper location of the windows, it being assumed that the houses face the south.

A map of the United States marked off in degrees of latitude is included as an aid to the builder, and a table showing the height in the varying latitudes at which to locate windows for hog houses 8, 10, and 12 ft. in width is given.

The Missouri poultry house, H. L. KEMPSTER (*Missouri Sta. Circ. 93 (1920), pp. 9, figs. 7*).—This bulletin describes and diagrammatically illustrates poultry house design, especially for Missouri conditions. Since the average farm

flock in Missouri is from 100 to 150 hens, this house is 20 ft. square, a square house being the most economical to construct and affording a maximum amount of floor space.

Economics of a sound house, H. B. YOUNG (*Cornell Reading Course for the Home*, No. 131 (1919), pp. 8, figs. 3).—Brief popular information on the planning of a farm house is given.

The preliminary treatment of sewage, J. H. EDMONDSON (*Surveyor and Munic. and County Engin.*, 58 (1920), No. 1487, pp. 41-44).—A number of laboratory and practical experiments on the preliminary treatment of sewage, including particularly the use of chemicals for clarification, are reported.

It is concluded that while laboratory experiments give useful information as to the value of various chemicals on a particular sewage, they do not necessarily represent working-scale results. In considering chemical precipitation the design of the settling tanks is considered to be quite as important a factor as the nature and class of the sewage to be treated. Sludge disturbance was found to be inhibitory to efficient settlement, particularly when iron salts were used as the precipitant. Even small quantities of iron added with aluminum sulphate had an adverse effect upon settlement in conjunction with sludge disturbance. The formation of iron sulphid in settling tanks is concluded to cause many difficulties in the efficient purification and disposal of sewage.

Action of the microbes of sewage purified by the activated sludge process on albuminoids, urea, and nitrates, P. COURMONT and A. ROCHAIX (*Compt. Rend. Acad. Sci. [Paris]*, 170 (1920), No. 16, pp. 967-970).—Studies of the action of organisms isolated from sewage purified by the activated sludge process on albuminous matter, urea, and nitrates are reported. Only seven species of organisms were isolated from the effluent used.

It was found that with two exceptions these organisms showed indol production, but with the exception of *Bacillus subtilis* had no action on coagulated serum, gelatin, egg albumin, or milk casein, although showing an energetic proteolytic ferment. Three of the organisms fermented urea, *B. subtilis* had a slight action, and the other three organisms were without action. Five of the seven organisms were found to have a direct denitrifying action on solutions containing potassium nitrate.

A correlation study of the colon-ærogenes group of bacteria, with special reference to the organisms occurring in the soil, C. C. CHEN and L. F. RETTGER (*Jour. Bact.*, 5 (1920), No. 3, pp. 253-298, figs. 8).—Experiments conducted at Yale University are reported (1) to determine the relative frequency of the colon and ærogenes types of bacteria in soils which from all appearances are free from animal pollution, (2) to ascertain whether or not there is a definite correlation between types of bacteria and their origin, and (3) to study the coli and ærogenes types of gas-fermenting organisms with reference to some of the most important reactions and media. Soils of known sanitary quality were used.

The studies showed the great predominance of the ærogenes-cloacæ type. Of 467 strains of bacteria isolated from various soils, 430 were identified as *Bacterium ærogenes*, 17 as *B. cloacæ*, and only 20 as *B. coli*. Furthermore, the sources of the coli strains were shown by the sanitary survey to be not entirely free from animal pollution. All of the 173 organisms found in the feces of 7 men, 2 monkeys, and 14 domestic animals were typical *B. coli*. It is apparent from these observations that there is a definite correlation between these types of bacteria and their origin. An almost perfect correlation could be established by the methyl red, the Voges and Proskauer, and the uric-acid tests.

The limiting hydrogen-ion concentration of the coli cultures, as determined by the colorimetric method, varied from pH 4.5 to 5.6 in the synthetic medium

and from 4.6 to 5.8 in the Witte peptone-phosphate-glucose medium. The final hydrogen-ion concentration of the cloacæ-ærogenes type could not be accurately determined on account of the simultaneous acid and alkali production. The pH value obtained under similar conditions ranged from 6 to 7.4 in the Witte peptone medium and from 6 to 6.8 in the synthetic medium.

"The respective hydrogen-ion concentrations of the colon and ærogenes types of bacteria may be adequately determined for practical purposes by methyl red as an indicator, provided the neutral tint reactions are compared with the reactions obtained by brom cresol purple or some other sharp indicator as a check."

The Voges and Proskauer method of distinguishing between *B. coli* and *B. aragenes* proved even more satisfactory than the methyl red test, in that it was simple in operation and when correctly carried out thoroughly constant in its results. When used with precaution the uric-acid test also was of fundamental importance in differentiating fecal coli from the soil ærogenes type of bacteria. No definite correlation could be established by means of the indol test. Neither did motility study prove to be of practical value. Adonitol fermentation did not prove itself to be a satisfactory method of differentiating fecal from nonfecal strains of *B. aragenes*.

A list of 80 references to literature bearing on the subject is appended.

Home laundering, L. R. BALDERSTON (*U. S. Dept. Agr., Farmers' Bul. 1099* (1920), pp. 32, figs. 12).—Methods and equipment for home laundering are described and illustrated, the purpose being to introduce convenience, economy, and saving of labor in the laundering process.

RURAL ECONOMICS.

Farm business analysis studies, H. M. DIXON (*Jour. Farm Econ.*, 2 (1920), No. 2, pp. 87-100, fig. 1).—Data accumulated in the Office of Farm Management of the U. S. Department of Agriculture by investigations of the same farms over a period of successive years and by repetition studies in the same area after a lapse of a period of years are compared and summarized in this paper, the aim being to illustrate the fund of material made available by such investigations.

Table 1 gives a summary of the results of four studies in Ohio and Indiana over seven years, Wisconsin over five years, and New Jersey over three successive years. The farm area, crop area, value of real estate per acre, productive animal units, number of work stock, months of labor, and investment per farm are shown for each of the four areas. The next table shows the percentage increase in receipts and expenses in the Ohio and Indiana areas for the years affected by increased prices and costs. Table 3 is in the form found satisfactory for showing the summary of the farm business, this one relating to that of a period of seven years on 100 farms in Clinton County, Ind. Table 4 summarizes results from a study of 500 white owner farms in Sumter County, Ga., made first in 1913 and repeated in 1918. The following table deals with farm loans and interest rates on these farms for the two periods, and the next with the cash required per farm for operating expenses and its sources, whether borrowed or furnished by the operator. Table 7 makes comparison of the use of man labor, mule labor, and machinery in the same area. The last is a chart, showing the number of farms producing cotton at various costs for the two years and variation in the cost.

Cost and price tendencies on the farm, R. M. GREEN (*Missouri Sta. Circ. 97* (1920), pp. 8, figs. 7).—Table 1 in this circular shows the cost and price indexes on corn, wheat, pork, and beef from 1915 to July, 1920, inclusive, based on the average for 1910-1914, inclusive, and Table 2 the average labor incomes

made in 1913-1919, inclusive, on Iowa farms (E. S. R., 43, p. 593), in Wisconsin (E. S. R., 41, p. 90), Indiana, as noted by Dixon above, and in Missouri.

Charts are given with explanatory notes illustrating the difference between cost and price indexes by years, 1915-1920, percentage of the previous year's number in Missouri, and in the United States January 1, and trend of home consumption in the United States in the same years for hogs and cattle. Similarly, charts are given for corn and wheat, showing the difference between the cost and price indexes, and percentage of the previous year's acreage seeded in Missouri and the United States by years.

This study illustrates the close relation between the supply of one year and the favorable and unfavorable margins of profit of earlier years.

[**Farm management studies in Missouri**], R. M. GREEN (*Missouri Sta. Bul.* 172 (1920), p. 32).—Brief reports are made here on two studies, one carried on in two regions representing, respectively, typical grain and live-stock feeding sections of the State, and the other of the fluctuation in amount of labor done month by month on different farms.

In the first, 56 farms in the live-stock feeding section, whose operators had only \$2,500 capital or less, were studied. The difference in income in favor of the more successful farms was accounted for as follows: Larger crop yields 30 per cent, larger size of enterprise 29.4 per cent, saving in running expenses 15.5 per cent, better net returns from live stock 11.4 per cent, more acres in farm 11 per cent, less interest charge on investment 2.2 per cent, and larger price for crop sold 0.5 per cent.

Profit-sharing in agriculture, R. CECIL (*Scot. Jour. Agr.*, 3 (1920), No. 2, pp. 151-154).—A scheme which has been drawn up by practical farmers in the author's own constituency, Hertford, England, is briefly outlined.

Social significance of hired labor, small holdings, and small farms, F. A. PEARSON (*Jour. Farm Econ.*, 2 (1920), No. 3, pp. 163-168).—This paper is principally concerned with the effect of size of farm on the population. Tabulations are given which represent the relation between the size of the farm and the number of children under and over 16 years of age on farms in northern Illinois. The number of children under 16 years of age was not influenced by the size of farms, but the number over 16 years varied with the size of the farms. The significance of the fact that small farms, small holdings, and married hired farm labor are factors in the production of urban labor and do not in any way produce a selective population is noted.

Agricultural labor, SCHICK (*Ztschr. Landw. Kammer Schlesien*, 24 (1920), Nos. 18, pp. 482-484; 19, pp. 513-516).—Various contributing factors to the rise in wages of agricultural labor, such as cityward trends in population, a decreased birth rate in the rural districts, housing facilities in the country, and the substitution of money wages for payment in kind are discussed. A table is given which shows the average wage in several sections of Silesia through the years 1904-5 to 1918-19, inclusive.

Land speculation, R. T. ELY (*Jour. Farm Econ.*, 2 (1920), No. 3, pp. 121-135).—It is pointed out that land speculation may be good in the economic sense in that it may bring into use land otherwise unproductive, but that legislation and control by means of land commissions and planning boards is needed. The question of public and private ownership is raised. It is said that public ownership is desirable for submarginal lands, while at the same time land investments are recommended as sound and conservative for certain economic classes.

The human side of farm economy, C. J. GALPIN (*Jour. Farm Econ.*, 2 (1920), No. 2, pp. 101-109).—The author seeks to point out the growing interest in the purely human factor in farm labor and farm-management problems, and

outlines a series of studies covering the needed census of farm population in the United States, also the health, psychology, education, and municipal privileges of the farm population. Investigations including the farm family as a basic institution and the religious development of farm life, also the American standard of living for the farm population and its social and political status, are suggested as invaluable both to the public and to the farmer.

[**Report of the office of farm markets**], J. PASSONNEAU (*Washington Sta. Bul.* 155 (1920), pp. 51-53).—A report is made on the year's activities of the Washington State Office of Farm Markets in cooperation with the Bureau of Markets of the U. S. Department of Agriculture. Several conclusions drawn up from the study of public marketing methods are summarized as follows:

(1) The extent to which farm products will be marketed through public markets will always be limited. (2) Only the producers living within a limited radius of the city can make use of such markets. (3) It is not likely that products other than those included as perishables or semiperishables will ever be offered on the public markets. (4) The costs of selling in this way are found to be excessive.

The Market Reporter (*U. S. Dept. Agr., Market Rptr.*, 2 (1920), Nos. 7, pp. 97-112, fig. 1; 8, pp. 113-128; 9, pp. 129-144; 10, pp. 145-160, figs. 2).—These numbers continue weekly and monthly summaries of marketing, exports and imports, and prices of specified commodities, and brief articles on important classes of agricultural products, together with notes on foreign market situations.

An article in No. 7 notes the commercial practice of preservation of fruits by freezing and its growing use. No. 8 includes a brief report of investigation of rumors of dumping, particularly of potatoes, concluding that they were groundless. Leading articles in No. 9 relate to receipts of produce in Washington, D. C., in 1918, as compared with earlier years, the economic value of cowpeas for planting purposes, and shipments of watermelons in Missouri. In No. 10 it is noted that the year's hay prices have shown wide fluctuations, also that the condensed and evaporated milk market is weaker, and that the British demand for American apples promises to be good if exchange rises.

Farmers' Market Bulletin (*North Carolina Sta., Farmers' Market Bul.*, 7 (1920), No. 37, pp. 12).—In this number is a note concerning changes in dates of the North Carolina cooperative wool sales, also the text of the provisions under the State law for grades for apples, effective September 1, 1920, together with the usual partial lists of products which farmers have for sale.

Rules and regulations of the Secretary of Agriculture under the Food Products Inspection Law of May 31, 1920 (*U. S. Dept. Agr., Off. Sec. Circ.* 151 (1920), pp. 8).—These rules and regulations are to take the place of those in effect for similar purposes, previously noted (*E. S. R.*, 42, p. 190).

Value of Government crop reports, [E. T. MEREDITH] (*U. S. Dept. Agr., Dept. Circ.* 152 (1920), pp. 7; also in *Weekly News Letter*, 7 (1920), No. 46, pp. 5, 6).—This letter answers a personal inquiry as to the value of crop reports by briefly outlining the general interest in and the benefit of Government crop and live-stock statistics to growers, marketing and distributing agencies, county agents, agricultural colleges and experiment stations, and others, and by calculating the cost of furnishing them relative to the size of the farming business.

Monthly Crop Reporter (*U. S. Dept. Agr., Mo. Crop Rptr.*, 6 (1920), No. 8, pp. 77-92, figs. 5).—This number contains the usual monthly estimates of acreage and condition, and brief articles, notes, and tabulated data as to stocks, farm value, and market prices, of important agricultural products.

Automobile statistics, previously referred to (E. S. R., 43, p. 689), are given, also a report showing the relative influence yearly of different factors affecting losses for important farm crops.

[**Field crop and live-stock report of Canada for 1918**], J. H. GRIDALE (*Canada Expt. Farms Rpt. 1919*, pp. 5-7).—Details of the yields and value of the principal field crops for 1917 and 1918 and of the numbers of various classes of live stock in Canada for the period 1914-1918 are given, continuing data previously noted (E. S. R., 41, p. 594).

Annual agricultural statistics of France, 1918 (*Statist. Agr. Ann. [France]*, 1918, pp. 430).—This volume continues agricultural statistics previously noted (E. S. R., 42, p. 594).

[**Agricultural statistics of Norway, 1919**] (*Statist. Aarbók Kongeriket Norge*, 39 (1919), pp. 25-37).—These pages continue statistical data previously noted (E. S. R., 41, p. 594).

Notes on agriculture in Cyprus and its products, W. BEVAN (*Bul. Imp. Inst. [London]*, 17 (1919), Nos. 3, pp. 302-358, pls. 5, fig. 1; 4, pp. 494-543, pls. 2).—Information regarding agricultural conditions, live stock, dairy produce, crops, and other produce of the land and minor agricultural industries is presented in these pages.

AGRICULTURAL EDUCATION.

[**Report on agricultural and veterinary education in the Dutch East Indies**], T. J. LEKKERKERKER, W. G. BOORSMA, P. VAN DER VLIES, and J. C. F. SOHNS (*Jaarb. Dept. Landb., Nijv. en Handel Nederland, Indië*, 1918, pp. 37-43, 105-114, 336-348).—This is a report on the activities in 1918 of the Department of Agriculture, Industry and Commerce of the Dutch East Indies in the promotion of agricultural and veterinary instruction.

Agriculture in the elementary schools of Los Angeles City, C. F. PALMER (*Nature-Study Rev.*, 16 (1920), No. 5, pp. 217-220, fig. 1).—The gardening work in the elementary schools of Los Angeles City is described.

The work usually begins in the fourth grade and continues through the eighth. The gardens vary in size from plats the size of a city lot to over an acre in extent. The course of study is so arranged as to correlate the actual garden work with the fundamentals relating to soils, insects, diseases, plant propagation, etc.

The author states that the agricultural department was established in Los Angeles City in 1912 and has steadily grown until at the present time it comprises a supervisor, 4 assistants, and about 40 teachers, all of whom spend full time in teaching agriculture. Over 100 school gardens are maintained, of which 65 are in part or wholly on borrowed ground, for which, with one or two exceptions, no rentals are paid. Over 13,000 pupils are receiving regular instruction in school gardening. Fifty schools have a teacher 2 days a week, 26 schools 3 days a week, 12 schools 1 day a week, and several schools are in charge of a regular grade teacher. During the past three years, through summer schools, the garden work has been carried through the entire year. Home gardening is also encouraged.

Annual report on vocational education and manual training for the year ending June 30, 1919, W. A. O'LEARY (*N. J. Dept. Pub. Instr., Ann. Rpt. Vocat. Ed. and Manual Training*, 1919, pp. 79, pls. 4).—According to this report, classes in agriculture were maintained in 5 high schools and 2 county schools giving instruction at 20 different points in the State. There are now 20 vocational teachers of agriculture employed, and 26 students were enrolled in the 4-year agricultural teacher-training course at Rutgers College.

A brief sketch is given of each of the 10 day vocational schools or departments giving instruction in home economics that have been established since the passage of the vocational school act in 1913. Instruction in home economics was also given in evening classes in 50 centers. One school maintained a part-time class in home economics for adults and 1 general part-time school was in operation for girls employed in industry. The 4-year teacher-training course in vocational home economics at Rutgers College was attended by 12 students.

A brief report on school gardens is included.

Biennial report of the Atlantic County vocational schools of agriculture and home economics (*Bien. Rpt. Atlantic Co. [N. J.] Vocat. Schools, 1919, pp. 48*).—This is a report on the organization and work of the vocational schools of agriculture and home economics in Atlantic County, N. J., for the two years ended October 31, 1919, including extension work, boys' and girls' club work, the community market, the chemical laboratory, etc. This form of instruction, it is stated, is now in its sixth year and is so conducted as to meet the provisions of the Federal Vocational Education Act and yet not conflict with the work of those intrusted with the administration of the Agricultural Extension Act. The sessions are maintained for the most part through the winter months to interfere as little as possible with farm operations. Evening classes and lecture courses in special subjects are also offered.

The study of a project in some definite crop or farm product or farm problem is encouraged rather than the study of a type of farming, such as vegetable growing, fruit growing, or general farming. The curriculum also provides for the study of material supplementary to the project, which will help round out a four-year agricultural course suitable for the average farmer of the county, and preparing for better citizenship. The four-year curriculum as revised in 1919 is outlined.

A plan has been perfected by which the agricultural work done by a high school student will entitle him to a diploma which will admit him to the agricultural courses of Rutgers College or Cornell University. A suggested four-year agricultural curriculum for a department of agriculture in secondary schools is outlined.

The home economics instructor offers courses of four to six or eight weeks in various centers, moving her equipment from place to place with no central location for a permanent school.

Report of the director of elementary agricultural education, A. C. GORHAM (*Ann. Rpt. Dept. Agr., New Brunswick, 1919, pp. 21-44, pls. 2*).—This is a report on elementary agricultural education in the Province of New Brunswick for the year ended June 30, 1919, including school gardens and home plats, poultry projects, school fairs, and the rural science school for teachers. A table showing the grants from the Department of Agriculture to teachers and trustees for nature study and agriculture during the year is included.

Educational gardens, J. B. HURRY (*Jour. Roy. Hort. Soc., 45 (1919) No. 1, pp. 56-59*).—The author discusses the school garden as a means of instruction in horticulture, botany, and industry and commerce, including, as an illustration of the latter, an account of the scheme as carried out at Westfield, Reading, England.

Boys' and girls' clubs (*Agr. Gaz. Canada, 7 (1920), No. 5, pp. 421-427*).—This is a series of brief reports on the organization and activities of boys' and girls' live stock, poultry, gardening, canning, and cooking clubs conducted under the auspices of rural education associations, school fair associations, agricultural societies, representatives of the Department of Agriculture, etc., in the Provinces of New Brunswick, Quebec, Manitoba, Saskatchewan, and Alberta.

A course of study in boys' and girls' club leadership for county normal training classes, E. C. LINDEMANN (*Mich. Dept. Pub. Instr. Bul. 26 (1919), pp.*

63, figs. 2).—The subject matter outlined for this course deals with the history and development of boys' and girls' club work and club reports, stories, and exhibits, to be taught by the county normal principal; principles of organization and follow-up work, to be taught by members of the State staff; and psychology of boys' and girls' club work and recreational activities related to club work, to be taught by the principal and reinforced by a member of the State staff.

[**Nature study and agriculture**], H. N. GODDARD (In *Manual of the Elementary Course of Study for the Common Schools of Wisconsin*. Madison, Wis.: Dept. Pub. Instr., 1919, 16. ed., rev., pp. 188-235, fig. 1).—This manual includes general suggestions and topics, in seasonal sequence, in nature study and general suggestions and outline of a course of study in agriculture, together with treatment of topics, tests, and examinations, and references for the common schools of Wisconsin.

Lessons with nature for school, garden, farm, and home, A. L. MEBANE (*Greensboro, N. C.: Agr. and Tech. Col., 1917, pp. 62, figs. 3*).—The author outlines lessons and experiments dealing with soils, manures, rotation of crops, production of new varieties of plants, seed testing, culture of field and garden crops, and treatment of diseases of garden plants, including the making of fungicides and insecticides.

Hints for special-class gardens, C. H. TETHER (*Albany, N. Y.: Univ. State New York [1920], pp. 8*).—The author presents simple hints for gardeners gained from two years' experience in the supervision of gardening projects of the special schools at the Oswego (N. Y.) State Normal School. Each child in the special class, regardless of his special physical handicap, had some part in the garden work.

Lessons in plant production for southern schools, E. H. SHINN (*Fed. Bd. Vocat. Ed. Bul. 53 (1920), pp. 183*).—This bulletin outlines suggestive lessons for a year's work in plant production arranged in seasonal sequence for southern schools of vocational agriculture. It includes a suggested weekly program as a plan upon which to base the work. The lessons suggest sources of information, illustrative material, class exercises, practical exercises, and a project study outline or shop practice. The subjects dealt with include crops, soils, fertilizers, gardening, orcharding, farm management, roads, farm implements and machinery, etc.

Principles of veterinary science: A text-book for use in agricultural schools, F. B. HADLEY (*Philadelphia and London: W. B. Saunders Co., 1920, pp. 420, figs. 101*).—This text, which is a development of the author's former publication entitled *The Horse in Health and Disease* (E. S. R., 34, p. 794), has been amplified to meet better the growing needs of the animal husbandman. It endeavors to bring out the close relationship that should exist between veterinary science and the natural and physical sciences now taught. Part 1 deals with the anatomy and physiology of animals, and part 2 treats of the common animal diseases including their prevention and control. An outline for the study of the control of communicable diseases, and lists of diseases of man carried by domestic animals, diseases of swine that render the flesh unfit for food, and the bones of the skeleton of the horse are appended.

Courses of study: Foods and related work, J. CALLAHAN and M. JOHNSTON (*Wis. Bd. Vocat. Ed. Monog. 9 (1920), pp. 40*).—This monograph contains outlines of 8 unit courses in foods, comprising a total of 34 lessons, and of 10 unit courses, with a total of 33 lessons, for first and second year courses, respectively, for part-time and evening schools of the State. Each lesson indicates topics for discussion, practical work, related work, and references.

Housekeeping: A textbook for girls in the public intermediate schools of the Philippines, S. M. BUTTS (*Manila, P. I.: Bur. Ed., 1919, 2. ed., rev., pp. 230, pl. 1, figs. 70*).—In this second revision of this text, previously noted (*E. S. R., 33, p. 598*), much new material has been added. Subject matter in housekeeping and cooking is outlined for grades 5 to 7, inclusive, in hygiene and sanitation for grade 5, and in home nursing for grades 6 and 7. Suggestions for practical work are included. Appendixes deal with household accounts, a fireless cooker, the cold-pack method of canning, digestion and absorption of food, and recipes.

Home projects in home economics, J. Cox (*[Salt Lake City, Utah: Dept. Pub. Instr., 1920], pp. 14*).—Suggestions are offered by the supervisor of home economics for the organization of home projects in home economics for Utah schools.

MISCELLANEOUS.

Twenty-ninth Annual Report of Arizona Station, 1918 (*Arizona Sta. Rpt. 1918, pp. 271-358, figs. 6*).—This contains the organization list, an administrative report on the work and publications of the station, a financial statement for the fiscal year ended June 30, 1918, and departmental reports, the experimental features of which are for the most part abstracted elsewhere in this issue.

Work and progress of the agricultural experiment station for the year July 1, 1918, to June 30, 1919 (*Missouri Sta. Bul. 172 (1920), pp. 48, figs. 13*).—This contains the organization list, a report by the director on the work and publications of the station, and a financial statement for the Federal funds for the year ended June 30, 1919. The experimental work reported is for the most part abstracted elsewhere in this issue.

Twenty-ninth Annual Report of Washington Station, 1919 (*Washington Sta. Bul. 155 (1920), pp. 57*).—This contains the organization list, a report on the work and publications of the station during the year, and a financial statement for the Federal funds for the fiscal year ended June 30, 1919, and the remaining funds for the fiscal year ended March 31, 1919. The experimental work reported is for the most part abstracted elsewhere in this issue. Data on the arsenic content of sprayed apples, and the effect of exercise on the vitality and breeding ability of bulls are also included.

Report of the Canada Experimental Farms, 1919 (*Canada Expt. Farms Rpt. 1919, pp. 196*).—This contains the reports of the director, the Dominion specialists, and the superintendents of the various substations. In addition to experimental work abstracted elsewhere in this issue, meteorological data are included.

Monthly Bulletin of the Ohio Experiment Station (*Mo. Bul. Ohio Sta., 5 (1920), No. 6, pp. 161-192, figs. 9*).—This number contains several articles abstracted elsewhere in this issue, miscellaneous notes, and answers to timely questions.

Monthly bulletin of the Western Washington Substation (*Washington Sta., West. Wash. Sta. Mo. Bul., 8 (1920), No. 5, pp. 65-80*).—In addition to an article abstracted elsewhere in this issue, this number contains brief articles on the following subjects: Hog Raising in Western Washington, by W. A. Linklater; Select Seed Potato Plants Now, by J. L. Stahl; Feeding of Poultry for Eggs and Longevity, by Mr. and Mrs. G. R. Shoup; Agricultural Fair Exhibits; and Western Washington Egg-laying Contest, by G. R. Shoup.

The Government scientist and the conditions of the service, C. L. ALSBERG (*Chem. Age [New York], 28 (1920), No. 9, pp. 305-307, fig. 1*).—A brief discussion with special reference to present conditions in the Bureau of Chemistry, U. S. Department of Agriculture.

NOTES.

Alabama College and Station.—The agricultural building, including much of the equipment and records of the station, was destroyed by fire October 30.

Florida Station.—Dr. O. F. Burger, pathologist in fruit disease investigations in the Bureau of Plant Industry, U. S. Department of Agriculture, has been appointed plant pathologist, beginning November 1. John H. Jeffries has been appointed superintendent of the Citrus Substation at Lake Alfred.

Purdue University and Station.—John June Davis has been appointed head of the department of entomology, succeeding James Troop, retired at his own request after nearly forty years' service. Prof. Troop retains his teaching duties.

Other appointments include H. D. Brooks as assistant in poultry husbandry and C. E. Baker as assistant in horticulture. S. F. Thornton has resigned as deputy State chemist to accept a commercial position.

Kansas College and Station.—The next legislature is to be asked to appropriate funds for continuing the construction of the group of agricultural buildings. Approximately \$400,000 will be requested to build the west wing of Waters Hall and annexes to the east and west wings, which will be used for a meats laboratory and creamery, respectively.

The enrollment of students in the division of agriculture is about 500, some 50 more than during the fall semester a year ago. The number of freshmen in agriculture exceeds that of any other fall semester in the history of the institution.

Recent appointments include P. C. McGilliard as assistant in dairy husbandry; W. R. Horlacher and D. C. Fetzer as fellows in animal husbandry; and W. S. Wiedorn as instructor in landscape gardening. M. F. Ahearn, for several years professor of horticulture, has resigned to take charge of the department of physical education, and has been succeeded by R. J. Barnett, professor of pomology at the Washington College.

Rutgers College.—Miss Florence Powdermaker, instructor in the School of Hygiene and Public Health at Johns Hopkins University, was appointed September 1 as specialist in nutrition.

Cornell University.—A State appropriation of \$10,000 for extension work on Indian reservations is to be employed in various ways. Scholarships may be offered at the winter courses, adults may be brought to the college during farmers' week, a rotary loan fund may be established to enable Indians to purchase improved seed, animals, machinery, etc., and there may be general extension work on the reservations. The work is to be under the direction of D. J. Crosby of the extension service, assisted by Dr. Erl A. Bates of Syracuse University, who is honorary president of the Indian Welfare Society and who has been appointed adviser in Indian extension. There are six Indian reservations in the State with a population of about 6,000 and an area of over 10,000 acres.

New York State Station.—Edward H. Francis and Rossiter D. Olmstead, assistants in horticulture and entomology, respectively, resigned October 1. The former has been succeeded by Harold B. Tukey, a 1920 graduate in horticulture from Cornell University.

South Carolina College and Station.—Dr. G. F. Lipscomb has resigned as station chemist to become professor of chemistry at the University of South

Carolina, and has been succeeded by W. L. Lippincott. W. W. Fitzpatrick has resigned as professor of dairy husbandry and head of the dairy division of the station to accept a position with the American Guernsey Cattle Club. T. S. Buie, formerly agronomist of the Georgia Station, has been appointed specialist in fertilizer investigations at the Pee Dee Substation, and is conducting cooperative fertilizer tests and soil fertility studies with the different soil types of the State.

Wisconsin University.—Erwin M. Tiffany has been appointed assistant professor of agricultural education.

Wyoming Station.—H. P. K. Agersborg has been appointed assistant in the department of zoology and parasitology.

Officers and Committees for 1921 of the Association of Land-grant Colleges.—The complete list of general officers selected at the Springfield meeting, noted editorially in this issue, is as follows: President, H. L. Russell of Wisconsin; vice president, Howard Edwards of Rhode Island; secretary-treasurer, J. L. Hills of Vermont; and members of the executive committee, R. A. Pearson of Iowa, chairman; W. M. Riggs of South Carolina, W. E. Stone of Indiana, A. R. Mann of New York, and F. B. Mumford of Missouri.

For the various sections the officers are as follows: Agriculture, Dean Mumford chairman; W. F. Handschin of Illinois vice chairman, and W. H. Candler of New York, secretary; engineering, C. R. Richards of Illinois, chairman, and R. L. Sackett of Pennsylvania, secretary; and home economics, Edna L. Skinner of Massachusetts, chairman, and Mildred Wiegley of Minnesota, secretary. For the three subsections of the section of agriculture, R. L. Watts of Pennsylvania and C. D. Jarvis of the U. S. Bureau of Education were chosen chairman and secretary, respectively in that of resident teaching; F. S. Harris of Utah and T. P. Cooper of Kentucky, chairman and secretary in experiment station work; and H. J. Baker of Connecticut and J. A. Wilson of Oklahoma in extension work.

The standing committee on graduate study was abolished. On the committee on instruction in agriculture, home economics, and mechanic arts, A. B. Cordley of Oregon and Bertha M. Terrill of Vermont were appointed for 3-year terms, vice T. F. Hunt of California and Edna M. White of Ohio. R. W. Thatcher of Minnesota was appointed to the committee on college organization and policy for three years vice Samuel Avery of Nebraska, and H. L. Russell of Wisconsin succeeded J. G. Lipman of New Jersey for a like period on the joint committee on projects and correlation of research. The remaining personnel of the various standing committees was continued unchanged.

Netherlands Institute of Animal Nutrition.—Plans are under way for a laboratory building for chemical, bacteriological, and other research work of this institute, and it is hoped to complete the structure in about two years. An annex to the laboratory is being built for immediate occupancy. This is a one-story structure about 117 by 62 ft., with basement and attic, and will be known as the vitamin laboratory. The main floor contains several offices and laboratories, but consists largely of quarters for mice, rats, monkeys, rabbits, fowls, and guinea pigs. Special facilities are to be provided for keeping many of the animals in open warrens during the day, for disinfecting cages, and otherwise maintaining the best of hygienic conditions. The library is on the attic floor, where considerable storage space is also available.

The institute is located in Amsterdam, and will be devoted to elaborate feeding experiments with animals. The staff is to consist of Director E. W. Van Leersum, an assistant director, and various assistants.

EXPERIMENT STATION RECORD.

VOL. 43.

ABSTRACT NUMBER.

No. 9.

RECENT WORK IN AGRICULTURAL SCIENCE.

AGRICULTURAL CHEMISTRY—AGROTECHNY.

Chemical reading courses (*Jour. Indus. and Engin. Chem.*, 12 (1920), Nos. 7, pp. 701-705; 8, pp. 806-812).—This report of a committee of the American Chemical Society appointed to prepare suitable lists of chemical texts for libraries consists of selected lists of books covering different phases of chemistry, with brief comment as to the scope of the books recommended. The subjects and compilers of the different lists are as follows: Elementary or Introductory Chemistry and Household Chemistry, by L. C. Newell; General and Physical Chemistry, Inorganic and Analytical Chemistry, and Organic and Biological Chemistry, by A. M. Patterson; and Industrial Inorganic Chemistry, Industrial Organic Chemistry, and Techno-Chemical Analysis, by W. Segerblom.

Optical properties of a series of heptitols, E. T. WHERRY (*Jour. Biol. Chem.*, 42 (1920), No. 3, pp. 377-382).

Sedoheptose, a new sugar from *Sedum spectabile*, II, F. B. LA FORGE (*Jour. Biol. Chem.*, 42 (1920), No. 3, pp. 367-374).

The absorption spectra of the nitric esters of glycerol, E. Q. ADAMS (*Jour. Amer. Chem. Soc.*, 42 (1920), No. 7, pp. 1321-1327, figs. 3).

Volemite, F. B. LA FORGE (*Jour. Biol. Chem.*, 42 (1920), No. 3, pp. 375, 376).

Acidity of ash-free and of commercial gelatin solutions, H. E. PATTEN and T. O. KELLEMS (*Jour. Biol. Chem.*, 42 (1920), No. 3, pp. 363-366, fig. 1).—A continuation of the study previously noted (*E. S. R.*, 41, p. 11).

Cockle-bur oil, a new seed oil, L. B. RHODES (*Jour. Amer. Chem. Soc.*, 42 (1920), No. 7, pp. 1507, 1508).—The kernels of a variety of cockle-bur known as the clot-bur (*Xanthium echinatum*) yielded on heavy pressure in the cold between steel plates 29.89 per cent of a light yellow oil, of a pleasant odor and taste. The following constants were obtained: Specific gravity at 15.5° C. 0.9251, refractive index at 15.5° 1.4773, Zeiss butyrometer at 20° 1.4771, refractometer at 40° 1.4691, solidification point -18°, iodine number (Hanus) 140.8, saponification number 190.2, Reichert-Meissl number 0.233, Hehner number 89.7, acetyl value 10.6, and melting point of the fatty acids +19°.

Samples of raw linseed oil and cockle-bur oil under the same drying conditions required four and five days, respectively, to reach the same degree of dryness. The meal remaining from the extraction of the oil was found to be highly toxic.

Pappea seeds of South Africa as a source of oil (*Bul. Imp. Inst. [London]*, 17 (1919), No. 4, pp. 488-491).—The seeds of *Pappea capensis*, the fruit of which is known as the South African prune, were found to contain 7.4 per cent of moisture and to yield 47.8 per cent of a viscous oil of golden yellow color. The analytical constants of the oil were as follows: Specific gravity at 15° C. 0.915, solidifying point of fatty acids 39.5° C., acid value 13.1, saponification

value 188, iodine value (per cent) 69.8, unsaponifiable matter (per cent) 0.54, soluble volatile acids 0.42, insoluble volatile acids 0.32, and acetyl value 21.1. These figures indicate that the oil is of a nondrying type suitable either for soap manufacture or as a lubricant.

The residual meal from the extraction of the oil from the entire seeds and that from the decorticated kernels had the following composition: Moisture 9.2 (entire seed) and 7.4 per cent (decorticated kernels), crude proteins 16.3 and 38.3 per cent, fat 1 and 0.4 per cent, carbohydrates (by difference) 51.9 and 42.9 per cent, crude fiber 18.6 and 5.1 per cent, and ash 3 and 5.9 per cent. The meal contained no alkaloid or cyanogenetic glucosid but a small amount of saponin. Feeding trials are necessary to determine whether the meal can safely be used as a cattle food.

The castor-oil industry, J. H. SHRADER (U. S. Dept. Agr. Bul. 867 (1920), pp. 40, figs. 15).—This is an extensive compilation of information on the castor-oil industry, including a discussion of the source of castor-oil; statistics on the trade and commerce in castor beans and oil during the past ten years; a description, contributed by A. C. Goetz, of the inspection and valuation of castor beans in New York City; a detailed description with illustrations of the manufacture of the oil; data on the composition of commercial samples of the oil of different grades, with specifications drawn up by the Bureau of Aircraft Production for castor oil for lubricating purposes and a comparison of the composition and properties of American-produced and imported oils; and a discussion of the various uses of the oil.

The general methods described for obtaining the oil include the use of the cage press, the Anderson oil expeller, and stationary and rotary extractors for solvent extraction of the residual oil from the press cake. Experimental evidence has been obtained indicating that a good grade of No. 1 oil can also be obtained by direct extraction of the slightly crushed but undecorticated beans with benzol by percolation. The residual oil, after evaporation of the benzol, is purified by heating to 95 or 100° C. for about 10 minutes with 5 per cent of fuller's earth, adding 2 per cent of decolorizing carbon, allowing the temperature to fall slowly to about 90°, and filtering.

Concerning the possibility of a permanent American castor-bean industry, attention is called to the fact that, through the campaign of castor-bean growing inaugurated in 1917 by the Bureau of Aircraft Production, considerable information is available concerning yields per acre and cost of handling in different parts of the country, the details of seed selection and methods of planting, cultivating, and harvesting.

"We are now in a good position from the standpoint of knowledge of farming conditions to adopt intelligently whatever measures may be necessary to meet foreign competition. . . . But the farmer who would raise castor beans as a crop will have to be shown that he can receive more money per acre than he is receiving from his present crops before there will be a satisfactory home production of castor beans. Cost, yield, market, and profit are the determining factors."

Urease content of Dutch seeds and different varieties of soy beans, D. H. WESTER (Pharm. Zentralhalle, 61 (1920), No. 28, pp. 377-382).—Essentially noted from another source (E. S. R., 43, p. 10).

Volumetric method for the determination of diastatic capacity, J. T. FLOHIL (Jour. Indus. and Engin. Chem., 12 (1920), No. 7, p. 677).—The technique of the method is as follows:

"A 5 per cent malt solution is prepared according to Lintner. One cc. of the extract is introduced into 100 cc. of a 2 per cent soluble starch solution in a 200 cc. flask, left to act for exactly one hour at 20° C., then treated with

10 cc. of N/10 sodium hydroxid to stop the diastatic action, and diluted with water to the 200 cc. mark.

"Twenty-five cc. of this solution is transferred to a 300 cc. Erlenmeyer flask, exactly 10 cc. each of Fehling's solutions I and II added, and the volume brought up to 50 cc. with 5 cc. water. The mixture is boiled slowly for 2 minutes and immediately cooled under the cold water faucet, but not much under 25°. Ten cc. of a 30 per cent potassium iodid solution, or 3 gm. potassium iodid and 10 cc. of a 25 per cent sulphuric acid solution, are added successively and the liberated iodine titrated with a N/10 thiosulphate solution to a creamy yellow color, the soluble starch present serving as an indicator."

The diastatic capacity in degrees Lintner is obtained by dividing the amount of thiosulphate equivalent to the copper sulphate reduced by the sugar by the amount of thiosulphate used in a blank test (25 cc., 5 cc. water, 20 cc. Fehling's solution) and multiplying the result by the factor 320.

A simple method for titrating electrometrically to a desired end point in acid-alkaline reactions, P. E. KLOPSTEG (*Science, n. ser., 52 (1920), No. 1331, pp. 18, 19*).—The author suggests the utilization of the hydrogen electrode as a means of titrating a solution of unknown pH value to a definite H-ion concentration. The technique is essentially as follows:

A solution having a pH value corresponding to the desired end point of the titration, selected from the standard formulas of Clark and Lubs (*E. S. R., 37, p. 506*), is placed in one vessel with a hydrogen electrode. This is connected by a salt bridge of saturated potassium chlorid with the cell containing another hydrogen electrode in the unknown solution. The two electrodes are connected by means of a tapping key and a galvanometer of high resistance. The titrating solution is then added to the unknown until the galvanometer shows no deflection upon tapping the key, thus indicating that the H-ion concentrations of the two cells are equal.

It is pointed out that such a titration can be carried out regardless of the color or turbidity of the solution, and that its accuracy is limited only by the accuracy with which the pH value of the standard solution is known.

Simplification of the reaction of manganese salts of Caron and Raquet, G. DENIGÈS (*Ann. Chim. Analyt., 2. ser., 2 (1920), No. 7, pp. 215, 216*).—A simplification of the reaction of manganese salts noted by Caron and Raquet (*E. S. R., 41, p. 504*) is described in which the active oxidizing agent is replaced by atmospheric oxygen in an alkaline medium, and potassium oxalate by free oxalic acid, thus obviating the necessity of using acetic acid.

The technique of the modified method consists in adding to 5 cc. of the solution of the manganese salt one or two drops of sodium hydroxid, shaking the mixture in the presence of air until a brown color appears, and then adding drop by drop with constant shaking a cold solution of oxalic acid until the brown color disappears and the characteristic red color of the alkaline manganic oxalate appears.

The determination of potassium and its separation with sodium as sodium potassium cobaltic nitrite, P. WENGER and C. HÉMEN (*Ann. Chim. Analyt., 2. ser., 2 (1920), No. 7, pp. 198, 199*).—Experimental data are reported verifying the formula $\text{NaK}_2\text{Co}(\text{NO}_2)_6$ for sodium potassium cobaltic nitrite by determining both the cobalt and the potassium in the precipitated salt. The authors recommend as a rapid method of determining potassium its precipitation with sodium cobaltic nitrite, the determination of cobalt either gravimetrically or volumetrically, and the use of the theoretical coefficients 2.5254 for $\frac{2\text{KCl}}{\text{Co}}$ or 1.5932 for $\frac{\text{K}_2\text{O}}{\text{Co}}$ for calculating KCl or K_2O from the ascertained weight of cobalt.

The determination of small quantities of phosphoric acid as barium phosphomolybdate in the presence and absence of phosphorus in organic combination, S. POSTERNAK (*Bul. Soc. Chim. France, 4. ser., 27 (1920), No. 12, pp. 507-518*).—The author states that it is possible to determine with great accuracy as small amounts as 0.05 mg. of phosphorus as barium phosphomolybdate by precipitating with the corresponding ammonium salt in a medium exclusively sulphuric or nitric.

In the first case, which applies to all determinations of phosphorus in the absence of organic matter, a mixture of 10 cc. of the solution containing the phosphorus, 10 cc. of 20 per cent ammonium sulphate, and 1 cc. of concentrated sulphuric acid is heated to boiling in a 100 cc. beaker of Bohemian glass, after which 5 or 10 cc. of a 10 per cent solution of ammonium molybdate is added and the mixture allowed to stand for 15 minutes. The precipitate is filtered, washed five times with a 5 per cent solution of ammonium nitrate, dissolved in a little ammonia, reprecipitated with a 10 per cent solution of barium chlorid, filtered, washed with a little water, dried, and heated for a few minutes at red heat. The precipitate thus obtained corresponds to the formula $4 \text{Ba}_{27} [\text{PO}_4 (\text{Mo O}_4)_{12}]_2 + \text{Ba}_6 \text{SO}_4 (\text{Mo O}_4)_3$ and the factor by which the weight of the precipitate must be multiplied to obtain the weight of phosphorus is 0.00739.

In the second case, which applies especially to the determination of inorganic phosphates in the presence of organic compounds of phosphorus, a mixture of 20 cc. of the phosphorus-containing solution, 10 cc. of 20 per cent ammonium nitrate, and 10 cc. of the molybdic reagent is allowed to stand, with occasional shaking, at a temperature of from 12 to 15° C. for two hours, after which the precipitate is filtered and treated as above. The resulting precipitate is said to have the formula $8 \text{Ba}_{27} [\text{PO}_4 (\text{Mo O}_4)_{12}]_2 + \text{Ba}_4 (\text{Mo O}_4)$, and the factor is 0.00786.

The technique of the determination of phosphoric acid as barium phosphomolybdate, S. POSTERNAK (*Bul. Soc. Chim. France, 4. ser., 27 (1920), No. 13, pp. 564-568*).—This article describes in detail the technique of the method noted above and calls attention to possible sources of error.

Determination of cyanamid and dicyandiamid in calcium cyanamid, MARQUEYROL, P. LORIETTE, and L. DESVERGNES (*Ann. Chim. Analyt., 2. ser., 2 (1920), No. 6, pp. 164-167*).—The authors present evidence, both from the literature and from laboratory investigation of different methods, indicating that the original methods of Caro for determining cyanamid and dicyandiamid in calcium cyanamid (*E. S. R., 25, p. 24*) are more accurate than later modifications of other authors. In particular, volumetric methods, such as that of Kappen (*E. S. R., 21, p. 419*), based upon the determination of the silver in silver cyanamid and dicyandiamid are considered to be inexact.

Degree of alkalinity necessary for the phloroglucin test for formaldehyde, P. J. HANZLIK (*Jour. Biol. Chem., 42 (1920), No. 3, pp. 411-413*).—The author presents evidence indicating that the phloroglucin test for free formaldehyde requires for a minimal positive reaction a rather high degree of alkalinity ($\text{pH}=12.13$), the equivalent of the alkalinity of a 0.04 per cent or $\text{N}/100$ sodium hydroxid solution, and for an optimal reaction an $\text{N}/10$ hydroxid or carbonate ($\text{pH}=13$). The neglect of this factor and the use of impure phloroglucin are considered to be the causes of frequent failures in the use of this reagent.

Determination of caffen in mixtures of coffee and coffee substitutes and in decaffeinated coffee, E. VAUTIER (*Ann. Chim. Analyt., 2. ser., 2 (1920), No. 6, pp. 168-172*).—The method for determining caffen in coffee previously described (*E. S. R., 40, p. 115*) is considered to give too high results with samples of low caffen content such as the so-called decaffeinated coffee and mix-

tures of coffee and coffee substitutes. The error is thought to be due to the impurities in the caffeine sublimate. In such cases the author recommends either the determination of nitrogen in the crude caffeine or a further purification of the caffeine. In the first process the nitrogen is determined by the Kjeldahl method on the crude caffeine as it is obtained after separation of the fats in the method previously noted. In the final titration with $N/10$ H_2SO_4 , Congo red is recommended as indicator. In the alternative method the crude caffeine is purified by repeated extraction with chloroform, followed by the addition of a small amount of sodium carbonate to unite with impurities on the order of humic acid. The solution is then filtered and evaporated and the caffeine dried at $100^\circ C.$ and weighed.

Samples of Kaffee Hag yielded 0.13 per cent of caffeine by the author's previous method, from 0.04 to 0.05 per cent by weighing the purified caffeine, and from 0.05 to 0.06 per cent by the nitrogen determination method.

Preservatives for fermentable beverage samples, J. S. McCUNE and A. N. THURSTON (*Jour. Indus. and Engin. Chem.*, 12 (1920), No. 7, pp. 689, 690).—Tests are reported of the efficiency of various preservatives for samples of untreated draft beer and of bottled beer treated with Fleischmann's yeast, which are to be tested for alcohol content.

Sodium benzoate, 0.2 per cent, proved unreliable, sodium bisulphite and boric acid, 0.2 per cent, worthless, and mercuric chlorid and salicylic acid, 0.2 per cent, satisfactory as preservatives. The use of 0.2 per cent of salicylic acid is recommended for preserving fermentable samples when immediate delivery to the laboratory is not possible.

Report of the committee on cottonseed products, division of industrial and engineering chemistry, American Chemical Society (*Jour. Indus. and Engin. Chem.*, 12 (1920), No. 7, pp. 707-711).—This report includes methods recommended by the committee for the sampling and examination of cotton seed, cottonseed oils, cake, and meal, crude cottonseed oil, crude peanut oil, crude coconut oil, crude soy-bean oil, refined oils, soap stock, and acidulated soap stock, titer tests, and an appendix specifying oil grades, both crude and refined.

A comparison of methods for estimating fat in butter, H. W. GREGORY, P. S. LUCAS, and G. SPITZER (*Indiana Sta. Bul.* 244 (1920), pp. 11, figs. 3).—The authors report parallel determinations of the fat in 20 samples of butter by the Official and four unofficial methods, and likewise the moisture, salt, and curd content by the Official and unofficial methods. Determination on 7 other samples by fewer methods are also reported.

In the 20 samples the percentages of fat given by the Official method averaged 0.21 higher than Kohman's gasoline extraction method (E. S. R., 40, p. 311), 0.08 lower than the Shaw method (E. S. R., 27, p. 614), 0.66 lower than the results from the Wright butter fat test bottle, and 0.42 higher than the so-called factory method.

In the factory method the fat is calculated by difference on the assumption that the curd forms 1 per cent of the butter, the moisture being estimated by heating a sample over a flame and the salt, after a single extraction, being determined by the volumetric silver nitrate method with potassium chromate as indicator. The factory method is considered the best suited for use by practical butter makers. Actual determinations of the curd by the gasoline extraction method showed it to be lower than 1 per cent in 20 out of 24 samples and lower than 0.8 per cent in 12 of them.

Correction for volume of precipitate in the polarimetric determination of lactose in milk, A. E. PERKINS (*Jour. Dairy Sci.*, 3 (1920), No. 2, pp. 134-142).—The author, at the Ohio Experiment Station, presents calculations from

data obtained on 100 representative samples of milk, indicating that the volume of the fat and protein in the 66 gm. of milk used as a sample in the Official method for the polarimetric determination of lactose is invariably higher than the correction of 2.6 cc. allowed for every sample. Calculations of the actual volume of precipitated milk fat and protein exceeded the correction of 2.6 cc. by amounts ranging from 0.6 to 5.53 cc., resulting in a discrepancy in the final lactose reading of from 0.03 to 0.28 per cent.

To overcome this inaccuracy a procedure is suggested which is based upon previous observations of the author (E. S. R., 36, p. 374) and of Haecker (E. S. R., 31, p. 670) that the protein content of normal milk can be estimated with a considerable degree of accuracy when the fat content is known. Tables are given in which the volume of fat and protein in 66 gm. of milk of varying percentages of fat and protein has been computed from the specific volumes of the milk fat and milk protein. This volume represents the correction for all samples of milk whose fat content places them within the group. This correction can be applied equally well by increasing the dilution of the sample to the proper amount, or by using the figure as V in the following formula:

Percentage lactose = $\frac{R}{2} \times \frac{100 - V}{100}$, where the samples are diluted to a uniform volume of 100 cc.

Tests of the accuracy of this method are reported, indicating with the representative samples used a maximum error of 1.46 cc. This amounts to a final error of 0.07 per cent, as compared with a maximum error of 5.53 cc. or 0.28 per cent in case of the Official method.

Iodometric method for the determination of reducing sugars, H. VAN NOUHUJIS (*Arch. Suikerindus. Nederland. Indië*, 28 (1920), No. 17, pp. 591-595; *abs. in Internatl. Sugar Jour.*, 22 (1920), No. 259, pp. 411, 412).—Detailed directions are given for the volumetric determination of reducing sugars in molasses by estimating the copper remaining in the unreduced Fehling's solution by adding potassium iodid, acidifying, and titrating the liberated iodine with standard thiosulphate.

A comparison of this method with the volumetric permanganate method is reported which indicates that the results by the iodometric method run a little low. The method is recommended, however, as being very rapid and convenient in practice.

A picnometer for the determination of density of molasses, W. B. NEWKIRK (*U. S. Dept. Com., Bur. Standards Technol. Paper 161* (1920), pp. 7, fig. 1; *also in Sugar [New York]*, 22 (1920), No. 9, pp. 508, 509, fig. 1).—An improved picnometer for determining the density of molasses and other viscous liquids is described and illustrated by a diagram.

The apparatus consists of a bottle with an enlarged rim ground optically flat and closed with a disk, also ground optically flat. When the bottle is to be filled, the disk is removed and replaced by a spherical expansion chamber which is fitted with a vacuum connection. The molasses to be analyzed is poured into the bottle and expansion chamber until the latter is about one-third full. The vacuum connection is then made and the pressure reduced until the gas expands to visible bubbles. The vacuum connection is then closed and the apparatus placed in a thermostat until all the bubbles have collected in the expansion chamber and the temperature has reached equilibrium, after which the expansion chamber is removed, the bottle closed by the disk, wiped, and weighed. The densities are determined by correcting the weights to vacuo and comparing with the weight of an equal volume of water at 4° C. in vacuo. The results are reported in degrees Brix.

Experimental data are reported indicating that the application of a vacuum as described above is preferable to heating as a means of deaerating the molasses. The individual accidental error in the density determination of molasses with this apparatus is shown to be within 0.1° Brix and, therefore, considerably less than hitherto attainable.

Factors determining the keeping quality of cane sugar, N. and L. KOPELOFF (*Louisiana Stas. Bul. 170 (1920), pp. 3-63, fig. 1*).—This bulletin includes the reports of a series of investigations on the deterioration of sugar by molds. Most of these studies have been previously noted from other sources as follows: (1) Do Mold Spores Contain Enzymes? (E. S. R., 42, p. 336); (2) The Invertase Activity of Mold Spores as Affected by Concentration and Amount of Inoculum (E. S. R., 42, p. 803); (3) The Effect of Concentration on the Deteriorative Activity of Mold Spores in Sugar (E. S. R., 42, p. 803); and (4) Effect of Varying the Amount of Inoculum and Concentration on the Deterioration of Sugar by Molds (E. S. R., 43, p. 507).

The general conclusions drawn in the above studies are summarized in part 5, entitled The Present Status of the Problem of Sugar Deterioration. In this attention is also called to the recently reported determinations by Kopeloff and Perkins of the deterioration of Cuban raw sugars in storage (E. S. R., 43, p. 616), and a chart is presented by means of which it is possible to predict the keeping quality of sugar from the standpoint of infection by molds. In this chart moisture ratios are plotted as abscissas and mold spores per gram as ordinates. The fields in which no deterioration, slight deterioration, and marked deterioration may be expected are appropriately differentiated.

[Cider investigations], O. GROVE (*Univ. Bristol, Ann. Rpt. Agr. and Hort. Research Sta., 1919, pp. 14-22; also in Jour. Bath and West and South. Counties Soc., 5. ser., 14 (1919-20), p. 106-113*).—Experimental studies on cider making during the year 1918-19 are reported in the following papers:

Cider making experiments for the season, 1918-19.—As a means of increasing the output of cider in seasons of scarcity and high prices of fruit, the following method was tested:

After pressing the apples in the usual way the pressed pomace was broken up and mixed in an open vessel with enough cold water to cover. After soaking for 24 to 48 hours the pomace was pressed again and the expressed juice mixed with the juice of the first pressing and varying amounts of sugar, either in the form of a sirup or added directly.

The fermentation of the diluted juice proceeded normally but at a slightly lower rate. Details are given of four mixed variety ciders, two single variety ciders, and one perry prepared in this way. It is stated that although these ciders and perry were not of as good quality as the average pure juice products, most of them were quite palatable.

Some experiments on ropiness in cider.—Eight pint bottles of cider were inoculated with two drops each of a pure culture of the bacillus previously found to be the cause of ropiness in cider (E. S. R., 40, p. 414). The inoculated and control samples were kept at 15° C. and examined at intervals for over a year. No trace of ropiness in the inoculated samples was discovered for nearly a year, when all but one developed the disorder, as did two of the controls.

The relation between the rate of fermentation and the content of nitrogenous matter in apple juice.—To study the relation between the rate of fermentation and the amount of nitrogen present in the juice, the juices from six varieties of apples were placed in 125 gm. quantities in Erlenmeyer flasks which, after sterilization, were provided with fermentation locks closed with sulphuric acid. After inoculating the juice in each flask with a trace of pure yeast the flasks

were placed in the cellar of a cider house, and the rate of fermentation determined by weighing the flasks at intervals. When the losses in weight became insignificant and microscopical examination showed that growth had ceased, the juices were examined for nitrogen and sugar content and specific gravity.

The four juices which had fermented rapidly had only a trace of sugar, while the sugar content of the other two was 6.3 and 1.04 per cent, respectively. The percentages of nitrogen in the completely fermented juices were from 0.0135 to 0.0221, while the other two were 0.0033 and 0.0094. These results indicate that for a slow fermentation resulting in a sweet cider the content of the juice in nitrogenous matter should be very small.

Home canning and food thrift, O. H. BENSON (*N. Y. State Dept. Farms and Markets, Agr. Bul., No. 130 (1920), pp. 61, figs. 18*).—This bulletin contains a description of the outfits used in home canning by the one period cold-pack method; general directions with time schedules for the home canning by this method of fruits, vegetables, meats, and fish; a brief description of other methods of canning; and miscellaneous suggestions. Special recipes are included for making sirups from sugar beets and apples, for the home canning of field corn, and for several camp rations.

Preserving fish in the home, S. L. LEWIS (*Oregon Agr. Col. Ext. Bul. 318 (1920), pp. 1, 2*).—Brief directions are given for the home preservation of fish by salting, smoking, and canning.

A new and successful type of fruit evaporator, W. V. CRUESS (*Better Fruit, 15 (1920), No. 2, pp. 3-5, figs. 4*).—This article consists of the plans and specifications of the evaporator described in Bulletin 322 of the California Experiment Station, previously noted (*E. S. R., 43, p. 715*). The evaporator holds 6 tons of fruit per charge and will dry from 6 to 10 green tons of fruit in 24 hours. The complete plant cost in 1919 about \$3,500. Sketches are included of the revised ground plan of the evaporator, a section of its more important parts, and a section of the dipping machine.

Palm gul manufacture in the Bombay Presidency, V. G. GOKHALE (*Dept. Agr. Bombay Bul. 93 (1919), pp. II+66, pls. 11*).—This bulletin consists of a brief historical account of attempts at gul making from date palms, the report of a series of investigations conducted from 1915-1919 on the possibilities of the commercial manufacture of palm gul, a detailed description of the process of tapping the juice and making gul, and appendixes by P. C. Patil on gul making from brab, coconut, and *Bherli* palms, including data on the quantity per tree, chemical composition, deterioration on keeping, and effect of different preservatives of the juice and gul of palms.

The commercial possibilities of the sun drying of vegetables in Baluchistan, G. L. C. HOWARD (*Fruit Expt. Sta. Quetta [India] Bul. 10 (1920), pp. 22*).—This bulletin deals with the commercial aspects in India of the process of sun drying vegetables described in a previous bulletin (*E. S. R., 41, p. 116*). The main points to which attention should be called in the adaptation of the process to large scale manufacture are indicated, improvements and changes in the original apparatus and treatment are outlined, and tables are given of the estimated cost of production. The subject matter also includes testimonials from users of the sun-dried vegetables and a discussion of the commercial openings for sun-dried vegetables in India. Brief notes on the sun drying of black and white cherries, apricots, and apples are appended.

Technique of potato starch manufacture, C. C. MOORE (*Potato Mag., 2 (1920), No. 12, pp. 10, 11, 20, 22, 23; 3 (1920), No. 1, pp. 8, 9, 20, 22, 23*).—This paper consists of a detailed description of the various processes in the manufacture of potato starch, together with a discussion of the marketing possibilities of the product.

A practical study of corncob utilization, F. B. LA FORGE (*Chem. Age [New York]*, 28 (1920), No. 9, pp. 332-336, fig. 1).—The author discusses the possibilities in the commercial utilization of corncobs on the basis of chemical studies conducted at the Bureau of Chemistry, U. S. Department of Agriculture, a report of which by La Forge and Hudson has been previously noted (*E. S. R.*, 40, p. 17). It is thought that 100 tons of cobs can be made to yield about 45 tons of adhesive "A," 30 tons of adhesive "B," 35 tons of cellulose, 3 tons of acetate of lime, and 1½ tons of furfural. Adhesive "A" is a thick brown solution of gums which is obtained by heating the dry cobs with water under pressure and concentrating the resulting extract. Adhesive "B" is obtained by grinding the press-cake resulting from the extraction of adhesive "A" and boiling it with 1 per cent sodium hydroxid solution to separate the alkali-soluble material from the true cellulose. The resulting black liquid is evaporated to proper consistency for adhesive uses. Adhesive "A" may, if desired, be converted into furfural by heating it with dilute mineral acids.

A brief description is included of the various steps in the proposed process, together with estimated costs and returns of plants dealing with 100 and with 50 tons of cobs daily.

METEOROLOGY.

Evidence of climatic effects in the annual rings of trees, A. E. DOUGLASS (*Ecology*, 1 (1920), No. 1, pp. 24-32, 66, figs. 10).—The evidence here presented "has emerged in the process of dating and measuring about 85,000 annual rings which had grown in some 275 different trees in the States of Oregon, California, Arizona, Colorado, and Vermont, as well as in England, Norway, Sweden, Germany, and Bohemia." The evidence is of three kinds, (1) the direct correlation between the annual rings of yellow pine (*Pinus ponderosa*) and the rainfall at Prescott, Ariz.; (2) the marked resemblance found in certain individual rings over a wide extent of the country in which climate is the only common factor; and (3) an extension of (2) which, however, instead of merely taking into account similarities in individual rings, uses similarity in ring variation over large areas as determined by a form of harmonic analysis using an instrument devised by the author, called a periodograph, capable of analyzing plotted curves into their component cycles, if such exist.

It is found that "the rings of the yellow pine in northern Arizona show varying thickness in marked correlation with rainfall; the sequoias of California show similar characteristics in less degree. Climatic effects may also be detected by similarity in ring-growth over large areas." The author concludes that such studies may be made to disclose climatic combinations advantageous to certain types of vegetation, and may enable us to outline what might be called agro-meteorological districts—that is, areas over which exist similar advantageous combinations of weather elements.

A characteristic called "mean sensitivity" is suggested as a possible measure of climatic reaction. "This may be described as the difference between each two successive rings divided by their mean." The application of this criterion "promises to make possible the proper selection of sequoia records, which, in turn, will give us much climatic information about the last 3,200 years."

Solar variation and the weather, C. G. ABBOT (*Nature [London]*, 105 (1920), No. 2648, pp. 678-680, figs. 2).—Pyrheliometric and spectrophotometric observations, especially at Washington, Mt. Wilson, Mt. Whitney, and at Calama, Peru, showing solar variability and indicating a correlation between it and the weather, are briefly reviewed. It is shown that solar changes produce large and prolonged temperature effects. The successful use of the observations

in forecasting both temperature and precipitation, reported by Clayton of the Argentine Meteorological Service, is referred to.

Temperature variations in the North Atlantic Ocean and in the atmosphere, B. HELLAND-HANSEN and F. NANSEN (*Smithsn. Misc. Collect.*, 70 (1920), No. 4, pp. VIII+408, pls. 48, figs. 113).—This introductory memoir on the cause of climatic variations is based on a detailed study of variations in the temperature of the air and surface waters along the steamer route from the English Channel to New York City. In the light of their studies the authors consider the theory of oceanic control of temperature inadequate, and accept the theory that meteorological changes are caused mainly by solar variation as evidenced in sunspots, solar prominences, and magnetic disturbances, acting through the atmospheric circulation.

It is shown as a result of the investigations that "a very close relation exists between variations in the solar activity and variations in the meteorological phenomena of the earth. Even short interval variations in the radiation of the sun are shown very distinctly in our meteorological phenomena and in the surface temperature of the ocean. They act through variations of the air-pressure distribution, but the expression on the earth may take different directions according to conditions, running inverted to the solar variations or parallel to them. . . .

"Different groups of regions vary intact in a definite direction, while another group of regions varies in an opposite sense, and again still other regions show transition phenomena, partly on account of phase displacements and partly on account of mixed relationships to the primary groups. All this gives us a variegated picture of the meteorological fluctuations, but out of this same variegated picture we find also by a proper analysis the influence of the variations in the solar activity, which in all probability make themselves felt first in the higher layers of the atmosphere and thereby produce disturbances which again introduce changes in the lower layers. Such dynamic changes will take different courses in respect to the temperature, cloudiness, precipitation, etc., at different stations of the earth. But it seems possible by a thorough evaluation of available observational material to work out sure and general rules to cover the phenomena."

Meteorological influences of the sun and the Atlantic, J. W. GREGORY (*Nature [London]*, 105 (1920), No. 2649, pp. 715, 716).—A review of the article noted above, with references to previous investigations bearing upon the same subject.

The world's rainfall (*U. S. Geol. Survey Press Bul.* 452 (1920), p. 6; also in *Jour. Franklin Inst.*, 190 (1920), No. 3, p. 430).—"The total annual rainfall upon all the land of the globe amounts to 29,347 cubic miles, and of this quantity 6,524 cubic miles drains off through rivers to the sea. A cubic mile of river water weighs about 4,205,650,000 tons and carries in solution an average of about 420,000 tons of foreign matter. In all, about 2,735,000,000 tons of solid matter is thus carried annually to the ocean."

Climatological data for the United States by sections (*U. S. Dept. Agr., Weather Bur. Climat. Data*, 7 (1920), Nos. 1, pp. [213], pls. 4, figs. 2; 2, pp. [212], pls. 4, fig. 1).—These volumes contain brief summaries and detailed tabular statements of climatological data for each State for January and February, 1920, respectively.

Meteorological summaries (*Kentucky Sta. Rpt.* 1919, pt. 1, pp. 61-64).—Tables compiled from the records of the U. S. Weather Bureau at Lexington, Ky., summarize data for temperature, precipitation, humidity, wind, and cloudiness for 1919, and for temperature, precipitation, and wind for 1872-1919.

Weather [at the North Central Minnesota Substation], O. I. BERGH (*Minnesota Sta., Rpt. Grand Rapids Substa., 1915-1919, pp. 7-13*).—Observations on temperature, length of growing season, and precipitation at this station, from 1915 to 1919, inclusive, are tabulated and briefly discussed.

It is shown that the average mean temperature for the three winter months, December, January, and February, for the 5-year period, was 6.5° F., for the spring months 37.7°, for the summer months 64.5°, and for the fall months 39.3°. The average yearly mean temperature for the five years was 37.1°. The lowest temperature recorded was -47°, in January, 1915, and the highest 102°, in July, 1917. The winters are characterized by very low temperatures, which, however, usually occur in still, dry weather. The summer is marked by cool nights and warm days.

The average length of growing season during the five years was 112.8 days. The shortest season was 89 days in 1916 and the longest 149 days in 1919. The average annual precipitation for the 5-year period was 22.57 in., the greater portion of the precipitation occurring during the growing season.

Comparative observations on upland soil and on peat land of the muskeg showed that temperatures on the latter averaged from 1 to 2° lower than on the upland soil. Summer frosts are more frequent and more severe on the peat than on the upland. For this reason tender crops, such as corn or potatoes, can not be recommended for peat soils in this region. However, under proper management and fertilizer treatments oats and peas and timothy and clover can be successfully grown for hay; Kentucky blue grass, redtop, timothy, and clover for pasture; rape for soiling and temporary pasture; and rutabagas, turnips, carrots, cabbage, onions, celery, and lettuce for stock and for table use.

The climate of the Netherlands: Air temperature, C. M. A. HARTMAN (*Nederland. Konink. Med. Inst., Meded. Verhandel., 24 (1918), pp. 104; abs. in Nature [London], 105 (1920), No. 2645, p. 600*).—The available data, in one case from observations running back to 1743, are summarized and discussed, especially with reference to variations with latitude and distance from the sea.

“The annual variation is given for 24 years from 1894 to 1917, inclusive, at 12 stations; the range of temperature varies with latitude and with an increased distance from the sea. Diurnal variation is much affected by the influence of the sea. . . . The highest temperatures observed are 99° F. and 97° at Maestricht, respectively, on August 4, 1857, and July 28, 1911, and 97° at Oudenbosch on June 8, 1915. The lowest readings are -8° at Winterswijk on February 7, 1895, and at Katwijk-on-Rhine on February 14, 1895. Frequency of different temperatures is given for several stations and for all months, and the occurrences of diurnal variations of temperature for each degree Centigrade are tabulated, also the diurnal range for each of the 24 hours. One of the many tables shows the temperatures which occur each month, with the different directions of the wind.”

[Meteorology in South Australia], W. L. JOHNSTON (*So. Aust. Statis. Reg., 1918-19, pt. 5, pp. 144-150*).—Tables show the amount and distribution of rainfall and wheat yields in the agricultural areas of South Australia, 1906-1918; rainfall in different counties, 1879-1918; rainfall in towns, 1916-1918; rainfall at Adelaide observatory, 1854-1919; and observations on temperature and pressure at Adelaide observatory, 1910-1919.

SOILS—FERTILIZERS.

Soil survey of Pulaski County, Ga., A. H. MEYER (*U. S. Dept. Agr., Adv. Sheets Field Oper. Bur. Soils, 1918, pp. 25, fig. 1, map 1*).—This survey, made in cooperation with the Georgia State College of Agriculture, deals with the soils

of an area of 165,120 acres in south-central Georgia situated in the Coastal Plain region. The prevailing topography is gently rolling to rolling, and in general the drainage is fairly good.

The upland soils are derived from unconsolidated sands, clay, and marl, and the terrace and flood plain soils are of alluvial origin. Including swamp, 16 soil types of 9 series are mapped, of which the Norfolk, Ruston, and Plummer sandy loams cover 35.2, 12.2, and 10.2 per cent, respectively, of the area.

Soil survey of Horry County, S. C., B. W. TILLMAN ET AL. (*U. S. Dept. Agr., Adv. Sheets Field Oper. Bur. Soils, 1918, pp. 52, fig. 1, maps 2*).—This survey, deals with the soils of an area of 705,920 acres in northeastern South Carolina lying within the flat imperfectly drained coastal portion of the Coastal Plain. The surface of the county is predominantly level to undulating with a few low ridges and knolls and some large flat areas. Surface drainage is fairly well established in the northern and western portions, but throughout the flatter eastern part there are large areas which are inadequately drained.

The soils are prevailing sandy in the surface portion and are underlain by sandy clay or friable clay subsoils. With a few exceptions, the soils are light colored and deficient in organic matter. Including swamp, sand hill, coastal beach, and tidal marsh, 31 soil types of 13 series are mapped, of which swamp, Norfolk fine sand, and Norfolk fine sandy loam cover 20.3, 16.2, and 10.8 per cent of the area, respectively.

A study of moisture movement in the soil (*Kentucky Sta. Rpt. 1919, pt. 1, p. 24*).—It was found that the distance through which moisture will move in saturated sand, varying in fineness from 40 to 100 mesh, is approximately one and two-thirds times the distance of movement through air-dry sand.

A capillary transmission constant and methods of determining it experimentally, W. GARDNER (*Soil Sci., 10 (1920), No. 2, pp. 103-126, figs. 10*).—This article is a contribution from the Utah Experiment Station, the first part being a general theoretical discussion of soil-moisture movement, in which a capillary transmission constant is defined on theoretical grounds which is similar to the specific electrical conductivity of metals and to the specific thermal conductivity of heat conductors. Methods are described for the measurement of this constant in the laboratory.

Experimental data from various laboratory and field experiments at the station gave transmission constant values under various conditions of porosity ranging from -1.8×10^{-3} for a very loose unpacked soil to -8.7×10^{-3} for a field plat, with a mean value of -5.8×10^{-3} c. g. s. units.

An illustrative calculation is made indicating that approximately 12 in. of water may be available from a 12-ft. water table in a period of 30 days. This result was not corrected for the influence of gravity.

The entire contribution emphasizes the method rather than the finality of the results obtained.

Hygroscopicity and hydrologic importance of moss, L. PICCIOLI (*Staz. Sper. Agr. Ital., 51 (1918), No. 7-8, pp. 312-315*).—Experiments to determine the absorptive capacity of samples taken from thick carpets of 10 species of moss in the natural state on forest soils are reported. As soon as gathered the moss was soaked in water for half an hour, drained until it released no more water, and then weighed. It was next dried in a well-ventilated place until the water content was reduced to from 12 to 15 per cent and weighed again. It was found that a square mile of steeply sloping land covered with moss may hold and conserve from 91,500 to 275,000 cu. ft. of water which would otherwise be wasted as run-off.

The carbon dioxide of the soil air, H. W. TURPIN (*New York Cornell Sta. Mem., 32 (1920), pp. 319-362, figs. 17*).—Following an historical review of the

subject, experiments are reported, the first of which consisted of a study for two seasons in the greenhouse of the relation between the carbon dioxide in cropped and uncropped soil where an oats crop introduced the only variable. The object of the second experiment was to determine the influence of some crop other than oats in the production of carbon dioxide. A third experiment on the subject was also performed with millet following oats. A clay loam soil maintained at a constant moisture content of 30 per cent was used.

It was found that an oats crop increased the production of carbon dioxide in the soil. The increase was marked after the first month from the time of seeding and reached a maximum just previous to or after the plants headed, after which there was a gradual decline. Millet produced about the same increase in carbon dioxide as oats, but the production by each millet plant was approximately half as much as that by each oats plant. The most marked rise in the carbon dioxide content of the soil occurred at a later period of growth in the case of the millet than of the oats.

The cropped soil maintained a higher carbon dioxide content after the crop was harvested than the bare soil, which is attributed to the decomposition of plant roots left in the soil. It seemed that increased plant growth was accompanied by increased carbon dioxide production, owing to the fact that a relationship was found between the carbon dioxide produced, presumably by the crop, and the water transpired. Fluctuations in the content of carbon dioxide in the bare soil were accompanied by similar fluctuations in the cropped soil only after the removal of the crop and before the crop had made much growth.

There appeared to be little relationship between the temperature of the soil at the time of sampling and the carbon dioxide in the cropped soil or that assumed to be produced by the crop. In the bare soil the carbon dioxide was usually high during warm weather and low when the temperature decreased. Very low atmospheric pressures were usually accompanied by an increase in the content of carbon dioxide in the bare soil. The carbon dioxide produced, presumably by the plant, was about the same in soils having a high initial carbon dioxide content as in those low in carbon dioxide, indicating the probability that plants and soil organisms act independently in producing carbon dioxide.

It is concluded that the plant itself and soil organisms produce most of the carbon dioxide in the soil, that the plant often produces at the period of its most active growth many times as much carbon dioxide as is produced by soil organisms, and that the excess carbon dioxide in the soil growing a crop is due to respiratory activity of the plants rather than to the decay of root particles from the crop growing on the soil at the time of analysis.

A bibliography is included.

Organic phosphorus content of Ohio soils, C. J. SCHOLLENBERGER (*Soil Sci.*, 10 (1920), No. 2, pp. 127-141, fig. 1).—Studies conducted at the Ohio Experiment Station are reported on the organic phosphorus content of samples from 12 types of Ohio soils and the relation of this to other soil constituents.

The observations made were based upon the examination of virgin and cultivated samples from each soil type, using both surface and subsurface soil. The average figures indicated that virgin surface samples are considerably richer in total phosphorus than the corresponding cultivated samples of the same type, and that virgin subsurface samples contain slightly more total phosphorus than cultivated soils at the same depth. The organic phosphorus contents of the several samples from the average soil type stood in the same order as the contents of total phosphorus. The organic phosphorus bore very nearly the same percentage relation to the total phosphorus in cultivated soils as in virgin soils at the same depths in the greater number of cases. One-third of the

phosphorus in the surface and one-fifth of that in the subsurface samples of both virgin and cultivated soils were found to be in the organic form.

The organic phosphorus and humus soluble in ammonia were shown to be closely related to each other, to total nitrogen in the soil, and, to a less extent, to the color of the ammonia extract. It was found that if 100 represents the percentage of ammonia-soluble humus obtained from a soil, the total nitrogen in the soil is 10 and the organic phosphorus in the ammonia extract 1. Except as noted, there did not appear to be any connection between other soil constituents and organic phosphorus present.

The soil reaction appeared to be without influence upon the quantity and nature of the organic phosphorus present. Some evidence was obtained that the organic phosphorus compounds of cultivated soils are decomposed slightly more readily than are those of the virgin soils examined. From general considerations it is thought that the phosphorus in organic combinations in the soil is not of a very high order of availability.

Deficiency of plant-food calcium in soils (*Kentucky Sta. Rpt. 1919, pt. 1, pp. 29-31*).—Studies by O. M. Shedd of six different Kentucky soils of relatively low calcium content and varying from slightly to strongly acid, to determine whether they were capable of supplying sufficient calcium for plant growth, are reported.

Calcium nitrate, calcium oxalate, and a calcium-sodium citrate were applied to the soils. The results showed marked differences in the response of the several soils to the application of calcium compounds. In some the crops were increased and in others decreased. The response was greater in the growth of the plant than in the seed, and the plants grown in the presence of calcium contained more of this element than those grown in soils to which none was applied.

This work is being continued.

Unreliable experimental methods of determining the toxicity of alkali salts, F. B. HEADLEY (*Science, n. ser., 51 (1920), No. 1310, pp. 140, 141*).—The author reviews the conclusions of others, drawn from investigational work on the toxicity of alkali salts, notably those by Harris and Pittman (*E. S. R., 40, p. 315*), and is of the opinion that such results and conclusions should be based upon the amounts of salts recoverable from the soil by analysis instead of on the amounts of salts added.

The management of Palouse soils, P. P. PETERSON (*Idaho Sta. Circ. 12 (1920), pp. [3], fig. 1*).—This is a summary of Bulletin 118 of the station, previously noted (*E. S. R., 43, p. 227*).

Agricultural value and reclamation of Minnesota peat soils, F. J. ALWAY (*Minnesota Sta. Bul. 188 (1920), pp. 7-136, figs. 111*).—The first sentence in the second paragraph of the abstract of this bulletin (*E. S. R., 43, p. 420*), should be corrected to read: Drainage is the first essential step in the reclamation of these soils, followed by liming as an indispensable step on the low-lime peats.

The best methods of laying down and improving grass land, D. A. GILCHRIST (*Jour. Farmers' Club [London], 1920, pt. 4, pp. 65-88*).—This is a very popular discussion on the use of fertilizers, lime, and seed mixtures in the improvement of pasture soils.

Soil fertility (*Kentucky Sta. Rpt. 1919, pt. 1, pp. 21, 22*).—Data on the effect of a four-year rotation of corn, soy beans, wheat, and clover on a field on which tests of various fertilizing materials were made are given, showing that the application of fertilizers has not produced any significant increase in crop but that the use of legumes has increased the corn crop.

Soil fertility investigations, O. I. BERGH (*Minnesota Sta., Rpt. Grand Rapids Substa., 1915-1919, pp. 34-50, figs. 4*).—In a manure and phosphate experiment

on upland soil a comparison was made of acid phosphate and ground rock phosphate on a three-year rotation of oats; clover and timothy meadow; and potatoes, rutabagas, and corn. The phosphates were applied with and without manure. It was found that the application of 10 tons of manure once in 3 years produced an average increase of 94.8 bu. of potatoes, 7.3 bu. of oats, and 0.43 tons of hay. The addition of either acid or rock phosphate along with the manure failed to produce a distinct increase in yield, and the same phosphates when applied without manure showed little or no effect even with rutabagas.

In a rate-of-manuring experiment stable manure was applied at the rates of 5, 10, and 20 tons per acre just before plowing for the cultivated crop. In this experiment potatoes proved to be the most satisfactory cultivated crop, the increase being especially marked with all three rates of manuring. The greatest return per ton of manure applied was obtained from the lowest rate, but the increased cost of application more than offset this gain. Each ton of manure at the 5-ton rate gave an increase of 10.5 bu. of potatoes, 1.4 bu. of oats, and 88 lbs. of hay. At the 10-ton rate the increases were 9.6 bu. of potatoes, 0.5 bu. of oats, and 92 lbs. of hay. At the 20-ton rate the increases were 5.8 bu. of potatoes, 0.5 bu. of oats, and 53 lbs. of hay.

In an experiment on the value of peat as a fertilizer six $\frac{1}{16}$ -acre plats received applications of peat just before plowing for the cultivated crop. The yields of corn, rutabagas, and potatoes so far obtained are not considered to be satisfactory evidence of the value of peat.

Further experiments on peat soil cropped to a 3-year rotation of grain, clover, and timothy meadow, and a cultivated crop, and receiving 10 tons of manure once in a rotation, showed that the peat soil did not produce crops equal to those produced by adjoining mineral soil. Marked increases in crops were obtained through the use of ground limestone, and there was a marked decrease in weeds. Where lime was not applied the legumes, such as clover and alfalfa, were entirely absent.

Manure v. commercial fertilizers for Maryland soils, A. G. McCALL (*Rpt. Md. Agr. Soc.*, 4 (1919), pp. 187-194).—Field experiments on ten of the important soil types of Maryland, conducted at the Maryland Experiment Station to obtain information regarding the use of stable manure and commercial fertilizers in the State, are reported.

On a reddish brown shale loam soil, part of which had been cleared for from 40 to 50 years and part for only about 5 years, it was found that for the old land organic matter is the limiting factor. Until this is supplied no combination of fertilizer elements is likely to bring about maximum production. On the other hand, it was found that phosphorus alone may be used with good results on the new land.

Experiments on an old, worn, silt-loam soil, with a tight clay subsoil, showed that for soils of this type good results will follow the use of stable manure, reinforced with phosphorus, or the use of several different commercial fertilizer mixtures.

Experiments on a silt-loam soil indicated the great need for organic matter. Neither a complete fertilizer nor phosphorus alone or in combination with potash gave increases in the yield of wheat and grass comparable with those produced with the use of manure alone or reinforced with floats or with acid phosphate. A complete fertilizer gave the largest increase in tomatoes, but manure alone and in combination with phosphorus gave the largest increase in the corn crop.

The occurrence and nature of the plant growth-promoting substances in various organic manurial composts, F. A. MCKERIDGE (*Biochem. Jour.*, 14 (1920), No. 3-4, pp. 432-450).—A number of experiments conducted at King's

College, London, are reported in which it was found that the ordinary organic manures, which are generally applied to soils in agricultural and horticultural operations, namely, leaf mold and fresh and well-rotted stable manures, contain water-soluble substances in varying proportions which are effective as plant growth-promoting substances or auximones. Such ingredients were also found in well-manured fertile soil.

A comparison between fresh and well-rotted stable manures showed that in all cases, in whatever proportions the materials were used, the extract of rotted manure was more effective than that of the fresh material, while an extract of peat, which had been artificially subjected to bacterial decomposition, was more effective than either. The increase in growth following the addition of these materials to the culture solutions was such as could not be attributed to the purely nutritive value of the materials added, and all these composts are, therefore, assumed to contain growth-promoting substances. The amount of these substances varied directly with the extent of the bacterial decomposition of the material, which was found to be an important factor in determining the practical effectiveness of the composts.

Microscopic examinations showed that the various auximones have a marked influence on the size and contents of the cell, especially on the nucleus. A detailed examination was, therefore, made of well-manured soil, leaf mold, and fresh and well-rotted stable manures to determine their content of derivatives of nucleic acid. It was found that all these materials contain appreciable quantities of nucleic acid and its derivatives in various stages of decomposition. The greater the extent of the decomposition, the more effective was a water extract of the material when added to a culture solution. Assuming that the whole effect is due to nucleic acid or its derivatives, it appeared that the free bases, individually or collectively, are of more value as growth-promoting substances than the nucleic acid. It is considered evident, therefore, that part at least of the beneficial effect of organic manures must be due to the direct value of these substances to plants.

The catalytic oxidation of ammonia to nitric acid, B. NEUMANN and H. ROSE (*Ztschr. Angew. Chem., Aufstz., 33* (1920), Nos. 14, pp. 41-44; 16, pp. 45-48, figs. 5; 18, pp. 51-55, figs. 6).—A series of experiments on the oxidation of ammonia to nitrates with different contact substances, such as platinum and the oxids of iron, chromium, copper, and vanadium are reported, and the results compared with the findings of other investigators.

The possible and actual reactions entering into the process are discussed, and the influence of ammonia concentration, current speed, and temperature studied. The best results were obtained with platinum with a 96 per cent transformation at 500° C. iron oxid with 90 per cent transformation at 670°, and iron bismuth oxid with 95 per cent transformation at 600°.

Diagrams showing the gas composition for these three catalyzers for temperatures of from 300 to 700° are given. On the basis of the gas compositions established, the temperatures of reaction for certain gas mixtures are computed, showing that under determined conditions the transformation of ammonia to nitrates is possible without further additions of heat.

Relative value of acid phosphate and rock phosphate on North Carolina soils, C. B. WILLIAMS, W. F. PATE, E. C. BLAIR, S. C. CLAPP, and F. T. MEACHAM (*Bul. N. C. Dept. Agr., 41* (1920), No. 6, pp. 22, figs. 8).—Experiments on the relative value of acid phosphate and rock phosphate conducted on several experimental farms in North Carolina are reported.

At the Buncombe farm, acid phosphate was found to give larger crop yields than rock phosphate when both were used (1) with nitrogen and potash, (2) with stable manure, and (3) with potash and legumes turned under. On

the Cherokee field, acid phosphate used with lime gave increased yields, while finely ground rock phosphate with lime on an average yielded less than did the use of lime alone.

At the Iredell farm, as an average of nine years' results, acid phosphate gave greater returns than rock phosphate when both were used (1) with nitrogen and potash and (2) with stable manure. On another field at the Iredell farm acid phosphate in a complete fertilizer mixture for a period of 10 years gave greater net returns above cost of materials applied than 500, 1,000, 1,500, 2,000, and 3,000 lbs., respectively, of rock phosphate per acre once per rotation just before turning into the soil the second crop of clover. In the same test the use of 4,000 lbs. of rock phosphate per acre applied once every three years yielded greater net returns than acid phosphate in a complete fertilizer applied annually.

At the Edgecombe farm, acid phosphate used with nitrogen and potash and with stable manure produced larger net returns over a period of 10 years than four times the same amount of rock phosphate used (1) with normal amounts of nitrogen and potash and (2) with stable manure.

It is concluded that acid phosphate is generally a more profitable carrier of phosphoric acid than finely ground phosphate rock when used under most crops grown on the main soil areas of the State. It is pointed out, however, that large applications of rock phosphate applied broadcast at 3-year intervals in crop rotations which include suitable green manuring appear to be advantageous treatments.

The value of raw phosphate in agriculture, W. V. KNIERIEM (*Deut. Landw. Presse*, 47 (1920), No. 48, pp. 345, 346).—The author reviews a number of experiments on the fertilizing value of raw rock phosphate on different soils with different crops.

It was found that phosphorite meal showed practically no fertilizing action on lowland moor soil rich in basic matter, except in cases where free sulphates existed which acted on the phosphorite. It is concluded that raw phosphate can be used to advantage only on upland moor soils, and then only after it has been composted with sulphates and peat litter or smelted with lime, sand, and soda.

Preliminary report on potash exploration in New Jersey greensands, G. R. MANSFIELD (*Ann. Rpt., Dept. Conserv. and Development, N. J., 1919*, pp. 99-104).—The general geology of the New Jersey greensand beds is described.

The fertilizer situation, M. WHITNEY (*Chem. and Metall. Engin.*, 22 (1920), No. 22, pp. 1021-1023).—This is a general review of the fertilizer situation in which the present tendencies of the fertilizer industry are discussed, with particular reference to the recovery of the phosphoric acid in the waste rock phosphate of the acid phosphate industry. Other features of the situation, including the theory of fertilizer use and the solution method of applying concentrated fertilizer salts, are also considered.

1920 yearbook of commercial fertilizer (*Yearbook Com. Fert., 1920*, pp. 324, figs. 64).—This yearbook contains a list of fertilizer manufacturers and directories of allied trades, together with data on cottonseed-oil mills, agricultural experiment stations, officials in charge of State fertilizer laws, and fertilizer machinery, materials, manufacturers, and dealers. A number of special articles on the subjects of fertilizers and soil fertility are also included.

Official fertilizer analyses, 1920, R. E. ROSE and G. HART (*Fla. Quart. Bul. Agr. Dept.*, 30 (1920), No. 3, pp. 78-81).—This section of this bulletin contains results of actual and guaranteed analyses of 31 samples of fertilizers and fertilizer materials collected for inspection in Florida during the second quarter of 1920.

Commercial fertilizers, E. G. PROULX ET AL. (*Indiana Sta. Bul.* 241 (1920), pp. 3-99, fig. 1).—This bulletin contains the results of actual and guaranteed analyses of 1,401 samples of fertilizers and fertilizer materials, representing 716 brands, collected for inspection in Indiana during the spring and fall of 1919.

It was found that the greatest number of deficiencies were in potash. Of the 31 classes available for inspection, 26 were found to equal or exceed the guaranty in every particular, 2 were below the guaranty in nitrogen, 3 in potash, and 1 in total phosphoric acid.

Analyses of fertilizers—spring season, 1920, J. K. PLUMMER, JR. (*Bul. N. C. Dept. Agr.*, 41 (1920), Nos. 9, Sup., pp. 7; 11, Sup., pp. 9).—These bulletins contain the results of actual and guaranteed analyses and valuations of 130 and 123 samples, respectively, of fertilizers and fertilizer materials collected for inspection in North Carolina during the spring season of 1920.

AGRICULTURAL BOTANY.

General botany, H. D. DENSMORE (*Boston: Ginn & Co.*, 1920, pp. XII+459, pl. 1, figs. 292).—Of the three main parts of this book, the first deals with biology of the higher seed plants, the second with the plant groups, and the third with representative families and species of the spring flora. Laboratory directions are printed under separate cover.

New methods and aims of botanical systematization, A. THELLUNG (*Naturw. Wchnschr.*, 33 (1918), Nos. 32, pp. 449-458, figs. 3; 33, pp. 465-474).—This method, employing in addition to the principles of morphology those of hybridization, phytogeography, and serology, is illustrated as dealing principally with the cereals *Avena*, *Triticum*, *Secale*, and *Hordeum*.

On the stability and heredity of *Cratægomespilus* and of *Pirocydonia*, L. DANIEL (*Compt. Rend. Acad. Sci. [Paris]*, 169 (1919), No. 11, pp. 513-515).—A study of *Cratægomespilus*, a graft hybrid between hawthorn and medlar, shows the hybrid to possess incomplete stability, separating in various degrees the parental characters, both morphological and physiological, and showing complete sterility. *Pirocydonia danieli*, completely lacking in sexuality, is said to be stable.

Survey of *Oenothera* problems, H. N. KOOIMAN (*Genetica [The Hague]*, 1 (1919), No. 2, pp. 134-148).—This is a synthetic review of work bearing on the problems presented by *Oenotheras*, including reference to about 20 related publications.

The *Oenotheras* as nuclear chimeras, J. P. LOTSY, H. N. KOOIMAN, and M. A. J. GOEDEWAAGEN (*Genetica [The Hague]*, 1 (1919), No. 2, pp. 113-129).—This is an analytical discussion of Morgan's crossing-over hypothesis.

Anomalous papayas and digitiform oranges, C. BERNARD (*Ann. Jard. Bot. Buitenzorg*, 31 (1920), pt. 1, pp. 26-36, pls. 2, fig. 1).—Accounts with discussion are given of anomalies of development and associated features mainly affecting the reproductive regions as exemplified in *Carica papaya* and in *Citrus medica limonum digitata*.

Heredity studies with beans, K. TJEBBES and H. N. KOOIMAN (*Genetica [The Hague]*, 1 (1919), No. 4, pp. 323-346, pl. 1).—This contribution is in two parts, each summarized in French. The first deals with experimentation in the crossing of two varieties of *Phaseolus vulgaris*, the results of which are held to indicate a Mendelian monohybrid segregation. The second part deals with a constant spotting in a spontaneous hybrid.

Recent methods of phylogenetic plant anatomy, W. NIENBURG (*Naturw. Wchnschr.*, 33 (1918), No. 8, pp. 105-112, figs. 26).—This is a review of what are

considered important contributions to the methods employed in phylogenetic study in plants.

Studies in electrophysiology, A. E. BAINES (*London: George Routledge & Sons, Ltd., 1918, pp. XXIX+291, pls. 10, figs. 167*).—The author gives an account of studies on animal and vegetable electrophysiology conducted by himself during some years. The principal conclusion arrived at is that everything living possesses a well-defined electrical system, while the nonliving has capacity only.

Every tree, shrub, fruit, vegetable, tuber, and seed is an electrical cell that can not be polarized or discharged so long as it remains structurally perfect. The skin, peel, rind, or jacket of fruits and vegetables is a sort of insulating substance designed primarily for the conservation of electrical energy. The electromotive force is the same in all, the current varying in accordance with Ohm's law.

Plants grown in pots or removed from the earth and placed in other receptacles differ materially in their electrical constitution from those grown in the earth. If a suitable electrolyte, other than water, is mixed with the soil it is possible to grow plants with much less moisture. Growth may be stimulated by means of a continuous current of electricity of low potential and proper sign.

Broadly speaking, the edible part of a fruit or vegetable is the positive element, or that part which yields a positive galvanometric reaction. Dry earth is a bad conductor of electricity, and therefore water is required as an electrolyte, being necessary also in the formation of protoplasm.

Physiological studies on tree architectonics, H. LUNDEGÅRDH (*K. Svenska Vetensk. Akad. Handl., 56 (1916), No. 3, pp. 64, pls. 11, figs. 17*).—These studies deal with tree form, structure, and modifications of these during growth under various influences.

Recent studies on growth in thickness of trees, P. JACCARD (*Nouvelles Recherches sur l'Accroissement en Épaisseur des Arbres. Zurich: Fondation Schnyder von Wartensee, 1919, pp. XII+200, pls. 32, figs. 74*).—These studies were intended to test the author's physiological theory of tree growth. They are divided into five main parts dealing respectively with the tree stem as offering equal resistance to flexion; the trunk considered as having equal conducting capacity for water; mechanical actions resulting from growth in thickness (also influence of weight and geotropism; experiments carried out with trees of numerous varieties; and considerations bearing upon a physiological theory of growth, concentric and eccentric.

Summing up a large number of detailed conclusions, the author holds that the general form of trees is not the product of a gradual selection of useful variations, but that it is determined principally by the factors, both mechanical and physiological, which act in analogous ways in all of the arborescent species.

Heat production and temperature in living plants, E. LEICK (*Biol. Zentbl., 36 (1916), No. 6-7, pp. 241-261*).—This is mainly a bibliographic discussion of biological production of heat, respiration being regarded as the most important source in plants as well as in animals.

The influence of light on the fructification of Agaricaceæ in pure culture, R. MAIRE and M. DE LARQUETTE (*Bul. Soc. Hist. Nat. Afrique Nord, 10 (1919), No. 5, pp. 94-106, pl. 1*).—The authors name 35 genera of Autobasidiomycetes with about twice as many species, from cultures of which various authors named have obtained fructification. The results are given of tests on the influence of factors (principally illumination) on fructification.

Length of day instead of temperature controls time of flowering and fruiting (*Torreyia, 20 (1920), No. 3, pp. 46-50*).—This is a condensed account of the work and conclusions reported by Garner and Allard (*E. S. R., 42, p. 818*).

An apparent daily autonomous periodicity [in plants], L.-G. ROMELL (*Svensk Bot. Tidskr.*, 12 (1918), No. 4, pp. 446-463, fig. 1).—In a preliminary report it is stated that under practically constant condition *Brassica oleracea* exhibited a certain daily periodicity.

Comparative studies on respiration, VII-X (*Jour. Gen. Physiol.*, 2 (1919), No. 1, pp. 1-3; pp. 5-15, figs. 5; pp. 17-24, figs. 3; 2 (1920), No. 4, pp. 331-336, figs. 3).—Four parts of this series (E. S. R., 41, pp. 524, 632) are here presented.

VII. *Respiration and antagonism*, by W. J. V. Osterhout.—The development of new methods for measuring respiration and photosynthesis has facilitated comparative investigations regarding the antagonistic effects of salts on different organisms. In this report (which is regarded as preliminary) certain improvements in the technique are discussed, and certain agreements and disagreements in results are noted.

VIII. *The respiration of Bacillus subtilis in relation to antagonism*, by M. M. Brooks.—The investigations here noted were undertaken to throw light on the question of the antagonistic effects of salts on certain bacteria in relation to respiration. Using the apparatus previously described by Osterhout (E. S. R., 41, p. 524), it was found that in relatively low concentrations of sodium chlorid, potassium chlorid, and calcium chlorid the rate of respiration of *B. subtilis* remains fairly constant for several hours, while in higher concentrations a gradual decrease in the rate occurs. Sodium chlorid and potassium chlorid increased the respiration rate of *B. subtilis* somewhat at concentrations of 0.15 N and 0.2 N, respectively. In sufficiently high concentrations they decreased the rate. Calcium chlorid increases the rate of respiration at 0.05 N and decreases the rate at somewhat higher concentrations.

The effects of salts upon respiration show a well-marked antagonism between sodium chlorid and calcium chlorid and between potassium chlorid and calcium chlorid. The antagonism between sodium chlorid and potassium chlorid is slight, the antagonism curve showing two maxima.

IX. *The effects of antagonistic salts on the respiration of Aspergillus niger*, by F. G. Gustafson.—The author has begun with *A. niger* a study of the relation of antagonistic salts to the respiration of higher fungi.

It was found that in the presence of 0.05 per cent of dextrose the respiration of *A. niger* is increased by sodium chlorid in concentrations of 0.25 to 0.5 N and by 0.5 N calcium chlorid. Stronger concentrations decreased respiration. The decrease corresponding to higher concentrations is thought to be due to an osmotic effect of these salts. A mixture of 19 cc. of sodium chlorid and 1 cc. of calcium chlorid (both at 0.5 N) showed antagonism, the respiration being normal in this case, although each salt alone caused an increase. Spores of *A. niger* which did not germinate on 0.5 N sodium chlorid (plus 0.05 per cent dextrose) germinated on 0.5 N calcium chlorid (plus 0.05 per cent dextrose) and on various mixtures of the two. This shows that a substance may have effects on respiration different from those which it has upon growth.

X. *Toxic and antagonistic effects of magnesium in relation to the respiration of Bacillus subtilis*, by M. M. Brooks.—Employing technique similar to that described above, the author found that concentrations of magnesium chlorid up to 0.01 N had little effect upon the respiration rate of *B. subtilis*; at 0.03 N an increase occurs in the rate, and at higher concentrations a gradual decrease. A well-marked antagonism is noted between magnesium chlorid and sodium chlorid, also a very slight antagonism between magnesium chlorid and calcium chlorid.

Phytochemical investigations on indigenous and naturalized plants, I, J. A. DOMÍNGUEZ, J. F. MOLFINO, and E. L. DE GALLELLI (*An. Soc. Quím. Argentina*, 7 (1919), No. 29, pp. 5-11).—Preliminary studies are indicated as fur-

nishing data for more specialized studies to follow regarding the content of numerous plants named in cyanoglucosids, saponins, alkaloids, oxidases, peroxidases, and other principles.

Review of the genus *Arceuthobium* (Razoumofskya) with particular reference to its biology and practical significance, C. VON TUBEUF (*Naturw. Ztschr. Forst u. Landw.*, 17 (1919), No. 6-9, pp. 167-273, figs. 50).—This contribution, which treats systematically, geographically, and practically of *Arceuthobium* (Razoumofskya) spp. and their hosts, is in four main sections dealing respectively with mistletoes and witches' brooms, mistletoes and their hosts, the biology and pathology of mistletoes, and the abundant literature of the subject.

Permeability in plant cells, F. WEBER (*Naturw. Wchnschr.*, 33 (1918), No. 7, pp. 89-95).—This is largely a synthetic and interpretative discussion of the data and conclusions of others regarding osmotic relations in plant cells.

Quantitative laws in regeneration, I, J. LOEB (*Jour. Gen. Physiol.*, 2 (1920), No. 3, pp. 297-307, figs. 4).—Regeneration, the growth of resting cells or bodies following removal of parts of the body, presents problems relating to the quantity of growth as measured by the mass of the regenerated parts and relating also to the problem of the inhibition of such growth pending removal of a portion of the body. A review is given by the author of his own studies and conclusions regarding such phenomena. It is claimed that equal masses of sister leaves of *Bryophyllum calycinum* produce equal masses of shoots and roots in equal time and under like conditions.

The mass of shoots and roots produced by different masses of sister leaves in equal time and under similar conditions is approximately in direct proportion to the masses of the leaves.

When a piece of stem inhibits the production of shoots and roots in a leaf of *Bryophyllum* connected with it, the stem gains in mass. This gain is equal approximately to the mass of shoots and roots the leaf would have produced if it had been detached from the stem. This suggests that the inhibitory influence of the stem upon formation of shoots and roots of the leaf is due to the fact that the material available for this process naturally flows into the stem.

The nature of the directive influence of gravity on the arrangement of organs in regeneration, J. LOEB (*Jour. Gen. Physiol.*, 2 (1920), No. 4, pp. 373-386, figs. 9).—It has been shown in previous papers (E. S. R., 42, p. 26) that the leaves of *Bryophyllum calycinum* suspended in moist air sidewise, in a vertical plane, form roots and shoots in the notches predominately or exclusively on the lower side of the leaves. Stem sections develop roots generally on the lower side but on both sides at the basal end. It has been suggested that this directive force of gravity may be due to a combination of two factors, namely, gravity (collecting more sap on the lower side), and an inhibitory factor (organs growing at first or growing quickly, generally retarding or inhibiting the growth of similar organs elsewhere).

The present paper shows that in leaves suspended in moist air a red pigment is formed which tends to collect gradually in the lower parts of a vertically suspended leaf, thus serving as an indicator for the distribution of the sap and proving its tendency to collect in greater abundance at the lower end of a leaf so suspended. It is also stated that leaves or stems of *Bryophyllum* suspended as described under water develop roots on both upper and lower sides, the directive force of gravity upon the organs being absent in this case, since the abundance of outside water reduces the effect of a slight difference in the sap distributed (as between the upper and lower side) to a negligible factor.

It is claimed that in the lower halves of leaves suspended sidewise and vertically in moist air, the dry weight is greater than in the upper halves, this fact indicating a greater movement of materials into the growing organs of the lower half. In the water no such difference develops.

Resistance of intracellular organisms to certain chemical substances, V. GALIPPE (*Compt. Rend. Acad. Sci. [Paris]*, 169 (1919), No. 11, pp. 515-518).—Notes are given of studies on intracellular microorganisms in both plant and animal tissues. These organisms resisted ordinary disinfectants and remained viable for a considerable time.

The influence of some organic substances on the development of plants, III, G. CIAMICIAN and C. RAVENNA (*Atti R. Accad. Lincei, 5. ser., Rend. Cl. Sci. Fis., Mat. e Nat.*, 28 (1919), I, No. 1-2, pp. 13-20).—This work, a continuation of that previously noted (*E. S. R.*, 39, p. 526), deals principally with the development of beech seedlings under conditions involving the addition of certain organic substances to the nutritive medium. The authors' results and observations are given in some detail.

A device for regulating the temperature of incubators either above or below room temperature, J. H. NORTROP (*Jour. Gen. Physiol.*, 2 (1920), No. 4, pp. 309-311, fig. 1).—The device described in this paper is said to have been in use continually during several years and to have proved reliable and accurate. It consists essentially in regulating the flow of water through the jacket of a double-walled incubator. The device is described, with explanation of adjustments.

FIELD CROPS.

The unreliability of short-time experiments, F. S. HARRIS and N. I. BUTT (*Jour. Amer. Soc. Agron.*, 12 (1920), No. 5, pp. 158-167).—This paper, a contribution from the Utah Experiment Station, reports studies of a number of irrigation, fertilizer, soil, and crop experiments at the station, the purpose of which was to show the extent of fluctuations in yields during different years, the influence of these fluctuations on results variously summarized, and the specific dependence that should be given to data obtained in a given length of time. Data are included from experiments using as crops potatoes, sugar beets, alfalfa, corn, oats, and wheat.

It was found that short-time experiments are especially subject to error where a complete cycle of seasonal fluctuations is not included. All treatments in an experiment are not affected relatively the same each season, the amount of divergence varying in different years. Where variations from the average conditions are large a greater number of years are required for accurate conclusions than where the variations are small. Manuring experiments show wider variations from the average than irrigation experiments. Under dry-farming conditions variations are wider than under irrigation conditions, and small irrigations vary more than where the plant does not suffer for water.

In these experiments potatoes varied the most in yield, followed in order by sugar beets, alfalfa, corn, oats, and wheat. Experiments requiring personal judgment varied more than where measurements were mechanical. Average results during several abnormal years ran contrary to results in normal years that followed. Progressive seasonal averages showed a gradual shifting of the relative positions of part of the treatments in an irrigation experiment with corn. In experiments where variations are comparatively large an exceptional season may seriously affect the average of a 10-year period.

[Report of field crops work at the Grand Rapids, Minn., Substation], O. I. BERGH (*Minnesota Sta., Rpt. Grand Rapids Substa., 1915-1919, pp. 14-33*,

figs. 7).—Cultural, variety, fertilizer, and rotation tests are reported, and field practices and cultural methods with potatoes and root crops described.

Maximum average yields in the spring wheat variety tests for 1915 to 1918 were made by Minnesota 951 and Kubanka, both durum wheats, with 24.58 and 22.72 bu., respectively; Red Chaff, fife wheat, 22.24 bu.; and Prelude, 22.3 bu. The leaders in the 1919 tests included emmer and Acme (durum) with average yields of 21.48 and 10.41 bu. per acre, respectively. Poor yields in 1916 and 1919 were attributed to black stem rust. Although Prelude, a very early short-strawed variety of durum, was susceptible to the disease, it showed superiority over the fifes and bluestems as to hardiness, and is recommended as one of the best hard spring wheats for the district. Milling tests indicated that Prelude is fully as good as any of the common varieties.

Variety tests of winter wheat showed Minnesota Selections No. 1507 and 1493, Turkey×Odessa hybrids, leading in the average of two crops, 1916 and 1919, with respective acre yields of 24.7 and 23 bu. Lack of moisture rather than hardiness was the determining factor in 1917 and 1918, and the yields for those years were not considered indicative of winter hardiness. No evidence was presented showing that bearded varieties were better yielders than awnless.

Kherson, an early variety, with acre yields of 76.75 bu., and Banner, a mid-season sort, with 75.24 bu., averaged best in oat tests during the period 1915 to 1918; and Iowa No. 103, with 45.67 bu., was first in 1919 tests. Odessa, a 6-rowed barley, and Austrian Hannah, a 2-rowed variety, were first with respective average acre yields of 38.68 and 37.54 bu. for the 4-year period, and Minsturdi led the tests in 1919 with 40.27 bu. per acre. In 1919 tests of winter rye Rosen was highest with a yield of 31.7 bu. per acre and a total yield of 4,069 lbs. of grain and straw. Spring rye yielded only about one-third as much as the winter varieties and the grain was of poorer quality.

Rate-of-seeding tests with winter wheat and winter rye indicated that 6 pk. is the minimum amount that can be recommended for both crops. This amount gave maximum yields when sown between August 20 and September 1. Winter wheat and winter rye sown August 15 in time-of-seeding tests made 2-year average yields of 24.49 and 33.25 bu. per acre, respectively, surpassing all later plantings in yield.

In a test of 8 field pea varieties, Wisconsin No. 508 was first with an acre yield of 30.5 bu.

Northwestern Dent and Squaw Flint, with respective acre yields of 47.5 and 36 bu. of air-dry shelled grain, were the highest producers among the corn varieties in 1919. The improvement work with Minnesota No. 13 was continued. This variety is recommended for silage and forage purposes in the district but is considered rather late for ripe grain.

Grimm alfalfa has given consistently most satisfactory yields, producing a 3-year average of 3,789 lbs. of hay per acre. This variety planted in a rotation in April, 1918, with Prelude wheat as a nurse crop, yielded 11,446 lbs. of hay per acre in 1919 in two cuttings. Inoculation with soil from an old field was decidedly beneficial, while an application of 1 ton of lime per acre was of no noticeable value. Meadow fescue, with a 3-year average yield of 1.32 tons of hay per acre, was best among the grasses.

Potato investigations included variety, cultural, and fertilizer tests, together with improvement work conducted in cooperation with the Bureau of Plant Industry of the U. S. Department of Agriculture. Green Mountain was the highest yielder among 8 standard varieties, producing a 3-year average yield of 354.16 bu. per acre, 92.9 per cent of which was of U. S. grade No. 1. Itasca, a Green Mountain seedling, averaged 378.75 bu. per acre for the period 1918-19.

Fertilizer treatment of rock phosphate, acid phosphate, rock phosphate with manure, acid phosphate with manure, and manure alone produced 5-year average yields of 146.58, 146.7, 231.4, 241.38, and 230.84 bu. per acre, as compared with 130.12 bu. from the untreated check. The only application showing a decided beneficial effect was 10 tons of stable manure.

Limited results from studies of cultural methods with potatoes may be summarized as follows: Immature seed yielded fully as much as mature seed. Yields increased directly with the size of the seed piece, whole potatoes giving the largest and quarters the smallest yields, but a higher percentage of small tubers was produced where whole tubers were planted. The crop from seed grown on peat land was equally as good as that from seed grown on mineral soil.

Rutabagas have given the most satisfactory results of the various root crops grown for stock feed at the station, producing an average acre yield of 24.5 tons in 1918, as compared with 19.15 tons from flat turnips and 13.12 tons from mangels. The American Purple Top rutabaga made a 2-year average yield of 27.6 tons per acre, and is recommended on account of hardness.

[Report of field crops work in Kentucky, 1919] (*Kentucky Sta. Rpt. 1919, pt. 1, pp. 22-24, 25-28, 45*).—The progress of work conducted along the same general lines as previously noted (*E. S. R., 43, p. 331*) is reported.

Data are reported showing that the yield of corn under continuous culture was not increased by the application of potash salts or of other fertilizing materials.

Tobacco experiments included curing studies, rotations, and fertilizer tests. Studies of curing Burley tobacco by artificial heat indicated that as high a grade of leaf can be obtained by flue curing at a relatively low temperature as by air curing, thus eliminating completely the danger of house burning. Although fair yields and quality were secured in the 4-year rotations of tobacco, wheat, clover, and orchard grass, and tobacco, wheat, clover, and corn, the quality of the leaf was not equal to that from land in blue grass from 6 to 8 years. Fertilizer tests with tobacco, conducted on a heavy blue-grass sod during the 2-year period 1917-18, included applications of nitrogen alone and in combination with phosphorus, potassium, and ground limestone. The increase in yield due to fertilizer was chiefly in the heavier grades, leaf and red.

The wheat selection known as Fultz No. 1 continued to show its superiority over the parent variety in yield, stiffness of straw, and other characteristics, besides resisting scab better than any other variety or strain in 1919. Tests of wheat varieties substantiated previous results, indicating that those grown in Kentucky were superior to newly introduced varieties. Fultz was not surpassed by any variety tested on the station farm.

During the first year of an experiment on the effect of soil electrification on plant growth, electrified plats produced yields of 52 lbs. of green beans, 337 lbs. of marketable tomatoes, 1,560 lbs. of tobacco, and 14.5 bu. of potatoes as compared with 50 lbs., 434 lbs., 1,220 lbs., and 13 bu., respectively, on the non-electrified area.

[Field crops work in Western Australia], G. L. SUTTON ET AL. (*Dept. Agr. and Indus. West Aust. Ann. Rpt. 1919, pp. 11-23*).—Field tests of wheat, oats, flax, and various grasses and fodders, and fertilizer experiments with flax on the State farms are reported for the year ended June 30, 1919.

Experiments on the influence of spring and fall grazing on the yields of grasslands, R. D. TONNESSON (*Norges Landbr. Høiskoles Akervekst. Aarsber., 1917-18, pp. 8-30*).—The results of 21 grazing experiments conducted cooperatively in different sections of Norway from 1906 to 1918 are tabulated and discussed.

It was found that grazing generally reduces the succeeding grass crop, especially when spring grazing is practiced. The reduction in hay yield due to

fall grazing was, as a rule, offset by the value derived from the pasturage, but in the Nordenfjelske region the reduction in hay yield was somewhat greater than the corresponding quantity of grass consumed in grazing. When the yield of rowen was over 350 lbs. per acre, mowing the crop proved the more profitable. In all regions concerned, grazing reduced the yield of hay most when grasslands newly laid down were pastured.

The shrinkage of market hay, H. B. McCLURE (*U. S. Dept. Agr. Bul. 873 (1920), pp. 33, fig. 1*).—A résumé of experimental data on the shrinkage of hay, together with a discussion of the factors affecting the determination of shrinkage and losses, and suggested methods of making hay to prevent unnecessary shrinkage. The author disparages the indiscriminate use of conflicting terms in the hay industry and offers definitions dealing with hay in the several stages in the process of curing. The data reviewed and the recommendations may be summarized as follows:

The percentage of shrinkage in hay is influenced by water content when cut, maximum water content when stored, normal water content when cured, minimum water content, atmospheric humidity, and effect of time. In experiments conducted during the last 30 years to determine the rate of shrinkage in hay in the barn and stack, the loss in weight was found to range from 0.29 to 42.2 per cent and the gain in weight ranged from 0.4 to 10.7 per cent, making a total variation of about 53 per cent.

All efforts by investigators to determine the average rate of shrinkage, in order to formulate a definite rule to be used at harvest time to calculate the percentage of "dry" or marketable hay, have failed because of the effect of such factors as variation in the time of cutting, methods of curing, and the weather, which will always cause a wide difference in the percentage of shrinkage in hay on individual farms within a given territory. The experiments show that there is no correlation between the lapse of time and the percentage of loss by shrinkage.

The author holds that the widespread publication of experimental data showing comparatively large losses by shrinkage, during several months, has been misleading, especially to producers, because the investigators failed to point out that the greater part of the loss occurs before the hay is in proper condition to be baled or marketed and that the loss, which is practically of water only, is simply a part of the natural curing process, and therefore should have no commercial value.

If hay is marketed in the proper condition, shrinkage does not affect the profits of the producer until after the final curing stage, known as fermenting or sweat stage, has been finished and the water content has become normal. Continued dry weather which lowers the normal water content of marketable hay may cause a shrinkage which affects the producer's profits, but this loss is liable to be offset by the increase in water above normal, which takes place during the damp weather when hay absorbs water from the air. Shrinkage causes an actual loss to the shipper or dealer when he buys and stores hay containing more than the normal water content for well-cured barn or stack-cured hay.

Practically no loss of dry or nutrient matter occurs during the shrinkage of hay while in the barn or stack, provided the hay has been properly cured before it is hauled from the field. Undercured hay, containing an excessive amount of water, is liable to become so hot in the barn or stack that it will become discolored, charred, or in extreme cases, entirely burned up by spontaneous combustion.

Under certain conditions necessitating an adequate, full sized, experienced haymaking crew, the use of a definite, efficient, and practically unchangeable

method of operation and curing, and comparative freedom from interference by unfavorable weather, the average shrinkage can be determined by weighing a given quantity or by a water analysis. The percentage of shrinkage found will be applicable until the conditions are changed.

Abaca (Manila hemp): The fiber monopoly of the Philippine Islands, G. S. LEE (*Sci. Mo.*, 11 (1920), No. 2, pp. 159-170, fig. 1).—The author discusses the nature, use, and climatic adaptation of the abaca plant (*Musa textilis*), and describes cultural methods and practices employed in growing the crop and preparing the fiber for market. Data on the fiber industry in the Philippine Islands are included, together with brief notes on the culture and uses of maguey, sisal, and minor fiber plants.

Daily development of kernels of Hannchen barley from flowering to maturity at Aberdeen, Idaho, H. V. HARLAN (*Jour. Agr. Research [U. S.]*, 19 (1920), No. 9, pp. 393-430, pls. 9, figs. 17).—This paper, a contribution from the Bureau of Plant Industry, U. S. Dept. of Agriculture, in cooperation with the Idaho Experiment Station, reports studies on the growth of barley kernels from flowering to maturity. In describing the technique of measurement and discussing experimental methods, the author notes at the emergence of the awns offered a very accurate index of the stage of the development of the spike. Detailed daily measurements of the developing kernels are included in tabular and graphic form. The observations may be summarized as follows:

In the early stages of development of the barley kernel measurable growth occurred during 12-hour intervals, and during 24-hour intervals until near maturity. The period from flowering to maturity in three successive years at Aberdeen was 26 days.

The growth immediately after flowering was so rapid that the increase in length was readily measurable at 12-hour intervals. The length growth was completed by the seventh day, and as soon as the rate of growth in length decreased the lateral diameter showed its most rapid increase. The dorsoventral diameter continued to increase almost until maturity. The increase in dry matter was very uniform throughout the period of growth, the percentage of water decreasing uniformly from flowering to maturity. Analyses indicated that during growth carbohydrates increased most rapidly and the ash least rapidly.

Several well-marked steps in development were observed. About the fifth or sixth day after flowering the growth in length was checked, and a rapid gain in dry matter began. On the ninth or tenth day a sticky substance was secreted, causing the glumes to adhere to the kernels. About the fifteenth or sixteenth day the kernel toughened, the lemma began to lose color in the dorsal surface, some of the awns dropped off, and the kernel had reached its maximum water content.

Maturation occurred gradually, the cells along the furrow continuing active longer than elsewhere. The actual date of cessation of growth, even under unusually uniform external conditions, is held to be largely dependent on the temperature and humidity at the time of ripening.

Development of barley kernels in normal and clipped spikes and the limitations of awnless and hooded varieties, H. V. HARLAN and S. ANTHONY (*Jour. Agr. Research [U. S.]*, 19 (1920), No. 9, pp. 431-472, figs. 13).—Data are presented showing the results of studies of the development of barley kernels in normal and clipped spikes in an effort to ascertain the value of the awn, an undesirable factor in barley production, and the reasons for the limitations of bearded and awnless varieties.

The studies of the effect of removing the awns were conducted in 1915 by the Bureau of Plant Industry at University Farm, St. Paul, Minn., with Manchuria

barley, and in 1916 in cooperation with the Idaho Experiment Station at the Aberdeen Substation with Hannchen barley. Detailed weights, measurements, and analyses of the individual kernels are included in tabular form, and, with the aid of numerous graphs, are fully discussed. The results obtained and conclusions reached may be summarized as follows:

The removal of the awns from a barley spike had a marked effect on the development of the kernels of the spike, kernels from clipped spikes having smaller volume and a lower weight of dry matter at maturity than those from normal spikes. This difference was not held to be due to the injury or shock of removing the awns, as the kernels in the clipped spikes developed as rapidly as those in the normal spikes for several days after the awns were clipped.

About one week after flowering, coinciding roughly with the beginning of the period of rapid starch infiltration, the deposit of dry matter in the kernels of the normal spikes began to exceed that in the kernels of the clipped spikes. The daily deposit of nitrogen and ash was found to be more nearly equal in the two classes of spikes than was the deposit of starch. In normal spikes at Aberdeen, Idaho, the awns contained more than 30 per cent of ash at maturity, but when the awns were removed a part of this ash apparently was deposited in the rachis. The rachises of the clipped spikes contained about 25 per cent more ash than the rachises of the normal spikes.

The additional ash in the rachises of the clipped spikes was thought probably to be responsible for the tendency of these spikes to break. The indications were that the elimination of the awns resulted not only in lower yields but in shattering as well.

From results of experiments conducted it appeared that hooded and awnless barleys generally yielded less and shattered more than awned varieties, and there seemed to be physiological reasons for this fact. These results led the authors to suggest that it may be possible to produce nonshattering hooded and awnless sorts by using parents which normally have a low percentage of ash in the rachises, and to obtain strains that will give good yields under arid conditions. Under humid conditions it is deemed likely that the objections to the awns are more easily met by the use of strains with smooth awns, which, so far as known at present, have no physiological limitations.

Castor oil as a crop, E. MATHIEU (*Gardens' Bul. Straits Settlements*, 2 (1920), No. 8, pp. 282-294).—This includes a brief description of the castor bean, methods of cultivation recommended for the Malay Peninsula, varieties, insect and disease pests, and notes on oil extraction and utilization. The practice of intercropping castor beans with peanuts is said to return a net profit estimated to range from \$396.85 to \$532.50 per acre.

Freezing injury of seed corn, T. A. KIESSELBACH and J. A. RATCLIFF (*Nebraska Sta. Research Bul. 16* (1920), pp. 96, figs. 22).—The authors give the results of a study of conditions under which freezing injury may occur to seed corn, indicating some of the changes in the embryo resulting from such injury and pointing out ways by which seed corn of strong vitality and satisfactory yielding capacity may be obtained.

It is claimed that the embryo and endosperm of a corn kernel develop approximately at the same rate from the time of fertilization until maturity, and that the power of germination is attained in about 20 days after fertilization. The embryo and endosperm in an air-dry kernel contain practically the same amount of moisture. However, in the period prior to maturity the embryo has a higher water content than other portions of the grain.

When immature or moist kernels of corn are exposed to freezing temperatures, ice is said to form in the intercellular spaces and in the larger spaces

around the scutellum, plumule, primary root, and root sheath. Severe freezing of immature or moist corn causes the embryo to change from a normally light or creamy color to a dark or yellowish-brown color, and this change is usually accompanied by a loss of vitality. The appearance of the embryo, therefore, is said to be a fairly safe guide in judging the germinative power of seed corn which has been subject to freezing injury.

So far as they were able to detect, the authors found no injury of cell walls or other cytological effect of freezing or ice formation. They consider from the evidence at hand that freezing produces a physical or chemical change, aside from the withdrawal of water, in the protoplasmic and nuclear material of the cell so that life no longer exists.

The vitality of corn containing from 15 to 20 per cent of moisture is not injured by ordinary autumn freezing, and corn with from 10 to 14 per cent of moisture will withstand the most severe winter temperatures without injury to its germinative power. The kernels on an ear of corn are said to vary in moisture content, which may explain partial germination of an ear of corn after exposure to freezing temperatures.

The variations in freezing weather, together with the great seasonal variations in time of corn maturity, are said to make freezing inevitable in occasional years. Under Nebraska conditions the best types of corn should ripen two or three weeks before the mean date of the first killing frost. Where varieties ripen too late, their maturity may be hastened by field selection of seed and by selection of drier and more mature ears later in the season. Crib selection of seed corn may be practiced as a last resort. In years when corn matures well, it is said to be a good practice to select sufficient seed for two years' planting. The viability of seed corn should be ascertained before planting time, either by a germination test or by observing the color of the germ.

Considerable attention has been given to the relation between the yields of corn and seed corn injury due to freezing, and from a study of the average yield of corn for the past 28 years it is believed that a low yield does not necessarily follow years of severe seed injury.

Cotton culture in the Belgian Kongo, R. MEES (*La Culture du Coton au Congo Belge. Brussels: Govt., 1919, pp. 74, pls. 17*).—This report comprises descriptions of the cotton-producing regions, transportation facilities, the various tribes of natives and their state of advancement, and discusses the conditions deemed necessary to the rapid development of cotton culture in the region.

Cotton in British West Africa, N. M. PENZER (*London: Fed. Brit. Indus. Intel. Dept., 1920, pp. 53, pl. 1, fig. 1; abs. in Bul. Imp. Inst. [London], 17 (1919), No. 4, pp. 609, 610*).—This volume outlines the history and development of cotton culture in West Africa, describing in some detail the status of the industry, including notes on transportation, cultural practices, crop pests, and varieties, in Nigeria, Gold Coast, Sierra Leone, Gambia, Togoland, Cameroons, and the Lake Chad district. The author discusses the future of cotton growing in the region, and presents tabulated statistics on the exports of cotton from the various countries mentioned. A special introduction by Viscount Milner is included, and a bibliography of cotton from 1881 to 1920, embracing 241 titles, is appended.

Native fiber plants, G. SELLERGRÉN (*K. Landtbr. Akad. Handl. och Tidskr., 59 (1920), No. 1, pp. 54-63, figs. 5*).—Historical notes on the use of native fiber plants in Sweden are presented, and descriptions of *Phragmites communis*, *Scirpus maritimus* and related species, and of different species of pines as sources of fiber and pulp are given.

Fibers from India, Africa, and the West Indies.—Flax, jute, and hemp substitutes (*Bul. Imp. Inst. [London], 17 (1919), No. 4, pp. 455-485*).—This re-

ports chemical examinations, together with brief descriptions, of samples of the following fibers at the Imperial Institute: Flax from India and Egypt; Sunn hemp (*Crotalaria juncea*) and jute from India; *Hibiscus cannabinus* from India, Rhodesia, and Sudan; *Sida rhombifolia* from South Africa; sisal from Jamaica and Sierra Leone; henequen from British Honduras and Jamaica; and Mauritius hemp (*Furcraea gigantea*) and sansevieria from Rhodesia.

The Kawai, C. H. KNOWLES and R. KNIGHT. (*Fiji Dept. Agr. Circ.*, 1 (1920), No. 5, pp. 86, 87).—A brief description of the small yam indigenous to Fiji, with notes on cultural practices and utilization of the crop.

Experiments in growing peas, K. VIK (*Norges Landbr. Høiskoles Akervekst. Aarsber.*, 1917-18, pp. 36-85).—The experiments reported, covering a period of over 20 years, were conducted cooperatively in various parts of Norway, and comprised inoculation, culture, and variety tests.

Mixing from 10 to 20 per cent of peas with the seed of other crops for the purpose of increasing the nodule organisms in the soil did not reduce the yield, and had a beneficial influence, from the standpoint of soil inoculation, on the succeeding crops of peas on land not producing peas regularly. The crop coming after peas also derived benefit from this method of inoculation. Mixing peas with the seed of a crop grown two years before peas gave as good results as when the crop immediately preceding peas was treated in the same way. This method of providing for adequate soil inoculation seemed more effective and reliable in the eastern part of Norway than in other sections in which the experiments were in progress. Liming the soil increased the effectiveness of this method of inoculation.

In seeding experiments, peas were sown at the rates of 160, 200, and 240 peas per square meter, and based on the results secured, the following approximate rates of seeding for different varieties are recommended: Onsrud, 175 to 225 lbs.; Norwegian Green, 225 to 270 lbs.; Snedinge, Michelet Green, and Rapide, each 285 lbs.; Solo, 320 lbs.; and Norwegian Gray, 140 to 175 lbs. per acre. Early, as compared with late, seeding in practically all tests gave the best results. The different varieties grown in the experiments are described, and notes on their behavior are given. The varieties of yellow peas reported as leading in yield are Snedinge and Onsrud, and Svalöf Concordia, a green variety, as ranking above all garden varieties in the tests. Michelet Green, a very early variety, is recommended for northern localities.

The annual yields of Snedinge peas, Finne barley, Duppauer oats, and Lerdals spring wheat on the experiment fields from 1898 to 1914, inclusive, are given in a table. The average yields per unit area for the entire period were as follows: Peas, 299 kg. vines and 180 kg. peas; barley, 352 kg. straw and 235 kg. grain; oats, 378 kg. straw and 265 kg. grain; and spring wheat, 379 kg. straw and 226 kg. grain.

The technique of cross-fertilization in potatoes, R. N. SALAMAN (*Jour. Min. Agr.* [London], 27 (1920), No. 2, pp. 138-144, figs. 4; also in *Potato Mag.*, 3 (1920), No. 2, pp. 8, 12, 26, figs. 4).—A brief discussion of methods of interest to the potato breeder.

Potato culture, H. WERNER, revised by C. VON ECKENBRECHER (*Der Kartoffelbau nach Seinem Jetztigen Rationellen Standpunkte*. Berlin: Paul Parey, 8. ed., rev. and enl., 1919, pp. 190, figs. 29).—This is the eighth edition of this popular handbook, comprising descriptions of German varieties and a general discussion of cultural methods and field practices employed in growing the crop in Germany, with notes on storage and marketing of the product.

Potato storage and storage houses, G. SCHNEIDER (*Zehn Gebote für die Sachgemässe Aufbewahrung und Pflege der Kartoffeln*. Berlin: Paul Parey, 1918,

pp. 29, figs. 32).—Approved methods of handling and storing potatoes and the structural details of a modern storage house are illustrated and fully discussed. The results of storage experiments, previously noted (E. S. R., 43, p. 436), including tests of storing tubers in the dark, in daylight, and under light of different colors, such as red, blue, yellow, and green, are reported.

Notice of public hearings [on] proposed official grain standards of the United States for milled rice, D. F. HOUSTON (*U. S. Dept. Agr., Bur. Markets Serv. and Regulatory Announcement 59 (1920), pp. 15*).—An announcement of public hearings on the proposed official grain standards of the United States for milled rice, described in this circular.

Soy bean (*U. S. Dept. Agr., Dept. Circ. 120 (1920), pp. 4*).—A popular description of the soy bean with brief notes on adaptation, inoculation, culture, harvesting, thrashing, storing, and varieties.

An acreage census of cane varieties for the crops of 1919, 1920, 1921, H. P. AGEE (*Hawaii. Sugar Planters' Assoc. Circ. 34 (1919), pp. 40*).—Tabulated statistics similar to those previously noted (E. S. R., 40, p. 634) are presented showing different varieties of sugar cane and the areas devoted to each for the crops indicated on the islands of Hawaii, Kauai, Maui, and Oahu. Although Yellow Caledonia is said to be still the leading variety, over 100,000 acres being under this cane, the area is being slowly reduced, a loss of 4,894 acres appearing between the 1917 census and that of 1919.

Cane production and sugar manufacture in the Philippine Islands, C. W. HINES (*Philippine Bur. Agr. Bul. 33 (1919), pp. 202, pls. 27, figs. 35*).—The author presents a comprehensive, profusely illustrated handbook of sugar-cane growing and sugar manufacture in the Philippines. The history of the industry in the islands is reviewed, and varieties, propagation, soils, cultural methods, and field practices are described in detail. The second part of the bulletin treats of the various processes involved in the manufacture of sugar under scientific control, and includes detailed laboratory instructions, formulas, and tables useful in sugar-factory work.

Notes on sweet tussock (*Phalaris bulbosa*), P. A. BOVET (*Bol. Agr. Prov. Buenos Aires, 1 (1920), No. 7, pp. 3-14, figs. 10*).—This briefly reports work with the seeding and propagation of sweet tussock grass, said to be a valuable forage for the drier regions of Argentina.

Tobacco investigations, G. H. CHAPMAN (*Massachusetts Sta. Bul. 195 (1920), pp. 1-22, 31-38, figs. 5*).—This reports the progress of work including studies of the meteorological factors related to the growth of tobacco, biochemical studies of the soil of normal and "sick" fields, fertilizer experiments, and observations on root rots, mammoth types of Cuban and Connecticut Havana tobacco, high pressure *v.* low pressure seed bed sterilization, vitality of tobacco seed, and top-dressing of tobacco seed beds with dry ground fish. An examination of climatic data and the statistics of yearly production led to conclusions which may be summarized as follows:

The yield of tobacco in Massachusetts has not been gradually decreasing during the past 10 years. The low yields since 1914 were due primarily to adverse climatic conditions. In general, rainfall is the major limiting factor of growth (and this necessarily includes soil moisture) together with temperature. Excessive rainfall is invariably followed by a reduction in yield independent of temperature. Subnormal rainfall, when accompanied by temperatures excessively above normal, reduces the yield, but when accompanied by subnormal temperatures does not apparently reduce the yield to any extent unless the rainfall is very much below normal.

The author classifies the tobacco soils into three groups as regards acidity or "lime requirement." Soils requiring up to 3,000 lbs. calcium oxid per acre are not producing good crops as a rule, but are comparatively free from root rots. Soils requiring from 3,000 to 8,000 lbs. calcium oxid per acre are in good tobacco condition, but in this group pathogenic fungi, which may cause root-rot during certain seasons, are abundant in the soil. Soils requiring over 8,000 lbs. of calcium oxid are usually comparatively free from such fungi, and even in unfavorable seasons little disease is found, but the tobacco may be of slightly inferior quality.

Although applications of two tons of peat per acre produced 10 per cent increase in yield, this form of organic matter was deemed too expensive, and cover crops, especially timothy, with rye as a second choice, were recommended. Low-yielding soils are said to have responded favorably to additional applications of organic matter and acid phosphate, but presented no evidence showing the lack of potash.

Selection experiments with Deli tobacco, IV, J. A. HONING (*Meded. Deli-Proefsta. Medan, 2. ser., No. 10 (1920), pp. 43-59*).—In continuation of work previously noted (*E. S. R., 42, p. 237*), the author describes further observations on pure line selections of Deli tobacco.

Velvet beans (*U. S. Dept. Agr., Dept. Circ. 121 (1920), pp. 3*).—This contains a brief description of the velvet bean, with notes on planting, feeding value, and varieties.

Hairy vetch seed production in the United States, L. W. KEPHART and R. MCKEE (*U. S. Dept. Agr. Bul. 876 (1920), pp. 32, figs. 7*).—A detailed discussion of the merits of hairy vetch, factors involved in seed production, and the cultural methods and field practices employed in the raising of seed of the crop in Michigan and other northern States. The practices followed in seed growing in the southern States are also indicated, together with brief notes on disease and crop pests. A description of a spiral vetch separator, which is considered the most efficient separator for removing rye or other cereals from vetch, is included.

The authors consider hairy vetch a valuable legume for green manuring and general soil improvement, especially in Michigan, other States bordering on the Great Lakes, and in most of the Atlantic and Gulf Coast States. The plant is adapted to a wide range of soil types, but is said to do best on rich, sandy loam. The crop can be seeded with ordinary farm machinery with but little or no modification. The difficulty encountered in separating seed of hairy vetch from cereals with the ordinary seed separators has been obviated by the use of the spiral vetch separator.

Formerly the bulk of the seed was imported from the Baltic Provinces of Russia and northeastern Germany, but the quantity has been greatly reduced in recent years, resulting in a high price for seed and stimulating domestic production. Michigan has been the principal center for hairy vetch seed in the United States, producing about 1,000,000 lbs. annually during the period 1915-1919, or one-half or more of the seed used in this country. However, seed production has proved successful in practically all localities where the crop can be grown.

Experiments with Indian wheat in Mesopotamia, 1917-18, C. C. GARRETT (*Bagdad: Govt., 1918, pp. 12*).—This reports field tests of Indian and Iraq wheat varieties in the vicinity of Bagdad and other points in the Tigris-Euphrates Valley.

Wheat varieties of the Ahaggar District, Sahara, L. DUCCELLIER (*Bul. Soc. Hist. Nat. Afrique Nord, 11 (1920), No. 6, pp. 91-93*).—This article includes brief

descriptions of the principal varieties cultivated in the oases of the Ahaggar region, and discusses the adaptation of the wheat to the conditions peculiar to Sahara.

Wheat grade announcement, E. T. MEREDITH (*U. S. Dept. Agr., Bur. Markets Serv. and Regulatory Announcement* 62 (1920), pp. 12, figs. 3).—This includes the announcement of the Secretary of Agriculture that no change will be made in the present standards for wheat, noted previously (*E. S. R.*, 40, p. 39), and a discussion of proposed modifications in which the relation of the test weight per bushel to the flour yield as determined by the North Dakota Experiment Station and this Department, the relation between moisture content and value of wheat, and the moisture content of spring wheat crops in the years 1911–1916 are illustrated graphically.

Longevity of the seeds of cereals, clovers, and timothy, H. B. SIFTON (*Amer. Jour. Bot.*, 7 (1920), No. 6, pp. 243–251, figs. 5).—The author reports observations on annual germination tests made from 1903 to 1919, inclusive, at the Seed Laboratory, Ottawa, Canada, of samples of spring wheat and oats of the 1900–1902 crops, and clover and timothy of the 1902–3 crops. The samples included all standard varieties of the time, and were collected in successive years from the same farmers in representative parts of Canada. The author discusses the factors underlying the results and includes much data in tabular and diagrammatic form.

The investigations showed that during extended storage of an average sample of wheat its depreciation could be divided into three more or less distinct periods. During the first 10 or 11 years the weak grains gradually died, and then followed a period of 3 to 4 years when the grains of average vitality died very rapidly. A few seeds, very tenacious of life, were still left and slowly lost their vitality during the final period of about 3 years.

The longevity of oats proved much greater than that of wheat, possibly owing to the protection of the hulls. In the majority of cases a slight rise in germination was noted during the first 4 or 5 years of storage. The longevity curve differed from that of wheat in two respects, the first period being longer and the drop in the second period not nearly so steep, as the oat kernels lived longer and more variations were observed in their span of life. Forty-one per cent of the 19-year-old kernels were still alive.

Timothy seed began to depreciate in value at once, the strongest kernels being comparatively short-lived. The three periods of depreciation were not so sharply defined as in the case of hardier seeds. The germination began to fall off rapidly after the seventh year when it was 84 per cent, further reduced by the twelfth year to 11.5 per cent, and gradually decreased to the seventeenth year when the seed was practically all dead.

Both alsike and red clovers possessed a larger proportion of long-lived seeds (over 15 years) than wheat, but from the standpoint of the practical seedsman their longevity was not nearly so great. After 11 years on the average, wheat still germinated over 85 per cent, while alsike or red clover of the same age germinated less than 40 per cent.

The Danish State seed testing station (*Copenhagen: Danish State Seed Testing Sta.*, [1920], pp. 16).—This pamphlet describes the methods and scope of work of the State seed-testing station at Copenhagen, claimed to be now the oldest in the world.

Cocklebur, A. A. HANSEN (*U. S. Dept. Agr., Dept. Circ.* 109 (1920), pp. 6, fig. 1).—The weed and its manner of growth are described, and its distribution, harmful effects, and uses indicated. In outlining methods of eradication, the author urges the prevention of seed production and the destruction of the seed

already in the soil, taking into consideration the fact that one of the two seeds contained in the bur normally sprouts during the first season while the other germinates the following season.

Dodder in Idaho, B. F. SHEEHAN (*Idaho Agr. Col. Ext. Circ. 41 (1920), pp. 11, figs. 3*).—Dodder, a serious weed in the clover and alfalfa seed-producing sections of the State, is described and control measures indicated.

HORTICULTURE.

Practical amateur gardening, H. H. THOMAS (*London and New York: Cassell & Co., Ltd., 1920, pp. XII+276, pls. 49, figs. 40*).—A practical elementary work taking up especially those details about which the amateur generally seeks advice. It discusses hardy fruits, flowers, trees, and shrubs; greenhouse flowers, fruits, and vegetables; and diseases, pests, and fertilizers; and gives much other general information on gardening, including a monthly working calendar.

[**Report on horticultural work at the North Central Minnesota Substation, 1915-1919**], O. I. BERGH (*Minnesota Sta., Rpt. Grand Rapids Substa., 1915-1919, pp. 51-56, fig. 1*).—Summarized data are given on variety tests of orchard and small fruits and vegetables conducted for several years at the Grand Rapids Substation.

Of the orchard fruits, the losses from winterkilling were very great among apples. Only 25 per cent of the trees planted in 1916 were living as compared with 47 per cent for crab apples and 60 per cent for plums. Charlamoff, Hibernial, Jewell Winter, and several University seedlings are relatively hardy apples. The hardiest varieties of the plums are Surprise, Kahinta, Egama, Topa, Terry, Toka, Wyant, and Yuttecca. The Compass cherry seems to be as hardy as the plums.

Report of the horticulturist, A. G. TURNEY (*Ann. Rpt. Dept. Agr., New Brunswick, 1919, pp. 54-76*).—A report on the condition of fruit crops and markets in New Brunswick in 1919, together with notes on illustration and demonstration orchards, data on cooperative orchard-spraying experiments, and recommendations for potato spraying in 1920.

Report of the horticulturist, P. J. SHAW (*Ann. Rpt. Sec. Agr. Nova Scotia, 1919, pt. 5, pp. 67-78, pl. 1, figs. 2*).—A report on different lines of horticultural work conducted in Nova Scotia during 1919, including some data on a fertilizer test with apples and notes on various model orchards and orchard demonstration work.

In the fertilizer test with apples, a complete fertilizer was more effective than individual elements. Barnyard manure appeared to produce as good results as the complete fertilizer, if the size and condition of the tree at the beginning of the test are taken into account.

[**Report on horticultural investigations in 1919**], J. ALLAN (*Ann. Rpt. Sec. Agr. Nova Scotia, 1919, pt. 6, pp. 87-95*).—A report on horticultural investigations conducted at the Nova Scotia Agricultural College during 1919.

Tabular data are given on a fertilizer investigation with strawberries started on two half-acre plats in 1917. The results in general indicate that a good supply of humus is essential for this crop, and where the land is lacking in humus it must be applied in some form. Where the soil is fairly well supplied with humus, a good mixed fertilizer is preferable to manure on account of the troublesome weeds that arise from the use of manure applied directly to the strawberry land prior to planting. Some data are also given on a variety test of tomatoes.

A general view of the Netherlands, II.—Nurseries (*The Hague: Netherlands Min. Agr., Indus. and Com., 1915, pp. 32, pl. 1, figs. 17*).—A brief sketch of horticulture and horticultural education in the Netherlands, with special reference to the nursery industry.

Use of dry lime sulphur in sprays (*Kentucky Sta. Rpt. 1919, pt. 1, pp. 44, 45*).—Analyses that were made of different samples of dry lime sulphur show that upon following the directions given by the manufacturer for making the lime-sulphur solution, about one-fifth of the total sulphur remained undissolved, and the solution obtained was much weaker than the desired strength. The directions called for a solution of the material in cold water. Experiments conducted at the station show that practically all of the sulphur was brought into solution if a small quantity of boiling water was used on the material, thus giving a solution capable of being diluted later to the proper strength. Under this treatment the free sulphur recombines to form approximately calcium pentasulphid, which is not the case when cold water is used.

Use of insecticides and fungicides in South Africa, C. J. PISAR (*U. S. Dept. Com., Com. Rpts., No. 241 (1920), pp. 199–202*).—A brief sketch of the fruit and vegetable industry in South Africa, with a list of the more important insect pests and diseases and remedies used for their control.

The profitable culture of vegetables, for market gardeners, small holders, and others, T. SMITH (*London and New York: Longmans, Green & Co., 1919, pp. XVI+452, figs. 163*).—A reprint of the author's treatise on market gardening (*E. S. R., 27, p. 144*).

Observations on the root development of vegetable plants, K. KROEMER (*Landw. Jahrb., 51 (1917), pp. 731–745, pls. 3*).—The author presents data on studies of root development in the tomato, eggplant, kohlrabi, cabbage, cauliflower, kidney bean, Lima bean, lettuce, celery, carrot, radish, and leek.

The process of ripening in the tomato, considered especially from the commercial standpoint, C. E. SANDO (*U. S. Dept. Agr. Bul. 859 (1920), pp. 38, pls. 4, figs. 3*).—A contribution from the Bureau of Plant Industry. It briefly describes prevailing methods of growing, harvesting, and marketing early tomatoes in the South for shipment to northern markets, and presents and discusses analytic data showing progressive changes in the composition of Livingston Globe tomatoes during the process of ripening; the composition of artificially ripened and vine-ripened tomatoes; and of commercially picked green tomatoes allowed to ripen under different conditions as compared with artificially ripened and vine-ripened tomatoes. Data are also given showing the effect of lack of ventilation on the normal coloring of tomatoes held at room temperature, and the effect of age and temperature upon the resistance to wounding of the epidermis, showing also color conditions. Previous chemical studies of the tomato are briefly reviewed, with 58 references to cited literature. Data comparing the composition of "puffy" and normal Livingston Globe tomatoes are appended.

The author found a wide range of variation in the size of tomatoes within the same variety. Ripening was dependent upon age and proceeded at a uniform rate regardless of size.

The most striking change which occurs during ripening is that undergone by carbohydrates. Sugars increase from 25.66 per cent in fruit 14 days old to 48.32 per cent in ripe fruit. Starch decreases in the same interval from 15.84 to 2.65 per cent. The most marked decrease takes place during the period of transition from green to red.

The percentage composition of fruit picked green but ripened with free access of air compared with analyses of turning and vine-ripened fruit did not show

enough variation to account for the great differences in taste found in commercially shipped fruit. Lack of ventilation during ripening increased the acid content approximately 138 per cent over that of vine-ripened fruit. Wrapping the tomatoes also greatly increased the acidity.

The author concludes that wrapping probably modifies the course of ripening to such an extent as to account for marked changes in taste and flavor. The combined results of picking fruit green, of wrapping, and of closing the cars in transit probably account for the total differences existing in quality between commercially shipped and vine-ripened tomatoes.

Selecting and saving tomato seed, W. A. HUELSON (*Indiana Sta. Bul.* 250 (1920), pp. 26, figs. 13).—This bulletin outlines a method of selection that can be used by the grower or the canner, and gives definite information as to the characteristics of plant and fruit most desirable for different purposes. A method of saving, cleaning, and drying tomato seed worked out by the station in cooperation with the Indiana Cannery Association is described in detail, and illustrations are given of the machinery required for the work. Data are also given showing variations in yield between strains of the same varieties of tomatoes secured from seedsmen in different parts of the country. A short bibliography of literature dealing with strain tests and breeding work with tomatoes is appended.

Modern fruit growing, W. P. SEABROOK (*Chelmsford, England: W. Seabrook & Sons, Ltd.*, 2. ed., 1919, pp. XXXIX+176, pls. 5, figs. 77).—A treatise on commercial fruit growing, with special reference to English conditions. The successive chapters discuss capital required and terms of tenure; selection and preparation of land; wiring, marking out, planting, and distances; age and shape of tree to plant; stocks; varieties; pollination; the first year's work; the second year's work; subsequent routine work; loganberries, raspberries, and strawberries; manures; spraying; spraying appliances and methods employed; thinning and picking; grading and packing; storing; finance; cordons; drying, canning, bottling, and pulping; and organization.

[Investigations on fruit culture], B. T. P. BARKER, G. T. SPINKS, and A. H. LEES (*Jour. Bath and West and South. Counties Soc.*, 5. ser., 14 (1919-20), pp. 163-187).—This comprises the following papers previously noted from another source (E. S. R., 43, p. 742): Fruit Breeding Investigations, Factors Governing Fruit-bud Formation, and The Effect of Notching and Ringing on Apple Trees.

Atlixco, W. POPENOE (*Ann. Rpt. Calif. Avocado Assoc.*, 1919-20, pp. 24-43, pls. 7, fig. 1).—A report on the fruits, especially avocados, in the Valley of Atlixco, Mexico, based upon a personal investigation of the valley conducted on behalf of the University of California.

Notes on fruit growing in Morocco, L. BEY (*Pomol. Franç.*, No. 7-8 (1920), pp. 81-92).—A short survey of the tree-fruit and grape industries in Morocco, including information relative to their extent, varieties grown, and cultural practices, together with suggestions for improving the status of fruit growing.

The reconstitution of fruit plantations in the liberated regions and the valuation of damage caused to the trees, J. NANOT (*Reconstitution des Plantations Fruitières dans les Régions Libérées et Évaluation des Dommages Causés aux Arbres. Paris: Libr. Agr. Maison Rustique*, 1920, pp. 84, figs. 50).—A small work containing practical suggestions for the renovation of fruit orchards and vineyards in those portions of France devastated during the World War. The work concludes with a discussion of methods of appraising damage caused to the trees.

A survey of the important commercial peach and apple sections of New Jersey, H. B. WEISS (*N. J. Dept. Agr. Circ.* 34 (1920), pp. 32, figs. 15).—The re-

sults are given of a joint survey conducted by the New Jersey Bureau of Markets and of Statistics and Inspection. The data given for both the apple and peach show the location of the producing districts, the number of bearing and nonbearing trees, and the varieties and ages of bearing and nonbearing trees. Summarized data relative to the apple and peach industries in the United States as a whole and in the principal producing States of the East are also included.

An introductory discussion is given by A. L. Clark on Commercial Peach and Apple Plantings in New Jersey and Their Relation to the Future Market Supply.

A peach-sizing machine, M. STOCKTON and J. F. BARGHAUSEN (*U. S. Dept. Agr. Bul. 864* (1920), pp. 6, figs. 6).—A contribution from the Bureau of Markets describing a peach-sizing machine, patented by the junior author, free use of which is dedicated to the people of the United States.

The machine was developed to meet a demand from peach growers for a simple and efficient machine that would accurately and carefully size and distribute peaches to the packing bin. Its construction and operation is illustrated and described.

The packing of fruit, W. J. ALLEN and W. LE G. BRERETON (*Dept. Agr. N. S. Wales, Farmers' Bul. 130* (1920), pp. 46, figs. 50).—This bulletin discusses the grading and packing of deciduous and citrus fruits, with special reference to conditions in Australia.

The effect of cloudiness [on submerged cranberry plants], H. F. BERGMAN (*Ann. Rpt. Cape Cod Cranberry Growers' Assoc., 32* (1919-20), pp. 19-30, figs. 3).—A contribution from the Bureau of Plant Industry of the U. S. Department of Agriculture giving the results of an investigation of serious injury to cranberry plants, after flooding with water on the State experimental bog at East Wareham, Mass.

The author found that injury is most apt to occur to the plants by flooding the bog during a period of cloudy weather, the amount of light being the most important factor among weather conditions affecting the process of photosynthesis. Cloudiness or dark water greatly decreases the oxygen content of the water. The effect of cloudiness is less noticeable when the bog water is clear. All other factors remaining the same, injury from flooding may increase during a period of warm weather, since the rate of respiration of the submerged plants increases and they require more oxygen. Flowers and growing tips are more seriously injured than old shoots, since their rate of carbon dioxide production and consequently their oxygen requirement are higher.

The renewal of old strawberry plantations, J. BLANCHOUIN (*Jardin, 24* (1920), No. 737, p. 110).—For certain varieties that stool out freely, the author recommends the reduction of the number of hearts in the early fall, previous to fertilizing the plants. The remaining hearts, it is claimed, produce much better fruit the following spring.

A discussion of three types of the Smyrna fig, I. J. CONDIT (*Fig and Olive Jour., 5* (1920), No. 3, p. 5, fig. 1).—The author describes three types of Smyrna figs recently observed in certain nurseries and young fig orchards.

Investigations on the root growth of grape stocks, K. KROEMER (*Landw. Jahrb., 51* (1917), pp. 673-729, pls. 2).—A biological study of root formation and development in grape seedlings, cuttings, and older stocks, including a review of literature dealing with root growth in grapes and other plants.

Marketing eastern grapes, D. ALLEMAN (*U. S. Dept. Agr. Bul. 861* (1920), pp. 61, figs. 3).—A contribution from the Bureau of Markets, discussing the history of varietal development, the rise and fall of commercial production, changes in market outlets, commercial varieties, methods of preparation for

market, the leading producing sections, market preference, and distribution. Appended data show the destinations of carlot shipments from each important producing section.

The California grape industry in 1919, R. L. NOUGARET (*Calif. Dept. Agr., Vitic. Serv. Rpt. 1 (1920), pp. 20*).—A statistical report on grapes and grape products in 1919, with a discussion of prospects for the grape industry in 1920.

Currant-grape growing: A promising new industry, G. C. HUSMANN (*U. S. Dept. Agr. Bul. 856 (1920), pp. 16, pls. 7, figs. 3*).—A contribution from the Bureau of Plant Industry presenting the results to date of the successful work of this Department in introducing the Panariti currant grape (the black commercial currant) into California, determination of congenial phylloxera-resistant stocks for the variety, and the development of profitable yields of currants by the practice of ringing the vines (*E. S. R., 38, p. 346*).

The bulletin discusses the history of the currant industry, its importance in Greece, imports of currants into the United States, currant-grape varieties, the introduction of Panariti grapes, conditions suited to currant-grape culture, experimental work and composition of soil at the Fresno experimental vineyard, cultural practices, including details of ringing the vines to increase the yield, congeniality of the Panariti variety to different stocks, and harvesting and curing currants.

Contributions to the botanical study of cultivated plants.—I, A monograph on the genus Ananas, M. S. BERTONI (*An. Cient. Paraguay., Ser. II, 1919, No. 4, pp. 248-322*).—A descriptive account of the species and varieties of *Ananas* with reference to their botanical characters, habitat, peculiar qualities, and uses, including also a discussion of evolutive changes within the genus, the origin of cultivated varieties, and climatology of the genus.

Method of grafting and top-working the avocado, S. W. FUNK (*Ann. Rpt. Calif. Avocado Assoc., 1919-20, pp. 78-80, figs. 3*).—A diagram is here presented and discussed showing different methods of making cambium connections without splitting and injuring the wood.

Top-working old avocado trees, W. R. MANNING (*Ann. Rpt. Calif. Avocado Assoc., 1919-20, pp. 14-16, pl. 1*).—In top-working old avocado trees, cleft-grafting gave much better results than budding either on old wood or on new after the tree was cut back.

Maturity work on avocados, E. M. CHACE (*Ann. Rpt. Calif. Avocado Assoc., 1919-20, pp. 59-63*).—A contribution from the Citrus By-Products Laboratory of the U. S. Department of Agriculture outlining work being conducted with eight varieties of avocados to determine the best period for harvesting, with reference both to storage and quality. Analyses are given of several miscellaneous avocado samples.

Avocado performance records, A. D. SHAMEL (*Ann. Rpt. Calif. Avocado Assoc., 1919-20, pp. 44-50*).—The method of keeping individual tree records here described is similar to that used in keeping tree records of citrus trees (*E. S. R., 37, p. 144*).

Guatemalan and Mexican avocados fruiting in Florida, J. B. BEACH (*Ann. Rpt. Calif. Avocado Assoc., 1919-20, pp. 73-76*).—Notes are given on the character of the fruits of several varieties of Guatemalan and Mexican avocados that have been grown for a greater or less period in different parts of southern Florida.

Some facts and figures regarding banana cultivation, W. BURNS and P. G. DANI (*Agr. Jour. India, 15 (1920), No. 4, pp. 386-392, fig. 1*).—Based on the records of two plantations in the Ganeshkhind Botanical Garden, observations

are given on various phases of banana culture, including also cost of cultivation and probable income.

Actual conditions of citrus culture in Syria, M. N. HADDAD (*Bul. Soc. Hort. Tunisie*, 18 (1920), Nos. 145, pp. 117-122; 146, pp. 131-134).—A survey of the present status of the citrus industry in Syria, with reference to cultural and marketing practices, varieties grown, and the economic situation; including brief recommendations for bringing about a better condition both from the cultural and economic standpoints.

The orange: A trial of stocks at Peshawar, W. R. BROWN (*Agr. Research Inst. Pusa Bul.* 93 (1920), pp. [4]+7, pls. 13).—A contribution from the Agricultural Research Institute, Pusa, giving the results of experiments with various orange stocks in the Northwest Frontier Province of India.

Of the stocks tested for the Malta orange, the rough lemon gave the greatest vigor and fruitfulness. The sweet lime was suitable for the Malta in the small private garden only where a dwarf tree with a few oranges of high quality are desired. The citron and sour orange were not suitable stocks for the Malta orange.

The sweet lime proved to be the best stock for the Sangtara orange. The rough lemon and citron were unsuitable for this variety.

"The stock and scion influence each other profoundly in producing vigor and fruitfulness in the orange tree, and in developing color, shape, size, quality, flavor, beauty, and seedlessness in the fruit."

Report of the seed garden for coffee at Bangelan, P. J. S. CRAMER (*Jaarb. Dept. Landb., Nijv. en Handel Nederland, Indië*, 1918, pp. 161-194).—A progress report on breeding and selection work with coffee, including a list of new selections and tabular data on yields of selected trees of various varieties and hybrids for 1918, and in some cases for the three previous years.

Culture of medicinal plants, A. ROLET and D. BOURET (*Plantes Médicinales Culture. Paris: J. B. Baillièrre & Sons*, 1919, pp. 636, figs. 237).—This is one of the volumes of the *Encyclopédie Agricole* published under the direction of G. Wery, and comprises a guide for the collector and cultivator of medicinal plants. Part one contains a synopsis of the majority of the medicinal plants native to France, including information relative to the parts used, and discusses the regions of wild plant production, the desirability of cultivating medicinal plants, regions adapted to their culture, methods of harvesting, drying, and preparation for market. Part two takes up the botany, properties, uses, and culture of the individual species.

Native plants suitable for the gardens of Missouri and adjoining States.—VI, Native perennials for natural and wild gardens.—VII, Hardy native ferns and plants of similar culture (*Missouri Bot. Gard. Bul.*, 8 (1920), No. 7, pp. 85-94).—A further contribution from the Missouri Botanical Garden (E. S. R., 43, p. 441), comprising tabular lists of plants that will flourish under minimum care and attention if given proper soil, light, and moisture.

New species of Rhododendron, B. BALFOUR (*Notes Roy. Bot. Gard. Edinb.*, 12 (1920), No. 57-58, pp. 85-186).—Descriptions are given of 40 new species of Rhododendron.

Climbing and rambling roses, H. H. THOMAS (*London and New York: Cassell & Co., Ltd.*, 1920, pp. 80, figs. 12).—A small popular treatise on the culture and care of climbing and rambling roses, including descriptive notes on the best varieties.

The practice of cut-flower growing, C. REITER (*Die Praxis der Schnittblumengärtneri. Berlin: Paul Parey*, 1916, pp. VI+659, figs. 310).—A guide and manual on commercial floriculture, discussing general principles, equipment,

cultural rules, and formulas, including the control of pests and diseases, and giving specific directions for growing commercial plants and flowers both under glass and in the open.

FORESTRY.

National forest policies: A critical review of the several plans, F. E. OLMSTED (*Jour. Forestry*, 18 (1920), No. 6, pp. 598-609).—A critical review of National Forest programs advocated by the Forest Service of the U. S. Department of Agriculture, the American Paper and Pulp Association, the National Lumber Manufacturers' Association, and the Society of American Foresters.

Annual report of the National Forest Reservation Commission for the fiscal year ended June 30, 1919 ([U. S.] *Natl. Forest Reserve. Comm. Ann. Rpt.*, 1919, pp. 20).—The report contains tabular data as of June 30, 1919, as to purchase areas and lands being acquired under the Watershed Protection Act of March 1, 1911, together with a statement of expenditures. It also discusses the future purchase policy, establishment of new areas, consolidation of established areas, development of the purchased forests, and the status of expenditures and purchase.

Sixteenth annual report of the State forester [of Massachusetts], F. W. RANE (*Ann. Rpt. State Forester Mass.*, 16 (1919), pp. 61, pls. 5, figs. 3).—This is the usual annual report relative to the administration and management of the State nurseries, plantations, and forests in Massachusetts, including accounts of general reforestation activities in the State and moth and fire control work, together with recommendations relative to needed legislation.

[**Report on forestry investigations at the North Central Minnesota Substation, 1915-1919**], O. I. BERGH (*Minnesota Sta., Rpt. Grand Rapids Substa.*, 1915-1919, pp. 56-58, figs. 2).—A brief review of tree planting operations conducted since 1897, including data showing the growth of pines planted at varying distances in plats of one species and in mixed plats.

Twenty years of forest tree planting, J. S. ILLICK (*Canad. Forestry Mag.*, 16 (1920), No. 8-9, pp. 397-404, figs. 7).—A contribution from the Pennsylvania Department of Forestry, sketching the progress of tree planting operations on State and private lands in Pennsylvania since 1899, and briefly describing nursery experience gained in the State work.

Forestry (Ann. Rpt. Reforms and Prog. Chosen (Korea), 1917-18, pp. 98-101, pl. 1).—A brief report on forestry activities in Korea, with special reference to the administration of the State forests and nurseries and work in afforestation.

Annual report of the forest department for the year ending March 31, 1919, including report on railway sleeper plantations for the same period, C. R. ROSS (*Union So. Africa, Ann. Rpt. Forest Dept.*, 1919, pp. 34).—This is the usual progress report relative to the administration and management of the State forests in the Union of South Africa, including data showing operations on plantations, nurseries, and drift sand areas, artificial reproduction in the indigenous forests, yields of major and minor forest products, revenues, expenditures, etc.

West African forests and forestry, A. H. UNWIN (*London: T. Fisher Unwin, Ltd.*, 1920, pp. 527, pls. 41).—A compiled work describing the various forest types, the principal timber trees, the conditions of working timber, forest industries and products, forest exports, etc., in the following countries of West Africa: Gambia, Sierra Leone, Liberia, Ivory Coast, Gold Coast, Togo, Nigeria, and in the British sphere of the Kamerun, including a note on the French and Belgian Congo and Spanish Guinea. Concluding chapters discuss the oil beans, seeds, and nuts of the forest, the oil palm and palm kernel industry, the forest

in relation to agriculture, and a bibliography of West African forests. Special consideration is given to the Nigerian timber trees.

Forestry in Rhodesia, J. S. HENKEL (*Rhodesia Agr. Jour.*, 17 (1920), No. 4, pp. 335-339, pls. 2).—Notes are given on timber trees in the Umtali Park.

Forests and silviculture in warm-arid regions, A. PAVARI (*Agr. Colon. [Italy]*, 14 (1920), No. 8, pp. 326-345).—A brief examination of the principal aspects of the forests and forestry in tropical and semitropical arid regions of the world.

Tolerance of forest trees and its relation to forest succession, G. P. BURNS (*Jour. Forestry*, 18 (1920), No. 6, pp. 610-615).—In this contribution from the Vermont Experiment Station, the author briefly reviews some of the literature dealing with tolerance of forest trees with the idea of showing that the word tolerance does not mean to all foresters a light relationship only; that it is a confusing term; and that if its use is to be continued, it should be given an exact definition.

Timber line and climate character, H. BROCKMANN-JEROSCH (*Schweiz. Naturf. Gesell. Pflanz. Geogr. Komm., Beitr. Geobot. Landesaufnahme*, 6 (1919), pp. VIII+255, pls. 4, figs. 17).—A contribution from the Plant Geographical Commission of the Swiss Natural Research Society. This work comprises a study of timber line in relation to various climatic factors and various combinations of these factors. The introductory chapter discusses the method of conducting the investigation. In the succeeding chapters, consideration is given to the timber line in the Swiss Alps and in the north and south polar regions of the world. Comparisons are then made between the alpine timber line and the polar timber lines. The continental timber line is considered in its relation to both the alpine and polar timber lines. In the final chapter the author presents certain conclusions relative to the effect of various climatic factors on timber line and the formation of different plant groups. A bibliography of consulted literature is appended.

The technique of natural reproduction once and now, EBERHARD (*Forstwiss. Centbl.*, 42 (1920), Nos. 5, pp. 161-183; 6, pp. 204-226).—A study of forest regeneration practices in Germany.

The care of the woodlot, B. R. MORTON (*Dept. Int. Canada, Forestry Branch Bul.* 69 (1920), pp. 52, figs. 28).—The bulletin supersedes Circular 10 of the same series. It discusses protection, thinning, improvement cuttings, pruning for marketable timber, reproduction, collecting tree seed, and the farm nursery. It also contains notes on various species of trees and tables of distances and quantities.

Forest fires in Canada, 1918, R. G. LEWIS (*Dept. Int. Canada, Forestry Branch Bul.* 70 (1920), pp. 20, figs. 12).—This is a statistical report for 1918 on forest fires in the several Provinces of Canada, with reference to areas burned, causes, damage, and areas patrolled.

Air maps for flying patrols (*Canad. Forestry Mag.*, 16 (1920), No. 8-9, pp. 406, 407, fig. 1).—The method of map squaring adopted by the Quebec Forestry Branch, forest fire protective associations, and several large paper and lumber companies who operate aerial surveys and patrols of timber limits is illustrated and described.

Yield tables for single trees of deodar, kail, chil, spruce, and silver fir, C. G. TREVOR (*Indian Forester*, 46 (1920), No. 9, pp. 439-451).—The data given are the results of large numbers of measurements recorded during the last 20 years in the Kulu forest division of India.

The soap tree, L. TRABUT (*Prog. Agr. et Vitic. (Ed. l'Est-Centre)*, 40 (1919), No. 17, pp. 398-401).—A brief account is given of the importation in 1845 and subsequent history of a *Sapindus*, its varieties, and the utility of its products.

Summer planting of white pine on the Michigan State forests, R. WATSON (*Jour. Forestry, 18 (1920), No. 6, pp. 623, 624*).—Planting experiments conducted on the Higgins Lake State Forest, Mich., indicate that summer planting of white pine can be carried on in that region without serious mortality.

A study of windfall loss of western yellow pine in selection cuttings fifteen to thirty years old, R. H. WEIDMAN (*Jour. Forestry, 18 (1920), No. 6, pp. 616-622*).—The study reported was conducted on representative plats in and near three National Forests in the Blue Mountain region of eastern Oregon.

The author concludes that heavy windfall in the first few years following cutting does not presage the total destruction of the reserve stand or even endanger the method of cutting. As high a loss as 25 per cent by volume on bad windrisk areas may be expected in the course of 20 years. Of all the windthrow which occurs over a long period of years, a proportion as great as two-thirds or more usually takes place in the first four or five years immediately after cutting, and the remainder is thrown in rapidly decreasing percentages until about 20 years later when the windfall is so slight as to be negligible. Measured by the heaviest loss encountered, the selection method of cutting is not prohibitive in the yellow pine stands of eastern Oregon.

Report on some preliminary practical trials relative to a study of alternate tapping, G. VERNET (*Bul. Agr. Inst. Sci. Saigon [Cochin China], 2 (1920), No. 8, pp. 227-238*).—A contribution from the Scientific Institute of Saigon presenting data on preliminary tapping experiments with Hevea trees, conducted during the first four months of 1920.

Philippine forest production as sources of paper pulp, W. H. BROWN and A. F. FISCHER, trans. by J. BRIANT (*Bul. Agr., Inst. Sci. Saigon [Cochin China], 2 (1920), No. 8, pp. 238-245*).—A summary in French of Bulletin 16 of the Philippine Bureau of Forestry (E. S. R., 40, p. 745).

Relation of research to forest management, H. F. WEISS (*Jour. Forestry, 18 (1920), No. 6, pp. 590-597*).—A paper read before the Madison, Wis., section of the Society of American Foresters on May 10, 1920, in which the author presents illustrations showing the importance of research in developing and extending forest industries.

DISEASES OF PLANTS.

Mycological contributions, E. FISCHER (*Mitt. Naturf. Gesell. Bern, 1918, pp. 72-95*).—Of the three sections included in this portion of these contributions, one deals with the inheritance of susceptibility of plants to parasitic fungi, and another with parasitic fungi collected in the eastern portion of Java.

Some new fungi, N. RANOIÉVITCH (*Bul. Trimest. Soc. Mycol. France, 35 (1919), No. 1-2, pp. 14-26, figs. 14*).—The 17 species here described as new (some being parasitic), represent 13 genera in 7 families.

Puccinia antirrhini, H. W. THURSTON, JR. (*Phytopathology, 9 (1919), No. 8, p. 330*).—The occurrence of *P. antirrhini* on snapdragons in the greenhouse of the University of Nebraska is reported, and inquiry is said to have shown that the disease has been present in the State since 1916. In some greenhouses from 25 to 50 per cent of the plants have been killed. It is thought the rust was introduced on cuttings from some infected region, but efforts to trace it to such source have been unsuccessful.

The minimum, optimum, and maximum temperatures of spore germination in some Uredinales, W. L. DORAN (*Phytopathology, 9 (1919), No. 9, pp. 391-402, fig. 1; reprinted as New Hampshire Sta. Sci. Contrib. 44¹ (1919), pp. 391-402*).—A study has been made of the germination of a number of species of

rusts to determine the effect of temperature and supply of oxygen and water on germination. The spores studied were found to germinate over a wide range of temperature. The aëriospores of *Cronartium ribicola* germinated through a range of 12° C., the urediniospores of the same fungus through a range of 17°, the aëriospores of *Gymnosporangium clavipes* through a range of 20°, the urediniospores of *Puccinia antirrhini* through a range of 15°, the teliospores of *P. malvaccarum* through a range of 27°, and the urediniospores of *Uromyces caryophyllinus* through a range of 25°. The germination of the spores of the different species was found to decrease very rapidly above and below the optimum.

The author claims that although spores may germinate over a wide range of temperature there is a material degree of host infection only when the temperature is near the optimum, and that the optimum temperature for the germination of rust spores is relatively low. There is believed to be a relation between the time of year when spores occur and the optimum temperature for their germination.

Wind and the distribution of pathogenic soil organisms, H. G. MACMILLAN (*Phytopathology*, 9 (1919), No. 10, pp. 471-473, pl. 1).—The author describes conditions occurring in eastern Colorado in 1919 in parts where severe dust storms occurred, and the observations are believed to indicate that wind is an active agent in the distribution and dissemination of organisms present in the soil and pathogenic to field and truck crops.

Insect carriers of plant diseases, E. M. DUPOURTE (*Ann. Rpt. Quebec Soc. Protect. Plants [etc.]*, 11 (1918-19), pp. 59-65).—A consideration of the part played by insects in the dissemination of plant diseases is said to show that a large number of the most serious fungus diseases can be more effectively controlled by insecticides than by fungicides.

Some newer phases of disease and insect control, J. OSKAMP (*Trans. Ind. Hort. Soc.* 1918, pp. 33-42).—The last two or three years have been fruitful as regards disease control suggestions and methods, largely due to the war, directly or indirectly.

The spray gun is regarded as a time saver, but of doubtful efficiency as compared with the spray rod. Dry-lime sulphur (which is essentially lime sulphur evaporated to dryness under pressure and finely ground) proves reasonably satisfactory.

Calcium arsenate burning appears to be due to the free arsenic and is lessened by the addition of lime. Dusting experiments, while not very conclusive, have given interesting results as regards comparative costs and relative amounts of materials and labor. Double strength lime sulphur has not shown any considerable value in controlling apple blotch. Raspberry anthracnose is said to have been controlled elsewhere with Bordeaux mixture (4:4:50) or lime sulphur.

Relative adhesiveness of the copper fungicides, O. BUTLER and T. O. SMITH (*Phytopathology*, 9 (1919), No. 10, pp. 431-444; reprinted as *New Hampshire Sta. Sci. Contrib.* 13 (1919), pp. 431-444).—A report is given of studies made of Bordeaux mixture, Burgundy mixture, copper acetate, and cuprammonium sulphate to determine their adhesiveness. This was tested by spraying Coleus plants which were allowed to stand 48 hours before they were rained on. The plants were then dried and the adhesive qualities tested.

Neutral and alkaline Burgundy mixtures were more adhesive than Bordeaux, and alkaline Burgundy mixture was more adhesive than the neutral wash. The adhesiveness of Bordeaux mixtures was found to vary with the different formulas used in its manufacturing, and the effect of the temperature of the

water with which the mixture was made had little influence on the adhesive quality. Deteriorated Bordeaux mixture 1:1 was said to be more adhesive than deteriorated Burgundy mixture. The copper acetate solutions were more adhesive than Bordeaux mixture, and the addition of ferrous sulphate to Bordeaux mixture was found to decrease the adhesiveness in a very marked degree. The addition of Paris green or arsenite of soda did not change the adhesive property, but lead arsenate increased it slightly. The addition of casein to Bordeaux mixture 1:1 did not affect the adhesiveness, while the addition of gelatin to normal and basic acetate of copper increased the adhesiveness of both salts. Cuprammonium sulphate was found more adhesive than Johnson's mixture. The proprietary copper fungicide and arsenical insecticide, Pyrox, possessed a fair degree of adhesiveness, but were noticeably inferior to 1 per cent Bordeaux mixture plus 0.5 per cent arsenate of lead.

Pickering sprays, F. C. Cook (*U. S. Dept. Agr. Bul. 866 (1920), pp. 47, pls. 2, fig. 1*).—Results are given of an investigation carried on by the Bureau of Chemistry in cooperation with the Bureau of Plant Industry and the Maine Experiment Station to determine the efficacy of the so-called Pickering sprays, which are prepared by mixing saturated limewater with dilute solutions of copper sulphate and contain their copper in the form of basic copper sulphates.

Two formulas of Pickering sprays were used, one composed of 1 oz. of copper sulphate to 134 oz. of limewater; the other, 1 oz. of copper sulphate to 161 oz. of limewater, these fungicides being compared with ordinary Bordeaux mixture composed of equal parts of copper sulphate and lime. Experiments were conducted to determine whether sprays made in accordance with the various Pickering formulas were effective when applied under American field conditions, and to ascertain how much copper in the different Pickering formulas is required per given quantity of spray to insure effective control of fungus diseases; also, to compare the fungicidal values of the sprays with standard Bordeaux mixture, and to determine the injurious action of the Pickering sprays on various kinds of vegetation.

The strongest Pickering sprays, those containing from 0.6 to 0.7 per cent of copper sulphate, were found to control fungus diseases on potatoes and cranberries very effectively. Their control on grapes and apples was not definitely determined, as the results were complicated by burning or other injury to the foliage and fruit. Pickering sprays containing less than 0.6 per cent of copper sulphate were not so effective for potatoes and probably not for cranberries. No difference between the efficacy of sprays made by the two formulas was observed.

The results of the tests made on potatoes indicated that per unit of copper present the sprays were twice as effective as Bordeaux mixture. Increased yields of tubers were obtained on plats of potatoes treated with Bordeaux mixture and with the stronger Pickering sprays, indicating that both fungicides exerted a protective action on the potato plants.

The adhesive properties of Pickering sprays were found to vary with the foliage to which they were applied. They adhered to potato and cranberry leaves in practically the same degree as Bordeaux mixture, to apple leaves in a somewhat higher proportion, and to grape leaves in a lower proportion. No injurious effects followed the application of Pickering sprays to potatoes in Maine or to cranberries in New Jersey. The sprays, however, proved too caustic for use on the apple in Virginia and grapes in New Jersey and Virginia. On this account Pickering sprays are not recommended for use on tender foliage.

Barium water sprays, made with barium hydrate and containing 0.7 per cent copper sulphate, proved very successful as a fungicide for potatoes, and such

a spray containing 0.6 per cent copper sulphate did not injure the fruit or foliage of the apple.

The results of this investigation are presented as a basis for further studies to be conducted in various parts of the country.

How the protection of plants has progressed in Quebec, G. MAHEUX (*Ann. Rpt. Quebec Soc. Protect. Plants [etc.]*, 11 (1918-19), pp. 56-58).—The author deals concretely with the use of fungicides and insecticides with a few crops, notably wheat and potatoes, both of which showed striking net gains due to protective treatments.

Flag smut and take-all, G. M. REED and G. H. DUNGAN (*Illinois Sta. Circ.* 242 (1920), pp. 4, fig. 1).—Results are given of an extensive survey of the wheat fields in the vicinity of Granite City, Ill., where flag smut made its appearance in 1919. Flag smut is reported as having been found in 111 fields, comprising 2,500 acres, but so far has not been found outside this area. The authors give a brief discussion of the appearance and methods of control of the disease, the most promising control measures being the treatment of seed grain, burning of straw, and planting of resistant varieties.

The same measures are recommended for the control of take-all, and precautionary measures are also being taken to prevent the further spread of this disease.

A comparative morphological study of æcia of four different rusts found upon barberries in North America, H. R. ROSEN and R. S. KIRBY (*Phytopathology*, 9 (1919), No. 12, pp. 569-574, pls. 2, fig. 1).—Results are given of morphological studies of *Puccinia fendleri*, *P. oxalidis*, *P. graminis*, and *Æcidium butlerianum*, heteroecious rusts which produce æcia on barberries. The last species is described as new.

Presoak method of seed treatment: A means of preventing seed injury due to chemical disinfectants and of increasing germicidal efficiency, H. BRAUN (*Jour. Agr. Research [U. S.]*, 19 (1920), No. 8, pp. 363-392, pls. 14, figs. 9).—According to the author, the use of formalin and copper sulphate as now practiced usually causes retardation and injury to seed germination. Greenhouse and field experiments, carried on by the Bureau of Plant Industry, U. S. Department of Agriculture, have shown that this detrimental effect can be eliminated for standard varieties of wheat by allowing the seeds to absorb water for six hours before submitting them to treatment with formalin or copper sulphate. Soaking for a short period (10 minutes) and covering for 6 hours is said to be better than leaving the seed in water for 6 hours. Similar results were obtained in experiments with barley, oats, and corn.

The saturation of the seed cells and cell walls with water during the presoak period is thought to be the factor counteracting the injurious effect upon seed germination by diluting the disinfectant beyond the point of injury. Actual stimulation of germination is said to have been observed in presoak-treated seeds, a factor which by shortening germination minimizes the danger of exposure to the attack of soil organisms during the susceptible period.

The use of the presoak method is said to increase the efficiency of the disinfectant, in that the presoaking stimulates dormant bacteria and possibly fungi into vegetative activity, thereby rendering them extremely susceptible to the subsequent action of the disinfectant.

In applying the principles stated by the author to other seeds, the determination of the length of time for the presoak period and the subsequent disinfectant treatment is governed by the rate of absorption of water by the seed, the susceptibility of the seeds and pathogens to the disinfectant, and the periods necessary for the beginning of seed germination and of vegetative activity on the part of the pathogen.

The treatment of certain seed-carried diseases, G. W. WILSON (*Abs. in Science, n. ser., 52 (1920), No. 1334, p. 87*).—The author reports that he and his associates have perfected a method of treating cotton seed for the prevention of certain seed-carried diseases. The method is deemed practicable on a commercial scale, and bids fair to be of considerable value in the treatment of seed-carried diseases of other crops.

Diseases of grains, sorghums, and millet, and their control in Texas, J. J. TAUBENHAUS (*Texas Sta. Bul. 261 (1920), pp. 3-34, figs. 15*).—A nontechnical account is given of the more common diseases occurring on wheat, oats, rye, barley, sudan grass, corn, sorghum, and millet, and so far as definite means are known suggestions are given for their control.

Greenhouse lettuce disease (*Kentucky Sta. Rpt. 1919, pt. 1, pp. 45, 46*).—It is reported that experiments conducted by the department of horticulture in the growing of head lettuce in the greenhouse failed in 1918 and again in 1919, and an investigation has been begun to determine the cause of the trouble. Believing that the disease was due to soil organisms, some of the benches were treated with a 1:100 solution of formalin at the rate of 4 qts. per square foot of bench space. Other benches were untreated to provide check plants.

After varieties of lettuce became well established in the soil, many of the plants were observed to show various irregularities of growth, such as stunting of the midvein and wrinkling of the leaf blade, irregular distribution of chlorophyll, tip burning, etc. Examination of the root systems of about 400 plants showed numerous lesions on the roots, and in many instances stubs were observed where the roots had completely rotted off. Cultures from the roots yielded a species of *Fusarium*, and experiments are under way to determine the specific organism and methods of control. Surface sterilization of seeds proved of no value as a control measure.

In addition to the foregoing, *Sclerotinia libertiana*, *Botrytis cinerea*, *Rhizoctonia* sp., and *Septoria consimilis* are reported as causing damage to greenhouse lettuce.

The comparative rate of desiccation of tubers from normal and diseased potato plants, A. L. BAKKE (*Phytopathology, 9 (1919), No. 12, pp. 541-546, fig. 1*).—The results are given of a study of the rate of desiccation of tubers of the varieties Rural New Yorker and Eureka, the latter known to be very susceptible to the curly dwarf disease. It was found that curly dwarf potato tubers on being desiccated reached an equilibrium with the evaporating power of the air before the normal potatoes of the same variety. The diseased tubers contained more suberin at the beginning, but later fissures developed which caused the tubers to reach the equilibrium earlier. Curly dwarf potatoes on being placed in water showed a greater absorption than desiccated normal tubers similarly placed.

Tobacco diseases, G. H. CHAPMAN (*Massachusetts Sta. Bul. 195 (1920), pp. 23-31*).—In a report on tobacco investigations the author gives a summary of experiments on the control of tobacco diseases carried on since 1916. In the seed bed control is largely through the practice of sterilization. In the field a considerable number of diseases have been observed, the most important of which is the root rot caused by *Thielavia basicola*. Other diseases observed are the mosaic, leaf spots, rusts, damping-off, stem canker, root rots induced by various species of *Fusarium*, sun scald, bud scald, etc.

In connection with the investigations, a root rot which is more or less similar in its effect to that caused by *Thielavia* was observed. In this rot there were no pronounced black lesions on the roots but a uniform browning and dirty discoloration, most of the injury being confined to the fine, feeding rootlets. A

form of *Rhizoctonia* was isolated from the diseased roots, but the relation of the fungus to the disease has not been definitely established.

In connection with the *Thielavia* root rot, the control of the disease in the seed bed through sterilization is deemed practicable. In the field the question of the relation of the fungus to soil reaction seems to be of importance, and the author claims that by the use of cover crops and acid fertilizer materials the acidity of heavily infected fields has been restored in a remarkably short time.

Some experiments are reported showing the effect of various chemicals when added to the soil for the control of root rot. Formaldehyde was the only substance used that checked the development of root rot to any considerable extent. At the lower concentrations this substance apparently stimulated root growth. Sulphur, mercuric chlorid, and ferrous sulphate reduced root rot to some extent but had an injurious effect on the root development of the plants.

Laboratory experiments are said to be in progress with the *Thielavia* fungus to determine the specific action of the different acids and bases on the growth and development of the fungus in culture, as well as to determine the limits between which the fungus is actively parasitic.

Effect of copper soap and of Bordeaux soap spray mixtures on control of tomato leaf spot, F. J. PRITCHARD and W. B. CLARK (*Phytopathology*, 9 (1919), No. 12, pp. 554-564, figs. 7).—The authors have undertaken to develop better methods of spraying and cheaper and more effective spraying mixtures for control of tomato leaf spot. A test was made of a number of different fungicides, among them Bordeaux mixture made of different formulas, copper sulphate, copper sulphate and soap, copper oleate, copper stearate, and copper resinate.

The most promising spraying mixtures were Bordeaux mixture, Bordeaux mixture to which soap was added, and a copper sulphate soap mixture. The copper soap mixture composed of 0.5 lb. copper sulphate, 3 lbs. fish oil soap, and 50 gal. of water gave the best results as far as yield is concerned, and it has the additional advantage of being much cheaper than Bordeaux mixture, but it was not quite so effective in control of the disease as Bordeaux mixture to which fish oil soap was added.

Wilts of the watermelon and related crops, J. J. TAUBENHAUS (*Texas Sta. Bul.* 260 (1920), pp. 3-50, figs. 17).—A summary is given of the results of investigations on the *Fusarium* wilts of cucurbits in Texas. The author claims that the *Fusarium* wilt of watermelon is caused by three distinct species, *F. niveum*, *F. citrulli*, and *F. poolensis*. The wilt of squash and cashaw is attributed to a distinct species, *F. cucurbitæ*. The species occurring on the watermelon and squash were found unable to attack cotton, okra, cowpea, potato, tomato, or any other plants.

As a result of his investigations, the author claims that *F. niveum* of watermelon is in no way related to *F. vasinfectum*, which attacks cotton and okra only. *F. malvacearum* was found to be a weak parasite of okra, but did not affect the cotton plant. A number of other species of *Fusarium* are reported as being limited to specific host plants in Texas. It is stated that a wilt is produced in cucumbers and cantaloup by *Bacillus tracheiphilus*, and that a *Fusarium* is often associated with this wilt but is present only as a secondary invader.

For the prevention of the wilt of watermelon the author recommends a three-year rotation accompanied by the planting of immune or resistant varieties.

Molding of snow smothered nursery stock, C. HARTLEY, R. G. PIERCE, and G. G. HAHN (*Phytopathology*, 9 (1919), No. 11, pp. 521-531).—The frequent destruction by parasites of seedling conifers in nurseries has led to a study of

the problem, and it was found that evergreen plants partially smothered by tight packing or prolonged mulch or snow cover during the winter are liable to injury from weakly parasitic fungi attacking the leaves. A number of organisms have been obtained from such plants, among them *Botrytis cinerea* and a dark sterile mold thus far unidentified. Observations and experiments have shown that young plants, cutting off of roots, and prolonged smothering all decrease the resistance, and that contact with the soil or dead organic matter increases the likelihood of injury. Crowding the seedlings together or surfacing the soil with gravel seems to result in decreasing loss slightly, probably due to keeping the plants from intimate contact with the soil. Spraying and soil treatment experiments with a number of fungicides have given no promise of developing any disinfectant or protective treatment of practical value.

Diseases of Illinois fruits, H. W. ANDERSON (*Illinois Sta. Circ. 241 (1920)*, pp. 3-155, pls. 2, figs. 58).—After giving an account of plant diseases in general and an introductory chapter on the control of fruit diseases, the author describes the principal diseases occurring on fruits within the State and suggests methods of control. Each disease is described and illustrated in such a manner that it is hoped that growers will be able to recognize it when it is encountered. Whenever possible, the complete life history of the organism causing the disease is given.

The diseases enumerated are those attacking the apple, pear, quince, peach, plum, cherry, raspberry, blackberry, dewberry, currant, gooseberry, grape, and strawberry.

Apple blotch control, W. S. BROCK (*Trans. Ind. Hort. Soc. 1918*, pp. 103-111, fig. 1).—Apple blotch, known in the South for 20 years, is said to be gradually disseminating northward, being serious as far north as Greencastle, Ind., and Champaign, Ill. Treatments are discussed.

The cause of bitter pit, A. J. EWART (*Proc. Roy. Soc. Victoria, n. ser., 30 (1917)*, No. 1, pp. 15-20).—This is a review of the fourth report by McAlpine (*E. S. R.*, 37, p. 455), also of contributions by others on the subject. The present position in regard to bitter pit is summed up as regards the groups of facts supporting the different theories, of which those based respectively on the bursting of cells and on vascular interruptions are criticized, while that based on poisoning by sprays is favorably discussed.

An undescribed apple spot (*Kentucky Sta. Rpt. 1919, pt. 1, p. 47*).—A brief description is given of a form of injury to apples first noticed in 1919. It is characterized by a depression of the surface of the fruit that may be either very dark or normal green. The spots vary from 5 to 20 mm. in diameter. Sections of deep green spots showed them to be from 5 to 8 mm. in diameter and rather spherical in outline. Sometimes the centers of the spots showed a brown area of dry, punky tissue. Where no discoloration was observed, sections frequently revealed identical spots, but often 3 or 4 mm. below the surface of the fruit, with perfectly normal tissue intervening. The diseased tissues are said to be bitter in taste. Sections made of spots showed a fungus constantly associated with their presence, and the greatest growth of the fungus seemed to be just outside the zone of dense greenish cells, but not extending more than 1 mm. into the healthy tissue surrounding the spot.

Peach canker, W. A. McCUBBIN (*Canada Expt. Farms Bul. 37, 2. ser. (1918)*, pp. 20, pls. 6, figs. 2).—The results are given of six years' investigation on the cause and method of control of peach canker due to *Valsa leucostoma*. This fungus is said to establish itself in dead portions of trunks, twigs, etc., from which it attacks the living tissue, stimulating the surrounding tissue into excessive growth, so that a pronounced callus ring is formed around the canker.

The fungus advances into the surrounding living tissue while the tree is dormant, and its attacks may be assisted by the freezing of the stimulated and unripened callus around the canker. A copious flow of gum is associated with the canker development.

For the control of this disease the author recommends keeping the trees free of all dead and dying wood as much as possible, removing all unnecessary sucker growth during the summer, and destroying rotten fruits at picking time. All wounds should be clean cut, and the later in the spring the pruning is done the better the wounds will heal. Large cankers on trunks or main limbs are said to heal if carefully cleaned out during the summer, preferably after a rain. After the treatment the wound should be disinfected with a corrosive sublimate solution and when dry painted with lead paint.

Fanning strawberries in relation to keeping quality, N. E. STEVENS and A. H. CHIVERS (*Phytopathology*, 9 (1919), No. 12, pp. 547-553).—The experiments reported were undertaken with the hope of discovering whether under New England conditions fanning wet strawberries would improve their keeping qualities.

The results are held to offer no evidence in support of the idea that it is injurious to pick strawberries while they are wet. In general, wetting berries which have been picked dry is not to be recommended, but if the berries have been picked wet or for any reason have become wet after picking, the best practice is believed to be immediate shipping without any attempt at drying. In northern and eastern New England the authors found *Rhizopus nigricans* much less abundant on ripe strawberries than in any of the more southern regions thus far studied. Under New England conditions *Botrytis* seems to be the most common fungus occurring on strawberries.

Banana wilt, E. W. BRANDES (*Phytopathology*, 9 (1919), No. 9, pp. 339-390, pls. 14, figs. 5).—This is a detailed account of an investigation begun while the author was connected with the Porto Rico Experiment Station, and concluded as postgraduate work at Cornell and Michigan Universities. Some phases of the work have already been noted (*E. S. R.*, 41, p. 845.)

Relative susceptibility to citrus canker of different species and hybrids of the genus *Citrus*, including the wild relatives, G. L. PELTIER and W. J. FREDERICH (*Jour. Agr. Research [U. S.]*, 19 (1920), No. 8, pp. 339-362, pls. 12).—In a previous publication (*E. S. R.*, 39, p. 757), the senior author gave a preliminary report of inoculation experiments carried on under greenhouse conditions for a period of six months on the susceptibility and resistance to citrus canker of a number of plants, including some of the wild relatives, citrus fruits, and hybrids of the genus *Citrus*. In the present report the results are given of continued observations carried on cooperatively by the Alabama College Experiment Station and the Bureau of Plant Industry, U. S. Department of Agriculture, in the summers of 1917, 1918, and 1919, in which both greenhouse and field tests were made. A large number of species and varieties have been successfully inoculated, others have proved to be extremely susceptible, while some still show considerable resistance.

The successful inoculation of a large number of wild relatives in the greenhouse shows that the organism *Pseudomonas citri* has a wide range of hosts and is not limited to the genus *Citrus*. In the field, only those wild relatives which were most susceptible under greenhouse conditions were successfully inoculated. Of these *Poncirus trifoliata* and *Microcitrus australis* proved to be susceptible, while *M. australasica* and *Fortunella hindsii* are somewhat susceptible. So far as the menace of citrus canker to the citrus industry of the United States is concerned, the authors believe that with the exception of

P. trifoliata none of the wild relatives growing in citrus districts are susceptible enough to have any bearing on the eradication program.

Little or no change in susceptibility or resistance to citrus canker was noted among the citrus fruits from that previously reported. All hybrids were attacked by citrus canker in various degrees, and all false hybrids were found extremely susceptible. The authors consider that leaf texture is apparently an important factor in influencing resistance to *Pseudomonas citri* by its host plants.

A disease of oil palm, A. MAUBLANC and H. C. NAVEL (*Agron. Colon.*, 4 (1920), No. 30, pp. 187-191, pl. 1).—Oil palm (*Elæis guineensis*), on St. Thomas and Principe and at points farther south on the West African mainland, is attacked by a fungus said to be *Ganoderma applanatum*, the habits of which are discussed in this connection.

Sclerotinia ricini n. sp. parasitic on the castor bean (*Ricinus communis*), G. H. GODFREY (*Phytopathology*, 9 (1919), No. 12, pp. 565-567, pls. 2).—A description is given of *S. ricini* n. sp., which is said to cause a serious disease of the castor bean in extensive plantings in Florida and other southern States.

"Crack-neck": A nonparasitic disease of chrysanthemums, G. H. CHAPMAN (*Phytopathology*, 9 (1919), No. 11, pp. 532-534, pl. 1).—This term is applied to a trouble occurring on fancy forced chrysanthemums and to a less extent on ordinary potted ones. It is characterized usually by a horizontal rupturing of the stem or neck just below the flower head. Occasionally a longitudinal splitting occurs, but this condition is rather infrequent. The condition capable of producing cracking of the necks appears to be related to temperature and moisture, and it is suggested that the night temperatures be raised as much as possible consistent with the best development of the plants, and that during dull weather water be withheld as much as possible.

Frost necrosis of tulip leaves, L. R. JONES and M. MILLER (*Phytopathology*, 9 (1919), No. 10, pp. 475, 476, fig. 1).—A description is given of injury to Darwin tulips attributed to frost. The injury is characterized by the appearance of small spots on or between the veins, the lesions resembling those due to bacteria. No evidence of bacterial invasion, however, was found, and it is considered that frost was the cause of the trouble.

A Tuberculariaceæ on box, F. MOREAU (*Bul. Trimest. Soc. Mycol. France*, 35 (1919), No. 1-2, pp. 12-14, figs. 4).—Box in the English garden at Chateau Fontainebleau was attacked April, 1915, by a number of parasites, among them *Volutella buxi*, which is here briefly discussed in this connection.

The overwintering of *Cronartium ribicola* on *Ribes*, M. W. TAYLOR (*Phytopathology*, 9 (1919), No. 12, p. 575).—The author reports inoculations made of *Ribes* plants with spores taken from the leaves of *Ribes nigrum* collected on March 25, 1919. After about 12 days uredinia were noted on the inoculated leaves. This seems to confirm the conclusion that *C. ribicola* may occasionally overwinter on dead currant leaves.

ECONOMIC ZOOLOGY—ENTOMOLOGY.

Mammals of Panama, E. A. GOLDMAN (*Smithsn. Misc. Collect.*, 69 (1920), No. 5, pp. 309, pls. 39, figs. 24; rev. in *Jour. Mammalogy*, 1 (1920), No. 4, pp. 188, 189).—This summary of knowledge of the mammal forms of Panama is based mainly upon material gathered by the author, in the course of a biological survey of the Panama Canal Zone in 1911 and 1912 by the U. S. Department of Agriculture in cooperation with the War Department, working under the auspices of the Smithsonian Institution.

In an introduction field investigations of the author and the work conducted by others are considered. This is followed by an account of the physiography of Panama and the faunal relations, three life zones, namely, lower tropical, upper tropical, and temperate, being considered. A list is given of the forms recognized. A general account of the mammals, of which 175 species and subspecies are recognized, takes up the greater part of the work (pp. 44-235). An annotated bibliography which comprises 77 titles of the principal publications bearing upon the mammals of Panama, especially those dealing exclusively with species inhabiting the region, covering 10 pages (pp. 235-245), and a general index of 43 pages, are included. A map 15 by 27 in. showing the provisional life zones of Panama, prepared by the author, is attached.

The review is by J. A. Allen.

Plague in California ground squirrels, W. T. HARRISON (*Mo. Bul. Dept. Agr. Calif.*, 9 (1920), No. 5-6, pp. 187-194).—A brief discussion of the occurrence and eradication work with this disease in the ground squirrel in California.

An introduction to entomology, J. H. COMSTOCK (*Ithaca, N. Y.: The Comstock Pub. Co.*, 1920, 2. ed., pp. IX+220, figs. 220).—This first part of a second fully rewritten edition of the work first published in 1888 deals with the structure and metamorphosis of insects.

Proceedings of the Entomological Society of Nova Scotia for 1919 (*Proc. Ent. Soc. Nova Scotia*, No. 5 (1919), pp. 1-94, pls. 4).—Papers presented at the fifth annual meeting of this society include the following: The Chloral Hydrate Method of Preserving Insects for Dissection, by J. D. Tothill (pp. 8-10); Notes on the Life History, Habits, and Control of the Pea Moth (*Laspheyresia nigricana* Steph.), by W. H. Brittain (pp. 11-20); The Use of White Arsenic as an Insecticide in Bordeaux Mixture, by G. E. Sanders and A. Kelsall (pp. 21-33); Notes on the Life History of Two Chrysomelids [*Galerucella 6-vittata* Lec., *Chrysomela bigsbyana* Kirby], by W. E. Whitehead (pp. 34-40); Experiments in the Control of the Cabbage Maggot (*Chortophila brassicæ* Bouche), by W. H. Brittain (pp. 41-66); Notes on the Life History and Nymphal Stages of *Entylia bactriana* Germar, by W. E. Whitehead (pp. 67-72); The Occurrence of the Apple Sucker (*Psyllia mali* Schmidbg.) in Nova Scotia, by W. H. Brittain (pp. 73-76); and A Further Report of the New Copper—Arsenic Dust, by G. E. Sanders and A. Kelsall (pp. 77-94).

Factors influencing fumigation results, R. S. WOGLUM (*Calif. Citrogr.*, 5 (1920), No. 11, p. 345).—This is an address delivered by the author in July, 1920, at Covina, Calif.

[Economic insects in South Dakota] (*State Ent. S. Dak. Circ.* 1919, Nos. 9, pp. 10, figs. 2; 10, pp. 6, figs. 3; 11, pp. 5, fig. 1; 12, pp. 6, figs. 2; 13, pp. 7, fig. 1; 14, pp. 8, fig. 1; 15, pp. 7, figs. 2; 16, pp. 6, figs. 5; 17, pp. 4, fig. 1).—These circulars in continuation of those previously noted (*E. S. R.*, 41, p. 58) deal with Cabbage Worms, Currant and Gooseberry Worms, Currant and Gooseberry Lice, The Striped Cucumber Beetle, The Colorado Potato Beetle, The Melon Aphis, The Bean Weevil, The Potato Flea Beetle, and The Common Stalk Borer, respectively, all by H. C. Severin.

Annual loss caused through insects in British Guiana, L. D. CLEARE, JR. (*Jour. Bd. Agr. Brit. Guiana*, 13 (1920), No. 3, pp. 115-126).—This account includes a tabulated list of the produce and value of crops, with the loss due to insects during the year 1917.

"From the figures given it is estimated that the annual loss caused to the colony through insect attacks on agricultural products is \$4,280,702. With an estimated population of 300,000, this works out at an annual loss of \$14 per capita of the inhabitants."

Some potato insects and how to fight them successfully, C. H. HADLEY (*Potato Mag.*, 3 (1920), No. 1, pp. 6, 7, 36, figs. 3).—This is a popular account.

Annotated list of the injurious and beneficial insects of the avocado in Florida, G. F. MOZNETTE (*Fla. Buggist*, 3 (1919), No. 3, pp. 45-48).—The pests of the avocado briefly considered include the avocado white fly (*Trialeurodes floridensis* Q.); avocado red spider mite (*Tetranychus yothersi* McG.); greenhouse thrips; dictyospermum scale (*Chrysomphalus dictyospermi* Morg.); black scale; coconut mealy bug (*Pseudococcus nipæ* Mask.); pyriform scale; *Frankliniella cephalica masonii* Watson; avocado leaf hopper (*Empoasca minuenda* Ball); avocado leafroller (*Gracilaria* sp.); cotton stainer (*Dysdercus suturellus* H. Schf.); avocado tingid (*Acysta perseæ* Heid.); *Anomala undulata* Mels.; *Caulophilus latinasus*; *Sparganothis (Platynata)* sp.; *Lypsimena fuscata* Lec.; *Elaphidion inerme* Newm.; and several insects of minor importance. Beneficial insects are also listed.

Orthoptera of Northeastern America, W. S. BLATCHLEY (*Indianapolis, Ind.: The Nature Pub. Co.*, 1920, pp. 784, pl. 1, figs. 254; rev. in *Ent. News* 31 (1920), pp. 235-237).—This manual is an outgrowth or expansion of the author's Orthoptera of Indiana¹ published in 1903 and long since out of print. It aims to furnish means for identifying any species of orthoptera occurring in the United States east of the Mississippi River and Canada, east of the ninetieth meridian. Keys to families, subfamilies, tribes, genera, and species are an important feature. Three hundred and fifty-three species and 58 varieties are recognized. The area and life zones covered are briefly considered. Following the description of each species are notes on its distribution, food habits, song, etc. A 21-page bibliography of the works cited, a glossary of terms used in the text, an index to synonyms and new generic assignments as recognized in the work, and a general index are included.

The review is by J. A. G. R[ehn].

Coconut scale (*Aspidiotus* sp.) (*Fiji Dept. Agr. Circ.*, 1 (1920), No. 1, pp. 6, 7).—Examinations made on the islands of Vatulele and Malolo resulted in the finding of 22 scale-infested groves of coconut on Vatulele but none on the two Malolo islands. Scale was also found on coconut on Vitilevu and Wakaya. The leaf miner *Promecotheca reichii* was found to be doing a great deal of injury to coconut leaves on all the islands visited, on some palms practically every leaf being attacked.

The relation of phototropism to swarming in the honeybee (*Apis mellifera* L.), D. E. MINNICH (*Psychobiology*, 2 (1920), No. 2, pp. 177-180).—"The evidence seems clear that although phototropism may be an important feature of swarm behavior, it is neither peculiar to this activity nor the primary causal agent of it."

Classification and morphology of the bumble bees of central Europe, E. KRÜGER (*Zool. Jahrb., Abt. System., Georg. u. Biol. Thiere*, 42 (1920), No. 5-6, pp. 289-464, figs. 8).—Part I (pp. 292-371) of this paper deals with the plastic characteristics of bumble bees, while Part II (pp. 372-462) consists of descriptions of species of the genus *Bombus*, of which 33 are recognized. A bibliography of 19 titles is included.

The feeding habits of pseudomyrmine and other ants, W. M. WHEELER and I. W. BAILEY (*Trans. Amer. Phil. Soc., n. ser.*, 22 (1920), No. 4, pp. 235-279, pls. 5, figs. 6).—This account is based upon a review of the literature and personal observation. A bibliography of 61 titles is appended.

Scale insects of the Santa Cruz Peninsula, G. F. FERRIS (*Stanford Univ. Pub., Univ. Ser. Biol. Sci.*, 1 (1920), No. 1, pp. 57, figs. 35).—The author records

¹ Ind. Dept. Geol. and Nat. Resources Ann. Rpt., 27 (1903), pp. 123-471.

92 species as occurring in the Santa Cruz Peninsula, of which 5 are described as new. A synonymical list of the species is included.

Note on the Indian peach aphid (*Anuraphis helichrysi* Kalt.), A. C. BAKER (*Mo. Bul. Dept. Agr. Calif.*, 9 (1920), No. 5-6, p. 203).—This aphid is now known to occur from Washington State south to California and across into Colorado. While found during the past two years on one or more of its summer hosts, various weeds of the family Compositæ, recent collections are said to have been received from plum trees in the north Pacific region. It has been reported by Das to be very destructive to peaches in northern India.

Experimental investigation of louse control, A. HASE (*Ztschr. Hyg. u. Infektionskrank.*, 81 (1916), No. 2, pp. 319-378).—This paper includes a bibliography of 11 pages.

The use of corn as a trap crop for the cotton bollworm, A. W. MORRILL (*Ariz. Agr. Col. Ext. Circ. 30* (1920), pp. 3-10, figs. 3).—In the present account the author presents information on the trap crop method of bollworm control, which is the only method the practicability and effectiveness of which in Arizona has thus far been demonstrated.

The use of corn as a trap crop for the cotton bollworm in Arizona was tested in 1914 by H. B. Atha in an Egyptian cotton field near Glendale, the results being strikingly successful. Rows of corn planted in May at intervals of about 300 ft. through a field of Egyptian cotton gave practically perfect protection to the cotton. Observations made in southern Arizona indicate that corn producing fresh silks through the month of June and half of July is not detrimental to near-by cotton and may be a great benefit to the cotton crop in a near-by field. It is recommended that the time of first planting of corn be advanced in Arizona so that it will be in silk during the month of July as well as August.

The sugar cane borer and its control, R. S. KASARGODE (*Dept. Agr. Bombay Bul. 94* (1919), pp. [2]+10, pls. 3).—This paper on the sugar cane borer of western India deals in the main with *Diatraea auricilia*.

Report of the spruce budworm, M. W. BLACKMAN ([*Augusta*]: *Maine Forestry Dept.*, 1919, pp. 10).—This is a brief account of *Tortrix fumiferana* Clemens, the most serious pest of spruce, fir, and hemlock in Maine, based upon investigations by the author including a week in the forests of Piscataquis County, several days in the Rangeley Lake region, and a week in observation in the coast region from Bangor to Kittery Point. A bulletin on this insect from the Maine Experiment Station by Johannsen has been noted (E. S. R., 29, p. 255).

The outbreak which has taken place since 1911 is a much more serious and destructive one than that which occurred 30 years ago, as reported upon by Packard.¹ In the infestation which reached its apex in 1878-79, this insect, probably a native of this country, though well known in England, was responsible for the death of a large percentage of red spruce in the Casco Bay region and in many other localities along the coastal area of Maine from Portland to Rockland. The present outbreak comprises not only the coast regions but practically every wooded area of the State, the greatest amount of damage having occurred in the inland portions, especially in Somerset, Piscataquis, Aroostook, and Washington Counties, in regions remote from the coast and covered with dense forests of spruce, balsam, fir, and mixed hardwoods.

Attention is first attracted to it in the spring or early summer by the wilted or blighted appearance of the new growth at the ends of the branches and twigs of spruce and balsam. Investigations have shown the weakened trees to be

¹ U. S. Ent. Comn. Rpt. 5 (1890), p. 830.

attacked by a number of other insect enemies. The destructive work of the budworm is said to be decidedly on the decrease at the present time.

On some forest Lepidoptera, with descriptions of new species, larvæ, and pupæ, C. HEINRICH (*Proc. U. S. Natl. Mus.*, 57 (1920), pp. 53-96, pls. 13).—Sixteen species and three varieties, representing eleven genera, are described as new, quite a number being of economic importance. The genus *Tosca* is erected.

Coccobacillus insectorum malacosomæ (n. sp.), a pathogen from the blood of the caterpillar of *Malacosoma castrensis* L., HOLLANDE and P. VERNIER (*Compt. Rend. Acad. Sci. [Paris]*, 171 (1920), No. 3, pp. 206-208).—The organism here described as new was isolated in May, 1920, from the blood of living caterpillars of *M. castrensis* L., for which it is said to be very pathogenic. Fifty per cent of the caterpillars collected on *Poterium sanguisorba* in the vicinity of Nancy were infected. The caterpillars of *M. castrensis* and *Vanessa urticæ* are killed in 24 hours when the organism is ingested or is introduced into the blood stream. The caterpillars of *M. [Bombyx] neustria* are killed in 12 hours after its injection into the blood; when ingested a mortality of but 30 to 63 per cent resulted. It is not pathogenic for the guinea pig when introduced intraperitoneally in large numbers.

Insect life on sewage filters, W. H. PARKINSON and H. D. BELL (*London: The Sanitary Publishing Co., Ltd.*, pp. VIII+64, pl. 1, figs. 13; *abs. in Nature [London]*, 105 (1920), No. 2631, p. 131).—This small book deals mainly with the podurid (springtail) *Achorutes viaticus* L. in relation to the efficiency of sewage filters, where it is very frequently found in large numbers. The authors' experiments are thought to prove that *Achorutes* attacks and consumes the colloidal growth which often chokes the upper layers of the filters, and in this way enables a larger volume of sewage to be purified than is possible when this insect is not present. Analyses of the effluents produced by two filters showed that in the one where *Achorutes* was excluded the purification effected was less than in the other filter, but when the insects were added to the first filter nitrification improved at once.

The ox warbles and their agricultural importance, E. FRITSCHÉ (*Naturwissenschaften*, 8 (1920), No. 27, pp. 523-529).—This is a general discussion with reference to the literature.

Use of trioxymethylene powder for the destruction of *Anopheles* larvæ, E. ROUBAUD (*Compt. Rend. Acad. Sci. [Paris]*, 170 (1920), No. 25, pp. 1521, 1522).—The fact that petroleum and other materials used in the control of mosquito larvæ are more or less injurious to fish, and render water thus treated unfit for consumption by cattle, led to the investigations here reported.

It was found that when powdered formalin is placed upon the surface it becomes uniformly diffused, the traces at the surface being sufficient, when ingested, to destroy the surface-living *Anopheles* larvæ. By the end of a period varying from 5 to 20 minutes the larvæ swim by small convulsive jerks, progressively lose their mobility, and become inert, the intensity of the effect depending upon the quantity of the powder ingested. *Culex* larvæ, which feed at the surface, and other invertebrates and vertebrates occurring in pools are not affected by it. Thus, the action upon *Anopheles* larvæ is specific and comparable to that of quinin upon the malarial plasmodia. The powdered formalin is said to be effective in minimum amounts, 0.25 gm. being sufficient to cover effectively a square meter of surface.

Conditions affecting the nutrition of *Anopheles maculipennis* in France and the rôle of cattle in malarial prophylaxis, E. ROUBAUD (*Ann. Inst. Pasteur*, 34 (1920), No. 4, pp. 181-228).—This is a more extended report of the author's investigation than that previously noted (*E. S. R.*, 43, p. 454).

Experimental inoculation of malaria by means of *Anopheles ludlowi*, S. T. DARLING (*Jour. Expt. Med.*, 32 (1920), No. 3, pp. 313-329, pls. 3).—"Three persons were experimentally inoculated with malaria by means of *A. ludlowi* reared from larvæ and infected with a pure strain of subtertian plasmodium (*Plasmodium falciparum*), thus proving that there exists no mechanical impediment or obstacle to the free exit of sporozoites from the salivary ducts or proboscis. In the dissection of infected mosquitoes there were no evidences of degenerated zygotes. Sporozoites appeared promptly in the salivary glands (9 to 12 days). Inoculation occurred with ease either in an interrupted feeding or after mosquitoes had been fed twice previously. The period of incubation was 14 and 18 days. The clinical manifestations were more severe in the subject that had never been infected with malaria previously, while the splenic enlargement was most pronounced in the subject infected after a long interval of freedom from malaria. In a third subject already suffering from tertian malaria, there was only the slightest evidence of physical illness elicited by the superimposed subtertian infection; his temperature, however, became duly elevated.

"The type of febrile reaction in the two uncomplicated cases was at first tertian, becoming quotidian later, and this phenomenon in a pure strain leads strongly to the supposition that *P. falciparum* possesses inherently both tertian (or subtertian) and quotidian tendencies, as well as its well-known tendencies to cause fever of the irregularly remittent or continued type. The creation of a specific plasmodium to account for clinical forms of æstivo-autumnal or subtertian malaria having a quotidian periodicity is probably unwarranted.

"In consideration of the facility with which this species can be infected and man inoculated experimentally, the occurrence of naturally infected wild specimens, and the positive epidemiological evidence, there should no longer exist in the minds of sanitarians any doubt as to its being a malarial carrier. Operations against this species can, therefore, be recommended without reservation and should be carried out without delay."

A new species of *Phyllotreta*, F. H. CHITTENDEN (*Jour. Wash. Acad. Sci.*, 10 (1920), No. 13, pp. 389, 390, fig. 1).—*Phyllotreta utana* n. sp., has been observed to attack sugar beet in Utah and to be abundant in a beet field overgrown with hedge mustard, on which it was also taken. It is recorded as occurring at Logan, Alta, and Park City, Utah; Elko, Nev.; and Corvallis, Oreg.

Wood-boring beetles of black locust, O. W. ROSEWALL (*Canad. Ent.*, 52 (1920), No. 9, p. 203).—A list is given of eight species of beetles reared from *Robinia pseudacacia* at Baton Rouge, La.

Larvæ of North American beetles of the family Cleridæ, A. G. BÖVING and A. B. CHAMPLAIN (*Proc. U. S. Natl. Mus.*, 57 (1920), pp. 575, 649, pls. 12).

The influence of chemical constitution on the toxicity of organic compounds to wireworms, F. TATTERSFIELD and A. W. R. ROBERTS (*Jour. Agr. Sci. [England]*, 10 (1920), No. 2, pp. 199-232).—This is a report of work at the Rothamsted Experimental Station.

"The relationship between chemical constitution and toxicity to wireworms [Agriotes] of organic compounds is found to be of a twofold nature. The general effect of a group of compounds of the same type is directly determined by the chemical constitution of the type. The particular effects of individual members of the groups are limited by their physical properties, such as volatility, etc., which may be regarded as indirect consequences of their chemical constitution.

"The aromatic hydrocarbons and halids are on the whole more toxic than the aliphatic hydrocarbons and halids. The groups that influence toxicity

most when introduced singly into the benzene ring are in order of importance the methylamido (most effective), dimethylamido, hydroxy, nitro, amido, iodine, bromine, chlorine, methyl groups (least effective). But this order is modified in presence of another group; thus, when there is a CH_3 already present in the ring, the order becomes chlorine (side chain), amido, hydroxy, chlorine (ring), methyl. Chlorine and hydroxy groups together give rise to highly poisonous substances considerably more effective than when present separately. The association of chlorine and nitro groups in chloropicrin gives rise to one of the most toxic substances tested. Methyl groups substituted in the amido group of aniline increase toxicity more than if substituted in the ring. Compounds with irritating vapors have usually high toxic values, e. g. allyl isothiocyanate, chloropicrin, benzyl chloride.

"The toxic values of these substances are not closely correlated with their vapor pressures or rates of evaporation. There is a fairly close relationship between toxicities and the vapor pressures, rates of evaporation, and volatilities of compounds of the same chemical type. In a series of similar compounds decreases in vapor pressure and in volatility are associated with an increased toxicity. A possible explanation is that condensation or adsorption takes place along the tracheal system when insects are submitted to the action of these vapors. On exposure once more to the open air these vapors diffuse out into the atmosphere, the rate at which they do so being a measure of the rapidity with which the insect recovers. A limit is put upon toxicity by the decrease in vapor pressure when it sinks too low to allow a toxic concentration in the vapor phase.

"Chemically inert compounds boiling above 170°C . are generally uncertain in their poisonous effect on wireworms after an exposure of 1,000 minutes at 15° . Nearly all organic compounds boiling above 215° are uncertain in their action, while those boiling above 245° are nontoxic. These limits depend on the resistance of the insect, the length of exposure, and the temperature at which the experiment is carried out."

The ribbed pine-borer (*Rhagium lineatum* Oliv.), W. N. HESS (*New York Cornell Sta. Mem.* 33 (1920), pp. 367-381, pl. 1, figs. 6).—This is an account of one of the commonest and most widely distributed species of cerambycids occurring in North America, being especially abundant in the vicinity of central Pennsylvania and about Ithaca, N. Y., where the study was conducted. The species, which was originally described in 1795, is commonly and widely distributed throughout the greater part of North America, and probably ranges in distribution from northern Mexico to central Canada, extending across the continent from coast to coast wherever pine is found. In New York and Pennsylvania all the common species of pine are attacked by it, the white pine, pitch pine, and red pine being most commonly found infested. The author has never found it to infest other conifers, such as larch and spruce, though he considers it possible that they may be attacked by it.

In the strict sense it can hardly be considered as an insect of economic importance in so far as any damage to living pines is concerned. Its attack is limited to the region of the inner bark and the outer sapwood, and it doubtless causes considerable damage to recently dead timber. Its excavations are usually extensive, and as a result the bark is frequently loosened, allowing moisture to enter. Water having once gained access is held by the large masses of frass, which furnish a condition favorable to fungus growth, thus hastening the decay of the tree. "During the second and third years after the trees die the exit holes made by the emerging adults admit large quantities of water, other insects, and fungi, by means of which the log is soon rendered useless for commercial purposes."

The adult beetle usually emerges during the last week in April and then becomes a pollen feeder, feeding on such flowers as the dogwood, notwithstanding the fact that previous to emergence the adult feeds on the bark. The eggs are deposited in crevices between the layers of the corky outer bark, in masses of from 1 to 25 or more. Oviposition continues from about the middle of May until the last of June or the first of July, from 120 to 165 eggs being deposited by a single female. The eggs hatch in from eight to ten days, when the larvæ at once work their way through the bark and feed on the tissues of the cambium layer. Two years are required for the completion of the cycle, the first winter being spent in the larval stage, and toward fall of the second year the larvæ transform to pupæ. Pupation begins the latter part of August and continues until late in October, from 16 to 30 days or longer being required for the transformation. About three weeks later they transform to adults, remain in the pupal cells over winter, and emerge the following spring.

So far as known, the species has never been found to infest healthy trees or trees that have been dead for more than three years. They have been found from the very base of the stumps of the infested tree to near the top, where the trees were about 6 in. in diameter, but were seldom seen above this, and never in limbs unless these happen to be very large.

Among the natural enemies mentioned are a larval parasite, *Atanycolus simplex* Cress., which seems fairly effective in reducing the number of the species, especially in Pennsylvania, where as many as 5 per cent of the larvæ are found infested. The insect can be artificially controlled by cutting all recently killed pines and removing bark before the first of March.

Cotton boll weevil control by the use of poison, B. R. COAD and T. P. CASSIDY (*U. S. Dept. Agr. Bul. 875 (1920), pp. 31*).—This is a general summary of information on the present status of knowledge of the control of the boll weevil by means of dusting with calcium arsenate, and includes information gained as the result of experiments conducted since the publication of the bulletin by the senior author previously noted (*E. S. R., 39, p. 767*). It deals with the principles governing poisoning operation, kind of poison to use, how to apply poison, number of applications, time to stop poisoning, organization of poisoning operation, dusting machinery to use, a Farmers' Bulletin on which has been previously noted (*E. S. R., 42, p. 786*), features to be noted in purchasing cotton-dusting machinery, cost of poisoning, gains to be expected from poisoning, advisability of poisoning under present conditions, and control of the cotton leafworm and fall army worm with calcium arsenate. It is stated that where poisoning "has been conducted on an individual field basis requiring in the neighborhood of four applications, it has been found that the cost of poison, labor of application, and reasonable depreciation on the investment for machinery has been in the neighborhood of \$7 to \$10 per acre for the season. On a large plantation basis the investment in poison and machinery has naturally been lower, but the additional cost of supervision, etc., has generally been sufficient to offset this difference. At present prices, it is hardly safe to figure on a cost of less than \$2 an acre per application."

Bees and their relation to arsenical sprays at blossoming time, W. A. PRICE (*Indiana Sta. Bul. 247 (1920), pp. 3-15, figs. 7*).—This reports upon field and laboratory experiments conducted with a view to determining the amount of soluble arsenic required to kill a honeybee, whether a bee working upon a mixture of insoluble arsenic and sirup takes up the arsenic particles, and whether bees found near sprayed trees contain arsenic internally that accounts for their death.

In order to determine the fatal dose of arsenic, bees were fed upon a sirup (40 per cent solution of cane sugar) to which was added soluble arsenic suf-

ficient to give 0.000581 gm. to each gram of sirup. The examination of dead bees to determine the presence of arsenic was made by the Gutzeit method, which appears to be sensitive enough for most doses that kill bees, although it is believed that some very small fatal doses may escape detection.

"A very small amount of arsenic (less than 0.0000005 gm. As_2O_3) is a fatal dose for a bee. The time required to kill the bee with arsenic depends upon the size of the dose. Some expire within one and one-half hours from the time of administration of the poison, others linger on for a period of five or six hours. Most of those observed to die from a dose gathered in the field did so within three hours. Bees work freely on sprayed trees in the open, even when there are unsprayed trees all about. The mortality in the check cage was 19 per cent, as compared with 69 per cent in the lime-sulphur-arsenate of lead sprayed cage, and 49 per cent in the sulphur-arsenate of lead dusted cage. For the sake of the bee, fruit trees should not be sprayed while in full bloom."

Fertilization in the honeybee, G. H. BISHOP (*Jour. Expt. Zool.*, 31 (1920), No. 2, pp. 225-286, figs. 6).—The first part of this account deals with the male sexual organs, their histological structure, and physiological functioning (pp. 225-266); the second part with the disposal of the sexual fluids in the organs of the female (pp. 267-286).

Three new species of Indian dryinid parasites of rice leaf hoppers, S. A. ROHWER (*Proc. U. S. Natl. Mus.*, 57 (1920), pp. 159-161, pl. 1).—*Digonatopus lucidus*, reared from a nymph of the jassid rice leaf hopper (*Nephotettix bipunctatus* Fab.) at Pusa; *Haplogonatopus orientalis*, reared from Sogata species on rice at Bilaspur; and *Pseudogonatopus sogatea*, reared from Sogata species on rice at Pusa, are described as new.

The North American ichneumon flies of the tribes Lycorini, Polysphinctini, and Theroniini, R. A. CUSHMAN (*Proc. U. S. Natl. Mus.*, 58 (1920), pp. 7-48, pl. 1, figs. 5).—Two genera and eight species are described as new.

The North American ichneumon flies of the tribes Labenini, Rhyssini, Xoridini, Odontomerini, and Phytodietini, S. A. ROHWER (*Proc. U. S. Natl. Mus.*, 57 (1920), pp. 405-474, figs. 13).—Among the species here described as new that are of economic importance are *Labena confusa* reared as a parasite of *Thrinopyge alacris* in Texas and from *Chion cinctus* at Mount Vernon, Va.; and *L. confusa minor*, reared from *Chrysobothris femorata* in Washington, D. C. The genera *Labenidea* and *Rhyssella* are erected. A host catalogue and index are included.

Descriptions of twenty-five new species of North American Hymenoptera, S. A. ROHWER (*Proc. U. S. Natl. Mus.*, 57 (1920), pp. 209-231).—Among the species of economic importance here described as new are species of Tenthredinidae and the parasites *Lissonota evetria*, parasitic in the cocoons of *Evetria taxifoliella* in the Cheyenne Mountains, Colo., and Ashland, Oreg.; *L. dioryctria*, a parasite of *Dioryctria xanthanobares* at Patricks Creek, Calif.; *L. conocola*, parasitic on insects living in the cones of *Abies shastensis* at Mineral King, Calif.; *Eoachus (Trichlistus) evetria*, reared as a parasite of the pupæ of *E. taxifoliella* and *E. siskiyouana* at Butte Falls, Grant Pass, and Ashland, Oreg.; *Mesoleius gymnonychi*, parasitic on *Gymnonychus californicus* Marl., at Wenatchee, Wash.; *Exenterus affinis*, reared from a cocoon of *Neodiprion* sp. feeding on *Pinus resinosa* in Maine; and *Microtypus dioryctria*, a parasite of *D. xanthanobares* at Patricks Creek, Calif.

Notes and descriptions of species of Telenomus having ten-jointed antennæ (Hymenoptera; Scelionidæ), A. M. WILCOX (*Psyche*, 27 (1920), No. 4, pp. 78-81).—Notes are cited on four species of this genus, of which two, *T. hemerocampæ* reared from eggs of *Hemerocampa leucostigma* Abb. & Sm.

in New Hampshire and *T. euproctidis* reared from the eggs of *Euproctis conspersa* Butl. in Japan, are described as new.

The North American ichneumon flies of the tribe Acenitini, R. A. CUSHMAN and S. A. ROHWER (*Proc. U. S. Natl. Mus.*, 57 (1920), pp. 503-523, figs. 3).—Of the five genera belonging to this tribe, the only two, *Coleocentrus* and *Arotes*, known to occur in our region, are treated at length.

Holarctic tribes of the ichneumon flies of the subfamily Ichneumoninae (Pimplinae), R. A. CUSHMAN and S. A. ROHWER (*Proc. U. S. Natl. Mus.*, 57 (1920), pp. 379-396, figs. 14).—This paper is a result of studies extending over a period of several years, and embodies the opinion of the authors as to the relationship and number of tribes of the Ichneumoninae (Pimplinae, authors) as represented in the Holarctic region.

Description of an Apanteles parasite of Pionea forficalis, C. GAUTIER and P. RIEL (*Bul. Soc. Ent. France*, No. 17 (1919), pp. 309-312).—Under the name *A. gabrielis*, the author describes a braconid which parasitizes nearly 50 per cent of the caterpillars of *P. forficalis* L., an important enemy of cabbage.

The parasites of Pyrausta nubilalis Hb. in France, A. VUILLET (*Bul. Soc. Ent. France*, No. 17 (1919), pp. 308-309; *abs. in Rev. Appl. Ent.* 8 (1920), Ser. A, No. 3, p. 120).—Investigations conducted in France have shown the European corn borer to be parasitized by the tachinids *Paraphorocera senilis* Rond., and *Lydella stabulans* Mg. Two unidentified ichneumonids were also found to attack it.

On the pleophagy of the insect-attacking fungus Metarrhizium anisopliae (Metsch.) Sor., K. FRIEDERICHS (*Centbl. Bakt. [etc.]*, 2. Abt., 50 (1920), No. 13-19, pp. 335-356).—This paper includes a report of the experimental infection of a number of different insects by this fungus parasite, and a bibliography of 48 titles.

FOODS—HUMAN NUTRITION.

A chemical study of frozen fish in storage for short and long periods, E. D. CLARK and L. H. ALMY (*Jour. Indus. and Engin. Chem.*, 12 (1920), No. 7, pp. 656-663).—This contribution from the Bureau of Chemistry, U. S. Department of Agriculture, consists of the detailed report, with analytical data, of the chemical study of frozen fish made in the course of the investigation of the commercial freezing and storing of fish previously noted (*E. S. R.*, 39, p. 165).

Two species of salt water fish, bluefish (*Pomatomus saltatrix*) and weakfish (*Cynoscion regalis*), were frozen, stored in a holding room at 15° F., and examined after different storage periods for appearance, gross analysis, nitrogenous constituents, and constants of fat extracted from the flesh. The bluefish were eviscerated before freezing and were kept glazed with a thin covering of ice during the storage period. The weakfish were divided into four lots, unglazed, eviscerated, stored without wrapping; glazed, eviscerated, stored without wrapping; unglazed, eviscerated, with paper wrapping; and glazed, uneviscerated, and without wrapping.

As noted in the previous publication, the fish protected by the thin ice glazing kept much better than the unglazed fish even when the latter were protected by a paper covering. Both bluefish and weakfish stored in a glazed condition remained palatable during storage for 16 and 13 months, respectively, while unglazed, unwrapped weakfish dried out so rapidly that it was considered unmarketable at the end of 4 months. Glazed uneviscerated weakfish kept practically as well as glazed eviscerated fish. All samples became unpalatable after 2 years of storage.

The chemical changes in the composition of the fish during storage are summarized as follows:

"Water-soluble and coagulable nitrogen decreased in the bluefish, and increased at first, then decreased, in all weakfish except those stored in the eviscerated condition without glazing or wrapping. In the latter the changes were irregular. Proteose nitrogen decreased in the bluefish but underwent no distinctive change in the weakfish. Amino-acid nitrogen increased slightly in both bluefish and weakfish. Ammonia and amin nitrogen increased markedly in the glazed uneviscerated weakfish and only slightly in the other fish.

"The acid value of the extracted fat increased in all samples. The iodine number of the extracted fat decreased in all samples, the change being greatest in the bluefish."

Contribution to the solution of the bread question, W. H. JANSEN and F. MÜLLER (*München. Med. Wchnschr.*, 66 (1919), No. 30, pp. 829-832).—As the result of baking tests and of metabolism experiments on human subjects, the data for which are presented, the authors recommend the substitution for the German war bread of 94 per cent extraction a bread made from 75 parts of a mixture of wheat and rye flour 8:2, and 25 parts of rolled potato flour. This bread is said to have a pleasant taste, to be much more readily digested than the war bread, and to be of special value on account of its high protein content.

The twenty-fourth report on food products and the twelfth report on drug products, 1919.—I, [Foods and drugs], E. M. BAILEY (*Connecticut State Sta. Bul.* 219 (1919), pp. 213-259).—In addition to work with drugs, the bulletin reports data on the examination of 2,093 samples of food and food accessories, among others ice cream, baking powder, gelatin, cooking and other fats and oils, mothers' milk, soups, bouillon, etc., jams and jellies, and commercial and home-brewed beverages. Of these 588 were found adulterated or below standard or otherwise illegal. In the majority of cases the analyses are reported.

In discussing baking powder, it is pointed out that "low available carbon dioxid content may be the result of faulty preparation of the powder originally, but is more likely due to subsequent deterioration occasioned by long storage or storage under unfavorable conditions. Moisture, once having gained access to a preparation, causes it to decompose rapidly." Of 19 brands examined, 11 samples "contained less than 12 per cent of available carbon dioxid; in 7 of these the deficiency exceeded 10 per cent of the standard." Contrary to what has been stated in foreign journals regarding an unusual occurrence of arsenic in food products, it was not found in excess "in any baking powder examined, none of them containing more than one part per million of this impurity."

In discussing the analyses of canned soups, meat extract cubes, etc., the following statements are made regarding the nutritive value of such foods: "The food value of soups, broths, and similar preparations is qualitative rather than quantitative; they are valuable, not for the actual amount of food material they contain but rather for their palatability, the stimulation they give to the production and flow of digestive juices, and the desirable water-soluble constituents of meats and vegetables which they may include. Quantitatively their food value rarely exceeds from 25 to 100 calories per serving."

The respiratory metabolism in a case of prolonged undernutrition, J. JOFFE, E. P. POULTON, and J. H. RYFFEL (*Quart. Jour. Med.*, 12 (1919), No. 48, pp. 334-346, fig. 1).—To determine whether in individuals who had for a long time lived on low caloric value diets the ordinary occupations of life were carried out with a less expenditure of energy, an investigation has been made of two

possibilities: (1) That the resting metabolism in the post-absorptive state might be unusually low, and (2) that the output of heat corresponding to a given amount of muscular work might be diminished. Data confirming the first possibility are summarized from the literature, and additional data to the same effect are presented. These were obtained in metabolism experiments similar to those reported by Caspari.¹

The subject in the present case was a vegetarian who lived mainly on a diet of uncooked fruit, vegetables, and nuts. The experimental period covered more than two months, during which time the caloric value of the diet beginning at from 400 to 500 calories per day was adjusted to 1,000 calories, at which value the weight remained constant for six weeks. Throughout the whole series of experiments, the resting metabolism in the post-absorptive state determined by the Douglas bag method and calculated per kilogram of body weight was constant at 19.1, the mean for this weight under ordinary conditions being 25.5 per kilogram.

The second possibility was tested by determining the increase in the respiratory exchange at different rates of walking in the subject of the above study and in a person of approximately the same size and weight on a normal diet. No increase in efficiency during the muscular work was noted as the result of under-feeding. The conclusion is, therefore, drawn that the saving in energy in prolonged undernutrition is due to a diminution in the resting metabolism as well as in the metabolism during muscular relaxation, but not to an increased efficiency during muscular work.

Fats and vitamins (*Chem. Umschau Geb. Fette, Oele, Wachse. u. Harze*, 27 (1920), Nos. 10, pp. 97-108; 11, pp. 109-120).—This is a brief discussion of the fat-soluble vitamin from the standpoint of technical fat chemistry.

The fat-soluble A vitamin and xerophthalmia, A. D. EMMETT (*Science*, n. ser., 52 (1920), No. 1337, pp. 157, 158).—With a view to determining whether a positive lack of fat-soluble A is the direct cause of xerophthalmia or whether the condition is due primarily to infection, as claimed by Bulley (*E. S. R.*, 42, p. 59), the author has compiled data bearing upon the prevalence of xerophthalmia among a large number of white and black and white rats fed on various synthetic rations in which the presence or absence of fat-soluble A was known.

Of 122 rats on a ration lacking in fat-soluble A, 120 sooner or later showed positive signs of xerophthalmia, while in 103 rats whose ration contained fat-soluble A, but no water-soluble B, and 216 controls whose ration contained both fat-soluble A and water-soluble B, no cases of xerophthalmia developed.

Repeated attempts to transmit the disease by passing sterile gauze threads over the edge of the lids of the sore eyes and inoculating the eyes of the other rats gave negative results. Treatment of advanced cases of sore eyes with saturated boric acid or with a silver protein solution failed to relieve the condition. When, however, as little as 1 to 2 per cent of an extract containing fat-soluble A was added to the deficient ration the xerophthalmia disappeared and the rats increased in weight.

The author concludes that "xerophthalmia is primarily a dietary deficiency disease, due to a lack of the fat-soluble vitamin. The certainty of the prevalence of the disease depends on the high purity of the essentials that enter into the ration and on the length of time of feeding, younger animals showing the symptoms much sooner than older ones."

Contribution to the knowledge of organic food materials with specific action, E. ABDERHALDEN and H. SCHAUMANN (*Pflüger's Arch. Physiol.*, 172

¹ *Arch. Physiol.* [Pflüger], 109 (1905), p. 473.

(1918), pp. 1-274).—This paper consists of a general discussion with references to the literature of the work on deficiency factors, together with the reports of work conducted in the authors' laboratory with a view to throwing some light on the nature of the accessory food factors.

The theory is advanced that the vitamins of yeast consist of several substances which are labile compounds united directly or indirectly with phosphoric acid but not depending upon this union for their specific action. The term "alimentary dystrophy" is suggested for the polyneuritis of pigeons and the name "eutinin" for the antineuritic vitamin.

The twenty-fourth report on food products and the twelfth report on drug products, 1919.—II, Diabetic foods, E. M. BAILEY (Connecticut State Sta. Bul. 220 (1920), pp. 261-342).—A summary of theories regarding the nature of diabetes and its treatment, particularly with reference to diet. The examination and analyses of diabetic food products (E. S. R., 29, p. 660) was continued. Of the 107 analyses reported 85 were commercial goods (gluten foods, soy-bean products, gluten flours, breads, casein products, and other special foods) and 22 were special and experimental products, including washed brans, experimental gluten-bran bread and muffins, thrice-cooked and other vegetables, diabetic broths, and artificial or modified milks.

According to the author the inspection of commercial products in general "reveals an evident purpose on the part of manufacturers to maintain standards and market their products for what they are. The practice of controlling their output by chemical analysis is increasing. Inquiry generally reveals a knowledge, on their part, of the essential composition of their products; but this might, however, be better or more fully stated on the labels in many cases. Since there is no universal diabetic food, particular claims of merit for any product which might lead the patient to believe that he could safely introduce that article into his dietary should be discouraged. The production of a food-stuff of standard or declared composition, marketed under a label which adequately states what that composition is, should be the prime duty of the manufacturer, leaving the responsibility of recommending and prescribing that food to the attending physician."

For greater accuracy comparison is made on a water-free basis of washed and unwashed brans. These included ordinary bran marketed for cattle feed and "health" bran sold for clinical but not particularly for diabetic purposes. According to the author "protein is higher in the unwashed material; yet considerable amounts of protein have been lost in material mechanically removed. . . ."

"The effect of the washing in these trials was to remove from 70 to 83 per cent of the available carbohydrate; the 'health' brans still contained, however, between 5 and 10 per cent of this material. Large and variable proportions of other constituents were also removed. For example, there was a loss of ash ranging from 23 to 58 per cent and of protein ranging from 27 to 46 per cent."

A comparison of the analyses of vegetables uncooked, thrice-cooked, and extracted shows "a very complete removal of the more readily available portion of the nitrogen-free extract, i. e., reducing sugars; and a decrease also, though less conspicuous, in what is usually reckoned as carbohydrates, in this case sugar and other nitrogen-free extract. Protein is not substantially changed, but there is a notable loss of mineral matter."

The compilation of analyses of diabetic foods which occupies over half of the bulletin is of special interest and will make available for specialists and others interested in the treatment of this disease a large amount of analytical data not hitherto readily procurable regarding proprietary, commercial, and other diabetic foods.

Experimental studies on diabetes.—I, Production and control of diabetes in the dog, F. M. ALLEN (*Jour. Expt. Med.*, 31 (1920), No. 5, pp. 555–608, pls. 2).—In continuation of the experimental studies on the control of diabetes in the dog (E. S. R., 43, p. 370), three papers are presented.

(3) *Effects of protein diets* (pp. 555–573).—In this paper the results are reported of the effect of different proteins, of excess of proteins, and of prolonged protein or protein-fat diets on the course of experimental diabetes in the dog.

No specific differences were observed between the glycosuric effects of different kinds of protein, indicating that there are no differences of therapeutic importance for diabetics in different proteins as has been alleged by some authors in connection with the oatmeal cure. Excess of protein caused a very rapid course of diabetes and cachexia.

To study the progress or arrest of diabetes during a long period in which the animals were kept on a uniform diet which seemed to be within their tolerance, observations were made during an extended period on a series of dogs fulfilling the general conditions of mild diabetes apparently kept under control by a carefully selected diet. Of these animals two were carried through a sufficiently long period to confirm the benefit of the classical treatment of diabetes. With a demonstrated susceptibility of both of these animals to injury from excess of carbohydrates or proteins this injury was checked when carbohydrate was omitted, protein restricted, and a full caloric diet made up by the use of fat. It was found safer for these animals to be obese on a fat diet than to eat carbohydrate or a carbohydrate-forming food such as protein. On the death of these animals, autopsy showed acidosis to be the cause of the death in one case. While unproved in the other, the conclusion is drawn that even the mildest diabetes will ultimately undergo aggravation from luxus diets leading to a fatal termination.

(4) *Control of experimental diabetes by fasting and total dietary restriction* (pp. 575–586).—The treatment of diabetes in this paper represented the author's method of fasting and total dietary restriction in contrast to the no-carbohydrate, low protein, and high fat dietary of the preceding study.

Several observations, one extending over a period of nearly two years, are reported, all of which indicate that the tolerance created by undernutrition was genuine and permanent, and that the feeding of carbohydrate within the limits of this tolerance did not damage the assimilation or the islands of Langerhans.

(5) *Various failures of dietetic treatment, and their causes* (pp. 587–608).—The cases reported in this paper have been selected to illustrate the causes of various failures in the dietetic treatment of diabetes. These include a case of such severity that the glycosuria was controllable only by fatal undernutrition, a case of originally mild diabetes in which prolonged slight overfeeding (as would be illustrated by slight dietary indiscretion) led to a fatal termination, cases in which the glycosuria became uncontrollable after protein overfeeding or prolonged protein-fat overfeeding, and cases in which the severity of the diabetes was too great to be checked by fasting.

In conclusion the author discusses the general application of the observations of this series of studies to the treatment of human diabetes of varying degrees of severity, emphasizing particularly the greater permanence of the control of the disease by undernutrition with limitation of fat than by exclusion of preformed carbohydrate and limitation of protein.

Types and treatment of pellagra, S. R. ROBERTS (*Jour. Amer. Med. Assoc.*, 75 (1920), No. 1, pp. 21–26).—The author reviews briefly the history of pellagra, pointing out the changes in type and present tendencies of the disease and sum-

marizing particularly the studies of Goldberger et al. previously noted (E. S. R., 40, p. 69). Attention is called to the fact that these studies dealt with convicts, cotton-mill operatives, and inhabitants of insane asylums and orphanages. For the purpose of throwing light upon the incidence of pellagra among the well-to-do, case reports are given of 25 patients who had access to an abundance of well-balanced foods and yet developed the disease.

These reports indicate that the patients of their own selection had been living on an unbalanced and in some cases a quantitatively incomplete diet, the items of food in most cases being practically the same as those used by Goldberger in his experimental work. Rapid improvement took place in most cases with improved diet.

Suggestions are given for the dietary treatment of the disease, including two diet lists, one for the attack and one a preventive diet.

Pellagra incidence in relation to sex, age, season, occupation, and "disabling sickness" in seven cotton-mill villages of South Carolina during 1916, J. GOLDBERGER, G. A. WHEELER, and E. SYDENSTRICKER (*Pub. Health Rpts. [U. S.]*, 35 (1920), No. 28, pp. 1650-1664, figs. 3).—This paper, in continuation of the detailed report of the pellagra investigation in South Carolina during 1916 previously noted (E. S. R., 43, p. 264), deals with the incidence of the disease in relation to certain social factors. The results of this phase of the investigation are summarized as follows:

"The data appear to indicate that the disease is rare in children at the age of 2 and under; that among both males and females up to 20 years the incidence is similar, being higher among children between 2 and 10 years than in persons of the ages of 10 to 19, inclusive; and that among adults 20 to 54 years old the incidence is many times higher in females than in males.

"There was a sharp rise in incidence during April and May, reaching a well-defined peak in June. The season of onset appeared to be confined almost entirely to the six months April to September, inclusive.

"The pellagra rate among both males and females was considerably higher for the nonmillworkers than for the millworkers. While the pellagra rate among nonmillworking females was approximately four times as high as that among millworking females, the rate for disabling sickness appeared distinctly higher in millworking than in nonmillworking females. The disability indicated by the higher sickness rate among millworking females appeared not to influence materially the pellagra rate in this group."

A study of the relation of factors of a sanitary character to pellagra incidence in seven cotton-mill villages of South Carolina in 1916, J. GOLDBERGER, G. A. WHEELER, and E. SYDENSTRICKER (*Pub. Health Rpts. [U. S.]*, 35 (1920), No. 29, pp. 1701-1714, fig. 1).—In this paper are recorded the results of the part of the investigation noted above dealing with the relation of sanitation to the incidence of the disease.

"This study of the relation of factors of sanitary importance to the incidence of pellagra in seven representative mill villages has failed to reveal any consistent correlation between them. Although based on a rather small mass of data and in itself not warranting any conclusions, it may, nevertheless, be noted as not without significance that this result at any rate affords no support for the view until recently, at least, quite widely entertained in this country, that pellagra is 'an intestinal infection transmitted in much the same way as typhoid fever'; nor does the evidence adduced in favor of this view by other workers, when rightly considered, afford it any real support."

The pellagra outbreak in Egypt.—I, Pellagra among Ottoman prisoners of war, A. D. BIGLAND (*Lancet [London]*, 1920, I, No. 18, pp. 947-953, figs. 6).—

In this paper the author discusses the epidemic of pellagra occurring in the winter of 1916-17 among the Ottoman prisoners of war in Egypt, the epidemic being coincident with and following the outbreak of edema previously noted (E. S. R., 43, p. 66). The symptoms, post-mortem findings, treatment, and experimental study of the disease are described, and the theories concerning the causation of the disease are discussed in detail.

The author is of the opinion that pellagra is a syndrome of three grades with possibly a different etiology. The first grade is a condition which can promptly be remedied by a slight improvement in the diet, the second a condition which can be cured only by extreme overfeeding, and the third a state in which the balance is lost completely and nothing can reestablish it. It is thought that the majority of pellagra outbreaks, including the present one, can be accounted for on the ground of food deficiency, probably in the sense of low biological value of the protein as brought out in the report of the Egyptian Pellagra Commission. In cases of pellagra involving no food deficiency, such as the one described by Enright, as noted below, the explanation suggested is the presence of some toxic substance which prevents proper assimilation of the protein. This hypothetical toxic substance is assumed to be of the nature of a virus, which enters the body from without and possibly produces its effect by attacking the endocrine organs, especially the suprarenals.

The pellagra outbreak in Egypt.—II, Pellagra amongst German prisoners of war: Observations upon the food factor in the disease, J. I. ENRIGHT (*Lancet* [London], 1920, I, No. 19, pp. 998-1004, figs. 4).—The outbreak described in this paper occurred in the fall of 1918 among the German prisoners in Egypt to the extent of 65 cases, details of 32 of which are presented.

The striking feature of this outbreak was the fact that the prisoners had been living on a varied diet ample both in quantity and quality for normal requirements, hence something more than a dietetic factor must have been involved. It is pointed out that an originally good diet may be vitiated by loss through abnormal expenditure of energy, defective assimilation consequent on impaired digestive function, and the absence of some internal secretion necessary for protein metabolism. In the present case the first factor is thought to be ruled out, but considerable evidence is presented that the pellagrins suffered from defective digestive assimilation. In support of the third factor attention is called to the relatively common occurrence among the patients of a peculiar afebrile parotitis or enlargement of the parotid glands. The suggestion is made that this gland "may possess an internal secretion, the function of which is concerned in the economy of protein, just in the same manner as the pancreatic secretion is essential for normal carbohydrate metabolism."

Report of a committee of inquiry regarding the prevalence of pellagra among Turkish prisoners of war (*Jour. Roy. Army Med. Corps*, 33 (1919), Nos. 5, pp. 426-447; 6, pp. 508-527; 34 (1920), Nos. 1, pp. 70-79, pl. 1; 2, pp. 173-184; 3, pp. 272-292, figs. 10).—This is the detailed report of the committee appointed on October 6, 1918, by D. M. S., Egyptian Expeditionary Force, to study the pellagra situation among the Turkish prisoners of war in Egypt. The report consists of a brief statement of the terms of reference to the committee and the committee's conclusions, a summary of the course and scope of the inquiry, final conclusions, recommendations, acknowledgments, appendixes containing the detailed reports of the various sections, and a series of maps, charts, and graphs covering the statistical data.

The general conclusions of the committee were that the disease from which the Turkish prisoners were suffering was true pellagra, that the cases were

generally pellagrous prior to capture, and that cases developing subsequent to capture were not caused by infection from case to case or by any other local or general conditions with the exception of the diet. No evidence as to the etiology of the disease was found in relation to bacteria, protozoa, blood conditions, or pathology.

With regard to the diet before and after capture, a low biological value of the protein, either absolute or relative, was considered to be an exciting and possibly the determining factor in the etiology of the disease. An examination of the dietaries of the prisoners before and subsequent to capture indicated that in all cases of pellagra the biological value of the protein of the diet had been less than 40 gm., although the diet was adequate in all other respects. By increasing the biological value of the protein in the diet it was possible to arrest the manifestations of pellagra in their early stages. In this connection it is emphasized that a diet in which the biological value of the protein is adequate under normal conditions may be rendered inadequate by defective digestion and assimilation, frequently noted in cases of pellagra.

The appendixes containing the detailed reports of the collaborators in the investigation are as follows: The clinical aspect of the illness among Turkish prisoners of war, by F. D. Boyd; biochemical investigations in regard to pellagra, by H. E. Roaf; pathological section, by A. R. Ferguson and W. Campbell; bacteriological and hematological investigations on pellagrous prisoners of war, by R. Paton; protozoological and other parasitological investigations on pellagra, by H. M. Woodcock; statistical data, by P. S. Lelean; dietetic report, with an analysis of food materials, a comparison of ration scales, and the results of metabolism experiments undertaken to determine the degree of absorption of food, by W. H. Wilson, P. S. Lelean, and H. E. Roaf; notes on the relation of the biological value of protein to some established facts regarding the epidemiology of pellagra, by W. H. Wilson, P. S. Lelean, and H. E. Roaf; and water constituents, by P. S. Lelean.

The influence of an alcoholic extract of the thyroid gland upon polyneuritic pigeons and the metamorphosis of tadpoles, E. C. SEAMAN (*Amer. Jour. Physiol.*, 53 (1920), No. 1, pp. 101-108, figs. 7).—An acid alcoholic extract of fresh thyroid glands was found to have marked curative action on polyneuritic pigeons, thus indicating the presence of the antineuritic vitamin. The same extract had a marked accelerating action on the metamorphosis of tadpoles. That the results in both cases were not due to iodine alone was demonstrated by the fact that a thyroid residue, consisting of the noncoagulable portion of a slightly alkaline extract of the glands after the nucleoproteins had been removed and containing the same amount of iodine as the extract, possessed no curative action for polyneuritic pigeons nor accelerating effect on the growth of tadpoles.

Botulism from canned beets, W. G. RANDELL (*Jour. Amer. Med. Assoc.*, 75 (1920), No. 1, pp. 33-35).—An outbreak of botulism with five fatalities is reported from Florence, Ariz. The outbreak was traced to commercially canned beets in tin containers. The beets, which are said to have had no offensive odor, were served without reheating. Administration of botulinus antitoxin (polyvalent) four days after the onset of the illness was without effect in the two cases in which it was tried.

Botulism from canned ripe olives, H. W. EMERSON and G. W. COLLINS (*Jour. Lab. and Clin. Med.*, 5 (1920), No. 9, pp. 559-565, figs. 8).—This is the report of the bacteriological investigation of the olives involved in the Detroit outbreak of botulism previously described by Jennings et al. (*E. S. R.*, 42, p. 262). The toxin-antitoxin experiments indicated that the botulinus bacillus isolated from these olives was of the Boise type or type A.

Poisoning following the eating of solanin-containing potatoes, J. C. ROTHE (*Ztschr. Hyg. u. Infektionskrankh.*, 88 (1919), No. 1, pp. 1-12).—The author reports 14 cases of illness occurring in Leipzig in February, 1918, as a result of eating potatoes containing about 3.8 per cent of solanin. A brief review of the literature on solanin poisoning is included.

ANIMAL PRODUCTION.

The generative value of an individual as estimated by the method of diallel crossing, J. SCHMIDT (*Compt. Rend. Lab. Carlsberg*, 14 (1919), No. 6, pp. 34).—By diallel crossing is meant any method of experimental breeding whereby offspring of known parentage are secured from all possible matings of several males and several females of any animal or plant form in which such matings are possible. If a particular quantitative character is measured in all the offspring, the author shows that it is possible to assign to each parent a numerical value for the character in question which represents the individual's transmitting or generative value as distinct from the personal value determined by measuring the character as it is manifested in the individual.

One of the original males or females is selected as the basis of reference and its transmitting value is assigned an arbitrary number, usually the individual's personal value. The transmitting values of the remaining parents are treated as unknowns, and are found by solving a set of equations in which the average measurement of the offspring of each pair is considered equal to the average of the transmitting values of the two mates.

The author points out that the method can not be used if the characters dealt with show dominance, and he is aware of various practical limitations. However, the method is considered useful in the study of the inheritance of quantitative characters where it can be applied. Mention is made of a possible practical application in testing the relative capacities of boars and sows to produce rapidly growing pigs.

Racial studies in fishes.—III, Diallel crossings with trout (*Salmo trutta* L.), J. SCHMIDT (*Jour. Genetics*, 9 (1919), No. 1, pp. 61-67).—The author reports a study of the number of vertebræ in the trout by his method of diallel crossing. The arithmetical process of determining the generative values of the parents is also explained, but for an exposition of the general utility of the method of diallel crossing it is necessary to consult the publication noted above.

On certain factors concerned in the production of eye color in birds, C. J. BOND (*Jour. Genetics*, 9 (1919), No. 1, pp. 69-81).—The author reports histological observations on the irides of pigeons, domestic fowl, and other birds and states the results of some of his breeding experiments.

In the bull eye and the pearl eye of pigeons and in the daw eye of the Malay fowl no pigment occurs in the outer stroma of the iris. The bull eye is dark because the inner pigmented layer is visible through the translucent stroma, while the pearl eye and the daw eye are light in color because the pigmented layer is obscured by opaque colorless granules in the stroma. All other eye colors are brought about by pigment granules in the stroma. There is usually a network of branching cells covered with small spherical granules, and similar granules surround the capillary blood vessels and striated muscle fibers. In the yellow or gravel eye of pigeons, the ruby eye of ring doves, and the eyes of Buff Orpington and Dorking fowls these granules are yellow. In brown or black eyed birds the granules are dark brown or black. In some breeds of poultry, such as the Silky, the Croad Langshan, and the Houdan, both black and yellow granules occur in the stroma.

In pigeons the pearl eye is recessive to red or to gravel, and in fowls the daw eye is recessive to the type of black due to pigment in the stroma. In the mating black-eyed Black Orpington ♂ × daw-eyed Malay ♀, the F₁ all showed black pigment in the outer iris when young, but as the cockerels matured the irides became yellow. Similar but less clear-cut results were secured from the mating of black eyed ♂ × gravel eyed ♀.

"The change to the yellow color in the developing cockerels occurs in patches on the surface of the iris, and seems to be due to the removal of the cells containing brown or black pigment and of the substitution in their place of cells containing yellow pigment granules, together with (in the case of the half-bred Malay fowl) the deposition of yellow pigment granules in the striated muscle cells of the iris."

When a gravel-eyed Game Bantam cock was mated to Silky hens the F₁ cocks were gravel eyed and the eyes of the F₁ hens were mostly black and yellow. In the F₂ also the black and yellow eye was associated with females and the yellow eye with males.

It is noted that black granules of the iris are not affected by formalin, whereas the yellow granules disintegrate after a few weeks' immersion.

Substitutes for the words homozygous and heterozygous, F. J. KELLEY (*Science, n. ser.*, 50 (1919), No. 1298, pp. 458-460).—The author suggests that in popular discussions the word "constant" be used instead of homozygous and "inconstant" in place of heterozygous. The use of substitutes like "pure," "impure," and "crossbred" is considered misleading.

Commercial feeding stuffs, quarterly report, October 1 to December 31, 1919, E. G. PROULX ET AL. (*Indiana Sta. Bul.* 242 (1920), pp. 83).—This bulletin tabulates the proximate composition of 909 samples of feeding stuffs and the ingredients identified. The materials analyzed include feed barley, brewers' dried grains, corn bran, corn feed meal, corn germ meal, corn gluten feed, hominy feed, cottonseed meal and feed, linseed meal, linseed meal and screenings oil feed, unhulled peanut oil feed, peanut oil meal, rye middlings, wheat bran with and without screenings, shorts, middlings with and without screenings, red dog, wheat mixed feed, tankage, meat scrap, and a variety of stock and poultry feeds, calf meals, and condimental foods.

The compilers note that farmers are finding it increasingly difficult to secure straight by-product feeds owing to the competition of mixed-feed manufacturers.

Commercial feeding stuffs, quarterly report, January 1 to March 31, 1920, E. G. PROULX ET AL. (*Indiana Sta. Bul.* 243 (1920), pp. 64).—This bulletin includes analyses of 995 samples of feeding stuffs, the assortment of materials being the same as in the publication noted above except for the omission of peanut oil meal and the addition of alfalfa meal, cottonseed hulls, dried buttermilk, ground wheat screenings, rice bran, oat shorts, and dried beet pulp.

Feeding stuffs report, 1919, J. W. KELLOGG (*Penn. Dept. Agr. Bul.* 342 (1920), pp. 280).—The moisture, protein, fat, and crude fiber content, and the identified ingredients are reported of samples of cottonseed meal, cottonseed feed, linseed meal, coconut oil meal, distillers' dried grains, yeast dried grains, brewers' dried grains, barley feed, corn gluten feed, hominy feed, corn bran, corn feed meal, wheat bran, wheat middlings, red dog, wheat mixed feed, rye middlings, rye red dog, buckwheat middlings, alfalfa meal, dried beet pulp, tankage, meat-and-bone scrap, bone meal, and the usual assortment of proprietary compounded feeds. The retail prices are also tabulated.

Revised rules and regulations adopted under the provisions of the Texas feed law (*Texas Sta. Control Circ. E* (1919), pp. 3-8).—This is a revised edition of Control Circular C (E. S. R., 42, p. 370).

Shrimp meal and starfish meal, C. J. KOLE (*Pharm. Weekbl.*, 56 (1919), No. 12, pp. 346-351).—A sample of dried whole shrimps consisted of 66 per cent protein, 8.1 per cent fat, and 20.7 per cent ash. Market samples contained less protein and fat, due, it was found on microscopical examination, to adulteration with calcareous matter from other marine invertebrates. The meal is said to be widely used in Holland for poultry and swine feeding.

Starfish meal, it is stated, was originally sold as a fertilizer, but is now used also as a feed. A commercial sample analyzed consisted of protein 31.6 per cent, fat 6.9, water 12.1, sand 3.9, and other mineral matter 43.9 per cent.

Recleaned elevator screenings (standard stock food) as a food for live stock, G. B. ROTHWELL (*Canada Expt. Farms Pamphlet* 18 [1919], pp. 4).—Trials of elevator screenings as feed for sheep, hogs, and dairy cattle made in 1914-15 (E. S. R., 36, pp. 66, 68, 75) are summarized, and a brief report is made of a 1918 test of the recleaned screenings for growing pigs.

Four lots were employed in the latter test, each being fed screenings and skim milk, and in three cases another concentrate. Lot 1 gained 1 lb. per head per day and consumed 2.8 lbs. of screenings and 6 lbs. of milk per pound of gain. Lot 2 gained at the rate of 0.79 lb. per head and consumed 2.6 lbs. of screenings and shorts (1:1) and 7.2 lbs. of milk per pound of gain. Lot 3 gained 0.85 lb. daily and consumed 2.1 lbs. of screenings and linseed meal (8:1) and 6.8 lbs. of milk per pound of gain. Lot 4 gained 0.76 lb. daily and consumed 2.6 lbs. of screenings and tankage (8:1) and 8.6 lbs. of milk per pound of gain.

Stock feed by the system of Professor van Calcar, G. DE CLERCQ (*Chem. Weekbl.*, 16 (1919), No. 8, pp. 226-232).—A process devised by R. P. van Calcar for reducing the fiber content of dried roughages is reported. The material is treated with calcium carbonate and then allowed to ferment through the action of bacteria derived from animal feces. The calcium carbonate, apparently, is employed partly to provide an atmosphere of carbon dioxide for the anaerobic bacteria and partly because its presence promotes the formation of methane by the cellulose. The material is dried and sterilized by a process like that noted below before it is fed, and is said not to be in any way toxic. The presence of calcium carbonate did not seem to inhibit the action of pepsin in the stomach.

Results of experiments are also given in which untreated buckwheat chaff, cabbage stalks, and bean tendrils were fed to pigs in conjunction with various amounts of calcium carbonate. The proportion of crude fiber in the feces decreased in all cases with an increase in calcium carbonate, this being due, it is thought, to greater production of methane.

Preparation of stock feed by the system of Professor van Calcar, G. DE CLERCQ (*Chem. Weekbl.*, 16 (1919), No. 10, pp. 314-319, figs. 2).—The author describes the Van Calcar method of preparing feed from mixtures of blood, slaughterhouse waste, fish waste, potato peelings, and other vegetable wastes. The mixture is placed in a revolving wire mesh drum (inclosed in a stationary sheet-iron cover) through which flows a current of air heated to a temperature of from 150 to 250° C. By this process the material is dried and rendered thoroughly sterile. The finished product contains from 16 to 20 per cent of protein and 2 to 4 per cent of fat. It is relished by hogs and does not impart a fishy flavor to the pork.

Cattle feeding.—XV, **Winter steer feeding, 1918-19**, J. H. SKINNER and C. M. VESTAL (*Indiana Sta. Bul.* 240 (1919), pp. 24, fig. 1; pop. ed., pp. 8, fig. 1).—The authors report a 140-day feeding trial with 69 two-year-old steers divided into 7 lots. The experiment was essentially a repetition of that reported in the preceding bulletin of this series (E. S. R., 41, p. 68), and involved comparisons of full *v.* limited corn feeding, protein supplement *v.* no supple-

ment, and corn silage v. mixed corn and soy-bean silage. The following table summarizes the main results:

Results of a 140-day feeding trial with steers, 1918-19.

Lot.	Kind of silage fed.	Average corn ration.	Consumed per pound of gain.				Daily gain per head.	Total gain per head.	Selling price per 100 pounds.
			Shelled corn.	Cotton-seed meal.	Silage.	Clover hay.			
1	Corn.....	Pounds. 1 5.79	Pounds. 2.58	Pounds. 1.14	Pounds. 18.98	Pounds. 1.87	Pounds. 2.24	Pounds. 314.2	\$14.85
2	do.....	Pounds. 1.23	Pounds. 24.76	Pounds. 2.13	Pounds. 2.07	Pounds. 389.8	14.50
3	do.....	Pounds. 6.54	Pounds. 2.77	Pounds. 1.11	Pounds. 17.95	Pounds. 1.66	Pounds. 2.36	Pounds. 330.0	14.75
4	do.....	Pounds. 12.84	Pounds. 5.44	Pounds. 1.09	Pounds. 12.34	Pounds. 1.77	Pounds. 2.36	Pounds. 330.3	15.65
5	Corn and soy bean.....	Pounds. 12.82	Pounds. 4.95	Pounds. 1.01	Pounds. 10.17	Pounds. 1.58	Pounds. 2.59	Pounds. 362.8	16.00
6	do.....	Pounds. 15.37	Pounds. 5.99	Pounds. 10.29	Pounds. 1.60	Pounds. 2.57	Pounds. 359.6	15.85
7	Corn.....	Pounds. 15.28	Pounds. 6.12	Pounds. 11.52	Pounds. 1.66	Pounds. 2.50	Pounds. 349.5	16.10

¹ Received no corn first 80 days.

It is pointed out that the rate of gain and the finish were in general proportional to the amount of corn fed. When the gains made by hogs were included, the profits were also proportional to the amount of corn. For the first time in these trials the addition of cottonseed meal to the ration failed to show beneficial results.

Cattle feeding.—[XVI], Winter steer feeding, 1919-20, J. H. SKINNER and F. G. KING (*Indiana Sta. Bul. 249 (1920), pp. 24, fig. 1; pop. ed., pp. 7, fig. 1*).—The feeding trial reported was planned as a duplication of that noted above. The following table gives the more important data:

Results of a 140-day feeding trial with steers, 1919-20.

Lot.	Kind of silage fed.	Average corn ration.	Consumed per pound of gain.				Daily gain per head.	Total gain per head.	Selling price per 100 pounds.
			Shelled corn.	Cotton-seed meal.	Silage.	Clover hay.			
1	Corn.....	Pounds. 1 4.91	Pounds. 2.63	Pounds. 1.49	Pounds. 22.39	Pounds. 2.67	Pounds. 1.87	Pounds. 279.8	\$11.40
2	do.....	Pounds. 1.67	Pounds. 28.08	Pounds. 3.47	Pounds. 1.66	Pounds. 248.7	11.15
3	do.....	Pounds. 6.32	Pounds. 3.20	Pounds. 1.40	Pounds. 22.09	Pounds. 2.20	Pounds. 1.98	Pounds. 296.4	11.50
4	do.....	Pounds. 12.54	Pounds. 6.23	Pounds. 1.38	Pounds. 15.86	Pounds. 1.92	Pounds. 2.01	Pounds. 302.0	11.65
5	Corn and soy bean.....	Pounds. 12.54	Pounds. 5.88	Pounds. 1.30	Pounds. 15.30	Pounds. 1.70	Pounds. 2.13	Pounds. 320.0	11.65
6	do.....	Pounds. 12.58	Pounds. 6.49	Pounds. 16.82	Pounds. 1.98	Pounds. 1.94	Pounds. 290.7	11.50
7	Corn.....	Pounds. 13.26	Pounds. 6.49	Pounds. 17.42	Pounds. 1.96	Pounds. 2.04	Pounds. 306.4	11.50

¹ Received no corn first 80 days.

With the price schedule used—current market prices—all the lots were sold at a loss.

Steer feeding experiments (*Kentucky Sta. Rpt. 1919, pt. 1, p. 39*).—It was found that steers receiving sorghum silage made an average daily gain of 1.96 lbs., whereas steers on corn silage gained 2.15 lbs. per day. The grain ration consisted of corn and cottonseed meal in both cases, and the length of the feeding period is not stated.

On the basis of four years' work, it is estimated that sorghum yields 73.5 per cent more silage per acre than corn.

Value of alfalfa hay for fattening cattle, J. H. SKINNER and F. G. KING (*Indiana Sta. Bul.* 245 (1920), pp. 8, fig. 1).—The authors present average results of four experiments involving comparisons between alfalfa hay and clover hay (with or without silage) as roughages in steer feeding. It is concluded that the two hays are approximately equal in value. The detailed results have been noted from Bulletins 178, 183, 191, and 206 (E. S. R., 38, p. 873).

Pea straw for fattening cattle, H. HACKEDORN (*Breeder's Gaz.*, 77 (1920), No. 15, p. 966, fig. 1).—At the Washington Experiment Station 4 lots of 6 grade Shorthorn steers were fed for 95 days. Each lot received the same grain mixture, steam-rolled barley and choice cottonseed meal (7:1).

The lot receiving pea straw as sole roughage made an average daily gain of 2.44 lbs. per head and consumed 6.2 lbs. of grain and 7.7 lbs. of pea straw per pound of gain. The lot receiving alfalfa hay as sole roughage made an average daily gain of 2.43 lbs. and consumed 6.2 lbs. of grain and 6.1 lbs. of alfalfa per pound of gain. The third lot consumed 6 lbs. of grain, 4 lbs. of pea straw, and 2.9 lbs. of alfalfa per pound of gain and made an average daily gain of 2.49 lbs. The fourth lot consumed 5.6 lbs. of grain, 3.2 lbs. of pea straw, and 7.7 lbs. of corn silage per pound of gain and made an average daily gain of 2.22 lbs. It is concluded that pea straw is about 30 per cent less efficient than alfalfa.

Winter rations for breeding ewes, A. A. DOWELL and G. L. FLACK (*Farm and Ranch Rev.*, 16 (1920), No. 19, pp. 9, 18–20, figs. 5).—The authors report experiments conducted during the winter of 1919–20 at the University of Alberta, 10 lots of 4 or 5 ewes each being fed during the period of pregnancy.

The ewes wintered on alfalfa hay alone made greater gains, were in better condition at lambing, produced larger lambs, and sheared heavier fleeces than those on any other roughage or combination of roughage and oats tested. Those fed on prairie hay and whole oats also lambed in very good condition. Lots fed either oat straw and alfalfa (1:1), "oat green feed hay," or "oat green feed hay" and prairie hay are described as being in good condition at lambing, but the lamb crop was poor when the oat hay alone was fed. Ewes fed timothy hay alone were in fair condition. Those fed oat straw and whole oats were thin, and those fed either prairie hay alone or oat straw and swede turnips were very thin.

Two lots were fed prairie hay and whole oats, one receiving snow and the other water, but there were no marked differences between the two at the end of the test.

The searing iron v. the knife for docking or detailing lambs, J. M. JONES and C. M. HUBBARD (*Texas Sta. Bul.* 262 (1920), pp. 3–12, fig. 1).—In the course of a 4-year experiment 84 lambs were detailed with the hot iron or the docking pincers and 84 were detailed with a sharp knife without searing or ligating the artery. The latter group seemed to suffer less pain, their wounds healed a week sooner, and they gained more rapidly the first few weeks following the operation. A third group consisting of 32 lambs were docked with a knife and the artery seared, but the wounds healed less rapidly than the unseared wounds and the lambs grew more slowly than those docked with a hot iron. Male lambs castrated at the time of docking grew more rapidly than the ewe lambs.

The training of the camel, I. DROANDI (*Agr. Colon. [Italy]*, 14 (1920), No. 5, pp. 201–218, pl. 1).—Methods used in Africa and Arabia in breaking camels to the saddle and in training them to travel in caravans are described.

Value of barley for fattening hogs, C. P. THOMSON (*Duroc Bul. and Live Stock Farmer*, 16 (1920), No. 23, pp. 97–99).—Results from feeding two lots of

8 140-lb. hogs for 40 days at the Oklahoma Experiment Station are reported. The lot fed corn and tankage (12:1) made an average daily gain of 1.82 lbs. per head and required 4.17 lbs. of feed per pound of gain. The lot fed barley and tankage (12:1) made an average daily gain of 1.8 lbs. and required 4.98 lbs. of feed per pound of gain.

Hogging-down experiments (*Kentucky Sta. Rpt. 1919, pt. 1, pp. 39, 40*).—Hogs on a soy bean field, receiving corn in a self-feeder, produced 844 lbs. of pork and consumed 72.1 bu. of corn per acre. Hogs on a soy bean field with a 2.5 per cent corn ration made 632 lbs. of pork and consumed 54.3 bu. of corn per acre. Hogs on a field of corn and soy beans grown together, and receiving no supplementary feed, produced 350 lbs. of pork per acre. Hogs on a corn field without supplement produced 355 lbs. of pork per acre, and those turned on a corn field and allowed tankage in a self-feeder produced 616 lbs. of pork and consumed 145 lbs. of tankage.

Seven years' feeding experiments with work horses, N. HANSSON (*Fühling's Landw. Ztg., 65 (1916), No. 13-14, pp. 289-315, figs. 6*).—The author reports 27 feeding trials with work horses at the Central Station for Agricultural Investigation in Stockholm. The values of the feeds tested were estimated by changes in the weights of the animals.

If 1 kg. of barley is used as a feed unit, it was found that the designated amounts of the following materials are each equal to a feed unit: Oats 1.2 kg., corn meal 0.95 to 1 kg., molasses 1 kg., potato flakes 1 kg., shredded sugar beets 1.1 kg., wheat bran 1.2 kg., oat hulls 1.8 kg., dried matter in cooked potatoes 0.9 kg., and dried matter in mangels or carrots 1.1 kg. From 7 to 15 feed units are required per day per head according to the amount of work performed, and each feed unit should include at least 75 to 80 gm. of digestible protein. Proximate analyses of materials fed are tabulated.

Source [and amount] of protein for hens (*Kentucky Sta. Rpt. 1919, pt. 1, pp. 40-42*).—Average annual egg yields of hens receiving various protein supplements during 1917-18 and 1918-19 are reported. With cottonseed meal the respective average records were 17.5 and 23.2 eggs, with cottonseed meal and tankage (1:1) they were 77.7 and 86.4 eggs, with tankage 109.4 and 109.8, and with buttermilk 114.8 and 149.8.

In another experiment it was found that when meat scrap formed 5 per cent of the mash the average production was 116 eggs, when 10 per cent 142 eggs, when 15 per cent 149 eggs, and when 20 per cent 158 eggs. The amount of mash fed equaled the amount of grain.

Comparison of poultry breeds, O. I. BERGH (*Minnesota Sta., Rpt. Grand Rapids Substa., 1915-1919, pp. 71, 72*).—The following table summarizes 3 years records of production. The flocks were managed as in a commercial establishment and consisted chiefly of pullets and yearlings.

Average annual production records of hens of four breeds.

Breed.	Eggs per hen.	Feed consumed per hen.	Eggs per pound of feed.	Average weight of an egg.	Weight of eggs per hen.	Body weight of hen.	Ratio body weight to weight of eggs.	Net returns per hen.
		<i>Pounds.</i>		<i>Ounces.</i>	<i>Pounds.</i>	<i>Pounds.</i>		
Single Comb White Leghorn..	121.91	58.50	2.35	2.15	16.38	3.90	1:4.20	\$3.12
Rhode Island Red.....	104.82	97.98	1.08	2.12	13.89	5.80	1:2.40	1.25
Barred Plymouth Rock.....	86.30	86.73	1.00	2.02	10.89	6.70	1:1.63	.85
White Orpington.....	81.78	115.23	.71	2.02	10.32	7.10	1:1.45	— .19

How to cull a flock of hens, B. ALDER (*Utah Sta. Circ. 42 (1920)*, pp. 3-8, figs. 5).—The author describes the physical characteristics that are supposed to indicate laying ability in hens.

A study of selections for the size, shape, and color of hens' eggs, E. W. BENJAMIN (*New York Cornell Sta. Mem. 31 (1920)*, pp. 189-312, pl. 1, figs. 37).—This study of egg characters with reference to the season of year, age of hens, size and vigor of chicks, and transmissibility to offspring was begun in 1911 with the incubation of 450 Single Comb White Leghorn eggs selected for diversities in size, shape, and color. The chickens raised were mated in various ways and records were made of the characteristics of their eggs and the eggs laid by their descendants in several generations. Weight was used as a measure of size and the width-length index as a measure of shape. Color was determined by comparison with a set of 17 sample egg-shells arranged in order from chalk-white to brown, and the rank of the sample shell most closely resembling the egg to be graded was used as the numerical expression for the color of the latter. The results are presented in over 100 correlation tables, and a bibliography is included.

It was found that egg-weights increased during the pullet year and thereafter remained practically constant. There were no consistent differences in shape between the eggs of pullets and the eggs of hens. Whatever the age there seemed to be a tendency for the eggs laid in the spring to be rounder than eggs produced at the beginning or the end of the laying year. Spring eggs were also of lighter color. Eggs laid by hens 2 years of age or older were darker in tint than those laid by the same birds when pullets. Eggs laid by a bird after a rest period of several days were in general heavier, narrower, and more darkly colored than eggs laid after several days of consistent production.

A special study was made of the 1911 and 1912 hatches to determine the relationship between egg-weights and the weights and growth of the chicks. The correlation between egg-weight and the weight of the day-old chick was $+0.844 \pm 0.021$ in 1911 and $+0.745 \pm 0.017$ in 1912. The correlations were lower for older chicks but remained positive and with a few exceptions significant throughout the recorded ages (through 128 weeks). The correlations between egg-weight and estimates of the vigor of the chicks at different ages were also positive. Egg-weight seemed without definite influence on the fertility and hatching percentages.

In the inheritance studies, which were mainly Galtonian in viewpoint, a hen's personal capacity in the matter of egg size, shape, or color, as determined by averaging the measurements of all her eggs, is termed her life mean for the character in question. In the case of a first generation cock the measurements of the egg from which he was derived constituted his life mean, and in the case of a later generation cock the average of the life means of his sire and dam was taken as his life mean. The correlation between life means of the daughters and the life means of their sires was found to be 0.36 ± 0.04 in the case of egg size, 0.21 ± 0.07 in the case of shape, and 0.53 ± 0.03 in the case of color. The corresponding correlations between daughters and dams were 0.22 ± 0.05 , 0.47 ± 0.06 , and 0.67 ± 0.03 , respectively. The correlation between the average size of the eggs laid by a hen and the size of the egg from which she was hatched was found to be higher than the correlation between her average egg size and the average size of her dam's eggs, and about equal to the correlation between her egg size and her sire's life mean for size. Correlation between the average shape of a hen's egg and the shape of the egg from which she was derived was intermediate between the two "inheritance" correlations

for shape. The color of the egg laid by a pullet was found to be useless as an indication of the color of the eggs laid by the chick hatched from it, but the color of the egg of an older bird was slightly correlated with the color life mean of the hatched chick.

Report on the ninth Victorian egg-laying competition, A. V. D. RINTOUL (*Jour. Dept. Agr. Victoria, 18 (1920), No. 6, pp. 321-350, figs. 20*).—This is a report of the egg-laying contest held at Burnley, Victoria, during the year ended March 31, 1920. It differs from reports of preceding contests (E. S. R., 42, p. 874) in that only yearly totals are given. During this contest the birds in the group pens were trap-nested, but there were a considerable number of floor eggs.

Discussions of egg packing and the utility of type of Black Orpington are included.

Care and management of rabbits, C. C. SHERLOCK (*Philadelphia: David McKay Co., 1920, pp. 253, pls. 6, figs. 4*).—The author discusses in considerable detail the breeding, housing, and hygiene of rabbits and devotes particular attention to rabbits as meat and fur animals.

Rabbit breeding, V. FORTIER (*Canada Expt. Farms Bul. 34, 2. ser. (1918), [French ed.], pp. 48, figs. 18*).—This bulletin is designed as a manual for persons engaged in raising rabbits for skins. Among the topics discussed are breeds, breeding, feeding, housing (including plans for cages), castration, preparation of skins, and diseases.

DAIRY FARMING—DAIRYING.

Relative values of feed proteins for dairy cows, C. LARSEN, T. H. WRIGHT, JR., H. M. JONES, H. HOOVER, and B. L. JOHNSON (*South Dakota Sta. Bul. 188 (1920), pp. 163-204*).—The authors report two series of balance experiments with dairy cows to compare the utilization of proteins derived from linseed meal and gluten feed. The first series involved 3 cows and was continued through six 10-day periods in 1917. The second was begun late in 1918 and involved 4 cows during 4 periods. The successive periods were separated by 5-day transition periods. The roughage ration during the first series consisted of 30 lbs. of corn silage and from 12 to 17 lbs. of prairie hay, and during the second series 20 lbs. of silage and from 20 to 24 lbs. of prairie hay. Only the roughages were supplied in the first period of each series and the nitrogen balance in every case was negative. In the subsequent periods of series 1 and in periods 2 and 3 of series 2, either linseed meal or gluten feed was furnished in amounts that were expected to overcome the negative balance, but positive balances were not realized in all cases. The cows used in series 1 weighed 1,153, 1,378, and 1,040 lbs., respectively, at the beginning of the first period, while those in the second series weighed 1,048, 830, 936, and 864 when the experiment began. The complete results are presented in 26 pages of tabular matter, together with a brief discussion and a review of the literature.

Two methods were employed to compute the relative utilization of the nitrogen furnished. By one method—a modification of the procedure of K. Thomas—the increase of body nitrogen during a period of concentrate feeding in comparison with the period on roughage alone is expressed as a percentage of the increased amount of nitrogen available for storage and katabolism. By the second method the increase of nitrogen utilized for milk production and body storage is expressed as a percentage of the increase of nitrogen digested. A summary of the data computed according to the second method appears in the following table:

Utilization of increased supply of nitrogen by dairy cows for body and milk proteins in relation to concentrates fed and energy supplied by roughage.

Concentrates fed in successive periods. ¹	Part of energy requirement supplied by roughage.						Increased available nitrogen utilized.					
	1917			1918			1917			1918		
	Cow 1.	Cow 2.	Cow 3.	Cow 1.	Cow 2.	Cow 3.	Cow 1.	Cow 2.	Cow 3.	Cow 1.	Cow 2.	Cow 3.
Linseed meal...	P. ct. 67.8	P. ct. 72.6	P. ct. 79.0	P. ct. 85	P. ct. 97	P. ct. 96	P. ct. 43.1	P. ct. 35.7	P. ct. 42.7	P. ct. 99	P. ct. 87	P. ct. 106
Do.....	70.8	72.9	76.3	53.2	49.6	52.8
Do.....	66.6	77.6	73.2	39.9	44.5	37.3
Gluten feed.....	81.9	76.3	82.7	100	104	86	70.9	62.9	47.7	119	115	74
Do.....	91.2	83.9	89.0	76.9	77.4	67.9

¹ In the case of cow 3 of the 1918 series the gluten feed period preceded the linseed meal period.

The computations by the modified Thomas method gave results very closely resembling those in the table, on the average 52.4 per cent of the linseed meal nitrogen and 76.4 per cent of the gluten feed nitrogen being utilized to establish nitrogen equilibrium.

The fluctuations in the degree of utilization of nitrogen are thought to be due in great part to fluctuations in the energy intake. "When the percentage of therms furnished by the hay and silage was low the protein in the gluten feed or oil meal was used principally as a source of energy and could not be used to build up the body tissue or to furnish milk protein. Therefore the percentage availability of the feed nitrogen was extremely low in these cases." The Armsby standards were used in estimating the energy requirements. The sequence of feeds also seemed to influence the utilization. Although in the last period of series 2 no concentrates were fed, all the 4 nitrogen balances were positive.

Cow 4 of the 1918 series was aberrant in that more nitrogen was digested in period 1 than in periods 2 and 3. However, the negative nitrogen balance during the first period was slight, and consequently only small amounts of concentrates were fed the following periods.

Proximate analyses of the feeds offered in each period are tabulated, and besides the nitrogen data the records include the intake and outgo of fats, fiber, nitrogen-free extract, and ash.

The effects of high protein and high energy rations in feeding dairy cows [I (continued)], W. B. ELLETT and C. W. HOLDAWAY (*Virginia Sta. Tech. Bul. 20 (1920), pp. 3-16*).—The authors report the results of a 10-day digestion and nitrogen-balance experiment conducted in June, 1917, with two Holstein cows that had been kept continuously on a high energy and a high protein ration, respectively, since September, 1915. The amounts of feed offered (11 lbs. of grain and a maximum of 40 lbs. of silage per day) were the same in both cases, but the grain mixture for the cow on the high energy (low protein) ration consisted of corn meal and bran (9:2), while the high protein grain mixture consisted of gluten meal, bran, and cottonseed meal (7:2:2). During the trial the low protein ration provided 9.9 therms of energy (using actual digestion coefficients), while the cow required on the Armsby standard only 7.43 therms. The protein-rich ration provided 13.06 therms, which was also higher than the cow's requirement of 11.56. The former cow gave 1.84 kg. of milk per day and the latter 6.8 kg. A similar experiment with the other two cows in this project was reported in Technical Bulletin 12

(E. S. R., 39, p. 75), and many of the results are restated in a new form in the present publication. The following table summarizes some of the main results of the two trials:

Influence of the protein plane of dairy cows on protein metabolism and utilization of feeds.

Character of ration.	Body weight.	Protein in ration.	Protein digested daily.	Protein in milk.	Protein stored daily.	Protein katabolized. ¹	Digestibility of ration.				Fat digested daily.	Milk fat secreted.
							Crude protein.	Ether extract.	Crude fiber.	N-free extract.		
High energy:	Lbs.	Lbs.	Lbs.	Lbs.	Lbs.	Lbs.	P. ct.	P. ct.	P. ct.	P. ct.	Kg.	Kg.
1916 trial.....	890	1.76	0.59	0.375	-0.12	0.335	33.3	65.7	30.4	60.9	1.83	1.80
1917 trial ²	845	1.96	.97	.175	+ .45	.345	49.2	51.7	30.8	66.8	1.55	.80
High protein:												
1916 trial.....	1,057	3.53	2.67	.431	+ .19	2,045	75.5	74.4	59.6	74.0	1.17	2.42
1917 trial.....	1,229	5.08	3.98	.610	+ .27	3,100	78.4	68.7	55.7	77.5	1.58	2.79

¹ Urinary nitrogen × 6.25.

² Cow at end of lactation.

The substantial equality of the urinary nitrogen excreted by the two cows on the low protein ration, despite the fact that they were in different stages of lactation and one was losing and the other gaining in flesh, is held to indicate that 0.34 lb. of digestible protein per day is sufficient for body maintenance provided only 1 lb. of digestible protein is required to offset a pound of milk protein. The fact that cows on the high protein rations secreted more fat in the milk than they derived from their feed confirms previous conclusions that such rations promote the formation of milk fat from carbohydrates or proteins. It is also pointed out that cows on such rations required a considerable amount of drinking water due to the excess of nitrogen in the urine.

“These experiments indicate that when a cow begins her lactation period with a lack of digestible protein and excess of energy or even a sufficiency of energy in her ration her digestion coefficients fall, she loses flesh rapidly, and her milk flow continues to fall, at first rapidly, later more slowly, until she can support the flow of milk. When the flow of milk has become so small that she can begin to gain weight, generally near the end of the lactation period, her digestion coefficients begin to rise again, but this results in an increased gain in flesh and has no marked effect on the milk flow.”

A table gives the proximate composition of the feeding stuffs supplied to the animals in the 1917 trial.

Feeding dairy cattle, A. C. McCANDLISH (*Iowa Sta. Circ. 64 (1920), pp. 32, fig. 1*).—This circular includes definitions of feeding stuffs and suggestions for feeding dairy cows, calves, and bulls.

The efficiency of milk substitutes in calf feeding, G. SPITZER and R. H. CARR (*Indiana Sta. Bul. 246 (1920), pp. 8, figs. 2*).—A group of 36 grade Holstein calves, varying in age from 10 to 20 days and in weight from 85 to 126 lbs., were fed for 140 days. A lot of 12, receiving whole milk throughout, made an average daily gain of 1.91 lbs. per head. A similar lot fed skim milk after the first 10 days made an average daily gain of 1.73 lbs., and a third lot fed Purdue calf meal gained 1.18 lbs. Ground corn and oats (1:1) was fed as a dry mash to each lot, and for part of the time the calves had access to blue grass pasture or clover hay. The calf meal lot were thrifty and remained in good condition, and during six months of pasture following the feeding period they made about the same gains as the other lots.

The Purdue calf meal consists of corn meal, linseed meal, and liquid beef blood (8:1:12) plus steamed ground bone to the extent of 1 per cent. This is dried for from 4 to 6 hours at a temperature not over 140° F. and then ground. An hour or so before feeding it is mixed with four times its weight of warm water, forming a jelly. This is again diluted at the time of feeding and is fed at blood heat. Liquid blood meal was selected because metabolism trials at the station (E. S. R., 42, p. 471) had shown that it is more readily digested than commercial dried blood.

The normal growth of dairy cattle, C. H. ECKLES (*Missouri Sta. Research Bul.* 36 (1920), pp. 3-20, figs. 5).—The author tabulates and presents in graphical form, by breeds, the average weight and the average height at withers each month from birth to first calving of pure-bred heifers raised in the University of Missouri dairy herd. The maximum and minimum weight and height at each age are also given. The records are continued beyond the first calving by using weights and measurements taken 6 months after each parturition. Jerseys, Holsteins, Ayrshires, and Shorthorns are included, the Jerseys being mainly of the American type. The following statements are made concerning the method of management:

“The calves receive a portion of the milk from their mothers from birth to about two weeks of age. At this point they are gradually changed to skim-milk supplemented by hay, usually alfalfa, or pasture, and a small amount of grain which is mostly corn meal. From the time when the feeding of milk is discontinued, which is about 6 months of age, until within a few weeks of the date of first parturition, the heifers are placed on pasture during the summer, while the winter ration is corn silage, some legume hay, and generally from 1 to 2 lbs. of grain daily. The object is to keep them in good growing condition without allowing them at any time to become unnecessarily fat. . . . The age at first calving was higher than in many herds, averaging 30 months for the Holsteins, 29 for the Jerseys, and 28 for the Ayrshires.”

The data were compiled primarily for use in research work as a basis for comparing the growth of experimental animals, but they are expected also to be of use to breeders. Breed averages for heights and weights at maturity are also presented.

[A herd of grade Guernseys], O. I. BERGH (*Minnesota Sta., Rpt. Grand Rapids Substa., 1915-1919, pp. 74-79, figs. 2*).—The annual milk and butter fat production and the feed records from 1911 to 1919 of the substation's herd of grade Guernseys are presented. An earlier report has been noted (E. S. R., 38, p. 176). Considerable increases in production and in economy of production are attributed to the systematic grading.

Announcement of the California State dairy cow competition, 1920-1922, F. W. WOLL and P. I. DOUGHERTY (*California Sta. [Pamphlet], 1920, pp. 8*).—This competition is being conducted according to the plan of the first one, a report of which has been noted (E. S. R., 40, p. 375).

The Argentine milking ewe, R. F. LURO (*Bol. Agr. Prov. Buenos Aires, 1 (1919), No. 2, pp. 6, 8, 10, 12*).—The method of managing milking ewes is outlined. It is stated that the ordinary ewe will average 0.35 to 0.4 liters of milk daily throughout a lactation period of five months. The use of ewes' milk for cheese making in Argentina appears to be increasing.

The retention of milk, C. PORCHER (*Compt. Rend. Acad. Sci. [Paris], 170 (1920), No. 16, pp. 963-965*).—The author finds that if the milk of a cow is retained in the udder the lactose is resorbed and eliminated through the kidneys. The osmotic pressure in the udder is maintained by an increase in the amount of sodium chlorid present. These results are used to explain the abnormal composition of colostrum and of milk secreted under certain pathological conditions.

Milk and foot-and-mouth disease, C. PORCHER (*Compt. Rend. Acad. Sci. [Paris]*, 171 (1920), No. 2, pp. 122-125).—The author confirms the conclusions noted above by observations on the milk secreted in an infected quarter of the udder of a cow suffering from foot-and-mouth disease.

The production of clean milk at the Kentucky Agricultural Experiment Station, J. J. HOOPER and J. W. NUTTER (*Kentucky Sta. Circ. 24* (1920), pp. 15, figs. 12).—Success in producing and marketing raw milk of very low bacterial content is reported. Prompt cooling of the milk, care in sterilizing utensils after washing and again before use, and simple but not primitive apparatus are considered the important factors in this success. Milk from inflamed udders is discarded.

Organization of control of pasteurization, F. O. TONNEY (*Amer. Jour. Pub. Health*, 10 (1920), No. 9, pp. 716-723).—The author describes the licensing and inspection of pasteurizing plants in Chicago. Complete automatic records of pasteurizing temperatures are required, and frequent samples of milk are collected by field agents. Licenses are renewed annually, and are subject to revocation without notice in the case of failure to comply with the requirements.

"The result [of such revocation] is the display of remarkable alacrity in carrying out orders for the improvement of sanitary conditions. Repairs which have been pending for months are accomplished over night. Old nuisances are abated, flies are kept out of the premises, the methods of operation are improved, and bacterial counts in the product which have been persistently above the legal standard suddenly drop to a satisfactory level."

Experiments with the Lobeck biorizator, W. WEDEMANN (*Arb. Reichsgesundheitsamt.*, 51 (1919), No. 3, pp. 397-459).—The author reports an extended series of bacteriological and chemical studies on biorized milk. Apparatus of different models and varied capacities was used.

The biorization process had little influence on the chemical characteristics of the milk. There was a slight coagulation of the albumins and globulins, a decrease in the capacity for reducing hydrogen peroxid, a lowering of the acidity, and a more rapid formation of cream. The taste and odor were improved, and the milk remained sweet twice as long as the raw milk.

Milks were inoculated with various organisms including *Bacterium coli communis*, *B. suispestifer*, *B. pyocyaneus*, *B. cyanogenus*, and tubercular organisms of both human and bovine types. These organisms were all destroyed by biorization. Milk normally infected with tubercle bacillus from a cow with udder tuberculosis was freed by biorization from organisms toxic to guinea pigs. Not all the lactic acid and mastitis streptococci were killed by the biorization temperature (75° C.). However, the lactic acid organisms remaining in milk lost some of their capacity to grow at room temperature, and the milk, therefore, did not sour at the normal time.

A bibliography of 25 titles is appended.

Market milk problems simplified, G. H. DACY (*Milk Mag.*, 8 (1920), No. 7, pp. 9, 14, 64, 66, 68).—This is an account of the methods of milk control in the District of Columbia and the efforts of the producers' association to encourage winter dairying. The text of the act of Congress regulating the sale of milk in the District is included. A system of inspecting and scoring dairy farms was inaugurated in 1896.

The city milk supply (*Agr. Gaz. Canada*, 7 (1920), No. 7, pp. 593-600).—This is an account of milk standards and the characteristics of the milk supplies of cities in Nova Scotia, New Brunswick, Quebec, Ontario, Manitoba, Saskatchewan, Alberta, and British Columbia.

Consumers' prices and distribution policies in their relation to farmers' prices, C. L. KING (*N. J. Dept. Agr. Bul. 20* (1919), pp. 319-328).—In this ad-

dress, made at a meeting of the New Jersey State Dairymen's Association, the author draws some conclusions from his work as Federal Milk Commissioner for Pennsylvania.

It is pointed out that increased volume of business in milk plants and increased load on retail wagons have in recent years brought about economies in distribution sufficient to offset rising costs of labor and material. In Philadelphia an agreement among dealers as to minimum load per wagon has made the elimination of duplicating routes almost automatic. The "cash and carry" plan of retailing milk is considered less economical than the house to house delivery, since the consumption is smaller and less regular and the unit cost of delivering the milk is thereby increased.

Method for determining milk prices at Evansville, Ind., W. L. HANNING (*Hoard's Dairyman*, 58 (1920), No. 25, pp. 1168, 1169).—Two schemes used in Evansville, Ind., are reported.

By the first scheme production cost was determined by the so-called Purdue formula, which was based upon the investigations of Bain and Posson in Porter County, Ind. (E. S. R., 43, p. 678). The sum of the prices of 20 lbs. of corn, 20 lbs. of mill feed, 48 lbs. of hay, 150 lbs. of silage, 20 lbs. of stover, 20 lbs. of straw, and 3 hours' labor, to which is added a 10 per cent managerial charge, is assumed to equal the cost of producing 100 lbs. of milk testing 3.5 per cent fat.

This scheme was in operation from November, 1918, to June, 1919, when the second scheme was inaugurated. By this plan the fat in 100 lbs. of milk is charged at the prevailing market price for butter fat, and the value of the skim milk in 100 lbs. of milk is assumed to equal the market price of 30 lbs. of shorts (on the ton basis). There is a 40-cent premium per hundredweight for clean milk and a sliding scale of additions and subtractions to encourage winter production. The second plan is said to be working out to the satisfaction of producers and consumers.

A city-owned milk plant, P. A. DAVIS (*Hoard's Dairyman*, 60 (1920), No. 8, p. 290).—It is stated that Jamestown, N. Y., has recently voted to increase its bonded debt for the purpose of erecting a milk plant and retailing milk. Advocates of the measure pointed out the possibility of complete sanitary control of the milk supply and the prevention of a threatened shortage due to competition with the condensaries.

Operation of the Twin City Milk Producers' Association, H. R. LEONARD (*Hoard's Dairyman*, 59 (1920), No. 4, pp. 187-189, fig. 1).—This is an account of a cooperative association of milk producers which maintains milk plants in St. Paul and Minneapolis, selling market milk to retailers and manufacturing any surplus into butter and cheese.

The different systems of cooperative dairy plants, C. BOVY (*Jour. Soc. Natl. Agr. Belg.*, 2 (1920), Nos. 31, pp. 285, 286; 35, pp. 317, 318; 39, pp. 349, 350).—The author discusses the organization and activities in Belgium of local milk plants, regional milk plants, central creameries, central milk plants, and Federal milk plants.

A classification of ledger accounts for creameries, G. O. KNAPP, B. B. MASON, and A. V. SWARTHOUT (*U. S. Dept. Agr. Bul.* 865 (1920), pp. 40).—The creamery ledger accounts are divided into 15 classes and the scope of each is defined. Some of the procedures suggested differ from those in Bulletin 559 (E. S. R., 37, p. 875). "These changes have been found desirable after observation of actual operations extending over a period of several years." The preparation of balance sheets and of statements of income and expense is included.

"Garlic taste" in butter and experiments to produce from garlicky cream butter entirely free from this flavor, E. HAGLUND (*Meddel. Central-*

unst. Försöksv. Jordbruksområdet, No. 154 (1917), pp. 12; also in K. Landtbr. Akad. Handl. och Tidskr., 57 (1918), No. 1, pp. 19-28).—The author describes in detail the method of Ayers and Johnson (E. S. R., 31, p. 771) for the removal of garlic flavor, and reports a successful modification in which the cream is warmed in a pasteurizing apparatus and cooled in thin films exposed to the air, but without the use of an air blast.

It is also noted that heating garlicky butter to 100 C.° may render it suitable for cooking purposes.

A cooperative laboratory [for dairy bacteriology] (*Better Business, 5 (1920), No. 4, pp. 314-317, fig. 1*).—An account is given of a bacteriological laboratory established in Dublin for the use of cooperative creameries affiliated with the Irish Agricultural Organization Society. Butter control is the main activity, but recently a cheese control has been inaugurated and it is expected soon to include the control of market milk.

VETERINARY MEDICINE.

A text-book of the principles and practice of veterinary medicine, D. S. WHITE (*Philadelphia: Lea & Febiger, 1920, 2. ed., rev., pp. XVI+531*).—This is a revised and enlarged edition of the work previously noted (E. S. R., 37, p. 176).

A modification of Van Leersum's bloodless method for recording blood pressures in animals, A. E. COHN and R. L. LEVY (*Jour. Expt. Med., 32 (1920), No. 3, pp. 351-355, pls. 4, figs. 3*).—The fact that there was no satisfactory method for taking the blood pressure of laboratory animals so that observations can be repeated on successive days over long periods of time led the authors to make use of the method here described and illustrated, the essential part of which was first described by Van Leersum in 1911 and utilized by him for studies on rabbits. It consists in making the carotid artery accessible to direct examination.

A contribution to the knowledge of acetonuria in domestic mammals, G. SINN (*Arch. Wiss. u. Prakt. Tierheilk., 42 (1916), No. 4-5, pp. 322-367*).—In investigations conducted by the author acetone was regularly found in the urine of normal horses and cattle. It varied in amount from 0.38 to 3.86 mg. per liter of urine in horses and from 0.2 to 2.4 mg. per liter in urine of cattle. There was no increase in the amount of acetone in the urine of tubercular cattle, but there was an increased acetone content in the urine of horses suffering from a fever. A list of 27 references to the literature is included.

Principles in serologic grouping of *B. abortus* and *B. melitensis*.—**Correlation between absorption and agglutination tests**, M. L. FEUSIER and K. F. MEYER (*Jour. Infect. Diseases, 27 (1920), No. 3, pp. 185-206, figs. 14*).—“Unless an antiserum is absorbed to extinction of the absorbing strain, the residual agglutinins can not be classed as specific.

“A series of absorption tests with formalinized suspensions in *B. abortus* and *B. melitensis* antisera led to a fourfold grouping of 14 *B. abortus* and *B. melitensis* strains. Groups one and four were represented by two and group three by one strain, the majority falling in group two. All *B. abortus* strains belonged serologically to group one. Groups one and two are closely related. They are sharply defined from groups three and four. The grouping revealed these principles:

“(1) An antiserum can not be exhausted by strains of another group. It is always exhausted by its homologous strain, and may be exhausted by other members of the same group.

"(2) A strain acts in a uniform manner (qualitatively) on all strains in another group under the same absorption conditions. This uniform action constitutes the basis for group affiliation.

"(3) Strains within the same group do not necessarily act in a uniform manner on one another when absorbed from the same antiserum. This constitutes the basis for individual differentiation.

"In conforming to the main classification adopted by the Society of American Bacteriologists, we suggest that *B. abortus* and *B. melitensis* group be given generic rank in the Bacteriaceæ family as the genus 'Brucella.'

"A series of agglutination tests in *B. abortus* and *B. melitensis* antisera disclosed gradation in titer limits for the different strains, and the gradations were constant for the same strains in the various antisera. It was found that the sets so formed correlated with the groups resulting from the absorption tests.

"The sera of cows and hogs suffering from natural abortion disease may also react to both *B. abortus* and *B. melitensis* organisms."

A comparison of the morphologic, cultural, and biochemical characteristics of *B. abortus* and *B. melitensis*, K. F. MEYER and E. B. SHAW (*Jour. Infect. Diseases*, 27 (1920), No. 3, pp. 173-184, figs. 2).—"A comparative study of 21 cultures of so-called '*Micrococcus*' *melitensis* obtained from various sections of the world and of 32 cultures of *B. abortus* (Bang) isolated in this country and England justifies the following conclusions:

"The causative organism of undulant fever of man and of Malta fever of goats can not be distinguished morphologically or biochemically from the organism responsible for infectious abortion in domesticated animals.

"So-called '*Micrococcus*' *melitensis* appears in young cultures as a short rod and should therefore be designated as *Bacterium melitensis*.

"The pigment production of the majority of actively growing *B. melitensis* strains on glycerol peptic digest agar and on alkaline potato cylinders after five days' incubation is more intense than with the strains of *B. abortus*.

"Both *B. melitensis* and *B. abortus* cultures produce after 20 days' incubation in glucose and lactose-broth an alkaline reaction and a characteristic reduction of the H-ion concentration equal to about 0.6 to 1.0 Ph."

Contributions to the biochemistry of pathogenic anaerobes.—IX, The biochemistry of *Bacillus edematis*, C. G. L. WOLF (*Jour. Path. and Bact.*, 23 (1920), No. 3, pp. 254-265).—In continuation of the studies on the biochemistry of pathogenic anaerobes by Wolf and Harris (*E. S. R.*, 42, p. 271), a series of experiments along the same lines as previous work with other anaerobic microorganisms was carried out with three strains of *B. edematis*. The results of the present study are summarized as follows:

"*B. edematis* possesses characteristics which are found in both the proteolytic and saccharolytic organisms previously examined. The saccharolytic characters are greatly predominant. In glucose- and lactose-containing media it is an efficient gas producer. Lactose is consumed in considerable quantity. It also has the property of hydrolyzing this sugar.

"Large quantities of gas are produced in cooked-meat media containing no free carbohydrates. Notable quantities of amino-acids and ammonia may also be found."

On the cultivation and isolation of *Bacillus tetani*, R. S. ADAMSON (*Jour. Path. and Bact.*, 23 (1920), No. 3, pp. 241-253, pl. 1).—This paper, in continuation of the general investigation of the bacteriology of wounds previously noted (*E. S. R.*, 41, p. 476), consists of a study of special methods for the isolation of *B. tetani*.

A preliminary study of the cultural characteristics of the organism when grown in the media used in the previous study has led to the conclusion that for the isolation of *B. tetani* anaerobic culture in alkaline broth (—10 or —20 on Eyre's scale) is most satisfactory. In either case frequent platings out on agar with an alkaline reaction are recommended. If the presence of the organism is suspected, the inoculation should be made into a guinea pig. All isolated strains should be grown in neutral broth for from 4 to 8 days and inoculations made. The cultural characteristics of the organism as thus isolated are described, and a plate is included showing the appearance of 7- to 8-day colonies of the pure organism on agar.

The author recommends as the best medium for the production of tetanus toxin neutral or slightly alkaline broth without the addition of glucose, and for the preservation of strains in the laboratory for some time alkaline —20 broth or stab cultures in —10 agar, the tubes in either case to be sealed up.

The precipitation of *Bacillus welchii* toxin, H. HENRY and M. LACEY (*Jour. Path. and Bact.*, 23 (1920), No. 3, pp. 273-280).—On account of the instability and low potency of *B. welchii* toxin as obtained in filtrates from meat-broth cultures of the organism, a series of experiments was undertaken for the purpose of obtaining a more stable form of toxin suitable for measuring the value of sera containing antitoxin to *B. welchii* and at the same time a more potent form for use in the production of antitoxic sera of higher titer than those as yet obtained.

The precipitating agents tested with cultures of *B. welchii*, filtered through layers of paper pulp and sand and then through large Berkefeld candles under pressure, included ammonium sulphate in different concentrations, alcohol, and ammonium sulphate followed by alcohol. The last method proved most satisfactory, the secondary precipitation with absolute alcohol being carried out on solutions of the precipitates obtained by two-thirds ammonium sulphate saturation.

It has been found possible by this method to obtain solutions containing from 50 to 250 mouse minimal lethal doses per cubic centimeter as against from 5 to 10 mouse lethal doses by the ordinary methods. The toxin as thus prepared underwent no deterioration during a period of 11 months when stored at room temperature in amber colored bottles fitted with rubber corks.

The effect of the intradermal mallein test on subsequent complement fixation tests for glanders, R. A. KELSER and J. G. HARDENBERG, JR. (*Jour. Amer. Vet. Med. Assoc.*, 57 (1920), No. 3, pp. 282-294).—The possible effect of the interdermal mallein test on subsequent complement fixation tests was studied on horses which had never received intradermal injections of mallein previous to the experiment and on others that had previously been given several intradermal tests. The technique employed was as follows:

Healthy horses were bled for preliminary tests to demonstrate the absence of complement-fixing bodies, and were then given injections of either 0.1 cc. or 0.2 cc. of army intradermal mallein into the lower palpebrum of the left eye, after which they were kept in separate corrals and specimens of blood taken daily, commencing 24 hours subsequent to the mallein injection and continuing for 21 days or longer if the animal still gave a positive reaction. Immediately following the final bleeding a second injection of mallein was made in the lower palpebrum of the right eye and the bleeding continued for the same length of time. The serum obtained from the blood samples was tested in the usual way for complement fixation, each specimen that gave any reaction being tested from three to five times. The tests were controlled by simultaneous tests with negative sera from animals that had never been subjected to

the intradermal mallein test. In the four different series of studies reported over 1,050 specimens were examined. The conclusions drawn from the extensive data reported are as follows:

"The injection of the prescribed dose (0.1 cc.) of intradermal mallein in horses that have never been previously subjected to injections of mallein produces complement-fixing bodies in the blood serum of a much greater percentage of such animals than in those that have had numerous previous injections. In our test of the previously injected animals 33½ per cent developed complement-fixing bodies following the injection of 0.1 cc. of mallein, whereas of the 'green' horses 83½ per cent gave reactions to the complement fixation test as a result of such injection.

"There was a tendency toward a greater percentage of reactions among the previously injected horses where twice the dose (0.2 cc.) of mallein was administered. This did not hold true as regards the horses that had never been previously injected.

"Complement-fixing bodies may be demonstrated as early as 24 hours subsequent to the mallein injection, and may persist for 32 days subsequent to its injection. The average animal, however, develops them after 4 to 7 days subsequent to malleinization, and they persist for approximately 2 weeks after their appearance.

"Due to the fact that the greater percentage of animals at present in the Army have been subjected to numerous intradermal mallein tests, it is believed that, generally, comparatively little difficulty will be experienced with serological tests subsequent to the mallein tests of these animals, particularly if the blood specimen is procured immediately after the 48-hour reading of the mallein test. Newly purchased animals, however, will undoubtedly give trouble in this respect.

"Where it is desired to supplement an intradermal mallein test with the complement fixation tests for glanders, the blood specimen should be taken immediately following the 48-hour reading of the mallein test. After this time a period of approximately 30 days from the date of the mallein injection should be allowed to elapse before taking the blood sample, as no reaction other than negative obtained with a specimen procured sooner could be considered reliable."

The immunizing value of commercial vaccines and bacterins against hemorrhagic septicemia, L. VAN ES and H. M. MARTIN (*Nebraska Sta. Research Bul. 17 (1920), pp. 3-19*).—This bulletin reports the results of a series of experiments in which the immunity of rabbits injected with various commercial hemorrhagic septicemia bacterins and vaccines was tested by subsequent inoculations with *Bacterium bipolaris*. In nearly all cases the vaccines or bacterins were purchased directly from the manufacturer. The dosage used was the one recommended on the label and was repeated from 1 to 12 times. The degree of immunity produced was always tested by the use of *B. bipolaris* cultures or material obtained from the same species as one upon which the vaccine was supposed to confer protection. The preparations tested included "Mixed Infection Bacterin," "Hemorrhagic Septicemia Vaccine (Avian)," "Hemorrhagic Septicemia Bacterin for Cattle," "Hemorrhagic Septicemia Combined Bacterin (Bovine)," "*Bacillus suisepiticus* Bacterin (for swine plague)," "Hemorrhagic Septicemia Vaccine for Cattle," "Hemorrhagic Septicemia Vaccine for Swine," and "Swine Plague Bacterin."

In only a few cases did the injections of the preparation produce any immediate unfavorable effect on the test rabbits even when used in relatively large doses. In the entire series of experiments, however, only 3 out of 187 animals acquired immunity to *B. bipolaris* infection. The conclusion is drawn that the

present commercial hemorrhagic septicemia vaccines have no antigenic value as expressed by actual resistance to *B. bipolaris* infection.

The classification of the piroplasms, P. J. DU TOIT (*Arch. Protistenk.*, 39 (1918), No. 1, pp. 84-104, figs. 10).—This paper on the classification of the piroplasms includes a bibliography of 62 titles.

The piroplasma affecting bovines and their intermediate hosts, E. BRUMPT (*Bul. Soc. Path. Exot.*, 13 (1920), No. 6, pp. 416-460, figs. 12).—In this report the author deals with *Piroplasma bovis* (Babes, 1888 pro parte); *P. argentinum* (Lignières, 1901); *P. bigeminum* (Smith and Kilborne, 1893), including the piroplasm of spleen rupture; *Theileria parva* (Theiler, 1904); *T. mutans* (Theiler, 1906); *Anaplasma marginale* (Theiler, 1910); *A. centrale* (Theiler, 1911); and *A. argentinum*. (Lignières, 1914). In a first appendix, two piroplasms rare or of which the pathogenic rôle has not been determined, are considered, namely, *P. hudsonius bovis* (Bowhill, 1908) and *Achromaticus macfei* (C. França, 1918). The jaundice of bovines in Africa is considered in a second appendix.

The protozoal parasites of the rat, with special reference to the rat as a natural reservoir of Spirochæta icterohæmorrhagiæ, A. G. R. FOULERTON (*Jour. Path. and Bact.*, 23 (1919), No. 1, pp. 78-103, pls. 2).—This paper deals with the occurrence of *Trypanosoma lewisi*, *S. icterohæmorrhagiæ* Inada (*Leptospira icterohæmorrhagiæ* Noguchi), *S. morsus muris* Futaki, and *S. herbdomadis* Ido et al. A list of 65 references to literature is included.

Relationship of insects to parasitic diseases in stock, G. F. HILL (*Proc. Roy. Soc. Victoria, n. ser.*, 31 (1918), No. 1, pp. 11-107, pls. 7).—This paper consists of two parts:

I. *The life history of Habronema muscæ, H. microstoma, and H. megastoma* (pp. 11-76).—In investigations conducted in Australia, the author confirms the results obtained in studies of the life history of *H. muscæ* by Ransom (E. S. R., 29, p. 82) and reports upon the life cycle of *H. microstoma* and of *H. megastoma*, which he has worked out. The eggs of *H. megastoma* gain entrance to the horse's stomach from the tumors produced by it, and in the voided feces for a period of at least 15 days the embryos, after a slight amount of development, enter the larvæ of the house fly. They continue to develop in the pupæ and adult of the house fly. The life cycle is completed upon the entrance of the infested fly into the horse's stomach by ingestion in feed or water. "The experiments show that (1) *Musca domestica* is an intermediary host of *H. megastoma*, and (2) all the available evidence is against *Stomoxys calcitrans* acting, even accidentally, in such capacity."

The life cycle of *H. microstoma* is similar to *H. megastoma*, except that the stable fly is the principal intermediate host. "The experiments show undoubtedly that while *H. muscæ* only occurs in *M. domestica*, even when *S. calcitrans* is in the presence of an intense infection, *H. microstoma* occurs almost entirely in *S. calcitrans* but also rarely in *M. domestica*." No evidence was found that the *Habronema* larvæ ever occur in the blood stream. It is pointed out that in Australia these species are important nematodes of the horse's stomach, *H. megastoma* causing splenic and stomach abscesses, and there is reason to believe that under certain conditions the mortality caused in stock is considerable.

II. *Certain points in the life history of Melophagus ovinus Linn., the sheep lousefly, or "sheep tick"* (pp. 77-107).—This is a report of biological studies. Studies of this parasite by Swingle at the Wyoming Experiment Station have been previously noted (E. S. R., 29, p. 756).

An intestinal parasite affecting cattle in Fiji, W. RAINEY (*Fiji Dept. Agr. Circ.*, 1 (1920), No. 1, pp. 4, 5).—The author reports the occurrence of *Æsopha-*

gostoma columbianum in a large proportion of the carcasses of cattle examined in the Suva and Tavuni districts of Fiji. In three cases in which the nodules were very numerous and where there was an accompanying inflammation of the mucous lining of the intestine, the emaciated condition of the animal was at least partly due to the extensive formation of the nodules. The cattle in Fiji appear to be infested more extensively than cattle in the United States, with correspondingly more severe symptoms and results.

Pathogenic bacteria in hog cholera blood, L. P. DOYLE and R. S. SPRAY (*Jour. Infect. Diseases*, 27 (1920), No. 3, pp. 245-249).—"After the fifth day following inoculation with hog cholera virus there was a marked increase in the proportion of cholera-infected hogs having gas-producing bacteria in the blood.

"Hog-cholera blood containing gas-producing bacteria was usually fatal to rabbits when injected subcutaneously. Hog-cholera blood not containing gas-producing bacteria was nearly uniformly harmless to rabbits when injected subcutaneously. Hog-cholera blood containing gas-producing bacteria was no more harmful than blood not containing gas-producing bacteria when injected in large quantities intravenously into hogs in the production of antihog-cholera serum.

"One strain of *B. paratyphosus* A was isolated by direct planting of hog-cholera blood; another strain of *B. paratyphosus* A, and two strains of *B. paratyphosus* B, were isolated from the heart blood of rabbits dying following inoculation with hog-cholera blood. These strains were identical in all respects with human strains of *B. paratyphosus* A and B.

"Three identical intermediates were isolated, two by direct plating of hog-cholera blood and one from heart blood of a rabbit, which died after inoculation with hog-cholera blood. This same type has been isolated before and since from the spleens of pigs."

The relation between the quantity of serum administered and the active immunity produced in the simultaneous vaccination against hog cholera with virus and serum, T. P. HASLAM (*Jour. Path. and Bact.*, 23 (1920), No. 3, pp. 333-341).—The author reviews the conflicting opinions regarding the necessity of an exact balancing of the serum and virus in the serum simultaneous vaccination against hog cholera, and reports a series of experiments undertaken to determine whether or not the administration of large doses of hog-cholera serum inhibits the immunizing action of the virus.

The plan of the experiment was to vaccinate groups of pigs with a constant dose of virus and gradually increasing doses of serum and after six months to test the pigs for immunity. Eleven groups of 4 pigs each were vaccinated with 2 cc. of defibrinated blood virus preserved with 0.5 per cent phenol and with amounts of serum varying from 0.1 to 10 cc. per pound of body weight. Two groups of 4 each were vaccinated with 2 cc. of filtered virus and 0.5 and 5 cc. of serum per pound of body weight, respectively. The virulence of both lots of virus was checked by the inoculation of susceptible pigs. Nonvaccinated pigs and pigs vaccinated with serum and no virus were used as controls. The animals in all cases were secured from noninfected farms and were held in quarantine for two weeks previous to the beginning of the experiment. Six months after the vaccination all of the pigs, including the controls, received 10 cc. each of defibrinated blood virus and in addition were fed liberally with muscle virus from the pigs from which the blood virus was obtained.

In the series in which the defibrinated virus was used, all of the 10 pigs given virus alone sickened in 7 days; of the 43 pigs receiving virus and varying amounts of serum, 42 survived; of 11 controls receiving no treatment only 1 sickened slightly, while none of the 8 controls receiving serum alone sickened.

The reaction following the simultaneous serum-virus treatment varied considerably with the amount of serum administered. The animals receiving amounts of serum up to 1 cc. per pound developed definite temperature reactions, while those receiving 1 cc. or more did not show a rise in temperature.

The immunity tests, carried out six months later, gave the following results: Thirty-one of the 42 simultaneously vaccinated pigs were tested and all proved immune. Of 5 control pigs receiving serum alone none proved immune, and of 7 receiving no treatment but kept in the same pens, only 1 was immune. In the experiments in which filtered virus was used, none of the pigs receiving 0.5 cc. of serum per pound and 2 cc. of virus per pig were permanently immune, and only 2 out of the 4 receiving 5 cc. of serum per pound and 2 cc. of virus were permanently immune.

The author concludes that the immunity shown by the simultaneously vaccinated pigs depends upon the character of the virus employed and not upon the amount of serum administered.

Ulcerative lymphangitis or "Preisz-Nocard disease" of horses, with especial reference to immune sera, toxin, and antitoxin, E. A. WATSON (*Jour. Amer. Vet. Med. Assoc.*, 57 (1920), No. 3, pp. 257-269).—This paper, presented at the annual meeting of the American Veterinary Association at New Orleans in November, 1919, consists of brief reports of an experimental study of ulcerative lymphangitis, the term being used to cover only those forms of the disease originating in infection with the bacillus of Preisz-Nocard. The experiments, which were conducted in part at the veterinary bacteriological laboratory at Rouen, France, and in part at the veterinary research laboratory at Lethbridge, Canada, included a study of infectivity and period of incubation, pathogenicity for guinea pigs, immunization, specific properties of anti-Preisz-Nocard serum, and the preparation, properties, and action of a soluble toxin. The results obtained are summarized as follows:

"There is a high degree of infectivity when opportunity is given the bacillus of penetrating the skin by means of a recently scratched or injured surface. The interval between entry of the bacilli and the development of the primary sore varied between 7 and 25 days. The intervals between primary and secondary lesions are still more variable, and, at any stage in the disease, long or short periods of tolerance or local immunity are to be met with and expected. The range of virulence is a wide one. All degrees of pathogenic activity may be noted between that causing (1) an acute septicemia or toxemia, (2) slowly evolved chronic or recurring purulent and ulcerous processes, and (3) one or several isolated abscesses.

"Attempts to immunize and hyperimmunize horses were only partially successful. A serum was obtained decidedly antitoxic and to some extent antibacterial, but the horses furnishing the serum eventually succumbed to generalized infections in a more or less acute form.

"An active soluble toxin can be obtained in the filtrates of cultures of the Preisz-Nocard bacillus of races specially selected for their virulent and toxigenic properties. The properties of the serum of diseased horses permit of specific toxin-antitoxin methods of diagnosis."

Further studies on "blackhead" in turkeys, with special reference to transmission by inoculation, E. E. TYZZER and M. FABYAN (*Jour. Infect. Diseases*, 27 (1920), No. 3, pp. 207-239, figs. 6).—"A distinct form of blackhead may be produced in turkeys by the subcutaneous inoculation of liver lesions from acute cases, and this disease may be propagated apparently indefinitely by subinoculation into normal turkeys. This form of the disease is characterized by the appearance of a primary local lesion which first shows appreciable development from five to seven days after inoculation; by the occurrence

of secondary lesions regularly in the lungs, rarely in the liver and kidney, and by the later involvement of the liver and kidney (tertiary lesions) through the dissemination of the parasite from the involved lungs. In addition to weakness, loss of appetite, and sulphur-colored feces—symptoms which are seen in the spontaneous disease—there is coughing and more or less dyspnea. The inoculated disease has been invariably fatal.

“The incubation period is commonly 11 days, but varies between 11 and 17 days. The appearance of symptoms evidently indicates sufficient involvement of vital organs to interfere seriously with function. The rapid development of the subcutaneous lesion is not attended either by loss of weight or by symptoms, neither of which appears until after internal organs are involved.

“In the course of their migration through the tissues from the site of inoculation, some of the parasites penetrate the veins and are carried to the lungs where they, for the most part, lodge and produce lesions. The disease thus metastasizes by way of the blood stream in a manner similar to that of certain tumors. The distribution of the parasites is thus governed by their ability to penetrate vessels and by their size and physical properties, which cause them to lodge in capillaries.

“The expansion and contraction of the lungs evidently serve to dislodge organisms, so that these organs are not as effective filters as the liver.

“The parasites develop readily in a variety of tissues and organs, mucous membranes, connective tissues, both smooth and striated muscle, lung, liver, and kidney. Macroscopic lesions of the kidney and microscopic lesions of the lung have been found in spontaneous blackhead.

“The inoculation of chickens has resulted negatively except in newly hatched chicks, in which self-limited local lesions, and in one instance secondary lesions in the lungs were produced.

“A certain proportion of pigeons have proved susceptible to the extent of developing transient self-limited local lesions. Positive results were obtained in 30 per cent of those inoculated. The lesions are essentially similar to the subcutaneous lesions of the turkey, but after developing actively from the fifth to the eighth day undergo regression. Rabbits, guinea pigs, and mice have proved nonsusceptible.

“Blackhead may be contracted spontaneously from acute cases of its inoculated form, probably from the ingestion of food or water contaminated by discharges from the respiratory tract. An attempt to transmit the disease through the agency of a species of “blow fly” has failed, but it is possible that this or related species may play a part in the dissemination of the disease.

Exposure of a young turkey to common fowls, after a long period of isolation, has been followed by the contraction of blackhead, unless the infection is to be attributed to the “blackhead-fed” flies ingested by it 37 days previously.

“Neither the administration of tartar emetic nor of quinin has served to check the course of the infection.

“Blackhead may be produced by the introduction of organisms beneath the skin, and is not dependent on the invasion of the tissues by myriads of flagellates that have multiplied in the lumen of the gut. No flagellates have appeared in the ceca of newly hatched chickens following the ingestion of large amounts of blackhead virus derived from subcutaneous and lung lesions. Cases of spontaneous blackhead occur in which there are no demonstrable flagellates in the cecal contents or in the gland lumina.

“The definite transmission of the disease from one turkey to another by inoculation at once removes the great uncertainty which has attended all experiments in the past which have had to depend on the natural and not well understood method of transmission by the exposure of healthy turkeys to supposedly

infected turkeys. The demonstration of the uniform susceptibility of the normal turkey throughout its period of growth not only opens the way for further investigation of the question of transmission, but also serves as a basis for future work on other problems relating to the virus of blackhead."

The value of commercial vaccines and bacterins against fowl cholera, L. VAN ES and H. M. MARTIN (*Nebraska Sta. Research Bul. 18 (1920), pp. 3-11*).—This is the report of a study, conducted along similar lines to the one noted on page 882, of commercial vaccines and bacterins against fowl cholera. The preparations, purchased from six different manufacturers, included "Hemorrhagic Septicemia Vaccine (Avian)," "Hemorrhagic Septicemia Combined Bacterin (Avian)," "Avian Hemorrhagic Septicemia Bacterin," "Aviscpticus Bacterin," "Hemorrhagic Septicemia Vaccine (for fowls)," and "Fowl Cholera Bacterin." Several fowls were treated with each of these preparations and subsequently tested for immunity by means of inoculations with fowl cholera organisms secured from field outbreaks and cultivated in the laboratory.

Of 100 chickens, the immunity of which was tested after from one to three injections of the bacterin or vaccine, one only survived the immunity test. It is concluded that no reliance can be placed on these commercial vaccines and bacterins against fowl cholera.

Rabbit and cat diseases, C. G. SAUNDERS (*Chicago: Amer. Vet. Pub. Co., 1920, pp. 121*).—The first part of this work deals with the diseases of rabbits (pp. 1-64). The second part deals with diseases of the cat (pp. 65-121).

RURAL ENGINEERING.

Topographic maps and sketch mapping, J. K. FINCH (*New York: John Wiley & Sons, Inc., 1920, pp. XI+175, pls. 4, figs. 78*).—This is a manual of instruction on topographic and sketch mapping. Part 1 deals with map reading, part 2 with sketch mapping, and part 3 with landscape sketching. An appendix contains a descriptive list of the principal topographic maps of the world, by F. K. Morris, suggestions for a course in map reading and sketch mapping, and a bibliography.

Dredging engineering, F. L. SIMON (*New York and London: McGraw-Hill Book Co., Inc., 1920, pp. X+182, pl. 1, figs. 56*).—It is the purpose of this book first to describe the principal types of dredges in such a manner as to impart a fundamental working knowledge of their construction and operation, and then to consider in concise form the usual problems confronting the engineer in the conception and accomplishment of dredging projects. The following chapters are included: Definition and classification, grapple dredges, dipper dredges, ladder dredges, scows, hydraulic dredges of the river type, hydraulic dredges of the seagoing hopper type, objects and phases of the subject, preliminary engineering, preliminary construction, operating, and removal of subaqueous rock.

A study of the Venturi flume as a measuring device in open channels, P. S. WILSON and C. A. WRIGHT (*Engin. News-Rec., 85 (1920), No. 10, pp. 452-457, figs. 6*).—Experiments with two different designs of rectangular Venturi flumes, conducted at Cornell University, are reported. Each flume had a throat width of 8 in., equal to one-third the width of the channel, and each converged in a distance of 3 throat widths and diverged in a distance of 10 throat widths. One had a throat length equal to 3 throat widths and the other a throat length equal to 1 throat width.

It was found that the coefficient of the Venturi flume for any particular condition of flow within rather wide limits is a fixed determinable quantity close to unity. With the flumes experimented upon, however, the value of the coefficient varied over a range of possibly 10 per cent with varied conditions of flow, most of this variation being apparently due to surface phenomena, waves, etc.,

the effect of which could be controlled by the design of the flume so as to obtain a more definite coefficient.

The maximum loss of head necessary in the use of the Venturi flume is very small compared to that lost with other measuring devices under similar conditions. A weir with the same range of capacity would probably involve at least five or six times as much loss of head. The necessity for connecting each of the gauge wells to a pair of opposite gauge openings in the channel was verified. The exact location of the upstream gauge openings was found to be immaterial as long as they were placed upstream from, and fairly close to, the beginning of the convergence.

The determination of the discharge of the Venturi flume, from the readings of the upstream and throat gauges, is slightly more involved than in the case of the Venturi meter in a pipe since, besides the Venturi difference, the depth must also be taken into account. For this reason an automatic recording device such as is commonly used with the Venturi meter, while undoubtedly practical, would probably be more complicated.

Curves and tabular data are included.

The stopping of sink holes in canals and the construction of drops in very light soil, C. J. MOODY (*Reclam. Rec. [U. S.], 11 (1920), No. 8, pp. 374-378, figs. 7*).—Construction methods used by the U. S. Reclamation Service on the Flathead irrigation project in Montana for the repair of sink holes in canals and the construction of canal drops are described.

Water supplies and public health (*Health Bul., 35 (1920), No. 8, pp. 32, figs. 23*).—This bulletin contains considerable popular information on water supplies and their purification, with particular reference to residential and farm water supplies. The appearance of methods and apparatus for the purification of small farm water supplies, some of which were described by the U. S. Department of Agriculture several years ago, would indicate that little advance has been made on the subject.

Land clearing, O. I. BERGH and A. H. BENTON (*Minnesota Sta., Rpt. Grand Rapids Substa., 1915-1919, pp. 59-70, figs. 8*).—This report gives information on a land clearing project, the purpose of which was to determine the relative merits and cost of (1) clearing land of stumps with a horsepower stump puller, (2) shattering the larger stumps with dynamite before pulling with a horsepower stump puller, and (3) blasting out the stumps with dynamite. The tract of land selected had about an equal mixture of hard and soft wood stumps. The hardwood stumps had been cut from 3 to 10 years and the softwood from 20 to 30 years. The soil on the east half of the tract was silty loam and on the west half sandy loam to pure sand.

The data indicate very conclusively the advantage of pulling over dynamiting in stump removal. Shattering before pulling had a slight advantage over pulling without shattering. There did not seem to be much difference in the amounts of 20 and 40 per cent dynamite used, although the 40 per cent blasted out the stumps more effectively than the 20 per cent. An advantage of shattering stumps before pulling was that much less dirt was turned up with the roots and the parts of the stump were much more easily handled. The cavities left after blasting were much larger than those left where stumps were pulled. It was observed that many more roots were removed when stumps were pulled than where dynamite was used. Another advantage of pulling was that a large number of small stumps were removed that still remained when dynamiting was completed.

Land clearing and wood utilization by distillation, W. R. JAMES (*[Wilmington, Del.]: Hercules Powder Co. [1920], pp. [1]+32, pls. 6*).—This is a paper delivered at the Agricultural Extension Directors' Convention at Gulf-

port, Miss., December 18, 1919, in which an experiment on clearing 25 acres of cut-over longleaf pine land and the destructive distillation of stumps is reported. Tables of data and cost analyses are also included.

The tract selected was of fairly average condition and the stumps ranged from 6 to 15 years in age. The stumps were removed with dynamite at a total cost per acre varying from \$22.14 to \$41.39. While the average of these figures is not considered a true indication of the average cost of clearing such lands in general, it is noted that the cost per ton of wood recovered was lowest on the land costing the most to clear. It is also noted that in shooting longleaf pine stumps the character of the soil did not vitally affect the cost because the charge of explosive was confined within the root.

A small-sized horizontal retort was used for the distillation. The products of distillation of these stumps were charcoal, tar, and so-called mixed tar oils. The cost of equipment and construction was \$4,046.82. Considering total operating costs, interest, depreciation, repairs, supplies, and labor, and profit per acre on a 24-hour operating schedule was \$12.33 and on a 36-hour schedule \$12.81.

While the plant used proved to be slightly too small, it is concluded that destructive distillation offers great possibilities for anyone who contemplates clearing longleaf pine lands on a fairly large scale. "Generally speaking, a man would hardly employ the distillation process on less than 1,000 acres, even though . . . it might be possible to make a profit by using 500 acres, and doubling the depreciation figures."

Experiments on the horizontal pressure of sand, P. M. CROSTHWAITE (*Surveyor and Munic. and County Engin.*, 57 (1920), No. 1466, p. 182).—This is a review of a report, presented before the Institution of Civil Engineers, describing experiments the results of which led to the conclusion that the wedge theory, when modified by leaving out wall friction and introducing instead of the angle of repose the angle of internal friction, gives correct results in all cases whether for the maximum thrust or that produced by individual wedges.

Test of bearing capacity of rock at Iron Canyon dam site, Calif., H. J. GAULT (*Reclam. Rec. [U. S.]*, 11 (1920), No. 8, pp. 378, 379, fig. 1).—These tests indicated that the softest rock on the site could stand a pressure of nearly 40 tons per square foot without yielding. The material is mainly agglomerate. It is considered safe to design a dam with pressure on this foundation not to exceed 10 tons per square foot. The testing apparatus is described and illustrated.

How to use cement for concrete construction for town and farm, H. C. CAMPBELL (*Chicago: Stanton & Van Vliet Co.*, 1920, pp. [1]+380, figs. 214).—This is a popular treatise on how to build concrete structures for town and farm and includes formulas, drawings, and tabular data. Special sections are included on the proportioning, mixing, and laying of concrete and on form construction.

California highways, B. BLOW (*San Francisco: Author*, 1920, pp. XVIII+308, pls. 187, figs. 25).—This is a descriptive record of road development by the State of California and by such counties as have paved highways. It is profusely illustrated.

First biennial report of the Kansas Highway Commission (*Kans. Highway Comm. Bien. Rpt.*, 1 (1917-18), pp. 276, pls. 18, figs. 4).—This is the first biennial report of the Kansas State Highway Commission, which includes a short résumé of road and bridge building and legislation pertaining thereto up to the time a State highway commission was established, together with data on the work and expenditures on roads and bridges in the State for the period from April 4, 1917, to January 1, 1919. A special section describes tests of road building materials as conducted at the Kansas State Agricultural College.

Report of the State commissioner of highways for the year ending December 31, 1918, E. DUFFEY (*Rpt. State Commr. Highways, N. Y., 1918, pp. 580, pls. 8*).—This report contains data on the work and expenditures of the New York State Highway Commission for the year ended December 31, 1918.

Thirteenth annual report of the State highway commissioner to the governor of Virginia, G. P. COLEMAN (*Ann. Rpt. State Highway Commr. Va., 13 (1919), pp. 60*).—The work and expenditures of the Virginia State Highway Commission on road construction and maintenance in the State for the year ended September 30, 1919, are reported.

Road transport by steam vehicles, P. W. ROBSON (*Surveyor and Munic. and County Engin., 58 (1920), No. 1489, pp. 81, 82, fig. 1*).—The results of investigations into the actual running costs of various types of steam and gas motor vehicles operating on road transportation work in England are reported, together with an analysis of total costs. The figures analyzed represent in the aggregate 15,000,000 ton-miles hauled. The capacities of the vehicles examined varied between 3 and 6 tons.

It was found that the steam motor vehicle is the most economical and reliable form of road transportation.

Engine design for maximum power and economy of fuel, C. A. NORMAN (*Jour. Soc. Automotive Engin., 7 (1920), No. 2, pp. 182-185, figs. 2*).—This paper, a contribution from Ohio State University, deals with the subject merely from the thermodynamic standpoint and develops graphic data on the influence of the air-to-fuel ratio upon power developed and fuel consumption.

Intake-manifold temperatures and fuel economy, W. S. JAMES, H. C. DICKINSON, and S. W. SPARROW (*Jour. Soc. Automotive Engin., 7 (1920), No. 2, pp. 131-136, figs. 11*).—Experiments conducted at the U. S. Bureau of Standards are reported, which showed that (1) at constant speed, mixture ratio, and power output the fuel consumption in pounds per brake-horsepower-hour is independent of the temperatures and methods of heating the intake charge within the range tested, and (2) the rate at which an engine will accelerate with a given mixture ratio or carburetor setting is markedly affected by the amount of heat supplied and its method of application. Within the limits of this work, the greater the amount of heat supplied to the charge and the higher its temperature at the intake port, the more rapidly the engine will accelerate.

Saving fuel with the carburetor, W. E. LAY (*Jour. Soc. Automotive Engin., 7 (1920), No. 2, pp. 188, 189, figs. 2*).—Experiments conducted at the University of Michigan on the effect of varying mixture ratios on the thermal efficiency and torque of an engine operating under different conditions of speed, power output, and temperature of the fuel-intake system are reported.

The object of the first series was to determine whether the mixture giving the best economy and that giving the greatest power is a constant quantity for all conditions of speed and power output of the engine at quarter, half, three-quarters, and full load. It was found that the mixture giving the greatest power was very different from that giving the best economy. The engine used approximately 25 per cent more gasoline per brake-horsepower-hour when running on the mixture giving the greatest power output than on the most economical mixture. The mixture giving the maximum economy became somewhat leaner as the power output was increased.

The object of the second series of tests was to determine what effect changes in the temperature of the fuel-intake system have on the quality of the mixture which gives the maximum power and on that giving the best economy. It was found that over the temperature range investigated an increase in the carburetor-intake temperature caused an increase in the thermal efficiency. The

mixture giving the best economy at a high temperature was a leaner mixture than that giving the best economy at a lower temperature.

Kerosene as a tractor fuel, J. A. SECOR (*Jour. Soc. Automotive Engin.*, 7 (1920), No. 2, pp. 140-144, 156, fig. 1).—Recent data and developments on the use of kerosene as a fuel for tractors are summarized.

Operation and care of vehicle-type batteries (*U. S. Dept. Com., Bur. Standards Circ. 92* (1920), pp. 94, pls. 9, figs. 43).—This is a manual of information and instruction, prepared by A. L. Pearson and G. W. Vinal, on the operation and care of batteries for mechanically propelled vehicles.

Geometry of belt drives, G. DUFFING (*Ztschr. Ver. Deut. Ingen.*, 63 (1919), pp. 951-956; *abs. in Sci. Abs., Sect. B—Elect. Engin.*, 23 (1920), No. 266, p. 79).—It is pointed out that the geometrical form of a belt drive consists of two curves touching two given circles. These curves become straight lines only in the case of a perpendicular drive between pulleys of equal diameter. Simple formulas are developed by the process of progressive approximations for the main geometrical quantities of a belt drive, namely, arc length, sag, etc. It is assumed that the form of the center line of the belt at rest is the elastic extensible catenary, neglecting the resistance to bending and assuming a linear law of extension. The accuracy of the formulas is demonstrated by numerical examples and is shown to be ample for all practical requirements.

Wire belts with paper driving surface, H. MITTERMAYR (*Ztschr. Ver. Deut. Ingen.*, 63 (1919), pp. 1057-1061; *abs. in Sci. Abs., Sect. B—Elect. Engin.*, 23 (1920), No. 266, pp. 79-81, figs. 2).—Belts are described consisting of flat wound wire spirals with alternately right and left-hand lead coupled together by cross pins. Paper yarn is wound between the spirals, giving the belt a soft running surface and securing the adhesion required for power transmission.

Tests were made to determine the capability of these belts to transmit the same power as leather belts when running on the same pulleys. The tests showed no appreciable slip between belt and pulley until the load became excessive. Three degrees of slipping were then observed, namely, slight waves, sharp flickering movements, and a swinging of the whole span of the belt. A little wax increased the power transmitted by the belt, but an excess caused unsteady running by accumulating on the pulley. It was found that the possible power transmission increased with the distance between axes, which must not be less than a certain minimum if favorable conditions are to be obtained. About the same transmission was obtained with wooden as with iron pulleys. Thicker belts of this construction employed coils of greater pitch and relatively smaller adhesion surface, so that the permissible belt tension per inch width increased slowly or even decreased with increasing belt thickness.

The maximum permissible tension in pounds per inch of belt width for a belt of medium thickness was found to vary approximately as shown in the following table:

Permissible belt tension per inch width.

Pulley diameter.	Belt tension per inch width at various belt speeds.			
	Belt speed per second.			
	6.56 ft.	19.685 ft.	39.37 ft.	59.055 ft.
<i>Inches.</i>	<i>Pounds.</i>	<i>Pounds.</i>	<i>Pounds.</i>	<i>Pounds.</i>
7.8742	81.20	74.48	70.56	67.200
19.6853	112.00	103.04	96.32	91.280
31.4966	133.28	122.08	113.12	106.960
59.0561	161.28	145.60	133.28	123.200

Lower values of tension must be used for inclined or vertical drives or if the distance between pulley centers is unduly short. These belts are said to be particularly suitable for slow drives, large pulleys, and long spans, and can be substituted directly for leather belts of the same width and will transmit considerably more power than leather. However, they lack the elasticity of leather.

Effects of oils, greases, and degree of tannage on the physical properties of russet harness leather, R. C. BOWKER and J. B. CHURCHILL (*U. S. Dept. Com., Bur. Standards Technol. Paper 160 (1920), pp. 18, figs. 19*).—Studies on the effects of the amount and kind of stuffing content and on the degree of tannage on the physical properties of harness leather are reported. Russet harness leather was used.

It was found that the amount of stuffing content affects the tensile strength of the leather and that there is a point beyond which the amount of stuffing content used does not add to the strength and may actually serve to decrease it. The tensile strength was found to be greater for leather tanned a short time than for leather given a long-time tannage, and the longer-time tannage produced leather more resistant to shear when used with a buckle.

Stuffing with a mixture of 50 per cent Breton mineral oil and 50 per cent tallow did not affect the physical properties of new leather in a manner different from that of a mixture of 50 per cent cod oil and 50 per cent tallow.

Notes on power farming, R. W. LOHMAN (*Jour. Soc. Automotive Engin., 7 (1920), No. 2, pp. 160-174, 185, figs. 37*).—Data on some of the methods and apparatus which can be used to advantage in large-scale farming operations are reported, together with numerous illustrations. These include especially different types of tillage, traction, and harvesting machinery.

The cultivation of cereals and mechanical cultivators, L. MALPEAUX (*Vie Agr. et Rurale, 9 (1920), No. 20, pp. 340-346, figs. 4*).—Hoes, harrows, rollers, and cultivators for the cultivation of cereals and truck crops are described, and evidence as to the importance of their proper use in increasing crop yields is presented.

List of farm building plans (*Iowa State Col. Agr. Ext. Bul. 33 (1919), 4 rev., pp. 8, fig. 1*).—This is the fourth revision of this bulletin.

Farm building ventilation, R. L. PATTY (*S. Dak. Agr. Col. Ext. Circ. 31 (1920), pp. 12, figs. 11*).—Practical information on the installation of ventilation systems in dairy and stock barns to properly meet South Dakota conditions is given.

Buildings for small holders: Experiments in adaptation, S. D. MEADOWS (*Jour. Min. Agr. [London], 27 (1920), No. 5, pp. 467-478, pl. 1, figs. 6*).—Plan drawings of houses for small farms in England are presented and discussed.

Small portable granary, M. R. BENTLEY (*Okla. Agr. Col. Ext. Circ. 119 (1920), pp. [4], figs. 3*).—A small portable frame granary adapted to Oklahoma conditions is described and illustrated.

Design of circular reinforced concrete bins, W. W. HAY (*Concrete [Detroit], 17 (1920), No. 3, pp. 73-76, figs. 7*).—Formulas and graphic data on the design of circular reinforced concrete bins for the storage of grain are given.

The Department of Agriculture cold storage plant, L. A. HAWKINS (*Better Fruit, 14 (1920), No. 10, pp. 10, 36, figs. 2*).—This cold storage plant for fruit and vegetables is described and illustrated.

Housing farm poultry, A. G. PHILIPS (*Indiana Sta. Circ. 98 (1920), pp. 22, figs. 22*).—The principles underlying practical poultry house building are explained and illustrated with drawings, and working plans are given for model houses to care for 100 and 150 fowls, together with poultry-house equipment, including indoor and outdoor feed hoppers.

The improved New Jersey multiple unit laying house, I. L. OWEN and G. H. POUND (*New Jersey Stas., Hints to Poultrymen*, 8 (1920), No. 12, pp. 4, figs. 2).—This circular presents working plans incorporating certain improvements in this laying house.

Septic tank for sewage disposal on the farm, R. L. PATTY (*S. Dak. Agr. Col. Ext. Circ. 35* (1920), pp. 4, fig. 1).—This circular briefly describes the septic tank and tile absorption area for the disposal of farm sewage, which is presumably adapted to conditions in South Dakota.

RURAL ECONOMICS.

Farm land values in Iowa, L. C. GRAY and O. G. LLOYD (*U. S. Dept. Agr. Bul. 874* (1920), pp. 45, fig. 1).—The matter of increases occurring in farm land values, farm earnings, and the shares received by landlords and by tenants, also the probable effect of these changes upon the opportunity of farmers to acquire the land they cultivate, is presented in this bulletin, prepared by the Office of Farm Management and Farm Economics in cooperation with the Iowa Experiment Station.

The data concerning actual sales were obtained in 60 counties in northern and western Iowa. Comparison is made of land values, distribution of farm earnings, and receipts and expenses on 965 farms in adjacent townships of Black Hawk, Tama, and Grundy Counties for the year 1913, and of 832 farms in Warren County in 1915, with similar data from about 400 farms in the same areas for the year ended with March, 1918.

Trends of land values in the country as a whole as shown by estimates of average values of farm land and improvements by States, 1915, 1919, and 1920, obtained by the Bureau of Crop Estimates are set forth, as well as census and farm-management survey statistics for the increase in the average value per acre of Iowa farm land since 1850 and the range of prices paid for farm land. An average increase from March 1, 1918, to August, 1919, of \$65 per acre is shown, which compared with the increase of \$81 per acre from March, 1918, to March, 1920, reflects the full extent of the "boom." Sixty-six dollars an acre is given as the figure for the average increase, 1919. Information was obtained regarding the extent of activities in buying and selling farms in Iowa, 1919, and details as to the occupations and intentions of buyers and sellers. Numerous details of terms of sale are also noted.

Special emphasis is then given to data on farm earnings and incomes of owners, tenants, and landlords, 1913, 1915, 1918, and 1919, and their net worth on March 1, 1919. The percentages of increase of farm income per acre between 1913 and 1918 were 47 for owner, 84 for owners additional, and 74 for tenants. For all farms, the increase in farm income per acre was 65 per cent. In contrast with these rates of increase, average farm-land values of these farms increased only from 17 to 23 per cent during the same period. On the basis of land values in 1918, farmers of all classes of tenure in what is termed the Tama district made farm labor incomes averaging \$1,537, whereas in 1913 the average for all farms, after deducting 5 per cent on the value of all farm capital, including land, was only \$306. The farm labor incomes of owner operators in the Tama district were 361 per cent higher, those of owners additional 367 per cent higher, and those of tenants 478 per cent higher than in 1913. Allowing 5.5 per cent for the use of capital, the average farm labor income was about 16 times as great as in 1913. When farm labor incomes of 1918 are similarly calculated on the basis of the land values of August, 1919, however, the result is a minus labor income of \$148 for owners in the Tama

district and a minus labor income of \$207 for the same class in the Warren district. The labor incomes of 1913 represented a greater amount of purchasing power than those based on land values of August, 1919.

Operators' labor income of tenants and owners additional, percentage of landlords' net return on present value of investment, and economic rent, net return of all classes of operators on operators' capital, and precariousness of farmers' incomes are made the subjects of similar comparative study.

The conclusions are reached that probably the principal cause for the "boom" was the large increase in net earnings of farmers, the speculative interest which developed being secondary. One important immediate consequence was the rapid recapitalization of Iowa farm lands on the basis of high prices of farm products, and due to the fact that the advance in land values more than absorbed all the gain, and labor incomes were forced below what they were in 1913, it has become financially undesirable as well as almost impossible for tenants to acquire ownership of farms.

The economic problem of the Ozark Highland, C. O. SAUER (*Sci. Mo.*, 11 (1920), No. 3, pp. 215-227).—Social and economic traditions of dwellers in this region are discussed here. Geographic features, crops, and live-stock industries are described. Among the steps recommended as the solution for the stagnation of rural life in the Ozark region are better roads, better live stock, development of the dairy industry, and a forest policy for both Missouri and Arkansas.

Helping men own farms, E. MEAD (*New York: The Macmillan Co.*, 1920, pp. [4]+228, pls. 9).—This discussion sets forth the conditions and influences which led to the passage of the Land Settlement Act in California, and explains methods and policies of planned rural development which it has brought into operation. A brief account is given of State aid to farm settlement on irrigated land in Victoria, Australia, as well as of Government encouragement of small farm owning in Italy, Denmark, Holland, and the British Isles. Five of the 14 chapters are given to details of the establishment of the Durham State land settlement, in Butte County, Calif. The author maintains that public control of utilities and natural resources is profitable and necessary.

The rural community, N. L. SIMS (*New York: Charles Scribner's Sons*, 1920, pp. XXIII+916, pl. 3, figs. 34).—This is a book of readings, the excerpts arranged in three parts, the first, historical and relating to the ancient and medieval agricultural community, the early village community in America, and the history and theory of communal disintegration. The other parts are composed of records of typical community experiences and institutions and of community reconstruction.

The farm woman tells her own story, F. E. WARD (*U. S. Dept. Agr., Weekly News Letter*, 7 (1920), Nos. 48, pp. 5-8, fig. 1; 49, pp. 5-7).—Findings of a recent survey of a large number of farm homes in the 33 Northern and Western States are written up to show the extent to which power and labor-saving devices, improved means of sanitation and communication, etc., are now in use or needed in farm homes, and how some of these conditions may be remedied.

Agriculture during two great wars: 1793-1815 and 1914-1918, ERNLE (*Jour. Min. Agr. [London]*, 27 (1920), No. 3, pp. 227-240).—The contrast between England's policy of taxation during and after the French and the German wars and of the position of agriculture and of labor conditions is pointed out. It is maintained that in the latter war producers carried the burden of a taxation policy favoring the consumer, while on the other hand the position of agricultural labor has been materially improved instead of being made worse as it was in 1816.

The agriculture of Creuse, G. MAUMY (*La Creuse Agricole. Paris: Émile La Rose, 1919, pp. II+291, pls. 4*).—This is a description of geographic and geologic features of this department in central France, also of methods of agriculture, acreage and yields of the principal agricultural products, and the prevalent practices of live-stock raising. The discussion includes local economic and social problems such as land values, typical methods of farm operation, taxes on agriculture, bookkeeping, labor, marketing, and prices of agricultural products. An account is given of the movement of population into the city, the death rate, and the organization of rural life.

Peasant holdings and the property tax, F. SCHWARZACHER (*Nachr. Deut. Landw. Gesell. Österr., n. ser., 3 (1919), No. 32, pp. 270-274*).—Some of the difficulties of an equitable assessment of farm business for the property tax are discussed. The author advances his theory that the tax should be levied after the business has paid all expenses, including the upkeep of the household and wages for the family labor, taxes, interest, etc., and offers a formula for the determination of the amount of the tax. It is granted that this computation for each individual peasant undertaking is complex and expensive, and so it is recommended that for the present the assessment be made on the basis of the income as reported on the land register.

Profit and loss sharing in agriculture, J. WYLLIE (*Jour. Min. Agr. [London], 27 (1920), No. 3, pp. 254-261*).—Certain farm accounts kept since 1905 are summarized and analyzed to show how a scheme of profit and loss sharing actually worked out in practice.

What the N. F. U. is doing for the farmer (*London: Natl. Farmers' Union, 1920, pp. 45*).—In this bulletin is given the outline of work of committees of the National Farmers' Union during the past year.

The progress of agricultural cooperation in England and Wales since the Armistice (*Jour. Min. Agr. [London], 27 (1920), No. 5, pp. 428-436*).—This takes up briefly the various phases of the spread of the principles of this movement in England recently.

Cooperation in Scotland, J. LUCAS (*Manchester, England: The Cooperative Union, Ltd., 1920, pp. 93, pls. 13*).—This is another of the international cooperative series, which has been previously noted (*E. S. R.*, 43, p. 694). The development of cooperative effort in Scotland is traced briefly, and some of the chief phases of modern cooperation are exhibited.

In the appendix, detailed statistics have been compiled by counties for various years and periods of years. A bibliography is appended.

The organization of cooperative grain elevator companies, J. M. MEHL and O. B. JESNESS (*U. S. Dept. Agr. Bul. 860 (1920), pp. 40*).—A plan of organization and method of procedure in the formation of cooperative grain elevator companies is furnished, with special reference to conditions existing in the grain States. The three forms of organizations noted are joint stock companies and unincorporated societies, ordinary private corporations of the capital-stock form, and cooperative associations incorporated under special cooperative law. It is said that success depends upon the social or economic need, a sound organization plan, and efficient management.

In the appendix are given suggested forms for various technical details.

The Grain Corporation and the guaranteed wheat price, W. ELDED (*Quart. Jour. Econ., 34 (1920), No. 4, pp. 698-719, pl. 1*).—This is a review, annotated with official statistics and including a graph of average Chicago prices of No. 1 northern spring wheat weekly through the crop years 1918-19 and 1919-20, of the scheme of control of the Nation's wheat crop, beginning with the export and import embargo through the suspension of future trading, license control, price fixation in 1917, and minimum guaranteed prices in 1918 and

1919, the injection of the Government into the market as a trader on a commercial basis, and the positive direction of export business by a Government agency down to the permitted resumption July 15 of trading in futures, which marked the end of the undertaking.

A short discussion of the United States Warehouse Act, what it provides, and its purposes (*U. S. Dept. Agr., Bur. Markets Serv. and Regulatory Announcement 61 (1920), pp. 36*).—A short discussion is given of the United States Warehouse Act and its amendments (E. S. R., 41, p. 891). Recent revision of the regulations for cotton warehouses (E. S. R., 42, p. 34) and amendments to the above-noted circular, also a list of cotton warehousemen licensed under the United States Warehouse Act prior to April 1, 1920, notes and extracts from correspondents showing the efforts of the Bureau of Markets to secure equitable credits by reduced insurance rates on contents stored in licensed warehouses, and to have receipts under the United States Warehouse Act approved as collateral by the Federal Farm Loan Board and other similar special agreements, lists of licensees, and suggested blank forms, are given.

International annual of agricultural statistics, 1915-16 and 1917-18 (*Inst. Internatl. Agr. [Rome], Ann. Internatl. Statist. Agr., 1915-16, pp. L+949; 1917-18, pp. XLIX+477*).—These volumes continue information previously noted (E. S. R., 34, p. 490).

Monthly Crop Reporter (*U. S. Dept. Agr., Mo. Crop Rptr., 6 (1920), No. 9, pp. 93-108, figs. 2*).—The usual monthly summaries of acreage and condition, and brief articles, forecasts, and tabulated data as to stocks, farm value, and market prices of important agricultural products, including live stock, are given. A summary of foreign crop prospects on August 31, 1920, estimates of the percentage of various crops which is harvested in the several months and of the per capita flour consumption by States, and other data are included.

Prices and supplies of grain, live stock, and other agricultural produce in Scotland, J. M. RAMSAY (*Agr. Statist. Scot., 6 (1917), pt. 3, pp. 79-109*).—Tables with interpretative notes, previously noted (E. S. R., 41, p. 795), are continued for the later year.

[Agricultural statistics of Italy] (*Ann. Statist. Ital., 2. ser., 7 (1917-18), pp. 157-182, pl. 1*).—Agricultural statistics for the later year are continued as previously noted (E. S. R., 40, p. 194).

[Agricultural statistics of British India] (*Statist. Abs. Brit. India, 52 (1908-1917), pp. 128-136; 53 (1909-1918), pp. 128-136*).—These pages continue current summaries of agricultural statistics, as noted for an earlier year (E. S. R., 38, p. 695).

AGRICULTURAL EDUCATION.

Agricultural education and its needs, G. A. SMITH (*Scot. Jour. Agr., 3 (1920), No. 2, pp. 155-160*).—The author briefly reviews the development of agricultural education at the University of Aberdeen and the Aberdeen and North of Scotland College of Agriculture under a system of close cooperation which has done excellent and effective work. Attention is called to the advantages of this alliance to the college. A board of 46 governors has charge of the organization of the college and administers its finances subject to the Board of Agriculture. It also manages the experimental farm at Craibstone and a demonstration croft at Alness, and has oversight of all the extension work throughout the counties of the college area. The university provides the courses in pure science for the first part of the degree, appoints the external examiners, and determines and conducts the degree examinations, etc. A candidate for a degree must satisfy the examiners that he possesses a practical knowledge of agri-

culture obtained by residence on a farm during a complete year of farm operations.

As regards the necessary improvements, it is suggested that a degree of differentiation of courses is necessary as between students who are to be practical farmers or planters or are to occupy only minor positions in agricultural education, and those who aim at and by their abilities are fitted for higher positions as lecturers in agricultural colleges or as leaders in agricultural research and organization or as expert consultants and advisers. The latter, besides completing the curriculum for the degree of B. S. in agriculture, should study for the degree of bachelor of (pure) science with distinction in one or other of its departments. For those who are to be farmers a scientific training is absolutely necessary.

In the author's opinion agricultural education in Scotland needs, above all, the close association of the colleges with institutes for research, and in addition to this the teachers themselves should have some time and opportunities for sharing in research as a means to familiarize even ordinary students with the methods and value of research. The practical farmer requires fuller instruction in economic principles as applied to agriculture and in bookkeeping and modern business methods. The colleges need additions to their staffs, both teaching and research, increased funds, additional scholarships for agricultural students, both for study and research, enlarged demonstration areas, and a wider and more thorough system of bringing instruction to the great number of apprentice farmers and farm servants who can not attend the central courses.

Status of agricultural instruction (*Rap. Trien. Min. Agr. et Trav. Pub. [Belgium], 1912-1917, pp. XXVI+412*).—This is a report for the years 1912-1917, inclusive, submitted by the Minister of Agriculture and Public Works to the legislative chambers of Belgium, on the collegiate, secondary, elementary, and extension instruction in agriculture, horticulture, and home economics. In the appendixes more detailed information is given concerning the general organization, curriculum, experimental work, publications, attendance, etc., of the individual institutions under the direction of the department.

Agricultural instruction in the agricultural high schools and agricultural university institutes, O. LEMMERMANN (*Illus. Landw. Ztg., 39 (1919), No. 87-88, pp. 437-439*).—This is a discussion in defense of the agricultural high schools in Prussia against criticisms by university instructors which, the author states, have been called forth by a rumor that the Minister of Agriculture was pursuing a plan of discontinuing the university agricultural institutes and establishing instead a number of independent agricultural high schools. A brief statement is included of the changes that have taken place in the organization of higher agricultural instruction in Germany since its inception in the first half of the eighteenth century.

The function and organization of the high school course of study in agriculture, W. G. HUMMEL (*Wash. Bd. Vocat. Ed., Bul. 2 (1920), pp. 22*).—This is a discussion, from a social and economic as well as an academic viewpoint, of the objectives and function of the high school course in agriculture; extra-agricultural subjects of the course; agricultural subjects; the importance of balance and breadth in agricultural training; the nature and sequence of agricultural subjects in a four-year high school course; special factors influencing materials, method, and sequence of instruction; the relation of practice work to systematic instruction; the nature, purpose, and organization of practice work; the necessity for, value, utilization, and nature of definite outlines, plans, etc., needed as guides in conducting high school agricultural instruction; the relationships between agricultural courses; and the results of systematic organization of agricultural work.

A study of rural school conditions in Ohio, V. M. RIEGEL (*Columbus, Ohio: Supt. Pub. Instr., 1920, pp. 175, figs. 59*).—This is a study of rural school progress in Ohio which, it is stated, has been very marked during the past five years since the enactment of the school code of 1914 which made adequate provision for the administration and supervision of rural schools. It deals with legislative history, the one-room school, the 1913 school survey, supervision, centralization and consolidation, community activities and extension work of schools, including agriculture and home economics, as a result of supervision under the new code, the rural high school, and the purposes and activities of the modern rural schools of the Bowling Green State Normal College.

Efficient method of teaching commercial poultry finishing work to students in agricultural colleges, B. F. KAUPP and J. E. IVEY (*Jour. Amer. Assoc. Instr. and Invest. Poultry Husb., 6 (1920), No. 8, pp. 46, 47, pls. 2*).—A brief description is given of the method followed at the North Carolina State College of Agriculture and Engineering of giving students practical feeding work with the theoretical teaching in the finishing of poultry for market.

Farm gardening as a vocation, W. J. QUICK (*Fed. Bd. Vocat. Ed., Rehabil. Ser., No. 44 (1920), pp. 24, figs. 9*).—This monograph is intended to aid disabled soldiers, sailors, and marines in choosing a vocation. It calls attention to gardening opportunities and cooperative benefits and discusses briefly home, market, city, and farm gardening or truck farming.

The school garden as a means of education, R. P. SNYDER (*Brooklyn Bot. Gard. Rec., 9 (1920), No. 3, pp. 91-100*).—The author discusses the value of garden work as a means of education in mind and character training and development, and of interesting pupils in and teaching them about practical agriculture.

A course of practical chemistry for agricultural students, L. F. NEWMAN and H. A. D. NEVILLE (*Cambridge, England: Univ. Press, 1920, vol. 1, pp. 235*).—This volume treats of the chemistry and physics of the soil and is intended to cover the first year's work of the course. It is designed primarily for the use of students taking the course for the degree in agricultural science at Cambridge University.

Elementary agricultural chemistry, H. INGLE (*London: Charles Griffin & Co., Ltd., 1920, 3. ed., rev., pp. IX+250, figs. 5*).—This is the third edition of this text, previously noted (*E. S. R., 21, p. 192*), in which only a few minor corrections and additions have been made.

MISCELLANEOUS.

Thirty-second Annual Report of Kentucky Station, 1919, Part 1 (*Kentucky Sta. Rpt. 1919, pt. 1, pp. 64, figs. 4*).—This contains the organization list, a financial statement as to the Federal funds for the fiscal year ended June 30, 1919, a report of the director on the work and publications of the year, and meteorological data. The experimental work reported is for the most part abstracted elsewhere in this issue.

General report, North Central Experiment Station, Grand Rapids, 1915-1919 (*Minnesota Sta., Rpt. Grand Rapids Substa., 1915-1919, pp. 80, figs. 30*).—This is a summary of the work of this substation from 1915 to 1919. The experimental data reported are for the most part abstracted elsewhere in this issue.

NOTES.

Florida University and Station.—P. H. Rolfs, for fifteen years director of the station, director of extension for seven years, and dean of the college of agriculture for six years, has been granted leave of absence beginning about January 1, 1921, to organize and conduct an agricultural institution in the State of Minas Geraes, Brazil. This State is nearly as large as Texas, with somewhat greater population, and its agricultural productions range from wheat to rubber. Headquarters of the institution will be for the present at Bello Horizonte. It is the intention to recruit a full corps of American instructors and investigators.

Iowa College.—Dr. E. W. Stanton, at various periods dean of the junior college, vice president, and acting president, died September 12, after an extended illness. Dr. Stanton was connected with the college continuously for over fifty years, graduating with the first class in 1872. He was immediately appointed instructor, and for forty-eight years was instructor or professor of mathematics. He served as acting president in 1890-91, 1902-3, and 1911-12, as well as during the recent absence on war service of President Pearson. He was for many years secretary of the board of trustees, and throughout his long service was closely identified with institutional policies.

Kentucky University and Station.—On September 22 the departments of farm management and markets were consolidated into a department of farm economics. W. D. Nicholls has been appointed head of the new department, which comprises sections of farm management, markets, and agricultural economics. O. B. Jesness, of the Bureau of Markets, U. S. Department of Agriculture, has been appointed chief of the section of markets.

The resignations are noted of G. W. Forster, professor of agricultural economics, September 1; J. R. Humphrey, head of the department of markets, October 1; and Gertrude McCheyne, State leader of home demonstration agents, August 31. J. C. Grimes, instructor in animal husbandry and assistant animal husbandman, has been appointed head of the department of animal husbandry in the Alabama College and Station, and has been succeeded by W. J. Harris, transferred from the extension staff. Ralph Kenney has been appointed extension specialist in agronomy, and Anita Burnam, M. L. Hall, and C. A. Mosgrove field agents in club work.

Maine Station.—Dr. Charles D. Woods, director for over twenty-four years, was removed from office by the board of trustees November 30.

Montana College.—The acceptance by substantial majorities of initiative measures voted on at the November election insures to the various States educational institutions comprising the University of Montana \$3,750,000 for buildings. Of this, it is expected that from \$1,200,000 to \$1,500,000 will be available for the college of agriculture. A tax amendment also provides an assessment of 1.5 mills for the maintenance of the university institutions.

Dr. E. H. Riley, extension live-stock specialist, has resigned to engage in farming.

Nebraska University and Station.—The resignations are noted of J. H. Frandsen, dairy husbandman, to enter commercial work, and H. B. Pier, assistant professor of animal husbandry. Harry H. Smith has been appointed instructor in animal husbandry, beginning November 1.

Cornell University and Station.—A professorship of farm finance has been established in the department of farm management and rural economics to which Dr. W. I. Myers has been appointed. H. E. Babcock, formerly State director of farm bureaus, has returned as professor of marketing. W. F. Lusk has resigned to become head of the department of agricultural education at the Mississippi College, and has been succeeded by Dr. T. H. Eaton, head of the department of agricultural education at the Connecticut College. David Lumsden, assistant professor of floriculture, has resigned to take up horticulture and landscape gardening work at Walter Reed Hospital, Washington, D. C. A year's leave of absence has been granted K. C. Livermore, professor of farm management, to engage in farming.

North Dakota College and Station.—The election of President E. F. Ladd to the United States Senate is noted. George B. Rogers, dairy husbandman, has resigned to take charge of a dairy herd in Wayne County, Mich. J. W. Haw, assistant county agent leader, has been transferred to the station as animal husbandman.

Ohio State University and Station.—J. B. Green, specialist in agricultural engineering, has resigned from the university staff to accept a commercial position, and has been succeeded by Robert Thompson, of the extension service, as assistant professor of agricultural engineering. Miss Faith R. Lauman has been appointed head of the department of home economics. Miss Treva E. Kauffman has resigned as assistant professor of home economics.

O. A. Alderman, a 1920 graduate of the Michigan College, has been appointed assistant in forestry in the station.

Pennsylvania College and Station.—J. F. Adams, associate professor of botany and assistant botanist, resigned November 15. E. J. Walter has been appointed assistant professor of agronomy extension.

Tennessee University and Station.—The college of agriculture and station have undergone a reorganization, resulting in a more complete division of the teaching and investigational forces. Of those formerly in both branches of the work, C. A. Willson, animal husbandman, L. R. Hesler, botanist, O. M. Watson, horticulturist, and M. Mulvania, bacteriologist, have been transferred entirely to the teaching staff. The veterinary department and the farm foreman have been eliminated from the station organization.

The college agronomy work has been divided, with R. B. Lowry in charge of instruction in soils and O. W. Dynes, recently appointed associate professor of agronomy, of that in farm crops. Professor Dynes will also conduct plant breeding work under the Oliver Perry Temple Foundation.

Dr. C. D. Sherbakoff, assistant plant pathologist of the Florida Station, has been appointed plant pathologist, and will have charge of the projects relating to plant diseases. W. M. Shaw, assistant soil chemist at the Minnesota Station, has succeeded F. J. Gray, resigned as assistant chemist.

Utah Station.—The station and the Bureau of Soils, U. S. Department of Agriculture, have just completed the field work of a cooperative soil survey of Ashley Valley, Uintah County. The county commissioners made a special appropriation in order to insure the early completion of this work. Several of the irrigation companies of the valley also levied special assessments for a study and reorganization of their irrigation systems by the irrigation department of the station.

J. R. Bateman has been appointed superintendent of the Pangultch Farm in Garfield County, which is devoted to pure-bred cattle with a view of improving the range stock in the southern part of the State. Peter Nelson has been appointed foreman of the college farm.

INDEX OF NAMES.

- Abbey, M. J., 598.
 Abbot, C. G., 511, 719, 809.
 Abelous, J. E., 369.
 Aberhalden, E., 860.
 Abraham, H., 186.
 Abreu, E. S., 661.
 Acél, D., 63.
 Acharya, K. R., 477.
 Ackerman, A. J., 357.
 Acree, S. F., 313.
 Adames, H. B., 17.
 Adams, B., 300.
 Adams, E. Q., 801.
 Adams, H. E. F. G., 218.
 Adams, J. F., 544, 552, 900.
 Adams, M. G., 97.
 Adamson, R. S., 880.
 Adkins, C., 661.
 Adrianzen, J. II, 289.
 Aereboe, F., 570.
 Afzel, M., 150.
 Agee, H. P., 830.
 Agee, J. H., 511.
 Agersborg, H. P. K., 800.
 Agg, T. R., 284.
 Ahearn, M. F., 799.
 Ahr, 173.
 Aicher, L. C., 637, 739.
 Ainslie, C. N., 259.
 Ainslie, G. G., 762.
 Aitchison, D. A. D., 180.
 Ajrekar, S. L., 40.
 Åkerman, Å., 34, 334, 432, 500.
 Albrecht, W. A., 625, 721, 722.
 Alciatore, H. F., 16.
 Alder, B., 872.
 Alderman, O. A., 900.
 Alderman, W. H., 645.
 Aldrich, E., 204.
 Allan, J., 833.
 Allder, C. T., 621.
 Alleman, D., 836.
 Allen, A. C., 656.
 Allen, E. W., 698, 707.
 Allen, F. M., 370, 862.
 Allen, J. R., 592.
 Allen, N., 399.
 Allen, W. J., 836.
 Allison, F. E., 217.
 Allred, C. E., 690.
 Almy, L. H., 858.
 Alsberg, C. L., 798.
 Alter, J. C., 16.
 Alway, F. J., 420, 814.
 Alwens, 667.
 Amadeo, T., 296.
 Ames, 713.
 Ames, J. W., 725.
 Amos, A., 46.
 Anderegg, L. T., 729.
 Anders, C. B., 700.
 Anderson, A. C., 178, 378.
 Anderson, A. K., 399.
 Anderson, A. P., 689.
 Anderson, E., 25, 399.
 Anderson, G. F., 428, 437, 464, 613.
 Anderson, H. W., 753, 847.
 Anderson, J. A., 610.
 Anderson, M. S., 624.
 Anderson, P. J., 658.
 Anderton, B. A., 689.
 Andrade, C. D., 500.
 André, G., 203.
 Andres, A., 51.
 Andrews, C. A., 694.
 Andrews, F. M., 132, 327, 328.
 Annett, H. E., 777.
 Anthony, R. D., 645.
 Anthony, S., 826.
 App, F., 532.
 Appleman, C. O., 138, 154.
 Archer, R. T., 178.
 Archibald, E. S., 773.
 Arens, P., 49.
 Arisz, W. H., 43.
 Arkell, H. S., 403.
 Armitage, H. M., 659.
 Arms, F. W., 676.
 Armsby, H. P., 62, 372.
 Armstrong, E. F., 410.
 Arnaud, G., 752.
 Arnett, C. N., 68, 498.
 Arnold, J. H., 437.
 Arnold, J. W., 511.
 Aronsson, L., 231.
 Arrow, G. J., 50.
 Arthur, J. C., 222, 244, 346.
 Ashby, A. W., 487.
 Ashby, M. K., 487.
 Ashby, R. C., 572, 673.
 Ashby, S. F., 151.
 Ashby, W., 484.
 Ashe, W. W., 222.
 Ashworth, R. R., 679.
 Atack, F. W., 201.
 Atha, H. B., 852.
 Athanassof, N., 72.
 Atkeson, F. W., 199, 677.
 Atkinson, A., 35.
 Atwater, C. G., 25.
 Atwood, G. G., 661.
 Atwood, M. V., 300.
 Auchinleck, G. G., 745.
 Auchter, E. C., 143, 646, 744.
 Auer, A., 62.
 Augé-Laribé, M., 292.
 Auld, R. C., 171.
 Avery, 703, 707.
 Avery, S., 800.
 Ayres, W. E., 99.
 Baatz, 583.
 Babcock, C. G., 660.
 Babcock, C. M., 591.
 Babcock, H. E., 299, 900.
 Bachtell, M. A., 322.
 Back, E. A., 53.
 Bacon, M. I., 651.
 Bacot, A., 453.
 Baerg, W. J., 763.
 Bailey, D. E., 75.
 Bailey, E. M., 221, 859, 861.
 Bailey, G. W., 499.
 Bailey, I. W., 851.
 Bailey, L. H., 396, 598.
 Bailey, M. A., 444.
 Bailey, W. A., 543.
 Bain, J. B., 678.
 Baines, A. E., 819.
 Baird, R. O., 368.
 Baird, W. P., 738.
 Baird, W. W., 771.
 Baker, A. C., 54, 557, 758, 852.
 Baker, C. E., 799.
 Baker, C. L., 482.
 Baker, H. J., 800.
 Baker, J. C., 578, 579, 681.
 Baker, R. S., 300.
 Baker, R. T., 149.
 Baker, S. A., 595.
 Bakke, A. L., 845.
 Balderston, L. R., 792.
 Balderston, R., 177.
 Balfour, B., 838.
 Ball, E. D., 199, 356, 655.
 Ballard, W. R., 143, 299.
 Ballou, F. H., 339, 340, 341, 647.
 Balls, W. L., 633.
 Bally, W., 748.
 Bamer, F. G., 498.
 Bancroft, M. J., 182.
 Bandeen, S. G., 182.
 Banks, N., 256.

- Barber, E. R., 259.
 Barber, G. W., 450.
 Barber, H. S., 562.
 Barbour, H. G., 370, 371.
 Barclay, J. R., 171.
 Bardsley, J. H., 497.
 Barger, G., 409.
 Barghausen, J. F., 836.
 Barile, M. C., 687.
 Barkdell, C. C., 99.
 Barker, B. T. P., 742, 835.
 Barker, H. D., 399.
 Barnes, H., 588, 788.
 Barnes, J. H., 489.
 Barnett, R. C., 790.
 Barnett, R. J., 799.
 Barnhart, A. S., 200.
 Barnitz, H. L., 416.
 Barrett, F. N., 299.
 Barrows, E. L., 738.
 Barss, H. P., 347.
 Bartholomew, E. T., 99.
 Bartlett, H. H., 632.
 Barton, H., 402.
 Bassette, F. A., 300.
 Basu, P. C., 292.
 Batchelder, D. T., 198.
 Bateman, E., 283.
 Bateman, J. R., 900.
 Bates, C. G., 650.
 Bates, E. A., 799.
 Bates, E. N., 390.
 Bates, S. B., 591.
 Bateson, W., 433, 632.
 Baudon, F. A., 344.
 Bauer, F. C., 427.
 Baughman, W. F., 13, 502.
 Baumann, J., 519.
 Baumberger, J. P., 51.
 Bavendick, F. J., 120, 718.
 Baxter, F. H., 746.
 Baxter, G. P., 112.
 Bayard, E. S., 82.
 Bayles, J. J., 576.
 Bayliss, W. M., 79, 611.
 Beach, B. A., 683.
 Beach, F. H., 348.
 Beach, J. B., 837.
 Beach, S. A., 742.
 Beal, W. H., 300.
 Beals, C. C., 327, 419.
 Beam, A. L., 576.
 Bear, F. E., 210.
 Bearce, B., 272.
 Beath, O. A., 782, 783.
 Beattie, J. M., 778.
 Beavers, J. C., 124.
 Beccard, E., 413.
 Bechdel, S. I., 569.
 Becker, E., 663.
 Becker, J., 206.
 Becker, R. B., 497.
 Beckmann, E., 267.
 Beddoes, W. F., 442.
 Beegle, F. M., 116.
 Beekman, H., 443, 450.
 Beeson, C. F. C., 57.
 Beeson, M. A., 32, 137, 400.
 Beger, C., 266.
 Begin, J., 775.
 Behn, P., 83.
 Belle, L., 342.
 Belden, W. S., 16.
 Belgrave, W. N. C., 45.
 Bell, F. W., 674.
 Bell, G. A., 464.
 Bell, H. D., 853.
 Bénabeng, J., 689.
 Bender, H. E., 780.
 Bendixen, H. A., 198.
 Benedict, 414.
 Benedict, F. G., 66, 166, 266.
 Benedict, H. M., 634.
 Benjamin, C. H., 287.
 Benjamin, E. W., 872.
 Benner, J. W., 471, 688.
 Bennet, I. D., 741.
 Bennett, C. J., 481.
 Bennett, J. P., 99.
 Benson, A. H., 457.
 Benson, J. P., 683.
 Benson, O. H., 808.
 Bentley, M. R., 185, 892.
 Benton, A. H., 888.
 Berg, A., 447.
 Berger, E. W., 557.
 Bergh, O. I., 811, 814, 822,
 833, 839, 871, 876, 888.
 Bergin, J. J., 288.
 Bergman, E., 500.
 Bergman, H. F., 836.
 Bernard, C., 247, 818.
 Berthelot, 214.
 Bertoni, M. S., 418, 837.
 Bertrand, G., 157, 184.
 Berumen, D. O., 290.
 Berzelius, 214.
 Besredka, A., 473, 581.
 Bethel, E., 444.
 Betten, C., 100.
 Beumée-Nieuwland, N., 320.
 Bevan, L. E. W., 582, 780.
 Bevan, W., 795.
 Beveridge, W., 416.
 Bews, J. W., 326.
 Bey, L., 835.
 Beyer, O., 12.
 Bezssonof, N., 226, 524.
 Bezzi, M., 258.
 Bezzi, N., 56.
 Bianchi, A., 580.
 Bie, H. C. H. de, 296.
 Biers, P. M., 750.
 Biery, R., 97.
 Biester, A., 664.
 Biffen, R. H., 44, 45.
 Bigelow, Z. E., 495.
 Bigland, A. D., 863.
 Biles, G. H., 387.
 Birch, R. R., 683, 688, 787.
 Bishop, G. H., 857.
 Bischoff, F. C., 362.
 Bisson, C. S., 504.
 Bizzell, J. A., 215.
 Blaauw, A. H., 729.
 Black, E. J., 790.
 Black, J. D., 489.
 Blackfan, K. D., 769.
 Blacklock, B., 55.
 Blackman, M. W., 852.
 Blackman, V. H., 29.
 Blackwell, C. P., 126.
 Blair, A. W., 128, 218, 220,
 421, 627.
 Blair, E. C., 419, 816.
 Blair, R. E., 318, 329, 339,
 352, 376, 391, 392, 397.
 Blair, W. S., 438, 729, 771.
 Blake, 359.
 Blake, E. G., 478.
 Blake, S. F., 239, 241, 328.
 Blanchard, A. H., 85, 186.
 Blanchouin, J., 836.
 Black, E., 267, 823.
 Blanton, A. W., 598.
 Blaringhem, L., 632, 729.
 Blarleigh, W. S., 851.
 Bley, H., 277.
 Blish, M. J., 501, 770.
 Bliss, G. S., 16.
 Blizzard, W. L., 400.
 Bloch, E., 732.
 Blow, B., 889.
 Blume, [A.], 570.
 Boas, F., 523, 524, 525.
 Bobilloff, W., 659.
 Bodkin, G. E., 159.
 Boeger, E. A., 290.
 Boerner, E. G., 642.
 Bobstedt, G., 485, 774.
 Bokorny, T., 430.
 Bolin, P., 231.
 Bonquet, P. A., 247.
 Bond, B. W., jr., 694.
 Bond, C. J., 866.
 Bond, C. O., 734.
 Bonnet, L. O., 239.
 Bonnet, R. K., 699, 738.
 Bontrager, W. E., 342.
 Boorsma, W. G., 296, 795.
 Boquet, 383.
 Boquet, A., 583.
 Borden, A. D., 557.
 Boresch, K., 526.
 Borghesani, 728.
 Bornemann, F., 321.
 Boruttau, H., 526.
 Bos, J. R., 546, 547.
 Bose, J. C., 526.
 Bose, P. C., 293.
 Bosshart, J. K., 473.
 Bottner, J., 743.
 Bottomley, A. M., 156.
 Bottomley, W. B., 514.
 Boughton, T. H., 780.
 Boulnois, H. P., 481.
 Bouret, D., 838.
 Boutaric, A., 718.

- Boutwell, P. W., 367, 600.
 Bouyoucos, G., 600.
 Bovet, P. A., 830.
 Boving, A. G., 762, 854.
 Boving, P. A., 693.
 Boy, C., 878.
 Bowers, W. G., 314, 368, 413.
 Bowker, R. C., 892.
 Bowlby, H. L., 591.
 Bowles, E. A., 326.
 Boyd, F. D., 865.
 Boyle, J. E., 488.
 Bradford, M. C. C., 396.
 Bradley, A. B., 412.
 Bradt, S. E., 186.
 Branch, L. V., 89.
 Branch, M. E., 492.
 Brandenburg, F. H., 16.
 Brandes, E. W., 547, 848.
 Brandt, A. E., 100.
 Braun, A. F., 55.
 Braun, H., 844.
 Braunton, E., 451.
 Breakwell, E., 528.
 Breed, R. S., 433, 578, 680.
 Bregger, T., 100.
 Bremekamp, C. E. B., 132.
 Brereton, W. le G., 836.
 Bret, 342, 344.
 Brevi, B. E., 284.
 Brew, J. D., 681.
 Briant, J., 841.
 Bridges, 269.
 Bridges, C. B., 268.
 Bridwell, J. C., 661, 662.
 Brierley, W. G., 646.
 Briganti, G., 438.
 Briggs, G., 638.
 Bright, J. W., 200, 679.
 Brightman, C. L., 313.
 Brintnall, E. E., 99.
 Brist, F. W., 16.
 Brittain, W. H., 850.
 Brittlebank, C. C., 49, 152,
 154, 642.
 Britton, W. E., 250, 358.
 Brock, J. A., 26.
 Brock, W. S., 847.
 Brockmann-Jerosch, H., 840.
 Brocq-Rousseau, 157, 775.
 Brödermann, 570.
 Brodie, F. J., 621.
 Brodie, I., 240.
 Brody, S., 498.
 Bronfenbrenner, J., 113.
 Brooks, A. J., 689.
 Brooks, B. E., 299.
 Brooks, C. E. P., 620.
 Brooks, C. F., 119, 718, 719.
 Brooks, F. E., 760.
 Brooks, H. D., 799.
 Brooks, M. M., 820.
 Brooks, S. C., 780, 781.
 Brooks, W. P., 537.
 Broughton, T. H., 682.
 Brown, E., 437, 682.
 Brown, G. A., 698.
 Brown, G. G., 145.
 Brown, J. H., 581.
 Brown, L., 685.
 Brown, N. C., 242.
 Brown, P. E., 432.
 Brown, R. H., 535.
 Brown, W. G., 258.
 Brown, W. H., 149, 443, 841.
 Brown, W. R., 148, 552, 838.
 Brown, W. S., 659.
 Browne, L. McD., 366.
 Brownell, G. H., 178.
 Brownell, S. J., 698.
 Brownlie, T. A. M., 386.
 Broyles, W. A., 700.
 Bruce, D., 443.
 Bruce, E. A., 471.
 Bruce, J. L., 575.
 Bruce, W. F., 97.
 Bruhns, G., 314.
 Bruins, 384.
 Brumley, D. J., 236.
 Brumpt, E., 82, 83, 84, 883.
 Bruner, S. C., 448.
 Bruner, S. E., 780.
 Brünmfch, 51.
 Bruntz, L., 168.
 Bryan, W. E., 734.
 Buc, H. E., 116.
 Buchanan, G. H., 628.
 Buchholz, J. T., 133.
 Buck, F. S., 753.
 Buckman, H. O., 196.
 Buckner, G. D., 72, 431.
 Budington, R. A., 225.
 Bufflington, H. C., 88.
 Buie, T. S., 800.
 Bujard, E., 73.
 Bull, L. B., 585.
 Buller, A. H. R., 640.
 Burch, D. S., 464.
 Burchard, E. F., 282.
 Burger, O. F., 41, 656, 799.
 Burgess, C. H., 674.
 Burgess, J. L., 26, 325.
 Burgst, C. A. L. S. van, 259.
 Burke, G. S., 169.
 Burke, H. E., 57.
 Burkhardt, F., 51.
 Burkhart, F. L., 699.
 Burnam, A., 899.
 Burnett, 708.
 Burns, 462.
 Burns, D., 462.
 Burns, G. P., 840.
 Burns, J. C., 200.
 Burns, W., 564, 837.
 Büsgen, M., 750.
 Bushnell, J. W., 399.
 Bushnell, L. D., 682.
 Bushnell, T. M., 281.
 Buss, W. J., 700.
 Buster, S., 123.
 Butcher, J. W., 491.
 Butler, A. M., 495.
 Butler, E. J., 652.
 Butler, O., 842.
 Butler, O. M., 41.
 Butler, O. R., 23, 34, 44.
 Butt, C. A., 13.
 Butt, N. I., 822.
 Butterfield, K. L., 499.
 Butts, S. M., 798.
 Byall, S., 433.
 Byars, L. P., 751.
 Byfield, A. H., 460.
 Bynum, E. K., 162.
 Byrne, A. T., 481.
 Caesar, L., 662.
 Caffrey, D. J., 661.
 Cahill, E. A., 780.
 Caillas, A., 314.
 Cain, G. D., 630, 635, 673.
 Cain, J. C., 409.
 Caird, E., 316.
 Calcar, R. P. van, 868.
 Calderwood, H. N., jr., 717.
 Caldieri, S., 281.
 Caldwell, D. W., 674.
 Call, L. E., 176.
 Callahan, J., 797.
 Callarman, C. W., 192.
 Calvin, J. W., 498.
 Camacho, C., 350.
 Camp, W. R., 294, 490.
 Campbell, C. H., 616.
 Campbell, H. C., 889.
 Campbell, J. A., 65.
 Campbell, R. H., 542.
 Campbell, W., 865.
 Campos Penteado, M. de, 68.
 Campos Porto, P., 40.
 Camuñas, M., 291.
 Canaby, E., 685.
 Cannon, H. G., 256.
 Cannon, P. R., 275.
 Capper, A., 91.
 Capus, J., 652, 657.
 Card, D. G., 497.
 Card, F. W., 643.
 Cardinell, H. A., 643.
 Carhart, A. H., 442.
 Carlson, A. J., 568.
 Carmichael, W. J., 571.
 Carmick, L. G., 690.
 Carmody, 93.
 Caro, N., 426, 519.
 Carpenter, C. M., 183, 683.
 Carpenter, E. J., 512.
 Carpenter, R. W., 700.
 Carr, 67.
 Carr, H. A., 66.
 Carr, R. H., 419, 875.
 Carrier, L., 233.
 Carroll, M., 162.
 Carroll, W. E., 180.
 Carsner, E., 752.
 Carter, H. F., 55.
 Carter, W. T., jr., 281.
 Caselli, E. P., 587.

- Casler, E. T., 187, 790.
 Caspari, 860.
 Cassidy, T. P., 856.
 Castella, F. de, 155.
 Castle, C. V., 99.
 Castle, W. E., 268.
 Cathcart, C. S., 37, 69, 129,
 326, 671.
 Cation, J. G., 495.
 Catlin, C. N., 724, 764, 789.
 Catrain, F., 17.
 Cauda, A., 721.
 Caudell, A. N., 556.
 Cauthen, E. F., 135, 233, 333.
 Cavett, C. E., 596.
 Cayla, V., 344.
 Caziot, P., 94, 487.
 Cecil, R., 793.
 Chace, E. M., 837.
 Chagas, C., 182.
 Chamberlain, W. I., 398.
 Chambers, C. O., 44.
 Chambers, E. L., 362.
 Chambliss, C. E., 139.
 Champlain, A. B., 854.
 Champlin, M., 235.
 Chancerel, L., 651.
 Chandler, B. A., 42.
 Chandler, E. L., 589.
 Chandler, S. C., 558.
 Chandler, W. H., 299, 644,
 708, 800.
 Chapin, R. M., 614.
 Chapman, E. H., 208.
 Chapman, G. H., 830, 845,
 849.
 Chapman, P. W., 497.
 Charles, T. B., 100, 200.
 Charters, 705.
 Charters, W. W., 705.
 Chase, A., 522.
 Chase, W. W., 238.
 Chassignol, F., 753.
 Chen, C. C., 299, 791.
 Cheplin, H. A., 769.
 Chestnut, V. K., 711.
 Chick, H., 461.
 Chidester, F. E., 162.
 Childs, L., 660.
 Ching, K. A., 398.
 Chittenden, A. K., 649.
 Chittenden, F. H., 159, 455,
 854.
 Chittenden, F. J., 31, 237.
 Chivers, A. H., 848.
 Christensen, A. M., 398.
 Christensen, F. W., 527.
 Christensen, H., 631.
 Christensen, H. R., 630.
 Christie, A. W., 504, 715.
 Christie, G. I., 198.
 Christie, W., 234.
 Christman, W. F., 240.
 Chudeau, R., 194.
 Church, L. M., 193.
 Churchill, J. B., 892.
 Ciamician, G., 632, 822.
 Cirotteau, H., 573.
 Clapp, S. C., 816.
 Clark, A. B., 112.
 Clark, A. L., 836.
 Clark, E. D., 858.
 Clark, J. A., 771.
 Clark, J. E., 17.
 Clark, W. B., 656, 846.
 Clark, W. D., 497.
 Clark, W. G., 89.
 Clark, W. S., 239.
 Clarke, A. M., 700.
 Clarke, F. W., 419.
 Claughton-Wallin, H., 149.
 Clausmann, P., 523.
 Clawson, A. B., 77, 470.
 Clayberg, H. D., 523.
 Clayton, H. H., 120.
 Cleare, L. D., 159.
 Cleare, L. D., jr., 850.
 Cleghorne, W. S. H., 591.
 Clement, C. E., 682.
 Clemmons, W. H., 596.
 Clercq, C. de, 868.
 Clifford, J. M., 299.
 Cline, I. M., 16, 511.
 Clinton, G. P., 249.
 Clowes, E. S., 511.
 Coad, B. R., 856.
 Cobb, N. A., 449.
 Cobbs, J. L., jr., 442.
 Cockayne, A. H., 244.
 Cockle, W., 558.
 Coe, H. S., 640.
 Coffin, G. P., 676.
 Cohn, A. E., 879.
 Cohn, E., 265.
 Coit, J. E., 198.
 Cole, L. J., 672, 771.
 Colebatch, W. J., 527.
 Coleman, G. P., 387, 890.
 Coleman, L. C., 745.
 Collings, G. H., 126.
 Collins, B. L., 468.
 Collins, E. V., 89.
 Collins, G. N., 529.
 Collins, G. W., 865.
 Collins, R. G., 186.
 Collins, S. H., 671.
 Collison, L. G., 399.
 Collison, S. E., 342.
 Colman, H. N., 100, 400.
 Colvin, C., 698.
 Colvin, F. H., 89.
 Combs, S., 678.
 Cominotti, L., 582.
 Compain, L., 292.
 Compton, W., 343.
 Comstock, A. B., 397.
 Comstock, J. H., 850.
 Conacher, H. M., 594.
 Condit, I. J., 238, 246, 439,
 836.
 Conn, G. H., 278.
 Conn, H. J., 399, 433, 681.
 Connaaway, J. W., 784.
 Conner, S. D., 27, 115, 325.
 Connors, C. H., 359, 540.
 Conradi, C. G., 484.
 Cook, F. C., 843.
 Cook, M. T., 531.
 Cook, M. W., 381.
 Cook, O. F., 446.
 Cook, W. C., 55.
 Cook, W. M., 398.
 Coledge, L. H., 503, 615, 681.
 Cooley, R. A., 758.
 Cooley, R. B., 497.
 Coombs, H., 366.
 Coons, G. H., 698.
 Cooper, H. P., 700.
 Cooper, T. P., 800.
 Coote, H. G., 48.
 Cooter, J. E., 512.
 Copeman, S. M., 670.
 Corbett, L. C., 642.
 Cordley, A. B., 100, 800.
 Corfield, C. E., 316.
 Corner, H., 777.
 Corning, P., 200.
 Cornman, C. T., 174.
 Cornthwaite, H. G., 120, 718.
 Cortesi, F., 41.
 Cory, E. N., 158, 559.
 Cory, H. T., 123.
 Coryell, J., 299.
 Cosby, H. E., 100.
 Cossette, R., 752.
 Cotte, J., 754.
 Cotterman, H. F., 705.
 Cottrell, F. C., 99.
 Couch, J. F., 470.
 Coupan, G., 289.
 Coupin, H., 526, 730.
 Courmont, P., 791.
 Cousins, H. H., 48.
 Cowie, G. A., 628.
 Cox, A. B., 291.
 Cox, J., 798.
 Cox, J. F., 639, 698.
 Coyajee, J. C., 294.
 Coye, J. S., 283.
 Crabb, R. W., 99.
 Craig, J. A., 697.
 Craighead, F. C., 560.
 Cramer, P. J. S., 838.
 Crandall, C. S., 645.
 Crawford, D. L., 450.
 Crawford, W. H., 191.
 Crawley, 786.
 Creelman, G. C., 400.
 Crespo, M. A., 57.
 Cretcher, W., 100.
 Crews, W. F., 272.
 Cribbs, J. E., 223.
 Crider, F. J., 733, 740.
 Cromer, C. O., 198, 234.
 Crosby, D. J., 799.
 Cross, F. B., 200.
 Cross, H. E., 584.

- Crosthwaite, H. R., 192.
 Crosthwaite, P. M., 889.
 Crow, J. W., 235, 404, 535.
 Crowley, J. F., 285.
 Cruess, W. V., 316, 715, 717, 808.
 Crumley, J. J., 391.
 Cubitt, E., 542.
 Cugini, A., 383.
 Cullen, G. E., 205.
 Cumming, J. G., 81, 261.
 Cumming, M., 403, 404.
 Cummings, A. L. T., 300.
 Cunningham, A. R., 471.
 Cunningham, G. C., 552, 772, 775, 777.
 Currier, E. L., 35.
 Curry, B. E., 28.
 Curtis, H. E., 28.
 Curtis, R. H., 207.
 Curtis, R. S., 494.
 Cushman, R. A., 60, 857, 858.
 Cusick, J. T., 469.
 Cuthbertson, W., 441.
 Czapek, F., 524.
 Daane, A., 137.
 Dacy, G. H., 877.
 Dadant, M. G., 57.
 Dadisman, A. J., 92.
 Dahlberg, A. O., 779.
 Dakin, H. D., 111.
 Dalling, T., 472.
 D'Alviella, F. E. G., 343.
 da Matta, A., 57.
 Dammerman, K. W., 456.
 Damon, S. C., 643.
 Dana, B. F., 242.
 Dani, P. G., 837.
 Daniel, L., 523, 818.
 Daniels, A. L., 460, 764.
 Daniels, A. M., 486.
 Dantony, 544, 550.
 Darling, S. T., 854.
 Darlington, P. S., 558.
 Darmstadt, W. E., 76.
 Darnell, A. L., 299, 497.
 Darrow, G. M., 439.
 Darwent, H. J., 155.
 Dassonville, 184, 157.
 Datt Joshi, S., 241.
 Daudt, H. W., 116.
 Davenport, A., 411.
 Davenport, E., 705.
 Davey, D. R., 201.
 Davidson, W. M., 660.
 Davies, G. W., 598.
 Davis, A. P., 85.
 Davis, B., 697.
 Davis, H. P., 378.
 Davis, I. W., 251.
 Davis, J. J., 362, 558, 799.
 Davis, K. C., 40.
 Davis, M. B., 438, 540.
 Davis, M. D., 209.
 Davis, P. A., 878.
 Davis, R. A., 148.
 Davis, R. O. E., 220, 426.
 Davison, B., 198.
 Dawson, J. R., 100, 299.
 Day, J. W., 492, 527.
 Dean, E. W., 187, 389.
 Dean, G. A., 354.
 Dean, W. C., 512.
 Dearborn, N., 365, 378, 449.
 Deardorff, C. R., 174.
 Dearstyne, R. S., 680.
 De Baum, R. W., 140.
 de Bie, H. C. H., 296.
 De Bord, G. G., 168.
 de Campos Penteado, M., 68.
 de Castella, F., 155.
 Decker, G. De., 463.
 Decker, W. L., 479.
 de Clercq, G., 868.
 De Decker, G., 463.
 Deemer, R. B., 312.
 de Flon, L., 399.
 de Fonteny, P. B., 442.
 Defren, G., 366.
 de Gallelli, E. L., 820.
 Degrully, L., 40.
 D'Herelle, F., 84.
 de Jong, A. W. K., 43.
 de Koning, A., 296.
 de la Lance, G. R. M., 173.
 de La Pommeraye, 342.
 de Laroquette, M., 819.
 de Lavalley, J. A., 720.
 Delf, E. M., 567.
 Delmer, A., 184.
 De Long, D. M., 352.
 Delos, A., 292.
 de Magalhães, M. F., 476.
 Demolon, A., 212.
 Dempster, W., 74.
 Dendý, A., 253, 254.
 Denigès, G., 803.
 Dennis, L. M., 12.
 Densch, 20.
 Densmore, H. D., 818.
 Derrick, W. W., 700.
 Derschau, M. von, 524.
 Descombes, P., 16.
 de Seabra, A. F., 452.
 Desmoulins, A., 745.
 de Soroa, J. M., 423.
 de Sousa Reis, F. T., 396.
 Desvergnès, L., 804.
 Detjen, L. R., 198, 438.
 Detlefsen, J. A., 669.
 Detwiler, S. B., 248.
 Deuel, H. J., 365.
 De Vault, S. H., 141.
 Devenis, M. M., 371.
 de Vries, H., 222, 521, 729.
 De' Warren, E., 292.
 Dey, P. K., 46.
 Dichtl, G., 274.
 Dick, G. F., 227.
 Dickerson, E. L., 556.
 Dickinson, H. C., 890.
 Dickinson, S., 699.
 Dickson, B. T., 444.
 Dickson, E. C., 169.
 Dickson, J. G., 545.
 di Domizio, G., 83.
 Diels, L., 204, 732.
 Dienes, L., 204.
 Diffloth, P., 438.
 Digges, D. D., 336.
 Dille, A., 100, 492.
 Dixon, H. M., 692, 792.
 Dixon, J., 250.
 Dixon, S. G., 274.
 Dodd, S., 184, 380.
 Dodd, W. L., 458.
 Dodge, F. W., 76.
 Dodson, W. R., 698.
 Dofein, F., 659.
 Doidge, E. M., 153, 156, 444.
 Dominguez, F. A. L., 727.
 Dominguez, J. A., 820.
 Domizio, G. D., 83.
 Doncaster, L., 256.
 Donovan, J. T., 177.
 Doolittle, S. P., 654.
 Doran, W. L., 841.
 Dore, W. H., 506.
 Dornis, 683.
 Dorno, C., 117, 119, 719.
 Dorph-Petersen, K., 35.
 Dorrance, J. G., 651.
 Dorris, G. A., 746.
 Dorsey, M. J., 539.
 Dougherty, P. I., 576, 876.
 Douglas, C., 176.
 Douglass, A. E., 809.
 Dowell, A. A., 870.
 Dowell, C. T., 68, 137.
 Dowell, S., 99.
 Downes, J. R., 221.
 Dowson, W. J., 247.
 Dex, A. W., 99, 203, 501, 610.
 Doyle, L. P., 586, 884.
 Drager, W. L., 589.
 Draisbach, F., 519.
 Drake, E. F., 279.
 Drechsler, C., 751.
 Dreyer, J., 623.
 Driftmier, R. H., 699.
 Droandi, I., 870.
 Drude, O., 731.
 Dubosc, A., 344.
 Ducellier, L., 831.
 Duddleston, B. H., 135.
 Duerden, J. E., 776.
 Duffey, E., 890.
 Duffing, G., 891.
 Dufrénoy, J., 552.
 Duggar, J. F., 98.
 Duke, A. N., 349.
 Duke, S. P., 597.
 Duley, F. L., 124, 721, 722.
 Dungan, G. H., 844.
 Dunham, G. C., 782.
 Dunn, J. E., 719.
 Dunn, R., 774.

- Dunnewald, T. J., 622.
 Dunoyer, L., 319.
 DuPorte, E. M., 842.
 Dupuy, O., 344.
 Durant, A. J., 784.
 Durrell, L. W., 653.
 Durst, C. E., 643.
 Dutcher, R. A., 664.
 du Toit, P. J., 883.
 Dutrieux, O., 414.
 Dyar, H. G., 258.
 Dyer, C. L., 440.
 Dynes, O. W., 900.
- Earle, F. S., 47, 548.
 Easlea, W., 247.
 East, E. M., 693.
 Eaton, T. H., 900.
 Eberhard, 840.
 Eberwine, J. G., 200.
 Eckenbrecher, C. von, 829.
 Eckles, C. H., 73, 176, 876.
 Eddy, H. T., 183.
 Edgerton, C. W., 348.
 Edlbacher, S., 504.
 Edlefsen, N. E., 743.
 Edmiston, H. D., 116, 511.
 Edmond, H. D., 120.
 Edmondson, J. H., 791.
 Edmondson, R. B., 168.
 Edmunds, E., 532.
 Edson, H. A., 732.
 Edwardes, V. P., 650.
 Edwards, E. G., 689.
 Edwards, H., 703, 800.
 Eggleston, W. W., 470.
 Eglene, L., 617.
 Ehle, H. N., 500.
 Ehrenberg, P., 513.
 Ehrlich, W., 486.
 Eichholz-Darmstadt, W., 76.
 Eichhorn, A., 780.
 Eldred, W., 895.
 Eldredge, I. F., 42.
 Elford, F. C., 776.
 Eliason, O. H., 683.
 Elkington, H. D., 253, 254.
 Ellenberger, H. B., 178.
 Ellenwood, C. W., 341.
 Ellett, W. B., 874.
 Elliott, C., 545.
 Elliott, C. G., 280.
 Elliott, F. A., 747.
 Elliott, N. R., 339.
 Ellis, N. R., 766.
 Elsdon, G. D., 201.
 Elwell, G. B., 298.
 Ely, R. T., 793.
 Embleton, H., 73.
 Emerson, F. V., 719.
 Emerson, F. W., 731.
 Emerson, H. W., 865.
 Emerson, W. R. P., 167.
 Emmett, A. D., 860.
 Emrys-Roberts, E., 684.
 Englund, E., 75.
- Enlows, E. M. A., 245.
 Enright, J. I., 66, 864.
 Ensign, M. R., 133.
 Eppley, G., 299.
 Epstein, A., 523.
 Eriksson, J., 547, 731.
 Ernest, L. B., 473.
 Ernle, 894.
 Esam, G., 39.
 Eskstein, 51.
 Espe, K., 122.
 Espino, R. B., 441.
 Essig, E. O., 255, 256, 699.
 Etheridge, W. C., 735.
 Evans, A. C., 779.
 Evans, A. T., 700.
 Evans, J. A., 240, 746.
 Evans, M., 599.
 Evans, R. J., 71.
 Evvard, J. M., 71, 774.
 Ewart, A. J., 202, 847.
 Ewing, C. L., 680.
 Ewing, H. B., 60.
 Eyck, P. G. T., 200.
- Faber, H., 177.
 Fabry, P., 581.
 Fabyan, M., 885.
 Fahrenheit, H., 51.
 Fahrion, W., 201.
 Fairbank, J. P., 400.
 Fairfield, W. H., 772, 773.
 Falck, K., 437.
 Falconer, J. I., 486.
 Falk, K. G., 414.
 Faragó, D., 393.
 Fareham (Lord Lee of), 493.
 Farrell, F. D., 708.
 Farrell, J., 155.
 Farrington, E. H., 682.
 Farrington, H., 287.
 Farrington, H. A., 651.
 Fassio, G. A., 500.
 Fatout, P. L., 700.
 Fauconnier, H., 344.
 Fawcett, H. S., 156.
 Fawtier, 342.
 Fearon, W. A., 316.
 Feigl, J., 266, 463.
 Feilitzen, H. von, 423, 631.
 Fellers, C. R., 217.
 Felt, E. P., 162, 661.
 Fenton, F. A., 356.
 Ferdinandsen, C., 750.
 Fergus, E. N., 325.
 Ferguson, A. R., 865.
 Ferguson, T. H., 82.
 Fergusson, S. P., 718.
 Fernald, H. T., 359.
 Ferris, G. F., 452, 851.
 Fetzer, D. C., 799.
 Feusier, M. L., 879.
 Finch, J. K., 887.
 Finch, M. W., 200.
 Fingerling, G., 267.
 Finks, A. J., 763.
- Fippin, E. O., 428, 519, 729.
 Firor, J. W., 741.
 Fischer, A. F., 841.
 Fischer, E., 841.
 Fischer, G., 188.
 Fischer, H., 432, 629, 728.
 Fisher, D. F., 549.
 Fisher, R. C., 767.
 Fisher, R. T., 149.
 Fisher, W. H., 482.
 Fisher, W. S., 57.
 Fiske, G. B., 490.
 Fiske, J. G., 141.
 Fitch, C. P., 82.
 Fitch, J. B., 176, 576, 677, 682.
 Fitch, W. E., 261.
 Fitz, R., 370.
 Fitzpatrick, W. W., 800.
 Fixmer, H. J., 284.
 Flack, G. L., 870.
 Flahault, C., 746.
 Flammarton, C., 17.
 Fleming, C. E., 77, 273.
 Fletcher, A. B., 186.
 Fletcher, C. C., 428.
 Fletcher, S. W., 643.
 Flint, L. H., 428, 437, 464.
 Flint, W. P., 353, 661.
 Flöhil, J. T., 802.
 Flood, M. G., 633.
 Flon, L. de, 399.
 Flora, S. D., 511, 718.
 Flossfeder, F. C. H., 715.
 Flu, P. C., 278.
 Fluke, C. L., jr., 257.
 Foex, E., 750, 751, 753, 754.
 Fogle, F. E., 691.
 Fohrman, M. H., 399.
 Folsom, D., 546.
 Fontana, I. R., 320.
 Fonteny, P. B. de, 442.
 Foot, K., 160.
 Foote, H. E., 220.
 Forbes, E. B., 700.
 Foreman, F. W., 202.
 Forhman, M. H., 770.
 Forkner, J. G., 261.
 Forman, L. W., 21.
 Forsberg, L., 623.
 Forster, G. W., 899.
 Fortier, V., 873.
 Foster, L., 777.
 Foster, W. A., 485.
 Foster, W. D., 275.
 Fouassier, M., 206.
 Foulerton, A. G. R., 883.
 Foulkes, T. R., 495.
 Foust, J., 622.
 Fouts, R. M., 259.
 Fowlds, M., 235.
 Fox, D. S., 100, 498, 599.
 Fox, F. W., 64.
 Francis, E. H., 799.
 Francis, H. R., 543.
 Frandsen, J. H., 899.

- Frank, A., 155, 349, 496.
 Frank, L. C., 189.
 Fränkel, S., 609.
 Franklin, H. J., 15, 119, 146,
 155, 158.
 Franklin, O. M., 382.
 Fraps, G. S., 724.
 Fraser, A., 85.
 Fraser, E. S., 187.
 Frear, W., 116, 511, 520, 533.
 Fred, E. B., 411, 422, 610.
 Frederick, W. J., 848.
 Freeborn, S. B., 699.
 Friedemann, W. G., 68.
 Friedenthal, H., 78.
 Friederichs, K., 51, 858.
 Friedrichs, F., 112.
 Fries, J. A., 170, 372.
 Fritsche, E., 853.
 Frödin, J., 430.
 Froggatt, W. W., 456.
 Frohawk, F. W., 659.
 Fröhmer, E., 585.
 Fronzi, L., 281.
 Frudden, C. E., 288.
 Fruwirth, C., 234, 528.
 Fry, W. H., 624.
 Fujikawa, K., 568.
 Fullaway, D. T., 455.
 Fuller, A. V., 611.
 Fulton, H. R., 551.
 Fulton, R. R., 550.
 Funaro, A., 458.
 Funk, S. W., 837.
 Funk, W. C., 691.
 Fürth, O., 264, 368.
 Fyles, F., 335, 380.

 Gäbel, K., 94.
 Gabotto, L., 347.
 Gaddis, P. L., 498.
 Gaban, A. B., 363.
 Gaillard, D. P., 425, 426.
 Gaines, E. F., 400.
 Galant, S., 328.
 Gale, H. S., 728.
 Galippe, V., 822.
 Gallard, L., 563.
 Gallelli, E. L. de, 820.
 Gallenkamp, W., 16.
 Galloway, B. T., 444.
 Galpin, C. J., 595, 598, 793.
 Gamble, J. L., 769.
 Garber, R. J., 497.
 Garbett, C. C., 831.
 Garbutt, P., 458.
 Garby, C. D., 563.
 Gardiner, H. C., 91.
 Gardner, J. A., 64.
 Gardner, M. W., 751.
 Gardner, V. R., 146, 536.
 Gardner, W., 210, 812.
 Gariboldi, G., 480.
 Garman, H., 359.
 Garrett, C. C., 16.
 Garrett, P. W., 394.

 Gaté, J., 584.
 Gatenby, J. B., 457.
 Gates, F. L., 274.
 Gaudot, G., 532.
 Gault, H. J., 889.
 Gäumann, E., 247, 653.
 Gautier, A., 523.
 Gautier, C., 858.
 Gay, C. W., 399.
 Geerligs, H. C. P., 509.
 Gegenbauer, V., 180.
 Geib, W. J., 123.
 Geilmann, 424.
 Geise, F. W., 600.
 George, D. C., 547, 652.
 Gerlach, 423.
 Gerlaugh, P., 569, 570, 572.
 Gersdorff, C. E. F., 240.
 Gethler, A. O., 614.
 Ghosh, D. N., 492.
 Gibbs, H. D., 14, 712.
 Gibbs, W. M., 216.
 Gibson, A., 354.
 Giddings, N. J., 447.
 Gide, C., 292.
 Gierisch, W., 670.
 Giese, 786.
 Gilbert, 371.
 Gilbert, C. G., 323.
 Gilbert, H. C., 546.
 Gilbert, W. W., 654.
 Gilchrist, D. A., 814.
 Gilg, E., 204.
 Gill, W., 42.
 Gillespie, L. J., 11, 211, 421.
 Gillespie, W. C., 538, 554.
 Gjillett, D. C., 550.
 Gillett, L., 366.
 Gillette, C. P., 157, 161.
 Gillette, H. P., 589.
 Gilman, J. C., 150.
 Gilmour, G. V. B., 315.
 Giltner, W., 82, 182.
 Ginstous, G., 18.
 Gini, C., 500.
 Girard, 342.
 Girard, A., 192.
 Girola, C. D., 436, 437, 745,
 746.
 Girousse, 625.
 Gissing, F. T., 129.
 Giua, M., 24, 428.
 Given, G. C., 515.
 Givens, M. H., 765.
 Gladish, N. G., 196.
 Gladwin, F. E., 341.
 Glazebrook, O. A., 120.
 Gleason, H. A., 223.
 Glenn, P. A., 356.
 Gnadinger, C. B., 115.
 Gockel, A., 225.
 Goddard, H. N., 797.
 Godfrey, G. H., 849.
 Goedewaagen, M. A. J., 223,
 818.
 Goergens, G. R., 698.

 Goerrig, E., 633.
 Goetz, A. C., 802.
 Goffon, R., 416.
 Gokhale, V. G., 52, 185, 808.
 Gold, E., 17.
 Goldberg, S. A., 683.
 Goldberger, J., 264, 863.
 Goldman, E. A., 849.
 Gómez, M. T., 487.
 Gongwer, R. E., 699.
 Gonnermann, M., 202.
 Good, E. S., 373.
 Goodacre, W. A., 259.
 Gooderham, C. B., 662.
 Goodkind, M., 186.
 Goodman, J. W., 246.
 Goodrich, R. D., 477.
 Goodspeed, H. C., 598, 695.
 Good-Adams, H. E. F., 218.
 Goot, P. van der, 452.
 Gorbea, 488.
 Gordon, L. S., 74, 94, 594,
 694.
 Gorham, A. C., 796.
 Gortner, R. A., 12, 110, 111,
 373.
 Goss, L. W., 584.
 Goss, R. W., 199.
 Gossard, H. A., 340, 758.
 Gottlich, S., 120.
 Gough, G. C., 635.
 Gough, L. H., 160.
 Gould, H. P., 438.
 Gourley, J. H., 36, 498.
 Gowen, J. W., 174, 175, 645,
 676, 677.
 Grace, L. G., 381, 383.
 Graebner, P., 204.
 Gräfe, F., 181.
 Graham, R., 580.
 Graham, W. G., 93.
 Grainger, M. A., 747.
 Granström, A., 231.
 Grant, G., 398.
 Grantham, G. M., 622.
 Graves, R. R., 378.
 Gray, D., 599.
 Gray, D. T., 465, 467, 469.
 Gray, E. R., 398.
 Gray, F. J., 900.
 Gray, G., 197.
 Gray, J., 131.
 Gray, L. C., 893.
 Gray, R. B., 699.
 Graybill, H. B., 441.
 Graybill, H. W., 475, 586.
 Greaves, J. E., 311.
 Greeley, S. A., 479.
 Green, F. E., 93.
 Green, J. B., 900.
 Green, W. J., 397, 744.
 Green, R. M., 190, 389, 599,
 792, 793.
 Green, R. W., 300.
 Greene, J. H., 396, 695.
 Greene, L., 337.

- Greene, T. W., 789.
Greenfield, W. P., 651.
Greenwood, H. C., 627.
Gregg, W. R., 118, 119, 718.
Gregory, C. T., 752.
Gregory, H. W., 398, 805.
Gregory, J. W., 810.
Grellsammer, R., 289.
Greville, R. P., 43.
Grier, T. C., 236.
Griessen, A. E. P., 150.
Grieve, J. W. A., 543.
Grieve, (Mrs.) M., 344.
Griffee, F., 599.
Griffith, A. S., 686.
Griffith, J. P., 600.
Griffiths, D., 35, 222.
Grimes, J. C., 899.
Grimes, M. F., 572.
Grisdale, J. H., 734, 750, 754, 795.
Grose, L. R., 497.
Gross, F. P., Jr., 400.
Grounds, G. L., 422.
Grove, O., 807.
Groves, H. L., 289.
Grün, A., 112.
Grunsky, C. E., 209.
Guba, E. F., 658.
Guillaume, A., 271.
Guillebaud, W. H., 748.
Guinier, F., 755.
Guldin, P. R., 200.
Gullickson, T. W., 399.
Gunter, B. T., 260.
Gurjar, A. M., 430.
Gurlitt, L., 523.
Gurney, E. H., 24.
Gurney-Dixon, S., 274.
Gustafson, F. G., 820.
Gutheim, A. G., 186.
Guthrie, J. D., 442.
- Haag, J. R., 299.
Haas, A. R. C., 422.
Haber, V. R., 398.
Hackedorn, H., 772, 870.
Haddad, M. N., 838.
Hadley, C. H., 362, 851.
Hadley, F. B., 76, 82, 683, 797.
Hadley, P., 674, 700.
Hadlington, J., 674.
Hadwen, S., 55, 471.
Hagan, W. A., 183, 384, 473.
Hager, G., 413.
Haglund, E., 878.
Hahn, G. G., 846.
Haigh, L. D., 129.
Haines, F. M., 32.
Haldane, J. B. S., 268.
Hall, A. D., 570, 621, 694.
Hall, C. C. J. van, 45.
Hall, E. C., 719.
Hall, L. D., 464.
Hall, M. C., 381, 683.
- Hall, M. L., 899.
Hall, R. C., 442.
Hallenbeck, C., 16, 118, 119.
Halliburton, W. D., 365, 367.
Halligan, C. P., 649.
Halversen, W. V., 432.
Halverson, J. O., 399.
Hamilton, C. C., 299.
Hammer, B. W., 76.
Hammer, E. W., 75.
Hammett, F. S., 264.
Hammond, J. W., 700.
Hammond, R. L., 497.
Hampel, H., 126.
Handschin, W. F., 692, 800.
Hankins, O. G., 299.
Hanna, F. W., 123.
Hannas, R. R., 173, 575.
Hanning, W. L., 878.
Hansen, A. A., 832.
Hansen, D., 418, 435, 451, 465, 468.
Hansen, H. B., 810.
Hansen, J., 23.
Hansen, T. S., 399.
Hanson, E. O., 398.
Hanson, H. H., 100.
Hansson, N., 871.
Hanzlik, P. J., 804.
Harcourt, 95.
Harde, E., 580.
Harden, A., 460, 461, 462.
Hardenberg, J. G., Jr., 881.
Harding, H. A., 579, 778.
Hardy, G., 295.
Hardy, J. I., 172, 571.
Haring, C. M., 99.
Harlan, H. V., 826.
Harloff, W. H. T., 509.
Harms, H., 204.
Harney, T. R., 424.
Harper, J. N., 727.
Harper, R. A., 132.
Harrell, D., 464.
Harreveld, P. van, 548.
Harris, E. G., 481.
Harris, F. S., 218, 230, 708, 800, 822.
Harris, J. A., 526.
Harris, J. B., 714.
Harris, R. H., 668.
Harris, W. J., 497, 899.
Harrison, F. C., 404.
Harrison, J. B., 532.
Harrison, W. T., 850.
Harry, S. G., 351.
Hart, E. B., 270, 766.
Hart, G., 817.
Hart, G. H., 84.
Hart, H., 597.
Hart, J. C., 499.
Harter, L. L., 752.
Hartert, E., 50.
Hartley, C., 846.
Hartman, C. M. A., 811.
Hartnack, 580.
- Hartwell, B. L., 643.
Hartzell, F. Z., 354.
Harvey, A., 317.
Harvey, E. J., 59.
Harvey, E. M., 505.
Harvey, F. H., 674.
Harvey, R. B., 11, 750.
Hasche, R. L., 505.
Hase, A., 852.
Haselhoff, E., 428.
Haseman, L., 160, 757, 758, 759.
Haskell, R. J., 447.
Haslam, T. P., 382, 884.
Hastings, C. S., 718.
Haswell, J. R., 478.
Hatt, G., 172.
Hatton, R. G., 238, 438.
Haughwout, F. G., 472.
Hauser, A., 580.
Havelock, W. B., 43.
Havner, H. H., 572.
Haw, J. W., 900.
Hawes, A. F., 345.
Hawker, H. W., 209.
Hawkins, L. A., 39, 892.
Hawkins, L. S., 706.
Hawley, L. F., 409, 717.
Hay, W. W., 892.
Hayden, A., 130.
Hayes, F. A., 209.
Hayes, W. P., 760, 763.
Hays, F. A., 577.
Hayter, E. S., 672.
Haywood, A. H., 532.
Hazelwood, J. A., 387.
Hazen, A., 280.
Headden, W. P., 216.
Headlee, T. J., 162, 357, 532.
Headley, F. B., 418, 420, 435, 437, 814.
Heald, F. D., 749.
Healy, J. S., 683.
Hearn, W. E., 419.
Heath, B. M., 400.
Hedman, E., 398.
Hedrick, W. O., 178.
Heetson, W. T., 180.
Hehir, P., 262.
Heide, R. von der, 500.
Heinicke, A. J., 539.
Heinrich, 661.
Heinrich, C., 853.
Heise, G. W., 220.
Helland, Hansen B., 810.
Helm, C. A., 735.
Helwig, L., 638.
Hémen, C., 803.
Henderson, E. B., 695.
Henderson, G. S., 624.
Henderson, H. O., 577.
Henderson, W. M., 482.
Henderson, W. W., 499.
Hendrickson, A. H., 541.
Hendrickson, B. H., 123.
Hendrix, R. B., 16.

- Henke, L. A., 70, 71, 73.
 Henkel, J. S., 42, 840.
 Henley, F. R., 502.
 Henry, H., 881.
 Henry, Y., 344.
 Hensel, M. W., 532.
 Hepner, F. E., 120.
 Herbert, D. A., 243.
 Herbert, F. B., 452.
 Herdman, F. V., 287.
 Heribert-Nilsson, N., 500.
 Herms, W. B., 699.
 Hernandez, A., 294.
 Herrick, G. W., 455, 659.
 Herrmann, F., 437.
 Herter, W., 14.
 Hesler, L. R., 900.
 Hess, A. F., 369.
 Hess, W. N., 855.
 Hesselman, H., 755.
 Heuser, W., 328.
 Hewes, L. L., 790.
 Hewett, L., 342.
 Hewitt, C. G., 449.
 Heywood, A. D., 201.
 Hibbard, R. P., 639.
 Hickinbottom, W. J., 502.
 Hicks, W. B., 26.
 Higgins, B. B., 146.
 Higgins, J. E., 398.
 Highberger, F., 381, 383.
 Hildt, E., 14, 114, 505.
 Hildt, M., 615.
 Hill, C. E., 736.
 Hill, G. F., 349, 883.
 Hill, H. H., 400.
 Hill, H. S., 96.
 Hill, J. E., 695.
 Hill, T. G., 223.
 Hills, J. L., 395, 428, 437,
 464, 703, 800.
 Hills, T. L., 514.
 Himer, F. C., 368.
 Hime-Shinkui, N., 456.
 Hinds, W. E., 55, 57, 561.
 Hines, C. W., 330.
 Hines, E. N., 481.
 Hinman, R. B., 299.
 Hinton, M. A. C., 250.
 Hirschfeld, 685.
 Hirst, A. R., 186.
 Hirst, C. T., 311.
 Hirst, S., 80.
 Hitchcock, A. S., 522, 729.
 Hoagland, D. R., 224.
 Hobbs, C. M., 237.
 Hodgkiss, H. E., 354.
 Hodsoil, H. E. P., 209.
 Hodson, E. A., 436, 530, 531,
 739.
 Hoelt, G., 299.
 Hoerner, G. R., 653.
 Hoffecker, E., 719.
 Hoffer, G. N., 34.
 Hoffman, H. A., 385.
 Hoffman, I. C., 99.
 Hoffman, M. H., 420.
 Hoffman, W., 399.
 Hoffmann, M., 373.
 Höfker, H., 732.
 Hofmann, J. V., 543, 650.
 Hogg, R., 697.
 Hogue, G. E., 399.
 Hohenstein, V., 320.
 Holben, F. J., 520.
 Holdaway, C. W., 874.
 Hole, R. S., 448.
 Hollande, 853.
 Hollande, C., 584.
 Hollister, W. O., 159.
 Holm, G. E., 110, 111.
 Holmes, A. D., 564.
 Holmes, G. K., 437.
 Holmes, M. G., 31.
 Holstein, P. F., 25.
 Holt, L. W., 788.
 Holtzhauer, E., 583.
 Homer, A., 76.
 Hommell, R., 57.
 Hommon, H. B., 189.
 Honcamp, F., 267, 569.
 Honing, J. A., 831.
 Hood, C. C., 651.
 Hood, G. W., 644.
 Hooker, H. D., jr., 642.
 Hooper, C. H., 438, 744.
 Hooper, J. J., 72, 877.
 Hoover, H., 873.
 Hope, E., 201.
 Hopkins, 12, 600, 713.
 Hopkins, A., 592.
 Hopkins, A. D., 509, 511, 718.
 Hopkins, C. G., 600.
 Hopkins, E. F., 700.
 Hopkins, F. G., 262.
 Hoppe-Seyler, 214.
 Horgan, J., 599.
 Horlacher, L. J., 278.
 Horlacher, W. R., 799.
 Horning, H. L., 88.
 Horton, R. E., 120.
 Hosman, D. F., 779.
 Hostetler, E., 467.
 Hotta, 80.
 Hottes, A. C., 240.
 Houben, J., 11.
 Houser, J. S., 356.
 Houston, D. F., 830.
 Houwink, R., 375.
 Howard, G. L. C., 808.
 Howard, L. H., 780.
 Howard, L. O., 558, 661.
 Howard, L. P., 115, 212.
 Howard, W. L., 237, 745.
 Howell, C. E., 400, 699.
 Howell, S. P., 282.
 Howes, E. A., 403.
 Howes, P. G., 50.
 Howley, W. J. J., 477.
 Hoxie, F. J., 651.
 Hubbard, C. M., 197, 397, 870.
 Hubbard, P., 387.
 Huddleson, I. F., 688.
 Hudelson, R. H., 721.
 Hudson, C. S., 410, 411.
 Huelson, W. A., 835.
 Huerre, R., 315.
 Huff, L. B., 683.
 Huffman, C. F., 497.
 Hughes, E. H., 498.
 Hughes, H. D., 235.
 Hulbert, H. W., 699.
 Hullihen, W., 99.
 Humboldt, E., 187.
 Hume, A. N., 235, 546.
 Hume, E. M., 461.
 Hummel, W. G., 897.
 Humphrey, D. S., 185.
 Humphrey, G. C., 270.
 Humphrey, J. R., 334, 673,
 899.
 Hungerford, C. W., 546.
 Hungerford, J. D., 200.
 Hunnicutt, B. H., 90.
 Hunt, C. H., 400, 700.
 Hunt, H. A., 208.
 Hunt, N. R., 444.
 Hunt, T. F., 99, 699, 800.
 Hunter, A., 667.
 Hunter, A. C., 663.
 Hunter, W. D., 454.
 Hunziker, O. F., 380, 779.
 Hurd, W. E., 120, 157.
 Hurley, J. M., 531.
 Hurry, J. B., 242, 796.
 Hursh, C. R., 399.
 Hurwitz, 503.
 Husain, M. A., 553.
 Husmann, G. C., 837.
 Hutchings, C. B., 449.
 Hutchins, D. E., 651.
 Hutchinson-MacLennan, 713.
 Hutton, F. Z., 123, 209.
 Hutton, G. H., 773.
 Hutton, J. C., 556.
 Hutyra, F. V., 181.
 Ichimura, T., 327.
 Ikeler, K. C., 99.
 Illick, J. S., 442, 839.
 Illner, L., 86.
 Imes, M., 688.
 Imms, A. D., 553.
 Ingerson, H. G., 454.
 Ingle, H., 898.
 Insley, H., 630.
 Ise, J., 746.
 Isely, D., 60, 357.
 Ivey, J. E., 573, 898.
 Jablons, B., 275.
 Jaccard, P., 819.
 Jack, R. W., 52, 456.
 Jackson, F. H., jr., 85.
 Jackson, H. S., 328, 329, 731.
 Jacobs, M. H., 167.
 Jacobson, J., 534.
 Jacques, P., 509.

- Jahn, 586.
 James, E. J., 198.
 James, E. W., 790.
 James, McN. C., 196.
 James, W. R., 888.
 James, W. S., 890.
 Jamieson, G. S., 502.
 Jannasch, P., 413.
 Janse, J. M., 131.
 Jansen, W. H., 859.
 Jaramillo, P. J., 31.
 Jardine, J. T., 100, 148.
 Jardine, W. M., 705.
 Jarvis, C. D., 800.
 Jatindra Math Sen, 777.
 Jefferson, L. P., 700.
 Jefferies, J. H., 799.
 Jehle, R. A., 244, 246.
 Jenkins, E. H., 221.
 Jenks, A. R., 643.
 Jensen, A. C., 167.
 Jensen, S. O., 680.
 Jensen, V. W., 568.
 Jesness, O. B., 895, 899.
 Jeter, F. H., 300.
 Jewett, H. H., 359.
 Jobin, P., 342.
 Joffe, J., 859.
 Joffe, J. S., 515, 635.
 Johann, H., 545, 749.
 John, W. O., 676.
 Johns, C. O., 410, 763.
 Johnson, A. G., 751.
 Johnson, A. H., 399.
 Johnson, A. N., 284, 482.
 Johnson, B. L., 873.
 Johnson, D. B., 237.
 Johnson, D. S., 328.
 Johnson, E. R., 400.
 Johnson, O. R., 190.
 Johnson, T. C., 27.
 Johnson, W. H., 652.
 Johnson, W. T., 397, 689.
 Johnston, E. S., 39, 511.
 Johnston, J. R., 448.
 Johnston, M., 797.
 Johnston, T. H., 182, 457.
 Johnston, W. L., 171, 811.
 Johnston, W. W., 21.
 Joly de Lotbiniere, A., 746.
 Jones, C. H., 428, 437, 464,
 613, 627.
 Jones, D. F., 529.
 Jones, E. E., 669.
 Jones, G. B., 719.
 Jones, H. M., 383, 682, 873.
 Jones, H. W., 662.
 Jones, J. M., 870.
 Jones, L. R., 849.
 Jones, O. L., 71.
 Jones, R. B., 187.
 Jones, S. V. H., 771.
 Jones, T. H., 398.
 Jong, A. W. K. de, 43.
 Jongenard, M., 368.
 Jordan, E. O., 275.
 Jordan, W. H., 598.
 Jorgensen, L., 281.
 Joseph, W. E., 68, 770.
 Joshi, P. G., 564.
 Joshi, S. D., 241.
 Jossier, G., 617.
 Jourdain, F. C. R., 50.
 Judd, H. M., 507.
 Julien, 342.
 Jull, M. A., 676.
 Junge, E., 15.
 Juritz, C. F., 317.
 Juve, O. A., 483.
 Kadel, B. C., 718.
 Kains, M. G., 536.
 Kaiser, W. G., 790.
 Kale, V. G., 292.
 Kalkus, J. W., 384, 473, 784.
 Kalmbach, E. R., 50.
 Kalshoven, H., 508, 509.
 Kalshoven, L. G. E., 450.
 Kalt, B., 132.
 Kammann, 691.
 Kasargode, R. S., 852.
 Kauffman, T. E., 900.
 Kaupp, B. F., 467, 494, 573,
 674, 675, 898.
 Kay, A. O., 279.
 Kearney, T. H., 516.
 Keen, B. A., 16, 20, 320.
 Keenan, G. L., 313, 352.
 Keibel, F., 169.
 Keil, J. B., 740, 744.
 Keim, 691.
 Keitt, T. E., 127, 136.
 Kellems, T. O., 801.
 Keller, W. S., 186.
 Kelley, F. J., 867.
 Kelley, W. P., 215, 724.
 Kellogg, J. W., 326, 520, 867.
 Kellogg, R. S., 344.
 Kelsall, A., 850.
 Ketsler, R. A., 881.
 Kelly, E., 682.
 Kelly, E. G., 354.
 Kem, F. L., 195.
 Kempster, H. L., 174, 776,
 790.
 Kempton, F. E., 226.
 Kempton, J. H., 529.
 Kenney, R., 899.
 Kephart, L. W., 831.
 Keppeler, G., 213.
 Kern, C. A., 511.
 Kern, E. J., 506.
 Kern, J., 413.
 Kerr, C. M., 85.
 Keuchenius, P. E., 43.
 Keyser, C. N., 718.
 Kidd, F., 224.
 Kidder, A. F., 635, 670, 673.
 Kidwell, W. R., 699.
 Kiernan, J. A., 473.
 Kiesselbach, T. A., 827.
 Killion, R. M., 495.
 Kimball, M., 398.
 Kime, C. D., 551.
 Kincer, J. B., 116, 119.
 King, A. M., 152.
 King, C. L., 877.
 King, E. E., 283.
 King, F. G., 375, 570, 869,
 870.
 King, H. T., 198.
 King, W. E., 274.
 Kinley, D., 198.
 Kinzel, W., 170.
 Kirby, L., 316.
 Kirby, R. S., 653, 844.
 Kirkland, B. P., 42.
 Kitchin, P. C., 42.
 Kitto, F. H., 620.
 Kittredge, J., 442.
 Klare, K., 584.
 Klebahn, H., 449, 544.
 Klein, L. A., 780.
 Kleinschmidt, H., 567.
 Kleylein, K., 629.
 Klieneberger, E., 524.
 Klinck, L. S., 402, 404.
 Kling, M., 170.
 Kling, M. A., 415.
 Klopsteg, P. E., 803.
 Knapp, A. W., 279.
 Knapp, B., 490.
 Knapp, G. O., 878.
 Knieriem, W. V., 817.
 Knight, C. S., 228.
 Knight, H. G., 12, 612, 713.
 Knight, M. M., 94.
 Knight, R., 829.
 Knopf, S., 186.
 Knowles, C. H., 52, 829.
 Knowles, R. H., 472.
 Knudson, L., 130.
 Knuth, P., 83.
 Kobayashi, M., 112.
 Koch, A., 27.
 Koch, J., 264.
 Kocher, A. E., 512.
 Koehler, A. E., 204, 615.
 Koehne, 210.
 Koettgen, P., 621.
 Kohman, E. F., 164.
 Kole, C. J., 868.
 Kolkwitz, R., 526.
 Kolthoff, I. M., 204.
 König, J., 122, 610.
 Koning, A. de, 296.
 Kooiman, H. N., 223, 818.
 Kopeloff, L., 807.
 Kopeloff, N., 433, 507, 616,
 699, 807.
 Köppen, W., 16, 418.
 Kosterz, W., 722.
 Kozitschek, H., 264.
 Kramer, H. E., 490.
 Kraybill, H. R., 498, 533.
 Kress, O., 650.
 Kroeber, L., 478.
 Kroemer, K., 834, 836.

- Krout, W. S., 153.
 Krueck, W. B., 198.
 Krüger, E., 851.
 Krusekopf, H. H., 729.
 Kuhlmann, G. J., jr., 515.
 Kuhn, F. A., 480.
 Kuhn, J., 519.
 Kühn, O., 130.
 Kühne, W., 414.
 Kuiper, K., jr., 375.
 Kuntz, A., 269.
 Kuppelmayr, 672.
 Küster, E., 729.
 Kuttenheuler, H., 563.
- Labaste, M., 484.
 Labergerie, 657.
 Laby, E. P., 239.
 Lacey, M., 881.
 Ladd, E. F., 368, 642, 900.
 Lafferty, H. A., 447.
 La Forge, F. B., 801, 809.
 La Grange, W. F., 673.
 Lahille, A., 177.
 Lakeman, A., 188.
 la Lance, G. R. M. de, 173.
 Lamb, A. R., 369.
 Lamkey, E. M. R., 198.
 Lance, G. R. M. de la, 173.
 Landon, W. F., 679.
 Lane, E. W., 589.
 Lange, C., 181.
 Langelier, G. A., 727, 763,
 775, 776.
 Langworthy, C. F., 365.
 Lantos, E., 412.
 Lapique, 775.
 La Pommeraye, de, 342.
 Laribé, M. A., 292.
 Laroquette, M. de, 819.
 Larrimer, W. H., 661.
 Larsen, C., 873.
 Larson, J. A., 770.
 Larsson, R., 500.
 Lassieur, A., 415.
 Last, E., 114.
 Lathrop, B., 400.
 Latshaw, W. L., 729.
 Laubert, R., 549.
 Laude, H. H., 199, 229.
 Laufer, B., 172.
 Lauman, F. R., 900.
 Lavalley, J. A. de, 720.
 Lawes, 371.
 Lawry, R. C., 494.
 Lawson, J. S., 399.
 Lay, W. E., 890.
 Leach, A. E., 313.
 Leach, B. R., 743.
 Leach, J. G., 150, 399.
 Leavenworth, C. S., 409.
 Le Clerc, J. A., 563.
 Ledent, R., 415.
 Ledig, P. G., 611.
 Lee, A. R., 174.
 Lee, G. S., 826.
- Lee, H. A., 550.
 Lee, J. W., 294.
 Lee (Lord) of Fareham, 493.
 Lees, A. H., 742, 835.
 Leeuwen, C. A. E. van, 691.
 Le Fevre, E., 616.
 Legras, M. P. M., 484.
 Lehmann, E. W., 498, 787.
 Lehnert, E. H., 179.
 Leiby, R. W., 759.
 Leick, E., 819.
 Leighou, R. B., 389.
 Leitch, A., 291.
 Leith, R. F. C., 778.
 Lek, H. A. A. van der, 547.
 Lekkerkerker, T. J., 795.
 Lelean, P. S., 865.
 Lemmermann, O., 124, 220,
 232, 897.
 Lenhartz, M., 170.
 Lenk, E., 416.
 Leonard, H. B., 473.
 Leonard, H. R., 878.
 Leone, G., 48.
 Leopold, A., 148.
 Leprince, J. A., 85.
 Leroide, 342.
 Lescoeur, L., 414.
 Lescohier, D. D., 193.
 Letteer, C. R., 120, 134, 144,
 153, 171.
 Leukel, R. W., 751.
 Levi, C., 500.
 Levine, C. O., 171.
 Levine, M., 242.
 Levy, R. L., 879.
 Lewin, R., 500.
 Lewis, C. I., 145.
 Lewis, F. C., 778.
 Lewis, H. B., 663.
 Lewis, H. G., 512.
 Lewis, H. R., 173, 468.
 Lewis, I. P., 339, 340, 341,
 647.
 Lewis, L. L., 79.
 Lewis, P. A., 76.
 Lewis, R. C., 668.
 Lewis, R. G., 840.
 Lewis, S. L., 808.
 Liechti, P., 325.
 Liesegang, R. E., 412.
 Lignières, J., 77.
 Lima, J. G. P., 488.
 Lindemann, E. C., 796.
 Linden, T. Van der, 508, 509.
 Lindgren, G. S., 511, 719.
 Lindley, E. H., 198.
 Lindley, J. W., 246.
 Lindley, L. E., 122.
 Lindsey, D. W., 200.
 Linskog, G. E., 511, 719.
 Linhart, G. A., 279.
 Link, G. K. K., 751.
 Linklater, W. A., 798.
 Linter, E., 426.
- Lipman, J. G., 128, 532, 627,
 800.
 Lippincott, W. L., 800.
 Lipscomb, G. F., 799.
 List, G. M., 161.
 Little, C. C., 669.
 Livermore, K. C., 900.
 Liverseege, J. F., 279.
 Livingston, B. E., 733.
 Livingston, G., 294, 489.
 Lloyd, F. E., 132.
 Lloyd, J. W., 643.
 Lloyd, L., 453.
 Lloyd, O. G., 198, 593, 893.
 Lloyd, W. A., 486.
 Lloyd-Jones, O., 71.
 Lodge, O., 778.
 Loeb, J., 821.
 Loesener, T., 204.
 Löffler, B., 525.
 Lohman, R. W., 892.
 Long, J., 779.
 Longwell, J. H., 400.
 López Domínguez, F. A., 727.
 Lo Priore, G., 49.
 Lorette, P., 804.
 Lorimer, R. C., 177.
 Lotbiniere, A. J. de, 746.
 Lothe, H., 683.
 Lotsy, J. P., 67, 223, 818.
 Loughlin, G. F., 630.
 Loughlin, R., 460, 764.
 Lounsbury, C., 123, 720.
 Lovett, A. L., 457, 755.
 Low, W. H., 610.
 Lowry, R. B., 900.
 Loyd, L., 454.
 Lubatti, O. F., 14.
 Lubin, D., 499, 699.
 Lubs, 211.
 Luc, 344.
 Lucas, F., 741.
 Lucas, J., 895.
 Lucas, P. S., 805.
 Luckett, J. D., 422.
 Ludwig, 24.
 Lugnibill, P., 556.
 Lührig, H., 610.
 Lührs, 787.
 Lumsden, D., 900.
 Lundborg, H., 500.
 Lundegårdh, H., 819.
 Lunn, A. G., 100.
 Luro, R. F., 876.
 Lusk, W. F., 900.
 Lutman, B. F., 131, 153, 154.
 Lutz, 80.
 Lyman, G. R., 443.
 Lynde, H. M., 280.
 Lyon, T. L., 215.
 Lyons, M. A., 313.
- Macallum, A. B., 404.
 MacArthur, L., 399.
 McAtee, W. L., 50.
 McCall, A. G., 121, 517, 815.

- McCall, F. E., 644.
 McCall, M. A., 736.
 McCandlish, A. C., 875.
 McCarrison, R., 664.
 McCartney, H. E., 269.
 McCarty, A. C., 569.
 MacCaughy, V., 747.
 McCheyne, G., 899.
 McClugage, H. B., 765.
 McClure, F. D., 700.
 McClure, G. M., 210.
 McClure, H. B., 825.
 McColloch, J. W., 358.
 McCullough, J. H., jr., 286.
 McCollum, E. V., 365.
 McCool, M. M., 515, 516, 622.
 McCord, J. L. E., 700.
 McCormick, F. A., 249.
 McCreedy, S. B., 195.
 McCreary, O., 499, 700.
 McCubbin, W. A., 348, 349, 847.
 McCue, C. A., 744.
 McCulloch, T. B., 398.
 McCune, J. S., 805.
 McDaniel, E., 660.
 McDole, G. R., 699.
 McDonald, E. M., 735.
 McDonald, T. H., 284, 387, 790.
 McDonnell, C. C., 352.
 McDonnell, H. B., 221.
 MacDougal, D. T., 428, 429.
 McDowell, J. C., 291.
 Mace, W. A., 600.
 McEwen, G. F., 16.
 M'Fadyean, J., 181, 384.
 McFadzean, J. S., 177.
 Macfarlane, J. M., 521.
 Macfarlane, M., 316.
 McGilliard, P. C., 799.
 McGinty, R. A., 198.
 McGowan, N. S., 172.
 MacGregor, J., 342.
 McGuire, A. J., 682.
 Mach, F., 315.
 McHargue, J. S., 431.
 McHatton, T. H., 741.
 McIlvaine, T. C., 524.
 McInerney, T. J., 415.
 MacIntire, W. H., 115, 127, 713.
 McIntosh, J., 10.
 McKay, A. W., 339.
 Mackay, W., 171.
 McKee, 831.
 McKee, R. H., 416.
 McKelvey, H. G., 387, 388.
 Mackenna, J., 192.
 Mackenzie, C. J., 482.
 Mackie, T. J., 684.
 McKillican, W. C., 774.
 McKinney, H. H., 655.
 McKinney, W. H., jr., 548.
 McLaughlin, W. W., 722.
 MacLean, H. C., 393.
 McLean, R. C., 241.
 MacLeod, G. F., 498.
 McMahan, D., 673.
 MacMillan, H. G., 842.
 McMurrin, S. M., 48.
 McNab, G. T., 387, 388.
 McNeal, D., 719.
 McNess, G. T., 17, 33, 36, 37, 98.
 McNutt, J. C., 497, 700.
 Macoun, W. T., 438, 540, 657, 741, 759.
 Macpherson, A., 290.
 MacRae, W., 658.
 McVicker, F., 149.
 Magalhães, M. F. de, 476.
 Maheux, G., 556, 844.
 Mahoney, J. P., 483.
 Maiden, J. H., 543.
 Mains, E. B., 244.
 Maire, R., 819.
 Makins, F. K., 543.
 Maldonado, E., 96.
 Malloch, J. R., 661.
 Mallory, A. E., 456.
 Malone, J. Y., 269.
 Malpeaux, L., 427, 892.
 Maltby, R. D., 497.
 Manetti, C., 173.
 Maneval, W. E., 749.
 Mangin, L., 347.
 Mann, A. R., 708, 800.
 Mann, F. C., 180.
 Mann, H. H., 95, 293.
 Manning, D. F., 119.
 Manning, W. R., 837.
 Manninger, R., 181.
 Manns, T. F., 198.
 Mansfield, G. R., 817.
 Marage, 478.
 Marcusson, J., 321.
 Marinus, C. J., 67.
 Marion, F., 615.
 Maris, P. V., 400.
 Markham, F., 339.
 Markle, M. S., 732.
 Marlatt, C. L., 162, 661.
 Marqueyrol, 804.
 Marsden, R. E., 748.
 Marsh, C. D., 77, 464, 470, 471.
 Marsh, C. W., 470.
 Marsh, H. O., 455.
 Marshall, G. A. K., 50, 163.
 Marshall, R. E., 541.
 Marston, A., 387.
 Martelli, G., 250.
 Martin, 275.
 Martin, F. S., 400.
 Martin, H. H., 118, 120, 511.
 Martin, H. M., 882, 887.
 Martin, J. F., 350.
 Martin, J. N., 640.
 Martfn, R., 388.
 Martin, W. H. (N. J.), 532.
 Martin, W. H. (Pa.), 700.
 Martushin, G. A., 488.
 Marvin, C. F., 511.
 Mascré, 525.
 Mason, B. B., 878.
 Mason, C. C., 459.
 Mason, T. G., 633.
 Massa, C., 449.
 Massias, J., 241.
 Masters, H., 458.
 Masuy, K., 670.
 Masuri, A. F., 286.
 Mathai, J., 488.
 Mather, W., 201.
 Mathews, J. W., 70.
 Mathewson, W. E., 508.
 Mathieu, E., 827.
 Mathieu, M. L., 311.
 Mathot, E. R., 591.
 Matta, A. da, 57.
 Matthews, D. J., 211.
 Mattimore, H. S., 186.
 Matula, J., 524.
 Matzdorff, O., 414.
 Maublanc, A., 849.
 Maumy, G., 895.
 Maung, Po Saw, 27.
 Maxey, G., 497.
 May, W. L., 141.
 Mayer, O., 206.
 Mayland, E., 693.
 Mayr, C., 173.
 Malcomson, A. W., 572.
 Meacham, F. T., 816.
 Meachem, M. R., 313.
 Mead, E., 894.
 Meade, G. P., 714.
 Meadows, S. D., 892.
 Meadows, T. B., 494.
 Mebane, A. L., 797.
 Meeks, J. R., 777.
 Mees, R., 828.
 Mege, C. R., 333, 639.
 Megnin, 587.
 Mehl, J. M., 488, 895.
 Mehta, J. K., 269.
 Meier, F. C., 348, 656.
 Meillère, G., 612.
 Meinicke, E., 277, 278, 471, 685.
 Meisinger, C. L., 120, 417, 718.
 Melchers, L. E., 659.
 Melhus, I. E., 653.
 Mellanby, E., 166, 663.
 Mellick, A. H., 119.
 Mellor, J. W., 201.
 Mendel, L. B., 10, 165, 409, 765.
 Meneghini, D., 500.
 Menier, G., 342.
 Mennessier de la Lance, G. R., 173.
 Meredith, E. T., 91, 101, 103, 104, 490, 543, 704, 707, 794, 832.
 Meredith, R. M., 498.

- Merkel, F., 528.
 Merkel, F. G., 700.
 Merrill, E. C., 116.
 Merrill, E. D., 443.
 Merrill, G. B., 258.
 Merrill, J. H., 163.
 Merriman, M., 278.
 Merrison, J. G., 589.
 Mertens, R., 15.
 Mesnard, E., 417.
 Metzger, J. E., 133.
 Meyer, 503.
 Meyer, A., 729.
 Meyer, A. H., 811.
 Meyer, A. J., 399.
 Meyer, F. N., 400.
 Meyer, K. F., 879, 880.
 Mezger, C., 321.
 Middleton, H. E., 210.
 Middleton, T., 519.
 Middleton, T. H., 652.
 Miège, E., 126.
 Miebe, H., 133, 731.
 Millar, C. E., 515, 516, 622.
 Millen, F. E., 563.
 Miller, E. R., 719.
 Miller, F. G., 344, 650.
 Miller, G. H., 649.
 Miller, H. E., 290.
 Miller, M., 849.
 Miller, M. F., 721, 722, 729.
 Miller, M. R., 273.
 Miller, N. H. J., 19.
 Miller, R. C., 497.
 Miller, R. F., 198.
 Miller, R. S., 542.
 Miller-Brownlie, T. A., 386.
 Milne, B. C., 773.
 Minch, W. L., 528, 532.
 Minchin, 786.
 Miner, J. R., 175.
 Minge, F. L., 236.
 Minnich, D. E., 851.
 Minot, A. S., 615.
 Mirande, R., 754.
 Mitchell, C. A., 409.
 Mitchell, H. H., 504.
 Mitchell, S. C., 99.
 Mitchelson, A. T., 787.
 Mitterlich, E. A., 518.
 Mittermayr, H., 891.
 Mixer, E. S., 200.
 Miyagawa, Y., 82.
 Miyashima, K., 260.
 Möbius, M., 730.
 Mock, H. E., 564.
 Mockeridge, F. A., 815.
 Modine, A. B., 88.
 Mohler, J. C., 72, 593.
 Mohler, J. R., 471.
 Mohorčić, H., 64.
 Moles, M. L., 557.
 Molino, J. F., 820.
 Molinari, E., 500, 609.
 Molisch, H., 634, 730.
 Molliard, M., 730.
 Molz, E., 244.
 Montagu, E. S., 50.
 Montgomery, C. W., 392.
 Montgomery, E. G., 638.
 Moody, C. J., 888.
 Mooney, C. N., 719, 720.
 Moor, H. W., 44.
 Moore, C. C., 808.
 Moore, F. L., 542.
 Moore, H. C., 714.
 Moore, H. D., 273.
 Moore, H. J., 240.
 Moore, H. L., 491.
 Moore, J. G., 540.
 Moore, P., 269.
 Moore, T., 404.
 Moore, V. A., 81, 683.
 Moorhouse, H. W., 498.
 Morange, P., 484.
 Moreau, F., 849.
 Moreland, C. C., 348.
 Morelli, L., 580.
 Moreschi, T., 78.
 Morgan, G. W., 332.
 Morgan, H. P., 464.
 Morgan, T. H., 268, 269.
 Morgen, A., 97, 266.
 Morgenthaler, O., 445.
 Moritz, E. Z., 85, 587.
 Morman, J. B., 393.
 Morrill, A. W., 757, 852.
 Morris, E. B., 486.
 Morris, H. E., 45.
 Morris, O. M., 715, 743, 744.
 Morrison, F. B., 774.
 Morrow, C. A., 18.
 Morrow, F. J., 703.
 Morse, F. W., 423, 537.
 Morton, B. R., 840.
 Mosgrove, C. A., 899.
 Mosler, 80.
 Moss, E. G., 245.
 Moyer, J., 314, 368, 413.
 Moznette, G. F., 53, 54, 255, 560, 851.
 Muhammed Afzal, 150.
 Mulford, W., 99.
 Müller, 573.
 Müller, F., 859.
 Müller, H. C., 244.
 Muller, H. J., 268.
 Müller, J., 65.
 Müller-Lenhartz, 170.
 Mullett, H. A., 642.
 Mulvania, M., 900.
 Mumford, F. B., 129, 703, 800.
 Munce, T. E., 780.
 Mundy, H. G., 638.
 Munger, H. B., 92.
 Munger, T. T., 343.
 Munn, M. T., 399, 535.
 Munro, W. A., 771.
 Munroe, C. E., 282.
 Munroe, H. D., 100.
 Münter, F., 504, 518.
 Murlin, J. R., 668.
 Murphy, H. F., 400.
 Murray, A. W., 127, 136.
 Murray, J. A., 371, 372.
 Murray, P. W., 48.
 Murray, T. J., 400, 726.
 Murschhauser, H., 65.
 Musante, L., 458.
 Musbach, F. L., 23.
 Musgrave, G. W., 720.
 Mussehl, F. E., 776.
 Musser, K. B., 698.
 Myers, C. E., 537.
 Myers, C. N., 459.
 Myers, D. S., 99.
 Myers, W. I., 900.
 Naden, G. R., 747.
 Nagao, M., 82.
 Nakayama, Y., 684.
 Namikawa, I., 327.
 Nanneson, L., 594.
 Nanot, J., 835.
 Nansen, F., 810.
 Narayanamurti, J., 477.
 Nash, J. P., 482.
 Nassy, J. G., 583.
 Nath Sen, J., 777.
 Navel, H. C., 849.
 Neal, D. C., 99.
 Neal, R. W., 700.
 Neale, J. C., 291.
 Neger, F. W., 154, 732.
 Nègre, L., 583.
 Nehf, R. A., 198.
 Neill, M. H., 667.
 Neilsen, L. H., 387.
 Neilson, J. A., 656.
 Neller, J. R., 625.
 Nelson, E. K., 502.
 Nelson, J. B., 35.
 Nelson, J. W., 512.
 Nelson, M., 137, 436.
 Nelson, P., 900.
 Nelson, V. E., 369.
 Nepveux, F., 416.
 Ness, H., 535.
 Nestell, R. J., 25.
 Neumann, B., 519, 629, 816.
 Neumann, E., 471.
 Neville, H. A. D., 898.
 Nevius, J. R., 100.
 Newell, L. C., 801.
 Newell, W., 162.
 Newkirk, W. B., 806.
 Newland, H. O., 240.
 Newman, H. G., 784.
 Newman, L. F., 898.
 Newman, L. H., 402.
 Newman, L. J., 252.
 Nicholls, W. D., 389, 899.
 Nichols, E., 209.
 Nichols, E. S., 16.
 Nichols, C. B., 299.
 Nicolay, A. S., 57.
 Nienburg, W., 818.

- Nieuwland, N. B., 320.
 Nightingale, W. I., 499.
 Niklas, H., 513, 622.
 Nikolai, F., 279.
 Niles, W. B., 184.
 Nilsson, N. H., 500.
 Nilsson-Ehle, H., 500.
 Nishi-Hime-Shinkui, 456.
 Nitrious, 628.
 Nix, L. A., 748.
 Nohavec, F. R., 700.
 Nolan, A. W., 695.
 Nolan, O. L., 409.
 Noll, C. F., 519.
 Noll, F., 413.
 Nolte, 221.
 Nolte, O., 267, 516.
 Nordhausen, M., 131.
 Norman, C. A., 287, 479, 485, 890.
 Normington, R., 114.
 Norris, E. R., 399.
 North, C. E., 270.
 Northrop, J. H., 611, 822.
 Northrup, Z., 227.
 Norton, H. W., jr., 698.
 Norton, J. B. S., 151.
 Norton, S. V., 286.
 Nottnagel, M., 329.
 Nottbohn, F. E., 272.
 Nougaret, R. L., 453, 837.
 Nouhuijs, H. van, 806.
 Nourse, E. G., 193.
 Nowell, W., 551.
 Noyes, H. A., 115, 329, 422.
 Noyes, H. M., 414.
 Nuckols, S. B., 35.
 Nunn, H., 186.
 Nutter, J. W., 877.
 Nutting, G. B., 321.
 Nyström, E., 631.
 Oberholser, H. C., 49, 50, 659.
 O'Brien, C., 594, 694.
 O'Brien, D. G., 47.
 O'Brien, G. E., 69.
 O'Callaghan, M. A., 75.
 Odegaard, N., 98.
 Odén, S., 213, 325, 515.
 Oelsner, A., 27.
 Ohlmer, E., 266.
 O'Kane, W. C., 237, 252.
 O'Kelly, J. F., 399.
 Okimoto, T., 569.
 Okuda, Y., 505, 506, 563, 568, 569.
 Okumura, T., 260.
 Older, C., 387.
 Oldershaw, A. W., 321.
 O'Leary, I. P., 596.
 O'Leary, W. A., 795.
 Olmstead, L. B., 220.
 Olmstead, R. D., 355, 799.
 Olmsted, F. E., 42, 839.
 Olmsted, R. W., 587.
 Olney, A. J., 37, 446.
 Olson, G. A., 736, 764.
 Olson, O., 533.
 Oman, D. S., 642.
 Opazo G., R., 289.
 Orban, G., 524.
 Orcutt, M. L., 581.
 O'Roke, E. C., 786.
 Orr, 462.
 Orr, F. L., 700.
 Orton, C. R., 548.
 Osborn, L. W., 137.
 Osborn, M. G., 300.
 Osborn, T. G. B., 130, 654.
 Osborne, E. B., 100.
 Osborne, T. B., 10, 165, 409, 765.
 Osborne, W. F., 483.
 Oshima, K., 503.
 Oshigan, V. K., 557.
 Oskamp, J., 99, 842.
 Osner, G. A., 243.
 Osterberg, 414, 503.
 Osterhout, W. J. V., 431, 820.
 Ostertag, R. von, 570.
 Ostheimer, M., 462.
 Ostrander, J. E., 207, 511, 719.
 Osvald, H., 623.
 Ostwald, W., 609.
 Overholser, E. L., 238.
 Overpeck, J. C., 200.
 Owen, I. L., 893.
 Paál, A., 132.
 Paaswell, G., 485.
 Pack, H. J., 499.
 Paddock, F. B., 561, 758.
 Painter, C. C., 258.
 Palm, B., 242, 247.
 Palma, J. R., 500.
 Palmer, A. H., 509, 511, 618.
 Palmer, C. F., 795.
 Palmer, L. S., 712, 778.
 Palmer, T. G., 728.
 Palmer, W. C., 300.
 Pams, J., 96.
 Pantanelli, E., 226.
 Paranjpe, H. P., 745.
 Pardee, A. M., 505.
 Pardoe, W. S., 477.
 Parfitt, E. H., 299.
 Parham, G. E., 776.
 Parish, W. F., 86.
 Parker, J. R., 354, 758.
 Parker, R. R., 164.
 Parkinson, W. H., 853.
 Parks, H. B., 258.
 Parlin, C. C., 92.
 Parnell, F. R., 423.
 Parnell, R., 150.
 Parodi, L. R., 731.
 Parrott, P. J., 354, 355.
 Parshall, R. L., 185.
 Parsons, J. D., 699.
 Partridge, N. L., 647.
 Pascal, T., 174.
 Passelègue, G., 484.
 Passonneau, J., 794.
 Patch, E. M., 159.
 Pate, W. F., 419, 816.
 Patil, P. C., 51, 808.
 Paton, R., 865.
 Patschovsky, N., 327.
 Patten, A. J., 326, 626.
 Patten, H. E., 801.
 Patterson, A. M., 801.
 Patterson, T. B., 192.
 Pattullo, T. D., 747.
 Patty, R. L., 892, 893.
 Paul, T., 682.
 Pavari, A., 840.
 Pearce, W. J., 148.
 Pearl, R., 377, 500.
 Pearce, L., 479.
 Pearson, A. L., 891.
 Pearson, F. A., 793.
 Pearson, R. A., 800, 899.
 Pedersen, J., 15.
 Peek, L., 495.
 Péé-Laby, E., 239.
 Peirce, G. J., 131.
 Pellett, F. C., 259.
 Pellew, C., 632.
 Peltier, G. L., 199, 848.
 Pemberton, C. E., 450.
 Pendeado, M. de C., 68.
 Pennington, L. H., 249.
 Pennington, M. E., 90.
 Penzer, N. M., 828.
 Peres, O., 390.
 Perkins, A. E., 805.
 Perkins, F. M., 201.
 Perkins, F. W., 698.
 Perkins, H. Z. E., 616.
 Perley, G. A., 25, 201.
 Petch, C. F., 752.
 Petch, T., 552.
 Peter, A. M., 72, 324, 373.
 Peters, F. H., 279.
 Peters, J. G., 441.
 Peterson, K. D., 35.
 Peterson, A., 359.
 Peterson, N. F., 77, 700.
 Peterson, P. P., 227, 814.
 Peterson, V., 597.
 Peterson, W. H., 411, 610.
 Pethybridge, G. H., 49, 447.
 Petit, P., 260.
 Petri, L., 44, 448, 449.
 Petroff, S. A., 685.
 Pettit, R. H., 360, 660.
 Peyton, J. S., 148.
 Pfeiffer, 83.
 Pfeiffer, T., 322.
 Pfeiler, W., 181, 583.
 Pfenninger, W., 184.
 Phares, V. R., 419.
 Phelps, I. K., 116.
 Phillips, A. G., 892.
 Phillipe, G., 344.
 Phillips, C. A., 400.
 Phillips, H. D., 174.

- Phillips, S., 595.
 Phipps, W. H., 240.
 Piccoli, L., 812.
 Piché, G. C., 149.
 Pickens, E. M., 384.
 Pickering, S., 327.
 Pickering, S. U., 29.
 Piepmeier, B. H., 186.
 Pier, H. B., 899.
 Pierce, R. G., 846.
 Pierce, W. D., 450, 560.
 Pierson, A. H., 150.
 Pierson, E. M., 664.
 Pierson, H. B., 556.
 Pillsbury, G. B., 689.
 Pipal, F. J., 546.
 Piper, C. V., 233, 334, 522.
 Pisar, C. J., 834.
 Pitcairn, R. C., 416.
 Pitt, F., 375.
 Plissonnier, S., 95.
 Plumb, C. S., 399, 770.
 Plummer, J. K., 419.
 Plummer, J. K., jr., 818.
 Poelma, L. J., 299.
 Pohlman, A. G., 169.
 Pomeroy, C. S., 440.
 Pommeraye, de La, 342.
 Ponce, G. S., 500.
 Poole, J., 200.
 Poole, J. L., 99.
 Pope, T. H., 609.
 Pope, W. R., 312.
 Pope, W. T., 398.
 Popenoe, W., 342, 835.
 Popp, H. W., 599.
 Popp, M., 628.
 Porch, E. L., jr., 482.
 Porcher, C., 415, 876, 877.
 Portier, P., 166, 369.
 Porto, P. C., 40.
 Po Saw, M., 27.
 Posson, R. J., 678.
 Posternak, S., 525, 804.
 Postma, J., 679.
 Potter, G. M., 82, 181.
 Potts, H. W., 96.
 Poulton, E. P., 859.
 Pound, G. H., 893.
 Powdermaker, F., 799.
 Powell, G. T., 744.
 Power, F. B., 711.
 Powers, W. L., 21.
 Prausnitz, W., 64.
 Prescott, S. C., 316, 368.
 Presquera, G., 685.
 Price, J. C. C., 99.
 Price, W. A., 856.
 Price, W. H., 566.
 Priestley, J., 100.
 Prince, A. L., 421.
 Pritchard, F. J., 656, 846.
 Privat, A., 477.
 Proescher, F., 385.
 Pröscholdt, 687.
 Proulx, E. G., 69, 631, 818, 867.
 Prucha, M. J., 579, 778.
 Puchner, H., 725.
 Purcell, J. T., 683.
 Purdy, C., 746.
 Punnett, R. C., 73.
 Putnam, G. A., 404.
 Putterill, V. A., 156.
 Puttick, G. F., 399.
 Quarnberg, A. A., 746.
 Quartaroli, A., 629.
 Quayle, E. T., 319.
 Quevedo, J. M., 182.
 Quick, W. J., 898.
 Quittner, M. R., 205.
 Radcliffe, L. G., 201.
 Radder, N., 682.
 Radebaugh, G. H., 483.
 Rae, K. T., 637.
 Raghava Acharya, K., 477.
 Ragsdale, A. C., 770, 776, 778.
 Ragsdale, E., 741.
 Rainey, W., 883.
 Raistrick, H., 112.
 Ramaley, F., 129, 224.
 Ramann, E., 624.
 Ramsay, A. A., 75.
 Ramsay, J. M., 896.
 Ramsbottom, J. K., 49, 247, 350.
 Ramser, C. E., 478.
 Ramsey, G. B., 654.
 Rand, F. V., 245, 450.
 Randall, L., 399.
 Randell, W. G., 865.
 Randoin, L., 166.
 Rands, R. D., 659.
 Rane, F. W., 343, 658, 839.
 Ranoievitch, N., 841.
 Ransom, B. H., 80, 275, 384, 587.
 Rapeer, L. W., 297.
 Rapelje, A. C., 186.
 Rapp, W. C., 498.
 Rasch, W., 14.
 Rasmuson, H., 222, 328.
 Rasmussen, M. P., 200.
 Rasmusson, H., 500.
 Rasmusson, J., 500.
 Ratcliff, J. A., 827.
 Rathbone, H. R., 253.
 Rau, K. R. S., 477.
 Ravaz, L., 544.
 Ravenna, C., 10, 632, 822.
 Rawes, A. N., 237.
 Rayleigh (Lord), 618.
 Reboul, G., 319.
 Recknagel, A. B., 748.
 Record, S. J., 225, 443.
 Records, E., 272.
 Reddick, D., 751.
 Reddy, E. V. S., 292.
 Redfield, A. H., 291.
 Redfield, H. W., 414.
 Redway, J. W., 207.
 Redwood, B., 86, 389.
 Reed, C. A., 41, 240, 441.
 Reed, G. M., 844.
 Reed, H. S., 41.
 Reed, O. E., 398, 682.
 Reed, T. R., 511.
 Regan, W. M., 575.
 Regan, W. S., 246.
 Régnier, R., 552.
 Rehn, J. A. G., 851.
 Reid, D. L., 396.
 Reid, E. E., 505.
 Reid, F. R., 131.
 Reid, H. A., 82.
 Reid, P., 657.
 Reid, W. A., 94.
 Reihle, J. A., 511.
 Reilly, J., 502.
 Reiman, C. K., 615.
 Reimer, F. C., 145.
 Reimers, J. H. W. T., 378.
 Reinan, E., 510.
 Reinhard, H. J., 561.
 Reinhardt, R., 277.
 Reinking, O. A., 156.
 Reis, F. T. de S., 396.
 Reischer, 185.
 Reiter, C., 838.
 Remlee, R. F., 400.
 Remler, R. F., 700.
 Remlinger, P., 81.
 Renner, O., 521, 729.
 Rennie, J., 59.
 Renwick, V. A., 637.
 Reste, 342.
 Rettger, L. F., 584, 769, 791.
 Reynolds, H. A., 258, 661.
 Reynolds, J. B., 400, 403.
 Reynolds, L. A., 690.
 Rhoads, A. S., 552.
 Rhoads, McH., 695.
 Rhodes, L. B., 801.
 Rhodin, S., 24.
 Rhynus, C. P., 189.
 Rice, J. B., 571.
 Richards, C. R., 800.
 Richards, E. H., 19.
 Richardson, A. E. V., 642.
 Richardson, A. G. G., 497.
 Richardson, F. B., 700.
 Richardson, W. D., 431.
 Richter-Quittner, M., 205.
 Riddell, F. T., 378.
 Riddle, O., 66, 67.
 Rideal, S., 627.
 Rider, H., 399.
 Ridgell, R. H., 299.
 Ridgway, C. S., 534.
 Riegel, V. M., 898.
 Rieger, T., 278.
 Riel, P., 858.
 Rietz, J. H., 184.
 Rigg, G. B., 224.

- Riggs, W. M., 800.
 Rigotard, L., 513.
 Rigotard, M., 513.
 Riley, E. H., 899.
 Rintoul, A. V. D., 73, 873.
 Rippel, A., 225, 322, 525.
 Rippert, 22.
 Ripperton, J. C., 398.
 Ritter, G., 523.
 Ritzman, E. G., 172.
 Rivera, V., 431.
 Rixford, G. P., 239, 439.
 Roaf, H. E., 865.
 Roark, G. W., jr., 203.
 Roark, R. C., 352.
 Roark, R. J., 282.
 Robbins, W. W., 337.
 Roberts, A. W. R., 854.
 Roberts, E. E., 684.
 Roberts, G., 320, 331.
 Roberts, J. W., 743.
 Roberts, M. H., jr., 176.
 Roberts, R. H., 448.
 Roberts, S. R., 862.
 Robertson, C. J., 398.
 Robertson, J. W., 403.
 Robertson, M., 581.
 Robertson, W. F., 700.
 Robertson, W. H., 95.
 Robin, M., 342.
 Robinson, C. S., 113.
 Robinson, G., 747.
 Robinson, R. H., 129, 235, 312.
 Robison, R., 460.
 Robison, W. L., 377, 700.
 Robotka, F., 398.
 Robson, P. W., 890.
 Robson, R., 47.
 Rochaix, A., 791.
 Rockwell, C. S., 780.
 Rodd, E. H., 201.
 Rodenwold, B. W., 100.
 Rodes, W., 28.
 Roe, G. C., 464.
 Roethe, H. E., jr., 390.
 Rogers, A., 609.
 Rogers, C. C., 650.
 Rogers, E. C., 42.
 Rogers, G. B., 900.
 Rogers, L. A., 779.
 Rogers, R. F., 720.
 Rohwer, S. A., 857, 858.
 Rolet, A., 838.
 Rolfs, F. M., 36.
 Rolfs, P. H., 899.
 Roller, E. M., 497.
 Rollot, 342.
 Roman, F. L., 86.
 Rommel, G. M., 464, 674.
 Romell, L. G., 820.
 Ronca, V., 685.
 Root, A. I., 661.
 Root, E. R., 661.
 Ropes, E. H., 642.
 Rosa, J. T., jr., 643, 740, 741, 742.
 Rosé, 458.
 Rose, H., 816.
 Rose, M. S., 366.
 Rose, R. E., 187, 790, 817.
 Rosen, H. R., 844.
 Rosewall, O. W., 854.
 Rosewell, O. W., 163.
 Ross, C. R., 839.
 Ross, J., 186.
 Ross, P. H., 399.
 Ross, W. H., 312.
 Rossem, C. van, 425.
 Rostrup, S., 750.
 Roth, W. F., 174.
 Rothe, J. C., 866.
 Rothermel, E., 366.
 Rothgeb, B. E., 232.
 Rothwell, G. B., 868.
 Roubaud, E., 454, 853.
 Rouget, F., 651.
 Rousseau, B., 157.
 Rousseu, B., 775.
 Routh, G. C., 447.
 Rowley, F. B., 592.
 Roy, C., 63.
 Rubinow, S. G., 399.
 Ruddick, J. A., 779.
 Rudolf, D., 691.
 Rudolfs, W., 281, 343.
 Rühle, J., 365.
 Runner, G. A., 454.
 Russell, E. J., 19, 201, 209, 393, 518, 621, 642.
 Russell, E. T., 409.
 Russell, G. A., 90.
 Russell, H. L., 703, 800.
 Russell, W. A., 258.
 Ruth, C. C., 100.
 Ruzek, C. V., 512.
 Ryffel, J. H., 859.
 Saceghem, R. van, 583.
 Sackett, R. L., 800.
 Sackett, W. G., 163.
 Saillard, E., 206.
 Sakata, K., 568.
 Salaman, R. N., 829.
 Salisbury, E. J., 241.
 Salisbury, F. M., 700.
 Salmon, 587.
 Salmon, E. S., 346, 446.
 Solomon, R., 657.
 Salter, R. M., 524.
 Salvaterra, H., 15.
 Samec, M., 524.
 Sanada, K., 506.
 Sanborn, C. E., 51, 58, 498, 587.
 Sanders, G. E., 850.
 Sanders, J. G., 352.
 Sanderson, T., 366, 642.
 Sando, C. E., 39, 632, 834.
 Sandsten, E. P., 144.
 Sandstrom, M. W., 399.
 Sanford, H. L., 360.
 Sarle, C. F., 92.
 Sarti, C., 581.
 Sarvis, J. T., 522.
 Sasscer, E. R., 352.
 Sato, S., 395.
 Satterthwait, A. F., 762.
 Sauer, C. O., 894.
 Saunders, A. A., 250.
 Saunders, C. E., 366.
 Saunders, C. F., 649.
 Saunders, C. G., 887.
 Sauvage, E., 342.
 Sauzéat, 549.
 Savage, E. S., 671.
 Savage, W. G., 261.
 Savastano, L., 346, 349.
 Saw, M. P., 27.
 Sawers, G. C., 178.
 Scala, A., 462.
 Scales, G. C., 387.
 Scalia, G., 49.
 Scard, F. I., 507.
 Schaefer, C. T., 285.
 Schaefer, E. G., 736.
 Schaffer, J. M., 273.
 Schaffner, J. H., 522.
 Schaubmann, H., 860.
 Schenck, H., 732.
 Scherago, M., 683.
 Schick, 793.
 Scherlinger, L., 241.
 Schleinitz, M. F. von, 63.
 Schlesinger, M. J., 113.
 Schloss-Weill, B., 431.
 Schmidt, E. W., 124.
 Schmidt, J., 866.
 Schmidt, K., 267.
 Schmidt, R., 15.
 Schmitz, N., 528.
 Schneider, G., 436, 829.
 Schneidewind, 125.
 Schoellhorn, K., 730.
 Schoevers, T. A. C., 544.
 Schollenberger, C. J., 713, 813.
 Scholz, 221.
 School, E. E., 161.
 Schoonover, W. R., 212, 214.
 Schroeder, E. C., 82, 784.
 Schüepp, O., 130.
 Schultz, E. S., 546.
 Schulz, J. A., 700.
 Schulze, J. F. W., 25.
 Schulze, P., 83.
 Schulz van Vlissingen, L. R. E., 43.
 Schutte, W. M., 185.
 Schwab, J. W., 485.
 Schwartz, B., 380.
 Schwarz, H., 369.
 Schwarzacher, F., 895.
 Scott, H. P., 198.
 Scott, J. M., 335, 528, 775.
 Scott, J. W., 189, 786.
 Scott, L. B., 440.

- Scott, W., 585.
 Scott, W. R., 594.
 Seabra, A. F. de, 452.
 Seabrook, W. P., 835.
 Seabury, V. H., 209.
 Seal, J. L., 399.
 Seaman, E. C., 865.
 Seamans, A. E., 332.
 Sears, F. C., 40.
 Secor, J. A., 891.
 Secrest, E., 746.
 Segerblom, W., 801.
 Selby, H. E., 199, 498.
 Seligmann, E., 261.
 Sellergren, G., 828.
 Sen, J. N., 777.
 Serpieri, A., 747.
 Severin, H. C., 850.
 Severson, B. O., 570.
 Seyler, H., 214.
 Shalot, C., 342.
 Shamboo Datt Joshi, 241.
 Shamel, A. D., 239, 439, 440,
 542, 837.
 Shanahan, E. W., 593.
 Shapovalov, M., 732, 751.
 Sharp, D., 250 .
 Sharp, P. F., 399.
 Shaver, R. M., 16.
 Shaw, E. B., 880.
 Shaw, J. K., 199.
 Shaw, N., 208.
 Shaw, P. J., 833.
 Shaw, R. S., 698.
 Shaw, W. M., 900.
 Shaw, W. T., 350.
 Sheals, R. A., 350, 658.
 Sheather, A. L., 688.
 Shedd, C. K., 485, 498, 700.
 Shedd, O. M., 814.
 Sheehan, B. F., 833.
 Sheehy, E. J., 578.
 Shellard, I. F., 284.
 Sherbakoff, C. D., 599, 900.
 Sheridan, J. Z., 99.
 Sherlock, C. C., 873.
 Sherman, F., 449, 562, 759.
 Sherman, H. C., 311.
 Sherman, J. M., 569, 579.
 Shilston, A. W., 688.
 Shinkui, N. H., 456.
 Shinn, E. H., 797.
 Shipley, A. E., 50.
 Shipman, T. G., 117, 119.
 Shirras, G. F., 491, 492.
 Shive, J. W., 210.
 Shivers, C. C., 384.
 Shonle, H. A., 164, 504.
 Shorten, J. A., 63.
 Shoup, G. R., 189, 392, 496,
 675, 798.
 Shoup, (Mrs.) G. R., 496,
 675, 798.
 Shrader, J. H., 802.
 Shull, C. A., 433.
 Shull, G. H., 434.
 Shutt, F. T., 726, 728.
 Sicard, H., 40.
 Siecke, E. O., 747.
 Sieglinger, J. B., 232.
 Sievers, F. J., 722, 726.
 Sifton, H. B., 832.
 Silver, A. H., 269.
 Silvestri, F., 252.
 Sim, T. R., 441.
 Simmermacher, W., 322.
 Simmins, S., 57.
 Simmons, J. E., 379.
 Simon, C., 525.
 Simon, F. L., 887.
 Simens, L. R., 299.
 Simpich, F., 94.
 Simpson, R. A., 237.
 Sims, N. L., 91, 894.
 Sinclair, J. M., 780.
 Singleton, W. M., 73, 778.
 Sinn, G., 879.
 Skidmore, L. V., 700.
 Skinner, E. L., 800.
 Skinner, J. H., 375, 868, 869,
 870.
 Skinner, J. J., 131, 519.
 Skinner, W. W., 13.
 Sladen, F. W. L., 762.
 Slocum, R. R., 468, 675.
 Slosse, A., 416.
 Small, C. P., 669.
 Small, W., 350.
 Smart, W. A. M., 10.
 Smies, E. H., 720.
 Smith, A. F., 174.
 Smith, A. M., 132, 517.
 Smith, E. B., 387, 388, 389.
 Smith, F. H., 44, 150.
 Smith, G. A., 896.
 Smith, G. E. P., 788.
 Smith, G. S., 207, 511.
 Smith, H. A., 191.
 Smith, H. C., 511.
 Smith, H. H., 899.
 Smith, H. S., 659.
 Smith, J. W., 15, 717, 718.
 Smith, K. G., 486.
 Smith, L. B., 451, 547.
 Smith, L. J., 400.
 Smith, R. S., 196.
 Smith, T., 475, 586, 834.
 Smith, T. O., 28, 29, 842.
 Smith, W. H., 199.
 Smith-Gordon, L., 74, 94,
 594, 694.
 Smits van Burgst, C. A. L.,
 259.
 Smyth, E. G., 252.
 Smyth, J. R., 497.
 Smyth, P. H., 511.
 Snell, W. H., 754.
 Snyder, E. M., 497.
 Snyder, J. M., 719.
 Snyder, R. M., 698.
 Snyder, R. P., 898.
 Snyder, T. E., 256, 556, 592.
 Soar, M. C., 458.
 Söderberg, E., 328.
 Sohler, W. D., 186.
 Sohns, J. C. F., 795.
 Solomon, D. D., 528.
 Solopkar, M. B., 502.
 Sorenson, C. J., 499.
 Sorenson, J., 75.
 Soroa, J. M. de, 423.
 Soula, L. C., 369.
 Sousa Reis, F. T. de, 396.
 Southard, A. E., 563.
 Spafford, R. R., 437.
 Spafford, W. J., 528, 721.
 Spann, T., 576.
 Sparrow, S. W., 890.
 Spaulding, P., 249.
 Speakman, H. B., 712.
 Spears, H. D., 373.
 Spencer, G. C., 630.
 Spengel, A., 624.
 Speyer, E. R., 54.
 Spiller, A., 671.
 Spillmann, L., 168.
 Spinks, G. T., 742, 835.
 Spitzer, G., 805, 875.
 Spoehr, H. A., 227, 429.
 Sprague, T. O., 100.
 Spratt, E. R., 30.
 Spray, R. S., 586, 884.
 Sprenger, A. M., 546.
 Spurway, C. H., 124.
 Stadler, L. J., 735.
 Stahel, G., 349.
 Stahl, J. L., 197, 397, 496,
 693, 798.
 Staley, R. M., 780.
 Stanoiévitch, G. M., 618.
 Stanton, E. W., 899.
 Stanton, T. R., 639.
 Stapledon, R. G., 638.
 Stead, A., 624.
 Stearns, L. A., 558.
 Steenbock, H., 367, 766.
 Stehle, R. L., 569.
 Stelk, K., 789.
 Steinberg, R. A., 130.
 Steinmetz, C. P., 323.
 Stemple, F. W., 135, 139.
 Stene, A. E., 350.
 Sterrett, W. D., 443.
 Stevan, H. M., 748.
 Stevens, E. H., 513.
 Stevens, F. L., 445.
 Stevens, H. E., 550, 599.
 Stevens, H. J., 246.
 Stevens, J. C., 279.
 Stevens, N. E., 848.
 Stevenson, C., 179.
 Stevenson, J. A., 544, 548,
 551.
 Stewart, E. G., 226.
 Stewart, F. C., 544.
 Stewart, F. E., 494.
 Stewart, J. G., 487.
 Stewart, J. P., 538, 554.

- Stewart, R., 517, 700.
 Stewart, V. B., 751.
 Stieger, G., 570.
 Still, G. F., 568.
 Stillman, E., 370.
 Stinson, L., 398.
 Stirling, F., 550.
 Stivelman, B., 278.
 Stockdale, F. A., 243, 532.
 Stockfeth, B., 287.
 Stocking, W. A., jr., 680.
 Stockton, M., 836.
 Stoddard, E. M., 237.
 Stoker, F., 366.
 Stoll, A., 525, 526.
 Stone, G. W., 598.
 Stone, R. E., 656, 732.
 Stone, W. E., 800.
 Stone, W. O., 100.
 Stookey, E. B., 197, 333, 436, 738.
 Stout, A. B., 521.
 Straight, E. M., 771.
 Strait, E. D., 692.
 Strite, G. T., 87, 89.
 Stroud, J. F., 281, 511.
 Struck, F. T., 599.
 Stuckey, H. P., 139, 146, 147.
 Studley, L. A., 399.
 Sturtevant, A. H., 268.
 Stutzer, A., 413, 513, 628.
 Sullivan, K. C., 757.
 Sundstroem, E. S., 564.
 Süpfle, K., 181.
 Süring, R., 321.
 Sutherland, R. W., 695.
 Sutton, G. L., 347, 376, 445, 824.
 Sutton, I., 632.
 Svoboda, H., 170.
 Swain, A. F., 452.
 Swaine, J. M., 403.
 Swan, R. G., 787.
 Swann, H. K., 250.
 Swanson, C. O., 729.
 Swarthout, A. V., 878.
 Sweeney, W. J., 498.
 Swenk, M. H., 54.
 Swett, W. W., 776.
 Swift, R. W., 700.
 Swingle, D. B., 321.
 Sydenstricker, E., 264, 863.
 Symon, J. A., 47.
- Tacke, 20, 323, 623.
 Täckholm, G., 328.
 Tacussel, A., 745.
 Taggart, W. G., 626, 635, 659.
 Takamine, J., jr., 503.
 Takemoto, S., 82.
 Talbot, F. B., 368.
 Talbot, G., 453.
 Tallman, C., 486.
 Talmage, H. R., 531.
 Tamayo, L. E., 500.
- Tammes, T., 133, 327.
 Taniguchi, T., 82.
 Tapley, W. T., 399.
 Tarr, L. W., 198.
 Tattersfield, F., 854.
 Taubenhaus, J. J., 845, 846.
 Taylor, A. E., 489, 490, 704, 705.
 Taylor, C. A., 299.
 Taylor, C. C., 787.
 Taylor, D. G., 689.
 Taylor, E. A., 719.
 Taylor, E. M., 623.
 Taylor, E. P., 398.
 Taylor, F. W., 34, 35, 520.
 Taylor, G., 718.
 Taylor, M. W., 849.
 Taylor, W. S., 599.
 Tchikoff, V. V., 319.
 Tedin, H., 500.
 Teichmann, E., 51.
 Teller, G. L., 615.
 Temple, O. P., 900.
 Tenbroeck, C., 685, 782, 785.
 Ten Eyck, P. G., 200.
 Tennent, R. B., 271, 379.
 Teppaz, L., 583, 584.
 Terrill, B. M., 800.
 Terry, E. I., 149.
 Tether, C. H., 797.
 Thach, C. C., 99.
 Tharp, W. E., 720.
 Thatcher, R. W., 800.
 Thaxter, R., 250.
 Thayer, P., 339, 341, 744.
 Thaysen, A. C., 502.
 Theiler, A., 683.
 Thellung, A., 818.
 Thilo, H., 271.
 Thjótta, T., 382.
 Thom, C., 168.
 Thomas, A. O., 696.
 Thomas, H. H., 236, 833, 838.
 Thomas, K., 873.
 Thomas, M., 123.
 Thomas, M. G., 577.
 Thomas, W., 116.
 Thompson, C., 622.
 Thompson, C. A., 738.
 Thompson, C. P., 70, 485.
 Thompson, G. E., 137, 733.
 Thompson, M. J., 480, 627, 636, 671, 674, 679, 698.
 Thompson, R., 900.
 Thompson, R. J., 395.
 Thompson, T. G., 224.
 Thompson, W. C., 174, 787.
 Thompson, W. G., 387.
 Thompson, W. P., 404.
 Thomsen, F. L., 681.
 Thomson, O. P., 870.
 Thomson, E. H., 191, 291.
 Thomson, R., 50.
 Thone, F., 733.
 Thornber, J. J., 749.
- Thorne, C. E., 322, 324, 333, 486, 726.
 Thornton, S. F., 799.
 Thornton, T., 637.
 Thurston, A. N., 805.
 Thurston, H. W., jr., 841.
 Ticehurst, N. F., 50.
 Tiemann, H. D., 590, 591.
 Tiffany, E. M., 800.
 Tillman, B. W., 812.
 Timberlake, P. H., 662.
 Tingley, R. H., 557.
 Tinkler, C. K., 458.
 Tinline, M. J., 773.
 Titze, 786.
 Tjebbes, K., 818.
 Toan, L. A., 299.
 Tocher, J. F., 74.
 Tognoli, E., 65.
 Toit, P. J. du, 883.
 Tolley, H. R., 193.
 Tolman, L. M., 409.
 Tomhave, W. H., 569.
 Tompkins, C. M., 144.
 Tomson, W. E., 699.
 Tonnesson, R. D., 824.
 Tonney, F. O., 877.
 Torney, J. L., 494.
 Tosterud, M. O., 123.
 Tothill, J. D., 850.
 Tottingham, W. E., 431.
 Trabut, L., 840.
 Tracy, N., 99.
 Tracy, S. M., 638.
 Trask, C. A., 89.
 Traum, J., 585.
 Travers, W. C., 559, 743.
 Traverso, G. B., 49.
 Tressler, D. K., 663.
 Tretsven, O., 68.
 Trevor, C. G., 840.
 Trewartha, W. C., 513.
 Troop, J., 799.
 Trowbridge, E. A., 775.
 Trowbridge, P. F., 397, 708.
 Troy, H. C., 415, 469.
 Truax, H. E., 236, 335, 336.
 True, G. H., 198.
 Trullinger, R. W., 321.
 Truniger, E., 325.
 Truog, E., 622.
 Tryon, H., 456, 457, 560.
 Tsuji, T., 730.
 Tubeuf, C. von, 821.
 Tuch, R., 210.
 Tucker, W. C., 290.
 Tufts, W. P., 237.
 Tukey, H. B., 799.
 Tullgren, A., 256.
 Tunstall, A. C., 552.
 Turley, T. B., 629.
 Turner, A. W., 420.
 Turner, C. A. P., 188.
 Turner, C. C., 695.
 Turner, C. W., 778.
 Turner, E. P., 542, 747.

- Turner, H. W., 81.
 Turner, J. D., 378.
 Turney, A. G., 833.
 Turpain, A., 790.
 Turpin, H. W., 812.
 Tuttle, G. M., 29.
 Tweedy, R. N., 287.
 Tyler, R. G., 482.
 Tyzzer, E. E., 476, 885.
- Uematsu, S., 568.
 Ullrich, F. T., 513.
 Ullsperger, H. W., 22.
 Ulrichs, 570.
 Underhill, B. M., 580.
 Unger, L. J., 369.
 Unwin, A. H., 839.
 Upham, C. M., 387.
 Upton, G. E., 199.
 Upton, H. E., 378.
 Urbahns, T. D., 364.
 Ursprung, A., 225.
 Uyeda, Y., 617.
- Valgren, V. N., 193.
 Valleau, W. D., 446, 653.
 Vallejo, C., 279.
 Van Asbeck, 748.
 van Burgst, C. A. L. S., 259.
 van Calcar, R. P., 868.
 van der Goot, P., 452.
 van der Lek, H. A. A., 547.
 Van der Linden, T., 508, 509.
 van der Vlies, P., 795.
 Vandormael, J., 127.
 Van Dyke, E. C., 699.
 Van Elk, A., 532.
 Van Es, L., 882, 887.
 van Hall, C. J. J., 45.
 van Harreveld, P., 548.
 Van Leersum, 879.
 Van Leersum, E. W., 800.
 van Leeuwen, C. A. E., 691.
 van Noughijs, H., 806.
 Van Pelt, C., 149.
 van Rossen, C., 425.
 van Sacceghem, R., 583.
 Van Slyke, D. D., 205.
 Van Slyke, L. L., 578, 579, 626.
 Van Valkenburgh, H. B., 12.
 van Vlissingen, L. R. E. S., 43.
 Varney, B. M., 719.
 Vass, A. F., 134, 436.
 Vaughan, H. W., 697.
 Vaughan, R. E., 46, 153, 654.
 Vautier, E., 804.
 Vawter, L. R., 700.
 Vayssièrè, P., 452, 661.
 Veatch, J. O., 512.
 Veitch, 713.
 Veitch, R., 52.
 Venkata, M. K., 745.
 Vercier, J., 195.
 Verda, A., 588.
- Vermilye, E., 494.
 Vermorel, 544, 550.
 Vernet, G., 841.
 Vernerd, L., 415.
 Vernier, P., 853.
 Vestal, C. M., 375, 868.
 Vigiani, D., 41.
 Vik, K., 829.
 Villard, V., 745.
 Vinal, G. W., 891.
 Vinall, H. N., 639.
 Vincent, C. C., 744.
 Vinson, A. E., 724, 745, 764, 789.
 Vinson, C. G., 599.
 Vishar, S. S., 491, 618.
 Viswalingam, A., 263.
 Vivian, A., 697.
 Vlies, P. van der, 795.
 Vlissingen, L. R. E. S. van, 43.
 Voegtlin, C., 459, 667, 668.
 Voelcker, J. A., 28.
 Vogel, I. H., 753.
 Vogt, P. L., 495.
 Voigt, E., 422.
 Völtz, W., 64, 367.
 Vories, R. E., 274.
 Vosbury, E. D., 342.
 Vries, H. de, 222, 521, 729.
 Vuillet, A., 858.
- Wacker, H., 638.
 Wadley, F. M., 164.
 Waentig, P., 670.
 Waeser, I. B., 617.
 Waggaman, W. H., 629.
 Waite, R. H., 574, 575, 586.
 Wakeland, C., 457.
 Wakeman, A. J., 409.
 Waksman, S. A., 634, 635.
 Waldbott, S., 712.
 Walden, B. H., 252.
 Waldron, L. R., 527.
 Walker, 586, 587.
 Walker, F. R., 188.
 Walker, H. S., 507.
 Walker, J. C., 153.
 Walker, J. H., 284.
 Walker, S. S., 212.
 Wallace, H. A., 394.
 Wallace, H. F., 100.
 Wallace, L., 700.
 Waller, A. D., 463.
 Wallin, H. C., 149.
 Wallis, T. E., 53.
 Walter, E. J., 900.
 Walton, W. R., 55, 161.
 Wann, F. B., 430.
 Warburton, C. W., 639.
 Ward, E. S., 169.
 Ward, F. C., 456.
 Ward, F. E., 894.
 Ward, R., 532.
 Ware, J. W., 496.
 Warren, E., 222, 450.
- Warren, E. De, 292.
 Warren, G. M., 485.
 Warth, F. J., 27.
 Waterbury, H. E., 549.
 Waterman, H. C., 410.
 Watkins, H., 291.
 Watkins, J. B., 562.
 Watson, E. A., 885.
 Watson, E. B., 512.
 Watson, J. A. S., 67.
 Watson, J. R., 551, 558.
 Watson, M. W., 387.
 Watson, O. M., 900.
 Watson, R., 841.
 Watt, A. S., 241.
 Watts, F., 252.
 Watts, R. L., 705, 707, 800.
 Waugh, F. A., 702.
 Way, C., 780.
 Way, W. D., 384.
 Weatherwax, P., 222.
 Weaver, E. R., 611.
 Weaver, L. A., 772.
 Webb, J. L., 252.
 Webber, H. J., 41, 99, 710.
 Weber, F., 821.
 Weber, F. C., 111.
 Weber, H., 343.
 Webster, A. D., 350, 542.
 Webster, A. G., 122.
 Wedel, H. O. von., 687.
 Wedemann, W., 877.
 Wehmer, C., 15, 523.
 Weidman, R. H., 841.
 Weigel, C. A., 360, 362.
 Weightman, R. H., 511.
 Well, L., 415.
 Weill, B. S., 431.
 Welmer, J. L., 752.
 Weir, W. W., 719.
 Weiss, H. B., 556, 659, 835.
 Weiss, H. F., 841.
 Weitzel, A., 63.
 Welch, M. F., 384.
 Wellington, R., 299, 527, 741.
 Wells, E. B., 399.
 Wells, P. V., 613.
 Wells, S. D., 650.
 Welton, F. A., 334.
 Wendt, G. L., 313.
 Wene, E. H., 173.
 Wenger, P., 803.
 Wenzholz, H., 422, 671.
 Wennink, C. S., 546.
 Wentworth, E. N., 499.
 Werner, H., 829.
 Wery, G., 499, 838.
 Wessen, M. H., 594.
 Wessels, P. H., 672.
 West, C., 224.
 West, E., 659.
 West, F. L., 743.
 West, R. M., 115.
 Wester, D. H., 10, 802.
 Wester, P. J., 487.
 Weston, R. S., 520.

- Weston, W. H., jr., 545.
 Westover, E. L., 400.
 Westover, H. L., 528.
 Wheeler, F. E., 199.
 Wheeler, G. A., 264, 863.
 Wheeler, W., 661.
 Wheeler, W. M., 851.
 Wheeler, W. P., 574.
 Wherry, E. T., 119, 801.
 Whinyates, L., 201.
 Whipple, O. B., 46, 531.
 Whitby, S., 31.
 White, A., 143.
 White, A. H., 24, 219.
 White, D. S., 879.
 White, E. M., 800.
 White, F. M., 790.
 White, F. R., 186.
 White, G. C., 584.
 White, G. F., 58.
 White, R. G., 777.
 White, T. H., 143.
 White, T. P., 474.
 Whitehead, W. E., 850.
 Whitehouse, W. E., 38.
 Whiting, A. L., 212, 214.
 Whitman, C. O., 66, 67.
 Whitney, M., 817.
 Whitson, A. R., 622.
 Whitten, J. C., 141, 235.
 Wiancko, A. T., 234.
 Wichers, L., 124.
 Widmark, E. M. P., 205.
 Wiedorn, W. S., 799.
 Wiegley, M., 800.
 Wiessmann, H., 220.
 Wiggans, C. C., 146.
 Wilbur, J. W., 399.
 Wilcox, A. M., 857.
 Wilcox, E. M., 199.
 Wildermuth, V. L., 357.
 Wilkins, F. S., 235.
 Wilkins, R. H., 72.
 Whitson, A. R., 22, 489.
 Willard, J. D., 300, 489.
 Willard, W. C., 288.
 Willcox, W. H., 263.
 Williams, C. B., 419, 424,
 425, 427, 434, 816.
 Williams, F. X., 661, 662.
 Williams, G. M., 590.
 Williams, R. H., 772, 775,
 777.
 Williams, R. J., 614.
 Williams, R. S., 779.
 Williams, W. L., 183, 532,
 683.
 Williamson, C. O., 699.
 Williamson, J. T., 233, 333.
 Willis, J. C., 31, 129, 148.
 Willis, R. L., 37.
 Wills, J. G., 473.
 Willson, C. A., 900.
 Willstätter, R., 525, 526.
 Wilson, A. L., 499.
 Wilson, B. D., 215.
 Wilson, B. S., 497.
 Wilson, C. B., 493, 699.
 Wilson, C. S., 399, 661.
 Wilson, E., 543.
 Wilson, E. B., 269.
 Wilson, E. D., 285.
 Wilson, G. W., 845.
 Wilson, J., 601, 602, 603,
 604, 605, 606, 607.
 Wilson, J. A., 506, 800.
 Wilson, J. B., 111.
 Wilson, P. S., 887.
 Wilson, P. St. J., 186.
 Wilson, W., 101, 699.
 Wilson, W. H., 865.
 Wimer, D. C., 498, 700.
 Winckel, F. W., 583.
 Windrow, R. J., 591.
 Winge, O., 433, 632.
 Winner, G. B., 628.
 Winslow, K., 683.
 Winston, H. L., 498.
 Winston, J. R., 157.
 Winters, A. R., 700.
 Winters, R. Y., 244.
 Winterstein, E., 204, 632.
 Wiprud, A. C., 394.
 Witherby, H. F., 50.
 Withers, W. A., 411.
 Winton, A. L., 313.
 Witt, J. F., 689.
 Witte, 502.
 Wöber, A., 444.
 Wocke, E., 431.
 Wodsedalek, J. E., 670.
 Woglum, R. S., 54, 319, 557,
 850.
 Wolbach, S. B., 60.
 Wolf, C. G. L., 880.
 Wolf, F. A., 245.
 Wolfe, H., 393.
 Wolff, H. H., 293.
 Wolff, M. H., 441.
 Wolff, W. H., 199.
 Woll, F. W., 576, 876.
 Wolseley (Viscountess), 236.
 Woo, M. L., 225.
 Wood, C. J., 137.
 Wood, D. C., 199.
 Wood, E. G., 559.
 Wood, J. A., 300.
 Wood, R. C., 477.
 Woodbury, C. G., 198, 395.
 Woodbury, T. D., 442.
 Woodcock, H. M., 865.
 Woods, A. F., 221.
 Woods, C. B., 337, 662, 899.
 Woods, J., 689.
 Woodward, E. G., 197, 780.
 Woodward, K. W., 41.
 Woodward, S. M., 788.
 Woolard, E. W., 718.
 Wooley, J. C., 498, 699.
 Woolsey, T. S., 442.
 Working, H., 497.
 Works, G. A., 695.
 Wormald, H., 48, 246.
 Wormald, L. K., 346.
 Worthley, H. N., 700.
 Worthley, H. P., 199.
 Wriedt, C., 375.
 Wright, A. H., 335.
 Wright, C. A., 887.
 Wright, L. H., 83, 700.
 Wright, R. V., 699.
 Wright, T., 464.
 Wright, T. H., jr., 873.
 Wünsche, F., 503.
 Wyant, R. W., 615.
 Wyant, Z. N., 115, 329, 698.
 Yallie, J., 895.
 Wyman-Stone, G., 598.
 Yada, T., 569.
 Yamandi, J., 290, 294.
 Yao, H. H., 673.
 Yapp, W. W., 669.
 Yarnell, D. L., 788.
 Yeld, E., 272.
 Yoder, L., 501.
 York, H. H., 249.
 Yoshida, S., 80, 381.
 Yothers, W. W., 157, 554.
 Young, F. D., 16, 417.
 Young, H. B., 791.
 Young, S. E., 780.
 Youngberg, S., 472.
 Youngblood, B., 496.
 Zacharewicz, E., 745.
 Zannelli, P., 781.
 Zappe, M. P., 251.
 Zeleny, C., 668.
 Zell, C. A., 79.
 Zilva, S. S., 461, 462, 568.
 Zimmerman, O. B., 390, 592.
 Zinn, J., 641.
 Zitkowski, H. E., 416.
 Zuber, N. D., 550, 554.
 Zundel, G. L., 242.

INDEX OF SUBJECTS.

NOTE.—The abbreviations "Ala. Col.," "Conn. State," "Mass.," etc., after entries refer to the publications of the respective State experiment stations; "Guam," "Hawaii," and "P. R.," to those of the experiment stations in Guam, Hawaii, and Porto Rico; "Can.," to those of the experiment stations in Canada; and "U.S.D.A.," to those of this Department.

- Abaca, culture and uses, 826.
- Abortion—
 and sterility, 780.
 contagious, control, 181.
 contagious, in cattle, 683.
 contagious, in cattle, Conn. Storrs, 584.
 contagious, in swine, 585, 586.
 contagious, new vaccine, 82.
 contagious, review of literature, 784.
 contagious, studies, Mo., 784.
 contagious, summary of information, 82.
 (See also *Bacillus abortus*.)
 in goats, Mich., 688.
- Absorption and agglutination tests, correlation, 879.
- Abutilon theophrasti*, variation in, 433.
- Acarids, studies, 80.
- Accessory food factors. (See Vitamins.)
- Accipitres, synoptical list, 250.
- Acetaldehyde—
 effect on protein hydrolysis, 110.
 exhalation from ripe apples, 711.
- Acetone—
 concentration in blood, studies, 205.
 production process, 712.
- Acetone-butyl alcohol fermentation of carbohydrates, 502.
- Acetonuria in domestic mammals, 879.
- Acetylsalicylic acid, antipyretic action, 371.
- Achorutes viaticus* on sewage filters, 853.
- Achromaticus macfel*, notes, 883.
- Acid phosphate. (See Superphosphate.)
- Acid solutions, taste of, relation between total acidity and H-ion concentration, 11.
- Acidimetry of soils, 12, 612, 713.
- Acidity—
 determination, H-electrode, 313.
 in cream, partial neutralization, 75.
 of culture media, 329.
 rôle in sugar inversion, 416.
- Acids—
 amino. (See Amino acids.)
 fatty. (See Fatty acids.)
- Acriflavin, antiseptic value, 79.
- Acronycta oblongata*, notes, Conn. State, 251.
- Actinomyces*—
chromogenus, notes, 243, 655.
scabies, notes, 751.
- Actinomycetes—
 effect on reaction of culture media, 635.
 nitrogen metabolism, 634, 635.
- Acysta perseæ*, notes, 851.
- Adhesives, manufacture from corncobs, 809.
- Adoretus*—
tenuimaculatus on cacao leaves, 52.
versutus, notes, 52.
- Adrenal insufficiency cause of edema, 66.
- Aeration—
 apparatus for ammonia determination, 212.
 effect on roots of *Zea mays*, 327.
- Aerial photographs, interpretation of, 748.
- Aerological—
 apparatus, new, U.S.D.A., 718.
 observations, U.S.D.A., 118.
 observations in West Indies, U.S.D.A., 718.
- Aerology. (See Atmosphere.)
- Afforestation. (See Forestation.)
- African coast fever, 582.
- Agaricaceæ, effect of light on fructification, 819.
- Agglutination—
 and absorption tests, correlation, 879.
 studies, 781.
- Aggregates, road. (See Road materials.)
- Agrarian reform in Roumania, 94.
- Agricultural—
 associations in Porto Rico, 291.
 bargaining, collective, 488.
 by-products as feeding stuffs, 170.
 chemistry. (See Chemistry.)
 colleges—
 and Department of Agriculture, cooperation, 704.
 present problems, 703.
 (See also Alabama, Arizona, etc.)
 colonization. (See Land settlement.)
 conditions—
 in Deccan Canal areas, 95.
 in Greece, 600.
 in India, 293.
 in Ozark Highland, 894.
 (See also Agriculture.)
 cooperation—
 causes of failure, 192.
 in Burma, 94.
 in Denmark, 292, 694.
 in England and Wales, 895.
 in India, 192, 293, 488.
 in Italy, 94.
 in Nebraska, 594.

Agricultural—Continued.

- cooperation—continued.
 - in Philippines, 294.
 - in Roumania, 94.
 - in Scotland, 895.
 - treatise, 594.
- Council in Denmark, 600.
- credit—
 - farm loans types, 192.
 - Federal farm loan system, 394.
 - function of central banks, 294.
 - in Illinois, 593.
 - in India, 293, 294.
 - in Philippines, 294.
 - institutions in United States, 393.
 - short-term, 294.
- development, need for in New England, 123.
- economics. (*See Rural economics.*)
- education—
 - elementary, in New Brunswick, 796.
 - in Argentina, 296.
 - in Belgium, reorganization, 295.
 - in Chile, 96.
 - in Dutch East Indies, 795.
 - in England and Wales, 493.
 - in England, development, 487.
 - in France, reorganization, 95.
 - in New South Wales, 96.
 - in Scotland, 896.
 - project method, 492.
 - regulations for grants in England and Wales, 195.
 - vocational, equipping school plant, 695.
 - vocational, field trips for, 97.
 - vocational, in Idaho, 298, 493.
 - vocational, in Illinois, 695.
 - vocational, in New Jersey, 796.
 - vocational, in South Carolina, 597.
 - vocational, in Virginia, 597.
 - vocational, time emphasis in, 492.
 - (*See also Agricultural instruction and Vocational education.*)
- engineering in Bombay, 185.
 - (*See also Engineering.*)
- experiment stations. (*See Experiment stations.*)
- extension, Ind., 395.
- extension—
 - in Manitoba, 297.
 - in Massachusetts, 194.
 - junior, 396, 695.
 - on Indian reservations, 799.
 - relation to farm-bureau movement, 706.
- fair exhibits, Wash., 798.
- holdings, distribution in India, 292.
- hydraulics in Cochin China, 689.
- implements, normal day's work, U.S.D.A., 193.
- instruction—
 - courses, 196, 696, 697.
 - elementary, in Los Angeles, 795.
 - elementary, in Montana, 598.
 - elementary, in Texas, 598.

Agricultural—Continued.

- instruction—continued.
 - elementary, in Wisconsin, 797.
 - for service men, 395.
 - function and organization of course of study, 897.
 - illustrative material for, 396.
 - in Belgium, 897.
 - in Brazil, 97, 396.
 - in colleges, improvement, 705.
 - in Colorado, 396.
 - in Dutch East Indies, 296.
 - in Germany, 897.
 - in high schools, credits for, 298.
 - in Illinois, 695.
 - in secondary schools in Maine, 96.
 - lessons, 797.
 - preapprenticeship and apprenticeship in Africa, 295.
 - schoolhouse and shops for, 598.
 - (*See also Agricultural education.*)
- insurance in Philippines, 294.
- investigation. (*See Agricultural research.*)
- journals, new, 499.
- labor—
 - conditions for, 193.
 - efficiency, in India, 293.
 - factors affecting wages, 793.
 - statistics of Belgium, 292.
 - wages in Bessarabia, U.S.D.A., 694.
 - (*See also Labor.*)
- laborers, normal day's work, U.S.D.A., 193.
- laws in France, 292.
- machinery—
 - development in England, 483.
 - for cultivation of silage crops, 289.
 - foreign markets for, 289.
 - repairing, post drill press for, 483.
 - selection and cost, 790.
 - use in Brazil, 90.
 - (*See also Harvesting and Thrashing machinery.*)
- organization—
 - earliest, in India, 292.
 - in Ireland, 488.
- prices—
 - fixing, 489.
 - future, 193.
 - treatise, 394.
- production—
 - as affected by depreciation of exchange, 489.
 - in Brazil, survey, 488.
 - relation to population, 693.
- products—
 - export trade of Philippines, 487.
 - Federal inspection, U.S.D.A., 490.
 - foreign trade in, U.S.D.A., 595.
 - marketing. (*See Marketing.*)
 - of Brazil, 291.
 - prices, Government control, 394.
- prosperity—
 - and European credits, 393.
 - in 1920, 92.
- purchase societies in Germany, 94.

- Agricultural—Continued.
 reconstruction. (*See Reconstruction.*)
 research—
 as affected by the war, 707.
 impartiality of, 598.
 importance and needs, 704, 707,
 710.
 need of funds, 395.
 organization, 698.
 project essentials, editorial, 302.
 regulations for grants in England
 and Wales, 195.
 resources of Argentina, 487.
 school, high, of Hohenheim, historical
 sketch, 97.
 schools—
 in Brazil, 97.
 rural junior high, in Virginia, 597.
 statistics—
 international, 896.
 of Austria, 595.
 of Brazil, 595.
 of British India, 896.
 of Canada, Can., 795.
 of Chile, 295.
 of Denmark, 295.
 of England and Wales, 395.
 of France, 795.
 of French colonies, 194.
 of India, 492.
 of Italy, 393, 896.
 of New Zealand, 491.
 of Norway, 795.
 of Ohio, Ohio, 486.
 of Scotland, 95, 896.
 of South Dakota, 491.
 of United Kingdom, 95, 491.
 teachers—
 academic standards for, 705.
 training, 296, 297, 596, 696, 697,
 705, 706.
 tenancy. (*See Land tenure.*)
 terminology, Norwegian, 98.
 training for ex-service men, 93.
 war damages, guide for estimating, 290.
- Agriculture—
 land foreign trade, U.S.D.A., 490.
 books for high schools, 698.
 Department of. (*See United States
 Department of Agriculture.*)
 importance in America, 393.
 in central France, 895.
 in Cyprus, 795.
 in England, development, 487.
 in England during two wars, 894.
 in France, comparison with other coun-
 tries, 94.
 in Germany, present condition, 94.
 in Japan, 395.
 in Philippines, 487.
 in Scotland, economics of small farms,
 594.
 in Spain, relation to transportation
 rates, 488.
 in Tropics for ex-service men, 93.
 (*See also Agricultural conditions.*)
 power applied to, 591.
- Agriculture—Continued.
 profit and loss sharing, 895
 profit-sharing in, 793.
 use of electricity in, 285.
Agrius restrictus, notes, 57.
Agrotis ypsilon. (*See Cutworm, black.*)
 Air—
 conditioning in private houses, 486.
 ionization by plants, 225.
 maps for forest areas, 840.
 movements, studies, U.S.D.A., 118.
 (*See also Atmosphere.*)
 Airplanes, effect on hail, 618.
 Alabama—
 College, notes, 99, 799.
 College Station, report, 98.
 Station, notes, 799.
 Albina, use of term, 433.
 Albinism, inheritance in cereals, 132.
Albugo spp. on sweet potato, 152.
 Albumin—
 determination in urine, 206.
 egg, gold number determination, 12.
 Albuminoids, as affected by sewage organ-
 isms, 791.
Alcides mali n. sp., description, 163.
 Alcohol—
 as fuel, new sources, 617.
 as gasoline substitute, 187.
 denatured, from waste molasses, 591.
 from sulphite waste liquor, 416.
 industry in France, 261.
 testing device, 712.
 use for power, 389.
 (*See also Butyl, Benzyl and Methyl al-
 cohols.*)
 Aldehydes—
 effect on protein hydrolysis, 110.
 in soils, effect of fertilizers on, Pa., 519.
Aleyrodes—
 azalea n. sp., description, 557.
 comata, notes, 52.
 Alfalfa—
 as cover crop, Wash., 743.
 as hog pasture, U.S.D.A., 376.
 as shade crop for orchards, Oreg., 145.
 caterpillar, control, U.S.D.A., 357.
 cost of production in Argentina, 487.
 culture, U.S.D.A., 738.
 culture experiments, Idaho, 738;
 Mont., 332.
 culture on Yuma project, U.S.D.A., 393.
 culture, papers on, 528.
 fertilizer experiments, Okla., 32.
 for improvement of sandy soil, 721.
 Fusarium wilt, N. Mex., 345.
 germination as affected by H-ion con-
 centration, 525.
 hay and sunflower silage, comparison,
 Mont., 68.
 hay feeding racks, design, 91.
 hay for breeding ewes, 870.
 hay for fattening cattle, Ind., 870.
 heat-resistant varieties, Ariz., 734.
 irrigation experiments, Nev., 228;
 Utah, 230.
 leaf spot, notes, 652.

Alfalfa—Continued.

- meal, analyses, 867; Ind., 69, 867; Ky., 373; N. J., 69, 672.
- meal production, U.S.D.A., 694.
- nurse crop for, Wash., 737.
- pasture for pigs, U.S.D.A., 466.
- Peruvian, culture in United States, U.S.D.A., 528.
- resistance to alkali, Ariz., 724.
- root fungus, notes, 243.
- seed, chalcis fly in, U.S.D.A., 364.
- seedlings, growth as affected by H-ion concentration, 525.
- supplements, effect on finish of steers, N. Mex., 374.
- variety tests, Can., 735; Minn., 823; N. Mex., 332; Nev., 229.
- vitamin A extraction from, 367.
- vitamin A in, 165.
- water requirements, Colo., 185.
- weevil, control, 457.
- weevil, notes, Colo., 158; Mont., 758.
- yields in relation to soil moisture movement, N. Mex., 738.
- yields on irrigated wild meadows, Oreg., 22.

Algae—

- green, nitrogen fixation by, 430.
- in reservoirs, treatment, 479.
- marine, as feed for horses, 775.
- of New Jersey soils, 217.

Algaroba meal for pigs, 70.

"Alimentary dystrophy," use of term, 861.

Alkali—

- effect on cement, Wyo., 789.
- lakes in Texas, potash and bromin in, 127.
- resistance of crops to, Ariz., 724.
- salts, effect on nitrification, 216.
- salts, toxicity of, methods of determining, 814.
- salts. (*See also* Sodium salts.)
- soils, concrete mixtures in, 482.
- soils, gypsum for, Ariz., 724.
- soils, in South Africa, 624.
- soils, management, Calif., 724.
- soils, reclamation, U.S.D.A., 420.
- soils, reclamation in Egypt and India, 624.
- solutions, method of standardizing, 12.
- spots, reclamation, Oreg., 22.

Allocarya, studies, 522.

Almond shot hole, notes, 243.

Almonds, variety tests, U.S.D.A., 144.

Aloes rust, studies, 156.

Alternaria—

- solani*, notes, 154, 243.
- sp., notes, 652.

Altitude—

- determinations from barometric readings, U.S.D.A., 120.
- high, adaptation of man to, 564.
- relation to frost, 417.

Aluminum—

- determination, 202.
- in soil extracts, effect of fertilizer salts, Mich., 125.

Amaranthus retroflexus, composition, 225.*Amaranthus* seeds, analyses, 225.*Amblymerus* sp. parasite of chrysanthemum midge, U.S.D.A., 361.*Amelanchier*—

- micropetala potomacensis*, new variety, 222.

n. sp., notes, 222.

American—

Association for Agricultural Legislation, study program, 291.

Association of Agricultural College Editors, 300.

National Live Stock Association, proceedings, 171, 672.

plant pathologists, advisory board, 443.

Amino acid—

in blood, variability, 265.

new, synthesis, 111.

Amino acids—

effect on hydrolysis of starch, 311.

esterification, 504.

esters of, preparation, 202.

in protein of Georgia velvet bean, 410.

Amitermes, new species, 256.

Ammonia—

catalytic oxidation, 816.

decomposition, furnace for, 220.

determination in soils, 211.

distillation with Davison scrubber, 13.

fixation, new method, 126.

nitrogen, separation from liquid manure, 220.

oxidation, paper on, 25.

production, 220.

volatilization, prevention, 628.

Ammonium—

chlorid, action and use, 125.

chlorid, fertilizing value, 221.

citrate solutions, standardization, Mich., 113.

nitrate, action and use, 125.

nitrate, effect on solubility of rock phosphate, 427.

nitrate, fertilizing value, 427; La., 627.

phosphates, solubility equations, 628.

sulphate, action and use, 125.

sulphate, cause of caking, 25.

sulphate, fertilizing value, 221, 627, 628; Ala. Col., 135; Can., 727; La., 627; Wis., 336.

sulphate, nitrification, 215.

sulphate, nitrogen availability, Ala. Col., 135.

sulphate, preparation, 126.

Amoeba meleagridis, notes, 476, 586.*Amphicoma vulpina*, notes, Mass., 158.

Amylases, studies, 311.

Anaerobes—

methods of plating, 227.

pathogenic, biochemistry of, 880.

pathogenic, studies, 275.

Anagyris nigricornis, notes, 662.

Ananas, botanical study, 837.

Anaphothrips striatus on corn, Conn. State, 252.

- Anaphylaxis—
and allied phenomena, 780.
review of literature, 471.
- Anaplasma—
argentinum, notes, 77.
sp., notes, 883.
- Anaplasma, isolation of, 77.
- Anaplasmas and anaplasmosis, 685.
- Anaplasmosis, bovine, immunization, 77.
- Anastrepha bistrigata* n. sp., description, 258.
- Anastrepha* spp., in Brazil, 258.
- Anemia—
infectious equine, 585, 787.
infectious equine, immunity, 83.
infectious equine, notes, Nev., 272.
infectious equine, organism causing, 82.
infectious equine, study of long bones in, 83.
infectious equine. (See also Swamp fever.)
- Anemone hepatica*, flower variations in, 328.
- Anicetus annulatus*, notes, 662.
- Animal—
breeding problems, 67.
breeding. (See also Heredity and specific animals.)
chromosomes. (See Chromosomes.)
diseases—
and control, 780.
eradication, U.S.D.A., 471.
in Canada, 272.
in India, 272.
in Madras, 180.
in Maine, 272.
in North Dakota, 272.
in Rhodesia, control, 780.
transmission by insects, 450.
(See also specific diseases.)
foods, world's supply, 593.
husbandry, course of study, 494.
husbandry exhibit, Mich., 698.
husbandry, textbook, 494.
parasites, studies, Okla., 79.
parasites. (See also specific parasites.)
pests, trapping on the farm, U.S.D.A., 449.
tissue, inorganic phosphorus in, 116.
waste, preparation for feeding stuffs, 868.
- Animals—
domestic, consumption of nutrients, 62.
domestic, parasitic diseases of, 580.
fur-bearing, exhibition standards, 575.
injurious to plants, 152.
insects attacking, 556.
laboratory, recording blood pressure, 879.
resistance of intracellular organisms to disinfectants, 822.
(See also Live stock, Mammals, Cattle, Sheep, etc.)
- Anomala undulata*, notes, 851.
- Anomalaphis comperci* n. g. and n. sp., U.S.D.A., 758.
- Anopheles*—
bifurcatus, infection with *Plasmodium vivax*, 55.
(*Cæloidiæzesis*) *plumbeus*, breeding places and relation to malaria, 55.
ludlowi, infection with *Plasmodium falciparum*, 854.
maculipennis, blood nutrition of, 454, 853.
plumbeus, infection with *Plasmodium vivax*, 55.
spp. in salt water, 162.
- Anopheles larvæ, destruction, 853.
- Anoplotermes, notes, 256.
- Anthelmintics, experiments with fluid extracts, 381.
- Anthocyanin—
in beets, 132.
localization in spring leaves, 327.
(See also Pigmentation.)
- Anthonomus*—
grandis. (See Cotton-boll weevil.)
quadrigibbus. (See Apple curculio.)
- Anthrax—
atypical form, 582.
control, 272.
efficacy of normal sera, 181.
immunity, 582.
precipitinogen, detection of, 583.
spores, destruction in hides, 180.
symptomatic. (See Blackleg.)
- Anthribus fasciatus*, notes, 252.
- Antigen, rate of absorption, relation to immunity production, 381.
- Antineuritic vitamin. (See Vitamin.)
- Antinia theivora* n. sp., description, 163.
- Antipyretics, studies, 370.
- Antirrhinums, culture, treatise, 441.
- Antiscorbutic. (See Scurvy.)
- Antiscorbutic—
value. (See Vitamin C.)
vitamin. (See Vitamin C.)
- Antiseptics. (See specific antiseptics.)
- Antiserum, preparation and distribution, Nev., 272.
- Antitoxins, associations with proteins of horse serum, 76.
- Antixerophthalmic vitamin. (See Vitamin A.)
- Ants—
Argentine, control, U.S.D.A., 259.
Argentine, eradication, 554.
feeding habits, 851.
white. (See Termites.)
- Anuraphis helichrysi*, notes, 852.
- Apanteles*—
gabrielis, parasitism by, 858.
glomeratus, life history notes, 457.
oblinita, notes, Conn. State, 251.
- Apechoneura* n. sp., description, 60.
- Aphidæ, parasitism among, 457.
- Aphididæ—
generic classification, U.S.D.A., 753.
of California, synopsis, 452.
oriental, notes, 452.
- Aphidius* sp., bionomics of, 457.

Aphids—

- affecting roses, Me., 159.
- food plants of, Me., 160.
- pine-bark, notes, Conn. State, 251.
- pink and green, control, Va. Truck, 451.

Aphis—

- rosy, studies, N. Y. State, 354.
- woolly, control, Md., 158.

Aphis—

- avenæ* in Southeast, biology of, 556.
- brassicæ*. (See Cabbage aphid.)
- gossypii*. (See Cotton aphid and melon aphid.)
- pomi*. (See Apple aphid.)
- sorbi*, studies, N. Y. State, 354.

Aphycomorpha araucariæ, notes, 662.*Aphycus* spp., notes, 252.

Apiaries—

- inspection, Conn. State, 251.
- out, management, 57.

Apiculture. (See Beekeeping.)

Apoplexy in garden plants, 346.

Apparatus—

- aerological, new, U.S.D.A., 718.
- calomel electrode, design, 204.
- comparator, improved, 503.
- condensers, types, 112.
- extraction, new, description, 413.
- fermentation tube, modified, 611.
- for determining alcohol, 712.
- for determining ammonia, 212.
- for determining amount and temperature of evaporation, 16.
- for determining arginin, 615.
- for determining consistency of concrete, 86.
- for determining density of molasses, 806.
- for determining melting points, 12.
- for determining small quantities of gas, 611.
- for determining standard turbidity, 614.
- for electrical treatment of milk, 778.
- for hydrogenation of oils, 416.
- for measuring plant growth, 32.
- for measuring relation between wind and evaporation, 16.
- for plant growth in sterile soil, 422.
- for recording weight variations in beehives, Okla., 58.
- for soil acidimetry, 612.
- inoculation chamber, 444.
- pursuit pendulum and meter, 266.
- respiration chamber for large animals, 266.
- soil, elutriator, description, 210.
- turbidimeter, photometric, 413.

Apple—

- aphid, green, dusting for, 451.
- aphid, relation to abnormal structure of apples, N. Y. State, 354.
- bitter pit, cause, 847.
- bitter rot, notes, 155.
- black spot, notes, 155.
- blotch, control, 348, 847; Ind., 345; Pa., 554.

Apple—Continued.

- Botrytis, new species, 244.
 - bread, digestibility and food value, 64.
 - brown rot, notes, 45, 246.
 - canker, notes, 45, 246; N. Mex., 345.
 - crinkle, notes, 448.
 - curculio, control, Ind., 338.
 - diseases, control, 544, 743; Ill., 847.
 - fire blight, notes, 656.
 - fruit spur, structure, N. H., 44.
 - fungus diseases, treatment, 155.
 - glassy disease, notes, 45.
 - juice, relation of fermentation to nitrogenous matter, 807.
 - juice, unfermented, manufacture, Calif., 717.
 - June drop, cause, Wash., 743.
 - leaf roller, notes, Mont., 758.
 - maggot, control, N. Y. Cornell, 455.
 - mildew, notes, 246.
 - moldy core and rot, notes, 155.
 - oil, notes, 712.
 - orchard survey, Colo., 144.
 - orchards, soil management, Ohio, 340; Pa., 538.
 - Ozark Mountain measles, N. Mex., 345.
 - powdery mildew, control, U.S.D.A., 549.
 - root fungus, notes, 155.
 - rots in cold storage, control, Iowa, 38.
 - scab, control, 743; Ind., 338.
 - scab, notes, 45, 243, 246; Okla., 44.
 - scald, control, Iowa, 38.
 - sirup, keeping quality, tests, Wash., 715.
 - sirup, recipe, 808.
 - spot, Ky., 847.
 - sucker, occurrence in Nova Scotia, 850.
 - survey in New Jersey, 835.
 - tree borer, roundheaded, life history and control, U.S.D.A., 760.
 - trees, bridge-grafting, Conn. State, 237.
 - trees, distribution of food materials, N. H., 28.
 - trees, girdling by mice, prevention, Conn. State, 237.
- Apples—
- abnormal structure, N. Y. State, 354.
 - abscission phenomena, 539.
 - as affected by grass, 237.
 - blossoming habit as affected by fertilizers, Oreg., 145.
 - blossoming period, U.S.D.A., 437.
 - breeding experiments, 645, 742; Md., 143; Pa., 539.
 - breeding for Canadian prairies, 540.
 - bud selection, 536, 744.
 - cold storage, effect of temperature changes, Iowa, 38.
 - color and size, factors affecting, Pa., 539.
 - color as affected by nitrate, Oreg., 145.
 - cost of production in New York, U.S.D.A., 649.
 - culture in New Hampshire, 237.
 - culture, Nebr., 644.
 - dusting experiments, 752.
 - dusting v. spraying, 743, 752.

Apples—Continued.

- effect of handling on cold storage, 39.
 effect of self and cross pollination on yield, Me., 645.
 export trade in United States, 37.
 fertilizer experiments, 833; Ohio, 340, 648; Oreg., 145.
 fruit setting as affected by fertilizers, Oreg., 145.
 fruit spurs, yearly yield, 646.
 grafting experiments, Ind., 338.
 in Great Britain, life histories, 744.
 keeping qualities, factors affecting, 238.
 Malinda, open-pollinated seedlings, 539.
 notching experiments, 743.
 odorous constituents, 711.
 physiology of, N. H., 28, 29.
 pollination experiments, 744; Me., 646.
 pruning experiments, 744; Ind., 338; Ohio, 341.
 pruning instructions, Mo., 146.
 pruning time in Minnesota, 646.
 ringing experiments, 742.
 scion root production by, 540.
 size of fruit, factors affecting, 647.
 sprayed, arsenic content, 798.
 spraying, Ohio, 340.
 spraying experiments, 358; Ind., 338; N. Mex., 358; N. Y. Cornell, 455; U.S.D.A., 843.
 spraying schedule, 743; N. J., 37.
 sterility in, Me., 645.
 storage tests, Wash., 744.
 sun drying, 808.
 thinning experiments, 646; Ohio, 341.
 use in bread making, 64.
 varieties for Canada and United States, 438.
 varieties for Ohio, Ohio, 744.
 varieties in England, 238.
 varieties unsuited to southern Indiana, 237.
 vitamin B in, 765.
 winter injury, U.S.D.A., 435.
 winterkilling, Minn., 833.
 yield in relation to growth, 647.
- Apricot—
 orchard survey, Colo., 144.
 shot hole, notes, 243.
- Apricots—
 sun drying, 808.
 variety tests, U.S.D.A., 144.
- Arceuthobium* spp., biology and significance, 821.
- Archips* spp., notes, Mont., 758.
- Ardisia crispa*, symbiosis studies, 133.
- Areca—
 nuts, preparation for market, 745.
 palm, culture and uses, 745.
 palm mahali disease, notes, 445.
- Arginin determination, 615.
- Arithmetic, rural, problems, 495.
- Arizona—
 Station, report, 798.
 University, notes, 398.
- Armillaria mellea*, notes, 155, 243.
- Armillaria* root rot on mushrooms, 347.

Army—

- agricultural committee, British, report, 95.
 rations, graphic method for balancing, 167.
 worm, fall, on rice, control, U.S.D.A., 253.
 worm, notes, 52, 450; Conn. State, 251; Ind., 352; N. C., 450.
 worm, semitropical, biology and control, 557.
 worm, western wheat-head, life history and control, 54.
 worms of Minnesota, key, 55.
- Arotes, notes, 858.
- Arrow grass, poisonous to live stock, Nev., 77, 273.
- Arsenates—
 for boll weevil control, 162.
 toxicity, Oreg., 755.
- Arsenic—
 dust, notes, 850.
 sprays, effect on bees, Ind., 856.
 white, use in Bordeaux mixture, 850.
- Arsenicals, poisoning of bees by, Ind., 351.
 (See also Calcium arsenate and Lead arsenate.)
- Arsenious acid, disinfecting power, 78.
- Artemisia spinescens*, poisonous to live stock, Nev., 273.
- Arvicole in Itlay, biology of, 250.
- Ascarids in man and hog, differentiation, 380.
- Ascaris*—
anoura, notes, U.S.D.A., 276.
lumbricoides in man and hog, 380.
lumbricoides, life history, U.S.D.A., 275.
lumbricoides, relation to pulmonary disease, 80.
suum or *suilla*, life history, U.S.D.A., 275.
- Ascaris—
 eggs, resistance of, 80, 381.
 larvae, migration of, U.S.D.A., 276.
- Asclepias mexicana*, poisonous to live stock, Nev., 273.
- Ascochyta* species on tomato, 346.
- Ash—
 translocation in apple trees, N. H., 28.
 wood, water conductivity, 31.
- Ashes. (See Wood ashes.)
- Asparagus—
 culture, Wash., 397.
 edible portion and waste, analyses, 63.
 fertilizer experiments, Mass., 537; Md., 144; Pa., 537.
 resistance to alkali, Ariz., 724.
 root rot, notes, 347.
 rust, control, Mass., 538.
 rust, notes, 151.
 variety tests, Pa., 537.
- Aspergillus*—
fumaricus, fermentation of sugar by, 15.
niger, autotoxicity in, 524.
niger, effects of acids on, 523.

Aspergillus—Continued.

- niger*, formation of soluble starches by, 523.
niger, growth stimulation, 130.
niger, oxalic acid production by, 112.
niger, respiration of, 820.
niger, utilization of α -methylglucosid by, 203.
oryzae, enzymic extract of, comparison with malt diastase, 503.
repens, enzym activity, 779.
 spp., conidia formation, 524.
 Asphalt and allied substances, treatise, 186.
Aspidiotus—
perniciosus. (See San José scale.)
 sp. on coconut, 52, 851.
uvæ. (See Grape scale.)
 Aspirin, effect on heat regulation, 371.
 Association—
 of Land-grant Colleges, 701, 800.
 of Official Agricultural Chemists, proceedings, 115.
 Aster disease, new, 544.
Astragalus tetrapterus, poisoning of live stock by, U.S.D.A., 77.
 Atmosphere—
 evaporation capacity in relation to aridity, 16.
 optical properties, 618.
 standard, U.S.D.A., 718.
 (See also Air.)
 Atmospheric—
 moisture, withdrawal by trees, 16.
 pressure. (See Barometer readings.)
 temperature. (See Temperature.)
 Atmometers, nonabsorbing mounting for, description, 733.
Atriplex—
canescens, analyses, N. Mex., 374.
 spp., poisonous to live stock, Nev., 273.
 Automobiles—
 economy of operation, 187.
 use in soil surveying, Tex., 281.
 Auxanometer, new, 32.
 Avocado—
 diseases, notes, 550.
 red spider, control, 255.
 tree records, methods of keeping, 837.
 Avocados—
 culture in Atlixco Valley, 835.
 culture in Florida, 342, 837.
 grafting and top-working, 837.
 insects affecting in Florida, 53, 851.
 insects affecting, remedies, 255.
 preliminary revision, 239.
 spraying experiments, 255.
 time for harvesting, 837.
 varieties in Florida, 342.
 Azalea, new species of Aleyrodidæ on, 557.
Azotobacter—
chroococcum, studies, 514.
chroococcum, volutin in, 124.
 Azotobacter, effect of nitrates on growth, Pa., 514.
 Babassu, culture and expression of oil, 240.

Babesia—

- minor*, specificity of, 182.
 (*Piroplasma*) *caballi*, notes, 83.
Bacillus—
abortus and *Bacterium melitensis*, comparison, 880.
abortus, power to cause abortion, 683.
abortus, serologic grouping of, 879.
 (See also Abortion.)
acidophilus, Conn. Storrs, 767, 769.
atrosepticus, studies, 655.
 B, studies, 111.
bifidus, studies, Conn. Storrs, 767.
botulinus—
 from ripe olives, 168.
 notes, 84.
 resistance of spores, 169.
bovisepiticum, bacterin from, Nev., 272.
bulgaricus, studies, Conn. Storrs, 767, 769.
bulgaricus milk, Conn. Storrs, 768.
cholerae suis in man, 685.
coli communior in meconium of calf, 183.
coli communis, longevity in honey, Colo., 164.
coli on coconut, 551.
dysenteriae, longevity in honey, Colo., 164.
edematiens, biochemistry of, 880.
enteritidis infection in rats, 275.
enteritidis, longevity in honey, Colo., 164.
fecalis alkaligenes, longevity in honey, Colo., 164.
lactis aerogenes, longevity in honey, Colo., 164.
melitensis. (See *Bacterium melitensis*.)
mesentericus, notes, 261.
mesentericus vulgatus, on copra, 151.
murisepticus, studies, 785.
necrophorus in swine, 683.
 (See also Necrobacillosis.)
oedematis maligni, studies, 385.
paratyphosus A and B in hog cholera blood, 884.
paratyphosus A and B, longevity in honey, Colo., 163.
paratyphosus B, notes, Ind., 385.
pluton, studies, U.S.D.A., 58.
proteus vulgaris, longevity in honey, Colo., 164.
pyocyaneus, rôle in swine pneumonia, 688.
pyogenes, studies, 581.
radicicola, longevity of, Mo., 721.
radicicola, notes, 30.
radicicola, studies, 514.
 (See also Nodule bacteria.)
solanacearum, notes, 243.
solanacearum on tomato, 154.
 (See also *Bacterium solanacearum*.)
subtilis, respiration of, 820.

Bacillus—Continued.

- suipestifer*, longevity in honey, Colo., 164.
- suipestifer*, notes, Ind., 385.
- tetani*, cultivation and isolation, 880.
- tracheiphilus*, notes, Tex., 846.
- tracheiphilus*, studies, U.S.D.A., 245.
- typhosus*, attenuated, agglutinability, 581.
- typhosus*, longevity in honey, Colo., 163.
- vascularum*, notes, 548.
- viscosus*, notes, 261.
- walvischrauschbrand*, studies, 111.
- welchii*, description, 275.
- welchii* toxin, precipitation of, 881.
- xerosis*, notes, 472.

Bacillus, "nerve," studies, 472.

Bacteria—

- colon-aerogenes group, correlation, 791.
- effect on etching power of roots, 422.
- fermenting carbohydrates, identification, 113.
- in frozen soils, 422.
- in pure cultures, determination of number, 274.
- in suspension, estimating number, 274.
- lactic acid, monograph, 680.
- nitrifying, studies, 216.
- pathogenic, in hog cholera blood, 884.
- pentose-destroying, fermentation, characteristics, 411.
- relation to soil productivity, 124.
- rôle in plant diseases, 444.
- transmutation, 274.

Bacterial—

- cultures, H-ion concentration, 383.
- cultures, number of colonies for soil plate, 422.
- cultures, petri plates, time of incubation, 422.
- cultures, reduction potentials, 421.
- fertilizers, analyses, 424.
- flora of eyes of horses, 472.
- flora of reproductive organs of cow, 182.

Bacterins, immunizing value, Nebr., 882, 887.

Bacteriological culture media. (*See* Culture media.)

Bacteriological laboratory for cooperative creameries, 879.

Bacteriology, international catalogue, 227.

Bacteriophage microorganism, rôle in fowl typhoid, 84.

Bacterium—

- angulatum*, notes, 246.
- bipolaris*, antigenic value of vaccines against, Nebr., 882.
- citri*. (*See* Citrus canker.)
- coronafaciens* n. sp., description, 545.
- herbicola*, notes, 445.
- ichthyosmius*, notes, N. Y. Cornell, 470.
- juglandis* on walnut, 152.
- lactis acidii*, volatile acidity, Iowa, 75.
- maculicolum* on crucifers, 152.
- malvacearum*, notes, 243, 652.

Bacterium—Continued.

- melitensis* and *Bacillus abortus*, comparison, 880.
- melitensis*, serologic grouping of, 879.
- pullorum*, intradermal test for, 683.
- pruni*, notes, Okla., 36.
- sanguinarium*, notes, 84.
- solanacearum*, notes, 245; Pa., 549.
- (*See also* *Bacillus solanacearum*.)
- tabacum*, notes, 246.
- tumefaciens*, notes, 246, 444.
- tumefaciens*, studies, 242.

Bactrocera cucurbitæ, control, 455.

Bagnisiopsis dioscoreæ n. sp. on yams, 652.

Bagworm on citrus, 555.

Bagworms, popular account, Mo., 160.

Bahia grass, culture experiments, 528.

Baking powder—

- analyses, Conn. State, 859.
- analysis, 415.
- ingredients and standards, 415.

Balansia genus, notes, 152.

Ballistite for rock and soil blasting, 480.

Balloon flight, observations on, U.S.D.A., 719.

Balsam of Peru, chemical constants, 116.

Banana—

- Panama disease, control, 48.
- Panama disease, notes, 151.
- root-borer, habits and remedies, 457, 560.
- root-borer, notes, 52.
- wilt, notes, 848.

Bananas—

- as affected by ultraviolet rays, 731.
- culture, 837.
- culture experiments, 40.
- culture in Fiji, 40.
- drying, 564.
- insects affecting, 52.

Barberry—

- eradication, 45, 546.
- relation to stem rust, Iowa, 653.
- relation to wheat rust in Indiana, 546.
- rusts, morphological study, 844.

Barium—

- in plants and soils, Ky., 327.
- phosphomolybdate, determination, 804.
- water sprays, fungicidal value, U.S.D.A., 843.

Barley—

- as hay crop, 527.
- as nurse crop, Wash., 737.
- culture experiments, Mont., 332, 739; Nebr., 637.
- culture on Yuma project, U.S.D.A., 393.
- diseases, control, Tex., 845.
- effect of osmotic pressure on cell sap, 224.
- feed, analyses, 867; Ind., 69, 867; Ky., 373.
- fertilizer experiments, 232.
- flour, analyses, Ariz., 764; N. J., 69.
- for fattening pigs, 774, 870.
- for fattening steers, N. Dak., 374.

Barley—Continued.

- for pigs, methods of preparation, Nebr., 673; Okla., 70.
- Fusarium disease, 751.
- hulls, analyses, Ind., 69.
- inheritance of albinism, 132.
- kernels, daily development, 836.
- kernels, effect of removing awns, 826.
- leaf rust, studies, Ind., 345.
- leaf stripe, control, 45.
- mixed feed, analyses, Ky., 373; N. J., 69.
- pearl, manufacture and composition, 563.
- resistance to alkali, Ariz., 724.
- scab organism, production of conidia, 545.
- seed treatment, 642.
- smut, notes, 445.
- straw, digestibility, 569.
- stripe disease, prevention, 346.
- use of soil potassium by, 218.
- v. corn for fattening pigs, Mo., 772.
- varieties, Ariz., 733; U.S.D.A., 637.
- variety tests, 232, 528; Can., 735; Minn., 636, 823; N. Dak., 332; N. H., 34; Nev., 228; Okla., 32; U.S.D.A., 435; Wash., 737; Wyo., 135.
- water requirements, Colo., 185.
- yield in Australia, 527.
- yields, 829; Mo., 736.

Barns, concrete, construction, 90.

Barnyard manure. (*See* Manure.)

Barometer readings, high, in Bering Sea, U.S.D.A., 119.

Basic slag. (*See* Phosphatic slag.)

Batocera—

rubus, notes, 252.

spp., hybrids of, 456.

Batocera sp., description, 57.

Batteries, vehicle-type, operation and care, 891.

Bean—

- anthracnose, notes, 151.
- army worm, notes, 52.
- beetle, western, control, Colo., 158.
- blight, notes, 153, 652.
- bran, composition and digestibility, 267.
- bug, Mauritius, notes, 52.
- ladybird, studies, U.S.D.A., 455.
- mosaic virus, transmission and thermal death point, 751.
- pod disease, notes, 152.
- rust, notes, 45.
- weevil in South Dakota, 850.

Beans—

- analyses, 63.
- breeding experiments, Ariz., 734.
- cull pinto, feeding value, N. Mex., 377.
- description and agricultural value, 528.
- effect of soil electrification, Ky., 824.
- Glœosporium lindemuthianum* attacking, 546.
- ground, use as grasshopper bait, 353.
- horse, culture, on peat soil, 23.
- hydrocyanic acid content, 610.

Beans—Continued.

- inheritance in, studies, 818.
- lima, variety tests, U.S.D.A., 134.
- pinto, yields, Nev., 229.
- production in Brazil, 292.
- rice, as green mulch for bananas, 532.
- root development, 834.
- staking, 339.
- string, variety tests, U.S.D.A., 437.
- Tornillo, feeding value, N. Mex., 377.
- variety tests, 528; Minn., 636; Tex., 36. (*See also* Tepary beans and Velvet beans.)

Bee Farm, modern, economic management, 57.

Beech seedlings, growth as affected by organic substances, 822.

Beef—

- cost and price indexes, Mo., 792.
- prices, U.S.D.A., 595.
- raw, vitamins in, 664.
- trade in Union of South Africa, 673. (*See also* Cattle.)

Beehives, weight variations, recording apparatus for, Okla., 58.

Beekeeping—

- experiments, 662.
- for Oregon farmer, 457.
- summary of information, 259; Ark., 763; Tex., 258.
- treatise, 57, 661.

Bees—

- as affected by sprays, 662; Ind., 351, 856.
- fertilization in, 857.
- foulbrood. (*See* Foulbrood.)
- Isle of Wight disease, 57.
- management, Wash., 496.
- Nosema-affected stocks, 59.
- paralysis, control, Okla., 51.
- stimulative feeding, 662.
- swarming, relation to phototropism, 851.
- temperature of, 51.
- transferring, 563.
- winter protection for, 163.
- winter stores for, Can., 762. (*See also* Honey.)

Beet—

- eel-worm, notes, 243.
- molasses, effects on weanling pigs, 180.
- pulp, dried, analyses, 867; Ind., 867; Ky., 373; N. J., 69, 672; Vt., 464.
- straw, digestibility, 569.
- sugar industry in Victoria, 532.
- sugar plant, waste disposal, 479.

Beetles—

- attacking hazelnut scale, 252.
- green Japanese, notes, 362.
- Japanese, life history and control, 558.
- North American, larvae of 854.
- powder-post, 456.
- wood-boring on black locust, 854.

Beets—

- analyses, 63.
- anthrocyanin in, 132.
- canned, botulism from, 865.
- culture, experiments, 638.

Beets—Continued.

- fertilizer experiments, 427.
 - field or fodder. (*See* Mangels.)
 - iodin content, 204, 632.
 - manuring experiments, 24.
 - sugar. (*See* Sugar beets.)
 - variety tests, 528, 638.
- Begonia, double flowers and linkage in, 632.
- Belascaris marginata*, notes, U.S.D.A., 276.
- Belt drives, geometry of, 891.

Belts—

- data charts on transmission of horse-power, 483.
- for power transmission, tests, 285.
- wire, tests, 891.

Benzaldehyde, effect on protein hydrolysis, 110.

Benzidin sulphate, solubility in water, 504.

Benzyl alcohol in experimental tuberculosis, 584.

Beriberi—

- among British troops, 262, 263.
- studies, 462.

Berries. (*See* Fruits, small, and specific kinds.)

Betabacterium, new genus, erection, 680.

Betacoccus, new genus, erection, 680.

Betain, cleavage by bacteria of "guanol," 27.

Beverage samples, fermentable, preservatives for, 804.

Beverages—

- analyses, Conn. State, 859.
- industry in France, 261.
- substitutes in Germany, 204.

Bibliography of—

- agricultural books for high schools, 698.
- ammonium citrate solutions, Mich., 113.
- anaphylaxis, 471, 780.
- Anopheles plumbeus*, 55.
- ants, feeding habits, 851.
- Arceuthobium* spp., 821.
- Ascaris lumbricoides*, U.S.D.A., 275.
- Bacillus pyogenes*, 582.
- Bacillus welchii*, 275.
- bacteria, rôle in plant diseases, 444.
- bean ladybird, U.S.D.A., 456.
- blood analysis, 205.
- botryomycosis, 181.
- bread making, use of apples and pears in, 64.
- bumblebees of central Europe, 851.
- carbon as an adsorbent, 412.
- carbon dioxid in soil, N. Y. Cornell, 813.
- cestodes of dogs and cats, 80.
- chemistry, reading courses, 801.
- chrysanthemum midge, 362.
- colorimetric determination of pH, 211.
- cotton, 828.
- cotton aphid, Tex., 759.
- cotton bollworm, pink, 161.
- cowpea weevil, Tex., 561.
- dairying, 73.
- flour, offal content, 314.
- food chemistry, 563.
- forests of West Africa, 840.

Bibliography of—Continued.

- foulbrood, European, U.S.D.A., 59.
 - gardens, form and design, 236.
 - grasses as paper making material, 317.
 - horses, 173.
 - humic acids, 214.
 - insect transmission of diseases, 450.
 - insecticides, adulteration, U.S.D.A., 353.
 - insects, chemotropic response, 554.
 - insects, nutritional studies, 51.
 - lice, 51, 852.
 - lymphangitis, epizootic, 583.
 - mammals of Panama, 850.
 - melon aphid, Tex., 759.
 - Metarrhizium anisopliae*, pleophagy of, 858.
 - milk, biorized, 877.
 - moor soils, effect of water level on rooting of plants, 623.
 - nitrification of semiarid soils, 216.
 - nitrifying bacteria, 216.
 - nitrogen industry, 324.
 - piroplasm, classification, 883.
 - plants, poisonous, Can., 380.
 - potato Rhizoctonia, 47.
 - protozoa of New Jersey soils, 218.
 - pyotherapy, 580.
 - rats, protozoal parasites of, 833.
 - root formation, 836.
 - rubber culture, 344.
 - rural communities, 595.
 - rural schools, consolidation, 298.
 - sawfly of Europe, U.S.D.A., 364.
 - sodium chlorid affecting trees, 344.
 - soil acidity, 212.
 - soil extracts as affected by fertilizer salts, Mich., 125.
 - soil moisture, capillary movement, U.S.D.A., 724.
 - soil potassium liberation, 128.
 - soils of eastern Germany, 320.
 - soils, reduction potentials, 422.
 - spotted fever, Rocky Mountain, 60.
 - sweet clover seed production, U.S.D.A., 640.
 - thyroid and pituitary glands, correlation, 771.
 - tick resistance in cattle, 182.
 - tomatoes, breeding experiments, Ind., 835.
 - tomatoes, ripening process, U.S.D.A., 834.
 - walls, concrete retaining, construction, 485.
 - wood, chemistry of, 617.
 - woods of United States, 443.
 - zoology, 250.
- Bichlorid of mercury. (*See* Corrosive sublimate.)
- Billbugs, habits of, 762.
- Bioclimatic law, U.S.D.A., 718.
- Bioclimatic law, effectiveness of applying, U.S.D.A., 509.
- Bloenergies, treatise, 521.
- Biorizator, Lobeck, experiments with, 877.
- Birches as affected by sodium chlorid, 344.
- Bird Treaty, Migratory, U.S.D.A., 449.

Birds—

- attacking tent caterpillars, 250.
- beneficial to agriculture, 659.
- British, list, 50.
- course of study, 397.
- of North America, check list, 50.
- of prey, diurnal, synoptical list, 250.
- production of eye color in, 866.
- wild, protection of, report, 50.

Bituminous—

- materials, bitumen content, 389.
- road materials, treatise, 186.

Black wattle ashes, analyses, 324.

Blackberries—

- breeding experimen'ts, 536.
- culture and marketing, 40.
- effect of temperature on resistance to wounding, U.S.D.A., 39.
- insects affecting, Wash., 155.

Blackberry—

- anthracnose, Wash., 155.
- disease, control, Ill., 847.
- gall, Wash., 155.
- orange rust, Wash., 155.

Blackberry-dewberry hybrid, 438.

Blackhead—

- in chickens, 586.
- in turkeys, epidemiology, 475.
- in turkeys, transmission, 885.
- parasite, flagellate character and re-classification, 476.

Blackleg—

- immunization, 471.
- immunization with pseudoblackleg pellets, 382.
- infection by ingestion, 685.

Bladder as affected by scorbutic diet, 665.

Blast furnace dust, potash content, 28.

Blastophaga grossorum, life history, Calif., 238.*Blastothrix sericea*, notes, 252.*Blepharospora cambivora*, notes, 448.*Blissus leucopterus*. (See Chinch-bug.)

Blood—

- acetone determination, 205.
- analysis, comparison of methods, 205.
- calcium determination in small amounts, 204.
- carbon dioxide content as affected by high altitudes, 565.
- catalase content, variations in, 569.
- corpuscles, red, resistance of, 63.
- dried. (See Dried blood.)
- effect of muscular work on hemoglobin and protein content, 265.
- H-ion concentration as affected by high altitudes, 565.
- magnesium determination in small amounts, 204.
- manganese content, 615.
- meal, digestion coefficient, 266.
- meal, feeding value, Can., 771.
- nitrogen, nonprotein, content, 463.
- of pellagrins, analyses, 668.
- phosphorus determination in small amounts, 204.

Blood—Continued.

- pressure as affected by high altitudes, 565.
- pressure of laboratory animals, recording, 879.
- pressure, raising, 79.
- proteins, determination, 205.
- urea content, methods of determination, 416.
- variations in composition, 264.

Blow flies, remedies, 258.

Blue grass, culture experiments, Wash., 436.

Blueberries—

- culture, Mass., 147.
- propagation, N. H., 36.

Body—

- fluids, sugar determination in, 416.
- tissues, manganese determination, 615.

Bog—

- soils, effect of rotation on crop yield, 231.
- water, colloidal properties, 224.
- water, toxicity of, 224.

Boll weevil. (See Cotton-boll weevil.)

Bollworm on corn, control, Mo., 757.

(See also Cotton bollworm.)

Bone—

- glue as feed for pigs, 172.
- ground, analyses, N. J., 326.
- meal, analyses, 867; N. J., 672.
- meal, digestion coefficients, 266.
- meal, nitrification, 215.

Book lice, control, U.S.D.A., 53.

Books on—

- agricultural cooperation, 594, 895.
- agricultural cooperation in Denmark, 694.
- agricultural cooperation in India, 293.
- agricultural education in France, re-organization, 95.
- agricultural education, project method, 492.
- agricultural machinery in Brazil, 90.
- agricultural prices, 394.
- animal foods, 593.
- animal husbandry, 494.
- antirrhinums, 441.
- beekeeping, 57, 661.
- bioenergies, 521.
- birds, British, 50.
- botany, 818.
- butter industry, 779.
- carbohydrates and glucosids, 410.
- cattle, dairy, feeding and management, 176.
- cheese making on the farm, 272.
- chemistry, 201, 609, 697.
- chemistry, agricultural, 10, 898.
- chemistry, food, 10.
- chemistry of building and machine materials, 389.
- chemistry of leather, 617.
- concrete construction, 188, 889.
- concrete, reinforced, 289.
- conifers, characteristics of, 650.
- cooking, 494.

Books on—Continued.

corn, 638.
 dairy record and feeding chart, 176.
 dairying, 580.
 dietotherapy, 261.
 drainage, 280.
 drug plants, culture, 838.
 drugs, useful, 580.
 earthwork and its cost, 589.
 electrical power in France, 790.
 electrophysiology, 819.
 engineering, civil, 278.
 engineering, dredging, 887.
 engineering for land drainage, 280.
 engineering, waterproofing, 186.
 entomology, 850.
 enzymes, 611.
 estimating cost of buildings, 188.
 evolution, organic, 521.
 farm animals, 770.
 farm buildings, 592.
 farming, 93, 396.
 fauna of British India, 50.
 feeding stuffs, concentrated, 170.
 feeding stuffs, microscopic control of, 170.
 feeding stuffs, wartime, 170.
 ferns, 148.
 fig recipes, 261.
 flowers, cut, industry, 838.
 food chemistry, 10.
 food industries of France, 260.
 food inspection and analysis, 313.
 food poisoning, 261.
 food production in Denmark, 292.
 food regulations, in Italy, 65.
 food resources of United States, 60.
 food substitutes in Germany, 204.
 forest policy of United States, 746.
 forestry, 343, 442, 542, 651.
 forests and forestry in West Africa, 839.
 forests in French colonies, 651.
 fruit culture, fancy, 743.
 fruit growing, 835.
 fruit preserving, 15.
 fruits, small, 40.
 gardening, 697, 741, 833, 834.
 gardens, form and design, 236.
 gardens, monthly working calendar for, 236.
 gardens of celebrities, 342.
 gases, industrial, 627.
 geology, agricultural, 719.
 heredity, 632.
 household physics, 495.
 housekeeping, 798.
 insect behavior, 50.
 insect life on sewage filters, 853.
 insects, 659.
 irrigation, 387.
 land and labor in India, 293.
 leather chemistry, 317.
 live-stock judging, 494, 697.
 live stock, types and market classes, 697.
 lumber and its uses, 344.

Books on—Continued.

manures, 621.
 medicine and surgery, industrial, 564.
 meteorology, 208.
 milk, clean, production, 679.
 motor trucks, design and construction, 285.
 motor vehicles, 187.
 oils, vegetable, 240.
 organic evolution, 521.
 Orthoptera of northeastern America, 851.
 parasites and parasitosis of domestic animals, 580.
 peat industry, 129.
 physiology, chemical, 365.
 pigeons, evolution, heredity, and behavior, 67.
 pigs, Duroc-Jersey, history, 71.
 plants, flowering, 148.
 plants, wild, uses, 649.
 potash production in United States, 728.
 potatoes, culture, 829.
 poultry raising, 174, 494, 676.
 prosperity in 1920, 92.
 protozoology, 659.
 quit-rent system in American colonies, 694.
 rabbits, raising, 174, 873.
 road materials, bituminous, 186.
 roads, 481.
 roses, climbing, culture, 838.
 rural communities, 894.
 rural development, 894.
 rural schools, consolidation, 297.
 rural science, 195.
 soil survey mapping, 887.
 soils, 621, 719.
 sweet peas, 441.
 tractors and implements for 1920, 287.
 trees, economic, in Great Britain, 344.
 vegetable gardening, 236.
 veterinary medicine, 76, 683, 797, 879.
 walls, concrete retaining, construction, 485.
 weather, 208.
 wheat culture in Manitoba, 640.
 woodlands, English, management, 442.
 woods of United States, 443.
 Borax in fertilizers—
 determination, 312, 613.
 effect on corn, Ind., 325.
 effect on corn and cotton, S. C., 126.
 Bordeaux mixture—
 adhesiveness, N. H., 842.
 analyses, N. J., 37.
 composition, 444.
 effect on plants, N. H., 44.
 effect on potato plants, 547.
 fungicidal value, 544.
 ordinary v. casein, 550.
 preparation and use, 155.
 use of white arsenic in, 850.
 with soap, fungicidal value, Mass., 846.
 Bordeaux-oil emulsions, spraying experiments, 157.

- Boric acid—
determination, 413.
disinfecting power, 78.
- Borna disease in mules, 83.
- Botanical systematization, methods and aims, 818.
- Botany—
international catalogue, 227.
treatise, 818.
- Bothriocera* sp., notes, 556.
- Botryococcus* and *Staphylococcus pyogenes aureus*, identity, 181.
- Botryomycosis, studies, 181.
- Botryosphaeria gregaria* on willow, 350.
- Botrytis*—
cinerea, notes, 152, 246, 847.
cinerea on greenhouse lettuce, Ky., 845.
cinerea, studies, 750.
sp., on tomato, 656.
- Botrytis—
new species on apples, 244.
on strawberries, notes, 848.
- Botulism—
epidemiology, card for recording, 369.
from canned beets, 865.
from canned ripe olives, 865.
in chickens, 84.
prevention, 168.
studies, 169.
- Bouillon cubes for culture media, 329.
- Bovines, immunization against anaplasmosis, 77.
- Box, Tuberculariaceæ on, 849.
- Boys'—
club leadership, course of study for, 796.
clubs in Canada, 796.
clubs in United States, 195.
metabolism, 167.
State corn contest in Indiana, 195.
- Brachyplatys pacificus*, notes, 52.
- Bracken, common, poisonous to horses, 471.
- Brains of animals as food materials, 63.
- Bran. (See Corn, Rye, Wheat, etc.)
- Bravaisia floribunda*, durability test of wood, 44.
- Bread—
chemistry, 609.
making in France, 261.
making, peanut flour as wheat supplement, 764.
making, use of apples and pears in, 64.
making, use of horse-chestnuts in, 64.
ropy, bacteriology of, 261.
substitute for war bread in Germany, 859.
(See also Flour.)
- Breeding. (See Heredity, Hybridization, Plant breeding, and specific plants and animals.)
- Brewers' dried grains, analyses, 867; Ind., 69, 867; Ky., 373; N. J., 69, 672; R. I., 672; Vt., 464.
- Bridges—
Federal control of, U.S.D.A., 689.
paints suitable for, list, 284.
strengthening for motor-truck traffic, 186.
- Brines—
iodin in, 13.
bromin in, 13, 127.
potash in, 127.
- Brome grass, culture experiments, Mont., 332.
- Bromin—
determination, 503.
determination in mineral waters, 13.
in Texas lakes, 127.
- Brooder stove, hover for, Wash., 189.
- Broom corn—
culture experiments, U.S.D.A., 232.
imported, European corn borer on, 161.
seed for live stock, 671.
time of harvesting, U.S.D.A., 233.
variety tests, U.S.D.A., 232.
- Brown coal, decomposition, determination of degree, 213.
- Brown-tail moth—
insect enemies, 252.
notes, Conn. State, 251.
- Brucella, proposed term, 880.
- Bruchidæ and parasites in Hawaiian Islands, 661.
- Bruchophagus funebris*. (See Clover seed chalcid fly.)
- Bruchus. (See Bean and Cowpea weevils.)
- Brusone on Japanese medlar, remedy, 349.
- Brussels sprouts—
analyses, 63.
variety tests, 236.
- Bryophyllum calycinum*, regeneration, 821.
- Bucculatrix thurberiella*, notes, U.S.D.A., 352.
- Buckwheat—
as green manure, Md., 122.
as purse crop, W. Va., 135.
culture, U.S.D.A., 435.
culture experiments, Ariz., 733; Ind., 330.
feed, analyses, N. J., 69, 672.
fertilizer experiments, W. Va., 135.
middlings, analyses, 867; N. J., 69, 672.
nutrient requirements, Md., 121.
offal, analyses, N. J., 69, 672.
relation of potassium to growth, N. H., 29.
seeding experiments, W. Va., 135.
use of soil potassium by, 218.
variety tests, W. Va., 135.
- Buffalo grass, diæcious nature, 522.
- Buffaloes, *Syngamus laryngeus* in, 688.
- Building estimator's reference book, 188.
- Buildings, small, concrete construction, 188.
- Bulbs—
for Nebraska, list, 240.
imported, inspection, Conn. State, 251.
- Bumblebees of central Europe, classification, 851.

- Buprestidæ, little known, collecting, 57.
- Bureau of—
 Animal Industry, Pennsylvania, scope and policy, 780.
 Chemistry, color laboratory, problems, 14.
 Public Roads, relations to States, U.S.D.A., 387.
- Burgundy mixture—
 adhesiveness, N. H., 842.
 and Pickering sprays, comparison, U.S.D.A., 843.
 fungicidal value, 544.
 preparation and use, 155.
- Butter—
 adulteration, detection, 315.
 color defects in, 380.
 fat. (*See Milk fat.*)
 fishy flavor in N. Y., Cornell, 470.
 flour for infants, 567.
 garlic flavor removal, 879.
 imports and exports, 74.
 leaky, cause, 682.
 making, neutralized cream in, 75.
 manufacture, 580, 779.
 method of preserving, 682.
 methods of analysis, Ind., 805.
 mottled, cause and prevention, 779.
 phosphorus in, N. Y. Cornell, 469.
 production and prices, statistics, 74.
- Buttermilk—
 dried, analyses, Ind., 867.
 phosphorus in, N. Y. Cornell, 470.
 v. tankage for fattening pigs, Mo., 772.
- Butyl alcohol—
 for quantitative saponification, 505.
 production, process, 712.
- Cabbage—
 aphid, control, N. Mex., 342.
 bacterial black rot, studies, 751.
 black rot, notes, 151.
 blackleg, control, 46.
 blackleg, notes, 151, 654.
 breeding experiments, Md., 144; Pa., 537.
 club root, notes, 244.
 culture experiments, Pa., 536.
 disease resistant varieties, Md., 144.
 juice, vitamin C as affected by heat, 567.
 maggot, control, 850; Can., 759.
 red and white, edible portion and waste, analyses, 63.
 root development, 834.
 storage experiments, N. H., 36.
 sun-dried, vitamin B and C in, 63.
 varieties, Pa., 536.
 vitamin A in, 165.
 vitamins B and C in, 63.
 worms, control, N. C., 449.
 worms in South Dakota, 850.
 yellows, notes, 151.
 yellows, studies, Ind., 345.
- Cacao—
 beans, culture and expression of oil, 240.
 coconut bud rot on, 156.
- Cacao—Continued.
 culture in French colonies, papers on, 342.
 insects affecting, 52.
 production in Brazil, 292.
- Cactaceæ, perennation and proliferation of fruits, 328.
- Cactus—
 mucilage formation in, 226.
 mucilage in, origin, 132.
 prickly pear, as stock feed, U.S.D.A., 35.
 stability of spineless character, U.S. D.A., 35.
 (*See also Opuntia.*)
- Cafeterias for industrial plants, 663.
- Caffein, determination, 804.
- Cake. (*See Oil cakes and specific materials.*)
- Calandra—
granaria. (*See Granary weevil.*)
oryza. (*See Rice weevil.*)
- Calcium—
 arsenate, insecticidal value, Colo., 158; Oreg., 756.
 carbid, as source of alcohol, 618.
 carbonate, effect on availability of soil potash, Md., 121.
 carbonate, effect on composition of soil extracts, Mich., 124.
 carbonate, effect on nitrification in soils, Tex., 725.
 chlorid, use in fixing ammonia, 628.
 cyanamid, ammonium sulphate from, 628.
 cyanamid as top-dressing, 519.
 cyanamid, deteriorated, injurious effects, 628.
 cyanamid, dicyandiamid determination in, 413.
 cyanamid, fertilizing value, 126, 628; La., 627.
 cyanamid for root knot control, 551.
 cyanamid, formation, 628.
 cyanamid, improvement, 519.
 cyanamid, reduction of dustiness, 519.
 cyanamid, use, 427.
 cyanamid v. sodium nitrate for beets, 232.
 deficiency in soils, Ky., 814.
 determination in organic solutions, 204.
 metabolism in fowls, N. Y. State, 574.
 nitrate, artificial, action and use, 125.
 nitrate, fertilizing value, Can., 727.
 nitrate, manufacture and use, 628.
 oxalate in plants, abnormal abundance, 327.
 oxid, effects on availability of soil potash, Md., 121.
 phosphate, effect on solubility of soils, 517.
 phosphate, reverted, determination, Mich., 113.
 rôle in nutrition, N. Y. State, 574.
 sulphate. (*See Gypsum.*)
 (*See also Lime.*)
- Calcium-containing soaps, ash of, 412.

- Calendra pertinax*, habits of, 762.
- Calf meal—
 Purdue, feeding value, Ind., 375.
 Purdue, preparation, Ind., 876.
- Calf meals, analyses, Ind., 69, 867; Ky., 373; N. J., 69, 672; R. I., 672.
- Calf scours, prevention and treatment, 183.
- Calfskins, exports from Argentina, 95.
- California—
 Station, notes, 99, 198, 699.
 University, notes, 99, 198, 599, 699.
- Caliroa cerasi*, parthenogenesis, 60.
- Calliphora erythrocephala*, chemotropic response, 554.
- Calomel electrode, new design, 204.
- Calotermes tectonæ*, notes, 450.
- Calves—
 birth, weight, studies, Mo., 176.
 feeding experiments, 575; Ind., 375; U.S.D.A., 469.
 fish meal for, 671.
 inheritance of congenital cataract, 669.
 inheritance of defect of hair and teeth, 672.
 milk substitutes for, Ind., 875.
 newborn, intestinal flora, 183.
 red, occurrence in black breeds of cattle, Wis., 771.
 skim milk for, U.S.D.A., 469.
- Cambuci, possible economic value, 40.
- Camels, training, 870.
- Campanula carpatica*, genetics of, 632.
- Camphor—
 red scale, effect of freeze of 1917, 555.
 trees, machine for trimming, U.S.D.A., 90.
- Canada Experimental Farms, report, Can., 798.
- Canadian Society of Technical Agriculturists, editorial, 401.
- Canals—
 effect on ground water level, 210.
 irrigation. (See Irrigation.)
- Cancer, relation to diet deficiency, 667.
- Cane. (See Sugar cane.)
- Canned—
 foods, bacteriology of, Mich., 115.
 vegetables, spoilage in, Mich., 114.
- Canning—
 cold-pack method outfits, 808.
 directions, Can., 316.
 industry in France, 261.
 methods for destroying botulinus spores, 169.
 vegetables, time for processing, Mich., 115.
- Cantaloups. (See Muskmelons.)
- Capons and cockerels, growth and feed consumption, Md., 574.
- Capri figs, varieties, Calif., 238.
- Caprification of Smyrna figs, Calif., 238.
- Carabao. (See Water buffalo.)
- Carbazol test for nitrites, 316.
- Carbohydrate diets, effect on diabetics, 370.
- Carbohydrates—
 and glucosids, treatise, 410.
 as effected by enzymes in serum, 782.
- Carbohydrates—Continued.
 fermentation products, 502.
 fermenting, identification of bacteria in, 113.
 in apple trees, form and location, N. H., 28.
 in diet, effect on pancreas, 568.
 production and consumption in United States, 61.
- Carbon—
 as an adsorbent, 412.
 bisulphid, insecticidal value, N. Mex., 352.
 determination in urine, 414.
 dioxid and water, polymerization to sugar, 202.
 dioxid assimilation, studies, 525.
 dioxid content of blood, as affected by high altitudes, 565.
 dioxid content of milk, N. Y. State, 579.
 dioxid content of soil, N. Y. Cornell, 813.
 dioxid, effect on availability of phosphates, 630.
 dioxid, effect on plant growth, 321.
 dioxid in soil extracts, effect of fertilizer salts, Mich., 125.
 dioxid, relation to plant growth, 510.
 vegetable decolorizing, 412.
- Carotin in leaves, 633.
- Carpet grass—
 culture, U.S.D.A., 233.
 seed, harvesting and cleaning, U.S.D.A., 233.
- Carpocapsa pomonella*. (See Codling moth.)
- Carpophilus hemipterus* on dried fruit, 255.
- Carrots—
 analyses, 63.
 as affected by fineness of lime, 325.
 breeding experiments, Can., 735.
 culture experiments, 638.
 fertilizer experiments, Can., 735.
 iodine content, 204, 632.
 root development, 834.
 sun-dried, vitamins B and C in, 63.
 variety tests, 232, 236, 638; Can., 735.
 vitamin A extraction from, 367.
 vitamin A in, 165.
 vitamins B and C in, 63.
 yields, Wash., 737.
- Carya glabra hirsuta* n. comb., notes, 222.
- Casein—
 hydrolized, utilization, 65.
 in Bordeaux mixture, value, 550.
 processes of manufacture in New Zealand, 15.
- Caseinogen, composition, 202.
- Cashaw wilt, studies, Tex., 846.
- Cassava meal—
 for dairy cattle, 73.
 v. sweet potatoes for pigs, 71.
- Cassava, production in Brazil, 292.
- Cassia oil, determination of lead in, 14.
- Castor—
 bean disease, 45, 849.
 bean poisoning, 78.
 beans, army worm on, 557.

- Castor—Continued.
 beans, culture, 827.
 oil, extraction and utilization, 827.
- Castor-oil industry, U.S.D.A., 802.
- Casuarina equisetifolia*, fungus symbiosis in, 731.
- Cat diseases, 687.
- Catalase—
 content of blood, variations in, 569.
 relation to animal oxidations, 569.
- Catalysers for oxidation of ammonia, 816.
- Catharrhal fever, malignant, in cattle, 384, 584.
- Caterpillars—
 salt-marsh, on cotton, U.S.D.A., 352.
 (See also Tent caterpillar.)
- Cats, cestodes of, keys, 80.
- Cattle—
 Aberdeen-Angus, history, 171.
 advanced registry testing, Idaho, 378.
 alfalfa v. clover hay for, Ind., 870.
 Ayrshire, origin, 176.
 breeding, diseases of, 683.
 breeding in Scotland, 67.
 breeding, occurrence of red calves in
 black breeds, Wis., 771.
 breeding records, Me., 175.
 broom corn seed for, 671.
 dairy, advanced registry rules, 176.
 dairy, breeding experiments, 575.
 dairy, efficiency standard, 683.
 dairy, elevator screenings for, Can.,
 868.
 dairy, feeding, Iowa, 875.
 dairy, feeding and management, treatise, 176.
 dairy, judging systems, 176.
 dairy, normal growth, Mo., 876.
 dairy, official testing, Mo., 778.
 dairy, Sudan grass for, Kans., 176.
 dipping tanks, construction, 90.
 disease due to crab grass, 384.
 disease, unidentified, in New York
 State, 473.
 diseases. (See also specific diseases.)
 feeding experiments, Ind., 375; N. Dak.,
 374.
 feeding rack, design, 91.
 Guernsey, breeding, 378.
 Guernsey, transmitting qualities of
 sires, Me., 175.
 hemorrhagic disease, Nev., 272.
 inheritance of color and markings, 375.
 inheritance of congenital cataract, 669.
 inheritance of defect of hair and teeth,
 672.
 intestinal parasite of, in Fiji, 883.
 Irish, origin, 171.
 Jersey, transmitting qualities of sires,
 Me., 175.
 judging for selecting dairy cows, Me.,
 175.
 judging, treatise, 697.
 loss of weight during transportation,
 672.
 pea straw for, 870.
 plague. (See Rinderpest.)
- Cattle—Continued.
 poisoning by arrow grass, Nev., 77.
 poisoning by *Astragalus tetrapterus*,
 U.S.D.A., 78.
 poisoning by lupine, Wyo., 783.
 poisoning by whorled milkweed, U.S.
 D.A., 470.
 (See also Plants, poisonous.)
 poppy seed cake for, 777.
 prices, U.S.D.A., 595.
 range, feeding experiments, N. Mex.,
 374.
 rice meal for, 172.
 rôle in malaria prophylaxis, 454, 853.
 scab, control, 272.
 scab, eradication, U.S.D.A., 471.
 Shorthorn, history, 171.
 spermatogenesis, 670.
Syngamus taryngeus, in, 688.
 tick, eradication, U.S.D.A., 471.
 (See also Ticks.)
 tick-resistant, studies, 182.
 (See also Calves, Cows, and Steers.)
- Cauliflower—
 analyses, 63.
 bacterial disease, 152.
 root development, 834.
 (*Oecidomyia*) *Mayetiola destructor*. (See
 Hessian fly.)
- Caulophilus latinasus*, notes, 851.
- Celery—
 analyses, 63.
 diseases, remedies, N. J., 153.
 iodine in, 632.
 root development, 834.
 roots, iodine content, 204.
 varieties, disease resistant, Md., 144.
- Cell—
 growth, relation to energy, 131.
 nuclei, passage of undissolved sub-
 stance from, 524.
 nuclei, size and function, 524.
- Cellars, damp-proofing, U.S.D.A., 485.
- Cells—
 detached root-cap, viability, 130.
 meristemic, as affected by stimulation,
 130.
 (See also Plant cells.)
- Cellulose—
 as emergency feed, 170.
 digestion in vitro, 670.
 manufacture from corncobs, 809.
 raw and hydrolized, method of dis-
 tinguishing, 315.
- Cement—
 as affected by alkali, Wyo., 789.
 joints for cast-iron gas pipes, 482.
 production and use in 1918, 282.
 (See also Concrete.)
- Central Agricultural Council in Denmark,
 600.
- Centrinus penicellus*, life history, 762.
- Cephalonomia kiefferi*, notes, 259.
- Cephus—
cinctus, studies, U.S.D.A., 259.
 spp. differentiation, key, U.S.D.A., 260.
 spp., notes, U.S.D.A., 363.

- Cerambycini* larvæ, construction of calcareous opercula, 57.
- Ceraphron pallidiventris*, parasitism by, Mass., 158.
- Cerapterocerus mirabilis*, notes, 252.
- Cercospora*—
medicaginis, notes, 652.
nicotianæ, notes, 246.
rosicola, notes, 152.
 spp., notes, 544.
- Cereal—
 crops, relation to weather, 44.
 diseases, 652.
 leaf rusts, studies, Ind., 345.
 mildew, notes, 45.
 rusts, notes, Okla., 44.
 smut, control, Colo., 150.
 smuts, notes, 445; Okla., 44.
 stalk disease, control, 750.
- Cereals—
 cultivation, implements for, 892.
 culture in Nigeria, 637.
 culture under irrigation, U.S.D.A., 637.
 effect of cold on, 432.
 insects affecting, 652.
 relation of potassium to growth, N. H., 29.
 variety tests, U.S.D.A., 638.
 (See also Grain and specific kinds.)
- Cervicitis of swine, 683.
- Cestodes of dogs and cats, keys, 80.
- Cetoniinæ of British India, descriptions, 50.
- Chaetodacus* spp., descriptions, 57.
- Chagas disease—
 in Brazil, 182.
 notes, 57.
- Chalcis fly in clover and alfalfa seed, U.S.D.A., 364.
- Chamiso brush, analyses, N.Mex., 374.
- Changa on grass roads, 53.
- Chataigne wood, durability tests, 44.
- Cheese—
 cream, cold-storage tests, Vt., 179.
 imports and exports, 74.
 making in Great Britain, 682.
 making on the farm, 272.
 making with lactic acid bacteria, 681.
 manufacture, 580.
 manufacture, pasteurization in, 179.
 Neufchâtel, cold-storage tests. Vt., 179.
 production and prices, 74.
 rind rot, cause, 179.
 soft, cold-storage tests, Vt., 178.
- Chemical compounds, disinfecting power, 78.
- Chemistry—
 agricultural, textbook, 10, 898.
 analytical, manual, 10.
 colloid, application to food chemistry, 609.
 fat, progress in 1918, 201.
 fat, review of literature, 112.
 industrial, manual, 609.
 inorganic, treatise, 609.
 medical, treatise, 609.
 of building and machine material, 389.
- Chemistry—Continued.
 of condiments, 609.
 of foods, 409, 563, 609.
 of humin acids, 321.
 of leather, treatise, 317, 617.
 of soils, 122.
 of wood, 409, 617.
 progress, 409.
 reading courses in, 801.
 textbook, 697.
 yearbook, 201.
- Chenopodium, fluid extract, ascaricidal value, 381.
- Chenopodium oil—
 ascaricidal value, 381.
 composition, 502.
- Chermes, larch, life history, 54.
- Chermes pinicorticis*, notes, Conn. State, 251.
- Chermidæ, new genera and species, keys, 450.
- Cherries—
 breeding experiments, 742.
 culture, Nebr., 644.
 effect of temperature on resistance to wounding, U.S.D.A., 39.
 hardy variety, Minn., 833.
 origin and characteristics, 744.
 sour, insects affecting, 352.
 sour, time for transplanting, Mo., 142.
 spray calendar, N.J., 37.
 sun drying, 808.
 winter injury, U.S.D.A., 435.
- Cherry—
 bacterial leaf spot, notes, Okla., 36.
 brown rot, notes, 349.
 curculio, control, 352.
 diseases, control, Ill., 847.
 leaf scorch, notes, 246.
 leaf spot, control, 352.
 orchard survey, Colo., 144.
 shothole, control, 155.
 slug, control, 352.
 slug sawfly, parthenogenesis, 60.
- Chestnut—
 bark disease, history, 658.
 black canker, studies, 448.
 tuberosities, 753.
 white, ashes, analyses.
- Chestnuts—
 European varieties, classification, 41.
 time for transplanting, Mo., 142.
- "Chiai" flesh, chemistry of, 563.
- Chiasmatype and linkage, 269.
- Chicken—
 mite, notes, Okla., 51.
 skin, digestibility, 164.
 sticktight flea, Okla., 587.
- Chickens—
 botulism in, 84.
 calcium metabolism, N.Y.State, 574.
 contagious epithelioma, Nev., 272.
 digestive organs of, Wash., 689.
 selection for egg characters, N.Y.Cor-nell, 872.
 (See also Fowls and Poultry.)

- Chick-peas, description and agricultural value, 528.
- Chicks—
causal factor in hatching, 169.
feeding, Mo., 174.
feeding experiments, 573; N.C., 467.
growth as affected by feed, Ky., 72.
growth rate, 675.
soy bean meal for, 674.
- Chil, yield tables, 840.
- Children—
energy requirements, 166.
food requirements. (*See also* Infants, feeding.)
malnourished, nutrition clinics for, 167.
pulmonary symptoms, relation to Ascaris, 80.
(*See also* Boys and Girls.)
- Children's gardens. (*See* School gardening.)
- Child-welfare teaching in rural communities, 694.
- Chilies. (*See* Pepper.)
- Chilo plejadellus*, notes, U.S.D.A., 253.
- Chinch bugs—
barriers for, Ohio, 758.
in Montana, 758.
- (*Chloridea*) *Heliothis obsoleta*. (*See* Cotton boll-worm.)
- Chloridea of Argentina, 731.
- Chlorids in soil, determination, 311.
- Chlorin—
antiseptics. (*See* Dakin's solution.)
conversion into hydrochloric acid, 712.
loss from soil by drainage, 19.
- Chlorophyll in plants, changes affecting, 526.
- Chloropicrin—
effect of temperature on insecticidal value, 157.
for horse mange treatment, 184.
- Chloropicrination, use of term, 184.
- Chokecherry, wild, poisonous to live stock, Nev., 273.
- Cholesterol, synthesis by infants, 769.
- Chondriomes, notes, 524, 525.
- Chortophila brassicae*, control, 850.
- Chromogen, new, in *Calanthus*, 327.
- Chromosomes—
arrangement of genes, 268.
distance between genes, 268.
number in relation to number of types, 632.
number in dog, 269.
sex, studies, 670.
- Chrysanthemum—
"crack-neck," 849.
gall midge, control, Conn. State, 251.
midge, studies, U.S.D.A., 360.
fumigation, U.S.D.A., 362.
- Chrysis shanghaiensis*, parasite of oriental peach moth, 359.
- Chrysomela bigsbyana*, life history, notes, 850.
- Chrysomphalus*—
aonidum, notes, 555.
dictyospermi, notes, 851.
- Chrysophlyctis endobiotica*, notes, 245.
- Cicada, 17-year, notes, Ind., 352.
- Cicadellidae, North American, distribution, 450.
- Cicuta occidentalis*, poisonous to live stock, Nev., 273.
- Cider—
making experiments, 807.
ropiness in, 807.
- Cinchona culture, 344.
- Cinnamomum sieboldi*, pollen development, 328.
- Cirphis* spp., notes, 52.
- Cistern water, treatment, 279.
- Cisterns, concrete, construction, 188.
- Citrina, use of term, 433.
- Citrus—
blast, studies, 156.
canker, eradication work, 550.
canker, history of, 349.
canker organism, behavior in soil, 550.
canker, relative susceptibility of species, 848.
diseases in Cuba, 448.
diseases, spraying for, 550.
Euphaterus citri on, 451.
groves, use of manure in, 239.
insect pests, effects of freeze of 1917, 554.
insect pests in Porto Rico, 555.
leaf roller, notes, 556.
mealy bug, control, 557, 659.
melanose, notes, 550.
plants, polyembryonic, venation and senescence, 133.
root-bark channeller, habits and control, 456.
scab, notes, 550.
scaly bark, control, 551.
trees, effects of cold on, 550.
trees, injury from windstorm in southern California, 41.
withertip, notes, 550.
- Citrus grandis*, polyembryonic shoots, 133.
- Citrus fruits—
bud selection, 542.
culture experiments, 40; U.S.D.A., 339.
culture in Bombay, 745.
culture in Fiji, 40.
culture in Syria, 838.
decay, causes, 41.
dodder affecting, 652.
fertilizer experiments, 342.
fumigation experiments, 54.
grading and packing in Australia, 836.
improvement, U.S.D.A., 439, 440.
insects affecting, 52.
spraying experiments, 157.
stocks for, 41.
unfermented juice, manufacture, Calif., 717.
variety experiments, U.S.D.A., 339.
(*See also* Oranges, Lemons, etc.)

Cladosporium—

- citri*, notes, 550.
- citri* on avocado, 550.
- herbarum citricolum*, notes, 551.
- sp. on rubber, 45.

Clams, analyses, Me., 662.

Clapper rail, new, from Florida, 659.

Clasterosporium carpophilum, notes, 243.

Clastoptera vittata, notes, Mass., 158.

Clay, coagulation, protective action of humus, 515.

Cleora pampinaria. (See Cranberry spanworm.)

Cloridae, North American, larvæ of, 854.

Climate—

- and soil conditions for broom corn, U.S.D.A., 232.
- classification, 418.
- of Netherlands, 811.
- of Saskatchewan, 620.
- of South Dakota, 618.
- (See also Meteorology.)

Climates of British Empire suitable for cotton, 620.

Climatic—

- conditions in a greenhouse, U.S.D.A., 511.
- control, relation to plant growth, 431.
- data from tree rings, 809.
- factors, effect on timber line, 840.

Climatological data. (See Meteorological observations.)

Climograph charts, notes, U.S.D.A., 718.

Clothing—

- contest, girls', plans, 495.
- selection, demonstration, 495.

Cloudiness, in New York State, U.S.D.A., 511.

Clouds—

- cirrus, use in weather forecasting, 319.
- iridescent, U.S.D.A., 718.

Clover—

- alsike, culture experiments, Wash., 436.
- alsike, culture in lead and zinc regions, 514.
- alsike, yields, Minn., 636.
- alsike, yields on irrigated wild meadows, Oreg., 22.
- as cover crop, Wash., 743.
- as forage crop in Denmark, 177.
- as shade crop for orchards, Oreg., 145.
- berseem, yield in Australia, 527.
- cost of production, Ohio, 392.
- culture on peat soil, 23.
- effect on nitrate formation in soil, 215.
- fall planting, Wash., 738.
- fertilizer experiments, Can., 727, 729; Ind., 331; Ohio, 726.
- ground, use as grasshopper bait, 353.
- hay, composition and digestibility, Mont., 771.
- hay for fattening cattle, Ind., 870.
- liming experiments, Can., 729.
- red—
 - as affected by fineness of lime, 325.
 - as orchard cover crop, Pa., 538.

Clover—Continued.

- red—continued.
 - culture experiments, Wash., 436.
 - factors affecting failure, Wash., 333.
 - nematode affecting, 46.
 - seed, studies, 638.
 - stemrot, control, 46.
 - root, development as affected by water level, 623.
 - rotation experiments, Ohio, 726.
 - seed, chalcid fly in, U.S.D.A., 364.
 - seed, crimson, production and imports, U.S.D.A., 695.
 - seed production, U.S.D.A., 435.
 - seeds, longevity of, 832.
 - Shearman's, new forage plant, 528.
 - sickness, cause, 46.
 - sickness, notes, 45.
 - sweet. (See Sweet clover.)
 - tops, green and cured, rate of decomposition, 212.
 - variety tests, Can., 735.
 - vitamin A extraction from, 165.
 - white, culture experiments, Wash., 436.
 - worm, green, notes, N. C., 450.
 - worm, green, on beans, Conn. State, 251.
 - worm, green, on soy beans, 759.
- Club work. (See Boys' clubs and Girls' clubs.)
- Cnaphalodes strobilobius*, life history, 54.
- Coal—
 - brown, decomposition, 213.
 - stoves, efficiency tests, 592.
- Coat color. (See color.)
- Coccidæ of São Thome, 452.
- Coccidiosis in cattle, 384.
- Coccinella transversoguttata*, notes, U.S. D.A., 455.
- Coccobacillus insectorum malacosomæ* n. sp., description, 853.
- Coccophagus* spp., notes, 252.
- Cockerels—
 - and capons, comparison of growth and feed consumption, Md., 574.
 - surplus, early elimination, 73.
- Cocklebur—
 - oil, analyses, 801.
 - paired seeds, mineral constituents, 431.
 - popular account, U.S.D.A., 832.
- Cocoa—
 - analyses, Ariz., 764.
 - bean shell meal, analyses, N. J., 672.
 - butter, digestibility, 64.
- Coconut—
 - bud rot, cause, 551.
 - bud rot, control, 653.
 - bud rot, description, 151, 152.
 - bud rot, in Jamaica, 48.
 - bud rot, in Philippines, cause, 156.
 - diseases in Grenada, 551.
 - leaf miner, notes, 52, 851.
 - meal, analyses, 867; Ky., 373; N. J., 69, 672.
 - mealy bug on avocado, 851.
 - oil, rancidity of, 201.

- Coconut—Continued.
oil, sampling and examination, 805.
palm, insects affecting, 57.
scale, notes, 851.
- Coconuts—
culture and expression of oil, 240.
culture in Philippines, 441.
insects affecting, 52.
- Cod muscle, composition, 569.
- Codling moth—
control, 743; Ind., 338; Mo., 757;
Oreg., 756.
control in Colorado, 161.
control in New Jersey, 357.
control in Oregon, 660.
control in Ozarks, 357.
control *v.* extermination, 558.
life history, Ind., 351.
life history, N. Mex., 358.
notes, Colo., 158; Mont., 758.
- Coffee—
borer, red, notes, 450.
breeding and selection, 838.
culture in French colonies, 342.
determination of caffeine in, 804.
disease, new, 247.
insects affecting, 252.
leaf disease, notes, 444.
production in Brazil, 292.
selection experiments, 748.
substitutes, determination of caffeine in,
804.
thread blight, notes, 152.
varieties in Uganda, 342.
- Cold storage—
diseases of apples, control, Iowa, 38.
of fruits as affected by handling and
packing, 39.
plant of U. S. Department of Agriculture,
892.
stocks, U.S.D.A., 694.
- Coleocentrus, notes, 858.
- Colleges. (*See* Agricultural colleges.)
- Colletotrichum*—
falcatum on sugar cane, La., 348.
glucosporioides, notes, 550.
Indemuthianum, parasitism by, 46.
sp. on rubber, 45.
- Colloid chemistry, application to food
chemistry, 609.
- Colloidal—
action of protoplasm, 429.
properties of bog water, 224.
substances, gold number determination,
12.
- Colloids, plant, studies, 524.
- Colocasia antiquorum*, exudation of water
by, 633.
- Colon-aerogenes group, correlation studies,
791.
- Colonization projects for Argentina, 290.
- Color—
changes in green vegetables on cooking,
458.
chart for blending colors in flowers,
240.
- Color—Continued.
eye, production in birds, 866.
inheritance in cattle, 375; Wis., 771.
inheritance in dogs, 669.
inheritance in horses, 378.
inheritance in swine, Iowa, 71.
laboratory of Bureau of Chemistry,
problems, 14.
standards for colorimetric determina-
tion of H-ion exponent, 211.
(*See also* Pigmentation.)
- Colorado—
College, notes, 198.
Station, report, 197.
- Colorimetric estimations with two colored
substances, 414.
- Coloring matters prohibited in food in
Italy, 65.
- Community—
consciousness, development, 91.
gardens. (*See also* Gardening and
School gardens.)
improvement. (*See also* Rural com-
munities.)
organization, plan, 192.
tile drainage organizations, U.S.D.A.,
478.
- Comparator, improved, 503.
- Complement—
deviation reaction, polyvalent extracts
for, 181.
deviation, studies, 382.
fixation test as affected by previous
mallein test, 881.
fixation test for tuberculosis, 278, 687.
of animals, constitution of, 684.
regeneration, after radiation or heating,
781.
titration of, 780.
- Complement-deficient serum, phagocytic in-
dex, 274.
- Concrete—
aggregates producing equal strength,
482.
beams, reinforced, tests, 482.
bins, circular reinforced, design, 892.
bituminous, bitumen content, 389.
blocks, manufacture and use, 86.
buildings, small, construction, 188.
consistency, apparatus for determining,
86.
consistency, measuring by flow table,
590.
construction, treatise, 889.
curbs and gutters, construction, 90.
dipping tanks, construction, 90.
farm buildings, 90.
fences and gateposts, 188.
fence posts, Ohio, 391.
floors, construction, 188.
forms, pressure formula, U.S.D.A., 388.
greenhouses, construction, 90.
hotbeds, construction, 90.
mixing and laying, 889.
mixtures in alkali soils, 482.
pavements, reinforcing, 790.

Concrete—Continued.

- pig houses, construction, 90.
 - poultry houses, construction, 90.
 - pressure against forms, U.S.D.A., 388, 389.
 - reinforced, construction, 188.
 - reinforced, handbook, 289.
 - road finisher, description, U.S.D.A., 388.
 - roads, available aggregates, 284.
 - roads, reinforced, design and construction, 284.
 - roads, reinforced, factors affecting design, 284.
 - roads, reinforcement, determining position of, 284.
 - root cellars, construction, 90.
 - selection of materials and mixing, 186.
 - sidewalks, construction, 90, 188.
 - slabs, precast, for irrigation structures, 587.
 - tanks and cisterns, construction, 188.
 - troughs, construction, 90.
 - walls, construction, 188.
 - walls, retaining, design and construction, 485.
 - wells, construction, 90.
- Condensers, types compared, 112.
- Condiments, chemistry of, treatise, 609.
- Conifer rusts, notes, Pa., 552.
- Conifers—
- as affected by emanations from munition plants, 347.
 - characteristics of, 650.
 - in British Isles, rate of growth, 748.
 - ontogeny of cotyledons in, 133.
 - seedling, mold of, 846.
 - time for transplanting, Mo., 142.
- Coniothyrium* spp., notes, 753.
- Connecticut Storrs Station, report, 197.
- Conorhinus megistus*, notes, 182.
- "Constant," use of term, 867.
- Constrictotermes, notes, 256.
- Contarinia tritici*. (See Wheat midge.)
- Contractors' and estimators' reference book, 188.
- Cooking, textbook, 494.
- Cooperation. (See Agricultural cooperation.)
- Cooperative—
- grain elevator companies, U.S.D.A., 895.
 - milk societies in Calcutta, 177.
 - societies in Burma, 94.
- Copper—
- acetate, adhesiveness, N.H., 842.
 - acetates, properties and cost, 155.
 - fungicides, composition and use, 155.
 - fungicides, relative adhesiveness, N.H., 842.
 - soap mixture, fungicidal value, 846.
 - sprays, preparation and use, 544.
 - sulphate for algæ growths in reservoirs, 479.
 - sulphate, fungicidal value, 346.
 - sulphate, use against weeds in coniferous nurseries, 42.
- Copperas. (See Iron sulphate.)

Copra disease, notes, 151.

Coprinus spp., parasitism of, 750.

Cordia spp., notes, 555.

Corn—

- ancestry of, 222.
- and cob meal, analyses, N. J., 69, 672.
- and oats, analyses, N.J., 69.
- and pigs, price relations, U.S.D.A., 694.
- and soy beans, hogging-down, Ky., 871.
- as dry farm crop for silage, Ariz., 733.
- as forage crop, 527; Mont., 739.
- as trap crop for cotton bollworm, 852.
- beetles, poison bait for, 456.
- belt, location as affected by inclination of earth's axis, 207.
- bollworm affecting, Conn.State, 252; Mo., 757.
- borer, European—
 - control, 661; Mo., 759.
 - discussion, 162.
 - distinguishing characters, 661.
 - in imported broom corn, 161.
 - life history, 661.
 - notes, Mich., 660.
 - parasites of, 858.
 - present status, Conn.State, 251.
 - situation in America, 661.
- bran, analyses, 867; Ind., 69, 867; Ky., 373.
- breeding experiments, 529, 637; Ind., 331.
- breeding, method of procedure, 529.
- brown spot, notes, 243.
- canning, recipe, 808.
- chop, analyses, Ky., 373.
- cobs, chopped, composition and digestibility, 267.
- cost and price indexes, Mo., 792.
- cost of production, Ohio, 392.
- cost of production in Argentina, 487.
- culture, Ariz., 733.
- culture experiments, Ky., 331; Mo., 736; Mont., 332, 738; Tex., 33; U.S. D.A., 134.
- culture in lead and zinc regions, 513.
- diseases, Ind., 345.
- diseases, control, Tex., 845.
- disking *v.* plowing, Mont., 739.
- downy mildew in Philippines, 545.
- earworm, oviposition of, 358.
- exports from Argentina, 95.
- feed meal, analyses, 867; Ind., 69, 867; Ky., 373; N.J., 69, 672.
- fertilizer experiments, 423; Ala.Col., 135, 333; Ky., 824; N.C., 424, 427; Ohio, 726; S.C., 126; Tex., 33, 229.
- for finishing steers, Ind., 869.
- Fusarium disease, studies, Mo., 749.
- germ meal, analyses, Ind., 69, 867.
- germination as affected by H-ion concentration, 525.
- germination as affected by rolling of soil, 722.
- gluten feed, analyses, 867; Ind., 69, 867; Ky., 373; N.J., 69, 672; R.I., 672.

Corn—Continued.

- gluten meal, analyses, Ind., 69; N. J., 69, 672.
 growing contest, Ind., 395.
 Guam, origin and growth, 638.
 head smut, description, Wash., 242.
 hogging-down experiments, Ky., 871; U.S.D.A., 466.
 hybrids, studies, 529.
 insect control, Ala.Col., 57.
 insects affecting, 450.
 irrigation experiments, Utah, 230.
 leaching effect on utilization of rock phosphate, 427.
 manuring experiments, 423; Mont., 739; Utah, 218; U.S.D.A., 134.
 meal, analyses, Ariz., 764; N.J., 672; Vt., 464.
 nitrogenous fertilizers for, relative value, N.C., 427.
 oil as substitute for ghee, 563.
 period of greatest nitrate utilization, Ill., 215.
 planting dates in relation to earworm, 358.
 plants, composition as affected by disease, Ind., 345.
 relation of potassium to growth, N.H., 29.
 root disease, notes, 243.
 root rot, relation to seed infection, Ky., 653.
 root rots, control, Ind., 34.
 rootworm on rice, U.S.D.A., 253.
 rotation experiments, Ohio, 726.
 rust, false, notes, Okla., 44.
 scab organism, production of conidia, 545.
 seed, freezing injury, Nebr., 827.
 seed, infection, Ky., 653.
 seed testing, rag doll, modified, Ind., 135.
 seedlings, growth as affected by H-ion concentration, 525.
 shelled, analyses, Ky., 373.
 silage. (*See* Silage.)
 smut, head and common, differentiation, Wash., 243.
 smut, notes, 152.
 stalk borer, notes, N.C., 450.
 stalk borer, studies, 358.
 stalk rot, relation to seed infection, Ky., 653.
 supplements for fattening pigs, Ohio, 377.
 sweet. (*See* Sweet corn.)
 textbook, 638.
 time for applying sodium nitrate to, Ala.Col., 333.
 v. barley for fattening pigs, Mo., 772.
 v. hominy feed for fattening pigs, Mo., 772.
 varieties, N.C., 434.
 variety tests, Can., 735; La., 636; Md., 133; Minn., 823; Tex., 33, 230; U.S. D.A., 134, 435.

Corn—Continued.

- weevil, life history, 762.
 weevil, notes, N.C., 450.
 wireworms, notes, Conn. State, 252.
 yellow, vitamin A extraction from, 367.
 Corneobs, utilization, 809.
 Cornell—
 Station, notes, 299, 900.
 University, notes, 100, 299, 799, 900.
 Cornstalk borer, lesser, on beans, Ariz., 733.
 Cornstarch, raw, digestibility, 365.
 Corrosive sublimate—
 for cabbage blackleg, 46.
 use against subsoil nematodes, 47.
Corticium vagum—
 notes, 246.
solani on yams, 151.
Coryneum perniciosum, notes, 448.
Cosmopolites sordidus—
 notes, 457, 560.
 on banana, 52.
Cosmopteryx n. sp., notes, 52.
 Cotton—
 American Egyptian, value of, Ariz., 137.
 angular leaf spot, notes, 243, 652; Okla., 44.
 anthracnose, control, 244.
 anthracnose, notes, 243.
 aphid, life history studies, Tex., 758.
 aphid, notes, U.S.D.A., 352.
 army worm on, 557.
 boll rot, notes, 243.
 boll weevil, notes, N.C., 450.
 boll weevil, poisoning, 456, 561, 562; Ala.Col., 57; U.S.D.A., 856.
 boll weevil poisoning as affected by dew and rain, 162.
 bollworm, control in India, 51.
 bollworm, corn as trap crop for, 852.
 bollworm, notes, U.S.D.A., 352.
 bollworm, pink, effect on yield of seed and lint, 160.
 bollworm, pink, eradication, 161.
 bollworm, pink, in India, 450.
 bollworm, pink, life history, 160.
 bollworm, pink, notes, 554; Ala.Col., 57.
 bollworm, pink, summary, U.S.D.A., 454.
 breeding experiments, N.C., 434; Okla., 32; U.S.D.A., 329.
 classing, N.C., 490.
 club leaf or cyrtosis, 446.
 correlations of characters, Ark., 530.
 culture, Ariz., 137.
 culture, climates suitable for in British Empire, 621.
 culture experiments, Ariz., 733; Tex., 33; U.S.D.A., 134, 329.
 culture in Asiatic Turkey, 531.
 culture in Belgian Kongo, 828.
 culture in West Africa, 828.
 culture on Yuma project, U.S.D.A., 393.
 diseases, control, 544.

Cotton—Continued.

- fertilizer experiments, Ala.Col., 135, 233; Ga., 136, 137; Mo., 736; N.C., 424, 427; Okla., 32; S.C., 126; Tex., 230.
- fertilizer quantity effect on profit, N.C., 425.
- growing contest, 436.
- insects affecting, 252, 450.
- insects in Porto Rico, 252.
- irrigation, notes, Ariz., 137.
- leaf-perforator, U.S.D.A., 352.
- lint frequency, Ark., 530.
- manuring experiments, U.S.D.A., 134.
- nitrogenous fertilizers for, relative value, N.C., 427.
- production in Brazil, 292.
- resistance to alkali, Ariz., 724.
- root rot, notes, 652; Okla., 44.
- rotation experiments, Okla., 32.
- seed, culture and expression of oil, 240.
- seed hairs, daily growth rings in, 633.
- seed improvement, 244.
- seed treatment, 161, 845.
- selection experiments, Ark., 739.
- stainer on avocado, 851.
- stem weevil in India, 450.
- time of applying sodium nitrate, Ala. Col., 233.
- time of maturity, factors affecting, Ga., 136.
- upland long staple, value, Ark., 531.
- variety tests, 637; Ark., 436; Ga., 136; La., 636; Mo., 736; N.C., 434; N.Mex., 332; Tex., 33, 230; U.S.D.A., 134, 329.
- warehouses, regulations, U.S.D.A., 896.
- warehouses, regulations, revision, N. C., 490.
- wilt, control, 244.
- wilt, notes, 243.
- woolly mite, notes, 51.
- worm, control, Ala.Col., 55.
- worm, notes, 252.

Cottonseed—

- feed, analyses, 867; Ky., 373; N.J., 69, 672.
- hulls, analyses, Ind., 867.
- meal, analyses, 867; Ind., 69; Ky., 373; N. J., 69, 672; Vt., 464.
- meal and feed, analyses, Ind., 867; R.I., 672.
- meal and soy beans, comparison, Ind., 570.
- meal as affected by heating, N.C., 411.
- meal as source of ammonia in composts, 127.
- meal, fertilizing value, Ala.Col., 135; La., 627; Tex., 33, 37.
- meal for laying hens, N.Mex., 378.
- meal, nitrogen availability, Ala.Col., 135.
- oil, composition, 502.
- oil, vitamin A in, 764.
- oil mills, data, 817.

Cottonseed—Continued.

- products, gossypol in, N.C., 411.
- products, sampling and examination, 805.
- Cottonwood disease, Ariz., 749.
- Cottony cushion scale, notes, 554.
- Cotyledons, evolution of, 133.
- Country house, plans and specifications, 289.
- Country. (See also Rural.)
- Cover crops—
 - culture in Nigeria, 637.
 - experiments, Md., 133.
 - for orchards, Ind., 338.
- Cow—
 - stables, concrete, construction, 90.
 - stables, plans, 592.
- Cowpea—
 - weevil, four-spotted, control, Okla., 51.
 - weevil, studies, Tex., 561.
 - as green manure, Ariz., 733; Md., 122; U.S.D.A., 134.
 - economic value, U.S.D.A., 794.
 - fertilizer experiments, Okla., 32.
 - hay yields, Mo., 736.
 - rotation experiments, Okla., 32.
 - seed production, Mo., 736.
 - variety tests, Ariz., 733; La., 636; Md., 133; Mo., 736; Okla., 32; Tex., 33; U.S.D.A., 134.
- Cows—
 - advanced-registry feeding, Pa., 577.
 - advanced-registry tests, Calif., 576; Kans., 677.
 - Aryshire, milk records, analysis, 74.
 - cassava meal for, 73.
 - cellulose as emergency feed for, 170.
 - cottonseed cake for, Ariz., 777.
 - dairy, care at calving time, Wash., 197.
 - dairy, competition, Calif., 876.
 - dairy, judging in relation to milk yield, Me., 175.
 - dairy, milk yield in relation to age, Me., 174.
 - dairy, nitrogen metabolism, S.Dak., 873; Va., 874.
 - dairy, pure-bred, testing, 73.
 - dairy, record and feeding chart, 176.
 - feeding experiments, 270; New Mex., 777.
 - forced feeding, Pa., 577.
 - Guernsey, milk records, Minn., 876.
 - Jersey, milk records, 777.
 - kudzu as soiling crop for, La., 671.
 - milk production. (See Milk production.)
 - pasturing experiments, Minn., 671; U.S.D.A., 468.
 - potato tops poisoning, 180.
 - records. (See Dairy herd records.)
 - reproductive organs of, bacterial flora, 182.
 - soiling crops for, 777.
 - sterility of, treatment, 683.
 - sunflower silage for, Mont., 68.
 - udders. (See Udder infection.)
 - (See also Calves, Cattle, and Heifers.)
- Coyote, methods of destruction, Calif., 250.

- Crab grass, effects on cattle, 384.
 Cracklings, analyses, N.J., 69.
Crambus praelectellus—
 notes, Conn.State, 251.
 on corn, 358.
- Cranberries—
 fertilizer experiments, Mass., 147.
 insects affecting, Mass., 158.
 spraying experiments, U.S.D.A., 843.
 storage experiments, Mass., 146.
 winterkilling and frosts, Mass., 119.
- Cranberry—
 black-head fireworm, control, Mass., 159.
 diseases, Mass., 155.
 fruit-worm, parasite of, Mass., 159.
 plants, submerged, as affected by cloudiness, 836.
 root grub, notes, Mass., 158.
 spanworm, notes, Mass., 158.
 spittle insect, control, Mass., 158.
- Craniotabes and rickets diagnosis, 369.
 Cratægomespilus, stability and heredity, 818.
- Cream—
 buying, permit system, Kans., 682.
 churning and whipping, Wash., 780.
 garlic flavor removal, 878.
 imports and exports, 74.
 neutralization with lime, 75.
- Creameries—
 cooperative, in Minnesota, 75, 682.
 cooperative, in Oregon, Oreg., 75.
 inspection, Ind., 682.
 ledger accounts for, classification, U.S.D.A., 878.
- Creatin in blood, variability, 265.
- Creatinin—
 excretion as affected by purgation, 462.
 in blood, variability, 265.
- Credit unions—
 formation and supervision, N.C., 490.
 negro, in the South, 192.
- Créosote, effect of viscosity on penetrance in wood, 283.
- Cresol solutions, saponified, preparation, U.S.D.A., 273.
- Cresylic solutions, determining strength of, 614.
- Crickets—
 mole, in South Carolina, 159.
 mole, on grass roads, 53.
- Cronartium*—
occidentale, notes, 249.
ribicola. (See White pine blister rust.)
- Crop—
 estimates, prewar, in Germany, U.S.D.A., 490.
 forecasting in the Dakotas, 491.
 introduction tests, Tex., 34.
 production in Great Britain, 393.
 reports, U.S.D.A., 193, 294, 491, 694, 794, 896.
 reports, Government, value of, U.S.D.A., 794.
 residue work in jars, Wash., 726.
 rotations. (See Rotation of crops.)
 valuation, feed unit system, 693.
- Crops—
 as affected by soil and climate, Idaho, 227.
 irrigation experiments, 387.
 periodicity in, 416.
 time of planting, application of bioclimatic law, U.S.D.A., 509.
 v. pasture, relative labor income, 92. (See also Field crops.)
- α -Crotonic acid as affected by phosphates, 131.
- Crows—
 control, Okla., 51.
 popular account, 50.
- Crucifer finger-and-toe, 546.
- Crude fiber. (See Cellulose.)
- Crustacea muscle, composition, 568.
Cryptolemus montrouzieri, notes, 660.
 Cryptotermes new species, 256.
- Cucumber—
 bacterial wilt, control, U.S.D.A., 245.
 beetle, striped, control, Mo., 757.
 beetle, striped, in South Dakota, 850.
 beetles, studies, U.S.D.A., 245.
 diseases, notes, 151.
- Cucumbers—
 analyses, 63.
 wild, rôle in cucurbit mosaic transmission, 654.
- Cucurbit—
 bacterial wilt, U.S.D.A., 245.
 diseases, studies, Ind., 345.
 Fusarium wilt, studies, Tex., 846.
 mosaic, transmission, 654.
- Culex subgenera, notes, 258.
- Cultivation—
 effect on soil moisture, 210.
 mechanical, of rice in China, 484.
 motor, apparatus for in France, 289.
- Cultivator, 6-shovel, draft of, Mo., 787.
- Cultivators, mechanical, 892.
- Culture media—
 changes in reaction due to actinomycetes, 635.
 for testing disinfectants, 181.
 from bouillon cubes, 329.
 from fish, 580.
 reactions, 10, 329.
 variations in H-ion concentration, 381.
- Culverts, metal, galvanizing, tests, U.S.D.A., 690.
- Cuprammonium—
 sulphate, adhesiveness, N.H., 842.
 washes, studies, N.H., 44.
- Cupressus* spp., disease affecting, 156.
- Curbs, concrete, construction, 90.
- Currant—
 diseases, control, Ill., 847; Wash., 349.
 industry in California, history, 837.
 lice in South Dakota, 850.
 worms in South Dakota, 850.
- Currants—
 black, blister rust affecting, 249.
 black, classification, 438.
 black, reversion, 448.
 breeding experiments, 742.

Currants—Continued.

- Cronartium ribicola* overwintering on, 849.
 culture, Nebr., 644.
 culture and marketing, 40.
 culture in California, U.S.D.A., 837.
 eradication by chemicals, 246, 248.
 insects affecting, Wash., 349.
 new varieties, 438.
 (See also Ribes.)
- Cut-over lands, program for reforestation, 343.
- Cutworm, black, affecting tobacco, 52.
- Cutworms—
 of Minnesota, key, 55.
 on cotton, U.S.D.A., 352.
 pale western, notes, Mont., 758.
- Cyanamid, determination, 804.
- Cyanid. (See Hydrocyanic acid.)
- Cyanized briquets, ammonia production from, 220.
- Cyanophyceæ, coloration, effect of colored lights on, 526.
- Cyloconium oleaginum*, lime-sulphur for, 346.
- Cyclone, cloud cross-section of, U.S.D.A., 119.
- Oylas formicarius*. (See Sweet potato weevil.)
- Cynodon dactylon* affected by Balansia, 152.
- Cypress bark scale, studies, U.S.D.A., 452.
- Cyrtacanthacris guttulosa*, notes, 52.
- Cyst—
 content of proteins, relation to their efficiency, 663.
 determination, 505.
- Cytospora*—
chryso sperma, notes, Ariz., 749.
 sp. on rubber, 45.
- Dacus sensu latiore*, description, 56.
- Daffodils, seedlings, notes, 240.
- Dairy—
 bacteriology, cooperative laboratory for, 879.
 barns, ventilation, 892.
 buildings, plans, 592.
 cows. (See Cows.)
 exhibit, Mich., 698.
 farming, alpine, decline, 576.
 farming, bibliography, 73.
 farming, capital required, 94.
 farming in Kansas, Kans., 576.
 farming in Switzerland, 779.
 farming in Victoria, 177.
 farms, forage crops on, 177.
 farms, labor income, W.V., 92.
 farms, soil fertility maintenance, 23.
 herd, accredited, testing, 683.
 herd records, Minn., 876; N.Y.Cornell, 469.
 herd records, studies, Pa., 576.
 plants, cooperative in Belgium, 878.
 products, advertising methods, U.S.D.A., 580.
 products, legislation in New York, 176.

Dairy—Continued.

- products, production, U.S.D.A., 179.
 rations, computing, Pa., 176.
 record and feeding chart, 176.
- Dairying—
 cooperative, effect on a community, 291.
 cooperative, in India, 192.
 cooperative, problems, 580.
 importance of, U.S.D.A., 490.
 in Canada, 779.
 in Germany, 177.
 manual, 580.
 research institute at Reading, 779.
 statistics of Michigan, 272.
 (See also Creamery, Milk, etc.)
- Daisy, ox-eye, floral variations in, 729.
- Dakin's solution, use, Wyo., 179.
- Dams—
 cause of failure, 281.
 hydraulic-fill, testing, 280.
 measuring upward pressure under, 589.
- Dandelion seeds, germination tests, N.Y. State, 535.
- Dandelions, eradication from laws, N.Y. State, 535.
- Darso—
 description and analyses, Okla., 137.
 feeding value, Okla., 137.
 yields, Ariz., 733.
- Dasyneura vaccini*, parasite of, Mass., 158.
- Date industry, Ariz., 745.
- Dates—
 culture experiments, U.S.D.A., 339.
 propagation method, Ariz., 740.
 variety tests, U.S.D.A., 339.
- Day, length of, effect on flowering and fruiting, 819.
- Death camas, poisonous to live stock, Nev., 273.
- Deciduous Fruit Station, outline of projects, 237.
- Decilaua citriperda*, habits and control, 456.
- Dehydration. (See Drying.)
- Delaware—
 College, notes, 99, 198.
 Station, notes, 198.
- Delphinium andersonii*, poisonous to live stock, Nev., 273.
- Demodex*—
ermineæ n. sp., studies, 80.
folliculorum suis, notes, U.S.D.A., 688.
 spp., studies, 80.
- Demonstration farm, national, in Great Britain, 600.
- Dendrophoma obscurans* n. sp., description, Ill., 753.
- Deodar, yield tables, 840.
- Department of Agriculture. (See United States Department of Agriculture.)
- Depressaria heracliana*, notes, Conn. State, 252.
- Dermacentor*—
reticulatus, notes, 83, 84.
venustus, control, 164.

- Dermacentroænus rickettsi*, notes, 60.
 Detroit Milk Commission, report, Mich., 178.
 Dew, effect on boll weevil poisoning, 162.
 Dewberries, breeding experiments, 536.
 Dewberry diseases, control, Ill., 847.
 Dextrin, gold number determination, 12.
 Dextrins, cellulose, studies, 524.
 Dextrose and levulose, ratio of utilization by plants, 730.
 Diabetes—
 control by fasting and dietary restriction, 862.
 dietetic treatment, causes of failure, 862.
 effect of protein diets, 862.
 experimental production in dog, 370.
 treatment, monograph, 370.
 Diabetic foods, 63.
 Diabetic foods, analyses, Conn.State, 861.
Diabrotica spp., relation to cucumber wilt, U.S.D.A., 245.
Diabrotica vittata. (See Cucumber beetle, striped.)
 Diallel crossing, use of term, 866.
Diaprepes abbreviatus, notes, 252.
Diarrhronomyia hypogræa—
 notes, Conn.State, 251.
 studies, U.S.D.A., 360.
 Diastase, effect on cellulose dextrins, 524.
 Diastatic capacity, determination, 802.
 Diatoms of New Jersey soils, 217.
Diatraea—
 auricilia, notes, 852.
 saccharalis. (See Sugar cane borer.)
 Diazo value of urine as affected by nutrition, 368.
 Dicyandiamid—
 in calcium cyanamid, determination, 413, 804.
 toxic action in soils, 426.
Didymana perforans on lettuce, 152.
 Diet—
 accessory factors. (See Vitamins.)
 balancing, graphic method, 167.
 deficiency—
 as related to edema, 66.
 disease, pathogenesis, 664.
 diseases, 166, 262, 263, 264, 461, 462.
 disease in French army, 168.
 diseases in Vienna, 667.
 (See also Beriberi, Pellagra, Polyneuritis, Rickets, and Scurvy.)
 studies, 62, 63, 165, 369.
 deficient—
 effect on monkeys, 666.
 relation to cancer, 667.
 for adults and children, textbook, 494.
 of British and Indian troops in relation to disease, 262.
 of children. (See Children.)
 of hotel employees, supervising, 663.
 of infants. (See Infants.)
 value of coarse ground grain in, Can., 366.
 Dietotherapy, treatise, 261.
Digonatopus lucidus n. sp., description, 857.
 Dille, A., biographical sketch, 100.
Diloboderus abderus, notes, 450.
 Diphenylamin reaction, color changes of, 505.
Diplocarpon rosæ, notes, 152.
Diplodia—
 corchori, notes, 444.
 gossypina, notes, 243.
 griffoni, notes, 753.
 sp. on rubber, 45.
 Diplodia, studies, Mo., 749.
 Dipping tanks for cattle, construction, 90.
 Diptera, muscoid, parasites of, 662.
 Disease control by machine dish-washing, 261.
 Diseases—
 contagious, diagnosis, prophylaxis, and therapy, 76.
 deficiency. (See Diet deficiency diseases.)
 of animals. (See Animal diseases.)
 of plants. (See Plant diseases.)
 Dish washing, machine, relation to disease control, 261.
 Disinfectants—
 chemical, absolute and relative power, 78.
 culture media for testing, 181.
 resistance of intracellular organisms to, 822.
 seed injury from, prevention, 844.
 Distillers' dried grains, analyses, 867; Ky., 373.
 Ditch digging, dynamite for, 480.
 Ditches, drainage and irrigation. (See Drainage and Irrigation.)
 Divining rod, use, 478.
 Dockage, in wheat, method of determining, U.S.D.A., 535.
 Dodder—
 in Idaho, control, 833.
 on citrus and olive, 652.
 Dogs—
 cestodes of, keys, 80.
 degeneration of testes, 269.
 Great Dane, inheritance of coat color, 669.
 piebald spotting in, origin, 669.
 spermatogenesis of, 269.
 Domestic science. (See Home economics.)
Dothiorella gregaria on walnut, 350.
 Douglas fir—
 forest, establishment, 650.
 region, forestry in, 343.
 Dourine, control, 272.
 Drainage—
 as an antimalaria measure, 85.
 ditch, Tempe, Ariz., 789.
 ditches, dredged, water flow in, U.S.D.A., 478.
 ditches, maintenance, 280.
 for reclamation of peat soils, 420; Minn., 814.
 for reclamation of push soils, Iowa, 21.
 in St. Louis, 689.

- Drainage—Continued.
 machinery, farm, 589.
 of swamp land in Argentina, 478.
 structures of roads, design, U.S.D.A., 387.
 tile, construction, c o m m u n i t y, U.S.D.A., 478.
 tile, for moors in Holstein, 185.
 treatise, 280.
 water, washing out of nitrates by, 19.
- Draintile—
 cement and clay, tests, 689.
 flow of water in, U.S.D.A., 788.
 for U. S. Reclamation Service, inspection, 589.
- Dredges, types, 887.
 Dredging engineering, treatise, 887.
- Dried blood—
 fertilizing value, 627; Can., 727; Wis., 336.
 nitrification of, 215.
- Drill press, post, use, 483.
- Drought—
 effect on critical periods of plant growth, 207.
 in California, U.S.D.A., 511.
- Droughts, probable, method of constructing diagram, 319.
- Drug—
 and food manual, U.S.D.A., 164.
 plants, culture, 838.
 plants, unexploited source of supply, 41.
- Drugs—
 analyses, Conn.State, 859; Me., 662.
 effect on milk production, 577.
 proprietary preparations, analyses, N. Dak., 368.
 useful, handbook, 580.
- Dry farming experiments, Mont., 332.
- Drying—
 of food, bacteriological aspects, 316.
 of food, standards for, 368.
 of foods and feeding stuffs, 15.
 of fruits and vegetables, Can., 316.
 of fruits, Wash., 715.
 of grapes, Calif., 715.
 (See also Fruits, drying, and Vegetables, drying.)
- Ducks—
 calcium metabolism, N.Y.State, 574.
 wild, of Nebraska, and their food plants, U.S.D.A., 50.
- Dunes, sand, forestation methods, 651.
Duomitus ceramicus, notes, 450.
- Dust-collecting fans for thrashing machines, U.S.D.A., 390.
- Dusting—
 experiments, 842.
 v. spraying, 238, 255, 352; Ind., 338; Ohio, 340.
- Duty of water. (See Irrigation.)
- Dwarf, metabolism of, 368.
- Dyes, photosensitizing, production, 14.
- Dynamite—
 as affected by soil moisture, U.S.D.A., 282.
 use in agriculture, 480.
 v. horsepower for stump removal, Minn., 888.
- Dynastinae of British India, description, 50.
- Dyscerus* n. spp., descriptions, 163.
- Dysdercus suturellus*. (See Cotton stainer.)
- Eantis thraso*, notes, 556.
- Earthwork and its cost, 589.
- Earthworms, rôle in transmission of gapes, Md., 586.
- Eating utensils, machine-washed v. hand-washed, 261.
- Ecology—
 of *Tilia americana*, 223.
 of tropical rain forests, 241.
 plant, of Kansas sand hills, 731.
 quadrant method of study, 223.
- Economic conditions in Deccan Canal areas, 94.
- Economics, rural. (See Rural economics.)
- Edema—
 in Turkish prisoners of war, studies, 66.
 malignant, in swine, 385.
- Education—
 agricultural. (See Agricultural education.)
 vocational. (See Vocational education.)
- Eelworms, parasitism of, 350.
- Egg—
 albumin. (See Albumin, egg.)
 characters, studies, N.Y.Cornell, 872.
 market, fluctuations in, 73.
 packing, discussion, 873.
 production—
 as affected by rations of chicks, Ky., 72.
 breeding for, Can., 776; Mich., 674.
 feeding for, 174; Idaho, 269; Mo., 776; N.Mex., 378.
 rôle of protein in, Ky., 871.
 (See also Hens, laying.)
 products, frozen, analyses, U.S.D.A., 414.
- Egg-laying contest—
 in Australia, 674, 873.
 in New Jersey, N.J., 173, 468.
 Western Washington, Wash., 798.
- Eggplants, root development, 834.
- Eggs—
 effect of age on hatching quality, Md., 575.
 exports from Orkney Islands, 174.
 exports from South Africa, 676.
 hard boiled, ferrous sulphid formation in, 458.
 marketing in New York City, 174.
 prices and quality on New York market, 174.
 rare anomaly of, 73.
 unturned, position of yolks, 675.
 weight, inheritance of, 674.
 weight, normal distribution, R.I., 674.

- Ehrhornia cupressi*, studies, U.S.D.A., 452.
- Elachista*—
n. spp., descriptions, 55.
spp., notes, 55.
- Elaphidion inerme*, notes, 851.
- Electric—
arc nitrification, studies, 323.
current from traction lines, leakage into soils, 625.
vehicles, tests, 484.
- Electrical power in France, 790.
- Electricity—
on the farm, U.S.D.A., 486.
use in agriculture, 285.
- Electrodes of platinized glass, 612.
- Electrolytes in leaf sap, concentration, 633.
- Electrophysiology, studies, 819.
- Elevator screenings—
for fattening steers, Can., 672.
reclaimed, for live stock, Can., 868.
- Elm gummosis, 449.
- Emmer, wheat nematode attacking, 751.
- Empoasca*—
mali, studies, 355, 655.
minuenda, notes, 255, 851.
- Encyrtida*, Hawaiian, 662.
- Encyrtus*—
barbatus, notes, 662.
infidus, notes, 252.
- Enderleinellus, new genus, 453.
- Energy—
expenditure of laborers, 463.
requirements of children, 166.
supply for cell growth, 131.
values and starch values, 372.
- Engine—
cooling, principles of, 88.
design, paper on, 890.
- Engineering—
agricultural. (See Agricultural engineering.)
dredging, treatise, 887.
experiment station legislation, 395.
for land drainage, 280.
handbook, 278.
waterproofing, treatise, 186.
- Engineers, shortage, how to meet, U.S.D.A., 186.
- Engines—
fuel saving with carburetor, 890.
gas, valve adjustments for low-grade fuel, 483.
intake-manifold temperatures, 890.
internal-combustion, effects of heat flow, 86.
internal-combustion, fuels for, 389.
internal-combustion, lubrication, 86, 483.
internal-combustion, new fuel mixtures for, 187.
internal-combustion, valve springs for, 591.
lubricating troubles, causes, 483.
- Engines—Continued.
temperature and pressure stress, formulas, 86.
tractor. (See Tractor engines.)
- Enteritis, necrotic, in calves and lambs, Wyo., 179.
- Enterohepatitis, infectious. (See Black-head.)
- Entomology, treatise, 850.
(See also Insects.)
- Entylia bactriana*, life history notes, 850.
- Enzym—
action, treatise, 611.
activity of seeds, 10.
- Enzymes—
effect of concentration on rate of digestion, 611.
in serum, effect on carbohydrate media, 782.
of *Aspergillus oryzae* and malt, comparison, 503.
of *Aspergillus repens* in condensed milk, 779.
of milk, relation to abnormal flavors, Mo., 712.
studies, 311.
- Epelis truncataria fawonii* on cranberry bogs, Mass., 158.
- Ephestia*—
caustella on dried fruit, 255.
kuehniella. (See Flour moth, Mediterranean.)
- Epilachna corrupta*—
notes, Colo., 158.
studies, U.S.D.A., 455.
- Epitrix cucumeris*. (See Potato flea-beetle.)
- Epyris extraneus*, parasite of *Gonocephalum seriatum*, 662.
- Eriodendron anfractuosum*, durability test of wood, 44.
- Eriophyes*—
gossypii, notes, 252.
olsivorus, notes, 555.
- Eriopyga incincta*, notes, 164.
- Eschscholtzia californica*, color pigments of, 632.
- Essential oils. (See Oils, essential.)
- Estigmene acrea*. (See Caterpillar, salt-marsh.)
- Ether—
as gasoline substitute, 187.
extract, determination, 115
- Eucalyptus—
culture, instructions for in Brazil, 442.
revision of genus, 543.
- Eulecanium coryli*, notes, 252.
- Eumenes* spp., synopsis, 60.
- Eumenidæ, synopsis, 60.
- Eupelmus* sp., notes, U.S.D.A., 365.
- Euphalerus citri*, notes, 451.
- Euphorbia, latex vessels, function, 525.
- Euproctis chrysorrhæa*. (See Brown-tail moth.)
- Eutelus bruchaphagi*, notes, U.S.D.A., 365.

- "Eutinia," use of term, 861.
- Euvooa segetis* on tobacco, 52.
- Evaporation**—
amount and temperature of, 16.
as affected by wind, 16.
- Evaporator**—
for drying fruit, description, 808.
for drying grapes, description, Calif., 715.
- Evergreens**—
broad-leaved for Ohio, Ohio, 342.
ornamental, notes, U.S.D.A., 339.
- Evetria buoltana*, parasites of, 259.
- Evolution, organic, treatise, 521.
- Ewes**—
breeding, winter rations for, 870.
feeding experiments, Wash., 772.
milking, management in Argentina, 876.
sunflower silage v. alfalfa hay for, Mont., 69.
- Exenterus affinis* n. sp., description, 857.
- Exoascus*—
deformans, notes, 246, 445.
spp., lime-sulphur for, 346.
(*Taphrinella*) *purpurascens* on sumac leaves, 49.
- Exobasidium*—
hesperidum n. sp., notes, 152.
oxycoeci on cranberry bogs, Mass., 155.
- Exochus* (*Triclistus*) *evetrie* n. sp., description, 857.
- Experiment farms, county, Ohio, 339.
- Experiment Station Record, classification of abstracts, 404.
- Experiment stations**—
and their funds, editorial, 1, 708.
cooperation in research, 708, 709.
need of increased Federal aid, 708.
present problems, 703.
project essentials, editorial, 302.
publication of results, 709.
research work as affected by the war, 707.
(See also Alabama, Arizona, etc.)
- Explosives**—
use in land clearing, U.S.D.A., 282.
war, use in land clearing, 480.
- Export trade of Argentina in 1919, 95.
- Extension work. (See Agricultural extension.)
- Extraction apparatus, new, description, 413.
- Fans, dust-collecting, for thrashing machines, U.S.D.A., 390.
- Farcy. (See Glanders.)
- Farm**—
animals. (See Live stock and Animals.)
buildings, concrete, construction, 90, 188.
buildings, plans, 892.
buildings, treatise, 592.
buildings, ventilation, 892.
bureau, relation to horticulture, 643.
business analysis, 792.
cost and price indexes, Mo., 792.
credit. (See Agricultural credit.)
- Farm**—Continued.
drainage machinery, 589.
Home Business Unit, descriptive leaflet, 191.
homes, improved conditions in U.S.D.A., 894.
houses for England, plans, 892.
houses, plans, 791.
income, division between landlord and tenant, 489.
labor. (See Agricultural labor.)
land values in Iowa, U.S.D.A., 893.
life studies, research projects, 595.
Loan Act, Federal, for Porto Rico, 291.
loans, Federal, 394.
loans, types, 192.
machinery. (See Agricultural machinery.)
management—
human factor in, 793.
in Pennsylvania, U.S.D.A., 692.
problems, 693.
studies, Mo., 793.
survey in Ontario, 291.
survey, W.Va., 92.
organization, 692.
products. (See Agricultural products.)
selection, U.S.D.A., 291.
size of, effect on population, 793.
tenancy—
and property tax, 895.
in Illinois, 593.
in wheat belt, forms of lease, U.S.D.A., 290.
systems, comparison, Mo., 190.
(See also Land tenure.)
tramways in England, 484.
- Farmer**—
and farm market, address, 91.
rôle as a producer of wealth, 91.
- Farmers'**—
club of Pennsylvania, notes, 486.
purchase power, organization, U.S.D.A., 488.
- Farming**—
books on, 93, 396.
cooperative. (See Agricultural cooperation.)
dairy. (See Dairy farming.)
initial capital required, 94.
types, labor income, 92; W.Va., 92.
(See also Agriculture.)
- Farms**—
near Washington, D. C., economic study, U.S.D.A., 691.
use of electricity on, U.S.D.A., 486.
use of horse power on, U.S.D.A., 483.
- Fat**—
chemistry, progress in 1918, 201.
chemistry, review of literature, 112.
content of dried potato preparations, 414.
content of skim milk, methods of determining, N.Y.Cornell, 415.
in butter, determination, Ind., 805.

- Fat—Continued.
 industry in France, 261.
 industry in 1914–1918, 112.
 production in plants, 430.
- Fats—
 in apple trees, N.H., 28.
 iron content, 202.
 of coconut group, method of estimating, 315.
 production and consumption in United States, 61.
 saponification number determinations, 505.
 substitutes in Germany, 204.
 vegetable, digestibility, 64.
 (See also Oils.)
- Fat-soluble A. (See Vitamin A.)
- Fauna of British India, 50.
- Feces, bacteriological examination, 113.
- Federal—
 farm loan act for Porto Rico, 291.
 farm loans, 394.
- Food and Drugs Act, enforcement, 662.
- Feeding—
 experiments. (See Cows, Pigs, etc.)
 racks for alfalfa hay, design, 91.
- Feeding stuffs—
 analyses in Pennsylvania, 867.
 chemistry of, treatise, 609.
 concentrated, production and use, 170.
 condimental, analyses, Ind., 69, 867.
 containing cellulose, digestibility, 670.
 differentiation by serum reactions, 206.
 digestion coefficients, 266.
 drying, discussion, 15.
 economy in, Wash., 698.
 from plants in Germany, 170.
 inspection and analyses, Ind., 69, 867;
 Ky., 373; N.J., 69, 671; R.I., 672;
 Vt., 464.
 international trade, 170.
 law, Tex., 867.
 law, revision, N.J., 373.
 method of valuation, 315.
 microscopic control of, 170.
 nutritive value, 372.
 prices, N.J., 69, 672.
 process for reducing fiber content, 868.
 public formulas for, 671.
 quantitative microanalysis, 14.
 substitutes in Germany, 204.
 sugar content, 671.
 wartime, 170.
 wartime, composition and digestibility, 267.
 (See also specific kinds.)
- Feltia annexa*, poison bait for, Ariz., 757.
- Fence posts—
 steel and concrete, Ohio, 391.
 willow, treatment, U.S.D.A., 391.
- Fences, concrete, construction, 188.
- Fermentation tube, modified, 611.
- Ferments. (See Enzyms.)
- Ferns—
 dictionary of, 148.
 hardy native, for Missouri, 838.
- Ferrous sulphid formation in hard boiled eggs, 458.
 (See also Iron.)
- Fertilizer—
 experiments—
 Can., 726, 727.
 on Palouse silt loam, Idaho, 227.
 on peat bogs, 23.
 short-time, unreliability of, 822.
 with a crop rotation, Ky., 814.
 (See also special crops.)
 formulas for Georgia soils, 727.
 industry, present tendencies, 817.
 law, Conn.State, 326; Ind., 631; N.H., 28.
 law in Illinois, 28.
 law in Pennsylvania, 326.
 laws, State, officials in charge, 817.
 manufacturers and dealers, list, 817.
 requirements of soil. (See Soils.)
 resources of Italy, 728.
- Fertilizers—
 analyses, Md., 122.
 as affected by soil acidity, 212.
 as affected by the war, N.Y.State, 626.
 bacterial, analyses, 424.
 borax in, 312, 613.
 borax in, effects on crops, Ind., 325;
 S.C., 126.
 commercial, and phos-pho-germs, comparison, 27.
 consumption in United States, 425.
 cost in 1919, Vt., 428.
 effect on soil aldehydes, Pa., 519.
 effect on pH of soils, 423.
 high-grade, value of, Mich., 626.
 home-mixed, analyses, N.H., 520.
 injurious effects on plants, 513.
 inspection, N.J., 129.
 inspection and analyses, Conn.State, 221; Ind., 818; Kans., 729; Ky., 28; Mich., 326; Mo., 129; N.H., 28; N.J., 326; N.Y.State, 520; Oreg., 129; Vt., 428.
 inspection and analyses in Florida, 817.
 inspection and analyses in Illinois, 28.
 inspection and analyses in Maryland, 221.
 inspection and analyses in North Carolina, 28, 428, 818.
 inspection and analyses in Virginia, 521, 631.
 manufacture and function, 424.
 new, action and use, 125.
 "nitrogen bacteria," tests, 221.
 nitrogen determination in, 714.
 nitrogenous. (See Nitrogenous fertilizers.)
 orchard, studies, Oreg., 145.
 phosphatic. (See Phosphates.)
 potash. (See Potash.)
 registrations for 1920 in Pennsylvania, 326.
 selection and mixing, 727.
 v. manure for market gardening, R.I., 643.

Fertilizers—Continued.

v. manure for Maryland soils, 815.
yearbook, 817.

(See also specific materials.)

Fescue, meadow, culture experiments,
Minn., 823; Wash., 436.

Feterita, resistance to alkali, Ariz., 724.

Fiber—

crude. (See Cellulose.)
industry in Philippines, 826.
plants, native, use in Sweden, 828.

Fibers, analyses, 828.

(See also Hemp, Henequen, etc.)

Field crops—

cost of production, Ohio, 392.
exhibit, Mich., 698.
fall seeded, Wash., 738.
insects affecting, Mo., 758.
soil preparation for, 321.
work in Australia, 824.
work in Canada, Can., 734.
work in Nigeria, 637.
work in South Australia, 528.
(See also Crops, Forage crops, Root
crops, etc.)

Field experiments—

heterogeneity as factor affecting yields,
526.
probable error in, 527.
short-time, unreliability, 822.

Fig—

cuttings, preparation and treatment,
238.
die-back, notes, 246.
wasp, life history and habits, Calif.,
238.

Figs—

analyses, Calif., 238.
breeding experiments, 439.
caprification, Calif., 238.
culture experiments, 40; U.S.D.A., 339.
Kadota, origin and culture, 239.
recipes, 261.
Smyrna, non-splitting variety, 239.
Smyrna, types, 836.
souring, cause, 439.
splitting, cause, 439.
"Stanford," proposed name, 239.
variety tests, U.S.D.A., 339.

Filberts—

culture in England, 746.
culture in Northwest, 746.

Fir—

budworm attacking, 852.
silver, yield tables, 840.

Fire insurance—

farmers' mutual, system of records,
U.S.D.A., 193.
for standing timber, 148.

Fires, forest. (See Forest fires.)

Fish—

canning, cold-pack method outfits, 808.
chiai flesh, composition, 563.
dried, fertilizing value, 627.
frozen, changes in composition, 858.
frozen, as poultry feed, Minn., 674.
meal as stock feed, 671.

Fish—Continued.

moth, notes, Okla., 51.
muscle, composition, 569.
preserving in the home, 808.
salting, factors affecting final product,
663.
sauce, Indochinese, condensed, 458.
scrap, analyses, N.J., 672.
use in culture media, 580.

Fishmeal *v.* tankage for fattening pigs,
Mo., 772.

Flavin, antiseptic value, 79.

Flavone pigment of *Eschscholtzia cali-*
formica, 632.

Flax—

analyses, 829.
blooms, structure and fertilization,
133.
culture, 638; Ariz., 734; U.S.D.A.,
435.
culture experiments, 528, 824; Mont.,
332, 739; U.S.D.A., 134.
culture in Argentina, 436.
culture in British Empire, 639.
false, culture, 638.
fertilizer experiments, 824.
fiber grading, Can., 735.
fungus attacking rootlets, 244.
industry in Russia, 488.
rotation experiments, N.Dak., 332;
U.S.D.A., 435.
Russian, culture experiments, Tex.,
34.
seeding experiments, U.S.D.A., 330.
variety tests, Can., 735; U.S.D.A.,
134.

Flaxseed screenings, ground, analyses,
Ind., 69.

Flea beetles, notes, Mont., 758.

Flies—

house. (See House fly.)
Pipunculus, parasitism by, 661.

Flood control, 788.

Floods, maximum, distribution, U.S.D.A.,
511.

Flora—

of islands near New Zealand, 31, 129.
of woods of Hertfordshire, 241.
(See also Vegetation.)

Florida—

Station, notes, 599, 799, 899.
University, notes, 599, 899.

Flour—

analysis, graphical representation, 615.
baking qualities, Wash., 764.
baking tests, Ariz., 734; Me., 641.
determining quality and market value,
615.
from lupines, analyses, 458.
moth, Mediterranean, biology of, 51.
ofal content determination, 313.
production in Brazil, 292.
red dog, analyses, 867; Ind., 69, 867;
Ky., 373; N.J., 672; Vt., 464.
substitutes in bread making, 64.
substitutes in Germany, 204.
(See also Bread.)

Flowers—

- blending colors in, 240.
- culture, Nebr., 644.
- cut, industry, manual, 838.
- genetics of coloration, 328.
- monthly working calendar for, 236.
- (*See also* Plants, ornamental.)

Flue dust, potash content, 28.

Flume, Venturi, as measuring device in open channels, 887.

Fluorin, effect on plants, 523.

Fodder crops. (*See* Forage crops.)

Fog phenomenon of San Francisco Bay, U.S.D.A., 719.

Fomes—

- ludicus* on oil palms, 652.
- pseudoferreus*, new name for *Poria hy-polaritica*, 45.

Food—

- and drug manual, U.S.D.A., 164.
- and Drugs Act, Federal, effects of enforcement, 662.
- chemistry, 563.
- chemistry, survey of literature, 365.
- chemistry, treatise, 609.
- consumption in United States, 61.
- control in England and Germany during war, 459.
- for hotel employees, supervising, 663.
- in industrial plants, 564, 663.
- industries of France, treatise, 260.
- inspection and analyses, 313.
- manufacture, chemical control, 409.
- poisoning, discussion, 458.
- poisoning, identification of bacteria in, method, 113.
- poisoning organisms, effects of dehydration, 317.
- poisoning, treatise, 261.
- prices, government control, 394.
- production in Denmark, before and after the war, 292.
- Products Inspection Law, rules and regulations, U.S.D.A., 794.
- regulations in Italy, 65.
- resources of United States, 60.
- substitutes in Germany, treatise, 204.
- supply of United Kingdom, 694.
- values, modern science of, 62.
- values, teaching in elementary schools, 97.
- (*See also* Diet.)

Foods—

- analyses, Conn.State, 859; Me., 662.
- animal, production and consumption in British Empire, 593.
- animal, world's supply, 593.
- canned. (*See* Canned foods.)
- courses of study, 797.
- determination of acidity, 11.
- diabetic, analyses, Conn.State, 861.
- dried, standards for, 368.
- drying. (*See* Drying.)
- green, vitamin A extraction from, 165.
- nitrogen determination, modified method, 316.

Foods—Continued.

- quantitative microanalysis, 14.
- sanitary survey, N.Dak., 368.
- stored, bacteriological character, 317.

Foot and mouth disease—

- eradication, U.S.D.A., 471.
- immunization, 383.

Forage crops—

- cultivation and use in Brazil, 68.
- culture experiments, Mont., 332.
- culture in Nigeria, 637.
- diseases, 652.
- for cotton belt, U.S.D.A., 638.
- insects affecting, 652.
- for nonirrigated lands, Idaho, 738.
- notes, 527.
- of Denmark, 177.
- variety tests, Can., 735; La., 636; Nev., 229.
- (*See also special crops.*)

Forage poisoning—

- by whorled milkweed, Colo., 141.
- investigations, Ind., 385.
- summary of information, 580.
- (*See also* Plants, poisonous, and specific plants.)

Forest—

- administration. (*See* Forestry.)
- aerial photographs, 748.
- communities, regulations, 441.
- conservation, discussion, 343.
- control in Portugal, 442.
- devastation, national control, 42.
- fire control in Washington, 748.
- fire control, use of airplanes in, 543.
- fire laws of California, handbook, 42.
- fires in Canada, 840.
- fires in Oregon, handbook, 748.
- fires, nature of injuries from, 543.
- fires, protection, 747.
- flora of New South Wales, 543.
- insect control, sunlight as factor, 560.
- insects in Dutch East Indies, 450.
- land in Himalayas, use of, 543.
- laws in new province of Italy, 747.
- laws in Oregon, 748.
- lepidoptera, new species, 853.
- mapping, methods, 840.
- operations, methods of financing, 42.
- policy of American Paper and Pulp Association, 542.
- policy of United States, 746.
- products, Philippine, for paper pulp, 841.
- regeneration in Germany, 840.
- research, effect on forest policy, 41.
- research, relation to management, 841.
- resources, survey, U.S.D.A., 650.
- species suitable for Zululand, 42.
- trees. (*See* Trees.)
- Forestation—
 - dry land, in India, 150.
 - effect on water supply, 16.
 - in Belgium, 343.
 - in New Zealand, 542, 747.

Forestation—Continued.

- in Zululand, 42.
- of cut-over lands, 343.
- of sand dunes, 651.

Forestry—

- Federal and State, cooperation, 441.
 - handbook, 542.
 - in Africa, 839.
 - in Ajmer-Merwara, 241.
 - in arid regions, 840.
 - in Australia, 150.
 - in Baluchistan, 150.
 - in Bombay, 748.
 - in British Columbia, 747.
 - in California, 442.
 - in Canada, 442, 542.
 - in Douglas fir region, 343.
 - in early England, 442.
 - in Federated Malay States, 542.
 - in France, 442.
 - in Illinois, 542.
 - in India, 150, 651.
 - in Interior Department, 148.
 - in Ireland, 747.
 - in Italy, 747.
 - in Korea, 839.
 - in Massachusetts, 343, 839.
 - in Minnesota, Minn., 839.
 - in Morocco, 651.
 - in Netherlands India, 748.
 - in New Zealand, 542, 651, 747.
 - in Pennsylvania, 442, 839.
 - in Porto Rico, 241.
 - in Rhodesia, 840.
 - in South Australia, 42.
 - in Texas, 747.
 - instructions for Brazil, 442.
 - of the Prophets, 148.
 - private, economics of, 42.
 - science of, 343.
 - treatise, 343, 442, 651.
 - Tri-State Conference, 441.
- Forests—
- Douglas fir, natural production, 650.
 - fertilizer experiments, 24.
 - growth data, N.H., 41.
 - hardwood, in Appalachians, management, 42.
 - in French colonies, 651.
 - National, grazing regulations, 148.
 - National, insect control, 148.
 - National, nurseries, weed control in, 42.
 - National, policies, 839.
 - National, recreational features, 442; U.S.D.A., 543, 747.
 - National, roads through, U.S.D.A., 442.
 - of Greece, 241.
 - of Quebec, statistics, 149.
 - of South Brazil, moisture and illumination, 241.
 - of West Africa, 839.
 - State, economic aspects, 343.
 - State, for Massachusetts, 543.
 - tapestry, of Hawaii, 747.
 - tropical rain, ecology of, 241.
 - white pine, in New England, 149.

Formaldehyde—

- disinfecting power, 78.
- effect on protein hydrolysis, 110.
- phloroglucin test, degree of alkalinity necessary, 804.
- polymerization to sugar, 202.
- treatment for cereal smut, 150.
- use against tobacco root rot, Mass., 846.

Formates, production, 220.

Foulbrood—

- European, U.S.D.A., 58.
- notes, Mont., 758.

Fowl—

- cholera, immunizing value of commercial vaccines, Nebr., 887.
- cholera, treatment, 586.
- typhoid in France, papers on, 84.

Fowls—

- calcium metabolism, N.Y. State, 574.
- immunity to plague, 278.
- production of eye color in, 866.
- visceral anatomy, Wash., 397.
- (See also Poultry.)

Fractionation in analysis, 503.

Frankliniella cephalica masonii, notes, 851.

Freesia disease, notes, 243.

Freezing—

- effect on plants, relation to manner of thawing, 432.
- effect on wheat composition, 501.

Frost—

- as affected by altitude and topography, 417.
- effect on critical periods of plant growth, 207.
- injury, protection from, U.S.D.A., 237.
- injury to cereals and legumes, 432.

Frosts—

- Cape Cod cranberry, U.S.D.A., 15.
- forecasting, 16.
- of 1916-17, effect on vegetation, 326, 431.
- prevention by smudging, Ohio, 397.
- spring, date chart, U.S.D.A., 118.

Fruit—

- brown rot, notes, Okla., 44.
- brown rot, studies, 48, 246.
- bud formation, effect of light, N.H., 36.
- bud formation, factors affecting, 742.
- bud formation, studies, Okla., 36.
- buds, freezing, 743.
- buds, moisture content as index of hardness, 40.
- crops and markets in New Brunswick, 833.
- culture of grassland, 30.
- diseases and pests in Cuba, 438.
- diseases and pests in Oregon, 656.
- diseases in India, 445.
- evaporator, description, 808.
- farming in New Hampshire, 237.
- flies of Brazil, notes, 258.
- flies of Philippines, 56.
- fruit growing in Atlixco Valley, 835.
- growing in Morocco, 835.
- growing treatise, 835.

Fruit—Continued.

- industries in Italy, 438.
 industry, need for development in France, 195.
 industry in South Africa, 148.
 juices, dried, antiscorbutic value, stability of, 460.
 juices, equipment for manufacture, Calif., 717.
 market at Kansas City, U.S.D.A., 595.
 moth, oriental. (*See* Peach moth, oriental.)
 scab, notes, Okla., 44.
 silver leaf disease, notes, 246.
 stocks, Paradise, selecting and propagating, 238.
 tree borers, control, Pa., 554.
 trees as affected by grass, 237.
 trees, diseases and remedies, 246.
 trees, girdled, bridge grafting, Ohio, 340.
 trees, nitrogen fertilizers for, Oreg., 145.
 trees, pollination experiments, 237.
 trees, protection from frost, U.S.D.A., 237.
 trees, protection from rodents, Ohio, 340.
 trees, pruning, response to, 644.
 trees trained to special forms, treatise, 743.
 trees, transplanting directions, Mo., 143.
 trees, war devastated, appraising, 835.
 trees, winter injury, 656, 657.

Fruits—

- breeding experiments, 742.
 canning, cold-pack method outfits, 808.
 citrus. (*See* Citrus fruits.)
 culture, Nebr., 644.
 culture experiments, Can., 741; N.Mex., 339.
 deterioration in transit, 656.
 dried, insects affecting in California, 255.
 dried, nomenclature, Calif., 716.
 drying, Wash., 715.
 for canning, Wash., 698.
 for Iowa, 742.
 for Nebraska, list, 240.
 grading and packing in Australia, 836.
 insects affecting, 438.
 monthly working calendar for, 236.
 preservation by freezing, U.S.D.A., 794.
 preservation for home use, Can., 316.
 preserving, manual, 15.
 production in Australia, 337.
 receipts in Cincinnati, U.S.D.A., 490.
 refrigeration, 339.
 resistance to cold, 438.
 small, culture, 40.
 small, effect of temperature on wounding, U.S.D.A., 39.
 small, new varieties, 438.
 small, variety tests, Minn., 833.
 substitutes in Germany, 204.

Fruits—Continued.

- varieties for Illinois, 438.
 variety tests, Can., 741; Minn., 833.
 vitamin B in, 765.
 (*See also* Orchards, Apples, Peaches, etc.)
- Fuel—
 alcohol, new sources, 617.
 low-grade, valve adjustments for, in gas engines, 488.
- Fuels—
 for tractor engines, manufacture and tests, 389.
 motor, discussion, 187.
- Fumagine in cultivated trees, remedies, 346.
- Fumaric acid, formation in sugar fermentation, 15.
- Fumigation—
 of chrysanthemums, U.S.D.A., 361.
 results, factors affecting, 850.
 value of weather records for, 319.
- Fungi—
 damping-off, control in coniferous nurseries, 42.
 mold, effects of acids, 523.
 mold, formation of soluble starches by, 523.
 fungi, new, 841.
 on moldy grain, 445.
 parasitic, of Java, 841.
 (*See also* Plant diseases and specific fungi.)
- Fungicides—
 analyses, Me., 339; N.J., 37.
 commercial, value against mildew, 549.
 copper, relative adhesiveness, N.H., 842.
 effect on plants, N.H., 44.
 law in Maine, Me., 339.
 soil, effect on tobacco root rot, 447.
 toxic action, N.H., 44.
 use in Quebec, 844.
 use in South Africa, 834.
 (*See also* Sprays and specific forms.)
- Fungus and host plant, differential staining, 444.
- Fur—
 Astrakhan, production in Canada, 69.
 Persian lamb, production in Canada, 69.
- Furfural, manufacture from corncobs, 809.
- Furnace for decomposition of ammonia, description, 220.
- Fusarium—
annuum n. sp., notes, N.Mex., 348.
lycopersici, notes, Pa., 549.
montiforme on seed corn, Ky., 653.
oxysporum, notes, 447, 752.
pirinum on Japanese medlar, 349.
solani on tomato, 154.
 sp. on lettuce, 447; Ky., 845.
 spp., notes, 243.
 spp. on cucurbits, Tex., 846.
 spp. on banana, 151.
udum, notes, 444.

- Fusarium diseases, studies, Mo., 749.
- Fusicladium*—
dendriticum. (See Apple scab.)
pirinum, notes, 243.
 spp., lime-sulphur for, 346.
- Fusicoccum putrefaciens*, notes, Mass., 155.
- Galactose, fermentation of, 610.
- Galanthus* spp., new chromogen in, 327.
- Galerucella 6-vittata*, life history notes, 850.
- Galium* spp., Peronosporas on, 653.
- "Galloserin" for fowl cholera, 586.
- Galls—
 giant crown, of Florida Everglades, 444.
 leafy crown, mechanism of formation, 242.
- Game law in Alaska, U.S.D.A., 350.
- Ganoderma applanatum*, habits of, 849.
- Gapes, transmission by earthworms, Md., 586.
- Garages, plans, 592.
- Garbage—
 cantonment, for pigs, Ky., 374.
 feeding value for pigs, Ariz., 772; Okla., 70.
- Garden—
 crops. (See Vegetables.)
 insects, control, Wash., 496.
 insects, notes, N.Mex., 352.
- Gardening—
 cooperative, 644.
 for service men, 898.
 treatise, 697, 741, 833, 834.
 work in, Wash., 496.
 (See also School gardening and Vegetable gardening.)
- Gardens—
 form and design, treatise, 236.
 home, all-the-year, Ariz., 741.
 monthly working calendar for, 236.
 of celebrities near London, 342.
 school. (See School gardening.)
- Gas—
 as source of power in motor vehicles, 86.
 asphyxiating, effect on horses, 82.
 burette, description, 611.
 engines. (See Engines, gas.)
 formation in condensed milk, Iowa, 76.
 semirigid containers for, 87.
- Gases—
 effect on vegetation, 523.
 industrial, treatise, 627.
- Gasoline—
 chemical properties, 187.
 inspection and analyses, 187, 790.
 production and use, 187.
 substitutes, possibilities, 187.
- Gastro-intestinal tract as affected by deficient diet, 665.
- Gelatin—
 acidity of, 801.
 analyses, Conn.State, 859.
 gold number determination, 12.
- Gelechia gossypiella*. (See Cotton bollworm, pink.)
- Genetics—
 method of diallel crossing, 866.
 of flower coloration in *Tropaeolum majus*, 328.
 (See also Heredity and Hybridization.)
- Geochemistry, data, 419.
- Geography courses in Texas, 598.
- Geological Survey. (See United States Geological Survey.)
- Geology, agricultural, treatise, 719.
- Georgia—
 College, notes, 497, 599.
 Station, report, 197.
- Ghee, corn oil as substitute, 563.
- Gibberella saubinetii*—
 production of conidia in, 545.
 studies, Mo., 749.
- Gilia tricolor*, new disease of, 544.
- Ginger—
 disease, notes, 445.
 soft rot, notes, 652.
- Gipsy moth—
 control, Mass., 159.
 insect enemies, 252.
 notes, Conn.State, 251.
- Girls'—
 clothing contest, plans, 495.
 club leadership, course of study for, 796.
 clubs in Canada, 796.
 clubs in United States, 195.
- Girls—
 metabolism, 167.
 vocational education for, 197.
- Glacial drift as liming material for peat soils, 631.
- Gladiolus seed, germination tests, 240.
- Glanders—
 control, 272, 277.
 diagnosis, 277, 278, 471, 583, 685, 881.
 diagnosis, polyvalent extracts for, 181.
- Glass, platinized substitute for platinum, 612.
- β -Globulin, of Georgia velvet beans, 410.
- Glæosporium*—
fructigenum, notes, 155.
lindemuthianum, notes, 546.
nerwisequum, notes, 754.
 sp. on pepper, 45.
 sp. on rubber, 45.
 spp., notes, 544.
- Glomerella*—
cingulata vaccinii, notes, Mass., 155.
gossypii, notes, 243.
- Glucose—
 determination, 114.
 fermentation of, 610.
- Glucosids and carbohydrates, treatise, 410.
- Glue feed, composition and digestibility, 267.
- Gluten feed—
 analyses, Vt., 464.
 protein, utilization by dairy cows, S. Dak., 873.
- Glycerol, nitric esters of, absorption spectra, 801.
- Gnats, fungus, of Canary Islands, 661.

Gnomonia—

- erythrostoma*, notes, 246.
- illia* on sugar cane, La., 348.
- veneta*, notes, 652, 754.

Goats—

- raising in China, 171.
- wasting disease, Mich., 688.

Goiter, prevention, Wash., 384, 784.

Gonocephalum—

- notes, 456.
- seriatum*, parasitized by *Epyris ex-transicus*, 662.

Gooseberries—

- breeding experiments, 742.
- culture, Nebr., 644.
- culture and marketing, 40.
- eradication by chemicals, 246, 248.
- insects affecting, Wash., 349.
- (See also *Ribes*.)

Gooseberry—

- die-back, notes, 246.
- diseases, control, Ill., 847; Wash., 349.
- lice in South Dakota, 850.
- mildews, notes, 246.
- worms in South Dakota, 850.

Gossypol in cottonseed products, N.C., 411.

Gracilaria sp., notes, 851.

Graft hybrids, infection studies, 544.

Grain—

- coarse, for human food, Can., 366.
- Corporation and guaranteed wheat prices, 895.
- culture under irrigation, U.S.D.A., 637.
- dried, analyses, R.I., 672.
- effect of early seeding, Wyo., 134.
- elevator companies, cooperative, U.S. D.A., 895.
- market as affected by car shortage, U.S.D.A., 595.
- rusts in South Dakota, 546.
- sampling device, U.S.D.A., 642.
- situation in southeastern Europe, U.S.D.A., 695.
- small, culture experiments, Wash., 738.
- small, harvesting and thrashing, U.S.D.A., 637.
- smut, treatment, 244.
- stored, insects affecting, 252, 253, 254.
- supply, future, of Austria-Hungary, 393.
- transpiration of in relation to light, 131.
- warehouses, regulations, U.S.D.A., 896.

Grains, whole, as poultry feed, N. Mex., 378.

(See also *Cereals and special crops*.)

Granary—

- portable, 892.
- weevil as affected by air-tight storage, 254.
- weevil, notes, 450.
- weevil, paper on, 51.
- weevil, vitality and rate of increase, 254.

Granite paving block, modified abrasion test, 85.

Grape—

- anthracnose, notes, 244.
- black rot as affected by dry weather, 652.
- black rot, treatment, 657.
- diseases, control, Ill., 847.
- downy mildew, factors affecting, 657.
- downy mildew, treatment, 657.
- industry in California in 1919, 837.
- juice, unfermented, manufacture, Calif., 717.
- juice, vitamin B in, 765.
- oidium, notes, 244.
- oidium, treatment, 657.
- rots, control, 657.
- scale in California, notes, 256.
- sirup, manufacture, Calif., 716.
- sphinx moth, studies, 453.
- Grape-berry moth, control, U.S.D.A., 454.
- Grapefruit—
 - fulgid leafhopper affecting, 556.
 - juice, vitamins A and B in, 765.
 - pink-fleshed, origin, 440.
 - pruned *v.* unpruned, 439.
 - spraying experiments, 157.

Grapes—

- American, market position, U.S.D.A., 694.
- animal parasites of, 657.
- breeding experiments, Md., 143.
- copper fungicides for, 155.
- culture and marketing, 40.
- culture experiments, 40.
- culture in Morocco, 835.
- direct-bearing hybrid, 239, 745.
- drying, factors affecting, Calif., 715.
- eastern, marketing, U.S.D.A., 836.
- Franco-American hybrids, 239.
- muscadine, breeding experiments, Ga., 147.
- muscadine, new varieties, Ga., 148.
- protection from spring frosts, 40.
- pruning and training, Md., 143.
- pruning experiments, New York State, 341.
- root formation and development, 836.
- spraying experiments, U.S.D.A., 843.
- stocks, drought resistance of, 40.
- varieties for calcareous soil, 745.
- varieties, new, 438.
- variety tests, U.S.D.A., 144.
- (See also *Vineyards*.)

Grass—

- Bahia, culture experiments, 528.
- Bermuda, variety tests, U.S.D.A., 330.
- buffalo, dioecious nature, 522.
- land management, 814.
- mixtures as pasture for dairy cows, U.S.D.A., 468.
- mixtures, comparative yields, Idaho, 738.
- roads, injury from mole crickets, 53.
- rusts, comparison, 244.

- Grass—Continued.
seed testing, method, 44.
seeds, infestation of skin of sheep by, 184.
- Grasses—
as forage crops in Denmark, 177.
as paper-making material, 317.
culture, Idaho, 738.
culture experiments, 824.
culture on peat soil, 23.
effect on fruit trees, 29, 237.
fall seeding, Wash., 738.
for lawns in South China, 441.
Linnæan genera of, 729.
meadow, on swamp lands, Oreg., 21.
North American, revision, 522.
root development as affected by water level, 623.
variety tests, Can., 735.
wild, rôle in stem rust epidemics, Iowa, 654.
(See also Meadows, Pastures, and specific grasses.)
- Grasshopper catching machine, design, 53.
- Grasshoppers—
control, 53.
control, organization for, 354.
differential, poison baits for, Ariz., 757.
notes, Mont., 758.
on cotton, U.S.D.A., 352.
on wheat, Ind., 352.
poison baits for, 353.
(See also Locusts.)
- Grassland. (See Grass, Meadows, and Pastures.)
- Grasslands, effect of spring and fall grazing, 824.
- Gravel for roads. (See Road materials.)
- Grazing—
as affected by rainfall, U.S.D.A., 717.
in National forests, management, 148.
(See also Ranges.)
- Green—
manures—
effect on nitrate production, Ill., 214.
effect on soil acidity, 212.
for paddy soils, 423.
relation to wheat take-all, 153.
manuring experiments, Md., 122, 133.
- Greenhouse thrips on avocado, 851.
- Greenhouse thrips on avocado, control, 255.
- Greenhouses—
chrysanthemum midge in, U.S.D.A., 360.
concrete, construction, 90.
monthly working calendar for, 236.
- Greensand—
and sulphur, effects on soil potash, Md., 121.
effect of sulfonation, 517.
New Jersey, potash exploration in, 817.
- Grocery stores in Fargo, economic study, N.Dak., 368.
- Ground squirrels. (See Squirrels, ground.)
- Growth—
and hydration, studies, 428.
rings, daily, in cell wall of cotton hairs, 633.
- Growth-promoting accessory. (See Vitamin.)
- Guano—
bat, fertilizing value, Mo., 721.
of Sardinia, analyses, 24.
whale, fertilizing value, Can., 727.
- Guanol fertilizer, decomposition of betain in, 27.
- Guavas, culture experiments, 40.
- Guinea pigs, exhibition standards, 575.
- Gum—
acacia, effect on circulation, 79.
arabic, gold number determination, 12.
resins, iron content, 202.
- Gummosis in garden plants, 346.
- Gums—
iron content, 202.
substitutes in Germany, 204.
- Gum-tree ashes, fertilizing value, 324.
- Gutta percha substitutes in Germany, 204.
- Gutters, concrete, construction, 90.
- Gymnosporangium clavipes*, temperature of spore germination, N.H., 842.
- Gymnosporangium*, Russian species, 731.
- Gypsum—
analyses, Oreg., 129.
effect on alkali soils, Ariz., 724.
effect on composition of soil extracts, Mich., 124.
effect on solubility of soils, 516.
- Habrocytus mediscaginis*, notes, U.S.D.A., 365.
- Habronema* spp., life history, 585, 883.
- Habronemiasis*, studies, 585.
- Hadena*—
oleracea, control, 454.
semicana, notes, Conn.State, 251.
- Hamaphysalis leachi*, notes, 84.
- Haematopinus suis*, notes, U.S.D.A., 688.
- Hail—
as affected by airplanes, 618.
frequency and distribution, U.S.D.A., 119.
frequency in Sweden, 621.
- Hailstorms, papers on, U.S.D.A., 511.
- Hairlessness, prevention, Wash., 384, 784.
- Halerpestis cymbalaria*, poisonous to live stock, Nev., 273.
- Halos, papers on, U.S.D.A., 718.
- Halticini of College Park, list, Md., 158.
- Haplogonotopus orientalis* n. sp., description, 857.
- Hardwood distillation plants, tar-still in, 717.
- Hardwoods of Australia, uses, 149.
- Harvesting machinery, notes, 892.
- Hawaii Federal Station, notes, 398.
- Hay—
chopped, digestion coefficients, 266.
crops, culture experiments, Mont., 332.
crops, notes, 527.
crops, short season, Mich., 333.
market, shrinkage, U.S.D.A., 825.

Hay—Continued.

- meal, digestion coefficient, 266.
- prices, fluctuations, U.S.D.A., 794.
- stacks, measurement, 290.
- (See also Meadows, Grass, and Alfalfa, Clover, Timothy, etc.)

Hazel wood, water conductivity, 31.

Hazelnut scale, notes, 252.

Heat, effect on critical periods of plant growth, 207.

(See also Temperature.)

Heather, effect on pine forest, 24.

Heating system, hot water, design, 486.

Hedges for Nebraska, list, 240.

Hegari, yields, Ariz., 733.

Heifers—

- feed cost of raising, Can., 777.
- pasturing experiments, Minn., 671.
- protein requirements, Mo., 776.
- (See also Cows.)

Heliophila—

albilinea. (See Army worm, wheat-head.)

spp. (See Army worms.)

Heliothis obsoleta. (See Cotton bollworm.)

Heliothrips, hæmorrhoidalis. (See Greenhouse thrips.)

Helminthosporium spp., notes, 45, 445, 446.

Hemileia vastatrix, notes, 445.

Hemlock, budworm attacking, 852.

Hemoglobin of blood as affected by muscular work, 265.

Hemoglobinuria of cattle, immunization, 687.

Hemorrhagic septicemia. (See Septicemia.)

Hemp—

- analyses, 617.
- culture, 638.
- culture experiments, Ky., 332.
- Manila, culture and uses, 826.
- marketing, Ky., 334.
- sun, analyses, 829.
- (See also Sisal.)

Heneguen, analyses, 829.

Hens—

- culling, Utah, 872.
- egg production and broodiness, N.J., 173.
- feed consumption per dozen eggs, 674.
- laying, egg-weight studies, R.I., 674.
- laying, egg yield in relation to protein of feed, Ky., 871.
- laying, feeding experiments, Idaho, 269.
- laying, selection, Nebr., 776.
- (See also Egg production.)

Heptitols, optical properties, 801.

Hereditary factors, arrangement of, 268.

Heredity—

- factorial values, tabulation, 668.
- in beans, 818.
- in *Campanula carpatica*, 632.
- in cattle, 375, 669, 672.
- in corn, 529.
- in *Oenothera*, 729, 818.
- in peaches, 540.
- in petunia, 222.
- in pigeons, 67.

Heredity—Continued.

- in poultry, N.Y.Cornell, 872.
 - in shepherd's purse, 434.
 - in swine, Iowa, 71.
 - in trout, 866.
 - in variegated plants, 433.
 - in wheat, S.Dak., 235.
 - of albinism in cereals, 132.
 - of color. (See Color inheritance.)
 - of congenital cataract in cattle, 669.
 - of defect of hair and teeth in cattle, 672.
 - of doubleness in Begonia, 632.
 - of egg-weight, R.I., 674.
 - of eye color in birds, 866.
 - of immunity to rinderpest, 583.
 - of milk yield, Me., 175.
 - of smut resistance in wheat, Wash., 737.
 - of susceptibility to parasites, 841.
 - pure line hypothesis, 222.
 - treatise, 632.
 - (See also Linkage, Mutation, Selection, and Variation.)
- Herrings, for sardines, chemical studies, 111.
- Hessian fly—
- life history, Ind., 352, 661.
 - summary of information, U.S.D.A., 55.
- Heterakis papillosa*—
- notes, 586.
 - rôle in turkey blackhead, 475.
- Heterodera radicola*—
- control, 659.
 - on tobacco, 52, 246.
 - on tomatoes, control, 47.
 - parasitism of, 350.
- Heterosporium*—
- gracile* on freesia, 243.
 - phlei* n. sp., description, 752.
- Heterozygous, substitute for term, 867.
- Hevea brasiliensis*. (See Rubber.)
- Hewitt, C. G., writings of, 449.
- Hickories, time for transplanting, Mo., 142.
- Hides—
- disinfection, 180.
 - market for, U.S.D.A., 595.
- Highway—
- research, national program for U.S.D.A., 387.
 - situation in United States, U.S.D.A., 186.
 - transportation, theory, 790.
 - (See Roads.)
- Hippodamia* spp., notes, U.S.D.A., 455.
- Histomonas* (n. g.) *meleagridis*, studies, 476.
- Hog cholera—
- bacilli in man, 685.
 - bacteriological study, Ind., 385.
 - blood, bacteria in, 884.
 - control, 272, 780, 787; U.S.D.A., 474.
 - diagnosis, 780.
 - immunity, duration, 184.
 - losses, U.S.D.A., 471.
 - serum, cause of failure, 278.
 - serum production, Ind., 385.

- Hog cholera—Continued.
v. hemorrhagic septicemia, 683.
 vaccination, balancing serum and virus, 884.
 virus, number of days virulent, Ind., 384.
 virus, passage through foreign species, N.Dak., 385.
- Hog—
 houses, design, in relation to sunshine, 790.
 louse, control and eradication, U.S.D.A., 688.
 mange, control and eradication, U.S. D. A., 688.
- Hogs. (*See* Pigs.)
 Hogging-down experiments, Ky., 871.
- Hollyhock rust and mycoplasma theory, 444.
- Home economics—
 clothing selection, 495.
 course, account keeping in, 495.
 course, child training in, 494.
 course for State-aided high schools, 493.
 course in household physics, 495.
 course in mechanics, 495.
 courses, 196, 296, 297, 396, 696, 697.
 experiment stations, 395.
 home projects in, 97, 798.
 instruction, arrangement of kitchen, 598.
 instruction in French West Africa, 296.
 instruction in Illinois, 695.
 instruction in New Jersey, 796.
 requirements for Idaho schools, 298.
 research projects, 595.
 schools in Massachusetts, 494.
 teachers, training, 596, 696, 697.
 textbook, 798.
 (*See also* Vocational education.)
- Home—
 gardens, Ind., 395.
 project work in Indiana, 195.
 projects in home economics, 97, 798.
- Hominy feed—
 analyses, 867; Ind., 69, 867; Ky., 373; N.J., 69, 672; R.I., 672; Vt., 464.
v. corn for fattening pigs, Mo., 772.
- Homozygous, substitute for term, 867.
- Honey—
 as carrier of intestinal diseases, Colo., 163.
 invertin in, 314.
 larva feeding on, 558.
 plants, American, 259.
 prices, July, 1920, U.S.D.A., 695.
 production, Can., 762.
 uses in health and disease, 57.
- Honeybees. (*See* Bees.)
- Hops, resistance to mildew, 446.
- Hornbeam, oak, woods in Hertfordshire, 241.
- Hornets, notes, 52.
- Horse—
 disease, orchard, 473.
 diseases. (*See specific diseases.*)
 mange, control, 184, 272.
- Horse—Continued.
 spermatogenesis, 670.
 stables, construction in Mexico, 290.
- Horse-chestnuts, use in bread making, 64.
- Horsehides, exports from Argentina, 95.
- Horse-power on the farm, U.S.D.A., 483.
- Horses—
 algæ as substitute for oats, 775.
 bacterial flora of eyes, 472.
 bibliography of, 173.
 broom corn seed for, 671.
 cellulose as emergency feed for, 170.
 color inheritance, 378.
 corn silage for, Ariz., 775.
 displacement by tractors, U.S.D.A., 690.
 effect of asphyxiating gas on, 82.
 feed records, Can., 775.
 feeding experiments, 871.
 in Europe, address, Kans., 674.
 judging, treatise, 697.
 long bones as affected by infectious anemia, 83.
 oat straw for, Mo., 775.
 pasturing experiments, Minn., 671.
 poisoning by common bracken, 471.
 poisoning by whorled milkweed, U.S.D.A., 470.
- Horticultural—
 agent, county, functions, 643.
 conditions in France, 643.
 education in Netherlands, 834.
 investigations, need of coordination, 642.
 problems, diversity of opinions, 642.
 laws of California, 741.
 extension problems, 643.
- Hotbeds, concrete, construction, 90.
- House fly as carrier of disease, 558.
- Household. (*See* Home economics.)
- Housekeeping textbook, 798.
- Humidity—
 and hot weather, U.S.D.A., 718.
 effect on critical periods of plant growth, 207.
- Humic—
 acids, chemistry and physics of, 213, 321.
 nitrogen of protein hydrolysis, 110, 111.
- Humus—
 acids, effect on coagulation of clay, 515.
 formation in soils, 213.
- Hurricanes, relation to storm tides, U.S.D.A., 511.
- Hyacinthus orientalis*, periodicity of, 729.
- Hyalomma aegyptium*, notes, 83.
- Hybridization, plant, experiments, 535.
 (*See also* Plant breeding.)
- Hydration and growth, studies, 428.
- Hydraulic formula, Manning, diagram for solving, 477.
- Hydrochloric acid—
 from munition plants, effect on conifers, 347.
 production from chlorin and water, 712.
- hydrocyanic acid, determination, in beans, 610.

- Hydrogen—
 and nitrogen mixture, preparation, 220.
 electrode, new cell, description, 612.
 peroxid decomposition in pasteurized
 milk, 206.
 peroxid, disinfecting power, 78.
- Hydrogen-ion concentration—
 determination for milk grading, 615.
 effect on activation of pepsin, 611.
 effects on seed germination and growth,
 524.
 of bacterial cultures, 383.
 of blood as affected by high altitudes,
 565.
 of culture media, variations in, 381.
 of soils as affected by fertilizers, 423.
 of soils, colorimetric determinations,
 211.
 of soils, relation to lime requirements,
 421, 515.
 of solutions, salt effects on value, 313.
 variation in fresh milk, N.Y.State, 578.
- Hydrophobia. (*See Rabies.*)
- β -Hydroxyglutamic acid, synthesis, 111.
- Hylemyia strigosa*, chemotropic response,
 554.
- Hymenolepis cartoca*, notes, Okla., 79.
- Hymenoptera—
 entomophagus parasitism in, 457.
 North American, new species, 857.
 new species, description, 259.
- Hyperaspis campestris*, notes, 252.
- Hypochnus* sp., notes, 444.
- Hypoderma* spp., summary of information,
 55.
- Ice—
 cream, analyses, Conn.State, 859.
 cream, fillers for, Wash., 780.
 storms, papers on, U.S.D.A., 119.
- Icerya purchasi*. (*See Cottony cushion-*
scale.)
- Ichneumon flies—
 new genera and species, 857.
 notes, 858.
- Ichneumoninae, Holarctic tribes, 858.
- Ichthyomethia, revision of genus, 328.
- Idaho—
 Station, notes, 198, 497, 699.
 Station, publications for free distribut-
 tion, 496.
 Station, report, 98.
 University, notes, 198, 699.
- Illinois University, notes, 198.
- Immigration laws of Bolivia, synopsis, 94.
- Immune sera, coagglutinins in, 581.
- Immunity—
 of fowls to cholera, 278.
 production, relation to absorption rate
 of antigen, 381.
 reactions, analyses by colorimetric pro-
 tein determinations, 181.
 relation to complementary and opsonic
 functions, 273.
 research, progress during the war, 76.
- Immunization. (*See Anthrax, Hog cholera,*
etc.)
- Inanition, effect on resistance of red blood
 corpuscles, 63.
- "Inconstant," use of term, 867.
- Incubators, devices for regulating temper-
 ature, 822.
- Indiana Station—
 experimental orchard, report, 237.
 notes, 99, 198, 398, 799.
 report, 397.
- Indicators, equation for pH determination
 of soils, 211.
- Indigo—
 insects affecting, 252.
Psylla isitii on, 451.
- Industrial—
 by-products as feeding stuffs, 170.
 prosperity in 1920, basic facts, 92.
- Infants—
 cholesterol synthesis by, 769.
 feeding—
 artificial, 462.
 butter flour for, 567.
 directions, 167.
 milk powders for, 566.
 rôle of vitamins in, 166, 567, 663.
 with milk from cows at end of
 lactation, 272.
 metabolism, 166.
 nursing, pellagra in, 668.
 (*See also Children.*)
- Infections, sputum-borne, control, 261.
- Influenza, equine. (*See Pleuro-pneumonia.*)
- Influenza-pneumonia, transmission by eat-
 ing utensils, 261.
- Inheritance. (*See Heredity.*)
- Inoculation chamber, iceless refrigerator
 for, 444.
- Insect—
 behavior, treatise, 50.
 powder adulteration, U.S.D.A., 352.
 survey, N.C., 450.
- Insecticides—
 adulteration, detection, U.S.D.A., 353.
 analyses, Me., 339; N.J., 37.
 effect on plants, N.H., 44.
 law in Maine, Me., 339.
 investigations, Oreg., 755.
 use in Quebec, 844.
 use in South Africa, 834.
 (*See also Sprays and specific forms.*)
- Insects—
 as carriers of plant diseases, 842.
 chemotropic responses of, 553.
 control, 842.
 control, application of bioclimatic law,
 U.S.D.A., 509.
 control in National Forests, 148.
 dissemination by wind, U.S.D.A., 157.
 dried, from Mexico, use in poultry
 feeds, 53.
 forest. (*See Forest insects.*)
 fungus hosts of, lists, 659.
 fungus parasites of, 250.
 garden. (*See Garden insects.*)
 in British Guiana, annual loss caused
 by, 850.

Insects—Continued.

in relation to white pine blister rust,
754.

injurious—

in Australia, 252.
in Connecticut, Conn.State, 252.
in Cuba, 438.
in England and Wales, 652.
in Missouri, Mo., 758.
in Montana, Mont., 758.
in South Dakota, 850.
in Texas, 554.
in West Indies, 252, 450, 554.
to corn, cotton, sugar cane, etc.
(See Corn, Cotton, Sugar cane,
etc.)

treatise, 659.

nutritional study, 51.

of stored grains as affected by air-
tight storage, 253.

of stored grain, vitality and rate of
increase, 254.

on imported nursery stock, 352.

on sewage filters, 853.

orchard. (See Fruits, insects affect-
ing.)

predatory, value of experiments with,
559.

preserving for dissection, 850.

relation to parasitic diseases in stock,
883.

scale. (See Scale insects.)

(See also specific insects.)

International—

catalogue of bacteriology, 227.

catalogue of botany, 227.

catalogue of serum physiology, 227.

White Pine Blister Rust Conference,
755.

Intestinal—

diseases, honey as carrier, Colo., 163.

flora, transformation of, 769.

parasites. (See specific parasites.)

worms in hogs, 384.

Invertase activity of mold spores in sugar,
433.

Invertin in honey, 314.

Iodin—

determination in mineral waters, 13.

determination in plants, 204.

in plants, 632.

number of essential oils, 315.

Iodin-neol preparations as disinfectants,
683.

Iodometric studies, 204.

Iowa—

College, notes, 99, 198, 398, 899.

Station, notes, 99, 198.

Iron—

determination of small quantities, 311.
in soil extracts, effect of fertilizer salts,
Mich., 125.

metabolism as affected by high alti-
tudes, 565.

sulphate for dandelion eradication, N.Y.
State, 535.

sulphate, fungicidal value, Mass., 155.

Iron—Continued.

sulphid, use as indicator, 11.

(See also Ferrous.)

Irrigation—

by well water in Argentina, 279.

canal drops, construction, 888.

canals, concrete lining for, 588.

canals, siphon spillways for, U.S.D.A.,
787.

canals, stopping of sink holes in, 888.

canals, water flow in, U.S.D.A., 788.

experiments, short-time, unreliability
of, 822.

(See also special crops.)

in Argentina, 279, 477.

in India, 477.

in Italy, 587.

in New South Wales, 477.

in Oklahoma, 185.

in southern States, 476.

of peat soil, Oreg., 22.

of wild meadow and tule land, Oreg., 21.

on Yuma project, U.S.D.A., 392.

pipe line, cement pipe for, Ariz., 788.

practices, discussion, 279.

pump, Ariz., 788.

relation to brak or alkali, 624.

reservoirs, siphon spillways for, U.S.
D.A., 787.

rice, rôle of tides in, 689.

seepage and waste water losses, 788.

structures, precast concrete slabs for,
587.

surveys in Canada, 279.

systems, water requirements, 588.

treatise, 387.

water—

duty of, 279; Oreg., 22.

duty of in relation to yield, Utah,
230.

duty of with pumping system, 477.

from King's River, use, 588.

in India, analyses, 185.

movement in soil, N.Mex., 386.

supplies, Ariz., 788.

use, 587.

Ivory nut chips and meal, digestion co-
efficient, 266.

Jack beans, analyses, culture, and uses,
U.S.D.A., 233.

Jacks in Indiana, Ind., 269.

Jams, analyses, Conn.State, 859.

Jaundice, infectious. (See *Spirochæta*
icterohæmorrhagicæ.)

Jaundice—

malignant. (See Piroplasmosis, canine.)
of bovines in Africa, 883.

Jellies, analyses, Conn.State, 859.

Jelly, proportions of acid, pectin, and sugar
for, 616.

Jewish agricultural and industrial aid so-
ciety, report, 192.

Jiggerwood, durability tests, 44.

Joint-ill—

in foals, prophylaxis of, 585.

serum treatment, 278.

Jowar smut, control, 445.

- Jute—
analyses, 829.
black band, notes, 444, 652.
- Kafir—
ants attacking, Kans., 763.
culture experiments, Okla., 32.
variety tests, Okla., 32.
yields, Ariz., 733.
- Kaill, yield tables, 840.
- Kainit, fertilizing value, 630.
- Kale—
analyses, 63.
paper on, Wash., 197.
- Kalmia microphylla*, poisonous to live stock, Nev., 273.
- Kalotermes, new species, 256.
- Kamala, powdered *v.* fluid, tæniacidal value, 381.
- Kansas—
College, notes, 199, 497, 599, 699, 799.
Station, notes, 199, 497, 599, 799.
- Katabolism, basal, studies, 372.
- Kauri-gum industry in New Zealand, 43.
- Keithia thujina*, notes, 49.
- Kelp distillation at low temperatures, 630.
- Kentucky—
Station, notes, 299, 497, 899.
Station, report, 397, 898.
University, notes, 299, 899.
- Kerosene—
as fuel for tractors, 891.
injury to shade trees, 732.
inspection and analyses, 187, 790.
- Kidneys, changes of, in deficiency disease, 664.
- Kohl-rabi—
analyses, 63.
root development, 834.
- Kudzu—
as forage crop, Ariz., 734.
culture and uses, U.S.D.A., 334.
feeding value, La., 670.
- Labena n. spp.*, description, 857.
- Labenidea, new genus, erection, 857.
- Labenidae, notes, 60.
- Labor—
income from crops *v.* pasture, 92.
income from farms of different types, 291; W. Va., 92.
income on farms in Pennsylvania, U.S. D.A., 692.
income on farms near Washington, D. C., U.S.D.A., 692.
(See also Agricultural labor.)
- Lachnosterna spp.*, life histories, 760.
- Lachnus strobi*, notes, 556.
- Lactic—
acid bacteria, monograph, 680.
acid in milk, germicidal effect of, Conn. Storrs, 768.
acid producing organisms and preparations, 470.
acid production as affected by bacteria, N.Y.State, 681.
acid, refined, use in food products, 366.
starters, volatile acidity of, Iowa, 75.
- Lactobacillus pentoaceticus*, fermentation of hexoses by, 610.
- Lactose—
determination in altered milk, 14, 505.
effect on intestinal flora, Conn.Storrs, 768.
in milk, polarimetric determination, 805.
- Lady-bird beetles—
attacking prune scale, 252.
collection and storage, 559.
- Lambs—
docking, searing iron *v.* knife, Tex., 870.
feeding experiments, Can., 772; Ind., 375; Wash., 772.
growth in relation to fat content of ewes' milk, N.H., 172.
twins and single, growth data, N.H., 172.
vetch seed for, 373.
(See also Sheep.)
- Lamellicornia of British India, 50.
- Laminaria flexicaulis*, notes, 775.
- Land—
clearing, forced *v.* delayed systems, Minn., 480.
clearing, horsepower *v.* dynamite, Minn., 888.
clearing, use of explosives in, 480.
clearing, use of salt and sulphur in, 281.
clearing, use of TNT in, U.S.D.A., 282.
credit. (See Agricultural credit.)
grant colleges. (See Agricultural colleges.)
mortgage credit, cooperative, for India, 192.
plaster. (See Gypsum.)
settlement—
in California, 393.
in Canada for ex-service men, 93.
in Denmark, 487.
in Italy for ex-service men, 93.
in New South Wales, 191.
in New Zealand, 491.
in Queensland for ex-service men, 93.
in Scotland, 94.
in United States, history, 487.
speculation, 793.
- tenure—
in American colonies, 694.
in France, development, 487.
in New Zealand, 491.
share rental determination, 489.
systems, comparison, Mo., 190.
values in Iowa, 593; U.S.D.A., 893.
values in Sweden, 594.
- Lands—
cut-over. (See Cut-over lands.)
forest. (See Forest land.)
public, and immigration laws of Bolivia, 94.
swamp. (See Swamps.)
unused in United States, reclamation, 123.

Lands—Continued.

waste, reclamation in India, 150.

(See also Reclamation.)

Laphygma—

exigua on tobacco, 52.

frugiperda. (See Army worm, fall.)

Larch—

Chermes, life history, 54.

growth as affected by locality, 748.

seedlings, fungus attacking, 49.

species, comparative growth data, 43.

western, growth measurements, 43.

Lard, vitamin A in, 764.

Laspeyresia—

molesta. (See Peach moth, oriental.)

nigricana, life history notes, 850.

Lath production in 1918, U.S.D.A., 150.

Lathyrus spp., chromosome number in, 632.

Laundering, home, methods and equipment, U.S.D.A., 792.

Lawn grasses for South China, 441.

Lawns—

injury from mole crickets, 53.

papers on, Wash., 197.

spraying experiments, N.Y.State, 535.

Lead—

action of water on, 279.

arsenate, analyses, N.J., 37.

arsenate, fungicidal value, Mass., 155.

arsenate, insecticidal value, Colo., 158; Oreg., 755.

determination in cassia oil, 14.

Leaf blister mite, notes, 252.

Leafhoppers—

on avocado, control, 255.

on potato, relation to tipburn, 345.

transmitting curly top, duration of virulence, 752.

Leather—

chemistry, laboratory manual, 317.

chemistry of, 617.

harness, physical properties, 892.

refuse, analyses, 28.

Leaves—

anthocyanin in, localization, 327.

carotin and xanthophyll content, 633.

color changes in life course, 729.

evergreen, changes in reserve materials, 29.

penetrability for gases, 732.

senile, changes in, 634.

Lebbra, new sumac disease in Italy, 49.

Lecanium n. spp., description, Mich., 660.

Leeks, root development, 834.

Legume diseases, 652.

Legumes—

culture, Idaho, 738.

effect of cold on, 432.

flagellation of nodule organism, 433.

inoculation, Mont., 321; Wyo., 436.

inoculation with nitragin, 217.

(See also Nodule bacteria.)

insects affecting, 652.

substitutes in Germany, 204.

use as grasshopper bait, 353.

(See also Green manures and Alfalfa, Clover, etc.)

Leguminosæ, root nodules of, comparative studies, 30.

Lemon—

brown rot, notes, 243.

juice, antiscorbutic value, 667.

juice, vitamins A and B in, 765.

orchards, frost protection, U.S.D.A., 440.

wither tip, notes, 243.

Lemons—

bud variations, U.S.D.A., 440.

pruned *v.* unpruned, 239.

spraying experiments, 157.

Lepidoptera, forest, new species, 853.

Lepidosaphes ulmi. (See Oyster-shell scale.)*Leptinotarsa decemlineata*. (See Potato beetle, Colorado.)*Leptocorisa varicornis*, summary of information, 556.*Leptosphaeria herpotrichoides*—

behavior of ascospores, 750.

notes, 750.

Leptospira icterohæmorrhagiæ. (See *Spirochæta icterohæmorrhagiæ*.)*Leptus autumnalis*, notes, 260.

Lettuce—

analyses, 63.

anthracnose, notes, 152.

disease, greenhouse, Ky., 845.

disease-resistant varieties, Md., 144.

failure to head, cause, 446.

iodin content, 204, 632.

root development, 834.

variety tests, Tex., 36.

Levulose and dextrose, ratio of utilization by plants, 730.

Lice—

and nits, destruction, 453.

bibliography, 51.

book, control, U.S.D.A., 53.

control, 852.

determination of sex, 160.

spermatogenesis, 256.

sucking, monograph, 452.

(See also Louse.)

Light—

effect on action of stomata, 131.

effect on fruit bud formation, N.H., 36.

effect on plant growth, 431.

effect on submerged cranberry bog, 836.

(See also Sunlight.)

Lilies, culture on Pacific Coast, 746.

Lime—

absorption by soils, method of determining, 27.

agricultural, analyses, 520; N.J., 326.

and potash, analyses, 521, 631.

arsenate. (See Calcium arsenate.)

burnt, analyses, 521, 631.

burnt, effect on organic matter in soil, 729.

burnt, *v.* limestone, Can., 727.

coarse-grained *v.* fine, 325.

effect on soil extracts, Mich., 124.

effect on tobacco root rot, 447.

effect on soil potassium, 127.

factor in soil improvement, 128.

- Lime**—Continued.
 industry, agricultural, future of, address, 27.
 inspection in Pennsylvania, 326, 520.
 juice, antiscorbutic value, 263.
 niter. (*See* Calcium nitrate.)
 nitrogen. (*See* Calcium cyanamid.)
 production and prices in 1918, 630.
 production by farmer, U.S.D.A., 428.
 refuse, analyses, 28.
 requirement of soils. (*See* Soils.)
 resources of New Brunswick, 623.
 role in soil improvement, 428.
 unburnt, analyses, 521, 631.
 use on soils, 519.
 use on Missouri soils, Mo., 729.
 value in lime-sulphur mixtures, 235.
 (*See also* Calcium and Liming.)
- Limes**, insects affecting, 450.
- Limestone**—
 analyses, Can., 727; Oreg., 129.
 effect on nitrate production, Ill., 214.
 ground, analyses, Pa., 520.
 ground, effect on availability of phosphates, 27.
 ground, fertilizing value, 325; Wis., 336.
 resources of Pennsylvania, Pa., 520.
 v. burnt lime, Can., 727.
 v. glacial drift for peat soils, 631.
- Lime-sulphur mixtures**—
 action of lime in, 235.
 analyses, N.J., 37.
 as substitute for Bordeaux, 346.
 composition, 544.
 effect on peach foliage, Ga., 146.
 fungicidal value, Ind., 345.
 insecticidal value, 255.
 preparation, Ky., 834; Pa., 539.
 use in winter, 346.
 value of saponin in, 346.
- Liming**—
 effect on peat bogs, 325.
 effect on soil acidity, 212.
 effect on solubility of soil phosphates, 629.
 experiments, Can., 727, 729; Md., 122; Okla., 32.
 (*See also* Lime and special crops.)
- Linkage**—
 and chiasmotype, 269.
 in Begonia, 632.
 in cattle, 375.
 in mice, 669.
 strength, use of term, 268.
 studies, 268, 269.
 values, probable errors, 268.
- Linseed meal**—
 analyses, 867; Ind., 69, 867; Ky., 373; N.J., 69, 672; Vt., 464.
 and screenings oil feed, analyses, Ind., 867.
 as corn supplement for pigs, Ohio, 377.
 protein, utilization by dairy cows, S.Dak., 873.
- Lint** frequency in cotton, Ark., 530.
Liodontomerus spp., notes, U.S.D.A., 365.
- Lipase**, action on milk fat, Mo., 712.
- Lipoid fixation**, reaction—
 description, 685.
 for glanders diagnosis, 277, 471.
 new method for preparing, 278.
- Lipoids** in plant cells, demonstration, 524.
- Lipovaccines**, method of sterilization, 76.
- Lissonota* n. spp., description, 857.
- Lissorhoptrus simplex*, studies, U.S.D.A., 252.
- Live stock**—
 as affected by St. John's wort, 380.
 breeding, ratio of sires and dams, U.S.D.A., 770.
 conditions in Europe, U.S.D.A., 464.
 diseases. (*See* Animal diseases.)
 drought relief work in 1919, U.S.D.A., 464.
 emergency feeding in Sweden, 170.
 farming, profits, Ohio, 322.
 feeding and improvement, 68.
 grazing rate in relation to rainfall, U.S.D.A., 717.
 improvement, U.S.D.A., 464, 473.
 judging, treatise, 494, 697.
 loss of weight during transportation, 672.
 loss through simuliids, 51.
 markets, Federal supervision, U.S.D.A., 464.
 parasitic diseases, relation to insects, 883.
 poisoning, Nev., 273.
 poisoning by whorled milkweed, Colo., 141; U.S.D.A., 470, 471.
 (*See also* Plants, poisonous, and specific plants.)
 pure bred, exporting to South America, U.S.D.A., 464.
 pure bred, list of breeders, Mont., 171.
 pure bred, Scottish, history, 171.
 State requirements for admission, U.S.D.A., 272.
 statistics of Australia, 171.
 statistics. (*See also* Agricultural statistics.)
 types and market classes, 697.
 textbook, 770.
 (*See also* Animals, Cattle, Sheep, etc.)
- Liver**—
 changes in deficiency disease, 664.
 manganese content, 615.
- Locust**, black—
 culture, Idaho, 344.
 use of bark as grasshopper bait, 353.
 wood-boring beetles attacking, 854.
- Locusta danica*, notes, 52.
- Locusts**—
 invasion of British Guiana, 159.
 notes, 52.
 (*See also* Grasshoppers.)
- Loganberries**, insects affecting, 155, 659.
- Loganberry**—
 anthracnose, Wash., 155.
 gall, Wash., 155.
 juice, manufacture, Calif., 717.
 orange rust, Wash., 155.

- Log-piles, fire hazard, 651.
 Loquat, apple scab on, 243.
 Louse—
 egg, maturation, 256.
 spermatogenesis, 256.
 (See also Lice.)
 Louisiana—
 Stations, notes, 398, 699.
 Stations, report, 698.
 University, notes, 398.
Loxostege sticticalis, notes, Colo., 158.
 Lucern. (See Alfalfa.)
 Lumber—
 aircraft, preparation of, 544.
 and its uses, treatise, 344.
 industry in the United States, history,
 44.
 market in Italy, 242.
 production in 1918, U.S.D.A., 150.
 (See also Timber and Wood.)
 Lumbering in Douglas fir region, 343.
 Lunar phases, effect on rainfall, 417.
 Lungworms in sheep, Okla., 79.
 Lupine—
 silvery, studies, Wyo., 783.
 Lupines—
 flour from, analyses, 458.
 for improvement of poor soils, 321.
Lyctus brunneus, notes, 456.
Lydella stabulans, parasitism by, 858.
 Lye, use as vermifuge, Okla., 80.
Lygus spp., remedies, Ariz., 757.
 Lymphangitis—
 epizootic, 583, 685.
 epizootic ulcerative, treatment, 184.
 ulcerative, from Preisz-Nocard infec-
 tion, 885.
 ulcerative, studies, 383.
Lypsomena fuscata, notes, 851.
 Lysabincic acid, gold number determination,
 12.
 Lysimeter experiments, 127.
 Lysin, rôle in nutrition of chicks, Ky., 72.
 Machine—
 for road finishing, U.S.D.A., 388.
 for trimming camphor trees, U.S.D.A.,
 90.
 Machinery. (See Agricultural machinery.)
Macrosiphum—
 n. spp., description, Me., 160.
 solanifolii, studies, Va. Truck, 451.
 spp., studies, Me., 159.
Macrosporium solani, notes, 152.
 Magnesia—
 cement, physical properties, 282.
 effects on soil potassium, 127.
 Magnesium—
 antagonistic effects on respiration of
 organisms, 820.
 arsenate, insecticidal value, Colo., 158.
 determination in organic solutions, 204.
 in soil extracts, effect of fertilizer
 salts, Mich., 125.
 Magnolias, time for transplanting, Mo.,
 142.
 Maguey, culture and uses, 826.
 Mahoe wood, durability tests, 44.
 Mahoganies, true, revision, 241.
 Maine Station, notes, 497, 899.
 Maize. (See Corn.)
Malacosoma—
 americana. (See Tent caterpillar.)
 castrensis, notes, 853.
 Malaria—
 control by drainage, 85.
 inoculation, 854.
 prophylaxis, rôle of cattle in, 454, 853.
 transmission by Anopheles, 55.
 (See also Mosquitoes and Anopheles.)
 Mallein test, intradermal, effect on subse-
 quent complement fixation tests, 881.
 Mallows, mucilage in, origin, 132.
 Malt sprouts, analyses, N.J., 69, 672.
 Mammals—
 domestic, acetoneuria in, 879.
 domestic, spermatogenesis, 669.
 of Panama, 849.
 Man, adaptation to high altitudes, 564.
 Manganese—
 in human tissues and blood, 615.
 in phosphatic slag, 127.
 salts, simplification of reaction, 803.
 Mange, parasitic, papers on, 81.
 (See also Hog, Horse, and Mule mange,
 Cattle and Sheep scab.)
 Mangel diseases, notes, 45.
 Mangels—
 analyses, 63.
 as affected by potassium salts, 630.
 as affected by sodium chlorid, 630.
 as forage crops in Denmark, 177.
 breeding experiments, Can., 735.
 digestion coefficients, 373.
 fertilizer experiments, 231; Can., 735.
 seed production, Can., 735.
 seed testing, Can., 735.
 variety tests, 232; Can., 735.
 yields, Minn., 824.
 Mango—
 hopper, control, 51.
 scale insects, control, 54.
 Mangoes—
 culture experiments, 40.
 insects affecting, 52.
 Manioc. (See Cassava.)
 Mannan, salep, coefficients of digestibility,
 366.
 Mannose, fermentation of, 610.
 Manure—
 application, time for, 24.
 conservation and application in citrus
 groves, 239.
 conservation and use, Mo., 124.
 conservation in Spain, pits for, 423.
 conservation in Sweden, 423.
 effect on carbon dioxid production in
 soil, 321.
 effect on nitrification in soils, Tex.,
 725.
 effect on soil moisture, 722.
 fertilizing value, Okla., 32; Tex., 37;
 Utah, 218.
 heaps, vegetation around, 430.
 liquid, ammonia nitrogen from, 220.

- Manure**—Continued.
 liquid, conservation, 423.
 liquid, nitrogen loss in, cause, 323.
 liquid, use of calcium chlorid with, 628.
 making and use, 518.
 mule, effect of weathering and storage, Mo., 721.
 organic, growth-promoting substances in, 816.
 refuse, analyses, 28.
 treatise, 621.
 v. fertilizers for market gardening, R.I., 643.
 v. fertilizers for Maryland soils, 815.
- Manuring** for reclamation of push soils, Iowa, 21.
- Maples**—
 as affected by sodium chlorid, 344.
 kerosene injury to, 732.
 variegation in foliage, 729.
- Maps**, topographic, and sketch mapping, 887.
- Marasmius**—
perniciosus, notes, 349.
plicatus on sugar cane, La., 348.
- Marble**, etching by roots, 422.
- Margaropus**—
annulatus. (See Cattle tick.)
australis, notes, 82.
- Market**—
 diseases of vegetables, 751.
 gardens. (See Truck crops.)
 reports, U.S.D.A., 194, 294, 490, 595, 694, 794.
 stations, use of, U.S.D.A., 490.
- Marketing**—
 banker's part in, 294.
 cooperative, demonstrations, U.S.D.A., 490.
 cooperative, of woodland products, U.S.D.A., 345.
 in North Carolina, N.C., 394, 595, 794.
 organizations, N.C., 490.
 problems, 489.
- Markets**, public, studies, Wash., 794.
- Marl** production and prices in 1918, 631.
- Marsh**—
 border soils, chemical composition, 22.
 soils, fertilizer needs, 22.
- Marssonina perforans** on lettuce, 152.
- Maryland**—
 College and Station, notes, 299.
 Station, report, 197.
 University, notes, 99.
- Massachusetts**—
 College, notes, 199, 497, 699.
 Station, notes, 199, 699.
- Mayetiola destructor**. (See Hessian fly.)
- Meadow**—
 fescue. (See Fescue.)
 plant bug, studies, 256.
 wild, reclamation, Oreg., 21.
- Meadows**—
 culture experiments, Wash., 436.
 fertility, notes, Ohio, 322.
 (See also Hay, and Grass.)
- Mealybugs**, citrus, control, 659.
- Meat**—
 and bone scrap, analyses, 867.
 canning, cold-pack method outfits, 808.
 chemistry, 609.
 inspection, Federal, 780.
 juice, antiscorbutic value, 263.
 prices, July 1920, U.S.D.A., 695.
 production, fattening and growth, 371, 372.
 production in Brazil, 292.
 products, added water in, determination, 415.
 scrap, analyses, Ind., 69, 867; Ky., 373; N.J., 69, 672.
 (See also Beef, Pork, etc.)
- Media**. (See Culture media.)
- Medical chemistry**, treatise, 609.
- Medicinal**—
 plants. (See Drug plants.)
 substances, substitutes in Germany, 204.
- Medicine**—
 and surgery, industrial, 564.
 patent, notes, N.Dak., 368.
- Medlar**, Japanese, brusome in, remedy, 349.
- Melampsora** sp. on willow, 350.
- Melanconium sacchari**—
 notes, 152.
 on sugar cane, La., 348.
- Melanosis and Melanosarcoma**, differentiation, 683.
- Meliana albivinea limitata**, life history and control, 54.
- Mellilotus**. (See Sweet clover.)
- Mellessis** spp., descriptions, 57.
- Melon**—
 aphid, dusting for, 451.
 aphid in South Dakota, 850.
 aphid, life history studies, Tex., 758.
 diseases, notes, 151.
 fly, control, 455.
 shipments, U.S.D.A., 695.
- Melons**—
 disease resistant varieties, Md., 144.
 insects affecting, Mo., 757.
- Melophagus ovinus**. (See Sheep tick.)
- Melting point determination, apparatus, 12.
- Merulius lacrymans**, notes, 350.
- Mesochorus pallidus**, bionomics of, 457.
- Mesoletus gymnonychi** n. sp., description, 857.
- Metabolism**—
 as affected by nature of rations, S.Dak., 874; Va., 875.
 as affected by secretin, 369.
 of a dwarf, 368.
 of actinomycetes, 634, 635.
 of children, 166.
 plant, carbon-nitrogen ratio, 430.
 respiratory, during undernutrition, 859.
- Metals** suitable for kitchen utensils, 65.
- Metamasius mosieri** n. sp., description, 562.
- Metarrhizium anisopliae**, pleophagy of, 858.

Meteorological—

- instrument shelters, shading, U.S.D.A., 718.
- instruments, discrepancies, U.S.D.A., 511.
- instruments for determining temperature, U.S.D.A., 237.
- observations—

Conn.Storrs, 120; Ky., 318, 810; Mass., 207, 511, 719; Minn., 811; Okla., 16; Pa., 511; Tex., 17, 229; U.S.D.A., 119, 120, 318, 418, 510, 511, 718, 810; Wyo., 120.

at Santo Domingo, 17.

at Wisley, 207.

in Australia, 208.

in Canada, Can., 798.

in France, 17.

in Great Britain, 621.

in South Australia, 811.

in Sweden, 621.

of bombing pilot in France, U.S. D.A., 511.

value in fumigation, 319.

phenomena as affected by lunar phases, 417.

phenomena, relation to variations in solar activity, 810.

Meteorology—

- Antarctic, value to agriculture, 418.
- in relation to agriculture, U.S.D.A., 718.
- manual, 208.
- papers on, U.S.D.A., 15, 119, 511, 718.
- (See also Climate, Rainfall, Temperature, Weather, etc.)

Methyl alcohol, detection, 614.

Methylene blue reductase test, notes, 271.

-Methylglucosid, utilization by *Aspergillus niger*, 203.

Meyer Memorial Medal, notes, 400.

Mice—

- as enemies of man, 250.
- entozoa of, 457.
- exhibition standards, 575.
- girdling of apple trees by Conn.State, 237.
- linkage in, 669.
- meadow, control in Italy, 250.
- protection of fruit trees from, Ohio, 340.
- (See also Rodents.)

Michigan Station, quarterly bulletin, 698.

Microbracon cephi, parasitism by, U.S.D.A., 260.

Micrococcus—

- caprinus*, notes, Mich., 688.
- melitensis*. (See *Bacterium melitensis*.)
- populi*, notes, 552.

Microgaster connexus, bionomics of, 457.

Microorganisms—

- as food supply for insects, 51.
- attenuated, agglutinability of, 581.
- heat resistant, in canned peas, Mich., 114.
- (See also Bacteria.)

Microphthirus, new genus, 453.

Microsphaera—

grossulariae, notes, 246.

quercina on oak, 754.

Microterys spp., notes, 252.

Microtypus dioryctria n. sp., description, 857.

Middlings—

analyses, Ind., 69, 867; Ky., 373.

offal content, 314.

(See also Wheat, Rye, etc.)

Mildew—

false, transmission by seed, 549.

powdery, experiments, conclusions, 549.

Milk—

abnormal, detection, N.Y.State, 579.

advertising methods, U.S.D.A., 580.

altered, determining extent of, 14.

altered, lactose determination, 505.

analysis, sources of error, 415.

analyses in China, 177.

antiscorbic value, as affected by diet of cow, 766.

as source of vitamin, 165.

bacterial contamination from straining cloth, 679.

bacterial counts, accuracy of, N.Y. State, 680.

bacteriological analysis, methods, 379; Pa., 579.

bacteriological control, 379.

biorized, bacteriological studies, 877.

bottles, bacteria on rims, 680.

carbonic acid and carbonates in, N.Y. State, 579.

chemistry, 609.

clean, production, Ky., 877.

clean, production, manual, 679.

composition as affected by stage of lactation, 272.

composition, factors affecting, Mo., 778.

composition, variations in, 74, 578.

condensed, "buttons" in, 779.

condensed, prices, U.S.D.A., 595.

condensed, sweetened, formation of gas in, Iowa, 76.

cost of production at Rochester, 271.

cost of production in Indiana, U.S.D.A., 678.

cost of production in Michigan, 178; Mich., 378.

cost of production in North Carolina, 678; N.C., 469.

cultures, volatile acidity of, Iowa, 75.

diets, Conn. Storrs, 767.

distribution in cities, 178, 681; Mich., 698.

enzymes, relation to abnormal flavors, Mo., 712.

fat as affected by rations, Va., 875.

fat, Babcock test, 75.

fat, composition, as affected by poppy seed cake, 777.

fat, method of determining, 578.

fat tests, comparison, N.Y.Cornell, 469.

Milk—Continued.

fermented, effect on intestinal flora, Conn. Storrs, 767.
 freshly drawn, cause of variation in reaction, N.Y.State, 578.
 from pellagrous mothers, composition, 668.
 from udder infected with foot-and-mouth disease, 877.
 grading at Rouen, 271.
 human, analyses, Conn.State, 859.
 imports and exports, 74.
 keeping quality, judging, 615; Mich., 681; N.Y.State, 579.
 lactose in, polarimetric determination, 805.
 marketing, 178, 580, 681; Mich., 698.
 methylene blue reductase test, 271.
 pasteurization, control in Chicago, 877.
 pasteurization, electrical, 778.
 pasteurized, decomposition of hydrogen peroxid in, 206.
 plant, city, at Jamestown, 878.
 plant, city, construction and arrangement, U.S.D.A., 682.
 plant, cooperative, 682.
 powders for infants, 566.
 prices, determination at Evansville, 878.
 prices in 1919, U.S.D.A., 178.
 prices, relation to distribution, 877.
 prices, relation to fat content, 178.
 prices, statistics, 74.
 Producers' Association, Twin City, 878.
 production, statistics, 74.
 production, effects of drugs on, 577.
 production, proteins for, 270.
 products in America and Europe, 74.
 reaction in relation to blood cells and bacterial infections, 578.
 records, analyses, Me., 174.
 records of Ayrshire cows, analysis, 74.
 records of Jersey cows, 777.
 retention of, 876.
 rosy, cause and control, Ill., 579.
 secretion studies, Me., 175.
 secretion, variation with age, 676; Me., 677.
 skimmed. (See Skim milk.)
 sour skim, for chicks, N.C., 468.
 souring, as affected by bacterial growth, N.Y.State, 681.
 substitutes in calf feeding, Ind., 875.
 supply, city, control, 778.
 supply, city, in Canada, 877.
 supply of Calcutta, 177.
 supply of China, sanitary aspects, 177.
 supply of Detroit, Mich., 178.
 supply of District of Columbia, 877.
 supply of Ireland, 74.
 survey at Rochester, 270.
 tests, daily variations in, 778.
 variations in composition, 74, 578.
 yield as affected by cassava feeding, 73.
 yield as affected by poppy seed cake, 777.

Milking machines, studies, Minn., 679; N.Y. State, 679.

Milkweed, whorled—

poisonous to live stock, U.S.D.A., 470, 471.
 toxicity and eradication, Colo., 141.
 Mill stocks, offal content, 314.
 Millet—
 as affected by carbon dioxide in soil, N.Y.Cornell, 813.
 as hay crop, 527.
 as orchard cover crop, Pa., 538.
 as silage crop, S.Dak., 200.
 diseases, control, Tex., 845.
 yields, Minn., 636.

Milo—

breeding experiments, Ariz., 734.
 culture experiments, U.S.D.A., 134.
 manuring experiment, U.S.D.A., 134.
 resistance to alkali, Ariz., 724.
 variety tests, U.S.D.A., 134.
 yields, Ariz., 733.

Mineola vaccini. (See Cranberry fruit-worm.)

Mines, effect on ground water level, 210.

Minnesota—

Grand Rapids Substation, report, 898.
 Station, report, 698.
 University and Station, notes, 398, 497, 599.

Miris dolobratus, notes, 256.

Mississippi—

College, notes, 199, 700.
 Station, notes, 99, 399, 700.

Missouri—

Station, notes, 497.
 Station, report, Mo., 798.
 University, notes, 399, 497.

Mistletoes and their hosts, studies, 821.

Mites from Japan and Formosa, 260.

Molasses—

as source of alcohol, 617.
 beet, effects on pigs, 180.
 beet pulp. (See Beet pulp.)
 density of, apparatus for determining, 806.
 determination of grain in, 508, 509.
 formation and exhaustibility, 508.
 reducing sugars in, determination, 806.
 waste, motor fuel from, 591.
 water content, 509.

Mold—

fungi, effects of acids, 523.
 fungi, formation of soluble starches by, 523.
 spores in sugar, factors affecting activity, 507.
 spores, invertase activity in sugar, 433.

Molding, of snow-smothered nursery stock, 846.

Molds—

breeding on concentrated sugar solutions, 524.
 formation of fruiting bodies in concentrated sugar solutions, 226.
 in soil, effect of seasonal conditions, Iowa, 432.
 on dehydrated food products, 317.

- Mole crickets—
 in South Carolina, 159.
 on grass roads, 53.
- Mollusk muscle, composition, 568.
- Momordica cochinchinensis*, oil from seeds, analysis, 316.
- Monacrostichus* sp., description, 57.
- Monilia*—
cinerea and *fructigena*, differentiation, 246.
cinerea and *fructigena*, two forms, studies, 48.
 spp., notes, 246.
- Monocalcium phosphate, effect on soil extracts, Mich., 124.
- Monocrepidius* sp., notes, U.S.D.A., 352.
- Montana—
 College, notes, 498, 899.
 Station, notes, 199, 498.
- Moor soils—
 decomposition, determination of degree, 213.
 effect of water level on meadow plants, 623.
 of Russia, agricultural value, 623.
 reclamation in Holstein, 185.
 relation of root development to lime in, 623.
 sanded and unsanded, evaporation of moisture, 20.
 use for soil improvement, 22.
 (See also Peat soils.)
- “Morgan,” use of term, 269.
- Mosquitoes—
 as affected by weather, 51.
 control, Conn.State, 252.
 eradication, 258; N.J., 162.
 malarial, of Illinois, studies, 558.
 of British Columbia, 258.
 State laws for control, N.J., 162.
 (See also Anopheles, Culex, etc.)
- Moss, absorptive capacity, 812.
- Moths, new, from Mexico, 258.
- Motor—
 cultivators. (See Cultivators.)
 fuel from waste molasses, 591.
 fuels, discussion, 187.
 plows. (See Plows, motor.)
 trucks, army, housing and equipment, U.S.D.A., 591.
 trucks, design and construction, treatise, 285.
 trucks, economy of operation, 187.
 trucks, operating cost, relation to roads, 85.
 trucks, pneumatic v. solid tires, 286.
 vehicles, care and operation, treatise, 187.
 vehicles, gas as source of power, 86.
 vehicles in United States, U.S.D.A., 689.
 vehicles, steam and gas, running costs, 890.
- Motting disease of sugar cane. (See Sugar cane.)
- Mouse. (See Mice.)
- Mucilage formation in cacti, 226.
- Muck soils—
 chemical composition, 22.
 factors affecting lime requirement, 212.
- Mucor zygotes*, resistance of, 329.
- Mule mange, treatment, 184.
- Mules—
 as substitutes for work horses and oxen, 573.
 Borna disease of, 83.
- Muriate of potash. (See Potassium chlorid.)
- Muridæ, structure and classification, 250.
- Musca domestica*. (See House-fly.)
- Muscular work, effect on hemoglobin and protein content of blood, 265.
- Musculus complexus, factor in hatching of chicks, 169.
- Mushroom root rot, 347.
- Mushrooms—
 culture, 437.
 substitutes in Germany, 204.
- Muskmelon bacterial wilt, control, U.S.D.A., 245.
- Muskmelons, variety tests, Tex., 36.
- Mustard culture, 638.
- Mutation, studies, 729. (See also Variation.)
- Mutations—
 half and mass, studies, 222.
 theoretical discussion, 67.
- Mycetophilidæ, monograph, 661.
- Mycoplasma theory, discussion, 444.
- Mycorrhiza, notes, 731.
- Mycospharella, life history, Md., 151.
- Myzocallis alhambra* n. sp., description, 660.
- Narcissus—
 disease, studies, 350.
 eelworm disease, control, 49, 247.
- Nasturtiums, breeding experiments, 222.
- Nasutitermes, new genus, 256.
- Nature study—
 courses in Texas, 598.
 elementary in Wisconsin, 797.
- National—
 Farmers' Union, outline of work, 895.
 Forest Reservation Commission, report, 839.
- Nebraska—
 Station and University, notes, 199, 498, 700, 899.
 Station, report, 698.
- Necrobacillosis, studies, Wyo., 179.
- Nectria*—
cinnabarina, notes, 444, 552, 754.
ditissima, notes, 246.
- Neleucania albilinea limitata*, life history and control, 54.
- Nematodes—
 affecting clover, 46.
 affecting coconuts, 551.
 affecting Narcissus, 49.
 affecting orange roots, 48.
 affecting tomatoes, control, 47.
 control, 350, 659.
 transference for economic purposes, 449.

- Neosomydobius*, new genus erection, U.S. D.A., 758.
- Neotermes*, notes, 256.
- Neothomasia*, new name, U.S.D.A., 758.
- Neotroptera violæ* and its allies, 54.
- Neotrama*, new genus erection, U.S.D.A., 758.
- "Nerve bacillus," studies, 472.
- Nesomimesa hawaiiensis*, parasitic on sugar cane leafhopper, 662.
- Netherlands Institute of Animal Nutrition, notes, 800.
- Nettle meal, composition and digestibility, 267.
- Nevada—
 Station, notes, 498, 700.
 Station, report, 298.
 University, notes, 700.
- New Hampshire—
 College and Station, notes, 199, 498.
 Station, report, 98.
- New Jersey—
 Alfalfa Association, proceedings, 528.
 State Potato Association, proceedings, 531.
 Stations, notes, 199.
- New Mexico Station—
 notes, 200.
 report, 397.
- New York State Station—
 notes, 100, 200, 399, 498, 700, 799.
 report of director, 598.
- Nicotin—
 preparations, analyses, N.J., 37.
 sulphate, insecticidal value, Oreg., 756.
- Nitragin, inoculation of legumes with, 217.
- Nitrate—
 Chilean, as source of potash, 25.
 industry of Chile, 728.
 of ammonia. (See Ammonium nitrate.)
 of lime. (See Calcium nitrate.)
 of potash. (See Potassium nitrate.)
 of soda. (See Sodium nitrate.)
 plants, Government, need for continuous operation, 25.
 production from catalytic oxidation of ammonia, 816.
 production in soils, Ill., 214; Mo., 722.
 production, most active periods of, Ill., 214.
- Nitrates—
 absorption and storage by *Amaranthus*, 225.
 accumulation in soils, excessive, 216.
 as affected by sewage organisms, 791.
 effect on *Azotobacter* growth, Pa., 514.
 effect on color of apples, Oreg., 145.
 formation after clover and timothy, 215.
 in orchard soil, determination, Ind., 338.
 loss in uncropped land, 19.
 nitrogen determination in, 714.
- Nitrification—
 as affected by alkali salts, 216.
 as affected by soil moisture, Wash., 722.
 as affected by time of year, 124.
 in semiarid soils, 215.
- Nitrification—Continued.
 in soils, velocity of, Pa., 515.
 in Texas soils, Tex., 724.
 of ammonium sulphate, 215.
 of bone meal, 215.
 of dried blood, 215.
- Nitrites, carbazol test for, 316.
- Nitrifying bacteria, isolation and studies, 216.
- Nitrogen—
 and hydrogen mixture, preparation, 220.
 availability in various fertilizers, Ala. Col. 135.
 bacteria fertilizers, value of, 221.
 content of oats as affected by fertilizers, 322.
 content of soil as affected by cultivation and fertilization, Ohio, 725.
 determination, 116.
 determination in blood, 205.
 determination in nitrates and fertilizers, 714.
 determination, modified method, 13, 316.
 distribution in soils, studies, 18.
 fixation—
 by electric arc, 323.
 by green plants, 430.
 in Germany, before and after the war, 426.
 processes, 219, 627; U.S.D.A., 426.
 symbiotic, relation to soil nitrogen, 625.
 in blood, variability, 265.
 inorganic, consumption and supply in United States, 425.
 inorganic, demand in United States, 24.
 inorganic, supply in United States, 24, 426.
 lime. (See Calcium cyanamid.)
 loss from soil by drainage, 19.
 loss in liquid manure, cause, 323.
 manufacture, 627.
 metabolism, formation of soluble starch in, 525.
 metabolism of actinomycetes, 634.
 metabolism of leaves, 729.
 metabolism of milch cows, 270.
 nitrate and organic, relative availability, 220.
 nonprotein, of blood, 265, 266, 463.
 partition in urine of races in Singapore, 65.
 Products Committee, British, report, 218.
 world's supply, control of, 323.
- Nitrogenous fertilizers—
 comparison, 221, 232, 627; Can., 727; La., 627; N.C., 427.
 laws in Germany, 221.
- Nodule—
 bacteria, flagellation of, 433.
 (See also *Bacillus radicola*, and Legumes, inoculation.)
 production, notes, 30.

North Carolina—

College, notes, 399.
Station, report, 496.

North Dakota—

College and Station, notes, 900.
Station, report, 397.

Nosema apis in hive bees, 59.

Nuclear bodies, nature and behavior, 524.

Nucleic acid derivatives, effect on plant growth, 514.

Nursery—

inspection, 237; Conn.State, 251.
stock, imported, insect pests on, 352.
stock, nematodes affecting, 350.
stock, selection, Ohio, 339.
stock, snow smothered, molding, 846.

Nut—

industry, American, 240.
industry, in Italy, 438.

Nutrient—

media. (See Culture media.)
solution, relation to composition of cell sap, 224.
solutions as affected by sand, 210.

Nutrition—

and physical efficiency, 365.
clinics and classes, 167.
effect on diazo value of urine, 368.
human, treatise, 261.
in Germany during the war, 459.
laboratory of Carnegie Institution, report, 66, 266.
of infants, rôle of vitamins in, 663.
rôle of calcium in, N.Y.State, 574.
studies, 763.
(See also Diet, Metabolism, Vitamins, etc.)

Nutritive media, effect of concentration on plants, 523.

Nuts—

culture, Mich., 649.
culture and expression of oil, 240.
culture experiments, Md., 143; U.S.D.A., 339.
variety tests, U.S.D.A., 339.

Nuttallia equi, notes, 83.

Oak—

diseases, notes, 754.
mildew, effect on seedlings, 241.

Oaks—

as affected by sodium chlorid, 344.
breeding experiments, 536.
natural regeneration, cause of failure, 241.

Stereum gausapatum on, 449.

Oat—

crown rust, biologic forms, 653.
diseases, control, Tex., 845.
Fusarium disease, 751.
grass, tall, culture experiments, Wash., 436.
halo blight, studies, 545.
hulls, analyses, N.J., 672; R.I., 672; Vt., 464.
rust, studies, Iowa, 654.
scab organism, production of conidia, 545.

Oat—Continued.

shorts, analyses, Ind., 867.
smut, notes, 445.
smut, studies, Wash., 750.
straw, digestibility, 569.
straw for farm horses, Mo., 775.
straw, sugar content, 671.

Oats—

and peas as orchard cover crop, Pa., 538.
and peas as spring forage, Mo., 736.
as affected by carbon dioxid in soils, N.Y.Cornell, 813.
as affected by fineness of lime, 325.
as hay crop, 527.
cost of production, Ohio, 392.
culture, Mich., 639.
culture experiments, 824; Ark., 137; Mont., 332, 739; Nebr., 637; Ohio, 334; U.S.D.A., 134.
culture in lead and zinc regions, 513.
culture on peat soil, 23.
culture on reclaimed peat swamps, Oreg., 22.
fall planting, Wash., 738.
fertilizer experiments, 322; Can., 727; Minn., 627; N.C., 424; Okla., 32; S.C., 126.
ground, analyses, Vt., 464.
irrigation experiments, Utah, 230.
manuring experiments, Minn., 627, 815; Utah, 218.
period of greatest nitrate utilization, Ill., 215.
phosphoric acid content, relation to fertilization, 518.
rotation experiments, Okla., 32; U.S.D.A., 435.
seed treatment, 642.
seeding experiments, Ark., 138; N.C., 434; Ohio, 334.
seeds, longevity of, 832.
v. rice meal as cattle feed, 172.
varieties, Ariz., 733; U.S.D.A., 637.
variety tests, 34, 231, 232, 528; Ark., 137; Can., 735; Md., 134; Minn., 636, 823; Mo., 736; N.Dak., 332; N.H., 34; Nev., 228; Ohio, 334; Okla., 32; U.S.D.A., 134, 639; Wash., 737; Wyo., 135.
wheat nematode attacking, 751.
wheat-head army worm affecting, 54.
winter, as pasture feed, U.S.D.A., 171.
winter, variety tests, Md., 134.
winterkilling, remedies, Ark., 138.
yields, 829.
yields in Australia, 528.

Oebalus pugnax on rice, U.S.D.A., 253.

Oenothera—
hybrids, Mendelian splitting in pollen, visibility of, 521.
inheritance studies, 729, 818.
Oenothera lamarckiana simplex, notes, 521.
Oenotheras as nuclear chimeras, 223.
Esophagostoma columbianum, notes, 883.
Offal content of flour, 314.

- Ohio—
 State University, notes, 399, 900.
 Station, monthly bulletin, 397, 798.
 Station, notes, 399, 700, 900.
 Station, report, 397.
- Oidium*—
leucoconium on peach, 349.
 sp., new leaf disease of Hevea, 49.
- Oil—
 cakes, feeding value, 573.
 cassia, determination of lead in, 14.
 coconut, rancidity of, 201.
 from cockle-bur, analyses, 801.
 from Momordica seeds, analyses, 316.
 from Pappia seeds, analyses, 801.
 from soy beans, composition, 610.
 meal. (*See* Linseed meal.)
 of chenopodium, composition, 502.
 of *Rubieva multifida*, analysis, 502.
 palm disease, 849.
- Oils—
 and fats, analyses, Conn.State, 859.
 and fats, production from oil seed
 plants, 638.
 essential, from apples, 711.
 essential, iodine number defined, 315.
 essential, substitutes in Germany, 204.
 for lubrication of tractor engines, se-
 lection, 89.
 hydrogenation, discussion, 416.
 industry in France, 261.
 iron content, 202.
 lubricating, effect of dilution, 86.
 measurement of viscosity for wood
 treatment, 283.
 refined, sampling and examination, 805.
 rancidity, cause and nature, 201.
 saponification number determinations,
 505.
 substitutes in Germany, 204.
 vegetable, handbook, 240.
 (*See also* Fats, and Corn oil, Cotton-
 seed oil, etc.)
- Oklahoma—
 College, notes, 200, 498.
 Station, notes, 200, 400, 498.
 Station, publications available, 496.
 Station, report, 98.
- Okra as trap crop for cotton bollworm, 51.
- Oleomargarin, production, U.S.D.A., 179.
- Olive production in Spain, 439.
- Olives—
 canned ripe, botulism from, 865.
 dodder affecting, 652.
 pollination experiments, 239.
 ripe, poisoning, summary, 168.
 ripe, processing, 316.
- Olive-wood ashes, analyses, 324.
- Onion—
 downy mildew, notes, 243.
 market, U.S.D.A., 595.
 red root, notes, 243.
 Rhizoctonia disease, studies, Wash.,
 750.
 seed production, Ind., 339.
- Onion—Continued.
 smut, control, 153, 654.
 thrips, dusting for, 451.
- Onions—
 analyses, 63.
 Bermuda, grades, U.S.D.A., 335.
 insects affecting, 450.
 malnutrition of, Ind., 345.
 northern-grown, grades for, U.S.D.A.,
 236.
 sun-dried vitamins B and C in, 63.
- Ontario Agricultural College, notes, 400.
- Oospora scabies*. (*See* Potato scab.)
- Oozonium omnivorum*, studies, U.S.D.A., 153.
- Ophiobolus graminis*, notes, 152, 243, 347,
 750.
- Ophthalmia—
 recurrent, bacterial flora in, 472.
 specific, studies, 472.
- Opius fletcheri*, parasitism by, 455.
- Opuntia*—
fulgida, perennation and proliferation
 of fruit, 328.
 spp., studies, 222.
- Orange—
 bud abortion, relation to June drop, 247.
 diseases in Cuba, 448.
 diseases, notes, 243.
 juice, analyses, 203.
 juice, antineuritic and growth-promot-
 ing value, 460.
 juice, antiscorbutic value, 667.
 juice, dried, antiscorbutic value, 460.
 juice, vitamins A and B in, 765.
 juice, vitamin C as affected by heat, 567.
 June drop, 247.
 root rot, studies, 48.
 stocks, studies, 838.
- Oranges—
 beetle attacking, 456.
 culture in Bombay, 745.
 digitiform, notes, 818.
 fumigation experiments, 54.
 navel, citrus blast affecting, 156.
 spraying experiments, 157.
 stored, changes in sugar content, 203.
- Orchard—
 grass, culture experiments, Wash., 436.
 horse disease, 473.
 inspection. (*See* Nursery inspection.)
 management, 833; Ind., 337; Mich.,
 649; Ohio, 340, 648; Oreg., 145.
 management in New York, U.S.D.A., 649.
 management in Nova Scotia, 438.
- Orchards—
 cover crops for, Ind., 338; Pa., 538;
 Wash., 743.
 fertilization, 744.
 fertilizer experiments, 645; Ind., 337;
 Ohio, 339; Oreg., 145.
 fertilizer experiments, interpreting re-
 sults, 645.
 pruning experiments, Ohio, 339.
 rejuvenation, Ohio, 647.
 shade crops v. fertilizers, Oreg., 146.

Orchards—Continued.

- spray schedules, N.J., 37; Ohio, 339.
- spraying experiments, Ohio, 357.
- spraying experiments, cooperative, 833.
- war devastated, renovation, 835.
- (See also Fruits, Apples, Peaches, etc.)

Oregon—

- College, notes, 100, 299, 400.
- Station, notes, 100, 299.

Organic—

- compounds, analysis, 503.
- evolution, treatise, 521.
- matter in soils, 18.
- mixtures, carbon determination in, 414.

Oriental peach moth. (See Peach moth.)

Ormenis pygmaea, notes, 555.

Ornamental plants, shrubs, or trees. (See Plants, Shrubs, and Trees.)

Orthoptera of northeastern America, 851.

Osmotic pressure in potato plants, 131.

Osteomalacia, relation to undernutrition, 667.

Osteoporosis, relation to undernutrition, 667.

Ostrich eggs, absence of xenia in, 776.

Ox warbles, agricultural importance, 853.

Oxalates in plants, 730.

Oxalic acid production, mechanism, 112.

Oxen, growth estimation, 371.

Oysters, spoilage, due to pink yeast, 663.

Oyster-shell scale, forms, in Illinois, 356.

Ozonium omnivorum, notes, 652.*Pachira insignis*, durability test of wood, 44.*Pachyneuron coccorum*, notes, 252.*Pachypappelia*, new name, U.S.D.A., 758.

Paddy. (See Rice.)

Paint—

- protective value on steel, 233.
- white-lead, for control of apple-tree borer, U.S.D.A., 762.

Paints, suitable for bridges, list, 284.

Paivva langsdorffi, possible economic value, 40.*Paleopus dioscorea*, notes, 258.

Palm—

- coconut. (See Coconuts.)
- gul manufacture, 808.
- kernel cake, sugar content, 671.

Palms—

- and palm products in Philippines, 443.
- oil, disease, 849.
- oil, *Fomes lucidus* on, 652.
- ornamental, notes, U.S.D.A., 339.

Palmyra bud rot, notes, 445.

Pancreas—

- changes in deficiency disease, 664.
- relation to diabetes, 370.

Papaipema nitela. (See Stalk borer.)

Papaver, latex vessels, function, 525.

Papaya disease, notes, 445, 652.

Papayas—

- anomalies of development, 818.
- coconut bud rot on, 156.
- culture experiments, 40.

Paper—

- industry, discussion, 317.
- making, chemistry of, 409.
- making, possibilities of grasses, 317.
- pulp materials, Philippine, 841.
- pulp. (See Pulpwood and Wood pulp.)

Pappea capensis seeds, oil from, analyses, 801.

Pappea meal, analyses, 802.

Paraguay kernels, oil from, 240.

Paraphorocera senilis, parasitism by, 858.Parasites, hymenopterous, new species, 662.
(See also Animal parasites, Poultry parasites, and specific forms.)

Parasitism in plants, studies, 46.

Paratyphoid—

- bacilli, differentiation, 785.
- C, studies, 685.
- enteritidis group, studies, 275.

Parva cancellus on roses, 362.*Paridris brevipennis*, notes, 259.

Paris green—

- analyses, N.J., 37.
- insecticidal value, Colo., 158.

Parks and reserves in Maryland, 651.

Parsnip web worm, notes, Conn.State, 252.

Parthenogenesis in pear-slug sawfly, 60.

Pasteurization. (See Milk and Cream.)

Pasture—

- experiments, cooperative, Ind., 331.
- management experiments, Wash., 436.
- v. barn for finishing steers, Ky., 373.
- v. crops, relative labor income, 92.

Pastures—

- improvement in Rhodesia, 638.
- mixed-grass, for dairy cows, U.S.D.A., 468.

(See also Grass and Grassland.)

Patchia virginiana n. g. and n. sp., U.S.D.A., 758.*Pauridia* (n. g.) *peregrina*, notes, 662.

Pavements, concrete, reinforcing, 790.

(See also Concrete and Roads.)

Paving block, granite, laboratory tests, 85.

Pea—

- moth, life history notes, 850.
- moth, studies and control, Wis., 257.
- straw, digestibility, 569.
- straw for fattening cattle, 870.
- straw for sheep, Wash., 772.
- wilt, notes, 444.

Peach—

- aphis, Indian, notes, 852.
- as short-season fruit, U.S.D.A., 595.
- bacterial leaf spot, notes, Okla., 36.
- borer, control, 359; Pa., 554.
- brown rot, control, 238.
- brown rot, notes, 349.
- buds, moisture content as index of hardness, 39.
- canker, cause and control, Can., 847.
- crown gall, notes, 246.
- curculio, control, 238, 743.
- diseases, control, Ill., 847.
- leaf curl, control, 445.
- leaf curl, notes, 246.

Peach—Continued.

- moth, oriental, control, 558.
- moth, oriental, in Japan, 456.
- moth, oriental, notes, 359.
- oïdium, prevention, 349.
- orchard survey, Colo., 144.
- parasites, 238.
- scab, control, 238, 743.
- shot hole, notes, 243.
- survey in New Jersey, 835.
- thrips, dusting for, 451.

Peaches—

- culture, 438.
- dusting *v.* spraying, 238, 743.
- fertilizer experiments, Oreg., 145; Pa., 539.
- inheritance of unit characters, 540.
- spray calendar, N.J., 37.
- spraying directions, Ga., 146.
- spraying experiments, 238; Pa., 539.
- thinning experiments, Ohio, 341.
- time for transplanting, Mo., 142.
- variety tests, U.S.D.A., 144.

Peach-sizing machine, U.S.D.A., 836.

Peanut—

- cake, sugar content, 671.
- feed, analyses, Vt., 464.
- feed, unhulled, analyses, Ind., 69, 867.
- flour, nutritive value as wheat supplement, 763.
- meal, analyses, Ind., 867; N.J., 69.
- meal, fertilizing value, Ala.Col., 135.
- meal, nitrogen availability, Ala.Col., 135.
- oil, sampling, and examination, 805.
- rust, notes, 346.

Peanuts—

- breeding experiments, 637.
- culture and expression of oil, 240.
- culture experiments, Tex., 34.
- fertilizer experiments, N.C., 424.
- steam-cooked, digestibility, 564.
- variety tests, 637; Okla., 32.

Pear—

- blight, control, 550.
- borer in Japan, 456.
- bread, digestibility and food value, 64.
- diseases, control, Ill., 847.
- fire blight, notes, 656.
- orchard survey, Colo., 144.
- rust, immunity of a pear variety to, 753.
- scab, notes, 246.
- slug sawfly, parthenogenesis, 60.
- twig blight, control, 753.

Pears—

- abscission phenomena, 539.
- blossoming period, U.S.D.A., 437.
- breeding experiments, Md., 143.
- effects of handling on cold storage, 39.
- fertilizer experiments, Oreg., 145.
- keeping qualities, factors affecting, 238.
- notching experiments, 743.
- origin of, 438.
- ringing experiments, 742.
- spray calendar, N.J., 37.
- spraying experiments, N.Mex., 358.
- stocks for, value of different roots, 745.

Pears—Continued.

- use in bread making, 64.
- vitamin B in, 765.

Peas—

- analyses, 63.
- and oats. (*See* Oats and Peas.)
- as dry-farm crop, Ariz., 733.
- canned, heat resistant organisms in, Mich., 114.
- culture experiments, 829.
- culture on peat soil, 23.
- culture on reclaimed peat swamps, Oreg., 22.
- field, as green manure, 134.
- field, as hay and forage, 527.
- field, use of soil potassium by, 218.
- field, variety tests, 528; Ariz., 733; Minn., 823; Wash., 737.
- seeding experiments, 829; Wash., 738.
- staking, 339.
- variety tests, 231, 829; Can., 735; Tex., 36; U.S.D.A., 330.
- yields, 829.

Peat—

- bacterized, effect on plant growth, 514.
- bogs, effects of liming, 325.
- bogs, fertilizer experiments, 23.
- bogs, sand covering for, 23.
- fertilizing value, Minn., 815.
- industrial utilization, digest, 129.
- litter as affected by moisture in air, 323.
- litter for conservation of liquid manure, 423.
- nitrogen recovery from, 219.
- soils, agricultural value, Minn., 420, 814.
- soils, chemical composition, 22.
- soils, decomposition, determination of degree, 213.
- soils, fertilizer experiments, N.C., 424.
- soils, glacial drift as liming material for, 631.
- sphagnum-covered, nitrogen distribution, 19.
- studies, 725.
- swamps, reclamation, Oreg., 21.
- treated, fertilizing value, 23.
- use for soil improvement, 22. (*See also* Moor soils.)

Pecan—

- rosette in relation to soil deficiencies, 48.
- wood rot, 48.

Pecans—

- budding and grafting, 746.
- culture experiments, Md., 143.
- grades and standards, 41.
- patch-budding, method, Tex., 240.
- preparing for market, 441.
- time for transplanting, Mo., 142.
- varieties, classification, 41, 441.

Pectin content of jelly, 616.

Pectinophora gossypiella. (*See* Cotton boll-worm, pink.)

Pediculoides ventricosus, notes, 252.

- Pediculus. (See Lice.)
Pegomyia brassicae. (See Cabbage-maggot.)
 Pellagra—
 among war prisoners in Egypt, 863, 864.
 studies, 263, 264, 461, 667, 863.
 types and treatment, 862.
Pellicularia koleroga, notes, 152.
Pempheres affinis, notes, 450.
Penicillium—
 glaucum, formation of fruiting bodies, 226.
 glaucum, notes, 155.
 spp., on moldy grain, 445.
 Pennsylvania—
 College, notes, 100, 200, 498, 599, 700, 900.
 Institute of Animal Nutrition, notes, 498.
 Station, notes, 100, 200, 599, 700, 900.
 Station, report, 598.
 Peonies, new, descriptive list, 240.
 Pepper—
 Chile, wilt disease, N.Mex., 347.
 die-back, notes, 444.
 disease, notes, 45; Ariz., 749.
 Pepsin activation as affected by H-ion concentration, 611.
 Peptone, preparation, 502.
Peridermium—
 pini, control, 755.
 pini, transmission, 449.
 strobi, notes, 552.
 (See also White pine blister rust.)
Peridermiums, sexual cell fusions, Pa., 544.
Peridroma sp., notes, U.S.D.A., 352.
Perilampus batavus n. sp., description, 259.
Perisopterus zebra, notes, 252.
Perkinsiella—
 saccharicida, notes, 450.
 saccharicida, parasites of, 661.
 vitiensis, notes, 52.
 Permeability—
 alterations at freezing temperature, 226.
 cell, relation to immunity production, 382.
 in plant cells, 821.
 studies, 225.
Peronospora—
 calotheca, specialization in, 653.
 n. spp., notes, 653.
 schleideni, notes, 243.
 spp., descriptions, 248.
 spp., viability in seed, 550.
Perrisia affinis, on violets, 661.
 Persimmons, time for transplanting, Mo., 142.
 Petroleum products, substitution of gas for, 86.
 Petunia—
 disease, new, 544.
 fungus disease, studies, 447.
 hybrids, studies, 222.
Phanodiscus aeneus, notes, 252.
Phakopsora zizyphi vulgaris, notes, 152.
Phassus (?) *damoor*, notes, 450.
- Phenol—
 determination, 614.
 disinfecting power, 79.
 Phenological—
 effect of the sea on plants, 523.
 observations in British Islands, 17.
 Phenolsulfonphthalein salts, effect of phosphates on color, 313.
Phlegethontius—
 quinque-maculatus. (See Tobacco worm.)
 sexta. (See Tomato-worm.)
 Phloroglucin test for formaldehyde, degree of alkalinity necessary, 804.
Pholus achemon, studies, 453.
Phoma—
 lingam, notes, 46, 654.
 omnivora, notes, 243.
 sp. on coffee, 247.
 sp. on Cupressus, control, 156.
Phomopsis citri, notes, 550.
Phormidium foveolarum, effect of colored lights on, 526.
Phorocera claripennis, parasitism by, 759.
 Phosphate—
 of lime. (See Calcium phosphate.)
 requirement of soils, relation to phosphoric acid in oats, 519.
 rock, availability as affected by leaching, 427.
 rock, effect on nitrate production, Ill., 214.
 rock, fertilizing value, 817.
 (See also Phosphates, comparison.)
 rock smelting, 629.
 Phosphates—
 acid and native, relative availability in presence of lime, 26.
 availability, factors affecting, 629.
 comparison, 26, 629, 816; Ga., 136; La., 630; Md., 122; Minn., 815; Mo., 721; Ohio, 324.
 effect on action of α -crotonic acid, 131.
 effect on colorimetric values, of pH, 313.
 effect on maturity of cotton, Ga., 137.
 effect on nitrification in soils, Tex., 725.
 insoluble, effects of composting on availability, Ga., 127.
 solubility as affected by lime, 629.
 soluble, manufacture and function, 424.
 (See also Superphosphate.)
 Phosphatic—
 fertilizers, composition and action, 26.
 slag, analyses, 127.
 slag, fertilizing value. (See also Phosphates, comparison.)
 slag for pasture improvement, 519.
 slag, increasing supplies, 519.
 slag v. superphosphate, Ohio, 324.
 Phos-pho-germs, fertilizing value, 27.
 Phospho-organic reserves in green plants, 525.
 Phosphoric acid—
 content of oats as affected by fertilizers, 322.

- Phosphoric acid—Continued.
 determination, 115, 804.
 fertilizing value, 26.
 production from phosphate rock, 629.
 reverted, fertilizing value, 428.
 use in Bavaria, 629.
- Phosphorus—
 content of marsh soils, 22.
 determination in organic solutions, 204.
 in butter, N.Y.Cornell, 469.
 in apple trees, N.H., 28.
 income and outgo on dairy farms, 23.
 organic, of soil, 813.
- Photometer, tint, use with raw sugars, 714.
- Photosynthesis—
 development of conceptions, 227.
 temperature-coefficient, 132.
- Phototropic stimulation, transmission, 132.
- Phototropism—
 relation to swarming of bees, 851.
 theory of, 132.
- Phragmites communis* as emergency feed, 170.
- Phthorimæa heliopa* on tobacco, 52.
- Phycomyces nitens*, sexuality of, 524.
- Phyllactinia corylea* on oak, 754.
- Phylloglossum drummondii*, new method of reproduction, 130.
- Phyllosticta* sp. on snapdragon, 658.
- Phyllostreta utana* n. sp., notes, 854.
- Phymatotrichum omnivorum*, notes, 652.
- Physiology, chemical, treatise, 365.
- Physoderma zæe maydis*—
 notes, 243.
 zoospores, destruction by natural enemies, 750.
- Phytopathology, practical applications of, 44.
- Phytophthora*—
cryptogea n. sp., description, 447.
faberi, on coconut, 156.
infestans. (See Potato late blight.)
 sp. on coconut, 151.
 sp. on poppy, 49.
 spp., notes, 445, 658.
- Picric acid for rock and soil blasting, 480.
- Pickering sprays, preparation and adhesive properties, U.S.D.A., 843.
- Picnometer, description, 806.
- Pig—
 clubs in Indiana, 195.
 houses, concrete, construction, 90.
- Pigeons—
 behavior, 67.
 effect of deficient diet on organs, 369, 664.
 polyneuritic, as affected by thyroid gland extract, 865.
 production of eye color in, 866.
 wild, inheritance in, 67.
- Pigmentation, relation of flavonol and anthocyanin pigments, 632.
 (See also Anthocyanin, and Color inheritance.)
- Pigs—
 algaroba meal for, 70.
 and corn, price relations, U.S.D.A., 694.
- Pigs—Continued.
 as affected by beet molasses, 180.
 barley for fattening, 774, 870; Okla., 701.
 birth weight, Ill., 571.
 bone glue for, 173.
 broom corn seed for, 671.
 cassava meal v. sweet potatoes for, 71.
 city bred, profits, 695.
 color inheritance, Iowa, 71.
 dipping plants, U.S.D.A., 688.
 Duroc-Jersey, history, 71.
 elevator screenings for, Can., 868.
 feed, cooperative buying, 673.
 feeding experiments, 71, 573, 774; Ariz., 772; Can., 773; Ky., 373; Mo., 772; N.C., 465; Nebr., 673; Okla., 70; Pa., 572; U.S.D.A., 465.
 feeding with barley variously prepared, Okla., 70.
 garbage for, Ky., 374; Okla., 70.
 growth estimation, 371.
 hogging-down corn, U.S.D.A., 466.
 hogging-down corn and soy beans, Ky., 374.
 housing, 485.
 intestinal worms in, 384.
 individual variation in economy of gain, 572.
 judging, treatise, 697.
 of southern Albania, physical characteristics, 173.
 pasturing experiments, 773; La., 673; N.C., 465; U.S.D.A., 376, 466.
 raising, Wash., 798.
 raising, crop rotations for, Ohio, 333.
 raising in Brazil, 72.
 raising in China, 171, 673.
 raising in Kansas, treatise, 72.
 self-feeder experiments, 71.
 self-feeders for, design, 485.
 soy bean meal for, Ohio, 377.
 sweet potatoes v. cassava meal for, 71.
 Tornillo and Pinto beans for, N.Mex., 377.
 vetch seed for, 373.
 wallow for, plans, U.S.D.A., 688.
 worm infested, value of medicinal mixtures, 467.
 young, immunizing, 683.
 (See also Sows and Swine.)
- Piles, sheet, wood, solid v. laminated, 590.
- Pimento fungus disease, 151.
- Pine—
 as source of fiber and pulp, 828.
 bacterial tumors, studies, 552.
 blister rust. (See White pine blister rust.)
 borer, ribbed, studies, N.Y.Cornell, 855.
 jack, studies, U.S.D.A., 443.
 maritime, disease of, 755.
 plantation, fertilizer experiments, 24.
 resin, usufruct of, 241.
 rust, control, 755.
 rust, transmission, 449.
 Scots, growth as affected by locality, 748.

Pine—Continued.

- shoot moth, European, parasites of, 259.
- sugar, analysis, 506.
- western yellow, windfall loss, 841.
- yellow, analysis, 506.
- (See also White pine.)

Pineapples, as affected by ultraviolet rays, 731.

Pink bollworm. (See Cotton bollworm, pink.)

Pionca forficatis, parasite of, 858.

Pipes, gas, cement joints for, 482.

Piricularia oryzae, notes, 444.

Pirocyonia danieli, stability and heredity, 818.

Piroplasma—

- (*Babesia caballi*, notes, 83.
- spp., affecting bovines, 883.
- spp., notes, 77, 82.

Piroplasmosis—

- bovine. (See Texas fever.)
- canine, transmission in France, 83.
- canine, transmission in Tunis, 84.
- of the horse, 83.

Piroplasms, classification, 883.

Pissodes strobi, notes, Conn.State, 251.

Pistache collar disease, control, 243.

Pits, construction for manure conservation, 423.

Pituitary—

- body, changes in deficiency disease, 664.
- feeding of white rats, effects, 67.
- gland and thyroid, correlation, 770.

Plasius javanus, notes, 52.

Plane—

- tree disease as affected by dry weather, 652.
- trees, parasites of, 754.

Plant—

- analyses and fertilizer requirements of soil, 518.
- assimilation, theory of, 526.
- breeding in Ontario, 235.
- breeding, methods, 535.
- (See also Heredity and Hybridization.)
- breeding experiments. (See Apples, Corn, Cotton, Tomatoes, Wheat, etc.)
- cancers, studies, 242.
- cells, abnormalities, 732.
- cells, concentrations of electrolytes in, 633.
- cells, lipoids in, 524.
- (See also Cells.)
- chromosomes. (See Chromosomes.)
- colloids, studies, 524.
- disease—
 - inspection in Jamaica, 48.
 - survey, notes, Okla., 44.
- diseases—
 - and pests, 750.
 - control, 842.
 - development in dry weather, 652.
 - dissemination by insects, 842.
 - effect of soil and fertilization, 513.

Plant—Continued.

diseases—continued.

- in Dutch East Indies, 45.
 - in England and Wales, 45, 652.
 - in Indiana, 243.
 - in Italy, 346.
 - in Porto Rico, 544.
 - new, 544.
 - notes, N.Y.State, 544.
 - perpetuation, 242.
 - relation to soil reaction, 513.
 - rôle of bacteria in, 444.
 - transmission by insects, 450.
 - (See also Fungi and different host plants.)
 - distribution in undrained depressions near Sacramento, 224.
 - ecology of Kansas sand hills, 731.
 - formations at different altitudes, 149.
 - growth—
 - apparatus for measuring, 32.
 - as affected by bacterized peat, 514.
 - as affected by carbon dioxide, 321.
 - as affected by light, 431.
 - as affected by meteorological phenomena, 207.
 - as affected by thyroid constituents, 225.
 - compound-interest law, 29.
 - effect of aeration on roots, 327.
 - function of sunshine in, U.S.D.A., 509.
 - infertile soil, 422.
 - relation to carbon dioxide, 510.
 - relation to climatic control, 431.
 - relation to soil reaction, 513.
 - studies, 428, 431.
 - (See also Plants.)
 - growth-promoting substances in composts, 815.
 - hybridization experiments, 535.
 - hygiene, illustrative material, 635.
 - inspection. (See Nursery inspection.)
 - lice, jumping, of Palæotropics, 450.
 - life zones, rôle of sedges in, 129.
 - metabolism, carbon-nitrogen ration, 430.
 - parts, orientation, studies, 730.
 - pathogen and host, differential staining, 444.
 - pigmentation. (See Pigmentation.)
 - production, course of study, 797.
 - societies of Petoskey-Walloon Lake region, 523.
 - tissues, semipermeability in, 225.
 - tissues, vitamin A extraction from, 165.
- Plants—
- animals injurious to, 152.
 - as affected by centrifugal force, 327.
 - as affected by fluorin, 523.
 - as affected by gases, 523.
 - as affected by organic substances, 822.
 - as affected by winter of 1916-17, 326.
 - as food substitutes in Germany, 204.
 - as wild-duck food in Nebraska, U.S. D.A., 50.
 - barium in, Ky., 327.

Plants—Continued.

- behavior of organic substances in, 632.
 chlorophyll in, fate in autumn, 526.
 classification by cell nuclei, 524.
 daily periodicity in, 820.
 distribution as affected by solar radiation, 731.
 drug, culture in Argentina, 746.
 drug, culture in France, 746.
 dune, ash of, 431.
 dye, culture in Nigeria, 637.
 effect of concentration of nutritive media, 523.
 effect of phosphates on α -crotonic acid action, 131.
 fat production in, 430.
 fermentation of nectar, 730.
 fertility problems, 521.
 fiber. (*See* Fiber.)
 flowering and fruiting as affected by length of day, 819.
 flowering, dictionary of, 148.
 for feeding stuffs in Germany, 170.
 for Nebraska, list, 240.
 freezing-point lowering, studies, 515.
 frozen, as affected by manner of thawing, 432.
 green, nitrogen fixation by, 430.
 green, phospho-organic salts in, 525.
 hardening, nature of, 643.
 heat production, 819.
 honey, American, 259.
 importation, rules and regulations, U.S. D.A., 741.
 imported for trial, U.S.D.A., 635.
 inheritance of susceptibility to parasites, 841.
 iodine determination, 204.
 iodine in, 632.
 ionization of air by, 225.
 maritime, water economy of, 223.
 medicinal. (*See* Drug plants.)
 mycelage in, origin, 132.
 new forms due to half and mass mutations, 222.
 nitrophile, around manure heaps, 430.
 oil seed, culture in Germany, 638.
 ornamental, culture experiments, Can., 741.
 ornamental, for Missouri, 838.
 ornamental, variety tests, Can., 741.
 oxalates in, 327, 730.
 perennial, for hardy border, 441.
 perennial, for Missouri, 838.
 perennial, old age in, 634.
 permeability. (*See* Permeability.)
 phenological effect of bodies of water, 523.
 photosynthesis. (*See* Photosynthesis.)
 phylogenetic studies, 818.
 phytochemical investigations, 820.
 poisonous, 470, 471.
 poisonous, U.S.D.A., 470, 471.
 poisonous, of Canada, Can., 380.
 poisonous, of United States and Canada, 649.

Plants—Continued.

- poisonous, of Utah and Nevada, U.S. D.A., 77.
 (*See also* Forage poisoning, and specific plants.)
 pollination. (*See* Pollination.)
 prairie, subterranean anatomy, 130.
 regeneration, quantitative laws in, 821.
 resistance to cold, 226.
 resistance to disinfectants, 822.
 respiration. (*See* Respiration.)
 response to wireless stimulation, 526.
 root cork in, ecological significance, 732.
 succession and distribution in Africa, 326.
 tendril tips, regeneration of, 525.
 toxic effect on one another, 29, 327.
 transpiration. (*See* Transpiration.)
 transplanting, fall *v.* spring, Mo., 141.
 twining, contact sensitivity, 525.
 variation. (*See* Variation.)
 variegated, non-Mendelian inheritance in, 433.
 variegation in, 433.
 vegetative points, studies, 130.
 water as affected by light, 431.
 wild, uses, treatise, 649.
 woody. (*See* Woody plants.)
Plasmodiophora brassicæ. (*See* Cabbage clubroot.)
Plasmodium—
 falci-parum, infection of *Anopheles ludlowi* with, 854.
 vivax, infection of *Anopheles* with, 55.
Plasmodium ricicola spores as affected by cuprammonium washes, N.H., 44.
 Plat experiments—
 heterogeneity as factor affecting yields, 526.
 probable error in, 527.
Platypena scabra—
 notes, N.C., 450.
 on beans, Conn.State, 251.
 studies, 759.
Platygyaster spp., notes, 259.
Platynata sp., notes, 851.
Platyus compositus on sweet potatoes, 163.
Pleospora graminea, notes, 45.
Plestiothrips perplexus on corn, Conn.State, 252.
 Pleuropneumonia—
 bovine, diagnosis, 786.
 contagious bovine, control, 584.
 contagious, eradication, U.S.D.A., 471.
 (*See also* Pneumonia.)
Pleurotropis utahensis, parasitism by, U.S. D.A., 260.
 Plowing, tractor. (*See* Tractor plowing.)
 Plows—
 motor, in France, 289.
 tractor, light, design, 288.
 Plum—
 brown rot, notes, 45, 349.
 diseases, control, Ill., 847.
 hog, durability tests of wood, 44.
 rust, notes, 45.

Plums—

- blossoming period, U.S.D.A., 437.
- breeding experiments, 742.
- culture, Nebr., 644.
- hardy varieties, Minn., 833.
- in England, histories, 744.
- orchard survey, Colo., 144.
- pollination experiments, 541.
- spray calendar, N.J., 37.
- thinning experiments, Ohio, 341.
- variety tests, Minn., 833; U.S.D.A., 144.
- winter injury, U.S.D.A., 435.

Pneumococci, H-ion concentration of, 383.

Pneumococcus vaccine, preparation, 76.

Pneumonia—

in lambs, studies, Wyo., 179.

verminous, in sheep, 384.

(See also Pleuropneumonia.)

Podosphera leucotricha, notes, 246, U.S. D.A., 549.

Poison baits for grasshoppers, 353.

Poisonous plants. (See Forage poisoning, Plants, poisonous, and specific plants.)

Polistes macensis, notes, 52.

Pollen—

behavior of, studies, 328.

development in Cinnamomum, 328.

nutritive layer of, 525.

types, phylogenetic significance, 328.

Pollination studies, 237.

(See also specific plants.)

Polycotyledony, evolutionary status of, 133.

Polynuritis of pigeons, new term for, 861.

(See also Vitamin B.)

Polyporus—

pargamenus, biology of, 552.

sp. on red gum, 243.

Polysaccharids, new fungus destroying, 523.

Polyzime, starch liquefying power, 503.

Pomegranate juice, manufacture, Calif., 717.

Popillia—

japonica, life history and control, 558.

japonica, notes, 362.

Poplar—

bacterial canker, treatment, 552.

disease, Ariz., 749.

disease, parasitic, 449.

Poppies—

culture, 638.

oriental, test of stock, 240.

Poppy—

Iceland, disease, control, 49.

seed cake as cattle food, 777.

Population, relation to agricultural production, 693.

Poria hypolateritia. (See *Fomes pseudo-ferreus*.)

Pork—

cost and price indexes, Mo., 792.

cost of production, 773.

curing, shrinkage as affected by feed, N.C., 465.

production as affected by pastures, 773.

(See also Pigs.)

soft, studies, Fla., 775.

Porosagrotis orthogonia, notes, Mont., 753.

Portheria dispar. (See Gipsy moth.)

Porto Rico Federal Station, notes, 100, 600.

Potash—

American sources, 519.

content of oats as affected by fertilizers, 322.

deposits of Eritrea, 428.

deposits of Spain, 728.

determination, 115.

exploration in New Jersey greensands, 817.

fertilizers in England, 26.

fertilizing value, Tex., 33.

from feldspar, processes for separation, 519.

from greensand as affected by manure-sulphur composts, 517.

from kelp, 630.

from wood ashes, 324.

German v. American, Ind., 325.

in Texas lakes, 127.

methods of separation from Chilean nitrate, 25.

production and use in 1918, 26.

production in United States during the war, 728.

resources of Italy, 728.

soil, factors affecting availability, Md., 121.

Trona, fertilizing value, S.C., 126.

Potassium—

ammonium nitrate, action and use, 125.

ammonium nitrate, fertilizing value, 221.

carbonate, fertilizing value, 23.

chlorate as standardizing substance, 12.

chlorid, effect on composition of soil extracts, Mich., 124.

chlorid, fertilizing value, Wis., 336.

content of marsh soils, 22.

potassium cyanid, use against subsoil nematodes, 47.

cyanid, use for fumigation of oranges, 54.

determination, 112, 803.

iodid for invert sugar determination, 314.

magnesium sulphate, fertilizing value, 126.

nitrate, preparation, 126.

nitrate, production in Chile, 25.

permanganate, use in nitrogen determination, 116.

salts, control of importation, 26.

salts, effect on soil structure, 516.

salts, fertilizing value, 630.

salts, refined, production in United States, 26.

soil, as affected by sulfonation, 517.

soil, liberation, 127.

soil, utilization by intermediary crops, 218.

sulphate, fertilizing value, 126; Tex., 37; Wis., 336.

thiocyanate for invert sugar determination, 314.

Potato—

- beetle, Colorado, in South Dakota, 850.
- black rot, notes, 243.
- black scurf, notes, 150.
- blackleg, notes, 150, 245.
- blackleg, viability of organism, 654.
- blight, early, notes, 152.
- blight, late, comparison with tomato late blight, 447.
- blight, late, notes, 44, 151, 152.
- blight, late, remedies, 243.
- blight, late, studies, 547.
- blight on tomato, 154.
- blights, notes, 150.
- brown ring, notes, 243.
- diseases, notes, 45, 652.
- diseases in British Isles, 245.
- flea beetle in South Dakota, 850.
- Fusarium wilt, studies, 447; Ind., 345.
- hopper burn, control, 655.
- insects, control, 851.
- leaf roll, effect on tubers, 546.
- leaf roll, studies, 154.
- leafhoppers, studies, 355, 356, 655.
- mosaic disease, transmission, 546.
- Rhizoctonia, control, 547.
- Rhizoctonia, notes, 47, 243, 652.
- Rhizoctonia, studies, Wash., 749.
- rust, notes, 346.
- scab, notes, 243, 652.
- scab, control, 532, 547, 751.
- scab organism, nomenclature, 655.
- scab, resistant varieties, Vt., 153.
- shipments for 1919, U.S.D.A., 595.
- starch manufacture, processes, 808.
- starch, raw, digestibility, 365.
- tipburn, studies, 356; Ind., 345; Vt., 154.
- tops, poisoning of cows, 180.
- tuber worm on tobacco, 52.
- tubers, rate of desiccation, 845.
- tubers, spindling sprout disease, Md., 154.
- wart disease, certification of immune varieties, 47.
- wart disease, in England, control, 348.
- wart disease, notes, 45, 245.
- wart disease, resistant varieties, 245.
- wet rot, notes, 243.
- wilt diseases, 547.

Potatoes—

- American Giant, situation in New York, 531.
- aphids affecting, control, Va.Truck, 451. as affected by potassium salts, 630.
- as affected by sodium chlorid, 630.
- as dry-farm crop, Ariz., 733.
- changes after frost kills vines, Md., 139.
- cost of production in New Jersey, 532.
- cross-fertilization, technique, 829.
- culture experiments, 234; Minn., 637, 823, 824; Mo., 740; N.Mex., 332.
- culture, handbook, 829.
- culture, losses from poor seed, 531.
- culture on peat soil, 23.
- degeneration in, Mont., 46.

Potatoes—Continued.

- degeneration, relation to depth of eyes, 531.
- dried, fat determination in, 414.
- effect of Bordeaux mixture on plants, 547.
- effect of cold storage on seed value, Md., 138.
- effect of new location, Minn., 636.
- effect of reduced oxygen on keeping quality, N.H., 34.
- effect of soil electrification, Ky., 824.
- fertilizer experiments, 126, 231, 234, 532; Can., 727; Minn., 627, 824.
- grades, U.S.D.A., 335.
- grading and inspection, N.C., 490.
- hill selection experiments, 527.
- insects affecting, 532, 652.
- iodin content, 204, 632.
- irrigation experiments, N.Mex., 332; Utah, 230.
- late, culture, Mo., 740.
- manuring experiments, 24; Minn., 627, 815; Utah, 218.
- nematodes affecting, 243, 350.
- osmotic pressure in, 131.
- planting dates, U.S.D.A., 435.
- planting, digging, and sorting machines, 188.
- planting distances, Idaho, 740.
- protection in Quebec, 844.
- raw and dried, vitamin C in, 765.
- rotation experiments, U.S.D.A., 435.
- rumors of dumping, U.S.D.A., 794.
- seed, as affected by sprout production, Md., 138.
- seed certification, 531.
- seed inspection, 531.
- seed, irrigated *v.* dry-land, Idaho, 739.
- seed, planting date, Ohio, 740.
- seed, preparation, Mich., 639.
- seed production in Maine, 532.
- seed selection, Wash., 798.
- seed stocks, comparison, Ind., 339.
- seed, treated *v.* untreated, Minn., 637.
- seed treatment, 547, 732; Mich., 698.
- seed, whole *v.* cut, Idaho, 739.
- solanin-containing, poisoning, 866.
- spraying, notes, 833.
- spraying experiments, 356, 447; N.C., 450; U.S.D.A., 843; Va.Truck, 451.
- sprouting and greening, prevention, 436.
- sprout production, relation to seed value, Md., 138.
- storage experiments, 436, 830.
- storage houses, 829.
- storage methods, Ariz., 734.
- thinning experiments, 531.
- variety tests, 232, 234; Ariz., 734; La., 636; Minn., 636, 823; N.Mex., 332; Nev., 229; Tex., 34; U.S.D.A., 330, 435; Wyo., 135.
- vitamin A in, 165.
- wound cork formation in relation to seed piece decay, 732.

Potatoes—Continued.

yield as affected by late blight, 44.
yields, Ariz., 734.

Poultry—

Black Orpington, utility of type, 873.
botulinus poisoning, 84.
breeders, classified list, Mont., 575.
breeding contest, N.J., 468.
breeding contest at Vineland, N.J., 173.
breeding experiments, Mich., 674.
breeding, pedigree, 675.
breeds, comparison, Can., 776; Minn., 871; N.J., 173.
broodiness, effect and control, N.J., 575.
broom corn seed for, 671.
capons v. cockerels, growth and feeding records, Md., 574.
culling, Wash., 496.
culling equipment, Wash., 675.
diseases. (*See specific diseases.*)
exports from South Africa, 676.
farm, initial capital required, 94.
feeding, Wash., 798.
feeding experiments, Can., 776; N.Mex., 378.
feeding for egg production, 174.
feeds, analyses, Ind., 69, 867; Ky., 373; N.J., 69, 672; R.I., 672.
feeds, Mexican insects in, 53.
feeds, palatability, Nebr., 675.
feeds, protein sources, Okla., 73.
feeds, potential acidity or alkalinity, 573.
finishing, method of teaching, 898.
frozen fish for, Minn., 674.
grading experiment, N.C., 467.
house equipment, Wash., 392.
houses, colony, care, N.J., 174.
houses, concrete, construction, 90.
houses, multiple unit laying, N.J., 893.
houses, plans, 676; Ind., 892; Mo., 790.
houses, standard, N.J., 188.
industry of Orkney Islands, 174.
inheritance of egg characters, N.Y. Cornell, 872.
lice in Colorado, 660.
maturity, factors affecting, Nebr., 675.
parasites, control, N.J., 787.
parasites, transmission, 378.
raising, U.S.D.A., 468.
raising in Canada, manual, 676.
raising in Maine, 676.
raising, treatise, 174, 494.
range, care, N.J., 174.
selection experiments, Nebr., 675.
sunflower silage for, Minn., 674.
vermifuges for, Okla., 79.
yards, soil contamination, 378.
(*See also Chickens, Ducks, Fowls, Hens, Turkeys, etc.*)

Power—

on the farm, 591.
transmission belts, 285, 790.

Prairie—

plants, subterranean anatomy, 130.
rice, culture, U.S.D.A., 139.

Precipitation—

in California, 618.
mackerel sky as prognostic, U.S.D.A., 511.

(*See also Rainfall, Snowfall, etc.*)

Prickly pear. (*See Cactus.*)

Primroses, evening, insects affecting, 556.

Primulas, hardy and semihardy, list, 240.

Prodenia—

eridania, notes, 557.

litura, notes, 52.

Proflavin, antiseptic value, 79.

Promocotileca reichii on coconut, 52, 851.

Proprietary preparations, therapeutic, 470.

Prorhinotermes, notes, 256.

Prosyleus phytolymus, notes, 563.

Protalbinic acid, gold number determinations, 12.

Protein—

animal v. vegetable for egg production, 270.

color reaction, 504.

content of blood as affected by muscular work, 285.

determination in urine, 416.

metabolism as affected by high altitudes, 565.

source and amount for hens, Ky., 871.

source in poultry feeds, Okla., 73.

Proteins—

absorption, studies, 65.

digestion as affected by concentration of enzym, 611.

hydrolysis, 110, 111.

method of analysis, 504.

of Georgia velvet beans, 410.

of green leaves, 409.

production and consumption in United States, 61.

removal in blood analysis, 205.

vegetable, studies, 10, 409.

(*See also specific proteins.*)

Protoparce cingulata, notes, 252.

Protoplasm—

components and colloidal behavior, 429.
growth curves, 525.

growth mechanism, 429.

structure, 132.

Protozoa of New Jersey soils, 217.

Protozoology, textbook, 659.

Protrama, new genus erection, U.S.D.A., 758.

Prune—

brown rot, notes, 656.

orchard survey, Colo., 144.

orchards, fertilizer experiments, Wash., 744.

scale, notes, 252.

Prun —

crop failures, causes, Wash., 745.

culture, Wash., 744.

fertilizer experiments, Wash., 744.

stocks for, value of different roots, 745.

vitamin B in, 765.

- Pruning—
and economy of water, 235.
effect on grapefruit, 439.
effect on lemons, 239.
- Pseudococcus*—
bromeliæ, notes, 52.
citri. (See Citrus mealy bug.)
nipæ, notes, 851.
spp., control, 660.
- Pseudogonatopus sogatea* n. sp., description, 857.
- "Pseudo-index for iodine," use of term, 315.
- Pseudomonas*—
campestris on cabbage seedlings, 751.
citri. (See Citrus canker.)
juglandis, control, 350.
phaseoli, notes, 652.
polysaccharidarum n. sp., studies, 524.
radicicola. (See *Bacillus radicicola*.)
- Psocids, control, U.S.D.A., 53.
- Psylla*—
isitis, notes, 451.
mali, occurrence in Nova Scotia, 850.
- Psyllids, new genera and species, keys, 450.
- Puccinia*—
antirrhini, notes, 841.
asparagi. (See Asparagus rust.)
coronata, biologic forms, 653.
glumarum, notes, 45.
graminis, notes, 45, 347.
graminis, studies, Iowa, 653.
graminis tritici, notes, 546.
malvacearum and mycoplasma theory, 444.
phakopsoroides n. sp., description, 244.
spp. and *Uredo* sp. comparison, 244.
spp., morphological study, 844.
spp. notes, 346.
spp., temperature of spore germination, N.H., 842.
subnitens and æcial hosts, 444.
- Pullets—
care in summer, N.J., 174.
egg production and broodiness, N.J., 173.
(See also Hens.)
- Pulmonary disease, relation to *Ascaris*, 80.
- Pulpwood—
American, 650.
fungi attacking, 651.
(See also Wood pulp and Paper-making materials.)
- Pulse, as affected by high altitudes, 565.
- Purdue University and Station, notes, 198, 398, 799.
- Pycnidia, origin and development, 226.
- Pyotherapy, review of literature, 580.
- Pyrausta*—
ainsliei, studies, Conn.State, 251.
caffrei, n. sp., description, 661.
nubilalis, notes, Mo., 759.
nubilalis on broom corn, 161.
nubilalis, parasites of, 858.
spp., distinguishing characters, 661.
- Pyrheliometer, Callendar, notes, U.S.D.A., 719.
- Pyridin sulphate, cause of caking in ammonium sulphate, 25.
- Pythium*—
butleri n. sp., notes, 445.
gracile, notes, 652.
palmivorum, notes, 445.
- Quarantine—
orders, horticultural, of California, 741.
work with green Japanese beetle, 362.
- Quayle* (n. g.) *aliena*, notes, 662.
- Quebracho logs, exports from Argentina, 95.
- Quince diseases, control, 544; Ill., 847.
- Quinces—
spray calendar, N.J., 37.
variety tests, Md., 143.
- Rabbit—
diseases, 887.
meat, digestibility, U.S.D.A., 365.
meat, recipes, U.S.D.A., 365, 378.
- Rabbits—
as affected by vitamin deficiency, 369.
care and management, 873.
exhibition standards, 575.
feeding experiments, Wash., 676.
protection of fruit trees from, Ohio, 340.
raising, U.S.D.A., 378.
raising for skins, Can., 873.
treatise, 174.
- Rabies virus—
effect of ether on, 81.
preservation, methods, 583.
- Radiation—
nocturnal, intensity at high altitudes, 718.
solar, in relation to plant distribution, 731.
solar, measurements, U.S.D.A., 719.
solar, observations, U.S.D.A., 117.
solar, variation in, effect on weather, 809.
solar, world observatories for, U.S.D.A., 719.
- Radishes—
carbon-nitrogen ratio for, 430.
culture, 638.
root development, 834.
variety tests, Tex., 36.
- Rain—
absorption, factors affecting, Mo., 721.
effect on boll weevil poisoning, 162.
effect on sprays, 657.
fertilizing value, Can., 728.
- Rainfall—
as affected by large reservoir, U.S.D.A., 119.
as affected by lunar periods, 417.
data for determining road conditions, U.S.D.A., 117.
effect on critical periods of plant growth, 207.
effect on nitrate loss by drainage, 19.
effect on wheat yield in Australia, 208.
of Australia, 208, 319.
of California, 209.
of South America, forecasting, 418.
of South Dakota, 619.

- Rainfall—Continued.
 of Sweden, 231.
 of Tunis, seasonal distribution, 18.
 of Utah, Utah, 230.
 of world, 810.
 papers on, U.S.D.A., 718.
 relation to grazing rate, U.S.D.A., 717.
 (See also Precipitation.)
- Raisin grapes, drying, factors affecting, Calif., 715.
- Raisins, stemming, seeding, and packing, Calif, 716.
- Ramie, analyses, 617.
- Ramularia ærea*, notes, 544.
- Range plants, poisonous to live stock, Nev., 273.
 (See also Forage poisoning, Plants, poisonous, and specific plants.)
- Ranges of Great Plains, carrying capacity, 522.
- Rape—
 as forage crop, 527.
 culture, 638.
 straw, digestibility, 569.
 use of soil potassium by, 218.
 winter, treatise, 234.
- Rapeseed oil production, 234.
- Raspberries—
 American, origin, 439.
 breeding experiments, 536, 742.
 culture and marketing, 40.
 effect of temperature on wounding, U.S.D.A., 39.
 new varieties, 438.
- Raspberry diseases, control, Ill., 847.
- Rats—
 as enemies of man, 250.
 entozoa of, 457.
 exhibition standards, 575.
 protozoal parasites of, 883.
 white, effect of feeding pituitary glands, 67.
 (See also Rodents.)
- Razoumofskya* spp., biology and significance, 821.
- Reclamation—
 and irrigation in Argentina, 477.
 projects, U.S.D.A., 435.
- Reconstruction in Belgium, 292.
- Red dog flour. (See Flour, red dog.)
- Red spider mite—
 as affected by freeze of 1917, 555.
 on avocado, 851.
 on avocado, control, 53, 255.
 on cotton, U.S.D.A., 352.
- Redtop, culture experiments, Wash., 436.
- Reductase test for milk, 271.
- Redwood, analysis, 506.
- Refrigeration in transportation of perishable products, 339.
- Refrigerator—
 car, standard, description, 90.
 iceless, as inoculation chamber, 444.
- Reindeer—
 domestication, 172.
 moss, digestion coefficients, 266.
 nomadism, notes, 172.
- Remedies, new and nonofficial, 470.
- Research, agricultural. (See Agricultural research.)
- Reservoirs, algal growths in, treatment, 479.
- Resin, formation and flow, factors affecting, 241.
- Resins—
 dark-colored, determination of saponification number, 15.
 iron content, 202.
 substitutes in Germany, 204.
- Respiration—
 and antagonism, studies, 820.
 as affected by high altitudes, 565.
 chamber at New Haven Hospital, 370.
 chamber for large animals, 266.
 chambers, description, 166.
 in plants as source of heat, 819.
 in plants, measuring, 431.
 in plants, studies, 820.
- Restaurant economics in England, 663.
- Reticulitermes, new species and variety, 256.
- Rhabdocnemis obscura* on sugar cane, 52.
- Rhagium lineatum*, notes, N.Y.Cornell, 855.
- Rhagoletis pomonella*. (See Apple maggot.)
- Rhinoceros beetle injurious to coconut palm, 57.
- Rhipicephalus*—
appendiculatus, life history, 582.
bursa, notes, 83.
sanguineus, notes, 83, 84.
- Rhizoctonia, studies, Wash., 749.
- Rhizoctonia*—
solani, notes, 444.
solani on tobacco, 246.
solani on tomato, 154.
 sp. on greenhouse lettuce, Ky., 845.
 spp., notes, 652.
violacea, notes, 347.
violacea on alfalfa, 244.
- Rhizopertha dominica*, notes, 253, 254.
- Rhode Island—
 college, notes, 600, 700.
 Station, notes, 400, 700.
- Rhodes grass, culture experiments and variety tests, U.S.D.A., 134.
- Rhodnius brethesi*, n. sp., life history studies, 57.
- Rhododendron, new species, 838.
- Rhopæa* spp. on sugar cane, 52.
- Rhopalosiphoninus*, new genus, erection, U.S.D.A., 758.
- Rhopalosiphum violæ* and allied form, 54.
- Rhubarb—
 analyses, 63.
 root rot, notes, 243.
 varieties, variation in, Pa., 537.
- Rhynchophora on sweet potatoes, 163.
- Rhyphus punctatus*, chemotropic response, 554.
- Rhysella, new genus, erection, 857.
- Ribes, eradication by chemicals, 246, 248, 249.
 (See also Currants and Gooseberries.)
- Ribs, scorbutic beading of, 369.

- Rice—
 beans as green mulch for bananas, 532.
 blast, notes, 444.
 bran, analyses, Ind., 867; Ky., 373.
 bug, summary of information, 556.
 corn rootworm affecting, U.S.D.A., 253.
 cultivation, mechanical, experiments, 484.
 culture in British Guiana, 532.
 fertilizer experiments, 425; Tex., 229.
 insects affecting, 52, 252; U.S.D.A., 252.
 irrigation, rôle of tides in, 689.
 leafhoppers, parasites of, 857.
 meal, feeding value, 172.
 meal v. oats as cattle feed, 172.
 milled, proposed standards, U.S.D.A., 830.
 prairie, culture, U.S.D.A., 139.
 production in Brazil, 292.
 seeding experiments, Tex., 229.
 stalk borer, notes, U.S.D.A., 253.
 stem borer, notes, 52.
 straw as mulch for sugar cane, 532.
 ufra disease, 444, 652.
Ustilagoidea sp. affecting, 45.
 variety tests, Tex., 229.
 water weevil, investigation, U.S.D.A., 252.
 weevil as affected by air-tight storage, 254.
 weevil, notes, 563.
 weevil, paper on, 51.
 weevil, vitality and rate of increase, 254.
 wild, culture and germination studies, Can., 335.
- Ricinus. (*See* Castor beans.)
- Rickets—
 as a deficiency disease, 166.
 beading of ribs in, 369.
 diagnosis, value of craniotables in, 369.
 studies, 264, 664.
- Rinderpest, inheritance of immunity, 583.
- River measurement. (*See* Stream flow measurement.)
- Road—
 conditions, determining from rainfall data, U.S.D.A., 117.
 development in California, 889.
 law in Louisiana, 85.
 maps for public use, U.S.D.A., 387.
 materials, bituminous, consistency of, U.S.D.A., 387.
 materials, bituminous, treatise, 186.
 materials, tests, 482, 889; U.S.D.A., 387.
 oils, asphalt content, U.S.D.A., 698.
 surfaces, design, U.S.D.A., 387.
 traction, mechanical, types of vehicles, 484.
 work, winter, U.S.D.A., 689.
- Roads—
 administration, U.S.D.A., 387.
 administration in Argentina, 388.
 administration in Connecticut, 481.
 administration in Kansas, 889.
- Roads—Continued.
 administration in Louisiana, 85.
 administration in Michigan, 481.
 administration in Minnesota, 591.
 administration in New York, 890.
 administration in Vermont, 591.
 administration in Virginia, 890.
 classification by Bureau of Public Roads, 284.
 construction—
 and maintenance, 481; U.S.D.A., 186.
 and maintenance, motor vehicles' share, U.S.D.A., 186.
 contract bonds for, U.S.D.A., 387.
 cooperation of railroads, U.S.D.A., 186.
 field manual, 284.
 handling Federal equipment, U.S. D.A., 591.
 in the Ozarks, 481.
 surplus war materials for, U.S. D.A., 591.
 treatise, 481.
 value of top soil as base, 185.
 vertical curves, short method of computing, 284.
 country, foundation types for, 85.
 cross sections, method of computing, U.S.D.A., 388.
 drainage structures, design, U.S.D.A., 387.
 Federal aid types, U.S.D.A., 790.
 grass, injury from mole crickets, 53.
 improved, economic value, 284.
 in the National Forests, U.S.D.A., 442, 790.
 Iowa, tonnage of traffic, 284.
 macadam and gravel, bituminous treated, U.S.D.A., 689.
 papers on, U.S.D.A., 186, 387, 591, 689, 790.
 public, in Quebec, historical development, 85.
 relation to motor truck operating cost, 85.
 subgrade investigations, U.S.D.A., 591.
- Robins, winter and summer, Ohio, 351.
- Rock—
 at Iron Canyon dam site, bearing capacity, 889.
 blasting, dynamite for, 480.
 for road building. (*See* Road materials.)
 phosphate. (*See* Phosphate.)
- Rodents in Australia, internal parasites of, 457.
 (*See also* Mice and Rats.)
- Roestelia cancellata*, immunity of pear variety to, 753.
- Root—
 cellars, concrete, construction, 90.
 cork in plants, ecological significance, 732.
 knot, control, 551.
 nodules. (*See* Nodule bacteria.)
 rot control, U.S.D.A., 153.
 tips, absorption of minerals by, 730.

- Root crops—
 culture experiments, 528 ; Minn., 823.
 culture in Nigeria, 637.
 paper on, Wash., 197.
 storage experiments, N.H., 36.
 variety tests, Can., 735 ; Minn., 824.
 (See also special crops.)
- Roots—
 anatomical modifications, 732.
 artificial budding, 634.
 banding and forking in, 732.
 development in relation to lime in soil,
 623.
 etching effect on marble, 422.
 resting period, 634.
 water absorption region, 526.
- Rose—
 aphids, studies, Me., 159.
 beetle, Japanese, notes, 52.
 canker, 753.
 diseases in Trinidad, 152.
 graft disease, studies, 753.
- Roses—
 climbing, culture, 838.
 for Nebraska, list, 240.
 for Yuma region, U.S.D.A., 339.
 mildew-resistant varieties, 247.
 propagation and culture, 240.
 strawberry rootworm on, 362.
- Rostrella coffea* on pimento, 151.
- Rotation—
 fertilizer experiments, Can., 727 ; Ky.,
 814 ; Ohio, 322, 726.
 of crops, Md., 133 ; U.S.D.A., 134.
 of crops, alfalfa in, 721.
 of crops, effect on soil moisture, 210.
 of crops for hog farm, Ohio, 333.
 of crops on bog soils, 231.
 of crops on Palouse silt loam, Idaho,
 227.
 of crops under irrigation, Nebr., 637.
 with and without legumes, as affected
 by lime, 128.
- Roughages, process for reducing fiber con-
 tent, 868.
- Rubber—
 bark rot, prevention, 658.
 brown bast, cause, 659.
 brown bast, notes, 445.
 brown bast, treatment, 552.
 coconut bud rot on, 156.
 culture experiments in Uganda, 344.
 diseases in Federated Malay States, 45.
 diseases in India, 658.
 diseases in Uganda, remedies, 350.
 diseases, notes, 445.
 in French colonies, papers on, 344.
 in West Africa, improvement, 149.
 industry in Brazil, 344.
 latex, effect of heavy tapping on com-
 position, 43.
 latex rings, studies, 43.
 latex, variation in rubber content, 31.
 leaf disease, new, in Java, 49.
 plantations in Netherlands India, 748.
 planters, courses for training, 659.
- Rubber—Continued.
 root disease, notes, 653.
 selection experiments, 748.
 substitutes in Germany, 204.
 tapping experiments, 43, 344, 748, 841.
 tapping methods, 344.
 tapping rot, remedies, 658.
 yields, variation in and improvement,
 81.
- Rubieva multifida*, essential oil from, 502.
- Rumen—
 atony of, 780.
 feed, composition and digestibility, 267.
- Run-off as affected by cropping and cultiva-
 tion, Mo., 721.
- Rural—
 communities, child-welfare teaching,
 694.
 communities, list of publications, 595.
 communities, treatise, 894.
 credit. (See Agricultural credit.)
 development, methods and policies, 894.
 economics in India, 292.
 juvenile court, problems, 294.
 labor. (See Agricultural labor.)
 life in England, organization, 487.
 life in France, papers on, 292.
 life in India, 293.
 reconstruction. (See Reconstruction.)
 schools. (See Schools, rural.)
 science, textbook, 195.
 service, training for, 495.
 socialization, 91.
 (See also Community and Country.)
- Rust—
 mite, effect of freeze of 1917, 555.
 spores, temperature of germination,
 N.H., 842.
- Rusts—
 of Delaware, list, 328.
 studies, Iowa, 654.
 (See also Cereal, Wheat, etc.)
- Rutabagas. (See Swedes.)
- Rutgers College, notes, 199, 799.
- Rye—
 and vetch as fall forage, Mo., 736.
 as green manure, U.S.D.A., 134.
 bran, analyses, N.J., 69, 672.
 culture experiments, Ariz., 733.
 culture on peat soil, 23.
 diseases, control, Tex., 845.
 fall planting, Wash., 738.
 feed, analyses, R.I., 672.
 fertilizer experiments, 126.
 grass, Italian, culture experiments,
 Wash., 436.
 inheritance of albinism, 132.
 leaf rust, studies, Ind., 345.
 middlings, analyses, 867 ; Ind., 69,
 867 ; Ky., 373 ; N.J., 69, 672.
 mixed feed, analyses, Ky., 373.
 red dog, analyses, 867.
 sawfly, black grain-stem, U.S.D.A., 363.
 scab organism, production of conidia,
 545.
 smut, notes, 445.

- Rye—Continued.
 straw, digestibility, 569.
 straw, hydrolyzed, digestion, coefficients, 267.
 varieties, N.C., 434.
 variety tests, 231, 232, 528; Can., 735; Minn., 823; N. Dak., 332; Okla., 32.
 wheat nematode attacking, 751.
 winter, culture experiments, Mont., 332.
 winter, seeding experiments, Minn., 823.
 yield in Australia, 528.
- Saccharin—
 in foods, determination, 115.
 tablets, chemical changes in, 12.
 use of, N.Dak., 368.
- Saffron, culture in Macedonia, 746.
- Sailors. (*See* Service men.)
- Salt—
 as affected by badly aerated soils, 448.
 natural reproduction, 543.
 root rot inoculations, 652.
 seedlings, growth of, 543.
- Salad plants, culture on seashores, 523.
- Salads, substitutes in Germany, 204.
- Salep, mannan of, utilization, 366.
- Salt—
 impurities, effects on fish salting, 663.
 in poison bait for grasshoppers, 354.
 metabolism, as affected by high altitudes, 566.
 rock, effect on live stumps, 281.
- Saltpeter. (*See* Potassium nitrate and Sodium nitrate.)
- Salts—
 antagonistic, effects on respiration of organisms, 820.
 crude mixed, potash content, 26.
 double, equilibrium concentration, 25.
 from evaporation of soil extract, 625.
- Salvarsan, disinfecting power, 79.
- San José scale—
 control, Ohio, 356.
 notes, Mo., 758.
- Sanbornia juniperi*, n.g. and n.sp., U.S.D.A., 758.
- Sand—
 covering for peat bogs, 23.
 dunes, ash of plants from, 431.
 dunes, forestation methods, 651.
 effect on reaction of nutrient solutions, 210.
 hills of Kansas, studies, 731.
 horizontal pressure, 889.
 wet, angle of repose, 122.
- Sandal spike disease, 448.
- Sanninoidea exitiosa*. (*See* Peach borer.)
- Sap. (*See* Osmotic pressure.)
- Saperda candida*. (*See* Apple-tree borer, round-headed.)
- Saponin, value in lime-sulphur wash, 346.
- Sarcocystis tenella*, studies, Wyo., 786.
- Sarcopsylla gallinacea*, notes, Okla., 587.
- Sarcoptes scabiei suis*, notes, U.S.D.A., 688.
- Sardines, bacteriology, 111.
- Sauce, Indochinese fish, condensed, 458.
- Sauerkraut production controlled by heat, 616.
- Sawflies, differentiation, U.S.D.A., 363.
- Sawfly—
 black grain-stem of Europe, U.S.D.A., 363.
 western grass-stem, studies, U.S.D.A., 259.
- Scabies. (*See* Hog, Horse and Mule mange, and Cattle and Sheep scab.)
- Scale insects—
 affecting mango in Florida, 54.
 of Santa Cruz Peninsula, lists, 851.
 (*See also specific insects.*)
- Scalecide, fungicidal value, Mass., 155.
- Scapteriscus*—
didactylus, notes, 53.
vicinus, notes, 159.
- Schistocerca* spp., life history, 159.
- Schoenobius bipunctifer*, notes, 52.
- School—
 districts, rural, social surveys of, 598.
 gardening hints, 797.
 gardening in Los Angeles, 795.
 (*See also* Gardening.)
 gardens, value, 796, 898.
 lunch project, 663.
- Schools—
 agricultural. (*See* Agricultural schools.)
 elementary, lessons on food values, 97.
 home economics, administration, 494.
 rural, arithmetic problems for, 495.
 rural, conditions in Ohio, 898.
 rural, consolidation, 297.
 rural, reorganization, U.S.D.A., 492.
 vocational. (*See* Vocational schools.)
- Scientific institutions, research spirit in, Texas, 496.
- Scientists, Government, conditions of service, 798.
- Sclerospora philippinensis* n. sp., description, 545.
- Sclerotinia fruit rot on tomato, Md., 151.
- Sclerotinia*—
libertiana on greenhouse lettuce, Ky., 845.
libertiana, studies, 247.
ricini, n. sp., description, 849.
 sp. on tomato, 154.
 spp., notes, 152, 246.
trifoliorum, notes, 46.
- Sclerotium* sp. on castor bean, 45.
- Scolia manilæ*, notes, 52.
- Screen wire, durability tests, Wyo., 189.
- Screenings, cleaned, feeding value, 774.
- Scrophulariaceæ, specialization of *Peronospora* on, 247.
- Scurvy—
 among troops in Mesopotamia, 262, 263.
 beading of ribs in, 369.
 infantile, studies, 667.
 studies, 461, 567, 568.
 (*See also* Vitamin C.)
- Seaweed, ground, fertilizing value, Can., 727.
- Secretin, effect on metabolism, 369.

- Sedges, rôle in Colorado plant communities, 129.
- Sedoheptose, new sugar from, 801.
- Sedum spectabile*, new sugar from, 801.
- Seed—
- bed diseases, 150.
 - diseases, studies, Md., 151.
 - inspection, Vt., 437.
 - inspection in Sweden, 35.
 - inspection, value to farmer, U.S.D.A., 437.
 - law in Colorado, Colo., 337.
 - law in Maine, Me., 337.
 - sampling device, U.S.D.A., 642.
 - tester, rag doll and germinator box, Ind., 135.
 - testing in England and Wales, 642.
 - testing station at Copenhagen, 832.
 - treatment, 845.
 - treatment for grain smut, 244.
 - treatment for onion smut, 153.
 - treatment, presoak method, 844.
- Seed-bed preparation, 321.
- Seeding machine for different seeding widths, 691.
- Seedlings, growth as affected by reaction of solution, 524.
- Seeds—
- differentiation by serum reactions, 206.
 - Dutch, urease content, 802.
 - effects of physiological condition on growth and yield, 224.
 - germination, effect of reaction of solution, 524.
 - germination tests, N.H., 35.
 - imported for trial, U.S.D.A., 635.
 - longevity of, 832.
 - oil. (*See Oil.*)
 - paired, of cocklebur, germination, 431.
 - urease content, 10.
- Self-feeder for pigs, 71, 485.
- Sepsis, treatment with horse serum, 684.
- Septic tank for farm sewage disposal, 893.
- Septicemia, hemorrhagic—
- in swine, Ind., 385.
 - treatment with flavin, 79.
 - v. hog cholera*, 683.
 - value of commercial vaccines and bacterins for, Nebr., 882.
- Septoria—
- cosmimilis* on greenhouse lettuce, Ky., 845.
 - glumarum*, studies, Can., 750.
 - lycopersici*, notes, 154; Md., 151.
 - lycopersici* on tomato, 243, 244.
 - rhotina*, description, 49.
- Sericulture, possibility in America, 557.
- Serum—
- physiology, international catalogue, 227.
 - reactions for tests of seeds and feeding stuffs, 206.
- Serums—
- administration by respiratory tract, 581.
 - agglutinating, as affected by an electric current, 781.
- Serums—Continued.
- antitoxic, studies, 76.
 - as new and nonofficial remedies, 470.
 - guinea pig, complement-deficient, 273.
 - horse, for human septic wounds, 684.
 - immune, coagglutinins in, 581.
 - immune, complement deviation in, 382. (*See also Antiserum.*)
- Service men—
- agricultural instruction for, 93, 395.
 - agricultural opportunities in Italy, 93.
 - agricultural opportunities in Tropics, 93.
 - farm colonies for, 93.
 - farm gardening for, 898.
 - land settlement for, 93.
 - loans for, 93.
- Sesame, culture and expression of oil, 240.
- Sesbania, composition, 170.
- Settlers. (*See Land settlement.*)
- Sewage—
- disposal for country homes, 189, 290, 479.
 - disposal in Tropics, 691.
 - on the farm, septic tank for, 893.
 - small community, 189.
 - filters, insect life on, 853.
 - from beet sugar plant, treatment, 479.
 - nitrogen recovery from, 219.
 - organisms, action on organic matter, 791.
 - preliminary treatment, 791.
 - purification, 190.
 - purification plant, injury from industrial sewage, 691.
 - sludge by-products, 520.
 - sludge, fertilizing value, 221.
- Sex—
- determination experiments, 670.
 - determination in *Pediculus vestimenti*, 160.
- Shea nuts, culture and expression of oil, 240.
- Sheep—
- blow fly, remedies, 258.
 - breeding, pedigree, cost, in England, 571.
 - breeding, factors affecting, N.H., 172.
 - breeding problems, 570.
 - broom corn seed for, 671.
 - care of flock at lambing time, Wash., 197.
 - dips, effects on wool, Wyo., 172.
 - diseases affecting reproduction, 683.
 - diseases and parasites, 673.
 - diseases of genital organs, 683. (*See also specific diseases.*)
 - elevator screenings for, Can., 868.
 - farm, initial capital required, 94.
 - feeding experiments, Ind., 375; Pa., 570.
 - feeding in Australia, 376.
 - feeding rack, design, 91.
 - growth estimation, 371.
 - husbandry in North Dakota, 673.
 - hydrolysed straw for, digestibility, 569.
 - infestation of skin by grass seed, 184.

Sheep—Continued.

- judging, treatise, 697.
 Karakul, breeding in Canada, 69.
 lungworms in, Okla., 79.
 muscle parasite of, Wyo., 786.
 pasturing experiments, U.S.D.A., 465.
 pea straw for, Wash., 772.
 poisoning by arrow grass, Nev., 77.
 poisoning by *Astragalus tetrapterus*, U.S.D.A., 78.
 poisoning by lupine, Wyo., 783.
 poisoning by whorled milkweed, U.S. D.A., 470.
 poisoning by woody aster, Wyo., 782.
 (See also Forage poisoning, Plants, poisonous, and specific plants.)
 pox, immunization, 685.
 raising, decline in England, 571.
 raising, in China, 171.
 raising, in India, 269.
 scab, control, 272.
 scab, eradication, U.S.D.A., 471.
 stomach worms in, 278, 384.
 stomach worms, treatment, Okla., 79.
 sweet clover seed screenings for, U.S. D.A., 464.
 tick, life history notes, 883.
 transformation of alveolar epithelium, 384.
 weight loss during transportation, 672.
 (See also Ewes and Lambs.)
- Sheepskins, handling, need for improved methods, 70.
 Shepherd's purse, crossing experiments, 434.
 Shingles, production in 1918, U.S.D.A., 150.
 Shore water, as affected by off-shore winds, U.S.D.A., 719.
Shorea robusta. (See Sal.)
 Shorts, analyses, Ind., 867; Ky., 373.
 Shrimp meal, analyses, 868.
 Shrubs—
 culture, Nebr., 644.
 for Nebraska, list, 240.
 new, near Washington, D. C., 222.
 ornamental, culture experiments, U.S. D.A., 339.
 ornamental, for Iowa, 742.
 ornamental, in South Africa, 441.
 ornamental, tests, U.S.D.A., 339.
 ornamental, winter injury, 753.
- Sidewalks, concrete construction, 90.
 Silage—
 bacteriology of, Pa., 569.
 corn, for horses, Ariz., 775.
 corn, for steers, Ind., 375.
 corn, from shock and ear, Mo., 770.
 corn, preservation, studies, Pa., 569.
 corn, starch content as affected by fermentation, 501.
 crops, machinery for cultivating, 289.
 crops, yields, Ariz., 733.
 from corn and sunflowers, comparison, Nebr., 677.
 from wheat, barley, and oats, 527.
 from wild sunflowers, 677.

Silage—Continued.

- Sudan grass, composition, Okla., 68.
 sunflower, as poultry feed, Minn., 674.
 sunflower, comparison with corn silage, Nebr., 677.
 sunflower, composition, Mont., 69.
 sunflower, composition and digestibility, Mont., 770.
 sunflower, feeding experiments, Mich., 677.
 sunflower, feeding value, Mont., 68.
 Silica, relative solubility on acid and alkaline soils, Mich., 125.
 Silicic acid determination, 202.
 Silk cotton wood, durability tests, 44.
 Silk substitutes in Germany, 204.
 Silkworms. (See Sericulture.)
 Silos—
 concrete, construction, 90.
 construction, 485.
 pit, use in dairying, Kans., 576.
 types, Mich., 691.
 types as affecting quality of silage, Pa., 569.
Silvanus surinamensis on dried fruit, 255.
 Silver leaf disease, 346.
Simodactylus cinnamomeus on sugar cane, 52.
 Simulidæ, investigations, 51.
 Sires—
 pure-bred, for live stock improvement, U.S.D.A., 464.
 ratio to dams, U.S.D.A., 770.
 Sirup—
 from apples, recipe, 808.
 from sugar beets, recipe, 808.
 manufacture from sorghum, Wis., 335.
 Sisal—
 analyses, 829.
 culture and uses, 826.
 Skim milk—
 fat content, determining, N.Y. Cornell, 415.
 for dairy calves, U.S.D.A., 469.
 rôle in nutrition of chicks, Ky., 72.
 sour, for chicks, N.C., 468.
 Skins—
 disinfection, 180.
 preparation of, U.S.D.A., 449.
 rabbit, preparing, U.S.D.A., 378.
 Skunks, exhibition standards, 575.
 Sky—
 blue color of, 618.
 radiation, observations, U.S.D.A., 117.
 Slag. (See Phosphatic slag.)
 Sleet—
 and glaze, formation, U.S.D.A., 119.
 and snow, effect on New York City traffic, U.S.D.A., 120.
 Sludge—
 by-products, 520.
 fertilizing value, 189, 221.
 (See also Sewage.)
 Small holdings in Scotland, economics, 594.
 (See also Land settlement.)

- Smoke formations in air drainage, U.S.D.A., 118.
- Smuts of Indiana, list, 329.
(See also Barley smut, Corn smut, etc.)
- Snapdragon—
damping-off, notes, 658.
leaf spot, control, 658.
rust, control, N.H., 44.
rust, notes, 841.
- Snow—
and sleet, effect on New York City traffic, U.S.D.A., 120.
crystals, paper on, U.S.D.A., 119.
effect on development of vegetation, 509.
effect on growth of winter wheat, 417.
fertilizing value, Can., 728.
- Snowfall—
measurements, methods, U.S.D.A., 120.
relation to run-off in California, 618.
- Snowstorm in Palestine, U.S.D.A., 120.
- Snowstorms, blizzards, and chinooks, U.S.D.A., 120.
- Soap—
stock, sampling and examination, 805.
substitutes in Germany, 204.
tree, importation and use, 840.
- Soaps containing calcium, ash of, 412.
- Sodium-ammonium—
nitrate, action and use, 125.
nitrate, fertilizing value, 221.
sulphate, action and use, 125.
- Sodium—
bicarbonate, effect on color of cooked vegetables, 453.
bisulphate, use in phosphate production, 629.
carbonate and sodium chlorid, relative absorption by soil, 516.
chlorid—
and sodium carbonate, relative absorption by soil, 516.
effect on availability of soil potash, Md., 121.
effect on composition of soil extracts, Mich., 124.
effect on maritime plants, 223.
effect on trees, 343.
fertilizing value, 630.
(See also Salt.)
compounds as neutralizing agents for cream, 76.
cyanid, ammonia production from, 220.
cyanid, for peach borer control, 359.
cyanid, use against subsoil nematodes, 47.
ferrocyanid, ammonia production from, 220.
nitrate—
artificial, action and use, 125.
effect on composition of soil extracts, Mich., 124.
fertilizing value, 221, 627; Ala. Col., 135; Can., 727; La., 627; Tex., 37.
for orchards, Oreg., 145.
- Sodium—Continued.
nitrate—continued.
time of applying to corn and cotton, Ala. Col., 233, 333.
oleate, gold number determination, 12.
perchlorate, disinfecting power, 79.
potassium cobaltic nitrite, verification of formula, 803.
salicylate, disinfecting power, 79.
salts, effect on soil structure, 516.
- Soil—
absorption, studies, 624.
acidity—
as affected by green manure, 212.
determination, 12, 21.
determination, factors affecting, 312.
of virgin *v.* cultivated soil, N.Dak., 319.
review of literature, 212.
studies, 612, 713.
tests, Wis., 622.
(See also Lime, Limestone, and Liming.)
aeration, effect on lime requirement of muck soil, 212.
analysis, 504, 621.
analysis as affected by moisture equivalent, 210.
bacteria—
correlation of colon and aerogenes types, 791.
effect of seasonal conditions, Iowa, 432.
effect on availability of phosphates, 630.
effect on etching power of roots, 422.
potential activity of spores, 625.
compression, effect on germination, 722.
contamination in poultry yards, 378.
elutriator, new, description, 210.
erosion, prevention, 281, 420, 481; Mo., 721.
extracts, effect of fertilizer salts on composition, Mich., 124.
extracts, salts from evaporation of, 624.
fertility—
experiments, Minn., 627, 814; N.Dak., 322; Ohio, 322.
maintenance, Ohio, 726.
maintenance in Queensland, 24.
maintenance on dairy farms, 23.
of meadows, Ohio, 322.
relation of sulphur to, Ill., 517.
rôle of bacteria in, 124.
studies, Ky., 814.
inoculation. (See Legumes, inoculation.)
making, requirements for, 209.
management, Md., 122; Mo., 722.
moisture—
as affected by afforestation, 16.
as affected by manure, 722.
as affected by rolling, 722.

Soil—Continued.

- moisture—continued.
 - colloidal hypothesis, 20.
 - conservation by pruning, 235.
 - effect on explosives, U.S.D.A., 282.
 - equivalent, effect on analysis, 210.
 - factors affecting, 210, 320.
 - movement, Ky., 812; N.Mex., 738.
 - movement after irrigation, N.Mex., 386.
 - movement as affected by gravity, U.S.D.A., 723.
 - movement as affected by initial moisture, Ky., 320.
 - movement, capillary, U.S.D.A., 722.
 - movement, capillary transmission constant, 812.
 - studies, Wash., 722.
- molds, factors affecting number, Iowa, 432.
- organisms, dissemination by wind, 842.
- plate, number of colonies for, 422.
- potassium, liberation, 127.
- preparation for field crops, 321.
- reaction, relation to health and growth of plants, 513.
- science, methods of teaching, 196.
- solution, concentration, effect on cell sap, 515.
- survey in—
 - Alabama, Shelby Co., U.S.D.A., 511.
 - California, Ventura area, U.S.D.A., 512.
 - Delaware, Kent Co., U.S.D.A., 719.
 - Florida, St. Johns Co., U.S.D.A., 719.
 - Georgia, Pulaski Co., U.S.D.A., 811.
 - Indiana, Cass Co., 419.
 - Iowa, Hamilton Co., U.S.D.A., 122.
 - Louisiana, La Salle Parish, U.S.D.A., 720.
 - Mississippi, Madison Co., U.S.D.A., 720.
 - Nebraska, Morrill Co., U.S.D.A., 209.
 - North Dakota, Sargent Co., U.S.D.A., 123.
 - North Dakota, Traill Co., U.S.D.A., 209.
 - Oregon, Yamhill Co., U.S.D.A., 512.
 - South Carolina, Horry Co., U.S.D.A., 812.
 - Texas, Lubbock Co., U.S.D.A., 512.
 - Virginia, Accomac and Northampton Counties, U.S.D.A., 513.
 - West Virginia, Webster Co., U.S.D.A., 720.
 - Wisconsin, Waupaca Co., U.S.D.A., 123.
- survey mapping, 887.
- surveys, device for making, Tex., 281.
- temperature, daily changes, 321.

Soil—Continued.

- temperature, relation to that of springs, 321.
- water. (*See* Soil moisture.)
- Soils—
 - acid, effect on zinc-coated pots, 27.
 - acid humiferous, as affected by lime, 325.
 - acid, lime requirements, 115.
 - acid, Trufast test for, 20.
 - alkali. (*See* Alkali.)
 - ammonia determination in, 211.
 - as affected by dicyandiamid, 426.
 - as affected by straw, Wash., 726.
 - as affected by sulfocation, 517.
 - barium in, Ky., 327.
 - bog. (*See* Bog.)
 - carbon dioxid balance, factors affecting, 510.
 - carbon dioxid of, N.Y.Cornell, 812.
 - chemistry of, 122.
 - chlorid determination in, 311.
 - colorimetric determination of pH, 211.
 - cropped and cultivated, water absorption and run-off on, Mo., 721.
 - cropped and virgin, Mich., 622.
 - distribution of electric currents from traction lines, 625.
 - effect of fertilizers on pH, 423.
 - effect of lime and manure, Okla., 32.
 - fertilizer requirements as determined by crop analysis, 323, 518.
 - freezing-point lowering, studies, 515.
 - frozen, bacteria in, 422.
 - heated, relation to root cork, 732.
 - humus, aqueous solutions of, 725.
 - humus, humin acids in, 213.
 - improvement—
 - for corn, 422.
 - rôle of lime in, 128, 428.
 - with lupines, 321.
 - with peat and moor soils, 22.
 - injurious effects on plants, 513.
 - introductory courses in, 196.
 - leaching, effect on availability of rock phosphate, 427.
 - lime requirement, Wis., 622.
 - lime requirement—
 - factors affecting, 312.
 - methods of determining, 713.
 - relation to pH, 421, 515.
 - limed and unlimed, analyses, 128.
 - loss of nitrates in drainage water, 19.
 - magnesium determination in, N.Dak., 319.
 - marsh. (*See* Marsh soils.)
 - moor. (*See* Peat and Moor.)
 - muck. (*See* Muck soils.)
 - nitrate accumulation in, excessive, 216.
 - nitrate production after timothy and clover crops, 215.
 - nitrate production, factors affecting, Ill., 214.
 - nitrification studies, Pa., 515.
 - nitrifying bacteria in, isolation, 216.

Soils—Continued.

- nitrogen content. (*See* Nitrification, Nitrogen, *etc.*)
 nitrogen distribution in, 18.
 of Bavaria, classification, 513, 622.
 of Burma, lime absorption by, 27.
 of Detroit area, Mich., 622.
 of eastern Germany, 320.
 of Eritrea, analyses, 721.
 of Georgia, fertilizer formulas, 727.
 of Indiana, analyses, 419.
 of Iowa, reclamation, Iowa, 21.
 of Java, analyses, 320.
 of La Jaille, analyses, 621.
 of low calcium content, studies, Ky., 814.
 of Maryland, analyses, Md., 122.
 of Maryland, fertilizer requirements, 815; Md., 122.
 of Morocco, analyses, 513.
 of New Brunswick, lime requirements, 623.
 of New Jersey, protozoan fauna, 217.
 of North Carolina Coastal Plain, analyses, 419.
 of North Carolina, fertilizer experiments, N.C., 424.
 of North Carolina, lime requirements, 420.
 of North Carolina, phosphate requirements, 816.
 of northern Wisconsin, Wis., 622.
 of Ohio, Ohio, 486.
 of Ohio, organic phosphorus content, 813.
 of Peru, analyses, 720.
 of Sweden, lime requirements, 623.
 of Texas, nitrification, Tex., 724.
 organic matter in. (*See* Organic matter.)
 origin of, 719.
 paddy, green manure for, 423.
 Palouse, management, Idaho, 814.
 peat. (*See* Peat.)
 phosphorus determination in, 115.
 physical properties, 320.
 physics of, 122.
 productive, treatise, 719.
 productivity, restoration near zinc roasters, 513.
 properties and maintenance, 209.
 push, analyses, Iowa, 21.
 residual limestone in, 115.
 sampling, 210.
 sandy, absorption of sodium carbonate and sodium chlorid by, 516.
 sandy, in South Australia, improvement, 721.
 sandy loam, fertilizer experiments, N.C., 424.
 solubility, effect of calcium sulphate on, 516.
 sterile, plant growth in, 422.
 sterilization by steam, 659.
 structure as affected by potash and sodium salts, 516.

Soils—Continued.

- suitable for nitragin inoculation, 217.
 swamp. (*See* Swamps.)
 temperature fluctuations in, Md., 121.
 tobacco, survey, Can., 735.
 treatises, 621.
 use of lime on, 519.
 virgin and cropped, Mich., 622.
 water level as affected by canals and mines, 210.
 water-logged, reduction potentials, 421.
 Solanaceæ, opening of anthers in, 327.
 Solanin poisoning, review of literature, 866.
 Solar—
 activity variations, meteorological effects, 810.
 radiation. (*See* Radiation, solar.)
 Soldier Settlement Act of Canada, 93.
 Soldiers. (*See* Service men.)
Solenopsis molesta, studies and synonymy, Kans., 763.
Solidago spectabilis, poisonous to live stock, Nev., 273.
 Solutions, nutrient. (*See* Nutrient.)
 and soy beans as summer forage, Mo., 736.
 as silage crop, Minn., 636.
 breeding experiments, 637.
 culture, Ariz., 733.
 culture experiments, U.S.D.A., 134.
 culture for sirup, Wis., 335.
 diseases, control, Tex., 845.
 grain, culture experiments, U.S.D.A., 330.
 grain, fertilizer experiments, Okla., 32.
 grain, rotation experiments, Okla., 32.
 grain, variety tests, Okla., 32, 137; Tex., 230; U.S.D.A., 134, 329.
 head smut, description, Wash., 242.
 sweet, varieties for North Carolina, 532.
 sweet, variety tests, Okla., 32.
 variety tests, 637; Ariz., 733; La., 636; U.S.D.A., 134, 330.
 (*See also* Kafir, Milo, *etc.*)
 Sorghums, ants attacking, Kans., 763.
 Soup preparations and extracts, analyses, Conn.State, 859.
 South Carolina College and Station, notes, 799.
 South Dakota—
 College, notes, 700.
 Station, notes, 200.
 Sows—
 brood, barley *v.* corn for, 774.
 brood, feeding experiments, Pa., 572; U.S.D.A., 466.
 brood, sunflower silage *v.* alfalfa hay, Mont., 69.
 variations in farrow, Ill., 571.
 Soy bean—
 hay, cost of production, Ohio, 392.
 meal, analyses, Ohio, 377.
 meal as corn supplement for hogs, Ohio, 377.
 meal for chicks, 674.

- Soy bean—Continued.
oil, composition, 610.
oil, sampling and examination, 805.
seedlings, growth as affected by H-ion concentration, 525.
- Soy beans—
and other crops for hay, W.Va., 139.
and sorghum as summer forage, Mo., 736.
as green manure, Md., 122; Mich., 639.
as hay crop, Mich., 639.
as orchard cover crop, Pa., 538.
as silage crop, Mich., 639.
breeding and selection, Ind., 331.
breeding for high oil content, N.C., 434.
culture and expression of oil, 240.
culture and value, Ind., 234; Iowa, 235.
culture experiments, Ind., 330; Ky., 331; W.Va., 139.
description and agricultural value, 528.
for fattening cattle, Ind., 570.
fertilizer experiments, Ohio, 726.
germination as affected by H-ion concentration, 525.
green clover worm on, 759; N.C., 450.
ground, as corn supplement for pigs, Ohio, 377.
hay yields, Mo., 736.
hogging-down, Ky., 374, 871.
inoculation, Mich., 698.
nutrient requirements, Md., 121.
popular account, U.S.D.A., 830.
rotation experiments, Ind., 234; Ohio, 726; W.Va., 139.
seed production, Mo., 736.
seeding tests, Mo., 735; W.Va., 139.
steam-cooked, digestibility, 564.
time of harvesting, W.Va., 139.
urease content, 10, 610, 802.
use of soil potassium by, 218.
varieties, N.C., 434.
varieties for Iowa, Iowa, 235.
variety tests, Ariz., 733; Ind., 234; Md., 153; Mich., 639; Mo., 735; Okla., 32; Tex., 33; W.Va., 139.
- Sparganothis* sp., notes, 851.
- Spectrophotometry in analysis, 503.
- Spelt, wheat nematode attacking, 751.
- Spermatogenesis—
of dogs, 269.
of domestic mammals, 670.
- Sphacelotheca reiliana*, notes, Wash., 242.
- Sphaerella citri*, notes, 243.
- Sphaerolecanium prunastri*, notes, 252.
- Sphaerotheca*—
humuli, notes, 446.
mors-uvæ, notes, 246.
pannosa, notes, 152.
- Sphincter, tonicity of, studies, 180.
- Sphingidæ species, studies, Ky., 359.
- Spices—
culture in Fiji, 40.
substitutes in Germany, 204.
- Spider mite. (*See* Red spider mite.)
- Spillways, siphon, summary of information, U.S.D.A., 787.
- Spinach—
analyses, 63.
blight, transmission by insects, 547.
disease, new, 544.
handling for long-distance shipment, U.S.D.A., 144.
protein, 409.
sun-dried, vitamin B in, 63.
vitamin A extraction from, 165.
- Spinal cord of animals as food material, 63.
- Spirochæta*—
icterohæmorrhagiæ, rat as natural reservoir of, 883.
theileri, synonymy, 82.
- Spirochetes as cause of infectious anemia, 83.
- Spirochetosis, bovine, in Brazil, transmission, 82.
- Spleen, changes in deficiency disease, 664.
- Spondias lutea*, durability test of wood, 44.
- Sporonema oxycocci*, notes, Mass., 155.
- Spotted fever, Rocky Mountain, monograph, 60.
- Spray—
gun v. rod, 842.
nozzles, Bordeaux v. disc, Mo., 757.
schedule for apples, 743.
schedule for Georgia, 256.
schedule for orchards, Ohio, 339.
- Spraying—
dust. (*See* Dusting.)
relation to bees, 662.
(*See also* Apples, Potatoes, etc.)
- Sprays—
as affected by rain, 657.
copper. (*See* Copper.)
Pickering, adhesive properties, U.S.D.A., 843.
Pickering, formulas, U.S.D.A., 843.
spreaders for, Oreg., 756.
(*See also* Insecticides, Fungicides, and specific forms.)
- Springs—
contamination and protection, 392.
temperature of, 321.
- Spruce—
budworm attacking, 852.
growth as affected by locality, 748.
Production Division, history, 544.
yield tables, 840.
- Squash—
bacterial wilt, control, U.S.D.A., 245.
bug, control, Mo., 757.
storage tests, 644.
wilt, studies, Tex., 846.
- Squirrels—
control, Wash., 350.
ground, plague eradication, 850.
- Stable fly, studies, U.S.D.A., 362.
- Stables, construction in Mexico, 290.
- Staining, differential, of fungus and host plant, 444.
- Stalk borer—
in South Dakota, 850.
notes, Conn.State, 251.

- Stallion registration and licensing, Ind., 269; Kans., 674.
- Staphylococcus*—
albus, notes, 472.
pyogenes aureus and *botryococcus*, identity, 181.
 spp. in meconium of calf, 183.
- Star scale on citrus, 555.
- Starch—
 absence in evergreen leaves at low temperatures, 29.
 content of corn silage, as affected by fermentation, 502.
 hydrolysis, as affected by amino acids, 311.
 soluble, gold number determination, 12.
 substitutes in Germany, 204.
 values and energy values, 372.
- Starfish meal, analyses, 868.
- States Relations Service, notes, 100.
- Steel—
 fence posts, Ohio, 391.
 structural, value of paint on, 283.
- Steers—
 alfalfa *v.* clover hay for, Ind., 870.
 body measurements, Pa., 570.
 corn silage for, Ind., 375.
 elevator screenings for, Can., 672.
 feeding experiments, Can., 771.
 feeding experiments, Ind., 570, 868, 869; Ky., 373, 869; Mont., 770; Pa., 569; U.S.D.A., 172.
 finishing, N.Mex., 374.
 finishing, pasture *v.* barn, Ky., 373.
 pasturing experiments, N.Dak., 374.
 pea straw for, 870.
 winter feeding, Nebr., 672.
 (See also Cattle.)
- Sterculia caribæa*, durability test of wood, 44.
- Stereum*—
gausapatum on oak, 449.
purpureum, notes, 246.
- Sterigmatocystis nigra*, utilization ratio of glucose and levulose, 730.
- St. John's wort, toxic effect on live stock, 380.
- Stock. (See Live stock.)
- Stock foods. (See Feeding stuffs.)
- Stocks—
 double, notes, 31.
 Paradise, selecting and propagating, 238.
- Stockyards fever. (See Septicemia, hemorrhagic.)
- Stomach worms—
 in sheep, 278, 384.
 in sheep, treatment, Okla., 79.
- Stomata, relation to transpiration, 131.
- Stomoxys calcitrans*. (See Stable fly.)
- Stone for road building. (See Road materials.)
- Storage—
 bins, circular reinforced concrete, 892.
 rooms, lighting for potatoes, 436.
 rooms, underground, construction, 691.
- Storms and their course, detection, U.S.D.A., 718.
- Stoves, coal, efficiency tests, 592.
- Straw—
 effect on soil, Wash., 726.
 hydrolysis, effect on availability of nutritive material, 267, 569.
 seed beet, feeding value, 373.
 stacks, building, 91.
- Strawberries—
 breeding experiments, 742.
 bud selection, results, 536.
 culture, Nebr., 146, 644.
 culture and marketing, 40.
 dusting experiments, 743.
 fanning in relation to keeping quality, 848.
 fertilizer experiments, 833.
 insects affecting, Wash., 155.
 new varieties, 438.
 variety tests, Ky., 339.
- Strawberry—
 diseases, control, Ill., 847.
 leaf beetle, control, Md., 559.
 leaf blight, studies, Ill., 753.
 leaf spot, Wash., 155.
 mildew, Wash., 155.
 plantations, renewal, 836.
 Rhizoctonia, Wash., 155, 750.
 rootworm on roses, 362.
- Stream flow measurements, 787.
- Streptobacterium casei*, notes, 681.
- Streptobacterium* new genus, erection, 680.
- Streptococci toxin for leucocytes, 684.
- Streptococcus*—
cremoris, new name, 681.
lacticus as cheese starters, 681.
viridans, acid production by, 383.
- Streptococcus—
 infection, relation to rickets, 264.
 redefined, 680.
- Streptoleucocidin, studies, 684.
- Strychnin, test for, 116.
- Stumps—
 destructive distillation, 888.
 removal, forced *v.* delayed systems, Minn., 480.
 removal, horsepower *v.* dynamite, Minn., 888.
 removal with dynamite, 480.
 removal with TNT, U.S.D.A., 282.
- Sturmia distincta*, parasitism by, 453.
- Subsoiling, dynamite for, 480.
- Sudan grass—
 as dry-farm crop, Ariz., 733.
 as hay and forage, 527.
 as pasture feed, U.S.D.A., 171.
 culture, Iowa, 235; U.S.D.A., 435, 639.
 culture experiments, Idaho, 738; Tex., 34; U.S.D.A., 134.
 diseases, control, Tex., 845.
 fertilizer experiments, Tex., 230.
 for dairy cattle, Kans., 176.
 seed production, Nev., 229.
 seeding experiments, Ind., 330; Iowa, 235; Mo., 736; Okla., 33; Tex., 230.

Sudan grass—Continued.

- silage, composition, Okla., 68.
- variety tests, U.S.D.A., 134.
- wheat-head army worm affecting, 54.

Sugar—

- deterioration by molds, factors affecting, 507.
- determination in urine, 416.
- fumaric acid fermentation, 15.
- in blood, variability, 265.
- in body fluids, determination, 416.
- in cattle feeds, 671.
- inversion during manufacture, prevention, 416.
- inversion in stored oranges, 203. (*See also* Invertase activity.)
- invert, determination, 314.
- keeping quality, factors affecting, La., 807.
- manufacture, determination of inversion, 507.
- manufacture in France, 261.
- manufacture in Philippines, 830.
- manufacture, prevention of inversion, 416.
- oxalic acid production from, 112.
- production in Brazil, 292.
- quantity for jelly making, 617.
- raw, deterioration in storage, 616.
- rôle in respiratory combustion in plants, 226.
- seeding method of graining, 416.
- solutions, concentrated, mold fruiting bodies in, 226.
- solutions, invertase activity of mold spores in, 433.
- substitutes in Germany, 204.
- synthesis, 202.
- (*See also* Sugars.)

Sugar beet—

- curly top, susceptibility of other plants to, 752.
- products, nitrogen distribution in, 206.
- root-louse, control, U.S.D.A., 451.
- sirup, recipe, 808.
- stalks, digestion coefficients, 373.
- waste, composition and digestibility, 267.
- webworm, notes, Colo., 158; Mont., 758.
- (*See also* Beet.)

Sugar beets—

- culture, Mont., 35.
- culture experiments, N.Mex., 332.
- fertilizer experiments, 126, 231.
- irrigation experiments, Utah, 230.
- manuring experiments, Utah, 218.
- Phyllotreta utana* on, 854.
- rotation experiments, U.S.D.A., 435.
- seed, isolation of, 532.
- sugar content, Can., 735.
- thinning experiments, Nebr., 637.
- variety tests, 528; Can., 735.
- water requirements, Colo., 185.

Sugar cane—

- as affected by ultraviolet rays, 730.
- borer, control, 852; La., 659.
- borer, notes, 52.
- fertilizer experiments, 425, 532; La., 626.
- germination as affected by fungi, La., 348.
- insects affecting, 252, 450.
- insects affecting in Fiji, 52.
- Japanese, seeding experiments, Tex., 230.
- juices, clarification, effect of temperature, 507.
- leafhopper in Hawaii, 450.
- leafhopper, notes, 52.
- leafhopper, parasites of, 661, 662.
- leaf miner, notes, 52.
- mealy bug, notes, 52.
- mosaic. (*See* Sugar cane mottling disease.)
- mottling disease, control, 47.
- mottling disease, notes, 548.
- mottling disease, transmission, 547, 548.
- production in Philippines, 830.
- rind disease, notes, 152.
- root disease, notes, 243.
- sieve tube disease, cause and control, 548.
- smut, notes, 444.
- varieties in Hawaiian Islands, 830.
- variety resistant to mosaic, 152.
- variety tests, La., 636.
- white grubs affecting, 52.
- wireworms, notes, 52.
- yellow stripe. (*See* Sugar cane mottling disease.)

Sugars—

- color absorption from, 412.
- color determinations, 715.
- determination by inversion, 615.
- idiometric determination, 507.
- reducing, determination, 806.
- reducing, movement in apple trees, N.H., 28.
- (*See also* Sugar, Glucose, Dextrose, etc.)

Sulfonation, effect on potassium of greensand, 517.

Sulphate—

- of ammonia. (*See* Ammonium sulphate.)
- of potash. (*See* Potassium sulphate.)

Sulphates, double salts of calcium and potassium, equilibrium concentration, 25. Sulphite waste liquor, alcohol from, 416, 617.

Sulphites, effect on sugar beet juice, 207.

Sulphur—

- compounds, soluble, analyses, N.J., 37.
- dioxid for mange treatment, 184.
- effect on grape oïdium, 657.
- effect on live stumps, 281.
- in phosphatic slag, 127.
- in plants and soils, Ky., 324.

- Sulphur—Continued.
 metabolism, 663.
 mixtures. (See Lime-sulphur mixtures.)
 relation to soil fertility, Ill., 517.
 value on swamps, Oreg., 22.
- Sulphur-arsenate, fungicidal value, 352.
- Sulphuration, as treatment for mange, 184.
- Sulphurous acids, effect on sugar beet juice, 207.
- Sumac—
 diseases, new, in Italy, 49.
 leaves, reddening of, 49.
- Sun as source of power, U.S.D.A., 117.
- Sunflower—
 ashes, analyses, 324.
 silage and alfalfa hay, comparison, Mont., 68.
 silage as poultry feed, Minn., 674.
 silage, composition and digestibility, Mont., 69, 770.
 silage, feeding value, Mich., 677; Mont., 68.
- Sunflowers—
 as forage crop, 527.
 as silage crop, Minn., 636; U.S.D.A., 435.
 culture, 638.
 culture experiments, Mont., 35.
 Russian, as silage crop, Nev., 229.
 wild, as silage crop, 677.
- Sunlight—
 effect on blister rust fungus, Can., 754.
 rôle in forest insect control, 560.
- Sunshine—
 and cloudiness in Canal Zone, U.S.D.A., 718.
 geographic distribution in United States, U.S.D.A., 116.
 variation in California, U.S.D.A., 509.
- Superphosphate—
 effect of pulverized limestone on, 27.
 effect on composition of soil extracts, Mich., 124.
 effect on tobacco root rot, 447.
 fertilizing value, Tex., 33, 37; Wis., 336.
 (See also Phosphates, comparison.)
 production, 629.
 production on the farm, Ky., 324.
 reverted, fertilizing value, 428.
 v. phosphatic slag, Ohio, 324.
- Surgery and medicine, industrial, 564.
- Surra in camels, treatment, 584.
- Swamp fever—
 in horses, N.Dak., 386.
 studies, Wyo., 179.
 (See also Anemia, infectious equine.)
- Swamps—
 peat, reclamation, Oreg., 21.
 reclamation, use of tractors in, 484.
- Sweating, effect on hemoglobin and protein content of blood, 265.
- Swede—
 diseases, notes, 45.
 dry rot, studies, 244.
- Swede—Continued.
 juice, raw, antiscorbutic value, 667.
 juice, vitamin C as affected by heat, 567.
- Swedes—
 analyses, 63.
 as affected by potassium salts, 630.
 as affected by sodium chlorid, 630.
 as forage crops in Denmark, 177.
 culture on peat soil, 23.
 fertilizer experiments, Minn., 627.
 manuring experiments, Minn., 627.
- Swedes, yields, Minn., 824.
- Sweet clover—
 as dry-farm crop, Ariz., 733.
 as hay and forage, 527.
 culture, Nebr., 637.
 culture experiments, Idaho, 738; Mont., 332.
 fertilizer experiments, Ky., 331.
 pollination studies, 640.
 rotation experiments, N.Dak., 332.
 seed coats, studies, U.S.D.A., 640.
 seed production, pollination studies, U.S.D.A., 640.
 seed screenings, effect on sheep, U.S.D.A., 464.
 seeding experiments, Okla., 33.
- Sweet corn—
 canning, Ind., 34.
 disease-free seed selection, Ind., 34.
 root-rot, studies, Ind., 345.
 seed production, Md., 133.
 seed selection, Ind., 339.
 variety tests, U.S.D.A., 437.
- Sweet—
 gum trees, time for transplanting, Mo., 142.
 peas, culture, treatise, 441.
- Sweet potato—
 diseases, 152, 243.
 gall disease, 151, 152.
 surface rot, control, 752.
 potato weevil, control, 258; Ala.Col., 57.
 worm, notes, 252.
- Sweet potatoes—
 breeding experiments, 637.
 culture, N.J., 140.
 fertilizer experiments, 637; Fla., 335; Ga., 139.
 grades, U.S.D.A., 336.
 insects affecting, 450.
 Rhynchophora on, 163.
 rotation experiments, Fla., 335.
 storage, N.J., 140.
 storage and marketing, 243.
 storage tests, Ga., 140.
 v. cassava meal for pigs, 71.
 variety tests, U.S.D.A., 330.
- Swietenia cirrhata* n. sp., description, 241.
- Swietenia* species, revision, 241.
- Swine—
 breeding, seasonal distribution, 377.
 diseases, Ind., 384.
 diseases affecting reproduction, 683.
 dysentery, notes, Ind., 385.

Swine—Continued.

- erysipelas, studies, 785.
- plague, notes, Ind., 385.
- pneumonia, studies, 688.
- (See also Pigs.)

Symbiosis—

- fungus, in *Casuarina equisetifolia*, 731.
- studies, 133.

Symptomatic anthrax. (See Blackleg.)

- Synchytrium endobioticum*, notes, 245.
- Syngamus laryngeus* in cattle and buffaloes, 688.

Tadpoles, growth as affected by thyroid gland extract, 865.

Tamalia, new genus erection, U.S.D.A., 758.

Tamarind juice, antiscorbutic value, 263.

Tanaomastix abnormis, notes, 660.

Tankage—

- analyses, 867; Ind., 69, 867; Ky., 373; N.J., 69.
- as corn supplement for pigs, Ohio, 377.
- digester, analyses, N.J., 672.
- fertilizing value, La., 627.
- for fattening pigs, Mo., 772.

Tanks, concrete, construction, 188.

Tannery wastes, purification and disposal, 189.

Tanning materials, vegetable, value of, 506.

Tanymecus, notes, 456.

Taphrina, Swedish species, 242.

Taurin, determination in muscles, 506.

Tea—

- analyses, 745.
- black rot, notes, 444.
- culture in French colonies, 342.
- fertilizer experiments, 425.
- insects affecting, 252.
- production and quality in Mauritius, 745.
- root diseases, notes, 247.
- stem disease, notes, 444, 552.

Teak, insects affecting, 450.

Telenomus n.spp., description, 857.

Telephoraceæ on oak, 449.

Temperature—

- as affected by wind direction, U.S.D.A., 118.
- body, as affected by high altitudes, 565.
- distribution in California, effect of altitude and topography, 417.
- effect on action of chloropicrin, 157.
- effect on resistance to wounding of small fruits, U.S.D.A., 39.
- fluctuation in soils, Md., 121.
- injurious to plants, U.S.D.A., 237.
- low, damage to fruit, U.S.D.A., 16.
- measurement, U.S.D.A., 718.
- minimum, new method of computing, Mass., 119.
- minimum, of Paraguay in 1918, 418.
- minimum, predicting, papers on, U.S.D.A., 15.
- of springs, 321.
- of surface soil, daily changes, 321.

Temperature—Continued.

- orchard, new methods of predicting, U.S.D.A., 16.
- regulator for incubators, 822.
- variations in Atlantic Ocean, 810.
- variations in South Temperate Zone, 418.
- (See also Soil temperature.)

Tennessee—

- Station, notes, 900.
- University, notes, 300, 900.

Tent caterpillars—

- control, Oreg., 756.
- destruction by birds, 250.

Tenthredinidæ, new species, 857.

Tenuipalpus bioculatus, notes, 555.

Teosinte-maize hybrid, 529.

Tepary beans—

- culture, Ariz., 733.
- resistance to alkali, Ariz., 724.

Termites—

- and termitophiles, 450.
- colonizing reproductive adults, 556.
- Nearctic, revision, 256.
- protecting buildings against, 592.

Termopsis, notes, 256.

Terracing to prevent soil erosion, 481.

Testes, degeneration in dogs, 269.

Testicles, of pigeons, as affected by diet deficiency, 369.

Tetracoccus liquefaciens, as cheese starter, 681.*Tetradymia glabrata*, poisonous to live stock, Nev., 273.*Tetranychus*—

- binaculatus*, notes, U.S.D.A., 352.
- spp., notes, 555.
- yotheri*, notes, 255, 851.

Tetrastichus—

- sp., parasite of chrysanthemum midge, U.S.D.A., 361.
- spp., notes, U.S.D.A., 365.

Texas—

- College, notes, 200.
- fever in Queensland, 182.
- Substation No. 11, report, 98.

Textile materials, substitutes in Germany, 204.

Theileria spp., notes, 883.*Theobroma* spp., deformation of inflorescence, 349.*Thermobacterium helveticum*, as cheese starter, 681.*Thermobacterium*, new genus, erection, 680.*Thielavia basicola*, notes, 246; Mass., 845.*Thielaviopsis paradoxa*—

- on pineapple, 152.
- on sugar cane, La., 348.

Thistle, Russian, as forage crop, 527.

Thistles, differentiation and control, N.J., 141.

Thomas slag. (See Phosphatic slag.)

Thrashing machines, dust-collecting fans for, U.S.D.A., 390.

Thrips, greenhouse, on avocado, 53, 851.

Thrips tabaci. (See Onion thrips.)

Thuja seedlings, fungus attacking, 49.
 Thunderstorms, distribution in United States, U.S.D.A., 119.
 Thymolphthalein, use as indicator, 10.
Thyridopteryx ephemeraformis. (See Bagworm.)
 Thyroid—
 and pituitary gland, correlation, 770.
 changes in deficiency disease, 664.
 gland extract, effect on polyneuritic pigeons and tadpoles, 865.
 material, effect on plant growth, 225.
Tibicen septendecim. (See Cicada, 17-year.)
 Tick—
 fever. (See Texas fever.)
 fever, Rhodesian. (See African coast fever.)
 worry, in Queensland, 182.
 Ticks—
 migration and reaction to light, 164.
 relation to piropilosis, 83.
 (See also Cattle tick and Fowl tick.)
 Tides, rôle in rice irrigation, 689.
 Tile drainage. (See Drainage.)
 Tillage machinery, notes, 892.
Tilletia—
 sp. on wheat, 347.
 spp., notes, 445.
Tilia americana, foliar transpiring power, 223.
 Timber—
 census of New York, results, 748.
 depletion, remedies, U.S.D.A., 649.
 dry rot, notes, 350.
 estimation, volume tables, 443.
 growth, collection of data, 748.
 line, relation to climatic factors, 840.
 measurement, "absolute form quotient," 149.
 "pooli," mechanical properties, 483.
 preservation, processes, 283.
 trees, Nigerian, 840.
 warped and seasoned, tests, 789.
 (See also Lumber and Wood.)
 Timberland insurance, factors affecting, 149.
 Timothy—
 effect on nitrate formation in soil, 215.
 leaf spot, 752.
 seed, longevity of, 832.
 vitamin A in, 165.
 wheat-head army worm affecting, 55.
 yield on irrigated wild meadows, Oreg., 22.
 Titration—
 curves, colorimetric determination, 11.
 electrometric, 803.
 TNT. (See Trinitrotoluol.)
 Tobacco—
 as affected by soil electrification, Ky., 824.
 burning quality, relation to grain, Pa., 534.
 Connecticut Valley, production, Mass., 141.

Tobacco—Continued.

culture experiments, 637; Can., 336, 735.
 culture, Mass., 830.
 culture, history, U.S.D.A., 437.
 culture in Spain, regulations, 35.
 cured, factors affecting color, 637.
 curing experiments, Ky., 824.
 cutworm, control, Can., 337.
 Deli, selection experiments, 831.
 disease, notes, 445.
 diseases, control, Mass., 845.
 fertilizer experiments, Can., 336, 735; Ky., 331, 824; Mass., 830; N.C., 425, 434; Pa., 533; Tex., 33.
 flue-cured, diseases, 245.
 grain, defined, Pa., 534.
 harvesting experiments, N.C., 434.
 harvesting, method, Can., 337.
 horn worm, control, Can., 337.
 insects affecting in Rhodesia, 52.
 leaf spot, notes, 246.
 marketing, Mass., 141.
 mosaic, control, 548; Can., 735.
 root knot, notes, 246.
 root rot, control, 447; Can., 735.
 root rot, notes, 246; Mass., 845.
 rotation experiments, Ky., 332, 824.
 seedlings, *Pythium gracile* on, 652.
 selection experiments, Pa., 533.
 soils, classification, Mass., 831.
 spacing and topping experiments, Pa., 534.
 substitutes in Germany, 204.
 tokra disease, 445.
 use as vermifuge, Okla., 80.
 variety tests, Can., 336, 735; Md., 134; Pa., 533.
 wilt, notes, 245.
 worms, studies, Ky., 359.
 yields, factors affecting, Mass., 830.
 Tomato—
 bacterial wilt, control, Pa., 549.
 blight, late, comparison with potato late blight, 447.
 blight, late, control, 246.
 blight, studies, Md., 151.
 blights, 243.
 blossom drop, notes, Okla., 36.
 brown rot, 154.
 curly top, notes, Pa., 548.
 disease, new, 544.
 diseases in Victoria, 154.
 diseases, key and remedies, Can., 348.
 diseases, notes, 151; Pa., 548.
 edema, control, Pa., 549.
 end rot, 243.
 fungus disease, studies, 447.
 Fusarium disease, studies, Ind., 345.
 Fusarium wilt, notes, 243; Okla., 36.
 Irish blight, notes, 154, 244.
 leaf blight, control, Md., 151.
 leaf spot, control, 846.
 leaf spot, notes, Okla., 44.
 mosaic, 243.
 mosaic, studies, Ind., 345.

Tomato—Continued.

- moth, control, 454.
- Rhizoctonia, studies, Wash., 749.
- root knot, control, 47.
- root rot, notes, 154.
- rust, notes, 346.
- seed distribution, Ind., 338.
- seed, selecting and saving, Ind., 835.
- Septoria leaf spot, notes, Ind., 345; Okla., 36.
- sleeping sickness, 244.
- sleepy disease, control, Pa., 549.
- spotted wilt, 154.
- stem rot, notes, 656.
- stigmonose, control, Pa., 549.
- white leaf curl, control, Pa., 549.
- wilt, notes, 151, 656; Okla., 44.
- worms on tobacco, Ky., 359.

Tomatoes—

- as affected by deteriorated calcium cyanamid, 628.
- as affected by soil electrification, Ky., 824.
- breeding experiments, 741; Md., 144; Pa., 537.
- carbon-nitrogen ratio for, 430.
- changes in composition during ripening, U.S.D.A., 834.
- culture, Ky., 37.
- fertilizer experiments, Ind., 338; Mo., 742; Tex., 37.
- Fusarium resistant varieties, Md., 151.
- grade specifications, U.S.D.A., 144.
- pollination tests, 437.
- pruning and training, 644; Ky., 37.
- ripening process, U.S.D.A., 834.
- root development, 834.
- spraying experiments, 246, 656.
- staking, 339; Ky., 37.
- variety tests, 833; Ind., 338.
- wilt-resistant strains, 742.

Topography, relation to frost, 417.

Tornadoes, papers on, U.S.D.A., 511, 719.

Tortrix fumiferana, notes, 852.*Torula lactis-condensæ* n. sp., description, Iowa, 76.

Tourmalin, boric acid determination in, 413.

Tosca, new genus, erection, 853.

Toxoptera graminum, notes, 556.*Trachelus tabidus*, notes, U.S.D.A., 363.*Trachycentra chlorogramma*, notes, 52.

Tractor—

- development, 286.
- engines, cooling, principles of, 88.
- engines, design, 88.
- engines, lubrication, 89.
- engines, tests, 287.
- engines, valves for, 288.
- farming, notes, 892.
- fuel, kerosene for, 891.
- parts, standardization, 89.
- plowing speeds, 390.
- plowing tests, 690.
- plows. (See Plows, tractor.)
- power on farms, Ariz., 788.

Tractor—Continued.

- testing at Purdue University, 287.
- tests, 287.

Tractors—

- American v. Swedish, tests, 690.
- and implements blue book for 1920, 287.
- artillery, use in dam construction, 89.
- design, 87.
- design, factors affecting, 592.
- economy of operation, 187.
- effect of speed on power required, 288.
- effect on use of horses, U.S.D.A., 690.
- friction transmissions, 89.
- gas, recent changes in design, 88.
- in France, 289.
- in Iowa farming, Iowa, 89.
- in Tennessee farming, 690.
- in United States, 390.
- mechanical analysis, 287.
- protection against freezing, 484.
- track-laying, building, 89.
- use in Kentucky, Ky., 389.
- use in reclaiming swamp land, 484.

Tragacanth—

- ashes, fertilizing value, 324.
- mucilage in, origin, 132.

Trametes pini on maritime pines, 755.

Transpiration—

- as affected by light, 131.
- in *Tilia americana*, 223.
- negative pressure and water requirements, 131.
- of maritime plants, 223.

Transplanting, season for, studies, Mo., 142.

Transportation rates, relation to agriculture in Spain, 488.

Tree—

- architectonics, studies, 819.
- chlorosis, notes, N.Mex., 345.
- chlorosis, treatment, 752.
- planting, dynamite for, 480.
- wounds, treatment, 349.

Trees—

- annual rings, climatic effects, 809.
- as affected by sodium chlorid, 343.
- as agents in condensation of moisture, 16.
- as windbreaks, 650.
- coniferous. (See Conifers.)
- economic, in Great Britain, 344.
- foliage, variegation in, 729.
- for Iowa, 742.
- for Nebraska, list, 240.
- forest, culture, Nebr., 650.
- forest for Idaho, Idaho, 650.
- forest, winter injury, 732.
- growth studies, 819.
- new, near Washington, D. C., 222.
- ornamental, culture experiments, U.S.D.A., 339.
- ornamental, for Ohio, Ohio, 342.
- ornamental in South Africa, 441.
- ornamental, tests, U.S.D.A., 339.
- ornamental, winter injury, 753.

Trees—Continued.

- roadside, management, 543.
 - shade, insects affecting, 159.
 - shade, kerosene injury to, 732.
 - shade, for Idaho, Idaho, 650.
 - shade, for Ohio, Ohio, 342.
 - shade, protection for, Ohio, 746.
 - street, laws, Mich., 342.
 - tolerance of, use of term, 840.
 - transplanting, fall v. spring, Mo., 141.
- Trench-foot, relation to deficiency diseases, 168.
- Trialeurodes floridensis*, notes, 851.
- Triatoma megistus*, notes, 182.
- Tricalcium phosphate, effect on composition of soil extracts, Mich., 124.
- Trichogramma*—
- minuta*, parasitism by, Mass., 159.
 - pretiosa*, parasitism by, 759.
- Trifolium fragiferum* var., new forage plant, 528.
- Trimeromicrus maculatus*, notes, U.S.D.A., 365.
- Trinitrotoluol—
- for rock and soil blasting, 480.
 - water resisting properties, U.S.D.A., 282.
- Trioxymethylene powder for mosquito control, 853.
- Trissolcus edessæ*, notes, 259.
- "Tristeza," cause, 182.
- Trochorrhopalus strangulatus*, notes, 52.
- Troctes divinatoria*. (See Book-lice.)
- Trombicula mediocris*, notes, 260.
- Trombidium akamushi*, notes, 260.
- Trona potash, fertilizing value, S.C., 126.
- Tropæolum majus* flowers, genetics of coloration, 328.
- Troughs, concrete, construction, 90.
- Truck crops—
- cultivation, implements for, 892.
 - variety tests, Tex., 36.
- (See also Gardening and Vegetable gardening.)
- Trucks. (See Motor trucks.)
- Trypanosoma*—
- cruzi*, notes, 57, 182.
 - lewisi*, parasite of rat, 883.
- Trypanosome of carabao, 472.
- Trypanosomiasis, American, summary, 182.
- Tryptophan—
- detection in urine, 316.
 - determination, 504.
- Tubercle bacilli—
- solubility, 583, 584.
 - types in human tuberculosis, 686.
- Tuberculariaceæ on box, 849.
- Tuberculin, tests and retests, 81.
- Tuberculosis—
- bovine, control, 272.
 - bovine, economic significance, 81.
 - bovine, eradication, U.S.D.A., 471.
 - bovine, paper on, 683.
 - chemotherapy, 584.
 - complement fixation test for, 278, 687.
 - control, 272, 780.

Tuberculosis—Continued.

- eradication, accredited herd plan, 473; U.S.D.A., 473.
 - eradication methods, comparison, 473.
 - human, transmission to fowls, 687.
 - human, types, 686.
 - intra-dermal test, 683.
 - status, 584.
 - transmission, studies, 81, 685.
- Tule lands, reclamation, Oreg., 21.
- Tulip—
- leaves, frost necrosis, 849.
 - trees, transplanting, Mo., 142.
- Turbidimeters, description, 413, 614.
- Turkeys, raising with special reference to blackhead, 475.
- Turnip finger-and-toe disease, 47.
- Turnips—
- breeding experiments, Can., 735.
 - carbon-nitrogen ratio for, 430.
 - culture, 638.
 - culture experiments, 638.
 - culture on peat soil, 23.
 - feeding value, Can., 771.
 - fertilizer experiments, Can., 735.
 - storage experiments, Can., 735.
 - variety tests, 232, 638; Can., 735.
 - yields, Minn., 824.
- Turpentine operations, notes, 241.
- Tussock grass, sweet, notes, 830.
- Tylenchus*—
- angustus*, notes, 444, 652.
 - devastatrix*, control, 49.
 - devastatrix*, on red clover, 46.
 - devastatrix*, notes, 350.
 - spp., notes, 445.
 - tritici*, notes, 751.
- Typhoid—
- fowl, in France, 84.
 - immunity, studies, 473.
 - vaccine, preparation, 76.
- Typophorus canellus*, control, Md., 559.
- Udder infection, effect on milk, 877.
- Ulla grass, deterioration, 448.
- Ultraviolet rays—
- effect on bananas, 730.
 - effect on blister rust fungus, Can., 754.
 - effect on pineapples, 730.
 - effect on sugar cane, 730.
 - sterilization of water by, 479.
- United States Department of Agriculture—
- and agricultural colleges, cooperation, 704.
 - appropriations, 1920-21, 101.
 - cold storage plant, 892.
 - motion pictures, U.S.D.A., 698.
 - report, 298.
 - States Relations Service. (See States Relations Service.)
 - Weather Bureau. (See Weather Bureau.)
 - yearbook, 496.
- United States Geological Survey, Reclamation Service, report, 85,

- Urea—
 as affected by sewage organisms, 791.
 in blood, determination, 416.
 in blood, variability, 265.
- Urease—
 content of Dutch seeds, 802.
 determination of soy beans, 10, 610, 802.
 from jack beans, U.S.D.A., 233.
- Uredineæ, new species, 222.
- Uredinales—
 of Delaware, list, 328.
 of Indiana, 731.
 temperature of spore germination, N.H., 841.
- Uredo—
arachidis on peanuts, 346.
 sp. and *Puccinia* spp., comparison, 244.
- Uric acid in blood, variability, 265.
- Urine—
 albumin determination, 206.
 ammonia nitrogen from, 220.
 analysis, 316.
 calorimetry, modified method, 264.
 carbon determination in, 414.
 containing lactose, glucose determination, 114.
 creatinin content and purgation, 462.
 diazo reaction, 368.
 energy value in undernutrition, 264.
 nitrites in, test for, 316.
 nitrogen determination, method, 316.
 nitrogen partition, of races, 65.
 of pellagrins, analyses, 667.
 protein determination in, 416.
 reducing substances, colorimetric determination, 414.
 sugar determination in, 416.
 tryptophan in, test for, 316.
 (See also Manure, liquid.)
- Urocystis—
cepula, notes, 654.
 spp., notes, 445.
- Uromyces—
aloës, life history, 156.
appendiculatus, notes, 152.
caryophyllinus, temperature of spore germination, N.H., 842.
- Ustilaginales of Indiana, list, 329.
- Ustilaginoidca* sp. on rice, 45.
- Ustilago*—
maydis, notes, 152.
sacchari, notes, 444.
 spp., notes, 445.
tritici, notes, 751.
- Ustilina zonata*, notes, 247.
- Utah—
 College, notes, 498.
 Station, notes, 498, 900.
- Vaccination—
 by ingestion of typhoid bacilli, 473.
 in the field, hints, 683.
- Vaccine—
 new, against contagious abortion, 82.
 organisms in, estimating number, 782.
- Vaccines—
 as new and unofficial remedies, 470.
 commercial, immunizing value, Nebr., 882, 887.
 preparation, 76.
 standardization, 181.
- Vaiolo, new sumac disease in Italy, 49.
- Valsa leucostoma*, notes, Can., 847.
- Valves for tractor engines, 288.
- Vanessa urticae*, notes, 853.
- Vanilla analysis, N.Dak., 315.
- Vanillin—
 determination, N.Dak., 368.
 oxidation products, analysis, N.Dak., 314.
- Variation—
 in *Abutilon theophrasti*, 433.
 of flowers in *Anemone hepatica*, 328.
 (See also Mutation and Heredity.)
- Variations, casual, inheritance of, 222.
- Variegation—
 in tree foliage, 729.
 studies, 433.
- Vegetable—
 fats. (See Fats, vegetable.)
 gardening, treatise, 236.
 (See also Gardening.)
 oils. (See Oils.)
 investigations, need for, 643.
 proteins. (See Proteins.)
 waste, use for feeding stuffs, 868.
- Vegetables—
 analyses, 63.
 canning, cold-pack method outfits, 808.
 culture experiments, Ariz., 741; Can., 741; N.Mex., 339; U.S.D.A., 339.
 dried, nomenclature, Calif., 716.
 economic values, 366.
 for diabetics, analyses, Conn.State, 861.
 fertilizer experiments, R.I., 643.
 fresh, antiscorbutic value, 263.
 garden, early transplanting, Mo., 143.
 green, losses in cooking, 458.
 green, vitamins in, value, 165.
 hardening, nature of, 643.
 home-canned, spoilage in, Mich., 114.
 insects affecting. (See Garden insects.)
 market at Kansas City, U.S.D.A., 595.
 market diseases of, 751.
 monthly working calendar for, 236.
 preservation for home use, Can., 316.
 receipts in Cincinnati, U.S.D.A., 490.
 refrigeration, 339.
 sun drying, 808.
 sun-dried, directions for cooking, 64.
 sun-dried, vitamin content, 63.
 spoilage in transit and storage, 656.
 storages and caves for, 691.
 transplanting investigations, Mo., 741.
 variety tests, Can., 741; Minn., 833; U.S.D.A., 339.
 (See also specific kinds.)
- Vegetation—
 around manure heaps, 430.
 as affected by altitude, 149.

Vegetation—Continued.

- as affected by soil acidity, 212.
of depressions near Sacramento, 224.
of Great Plains, composition, 522.
winter injury of 1916-17, 326.
(See also Flora.)
- Velvet bean meal—
analyses, Vt., 464.
fertilizing value, Ala.Col., 135.
nitrogen availability, Ala.Col., 135.
- Velvet beans—
culture experiments, La., 635.
Georgia, proteins of, 410.
popular account, U.S.D.A., 831.
variety tests, Ariz., 733; U.S.D.A., 330.
- Ventilation of farm buildings, 892.
- Venturia*—
inaequalis, notes, 155.
pomi, notes, 246.
- Vermicularia capsici*, notes, 444.
- Vermifuges for poultry, Okla., 79.
- Vermont—
Station, report, 197.
University, notes, 200, 499.
- Veronica, Peronospora on, 248.
- Verticillium alboatrum*, notes, 547.
- Vetch—
and rye as fall forage, Mo., 736.
description and value, 528.
fall planting, Wash., 738.
fertilizer experiments, N.C., 424.
hairy, as cover crop, Pa., 538.
hairy, seed production, U.S.D.A., 831.
seed, wild, feeding value, 373.
variety tests, Can., 735.
- Veterinary—
education in Dutch East Indies, 795.
education in South Africa, 683.
instruction in Dutch East Indies, 296.
medicine, textbook, 797, 879.
medicine, treatise, 683.
science, principles of, 76.
specimens, collecting, 683.
- Vibron septique*, groupings, 581.
- Vinegar—
making on the farm, Mich., 698.
treatise, Mich., 115.
- Vines—
for Nebraska, list, 240.
for Yuma region, U.S.D.A., 339.
resistance to cold, 438.
- Vineyards, devastated, reconstitution, 835.
(See also Grapes.)
- Vinsonia stellifera*, notes, 555.
- Violets, *Perrisia affinis* on, 661.
- Virginia—
College and Station, notes, 499.
Truck Station, index to bulletins, 98.
Truck Station, notes, 200, 600.
- Vitamin—

Vitamin—Continued.

- antineuritic, new term for, 861.
(See also Vitamin B.)
- B, in fruits, 765.
B, in milk, 165.
B, in orange juice, 460.
C, as affected by heat, 567.
C, in milk, as affected by diet, 766.
C, of beef, raw, 664.
C, of cabbage, sun-dried, 63.
C, of carrots, sun-dried, 63.
C, of dried orange juice, 460.
C, of fruit juices, 263, 667.
C, of meat juice, 263.
C, of milk, 166.
C, of onions, sun-dried, 63.
C, of potatoes, raw and dried, 765.
C, requirements of monkeys, 461.
deficiency, effect on animals, 369.
number defined, 614.
requirements of frogs, 462.
- Vitamins—
antineuritic and antiscorbutic, 461.
chemical isolation of, 459.
determination, 614.
effect on course of pellagra, 667.
in sun-dried vegetables, 63.
nature and significance, 367, 860.
present state of knowledge, 262.
rôle in chick feeding, 174.
rôle in infant feeding, 166.
studies, 262, 263, 664, 861.
synthesis in intestines of rabbits, 166.
- Vitula serratilineella* feeding on honey, 558.
- Vocational education—
and general science, 396.
elementary, for Colorado, 396.
for girls, 197.
in Alabama, 296.
in Colorado, 297.
in Florida, 595.
in Georgia, 297.
in Indiana, 195, 695.
in Kentucky, 695.
in Maine, 696.
in Massachusetts, 194.
in Missouri, 595.
in Nebraska, 596.
in New Jersey, 795.
in New Mexico, 596.
in North Carolina, 696.
in North Dakota, 397, 596.
laws in Wisconsin, 598.
(See also Agricultural education.)
- Vocational schools for girls, 596.
- Volemite, 801.
- Volutella buxi*, notes, 849.
- Volutin in *Azotobacter chroococcum*, 124.
- Wallflower disease, new, 544.
- Walls—
concrete, construction, 188.
retaining, construction, 485.
- Walnut—
aphis, dusting for, 451.
bacteriosis, control, 350.
blight and bacteriosis, identity, 156.

- Walnut—Continued.
diseases, control, 350.
shell disease, 754.
- Walnuts—
culture in Canada, 746.
time for transplanting, Mo., 142.
variety tests, Md., 144.
- War damages, agricultural, estimating, 290, 835.
- Warble flies, summary of information, 55.
- Warbles, ox, importance, 853.
- Warehouses, wool, regulations, U.S.D.A., 571.
- Washington—
College, notes, 400.
Station, notes, 400, 499.
Station, report, Wash., 798.
Substation, Western, monthly bulletin, 197, 397, 496, 698, 798.
- Wasp, leafhopper, notes, 662.
- Wasps, petiolate, synopsis, 60.
- Water—
absorption by maritime plants, 223.
analysis, turbidity standard, 613.
buffalo, trypanosome of, 472.
chlorin contamination, 478.
colloidal state in, 224.
conductivity of ash and hazel wood, 31.
content of soil, relation to soil, 20.
disinfection in Argentina, 392.
duty of. (*See Irrigation water.*)
erosion test, 279.
evaporation from moor, 20.
flow, as affected by afforestation, 16.
flow, in drain tile, U.S.D.A., 789.
flow, in dredged ditches, U.S.D.A., 478.
flow, in open channels, measuring, 887.
irrigation. (*See Irrigation water.*)
level of moor soils, 623.
level, variations, 210.
locating, use of divining rod, 478.
meters, Venturi, computation of coefficient of discharge, 477.
of Germany, nutrient content, 728.
plants as affected by light, 431.
potable, for country houses, 392.
potable, hygienic inspection of, 478.
potable, in Switzerland, studies, 588.
power of United States, 280.
purification for laboratory, 279.
quantities on reclamation projects, 85.
rain. (*See Rain.*)
sterilization by ultra-violet rays, 479.
supplies, moorland, purification, 478.
supplies, purification, 888.
supply by means of cisterns, 279.
supply contamination, Mo., 787.
supply from tube wells, 386.
supply, increasing by reforestation, 16.
supply on the farm, 479.
tidal saline, use for irrigation, 185.
works, effect on water level, 210.
- Waterfowl—
breeding grounds, U.S.D.A., 49.
of Nebraska and their food, U.S.D.A., 49.
- Watering troughs, concrete, 90.
- Watermelon—
anthracnose, control, U.S.D.A., 348.
bacterial wilt, control, U.S.D.A., 245.
wilt, studies, Tex., 846.
- Watermelons—
shipments in Missouri, U.S.D.A., 794.
variety tests, Tex., 36.
- Water-power resources in France, 790.
- Water-soluble B. (*See Vitamin B.*)
- Water-soluble C. (*See Vitamin C.*)
- Waterspout in Adirondacks, U.S.D.A., 719.
- Waxes—
iron content, 202.
saponification determinations, 505.
- Weather—
and solar variation, 809.
Bureau, report, U.S.D.A., 318.
forecasting, U.S.D.A., 120, 511.
forecasting, cirrus clouds in, 319.
hot, and humidity, U.S.D.A., 718.
periodicity in, 416.
textbook, 208.
(*See also Meteorological observations and Meteorology.*)
- Weeds—
control in coniferous nurseries, 42.
eradication from lawns, N.Y.State, 535.
(*See also specific plants.*)
- Weevils—
new from Asia, 163.
new tropical, 562.
- Weight burette for gas analysis, 611.
- Well waters for irrigation, 279.
- Wells—
boring, artesian and shallow, 477.
concrete linings and curbs for, 90.
contamination and protection, 392.
hygienic inspection of, 478.
tube, relation to subsoil water, 386.
- West Virginia Station, notes, 100.
- Whale muscle, composition, 569.
- Wheat—
and rye middlings, analyses, N.J., 69.
as nurse crop, Wash., 737.
belt, rent contracts in, U.S.D.A., 290.
black chaff, notes, Okla., 44.
bran, analyses, 867; Ind., 69, 867; Ky., 373; N.J., 69, 672; R.I., 672; Vt., 464.
breeding experiments, Ariz., 734; Ky., 332, 824; Mo., 736; Wash., 737.
breeding, pure lines, Me., 641.
bud-sports, 534.
bunt, notes, 45.
chimeras, speltoid, 534.
composition, effect of freezing, 501.
cost and price indexes, Mo., 792.
cost of production, Ohio, 392.
cost of production in Argentina, 487.
cost of production in Kansas, 593.
culture experiments, 528, 824; Ky., 332; Mont., 332, 739; Wash., 737, 738.
culture, farm practices, U.S.D.A., 437.
culture in Manitoba, 640.
culture on Yuma project, U.S.D.A., 393.

Wheat—Continued.

- diseases, control, Tex., 845.
- diseases, notes, 45.
- dockage, determining, U.S.D.A., 535.
- durum, red, tests, N.Dak., 366.
- drought-resistant, Wash., 737.
- ear cockle, notes, 243, 445.
- eelworm disease, 751.
- exports from Argentina, 95.
- fall planting, Wash., 738.
- feeding flour, analyses, N.J., 69.
- fertilizer experiments, 126, 518, 528;
 - Can., 729; Idaho, 227; Ky., 332;
 - Ohio, 726; Wash., 722.
- flag smut, control, Ill., 844.
- flour. (*See Flour.*)
- foot disease, 750.
- foot rot, studies, 445.
- Fusarium disease, control, 345.
- Fusarium disease, studies, Mo., 749.
- germination as affected by H-ion, 525.
- glume spot, Can., 750.
- gluten content, Me., 641.
- grade requirements, U.S.D.A., 535.
- grading, announcement, U.S.D.A., 832.
- grading, equitable, N.Dak., 642.
- heads, anatomical structure, 328.
- heads, effect of length, S.Dak., 235.
- heads, partial smutting of, 750.
- Indian, in Mesopotamia, 831.
- injury by squirrels, Wash., 351.
- insects affecting, summary, 253.
- irrigation experiments, Nebr., 637;
 - Nev., 228; Utah, 230.
- joint-worm, notes, Ind., 352.
- leaf rust, studies, Ind., 345.
- liming experiments, Can., 729.
- loose smut, notes, 45.
- manuring experiments, Okla., 32;
 - Utah, 218.
- microflora of, 445.
- middlings, analyses, 867; N.J., 69,
 - 672; R.I., 672; Vt., 464.
- midge, notes, Ind., 352.
- milling and baking tests, N.Dak., 642.
- mixed feed, analyses, 867; Ind., 69,
 - 867; Ky., 373; N.J., 69, 672; Vt.,
 - 464.
- nematode, notes, 751.
- nitrogen content, Wash., 737.
- nutrient requirements, Md., 121.
- period of nitrate utilization, Ill., 215.
- price regulation by Government, 489.
- prices and world's supply, 705.
- prices, guaranteed, 895.
- production in Brazil, 292.
- production in South Africa, 393.
- production in Victoria, 642.
- protection in Quebec, 844.
- protein content, Me., 641.
- relation of potassium, N.H., 29.
- rotation experiments, 518; Idaho,
 - 228; Ohio, 726; U.S.D.A., 435.
- rust as affected by dry weather, 652.
- rust in seed, seedling infection, 546.
- rust, notes, 45, 243, 347, 546.
- rust, relation to barberry, 546.

Wheat—Continued.

- rust, studies, Iowa, 654.
 - sawfly, black grain-stem, U.S.D.A.,
 - 363.
 - scab, production of conidia, 545.
 - screenings, analyses, Ind., 867; Vt.,
 - 464.
 - seed treatment, 642.
 - seeding experiments, Ind., 330; Minn.,
 - 823; N.C., 434; Wash., 737.
 - seedlings, growth H-ion, 525.
 - selection experiments, Me., 641.
 - selection and hybrids, 528.
 - Septoria blight, notes, 347.
 - shorts, analyses, R.I., 672.
 - smut, notes, 243.
 - smut, prevention, 347, 445.
 - smut resistance, Wash., 737.
 - smut, studies, Wash., 749.
 - spring, seed, longevity of, 832.
 - spring, variety tests, N.H., 34.
 - spring, yields, 829.
 - starch, raw, digestibility, 365.
 - stored, insects affecting, 253, 254.
 - take-all, control, 347; Ill., 844.
 - take-all, notes, 243; Ind., 345.
 - take-all, relation to green manure, 152.
 - varieties, N.C., 434; U.S.D.A., 637.
 - varieties, Argentine, 437.
 - varieties in Sahara cases, 831.
 - variety tests, 231, 232, 528; Ariz., 733;
 - Can., 735; Ky., 824; Md., 134;
 - Minn., 636, 823; Mo., 736; N.Dak.,
 - 332; Nebr., 637; Nev., 228; Okla.,
 - 32; U.S.D.A., 435; Wash., 737;
 - Wyo., 135.
 - water requirements, Colo., 185.
 - weevils, oxygen requirements, 254.
 - weevils, studies, 253.
 - winter, fertilizer experiments, Idaho,
 - 227.
 - winter, irrigation experiments, Nebr.,
 - 637.
 - winter, seeding experiments, Minn.,
 - 823.
 - winter, snow effect on growth, 417.
 - yield as affected by rainfall, 208.
 - yield in Australia, 527.
- White—
- ants. (*See Termites.*)
 - grubs on sugar cane, notes, 52.
- White pine—
- aphid, infestation, 556.
 - blister rust—
 - conference, international, 755.
 - control, 248, 658.
 - dissemination by insects, 754.
 - distribution of spores, 249.
 - identification and prevention, 350.
 - on Ribes, control, N.H., 44.
 - overwintering on Ribes, 849.
 - spore germination, N.H., 842.
 - studies, 249, 552; Can., 754.
 - summary, 248.
 - forests in New England, 149.
 - infection experiments, 250.
 - summer planting, 841.

- White pine—Continued.
 thinning experiments, N.H., 42.
 weevil, notes, Conn.State, 251.
- White scours of calves, 183.
- Whitman, C. O., posthumous works, 66.
- Willow—
 canker, control, 350.
 fence posts, treatment, U.S.D.A., 391.
 rust, control, 350.
- Willows—
 basket, insect and fungus pests, 556.
 basket, insects affecting, 350.
- Wilson, Jas., biographical sketch, 601.
- Wind—
 and pressure charts, U.S.D.A., 718.
 direction, effect on temperature, U.S.
 D.A., 118.
 effect on soil organisms, 842.
 effect on insects, U.S.D.A., 120, 157.
 off-shore, U.S.D.A., 719.
 relation to evaporation, 16.
 turbulence, U.S.D.A., 719.
- Windbreak trees on prairie farms, 650.
- Windmills, use in South Dakota, 620.
- Winds, paper on, U.S.D.A., 119.
- Windstorm of November 20, 1919, injury to
 citrus trees, 41.
- Wire—
 belts with paper driving surface, 891.
 screen, durability tests, Wyo., 189.
- Wireworms—
 on cotton, U.S.D.A., 352.
 toxicity of organic compounds to, 854.
- Wisconsin University, notes, 600, 800.
- Witches' Broom, studies, 821.
- Woburn Fruit Farm, report, 29.
- Women, labor-saving for, U.S.D.A., 894.
- Women's institutes in Canada, 395.
- Wood—
 as source of alcohol, 617.
 ashes as source of potash, 324.
 chemistry of, 617.
 coniferous, proximate analysis, 506.
 decay by *Polyporus pargamenus*, 553.
 distillation, chemistry of, 409.
 distribution of chemical constants, 506.
 drying, internal stresses, 590, 591.
 of stumps, distillation, 888.
 preservation, chemistry of, 409.
 preservation, relation to oil, 283.
 pulp cellulose as emergency feed, 170.
 pulp. (See also Pulpwood.)
 substitutes in Germany, 204.
 (See also Lumber and Timber.)
- Woodland products, cooperative marketing,
 U.S.D.A., 345.
- Woodlands—
 English, management, treatise, 442.
 farm, management, 543.
- Woodlots, care and improvement, 840.
- Woods—
 American, pulp and paper value, 650.
 dicotyledonous, structure, 225.
 inferior, in Trinidad, durability, 44.
 62212°—21—9
- Woods—Continued.
 of Hertfordshire, 241.
 of Java, 443.
 of United States, manual, 443.
- Woody—
 aster, poisoning of sheep, Wyo., 782.
 aster, toxic substance, Wyo., 782.
 plants, sprouting, 130.
- Wool—
 as affected by dips, Wyo., 172.
 cooperative sales, N.C., 595.
 farm-flock, preparing, Wash., 397.
 fiber as affected by humidity, 571.
 Karakul, production in Canada, 69.
 Kentucky, plan for marketing, 673.
 production and prices, U.S.D.A., 695.
 warehouses, regulations, U.S.D.A., 571.
 trade in India, 269.
- Woolly aphid. (See Aphid, woolly.)
- Worm infection of pigs, treatment, 467.
- Wounds—
 bacteriology of, 880.
 treatment with flavin, 79.
- Wyoming—
 Station, notes, 200, 800.
 Station, report, 197.
 University, notes, 200.
- Xanthoencyrtus fullawayi*, notes, 662.
- Xanthophyll in leaves, 633.
- Xerophthalmia—
 production in rabbits, 369.
 relation to vitamin A, 860.
- Xyleborinus pecania* on sweet potatoes, 163.
- Yam—
 rot, notes, 151.
 weevil, notes, 258.
- Yams—
 culture and use in Fiji, 829.
 fungus attacking, 652.
- Yeast—
 brewery and mineral, digestibility, 367.
 dried grains, analyses, 867; N.J., 69,
 672.
 fermentation of plant nectar by, 730.
 pink, cause of spoilage in oysters, 663.
 utilization by animal organism, 64.
- Yeasts—
 chemical, composition, 415.
 substitutes in Germany, 204.
- Yerba mate, production in Argentina, 745.
- Yuma experiment farm, report, U.S.D.A.,
 397.
- Zea, direct origin of, 222.
- Zethus*, spp., synopsis, 60.
- Zeuzera* spp., notes, 450.
- Zinc—
 chlorid, use against weeds, 42.
 determination, new method, 11.
 effect of acid soils on, 27.
 sulphate, use against weeds, 42.
- Zoology, bibliography, 250.
- Zoraptera, classification of, 556.

ADDITIONAL COPIES
OF THIS PUBLICATION MAY BE PROCURED FROM
THE SUPERINTENDENT OF DOCUMENTS
GOVERNMENT PRINTING OFFICE
WASHINGTON, D. C.
AT
10 CENTS PER COPY
SUBSCRIPTION PRICE, 75 CENTS PER VOLUME





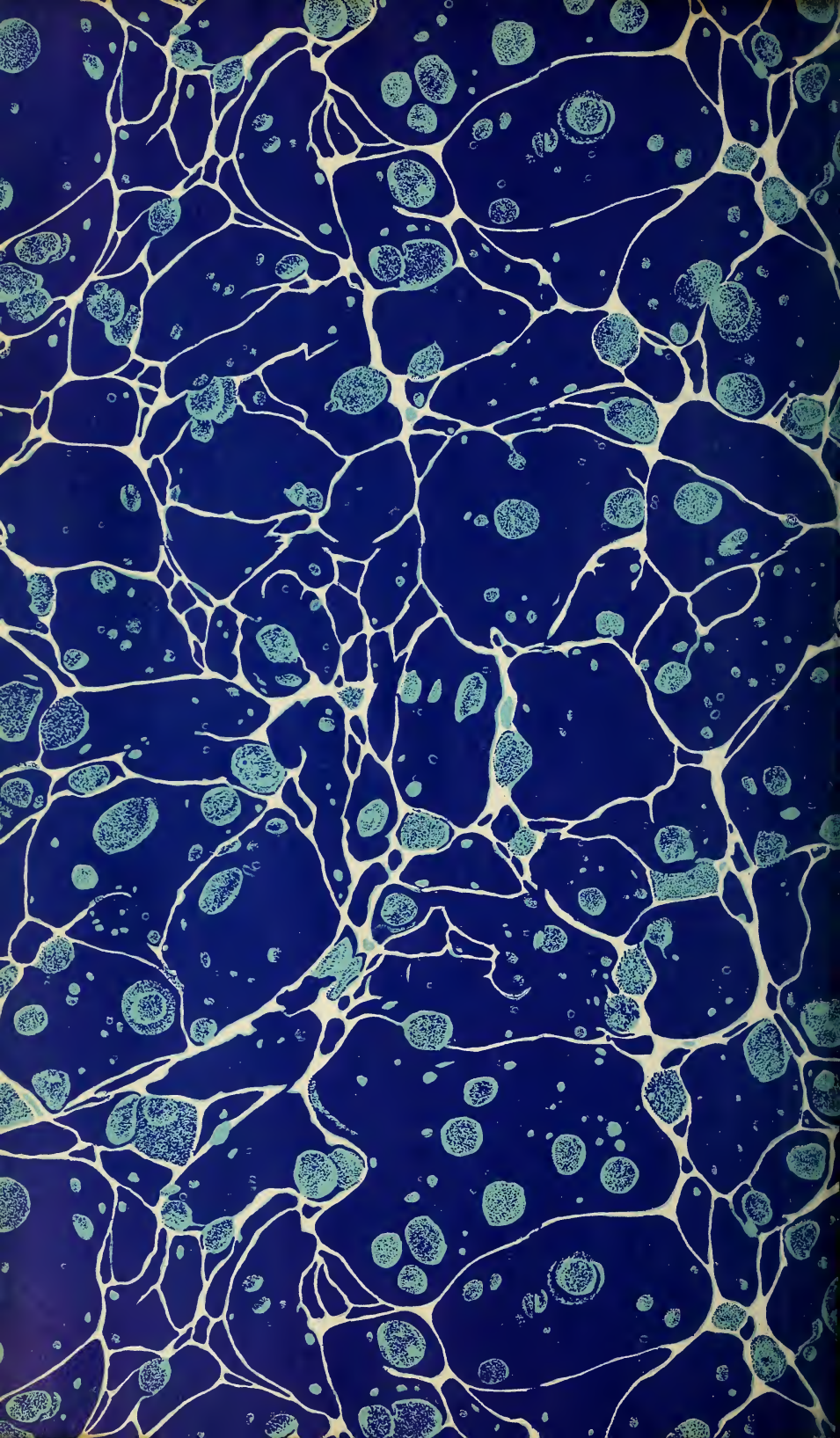

**U. S. DEPARTMENT OF AGRICULTURE
LIBRARY**

NOTICE TO BORROWERS

Please return all books promptly after finishing your use of them, in order that they may be available for reference by other persons who need to use them.

Please do not lend to others the books and periodicals charged to you. Return them to the Library to be charged to the persons who wish them.

The mutilation, destruction, or theft of Library property is punishable by law. (20 Stat. 171, June 15, 1878.)

Lib. 9



o p o

