

河工器具圖說

452

18

河工器具圖說

卷三 搶護器具

長白麟 慶見亭纂輯

大埽

捆廂船

葦纜 麻纜

埽腦 鈎繩杓 揪頭繩杓

騎馬杓 騎馬

撞杓 齊板

太平棍 跳棍

木華 鈎竿

戣椿船

大椿 替椿 梯鞋

雲梯 高橈

雲碓

埽枕

木榔頭 木斧 鉞 斧

月鏟

抓鈎 鐵錨

鐵槓頭 鐵杖

逼菱椿 塘凌把

打凌槌

鐵穿 三稜槓

打凌船

鐵鍋

瓦盆

布口袋

棉被 棉襖

石磨

木筏

木龍全式

木龍一層編底二三層橫梁

木龍四五層龍骨邊骨六七層齊梁

木龍八層縱木九層面梁

水閘 天平架 地成障

眠車

大戣 直柱

股車 轆轤架

天戣 地犁

通水木 冰滑

大埽

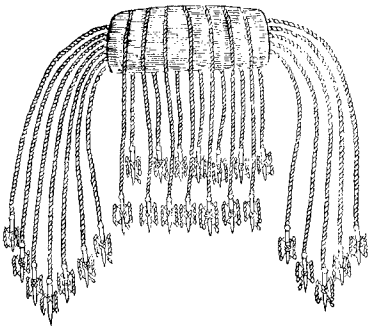

婦卽古之茨防高自一尺至四尺曰由自五尺至一丈曰婦史記
河渠書下淇園之竹以爲槩是也其實於婦中而兩頭餘出甚長
者曰揪頭連婦兩頭所捆者曰邊戩連婦外通身皆捆每離五尺
一根者曰底鈎婦中段用纓子捆紮者曰滾肚皆爲繫婦之繩逐
頭有檣檣長四五尺五六尺不等婦名不一有等婦邁婦肚婦而
婦套婦護厓磨盤雁翅鼠尾蘿蔔之別又有龍尾婦伐大柳樹連
梢繫之長堤根隨水上下破嘴岸浪俗名曰掛柳從鋪衡鋪卽俗
謂丁廂管心索卽俗謂揪頭繩其分上下水揪頭者凡婦下水頭
必高上水頭二三尺不等拉時須從下水頭先拉兩號然後一齊
叫號兩頭自然平整婦初下時未曾得底繩快須時時派兵看守

緣揪頭過鬆則無力鈎戰過緊則發櫛迨埽沉水卽行加廂每尺
壓上五寸廂二尺用騎馬一路俟埽平水簽釘長椿釘椿須靠山
迎上水不宜陡直否則防推埽離當倘水深溜急新做之埽身輕
難以下墜每坯必高廂料厚四五尺不等再點花土如已得底方
可用重土按坯盤壓但此論尋常廂做設遇脫胎陡蟄卽爲捨廂
顧名思義自當以速爲主而廂做之法仍不外是

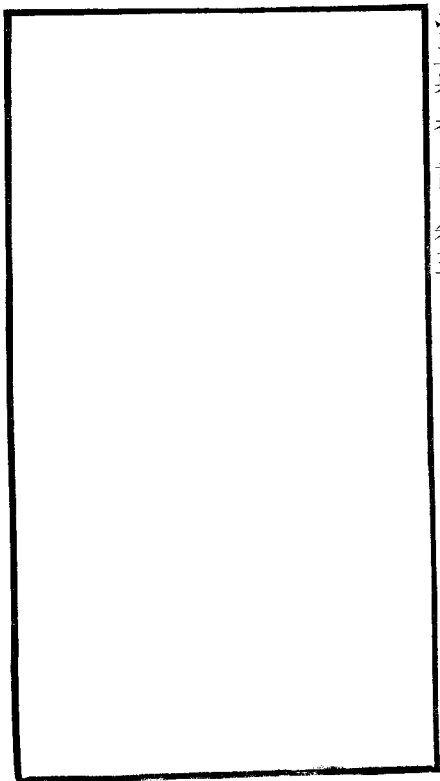

船大廂捆

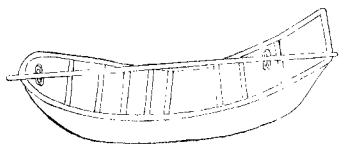

方言自關而西謂舟爲船自關而東或謂之舟劉熙釋名船循也
循水而行也至正河防記賈魯下埽先排大船二十餘隻以麻竹
束縛連爲方舟用竹編笆夾以草石立之桅前名曰水簾桅復以
木指住使簾不偃仆然後選水工便捷者每船二人各執斧鑿以
鳴鼓爲號一時齊鑿須臾舟穴水入舟沉過決河水怒溢今則用
大船捫廂船上紮稽捫二箇安置兩頭名曰龍枕上卧大木一根
名曰龍骨廂埽時將船泊於埽前用上下水揪頭繩纜繫於龍骨
兩頭除埽徐徐推下而船仍如故龍骨須大木急切難購多用船
桅但此係捫廂正法近時東河多用兜纜軟廂較爲便捷如遇大
汛溜急之時仍非捫船不可

纜 葦



纜 麻

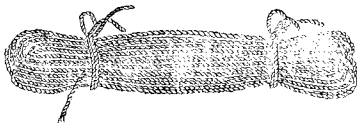

玉篇纜維舟索也物原軒轅作綿索堯作維牽小爾雅大者謂之索小者謂之繩纂文竹索謂之篑漢溝洫志云攀長菱兮湛美玉注臣瓚曰竹葦絙謂之菱所以引置土石也師古曰絙索也菱字宜從竹今河工所用麻纜卽綿索葦纜卽葦絙捆船廂埽非此不爲功然維持得力麻勝於葦入水耐浸葦勝於麻若竹纜質硬而脆用以維舟則宜

腦 埽



揪頭繩杖



杖繩鈎



檝說文杙也爾雅釋宮檝謂之杙注檝也蓋直一段之木也列子
黃帝篇若檝株駒注斷木詩小雅旣備乃事疏引漢農書云孟春
土長冒檝陳根可拔耕者急發如揪頭繩鈎繩等快皆埽工所用
鈎繩快長四五尺揪頭快長五六尺又大埽沉水旣已到底將纓
子頭用小繩挽結緊實再用柳檝有倒鈎者釘繩頭於埽內名曰
埽腦

騎馬杖

馬 騎

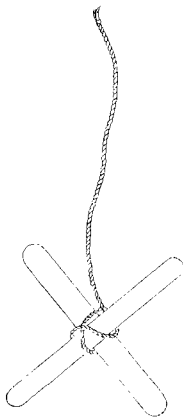

騎馬以二木釘成十字長四五尺有一騎馬必有一纜一枋是以
騎枋爲一副廂埽一坯須用騎馬一路恐埽往前游釘枋摟住則
埽穩固矣說文騎跨馬也逸雅騎支也兩脚支別也以一木跨於
一木之上而脚支別故曰騎馬

齊板



撞杵



說文撞瓦擣也瓦持也象手有所瓦據也讀若戟擣手椎也壩臺土頭結實須用撞槓先撞成穴則鈎挾揪頭槓易於深入矣齊板一名邊棍廂工堆料所用一恐埽眉參差不齊一恐料梁凹凸不平用此拍打以期一律玉篇齊整也故名之曰齊板

太平棍

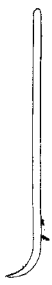

跳棍

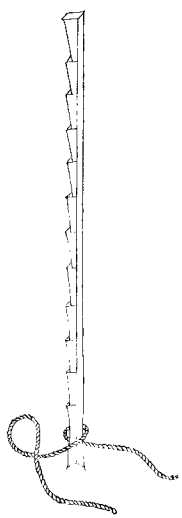

太平棍約長三尺下帶彎拐新做之埽層柴層土按坯加廂每廂一坯繩隨埽下拴枋之結徐徐鬆放此棍用以挑鬆結纒埽因之而得底俗名曰開棍因有避忌以此名之又有跳棍一名挑桿擇堅勁之本爲之圍圓一尺四五寸長八九尺至一丈以外面刻梯級便於上下跣踏梢刻月牙便於加勁拴繩起擰故枋凡起枋均在埽段穩定以後枋眼務填補堅實說文跳躍也六書故大爲躍小爲踊躍去其所踊不離其所使故枋躍然以去其所則非跳棍不爲功

竿 鈎



竿 木

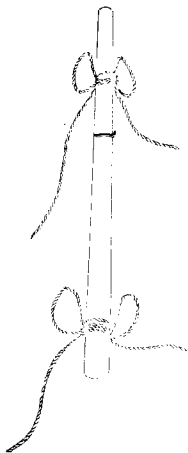

字彙屋斜用竿又以木石遮水亦曰竿木竿一名竿桿埭至河涯人不得力須用木竿視埭長短每埭檔長一尺用行繩一條每行繩兩條中用竿木一根前以繩拉後以木竿埭倚方能捲緊行速凡撐枕撐船皆須用之木竿或用楊椿或用長大杉木均可近時購材爲難多以大船二桅代之又有鈎竿專用以啓閘板每根長三丈六尺圍圓一尺二三寸其下鐵鈎曲長二尺許寬二寸束以鐵箍二道

船 椿 戣



戣椿爲下埽栓繫揪頭纜之用所關最重黃河隄壩寬厚地尙易擇惟洪湖下埽兩面皆水必須選長大椿木簽釘湖心以爲根本而水深浪急顛簸不定簽釘甚難其法用船二隻首尾聯以鐵鍊每船設高橈一具上搭蹉板中畱空檔安置戣椿選椿手攜礮登板逐漸打下較準水深以入土丈餘爲度

式 椿 大 簽 一

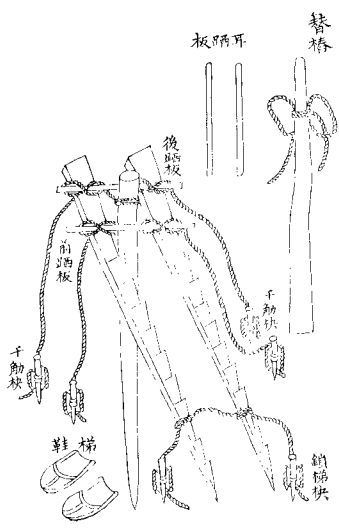

河工器具圖說

卷三 搶護

十一

下埽穩固應簽大椿若壩臺鋪柴多椿木撐起兵在上面打椿恐新埽易致落空必用梯鞋方穩否則梯尖插入埽臺急難復退椿受傷人落河矣軟騎臺尤其非此不可椿維楊木可用其性綿杉木性脆斷乎不可梯前後必用晒板左右有耳晒板可以容人足管定椿木四面用干筋枋鎖緊椿木以鎖梯枋鎖住梯脚梯鞋剗木肖鞋形以承梯脚戴側六書故今人以履無踵直曳之者爲鞞中華古今注鞞鞋蓋古之履也秦始皇常鞞望仙鞋以對隱逸求神仙梯鞋古之鞞鞋式也但此係河工舊制自乾隆三十六年以後概不簽椿緣椿木極長五六丈大河埽前水深每至四五丈加以埽高水面二丈計高深六七丈埽心簽椿斷難入土卽或水淺

一
之工入土亦不過丈許埽大椿淺何能屹立倘埽一墊動椿鯁於
中轉難加廂搶歷實屬無益惟尋常淺水河身形如鍋底埽工游
蟄不止者得此自臻穩固

雲梯

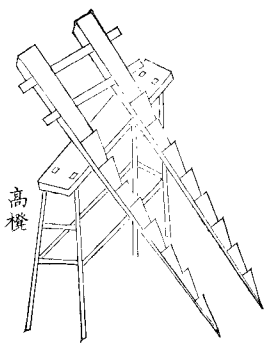

高橙

事物紺珠梯木階軒轅制續事始雲梯魯人公輸般造毛詩注鈎
援鈎梯也所以鈎引上城卽雲梯也雲梯打椿所用梯之高矮視
椿之長短爲率約在三丈以外梯用二木鋸級兩人並上謂之雲
梯亦猶通天臺上之通天梯太白陰經之飛梯言其高而已橈正
韻晉癸几屬晉書王獻之傳魏淩雲殿榜未題匠人誤釘不可下
使韋仲將懸橈書之雲梯不用時以高橈架起將草覆蓋恐日久
朽爛用時人夫受傷耳 一

碇

雲

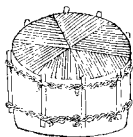

雲礮鑿石如礎厚數寸比地礮輕一二十觔打礮兵夫用十二名
礮肘雞腿俱用雜木全恃盤礮之人盤得結實礮夫在梯上用以
簽椿椿高則礮自空而下有似雲落故曰雲說文礮石巖也玉篇
礮礮山高貌郭璞江賦陽侯礮礮以岸起注礮礮搖動貌未間用
以名物顧礮夫舉礮聲揚則力齊其音類莪稱之曰礮殆六書所
謂諧聲者乎

枕 埽



枕長數丈至十丈許不等大埽上而所用先用小繩挽住後尾再用木簽在枕上一路實釘然後在裏面加上卽遇大汛盛漲水上埽面能收淤閉之效又漫灘水抵堤根過於寬深堤爪恐有風浪汕刷之虞應先紮枕備防臨期將枕推入水中用小木簽釘住使水流少緩亦必停淤矣禮記少儀篇穎注穎警枕也謂之穎者穎然警悟也攔土而曰枕其有先事預防之警歟

鉞

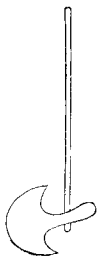

木斧



斧

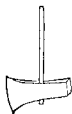

木榔頭

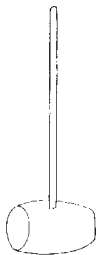

逸雅斧甫也甫始也凡將制器始用斧伐木已乃制之也木斧者鎖椿之物倘各繩鬆緊不一用木斧在椿上捶打緊奏恐用鐵斧致傷各繩之故木榔頭打埽上小木簽擺秧用之斧卽鐵斧鉞卽大柄斧椿手均須預備凡埽上繩纜有不妥之處用以斬截甚利

月 鏟

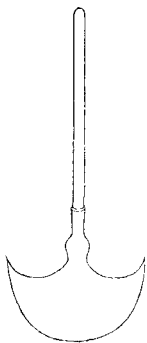

古史考公輸般作鏟說文鏟平鐵博雅籤謂之鏟木華海賦鏟臨
厓之阜陸杜甫詩意欲鏟疊嶂鐵首木身形如半月凡舊埽舊椿
樹根盤踞埽眉不齊皆用之

鉤 爪

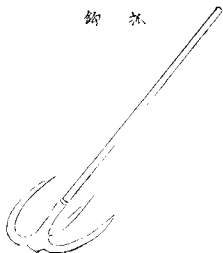

鉤 鐵

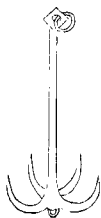

韻會古兵有鈎有鑲皆劔屬引來曰鈎推去曰鑲純鈎劔也吳鈎刀也刈鈎鑷也鈎之名不一鈎之用亦各不同抓鈎係拆廂舊埽所用博雅抓搔也又搯也三股內向如搔手然故名俗書刊誤船上鐵猫曰錨其製尾叉四角向上首戴環以鐵索貫之投入水中使船不動河工廂埽每遇水深溜急提腦不得箴椿用錨掛纜謂之神仙提腦

鐵
槓
頭

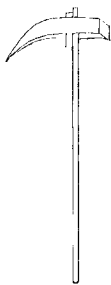

鐵
杈

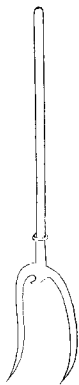

鐵鋤頭一名斫斫鋤屬鋤之爲言掘也持以刨挖東土物原神農
作耜耨以墾草莽然後五穀興則鋤蓋神農造也鐵杈說文杈枝
也徐曰岐枝木也木幹鐵首二其股者利如戈戟又軟草與埽眼
挑碎楷用之

通 凌 椿

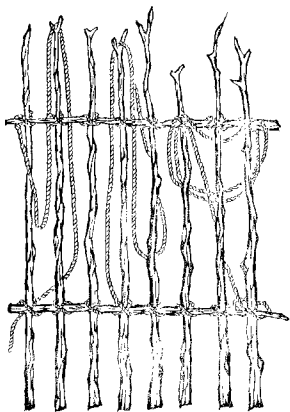

塘 凌 把



上游冰凌隨水下謂之淌凌或大如山或小如盤其性甚利埽
段遇之最易擦損則用丈餘長木排護迎溜埽前名逼凌替又用
細木二三根紮把排於拖溜埽前名塘凌把倘逢溜急凌大之時
椿把以外仍加大柳樹以粗鐵鍊繫之名臥椿以作重衛惟是排
椿之法必須先將下節用蘇纜連鐵扣住然後入水再於上埽生
根用細鍊扣緊庶幾冰凌過時不致擠動仍擦埽眉又凌鋒利能
截木必用毛竹片或鐵片密釘椿木迎水一面方免此患

打 凌 槌

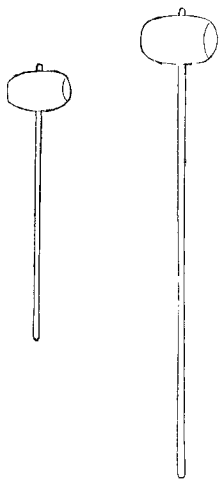

禮記孟冬之月水始冰地始凍仲冬之月冰益壯季冬冰方盛水
澤腹堅命取冰冰以入則鑿冰宜急矣鎚有石有鐵有木說文礮
擣也呂氏春秋礮之以石此石鎚也抱朴子僊藥卷以鐵鎚鍛數
千下此鐵鎚也魏書宋崇傳雙槌亂擊此木鎚也皆可用以打凌
者而柳根尤佳緣冰由寒結非陽和不能疏其氣柳性暖發榮最
早根大而重用以鑿冰有相悅而解之義

穿 絨

三 稜 鈎



鐵穿其式兩頭似戈而寬大中挺圓又有橢形三稜均以堅木爲柄約長七八尺至一丈此船上用者易曰履霜堅冰陰始凝也馴致其道至堅冰也大河水湍不易結冰冰至於堅非鑿不可苟器勿備其何以鑿冰沖沖故鎚之外又有穿說文穿通也穴也夫然後冰可以斬矣

打 凌 船

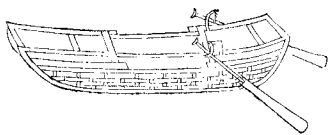

風俗通積冰曰凌水壯曰凍水流曰澌冰解曰泮河工向有凌汛當冬至前後天氣偶和凌塊滿河擦損埽眉其病尙小所慮忽值嚴寒凡河身淺窄灣曲之處冰凌壅積竟至河流涓滴不能下注水勢陡長急須搶築而地凍堅實簣土難求每易失事所以必須多備打凌器具分撥兵夫駕淺如扁舢小如舢舨之舟各攜器具上下往來以鑿之但船底須用竹片釘滿凌遇竹格格不相入庶幾可以禦之

鍋

鐵

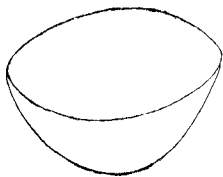

玉篇鍋盛膏器揚子方言自關而西盛膏者乃謂之鍋正字通俗
謂釜爲鍋凡遇河水盛漲漫灘時大堤裏面忽然過水名曰走漏
見有旋窩處卽是進水之穴蛟龍畏鐵急以鐵鍋扣住然後壅土
自可化險爲平

盆 凡



考工記盆實二鬴厚半寸唇寸禮記竈者老婦之祭也盛於盆尊於甝然盆有金有銅有錫有鐵有石有瓷至於瓦盆乃缶也易有孚盈缶漢五行志穿井得土缶師古注缶盎也卽今之盆爾雅盎謂之缶郭璞注盆也邢昺疏缶是瓦器可以節樂地志廣陵龍潭寺僧得古瓦盆貯粟菽少許經夕輒充叔其中謂爲水宮神物仍投諸潭中云今堡房例備二具平時用以盛米盛水急時以之堵漏其用與鐵鍋同

布口袋



玉篇袋囊屬魚袋照袋錦縹袋藻豆袋算袋皆古人攜貯什物之具若今之布口袋卽古有底之囊也凡遇漫灘走漏時其進水之穴形勢斜長非鍋盆所能扣住者急將口袋裝土兩人擡下隨勢堵塞卽可閉氣然後從容齊集兵夫夯礮填墊自保無虞但袋中土不可裝滿以六分爲度

棉
襖



棉
被

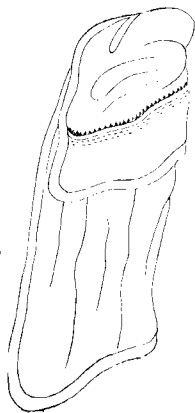

物原神農作被伊尹作襖釋名被被也被覆人也身章撮要大被曰衾單被曰裯宋子京詩春寒到被池田藝衡畱青日札今之色被橫其卧邊緣幅作異色曰當頭當去聲卽古之被池遺製南史宋武帝微時有衲衣布襖旣貴與公主曰後有驕奢不節者以此示之當大河盛漲時大隄走漏穴小用棉襖如穴大且曲必需棉被堵塞之法與布口袋同

磨石

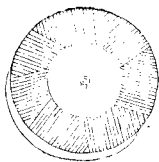
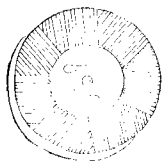

說文磨石磴也僧園逸記都下寺院每用歲除鍛磨是日作鍛磨齋稗史類編後漢書云崔亮在雍州讀杜預傳見其爲八磨嘉其有濟時用凡遇大汎水漲漸激挂柳護堤非石磨不足以墜柳株久之上淤磨沉泥內掘出仍可用再凌汎時水澤腹堅一時難解用繩繫磨鑿冰亦以剛克剛之義也

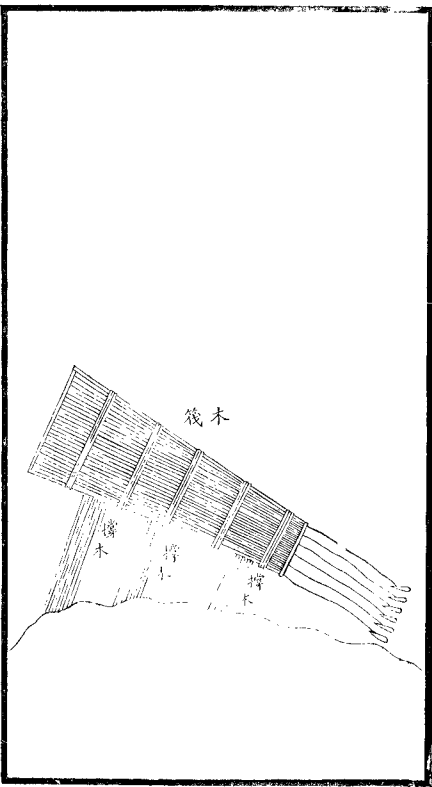

方言澗謂之簞簞謂之筏註木曰簞竹曰筏小筏曰澗木筏又名木把係紮杉木製成凡工頭工尾淤閉舊埽忽爾澗到築壩木及趕紮木筏撫護後安撐木以順澗勢再漫水上灘攔截串溝及壩工搜後均可用此其紮法每筏用木一二層長寬丈尺隨時酌定

木龍全式

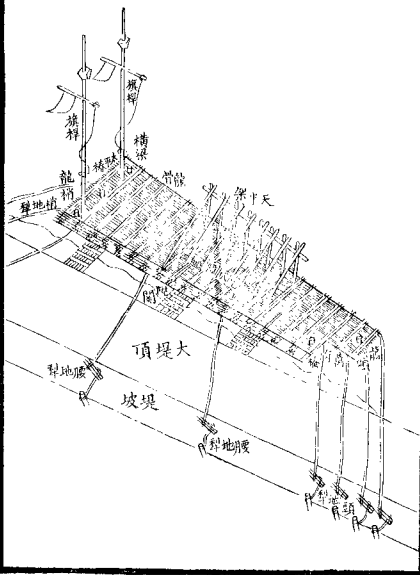

木龍之制，始於宋。按史載：天禧五年，陳堯佐知滑州，以西北水壞城，無外禦，築隄，疊埽於城北，復就鑿橫木，下垂木數條，置水，以護岸，謂之木龍。元賈魯塞北河口，亦曾用之。而其法初不傳。我朝乾隆初年，陶莊漲灘，屢挑不成，河督高文定公用州同李昞所獻圖議，照法試辦，立見成效。

高宗南巡，閱視製詩獎勵。今南河有木龍成規一冊，李昞所刊。又外南營額設鈎手，專備編紮木龍之用。

木龍一層編底三層橫梁

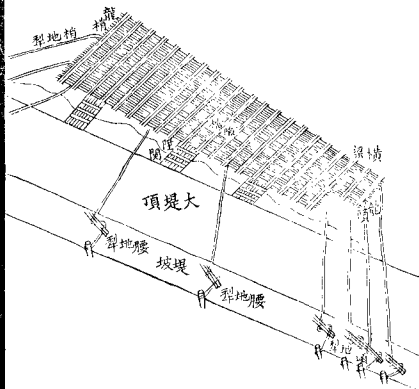

木籠每長十丈寬一丈九層得單長九十丈其第一層密編縱木爲底每排用木十三根共計七排仍於中心酌畱空檔以備插障安箠其二三層橫梁每道用木六根雙層疊紮均用犁頭竹纜兜縮下層縱木每間二根交股順去疊回編紮陞關爲傘龍挑溜之用其第一層亦用縱木每排十根計五排二層亦用橫梁每道用木二段三四層各用直梁一長十丈亦用七節扣纜等法則均如紮籠式樣惟祇四層耳

木龍四五層龍骨邊骨

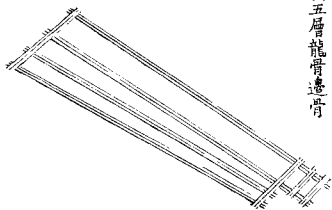

六七層齊果

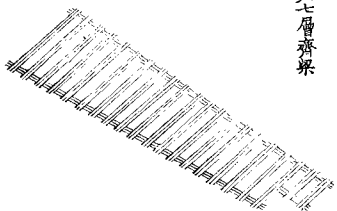

木龍第四五層曰龍骨用木六根曰邊骨用木四根均疊作雙層每節長一丈五尺計七節餘稍連搭次節先用連半竹纜雙行箍紮又用纜兜縮下層橫梁其龍身寬長者另用行江大竹纜絞三爲一名曰龍筋每層各加二條節節扣緊其第六七層仍用橫梁紮法如二三層一曰齊梁

木龍八層縱木九層面梁

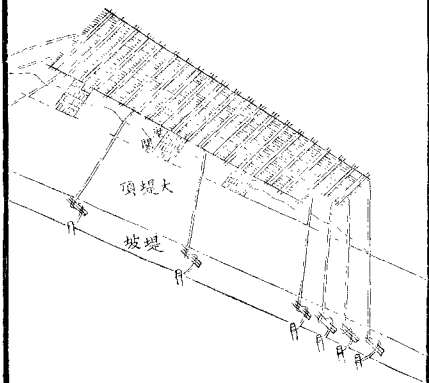

木龍第八層如第一層用縱木惟在水面不比底層塘漚祇須六排第九層仍用橫梁一名面梁每道用木二根以揀把竹纜貫過八層縱木扣住六七層橫梁交股編紮

水閘



天平架

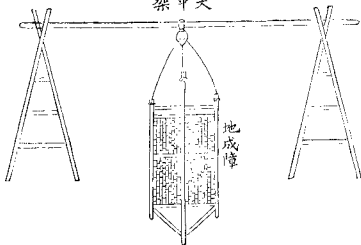

類篇架杙也所以舉物說文障隔也天平架每座用直木二橫木一左右架木仍各繫橫擔木三以便人夫上下地成障中柄長二丈一尺邊木長一丈八尺上中下橫擔木各長一丈下用交叉小木中編竹片從龍身空檔插下用截河底之溜所以溜緩沙淤化險爲平又有水閘一名水欄其法與編障相仿但直木俱用銳首障則施於大溜懸出龍底使之不激閘則用於餘溜插入河底使之截流用雖少異功實相侔也

車眠

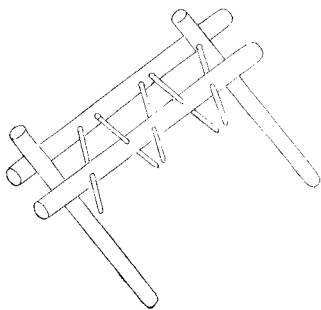

眠車爲升龍之用每部長三丈需用四尺四楓木每間二尺鑿通
交叉圓孔仍留空處繫纜扣緊犖木頂佳升關兩頭用枕木二擱
住再用橫木一根墊起枕木使前高後低然後用八尺長檀木棍
絞車向前推轉加緊收纜則龍身自出挑溜用力較省

大 箴

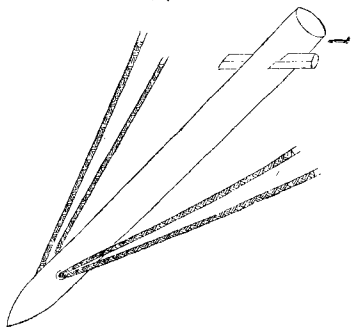

直 柱

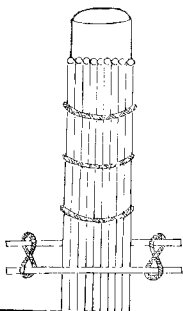

直柱爲龍身內繫纜要具需用三尺八松木長二丈下用翦木二根扣緊兩旁用木九根圍抱排擠以竹纜三扣箍紮豎於龍身底層仍於縱橫各木層層擠緊至出龍面再用尺二抱木加纜箍定用以扣繫大纜方能堅固大戣用四尺二松木長四丈五尺銳首象眼貫以行江大竹纜二條楔緊以便挽住股車易於起下其戣上方眼橫木係備安戣時繫纜豎立之用

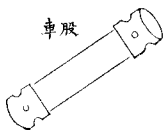

架轆轤

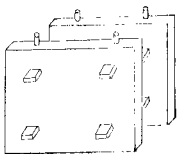

周禮考工記輪人參分其股圍註股近轂者也股車之制長五尺五寸兩頭各留七寸五分鑿交叉圓孔二中四尺細二寸擱於轆轤架上穩子之內將大轂所繫之纜挽於車身用人把住纜頭用檀棍插入圓孔輪轉轂隨纜起升牽定位縱纜下轂直貫河底穩住木龍安轂後用以起下殊省人力至轆轤架其式每架用松板二長五尺寬一尺三寸厚三寸兩頭上下各鑿方眼二另用五尺長松枋四根插入眼內楔緊套住大轂仍於架板邊上兩頭各鑿一寸二分圓孔加檀木穩子夾住股車使可旋轉而不旁出

天戩

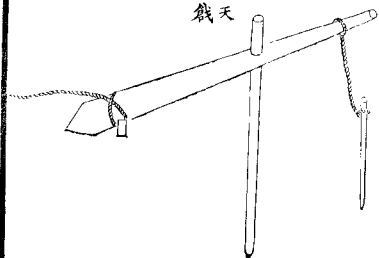

地犁

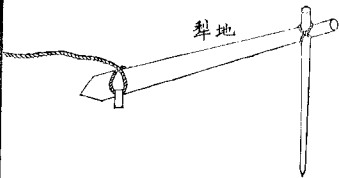

天戩地犁均爲扣帶繫龍大纜之用天戩以二尺四木爲之長二丈大頭小尾銳首旁加管楔平斜入地五尺地犁以二尺一木爲之長一丈八尺做法仿前斜插入地四尺犁尾釘青椿一戩則腰尾各簽一椿用纜穩住使不搖動

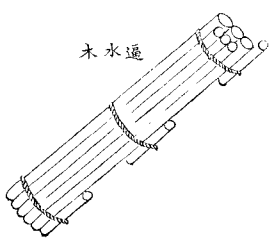

木水通

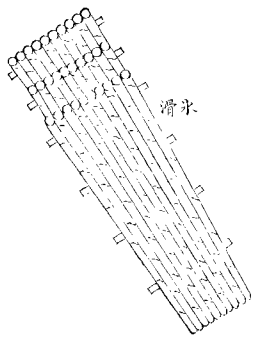

滑水

周禮疏滑通利往來冰滑每排以毛竹十雙層併疊每三排以大竹劈片貫串編成凡安木龍多在霜後大河冰凌下注簞纜最易擦損置此龍旁以爲外護又有通水木其制用尺二木六段長一丈疊紮三層側攬龍身外邊使大溜不能衝入故名通水

竹 篾

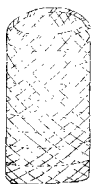

荆 篾

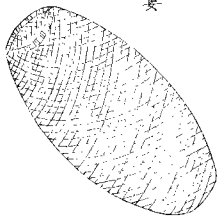

集韻篋竹籠也急就篇註篋者疏目之籠言其孔樓樓然也或長
或圓形製不同或竹或荆質地不一河工用以滿貯碎石爲護埽
壅水之用排砌成壩者亦名竹絡壩

河工器具圖說

卷四 儲備器具

土簣箕

土車

條船

圓船

浚幫

柳船

簣 簣鉤

長白麟
慶見亭纂輯

水誌 犁 關

搭爪

四輪車

箱

靴 千筋靴

刈刀 苧刮刀

繩車 縛繩架 繩牀 滑子

篾箍頭 手鈎 攔腳板 皮皴

抽子 竹響板 鋤刀 滑皮石礮

人字架 乾架 抽子木

鐵槌 鐵錘 小錘

鐵手錘 鐵手鑿 鐵樵 鐵樵

釣杆

麻龍頭 麻小扣 石杠

拖 拖椿

大磚模 小磚模 竹盪刀 拐鉞

浮梯 草叉 泥叉

鋸 鑽 鑿 鉋

墨斗 墨筆 曲尺 手鋸

喚錐 喚針 策籬

脚耙 拍板 刮刀

脾

蒲鋤 磚架 木灰刀

水缸

水斗 麻搭 抓鉤

太平桶

土 簍 箕

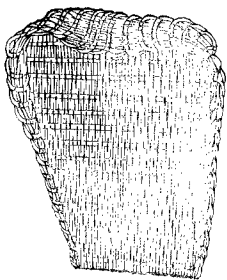

篇海箕簸箕揚米去糠之具方言陳魏宋楚之間謂之籬陳宋楚魏之間謂笱謂籬詩云成是南箕箕四星二爲踵二爲舌踵在上舌在下踵狹而舌廣又維南有箕載翁其舌故箕皆有舌易播物也諺云箕星好風謂主簸揚農家用以揚糠工次則用以盛上南竹北柳其制不同其用一也

土 車

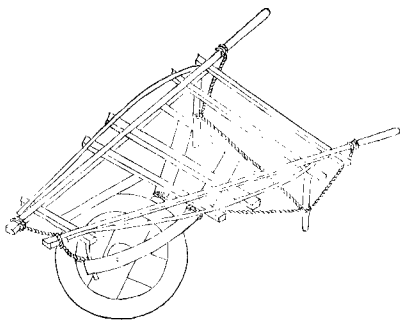

可工器差司免

參可儲備

土車獨輪料土兼載稗編蜀相諸葛亮出征始造木牛流馬以運
餉木牛卽今小車之有前轆者流馬卽今獨推者是後山談叢蜀
中有小車獨推載八石前如牛頭今之土車獨推猶存諸葛遺制

船 條

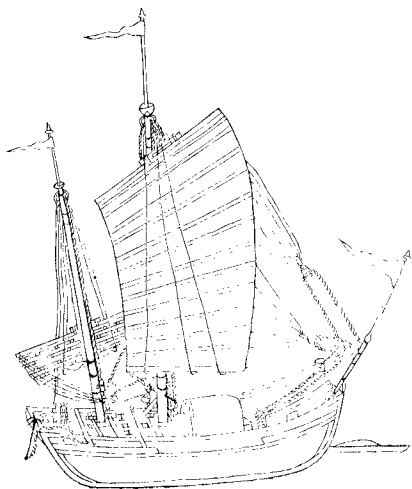

晉書天船九星一曰舟星所以濟不通易繫詞伏羲氏剡木爲舟
物原顛項作槳作篙帝學作櫓作柁夏禹加以篷碇帆檣蓋至是
而行舟之具大備後世因之制度不一而工次轉運料物則以條
船爲最

圓船

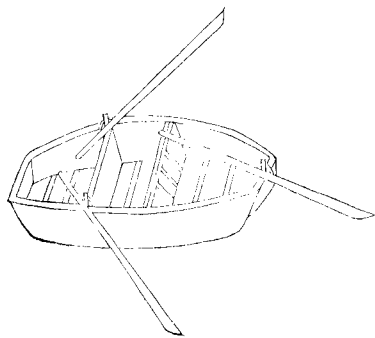

大河中又有圓船效蠶製帆象龜創櫓隨中泚大溜旋轉便利惟宜於順流而下滯於溯流而上且不任滿載終不若條船之適用也

帮 凌

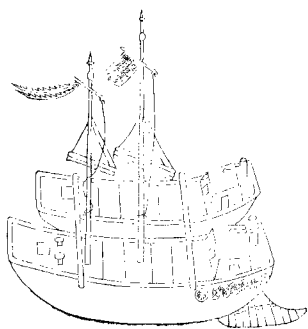

浚船康熙間靳文襄公爲疏濬海口而設旋因無效撥給各廳運料逮乾隆八年白莊恪公請復試行仍無效二十四年乃設船務營統歸管轄襄運蕩柴定制分大中小三號大者長四丈二尺中寬七尺六寸艙深三尺二寸中者長三丈九尺中寬七尺艙深三尺小者長三丈六尺中寬六尺五寸艙深二尺七寸其行以兩隻相並俗謂一幫按爾雅維舟方舟注連四船曰維併兩船曰方幫與方音同殆傳訛爾

船 柳

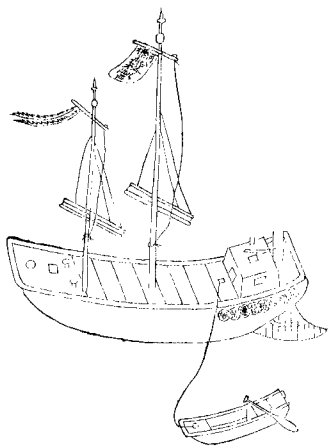

柳船定制長八丈中寬一丈六尺船深五尺按船務營原設浚石船七百三十二隻配成三百六十六幫嗣因易於風損道光八年經張芥航河帥奏明分年改四爲一應成一百八十三隻連舊額柳船十六隻添造一隻共成二百分隸左右兩汛計至十六年以後無浚船矣至柳字之義俗謂用以運柳故名按漢書服虔曰東郡謂廣轍車爲柳又李奇曰大牛車爲柳則柳蓋訓大爾

箕



鈎箕



柴簍爲柳船承柴之用簍鈎爲捆紮柴簍之用其法先以上茂葦柴捆紮成簍二人上船持鈎鈎定貼緊船幫用纜跨繫使兩面相平然後用柴層層勾搭狀比魚鱗堆積如山雖遇風浪船行穩重不致脫卸至用簍多寡以柴長短爲準每邊或六節或八節俱可簍鈎則鍛鐵爲首灣長尺餘受以木柄約長二尺

可仁器其圖發 卷二 儲備

水 誌

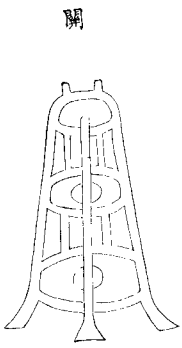

物原遂人以匏濟水伏羲乘桴軒轅作舟楫顓頊作槳作篙帝嚳作舵作櫓堯作維牽大禹加以篷碇帆檣行具大備後又增以鐵錨艫板招杆等器近時又增二具曰犁曰關凡遇風逆溜激牽挽不能得力上水設關絞行下水安犁畱拽甚便至運關之木人各一根名曰關翅安關之所用土堅築名曰關盤一名升關壩又水誌以竹爲之長二丈凡軍船入境勾水尺寸既定則就其處紮棕爲誌持以量船卽知輕重持以探水卽知淺深亦駕駛之要具也

搭爪



可工器其圖免
客可備備

乙

搭爪燬鐵如彎爪形受以木柄通長尺許用如爪之搭物故曰搭爪料車到工或擲以下車或積以成柴日以萬計速於手挈

車輪四

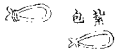
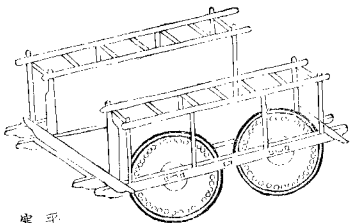

杆抬

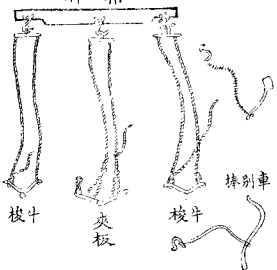

梭牛

夾板

梭牛

捺別車

四輪車卽任載之牛車縛輓以駕牛者工次用以載糶料俗謂之料車是也而什物行李亦以此裝運往來物原少吳制牛車奚仲制馬車稗編漢初馬少天子且不能具純駟將相或乘牛車晉王導之短轅犢車王濟之八百里駿石崇之牛疾奔人不能追皆牛車也今惟四輪車駕牛間有牛馬兼用若乘車則無駕牛者矣

箱

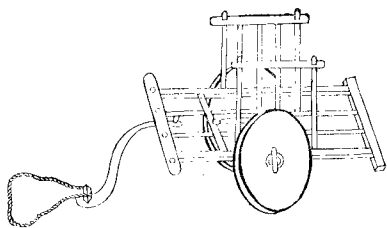

箱俗名板轂車卽古之行澤車也詩云乃求萬斯箱又云晄彼牽牛不以服箱周禮車人行澤者反輳又行澤者欲短轂農書板轂車其輪用厚潤板木相嵌斲成圓象就留短轂無有輻也泥淖中易於行轉了不沾塞獨轆著地如犁托之狀上有櫛以撥牛輓槃索上下坡坂絕無軒輕之患王楨咏箱詩下澤名車異爾輳服箱原自有耕牛雙輪不輻還成轂獨木非輳類作輳今河灘農家尙有此車爲衝泥甕運料石之用

リニキヤシヨリヤ
ニ丁儲備

千 筋 輪



輪

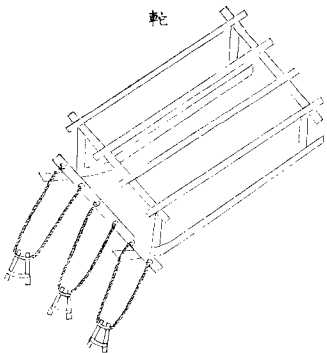

玉篇軫疾馳也今南河有軫車狀如車盤而無輪其行頗速專備淤地轉運柴料之用蓋淤地有輪必陷負重難行此則以繩爲轆駕牛三頭車盤下用欄杆架起祇以二木貼地平拉無前軒後輶之患故易爲力又有千筋軫其製三輪堅木爲之每旱運大石料多用此具

刈刀

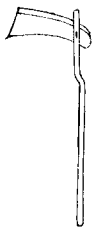

平刮刀



農書刈刀穫麻叉也兩尺但用鎌柯旋插其叉俯身控刈刮刀刮
苧皮叉也鍛鐵爲之長三寸許捲成槽內插短柄兩叉向上以鈍
爲用仰置手中將苧皮橫覆於上以大指按而刮之苧膚卽蛻近
有一式刀首鑄鈎形如偃月亦刮苧用按江南種麻惟用拔取頗
費工力河南西華一帶種植遍野穫刈全用此刀其治麻法隨刈
卽策漚之清水池中寒暖得宜卽可潔白柔韌漚苧則因皮厚難
輒必需用刀刮淨其治法先用石灰拌和累日抖淨後用灰水煮
待冷然後濯以清水用蘆簾攤曬擇細者績布粗者作繩纜用

車繩

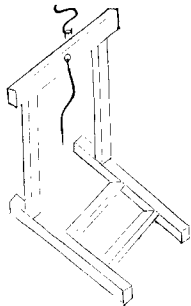

繩床

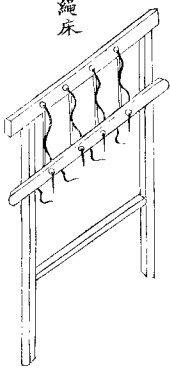

架繩緯

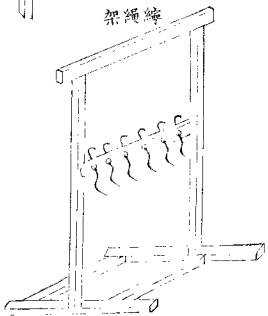

子滑



繩車絞麻作繩也元王楙農書繩車橫板中間排鑿八竅或六竅各竅內置掉枝或鐵或木皆彎如牛角此只一竅且車式迥殊繩床上下各四竅繩架則中排六竅却與農書繩車相彷彿而式亦不同豈古今異制抑南北各宜耶掉枝一名鐵搯手俗謂之吊子又有爪木置於所合麻股之首或三或四撮而爲一各結於掉枝復攬繫成繩爪木自行繩盡乃止所謂爪木者卽俗名滑子是也

鉤手

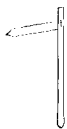

頭箍篾



鼓皮



板脚欄



集韻籬以篾束物也又皴治履邊也今圍柴篾籬熟竹皮爲之用
漆分畫尺寸定例葦營以銅尺二尺八寸爲一束手鈎又細而長
約四五寸橫安木柄凡柴由溝港筏運到廠樵兵兩手各持一鈎
勾柴上灘晾曬堆垛省力而速攔腳板狀如屐長一尺厚一寸寬
五寸前後鑿孔繫繩於履乾地採柴著之可禦柴簽皮皴狀如鞮
以牛皮爲之水地採柴著之可衝泥淖夜則浸以灰漿經久不爛
右四器皆蕩營樵採之具

板響竹

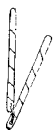

子抽



刀鋤



礫石皮滑

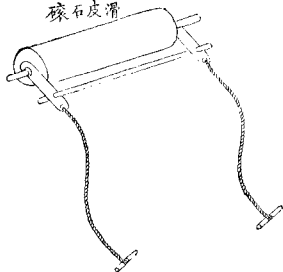

竹響板
抽子
鋤刀
滑皮石礫

河工捆船鑲埽非纜不可東河用麻南河用葦各取其宜而製葦
器具則與麻不同一鋤刀鍛鐵爲之双向下承以木床爲切去根
梢之用一抽子一名梳子截木一段長盈握中開一槽廣容指內
含鋼片爲抽劈皮膜之用一響板取竹片約長一尺每二片聯成
一副用時兩手相搏有聲爲剗削碎葉之用一滑皮石滾取石琢
圓徑闊三尺兩頭各安木臍上套木耳繫以長繩用時置葦於地
往還拉曳爲壓扁柴質之用

人字架

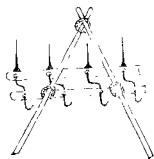

輪架

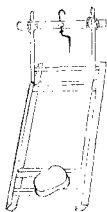

抽子木



葦纜之架與繩架不同其式有二一曰人字架用木二根其上縛成人字其下分埋上內中間橫架竹片二每片各鑿四孔每孔各安鐵枝一枚一曰靴架用木做成堅高二尺六寸橫觀三尺二寸均安框內其架上亦橫置竹片一中鑿一孔孔內安一鐵枝凡打葦纜先用繩袂絆定人字架再用巨石壓住靴架使不搖動然後將纜一頭分作四股安人字架上一頭合做一股安靴架上用人推遞抽子自然繫結成纜抽子以木爲之豎長尺二橫長尺八狀如十字打纜時將四股分擺其間推之卽合用與梭同鐵枝俗名釣子卽搯手也

鐵 錐 錘



鐵 錐



小 錐 錘



揚子方言鑿重也東齊曰鑿宋魯曰鑿集韻搗舉也凡開山採石
山有土戴石石戴土之分見山面露有浮石必先用銳鑿擊之審
定其下有石然後刨土開採銳鑿之製鑄鐵爲首大者形長而扁
兩頭皆可用中貫籐條或竹片以爲柄小者兩頭一方一圓以木
爲柄約重十五六觔均專備劈裁石料之用又鐵搗以鐵鍛成長
一尺六寸重十餘觔爲搗起石塊之用

鑿手鐵



錘手鐵



鐵槓

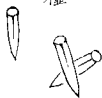

鐵樑



說文鑿小鑿也樨與椴同側擊也樨見字典而無考右四具皆採石所必需手錘尖頭圓底約重三觔手鑿圓腦尖嘴鐵樨圓腦扁嘴長四五六寸不等鐵樨上寬下窄其用與樨同凡開山既見石矣須審山之形勢順石之脈絡度量所需石料長短厚薄劃定尺寸先鑿溝槽約寬三寸深二寸每尺安鐵樨三根擊以錕錘用水浸灌刻許然後用錘鑿儘擊開採再樨名不同在平處爲劈樨直處爲鑿樨兜底橫處爲控樨擡樨得施以鐵撬而石出矣又黑麻豆青等石皆用鐵樨漸擊漸入匠人謂之含樨獨黃麻石用銅樨一擊卽起匠人謂之跳樨必須繫以線索不致跳遠則又石性之不同耳

釣 杆

肚 筋 繩

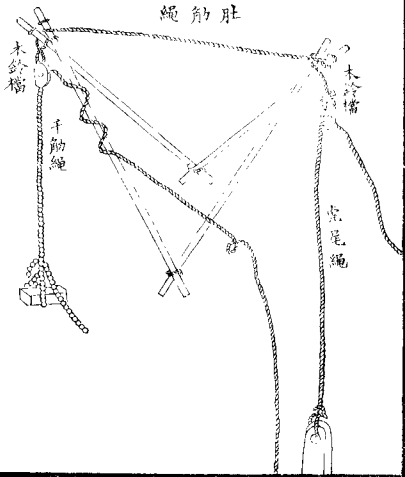

木鈴檔

手筋繩

木鈴檔

索尾繩

可已界其司兌

卷耳儲備

三

南河修補石工例應選四漆六舊石塌卸多沉水底既深且重人力難施撈取之法全仗釣杆其制用杉木四根交叉對縛仿架網式安置岸邊前繫鐵鍊名曰千筋後繫極粗麻繩名曰虎尾承繩之處名木鈴鎗然後遣水摸夫入水摸石引繩扣繫集夫拉挽虎尾繩釣撈上岸又採石裹船行運石重船浮非跳板所能上下裹載之法或於崖岸設立釣杆或用本船大桅繫索拉釣卸亦如之

頭龍



扣小



石

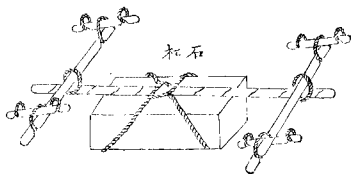

說文杠橫關對舉也凡擡條石人數或四或六或八視石之輕重
大小爲準其所用杠選大竹爲之俗名曰牛中用麻繩打結名麻
籠頭繫石四角兜而懸之竹杠兩頭用麻繩打結名麻小扣橫穿
短杠俗名大木牛兩頭再各用麻小扣穿小杠俗名小木牛

拖樁

木鈴鐺

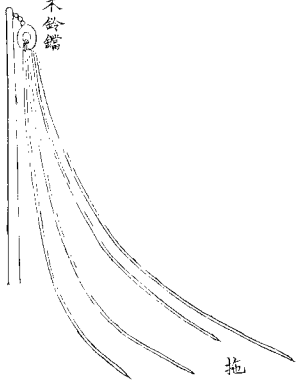

拖

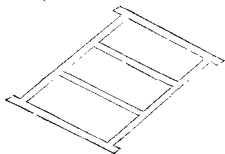

禮少儀疏拖引也集韻拖牽車也拖一名旱車江南運石用之北路石料長大者亦用此具其法於拖前遠立長椿椿頭繫以木鈴貫以長索一頭繫住拖上石料一頭以人力倒挽人退拖進一拖不及再立椿如法行之至拖之人數則以石之大小輕重爲準

模磚大

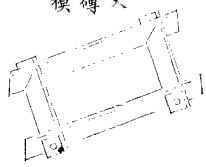

模磚小

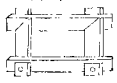

鋤拐



竹盪刀



甄卽瓠甃古史考烏曹作甄廣韻模形也左思魏都賦受全模於梓匠類篇盪動也說文盪滌器又鋏耒屬唐韻拐物枝也治甄之具有模大小均用堅木合成盪刀以竹爲之拐鋏剡木爲首以鐵片包鑲四邊中列釘頭受以丁字長柄用之拌和熟泥貯模成壑俗謂之坯再用竹刀盪平脫下曬乾積有成數然後入窰燒煉計日成甄

浮梯

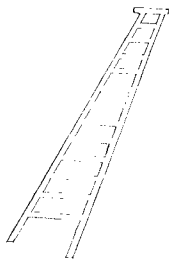

棍叉



草叉



正韻義兩歧也說文梯木階也釋名梯如階之有等差也草義削木爲柄鍛鐵爲首兩齒銛利而長備燒馱挑柴之用棍義鍛鐵爲之柄圓齒扁備燒窰撥火之用浮梯以木爲之修工匠人用以竚足隨等上下畫線俾得一律

鋸

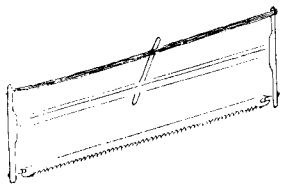

鑿



鑽

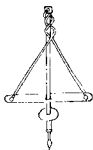
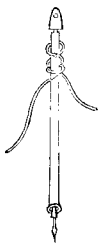

鉋



物原軒轅作鋸般作鑽古史考孟莊子作鋸作鑿事物紺珠推鉋平木器魯般作說文倉唐鋸也正字通鋸解器鐵葉爲齟齬其齒一左一右以片解木石也鉋正木器大小不一其式用堅木一塊腰鑿方匡面寬底窄匡面以鐵針橫嵌中央針後鑿鐵刃露出底口半分上加木片插緊不令移動木匡兩旁有小木柄手握前推則木皮從匡口出用撻於鏟凡騎馬椿橛之類或有長短不齊高低不平非此數具烏能治之



墨筆

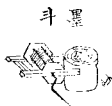

斗墨



手鋸



曲尺

廣韻商君書赭繩束枉木注赭繩卽墨斗也甘泉賦注鈎曲尺也
正字通鋸解器也凡匠人斷木分片必先用墨線墨筆彈畫方能
正直墨斗多以竹筒爲之高寬各三寸許下畱竹節作底筒邊各
釘竹片長五寸中安轉軸再用長棉線一條貯墨汁內一頭扣於
軸上一頭由竹筒兩孔引出以小竹扣定用時牽出一彈用畢仍
徐徐收還斗內墨筆亦取竹片爲之其下削扁用刀劈成細齒以
便蘸墨界畫曲尺形如勾股茲式惟股微長便於手取股長一尺
五六弦長尺四勾長一尺分寸注明勾上凡製木器合角對縫非
此不爲功手鋸係用鐵葉一片鑿成齟齬約長尺五受以木柄長
三寸爲解析竹頭木片之具

錐 喚



喚 針



籬 笊

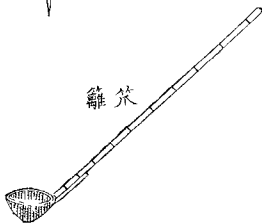

史記索隱江南謂葦籬曰笆今南河編紮牆屋多用葦竹是以有
笆匠之目其編紮利器喚錐喚針均鍛鐵爲之錐長一尺凹心式
如半邊破竹孔引麤纓針長五寸孔引細繩均名曰喚者蓋兩人
對編時一內一外彼此照會應聲後然後下錐穿針耳又有策籬
以竹絲編成受以長竹柄凡笆匠編紮旣成登高貫頂須和稀泥
苫草以此爲遞送之具

可工器具圖說
卷四
儲備

耙脚



板拍



刀刮



末

玉篇以草覆屋曰苫左傳乃祖吾離被苫蓋註白茅苫也江東呼爲蓋今工廠館舍兵房夫堡多用苫蓋其具有三一曰刮刀鑄鐵露及狀如弓以兩附爲柄凡未苫之先上梁豎柱用以刮垢摩光一曰脚杷斷木爲架式如丁字兩端各簽長鐵釘一攜以升屋隨處可插凡苫蓋之時鋪頂壓脊用以接高立脚一曰拍板析木爲片面布齊頭短鐵釘背安套手凡旣蓋之後刪繁除冗用以平治整齊

牌

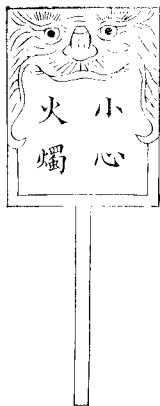

牌首亦繪虎頭大書小心火燭四字因料廠重地當風日燥烈之時誠恐遺漏火種所關非細立此示禁令兵弁觸目驚心加意防維庶幾帑項工需益昭慎重

刀 沃 木



架 磚

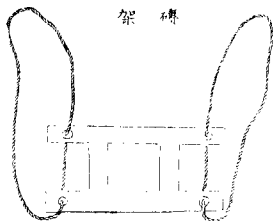

玉篇鍬也釋名蒲敷也廣韻架舉也蒲鍬以堅木爲質鐵葉裹口上安丁字木柄利除沙土磚架以木爲之中方兩頭鑿孔穿繩作繫便於抽動配平工次用以擡磚木灰刀形如瓦刀刻木爲之石匠用以勾砌

水缸

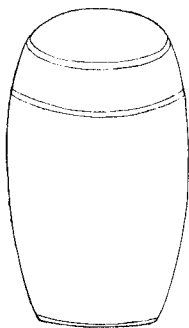

可
已
器
具
圖
說

器
可
儲
備

三

玉篇缸與珙同說文似罌長頸受十升漢書注缸長頸甕也唐詩
花撲玉缸春酒香水缸設於料廠以備火燭平時貯水更資利用

麻搭

水斗

抓鉤

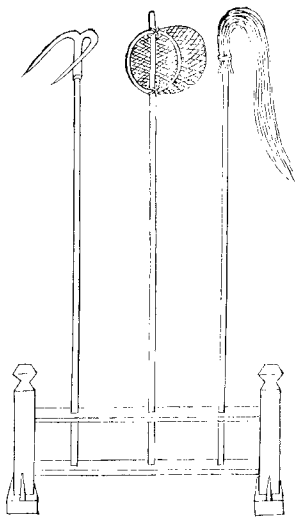

麻搭以麻爲之形似麈尾水斗柳筭編成卽小屏斗廣韻屏斗舟
中漂水器也搭鈎玉篇鐵曲也二股內向便於搭拉草料與拆廂
舊埽之三股抓鈎差別三者皆料廠備防火燭之用

太 平 桶

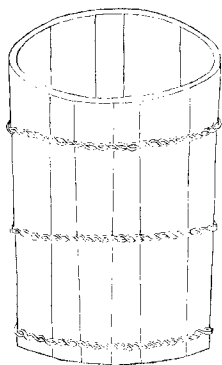

事物紺珠桶馬鈞作物原桶木器受六升博雅方斛謂之桶今時
用以挑水史記商君傳平斗桶又作甬禮月令仲春角斗甬料厥
既設水缸何以又設木桶蓋恐隆冬水凍缸易裂縫桶則貯水無
患故曰太平

跋

右河工器具圖說四卷

河帥見亭先生所手輯也分其目爲四門繪其象爲一百四十有五幀中有以類相從者共得二百八十有九種物物爲之圖卽物物爲之說目睹耳聞口講指畫事有繁簡制有損益名有雅俗用有古今精且審矣明且備矣昔宋呂大防撰考古圖王黼等撰宣和博古圖明呂震撰宣德鼎彝譜是亦器具圖也而近于玩好無論有說無說皆與政治無關至奇器圖說明鄧玉函所著其解木解石轉磨轉碓之屬共三十九圖各系以說諸器圖說王徵所著凡十一圖皆徵自造具

見思致然專尙奇巧終非日用行習之物豈若是書爲

國家之要務河渠之急需其信今傳後大非淺鮮哉且夫治河之道歷有成書元沙克什河防通議分列六門法則咸備明姚文灝浙西水利書歸有光三吳水利錄張內蘊周大韶三吳水考俱就一隅而言

國朝張伯行之居濟一得靳輔之治河方略傳澤洪之行水金鑑齊召南之水道提綱熟審形勢總括機宜得失利弊詳哉言之然立其說者未嘗製爲圖也其有圖而兼有說者宋單鍰作吳中水利書蘇軾嘗爲奏進狀稱原本有圖今已從佚元王喜治河圖略首列六圖末陳已說明潘季馴河防一覽

其圖說在辨惑檢要之前謝肇淛比河紀河道諸圖之後分
河程河源等八紀陳應芳敬止集有六圖十三論張國維吳
中水利書有東南七府水利總圖

國朝薛鳳祚兩河清彙將黃河運河繪爲二圖又著論四篇之
數書者覽其圖誦其說不愆不忘率由舊章何莫非效法之
所在邪雖然水道有變遷人事有因革非空言可以取驗也
非徒手可以奏功也且非親歷不能悉其形也非周諮不能
揆其宜也非好學深思不能知其故也易有之備物致用作
成器以爲天下利又云以制器者尙其象甚矣器之足以載
道而卽以行道也善其器者貴乎便事而尤貴乎因地隨時

此河工器具圖說一書誠有不容稍緩者爾

見亭河帥巡視南河已閱三載蒞工綜務謹慎周詳其于治河諸書早已徧觀盡識融會貫通而又于所用器具一一爲之循名核實積久成帙條分縷析綱舉目張卽小以見大山精以及蠡溯流以尋源明體以達用燦若列眉燎如指掌是真補前賢所未及垂後世以共由上爲

一人佐平成之績中爲四瀆奏安瀾之效下爲百官著考鏡之資所謂太平之鴻猷不朽之盛業其在斯乎其在斯乎國佐承乏下僚素蒙訓迪今夏特出是編見示是不以國佐爲不才也爰請任校勘之役卽付剞劂氏公諸天下庶幾哉河政有

全書河防有良灘已是爲跋

道光柔兆涖灘陽月同知銜揚糧通判大興王國佐拜撰

姑蘇閶門外洞涇
橋西吳學圃局刻

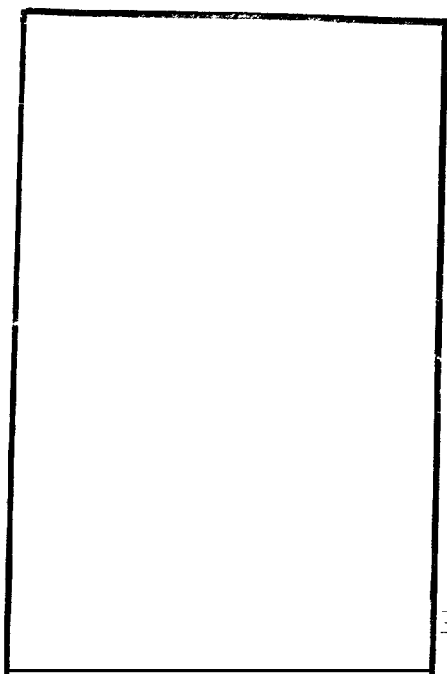

全書河防有良灘已是爲跋

道光柔兆涖灘陽月同知銜揚糧通判大興王國佐拜撰

姑蘇閶門外洞涇
橋西吳學圃局刻