

1932

62,37

Farm and Garden Supplies

Since 1860

CATALOG NO. 45

LIBRARY
 RECEIVED
 ★ MAR 31 1932 ★
 U. S. Department of Agriculture.



PETUNIAS (page 27)
Pink-Rose-Purple

	Pkt.
Double Flowering	.50
Double Flowering Mixed	.50
Dozen Pkts.	\$5.00
Single Fringed	.25
Single Fringed Mixed	.25
Dozen Pkts.	\$2.50

SNAPDRAGONS (page 25)

	Pkt.
Distinctive Colors	.10
Mixed Colors	.10
Dozen Pkts.	\$1.00

GRIFFITH & TURNER CO.

GENERAL OFFICES, 208-210 N. PACA ST.
BRANCH STORE - 338 N. GAY ST.

BALTIMORE, MD.

Griffith & Turner Co., Baltimore, Md.

1932 ANNUAL CATALOGUE 1932

Quality Goods

No. 45

Best Prices

It gives us great pleasure to present our 1932 Catalog. For over seventy years we have been keeping step with the changing methods of doing business.

Your loyalty to us has made this possible, and we want to do everything to show our appreciation of the confidence you have placed in us.

It has always been a pleasure to serve you, and we pledge to you our utmost endeavor, that this confidence may long continue.

If you cannot secure the within goods from your local dealer, kindly write to us direct.

GRIFFITH & TURNER COMPANY.

OUR SEEDS are the BEST that can be obtained anywhere, because we are as careful in our selection as it is possible for anyone to be, and are constantly on the lookout for the best of everything, but will not put on the market anything until it has been thoroughly tried and proved.

No matter what others may ask for their seeds, better quality cannot be obtained anywhere, as our constantly and rapidly increasing trade does and will testify.

Our Seeds are ALL TESTED thoroughly before being placed on the market.

If for any reason you change your postoffice address, please advise us, giving your old address as well as your new one, stating which is the old and new one.

By writing out your order on the Order Sheet sent with each Catalogue you will greatly facilitate our work. Extra Order Sheets sent on application. Be sure to sign your name in full, giving postoffice and shipping point. If you have rural delivery, give name and number of route. If you want goods shipped by boat or railroad, state which you prefer, and what line to send by.

PARCEL POST RATES

Weight in Pounds	Distance not over 150 miles	Over 150 and not over 300 miles
1	\$.07	\$.08
2	.08	.10
3	.09	.12
4	.10	.14
5	.11	.16
6	.12	.18
7	.13	.20
8	.14	.22
9	.15	.24
10	.16	.26
11	.17	.28
12	.18	.30
13	.19	.32
14	.20	.34
15	.21	.36
16	.22	.38
17	.23	.40
18	.24	.42
19	.25	.44
20	.26	.46
21	.27	.48
22	.28	.50
23	.29	.52
24	.30	.54
25	.31	.56

TO COUNTRY MERCHANTS

WE PUT UP VEGETABLE SEEDS in papers for the Country Trade in quantities to suit purchasers.

Our seeds are select and tested, and give satisfaction wherever used.

Beans, Peas, Corn, etc., in bulk, at lowest wholesale rates.

Write for special quotations in quantities.

Should you have placed your order for small papers for this year, we will be pleased to fill any shortage you may have, and solicit your patronage for another season.

Prospective Customers who are not rated in the Commercial Agencies will save time in having their goods shipped by accompanying their Orders either with the Cash or satisfactory reference. Baltimore references preferred.

NOTICE—We make a specialty of quoting on complete outfits. SEND FOR PRICES.

Filling Orders.—Every order is filled and forwarded as promptly as possible, but if not duly received please notify us and we will make every effort to trace it without delay. Do not fail to sign your name and give full address.

PACKING AND SHIPPING.—We make no charge for boxes or packing of retail orders and deliver all goods to any railroad of steamboat free of charge. We charge for cotton bags, 2 bushel 30c each.

HOW TO REMIT.—Remittances should be made by draft, Express Money Order, P. O. Money Order or Registered Letter.

We deliver by PARCEL POST FREE to any Postoffice in the United States all cash orders for Flower and Garden Seeds, up to ¼ lb.

No seed delivered free unless order is accompanied with the cash. For postage on Peas, Beans, Corn, Field Seeds in large quantities and All Merchandise, consult table below.

ON EVERY ORDER be sure to SIGN YOUR NAME and give your address PLAINLY, as we frequently receive orders lacking either or both; also give full shipping instructions. State if by freight or express and give route. This saves delay.

PRICES TO MARKET GARDENERS.—Market gardeners and all purchasers of Seeds in large quantities should submit us a list of their wants and we will name them special prices.

WEIGHT OF AGRICULTURAL SEED PER BUSHEL AND QUANTITY USUALLY SOWN PER ACRE

Weight per Bushel	Variety	Time to sow	Quantity per Acre
48 lbs.	Barley,	Aug. to Nov.	75 lbs.
48 "	Buckwheat,	June to Aug. 15	1 bu.
60 "	Clover, Alfalfa,	March, April and Aug. to Oct. 15	20 to 25 lbs.
60 "	Clover, Alsike,	Feb., Mch. and Aug.	8 "
60 "	Clover, Crimson,	July to Sept.	15 "
60 "	Clover, Sweet, Mch. and Apr.,	Aug. to Sept.	15 to 20 "
60 "	Clover, Red, Feb. and March		10 to 12 "
60 "	Clover, White, Aug. and Sept.,	Mch. and Apr. (alone)	6 "
56 "	Corn, for soiling,	May	1 to 2 bus.
20 "	Evergreen Lawn Grass,	Mch. and Apr., Aug. and Spt.	4 bus.
56 "	Field Corn (in hills),	May	4 to 6 qts.
50 "	German Millet,	May to Aug. 1st	75 lbs.
14 "	Kentucky Blue,	Apr. and May, Aug. and Sept.	42 lbs.
14 "	Orchard Grass,	Apr. and May, Aug. and Sept.	42 "
32 "	Oats, Spring, Mch. and April		75 "
32 "	Oats, Winter, Mch., Aug.,	Sept., Oct.	50 to 75 "
14 "	Rcd Top, unhulled, Apr.,	May, Aug. and Sept.	42 "
32 "	Red Top, Fancy, Apr.,	May, Aug. and Sept.	12 "
60 "	Rape, Feb. to Aug.		4 to 6 "
60 "	Rye, Aug. to Nov.		60 to 80 "
50 "	Sorghum (for Fodder),	May and June	50 "
45 "	Timothy, alone, Apr.,	May, Aug., Sept.	20 "
--	Timothy, with other grasses		8 "
	(Together for an acre: Red Clover, 6 lbs.;	Timothy, 12 lbs.)	
60 "	Wheat, Sept. to Nov. 15		100 to 120 "
60 "	Vetch, Winter, Aug. to Nov. (broadcast)		30 "

INSTRUCTIONS FOR PLANTING

Sow seed indoors for early plants of Cabbage, Cauliflower, Egg plant, Pepper, Lettuce and Tomato, February 20th to March 10th.

Set early plants outside, of Cabbage, Lettuce and Cauliflower, April 1st to April 30th.

Plant in the outside land, where they are to remain, Potatoes, Peas and Onion sets, March 17th to May 1st.

Sow on the outside, where they are to remain, Asparagus seed, Asparagus roots, Beet, Onion seed, Parsnip, Parsley, Lettuce, Kale, Turnip Radish, Spinach, Carrot, Salsify, also Celery seed for plants, April 1st to May 15th.

Set outside plants of Tomato, Pepper, Egg-plant, May 20th to June 20th.

Plant outside, Sugar Corn, Muskmelon, Cucumber, Squash and Pumpkin, May 15th to July 1st.

Watermelon, May 20th to June 20th.

Plant outside all kinds of String Beans and Stringless Beans, May 15th to August 15th.

Lima Beans, May 15th to June 20th.

For late crops of Kale, Turnip and Spinach, sow August 10th to Sept. 10th.

For plants for late crops of Cabbage, Borecole and Brussels Sprouts, sow seed May 15th to May 25th.

"We give no warranty, expressed or implied, as to description, purity, productiveness or any other matter of any seeds, or bulbs, we sell, and we will not be in any way responsible for them."

Griffith & Turner Co., Baltimore, Maryland

ASPARAGUS

This is one of the earliest spring vegetables, and should be in universal use. Many persons think it is difficult to grow, but we consider this a mistake, and believe it can be produced as cheaply and easily as any on the list. Sow the seed in the seed bed late in the fall or the early spring, as soon as the ground can be worked, in drills one foot apart, covering the seed about one inch deep. When the plants are four or five inches high, great care should be taken to keep the bed free of weeds. One ounce of seed will sow forty feet of row.

WASHINGTON ASPARAGUS.—Rust Resistant. This variety is the result of careful breeding by the U. S. Department of Agriculture, with the object of eliminating rust. A dark green color.

PALMETTO.—A very early maturing variety, producing an abundance of very large, deep green shoots.

BARR'S MAMMOTH.—The stalks are very large, and retain their thickness completely up to the top of the shoots; light in color.

CONOVER'S COLOSSAL.—A mammoth green sort of the largest size and of good quality. One of the best known and most generally cultivated varieties.

ASPARAGUS ROOTS.—A saving of one to two years is effected by planting roots. A bed 12x40 feet, requiring about 100 roots, should give a sufficient supply for an ordinary family. 8,000 roots will plant an acre. Select good loamy soil, plow deep, put in good quantity of manure and 100 pounds kainit to 1,000 square feet of bed. Incorporate thoroughly, make a trench eight inches deep, set plants 15 inches apart. In field culture rows are placed four feet apart.

ASPARAGUS SEED	Pkt.	Oz.	¼ lb.	Lb.	ASPARAGUS ROOTS (Postage Extra)	
					Per 100	Per 1000
WASHINGTON	\$0.10	\$0.20	\$0.50	\$1.60	\$1.75	\$12.00
PALMETTO10	.15	.30	.75	1.25	9.50
BARR'S MAMMOTH10	.15	.30	.75	1.25	9.50
CONOVER'S COLOSSAL.	.10	.15	.30	.75	1.25	9.50



WASHINGTON ASPARAGUS

BEANS

Dwarf or Bush-Wax Podded

Select light, warm soil and plant when danger from frost is past in the spring, in drills 2 to 2½ feet apart, dropping the beans about 6 to 8 inches apart in the drills, and cover 2 inches deep. A succession of sowings can be made from the first week in May until August.

IMPROVED RUSTPROOF GOLDEN WAX

This is the handsomest and hardiest of all the Wax Beans. The Pods are straight, long and thicker than the ordinary Golden Wax, much superior in quality, absolutely rustproof, and sure to become a favorite Wax Bean; in fact it has already gained great popularity with growers.

SURE CROP STRINGLESS WAX

Recently introduced by the largest bean grower and originator of new varieties in this country. Entirely stringless, black-seeded, thick, flat yellow pods. The most desirable sort for canning.

DWARF PROLIFIC BLACK WAX

Yellow pod, a very superior snap sort, ripening among the first earlies and having the best characteristics. Very tender.

WARDELL'S KIDNEY WAX BEAN

This is one of the best wax sorts. The vines are remarkably vigorous, hardy and productive. The pods are very large, smooth, showy, tender, perfectly stringless and of an unusually fine quality.

CURRIE'S RUSTPROOF BLACK WAX

For earliness and freedom from rust it is at the head of the Wax Bean family. Habit, upright and robust, holding the pods well from the ground. Pods long, straight, flat and every meaty, of a beautiful color; quality not surpassed, and for productiveness it is unequalled.

NEW BALTIMORE STRINGLESS WAX

Black seeded, early; thick flat, yellow pod. No strings. Have appearance of Currie's Rustproof Wax, but are better cropper, and absence of strings make them much more desirable for canning and other uses.

NEW PENCIL POD WAX BEAN

Very early and productive. Pods long, straight and handsome; color, light golden yellow; strong and vigorous bush. One of the best varieties.

WAX POD BUSH BEANS	(about)	(1 pt.)		
		(1 lb.)	(1 qt.)	(1 pk.)
Beans by Weight		1 lb.	2 lbs.	15 lbs.
IMPROVED RUSTPROOF GOLDEN WAX.....	\$0.25		\$0.40	\$2.75
SURECROP STRINGLESS WAX.....	.25		.40	2.25
DWARF PROLIFIC BLACK WAX.....	.25		.40	2.25
WARDELL'S KIDNEY WAX.....	.25		.40	2.50
CURRIE'S RUSTPROOF BLACK WAX.....	.25		.40	2.25
NEW BALTIMORE STRINGLESS WAX.....	.25		.40	2.25
NEW PENCIL POD WAX.....	.25		.40	2.25

Add for postage, 8c per lb., 10c for 2 lbs.

Ask for prices per Bushel.

Ask for prices in Quantity.



CURRIE'S RUSTPROOF GOLDEN WAX

USE STIMUGERM ON BEANS

BEANS—Green

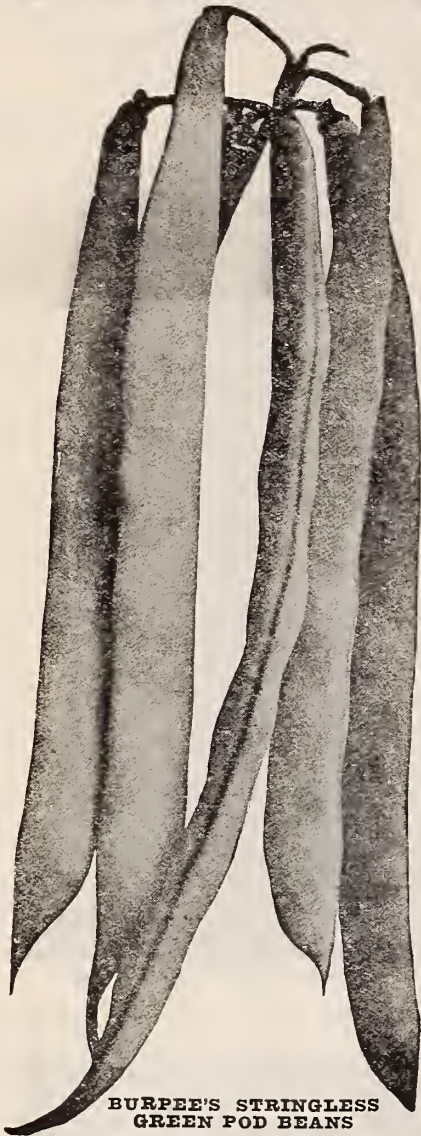

BURPEE'S STRINGLESS GREEN POD BEANS

G. & T. CO'S EXTRA EARLY RED VALENTINE.—Ten days earlier than the ordinary Red Valentine Bean. It is without doubt the very best earliest green snap short Bean.

BLACK VALENTINE.—This excellent extra early variety has perfectly round, straight pods of excellent quality. It is suitable both for early and late planting, being extremely hardy.

EXTRA EARLY BOUNTIFUL (Flat Green Pod).—A prolific and continuous bearer. The first in the spring, the last in the fall. Absolutely stringless, very tender and of delicious flavor.

EXTRA EARLY REFUGEE.—It is similar in every respect to the ordinary Refugee, but is nearly two weeks earlier.

REFUGEE or 1000 TO 1.—A medium to late variety, very productive and largely grown for pickling; handsome and tender pods.

GREEN-PODDED STRINGLESS REFUGEE.—Medium-early, round-podded, green stringless; exceptionally good cropper. Fine for canning and table use. Newest thing in Green Pod Stringless Beans.

FULL MEASURE (New).—Large cropper; stringless, green-podded, round Bean, not as early as Burpee's Stringless, but a heavy yielder. Best of quality.

BURPEE'S NEW STRINGLESS GREEN POD.—One of the earliest varieties, pods round and full, absolutely stringless and of beautiful fleshy appearance; quality excellent. The only green pod bean of which the pods never develop any strings.

GIANT STRINGLESS GREEN POD.—Resembles very much the old Valentine. The plants are of strong growth, very productive; pods 5 inches long, light green, slightly curved, very meaty, brittle and stringless at all stages, and of mild flavor.

DWARF HORTICULTURAL (Cherry).—Very green podded sort, used as a shell bean, and for this purpose is one of the finest in general use; long a favorite with those who use a shell bean in a green state.

WHITE MARROWFAT.—Extensively grown for sale as a dry bean for winter use.

WHITE NAVY, or SMALL PEA BEAN.—A well-known variety for field culture; very prolific.

Pole or Running

LAZY WIFE.—Large, pale green pods, very thick meated, stringless, rich, tender and buttery; ripens early; clings well to pole; enormously productive; splendid either as a snap or shell bean.

KENTUCKY WONDER, or OLD HOMESTEAD.—A very prolific sort, bearing its pods in large clusters; pods green, often reaching 9 to 10 inches in length; nearly round when young, and very crisp.

SPECKLED HORTICULTURAL, or WREN'S EGG.—An old favorite for both snap-shorts and dry beans.

BUSH LIMA BEANS

Plant in drills two to three feet apart, dropping the beans three to four inches apart and covering one and one-half to two inches deep. If planted in hills, make the hills two or three feet apart one way and two to two and one-half feet the other, and plant four beans in a hill. Hoe often but only when the leaves are dry.

FORDHOOK BUSH LIMA.—An improved dwarf Lima of the Kumerle type. The plant is vigorous and erect growing, bearing well above the ground. The pods are produced in large clusters, each containing three to five large beans of exceptionally fine quality. Much more productive than Kumerle and matures earlier. We consider this a decided acquisition to the dwarf Lima, possibly the best of the class.



FORDHOOK BUSH LIMA

BURPEE'S IMPROVED BUSH LIMA.—Will outyield Burpee's Bush Lima by fully one-third. This greater yield is due to the increased size of both pod and beans. The dried beans are very handsome, and generally show a greenish-white coloring, while dried beans of the Burpee Bush Lima, like those of the Large Pole Lima, are pure white.

BURPEE'S BUSH LIMA.—Bushes grow 18 to 20 inches high, stout growth and always erect, yet branching so vigorously that each plant develops into a magnificent circular bush 2 to 3 feet in diameter; an immense yielder, each bush bearing 50 to 200 handsome, large pods, well filled.

DREER'S BUSH LIMA.—Dwarf variety of Dreer's Improved Lima, which has been fixed in its character of a bush bean; very prolific, single plants often producing 150 to 200 pods. Equal in quality and tenderness to Dreer's Pole Lima.

DREER'S WONDER BUSH LIMA.—Very desirable on account of earliness, productiveness; of strong, upright growth, and are completely covered with large pods, many of which contain four beans, which are fully as large as the Pole Limas. The beans are flat in shape and of excellent quality.

HENDERSON BUSH LIMA.—These are very valuable, because they do not need poles, and, being so dwarf, can be planted close together. They are very early and prolific, continuing to bear until frost.

BEANS—Green-Podded Bush (about)				BEANS—Pole or Running (about)			
Beans by Weight		(1 qt.)	(1 pk.)	Beans by Weight		(1 pt.)	(1 pk.)
	1 lb.	2 lbs.	15 lbs.		1 lb.	2 lbs.	15 lbs.
G. & T. CO'S EXTRA EARLY RED VALENTINE	\$.25	\$.40	\$2.25	LAZY WIFE	.25	\$.50	\$2.75
BLACK VALENTINE	.25	.40	2.00	KENTUCKY WONDER	.25	.40	2.50
EXTRA EARLY BOUNTIFUL	.25	.40	2.25	SPECKLED HORTICULTURAL POLE or WREN'S EGG	.25	.50	2.75
EXTRA EARLY REFUGEE	.25	.40	2.25	BEANS—Bush Lima			
REFUGEE or THOUSAND TO ONE	.25	.40	2.25	FORDHOOK BUSH LIMA	.30	.50	3.25
GREEN-POD STRINGLESS REFUGEE	.25	.40	2.25	BURPEE'S IMP. BUSH LIMA	.30	.50	3.25
FULL MEASURE	.25	.40	2.25	BURPEE'S BUSH LIMA	.30	.50	3.00
BURPEE'S NEW STRINGLESS GR.-POD	.25	.40	2.25	DREER'S BUSH LIMA	.30	.55	3.25
GIANT STRINGLESS GREEN-POD	.25	.40	2.25	DREER'S WONDER BUSH	.30	.55	3.25
DWARF HORTICULTURAL	.25	.45	2.50	HENDERSON'S BUSH	.25	.50	2.75
WHITE MARROWFAT	.20	.40	2.25				
WHITE NAVY	.20	.40	2.25				

Ask for prices by the Bushel

Add for postage, 8c per lb., 10c for 2 lbs.
INOCULATE BEANS WITH STIMUGERM

Ask for prices in Quantity

Set the poles 3 to 4 feet apart and plant 6 to 8 beans, with the eyes downward, around each pole thinning to 4 healthy plants when they are up. They require the same soil and treatment as the dwarf varieties.

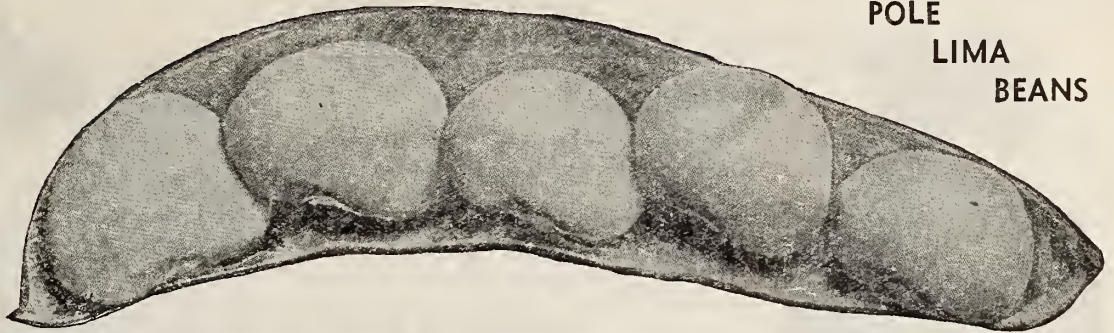

**POLE
LIMA
BEANS**

CARPENTERIA POLE LIMA.—The newest large pole Lima; enormously prolific; early green and delicious flavor.

HENDERSON'S EARLY LEVIATHAN.—This is the very earliest. It will not only give large Lima beans earlier than any other strain, but it is also much more productive, both early and throughout the season. It is a strong grower, clinging well to the poles, and is a sure cropper. The pods hang out from the foliage in large clusters and contain three or four and sometimes five large beans to the pod.

KING OF THE GARDEN LIMA—This bean has met with enormous sales the past few seasons. They are vigorous growers, setting their beans early at bottom of pole, producing continuously to the end of the season. They are more prolific than the ordinary Lima, bearing pods 5 to 7 inches long, in clusters of 4 and 5, with 5 or 6 beans in a pod.

EXTRA LARGE WHITE LIMA.—This is a splendid sort, and takes a leading place with growers, because of its many excellent qualities. As a shell bean surpasses all in quality and is the favorite with most people.

EXTRA EARLY JERSEY LIMA.—This variety is two weeks earlier than other sorts; the pods are large and numerous, making it a very profitable sort to grow.

DREER'S IMPROVED OR CHALLENGE POLE BEAN.—This popular bean is considered by many growers superior to all others in quality and productiveness. When green it is as large as the Large Lima, thicker, sweeter and more tender and nutritious, remaining green in the pod for a long time after maturing.

CAROLINA OR SIEVA.—A seedling variety of large White Lima, with small pods, usually about 2 inches long. A little earlier and harder.

BEANS	(about) 1 lb. Pt.	2 lbs. Qt.	14 lbs. Pk.	BEANS	(about) 1 lb. Pt.	2 lbs. Qt.	14 lbs. Pk.
CARPENTERIA POLE LIMA.....	\$0.25	\$0.50	\$3.00	EXTRA EARLY JERSEY LIMA.....	\$0.25	\$0.50	\$3.00
HENDERSON'S EARLY LEVTHN. LIMA	.25	.50	3.00	DREER'S IMP. or CHALLENGER			
KING OF THE GARDEN LIMA.....	.25	.50	3.00	POLE LIMA30	.60	3.50
EXTRA LARGE LIMA.....	.25	.50	3.00	CAROLINA or SIEVA POLE LIMA....	.25	.50	3.00



**CROSBY'S IMPROVED
EGYPTIAN**

SWISS CHARD

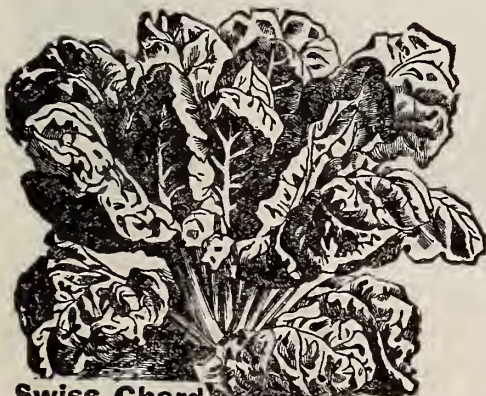

Swiss Chard.

(Sea Kale or Spinach Beet)

SWISS CHARD (Sea Kale or Spinach Beet).

—Used exclusively for greens; cooked like asparagus, makes a very delicious dish.

BEETS

One Ounce of Seed will sow One Hundred Feet of Drill

Select a deep, rich sandy loam and manure with well decomposed compost or a good chemical fertilizer. Sow in drills, 14 to 16 inches apart, and cover 1 inch deep. When the young plants appear, thin to 4 or 5 inches apart. For early use, sow as soon as the ground can be worked in the spring; for autumn use, about the middle of May; and for winter use, during June or July, according to the variety—the long varieties requiring more time to mature than the round early kinds.

ECLIPSE BEET.—This extra early Beet is remarkable for its fine quality and rapid growth; is of deep red color and handsome shape. As an early market sort it is unrivaled. It is to a large extent superseding the Egyptian, being earlier in development, more attractive in appearance, and of superior quality for the table.

CROSBY'S IMPROVED EGYPTIAN BEET.—A very superior strain of the well-known Egyptian, carefully selected, blood color, quick, rapid growth. The shape is very desirable, as shown in the accompanying photograph, being not so round as the Eclipse, or quite so flat as the ordinary Egyptian. It may be sown outside as late as July.

EARLY WONDER BEET.—This grand new Beet, recently introduced, is early, Red with short tops, fine for bunching. Roots are of good, uniform size, slightly oval, and of deep blood red, has slim tap roots, fine grain, tender and sweet. Never gets stringy or woody. Fine for both home use and market garden.

EXTRA EARLY EGYPTIAN.—This is a flat Beet, very early and deep red color. Owing to the small top it can be planted very close.

G. & T. CO'S EARLY BLOOD TURNIP BEETS.—This is our Special Stock of Early Blood Turnip Beet, which we have been growing for a number of years, and which the market gardeners of Baltimore and other places prefer. It is of dark red color, handsome shape, and early.

DETROIT DARK RED TURNIP BEET.—This is one of the finest formed and handsomest colored Beets on the market. It is unsurpassed in the uniformity and beauty of the crop. It is exceedingly early, and produces more marketable specimens on the same acreage than any other variety.

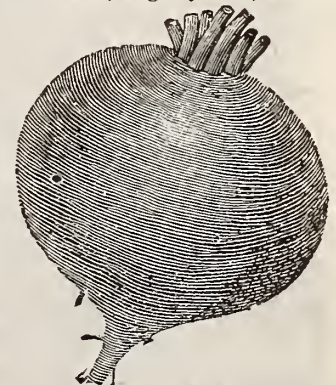

**DETROIT DARK RED
TURNIP BEET**

BEETS	Pkt.	Oz.	1/4 lb.	1 lb.
CROSBY'S IMPROVED EGYPTIAN.....	\$0.10	\$0.15	\$0.25	\$0.90
EARLY WONDER10	.15	.25	.90
DETROIT DARK RED.....	.10	.15	.25	.90
ECLIPSE10	.15	.25	.90
EXTRA EARLY EGYPTIAN FLAT.....	.10	.15	.25	.90
BLOOD TURNIP, G. & T. CO'S.....	.10	.15	.25	.90
SWISS CHARD10	.15	.25	.90

Add for postage, 8c per lb., 10c per 2 lbs. Ask for prices in Quantity.

BEETS FOR STOCK

SOW 4 POUNDS TO THE ACRE.

Stock Beets grow larger than any other Beets, and hence require more room. They should be sown from April to June, in drills 2½ feet apart, and the plants thinned to 12 to 15 inches in the row. The attention of farmers to the growing of Beets for stock feeding has rapidly increased.

LONG RED MANGOLD. The well-known, large, long variety, grows well out of ground. Color light red. Very productive.

GOLDEN TANKARD MANGOLD. The best type of Mangold—small top, smooth, rich skin, broad shoulders, very solid fleshed, golden stemmed, heavy producer.

WHITE SUGAR BEET. A large-growing sort, and used for feeding stock.

CHAMPION YELLOW INTERMEDIATE, OR GATE-POST MANGOLD. One of the very finest Mangolds ever introduced, giving unbounded satisfaction wherever grown. With good cultivation will crop at the rate of 200 bushels per acre.

BRUSSELS SPROUTS

1 Ounce of Seed to 100 Yards of Row.

Brussels Sprouts are used in the fall and early winter and by some considered more tender and delicious than any cabbage. The plant resembles the cabbage, the edible part being the numerous very small heads or sprouts an inch or two in diameter formed on the stalk at each leaf joint. The culture is the same in all essentials as for cabbage, except the leaves should be broken down in the fall to give the little heads more room to grow.

BORECOLE

This is often called Broccoli by market gardeners, but belongs to the Kale family. Very spreading in habit and beautifully curled. Seed should be sown in May and transplanted in July, in the open field, and treated same as Savoy Cabbage.

BROCCOLI

1 Ounce of Seed to 100 Yards of Row.

The heads resemble somewhat a coarse cauliflower, and the culture is the same as for that vegetable. Broccoli is well adapted only to those sections where the season is long, cool and rather moist. One of the most valuable features is that it withstands greater extremes of temperature than cauliflower.

EARLY PURPLE CAPE. Large, compact.

LARGE EARLY WHITE. Head white, like cauliflower, the best.

BROCCOLI. Used largely in the Delaware, Maryland and Virginia Peninsula for northern shipment. Makes fine greens. Sow about August first for fall cutting. Pkt. 10c., Oz. 15c., ¼ lb. 45c., Lb. \$1.50.

BROCCOLI—Italian Calabrese. This variety produces heads on the order of Cauliflower and is the latest and newest kind yet introduced. See Cut.

Sow seed in open ground and get plants in field in July or August. After the center head is cut, it will produce side shoots with a smaller head. One of the best on account of the succulent Asparagus flavor. Pkt. 10c., Oz. 50c., ¼ lb. \$1.25, Lb. \$4.50.

MANGOLD WURZEL	Pkt.	¼ lb.	1 lb.	BRUSSELS SPROUTS	Pkt.	Oz.	¼ lb.	1 lb.
Long Red	\$.10	\$.15	\$.40	White Cape	.10	.50		
Golden Tankard	.10	.15	.40	Purple Cape	.10	.50		
White Sugar	.10	.15	.40					
Champion Yellow Intermediate or Gate-Post	.10	.15	.40					

ABOVE PRICES ARE POSTAGE PAID



Golden Tankard Mangold.



Brussels Sprouts



BROCCOLI (Italian Calabrese)

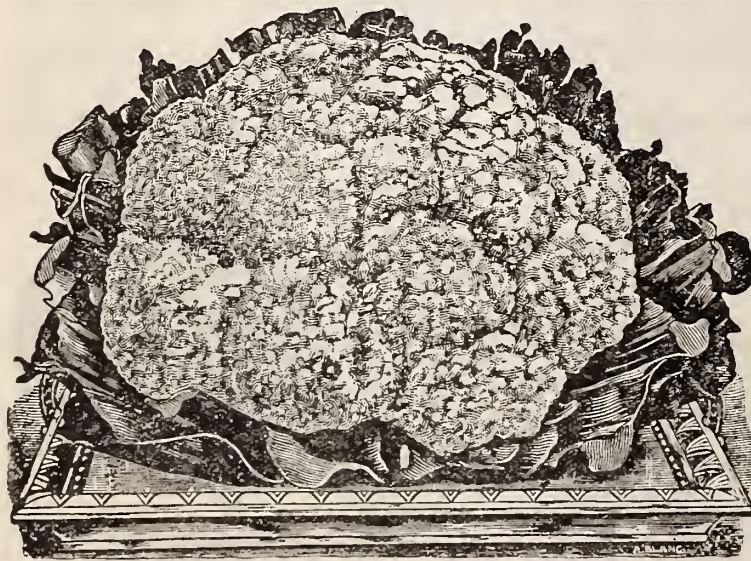

G. & T. CO.'S LARGE GILT EDGE SNOWBALL CAULIFLOWER

Is without exception one of the finest sorts now in cultivation. It is very early. Nearly every plant will, under proper cultivation, form a perfect, snow-white head and its close growing, compact habit enables the grower to plant one-third more on the same space of ground than other varieties. Pkt. 25c., Oz. \$1.50, ¼ lb. \$5.00.

EXTRA EARLY SNOWBALL.—Our stock of this well-known variety is unexcelled. It is one of the best sorts for open ground or forcing under glass. Pkt. 25c., Oz. \$1.50, ¼ lb. \$5.00.

G. & T. CO.'S "DROUTH-RESISTING."—Produces larger, white, solid heads, maturing about a week later than our large Gilt Edge Snowball. The best for hot, dry weather. Pkt. 25c., Oz. \$1.50, ¼ lb. \$5.00.

G. & T. CO.'S SELECT EARLY DWARF ER-FURT.—Long the standard of highest excellence, and still holding its own with a great many people. Pkt. 25c., Oz. \$1.50, ¼ lb. \$5.00.

CULTURE.—The same as for Cabbage, except that extra manure and plenty of water will pay upon cauliflower.

CORN SALAD

Three Ounces of Seed to 100 Feet of Row.

A favorite salad plant, and very hardy. Sow in August or September, and protect with leaves during the winter; it can be gathered in the spring very early. Sown in April, it is soon ready for use. The leaves are sometimes boiled and served as spinach. Pkt. 10c., Oz. 15c., ¼ lb. 25c., Lb. 75c.



CURLED CRESS, OR PEPPER GRASS

Used as a small salad. Sow very thickly in shallow drills, on a smooth surface, at short intervals throughout the season. Pkt. 10c., Oz. 15c., ¼ lb. 25c., Lb. 75c.

WATER CRESS.—Water cress may be grown along the margin of running streams, ditches or ponds, and has a ready sale in the hotels and markets. Pkt. 10c., Oz. 40c., ¼ lb. \$1.00, Lb. \$3.00.

EARLY CABBAGE

One Ounce of Seed to 100 Feet of Row.

Cabbage will thrive on any good corn land, though the stronger the soil the better they will develop. Plow deep and manure very liberally, as cabbage is a strong feeder, and will repay for the care bestowed upon it. The early sorts bear planting from eighteen inches to three feet apart in the rows, with the rows from two to two and a half feet apart. The distance varying with the size. For early use sow in a hotbed in February or March. In April the plants may be set out in the rows. For late crop, sow in May or June, and transplant as soon as the plants are five or six inches high. The ground should be thoroughly cultivated every week until the plants meet in the rows.

EXTRA EARLY JERSEY WAKEFIELD—Identical to the Jersey Wakefield, but smaller and about a week earlier.

EXTRA EARLY EXPRESS—Heads are comparatively thicker and less pointed than Jersey Wakefield and slightly earlier.

SELECT EARLY JERSEY WAKEFIELD—American Grown—The very best early Cabbage, and grown more extensively by market gardeners than any other variety. It is early, the heads are pyramidal in shape, very large and solid, and having but few outside leaves, the plants can be set close together. We secured our seed from a grower of the best Wakefield Cabbage in the country, and it is giving good results wherever it is used, so much so that our sales of this sort are rapidly increasing each year.

CHARLESTON, OR LARGE WAKEFIELD—Has all the characteristics of the Jersey Wakefield, but larger. It is five to six days later than Early Jersey Wakefield. The heads are fully one-half larger and quite solid. It is very compact in growth, and can be easily planted in rows two feet apart and twenty inches in rows.

COPENHAGEN MARKET—A new round head, solid cabbage, recently introduced from Denmark. It is without doubt the finest large round-headed early cabbage in cultivation. The type is thoroughly fixed and the heads mature uniformly, which enables the crop to be harvested at one time, so that the ground can be cleared in two cuttings. As early as Jersey Wakefield.

GOLDEN ACRE—A new round extra early variety. Earlier than Jersey Wakefield.

Second Early Varieties

ALL-HEAD EARLY—AMERICAN GROWN—is the largest of all early Cabbages, fully one-third larger than the Early Summer. It is the nearest approach to a thoroughbred cabbage of any variety, both in size and uniform development. As the All-Head comes in quicker than any of the other flat cabbages, it is consequently more tender. It is also valuable for a late or winter Cabbage.

SUCCESSION CABBAGE—A fine early variety, coming in a few days later than Early Summer, it does well at all seasons, and one is almost sure of getting a crop, no matter when it is planted.

SUREHEAD—This popular cabbage is rightfully named Surehead, as it never fails to make a fine, large, solid head, with few outer leaves. It is a strong, vigorous grower, and very uniform in size and color. Always brings the highest price in our markets.

EARLY DWARF FLAT DUTCH—An old standard variety which stands the sun and produces fine, large heads, coming in soon after the Wakefield.

BOSS FLAT DUTCH CABBAGE—The heads are large, hard, thick and flat, the leaves lapping across the center, making it the most desirable winter variety in cultivation. Try it and be convinced of its superior quality.

RED DUTCH CABBAGE—The head is round, large, solid and a deep red color, the best of the red cabbages.

DANISH BALL HEAD—This most excellent variety of cabbage, coming from Denmark, has grown very rapidly into favor with both market and private gardeners. It is a large, round, solid heading, medium early variety; a very sure header, having few loose leaves, consequently can be planted very close together. Although a medium early, can also be grown for a fall and winter crop, being one of the best keepers. Very popular in Philadelphia, New York, and Boston markets.

PREMIUM LARGE FLAT DUTCH—LATE CABBAGE—Large and excellent for winter; very extensively grown. The head is broad, thick and flat, well covered in by leaves lapping across the center, outside leaves feathered to the base of the leaf stem.



SELECT EARLY JERSEY WAKEFIELD

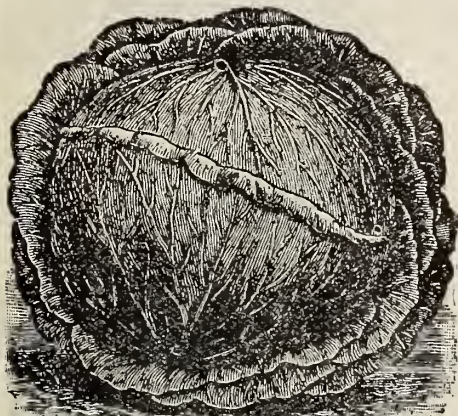

ALL-HEAD EARLY CABBAGE



PREMIUM LARGE FLAT DUTCH—LATE CABBAGE

CABBAGE	Pkt.	Oz.	¼ lb.	1 lb.	CABBAGE	Pkt.	Oz.	¼ lb.	1 lb.
Select Early Jersey Wakefield	\$.10	\$.25	\$.75	\$2.25	Succession	\$.10	\$.25	\$.75	\$2.25
Extra Early Jersey Wakefield	.10	.25	.75	2.25	Surehead	.10	.25	.75	2.25
Charleston Wakefield	.10	.25	.75	2.25	Early Dwarf Flat Dutch	.10	.25	.75	2.25
Copenhagen Market	.10	.25	.75	2.25	Boss Flat Dutch	.10	.20	.60	2.00
Extra Early Express	.10	.25	.75	2.25	Red Dutch	.10	.25	.75	2.50
Golden Acre	.10	.30	1.25	4.50	Danish Ballhead	.10	.25	.75	2.50
All Head Early	.10	.25	.75	2.25	Premium Flat Dutch	.10	.25	.60	2.00



DRUMHEAD SAVOY

CABBAGE—Continued

PERFECTION DRUMHEAD SAVOY—This is without any exception the finest stock of Savoy Cabbage to be found anywhere. The heads are large and solid, the leaves beautifully curled, and in tenderness and flavor it is almost equal to cauliflower, while its keeping quality is first class. **Pkt. 10c, oz. 25c, ¼ lb. 75c, 1 lb. \$2.25.**

GEORGIA COLLARDS

Called the Cabbage Collard on account of its close bunching growth. The plant produces center leaves generally perfectly white, though sometimes dashed with pink. It is a very delicate vegetable and of the finest quality. **Pkt. 10c, oz. 15c, ¼ lb. 25c, 1 lb., 75c.**

CARROTS

1 Oz. of Seed to 100 Feet of Row

Carrots thrive best in rather a light, rich loam. The ground should be well manured with fine, well-rotted or composted manure, and be thoroughly worked quite deep. Sow from middle of April to middle of May, in rows 14 inches apart, and thin the plants to 5 or 6 inches in the row. For late crops sow in June or July. An important point is to tread the rows firmly after sowing. For field culture, Carrots should be sown in drills 3 to 3½ feet apart, so as to cultivate with horse.

OXHEART OR GUERANDE

One of the heaviest yielders and the best for stiff and heavy soils where the long varieties would fail. The roots are often 3 to 3½ inches thick at the top; nearly oval in shape; the flesh is bright orange, fine grained and sweet. Of the finest table quality and equally good for stock. **Pkt. 10c, oz. 15c, ¼ lb. 30c, 1 lb. 90c.**

CHANTENAY

A most excellent, medium early, half long variety. It is one of the best in quality for the market and home garden, while its great productiveness and the ease with which it can be harvested make it desirable as a field sort. The tops are medium sized, uniformly half long or stump rooted but tapering slightly, smooth, deep orange-red in color. The flesh is very crisp and tender. Although a medium early sort the roots are suitable for use nearly as early as any. The variety is extensively used for bunching. **Pkt. 10c, oz. 15c, ¼ lb. 30c, 1 lb. 90c.**

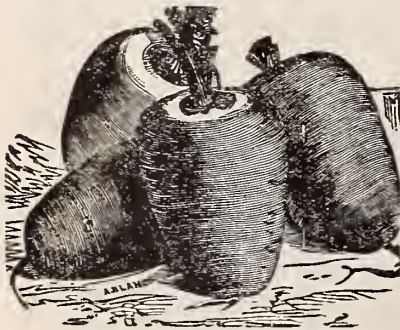

OXHEART OR GUERANDE



HALF LONG DANVERS

EARLY SCARLET HORN

The earliest variety in our list. Blunt-pointed, about 3 inches long, 1½ inches thick, very fine grained, sweet flavored; deep rich orange color. Fine for bunching. **Pkt. 10c, oz. 15c, ¼ lb. 30c, 1 lb. 90c.**

HALF LONG DANVERS

A decided acquisition of the half-long type, broad-shouldered, cylindrical, admirable in color, fixed in habits, a wonderful producer. It is a first-class Carrot for all soils. **Pkt. 10c, oz. 15c, ¼ lb. 30c, 1 lb. 90c.**

IMPROVED LONG ORANGE

Deep orange color, long, smooth, fine for either garden or field culture. All who have cattle should raise a surplus of this Carrot for feeding milch cows during winter. It increases the flow of milk and imparts to the butter a delicious flavor and a rich golden color. **Pkt. 10c, oz. 15c, ¼ lb. 30c, 1 lb. 90c.**

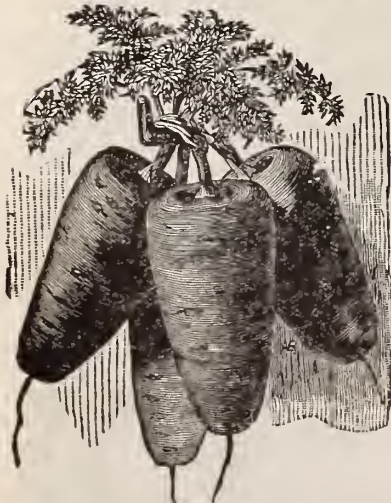

CHANTENAY



IMPROVED LONG ORANGE

CELERY

1 Oz. Will Produce 2,000 Plants

Plant seed in hotbed or very early in open ground. Transplant 4 inches apart when 3 inches high in rich soil, finely pulverized, water and protect until well rooted. In June or July transplant into rows 3 to 4 feet apart, either on surface or well-manured trenches a foot in depth, half filled with well-rotted manure. Set the plants from 6 to 8 inches apart. To blanch, draw earth around the plants from time to time, taking care not to cover the top of the center shoots.

GIANT PASCAL CELERY

A selection from the well-known Self-Blanching Celery. It partakes of the best qualities of that variety, is somewhat larger, and an excellent keeper. It is of fine nutty flavor, being entirely free from any bitter taste. It grows about 2 feet high. The stalks are very broad, thick, and crisp; the width and thickness of these are distinctive features of this variety.



GOLDEN SELF-BLANCHING CELERY



WINTER QUEEN CELERY

EASY BLANCHING CELERY

A second-early variety, maturing right after Golden Self-Blanching and resembling it in size and general characteristics of growth, but the foliage is a bright rich green. The stalks are thick and solid and of extra fine quality. They are unusually meaty, pure white, heavy, and crisp. A valuable variety for fall, winter, and early spring use. Easily blanched. It has quickly become a great favorite with many market growers.

WINTER QUEEN CELERY

It is without doubt the most valuable variety of Celery for winter and spring use ever introduced. It is also much stouter, thicker and heavier, with double the amount of heart of any known Celery. The plant is beautiful in appearance, of close habit and compact growth, and blanches to a beautiful cream white. Ribs perfectly solid, crisp and of delicious nutty flavor.

GOLDEN SELF-BLANCHING CELERY

This cannot be too highly recommended, as after being thoroughly tested it has fulfilled all that has been claimed for it. It is decidedly the very best and most profitable Celery in cultivation; it is very early and entirely self-blanching. The beautiful appearance of the plant, its close habit, compact growth, straight, vigorous stalks, solid, crisp, brittle ribs, fine quality and delicious flavor commend it to all lovers of Celery.

GOLDEN PLUME OR WONDERFUL CELERY

Recently introduced. Much better than White Plume in appearance, crispness, and fine nutty flavor, though somewhat earlier, larger and ranker growth. Blanches quickly, with full heart and rich, golden yellow color.



LARGE SMOOTH PRAGUE CELERIAC

WHITE PLUME CELERY

An early, handsome, self-bleaching variety, growing in popularity every year. Like the Golden Self-Blanching, it requires very little earthing up to blanch it, and as a Celery for fall and early winter use it is unsurpassed.

LARGE SMOOTH PRAGUE CELERIAC

The largest, smoothest and best of the Celeriacs. New apple shape small foliage, large round and smooth.

CELERY SEED FOR FLAVORING

This seed is used for flavoring pickles, soups, etc.



GOLDEN PLUME CELERY

CELERY	Pkt.	Oz.	¼ lb.	1 lb.
GOLDEN PLUME OR WONDERFUL	\$0.10	\$0.40	\$1.25	
GOLDEN SELF-BLANCHING	.10	.50	1.25	\$4.00
WHITE PLUME	.10	.25	.75	2.50
FLAVORING		.10	.15	.40
GIANT PASCAL	.10	.20	.50	1.75
WINTER QUEEN	.10	.25	.50	1.75
EASY BLANCHING	.10	.20	.60	2.00
CELERIAC				
LARGE SMOOTH	.10	.25	.50	1.75
NEW APPLE SHAPE	.10	.25	.50	1.75

CORN For Table Use

WHEN CORN IS WANTED BY MAIL, ADD 6 CENTS PER POUND TO PAY POSTAGE

CULTURE—Sugar Corn may be planted in rows 3 to 4 feet apart, and the seeds placed about 18 inches apart in the rows, or planted in hills 3 to 4 feet apart each way, according to variety grown or richness of soil. Do not let more than two or three plants remain in each hill. It can be planted in this vicinity from first of May to last of July for succession of crop. By planting every two weeks a family may have good corn throughout the whole season.

First Early Varieties 56 POUNDS PER BUSHEL

Not a sugar corn but makes fine roasting ears for early planting.

FIRST EARLY NECK CORN—By far the earliest roasting-ear corn we have. Can be planted in April without injury, as it is very hardy.

EXTRA EARLY ADAMS—Extremely hardy and early; one of the best for early planting.

EARLY ADAMS—A favorite in the South.

NINETY-DAY CORN (Red Cob)—This is an elegant corn for truckers and market gardeners, as it is as good a seller as green corn, and if not used as green corn makes a good variety for feeding purposes. It may be planted for early crop, and at intervals until the middle of July. Many truckers use it for their late planting, as it produces a very sure crop.

SWEET OR SUGAR CORN Extra Early Varieties BUSHEL SWEET CORN 44 POUNDS



GOLDEN BANTAM

GOLDEN BANTAM CORN—The earliest and best of sugar corns. It is of golden color and delicious flavor, with the sweetness of honey; can be planted earlier than the other varieties of true sweet corn, as it is very hardy. The stalks are dwarf in habit, growing about four feet high, producing two or three good ears five to six inches long, well set from the ground.

DE LUE'S GOLDEN GIANT CORN—The stalks grow 4½ to 6 feet tall and very near the ground; about one-third are purple in stalk, leaf and husk. They carry two or three good ears, 7 to 9 inches long; cob of small diameter, with 12 to 20 rows of long, deep kernels of deep orange color. The husk is very heavy, affording the end protection from worm and bird.

EARLY MINNESOTA—One of the first early among sugar corn.

WHIPPLE'S EARLY WHITE CORN—Of remarkable size, considering its earliness. Ears 8 inches long with 16 to 20 rows of rather narrow deep grains. Excellent quality, having rich, tender, well-filled ears. Very desirable for market gardeners.

HOWLING MOB—Howling Mob is one of the best flavored and most tender of all second-early white sweet corns. Ears of Howling Mob measure from 7 to 9 inches in length and they are closely set with 12 or 14 rows of large, pearly-white grains.

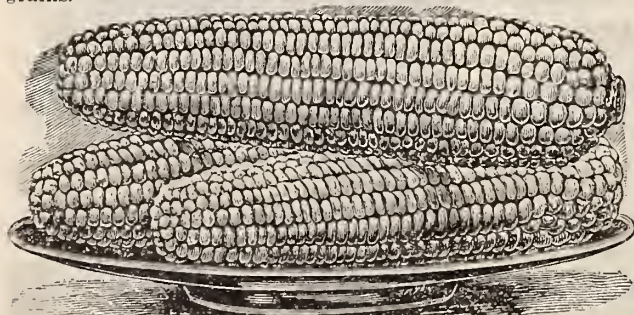

Stowell's Evergreen Sugar Corn

GARDEN CORN (About)	¾ lb. (1 pt.)	1¾ lbs. (1 qt.)	14 lbs. (1 pk.)
FIRST EARLY NECK	\$.15	\$.25	\$2.00
EXTRA EARLY ADAMS	.15	.25	1.50
EARLY ADAMS	.15	.25	1.50
NINETY DAY RED COB	.15	.20	.75
SWEET CORN (About)	¾ lb. (1 pt.)	1¾ lbs. (1 qt.)	11 lbs. (1 pk.)
DE LUE'S GOLDEN GIANT CORN	\$.15	\$.25	\$1.50
NEW GOLDEN BANTAM CORN	.15	.25	1.50
WHIPPLE'S EARLY WHITE	.15	.25	1.50
HOWLING MOB	.15	.25	1.50

Ask for Prices in Quantity and by the Bushel.

EARLY SHEFFIELD—Plant as early as Adams. Makes strong, vigorous growth with abundant foliage, growing about 5 feet and bearing usually two ears of handsome appearance.

BLACK MEXICAN—The black corn is especially rich in sugary qualities.

Main Crop Varieties

ASK FOR PRICES IN QUANTITY

COUNTRY GENTLEMAN CORN—This is the sweetest and most delicious flavored of all sugar corn. It is the finest variety for the table, and will delight the most fastidious epicure. It produces three to four ears to the stalk, and retains its greenness longer than other sorts.

STOWELL'S EVERGREEN—So well known that it scarcely needs description. Excellent; keeps green till cold weather; ears large; one of the best.

LATE MAMMOTH—The largest variety grown; very fine for market purposes.

ZIGZAG EVERGREEN—This is one of the sweetest and best late sweet corn, not even excepting the celebrated Country Gentleman and Shoe Peg. The ears resemble Stowell's Evergreen in size and shape, except that the kernels are placed irregularly or zigzag upon the cob, which is always an indication of great sweetness in any variety of sugar corn.

TRUCKER'S EARLY SUGAR CORN

This is the most desirable variety of sugar corn for truckers and gardeners to plant early. As its many excellent qualities are becoming generally known, it has come to be one of the standard sorts. It is ten days earlier than Evergreen; very productive.

EARLY MAMMOTH

A splendid market sort, producing large, handsome ears; grain large, white and sweet; fills out well at the end.

WHITE EVERGREEN

Has ears as large as Stowell's; is five days earlier; grains pure white. A valuable acquisition for the gardener and canner.

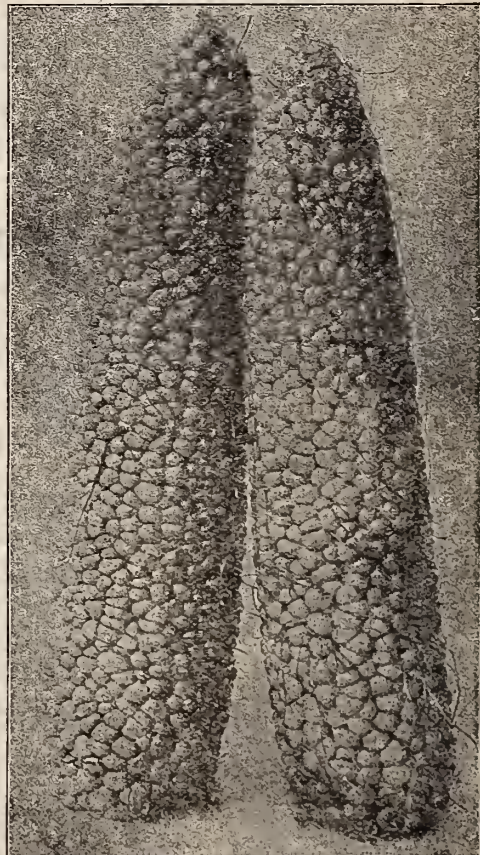

Country Gentleman Sugar Corn

SWEET CORN (About)	¾ lb. (1 pt.)	1¾ lbs. (1 qt.)	11 lbs. (1 pk.)
EARLY MINNESOTA	\$.15	\$.25	\$1.50
BLACK MEXICAN	.20	.40	2.00
COUNTRY GENTLEMAN	.15	.25	1.50
STOWELL'S EVERGREEN	.15	.25	1.50
TRUCKER'S EARLY	.15	.25	1.50
LATE MAMMOTH	.15	.25	1.50
EARLY MAMMOTH	.15	.25	1.50
WHITE EVERGREEN	.15	.25	1.50
EARLY SHEFFIELD	.15	.25	1.50
ZIGZAG EVERGREEN	.15	.25	1.50

Add for Postage, 8c per pound, 10c for 2 pounds.

CUCUMBERS

For very early Cucumbers sow the first of April in a hotbed upon pieces of sod (grass side down), so that they can be readily transplanted to the open ground in rich soil when danger of frost is over, or protect by hand-glasses. The vines require a warm location for early Cucumbers. Plant after the ground has become warm in hills 4 feet apart for the smaller varieties, and 5 feet for the larger sort. For pickling sow from middle of June to last of July. Manure with wood ashes, fertilizer or some well-rotted compost; working the manure just under the surface. Sprinkle the vines with slug-shot plaster, or air-slaked lime to protect from bugs. The Cucumbers should be gathered when large enough for use, whether required or not; if left to ripen, it destroys their productiveness.

1 Oz. Will Plant 50 Hills.
2 Lbs. Will Plant an Acre.

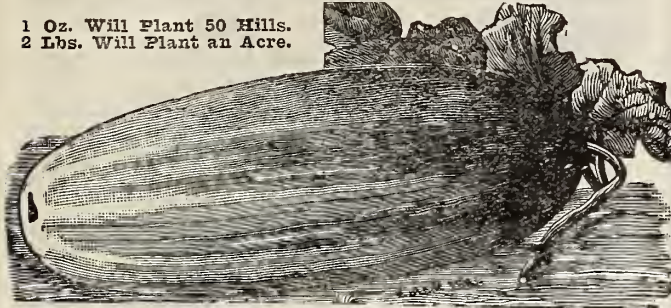

IMPROVED BALTIMORE WHITE SPINE

This is the best Cucumber for early planting, because it will retain its green color longer than any other sort. It is of good size and shape, and the popular variety with truckers around Baltimore and Norfolk, as well as the growers from Virginia to Florida.



EARLY FORTUNE CUCUMBER

One of the earliest and best dark green White Spine Cucumbers. Extremely early, and beautiful shape. Good for market gardeners, truckers or private family; in fact, any one who likes a dark green, white spine cucumber it cannot help but please. Fine for Southern growers, as it stands shipping remarkably well.

Telegraph (English Forcing)

Should be grown in hotbeds where the temperature does not fall below 65 degrees at night.



IMPROVED LONG GREEN

**Improved
Long
Green**

The skin is of a deep green, and the flesh is solid, crisp and of fine quality. We have the very best strains of this variety and recommend it as much the best cucumber of all, and the variety every one should plant. The best known and most popular variety for general use. Is vigorous and productive, and forms fruit fit for use as early as the shorter varieties. The mature fruit is almost 12 inches long.

Early Green Prolific

A very productive variety, having fruits of good length and handsome form. Desirable for producing pickles of medium size and fine quality when sliced for the table.

Ever-Bearing Cucumber

This variety is unique, and will prove valuable both for the table and for pickling. Is of small size, very early, enormously productive and extremely valuable as a green pickler. The peculiar merit of this new Cucumber is that the vines continue to flower and produce fruit until killed by frost, whether the ripe Cucumbers are picked off or not, in which respect it differs from all other sorts in cultivation.

Early Cluster

A short prickly variety, bearing in clusters near the root. A good bearer.

Jersey Pickling

This is the most popular sort with the market gardeners around Baltimore and Philadelphia for pickling. Said to green better than any other variety.

Japanese Climbing Cucumber

It bears abundantly throughout the season, while the climbing habit enables the hanging fruit to grow perfectly straight, from 12 to 16 inches in length; the Cucumbers are thick, tender and of delicate flavor; flesh white, skin dark green, turning to brown, and netted when ripe.

BURR, OR WEST INDIA GHERKIN

An extremely small fruited variety, grown exclusively for pickles. It has no value for slicing. Is very prickly, but tender and crisp if pickled when young. Seed germinates slowly.

GREEN CURLED ENDIVE



GREEN CURLED ENDIVE

Is One of the Best Salads for Fall and Winter Use. One Ounce of Seed to 150 Feet of Row.

For early use, sow as soon as the ground can be worked in the spring, in drills 15 inches apart, and then thin plants to 6 or 8 inches in row. To blanch the leaves, gather them carefully together when perfectly dry and tie them with matting or soft fibrous material. Another method is to invert flower pots over the plant. The leaves are very highly esteemed for use as salads.

CUCUMBER	Pkt.	Oz.	¼ Lb.	1 Lb.
IMPROVED BALTIMORE WHITE SPINE	\$.10	\$.15	\$.30	\$.90
EARLY FORTUNE	.10	.15	.30	.90
JERSEY PICKLING	.10	.15	.30	.90
IMPROVED LONG GREEN	.10	.15	.35	1.00
BURR OR WEST INDIA GHERKIN	.10	.15	.40	1.25

CUCUMBERS	Pkt.	Oz.	¼ Lb.	1 Lb.
EARLY GREEN PROLIFIC	\$.10	\$.15	\$.30	\$.90
EVERBEARING	.10	.15	.30	.90
EARLY CLUSTER	.10	.15	.30	.90
JAPANESE CLIMBING	.10	.15	.30	.90
TELEGRAPH	.25			
ENDIVE	Pkt.	Oz.	¼ Lb.	1 Lb.
GREEN CURLED	.10	.15	.40	1.25



BALTIMORE EGG PLANT

EGG PLANT

One ounce will produce about 1,000 plants.

CULTURE—Sow the seed in hot-beds early in March. When three inches high pot the young plants, using small pots, and plunge them in the same bed so that the plants will become stocky. They can be planted out from the pots when

the season becomes sufficiently warm in May or June, or they can be transplanted into a second bed to make them strong until the weather is warm enough to transplant about three feet apart each way in a thoroughly-worked and well-enriched soil. Draw the earth up to the stems when about a foot high. Egg Plant Seed will not vegetate freely without a strong, uniform heat, and if the plants get the least chilled in the early stages of growth they seldom recover. Therefore, repeated sowings are sometimes necessary.

BALTIMORE EGG PLANT—This is decidedly the best and most profitable Egg Plant in cultivation. It is large, thornless, of beautiful shape and handsome purple color. We have never seen finer specimens of Egg Plant than those grown from our seed.

BLACK BEAUTY EGG PLANT—The earliest of all large fruited Egg Plants and produces fruit quite as large as the New York Purple in 10 days less time. The fruit is symmetrical in shape, of uniform size, of a dark rich purple color, which does not fade or change to lighter color at blossom end like some other varieties. Just the variety for the market gardener and trucker for early spring trade.

NEW YORK IMPROVED LARGE PURPLE EGG PLANT—This market garden variety has plants of strong growth, and is very productive, producing plants of large size and fruits of smooth, deep purple color until frost.

KALE OR BORECOLE

One Ounce of Seed Will Sow a Drill About 200 Feet.



EXTRA CURLED NEW AMERICAN KALE

The Kales are more hardy than cabbage, and make excellent greens for winter and spring use, and are improved by frost. For early spring use, sow broadcast in August and protect during winter. It must be sown in April or May for later use.

GRIFFITH & TURNER CO.'S NEW KALE—Larger, more curled and longer-standing than any other Kale. Packet 10c., 1/4 lb. 30c., Lb., \$1.00.

EXTRA CURLED NEW AMERICAN KALE—This is an extra curled, long-standing variety of a beautiful green color; stands the winter well, and will stand longer in the spring before going to seed than any other variety.

DWARF GERMAN OR SIBERIAN KALE—Needs no description as it is a standard variety.

DWARF CURLED NORFOLK OR SCOTCH KALE—Yellowish-green foliage. Grows close to the ground and spreading. Used largely in the south.

BLUE DOUBLE CURLED SCOTCH KALE—A superior sort with a fine Blue-greenish color, much better than Norfolk or Scotch Kale.



LEEK

1 Oz. of Seed to 150 Feet of Row.

Select good Onion soil, manure liberally, plant in April in drills 6 to 8 inches deep, and 18 inches apart, and thin to 9 inches apart in the drill. Gradually draw the earth around the plants until the drills are filled level with the surface. Draw for use in October. To be used in soups or boiled as Asparagus.

EXTRA LARGE MAMMOTH—A large and strong plant; hardy. The best variety for general culture.



KOHLRABI

Improved White Vienna

1 Oz. of Seed to 100 Feet of Row.

Bulb light green, flesh white. Very rapid in growth and of early maturity. Fine in texture and symmetrical in form.

LETTUCE



BIG BOSTON

BIG BOSTON—The same in color, shape and general appearance as the Boston Market, double the size. A most desirable sort either for forcing in cold frames or planting in open ground. Is popular with truckers, as it makes large, solid, salable heads. Very highly recommended by those who have tried it.

BALTIMORE CABBAGE LETTUCE—The heads are large and solid; color pretty light green, and very slow to seed; in fact, it is just what the truckers and gardeners want. A large trucker in New Jersey writes: "The Baltimore Cabbage Lettuce I had of you was certainly very fine."

	Pkt.	Oz.	1/4 Lb.	1 Lb.
EGG PLANT				
BLACK BEAUTY	\$.10	\$0.40	\$1.00	\$3.75
NEW YORK IMPROVED	.10	.40	1.00	3.75
BALTIMORE	.10	.40	1.00	3.75
KALE				
G. & T. CO.'S NEW KALE	\$.10	\$0.30	\$1.00	\$1.00
EX. CURLED NEW AMERICAN KALE	.10	.30	.30	1.00
DWARF GERMAN OR SIBERIAN KALE	.10	.20	.20	.50
DWARF CURLED NORFOLK OR SCOTCH KALE	.10	.20	.20	.75
BLUE DOUBLE CURLED SCOTCH KALE	.10	.20	.20	.75
LEEK				
EXTRA LARGE MAMMOTH	\$.10	\$0.20	\$0.60	\$1.75
KOHL RABI	Pkt.	Oz.	1/4 Lb.	1 Lb.
WHITE VIENNA IMPROVED	\$.10	\$0.20	\$0.50	\$1.75
LETTUCE				
BIG BOSTON	\$.10	\$0.20	\$0.40	\$1.25
BALTIMORE CABBAGE	.10	.20	.40	1.25

ABOVE PRICES ARE POSTPAID.

LETTUCE

LETTUCE—Lettuce requires rich and rather moist soil. The rows should be about 12 inches apart, and the plants thinned to 10 or 12 inches apart for the leading varieties. The more rapid growth, the better the quality. Some varieties are peculiarly adapted for early culture, others for summer growth.

G. & T. CO'S WHITE SEED SUMMER LETTUCE—The Best Summer Lettuce Ever Introduced—This variety has exceeded our expectation. Those who purchased it were delighted with their crops, and came back for more seed. This Lettuce will stand the summer heat better than most sorts, and makes magnificent heads. It has a beautiful green color; head solid; light leaves, nicely crinkled; very tender, and of most excellent flavor.

NEW YORK-WONDERFUL or LOS ANGELES—Erroneously called Iceberg. The most talked of Lettuce today. It is grown largely in California and the West, shipped to the Eastern markets under the name of Iceberg. It is a crisp heading variety, producing very compact heads, with green leaves, slightly curled on edges.

BLACK SEED SUMMER LETTUCE—This lettuce is becoming very popular among gardeners for summer use; of the Cabbage type, remaining a long time in prime condition, before going to seed. It is light green in color, fine quality, crisp, tender, and nearly every plant will make a head.

"ICEBERG" LETTUCE—The heads are large, crisp, solid and tender, with pink tinge on edge.

EARLY PRIZE HEAD (Seed White)—A large, clustering, non-heading lettuce, most excellent for the home and garden, and undoubtedly the most easily grown variety in cultivation. It is too tender, however, to stand shipping or handling on the market. The leaves are finely curled and crumpled, bright green tinged with brownish red, and are very crisp, tender and sweet.

EARLY CURLED SIMPSON—Black seed. Very early; excellent for salads; forms a compact mass of leaves.

TENNIS BALL—Black seed. A favorite forcing variety; a very hard head.

MAY KING—A very early, new variety, forming fine, hard heads within a few weeks after planting. It is medium sized, light green, with buttery but crisp heads. There is just a faint tint of brown on the head.

We have had no end of praise from our friends and customers who have tried this variety. It is essentially a spring sort, and does well all summer. Being of rapid growth and quick heading, it is especially recommended for home garden, and is universally esteemed.

GRAND RAPIDS—This variety is considered by many the best loose-headed Lettuce for forcing under glass. Leaves medium size, of light, yellowish green color, much crimped and frilled, thin, but of very upright growth; crisp, tender and of good quality.

DEFIANCE—Stands summer heat better than any other variety; one of the finest large-growing varieties. It forms very large, solid heads, so firm that they have to be cut open to allow the flower heads to come through.

LARGE LOAF LETTUCE—This is so well known to truckers and gardeners around Baltimore and Norfolk that for them it scarcely needs description. For the benefit of those who are not acquainted with it, would say it makes large, compact heads, is of beautiful light green color, very tender and crisp. This is unsurpassed for frame use, and is also an excellent outdoor lettuce for fall or early spring.



W. S. SUMMER LETTUCE



COS LETTUCE

ROMAINE OR WHITE PARIS COS—The best of the Cos or celery varieties. Forms a large, light green plant with the head well folded and quite solid. Cos lettuce is also called Romaine, and is very popular with our foreign population, for it is highly prized in England and France.

HANSON—One of the most reliable sure-heading sorts. Makes a large globular head. Color, light green. Excellent quality. A fine variety for summer planting, as it stands hot weather better than most sorts.

BALTIMORE OAK LEAF—This lettuce will resist the heat of summer and stand longer before running to seed than any variety we have ever known. It makes a large, solid head and is very popular with those who know it.

BOSTON MARKET—White seed. A celebrated variety in New England, of good heading habit; small, early and compact; quite desirable.



LARGE LOAF LETTUCE

LETTUCE	Pkt.	Oz.	¼ Lb.	1 Lb.
LARGE LOAF LETTUCE.....	\$0.10	\$0.20	\$0.40	\$1.25
BALTIMORE OAK LEAF.....	.10	.20	.40	1.25
HANSON10	.20	.40	1.25
BOSTON MARKET.....	.10	.20	.40	1.25
GRAND RAPIDS.....	.10	.20	.40	1.25
DEFIANCE10	.20	.50	1.50
G. & T. CO'S WHITE SEED SUMMER10	.20	.60	2.00
G. & T. CO'S BLACK SEED SUMMER10	.20	.60	2.00
NEW YORK-WONDERFUL, OR LOS ANGELES10	.20	.60	2.00
MAY KING10	.20	.40	1.25
ICEBERG10	.20	.50	1.50
EARLY PRIZE HEAD.....	.10	.20	.40	1.25
EARLY CURLED SIMPSON.....	.10	.20	.40	1.25
TENNIS BALL10	.20	.40	1.25
ROMAINE, OR WHITE PARIS COS10	.20	.40	1.50

MUSKMELONS OR CANTALOUPE

CULTURE—One ounce of seed to 50 hills. Sow about the last of spring or the first of summer in hills of light, rich, sandy soil, 4 feet apart, allowing but three plants to grow in each hill; after they have grown about a foot long, pinch off the points of shoots, which causes the vines not only to become stronger, but makes them produce lateral branches and prove more productive and mature earlier. It should not be grown near squashes, cucumbers or pumpkins, as the flavor will be affected in consequence.

KNIGHT CANTALOUPE

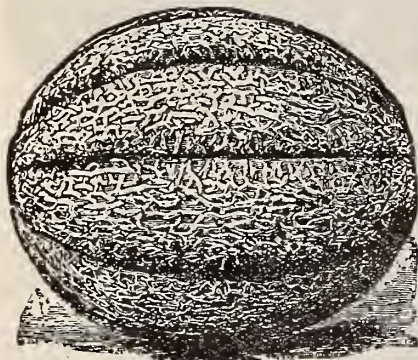

KNIGHT CANTALOUPE

This Cantaloupe has created a furore with our truckers, on account of its earliness, productiveness, uniformity in shape and appearance and its fine table qualities. It matures about a week earlier than the regular Rocky Ford, is larger in size and makes a most attractive and saleable melon. It has thick, green flesh, shading to orange at the center. The fruits are oblong in shape, well ribbed and well netted. It is a leader both for planting for home use and market and for shipping. Its early maturity, together with its fine qualities, are strong points in its favor. **Pkt. 10c., Oz. 20c., ¼ Lb. 40c., Lb. \$1.25.**

NEW MARYLAND CANTALOUPE—Is earlier, larger and cuts better than the Rocky Ford. Flesh is green, of fine flavor and heavily netted, making it the most attractive melon on the market. **Pkt. 10c., Oz. 15c., ¼ Lb. 30c., Lb., \$1.25.**

LONG JOHN—Grown extensively in Anne Arundel county. It is oblong, growing from 7 to 11 inches long. Deeply netted and ribbed. Green-fleshed and wonderful flavor. Thick meshed, with small seed cavity. **Pkt. 10c., Oz. 20c., ¼ Lb. 50c., Lb. \$2.00.**

EMERALD GEM—Meat, salmon color, exceedingly sweet and delicious; very early and prolific. One of the best for family use. Its appearance is not attractive, but try it, and you will want it again. **Pkt. 10c., Oz. 15c., ¼ Lb. 30c., Lb. 90c.**

EARLY NETTED GEM—Extensively grown, and many prefer it to all others for table use. Thick meated; flesh light green in color, and of fine, luscious flavor; skin green, regularly ribbed and thickly netted. **Pkt. 10c., Oz. 15c., ¼ Lb. 30c., Lb. 90c.**

IMPROVED JENNY LIND—A small, early variety of surpassing good quality, highly recommended for family garden. We consider this the most delicious Cantaloupe we have ever eaten, and while the fruit is small, it is an abundant bearer. **Pkt. 10c., Oz. 15c., ¼ Lb. 30c., Lb. 90c.**

PAUL ROSE—The fruit is oval, about 5 inches in diameter, and in shape and general appearance similar to the well-known Netted Gem or Rocky Ford. The firm flesh is a rich orange-red color. **Pkt. 10c., Oz. 15c., ¼ Lb. 30c., Lb. 90c.**

EXTRA EARLY HACKENSACK—Netted green flesh and excellent; very showy market variety and an excellent keeper. Ten days earlier than the Old Hackensack. **Pkt. 10c., Oz. 15c., ¼ Lb. 30c., Lb. 90c.**

HONEY DEW MELON—This new melon averages about 6½ inches in diameter. Smooth skin, almost white, rind thin and tough, good keeper and fine flavor. **Pkt. 10c., Oz. 20c., ¼ Lb. 50c., Lb. \$1.50.**

BOTTOMLY—A production of Anne Arundel County, Maryland. One of the newest and best Cantaloupes in existence. About a week later than the Knight. Fair size, excellent flavor, beautiful form and comprises all that is necessary for a good melon. **Pkt. 10c., Oz. 20c., ¼ Lb. 40c., Lb. \$1.25.**

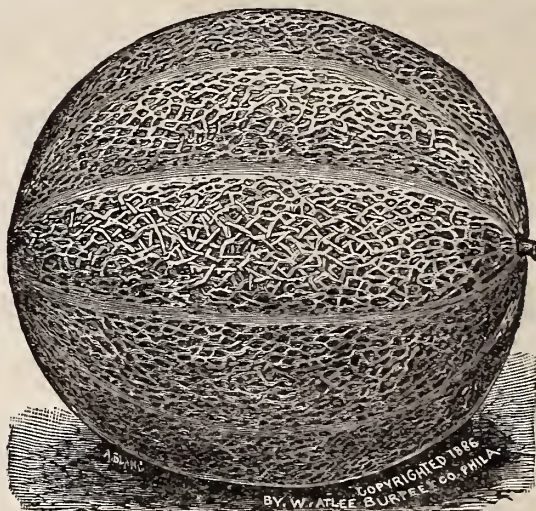

BALTIMORE NUTMEG CANTALOUPE

BALTIMORE NUTMEG CANTALOUPE—It is green-fleshed and the rind is handsomely netted. It is well known and popular with the truckers and market gardeners of Baltimore. It is a leading sort all over the country. **Pkt. 10c., Oz. 15c., ¼ Lb. 30c., Lb. 90c.**

ANNE ARUNDEL CANTALOUPE—One of the largest melons grown around Baltimore. Flesh green, flavor delicious. Heavily netted and ribbed. Fine for market or home use. **Pkt. 10c., Oz. 15c., ¼ Lb. 30c., Lb. 90c.**

ROCKY FORD MELON



This has become one of the most popular of small or basket melons, largely owing to the fact that growers in the Rocky Ford region pack and ship their fruit in a most attractive manner. The fruit is oval, slightly ribbed, densely covered with coarse netting. Flesh thick, green, very sweet and highly flavored. **Pkt. 10c., Oz. 15c., ¼ Lb. 30c., Lb. 90c.**

WATERMELONS

CULTURE—One ounce of seed to 30 hills; 4 pounds to the acre. Watermelons require a rich, sandy soil for best development. Cultivate the same as for cantaloupes, except that the hills should be eight or ten feet apart.



LORD BALTIMORE

LORD BALTIMORE—It is very early, of oblong shape, and the flesh is of handsome crimson color, deliciously sweet. It has a thin, hard rind, beautifully mottled light and dark green. Its perfect shape, faultless color, fine texture and excellent flavor combine to make it one of the very best melons that grow.

FLORIDA FAVORITE—This we consider one of the richest and sweetest flavored melons grown, of medium size and prolific. It is now very popular with the truckers and melon-growers of Maryland and Virginia, and sells readily in the Baltimore markets.

RIBAULT WATERMELON—This new melon grows from 24 to 30 inches long, and 14 to 18 inches in diameter. The rind is dark green, slightly striped with lighter green. Rind is thick and makes a good shipper. Free from hard centers. Seed large white, with black rings on the tips. Has a small seed cavity and will mature in 95 days.

STONE MOUNTAIN—A very large nearly round or "blocky" melon of high quality. Rind fairly tough, dark green; flesh sweet, rich scarlet, with few seeds.

DARK ICING—An extra early and extra good melon for home use and nearby market. One of the most delicious of melons; rich red and sugary to the very rind.

TOM WATSON—A recent introduction. A large oblong melon, dark green skin, with thin, tough rind, which gives it excellent shipping qualities. Melons are produced from 18 to 24 inches long and from 8 to 12 inches in diameter. Flesh deep red, crisp, melting and of finest flavor. Heart large, with little or no core. One of the best eating melons known.

GRAY MONARCH OR WHITE ICING—This distinct melon is without a doubt one of the largest of all. The skin is a mottled gray color, shape long, flesh bright crimson, and of sweet delicious flavor.

EXCEL—In appearance it strongly resembles the Watson, has a very thin, tough rind, is uniformly large. It is an unusual melon in that, although a grand shipper, it is also one that we can highly recommend for private garden, the beautiful red meat being decidedly crisp, sweet and luscious, and solid to the center.

RATTLESNAKE WATERMELON—Large, oblong, striped and mottled; flesh bright red; a good shipper, a favorite variety in the South.

KLECKLEY'S SWEET—Skin dark green, thin rind, flesh scarlet, very solid, firm and most luscious quality for the home market or family garden. It is decidedly one of the best.

INDIAN CHIEF WATERMELON—A large oblong dark green melon, with thick netting, the rind is thin but very tough. The flesh is a bright attractive red, and has a crisp delicious flavor.

THURMOND GRAY WATERMELON—Thurmond Gray is similar to Irish Gray, except with larger melons and brown seed instead of white. The rind is very tough and stands shipping as well as any melon grown. The flesh is free from strings, is fine grained, crisp and tender. Its eating qualities are excellent.

GENERAL PERSHING WATERMELON—One of the best yet introduced. Tough rind, making it a good shipper. Red, sweet flesh. Big crop of enormous size.

IRISH GRAY WATERMELON—This new South Georgia variety is one that has attained great popularity on its merit. It's a combination melon, equally good for shipping or home use.

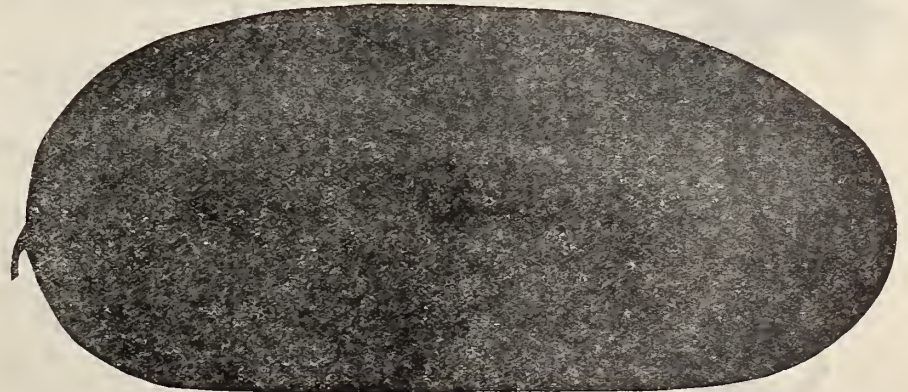

NEW WATERMELON—THURMOND GRAY

CITRON—For Preserves. Fruit round and handsome. Used in making preserves only.

WATERMELON				WATERMELON							
	Pkt.	Oz.	¼ Lb.	1 Lb.		Pkt.	Oz.	¼ Lb.	1 Lb.		
LORD BALTIMORE	\$0.10	\$0.15	\$0.25	\$0.90	GRAY MONARCH OR LONG	\$0.10	\$0.15	\$0.25	\$0.75
FLORIDA FAVORITE10	.15	.25	.75	WHITE ICING10	.15	.25	.75
DARK ICING10	.15	.25	.75	INDIAN CHIEF10	.15	.25	.75
TOM WATSON10	.15	.25	.60	KLECKLEY'S SWEET10	.15	.25	.75
THURMOND GRAY10	.15	.25	.75	EXCEL10	.15	.25	.75
RATTLESNAKE10	.15	.25	.75	IRISH GREY10	.15	.25	.75
CITRON10	.15	.25	.90	RIBAULT WATERMELON10	.15	.35	1.00
STONE MOUNTAIN10	.15	.25	.75	GENERAL PERSHING10	.15	.25	.75

ALL PRICES IN CATALOG SUBJECT TO CHANGE WITHOUT NOTICE.

ONION SEED



YELLOW DANVERS ONION

CULTIVATION—TO GROW LARGE ONIONS FROM SEED—The seed should be sown as early as possible in the spring, as they grow much better during the cool weather, and should make most of their growth before the hot weather sets in. Sow 5 pounds of seed to the acre for large onions.

THE NEW ONION CULTURE—Sow the seed in hotbed and transplant early as possible to open ground. They can be grown very successfully by this plan.

YELLOW GLOBE DANVERS—A very handsome, round, yellow onion; a large yielder and splendid keeper; the preferred sort with market gardeners and large growers all over the country. We unhesitatingly recommend it for growing either sets or large onions.

PRIZE TAKER—This is the large, beautiful onion that is seen every fall offered for sale at the fruit stores in Baltimore and other large cities. It has a rich straw color, and is of enormous size. Although of such large size, it is very hardy and an excellent keeper. The flavor is mild and delicate, making the Prize-taker a favorite variety for salads. By sowing this sort early you can raise a large crop of large onions the first season with very little trouble. All that is necessary is good ground, proper cultivation, and not to have them too thick. Those of our growers who have tried this variety have had remarkably fine success.

ONION SETS



CULTIVATION OF SETS

Have a clean and very rich soil, which should be thoroughly cultivated, or it will not do well enough to pay for the trouble. Disturb the roots of the onion as little as possible, either in thinning or hoeing, and never hoe earth toward them to cover or hill, as we do most other things.

WHITE

1 lb., about 1 qt., 25c; mailed, 30c.

YELLOW

1 lb., about 1 qt., 25c.; mailed, 30c.

Ask for prices on sets by the bushel of 32 lbs. It requires 10 to 15-bushel sets to plant one acre.

WHITE SILVERSKIN or PORTUGAL—A good variety for family use, skin and flesh pure white, mild flavor and flat shape. The best white onion to grow largely for sets.

AUSTRALIAN BROWN—A Valuable Long-Keeping Onion. This new onion, introduced into the United States a few years since, has met with wonderful success, and is pronounced the best keeper of all onions. The outside skin is of a deep amber brown, distinct from all other onions, extremely hard and firm, of fine flavor, and will keep almost indefinitely. Australian Brown is the only onion Australian growers will plant.

WETHERSFIELD LARGE RED—Well-known and favorite sort. A large yielder and good keeper.

YELLOW DUTCH, or STRASBURG—The most popular and best variety for set purposes. Is similar to the Yellow Danvers. Flat in shape, color and size, but as a set onion it has the quality of ripening down earlier and more uniformly.

MUSTARD

GIANT CURLED—Highly esteemed in the South, where the seed is sown in the fall and used in the spring as a salad. Our stock is the true curled leaf, and produces plants two feet high and of great breadth, forming enormous bunches.

WHITE MUSTARD—Seed for Pickles.

OKRA, or GUMBO



Select warm location and rich soil, and plant when the ground becomes warm, in rows three feet apart, thinning plants a foot apart in the row. As the seeds are liable to rot in cool weather, they should be sown thickly. The pods are used to thicken soup, being gathered when young. It is one of the most wholesome vegetables in use.

DWARF OKRA

This is the preferred kind with the growers; is of dwarf habit and very productive.

Pkt., 10c. Oz., 15c. ¼ Lb., 20c. Lb., 50c.

WHITE VELVET

It is very distinct and the pods are perfectly round and smooth, of an attractive white velvet appearance, and of superior flavor and tenderness. The pods are of extra large size, and produced in great abundance.

Pkt., 10c. Oz., 15c. ¼ Lb., 20c. Lb., 50c.

ENGLISH MILL TRACK MUSHROOM SPAWN

Cake 30c, by mail 35c, 10 lbs. \$2.50 by Freight or Express. Two pounds of spawn are sufficient for a bed 3 feet by 6 feet.

CULTIVATION—Select fresh horse manure, with straw bedding. Put in a flat pile and cover with 2 inches or 3 inches of good soil. In the course of 3 or 4 days, turn over and mix thoroughly. Moisten with water, pile up and cover again with soil and allow the pile to heat. Turn again in 5 or 6 days and moisten as before. Repeat the above about 4 times, every 5 or 6 days. Put this mixture on floor about 8 inches deep in beds the size desired and pack down with shovel. When the heat rises to 100 degrees, wait until it recedes to about 70, then place the spawn. Keep same moist, make your bed in cellar, shed, pit or some building that can be darkened.

ONION	Pkt.	Oz.	¼ lb.	1 lb.
WHITE SILVERSKIN or PORTUGAL	\$0.10	\$0.25	\$0.60	\$2.00
AUSTRALIAN BROWN	.10	.25	.50	1.50
WETHERSFIELD LARGE RED	.10	.25	.60	2.00
YELLOW DUTCH or STRASBURG	.10	.20	.50	1.50
YELLOW GLOBE DANVERS	.10	.20	.50	1.50
PRIZE-TAKER	.10	.25	.50	1.75

MUSTARD

GIANT CURLED	.10	.20	.50
WHITE MUSTARD	.10	.20	.50

PARSNIP

The Parsnip will flourish best and give the longest, largest and smoothest roots in a very deep, rich soil—one that has been made rich from manure the previous year. Fresh manure makes the roots somewhat ill-shaped. Sow as early in the spring as the ground can be made ready, pretty thickly in drills from 12 to 18 inches apart, and about an inch deep. Thin the plants to five or six inches apart.

HOLLOW CROWN OR SUGAR—The Hollow Crown is superior in quality to all other varieties, and the preferred kind with Baltimore gardeners. The roots are smooth, tender, handsome shape and early. We have the finest stock of Hollow Crown Parsnips that we know of in this country.

Oz.	¼ lb.	1 lb.
\$0.10	\$0.20	\$0.65

RHUBARB OR PIE PLANT

1 oz. seed to 125 ft. of drill.

CULTURE—Good plants are easily grown in any good garden soil. Sow seed thinly in shallow drills a foot apart, thin to 4 or 5 inches. Keep soil loose and free from weeds. The plants are liable to vary considerably. Pick out the strongest and best. In fall or spring following transplant to the permanent bed, 4 feet apart each way, in deep, warm and very rich soil.

Pkt.	Oz.	¼ lb.	1 lb.
.10	.20	.35	1.25

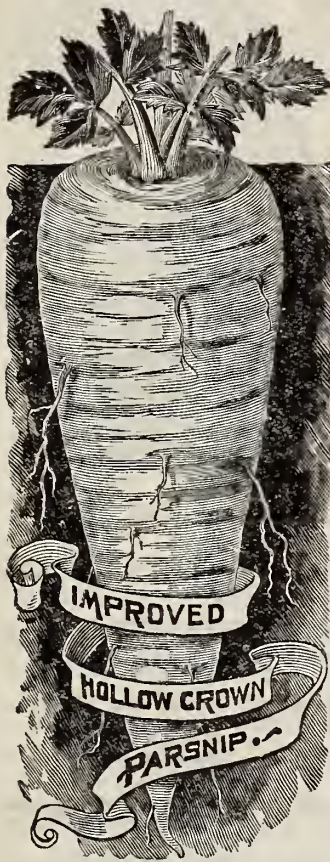

PARSLEY

Select rich soil; sow the seed in drills one foot apart, covering half an inch deep. It would be well to firm the soil with the foot after sowing the seed. As the seed is usually from 15 to 25 days in germinating, it will be necessary to sow early. Thin plants to 4 inches apart when 2 inches high. The beauty of the plant may be increased by several successive transplantings. It is used principally for flavoring soups, etc., and for garnishing in its natural state.

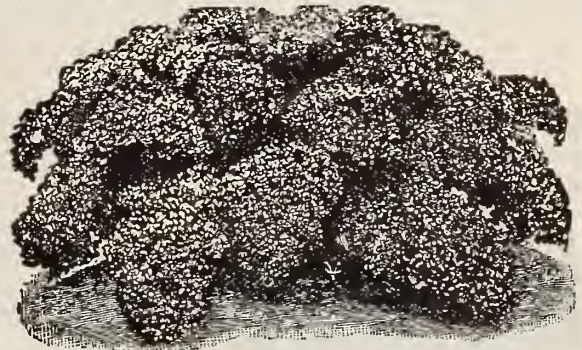

BALTIMORE EMERALD GREEN TRIPLE CURLED PARSLEY—The newest and best variety yet introduced. Beautiful green color and finely curled and crimped.

DWARF EXTRA CURLED—The most beautiful and valuable variety in use; handsome bright green color; finely crimped, beautifully curled.

MOSS CURLED—A very select crimped variety.
HAMBURG ROOTED or GERMAN—The root resembles a small parsnip and is the edible part of the sort; used for flavoring soups.

PARSLEY		Pkt.	Oz.	¼ lb.	Lb.
BALTIMORE EMERALD GREEN TRIPLE CURLED		\$0.10	\$0.15	\$0.35	\$1.00
DWARF EXTRA CURLED		.10	.15	.25	.75
MOSS CURLED			.15	.25	.75
HAMBURG ROOTED GERMAN		.10	.15	.25	.75

PEPPER OR CAPSICUM

Is cultivated mainly for pickles; used as a seasoning in many ways; sometimes medicinally. Sow seed early in hotbed, if possible; if not, select a warm place in the garden for seed bed; sow as soon as the soil is warm. Transplant when 3 or 4 inches high, in rows 18 inches apart.

LARGE BELL or BULL NOSE—Plant vigorous, compact, very productive, ripening its crop uniformly and early. Fruit large, with thick, mild flesh, of excellent quality for use in salads and pickles; color bright red when ripe.

RUBY KING—An improved American variety often four to six inches in length and quite symmetrical in shape. It is very bright colored and the flesh is sweet and mild flavored.

SWEET MOUNTAIN—Plants very vigorous, of compact, upright growth. The fruit does not ripen until very late. It is very large and long, often eight inches or more in length by two in diameter; very smooth and handsome, being when fully matured of a rich red color. Flesh very thick, sweet and mildly flavored.

CHINESE GIANT—Double the size of Ruby King; the finest mild Red Pepper grown. It is very productive, having a magnificent appearance, which makes it sell readily.

LONG RED CAYENNE—A well known variety, having a slender, twisted and pointed pod about four inches long, and, when ripe, bright red in color. Extremely strong and pungent flesh.

RED CHERRY—Plant tall, bearing a profusion of round, bright red fruit which are very pungent when ripe. The plant, when in fruit, is very ornamental.

RED CHILI—Used in the manufacture of pepper sauce. The bright, rich red pods are about two inches long, one-third to one-half inch in diameter at the base, tapering to a sharp point and exceedingly pungent when ripe.

PIMIENTO—The mildest flavored of all peppers. Its productiveness makes it a desirable sort for the home garden or market. Its smooth, thick flesh and uniform shape makes it an excellent shipper. Should be planted in every garden where a delicious sweet-flavored pepper is wanted both for salad and for stuffing.

CALIFORNIA WONDER—Plants very vigorous. Is large, prolific and of good weight. Of finest quality and should be planted by all pepper growers.

PEPPER		Pkt.	Oz.	¼ lb.	Lb.
LARGE BELL or BULL NOSE		\$0.10	\$0.25	\$0.75	\$2.75
RUBY KING		.10	.30	.75	2.75
SWEET MOUNTAIN		.10	.30	.75	2.75
CHINESE GIANT		.10	.40	1.25	4.50
LONG RED CAYENNE		.10	.30	.75	3.00
RED CHERRY		.10	.40		
RED CHILI		.10	.40		
PIMIENTO		.10	.35	.75	
CALIFORNIA WONDER		.15	.50	1.50	5.00



HERBS

A well assorted selection of the various kinds of herbs should have a place in every garden. Their value in seasoning and flavoring is well known and appreciated. Sow in spring in shallow drills, one foot apart, and when well up thin out or transplant to a proper distance. Care should be taken to harvest on a dry day just before they fully blossom.

	Pkts.	Oz.	¼ lb.	Lb.		Pkts.	Oz.	¼ lb.	Lb.
ANISE	5c.	15c.			DILL	5c.	15c.		50c.
BASIL	5c.	15c.			FENNEL (Sweet)	5c.	15c.		
BENE, use medicinally	5c.	15c.			LAVERANDER	5c.	15c.		
BORAGE, excellent for bees	5c.	15c.			MARJORAM	5c.	25c.		
CARAWAY	5c.	15c.			ROSEMARY, an aromatic herb	5c.	35c.		
CHERVIL	5c.	25c.			SAGE (American)	5c.	20c.		
CHICKORY	5c.	15c.			THYME (broad-leaved English)	5c.	25c.		
CORIANDER	5c.	10c.							

PEAS—SELECTED STOCKS

Ask for prices in quantity. Add for postage 8c per lb., 10c per 2 lbs.

The Dwarf Varieties should be liberally manured; the tall sorts will run too much to vine if heavily manured, it being better to depend on the richness of the land that was previously in good condition. Plant the dwarf in rows two feet apart; those varieties attaining a height of from two to three feet in rows three feet apart, and the rows of the tallest sort four feet apart. Bushing the tall kind when six inches high, on poles set every six or eight feet, with twine fastened to them about four inches apart, will answer finely.

Extra Early Varieties

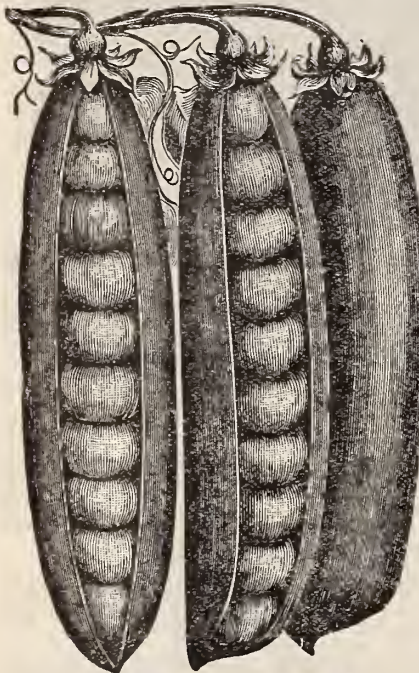

THOMAS LAXTON PEAS

ALASKA—Our best roged and hand-picked stock. Height 28 inches. The earliest Blue Pea. Very uniform in growth and time of ripening. The dark green color of pods makes this a most desirable sort for canners and shippers, as it can be carried long distances without losing color.

FIRST AND BEST—Height 2½ feet. Grown with special care. One of the earliest varieties.

PEDIGREE EXTRA EARLY—Introduced several years ago, has steadily increased in favor until now the truckers all want it. Early as Alaska, large pods, white seeded, very prolific. All mature at one time and can be gathered in one picking.

G. & T. CO.'S FIRST EARLY PEAS—This is the earliest of all and the most profitable early market Pea, because of its early maturity, uniformity of growth, and ripening, and its productiveness. It ripens up so evenly as only to require about two pickings to secure the crop.

NEW LARGE PODDED ALASKA—In general habit and growth resembles the well-known Alaska. Ripening about three days later, but with much longer and thicker pods. Handsomely shaped, of a beautiful dark green color, which is retained long after other varieties have lost their usefulness. The seed is somewhat dented. We strongly recommend this new Pea to gardeners, truckers and shippers as a most productive and large extra early variety.

BOUNTIFUL—Ripening about three to four days later than extra early sorts. Much longer and thicker pods. Beautifully shaped, dark green color which is retained after earlier varieties have turned grey. Seed dented, and we recommend this pea to all market gardeners and truckers.

PROLIFIC EARLY MARKET—New. Recently introduced. The finest, largest and most prolific extra early variety. Larger than Alaska, nearly as early, quite as prolific. Handsome pods, which command the highest prices. Just the pea for the trucker, market gardener and family garden.

EARLY BIRD—As large as Thomas Laxton or Gradus. Earlier than either. Vines about two feet high with large well-filled pods. Can be planted earlier than Thomas Laxton or other wrinkled varieties.

Large Podded Extra Early Variety

MARYLAND PRIDE PEAS—Introduced by us recently for the first time, giving universal satisfaction to the market gardeners and shippers. Pods large, of a deep green color, and nearly as early as Alaska.

THOMAS LAXTON—Habit and growth same as Gradus, but pods are a deeper green color, square at the ends, having fine flavor.

GRADUS or PROSPERITY—Pale Green Wrinkled. The most attractive novelty of recent years. Large, handsome pods, well filled, ripening with the earliest, and of vigorous habit.

IMPROVED LAXTONIAN—A fine, large mammoth-podded wrinkled pea. Vine is dwarf and is fine for home garden. Dark green.

Medium and Late Varieties

EVERBEARING—Vines are about 2 feet high, of a branching character, forming as many as 10 stalks from a single root stalk. Peas large and of fine quality.

HEROINE PEA—A medium early, green, wrinkled Pea, and one of the best of recent introduction; large, curved, showy pods; an immense cropper; Peas of finest quality. Height 2 to 2½ feet.

CHAMPION OF ENGLAND—Height 4 feet. An old favorite, rich flavored and very productive.

TELEPHONE—Height 3 to 4 feet. Large wrinkled seeds; pods large and well filled.

IMPROVED SUGAR MARROWFAT PEAS (Genuine Stock)—Height 3½ feet. Grows a strong vine, bears in abundance large filled pods. The truckers' favorite.

MELTING SUGAR (Edible Pods)—This variety is ahead of all other Sugar Peas, not only in size of pod and prolific bearing, but also for its delicious flavor. It grows to the height of 5 feet, bears a profusion of very large, broad, handsome light green pods, which are so brittle that they snap without any strings.

TALL GRAY SUGAR (Edible Pods)—Cooked in the pods same as Snap Beans.

DWARF GRAY SUGAR (Edible Poda)—Quite a favorite.

Dwarf Wrinkled Varieties

NOTT'S EXCELSIOR—Is the best of dwarf wrinkled extra early of recent introduction. The vines are larger and more vigorous than the American Wonder, while the pods are fully one-third larger, containing 6 to 8 fine, large Peas, packed so closely together in the pods that the Peas are always more square than round. The pods are always well filled with Peas, which in sweetness and quality have no superior.

AMERICAN WONDER—Very luscious in flavor. Try it. Height 12 inches. The earliest wrinkled Pea; very productive and sweet. Better suited to the private than to the market garden.

PREMIUM GEM—Height 15 inches. An improvement upon the Little Gem. A splendid wrinkled dwarf Pea; very luscious in flavor.

MCLEAN'S LITTLE GEM—Similar to Premium Gem, but more straggling in growth; pods not so well filled; height 18 inches; seed, green wrinkled.

PEAS	(1 pt.) (about) 1 lb.	(1 qt.) 2 lbs.	(1 pk.) 15 lbs.
ALASKA	\$.25	\$.40	\$2.25
FIRST AND BEST	.25	.40	2.25
PEDIGREE EXTRA EARLY	.25	.40	2.25
G. & T. CO.'S FIRST EARLY	.25	.40	2.25
NEW LARGE PODDED ALASKA	.25	.40	2.25
BOUNTIFUL	.25	.40	2.25
PROLIFIC EARLY MARKET	.25	.40	2.25
EARLY BIRD	.25	.40	2.25
MARYLAND PRIDE	.25	.40	2.25
THOMAS LAXTON	.25	.40	2.25
GRADUS or PROSPERITY	.25	.40	2.25
IMP. LAXTONIAN	.25	.40	2.25

PEAS	(1 pt.) (about) 1 lb.	(1 qt.) 2 lbs.	(1 pk.) 15 lbs.
NOTT'S EXCELSIOR	.25	.40	2.25
AMERICAN WONDER	.25	.40	2.25
PREMIUM GEM	.25	.40	2.25
MCLEAN'S LITTLE GEM	.25	.40	2.25
EVERBEARING	.25	.40	2.25
HEROINE	.25	.40	2.25
CHAMPION OF ENGLAND	.25	.40	2.25
TELEPHONE	.25	.40	2.25
IMP. SUGAR MARROWFAT	.25	.40	2.25
MELTING SUGAR	.25	.50	
TALL GRAY SUGAR	.25	.50	
DWARF GRAY SUGAR	.25	.50	

Ask for Prices by the Bushel



G. & T. CO'S MARYLAND SWEET POTATO

PUMPKIN

Plant in May, in hills 8 feet apart. Allot 10 seed to each hill, as bugs often destroy the young plants, but only allow 2 or 3 healthy plants to remain in each hill. They are usually planted in fields with corn or potatoes.

G. & T. CO'S MARYLAND SWEET POTATO—This is the best table pumpkin in cultivation. In shape and size it somewhat resembles the Cashaw, but much more beautiful in color, being a handsome green and white striped. The flesh is a rich yellow color, solid, fine grained, very thick; flavor delicious.

LARGE CHEESE or KENTUCKY FIELD—A very large flattened pumpkin, averaging about 2 feet through. When ripened the skin is a rich cream color. Flesh yellow and of fine quality.

TENNESSEE SWEET POTATO—A splendid pie and cooking pumpkin. They grow pear-shaped, of medium size, slightly ribbed; skin is creamy white, lightly striped with green; flesh very thick, creamy white, dry and fine-grained, keeping well until late in the spring. When cooked resembles sweet potatoes, but much more delicious in taste.

CONNECTICUT FIELD—A fine, large, orange-colored variety used for field culture and stock feeding. The skin is smooth and ribbed and the flesh is brittle and sweet.

YELLOW CASHAW or CROOKNECK—Solid flesh, fine and sweet; keeps well.

RADISH

One Ounce Will Sow 100 Feet of Drill

For an early supply sow in hotbed in February. For a successive supply sow from middle of March to September. Radishes thrive best in light, rich, sandy loam. The radish must make a rapid growth to



WHITE ICICLE

be fit for use; it will then be crisp and tender and of a mild flavor. If it grows slowly, it will be hard, fibrous and disagreeably pungent.

EARLY SCARLET or PRUSSIAN GLOBE RADISH—This is the very best forcing variety; is sown largely by market gardeners and truckers, and they are delighted with it. It is of a globular shape and brilliant, beautiful crimson color, short top, and will stand a large amount of heat without becoming pithy.

FRENCH BREAKFAST—Of oval form; color scarlet, white tipped.

EARLY RED TURNIP—Turnip shaped, red skin, for forcing. Sometimes called Red Button Radish.

SCARLET OLIVE SHAPED RADISH—A showy half-long variety of pretty shape and bunches beautifully.

EARLY WHITE TIPPED SCARLET—An excellent variety for forcing, with very snort leaves; bright scarlet in color, with a white tip.

Summer Varieties

WHITE STRASBURG—This is becoming one of the most popular summer sorts; it is of handsome tapering shape, skin pure white; very tender.

GIANT STUTTGART—A splendid new variety, of excellent quality; withstands summer heat.

CHARTIER—A good variety for private or market garden purposes. Stands long before going to seed, and is tender and crisp.

DELICACY—Resembles White Strasburg, being more evenly shaped and smaller topped; grows into full size and perfection during the hottest months.

WHITE ICICLE—A beautiful long, slender radish, of recent introduction. Beautiful pearl-white color, firm and solid, slow to get woody. A good seller.

Long Varieties

WHITE VIENNA or LADY FINGER—This is unquestionably the finest long white Radish. Of most handsome shape, color a beautiful snowy white. It is of very rapid growth, and remarkably crisp, brittle and tender; equally desirable for the market or home garden.

LONG SCARLET (Finest Grown)—Very attractive and sells rapidly. Owing to its handsome shape, brilliant color and fine qualities, it commands a higher price and more ready sale than the ordinary Long Scarlet as generally sold.

Winter Varieties

WHITE CHINESE WINTER or CELESTIAL—This excellent variety is sold also as Chinese White Winter. The roots are long, cylindrical, with beautiful white skin and flesh, the whitest and usually the least pungent of the winter varieties. When fully matured the roots are six to nine inches long by about two and one-half to three and one-half inches in diameter. The flesh is compact and crisp.

CHINESE ROSE WINTER—Remarkably fine for winter use. The best of the winter sorts.

PUMPKIN	Pkt.	Oz.	¼ lb.	1 lb.
G. & T. CO'S MARYLAND SWEET POTATO	\$0.10	\$0.15	\$0.20	\$0.70
LARGE CHEESE or KENTUCKY FIELD		.10	.20	.60
TENNESSEE SWEET POTATO	.10	.15	.20	.70
CONNECTICUT FIELD		.10	.20	.50
YELLOW CASHAW or CROOKNECK	.10	.15	.25	.70
RADISH	Pkt.	Oz.	¼ lb.	1 lb.
EARLY SCARLET or PRUSSIAN GLOBE	\$0.10	\$0.15	\$0.25	\$0.70
FRENCH BREAKFAST	.10	.15	.25	.70

RADISH	Pkt.	Oz.	¼ lb.	1 lb.
EARLY RED TURNIP	.10	.15	.25	.70
SCARLET OLIVE SHAPED	.10	.15	.25	.70
EARLY WHITE TIPPED SCARLET	.10	.15	.25	.70
WHITE STRASBURG	.10	.15	.30	.70
GIANT STUTTGART	.10	.15	.25	.75
CHARTIER	.10	.15	.25	.75
DELICACY	.10	.15	.25	.75
WHITE VIENNA or LADY FINGER	.10	.15	.25	.75
LONG SCARLET	.10	.15	.25	.65
WHITE ICICLE	.10	.15	.25	.70
WHITE CHINESE or CELESITAL	.10	.15	.25	.75
CHINESE ROSE WINTER	.10	.15	.25	.75

SPINACH

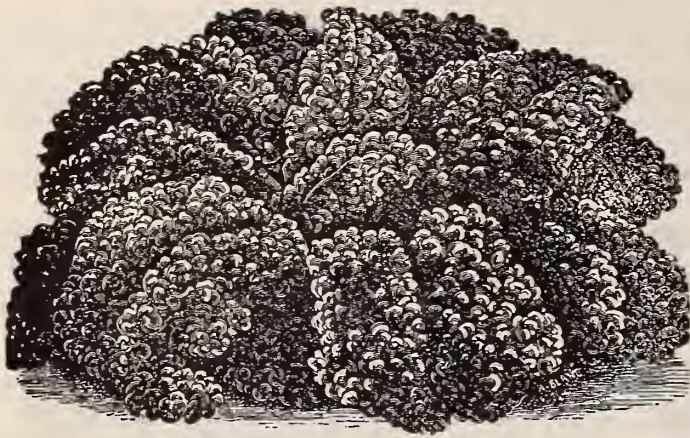

BLOOMSDALE SAVOY SPINACH

VIRGINIA BLIGHT RESISTING—Fine for carrying over winter.

VICTORIA LONG STANDING—Slow to run to seed, dark green in color. Good for spring sowing.

LONG SEASONS—Long standing; slow to run to seed; crimped, dark green. For spring sowing.

TRIUMPH—Long standing; slow seeder, crimped dark green. Good for spring sowing.

This is quite an important crop with market gardeners, and one easily managed. For summer use, sow early in spring, in drills eight inches to one foot apart, covering the seed one inch deep. Select rich soil and manure liberally. A succession may be obtained by sowing at intervals of two weeks through the season. For very early spring sow in August, and protect the plants through the winter by a thick covering of clean straw or some other similar light covering. Spinach is used principally as greens for boiling, and is very highly esteemed for this purpose.

DARK GREEN BLOOMSDALE SAVOY SPINACH.—As its name implies, it has all the merits of the Reselected Bloomsdale Savoy plants. Very much crumpled, stands long before going to seed and only two days later than the Savoy Spinach.

RESELECTED BLOOMSDALE SAVOY SPINACH.—Grown from pedigree stock, carefully rogued each year for the true Bloomsdale Savoy Spinach plants.

IMPROVED LONG STANDING BLOOMSDALE SAVOY SPINACH.—A most desirable sort, very curly and dark green. Stands ten days longer, or more, than the other savoy types before going to seed. While it is a slow seeder, it requires a longer time before it is fit to cut, because it is a slower grower than the other Bloomsdale varieties.

JULIANA—Long standing. The finest crinkled sort of the flat types. Lots of foliage and very shy seeder. Dark green foliage and fine for summer sowing.

NEW ZEALAND SPINACH—The hot weather spinach will resist heat and make a strong growth during the summer. The plants will continue to grow until late fall, supplying all during summer and fall an abundance of rich green leaves. It cannot stand frost like other spinach; for family gardens only.

SQUASH



Early White Bush Scallop

The squashes are all quite tender, and therefore no progress can be made in starting them until the weather becomes somewhat warm and settled. Plant in hills five feet apart each way for the bush varieties and eight feet for the running varieties; put eight seeds to the hill, but don't allow over three to stand.

EARLY WHITE BUSH SCALLOP—A desirable and marketable sort. Best known and most productive of all the summer sorts.

BENNING'S WHITE BUSH—Tinted green. Same shape as White Bush, but preferred by growers, on account of its beautiful rich green-tinted color.

SUMMER CROOK NECK (Early)—Fine flavor; a desirable table sort.

WINTER CROOK NECK—Flesh red, fine flavor; largely grown for winter use.

HUBBARD—The most popular winter squash. Fruit is oblong and pointed, heavily warted, dark green in color, with orange-colored flesh. Is remarkable for its keeping qualities.

BOSTON MARROW—A popular variety, with large oval fruit. Skin bright reddish-orange, with light cream netting. Flesh orange, fine grained and of excellent quality. This is the most popular variety for canning. The fruit makes a rich orange-red and delicious flavored dish.



Boston Marrow



SALSIFY

SALSIFY OR VEGETABLE OYSTER

Sow in early spring in light, rich soil, in drills 14 inches apart, and thin the plants to six inches in the row. The roots will be ready for use in October and will sustain no injury by being left in the ground during the winter.

SANDWICH ISLAND MAMMOTH—The new salsify grows fully twice the size of the old sort, and is superior in quality. Invaluable to market gardeners.

LARGE WHITE—The old, well-known variety.

SPINACH	Pkt.	Oz.	¼ lb.	1 lb.
VIRGINIA BLIGHT RESISTING...		\$0.10	\$0.15	\$0.30
RESELECTED BLOOMSDALE SAVOY		.10	.15	.30
IMPROVED LONG STANDING BLOOMSDALE SAVOY		.10	.15	.30
DARK GREEN BLOOMSDALE SAVOY		.10	.15	.30
VICTORIA LONG STANDING.....		.10	.15	.30
LONG SEASONS10	.15	.30
TRIUMPH10	.15	.30
JULIANA10	.15	.30
NEW ZEALAND	\$0.10	.15	.25	.75

ASK FOR PRICES IN QUANTITY

SQUASH	Pkt.	Oz.	¼ lb.	1 lb.
EARLY WHITE BUSH.....	\$0.10	\$0.15	\$0.25	\$0.75
SUMMER CROOK NECK.....		.15	.25	.75
WINTER CROOK NECK.....		.15	.25	.75
HUBBARD10	.15	.25	.90
BOSTON MARROW10	.15	.20	.60
BENNING'S WHITE BUSH SQUASH	.10	.15	.35	1.00

SALSIFY

SANDWICH ISLAND MAMMOTH..	.10	.20	.50	1.75
LARGE WHITE10	.20	.50	1.75

TOMATOES—Extra Early Varieties

For early fruit sow the seed in March or April in the hotbed or in pots in a sunny exposure in the house. When the plants are about three or four inches high they should be set out four or five inches apart in another hotbed or cold frame into small pots, allowing a single plant to a pot. Expose to the air as much as possible to harden, and about the middle of May set the plants in the open ground at a distance of four or five feet each way. Water freely at the time of transplanting and shelter from the sun for a few days until the plants are established.

Tomatoes will admit of training to stakes or trellis of various kinds. The usual method is to set one strong plant to a stake, using stakes five to seven feet in height, tying the plant up with strong, soft twine, pruning out quite freely as the vines advance in growth. By adopting this method the plants may be set much closer than in the ordinary way.

BONNIE BEST TOMATO—As its name signifies, it is the best extra early tomato yet introduced. Is fully ten days earlier than Chalk's Early Jewel and, within a day or two, if not quite as early, as Spark's Earliana. Truckers who tested it claim it is as early as Earliana.

It is a vigorous grower, very prolific, with dense foliage, which protects the fruit from the hot sun when other varieties like the Earliana have scalded fruits. The fruit is even in size, smooth, round, red, of delicious flavor, ripening to stem. It does not have the green surface like Earliana and other extra early varieties.

CHALK'S EARLY JEWEL—Deep fruited and solid. The growth is very compact. Fruit of uniformly good size; very solid; brightest scarlet, ripening up to the stem without cracks or green core; sweet flavor.

SPARK'S EARLIANA—The earliest bright red Tomato; very large, smooth, color bright red; solid and excellent for slicing. The plants are of moderate growth, well set with fruits, nearly all of which ripen extremely early in the season. Grows in clusters; of medium size; smooth, solid, solid center, small seed cells, slightly acid.

BREAK O'DAY TOMATO—For early market only. This is a new variety of early red Tomato and was originated by Dr. F. J. Pritchard of the U. S. Department of Agriculture by



BONNIE BEST TOMATO

crossing the Marvana with the Marglobe. The vines are very open growing and somewhat resemble Earliana in appearance, altho the leaves are small and rather short for such a prolific plant. It is quite resistant to disease and can stand severe adverse weather conditions. The fruits are medium to large in size. It is very productive and only a few days later than our Earliana, and because of this and its smoothness and solidity, believe it will replace Earliana. Plant in rich soil.

MARGLOBE TOMATO — EARLY WILT-RESISTING VARIETY which originated from a cross between Marvel and Globe. This cross was made by an expert plant breeder of the United States Department of Agriculture, with the purpose in mind of developing an early type of Wilt-Resistant tomato.

By crossing with the Globe it was found possible to select from the resulting hybrids a very desirable type of second-early tomato, combining the scarlet color of the Marvel with the globular form, fine texture and mild flavor of the Globe. With this excellence of fruit was carried the equally desirable character of Wilt-Resistance to the extent that Marglobe will continue to bear fruit and retain its green foliage when planted on wilt-infested soil, where the early varieties such as Earliana and Bonnie Best will be overcome by the disease before their maximum fruit-bearing period has been reached.

JOHN BAER—New, early prolific. Fine flavor and shape; quite as early as Bonnie Best.

EARLY I.X.L. TOMATO—Earliest, largest, most prolific.

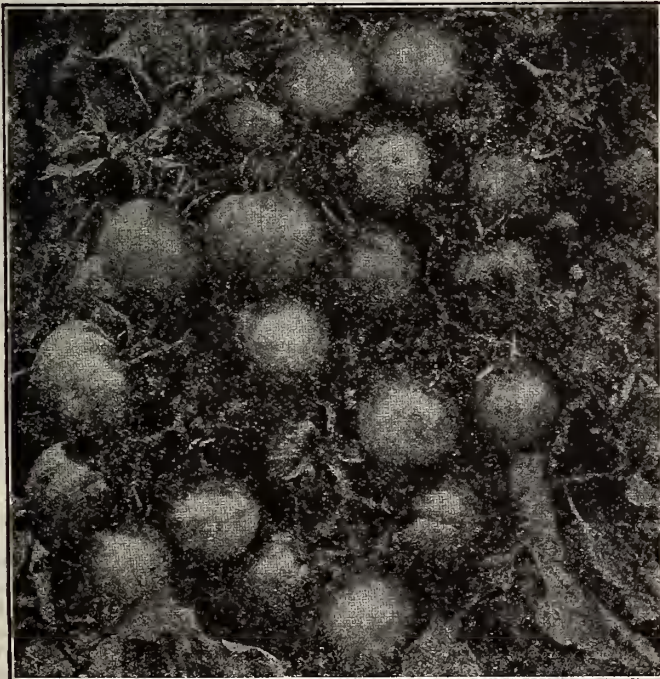

MARGLOBE TOMATO

	Pkt.	Oz.	¼ lb.	1 lb.
BONNIE BEST	\$0.10	\$0.30	\$0.75	\$2.75
CHALK'S EARLY JEWEL10	.30	.75	2.75
JOHN BAER10	.30	.75	2.75
SPARK'S EARLIANA10	.30	.75	2.75
EARLY I.X.L.10	.30	.75	2.75
MARGLOBE10	.30	.85	3.00
BREAK-O-DAY10	.40	1.00	4.00

TOMATOES—Continued

MAIN CROP VARIETIES



THE NEW STONE TOMATO.—Ripens for main crop; is very large and of bright scarlet color; very smooth; with occasionally a specimen very slightly octagon-shaped, ripening evenly to the stem without a crack; exceedingly solid and firm-fleshed (as its name indicates). It is an excellent shipper; not subject to rot.

NEW SUCCESS.—A magnificent new scarlet fruited Tomato of the finest quality, handsome appearance, large size and great productiveness.

MY MARYLAND TOMATO.—My Maryland is an exceptionally heavy yielder of wonderfully uniform, well shaped, solid, smooth, bright red tomatoes. It is a second early or main crop variety, and the fruit is entirely free from roughness and cracks.

GREATER BALTIMORE TOMATO—Introduced in Baltimore some years ago. It makes a fine main crop tomato, of large size, bright scarlet color, ripening uniformly up to the stem.

One of the best main crop varieties for canner and market.

GRIFFITH & TURNER CO.'S WORLD'S FAIR—The great canner. The six great points of this great canner—solidity, symmetry, handsome, bright red, ripens uniform, free from rot. Its shipping and keeping qualities are unexcelled.

WISDOM.—Recently introduced. Medium early; good cropper, fine size and flavor. Good for early or late planting.

MATCHLESS.—The color is rich red. The skin is so tough that it makes a splendid keeper and shipper, and is less liable to crack in wet weather than any other large Tomato. Unsurpassed for market or table; strong grower and very productive, bearing with undiminished vigor until frost. The fruit is free from core and the seed spaces comparatively small.

KELLY RED TOMATO.—This splendid Red Tomato originated in Anne Arundel County, Md., and through its superior qualities it has become the Tomato most largely used in that section. It is large, meaty, an abundant yielder, and withstands unfavorable conditions remarkably well.

RED ROCK—One of the finest for canning, being extraordinarily solid, smooth and red. No other variety has any better qualities than the Red Rock. Of fine flavor, very meaty and wonderfully free from acid. A heavy producer and good shipper. We think it is the coming tomato for main crop and canner's use.

PONDEROSA TOMATO—Remarkable for size and heavy fruits, sometimes weighing over a pound. Deep red flesh, thick, solid and fine quality. Fine for the home garden and to grow on Trellis. Sometimes called "Beefsteak." There is nothing better for slicing.

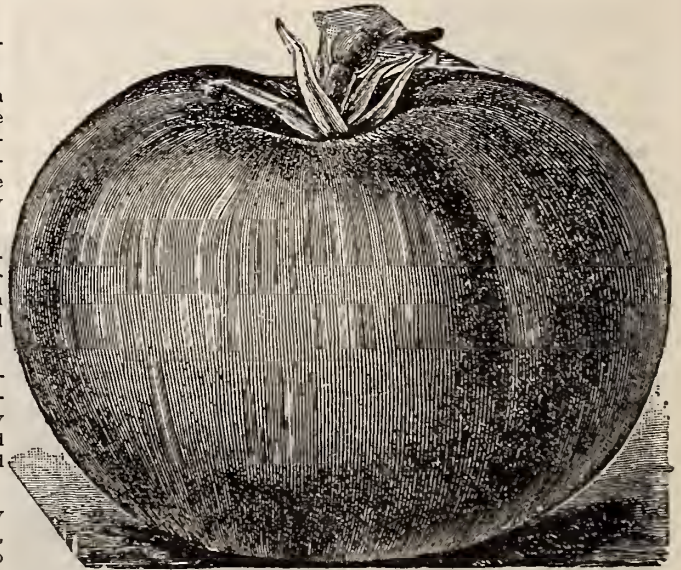

GREATER BALTIMORE

SMALL FRUITED VARIETIES

PEAR-SHAPED RED—

PEAR-SHAPED YELLOW—Used for preserves and pickles.

YELLOW PLUM—Color bright yellow; excellent for preserving.

TOMATO	Pkt.	Oz.	¼ lb.	1 lb.
WORLD'S FAIR	\$.010	\$.030	\$.075	\$2.50
PONDEROSA	.10	.40	1.25	
PEAR-SHAPED RED	.10	.35	1.25	
PEAR-SHAPED YELLOW	.10	.35	1.25	
YELLOW PLUM	.10	.35	1.25	
NEW STONE	.10	.30	.75	2.00

TOMATO	Pkt.	Oz.	¼ Lb.	1 Lb.
GREATER BALTIMORE	.10	.30	.75	2.00
NEW SUCCESS	.10	.30	.85	2.00
RED ROCK	.10	.30	.75	2.00
WISDOM	.10	.30	1.00	2.75
MATCHLESS	.10	.30	.75	2.00
KELLY RED	.10	.30	.75	2.00
MY MARYLAND	.10	.30	.75	2.00

TURNIP

For early use, sow the small sorts as soon as the ground can be worked in the spring, in drills 14 inches apart, the Rutabagas 30 inches. As the seed is very fine, it should be covered but slightly, excepting in very dry weather. Select light, and if possible, new soil and manure with plaster and ashes or phosphates. Should the young plants be troubled with insects, a sprinkling of slug shot will be beneficial. For fall and winter use the early kinds should be sown, from the middle of July to the middle of August, and the Rutabagas from the middle of June to the first of July, using from one to one and a half pounds of seed to the acre.

Improved Purple or Red Top Globe Turnip.

This excellent table variety is globular in shape, of good size and very attractive appearance. The roots are large, purple or dark red above ground, white below. The flesh is white, fine grained and tender. The roots when in best condition for the table are about three inches in diameter, but can be grown much larger for stock feeding. This sort keeps well for so early a variety, and is one of the best for market use. It is also known as Red Top White Globe.

Red or Purple Top Flat Strap-Leaved Turnip.

A very early, strap-leaved variety, very extensively used for the table. The leaves are few, entirely upright in growth. The roots are flat, of medium size, purple or dark red above ground, white below. The flesh is white, fine grained and tender. Roots when in best condition for table use are about two and one-half inches in diameter, but can be grown much larger for stock feeding. This sort is also known as Early Red Top, Strap-Leaved.

YELLOW ABERDEEN, or SCOTCH YELLOW—This is a highly approved Cattle Turnip, attaining a large size. It is solid, nutritious, a good keeper, and in every respect reliable.

LARGE AMBER or YELLOW GLOBE—Grows to a large size; flesh yellow, firm and fine grained. Excellent for either table use or feeding stock.

SEVEN TOP—For greens and salads. Used largely in the Southern States.

EXTRA EARLY PURPLE TOP MILAN—The earliest and handsomest Flat Turnip in cultivation; none equal to it for spring sowing.

WHITE FLAT—Differs from Red Top only in color.

EARLY WHITE EGG—A new variety of rapid growth; egg-shaped and white, as its name indicates.

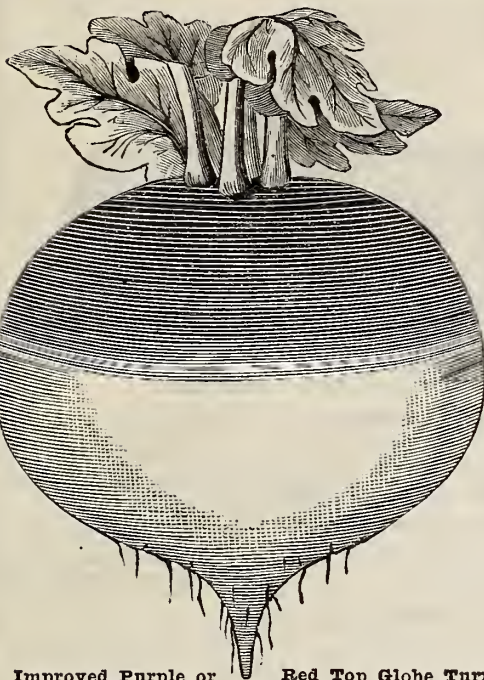

Improved Purple or Red Top Globe Turnip.

COW HORN (Large Croppers)—This variety is pure white, excepting a dash of green at the crown, and in shape is long, like the carrot.

SOUTHERN PRIZE—True strain of the favorite Turnip for greens in Virginia and Carolinas. Valued also for its bulk.

RUTABAGAS OR SWEDES—The Swede Turnips, or Rutabagas, grow much larger in size, and are of greater value for stock feeding than ordinary turnips. Every farmer and stock-raiser should grow Rutabagas and Stock Beets for winter feeding.

GRIFFITH & TURNER CO'S IMPROVED PURPLE TOP—Yellow-fleshed. A standard field variety for stock and fine for family use. This splendid Swede is the hardiest, most productive and most nutritious variety in cultivation.

TURNIPS	Oz.	¼ Lb.	1 Lb.
IMPROVED PURPLE OR RED TOP GLOBE	\$.10	\$.15	\$.40
PURPLE TOP STRAP-LEAF	.10	.15	.40
YELLOW ABERDEEN	.10	.15	.40
LARGE AMBER OR YELLOW GLOBE	.10	.15	.40
SEVEN TOP	.10	.15	.40
EXTRA EARLY PURPLE TOP MILAN	.10	.15	.40
WHITE FLAT	.10	.15	.40
EARLY WHITE EGG	.10	.15	.40
COW HORN	.10	.15	.40
SOUTHERN PRIZE	.10	.15	.40
RUTABAGAS			
G. & T. CO'S IMPROVED PURPLE TOP	.10	.15	.50

SEED POTATOES—MAINE OR NORTHERN GROWN

ALL POTATOES SOLD BY WEIGHT ONLY; BUSHEL, 60 POUNDS.

The soil best suited to the Potato is a rich, sandy loam; but it seems to thrive in almost any soil or climate. The Potato being a gross feeder requires a liberal application of manure. If stable manure is to be used it should be well-rotted, and not allowed to come in contact with the tubers. On no other crop are the results from the use of phosphates so manifest as on the Potato. Almost invariably the tubers are smoother, brighter and freer from rust and the destructive influence of wire worms. Plant as early in the spring as the ground can be thoroughly worked in rows three feet apart and one foot in the rows, covering in light, warm soil about four inches, and in cold wet ground three inches deep; draw the earth to the plants as they advance in growth. The soil should be constantly stirred through the season to prevent the surface from baking.

G. & T. CO'S EXTRA EARLY PRIZE.—This potato is in all respects a very popular early sort. It proved to be early and productive; also found its eating qualities first class. We consider it the best early potato on the market today.

IRISH COBBLER—Very productive, matures early; shape chunky, eyes strong and deep set, skin netted, flesh white, quality very superior. After years' experience we find that it is a very superior variety. Don't fail to get it.

RED BLISS TRIUMPH.—This beautiful variety combines the wonderful productiveness of the Peerless with all the good qualities of the Early Rose; is much more productive and matures its crop at least a week in advance of the Early Rose.

SPAULDING ROSE.—The Early Rose led the list for over 30 years, and is today one of the best early market Potatoes. Our stock of this is grown on new land near Houlton, Maine; is rugged and pure, and produces as good crops as those which made the Early Rose famous in its early years. Remember that this stock is not to be confounded with the old run-out Rose grown in other sections.

GREEN MOUNTAIN—This is a most excellent late Potato; it does remarkably well on poor soils, and is very free from disease; it resists drought wonderfully well and produces tubers of large size and attractive appearance; flesh white. It is a good keeper, and when put away in the fall will keep well until spring. Matures in 140 days.

PROSPERITY.—A middle-crop variety, one of the handsomest large Potatoes ever produced. The yield is immense, and even under unfavorable circumstances can be relied on; flesh very white; cooks dry and mealy.

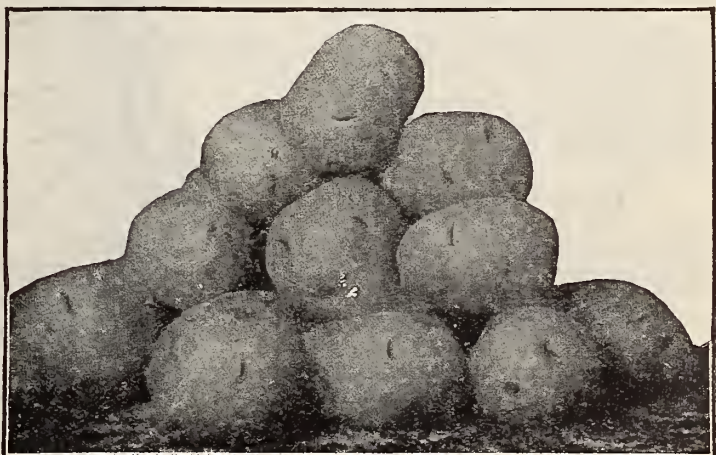

Irish Clobber Potatoes.

RURAL NEW YORKER, No. 2.—A valuable variety of large size, very smooth and a great cropper; in quality unexcelled. This variety is yearly becoming more popular as the best late long keeper, and we recommend it highly.

Price, per Peck, 50c. Postage extra. Write for price per Bushel and Barrel Lots.

CHOICE JERSEY SWEET POTATOES DURING SEASON

ALL PRICES IN CATALOG SUBJECT TO CHANGE WITHOUT NOTICE.

FIELD CORN

CHESTNUT GROVE YELLOW CORN—The ears are large, deep, medium-sized grain, and of beautiful color. 1¾ lbs. (about 1 qt.) 20c. 14 lbs. (about 1 pk.) 75c. 56 lbs. (about 1 bu.) \$2.50.

NEW MARYLAND YELLOW DENT—The grains are unusually deep, ears large, stalks grow from 7 to 10 feet high, does not exhaust soil so much. 1¾ lbs. (about 1 qt.) 20c. 14 lbs. (about 1 pk.) 75c. 56 lbs. (about 1 bu.) \$2.50.

REID'S YELLOW DENT CORN—Matures in 100 to 105 days. Has a rich yellow color, very solid heavy ears from 8 to 12 inches long, with 16 to 18 rows of grain. The grains are deep on a small red cob. Fodder from 7 to 8½ feet high, and produces a great many stalks with two ears. A fine early corn. 1¾ lbs. (about 1 qt.) 20c. 14 lbs. (about 1 pk.) 75c. 56 lbs. (about 1 bu.) \$2.50.

90-DAY YELLOW—This is an excellent quick-growing variety. May be planted after peas are taken off, and makes a good crop. Largely used by truckers around Baltimore. 1¾ lbs. (about 1 qt.) 20c. 14 lbs. (about 1 pk.) 75c. 56 lbs. (about 1 bu.) \$2.50.

SMOKY YELLOW DENT—The earliest dent Corn today; a good yielder. It is the most beautifully colored up corn in cultivation. Sides of grain red, with white cap. Grows strong, quick and has splendid seven to eight foot fodder. Will mature in 75 to 80 days. Price: 1¾ lbs. (about 1 qt.) 20c. 14 lbs. (about 1 pk.) 75c. 56 lbs. (about 1 bu.) \$2.50.

G. & T. CO.'S IMPROVED MARYLAND WHITE DENT CORN—After years of careful selection we have secured this improved White Field Corn; grows good-sized ears and makes splendid meal. Produces better crops on average land than most any other variety. 1¾ lbs. (about 1 qt.) 20c. 14 lbs. (about 1 pk.) 75c. 56 lbs. (about 1 bu.) \$2.50.

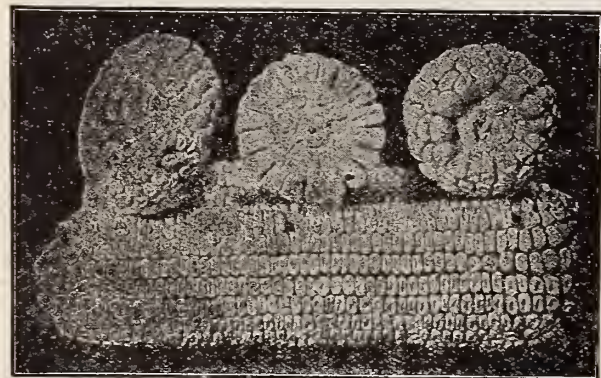

Maryland White Dent Corn.

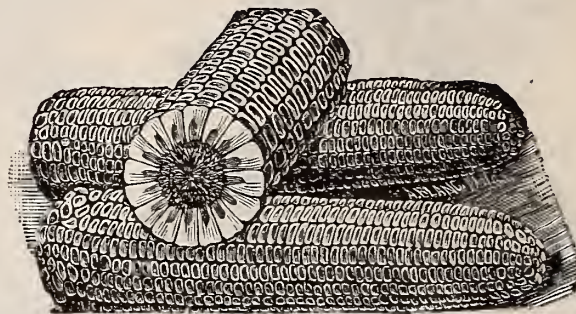

Maryland Yellow Dent Corn.

BOONE COUNTY WHITE—We believe this to be the best all around White Corn in existence. It is a heavy yielder; has large ears, deep grain, small cob and produces good-sized fodder, free from barren stalks. Matures in 110 to 115 days. Prices: 1¾ lbs. (about 1 qt.) 20c. 14 lbs. (about 1 pk.) 75c. 56 lbs. (about 1 bu.) \$2.50. Postage, 8c. per lb. extra.

IMPROVED EARLY LEAMING—An early selected variety of yellow corn; small grains, weighty and productive. Highly esteemed in Maryland and Pennsylvania. One of the earliest varieties of yellow corn in cultivation. 1¾ lbs. (about 1 qt.) 20c. 14 lbs. (about 1 pk.) 75c. 56 lbs. (about 1 bu.) \$2.50.

JOHNSON COUNTY WHITE CORN—A favorite white corn in the Western Corn Belt. Ears same size as Boone Co. White. Good deep grain on small, white cobs. It will shell from six to seven bushels per barrel.

We recommend it as a fine general main crop sort. Will mature in about 120 days. Has abundant foliage, which makes it also valuable for ensilage purposes. 1¾ lbs. (about 1 qt.) 20c. 14 lbs. (about 1 pk.) 75c. 56 lbs. (about 1 bu.) \$2.50.

90-DAY CORN (White with red Cob)—This is an elegant corn for truckers and market gardeners, as it is as good a seller as green corn. Is suitable for either early or late crop. 1¾ lbs. (about 1 qt.) 20c. 14 lbs. (about 1 pk.) 90c. 56 lbs. (about 1 bu.) \$3.00.

Postage, 8c. per lb. extra.

EUREKA WHITE ENSILAGE CORN—Specially adapted for ensilage. 56 lbs. (about 1 bushel) \$2.50.

POPCORN (White Varieties)—10c per lb.

POPCORN POPPERS—25c each.

BROOM CORN—To grow Broom Corn successfully the ground should be rich and well prepared. Plant seeds in rows 3 feet apart by 18 inches. Price: 1 lb., 30c.

SEED OATS

IMPROVED WHITE TARTAR

The most remarkable Oats now under cultivation. These grand Oats outyield all others. The very best for all-around purposes. Straw is of golden yellow color, while the grains are white, with a slight golden cast. A measured bushel weighs from 36 to 42 pounds. Would highly recommend these oats to all our customers. Bushel of 32 lbs., \$1.25.

NEW VICTORY OATS

This splendid heavy white branching Oat originated in Sweden. Has good length of straw, stands up well, with a strong root system. It has yielded in good season from 75 to 100 bushels per acre. Sow 1½ to 2 bushels per acre. Price \$1.25 per bushel.

WHITE-SEED OATS

For spring sowing. 32 pounds to the bushel. Extra heavy fancy White Oats. Ask for prices.

WINTER TURF OATS

Perfectly hardy in the Southern and Middle States, standing the winter nearly as well as wheat. Yields, on good land, from 50 to 70 bushels to the acre, of fine, heavy grain weighing from 30 to 40 pounds to the measured bushel. Furnishes excellent fall, winter and early spring grazing, without injury to the grain crop. Write for prices first of August.



SEED WHEAT AND RYE

We can offer choice stocks of Seed Wheat and Rye, re-cleaned and at reasonable prices. Write us August 1 for special prices for fall sowing.

SEED BUCKWHEAT

JAPANESE.—The best sort. The plants are large and vigorous, maturing their seed early. One-half the seed is required per acre.

BARLEY

BEARDLESS FALL BARLEY.—A fall variety without beards. Ask for prices.

BEARDED FALL BARLEY.—A heavy yielder, much better than spring sown. Sow in September for best results. Ask for prices.

WRITE FOR
PRICES OF FIELD SEEDS
IN QUANTITY

FORAGE AND SILO SEEDS

COW PEAS

The great soil enricher. Makes poor land rich and good land better. They also make the best quality of Hay when cured.

The sowing of **COW PEAS** is one of the cheapest as well as the best means of improving the soil. They can be turned down for green manuring, or, if allowed to ripen, cut and cure for hay; turn down roots, which will give as good results as when whole plant is used.

BLACK—This is the standard variety, makes a fine growth, both of vine and leaves, and a good yield of peas.

WHIPPOWILL—A favorite, early, upright-growing variety, more largely used and sold than any other kind.

NEW ERA—An early maturing variety which has proved very popular and satisfactory.

MIXED COW PEAS—Are fine for forage or improving the soil generally. Sold at a lower price than the named varieties.

SOJA BEANS

Unsurpassed in nutritive value for feeding; also makes a splendid soil improver.

MAMMOTH YELLOW SOJA—The largest-growing and most popular of soja beans for forage purposes. A little later in maturity than other kinds.

WILSON BLACK SOJA BEANS—One of the best, in our opinion, for the Northern States, where a quick, early variety is desired.

VIRGINIA BROWN SOJA BEANS—Coming into use very extensively; about the same size as the Wilson.

HOLLYBROOK SOJA BEANS—Makes a quicker growth and matures its crop two or three weeks earlier than the Mammoth Yellow Soja.

VETCHES OR TARES

SPRING VETCHES (*vicia sativa*).—Closely associated with peas in character. Highly valuable for soiling, for green manuring. Use 30 to 50 pounds to the acre. Sow in spring while ground is cool and moist. **Pound, 10c.**

WINTER VETCHES (*vicia villosa*).—Also called Sand Vetch or Hairy Vetch. Recommended for fall sowing with rye, as in many localities in the North it is hardy. Use 30 to 50 pounds per acre. **Price on application.**

FLAXSEED.—Lb., 12c. 3 lbs., 35c. Postage extra.

SORGHUM, OR SUGAR CANE FOR FODDER

EARLY AMBER grows 10 to 12 inches tall, which is relished by all kinds of stock.

ASK FOR QUOTATIONS ON ABOVE.



Cow Peas

KAFFIR CORN.—The heads contain small white seeds, which are greedily eaten by horses and cattle.

GERMAN MILLET.—A fine, quick-growing summer Hay crop. Should be sown thick, not less than one bushel per acre. Cut while in flower. It should be sown any time after the middle of May up to first of August.

CANADA FIELD PEAS.—Sown in February, March or April, with a small quantity of oats, they make forage. Sow 1 to 1½ bushels per acre broadcast with half bushel of oats.

RUSSIAN SUNFLOWER.—Is highly recommended for poultry—the best egg-producing food known. **Lb., 12c.**

DWARF ESSEX RAPE.—It can be sown all through the season; being perfectly hardy. 5 pounds to the acre, or 2 to 3 pounds in drills. It is unequalled as a pasture for sheep, and as a fattening food for all kinds of livestock. **Lb., 10c., by express, 10 lbs. and over, 8c. lb., not prepaid; \$7.00 per 100 lbs.**

HIGH-GRADE GRASS SEEDS

TIMOTHY (*Phleum Pratense*).—This makes one of the most popular, nutritious and salable of hay grasses. It is best adapted for sowing on clay or heavy loams, low lands, or in mountainous districts, although it will do well on any good, stiff, loamy soils. The best clover to sow with Timothy is Alsike, as they mature and ripen with Timothy. **Bushel, 45 lbs.**

RED TOP, OR HEED'S GRASS (*Agrostis Vulgaris*).—This grass makes excellent pasturage and good crop of hay. Is excellently adapted for seeding with Timothy for hay, and furnishes excellent pasturage afterwards. When it gets well established it will gradually supplant other grasses. The grades of seed usually sold are:

UNHULLED RED TOP.—Seed in hull but free of chaff and impurities. Sow 2 to 3 bushels to the acre; 14 pounds to the bushel.

FANCY CLEANED RED TOP.—Hulled seed, free from all impurities. We would advise our customers to sow the Extra Cleaned Unhulled or Fancy Cleaned Seed. Sow 12 to 15 pounds to the acre. **32 Lbs. to the Bushel.**

TALL MEADOW OAT GRASS (*Avena elatior*).—Relished by cattle, early and late. Height, 2 to 4 feet. 50 pounds to the acre. (10 pounds to bushel.)

KENTUCKY BLUE GRASS (*Poa Pratensis*).—It is rather sensitive to heat, but not so to cold weather, and on this account does its best in the fall, winter and spring. It grows slowly at first, forms a very compact turf, making a fine pasturage when once established. It is much the best, however, to combine other grasses with it for either lawn or pasturage. Sow in the spring or fall. **14 Lbs. to Bushel.**

ORCHARD GRASS (*Dactylis glomerata*).—One of the best and most reliable grasses for hay or pasturage. It succeeds well on nearly all soils, but does best on upland, loamy or moderately stiff soils. It is of quick growth and relished by stock, especially when young, and bears close grazing. It makes excellent hay. It should be cut when in blossom, as the hay is injured if the seed is allowed to ripen. Sow 3 bushels per acre if sown alone; with Red Top, one and one-half bushels of Orchard and seven pounds of Red Top are the quantities usually sown. **14 Lbs. to Bushel.**

CREEPING BENT GRASS (*Agrotis stolonifera*).—Excellent for lawns; succeeds well in all conditions; makes a low, velvety growth.

MEADOW FESCUE, RANDALL, OR ENGLISH BLUE GRASS (*Festuca pratensis*).—It makes a very good pastur-

age grass, and is particularly valuable for fall and winter pasturage, as it remains green throughout the winter.

RED FESCUE.—It is a densely tufted perennial grass for dry, sandy and rocky soil where scarcely any other species will grow. It roots deeply, and forms a dense short tuft, suitable for lawns and pleasure grounds where the soil is sandy. It affords wholesome food for all cattle, especially sheep. Sow about 30 pounds per acre. **14 Lbs. to Bushel.**

ITALIAN RYE GRASS.—Is an annual and should be sown every year at the rate of 50 pounds per acre. It can be sown during August, September or October. **14 Lbs. to Bushel.**

ENGLISH RYE GRASS (*Lolium Perenne*).—This makes a quick growth very early in the spring, and is adapted for cool, moist locations. 60 pounds to the acre. **14 Lbs. to Bushel.**

SUDAN GRASS.—A tall growing annual grass, suitable for Hay. It grows, when sown broadcast, 3 to 5 feet high, according to the richness of soil. If sown middle of May, will make 2 to 3 cuttings of fine Hay, relished by all kinds of stock. Sow 30 to 40 pounds per acre broadcast. **Lb., 12c.** For larger quantities, ask for prices.

ASK FOR PRICES FOR ANY OF THE ABOVE.



PREPARATION AND CARE OF LAWNS.—The ground should be thoroughly drained and well enriched before sowing. Work the soil until well pulverized, and have the surface as smooth as possible, so that the grass may present an even appearance. After sowing, cover seed lightly and follow with roller. The best results are obtained by using plenty of seed, four bushels to the acre being about the right quantity. One quart is sufficient for 300 square feet. Let the grass obtain a good start before cutting, and then it should be trimmed with a lawnmower about every ten days. Old lawns may be improved and renewed by the application of fertilizers and seeding about half the quantity of seed required for new lawns. This should be done whenever they show any thin places.

GRIFFITH & TURNER CO.'S EVERGREEN LAWN GRASS.—This is a first-class mixture, prepared by ourselves, and containing nothing but choice seeds—just the thing for tennis, croquet and ball grounds, remaining green and fresh during the hot summer months. Widely known and extensively used on the finest private and public grounds with the most satisfactory results. Nothing adds to the attractiveness of suburban homes more than a well-kept, close-cut, velvety lawn; hence the importance of securing the best seeds. It is adapted to the small grass plots of city homes. $\frac{3}{8}$ lb. (about 1 pt.) 15c., $\frac{3}{4}$ lb. (about 1 qt.) 25c., by mail 45c.; $1\frac{1}{4}$ lbs. (about 2 qts.) 45c., $2\frac{1}{2}$ lbs. (about $\frac{1}{2}$ peck) 85c., 5 lbs. (about 1 peck) \$1.35, 20 lbs. (1 bushel) \$5.00. By freight or express not prepaid.

GRIFFITH & TURNER CO.'S GOLF LINK MIXTURE.—There being a growing demand for a grass mixture suitable for golf and cricket grounds, we have made a study of the grasses best adapted to these purposes, and have made a mixture in proper proportions to give desired results. It is highly essential that golf and cricket grounds should be mowed closer than ordinary lawns. 14 pounds to bushel. Bushel, \$7.00.

SHADY NOOK GRASS.—On nearly all lawns there are bare spots under the shade trees. With this mixture the above can be easily corrected. Ground that has been densely shaded by trees is frequently "sour" and is apt to be covered with moss. In such cases apply slacked lime at the rate of one bushel per thousand square feet, but the moss should be first removed with a rake. Price: Lb., 35c. 5 Lbs., \$1.60. Bu. of 20 lbs., \$6.00. Add 8c. per lb. for postage.

"TERRACE" SOD MIXTURE.—A special mixture of grasses best suited for sowing on terraces, railroad embankments and side hills—grasses that produce strong spreading roots, thus preventing heavy rains from washing them out; that will withstand drought and exposure, thrive on shallow soils. Pound, 35c. Peck, \$1.25. Bushel of 14 lbs., \$4.50.

PARK LAWN GRASS.—A very good mixture of Lawn Grass, made of the purest grasses, but not as good as our Evergreen Lawn Seed. Suitable where a fine lawn is not required. Pound, 25c. 5 lbs. (pk.), \$1.25. Bushel of 20 lbs., \$4.00.

GRASS MIXTURE FOR HAY AND PERMANENT PASTURES

Prepared especially to meet the demands for a mixture that will be desirable for cutting for Hay or to use for Pasture, and contains such grasses as are best adapted for these purposes. In ordering please state whether you want a mixture for upland or lowland.

MIXTURE FOR UPLAND.—14 lbs. to the bushel, 3 bushels to the acre. Per bushel, \$2.75; 10 bushels for \$27.00.

MIXTURE FOR LOWLAND.—14 lbs. to the bushel, 3 bushels to the acre. Per bushel, \$2.50; 10 bushels for \$22.50.



Alsike Clover.

Crimson Clover.

White Clover.

Red Clover.

Lucerne or
Alfalfa Clover.

RECLEANED RED CLOVER.—We take great pains to supply an extra quality of Red Clover at a reasonable price. Farmers should not sow a poor quality of Clover Seed. 25c. lb.

ALSIKE OR SWEDISH CLOVER.—Hardest of all the Clovers, and on rich, moist soils yields an enormous quantity of hay or pasturage. Lb. 25c.

WHITE DUTCH CLOVER.—Thrives most everywhere. The best to sow with lawn grass and valuable to sow with blue grass for permanent pastures. $\frac{1}{4}$ lb., 20c. $\frac{1}{2}$ lb., 30c. 1 lb., 60c. By mail, lb., 70c. 10 lbs., by express, not prepaid, \$5.50.

LUCERNE OR ALFALFA CLOVER.—One of the most valuable among Clovers, resisting drought and remaining green when other sorts are dried up. Prepare the land thoroughly and sow, either fall or spring, 20 pounds to the acre. Lb. 25c.

CRIMSON CLOVER (The Great Nitrogen Gatherer).—For hay it must be cut before it comes into full bloom, as otherwise it may cause hair-balls to form in the animal's stomach. It is used on poor and rich land. It is seeded in this country in June, July, August, September and October. 15 pounds to the acre. 12c per lb.

WRITE FOR SPECIAL PRICES ON CLOVERS.

FLOWER SEEDS

GENERAL DIRECTIONS FOR CULTIVATION

Hardy Flower Seeds should be sown in the open, after danger of frost is past, in well-worked and moist soil. Seeds of medium size, put at depth of one-quarter to one-half inch. Very fine seeds press into the soil, and cover slightly with a little sand or sphagnum moss. If seed is not deep, water frequently. When up, transplant from two to twelve inches apart, according to variety of plants. Do not leave too thick as the plants will be weak and spindling. Keep weeds out of the flower beds. Annuals may be planted in early spring, and bloom the first season only. Biennials bloom the second year from seed, and then die. Perennials bloom the second year from seed, and plants live to bloom during successive years. Varieties marked ("A") stand for Annuals. Marked ("B") Biennials. Marked ("P") Perennials. Order by Number.

1. **ACHILLEA** (Ptarmica, "The Pearl") (P).—Pure, double, white flowers. If sown early and transplanted it will flower the first season or can be sown later in the open ground. Packet, 15c.
2. **AGERATUM MIXED** (A).—Valuable for bedding as it is literally covered with blossoms all summer. Sow the seed early in the spring, either in boxes to transplant, or outdoors and thin to 4 to 6 inches. Packet, 10c.
- 2A. **AGERATUM** (P).—Dwarf blue. Packet, 10c.
3. **ALYSSUM** (A).—The Sweet Alyssum has pretty little flowers, useful in making small bouquets, and its fragrance, while sufficiently pronounced, is very delicate. The Alyssum grows freely from seed, blooms the whole season. Packet, 10c.
4. **ALYSSUM** (A) (Tom Thumb).—Of dwarf, compact habit, each plant covering a circle from 15 to 30 inches. It will bloom when small and remain covered with bloom from spring to autumn. Packet, 10c.
5. **ALYSSUM SAKATILE COMPACTUM** (P).—Hardy. Yellow. Pkt. 10c.
8. **AMARANTHUS, MIXED** (A).—Showy, blooming plants, with long, racemes of curious-looking flowers, and brilliant foliage; half hardy annuals. Packet, 10c.
9. **AMARANTHUS** (A).—Tricolor Splendens or summer Poinsettia. Very rich colorings. Packet, 10c.
10. **AMARANTHUS CAUDATUS** (Love Lies Bleeding) (A).—Graceful and handsome flowers of blood-red hue. Packet, 10c.
13. **ANTIRRHINUM**, (A) or **SNAP-DRAGON** has become very popular both for forcing and outdoor growing Mixed, Packet, 10c.
- 13A. **ANTIRRHINUM** (P).—Ruby—Rich, velvety Ruby Red. Packet, 10c.
- 13B. **ANTIRRHINUM** (P).—Cottage Maid—Handsome pale pink, with white throat. Packet, 10c.
- 13C. **ANTIRRHINUM** (P).—Pink Pearl—White ground, shaded peach-blossom; lip a deeper shade. Packet, 10c.
- 13D. **ANTIRRHINUM** (P).—Rose Pearl—Bright soft-rose; white lip and throat; lip slightly tipped yellow. Packet, 10c.
- 13E. **ANTIRRHINUM** (P).—Ruby Rose—Fine deep salmon-rose. Packet, 10c.
- 13F. **ANTIRRHINUM** (P).—Vermilion-Scarlet—Fine Orange-Scarlet. Pkt. 10c.
- 13G. **ANTIRRHINUM** (P).—Delila—Grandiflora. Pink, yellow and white. Packet, 10c.
- 13H. **ANTIRRHINUM** (P).—Majus—Mixed colors. Packet, 10c.
14. **ANTIRRHINUM—THE ROSE** (A).—Rose-pink. Packet, 10c.
15. **ANTIRRHINUM—CANARY BIRD** (A).—Canary yellow, golden yellow centre. Packet, 10c.
16. **ANTIRRHINUM—COPPER KING** (A).—Velvety-copper scarlet. Pkt. 10c.
17. **ANTIRRHINUM—NYMPH** (A).—Rosy-lilac, white tube. Packet, 10c.
20. **AQUILEGIA** (P)—Long-spurred mixed. Packet, 10c.
21. **AQUILEGIA** (P)—Single mixed. Packet, 10c.
22. **AQUILEGIA** (P)—Double mixed. Packet, 10c.
23. **AQUILEGIA** (P)—Blue Columbine. Packet, 10c.



ASTERS

Sow seed in March and April in cold-frame or boxes in the house, covering them ¼ inch deep, and when plants have three or four leaves, transplant about 18 inches apart each way in prepared beds.

25. **ASTERS, CHINA** (A).—Choice mixed varieties. Packet, 10c.
26. **ASTER, TRUFFAUT'S PERFECTION** (A).—A very favorite class; flowers large, almost round with incurved petals. Packet, 10c.
27. **VICTORIA ASTER** (A).—The most beautiful of all Asters, bearing flowers of all colors and shades. Double. Packet, 10c.
28. **COMET ASTER** (A).—This class of Asters have long, slender and curled petals, forming loose yet dense flowers of semi-globe shape, which resemble the Japanese Chrysanthemum. Packet, 10c.
29. **SEMPLER'S BRANCHING ASTER, MIXED** (A).—The finest, late blooming Aster. The deep, heavy, incurved flowers on rigid stems often 2 feet and more in length, which makes it one of the most valuable varieties for cutting. Packet, 10c.
30. **BRANCHING ASTER** (A).—White. Packet, 10c.
31. **BRANCHING ASTERS** (A).—Pink. Packet, 10c.
32. **BRANCHING ASTERS** (A).—Purple. Packet, 10c.
33. **BRANCHING ASTERS** (A).—Crimson. Packet, 10c.
- 33½. **BRANCHING ASTER**—Lavendar. Packet, 10c.
34. **ASTER—PERENNIAL MIXED**—(Michaelmas Daisy)—Packet, 10c.
35. **ASTER** (A).—Sunshine or Anemone flowered, for beds or borders. 18 inches high. Packet, 10c.
36. **BACHELOR'S BUTTON** (A) (Centaurea Cyanus).—A very old favorite garden annual with handsome flowers of various colors. It does best if sown in a hot-bed; half-hardy annuals; two feet. Packet, 10c.
- 36A. **CENTAUREA** (P).—Montana Blue. (Perennial Cornflower). Large violet-blue flowers. Packet, 10c.
37. **DOUBLE BALSAM, CAMELIA FLOWERED** (A) (Lady Slipper)—The well-known balsams are one of the finest summer blooming annuals, free bloomers, and highly colored. By transplanting them once or twice, the flowers are apt to be more double. Packet, 10c.

38. **BALSAM PERFECTION WHITE** (A).—This resembles the mixed balsams in shape, but the flowers are a pure white, and is the variety usually grown by florists. Packet, 10c.
41. **CALENDULA** (Pot Marigold) (A).—Very hardy annual, one foot high, blooming freely. Is of the easiest culture; desirable for rather inferior soils, where less sturdy flowers do not thrive. Packet, 10c.
42. **CALENDULA—ORANGE KING** (A).—Double rich orange-red. Pkt., 10c.
44. **CANDYTUFT, MIXED** (A).—Well-known favorite, hardy annuals; very pretty in beds or masses; useful for bouquets. Seeds may be sown in the fall for early flowering. Packet, 10c.
45. **CANDYTUFT—WHITE ROCKET** (A).—Packet, 10c.
46. **CANDYTUFT** (P).—White. Pkt., 10c.
47. **CANDYTUFT** (P).—Lilac. Pkt., 10c.
48. **CANNA, MIXED** (Extra Choice) (A).—Very slow to germinate. Pkt., 10c.
49. **CANTERBERRY BELLS SINGLE MIXED**.—Packet, 10c.



50. **CANTERBERRY BELLS, DOUBLE MIXED**.—Packet, 10c.
- 50A. **CAMPANULA LONGISTYLA**.—A very attractive rock plant, bearing small single blue flowers on about twelve-inch stalk. Perennial. Packet, 10c.

52. **CHRYSANTHEMUMS, SINGLE MIXED (A)**.—Showy and effective garden favorites extensively grown for cut flowers. The hardy annuals are summer flowering border plants; good for pot culture and quite distinct from the autumn flowering varieties. **Packet, 10c.**

53. **CHRYSANTHEMUMS FRUTESCENS (A)**.—(The Marguerite, or Paris Daisy.)—Produces freely its white star-like flowers under the most favorable conditions. **Packet, 10c.**

54. **CINERARIA HYBRIDA (P)**.—Large flowering prize varieties; very attractive, free blooming plants, producing large and brilliant flowers. **Packet, 25c.**

55. **CINERARIA HYBRIDA DWARF (P)**.—Large flowered, dwarf prize varieties; splendid strain. **Packet, 25c.**

58. **COCKSCOMB (Celosia Cristata) (A)**.—A half-hardy annual, growing 6 to 8 inches high, bearing a wide, wavy blossom that resembles a cock's comb. In brilliant colors. **Packet 10c.**

59. **COCKSCOMB (Celosia Plumosa) (A)**.—The plumes are 2 and 3 feet tall. **Packet 10c.**

61. **COWSLIP (P)**.—Beautiful hardy spring flowers of different colors. **Packet, 10c.**

62. **CONVOLVULUS, TRI-COLOR MINOR (Dwarf Morning Glory) (A)**.—**Packet 10c.**



63. **CALLIOPSIS (A)**.—Quick growing and free-flowering, fine for bedding and cut flowers, of yellow and brown color. Sow where they are to bloom and thin out to 6 to 12 inches apart. Height 18 inches to 2 feet. **Packet 10c.**

63A. **CALLIOPSIS (A)**.—Golden Wave—Rich golden yellow with small chestnut-brown centre. **Packet, 10c.**

64. **COREOPSIS LANCEOLATA (P)**.—This is one of the finest of hardy plants, with large, showy bright golden-yellow flowers on long stalks, from June till frost. Excellent for cutting; will thrive in almost any situation. **Pkt. 10c.**

COSMOS (A).—Beautiful and useful hardy annuals, producing large showy flowers in great profusion; excellent for cutting.

65. **EARLY FLOWERING (Dawn) (A)**.—This early flowering strain will begin blooming as early as July and will continue until frost; flowers large. **Packet, 10c.**

66. **COSMOS, Mixed (A)**.—**Packet, 10c. Oz., 35c.**

67. **COSMOS, Pink (A)**.—**Packet, 10c.**

68. **COSMOS, White (A)**.—**Packet, 10c.**

69. **COSMOS, Crimson (A)**.—**Packet, 10c.**

70. **COSMOS**.—Double crested or Anemone-flowered. A new late flowering variety, holding up well when cut. **Pkt., 10c.**

73. **DAISY (P)**.—Low growing plants entirely hardy. Seed may be sown early in shallow drills and later thinned out to stand one foot apart. **MIXED, Packet, 10c.**

74. **DAISY, LONGFELLOW (P)**.—This is a very pretty, large, double pink variety. **Packet, 10c.**

75. **DAISY, SNOWBALL (P)**.—An unusually large-flowered variety, and produces very double, pure white flowers. **Packet, 10c.**



76. **DELPHINIUM (Hardy Perennial Larkspur)**.—Sow seeds in early spring, in hot bed or shallow boxes indoors. When seedlings are about $\frac{3}{4}$ inch high, transplant to flats, three or four inches apart each way; transferring them to open ground when weather is suitable. Seeds can also be sown in open ground, but would not be likely to bloom until second year. **Packet of mixed varieties, 10c. each.**

77. **DELPHINIUM (Belladonna)**.—Clear turquoise blue. **Packet, 10c.**

78. **DELPHINIUM (Bellemosum)**.—Rich deep blue. **Packet, 10c.**

79. **DELPHINIUM (Cardinale)**.—Scarlet. **Packet, 10c.**

80. **EUPHORBIA HETEROPHYLLA or MEXICAN FIRE PLANT**.—**Packet, 10c.**

82. **FORGET-ME-NOTS (Myosotis) (P)**.—Neat and beautiful little plants, with star-like flowers, succeeding best in a shady, moist situation; half-hardy perennials; blooming the first year from seed, if sown early. **Packet, 10c.**

82A. **CYNOGLOSSUM (Chinese Forget-me-Not)**.—Annual, but very hardy; of deep blue color, with flowers on tall branches. **Packet, 10c.**

83. **FOXGLOVE (DIGITALIS) (P)**.—A handsome and highly ornamental, hardy perennial plant of stately growth; fine for shrubberies and other half hardy places. **Mixed, Pkt. 10c.**

84. **FOXGLOVE**.—White. **Packet 10c.**

85. **FOXGLOVE**.—Rose. **Packet 10c.**

86. **FOXGLOVE**.—Purple. **Packet 10c.**

87. **GAILLARDIA (A)**.—Very attractive plants, producing a profusion of bloom the entire summer and autumn. Half-hardy annuals. **Packet 10c.**

88. **GERANIUM (New Zonale) (A)**.—A grand strain of Geraniums, containing all shades of colors. **Packet 10c.**

88A. **GEUM (P)**.—Mrs. Bradshaw. A plant for rock gardens, of large double brilliant orange-scarlet flowers. **Pkt. 10c.**

90. **GYPSOPHILA (Baby's Breath) (P)**.—Single white flowers, fine for bouquets; bloom first year if sown early. **Pkt. 10c.**

91. **GYPSOPHILA (P)**.—Repens, for Rock Garden. Rosea and white mixed. **Packet 10c.**

92. **HELICHRYSUM (Straw Flower) (A)**.—The colors are bright and the flowers are very attractive when dried. **Packet 10c.**

93. **HELIOTROPE (A)**.—These are deliciously fragrant flowers remaining in bloom for a long time; fine for pot culture or bedding; half-hardy annuals. **Packet 10c.**

94. **HIBISCUS (Marshmallow)**.—Showy ornamental perennial plants for mixed beds or shrubby borders; blooms first year if sown early. **Packet 10c.**

- 95. **HOLLYHOCK (P)**—White.
- 96. **HOLLYHOCK (P)**—Pink.
- 97. **HOLLYHOCK (P)**—Maroon.
- 98. **HOLLYHOCK (P)**—Double mixed.
- 99. **HOLLYHOCK (P)**—Single mixed.
Packet, 10c each.

100. **KOCHIA (A)**—Summer Cypress or Mexican Fire Bush. Cypress-like annual, with feathery-green foliage, turning to deep red in autumn. Pkt. 10c.



LARKSPUR

102. **LARKSPUR (A)**
Sow seeds in open ground, before close of April, for plants to begin flowering in July, and then a continuous succession of blooms until frost. Effective for beds and fine for cut flowers. Mixed varieties. Packet, 10c.

103. **LARKSPUR (A)**—Emperor—Best double varieties. Packet, 10c.

103A. **LARKSPUR (A)**—Emperor—Bright rose. Packet, 10c.

103B. **LARKSPUR (A)**—Emperor—Azure Blue. Packet, 10c.

LOBELIA. A beautiful and popular flower, very desirable for pot culture, beds or hanging baskets because of its trailing habits. Grows easily and does well in beds and rockeries. Bears a profusion of blue and white flowers.

104. **MIXED VARIETIES (A)**—Pkt. 10c.

105. **CRYSTAL PALACE COMPACTA (A)**—Rich deep blue. The finest for bedding. Packet 10c.

105A. **LUPINUS**—A hardy border plant, blooming in May and June. Mixed varieties of many shades. Packet 10c.

MARIGOLDS

106. **MARIGOLD, DOUBLE AFRICAN (A)**—A well-known free-flowering plant of easy culture, with rich and beautiful tall double various colored flowers. Pkt. 10c.

107. **MARIGOLD, DOUBLE FRENCH (A)**—Of compact habit, with numerous bright, showy flowers. Very fine. Packet 10c.

108. **MARIGOLD, DWARF SINGLE FRENCH (A)**—Packet, 10c.

109. **MARIGOLD (Tagetes) (P)**—Signata Pumila, for rockery. Single bright-orange. Packet, 10c.



MARIGOLDS

109A. **MARIGOLD (A)**—Legion of Honor—Single dwarf golden-yellow flowers, marked with large spot of velvety-crimson at base of each petal. Packet 10c.

110. **MARVEL OF PERU, or FOUR O'CLOCK (A)**—The flowers are brilliant, singularly mixed and varied on the same plant. Two feet. Packet 10c.

115. **MIGNONETTE — SWEET (Reseda Odorata) (A)**—A well-known garden favorite. Pkt. 10c, oz. 20c.

NASTURTIUMS

Sow the seed where it is to remain late in the spring and after danger of frost is over. It is seldom necessary to thin the young plants, as they will bloom if close together.

117. **DWARF MIXED**—The dwarf variety of Nasturtiums is among the most useful and beautiful of annuals for bedding, massing, etc., owing to their compact growth, richness of color, and profusion of bloom; mixed colors. Oz. 10c.

118. **DWARF NASTURTIUM—AURO-RA**—Blush white and salmon, blotched with garnet. Oz., 15c.

119. **DWARF NASTURTIUM BEAUTY.**—Bright scarlet striped with yellow. Oz., 15c.

120. **DWARF NASTURTIUM (Empress of India)**—Very dark foliage with deep crimson flowers. Oz., 15c.

121. **DWARF NASTURTIUM (Golden King)**—Brilliant yellow. Oz., 15c.



NASTURTIUMS

122. **DWARF NASTURTIUM (King of Tom Thumb)**—Brilliant yellow flowers blotched with maroon. Oz., 15c.

123. **DWARF NASTURTIUM (Ruby King)**—Light ruby red. Oz., 15c.

124. **DWARF NASTURTIUM (Cloth of Gold)**—Golden yellow foliage, light scarlet flowers. Oz., 15c.

125. **KING THEODORE—DWARF**—Rich red. Black-brown foliage. Oz., 15c.

126. **TALL or CLIMBING NASTURTIUM**—Of quick growth, covering a wall, hedge or trellis in a short time. The seed pods can be gathered while green and tender for pickling. Oz., 10c.

OXALIS

128. Pretty little, half-trailing annual for hanging baskets. Mixed annual sorts. Packet, 10c.

PANSIES

Thrive best in a moist, shady location, and in rich loamy soil. Seed should be sown in July or August for early spring blossoms.



PANSIES

129. **HEARTSEASE (A)**—Mixed. An old but universally admired plant, producing an endless variety of color. They may be treated as annuals. Packet 10c.

130. **GIANT TRIMARDEAU (A)**—Remarkable for the extra large size of the flower and an endless variety of beautiful shades. Packet, 10c.

131. **G. & T. CO'S EXTRA MIXED (A)**—This mixture, contains the finest varieties. Packet, 15c.

PETUNIAS

grow with little attention or care and in any soil when once started and bloom profusely all spring and summer.

132. **ROSY MORN (A)**—Pkt. 10c.

132A. **PETUNIA—BALCONY (A)**—Free-flowering. Mixed varieties. For window boxes, hanging baskets or vases. Packet 15c.

133. **FINE MIXED (A)**—Good mixture of small, free-blooming colors. Pkt. 10c.

134. **PETUNIA (A)**—Double fringed and plain edge varieties. Large flowering. Mixed. Pkt. 25c.

135. **PETUNIA — SINGLE (A)** — Fringed, mixed. Pkt. 25c.

136. **PHLOX DRUMMONDII (A)**—A most brilliant and beautiful hardy annual, about one foot high, well adapted for bedding, making a dazzling show through the whole season. It succeeds well on almost any soil. Packet, 10c.

137. **PHLOX DRUMMONDII—Nana Compacta (A)**—Very fine mixed, of dwarf compact habit, and makes desirable pot plants; also excellent for ribbon lines and massing. Packet, 10c.

138. **PHLOX (P)**—For best results, should be sown as soon as frost is out of the ground in spring or as soon as gathered in the autumn. Packet, 10c.

142. **PINK CARNATION (Riviera Market, or Gillaud (P))**—This is the only variety that will produce flowers the first season. They will thrive either in open ground or in pots. Packet, 25c.

143. **PINK CARNATION (Marguerite) (P)**—Will produce flowers in a few weeks from seed and bloom all summer until frost or indoors in winter. Packet, 10c.

144. **PINK—CHINA (Dianthus Chinen-sis) (P)**—Free bloomers, and a general favorite for bouquets, also a useful bedding plant. Packet, 10c.

145. **POPPY (A)**—Alpine Poppy. Single fine mixed. For pots and rockeries. Pkt. 10c.
148. **POPPY-PEONY FLOWERED (A)**—A magnificent species, large, showy, globule flowers, resembling Peonies in shape. Pkt. 10c.
149. **SHIRLEY POPPY (A)**—These beautiful Poppies are generally single or semi-double. The colors are so varied that scarcely two are alike. Pkt. 10c.
150. **TULIP POPPY (A)**—A magnificent species. The plants attain a height of 14 to 16 inches, and produce from about 50 to 60 flowers of the brightest scarlet. Pkt. 10c.
151. **ICELAND POPPIES, MIXED (P)**—Single. Plant in Autumn. Hardy perennials. Pkt. 10c.
152. **ESCHSCHOLTZIA (California Poppy) (A)**—A bright and handsome flower. Grows easily and will re-seed itself. Pkt. 10c.
153. **ORIENTALE (P)**—The large Oriental Poppy. A hardy plant, bearing large, brilliant crimson flowers with black blotch on each petal. Pkt. 10c.
155. **PORTULACA (Mexican Rose) (A)**—One of the finest hardy annual plants, of easy culture, thriving best in rather rich, light loam or sandy soil; fine for massing in beds or edgings of rock work. Pkt. 10c.
156. **DOUBLE PORTULACA (A)**—Pkt. 10c.
157. **PYRETHRUM (Hybridum) (P)**—Single, resembling daisies, in varieties of colors. Will succeed best in sunny location, and allowed to remain in same place for several years. Mixed varieties. Pkt. 10c.
158. **RICINUS, CAMBOGIENSIS (A)**—Ornamental plants of stately growth and picturesque foliage; fine for lawns, massing or center plants for ribbon beds; half hardy annuals. Pkt. 10c.
159. **RICINUS ZANZIBARIENSIS, MIXED (A)**—Their immense leaves and gigantic plants exceed all other varieties. Pkt. 10c.
160. **SCABIOSA (Mourning Bride) (P)**—Especially adapted for cutting and massing. Flowers are double clear to the center, covering the thimble-shaped cone. Height 2½ ft. Pkt. 10c.
161. **SCABIOSA (Caucasia) (P)**—Lilac. Pkt. 10c.
162. **SCABIOSA (Caucasia) (P)**—White. Pkt. 10c.
163. **SALVIA SPLENDENS (A)**—Tall, erect, green foliage. A favorite greenhouse and bedding plant, bearing long spikes of flowers in great profusion from July to October. Pkt. 10c.
- 163A. **SALFIGLOSSIS (Velvet Flower) (A)**—Large funnel-shaped flower of varied colors. Start seed indoors in boxes. Pkt. 10c.
- 164A. **SCUTELLARIA (Skull Cap) (P)**—Short wiry stems, clothed with clear-blue snapdragon-like flowers. 1 ft. June to August. Pkt. 10c.
165. **SHASTA DAISY—Alaska (P)**—A splendid hardy variety, with flowers of purest glistening white. Pkt. 10c.
166. **STOKESIA (Cornflower or Stoke's Aster) (P)**—Is of easy culture and one of the most desirable plants for the hardy border, and also for cutting. Pkt. 10c.
167. **TEN WEEKS STOCKS (Gilliflower) (A)**—Brilliant and varied in color, equally well adapted for massing, bedding, edging or pot culture. Should be grown in rich soil. Pkt. 10c.
168. **STOCKS — SNOWFLAKE IMPROVED (A)**—A beautiful dwarf-growing variety; very large, double snow-white flowers. Pkt. 10c.
171. **SWEET VIOLET (P)**—Although these flowers do best propagated from cuttings, they grow readily from seed, and have a very fragrant blossom. Pkt. 10c.
172. **SWEET WILLIAM (Dianthus Barbatus) (P)**—A well-known, free flowering, popular favorite; hardy. Pkt. 10c.
173. **VERBENA (A)**—One of the most popular and useful bedding plants. Verbenas delight in sunny situations, rich soil and thorough cultivation. Pkt. 10c.

173A. **VERBENA—Venosa (P)**—Heliotrope purple. For rockery. Pkt. 10c.

174. **VINCA (Madagascar Periwinkle) (A)**—Rosea—Rose with dark eye. Pkt. 10c.

175. **VINCA (Madagascar Periwinkle) (A)**—Rosea Alba—White with rose center. Pkt. 10c.

ZINNIAS

will grow well in any fair soil, from July until frost. Can be used for beds or borders, as plants range from 2½ to 3 feet high, and the mass of varied colors will attract attention everywhere. The varieties here offered are all California grown Annuals.



**GOLD
MEDAL
DAHLIA-
FLOWERED
ZINNIA**

176. **WALLFLOWER, DOUBLE (P)**—Well-known, deliciously fragrant plants, with large spikes of double flowers similar to the Gilliflower. Succeed in light, rich soil, in a moist atmosphere. Perennials. Pkt. 10c.

177. **CHINESE WOOLFLOWER (A)**—Brilliant crimson flowers, like balls of silky wool, that can be cut and dried. Pkt. 10c.



SALVIA SPLENDENS

178. **OLD ROSE**—Of real old rose shade. Large and noted for its charm and beauty. Pkt. 10c.

179. **GOLDEN STATE**—A very rich orange yellow. In bud, yellow, and turning to an attractive orange when in full bloom. Pkt. 10c.

180. **LEMON BEAUTY**—Golden yellow on brown, a decidedly pastel shade. Pkt. 10c.

181. **PURPLE PRINCE**—A fine deep purple, large and well formed. Pkt. 10c.

182. **POLAR BEAR**—A very large pure white, of true Dahlia form. Pkt. 10c.

183. **SPECIAL GOLD MEDAL MIXTURE**—A well-blended mixture, with a variety of colors. Pkt. 10c.

184. **ZINNIA, ELEGANS — GRANDIFLORA ROBUSTA (Youth and Old Age) (A)**—This is one of the most brilliant of annuals, has long been a general favorite. The flowers are large, finely formed, in great variety of colors, and continue to bloom the entire season. Half-hardy annuals. Pkt. 10c.

185. **ZINNIAS CURLED AND CRESTED (A)**—New, odd and superb. Petals twisted, curled and crested into fantastic contortions and graceful turns. A magnificent variety of colors. Pkt. 10c.

186. **ZINNIA—DOUBLE POMPON (A)**—Long, coneshaped flowers. Pkt. 10c.

187. **ZINNIA—CRIMSON (Half Dwarf)**—Pkt. 10c.

188. **ZINNIA—WHITE (Half Dwarf)**—Pkt. 10c.

189. **ZINNIA—LILLIPUT (Canary Yellow)**—Pkt. 10c.

190. **CRIMSON MONARCH**—Largest of Red Shades. Pkt. 10c.

191. **DREAM**—Deep lavender turning to purple. Pkt. 10 cts.

CLIMBERS

- 200. **AMPELOPSIS VEITCHII** (Boston Ivy) (P)—Dark green leaves, turning to coppery red. Pkt. 10c.
- 201. **BALSAM APPLE**—Apple-shaped fruit. Pkt. 10c.
- 201½. **BALSAM PEAR**—Pear-shaped fruit, which is used medicinally. Pkt. 10c.
- 202. **BALLOON VINE** (Love in a Puff) (A)—A rapid growing plant; succeeds best in light soil and warm situation; flowers white; half-hardy annual. Pkt. 10c.
- 203. **CANARY BIRD FLOWER** (Peregrinum)—A tender climbing annual. Blossoms have curiously wrinkled petals and are light yellow. Soak seed overnight before planting. Pkt. 10c.
- 204. **COBEA SCANDENS** (P)—A beautiful, rapid-growing climber, with handsome foliage and large bell-shaped flowers; blue; half-hardy perennial; grows 20 to 30 feet high. Pkt. 10c.
- 205. **CYPRESS VINE, RED** (Ipomea Quamoclit) (A)—Fern-like foliage and masses of beautiful, small, star-shaped flowers. Sow last of May; 15 feet. Pkt. 10c.
- 206. **CYPRESS VINE, WHITE** (A)—Usually grown with the red, making a handsome effect. Pkt. 10c.
- 207. **HEAVENLY BLUE IPOMEA** (A)—The flowers are in large, airy clusters, and that lovely hue so rarely seen. Pkt. 10c.
- 208. **MORNING GLORY** (Convolvulus Major) (A)—One of the most free-flowering and rapidly-growing plants in cultivation, thriving in almost any situation. Hardy annuals. Pkt. 10c.
- 209. **GIANT JAPANESE MORNING GLORY** (A)—These are by far the handsomest of the Morning Glories, of gigantic size. Pkt. 10c.
- 210A. **CONVOLVULUS MAURETANICUS** (A) — Lavender blue, for rock work. Pkt. 10c.
- 210. **MOON FLOWER** (Ipomoea Noctiflora) (A)—Charming and popular blooming climbers; of rapid growth and showy effects; warm, rich soil, with a sunny exposure, suits them. Pkt. 10c.
- 211. **SCARLET RUNNERS** (A)—Very handsome climbing beans, with bright scarlet flowers. Pkt. 10c.
- 212. **JAPANESE KUDZU ZINE** (P)—Hardy growing climbing plant, with large foliage and rosy-purple pea-shaped blossoms, blooming in August. Pkt. 10c.
- 213. **HYACINTH BEAN** (Dolichos) (A)—Climber of quick growth, with bean-like flowers. Pkt. 10c.
- 215. **MIXED GOURD** (Cucurbita) (A)—Pkt. 10c.
- 216. **NEST EGG GOURD** (A)—White fruit shaped like an egg. Used as a substitute for nest eggs. Pkt. 10c.
- 217. **DISHCLOTH GOURD** (A)—Many women prefer a dishcloth made of this Gourd to anything else, as it is always sweet and clean as long as any part is left. Pkt. 10c.
- 218. **DIPPER GOURD** (A)—Makes an excellent dipper. Pkt. 10c.
- 219. **MOCK ORANGE** (A)—Fruit shaped like an orange. Pkt. 10c.
- 220. **CALABASH or PIPE GOURD** (A)—Odd shaped fruit, which is used to advantage in making pipes. Pkt. 10c.

ORNAMENTAL GOURDS



POPULAR ANNUALS

- | | |
|------------------------------|------------------------|
| Alyssum, Sweet | Mignonette |
| Alyssum, Tom Thumb | Nasturtium |
| Aster | Pansy |
| Antirrhinum (Some varieties) | Petunia |
| Bachelor's Button | Phlox Drummondii |
| Cockscomb (Half-hardy) | Pinks |
| Calliopsis | Poppy (Some varieties) |
| Cosmos | Portulaca |
| Gaillardia | Scarlet Sage |
| Strawflower | Verbena |
| Heliotrope (Half-hardy) | Vinca |
| Marigold | Zinnia |
| Four-o'-Clock | Sweet Peas |

PERENNIALS (Hardy)

- | | |
|------------------------------|---------------------|
| Achillea, The Pearl | Kudzi Vine |
| Alyssum, Yellow | Marigold Tagates |
| Ampelopsis Veitchii | Michaelmas Daisy |
| Aquilegia | Phlox Decussata |
| Antirrhinum (Some varieties) | Pyrethrum Roseum |
| Cantamea, Blue | Oriental Poppy |
| Cobea Scandens | Iceland Poppy |
| Coreopsis Lanceolata | Scabiosa Caucasica |
| Delphinium | Stokesia |
| Foxglove | Sweet William |
| Gypsophila | Wallflower |
| Hibiscus | Lathyrus Latifolius |
| Hollyhock | (Sweet Peas) |

SWEET PEAS



SWEET PEAS should be sown in drills later part of November for fall planting, or as early as possible in spring, in rich, friable soil. Prepare the bed thoroughly, working in a quantity of well-rotted manure, if it can be done, making a furrow four to six inches deep. In this sow the seed and cover two inches deep. As soon as the plants begin to show through, fill in the furrow. This will secure a deep planting without the bad effect of deep covering of the seed at first, and so enable the plant to bloom continuously through the heat of summer. The roots should not be allowed to become too dry. Water applied thoroughly once or twice a week, preferably early in the morning or in the evening, is usually better than light sprinkling more frequently.

- 224. **G. & T. CO'S EXTRA FINE MIXED** (A)—Consists of the very choicest varieties mixed in the newest colors and shades. Oz. 10c, ¼ lb. 25c, ½ lb. 40c, 1 lb. 75c. Postage extra.
- 225. **SUPERB SPENCER MIXTURE** (A)—This group includes the largest and most beautifully formed sweet peas. The Spencers have very large waved flowers which are produced abundantly on long, strong stems, making the blossoms most desirable for cutting. Oz. 15c, ¼ lb. 50c, 1 lb. \$1.50. Postage extra.

NEW VARIETIES—Late Flowering

- 226. **GOOD CHEER**—Lovely shade of deep Begonia Rose, both standard and wings being alike in color. Excellent for garden and cut flowers. Does not fade in the sun. Pkt. 25c.
- 227. **CELEBRITY**—Vigorous-growing of Orange color. Large flowers on long stems. Uniform color in standard and wings. Pkt. 25c.
- 228. **CONQUEROR**—Large clear glowing cherry-cerise. Standard and wings alike in brightness and color, which suggests a brilliant scarlet-red shade. Pkt. 25c.
- 229. **EOSINE**—A beautiful tone of Pink with a soft flushing of salmon. Unusually large flower on stout stems. Good for exhibitors and garden decoration. Pkt. 25c.
- 230. **PERENNIAL SWEET PEAS** (P)—Mixed. Pkt. 10c, oz. 35c.

FOR ROCK GARDEN PLANTING

- | | |
|---------------------------|--------------------------|
| Achillea, The Pearl | Convolvulus Mauritanicus |
| Alyssum, Yellow | Geum, Mrs. Bradshaw |
| Aquilegia | Scutellaria, Celestine |
| (Rocky Mountain Blue) | Verbena Venosa |
| Aquilegia, Long Spurred | Campanula, Longistyla |
| Candytuft, | Cowslip |
| Sempervirens, White | Balcony Petunia |
| Candytuft, Lilac | Rosy Morn Petunia |
| Gypsophila, Repens, White | Alpine Poppy |
| Centaurea, Montana Blue | |

SUMMER-FLOWERING BULBS

GLADIOLUS

"Super-Glads"

For Garden and Exhibition Purposes

8c each, 75c dozen, \$4.50 per 100. Add 10c dozen for Postage.

Gladiolus are the most attractive and useful for cut flowers of all the summer flowering bulbs.

Plantings each ten days from April to mid-June, will provide flowers from August to October.

CARMEN SYLVA—Pure White. Splendid for garden and cut flowers.

DR. F. E. BENNETT—Peach red with suggestion of flame scarlet. Throat creamy-white, speckled ruby red. Huge flowers.

HENRY FORD—Royal Rhodamine purple, shading deeper towards center. Huge flowers.

MRS. H. E. BOTHKIN—A ruffled type, with color of soft-salmon pink, with fine scarlet blotch, tempered by the ground color.

MRS. LEON DOUGLAS—Begonia rose with flecks of flame scarlet. Lower petal tinted lemon with specks of ruby red.

ROSE ASH—A subdued rose red overlaid with grey, producing a hue called "Ashes of Roses." Shaded yellow in throat, with ruby red speckles.

ORANGE QUEEN—Newest and finest Gladioli. Color true orange.

ROSE PRECOSE—Early. Double row of deep rose flowers, with faint salmon shading; a gorgeous tint, developing darker streaks and mottling, if left on stalk. 10c each.

Select Gladiolus

5c each, 50c dozen, \$3.50 per 100. Postage 10c dozen extra.

AMERICA—The color is a very beautiful soft pink.

BLUE JAY—Porcelain blue.

CRIMSON GLOW—Crimson. Tall grower. Eight to ten flowers.

EVELYN KIRKLAND—Color, salmon-pink. Tall grower, with eight to ten flowers on a stalk. 100 per cent Gladioli.

GRETCHEN ZANG—Soft shade of pink, blending into scarlet on lower petals. Large, heavy blooms.

HALLEY—Predominating color, delicate salmon pink, with slight roseate tinge, though the lower petals bear a creamy blotch with a stripe of bright red through the center.

LOUISE—Lavender.

LE MARCHAL FOCH—Rose-pink, resembling America in color but deeper. Blooms same time as the Halley.

LILY WHITE—Pure white and very early forcer.

MAIDEN'S BLUSH—Early flowering; apricot pink.

MRS. FRANCIS KING—Long, strong stalks bearing flowers of vermilion-scarlet color.

MRS. DR. NORTON—Pure, soft white, with tips of petals suffused La France Pink.



GLADIOLUS

PANAMA—An improved American, largest and most notable spike of bloom among all pink sorts.

PEACE—Immense, pure white flowers, with touch of carmine in lower petals. These are borne on tall, graceful spikes; a beautiful variety.

ROSE, 1910—Early. Rose color, with white vein through center of petal.

SHAYLOR—Pure deep pink. Large flowers on tall stems.

SCHWABEN—Clear canary yellow, shading to soft sulphur. Largest of flowering stalks and leaves of all. Planted 7 or 8 inches apart in rich soil produces wonderful blooms.

WILBRINK—A favorite forcing variety for cutting. Early-flowering, color delicate pink.

MRS. F. PENDLETON—Bright rose with crimson scarlet blotches on lower petals. Good for forcing. 8c each.

CANNA ROOTS

FOLIAGE WITH BRONZE LEAF, but do not bloom. Dormant roots at 6c each, 60c per dozen. By parcel post, 10c per dozen extra.

MIXED—In Splendid Variety, our selection. 6c each, per dozen 60c, per 100 \$5.00. By express, not prepaid. By Parcel Post add 10c per dozen extra.

DAHLIA ROOTS

In separate colors, not named varieties, our selection. Clumps 12c each, \$1.25 dozen. By express, not prepaid. If by mail, add 10c extra for 1 to 5 plants for postage.

TUBEROSES

One of the most fragrant and popular of the summer flowering bulbs. May be started early in hot-beds or pots, or planted in open ground after the first of May.

EXCELSIOR PEARL—Double white; dwarf. Each 3c, dozen 35c, per 100 \$2.50. If by mail, add, dozen, 10c.

CALADIUMS—Elephant Ears

The Caladium Esculentum is one of the handsomest of the ornamental-leaved plants. It will grow in any good garden soil.

FIRST SIZE BULBS (7 and 9 inches)—Each 6c, dozen 60c.

LARGE BULBS (9 and 11 inches)—Each 8c, dozen 90c.

EXTRA LARGE BULBS (11 inches and upwards)—Each 14c, dozen \$1.65.

If by mail, add, single bulbs 5c, dozen 15c.

HARDY CHRYSANTHEMUMS



All from 2-inch pots, for bedding outdoors, for cut flowers, but not the large greenhouse varieties.

Large-Flowering Or Aster Varieties

(These are not for exhibition purposes, but good results can be obtained by slight disbudding, leaving from six to eight flowers on a spray. Should also be protected from frost when desired for cutting).

- BRONZE QUEEN**—An even shade of golden bronze. Dwarf.
- ERMALINDA**—Old rose, with silvery sheen.
- FAIRY QUEEN**—Deep enchantress color.
- JULIA LA GRAVERE**—Tall red.
- LILLIAN DOTY**—Beautiful shell pink; strong grower.
- RED DOTY**—Deep wine red.
- UVALDA**—Earliest white, sometimes showing tinge of pink when opening.
- WHITE DOTY**—Large pure white.

Small-Flowering Or Button Varieties

- GOLDEN CLIMAX**—Bright yellow.
- GOLDEN CREST**—Golden yellow pompon.
- OURAY**—Dark mahogany-brown flowers of medium size.

Miniature Or Baby Varieties

- DAINTY MAID**—Pearly White.
- WHITE MIDGET**—Purest white.

Anemone Varieties

- CHESTNUT**—An even shade of tan, harmonizing with red and yellow.
- MAPLE LEAF**—Like a soft maple leaf, color in various shades of red and yellow, changing from day to day.
- VOLUNTEER**—Good shade of yellow. Long stiff stems.

Single Varieties

- DAZZLER**—Red.
- MRS. BUCKINGHAM**—Large flat flower of rosy pink. Price, 10c. each; per dozen, \$1.00; per 100, \$6.00. By express, not Prepaid. Add 10c. for 1 to 5 plants for postage.

BEGONIAS

Price, 15c each, \$1.50 dozen.

- CHATELAINE SUPREME**—Live pure pink.
 - LUMINOSA**—Red flower; foliage turning reddish bronze, when growing in sun.
 - PRIDE OF NEW CASTLE**—Red sport of chatelaine. Dwarf.
 - PRIMO DONNA**—Limped-rose shading to carmine in center.
- IVY**
- HARDY ENGLISH, GERMAN or PARLOR IVY**—15c each, \$1.50 per dozen.

ADD 10c. ON 1 TO 5 PLANTS FOR POSTAGE.

CANNAS

POTTED PLANTS ONLY

From 3 in. pots, and ready about May 1st to 15th, when all danger of frost is past. Subject to outturn of crop.

Prices, except where otherwise noted, 20c each, \$2.00 per dozen. Add 10c for 1 to 5 plants for postage.

For best results the beds should be spaded deeply and a liberal amount of sheep manure or soft ground bone dug in.

CITY OF PORTLAND—Beautiful glowing pink, green foliage. 3 1/2 feet. 25c each, \$2.50 per dozen.

EUREKA—Flowers of creamy white with rich green foliage. 4 feet.

FLORENCE VAUGHAN—The flowers are yellow spotted with scarlet and produce freely. 5 feet.

GLADIATOR—Strong, vigorous grower, with fine green foliage; flowers yellow spotted with red. 4 1/2 ft.

HUNGARIA—A beautiful clear rose, about 3 1/2 feet high.

INDIANA—Four feet. Color is a glistening orange daintily marked and striped with red.

KING HUMBERT—The finest type of orange scarlet flowers combined with the finest type of bronze foliage. 25c each, \$2.50 per dozen. 4 feet.

KING MIDAS—Clear yellow. Same type as President. 4 feet. \$1.00 each.

PENNSYLVANIA—Six feet. Hybrid orchid-flowering. Pure deep scarlet.

PRESIDENT—Brilliant red with green foliage. 4 feet. 25c each, \$2.50 per dozen.

RICHARD WALLACE—Green foliage, large canary yellow flowers. 4 1/2 feet.

RUBIN—Bright scarlet flowers, dark foliage. 4 feet.

VENUS—A gay rosy-pink with border of creamy yellow; green foliage. Four feet.

WYOMING—Orange-scarlet flowers; dark foliage. 4 1/2 feet.

GERANIUMS

FROM 2-INCH POTS.

Ivy-Leaved Varieties

ALLIANCE—Delicate lilac white, upper petals blotched bright crimson rose, semi-double flowers.

CESAR FRANK—Soft rich crimson, shading to rose at base of petals.

JAMES ATTFIELD—Extra large double flowers, of pretty tint of soft pink.

JAMES T. HAMILTON—Intense carmine-crimson.

MRS. BANKS—Blush white, upper petals feathered reddish Neuron. Light green foliage.

PIERRE CROZY—Semi-double bright scarlet flowers.

Standard Varieties

MRS. E. G. HILL—Single. A continual bloomer, of soft light salmon color. Semi-dwarf.

MRS. GEO. BURKE—Single. Soft velvety-crimson, free-flowering and good bedder.

MME. RECAMIER—Double pure white flowers. A strong grower.

ALPHONSE RICARD—Semi-double flowers of bright vermilion-scarlet, with bright green foliage.

BERTHA DE PEISSLY—Silver rose pink, slightly shading to an almost white centre; semi-double.

S. A. NUTT—Dark red double flowers. A good bedder and very popular.

SCARLET BEDDER—Semi-double flowers of dark-fery red. Fine as pot plant or bedder.

Scented-Leaved Varieties

BALM—Upper petals light lilac; lower petals dark.

CAPITATUM—Small leaf, rose-scented.

DALE PARK BEAUTY—Small, fragrant foliage.

FELICIFOLIUM ODO RATUM—Very attractive, having fern-like foliage.

SCHOTTESHAMPET—Filbert-scented.

LADY MARY—Sweet-scented; rose-lake color.

LEMON—Lemon-scented.

NUTMEG—Dwarf; bright green foliage; nutmeg scented.

ROSE—Rose-scented.

Price, 15c each, \$1.50 per dozen. By express, not prepaid. Postage 10c extra on 1 to 5 plants.

LANTANAS

- A. CLAVEN**—Primrose pink.
- A. COOK**—Orange and rose dwarf.
- CRAIGI**—Lemon yellow turning to orange.
- LYRE**—Pure white with yellow center.
- MER JAUNE**—Semi-dwarf, bearing golden yellow blossoms. Prices, 15c. each, \$1.50 per dozen.

MOON VINES

- NOCTIFLORA**—The standard white Moonvine.
- LEARI (Blue Dawn Flower)**—Generally known as the Blue Moonflower. Prices, 15c. each, \$1.50 per dozen.

DAHLIA ROOTS AND PLANTS

NEWEST AND LATEST VARIETIES

Prices are for roots, as named. Potted plants ready, after April 15th. If potted plants are wanted of same varieties, prices are one-half the price of roots.

Postage on one to three roots, 10c extra.

Postage on one root only, 5c extra.

Postage on plants, same as roots.

Collection of 12 standard varieties of Dahlia roots for \$1.50.

Collection of 12 extra selected varieties of Dahlia roots for \$3.00.

Collection of 12 exhibition varieties of Dahlia roots for \$5.00.

ALICE WHITTIER—(Hy. Cactus.) A beautiful primrose yellow variety, \$2.00.

AMARILLA GRAND—Light yellow with broad petals of the Cactus-hybrid type, \$1.50.

AMBASSADOR—Cactus. Soft yellow at centre, shading deeper towards tips, \$1.00.

AMUN RA or THE SUN GOD—(Dec.) Copper and Orange, shading to gold and amber deepening to reddish-bronze. Keeps well when cut, \$1.00.

BOB PLEUSE—Fancy decorative with deep crimson-maroon flowers, with white-tipped petals. Early, \$1.75.

COUNTESS OF LONSDALE—Cactus. Pointed petals of salmon-red, 30c.

CHEMAR'S EUREKA WHITE—Decorative, with a touch of pink, which disappears as flower becomes fully open. \$2.50.

CITY OF TRENTON—(Dec.) New. Reddish-Apricot, with rose-suffusion, of splendid form, growing about 6 feet tall. \$1.50.

DREAM—(Dec.) Broad petals, yellow at base and pink at outer ends, 50c.

EARL WILLIAMS—(Dec.) Brilliant crimson and white, 50c.

ELLINOR VANDEVEER—(Dec.) Satiny-rose-pink with long strong stems, \$1.00.

ELLA MAY (Cactus)—Deep rich crimson carmine flowers, large, with full centres. \$1.50.

F. W. FELLOWS—Cactus. Large flowers with narrow petals of intense coral-red with deeper suffusion at centre, 75c.

FORDHOOK CRAWFISH—Hyb. Cactus. Deep pink flushed with white at centre, base of petals shaded yellow, 75c.

FORDHOOK VICTORY—(Dec.) Tyrian-rose, \$2.00.

FRANCIS LOBDELL—Hyb. Cactus. Bright mallow-pink color shading to white. Fine for cutting, 50c.

JUDGE MAREAN—(Dec.) Large blooms with petals of salmon, pink, red, orange and yellow, in shading to glowing autumn coloring, 50c.

JANE COWL—(Dec.) Buff and Old Gold, blending to bright salmon at centre. Petals full and slightly twisted, \$1.50.

GRACE SPERLING—(Dec.) Golden iridescent buff with reverse of petals of amaranth purple, free blooming, 50c.

JERSEY BEAUTY—(Dec.) A garden beauty of pink color, 50c.

JERSEY BEACON—(Dec.) Chinese scarlet with paler reverse, 50c.

JEAN HARE—Hyb. Cactus. Yellow, buff and golden bronze, \$3.00.

JEAN KERR—(Dec.) Fine white, 35c.

KEMP'S VIOLET WONDER—(Dec.) Rich deep violet. Large blooms, on good stems, \$3.00.

KITTY DUNLAP—(Dec.) Color of American Beauty rose on long stems, 75c.

LEO NIESSEN—(Dec.) Brilliant red. Good for cutting, \$1.00.

MARGARET WOODROW WILSON—(Dec.) Creamy white shaded with pink and having deeper reverse, 75c.

MRS. JOHN SCHEEPERS—(Dec.) Large flowers, of canary-yellow color, shading to delicate pink on outer petals, 50c.

MRS. CARL SALBACH—(Dec.) Solferino pink with white suffusion. Large blooms, 50c.



DAHLIA

MARIPOSA—Cactus. Orchid pink, with deeper center with violet suffusion, 50c.

MRS. ELEANOR MARTIN—(Dec.) Beautiful mulberry, suffused gold, \$1.00.

MRS. I. DEVER WARNER—(Dec.) Deep mauve pink, \$1.00.

QUEEN OF THE GARDEN—(Dec.) Pure yellow, 75c.

MRS. LEO NIESSEN—Cactus. Yellow at base suffused and tipped rich bronzy-red, \$1.00.

MERRICK—(Dec.) Light maroon, tipped and edged mahogany, \$1.00.

MARMION—(Dec.) Pure golden yellow with bronze suffusion in centre, \$1.50.

ROSE FALLON—(Dec.) Large dark orange flowers, tinted with amber and salmon, 50c.

ROSE NELL—(Dec.) Deep rose, large and free flowering, 50c.

ROMAN EAGLE—(Dec.) Burnished copper-red. Long stems, \$1.00.

ROBERT TREAT—(Dec.) American Beauty Rose. Free bloomer, \$1.00.

SAGAMORE—(Dec.) Apricot-buff shaded, orange buff toward centre. Good keeper, 35c.

SNOWDRIFT—(Dec.) Giant variety with broad white waxy petals, 50c.

TRENTONIAN—(Dec.) A giant variety of distinct color of old gold, shading amber and coppery bronze, with centre of reddish-bronze, 50c.

THE WORLD—(Dec.) Rich deep rosy magenta overlaid garnet, with silver shadings on edges of petals, \$2.00.

ROSES

Roses prefer a rather heavy soil and sunny exposure. Any ordinary soil well worked-up with well-rotted stable manure and bone meal will grow Roses, providing there is good drainage. Roses do not like wet feet. The beds should be dug to a depth of at least twelve inches and deeper if possible.

Set plants two feet apart (narrow beds are best) and two inches deeper than the graft. Fill hole half full then fill with water to settle dirt around roots and prevent air pockets. Allow water to drain, then fill with dirt and cover with light mulch of Peat Moss, or well-rotted manure. Top dress with bone meal Spring and Autumn.

SPECIAL SELECTION

ETOILE DE HOLLANDE.—The finest dark red Rose for general purposes, having great vigor and floriferousness. This is unquestionably the best and most popular red Hybrid Tea Rose in the world.

PRESIDENT HERBERT HOOVER.—A splendid combination of cerise-pink, flame, scarlet and yellow. This combination of colors gives the most dazzling color effect imaginable. The buds are beautifully pointed, the flowers large, composed of broad, thick, heavy petals, with an exquisite fragrance. It is exceptionally free flowering. Price \$1.25.

TALISMAN.—Its brilliant orange-red buds open to a large, fragrant, high pointed bloom of glowing golden yellow stained with copper-red and orange-rose on the inside of the petal. The plants are vigorous and healthy out of doors and will stand severe winters unprotected. Especially good in Spring and late Autumn.

VILLA de PARIS.—Strong, vigorous plants, with bright yellow buds, opening into fadeless blooms of the Radiance type. Each \$1.25.

REV. F. PAGE ROBERTS.—Golden yellow flowers, stained with copper and reddish buff on the outside. Each \$1.25.

E. G. HILL.—Massive blooms of deep maroon, velvety on inside and glistening outside. Fragrant. Each \$1.50.

EVEREST.—New and vigorous variety with flowers of clear Ivory-white, intensely fragrant and resembling the hybrid perpetual in habit. Blooms are large and may be grown as a pillar. Each \$1.25.

STANDARD COLLECTION

CUBA.—Semi-double blazing red-orange blooms. Excellent foliage.

Mme. BUTTERFLY.—The finest Rose of the Ophelia type, bright light pink, shaded with gold. Very popular and always in demand.

DUCHESS OF WELLINGTON.—A low-spreading but vigorous grower with long saffron-yellow buds opening to very large light yellow flowers. Always popular and reliable.

MARGARET MCGREY.—Brilliant red petals on hinges of deep gold. Buds upright. Seldom out of bloom.

Mme. EDOUARD HERRIOT.—The original of all bright orange-pink varieties and still one of the best.

BETTY UPRIKARD.—One of the finest new roses, with brilliant copper-red buds and semi-double, salmon-pink flowers stained with copper-pink on the outside. It is a profuse bloomer and one of the outstanding varieties grown.

PINK RADIANCE.—Plants of wonderful foliage and vigor, constantly producing large, brilliant rose-pink blooms of excellent globular shape and intense fragrance. There are probably more Radiance Roses grown and planted than any dozen other varieties put together.

RED RADIANCE.—A bright rose-red form of Radiance with the same good habit and blooming qualities.

SOUV. de CLAUDIUS PERNET.—The old standby for a real yellow rose.

RAMBLER ROSES

Climbing roses require no pruning in the Spring except to cut out the old and dead wood and shortening of the long canes to keep them in bounds. However, a good pruning in July after blooming, is beneficial.

AMERICAN PILLAR.—A single flowering variety of great beauty. Flowers large brilliant pink with white eye, borne in enormous clusters and when in bloom is a sight not easily forgotten.

DR. W. VAN FLEET.—Large flowers of exquisite pink on fine, long stems. Extremely vigorous with beautiful foliage. Splendid for cutting.

CHAPLIN'S PINK CLIMBER.—A pink replica of Paul's Scarlet, being clear pink with a tuft of yellow stamens. \$1.25 each.

PAUL'S SCARLET CLIMBER.—Flowers are large, well-shaped, vivid scarlet-red, fading but little.

PRIMROSE.—The new yellow Rambler. Perfectly hardy, with double canary-yellow flowers borne in trusses of from 2 to 5 on long stems, 2 to 2½ inches in diameter. A vigorous climber. Dark green foliage.

SILVER MOON.—Flowers semi-double white, with brilliant yellow stamens.

Prices on Roses, except where otherwise noted, \$1.00 each; \$10.30 per dozen. Cash with order. No Roses sent by parcel post, or in Virginia.

Ready in May.

PERENNIALS

Name	Time of Bloom										Height in.
	April	May	June	July	August	September	October				
*Achillea (Milfoil)			X	X	X	X	X				18
Agrostemma (Lychnis Coronaria)			X	X	X	X	X				24
*Ajuga (Bugle)		X	X	X	X	X	X				6
*Alyssum Saxatile Compactum (Goldentuft)		X	X	X	X	X	X				12
Anchusa (Bugloss)		X	X	X	X	X	X				4
*Anemone (Windflower) various		X	X	X	X	X	X				30
*Aquilegia (Columbine) assorted Hybrids		X	X	X	X	X	X				6
*Arabis Alpina (Rockcress)	X	X	X	X	X	X	X				40
*Artemisia lactiflora (White Mugwort)					X	X	X				30
Asters, Hardy (fall flowering)					X	X	X				30
Asters, various					X	X	X				18
Campanula (Canterbury Bells) various					X	X	X				30
*Glomerata (Clustered Bellflower)			X	X	X	X	X				60
Persicifolia		X	X	X	X	X	X				24
Pyramidalis (Chimney Bellflower)					X	X	X				36
Centauria Montana (Hardy Corn Flower)					X	X	X				24
Chrysanthemums, various										X	36
Coreopsis lanceolata										X	24
Rosea										X	12
Delphiniums (Hardy Larkspur) Hybrids			X	X	X	X	X				40
Large Plants 50c. to \$1.00											24
Dianthus (Sweet William) various		X	X	X	X	X	X				36
Dicranthus (Gasplant)		X	X	X	X	X	X				30
Digitalis (Foxglove)		X	X	X	X	X	X				24
Doronicum (Leopard's Bane)	X	X	X	X	X	X	X				24
*Eryngium alpinum (Sea Holly)					X	X	X			X	18
Funkia (Plantain Lily)					X	X	X				24
Gaillardia (Blanket Flower)					X	X	X				24
Grasses Ornamentalis (Price on request)											16
*Geum (Avens)	X	X	X	X	X	X	X				24
Gypsophila (Baby's Breath) various											30
Bristol Fairy \$1.00					X	X	X				36
*Paniculata Flore Plena					X	X	X				48
Heather (Heath) various					X	X	X				36
Helenium (Sneezeweed) Riverton Jem, etc.					X	X	X				48
Helianthus multiflorus (Hardy Sunflower)					X	X	X				36
Hemerocallis (Day Lily)	X	X	X	X	X	X	X				48
*Iris											24
Sibirica (Siberian Iris)			X	X	X	X	X				36
Germanica (German Iris)			X	X	X	X	X				18
Kaempferi (Japanese Iris)			X	X	X	X	X				60
Iberis (Hardy Candytuft) various	X	X	X	X	X	X	X				18
Liatris (Gayfeather)				X	X	X	X				24
*Linum (Flax)				X	X	X	X				36
Lobelia (Cardinal Flower)				X	X	X	X				18
Lupinus polyphyllus (Lupine)				X	X	X	X				6
Lychnis (Ragged Robin)	X	X	X	X	X	X	X				18
*Myosotis (Forget-me-not)	X	X	X	X	X	X	X				36
Oenothera (Evening Primrose)	X	X	X	X	X	X	X				12
Papaver Orientale (Oriental Poppy)	X	X	X	X	X	X	X				12
Nudicaule (Iceland Poppy)	X	X	X	X	X	X	X				42
Pentstemon (Beard Tongue) various											6
*Pinks, Hardy	X	X	X	X	X	X	X				12
Physostegia (False Dragon Head)					X	X	X				6
*Phlox Subulata (Moss or Mountain Pink)	X	X	X	X	X	X	X				12
Divaricata Blue	X	X	X	X	X	X	X				24
Hardy, various. Named Varieties	X	X	X	X	X	X	X				18
Platycodon (Balloon Flower)	X	X	X	X	X	X	X				12
Polygonum (Knot-weed)					X	X	X				18
*Polemonium (Jacob's Ladder)				X	X	X	X				24
*Potentilla (Cinquefoil)				X	X	X	X				24
*Primula various				X	X	X	X				48
Pyrethrum (Painted Daisy)				X	X	X	X				12
Rudbeckia (Cone Flower) various				X	X	X	X				24
*Saxifraga (Megasea)	X	X	X	X	X	X	X				24
Scabiosa (Blue Bonnet)				X	X	X	X				24
*Sedum (Stonecrop) various				X	X	X	X				24
Statice (Great Sea Lavender)				X	X	X	X				18
Stokesia (Corn Flower) (Stokes Aster)				X	X	X	X				36
*Thalictrum (Meadow Rue) various				X	X	X	X				18
Tritoma (Kniphofia) Red-hot-poker				X	X	X	X				6
*Trollius (Globe Flower)	X	X	X	X	X	X	X				7
*Viola, Jersey Gem	X	X	X	X	X	X	X				84
*Vinca (Periwinkle)	X	X	X	X	X	X	X				84
Hollyhocks, various, double and single				X	X	X	X				

Price 35c. each, or \$3.00 per dozen, where not priced, Cash with order.

No plant sent by parcel post, or in Virginia.

Ready in April.

SEMPERVIVUM (House Leek).—Curios and interesting plants, forming rosettes of succulent leaves, of varying colors. All varieties.

SEDUM-STONECROP.—Dwarf and tall varieties. Plants marked * suitable for Rock Gardens, as well as Decorative uses. All plants subject to season's conditions and stock being unsold.

SUGGESTIONS FOR PERENNIAL BEDS

Prepare beds by incorporating a liberal dressing of well-rotted manure, and a dressing of raw ground bone, thoroughly mixed with good soil. If the beds are laid out irregularly and not too wide, the effect is better than in a straight line. Potted plants are less apt to suffer from transplanting and should be set out about April. When planting, firm the soil about plant and soak liberally with water, after planting. You can also set out in September and up to early November. A light dressing of sheep manure during summer is helpful.

For THE ROCK GARDEN, select your varieties to conform with size of the garden, and prepare soil as for Perennials.

STRAWBERRY PLANTS

In early Winter when the ground is frozen, cover the whole with long straw, which should be removed from the plant in the spring, but allowed to remain on the ground as a mulch, to keep the berries clean next summer.

PREMIER—One of the very best of extra early varieties; succeeds on almost all soil (if well drained). Produced in vast quantities, berries of good size, attractive appearance and excellent quality.

MISSIONARY—Med. ey. of medium size, dark red and rather tart. Does well on most any soil.

BIG JOE—Med-season. Large berry and vigorous grower.

CHESAPEAKE—Late. Large, firm and productive.

LUPTON—Late. Similar to Chesapeake and often growing where Chesapeake will not make a good bed. Attractive and good shipper.

GANDY—Very late. Large solid fruit. Fertilize liberally.

Prices on above—\$1.65 per 100. Postage 10c per 100 extra.

MASTODON—The supreme Everbearing Strawberry. Price \$2.75 per 100. Postage 10c per 100 extra.

FROST-PROOF CABBAGE PLANTS

WILL MATURE HEADS TWO TO THREE WEEKS EARLIER THAN YOUR HOME-GROWN PLANTS.

Early Jersey Wakefield, Charleston Wakefield, Succession, Early Flat Dutch and Copenhagen Market.

These plants are grown in the open field during the fall and winter months, which causes them to make a slow, tough, hardy growth—so hardy that the outer leaves turn to a reddish brown. They can be shipped to distant points without danger of spoiling, and should be planted in the open ground from four to five weeks earlier than frame plants.

They will stand a temperature of 10 to 15 degrees above zero without injury. Will do very much better planted early, as they will take root and start to grow as soon as warm weather sets in.

Orders filled from December 1st until May 1st. We do not advise planting later than this time.

Prices by Parcel Post, postage paid. In lots of 100 to 300 plants, 50c per 100 plants; 500 plants for \$1.60; 1,000 or more at \$3.00 per 1,000 plants.

Orders are filled by the 100, not 250 or 350. These prices are for even quantities of one variety to package; if you ordered 200 of one variety and 300 of another variety you would pay at the 100 rate.

Prices by Express, buyer paying express charges. In lots of 1,000 to 3,000 plants at \$2.00 per 1,000; 5,000 or more at \$1.50 per 1,000. Plants packed for express shipment, 1,000 or 2,000 plants of a variety to package, they weigh about 25 pounds per thousand plants, packed for shipment.

TERMS, CASH WITH ORDER, PLEASE
No Plants Shipped C. O. D.

ASPARAGUS ROOTS

	Per 100	Per 1000
MARY WASHINGTON	\$1.75	\$12.00
PALMETTO	1.25	9.50
BARR'S MAMMOTH	1.25	9.50
CONOVER'S COLLOSAL	1.25	9.50

Postage per 100, 10c extra.

RHUBARB ROOTS

20c. Each. Dozen, \$2.00. Postage 10c extra on 1 to 3 roots.

GERMACO HOTKAPS



Besides protecting the plant from the elements and from insects, "Hotkaps" are worth their cost alone because they aid in maturing crops earlier. That is the all-important thing to the grower, FOR IT MEANS THAT HE CAN BE FIRST TO MARKET AND SO COMMAND A BETTER PRICE FOR HIS CROP. Thus "Hotkaps" far more than pay for themselves. They represent one of the best investments a farmer can make. Thousands have proved it; thousands more are discovering it every season.

Price.

100 Pkg. Complete, cont. 100	1000 Hotkaps only.....	\$11.00
Hot C'ps & Gard. Setter, \$2.50	Steel Hotkap Setter....	2.50
250 Pkg. Complete, cont. 250	Paper Garden Setter....	.50
Hot C'ps & Gard. Setter, \$4.00	Tamper25

FRUIT TREES

APPLES—\$1.25 each.
Yellow Transparent—July.
Gravenstein—September to October.
Summer Rambo—September to October.
Stayman's Winesap—Winter.
Stark's Delicious—Fall.
Grimes Golden—Fall.
Jonathan—Fall.
York Imperial—Winter.

CRABAPPLES—\$1.25 each.

PEARS—\$1.25 each.
Bartlett—Summer.—
Koonce—Summer.
Kieffer—Winter.
Seckel—Autumn.

CHERRY—Leading varieties \$1.25 each.

PEACHES—50 cts. each.
Elberta—Yellow free-stone.
Georgia Belle—White free-stone.
J. H. Hale—Yellow free-stone.

PLUMS and SHROPSHIRE DAMSON—\$1.00 each.

QUINCE—\$1.50 each.

GRAPES

CONCORD **NIAGARA** **DELAWARE**
Price, 40c. each. If by mail add 10c.

RASPBERRIES

GREGG **KANSAS BLACK CAP** **MILLER RED**
Price, 15c. each; \$1.25 per doz. If by mail add 10c.

BLACKBERRIES

ELDORADO **LUCRETIA**
Price, 15c. each; \$1.25 per doz. If by mail add 10c.

CURRANTS

FAY'S PROLIFIC
Price, 40c. each; \$4.00 per doz. If by mail add 10c.

SHRUBBERY

BARBERRY THUNBERGI—2 year transplanted, 18 to 24 inches. Price, 35c. each; \$3.00 per 10; \$25.00 per 100.

CALIFORNIA PRIVET—2 year, 18 to 24 inches. Price, 10c. each; \$6.00 per 100.

ALTHEA—Double rose red, double red, double white, double white with cherry center, 3 to 4 feet. Price, 75c. each.

HONEYSUCKLE—18 to 24 inches. 30c. each.

HYDEANGEA—Hills of snow. White. June to August. 2 to 3 feet. \$1.00 each.

HYDEANGEA—Paniculata Grandiflora—Very showy. August. 2 to 3 feet. \$1.00 each.

LILACS—French budded, in colors of reddish purple, rosy-lilac, rosy-carmine, white. 2 to 3 feet. \$1.00 each.

WEIGELIA—Red-flowering, 3 to 4 feet. 75c. each. (Blooms in July and August).

WEIGELIA—Pink-flowering. 3 to 4 feet. 50c. each. (Blooms in June).

FLOWERING PEACH—4 to 5 feet. \$1.00 each.

HARDY VINES

AMPELOPSIS VEITCHII or **BOSTON IVY**—75c. each.

AMPELOPSIS QUINQUEFOLIA—Virginia Creeper. 75c. each.

CLEMATIS—White. \$1.25 each. Purple. \$1.25 each.

JASMINE—White. 75c. each.

PERIWINKLE—Blue-flowering. 75c. each.

WISTERIA—Purple. 75c. each.

GATOR-HIDE MULCH PAPER

WHAT GATOR-HIDE MULCH PAPER IS—HOW IT WORKS

Gator-Hide Mulch Paper is one of the toughest, strongest, most durable papers made. It is impregnated by a special process with a particular grade of asphaltum which has no harmful effect on soil or plant life.

Unrolled over the proposed plant beds, and anchored by soil or other available material along the edges, Gator-Hide Mulch Paper imprisons all the moisture in the soil. Its black surface catches and retains the sun's heat. This raises the soil's temperature, prevents cooling at night, and promotes continuous bacterial activity, liberating night and day nitrous food matter for the plant, producing bigger, better, and earlier crops.

Planting is done through holes made in the paper, or in the space between two strips or paper rolled out close together. Thus while ample space is provided for the plant, no space is left for weeds, and the nourishment they ordinarily steal from the soil is conserved for the crops you plant.

Type A—18-in. width—300 linear yards to the roll.....	\$3.00
36-in. width—300 linear yards to the roll.....	6.00
Type B—18-in. width—150 linear yards to the roll.....	3.00
36-in. width—150 linear yards to the roll.....	6.00
Garden Package.....	.65

HORTICULTURAL TOOLS AND SUPPLIES

GRASS HOOK



- No. 1 German Grass Hook.....\$.50
- No. 2 German Grass Hook..... .60
- Best English Grass—No. 2..... .75
- Best English Grass—No. 3..... .80
- Best English Hedge or Grass Hooks—No. 490
- American—plain50
- Lawn King—polished75
- Long Handle Grass Hook1.00

GARDEN TROWELS



No. 212—American, 16-gauge tool steel, 6-inch blade, a handle that will not come out in dry weather. Price, 30c.
 No. 213—American, 6-inch bright steel blade, plain handle, 15c.

ENGLISH PATTERN FORGED STEEL GARDEN TROWEL



No. 211.....75c.

TRANSPLANTING TROWEL



No. 217—5-inch blade.....20c.
 No. 217—8-inch blade.....30c.

Moe's All Steel Garden Trowels and Weeders

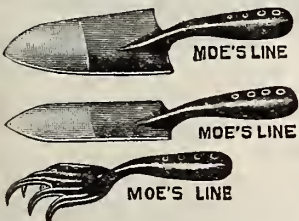

Heavy pressed steel black enamel finish with polished points. No loose wooden handles.

- No. 80—Garden trowel, 6-in. blade. Each..... 20c.
- No. 81—Transplanting trowel. Each..... 20c.
- No. 82—Garden Weeder. Each..... 20c.

No. 85—Galvanized Strong Steel Trowel, one piece, very durable. Parcel Post weight, 1 pound. Price 10c.

EUREKA HAND WEEDER



A Very Handy and Useful Weeder.

- No. E—Grip handle.....45c.
 - No. EL—2-foot handle.....55c.
- Parcel post weight, 1 pound.

LARGE HAND WEEDER



Parcel post weight, 1 pound.

- No. 400—4 Prong Hand Weeder.....30c
- No. G—Solid Steel Hand Weeder, 3 Prong.....50c

GRASWIP



No. 160 Graswip is made of Forged Tool Steel, and has two cutting edges, you swing it like a golf stick and it cuts both ways on the forward and backward stroke.

A very handy tool in high grass and for cutting weeds. It is easy to operate in a standing position.

Wonderful to use on dandelions and plantain on the lawn, when a lawn mower will not get the seed heads.

Price\$1.00

SCUFFLE HOE

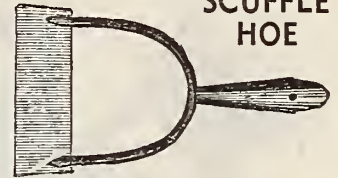

- 4-inch\$.70
- 6-inch80
- 8-inch 1.00

GRAPE SCISSORS



No. 4774—Grape Pickers, \$.60
 Flower Scissors..... 1.75

FRUIT PICKER

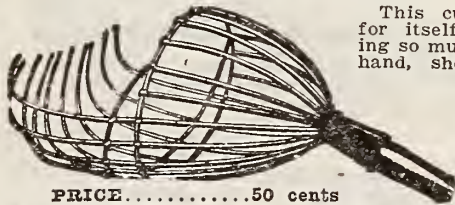

PRICE.....50 cents

This cut almost speaks for itself—the device, being so much like the human hand, shows at once the utility of the article. As a Fruit Picker it has no superior. It is made of heavy wire, and easily adjusted to a pole.

PRUNING KNIVES



No. 22408—Cocoa Handle.....\$1.00

BUDDING KNIVES No. 1508R.....\$1.00

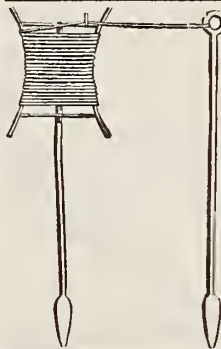

GARDEN REELS

Every gardener should have one of these handy reels. Straight rows add greatly to the looks of the garden. These reels are made of heavy iron, and will last a life time.

- Large size reel to hold 100 feet of line\$2.50
- No. 1 Garden Reel..... 1.50

GARDEN LINE.

Best grade 3/16-in. Cotton Garden Line, in any desired length.

Price, per 100 feet.....\$1.50

DIBBERS

For transferring plants. By far the best thing for the purpose ever introduced.

Right-angle shape, steel-polished, wood handle, 75c.



ASPARAGUS KNIFE



Made of solid steel; see the cutting point. Price...40c. each
 Parcel post weight, 1 lb.

ASPARAGUS BUNCHER

Put your asparagus up in bunches, with this Improved Asparagus Buncher. It is adjustable for all lengths of bundles, correct in design and quick in operation. It makes a well-formed, compact bundle, adding greatly to the looks of the vegetable. Parcel post wt. 5 lbs. Price each, \$4.50



HORTICULTURAL TOOLS AND SUPPLIES—Continued



"LITTLE WONDER" HEDGE TRIMMER

Hedge will improve in appearance after it is trimmed with the "Little Wonder," by reason of the straight cutting, no dips or round corners and other common faults often noticed in hedge trimmed by hand shears.

It is not near as hard work trimming with the "Little Wonder" as the hand shears. It really operates astonishingly easy.

30-inch machine.....\$25.00
40-inch machine..... 27.50
60-inch machine..... 35.00

Electric Driven

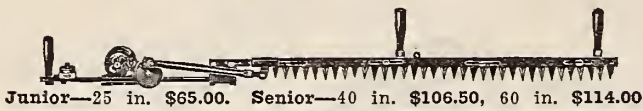

Junior—25 in. \$65.00. Senior—40 in. \$106.50, 60 in. \$114.00

HEDGE SHEARS

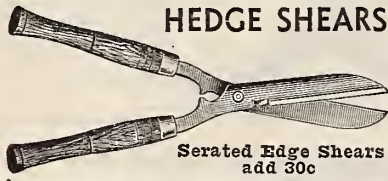

Serrated Edge Shears add 30c

(Plain)
No. 100—8-inch..\$2.00
No. 100—9-inch.. 2.25
No. 100—10-inch.. 2.50
No. 100—12-inch.. 3.00
(With Notch)
No. 101—8-inch..\$2.25
No. 101—9-inch.. 2.50
No. 101—10-inch . 2.75
No. 101—12-inch . 3.25

LOPPING SHEARS



The Baltimore Draw Cut Shears is extra strong, and will cut large limbs with the least exertion.

The No. 5406 Shear is light and strong and is very handy for light work. It will not tire you to handle it.

No. 5406—20-inch Handles.....\$1.60
No. 5406—24-inch Handles..... 2.00
No. 5402—Baltimore Draw Cut, 24-inch handles..... 3.50
No. 5403—Baltimore Draw Cut, 22-inch handles..... 3.00
No. 5408—Forged Solid Tool, Steel Blade, 24-inch Handle 2.75

This hedge trimming shear is hand forged, light and very strong. The handles are riveted on in a way they never come loose.

8-in.\$2.50
9-in. 3.00

TRIMSNIP



PRUNING SAWS

No. 16—14 in. Price, \$2.00



PRUNING SAW



No. 3 Saws. No. 1 Saws.
16-inch double.....\$1.65 16-inch single.....\$1.60
18-inch double..... 1.80 18-inch single..... 1.75
20-inch double..... 1.90 20-inch single..... 1.85



Sheep Shears

No. 055.....\$1.00
No. 3755—Full polish 2.25
No. 3757..... 2.65



Water's Tree Pruners

4 feet.....\$1.60
6 feet..... 1.80
8 feet..... 2.00
10 feet..... 2.20
12 feet..... 2.40
14 feet..... 2.60
Extra Knives..... .20

Telegraph Tree Pruners

Price, without pole.....\$1.40
Lineman Tree Pruner, No. 2.....\$4.00

Doo-Klip Pruners

A Firm, Sturdy Tool
Price \$1.25

HY-LO GRASS SHEARS

No. 595. Blade length 6 3/4 inches. The Hy-Lo is our Keen-Clip Grass Shear with heavier blades and handles fitted with a 30-inch hardwood handle in a green waxed finish. It is the only practical long handled grass shear selling at a popular price. Weight 2 pounds.
Price\$1.75

GRASS SHEARS



Bent Handle.....35c.
Trowel Handle.....60c.

BORDER SHEARS



No. 105 With Wheel
Price, \$4.50

LAWN SHEARS

No. 1062—2 wheels, 8-inch blade, for cutting on narrow borders, under fences and shrubs..\$4.90

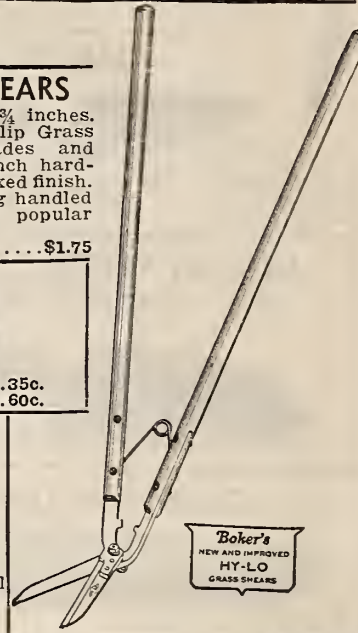

Boker's NEW AND IMPROVED HY-LO GRASS SHEARS

GRASSNIPPERS

Here is a tool that will cut grass easier than a shear. Built like hair cutters. Blades are forged steel, warranted. Handle is malleable, will not break.

No. 28\$0.50
No. 27 1.00

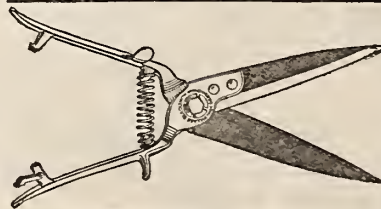

DOO-KLIP GRASS SHEARS

DOO-KLIP GRASS SHEARS have a unique up-and-down action which supplies the blades with maximum cutting power and yet requires the minimum amount of effort. Always easy running, they prevent blisters, skinned knuckles and grass stains, and allow the hand and arm to be used in a free and natural position.

Price, \$1.50.



PRUNING SHEARS



No. 4—Flat Spring, Steel Blade.....\$.60
No. 33—Coil Spring, Mal. Handle, Steel Blade..... .60
No. 4665—Solid Steel, 9-inch..... 1.00
No. 4666—Solid Steel, full polish, 9-inch..... 1.50
No. 544—Ladies', nickel-plated, 6-inch..... 1.75
Parcel post weight, 1 pound.

FLORISTS AND GARDEN SUPPLIES

IRON CLAD WATERING POTS



- 4-qt.\$.60
- 6-qt.70
- 8-qt.75
- 10-qt.85
- 12-qt. 1.05
- 16-qt. 1.25

These pots are made from the best grade of galvanized iron, and are very heavy and strong. The long spout makes them very desirable for greenhouse and flower bed use. Each can be equipped with a fine and coarse nozzle, with copper perforation.

- 4-quart\$4.50
- 6-quart 4.80
- 8-quart 5.25
- 10-quart 5.60
- 12-quart 6.10

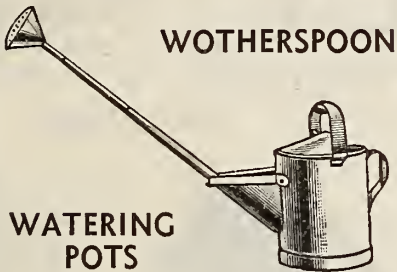

WOTHERSPOON

WATERING POTS

PLANT SPRINKLERS

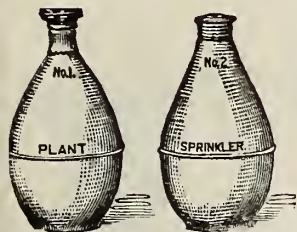

Putty Bulb

This Improved Putty Bulb is made from a good grade of rubber. For glazing greenhouses, new or old; will be found very handy.

Price\$1.50
Parcel Post weight, 1 pound.
We do not guarantee rubber goods.



For sprinkling cut flowers, seedlings, plants, clothes, etc.
No. 1—Standard, 12-ounce\$1.50
Parcel post weight, 1 pound.

MASTICA

Mastica.—For glazing greenhouses, sashes, new and old. It is elastic, adhesive and easily applied. It is not affected by dampness, heat or cold. "Mastica," when applied, in a few hours forms a skin or film on the entire mass, hermetically sealing the substance and preventing the evaporation of the liquids, and remains in a soft, pliable and elastic condition for years. "Mastica" is of great value in going over old houses with a putty bulb or machine on the outside of sash, as it makes it perfectly tight and saves the expense of relaying the glass.

1-Gallon Cans.....\$2.40

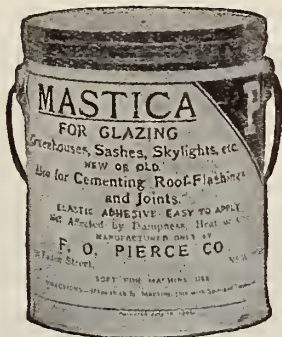

MASTICA GLAZING MACHINE
OUR SPECIAL PRICE.....\$2.85

ASPARAGUS TAPE

Spools of about 1,000 yards, \$2.00 each. Postage extra. Parcel Post Weight, 2 lbs.

RAFFIA

The best material for tying Plants, Vines, etc. Per pound.....25c.

GRAFTING WAX

- ¼-lb.15c.
- ½-lb.30c.
- 1-lb.50c.

BURLAP HOT-BED MATS

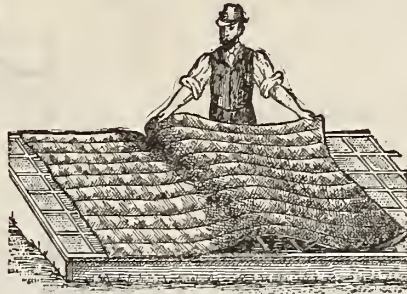

Made of strong burlap, interlined.

Price, 40 x 76, Each \$1.65

Price, 76 x 76, Each \$2.75

Special Price in Dozen Lots.

UNGLAZED HOT-BED SASH

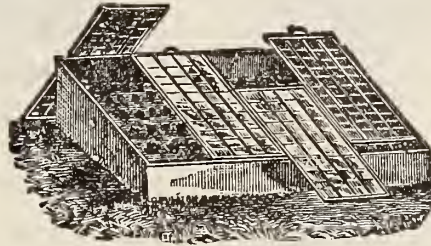

3 ft. 2 in. x 6 ft.

Price, \$1.75 each.

PEERLESS GLAZING POINTS

(Imp. Van Reyper.)

The finest glazing points on the market. The glass cannot slip; they are quickly and easily put in with special pincers; no "rights" or "lefts" to bother with.

Per box of 1,000.....75c.
Pincers, per pair.....85c.
Parcel post weight, 2 pounds.

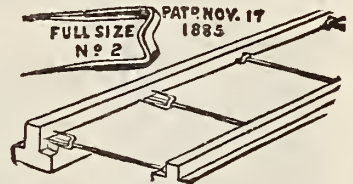

SPHAGNUM MOSS

For packing growing Orchids, Plants, etc. Per bale.....\$3.00

IMPORTED GRANULATED PEAT MOSS TORF TRADE MARK G.P.M. MULL

Used extensively by florists and growers of flowers for potted plants, shrubbery and lawns. Per bale.....\$2.75

OLMSTEAD MOLE TRAP

Without a doubt, the best mole trap made, built so that you can place a weight upon it, insuring perfect action, even in the softest ground. It is built low, and can be used

OUT-OF-SIGHT MOLE TRAP

in many places that a taller trap would not do.

Our Special Price \$2.00

Parcel post wt., 2 lb.

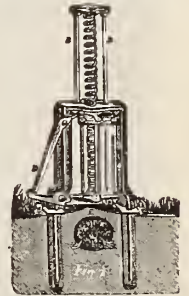
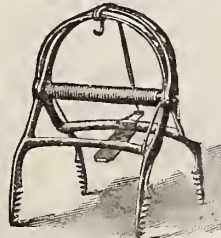

LITTLE GIANT MOLE TRAP

Self-setting by pressing down on lever. Very convenient feature found on no other trap. Made from best spring steel, thoroughly galvanized. Simple and durable in its construction.

Price\$1.00
Parcel post wt., 2 pounds.



FLORISTS AND GARDEN SUPPLIES—Continued

POT LABELS

	Plain	Painted
4-in., per 1000.....	\$1.60	\$2.00
5-in., per 1000.....	1.80	2.20
6-in., per 1000.....	2.00	2.50
8-in., per 250.....		1.50
12-in., per 100.....		1.00

Special price in quantities to florists.

PAINTED TREE LABELS

	Per 1000
3½-in., notched.....	\$1.80
3½-in., iron wired.....	2.20
3½-in., copper wired.....	2.40

ADJUSTO PLANT SUPPORT

A sturdy, hardwood stake seven-eighths inch square, 3, 4, or 5 feet long, with a strong wire support instantly adjustable to any height.

Enables you to cultivate close to the plant. "Adjusto" supported tomatoes ripen to perfection. "Adjusto" supports

bring out the full beauty of Dahlias, Chrysanthemums, and all the slender, tall-growing varieties.

4 ft., each.....	\$0.30
5 ft., each.....	.35

THE TIME SAVER PLANT SUPPORT

Your Flower and Vegetable Garden's Best Friend. Shove stake solidly into the ground—slide clip to the desired height—place twine around plant to any diameter.

No. 2—3 ft.....	\$1.15
No. 3—3½ ft.....	1.60
No. 3A—4 ft.....	2.20
No. 4—5 ft.....	2.75

THERMOMETERS

No. 5120—6-inch Cabinet, magnifying tube, black oxidized scale, white figures and graduation, brass screw clasps and guard, back oak finished, natural..\$1.00

No. 5140—8-inch Cabinet, magnifying tube, black oxidized brass scale, white filled figures, nicked straps and guard, wood back, finished in birch.....65c

No. 5440—10-inch tin japanned...30c

No. 5442—12-inch Tobacco Curing, best quality, tested.....75c

No. 5170—8-inch Distance Reading; an excellent thermometer for greenhouses and for use where it is necessary to get a quick reading.....30c

No. 125—Incubator Thermometer, may be used for a stand-up or reclining with proper holder. With holder, each..\$1.00

No. 128—Brooder Thermometer, round wood back, each.....60c

No. 127—Thermometer for all Brooders, metal back.....50c

No. 5316S—Temprite Window Thermometer with hanger for outside of window or door, Red Spirit, Large Figures, easy to read.....\$1.25

No. 5452—Self-Registering, boxwood scale, black filled figures, japanned tin case, 10 inch.....\$6.00

No. 5981—Hot Bed, 16 inch, wood frame, with handle, brass pointed ferrule, brass oxidized scale, white-filled figures and graduations.....\$3.00

No. 5740—Standard Dairy, stands boiling water; black oxidized brass scale, white-filled figures and graduations, range from 20 to 200 degrees.....\$1.00

No. 5715S—Floating Glass Dairy..30c

No. 7236—Milk Hydrometer (Quevne).....\$1.50

No. 7240—Lime-Sulphur Hydrometer.....\$1.50

No. 7410—Lime-Sulphur Hydrometer, with test jar.....\$2.25

If thermometers are wanted by parcel post, add 10 cents for postage and packing.



No. 5715S



No. 5120

STAKES

HEAVY OR DAHLIA STAKES

	Ea.	Per Doz.	Per 100
3 ft.	12c.	\$1.15	\$8.60
4 ft.	15c.	1.55	11.40
5 ft.	20c.	2.25	14.60
6 ft.	25c.	2.50	17.90

LIGHT PLANT STAKES

	Ea.	Per Doz.	Per 100
1½ ft. ..	3c.	\$.25	\$1.50
2 ft. ..	4c.	.40	2.80
2½ ft. ..	6c.	.60	4.10
3 ft. ..	8c.	.75	5.40

GALVANIZED STEEL STAKES

	100 weigh doz.	Per 100	Per 1000
2 ft. 10 lbs.	\$.25	\$1.25	\$9.75
3 ft. 14 lbs.	.40	2.00	13.75
3½ ft. 17 lbs.	.45	2.25	16.50
4 ft. 19 lbs.	.50	2.50	18.55
5 ft. 24 lbs.	.65	3.00	22.50

CANE STAKES

5 to 7 feet long.	
Per 100..	\$1.00
Per 1000..	\$7.00



BIRD HOUSES



These houses are made from ¾ inch White Pine, nicely painted, white enamel bodies with the roofs painted green, or finished in rustic brown stain. Both making a very fine finish, and a handsome house.

The No. 1 House is made with slanting sides so arranged that the bottom dovetails in, making it so it can be pulled out as a slide for cleaning the house. It can also be mounted on a pole by nailing the bottom on top of pole and sliding the house over it. The mounting cleat on the back can be used in putting the house up in many places, and if not needed can be taken off.

The No. 2 House has a removable bottom held in place by four screws, and this house can be mounted on a pole by nailing the bottom on top of pole, placing the house in position and replacing the screws, or can be nailed or hung up in numerous ways.

No. 1 Bird House for Wren or Bluebird, Painted.....	\$1.25
No. 1 Bird House for Wren or Bluebird, Rustic Brown.....	1.25
No. 2 Bird House for Wren or Bluebird, Painted.....	1.00
No. 2 Bird House for Wren or Bluebird, Rustic Brown.....	1.00

IMPORTED GRANULATED PEAT MOSS FOR GARDENS

Granulated Peat Moss is fine for garden mulch, as it conserves moisture.

When incorporated in the soil, it promotes growth and supplies humus, which is very essential for growing plants.

When used in connection with fertilizers, flowers and plants should grow very luxuriantly.

5 lbs. 30c—25 lbs. \$1.00—½ Bale \$1.50—Bale \$2.75



National Eezy Wear Garden Gloves

Made from special imported hides processed to render them amazingly soft and pliable. Permit almost barehand freedom yet provide complete all-leather protection. Ideal for garden and similar uses.

DIRT-PROOF—DURABLE—WASHABLE

Four sizes: "SMALL" and "MEDIUM" for Women, "MEDIUM" and "LARGE" size for Men.

Price 75c a pair, 2 pairs for \$1.40.

TRELLIS—ARBORS—PERGOLAS

PERGOLA

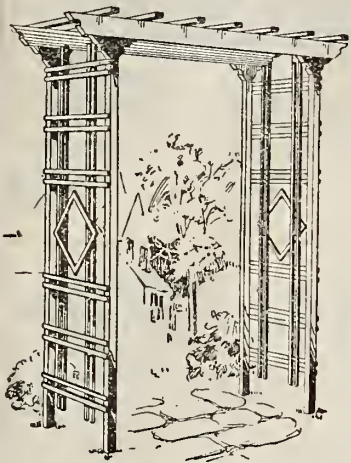

No. 121

Height 7 feet, width 8 feet, depth 35 inches, each.....\$8.75

ARBOR

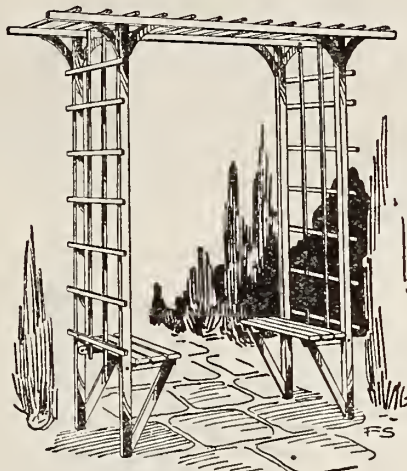

No. 904

Height 7 feet, width 6½ feet, depth 30 inches, each.....\$6.50

FAN TRELLIS

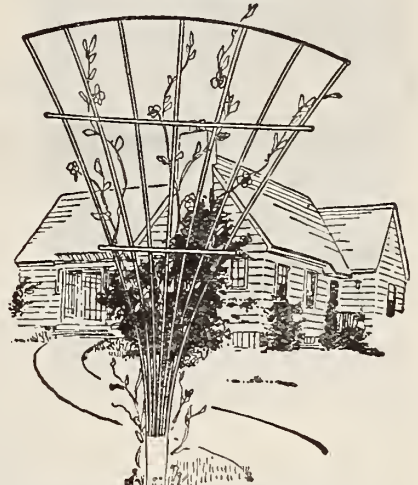

Nos. 926 and 928

No. 926—Height 6 feet, price.....\$1.00
No. 928—Height 8 feet, price..... 1.20

LUXOR DECORATED CUT FLOWER JAR



No. 2

7 inch\$0.40
9 inch60
11 inch80

BIRD BATHS

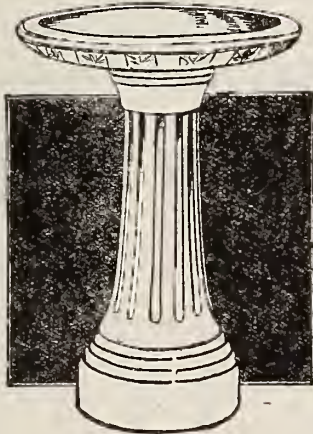

Height 27 inches, diameter of bowl 20 inches..\$4.00 and up

LUXOR BULB BOWL



No. 1

6½ inch20c

CIRCULAR TOP ARCH

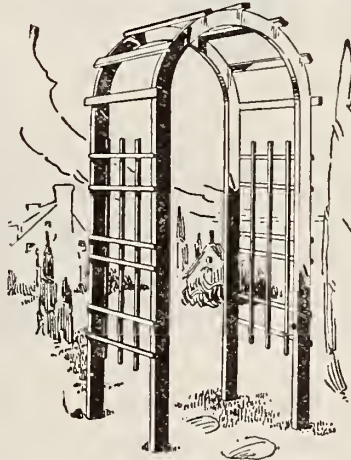

No. 130

Height 7 feet 6 inches, width 38 inches, depth 35 inches, each \$8.00

LUXOR BULB BOWL



No. 2

8 inch\$0.50
9 inch60
No. 3 Luxor Bulb Bowl, 7 inch.. .35

TRELLIS

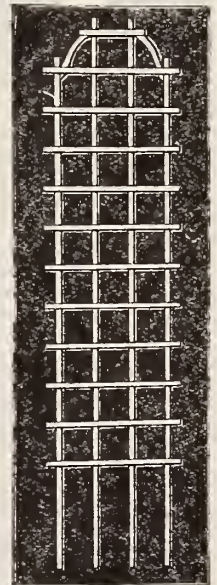

No. 923

Height 8 feet, width 24 inches, each \$1.15

MANY OTHER DESIGNS ON REQUEST

WRITE FOR INFORMATION RESPECTING MANY OTHER ATTRACTIVE DESIGNS

LENNOX HANGING BASKETS

With Saucer attached, complete with Hanging Chain.
Price: 8-inch 60c, 10-inch 85c

NO FREIGHT OR EXPRESS SHIPMENTS



U. S. PLANT TUBS

These plant tubs are made from best grade cedar, with strong iron handles and feet. Just the thing for Palms, Rubber Plants, etc. Painted Green with Black Trimmings.

Painted Green.

No.	Outside Top Diameter.	Depth.	Price.
No. 1	12	10 3/4	\$2.30
No. 2	13	12 3/4	3.00
No. 3	14 1/2	14 3/4	3.75
No. 3 1/2	16 1/2	15 3/4	4.85
No. 4	19 7/8	16 3/8	5.25
No. 5	22 7/8	18 1/2	6.80



RICHMOND STYLE

The Richmond style fills a long felt want for a cheap type of plant tub and is being used by many large florists in place of earthen pots. These plant tubs are nicely painted with the best oil paints—a handsome green color inside and out. The tops of the staves are slightly beveled, which gives them a neat, trim finish.

Size	Inside Top Diam. In.	Inside Bot. Diam. In.	Inside Depth In.	Thickness of Stave	Price Each
No. 3	8	6	8	3/8	\$.60
No. 4	9	7	9	3/8	.65
No. 5	10	7 1/2	9	7/16	.75
No. 6	11	8 1/2	10	1/2	.95
No. 7	12	9	11	1/2	1.15
No. 8	13	10	12	1/2	1.45
No. 9	14	11	13	5/8	1.60
No. 10	15	11 1/2	14	5/8	1.80

NEW WAY TO GROW VEGETABLES, FLOWERS AND POTTED PLANTS!



If you feed your potted plants, flowers and vegetables on Plantabbs each week or ten days they'll grow lots better than any fertilizer will make them grow. Plantabbs are a complete food in odorless tablet form—guaranteed to contain 11% nitrogen (ammonia), 15% phosphoric acid and 20% potash.

Include in your next order.	Price:
30 Tablets	25c.
75 Tablets	50c.
200 Tablets	\$1.00.
1000 Tablets	3.50.

FULTON'S
Plantabbs
ODORLESS PLANT FOOD TABLETS

PLANT BOXES—GALVANIZED Green Finish

Sub-irrigating device insures uniform distribution of water and air throughout the entire length of box. Best results obtained by putting gravel, charcoal, moss or something of the kind in bottom of box up level with top of horizontal water conductor. Then fill with rich earth. Water through upright tube.



Size 24"x8 1/2"x7 1/4"	\$1.25
30"x8 1/2"x7 1/4"	1.60
36"x8 1/2"x6 1/4"	2.40

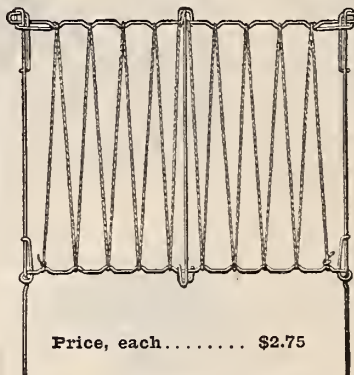

TIMESAVER SWEET PEA, GARDEN PEA AND VINE TRELLIS

Dimensions 5 feet by 5 feet over all. Stands 4 feet above ground when placed. Frame made of 1/4 inch Galvanized cold drawn steel, Green Rope center. Several can be used end to end for long rows. Easily assembled in a few minutes without use of tools. Various parts snap solidly together and center is then strung on the frame. Very quickly taken apart again, if desired, for storage purposes.

Price, each..... \$2.75

BIRD'S Improved Neponset FLOWER POTS

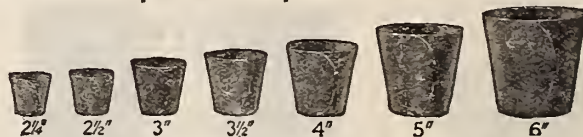

The Improved Bird Neponset Flower Pot is now ready for the truck gardener, the florist—every grower of plants on a large or small scale.

Month of testing under actual growing conditions have proven that this Improved Pot can be used successfully when seedlings are to be carried from six to eight weeks.

Size	Per Doz.			Per 1000			
	Per Doz.	Per 100	Per 1000	Per Doz.	Per 100	Per 1000	
2 1/2 in.	\$.10	\$.50	\$3.75	4 in.	\$.25	\$1.15	\$9.00
2 1/2 in.12	.60	4.25	5 in.30	1.60	14.00
3 in.15	.70	5.75	6 in.40	2.25	19.25
3 1/2 in.20	.85	7.25	Packed 500 to case on special order.			

STIM-U-PLANT

PLANT STIMULANT TABLET

1. Gives an EXACT FEEDING UNIT—No guesswork.
2. Provides for ABSOLUTE CONTROL of feeding, eliminating the danger of overfeeding.
3. No MESSY MIXING.
4. No unpleasant ODOR.
5. Is EASIEST TO APPLY.
6. Insures MAXIMUM EFFICIENCY because the plant gets all the food-value—none being lost through scattering where not available to the plant, leaching and run-off of surface soil-water.



7. Makes REPOTTING of house plants UNNECESSARY, as it replaces the food withdrawn by the growing plant.

Because of its ready solubility, **STIM-U-PLANT** can easily be used as a liquid manure, by dissolving the tablets in water at the rate of four to the gallon.

Small size, 30 tablets....\$0.25
Large size, 100 tablets... .75

EUREKA COAL BURNING BROODER STOVE

Eureka Coal Burning Brooder Stoves to take the place of the old Queen Brooder Stove, and is made by the same manufacturer.
 The Eureka Colony Coal Burning Brooder is an improved design of Brooder Stoves and is made of high quality cast iron, and will last indefinitely.
 There is no damper in smoke pipe on the Eureka. The check draft rests on top of the above and opens outward. When the fire is too warm, this gives a gentle inflow of air to retard the heat.
 The Eureka stove burns any kind of fuel with equally satisfactory results. We recommend chestnut sizes in all kinds of fuel, and hard or soft coal, coke or charcoal burn equally well. Of course, hard coal will not cause the pipe to become dirty as quickly as the others, but it will give no better heat.

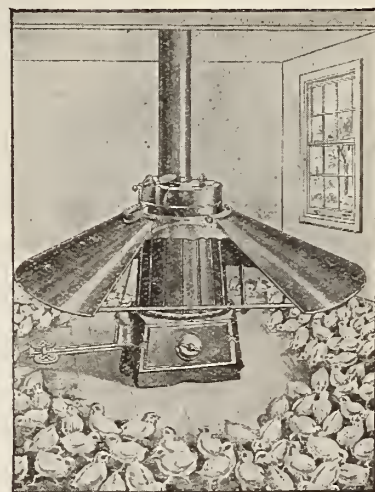

PIPE FOR STOVE BROODERS

4-inch Galvanized Pipe, in 10-foot lengths, per foot.....	12c
5-inch Galvanized Pipe, in 10-foot lengths, per foot.....	18c
4-inch Galvanized Elbows.....	35c
5-inch Galvanized Elbows.....	40c

	No. 10 Capacity 400 chicks	No. 11 Capacity 500 chicks	No. 22 Capacity 1000 chicks	No. 33 Capacity 1200 chicks	No. 61 Capacity 1500 chicks
Size Smoke Pipe.....	4 in.	4 in.	4 in.	4-in.	5 in.
Height to Top of Stove.....	18 in.	22 in.	25 1/2 in.	27 in.	35 in.
Diameter of Cylinder.....	10 in.	10 in.	11 in.	13 in.	15 in.
Diameter of Hoyer.....	42 in.	42 in.	52 in.	56 in.	60 in.
Coal Capacity.....	20 lbs.	26 lbs.	37 lbs.	50 lbs.	64 lbs.
Diameter of Grate.....	9 in.	9 in.	10 1/4 in.	11 1/4 in.	11 1/4 in.
Height of Hoyer from Floor.....	8 1/2 in.	8 1/2 in.	11 in.	13 in.	13 in.
Shipping Weights (complete).....	76 lbs.	82 lbs.	105 lbs.	122 lbs.	165 lbs.
Stove.....	\$10.50	\$13.50	\$15.50	\$19.50	\$29.50

MOE'S INCUBATORS

Remember, it is not how many chicks you hatch, but how many you raise. Chicks that hatch out weak and wobbly, and live but a few days, mean nothing to you but trouble and loss.

PROPER INSULATION. The Moe's is doubly insulated. First, we have double walls of California redwood, forming a dead air space. Second, corrugated strawboard is used between the wooden walls.

MOE'S HOT-WATER HEATING—The Moss System of hot-water heating prevents the drying out tendencies found in the hot-air incubators and provides a soft uniform heat over every part of the egg chamber—a heat that is most natural for the hatching eggs. The circulation of water through the radiator prevents any moisture being added or taken away from the eggs. When it becomes necessary to remove the lamp, the hot water circulating through the radiator maintains an even heat within the egg chamber without the slightest variation.

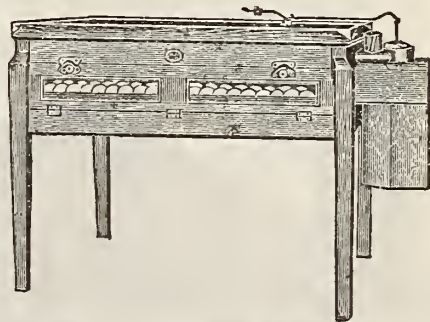

No.	Capacity	Price
165.....	85 egg	\$13.00
167.....	150 egg	22.00
168.....	250 egg	30.00
170.....	400 egg	42.00
172.....	600 egg	62.00
174.....	800 egg (2 tiers)	84.00
176.....	1200 egg (2 tiers)	124.00

Can supply Electric Incubators, sizes up to 600 eggs, at \$4.00 each higher than above price, all with egg-turning tray.

No. 100 Lamp Bowl, takes No. 1 Burner.....	\$0.50
No. 101 Lamp, takes No. 2 Burner.....	.60
No. 102 Lamp Bowl, takes No. 3 Burner.....	.75
No. 213 Burner, No. 1 size, 7/8 in. flue, 5/8 in. wick.....	.35
No. 202 Burner, No. 2 size, 1 1/8 in. flue, 7/8 in. wick.....	.40
No. 203 Burner, No. 3 size, 1 1/4 in. flue, 1 1/2 in. wick.....	.65
5/8 in. Wicks 3c each, 25c doz.	
7/8 in. Wicks 5c each, 45c doz.	
1 1/2 in. Wicks 8c each, 55c doz.	
Adjustable Roof Saddles, No. 440, 4 in.....	\$1.50
Adjustable Roof Saddles, No. 441, 5 in.....	1.65
Smoke Pipe Cap, No. 440, 4 in.....	.40
Smoke Pipe Cap, No. 445, 5 in.....	.45

INCUBATOR THERMOMETERS (Stand up)

No. 125 Tycos, each.....	\$1.00
No. 127 Brooder Thermometers, metal, each.....	.50
No. 128 Brooder Thermometers on wood, each.....	.60
DOUBLE UNIT WAFERS	3 in. 40c, 4 in. 75c, 5 in. \$1

LANSDOWNE POULTRY MARKER



Our special price 25c.

EGG TESTER

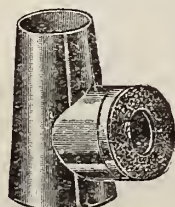

PRICE 25c
POSTPAID 35c

CAPONIZING TOOLS

You can do your own caponizing easily with this set of tools. Each tool is made for this especial work, and is of the highest grade. These sets are packed in a neat wooden box.

Philadelphia Set.....	\$3.50
Farmer's Set.....	3.50

PHILADELPHIA GAPE EXTRACTOR, 30c. each.



French Poultry Killing Knife
 Expeditious and humane way of killing and dressing poultry. Price, with instructions, each, 60c.

LICE KILLER AND NEST EGG Combined in One

Lasting, effective. Not expensive. Does not affect the flavor of the egg nor injure it for hatching. 60c dozen.

WIRE HEN NESTS

Each.....	20c
Per Dozen.....	\$2.35

PORCELAIN NEST EGG

The best and cleanest nest eggs used. Each 5c, doz. 30c. By mail 40c.

LEG BANDS

ALUMINUM BANDS					
No. Bnds.	12	50	100	500	1000
Price	\$0.15	\$0.40	\$0.65	\$3.00	\$5.50

CELLULOID BANDS

CELLULOID BANDS			
No.	91	92	93
	3/8-in.	1/2-in.	5/8-in.
12 Bands	\$0.15	\$0.15	\$0.15
50 Bands	.40	.35	.30
100 Bands	.70	.60	.50
500 Bands	3.25	2.75	2.25
1000 Bands	6.00	5.00	4.00

MaKomb Coal and Oil Brooders

MAKOMB GIANT COAL BROODER

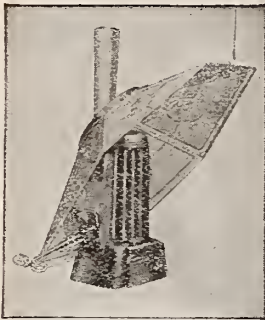

Famous for large capacity, positive control and convenience. The only large capacity brooder—equipped with many exclusive features—at popular prices. The famous By-Pass Control insures efficient operation with either soft coal or hard coal, checks fast burning, and prevents high winds effecting operation. The fluted barrel, larger at bottom, permits coal to settle without bridging, and gives greater radiation. Two-Way By-Pass Damper is positive in action, simple, nicely balanced. Ashes or smoke never contact it to cause trouble. Extraordinary

fuel capacity prevents burning out at night. New square base and ash pit lend massive appearance. New top coal door insures perfect fit and is extra large for easy firing, right from scuttle. Quick removable baffle plate makes soot disposal easy. New combination shaker handle to shake grate, open fire door, remove baffle plate, remove bottom door—makes operations most convenient. Stove finish gray, with orange head. New tilting canopy, hexagonal in shape, heavily ribbed and beaded.

	Capacity	Shipping Weight	Price Each	Catalog Number
47 in. MaKomb Giant	350	102 lbs.	\$15.00	B2-1147
56 in. MaKomb Giant	600	130 lbs.	19.50	B2-1256
65 in. MaKomb Giant	800	168 lbs.	23.50	B2-1365

KOAL-O-STAT—The Super Brooder

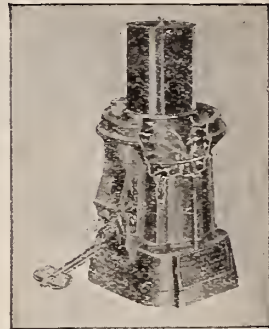

Equipped with the famous Globe furnace slotted fire pot—the last word in brooder design. Possesses all superior features of the Giant—plus greater capacity and the most efficient fuel burning system ever developed. Capacity for 85 pounds of coal. Fuel automatically burns directly against outside heating surfaces providing absolute uniform radiation in all directions under the canopy. No uneven heating!

The By-Pass Control provides positive temperature regulation. Big circulating dome head, convenient humidifier, soot drop—every desirable feature.

	Capacity	Shipping Weight	Price Each	Catalog Number
56 in. Koal-O-Stat	600	163 lbs.	\$28.00	B2-1956
65 in. Koal-O-Stat	800	180 lbs.	30.00	B2-1965

KER-O-STAT "BLUE FLAME" OIL BROODER

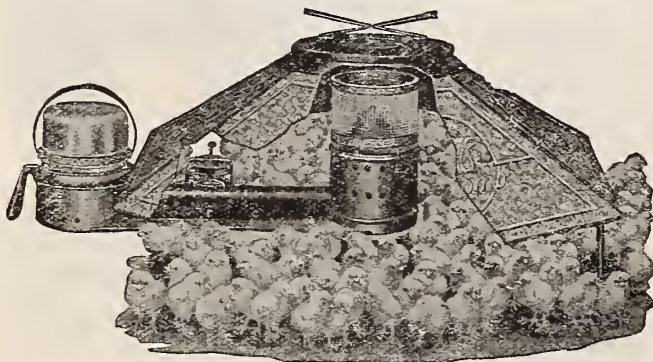

Only successful Automatic Blue Flame Brooder! Advanced in design and equipped with new hexagonal canopy. Automatic Safety Pilot Light and positive Thermostatic Control. Requires no gasoline priming. No complicated valves, floats or sliding joints. Thermostatic Control, effected by brooder temperatures, raises or lowers entire burner in a constant oil level. Pilot Light permits brooder to be turned off during warm days and started again at night by simply turning hand control. New Deflecting Shield prevents overheating floor. Positive trouble-proof construction! All Ker-O-Stat parts enclosed and protected by solid welded units of heavy sheet steel, finished in high gloss enamel. Large size has 5-inch Giant Burner.

	Capacity	Shipping Weight	Price Each	Catalog Number
36 in. Ker-O-Stat	200	36 lbs.	\$13.00	A2-735
45 in. Ker-O-Stat	300	47 lbs.	14.50	A2-745
55 in. Ker-O-Stat	500	53 lbs.	16.00	A2-855

SIMPLICITY "BLUE FLAME" OIL BROODER

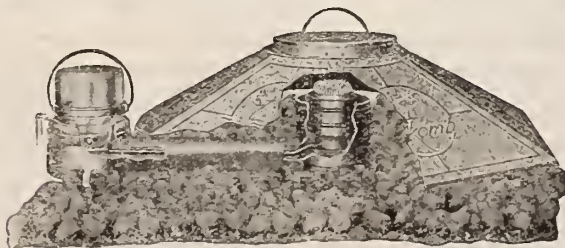

An outstanding value in blue flame brooders. Built like the Ker-O-Stat, but lacks the Automatic Control, Canopy Bracket and Burner Screen. Has the same simple, positive Hand Control.

	Capacity	Shipping Weight	Price Each	Catalog Number
35 in. Simplicity	200	31 lbs.	\$9.50	A2-535
45 in. Simplicity	300	40 lbs.	10.75	A2-545
55 in. Simplicity	500	49 lbs.	12.00	A2-655

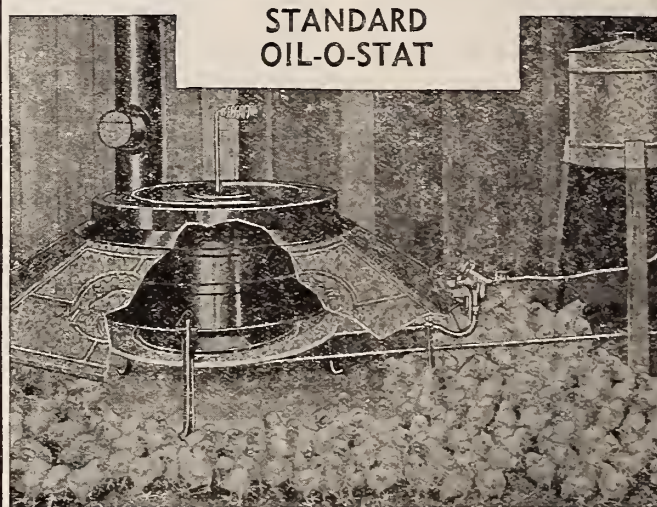

STANDARD OIL-O-STAT

A Drum Type Brooder, practical, trouble-proof and efficient, equipped with cast iron furnace type burner and die-cast automatic valve. Built in three styles, the Standard, Senior, and Junior. Burns distillate or furnace oil. Lowers fuel cost one-third to one-half. MaKomb design provides long heat travel. Twin blast furnace type burner requires no priming and will not go out. New Easy Clean device makes possible operating through entire season without lifting top door. Automatic draft adjuster prevents back draft and saves fuel. No smoke, gas or fumes. Provides automatic ventilation for brooder house. Maintains constant temperature under positive control. Tanks hold 8 gallons of fuel, sufficient for two to four days. Equipped with new hexagonal tilting canopy. Comes complete with tank and all fittings except smoke pipe.

	Capacity	Shipping Weight	Price Each	Catalog Number
56 in. Standard	600	100 lbs.	\$29.75	A2-1956
65 in. Standard	1000	100 lbs.	32.00	A2-1965

SENIOR OIL-O-STAT

Provides great room heating capacity at low cost. Seven 4-inch air tubes add to heating surface and circulating capacity. Air of ordinary 10x12 brooder house re-circulated every 10 minutes. 40 per cent greater heating area than similar brooders. Screen guards keep litter from base. 60 inches of copper tubing supplied. Made of 22 and 20 gauge steel. No canopy.

	Shipping Wt.	Price, Each	Catalog No.
Senior	110 lbs.	\$32.75	A2-23

JUNIOR OIL-O-STAT

A most efficient drum type oil brooder costing no more than blue flame brooders. Equipped with automatic draft adjuster with extra deep main drum and new baffle construction that doubles heat travel, greatly increasing efficiency. The new screen guard is provided. Equipped with oil filter and new hexagonal revolving canopy. Comes complete except smoke pipe.

	Capacity	Shipping Weight	Price Each	Catalog Number
55 in. Junior.....	500	67 lbs.	\$24.00	A2-2155

MaKomb Poultry House Equipment

THE NON-CLOG MASH FEEDER

BIRD AND VERMIN PROOF

Rain tight. For grain or mash. Holds 110 lbs. of commercial dry mash or 200 lbs. of grain (2½ bu.) Adjustable throat and feed guard along trough edge prevent waste. Self closing hinge covers are opened and feed agitated automatically when hen mounts platform. Built of heavy galvanized steel and mounted on heavy steel

truss stand. Preferred for range feeding. Length of hopper, 35 inches. Length of perches, 37 inches. Shipping Wt. Price Each Catalog No. (One in carton..... 34 lbs. \$8.00 H2-11)



THE LONG BOY FEEDER

Equipped with either wire grid or tumble guard. Maximum feeding space at low cost. Trough, made of 26 gauge prime galvanized steel, is 10 inches wide, 5 inches deep. Supported on wide, sturdy, black japanned stand. Easily supports 600 pound weight. Perches wide and adjustable. Feeds both sides.

The Long Boy above has heavy wire grid, firmly anchored in galvanized steel channels which act as non-wasting guard. Grid is practically indestructible and easily snapped in or out of position. No hinges. Grid and trough come assembled. Stand is knocked down and easily assembled.

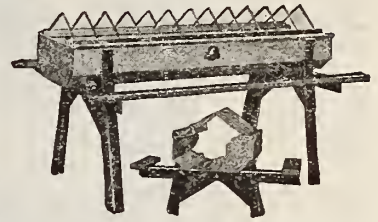

Shipping Weight Price Each Catalog Number

3 ft. Long Boy Feeder—Grid Guard...	14 lbs.	\$3.75	H2-93
6 ft. Long Boy Feeder—Grid Guard...	24 lbs.	5.50	H2-96
3 ft. Long Boy Feeder—Tumble Guard...	17 lbs.	3.75	H2-103
6 ft. Long Boy Feeder—Tumble Guard...	28 lbs.	5.50	H2-106

10-gal. HEATED FOUNT Float Controlled

Water flow controlled by positive copper float action. Screen in outlet keeps float action positive. Fount is constructed of heavy prime copper bearing steel. Strength and appearance greatly increased by heavy triple beads. The Cone top prevents roosting and lifts off to fill. A wide overhanging trough flange catches 90% of the water which usually drips from beaks to the floor. Drinking trough is 18 inches. 10 pint oil capacity burns 2 weeks. Efficient chimney burner or superior electric heater.

Shipping Price Catalog Weight Each Number

10-Gal. Float Fount only.....	15 lbs.	\$4.50	G2-1110
10-Gal. Electric Heated Fount.....	22 lbs.	8.45	G2-910E
10-Gal. Lamp Heated Fount.....	23 lbs.	7.50	G2-710



6 GALLON VACUUM FOUNT

An improved model. Lift off Outer can to fill. Equipped with handle for convenience in carrying and to prevent roosting—an appreciated feature. Positive lock holds together for easy handling. Improved shut-off valve stops flooding. Built of heavy copper bearing steel, reinforced with triple beads. 14-inch diameter trough—amply wide with wire rolled edge. Chimney equipped burner insures most satisfactory performance. Large oil bowl has capacity for three weeks operation. Guaranteed capacity.

Shipping Price Catalog Weight Each Number

6-Gal. Fount only.....	10 lbs.	\$2.95	G2-106
6-Gal. Electric Heated Fount.....	16 lbs.	4.95	G2-86E
6-Gal. Lamp Heated Fount.....	17 lbs.	4.25	G2-66



THE TOP-FILL INSOFOUNT

Top-Fill Insofount—Balsam Wool insulated—can be cleaned or filled by pulling off the outside can. Durable locking device holds Outer and Inner assemblies together for easy and safe handling. Wooden roller handle prevents roosting. Positive Spring Valve—exclusive trough when removing Drink all around.

Shipping Price Catalog Weight Each Number

3-Gallon.....	15 lbs.	\$4.25	G2-53
5-Gallon.....	18 lbs.	4.45	G2-55

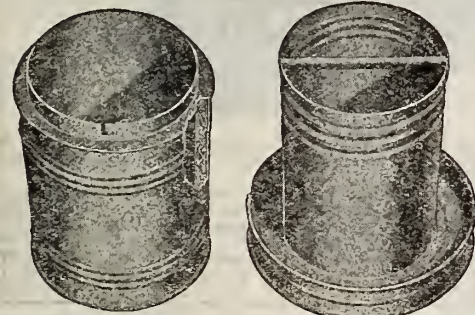

FLOAT FOUNTAIN

TOP FILL—10 QTS.

New fountain of most practical design. Built of heavy gauge galvanized steel. No clamps, no upset. Removable Cone Top comes off to fill. Handle provides for easy handling. Float can be locked to prevent flow.

Shipping Price Catalog Weight Each Number

6 to the carton.	4½ lbs.	\$1.65	G2-1
------------------	---------	--------	------



4-CUP INSOFOUNT

Has certain exclusive advantages because minimum water surface exposed makes it highly resistant to freezing. Will not spill, splash or overflow. Adequate drinking space. Space between cans packed with Balsam Wool—400% better insulation than ordinarily used. More easily handled with new outside bottom handle. Deep, triple rolled beads increase strength. Copper bearing steel throughout.

Shipping Price Catalog Weight Each Number

3-Gallon.....	14 lbs.	\$3.85	G2-33
5-Gallon.....	16 lbs.	4.45	G2-35



NEW MODEL "SPIL-PRUF"

Spil-pruf Stone Fount. Exclusive design eliminates splash. Easy grip ribs for handling. Glazed inside and out, with footed pan.

Shipping Price Catalog Weight Each Number

2 Qt. (24 in crate)...	7 lbs.	\$.45	S2-12
4 Qt. (24 in crate)...	9 lbs.	.60	S2-14
6 Qt. (18 in crate)...	12 lbs.	.75	S2-16

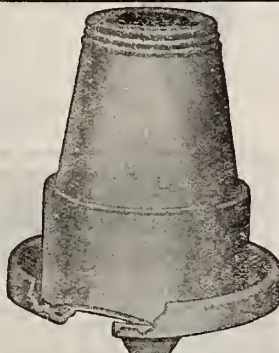

POULTRY LITTER

Imported from Germany; used largely in laying houses, will absorb moisture 8 to 10 times its weight. Better than straw or other litter for laying hens; will last 3 or 4 times longer than straw bales. \$2.75.

DREW POULTRY WATERER

NON-FREEZE TYPE

Fill waterers with hot water at night when chickens have gone to roost and water temperature will be just right in the morning. Warm water in winter—cool water in summer.

DB-519 Drew Non - Freeze Waterer, 2½-gallon capacity; weight 23 lbs. Price\$4.25

DB-518 Drew Non - Freeze Waterer, 4-gallon capacity; weight 32 lbs. Price\$5.40

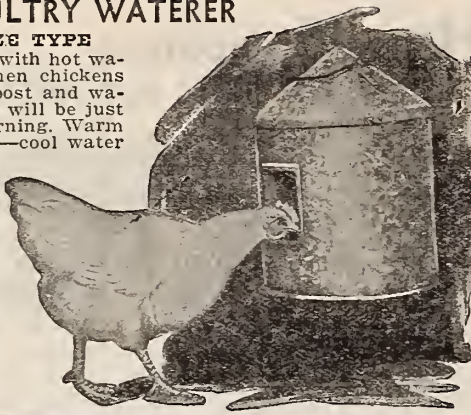

DREW CHICK TANK

This tank, 1½ gallon capacity, 100-chick size is built of heavy rust-resistant copper-steel, heavily galvanized. It is rust proof and sturdy—an ideal, large capacity waterer.

There are only two parts to this waterer—the bucket and the watering pan. It saves time and work in watering large flocks.

DB - 507 Drew Chick Tank; weight 6 pounds. Price\$1.25

DREW HANDY FEED SCOOPS



DB-542 Drew Handy Feed Scoop, 2-qt. capac.; wt. 1½ lbs. Price.....\$0.50

DB-544 Drew Handy Feed Scoop, 4-qt. capac.; wt. 2 lbs. Price\$0.75

DREW WATERER LAMP HEATED



A great waterer, 8 gals. capac. built of 26-gauge, hot-galv., copper bearing steel sheet. The drinking pan extends all the way around the waterer, allowing 10 to 15 birds to drink at one time.

The water level is controlled by a copper float

ALL-METAL LICE-FREE NESTS

Drew Line of Sanitary Nests.

The nest boxes are 11½ inches wide and 13 inches deep, with a 9¼-inch nest-hole, sufficiently large for average flocks.

Drew Trap Attachment with special double hinge, sure-drop construction as shown on DB-830

Nest Section above. Can be furnished if desired.

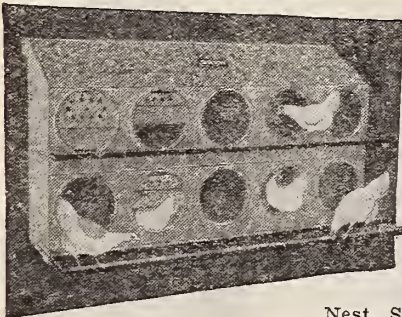

- DB-823C—Drew All Metal Nests, 3-hole section, weight 25 pounds. Price\$5.25
- DB-826D Drew All Metal Nests, 6-hole Double Tier Section, weight 35 pounds.....\$8.10
- DB-830D Drew All Metal Nests, 10-hole Double Tier Section, 55 pounds\$10.95
- DB-831A Drew Trap Attachments, weight 1 pound.....\$0.40

DREW POULTRY MASH FEEDER



Here is the greatest mash feeder on the market today — a real egg-maker and a big mash saver. It has a large egg-mash capacity.

The 50-pound size is equipped with a mash hopper 24 inches long, 22 inches deep. This size is designed to accommodate 75 hens.

The 100-pound size is similar in design and construction but is just twice as large in egg-mash capacity. Both sizes are made of the best galvanized steel and are of particularly sturdy construction.

- DB-870A Drew Mash Feeder; weight 40 pounds; capacity 50 pounds egg-mash\$10.20
- DB-871A Drew Mash Feeder; weight 60 pounds; capacity 100 pounds egg-mash\$13.80

This waterer will take care of 150 hens for a full day. The lamp is exceptionally well made and will burn for at least 90 hours without refilling.

For ease of cleaning there is nothing else like it, and in general it is the greatest value on the market in a heated waterer.

- DB-812 Drew Lamp Heated Waterer, with lamp and lamp base; wt. 21 lbs. Price...\$7.90
- DB-845 Stand for 8 gal. Waterer, wt. 20 lbs. Price\$1.50



Drew Droppings Board Scraper

The blade is of heavy galvanized steel, 18 inches long and 6 inches wide. The handle is 70 inches long.

DB-540 Drew Droppings Board Scraper, weight 5 pounds. Price.....\$1.25



Large capacity Drew Self-Feeders are for baby chicks and for chickens up to three months old.

- DB-862, 36-inch Feeder, 3-ft. size.....\$0.50
- DB-813, 12-hole Self Feeder, 13 inches long, wt. 1½ lbs...\$0.50
- DB-825, 24-hole Self Feeder, 25 inches long, wt. 2½ lbs...\$0.65

NESCO DRINKING FOUNTAIN

4 Quarts..... .40

BOTTOM FILL FOUNTAINS



The round taper shape prevents damage from freezing.

No. Capacity Each
19 1 Quart \$0.25
20 2 Quarts .30
24 1 Gallon .45

NO. 32 MOE'S STAR FOUNTAIN AND FEEDER

Made of a single piece of heavy metal. No solder, no seams, no loose parts. Suitable for feed as well as water. Little chicks cannot drown. Fits any Mason jar in 1 Pint, 1 Quart, and 2 Quart sizes.

No. 32 (Glass jar not included).
Each\$0.10
Dozen 1.20
Gross14.40
Packed 1 gross to case.



NO. 133 MOE'S STAR BUTTERMILK FEEDERS

Made of Bright Charcoal Tin Plate, which is not affected by milk acids. Makes an absolutely safe and sanitary feeder for buttermilk and sour milk.

Packed one gross in carton. Shipping weight, per gross, 35 lbs; per dozen 4 lbs.
No. 133 Star Fountain in Tin Plate.
Price, each\$0.10
Dozen 1.20
Gross 14.40

GEM CHICK FOUNTAINS

No. 158

A good, inexpensive fountain for chicks or grown fowl.
1 gallon55c
6 in box, 15 lbs.
2 gallons85c
6 in box, 18 lbs.



MOE'S TOP-FILL CLEANABLE FOUNTAIN

An inexpensive, cleanable fountain, suitable for chicks or grown fowl. Made of galvanized steel. Easy to fill and clean and the water feeds automatically; no valves; can be hung on the wall if desired. Capacity 2 gallons. Height 14 inches. Diameter of pan 1 1/2 inches. Packed 3 in a carton. Shipping weight, 13 pounds.

No. 40 Moe's Top-Fill Fountain,
Each.....\$1.75 Dozen.....\$19.80



WATER PANS

14 in.70c
16 in.80c



MOE'S TOP FILL CLEANABLE FOUNTAIN

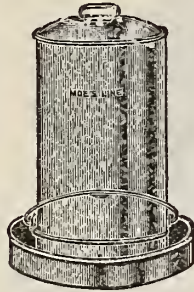

Made of heavy galvanized steel with double walls, which keeps the water cool in summer, and retards freezing in winter.

No. 33. Two gallons. Shipping weight 6 pounds. Each\$2.10

No. 34. Four gallons. Shipping weight 9 pounds. Each\$2.60

MOE'S TWIN CHAMBER FOUNT

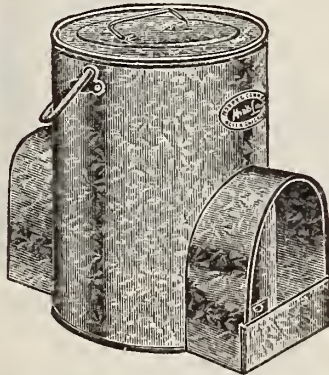

No. 97 Twin Chamber Fount, has two places to drink; capacity 3 gallons.
No. 97, price.....\$1.95

MASON JAR FOUNTAIN

No. 142. Mason Jar Fountain, made of tin, and is screwed on an ordinary glass jar.

Price, each..\$0.10
Dozen..... 1.20
(Glass jars are not included.)

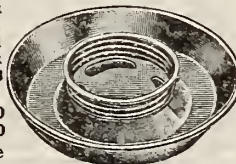

MOE'S WINTER FOUNTAIN

Capacity 5 and 10 Gallons

A simple and reliable fountain with heater. Made of heavy galvanized iron, easily filled, with nothing about it to get out of order.

Packed 1 to a case.



No. 75—Fountain and Heater, 5 gal.\$3.50
No. 78—Fountain only, capacity 10 gallons 2.65
No. 74—Tank only 1.75
No. 10—Heater only 1.90
No. 79—10 gal. Fountain and Heater 4.50

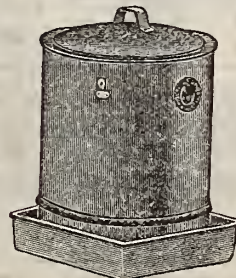

Moe's "Top Fill" Fountain
Automatic Feed
Easy to Fill and Keep Clean

1 Gallon..\$1.35
2 Gallons.. 2.10
4 Gallons.. 2.60
Packed 1 to case.

MOE'S INSULATED TOP-FILL CLEANABLE FOUNTAIN

Insulated Double Walls, Top and Bottom



In Winter. Fill with hot water (about 150 degrees). The hot water thoroughly heats the insulated walls, so freezing is retarded. In extremely cold weather it is advisable to add hot water about mid-day. The fountain should be emptied at night and refilled each morning.

In Summer. Fill with cool water, place in shady spot. Made in one size only. Capacity 4 gallons.

No. 54 Moe's Top-Fill Insulated Fountain, each\$4.50

MOE'S WINTER FOUNTAIN
Top Fill

No. 418 — Is our No. 34 High Grade Fountain with heater. Holds 4 gallons water. Diameter of pan 13 in. Total height 23 in. Shipping weight 13 lbs.

Price \$4.50, complete.



Drop Bottom Fountain

Drop bottom, easy to fill and to clean. May be hung on the wall out of the litter.

No. 40— 1/2 gallon 50c
No. 41— 1 gallon \$1.00
Packed 6 to case.
No. 42— 2 gals. \$1.25

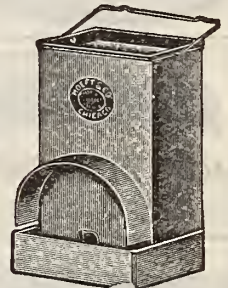

FEED AND DRINKING CUPS

GALVANIZED
Especially suitable for Exhibition Coops.
No. 61—Each\$.15
Doz. 1.80



MOE'S STEEL PAN

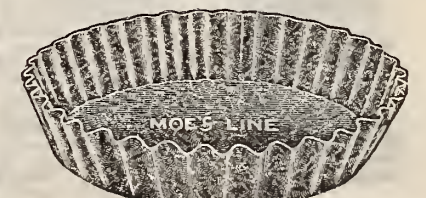

Diameter 17 in. Depth 3 1/2 in.
No. 195—Moe's Steel Pan. Each....50c

MOE'S FOUNTAIN AND BROODER HEATER

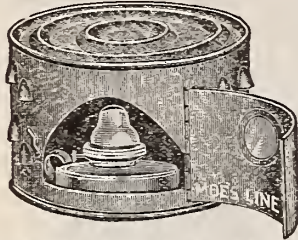

Can be used with all styles of fountains, and effectively prevents water from freezing.

The lamp fount or bowl holds sufficient kerosene to burn continuously for seven days. Simple and safe. Nothing to get out of order.

No. 10—Price, each.....\$1.90

MOE'S ADJUSTABLE MILK FOUNTAIN

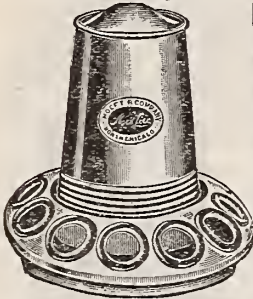

Magazine Feeder in Tin Plate. Adjustable up and down to feed slowly or rapidly, for any kind of milk or feed. Capacity about 2 quarts. Has 12 feeder holes.

No. 139. Magazine Tin Feeder. Each\$.65 Per doz... 7.80

Moe's Magazine Chick Feeder and Waterer



A new chick feeder and waterer with a magazine or container to hold a good quantity.

No. 18 2 Qts.\$5.00



MOE'S DIXIE CHICK FEEDERS

No. 460, 18 in. Long..... .20
No. 462, 30 in. Long..... .30

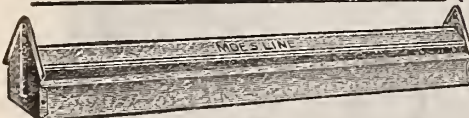

Moe's Swing Top Chick Feeders

No. 463, 3 ft. Long..... .65
No. 464, 4 ft. Long..... .90



DRY MASH HOPPERS

No. 35—Width 8 1/4 in.\$1.50 Packed 6 to case.
No. 36—Width 12 in.\$1.70 Packed 4 to case.
No. 13—Width 18 in.\$2.20 Packed 4 to case.
No. 37—Width 24 in.\$2.60 Packed 2 to case.

BABY CHICK FEEDERS

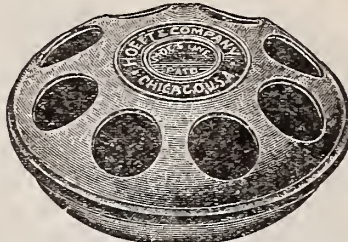

No. 11—Diameter 6 in., with 8 holes, each 10c. Packed 1 1/2 Gross to Case.
No. 12—Diameter 8 1/4 in., with 12 holes, each 20c. Packed 1/2 Gross to Case.

MOE'S PEERLESS FEEDER

For chicks and growing fowl. The magazine or hopper is adjustable and can be set to feed slowly or rapidly.

No. 192—Peerless Feeder. Diameter of base 12 inches. Adjustable magazine 30 feeder holes. Diameter of magazine 9 1/2 inches. Total height 12 inches. Capacity 10 quarts. Shipping weight 6 pounds. Each\$1.35 Per doz.....\$16.20

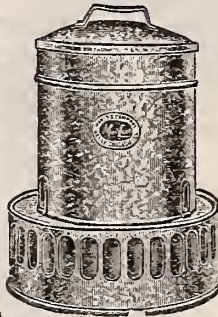

No. 193—Peerless Feeder. Diameter of base 12 inches. 30 feeder holes. Diameter of magazine 9 1/2 inches. Total height 18 inches. Capacity 18 quarts. Shipping weight 7 pounds. Each.....\$1.75 Per dozen.....\$21.00

Moe's Buttermilk Feeders

Made of Bright Charcoal Tin Plate, which is not affected by milk acids. Makes an absolutely safe and sanitary feeder for buttermilk and sour milk.

No. 131. Moe's Round Tin Feeders. Diameter 6 inches, with 8 feeder holes. Packed 1/2 gross in a carton. Shipping weight per gross 55 pounds; per dozen 5 pounds. Price, each 15c, per doz. \$1.80

No. 132. Moe's Round Tin Feeders. Diameter 8 1/2 inches, with 12 feeder holes. Packed 1/2 gross in a carton. Shipping weight per gross, 110 pounds; per dozen, 10 lbs. Each 30c, doz. \$3.60

Moe's Double Feeding Troughs



No. 58—12 in. Packed 24 to case...\$0.25
No. 59—18 in. Packed 12 to case... .35
No. 60—24 in. Packed 12 to case... .45
No. 76—36 in. Packed 12 to case... .60
No. 21—12 in., single row, 24 to case .30
No. 22—18 in., single row, 12 to case .40
No. 23—24 in., single row, 12 to case .50
No. 55—12 in., single row, 24 to case .25
No. 56—18 in., single row, 24 to case .35
No. 57—25 in., single row40

Moe's Eclipse Feeding Troughs



No. 27—10 in., Galvanized.....\$.20 Packed 24 to case.
No. 28—20 in., Galvanized..... .25 Packed 12 to case.



No. 137—10 inch, 10 holes. Packed 24 to case. Each.....25c. Doz.....\$3.00
No. 138—20 inch, 20 holes. Packed 12 to case. Each.....35c. Doz.....\$4.20

MOE'S INTERMEDIATE CHICK FEEDER



For small chicks, growing fowl and hens. 32 inches long. Holds 12 quarts. No. 154—Each..\$1.20 Per doz..\$14.40

Tin Plate Buttermilk Feeder

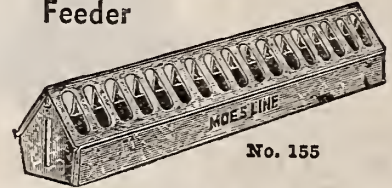

Same as No. 154, but can be used with buttermilk. Each \$1.75.

MOE'S OAT SPROUTER

Steel frame, well braced and painted. With six heavily galvanized iron pans which are interchangeable. Provides the very necessary green feeds at all seasons.

Total height 3 feet. Size of pans 16x18 in. No. 110—Oat Sprouter. Each\$5.50



MOE'S WIRE GUARD IRON FOOT FEEDER

The trough rests securely on the stand, but can be removed.

No. 355—Complete with stand and guards, 5 feet long.....\$4.75
No. 356—Trough only with wire guard, no stand.....\$ 3.00



GRIT and SHELL BOXES

No. 45—Two compartments. Packed 12 to case.....\$.40
No. 9—Three compartments. Packed 6 to case..... .75
No. 90—Four compartments. Packed 6 to case..... 1.00

Heavy Tin Buttermilk Feeders

Feeding Troughs in Tin Plate. Sliding Top. Easy to clean. No seams, rivets or solder. Clean, sanitary feeders. Each.....25c. Doz.....\$3.00
No. 137—10 inch, 10 holes. Packed 24 to case. Each.....25c. Doz.....\$3.00
No. 138—20 inch, 20 holes. Packed 12 to case. Each.....35c. Doz.....\$4.20

MOE'S BIG BOY FEEDER

A Feeder especially designed for growing stock—three or four-week-old chicks—and up to full-grown mature fowl.

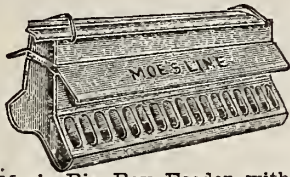

No. 160—Moe's Big Boy Feeder with sliding cover. Shipping weight 16 lbs. Each \$3.50
No. 161—Moe's Big Boy Feeder with wide adjustable rain cover. Covers project 5 1/4 inches on each side. Shipping weight 18 lbs. Each \$4.25

MOE'S TRAP NEST FRONTS

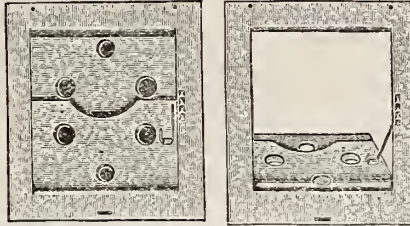

Can be easily fitted to any orange or ordinary wood box or coop and gives the breeder the opportunity to use a size nest adaptable to his birds. Dimensions—11 ins. wide by 12 ins. high; 12 to case.
No. 63 Trap Nest Front...Each 50c; doz. \$6.00.

CEL-O-GLASS

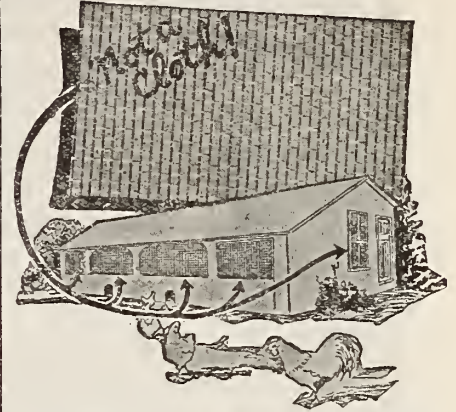

CEL-O-GLASS is made of coarse mesh galvanized wire cloth, treated in such a manner that the spaces between the strands are filled with a clear, translucent, tough, flexible substance that will not rub off, peel, or become brittle.
Prices: 3 feet wide, per running foot, 42c
 100 foot rolls, per foot.....40 1/2c

MOE'S LARGE CAPACITY FEEDER

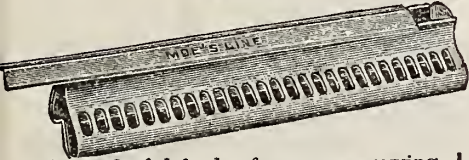

A wonderful feeder for young growing stock, and a great time and labor saver when chicks are raised in large numbers. Made of heavy galvanized iron in two sizes, both with a large capacity. Sliding top cover, easy to fill and clean, and the birds cannot roost on the cover or side to foul the feed.

No. 140—Feeder, capacity 10 quarts, length 21 ins., width 8 1/2 ins., height 7 ins. 16 openings on each side, so that 32 chicks can feed at one time. Each \$1.00
No. 141—Feeder, capacity 17 quarts, length 35 ins., width 8 1/2 ins., height 7 ins. 27 openings on each side, so that 54 chicks can feed at one time. Each \$1.50

Extra Hopper for Large Capacity Feeder
No. 146—Hopper for No. 140 Feeder, each 45c; doz. \$5.40. Packed 6 to case.



No. 148—Hopper for No. 141 Feeder, each 65c; doz. \$7.80. Packed 4 to case.

WIDE RAIN COVERS

No. 147 for No. 140 Feeder, each 30c; doz. \$3.60. Packed 12 to case.
No. 149 for No. 141 Feeder, each 45c; doz. \$5.40. Packed 12 to case.

WATER GLASS

Put up expressly for packing away eggs during the summer months. Use 1 part Water Glass to 9 parts of water. At a cost of only one cent a dozen, you will be able to have your own eggs.
Price: 1-qt. can.....\$0.30
 1-gal. can 1.00
 5-gal. can 4.00

MOE'S MAMMOTH DRY MASH HOPPER

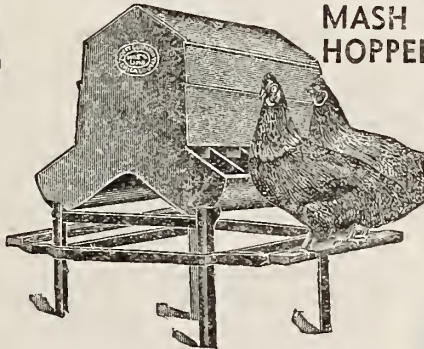

A large capacity hopper built on correct principles. Made of heavy galvanized iron. The stand is of heavy angle iron, painted, and has wooden bars for the poultry to rest on when feeding. Length of hopper 35 ins., width 21 ins., height 18 1/2 ins. Capacity, 100 lbs. Height of stand, 15 1/2 in. Total height 34 1/2 ins. Packed one in a box. Shipping weight 50 lbs.
No. 3 Hopper and Stand complete, price, each\$10.00

AUTOMATIC WATER VALVE

Valve is threaded for 1/4 in. iron pipe. The wire hook holds the float up while pan is being cleaned or removed.
No. 30—Automatic Valve and Float only. Packed 12 in a carton. Shipping weight 6 lbs. per dozen, 10 oz. each.
Price:
 Each \$1.00
 Dozen .. \$12.00

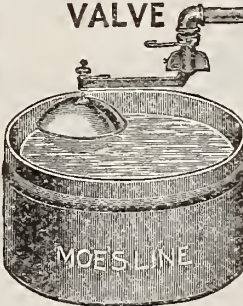

GLASS CLOTH

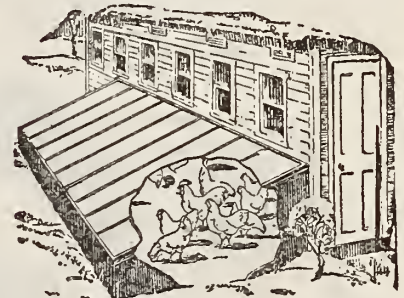

Much Cheaper Than Glass

is a strong fabric treated by a patented process to make it transparent and waterproof. It admits abundant light. The popularity of GLASS CLOTH has been sensational.
Price: 1 yard (9 sq. ft.).....\$0.35
 5 yards (45 sq. ft.)..... 1.50
 10 yards (90 sq. ft.)..... 3.00
 15 yards (135 sq. ft.)..... 4.25
 50 yards (450 sq. ft.).....15.00
 100 yards (900 sq. ft.).....30.00

WINDOW FABRIC

SUBSTITUTE FOR GLASS

Transmits Violet Rays

1 yard\$0.30
 5 yards 1.25
 10 yards 2.50
 50 yards12.50
 100 yards24.00

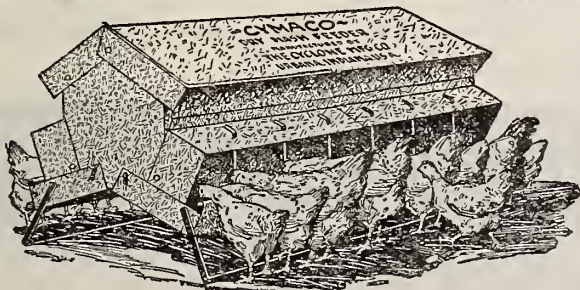

"CYMACO" DRY MASH FEEDERS

The CYMACO feeder is made of the best galvanized steel with enamelled steel legs to hold the feeder off the ground. The flow of the feed may be regulated by means of two thumb screws at either end of the feeder. Agitators are worked automatically by the fowls while feeding. The CYMACO accommodates twice as many hens as the ordinary hopper feeder. CYMACO is provided with a catch tray which prevents waste of feed and provides a means to close at night.
No. 12, capacity 1/2 bu., shipping weight 11 lbs., each \$2.00

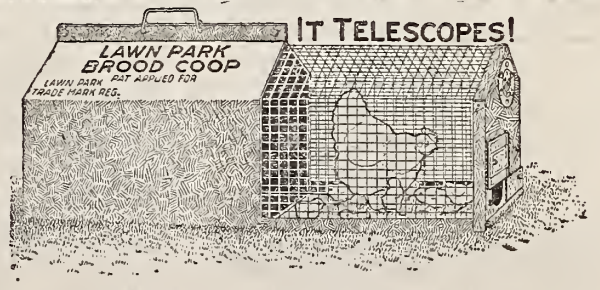

THE LAWN PARK COOP

It is made entirely of galvanized material, will not rust and is proof against all chick enemies. The body of coop is made from strong 28 gauge galvanized steel, the wire park is made from heavy 1/2-inch mesh galvanized wire screen. The Lawn Park is large and roomy, being 18 inches wide, 19 1/2 inches high, and 24 inches long, with park closed; and 48 inches long with park extended.
Price, each.....\$3.50 6 for.....\$20.00
 Coop without Park, each \$1.50, 6 for \$9.00

Pratts BUTTERMILK BABY CHICK FOOD



is appetizing, harmless, wholesome, non-stimulating, highly digestible, clean, low in moisture, high in quality, always uniform and complete in every element needed for bone, muscle, feathers and health. Pkgs. 25c and 50c.
MONEY CAN BUY NO BETTER
 100 lb. bags, 50 lb. bags, 25 lb. bags, 10 lb. bags, 5 lb. bags.
 Write for Prices

PRATTS BUTTERMILK GROWING MASH

It produces more pounds of weight on less food. So skillfully and thoroughly processed that all dust, hulls, or other foreign particles are removed. Every ounce is solid food that will build muscle, bone, nerve, feathers, and health. 100 lb. bags.
DIGESTIBLE APPETIZING ECONOMICAL
 Write for Prices

PRATTS BUTTERMILK LAYING MASH

This remarkable mash is the standard by which all others are judged. Not alone theoretically right but proven by practical test to be the greatest "egg producer" ever made. There is a good reason for every ingredient in this splendid mash. Pratt's Buttermilk Laying Mash produces more eggs at less cost per dozen and gives greatest profits.
 Victory and Supreme, 100 lb. bags.
 Write for Prices

PRATTS LARGE SCRATCH FEED

Gives such splendid results. Made only of the best of plump, sweet, well-seasoned grains—it is the very acme of quality and gives the maximum of results.
EVERY SINGLE GRAIN OF PRATTS IS REAL FOOD
 Victory and Utility, 100 lb. bags.
 Write for Prices

PRATTS CHICK SCRATCH FEED

Pronounced by authorities everywhere to be the finest, cleanest, purest, most economical and highest quality chick scratch ever offered to the public.
BRAINS CAN THINK OF NO BETTER, WE CAN MAKE NO BETTER, YOU CAN BUY NO BETTER, CHICKS CAN WANT NO BETTER.
 Every ingredient is of the highest quality, carefully cracked and processed and repeatedly cleaned to free it of all dust, hulls, flour or other useless or wasteful parts. Contains no large pieces that might choke the chicks.
 Victory, 100 lb. bags.
 Write for Prices

PRATTS INTERMEDIATE SCRATCH OR DEVELOPING FEED

Never in your life have you seen such a splendid scratch feed. Clean cut, uniform in size, attractive in variety and appearance, free from every particle of dust, hulls, chaff, weed seeds, or foreign materials, perfectly milled and mixed. Pratts Intermediate Scratch Feed is the envy and despair of other feed makers and the delight of the chickens.
 Victory, 100 lb. bags.
 Write for Prices



BLATCHFORD'S CALF MEAL, DOUBLED FARM PROFITS

Maturing or vealing all your calves rapidly on Blatchford's Calf Meal, at a cost of about one-fifth of what you get for your milk, then selling all the milk at a good profit, should appeal to you and to every wide-awake farmer as a good, profitable proposition. These profits both ways, need not be guessed at; they are discernible at a glance. Another source of profit that heretofore has been overlooked by most farmers is the raising of the fall and winter calf on this same milk-substitute. Many farmers and dairymen have taken up winter dairying, reaping the extra big profits on milk and cream during the winter months, but often the calf has been immediately "murdered." Calves raised during the winter give you veal during the term of high prices and are just as easily raised then as during the summer. Fall "freshening" is greatly to be desired. With the help of the silo or an abundance of alfalfa hay the winter feeding keeps up the milk supply until the new grass comes in the spring. The new pastures stimulate the milk-flow and keep it up through the summer. The winter milk prices more than offset the cost. When you stop to consider that this complete milk substitute costs you less than skim milk and is far better for calf-raising—made expressly for the calf—you will get some idea of its high efficiency. It is made from the several kinds of whole grains and seeds, and includes oil, sugar and albuminous compounds, pure locust-bean meal and pure flaxseed ground, with the oil left in. You cannot begin to get the results from any other method of calf-raising that you can get from feeding Blatchford's Calf Meal, the complete milk equal. **PRICES:** 25-lb. bag, \$1.25; 50-lb. bag, \$2.40; 100-lb. bag, \$4.50.

BLATCHFORD'S CHICK MASH

IT GIVES THE CHICKS A CHANCE
 Many poultrymen lose from one-third to one-half of all their chicks before they feather out. Improper feeding is the cause. Others are finding they can raise 90 to 95 per cent. of their chicks by starting and growing them on Blatchford's Chick Mash. It is the favored starting and growing feed of the most prominent and successful poultrymen in the country. It contains all the feeds and nourishment chicks need right from the start and shields them from **White Diarrhea, Bowel Trouble and Leg Weakness.** 10 lbs., 40c; 25 lbs., 90c; 100 lbs., \$3.25.

BLATCHFORD'S "FILL THE BASKET" EGG MASH

The excess nutriment taken by the hen from Blatchford's "Fill the Basket" Egg Mash causes the development of eggs so that she has to lay during the winter, while the ordinary unbalanced rations tend to produce fat hens, but lean profits.
 Blatchford's "Fill the Basket" Egg Mash is made up of Blatchford's Calf Meal, the complete milk-equal, combined with the best quality meat and fish scraps and alfalfa and grain meals. This makes a perfect, balanced egg-producing mash, consisting of protein, 19 per cent; fat, 4 per cent; fiber, 10 per cent.
 25 lb. bags....75c 100 lb. bags....\$2.75

BABY CHICKS

Bred to lay from big, healthy stock. We start shipping about March 1st, and will continue until June 1st.
 We will commence booking orders in February for future shipment, so, send in your order early to get prompt service.
 Owing to the perishable nature of Baby Chicks, we ask orders to be accompanied with cash or money-order.
 Prices for March subject to change without notice, in the following strains, only:

	25	50	100
SINGLE COMB WHITE LEGHORNS.....	\$3.75	\$7.50	\$14.00
SINGLE COMB BROWN LEGHORNS.....	3.75	7.50	14.00
BARRED PLYMOUTH ROCKS.....	4.00	8.00	15.00
RHODE ISLAND RED.....	4.00	8.00	15.00
BLACK MINORCAS.....	4.00	8.00	15.00

APRIL and MAY prices\$1.00 per 100 less than above
 All prices prepaid by parcel post and subject to change without notice.
 All orders for Baby Chicks, subject to our confirmation. Kindly send cash or money-order with your orders, please.



PRATTS POULTRY, HORSE AND CATTLE REMEDIES

PRATTS ANIMAL REGULATOR



Intelligent, humane and prudent owners of horses, cows and other livestock realize the value of good tonics, regulators and remedies. For nearly half a century Pratts has been adding to its successful record.

Packages: 25c., 50c., \$1.00
 25-lb. pails.....\$3.00
 100-lb. drums.....10.00

Keep your cows thrifty while forcing milk production, without increased cost for feeding or care by giving them



PRATTS COW TONIC

Promotes healthy appetite, good digestion, increased vigor, greater milk production. A wonderful all-around tonic. 50c.

PRATTS RED MITE SPECIAL

An effective liquid for exterminating the blood-sucking mites. To be sprayed or painted on roosts, dropping boards, nests, and other places where mites hide. Use these preparations regularly.



PRATTS RED MITE SPECIAL
 1 qt., 60c.; 1/2 gal., \$1.00;
 1 gal., \$1.60.

PRATTS DIP AND DISINFECTANT



Three times as powerful as crude carbolic acid. A sure deodorizer, germicide and liquid lice killer. Use it in Roup, Colds and other contagious diseases.

1/4 gallon.....\$.60
 1/2 gallon.....1.00
 1 gallon.....1.60

PRATTS COD LIVER OIL



Vitamin Tested for Poultry and Stock.
 1 gallon.....\$2.25
 5 gallon.....10.00
 30 gallon.....45.00



UDDER HELP
 Udder - Help contains pure animal fats which are more easily and naturally absorbed by the pores of the skin than most ointments having a mineral oil base.

Udder-Help is a superior all-purpose ointment for livestock. Its antiseptic and soothing properties and tendency to penetrate make it useful for cuts, bruises, sore and chapped teats and congested udders. (Surface wounds should be first washed out with a strong B-K dilution.)
 8-ounce.....50c 1-pound.....90c

HEALTHY HENS AND LOTS OF EGGS

You may expect vigorous, laying, paying birds when you give them

PRATTS POULTRY REGULATOR

daily. It contains just those elements needed to keep poultry in perfect health. Both a tonic and digestive. Prevents common poultry ailments. Produces growth, gives increased vitality, and hastens maturity. Makes pullets early and constant layers.

Packages: 25c. and 50c.
 12-lb. Pkg., \$1.40; 25-lb. Pail, \$3.00; 25-lb. Bags, \$2.60;
 100-lb. Drums, \$10.00.



PRATTS POULTRY WORM POWDER

Worms in poultry are one of the greatest menaces to the poultry raiser. There are a number of kinds of worms that infest poultry, sapping their vitality, reducing their egg-laying capacity. Pratts Worm Powder will greatly aid your flock and put them on a laying, paying basis.

Packages: 50c. and \$1.00
 12-lb. bags, \$1.90; 25-lb. bags, \$3.60;
 100-lb. bags, \$12.00.



PRATTS POWDER LICE KILLER

25c. and 50c.

Effective, non-poisonous, non-irritating. May be used wherever a powder is suitable. A splendid deodorizer. Will kill lice on horses, cattle, dogs or cats.

PRATTS SPECIAL COMPOUND

For indigestion, sour crop, and bowel troubles commonly called "cholera."

PRATTS SPECIAL COMPOUND is unequalled. Easy to use and very effective. Successfully used all over the world.

Packages: 50c.

PRATTS CHICK TABLETS



(Formerly called "Pratts White Diarrhea Remedy")

It is only necessary to give this remedy in the drinking water from the first drink. This remedy has saved many dollars worth of chicks to poultry raisers. You can depend on it.

25c. and 50c.



FLY SPRAY

Knox Out Spray is a product of the General Laboratories, Inc., makers of B. K. It is of the highest grade and very effective.

The 5-gallon container is an improved Easy Pour can making it very convenient to use.

1 gal. can..\$1.50 5 gal. can..\$6.75

PRATTS GAPE COMPOUND

PRATTS GAPE COMPOUND is an effective guaranteed treatment. For external administration—safe, sure, and gives quick relief.

Packages: 50c.

PRATTS N-K TABLETS

For Worms in Poultry



N-K TABLETS contain Nicotine and Kamala in the proper therapeutic dose. These two vermifuges are most highly recommended by all leading authorities.

PRATTS N-K TABLETS have an airtight, insoluble coating which keeps the contents fresh indefinitely. This coating is not dissolved by water, air does not penetrate through it.

When the tablet is given to the bird, it passes unchanged through throat, crop and glandular stomach until it reaches the gizzard, where it is broken, and the fresh, powerful drugs released directly into the worm-infested intestines.

Adult Size
 50 Tablet Pkg.....\$1.00
 100 Tablet Pkg.....1.75
 500 Tablet Pkg.....7.00
 1000 Tablet Pkg.....12.00

Chick Size for Birds under 4 lbs.
 50 Tablet Pkg.....\$.65
 100 Tablet Pkg.....1.00
 500 Tablet Pkg.....4.50

PRATTS R-P POWDER AND TABLETS



Tablets or Powder: 25c., 50c.

Contains remedies which are quickly absorbed, purify the blood and reduce fever. Pills are convenient for individual treatment. Many poultrymen use this remedy the year round as an effective preventive.

OLD HICKORY SMOKED SALT

Old Hickory Smoked Salt improves keeping qualities because the smoke on the salt is available when its preservative help is most needed and best utilized. The smoke permeates the meat while the other curing ingredients are being absorbed—resulting in perfect blending of all the flavors throughout every tissue and developing uniformly throughout the meats that delicious, genuine hickory wood flavor everybody likes.

Package, about 10 pounds.....\$1.00

DR. HESS POULTRY PAN-A-MIN



It is now a greatly improved product. More minerals have been added. It contains new medicinal ingredients, and other active ingredients in different proportions. The improved product has been given a new name. Pan-a-Min is of high value to moulting hens, in egg production, in reducing chick mortality, in bone and feather growth, and in maintaining health. It does not take the place of feed and no feed can take the place of Pan-a-Min. The cost is less than a penny per hen per month.

1½-lb. pkg., 25c; 3-lb. pkg., 50c; 7-lb. pkg., \$1.00; 15-lb. pkg., \$2.00; 25-lb. pkg., \$3.00; 100-lb. pkg., \$10.00.

DR. HESS POULTRY VER-MI-TROL



No individual handling of birds is necessary. It is simply given with the feed in two ten-day courses, three weeks apart. It is not drastic, does not throw hens or pullets off production and does not interfere with growth and development of young birds. As a preventive measure to avoid worm infestations, a twice-a-year flock treatment, early Summer and late Fall, is strongly recommended.

1½-lb. Pkg., 25c; 3-lb. Pkg., 50c; 4-lb. Pkg., \$1.25; 10-lb. Pkg., \$2.75; 25-lb. Pkg., \$6.25.

DR. HESS CHICK TABLETS

(Formerly White Diarrhea Tablets)

Most diarrhea conditions in chicks often mistaken for bacillary white diarrhea, are results of improper feeding or brooding, and can be corrected by Dr. Hess Chick Tablets. These tablets are a bowel stringent to be given in drinking water. Once the tablets are in solution, they remain so indefinitely. Packages.....50c and \$1.00

DR. HESS POULTRY TABLETS

(Formerly Roup Tablets)

While there is no absolute cure for roup, Dr. Hess Poultry Tablets are of high value in treating locally the swellings incident to the disease. The tablets are used as a local antiseptic and to medicate the drinking water. Thus used, they aid in preventing spread of the disease. Pkgs. 50c and \$1.

SAL-VET

SAL-VET is a medicated salt—a safe, simple, inexpensive remedy which gives stock the medicines they need along with the salt they crave. It requires no dosing, no drenching, no starving. It goes into the stomach and intestines and loosens the leach-like hold these blood-sucking parasites have on the tender linings. It drives the robbers out—without bother or trouble to you. Your animals eat SAL-VET in place of common salt and thus doctor themselves.

A SINGLE WORM-INFESTED HOG IN YOUR HERD IS A CONTINUAL MENACE TO YOUR HOG PROFITS

It is the worm-infested, half-starved animals that spread the deadly worm-curse over your farm. They are disease-breeders and disease-carriers of the worst kind. Helpless themselves to resist contagion, they let down the bars to the cholera scourge and death stalks through your herd. They are the danger spots in every herd.

10-lb. packages "Sal-Vet"at \$ 1.00 each
 25-lb. packages "Sal-Vet"at 2.00 each
 100-lb. kegs "Sal-Vet"at 6.75 each
 200-lb. barrels "Sal-Vet"at 12.00 each

BLACKMAN'S SALT BRICKS

Easiest and best way to give medicine to stock. It salts them too.

Blackman's Medicated Salt Brick, originated by a noted Veterinary Surgeon, insures stock getting the needed medicine without trouble or loss of time to their owners. When dropped in the feed-box, the brick is licked by the animal as needed, just as people use salt with their meals. Contains Copperas for Worms, Sulphur for the Blood, Saltpetre for the Kidneys, Nux Vomica, a blood tonic, and Pure Dairy Salt. It is a wonderful improvement over the old plan. Why not try it?

DOZEN\$3.00

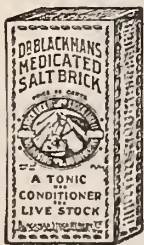

DR. HESS STOCK TONIC

This product has been serving the dairy interests of this country for upwards of thirty-five years. A summary of many improved tests covering three whole years shows that cows receiving Dr. Hess Stock Tonic produce on the average 54% more profit than cows not getting the Tonic. The Tonic has been recently improved in keeping with latest scientific discoveries and feeding practices. All the minerals proved necessary to the heavy producing dairy cow have been added. Pkg., 50c.; 5-lb. Pkg., 75c.; 15-lb. Pkg., \$2.00; 25-lb. Pkg., \$3.00; 100-lb. Pkg., \$10.00.



DR. HESS HOG SPECIAL

A conditioner and mineral supplement for hogs only. Dr. Hess Hog Special is an appetizer, laxative and diuretic—also a perfectly balanced mineral supplement. It supplies in all-sufficient quantities every mineral necessary for the hog's growth and thrift. Hog Special makes possible common sense worm control. It is given in the feed. No fasting or individual dosing is necessary. It greatly retards worm reinfestation. The cost of using Hog Special is only 12½c per hog per month. Pkg., 50c.; 15-lb. Pkg., \$2.00; 25-lb. Pkg., \$3.00; 100-lb. Pkg., \$10.00.

DR. HESS ANTISEPTIC POWDER

A ready help in emergencies—deserves a place on every stable shelf. For treatment of wire-cuts, scratches, galls and wounds. Quickly forms coating over wound and starts healing. Package.....25c

INSTANT LOUSE KILLER

Kills Lice on Poultry, Horses, Cattle, Sheep Ticks, Bugs on Cucumber, Squash and Melon Vines, Cabbage Worms, Slugs on Rose Bushes, etc. Sold in sifting-top cans—look for the word "Instant" before buying. Price: 1 lb. 25c.; 2½ lbs. 50c. GUARANTEED



Dr. Hess Dip and Disinfectant

One Gallon of Dip makes from 70 to 100 gallons effective solution. Spray it on roosts. Sprinkle it over the runs and in all cracks and crevices. Makes a splendid dip for hogs and sheep. It's a sure parasite and disease germ destroyer. Purifies stables, troughs, sinks, drains. 1 qt. 60c, ½ gal. \$1.00, 1 gal. \$1.75. 5-gal. can \$8.25, 50-gal. drum, per gal., \$1.25.



BOURBON REMEDIES

Bourbon Poultry Remedy—A few drops in fowls' drinking water cures and prevents white diarrhoea, cholera and other chick diseases. Use daily to keep your chicks healthy. Don't wait until disease strikes. Get it today.

Bourbon Poultry Remedy, trial bot. \$.60
 Bourbon Poultry Remedy, ½ pt. bot. 1.00
 Bourbon Poultry Remedy, pt. bottle 1.50
 Bourbon Poultry Remedy, qt. bottle 2.25
 Bourbon Poultry Remedy, ½ gal. 3.50
 Bourbon Poultry Remedy, gal. size 6.00
 Bourbon Hog Remedy, quart size 2.25
 Bourbon Hog Remedy, ½ gal. size 3.50
 Bourbon Hog Remedy, gal. size 6.00

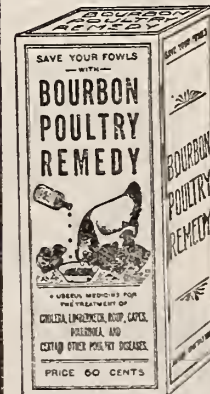

SODIUM FLUORIDE

Sodium Fluoride for lice is the method recommended and endorsed by the United States Department of Agriculture, by Purdue University and most other leading agricultural colleges and experiment stations everywhere.

other leading agricultural colleges and experiment stations everywhere.
 ½-pound box, with sifter top.....35c.
 1-pound box, with sifter top.....65c.

ROUP-OVER

A wonderful, new, prompt and positive treatment for Roup, Canker and Colds in Poultry.

Roup works fast. It usually begins with a cold; after that the disease progresses rapidly. Roup is one of the most serious of poultry diseases. Stop it quickly with Roup-Over.
 Large Bottle\$.50 Extra Large Bottle.....\$1.00



**BY USING
KOW-KARE
THE GREAT COW MEDICINE**

the milk. It is a medicine for cows only. Prices, small size, 65c.; large size, \$1.25.

BAG BALM

For all diseases of the cow's udder and teats there is no remedy so quick and certain in its curative powers as **Bag Balm**. It is a soothing, penetrating ointment, especially adapted for all those serious and annoying troubles known as caked bag, cow pox, chapped, cracked and sore teats, bunches, chafing and inflammation of all kinds. **Bag Balm** penetrates through the skin and inner tissues at once, reaching the glands, where it reduces the inflammation, breaks up the bunches and spreads its cooling, softening effect to all the affected parts. This remedy has met with unequalled success, and is found on the most progressive farms in the country. Price60c.

BONE MEAL FOR POULTRY

This is exactly the same as the Cracked Bone described below, only it is ground much finer. 5 lbs. 25c, 10 lbs. 40c, 50 lbs. \$1.50, 100 lbs. \$2.75.

CRACKED BONE FOR POULTRY

This article is manufactured from fresh, clean bones, and is perfectly pure and sweet. We carry two sizes—No. 1 for grown fowls, and 2 for young chicks. 5 lbs. 30c, 10 lbs. 50c, 50 lbs. \$2.25, 100-lb. sack \$3.75.

CRUSHED OYSTER SHELLS

It aids digestion as well as supplying lime. No. 3 for young chicks. 5 lbs., 15c. 100 lbs., \$1.00. 500 lbs., \$4.50. Special prices in larger quantities.

POULTRY GRIT

5 lbs. 15c, 100-lb. sacks \$1.00, 500 lbs. \$4.50.
(Poultry, Pigeon and Chick Sizes.)

FINE, MEDIUM AND COARSE CHARCOAL

A little ground charcoal mixed with the soft feed in the morning, once or twice a week, is an excellent corrective for the fowls, and keeps them healthy. We carry three sizes, one for grown fowls, one for small chicks, and pulverized. 5 lbs., 35c; 10 lbs., 60c; 25 lbs., \$1.25; 50-lb. sack, \$2.00; 100 lbs., \$3.00.

G. & T. CO.'S HIGH GRADE PURE MEAT SCRAP OR MEAT MEAL

45 and 50 per cent Protein

This Meat Scrap is the highest possible grade, and is made from Pure Meat trimmings and cracklings. It is fully guaranteed as to quality and will keep indefinitely. Price: 5 lbs.....25c 100-lb. bags\$2.25



White Diarrhoea and Chicken Cholera can be cured and prevented by **AVICOL**.

STOP THE LOSSES!

AVICOL SAVES THE CHICKS—Avicol has a specific and selective action on the germs causing Cholera and White Diarrhoea. It knocks the germs and gives the chick a chance. Prices.....50c. and \$1.00

HACKETT'S GAPE CURE

CURE FOR CHICKEN GAPES

No drugging; simply confine the chicks and dust the powder over them; they inhale it; kills both worm and germ; treat the whole brood at once in less than five minutes. Package, 40c. Postage on single package, 5c. extra.

Watch every cow, and at the first sign of disorder in appetite, digestion or flow of milk, give a dose of **KOW-KARE**. Carefully follow the directions as given on the box, and that cow will get well.

KOW-KARE is in powder form, to be given in regular feed. It cures abortion, barrenness and scours, caked udder, removes retained afterbirth, purifies the blood, strengthens the appetite, vitalizes the nerves and prevents disease. It increases

AMERICAN HORSE TONIC

This tonic is a specific for horses, an actual medicine that goes to the root of all horse ailments and removes the cause of the trouble. A few doses will send a dull, listless horse on its way rejoicing.

Its curative power is wonderful. **AMERICAN HORSE TONIC** is the best remedy known for worms, stoppage of water, all bowel complaints, inflammation of the lungs, recent founders, distemper, coughs, colds and swelling of the glands of the throat. Small size, 35c.; Large Size.....65c.

HORSE COMFORT

The Most Remarkable Remedy Ever Compounded for Healing Cuts and Open Sores of Every Kind. **HORSE COMFORT** is a liquid preparation which is unequaled in its power to quickly cure all kinds of open sores or abrasions of the skin. It is used by simply wetting the sore spot. No bandages or filthy rags, no rubbing or heating it in. Simply wet the spot and the cure begins. Price per bottle, 35c. and 65c.

POKE ROOT COMPOUND

This compound recommended for internal use in treating garget, caked bag and similar udder conditions. Price Per Can.....65c.

SPRATTS DOG CAKES

These remedies have been on the market for fifty years, and are sold in most every country in the world. In offering them for sale we recommend them as being the best in their line, and properly used will give satisfactory results.

We do not list but a few of the various remedies of this standard make and if you desire any of those we do not list, we will be glad to get them for you.

Spratt's Dog Cake, the standard dog food used at the different kennels and dog shows throughout the world. Prices, small carton, 20c.; medium carton, 40c.; large carton, 75c.; 25-lb. boxes, \$3.25; 50-lb. boxes, \$6.35; 100-lb. boxes, \$12.50.

THE GIZZARD CAPSULE

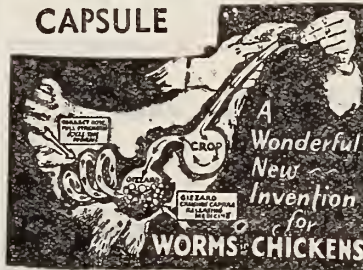

More than 75% of all chickens are infested with intestinal worms, according to poultry authorities—worms which rob a fowl of its food, lower vitality, decrease egg production, retard growth—rob you of your poultry profits.

The **GIZZARD CAPSULE** will quickly rid your chickens of both tape worms and round worms. Five times as effective as worm remedies given in food or drink. Why? The **GIZZARD CAPSULE** is insoluble and carries the medicines intact to the gizzard where it is taken like a grain of corn, releasing the medicines into the worm infested intestines in full strength and undiluted.

As easy to administer as giving a pill. Suitable for chicks at 10 weeks (2 lbs.) to full grown. Don't feed worms. Stop this waste and increase your profits. Give **GIZZARD CAPSULES** now. Satisfaction guaranteed or money refunded. 50 Capsules \$1.00; 100 Capsules \$1.75; 500 Capsules \$7.00.

DON SUNG

TABLETS FOR EGG LAYING—Scientifically compounded to make a balanced tonic and regulator for hens and to stimulate egg laying. A concentrated Medicine—no filler. Price 50 cents and \$1.00 Packages



COLIVEROL

Is unsurpassed as a Tissue Building Food for Poultry and Livestock. It retains all the vitamins of Cod Liver Oil, when mixed with mash, longer than pure cod liver oil itself.

Price: 1 pound.....\$0.40
2 pounds75
5 pounds 1.75

POULTRY LITTER

Used with great success by leading poultrymen instead of straw and shavings.

It absorbs all moisture, retains the ammonia and keeps dampness down in the laying house. One or two applications a season will give great results. Price, per bale.....\$3.00



ORIOLE GARDEN HOSE

LONG LASTING—FLEXIBLE—WILL NOT KINK



The rubber used in its construction is a high grade stock that will not rapidly deteriorate with age. The rubber lining or tube is made seamless and ample strength is given the hose by a braided cotton jacket directly applied by a special machine. The hose is protected against external wear by a tough, resilient, rubber cover.

3/4 inch, per foot.....\$12
 1/2 inch, per foot......10

GRITCO GARDEN HOSE

The Kind That Gives Long Service



Gritco has features that recommend it to discriminating purchasers. It will not kink. Drag it around and you cannot separate the cover from the hose, because the rubber is seamless and tough. The wall of the hose is reinforced with strong cords, braided on, which are firmly embedded in the rubber and cannot come loose. This affords great strength for the highest water pressures. Gritco Garden Hose is flexible, strong and long lasting. 3/4 inch, per foot.....\$18

HOSE REELS

Diameter of wheels.....22 in.
 Diameter of drums..... 9 in.
 Width between wheels..10 in.
 Length of handle.....23 in.
 Capacity, 100 ft. 3/4-in. hose.
 Weight about 17 lbs.



No. 10 All-Steel Reel.

The large wheels roll easily over rough or soft ground. Nothing to get out of order. Rigid, Durable, Attractive. Price, No. 10, All Steel..\$3.00

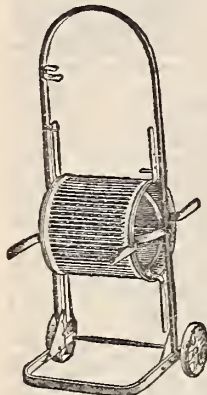

"Victor"

"VICTOR" REEL

is constructed with channel steel frame; strong, cast-iron wheels; solid steel reel arms and 9-inch drum of heavy corrugated steel.

Weight, 12 1/2 lbs., bundled for shipping. Capacity, 100 feet of 3/4-inch rubber hose.

Price.....\$1.75

HOSE FOR SPRAY PUMPS

We do not recommend a cheap Hose for spray work. Large sprayers handling a high pressure should use our No. 2, 1/2-inch spray Hose. This Hose is made especially for this work. It is extra strong and is wire wound, adding to its strength, and insuring long life, as the wire also protects it from rough usage.

The No. 1, 1/2-inch Spray Hose will be found satisfactory for the various hand pumps.

Spray Hose is made especially for spray pumps, being so constructed that spraying solutions have the least possible effect on them.

GIANT POWER SPRAY HOSE
 Made for the Highest Pressure

	Per Ft.
50-foot lengths, per foot.....	.30
1/2-inch Spray No. 1.....	.16
1/2-inch Spray No. 2, wire wound.....	.18
1-inch, 3-ply Hose.....	.30
1-inch, Hard Rubber Suction Hose.....	.40
2-inch, Wire-Lined Suction Hose.....	.75
1/2-inch Hose comes in 10, 15, 25, 30 and 50-foot lengths. We cannot cut other lengths. 2-inch Hose comes in 5, 10 and 20-foot lengths.	

HOSE REELS

PARK REEL No. 21

A tubular iron reel and frame mounted on steel wheels, tires 1 1/2 inches. Height of wheels.....28 in. Outside width over all. 26 in. Shipping weight.....45 lbs. Capacity, 3/4-in. hose. 200 ft. Capacity, 1-in. hose..100 ft.

Price.....\$15.00

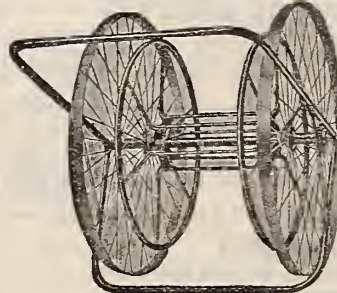

MAJESTIC RAIN KING SPRINKLER

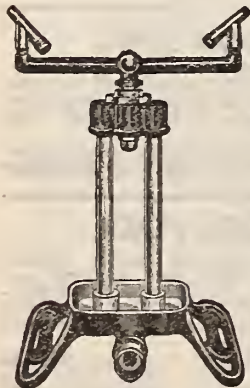

Like the famous Standard Rain King, this brand new Majestic throws any stream, whirling or stationary, with nozzles instantly adjustable for distance, direction and kind of spray—rainbow mist, fine stream, heavy shower or soaking downpour. Runs fast or slow—waters small, medium or large circles, and operates on low pressure. Beauty, efficiency and ornamental value are incorporated in this ace among sprinklers.

ornamental value are incorporated in this ace among sprinklers.

ORNAMENTAL BIRD BATH

MAJESTIC A

Height.....15 inches
 Width.....9 3/4 inches
 Weight.....7 pounds

Price \$8.50

THE RAIN KING



Absolutely nothing to get out of order.

Set instantly as a revolving or stationary sprinkler.

Distributes water perfectly at any pressure, either revolving or stationary. Nozzles adjust immediately to a fine spray or coarse spray, with any pressure.

Waters a greater area than any other sprinkler, under any water pressure.

Waters a small or large circle, from 8 to 80 feet in diameter. Instantly adapted to surface to be covered.

Waters strips, corners or any odd-shaped places, or sprays trees, shrubs, flower beds, etc., without "slopping over" on walks or adjacent buildings.

Lacks the troubles common to the ordinary sprinkler.

Runs fast or slow, as wanted. Price.....\$2.75

REVOLVING SPRINKLER

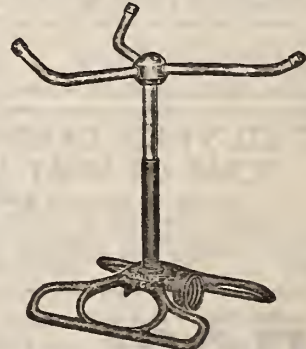

The Sprinklers are compactly and strongly made, with phosphor bearing.

Eureka Sprinkler, 12 in. high \$2.50

FOUNTAIN RING SPRINKLER



MADE OF HEAVY BRASS.

Easily moved over the lawn without turning off the water. The mist-like spray is a veritable "thing of beauty." Price 35c.

MISTY JR. NOZZLE

This nozzle has been tested under all conditions, and found to give entire satisfaction. It produces a perfect mist and covers a wide area.

Brass, with extra steel disk... \$1.00

Can also supply these nozzles with 45-degree angle. Same prices as above.

Extra Steel Disks for Misty, Jr., Nozzle 5c

THE BEST NOZZLE YET

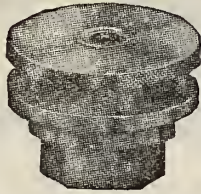

LONG SHANK HOSE COUPLING



Fig. 67 — Brass coupling, has one end cut 1/4-inch gas pipe and other end shank to wire into hose. Made from solid brass. Price, each... 35c



45° BEND BRASS Y

Fig. 1584 — Brass Y with the two branches of the Y bent as shown.

Price 50c

Fig. 1074 1/2 — Brass Y straight. Price 50c



60° BRASS ELBOW

Fig. 1107 — Sixty degree brass elbow, threaded both ends 1/4-inch pipe for use with any nozzle.

Price 30c

RAIN KING HOSE NOZZLE



The First Perfect Hose Nozzle
A New Patent

The world has never seen the equal of this wonderful hose nozzle. Picture any conceivable adjustment from a long, solid stream to the finest mist spray—and only a quarter turn of the nozzle from one extreme to the other.

This is the only hose nozzle without moving parts to wear, clog or give trouble. The different sprays are obtained by a new and unique principle. Throws more water farther than any other hose nozzle made.

Combines unusual simplicity with greater efficiency. Wear-proof, leak-proof, and guaranteed forever.

The Rain King Hose Nozzle is packed in individual boxes. Weight 10 ounces. Price, each \$1.50

THE FOUNTAIN SHOWER

A Hose Nozzle with the "Mist-like Spray"

This shower Sprinkler is the best thing for attaching to the hose to be used like a watering pot. It gives a fine gentle shower and does not injure the plants as a heavy stream might do. Parcel post weight 1 lb.

Price 40c

COOPER HOSE MENDER



No clamps necessary. Impossible to pull out of hose. Each 10c, dozen \$1.00

VERMOREL NOZZLE

This is an improvement on the old style Vermorel Nozzle; spray is finer and more evenly distributed. The cap with smaller hole makes finer spray.



Fig. 55—Gould's Vermorel Nozzle, each, One Discharge.....\$1.25

LEVER SHUT-OFF COCK



Fig. 64 — Lever Shut-off Cock, all brass. Made for use with Pipe Extension. Requires quarter turn only to shut off complete. This quick action makes it a practical device for the purpose. Tapped 1/4-inch pipe size.

Price, each....\$1.00

REDUCING COUPLING

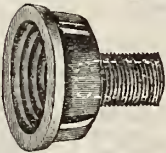

Fig. 65 — Coupling small end cut 1/4-inch pipe thread to fit our spray nozzles; large end cut to fit 3/8-inch, 1/2-inch or 3/4-inch male hose coupling.

Price 30c



BRASS Y

Brass Y is cut 3/4-inch. Female Hose inlet, with lateral discharges to fit 1/2 and 3/4 inch Hose Couplings. Price... 75c

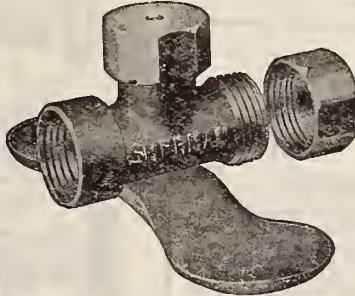

SHERMAN PORTABLE SPRAY HEAD

For connecting with hose in series to create a movable and flexible lawn sprinkling system.

The most effective Spray Head made, and at the lowest price.

Ingenious Spray Head construction produces a beautifully perfect mist-like spray, evenly covering wide area, yet conserving water volume to a degree that permits a greater number of heads to be used on normal pressures without reducing volume on those farthest from water supply. Price, each.....75c

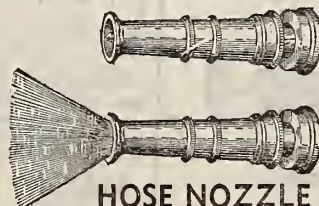

HOSE NOZZLE

This nozzle is made from solid brass and is adjustable for all kinds of spraying, from solid stream to the finest spray, or can be shut off entirely.

3/4-in. Diamond Nozzle.....75c
Parcel Post Weight 1 pound



BORDEAUX NOZZLE

The Bordeaux Nozzle can be readily changed from a solid stream to a mist-like, fan-shaped spray. Should there be any clogging of the nozzles with the spray material, it is easily remedied by turning the handle.

Price \$1.00

HOSE COUPLING



Fig. 1284

BRASS HOSE COUPLINGS, FIG. 1284

Fig. 1284 is a special Brass Hose Coupling, made with double length nipples, with heavy ribs, of sufficient length to use two hose bands if necessary. Especially adapted for use with Power Spray Pumps. Made in 1/2-in. size.

Price, each60c

HOSE NIPPLES

1/2-in. pipe and 3/4-in. hose.....\$0.40
3/4-in. pipe and 1-in. hose..... .40
1-in. hose, 1-in. iron pipe..... .60

Fig. 504 HOSE COUPLING



Size, inches	1/2	3/4	1	1 1/2
Complete	30c	30c	35c	\$1.00
Female Half	20c	20c	25c	.75

SHERMAN'S BRASS HOSE CLAMPS

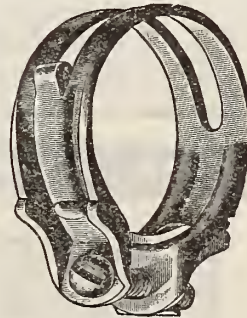
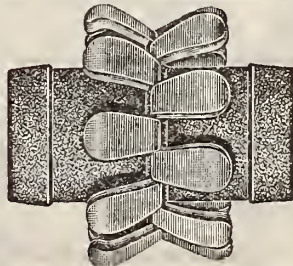

Fig. 1272, each, 1/2-in. 5c

Brass Hose, 3/4-in. 5c

Clamps, 1-in. 15c



GIBBS HOSE MENDER

The convenience of this mender lies in its simple application. Simply cut the hose apart where a leak occurs, insert the tube and hammer down the steel fingers.

Price, each, 3/4-inch.....\$0.10
Dozen, 3/4-inch 1.15

MIDGET TIN HOUSE SPRAYER

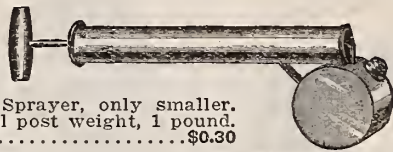

Similar to Tin Can Sprayer, only smaller. Holds half pint. Parcel post weight, 1 pound. Price\$0.30

GRITCO TIN CAN SPRAYER



For spraying insecticides, disinfectants, etc. Capacity, one quart. Parcel post weight, 2 pounds. Our special price.....\$0.40

THE ACME POWDER GUN



Consists of a tight valveless bellows equipped with a distributing tube or nozzle, a funnel, a spreader for diffusing the spray and an elbow for placing the spray on the underside of the leaves. Parcel post weight, 2 pounds. Special price \$1.50



AUTO SPRAY No. 26-AG

The glass tank enables the operator to know exactly how much liquid is in the container and it is more easily cleaned when a number of different solutions are to be sprayed. Capacity, 1 quart. Price \$1.25

AUTO SPRAY No. 26

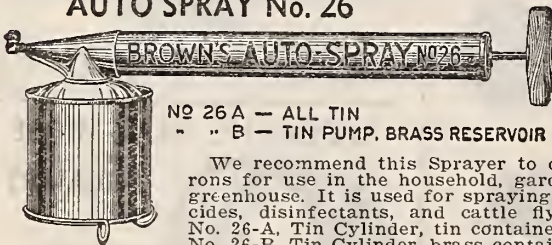

No 26 A — ALL TIN
" " B — TIN PUMP, BRASS RESERVOIR

We recommend this Sprayer to our patrons for use in the household, garden, and greenhouse. It is used for spraying insecticides, disinfectants, and cattle fly spray. No. 26-A, Tin Cylinder, tin container..\$1.00
No. 26-B, Tin Cylinder, brass container 1.60

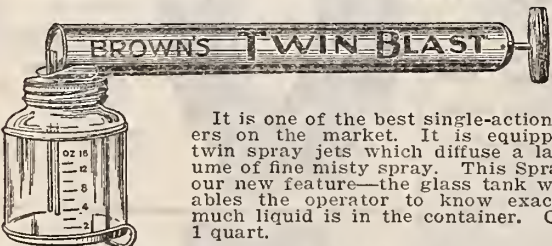

It is one of the best single-action atomizers on the market. It is equipped with twin spray jets which diffuse a large volume of fine misty spray. This Sprayer has our new feature—the glass tank which enables the operator to know exactly how much liquid is in the container. Capacity, 1 quart.
Tin Cylinder, glass container.....\$0.75

BROWN'S CRYSTAL DUSTER

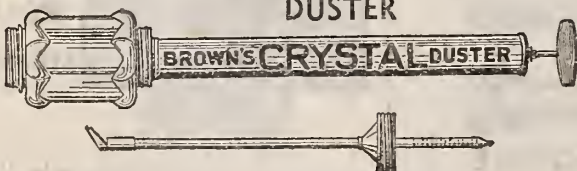

Brown's Crystal Duster is one of the newest type Dusters on the market. It is equipped with a long extension and adjustable nozzle which enables the operator to dust from underneath without bending. Capacity, 1 quart.
Brown's Crystal Duster.....\$1.30

HUDSON CRANK DUSTERS



The No. 604 Hudson Crank Duster has two agitators. The oscillating agitator keeps the powder from caking in the hopper. The Rotary Agitator feeds the powder down into the delivery spout. Indicator has an unusual range of adjustment and can be set to feed exactly the amount of powder required. Discharge equipment consists of two nozzles, two elbows, a Wye connection, and four 15-inch tubes. Capacity 5 to 10 pounds, depending on powder used. Weight 22 pounds.
No. 604 Hudson Crank Duster.....\$13.75

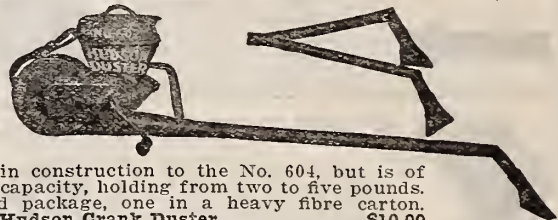

No. 603 Hudson Crank Duster, similar in construction to the No. 604, but is of smaller capacity, holding from two to five pounds. Standard package, one in a heavy fibre carton.
No. 603 Hudson Crank Duster.....\$10.00

HUDSON MIDGET SPRAYER

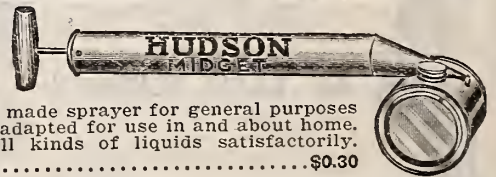

A small well made sprayer for general purposes and especially adapted for use in and about home. Will handle all kinds of liquids satisfactorily.
No. 202, price.....\$0.30

HUDSON MISTY SPRAYER

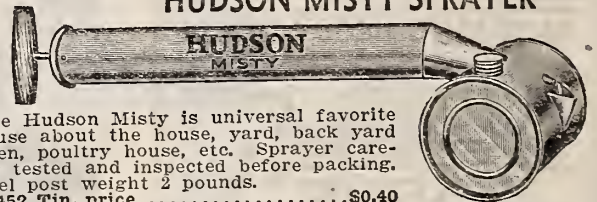

The Hudson Misty is universal favorite for use about the house, yard, back yard garden, poultry house, etc. Sprayer carefully tested and inspected before packing. Parcel post weight 2 pounds.
No. 452 Tin, price.....\$0.40

HUDSON CONTINUOUS SPRAYER

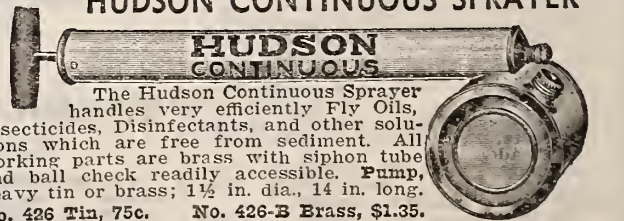

The Hudson Continuous Sprayer handles very efficiently Fly Oils, Insecticides, Disinfectants, and other solutions which are free from sediment. All working parts are brass with siphon tube and ball check readily accessible. Pump, heavy tin or brass; 1 1/2 in. dia., 14 in. long.
No. 426 Tin, 75c. No. 426-B Brass, \$1.35.

HUDSON TROMBONE SPRAYER



Equipment. Fitted with 3 feet of 3/8 inch spray hose, brass intake pipe and strainer, weighted so as to remain in barrel or pail when being used. Fog nozzle with reversible discs for various jobs. Can be used with extension if desired, for reaching under sides of plants, etc.
No. 133 Trombone, price, each.....\$4.35

HUDSON MAJOR DUSTER



Pump. Heavy tin, 2 3/4 inches diameter, 9 inches long. Fitted with special Hudson plunger leather and heavy rod.
No. 665, price.....\$1.00

LITTLE GIANT BRASS SPRAY PUMP AND FIRE EXTINGUISHER WITH AGITATOR

Fig. 639

Fig. 639 Spray Pump is constructed entirely of brass. It is provided with a large air chamber and has brass ball valves and detachable hose; the nozzle throws a continuous spray, and is not affected by the movement of the plunger. Will throw a solid stream fifty feet, and is of unusual value in spraying trees, washing windows, extinguishing fires, spraying flowers, etc.

No. 327½, Fig. 639. Bucket Brass Spray Pump, complete with hose and combination fine, coarse spray and solid stream nozzle.

Our Special Price.....\$4.00

No. 328, Fig. 639. Bucket Brass Spray Pump, complete with hose and combination fine, coarse spray and solid stream nozzle, and an eight-foot pipe extension.

Our Special Price.....\$4.65

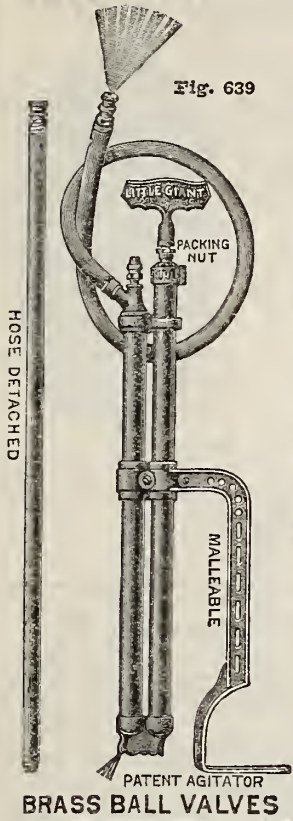

BRASS BALL VALVES

LEVER BUCKET SPRAY PUMPS

Fig. 632 represents the Myers Lever Bucket Spray Pump, made of brass and fitted with brass ball valves and patented agitator. The cylinder is 1½ inch in diameter. This pump can be operated with one-half the power of the ordinary bucket spray pump, owing to the advantage of the lever handle.

Fig. 632, No. R324 Lever Bucket Spray Pump, with agitator, complete with hose, Vermorel spray nozzle.

Our Special Price.....\$6.00

No. R324A Lever Bucket Spray Pump, with agitator, complete with hose, Vermorel nozzle and eight-foot pipe extension.

Our Special Price.....\$6.65

No. R324B Lever Bucket Spray Pump, with agitator complete with hose, Vermorel spray nozzle and eight foot pipe extension with stopcock. Our Special Price \$7.65

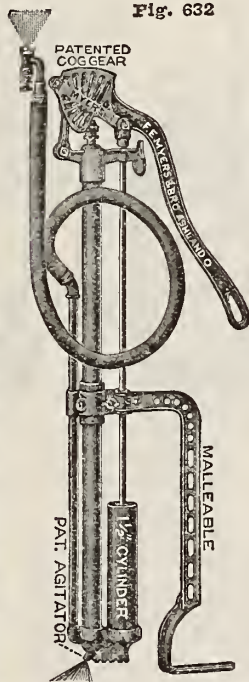

Fig. 632

THE LEVER KNAPSACK SPRAY PUMP

Fig. 547—No. 330

Galvanized tank holds 5 gallons, is fitted with lid and strainer. This Pump has lever, large air chamber, ball valves, solid plunger and agitator. Fitted with 5 feet ½ inch hose, pipe extension, and Bordeaux spray nozzle. Our Special price.....\$12.50

No. 331 Copper Tank.....\$18.00

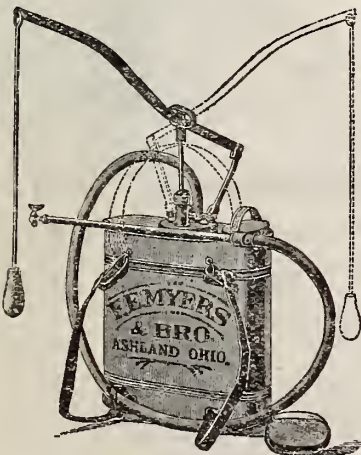

THE MYERS WHITEWASH, COLD WATER PAINTING MACHINE AND GENERAL PURPOSE SPRAYER No. 329

This General Purpose Sprayer with patent Double Agitator is a most complete and serviceable outfit. The tank is made of heavy galvanized iron with a wide bottom so as to set steady in operation. The cover is removable, is held securely in place by two thumb nuts, one on each side, which holds the cover tight and prevents spilling or splashing of the liquid. Holds 7 gallons.

This is an excellent outfit for whitewashing chicken houses, fences and outbuildings. For spraying trees, shrubbery, plants, and in fact anything where a small sprayer can be used. This outfit will be found just the thing.

The pump used in this outfit is the same as the No. 324 Sprayer as shown under Fig. 632, fitted with Bordeaux nozzle, brass ball valves, and has jet and dasher agitator.

Complete with Hose, Nozzle, Agitator and Extension Rod.

Our Special Price \$12.50

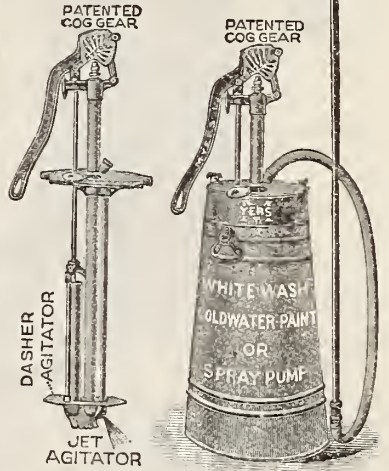

HUDSON MORO SPRAY PUMP

The Hudson Moro Spray Pump handles all spray solutions. Its high pressure adapts it for use in small orchards, vineyards and truck gardens; for use with whitewash and cold water paints, with insecticides, fungicides, disinfectants, stock dips, etc. A convenient portable outfit because it can be used with any bucket, pail or small tank. Unusually long foot rest permits using higher bucket than most pumps will accommodate. All working parts are brass. Valves and nozzle parts are easily accessible for cleaning, etc. Nozzle discs are reversible, producing any desired spray from finest mist to coarse stream.

No. 126 Moro, price.....\$6.00

HUDSON MODOC SPRAY PUMP

The Modoc is used in spraying fruit trees and vines, garden truck, ornamental shrubs and hedges; for whitewash, disinfectants, insecticides; for washing automobiles, wagons, windows, or in an emergency as a fire pump.

It is double acting and continuous, developing 150 pounds nozzle pressure. Makes a very convenient portable outfit because it can be used with a bucket or small tank. Valves and plunger are accessible for cleaning, etc. Nozzle discs are reversible or removable, producing any desired spray from the very finest to a solid stream. All parts except the handle and foot rest are brass.

SPECIFICATIONS
 Cylinder. 1¼ inch diameter, 13 inches long.
 Valves. Brass balls in brass cages.
 Air Chamber. ¼ inch diameter, 18 inches long.
 Discharge Equipment. 3 feet of ¾ inch spray hose, a 12-inch extension and fog nozzle.
 Price.....\$4.25





**HUDSON
PERFECTION
SPRAYER**

It is very practical for use around the orchard, barn, or outhouse, on small truck farms; on onion, melon and small potato fields; for removing old wall paper, spraying stock dip, etc.

Tank. 7½ inches diameter, 20 inches high; capacity approximately 4 gallons. All seams are riveted and soldered.

Pump. Seamless brass tubing, 1½ inches diameter, 15 inches long.

Nozzle. Is especially designed for high pressure work.

No. 110G.
Perfection,
Galvanized \$6.50

No. 110B.
Perfection,
Brass Tank,
Price \$9.75

**BROWN'S AUTO SPRAY
No. 1**



The Auto Spray No. 1 is an excellent compressed air sprayer for use in spraying small trees, gardens, field crops, chicken houses, etc. This Sprayer has the Brown drain-dry feature; the inverted flange on the cam lock does not interfere with drainage of liquid from the tank. This Sprayer, because of the cam lock device, is especially adapted for spraying gummy or heavy substances, besides agricultural insecticides, disinfectants and light floor oils. Corrugated tank of heavy sheet brass or strong copper bearing galvanized steel sheet.

Auto Spray No. 1-B, Brass Tank, priced at \$9.75.

Auto Spray No. 1-D, Galvanized Tank, priced at \$6.65.

**HUDSON
ECONOMY
SPRAYER**

Tank. 7¼ inches diameter, 20 inches high; capacity approximately 3¾ gallons. Made of first quality galvanized sheet. Sturdily built, with convex ends secured by double folded top and bottom seams, riveted side seams and heavily sweat soldered throughout. Tested under actual working conditions to insure safety in operation.

Price \$4.50



**HUDSON
ECONOMY
SPRAYER**

AUTO SPRAY No. 50



We highly recommend the Auto Spray No. 50. It is extremely desirable for use in spraying agricultural insecticides, disinfectants and where the spraying is not extensive, and is especially adapted for use by women or persons physically unable to carry a great weight. Tank is constructed of heavy, strong copper bearing galvanized sheet steel. Pump cylinder is of one piece seamless brass tubing. This Sprayer has the screw lock and drain-dry feature. Capacity, 2½ gallons.

Auto Spray No. 50-D, Galvanized Tank. Priced at \$5.70



**HUDSON
JUNIOR
SPRAYER**

**HUDSON
JUNIOR
SPRAYER**

It is particularly adapted for the backyard garden or small truck farm, for use around the chicken house, in the dairy barn, hog pen, for disinfectants in the home or in hotels, restaurants, theatres and other public buildings.

Tank. 6½ inches diameter, 17 inches long; capacity about 2½ gallons.

Pump. 1½ inches diameter, 15 inches long; seamless brass tubing.

Nozzle. Our "Perfection" automatic shut-off nozzle.

No. 140G Junior, galvanized tank, price \$4.50

**AUTO SPRAY No. 23-C—
All Brass**

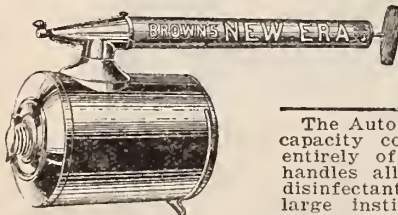

The Auto Spray No. 23C is a large capacity continuous Sprayer, made entirely of strong sheet brass. It handles all garden insecticides and disinfectants; it is very useful in large institutions where extensive spraying of disinfectants, insecticides, etc., is done. Valve is easily cleaned by removing valve cap and ball. Capacity 3 quarts. Price \$3.45

**BROWN'S
BRONCO
SPRAYER**

This Compressed Air Sprayer is complete in every detail, having most of the features of the best sprayers of this type. While it is competitive in price, the quality is very high. It has a brass pump and spray rod extension, galvanized tank. Suitable for spraying any of the liquid insecticides, disinfectants, fly sprays, etc. Do not judge its quality by its price.

PRICE \$4.25



**BROWN'S
BRONCO**

**AUTO
SPRAY
No. 5**



GENERAL PURPOSE HAND PUMP

It is made entirely of brass, doing away with all danger of corrosion.

The pump is double-acting. This feature makes the spray continuous. Anyone who has used a single-acting pump of this kind will immediately recognize the advantage in a pump that works on both the up and down stroke.

OUR SPECIAL PRICE \$4.45

GOULD'S POMONA SPRAY PUMP



Plunger—Diameter 2½ ins.; stroke adjustable to 3, 4, 5 ins.; discharge ½-in. hose.
Outside packed plungers. No. leather packings.

For small orchards of a few acres; a good barrel sprayer that will meet every requirement. All of the working parts are solid bronze.

The pump has a steel air chamber, extending from top of pump to valve chamber, making it easy to get up sufficient pressure to continue spraying for some time after pumping has stopped. It is equipped with a long adjustable handle. The pump may be placed in any length barrel, as the barrel plate is adjustable. The agitator is simple, very effective.

List Price. **Our Special Price.**

- Fig. 1100.—Pump only with Agitator and Hose Coupling \$35.20 **\$22.00**
- Fig. 1100.—**Outfit A.**—Pump with Agitator, Hose Bands and Couplings and one Mistry, Jr. Nozzle for one lead, but without Hose..... 37.52 **23.45**
- Fig. 1100.—**Outfit B.**—Pump with Agitator, Hose Bands and Couplings, one Mistry, Jr. Nozzle and 15-foot lead No. 1 Spray Hose..... 41.12 **25.70**
- Fig. 1100.—**Outfit C.**—Pump with Agitator, Hose Bands and Couplings, one Mistry, Jr. Nozzle, one 15-foot lead No. 1 Spray Hose, fitted in Barrel 51.12 **30.70**
- Fig. 1100.—**Outfit D.**—Pump with Agitator, Hose Bands and Couplings, one Mistry, Jr. Nozzle, one 15-ft. lead No. 1 Spray Hose, 8-foot Iron Extension Rod with Brass Stop-Cock, fitted in Barrel 53.76 **32.35**
- Fig. 1100.—**Outfit E.**—Pump with Agitator, Hose Bands and Couplings, Two Mistry, Jr. Nozzles, two 15-foot leads No. 1 Spray Hose..... 48.16 **30.10**
- Fig. 1100.—**Outfit F.**—Pump with Agitator, Hose Bands and Couplings, 2 Mistry, Jr. Nozzles, 2 15-ft. leads No. 1 Spray Hose, fitted in Barrel.. 58.16 **35.10**
- Fig. 1100.—**Outfit G.**—Pump with Agitator, Hose Bands and Couplings, Two Mistry, Jr. Nozzles, two 15-foot leads No. 1 Spray Hose, two 8-foot Iron Extension Rods with Brass Stop-Cocks, fitted in Barrel..... 63.44 **38.40**

GOULD'S "FRUITALL" SPRAY PUMP



All Working Parts Bronze
 The Fruitall Sprayer is first-class in every respect, while the simplicity of its design allows it to be sold at a very reasonable price. The sprayer is held in place in the barrel by an adjustable clamp at the top fitting over the end of a stave, and an anchor at the bottom of the barrel. The plunger is packed from the outside, so it is not necessary to take the entire pump apart to repack.

Plunger, 2 inches diameter; stroke, 4 inches.

List Price. **Our Special Price.**
 Fig. 1188.—Pump only with Agitator and Hose couplings \$19.20 **\$12.00**

- Fig. 1188.—**Outfit A.**—Pump with Agitator, Hose Bands and Couplings and one Mistry, Jr. Nozzle for one lead of hose, but without Hose.. 21.52 **13.45**
- Fig. 1188.—**Outfit B.**—Pump with Agitator, Hose Bands and Couplings, one Mistry, Jr. Nozzle and 15-foot lead No. 1 Spray Hose..... 25.12 **15.70**
- Fig. 1188.—**Outfit C.**—Pump with Agitator, Hose Bands and Couplings, one Mistry, Jr. Nozzle, one 15-ft. lead No. 1 Spray Hose, fitted in barrel 35.12 **20.70**
- Fig. 1188.—**Outfit D.**—Pump with Agitator, Hose Bands and Couplings, one Mistry, Jr. Nozzle, one 15-foot lead No. 1 Spray Hose, 8-foot Iron Extension Rod with Brass Stop-Cock, fitted in Barrel 37.76 **22.35**
- Fig. 1188.—**Outfit E.**—Pump with Agitator, Hose Bands and Couplings, Two Mistry, Jr. Nozzles, two 15-foot leads No. 1 Spray Hose..... 32.80 **20.50**
- Fig. 1188.—**Outfit F.**—Pump with Agitator, Hose Bands and Couplings, two Mistry, Jr. Nozzles, two 15-foot leads No. 1 Spray Hose, fitted in Barrel 42.80 **25.50**
- Fig. 1188.—**Outfit G.**—Pump with Agitator, Hose Bands and Couplings, two Mistry, Jr. Nozzles, two 15-foot leads No. 1 Spray Hose, two 8-foot Iron Extension rods with Brass Stop-Cocks, fitted in barrel..... 48.80 **28.80**

DOUBLE-ACTING SPRAY PUMP

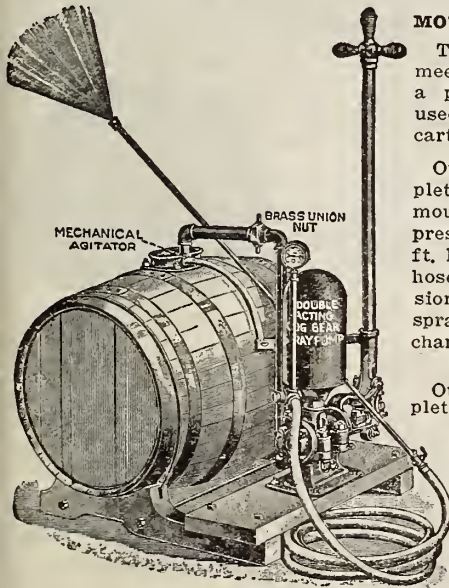

MOUNTED ON SKIDS

This desirable outfit meets the demand for a pump that can be used in a wagon or cart. It cannot upset.

Outfit B—Pump, complete, 50-gallon barrel mounted on skids, with pressure gauge; one 15-ft. lead ½-in. discharge hose, 8-ft. pipe extension with lever shut-off, spray nozzle and mechanical agitator.
Price... \$54.00

Outfit C—Pump, complete, 50-gallon barrel mounted on skids, with pressure gauge; two 15-ft. leads of ½-in. discharge hose, 8-ft. pipe extension with lever shut-off, spray nozzles and mechanical agitator.
Price \$60.00

McKENZIE THREE AND FOUR ROW SPRAYERS

This 110-Gallon High Pressure Sprayer, the latest addition to the popular McKenzie line, marks another step forward in sprayer construction. It embodies the improvements you want in your high pressure sprayer and is built to give years of satisfactory service.

The New McKenzie 100-Gallon High Pressure Sprayer is regularly equipped with wide evener and neckyoke, automatic pressure gauge and Nixon or No. 10 boom for spraying four rows with three nozzles per row, or No. 11 boom for six rows with two nozzles to the row. These booms are made of all galvanized iron pipe with ¾-inch and ½-inch main line with drop pipes of the same size. They can be adjusted to suit practically all crop conditions and are hinged for passing through narrow gates.

- 50 gallons, 3 rows, 3 nozzles to row..... \$125.00
- 100 gallons, 4 rows, 3 nozzles to row..... 200.00

MYERS OVERHEAD SPRAYER

For Potatoes, Cotton or other field crops. Nozzles adjustable to any required height and any width row.
 No. 6 Myers Hand Overhead 4 Row Adjustable Sprayer, complete with all necessary Hose and Nozzles (Pump and Barrel not included).
Our Special Price \$20.00

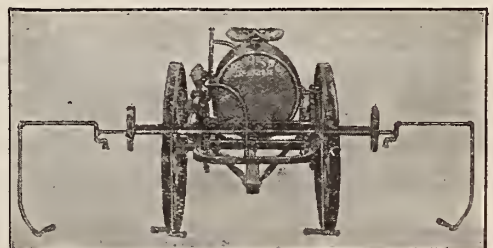
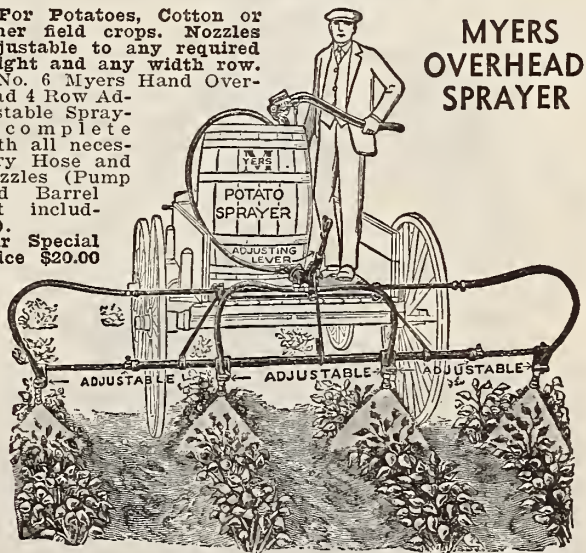

50 Gallon, 3 Row, 3 Nozzles to Row

THE MYERS SELF OILING JUNIOR POWER SPRAY OUTFIT

Fig. 2692

Fitted with 2 1/4x3 Double Acting Self-Oiling Pump

Fig. 2692 illustrates the Myers Junior Power Spray Outfit as furnished complete except the engine. TANK, cypress, 100 gallons, fitted with rotary agitator. FRAME, 3-inch channel steel. Length overall, 6 feet 8 inches. DECK space for Engine 36x36 inches. PUMP, No. 699.

Equipped as follows: One Myers Spray Gun. 50 feet of 1/2-inch Myers High Pressure Spray Hose with fittings complete, cut-off for discharge lines, pressure gauge, agitator, belt tightener, relief valve, strainer and suction hose.

No. 729, Myers Junior Spray Outfit with 100 gallon Tank and No. 699 Spray Pump, belt driven, equipped as shown.....\$120.00
 No. 739 with 2 h. p. Engine, chain drive.....\$197.00

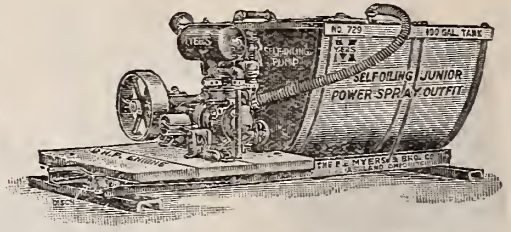

THE MYERS SELF OILING DUPLEX POWER SPRAY OUTFIT

Capacity 8 to 12 Gallons per Minute

Fig. 2572

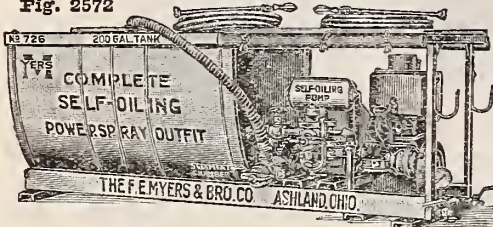

Fig. 2572 illustrates the Myers Complete Self-Oiling Duplex Power Spray Outfit as furnished ready for the field. Has 200-gallon Cypress Tank and Rotary Agitator. The Main Frame is 4-inch Channel Steel with cross members arc-welded. Entire length over all, 7 feet 8 inches. Height 34 inches. The Pump is the Myers Self-Oiling Duplex, No. 700, with Myers Pressure Regulator and Unloading Valve built in with by-pass. THE ENGINE, 4 h. p. roller bearing, variable speed (850 to 1500 R. P. M.), Throttle Governed, with Magneto, Hopper Cooled, Light Weight, Easy Starting and Dependable. Fitted with Canvas Side Curtains. A Fine Brass Gauge Strainer is furnished for the Filler Opening in top of the Tank. This Strainer is made of the same mesh gauze as that used on the suction hose and prevents any foreign substance from entering the Tank or Pump. Can be mounted on any Farm Wagon Gear or Farm Truck.

Equipped as follows: Two No. 1 Myers Spray Guns, two leads of 50 feet each, 1/2-inch Myers High Pressure Spray Hose, with fittings complete, with cut-off on discharge lines, pressure gauge, rotary agitator, pressure controller, unloading valve and sediment chamber. No. 726, Myers Complete Self-Oiling Duplex Power Spray Outfit, 200-Gallon Tank, No. 700 Duplex Self-Oiling Spray Pump and Pressure Unloading Valve, Chain Driven, equipped as above, 4 h. p. Engine included, price..\$402.00

THE MYERS POWER SPRAY GUN

Length overall 26 inches. Utilizes the entire capacity of any power spray pump and does away with all bamboo extensions, nozzles and fittings. All working parts on the outside. Not subject to corrosion.

Fig. 1824



Fitted for 3/4-inch Hose Coupling and 1/4 inch Pipe. Our special price.....\$6.00

HUDSON IDEAL SPRAYER

No. 32

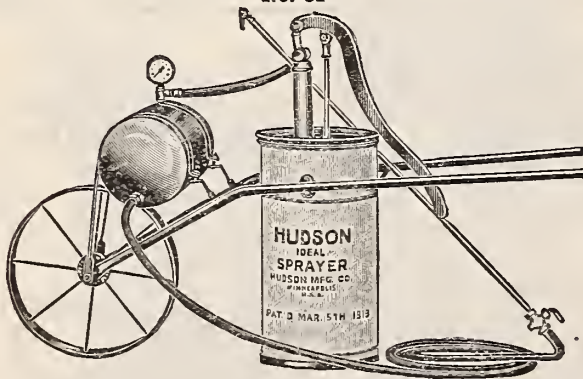

The Ideal is a high pressure portable outfit. It is equipped with a regular barrel pump which develops and maintains a working pressure of 200 pounds. Has capacity for two lines of hose if desired. It is a strong, durable machine, very well designed. Because of its portable construction, it is an exceptionally handy outfit for the orchardist or fruit grower. It is also a great favorite in the stock barns, cattle pens, poultry houses, etc. It is a practical outfit for whitewash, cold-water paints, insecticides, stock dips and remedies, etc. It can be used in a variety of ways throughout the entire year.

Tank. Heavy copper-bearing galvanized, reinforced at top and bottom with channel iron hoops. Easily removed. Capacity 15 gallons.

Frame. Heavy steel tubing.

Wheel. 18 inches diameter, 2 1/2-inch tire; strong, light and rigid.

Discharge Equipment. 6 feet of 3/8 inch spray hose and a 4-foot 1/4-inch pipe extension—total 10 feet, angle Ideal spray nozzle and leakless shut-off.

Shipping Weight. Crated securely, 75 pounds.

No. 32. IDEAL, Galvanized Tank, price, each.....\$23.00
 No. 33. IDEAL Sprayer with Pressure Tank..... 35.75

Fig. 1535

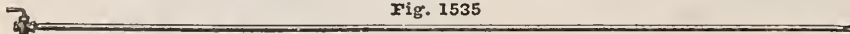

RUBBER GLOVES



Extra Heavy, All-Rubber, Seamless Gloves
 Just the thing to handle the poisonous chemicals used in the different spraying mixtures. Can be worn with canvas gloves inside or outside.
 Price\$3.00

MYERS DOUBLE CUT-OFF

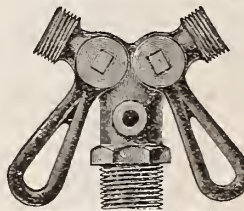

Is fitted for 3/4 or 1/2 inch hose couplings on the discharge ends, and 1 inch pipe thread on the inlet.
 Price\$3.25

PRESSURE GAUGE

Fig. 1721

Brass Pin Silvered Dial, with black figures. Up to 400 pounds pressure.
 Price, 3 1/2-inch\$3.00



PRESSURE REGULATING VALVE



Designed for controlling the pressure on Power Spray Pumps. All brass with specially Vulcanized Rubber Ball Valve and Brass Seat with ground surface. Can be set to operate against any pressure up to 400 pounds.

Myers Pressure Regulating Valve for 3/4-inch pipe, price\$8.00

Fig. 2138

EXTENSION SPRAY-RODS

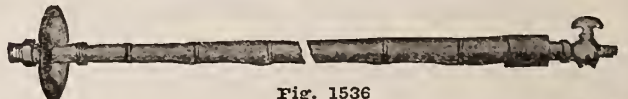

Fig. 1536

Bamboo—8 ft. with stop cock \$4.20; without stop cock...\$3.25
 10 ft. with stop cock \$4.75; without stop cock..... 3.75

Fig. 480—8-ft. extension, with couplings\$0.65

Fig. 1535—8-ft. pipe extension, with stop cock..... 1.65



STIMUGERM

LEGUME INOCULANT

HIGH-BRED NITROGEN-GATHERING BACTERIA

MEANS BETTER CROPS, BETTER SOILS, LESS FERTILIZER EXPENSE
STIMUGERM—The "Always Fresh" Inoculant

What Stimugerm is: A pure culture of nitrogen-fixing bacteria of highest quality. Stimugerm, always fresh, always strong and virile.

A sensible insurance and a profitable investment. We believe in inoculation, we favor the pure jelly medium, and we believe in Stimugerm. We recommend that all legume seeds purchased from us be inoculated before planting.

(A different culture is required for each legume group, so when ordering be sure to state what crops you wish to inoculate.)

New Low Prices—For Small Seeds, Clovers, Alfalfa, etc.

SMALL SEED LEGUME VARIETIES

Alfalfa—Clovers—Sweet Clovers	
1/4 bu. size retails at.....	\$0.35
1/2 bu. size retails at.....	.60
1 bu. size retails at.....	1.00
2 1/2 bu. size retails at.....	2.25

LARGE SEED LEGUME VARIETIES

Soybeans—Cowpeas—Vetch—Peas	
1/2 bu. size retails at.....	\$0.35
1 bu. size retails at.....	.60
5 bu. size retails at.....	2.25

Garden size for Garden Peas, Beans and Sweet Peas.
 Special Composite Culture, 25c.

CARBOLA

CARBOLA is a white paint in powder form combined with a disinfectant many times stronger than pure carbolic acid. It is non-poisonous and non-caustic. It kills lice, mites, fly eggs, etc., and helps prevent the start and spread of contagious diseases that affect man, beast and fowl.

CARBOLA is two things in one—a paint that disinfects or a disinfectant that paints. It dries a clear, snow white. It saves labor, time and money. It paints and disinfects at one operation in the same time and with the same labor required to paint or disinfect only.

CARBOLA is recommended for use instead of whitewash in every place where whitewash ordinarily is used.

- | | | |
|-----------|------------|--------------|
| Garages | Warehouses | Outbuildings |
| Factories | Cellars | Tree Trunks |

It is recommended for use instead of Whitewash and Disinfectants in

- | | | |
|----------------|----------------|-----------------|
| Stables | Rabbit Hutches | Hog Pens |
| Kennels | Barns | Dairy Buildings |
| Poultry Houses | Creameries | |

It is recommended for use as a disinfectant.

PRICES (Paints and Disinfects 200 square feet)

5 pounds (2 1/2 gallons) .75c 10 pounds (5 gallons) \$1.25 50 pounds (25 gallons) \$5.00

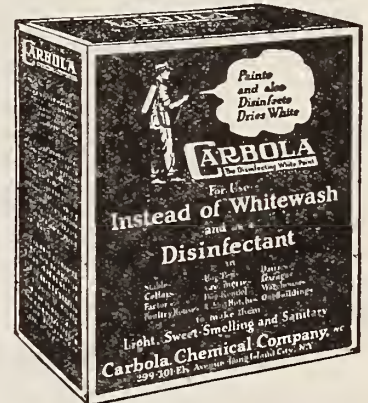

CYANOGEN GAS—A Dust

REG. U.S. PAT. OFF.

CYANOGEN GAS A-DUST is a powdered material that gives off hydrocyanic acid gas when exposed to the air. This gas is deadly to the rodent and insect pests and will kill them almost immediately.

CYANOGEN GAS A-DUST can be applied either with a duster or with a spoon.

The **CYANOGEN GAS** method of controlling rodent and insect pests is easy, quick and thorough.

CYANOGEN GAS A-DUST to kill Ants, Rats, Mice, Moles, Crayfish, Land Crabs, Land Turtles, Woodchucks or Ground Hogs, Prairie Dogs, Ground Squirrels, Pocket Gophers in Florida, Fleas, Bed Bugs, Clothes Moths, Wax Moths, Bats, Pigeons, Sparrows, Starlings, Yellowjackets, Wasps, Chinch Bugs on Lawns, Grape Leafhopper, Grape Mealy Bugs, Melon Aphid (Box Fumigators).

CYANOGEN GAS A-DUST—25-lb. tins \$10.00, 5-lb. tins \$3.00, 1-lb. tins 75c, 1/2-lb. tins 45c, Hand Pump \$1.25, Foot Pump \$5.00

VICTOR

MICE AND RAT TRAPS

Made of hard wood blocks, bait hook designed to make catching sure every time. Long clinched staples that can't come out.
Price, Mice Traps, 3 for...10c
 Postage extra 5c
Rat Traps, each.....10c
 Postage extra 5c

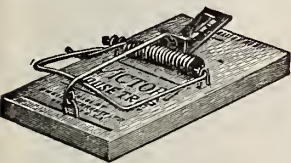

THE WIRE CAGE RAT TRAP

The size of this trap makes it the ideal for house use.

It is strong and will stand rough use.

The patent door eliminates all danger from the caged rats. Size, 16 inches long, 9 inches wide, 7 inches high.

No. 17 coppered wire, nine sheet-steel flanged ribs.

Price..... 75c

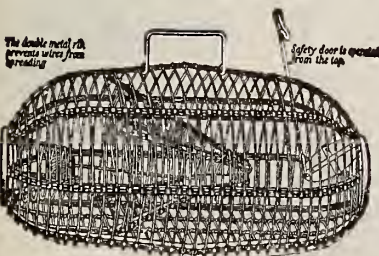

Dethol

SPRAY IN THE HOME AND ON THE FARM

IMPROVED DETHOL, sprayed lightly on tile, porcelain, wash basins and bath tubs, immediately loosens grime and grease, which can then be quickly and easily removed by wiping with rag, leaving a spotless and glistening surface. Also aids in disinfecting and deodorizing, and helps to purify foul-smelling air. Its cleansing spray penetrates where neither brush nor broom can reach.

On the farm, **IMPROVED DETHOL**, sprayed freely in hen houses, etc., and sprayed lightly and regularly on poultry and stock, keeps them free from many kinds of insects and vermin. Do not spray **IMPROVED DETHOL** on young animals, cats or vegetation.

1/2 pint 40c, 1 pint 60c, 1 quart \$1.00, 1 gallon \$3.00



THIS INSECTICIDE

is death to pests—is safe to plants—is harmless to user—is low in price—is free from disagreeable odor.

We recommend **Lemon Oil Co.'s Standard Insecticide**. It is used by the most prominent florists and seeds men to destroy **Scale, Mealy Bug, Kust, Aphid, Caterpillar, etc.**, on Palms, Rose Bushes, Rubber Plants, Ferns, etc. It leaves no disagreeable odor on blooms or foliage—advantages over the vile-smelling soaps and powders, especially for indoor use. Being poisonless, it is not dangerous to use.

This will be found an **excellent wash for dogs and other animals**; it relieves mange, destroys lice and other insects, and gives the coat a beautiful, glossy appearance. Contains no poison to injure the animal, and being liquid, gets through the hair to the hide.

It will destroy lice and other insects in poultry houses. It will also kill roaches, ants and other insects that infest houses.

½ pint 30c, 1 pint 50c, 1 quart 85c, ½ gallon \$1.50, 1 gallon \$2.50, 5 gallons \$10.00, 10 gallons \$19.50.

LIME SULPHUR SOLUTION

The universally accepted spray material for dormant use is lime-sulphur solution. Chemically made lime sulphur solution has now almost entirely supplanted the home-made solution because it is better.

This material combines the great fungicidal properties of sulphur with the scale remedy, and is especially recommended for peach and plum trees which need the combined treatment in the fall and spring. In spraying this material care should be exercised to avoid getting it in the eyes, and gloves should be worn to protect the hands.

Lime-Sulphur Solution is used both as an insecticide and a fungicide. As an insecticide it is used principally against scale insects, especially the San Jose Scale. For scale insects it is applied while the trees are dormant and is diluted with 8 or 9 parts of water. As a fungicide it is used chiefly for the control of apple scab, 1½ gallons to 50 gallons of water. Lime-Sulphur may be used in combination with arsenate of lead and tobacco extracts. Paris Green should not be used with Lime-Sulphur.

1-qt. Can	\$.30	30-gal. Drums, per gallon	.20
½-gal. Can50	Drums about 50 gal., per	
1-gal. Can80	gal.18
5-gal. Can	2.75		
10-gal. Can	4.75	No charge for Drums.	

POISON KILL-WEED POISON

NOT TO BE USED ON LAWNS

A SCIENTIFIC WEED DESTROYER. FREE FROM ODOR. By Analysis It Has Been Found There is No Stronger Weed Killer on the Market.

An unsurpassed preparation for the removal of grass, weeds, vines and bushes from paths, roadways, gutters, streets and any other place from which it is desired to remove any and all vegetable growths, thus destroying the breeding ground for mosquitoes. The work can be done in a speedy, thorough, economical and easy manner. The material has no bad effect on the ground, neither does it injure or discolor the brick, stone or marble curbing.

No more digging and disfiguring of paths and roadways. Saves expense of several men. **KILL-WEED** not only kills weeds but destroys seed germs and roots of plants. Can be used with an ordinary sprinkling can. **One gallon KILL-WEED will make 30 gallons treating liquid when mixed with water.** One man with a sprinkling can in one hour can do as much or more than six men could do in one-half day, and do the work better.

1-Quart Can	\$0.50	5-gal. Can	6.50
½-gal. Can90	10-gal. Can	12.00
1-gal. Can	1.50	1 Barrel, per gal.95

SCALECIDE

Pleasant to Use. Reduces Sprayer Troubles. Prolongs the Life of Your Sprayer. Spreads into Cracks and Crevices. Saves Half the Labor of Spraying.
—One spray tankful of dilute Scalecide goes as far on your trees as two spray tankfuls of dilute lime-sulphur or two and one half spray tanks of diluted oil emulsion.

A 50-gal. barrel of Scalecide sprays the same trees, until they drip, as three and one-half barrels of lime-sulphur.

PRICES A Size for Every Need

One gallon makes	16 gallons of spray.
1 qt. can	\$.70
1 gal. can	1.60
5 gal. can	6.00
10 gal. can	10.00
15 gal. drum	11.50
30 gal. drum	20.00
50 gal. drum	25.00
Plus Deposit on Drums	
15 gal.	\$2.00
30 gal.	2.50
50 gal.	3.00

DRY LIME SULFUR

Dry Lime Sulfur is the most valuable new spraying product that has been developed in recent years. For a long time Lime-Sulfur Solution had been the standard dormant and summer spray for apples, pears, plums and many other tree fruits. Orchardists are familiar with the disadvantages connected with the use of Lime-Sulfur Solution. These include heavy handlings of barrels, losses due to leakage, crystallization and freezing and freight on water.

This Dry Lime-Sulfur is a true Dry Lime-Sulphur. It is not a substitute for Lime-Sulfur Solution, but is standard 33° Baume Lime-Sulfur Solution in dry powdered form. It dissolves readily in water and will control insects and diseases just as effectively as Lime-Sulfur Solution.

Dry Lime-Sulfur is an effective remedy for San Jose and Oyster-Shell Scale, Peach-Leaf Curl, Peach Blight, Peach Twig Borer, Blister-Mite, Apple and Pear Scab, Brown Rot of Apricot, Powdery Mildew of Apples, Red Spiders, Mites and Thrips of Citrus fruits.

200-lb. steel drums	Pkg. \$22.00
100-lb. steel drums	12.00
50-lb. steel drums	7.00
25-lb. steel drums	4.00
10-lb. cans	2.00
5-lb. cans	1.25
1-lb. cans30

Trade **KAYLOX** Mark
Registered in U. S. Patent Office.

INSECTICIDE AND FUNGICIDE
Kills Insects and Prevents Blight

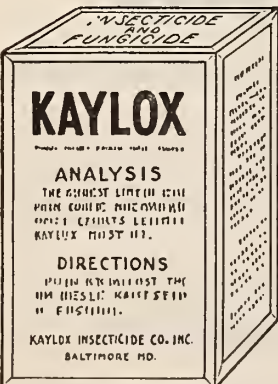

KAYLOX is adapted for spraying for late broods of Codling Moth on Apples, for Potato Beetles, most Caterpillars and many Leaf-eating Insects on fruit and other trees, Tomatoes, Grapes, Currants, Celery, Cabbage, Cauliflower and many other Plants.

A preventive of many Blights and certain Fungous diseases. Used as a general spray—1 pound to 10 gallons or 5 pounds to 50 gallons of water. For Potatoes, Bitter Rot and Blotch on Apples. Use 1 pound to 7½ gallons or 6½ or 7 pounds to 50 gallons of water.

Not to be used for late Spring or early Summer application on Apples, and not to be used on Peaches or Japanese Plums after blooming.

KAYLOX IS A POWDER, NOT A PASTE
HIGH FREIGHT RATES make it imperative that you buy **KAYLOX**, a highly concentrated spraying material, as you then do not have to pay freight on a preparation that is 50% water.

KAYLOX never spoils, **KAYLOX** never freezes, **KAYLOX** never becomes worthless, **KAYLOX** is always at your service, **KAYLOX** should be used, because it is your best insurance for a full crop.

KAYLOX is the outcome of many years of development in the use and manufacture of insecticides and fungicides. It meets the requirements of the largest growers as well as the small home gardener. **KAYLOX is in convenient size packages.**

½ Pound makes 5 gallons of spray	\$.30	25 Pounds make 250 gallons of spray	\$9.50
1 Pound makes 10 gallons of spray	.50	50 Pounds make 500 gallons of spray	17.50
5 Pounds make 50 gallons of spray	2.25	100 Pounds make 1,000 gallons of	
10 Pounds make 100 gallons of spray	4.00	spray	31.00

WRITE FOR SPECIAL CIRCULAR.

ARSENATE OF LEAD

Arsenate of Lead is an arsenical poison for use against insects that chew and for such insects as the fruit-flies that lap and suck up sweetened liquids.

The principal insects for which Arsenate of Lead is used are: Apple-maggot, brown-tail moth, bud-moth, cankerworm, codling moth, fruit-tree leaf roller, gypsy moth, tent caterpillar, pear slug, curculio, etc.

Directions: 1 to 1½ lbs. powder to 50 gallons of water. **Powdered Form.**
 1-lb. pkg., per lb. 25c
 4-lb. pkg., per lb. 20c
 48-lb. pkg., per lb. 15c



ARSENITE OF ZINC

Arsenite of Zinc.—This is a combination of arsenic with zinc to form a quick acting, adhesive insecticide for use on potatoes and some other truck crops. It is much more adhesive and less caustic than Paris Green and kills quicker than Arsenate of Lead.

1-lb. pkg., per lb. 25c. 4-lb. pkg., per lb. 21c.
 48-lb. pkg., per lb. 16c.

CALCIUM ARSENATE

1-lb. pkg., per lb. 15c. 4-lb. pkg., per lb. 11c.
 48-lb. pkg., per lb. 10c.

COPPERCARB

A new remedy for bunt or stinking smut in wheat. Being a powder which can be applied without any further mixing directly to the grain, makes it more economical than the old wet system, and as it can be done at any time, even months before sowing, does away with the evils of any soaking or wet process.

Raise clean wheat and save the loss in reduced prices when you sell your crop.

Use 2½ to 3 ounces to treat one bushel of wheat.
 5-Pound Packages, per pound... \$0.20

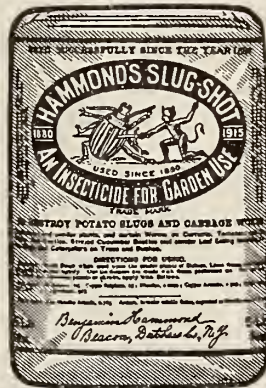

HAMMOND'S SLUG SHOT

Destroys potato bugs and beetles, green and black fly, slugs, worms, caterpillars, etc. Ten to forty pounds is sufficient for an acre.

1-lb. pkg. 25c.
 5-lb. pkg. 60c.

HAMMOND'S GRAPE DUST

5 lbs. 80c.



"NICO-FUME TOBACCO POWDER"

Tobacco Powder impregnated with a high-strength nicotine solution. Effective for fumigating in greenhouses to destroy Aphis, Thrips, etc. Fill an ordinary 2½-inch flower pot heaping full of "Nico-Fume" Powder (this being equal to about three heaping tablespoonfuls).

Pour the "Nico-Fume" Powder out upon the bare ground or cement walk in a narrow pile about seven inches long.

1 Pound \$1.00
 5 Pounds 3.50
 10 Pounds 6.15

F. O. B. Factory.

PURE WHITE HELLEBORE

One-quarter pound... 15c Half-pound... 30c Pound... 50c

FORMALDEHYDE, 40% SOLUTION

1-Pt. Bottles, 50c. 1-Qt. Bottles, 90c. 1-Gal. Jug, \$2.50

DRITOMIC SULPHUR

There has been a growing demand for fungicides in dry form. To meet this demand, the General Chemical Company has developed a highly concentrated sulphur product; a product that combines the advantages of Atomic Sulphur with the advantages particular to dry powdered materials. This new product will give the fruit the well-known sulphur finish, without interfering with the assimilatory functions of the foliage or the development of the plant treated.

PRICE

4-lb. Bags, per lb. 18c
 48-lb. Bags, per lb. 12c
 96-lb. Bags., per lb. 11c

BORDEAUX MIXTURE

is a combination of copper sulphate and lime. Its use is indispensable in the control of black rot of grapes and the blight of potatoes. It is also used for apple-scab, bitter-rot, cedar rust, leaf spot and downy mildew.

Directions: 6 to 7 pounds to 50 gallons of water.

1-lb. pkg., per lb. 25c
 4-lb. pkg., per lb. 20c
 48-lb. pkg., per lb. 15c



DOW MAGNESIUM ARSENATE

Dow Magnesium Arsenate gives best results when applied as a wet spray, using 2 pounds per 100 gallons of water. This gallonage is sufficient for about one acre of beans.

Should you be interested in a prepared product, ready for use in a duster, we recommend Dow Magnesium Arsenate Dust Mixture. This contains genuine Dow Magnesium Arsenate blended with hydrated lime in accordance with government recommendations.

2-lb. Packages \$.60
 100-lb. Drums 22.00

MAGNESIUM ARSENATE DUST

PREPARED READY TO USE

4-lb. Packages \$.60
 100-lb. Drums 12.00

"BLACK LEAF 40"

NICOTINE SULPHATE—40% NICOTINE

This is the insecticide that is so highly recommended by Experiment Stations. It destroys Aphis (plant lice), Thrips, Leaf-hoppers on all tree, bush and vine fruits, vegetables, field crops, flowers and shrubs; also Apple Red Bug, Pear Psylla and similar soft-bodied sucking insects—all without injury to foliage.

May be combined with other sprays. Highly concentrated. Soluble in water—easy to mix—does not clog nozzles.

You cannot go wrong by ordering "Black Leaf 40" for sucking insects.

PRICES

1 oz., \$.35, makes 6 gals. 5 ozs., \$1.00, makes 40 to 120 gals. 1 lb., \$2.25, makes 80 to 240 gals. 2 lbs., \$3.35, makes 160 to 480 gals. 5 lbs., \$6.25, makes 400 to 1,200 gals. 10 lbs., \$10.75, makes 800 to 2,400 gals.

NICO-FUME

Nico-Fume is a Tobacco Paper insecticide for fumigating greenhouses. Extensively used by prominent florists. Very easy to apply. Prices: 24 sheets, \$1.25; 144 sheets, \$4.75, and 288 sheets, \$8.25. Directions on each package.

APHIS PUNK (Nikoteen)

The Punk is lighted with a match and allowed to burn, which it does without flaming, at the same time giving off dense white fumes of Nikoteen that kill aphis and thrip very effectively. Per box, \$80.

TOBACCO STEMS

50-pound bale 4c pound.

TOBACCO DUST

Price..... 5 pounds, 25c; 25 pounds, \$1.00; 100 pounds, \$4.00.

TOBACCO SOAP

3-oz. cake makes 1½ gallons prepared solution, 10c. Mailed, postpaid, for 13c. 8-oz. cake makes 4 gallons prepared solution, 20c. Mailed, postpaid, for 25c.

**PARA-DICHLOROBENZINE
FOR PEACH BORER CONTROL**

Use one ounce to a tree 6 years old or older; in case of very large tree, 1½ ounces may be needed to form a satisfactory band. On trees four or five years old, use ½ to ¾ ounces to a tree. We do not recommend using it on younger trees. Do not use on apple trees.

Spring application in May—Fall application in September.

1-lb. package, per lb...\$0.45 25-lb. package, per lb...\$0.26
5-lb. package, per lb... .40 100-lb. package, per lb... .22

CYANO G FUMIGANT
REG. U.S. PAT. OFF.
FOR GREENHOUSES

One-eighth ounce to 1000 cubic feet is a sufficient dose if the house is fairly tight. Always start the fumigation about one hour after sundown—never before. Choose a still night. The house should not be watered for at least twenty-four hours before fumigation. Some plants will not stand the treatment and should be removed from the house.

Cyanogas G Fumigant (cannot be mailed):

5-pound pkgs.....\$3.00 25-pound pkgs.....\$10.00



BUG DEATH

kills Potato, Squash and Cucumber Bugs, Currant and Tomato Worms, and all bugs and worms that chew the leaves of plants; non-poisonous.

Directions for Applying Dry:

For potato and other vines which require a top application, apply dry with Shaker or Shifter at the rate of 15 to 25 pounds per acre to an application, according to size and conditions of the vines.

1-pound package\$0.20
5-pound package60
12½-pound package 1.45
100 pounds 8.75

BOURBON FLUOSILICATE DUST MIXTURE

Bourbon Remedy Company's Fluosilicate Dust Mixture contains a light, fine quality of sodium fluosilicate, carefully mixed with a suitable carrier so as to make a product adapted for dusting purposes, and ready for use without further preparation. Most of the ordinary commercial grades of sodium fluosilicate now available are not suitable for dusting.

Bourbon Remedy Company Fluosilicate Dust Mixture is adapted for the control of Mexican Bean Beetles, Potato Bugs (Beetles), Striped Cucumber Beetles, Blister Beetles, certain Flea Beetles, and Boll Weevils, and it may also be used to destroy Cutworms, to rid premises of Ants and Roaches, and to kill the Lice on fowls.

Price, 100-lb. Drums.....\$15.00

POMODUST

Pomodust is a combination of highly effective fungicides and insecticides in combination for the prevention of many blights, mildews and fungus troubles and to kill external leaf eating insects. Pomodust is especially adapted to use on roses, and is used and recommended by many prominent growers.

Price—1-lb. pkg. 40c—5-lb. pkg. \$1.25—10-lb. pkg. \$2.00.

POMO GREEN

1 lb.....50c 5 lbs.....\$1.75

VOLCK

Volck is one of the most powerful insecticides known. It is effective on practically all insects on ornamental and flowering plants. Wonderful results have been obtained against red spiders, cyclamen mite, aphid (green fly), scale, mealy bug, thrips, and caterpillars. Many pests that could not be controlled before are now killed with Volck. Even mildew and rusts are prevented and stopped by Volck. Not only does Volck give effective control of pests, but it also prevents reinfestation for a considerable period. Volck is odorless, colorless and non-poisonous. There is no unsightly residue. Plants are deep, glistening green after using Volck.

Prices, ½ pt. 35c; 1 pt. 60c; 1 qt. \$1.00; 1 gal. \$3.00; 5 gals. \$12.50; 14 gals. \$25.00.



KAYSO

Kayso is the combined casein spreader and adhesive which makes orchard and garden spraying more economical and more efficient. Kayso is now used by fruit and vegetable growers in all parts of the United States. Kayso enables you to get your trees completely covered by a protective film of poison, with no unprotected spaces.

Prices—2-lb. pkg.\$0.40
100-lb. pkg.....\$17.00

PARIS GREEN

¼ pound\$0.15
1 pound45
5 pounds 1.85



TREE TANGLEFOOT

For protecting trees against climbing insect pests in a simple, economical, and effective way. One pound will spread 8 feet long by 5 inches wide, 1-16 inch thick. Will stay on tree three months.

1-lb. can\$0.50
5-lb. can 2.25
10-lb. can 4.25



KEY BRAND TREE WOUND PAINT

PREVENTS DECAY AFTER PRUNING

This residuum, penetrating antiseptic paint is not affected by heat, cold or moisture. Does not peel, crack or get brittle. Stops tree bleeding.

NOTE: Antiseptic paint for wounds and pruning purposes.

1-gal. cans \$3.00 1-qt. cans \$1.20

FISH OIL SOAP

1 lb.\$0.30 10 lbs.\$2.25
5 lbs. 1.25 25 lbs. 3.25
100 lbs.\$10.00

FLOUR OF SULPHUR

1 lb.\$0.12 lb. 25 lbs.\$0.08 lb.
5 lbs.10 lb. 50 lbs.07 lb.
10 lbs.09 lb. 100 lbs.06 lb.

COMMERCIAL FLOUR OF SULPHUR

Sold in 100-lb. bags only. Per 100 lbs., \$3.25.

DUSTING SULPHUR

85-15 Dust. Contains 15 per cent Dry Arsenate of Lead and 85 per cent Flour Sulphur. A very effective dusting material for Strawberries, Cantaloupe, and other Melons, and in fact is an ideal dust for many uses.

100-pound Bags, per bag.....\$7.00

SULFOCID
A Better Summer Spray

A concentrated liquid sulfur fungicide. Used on both peaches and apples and on all kinds of fruits, vegetables, and flowers. Controls apple scab, brown rot of peaches, plums and cherries; blight and rot of potatoes, tomatoes and melons; mildew and rust of flowers and shrubs. Convenient, economical, effective. Dilute 1 to 200.

Prices: 1 pt. 70c; 1 qt. \$1.00; 1 gal. \$2.75; 5 gals. \$8.75; 10 gals. \$15.00; 30 gals. \$39.00; 60 gals. \$60.00.

BLUESTONE (OR COPPER SULPHATE)

5 lbs.\$0.50 50 lbs.\$4.25
10 lbs.90 100 lbs. 8.00

Snarol

The National Pest Control



Science provides new safe methods that does the work without fuss. Cutworms, sowbugs, grasshoppers, slugs, snails, earwigs, etc., are exterminated.

Prices: 1-lb. pkg. 45c; 3-lb. pkg. 95c; 15-lb. pkg. \$3.50; 50-lb. bags \$9.50.

SEMESAN

FOR FLOWER AND VEGETABLE SEEDS
Semesan is indispensable to those growing vegetables or flowers whether for market or home use. It may be applied in dust or liquid form to the seed before planting. It is harmless to the seed but deadly to any disease organisms that may be on the seed. One ounce treats 15 lbs. of seed. Effective in controlling damping off, the Brown Patch disease which affects gladiolus and such devastating gladiolus diseases as hard rot and scab.



SEMESAN BEL

FOR SEED POTATOES
Use the quick, easy, time-saving Semesan Bel treatment. Simply mix, dip, drain, dry and the potatoes are ready for planting. Controls such seed-borne disease organisms as scab, rhizoctonia and black-leg. By controlling these diseases, germination is generally increased, stand improved and the resultant crop of potatoes is bigger and of better quality. Crop increases of from 10 to 15% are common.

One pound treats 16 to 20 bushels of seed.

4 oz. tin.....\$.50	5 lb. tin..... 8.00
1 lb. tin..... 2.75	25 lb. pail..... 31.25

SEMESAN, JR.

FOR SEED CORN

Applied by the simple dusting operation at the rate of 2 oz. to each bushel of seed corn, Semesan, Jr., offers the cheapest and most effective form of disease insurance.

It is especially effective in controlling seed-borne infections of diplodia, Gibberella and Basiporium, without harming the seed embryo in the least.

Its use protects the seed from rotting in ground and makes possible earlier planting.

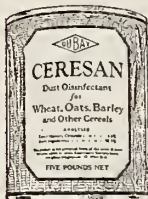

CERESAN

FOR SMALL GRAINS

For the seed treatment of wheat, oats, barley, rye and sorghum. For controlling such seed-borne diseases as bunt or stinking smut of wheat; stripe disease of barley; loose and covered smuts of barley and oats and covered kernel smut of sorghum.

This is the only dust treatment which has successfully controlled all of these grain diseases.

1 lb. tin.....75c	5 lb. tin.....\$3.00
25 lb. pail.....\$12.50	



4 oz. tin.....\$.50	5 lb. tin..... 8.00
1 lb. tin..... 1.75	25 lb. pail..... 31.25

Use EVER GREEN
NON-POISONOUS INSECTICIDE to PROTECT YOUR GARDEN



EVER GREEN is ideal for spraying vegetables because it is absolutely non-poisonous and will not harm the most delicate plant nor injure flavor in any way. For commercial use **EVER GREEN** is economical on the following:

Aphis, Asparagus Beetle, Big Caterpillar, Cabbage Worms, Cranberry Fireworm, Currant Worm, Leaf Hopper, Leaf Tier, Loopers, Mexican Bean Beetle, Rose Chafer, Rose Slug, Strawberry Leaf Beetle, Striped Cucumber Beetle, Spittle Bug, Squash (Stink) Bug, Tarnished Plant Bug (Aster Beetle), Tent Caterpillar, and White Fly.

1 oz. bottles.....\$.35
6 oz. bottles..... 1.00
16 oz. bottles..... 2.00
32 oz. cans..... 3.50
1 gallon cans.....11.50

Antrol ANTS DESTROYED

New method "gets" them at their source—safe, permanent, effective.

The complete system should cover every 15 feet around the outside of the house or "ant" trails in the garden. Once installed permanent, effective and safe protection is insured from these annoying pests. Prices:

Antrol sets containing 4 containers and 1 4-oz. bottle of syrup..... .95
Antrol extra containers (each)..... .15
Antrol syrup, 4-oz. bottles..... .45
Pints..... .95
Gallons.....\$3.75



RED ARROW INSECT SPRAY
VARIOUS USES

Red Arrow kills: Aphids, (Plant Lice), Mealy Bugs, Squash Bugs, Rose Chafers, Leaf Hoppers, Aster Beetles, Elm Leaf Beetles, Mexican Bean Beetles, Japanese Beetles, Striped Cucumber Beetles, 12 Spot Cucumber Beetles, 12 Spot Dahlia Beetles, White Flies, Stable Flies, Potato Beetles, Red Spiders, Fern Caterpillars, Cut Worms,

Cabbage Loopers, Harlequin Cabbage Bugs, Fall Web Worms, Thrips, Celery Leaf Tier, and many other insects.
1 oz., 35c; ¼ pt., \$1.00; ½ pt., \$1.75; 1 pt., \$3.25; 1 qt., \$6.00; ½ gal., \$11.00; 1 gal., \$20.00.



DISINFECTANT DEODORANT ANTISEPTIC

B-K is a powerful non-poisonous germicide with ten times the germ-destroying power of undiluted carbolic acid, yet contains no poison, acid, nor oil. It is fed in drinking water to calves, little pigs and poultry.

It is a powerful solvent of all protein matter such as casein milk solids on utensils, dead tissue, pus and mucus in animal tissue. It penetrates and dissolves these; destroys chemically the germs that cause the trouble, cleans surfaces of utensils; cleans and heals tissues of animals. It is ideal for colds, roup, flu, etc., in birds, and similar diseases acquired through mouths, throats and noses of animals.

It is a powerful deodorant. It destroys odors and leaves none of its own.

10-oz. Bottle.....\$0.50	1-gal. Bottle.....\$2.00
1-qt. Bottle..... .90	5-gal. Carboy..... 8.50

COW-EASE

RELIEVES CATTLE AND HORSES FROM FLIES

A liquid preparation carefully compounded from effective materials. It is of the right consistency for applying with a sprayer, and it will not gum the hair or blister the skin.

A SURE PREVENTATIVE FOR LICE, TICKS AND VERMIN

A light application of **Cow-Ease** will relieve cattle from lice, also prevent tick—the cause of Texas Fever.
¼ gal., 60c; ½ gal., 90c; 1 gal., \$1.50; 5 gal., \$7.25.

ARROW CARBOLINEUM Formerly **Avenarius Carbolineum**—Made in U.S.A.

PRESERVES WOOD EVERYWHERE

against rot and decay, adding at least 100 per cent to the life of fence posts, poles, sills, floors, bridge timbers, porches and to wood embedded in concrete.

COVERING CAPACITY

350 square feet per gallon on dressed timber.
250 square feet per gallon on rough lumber.
100 square feet per gallon on shingles.
Second coat only requires one-third or one-fourth the quantity for first coat.

KILLS MITES IN POULTRY HOUSES

1-gallon can.....\$1.75	5-gallon can.....\$7.00
-------------------------	-------------------------

DR. HESS FLY CHASER

Drives flies away. One application lasts six hours. Prevents milk slump. Keeps cattle and horses contented during the fly season. Most humane idea of the age. Its use during summer months will insure good profits. **GUARANTEED.** 1 gal. \$1.50, 5 gals. \$7.00.

SO-BOS-SO

Trade **KILFLY** Mark

Cows will give 15 to 20 per cent more milk if protected from the torture of flies with **So-Bos-So-Kilfly**. Kills flies and all insects; protects horses as well as cows. Perfectly harmless to man and beast. Rapidly applied with sprayer, 30 to 50 cows sprayed in a few minutes.

½-gallon can.....85c	1-gallon can.....\$1.50
Sprayer for applying So-Bos-So 50c.	

GRADE 1 CREOSOTE OIL

It is liquid. It is free from water. It has low evaporation loss. It has high specific gravity. It has low viscosity, and, being liquid, penetrates readily and deeply into the wood.

It has increased antiseptic and decay-preventing qualities. It is a clean oil and imparts a pleasing, dark-brown color to the wood.

It is uniform, standardized material.	
1-Gallon Can.....\$1.00	5-Gallon Can.....\$4.50

WORLD'S GREATEST SEPARATOR

And We Will Prove It



Forty-six years of experience have gone into the making of this new, latest model Sharples. It is the greatest Sharples ever produced; and that means a cream separator second to none in the world. Every improvement, every advantage which the separator industry has produced in the last 50 years is included in this wonderful new Sharples. And because of its exclusive, patented features, the new Sharples has important advantages which are shared by no other separator on the market. When we say that the new Sharples is our masterpiece—the greatest of cream separators—we back our claim with our reputation built up through 46 years of service to the American farmer. And we say further that the Sharples is today the greatest separator value ever offered. A standard separator, made in America by an old established, reputable firm, the greatest model in 46 years now sold at a big saving in price.

Motor Equipment, \$40.00.

The Sharples is made in a size to suit the requirements of every farmer. Choose a size that is large enough to do your job quickly and with the least work. You'll find it will pay you. The capacities listed below are based on 60 revolutions per minute. Through the exclusive Sharples combined Jet and Suction feed these capacities may be increased as much as 20% by turning faster.

No. 3—350 lbs. per hour.....	\$65.00
No. 4—450 lbs. per hour.....	75.00
No. 6—650 lbs. per hour.....	85.00

FLOATING GLASS DAIRY THERMOMETERS



8-inch. Price, 35c. each.

8-inch Flange Dairy Thermometer, stands boiling water. Price, \$1.25 each.

Milk Hydrometer, No. 2085 (Quevenne), \$1.50. Add 8 cents each if by mail.

WELL'S & RICHARDSON CO.'S BUTTER COLORING

Put up in four sizes.

Small size to color 500 lbs.....	\$.35
Medium size to color 1,250 lbs.....	.65
Large size to color 2,800 lbs.....	1.00
Gallon cans.....	5.00
35c. and 65c. size by mail add 15c. for postage and packing.	

THE "FROST KING" STEEL FRAME SINGLE MOTION FREEZER



Is a single-motion freezer, and is accordingly sold at a lower price than our other makes. It is, however, of exactly the same high-grade construction. The mechanism is very easy to operate, and the can being of the narrow model type makes the freezing very rapid. The operation of this freezer is extremely simple. The wood scrapers

on the dasher press automatically against the sides of the revolving can. These remove the frozen cream and throw it to the centre where the spoons on the beater mix it with the cream still unfrozen and return the whole to the sides to be refrozen. The "Frost King" Steel Frame freezer will produce a rich

and evenly frozen ice-cream in about three minutes.

Sizes	2-qt.	3-qt.	4-qt.	6-qt.	8-qt.
Retail Prices.....	\$2.95	\$3.50	\$4.25	\$5.45	\$6.95

THE BOSS SEPARATOR



VENTILATING AND AERATING CREAM SEPARATOR

In the Boss Dilutors or Water Mixers the milk and water is mixed together or, in other words, the water is poured right into the milk so as to chill it instantly and cause the cream to raise in about one hour.

In ordering a separator of this kind, be sure and order one that will hold twice the amount of milk that you wish to put into it, so as to make allowance for water.

No.—Sizes	Prices
6—8 gal., holds 4 gals. milk..	\$4.80
7—12 gal., holds 6 gals. milk..	5.60
8—16 gal., holds 8 gals. milk..	6.40
9—20 gal., holds 10 gals. milk..	7.20
10—24 gal., holds 12 gals. milk..	8.00

THE BOSS CREAM SEPARATOR

The Boss Cream Separator consists of a water vessel containing one or more milk vessels fastened together with our Patent Can Attachment.

The Water Vessel is made of the very best quality of 26 guage galvanized iron, and is provided with a large water faucet at the bottom and overflow pipe at the top.

The Milk Vessel is made of the best grade 3XXX 4AAAA Charcoal Tin Plate. It is oblong and deep with a sloping bottom, milk and cream will drain off rapidly. All seams are carefully soldered both on the inside and outside, and there is no chance whatever for milk to lodge and sour. All milk vessels are coated with Aluminum which is the best rust preventative known.

No.	Height	Width	Weight
No. 1—2½ gal. milk vessel..	18 in.	13 in.	14 lb. \$ 7.20
No. 2—4 gal. milk vessel..	20 in.	15 in.	17 lb. 8.00
No. 3—6 gal. milk vessel..	22 in.	17 in.	20 lb. 8.80
No. 4—8 gal. milk vessel..	24 in.	18 in.	22 lb. 9.30
No. 5—10 gal. milk vessel..	28 in.	18 in.	24 lb. 10.80

THE TWIN BOSS

No.	Height	Length	Width	Weight
22 two 2½ gal. milk vessels	18 in.	24 in.	13 in.	27 lbs. \$14.40
24 two 4 gal. milk vessels	20 in.	30 in.	15 in.	33 lbs. 16.00
26 two 6 gal. milk vessels	22 in.	30 in.	17 in.	38 lbs. 17.60
28 two 8 gal. milk vessels	24 in.	30 in.	18 in.	41 lbs. 19.20
210 two 10 gal. milk vessels	28 in.	30 in.	18 in.	46 lbs. 21.60

THE TRIPLE BOSS

No.	Gallon	Gallon	Ht.	Lth.	Wth.	Wt.
			in.	in.	in.	lbs.
32 two 2½ milk can, 2½ cream can,			18	24	13	30 \$16.00
34 two 4 milk can, 3 cream can,			20	30	15	37 17.60
36 two 6 milk can, 3 cream can,			22	30	17	42 19.20
38 two 8 milk can, 4 cream can,			24	30	18	45 20.80
310 two 10 milk can, 4 cream can,			28	30	18	50 24.00

"SNOW BALL" FREEZER

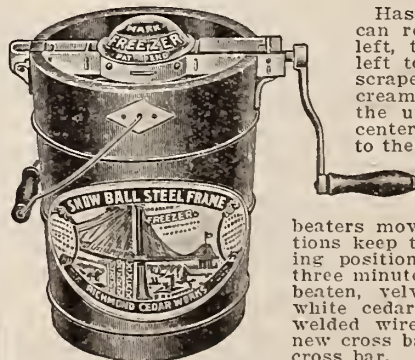

Has three motions. The can revolves from right to left, the outer beater from left to right, the two wood scrapers removing the frozen cream from the sides with the unfrozen cream in the center, and throws all back to the side to be again frozen and removed by the scrapers. The continuous action of the can and two

beaters moving in opposite directions keep the cream ever changing position, producing in about three minutes a very smooth, well-beaten, velvety cream. Virginia white cedar, bound with electric welded wire hoops. Fitted with new cross bar lock and reinforced cross bar.

Sizes	2-qt.	3-qt.	4-qt.	6-qt.	8-qt.
Retail Prices.....	\$3.50	\$4.20	\$5.15	\$6.45	\$8.35

Baltimore Favorite Churn

It is made of thoroughly seasoned material. It is finished smooth inside as well as outside. The iron ring head is strong and not liable to break. The balls are fastened to the iron ring.

We furnish pulleys for power. Prices extra, according to size desired. Directions for using in each Churn.

No.	Capacity, Gallons	To Churn, Gallons	List Price	Retail Price
0-6	6	3	\$12.32	\$7.70
1-10	5	5	13.96	8.15
2-15	7	7	15.20	9.50
3-20	10	10	16.94	10.60
4-25	12	12	21.56	13.50
5-35	17	17	24.44	15.30
6-50	25	25	48.00	30.00

12-inch Single Pulleys with Trunnions for above List, \$7.00. Retail, \$4.25. Pulley only. List Price, \$4.00. Retail, \$2.50. Trunnion only. List, \$3.00. Retail, \$1.75.



CEDAR CYLINDER CHURN

There are a number of Cylinder Churns on the market sold at a lower price, but they are made of pine or other inferior wood, while these are all of selected cedar, free of knots.

No. 1-2 3/4	gallons\$4.40
No. 2-4	gallons 5.20
No. 3-7	gallons 6.10
No. 4-10 1/2	gallons 6.95

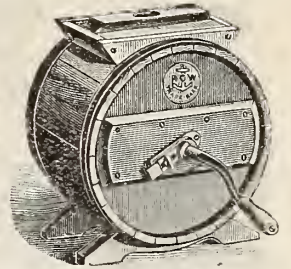

LAFAYETTE BUTTER PRINTER

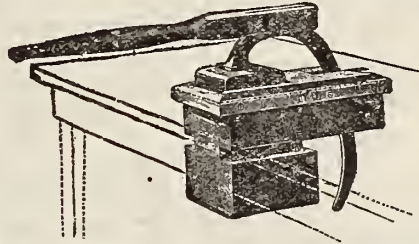

This is also self-gauging. Intended for use in creameries, but more especially for re-printing. Very simple and handy.

Either pound or half pound, with table, \$33.00.

Either pound or half pound, without table, \$15.50. Extra for initial or monogram, \$1.50

Cotton Pads for Sanitary Milk Strainers

These pads are cut round to fit in the strainer and are a necessity in producing clean milk.

They fit the Sanitary Strainer, as listed on page 66. 300 in carton, 6-inch.....\$1.00. 6 1/2-inch.....\$1.20

PERFECTION ANTI-COW KICKER

No Chain or Cutting-Edge Parts to Lacerate, Bruise or Blemish the Cow's Leg.



The grapple or hook parts are made from a special size round steel, so shaped and arranged to prevent torturing or injuring the animal's leg. Price \$1.25

PERFECTION COW TAIL HOLDER

Will not annoy or excite the cow. Put on in a few seconds and taken off in less. Impossible for animal to switch, when tail is placed between the springs.

Price35

ASEPTIC MILKING TUBES

FOR COWS WITH SORE TEATS.

Insert one in the teat and the milk will flow.



Self Retaining Tube, 25c.

RICE'S CALF WEANERS

ALSO PREVENTS COWS FROM SUCKING THEMSELVES.

No. 1—For Calves. Retail Price.....\$.50

No. 2—For Heifers. Retail Price..... .75

No. 3—For Cows. Retail Price..... 1.00



SHAW'S CALF WEANERS

The SHAW'S CALF WEANER is thoroughly practical. The action is entirely in the basket, it being hinged to the end of the nose piece. The basket is made of heavy galvanized wire, with extra bars running through. The halter that goes over the neck is made of solid leather, and can be adjusted to suit the calf's head.

Prices: No. 1, 50c. No. 2, 65c. No. 3, 80c.

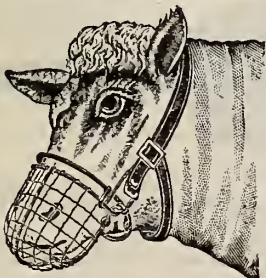

REID'S BUTTER WORKER

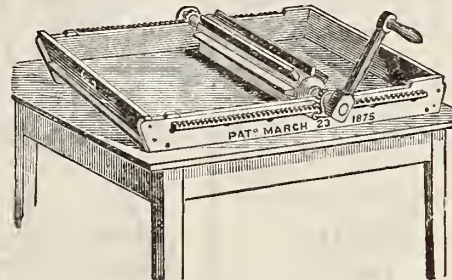

Inside No.	Measurement	Capacity, Pounds.	Weight, Pounds.	Retail Price.
4-	14x24x2 1/2 in.	10	20	\$12.00
3-	17x27x2 1/2 in.	20	25	14.00
2-	20x36x2 1/2 in.	30	29	16.50
1-	23x36x2 1/2 in.	50	45	19.00

BUTTER MOULD

SEELEY PATTERN

Furnished with Sheaf of Wheat. Movable block.

1/2 pound.....65c. 1 pound.....85c.

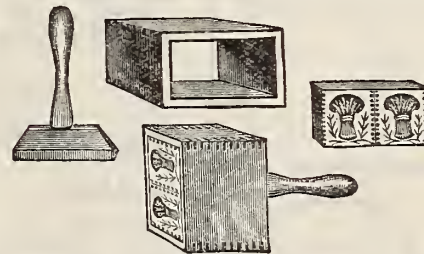

Baltimore Pattern Hand-Made Butter Mould

This Butter Print is hand-made out of solid hardwood, and is put together with brass screws, making it indestructible. Being a two-piece print makes it very handy to use. 1/2 lb Sheaf of Wheat Print, \$1.25; 1 lb. Sheaf of Wheat Print, \$1.50. 1/2 lb. Special Print, Carved with Initial, \$2.50; 1 lb. Special Print, Carved with Initial, \$2.75.

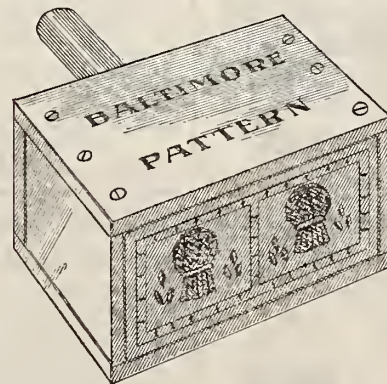

PHILADELPHIA PATTERN MOULD

Philadelphia Pattern, 1/2 pound.....\$2.00 Philadelphia Pattern, 1 pound..... 2.00

LADLES AND SPADES

4x12 Butter Spade.....15c. No. 1 Butter Ladle.....25c.



MARYLAND PATTERN MILK CANS

Furnished with our new Umbrella Cover, with seamless rim welded to top. The malleable iron handle on the Cans we stock are stationary, making the Can Handler to handle and Noiseless in shipping.

20-quart ... \$3.65
40-quart ... 4.55

MILK CANS OR KETTLES

Finest charcoal plate. Seamless cover and neck. Bottom reinforced with steel band. Heavy steel bail. Sanitary soldered. Full capacity.

2-quart ... \$1.05
4-quart ... 1.15
6-quart ... 1.40
8-quart ... 1.50
10-quart ... 1.75
12-quart ... 1.95
16-quart ... 2.20
20-quart ... 2.35



CREAM PAILS

These pails are made from 5A Charcoal plate, Mirror Finish, are very strong and durable.

We furnish them in two sizes, with or without Gauge or Faucets and with outside lids.

14-Qt. Without Gauge and Faucet.....\$1.05
20-Qt. Without Gauge and Faucet..... 1.25
20-Qt. With Gauge and Faucet 3.20



DOUBLE BOTTOM CEMENT PAIL

Heavy reinforced Galvanized Cement Pail. \$1.15



WOODEN STABLE BUCKET

J. I. C. Cedar—Heavy ironbound stable bucket. Each.....\$1.50.

WELL BUCKETS

Crown, \$1.00.

Well Bucket Pulleys

10 in.....\$.90
12 in..... 1.00



SANITARY FISH MOUTH DAIRY PAIL



Approved and recommended by State Dairy Inspectors. Used exclusively by many large and practical Dairy-men. Made from finest charcoal plate. One piece retinned top or hood. Steel Bail. Reinforced Ears. All seams sanitary soldered inside and out.

PLATE IXX. HEAVY CHARCOAL

12-quart\$1.45
14-quart 1.55

DAIRY STRAINER PAIL

Coppered Bail. Natural finish Bail wood. Reinforced ears Handle near bottom to use when pouring from pail.

IXX. CHARCOAL PLATE

14-quart\$1.50



MILK PAILS

These pails are extra heavy block tin, heavy steel bail, coppered. Reinforced ears with two rivets. Should not be confused with cheap tin pails.

12-quart Sanitary Soldered Pails 95c.

14-quart Sanitary Soldered Pails \$1.05.

EXTRA HEAVY IXX. BLOCK TIN

12-quart\$.75
14-quart80

HEAVY PAILS

12-quart\$.55
14-quart60



EXTRA HEAVY GALVANIZED PAILS

Made from extra heavy sheets, heavy steel bail, strong ears, are hot dipped galvanized after making, practically indestructible.

12-quart.....\$0.55
14-quart..... .70
16-quart..... .75

Heavy Galvanized Pails

12-quart.....\$0.45
14-quart..... .50



MILK STRAINERS

NEW SANITARY

Milk strainer is made from heavy steel pressed in one piece, has heavy removable steel well tinned discs, between which you use the Sanitary cotton filter pads. This is the heaviest and best sanitary strainer made; 12 quarts. Price....\$1.60



REGULAR STRAINERS

These milk strainers are made of extra heavy tin and brass wire cloth. They are warranted not to rust.

Prices:

4-qt...\$1.10 6-qt...\$1.25 10-qt...\$1.75



MILK CAN BRUSHES

Made of an excellent grade of durable fibre, very full, with solid backs. Unquestionably the best and most serviceable Milk Can Brushes on the market.



No. 416—Stiff Palmetto, brush part 4x5 inches, each.....40c



No. 08—Stiff Palmetto Fibre, length on face 9 inches, width on face 5 inches. Each50c

STABLE OR PUSH BROOMS



These brooms are of the highest quality. Made with heavy blocks. No. 2360—Genuine African Bass, 4 rows.....80c

Factory, Warehouse and Railroad Brooms

These brooms are made with heavy steel bands or heads, securely nailed together. By this method of construction it is impossible for the brooms to work loose on the handles. They will last longer and give better service than the ordinary corn broom.

No. 223—Japanese Fibre, length of broom part 14 inches.....\$0.60
No. 221—Japanese Fibre, length of broom part 16 inches..... .75
No. 200—All-Corn Heavy Warehouse Broom..... .75
No. 211—Corn and Bamboo Broom..... .80



REID CORRUGATED MILK COOLER

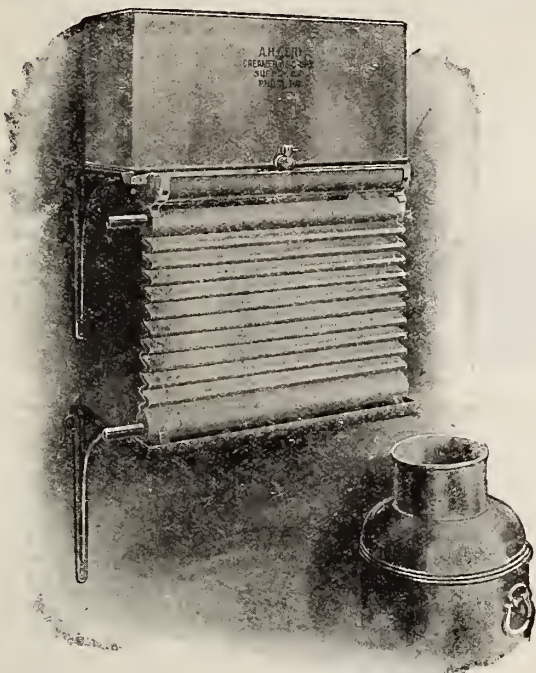

The Reid Corrugated Cooler is made of non-rusting or corroding material. The corrugations or cooling surface are of heavy tinned copper. The heads are made of castings of solid manganese bronze, which is the strongest tin and copper alloy made. The sheets are sweated to the heads and the inlet and outlet are made of seamless tinned brass tubing. The top and bottom troughs are made of tinned copper. The ends are of tinned brass. There is absolutely nothing about the body of the cooler to rust or wear out.

The standard reservoir is made of tinned steel with a sanitary removable plug faucet.

	Cooling capacity in gals. per hr.	Width of body	Capacity of reservoir	Price
No. 1.....	45	12 in.	5½ gals.	\$31.50
No. 2.....	55	15 in.	8 gals.	35.00
No. 3.....	65	18 in.	9 gals.	38.00
No. 4.....	80	21 in.	11 gals.	43.00

REID TUBULAR MILK COOLER FOR FARM USE

(The Pressure Type as Distinguished from the Gravity Type)

Reid Tubular Cooler consists of 17 1-inch tinned copper tubes, tinned brass manifolds, copper troughs and reservoir, double or single waterway, brackets, nipples, brush and tilting spout are standard equipment.

Length of Cooler Tubes	Capacity in Gallons per hour	Total Width	Total Height	Capacity of Reservoir	Price
18 in.	48	24 in.	39	8 gals.	\$57.00
24 in.	64	30 in.	39	10 gals.	63.00
30 in.	80	36 in.	39	12 gals.	69.00
36 in.	96	42 in.	39	14 gals.	75.00

MILK BOTTLE BASKET

These baskets are made from the best grade of flat and round steel wire. The welded joints make them the same as one piece, hence all strain and shocks are distributed over the entire body.

6 bottles.....\$1.75 8 bottles.....\$2.00

HOUSEHOLD LUBRICANT OIL

This very fine oil is put up in small oil cans, ¼-pint sizes, very convenient to use. It is especially adapted for use on sewing machines, lawn mowers, hinges and locks.

¼-pint cans20c

G. & T. CO.'S PERFECTION SEPARATOR OIL

This oil is put up expressly for the use of separators, and we recommend it to users of all hand machines, it being a light oil and having a very low cold test.

1-quart can\$0.40 1-gallon can\$1.25
 ½-gallon can75 5-gallon can5.00

MILK BOTTLES



These bottles are made by a factory devoted especially to bottle making. The glass is clear flint. This makes a bottle that the milk shows up to the best advantage. They are made to stand the rough usage of the street delivery and collection on routes, and washing and sterilizing in the dairy house. These bottles are made with a long neck, and will show a deep cream line.

	Quart	Pint	½ Pint
One dozen	\$1.00	\$0.75	\$0.60
One gross	9.00	6.75	5.50

MILK BOTTLE CAPS

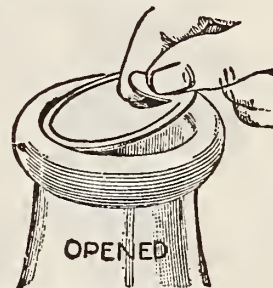

The great convenience of this cap will be appreciated, as it is made with a lift to take the cap out. This prevents spilling the milk, or having to use anything to pry it out.

These caps are made from 40-point thick board, and are thoroughly waterproofed with paraffine.

One thousand\$0.65
 Five thousand3.00

PELOUZE DAIRY SCALE

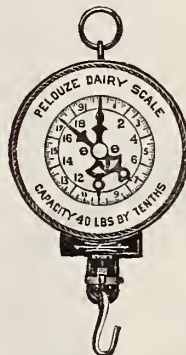

Graduated by Tenths of a Pound. GUARANTEED ACCURATE

Made to comply with Departments of Weights and Measures. Large Circular Brass Dial, with distinct, black figures and graduations.

No. D 40—Capacity, 40 lbs.....\$4.75
 No. D 60—Capacity, 60 lbs.....5.00

DOMINION DAIRY AND HOUSEHOLD CLEANSER



An improved cleanser and purifier for all dairy and household purposes. Just the thing for Churns, Pails and anything used in dairies. For household use, laundry work, all kitchen use, house-cleaning, public buildings, hotels and factories.

Dissolves with greatest ease in either hot or cold water, and rinses off perfectly clean without leaving a soapy scum. Price: 5-lb. bag, 35c.; 25-lb. bag, \$1.50

PARCHMENT BUTTER PAPER

It can be used in all cases where wax paper, tin foil or muslin has been adopted, and in many cases where these cannot, for preserving goods from the effects of moisture, etc. In sheets 24x36, or can furnish the paper cut in the following sizes without extra charge: 6x9 for half pounds, 9x12 for one pound, and 10x15 for two pounds. Price, 25c per pound. By mail 35c.



MICA AXLE GREASE

This is the highest quality of Axle Grease and contains ground mica, which forms a coating on the axle and makes a perfectly smooth surface. After this surface is formed you need use only half as much Mica as of any other axle grease.

Tin Box\$0.15 10-lb. Pail\$1.25
 3-lb. Pail40 25-lb. Pail2.75

THE UNIVERSAL MEAT CHOPPER

The Universal is the most perfect meat chopper on the market. The feed screw is so constructed that it feeds the meat to the knives without mashing it. The knives work against the plate giving a good clean cut, producing the best grade of chopped meat.

- No. 331..... 5.00
- No. 333 5.50
- No. 304 8.75
- Stuffing Attachment for Nos. 331 and 333.....\$1.00
- Stuffing Attachment for No. 304 1.15

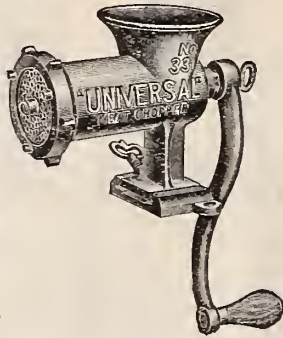

THE UNIVERSAL FOOD CHOPPER

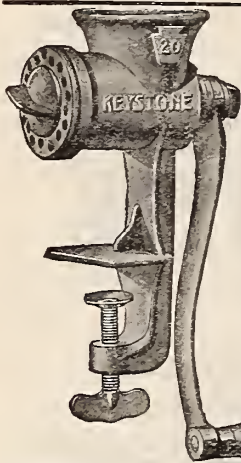

Chops all kinds of meat, raw or cooked, and all kinds of fruits and vegetables.
 No. 0, small family, 3 cutters...\$1.85
 No. 1 2.25

KEYSTONE FOOD CHOPPER

- No. 10, weight 3½ pounds, will chop 1½ pounds meat per minute. Price, each\$1.60
- No. 20, weight 4½ pounds, will chop 2 lbs. meat per minute. Price, each\$1.90
- No. 30, weight 6¼ pounds, will chop 3 pounds meat per minute. Price, each\$2.40
- No. 40\$3.00
- No. 45\$3.00
- Stuffing attachment for No. 20 or 30 Chopper.... 85c

OX BALLS

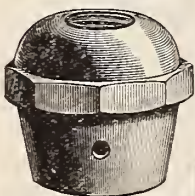

Pair 40c

BULL RINGS

- 2½ - in. Copper Rings ...45c
- 3 - inch Copper Rings ...50c
- Heavy Bull Ring ...\$1.60



Hill's Hog Ringer

- Price 25c
- HOG SNOOT CUTTER, Price\$2.00
- PIG RINGS.....20c
- SHOAT RINGS.....20c
- HOG RINGS, box...20c

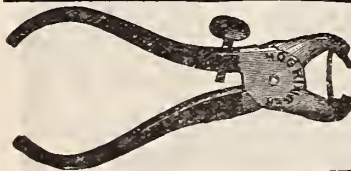

BULL LEADER SNAPS

Price, without pole.....\$1.25

SLIDING KRAUT CUTTER

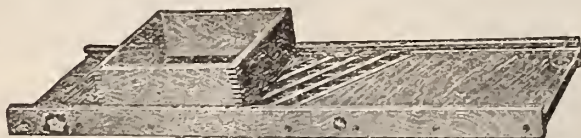

- Sliding Kraut Cutter with Two, Three or Four Knives.
- No. 50—2 Knives, 8x26 inches.....\$2.50
- No. 55—3 Knives, 8x26 inches..... 2.75
- No. 65—3 Knives, 9x30 inches..... 3.75
- No. 80—4 Knives, 13½x40 inches..... 8.00

UNIVERSAL LARD AND FRUIT PRESS AND SAUSAGE STUFFER

PRICES.

- No. 44—4 quarts..\$10.50
- No. 66—6 quarts.. 11.50
- No. 88—8 quarts.. 12.50

This Machine is an unexcelled Lard Press, an equally good Sausage Stuffer, and is also extensively used for pressing the juices from fruit for making jelly, etc. The Universal Press has many advantages over the old style press. It is rigid and strong, and is more easily handled because it is lighter.

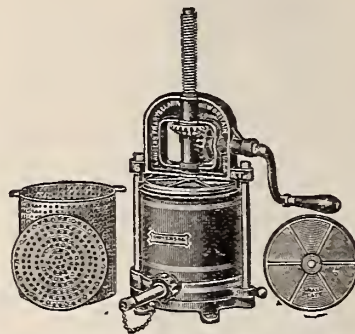

VIRGINIA HOME CAN SEALER

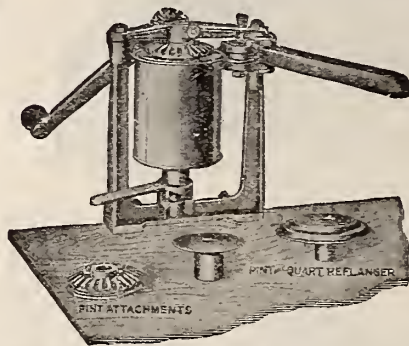

With this Virginia Home Can Sealer it is as easy and cheaply for you to do just as good canning in your own kitchen as if you had the finest canning plant in the world. In fact, you would have as good equipment only on a small inexpensive scale with the additional advantage of having absolutely fresh-picked products to start with.

Price \$21.00

KEYSTONE DEHORNING CLIPPER

The practice of dehorning cattle is coming more into vogue. It is a mercy to the animals. Prevents goring. The blades on the Keystone are made of best steel. No twisting motion or second cut on horn. Parts are all interchangeable, and can be replaced. It is approved by veterinary surgeons and leading dairymen. The horns must go, and they cannot go too soon.

Clipper with leader and rope, extra blades and screw, fully warranted. Our special price.....\$18.00

Clipper alone, our special price.....\$16.00

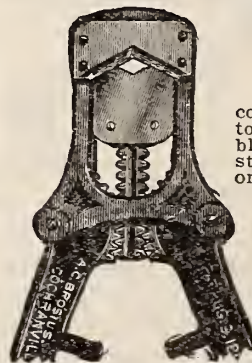

OIL CANS

- No. 77—Straight Spout.
- Bent Spout.
- No. 77—

These oil cans are made from Cold Rolled Steel and have Clock Spring Steel Bottoms.

Price, each, 15c

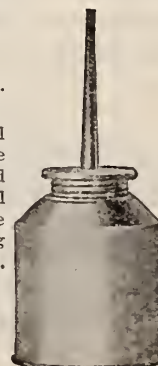

No. 620 — Cop- perized Steel Mowing Machine Oiler.

No. 620 — Bent or Straight Spout.

Price, each, 25c



PERFECTION FABRIC

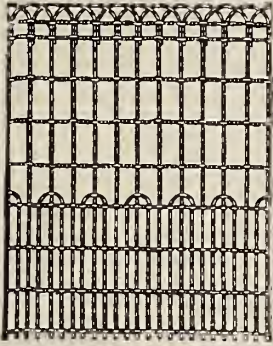

PAGE LAWN FENCE

Page Lawn Fence is designed especially to protect and beautify your property. It harmonizes with its surroundings and adds dignity and a feeling of privacy to your dwelling. Page Lawn Fence not only protects your property but also affords excellent protection for your children. Its construction is such that there is no foothold for children to climb over and it is dog, cat and chicken proof.

Lawn Fence is made of No. 9 heavy galvanized wire spacing between uprights at the bottom, being 1 3/4 inches, and at the top 2 3/4 inches; the cables are of heavily galvanized wire, spaced about six inches apart, except the two at top, which are spaced 2 1/4 inches apart, furnished regularly in rolls of 200 feet. Any length cut to order.

PRICE OF PERFECTION FENCING

Height	List Per Ft.	Our Price
36 inches.....	22c.	14c.
42 inches.....	24c.	15c.
48 inches.....	26c.	17c.

PRICE OF ECONOMY FENCING

Height	List Per Ft.	Our Price
36 inches.....	16c.	10c.
42 inches.....	18c.	11c.
48 inches.....	20c.	12c.

In 200-foot Rolls, 10% from Retail Prices.

ECONOMY FABRIC

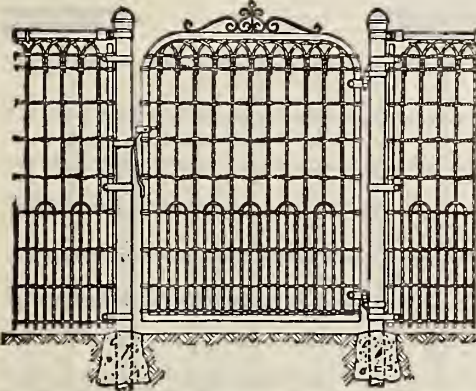
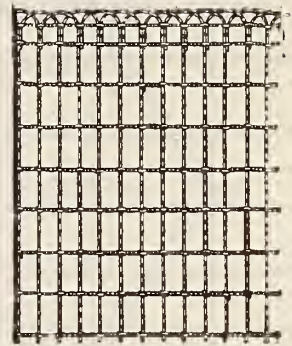

PERFECTION GATES

The frames are made of high-grade heavy steel tubing, and are regularly finished in galvanized frames. Filling of these gates is the regular Perfection Fence Fabric, described at top of page, and as shown by illustrations the gates have ornamental scroll tops. In giving the dimensions of gates, state first the height, and then the width. The width of these gates means the distance between the posts. The factory makes proper allowance for hinges and latch.

WALK GATES

Ht. In.	Width Ft.	List Price	Our Special Price
36	3	\$5.00	\$4.20
42	3	5.20	4.35
48	3	5.40	4.50
36	3 1/2	5.20	4.35
42	3 1/2	5.40	4.50
48	3 1/2	5.60	4.75
36	4	5.40	4.50
42	4	5.60	4.75
48	4	5.80	5.00

SINGLE DRIVE GATES

Ht. In.	Width Ft.	List Price	Our Special Price
36	8	\$12.00	\$10.00
42	8	12.20	10.25
48	8	12.40	10.35
36	10	14.00	11.65
42	10	14.20	11.75
48	10	14.40	12.00
36	12	16.00	13.35
42	12	16.20	13.50
48	12	16.40	13.75

DOUBLE DRIVE GATES

Ht. In.	Width Ft.	List Price	Our Special Price
36	8	\$11.60	\$9.65
42	8	11.80	9.85
48	8	12.00	10.00
36	10	13.60	11.35
42	10	13.80	11.50
48	10	14.00	11.65
36	12	15.60	13.00
42	12	15.80	13.20
48	12	16.00	13.35

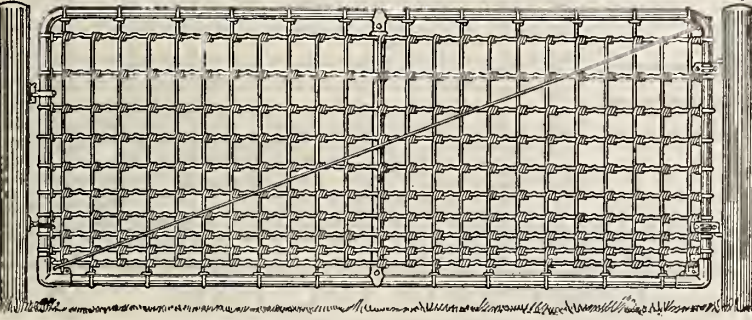

GENERAL PURPOSE FARM GATES

The frame is made from heavy 1 1/4 inch outside dimension tubing. The wire filling is Heavy Galvanized No. 9 Woven Wire. The frames are Galvanized, and electrically welded at the joints, thus insuring a gate that will not sag or twist out of alignment. In addition the gates are strengthened by internal braces.

The fabric is actually woven into the frame and not simply tied in with a lace wire.

Distance Between Posts

Height	10 Ft.	12 Ft.	14 Ft.	16 Ft.
48 inches	\$9.90	\$11.55	\$12.25	\$14.10
54 inches	10.25	11.75	12.85	14.50

PAGE POULTRY GATE

The gate for poultry enclosures where a small opening is desired. The wires are spaced close enough to hold back the smallest chicks. Frames are of 1 1/2-inch tubular steel with No. 12 1/2 gauge galvanized filler.

Distance between posts—3 1/2 ft.

Height	List Price	Retail Price
48 inches in height.....	\$4.10	\$3.50
58 inches in height.....	4.50	3.75
72 inches in height.....	7.05	6.00

TRELLIS

This trellis carries the general style of Perfection Fencing. It is extremely strong, embracing beauty and adaptability. Cut in any length desired.

Width	List Price	Our Price
18 inches.....	14c	9c
24 inches.....	16c	10c

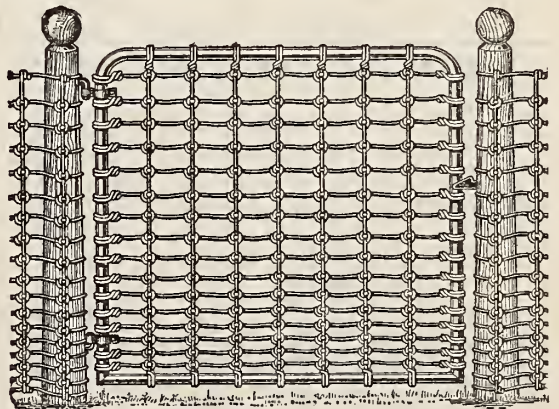
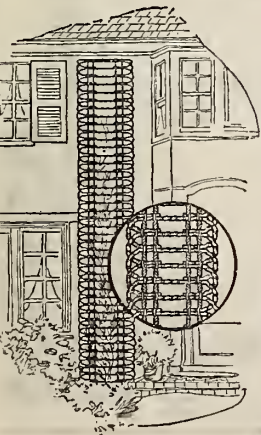

PERFECTION FLOWER-BED GUARD

18 inches and 12 inches above ground. Has 3 cables of two No. 13 wires. Has No. 9 crimped uprights. All heavy galvanized pickets project for insertion in ground. Requires no posts. Can be cut to length to any bed. It provides protection against dogs and chickens.

Height	Foot
18 inches above ground, list.....	13c
Our special price.....	8c
12 inches above ground, list.....	11c
Our special price.....	7c

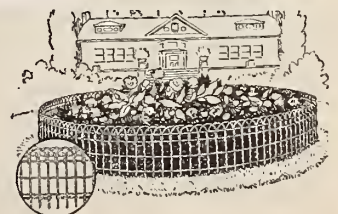

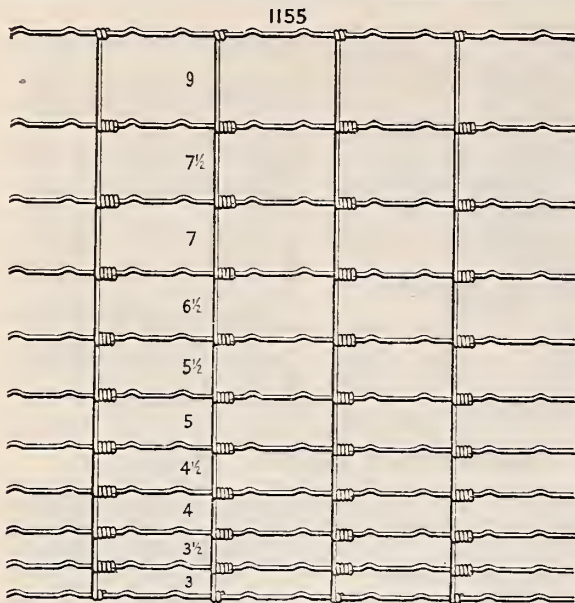

PAGE POULTRY AND GARDEN FENCE

It is an ideal fence against poultry and small animals. The spacing is graduated from 1 1/2 inches at the bottom to 5 1/4 inches at the top, as shown by the illustration and the distance between the stays or uprights is 6 inches. It is a great favorite. Furnished regularly in rolls containing 10 rods or 165 lineal feet.

Style No.	Distance Between Stays	Height, Inches	Approx. Weight per Rod	Retail Price per Rod
2371	6	73	11.4	\$0.74
2160	6	58	10.3	.68
1949	6	48	9.2	.62
1635	6	35	7.6	.49

ACTUAL SIZE OF WIRES

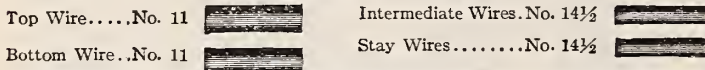

CATTLE FENCE

This is an ideal horse and cattle fence and is used largely for division fences. The stays are 12 inches apart, and we do not recommend its use for hogs. The top bar is No. 9, the bottom No. 9, the intermediate bars are No. 11 and the stays are No. 11 wire.

Style Number	Height in Inches	12-inch Stays, Approx. Weight per Rod, Pounds	Retail Price per Rod
949	49	10.3	\$0.53
845	45	9.3	.47
635	35	7.2	.38

GALVANIZED STEEL FENCE POSTS

These posts are neat, strong, durable and easy to erect. They will give you much more and better service than can be expected of wood posts because all being alike in size and quality of material, you get benefit of every post in the fence from year to year, while wood posts rot and decay. The line posts are strong enough to hold up any wire fencing, and furnish all necessary resistance. The end and corner posts are so strong that they will maintain any wire fence made.

Nos.	Length in Feet	Approx. Weight in Lbs.	Special Prices, Per Post
14 1/2 Line Post	5	7.4	\$.66
14 1/2 Line Post	6	8.4	.72
14 1/2 Line Post	6 1/2	9.3	.75
14 1/2 Line Post	7	10.	.82
14 1/2 Line Post	8	11.4	.97
8 End Post	7	51.	4.00
8 End Post	8	59.	4.50
8 Corner Post	7	75.	5.90
8 Corner Post	8	86.	6.35
Junior End Post	6		2.15
Junior End Post	8		2.55
Junior Corner Post	6		3.20
Junior Corner Post	8		3.90
Ball Top for Line Posts			.23
Ball Tops for End and Corner Posts			.50
Driving Caps for Line Posts			.50



PAGE GENERAL PURPOSE FENCE

The Name PAGE to Fence is What Sterling Means to Silver. The Page Steel and Wire Company steadily maintains a quality so high that its fence has always been a standard by which good fence is judged. As a result of this policy the first small building has grown into an immense plant covering many acres. Page Fence has been serving its owners honestly and faithfully for many years. To you, Page offers a long-time investment that will pay dividends in service and utility long after ordinary fence has passed into discard.

Style No.	Height in Inches	Approx. Weight Per Rod, Pounds	12-inch Stays, Retail Price, Per Rod	Approx. Weight Per Rod, Pounds	6-inch Stays, Retail Price per Rod
1155	55	12.2	\$0.61	16.7	\$0.86
1047	47	10.9	.55	14.8	.75
939	39	9.7	.49	13.1	.68
832	32	8.6	.44	11.4	.58
726	26	7.5	.39	9.8	.50

ACTUAL SIZE OF WIRES

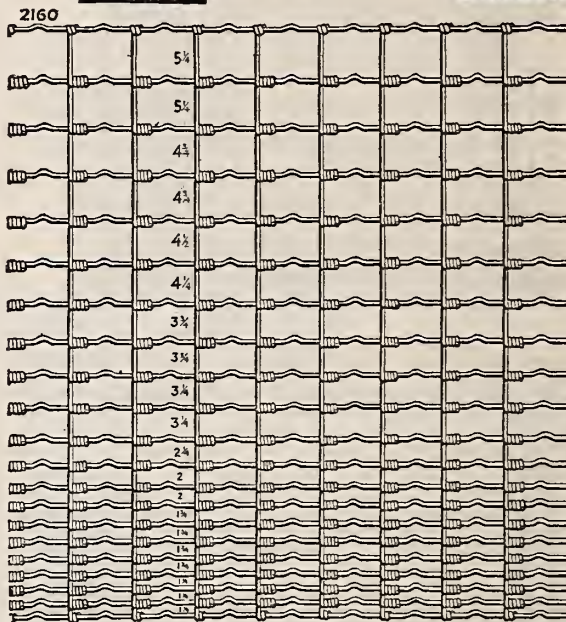
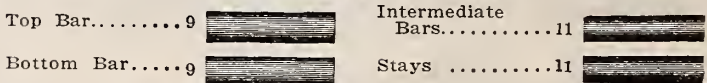

SWEET'S STEEL FENCE POSTS

This Year's Best Seller

A special high carbon steel post of extreme rigidity, for all types of fence construction. The design of these posts is a flanged leg channel section which assures maximum strength from an extraordinarily high section modulus. In addition to actual tests for strength to withstand the maximum bending strains of heavy weights and wind loads, these posts are further satisfying a need apparent to engineers, builders, manufacturers and property owners, for:

**Superior Strength Attractive Appearance
Maximum Durability Unequaled Economy**

These posts are heartily recommended for use with Field Fences of all types—Poultry, Garden, Arbor, Residences and Estates.

Sweet's Line Post with Ground Plate

Length	Weight	Price
3 ft.	4.38 lbs.	\$0.20
5 ft.	6.63 lbs.	.34
6 ft.	7.75 lbs.	.39
6 1/2 ft.	8.31 lbs.	.43
7 ft.	9.13 lbs.	.47
7 1/2 ft.	9.69 lbs.	.50
8 ft.	10.25 lbs.	.55
9 ft.	11.38 lbs.	.60
10 ft.	12.50 lbs.	.65
End Posts		
6 ft.	40.50 lbs.	2.50
7 ft.	42.75 lbs.	2.65
8 ft.	45.00 lbs.	3.00
10 ft.	49.50 lbs.	3.50
Corner and Two-Way Brace Posts		
6 ft.	67.50 lbs.	4.20
7 ft.	69.75 lbs.	4.50
8 ft.	72.00 lbs.	4.80
10 ft.	76.50 lbs.	5.50



DIAMOND MESH POULTRY NETTING

The wire we offer is No. 20, double twist, 2-inch mesh, thoroughly galvanized. Sold in bales of 150 running feet.

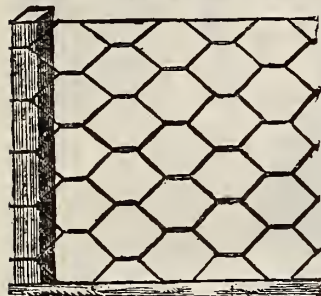

Galvanized After Weaving

No.	Inches Wide	Sq. Feet	Price Per Bale
20	12	150	\$1.05
20	18	225	1.50
20	24	300	1.90
20	36	450	2.60
20	48	600	3.45
20	60	750	4.30
20	72	900	5.10

Price 1½¢ per square foot in less than bale lots.

Staples for fastening, 10¢ per pound.

One Inch Mesh

1-inch Mesh Galvanized after Weaving

No.	Inches wide	Sq. ft.	Retail Price
No. 20	12 in. wide	150 sq. ft.	\$2.35 per bale
No. 20	18 in. wide	225 sq. ft.	3.35 per bale
No. 20	24 in. wide	300 sq. ft.	4.30 per bale
No. 20	36 in. wide	450 sq. ft.	5.85 per bale
No. 20	48 in. wide	600 sq. ft.	7.75 per bale
No. 20	60 in. wide	750 sq. ft.	9.70 per bale
No. 20	72 in. wide	900 sq. ft.	11.65 per bale

GALVANIZED STEEL WIRE CLOTH

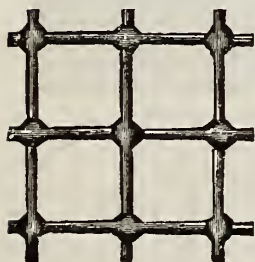

Made from heavy wire thoroughly galvanized after weaving. This insures long life, as every part of the wire is coated by the dipping process.

Used largely in corn cribs to make them mice and rat proof, also for sieves and fan screens and over windows for protection.

We carry it in stock in widths 2, 2½, 3 and 4 foot.

The word mesh means number of meshes to the inch (2x2, 2 to the inch; 4x4 mesh, 4 to the inch, etc.) Full rolls contain 100 running feet.

PRICE.	Full Rolls.	Less Than Full Rolls.
2x2 Mesh, per sq. ft.	\$0.04¼	\$0.05
3x3 Mesh, per sq. ft.	.04½	.05½
4x4 Mesh, per sq. ft.	.04¾	.06

"COTTAGE" LAWN AND GARDEN FENCE



This Fencing
IS
STRONG ENOUGH
FOR
LARGE ANIMALS,
AND
Small ones cannot pass
THROUGH THE
Fine Meshes.

Height, inches.	List Price, per rod.	Our Price, per rod.
24	\$2.00	\$1.20
36	3.00	1.80
48	4.00	2.40
60	5.00	3.00
72	6.00	3.60

GALVANIZED GATE HINGES and LATCHES

No. H1—Walk Gate Hinge Eye.....	1½ in. O. D.	\$0.50
No. H3—Walk Gate Hinge Eye.....	1½ in. O. D.	.45
No. H7—Post Hinge Hook.....	2 in. O. D.	.50
No. H9—Heavy Post Hinge Hook.....	2½ in. O. D.	.75
No. C105—2 Way Latch.....	2½ in. O. D.	.75
No. C102—2 Way Complete Latch.....	2 in. O. D.	.50
Pig Ear Latch.....	2 in. O. D.	.80
Pig Ear Latch.....	2½ in. O. D.	.90
Spring Latch for Walk Gate.....		.60
Spring Latch for Drive Gate.....		.65

Removable Steel Clothes-Line Post. No. 1



Complete with base, our special price, \$2.75

WIRE STRETCHER

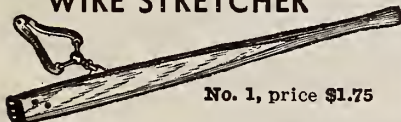

No. 1, price \$1.75

Trash Burner or Consumer

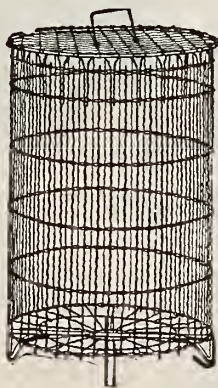

The best way to dispose of your waste paper and rubbish is to burn it in a Consumer. Avoids danger and helps to keep the yard and lawn clean from litter.

No. 1—19 in. dia., 30 in. high \$2.50

No. 2—17 in. dia., 24 in. high \$2.00

The Improved "Neverslip" Stretcher



The Neverslip Stretcher has no teeth to cut or injure wire. Simple and strong in construction. Made of strong, Malleable Iron and will last a lifetime. One man operates it, and both hands are left to drive staple. Price.....\$1.25

FOLDING CLOTHES DRYER

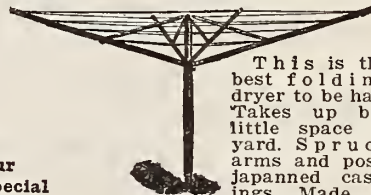

This is the best folding dryer to be had. Takes up but little space in yard. Spruce arms and post, Japanned castings. Made in two sizes.

Our Special Price:

Economy Clothes Dryer.....\$9.00
No. 2 Economy Clothes Dryer....10.00

LOTT STRETCHER

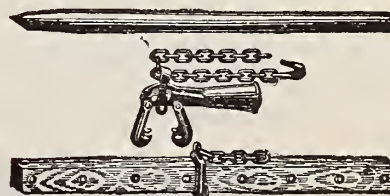

AM. S. & W. CO.

Clamp Bars made of reinforced half-oval iron to keep wire from slipping.

Lott Stretcher furnished complete except Lever. Use for this purpose an old piece of pipe or lever cut from wood.

Price \$10.00

BARBED WIRE

Write for Prices



CERTAIN-TEED ROOFING

—guaranteed 5, 10 or 15 years for No. 1, 2 or 3 respectively—backed by the responsibility of the World's greatest and biggest Roofing and Building Mills. The **Certain-teed** label on this Roofing stands for a definite guaranteed service—a protection for you. Why try to save a dollar or two by putting on a cheap Roof that is not guaranteed when you can buy **Certain-teed** for just a little more money and get much longer service on your Roof. In the long run it's less expensive to buy **Certain-teed**.

- No. 1, 108 square feet.....\$1.25
- No. 2, 108 square feet..... 1.60
- No. 3, 108 square feet..... 2.00
- No. 4, 108 square feet.....2.40

GUARD ROOFING

GUARD (Special Quality)

This roofing is offered as a good average quality product. It will give good service on the roof. Where the highest quality roofing is not necessary this product is recommended.

- No. 1—Light, about 35 lbs., per square....\$1.10
- No. 2—Medium, about 45 lbs., per square.. 1.40
- No. 3—Heavy, about 55 lbs., per square.... 1.70

CORPORAL (Competition Quality)

Not a quality product.

Made to meet price competition. Should be sold only where price is the principal consideration.

- No. 1—Light, about 35 lbs., per square....\$1.00
- No. 2—Medium, about 45 lbs., per square.. 1.25
- No. 3—Heavy, about 55 lbs., per square.... 1.50

SLATESURFACED ROLL ROOFING

Certain-teed Extra Quality

BLUE-BLACK, RED, OR GREEN

Weight, 90 lbs., Guaranteed 10 Years, per square.....\$2.25

MAJOR REGULAR QUALITY

BLUE-BLACK, RED, OR GREEN

Weight, 80 lbs., Guaranteed 8 Years, per square.....\$2.00

SLATER'S FELT

500 square foot rolls, 30 pounds......95c

INSULATING PAPER

500 square foot rolls, 35 pounds.....\$2.20

TARRED FELT

No. 15—Rolls 432 square feet, 65 pounds.....\$2.65

ROSIN SIZE SHEATHING PAPER

In Rolls of 500 Square Feet Each.

- 20-lb. Sheathing Paper, per roll of 500 square feet.....\$.65
- 30-lb. Sheathing Paper, per roll of 500 square feet..... .95
- 40-lb. Sheathing Paper, per roll of 500 square feet..... 1.30

Galvanized Steel Corrugated Roofing

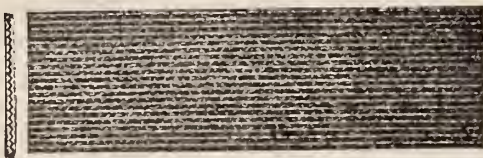

1½ and 2¼-inch corrugations, standard 29 gauge open hearth steel thoroughly galvanized. Made in sheets 26 inches wide; 6, 7, 8, 9 and 10 feet long. 12-foot sheets 25c. a square extra. Galvanized Ridge Roll, both in corrugated and plain. No. 29 Gauge. Per Square.....\$4.75
 Ridge Roll, Plain, Per Foot......10
 Ridge Roll, Corrugated, per foot......12

Certain-teed 4-Width Shingle

Blue-Black, Red or Green.

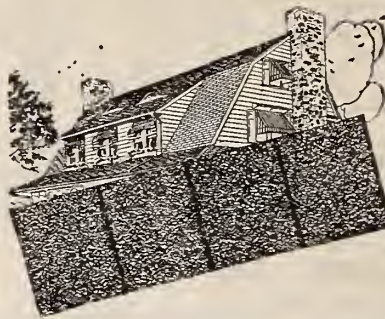

These shingles, when properly laid, offer weather protection in all climates. They are unaffected by atmospheric changes or by heavy rain or snow. Extreme heat or cold will not materially cause them to expand or contract. As an insulator they keep the house cooler in summer and warmer in winter.

Marked exactly 4 inches from the butt for spacing.

Weight about 196 lbs. Size 10x36 inches. Put up two packages per square.

Guaranteed 10 years, per square.....\$6.00

CERTAIN-TEED STRIP SHINGLES
SLATE SURFACED

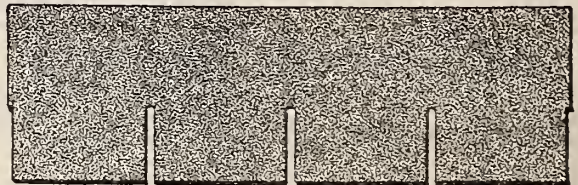

RED, BLUE BLACK AND GREEN

These shingles possess all the durability, attractiveness, weather protection and fire-resisting qualities of the modern asphalt shingle—plus 50 per cent, or more saving in the cost of application, because they can be laid so quickly.

Four shingles laid at a time—no spacing—no chalk line—one-half less nails—one-half less nail holes—four-fifths less cracks—no painting—no repairs.

CERTAINTEED STRIP SHINGLES are water-proofed, with pure refined asphalt. The wearing surface is natural chipped slate in handsome blue-black red and green colors. The colors are absolutely permanent.

Price, per square.....\$6.25

CERTAIN-TEED HEXAGONAL SHINGLES

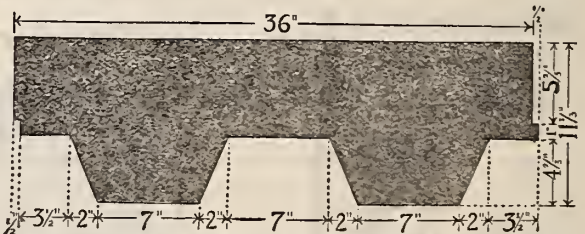

BEAUTY AND PERMANENCE FOR YOUR ROOF

The **Certain-teed Hexagonal Slab Shingle** is a shingle of beauty and permanence. It is made of highest grade, long-fibered felt, heavily saturated with asphalt, and surfaced with a rugged coat of natural colored crushed slate. This surface cannot fade but will always add the same pleasing touch of color to your home.

Price, Blue-Black, Red or Green.....\$5.00
 Color-Blend 5.50

CERTAIN-TEED SPEEDLAY SHINGLES

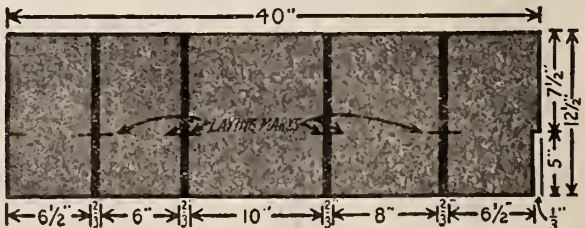

Certain-teed Speedlay Shingles are the very latest in roofing materials—they satisfy every demand of modern roofing, and they are way ahead of any other shingle on the market. Colors—rich in delightful assortments of pleasingly irregular design, adaptable to the taste of any artist, any architect. Self-spacing, with fewer nails used, moderately priced.

12½x40, Weight 200 pounds to square
 Red Cast, per square.....\$7.00
 Green Cast, per square..... 7.00



Certain-teed PAINT

HOUSE PAINTS

	Gals.	½ Gals.	Qts.	Pts.
400 Inside Gloss White	\$3.30	\$1.75	\$0.90	\$0.51
401 Silver Gray	3.05	1.50	.87	.48
402 Gray Tint	3.05	1.50	.87	.48
404 Steel Gray	3.05	1.50	.87	.48
408 Light Slate	3.05	1.50	.87	.48
412 Light Blue	3.05	1.50	.87	.48
414 Blue	3.05	1.50	.87	.48
415 Royal Blue	3.80	2.00	1.06	.57
416 Cream	3.05	1.50	.87	.48
418 Colonial Ivory	3.05	1.50	.87	.48
419 Primrose Yellow	3.05	1.50	.87	.48
424 Warm Buff	3.05	1.50	.87	.48
425 Rich Buff	3.05	1.50	.87	.48
431 Crimson Red	3.55	1.86	.99	.55
434 Golden Brown	3.05	1.50	.87	.48
435 Bungalow Brown	3.05	1.50	.87	.48
437 Brown	3.05	1.50	.87	.48
440 Apple Green	3.05	1.50	.87	.48
441 Nile Green	3.55	1.86	.99	.55
443 Window Blind Green	3.20	1.50	.87	.48
444 Olive Green	3.55	1.86	.99	.55
446 Dark Bronze Green	3.05	1.50	.87	.48
448 Outside White	3.30	1.75	.92	.51
449 Inside White	3.30	1.75	.92	.51



Stain—Varnish

Covering capacity about 500 to 600 sq. ft. per gallon, one coat. Dries dust-free in from 4 to 5 hours and hard overnight.

	Gals.	½ Gals.	Qts.	Pts.	½ Pts.	¼ Pts.
30 Ground Color	\$2.60	\$1.40	\$.76	\$.43	\$.27	\$.16
31 Mahogany	3.60	1.90	1.00	.55	.32	.20
32 Light Oak	3.60	1.90	1.00	.55	.32	.20
33 Dark Oak	3.60	1.90	1.00	.55	.32	.20
34 Walnut	3.60	1.90	1.00	.55	.32	.20
35 Cherry Red	3.60	1.90	1.00	.55	.32	.20
36 Golden Oak	3.60	1.90	1.00	.55	.32	.20

Flat Wall Paint

Covering capacity, one coat, about 700 sq. ft. per gallon on smooth plaster, and about 500 to 600 sq. ft. per gallon on rough plaster.

No.	Gals.	½ Gals.	Qts.	Pts.	½ Pts.
470 Pearl Gray	\$2.30	\$1.26	\$0.68	\$0.40	\$0.25
476 Royal Tan	2.30	1.26	.68	.40	.25
478 French Gray	2.30	1.26	.68	.40	.25
479 Old Rose Tint	2.30	1.26	.68	.40	.25
481 Pea Green	2.30	1.26	.68	.40	.25
485 Pale Green	2.30	1.26	.68	.40	.25
486 Ivory Tint	2.30	1.26	.68	.40	.25
488 Buff Stone	2.30	1.26	.68	.40	.25
489 Cream	2.30	1.26	.68	.40	.25
494 Pink Tint	2.30	1.26	.68	.40	.25
495 Light Buff	2.30	1.26	.68	.40	.25

Floor, Porch and Deck Enamel

Covering capacity about 250 to 300 square feet per gallon, two coats.

	Gals.	½ Gals.	Qts.	Pts.
575 Light Gray	\$3.10	\$1.66	\$0.88	\$0.50
576 Silver Gray	3.10	1.66	.88	.50
579 Medium Lead	3.10	1.66	.88	.50
581 Dark Oak	3.10	1.66	.88	.50
582 Brown	3.10	1.66	.88	.50
583 Dark Mahogany	3.10	1.66	.88	.50
585 Light Oak	3.10	1.66	.88	.50

Certain-teed Asphalt Roof Coating

1-gal. can 60c—5-gal. can \$2.35—50-gal. bbl. \$18.50

Certain-teed Asbestos Roof Coating

1-gal. can 61c—5-gal. can \$2.40—50-gal. bbl. \$19.00

Certain-teed Plastic Cement

Leaks in new or old roofs of wood, metal, slate, tile or prepared roofing may be repaired quickly, easily and permanently with Certain-teed Plastic Cement. It is excellent also for flashing around chimneys, metal cornices and skylights; for re-lining old gutters and metal valleys; and for use at all other points where there are leaks, holes, breaks, or cracks caused by contraction or expansion, or where the material has worn out or broken away.

1-lb. pkgs.	\$0.15	25-lb. pkgs.	1.85
5-lb. pkgs.	.45	50-lb. pkgs.	3.00
10-lb. pkgs.	.80	275-lb. pkgs.	11.40
		450-lb. pkgs.	20.25

Interior Enamel

	Gals.	½ Gals.	Qts.	Pts.	½ Pts.
600 Gloss White	\$4.00	\$2.10	\$1.10	\$.60	\$.35
604 Light Ivory	4.00	2.10	1.10	.60	.35
605 Pink	4.00	2.10	1.10	.60	.35
606 Puritan Gray	4.00	2.10	1.10	.60	.35
607 Blue	4.00	2.10	1.10	.60	.35
608 Light Blue	4.00	2.10	1.10	.60	.35
609 Cream	4.00	2.10	1.10	.60	.35
610 Green Tint	4.00	2.10	1.10	.60	.35
612 Light Gray	4.00	2.10	1.10	.60	.35

Stain—Shingle

1 Bungalow Brown	\$1.30	\$1.35
2 Weathered Brown	1.30	1.35
4 Moss Green	1.30	1.35
5 Sylvan Green	1.30	1.35
6 Silver Gray	1.60	1.65
8 White	1.30	1.35
9 Light Green	1.30	1.35

Barn, Bridge and Roof Paint

	Price Per Gallon	5 Gal. Cans	1 Gal. Cans
461 Red	\$1.30	\$1.35	
462 Green	1.40	1.45	
466 Bright Red	1.80	1.85	

VARNISHES

Covering capacity of all varnishes from 600 to 700 square feet per gallon, one coat.

Universal Varnish

Unexcelled for all general interior and exterior purposes. This varnish is a very superior product and gives satisfaction in all its many uses. It is pale in color, highly lustrous, waterproof and weather-resisting, very tough and elastic. Can be rubbed and polished if desired. Will dry dust-free in from 4 to 6 hours and hard overnight.

	Gals.	½ Gals.	Qts.	Pts.	½ Pts.
900 Universal Varnish	\$4.00	\$2.10	\$1.10	\$0.60	\$0.35

Floor Varnish

Dries dust-free in 3 hours, and dry enough overnight to be walked upon.

	Gals.	½ Gals.	Qts.	Pts.	½ Pts.
911 Floor Varnish	\$3.35	\$1.80	\$0.95	\$0.52	\$0.31

Interior Spar Varnish

Dries dust free in about 4 hours, and hard in 18 to 20 hours, rubbed in about 72 hours.

	Gals.	½ Gals.	Qts.	Pts.	½ Pts.
916 Interior Spar	\$3.35	\$1.80	\$0.95	\$0.52	\$0.31

Shellac

Pure Shellac, cut in alcohol.

	Gals.	½ Gals.	Qts.	Pts.
931 Orange	\$2.55	\$1.40	\$0.75	\$0.42
932 White	3.15	1.90	.90	.52

PAINT BRUSHES



VARNISH BRUSHES

1 in. Harmony Varnish	\$0.15
1½ in. Harmony Varnish	.25
2 in. Harmony Varnish	.30
2 in. Loyal Varnish	.35
2½ in. Loyal Varnish	.45
3 in. Loyal Varnish	.65
No. 1 Stag Varnish	.30
No. 2 Stag Varnish	.40
No. 3 Stag Varnish	.55
No. 4 Stag Varnish	.70
No. 5 Stag Varnish	.90
No. 2 Sash	.15
No. 4 Sash	.20
No. 6 Sash	.30
No. 10 Sash	.50

WALL BRUSHES

3 in. Ching Wan	\$0.60
3½ in. Ching Wan	.85
4 in. Ching Wan	1.10
4 in. O. K. Diamond Wall	2.25
4 in. Diamond Wall	2.00

CELEBRATED CROSS-CUT SAWS



Narrow American

5 ft.—Our Special Price.....\$1.85
 5½ ft.—Our Special Price..... 2.10
 6 ft.—Our Special Price..... 2.25

Narrow Champion

5 ft.—Our Special Price.....\$1.60
 5½ ft.—Our Special Price..... 1.75
 6 ft.—Our Special Price..... 1.95



Wide Back Saws

WIDE AMERICAN TOOTH

5 ft.—Our Special Price.....\$2.95
 5½ ft.—Our Special Price..... 3.25
 6 ft.—Our Special Price..... 3.60

CHAMPION TOOTH

5 ft.—Our Special Price.....\$2.65
 5½ ft.—Our Special Price..... 2.95
 6 ft.—Our Special Price..... 3.20

Price of Cross-Cut Saw is Without Handle.

Climax Handles, 40c per Pair.

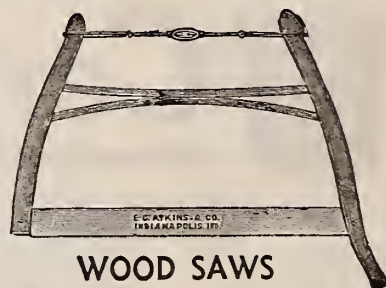

WOOD SAWS

No. 617—Wood brace frame, single rivet, painted red, plain tooth, breasted blade, 2½ inches wide. **Special price \$1.25**
 No. 523—Wood brace frame, single rivet, selected stock, high finish, painted red, jumbo rod tinned, Tuttle tooth, breasted blade, 2¼ inches wide. **Our special price \$1.50**
 No. 923—Jumbo rod tinned, Tuttle tooth blade, breasted, 2¼ inches wide. Double brace, double riveted. Painted vermilion and varnished. **Our special price \$1.55**

JUMBO 705 ALL STEEL SAW FRAME

BUILT ESPECIALLY FOR USE WITH 1½-3 H. P. MOTOR

The Frame of the 705 is strong and rigid, being made of 1¼" x 1½" x 3/16" angle steel. It has a swinging table, with steel angle legs and heavy hardwood table top, provided with steel brackets. The frame is well braced and will not get out of alignment.

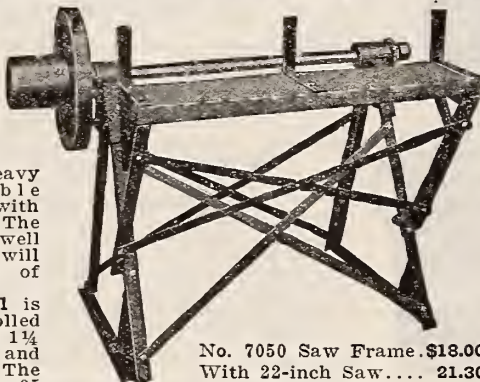

The Mandrel is of cold rolled steel shafting, 1¼ in. diameter, and 42 in. long. The flywheel weighs 35 pounds. The shipping weight of the 705 is 150 pounds.

No. 7050 Saw Frame. \$18.00
 With 22-inch Saw.... 21.30

FORDSON FARM-ALL AND McCORMICK-DEERING TRACTOR SAWING OUTFIT

SPECIFICATIONS

Mandrel—Cold rolled steel shafting, 36 inches long, 1½-inch diameter with arbor machined for saws having 1¾-inch hole. The mandrel washers are large and accurately machined.

Bearings—Ball and socket type. Self aligning. Can be adjusted to take up wear.

Pulley—Eight inches in diameter with 6-inch crown face. This pulley was designed especially for use with our Fordson Saw Attachments.

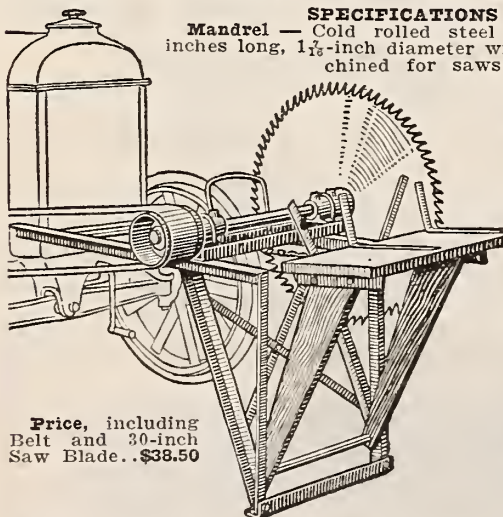

Price, including Belt and 30-inch Saw Blade...\$38.50

Belt—When specified we furnish a high-grade rubber belt 15 feet 2 inches long, which gives splendid satisfaction. A simple arrangement is provided for tightening belt when necessary.

Blade—When specified we can furnish cordwood blades in any size up to and including 30 inches. They are filed and set, ready for immediate use, and are fully guaranteed. We recommend the 30-inch size, which will be found most satisfactory for average conditions.

ONE MAN CROSS-CUT SAW



Champion—3 ft. \$1.95, 3½ ft. \$2.25, 4 ft. \$2.65

NO. 700 WITH TILTING TABLE

Built specially for sawing poles and cord wood with ease and in fastest time. Mandrel of finest cold rolled steel. 1½ in. diameter, 49 in. long—fitted for saw with 1¾ in. hole. Flywheel is accurately machined and carefully balanced, 10½ in. diameter, weight 65 pounds. Standard pulley, size 6x6 in. Special Self - Aligning Bearings lubricated with hard oilers; securely bolted together.

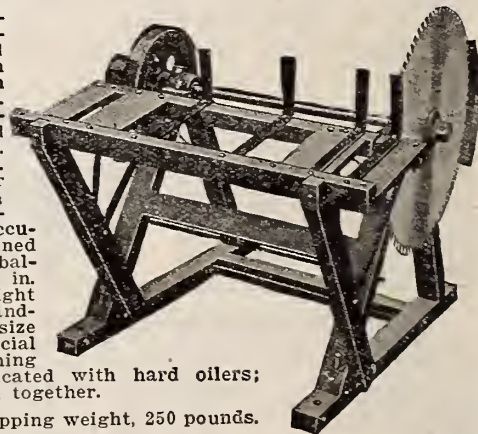

Complete shipping weight, 250 pounds.

Without Saw Blade...\$25.75	With 26-inch Saw....\$30.30
With 22-inch Saw.... 29.05	With 28-inch Saw.... 30.80
With 24-inch Saw.... 29.65	With 30-inch Saw.... 31.50

GRITCO CIRCULAR SAWS



These Saws are the result of over 50 years' study and experience. Absolutely the best steel is invariably used and each blade is given a tough, even temper and perfect tension, all of which is essential to the successful running of the saw. The workmanship of these blades is unequalled. The prices given are for saws sharpened and set. All blades with 1¾-inch hole.

	Retail
22-inch, No. 12 gauge...	\$3.30
24-inch, No. 11 gauge...	3.90
26-inch, No. 11 gauge...	4.55
28-inch, No. 10 gauge...	5.05
30-inch, No. 10 gauge...	5.75

**Griffith & Turner
Ball-Bearing
Grindstone**

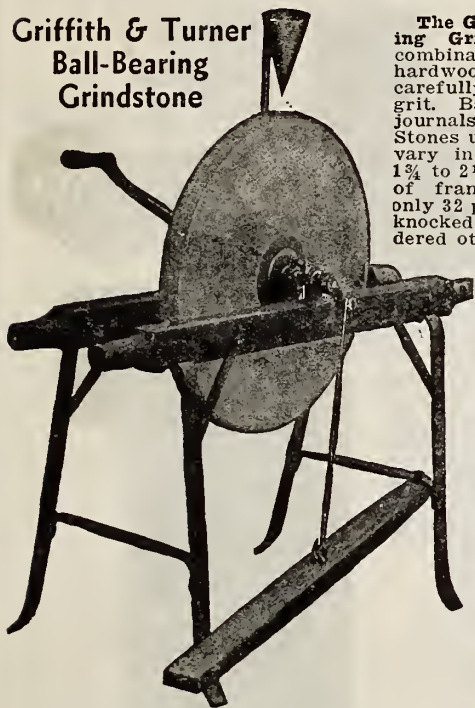

The G. & T. Ball Bearing Grindstone has a combination steel and hardwood frame. Stone carefully selected Berea grit. Ball-bearing steel journals and axles. Stones usually furnished vary in thickness from 1 1/4 to 2 1/4 inches. Weight of frame and fixtures only 32 pounds. Shipped knocked down unless ordered otherwise. If crated, an additional charge will be made.

No. 1 Stone, 90-110 pounds, each\$9.75

No. 2 Stone, 70-80 pounds, each\$8.75

No. 3 Stone, 40-50 pounds, each\$8.00

We carry a full line of loose stones.

Prices: From 40 lbs. to 200 lbs., per lb. 5c. Under 40 lbs., per lb., 5 1/2c. Over 200 lbs., per lb., 6c.

**GRITCO
BALL-BEARING
GRINDSTONE**

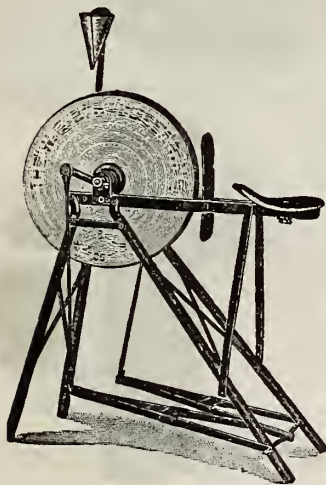

is one of the strongest built, and is practically indestructible, price\$8.75

**CAST GRINDSTONE
FIXTURES WITH SHAFT**

15-in., per set.....\$0.80
17-in., per set..... .90
19-in., per set..... 1.00

**HARVEST KING POWER
GRINDSTONE**

The frame is constructed of heavy angle steel strongly braced. It is equipped with high-grade selected Grindstone 24 in. by 2 in., furnished with 12-in. pulley with 2 3/8-in. face, and heavy steel roller bearings, drip cup and hand cranks.

The frame is shipped folded complete, stone crated, to save freight. Weighs about 125 lbs.

Price, regular, which includes 24 in. by 2 in. Stone, 12 in. x 2 3/8 in. Pulley, Hand Crank, and Drip Cup.....\$13.50

EXTRAS

Trough 1.75
Treadle, Pitman and Bearing 1.75

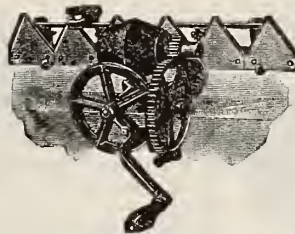
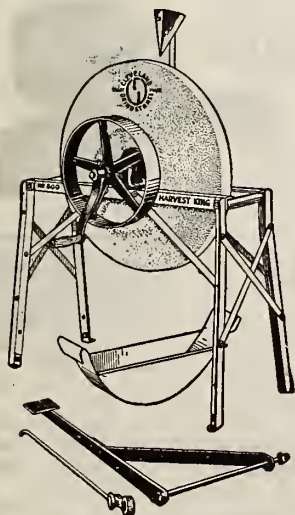

**No. 82 Sickle and Tool
Grinder**

The No. 82C Grinder is a simple, compact and serviceable hand-power sickle and tool grinder especially suited to farm work. It can be clamped either to a mower wheel or to a bench. The tool wheel is 4 1/4 x 1 1/2 inches.

83—With Bevel and Flat Tool Wheel.....\$7.00
82—With Bevel Wheel..... 6.00

TOOL GRINDERS

Domestic Kitchen Grinder, with smooth stone for sharpening knives \$2.25

No. 24—It is equipped with a 4x1-in. Grinding Wheel, and is intended for a Household Grinder. Weighs 6 lbs. boxed. Price\$3.10

No. 25—It is equipped with a 5x1-in. Grinding Wheel, and will be found a very handy tool for mechanics. Weighs 7 lbs. boxed. Price.....\$3.80

No. 26—It is equipped with a 6x1-in. Grinding Wheel. Weighs 11 lbs. boxed. Price\$5.10



NO. 309-C POWER BENCH GRINDER

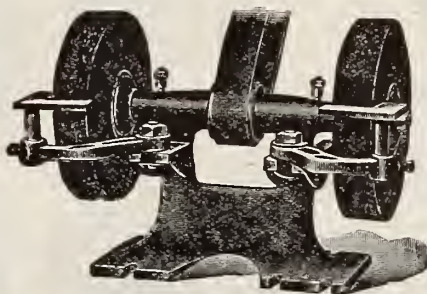

This grinder is constructed along the best mechanical lines. It can be bolted to any bench and its heavy design makes it the ideal grinder for power of any sort. It is equipped with two sharpening wheels of Light Dimo-Grit, 7 inches in diameter and 1 1/4 inches wide, one medium grit and the other coarse, and two univer-

sally adjustable tool rests. Weight, boxed, 32 lbs., price \$14.00
No. 306 Power Bench Grinder..... 7.00

**ALFALFA
BELTING**

Alfalfa water - proof belting is a belt woven especially with a view of obtaining great tensile strength. Nothing but the finest long, staple cotton is used.



	Our List Price
2-in., 4-ply, ft.	\$0.46 \$0.18
3-in., 4-ply, ft.	.65 .25
4-in., 4-ply, ft.	.82 .30
5-in., 5-ply, ft.	1.28 .50
6-in., 5-ply, ft.	1.53 .60

RAW-HIDE BELT LACING

3/8-in., per ft.....3c
1/2-in., per ft.....4c
5/8-in., per ft.....5c

BALING TIES



SINGLE LOOP BALE TIES—9 1/2-ft., No. 14.....\$1.75

ANNEALED BALING WIRE—Nos. 11, 12, 13, 14, and 16 always on hand at lowest market prices on application.

Special prices in quantity to Threshermen and Balers.

No. 20-2 BARN DOOR HANGER

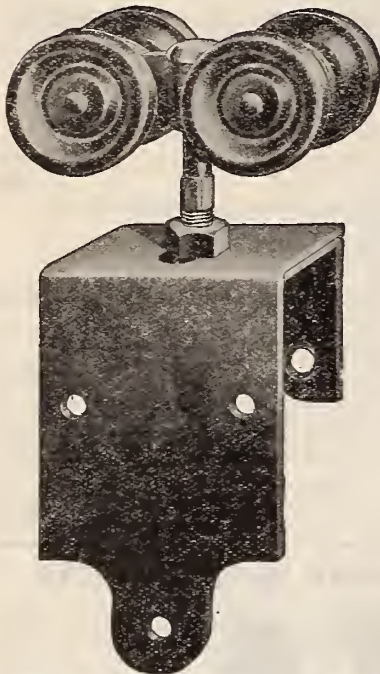

For doors weighing up to 300 pounds. 2 1/4-inch steel wheels, steel roller bearings, 6-inch apron. For doors 1 3/4 to 2 1/2 inches thick. Packed one pair of hangers with bolts, one joint and two end brackets. Hangers adjustable, vertical and lateral. 8 1/2 pounds per pair.
 Price\$2.50
 No. 31 Track, per foot..... .23

NO. 25 TROLLEY ROLLER-STEEL BARN DOOR

Has two adjustments—vertical and lateral. Has return apron. (See cut). Pendant 9 inches long, 3 1/2 in. wide, 3-16 inch thick. Suitable for doors 2 to 3 inches thick and weighing from 400 to 600 lbs. Made to run on No. 31 track. A pair of hangers consists of two hangers and carriers, one right and one left-hand bracket, complete with screws for hangers and lag screws for brackets. Hangers and track sold separately. When ordering always give thickness of door, exact width of opening and state whether for single or double door.

Per Pair.....\$2.70
 No. 31 Track, per foot..... .23

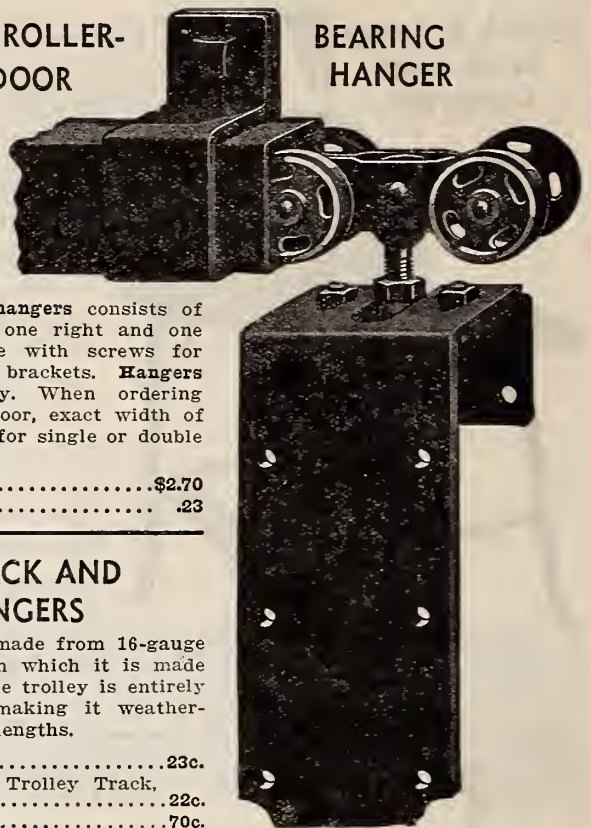

BEARING HANGER

TROLLEY TRACK AND TRACK HANGERS

No. 31 Trolley Track is made from 16-gauge steel. The square shape in which it is made gives it great strength. The trolley is entirely inclosed inside of track, making it weather-proof. 4, 6, 8 and 10-foot lengths.

Per Foot23c.
 Extra Single Brackets for Trolley Track, each22c.
 Double Brackets, each.....70c.

ANTI-FRICTION BARN DOOR HANGER No. 2

PRICE, PER PAIR, \$1.20
 1 1/4 in. Track, per foot, 12c

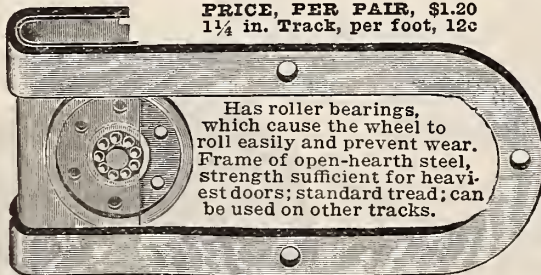

Has roller bearings, which cause the wheel to roll easily and prevent wear. Frame of open-hearth steel, strength sufficient for heaviest doors; standard tread; can be used on other tracks.

FLEXIBLE HINGE BARN DOOR HANGER

No. 843.

The door can be swung out from the bottom at any angle. The flexible feature allows the top of the door to move away from the building at least one-half an inch. The track is heavy special high-carbon flexible steel, 3-16x1 1/4 inch, supported by a heavy steel bracket with square shoulder mortised through the track every 17 inches. Weight, dozen pairs, 70 pounds. Weight, track, per 100 feet, 105 pounds. Retail, per pair, \$1.25. Track, Retail, 12c.



No. 1061—Cannon Ball Jr. Barn Door Hanger; flexible, non-adjusting roller bearing machined wheels, one-piece heavy steel door strap. Price, per pair, \$1.20



No. 1061

No. 1082—Cannon Ball Jr. Adjustable Barn Door Hanger. Lateral and vertical adjustments, tandem roller bearing machined wheels, heavy one-piece door strap, for doors weighing up to 250 pounds, 2 inches thick. Price, per pair\$1.70

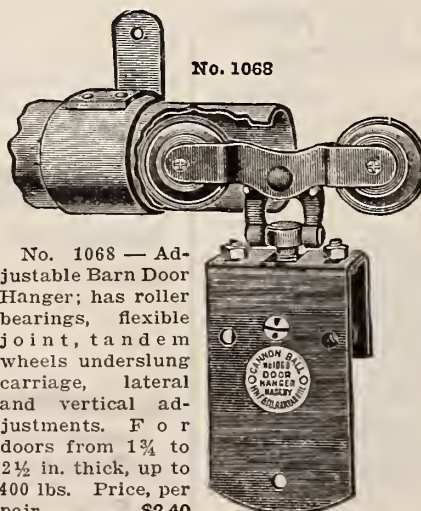

No. 1068

No. 1068 — Adjustable Barn Door Hanger; has roller bearings, flexible joint, tandem wheels underslung carriage, lateral and vertical adjustments. For doors from 1 3/4 to 2 1/2 in. thick, up to 400 lbs. Price, per pair\$2.40

STAY ROLLERS



For use with Barn Door Hangers. Price, each20c

Track Brackets not included in price of hangers.
 Track Brackets, Joint and Center, each\$0.17
 Track Brackets End, each..... .15
 Cannon Ball Track, in lengths 3, 4, 6 or 8 feet, per foot..... .22
 Cannon Ball Jr. Track, 3, 4, 6 and 8 feet, per foot..... .15
 Jr. Track Brackets, Joint and Center .11
 Jr. Track Brackets End..... .10
 Lag Screws for Track Brackets, each03

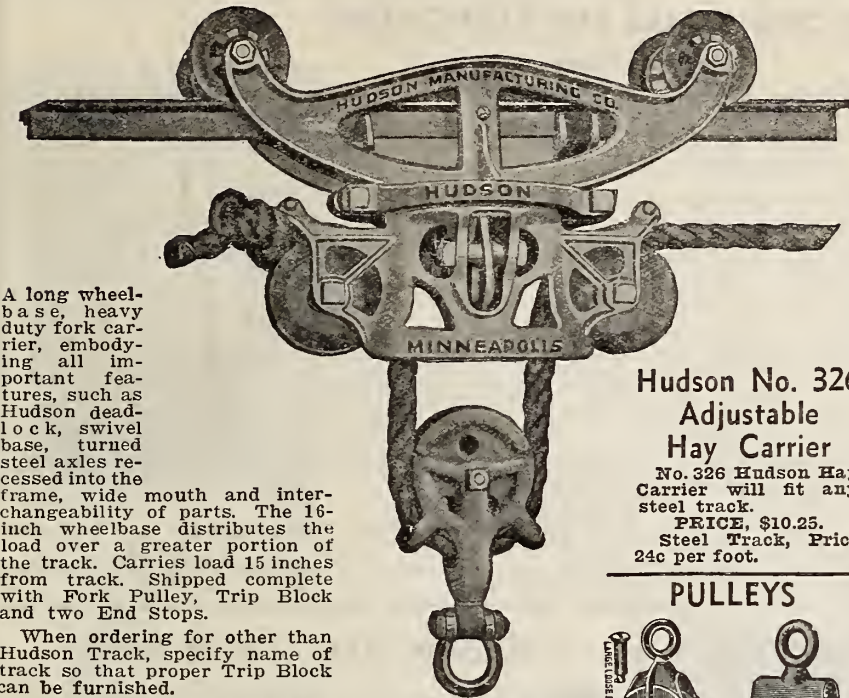

Hudson No. 326 Adjustable Hay Carrier
 No. 326 Hudson Hay Carrier will fit any steel track.
PRICE, \$10.25.
 Steel Track, Price 24c per foot.

A long wheel-base, heavy duty fork carrier, embodying all important features, such as Hudson dead-lock, swivel base, turned steel axles recessed into the frame, wide mouth and interchangeability of parts. The 16-inch wheelbase distributes the load over a greater portion of the track. Carries load 15 inches from track. Shipped complete with Fork Pulley, Trip Block and two End Stops.

When ordering for other than Hudson Track, specify name of track so that proper Trip Block can be furnished.

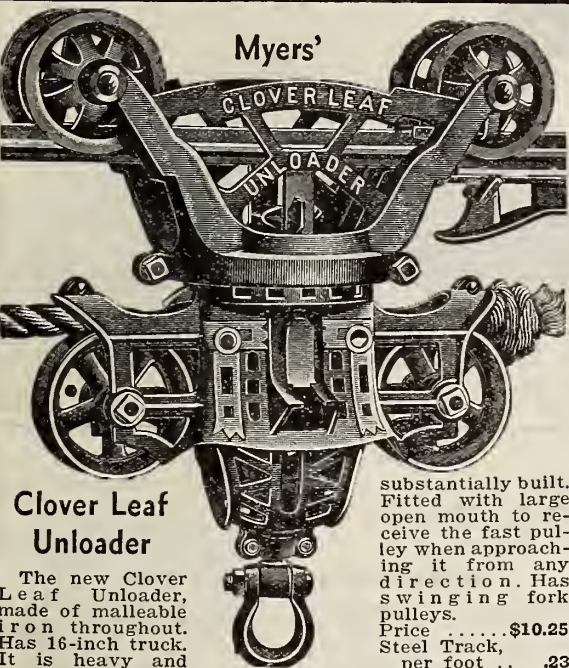

Clover Leaf Unloader

The new Clover Leaf Unloader, made of malleable iron throughout. Has 16-inch truck. It is heavy and

substantially built. Fitted with large open mouth to receive the fast pulley when approaching it from any direction. Has swinging fork pulleys. Price \$10.25
 Steel Track, per foot23



IRON-STRAPPED BLOCKS

Common Iron Bushed		Patent Roller Bushed		Sgle. Dble. Retail Price	
Size of Sheave Inches	Diam. Rope Inches	Lgth. Shell Inches			
3 1/2 x 1	x 1 1/2	3/4	6	\$0.88	\$1.60
4 3/4 x 1	x 1 1/2	7/8	7	1.04	1.92
4 3/4 x 1	x 1 1/8	1	8	1.32	2.28
3 1/2 x 1	x 1 1/2	3/4	6	1.20	2.28
4 1/4 x 1	x 1 1/2	7/8	7	1.36	2.68
4 3/4 x 1	x 5/8	1	8	1.80	3.32

HUDSON TRACK HANGERS

No. 6—Hanging Hook, steel track. Retail, 18c each.

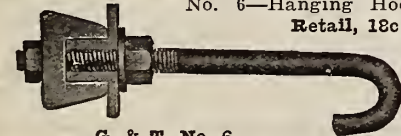

G. & T. No. 6



Price, 18c.

PULLEYS

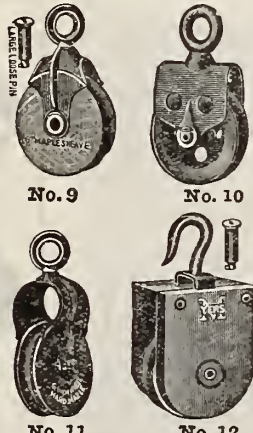

- No. 9 Maple Sheave 65c.
- No. 10 All Iron . . . 55c.
- No. 11 Knot Passing 75c.
- No. 12 Wood Frame with Hook 70c.
- No. 13 Wood Frame with Eye 70c.

Rafter Brackets



- G. & T. No. 4
- No. 4—Rafter Bracket, steel, retail, each . . . 5c
- No. 4—Rafter Bracket, malleable, retail, ea. . 8c

G. & T. No. 14 SWIVEL ROPE HITCH



No. 14—Swivel Rope Hitch. Retail, each, 40c.

MYERS' TRACK HANGERS

HARPOON HAY FORK



No. 1—Double Harpoon Hay Fork, 25-in. tines. Retail, \$2.50.

No. 1 1/2—Double Harpoon Hay Fork, 31-in. tines. Retail, \$2.75.

G. & T. No. 1

No. 2—Nellis Single Harpoon Fork. Retail, \$5.00. No. 2



Grapple Forks

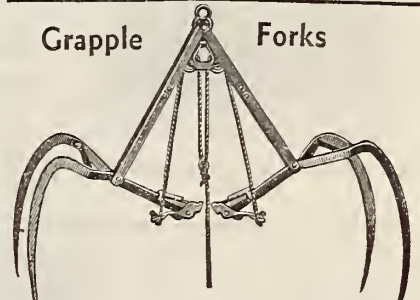

- G. & T. No. 4
- No. 4—4-Tine Aut. Grapple Fork. Retail, \$10.50.
- No. 6—6-Tine Aut. Grapple Fork. Retail, \$12.00.

FLOOR HOOKS.

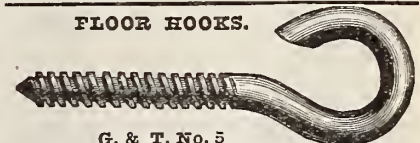

- G. & T. No. 5
- No. 5—Floor Hook, 3/4-inch. Retail Price, 18c. each.
- No. 5—Floor Hook, 5/8-inch. Retail Price, 15c. each.

GRITCO HOIST

No. 40—2 sheaves above, 2 sheaves below; for 1/2-inch rope; capacity, 1500 lbs. One man can lift 400 lbs. 3-inch sheaves. Factory list, \$4.00. Our Special Price, \$3.00.

No. 34—2 sheaves above, 2 sheaves below; for 1/2 inch to 5/8 inch rope; capacity, 3000 pounds. One man can lift 500 pounds 4-inch sheaves. Factory list, \$6.00. Our Special Price, \$4.50.

No. 28—2 sheaves above, 2 sheaves below; for 3/4-inch to 7/8-inch rope; capacity, 4000 pounds. One man can lift 600 pounds 5-inch sheaves. Factory list, \$10.00. Our Special Price, \$7.00. Rope not included in price.

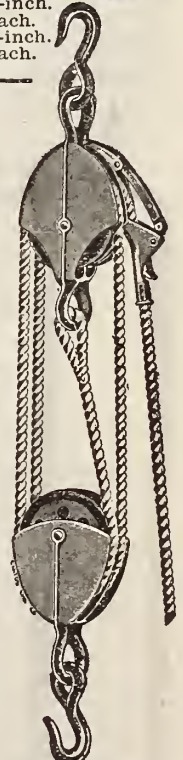

WOOD TRACK HANGERS



G. & T. No. 7
 No. 7—14-in. Hanging Hook, wood track. 15c. each.

HUDSON COW STALLS AND STANCHIONS

SPECIFICATIONS

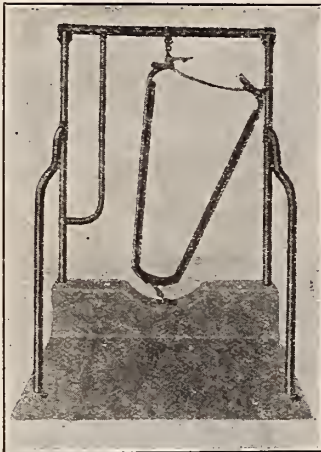

2A Stall With 105 Stanchion, \$10.15.

Horizontal Top Rail: 1½ inch square tubing. Non-twisting and absolutely rigid.

Partitions: 1½ O. D. high carbon steel tubing, triple bend. Extend backward 3 feet from stall post. Leaves ample room for milkers on platform. Other sizes on special order.

Uprights: 1½ O. D. high carbon steel tubing.

Sure Stop: Rigid, post to top rail type. Can be used on narrow stall without reducing head room; so essential for the cow's comfort. 1½ O. D. high carbon steel tube.

Fittings: Improved dust proof design. Made of malleable.

Anchors: Hudson angle iron anchor base. Anchors post, stanchion, partitions and the entire stall frame into concrete. A continuous anchorage the whole length of stall row across the width of stall at front and rear. Reinforces the concrete and binds the stall frame together down in concrete the same as square top rail binds it above.

Assembly: Hudson labor and money saving method of assembling at factory, made possible only by the Hudson continuous double angle iron anchors, reduces cost of erection and simplifies installation to greatest possible degree. Shipped three stalls set up in unit, ready to place in position on barn floor.

Curb: We recommend high curb, with cut-out for stanchions. Low curb may be used if preferred.

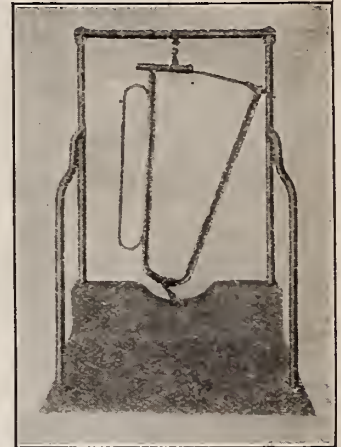

1A Stall With 110S Stanchion, \$10.35.

1A Stall With 105 Stanchion, \$9.05

The No. 500 Stall is shipped knocked down and without the Hudson Angle Anchor System.

Upright, Partition and Top Rail: 1½ inch O. D. carbon steel tubing.

Fittings: Malleable. Tee Couplings two bolt dust-proof type.

Anchors: No. 10B "U" bolt and yoke.

Width: Regular 3 feet 6 inches. Narrower stalls can be furnished when specified.

Weight: Complete with Stanchion 52 lbs.

Can be furnished with other Hudson Stanchions at difference in price of stanchions.

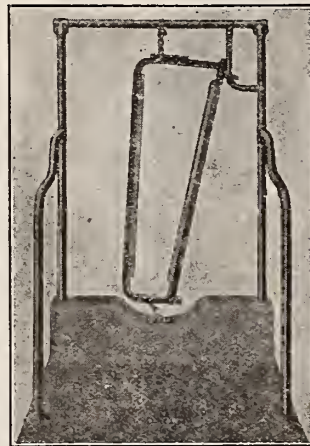

No. 500 Stall With No. 191 Stanchion, \$7.90.

HUDSON STEEL WATER BOWL



The Hudson New Steel Water Bowl will not break. The bowl has a greater capacity and is easier handled; made of one piece of heavy gauge steel, galvanized, and attached by means of a special designed clamp, which grips the bowl so firmly that there is no possibility of it being knocked off by the cow.

Size, 4½ inches deep, 10 inches across the top.

Best Malleable Fittings, Brass Valve Fitted with standard size Rubber Fuller Ball, same as used in any ordinary water faucet; easily replaced. Valve seat of brass; will not rust. Pressure plate made of Malleable Iron, and rests low

in the bowl, thus avoiding interference with the cow's muzzle in drinking. 1-inch pipe should be used for main supply pipe and ¾-inch for the short length to connect the bowl to the main supply pipe.

Bowl weighs 6½ pounds each.
Price\$3.60

HUDSON STANCHION No. 191

Steel U Bar Stanchion with heavy steel fittings; no castings used. Latch made of pressed steel, protected so the cow can not open it. Weight 19 lbs.

Price\$2.75.

HUDSON STANCHION No. 191W

This stanchion is the same as the No. 191, only that the steel U bar has a wood lining on it.

Price\$3.05.

HUDSON STANCHION No. 105

This stanchion has been made for over 25 years, and is one of the highest grade stanchions that sells for a reasonable price. High carbon, rust-resisting steel U bar and non-breakable malleable fittings. Wood linings specially seasoned hardwood, finished in oil. Linings are pressed into the steel U Bar so they can never split. Latch is of One Hand Lift type, locks automatically by the weight of the stanchion itself. Neck Space is adjustable from 6½ in. to 8 in., which is ample to take care of any cow. Weight approximately 23 lbs.

Price\$3.40.

HUDSON STANCHION No. 110

This stanchion is offered to dairymen who want the very best. It is the strongest and most easily operated stanchion ever built. High Carbon, rust-resisting steel U Bar and certified malleable fittings. Selected Hard Wood Linings thoroughly seasoned and polished. Inserted into U Bar under pressure and securely fastened. Adjustable Neck Space from 6½ to 8 inches. Weight approximately 27 lbs.

Price—110\$4.25.
Price—110S 4.70.



No. 191
No. 191W



No. 105

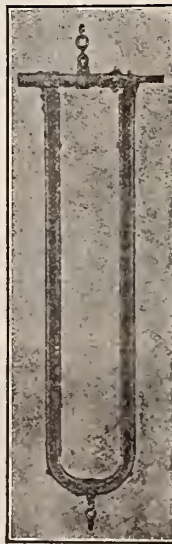

No. 110
No. 110S

HUDSON FEED AND LITTER CARRIERS

Chain Hoist Litter Carrier

No. 58B

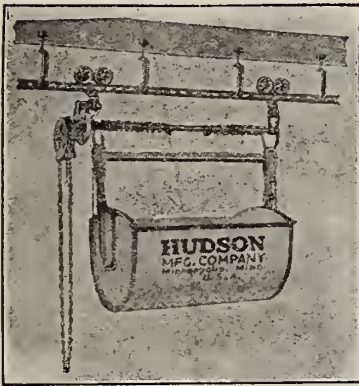

No. 58B Rigid Track

This Hudson Heavy Duty Back Geared Litter Carrier is the result of long years experience in the carrier business. This carrier combines great strength and rapid action. It will carry the heaviest loads with perfect ease. The hoisting chain is of special strength and is of a length to correspond with the shaft on which it winds. Longer chains furnished if specified for special jobs. Carrier is equipped with friction brake. The tub is

made of heavy galvanized sheet steel reinforced around the top and ends with 1-inch angle iron closely riveted. The carrier locks at both ends, which increases the life of the carrier. The bale is constructed of 1-inch by 1½-inch channel steel strongly reinforced. The chain shaft is 1 inch cold rolled steel. Pull swiveled, tandem trucks which give greater bearing on the track and ease in turning corners.

No. 58B—Tub, 44 inches long, 26 inches wide, 22 inches deep, inside measurements, capacity 13 bu. Weight, 200 lbs. Price, \$42.25.

Lever Hoist Litter Carrier

No. 40B

Make a Clean Job Out of a Dirty One

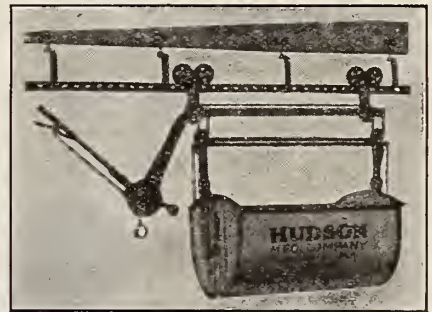

Specifications

Hoist: Ratchet and drum. Very simple. Drops tub to floor in an instant or it can be lowered slowly, as desired. Lifts loaded tub in 10 seconds or less. Tub has regular drop of 8 feet. Extreme leverage and little friction make it quickest and easiest lifting carrier. Hands do not become soiled with manure. Lever is always clean and is used to push carrier out of barn.

Drum: Gray iron, 3¼ inch x 7½ inch diameter.

Lifting Cable: Best crucible steel, ¼ inch diameter.

Lift Cable Pulleys: Gray iron, 4½ inch diameter, grooved and machined to prevent wear on cable.

Lever and Hoist Frame: 2 inch x ¼ inch steel bars, which support the drum and sheaves or cable pulleys.

Tub: Hudson long service construction, channel bail reinforcement.

Track Wheels: Roller Bearings, 4¼ inch diameter.

No. 40B: Capacity 13 bushels. Size of tub 42x28x24 inches. Weight 174 lbs.

Price\$43.25.

FLOOR FEED TRUCK

No. 141

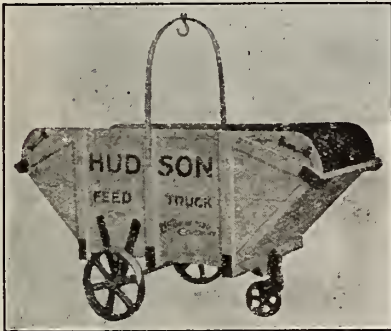

This is a very convenient and durable truck, built of selected lumber well put together and strongly reinforced.

Load is evenly balanced on wheels, making truck easy to handle. Wheels are located so that truck may be turned in its own length.

Main wheels are fourteen inches high with a two inch face. Castor wheel is seven inches in diameter. Axle is one inch cold rolled steel shafting. Capacity sixteen bushels.

This truck can be furnished with or without the Hudson Scale Arch.

No. 141 Hudson Floor Feed Truck, galvanized steel bottom. Weight, 210 pounds. Price, \$32.50.

FEED CARRIER

No. 40C

The Hudson Raising and Lowering Feed Carrier has all the track operating features found in our celebrated line of litter carriers, and is furnished with a tub or a carrier box, that is made of selected materials, and shaped so that the operator can work from either end when feeding.

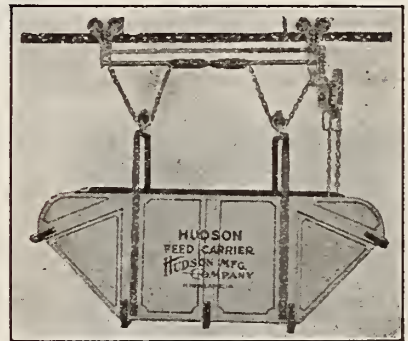

Equipment can be furnished for the installation of a system of trackage in connection with the litter carrier system.

Capacity, 16 bushels. Weight, 225 pounds. Price, \$41.25.

HUDSON TRACK EQUIPMENT

No. 102—Track, per foot.....	\$ 16
No. 90C—Track Hangers with short extension and Nailing Plate35
No. 90B—Hangers, 4 inch, each.....	.35
No. 90F—Hangers, 8 inch, each.....	.40
No. 90L—Hangers, 12 inch, each.....	.45
No. 90P—Hangers, 16 inch, each.....	.50
No. 103—Two Way Switch.....	8.00
No. 104—Three Way Switch.....	9.00

HUDSON MILK STOOLS

No. 96S



Hudson Milk Stools have proven extremely popular, not only for milking but for many uses around the home, in garages, filling stations, camps, offices and stores.

Pressed steel top. Comfortable for milking and will not tip. Legs high carbon steel, strongly reinforced and braced; will not twist.

Weight: Approximately four pounds.

Price\$1.00.

SAFETY BULL STAFF



Constructed of 1-1/16 inch O. D. extra heavy steel tubing with malleable lock hook. Will not break even when subjected to severe strain.

Can be operated from two places. To hook the nose ring into the staff, pull on the slide ring near the head of staff which will open lock bolt. To release staff from the bull ring, pull on the snap ring in handle of the staff. Latch bolt held in place by strong spring.

Length, 4 feet 9 inches. Weight, 8 pounds. Price, \$3.75.

SALT AND MINERAL BOWL



The Hudson Salt and Mineral Feeder is attractive in design, easy to clean and strongly built. The rust-proof cup is made of glazed stoneware; the unique supporting bracket is malleable iron guaranteed against breakage. The rim of the cup extends inward so that the salt will not be wasted. The opening in the cup is 4½

inches or just large enough to permit the animal to lick the salt. This small opening eliminates excessive slobbering and drooling, which reduces the caking of the salt. Furnished for either wood or steel stall.

Weight, 10 pounds. Packed one in carton. Price, \$1.60.

HUDSON SANITARY PENS

For Cows, Calves and Bulls. Write for prices, giving sketch and size of Pens needed.

FULLER AND JOHNSON FARM PUMP ENGINE

This is the original Farm Pump Engine—the acknowledged leader in the pumping field. The many thousands now in daily use all over the world testify to the merit and popularity of this remarkable pumping engine.

Here are some short, right-to-the-point facts.

Attaches quickly and easily to pump standard. Simple, compact—no complicated parts. Direct connected—no belts necessary. Comes complete in crate; no braces, special platforms or extras of any kind needed. Air cooled—won't freeze or over-heat. Weatherproof—runs perfectly winter and summer alike. Protected gears—lasts longer—safe to operate. Capacity 370 to 2,450 gallons per hour. Also runs washing machine, churn, separator, etc.

The vital question of every farm is its water supply.

With Batteries..... \$90.00
With Magneto..... 100.00

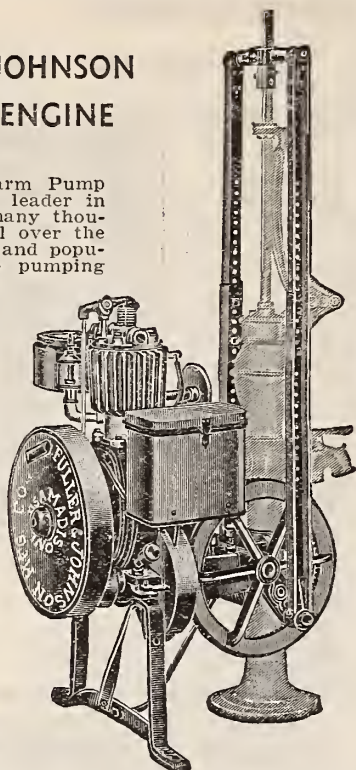

FULLER AND JOHNSON ENGINES

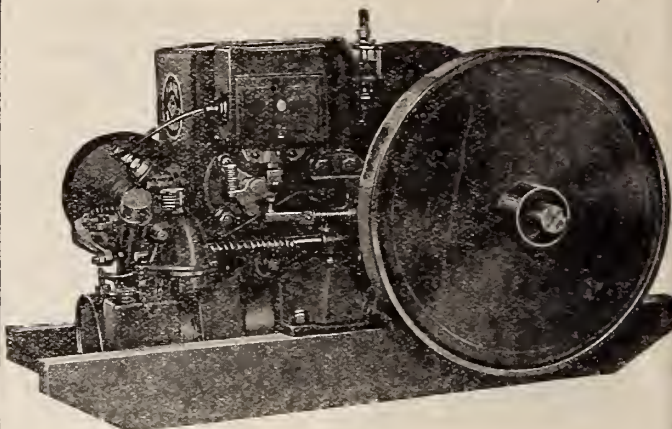

Model ND
2 Horsepower..... \$70.00
3½ Horsepower..... 115.00
Model NB
6 Horsepower..... \$185.00



ROUND-END GALVANIZED TANKS.

No.	Width, Ft.	Height, Ft.	Length, Ft.	Capacity, Gals.	Weight, Lbs.	Retail.
RE 224	2	2	4	91	74	\$9.00
RE 225	2	2	5	117	88	10.80
RE 226	2	2	6	144	102	12.55
RE2525	2½	2	5	145	93	12.05
RE2526	2½	2	6	178	110	14.05
RE 326	3	2	6	213	134	15.45
RE2528	2½	2	8	245	141	18.05
RE 328	3	2	8	295	156	18.90
RE3210	3	2	10	384	185	24.20
RE 428	4	2	8	386	169	22.95
RE4210	4	2	10	496	203	27.00

ROUND GALVANIZED TANKS.

No.	Diam., Ft.	Height, Ft.	Capacity, Gals.	Weight, Lbs.	Retail.
R32	3	2	91	69	\$10.90
S43	4	3	240	115	18.00
S44	4	4	310	145	21.95
R42	4	2	150	97	14.00
S45	4	5	408	168	26.20
S46	4	6	490	191	30.40
S54	5	4	520	181	27.90
S55	5	5	660	211	37.05

LIST OF PNEUMATIC TANKS. (Plain Tanks Without Fittings.)

Diameter in inches	Length in feet	Capacity in gallons	Price Galvanized	Price Black
*24	5	260	\$ 40.60	\$ 27.35
*30	6	600	71.90	43.75
30	10	850	105.50	66.40
*36	6	750	92.20	57.85
36	10	1075	123.80	82.05

BALTIMORE TANKS

Diameter in inches	Length in feet	Capacity in gallons	Price Galvanized	Price Black
*24	5	120	\$ 25.80	\$ 21.90
*30	6	220	46.50	37.50
30	10	365	89.85	54.80
*36	6	315	70.35	46.90
36	10	525	109.40	66.40

Tanks marked * thus are vertical.
33-Gallon Galvanized Tank..... \$11.50
66-Gallon Galvanized Tank..... 16.00
100-Gallon Galvanized Tank..... 22.00

ACCESSORIES FOR PNEUMATIC TANK

	Our Price.
Water Gauge	\$2.50
Pressure Gauge	2.75



Gulf Cypress Tanks With Round Hoops and Draw Lugs

These storage tanks are made of carefully selected red gulf cypress. We avoid the use of upland or cheaper grade of cypress, and in getting tanks from us you can rely upon high-grade material and workmanship.

Prices on Larger Tanks and Covers on request.

PRICE LIST.

Length of Stave, Feet.	Diameter of Bottom, Feet.	No. of Hoops.	Capacity, Gallons.	Price, 1½-inch Cypress.	Price, 2-inch Cypress.
3	3	3	110	\$ 18.15	\$ 21.90
3	4	3	220	25.00	31.60
4	4	4	283	31.50	38.80
4	5	4	472	43.15	54.40
5	5	5	598	53.15	66.60
6	6	5	1002	68.75	86.90
7	7	6	1701	98.50	123.15
8	8	7	2646	154.05

ARROW PNEUMATIC TANKS

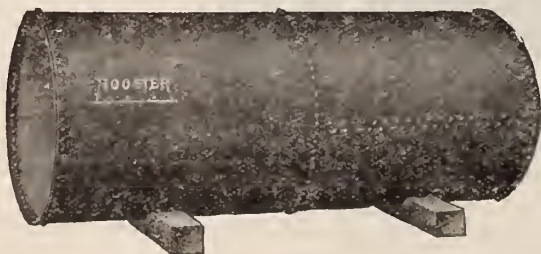

HOOSIER WATER SUPPLY SYSTEM

Hoosier Water Service—Using Hoosier Galvazink Well Pump Fig. 455

We recommend the use of this installation on wells where depth to water is not more than 50 feet.

The complete installation consists of Fig. 455 Hoosier Galvazink Deep Well Pump complete with V-belt and refrigerator type 1-4 H. P. motor, Hoosier Galvazinked water supply tank, Fig. 1351 Automatic Controller, combined pressure and water gauge, gate valve, relief valve, silent check valve, and necessary fittings to connect pump and tank as shown.

Frost-proofing attachment, for protection against damage by freezing, is supplied at a small additional charge.

Pumping cylinder and well pipe are not included as part of this installation.

Figure	Motor	Capacity of Tank	Weight	Price
456	¼ H. P.	33 gallons	290	\$100.50
456-A	¼ H. P.	66 gallons	370	103.75
456-B	¼ H. P.	100 gallons	415	107.00
Fig. 455 Pump only with Motor.....				73.00
Frost Proofing Attachment.....				6.00

Hoosier Water Service—Using Hoosier Galvazink Deep Well Pump Fig. 460

This Hoosier water service installation, Fig. 461-G, is recommended for use where depth to water is not more than 80 feet, Fig. 460, Hoosier Galvazink Deep Well Pump, completely galvanized and self-lubricating, is supplied with this outfit. This pump is equipped with V-Belt.

The complete installation consists of Hoosier Galvazink Deep Well Pump, Fig. 460, fitted with 1-2 horse power motor, galvanized pressure tank 22 by 60 inches, capacity 100 gallons; Hoosier Automatic Controller Fig. 1351, combined pressure and water gauge, relief valve, silent check valve, gate valve, and necessary fittings to connect pump and tank as shown.

Frost proofing attachment, for use in cold climates, will be supplied at a small additional cost.

Pumping cylinder and well pipe are not included as part of this installation.

Figure	Motor	Capacity of Tank	Weight	Price
461-A	½ H. P. A. C.	33 gallons	395	\$123.50
461-F	½ H. P. A. C.	66 gallons	475	128.25
461-G	½ H. P. A. C.	100 gallons	520	133.00
Fig. 4611 Pump only with ½ H. P. Motor.....				97.00
Frost Proofing Attachment.....				6.00
1/6 H. P. Motor A. C. 60 cycle 110 volt.....				30.00
1/4 H. P. Motor A. C. 60 cycle 110 volt.....				30.00
1/2 H. P. Motor A. C. 60 cycle 110 volt.....				35.00

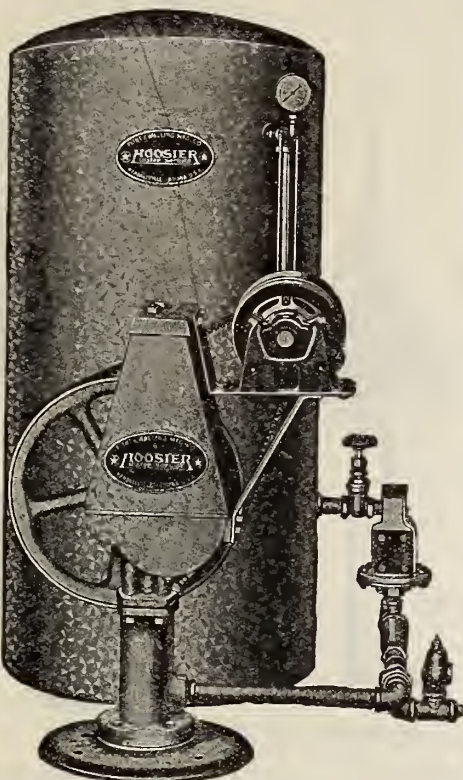

Fig. 456-B

Hoosier Automatic Pressure Controller

Fig. 1351—Automatic Pressure Controller is used for automatically controlling electric driven power pumps. It can be adjusted for any pressure up to 75 pounds and for a variation of 20 pounds. For domestic purposes, it is best to have it cut in and out at 30 to 50 pounds, respectively.

OUR SPECIAL PRICE..... \$6.60

The Hoosier Horizontal Double Acting Power Pump

A compact high-grade double acting horizontal pump for pumping from shallow wells to pneumatic water supply systems. The whole design of this pump is with a view to compactness, strength and accurate operation. The load is well equalized.

Size of Pulley.
 No. 1.....10x2½
 No. 2.....12x3
 No. 4.....20x4

Tapped Inlet Outlet.
 No. 1 1¼ 1 in.
 No. 2 1½ 1¼ in.
 No. 4 2½ 2½ in.

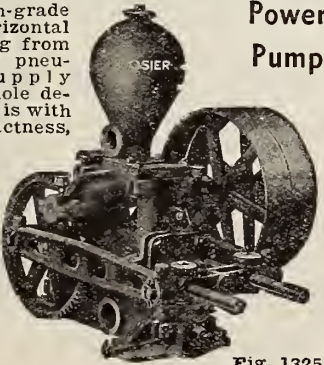

Fig. 1325

Fig.	Cylinder.	Capacity.	Price.
1325 No. 1.....	2½x4	510 gal.	\$44.80
1325 No. 2.....	3x5	850 gal.	77.00
1325 No. 4.....	5x5	2350 gal.	182.00
Hand Pumping attachment for No. 1...			3.00

HOOSIER WATER SERVICE INSTALLATION

USING SERIES 200 HOOSIER GALVAZINK TWIN PUMP

For use where vertical suction is not more than 22 ft. Capacity, 300 gallons an hour. May be had with 33, 66 or 100 gal. all-galvanized tank. Complete installation includes Series 200 pump complete with ¼ H. P. motor, V-belt, controller, vacuum chamber, pressure tank, floor base, gate valve, relief valve, combined pressure and water gauge, and fittings for connecting pump and tank, as illustrated.

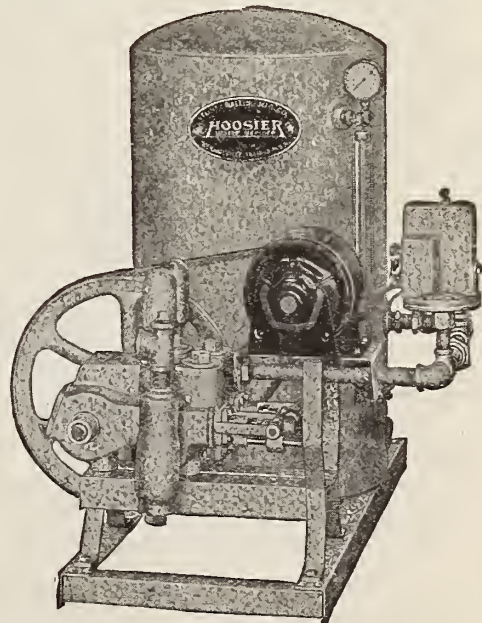

Fig. 261

Figure	Motor	Capacity of Tank	Wt.	Price
231	¼ H. P. A. C.	33 gallons	280	\$103.00
261	¼ H. P. A. C.	66 gallons	347	107.00
291	¼ H. P. A. C.	100 gallons	392	112.00

Series 200 Two cylinders and pump only with A. C. ¼ H. P. motor and controller.....\$78.00
 The above outfits have double cylinder pumps as shown in cuts.

Figure	Motor	Capacity of Tank	Wt.	Price
131	1/6 H. P. A. C.	33 gallons	244	\$80.00
161	1/6 H. P. A. C.	66 gallons	311	83.30
191	1/6 H. P. A. C.	100 gallons	356	91.50

Series 100 Pump with motor and controller..... 62.20
 These outfits have Series 100 Pumps which are single cylinder.

HOOISIER WELL PUMPS



Fig. 7904



Fig. 7994



Fig. 8113



Fig. 8553



Fig. 1050

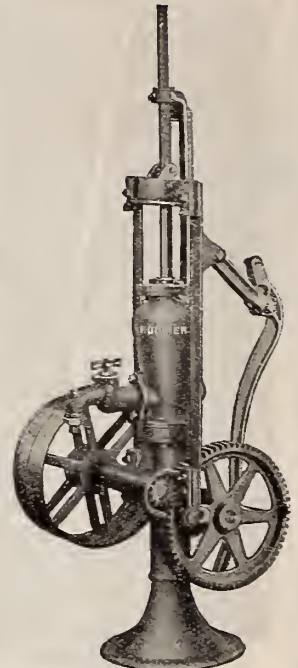

Fig. 1038

Fig. 7904.—Hoosier Open Top Hand Lift Pump, with wrought set length. It has large cast head, swivel bearer top, long handle and adjustable. The Standard or Barrel is made of 1½ inch pipe, and has the anti-freezing feature. 3-inch iron cylinder. **Price, \$9.25.**

Fig. 7994.—Hoosier Hand Force Pump, wrought set length, anti-freezing, has swivel bearer top, polished steel piston rod, brass stuffing box, compression cock spout and back inlet. Standard is tapped for pipe just below spout, and with the usual drip hole directly above cylinder makes the pump anti-freezing. Fitted with 3 inch brass lined cylinder. **Price, \$14.50.**

Fig. 8113.—Hoosier Windmill Force Pump, wrought set length, anti-freezing; has detachable polished piston rod, brass stuffing box, swivel bearer top, back outlet and detachable compression cock spout. The bearer top has removable guide bushing to prevent pump rod wearing directly on bearer guide. 2½ inch Brass Lined Cylinder, 6 inch stroke, weighs 81 pounds. **Price, \$18.00.**

Fig. 8553.—Hoosier Windmill Underground Force Pump, double acting, with wrought set length, anti-freezing. The pump has brass upper cylinder, positive three-way cock with union connection. Has adjustable platform base, fitted with 1 inch goose neck spout, and 1 inch three-way discharge. By removing upper cylinder and cap, the plunger valve can be withdrawn without disturbing the pump. Suitable for well from 25 to 125 feet in depth. Without Cylinder, **Price, \$17.00.**

Fig. 1050.—Hoosier Combination Set Length Pump and Jack. For hand, windmill or belt power. For shallow or deep wells. In this pump you get a true alignment of the jack and pump, with no side strain or uneven wear on the parts. Has cast gears and strong pitmans. Tight and loose pulleys. By removing upper cylinder and cap the plunger valve can be withdrawn without disturbing the pump. Can be used with 1¼, 1½, 2, 2½ or 3-inch pipe. **Price, \$42.00.**

Fig. 1038.—Hoosier Combination Pump Standard and Jack. Back geared 5 to 1, is designed to be operated by hand, windmill or belt power, for shallow or deep wells. This combined pump and jack is compact, strong and easy to install. Built in two sections, between which is a detachable flange, the upper pump section being the large air chamber with flanged top to which is bolted the flange bearer, making a firm connection; the lower section or barrel and main frame of the jack are of one-piece construction. This gives a true and permanent alignment of the jack and pump. Equipped with cast gears. The pinion shaft is extra long. Pitmans are made of heavy angle steel. The pitmans, gears, pinions and all wearing parts have No-Oil-Em Bearings. Has tight and loose pulleys. Adjustable stroke, 6 to 10 inches. One piece 1 1/16 inch piston rod, brass covered; brass stuffing box; compression cock spout with hose connection and back outlet. The jack has sufficient clearance above floor to admit of pulley being used as large as 30 inches. Suitable for wells from 25 to 200 feet. Weighs 190 pounds. **Price, \$35.00.**

Fig. 8584.—Hoosier Easy-Fix Windmill Force Pump. Single Acting, with detachable cast standard, for heavy service. Has positive Three Way discharge and brass hand wheel screw for regulating the three way distributing valve. Underground discharge elbow as union connection, Brass Stuffing Box and Brass Covered Piston Rod, fitted with 1½ inch pipe air barrel.

The stuffing box is set in extra cap or flange which screws into the bottom casting. By removing stuffing box cap the plunger may be withdrawn without disconnecting the pump. Bearer is provided with removable pump rod guide bushing to prevent wear directly on the bearer guide.

The bottom flange is interchangeable for the size cylinder or pipe to be used. Price of pump without cylinder, **\$19.60.**

ADDITIONAL FOR FITTING PUMPS

We give below a table of the additional charge for fitting, and the amount stated in table is to be added to the price of the pump selected. In fitting pumps we use galvanized pipe and galvanized pump rod and a strainer foot valve. For wells 26 feet deep or less we leave the cylinder 5 feet below platform. For wells deeper than 26 feet we place the cylinder close to the bottom of the well.

Prices Subject to Change Without Notice.

We Use an Extra Good Foot Valve.

With 1¼-in. Pipe for		With 1¼-in. Pipe for		With 1¼-in. Pipe for		With 1¼-in. Pipe for	
Depth of Well.	2½-in. and 3-in. Cylinder Pumps	Depth of Well.	2½-in. and 3-in. Cylinder Pumps	Depth of Well.	2½-in. and 3-in. Cylinder Pumps	Depth of Well.	2½-in. and 3-in. Cylinder Pumps
10 feet.....	\$3.55	20 feet.....	\$5.75	32 feet.....	\$9.50	44 feet.....	\$12.75
12 feet.....	4.00	22 feet.....	6.20	34 feet.....	10.00	46 feet.....	13.30
14 feet.....	4.40	24 feet.....	7.30	36 feet.....	10.60	48 feet.....	13.85
16 feet.....	4.85	26 feet.....	7.80	38 feet.....	11.10	50 feet.....	14.40
18 feet.....	5.30	28 feet.....	8.36	40 feet.....	11.70	Each additional foot.....	.27
		30 feet.....	8.90	42 feet.....	12.25		

ALL PRICES IN CATALOG SUBJECT TO CHANGE WITHOUT NOTICE.

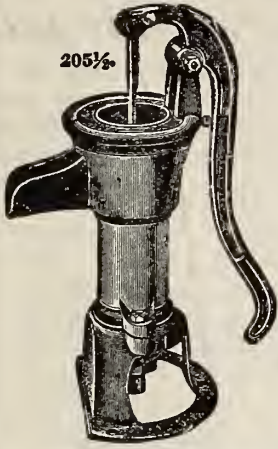

CLOSED TOP PITCHER SPOUT PUMP

SIZES AND PRICES

No. 2—Diameter of Cylinder, 3 in.; Suction, 1 1/4 in. Polished Iron Cylinder. Retail, \$2.00.

No. 3—Diameter of Cylinder, 3 1/2 in.; Suction, 1 1/4 in. Polished Iron Cylinder. Retail, \$2.25.

For 1 1/2-in. Couplings add 15c.

PITCHER PUMP LEATHERS.

No. 2—Valve and flat Plunger Leathers, each, 16c.

No. 3—Valve and flat Plunger Leathers, each, 20c.

No. 2—3-inch Leather Cups, 19c.

No. 3—3 1/2-inch Leather Cups, 25c.

PUMP CYLINDERS

	Iron Our Price	Brass Lined Our Price
2 1/2 x 14
3 x 10	\$5.10
3 x 12	5.25
3 x 14	5.35
3 1/2 x 12	6.25
3 1/2 x 14	7.50
4 x 12	8.75

Artesian Well Cylinder—No. 9171—Deep Well Brass Cylinder 1 1/2 for 1-in. pipe to be used in connection with 1355 and similar outfits. 6-in. Stroke, \$4.00.

2 1/2 and 3-in. cylinders take 1 1/4-in. pipe; 3 1/2 in. cylinders take 1 1/2-in. pipe; 4-in. cylinders take 2-in. pipe.

BRASS JACKET DRIVE WELL POINTS

No.	Diameter of Pipe.	Length.	No. 60 Gauge, List Price, Per Doz.	Retail Price Each.
90	1 1/4	24 in.	\$36.00	\$2.00
94	1 1/4	30 in.	46.00	2.50
98	1 1/4	36 in.	56.00	3.00
102	1 1/4	48 in.	76.00	4.00
136	1 1/2	24 in.	43.00	2.50
140	1 1/2	30 in.	60.00	3.50
144	1 1/2	36 in.	72.00	4.00
148	1 1/2	48 in.	96.00	5.00

Malleable Drive Caps, Hexagon-shaped, for 1 1/4-in. Pipe, 50c.
Malleable Drive Caps, Hexagon-shaped, for 1 1/2-in. Pipe, 50c.

IXL GALVANIZED STEEL CHAIN PUMP



Being made of No. 24 gauge galvanized steel, this pump will not rot, rust nor accumulate filth like pumps of less desirable construction, and it makes the water clear and pure. It is anti-freezing, as the reservoir piece has a small hole, which allows the water to run out. This style of pump is practical for use in wells as deep as 40 feet. The term curb means the complete upper part of pump with fixtures.

PRICES.

I X L Curb.....	\$ 6.50
Gem Curb.....	5.50
Tubing, per foot.....	.15
Coupling.....	.50
Rubber Buckets.....	.10
Iron Platform.....	9.00
Chain, per lb.....	.12

DIRECTIONS FOR FITTING UP CHAIN PUMPS

1. Use one foot more tubing than depth of well.
2. Multiply length of tubing by two and add 3 feet 6 inches to get proper length of chain.
3. Rubber buckets should be placed 6 or 7 feet apart.
4. See that tubing is held secure—by tubing brace at bot- of curb.

GALVANIZED PUMP RODS AND COUPLINGS

3/8-inch Round Galvanized Pump Rod in 20-foot lengths, not threaded, per foot, 5c.

7-16 in., 6c.

Threaded with coupling, add 1c per foot; cut lengths, add 3c.

Galvanized Pump Rod Couplings for 3/8 or 7-16 in. rod, 10c. each.



GOULD'S UNIVERSAL HOUSE FORCE PUMP



Fig. 1726

The Universal House Force Pump is an easy working, compact and substantial pump. It is well adapted to house pumping, furnishing water either at the spout or through opening to storage tank. Can be used outdoors over wells and cisterns. Pump should not be placed over 22 feet above the water. Has 2 1/2-inch cylinder and 4-inch stroke. Tapped for 1 1/4-inch pipe.

No. 2, Fig. 1725, plain spout \$7.50

No. 2, Fig. 1726, Cock Spout \$9.50



Fig. 1725

GALVANIZED PIPE FITTINGS.

	1/2	3/4	1	1 1/4	1 1/2	2
Elbows	\$.12	.20	.22	.36	.44	.76
Tees17	.26	.28	.52	.64	1.02
Street Elbows.....	.12	.18	.22	.32	.44	.72
45-Degree Elbows.....	.12	.18	.20	.30	.40	.68
Cross20	.32	.33	.56	.70	1.18
Bushings10	.10	.12	.13	.15	.20
Lock Nuts.....	.05	.05	.06	.10	.12	.18
Caps06	.10	.12	.20	.28	.42
Reducers10	.13	.14	.20	.30	.50
Couplings10	.14	.16	.28	.34	.60
Galv. Unions.....	.36	.42	.52	.74	.94	1.42

GALVANIZED FOOT VALVES

3/4-in.	\$1.00
1-in.	1.00
1 1/4-in.	1.25
1 1/2-in.	1.80



Hoosier Horizontal Double Acting

Hand Pump For Shallow Wells

Fig. 1248—Hoosier Horizontal Hand Pump, double acting, for general purpose work or pneumatic water service, for use where the suction is not more than 18 or 20 feet. Pump is equipped with large air chamber and rack head, insuring ease of operation. It has 3x5" Brass Lined cylinder and a 3 to 5" adjustable stroke. The pump is tested to 100 pounds pressure. All valve caps, including suction cap, are on the outside and easily accessible. The body is detachable from the base of the pump and in case of breakage of the base it is unnecessary to purchase an entire new pump.

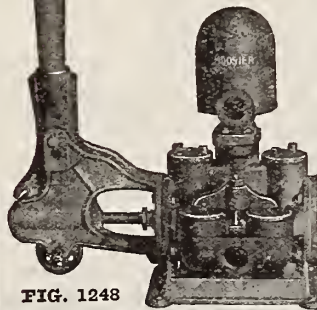

FIG. 1248

It is fitted with an intake air valve and it can pump both air and water at the same time.

Price of Pump.....\$19.25.

HOOSIER TANK PUMP

Hoosier Double Acting Tank Pumps are strongly built, of very large capacity, and especially adapted for threshermen's use. The cylinder is carefully bored and polished. The cylinder has 5-in. stroke, the valves have brass valve seats, and the valves are accessible through hand-holes by removing the plugs. The suction and discharge have 2-in. openings with swivel connections. Furnished with suction connection for 2-in. pipe or 2-in. hose, and the discharge connection for 2-in. pipe or 1-in. hose.

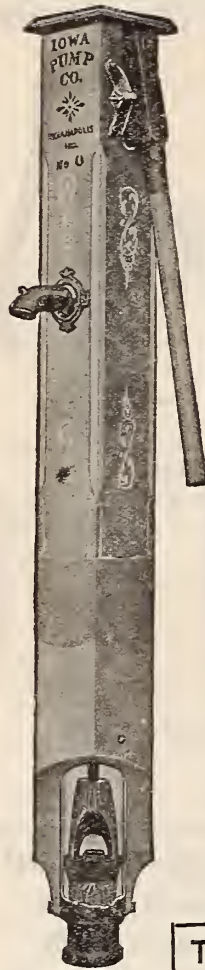

Fig. 8810

As the pump heads are reversible, the handle can be attached to either end of the pump.

By opening the upper and lower drainage plug, water can be drawn off the pump to prevent freezing.

Price\$15.50.



BALTIMORE WOOD PUMPS

PRICES OF PUMPS FITTED COMPLETE.
With and Without Porcelain Cylinder.

Depth of Well.	6x6 Unlined.		6x6 Lined.		7x7 Lined.	
		Price.		Price.		Price.
10 feet.....	\$11.50		\$14.10		\$16.30	
12 feet.....	12.10		14.70		16.95	
14 feet.....	12.75		15.35		17.60	
16 feet.....	14.30		15.95		18.20	
18 feet.....	15.00		17.55		19.80	
20 feet.....	15.60		18.15		20.40	
23 feet.....			19.55		22.05	
25 feet.....			20.45		23.20	
28 feet.....			22.45		24.70	
30 feet.....			23.95		27.45	
33 feet.....			26.00		29.65	
35 feet.....			29.00		32.90	
40 feet.....			32.70		36.80	
45 feet.....			37.00		41.40	
50 feet.....			39.75		44.40	

BALTIMORE WOOD PUMPS

NOT FITTED.

"No. 0."—STOCK PUMPS. 7x7 Inches, 4-inch Bore.

	Porc. Lined Price.
6 feet long.....	\$12.75
7 feet long.....	13.75
8 feet long.....	14.75
10 feet long.....	16.75
12 feet long, extension cylinder.....	17.25
6 feet long, reamed for 6x6 extension pipe, unlined.....	10.50

"No. 1"—THE FAVORITE HOUSE PUMPS

6x6 in., 3½-in. Bore. Porc. Lined Price.

6 feet long.....	\$10.50
7 feet long.....	11.25
8 feet long.....	12.00
10 feet long.....	14.00
12 feet long.....	15.50
6 feet long, reamed for 6x6 extension pipe, unlined.....	8.50

PUMP FOR DRIVE WELLS

To Fit 1¼, 1½-inch Iron Pipe.

Special No. 1 House, 5 feet wood, Porcelain-lined Cylinder, entire length 6 feet.

PRICE.....\$11.50

TUBING AND MISCELLANEOUS

	Retail Price.
4x4, 12 feet long and under, per foot.....	\$0.30
4x4, over 12 feet, per foot.....	.32
6x6 Extension Tubing, per foot.....	.75
Cylinder Block, Porcelain Lined, 3 feet long.....	4.40
Cylinder Block, Porcelain Lined, 4 feet long.....	5.20
Cylinder Block, Porcelain Lined, 5 feet long.....	6.00
Cylinder Block, Porcelain Lined, 6 feet long.....	6.50
Cylinder Block, Porcelain Lined, 7 feet long.....	7.60
Cylinder Block, Porcelain Lined, 8 feet long.....	8.40
6x6 Couplings for 4x4 Tubing.....	.90
Buckets, 5-in., each, No. 00, Price \$1.50; 4-in., each, No. 0.....	1.25
Buckets, 3½-in., No. 1, each, Price, \$1.00; 3-in., No. 2, each.....	.80
Handle, any size, each, Price, 40c.; Handle Links or Knuckles.....	.40
Check Valves, each.....	.14
Iron Connection for Drive Wells, fitted for 1¼-in. and 1½-in. iron pipe.....	1.50
Extra Iron Spout, with loose collar.....	.50
Extra Wood Spouts, each, Price 25c.; Extra Spout Braces, each.....	.40
Extra Bands, each.....	.12
Extra Ears or Brackets, Nos. 35 and 36, pair.....	.50
1-in. Rod Couplings, pair.....	.60
Plunger Rod, per foot.....	.05

IMPROVED BESTWAY WELL CLEANER

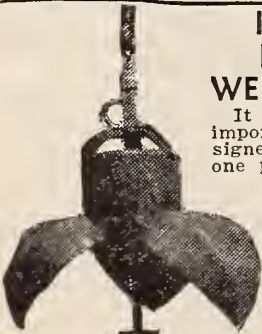

Keep your water pure and healthful; clean the well often with a Bestway. \$15.00

OCTAGON WOOD PUMP RODS

Wood Pump Rod for artesian wells is made of selected material and fitted with galvanized forged couplings.

Size of Rod 1½ in.

Size of Artesian Well Cylinder 1¾ in. to 2¼ in.

Price per foot.....25c

The above prices are for rod in standard lengths or from 16 to 20 feet, couplings included.

WOOD PUMP ROD.



HOOSIER PUMP JACK

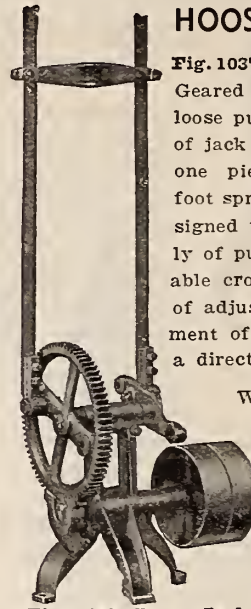

Fig. 1037, Pump Jack

Fig. 1037—Hoosier Pump Jack.

Geared 6 to 1, with tight and loose pulley. The main frame of jack and tripod base are of one piece construction. The foot spread is extra wide. Designed to operate independently of pump standard. Adjustable cross head with wide range of adjustments. The arrangement of gear and pinion gives a direct even lift.

Weight 95 pounds.

Price, \$16.25

Figure 1031—Hoosier Pump Jack, with tight and loose pulleys for gasoline engine or electric motor, with motor speed reduced. The drive shaft may be driven 200 R. P. M.; as a rule, however, we recommend 170 R. P. M., or about 34 strokes per minute.

The pitmans are made of hard wood, and with their wide range of adjustment the jack can be attached to a windmill-head pump without disturbing the pump or pipe connections.

This jack can be used on the wall, floor or ceiling.

Will operate a 3-inch cylinder, 125 foot lift on 8-inch stroke.

Price.....\$9.75



PUMP LEATHERS

Our pump leathers are cut from the best grade of selected Oak Tan leather. We offer only such leathers as we can recommend as being absolutely high grade.



Plunger Leather Crimped



Suction Valve Leather

CRIMPED PLUNGER OR CUP LEATHERS

Each		Each	
1 inch.....	\$0.08	3¼ inch.....	\$0.22
1¼ inch.....	.08	3½ inch.....	.25
1½ inch.....	.10	3¾ inch.....	.31
1¾ inch.....	.10	4 inch.....	.35
2 inch.....	.11	4¼ inch.....	.38
2¼ inch.....	.12	4½ inch.....	.40
2½ inch.....	.15	4¾ inch.....	.45
2¾ inch.....	.18	5 inch.....	.50
3 inch.....	.19		

PLUNGER AND LOWER VALVE LEATHERS

O'tside Cylinder			O'tside Cylinder		
Diam.	Diam.	Each	Diam.	Diam.	Each
2 in.	1½ in.	\$0.10	3½ in.	3 in.	\$0.16
2¼ in.	1¾ in.	.10	3¾ in.	3¼ in.	.17
2½ in.	2 in.	.11	4 in.	3½ in.	.20
2¾ in.	2¼ in.	.12	4½ in.	3¾ in.	.25
3 in.	2½ in.	.13	5 in.	4 in.	.30
3¼ in.	2¾ in.	.15			

NORGE ELECTRIC REFRIGERATOR—WITH ROLLATOR

Every electric refrigerator has a mechanism for compressing the fluid which later expands in the freezing unit where it absorbs heat and makes cold.

In the Norge compressor, the Rollator has been achieved, the mechanism which has long been the ideal of refrigeration engineers. It is simple with but three moving parts in a permanent bath of protective oil.

Simplicity and Quality

The perfect simplicity of the Norge Rollator makes it extremely compact and the smallness of this mechanism makes it possible to build the Norge with maximum food capacity space. The efficiency and power of the Rollator is so high that complete refrigeration is sure even in extremes of summer heat. Ice cubes freeze very quickly in the Norge—lots of them—and a food compartment temperature of between 40 and 50 degrees is automatically maintained.

The food compartment of the Norge is waist-high; it is not necessary to stoop or crouch to remove and replace foods. The glistening white porcelain lining has no dark depths and the wide opening door gives full visibility to the interior. The door has a semi-vacuum gasket which can be washed and cleaned as often as needed without harm, and this gasket assures a tight seal when the door is closed.

A white porcelain shield over the freezing compartment has a porcelain door which is spring hinged and makes a tight seal, promoting faster freezing and protecting the ice cubes from penetrating odors.

The Defrosting Switch and 5-point Cold Control are mounted on the ice compartment shield inside the cabinet at a point for convenient operation.

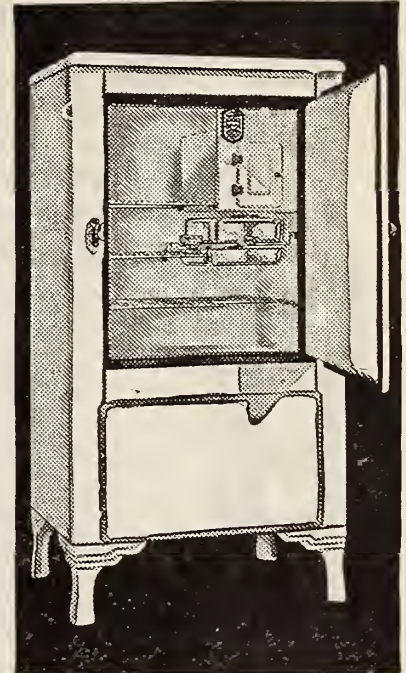

The Guardian—Model 71: Capacity, 7.53 cu. ft.; Shelf area, 11.35 sq. ft.; Ice, 4 trays, 21 cubes each, total 84. Finish: Exterior and Interior, Porcelain. Height, with 8½ in. legs, 61¼ in.; width, 32½ in.; depth, 25¾ in. Watervoir shown in this model is extra equipment.

See The Norge Before You Buy

PRICES—Net Cash or Convenient Terms

Capacity 5 cu. ft....\$179.50 Capacity 6 cu. ft....\$209.50 Capacity 7 cu. ft....\$269.50

FAIRBANKS PORTABLE SCALE

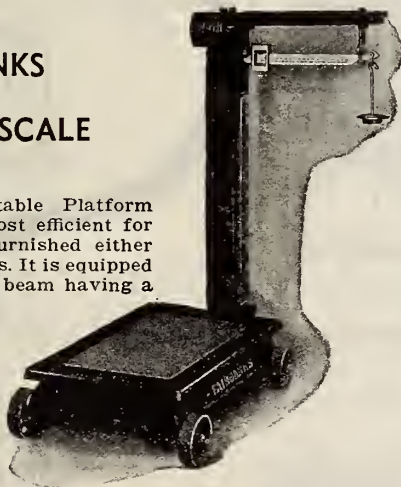

This type of Portable Platform Scale is one of the most efficient for general use and is furnished either with or without wheels. It is equipped with **arrow-tip** single beam having a center indicating sliding poise with set - screw, all of brass.

Durably and attractively finished in blue with bronze stripe, all well varnished for protection.

No. 1124, capacity 1000, size of platform 18x27 in., price. \$25.00
No. 1128, capacity 500, size of platform 16x25 in., price. 22.25

The Defender—Model 61: Capacity, 6.3 cu. ft.; Shelf area, 9.43 sq. ft.; Ice, 4 trays, 21 cubes, total 84. Finish: Exterior, Baked Enamel; Interior, Porcelain. Ht., with 8½ in. legs, 59¾ in.; width, 27¾ in.; depth, 23¾ in.

The Sentinel—Model 51: Capacity, 5.13 cu. ft.; Shelf area, 8.31 sq. ft.; Ice, 3 trays, 18 cubes each, total 54. Finish: Exterior, Baked Enamel; Interior, Porcelain. Height, with 5½ in. legs, 52¾ in.; width, 24¾ in.; depth, 22¾ in.

NEW VIGORO SPREADER

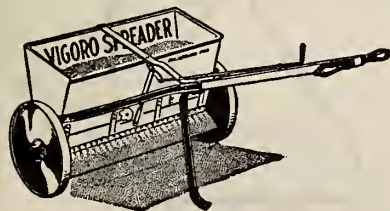

Little Vigoro, 14-in.\$ 1.95
Junior Vigoro, 14-in. 5.95
Standard Vigoro, 24-in. 10.45
Special Vigoro, 36-in. 16.25

Use a Vigoro Spreader for results.

BLOCKI WINDROWERS AND PEA HARVESTER

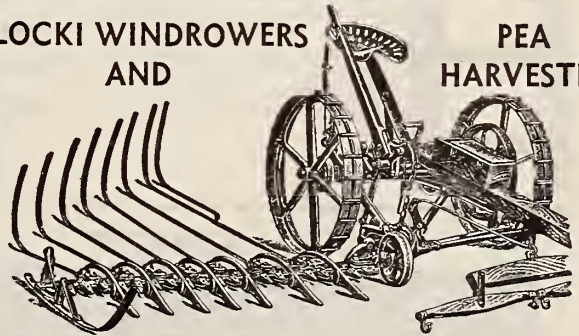

Use the Blocki Windrower for harvesting the seed crops of red, alsyke, mammoth and alfalfa clovers. Sometimes also used for harvesting flax, buckwheat, and even short tangled grain. Is an excellent tool to harvest cow peas, beans, etc. Can be readily attached to any mower and gives the best satisfaction. The guards are strong, being made of malleable iron; the rods retain their shape because they are made out of the right kind of steel.

Blocki Pea Harvester No. 7X consists of 7 Guards, 7 Rods and Divider.
Blocki Pea Harvester No. 8X consists of 8 Guards, 8 Rods and Divider.
Blocki Pea Harvester No. 9X consists of 9 Guards, 9 Rods and Divider.

Prices:
No. 7X.....\$27.00
No. 8X..... 30.00
No. 9X..... 33.00
Extra Guards, each..... 3.00
Windrower for 4½- or 5-ft. Mower, Rods only.. 15.00
Windrower for 6-ft. Mower, Rods only..... 17.00

SAFETY FIRST SPRUCE LADDERS We Carry a Complete Line of Ladders for Every Purpose

Superior

LUMBER: Spruce.
RUNGS: Hickory, Creosoted Ends.
AUTOMATIC HOOKS put on all our Extension Ladders.

Standard



GRITCO SUPERIOR

With Spring Lock and Straight Sides
LENGTH OF SECTIONS

20-ft. Extension—Top section 10 ft., bottom section 10 ft.....	\$9.00
22-ft. Extension—Top section 10 ft., bottom section 12 ft.....	9.80
24-ft. Extension—Top section 12 ft., bottom section 12 ft.....	10.60
26-ft. Extension—Top section 12 ft., bottom section 14 ft.....	11.40
28-ft. Extension—Top section 14 ft., bottom section 14 ft.....	12.20
30-ft. Extension—Top section 14 ft., bottom section 16 ft.....	13.00
32-ft. Extension—Top section 16 ft., bottom section 16 ft.....	13.80
36-ft. Extension—Top section 18 ft., bottom section 18 ft.....	17.00
40-ft. Extension—Top section 20 ft., bottom section 20 ft.....	19.00
42-ft. Extension—Top section 20 ft., bottom section 22 ft.....	22.60
44-ft. Extension—Top section 22 ft., bottom section 22 ft.....	24.60
48-ft. Extension—Three section....	29.50

GRITCO STANDARD

LENGTH OF SECTIONS

20-ft. Extension—Top section 10 ft., bottom section 10 ft.....	\$8.00
22-ft. Extension—Top section 10 ft., bottom section 12 ft.....	8.80
24-ft. Extension—Top section 12 ft., bottom section 12 ft.....	9.60
26-ft. Extension—Top section 12 ft., bottom section 14 ft.....	10.40
28-ft. Extension—Top section 14 ft., bottom section 14 ft.....	11.20
30-ft. Extension—Top section 14 ft., bottom section 16 ft.....	12.00
32-ft. Extension—Top section 16 ft., bottom section 16 ft.....	12.80
36-ft. Extension—Top section 18 ft., bottom section 18 ft.....	16.00
40-ft. Extension—Top section 20 ft., bottom section 20 ft.....	17.80
42-ft. Extension—Top section 20 ft., bottom section 22 ft.....	21.60
44-ft. Extension—Top section 22 ft., bottom section 22 ft.....	22.60

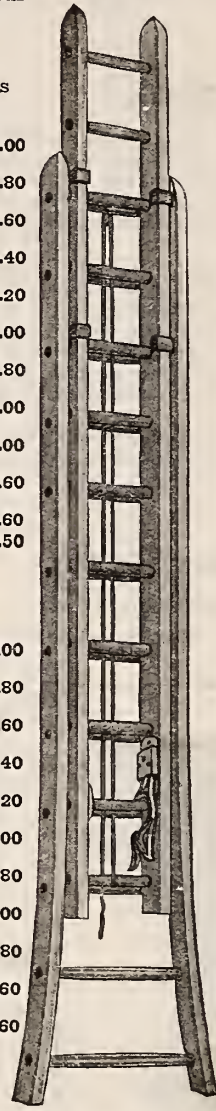

CLEVELAND SAFETY LADDER JACK

Per Pair
\$5.00



SINGLE LADDERS

10, 12, 14, 16 foot....28c per ft.
18, 20 foot.....32c per ft.
22 foot.....36c per ft.

ROOF HOOK



For Hanging Swinging Stages or can be used for many other purposes; strong and durable. **Pair \$6.25.**

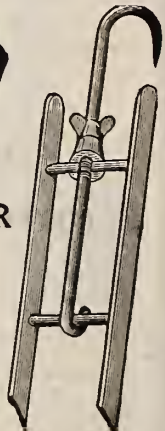

Price \$1.50

SCAFFOLD



Our Painters' Scaffolds are made from seasoned and selected stock. Slats are securely fastened on the top of the rungs, making a smooth platform. Our scaffolds are light in weight, but very strong and durable. 16, 18, 20, and 22 ft. without floor, per foot.....\$0.90
With floor 1.00

EXTENSION PLANKS



These adjustable Planks are used by Painters and Decorators and are now a part of their equipment. We can furnish Extension Planks in three sections in 8 and 10 ft. lengths.
6 ft., extends to 10½ ft.....\$5.60
8 ft., extends to 13½ ft..... 7.00
10 ft., extends to 17½ ft..... 8.40

TRIANGLE FOR GUARD RAIL

\$6.25
per
pair

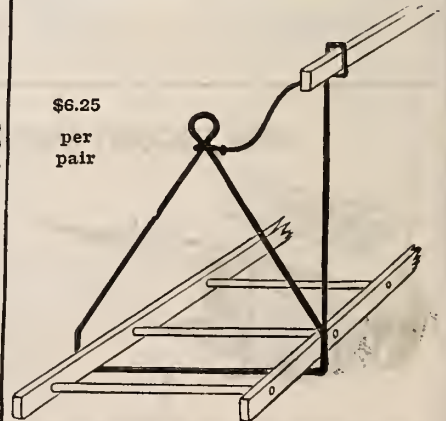

GRITCO TRUSS

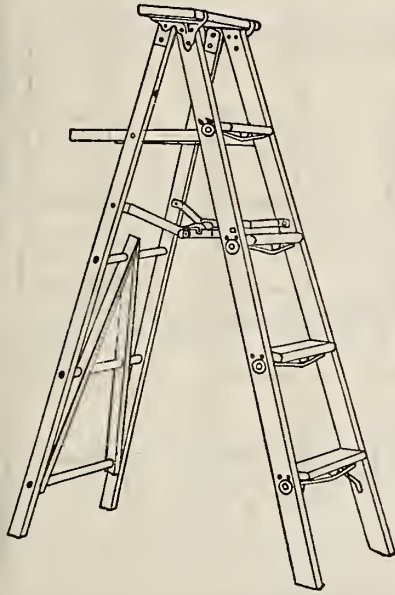

The GRITCO TRUSS STEP with 1/4-in. rod and truss block under each step with malleable iron washers, wood handle, four arm steel lock, malleable ears, wide cap and steps, dowel in the back legs opposite each step, solid risers made from Genuine Spruce.

4 ft...\$2.50	8 ft.....\$5.00
5 ft... 3.20	10 ft..... 6.40
6 ft... 3.80	12 ft. extra strong 8.80
7 ft... 4.50	16 ft. ex. strong. 14.30

GRITCO SECURITY

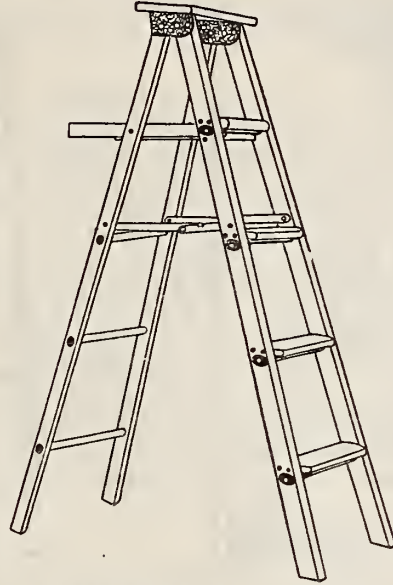

GRITCO STEP is standard built, 1/4-inch rod under every step, non-slip washers, wood handle, four arm lock, galvanized double ear, dowels in the back opposite each step.

4 ft...\$2.15	8 ft.....\$4.40
5 ft... 2.75	10 ft..... 5.50
6 ft... 3.25	12 ft. extra strong 7.50
7 ft... 3.75	14 ft. extra strong 8.80

GRITCO ELECTRIC

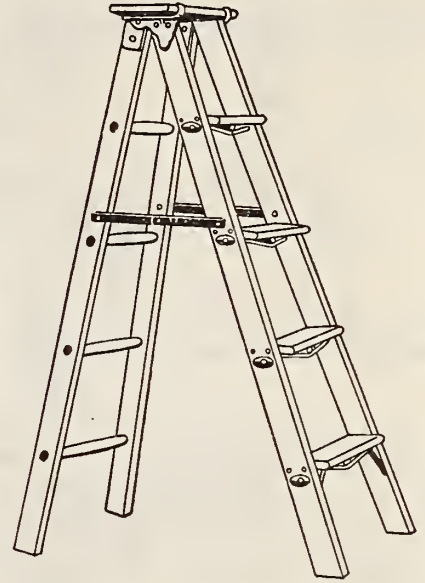

The GRITCO ELECTRIC is our very latest design and is intended for heavy work. It is made from selected SPRUCE, has wide steps, steel lock, malleable ears, truss block and is full rodded. Has reinforced back legs with 1/4-inch bolts and 1 1/2-inch HICKORY Rungs, so that ladder can be used on either side.

4 ft.....\$3.75	10 ft..... \$9.50
5 ft..... 4.75	12 ft..... 12.00
6 ft..... 5.50	14 ft..... 14.00
7 ft..... 6.50	16 ft..... 18.00
8 ft..... 7.50	18 ft..... 20.00

BALTIMORE ACME

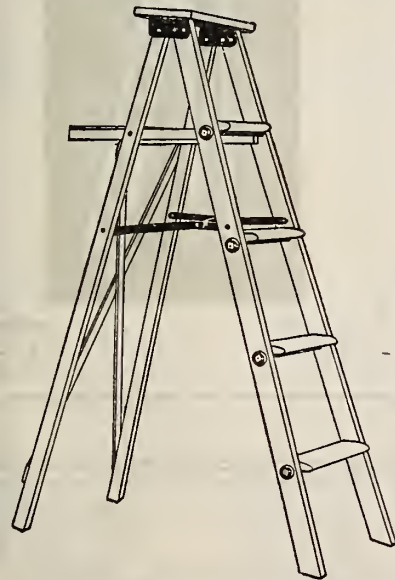

BALTIMORE STEP LADDER

Full Rodded, Steel Lock with Handle.

3 ft.....\$0.75	7 ft.....\$1.80
4 ft..... 1.00	8 ft..... 2.10
5 ft..... 1.35	10 ft..... 2.75
6 ft..... 1.60	

GRITCO PAINTERS' TRESTLES

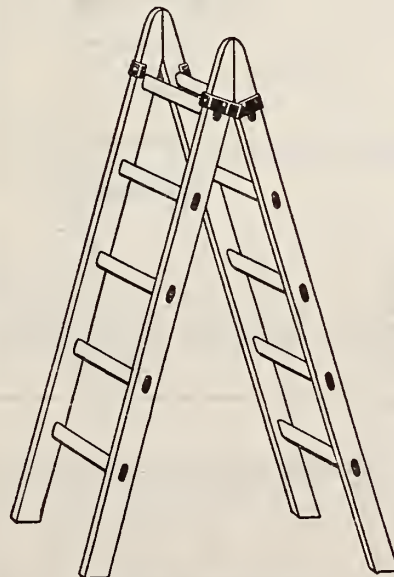

STRONG AND LIGHT

Made in all sizes, from 6 feet to 12 feet.

	Pair
2 6-ft.....	\$5.00
2 8-ft.....	6.50
2 10-ft.....	8.25
2 12-ft.....	11.00

GRITCO DECORATORS

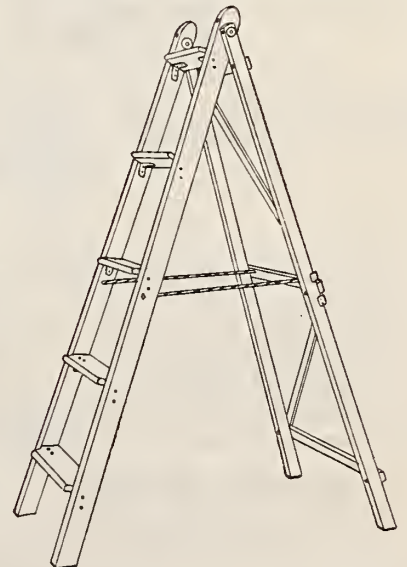

This ladder is for paper hangers, painters and interior decorators.

Made of Spruce material, approved specifications.

4 ft.....\$2.40	10 ft.....\$6.00
5 ft..... 3.00	12 ft..... 8.00
6 ft..... 3.60	14 ft..... 9.40
7 ft..... 4.20	16 ft.....11.20
8 ft..... 4.80	

ADJUSTABLE JACKS

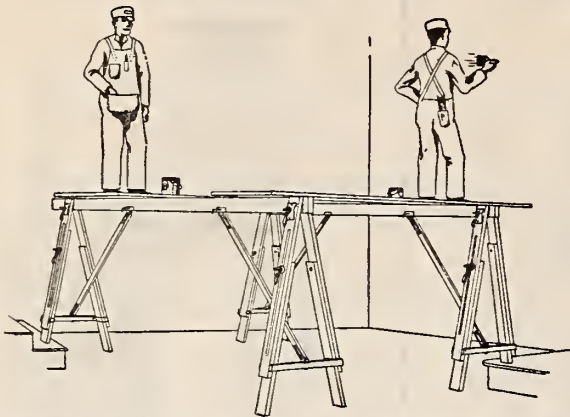

Above illustration shows four Adjustable Scaffold Jacks ready for use. It requires Four Jacks to properly scaffold a room, on which Planks can be laid, thus giving a safe platform to work on.

ADJUSTABLE SCAFFOLD JACKS

No. 3—4 ft. extends to 6.	Each \$6.60	No. 5—8 ft. ext. to 13.	Each \$11.00
No. 3½—5 ft. ext. to 8.	7.40	No. 6—10 ft. ext. to 16.	16.50
No. 4—6 ft. ext. to 9½.	8.40	No. 7—12 ft. ext. to 20.	19.50
Adjustable Scaffold Jack Iron Brackets, set of four.... 4.25			

GRITCO WINDOW CLEANERS

A very convenient ladder for window cleaning purposes or where a ladder has to be carried from one place to another.

It is made in sections, which makes it convenient to handle.

All sections are fitted into each other.

These ladders are made in 6-foot lengths.

\$2.50

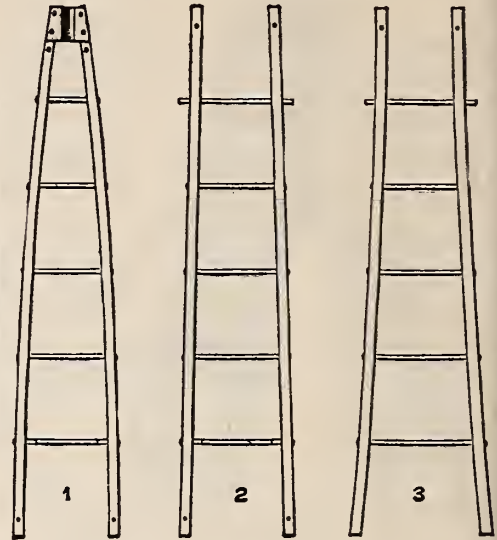

EXTENSION TRESTLES

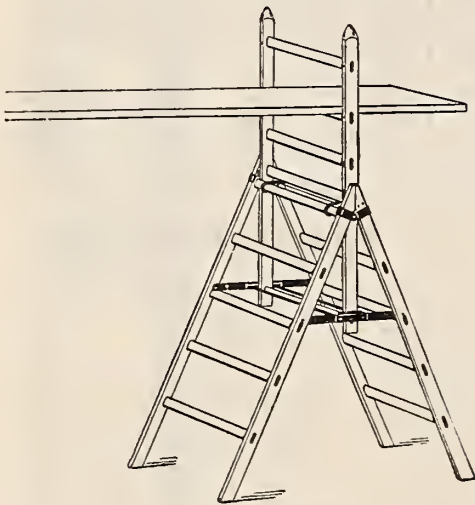

EXTENSION TRESTLES

6 ft. extending to 10 ft., each.....	\$11.00
8 ft. extending to 14 ft., each.....	14.00
10 ft. extending to 18 ft., each.....	16.50
12 ft. extending to 22 ft., each.....	19.00
14 ft. extending to 24 ft., each.....	25.00
16 ft. extending to 26 ft., each.....	32.00

GRITCO SECTIONAL LADDERS



Made in 6-foot sections, each end protected with iron plates and equipped with large bolts with thumb nuts, making them safe and durable. Hickory rungs. Sections 6 feet 5 inches.
\$3.50

PLATFORM STEP LADDERS



4 feet	\$7.00
6 feet	9.50
8 feet	12.50

WINDOW BRACKET

Made in Two Sizes

No. 1—4 feet 4 inches.....	\$10.00
No. 2—6 feet.....	11.00

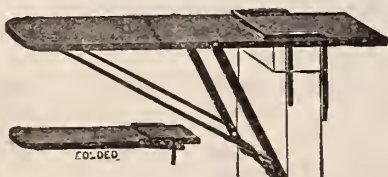

MASON OR BRICKLAYERS' LADDER

Made from clear, selected stock, carefully bored. Rounds made from hickory properly spaced for easy climbing.

16, 18, 20 and 22 feet, per foot.....	50c
---------------------------------------	-----

STEEL RAKES



- No. 10C—Curved tooth, 10-tooth.... \$0.85
- No. 12C—Curved tooth, 12-tooth.... .90
- No. 14C—Curved tooth, 14-tooth.... .95
- No. 16C—Curved tooth, 16-tooth.... 1.00
- No. 18C—Curved tooth, 18-tooth.... 1.10

STRAIGHT TOOTH RAKE



- No. 10—Straight tooth, 10-tooth.... \$0.70
- No. 12—Straight tooth, 12-tooth.... .80
- No. 14—Straight tooth, 14-tooth.... .90
- No. 16—Straight tooth, 16-tooth.... 1.00
- No. 18—Straight tooth, 18-tooth.... 1.10
- No. 10SZ—10-tooth, single shank... \$0.55
- No. 12SZ—12-tooth, single shank... .60
- No. 14SZ—14-tooth, single shank... .65
- No. 16SZ—16-tooth, single shank... .70

PRIZE BOW RAKE

- No. B12—Prize bow-braced rake, solid steel, 12 teeth. Price, each..... \$1.10
- No. B14—Prize bow-braced rake, solid steel, 14 teeth. Price, each..... \$1.20
- No. B16—Solid bow-braced rake, solid steel, 16 teeth. Price, each..... \$1.30

STEEL ROAD RAKES

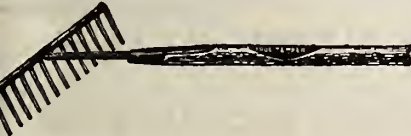

- No. X12—12-tooth \$1.40
- No. X14—14-tooth 1.45
- No. X16—16-tooth 1.55

WIRE RAKE

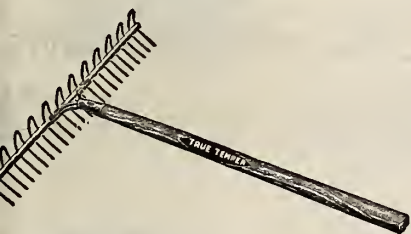

- No. 124E—24-tooth, each 80c

24-TOOTH RAKE

- 24-tooth,
3 wire bows 70c
- 10-tooth,
1 wire bow..45c
- Extra teeth,
each3c

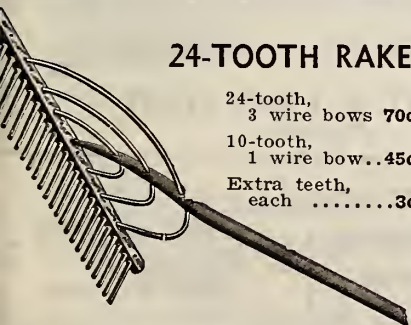

STEEL BRUME RAKE



- No. FBR22—Light and very flexible.90c

STEEL ASPHALT RAKES

- No. 1014—14-tooth, strap ferrule... \$2.25

HAY FORKS

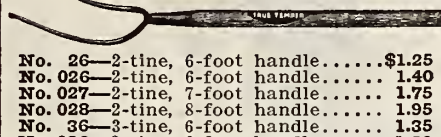

- No. 26—2-tine, 6-foot handle..... \$1.25
- No. 026—2-tine, 6-foot handle..... 1.40
- No. 027—2-tine, 7-foot handle..... 1.75
- No. 028—2-tine, 8-foot handle..... 1.95
- No. 36—3-tine, 6-foot handle..... 1.35
- No. 036—3-tine, 6-foot handle..... 1.50
- No. 037—3-tine, 7-foot handle..... 1.80
- No. 038—3-tine, 8-foot handle..... 2.00

4-TINE FORK



- No. 044 1/2 X—4-tine, 4 1/2-ft. handle.. \$1.45
- No. 054 1/2 X—5-tine, long handle.... 1.70
- No. 064 1/2 X—6-tine, long handle.... 1.90
- BACHELOR FORK**
- No. 044—4-tine, 4-foot handle..... 1.60
- D-HANDLE MANURE FORKS**
- No. 04D—D Handle, 4-tine, regular. 1.50
- No. 05D—D Handle, 5-tine, regular. 1.70
- No. 06D—D Handle, 6-tine, regular. 2.00

SPADING FORK



- No. OHW—4-tine, angular back.... \$2.00
- No. OLD—Medium weight 1.40
- No. JOW—Jumbo, 4 polished tines..2.25
- No. B4D—Boys' 4-tine, price..... 1.00

ENSILAGE FORKS



- No. 508—8 16-in. tines, iron D handle, each \$2.50
- No. 510—10 17-in. tines, iron D handle, each \$3.00



- No. 100S—10-tine, D handle, stone fork \$3.00
- No. 102S—12-tine, D handle, stone fork \$3.50
- No. 910—10-tine, scoop shape, malleable D handle, strap ferrule, each.. \$2.75
- No. 912—12-tine, scoop shape, malleable D handle, strap ferrule, each.. \$3.35
- No. 712—Coke Forks, 12-tine, D handle, strap ferrule, each..... \$3.35

MANURE HOOKS



- No. M40—4 oval tines, 5-ft. handle \$1.30
- No. M60—6 oval tines, 5-ft. handle \$1.50



- No. 1P—Sharp point hoe..... \$0.50
- No. 2P—2-point hoe55
- No. 4P—4-point hoe and rake..... 1.10

CRESCENT CULTIVATOR HOE

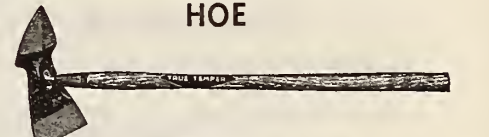

- No. 67—7-inch steel blade, 4 1/3-foot handle \$1.10

POTATO HOOKS



- No. 4BOH—Heavy broad oval tines, bent head, 4 1/2-foot handle..... \$1.20
- No. 5BOH—5 tines, heavy broad oval tines, bent head, 4 1/2-foot handle. \$1.45

DOCK DIGGERS



- No. 39D—Square point \$1.50
- No. 39A—V point 1.50

PLANTER HOES



- No. P75—Heavy-handed planter shank hoe, 7-in. blade..... \$1.10
- No. P7 1/2-5—Heavy-handed planter shank hoe, 7 1/2-inch blade..... 1.15
- No. P8 1/2-5—Heavy-handed planter shank hoe, 8-inch blade..... \$1.20

GARDEN HOES



- No. G0-67—Solid steel garden socket hoe, XX handle, each..... \$1.00
- No. G67—Solid steel garden shank hoe, XX handle, each..... .90c
- No. G0-78—Solid steel garden socket hoe, XX handle, each..... \$1.05
- No. LY5—Solid steel lady's shank hoe, XX handle, each..... .80c

NO. 1 SOD LIFTER

Each \$2.00

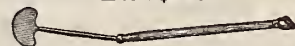

SCUFFLE HOES

No. XGS Brace or Shank Scuffle Hoe, 8-inch steel blade, with handle.....\$1.15



EDGING KNIFE

No. 040—Solid Steel Turf Edger.....\$1.25

Blood's Bush and Brier Hooks

No. 10—Axe handle hook.....\$1.60

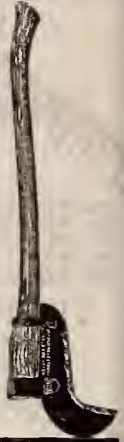

ENGLISH WALDRON BLADES

36-inch Grass Scythe.....\$3.00
 38-inch Grass Scythe.....3.10
 40-inch Grass Scythe.....3.20
 Bush Scythe.....3.00
 Weed Scythe.....3.25

SCYTHE SNATHES

No. 55—Patent loop, solid plate.....\$1.50
 No. 100—Two rings, bush.....1.65
 No. 105—Patent bush snathes.....1.65

GARDEN SETS

No. 3PF—3-piece, 5-T rake, shovel and hoe \$1.70



"YAMADE" BAMBOO RAKE

(Special)

Note the new style with the metal grip made of non-corrosive, never-rusting steel. Keeps every tooth permanently placed. Exclusive distributors for this style rake.

18-inch.....\$0.75
 24-inch.....1.25
 30-inch.....1.75



WEED SCYTHE

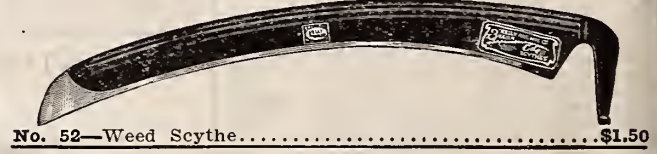

No. 52—Weed Scythe.....\$1.50

GRASS SCYTHE

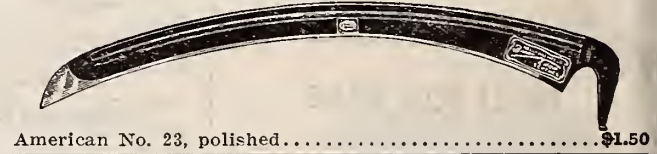

American No. 23, polished.....\$1.50

SIDEWALK CLEANERS

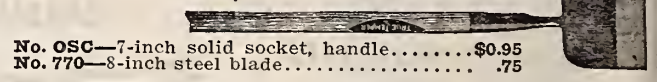

No. OSC—7-inch solid socket, handle.....\$0.95
 No. 770—8-inch steel blade......75

COTTON HOES

No. C75—7-inch, handled cotton hoe.....\$0.95
 No. C85—8-inch, handled cotton hoe.....1.10

MORTAR HOES

No. S9—9-inch blade, solid socket, 5½-foot handle.....\$1.25
 No. S10—10-inch blade, solid socket, 6-foot handle.....1.30

STREET HOE

No. 12S—12-inch blade, steel shank, 6-foot handle.....\$1.65

DIG EASY MATTOCK HOES

This Hoe is similar to Crescent Double-Bit Hoe, and is made in three sizes.

No. DE2—1¼-inch and 2-inch blades.....\$1.00
 No. DE3—1¾-inch and 3-inch blades.....1.05
 No. DE3½—1¾-inch and 3½-inch blades.....1.10

INVINCIBLE GARDEN CULTIVATORS



Tines can be adjusted by simply turning a nut.
 No. 1GC3—3 shank.....75c No. 1GC5—5 shank.....\$1.00

WIRE POTATO SCOOP

\$2.50

STEEL BARLEY FORKS

4 tine.....\$2.15

LIGHTNING PATTERN HAY KNIFE

\$1.75

AMERICAN SICKLE EDGE HAY KNIFE

\$1.75

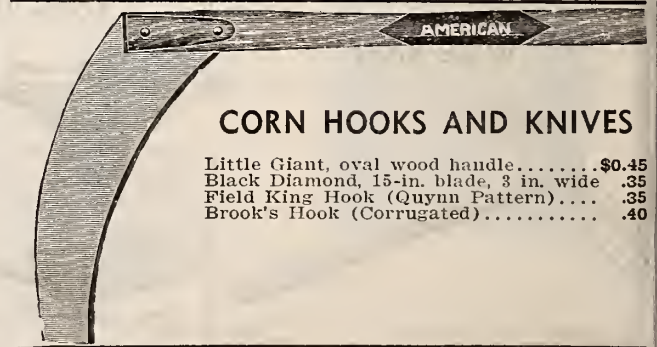

CORN HOOKS AND KNIVES

Little Giant, oval wood handle.....\$0.45
 Black Diamond, 15-in. blade, 3 in. wide .35
 Field King Hook (Quynn Pattern).... .35
 Brook's Hook (Corrugated)......40



PLANET JR. LAWN EDGER

Price \$1.60

MANURE FORK HANDLES WITH PLAIN AND STRAP FERRULE

No. X—4½ ft., with plain ferrule, with cap. Each..50c
 No. X—4½ ft., with strap

ferrule and cap. Each...60c
 No. X—Plain 4½ ft., each 35c
HAY FORK HANDLES
 No. X—Plain, 6 ft., each..55c
 No. X—Plain, 7 ft., each..80c
 No. X—Plain, 8 ft., each \$1.15

GARDEN HOE HANDLES

No. X—Plain, each.....30c

EYE HOE HANDLES

No. X—For D. E. hoe, 5 ft. 2 in. butt, each.....50c

SHOVEL HANDLES

No. X—L. H., 4½ ft., each 45c
 No. X—D. H.....65c

RAKE HANDLES

No. X—Plain, 5½ ft., ea. 40c

NAYLOR BRAND Plain Black SHOVELS

The blade and straps are made from separate pieces of steel; the straps are welded to the blade. In the blade, stiffness, strength and resistance to abrasion are essential. In the strap, steel is required which is tough, yet ductile enough to conform to the curve as well as the round of the handle.

Long Handle Round Point Shovels



No. 1047—Size 2, Long Handle, Round Point Shovel.....\$1.10

Round Point Dee Handle Shovels



No. 1037—Size 2, D Handle, Round Point Shovel.....\$1.10

Dee Handle Square Point Shovels



No. 1017—Size 2, D Handle, Square Point Shovel.....\$1.10
 No. 1017—Size 3, D Handle, Square Point Shovel..... 1.20
 No. 1017—Size 4, D Handle, Square Point Shovel..... 1.25

Dee Handle Spades



No. 1177—Size 2, Standard Spade, Long Handle.....\$1.10
 No. 1167—Size 2, Standard Spade, D Handle..... 1.10
 No. 1205—18-inch Ditching Spade, D Handle..... 1.90
 No. 1215—18-inch Drain Spade, Round Point, D Handle.. 1.90

Western Pattern Scoops



No. 1627—Size 4, D Handle, Western Pattern Scoop Sh'l. \$1.10
 No. 1627—Size 6, D Handle, Western Pattern Scoop Shovel 1.30
 No. 1627—Size 8, D Handle, Western Pattern Scoop Shovel 1.50
 No. 1628—Size 4, Long Handle, Western Pat. Scoop Shovel 1.10
 No. 1628—Size 6, Long Handle, Western Pat. Scoop Shovel 1.30
 No. 1628—Size 8, Long Handle, Western Pat. Scoop Shovel 1.50

Furnace Scoops

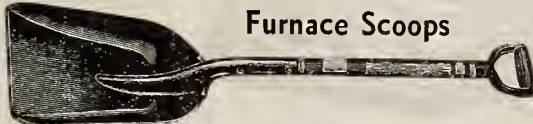

No. 80S—Furnace Scoop.....\$0.80

Snow Shovels



No. 91-2R—General Purpose Snow Shovel.....\$0.65

AMES SHOVELS AND SPADES

GENUINE OLIVER

Each shovel and spade which bears the signature "Oliver Ames," is your continued guarantee of matchless service. It is identified by the genuine O. AMES Label. Significant of the O. AMES grade, is the blade of Ames special alloy; heat treated for maximum resistance to abrasion; with selected second growth Northern Ash, extra strong, fine grained handle.

Long Handle Round Point Shovels



No. 45—Long Handle, Round Point Shovel.....\$2.00

Long Handle Square Point Shovels



No. 25—Long Handle, Square Point Shovel.....\$2.00

Square Point Dee Handle Shovels



No. 15—D Handle, Square Point Shovel.....\$2.00

Dee Handle Spades



No. 75—D Handle, Standard Spade.....\$2.00

Nursery Spades



No. 70—D Handle, Full Strapped Nursery Spade.....\$4.25

Lady or Boy Shovels and Spades

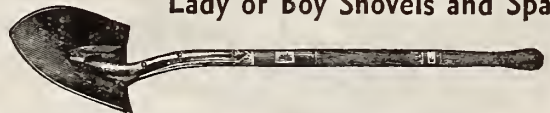

No. 60—Lady or Campers Shovel.....\$1.25
 Ladies' or Boys' Spade..... 1.25

PICKS, MATTOCKS AND GRUB HOES



No. 1 Gritco—6 to 7, 7 to 8 and 8 to 9 lbs., Best Quality Warranted Steel Railroad Picks.....\$1.10
 No. 2—6 to 7, 7 to 8 and 8 to 9 lbs., Regular Iron Railroad Picks90
 No. 1 Gritco—5-lb. Best Quality War, Steel Mattocks.... 1.05
 No. 1 Gritco—6-lb. Best Quality War, Steel Mattocks.... 1.15
 No. 2—5 and 6-lb. Best Refined Iron Mattocks (Steel Cutters)Each, 1.05
 No. 2 Gritco—Warranted Grub Hoes.....Each, 1.00

Pick and Mattock Handles

First Quality Hickory Pick Handles..... Retail \$.50
 No. 1—Good Quality White and Red Hickory Pick Handles .45
 No. 2—Mixed White and Red Hickory Pick Handles..... .40

ALL MOWERS MADE BY PENNSYLVANIA LAWN MOWER WORKS

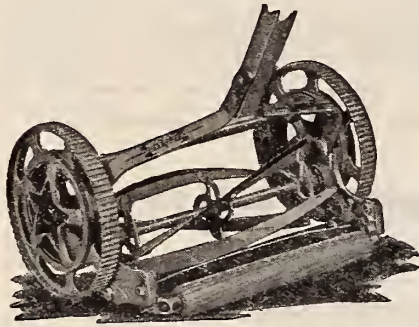

BANNER MOWER

Ball Bearing
8-inch Wheel
4 Blade

- 12-in. \$5.50
- 14-in. 5.75
- 16-in. 6.00

**K L I F T O N
M O N A R C H**

10-inch wheel
4 Blade

- 14-in. \$6.50
- 16-in. 7.00
- 18-in. 7.50

PENNSYLVANIA HIGH-WHEEL MOWER

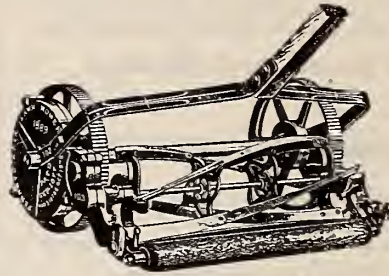

This high - grade Mower is constructed for cutting ordinary grass, as well as grass from 6 to 10 inches high. Wheel, 10½ inches; cylinder, 6½ inches. Four crucible steel knives.

- 15 inches \$24.50
- 17 inches 28.00
- 19 inches 31.50

WILLOW BROOK BALL-BEARING MOWER

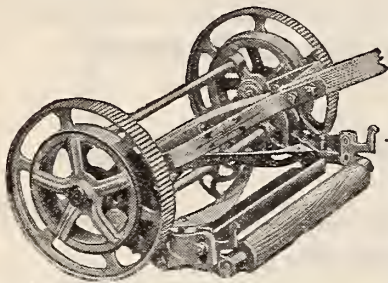

10-in. Wheel, 4 Blade

This machine is made from high-grade material. Its construction, while extremely simple, is very strong and durable. Ball bearing.

- 14-in. \$8.75
- 16-in. 9.25
- 18-in. 10.25

SUSQUEHANNA

- 10-in. Wheel, 5 Blade
- 14-in. Mower... \$9.25
- 16-in. Mower... 9.75
- 18-in. Mower... 10.75

CONTINENTAL HIGH-WHEEL MOWER

This very high - grade machine will cut fine grass two inches high; also grass six to eight inches. We highly recommend this machine.

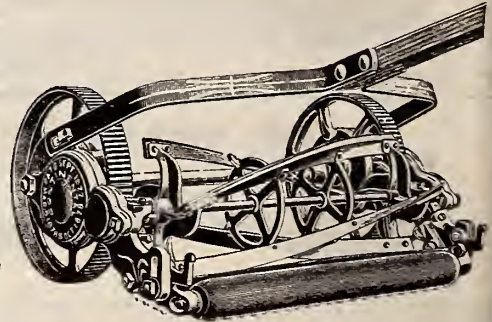

- 15-in. .. \$24.50
- 17-in. .. 28.00
- 19-in. .. 31.50

PENNSYLVANIA JR. BALL-BEARING MOWER

Same high - grade construction used in the Pennsylvania High-Wheel and Continental Mower.

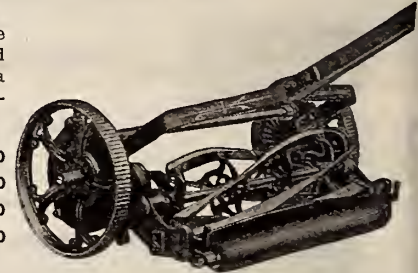

- 15-in. \$24.50
- 17-in. 28.00
- 19-in. 31.50
- 21-in. 35.00

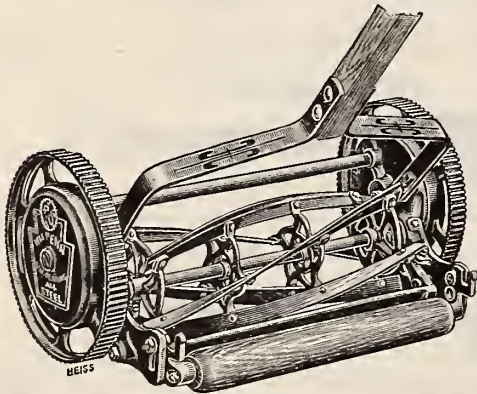

**WM.
PENN**

All Steel
Ball Bearing
10-in. Wheel
5 Blade

One Size Only

- 17-in. Mower, \$16.50

PENNSYLVANIA SUPER ROLLER MOWER

For Putting Greens

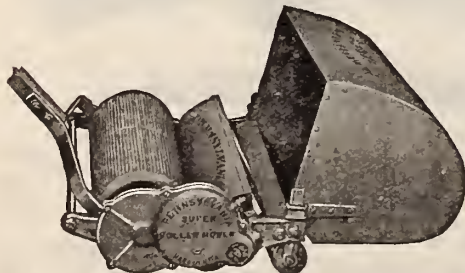

It has seven crucible tool steel blades, oil - hardened and water tempered Triple gears, insuring power and speed, cast-iron roller, 7 inches in diameter, improved curved pattern tempered crucible steel tool bottom knife, cuts ½ to 1½ inch.

Staytite hardwood handle with adjustable steel clamps on cross bar.

PRICE

- 18 inch \$50.00
- Grass Box 8.00
- Carriage 5.00

GREAT AMERICAN BALL-BEARING MOWER

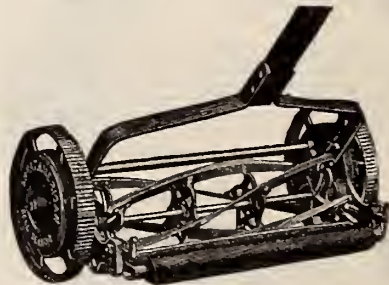

Every detail of this Mower is in keeping with the high grade of the Pennsylvania and Continental. Can be regulated to cut from ¾ to 1¾ inches from the ground.

- 15-in. \$16.50
- 17-in. 18.50
- 19-in. 21.50
- 21-in. 24.50

LAWN MOWER REPAIRING AND SHARPENING

Our well-equipped shop and competent mechanics, that have been repairing and sharpening lawn mowers for years, assures you of a first-class job.

Our repair department does not confine its operation to sharpening and repairing lawn mowers only. We are in position to do general repair work and solicit your patronage in other lines of work.

WATER BALLAST LAWN ROLLER



No. 601—Drum 14 in. dia., 24 in. long, weight empty 60 lbs., filled with water 250 lbs., price... **\$14.25**
 No. 602—Drum 18 in. dia., 24 in. long, weight empty 73 lbs., filled with water 330 lbs., price... **16.50**
 No. 603—Drum 24 in. dia., 24 in. long, weight empty 100 lbs., filled with water 440 lbs., price... **18.75**
 No. 604—Drum 24 in. dia., 32 in. long, weight empty 115 lbs., filled with water 590 lbs., price... **21.00**
 No. 607—Plain bearing, 14 in. dia., 15 in. long, price..... **\$10.00**

CAST IRON HAND LAWN ROLLER—Two Sections

No. 504—20 in. dia., 20 in. long, weight 250 lbs., price..... **\$26.00**
 No. 507—20 in. dia., 24 in. long, weight 300 lbs., price..... **\$32.00**
 No. 509—24 in. dia., 20 in. long, weight 400 lbs., price..... **\$42.00**

PENNSYLVANIA "NEW" FAIRWAY MOWER

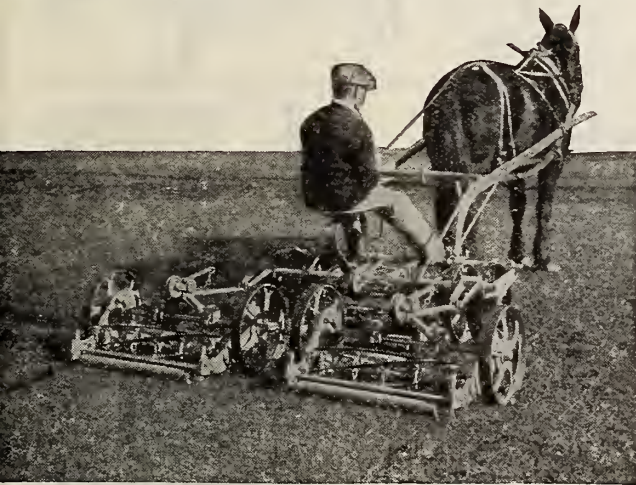

GOLF ROLLERS

No.	Dia.	Lgt.
374	28 in.	4 ft.
376	28 in.	6 ft.

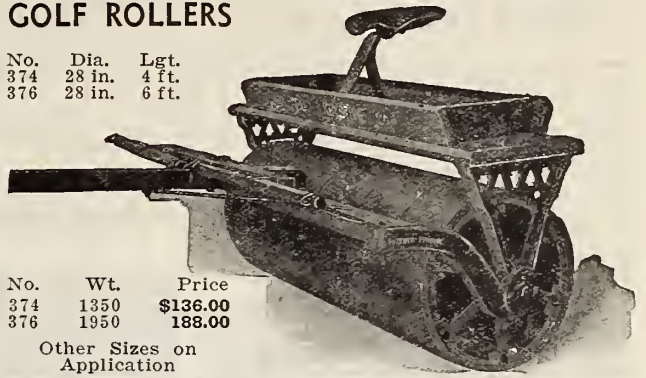

No.	Wt.	Price
374	1350	\$136.00
376	1950	188.00

Other Sizes on Application

BALTIMORE HORSE MOWER

Most satisfactory horse mower on the market.

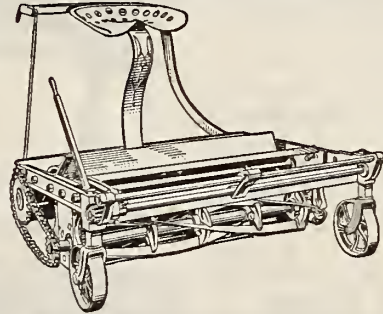

- 25-inch Pony with draft rod and single-tree **\$140.00**
- 30-inch with shafts and seat **\$170.00**
- 35-inch with shafts and seat **\$200.00**

Cylinders—7 inches in diameter, with accurate adjustment for even cutting. Have five crucible tool steel knives, oil-hardened and water tempered.

Bottom Knife—Raised edge, chrome steel; set screw adjustment.

Wheels—17 inches in diameter; tread, 2½ inches. Each fitted with two sets Timken Roller Bearings.

Bearings and Gears are all in dirt-proof, oil-retaining housings. The two intermediate gears are on roller bearings; the cutting cylinders run in the new and revolutionary Braun Self-aligning Ball Bearings. Three gears (on both sides) are cut from special blanks.

Fairway Trio Mower, horse drawn..... **\$400.00**

Fairway Trio Mower, tractor drawn..... **375.00**

Fairway 5-Unit Mower, tractor or 4-horse hitch..... **625.00**

MOTO-MOWER

The Moto-Mower offers efficient power mowing service at a moderate cost.

A twist of the wrist controls the power. The power from the engine is transmitted direct to the Cutting Reel, through Jack Shaft, chain and sprocket, the most efficient method of drive known.

It will operate on hills and terraces, and runs an average of eight hours on a gallon of gasoline.

The machine is shipped assembled ready to go to work. Has a fine 4-cycle valve-in-the-head Motor. All parts accurately machined and ground. Splash Oil System is used; has no complicated parts in carburetor.

27-inch Mower has clutch for throwing out when mowing.

Prices of Mowers—27 inch..... **\$285.00**

21 inch **195.00**

18 inch **150.00**

Grass Catchers—21 inch..... **5.00**

27 inch **5.50**

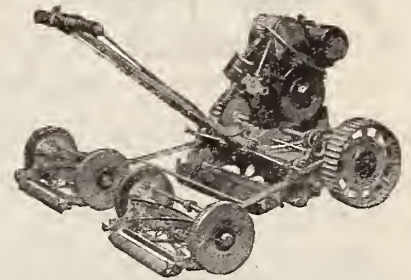

27 inch DeLuxe Mower..... **\$360.00**

27 inch Units..... **35.00**

Sulky **35.00**

Weed Clipping Attachment

for 27 inch..... **45.00**

LAWN CLEANER

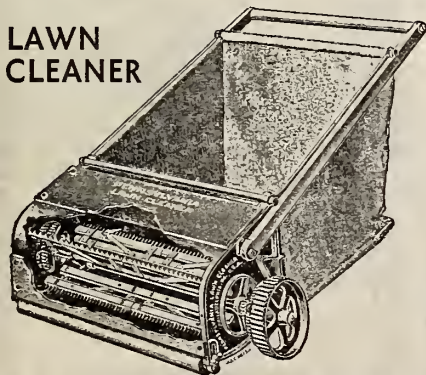

24 inch, either rakes or brushes, **\$35.00**

ACE TRIMMER

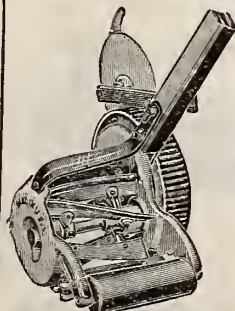

Price **\$7.50**

GRASS CATCHER

No. 151H — Metal Bottom Catcher, 13 inches deep, made of heavy duck; heavy galvanized wire frame; adjustable steel hooks; adjustable to mowers 12 to 16 inches wide.

Price **80c**

No. 156H—16 to 20 inches wide.

Price **\$1.00**

Canvas Catcher, both sizes..... **50c**

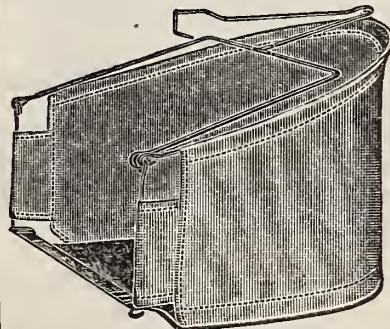

WINNER LAWN SWING

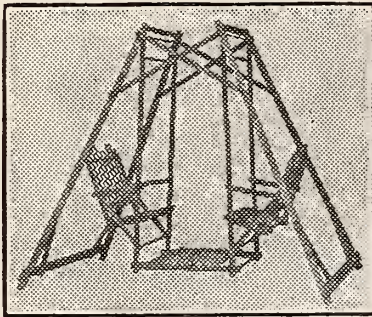

This Lawn Swing is made of hardwood, frame painted a bright vermilion, chairs, hangers and footrest a beautiful golden oak, and is a splendid value for the money. 4-passenger.....\$9.50

LAWN SWING—The Bonanza

Made of hardwood, with 3/4-inch bolted frame. Has three seat and foot rest adjustments. Frame painted red; balance of swing golden oak. Hooks where swing bars hang on iron rods at top of frame; height 9 feet; seat space 34 in.; ground space 9 ft. 4 in. by 6 ft.; 4-passenger\$12.50

BAUSMAN STEEL LAWN SWING



With Canopy.....\$16.50
Without Canopy .. 14.00

Seat is 30 inches wide; back 29 inches high; wooden arm rests. Height of frame is 7 feet. Floor space required 5x8 feet. Weight is 150 pounds.

CHILD'S LAWN SWING

This is a nicely made swing especially for children. Made in both two and four passenger. Every child would delight in having one of these swings. There is nothing that would give them as much pleasure.

Prices: 2 passenger.....\$6.25
4 passenger 7.00

No. 7 Porch Settee



Very popular and durable. Finished in weathered oak. All slats bolted to frame; no rivets.

No. 7—5 foot. Our special price..\$7.00
No. 6—4 foot. Our special price.. 5.00

LAWN SETTEES

The Lawn Settees listed below have strength and beauty, and at the same time are very reasonable in price. The frames are made from strong steel, and the seats and backs from smoothly finished hardwood.

Meadowbrook Settee

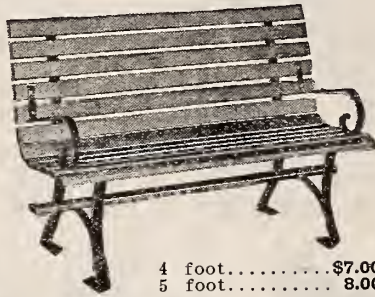

4 foot.....\$7.00
5 foot..... 8.00

Commonwealth Settees



4 foot.....\$6.00
5 foot..... 7.00

Universal Settee



4 foot.....\$3.50

BICYCLE WRINGER

Steel Spiral Springs, adjusted with thumb nuts for heavy or light work.

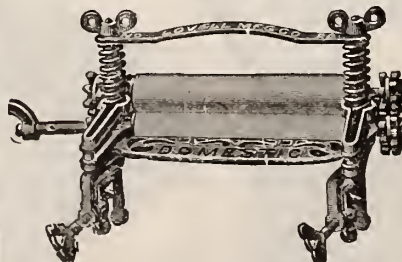

No. 740 Bicycle Rolls, 10x1 3/4 in....\$6.60
No. 741 Bicycle Rolls, 11x1 3/4 in.... 7.00

MAJESTIC WASHER



Electric welded wire hoops, Virginia white cedar tub, roller bearings.

Price \$13.50

RICHMOND HIGH SPEED WASHING MACHINE



Price \$18.35

MAJESTIC ELECTRIC POWER WASHER

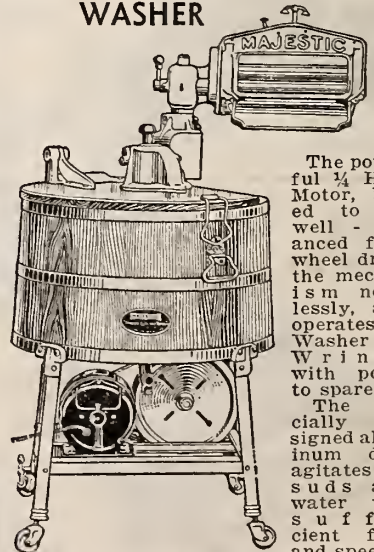

The powerful 1/4 H. P. Motor, belted to the well-balanced fly-wheel drives the mechanism noiselessly, and operates the Washer and Wringer with power to spare.

The specially designed aluminum dolly agitates the suds and water with sufficient force and speed to wash the clothes spotlessly clean in a few minutes. Price\$62.50

CAHOON'S BROADCAST SEED SOWER

For sowing Clover, Timothy, Millet, Oats, Wheat, Hemp, Barley, Rye, Rice, Buckwheat, etc. Standard Seeder of the World—A Model for Accuracy and Durability—Malleable Iron Frame—Steel Hopper and Gate—Brass Discharger.

The breadth of the cast will be according to the weight of the seed. Wheat and Rye, 30 to 36 feet. Oats, 21 to 25 feet. Barley, 27 to 33 ft. Clover, Millet, Hungarian Seed, 20 to 24 feet. Hemp, 27 to 30 feet. Timothy, 15 to 18 feet. Parcel post weight, 8 lbs.

PRICE, \$5.00

THOMPSON'S CLOVER AND GRASS SEEDER

Sows 14 to 16 feet Wide, Any Amount Desired Per Acre. Will

Sow 20 to 25 Acres Per Day.

This Grass Seeder is simple, without gearing, cams or intricate machinery. It cannot get out of order.



Perfection feed is attained in making it absolutely positive, yet a non-leaking carrier, when thrown out of connection. The quantity of seed to the acre is accurately shown by the index plate.

Rope Feed Seeder

It is strong, yet weighs but 40 pounds.

- No. 1—14-foot, single hopper, \$14.00
- No. 1—16-foot, single hopper, 15.00

No. 5—Complete Seeder, with Double Hopper, sows Red Top, Orchard Grass, Blue Grass, Lawn Grass, as well as Clover. 14-foot, \$17.00.

THOMPSON'S ROYAL CLOVER AND GRASS SEEDER

These Seeders are similar to the Thompson above, except they have Chain Feed.

- No. 11—14 ft., single hopper.....\$14.00
- No. 11—16 ft., single hopper..... 15.00
- No. 12—14 ft., double hopper..... 17.00
- No. 10—10 ft., double hopper, Universal Seeder for all grass seeds, grain, cow peas and soy beans..... 18.00

THOMPSON'S GOLF SPECIAL SEEDER

Golf greens, fairways and lawns must be seeded evenly to produce the desired uniform turf.

Thompson Golf Special Seeders are used on America's leading golf courses and private estates because they are speedy, accurate and economical. Wind or mud do not interfere with their accurate work because they sow close to the ground and cannot clog.



For a large amount of ground to cover we suggest two or three of these Seeders, providing the job of seeding needs to be done quickly just when the ground is in the right condition to receive the seed.

No. 106 SEEDER, 10-ft. HOPPER complete; wt. 60 lbs...\$24.00

THE ORIGINAL IMPROVED CYCLONE

It differs materially and very advantageously from all other Sowers in having a slope feedboard with an oblong hopper which terminates in a metal edge, on which edge oscillates a feed plate which does not allow the seed to become clogged, but makes a positive force feed and insures

a uniform flow and even distribution of seed. Anyone desiring a convenient, practical and an all-round first-class grain and grass seeder, a good, large sower that will meet the most exacting demands, we cannot recommend the CYCLONE too highly. Parcel Post weight, 6 lbs. PRICE, \$2.25.



THE CYCLONE SEED SOWER

THE SOWER THAT SCATTERS EVENLY

LIGHTNING SEED SOWER

Cheap, durable, weighs only 12 ozs. Simple; no repairs.

Will Sow 60 Acres per Day of Clover, Timothy, Millet, Alfalfa, Flax, etc.

Will spread seed evenly from 30 to 40 feet. Method of sowing is by swinging tube in horizontal position from right to left which closely resembles the old method by hand. Gives control over seed on a circle of 8 feet before it leaves the tube and the wind has no chance to blow seed into bunches before it strikes the ground.

PRICE, \$1.00.

Parcel Post wt., 1 lb.



MEEKER SMOOTHING DISC HARROW

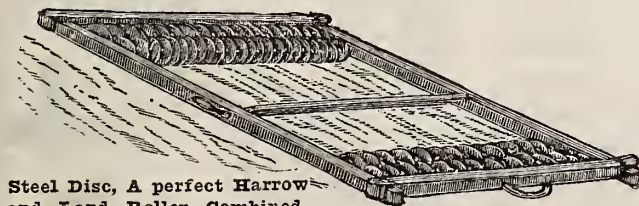

Steel Disc, A perfect Harrow and Land Roller Combined.

The frame measures 6 feet 8 inches by 6 feet, and has four sets of rollers, having 68 discs, 8 inches diameter on them. The discs grind all the lumps so fine that the seed must come up, leveling and leaving the land fine and smooth, and doing its work far better than the rake.

Our Special Price.....\$33.50

Planet Jr. Combined Seeder and Single Wheel Hoe No. 4

The No. 4 Seeder and Wheel Hoe is the most useful combination available for the Home or Market Gardener. Sows all vegetable seeds in the drill or drops in hills 4, 6, 8, 12 or 24 inches apart. Fine assortment of cultivating attachments take care of all garden work.

Capacity of seed hopper 2½ quarts. Quickly changed from hill to drill seeder and from seeder to wheel hoe.

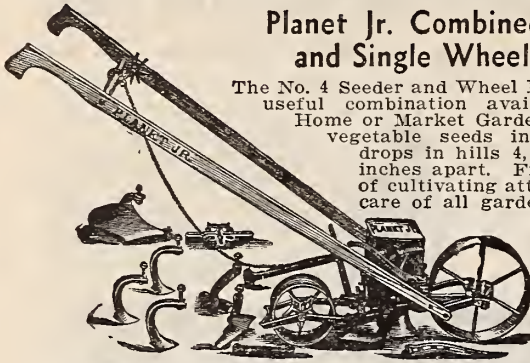

No. 4 Hill and Drill Seeder and Single Wheel Hoe Combined\$18.00
No. 4-D Seeder only..... 14.25

No. 25 Hill and Drill Seeder Double and Single Wheel Hoe Combined

Price \$21.50

The "Complete Gardener." Sows all vegetable seed in the drill and drops in hills 2, 6, 8, 12 and 24 inches apart. As a Double Wheel Hoe it straddles the row, cultivating both sides at one time until the plants are 20 in. high. Cultivating attachments consist of 1 pair of plows, 1 pair of



6-inch hoes, 4 steel cultivator teeth and a pair of leaf lifters.

Nos. 3 & 5 Planet Jr. Hill and Drill Seeder

These seeders are undoubtedly the most favored by market gardeners and other large commercial growers. They are identical in operation and construction, the only difference being that the No. 3 has a 15-inch drive-wheel and holds 3 quarts of seed, while the No. 5 has a 16½-inch drive-wheel and holds 5 qts. of seed.

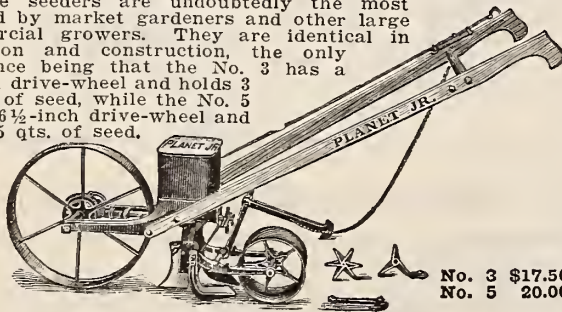

No. 3 \$17.50
No. 5 20.00

No. 300 Planet Jr. Drill Seeder

Capacity 4 Quarts

Price \$20.00

There has always been a demand for a quality seeder which will sow through holes in a plate rather than through a variable diamond-shaped opening.

Accurate Seeding

The seed is pushed through a hole in the plate by a patented feed wheel of a new type.



No. 19 Garden Plow and Cultivator

Packed Weight 18 lbs. 15-inch steel wheel.

Equipment—1 2-in. cultivating tooth; 1 10-in. sweep; 1 plow; 1 5-prong cultivating attachment.

Price \$5.00



No. 12 Planet Jr. Single and Double Wheel Hoe

The most popular combination of Double and Single Wheel Hoe for the Market Gardener and Home Gardener in use today.

The assortment of cultivating attachments consisting of one pair of plows, 1 pair of 6-inch hoes, 4 steel cultivator teeth, and 1 pair of leaf lifters. Cultivates both sides at one time.

Price \$10.75 No. 11, with 4½ in. Hoes and 4 Rakes, \$13.75



No. 17 Planet Jr. Single Wheel Hoe

As Illustrated \$7.75

No. 16—With Rakes and Leaf Guard, \$9.00

No. 18—With 2 6-inch Hoes only \$5.75



Fire Fly Garden Plow

This is an exceedingly useful tool to owners of small gardens. It will throw a furrow 4 to 6 in. wide and 1 to 3 inches deep.

Price \$4.25



Equipment

One 1¼-inch cultivat'g tooth.
One 4-inch cultivating tooth.
One plow.
One reversible scuffle blade.

Price \$4.00



No. 119 Planet Jr. Garden Plow and Cultivator

No. 119 has a wheel, with 1¼x¾ inch steel spokes, very strong, 24 inches in diameter. Furnished with Norcross 5-tooth weeder attachment in place of scuffle blade.

Price \$4.25



Five-Tooth Weeder Attachment

Can be attached to any of the Garden Plows. Price 80c each.



"Oriole" Garden Plow Complete

Price \$3.50

Mould 60c.
Sweep 40c.
Large Blade 30c.
Bull Tongue 25c.
Rake 50c.
Wheel \$1.50
Weeder 40c.

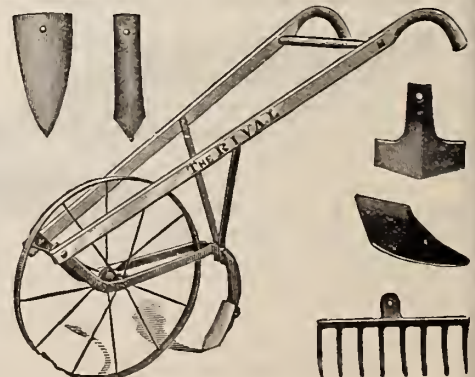

PLANET JR. HORSE HOES AND CULTIVATORS

It is an unquestioned fact that Planet Jr. horse-drawn cultivating implements are more universally known, and bear a higher reputation for quality, than any other cultivating machines ever made.

PLANET JR. CULTIVATOR

Planet Jr. Plain Cultivator
Four 3x8 Cultivator Shares.
One 4x8 Cultivator Share.



- No. 4—With Steel Wheel.....\$10.50
- No. 4D—Cultivator without Wheel..... 8.50
- No. 9—With Lever and Wheel..... 12.75
- No. 9D—With Lever, no Wheel..... 10.75

PLANET JR. HORSE HOE

Planet Jr. Horse Hoe
Equipment:
Four 3x8 Steels
One 4x8 Steel
One pair 6" Hillers
One 7" Shovel
Lever Expander

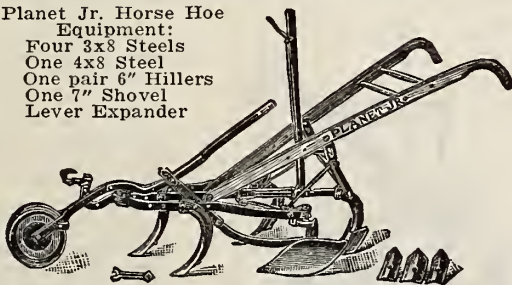

- No. 9—With Steel Wheel.....\$14.25
- No. 9D—Less Steel Wheel..... 12.25
- No. 8—With Wheel and Lever Wheel..... 16.25
- Vineturner add..... 2.50
- Roller add..... 4.75
- Steel Wheel as an extra..... 2.00

NO. 90 PLANET JR. 12-TOOTH HARROW, CULTIVATOR AND PULVERIZER

No. 90 Complete,
as shown, \$17.00



- No. 90B—Less Pulverizer.....\$14.00
- No. 90D—Less Pulverizer and Wheel..... 11.00

Shovel Steels Fit All Planet Jr. One and Two Horse Cultivators

- 7-inch Shovel Steel, No. 2539.....\$.35
- 8-inch Shovel Steel, No. 2540..... .40
- 6-inch Hillers, No. 1167/8, per pair..... 1.30
- 6-inch Hillers, with connecting pieces, per pair..... 2.30
- 7-inch Plows, No. 495/6, per pair..... 1.60
- 7-inch Plows, with connecting pieces, per pair..... 2.60

Furrowers Fit All Planet Jr. Cultivators Excepting 12-Tooth Harrows

- 10-inch Furrower, No. 1161.....\$1.00
- 12-inch Furrower and Bolt, No. 2621..... 1.35
- 15-inch Furrower and Bolt, No. 1162..... 1.75
- 20-inch Furrower and Bolt, No. 292X..... 3.25
- 20-inch Furrower, Sharp, No. 293X..... 3.25
- Wings for 20-inch Furrower, per pair..... 1.30
- Point for 20-inch Furrower, No. 1948..... .30
- Harrow Tooth, No. 1229..... .35

PLANET JR. CULTIVATOR

Light Weight

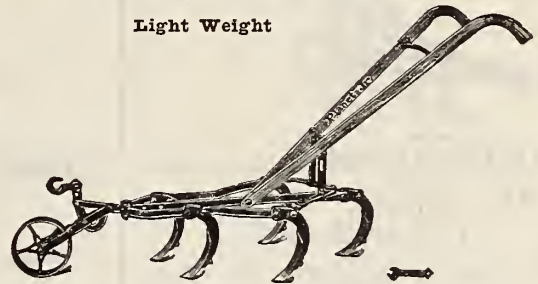

- No. 100D—Light Cultivator, no Wheel..... \$7.50
- No. 101—Light Cultivator with Lever and Wheel..... 11.00
- No. 101D—Light Cultivator, with Lever, no Wheel..... 9.25

NO. 220 PLANET, JR.

Saves Time, Labor—Produces Bigger Crops

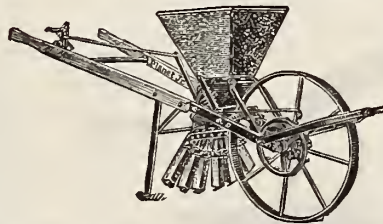

The No. 220 will distribute fertilizer in the middles of three rows 12 to 14 inches apart; it will side-dress one side each of two rows up to 36 inches apart (one complete row) and corn in wider rows. You can use it in very narrow rows—as close as 9 inches. You can use it in 42 to 48-inch rows by closing off the flow

in three spouts and distributing through the other three—either on the right or left-hand side.

It will distribute 100 to 2,000 pounds of commercial fertilizer to the acre. The shut-off rod is operated without stopping the distributor. Price\$27.00

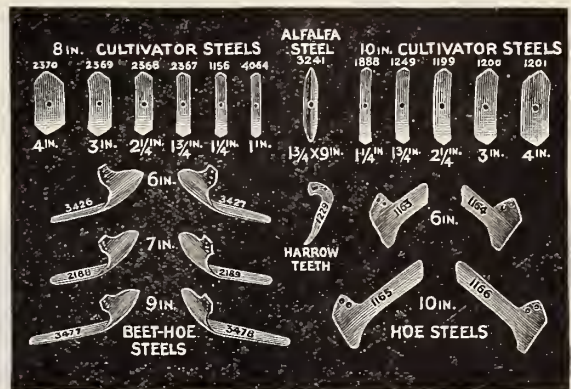

8-inch Steels Fit Planet Jr. Horse Hoes, Plain Cultivators and No. 72 Pivot Wheel Cultivator

- 1 x 8-inch Steels, No. 4064.....\$.16
- 1 1/4 x 8-inch Steels, No. 1156..... .17
- 1 3/4 x 8-inch Steels, No. 2367..... .18
- 2 1/4 x 8-inch Steels, No. 2368..... .20
- 3 x 8-inch Steels, No. 2369..... .22
- 4 x 8-inch Steels, No. 2370..... .27

10-inch Steels Fit All Planet Jr. Two-Horse Cultivators Excepting No. 72

- 1 1/4 x 10-inch Steels, No. 1888.....\$.19
- 1 3/4 x 10-inch Steels, No. 1249..... .22
- 2 1/4 x 10-inch Steels, No. 1199..... .24
- 3 x 10-inch Steels, No. 1200..... .28
- 4 x 10-inch Steels, No. 1201..... .32

Hoe Steels Fit Planet Jr. Horse Hoe Side Standards

- 6-inch Hoe Steel and Bolt, No. 1163/4, Pair.....\$1.30
- 10-inch Hoe Steel and Bolt, No. 1165/6, Pair..... 1.50



**OLD DOMINION (Straight Frame)
AND ORIOLE (Bent Frame)
CULTIVATORS**

With Outside Handle Braces and Wheel Clamp

- Cultivator, plain\$5.25
- Cultivator with Lever..... 6.00
- Wheels for Cultivators, each..... .90

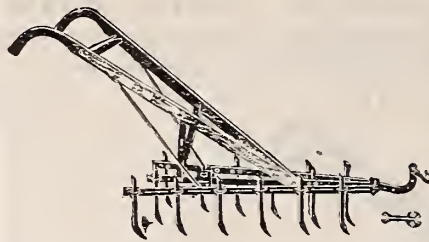

**COMBINED HARROW AND
CULTIVATOR**

14 Tooth—With Outside Handle Braces
and Wheel Clamp

- Price, without Lever.....\$6.40
- Price, with Lever..... 7.25

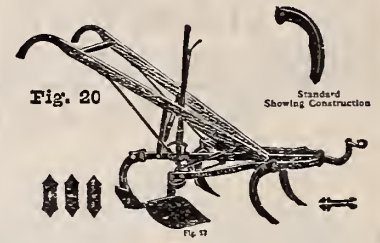

**Lord Baltimore Cultivators
and Horse Hoes**

Fig. 21—The same tool as shown in Fig. 20, with the addition of the Lever Wheel Attachment and Rear Wheel Depth Regulator. Weight 80 pounds. Price, \$11.00.

Fig. 20—With Lever, price..\$9.50.

SHOVEL PLOWS



- Farmers' Favorite, single-shovel plow.....\$4.25
- Farmers' Favorite, double-shovel plow..... 4.80
- Regular triple shovel plow..... 5.75
- Four shovel, steel beam..... 6.75

GENUINE "MALTA" SHOVEL PLOWS

- Double shovel plow.....\$5.50

Frank Beasley's Patent Disc Attachments

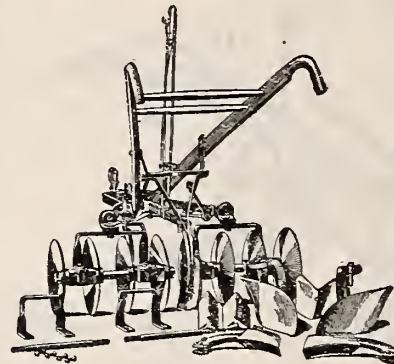

If you have a good five-tooth cultivator, you can secure these parts to attach to same and make your old cultivator as up-to-date as it would be possible to have it. These Disc Attachments come in gangs of either six or eight discs or can be had in combination of six and eight discs.

These disc gangs are sometimes used on fertilizer distributors with fine results.

To fit any five-tooth cultivator.

- Six-Disc Attachment, weight 43 pounds.....\$8.75
- Eight-Disc Attachment, weight 53 pounds.....10.75
- Combination 6 and 8 Disc Attachment.....12.00
- Disc Cultivator complete, 8 disc and standards for five-tooth and wheel\$25.25

CULTIVATOR STEELS

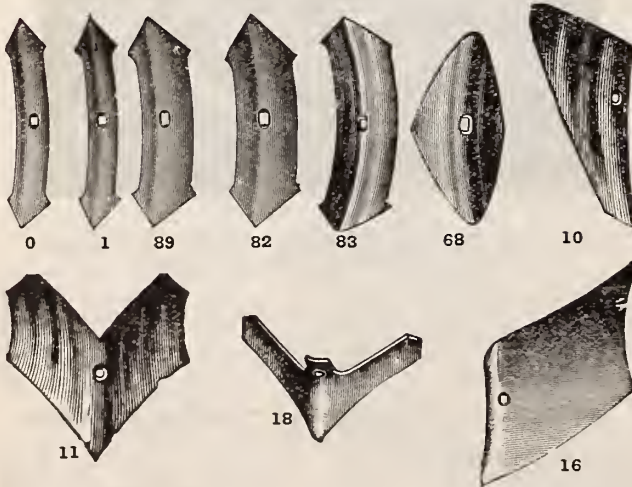

- Cultivator Handles, complete, per pair.....\$1.40
- Handles for single, double or triple shovel plows, complete with round and rod, per set..... 1.40

Steels for Riding and Walking Cultivators

- | Per 100 | | Each | |
|-----------------------|---------|--------------------|--------|
| No. 0—1¼x8 | \$11.20 | 1¼x10½ inches..... | \$0.17 |
| No. 1—2x8 | 12.50 | 1½x10½ inches..... | .17 |
| No. 89—2½x8 | 13.00 | 2 x10½ inches..... | .18 |
| No. 82—3x8 | 14.00 | 2½x10½ inches..... | .19 |
| No. 83—3½x8 | 16.00 | 3 x10½ inches..... | .20 |
| No. 84—4x8 | 18.00 | 3½x10½ inches..... | .23 |
| No. 68—Oval | 20.00 | 4 x10½ inches..... | .24 |
| No. 10—Turn shovel... | 25.00 | | |
| No. 16—Turn shovel... | 24.00 | | |
| No. 11—6-in. sweep... | 31.00 | | |
| No. 11—8-in. sweep... | 33.00 | | |

WITH BACKS

- | | |
|--------------------|--------|
| 1½x10½ inches..... | \$0.40 |
| 2 x10½ inches..... | .44 |
| 2½x10½ inches..... | .48 |
| 3 x10½ inches..... | .52 |
| 3½x10½ inches..... | .56 |
| 4 x10½ inches..... | .65 |

SPIKE HARROW TEETH

½, ⅝, ¾, and ⅞ in., 8c lb.

SHOVEL PLOW STEELS

- FF Triple Shovel Steels, per pound\$0.13
- FF Single and Double Shovel Steels, per lb. .12
- Bolts for Shovel Plow Blades, each03
- Shovel Plow Fender.... .70
- Wheels for Cultivator.. .90
- Levelers for Cultivators. .90
- Cultivtr. Plate Bolts, 1½ .03
- Cultivtr. Plate Bolts, 2½ .03
- Cultivator Frame Bolts. .03
- Wheel Cultivator Clamps Set Screw Cultivator Clamps35
- Horse Hoe Attachments, complete, per set of three pieces 2.40
- Teeth for Baltimore Combined Harrow.... .14

OLIVER CHILLED WALKING PLOWS

WHEN ORDERING PLOWS AND REPAIRS STATE RIGHT OR LEFT HAND

OLIVER CHILLED PLOWS AND EXTRAS	Capacity	Plain Plow	Plow with Wheel	Plow with Wheel and Jointer	Plain Shares	Slip Shares	Lands	Moulds	Standards	Beams
No. 6—Steel Beam.....	4½"x8"	\$8.25			\$0.23		\$0.50	\$1.45	\$1.50	
No. A-C-2—Steel Beam....	4½"x9"	10.50	\$12.45		.30	\$0.45	.55	1.60	2.25	
No. B-C-N—Steel Beam....	5" x10"	12.75	14.70		.42	.55	.75	2.05	2.35	
No. 10-N—Steel Beam.....	5½"x11"	16.00	17.95	\$21.80	.45	.60	.80	2.25	3.00	
No. 13-N—Steel Beam.....	6" x11"	18.00	19.95	23.80	.55	.70	.95	3.00	3.25	
No. 19-N—Steel Beam.....	6½"x12"	19.50	21.70	26.65	.60	.75	1.00	3.25	3.25	
No. 20-N—Steel Beam.....	7" x13"	21.00	23.20	28.15	.65	.80	1.05	3.40	3.50	
No. 40-N—Steel Beam.....	9" x16"	24.00	26.20	31.15	.70	.85	1.10	3.75	3.75	
No. 83-N—Steel Beam.....	7" x14"	21.50	23.45		.95	1.05	1.45	4.50	4.75	
No. 84-N—Steel Beam.....	8" x16"	24.50	26.45		.95	1.05	1.45	5.00	4.80	
No. A-C-2—Wood Beam....	4½"x9"	10.00	11.65		.30	.45	.55	1.60	2.80	\$3.85
No. B-C-N—Wood Beam....	5" x10"	12.00	13.65		.42	.55	.75	2.05	3.20	3.85
No. 10-N—Wood Beam.....	5½"x11"	16.00	17.65	21.25	.45	.60	.80	2.25	3.20	3.85
No. 13-N—Wood Beam.....	6" x11"	18.00	19.65	23.25	.55	.70	.95	3.00	3.55	3.85
No. 19-N—Wood Beam.....	6½"x12"	19.50	22.00	26.40	.60	.75	1.00	3.25	3.95	4.15
No. 20-N—Wood Beam.....	7" x13"	21.00	23.50	27.90	.65	.80	1.05	3.40	4.15	4.15
No. E-I-N—Wood Beam....	7" x14"	24.00	26.50	30.90	.70	.85	1.10	3.75	4.50	4.15
No. 40-N—Wood Beam.....	9" x16"	24.00	26.50	30.90	.70	.85	1.10	3.75	4.70	4.15
No. 40XX—Wood Beam....	9" x16"	27.00	29.50	33.90	1.00		1.45	4.25	6.50	4.95
No. 98—Wood Beam.....					.55		1.45	4.75		
No. 512—Hillside Steel Be'm	8" x13"	27.00	28.65		.90		1.10	3.75		
No. 513—Hillside Steel Be'm	8" x15"	28.00	29.65		.95		1.10	4.10		
No. 524—Hillside Iron Beam	8" 15"	23.75	24.85		.95		1.10	4.10		
No. A-225	.45	.55	1.60	2.75	
No. 3XDDS					1.05		1.60	5.80		
Goober23		.65	1.50	2.25	

Reversible Slip Noses.....\$0.15

WHEEL PARTS

Standards, one-horse, straight.....	\$1.00
Standards, two-horse, all kinds....	1.80
Wheels only, one-horse.....	.55
Wheels only, two-horse.....	.85
Hubs35
Center pins or hub bolts.....	.05
Wheel hook bolts.....	.15

Note—In ordering wheels, say if for right or left hand, wood or steel beam plows.

JOINTER PARTS

Jointer points, chilled, all numbers.	\$0.35
Jointer mouldboards60
1-horse jointer holders, steel beam. .80	
Wood beam	1.60
2-horse jointer holders, steel beam. 1.60	
Wood beam	1.95
1-horse jointer standards.....	1.20
2-horse jointer standards.....	1.60
E926A—Tractor Land, long.....	1.60
E905A—Tractor Land, short.....	.70
91N—Steel Beam F683.....	1.45

CLEVISES

Wood Beam—	Price
A	\$0.35
B90
D	1.25
Steel Beam—	
No. 295
No. 90A	1.40
No. 4-91	1.65

WOOD HANDLES (Single)

No. 1 R. & G., each.....	1.20
All others, each.....	.85
Handle Rounds, each.....	.10
Sets, all numbers up to 13.....	2.20
Sets, all numbers above 13.....	2.75

(State if old or new style handles)

CHILLED SHARES FOR RID- ING PLOWS

NC-23—16-inch QD	\$2.05
NC-23—14-inch QD	1.60
NC-23—12-inch QD	1.40
83—11-inch DS95
83-84-88—12-inch X DS.....	.95
84-88—12-inch DDS S.....	.95

BOLTS

For shares, mouldboards and land-slides, and jointer, each.....	\$0.05
For jointer and coulter holder, wheel standards, Nos. 20 and 40 steel beam to landside bolts, each10
For all standards and beams, spreading bottom of handles, each15

Cast Washers are not included in prices for bolts.

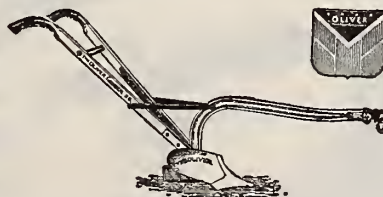

OLIVER STEEL BEAM PLOW

THE OLIVER SULKY

This Sulky is the most popular plow of its kind ever built. Turns square in-and-out corners with the bottoms cutting full width and depth.

FURNISHED IN BOTH RIGHT AND LEFT HAND

Regularly equipped with steel evener and No. 90 Chilled Jointer and Weed Hook

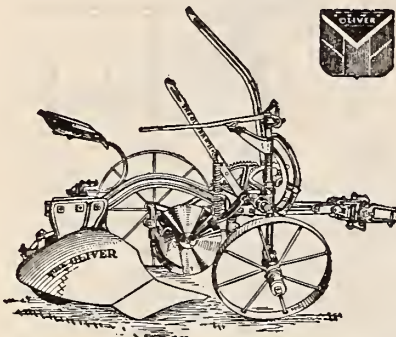

	Price
All Chilled, 12-inch.....	\$62.35
All Chilled, 14-inch.....	63.35
For tongue and neckyoke, add.....	3.45
For combination rolling coulter instead jointer, add	4.00
For plain rolling coulter instead of jointer, add75
Weed Hook, deduct.....	1.10
3 Horse Evener not taken, deduct.....	3.75

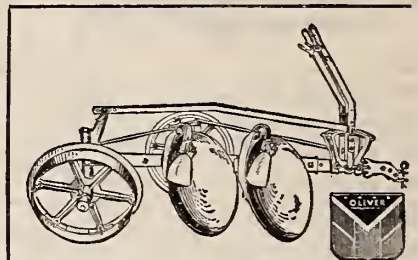

D75—2 24-in. discs, for tractor, \$122.50

OLIVER No. 9-XX ADJUSTABLE TRACTOR PLOW

The Oliver No. 9-XX adjustable plow can be set so that the bottoms will cut 11, 12, 13 or 14 inches. When the ground is hard and plowing is difficult the bottoms can be set to cut narrow; when plowing conditions are favorable they can be set to cut at full width, or 14 inches per bottom. The adjustment is made by expanding or closing the frame.

An Easily Operated Plow—A powerful ball-bearing screw control so multiplies human effort that it makes depth adjustment rapid and easy.

A Trip Rod for the Power Lift—The use of a trip rod eliminates thoublesome work with a trip rope. Note another advantage of this plow which is the position of the wheels to carry the weight of the plow, eliminating drag weight and lessening draft.

The Advantage of Great Clearance—The Oliver No. 9-XX has unusual clearance under the bottoms and between the bottoms. This is a decided advantage when plowing under high weeds, corn stalks, wheat stubble, etc. **Price.....\$90.00**

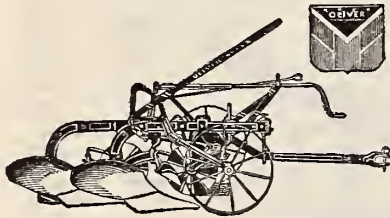

OLIVER No. 24 GRADING PLOW

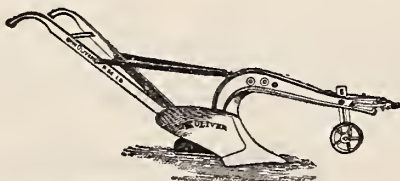

An extremely strong iron beam plow for road breaking, excavation work or the heaviest of field work. The beam standard and frog are one piece. This plow has a chilled mouldboard and a deep suck cutter share.

No. 24—Iron Beam, equipped with a gauge iron, price\$33.95

OLIVER No. 25 PAVEMENT PLOW

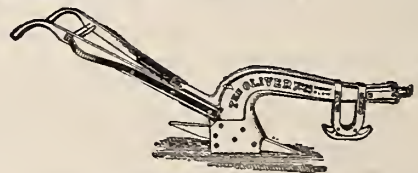

A popular plow for tearing up macadamized roads, streets, gravel roads, etc. Built extra strong and rigid, the beam standard and handle braces are cast in one piece. The pick is both reversible and adjustable. All wearing parts are renewable.

Regularly equipped with a gauge iron.
No. 25—Pavement Plow, price.....\$40.00
Reversible Steel point or spike, price..... 4.75

SYRACUSE CONTRACTORS' PLOW No. 1

One of the best two-four horse contractors' plows. A great favorite.

Hard iron wearing parts. Extra heavy beam, share and strip, steel wheel standard. Turn furrow 5 to 9 inches deep, 12 to 15 inches wide. For general grading purposes. Two to four-horse. Weighs 185 lbs. with wheel, \$32.00. Can furnish with Steel Handles. Extra\$1.50

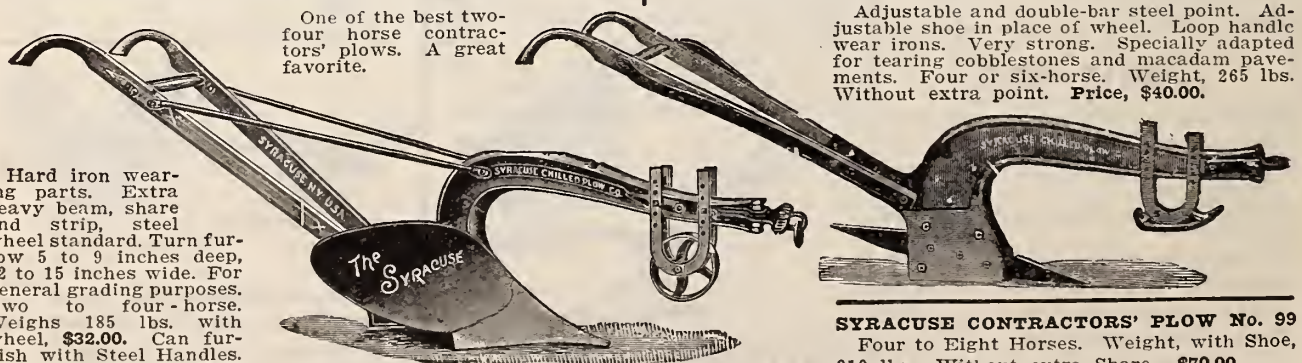

SYRACUSE PAVEMENT PLOW No. 98

Adjustable and double-bar steel point. Adjustable shoe in place of wheel. Loop handle wear irons. Very strong. Specially adapted for tearing cobblestones and macadam pavements. Four or six-horse. Weight, 265 lbs. Without extra point. **Price, \$40.00.**

SYRACUSE CONTRACTORS' PLOW No. 99
Four to Eight Horses. Weight, with Shoe, 310 lbs. Without extra Share. **\$70.00.**

PLOWS

Wiard Steel Beam Plows and Extras

No Wood-Beam Plows Carried in Stock	Price, Plain Plow	Plain Shares	Slip Nose Shares	Moulds	Lands	Standards	Shoes for Lands	Shims or Cutters
No. 25—R. H., Heavy 2-Horse	\$20.00	\$0.70	\$0.85	\$4.50	\$1.25			\$0.70
No. 44—R. H., 2 or 3-Horse	21.50	.70	.85	4.50	1.25	\$4.00	\$0.70	.70
No. 45—R. H., 3-Horse	25.00	.75	.85	4.75	1.25	4.50	.70	.70
No. 90—R. H., 2-Horse	22.00	.75	1.00	5.00	1.00	4.50	.70	.70
No. 91—R. H., 2-Horse	21.00	.85	1.00	4.50	1.00	4.50	.70	.70
No. 214—R. H., 1-Horse	12.75	.40		3.00	1.00	2.50		
No. 219—R. H., Light 2-Horse	19.50	.70		4.50	1.40	3.50		
No. 220—R. H., 2-Horse	21.00	.70		5.00	1.40	3.50		
No. 240—R. H., 2 or 3-Horse	24.00	.90		5.00	1.50	3.75		
No. 522—R. H., Light 2-Horse	17.25	.70		4.00	1.25	3.50		.75
No. 524—R. H., 2-Horse	19.75	.80		4.50	1.60	4.00		.75
No. 526—R. H., 2 or 3-Horse	21.50	.85		5.00	1.60	4.00		.75
No. 80—L. H., 2-Horse	22.00	.85	1.00	5.00	1.00	4.50	.70	.70
No. 103—L. H., Light 2-Horse	19.75	.70	.85	4.25	1.25	4.00	.70	.70
No. 104—L. H., 2 or 3-Horse	21.50	.70	.85	4.50	1.25	4.00	.70	.70
No. 106—L. H., 3-Horse	25.00	.75	.85	4.75	1.25	4.50	.70	.70
No. 440—L. H., 2 or 3-Horse	24.00	.90		5.00	1.50	3.75		
No. 544—L. H., 2-Horse	19.75	.80		4.50	1.60	4.00		.75
No. 546—L. H., 2 or 3-Horse	21.50	.85		5.00	1.60	4.00		.75
No. 546—L. H., 2 or 3-Horse	20.25	.85		5.00	1.60			.75
No. 548—L. H., 3-Horse	25.00	.95		5.50	1.60	4.50		.75
No. 548—L. H., 3-Horse	23.50	.95		5.50	1.60			.75

FARMERS' FRIEND PLOW



- No. 1/2\$5.00
- No. 5 5.00
- No. 1 Hillside..... 8.00
- Plain Castings, per lb..... .07
- Polished Castings, per lb..... .09

"BOY" DIXIE PLOW

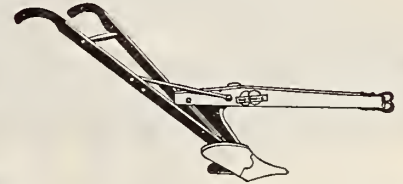

- "Boy" Dixie\$4.00
- No. X 5.00
- No. I 5.25
- No. II 7.00
- No. 2 8.00
- Plain Castings, per lb..... .07

WHITE'S CLIPPER PLOW

- No. 1 and 2, Cast, One-Horse.....\$6.00
- No. 12, Cast, Two-Horse.....10.75
- Castings for Clipper Plow, per lb... .08

"GIRL" CHAMPION PLOW

- No. "Girl"\$6.00
- No. A 6.50
- No. 2 7.00
- Castings, Plain, per lb.....\$0.07 1/2
- Castings, Polished, per lb..... .09 1/2

Syracuse Plows and Repairs

	Plain Plow	Plow with Wheel	Plow with Wheel and Jointer	Plain Shares	Slip Nose Shares	Moulds	Lands
No. 1-78 Regular				\$0.63	\$0.78	\$4.31	\$0.97
No. 2-78				.60	.75	4.12	.93
No. 95				.75	.90	4.75	1.45
No. 96				.80	.95	5.00	1.55
No. 97				.85	1.00	5.50	1.70
No. 35				1.10		6.25	2.00
No. 502, 362, 1362				.63	.78	5.00	1.50
No. 503, 363, 1363				.63	.78	3.37	1.40
No. 601, 461, 1461				.67	.82	5.50	1.50
No. 602, 462, 1462				.63	.78	5.00	1.50
No. 603, 463, 1463				.63	.78	3.37	1.40
No. X1441 Q. D. Tractor				.95	1.10	5.25	
No. X1442 Q. D. Tractor				.90	1.05	4.75	
No. 702 Hillside				.82		4.12	1.40
No. 1-78 R. H. Contractor Plow		\$32.00		.78		5.75	1.55
No. 98 Rooter Pavement Plow		40.00		5.50			
No. 99 R. H. All Steel Plow		70.00		7.75			
No. 10-78 R. H. Cast Beam Plow	\$23.50	25.15	\$28.90	.71	.78	4.68	1.08
No. 20-78 L. H. Cast Beam Plow	20.25	21.90	25.65	.63	.78	4.31	.93
No. 30-78 L. H. Cast Beam Plow	23.50	25.15	28.90	.71	.86	4.68	1.08
No. 501 L. H. Wood Beam Plow	24.00	25.75	30.25	.67	.82	5.50	1.50
No. 1361 L. H. Steel Beam Plow	24.00	25.65	30.15	.67	.82	4.12	1.12
No. 1362 L. H. Steel Beam Plow	23.00	24.65	29.15	.63	.78	3.75	1.12
No. 1461 R. H. Steel Beam Plow	24.00	25.65	30.15	.67	.82	4.12	1.12
No. 1462 R. H. Steel Beam Plow	23.00	24.65	29.15	.63	.78	3.75	1.12



PLOW HANDLES—Dressed

- 1 1/2 x 2 inches, 5 feet long, per pair.....\$0.75
- 1 1/4 x 2 1/4 inches, 5 feet long, per pair..... .80
- 1 1/4 x 2 1/4 inches, 6 feet long, per pair..... 1.00
- 1 1/2 x 2 1/2 inches, 5 feet long, per pair..... 1.20
- 1 1/2 x 2 inches, Side Bend, per pair..... .80

"MOON" ROLLING COULTER

The shoe presses down all weeds and trash and holds same firmly while being cut by the coulters.

- No. 1—8-inch disk.....\$4.25
- No. 2—10-inch disk.... 4.75
- No. 3—12-inch disk.... 5.50

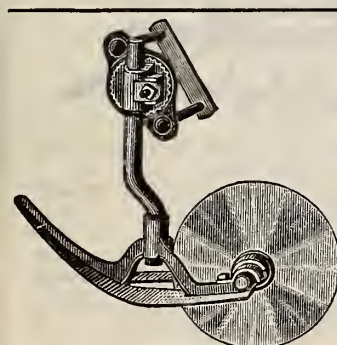

Repairs For Chattanooga Plows

	Slip Nose Shares	Slip Shares	Slips	Land-sides	Mould-boards
No. 62 1-Horse, W. B.	\$0.40	\$0.50	\$0.10	\$0.70	\$2.00
No. 62 1-Horse, S. B.	.40	.50	.10	.70	2.00
No. 63 2-Horse, S. B.	.60	.75	.15	1.10	3.00
No. 64 2-Horse, S. B.	.75	.90	.15	1.25	4.00
No. 65 2-Horse, S. B.	.85	1.05	.20	1.50	4.50
No. 66 2-Horse, S. B.	.90	1.10	.20	1.50	4.75

OLD DOMINION GRUB PLOW

- Two-Horse ... \$12.50
- Three-Horse .. 14.00
- Coulters 3.50
- Bottoms 6.25



OLIVER U. B. C. SPIKE HARROW

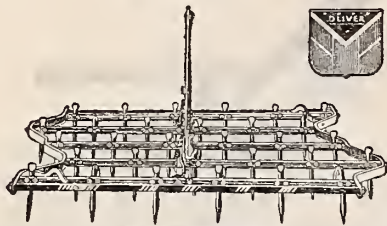

Horse Harrow

Regularly equipped with evener bar.
 50-Tooth, 2-section.....\$19.65
 60-Tooth, 2-section..... 22.15
 75-Tooth, 3-section..... 31.15
 90-Tooth, 3-section..... 35.15

Tractor Harrow

Regularly equipped with a tractor hitch.
 90-Tooth, 3-section.....\$36.20

OLIVER SPRING-TOOTH HARROW

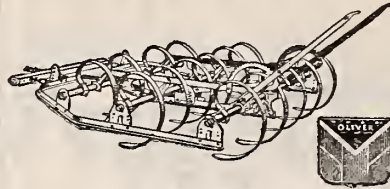

Oliver Horse Harrow

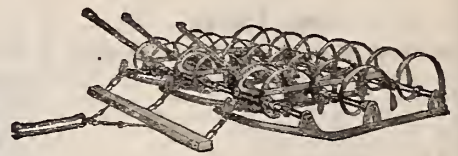

Oliver PB 3-Section Tractor Harrow

These are very strong and rugged implements well fitted for the hard work of spring-toothing. An inverted T-bar frame shod with a thick steel runner gives great strength and durability. Furnished with horse or tractor hitch. The levers are reversible and are set on the rear of the sections for horse use and on the front for tractor use.

HORSE HARROWS

9-Tooth, with handles and single tree.....	\$16.00
15-Tooth, 2-section with draw bar.....	23.70
17-Tooth, 2-section with draw bar.....	25.40
23-Tooth, 3-section with draw bar.....	35.70
25-Tooth, 3-section with draw bar.....	37.25

OLIVER HDH DISC HARROWS—SINGLE AND DOUBLE

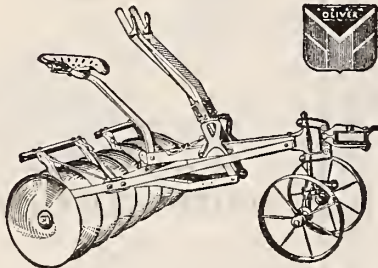

SINGLE DISC HARROWS

Regularly equipped with hard oil cups, rigid scrapers, 2 or 3-horse evener, seat, rigid pole, and neck yoke.

Number	Number of Discs	Cut in Feet	Size of Discs	Price
HDH-4	8	4	16 in.	\$42.50
HDH-5	10	5	16 in.	46.50
*HDH-6	12	6	16 in.	51.25
HDH-4	8	4	18 in.	45.60
HDH-5	10	5	18 in.	50.35
*HDH-6	12	6	18 in.	58.85

(*) Equipped with off-set irons and 3-horse eveners.

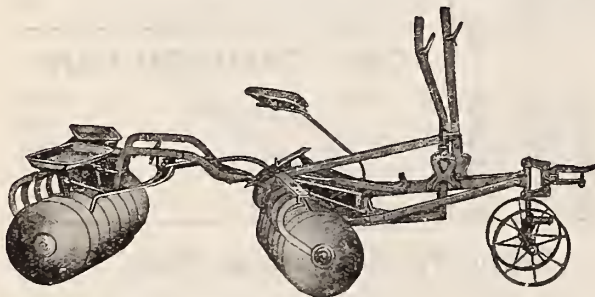

DOUBLE DISC HARROWS

Consists of single disc harrow and tandem complete, hard oil cups, rigid scrapers, 4-horse eveners, seat and forecarriage.

Number	Number of Discs	Cut in Feet	Size of Discs	Price
HDH-4	16	4	16 in.	\$97.50
HDH-5	20	5	16 in.	105.40
HDH-6	24	6	16 in.	111.25
HDH-4	16	4	18 in.	103.75
HDH-5	20	5	18 in.	113.15
HDH-6	24	6	18 in.	120.60

OLIVER TRACTOR DISC HARROW

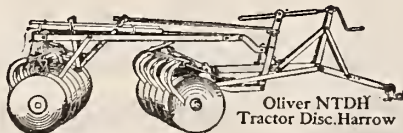

Oliver NTDH Tractor Disc Harrow

Number	Number of Discs	Size of Discs	Cut in Feet	Price
TDH-5	20	16 in.	5	\$ 88.50
TDH-6	24	16 in.	6	95.30
TDH-7	28	16 in.	7	106.90
TDH-8	32	16 in.	8	120.00
TDH-5	20	18 in.	5	96.25
TDH-6	24	18 in.	6	106.25
TDH-7	28	18 in.	7	118.00

Harrows Can Be Furnished with 20-inch Discs at Additional Cost.

NASH-ACME COULTER HARROW

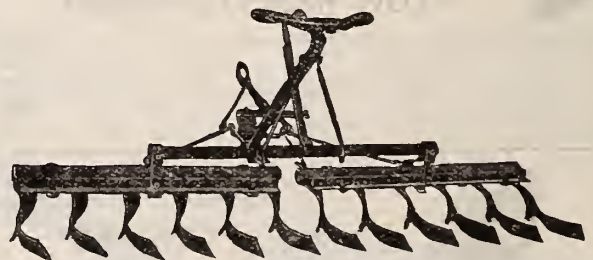

Flexible construction permits the harrow section to conform more closely to the shape of the surface of the soil.

No. 12F—12 coulters, 6½ ft. cut, 2-horse, 2-section....	\$ 30.00
No. 16F—16 coulters, 8½ ft. cut, 2-horse, 2-section....	37.00
No. 6—6 coulters, 3 ft. cut, 1-horse, 1-section.....	18.00
No. 8—8 coulters, 4 ft. 4 in. cut, 1-horse, 1-section....	23.00
No. X6—24 coulters, 18 ft. 6½ in. cut.....	120.00
No. X7—29 coulters, 18 ft. 7½ in. cut.....	130.00
Coulters for all.....	.85

Clark FAMOUS DISK HARROW

DOUBLE ACTION DISK HARROWS FOR HORSES

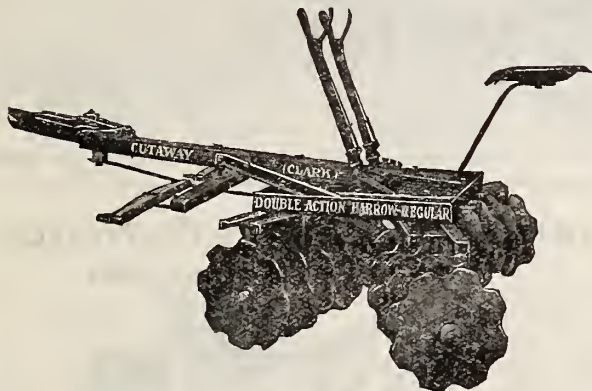

CLARK "CUTAWAY" Double Action Harrows are known for their light draft as well as for the amount and quality of work they do. Notice in the illustration how all four gangs of disks are attached to one main frame. Solid or cutout disks will be furnished at the same price or any combination of the two types, but cutout disks are regular equipment unless otherwise ordered. These harrows are also made with 18-in. disks and different hitches can be obtained on any sizes. Prices on application.

All disks are 16 inches in diameter; harrows hitch 4 horses.

Size A-4, 16 disks, 4½-ft. cut, weight 480 lbs., price..... \$77.05
 Size A-5, 20 disks, 5½-ft. cut, weight 570 lbs., price..... 89.50
 Size A-6, 24 disks, 6½-ft. cut, weight 630 lbs., price..... 97.35

CLARK "CUTAWAY" WONDER DISKER The All Purpose Disk



For reclaiming virgin brush land, bog land, cut-over wood land, etc.

For thorough and economical orchard tillage.

For difficult plowing and harrowing jobs.

FULLY EQUIPPED

- 8 Heavy 24-inch Disks
- Sturdy Weight Carriers
- Rigid Scrapers
- Reversible Gangs
- Powerful Screw Control
- Adjustable Hitch

8 disks, 24-in. dia., 5½-ft. cut, steel frame, 685 lbs..... \$110.70
 Steel weight box, extra, 90 lbs..... 6.25

Price

SINGLE ACTION DISK HARROW



The gangs on the **CLARK "CUTAWAY"** Single Action Harrow can be swung end for end, so that the soil may be thrown either out or in.

One of the outstanding features of all **CLARK "CUTAWAY"** Harrows is the quality of the disks. They are made of better steel than used in ordinary harrow disks but their strength and wearing qualities are greatly increased by forging the edge and heat-treating.

Solid Disks can be furnished at same price as Cutaway.

All disks on **CLARK "CUTAWAY"** Harrows are guaranteed for three years against breakage.

Size	No. of Disks	Diam. of Disks	Width of Cut	Hitch	Wt.	Price
A-4	8	16-in.	4-ft.	2-h.	255	\$43.00
A-5	10	16-in.	5-ft.	3-h.	295	49.65
A-6	12	16-in.	6-ft.	4-h.	350	56.80
A-7	14	16-in.	7-ft.	4-h.	460	63.00
X-4	8	18-in.	4-ft.	2-h.	300	46.35
X-5	10	18-in.	5-ft.	3-h.	350	54.30
X-6	12	18-in.	6-ft.	4-h.	430	63.25
Extra for Tongue Truck.....						8.50

CLARK "CUTAWAY" FLEXIBLE DOUBLE ACTION TRACTOR HARROW



The Flexible Tractor Harrow is equipped with screw control only. Notice the stand for supporting the pole while hitching to the tractor. The rear section may be removed and the front section used alone if desired.

Our new Flexible Double Action Tractor Harrow is the result of our many years experience in building tractor disk harrows. While the frame permits extreme flexibility on rough ground and in turning, at the same time the harrow is very efficient and does high class work.

Size A-6, 24 disks, 16-in. dia., 6½-ft. cut, 755 lbs., price \$111.00
 Size A-7, 28 disks, 16-in. dia., 7½-ft. cut, 860 lbs., price 119.00
 Size X-6, 24 disks, 18-in. dia., 6½-ft. cut, price..... 120.00
 Size X-7, 28 disks, 18-in. dia., 7½-ft. cut, price..... 130.00

SEND FOR CLARK'S SPECIAL CATALOGUE SHOWING FULL LINE OF FAMOUS CUTAWAY HARROWS

CLARK SINGLE ACTION HARROW— EXTENSION

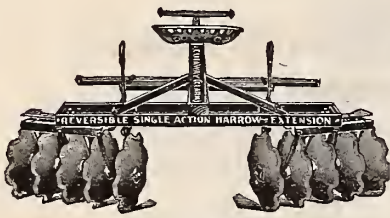

The CLARK "CUT-AWAY" Reversible Single Action Harrow—Extension is built along exactly the same lines and has the same valuable features as the Single Action Harrow—Regular described above. An orchard disk harrow to be efficient must have reversible gangs.

Size	No. of Disks	Diam. of Disks	Width of Cut	Hitch	Wt.	Price
A-4	8	16-in.	6-ft.	2-h.	280	\$44.55
A-5	10	16-in.	7-ft.	3-h.	320	52.25
A-6	12	16-in.	8-ft.	4-h.	395	60.85
X-4	8	18-in.	6-ft.	2-h.	340	48.95
X-5	10	18-in.	7-ft.	3-h.	385	57.25
X-6	12	18-in.	8-ft.	4-h.	460	67.25

Solid or cutout disks will be furnished at the same price.

CLARK ONE-HORSE DISK HARROWS

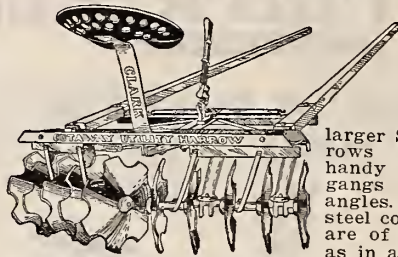

The CLARK "CUT-AWAY" Utility Harrow has 10 14-in. disks, cuts 4 feet wide. The gangs can be reversed in the same manner as the larger Single Action Disk Harrows described above. One handy lever easily sets the gangs at different working angles. The frame is of angle steel construction and all parts are of the same high quality as in all other CLARK "CUT-AWAY" Implements. Disks are of heat-treated cutlery steel with the edges forged sharp. Cutout disks are regular equipment but solid disks will be furnished at the same price.

10 disks, 14-in. dia., 4-ft. cut, hitch 1 h., 200 lbs., price.. \$36.00

OLIVER NO. 2 IMPROVED CULTIVATOR

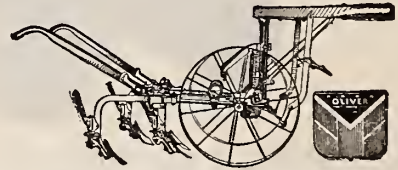

A popular and well-established favorite where either large or small acreages of cultivated crops are raised. Easy on the man because of the great ease with which it is handled. Lifting the gangs or shifting them to or from the row is an action almost without effort. Easy on the horses because of light draft, and there is no neck weight. There is not a single unnecessary part; there is nothing to get out of order.

- No. 2 FEC Imp. 6-shovel, spring trip gangs, pipe beam.. \$49.20
- No. 2 FO Imp. 4-shovel, spring trip gangs, pipe beam.... 45.25
- No. 2 HO Imp. 6-shovel, pin break gangs, pipe beam..... 43.25
- No. 2 LPO Imp. 8-shovel, pin break gangs, channel beam 40.30

OLIVER NO. 35 CULTIVATOR

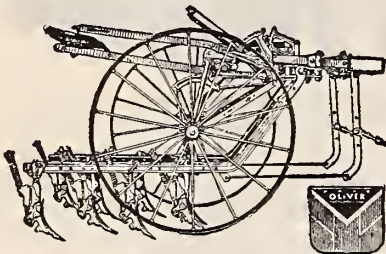

This Cultivator is built short and sturdy and the hitch is close and direct. The gangs extend back only a short distance beyond the wheels. This eliminates dipping and side-slipping and assures uniform work when going into depressions or over slight rises in the ground.

New and improved cultivator, better designed, more permanently constructed, easier operated—it is the Oliver No. 35.

Every farmer is entitled to have his cultivating work done easier. With the Oliver No. 35 it can be done both easier and better.

- No. 35 6-shovel, pin break gangs.....\$54.60
- No. 35 6-shovel, spring trip gangs..... 60.40
- No. 35 8-shovel, pin break gangs..... 56.70
- No. 35 8-shovel, spring trip gangs..... 64.50
- Front Disc Attachment 12-in..... 3.90
- Tobacco Hoe Attachment..... 10.50

SCHWOB LONG SWEEP GRAIN CRADLE

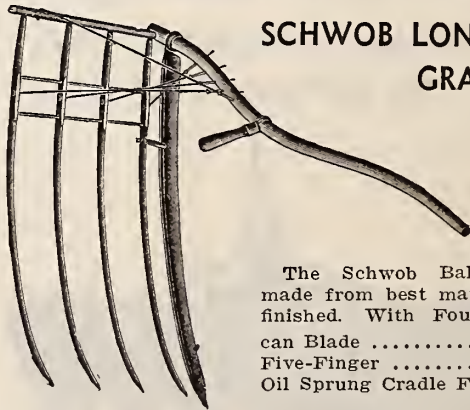

The Schwob Balance Cradle is made from best material and nicely finished. With Four-Finger American Blade\$6.50
Five-Finger 7.00
Oil Sprung Cradle Fingers, each .40

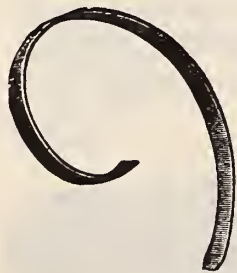

SPRING HARROW TEETH

For All Leading Harrows
Price55c each

THE BUTTS REVERSIBLE HARROW TOOTH POINTS



Can be used on all Spring Harrow Teeth.
Price, each.....30c
Osborne20c
Deering20c

SYRACUSE REVERSIBLE HARROW TOOTH POINTS

Price20c
Michigan25c

HARROW DISKS

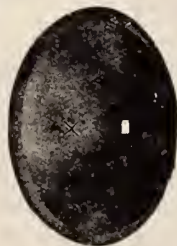

FRONT AND BACK REGULAR HARROW DISC



CUTAWAY HARROW DISC

HARROW DISCS

16 inch\$1.25
18 inch 1.50

CLARK CUTAWAY DISCS

16 inch\$2.10
18 inch 2.60

Furnished $\frac{1}{8}$ and $\frac{1}{4}$ square hole.

OLIVER SUPERIOR SPREADER No. 75

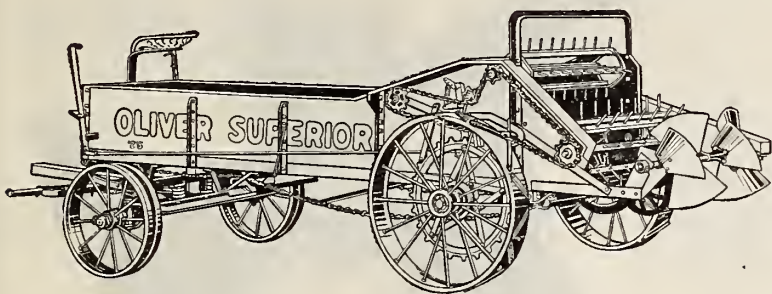

Has the biggest capacity of any Spreader, yet is easily pulled by two horses.

Exclusive features found on no other Spreader. Uses Hyatt Roller Bearings.

A lime sowing attachment for the most efficient distribution of lime can be furnished. Every desirable feature in spreader construction has been included in the new Oliver Superior 75 Spreader. Write for special illustrated circular.

No. 75 Oliver Superior Spreader with either 2-horse hitch or tractor hitch, with wide spread attachment.....\$166.87
 Brake attachment, complete..... 8.75
 3 horse hitch instead of 2 horse hitch, add. 3.13

OLIVER SUPERIOR PLANTERS

Are accurate and reliable. The 9A Planter and 9A Drill give you better stands. Plants accurately. No. 9A check wire Planter, adjustable for rows from 28 inches, every two inches to 48 inches apart. No. 9A Drill will drill corn 10, 12, 18, 20 and 26 inches apart in rows 28 to 48 inches. Thirty-inch wheels; open and closed tires.

- No. 9A—Runner Planter with check wire\$80.00
- No. 9A—Runner Drill Planter, no check wire 66.87
- No. 9A—Disc Planter, with check wire.. 85.00
- Fertilizer Attachment, add..... 25.00

OLIVER SUPERIOR CULTIVATORS

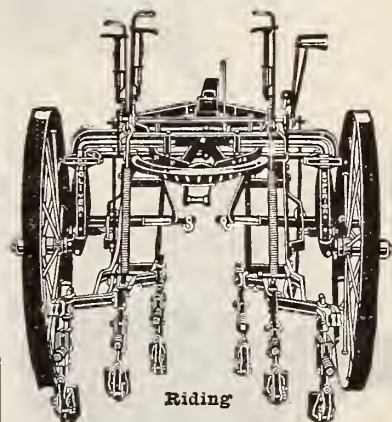

Riding

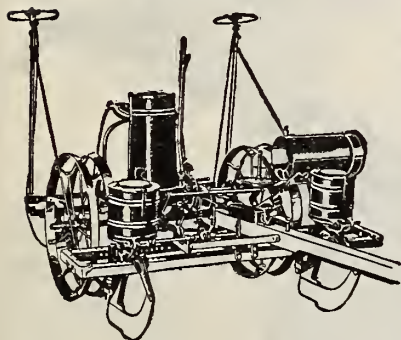

OLIVER SUPERIOR GRAIN DRILLS



Walking

No. 957½—6 Shovel, spring trip, round shank open sleeve, \$57.50.

No. 959½—6 Shovel, spring trip, round shank open sleeve, \$61.25.

No. 123—4 Shovel, spring trip, parallel beams.....\$40.50

No. 125—6 Shovel, spring trip, parallel beams..... 45.50

PLANET JR. GARDEN TRACTOR

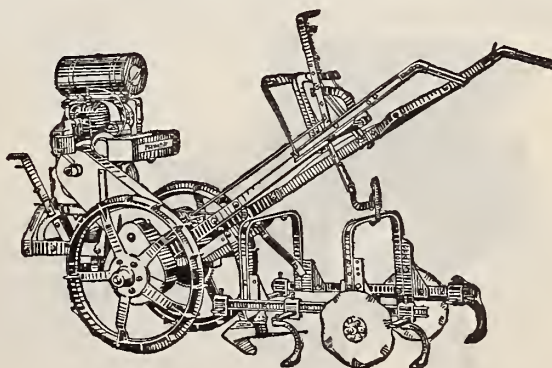

WRITE FOR CATALOGUE AND PRICES

No word we can say could make as deep an impression on the public as the widespread sale enjoyed by this, the best known drill on the market. It can be supplied in many different sizes, so we only mention those mostly used.

No. 26—Fertilizer Plow, for Disc Drills or Spring Hoe, with drag chains. No seat, agitator or scrapers. With Grass Seeder.

- 8x8 Disc, 2-Horse Hitch, 1 Pole.....\$143.56
 - 10x8 Disc, 2-Horse Hitch, 1 Pole..... 163.62
 - 9x7 Disc, 2-Horse Hitch, 1 Pole..... 152.62
 - 10x7 Disc, 2-Horse Hitch, 1 Pole..... 162.37
 - 11x7 Disc, 2-Horse Hitch, 1 Pole..... 171.81
 - 12x7 Disc, 3-Horse Hitch, 2 Poles..... 188.50
 - 13x7 Disc, 3-Horse Hitch, 2 Poles..... 202.00
 - 8x8 Spring Hoe, 2-Horse Hitch, 1 Pole..... 137.62
 - 10x8 Spring Hoe, 2-Horse Hitch, 1 Pole..... 156.75
 - 9x7 Spring Hoe, 2-Horse Hitch, 1 Pole..... 146.06
 - 10x7 Spring Hoe, 2-Horse Hitch, 1 Pole..... 155.50
- Large Sizes Can Be Furnished with Tractor Hitch.

PLANET JR. GARDEN TRACTOR

The remarkable efficiency and economy of operation of the Planet Jr. are due both to the engineering skill and practical farming knowledge of its designers; and to the integrity of the material and workmanship with which it is built.

Machines in the field are proving profitable investments for their owners. Stop and think what it would mean to you to be able to do from four to fifteen men's work in the same length of time—and to do it better than is possible by hand.

MASSEY-HARRIS SPREADER

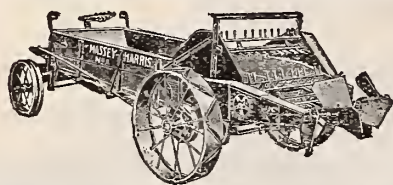

Price, with 2-Horse Hitch.....\$166.25
 Brake 7.85
 Write for circulars.

Farmers' Favorite One-Horse Fertilizer Distributor

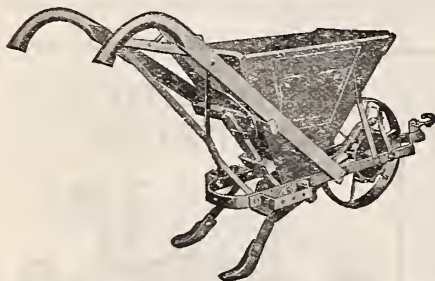

Commercial Fertilizer can be sown with this machine in quantities of from 200 to 2400 pounds per acre.
 Price\$11.50

NO. 68 STOVER COMBINED GRINDER

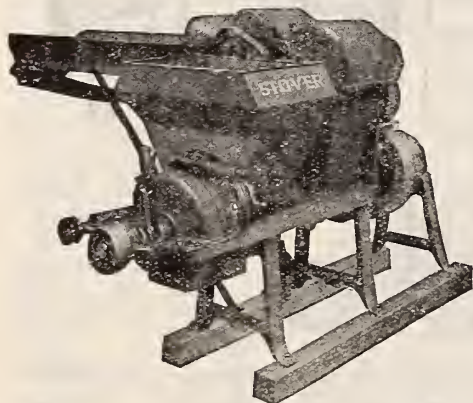

Price\$150.00

SPECIFICATIONS

Power required.....8 to 20 H. P.
 Speed.....600 to 1,000 R. P. M.
 Weight.....1,000 lbs.
 Pulley, regular.....10 in. x 8 in.
 Burrs, diameter8 in.

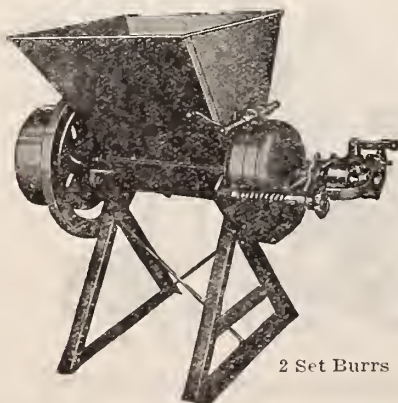

2 Set Burrs

COLE "LABOR SAVER" PLOW AND FERTILIZER DISTRIBUTOR No. 60

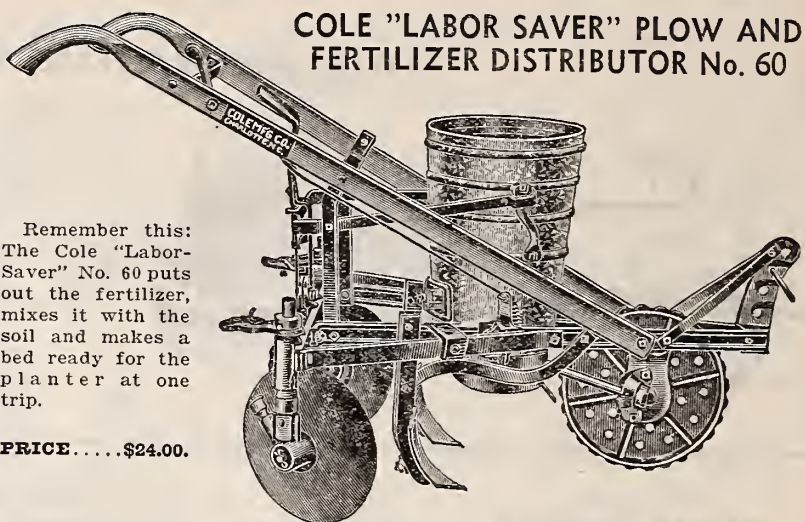

Remember this: The Cole "Labor-Saver" No. 60 puts out the fertilizer, mixes it with the soil and makes a bed ready for the planter at one trip.

PRICE....\$24.00.

COLE PLAIN VIEW PLANTER NO. 11

No. 11—PLAIN PLANTER.....\$24.00

No. 12—FERTILIZER PLANTER. 28.00



The Cole Plain View Planter is the most wonderful invention in seed planters. The perfect seed planter. Most accurate and reliable corn planter ever made.

LETZ PATENTED NO. 210 SHUCK MILL

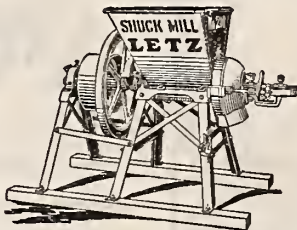

The amazing capacity at which this mill grinds corn with shuck, kaffir corn heads with 4 to 6" of stems attached, has made this mill a big seller.

Just the right size mill for 8-16 or Fordson tractors. Will grind 60 to 100 bushels of snapped corn. Many customers report 100 to 125 bushels of snapped corn per hour. All wearing parts are easily renewed at small expense. No parts need resharpening.

Grinding Plates.....10" in dia.
 Pulleys.....8, 10, 12, 14, 16, 18" in dia., 6" face
 Gross Weight.....380 lbs.

Letz No. 210 Shuck Mills are regularly built with A-234 coarse shuck plates in mill, and fine plates A-231 attached as extra plates to grate.

	15 H. P.	20 H. P.
Snapped corn	3000 to 4500	4500 to 7000
*Kaffir corn heads.....	2500 to 3500	3500 to 5000
All small grains.....	1500 to 2500	2000 to 3000

*Kaffir corn must be headed closely, with not more than 4" of stem. Not for machine headed Kaffir corn.
 Price.....\$52.50.

NO. 111X LETZ GRINDER

H. P.	R. P. M.	Capacity
10.....	600	25 to 40 bu.
15.....	750	45 to 60 bu.
20.....	850	50 to 75 bu.

Price.....\$45.00

NOS. 106, 108, STOVER SPECIAL FEED GRINDING MILLS

For Grinding Dry Ear Corn, Shelled Corn, and All of the Small Grains. Capacity, from 3 to 6 bushels per hour per horse power, depending upon the grinding condition of the grain and the fineness of the feed.

	Speed	Horse Power	Weight	Price
No.	R. P. M.	Required		
106	300 to 500	2 to 5	200 lbs.	\$23.00
108	400 to 600	3 to 8	275 lbs.	38.25

MASSEY-HARRIS POWER DRIVE CORN PLANTER

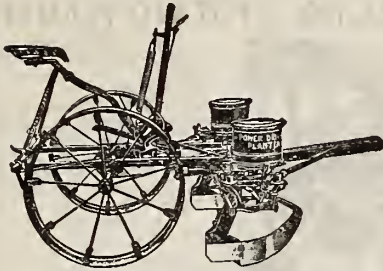

Our variable drop device, regularly supplied, enables the operator to vary the number of kernels in each hill according to the fertility of the soil. A lever in front of the seat can be shifted to drop 2, 3 or 4 kernels in the hill.

The round-hole plate we use for all kinds of corn kernels. Regular equipment of check rower planter includes:—Round or stub type runner, as ordered, open or concave tire wheels, optional. Also supplied with automatic reel, anchor stakes. Eighty rods of wire, and disc marker.

Drill planters are furnished with disc marker. All runner planters are shipped set at 3 feet 6 inches and adjustable from 3 feet 2 inches to 4 feet 0 inches.

Regular equipment of disc planters is the same as for runner planters. Disc planters come set at 3 feet 6 inches, but are adjustable from 3 feet 2 inches to 3 feet 10 inches.

Style No.	Description	Runners	Wheels	Weight	Price
No. 2 RH	Check Rower, Drill and Foot-Drop	Round	30"	522	\$79.50
No. 3 RH	Drill and Foot-Drop	Round	20"	416	63.00
No. 6	Drill Only	Round	30"	355	63.00
	Fertilizer Attachment			100	24.75
	Step Drop Attachment				2.25
	Automatic Marker				

MASSEY-HARRIS TRANSPLANTER

**SAVES TIME, LABOR AND GIVES YOU STRONGER PLANTS
CONVENIENT PRESSURE LEVER**

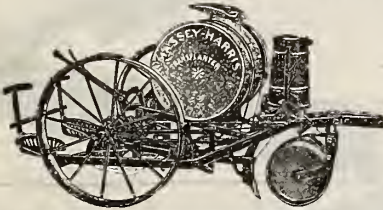

The pressure lever, within convenient reach of either of the plant setters, controls the pressure of the press wheels in pressing the earth about the roots of the plant. The runner is forced into the ground by a powerful spring attached to the raising lever, and can be set at depth desired.

Price \$95.75.
Fertilizer Attachment 16.25.

THE IMPROVED TIGER TRANSPLANTER

The Tiger Transplanter is adaptable to all conditions of planting and spacing; adjustable to all conditions of soil and ground—on hillside or level, will space plants from 14 to 64 inches apart, and operates as readily with either horse or tractor power.

Driver and two planters can set five acres a day without undue strain or hurry. Here is a definite, money-saving implement that will handsomely repay every owner.

Almost human in its operation here is one of the greatest boons to transplanting ever developed. Eliminates packing around the plant; eliminates pouring water on the surface to bake and crack the earth around the plant.

Price \$98.50
Additional for Double Wheel Fore Truck for Planting Sweet Potatoes 10.50
Fertilizer Attachment 18.00

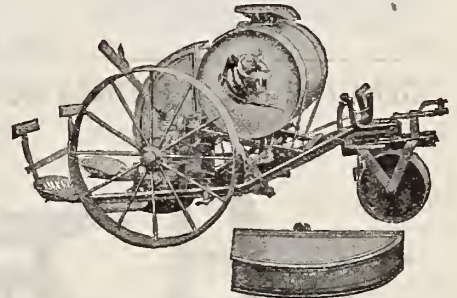

RODERICK LEAN ROTARY HOE

WITH CULTIVATING DEPTH REGULATED FROM SEAT

The Roderick Lean Rotary Hoe will cut your cultivating costs in half. Any boy with a team and a Roderick Lean Rotary Hoe can cultivate and weed as many acres in a day's time as can two men and two teams using other types of cultivating machines.

Because it is light draft, easy to handle and covers so much more ground in a day's time, it can be used frequently and effectively during that critical time when the crop is just getting its growth. Built in the most substantial way, to render years of good service. Split wood bearings at the ends simplify replacement of worn parts. Three bolts will release bearings at end of any gang.

SIZES AND WEIGHTS

7 feet 2-horse Weight 801 pounds Without Neck Yoke \$86.00
7 feet 3-horse Weight 839 pounds With Neck Yoke 94.60
Tongue Truck if desired, additional 13.75

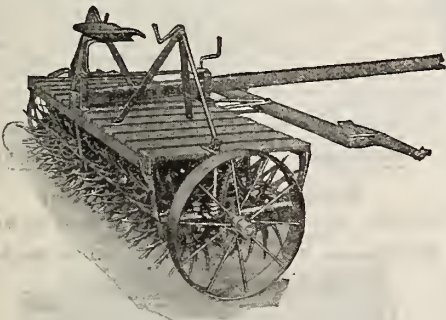

GRITCO RIDING WEEDER



Price

12-foot Weeder, with Pole. No double trees or neck yoke \$43.00
Regular Trees and Yoke add 2.75
Extra Wide Trees and Yoke add 3.50

GRITCO FLAT TOOTH WEEDER

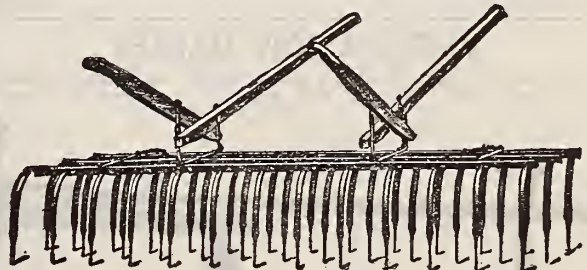

Price

7½-foot Gritco Flat-Tooth Weeder \$12.00
9-foot Gritco Flat-Tooth Weeder 14.00
Extra Teeth20

ASPINWALL POTATO DIGGER

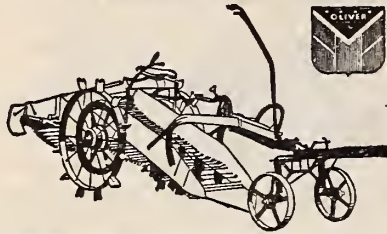

The Aspinwall Digger is favorably known throughout the potato growing sections of the world, enjoying high prestige, as it is unsurpassed in material, workmanship, serviceability and long life.

6-Foot Digger. \$135.00

GRITCO HAND CORN PLANTER

There is no chance of cracking the corn, beans, or other seed, because of the Chinese bristle brush cut-off. Slide quickly adjusted for different sized seeds. Galvanized iron hopper.

Each\$2.00.

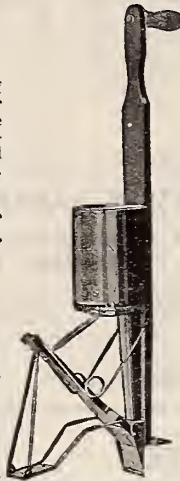

ACME HAND CORN PLANTER

ITS ROTARY SLIDE has a motion two ways—back and forth. It prevents skips. No matter how short the stroke, the pocket is pushed into the corn and back into the conveyor tube.

Each\$3.00.

GENUINE NO. 2 HAINES ROW MARKER

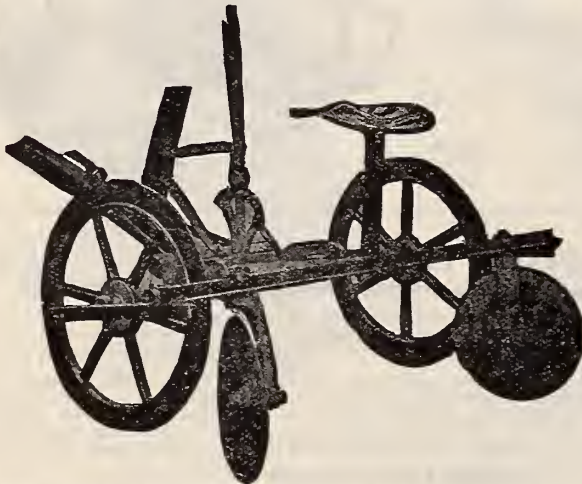

The Marker is of light draught and easily controlled by a light boy as it is not necessary for operator to dismount at ends of furrows to lift one pound.

The Marker is a perfect covering or listing machine, covering one or more rows as may be required and is under perfect control of operator by use of lever that may be adjusted while the machine is in motion.

Two-Row Marker\$45.00
 Three-Row Marker 52.00

VIRGINIA ROW MARKER

Very useful for farmers and gardeners for marking corn and potato rows. Fitted with extra side plates on runner.



No. 2—2 Row, will mark 3 to 5 feet in width (every 3 inches).....\$16.00
 No. 3—3 Row, will mark 3 to 5 feet..... 20.00

NEW ASPINWALL NO. 5 POTATO PLANTER

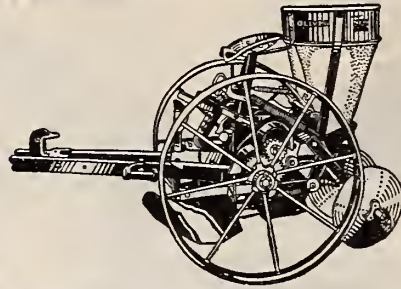

This is indeed the most perfect potato planter ever built—it leads everything in the field—and has made potato planting a science—is absolutely accurate in every degree at an immeasurable saving of time and labor.

The improvements in the pickers and concaves have made such excellent results possible—the misses have been reduced to about one in

a thousand potatoes, with uniform properly cut seed.
 No. 5 Plain Planter\$105.00
 No. 5 Planter with fertilizer attachment..... 136.00

O. K. CHAMPION HAND POTATO CUTTER

Price \$5.00



SUCCESS JUNIOR POTATO DIGGER

Price...\$12.50.

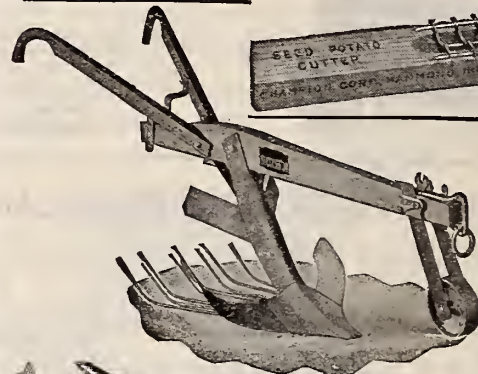

Master's Rapid Plant Setter

All kinds of Plants, such as Cabbage, Tobacco, Tomatoes, Cauliflower, Strawberries, Sweet Potatoes, Sugar Beets, etc. The only Hand Mechanical Plant Setter on the market; is built on scientific principles throughout. Its conical jaws are made of heavy sheet steel and the main body or water reservoir and plant tube of heavy tinned plate. The water valve is of brass with rubber packing. The valve rod and trip spring are of steel wire; thumb button and other fittings are also of brass. The machine is well put together with rivets and solder and should last for years.

Price, each\$6.00.

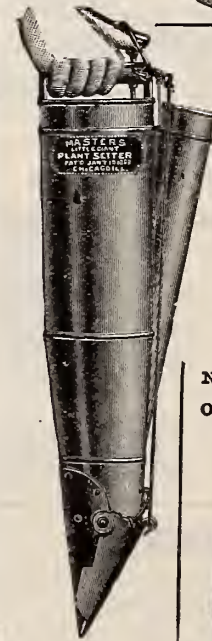

Perfection Corn Grader

No One Who Plants Corn Can Afford to Be Without a Corn Grader.
 Our Special Price.....\$1.25 Each.



THREE ROW SHOVEL MARKER



3-Row Shovel Marker..\$18.00.

Massey-Harris Two Horse Mower No. 22

Combined Plain and Vertical Lift.

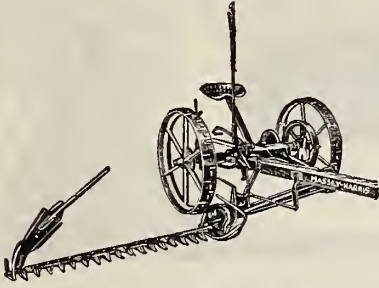

All bearings are held in positive alignment by a one-piece frame which is accurately bored in one operation by a lathe especially designed for the purpose.

Power is evenly applied from both wheels.

A perfectly lined cutter bar enables the knife to work effectively. Both the guards and the bar itself are planed or milled to fit one another perfectly. This assures an alignment that is not otherwise possible to get.

Ample speed to cut clean. The speed of the gearing is such that the forward advance of the cutter bar is only about 1 3/4 inches for each stroke of the knife. Clean cutting is thus always assured and yet because of the high, broad-faced, well-lugged wheels, the perfect alignment of all parts, the splendid balance and the use of roller and self-aligning bearings, the draft is never excessive.

- 4 1/2 Ft. \$85.00
- 5 Ft. 86.50

Massey-Harris Steel Hay Tedder

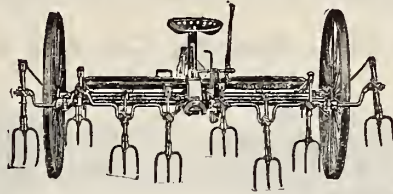

- 6 Fork \$75.00
- 8 Fork 85.00

Massey-Harris Runner Spring-Tooth Lever Harrow

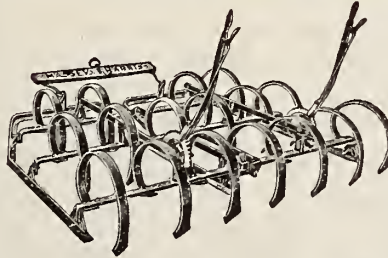

- 15-Tooth \$23.00
- 17-Tooth 24.50
- 23-Tooth, 2-section 31.00
- 23-Tooth, 3-section 35.00
- 25-Tooth, 3-section 36.50

An all-Steel, low-down Lever Spring Tooth Harrow with renewable steel runners. 15 or 17 teeth. Two sections.

No. 11 One-Horse Mower

- 3 1/2 Ft. Vertical Lift \$83.50
- 4 Ft. Vertical Lift 85.00

Massey-Harris Steel Hay Rake

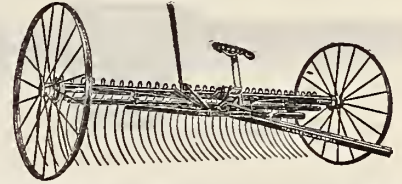

- | | |
|----------------------|--------------|
| | Price |
| 8 Ft.—24 Tooth..... | \$45.00 |
| 9 Ft.—22 Tooth..... | 46.50 |
| 10 Ft.—26 Tooth..... | 49.50 |

Massey-Harris Spike Tooth Harrow

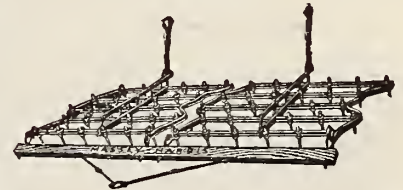

- 50-Tooth \$19.50
- 60-Tooth 22.00
- 75-Tooth 31.00

Massey-Harris No. 5 Grain Binder

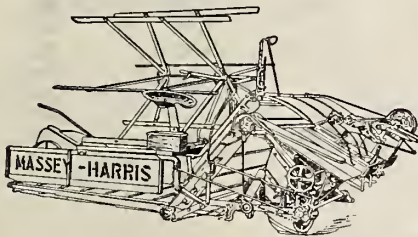

- 6 Foot with Bundle Carrier and 3-Horse Hitch \$216.00
- 7 Foot with Bundle Carrier and 3-Horse Hitch 222.50
- 8 Foot with Bundle Carrier and Tongue Truck 249.25

Farmer Boy Sulky Plow

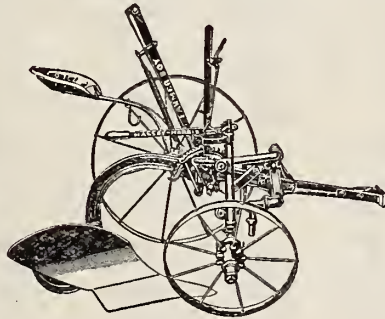

Specifications

A three horse hitch, adjustable caster, colter and weed hook are furnished with each plow. Extra cast shares can be furnished.

Style Bottom, SG; width Cut, 14 inch; style Moldboard, Turf and Stubble; Wt., 420 pounds. Price \$65.00.

Massey-Harris 3-Speed Pitman Drive Planter



The three-speed Pitman drive planter is the climax of many years of study and experience in building high grade planters of this type.

It is short and compact, which makes it especially valuable in planting on steep slopes or terraced land where there are sharp curves.

No. 225 Planter with Shovel Opener, Coverers, Variable and Hill Drop \$21.00

No. 226 Planter with Runner, Covering Blades, Press Wheel, Raising and Lowering Lever, both Variable and Hill Drop 24.00

Wood Frame Harrow, Steel Lined



- 16-Tooth Harrows \$18.00
- 18-Tooth Harrows 19.00
- 20-Tooth Harrows 20.75
- 22-Tooth Harrows 22.50
- 24-Tooth Harrows 25.00

MASSEY-HARRIS REPAIRS FOR PLOWS

(Formerly Case)

Plow	Cast Share Brand	Price	Steel Share Brand	Price	
				Solid	Hard
480 1/2 GEX	GM O	\$1.10	10 G	\$2.50	\$3.70
482 1/2 GEX	GM 2	1.20	12 G	2.80	4.25
484 1/2 GEX	GM 4	1.35	14 G	3.00	4.55
510 1/2 GPX	GP 0	1.10	GP 10	2.50
512 1/2 GPX	GP 2	1.20	GP 12	2.80
514 1/2 GPX	GP 4	1.35	GP 14	3.00
SG 12	SG 2	1.20	SG 12	2.80	4.25
SG 14	SG 4	1.35	SG 14	3.00	4.55
SG 16	SG 6	1.50	SG 16	3.55	5.00

Mower and Binder Extras to Fit Leading Machines

Parts for Older Machines Can Also Be Supplied

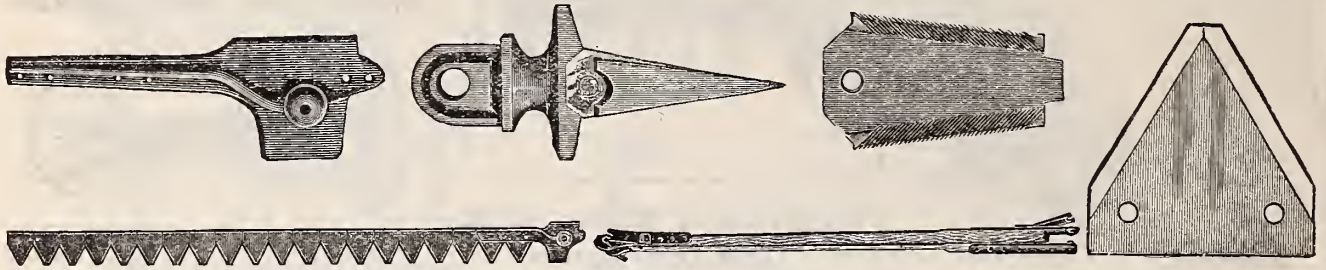

By following the name of machine across the page, you can find correct number of part wanted.

WHEN ORDERING Mower Knives and Sickles always state number of Knife Head, and how many cutting sections on Knife.

Name of Mower	No. of Knife Head	Section	No. of Guard	No. of Guard Plate	No. of Pitman	No. of Pitman Box	Price Pitman Box
Adriance (Buckeye).....	557F	745	3087D	716½C	3032H	61K	\$.80
Champion, New Draw Cut; 1905-12.	A870	MA333	A881	H253	Steel	AA1018	1.60
Champion Imp. and V. L.; 1909 since	A5792	MB333	AA881	H253	Steel	A1133	1.60
Deere, Dain Mower; 1895-1919.....	Z45	Z5059	Z1	Z5110	Z5076	Z205	.86
Deere Mowers; 1923 and since.....	Z502	Z5571	Z463H	Z5110	Z5661	Z513	.80
Deering, Ideal, Steel Pitman.....	F123	D1140	D442	D1043	Steel	D334	1.00
Deering, Ideal, Wood Pitman.....	D463	D1140	D698	D1739	D2907	D608	.65
Emerson, Standard; 1900 and since.	M203	M193S	M614	M301S	Z397	M517	.80
Emerson, 6 and 7-ft.; 1909 and since	M204	M193S	M614	M301S	Z397	M517	.80
Johnston; 1909 and since.....	2211	920	1811	912	2228C	2207C	.65
Massey-Harris No. 11, one horse...	919	920	1811	912	304X	256	.70
Massey-Harris No. 20 and 21.....	M802	M2492	M803	M2494	7120	M800½	.70
Massey-Harris No. 22.....	M802	M2492	M803	M2494	7120	M800½	.70
McCormick; 1888-1909.....	M139	MA333	M462	M219½	M392	M317	.65
McCormick; 1910 and since.....	M139	MB333	MD989	MA990	M392	MD317	.65
McCormick-Deering; 1923 and since.	MA139	MB333	MD989	MA990	M392	MD317	.65
Milwaukee, Chain Drive.....	PG6	PG155	PK5S	P201S	PV290	PJ50	.60
Moline-Adriance	557F	745	3087H	716½C	3032H	61K	.80
Osborne, Columbia; 1902-05.....	K284	K223	K280	K322	Steel	K826	.80
Osborne, Nos. 1, 2 and 3; 1905, since	K774	5406	K790	11565	J9439½	KA1158	.80
Thomas-Crown; 1888-1923	6	1077	03	1046	1069	25	.70
Thomas-New Crown; 1924 and since	CM402	1077	CM3	1238	1245	CM25	.70
Wood-Admiral; 1907-14.....	2862	3410	L	9571	8965	2941	1.20
Wood, Vertical Lift; 1925, since....	K366	3410	L	9571	K3434	AK367	1.20

Name of Binder	No. of Knife Head	Section	No. of Guard	No. of Guard Plate	No. of Pitman	No. of Pitman Box	Price Pitman Box
Adriance No. 7; 1915 and since....	JA102	A84	2090	716½A	J1230		
Champion, Improved; 1909 and since	2564	G241	3025	G167	Steel		
Deere; 1914 and since.....	HZ493	B4053	HZ147	HZ5183	H29140		
Deering, Ideal; 1898 and since.....	H877	E1328	286	E1330	H1255		
Johnson-Continental	K306	L787	K307	K364	K118C		
Massey-Harris; 1915 and since.....	S213	336A	S220	D157	S1032		
Milwaukee No. 12; 1907 and since..	SN342	SL877	SN37	SM681	SN844		
Moline; 1915 and since.....	JA102	A84	2090	716½A	J1230		
McCormick; 1911 and since.....	B756	762	HA495	H507	B763		
McCormick-Deering	BA756	762	HA495	H507	BA763		
Osborne; 1915 and since.....	CI044	11259	C752	11601	J9048		
Wood, New Century; 1917, since....	H2139	7268	H2620	H2620	C3373		

PRICES

Complete Knives, 4½ feet.....	\$2.50	Mower Guards.....	.30
Complete Knives, 5 feet.....	2.75	Binder Guards.....	.30
Complete Knives, 6 feet.....	3.00	Guard or Leger Plates.....	.05
Complete Knives, 7 feet.....	3.25	Wood Mower, Pitman's (Massey-Harris).....	3.25
Complete Knives, 8 feet.....	3.50	Wood Mower, Pitman's, all others.....	1.75
Knife Heads, Steel.....	.90	Wood Binder, Pitman's (McCormick).....	.90
Knife Heads, Malleable.....	.50	Wood Binder, Pitman's, all others.....	.75
Sections, per box of 25.....	1.50	Pitman Boxes (priced above).	
Sections, each.....	.08	Guard Bolts.....	.05
Rivets, per pound.....	.15	Binder Canvas Slats.....	.10

ALL PRICES IN CATALOG SUBJECT TO CHANGE WITHOUT NOTICE.

Mower and Binder Extras For Leading Machines

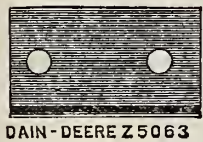

Name	No. of Pitman Bolt		No. of Pitman Strap		No. of Knife Clip	No. of Knife Cap		No. of Wearing Plate	
	Knife End	Box End	Knife End	Box End		Front	Rear	Under Clip	Under Cap
Adriance Buckeye.....	602C	607B	600-1E	605C	3093	3084	3086A	3094A	3098C
Champion Draw Cut.....	H609				A886	A816	A1163	A5859	A5857
Champion Improved.....	A5834				A1155	A1136	A1132	A5858	A5800
Deere-Dain.....	Z5040	Z5035	Z220-5	Z226	Z6	Z30	Z32	Z5064	Z5063
Deere.....	Z5040	Z5961	Z392-3	Z516	Z6060	Z6010	Z488	Z5925	Z5685
Deering.....	D2591	D2592	G211-2	G210	D927	DS26	D984	D3012	D1455
Deering, 6 and 7 foot.....	D3079	D3078	G211-2	G210	D927	D826	D984	D3012	D1455
Emerson.....	Z381	Z382	M417-8	M568	M503	M528	M505		M665
Johnson.....	2251	2252	2208-9C	2210	1814C	1885	926	1813	904
McCormick.....	M483	M483 1/2	M147 M304	M315 M316	M463	M290	M652	M468	M490
McCormick-Deering.....	M483	M483 1/2	M147 M304	M315 M316	M1000	M1239	MA652	MA468	MA490
Milwaukee Chain Drive.....	PG175	PG175	PM34-5	PL9 1/2	PJ1	PH2	PM3	PK156	PG157
Moline.....	602C	607B	600-1C	605C	3093	3084C	3086A	3094A	3098C
Osborne.....	9959 1/2	9960 1/2	8131-2	8130	K665	K494	K792	13461	10009
Thomas Crown.....	1004	1005	55-6	57	317	10-CM329	B40		1091
Thomas New Crown.....	1117	1005	55-6	57	CM352	1219	B40	1239-40	1091
Wood, Admiral.....	A2148	9534	[2853 2964	[2834 2835]	2865	2761	2959	K3139	K3138
Wood, Vertical Lift.....	K3435	K3460	[K3438 K3439	K3433	2865	K364	K306	K3139	K3423
Massey-Harris.....	MA1706	M2571	[M2489 M2490	M2491	M2292	M799	[M2515 M2516	M2277	M2278

Pitman Bolts... .15. Pitman Straps... .30. Knife Clips..... .15. Wearing Plates.. .15. Knife Caps on Application.

GEARS AND PINIONS

Dain—	
Z125, Bevel Gear.....	\$3.00
Z130, Bevel Pinion.....	.70
Deering Ideal—	
D356, Bevel Gear.....	3.50
D458, Bevel Pinion.....	.75
Deering New Ideal—	
D864, Bevel Gear.....	2.50
D865, Bevel Pinion.....	.75
D730, Spur Pinion.....	.85
D795, Bevel Gear.....	2.50
D989, Bevel Gear.....	2.50
Emerson—	
M522, Bevel Pinion.....	.75
McCormick New 4—	
M633, Spur Pinion.....	1.15
M635, Bevel Pinion.....	.75
M813, Bevel Gear.....	3.00
McCormick New Big 4—	
M837, Bevel Gear.....	3.00
M838, Bevel Pinion.....	.70
MA814, Clutch.....	1.00
M1400, Clutch.....	1.25
McCormick No. 6 Vertical—	
M1406, Spur Pinion.....	1.15
M1407, Bevel Gear.....	3.25
M1408, Bevel Pinion.....	.75
Thomas—	
65, Bevel Pinion.....	.75
301, Bevel Gear.....	2.25
302, Triple Gear.....	4.25
303, Drive Gear.....	3.50
20, Drive Gear.....	3.75
Wood—	
2525, Bevel Gear.....	3.70
2791, Bevel Pinion.....	1.15
2790, Spur Pinion.....	1.25

CORN PLANTER RUNNER

SINGLE ROW PLANTERS

	Each
Rock Island.....	\$2.00
Empire.....	2.00
Hench & Dromgold Daisy.....	2.00
Hoosier.....	2.00
Keystone, No. 6 1/2.....	2.00
Case, Farmers' Friend.....	2.00
Black Hawk.....	2.00
Avery, No. 27.....	2.75

FOR DOUBLE ROW PLANTERS

	Per Pr.
For Janesville, Nos. 1, 5, 7, and 8.....	\$4.50
For Black Hawk, No. 1.....	3.80
For Black Hawk, No. 3.....	3.80
For Black Hawk, Nos. 4 and 5.....	3.20
For Deere, No. 999, With Blocks... ..	4.50
For New Way.....	4.50
For Black Hawk, No. 15, With Block.....	4.50
For Deere, No. 9.....	3.80
For International With Block.... ..	3.80
For J. I. Case, No. P344.....	3.80
For Superior, With Block.....	4.50
For Superior, Without Block.....	3.80
For Hoosier, No. 10.....	3.80
For Hoosier, No. 11.....	3.80
For Tiger Transplanter, Shallow, each.....	4.00
For Tiger Transplanter, Deep, each.....	4.50
For Case Transplanter.....	4.50

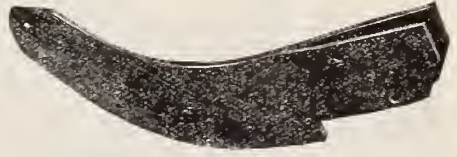

In ordering Planter Runners always state, as near as possible, the year Planter was made; whether steel or wood frame; or, better still, a diagram showing position of hole and size of bend.

CHECK-ROWER WIRE



FOR LEADING PLANTERS

We carry in stock the following sizes:
 3 ft. 3 ft. 2 ins. 3 ft. 4 ins. 3 ft. 6 ins.
 3 ft. 8 ins. 3 ft. 10 ins. 4 ft.
 The above comes in 10, 20, 40 and 80 rod rolls. Per rod.....8c

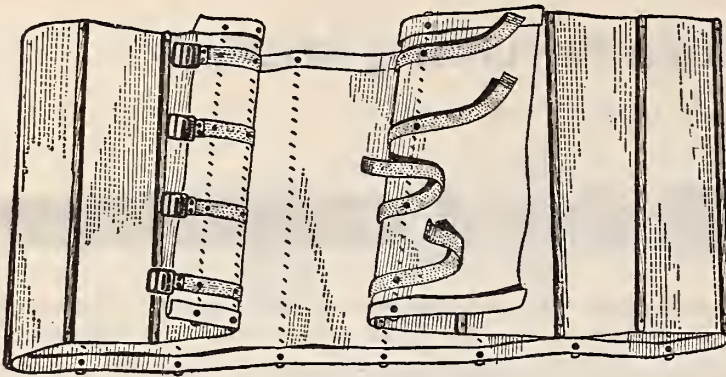

CONVEYOR CANVASES

No.	Description	Year	Price
J1402	Upper Elevator, 90x45 1/2", No. 3 Left Hand Binders	1906-15	\$5.60
JA1401	Lower Elevator, 90x52", No. 3 Left Hand Binders..	1906-15	5.85
2223A	6 ft. Platform, 137x41", No. 2 R.H. & 3 L.H. Binders	1897-15	7.75
2224A	7 ft. Platform, 158x41", No. 2 R.H. & 3 L.H. Binders	1897-15	9.00
ADRIANCE			
KA3145	Lower Elevator, 77x51 1/2", Improved Binders.....	1909-	4.75
KA3144	Upper Elevator, 96x43 3/4", Improved Binders.....	1909-	5.10
KA3147	6 ft. Platform, 137x43 3/4", Improved Binders.....	1909-	6.60
KA3148	7 ft. Platform, 157x43 3/4", Improved Binders.....	1909-	7.65
KA3149	8 ft. Platform, 185x43 3/4", Improved Binders.....	1909-	8.70
CHAMPION			
HZ9040	6 ft. Platform, 135x44 3/4", Light Draft Binders....	1911-	6.60
HZ9041	7 ft. Platform, 159x44 3/4", Light Draft Binders....	1911-	7.65
HZ9044	Upper Elevator, 93x46 3/4", Light Draft Binders....	1917-	4.75
HZ9043	Lower Elevator, 96x50 3/4", Light Draft Binders....	1917-	5.00
DEERE			
HA4562	Upper Elevator, 90x47", Ideal Binders.....	1908-	4.75
HA1725	Lower Elevator, 89x50 3/4", Ideal Binders.....	1899-	5.00
HA1772	6 ft. Platform, 133 1/2 x43 3/4", Ideal Binders.....	1899-	6.60
HA1773	7 ft. Platform, 157 1/2 x43 3/4", Ideal Binders.....	1899-	7.65
DEERING			
BD65	Upper Elevator, 91x47 1/4", R. & L. Binders.....	1901-	4.75
BA66	Lower Elevator, 97x51 1/4", R. & L. Binders.....	1901-13	5.10
BB835	Lower Elevator, 89x51", R. & L. Binders.....	1911-	5.00
BB466	5 ft. Platform, 110x45", R. & L. Binders.....	1901-	5.50
BC467	6 ft. Platform, 134x45", R. & L. Binders.....	1901-	6.60
BB468	7 ft. Platform, 158x45", R. & L. Binders.....	1901-	7.65
MCCORMICK-DEERING			
A1260	6 ft. Platform, 138x39", No. 5 Binders.....	1915-	7.75
A1261	7 ft. Platform, 162x39", No. 5 Binders.....	1915-	9.00
S1107	Lower Elevator, 88x53", No. 5 Binders.....	5.85
S1106	Upper Elevator, 84x50", No. 5 Binders.....	5.60
MILWAUKEE			
SB400	Upper Elevator, 90x52 1/2", No. 10 Steel Jr. (SA400)..	1899-20	5.65
SA401	Lower Elevator, 92 1/2 x52 1/2", No. 10 Steel Jr. (S401)	1889-20	5.85
SA402	6 ft. Platform, 136x42 1/2", No. 10 Steel Jr. (S402)..	1889-20	7.75
SA404	7 ft. Platform, 160x42 1/2", No. 10 Steel Jr. (S404)..	1892-20	9.00
SN812	Upper Elevator, 88x47 1/4", No. 12 Binders.....	1907-	5.60
SN813	Lower Elevator, 83x52 1/4", No. 12 Binders.....	1907-	5.85
SP817	6 ft. Platform, 137x42 5/8", No. 12 (works for SN817)	1902-	7.75
SM818	7 ft. Platform, 158x42 1/2", No. 12 (works for SL818)	1906-	9.00
MOLINE			
JD1401	Lower Elevator, 90x52", Nos. 4, 6, 7 and 25 Binders	1913-	5.85
JD1402	Upper Elevator, 90x45 1/2", Nos. 4, 6, 7 & 25 Binders	1913-	5.60
J1450	6 ft. Platform, 137x41", Nos. 4, 6 and 7 Binders....	1913-	7.75
J1451	7 ft. Platform, 158x41", Nos. 4, 6 and 7 Binders....	1913-	9.00
OSBORNE			
CA2022	Upper Elevator, 88x42 3/4", New Osborne Binders...	1909-	5.60
CA2023	Lower Elevator, 90x48 1/2", New Osborne Binders...	1909-	5.85
CA2008	6 ft. Platform, 134x42 3/4", Col. & New Osb. Binders	1896-	7.75
CA2009	7 ft. Platform, 158x42 3/4", Col. & New Osb. Binders	1896-	9.00

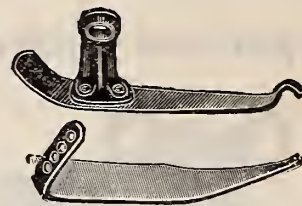

SHOE SOLES

SHOE SOLES FOR MOWERS

ADRIANCE		
3099D, Inner, Nos. 7 and 8.....		\$1.20
3073G, Outer, Nos. 7 and 8.....		.50
CHAMPION		
H381, Inner Draw Cut.....		.95
H483, Outer Draw Cut.....		.35
A6207, Inner, Improved Mower.....		.85
A5847, Outer, Improved Mower.....		.75
DEERE-DAIN		
Z5134, Inner, Dain.....		.90
Z5231, Outer, Dain.....		.60
Z5786, Inner, Deere.....		.90
Z5331, Outer, Deere.....		.60
DEERING		
D2097, New Ideal, Inner.....		.90
D1647, New Ideal, Outer.....		.65
EMERSON		
M95S, Inner.....		1.00
M173S, Outer (0-10959).....		.75
JOHNSTON		
63FC, Outer with Bracket.....		1.00
1812, Inner, Nos. 9, 12, 14.....		.90
2323, Inner, No. 12.....		.90
63FD, Outer, No. 14.....		1.00
MCCORMICK		
M465, Inner, New 4-1896-11.....		1.00
MB465, Inner, New 4-1912.....		1.00
MA259, Outer, New 4.....		.70
MCCORMICK-DEERING		
MB465, Inner.....		1.00
MA259, Outer.....		.70
MASSEY-HARRIS		
M2216, Outer.....		.55
M2217, Outer.....		1.00
M2276, Inner.....		.90
MILWAUKEE		
PJ108, Inner.....		.90
PJ218, Outer.....		.85
OSBORNE		
7010, Inner.....		.75
10959, Outer.....		.60
THOMAS		
1041, Outer.....		.60
1096, Inner.....		.75
1107, Inner (New Mower).....		.75

GRAIN DRILL TUBES



Plain Top.

IN ORDERING TUBES it is always best to send an old tube as a sample. If that cannot be done, be sure to state name of **Drill**, the kind of **Tube**, whether ring flange or plain top, or special bell-shaped top with straps, and by all means the length and diameter at top and bottom.
Plain tubes, each.....40c

GRAIN DRILL POINTS

We are one of the largest distributors of **GRAIN DRILL POINTS AND TUBES** in the Country.

For All the Leading Grain Drills.

IN ORDERING POINTS, either send an old one or give name of Drill, length of point, and be sure to give distance from center of hole to end of point. It is always best, if possible, to send an old sample.
Price, Points, each.....18c.

SPRING COTTERS



Assorted, box of 100.....75c.



PLOW BOLTS

Length	List 3/8	Retail Each	List 7/16	Retail Each	List 1/2	Retail Each
1 1/4	\$3.35	4c	\$4.10	4c	\$6.20	5c
1 1/2	3.50	4c	4.75	4c	6.45	5c
1 3/4	3.65	4c	5.00	4c	6.70	5c
2	3.80	4c	5.25	4c	6.95	5c
2 1/4	3.95	4c	5.50	4c	7.25	5c
2 1/2	4.10	4c	5.75	4c	7.55	5c
2 3/4	4.35	4c	6.05	4c	7.85	5c
3	4.60	4c	6.40	4c	8.20	5c

THE CLIPMASTER

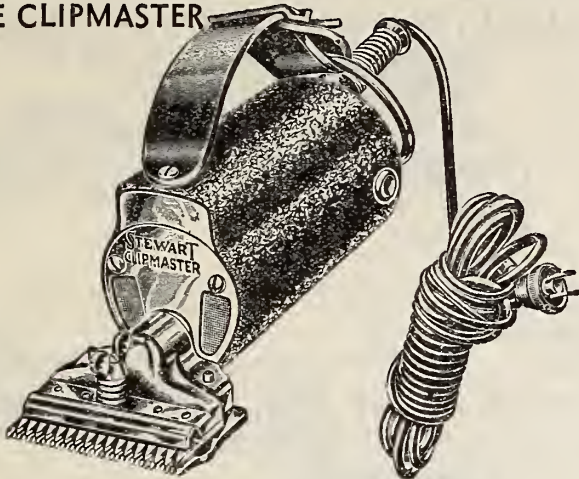

The CLIPMASTER is extremely substantial in construction despite its very light weight. All moving parts are scientifically hardened and tempered. Has enclosed bronze bearings packed in special lubricant, requiring no attention for at least a year. Switch is conveniently located at the back of the clipper. The tension is ball bearing and because of its extreme accuracy, will clip with much lighter tension than any other machine ever developed.

Price\$18.50

THE STEWART NO. 9 BALL-BEARING SHEEP SHEARING MACHINE

Gears are all cut from solid tool steel, are hardened and are enclosed in dust-proof metal box. Has large balance wheel to assist in easy running. Every joint in the shaft and shearing head is fitted with ball-bearings. Fitted with No. 7 ball-bearing shear, two combs and four cutters. Weight, 50 pounds.

Price\$24.00

LINK CHAIN BELTING

No.	Links per ft.	Av. Ult. strength lbs.	Price per ft.	Price all plain links
25	13.3	700	17c.	3c.
32	10.4	1100	17c.	3c.
33	8.6	1190	16c.	3c.
34	8.6	1300	18c.	3c.
35	7.4	1200	20c.	3c.
42	8.75	1500	19c.	4c.
45	7.4	1600	18c.	3c.
48	6.	1660	4.4c.	4c.
50	8.7	1900	22c.	5c.
51	10.4	1900	24c.	5c.
52	8.	2300	23c.	5c.
53	7.9	2866	32c.	5c.
54	7.4	2200	20c.	5c.
55	7.25	3100	27c.	5c.
56	5.66	2460	30c.	8c.
72	5.9	4240	45c.	8c.
72 1/2	7.25	4590	55c.	9c.
76 1/2	5.8	3890	42c.	9c.
77	5.2	3600	35c.	9c.

Attachment Links Also Furnished. Also Steel Links.

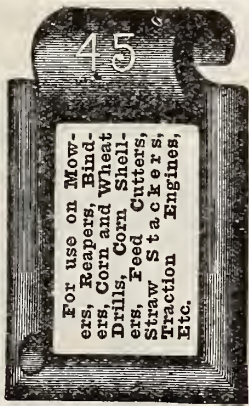

The Stewart No. 10 Ball-Bearing Horse Clipping Machine

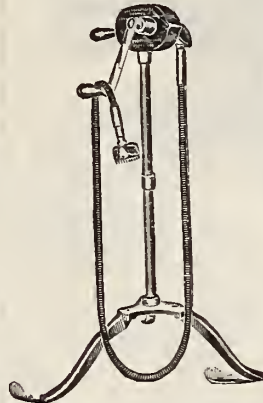

A very rigid and very durable machine, weighing, complete, 36 lbs. Gears enclosed in dust-proof metal box are cut from special steel and hardened. Has six-foot, easy running, flexible shaft and famous Stewart clipping head.

Price, complete...\$15.00



Horse Clipping Attachment

Will fit any Stewart Sheep-shearing Machine. Consists of eye spindle and six feet of high quality flexible shaft. Also the famous Stewart clipping head. Can be attached in a few seconds. Owners of a Stewart Shearing Machine who have horses should have this attachment. Packed in box. Price \$10.50.



Sheep-Shearing Attachment

For Use on Our No. 1 and No. 10 Clipper

This attachment consists of complete No. 5 Stewart Shear head, two combs and four cutters, the solid core, universal jointed shaft and cogs, as shown here. Weight, boxed, 15 pounds. Price of complete attachment, as described, \$16.00.

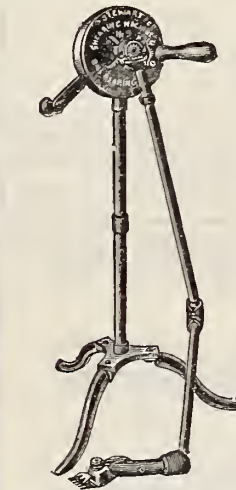

STEWART No. 11 Improved Grinder Attachment

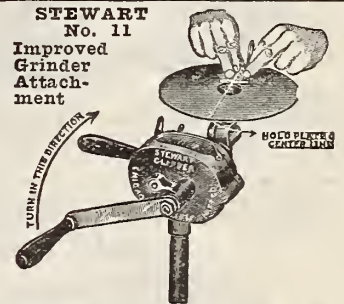

Attaches to a No. 1 Stewart Horse-Clipping Machine or Stewart No. 8 or No. 9 Sheep-Shearing Machine. Puts a perfect edge on horse-clipping or sheep-shearing knives. Every user of a horse-clipping or sheep-shearing machine should have one. Price, \$6.75.

CARRIAGE BOLTS



Length, Inches.	1/4		5/16		3/8		7/16		1/2	
	List, 100.	Retail, Each.	List, 100.	Retail, Each.	List, 100.	Retail, Each.	List, 100.	Retail, Each.	List, 100.	Retail, Each.
1 1/2	\$1.50	\$.03	\$2.20	\$.03	\$2.80	\$.03	\$3.80	\$.04	\$5.25	\$.05
2	1.65	.03	2.40	.03	3.12	.03	4.25	.04	5.70	.06
2 1/2	1.85	.03	2.65	.03	3.45	.03	4.75	.04	6.15	.06
3	2.00	.03	2.85	.03	3.75	.04	5.15	.05	6.60	.07
3 1/2	2.20	.03	3.10	.03	4.10	.04	5.60	.05	7.05	.07
4	2.90	.03	3.35	.03	4.45	.04	6.05	.05	7.50	.07
4 1/2	3.05	.03	4.05	.04	4.75	.04	6.45	.05	7.95	.07
5	3.20	.04	4.30	.04	5.35	.05	6.90	.06	8.40	.07
5 1/2	3.35	.04	4.50	.04	5.65	.05	7.35	.06	8.85	.08
6	3.50	.04	4.70	.04	6.00	.05	7.80	.07	9.30	.08
6 1/2	3.65	.04	4.90	.04	6.30	.05	8.25	.07	9.75	.08
7	3.85	.04	5.15	.04	6.65	.06	8.70	.08	10.20	.09
7 1/2	4.00	.04	5.35	.05	6.95	.06	9.15	.08	10.65	.09
8	4.20	.04	5.60	.05	7.30	.06	9.60	.09	11.10	.10
8 1/2	4.35	.05	5.80	.05	7.60	.07	10.05	.09	12.05	.11
9	4.55	.05	6.05	.06	7.95	.07	10.50	.09	12.50	.11
9 1/2	4.70	.05	6.25	.06	8.25	.08	10.95	.10	12.95	.12
10	4.90	.05	6.50	.06	8.60	.08	11.40	.10	13.40	.12
11	5.25	.05	6.95	.06	9.30	.09	12.25	.11	14.30	.13

All 1/4-inch Bolts 100 to a Package. Other Sizes 50 to a Pkg.



MACHINE BOLTS

Length, Inches.	1/4		5/16		3/8		7/16		1/2	
	List, 100.	Retail, Each.	List, 100.	Retail, Each.	List, 100.	Retail, Each.	List, 100.	Retail, Each.	List, 100.	Retail, Each.
1 1/2	\$1.60	\$.03	\$2.30	\$.03	\$2.95	\$.03	\$4.75	\$.04	\$5.65	\$.05
2	1.80	.03	2.60	.03	3.25	.03	5.20	.04	6.10	.05
2 1/2	2.00	.03	2.85	.03	3.60	.03	5.70	.04	6.55	.06
3	2.15	.03	3.05	.03	3.90	.04	6.10	.05	7.00	.06
3 1/2	2.35	.03	3.30	.03	4.25	.04	6.55	.05	7.45	.06
4	3.05	.03	3.55	.03	4.60	.04	7.00	.06	7.90	.07
4 1/2	3.20	.04	4.25	.04	4.90	.04	7.40	.06	8.35	.07
5	3.35	.04	4.50	.04	5.55	.05	7.85	.06	8.80	.07
5 1/2	3.50	.04	4.70	.04	5.85	.05	8.30	.07	9.25	.08
6	3.65	.04	4.90	.04	6.20	.05	8.75	.07	9.70	.08
6 1/2	3.80	.04	5.10	.04	6.50	.05	9.20	.08	10.15	.08
7	4.00	.04	5.35	.04	6.85	.06	9.65	.08	10.60	.09
7 1/2	4.15	.04	5.55	.04	7.15	.06	10.10	.09	11.05	.09
8	4.35	.05	5.80	.05	7.50	.06	10.55	.09	11.50	.09
9	4.70	.05	6.25	.05	8.15	.06	11.45	.10	12.40	.10
10	5.05	.05	6.70	.05	8.80	.06	12.35	.10	13.30	.10
11	5.40	.05	7.15	.05	9.50	.07	13.20	.10	14.70	.12
12	5.75	.05	7.60	.05	10.20	.08	14.05	.10	15.60	.15

BALTIMORE GARDEN BARROWS

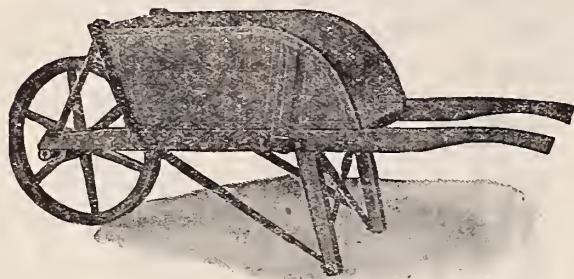

Made of seasoned wood, double frames, firmly bolted, iron braced.

No.	Length	Front Width	Back Width	Wheel	Tread	Price
1—Garden.....	30	24	25	21	1½	\$10.00
4—Garden.....	26	19	22	20	1¾	7.60
5—Garden.....	28	20	24	20	1¾	8.00
67—Greenhouse.....	31	15	18	20	2	10.60

Nos. 4 and 5, with steel wheel add..... .80
 3-inch tire wheel on Nos. 4 and 5 add..... .60

SOLID PRESSED STEEL TRAY BARROW

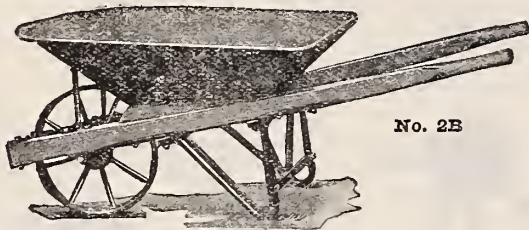

No. 2B

Durable Steel Wheel, Channel Steel Legs, Improved Steel Nose Guard, Tray Riser and Dash Straps. Capacity 4 cubic feet. Weight 68 pounds, \$8.00.
 1B Barrow, 3 cubic feet, 4-in. tire wheel.....\$12.00

TUBULAR FRAME SOLID PRESSED STEEL TRAY BARROW

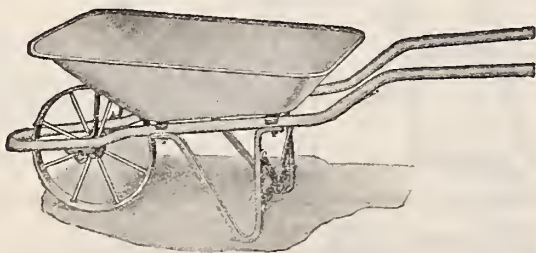

No. 4, Tray 15-gauge Steel. Capacity 3 cubic feet. Weight, 70 pounds. Wheel, 16-inch diameter; tire 1½x¾-inch, bored for ¾-inch. Cold Rolled Steel Axle. For moving earth, ashes and light work.....\$7.00.

No. 5, Tray 16-gauge Steel. Capacity 4 cubic feet. Weight 75 pounds. Mounted on same frame as No. 4. For general purposes and light running. Will stand hard usage. \$8.50.

WAGON OR TRUCK SKIDS



These skids are made from strong, select hickory side bars one end being ironed with wedge shaped steel points, between which the side bars extend, which prevents them from splitting. The upper end is ironed in a similar way, only it is equipped with hooks to fasten to the body of the vehicle.

Size	Price	Size	Price
6 Ft.	\$8.00	10 Ft.	\$11.00
8 Ft.	10.00	12 Ft.	15.50

HANDA HOME AND FARM WHEELBARROW

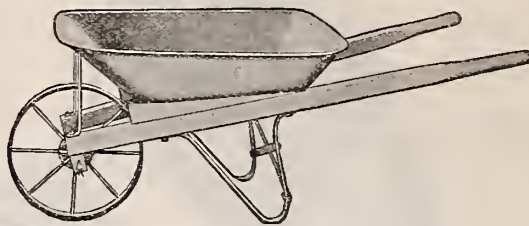

HANDA—16-gauge pressed steel tray, capacity 3 cubic feet. Flat Steel Legs, substantial steel wheel. Weight 45 pounds. Price\$4.50

SOLID PRESSED STEEL TRAY COAL AND COKE BARROW NO. 10



Tray of best quality steel, with wired edge. Size No. 13—Gauge of steel in tray, 13; length of top of tray, 41½ in.; width of top of tray, 33 in.; depth at wheel, 11½ in.; depth at handle, 8 in.; capacity, 6 cubic feet; weight 100 lbs. Price\$11.00

WHARF OR OYSTER BARROW

Steel Wheel. Price.....\$7.50.

CONCRETE AND MORTAR BARROWS

No. 77—Deep, narrow Tray, rounded front and corners. 4 cubic feet. Weight, 80 lbs. Made especially to carry a full load of soft concrete or mortar without slopping. \$9.60.

STORE TRUCKS

New York Pattern



Baltimore Store Truck
 Price.....\$4.60

	Half Strapped	Full Strapped	Price
1			\$8.00
2			9.25
3			11.00
4			15.00
	A1		9.00
	A2		11.00
	A3		12.75
	A4		16.00

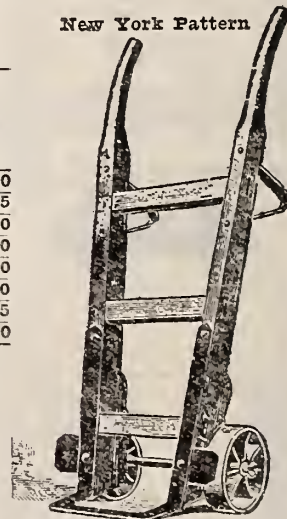

New York Pattern—Sizes

	Length Handles	Width Nose	Width at Upper Bar	Diam. Whs.	Weight
No. 1	48 in.	13 in.	18 in.	6 in.	42 lbs.
No. 2	51 in.	14 in.	19½ in.	8 in.	58 lbs.
No. 3	54 in.	15 in.	21 in.	8½ in.	72 lbs.
No. 4	60 in.	16 in.	22½ in.	10 in.	91 lbs.

GRITCO BROADCAST LIME DISTRIBUTOR

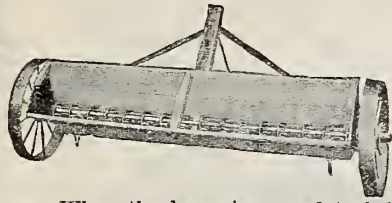

Truss rods on both sides, with a brace rod and board in the center, make an exceptionally rigid construction. There can be no sag or warp. Axle and bearings cannot get out of alignment, no matter how heavy the load or rough the land.

Hopper is fitted with two screens to sift out lumps which might cause breakage or clogging.

The cut-off slide moves easily in a groove in the cast-iron bottom plates. When the cut-off lever is moved to right, all the feed holes are open for broadcast-

ing. When the lever is moved to left of center, three holes only are open for drilling. Box is full eight feet long; holds about ten bushels; will sow from 200 to 4,000 lbs. per acre, depending on condition and kind of fertilizer.

This Lime Sower is cheap only in price. We use the very best material obtainable. The few parts and simplicity of construction enable us to make a superior machine at a reasonable price.

Stock size: 8-foot Box with pole, \$55.00; 6-foot Box with Shafts, \$55.00; Doubletrees and Yoke, add \$3.40.



Lean Sprocket Pulverizer

Single Sections

8 Ft., 975 lbs. \$58.00
10 Ft., 1168 lbs. 75.00
Less Trees and Yoke

Snatch Rod regularly furnished with No. 2½ and No. 3.

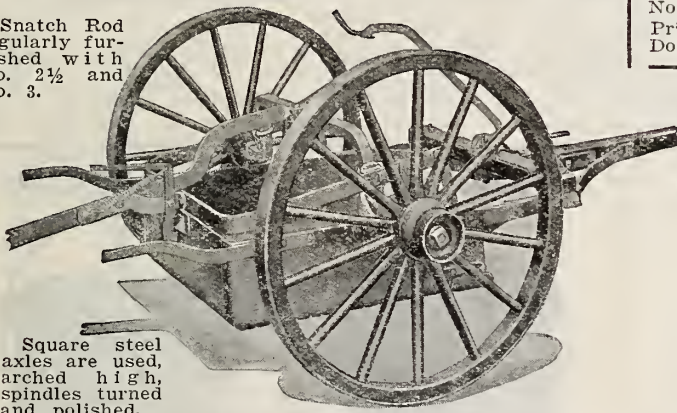

Square steel axles are used, arched high, spindles turned and polished.

KEYSTONE TONGUE SUPPORT

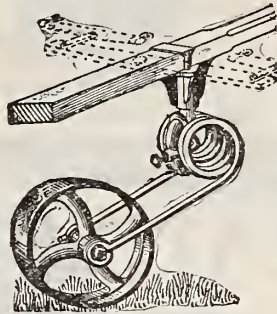

For Harvesting Machinery and Disk Harrows

This Tongue Support is simple and light in weight. The springs are made of best ½-inch spring steel. The coils are 4½ inches in diameter, and have arms extending 12 inches. The wheel is 11½ inches high, with 2¾-inch tread, thus assuring a light draft. No holes need to be bored in the tongue to fasten this support, thus allowing the tongue all its strength.

Price, \$5.00.

STEEL LAND ROLLERS

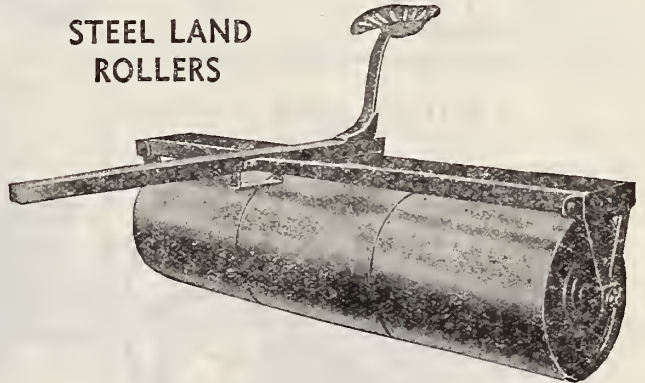

	Sections	Length feet	Diameter inches	Weight lbs.	Special Price.
No. 105½	2	8	24	550	\$38.00
No. 106½	3	8	24	585	40.50

Price does not include Doubletrees and Neck Yoke.

Doubletrees and Neck Yoke.....\$3.40

AMERICAN WHEEL SCRAPERS

These scrapers are very popular with the contractor trade on account of their splendid construction and convenience. The wood wheels are made of thoroughly seasoned stock and are very strong.

	Size of Bowl	Height of		Axle	
		Wheels	Tires		
	in. in.	in.	in.	in.	
No. 1	— 9 Cu. Ft.	35x34½	x11½	36 2¾ x ¼	1 ⅞
No. 2	— 13 Cu. Ft.	37x38	x13½	40 3 x ⅞	1 ¾
No. 2½	— 14 Cu. Ft.	41x38	x13½	44 3 x ⅞	1 ¾
No. 3	— 16 Cu. Ft.	41x44	x16	46 3 x ¾	1 ¾
No. 1—Weight, 450 lbs., price.....					\$73.00
No. 2—Weight, 600 lbs., price.....					\$92.00
No. 2½—With Snatch Rod, weight 700 lbs., price....					\$97.00
No. 3—With Snatch Rod, weight 750 lbs., price.....					\$105.00

Wood Doubletrees and Neck Yoke, \$6.00 extra.

AMERICAN ROUND BACK SOLID PRESSED DRAG SCRAPER

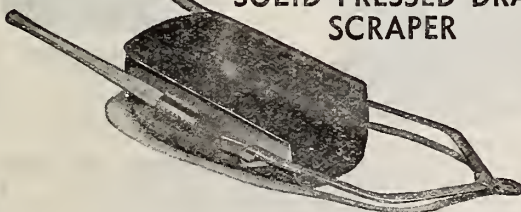

Size	Capacity	Weight	Price
No. 1	7 cu. ft.	97 lbs.	\$10.00
No. 2	5 cu. ft.	86 lbs.	9.60
No. 3	3 cu. ft.	76 lbs.	9.20

LIGHT DRAG SCRAPER

Size	Capacity	Weight	Price
No. 1	7 cu. ft.	86 lbs.	\$9.00
No. 2	5 cu. ft.	72 lbs.	8.75
No. 3	3 cu. ft.	67 lbs.	8.50

AMERICAN FRESNO SCRAPERS



With this scraper dirt can be carried any distance and dumped in bulk, or it can be scattered in layers from one to twelve inches deep simply by adjusting two tail nuts on the cross bar; no wrench required.

Three Sizes	Width	Weight	Price
No. 1—4-Horse	5 -ft.	315 lbs.	\$36.00
No. 2—2 or 4-Horse	4 -ft.	277 lbs.	34.00
No. 3—2-Horse	3½-ft.	250 lbs.	33.00

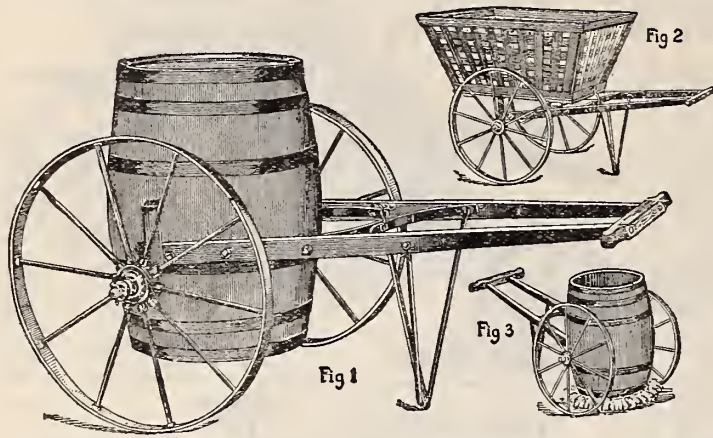

WATER TRUCKS AND PUSH CARTS

Water Truck, with Regular 1½-inch Tire Steel or Wood Wheels	\$12.25
Water Truck and Barrel.....	17.25
Water Truck and Box.....	15.50
Water Truck, Barrel and Box.....	20.50
Sprinkling Attachment	5.00
Leaf Rack	8.50
Barrel	5.00
Box	3.00
Trunnions, per pair.....	.75
Trucks with 2½-in. Tire Steel Wheels, add.....	.75
Trucks with 3½-in. Tire Steel Wheels, add.....	1.00
Trucks with 4-in. Tire Wood Wheels, add.....	1.00

BUTLER CART

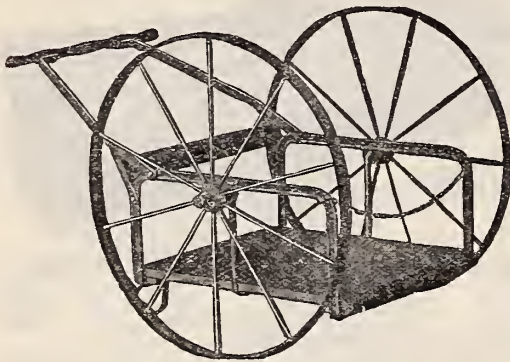

Size of platform 27x30 inches.
Price \$11.50

WHEELBARROW LEAFRACK ATTACHMENT



Can be attached to any style or size wheelbarrow with removable sides. Most convenient for gathering leaves, cut grass and rubbish. One of these attachments should be in use on every small suburban place, as well as the larger estates. Capacity 10 bushels; made of galvanized wire, bolted to a wooden base, price.....\$4.50

BALTIMORE PUSH CART

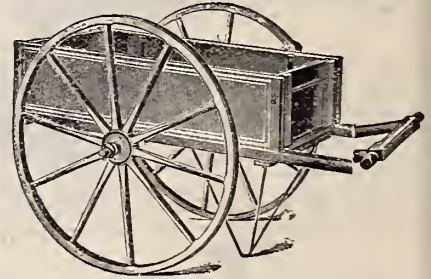

DIMENSIONS

Width of Tire.....	1½ inches
Height of Wheel.....	.36 inches
Axle	1½ inches
Hub	6 inches

BOX—Inside Measure

Length	40 inches
Width	22 inches
Depth	10 inches
Price	\$15.50
Extra Wheels, retail, each.....	3.50
Extra Axles	1.50

MONITOR CART NO. 53

HEAVY PATTERN



No. 53—Box 40x26x9½ inches, 30-inch wheels, ½-inch spokes, weight 110 pounds, price.....\$24.00
No. 23 MONITOR—Box 39x20½x9½ inches, capacity 600 pounds, 30-inch wheels, ½-inch spokes, weight 80 pounds, price

MERIMAC CART NO. 132

TWO WHEELS

Two 26-inch wheels, box 39x20½x8 inches, capacity 250 pounds, weight 55 pounds, price.....\$14.25

ASH CANS

With Cover

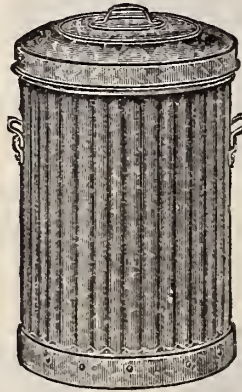

HEAVY ASH CANS

No. 171—16 gallons.....	\$3.50
No. 181—20 gallons.....	4.00
No. 191—24 gallons.....	4.50
No. 201—29 gallons.....	5.25
Deduct for Cover.....	.50

GARBAGE CANS

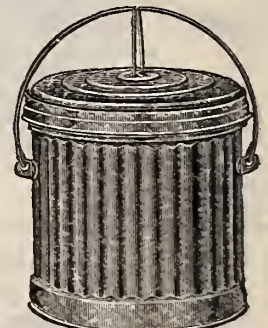

GARBAGE CANS

No. 311—4¼ gallons.....	\$0.65
No. 321—6 gallons.....	.75
No. 331—8½ gallons.....	.90
No. 341—10 gallons.....	.95

LIGHTER ASH CANS

No. 651—10 gallons.....	\$1.00
No. 661—12 gallons.....	1.05
No. 671—20 gallons.....	1.25

DUST PROOF COAL ASH SIFTER

This Ash Sifter saves coal and is dust-proof. It is made from extra heavy galvanized sheets heavily wired and braced and equipped with a cover at top which prevents the dust from escaping. The revolving cylinder is made from extra heavy galvanized wire mesh, operated by handle or crank equipped with wooden grip. The lip at the end of sifter allows the coal to drop directly into the hod. A strong hook holds the hod securely in place. Price.....\$2.75

GRIFFITH & TURNER WAGONS

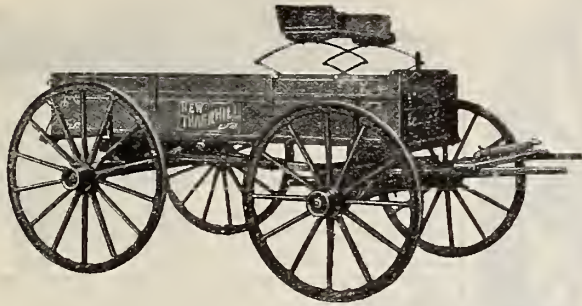

ONE-HORSE WAGON

Solid Steel Axle and Thimble Skein

If one horse wagon is wanted with Pole instead of Shafts, add\$5.75
 Poles for one-horse wagons.....12.00
 Bodies without seats, 7 ft. 6 in. long, 15 in. deep, no seat.16.00
 Wagon seats 5.00
 For 1 3/4 x 1/4 in. Tires on 1 1/2 in. Axle Wagon, add..... 3.00
 For 2 x 3/8 in. Tires on 1 1/2 in. Axle Wagon, add..... 4.75
 For 2 x 3/8 in. Tires on 2 3/8 Wood Axle Wagon, add..... 4.75
 Shafts as an extra.....

THIMBLE SKEIN ONE HORSE WAGON

Size Cast Skein	Reg. Tires	Height Wheels		Dimension of Body			Capacity	Weight	Gear only no brake	Gear with brake	Wagon comp. with body	Wagon comp. with body and brake
		Front Ft. In.	Rear Ft. In.	Leng. Ft. In.	Wid. Ft. In.	Dep. In.						
2 3/8 x 7 1/2	1 1/4 x 3/8	3' 4"	3' 8"	7' 6"	3' 4"	15"	1200 lbs.	550 lbs.	\$51.00	\$56.00	\$69.00	\$77.00

STEEL AXLE ONE HORSE FARM WAGON

1 1/8 x 6 1/2	1 1/8 x 3/8	3' 4"	3' 8"	7' 6"	3' 4"	15"	1000 lbs.	550 lbs.	\$51.50	\$57.00	\$70.00	\$78.00
1 3/8 x 7 1/2	1 3/8 x 1/2	3' 4"	3' 8"	7' 6"	3' 4"	15"	1500 lbs.	735 lbs.	72.00	77.50	90.00	98.00

A good truck, very strong, suitable for either farm or road work, 2-inch solid steel square axles, wood wheels 36-inch rear and 32-inch front, 2x8 1/2 box and with 3x3/8 inch tires. It is made in both drop and slip tongue. Top or swing side and tail brakes furnished when ordered.

Equipped regularly with Club Bolster stakes, but can be furnished with stationary stakes. Prices include single and double trees, and chains for stiff tongue, and neck yoke for drop tongue wagon.

Be sure to state just what you want when ordering.

THORNHILL FARM TRUCK



PRICES

Farm Truck, with Drop Tongues.....	\$77.00	3x1/2 inch Tires.....	4.50
Farm Truck, with Slip Tongue.....	79.00	4x3/4 inch Tires.....	5.60
For any of the following extras, add to the above wagon prices—		Seat and Springs.....	5.60
10-foot Body, with 16' 8" sides, no seat.....	27.00	Jersey Double and Singletrees.....	1.75
Body Brake Attachments.....	2.75	Side Brake.....	8.50
36-inch Front and 40-inch Rear Wheels.....	2.75	Tail Brakes.....	13.00
40-inch Front and 44-inch Rear Wheels.....	3.25	Both Brakes when Ordered at Same Time.....	18.75
		Stationary Bolster Stakes.....	2.75

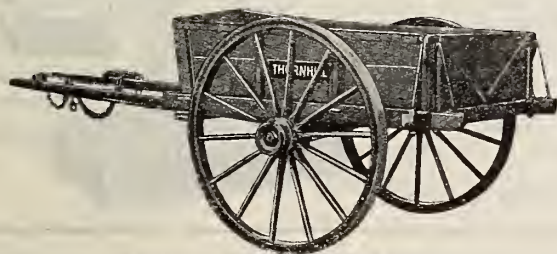

FARM CARTS

	Price
2-inch axle, 3-inch tire, 4-foot 4-inch wheels.....	\$22.50
2-inch axle, 4-inch tire, 4-foot 4-inch wheels.....	86.75

CONTRACTOR'S CARTS

2-inch axle, 3-inch tire, 4-foot 6-inch wheels.....	107.50
2-inch axle, 4-inch tire, 4-foot 6-inch wheels.....	112.50

THORNHILL JUNIOR—Best Ever Made



Wheels are 14 inches and 18 inches high, with heavy tires; bed is 16x36 inches, strongly made. These wagons are made of the very best materials and they are first class. Price \$12.50

HANDY STEEL WHEEL FARM TRUCK



Wood Hounds—Hickory Axles—Grooved Tines

No. 24—3 1/4 x 10 skeins, weight 500 pounds, capacity 4000 pounds. Price.....	\$52.50
Brake.....	7.75
Doubletrees and yoke.....	6.00
Shafts, extra.....	9.00
Shafts instead of pole, add.....	5.00

METAL TRUCK WHEELS

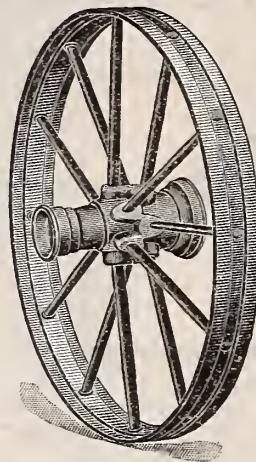
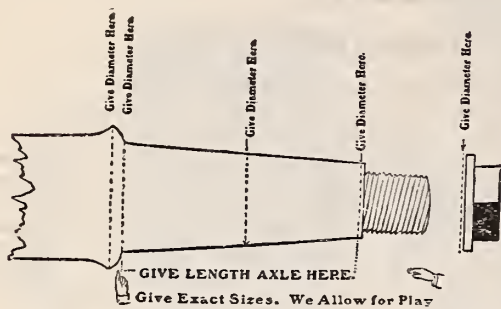

Diagram Showing How To Measure Your Skains.

We carry wheels in stock, sizes 3x9 and 3 1/4 x10. All other sizes will have to be ordered from the factory according to measurements sent at special prices. **If measured wrong, we will not take the wheels back.** Wood Wheels, prices on application. Prices on other sizes quoted on application.

As nearly every set of steel wheels we sell has to be made especially to correspond with measurements of axles for which it is intended, we generally make shipment direct from factory.

PRICES PER WHEEL WITH 4x3/8 TIRES.

24-inch.....	\$6.60
26-inch.....	6.90
28-inch.....	7.30
30-inch.....	7.70
32-inch.....	8.40
34-inch.....	8.80
36-inch.....	9.50

WOOD SINGLE, DOUBLE AND TRIPLETREES

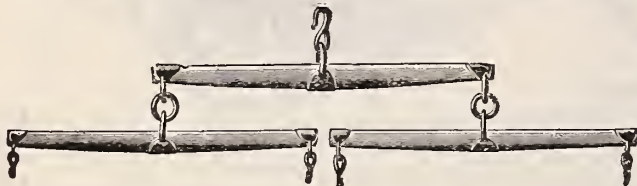

Our line of Single, Double and Tripletrees are the best on the market, CLIP ENDS. Made of second growth hickory, carefully selected and thoroughly seasoned.

26-in. Singletree.....	.55	34-in. Singletree.....	.75
28-in. Singletree.....	.60	36-in. Singletree.....	.80
30-in. Singletree.....	.65	36-in. Doubletree.....	1.00
32-in. Singletree.....	.70	40-in. Doubletree.....	1.40
Extra Heavy Tripletree.....		\$3.50	

WOOD NECK YOKE

40 inch.....	\$1.60
--------------	--------

WOOD SINGLETREE SETS

One 36-inch Doubletree and two 28-inch Singletrees, with open rings.....	\$2.60
One 36-inch Doubletree and two 30-inch Singletrees, with open rings.....	2.70
One 40-inch Doubletree and two 34-inch Singletrees, with open rings.....	3.25

FULL LENGTH STRAP, WAGON TREE SETS

48-inch Doubletree, 34-inch Singletrees and 40-inch Neck Yoke.....	\$5.20
Wagon Doubletrees, 48-inch, each.....	1.60
Wagon Singletrees, 34-inch, each.....	1.20
Wagon Neck Yokes, 40-inch, each.....	1.60
Double and Singletrees, less Neck Yoke for Rollers, Corn Planter, etc.....	2.00
Double and Singletrees, with Neck Yoke for Rollers, Corn Planters, etc.....	3.60

STEEL SINGLE AND DOUBLETREES

U SINGLE, DOUBLE AND TRIPLETREES

Prices: Singletrees, with Malleable Hooks, 24-inch, 75c.; 26-inch, 80c.; 28-inch, 85c.; 30-inch, \$1.10. Doubletrees, with Hooks, 36-inch, \$1.25. Steel Tripletrees Set, complete per set of 6 pieces, \$6.00.

PATENT STEEL SKEINS



Skins with Boxes, per Set

Size	With Nuts	Boxes Only, per Set
Size 2 1/4 x8 inches.....	\$17.50	\$3.40
Size 2 3/4 x8 inches.....	18.00	3.70
Size 3x9 inches.....	19.00	4.00
Size 3 1/4 x10 inches.....	22.00	5.00
Size 3 1/2 x11 inches.....	24.00	7.00
Size 3 3/4 x12 inches.....	29.00	7.00
Size 4x12 inches.....	34.00	7.50

Nuts for all sizes up to 3 1/2 inch, each... \$0.30
Nuts for 3 3/4 inch and 4 inch, each..... .40
3 1/2, 3 3/4 and 4 inch furnished also in Linch Pin.

D. V. TRADE SKEINS FOR STEEL WHEEL TRUCK

Skins with boxes, 3x9, per set, \$9.00; boxes only, per set, \$3.00
Skins with boxes, 3 1/4 x10, set, \$12.00; boxes only, per set, \$4.00

PATENT TRUSS CAST SKEINS AND BOXES

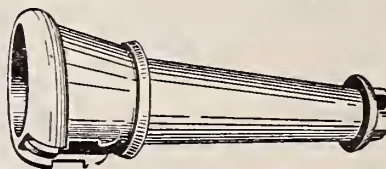

Size	Price.	Boxes Only.
Size 2 1/2 x8 inches, with boxes, per set.....	\$10.00	\$3.40
Size 2 3/4 x8 inches, with boxes, per set.....	11.00	3.70
Size 3x9 inches, with boxes, per set.....	12.00	4.00
Size 3 1/4 x10 inches, with boxes, per set.....	15.00	5.00
Size 3 1/2 x11 inches, with boxes, per set.....	20.00	7.00

CLARK ALL-DAY HEAT UNITS

No Flame—No Smoke—No Odor

PRICES

Per dozen in shipping carton. Shipping weight 6 1/2 pounds. \$1.20.

Per gross—12 cartons in wooden shipping case. Shipping weight 98 pounds. \$14.40.

Per 100—packed in wooden cases—no cartons. Shipping weight 65 pounds. F. O. B. Chicago. \$9.50.

Clark All-Day Heat Units are 2 1/2 inches wide by 1 1/2 inches thick by 7 inches long.

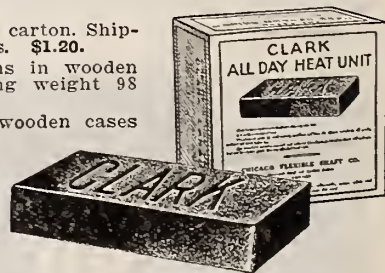

OPEN SIDE LAP LINKS

Open Side Lap Links, polished, 1/2 x 2 1/2.....	15c.
5/8 x 3.....	20c.
3/4 x 3.....	25c.

SET OF WELDED CLIPS

CLIPS FOR DOUBLETREES.

No. 77—Southern; one 5/8-inch Center Clip and Hook, with hook and two 1/2-inch Clips. Set, 60c.

No. 76—Pennsylvania; one 3/4-inch Center Clip and Hook, with 3/4-inch hook and two 9-16-inch End Clips. Set, 70c.

CLIPS FOR SINGLETREES.

No. 75—One Center 1/2-inch Clip, and two 3/8-inch End Clips; used on 28-inch Singletrees. Set, 40c.

No. 74—One Center 9/16-inch Clip, and two 7/16-inch End Clips. Set, 45c.

No. 73—One Center 5/8-inch Clip, and two 7/16-inch End Clips; used on 34 and 36-inch heavy Singletrees. Set, 50c.

No. 72—One Center 3/4-inch Clip, two 1/2-inch End Clips. Set, 60c.

GALVANIZED STEEL BASKETS



UTILITY STEEL BASKETS GALVANIZED

- With Drop Handles, 1 bushel...\$0.75
- 1½ bushels 1.10
- ½ bushel75
- SPLIT BAMBOO and OAK BASKETS**
- 1 bushel (iron bound).....\$1.35
- 1½ bushel (iron bound)..... 1.85
- 2 bushels (iron bound)..... 2.60
- 3 bushels (iron bound)..... 3.50

MEASURES

Each

- ¼-peck, flat hoops.....\$0.65
- Peck and ½-peck, flat hoops 1.00
- ½-bushel wire hoops..... 1.60
- ½-bushel, flat hoops..... 1.25



DAISY INDESTRUCTIBLE FARM BASKETS

No. 2-PB—½ bushel rounded full. Made of No. 12 Galvanized Wire, spaced approximately ⅝-inch apart. Hoop welded to each vertical wire. Patent ears that can never come off. Regular bails No. 6 galvanized wire. Price\$1.25



CHERRY SEEDERS

These cherry seeders are so constructed that they can be adjusted for different size cherries. They work very rapidly and do not tear up the fruit.

The No. 2 Seeder is made with Clamp.
The No. 1 Seeder has four legs which screw to the table.

- PRICE, No. 1**.....\$1.00
- PRICE, No. 2**..... 1.00

THE NEW CLIPPER Grain, Seed, and Bean Cleaner

These Cleaners are guaranteed to be first-class in every respect.

We furnish the best outfit of screens ever sent out with a farm Mill. Our perforated zinc screens are graduated in 64ths of an inch in both round and oblong holes. Our woven wire screens are made of plated wire with the meshes uniform and true to count. The zinc screens will not rust and our plated wire screens will last for years if properly cared for.

VERTICAL AIR BLAST. This is a feature that no other cleaner has and it makes possible some very difficult separations that can be made in no other way.

The No. 2-B differs from the No. 1-B only in size and capacity. Both machines are equipped with a set of 12 screens for general farm use. The No. 2-B is larger.

- No. 1-B**\$48.00
- No. 2-B** 55.00
- Power Attachment, extra.. 1.00



BALTIMORE IMPROVED GRAIN FAN

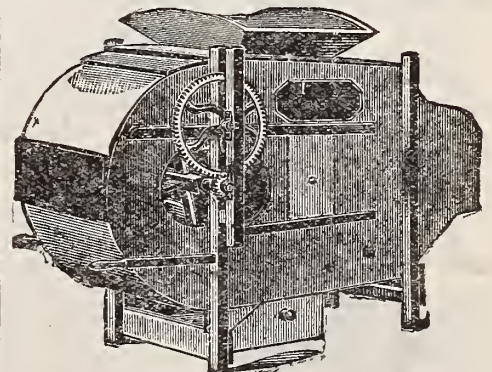

Will clean from 60 to 100 bushels per hour. Made of best material and finished in a neat and tasty manner.

- Price**\$45.00

CENTURY TIRES



Century Super Service and Ultra Service Balloons are specially built to fill the tire needs of modern cars. They provide the utmost in safety—an important factor in high-speed traffic. Then they say it with MILES, wearing slowly and uniformly even under conditions of severe service. The Century Super Service Balloon is a tire of outstanding appearance, is made of select materials under precision methods—a FINE tire in every sense of the word. Century Ultra Service Heavy-Duty 6-ply and 4-ply balloons are matchless values at their moderate prices. Many retailers sell them at chain store lists.

Tires and Tubes change in price so often that we ask you to write for current prices, which we will cheerfully furnish.

TURNTABLE APPLE PARER

No. 1338

A strong, rapid, durable machine. Pares very close at both ends of the apple. When passing the end of the fork the knife recedes, leaving ample room for placing the apple on the fork. Does not core or slice. Push-off is automatic.

- Price, each\$1.25
- White Mountain Parer and Corer..... 1.00

THE EAGLE SLAW CUTTER



Slaw Cutter and Vegetable Slicer is the speediest, handiest and most serviceable cutter on the market for cutting Slaw, Kraut, Noodles, Cucumbers, Potatoes, Onions, Parsnips, Pie Plant, Beets, Bananas, Turnips, Vegetable Oysters, String Beans, Pineapples, Saratoga Chips, etc.

The cleanest, quickest and nicest way to prepare fruits and vegetables that require cutting is to use an "Eagle" Slaw Cutter and Vegetable Slicer.

- PRICE**\$3.25

BUCH'S SHELLER

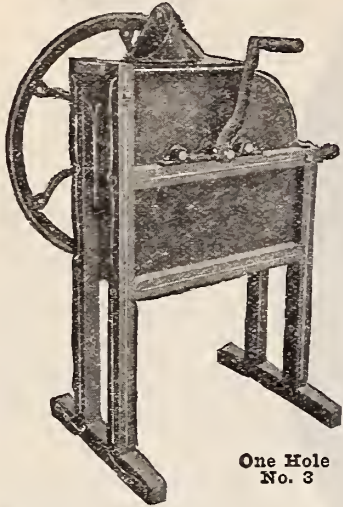

**One Hole
No. 3**

Separates corn and cob. Corn discharged beneath Sheller, cobs at end. Easily adjusted for large or small ears. Capacity 125 bushels a day. Weighs 130 pounds. Price.....\$14.00

**HOCKING VALLEY
DOUBLE CAGE MILL**



Best and strongest built. Adjustable for all sizes of apples. All have hinged tubs and iron roller.

Junior—2 to 4 barrels per day....\$30.00
Medium—4 to 6 barrels per day.... 34.00
Senior—6 to 8 barrels per day.... 50.00
Pulley extra 2.50



**Hocking Valley
Bantam
Cider
Mill**

This single cage mill is strongly built throughout. Will grind 1 to 2 barrels per day.

Price, with hinged tub,
\$22.00

THE BALTIMORE SHELLERS

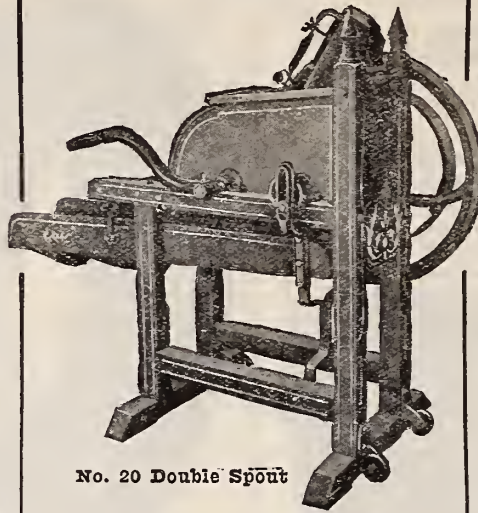

No. 20 Double Spout

This sheller is built very strong from the best materials, and has a combination flywheel and pulley.

Hand and power, with shaker belt and flywheel. Capacity 200 bushels per day. Capacity by power, 500 to 600 bushels. Weight 300 pounds.
No. 20, with shaker, price.....\$32.50

**FAMOUS LINE OF
OASIS PRESSES**

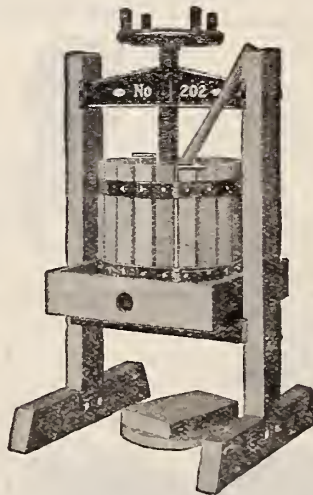

Guaranteed to be entirely satisfactory in execution, ease of operation, durability and finish. Made in 4 sizes.

	Size of Tub	Capacity	Price
No. 101	11½x11¼	½ bu.	\$10.00
No. 202	14¼x12¼	¾ bu.	13.00
No. 303	17¾x15½	1½ bu.	23.00
No. 404	23¼x20	3½ bu.	33.50

All Furnished with Hinged Tub.

LIGHT BERRY PRESSES

No. 1 W.....	\$9.50
No. 2 W.....	11.00
No. 3 W.....	13.00

GENEVA FEED CUTTER

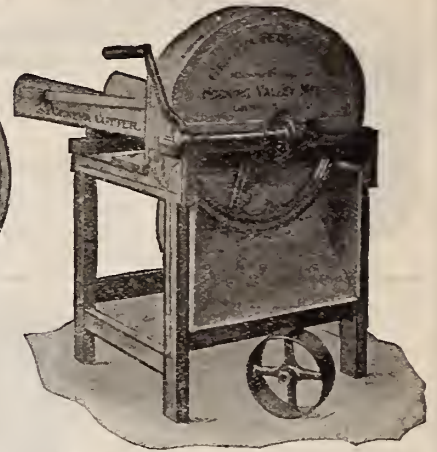

Easy running. Nicely balanced. Built for service. All equipped with two knives on balance wheel. All sizes are hand machines, but can be equipped with pulley for power. Special attachment for making ¼-inch cut.
No. 6—9-inch Knife, Hand Power, Price ¼ to 1¼-inch cut.....\$43.00
No. 8—10-inch Knife, Hand Power, ¼ to 1¼-inch cut..... 52.00
No. 10—10-inch Knife, Hand or Power, ¼ to 1¼-inch cut..... 61.00
Pulley 10x4, for Nos. 8 and 10... 2.40

**HOCKING VALLEY FEED
CUTTER**

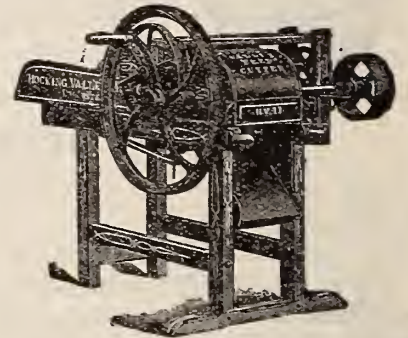

Best for sixty years. Upward cut is great advantage. Less power as drive is direct on knife shaft. No complicated gearing. Safety balance wheel. Thoroughly guaranteed. Pulley 10x6.

No. Knives	Cut	Power	Price
9	3-9 in. ¾-7½ in.	Hand	\$50.00
11	4-11 in. 1¼-1½ in.	1 Horse	80.00
13	4-13 in. 1½-1 in.	2 Horse	90.00

Carriers Furnished at Extra Cost

MARYLAND LEVER CUTTER



Strong, cheap, and durable.
Price.....\$6.50

GALVANIZED STEEL STOCK TROUGHS

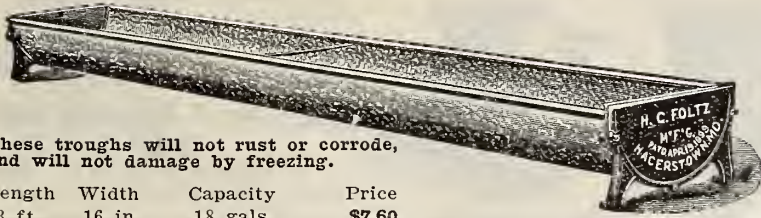

These troughs will not rust or corrode, and will not damage by freezing.

Length	Width	Capacity	Price
3 ft.	16 in.	18 gals.	\$7.60
4 ft.	16 in.	24 gals.	8.60
6 ft.	16 in.	36 gals.	10.25
8 ft.	16 in.	48 gals.	12.00
10 ft.	16 in.	60 gals.	14.40
12 ft.	16 in.	72 gals.	17.00
4 ft.	20 in.	40 gals.	10.75
6 ft.	20 in.	60 gals.	13.20
8 ft.	20 in.	80 gals.	15.20
10 ft.	20 in.	100 gals.	18.30
12 ft.	20 in.	120 gals.	20.25

CAST IRON CORNER MANGERS

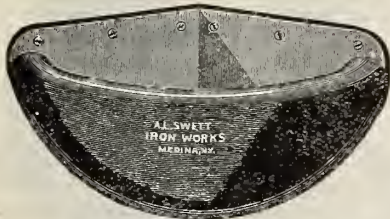

With Roll Front Food Guard.

No. 6—17 in. long, 17 in. wide, 10 in. deep	\$3.75
No. 7½—20 in. long, 20 in. wide, 10 in. deep	7.00



GALVANIZED HOG AND SHEEP TROUGHS

Length	Width	Capacity	Weight	Price
3 ft. 10 in.	6 in.	6 gals.	30 lbs.	\$4.50
4 ft. 10 in.	8 in.	8 gals.	35 lbs.	5.35
5 ft. 10 in.	10 in.	10 gals.	40 lbs.	5.75
6 ft. 10 in.	12 in.	12 gals.	45 lbs.	6.40
8 ft. 10 in.	16 in.	16 gals.	55 lbs.	7.60
10 ft. 10 in.	20 in.	20 gals.	65 lbs.	8.80



Heavy Cast-Iron Hog Troughs.
No danger of bursting in winter. Twelve inches wide at the top, 2 inches at bottom, and 7 inches deep. Made from 2 feet up to 12 feet.
Price 95c per foot

WROUGHT IRON HAY RACK



No. 12—Frame, 1 inch channel, 8 uprights, ½ inch round bar, exceptionally strong and heavy.
Price \$4.00

No. 13—Frame, 1 inch channel, 6 uprights, ½ inch round bars.
Price \$4.00

HORSE MUZZLES

Well made and of good stout wire.
No. 18—Plain. List Price, dozen, \$1.20. **Our Special Price, each, 10c.**
No. 16—Braced. List Price, dozen, \$2.00. **Our Special Price, each, 15c.**
No. 14—Braced. List Price, dozen, \$2.50. **Our Special Price, each, 20c.**

HEAVY HARNESS HOOKS

No. 1—Upper Hook projects 12 in., lower hook projects 5 in. Approximate weight 4 lbs.
Price \$1.00.
No. 2—Extra Heavy, Upper Hook projects 12 in., lower hook projects 7 in. Approximate weight, 8½ lbs.
Price \$1.75.

ROTO SALTS

SALT CAKES,
Each, 25c.

ROTO SALT HOLDERS,
50c.

HET-SON WATERPROOFED CANVAS COVERS

STANDARD STOCK SIZES

6' x 8'	10' x 16'	12' x 18'	16' x 20'
8' x 10'	12' x 14'	14' x 16'	20' x 20'
10' x 12'	12' x 16'	16' x 18'	

Other Sizes Made on Order.
WRITE FOR PRICES

1924 MODEL B DOUBLE DRUM HOIST

With Lever-Lock Brake, Price \$70.00

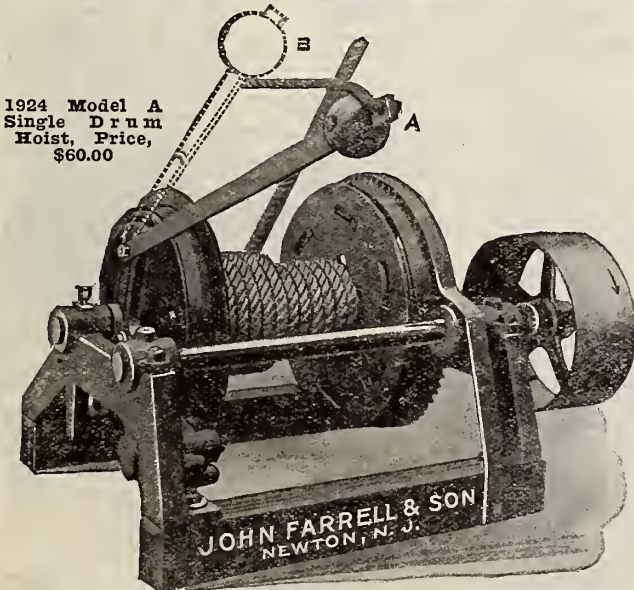

1924 Model A Single Drum Hoist, Price, \$60.00

JOHN FARRELL & SON
NEWTON, N. J.

NO. H15 HUDSON AUTOMATIC HOG WATERER



Extensively used for Hogs and all small stock. The Hudson Waterer is made so it will attach to a ¾-inch pipe line, water tank or barrel. When used with pipe line must be furnished with special coupling.
No. H15, Wt. each 12 lbs. \$2.75.

THE H. & Z. CONCRETE MIXER

Saves Cement and Insures Better Concrete.

Eliminates Much Hard Work and Does a Better Job

Hand mixing is a hard, back-breaking job, and because it is difficult it is often slighted—the concrete is poorly mixed, cracks, crumbles and goes to pieces. To insure a good job the concrete should be mixed with an H. & Z. Mixer—and that is the most economical way in the end.

A FAST WORKING MACHINE

The H. & Z. Mixer will mix a batch of thoroughly mixed concrete in a minute or less. The drum is always revolving and as soon as any material is put into it the mixing begins. The revolving discharge insures a quick pouring of the entire contents of the drum, throwing out the heavy and lighter materials in an even flow and not draining off the water and sand first as would be the case in a stationary discharge.

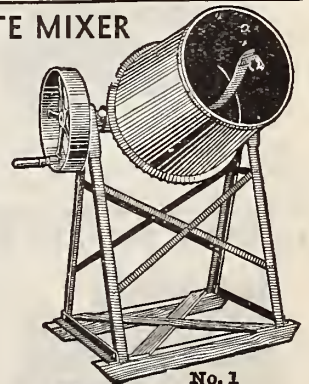

No. 1

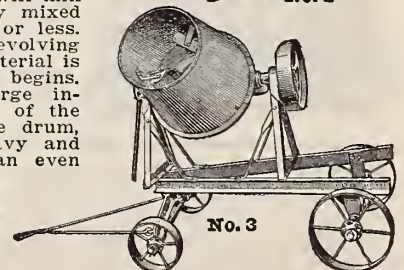

No. 3

No. 1—2½ cu. ft. capacity	\$ 34.85
No. 3—3½ cu. ft. capacity	67.00
No. 4—3½ cu. ft. capacity with 1½ H. P. Engine	175.00

BANNER ROOT CUTTERS



**FOR
HAND
OR
POWER**



No. 7, For Poultry, price \$8.00

Banner No. 25

No. 25 is a new style machine. It can be used by hand or light power. Is very strong and durable. Capacity 30 to 60 bushels per hour. Weight 100 pounds. Price, with Crank.....\$18.50

Banner No. 25

No. 35—Banner Root Cutter

Heavy construction for hand or power; weight, complete, 185 pounds; capacity of hopper about 3 bushels. This is a cylinder type cutter and is made strong to stand power. The hopper is large and deep. The Cutting Drum to which the knives are attached is strong and will not break or wear out. It is positive feed as the roots lay on top of the Cutting Drum. It has 30 gouge-shaped knives. Price, complete, with Pulley and Crank, \$47.50

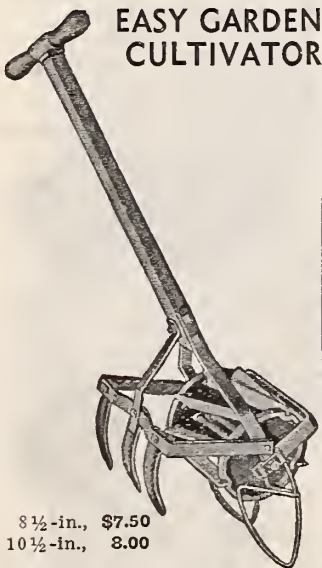

**EASY GARDEN
CULTIVATOR**

8 1/2-in., \$7.50
10 1/2-in., 8.00

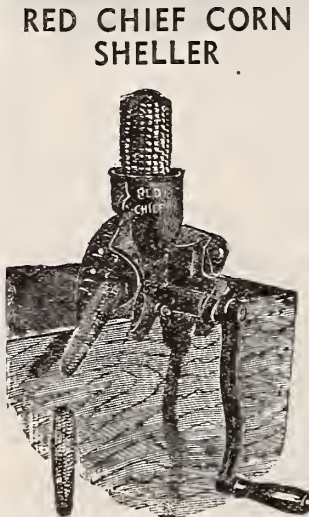

**RED CHIEF CORN
SHELLER**

Price, each\$2.75
Weight, 12 pounds.

WILSON NO. 0 FAMILY GRIST MILL

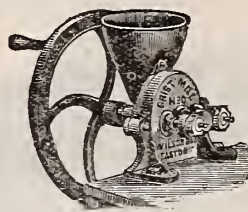

This mill is especially made for grinding Graham Flour or Cornmeal; can be adjusted for cracking grain if desired. Weight, 30 lbs., \$7.50. With iron stand; weight, 65 lbs., price \$10.50. Diameter of hand wheel, 20 in.

Wilson No. 1 Bone and Shell Mill

Weight, without stand, 33 lbs. \$7.50
Weight, with stand, 68 lbs.10.50

RED CHIEF MILLS

- No. 1—For Small Poultry Raisers. Price.....\$3.50
- No. 2—Best Crank Mill on earth. Feed gauge to regulate grinding. Price.....\$5.00
- No. 5—With large capacity, feed gauge and fly wheel. Clamps to box. Price.....\$7.00
- No. 10—With feed gauge, fly wheel and handsome stand to screw on table. Price.....\$8.50
- No. 12—Best Hand Mill on earth. Bronze boxes, steel axle, large fly wheel. Price.....\$14.00
- No. 15—Power Mill for one-horse engine; strong, durable and easy running. Price.....\$14.00



No. 10

Combined Hand and Power Mill

No. 20—Power Mill for two-horse engine; tight and loose pulley, best of bronze boxes and cold rolled steel axle, capacity 10 to 20 bushels per hour. Has no equal. Price, \$19.00.

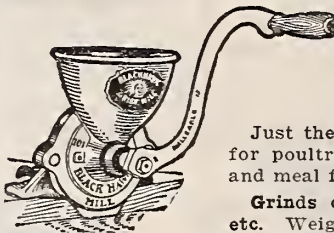

**BLACK HAWK
FEED AND GRIST
MILL**

Just the thing for cracking corn, etc., for poultry. Makes best Graham flour and meal for table use.

Grinds corn, wheat, rye, rice, spices, etc. Weight 17 pounds. Price...\$3.50

MANN'S GREEN BONE CUTTER

- No. 5C—With Crank Handle. Weight, 35 lbs.....\$12.00
- No. 5B—With Balance Wheel. Weight, 45 lbs..... 15.00
- No. 7—With Balance Wheel. For flocks of 100 hens.... 19.75
- No. 9—With Balance Wheel. For flocks of 300 hens.... 30.00

Larger Sizes, Price on Application

**PARCEL POST NEW
MODEL METAL EGG
CRATE**

The biggest thing to be said of the New Model is that it is designed and built—both inside and out—to eliminate waste of fillers and breakage of Eggs as well as deterioration of the carrier, thus insuring long life.

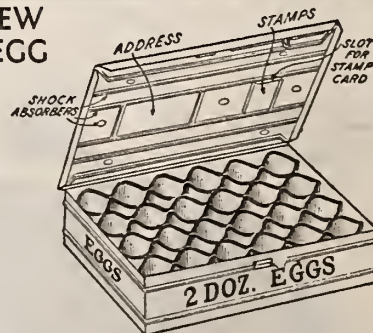

**METAL EDGE
FILLER**

The new patented Filler made of cardboard, circular in shape (like an egg) and reinforced with Metal Edges to insure strength, yet retain lightness in weight, is a wonder for safety and durability.

- 1 Dozen Egg Size.....\$1.00
- 2 Dozen Egg Size..... 1.50
- 3 Dozen Egg Size..... 1.75
- 4 Dozen Egg Size..... 2.00
- 6 Dozen Egg Size..... 2.50
- 9 Dozen Egg Size..... 3.25
- 12 Dozen Egg Size..... 4.00

COMBINATION CRATES

No. 1—2 lbs. Butter and 1 dozen Eggs.....\$1.50

HUMPTY DUMPTY FOLDING EGG CRATES



The Humpty Dumpty Egg Carriers are strong and durable cases, the favorite of thousands of shippers in the poultry industry. It delivers the eggs in the best shape, giving the largest return. The eggs it saves soon pays for itself.

Size	Price
3 Dozen.....	.50
6 Dozen.....	.60
9 Dozen.....	.70
12 Dozen.....	.75
15 Dozen.....	.80
30 Dozen.....	1.25

BOXES FOR FRESH EGGS FOR MARKET TRADE

This is not a Parcel Post or Express Box, but is intended for counter and private use. Any one selling eggs will find this box a great convenience, as it obviates any mistakes in the count and also avoids any breakage.

Delaware Egg Boxes, two rows for 12 eggs, per 100.....\$1.25
Eagle Egg Boxes, three rows for 12 eggs, per 100..... .80
SPECIAL PRICES IN QUANTITIES

G. & T. BOILER AND FEED COOKER



Unusual Rating	Actual Capacity	Diameter of Furnace	Shipping Weight	Price Furnace with Kettle	Price Furnaces only	Price Scalding Kettles only
No. 3—30 gallons	24 1/4 gallons	26 inches	160 pounds	\$29.75	\$10.50	\$11.70
No. 4—35 gallons	30 gallons	28 1/2 inches	190 pounds	23.00	11.00	13.50
No. 5—40 gallons	37 gallons	29 1/2 inches	200 pounds	27.00	11.50	16.50
No. 6—50 gallons	45 gallons	31 1/2 inches	253 pounds	31.00	12.00	20.00
No. 7—55 gallons	52 gallons	32 inches	280 pounds	33.00	13.00	22.00

We always ship furnaces without firepot for coal unless otherwise specified. For wood fuel no firepot or grate is required, but for coal it is necessary to use firepot. **Firepot, Price, \$7.85.**

IRON KETTLES WITH BAILS



Capacity	Price
No. 4..15 gals..	\$5.25
No. 5..20 gals..	6.00
No. 6..25 gals..	8.00
No. 7..30 gals..	10.00



FARMERS FAVORITE FEED COOKER AND AGRICULTURAL BOILER

Heating water for scalding hogs and poultry, Rendering Lard and Tallow, Boiling Sorghum, Heating Drinking Water for Stock.

No.	Capacity	Size	Boiler	Fire Box	Price
2	30 gal.	22x24x13 1/2	24 in.		\$21.00
3	40 gal.	22x30x14	30 in.		23.50
4	50 gal.	22x36x15	36 in.		26.00
6	100 gal.	22x60x17	60 in.		33.00

Top Plates with Holes for Kettles
 No. 2 Cooker. \$3.75 No. 4 Cooker. \$5.30
 No. 3 Cooker. 4.50 No. 6 Cooker. 8.15
 Grates and Linings
 For burning hard or soft coal or coke\$10.00

The MARTIN FARM DITCHER AND TERRACER

Model 20 Reversible Adjustable

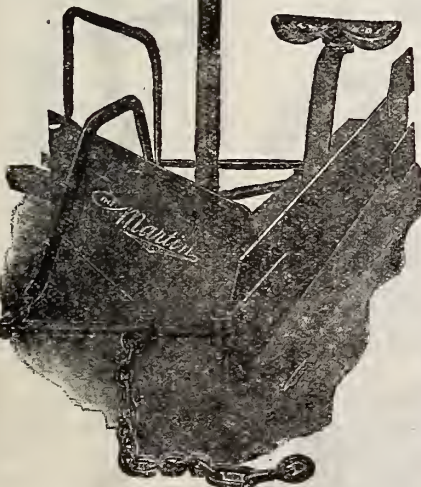

F. O. B. Factory
 Model 20—Standard Double Edge Cutting Blade, Steel Beam, reversible. No seat. 2 to 4-horse. \$75.00.
 Model 20-B—Like Model 20, but smaller; for 2 horses. Price without seat, \$70.00.
 Seats extra, \$3.50.
 Road Drag and Snow Blade for any model, extra, \$6.50.

STEEL HOG SCALDER AND COOKER

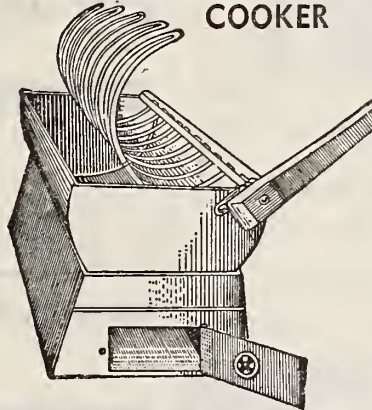

Plain Scalding does very well if placed over a ditch and fire built underneath, but most farmers prefer rack and fire-box complete. Shipping weight, 425 pounds.
 Plain Scalding, 6 ft. by 30 in. by 18 in. deep. Price, \$27.00.
 Fire-box with 5-inch pipe hole. Price, \$15.00.
 Dumping Rack with lever. Price, \$15.00.
 Scalding complete. Price, \$55.00.

CRYSTAL METAL FARM BELLS

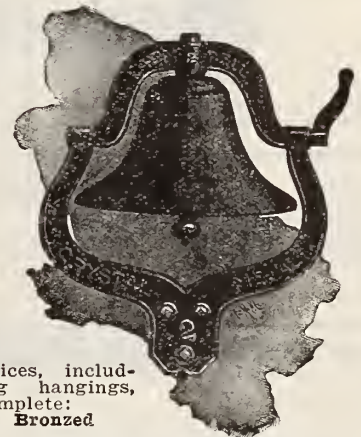

Prices, including hangings, complete:
Bronzed

Weight	Diameter of Bell	Price
No. Complete		
1. 40 lbs.	15 in.....	\$5.00
2. 50 lbs.	17 in.....	6.00
3. 75 lbs.	19 in.....	10.00
4. 100 lbs.	21 in.....	12.50

No. 4 Bell has a stand instead of yoke.

HUSKING PINS



No. 7-Y—With cot more open between the fingers. Grain leather25c
 No. 100-Y—Cold rolled steel, 4 1/2 inches, nickel-plated pin, with split leather shield and double compartment, adjustable finger strap.....15c
 No. 00X — Clark's "Hickory" Pin, 4 1/2 inches long, made of best cold rolled steel, with one compartment.....10c

IMPROVED KETTLE RANGE

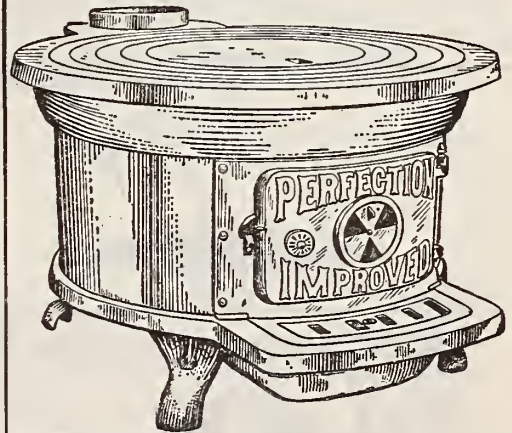

This Kettle Range is made to accommodate any kettle a farmer may happen to have. Any copper or iron kettle up to 40-gallon capacity can be used.

The largest opening, when all the rings are off, is 25 inches, and the smallest is 12 inches.

The outside of the firebox is made of heavy steel plates and lined inside with cast iron firebacks on all sides. The size of the firebox is 12 inches wide and 24 inches long and supplied with grate and ash pit, and has ash pan so that ashes can be removed without use of shovel.

Pipe opening for 6-inch pipe. Weight, 200 lbs. **Our Special Price, \$37.50.**

CHAMPION SPARK PLUGS



"C" Type
 Regular Blue Box Types—all sizes for all cars, except Ford75c.
 The New "C" type spark plugs made in three sizes, C-1, C-4, C-7, to service practically all passenger and commercial cars, 75c.
 Ford X Long 1/2 inch, price60c.
 Ford 3-X Long 7/8 inch75c.
 Send for special circular giving table showing what size to use on car.

Our Axes are of best quality. We only sell those we know to be first class, and have an established reputation.

Kelly, Single Bit—4, 4½ and 5½ lbs., each\$1.50

KELLY AXES



Kelly Axes, complete with handle, 4, 4½ and 5 lbs., price.....\$2.00

Kelly Half - Hatchets, price90c

CLAW HAMMERS

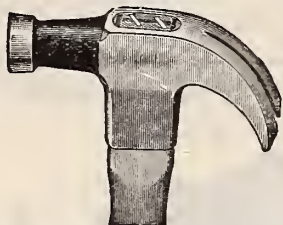

No. 5191½—Hand Made, each 55c.
No. 5171½—Falls City, each 65c.

AXE HANDLES

Oriole—Extra Selected Second Growth All White Hickory Axe Handles..... .40
Selected White Hickory Axe Handles..... .25

SNOW SCRAPERS



Snow Scraper Blades made of high carbon steel. Will wear a long time. Castings of best malleable iron fastened to blades and handle. Handles of ash, tough, strong and smoothed. All metal parts given a coat of black paint.

18-inch Kohler Scraper\$1.25
24-inch wide 2.00

PEAVIES



No. 9—2¾ inches by 5 feet, price.....\$5.00

ROCK ISLAND OVAL SLIDE VISE

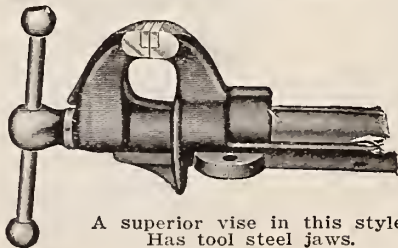

A superior vise in this style. Has tool steel jaws.

No.	Size	Opens	Weight	Price
361	2½ in.	3¾ in.	8 lbs.	\$3.10
362	3 in.	4 in.	14 lbs.	3.75
363	3½ in.	4½ in.	22 lbs.	4.60
364	4 in.	4½ in.	30 lbs.	7.25
365	5 in.	4½ in.	35 lbs.	10.00

ROCK ISLAND ANVIL VISE

No. 380—Width jaw 3 inches, opens 5 inches, weight 26 pounds. Price, \$4.00.

BELT PUNCHES

REVOLVING

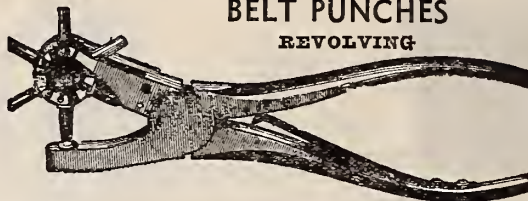

Price, each, Four tube 95c, Six tube \$1.15, Single tube 50c.

CAST MAULS WITH WOOD END AND WOOD HANDLE

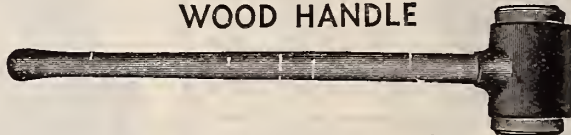

10 Pounds, Each.....\$1.90
12 Pounds, Each..... 2.10
16 Pounds, Each..... 2.70

TAMPERS FOR POST, SOD AND CEMENT

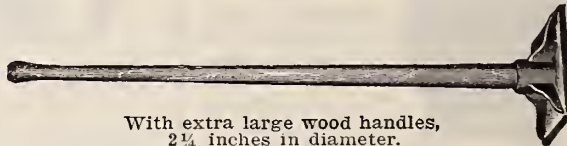

With extra large wood handles, 2¼ inches in diameter.

No. 2 Round Tamper, 5 in. Diameter, 15 lbs., Price.... \$1.60
No. 5 Square Tamper, 6 in. x 6 in., 12 lbs, Price..... 1.50
No. 6 Square Tamper, 8 in. x 8 in., 17 lbs., Price..... 1.80
No. 7 Square Tamper, 10 in. x 10 in., 20 lbs., Price..... 2.00

THE STANDARD EARTH AUGER



No. 5 bores holes 5, 6, 7 and 8 inches in diameter, 3½ feet deep. Each, \$6.00.
No. 8 bores seven holes, 8, 9, 10, 11, 12, 13 and 14 inches in diameter, 3½ feet deep. Each, \$7.00.

GIBBS' POST-HOLE DIGGER

Digs faster, works easier than any other on the market. All wearing parts have steel pins. Makes a hole of any desired diameter. First-class for tree-planting.

Price\$2.50.



TETHERING ANCHOR



Price, \$1.00

STRAP HINGES



	Light Pair	Heavy Pair
4-in.	.10	.12
6-in.	.16	.16
8-in.	.20	.27
10-in.	.40	.47
12-in.	.55	.72

SCREW HINGES



6 to 12 inches, per lb.	.10
14 to 20 inches, per lb.	.09½
22 to 36 inches, per lb.	.09

T-HINGES

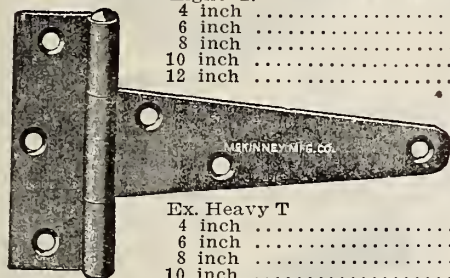

Light T.	Per Pair
4 inch	\$.10
6 inch	.15
8 inch	.20
10 inch	.32
12 inch	.45

Ex. Heavy T	Per Pair
4 inch	\$.16
6 inch	.20
8 inch	.35
10 inch	.50
12 inch	.78

HINGE HASPS

Each	
3-inch	.08
4-inch	.09
6-inch	.10
8-inch	.15



BELL BOTTOM JACK SCREWS

These Jack Screws have cast-iron stands with forged head screws. For workmanship and durability they cannot be excelled.

Diam Screw	Height Stand	Height over all	Our Special Price
1½ in.	12 in.	15 in.	\$4.00
1½ in.	14 in.	17 in.	4.50
1½ in.	16 in.	19 in.	5.10
2 in.	10 in.	14 in.	5.10
2 in.	12 in.	16 in.	5.65
2 in.	14 in.	18 in.	6.20
2 in.	16 in.	20 in.	7.00
2 in.	18 in.	22 in.	7.70
2 in.	20 in.	24 in.	

Capacity 1½-in. diameter screw, 10 tons.
Capacity 2-in. diameter screw, 12 tons.

Other sizes. Prices on Application.

IMPROVED SAMPSON JACK

MALLEABLE IRON.

Best Jack on the market. Can be used for any height axle. No breaking of cogs and standards.

No. 1—Will raise 2 tons.....	\$5.00
No. 2—Will raise 5 tons.....	6.25
No. 3—Will raise 5 tons, with drop hook.....	7.25

Can also furnish other Jacks. Prices on application.

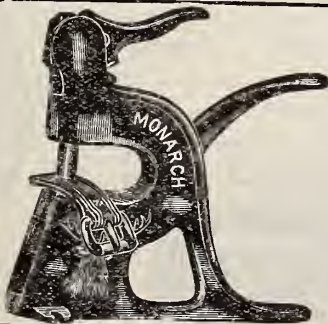

IDEAL RIVETING MACHINE

This is the best lowest-priced Riveting Machine made. Warranted to set Tubular Rivets perfectly.
Price85c.
Tubular Rivets—100...15c.

ICE HOOKS

No. 1 H 6—6-ft. Handle, Strapped Ferrule.....	\$1.25
No. 1 H 7—7-ft. Handle, Strapped Ferrule.....	1.50
No. 1 H 8—8-ft. Handle, Strapped Ferrule.....	2.00

WROUGHT SCREW AGRICULTURAL WRENCHES



6 in. 50c, 8 in. 60c, 10 in. 70c,
12 in. 85c, 15 in. \$1.00.

MACHINISTS' KNIFE HANDLE WRENCHES

6 in. \$1.00, 8 in. \$1.20, 10 in. \$1.40, 12 in. \$1.80, 15 in. \$2.55.



STILLSON WRENCHES



Size	Grips	Retail	Size	Grips	Retail
6 in.	½ pipe	\$0.75	18 in.	2 pipe	1.50
8 in.	¾ pipe	.85	24 in.	2½ pipe	2.25
10 in.	1 pipe	.90	36 in.	3½ pipe	5.00
14 in.	1½ pipe	1.10			

TWIN WRENCHES

Twin, 10 in. long, 75c. each.



COLD CHISEL

PUNCH



Retail price, each.....
½ in. \$0.20
¾ in. \$0.25

FILES

8-in. Mill Bastard.....	.20
10-in. Mill Bastard.....	.30
12-in. Mill Bastard.....	.40
8-in. Cross Cut.....	.40
10-in. Cross Cut.....	.50

SCREW DRIVERS

No. 903—4-in. Blade.....	.40
No. 904—6-in. Blade.....	.45
No. 905—9-in. Blade.....	.50

8-in. **BUTTON PLIERS**, per pair75c

SILVER & DEMING DRILLS



No. 112

Fitting Boynton & Plumer and Silver & Deming Blacksmith's Drill Presses, Nos. 1 and 2, with shanks ½-inch diameter.

Diam.	Length, in.	Pr. ea.	Diam.	Length, in.	Pr. ea.
1-3	6	\$0.35	1-2	6	\$0.76
3-16	6	.38	5-8	6	.89
1-4	6	.46	3-4	6	1.30
5-16	6	.53	7-8	6	1.60
3-8	6	.61	1	6	1.90
7-16	6	.69			

AUTOMOBILE JACKS

This Jack is made from best quality refined malleable iron, with high-grade Steel Screw, aluminum finish, and by single turn of the pawl raises or lowers. It is compact, neat and has sufficient strength to raise any automobile made.

No.	Capacity Pounds	Height Lowered Inches	Raises Inches	Wgt. Lbs.	Price Each
1...	2000	10	6	5	\$1.50
2...	5000	10	6	8	3.00

CROWBARS

Crowbars with Pinch Point, from 20 to 25 lbs., per lb., 10c.
Crowbars with Wedge Point, from 20 to 25 lbs., per lb., 10c.
Digging Bar with Rammer combined, each, \$2.50.
Digging Bar with Loop Handle, each, \$2.50.



WEDGES

Strong steel wedges for splitting wood, have the right taper and will stick in the wood.

Weight from three to six pounds.
Price, per pound.....12c.

HAMES

Virginia Cart Hames.....\$2.25
 Baltimore Strap Hames..... 2.25
 No. 1 Hame, Light..... 1.25

TUG CHAINS

Cart Tug Chains, 18-10-1, per pair..60c

REGULAR IRON TRACE CHAINS

Price
 7-8-2, pair\$0.80
 7-10-2, pair90
 7-12-2, pair 1.30

SPREADER CHAINS

Straight Link Slack Spreader Chain—
 11/32, our special price.....\$4.00
 13/32, our special price..... 5.00
 % Close Link Straight Spreader Chain
 for two horses, with three hooks each,
 our special price.....\$7.00

BUTT CHAINS

Retail
 3 ft.—8-2, per pair.....\$1.00
 3 ft.—10-2, per pair..... 1.10

LOG CHAINS

Long Link Log or Ox Chain, 5/16 in.,
 12 or 14 ft., retail price, lb.....15c
 Long Link Log or Ox Chain, 3/8 in.,
 12 or 14 ft., retail price, lb.....14c
 Long Link Log or Ox Chain, 1/2 in.,
 12 or 14 ft., retail price, lb.....13c

BREAST CHAINS

Single Slack
 27 in. 5/16 or 1/4 Taper Slack.....\$1.00
 27 in. 3/8 to 5/16 Taper Slack..... 1.25
 28 in. No. 10-2—Single Slack, pair.. 1.00
 28 in. Double Slack, pair..... 1.10

COW CHAINS

No. 3-0—Bulldog Cow Tie (Ohio pat.),
 each30
 4-040
 No. 3-0—4 1/2-ft. Halter, each..... .40
 6-ft.45
 No. 0—20-ft Chain, each..... .60
 No. 0—20-ft. Chain, each..... .70
 No. 000—20-ft. Chain, each..... .80
 No. 0—30-ft. Chain, each..... .80
 No. 00—30-ft. Chain, each..... 1.00
 No. 000—30-ft. Chain, each..... 1.10

LAP RINGS

Open Side Lap Links, polished—
 1/2x2 1/210
 3/8x315
 3/4x325

CHAIN REPAIR LINKS

Chain Repair Links, 1/4 or 10-2, doz.\$0.20
 9-32, or 10-1, doz..... .25

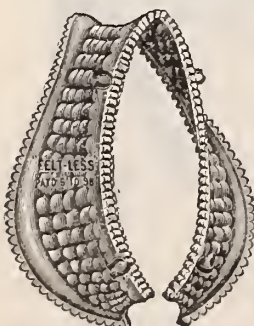

SWEAT PADS

Feltless
 Pinked, Felt
 Edges, Composite Filling,
 Four Hooks.
 Old Gold
 Drill; best on
 the market.
 18 to 20 in. 50c
 21 to 22 in. 55c
 23 to 24 in. 60c

FOLDED DUCK BACK BANDS

42 in., 44 in., 48 in.....\$1.00

WEB BACK BANDS

Less Hooks
 No. 1—3 1/2 in., 42 in. long.....\$0.40
 No. 1—4 in., 42 in. long..... .45
 No. 2—3 1/2 in., 42 in. long..... .35
 No. 2—4 in., 42 in. long..... .40

BACK BAND HOOKS

3 1/2 in.\$0.25
 4 in.30

HAME STRINGS—Black

5/8x42 in. slit, each.....\$0.20
 3/4x42 in. slit, each..... .25

Rawhide

5/8x42 in. slit, each.....\$0.20

HAME STRAPS

1 in. riveted.....\$0.25
 1 1/2 in. riveted and sewed..... .30
 1 1/4 in. riveted and sewed..... .35

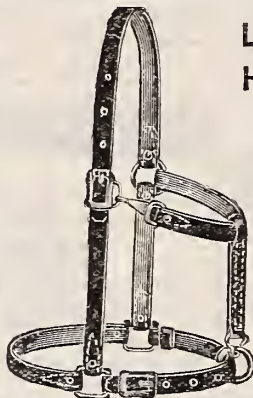

LEATHER HALTERS

No. 40—1 1/4 in.
 Hrg. leather,
 each ...\$2.00
 No. 21—1 1/4 in.
 double
 stitched,
 each ...\$2.25
 No. 90—7/8 in.
 Colt Halter,
 each ...\$1.75

COW HALTERS

Price, each\$2.00
 Calf Halters, each..... 1.50

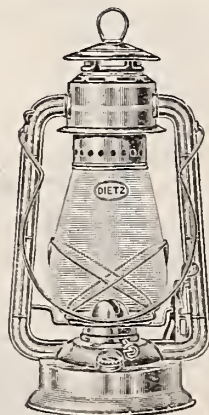

DIETZ LANTERNS

No. 2 Dietz Bliz-
 zard, price \$1.40
 Junior Wagon
 Lantern,
 price\$1.90
 Eureka Driving
 Lantern,
 price\$2.00
 No. 0 Victor,
 price90c

DANDY BRUSHES

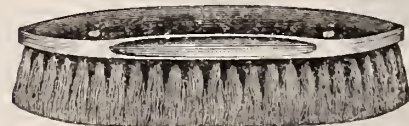

Price
 No. 985—Oval Brush, each.....\$0.60
 No. 940—Palmetto Dandy, each.... .45
 No. 950—Palmetto Dandy, each.... .50
 Leather Back Bristle Army Brush,
 each 1.00

HORSE COLLARS



Prices on Application

CURRY COMBS

No. 167—All steel, closed back, 6 bars,
 our special price,
 each25c



No. 083—Open Back
 Curry Comb, our
 special price,
 each20c

No. 167

All-Steel Closed Back

No. 800



No. 800—All steel, closed back, lac-
 quered, extra size, oval face, curved
 knockers, braced shank, extending
 through handle and riveted, enameled
 handle, brass ferrule, 8 bars, our special
 price, each.....30c

AMERICAN MANTLES



Price, per dozen.....\$1.00

READY-LITE GENERATORS

Generators with Automatic Cleaner,
 each50c



Fertilizer for the Farm, Lawn and Garden

All Plant Life Must Have Food

Like human beings they require a balanced diet for normal, healthy growth. Vigoro, the complete, scientifically prepared plant food, contains all the nourishment necessary to produce thick, velvety-green lawns; large, richly colored flowers; early delicious vegetables; and healthy, full-foliated trees.

Vigoro is clean, odorless, and easy to use. It's economical too. Full directions in every bag.

HOW MUCH VIGORO TO USE
 30 ft. x 125 ft. needs 75 lbs.
 50 ft. x 125 ft. needs 150 lbs.
 75 ft. x 150 ft. needs 250 lbs.
 100 ft. x 150 ft. needs 350 lbs.
 150 ft. x 150 ft. needs 675 lbs.

Prices

100-lb. bag --- \$5.00
 50-lb. bag --- 3.00
 25-lb. bag --- 1.75
 5-lb. pkg. --- .50
 12-oz. pkg. --- .10

Prices are f. o. b.
 Baltimore.

VIGORO

Complete plant food

A product of
 Swift & Company



For Lawns, Gardens, Flowers, Shrubbry and Trees

Ammoniated Alkaline Plant Food

Our old stand-by for summer crops; is used largely on Potatoes, Corn, Tobacco and other summer crops; stands the hot, dry weather particularly well.

5-pound Packages --- \$.25
 10-pound Packages --- .40
 50-pound Packages --- 1.25
 100-pound Packages --- 2.00
 167-pound Bag --- 2.50

Write for Special Prices in Ton Lots

Ammoniated Butchers' Bone Brand Phosphate

Is made largely from slaughter-house stock; used principally for wheat and Grass, as well as by growers of Corn and Tomatoes for canning purposes. A good article at a low price.

Price Per Bag, \$2.75

Dried Blood

Dried Blood is a quick-acting fertilizer. Running high in Nitrogen or Ammonia. Fine for greenhouse, potted plants and garden use.

5-Lb. Packages --- \$.60
 10-Lb. Packages --- 1.00
 25-Lb. Packages --- 1.75
 50-Lb. Packages --- 3.00
 100-Lb. Packages --- 5.00

Special Truck Mixture—A high grade complete fertilizer for Vegetables and Flowers, per 1 67 lb. bag --- \$3.50

Special Potato Fertilizer

Made especially for potatoes, running high in Potash and containing Ammonia and Available Phosphoric Acid in proper proportion for good results on this crop.

Price per 167-lb. Bag, \$2.75

Write for Special Prices in Ton Lots

Tomato Grower Fertilizer

167-Lb Bags, \$2.75

Write for Special Prices in Ton Lots

Land Plaster

In Bags, 200-Lbs. Each
 Per Bag, \$2.50

Fine-Ground Fish Ground Tankage

High-Grade Acid

Phosphate

Kainit, Muriate of Potash

Nitrate Soda

Soft Ground Bone

Made from softer material than the regular "Ground Bone," and contains some little meat and blood. The great objection to the use of Pure Bone (the price) no longer prevents its use by anyone wanting to restore worn-out land. Try it and be convinced!

PRICES:

5-pound Packages --- \$.30
 10-pound Packages --- .50
 50-pound Packages --- 1.75
 100-pound Bag --- 3.00
 167-pound Bag --- 4.75

Write for Special Prices in Ton Lots

Bone Meal (Pure Bone)

Splendid article for building up worn-out soil, lawns, etc.

5 lbs., 35c; 10 lbs., 60c; 25 lbs., \$1.25; 100 lbs., \$3.25; 167 lbs., \$5.00.

Nitrate of Soda

5-pound Packages --- \$.35
 10-pound Packages --- .60
 100-pound Bag --- 3.50

SULPHATE of AMMONIA

5 pounds --- \$.35
 10 pounds --- .60
 25 pounds --- 1.00
 50 pounds --- 2.00
 100 pounds --- 3.50

Write for prices in quantity.
 Good for Lawns, Golf Courses, Truck Gardens, Fruit Trees and Shrubbry.
 Feeds the Grass and starves the Weeds.

Hydrated Lime For Improving the Soil

Hydrated Lime is a soil sweetener and is free from injurious qualities. It is cheaper than any other lime product which can claim to be at all competitive, and is more easily handled.

There has been an enormous increase in its use in recent years, keeping pace with the growing of clover and alfalfa.

Hydrated Lime, while an indirect plant food, is as essential to the maximum production of some crops as is direct plant food.

In addition to producing chemical changes, Hydrated Lime also has mechanical effects, making clay soils more friable and more open to both air and water, and so less susceptible to extreme dry and wet weather. In sandy soil the action is practically reverse; Lime in such soil has a cementing tendency and helps the soil to retain moisture.

We recommend the free use of Hydrated Lime on lawns.

Per Bag of 50 Pounds, 75c

Write for prices in larger lots. Special inducements offered for car lots.

ADCO

converts garden refuse, such as leaves, stalks, cuttings, potato, bean and pea vines, etc., into **ARTIFICIAL MANURE**

ADCO is a powder which, when mixed with almost any non-woody vegetable waste, straw, leaves, weeds, and kept moist, gradually converts the mass into real manure fully equal to the farmyard product in fertilizing power, but free from foul odor, flies, weed-seeds, etc. The process is perfectly simple and not at all laborious.

FARMERS, by utilizing straw, corn stalks, etc., can secure their manure without the expense and labor of maintaining livestock.

GARDEN REFUSE

The refuse should be arranged in layers, each layer being thoroughly saturated with water and then sprinkled with ADCO in the proportion of one lb. to 25 lbs. of refuse.

Nothing further is required beyond keeping the heap moist or wet and perhaps turning it over once or twice to allow air to have access to the fermenting mass. In from three to six months it will become converted into real manure of excellent quality.

Fifty pounds of ADCO makes a ton of manure.

ADCO, in 150-lb. bags

(Enough for a heap 10 feet by 10 feet by six feet, making about three tons of manure) \$10.50

ADCO, 25-lb. bags

(Enough for 12 wheelbarrow loads of garden waste, making one-half ton of manure) \$2.00 Bag

PULVERIZED SHEEP MANURE HAS NO RIVAL

Remember that Pulverized Sheep Manure is aged for several years and will not burn your plants, no matter in what quantities you use it—but as it is highly concentrated, a little goes a long way. Used for top dressing, mulching, etc.

Valuable in a run-down city garden, as it adds humus and vegetable matter which are essential for all vegetation. It may also be used at the rate of 20 to 50 pounds to every 1000 square feet in a dry form, or 500 to 1000 pounds per acre.

Makes the richest and safest liquid manure, using 1 lb. to 5 gal. of water once a week. For Greenhouse Plants mix one part to about 10 parts of soil.

5 lbs., 30c; 10 lbs., 50c; 25 lbs., \$1.00; 50 lbs., \$1.75; 100 lbs., \$2.75.

Special price in one-half ton, tons and carload.

	Page
No. 1 Burpees Stringless Green Pod Beans	2
No. 2 Stowell's Evergreen Corn	8
No. 3 Marglobe Tomato	19
No. 4 Copenhagen Market Cabbage	5
No. 5 Chantenay Carrot	6
No. 6 Ford Hook Bush Lima Beans	2
Assortment including one pkt. of each of above	50c

Also:—	
Wax Stringless Beans	1
Pole Lima Beans	3
Beets	3
Broccoli	4
Brussels Sprouts	4
Celery	7
Cucumber	9
Kale	10
Lettuce	10
Watermelon	12
Cantaloupe	13
Onions	14
Parsley	15
Parsnip	15
Peas	16
Radishes	17
Spinach	18
Turnip	21
Potatoes	21

And many others.



GRIFFITH & TURNER CO.
BALTIMORE, MD.