

波  
鬼  
板

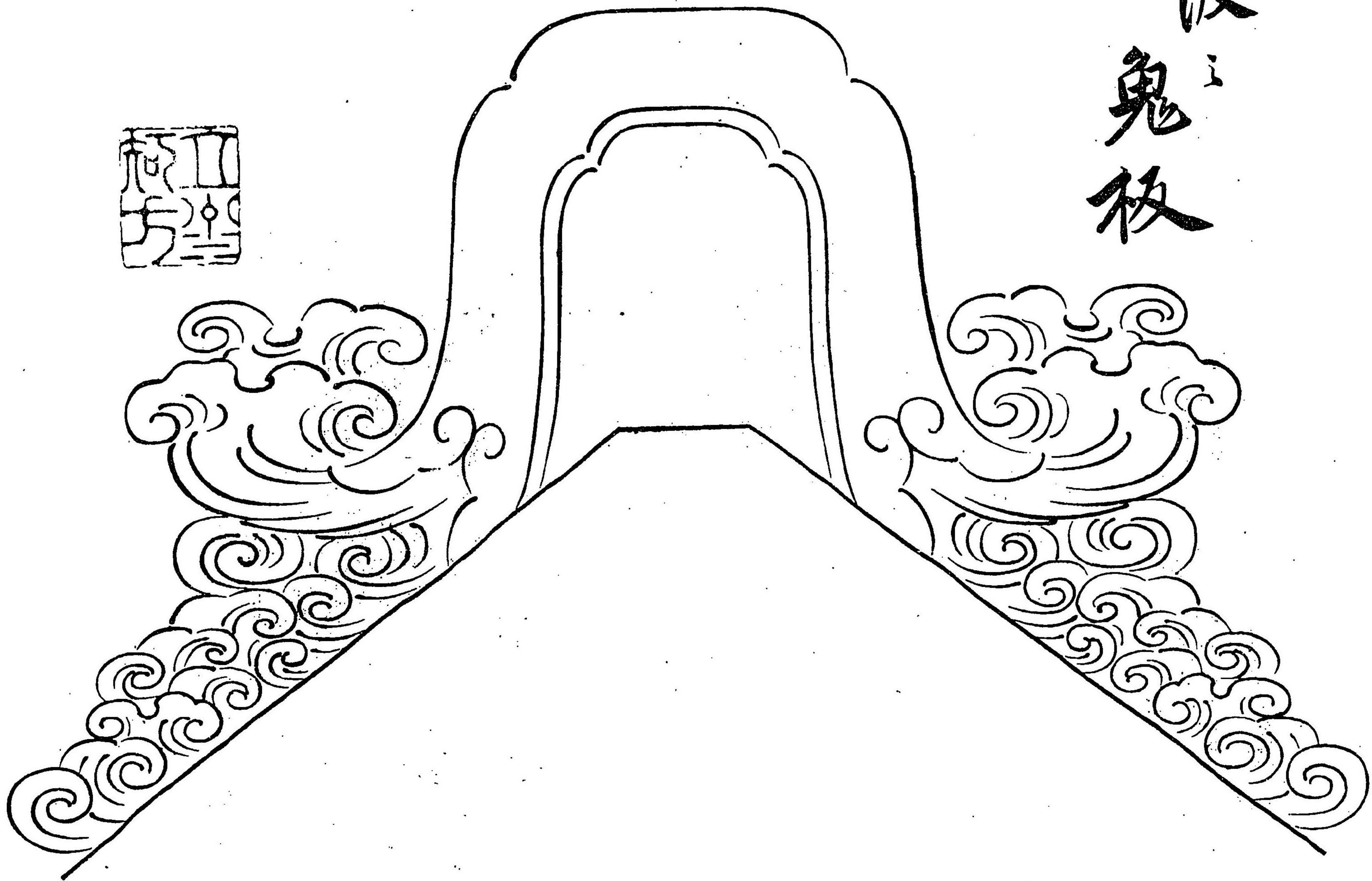

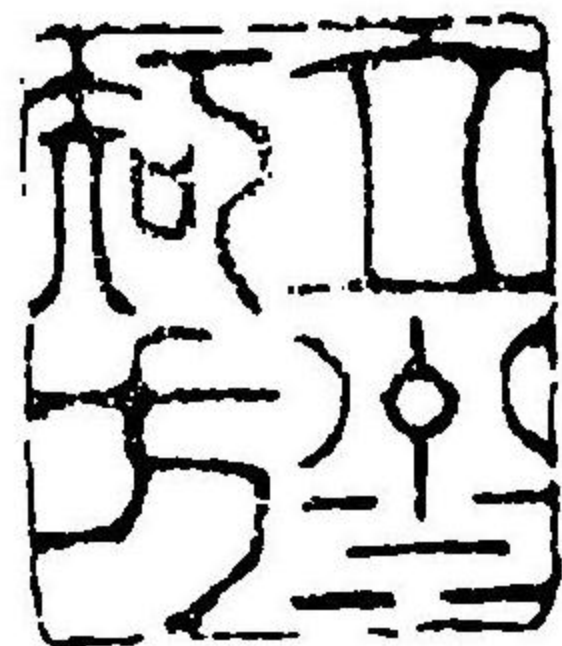

木鼻



鳥甲鼻

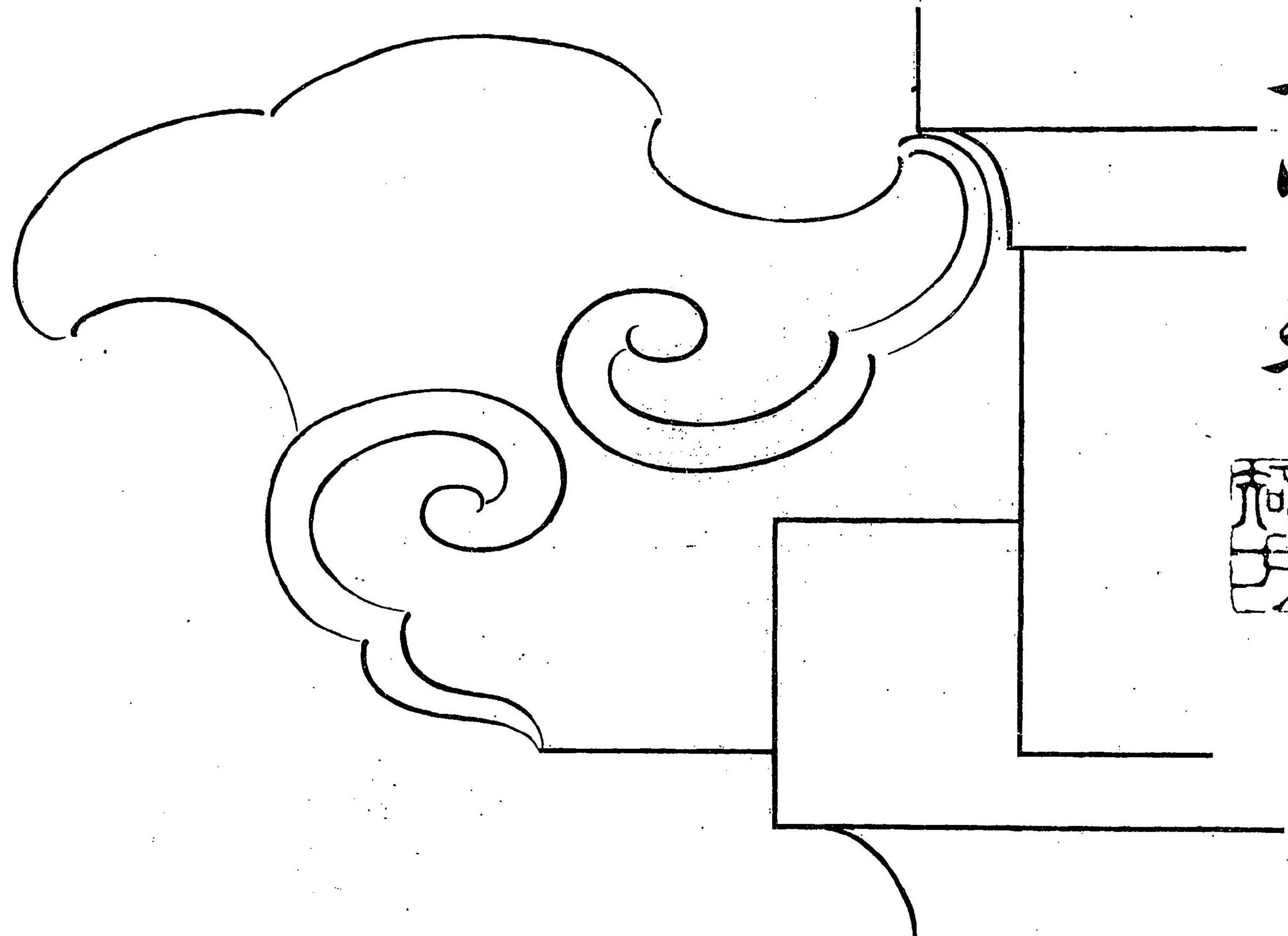
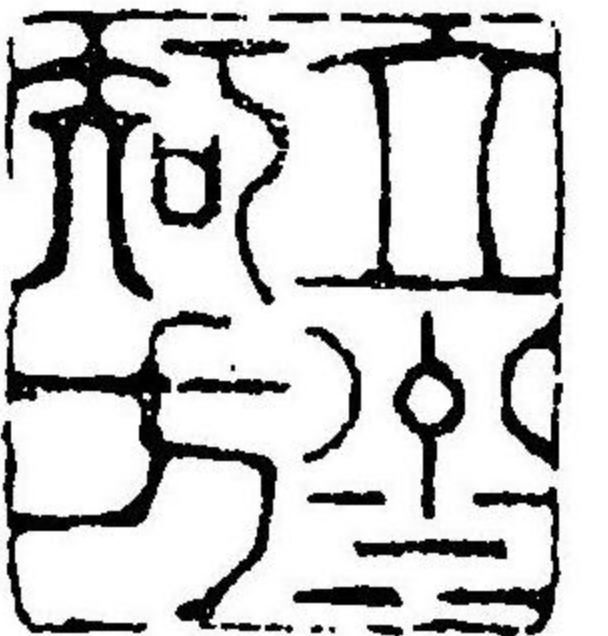

唐破  
鬼板  
風

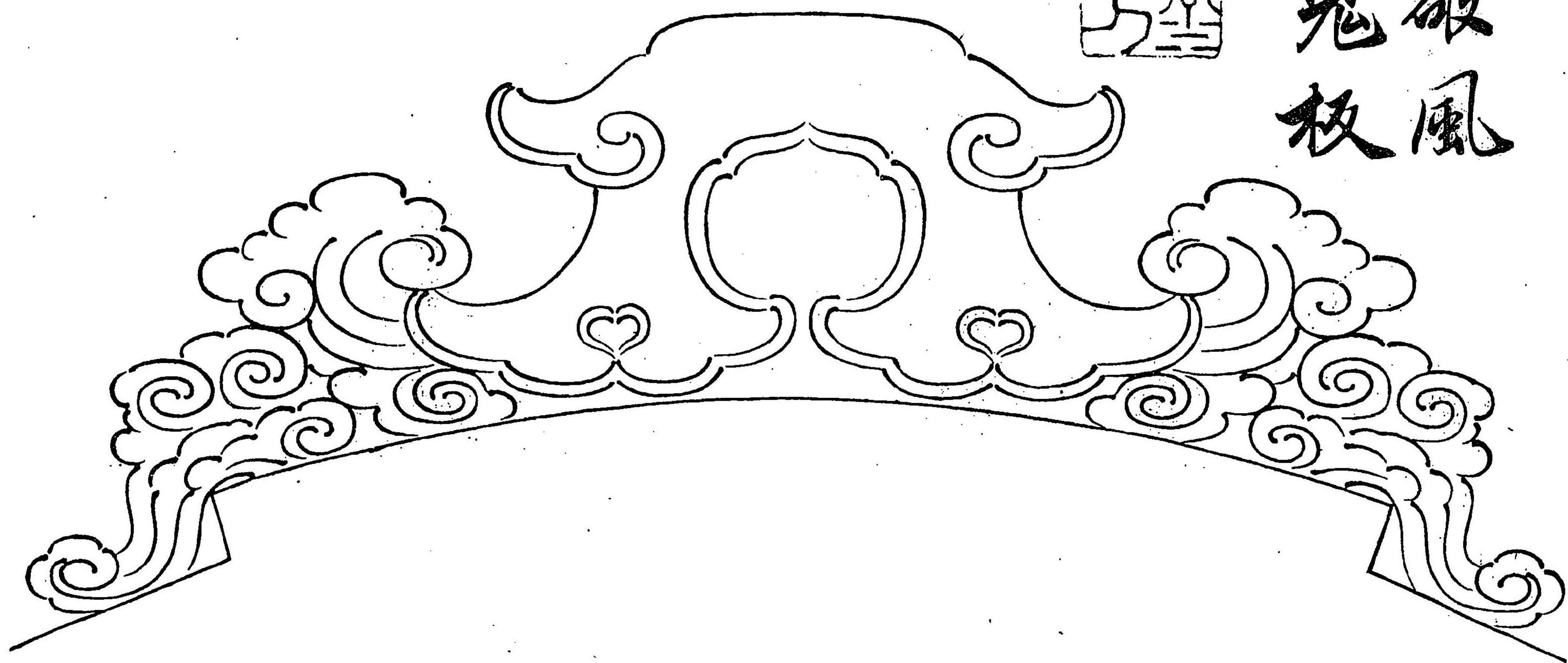
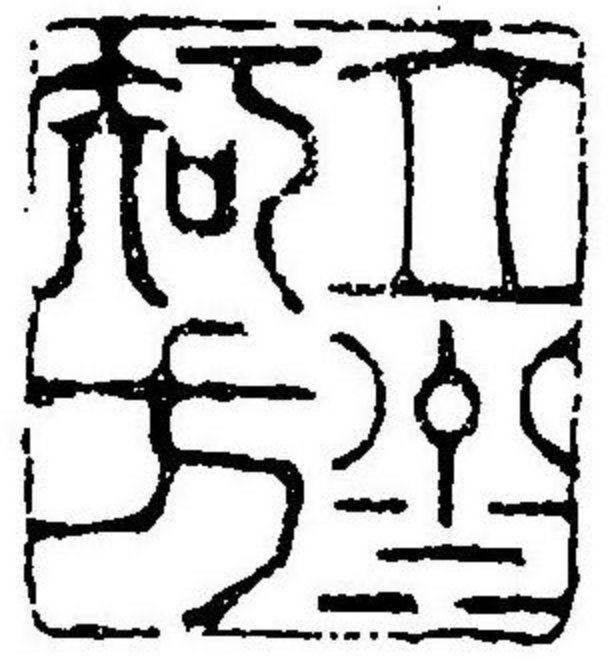



透棚筆返し割

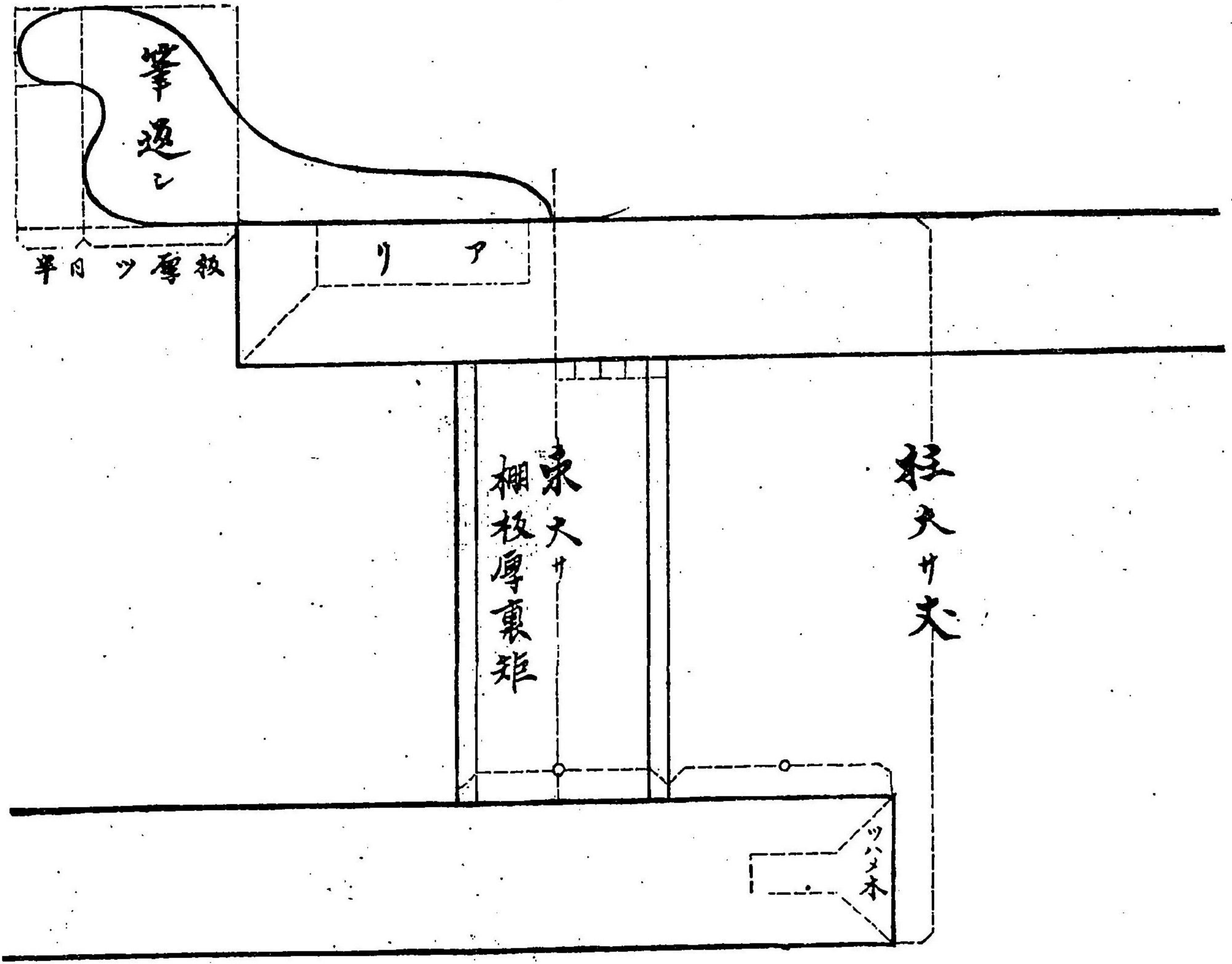
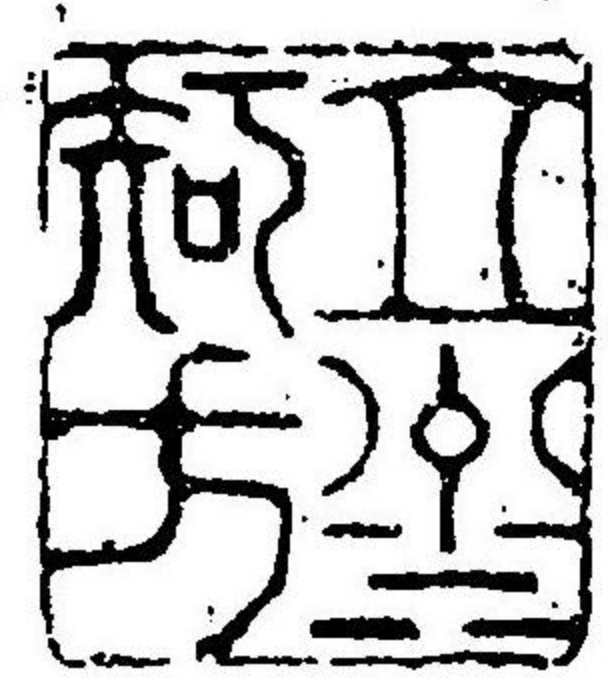

鬼板  
裏

箱棟

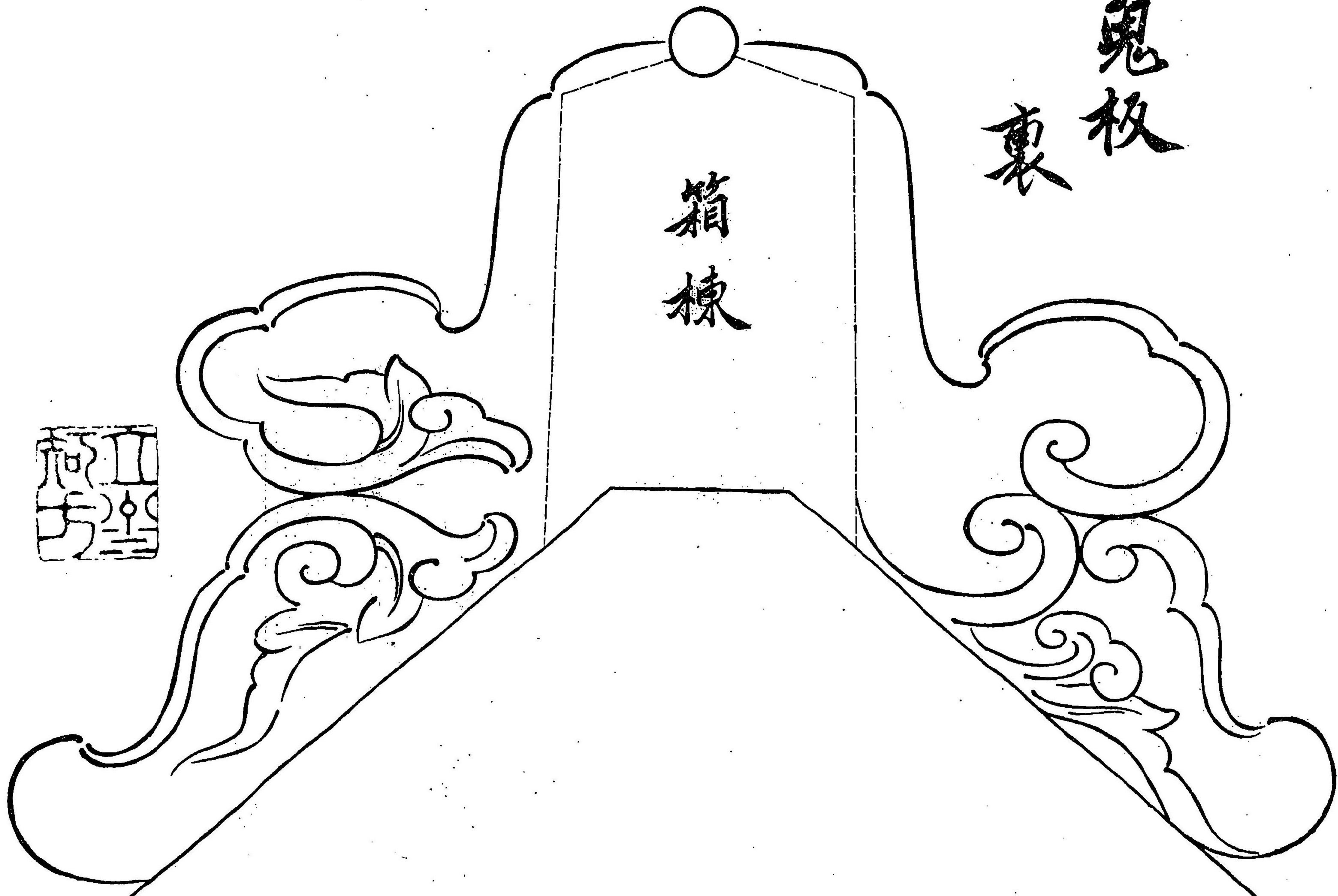
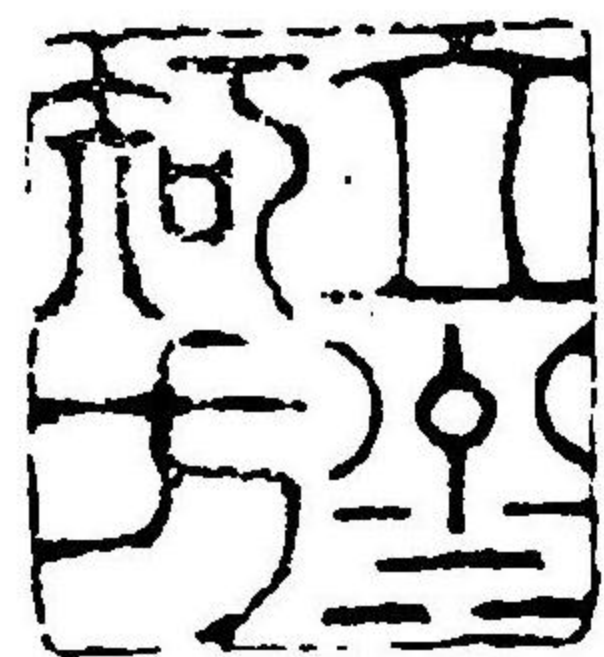



腕木鼻

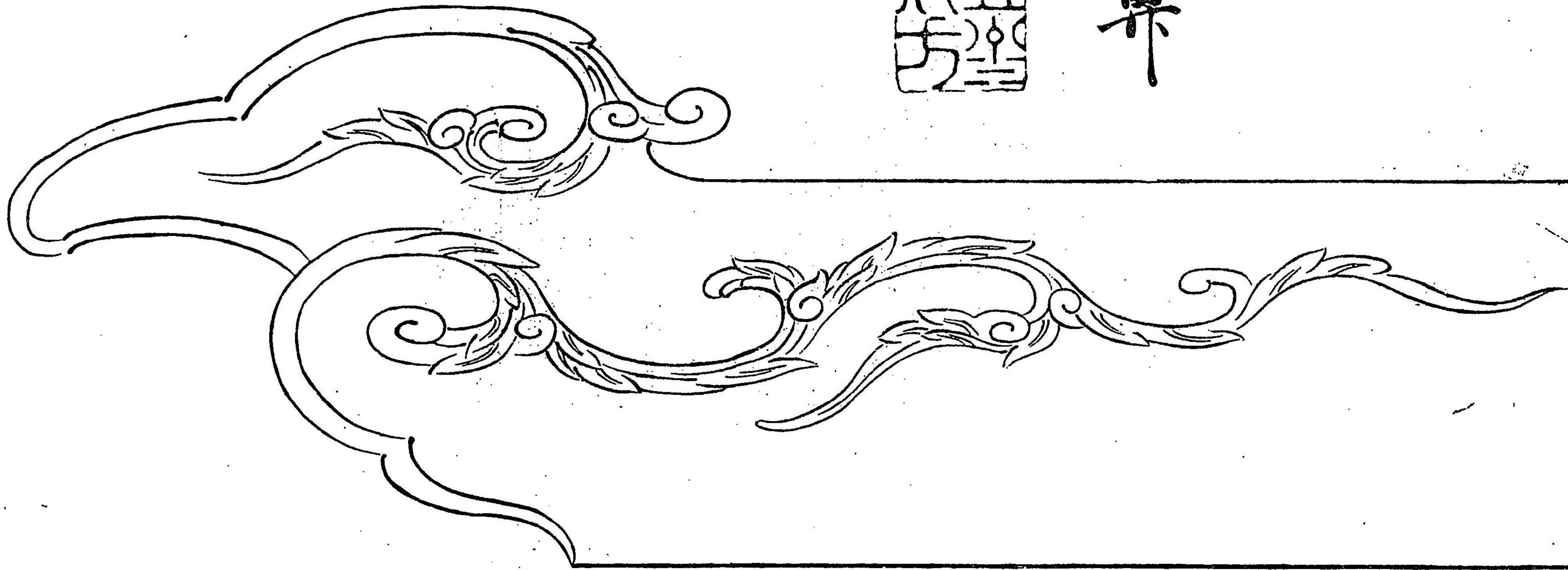

腕木鼻

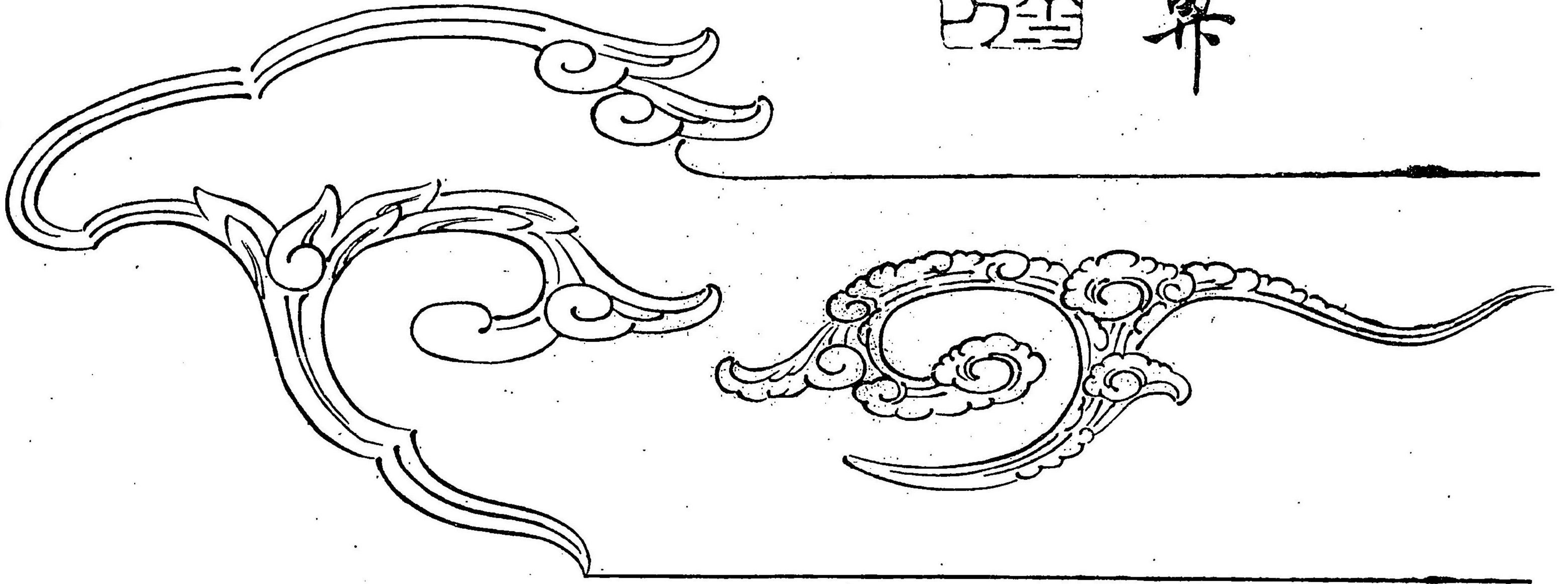
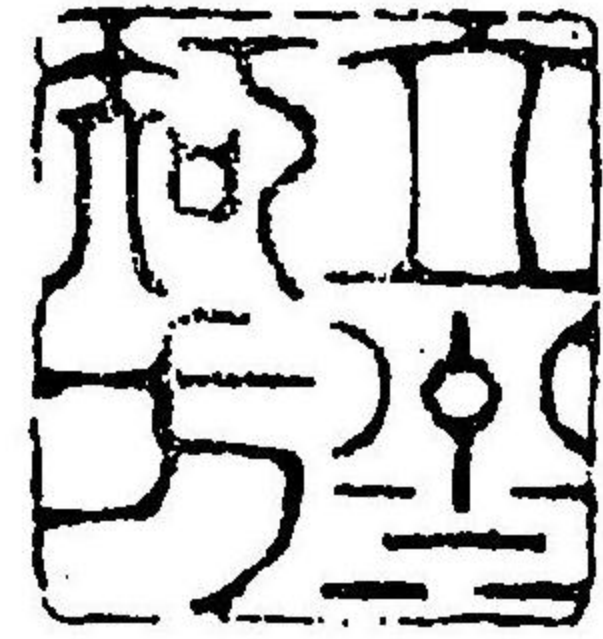



懷破

夙

懸矣

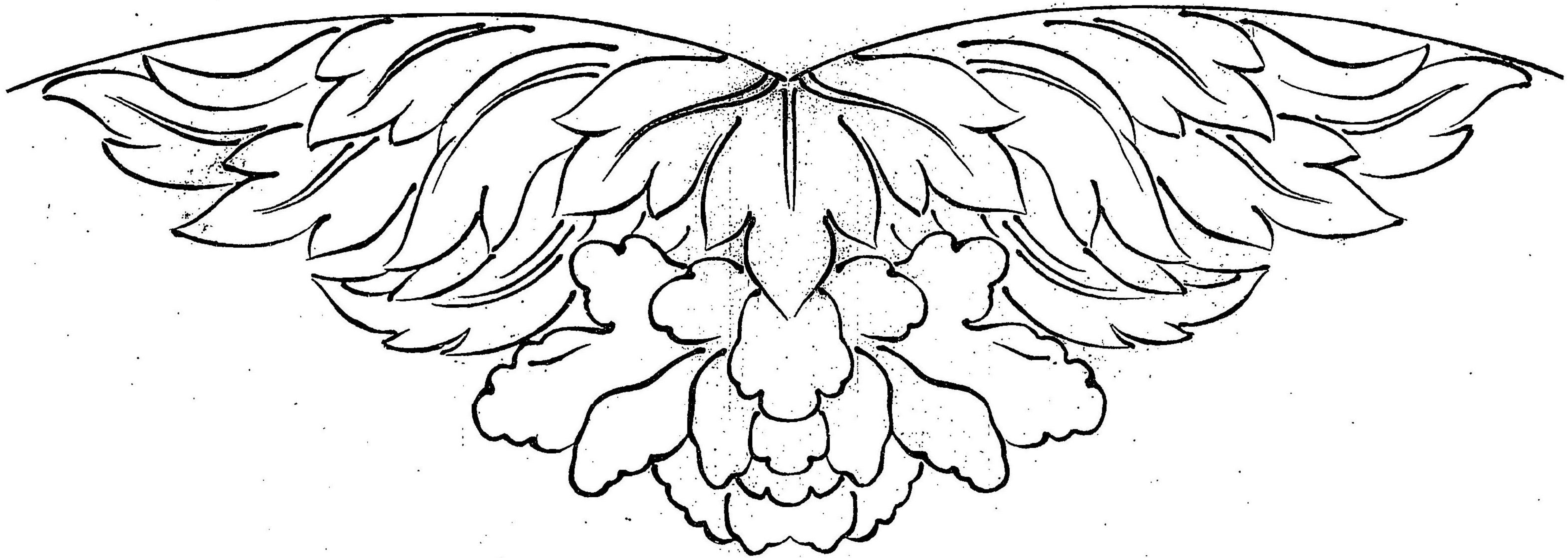
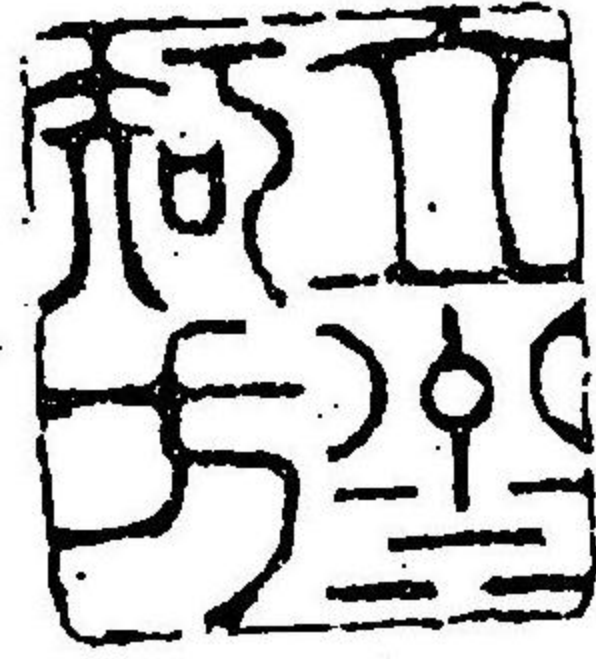

腕木鼻

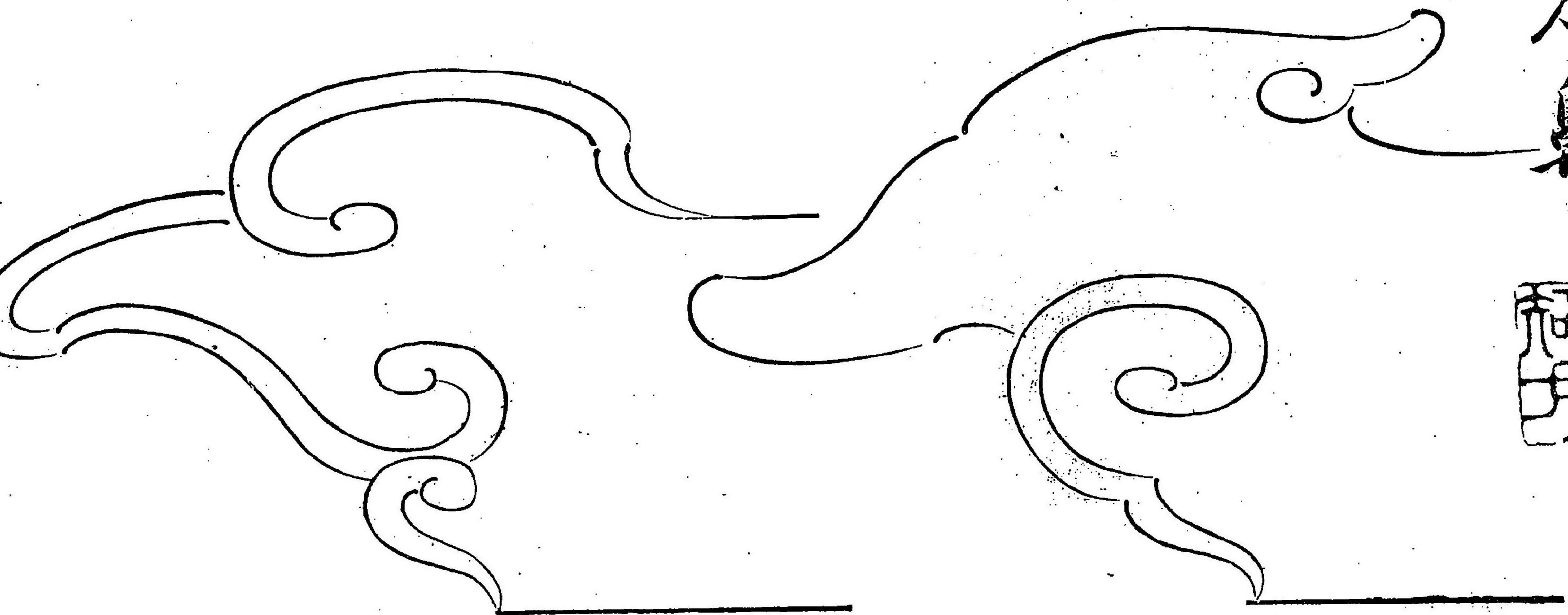
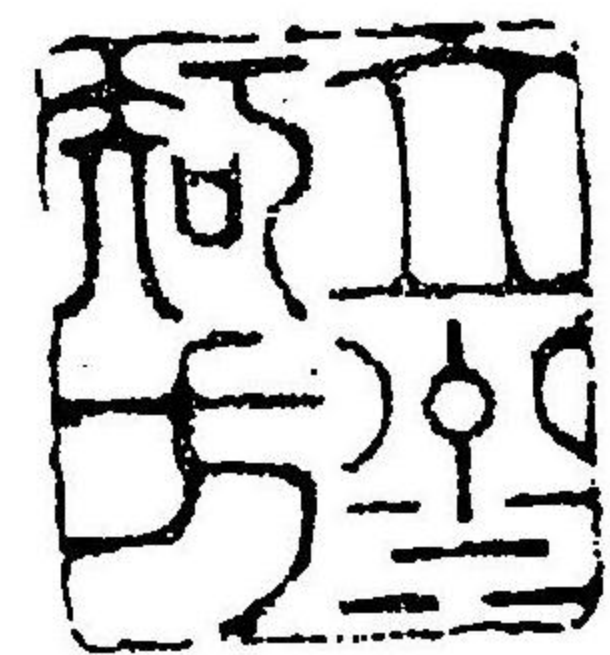



惠振板

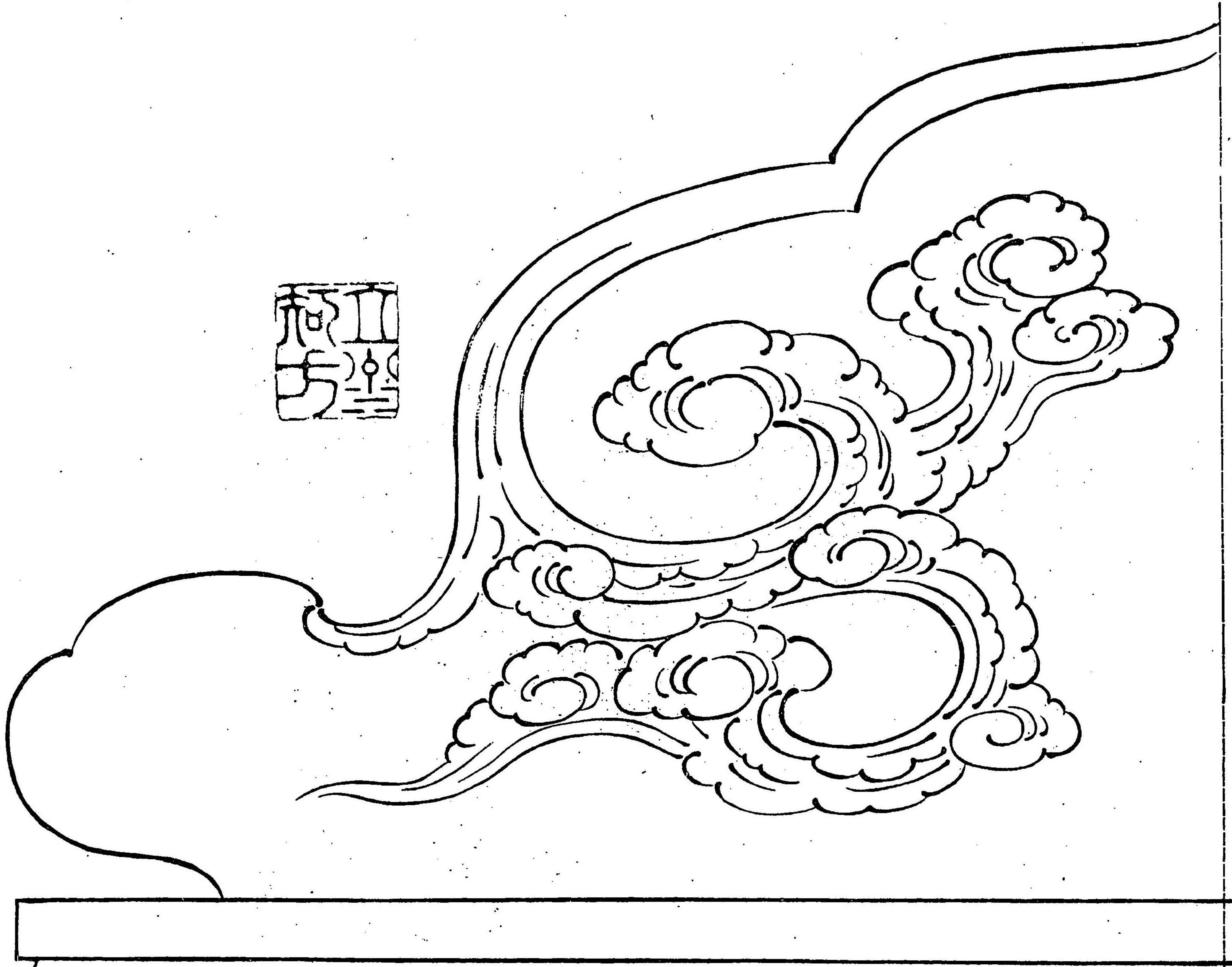

掛  
鼻

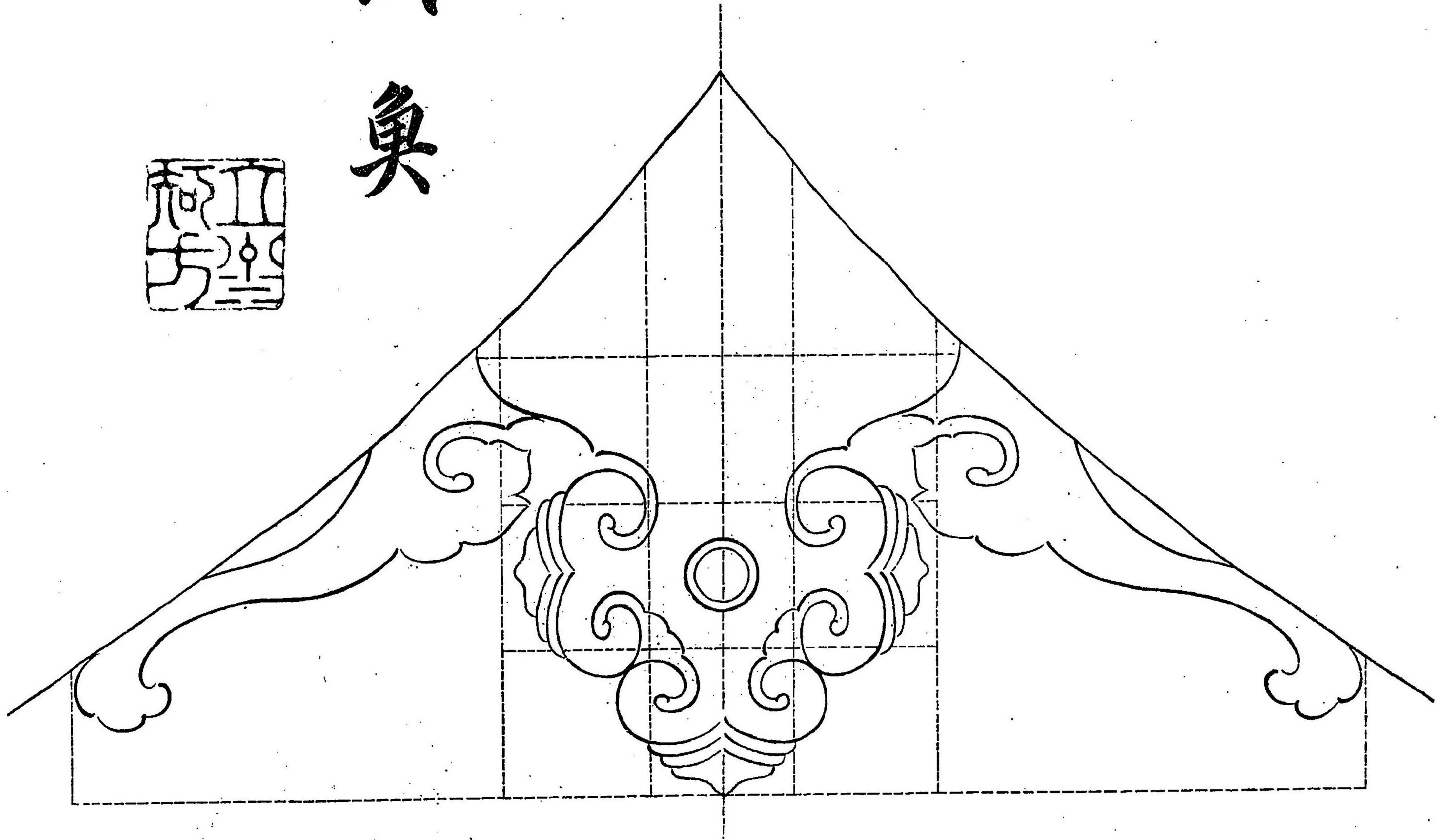
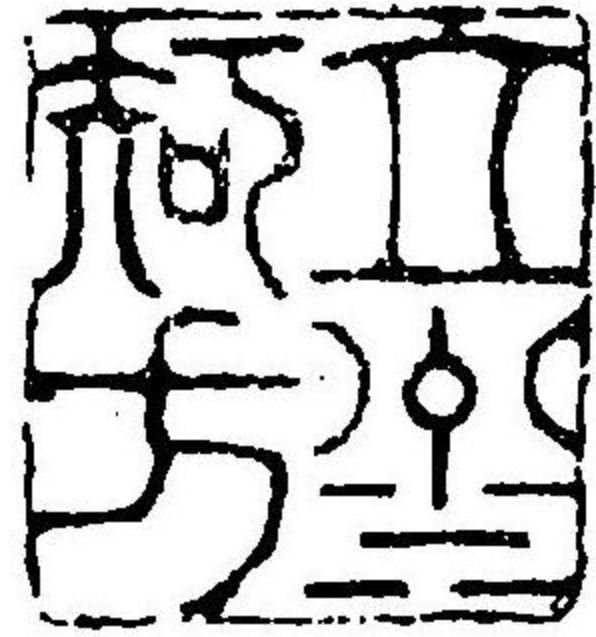



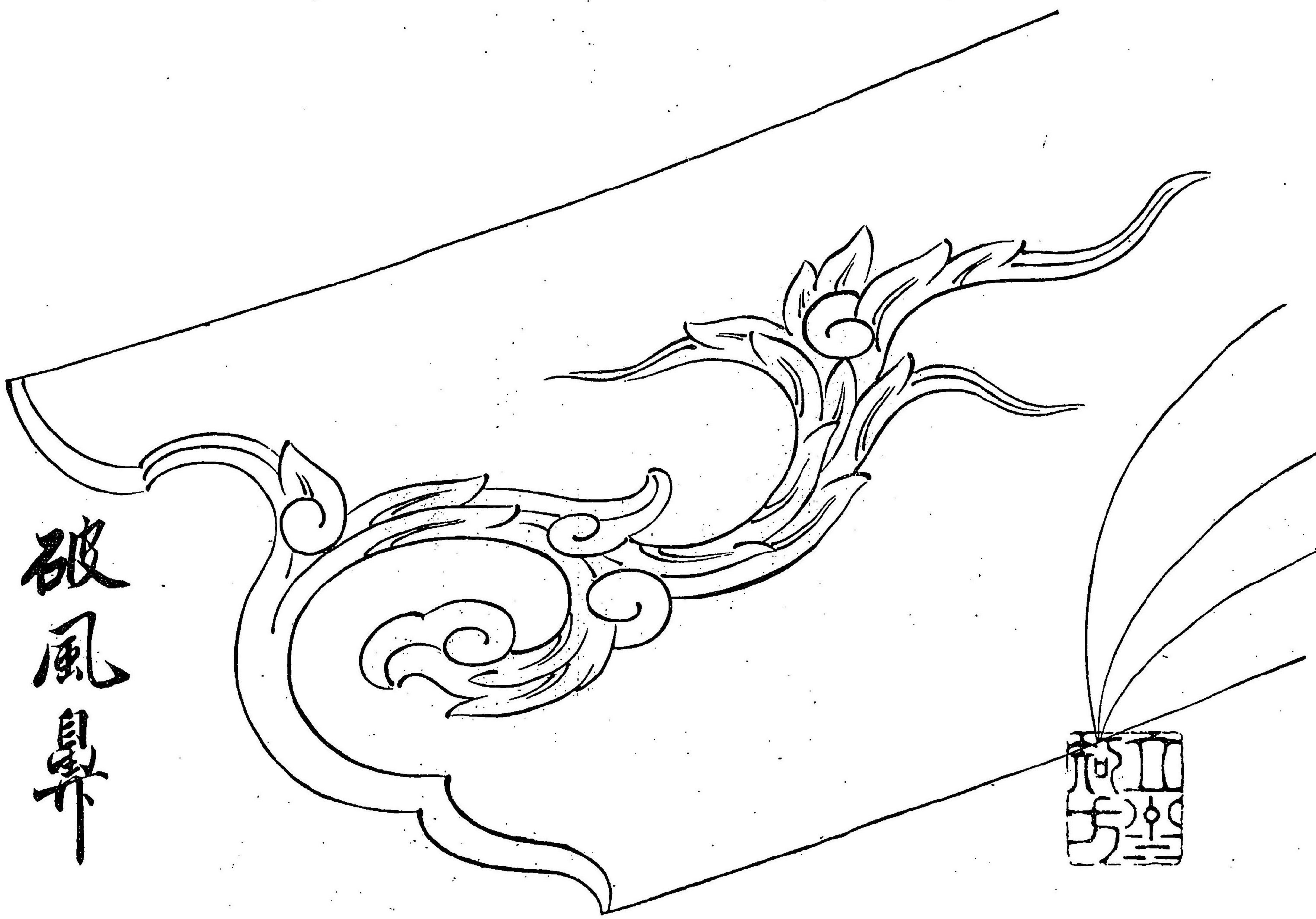

破  
風  
鼻

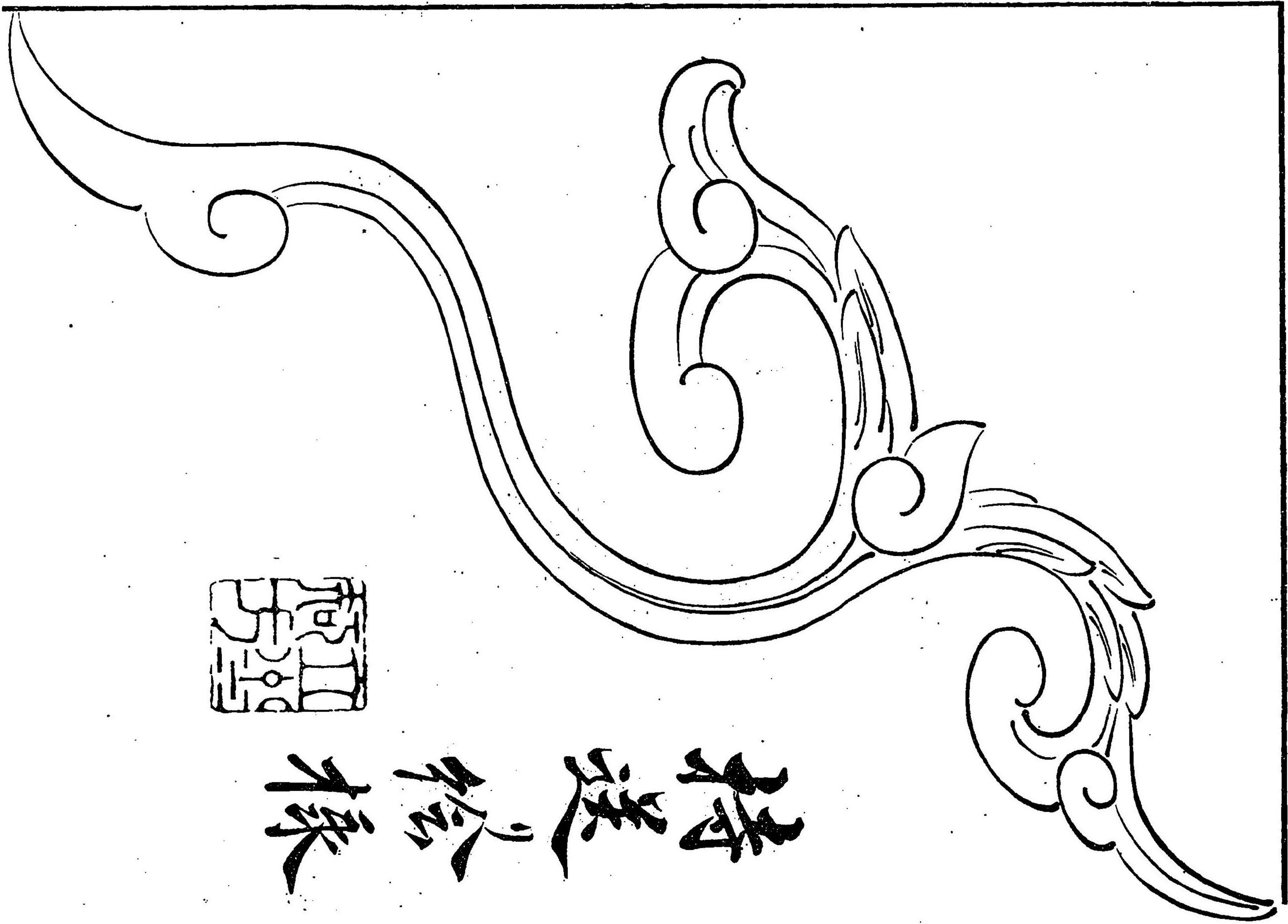

待送繪棟

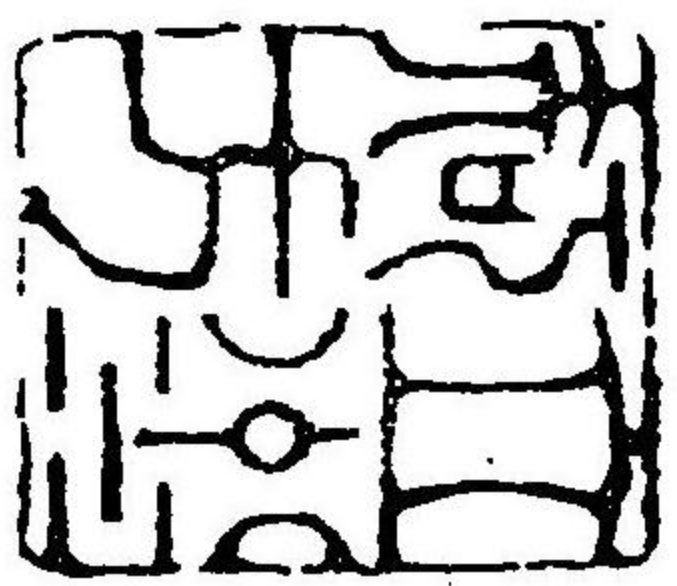



明治二十八年八月五日印刷

明治二十八年八月五日發行

定價金六十五錢

東京市京橋區瀧山町拾壹番地

編纂者 故立川知方

全市全町全番地

發行兼印刷者 立川通雄

全市全町拾壹番地

印刷所 開工舍









立川流匠家雜術

倭繪樣集

第十號



けしき

古く曰く良匠は規矩を離るるに能はずと宜る。我凡そ物あれば  
 には必ず則ち規矩の常として斯道に於ては殊に然りと故を  
 以てて古くは本邦建築の業頗る進歩の域に達せし者かとも  
 せども多くは家傳秘法を稱へ廣く人に傳へずる許さずる間種  
 の著書も亦これに非ざると雖も其載する所雜駁疎笨にして唯其梗  
 概を述ぐるに過ぎずしかる中子弟の模範ありて完ん後其力  
 を弊し日子を費すもの多し。て中際一便かると其甚だ稀か  
 りは最可惜き限にして我曾祖立川小兵衛密曆の昔に在り  
 工匠の技に精巧な所謂立川流を以て稱せし者も其傳へ  
 ざる者も亦多し。八世の久しき及び猶隆盛を極む古來我邦と  
 雖も亦石造等の建築之をきり流りし一朝先頃の如き震災  
 に遭ひて不幸の極か其毀壞亦將に測れずんとは故を以て  
 合せる。職由り故に祖父知方後其の著書多くは簡略に  
 笑し且其形極小之が應用を計るを頗る難き業と成  
 憾も移年種々の繪様を上梓せんを欲し終り果せず  
 て歿すや度予其意を承け大奉書者及美濃紙、廓  
 大して方圓曲直等墨繩を加順次出版せよ要は直之  
 を中地り用ひしむを得りし存し庶幾は斯業を  
 承る人此須臾の闕く可らざるを鑑むるに於て蓋  
 し餘節ありん









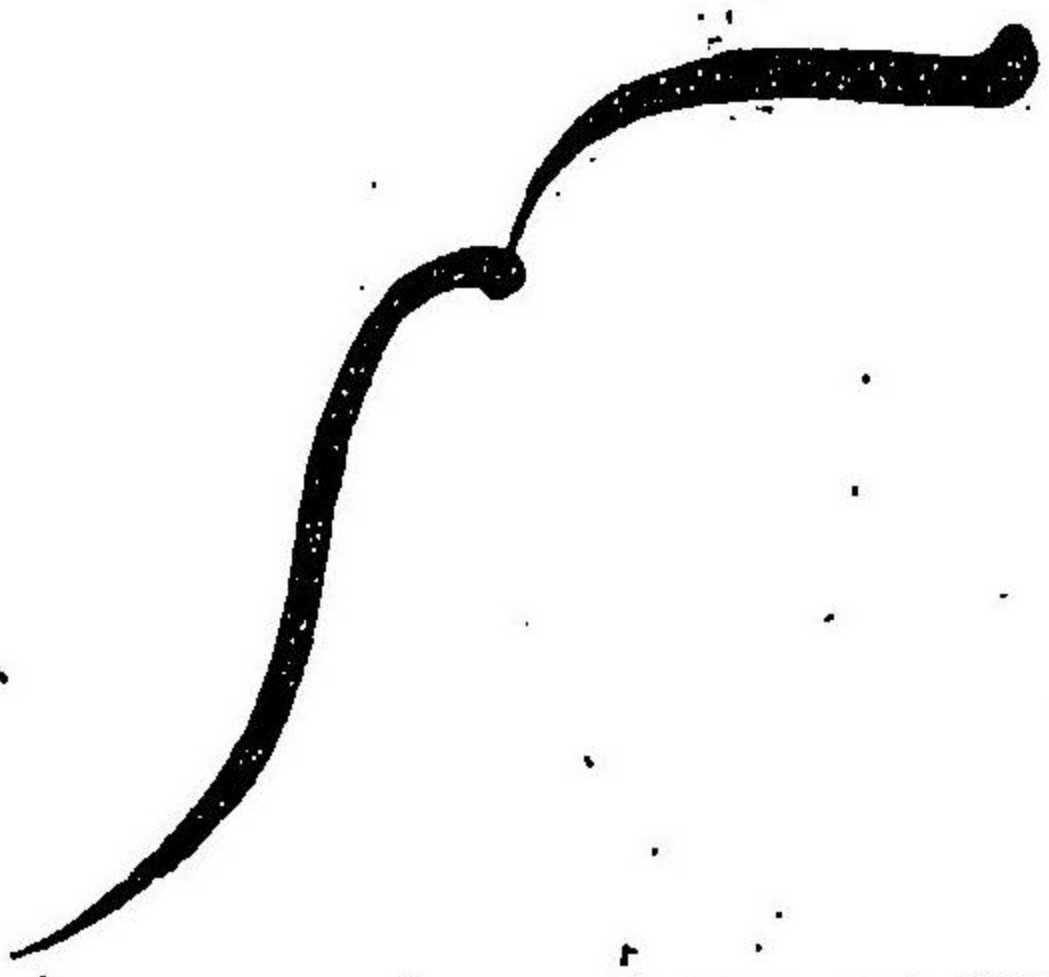

甲午小暑号

立川通雄談



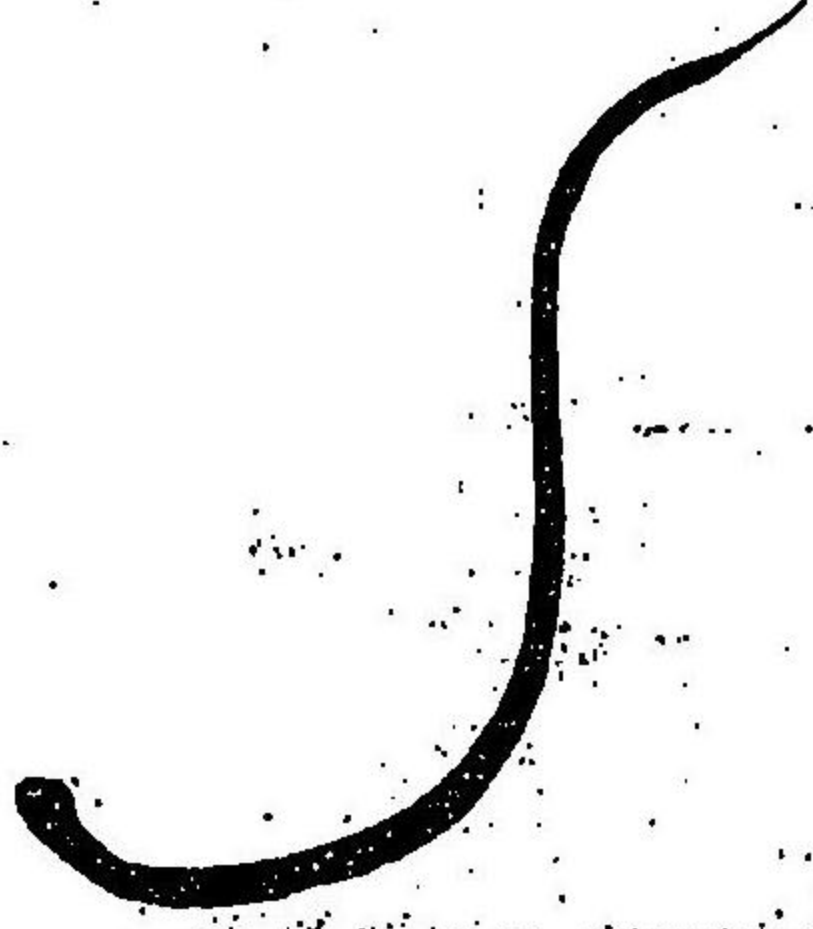
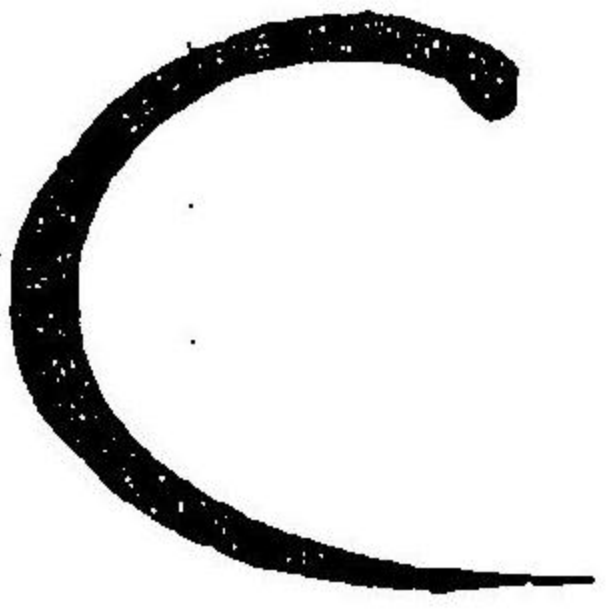
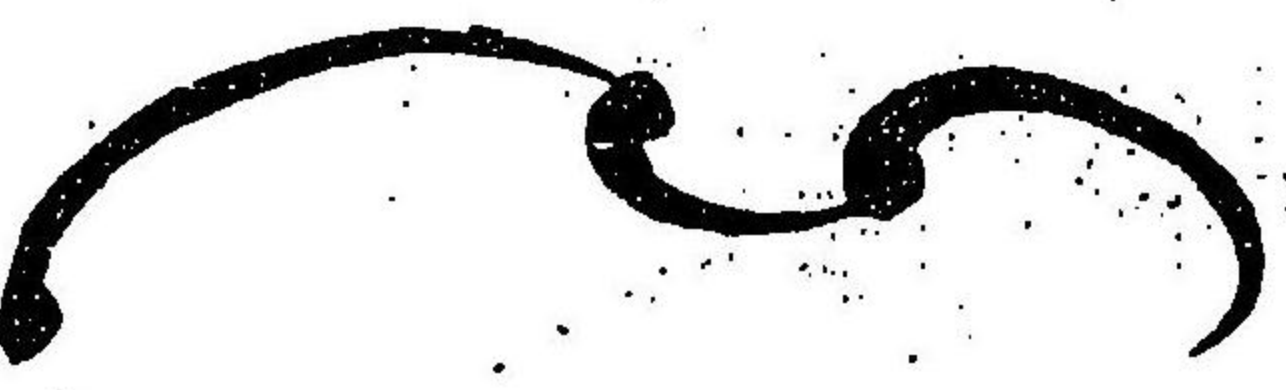

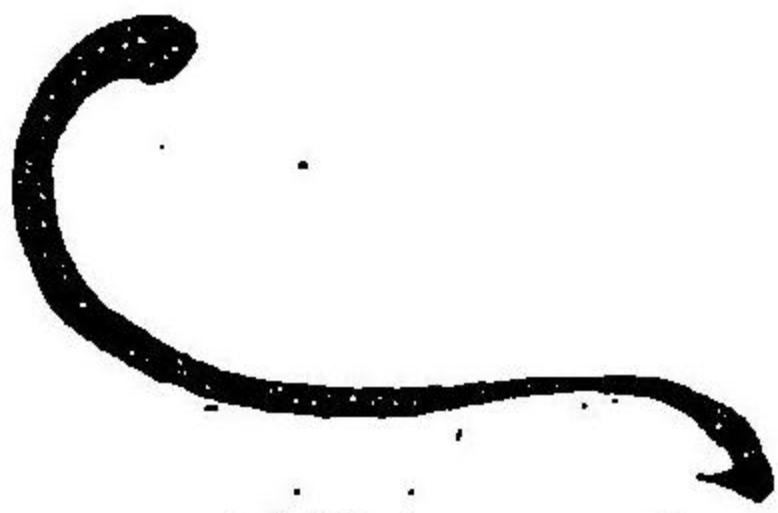
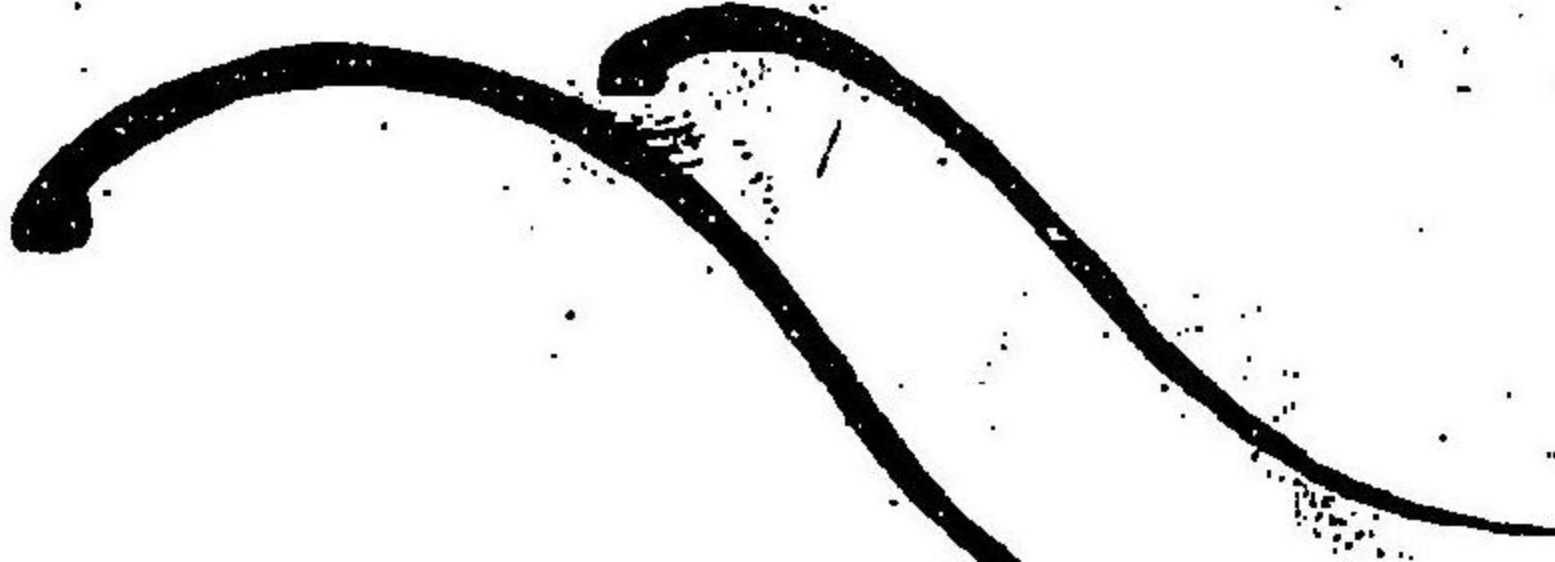

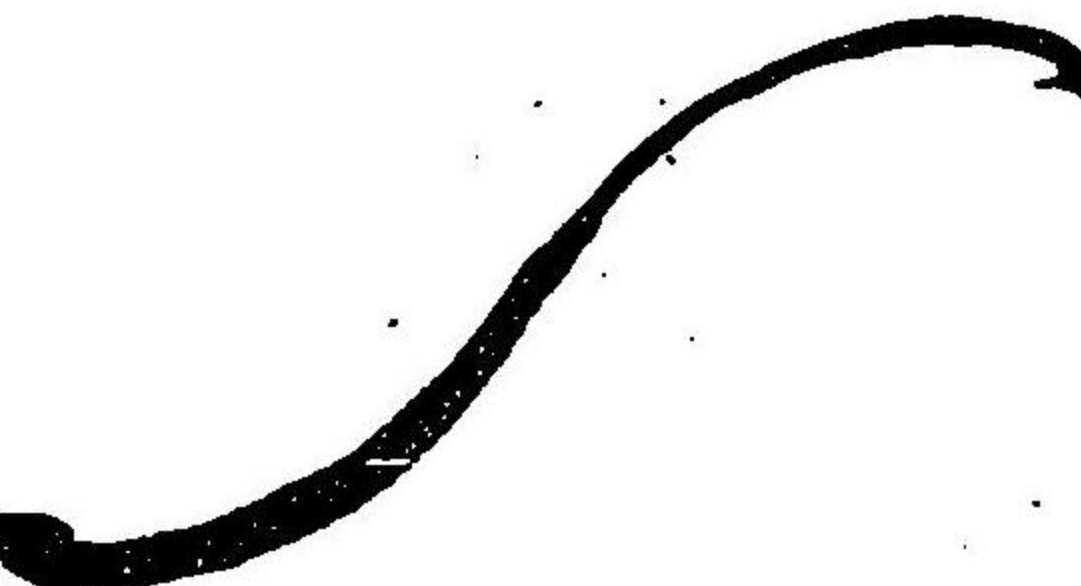



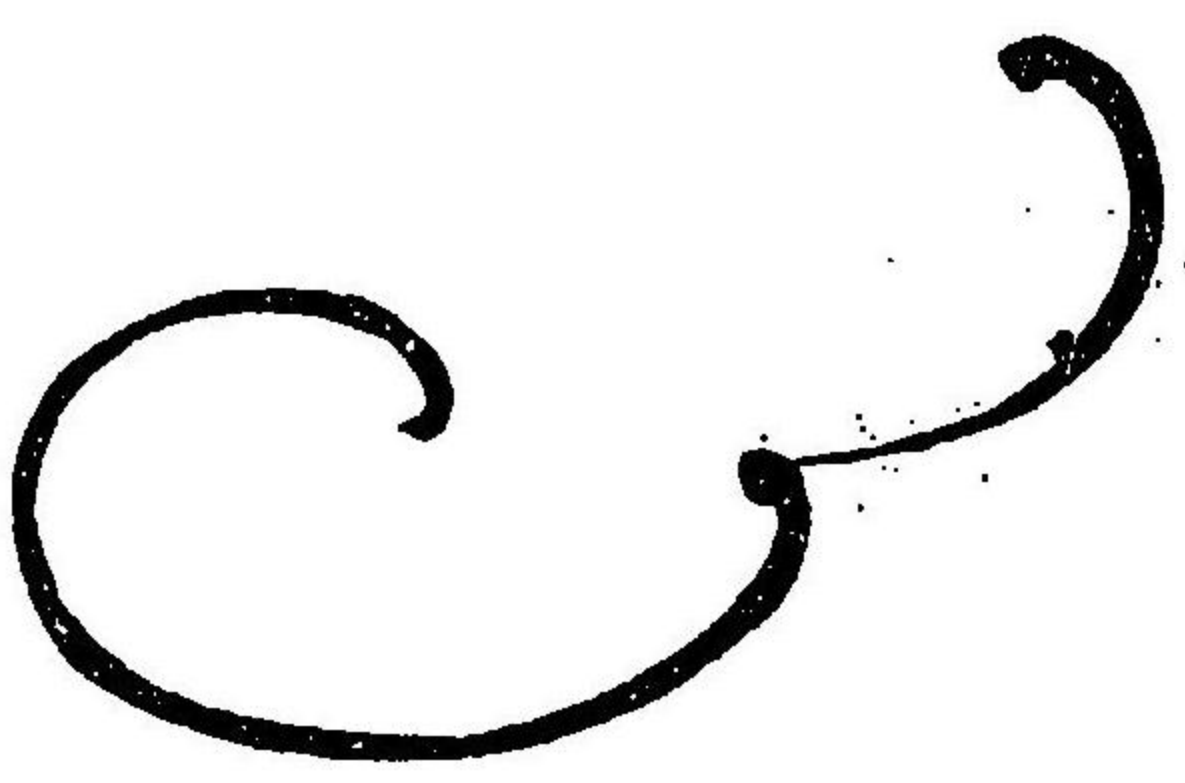
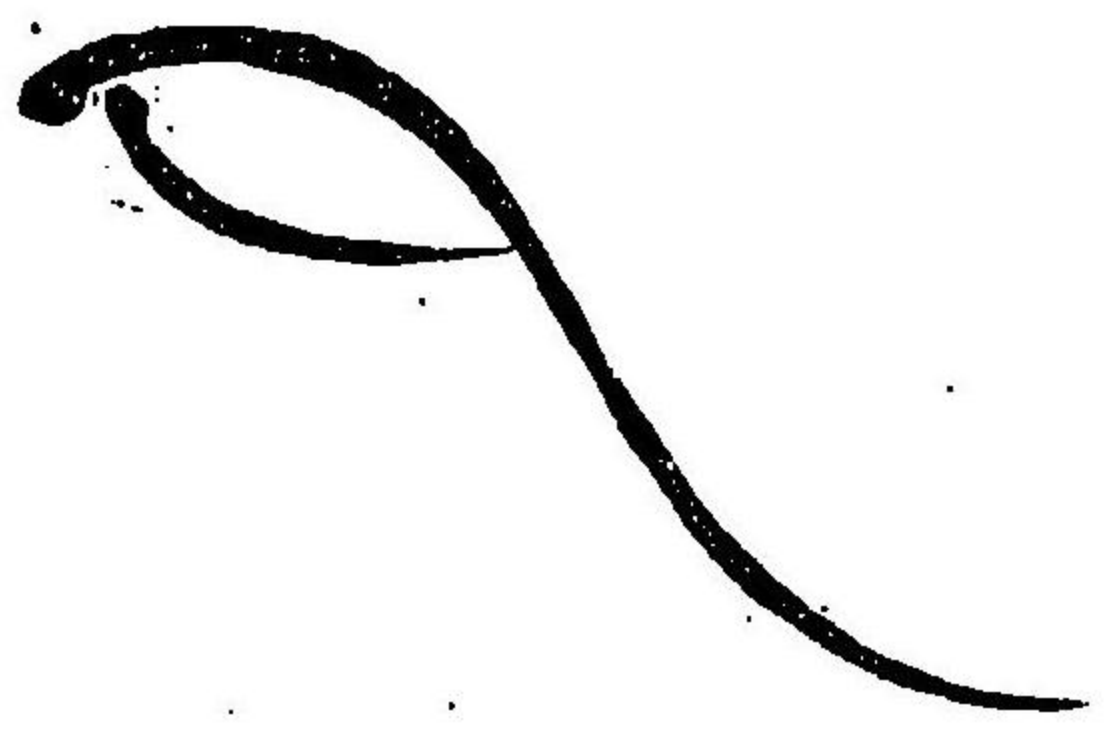

運筆法 才一

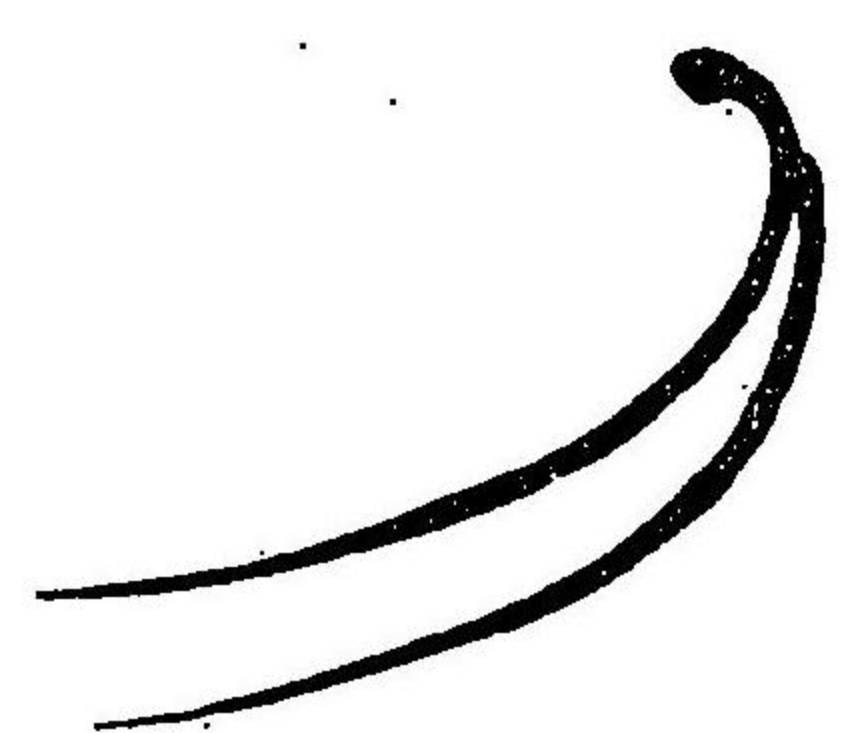
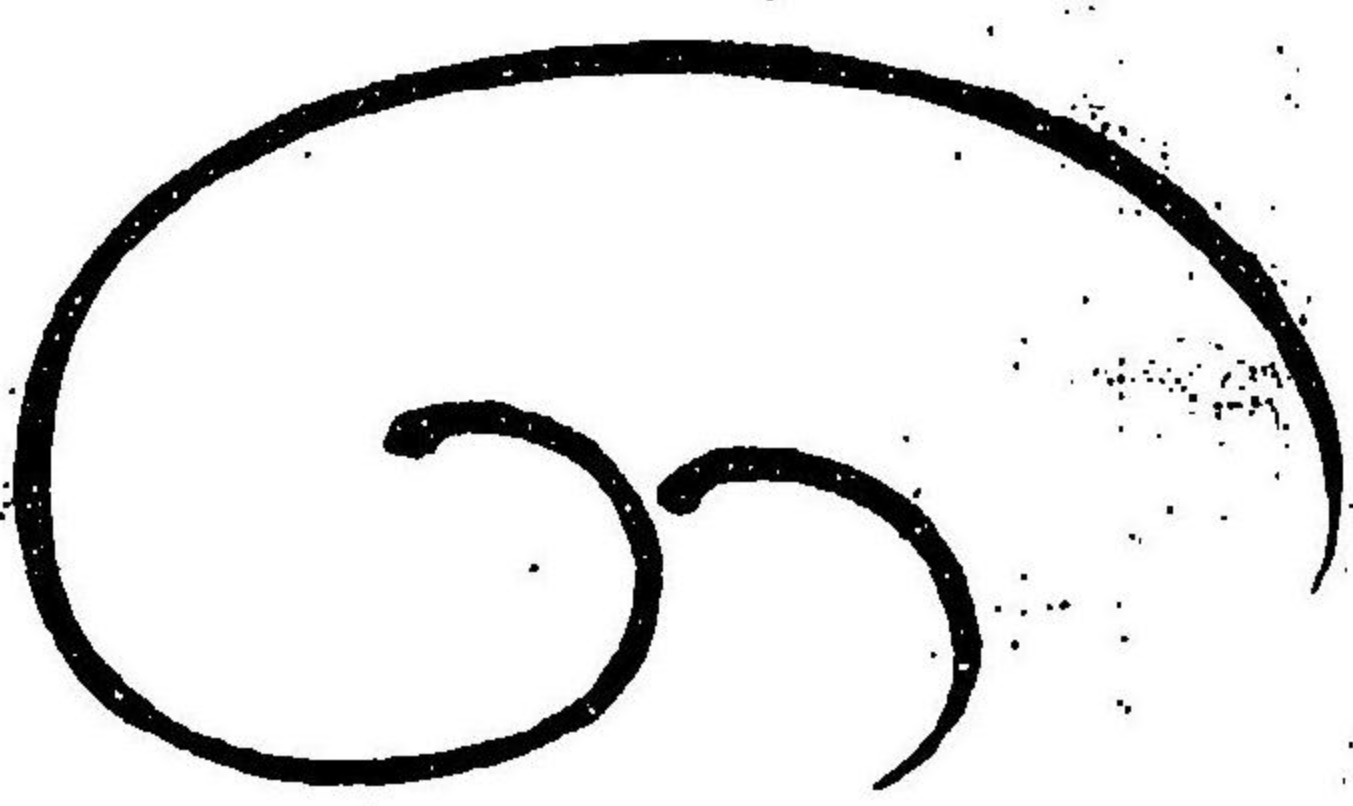
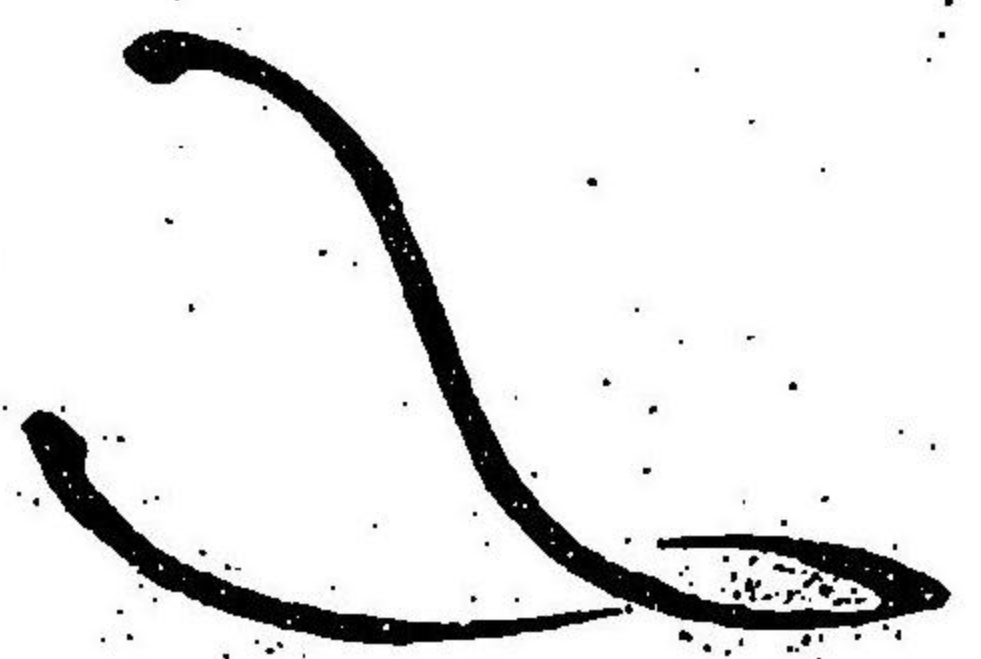

牙貳

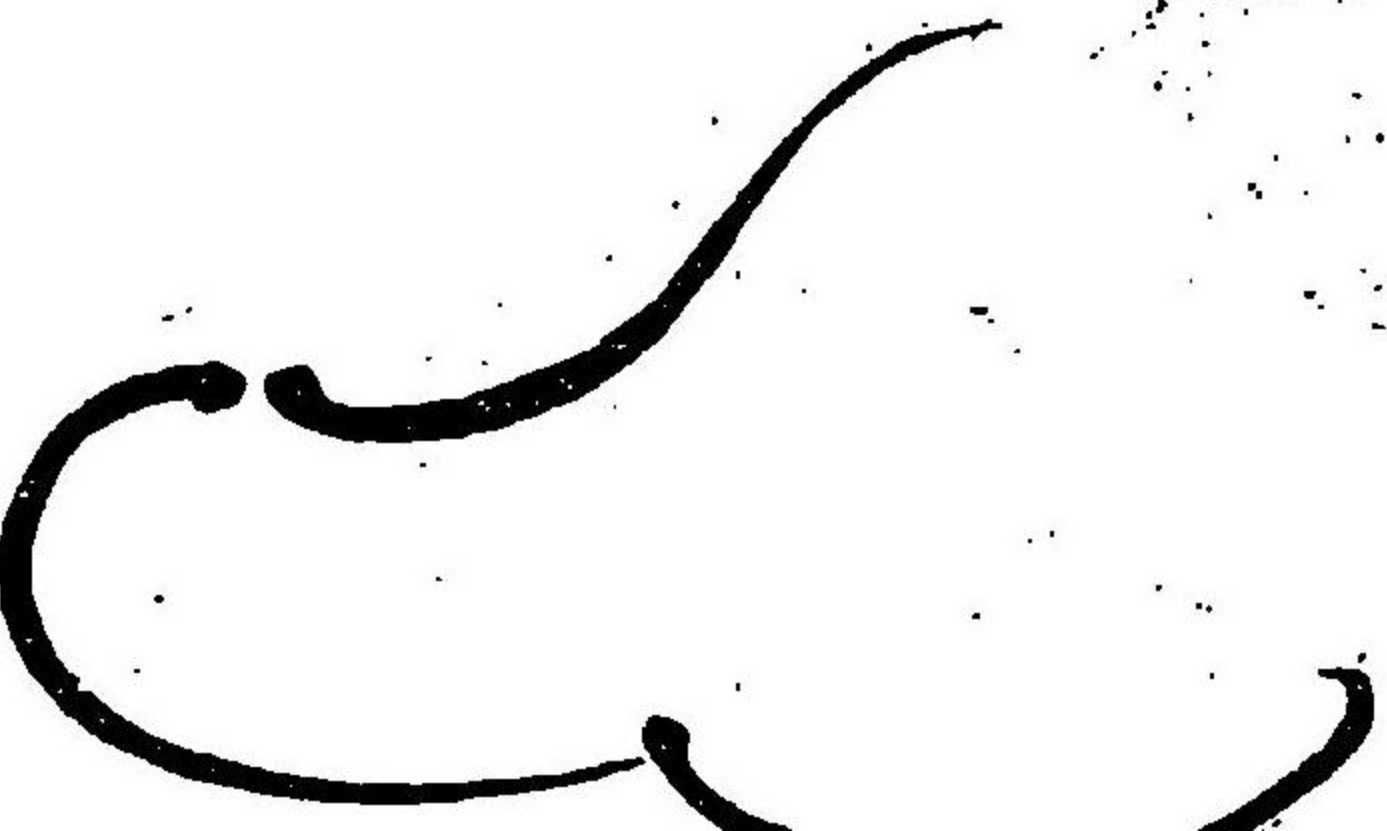

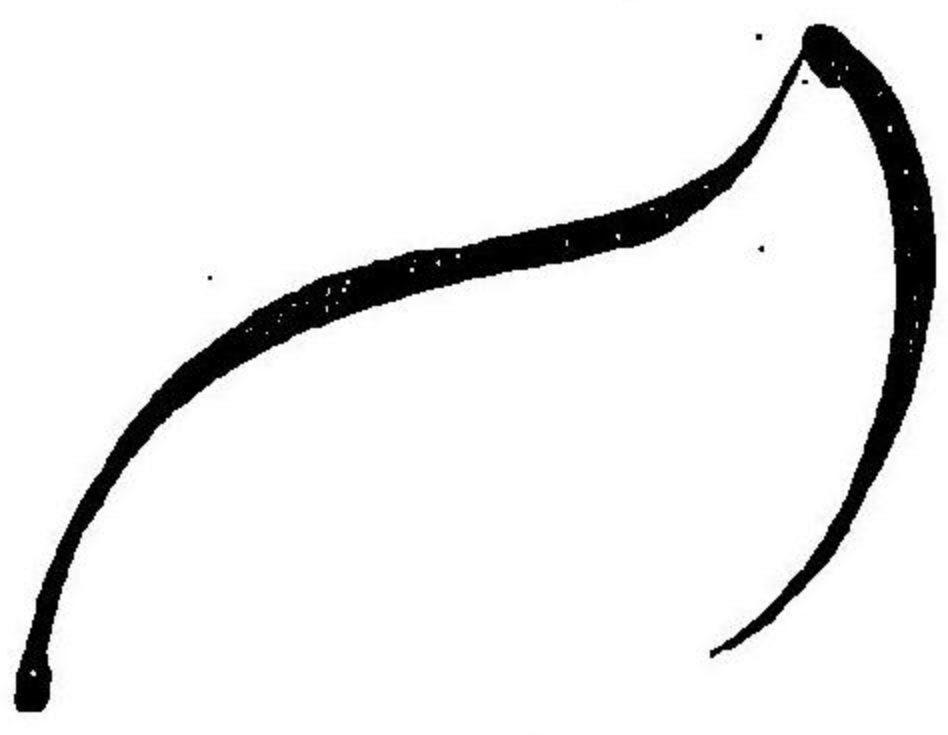

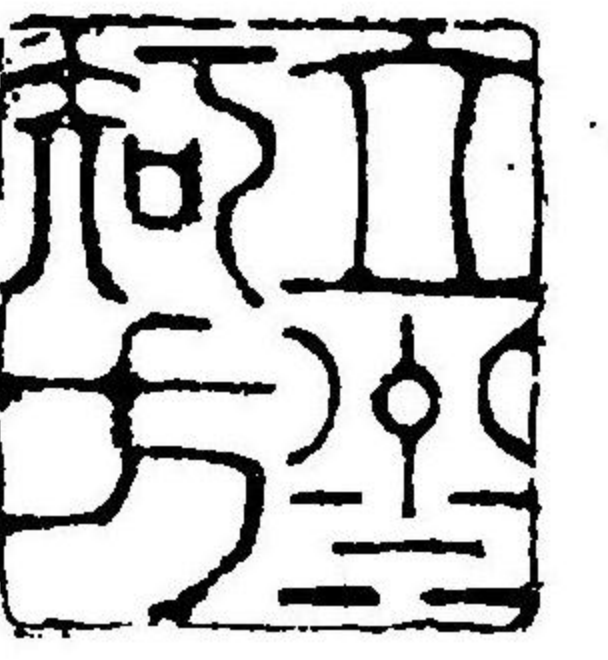



卷三

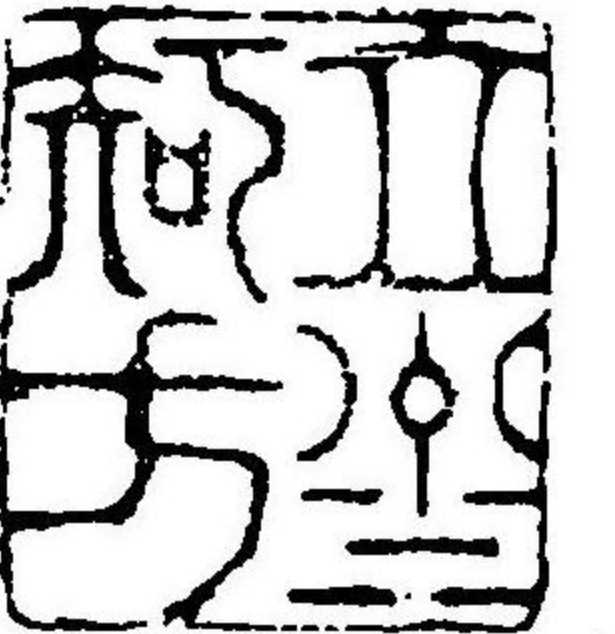
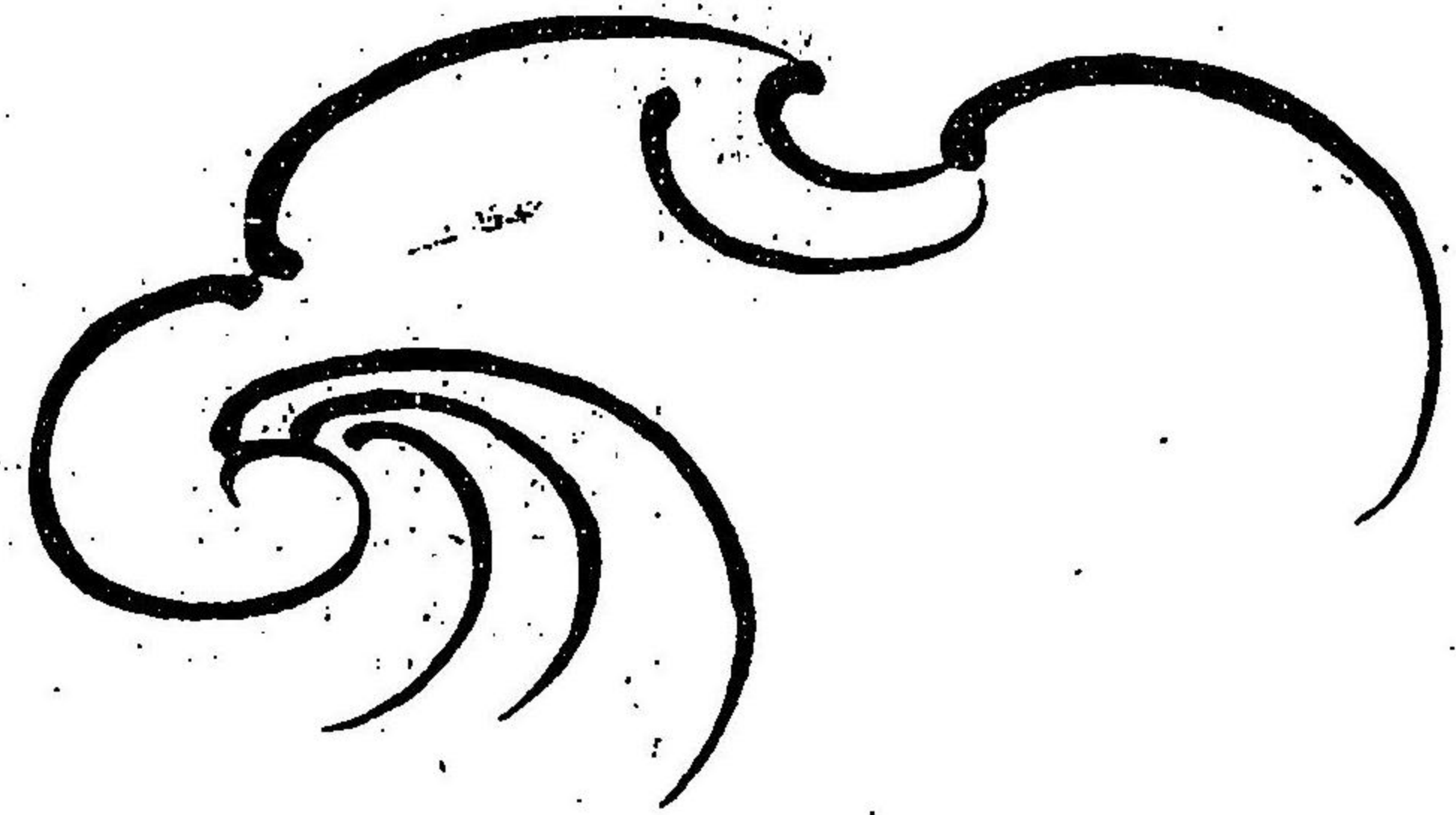
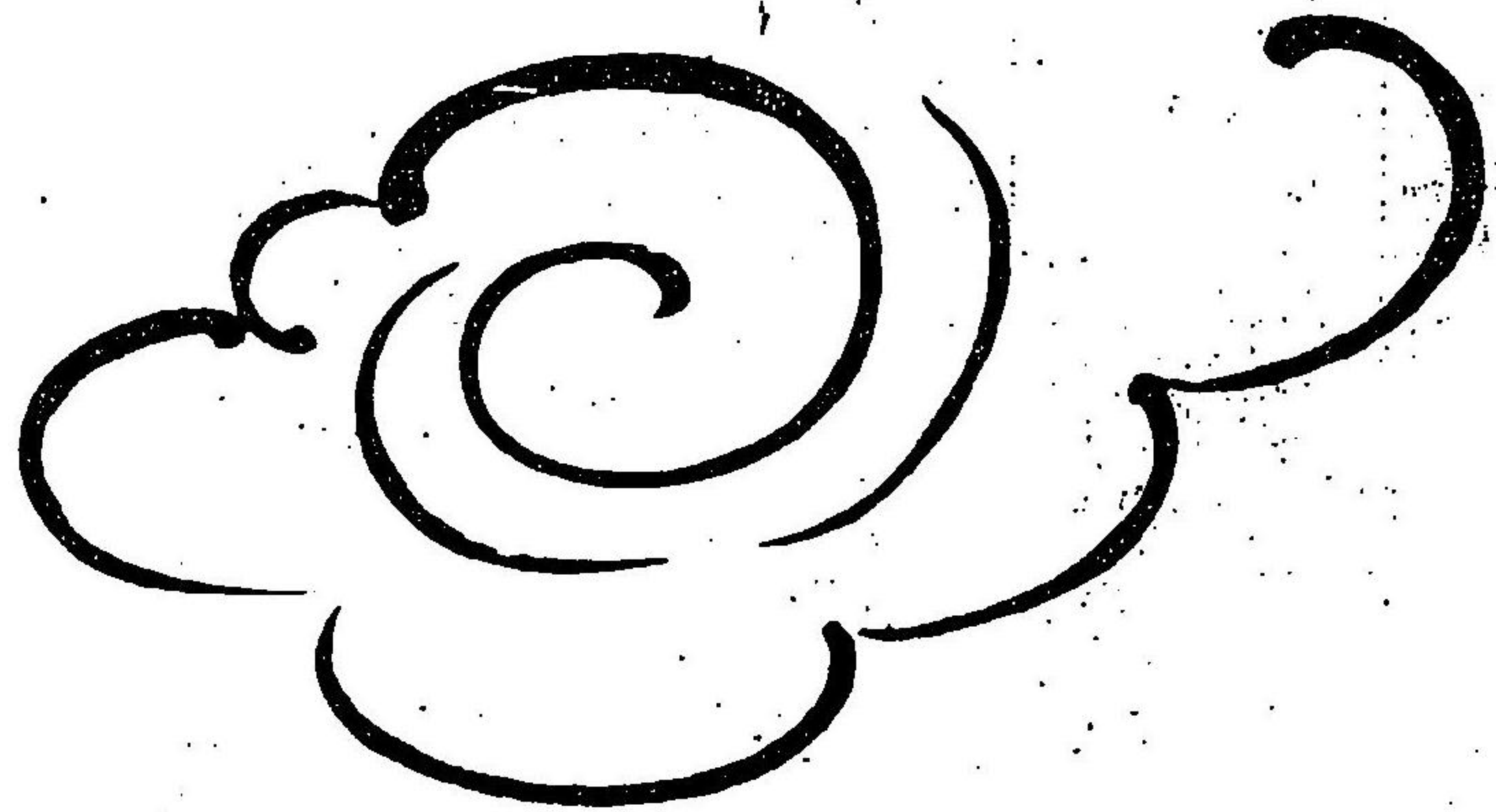



魚魚

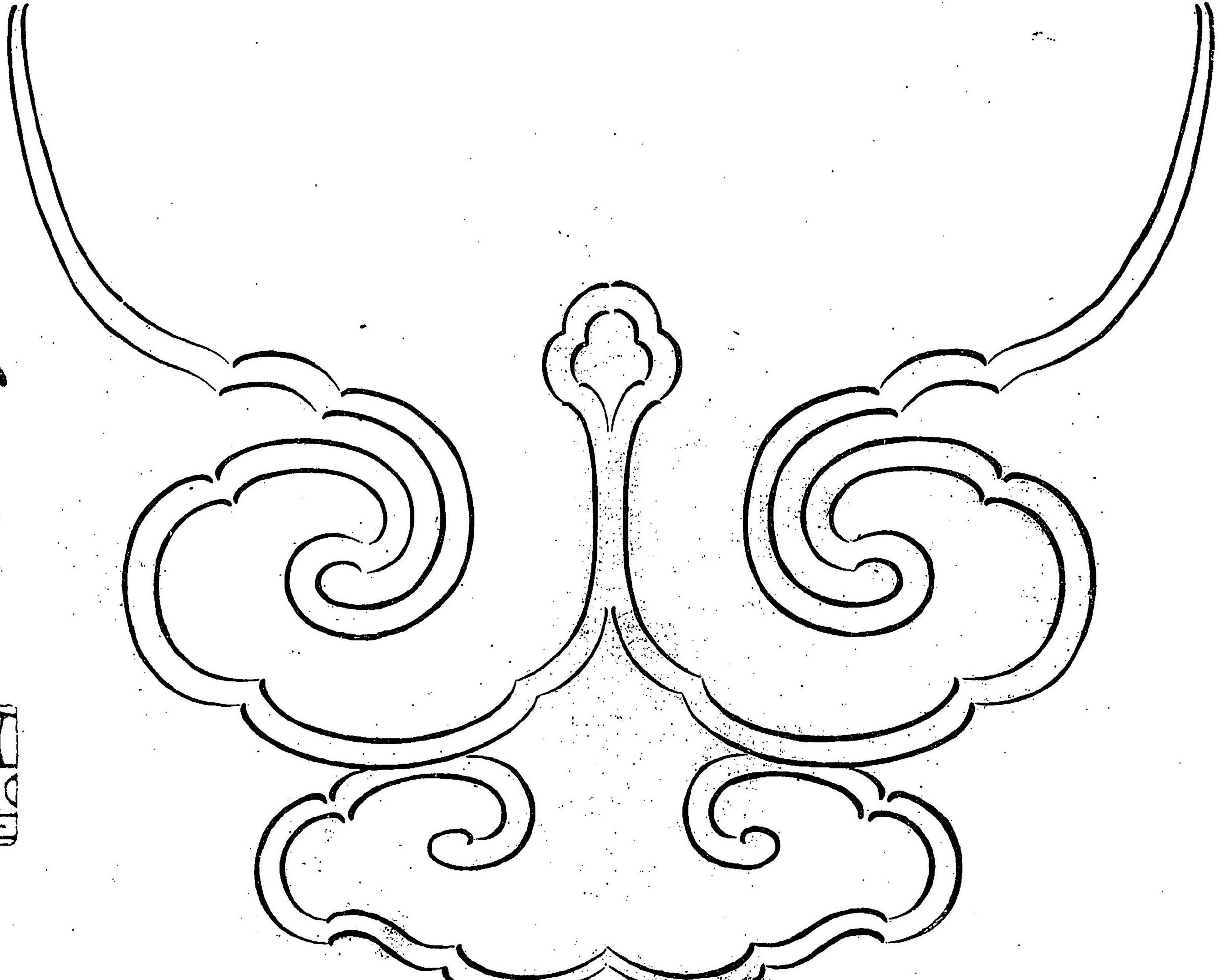
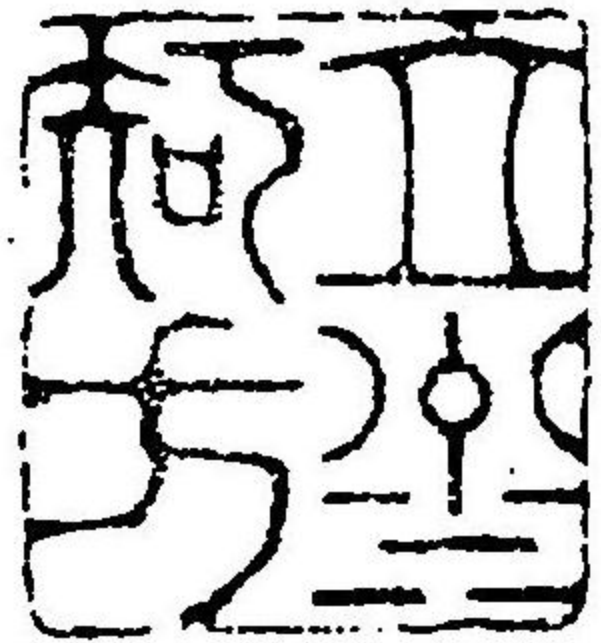



下ノ懸魚

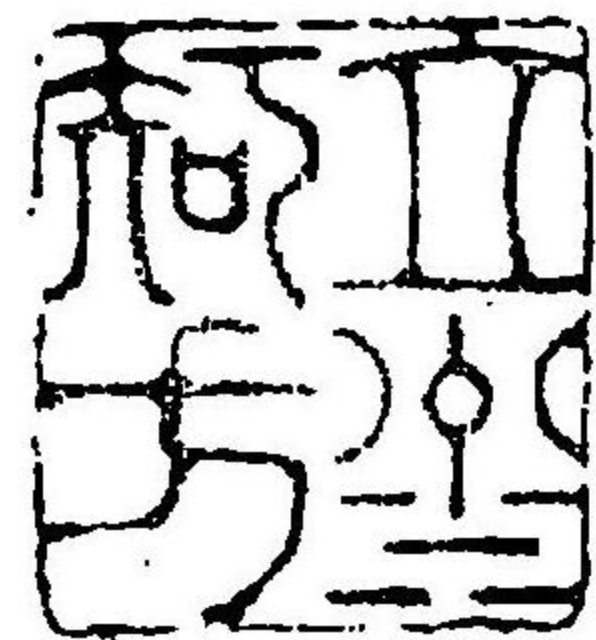
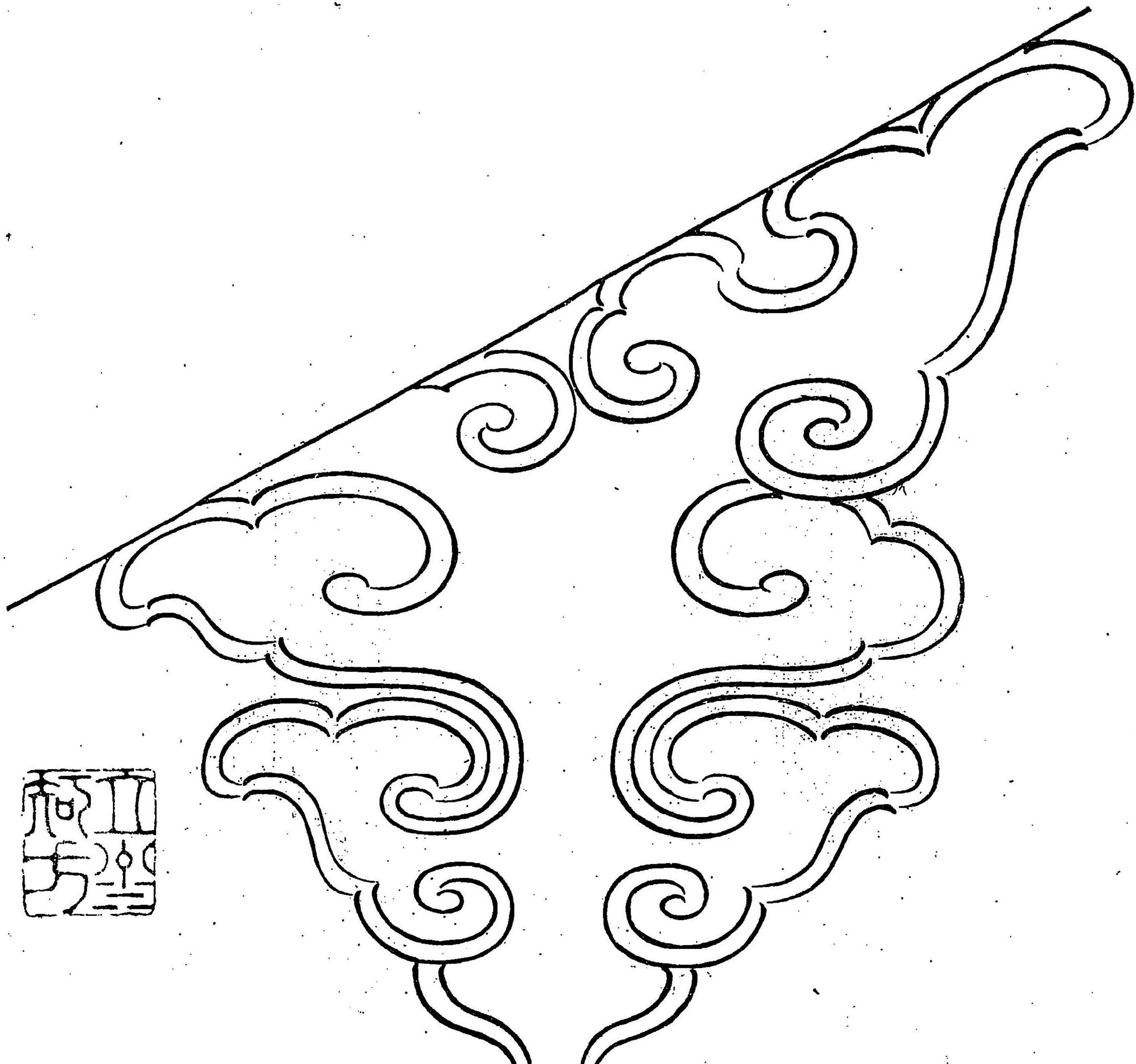



神鏡

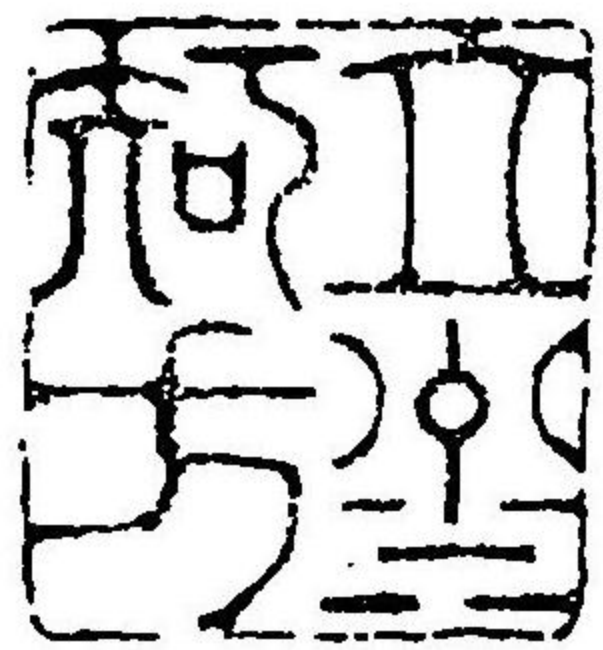
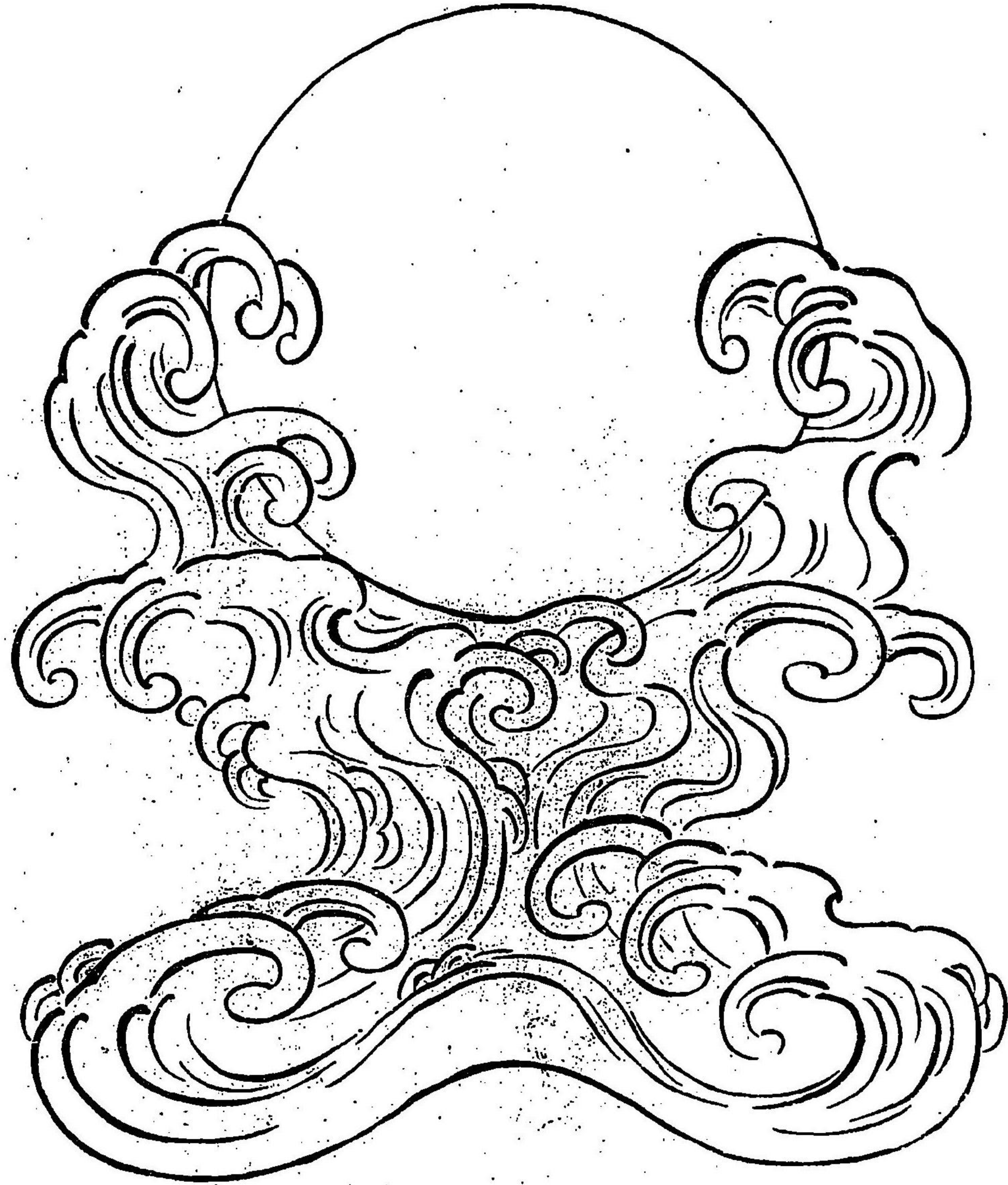



掃木鼻

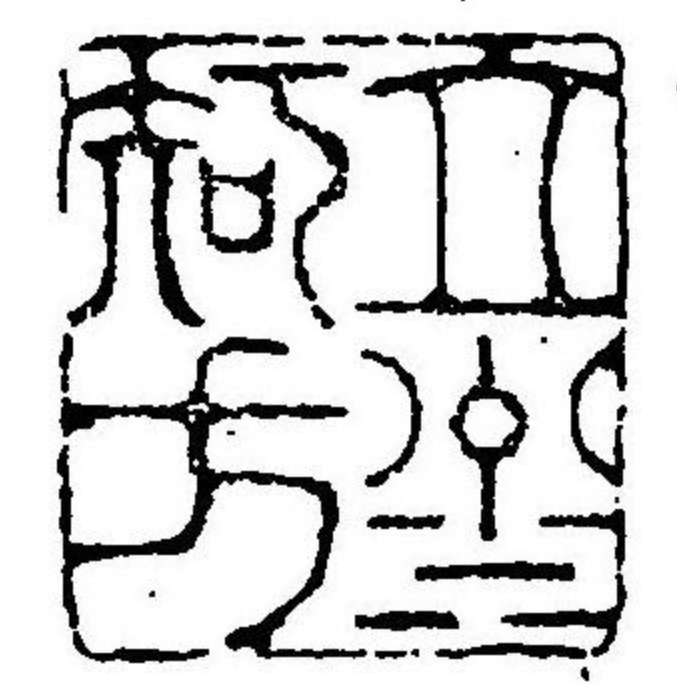
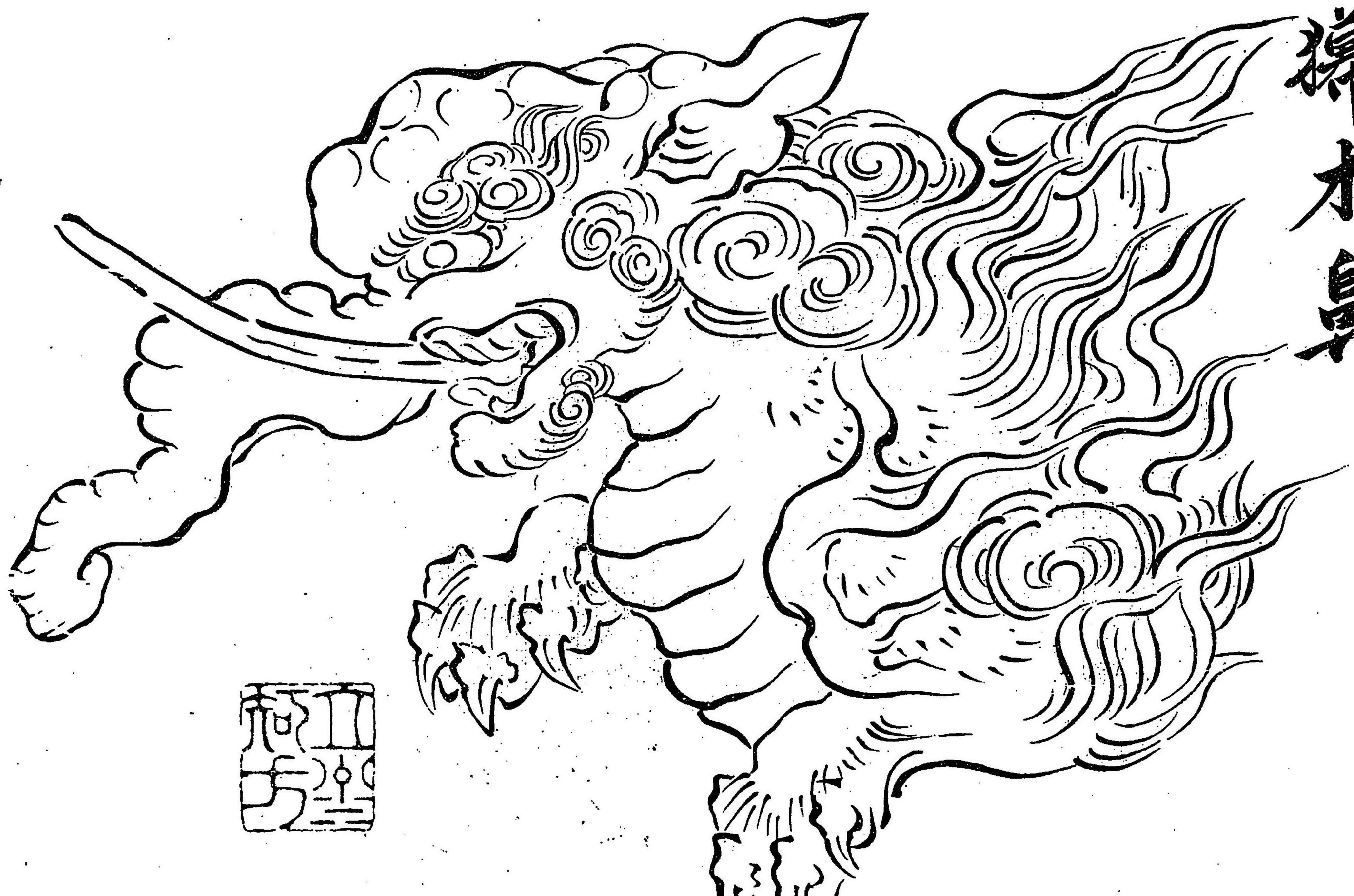



波  
濤  
頭

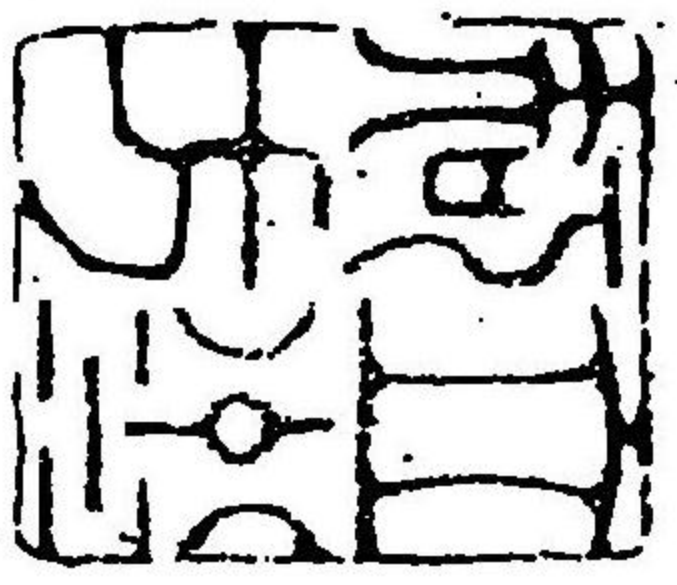



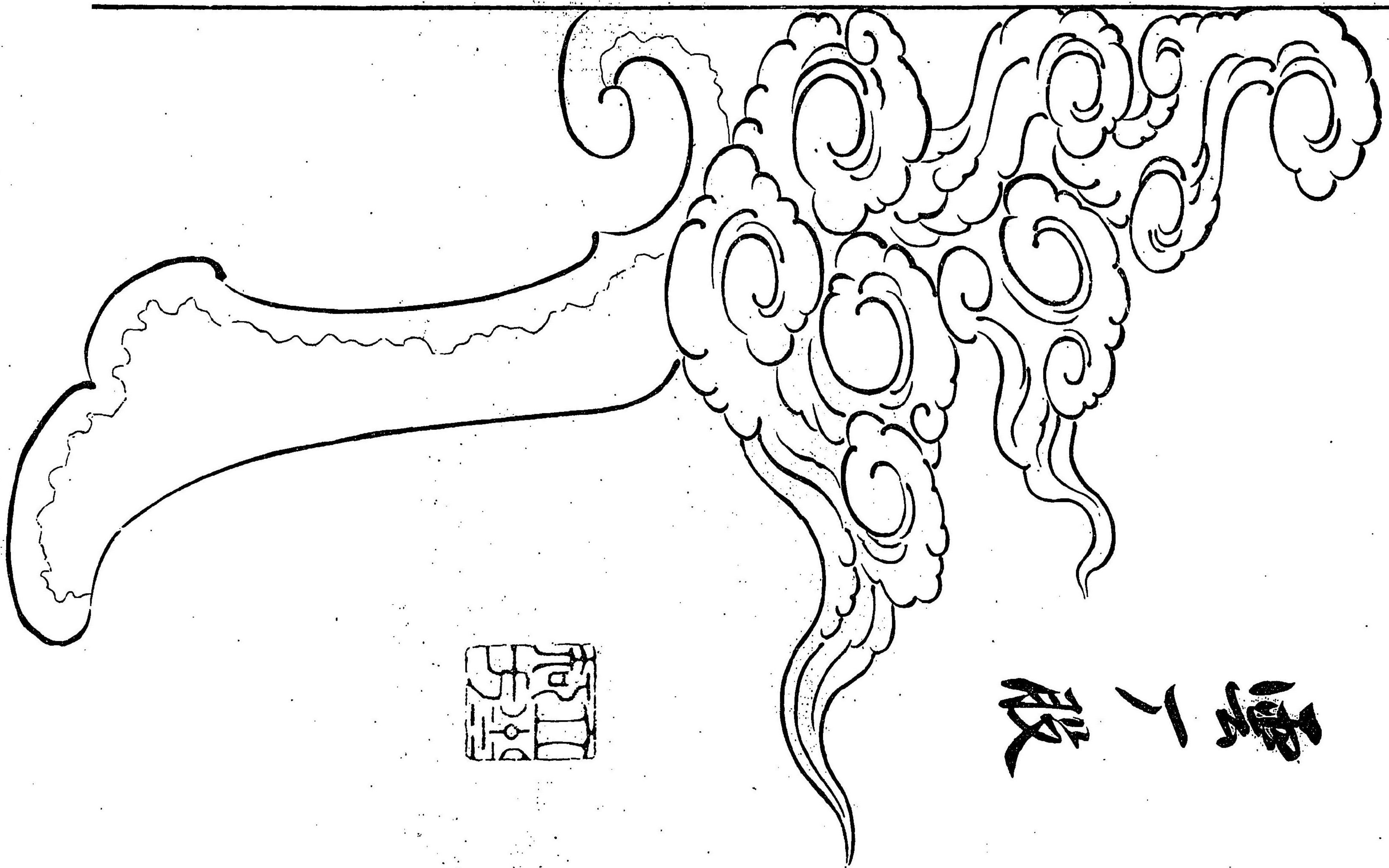

雲一股

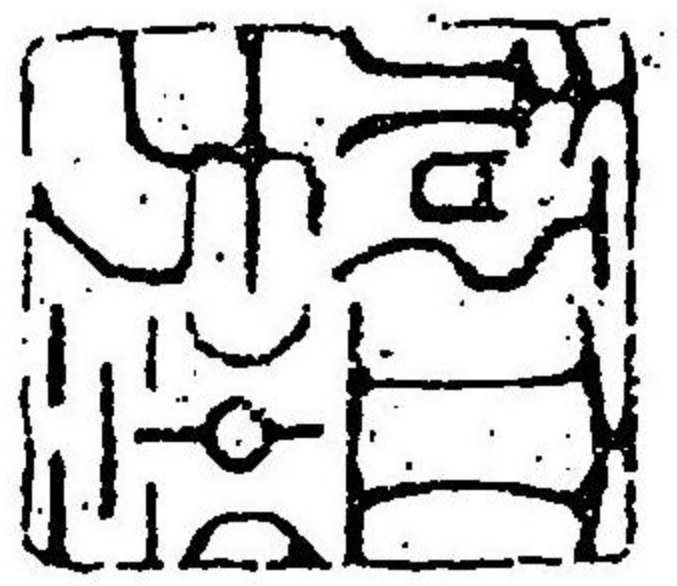



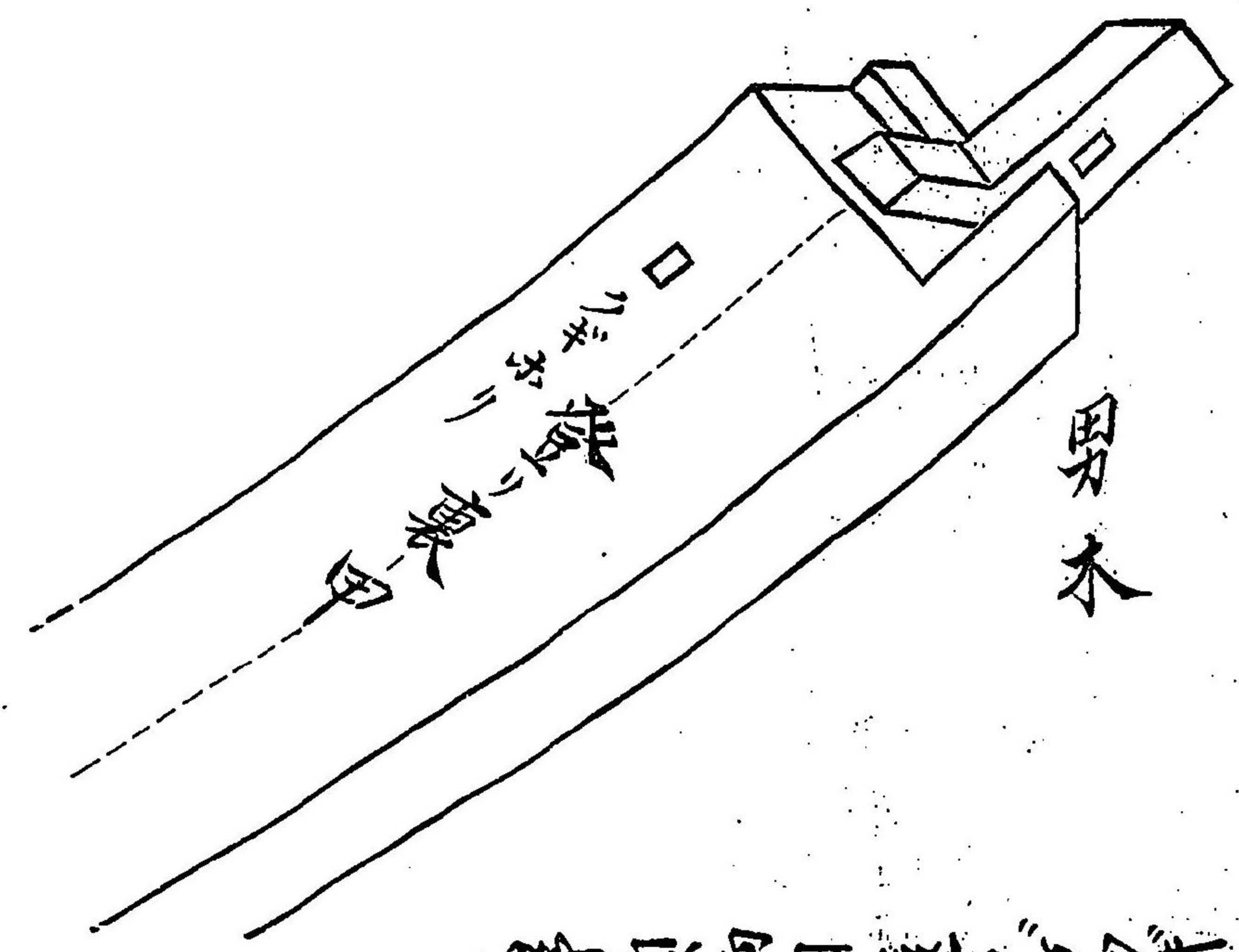
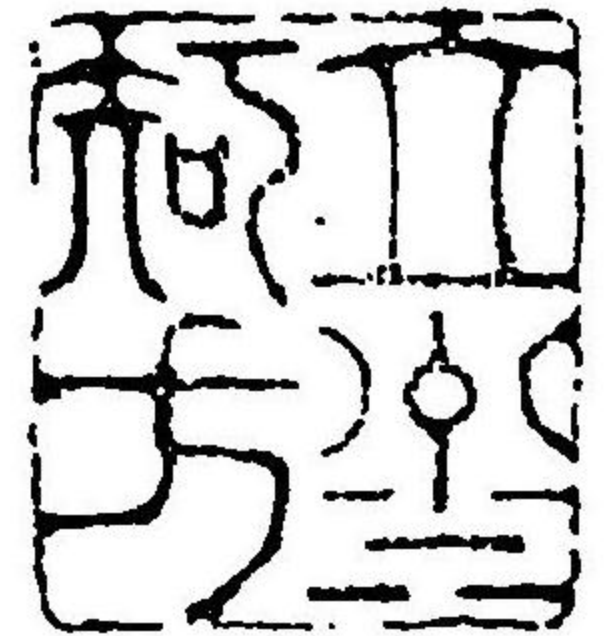

男木

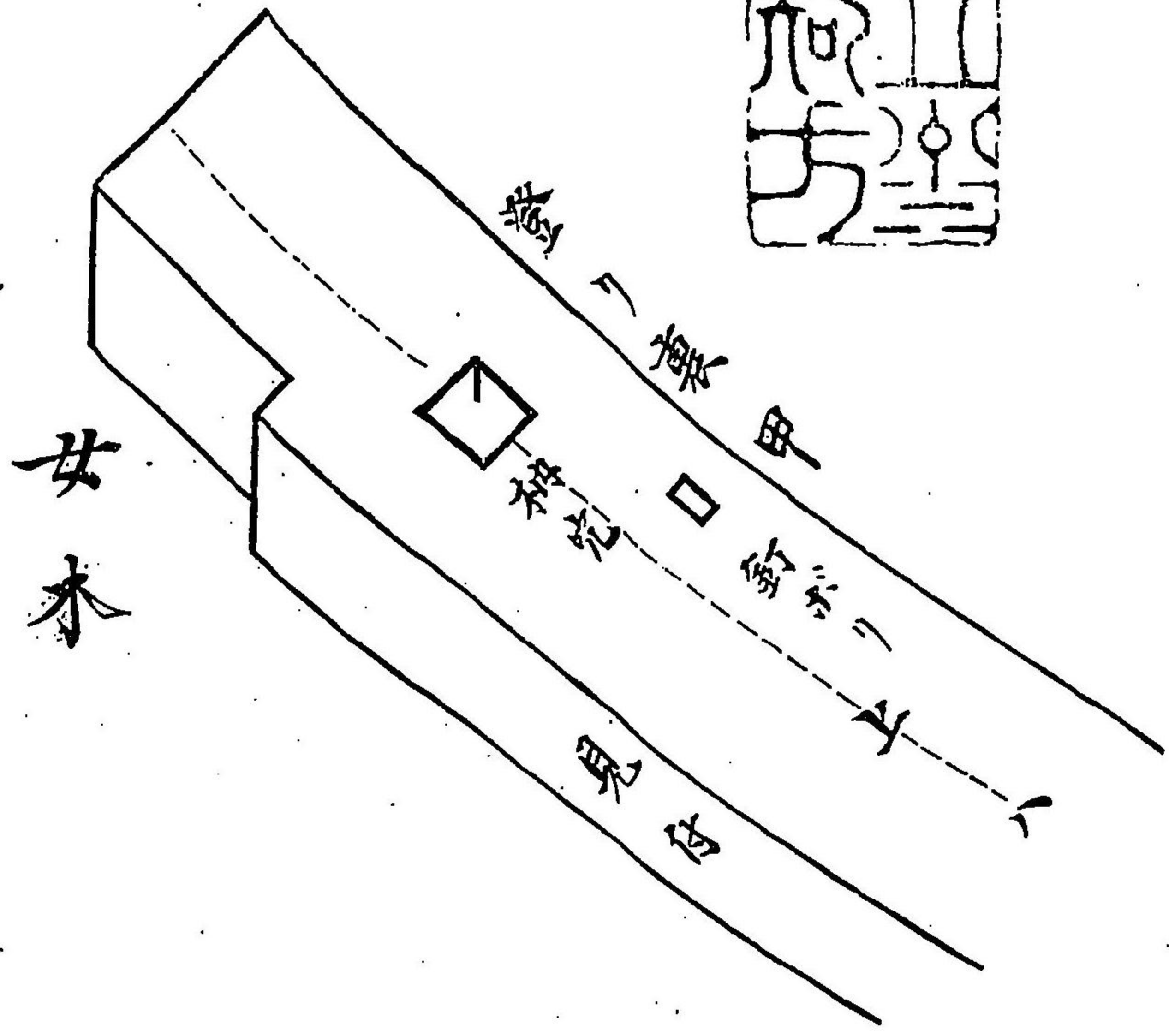

女木

斧負面目越「ハ」

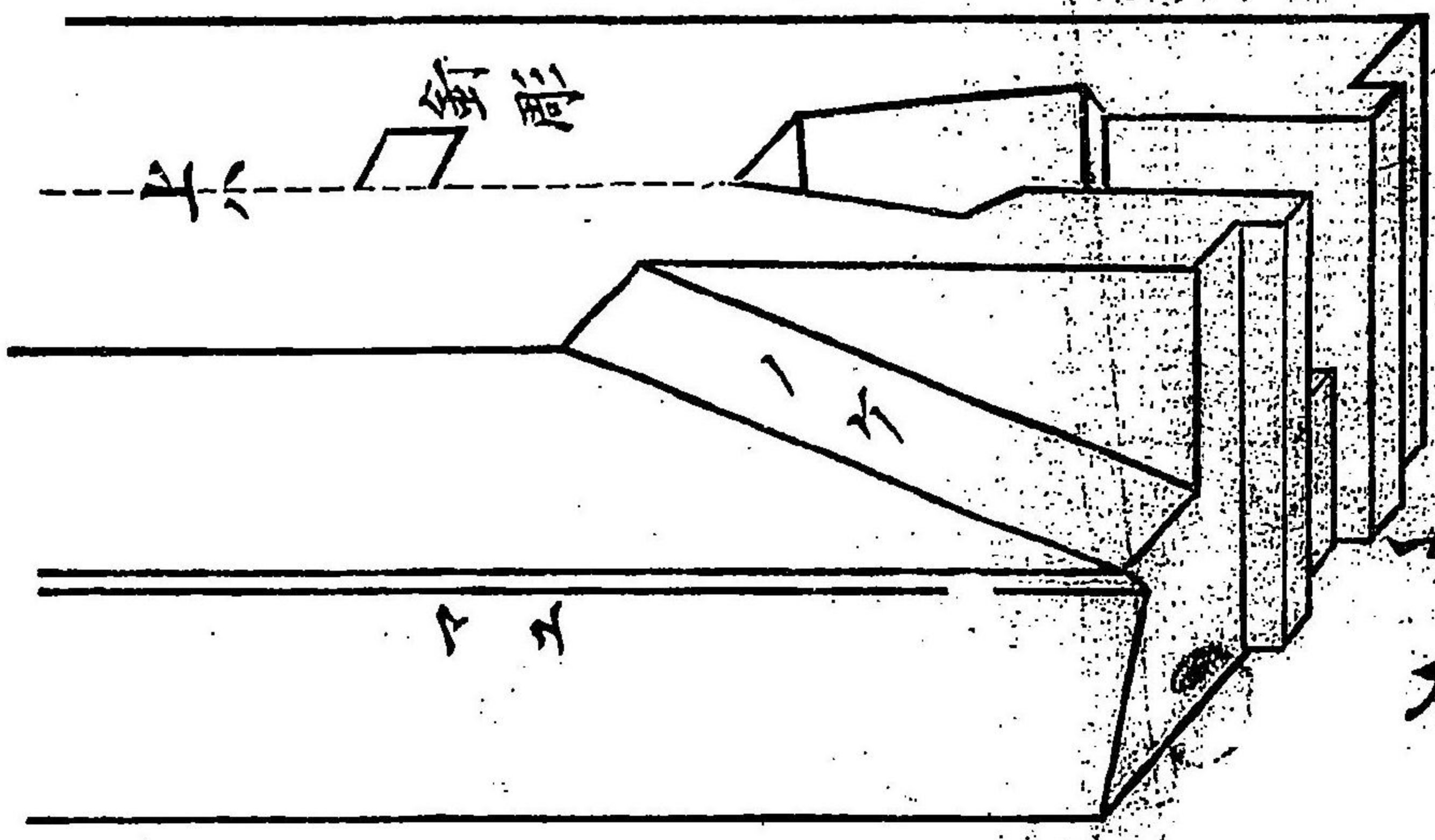

女木

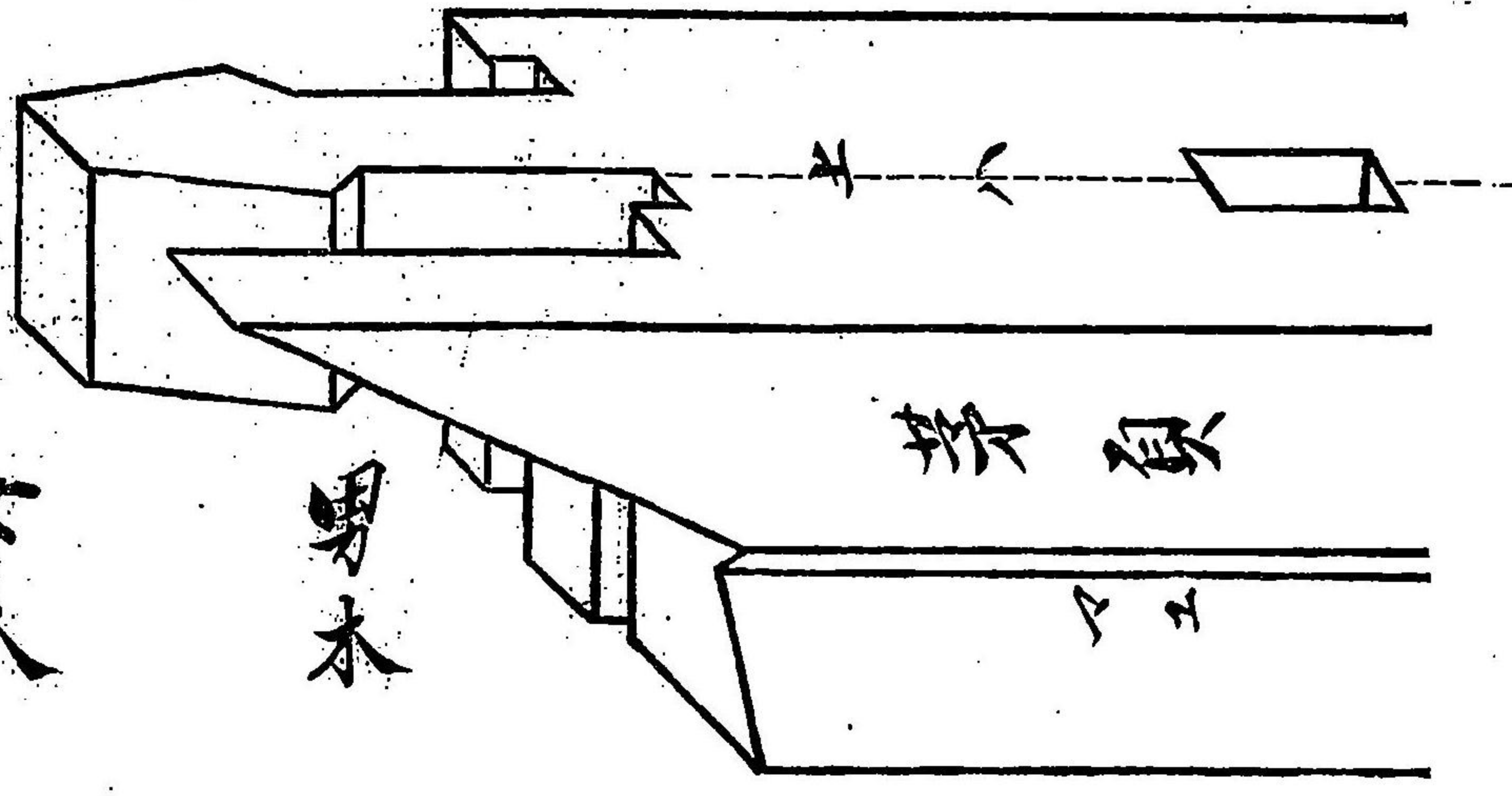

男木

斧負



隅木（入輪）

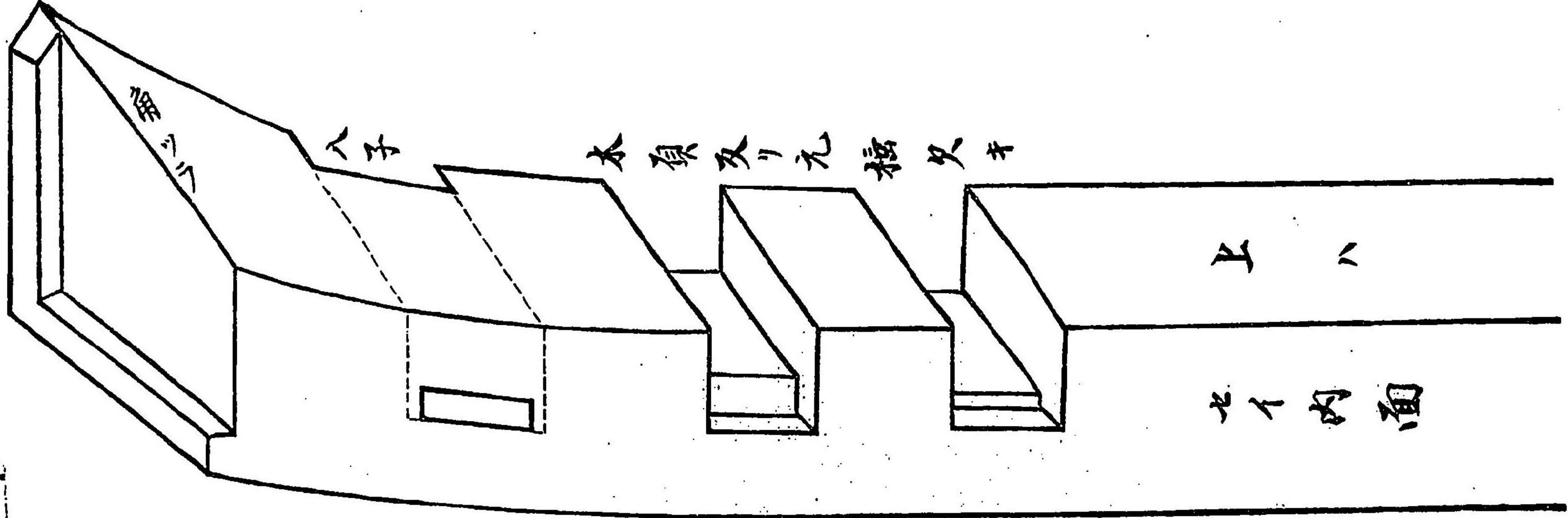

無  
三  
分

ノ  
子

本  
原  
双  
丸  
楕  
外  
半

山  
ノ

七  
ノ  
内  
面

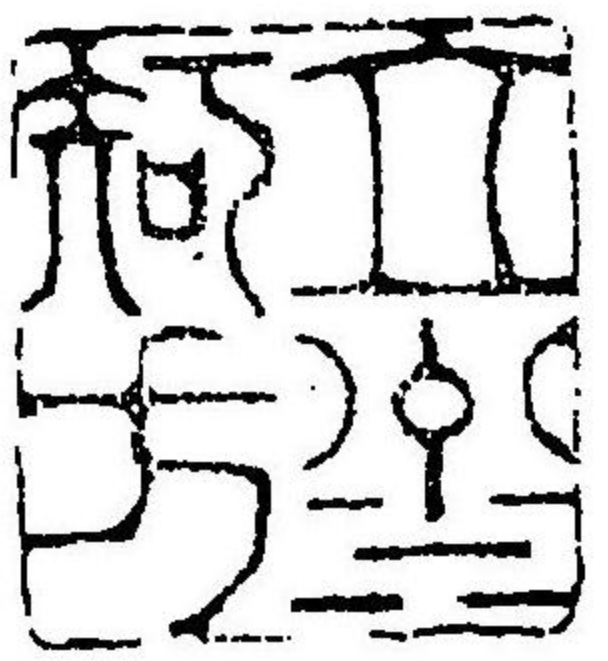

柄  
差  
鼻  
栓

渡  
楕  
半  
分  
撥

渡  
臆

本  
原  
内  
織  
掛

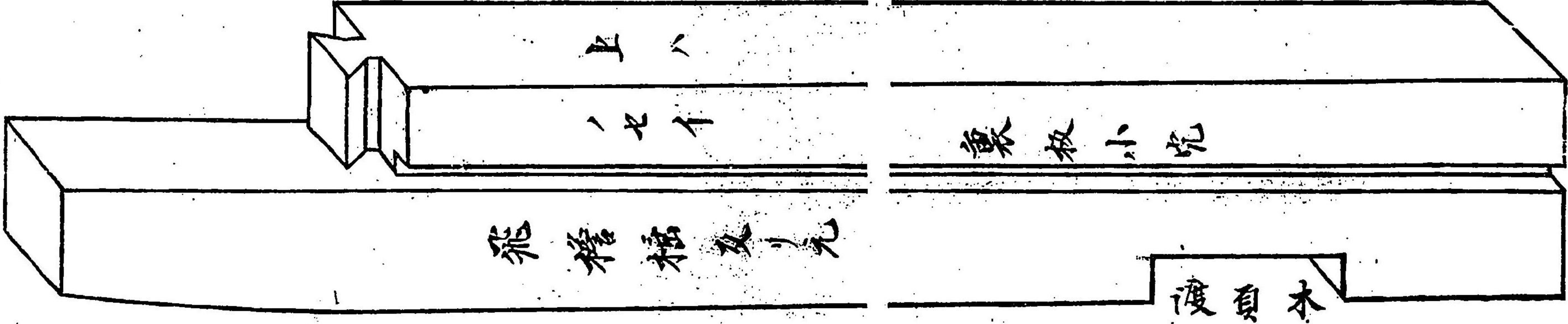

山  
ノ

七  
ノ

無  
双  
丸  
楕

飛  
楕  
楕  
外  
丸

渡  
真  
木



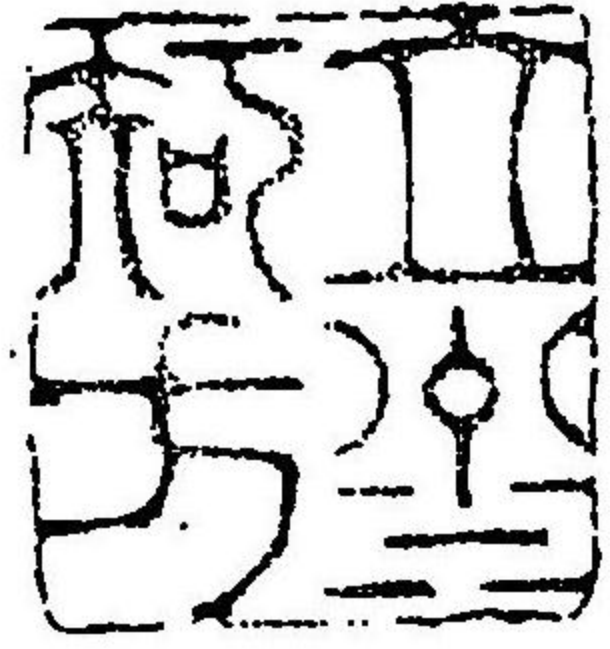

襟  
幅

男  
木

銅  
鈕  
跡  
存  
殘  
片

第  
一  
甲

第  
二  
甲

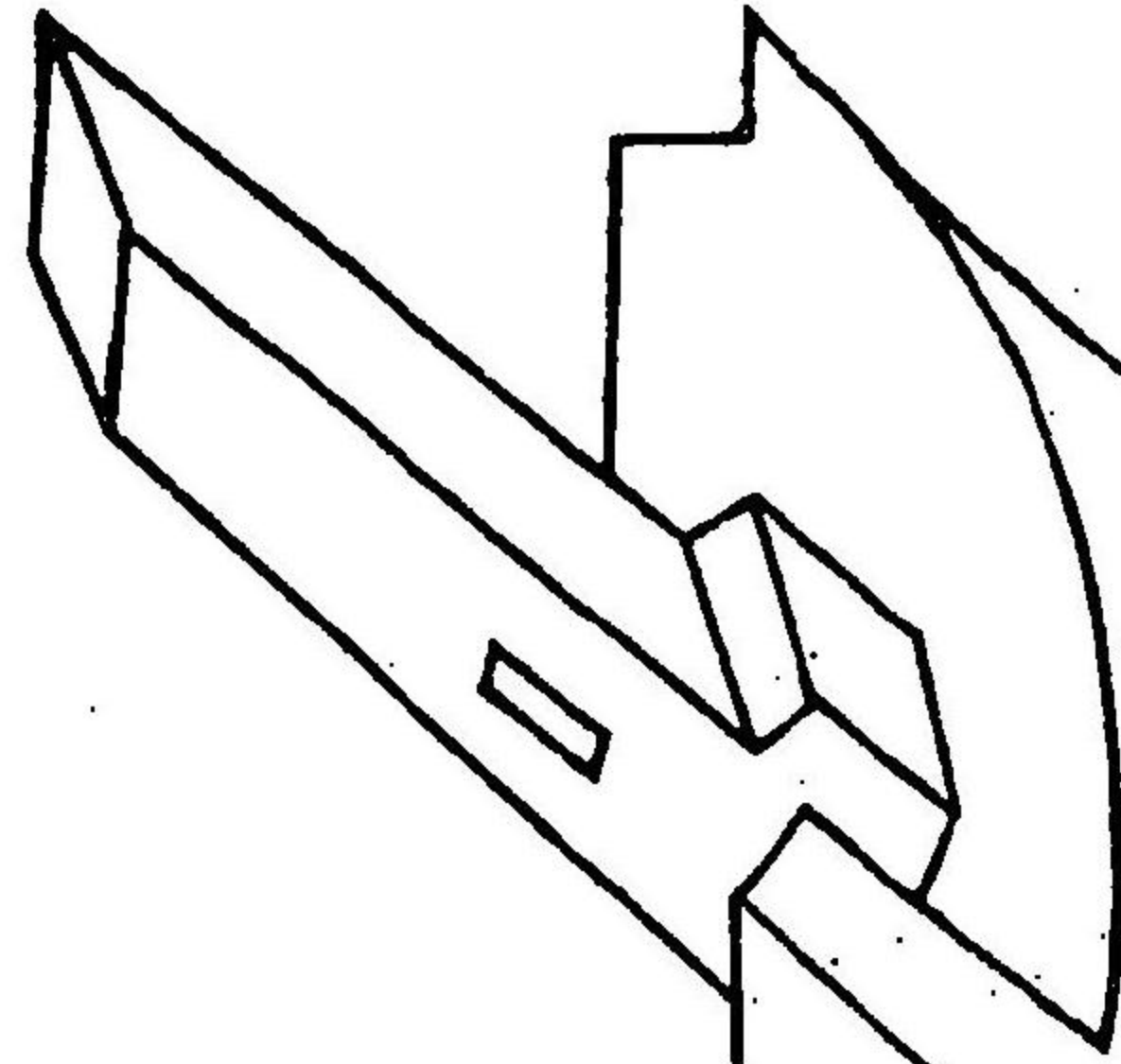

破  
銅  
鈕  
正  
片

第  
三  
甲  
下  
片

女  
木

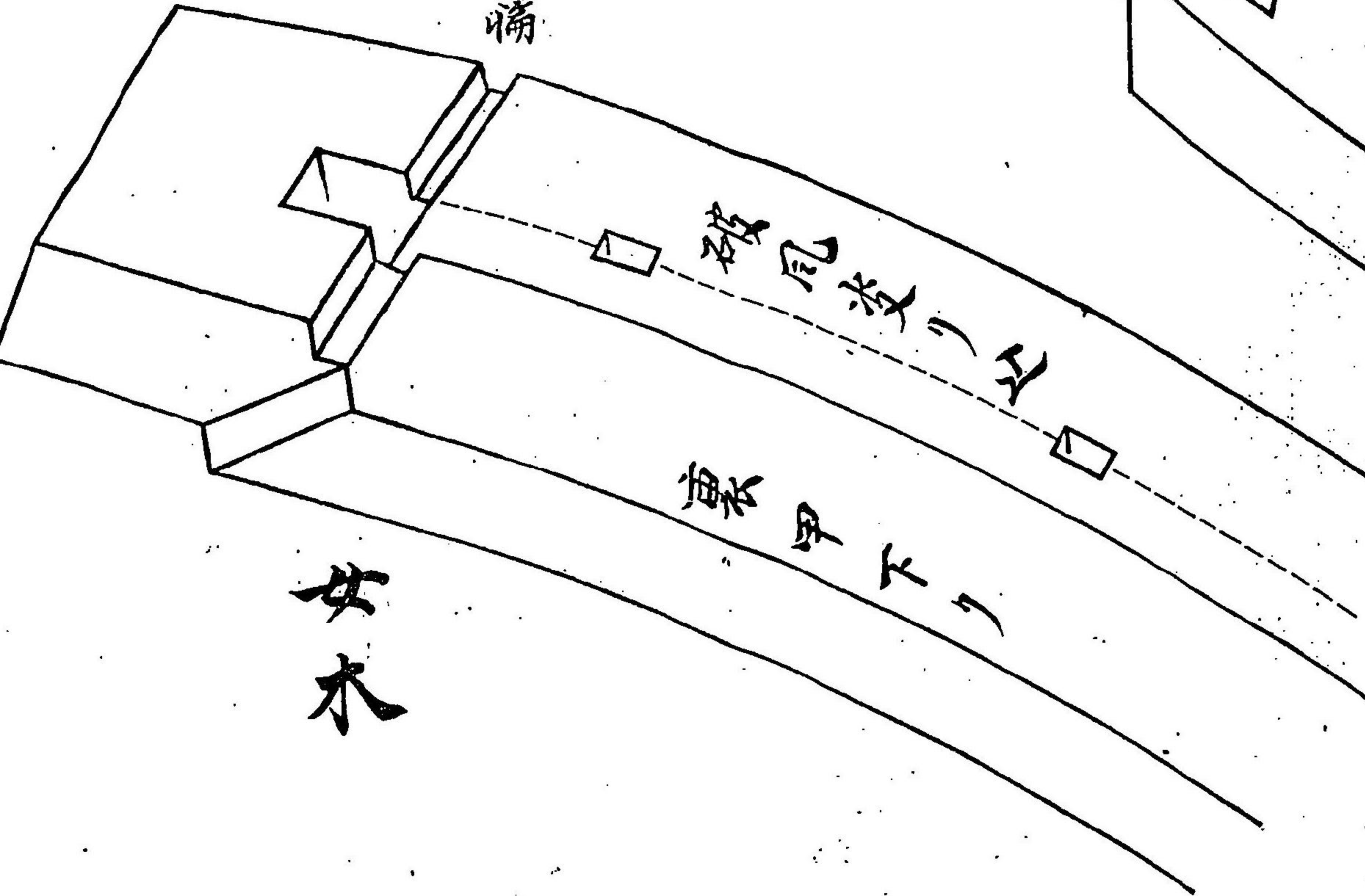



兩目透力口繼

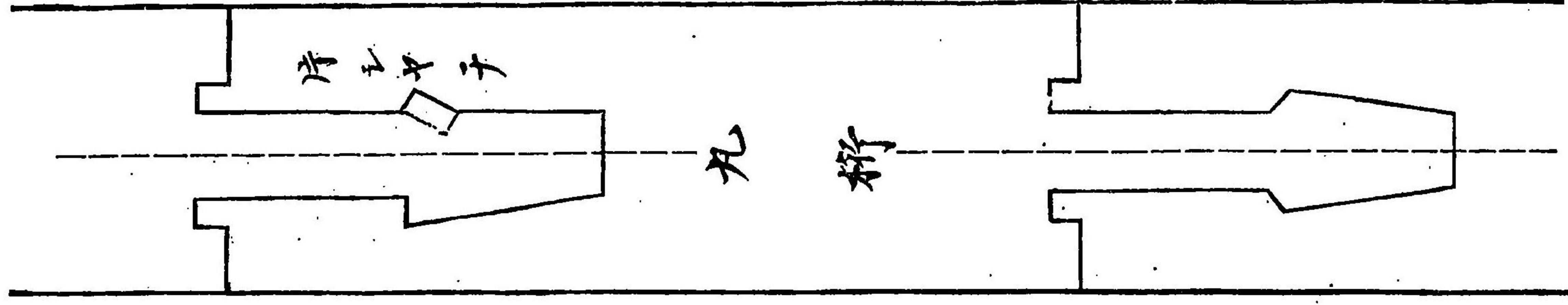

水 男

水 女

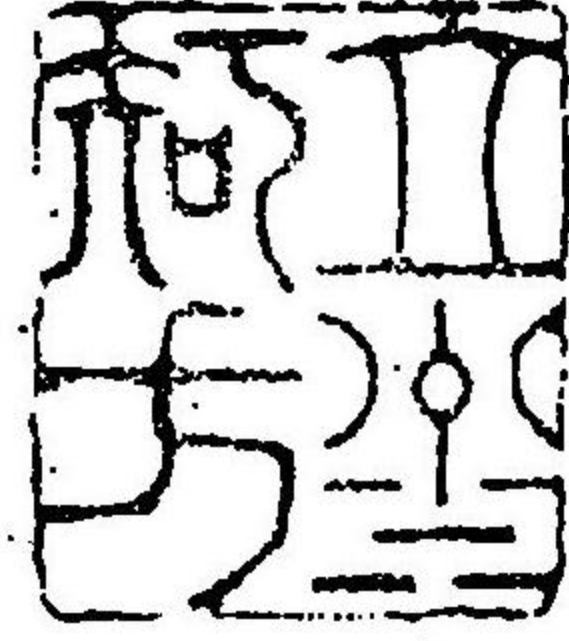

兩目透力口

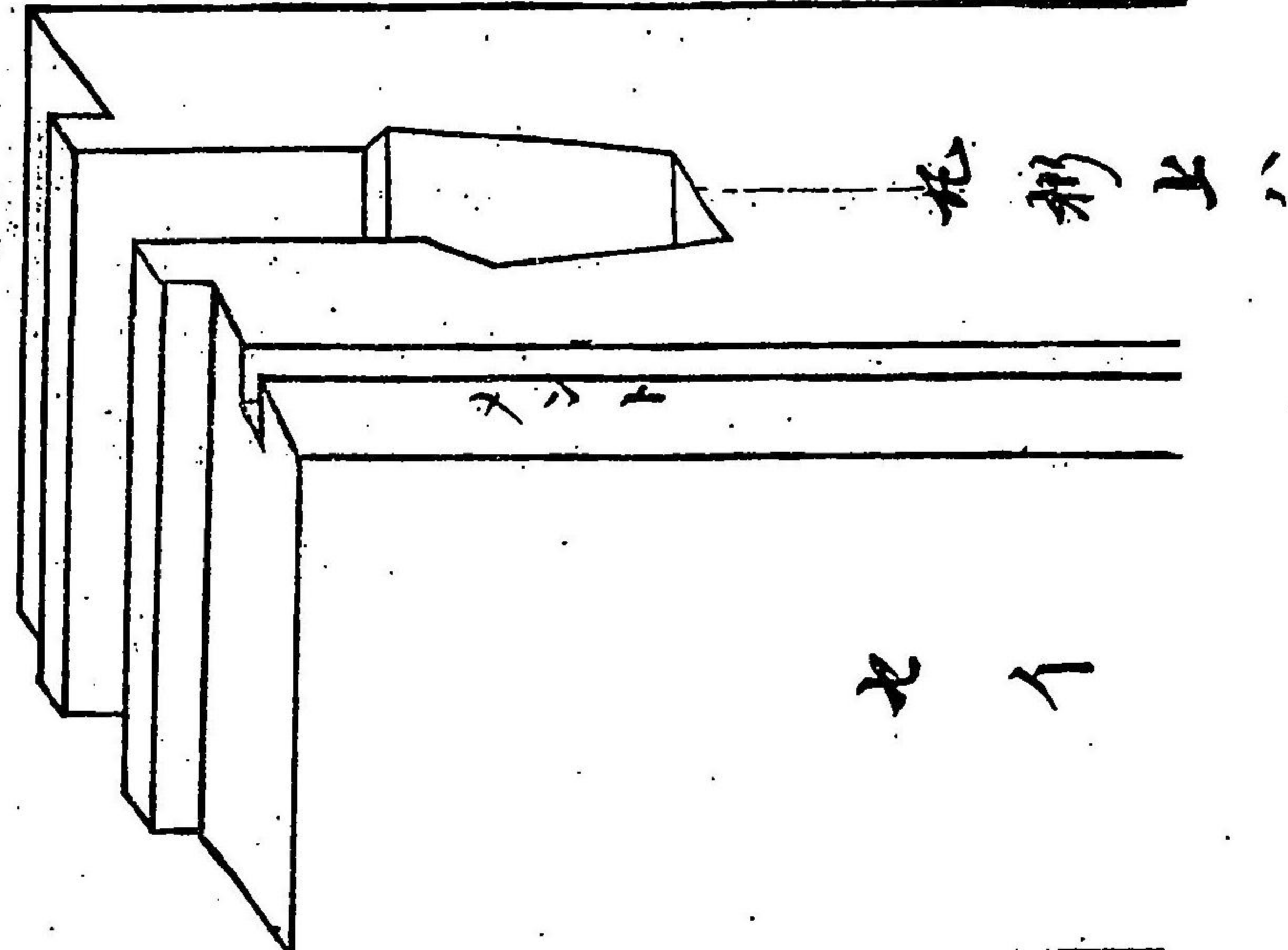
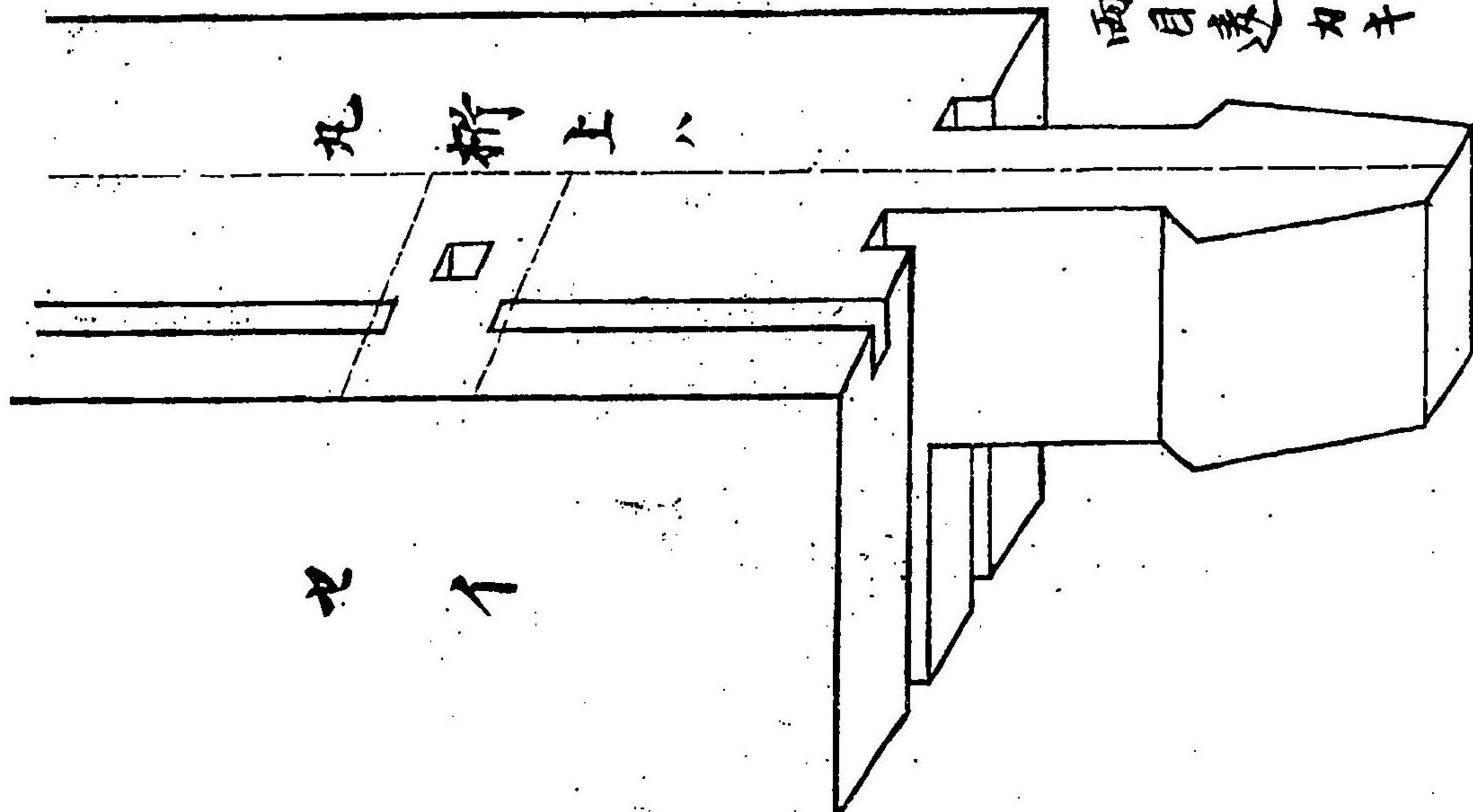



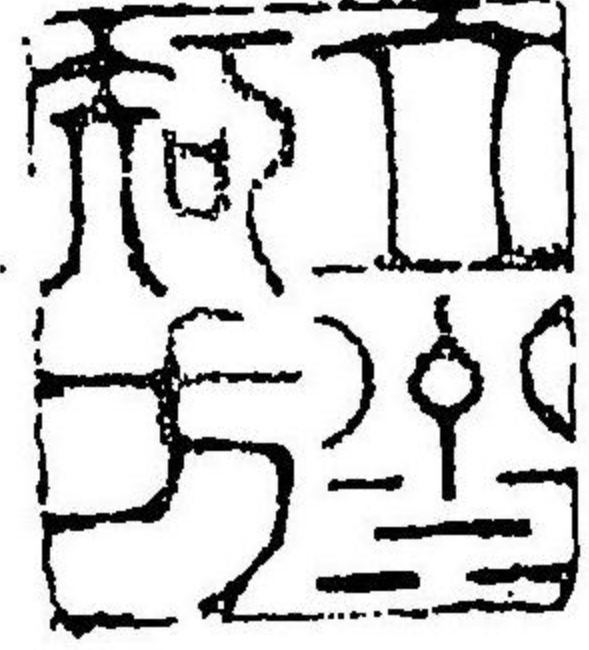

母屋梁の女半

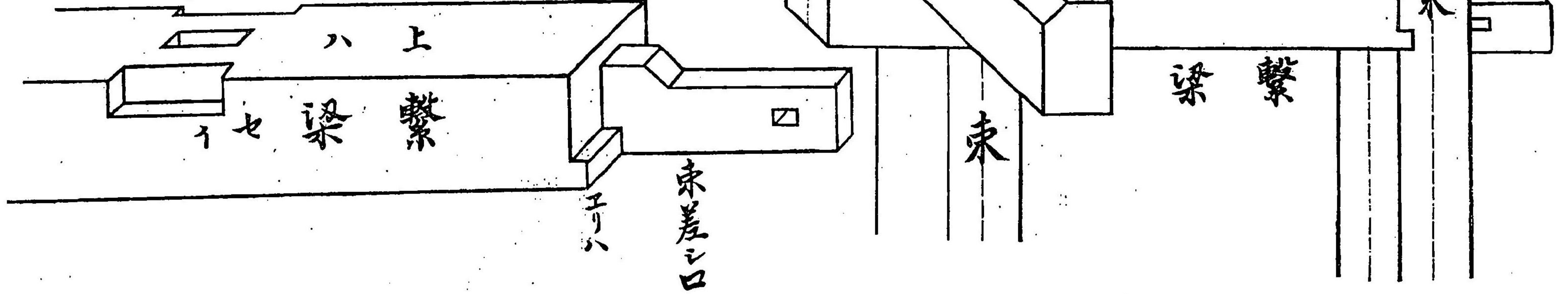

水女

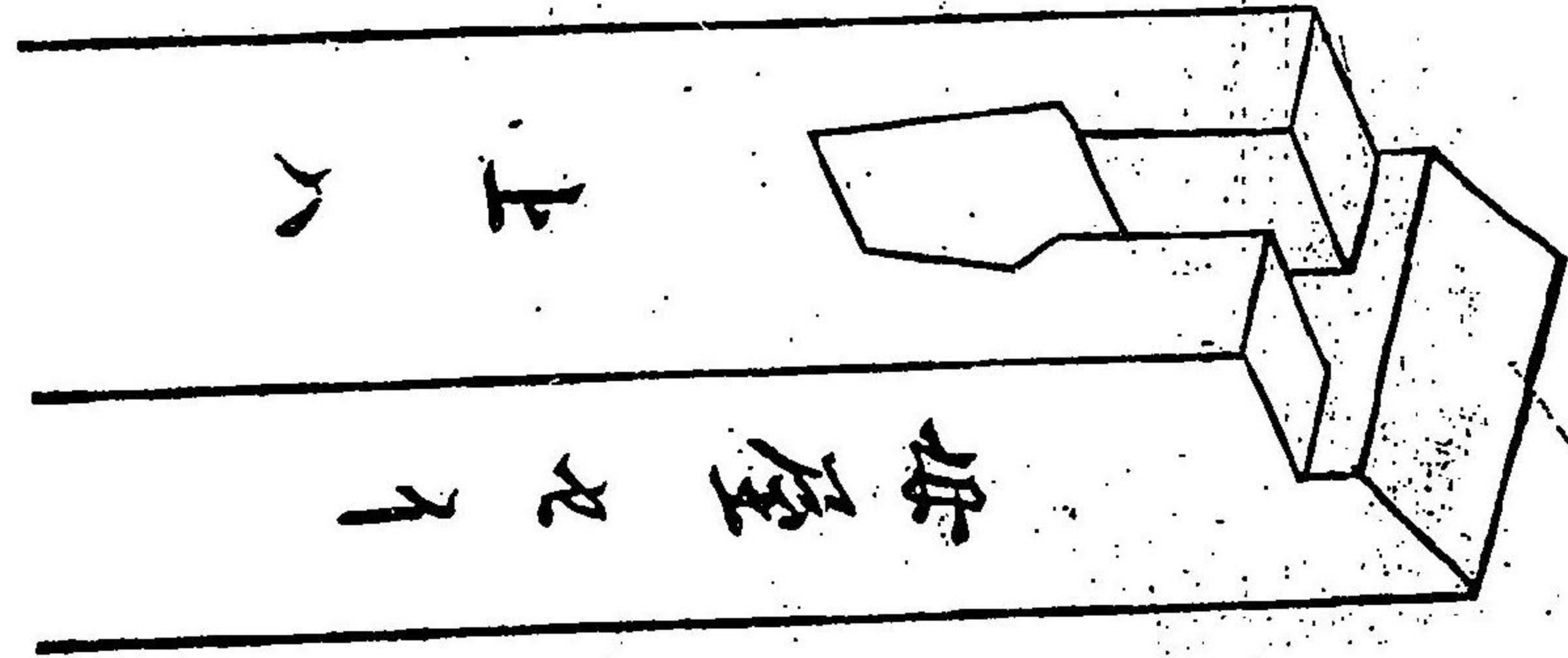

持出敷面録

水男

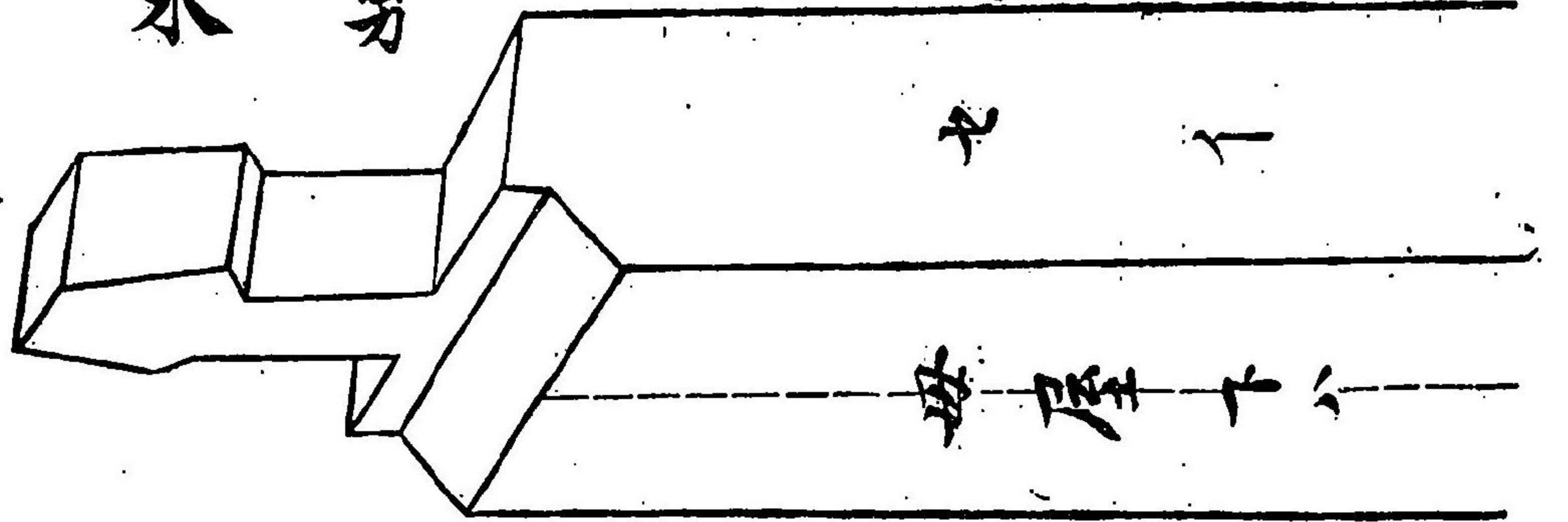



手組隅桁

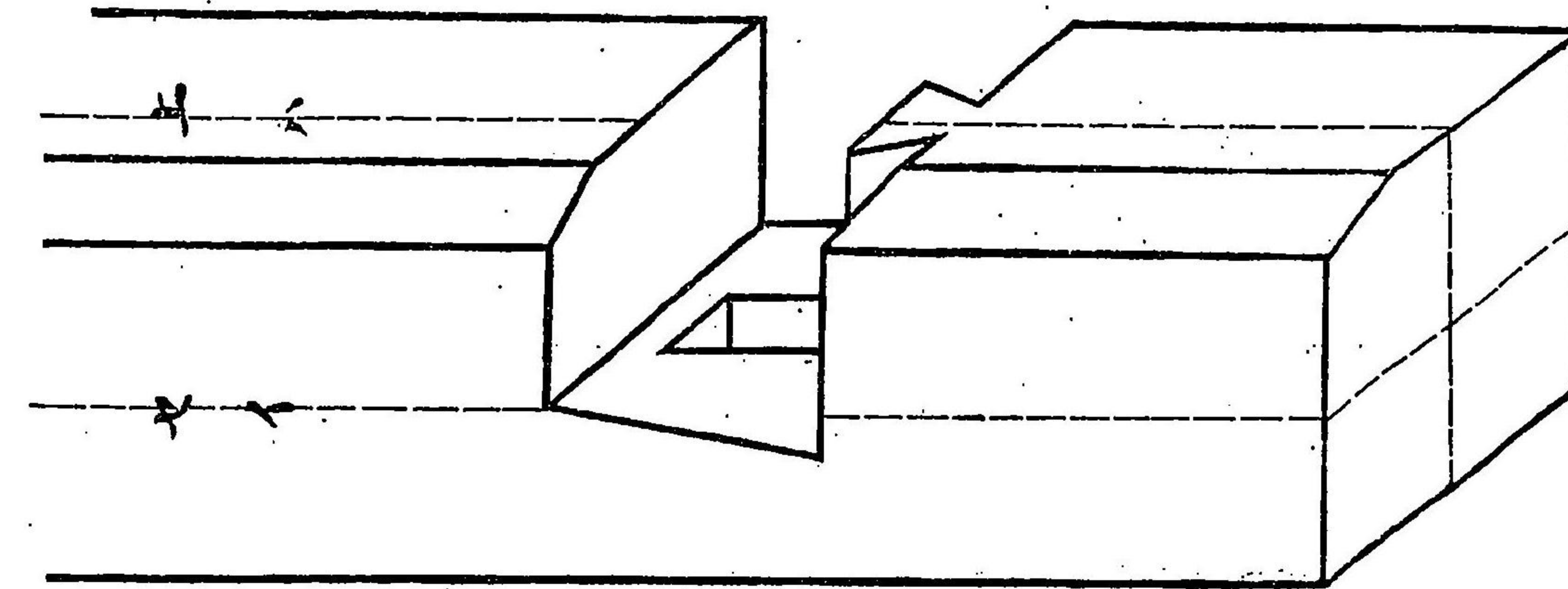

撥、渡梁屋小

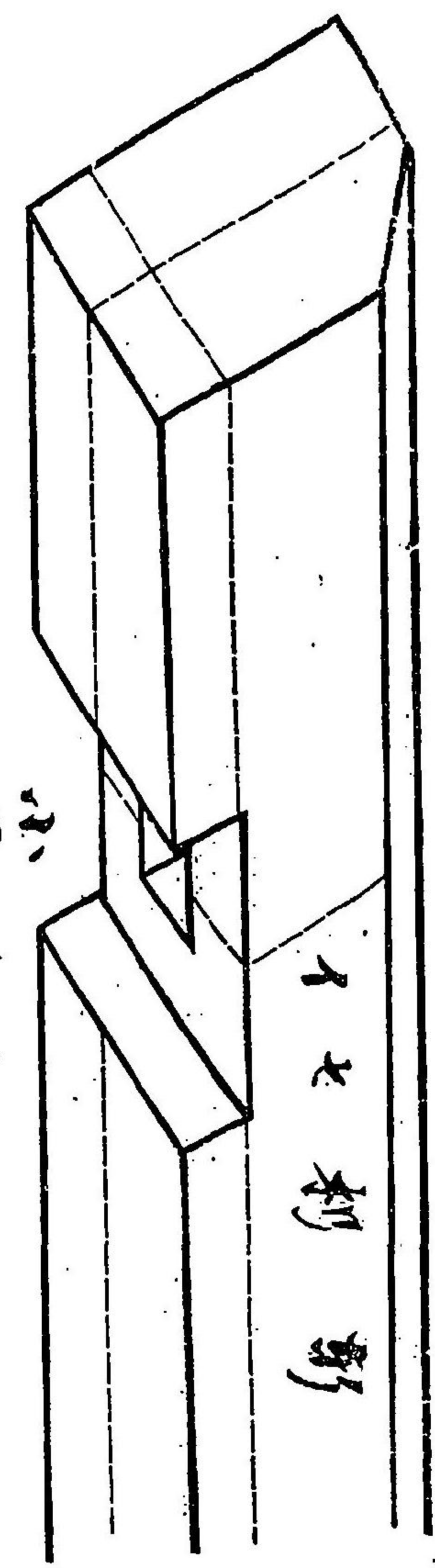

、渡、桁

梁、屋、小

下、梁、置

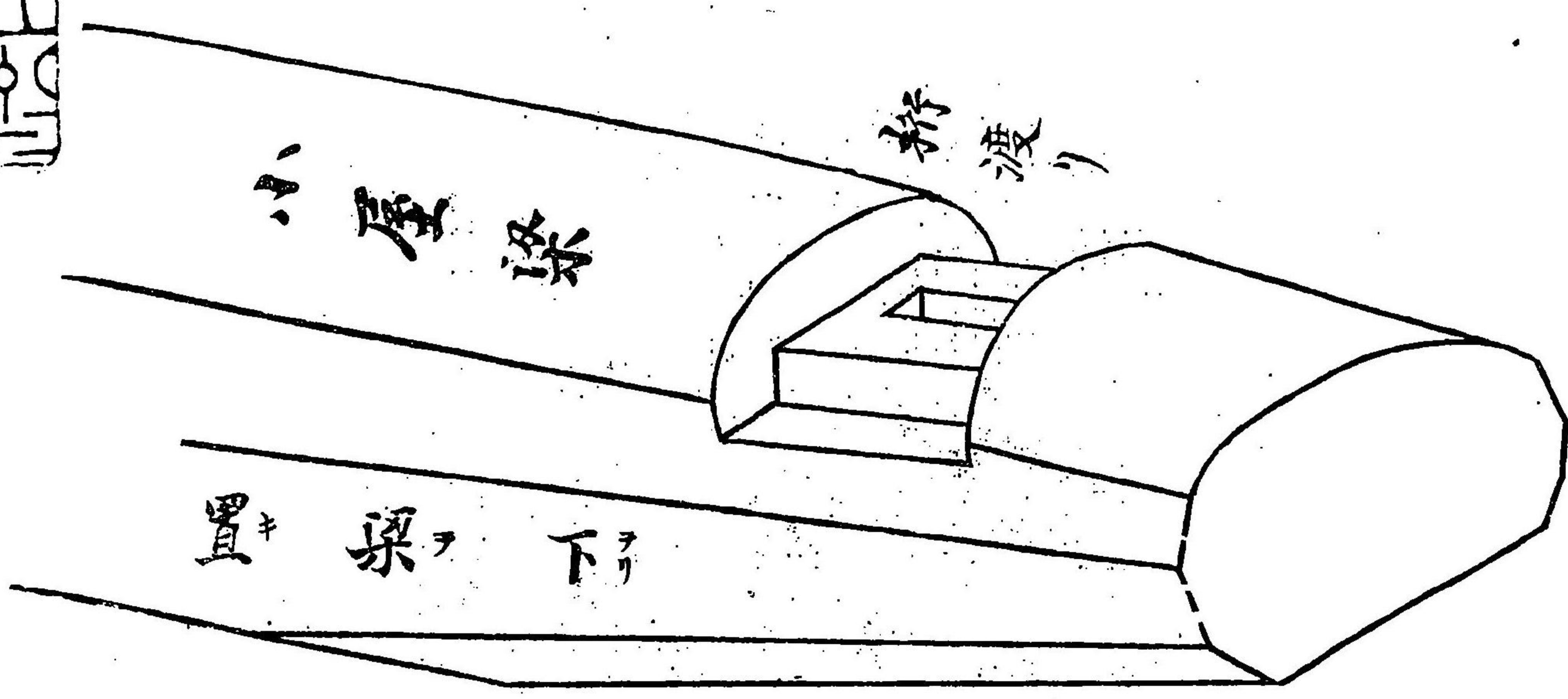



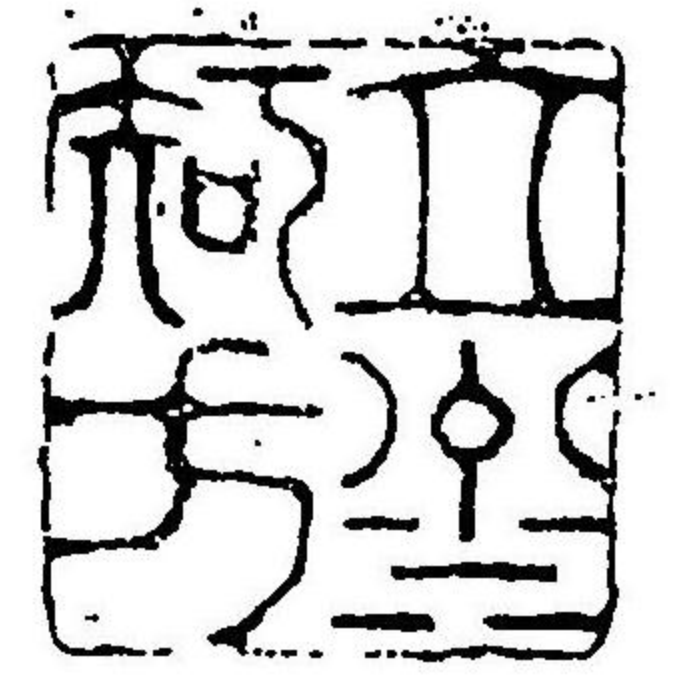
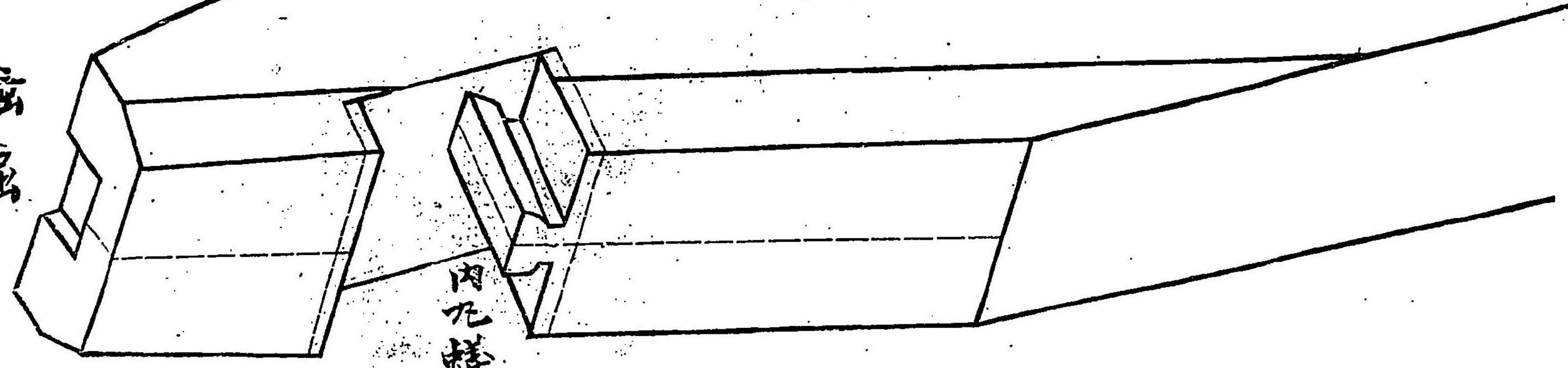
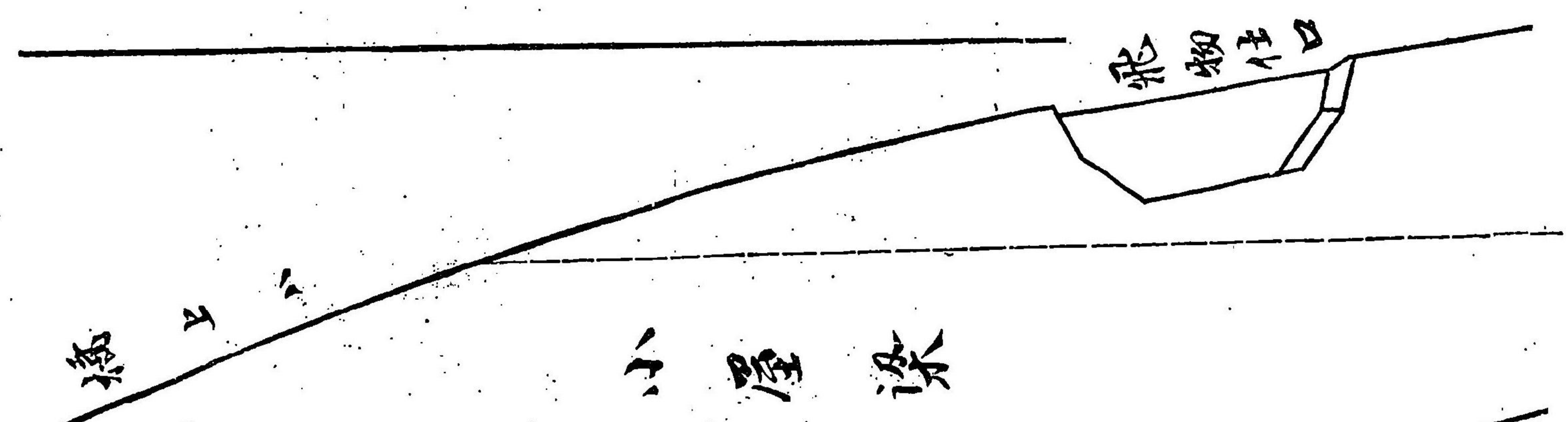
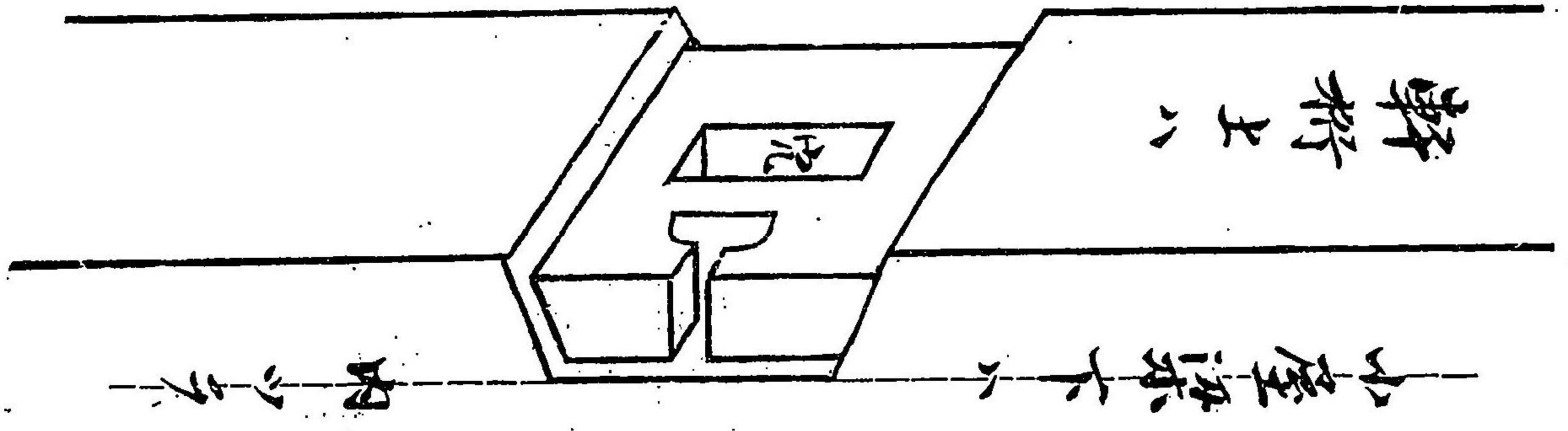

檼

内丸



丸桁隅組手

懸鼻

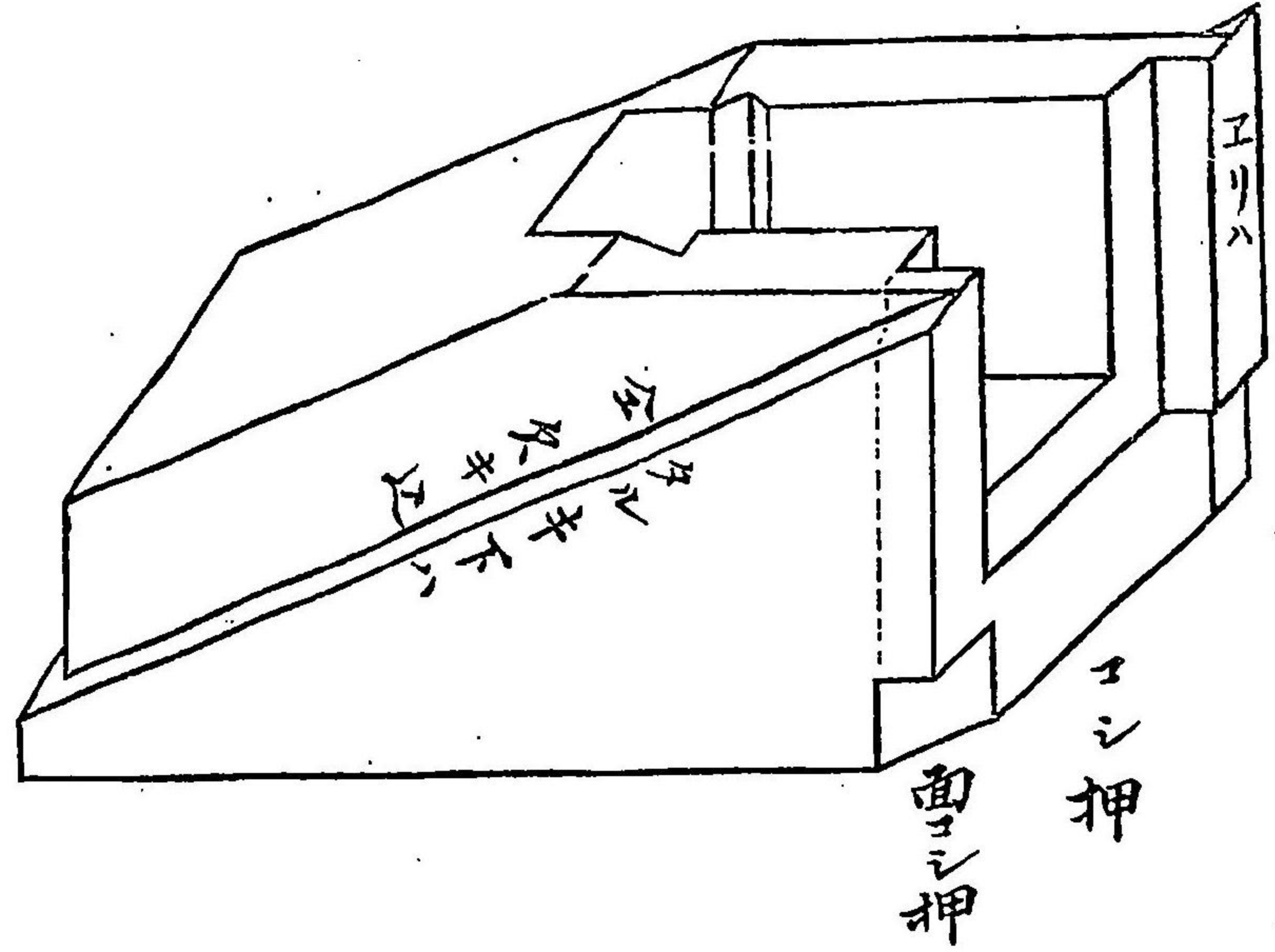
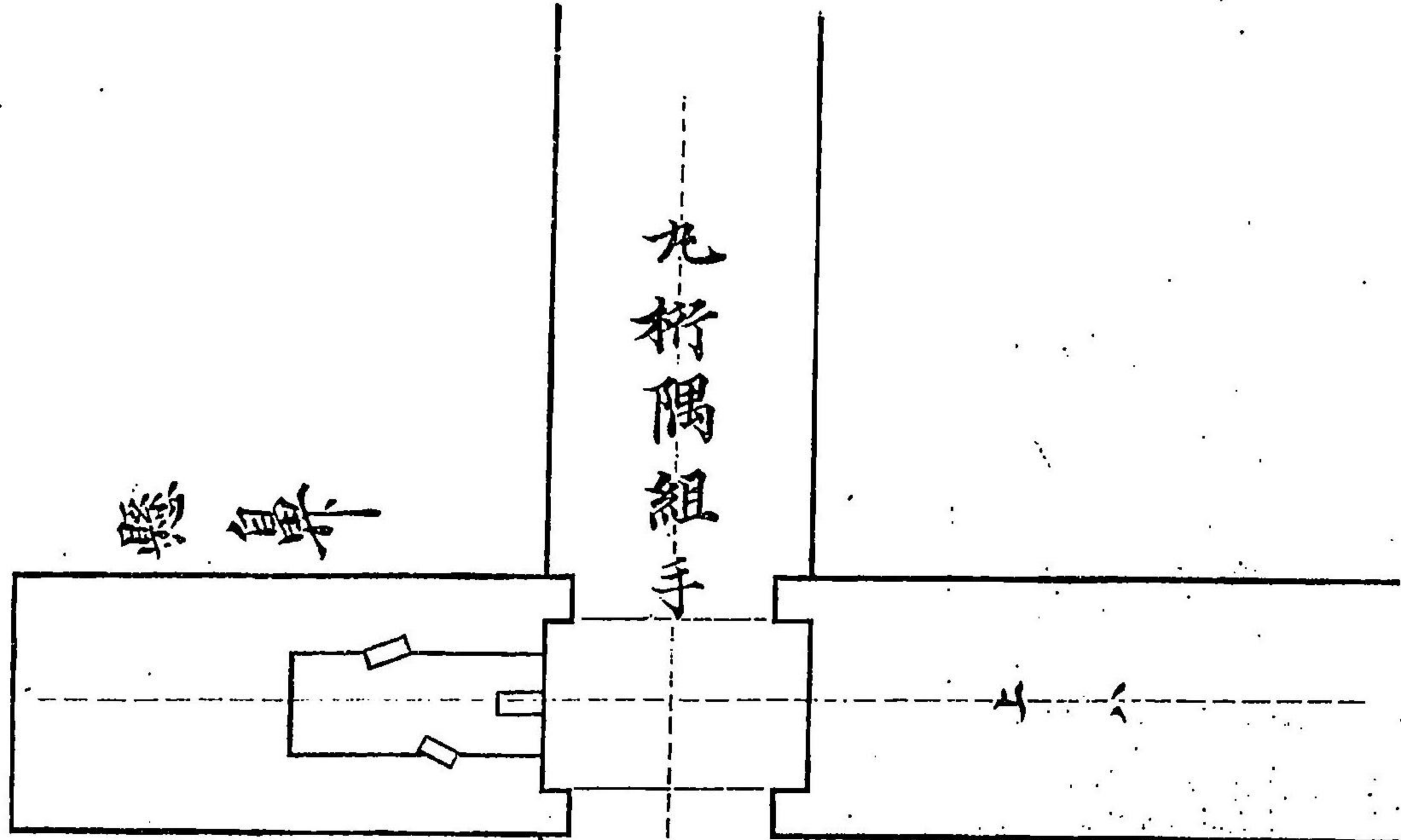

カケ子引ドツ堅メ

差堅メ之圖

上ハ

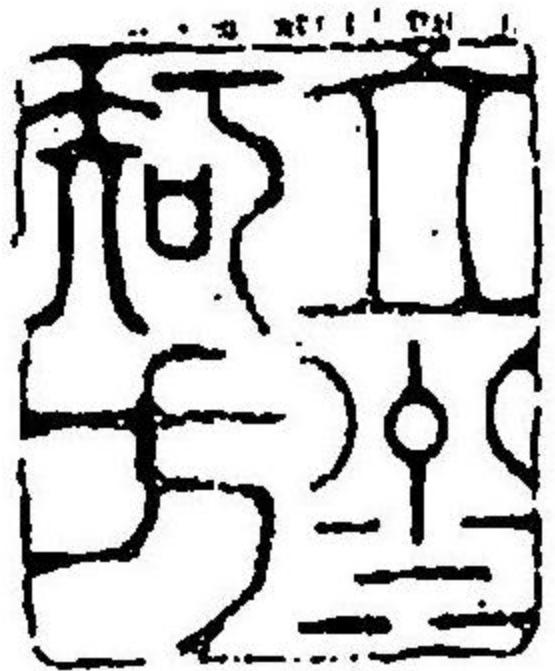
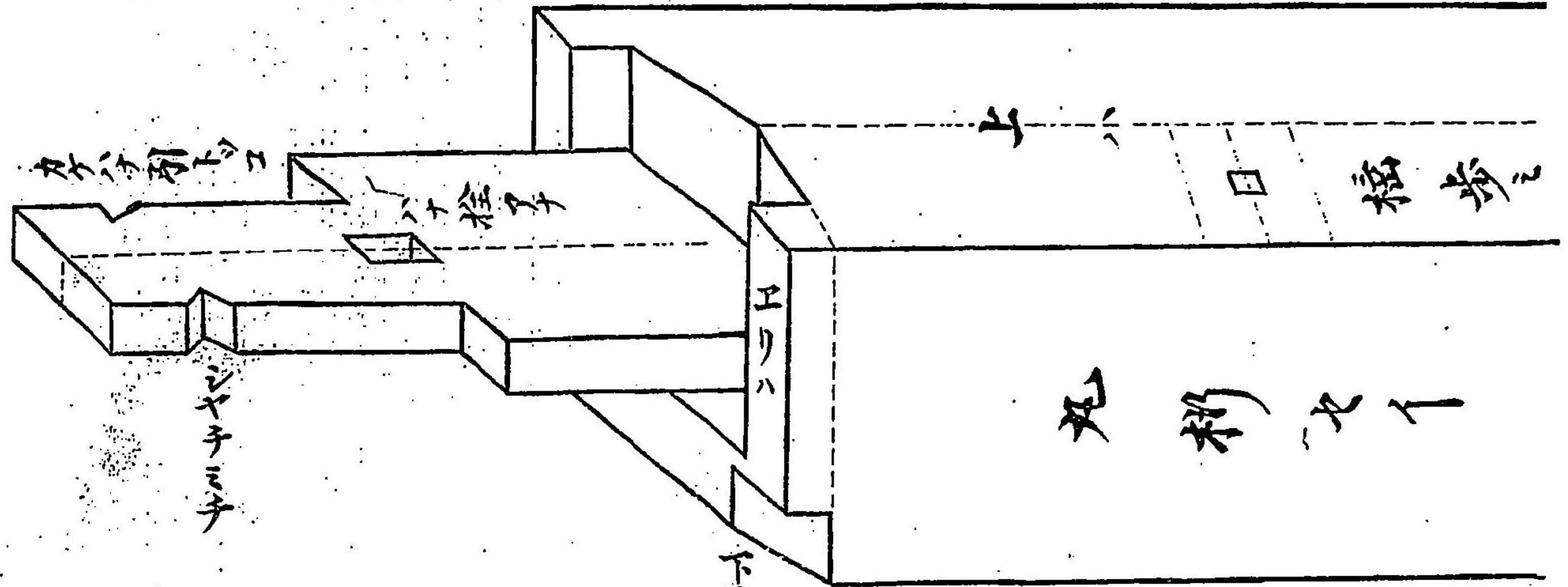



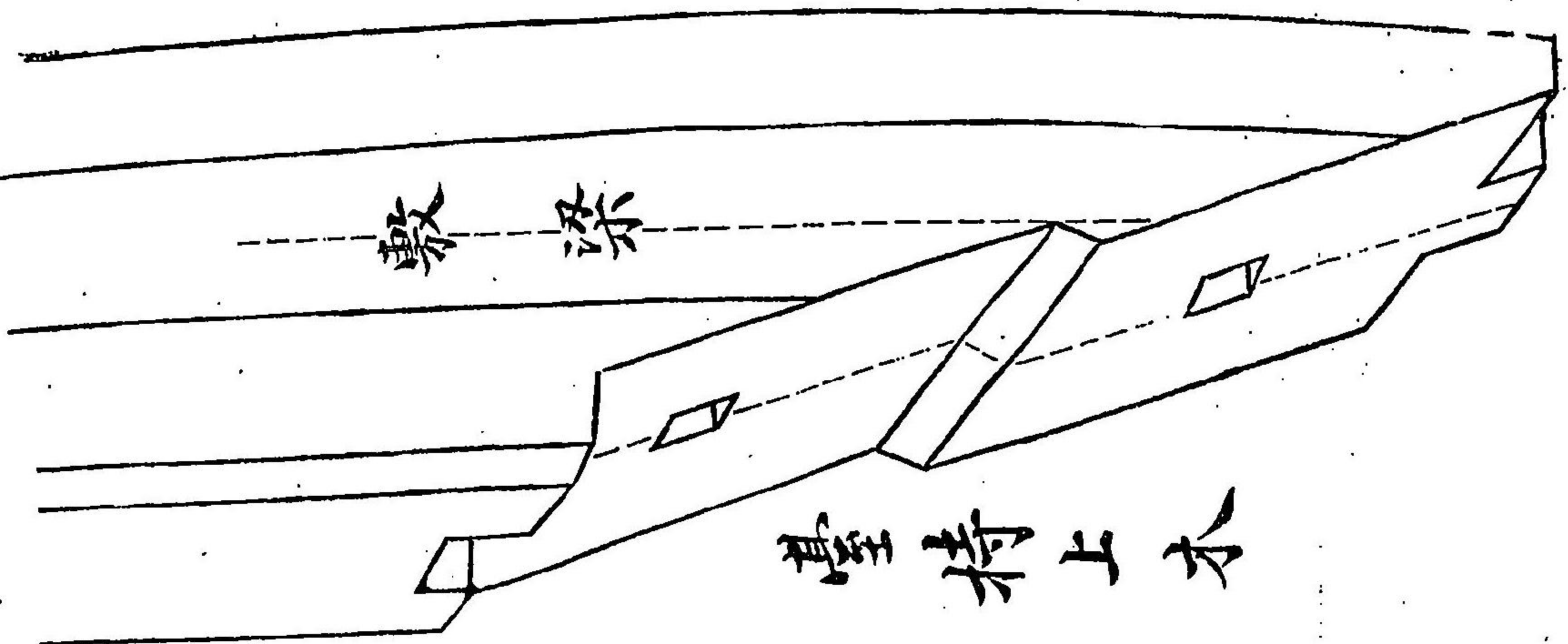

台下木

台下木

This label '台下木' (Daiji Soto-gi) is positioned between the two main diagrams.

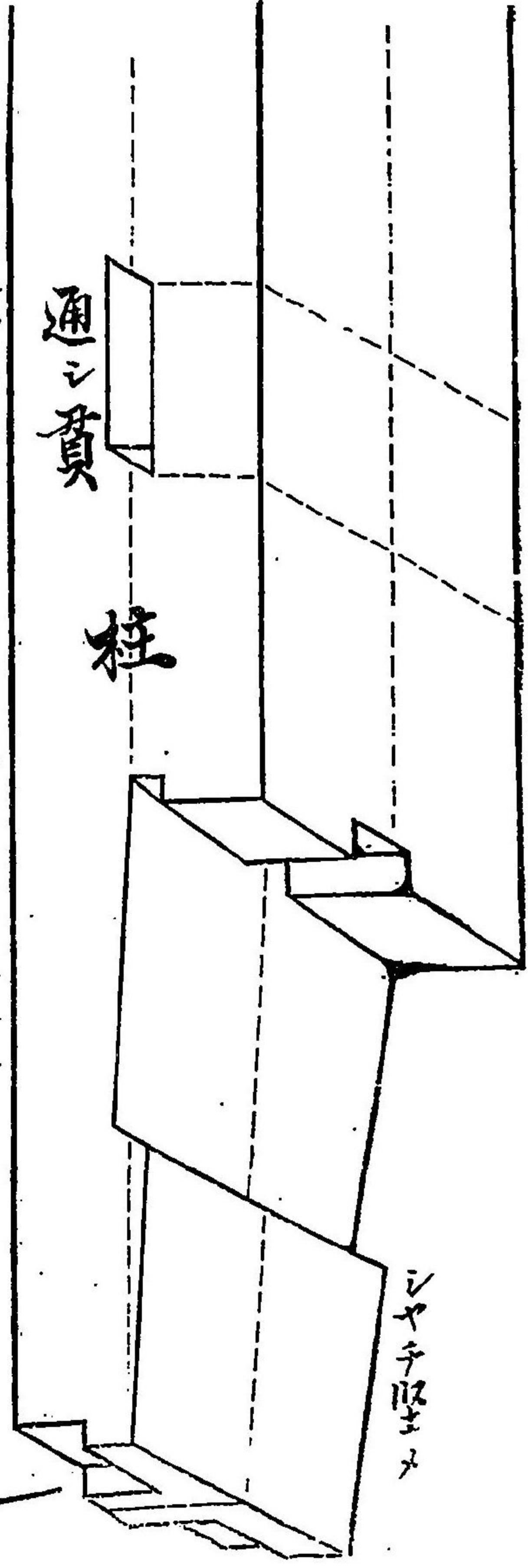
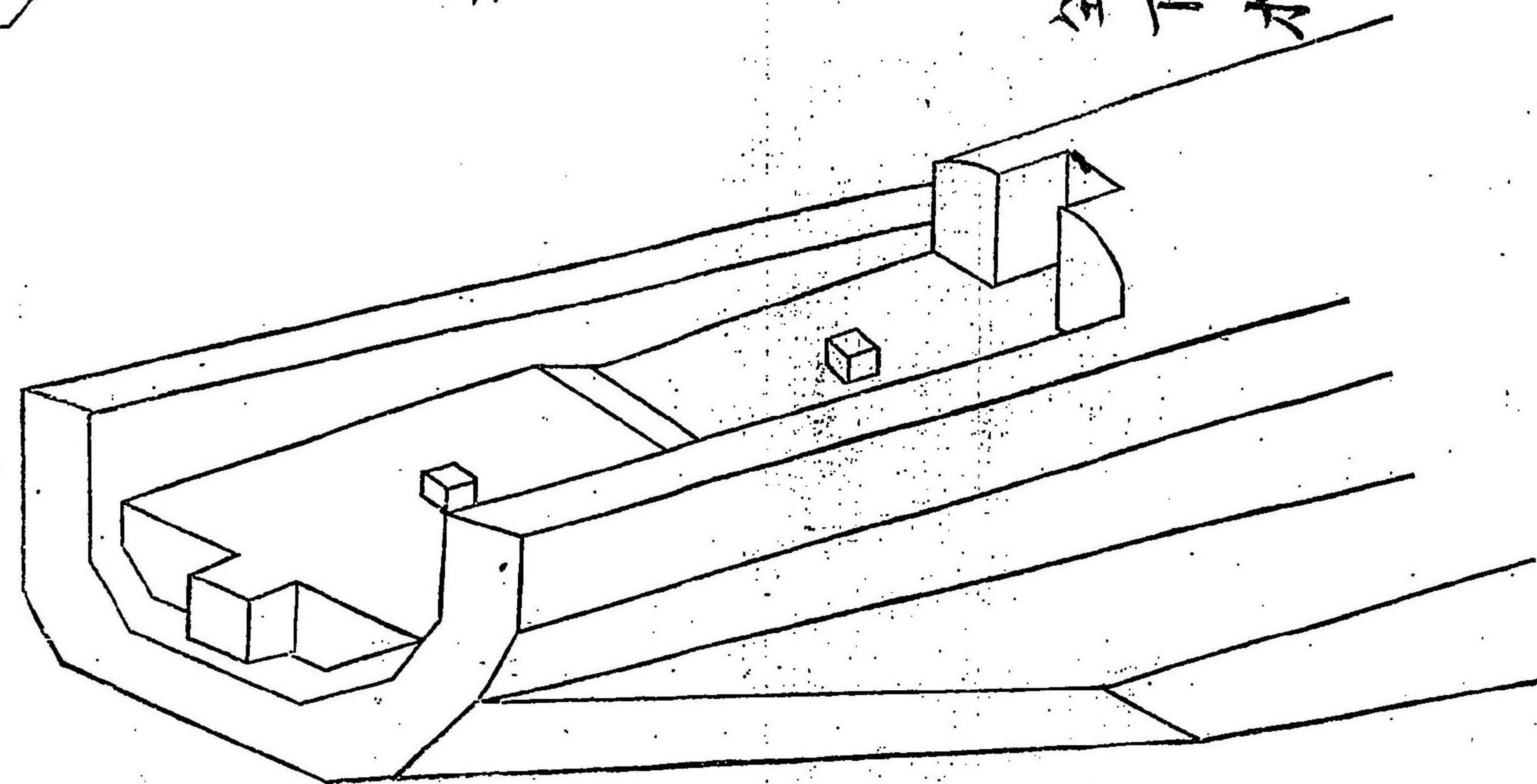



茅負落掛り

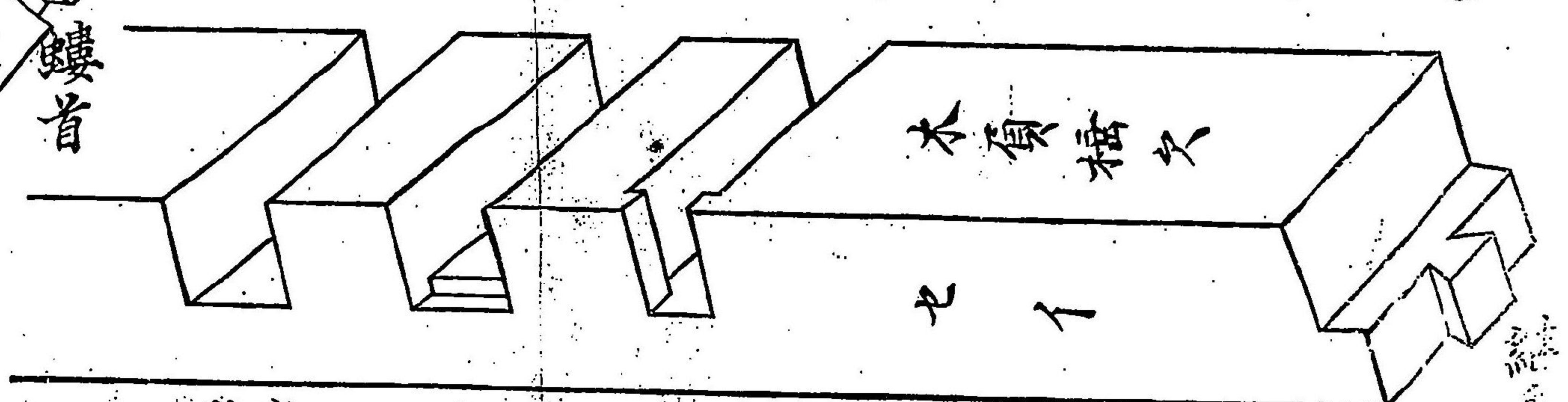
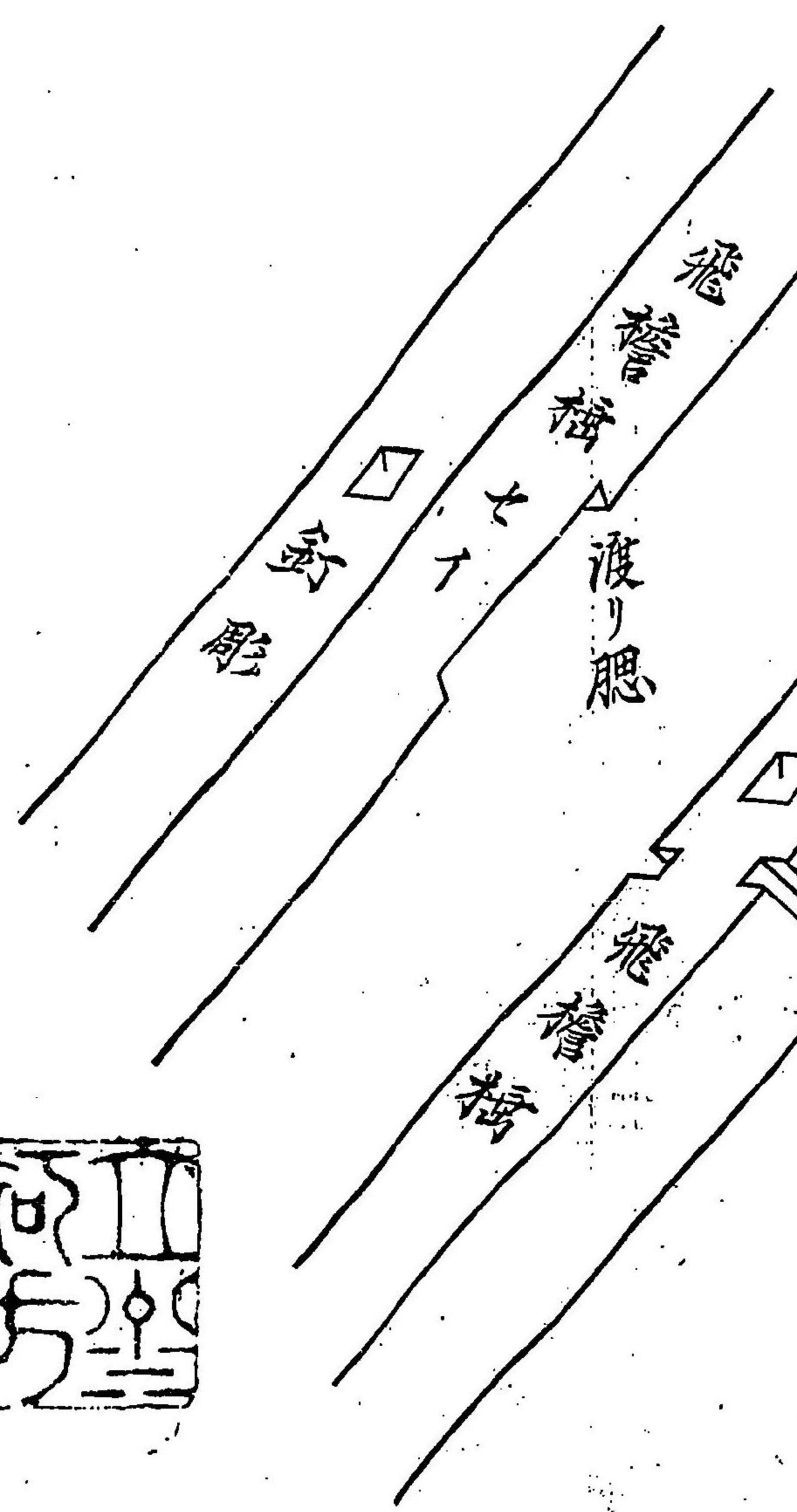
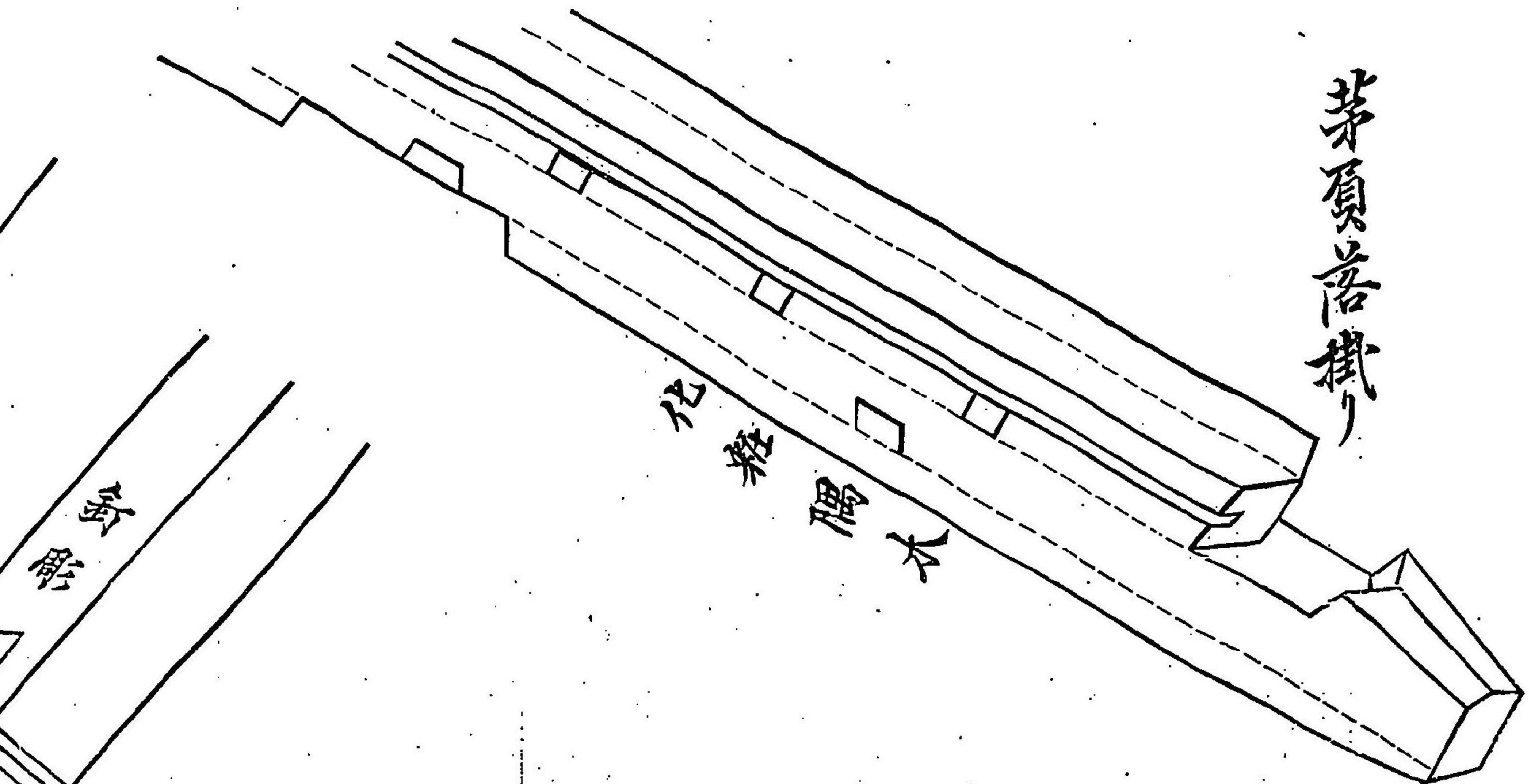

内方  
引懸三欠  
渡り懸  
懸首

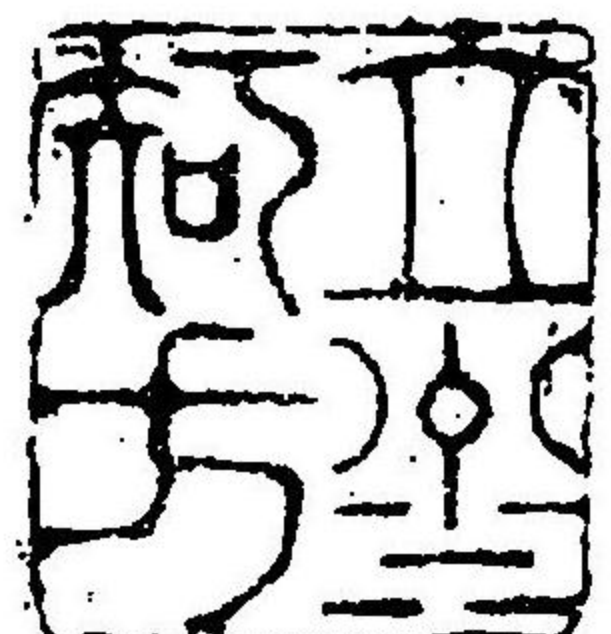



桁上枝輪

木口

野天井板

格天井縁組合間大分三

吸  
付

格  
縁

格板  
爲寸

格  
板

三  
寸半

葺  
茶

竿  
柄  
穴

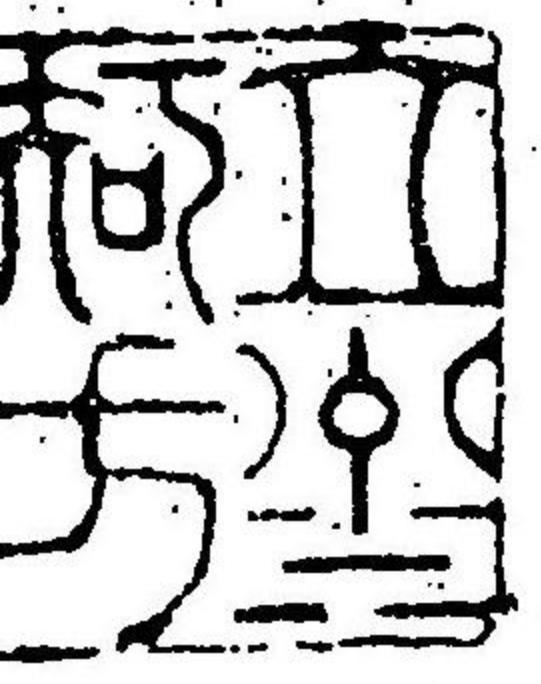

凡格下二

下  
三  
寸







明治二十八年九月廿八日印刷

明治二十八年十月二日發行

正價金六十五錢

東京市京橋區瀧山町拾壹番地

編纂者 故立川知方

全市全町全番地

發行兼印刷者 立川通雄

全市全町拾壹番地

印刷所 開工舍





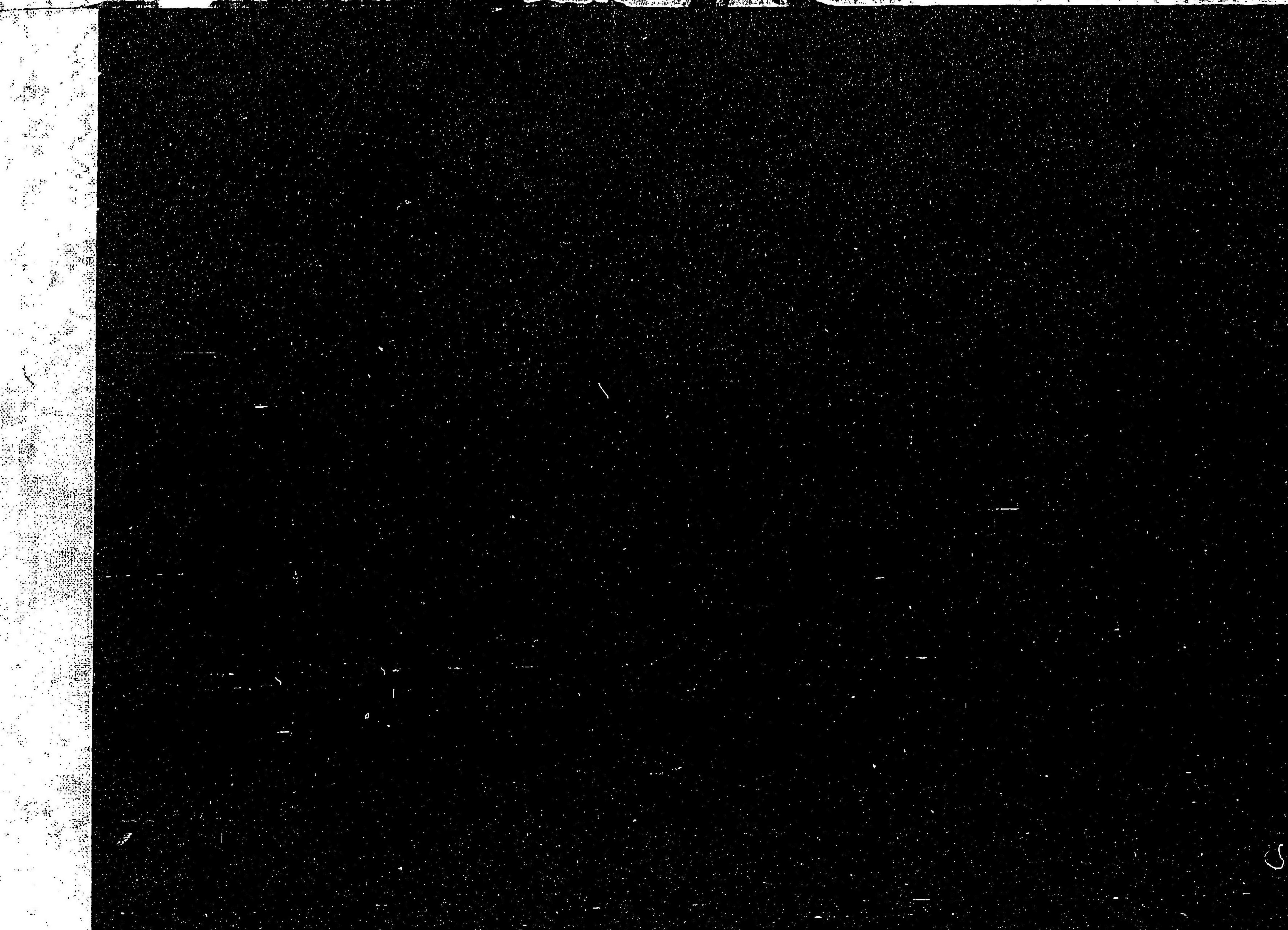



072418-000-5

401-79

立川流匠家矩術倭絵様集

立川 知方／編

M27-28

CEG-0238





