







Digitized by the Internet Archive
in 2007 with funding from
Microsoft Corporation

INDIANA UNIVERSITY

1820-1904

“IT · SHALL · BE · THE · DUTY · OF · THE · GENERAL
ASSEMBLY · AS · SOON · AS · CIRCUMSTANCES · WILL
PERMIT · TO · PROVIDE · BY · LAW · FOR · A · GENERAL
SYSTEM · OF · EDUCATION · ASCENDING · IN · A · REGULAR
GRADATION · FROM · TOWNSHIP · SCHOOLS · TO · A
STATE · UNIVERSITY · WHEREIN · TUITION · SHALL · BE
GRATIS · AND · EQUALLY · OPEN · TO · ALL.”

—*Indiana State Constitution of 1816.*



MAXWELL HALL — ADMINISTRATIVE OFFICES AND LIBRARY (ERECTED 1890)

INDIANA UNIVERSITY

1820-1904

Historical Sketch
Development of the Course of Instruction
Bibliography



EDITED BY
SAMUEL BANNISTER HARDING, PH.D.
JUNIOR PROFESSOR OF EUROPEAN HISTORY

BLOOMINGTON, INDIANA
Published by the University
1904

Wm. B. Burford
Contractor for State Printing and Binding
Indianapolis

Preface

The authorities of Indiana University, after mature deliberation, decided not to make an exhibit at the Louisiana Purchase Exposition at St. Louis—partly for lack of sufficient space, and partly because of the great expense necessary to make an adequate showing. Instead, it was determined to prepare a book which should set forth in permanent form, for those interested, the salient features of the history and present status of the University. Out of this determination arose the present volume.

In the first of the three parts into which the book is divided, are set forth the chief facts in the external history of the institution,—its incorporation in the fourth year after the admission of Indiana as a State into the Union, and the steps by which it passed successively from a Seminary to a College, from a College to a University in name, and ultimately to a University in fact.

In the second part the attempt has been made to trace the development of the course of instruction, from the condition presented in the first catalogue in 1831, to the curriculum as at present arranged. This development, it is believed, is typical especially for Western State Universities; and it is hoped that the careful study which is here presented, may prove a real contribution to the history of education in America.

The third part of the book is given up to a list of publications by the Faculty, alumni, and students of the University. One test—though by no means the sole one—of the efficiency of a University, is afforded by the quality and quantity of the publications put forth by its members. From the data here presented, it is believed that a fairly correct idea may be formed of the character of the intellectual discipline which has been here imparted at different stages of the University's history.

The illustrations, aside from the charts—which show the development of the course of instruction, and the recent growth of the University in comparison with the total body of colleges of Liberal Arts in the United States—have been selected with a view to affording means of judging of

Indiana University

the work of the University at the present time. In addition, therefore, to the ordinary views of buildings, laboratories, and the like, considerable space is devoted to representations of instruments devised for carrying on special lines of work, and to reproductions of photographs and drawings illustrative of results attained by some representative researches in various Departments of the University.

Many persons have assisted in the preparation of this volume. The general plan of the work, which was outlined with reference to a possible exhibit at St. Louis, was submitted to Professor Samuel B. Harding and has been carried out entirely under his editorial supervision. The plan for a study of the University curriculum, which had been developed by a number of preliminary studies, was proposed to Assistant Professor Lewis C. Carson of the Department of Philosophy, and has been carried out by him with painstaking thoroughness. The historical sketch with which the volume opens was compiled by Professor William A. Rawles of the Department of Economics and Social Science. Mr. W. A. Alexander of the Library staff has aided much in the compilation of the bibliography; Professor John A. Miller of the Department of Mechanics and Astronomy, and Professor John A. Bergström of the Department of Education, have superintended the preparation of the charts; Associate Professor Alfred M. Brooks of the Fine Arts Department has rendered aid in the selection of the illustrations; and the proof of large portions of the bibliographical section has been read by Professor Carl H. Eigenmann of the Department of Zoölogy, Assistant Professor Edgar R. Cummings of the Department of Geology, and Associate Professor Carl Osthaus of the Department of German.

WILLIAM LOWE BRYAN,
President of the University.

BLOOMINGTON, INDIANA, July 14, 1904.

Table of Contents

	PAGE
PREFACE	vii
PART I.—HISTORICAL SKETCH	1
By WILLIAM A. RAWLES, Ph.D., Junior Professor of Political Economy	
PART II.—DEVELOPMENT OF THE COURSE OF INSTRUCTION	
By LEWIS CLINTON CARSON, Ph.D., Assistant Professor of Philosophy	
I. INTRODUCTORY	35
II. DEPARTMENTS OF LIBERAL ARTS	
1. THE GENERAL DEVELOPMENT TO 1887	36
2. SPECIAL STUDIES	67
3. THE MAJOR SUBJECT SYSTEM	72
4. DEPARTMENTS AS NOW CONSTITUTED	76
III. RELATION OF THE UNIVERSITY TO THE SCHOOL SYSTEM OF THE STATE	
1. FORMER PREPARATORY DEPARTMENT	149
2. COMMISSIONED HIGH SCHOOL SYSTEM	152
IV. GRADUATE SCHOOL	161
V. SCHOOL OF LAW	167
VI. SCHOOL OF MEDICINE	176
VII. SUMMER SESSION	180
VIII. BIOLOGICAL STATION	183
IX. DEPARTMENTS NOW DISCONTINUED	
1. AGRICULTURAL DEPARTMENT	188
2. NORMAL DEPARTMENT AND MODEL SCHOOLS	189
3. ENGINEERING	191
4. MILITARY DEPARTMENT	192
PART III.—BIBLIOGRAPHY	
I. PUBLICATIONS BY PRESENT MEMBERS OF THE FACULTY	197
II. PUBLICATIONS BY FORMER MEMBERS OF THE FACULTY	225
III. PUBLICATIONS BY ALUMNI AND STUDENTS	251

List of Illustrations

	PAGE
MAXWELL HALL	<i>Frontispiece</i>
DAVID H. MAXWELL, M.D.	3
PRESIDENT ANDREW WYLIE	7
THE OLD COLLEGE	14
OWEN HALL	22
WYLIE HALL	24
KIRKWOOD HALL	26
SCIENCE HALL	28
MEN'S GYMNASIUM	29
STUDENTS' BUILDING	<i>facings</i> 30
CHARTS—Development of the Course of Instruction	48-50
Number of Instructors, Courses, and Hours of Instruction	57
Comparative Increase since 1890 in Number of Undergraduates	68
Comparative Increase since 1890 in Number of Graduate Students	70
Comparative Increase since 1890 in Number of Members of Faculty	71
Ratio of Students to Instructors	74
GREEK—A Recitation Room	76
LIBRARY—General Reading Room	78
Cataloguing Room	79
WALKS IN THE CAMPUS	82-83
HISTORY—Seminary Room	85
ECONOMICS—Hand Grist-mill	87
PHILOSOPHY—Main Lecture Room	89
Neurological Laboratory	89
Preparation Room in Neurology	90
Psychological Laboratory	91
EDUCATION—Pedagogical Museum	92-93
Pendulum Chronoscope	94
Tachistoscope	95
Apparatus for Combined Intervals	96
Apparatus for Experiments upon Memory	97
A New Form of Ergograph	98-99
MATHEMATICS—Seminary Room	100

Indiana University

	PAGE
ASTRONOMY—Kirkwood Observatory	101
Twelve-inch Refracting Telescope	102
Fifteen-inch Reflecting Telescope	103
Photographs of the Moon	104-105
Drawings of Sunspots	106
Nebula of Orion	107
Comet C, 1903	108-109
PHYSICS—Lecture Room	110
Elementary Laboratory	111
Modified Wehnelt Interrupter	112
Brashear Mounting for Rowland Grating	113
Apparatus for the Study of N-Rays	114
CHEMISTRY—Lecture Room	115
Laboratory for Organic and Physiological Chemistry	116
Laboratory for Qualitative Analysis	116
Apparatus for Measurement of Single Potential Differences	117
Laboratory for Electro-Chemistry	118
Laboratory for Bacteriology	118
Rotating Cathode for Rapid Quantitative Analysis by Electrolysis	119
Iodoform from Acetone by Electrolysis	120
Differentiation of Bacillus Typhi Abdominalis and Bacillus Coli Communis	121
GEOLOGY—Research Laboratories	122-123
Geological Museum	124
Mineralogical Laboratory	124
Lecture Room	125
ZOOLOGY—Elementary Laboratory	126
Office and Private Laboratory	127
Models to Illustrate Lectures	128
Embryological Laboratory	128
A Cuban Blind-fish with Unborn Young	129
Ablystoma Opacum	129
South American Fresh-water Fishes	130
Aberrant Spelerpes Maculicanda	131
Leptocephalus of the American Eel	131
Leptocephalus	131
Differentiation of the Eyes in the Blind-fishes of North America	132
Cave Farm near Mitchell, Ind.	133
Photographs of Bird-life	134

List of Illustrations

	PAGE
BOTANY—Laboratory for Plant Physiology	135
Photomicrograph of a Vascular Bundle of Sweet Clover	136
Division of the Hereditary Substance in Reproductive Cells of Higher Plants	137-140
Fecundation of the Egg-cell in the Lily	141
ANATOMY—Private Laboratory	142
Anatomical Laboratory	143
PHYSIOLOGY—Laboratory	144
FINE ARTS—Lecture and Drawing Room	146-147
SCHOOL OF LAW—Law Library	171-172
Moot Court Room	173
BIOLOGICAL STATION—View of Winona Lake, Ind.	183
Lecture Room	184

I

Historical Sketch

“IN AN IDEAL UNIVERSITY, AS I CONCEIVE IT, A MAN SHOULD BE ABLE TO OBTAIN INSTRUCTION IN ALL FORMS OF KNOWLEDGE, AND DISCIPLINE IN THE USE OF ALL THE METHODS BY WHICH KNOWLEDGE IS OBTAINED. IN SUCH AN UNIVERSITY, THE FORCE OF LIVING EXAMPLE SHOULD FIRE THE STUDENT WITH A NOBLE AMBITION TO EMULATE THE LEARNING OF LEARNED MEN, AND TO FOLLOW IN THE FOOTSTEPS OF THE EXPLORERS OF NEW FIELDS OF KNOWLEDGE. AND THE VERY AIR HE BREATHEES SHOULD BE CHARGED WITH THAT ENTHUSIASM FOR TRUTH, THAT FANATICISM OF VERACITY, WHICH IS A GREATER POSSESSION THAN MUCH LEARNING; A NOBLER GIFT THAN THE POWER OF INCREASING KNOWLEDGE; BY SO MUCH GREATER AND NOBLER THAN THESE, AS THE MORAL NATURE OF MAN IS GREATER THAN THE INTELLECTUAL; FOR VERACITY IS THE HEART OF MORALITY.”—HUXLEY.

HISTORICAL SKETCH

The Congress of the Confederation expressed its deep-seated faith in education in three separate acts. The Ordinance of 1785 reserved the sixteenth section of every township of public land "for the maintenance of public schools within the said township;" the Ordinance of 1787 declared that "Religion, morality and knowledge being necessary to good government and the happiness of mankind, schools and the means of education shall be forever encouraged;" and ten days later (July 23, 1787) Congress granted to the Ohio Company two entire townships of land for the support of a university. Thus was inaugurated a policy, the continuation of which made possible the early establishment of an institution of higher education in Indiana. The first action of the Federal Congress affecting immediately the founding of a university in Indiana was an act, approved March 26, 1804 — four years after the Territory of Indiana was organized — providing for the sale of public lands; among other provisions, it reserved one entire township of land, "to be located by the Secretary of Treasury, for the use of a seminary of learning" in Indiana Territory. In 1806, Albert Gallatin designated for that purpose a township in what is now Gibson County. Thereupon the territorial Legislature promptly proceeded to incorporate a university at Vincennes. The institution did not prosper, and when Indiana was admitted as a State its existence was ignored.

Acts of the
United States
Government.

The enabling act of Congress authorizing the formation of a state government for Indiana contained among other items the grant of an entire township to be designated by the President of the United States, in addition to the one previously given, the title to which was to be vested in the Legislature of the State for the use of a seminary of learning.

Indiana University

Action of the
Constitutional
Convention
(1816).

The convention which framed the Constitution under which Indiana was admitted as a State accepted the grants of Congress by a solemn ordinance, passed on the twenty-ninth day of June, 1816, which contains these words: "That we do, for ourselves and our posterity, agree, determine, declare and ordain that we will and do hereby accept the propositions of the Congress of the United States as made and contained in their act" of April 19, 1816; "and we do, moreover, for ourselves and our posterity, hereby declare and ordain that this ordinance and every part thereof, shall forever be and remain irrevocable and inviolate, without the consent of the United States." The State of Indiana is therefore pledged by this ordinance to maintain inviolate the fund derived from this source, and would seem bound to cherish and sustain the institution founded with this endowment, in such a manner that the noble purpose for which this generous gift was made may not be thwarted, but may be realized to its fullest possibilities.

This same convention, as a further indorsement of the broad plan, declared in the Constitution (Article IX, section 2) that "it shall be the duty of the General Assembly, as soon as circumstances will permit, to provide by law for a general system of education, ascending in a regular gradation from township schools to a state university, wherein tuition shall be gratis, and equally open to all."

The circumstances of time and place being considered, these are notable words. In that day it was the accepted theory of education that elementary instruction might properly be undertaken by the State, but that higher education should be left to the control of religious denominations or to individual benevolence. No other State in the Union had then incorporated into its constitution a declaration in favor of a university open to all alike and with free tuition. When, furthermore, the social and material environment is remembered, this broad conception of education seems the more remarkable. At that time barely one-fourth of the land within the State had been purchased from the Indians and thrown open to settlement. There were but thirteen counties represented in the constitutional convention. Settlements were few and far apart. The only means of communication were the uncertain Indian trails, the rough roads, and the waters of rivers and creeks. Even the Ohio River could boast of only two or

Historical Sketch

three small steamboats. The population of the State, all told, did not exceed 65,000. According to the accounts of this early period, the people were for the most part illiterate, impoverished and disheartened. But there were among them men whose minds, though lacking the graces and refinements of the highest culture, had a rude strength combined with acuteness and insight; they were the leaven of the lump. The members of that convention were honest, simple-hearted, unpretentious men, firm in their consciousness of the rights of the common people, clear in their sense of equity

Conditions of
the time.



DAVID H. MAXWELL, M.D.
Foster-father of the University.

and justice, and blessed with that saving quality called common-sense. They believed that education would most surely quicken that unresponsive mass, stimulate the people to greater activity, and inspire them with higher ideals. In that conviction and with prophetic hope they acted. It is a significant fact that the same man who drafted the clause of the Constitution excluding slavery from this State (Dr. David H. Maxwell) is also properly regarded as the "founder of Indiana University" — an institution dedicated to intellectual freedom, whose seal appropriately bears the motto *Lux et Veritas*.

Indiana University

STATE SEMINARY, 1820-1828

The township selected for the support of a university lay in what is now Monroe County, and was later named Perry Township—the present seat of Indiana University. It was stipulated in the Constitution that no lands intended for school purposes should be sold prior to 1820. In the first month of that year an act to establish a State Seminary was passed and received executive approval on January 20, 1820—the date now recognized by the University as Foundation Day. This act named as a Board of Trustees Charles Dewey, Jonathan Lindley, David H. Maxwell, John M. Jenkins, Jonathan Nichols and William Lowe.

Act establishing
a State Seminary
(1820).

Throughout its history Indiana University has been fortunate in having as trustees men who were devoted to the highest interests of the institution and to the cause of education in general. Foremost on this honorable roll should stand the name of Dr. David H. Maxwell. "During the Seminary period, while the institution was struggling for establishment, from 1820 to 1825 especially, he was not only the presiding officer of the board, but was also its executive officer and corresponding secretary, having the erection of new buildings under his supervision, carrying on a heavy correspondence with prominent men throughout the State in behalf of the institution, while having to contend with a disaffected element at home. Solely on behalf of the Seminary he solicited election to the Legislature, and from 1821 to 1826 he was a member of either the lower house (where he was once Speaker) or of the senate, and at all times he was especially interested in watching jealously the affairs of the new Seminary. In the establishment of institutions it seems that the life and services of some one man are paramount and essential. In the establishment of the Indiana Seminary Dr. David H. Maxwell was the essential man."¹

In accordance with the provisions of the law of 1820, the Board of Trustees selected for the Seminary a site in the reserved township. The location of the Seminary upon its own lands would, it was believed, greatly enhance the value of the property and would ultimately increase the revenues of the institution. Two years later the Legislature passed an act authorizing the sale of the Seminary township in Gibson County and directing the appli-

¹James Albert Woodburn, *Higher Education in Indiana* (Washington, 1891), p. 77.

Historical Sketch

cation of the proceeds to the support of the State Seminary. In justification of this apparent confiscation of the property of Vincennes University it was alleged that the trustees of that institution had illegally sold a portion of their land and had permitted their organization to lapse. By the decisions of the Supreme Court of the United States in 1852, and of the Supreme Court of Indiana in 1854, these funds were restored to Vincennes University. In 1826 the General Assembly increased the number of members of the Board of Trustees of Indiana Seminary to nine, and one year later empowered the Board to sell all the Seminary lands with the exception of the three sections contiguous to that section on which the buildings of the Seminary were located.

The Seminary meantime was opened in 1824 under the direction of Rev. Baynard R. Hall, an alumnus of Union College and Princeton Theological Seminary. Professor Hall was for three years the only instructor, and the only subjects taught were Latin and Greek. The number of students during the first three years was, respectively, 13, 15, and 21. In his sketch of the Indiana Seminary the late Judge David D. Banta places the following estimate upon the services of Professor Hall: "The choice [of Principal] could hardly have fallen upon a worthier man. He was an excellent classical scholar and a persuasive and sometimes eloquent preacher. As a teacher, he was enthusiastic, faithful and painstaking."¹ He entered into the pioneer life of the day with sympathy, but saw its rude and often ludicrous side. Under the pseudonym "Robert Carlton" he published in later life (1846) an entertaining account of his experiences, entitled 'The New Purchase, or Early Years in the Far West.'

The Seminary
opened (1824).

In 1828 it was deemed advisable to appoint another instructor to teach mathematics and such of the natural sciences as were considered of "sufficient importance to engage the attention of aspiring youth." John H. Harney, an alumnus of Miami University, was selected to fill this position. The election of Professor Harney elicited from local politicians and other dissatisfied persons a protest to the General Assembly, in which were alleged extravagance and careless and sectarian management. Dr. David H. Maxwell, the president of the Board of Trustees, reported to the Legislature that the salary of Professor Hall was \$250 per year, and that the only

¹Theophilus A. Wylie, *Indiana University* (1890), p. 43.

Indiana University

subjects taught were Latin and Greek. This evidence, together with other statements, seemed to satisfy the Legislature of the economy of management, for it took no action against the Seminary.

Even before the manifestation of dissatisfaction just mentioned, the General Assembly had appointed (January 26, 1827) a Board of Visitors consisting of the Governor, the Lieutenant-Governor, the Judges of the Supreme Court, and nineteen other distinguished men. They were required to visit the school, inspect its records and accounts, examine the students and report to the General Assembly, embodying in their report "any recommendations they may think proper to make of such measures within the competency of the Legislature as may tend to sustain, foster and improve the Seminary aforesaid." In November of the same year the Board of Visitors made its first visit. It reported that "there was but one opinion among the visitors—that more ability to teach was exhibited by the professors and apparent proficiency by the scholars than ever before witnessed on a similar occasion."

Upon this favorable report and the specific recommendations of the Board of Visitors, the President of the Board of Trustees and Governor Ray, the General Assembly proceeded, by an act approved January 24, 1828, to raise the Seminary to the rank of a college. From the Seminary period "no records remain of classes; no records even of names of students in attendance. But the few old men yet living who were students during Seminary times all speak in glowing terms of the activity of the professors and the application of the students."¹

INDIANA COLLEGE, 1828-1838

By the act of January 24, 1828, the "Indiana College" was established for the education of youth in the "American, learned and foreign languages, the useful arts, sciences and literature." The new institution was given authority to confer "such degrees in the liberal arts and sciences as are usually granted and conferred in other colleges in America." The Board of Trustees was increased to fifteen members, and they were empowered to fill vacancies in their own number. Provision was made for a Board

¹Judge D. D. Banta, in Theophilus A. Wylie's *Indiana University* (1890), pp. 45-6.

Historical Sketch

of Visitors consisting of five persons. Freedom of religious opinions was guaranteed to professors and students, and the teaching of sectarian principles was forbidden.

For the responsible work of organizing and developing the new college the Board of Trustees chose Rev. Andrew Wylie, D.D., at that time President of Washington College, Washington, Pennsylvania. At the age of twenty-one Mr. Wylie was graduated from Jefferson College, Canonsburg,

Dr. Andrew
Wylie elected
President
(1829).

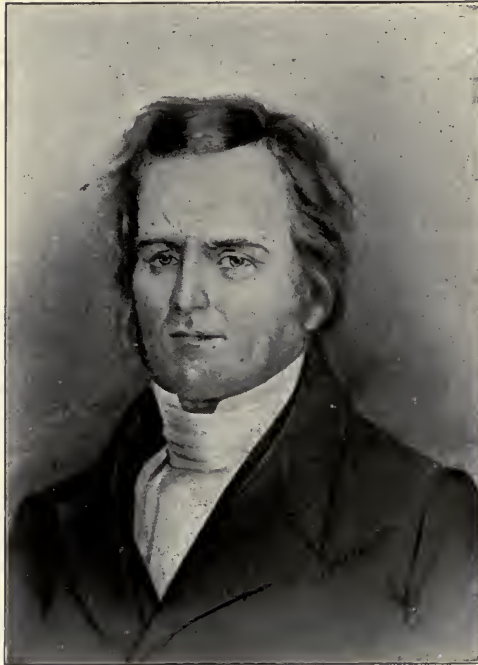

ANDREW WYLIE, D.D.
President of the University, 1829-51.

Pennsylvania, and immediately appointed a tutor in his alma mater. About a year later he was elected President of that institution; and in 1817 he was made President of Washington College. In these positions he displayed marked abilities as an administrator and a teacher.

The effect of Dr. Wylie's election to the presidency of Indiana University, together with the change in the rank of the institution, was soon appar-

Indiana University

Other members
of the Faculty.

ent in an enlarged faculty, an expanded curriculum, added buildings and an increased number of students. Dr. Wylie, in addition to his duties as President, gave instruction in moral and mental philosophy, political economy and polite literature. Rev. Baynard R. Hall, the former Principal of the Seminary, was retained as professor of ancient languages; while Professor John H. Harney occupied the chair of mathematics, natural and mechanical philosophy, and chemistry. Mr. W. H. Stockwell was superintendent of the Preparatory Department, which was established in 1829 because the secondary schools of the State were inadequate to prepare students for entrance to the College.

When the first College catalogue was published in 1831, there were 60 students in attendance. In the following year, owing to the existence of some trouble in the Faculty and among the students, Professors Hall and Harney resigned, and the number of students fell off, but recovered quickly in the next year. To fill the vacancies in the Faculty, Ebenezer N. Elliott, a graduate of Miami University, was appointed professor of natural philosophy and chemistry, and Beaumont Parks, a graduate of Dartmouth College, professor of languages. In 1836 Professor Elliott resigned to accept the presidency of Mississippi College. The following appointments were then made: James F. Dodds, an alumnus of Indiana College, as professor of mathematics; Augustus W. Ruter, an alumnus of Augusta College, Ky., as professor of Greek and French; William R. Harding, a graduate of Trinity College, Dublin, as principal of the Preparatory Department; and (in 1837) Theophilus A. Wylie, a graduate of the University of Pennsylvania, as professor of natural philosophy and chemistry.

The character of the students of that period is thus described by Dr. T. A. Wylie, whose connection with the institution was long and intimate: "Many of the students were young men brought up on farms, and used to hard work. They came to Bloomington, generally on their own resources, depending on money they had earned or borrowed. It was not unusual for students to attend to their studies for a year and then absent themselves for the same length of time in order to earn money by teaching or otherwise, and to return to complete their college course. Out of this kind of material have many of the graduates been made, who have done honor to their alma mater and their country."

Historical Sketch

In 1836 a new and more commodious building was completed for the College. It has been described as resembling "an old-fashioned New England cotton mill," but it at least furnished additional space for actual work.

INDIANA UNIVERSITY, 1838-1904

The importance of the College, the growth of the State, and the need for instruction in the professions of law and medicine induced the General Assembly in 1838 to enlarge the scope of the institution and to transform it into a university. By an act of February 25, 1838, Indiana College became the Indiana University, with authority to grant additional degrees in law and medicine. The Board of Trustees was to consist of the Governor of the State and twenty-one other members; but three years later the number was again reduced to nine.

Act establishing
the Indiana Uni-
versity (1838).

Dr. Wylie continued as President of the enlarged institution, and exhibited during his administration still greater power as an executive. But for two or three years the University did not make much progress. In 1839 the Faculty consisted of three members, including the President; and in the following year there were but 64 students. The year 1840 proved a turning point in the University's history. In that year was erected another building adapted to the use of the Department of Natural Philosophy and Chemistry. Lieutenant Jacob Ammen, a graduate of West Point and at that time professor of mathematics in Jefferson College, Mississippi, was appointed professor of mathematics in Indiana University; and John I. Morrison, an alumnus of Miami University, was made professor of languages. Professor Ammen organized a Military Department, which, however, was discontinued soon after his resignation in 1843. By that year the number of students had increased to 115. Upon the resignation of Professors Ammen and Morrison in 1843 their places were filled respectively by the appointment of Professors Alfred Ryors and Daniel Read, both of Ohio University.

After several ineffectual attempts a Law School was established in 1842 by the election of Judge David McDonald as professor of law. Under Judge McDonald and his successors the law school prospered for many years, and added materially to the number of students in attendance. During the last ten years of Dr. Wylie's administration the University enjoyed

Indiana University

a high degree of prosperity. The Faculty and the Board of Trustees acted in harmony; outside interference ceased; and the institution commanded more and more the respect and confidence of the public.

Dr. Wylie's long and successful administration ended with his death on November 11, 1851, from an attack of pneumonia. His place in the history of the institution is thus summed up:

"Dr. Wylie's services to Indiana in the capacity of first president of her University, are not easily estimated. As a class-room instructor he disciplined the minds and molded the characters of young men for useful service in the State. By his personal power he attached every student who had received the benefit of his tuition, to the welfare of the University. As a public educator and lecturer, and as a man among the people, he performed an enormous amount of labor in making known to the citizens of the State, and of other States as well, the advantages of higher education. He thus popularized the University and gave it strength in its appeals for legislative support."¹ That he had great magnetic force is shown by the fact that when he came to Indiana College he was followed by many young men from Pennsylvania and Virginia who had come under his influence while he was teaching in the East; during his entire presidency there was a large attendance at the University of men from the South, even from the Gulf States. Dr. Theophilus Parvin, formerly professor in Jefferson Medical College of Philadelphia, and a pupil of Dr. Wylie, assures us "that the students of Dr. Wylie are guilty of no blind idolatry, or no idolatry at all, when they declare that in ability he was one of the first men in all the country." It is interesting to have estimates of his character from his co-workers in the Faculty. Judge David McDonald, professor of law, in speaking of him, used the following language: "Andrew Wylie was a man of truth. He was so not merely because of his views of policy, but because he loved the truth. In thought, in word, in action, he was truthful; and no man during a long life ever pursued the truth with more unwearied search through all the fields of learning and science." Professor T. A. Wylie gives the following estimate: "He had many strong friends, and there were also some bitterly opposed to him. Those intimately acquainted with him will not find it difficult to account for this trait of

¹J. A. Woodburn, *Higher Education in Indiana*, p. 80.

Historical Sketch

character. He was tolerant and patient to a fault of everything but meanness and duplicity. A person in whom he had no confidence he would keep at arm's length, and although policy might dictate an opposite course he would hardly treat one thus regarded with common courtesy. He would never, to use his own expression, 'throw a sop to Cerberus.' On the other hand, to those in whom he had confidence, no one was more affable. There was sometimes, however, an apparent want of civility, a brusque manner." This was due, our authority informs us, to his habit of so concentrating his thought upon the subject in mind that he scarcely noticed any one or anything else.

Such was the character of the man who shaped the University during its formative period and touched the lives of young men as if with a magic wand, arousing within them aspirations for scholarship, truth and service. The list of alumni of this period is illumined with the names of James S. Rollins, founder of the University of Missouri and prominent in the politics of that State; James Wilson Dunn, lawyer, business man, Lieutenant-Colonel of volunteers; William McKee Dunn, lawyer, Congressman, brevet Brigadier-General and Judge Advocate General of the United States Army; Andrew Wylie, Justice of the Supreme Court of the District of Columbia, 1863-1884; James Darwin Maxwell, physician and member of the Board of Trustees of Indiana University, 1860-1892; Parker Campbell, banker, sugar planter, and Major in the Confederate Army; John S. Watts, Chief Justice of the Territory of New Mexico; William Mitchell Daily, President of Indiana University, 1853-1859; Addison Locke Roache, Judge of the Supreme Court of Indiana; Joseph A. Wright, Governor of Indiana, 1849-1857, United States Senator from Indiana, and Minister to Prussia; George Grover Wright, Chief Justice of the Supreme Court of Iowa, United States Senator from Iowa, 1871-1877; Richard Taylor Allison, lawyer, Paymaster in the United States Navy under Commodore Perry in his expedition to Japan in 1854, and later Paymaster in the Marine Corps of the Confederate States; William Alexander Parsons Martin, missionary, diplomatist, President of the Imperial College, Peking, author and translator, and mandarin of the third rank; Russell Bigelow Abbott, President of Albert Lea College, Minnesota; Theophilus Parvin, professor in Jefferson Medical College, Philadelphia, and a noted medical author; Michael Steele Bright, lawyer and

Some Alumni of
this period.

Indiana University

banker; John Henry Wise, Deputy Collector of the port of San Francisco, wool and commission merchant; George D. Wise, lawyer and statesman; Obadiah Jennings Wise, editor of the Richmond (Va.) Enquirer, Captain in the Confederate Army; John James Wise, physician and Captain in the Confederate Army. To this list might be added the names of many others, who won distinction in law, medicine, education or business, or in humbler walks spent their lives in the service of their fellow-men, true to their youthful ideals.

The Constitution of Indiana adopted in 1851 does not expressly refer to Indiana University as a State institution, but it does declare that "all trust funds held by the State shall remain inviolate, and be faithfully and exclusively applied to the purpose for which the trust was created." At the first session of the General Assembly under the authority of the new Constitution, the University was explicitly "recognized as the University of the State." (Act of June 17, 1852.) In 1852 the Federal Government made an additional grant of 4,166 acres for the use of the University; this yielded in time about \$10,000, but the proceeds were not immediately available.

The vacancy caused by the death of President Wylie in November, 1851, was not immediately filled by the Board of Trustees, and for that school year Professor Daniel Read and later Professor Theophilus A. Wylie acted as President. The permanent position was first tendered to Dr. John H. Lathrop, Chancellor of Wisconsin University, and upon his declination a similar offer was made to the eminent educator, Henry Barnard of Connecticut. Owing to a carriage accident Dr. Barnard was compelled to decline the invitation, and Rev. Alfred Ryors, D.D., who had been professor of mathematics in 1844-48, and was now President of Ohio University, was elected to the office.

Dr. Ryors began his administration under inauspicious conditions. The University was involved for a number of years in the suit with Vincennes University over the Seminary lands in Gibson County, which terminated adversely to Indiana University. The decision of the Supreme Court of the United States threatened to curtail the revenues of the institution, and the number of students declined. Still more discouraging and annoying to President Ryors was the presence of a disaffected and intriguing element

Presidency of
Dr. Alfred Ryors
(1852-53).

Historical Sketch

in the Faculty and Board of Trustees. So great was the disappointment of Dr. Ryors that within six months after his coming he tendered his resignation, but upon the earnest request of the President of the Board he withdrew it. The situation, however, did not improve, and at the end of his first year he again presented his resignation, which was then accepted. Dr. Ryors was a man of fine attainments and had been very successful both as a disciplinarian and as an instructor, in the position of President of Ohio University. His presidency of Indiana University was too brief and was begun under circumstances too unfavorable to leave the permanent impression which was properly anticipated from a man of his talents.

The only important change made during his administration was the establishment of a Normal Department under the management of Professor Read, which was discontinued after Professor Read's resignation in 1856.

Rev. William Mitchell Daily, D.D., an alumnus of the class of 1836, was next chosen President, which position he filled from 1853 to 1859. Under his presidency the University progressed favorably, until a disastrous fire in April, 1854, completely destroyed the main building, the University library of 1,200 volumes, and the furnishings and libraries of the students' literary societies. This was a severe blow to the institution; but the loss of material equipment was more than compensated for by the zeal and loyalty of the students, alumni, Faculty, Board of Trustees, and citizens of Bloomington. The Board of Trustees within three weeks appointed a building committee. The people of Bloomington and Monroe County subscribed \$10,000. A sale of scholarships was authorized by the Board, and the subscriptions were made convertible into scholarships which entitled the holders to free tuition. Money was borrowed, and a new building was ready for use in 1855. The nucleus of a new library was acquired through liberal donations of books from Mr. Henry W. Derby, a bookseller and publisher of Cincinnati, and from Mr. W. H. Jones, of Ft. Wayne.

Presidency of
Dr. William M.
Daily (1853-59).

In 1856 the Federal Government donated to the University about 22,000 acres of land in this and in other States to make up the loss occasioned by the decision of the United States Supreme Court in respect to the Gibson County lands. Thus the financial basis of the University was made more solid, and the material equipment enlarged and modernized. At the same time the inner life of the institution was enriched by the coming of two



THE OLD COLLEGE (ERECTED 1855)

The only building now standing on the old college campus. Since 1897 the property of the city of Bloomington, and used for the Bloomington High School.

Historical Sketch

men who for nearly thirty years gave their services and the inspiration of their lives to the University. In 1854 Elisha Ballantine, of Ohio University, came to Indiana University as professor of mathematics; two years later, upon the resignation of Professor Read, he was transferred to the professorship of languages. At the same time Daniel Kirkwood, then President of Newark College, Delaware, was made professor of mathematics.

In the resignation of Professor Daniel Read, to accept the professorship of ancient languages in Wisconsin University, Indiana University suffered a loss. Dr. Read was an excellent scholar, a superior teacher and a man of practical affairs. His energy and diplomacy were of great value during the dark days of the early fifties. He was a member of the Constitutional convention of 1850-51, and took an active part in the deliberations of that body, especially upon all questions relating to education.

Dr. Daily was untiring in his efforts in behalf of the University. He was much liked by the students on account of his kindly disposition and his interest in their welfare. But because of some untoward circumstances, resulting in a trial in an ecclesiastical court, in which charges were brought against Dr. Daily, and a popular clamor excited, which he feared might be injurious to the University, he handed in his resignation January 27, 1859, which was accepted. During the remainder of the college year Professor T. A. Wylie again served as temporary President.

In this period another change should be noted in the law governing the number and appointment of Trustees. In 1855 the number of members of the Board was reduced to eight—the present number—and the power to fill vacancies in their body, which they had had from 1838, was taken away and vested in the State Board of Education.

In 1859 Dr. Lathrop was again offered the presidency of Indiana University, and this time accepted, although he occupied the office but one year. With the exception of an increase in the number of professors and tutors no important changes were made during that time. In 1860 Dr. Lathrop resigned to accept a professorship in Missouri University, of which institution he had been the first President, from 1840 to 1849.

Dr. Cyrus Nutt was elected President in 1860, and at once took up the duties of the office. His formal inauguration occurred on June 7, 1861, at which time Governor Oliver P. Morton delivered the address of investiture.

Presidency of
Dr. John H. La-
throp (1859-60).

Indiana University

Presidency of
Dr. Cyrus Nutt
(1860-75).

The outbreak of the Civil War inevitably reacted disastrously on the growth of the University in President Nutt's administration, as is seen in the record of attendance. In 1860 the number of students enrolled, exclusive of those in the law and preparatory departments, was 99; in 1861 it rose to 112; in 1863 it fell to 67. After the close of the war, the ground lost was steadily recovered, and by 1869 the number of students had risen to 182.

One of the first questions to occupy the attention of President Nutt and the Board of Trustees was the disposition to be made of Indiana's portion of the public lands granted to the several States, by an act of Congress of July 2, 1862, for the establishment of "Colleges for the benefit of agriculture and the mechanic arts." Indiana received as her share of this donation the land scrip of 390,000 acres, from which was realized by sale and by careful management of the proceeds about \$340,000. Three propositions for the use of this trust fund were considered by the Legislature: (1) the endowment of agricultural departments in some five of the leading colleges of the State, including a central institution of research at Indianapolis; (2) the founding of a separate agricultural college; (3) the establishment of an Indiana State Agricultural College in connection with Indiana University. Dr. Nutt and the friends of the University labored zealously for the adoption of the third plan. The claim of Indiana University would probably have been stronger if the Board of Trustees had previously established an agricultural department, which they had authority to do under an act passed by the Legislature in 1852. All arguments, however, were overpowered by the generous gift of \$150,000 by John Purdue of Lafayette, and donations of \$50,000 by Tippecanoe County and 100 acres of land by the town of West Lafayette, conditioned upon the location of the institution at West Lafayette.

However, at about this time Indiana University received an indorsement from the State Legislature which was full of significance. Prior to 1867 the University had received no money from the treasury of the State. In that year an important innovation was made. The General Assembly, recognizing that the "endowment fund of the State University" was "no longer sufficient to meet the growing wants of education and make said University efficient and useful," and believing that "it should be the pride

Historical Sketch

of every citizen of Indiana to place the State University in the highest condition of usefulness, and make it the crowning glory of our present great common school system," appropriated \$8,000 to the use of the University, and in 1873 increased the amount of the annual appropriation to \$15,000.

The most important innovation during this period was the admission of women to all the rights and privileges of the University on equal terms with men. Hon. Isaac Jenkinson, then a member and now President of the Board of Trustees, had advocated this change for several years, but for some time he had stood alone. In the year 1867 Miss Sarah Parke Morrison, without any knowledge of the discussion upon the subject within the Board of Trustees, presented a petition to that body requesting that the privilege of attendance at the University be granted to women. This brought the question to a focus, and by a vote of four to three the petition was granted. Miss Morrison entered the University the next fall, and was graduated with the class of 1869. To Mr. Jenkinson is due the credit for this advanced step. At that time no other State University had adopted the system of co-education; although Oberlin University and two other institutions of collegiate rank were committed to such a policy, Indiana University was, among the State Universities, the pioneer in this movement.

Admission of
Women to the
University
(1868).

In 1868 the Military Department of the University was revived under the control of Major-General Eli Long, who began his work in 1869. In the following year he was recalled by the War Department, and Colonel James Thompson was appointed professor of military science and engineering. For two or three years considerable interest was shown in military training; but on account of the time required and the inconvenience to many students their zeal declined and greater emphasis was put upon the civil engineering. In 1875 the military training was discontinued, but Colonel Thompson remained as professor of civil engineering. An effort at this time to secure the construction of a gymnasium proved unsuccessful.

For some time the University had felt the need of a Medical Department, but because the University was in a small town it was deemed inadvisable to establish a department at Bloomington. In 1871 an arrangement was made with the Indiana Medical College by which that school became the

Indiana University

Medical Department of Indiana University; and for a few years it was recognized in the annual catalogues as a part of the University. The connection, however, was not close, and in 1877 it was completely severed.

Commissioned
high school
system begun
(1873).

Of scarcely less importance than the admission of women to the University was the attempt made in 1873 to establish a more intimate connection between the University and the High Schools of the State. The framers of the first Constitution had as their ideal a system of education extending from the graded schools to the University; this had been only partially realized. There existed a hiatus between the common schools and the University, because of the narrow field of the Preparatory Department and the small number of High Schools that were capable of doing work of a high grade, especially in Greek. In 1873 the State Board of Education and a convention of school superintendents and teachers recommended to the Board of Trustees that an increased amount of mathematics and science be accepted as an equivalent for the Greek required for admission, and that the High Schools prepare students for admission to the University. The Board acceded to this request, fixed the minimum standard for admission, and agreed to admit to the University, without further examination, all applicants bearing certificates of a satisfactory examination in the required subjects from certain High Schools, to be thereafter designated by the State Board of Education. As soon as the arrangement went into effect, twenty-one High Schools were chosen and commissioned by the State Board of Education to prepare students for admission to the Freshman class. While the number of commissioned High Schools did not increase very rapidly, a standard was set to which the better High Schools tried to conform. It was not until the presidency of Dr. David Starr Jordan that the importance of this relation was fully appreciated and the unification made more perfect.

During this period the Faculty was enlarged, and there were several changes in its personnel. The most notable of these was the appointment in 1863 of Colonel Richard Owen as professor of natural philosophy and chemistry. In 1864 he was transferred to the chair of physics and chemistry, and in 1868 to the professorship of natural science and chemistry.

This increase in the number of instructors, and the growth in the attendance, reaching 182 in 1869, caused a demand for better equipment and

Historical Sketch

accommodations. From the beginning of the annual appropriations by the State in 1867, considerable sums of money were spent upon apparatus and materials for use in the departments of physics, chemistry and natural science. In 1870 the extensive cabinet of the distinguished geologist, David Dale Owen, of New Harmony, was purchased by the University. In order to utilize this valuable collection advantageously and to afford adequate accommodations for the library, the law school and the scientific departments, it was determined to erect a new building, which was completed in 1874.

After fifteen years' service, Dr. Nutt resigned June 30, 1875. During his administration many important changes were made, but in most cases they originated with, and their details were worked out by, the Board of Trustees.

In September, 1875, Dr. Lemuel Moss, who had a few months before resigned the presidency of the old Chicago University, was elected President, and at once assumed, under favorable auspices, the duties of the office.

Presidency of
Dr. Lemuel Moss
(1875-84).

In the next year the relation between the Indiana Medical College and the University was terminated, and in 1877 the Law School was discontinued after an honorable existence of thirty-five years. Inasmuch as tuition was free, according to a ruling of the Board, the funds of the University did not justify so large an expenditure of money as was needed to maintain these schools with high standards.

The administration of Dr. Moss saw a further expansion of the college course. The course leading to the degree of Bachelor of Science had existed as early as 1854; in 1867 this course was enlarged. In 1878 an additional course leading to the degree of Bachelor of Letters was introduced, which permitted the substitution of French or German in place of the Greek in the classical course.

Another innovation of this period was the introduction of courses of special lectures given by the most eminent scholars in science and letters. Among these special lecturers were Professor George F. Barker, M.D., LL.D., of the University of Pennsylvania; President James B. Angell of the University of Michigan; Richard A. Proctor, B.A., of Cambridge, England; and Professor William T. Harris, LL.D., now Commissioner of Education, Washington, D. C.

Indiana University

The people of the State showed their increasing confidence in the University by the provision made in 1883 for the first permanent endowment of the institution out of State funds. For this purpose the Legislature in 1883 authorized an annual levy of a tax of five mills on each one hundred dollars' worth of taxable property in the State, to be continued for thirteen years. From the operation of this law there was realized a fund of \$358,333, the interest on which amounts to \$21,500 annually.

In the summer of 1883 the University again suffered a severe loss from fire. Science Hall, with practically all of its contents—the library of 13,000 volumes, the apparatus of the physical and chemical departments, the museum, and the private collections of Dr. David Starr Jordan, then professor of biology—was totally destroyed. The calamity at first seemed overwhelming. But the President, the Faculty, the Board of Trustees, and the loyal friends of the University turned their faces resolutely towards the future. It was a crisis of great import. The momentous question was whether the University should be continued on the old site, with its narrow limits and the annoyances from the noise of the railroad, or whether a new site should be selected which would afford relief from the existing vexations and give wide opportunity for future growth. After careful deliberation the Board of Trustees determined upon removal, and a beautiful tract of land known as Dunn's woods, lying on the east edge of the town, was purchased. With \$20,000 insurance money, and the liberal donation of \$50,000 from Monroe County, the erection of buildings was begun in April, 1884, the cornerstone being laid June 10th in that year.

Until the new buildings were ready for occupation, the regular work of the University was continued in the one building still remaining on the old site. Notwithstanding the difficulties occasioned by the cramped quarters and the inadequate equipment of the library and the laboratories, the students were enthusiastic and patient, and the attendance in the Collegiate Department during the first year after the fire was only 24 less than that of the previous year, and in the second year but 10 less; while in the next year it was even 35 more than in the last year preceding the fire.

On November 8, 1884, the resignation of Dr. Moss was announced. Rev. Elisha Ballantine, formerly professor of Greek, was made temporary president, serving until January 1, 1885. Dr. Moss was a man of great

Removal of the University to a new site (1885).

Historical Sketch

intellect and power, and an eloquent preacher. As a teacher he made a deep impression upon his students. While the University made progress under his administration, it was still essentially a college with the old ideals and methods.

The usefulness of the old forms and methods should not, however, be misunderstood. That the range of subjects was restricted, that the equipment of laboratories was meager, that the opportunities for investigation were lacking, must be admitted. But it must not be inferred that the efforts at this time were fruitless. In spite of all difficulties the young men and women who were graduated during the days of the College acquired a discipline and a culture which made it possible for them to enter upon careers crowned with success and honor. In some part, at least, the want of a variety of courses was compensated for by the close and often intimate relation between the student and the teacher. The contact with such men as Professors Wylie, Owen, Ballantine and Kirkwood was a liberalizing and inspiring influence which wrought in the minds and hearts of the youth subtle and abiding changes.

Nevertheless it must be admitted that Indiana University had not kept pace with the younger universities of neighboring States. There was needed an infusion of new and vigorous blood—a rejuvenation which would put the institution in touch with the modern movement in higher education—a need fully supplied in the administration next following, that of David Starr Jordan.

On January 1, 1885, Dr. David Starr Jordan, professor of biology in the University, entered upon his duties as President, in succession to Dr. Moss. His administration was the beginning of a new epoch in the history of the University, in which it was raised to the level of other State Universities and to an honorable rank among the leading institutions of the country. The chief means by which this was accomplished was the "reorganization of the curriculum to the form in which it now stands, a form which harmonizes individuality with thorough work, and secures an education at once broad and of specific content."

Dr. Jordan's conception of a university is stated clearly in his own words: "The highest function of the real university is that of instruction by investigation. The essential quality of the university is the presence

Presidency of
Dr. David
Starr Jordan
(1885-91).



OWEN HALL (ERECTED 1884)

One of the first two buildings erected on the new college campus.

Historical Sketch

in its Faculty of men qualified to do university work. It matters not how many or how few the subjects taught, or what may be the material equipment of the teacher, the school in which study and investigation go hand in hand is in its degree a university." It was this ideal which determined the course of his entire policy in the modification of the curriculum and in the selection of his staff of instructors. It was his plan to choose as professors young men fresh from the best schools where opportunities for graduate work of the best type were offered. He believed that these men, imbued with the spirit of investigation, would instil into their own students the desire for research work. His expectations were amply realized.

Many changes in the personnel of the Faculty were made during his administration. This was due in part to the fact that as the success of the young teachers became known they were called to more responsible and more lucrative positions elsewhere. But their places here were in turn filled by men of the same stamp.

Second in importance only to the reorganization of the curriculum was the service of Dr. Jordan in articulating more closely the University and the High Schools of the State, and in popularizing the University without lowering its standard. In the belief that the High Schools had attained such a position that they could offer the secondary instruction necessary for admission to the University, the Preparatory Department was abolished in 1890. The number of commissioned High Schools was increased rapidly, and the quality of their instruction was improved. In this way the influence of Dr. Jordan touched not only the University but the High Schools and even the common schools of the State.

The Preparatory
Department
abolished (1890)

In 1885 the buildings on the new campus—Owen Hall, Wylie Hall and a frame chapel building now called Mitchell Hall—were ready for occupation. In 1890 was erected the present Maxwell Hall, used for the library and the administration offices. Under Dr. Jordan's care the equipment of the chemical, physical and zoölogical laboratories was increased in quantity and improved in quality.

In 1889, after a discontinuance of thirteen years, the Indiana University School of Law was re-established with Judge David Demaree Banta as Dean. Since that time it has made continuous progress by increasing the requirements for admission and by extending the length of the course to three years.

The School of
Law revived
(1889).



WYLIE HALL (ERECTED 1884)

Partially destroyed by fire, 1900; rebuilt with additional story, 1900.

Historical Sketch

In 1891 an important change was made in the method of selecting part of the Board of Trustees. Three members since that time have been elected by the alumni of the University residing in Indiana. Each member serves for a term of three years, one retiring annually. This arrangement has proved to be quite satisfactory and assists in keeping alive the interest of the alumni in their alma mater.

In 1891 Dr. Jordan resigned to take the presidency of a new university planned by Senator Leland Stanford at Palo Alto, California. His loss to Indiana University was a severe blow. As a teacher Dr. Jordan was thorough and inspiring. His success in arousing in young men a thirst for knowledge obtained by original investigation is shown by the long list of his students who have achieved scientific distinction. As an executive he was original and positive in his convictions; to many, his advanced conceptions seemed radical. But he comprehended as no one else did at the time, the future possibilities of Indiana University; and time has only confirmed the wisdom and saneness of his views. It is not extravagant to say that the present position and tendency of the University are due to the influence of Dr. Jordan more than to that of any other one man.

The immediate successor of Dr. Jordan was John Merle Coulter, professor of botany at Wabash College, whose doctorate of philosophy was conferred by Indiana University in 1884. Imbued with the same spirit, President Coulter continued Dr. Jordan's policy; his presidency was too short for him to work out any individual policy of his own. With diplomatic skill he harmonized some differences which had arisen within the Faculty. His influence tended to allay an unwarranted alarm in some quarters lest the spirit of scientific inquiry at the University might have a detrimental effect on the religious belief of the young people. It was in the first year of his administration that a branch of the Young Men's Christian Association was established in the University, superseding an older, less defined organization composed of men and women students known as the Christian Association. In this movement Dr. Coulter took an active interest, not only in the local branch but in the State Association as well. In 1893 Dr. Coulter resigned to take the presidency of Lake Forest University, and shortly after (1896) accepted the professorship of botany in the University of Chicago.

Presidency of
Dr. John M. Coulter (1891-93).

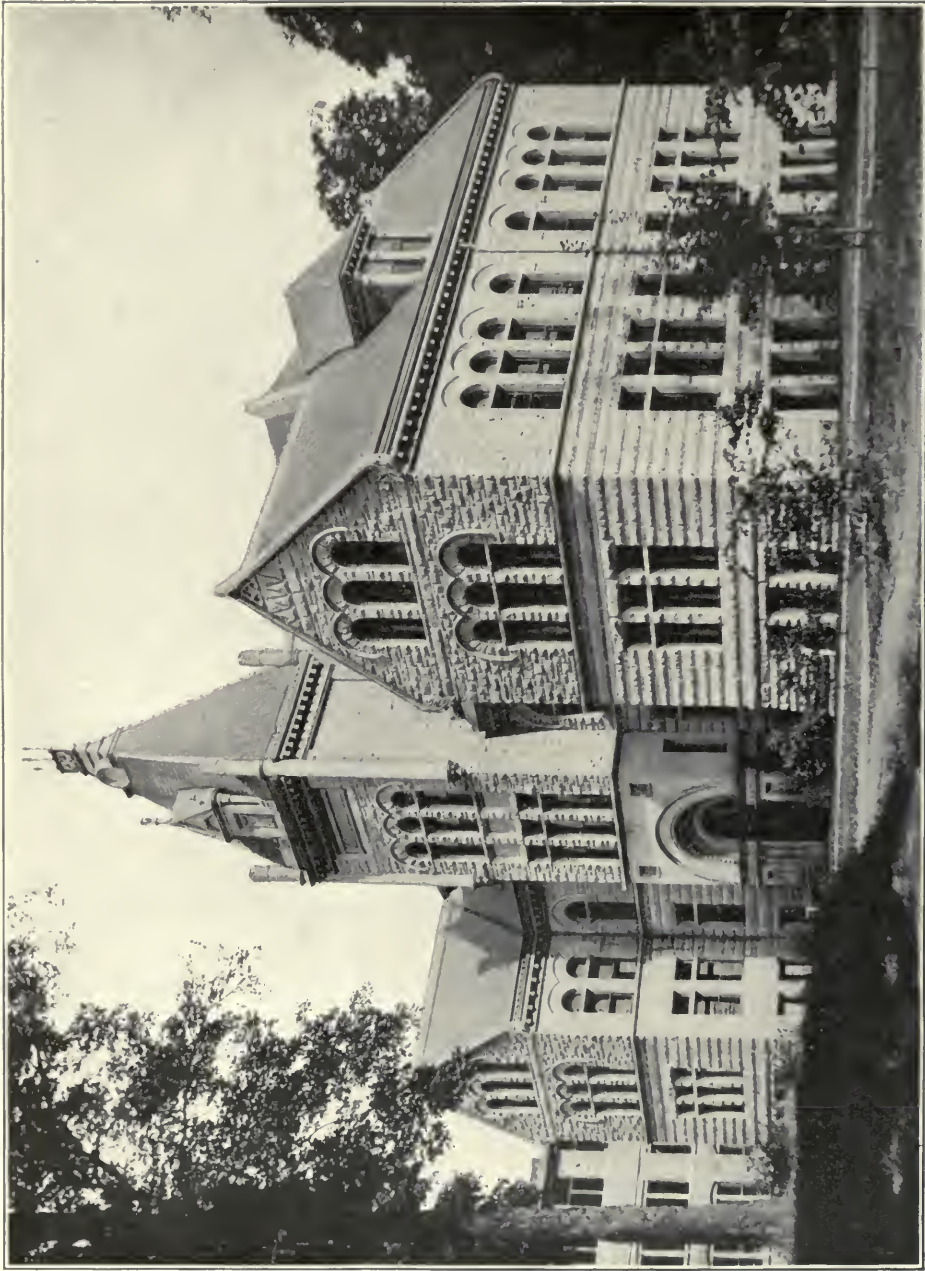

KIRKWOOD HALL (ERECTED 1894)

Historical Sketch

Dr. Joseph Swain, who succeeded Dr. Coulter in 1893, was the second President of the University who had completed within its walls his undergraduate course. He entered the University in the same year (1879) in which Dr. Jordan began his work as professor of biology, and soon came under his influence. After graduating in 1883, he held an instructorship at the University in mathematics and zoölogy for two years, and in 1885 received the degree of Master of Science. The following year he studied mathematics and astronomy at Edinburgh University, Scotland, and in 1886 he returned to his alma mater as professor of mathematics. Dr. Jordan was so impressed with the soundness of his opinions and the wisdom of his advice that he chose him among the first of the members of the new faculty of Stanford University in 1891 and made him professor of mathematics. During the period of organizing that institution he was one of the most confidential advisers of President Jordan. In this close association he acquired an intimate knowledge of the details of university administration, and upon the resignation of President Coulter in 1893, Professor Swain was elected President of Indiana University.

Presidency of
Dr. Joseph Swain
(1893-1902).

Dr. Swain's educational policy was along the lines marked out by President Jordan. New courses were added to the curriculum and other men of the same type as the old were added to the corps of instructors. There was a leveling up of the departments—especially those dealing with the humanities, which to some seemed in danger of being overshadowed by the rapid development of the scientific departments.

The maintenance of old standards and the realization of new ideals increased expenditures. In the field of university finance President Swain rendered preëminent service to the University and the cause of higher education in Indiana. In addition to special appropriations for the erection of three new buildings—Kirkwood Hall, a larger heating plant, and Science Hall—the Legislature, largely through his influence, was induced to provide a more permanent financial support for the University. In 1895 an act was passed imposing an annual tax equivalent to one-fifteenth of a mill upon each dollar of taxable property within the State for the use of the University—a rate subsequently raised (in 1903) to one-tenth of a mill. The increased revenue was expended with strict economy. The growth of the institution in



SCIENCE HALL (ERECTED 1902)

Historical Sketch

the estimation of the public is attested by the rapid increase in the attendance, which rose in this period from 638 in 1894, to 1,285 in 1902.

In 1900 a step was taken which has made the University more fully than ever before a school for the people. Although tuition was free, it had long been customary to charge a small fee of five dollars per term for contingent purposes. At the November meeting of the Board of Trustees in 1900, all contingent fees, excepting those in the School of Law, were abolished from and after January 1, 1901. This however did not do away with "reasonable

Abolition of
Contingent Fees
(1900).



MEN'S GYMNASIUM (ERECTED 1896)

charges for the use of the gymnasium, library, and equipment and supplies for the laboratories."

Equally with President Coulter, Dr. Swain encouraged the work of the Young Men's and Young Women's Christian Associations and was largely instrumental in making the organizations here the leading branches of the college associations in Indiana. Mainly through the interest and energy of

Indiana University

his wife, Mrs. Frances Morgan Swain, there was raised from students, alumni, and friends of the University, in the last years of President Swain's administration, a sum which, with an equal amount given by Mr. John D. Rockefeller, secures the erection of a Students' Building to cost approximately \$100,000. The building, which is now in process of construction, will contain the women's gymnasium, rooms for the Young Men's and Young Women's Christian Associations, and a small auditorium; and it will become a center for the student life of the University.

In 1902 Dr. Swain resigned to accept the presidency of Swarthmore College, Swarthmore, Pennsylvania, in response to an urgent call from those of his own faith—the Society of Friends. His most distinctive services to the University were in enriching its material resources and equipment, in defending it against unreasonable attacks, and in perfecting its organization.

Presidency of
Dr. William
Lowe Bryan,
from 1902.

Dr. William Lowe Bryan, who is now President of the University, was graduated from Indiana University in 1884; he was instructor in Greek in the University from January to June in 1885, and associate professor of philosophy from 1885 to 1887. During the year 1886-87 he was a student at the University of Berlin; and during the year 1891-92, he studied at Clark University, from which institution he received the degree of Doctor of Philosophy in 1892. From 1887 until his election to the presidency in 1902, he was professor of philosophy in the University. As Vice-President, under Dr. Swain, he was closely associated with the administration of the University; and, because of his peculiar fitness on account of natural ability, temperament and special training, the Board of Trustees, the Faculty, the students, the alumni and all other friends of the University, with unanimity turned to him as the logical successor to the presidency. His formal installation took place in connection with the celebration of Foundation Day, January 20, 1903—a celebration made doubly memorable by the dedication at the same time of the new Science Hall.

In the two years of the present administration, the prosperity of the University has continued unimpaired, and it is believed that the efficiency and usefulness of the institution are at as high a level of excellence as ever before in its history. President Bryan has expressed one of the chief objects of his administration, as follows:

STUDENTS' BUILDING

BLOOMINGTON, IND.

VONNEGUT & BOHN,

ARCHITECTS

INDIANAPOLIS, IND.

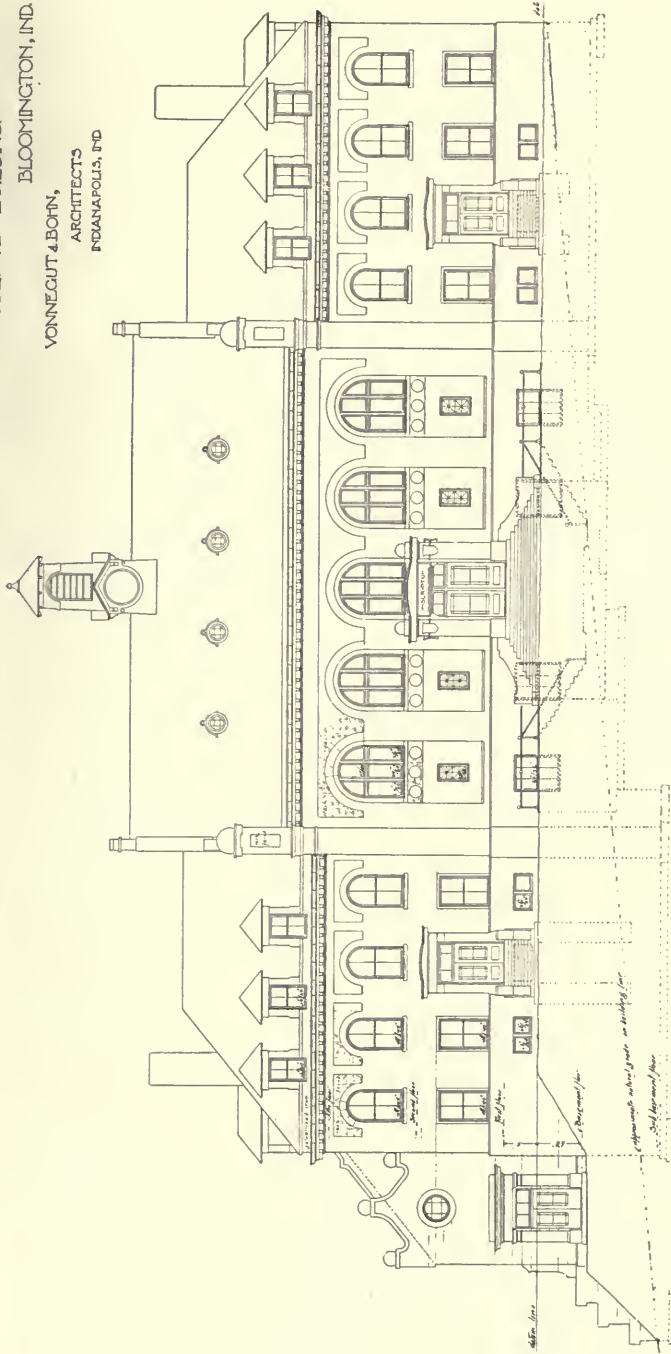

SOUTH FRONT ELEVATION

INDIANA UNIVERSITY STUDENTS' BUILDING

This building, the funds for which were provided by contributions from alumni students and friends of the University, with an equal donation from Mr. John D. Kockefeller, is now in process of erection. The central entrance in the plan above leads to a small auditorium, to be used for public lectures and other University entertainments.

The left wing will be used by women students. It will contain plunge and shower baths in the basement; parlors, rest rooms, and women's gymnasium on the first floor; and offices, club rooms, and the rooms of the Young Women's Christian Association on the floor above. The right wing is for the use of men students. In the basement will be baths, lockers, etc.; on the first floor will be parlors; and on the second floor will be club rooms for men, offices of the Young Men's Christian Association, etc. Space in the third story, in both wings, has not as yet been assigned.

Historical Sketch

“For eighteen years the chief feature of our curriculum has been the major subject. The major subject has meant some one department of learning—chemistry, Greek, or the like—in which the candidate for graduation spends one third or one fourth of all his time and in which he has therefore a chance to gain the beginnings of mastery.

“Now I believe in vastly widening the meaning of the major subject. It has meant as I have said a department of *learning*. I wish to see it mean also any group of subjects leading to a learned occupation. I wish to see men given the degree of A.B. in law, medicine, architecture, commerce, journalism or any such profession. Second, I wish to see the major subject mean also any group of subjects leading to one of the fine arts. Our whole system of education is one-sided through the almost total neglect of the arts. I hope soon to see the time when all the great arts will be adequately represented in that free public school system which rises ‘in regular gradation from the township schools to the State University.’

“Toward the accomplishment of these ideals, there has been no rash or sweeping change but, as the official announcements of the University show in detail, a rapid and substantial progress.”

In reviewing the history of the four-score years of the institution, many vicissitudes are noted. “During the first generation of its history the Indiana University endured a continuous struggle. It had to contend against the reluctance of the State to give to it a vigorous and liberal financial support; its lands were unfortunately, or unwisely, managed, and by their too early sale it never realized from its land endowment an income of more than \$8,000; it was troubled by uncertainty and confusion and subsequent litigation concerning this endowment; it was hampered (in the early history of the State) by the antagonisms of religious sects, whose adverse influence was seen sometimes in the management of the institution, but more often in unkind and uncalled for opposition to its management and interests; it suffered two disasters by fire; it had to resist an unreasonable, but common, feeling of suspicion, among many of the masses, toward higher education by the State;—all these causes, with some minor ones, have operated to make the growth of the University slow and difficult.”¹

Summary: the University and the people.

¹Woodburn, *Higher Education in Indiana*, p. 84.

Indiana University

As the material resources of the State have been developed; as the people have acquired that competency which brings leisure and opportunity for culture and refinement; as men have become more tolerant in their religious beliefs; as the conviction has grown wider and deeper that trained leaders are indispensable in a democracy, the State has become more generous in its support of higher education and made it possible to carry out the ideals of the founders of the University and to accomplish its real functions as conceived by its recent presidents. It bids fair to do its full share in the education of the youth and in the endeavor to attain the ideal democracy. The spirit of its administration is set forth in these words, from President Bryan's inaugural address:

“What the people need and demand is that their children shall have a chance—as good a chance as any other children in the world—to make the most of themselves, to rise in any and every occupation, including those occupations which require the most thorough training. What the people want is open paths from every corner of the State, through the schools, to the highest and best things which men can achieve. To make such paths, to make them open to the poorest and lead to the highest, is the mission of democracy.”

II

Development of the Course of Instruction

“THAT YOUTHFUL COMMUNITY (THE UNIVERSITY) WILL CONSTITUTE A WHOLE, IT WILL EMBODY A SPECIFIC IDEA, IT WILL REPRESENT A DOCTRINE, IT WILL ADMINISTER A CODE OF CONDUCT, AND IT WILL FURNISH PRINCIPLES OF THOUGHT AND ACTION. IT WILL GIVE BIRTH TO A LIVING TEACHING, WHICH IN COURSE OF TIME WILL TAKE THE SHAPE OF A SELF-PERPETUATING TRADITION, OR A *GENIUS LOCI* AS IT IS SOMETIMES CALLED; WHICH HAUNTS THE HOME WHERE IT HAS BEEN BORN AND WHICH IMBUES AND FORMS MORE OR LESS AND ONE BY ONE EVERY INDIVIDUAL WHO IS SUCCESSIVELY BROUGHT UNDER ITS SHADOW.”—CARDINAL NEWMAN.

INTRODUCTORY

This history of the development of the course of instruction at Indiana University is derived chiefly from the published annual catalogues, of which the first appeared under the date of August 17, 1831, in the third year of the existence of the institution as a college and the eleventh from its foundation as the State Seminary. With the exception of these catalogues, the official records of the early and middle periods of the institution were nearly all lost in the fires of 1854 and 1883.

Sources of
information.

Throughout the following pages and in the accompanying tables, an academic year is uniformly referred to by mentioning only the later of the two calendar years into which the academic year extends,—thus 1850 stands for the academic year 1849-50.

For convenience of reference a list of the presidents of Indiana University from the time of its foundation as a college is here given, with the dates of their administrations.

List of Presi-
dents of the
University.

- | | |
|---|-----------|
| 1. Andrew Wylie, D.D. | 1828-1851 |
| 2. Alfred Ryors, D.D. | 1852-1853 |
| 3. William Mitchell Daily, D.D., LL.D. | 1853-1858 |
| 4. John Hiram Lathrop, LL.D. | 1859-1860 |
| 5. Cyrus Nutt, D.D., LL.D. | 1860-1875 |
| 6. Lemuel Moss, Ph.D., D.D. | 1875-1884 |
| 7. David Starr Jordan, Ph.D., LL.D. | 1884-1891 |
| 8. John Merle Coulter, Ph.D., LL.D. | 1891-1893 |
| 9. Joseph Swain, M.S., LL.D. | 1893-1902 |
| 10. William Lowe Bryan, Ph.D. | from 1902 |

DEPARTMENTS OF LIBERAL ARTS

GENERAL DEVELOPMENT TO 1887

Rise of the
"Departments
of Liberal Arts."

In the early days of the University, there was no subdivision of the curriculum into separate courses of study or separate departments. The Preparatory Department, it is true, existed at least from 1830, but this was never an integral part of the "College proper," as the main institution came to be called. A Law School was established in 1842, Normal and Agricultural Departments were organized in 1852, a Department of Military Science was added in 1868, and a Medical Department in 1871. The broadening of the course of instruction by the addition of these various departments gradually emphasized the need of some distinctive name for the "College" itself. It is not until 1870, however, that we find the use of the expression "Department of Literature, Science, and the Arts." In the catalogue of the next year no distinctive name is employed, but from 1872, with the introduction of the course in medicine, the term "Collegiate Department" appears. In 1894 the appointment of a Dean of the Departments of Liberal Arts fixed the official usage for all the sub-departments included in the College proper.

Three periods in
the course of
instruction.

On the lines of educational policy, the history of the course of instruction in the Collegiate Department of Indiana University may be divided into three rather clearly defined periods. From 1831, when our earliest records begin, through 1840, the course of instruction was formed with reference to having the student pursue "one principal study at a time." This was the rule, though exceptions were admitted "to suit the convenience of the student."¹

¹Catalogue for 1840.

Departments of Liberal Arts

From the middle of President Wylie's administration, beginning with the year 1841, a change of policy appears. The new plan may be considered as announced in the following statement, which appears in the University catalogue for 1841 and for several years thereafter:

The object of the course of instruction given to the undergraduates in this Institution is to commence a thorough course, and continue the same, so far as the time of the students' residence at the University will permit. The course prescribed embraces those subjects only which ought to be understood by everyone who aims at a liberal education. The principles of science and literature are the common basis of all high intellectual attainments. They supply that furniture, and discipline, and elevation to the mind, which are the best aids in the study of any profession. The student, in further prosecution of his professional career, may enter a school of Law, or Medicine, or Theology. With these the undergraduate course is not intended to interfere. The object is, not to teach what is peculiar to any one of the professions, but to lay a foundation which is common to all.

The following extract from the catalogue of a few years later also serves to define the new policy of the institution:

It is the design of the Faculty of the University to maintain the highest standard of education which the state of the country will admit. It is an evil incident to a new state of society, that young men, from the want of means, from haste to enter professional life, and other causes, take only a partial course of study. But whatever studies the student undertakes, he is required to pursue in a rigorously accurate and thorough manner. None are permitted to graduate unless they have completed the prescribed course, which is as extensive as is usual in our oldest and best established American colleges.

In other words, while in the first decade of the recorded history of the University, emphasis was laid on one chief subject and on having that done well, in the second period the student was expected to divide his attention between several subjects of more or less coördinate rank. This second tendency is responsible for the introduction into the curriculum of many new lines of work, and so perhaps forms the natural stage of transition from a period of too great specialization to the period in which specialization is combined with breadth of interest.

Indiana University

The third period in the development of the University's educational policy was not definitely inaugurated until 1887. An account of its introduction and character will be found on a subsequent page, in its appropriate place.

Number of terms.

In the early history of the University the academic year was divided into two sessions, the first commencing with the first of November and ending with the last of April, the second commencing with the first of June and ending with the last of September. There were thus two vacation periods, comprising respectively the month of May and the month of October. Later the two sessions were so shifted as to bring the vacations in April and in October respectively. The three-term plan was introduced in 1850, or possibly the year before,¹ and has continued until the present time. The divisions of the year were practically as at present, except that the "summer term" so-called, corresponding to our "spring term," was separated from the winter term by a vacation period of about a month, thus bringing Commencement about the middle of August instead of, as at present, in the latter part of June.

Number and length of recitation periods.

Just how many recitations a day students were required to attend during the early period of the University's existence it is impossible to make out; but from the year 1841 we read in the catalogues the following rule: "Each of the four classes attends three recitations or lectures in a day." This is practically equivalent to the present requirement in number of periods, but we have no means of determining what was the length of the recitation period at that time. From 1878 the number of lecture or recitation periods a week was raised from fifteen to twenty, and we read: "Every student is required to attend four recitations or lectures a day, unless specially excused." In the first year of President Jordan's administration (1885) the number of periods was reduced once more to fifteen; but by a corresponding lengthening of the period itself it was estimated not only that no time would be lost, but that as a matter of fact some time would be gained. It was thought, also, that more could be accomplished in three studies a day with a relatively longer period than in four with the shorter period. In the two years 1898 and 1899, in order to make room on Tuesdays and Fridays for a chapel hour, the recitation period on those days was shortened in the

¹The University catalogue for 1849 is missing.

Departments of Liberal Arts

morning to forty-five minutes, while on the other days of the week it remained fifty-five minutes in length. From 1900 the period has been fixed uniformly at fifty minutes, with ten-minute intermissions. With the gradual introduction of fractional courses, moreover, it was found impracticable to insist on the student dividing his work so as to bring exactly three recitation periods into each day, consequently since 1895 the regular amount of work has been specified as fifteen hours a week, the student being left to distribute those hours as he thinks best.

In the College proper, as distinguished from the Preparatory and other Departments, one uniform course of instruction of four years leading to the degree of Bachelor of Arts was originally prescribed for all students who were candidates for graduation. In the earliest form in which it appears in the University catalogue, namely in 1831, the second year of President Wylie's administration, this course was as follows:

FIRST PERIOD
OF THE COURSE
OF INSTRUCTION
(1831-40).

FRESHMAN CLASS—

Greek Testament, Minora, Majora 1st vol., Majora 2d vol. commenced. Compositions in English and Latin. Greek Theses.

SOPHOMORE CLASS—

Majora finished, the Iliad. Colburn's Algebra, Cambridge Mathematics. Compositions and themes, as in the Freshman Class.

JUNIOR CLASS—

Mathematics finished. Mechanics, Astronomy, Physics, Mathematical and Physical Geography. Dissertations, and themes and compositions, as before.

SENIOR CLASS—

Moral and Mental Philosophy, Evidences of Christianity in connection with Natural Religion, Rhetoric, with a review of select portions of the Greek, Latin and English Classics, Logic, Political Economy, Constitution of the United States. Dissertations, and composition, in English and Latin.

At the end of the first decade already referred to as marking a distinct period in the educational policy of the University, namely in 1840, the course of instruction was as follows:

Indiana University

FRESHMAN CLASS—

First Session. Ovid (three first books and thirteenth), Virgil, Horace, Rhetorical Reading and Declamation.

Second Session. Greek Testament, Collectanea, Græca Minora, Majora commenced, Rhetorical Reading and Declamation. These are continued throughout the Course.

SOPHOMORE CLASS—

First Session. Græca Majora finished, the Iliad, Cicero de Oratore.

Second Session. Algebra (Davies' Bourdon), Geometry (Davies' Legendre).

JUNIOR CLASS—

First Session. With the Professor of Mathematics. Plane and Spherical Trigonometry, Surveying, Analytical Geometry, Differential and Integral Calculus (Davies).

With the Professor of Natural Philosophy and Chemistry. Heat, Electricity, Galvanism, Electro-Magnetism (Turner's Chemistry), Statics and Dynamics (Cambridge Mechanics).

Second Session. Hydrostatics and Hydrodynamics (Cambridge Mechanics), Optics (Bache's Brewster), Inorganic and Organic Chemistry (Turner), Astronomy (Herschel).

The instructions in the departments of Natural Philosophy and Chemistry are conveyed in part by Lectures, with experimental illustrations, but principally by the study of approved text-books.

THE SENIOR CLASS

Spends the whole year under the immediate direction of the President in the following Studies:

Rhetoric, by lectures, with critical reference to select portions of the Greek, Latin and English Classics, Blair and Campbell used as text-books; Logic (Whately); Mental and Moral Philosophy; Political Economy; Evidences of Christianity; Constitution of the United States. On all these subjects Lectures are given, Dissertations and Syllabuses are required, and a course of reading pointed out.

SECOND PERIOD
OF THE COURSE
OF INSTRUCTION
(1840-86).

The year 1841 marks the beginning of the period in the history of the University when, instead of emphasizing "one principal study at a time," the student was expected to pursue several distinct lines of work of coördinate rank. From this time until the end of President Wylie's administration the course of instruction shows comparatively little development. Two speci-

Departments of Liberal Arts

mens are subjoined, the first remaining practically unchanged from 1841 through 1845, and the second from 1846 through 1848:

FRESHMAN CLASS—

First Session. Horace's Odes and Epodes; Jacob's Greek Reader; Fiske's Classical Manual, Part I; Grammatical Exercises and Written Translations; Algebra. Course of study, 1840-45.

Second Session. Horace's Satires and Epistles; Xenophon's Anabasis; Fiske's Classical Manual, Part II; Grammatical Exercises and Written Translations; Davies' Legendre's Geometry and Trigonometry.

SOPHOMORE CLASS—

First Session. Folsom's Livy; Homer's Iliad, commenced; Classical Manual, Parts III and IV; Anthon's Greek Prosody, with Scanning; Davies' Surveying and Analytical Geometry.

Second Session. Virgil's Georgics and Cicero de Officiis; Homer's Iliad, finished; Classical Manual, Part V, with Ancient Geography; Greek Prosody, with Scanning; Davies' Differential and Integral Calculus.

JUNIOR CLASS—

First Session. Cicero de Oratore; Xenophon's Memorabilia of Socrates; Davies' Descriptive Geometry; Cambridge Mechanics, Statics and Dynamics; Turner's Chemistry; Heat and Electricity; Blair's and Campbell's Rhetoric, with Lectures.

Second Session. Juvenal and Persius, or Cicero de Senectute and Cicero de Amicitia; Æschines and Demosthenes de Corona; Cambridge Mechanics, completed; Inorganic Chemistry; Whately's Logic; Lectures by the President.

SENIOR CLASS—

First Session. Tacitus—History; Longinus; Optics, Bache's Brewster; Moral Philosophy and Evidences of Christianity, with Lectures by the President.

Second Session. Tacitus—Manners of the Germans, and Agricola; Woolsey's Greek Plays; Gummere's Astronomy; Chemistry completed; Say's Political Economy; Reid's and Stewart's Mental Philosophy, with Lectures; and Constitution of the United States.

Declamations, Essays, and Rhetorical Reading, by the Classes, on every Saturday during the whole course.

The course of instruction as it existed from 1846 to 1848, inclusive, was as follows:

Indiana University

Course of study, FRESHMAN CLASS—
1846-48.

First Session. Folsom's Livy; Græca Majora; Fiske's Classical Manual, Part I; Grammatical Exercises and Written Translations; Pierce's Algebra.

Second Session. Horace—Odes and Epodes; Græca Majora; Fiske's Classical Manual, Part II; Grammatical Exercises and Written Translations; Davies' Legendre's Geometry.

SOPHOMORE CLASS—

First Session. Horace—Satires and Epistles; Græca Majora; Classical Manual, Parts III and IV; Anthon's Greek Prosody, and Scanning; Pierce's Trigonometry and Surveying, and Analytical Geometry.

Second Session. Plays of Terence; Homer's Iliad, or Odyssey; Classical Manual, Part V, with Ancient Geography; Greek Prosody, with Scanning; Pierce's Differential and Integral Calculus.

JUNIOR CLASS—

First Session. Tacitus—History, and Manners of the Germans; Greek Drama—Enripides; Integral Calculus, completed; Cambridge Mechanics, Statics and Dynamics; Chemistry; Heat and Electricity; Blair's and Campbell's Rhetoric, with Lectures.

Second Session. Juvenal; Greek Drama—Sophocles; Cambridge Mechanics, completed; Inorganic Chemistry; Whately's Logic; Lectures by the President.

SENIOR CLASS—

First Session. Cicero—De Oratore; Pindar—the Olympic and Pythian Odes; Optics, Bache's Brewster; Moral Philosophy, and Evidences of Christianity, with Lectures by the President.

Second Session. Captivi or Miles Gloriosus of Plautus; Prometheus Vincetus of Æschylus; Astronomy, Gummere; Chemistry, completed; Say's Political Economy; Reid's and Stewart's Mental Philosophy, with Lectures; and the Constitution of the United States.

The following course of study, taken from the catalogue for 1850, represents the closing years of President Wylie's administration and shows an early stage of the three-term system:

Departments of Liberal Arts

FRESHMAN CLASS—

First Term. Livy (Folsom); Græca Majora; Fiske's Classical Manual, Part I; Bourdon's Algebra (Davies); Grammatical Exercises and Written Translations. Course of study for 1850.

Second Term. Horace—Odes; Græca Majora; Fiske's Classical Manual, Part II; Algebra, completed; Geometry (Davies and Legendre); Grammatical Exercises and Written Translations.

Third Term. Horace, continued; Græca Majora; Classical Manual, Part II; Geometry, completed.

SOPHOMORE CLASS—

First Term. Horace—Epistles, and Art of Poetry; Græca Majora; Classical Manual, Parts III and IV; Plane and Spherical Trigonometry (Davies' Legendre).

Second Term. Plays of Terence; Homer's Iliad, or Odyssey; Classical Manual, Parts IV and V; Greek Prosody, and Scanning; Surveying and Analytical Geometry.

Third Term. Plays of Terence; Homer's Iliad, or Odyssey; Classical Manual, Part V; Analytical Geometry, completed.

JUNIOR CLASS—

First Term. Tacitus—History, and Manners of the Germans; Greek Drama—Euripides; Cambridge Mechanics—Statics and Dynamics; Turner's Chemistry; Integral and Differential Calculus (Davies); Rhetoric—Blair, Campbell, and Lectures.

Second Term. Descriptive Geometry (Davies); Greek Drama—Sophocles; Cambridge Mechanics, completed; Logic—Whately and Lectures; Moral Philosophy.

Third Term. Juvenal; Political Economy; Inorganic Chemistry; Mental Philosophy.

SENIOR CLASS—

First Term. Mental Philosophy, continued; Political Economy, Lectures (Say); Cicero—De Oratore; Pindar—Olympic and Pythian Odes; Evidences of Christianity.

Second Term. Optics (Bache's Brewster); Moral Science, reviewed; Plautus—Captivi, or Miles Gloriosus; Prometheus Vincetus.

Third Term. Astronomy (Gummere); Chemistry, completed; Reviews and catechetical examinations on the main branches of the course; Declamations, Essays, Dissertations, and Rhetorical Reading and by the Senior Class, Original or Extemporaneous Speaking.

Indiana University

Under President Ryors, who held office for one year only (1853), the course of instruction followed closely that laid down in the later years of his predecessor.

Beginning of the
Scientific Course.

From 1845 a considerable body of undergraduates had been grouped together in the catalogue as "Scientific and Irregular." In 1854, the first year of President Daily's administration, there appears for the first time a list of studies which "constitutes the course necessary to be completed in order to receive the degree of Bachelor of Science." This degree was first granted in that year; but the course of instruction leading to the degree of Bachelor of Science was not graded until 1860. From this time on, however, it appears as a three-year course, and it is probable that before this time it had covered the same period.

The following courses of instruction for 1856 are representative of the work under the administration of President Daily, for both the regular and the scientific students:

REGULAR COURSE

Regular Course
in 1856.

FRESHMAN CLASS—

First Term. Livy; Græca Majora; Grecian and Roman Antiquities (Bojessen); Algebra (Davies' Bourdon); Latin, Greek, and English Composition; Elocution.

Second Term. Livy; Græca Majora; Grecian and Roman Antiquities; Algebra, completed; Geometry (Davies' Legendre) commenced; Latin, Greek, and English Composition; Elocution.

Third Term. Horace—Odes; Græca Majora; Geometry (Davies' Legendre) completed; History; Latin, Greek, and English Composition; Elocution.

SOPHOMORE CLASS—

First Term. Horace—Satires and Epistles; Græca Majora; Application of Algebra to Geometry; Plane and Spherical Trigonometry (Davies); Mensuration (Davies); Descriptive Geometry (Davies) commenced; History; Elocution; Latin, Greek, and English Composition.

Second Term. Horace, finished; Græca Majora; Descriptive Geometry; Surveying (Davies); Analytical Geometry (Davies), commenced; English Literature; Latin, Greek, and English Composition; Elocution.

Third Term. Terence; Homer's Iliad or Odyssey; Analytical Geometry; Rhetoric (Blair); Latin, Greek, and English Composition; Elocution.

Departments of Liberal Arts

JUNIOR CLASS—

First Term. Rhetoric (Campbell); Elements of Criticism; Chemistry (Silliman); Tacitus; Greek Drama; Analytical Geometry, completed; Calculus (Davies), commenced; Exercises in English Composition and Declamation.

Second Term. Mental Philosophy (Reid); Mechanics (Bartlett), commenced; Agricultural Chemistry; Juvenal; Greek Drama; Calculus; Exercises in English Composition and Declamation.

Third Term. Mechanics, completed; Logic (Whately); Evidences of Christianity; Juvenal; Greek Drama; Calculus, finished; English Composition and Declamation.

SENIOR CLASS—

First Term. Geology; Physiology; Political Economy (Say); Moral Philosophy (Stewart), commenced; Cicero—De Oratore; Pindar; Civil Engineering; English Composition and Declamation.

Second Term. Moral Philosophy, completed; International Law (Kent); Acoustics and Optics (Bartlett); Selections from the Latin and Greek Classics; German Language and Literature (optional); Hebrew Language and Literature (optional); English Composition and Declamation.

Third Term. Astronomy; Constitution of the United States (Story); Butler's Analogy; Selections from the Latin and Greek Classics; French Language and Literature (optional); Hebrew Language and Literature (optional); English Composition and Declamation.

SCIENTIFIC COURSE

The following studies constitute the course necessary to be completed in order to graduation to the degree of Bachelor of Science:

Mitchell's Ancient and Modern Geographies; Butler's English Grammar; Ray's Arithmetic; Algebra (Davies' First Lessons); Wilson's American History; English Composition and Declamation; Algebra (Davies' Bourdon); Geometry (Davies' Legendre); Application of Algebra to Geometry; Plane and Spherical Trigonometry (Davies); Descriptive Geometry (Davies); History; Analytical Geometry (Davies); English Literature; Rhetoric; Elements of Criticism; Chemistry (Silliman); Calculus (Davies); Mental Philosophy (Reid); Geology (Hitchcock); Agricultural Chemistry; Physiology; Mechanics (Bartlett); Logic (Whately); Evidences of Christianity; Political Economy (Say); Moral Philosophy; Surveying (Davies); Civil Engineering; International Law; Acoustics and Optics (Bartlett); Astronomy; Constitution of the United States; Butler's Analogy.

Scientific Course
in 1856.

Indiana University

President Lathrop's administration covered only the one year 1860. From this year through 1867 the Scientific Course comprised simply the Regular Course except the classics, and was designed to cover three years. The following is the complete course as announced in 1860:

The course in
1860.

FRESHMAN CLASS—

First Term. Xenophon—History; Sallust; Greek Grammar; Algebra; Geometry.

Second Term. Xenophon; Horace—Odes; Grammar; Algebra; Geometry; Trigonometry.

Third Term. Herodotus; Horace—Odes; Grammar; General History; Navigation; Surveying; Latin, Greek and English Composition, and Elocution, throughout the year.

SOPHOMORE CLASS—

First Term. Analytical Geometry; History of the United States; Plato, or Xenophon's Memorabilia; Greek Syntax; Horace—Satires; Antiquities.

Second Term. Calculus; English Analysis; Demosthenes, or Thucydides; Horace—Epistles; Antiquities; Syntax.

Third Term. Mechanics; English Composition; Homer's Iliad; Livy, or Terence; Antiquities; Syntax; Composition and Elocution throughout the year.

JUNIOR CLASS—

First Term. Mental Philosophy; Chemistry; Sophocles; Tacitus.

Second Term. Logic; Chemistry; Physiology; Euripides; Juvenal.

Third Term. Rhetoric; Acoustics; Optics; Descriptive Geometry; Elocution and Composition throughout the year.

SENIOR CLASS—

First Term. Criticism; Ethics; Astronomy.

Second Term. Geology; Civil Polity; Constitutional and International Law; Christian Evidences.

Third Term. Political Economy; English Literature; Longinus, or Pindar; Cicero—De Oratore; Composition and Elocution each term.

The course of instruction for the year 1865, which follows, differs from that just given in some respects, and may be taken as representative of the period from 1861 through 1867, which fell in the first half of the administration of President Nutt:

Departments of Liberal Arts

REGULAR COURSE

FRESHMAN CLASS—

First Term. Livy; Græca Majora, Vol. I; Grecian and Roman Antiquities; The course in Latin and Greek Composition; Algebra (Robinson's Second Part); Introduction to English Composition (Quackenbos). 1865.

Second Term. Odes of Horace; Græca Majora; Grecian and Roman Antiquities; Algebra (Robinson), completed; Geometry (Robinson), commenced; English Composition (Quackenbos).

Third Term. Horace's Odes; Græca Majora; Geometry (Robinson), completed; History of the United States.

SOPHOMORE CLASS—

First Term. Horace's Satires and Epistles; Græca Majora; Plane and Spherical Trigonometry (Robinson); Surveying begun (Robinson); English Composition.

Second Term. Horace, finished; Græca Majora; Surveying and Navigation (Robinson); Descriptive Geometry.

Third Term. Terence; Homer's Iliad or Odyssey; Analytical Geometry (Robinson); General History.

JUNIOR CLASS—

First Term. Mental Philosophy (Haven); Chemistry (Stoeckhardt); Tacitus; Greek Drama; Calculus (Robinson), commenced.

Second Term. Logic (Coppee); Juvenal; Greek Drama; Calculus (Robinson), completed; Organic Chemistry (Stoeckhardt); Physiology.

Third Term. Juvenal; Greek Drama; Natural Philosophy (Snell's Olmsted); Æsthetics (Moffatt), and Lectures; Civil Polity, Lectures.

SENIOR CLASS—

First Term. Political Economy (Wayland); Natural Philosophy (Snell's Olmsted); Cicero—De Oratore; Pindar; Elements of Criticism (Kames).

Second Term. Ethics (Lectures); Astronomy (Olmsted); Evidences of Christianity (Lectures); Selections from the Latin and Greek Classics.

Third Term. Constitutional and International Law; Geology (Dana's Text-Books); English Literature (Shaw).

Weekly exercise in Elocution and Composition throughout the Course.

SCIENTIFIC COURSE

The Scientific Course is the same as the above, without the Ancient Languages.

Indiana University

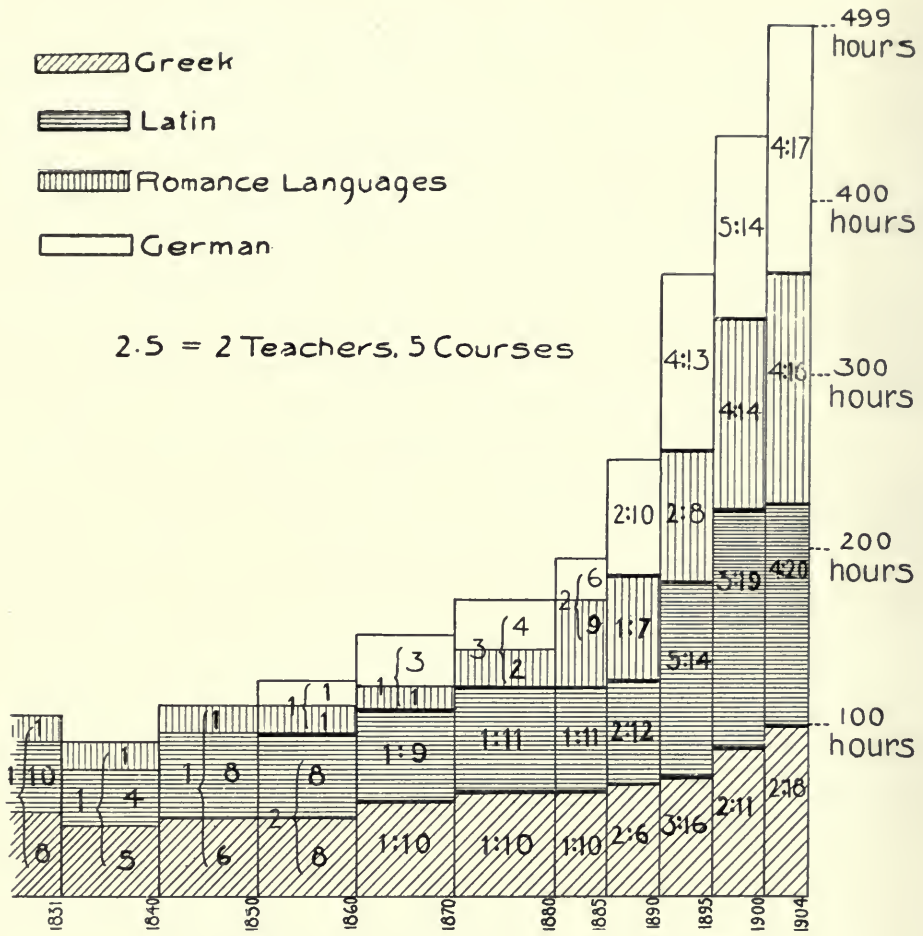

DEVELOPMENT OF THE COURSE OF INSTRUCTION - I

Admission of Women to the University (1867).

A change of far-reaching importance was made in the policy of the institution in 1867, when women were admitted to equal privileges with men. Indiana University was the first State University to adopt this policy, and among institutions of collegiate rank was preceded in the establishment of co-education only by Oberlin, Antioch and Fort Wayne Colleges. The change at Indiana University is described by the late Professor Theophilus

Departments of Liberal Arts

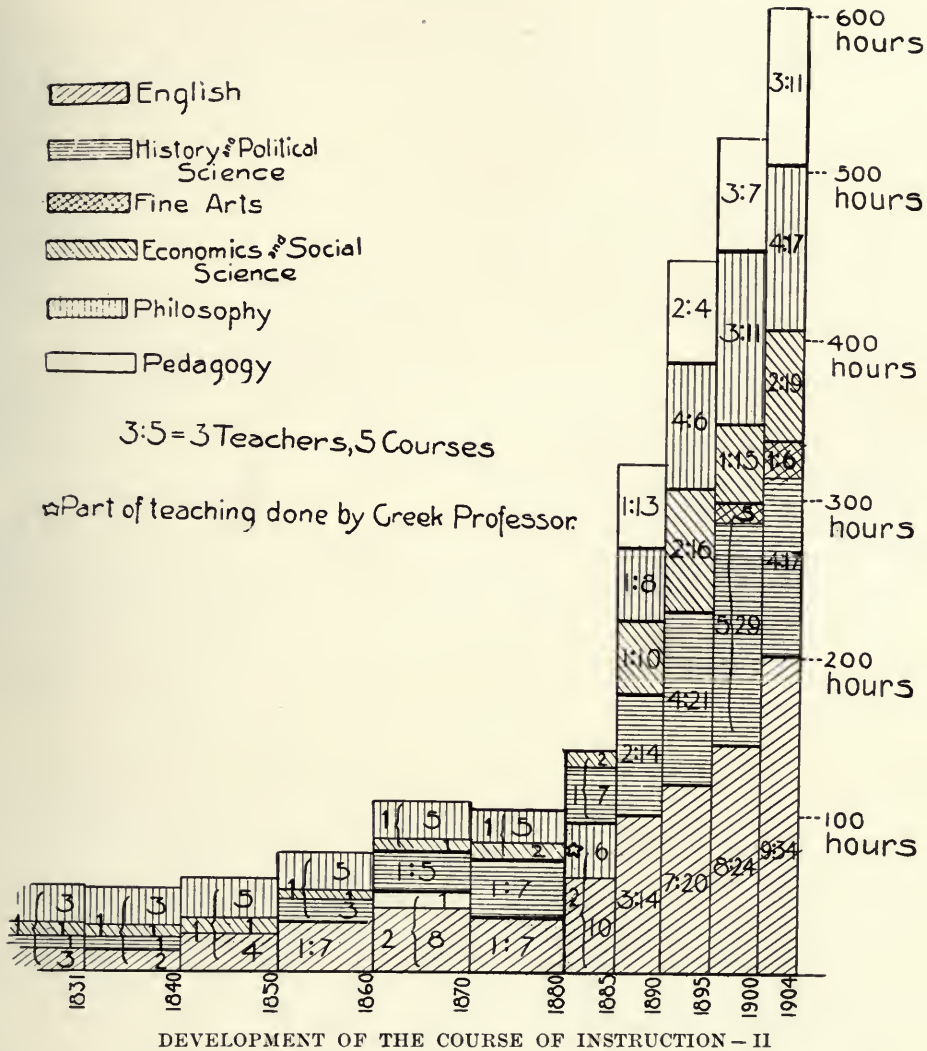

A. Wylie, in his 'Indiana University, Its History from 1820 to 1890,' as follows:

In the preceding year, Mr. [Isaac] Jenkinson, then of Allen County, a member of the Board of Trustees, offered a resolution to admit females to the same studies

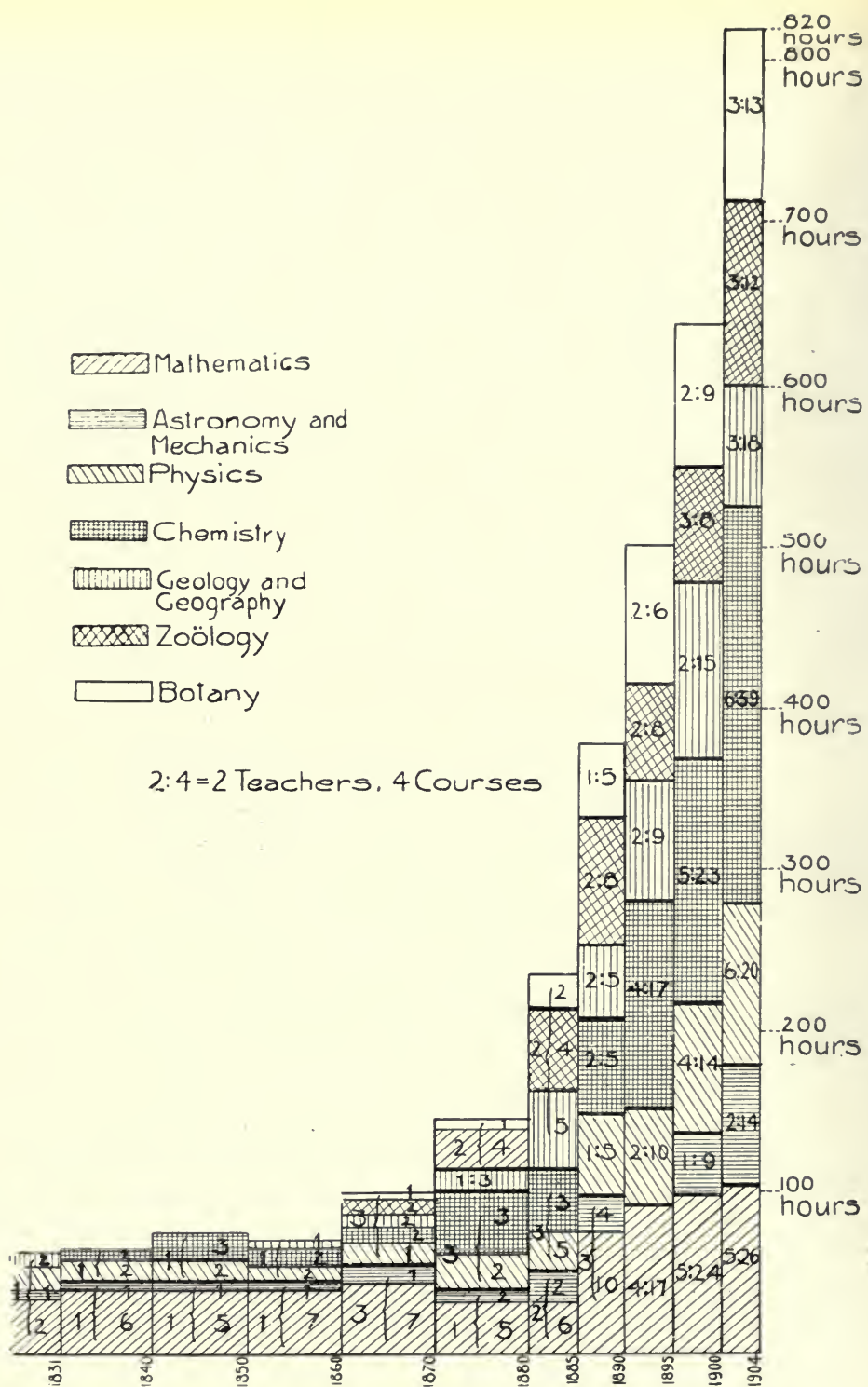

DEVELOPMENT OF THE COURSE OF INSTRUCTION - III

Departments of Liberal Arts

and the same standing as the males. For some time before this, the subject "The co-education of the sexes," had been agitated in various educational conventions, and Mr. Jenkinson was a strong advocate in its favor. Co-operating with others like-minded, he had been instrumental in opening the Fort Wayne Female College to males. The other members of the University Board were not prepared for the innovation; no member but himself approved of the resolution presented. At a subsequent meeting, Judge Rhoads offered a substitute for this resolution of Mr. Jenkinson, proposing to admit females to partial rights and privileges, but this was not agreed to by the Board. The original resolution was then pressed, and about the same time a petition was presented by Miss Sarah P[arke] Morrison, asking that the law of the University should be so changed that females, with regard to their studies and privileges, should be put on the same footing as the males. This request of Miss Morrison, coming when the question was before the Board, had, without doubt, influence in the Board's deciding in favor of Mr. Jenkinson's resolution. The motion, however, was carried only by a majority of one—four in favor, three against it. Miss Morrison, who knew nothing of the agitation of this question by the Board, received a reply to her petition that the laws of the University with regard to this matter required no change, and that its doors, with all its rights and privileges, were open to females. Miss Morrison then entered the Sophomore Class at the beginning of the next year, 1868-9; and about nine weeks after, a number of young ladies entered the Freshman Class; and before the end of the second term there were twelve female students.¹

In 1868 the Scientific Course was lengthened to four years and given a separate schedule of study. This was in accordance with a notice given in the catalogue of the preceding year: "The . . . course of study may be modified by the Board of Trustees at their coming session, since the Legislature, at their last session, have, by an appropriation of eight thousand dollars per annum, greatly increased the resources of the University. Some new chairs will likely be established, and the corps of instructors enlarged, and the facilities for education multiplied."

The regular course also at this time received the designation "classical," by which term the course in languages continued to be known until the definite introduction in 1887 of the "major subject" system. During the ten years ending with 1877, the Scientific Course and the Classical Course stood side by side as parallel and of coördinate rank. As representing this period,

Coördination of
Scientific and
Classical Courses
(1868).

¹Theophilus A. Wylie, *Indiana University: Its History from 1820 to 1890* (Indianapolis, 1890), pp. 74-75.

Indiana University

two tables of courses are subjoined, one for the year 1870, and the other for the year 1875:

CLASSICAL COURSE

Classical Course FRESHMAN CLASS—
in 1870.

First Term. Greek—Xenophon's Anabasis (Boise); Greek Grammar and Composition (Hadley's Grammar). Latin—Livy, Latin Composition. Mathematics—Algebra (Ray).

Second Term. Greek—Xenophon's Cyropædia, or Isocrates' Orations; Greek History (Smith). Latin—Cicero or Ovid; Roman Antiquities. Mathematics—Algebra, completed; Geometry (Ray), commenced.

Third Term. Greek—Herodotus; Greek Antiquities and Literature (Bojessen). Latin—Odes of Horace; Roman Antiquities and Literature (Bojessen). Mathematics—Geometry, completed. Physiology.

SOPHOMORE CLASS—

First Term. Greek—Homer's Iliad (Boise). Latin—Horace's Satires and Epistles. Mathematics—Plane and Spherical Trigonometry (Loomis); Surveying commenced. English Composition (Quackenbos).

Second Term. Greek—Plato's Crito and Phædo. Latin—Cicero. Mathematics—Surveying and Navigation completed; Analytical Geometry (Loomis) begun. English Composition (Quackenbos).

Third Term. Greek—Demosthenes. Latin—Cicero. Mathematics—Analytical Geometry completed. English Synonyms and Sentential Analysis.

JUNIOR CLASS—

First Term. Mental Philosophy (Haven), and Lectures. Greek—Theocritus, Bion, or Moschus. Latin—Tacitus or Juvenal. Chemistry—Inorganic (Stoekhardt's). Mathematics—Calculus (Loomis).

Second Term. Logic (Coppee). Greek—Sophocles' Œdipus Tyrannus. Latin—Juvenal or Pliny. Natural Philosophy—Mechanics (Olmsted) begun. Chemistry—Organic (Stoekhardt).

Third Term. Constitutional Law and Civil Polity, with Lectures. Greek—Euripides' Medea. Latin—Plautus or Terence. Natural Philosophy—Mechanics completed. Hydrostatics and Pneumatics.

Departments of Liberal Arts

SENIOR CLASS—

First Term. Moral Science (Wayland) with Lectures. Criticism—Kames' Elements. Greek—Pindar. Natural Philosophy—Acoustics, Optics, Electricity.

Second Term. Political Economy (Perry) and Lectures. Evidences of Christianity (Lectures). Latin—Selections from the Latin Classics. Astronomy (Loomis).

Third Term. International Law (Halleck). Astronomy completed. Geology (Dana). English Literature.

SCIENTIFIC COURSE

FRESHMAN CLASS—

First Term. Mathematics—Algebra (Ray). Latin—Livy. History.

Scientific Course
in 1870.

Second Term. Mathematics—Geometry (Ray) begun. Latin—Cicero or Ovid. History.

Third Term. Mathematics—Geometry completed. Latin—Odes of Horace, Classical Antiquities. Physiology. History.

SOPHOMORE CLASS—

First Term. Trigonometry—Plane and Spherical (Loomis). Latin, or Modern Languages. Botany and Physical Geography. English Composition (Quackenbos).

Second Term. Mathematics—Surveying and Navigation (Loomis). Analytical Geometry (Loomis) commenced. Latin or Modern Languages. Zoölogy. English Composition (Quackenbos).

Third Term. Mathematics—Analytical Geometry completed. Latin or Modern Languages. English Synonyms and Sentential Analysis.

JUNIOR CLASS—

First Term. Mental Philosophy (Haven) and Lectures. Mathematics—Calculus (Loomis), Descriptive Geometry (Davies). Chemistry—Inorganic (Stoekhardt).

Second Term. Logic (Coppee). Mathematics—Calculus (Loomis). Natural Philosophy—Mechanics commenced. Chemistry—Organic (Stoekhardt).

Third Term. Constitutional Law and Civil Polity, with Lectures. Practical Surveying and Civil Engineering. Natural Philosophy—Mechanics completed, Hydrostatics and Pneumatics.

Indiana University

SENIOR CLASS—

First Term. Moral Science (Wayland), with Lectures. Criticism—Kames' Elements. Natural Philosophy—Acoustics, Optics and Electricity (Olmsted).

Second Term. Political Economy (Perry), with Lectures. Evidences of Christianity (Lectures). Astronomy (Loomis) commenced.

Third Term. International Law (Halleck). English Literature. Geology (Dana). Astronomy completed.

Weekly exercises in all classes, in Elocution and Composition, throughout the course.

The second pair of courses mentioned above, those for 1875, represents the work as given in the last year of the administration of President Nutt:

CLASSICAL COURSE

Classical Course FRESHMAN CLASS— in 1875.

First Term. Greek—Grammar (Hadley); Boise's First Lessons. Latin—Cicero's Orations, and Latin Composition. Mathematics—Algebra (reviewed), Geometry (Loomis) beginning at the fifth book. Outline History. Weekly Lectures in Physiology and Laws of Health.

Second Term. Greek—Grammar, Lessons, Anabasis (Boise's First Three Books) begun. Latin—Cicero's Orations, and Latin Composition. Mathematics—Geometry, and Plane Trigonometry (Loomis). Outline History.

Third Term. Greek—Grammar, Lessons, Anabasis (two books completed). Mathematics—Spherical Trigonometry, Surveying and Navigation. Outline History. Latin—Ovid (Allen and Greenough); Roman Antiquities.

SOPHOMORE CLASS—

First Term. Greek—Herodotus (Boise and Freeman's Selections), Grammar, Greek Prose Composition (Jones). Latin—Horace's Odes, Prosody. Mathematics—Analytical Geometry (Loomis). English—Rhetoric (Hart).

Second Term. Greek—Odyssey in Selections, Syntax, Composition. Latin—De Amicitia. Chemistry—Organic. English—Rhetoric (Hart).

Third Term. Greek—Thucydides in Selections, Syntax, Composition. Latin—Horace's Satires and Epistles, Prosody. Chemistry—Organic. English—Writing and Analysis of Style.

Departments of Liberal Arts

JUNIOR CLASS—

First Term. Xenophon and Plato in Selections, Syntax, Composition. Elocution. Mental Philosophy (Porter) and Lectures. Lucretius, Calculus, Analytical Chemistry, Drawing, or German.

Second Term. Greek—Demosthenes in Selections (Boise), Exercises in Syntax. Natural Philosophy—Mechanics. Mental Philosophy finished, and Logic. Tacitus, Calculus, Analytical Chemistry, Drawing, or German.

Third Term. Greek—Alcestis of Euripides (Woolsey), Exercises in Syntax (Boise). Constitutional Law and Civil Polity (Andrews). Natural Philosophy—Hydrostatics, Pneumatics, Acoustics and Magnetism. Mineralogy and Lithological Geology.

SENIOR CLASS—

First Term. Moral Science (Haven) and Lectures. Natural Philosophy—Optics, Heat and Electricity. Geology—Stratigraphical. Greek, German, French, or Oratory.

Second Term. Political Economy (Perry) and Lectures. Evidences of Christianity (Lectures). Astronomy (Loomis). Geology (Paleontology), Greek, French, or German.

Third Term. International Law (Halleck), or Social Science. Astronomy completed. Latin, Greek, French, or Dynamical Geology. English Literature and Criticism.

SCIENTIFIC COURSE

FRESHMAN CLASS—

First Term. Mathematics—Algebra (reviewed); Geometry (Loomis, beginning at fifth book). Latin—Cicero's Orations, and Latin Composition. German—Grammar and Composition; Otto's Grammar commenced. Outline History. Weekly Lectures on Physiology and Laws of Health.

Scientific Course
in 1875.

Second Term. Mathematics—Geometry completed, Plane Trigonometry (Loomis). Latin—Cicero's Orations, and Latin Composition. German—Grammar and Composition; Grammar and Preparatory Course of Reading. Outline History.

Third Term. Mathematics—Spherical Trigonometry, Surveying and Navigation (Loomis). German—Syntax, Selections and Composition. Latin—Ovid (Allen and Greenough). Outline History.

Indiana University

SOPHOMORE CLASS—

First Term. Mathematics—Analytical Geometry (Loomis). German—Selections from German Literature. English—Rhetoric (Hart). Physical Geography.

Second Term. Mathematics—Analytical Geometry; Differential Calculus. English—Rhetoric (Hart). German—Scientific Selections; or French. Chemistry—Inorganic (Ellot and Storer's Manual).

Third Term. Chemistry—Organic. English—Writing and Analysis of Style. German—Scientific Selections. Analytical Chemistry (Fresenius).

JUNIOR CLASS—

First Term. Mental Philosophy (Porter) and Lectures. Mathematics—Integral Calculus. Zoölogy. Analytical Chemistry, Descriptive Geometry, Drawing, or Elocution.

Second Term. Mental Philosophy, completed. Logic. Civil Engineering (Mahan, revised by Wood). Natural Philosophy—Mechanics.

Third Term. Constitutional Law and Civil Polity. Natural Philosophy—Hydrostatics, Pneumatics, Acoustics and Magnetism. Civil Engineering (Mahan, revised by Wood). Mineralogy and Lithological Geology.

SENIOR CLASS—

First Term. Moral Science (Haven) with Lectures. Natural Philosophy—Heat, Optics and Electricity. Stratigraphical Geology. Oratory; or History of Civilization.

Second Term. Political Economy (Perry), with Lectures. Evidences of Christianity (Lectures). Astronomy (Loomis). Geology—Paleontology.

Third Term. International Law (Halleek); or Social Science. Astronomy, completed. English Literature and Criticism. Geology—Dynamical.

Two lines of transition to the Third Period of the Course of Instruction.

The third period in the development of the educational policy of the University is one, as has been stated, in which specialization is combined with a considerable breadth of interest. The student is expected fairly early in his college course to select as his major subject the work of some one Department, and from the other Departments to elect a sufficient amount of work to make up the prescribed number of hours of credit for graduation.

This last change in the general educational policy of the University seems to have worked itself out along two distinct lines which finally contributed to a single result. There was first the gradual differentiation of the course of instruction itself into several different courses, representing emphasis upon

Departments of Liberal Arts

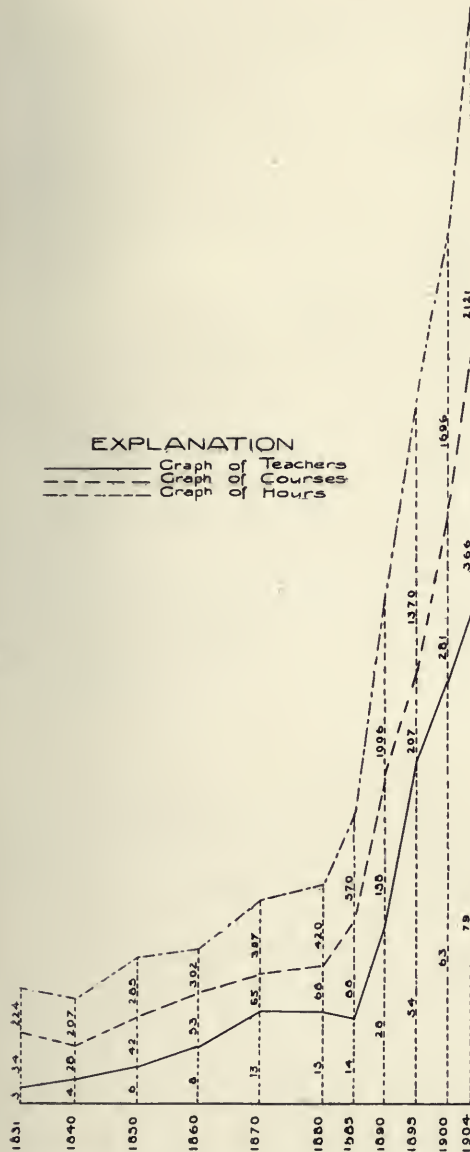

EXPLANATION

————— Graph of Teachers
 - - - - - Graph of Courses
 Graph of Hours

NUMBER OF INSTRUCTORS, COURSES,
AND HOURS OF INSTRUCTION

different lines of work to suit the choice of the student; and secondly, the introduction and development of the elective system. It is interesting, therefore, to find that in the same year in which the course of instruction itself begins to be differentiated beyond the twofold division already noticed, we find also the first systematic introduction of elective studies. This was in 1878, the third year of the administration of President Moss.

For a period of eight years, beginning with 1878 and ending with the first year under President Jordan, we find three parallel courses of instruction. In 1871 German and French had ceased to be special studies and were incorporated in the regular course. The Classical Course was differentiated, therefore, into "The Course in Ancient Classics," leading to the degree of Bachelor of Arts (B.A.), and "The Course in Modern Classics," which led to the degree of Bachelor of Letters (B.L.). The Scientific Course continued to be an independent course, leading to the degree of Bachelor of Science (B.S.). In the Junior and Senior years, moreover, a considerable range of "electives" was allowed, as is shown in the following table of courses for the year 1880, which fairly represents this period:

(1) Further differentiation of the curriculum.

The three-course epoch (1878-86).

Indiana University

A. THE COURSE IN ANCIENT CLASSICS

The curriculum
in 1880:
(a) Ancient
Classics Course.

FRESHMAN CLASS—

First Term. Greek—Goodwin's Grammar, First Lessons. Latin—Cicero's Orations, and Latin Composition. Mathematics—Geometry (Loomis), beginning at the fifth book. Outline History. Weekly Lessons in Elementary Ethics.

Second Term. Greek—Grammar, Lessons, Anabasis. Latin—Cicero's Orations, and Latin Composition. Mathematics—Plane Trigonometry (Loomis). Outline History. Weekly Lessons in Elements of Mental Philosophy.

Third Term. Greek—Anabasis, Prose Composition. Latin—Ovid (Allen and Greenough), Roman Antiquities. Mathematics—Spherical Trigonometry, Surveying and Navigation. Outline History. Weekly literary exercises.

SOPHOMORE CLASS—

First Term. Greek—Extracts from Xenophon's Memorabilia, and from Plato's Apology, Crito, and Phædo; Prose Composition. Latin—Horace's Odes; Prosody. Mathematics—Analytical Geometry (Loomis). Physiology. Weekly literary exercises.

Second Term. Greek—Iliad, Composition. Latin—Quintilian. English—Rhetoric (Hart). Chemistry—Inorganic.

Third Term. Greek—Iliad, Composition, Essays on Epic Poetry. Latin—Horace's Satires and Epistles, Prosody. English—Rhetoric (Hart). Chemistry—Organic.

JUNIOR CLASS—

First Term. Psychology—Porter's Elements. Greek—Demosthenes; Essays on the Orators. English—Writing and Analysis of Style. Electives—German, Latin, Analytical Chemistry, Zoölogy, Elocution.

Second Term. Logic—Gilmore's Outlines. Greek—Thucydides; Historical Essays. Natural Philosophy—Mechanics. Electives—German, Latin, Biology.

Third Term. Moral Science (Calderwood). Greek—Sophocles or Aristophanes; Essays on the Drama. Electives—German, Latin, Botany, Political History, Zoölogy.

SENIOR CLASS—

First Term. History of Philosophy. Natural Philosophy—Optics, Heat, and Electricity. Electives—French, Greek, Latin, Political History, Geology.

Second Term. Political Economy (Perry's Introduction); Lectures. English Classics. Astronomy (Loomis). Electives—Greek, Latin, Political History, Oratory.

Departments of Liberal Arts

Third Term. Social Science. Astronomy (Loomis). History of the English Language. Electives—Greek, Latin, Political History.

B. THE COURSE IN MODERN CLASSICS

FRESHMAN CLASS—

First Term. Mathematics—Geometry (Loomis, beginning at fifth book). Latin—Cicero's Orations, and Latin Composition. French—Grammar and Composition. Outline History. Weekly lessons in Elementary Ethics. The curriculum in 1880:
(b) Modern Classics Course.

Second Term. Mathematics—Plane Trigonometry (Loomis). Latin—Cicero's Orations, and Latin Composition. French—Grammar and Composition; preparatory Course of Reading. Outline History. Weekly lessons in Elements of Mental Philosophy.

Third Term. Mathematics—Spherical Trigonometry, Surveying and Navigation. French—Syntax, Selections and Composition. Latin—Ovid (Allen and Greenough). Outline History. Weekly Literary Exercises.

SOPHOMORE CLASS—

First Term. Mathematics—Analytical Geometry (Loomis). German—Grammar and Composition. *Latin—Horace's Odes; Prosody. Physiology. Weekly Literary Exercises.

Second Term. English—Rhetoric (Hart). German—Composition; Reading. Chemistry—Inorganic (Eliot and Storer's Manual). *Latin—Quintilian.

Third Term. Chemistry—Organic. English—Rhetoric (Hart). German—Selections; Syntax; Composition. *Latin—Horace's Satires and Epistles; Prosody.

JUNIOR CLASS—

First Term. Psychology—Porter's Elements. German—Selections. English—Writing, and Analysis of Style. Electives—Latin, Mathematics, Analytical Chemistry, Zoölogy, Elocution.

Second Term. Logic—Gilmore's Outlines. German—Scientific Selections. Natural Philosophy. Electives—Latin, Drawing, Analytical Chemistry, Biology.

Third Term. Moral Science (Calderwood). German. Electives—Latin, Botany, English, Political History, Zoölogy.

*During the Sophomore year, the student in this Course may, if he prefer, substitute (for the Latin) the Greek of the Freshman year.

Indiana University

SENIOR CLASS—

First Term. History of Philosophy. Natural Philosophy. Electives—Latin, German, Political History, Geology.

Second Term. Political Economy (Perry's Introduction), with Lectures. English Classics. Astronomy (Loomis). Electives—Latin, German, Political History, Paleontology.

Third Term. Social Science. Astronomy, completed. History of the English Language. Electives—Latin, German, Political History, Comparative Anatomy.

C. THE COURSE IN SCIENCE

The curriculum
in 1880:
(c) Scientific
Course.

FRESHMAN CLASS—

First Term. Mathematics—Geometry (Loomis, beginning at fifth book). Latin—Cicero's Orations, and Latin Composition. French or Greek. Outline History. Weekly Lessons in Elementary Ethics.

Second Term. Mathematics—Plane Trigonometry (Loomis). Latin—Cicero's Orations, and Latin Composition. French or Greek. Outline History. Weekly Lessons in Elements of Mental Philosophy.

Third Term. Mathematics. Spherical Trigonometry, Surveying and Navigation. French or Greek. Latin—Ovid (Allen and Greenough). Outline History. Weekly Literary Exercises.

SOPHOMORE CLASS—

First Term. Mathematics—Analytical Geometry (Loomis). German or Greek. *Latin—Horace's Odes; Prosody. Physiology.

Second Term. English—Rhetoric (Hart). German or Greek. Chemistry—Inorganic (Eliot and Storer's Manual). *Latin—Quintilian.

Third Term. Chemistry—Organic. English—Rhetoric (Hart). German or Greek. *Latin—Horace's Satires and Epistles; Prosody.

JUNIOR CLASS—

First Term. Psychology—Porter's Elements. English—Writing, and Analysis of Style. Electives—Physics, Descriptive Geometry, Analytical Chemistry, Zoölogy, Elocution.

Second Term. Logic—Gilmore's Outlines. Natural Philosophy. Electives—Physics, Drawing, Analytical Chemistry, Biology.

Third Term. Moral Science (Calderwood). Zoölogy. Electives—Botany, Civil Engineering, Analytical Chemistry, Mineralogy.

*If the student in this Course is taking the Modern Languages instead of Greek, he may now, if he prefer, substitute (for the Latin of the Sophomore year) the Greek of the Freshman.

Departments of Liberal Arts

SENIOR CLASS—

First Term. History of Philosophy. Natural Philosophy. Geology. Electives—French, Analytical Chemistry, Political History.

Second Term. Political Economy (Perry's Introduction), with Lectures. English Classics. Astronomy (Loomis). Electives—Analytical Chemistry, Paleontology. Political History.

Third Term. Social Science. Astronomy, completed. History of the English Language. Electives—Analytical Chemistry, Comparative Anatomy, Political History.

In 1886 a farther step was taken towards the definite introduction of the major subject system by the differentiation of the course of instruction into eight distinct courses, divided into three groups as follows: Differentiation into eight Courses (1886).

- A. Classical or Language Courses, leading to the Degree of A.B.
 - I. Course in Ancient Classics.
 - II. Course in Modern Classics.
- B. Courses in History, Philosophy and English Literature, leading to the Degree of Ph.B.
 - III. Course in English Literature.
 - IV. Course in History and Political Science.
 - V. Course in Philosophy.
- C. Courses in Science, leading to the Degree of B.S.
 - VI. Course in Mathematics and Physics.
 - VII. Course in Biology and Geology.
 - VIII. Course in Chemistry.

The germ of the elective system—the second factor in the growth of the curriculum to its present form—appeared in 1868, when students were allowed an option between Modern Languages and Latin. With more or less variation, such options continued to be permitted until 1875. In this year the range of options was considerably widened in the Junior and Senior years. The following tables show the development of this optional or narrow elective system from 1875 through 1884. In the first part of this period two, and in the second part three; courses of instruction were offered. The numbers in parentheses refer respectively to the year (Freshman, Sophomore, Junior or Senior,) and term of the course; the subjects named are those offered as electives for students of that year and term. (2) The Elective system.

Indiana University

1875-1877

I. CLASSICAL COURSE

Elections per-
mitted, 1875-77

1875. (III, 1). Lucretius, Calculus, Analytical Chemistry, Drawing, or German.
(III, 2). Tacitus, Calculus, Analytical Chemistry, Drawing, or German.
(IV, 1). Greek, German, French, or Oratory.
(IV, 2). Geology, (Paleontology,) Greek, French, or German.
(IV, 3). Latin, Greek, French, or Dynamical Geology.
1876. Same as for 1875.
1877. (III, 2). Tacitus, Calculus, Analytical Chemistry, or German.
(IV, 1). Greek, German, French, or Oratory.
(IV, 2). Geology, (Paleontology,) Greek, French, or German.
(IV, 3). Latin, Greek, French, or Dynamical Geology.

II. SCIENTIFIC COURSE

1875. (III, 1). Analytical Chemistry, Descriptive Geometry, Drawing, or Elocution.
(IV, 1). Oratory, or History of Civilization.
1876. Same as for 1875.
1877. (III, 1). Analytical Chemistry, Descriptive Geometry, or Elocution.
(IV, 1). Oratory, or History of Civilization.
(IV, 3). International Law (Woolsey), Social Science, or Constitution of the United States.

1878-1884

I. THE COURSE IN ANCIENT CLASSICS

Elections per-
mitted, 1878-84:
(a) In Ancient
Classics Course.

1878. (III, 1). German, Latin, Analytical Chemistry, Zoölogy, Elocution.
(III, 2). German, Latin, English.
(III, 3). German, Latin, Botany, Political History.
(IV, 1). French, Greek, Latin, English, Political History.
(IV, 2). Greek, Latin, Political History, Oratory.
(IV, 3). Greek, Latin, Political History.
1879. Same as for 1878, with the omission of English, which was made a part of the prescribed work.
1880. Same as for 1878, except as follows:
(III, 2). For English substitute Biology.
(III, 3). Add Zoölogy.
(IV, 1). Substitute Geology for English.

Departments of Liberal Arts

1881. (III, 1). German, Latin (Pliny's Letters), Analytical Chemistry, Zoölogy, English Language. (English forms also a part of the prescribed work.)
(III, 2). German, Latin (Livy), Biology.
(III, 3). German, Latin (Mostellaria of Plautus), Botany, Political History.
(IV, 1). French, Greek, Latin, Political History, Comparative Anatomy.
(IV, 2). Greek, Latin, Political History, Anglo-Saxon.
(IV, 3). Greek, Latin, Political History, Philosophy of English Literature.
1882. Same as for 1881, except as follows:
(III, 3). For Botany substitute Physiology.
1883. Same as for 1882, except as follows:
(III, 1). For Latin (Pliny's Letters) substitute Latin (Cicero's Letters).
(III, 2). For Latin (Livy) substitute Latin (De Natura Deorum), and add English Classics.
1884. Same as for 1883, except as follows:
(III, 1). Add Physics.
(III, 3). Add Physics.
(IV, 1). For elective studies substitute prescribed Greek.
(IV, 2). Add History of Philosophy.

II. THE COURSE IN MODERN CLASSICS

1878. (III, 1). Latin, Mathematics, Analytical Chemistry, Zoölogy, Elocution.
(III, 2). Latin, Drawing, Analytical Chemistry, English.
(III, 3). Latin, Botany, English, Political History.
(IV, 1). Latin, German, Political History.
(IV, 2). Latin, German, Political History, Geology.
(IV, 3). Latin, German, Political History, Geology.
- During the Sophomore year, moreover, the student was permitted, if he chose, to substitute for the Latin the Greek of the Freshman year. This option was allowed through 1884.
1879. Same as for 1878, with the omission of English in III, 2. The English in this course was not added to the prescribed studies.
1880. Same as for 1879, except as follows:
(III, 2). Add Biology.
(III, 3). Add Zoölogy.
(IV, 1). Add Geology.
(IV, 2). For Geology substitute Paleontology.
(IV, 3). For Geology substitute Comparative Anatomy.

Elections permitted, 1878-84:
(b) In Modern Classics Course.

Indiana University

1881. (III, 1). Latin, Mathematics, Analytical Chemistry, Zoölogy, English Language.
(III, 2). Latin, Drawing, Analytical Chemistry, Biology.
(III, 3). Latin, Botany, English, Political History.
(IV, 1). Latin, German, Political History, Comparative Anatomy.
(IV, 2). Latin, German, Political History, Anglo-Saxon
(IV, 3). Latin, German, Political History, Philosophy of English Literature.
1882. Same as for 1881.
1883. Same as for 1881, except as follows:
(III, 2). Add English Classics.
1884. Same as for 1883, except as follows:
(III, 1). Add Physics.
(III, 3). Add Physics.
(IV, 2). Add History of Philosophy.

III. THE COURSE IN SCIENCE

Elections per-
mitted, 1878-84:
(c) In Scientific
Course.

1878. (I, 1, 2, 3). French or Greek.
(II, 1, 2, 3). German or Greek.
(III, 1). German or Greek, Physics, Descriptive Geometry, Analytical
Chemistry, Zoölogy, Elocution.
(III, 2). German or Greek, Physics, Drawing, Analytical Chemistry.
(III, 3). German or Greek, Botany, Surveying, Analytical Chemistry,
Geology.
(IV, 1). French, Analytical Chemistry, Political History.
(IV, 2). Analytical Chemistry, Geology, Political History.
(IV, 3). Analytical Chemistry, Geology, Political History.
- If the student in this course took Modern Languages instead of Greek, he was
permitted also to substitute for the Latin of the Sophomore year the Greek
of the Freshman year. This option was allowed through 1883.
1879. Same as for 1878.
1880. Same as for 1878, except as follows:
(III, 1, 2, 3). Omit the option, German or Greek.
(III, 2). Add Biology.
(III, 3). For Surveying substitute Civil Engineering; for Geology substitute
Mineralogy.
(IV, 2). For Geology substitute Paleontology.
(IV, 3). For Geology substitute Comparative Anatomy.

Departments of Liberal Arts

1881. (I, 1, 2, 3). French or Greek.
 (II, 1, 2, 3). German or Greek.
 (III, 1). Physics, Descriptive Geometry, Zoölogy, English Language.
 (III, 2). Drawing, Analytical Chemistry, Biology.
 (III, 3). Civil Engineering, Analytical Chemistry, Mineralogy.
 (IV, 1). French, Analytical Chemistry, Political History, English Classics.
 (IV, 2). Analytical Chemistry, Paleontology, Political History, Anglo-Saxon.
 (IV, 3). Analytical Chemistry, Comparative Anatomy, Political History, Philosophy of English Literature.
1882. Same as for 1881.
1883. Same as for 1881, except as follows:
 (I, 1, 2, 3). For French or Greek substitute German or Greek.
 (III, 2). Add English Classics.
1884. Same as for 1883, except as follows:
 (III, 3). Add Physics.

In the year 1885 the elective plan was modified somewhat and the range of elective studies very considerably increased. This widening of the range of electives was another step from the old option scheme to the completely developed elective system which was instituted in the following year. According to the plan adopted in 1885, a list of elective studies was offered, from which in the Junior and Senior years a student in any one of the three courses might select any two subjects he chose. The other one of the three subjects required to make up his full work was prescribed for him. The list of electives thus offered is appended below. The studies marked with an asterisk (*) extended through two or three terms each, and students electing any one of these received no credit for the work until the whole was finished.

Extension of
 Elective system
 in 1886.

First Term	Second Term	Third Term
Greek	Greek	Greek
Greek Philosophy	Greek Philosophy	Greek Philosophy
Latin	Latin	Latin
English Orations	American Orations	English Classics
English Language	English Language	English Language
Comparative Study of the English Drama	Comparative Study of Epic Poetry	Comparative Study of Lyric Poetry
French (beginning)*	French (beginning)*	French (beginning)*
French Classics	French Classics	French Classics

Indiana University

First Term	Second Term	Third Term
German (beginning) *	German (beginning)*	German (beginning)*
German Classics	German Classics	German Classics
Spanish; Italian	Sanscrit *	Anglo-Saxon
Sanscrit *	Æsthetics	Norse
Romanic Philology	Special History	Sanscrit *
Political History of the United States	Sociology; Political Econ- omy	Special History
Special History	History of Philosophy	International Law
Psychology; Ethics	Philosophy	Logic; Rhetoric
Philosophy	Engineering *	Philosophy of Rhetoric
Calculus	Physics (Elementary)*	Engineering *
Quaternions	Physics (Special)	Surveying
Physics (Elementary)*	Chemistry (Elementary)*	Physics (Special)
Physics (Special)*	Chemistry (Qualitative Analysis)	Chemistry (Qualitative Analysis)
Chemistry (Elementary)*	Chemistry (Quantitative Analysis)	Chemistry (Quantitative Analysis)
Chemistry (Qualitative Analysis)	Mineralogy	Meteorology
Chemistry (Quantitative Analysis)	Geology (Elementary)*	Physiology
Geology (Special)	Geology (Special)	Geology (Elementary)*
Paleontology	Paleontology	Geology (Special)
Botany (Special)	Botany (Special)	Paleontology
Biology	Biology	Botany (Elementary)
Comparative Anatomy	Comparative Anatomy	Botany (Special)
Zoölogy (Special)	Zoölogy (Special)	Comparative Anatomy
		Special Zoölogy
		Biology

Completion of
development of
the Elective sys-
tem, 1886-87.

Although, as has been said, the major subject system was not fully matured until 1887, the elective feature of the system was complete in 1886, in so far, namely, that when the student was permitted to make an election at all, he was allowed to choose from the entire range of subjects offered for instruction. All that was then needed to bring the major subject system to its present form was to remove the restriction which permitted students to take elective studies only in their Junior and Senior years, in conjunction with other studies prescribed for those years. The student is now expected to choose his elective work with the advice of the head of the Department in which he has elected his major subject, in order that it may bear some useful

Departments of Liberal Arts

relation to his other work; and he is advised to leave this general elective work to the latter part of his course, as "he will then know better what to choose and be better prepared for the work he may elect;" but with the exception of these general directions he is allowed a range of freedom as wide as possible in shaping his own course and in making his work center about some one selected line of study. Under the new system the student is required to complete as much work for graduation as under the old, but within the course itself greater flexibility is made possible, both in the kind of studies pursued and in the relations of various subjects to one another in the matter of their sequence.¹

The more narrow use of the term "department" to designate all the courses of instruction offered within some one general field, as a subdivision of the general "Collegiate Department," did not become fixed until 1875. It is only, however, since 1887 that the organization of instruction in the liberal arts has been strictly on the departmental plan.

SPECIAL STUDIES

From the time of the earliest recorded history of Indiana University until the final development of the departmental system, certain subjects outside the regular curriculum are indicated in the University catalogues, which may be taken by the student as special studies. In some cases students selecting such subjects were required to have completed certain preliminary work, and in other cases no such requirement was made.

In the first catalogue of the University, for 1831, it is announced that "To such as may wish it, and who have completed the Latin Course, Hebrew and French will be taught." Whether these two subjects were offered continuously through the first ten years of the University's history, it is impossible now to make out.² It is probable that instruction was given at least in French, in which case French has been offered continuously throughout the history of the University; it appears certainly from 1837. No further notice

Hebrew and
French made
Special Studies,
in 1831.

¹The results of the elective system in Indiana University were set forth by Professor Richard G. Boone in two papers in the *Educational Review* (New York) for June and September, 1892, under the title, 'Results Under an Elective System.'

²The University catalogues in this period are missing for the years 1832, 1833, 1834, 1836; and the catalogues that remain are not clear in their specifications regarding extra subjects.

Indiana University

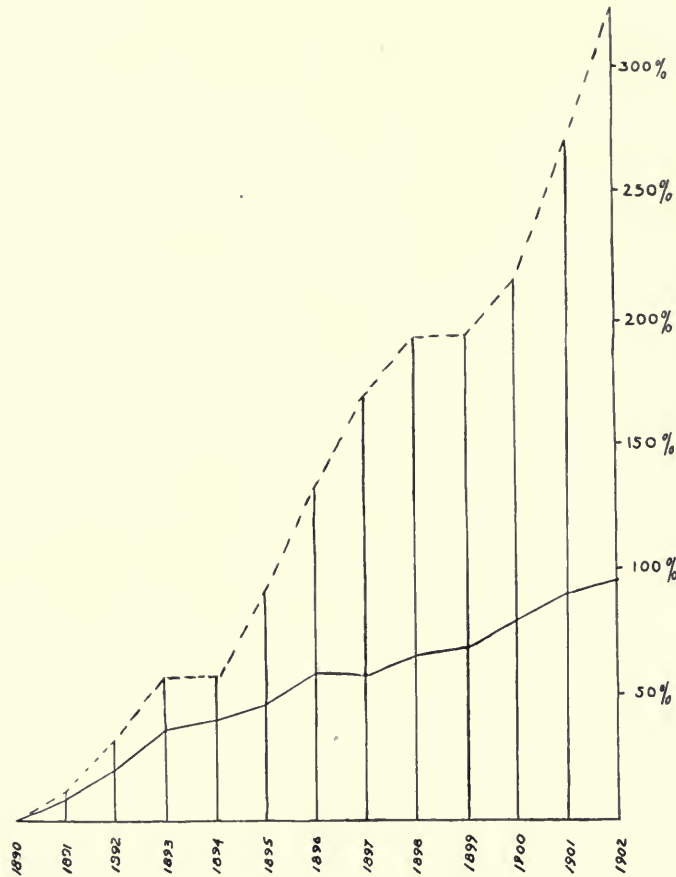

COMPARATIVE INCREASE SINCE 1890 IN THE NUMBER OF UNDERGRADUATE STUDENTS ENROLLED

DEPARTMENTS OF LIBERAL ARTS, INDIANA UNIVERSITY
 COLLEGES OF LIBERAL ARTS IN THE UNITED STATES

The standard of comparison is the enrollment for 1890. To construct the curve, the excess of enrollment for a given year over the enrollment for 1890 was found, and the ratio of this to the standard gave the ordinate for that year.

Number of Undergraduate Students enrolled in the Departments of Liberal Arts, Indiana University	1890	1902
	309	1,139
Number of Undergraduate Students enrolled in the Colleges of Liberal Arts in the United States	45,574	88,979

Departments of Liberal Arts

is made of Hebrew, however, until 1841, from which time it stands as an extra or special study until 1855, after which it disappears from the pages of the catalogue.

From 1841, also, dates separate instruction in civil engineering and bookkeeping. The full announcement is as follows: "In addition to the regular course of instruction here given, such as desire it may receive instruction in Hebrew, French, Civil Engineering, and Bookkeeping. And to those who wish to accomplish themselves in Civil Engineering, an opportunity is offered, during the summer session, of exercising under the direction of the Professor, in practical operations with the theodolite, compass and level, and in making maps and draughts for bridges, railroads and other public works." In the catalogue for 1850 the announcement of special studies includes only Hebrew and French. The next year, however, the announcement of all four subjects is made again, and so continues up to and including the year 1853. After this year instruction in bookkeeping seems to have been discontinued altogether. At the same time, in accordance with a provision made by the Board of Trustees in 1852, the work in engineering assumed a more important position in connection with the Departments of Mathematics and Chemistry.

Engineering and bookkeeping added, in 1841;

In 1854 German was introduced as a separate study, together with French and Hebrew, without any extra expense to the student. Whether a separate fee had been charged before this time for instruction in the special subjects does not clearly appear from the catalogues, but probably not. German, French and Hebrew were offered as special studies through 1863, after which Spanish was substituted for Hebrew.

German, in 1854; and Spanish, in 1863.

In 1868 the Scientific Course was lengthened to four years and placed upon an independent basis. In this year, in addition to being offered as special studies, "Modern Languages" were made an alternative with Latin in the second year of the Scientific Course, and so continued through 1870. Probably there was not much call for the Spanish, however, for it is plain that during this time classes were formed only in German and French. The option here noted between Latin and modern languages is the first germ of what later developed into the elective system. Beginning with the year 1871, German and French are regularly incorporated in the course of instruction and cease to be considered special studies.

Indiana University

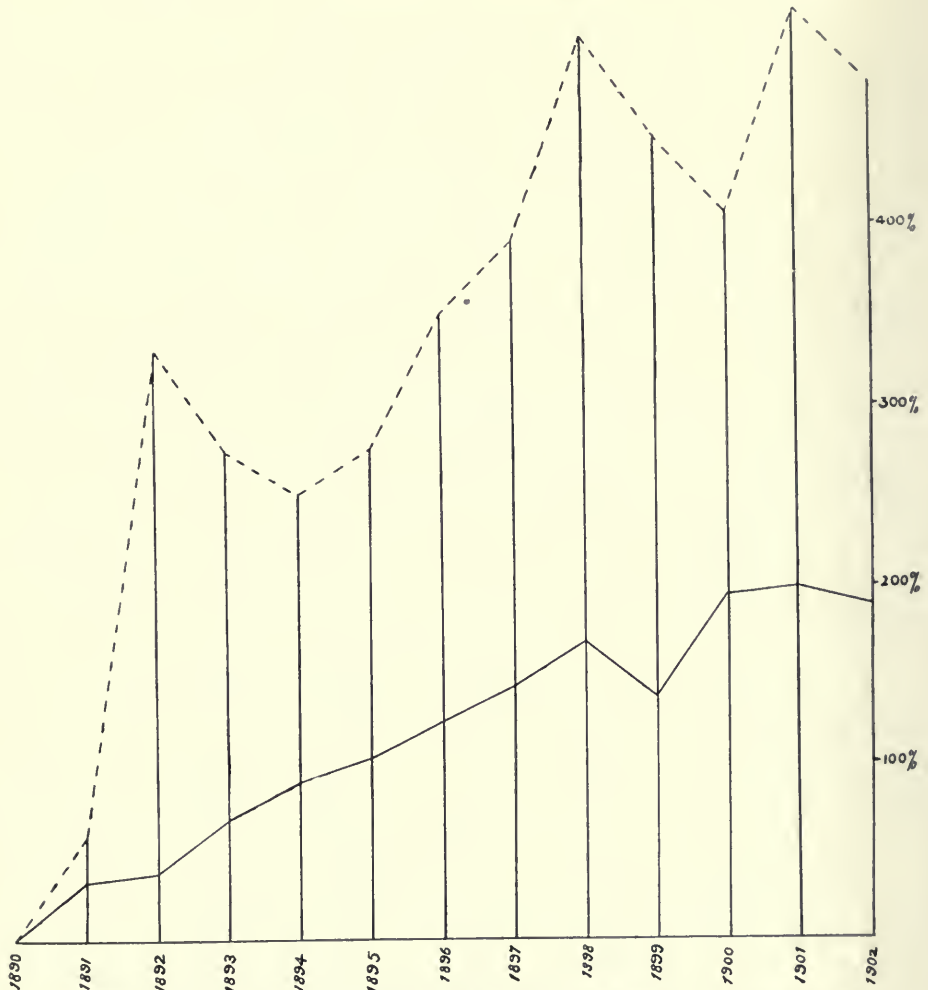

COMPARATIVE INCREASE SINCE 1890 IN THE NUMBER OF GRADUATE STUDENTS ENROLLED

DEPARTMENTS OF LIBERAL ARTS, INDIANA UNIVERSITY
 COLLEGES OF LIBERAL ARTS IN THE UNITED STATES

The standard of comparison is the enrollment for 1890. To construct the curve, the excess of enrollment for a given year over the enrollment for 1890 was found, and the ratio of this to the standard gave the ordinate for that year.

	<i>1890</i>	<i>1902</i>
Number of Graduate Students enrolled in Indiana University....	12	73
Number of Graduate Students enrolled in the Colleges of Liberal Arts in the United States.....	2,176	6,265

Departments of Liberal Arts

It is worthy of note, in this connection, that in 1881 instruction, not announced as part of any regular course, was given in Italian; after this year also work in Spanish or Italian was offered as an elective whenever a sufficient number of students applied for it. From 1885, with the introduction of a wider range of electives, the courses of instruction tended to become more flexible, and special studies ceased, in any formal way, to stand outside the regular courses.

End of the
Special Studies
system (1885).

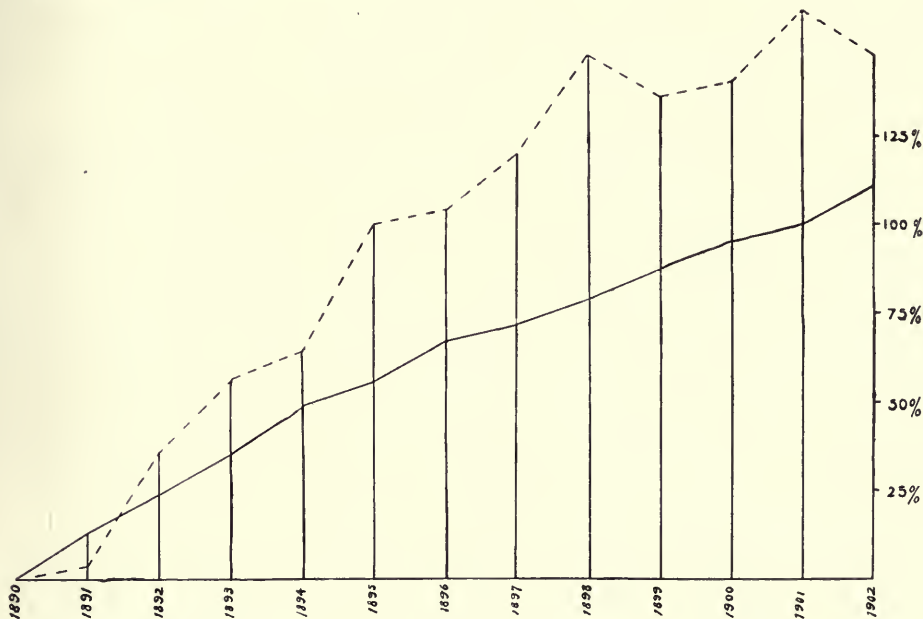

COMPARATIVE INCREASE SINCE 1890 IN THE NUMBER OF MEMBERS OF THE FACULTY

DEPARTMENTS OF LIBERAL ARTS, INDIANA UNIVERSITY
 COLLEGES OF LIBERAL ARTS IN THE UNITED STATES

The standard of comparison is the number of members for 1890. To construct the curve, the excess of membership for a given year over the membership for 1890 was found, and the ratio of this to the standard gave the ordinate for that year.

Number in the Faculty of Indiana University, Departments of Liberal Arts.....	1890 25	1902 62
Number in the Faculties of Colleges and Departments of Liberal Arts in the United States	4,509	9,511

Indiana University

THE MAJOR SUBJECT SYSTEM

THE THIRD PERIOD OF THE COURSE OF INSTRUCTION (since 1886).

The major subject system of instruction, which was the outcome of the foregoing lines of development, was fully worked out in 1887. By that date, the University was organized on the departmental basis; the degree of Bachelor of Arts (A.B.) had become the only degree offered in the Departments of Liberal Arts; and the plan of laying down a "course of instruction," with specifications for each of the four undergraduate years, was abandoned for a system of "prescribed" and "elective studies" with a "major subject" or "specialty,"—the whole constituting the University "requirements for graduation."

Adoption of the Major Subject system.

This last feature of the plan resulted immediately from a report to the Faculty by the Catalogue Committee, under the chairmanship of Professor Hans C. G. von Jagemann, which was adopted February 19, 1887. It laid down, under the four heads "General," "Special," "Collateral," and "Elective," the amount of work required of every candidate for graduation; and added: "The above general plan for the course of study is to go into effect immediately. All questions concerning the adjustment of the present students to the new course are referred, in the case of each student, to the professor or professors concerned in the adjustment."

The following account of the new plan, taken from the University catalogue for 1889, may be regarded as representative for the first years of the major subject system:

The Course as outlined in 1889.

Every candidate for the degree of Bachelor of Arts must complete the following work:

GENERAL—

English, one year, daily. Mathematics, one year, daily. Physical Science (Astronomy, Botany, Chemistry, Geology, Physics, Zoölogy or Physiological Psychology), three terms, daily. Ancient or Modern Languages, one language two years, or two languages one year each, daily. English Prose Composition and Rhetoric, three times a week throughout the Sophomore year.

SPECIAL—

Every student must select for a specialty the required work in some one department, extending over three or four years.

Departments of Liberal Arts

COLLATERAL—

The head of each department may lay out, in connection with his course, work in related subjects; such required collateral work not to exceed six terms of daily recitations, and to be especially arranged for each student.

ELECTIVE—

The remainder of the student's work, six terms of daily recitations, he may himself elect from any department in the University.

During the Freshman year, any three of the required general studies should be taken. The selection of a specialty is made at the beginning of the Sophomore year. The order in which the required general and collateral studies shall be taken may vary with the conditions in the case of each student. He is to be guided in this matter by the advice of the President, and, when he has chosen his specialty, by the professor in whose department he desires to work. A student may change his specialty at the end of a term, provided he have the consent of the professor in charge of the department which he leaves, and also of the one whose department he wishes to enter. No student will be graduated who has not finished all the work required for graduation in some one department, no matter how much work he may have done in other departments.

Explanation
of the plan.

A student may choose his specialty in any one of the sixteen departments now organized. Each department offers a four years' course leading to the degree of Bachelor of Arts. All the courses demand the same preparation for admission, all require four years for completion, and all oblige the student to follow some special line of study during three or four years. In each course three daily recitations or lectures of one hour each are required weekly, two hours of laboratory work being regarded as the equivalent of one hour of recitations or of lectures.

In the arrangement of the courses of study, several principles have been recognized. The beginnings of any study are easy compared with the difficulties the student meets after going beyond the mere elements of his subject, hence a better mental training can be obtained from the continued study of one subject during several years than from the study of various subjects for a short period each. The thorough study of any subject is conducive to good mental discipline, therefore all the departments should be placed on the same footing. Moreover, as no two minds are alike, and as different minds require different discipline, the student should be granted great freedom in the choice of studies, after the completion of certain subjects necessary to all culture, and the continued study of a specialty, necessary to efficient mental discipline. The educational value of the element of personal choice, on the part of the student, is also fully recognized. "One of the most important

Indiana University

functions of the school is to place the individual on his feet, to give him the ability of self-direction." To this end no method is more effective than a well-guarded elective system.

This plan, in its general outline, is still in force, with one change of detail, and several changes in terminology. The "Collateral" work has been abolished so as to increase the amount of the "Elective" work; and the terms "General" and "Special" (or "specialty") are now replaced by "Prescribed Work" and "Major Subject."

Success of the
Major Subject
system.

The course of instruction as now established is designed to secure a fundamental uniformity in the work of all students, and at the same time be

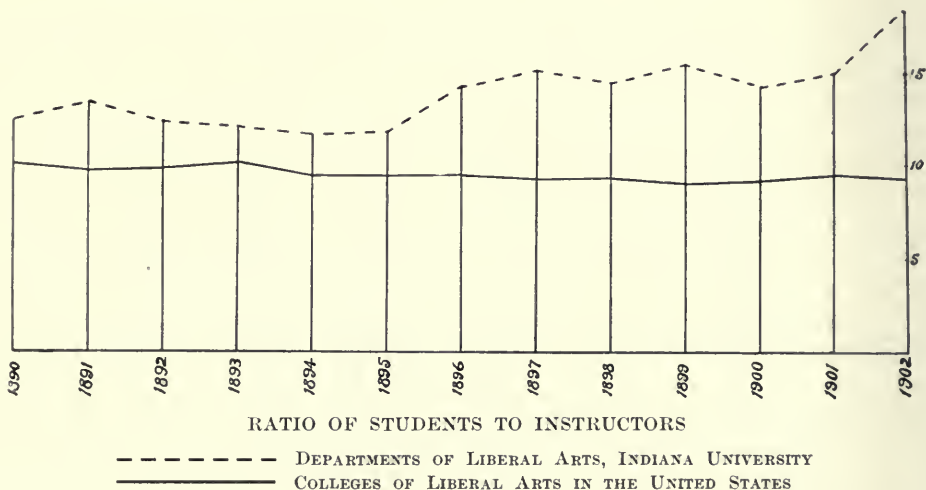

flexible and adaptable to the needs of individuals. An equal amount of preparation for admission is required of all students; all must take a group of similar prescribed studies, amounting to about one-third of the student's course; all must follow some special line of study during three or four years; and all students meeting the University requirements, receive the degree of Bachelor of Arts. This curriculum, with its stress on the major subject, has now been in operation for eighteen years. Its success has been generally recognized by educators, and may be attributed to three causes: the major requirement, which gives to the student's work continuity and consistency;

Departments of Liberal Arts

the flexibility, which permits each student to arrange his work as may best meet his needs and requirements as he sees them; the responsibility thrown upon the student in thus allowing him free choice of a third of his work and a large measure of freedom even in his prescribed studies, since comparatively few courses are specifically prescribed.

From the adoption of the curriculum in 1887 it has been possible for the student to arrange certain special courses, such as the old Premedical Course (see p. 178), which gave the student second-year standing when he entered a medical school. In recent years, however, there has been a tendency toward a greater variety in combination. This tendency has received official recognition, so that the term "major subject" has now a somewhat broader meaning. The major subject may, as hitherto, consist of three or four years of continuous work in some one department of the University; but it may also consist of the same amount of work in one of the Schools of the University, or in certain correlated groups of courses chosen from the two or more departments, and leading to a definite end, as for example a vocation in life.

With this change in the conception of "major subject," has come a change in the use of the term "department." The term still represents an instructional and administrative unit in the University organization, but in the case of some departments (for example, Fine Arts), the instruction offered does not constitute a major subject group of studies; conversely, as has just been stated, certain major subjects, as now recognized, fall not in one but in two or more departments. Such cases, however, are exceptions; and the general rule still is, that each department offers instruction which may be chosen by students as a major subject.

Recent changes
in the conception
of Major Subject,
and of Depart-
ment.

Indiana University

DEPARTMENTS AS NOW CONSTITUTED

A list of the Departments of Liberal Arts, as organized in the University at the present time, together with a brief description of the aims, methods and facilities for work in each, is given below.



DEPARTMENT OF GREEK—A RECITATION ROOM

1. Department of Greek.

The courses in Greek are designed to meet the needs of two classes of students: first and primarily, those who desire a knowledge of the Greek language and literature; secondly, those whose time is too limited for this, but who wish to know something of the language and literature as supplementary to their other studies.

Departments of Liberal Arts

To fulfill the first purpose, graded courses are offered which lead the student from the elements of the language, through Xenophon's *Anabasis* and *Hellenica*, Homer's *Iliad* and *Odyssey*, the lyric, dramatic and bucolic poets, the historians and orators, the philosophers, the Greek Testament and Church Fathers, to the Graduate Seminary, which is designed for those who are specialists in Greek, and intend to become teachers of the subject. In all of the more advanced classes regular lectures are given on the literature and antiquities.

To meet the requirements of the second class of students, courses are provided in Greek words in English, and in Greek literature in English. The former is a brief course in Greek, designed to facilitate the understanding of scientific and philosophical terms and other English words of Greek origin. The latter is conducted by means of lectures on the history of Greek literature from Homer to Theocritus, with special reference to the needs of the general student. Reading of the best available English translations, and constant attention to works in modern literature which were inspired by Greek models, are features of this work.

The Department is well equipped for doing thorough and scholarly work. The library consists of about two thousand well selected books covering the entire fields of philology, literature and art, and advanced students are allowed the privilege of admission to the book-stacks for purposes of research. The Department owns one of Walger's famous models of the Athenian Acropolis, besides numerous plaster casts and busts, the number of which is being increased from year to year. Besides several large and particularly fine Braun photographs, the number of smaller photographs of landscapes, sites, architectural remains and ancient works of art, is now upwards of six hundred. The Department also owns a stereopticon and has about five hundred slides illustrative of the various phases of Greek life, landscape, and art.

The purpose underlying the work in Latin is, in general, to give the student an accurate knowledge of the civilization of Rome and its relation to the civilization of our own time. A knowledge of the Latin language is the first essential in this investigation, and claims, of course, a large share of the student's time, because the sources can be appreciated fully only by those who

2. Department
of Latin.

Indiana University

can deal with them directly. A small part only of the students of Latin take the full work offered in the Department, but the courses are arranged with the idea of making even the earliest work of interest and practical value to the student. The six years' work is divided into three parts of two years each: (1) the foundation courses; (2) the intermediate courses; (3) the special courses.



UNIVERSITY LIBRARY—A PORTION OF THE GENERAL READING ROOM

The foundation courses form the preliminary work of students who make Latin their major subject, or the full work of those who take Latin merely to satisfy the language requirement for graduation. As the latter class of students far outnumbers the former, the effort is made to give them a first-hand knowledge of the best portion of the best authors in connection with the

Departments of Liberal Arts

language drill which is believed to be a valuable means of training the mental faculties. Three hours a week are devoted for two years to the reading of one of the longer orations of Cicero, a book of Livy, a play of Terence, selected odes of Horace, selected letters of Pliny, the *Agricola* or *Germania* of Tacitus. The remaining two hours are devoted in the first year to disciplinary drill upon the Latin sentence—one hour to the systematic study of the



UNIVERSITY LIBRARY—CATALOGUING ROOM

new Latin syntax, one hour to composition based upon the prose authors read. In the second year the composition is continued for one hour a week, the second hour being given to a study of the private life of the Romans.

The intermediate courses complete the work of those who make Latin their major subject, and are planned to give the student the general survey

Indiana University

of Latin literature that is necessary for the special courses which are to follow, together with an elementary knowledge of the subjects of paleography, criticism, epigraphy and the philology of the Latin tongue. To this end, a choice is offered each year of a three-hour course in prose and poetry, and in alternate years of the authors of the Republic and the Empire. Fixed courses, regularly repeated, are given in the history of literature, the history of the language, the use of manuscripts, and the reading of inscriptions. Students are taught the use of a library, and are made familiar with the primary and secondary sources of knowledge. Those who complete these courses are recommended with confidence for positions as teachers of Latin in secondary schools.

The special courses are offered to graduate students only, and to those who expect to make the study of Latin their life work. The effort is made to acquaint the student with the present position of the several disciplines of philology, to familiarize him with modern methods of research, and to fit him to undertake intelligently investigations of his own. The University is now well supplied with the material for the study of the language and life of Rome, and the courses offered aim to utilize this equipment.

3. Department of Romance Lan- guages.

Courses are offered in this Department in French, Spanish, and Italian. In French the work for the first two years is prescribed; it is entirely linguistic, the study of literature being deferred until the third and fourth years. After two years of training the student is allowed to choose his courses. During the first year much attention is given to pronunciation. Oral drill is insisted upon, but conversation is not emphasized. The aim of the second year's work is to give the student a fair reading knowledge of the language. The study of grammar is continued and a course in translation is offered which contains the largest possible variety of literary French. The courses in literature are so arranged as to cover the seventeenth and eighteenth centuries and the greater part of the nineteenth. The purpose of the work in these courses is primarily to enable the student to distinguish and to enjoy the best that is in French literature, and secondarily to give him knowledge of the history of the literature. In pursuance of the first object a large number of literary masterpieces are read in whole or in part, and the best criticism dealing with them is studied. The other end is attained through lectures and

Departments of Liberal Arts

frequent references to works contained in the library. Courses in advanced composition, sight reading and Old French are also offered. In Spanish and Italian two courses are offered in each. In the course in advanced Spanish various authors are read. The advanced course in Italian is devoted to the study of Dante.

The elementary courses in German are intended to give the student a command of the language, more as an approach to the literature than for the sake of conversational ability. This practical control of the language being taken for granted, the more advanced courses are intended to interpret the language, the literature, and the general culture of Germany to the student, so that he may be led to a sympathetic appreciation of the German spirit and what this spirit has contributed to modern civilization.

4. Department
of German.

The study of the literature is made central, at least during the undergraduate course. To emphasize the various important aspects of this study, the courses offered are organized on three different bases—historical, biographical, and critical. Under the first head, a cycle of courses is intended to afford both a rapid survey of the entire history of German literature, and a somewhat more detailed examination of important periods or movements,—in each case, with the reading and discussion of representative works that will illustrate the leading topics of the historical treatment. Under the second head, a series of courses treat as a unit the life-work of a few of the greatest individual authors. Under the third head, the purpose is to give the student an introduction to the methods and principles of criticism and literary research. In all these courses, the attempt is made to relate the literature studied to the other great national literatures, ancient and modern, with which a comparison may most profitably be made.

Parallel with the courses in literature, language courses are offered throughout the undergraduate period, intended to give the student greater facility in writing and speaking the language, and a better knowledge of the formal structure and idiomatic usage of modern German. The more strictly philological study of German—the history of the language and the study of its older historic forms—is considered as essentially graduate work. The philological courses in Germanic Languages, formerly divided between the Departments of English and German, are now given by a single instructor in

Indiana University

the Department of English. A short Teachers' Course is given, for the discussion of books and methods for the teaching of German, and of the relation of German to the other subjects of instruction in secondary schools.

The University Library contains a good collection of books for the study of German philology and literature, and a list of twenty-six literary and philological periodicals, pertaining altogether or in part to this Department. Five instructors devote their entire time to the teaching of the German lan-



A WALK IN THE UNIVERSITY CAMPUS

guage and literature; and most of the time of a sixth instructor is given to the courses in Germanic Philology.

5. Department
of English.

The work of the Department of English falls into three natural divisions — language, rhetoric, and literature.

An elementary knowledge of English philology is regarded as essential to the student who would master the spirit of our language and literature.

Departments of Liberal Arts

Each student, therefore, who makes a special study of English is required to take at least one linguistic course, Old English. Courses in Gothic, Old English poetry, Middle English, the history of the language, Old High German, and an introduction to the science of language based on the comparative philology of Greek and Latin, are also offered; and courses in Old Norse, Middle High German, and Old Saxon are listed in this Department, though not at present offered.



A WALK IN THE UNIVERSITY CAMPUS

In rhetoric, or composition, the object is to teach the student to express himself effectively. The regular work begins with a course in narration, description, and exposition. This is required of all students who make English their major subject. Students who distinguish themselves in this class may be admitted into an advanced course, which has as its specific purpose to stimulate original production on the part of those who appear

Indiana University

to have some literary instinct. Under the head of rhetoric comes also a course in the theory of teaching composition and literature. This course is open to all students who have taught English or who intend to teach it, and the discussion of problems and the exchange of views and experiences have proved valuable to the University in bringing it into closer contact with the high schools of the State. Courses in public speaking—debate and the more formal address—are offered. The University does not strive to produce “orators,” but encourages its students to learn to express themselves in public easily and unostentatiously.

In literature, the Department offers courses covering the more important epochs and authors. An elementary course in Milton, Shakespeare and modern novels leads the student to the study of drama, poetry and fiction. Accompanying this are elementary courses in American literature, in Tennyson, Browning, and Matthew Arnold, in Shakespeare, and in Chaucer, Spenser, and Milton. The critical study of poetry begins in the second year. Wordsworth, Coleridge, Byron, Shelley, and Keats are read. English prose style—Macaulay, De Quincey, Carlyle, Newman, Arnold—is made the main study of the third year. Courses in eighteenth century literature, in textual criticism, and in metrics, rank with the work of this year. The fourth year's work deals with Elizabethan and pre-Shakespearean drama. A literary seminary for the encouragement of original research is open to graduate students.

The aim of the Department is to give to its students an elementary knowledge of the development of the language, a proficiency in the art of expression, and a genuine appreciation of literature. These things can not be attained without careful and sympathetic study. Especially in the study of literature the student must bring his intellect to bear on what he reads. When literature is understood, the love of it will follow.

The Department hopes to send out young men and women of literary insight, sympathy, and judgment; to whom all that is good in literature old and new will constantly appeal, and in whom the forces that make toward true culture will find defenders discriminating, ardent, and modest.

Departments of Liberal Arts

The first year's work of the Department of History and Political Science consists of a term of daily work each in Greek, Roman, and medieval history, based on such text-books as those of Bury and Shuckburgh for Greece and Rome, and supplemented by lectures, collateral reading, and map-drawing. For those who are not special students of history, but wish to complete the survey of general history, a five-hour course is given in the history of modern Europe in the Spring term.

6. Department
of History and
Political Science.

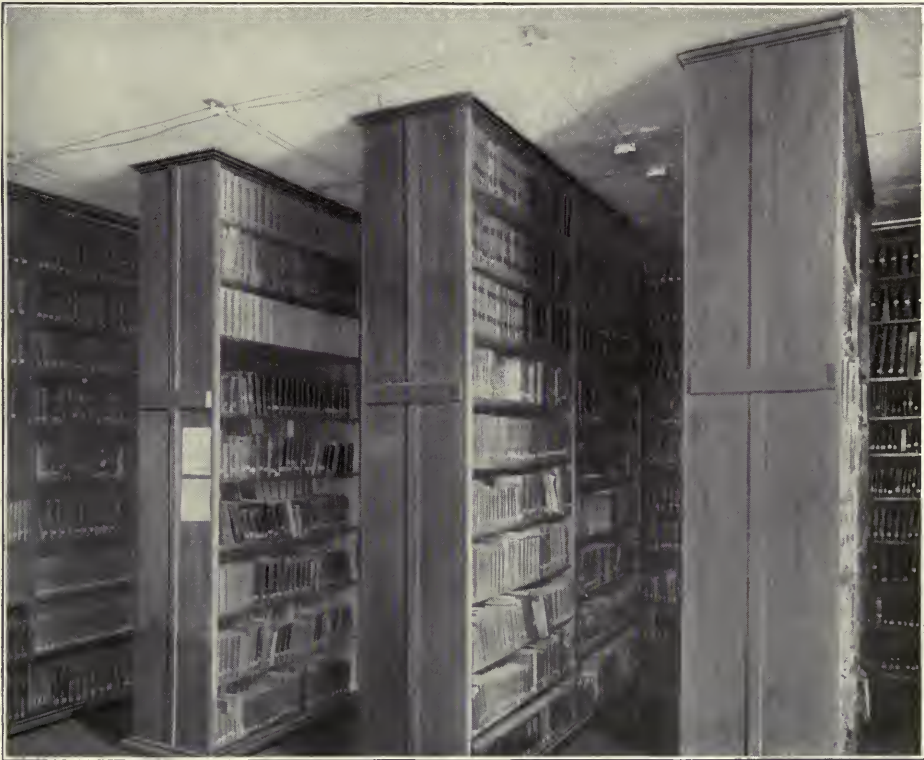

DEPARTMENT OF HISTORY AND POLITICAL SCIENCE—SEMINARY ROOM

After the first year's work, the student taking history as his major subject may pursue either advanced courses in European history, courses in American history, or courses in political science. In European history the advanced work consists of the following: a course in modern Europe (three

Indiana University

hours a week throughout the year); a course in the Renaissance and Reformation (two hours a week throughout the year); a course in the political and constitutional history of England (three hours a week throughout the year); and a brief course in the institutions of medieval France. In American history a course in colonial history to 1750 is offered, and a general lecture course covering the period 1700-1876, together with a course on American diplomatic history, 1776-1876. In political science there are courses in American government and American party machinery; in European politics; in international law; and in the history of political ideas, and the theory of the state.

Seniors in the Department are required to take a course in historical method, and to carry on, for at least two terms, research work in one of the Seminaries of the Department—in which also graduate research work may be done. There are three Seminaries in history: one in English history, devoted mainly to the study of subjects connected with modern England; a Seminary in modern European history, in which the topics are for the present drawn mainly from the French Revolution, and from the history of diplomacy and international law; and a Seminary in American constitutional and political history. The aims of the Department are not merely to teach the facts of history and government, but to inculcate the spirit of criticism and habits of independent thought and work; and in no way, it is believed, can this be done so well as by early introducing the student to research work among the sources, under the guidance of trained instructors.

7. Department of Economics and Social Science.

The work of the Department of Economics and Social Science covers the three closely related fields of political economy, sociology, and commerce. The course for students taking their major subject in this Department covers four years, the first year's work being taken in the Department of History and Political Science. In this first year the student is encouraged to acquire as thorough a basis of historical and political facts as possible which may serve as a preparation for the later work in theory. In the Sophomore year he takes up general political economy, which is the foundation course for all succeeding work in the Department.

From this point, although all "major" students are expected to take most of the courses offered, it is possible to concentrate the interest on the field

Departments of Liberal Arts

which is particularly congenial. In the line of political economy the sequence of courses is usually commercial geography, economic history, finance and financial history, advanced economic and social theory, and research work in the seminary. The latter is required of all students who graduate in the Department.



DEPARTMENT OF ECONOMICS AND SOCIAL SCIENCE—A HAND GRIST-MILL (PART OF A COLLECTION OF INDIANA ANTIQUITIES)

In sociology the foundation course, belonging also in the Sophomore year, is anthropology. Here are grouped three lines of study—ethnology, primitive technology, and social origins. This is followed by one year devoted to social pathology, where the work is again divided into three groups—charities, criminology and social problems. In the Senior year the work is the same as that in political economy.

Indiana University

For students who expect to enter business as a career a special curriculum is provided. The purpose is to group together the courses offered by this and other Departments so as to provide a line of work which, while its culture value is thought to be equal to that of the ordinary college course, will give a practical training for business life. These general courses are supplemented by certain semi-technical courses designed particularly to meet the needs of such students. Of this nature is the work in commercial law, business organization and management, transportation, accounting and insurance. To students who complete the commercial course, a special certificate, in addition to the ordinary diploma, is given.

The Department at present provides one year of graduate study. While the graduate student is expected to take certain regular courses, the chief stress is laid on research. The Department is well supplied with materials for advanced work on state and local finance, industrial organization, municipal problems and charitable and correctional agencies.

The purpose of the Department's work is to prepare students for law, journalism, business and the public service. In the earlier undergraduate years the student is not encouraged to a narrow specialization. In the Senior year, however, it is believed that he may, with profit, devote most of his time to work in this field.

8. Department of Philosophy.

The first year of work in the Department of Philosophy consists of courses in psychology, logic and ethics. These offer the student a general introduction to the fields of psychology and philosophy. The second year is devoted to experimental psychology and a laboratory study of the nervous system. The psychological laboratory occupies four large and fourteen small rooms of special construction. Among the rooms designed for special uses are a large dark-room for experiments on vision, equipped with large iris-diaphragm, are light, and heliostat attachments; a sound-proof room for the study of minimal auditory sensations; three small double rooms providing convenient isolation of subjects during experiments on reaction-time, circulation, etc. The laboratory is supplied throughout with water, gas, and electric light and power, and has apparatus for both practice and research courses. An aviary, an incubator and brooder, quarters for small animals, artificial nests for ants, etc., and other facilities for the study of compara-



DEPARTMENT OF PHILOSOPHY—MAIN LECTURE ROOM



DEPARTMENT OF PHILOSOPHY—MAIN ROOM OF NEUROLOGICAL LABORATORY

Indiana University

tive psychology are also included. The workshop of the psychological laboratory is equipped with two photographic dark-rooms; an electric motor; a Reed lathe, with screw-cutting and gear-cutting attachments, and the necessary tools for work in wood and metal; it is used both for repairing old and constructing new apparatus. The laboratory of neurology contains a large number of charts, a series of models of the nervous system, including



DEPARTMENT OF PHILOSOPHY—PREPARATION ROOM IN NEUROLOGY

Auzoux models of brain, eye, and ear; Ziegler models of the embryology of the human brain; a series of human and animal brains; dissecting outfits; microtomes, microscopes, and other appliances necessary to the study of the structure and functions of the nervous system.

During the third and fourth years the student may choose between courses in philosophy and those in psychology. The courses in philosophy include the history of philosophy (which covers two years), an introduction

Departments of Liberal Arts

to philosophy, the philosophy of evolution, the philosophy of religion, and advanced ethics. The lines of advanced psychology include hypnotism and suggestion, mental pathology, advanced comparative psychology, the psychology of religion and systematic psychology. During the past year a Philosophy Club, open to Seniors and graduates in the Department, has held fortnightly meetings for the informal discussion of the philosophical and ethical significance of Emerson.



DEPARTMENT OF PHILOSOPHY — A ROOM IN THE PSYCHOLOGICAL LABORATORY

The Department seeks to develop the spirit of investigation in psychology and in general philosophy, and a considerable number of graduate students are engaged in research. Studies chiefly in experimental, social and comparative psychology, mental hygiene, and the psychology of religion have been successfully completed or are now in progress. Some of these studies

Indiana University

have already been published in the *Psychological Review*, the *American Journal of Psychology* and other scientific journals.

9. Department of Education.

The work of this Department naturally falls into four divisions: (1) courses designed to give a general introductory survey of the elementary facts of education, (2) those designed to train the student by an extensive comparative study of educational facts, (3) those for the development of



PEDAGOGICAL MUSEUM—COLLECTION OF SCHOOL WORK FROM DIFFERENT CITIES IN INDIANA

habits of investigation, and finally, (4) those to aid the student in becoming acquainted with the practical routine of work of the high school teacher, supervisor, or superintendent—the classes of men the Department seeks to train.

The introductory courses may comprise either a year's work of one period a day devoted to elementary psychology, logic, and ethics; or a year's work

Departments of Liberal Arts

in elementary pedagogy, in which is given an introductory view of the general purposes and methods of education. Many of the students who enter the Department have already had the equivalent of the introductory



PEDAGOGICAL MUSEUM—COLLECTION OF TEXT-BOOKS, MODELS, ILLUSTRATIVE MATERIALS AND SCHOOL WORK FROM SCHOOLS IN GERMANY

Indiana University

courses, either through private reading and experience or by study at other institutions.

A comparative study of past and present educational conditions and ideals is regarded as an essential part of the training of an educator. Three hours a week for two years are given specifically to this work, besides which an historical treatment is given to many of the topics dealt with in other courses. The work is conducted not simply with a view to acquainting

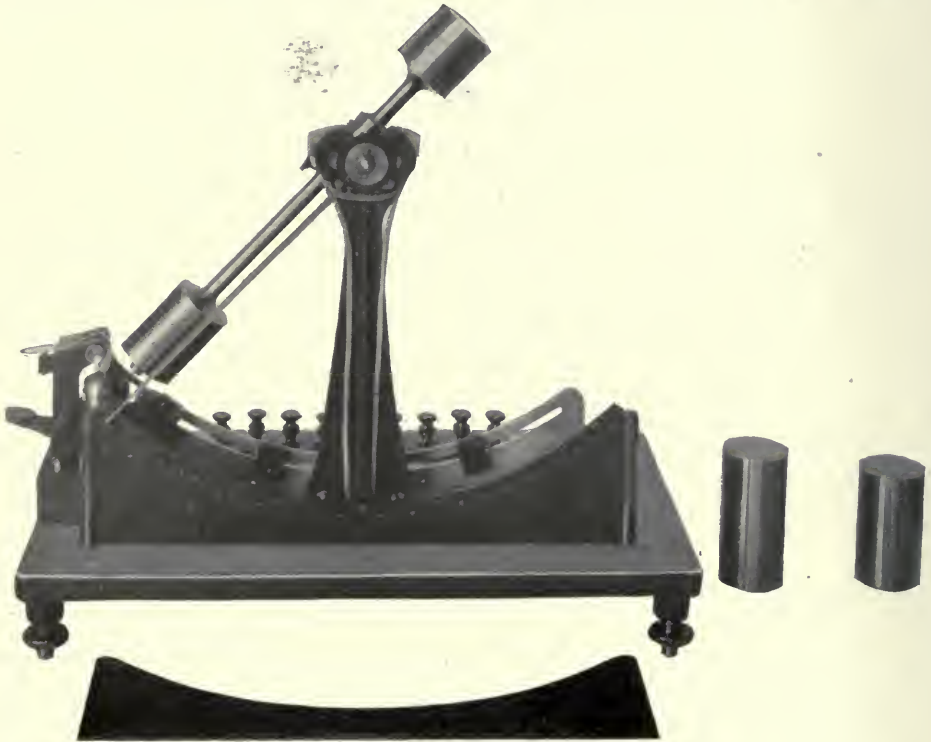

PENDULUM CHRONOSCOPE

Designed by Professor J. A. Bergström, and described in the *Psychological Review* for September, 1900.

New features consist in the mode of carrying and clamping the index, the silent escapement, and a system of movable keys which provide for intervals varying from about $\frac{1}{1000}$ of a second to 2 or more seconds. The apparatus is of special service in giving the time of exposure in the tachistoscope, in experiments upon the perception of time or the direction of attention to simultaneous events, and as a chronoscope for measuring short intervals of time with a very high degree of accuracy.

Departments of Liberal Arts

the student with the leading facts of past educational theory and practice or with modern school organization, purpose and method, but more especially to the end of developing a sense for educational values and of making possible the balance of judgment and the ingenuity and fertility in expedients that alone come from a study of well organized series of educational facts.

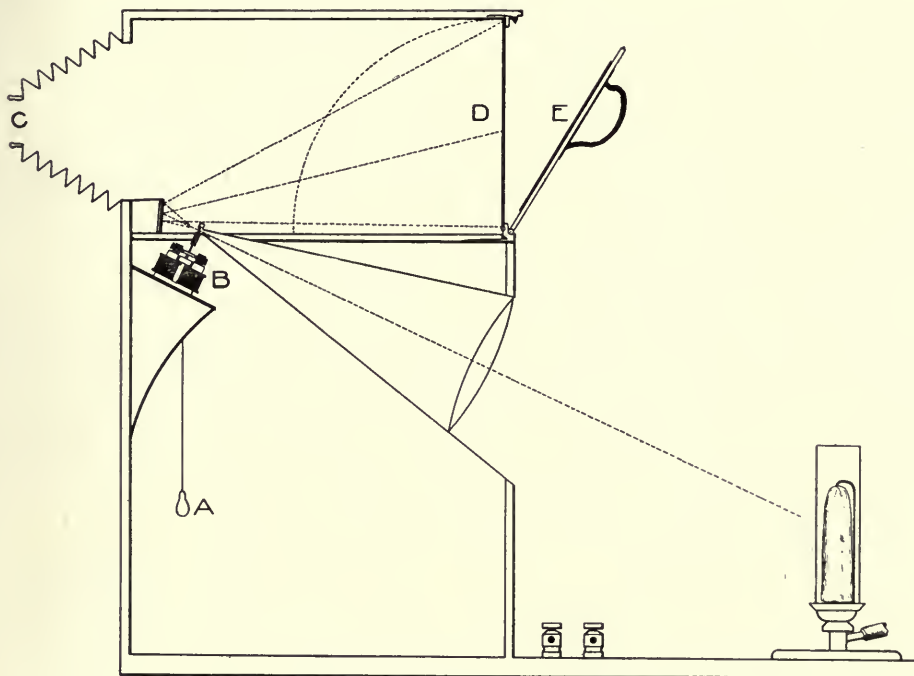

TACHISTOSCOPE

Designed by Professor J. A. Bergström.

For exposing to view colors, pictures, numbers, letters, phrases, sentences, and the like, for a very short and (as far as may be) for a definitely adjustable interval, with a view to ascertaining the degree of completeness of perception and recognition or the extent of the mental span under such conditions.

The principle of construction is that of producing a cone of light which at the apex passes through a small hole in the inclosing metal cone; on emerging it enlarges, and, after reflection from a mirror, illuminates a considerable surface on which are placed the objects to be studied. Noteworthy features are the relative simplicity of structure, the use of direct illumination instead of projection, the mode of securing adaptation of the eye, and the small noiseless electric shutter which makes its use in connection with the chronoscope especially convenient.

Indiana University

The importance for educational theory of studies in modern psychology is recognized not only by the continued use of its modes of interpretation in all subjects, but by special courses requiring two years of work of one period a day in social and educational psychology. In addition, courses in various other phases of normal, abnormal and experimental psychology,

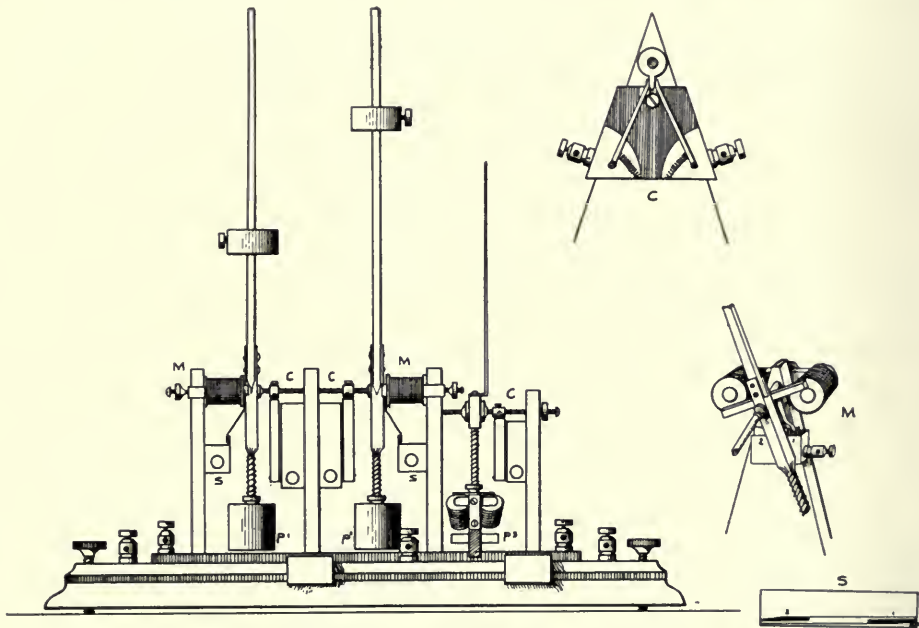

APPARATUS FOR COMBINED INTERVALS

Designed by Professor J. A. Bergström.

Consists essentially of two large pendulums (whose periods may be varied by changing the bobs), which are kept in constant oscillation by electrical means; and a small pendulum, which may be held at either extremity of its swing by electromagnets whose magnetization depends upon the movements of either of the large pendulums. The apparatus is used chiefly to regulate the duration of impressions and the interval between them in experiments upon memory.

and in neurology, are offered by the closely related Department of Philosophy. Moreover, many of the problems which have occupied educational seminaries and research students have come from this field.

Facilities for observation and practice, furnished by courses in grade supervision and school administration, have been limited largely to the schools

Departments of Liberal Arts

of Bloomington. Efforts to extend the work to other cities in the State have been only partially successful. The Department has no practice school of its own.

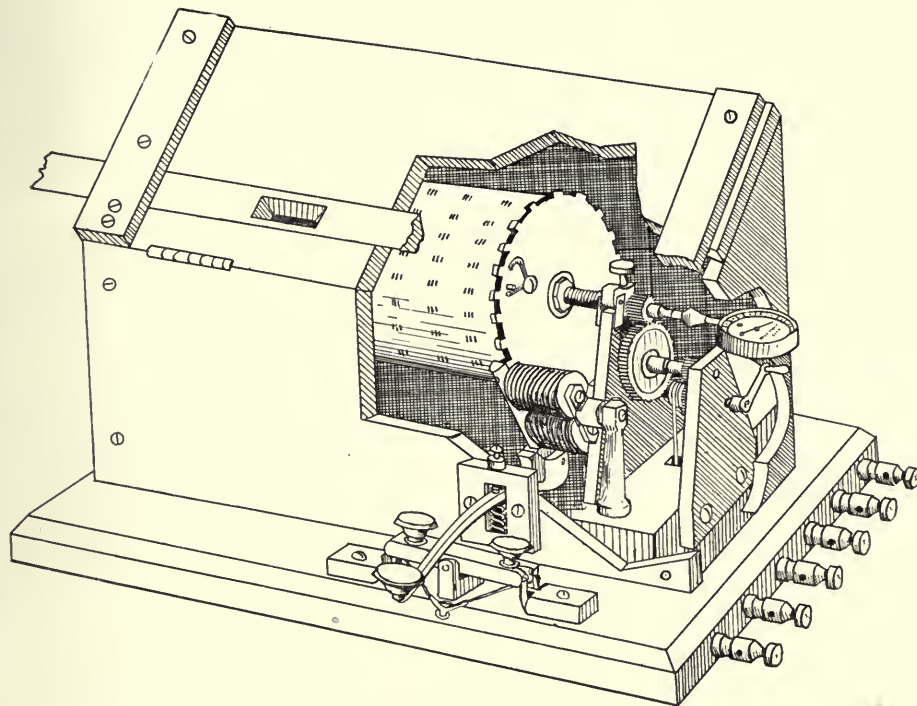

APPARATUS FOR EXPERIMENTS UPON MEMORY

Designed by Professor J. A. Bergström.

A light drum is kept under a certain pressure towards rotation by a weight, but is allowed to move only step-fashion by the cogs and an escapement, which in turn is regulated by the apparatus represented on the opposite page. Around the drum is fastened a paper bearing letters, syllables, words, or other characters, one of the series being brought into view for a certain time at each step of rotation. This apparatus is especially convenient for the study of the influence, upon retention and recollection, of changes in the elementary factors of duration of impressions, of intervals between them singly, or between series of impressions.

A pedagogical museum was begun seven or eight years ago, and at present contains a large collection of American text-books and books for collateral reading. The intention is to make it as far as practicable international. An exhibit of text-books, charts, specimens, manuals, training

Indiana University

models, and samples of written work and art work prepared by Dr. Ludwig Kotelmann of Hamburg is the best of the foreign exhibits; those from France, England and Sweden are relatively small. The museum contains also a large collection of samples of work done in the schools of a number of cities of Indiana, including not merely specimens of art work, but products of manual training, relief map work, and composition, also music lessons recorded phonographically.

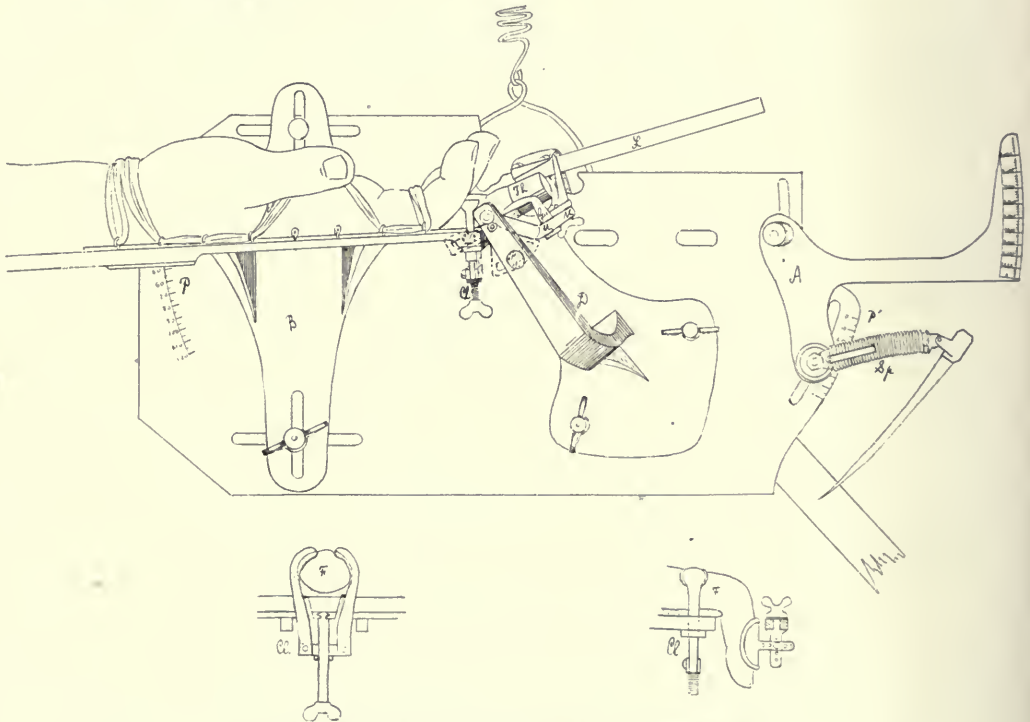

A NEW FORM OF ERGOGRAPH (FRONT VIEW)

Designed by Professor J. A. Bergström. Described in the Commemorative Number of the *American Journal of Psychology*, September, 1903.

For the study of neuro-muscular work and fatigue, and the kinæsthetic sensations of the fingers; and for experiments upon the Weber law for the discrimination of differences of resistance. It differs from other apparatus for this purpose: (1) in the greater degree of isolation of the muscle, especially through the introduction of the principle of suspension, and experiments with flexors of the last phalanges; (2) in its general adjustability; (3) in the higher degree of accuracy, attained through its special form of finger clamp and its mode of adjusting the phalanx to the lever; (4) in the possibility of employing different kinds of loads, including the uniform load attained by means of a compensating spring; (5) in its improved registration devices.

Departments of Liberal Arts

One year's work in this Department, consisting of college algebra, plane and spherical trigonometry and analytical geometry, is prescribed for all candidates for the A.B. degree. For students who take mathematics as their major subject the Freshman year's work is the same as the required work just mentioned. For the Sophomore year the work consists of calculus throughout the year, three hours a week; theory of equations, one term, two hours a week; and advanced conics, two terms, two hours a week. In the Junior year are given advanced calculus throughout the year, three hours a week, and solid geometry and theory of surfaces throughout the

10. Department
of Mathematics.

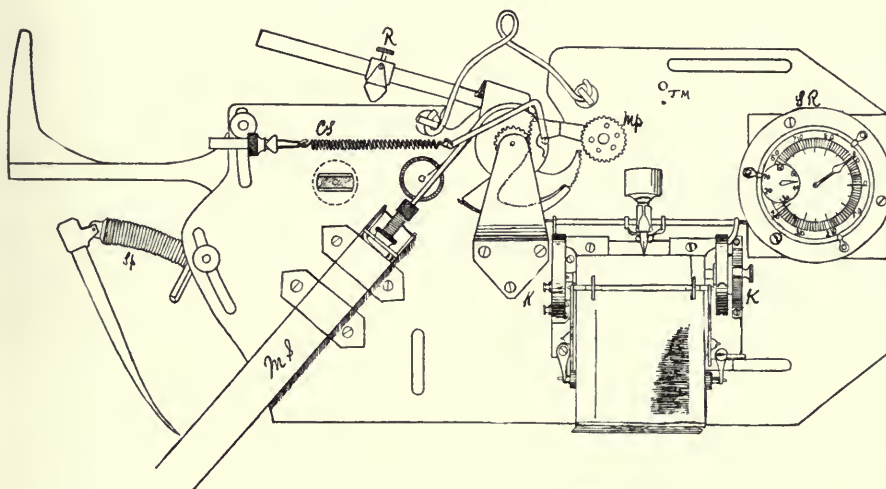

ERGOGRAFH (BACK VIEW)

year, two hours a week. For the Senior year the work varies, but always includes at least six hours in differential equations and two hours seminary work. The remaining part of the work is selected from courses in the theory of numbers, theory of functions, group theory, substitution theory, modern geometry, and projective geometry.

For students preparing for engineering, courses are given in descriptive geometry and surveying. The Department owns a surveyor's compass, plane table, two transits, two Y-levels, a solar compass, leveling rods, chains and steel tapes. For the work in drawing and platting there is a well-lighted

Indiana University

room furnished with drawing tables. A number of graduate courses are offered. The facilities for work of this grade are good. The mathematical library contains the following works: 'Acta Mathematica,' 'American Journal of Mathematics,' 'The American Mathematical Monthly,' 'The Analyst,' 'Annals of Mathematics,' 'Bulletin of the American Mathematical Society,'



DEPARTMENT OF MATHEMATICS—SEMINARY ROOM

'Bulletin of the New York Mathematical Society,' 'Bulletin of the French Mathematical Society,' 'Cambridge and Dublin Mathematical Journal,' 'Crelle's Journal für Mathematik,' 'Liouville's Journal de Mathématique,' 'The Mathematical Monthly,' 'Mathematische Annalen,' 'Mathesis,' 'Proceedings of the Edinburgh Mathematical Society,' 'Proceedings of the London

Departments of Liberal Arts

Mathematical Society,' 'The Quarterly Journal of Mathematics,' and 'The Messenger of Mathematics.' The collected works of Abel, Cauchy, Cayley, Clifford, Gauss, Jacobi, Lagrange, Möbius, Riemann, Schwartz, Smith, and Steiner, and a full line of the leading English, French, and German texts are also in the library of the Department.

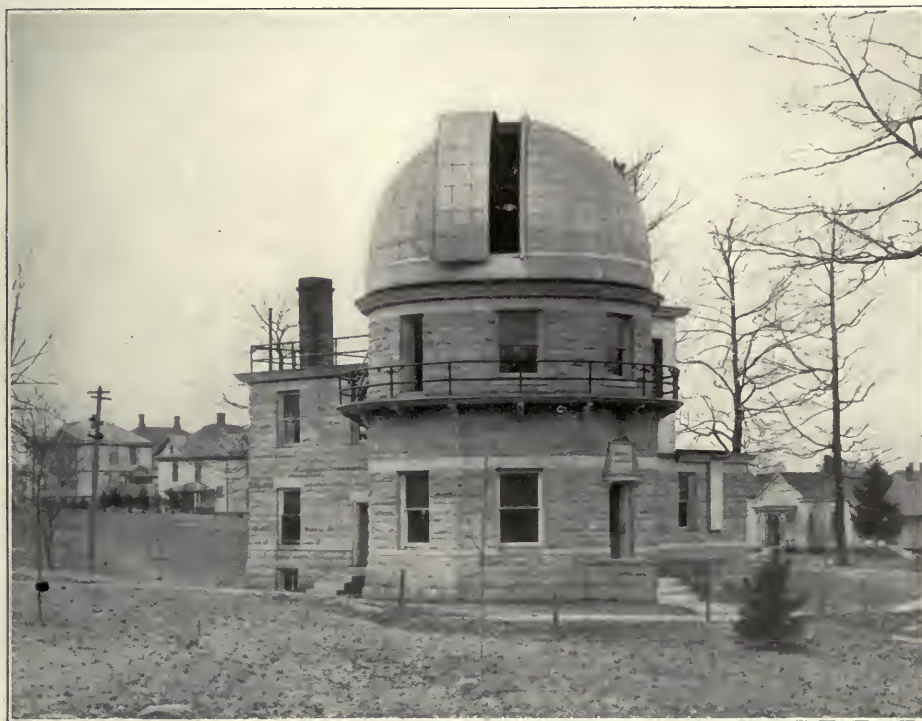

KIRKWOOD OBSERVATORY (ERECTED 1900)

Two elementary courses in astronomy, the one a text-book course, the other a series of lectures upon astronomical topics of eurrent general interest, are given each year in this Department. The more advanced and technical courses that are offered are intended to familiarize the student with astronomical instruments, with methods of eomputation and to give him a mathematical basis for research in gravitational astronomy. These courses

11. Department
of Astronomy
and Mechanics.



TWELVE-INCH REFRACTING TELESCOPE OF KIRKWOOD OBSERVATORY

Departments of Liberal Arts

include practical and spherical astronomy, theoretical astronomy, celestial photography, and celestial mechanics.



FIFTEEN-INCH REFLECTING TELESCOPE

Designed by Assistant Professor W. A. COGSHALL, and built by the Department of Astronomy.



THE MOON (SEVEN DAYS OLD)

Photographed by the Department of Astronomy. Made with the 12-inch Refracting Telescope, and enlarged.



THE MOON (EIGHT DAYS OLD)

Photographed by the Department of Astronomy. Made with the 12-inch Refracting Telescope, and enlarged.

Indiana University

Each student who chooses astronomy as his major subject undertakes in his Senior year, either conjointly with or under the direction of an instructor, some problem of astronomical research. These problems are usually a continuation of some piece of work suggested while he is pursuing some of the above named courses and are selected according to the taste and

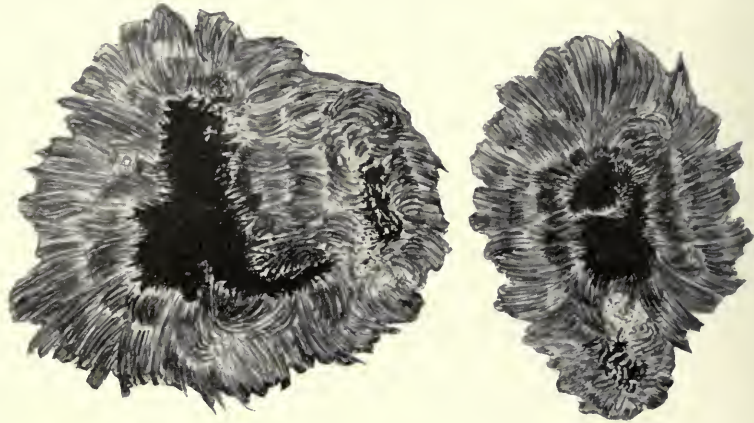

I.

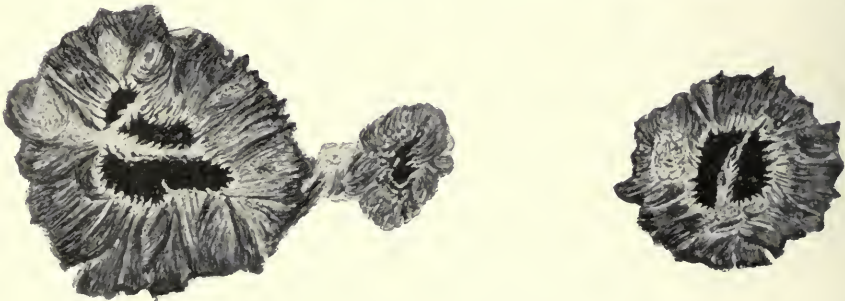

drawn by E.C. Slipher.

II.

DRAWINGS OF SUNSPOTS (STUDENT'S WORK)

ability of the individual. The major part of the work at this time is done with micrometer, or in celestial photography. Most of the accompanying illustrations are from photographs made by students working in this way.

The introductory courses in mechanics are intended as a preparation for the more advanced courses in either theoretical and celestial mechanics,



NEBULA OF ORION (MADE WITH 5-INCH PORTRAIT LENS)
Photographed by the Department of Astronomy.



NEBULA OF ORION (MADE WITH 15-INCH REFLECTOR)
Photographed by the Department of Astronomy.

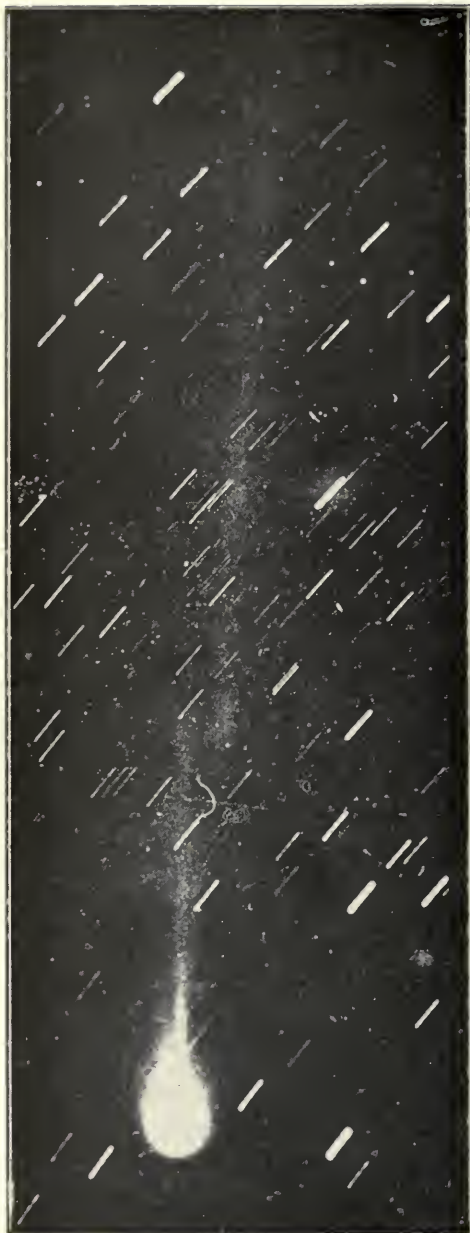

COMET C 1903 (JULY 24, 1903)

Photographed by the Department of Astronomy.

or in applied mechanics in which specific engineering problems are considered. While the primary purpose in all cases is to develop the principle and truths of mechanics, it is equally necessary that the student acquire facility in applying mathematical form to the investigation of physical phenomena, and that he should know when the condition of his problem warrants the use of mathematical formulæ already learned.

Kirkwood Observatory, which is occupied by the Department, contains a library and computing room; a lecture room; a dark-room; a transit-room in which is a Bamberg universal instrument, a Howard sidereal clock, a sidereal chronometer, and a chronograph; a dome-room twenty-six feet in diameter; and a room of the same size immediately below it. In the dome is the refractor, a cut of which is found on page 102, one of the finest specimens of American instrument making. The 12-inch objective is by Brashear, and is of high optical excellence, giving upon a black field stellar images without distortion or wings of any kind. The mounting is by Warner and Swasey of Cleveland, Ohio. The instrument has a focal

Departments of Liberal Arts

length of about sixteen feet, and is supplied with eyepieces giving magnifying powers of from 130 to nearly 1,000 diameters, and with a polarizing helioscope, diagonal eyepiece, and an electrically illuminated micrometer; there are also both coarse and fine circles in right ascension and declination, the fine ones being provided with reading microscopes and electrical illumination.



COMET C (BORELLY) 1903

Photographed by the Department of Astronomy, July 21, 1903.

The Department has now in use, in a separate building, a reflecting telescope of fifteen inches aperture, designed mainly for photographic work. The optical parts are by Petitdidier, of Chicago; the mounting was designed and constructed by the Department. A cut of this instrument is shown

Indiana University

on page 103. There is in course of construction a mounting to carry a Brown 4-inch refractor, and a portrait lens of five inches aperture.

12. Department of Physics.

The work of the Physics Department is arranged to meet the needs of four classes of students. (1) For those who desire a general knowledge of the subject of physics, as a part of a liberal education, the development and substantiation of fundamental theories takes precedence over the minutiae



DEPARTMENT OF PHYSICS—LECTURE ROOM

of the subject. (2) For teachers and those preparing to teach physics in the high school, the work includes more laboratory practice, besides a special course in the manipulation of physical apparatus, and another in shop practice. In the former of these two courses the student generates oxygen gas, manipulates ex-hydrogen, acetylene and electric stereopticons,

Departments of Liberal Arts

projects interference fringes and vibrating strings, demonstrates the oscillatory character of the Leyden jar discharge, reverses the D-line, etc. In all he repeats some fifty of the more difficult lecture demonstrations. In the latter course he is taught soldering, tempering, brazing, case-hardening, simple glass-blowing, wood and metal turning, screw-cutting, and such other operations as may be required in the repair or manufacture of physical



DEPARTMENT OF PHYSICS—A ROOM OF THE ELEMENTARY LABORATORY

apparatus. (3) For students of engineering, the Department offers special work in advanced electricity, a year's work in dynamo-electric machinery, courses in mechanical drawing and thermodynamics, and a more extended course in shop work than is offered for teachers. (4) For advanced students, the Department offers text courses in advanced mathematical

Indiana University

electricity and light, and facilities for research work along almost any line in physics. The Department is already fairly well equipped with accurate standards and delicate instruments, and special pieces may be provided when needed in any research. A well equipped shop and the services of a mechanic are at the disposal of research students. Investigations are now in

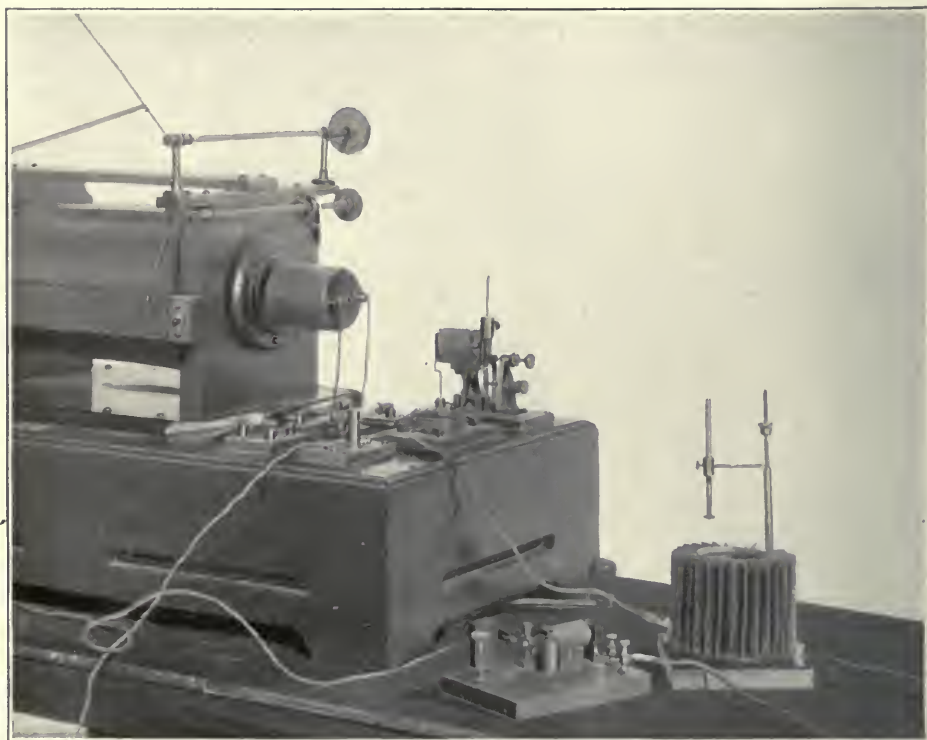

DEPARTMENT OF PHYSICS—A MODIFIED WEHNELT INTERRUPTER
Designed by Professor A. L. Foley and Mr. R. E. Nyswander.

progress in the laboratories along the following lines: the spectrum of radium; the N-rays and other radiations; the effect of radiation upon electrolytic resistance; the electromotive force in electrolytes in a variable magnetic field.

Departments of Liberal Arts

Besides a number of rooms for special purposes, the Department of Physics occupies two research laboratories, and five rooms are used for elementary laboratories, one devoted to general practice, and four small rooms for work in sound and light. The lecture room has an elevated floor and is seated with tablet-arm opera chairs. It is provided with auto-

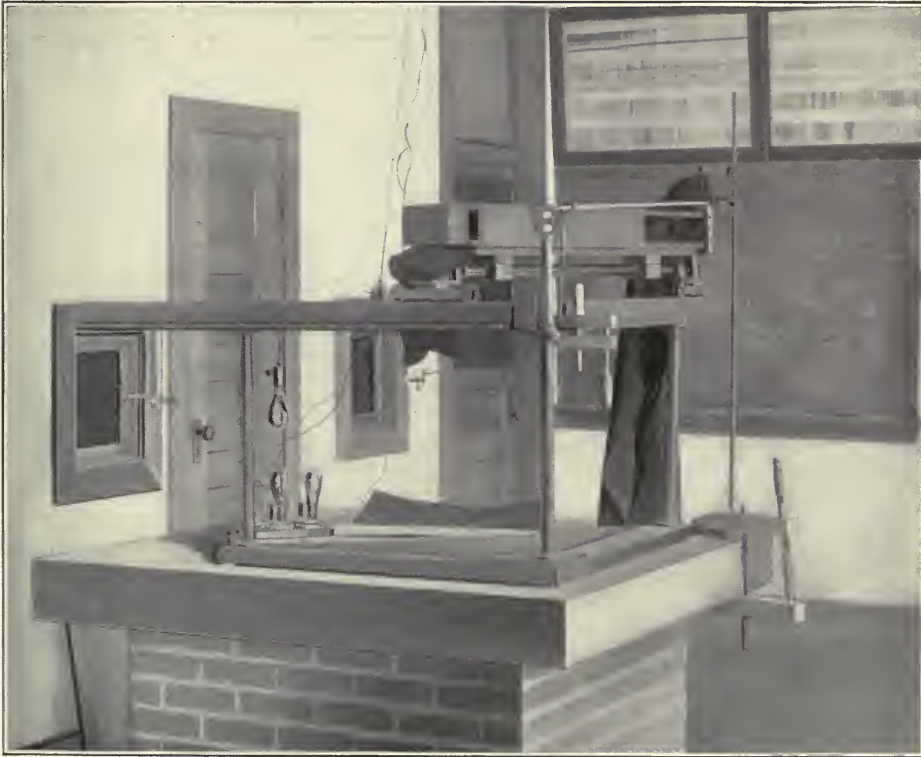

DEPARTMENT OF PHYSICS—A BRASHEAR MOUNTING FOR A ROWLAND GRATING
Constructed in the Department.

matic blinds, screens and blackboards, all under the immediate control of the lecturer. The lecture table is built in three sections, and the plumbing and wiring are arranged so that one, two, or three sections may be used at a time. At the table the lecturer has battery and dynamo currents (alternating and direct), rheostats, illuminated dial voltmeters and amme-

Indiana University

ters, electric motors, calcium and electric lanterns, low and high resistance projecting galvanometers, water, steam, gas, oxygen, acetylene, compressed air, exhaust cocks, and permanent connections to a standard clock. All the laboratories are supplied with water, gas and electricity. The floors are of concrete. There are fifteen large masonry piers and more than three hundred lineal feet of six-inch stone wall shelves. All the developing rooms

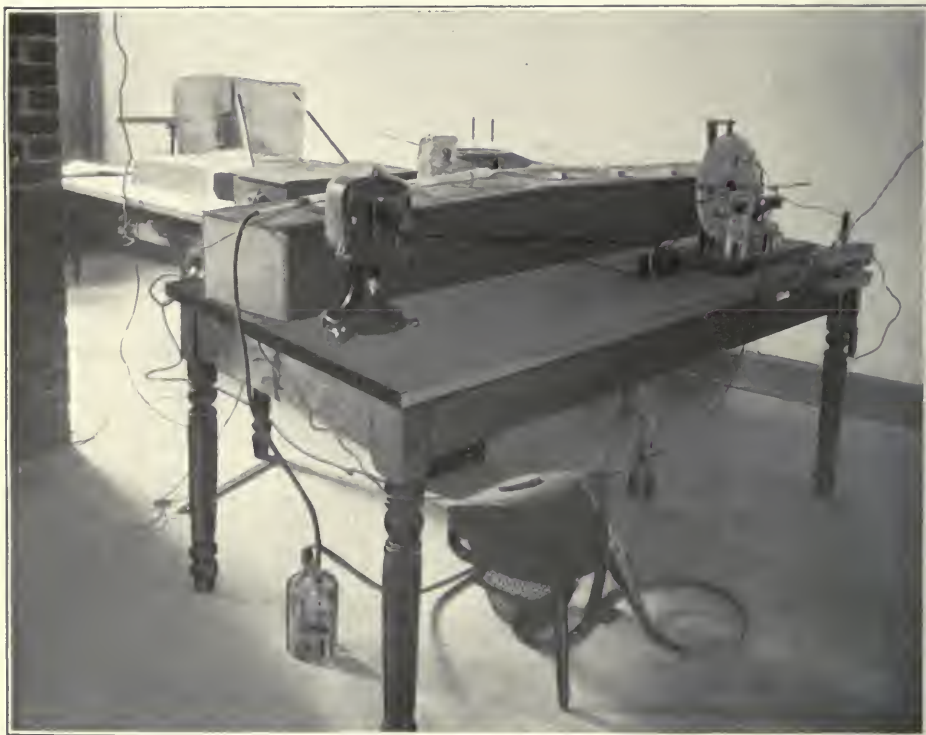

DEPARTMENT OF PHYSICS—APPARATUS FOR THE STUDY OF N-RAYS

have both gas and electric ruby lights, tile shelves, and lockers. Ten rooms are provided with blinds for making them light tight. There are two shop-rooms, equipped with forges, wood and metal-working lathes, screw-cutting lathes, power-saws, a trimmer, shaper, grinder, miller, and other wood- and metal-working tools. In the powerhouse of the University are

Departments of Liberal Arts

two engines, one of twenty and one of forty horse-power, and an alternator and direct current generator of thirty kilowatts capacity. A one-hundred-twenty-five horse-power engine and an eighty kilowatt generator are being added to the equipment.

The work of the Department of Chemistry is arranged to meet the needs of students preparing to become professional chemists, chemical electro-chemical mining or sanitary engineers, and physicians; as well as of students in other Departments of the University—such as Physics, Geology, Zoölogy,

13. Department
of Chemistry.



DEPARTMENT OF CHEMISTRY—LECTURE ROOM

Botany, and Law (medical jurisprudence)—who wish to acquire a knowledge of general chemistry, or to emphasize particular or more advanced lines of chemical work. For students who take chemistry as a major subject, the Department offers prescribed and elective undergraduate courses which cover a period of four years, and consist of lectures, recitations, and laboratory seminary and research work. In the laboratories each student works independently of the others.



DEPARTMENT OF CHEMISTRY—LABORATORY FOR ORGANIC AND PHYSIOLOGICAL CHEMISTRY



DEPARTMENT OF CHEMISTRY—LABORATORY FOR QUALITATIVE ANALYSIS

Departments of Liberal Arts

The general policy of the Department is: (1) To give the student comprehensive training in the fundamentals of general, theoretical, and analytical chemistry, both inorganic and organic, in certain prescribed courses covering eight terms of University work. (2) To permit election of the remainder of the undergraduate work, and specialization within the Department according to the desire and purpose of the student. Special attention

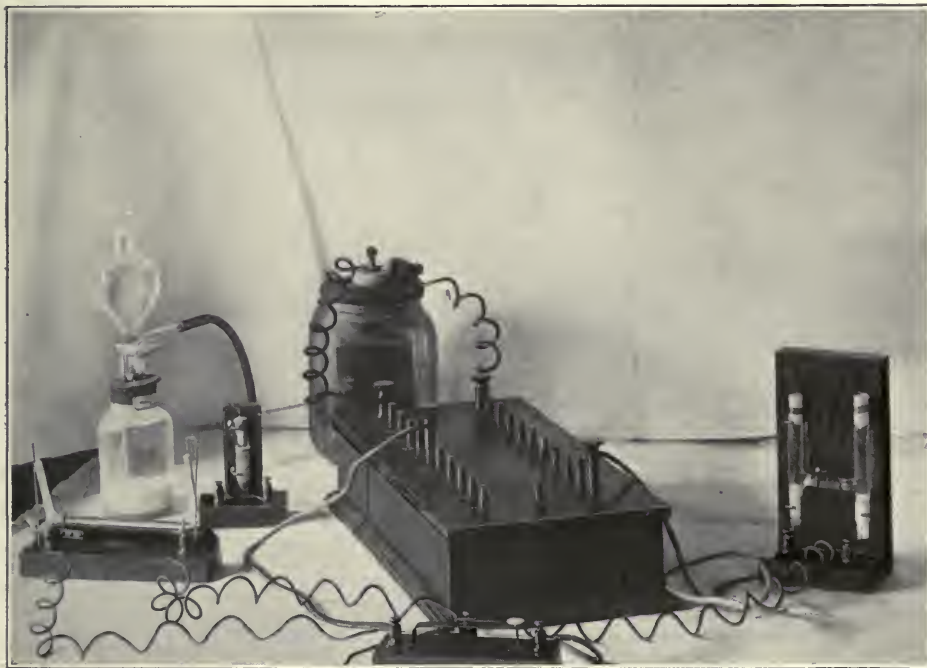

DEPARTMENT OF CHEMISTRY—APPARATUS FOR THE MEASUREMENT OF SINGLE POTENTIAL DIFFERENCES

Constructed by a student in Physical Chemistry.

has been given, in the past nine years, to organic, physiological, bacteriological, electro- and technical analytical chemistry, and toxicology; arrangements have now been completed for the expansion of the courses in physical and advanced inorganic chemistry. (3) To encourage research work in the phases of the subject undertaken. It is insisted, however, that the student



DEPARTMENT OF CHEMISTRY—LABORATORY FOR ELECTRO-CHEMISTRY



DEPARTMENT OF CHEMISTRY—LABORATORY FOR BACTERIOLOGY

Departments of Liberal Arts

must first have a knowledge of chemistry as a science, and have attained a high degree of accuracy in his work, before undertaking original investigations, which usually are not begun before the fourth year. The investigation is of some limited problem, usually emanating from the researches conducted by the instructors in the various divisions of the Department.

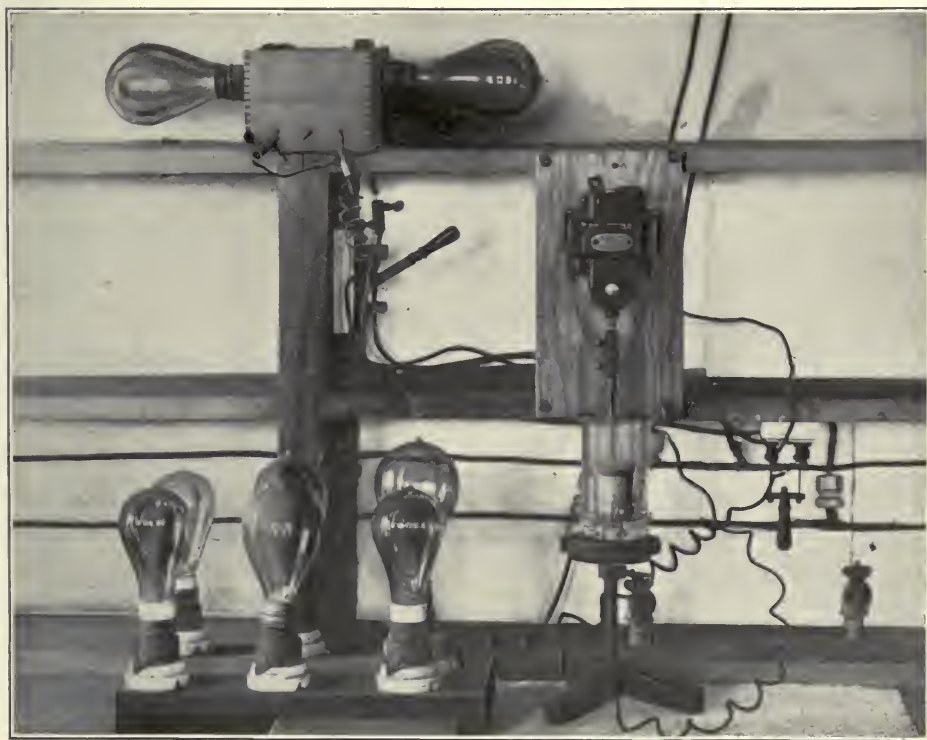

DEPARTMENT OF CHEMISTRY—ROTATING CATHODE FOR RAPID QUANTITATIVE ANALYSIS
BY ELECTROLYSIS

Many of the themes have to do with the study of analogy between sulphur, selenium, and tellurium, in combination with organic radicals; with problems in applied electro-chemistry, e.g. the production of chloroform, bromoform, and iodoform from acetone by electrolysis (see cut, next page); with the study of the salts of berberine; with clinical methods of urine analysis, e.g. an

Indiana University

exact method for the determination of albumen; with bacteriological problems, e.g. a study of pathogenic yeasts; with the distribution of bacteria in lake water; with the differentiation of bacillus coli and bacillus typhi in casein-sugar-agars (see cut, opposite); with fat-producing bacteria, etc.



DEPARTMENT OF CHEMISTRY—IODOFORM FROM ACETONE BY ELECTROLYSIS, USING TWO CATHODES AND A ROTATING ANODE

Method and apparatus devised in the Indiana University Laboratory for Electro-Chemistry, 1904

The results of these investigations, when sufficiently meritorious, are published in various chemical journals, as contributions from the Chemical Department of Indiana University. Fourteen such articles have appeared;

Departments of Liberal Arts

and one electro-metallurgical process, worked out in this series of investigations, has been patented (U. S. patent 742,830).

The graduate work of the Department follows in part the lines above described, and in part is embodied in separate graduate courses, consisting of laboratory lecture and seminary work.

The Department has general, special, and private laboratories adequately equipped to accommodate one hundred and sixty students. Special laboratories are provided for organic and physiological chemistry, toxicology, food analysis, assaying and electric-furnace work, physical and electro-chemistry,

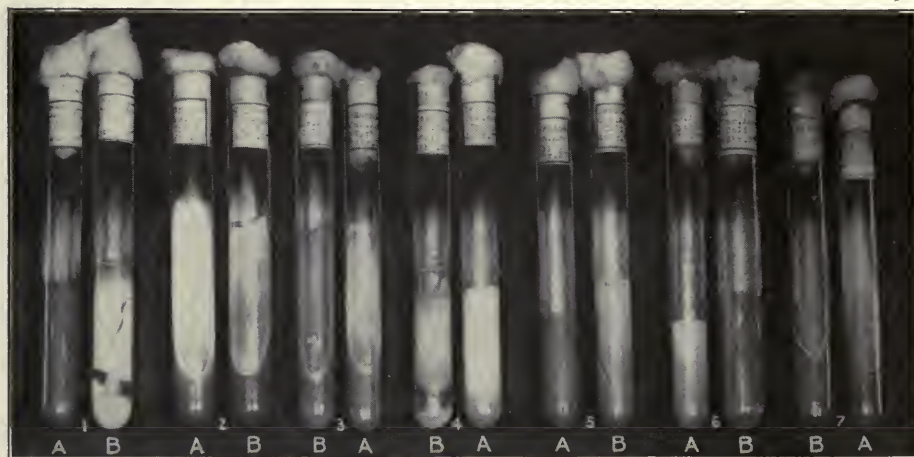

DEPARTMENT OF CHEMISTRY—DIFFERENTIATION OF *BACILLUS TYPHI ABDOMINALIS* AND *BACILLUS COLI COMMUNIS* BY USE OF CASEIN AGARS

Method devised in the Indiana University Bacteriological Laboratory, 1904.

- | | |
|------------------------------|--------------------------|
| 1. Casein-lactose-agar. | 4. Casein-dextrose-agar. |
| 2. Casein-glycerine-agar. | 5. Casein-lævulose-agar. |
| 3 and 6. Casein-mannit-agar. | 7. Casein-maltose-agar. |

A = bacillus typhi; B = bacillus coli. Cultures 46 hours at 37° centigrade.

spectrum gas and water analysis, and bacteriology. The general equipment for graduate work, including library facilities, has been materially increased during the past year.

In the period of nine years from 1896 to 1904, the degree of A.B. in Chemistry has been conferred upon three women and ninety-four men. Of

Indiana University

these ninety-seven graduates, forty-four have pursued or are pursuing the study of medicine, thirteen have received the degree of A.M. in Chemistry after one year of graduate study at Indiana University, four have received this degree elsewhere, and eight have received or are now candidates for the degree of Ph.D.—one each at Goettingen (Germany), Johns Hopkins, Yale and Chicago, and two each at Wisconsin and Cornell.



DEPARTMENT OF GEOLOGY—RESEARCH LABORATORY

14. Department
of Geology.

The courses in geological science are designed to meet the needs as well of those who pursue the subject as a part of a liberal education, as of those who intend to become professional geologists. A five-hour course in geology, extending through the entire year, and a five-hour course in elementary physiography, given in the Spring term, are open to all students

Departments of Liberal Arts

who have sufficient preparation in physics and chemistry, and ordinarily constitutes the entire work of the first of the two groups of students mentioned above. These courses serve also as an introduction to the science and a foundation for the work of the future specialist. Besides these general courses, there is a special course in field geology given in the fall and



DEPARTMENT OF GEOLOGY—RESEARCH LABORATORY

spring, in which attention is paid to the methods of the professional geologist in areal and topographic mapping, stratigraphy and the collection of fossils.

The courses in mineralogy, economic geology, advanced physiography and paleontology are largely professional and not designed for elementary students. Two terms are given to economic geology, one to non-metallic and one to metallic products; field and laboratory work constitute an important



DEPARTMENT OF GEOLOGY—A CORNER OF THE GEOLOGICAL MUSEUM
In the foreground are several relief maps made by members of the Department.



Departments of Liberal Arts

part of this course. Paleontology runs throughout the year, consisting entirely of laboratory work. The chief work of advanced students consists in the investigation of some definite problem or problems with a view to publication of the results when of sufficient merit.



DEPARTMENT OF GEOLOGY—A CORNER OF THE LECTURE ROOM

Several Zittel charts illustrating groups of fossils are shown, and other charts and maps made by members of the Department and by students. To the left are shown cases for topographic sheets and geologic folios.

The Department is supplied with commodious quarters. It has a departmental library, besides extensive collections of fossils, minerals, rock specimens, products treated in economic geology—such as petroleum, coal, clays, cements, ores, etc.—and a large series of maps, charts, and plaster models. Many of the latter have been made by students and members of

Indiana University

the Department. The Zittel charts in particular are of great use in paleontology and historical geology. This series is being extended by the addition of charts and a series of lantern slides to illustrate the modern paleobiological side of paleontology. An extensive series of maps, made by a member of the Department, illustrates the areal distribution of the several



DEPARTMENT OF ZOÖLOGY—ELEMENTARY LABORATORY

geological systems and the hypothetical land and water areas of past geological periods. The plaster models represent topographic types and regions of peculiar or characteristic structure, such as the Appalachian structure of Pennsylvania and Tennessee. The whole range of geology is illustrated by a large and rapidly increasing collection of lantern slides. A series

Departments of Liberal Arts

now in preparation is designed to illustrate Indiana geology and physical geography.

The general policy of the Department of Zoölogy is to give students the solution of original problems at the earliest moment possible, usually at the end of their second year in the Department. The first courses open

15. Department
of Zoölogy.



DEPARTMENT OF ZOOLOGY—OFFICE AND PRIVATE LABORATORY

to students are: (1) a course in general zoölogy extending through the year and devoted to the examination of a series of invertebrates and vertebrates in the laboratory, for their structure, and to the examination of biological problems illustrated by living animals, chiefly as they are found in their native habitat; (2) a course of general lectures extending through



DEPARTMENT OF ZOÖLOGY—MODELS TO ILLUSTRATE LECTURES



DEPARTMENT OF ZOÖLOGY—A CORNER IN THE EMBRYOLOGICAL LABORATORY

Departments of Liberal Arts

two terms on the evolution of organisms and the laws and theories of hereditary transmission of characters.

The second group of courses open to students are: (1) courses dealing with the minute structure and embryology of vertebrates, and leading to



A CUBAN BLIND-FISH (*LUCIFUGA*)

Itself without visible eyes, but containing unborn young with well-developed eyes. Prepared by Professor C. H. Eigenmann, of the Department of Zoölogy.

the study of medicine or the investigation of anatomical problems; or (2) courses dealing with the species of vertebrates, chiefly fishes.

For the course in elementary zoölogy and embryology the equipment



ABLYSTOMA OPACUM

From a water-color drawing by a student of the Department of Zoölogy.



SOUTH AMERICAN FRESH-WATER FISHES

Mylosoma albiscopus Cope (representing a new genus), *Mylopsis levis* Eigenmann and McAtee (representing a new genus), and *Myletes tiete* Eigenmann and Norris.

Departments of Liberal Arts

of the Department is equal to that of the best institutions in the country, and comprises charts, models, illustrative specimens, and a varied and prim-



ABERRANT SPELERPES MACULICANDA (DORSAL AND SIDE VIEWS)

From a drawing by Mr. C. H. Kennedy, a student in the Department of Zoölogy.

itive environment. During the third year each student works at the solution of some special problem. While the work of no two advanced students is alike, their problems usually radiate from the investigations being prose-

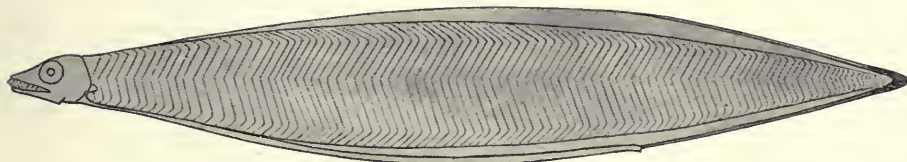

LEPTOCEPHALUS OF THE AMERICAN EEL

From a drawing by Mr. C. H. Kennedy. The specimen represented is the first recognized larva of the American Eel.

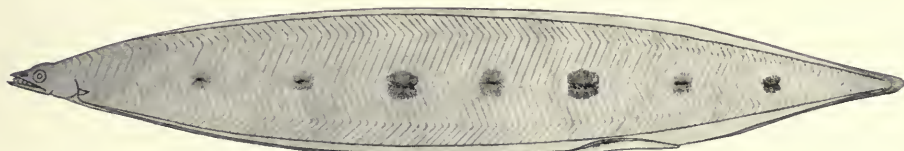

LEPTOCEPHALUS

From a drawing by Mr. C. H. Kennedy. The specimen represented was remarkable for its transparency and for the fact that the spots on the two sides alternate in such a way that they appear as a single regularly arranged series.

cuted by the instructors in the Department. The results of such investigations are published as 'Contributions from Zoölogical Laboratory of Indiana University.'



DEGENERATION OF THE EYES IN THE CAVE-FISHES OF NORTH AMERICA

Chologaster pappiliferus

Amblyopsis spelaeus

Typhlichthys subterraneus

Chologaster agassizii

Troglichthys roral

The heads of specimens of about the same size are photographed from the top to show the size of the eyes. Prepared by Professor C. H. Eigenmann of the Department of Zoölogy.

Departments of Liberal Arts

Two chief lines of work have been pursued by the Department: (1) Systematic zoölogy. The work along this line has dealt very largely with fishes, particularly those of the fresh waters of tropical America, including the region from the south of Mexico to central Argentina. A number of shorter papers have been published or are in preparation, and the greater



THE CAVE FARM NEAR MITCHELL, IND.—OUTLET OF THE UNDERGROUND RIVER

part of the work of compiling a general treatise is completed. For the work on the taxonomy of fishes, but two other universities possess library or museum facilities greater than those of Indiana University. For the work on tropical American fishes the facilities are exceeded only by Harvard with her matchless collection of Brazilian fishes. The University has several thousand species of fishes represented by perhaps 60,000 specimens. Dur-



1



2



3



4

DEPARTMENT OF ZOOLOGY - PHOTOGRAPHS OF BIRD-LIFE. Photographed by Mr. G. C. Littell, a student, in the Department.

1. - Nest and eggs of the Little Green Heron.

2. Two of the young hatched from the eggs shown in figure 1.

3. A Wren's nest in an old sack hanging on a fence.

4. A King-bird's nest, in an apple-tree.

Departments of Liberal Arts

ing the past year collections have been received from Cuba, Paraguay (through Prof. J. S. Anisits), the Hawaiian Islands (through the Bureau of Fisheries), and from Japan (through President David Starr Jordan).

(2) The second line of research work is on the problem of heredity, which has been approached from various directions. (a) The Department has issued several papers on the structure and history of the hereditary (sex) cells in the vertebrate, *Cymatogaster*. (b) A statistical inquiry into



DEPARTMENT OF BOTANY—LABORATORY FOR PLANT PHYSIOLOGY

the variation in successive years of the same species in the same unit of environment was started in 1895. To further this work a Biological Station was established at Turkey Lake and later transferred to Winona Lake (see page 183). While a large amount of material has been gathered and a number of papers published, this phase of the subject has been at least temporarily overshadowed by the line of investigation next described. (c) An inquiry into the process, method, and rate of ontogenic and phylogenic

Indiana University

modification of the sense organs in the cave animals of North America, particularly of the eyes of blind fishes. An important aid to this work was the recent acquisition by the University of a tract of about 180 acres of primitive woodland, containing numerous dry and wet caves and an underground stream which can be traversed for over a mile. The situation is ideal for transplanting cave animals into the light and epigeal forms into the dark. Six papers on this subject have been published, and another

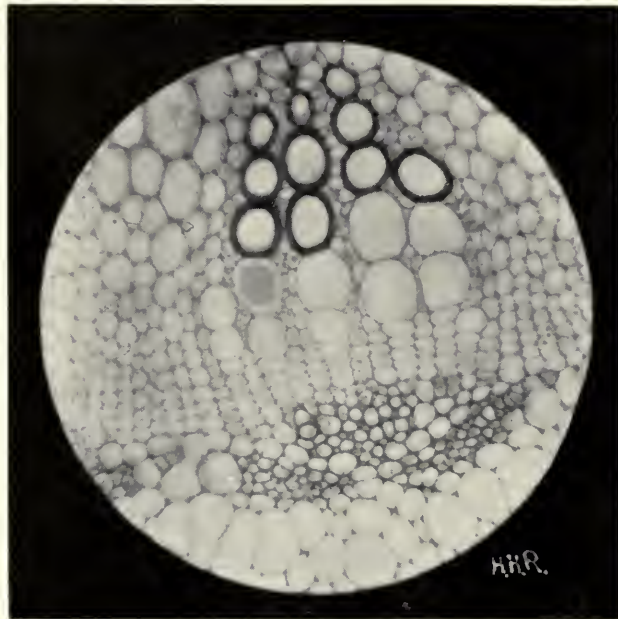

DEPARTMENT OF BOTANY—PHOTOMICROGRAPH OF A VASCULAR BUNDLE OF SWEET CLOVER
(MELELOTUS ALBA)

Prepared by Mr. H. H. Ratcliff, a second-year student in the Department. The cut illustrates a method in histology.

one on the eyes of the Cuban blind fishes is being prepared by Professor C. H. Eigenmann, with the aid of a grant from the Carnegie Institution. (d) The Department has begun a series of experiments to test certain features of Mendel's law of heredity.

Departments of Liberal Arts

The Department of Botany has three laboratories, devoted respectively to elementary botany, histology and physiology, and morphology and cytology. The morphological laboratory is well equipped with modern apparatus and accessories for the highest grade of cytological and morphological work.

16. Department
of Botany.

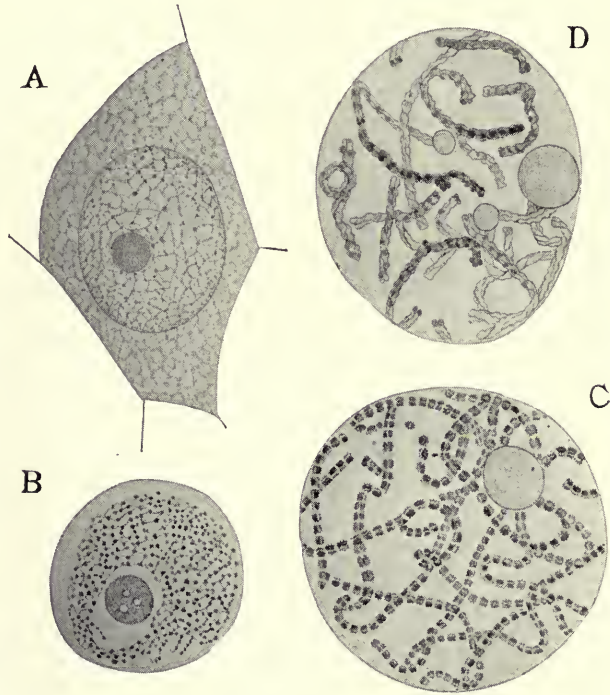

DEPARTMENT OF BOTANY—DIVISION OF THE HEREDITARY SUBSTANCE IN REPRODUCTIVE CELLS IN HIGHER PLANTS. I

A—Pollen mother-cell with nucleus in the resting condition (*Podophyllum peltatum*).

B—The nucleus at the beginning of mitosis. C, D—Nuclei showing the chromatin thread or spirem split lengthwise (*Lilium martagon*).

The physiological laboratory is provided with the usual apparatus necessary for physiological *practicum* as well as several pieces designed for special work. New additions are made to this equipment yearly. For research in plant physiology special apparatus is purchased as needed, or is designed

Indiana University

and constructed by instructor and student. In addition to the customary equipment the elementary laboratory is provided with a Zeiss projection



DEPARTMENT OF BOTANY—DIVISION OF THE HEREDITARY SUBSTANCE IN REPRODUCTIVE CELLS IN HIGHER PLANTS. II

E—Pollen mother-cell; the spirem has segmented into the chromosomes, a few of which only are shown; *n*, nucleolus. F, G—The mitotic spindle of the first mitosis; the chromosomes are arranged in the equatorial plate. H—Metakinesis; the daughter chromosomes are separating, and each is seen to be split again lengthwise.

Departments of Liberal Arts

apparatus for the projection upon the screen of both microscopic preparations and stereopticon views.



DEPARTMENT OF BOTANY—DIVISION OF THE HEREDITARY SUBSTANCE IN REPRODUCTIVE CELLS IN HIGHER PLANTS. III

I—The anaphase; the pairs of grand-daughter chromosomes resulting from the second longitudinal splitting are passing to the poles of the spindle. J, K—Formation of the daughter nuclei. L—The result of the first division (Podophyllum). M—Daughter nucleus ready for the second division.

Indiana University

The work of the department consists of three years of undergraduate instruction, and graduate work leading to the degrees of A.M. and Ph.D.

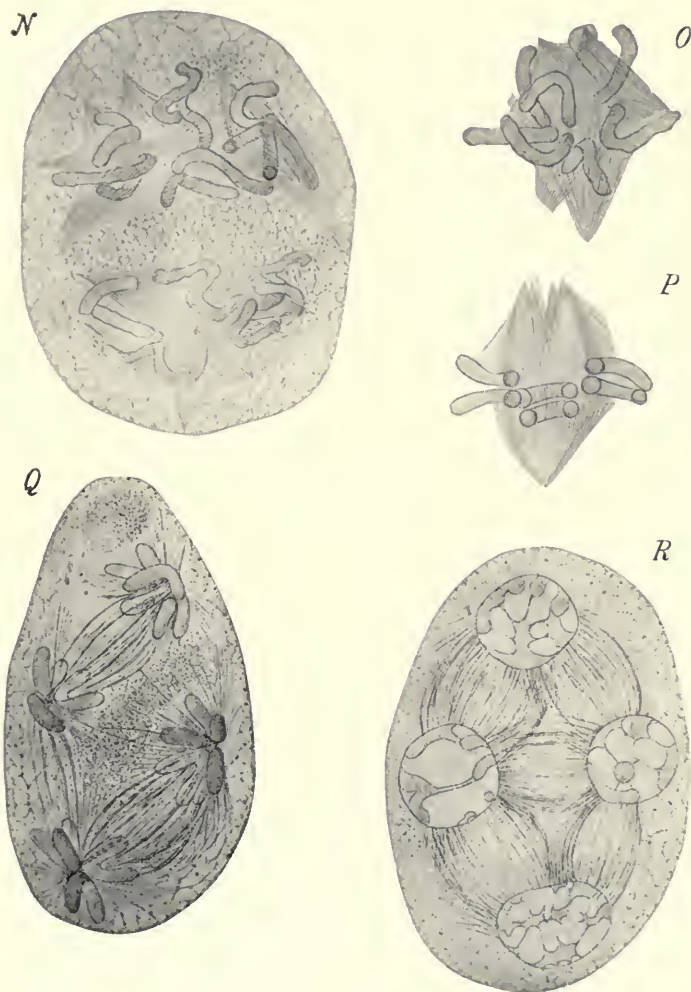

DEPARTMENT OF BOTANY—DIVISION OF THE HEREDITARY SUBSTANCE IN REPRODUCTIVE CELLS OF HIGHER PLANTS. IV

N to R—Successive steps in the second division in the pollen mother-cell (*Podophyllum*).

Departments of Liberal Arts

Of the undergraduate work the first year (elementary course) is devoted to a general survey of the plant kingdom in the study of selected types from the great group of plants, supplemented by simple physiological experiments, with instruction also in the adaptation of plants to their environment. This course is designed not only as a preliminary to the advanced work but especially for students desiring a general knowledge of plant life.

The undergraduate work beyond the first year is in the nature of advanced *practicum*, but its methods are the same as in original investigation.

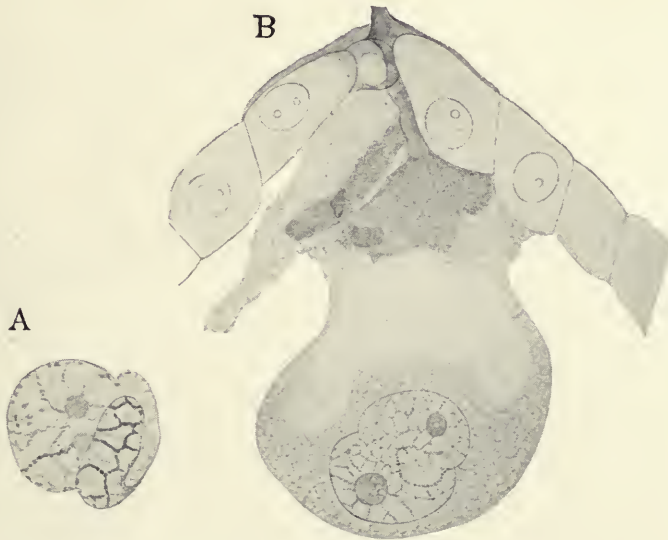

DEPARTMENT OF BOTANY—FECUNDATION OF THE EGG-CELL IN THE LILY

A—Male and female nuclei in contact (*Lilium martagon*). B—Fusion of the sexual nuclei in the egg-cell (*Lilium candidum*).

The student may select any of several courses, but his second year's work is, as a rule, histology and practice in plant physiology, and the third year some line of special morphology or embryology.

Candidates for advanced degrees are assigned or permitted to select problems for research along some line of morphology, cytology or physiology, the results of which are embodied in a thesis. During recent years the research work of the Department, carried on by instructors and graduate

Indiana University

students, has been along the line of cytology and embryology, dealing especially with problems of fecundation and the physical basis of heredity. The accompanying figures (pp. 136-141) will illustrate the nature and character of the work referred to.



DEPARTMENT OF ANATOMY—PRIVATE LABORATORY AND PREPARATION ROOM IN HISTOLOGY }

17. Department
of Anatomy.

The Department of Anatomy was established in the fall of 1903. Its work is planned especially for students enrolled in the new School of Medicine, but the courses which it offers may also be chosen as electives or as a major subject by students in the Departments of Liberal Arts. The equipment, which is entirely adequate for the number of students in attendance, is



DEPARTMENT OF ANATOMY—LABORATORY

The room is over seventy feet long, and is excellently lighted from the ends and from five large double windows at the side. During the Fall and Winter terms the room is used for dissection; in the Spring term it is used for a course in histology.



DEPARTMENT OF ANATOMY—A CORNER OF THE DISSECTING ROOM, WHERE BOOKS, MODELS, ETC., ARE KEPT FOR STUDENT REFERENCE

Indiana University

similar to that of the best medical schools. The study-room collection will, when completed, contain models, longitudinal and transverse sections of the body, dissections of every portion of the body to show superficial and deep structures, to all of which the student may have access at any time for aid in his work. The dissecting room is a large, airy, well-lighted room. The floor has been specially prepared so as to be easily cleaned. Twenty-five



DEPARTMENT OF PHYSIOLOGY—LABORATORY

Bausch and Lomb microscopes of high grade are provided for the work in histology. Thirteen courses are offered at present in this Department.

18. Department
of Physiology.

The work in physiology has hitherto been given in the Department of Zoölogy. For the coming year (1904-1905) the work will be modified and enlarged, and for the first time grouped into an independent Department of

Departments of Liberal Arts

Physiology. Five courses are announced, of which two are introductory and elementary and intended for the general student, and three are more advanced and intended for students in the School of Medicine, for teachers of science, and for others desiring a more thorough training in physiology. The Department is providing a well-equipped laboratory for experimental work in physiology. It is supplied with manikin and other models and charts, kymographs, inductoria, sphygmographs, cardiographs, plethysmographs, stethoscopes, manometers, tambours, hæmometers, hæmocytemeters, perimeters, ophthalmoscopes, artificial eyes, etc., necessary for the performance of the important experiments in physiology and for special work. A sufficient number of sets of these instruments is provided, so that the students working in groups of two can perform all of the more important experiments for themselves, the endeavor being to place the work upon a thoroughly experimental basis. The Department now takes about a dozen of the more important English, German and French physiological journals, and possesses many of the standard works in physiology.

Instruction in this subject was added to the University curriculum in 1896, and facilities for the work have since been steadily increased; but the work in fine arts has not as yet been constituted a study in which a major subject may be chosen. Accompanying cuts give views of the drawing and lecture room of the Department. In point of equipment, the aim has been to increase yearly the number of photographs, now amounting to several thousand, of subjects in architecture, sculpture, and painting. These photographs are used to illustrate the lectures and are always accessible to students. To the same end casts, charts and models are added from time to time, and the University Library has purchased, besides the commoner books of reference, a considerable number of valuable works, old and new, relating to the fine arts, and especially to architecture. It has not been forgotten also that a University Department of Fine Arts should have its museum—no matter how small in the beginning—of really fine things; because, in the pursuit of these studies, the purpose of which is to awaken appreciation and to develop critical power, original, even though slight works of masters, cannot fail to inspire the student, whose time must be devoted mainly to reading and hearing about, and examining repro-

19. Department
of Fine Arts.

Indiana University

ductions of, the works of masters. Among the material of this sort owned by Indiana University may be mentioned a fine early drawing by J. M. Turner; two drawings, one of them a water color, by Samuel Prout; a typical piece of color drawing by the English William Hunt; two drawings, one very characteristic, by John Ruskin; together with others by living



DEPARTMENT OF FINE ARTS—A PART OF THE LECTURE AND DRAWING ROOM

artists of repute. The collection contains wood and metal engravings, and etchings by Albert Dürer, Marc Antonio Raimondi, Hollar, Richard Earlom, Prout, Harding and John Lewis, Hogarth, and many others. In addition to these, all of them original works of first-rate quality, there are a number of the peerless landscapes from Turner's 'Liber Studiorum;' these represent the rare etchings for this work, and several states of the completed mezzotints.

Departments of Liberal Arts

The teaching in the Department consists of lectures and recitations, accompanied with instruction about the use of lead, ink and water colors; its aim is to lead students to an appreciation and understanding of the works of the greatest masters of architecture, sculpture and painting, rather than to train them technically for the practice of any one of these arts.



DEPARTMENT OF FINE ARTS—ANOTHER PART OF THE LECTURE AND DRAWING ROOM

Separate gymnasiums, and separate courses in physical training, under competent instructors, are provided for both men and women students. Both gymnasiums are supplied with baths and lockers. The women's gymnasium is equipped with Swedish apparatus; the men's with the usual apparatus and appliances. In both gymnasiums regular class work is given, supplementing such athletic sports as tennis and basketball for the women;

Physical
culture.

Indiana University

tennis, basketball, football, baseball, and track training for the men. For both the men and the women courses in physiology and hygiene are given—for the men by the director of the men's gymnasium, and for the women by a practicing woman physician. Physical examinations are given both men and women, and exercises prescribed according to individual needs. The director of the women's gymnasium gives, in the Spring term, a course in theory and practice for women who wish to direct physical training in the public schools. Physical training in the University is not compulsory; but a small amount of credit is given those students who take regular class work, and comply with certain other requirements.

RELATION OF THE UNIVERSITY TO THE SCHOOL SYSTEM OF THE STATE

FORMER PREPARATORY DEPARTMENT

A Preparatory Department was maintained in connection with the regular Collegiate Department from the first, and was not really discontinued until after 1890. This curtailment of the course of instruction in the University was the final outcome of a long process of adjustment between the University and the high schools of the State. In 1869 an effort was made by the Board of Trustees to abolish this Department, in the belief that "it is no part of the legitimate business of the University to furnish instruction in the branches usually taught in the common schools." There seems to have remained, however, a considerable demand for instruction in work lower than the Freshman grade. In the same year with the statement that the Preparatory Department as such had been discontinued, we find the enrollment of a so-called "sub-Freshman class;" and in 1872 the following announcement appeared: "It is no part of the legitimate business of the University to furnish instruction in the branches usually taught in the common schools, but opportunity is afforded to those deficient in Latin, Greek and algebra to bring up those studies in a sub-Freshman class." The next year, however, sees a complete retreat from the position taken in 1869, and it is announced that "Arrangements will be made for a Preparatory Department in connection with the University, in which students will be fitted to enter the Freshman class, and those deficient in sub-Freshman branches will have an opportunity of reviewing them under the instructions of able and thorough teachers."

Early attempts
to abolish Pre-
paratory Depart-
ment (1869-73).

Indiana University

Bloomington
High School as
Preparatory De-
partment (1874-
85).

In 1874, accordingly, provision was made "for a Preparatory Department for the University, in connection with the High School at Bloomington," and not only were the principal of the High School, with his assistants, counted as members of the University Faculty, but at least in the later period of this arrangement the principal and the first assistant were appointed and paid by the University Board of Trustees.

Revival of Pre-
paratory Depart-
ment (1885); its
abolition (1890).

In the first year of President Jordan's administration (1885) plans were made for separating the Preparatory Department from the Bloomington High School; and in the next year the following announcement appears: "The connection which formerly existed between the Preparatory Department and the Bloomington High School was dissolved at the end of the last year. The work of the Preparatory School is now carried on in the former main building of the University, which gives to all of its classes an abundance of room." The growth of the Department from this time seems to have been "steady and rapid;" and this new arrangement continued until 1890, after which date the Department went out of existence.

Admission to
Preparatory De-
partment.

The requirements for admission to the Preparatory Department, so far as requirements were made at all, did not vary much at different times. From 1850, "It is required that the applicant be able to read and write." From 1855, "All candidates for admission into the Preparatory Department must be at least twelve years of age. They will be examined, and must prove themselves able to write a legible hand, to spell with correctness English words in common use, and to read plain English prose with ease and intelligibility."

In 1866 the age requirement was reduced to eleven years. But with this exception the admission requirement remained the same until the Department was temporarily discontinued in 1869. After its re-establishment the maximum requirement was "a good knowledge of the 'Common Branches'—arithmetic, geography, English grammar, reading, writing and spelling, with the history of the United States. Each applicant must be at least fourteen years old and should have accomplished the equivalent of the first year of the High School. Unless admitted on a school certificate of proficiency, or a teacher's license, he will be examined on the above mentioned subjects."

Relation to School System

The first catalogue of the University (1831) announces "courses of instruction" in the Preparatory Department as follows: "English grammar, arithmetic, geography, Ross's Latin grammar, Viri Romæ, Cæsar (Mairs' Introduction), Compositions in English." Between the Preparatory Department and the Freshman class there appears also in this same catalogue a so-called "First Class," which seems to have been intermediary between the two. The course of instruction in the "First Class" was as follows: "Sallust, Cicero's De Officiis, Cicero's Select Orations, Ovid, Virgil, Horace, Juvenal, Cicero's De Oratore, Valpy's Greek Grammar, Compositions, Latin themes." Course of Study,
1831-67.

In the middle period of the Department's existence—say, for example, in 1867, just before the Board of Trustees decided upon abolishing preparatory instruction—the Preparatory Department was represented by the following course: "Ancient and modern geography, Butler's English grammar, arithmetic (Ray's), algebra, Latin grammar, Smith's Principia Latina, Greek grammar and exercises (Harkness'), Cornelius Nepos, Virgil, Latin and Greek exercises, English composition and declamation."

The Preparatory Department seems at first to have included work for one year only, but from 1855 the students are divided into two classes for two years of study. From 1862, moreover, students pursuing a "Preparatory Scientific" course are distinguished from those pursuing the "Regular Preparatory" course.

After the re-establishment of the Preparatory Department in connection with the Bloomington High School, the course covered two full years, the same instruction being given to all students. For 1890, the last year of the Department's existence, the following course of instruction was announced: Course of Study
at the time
when abolished
(1890).

JUNIOR YEAR—

Fall Term. Latin Grammar; Algebra; English—(1) American Poets, (2) Analysis of Sentences.

Winter Term. Latin Grammar; Algebra; English—(1) American Prose, (2) Principles and rules of Composition, with essay writing.

Spring Term. Latin—Cæsar; Algebra; English—(1) Victorian Literature, (2) Figures and Essays.

Indiana University

SENIOR YEAR—

Fall Term. Latin—Cicero; Geometry; General History.

Winter Term. Latin—Cicero, Latin Composition; Geometry; General History.

Spring Term. Latin Composition; Physiology; General History.

COMMISSIONED HIGH SCHOOL SYSTEM

Rise of the Commissioned High School System.

The maintenance of a Preparatory Department of the University is a witness to the unsatisfactory relation which long existed between the University and the school system of the State. The final adjustment of this relation gave rise to the system of Commissioned High Schools. In the annual report of the University for the academic year 1874 (which includes the University catalogue) we read the following: "The want of a proper adjustment of the High School and Collegiate courses of study has been long and deeply felt. This want of unity has been, for years, the subject of earnest and protracted discussions in State Teachers' and Collegiate Associations, in State Institutes, Educational Conventions and the State Board of Education. The much desired union has at length been reached; and the method by which it has been attained will be explained by the following documents, together with the reasons of the change in the curriculum of the University. The authorities of the University rejoice in this happy adjustment of the whole course of instruction in the educational system of Indiana, by which the student can pass without interruption or delay through all the grades, from the Primary through the Intermediate, High School, Collegiate and University courses of instruction, and thus thoroughly equip himself for life's duties. The hearty support and active coöperation of teachers, principals of High Schools, County Superintendents and all the friends of education in these new arrangements are earnestly desired."

The first of the documents referred to is the following, adopted May 5, 1873, at a meeting held in Indianapolis:

Recommendation of State Board of Education (1873).

Resolved, That the State Board of Education recommend the Trustees and Faculty of the Indiana University, in order to unite the High Schools of the State and the University more closely together, to so modify the Preparatory course of study, as

Relation to School System

to admit students to the Freshman class without the knowledge of Greek, putting in the place thereof an equivalent in the increased amount of Mathematics and Science.

A second document consists of the record of a meeting "of the Superintendents and Principals of schools having an enrollment of four hundred or more pupils," held in the city of Indianapolis, May 7 of the same year, "for the consideration of matters pertaining to the welfare of the schools," at which the following resolutions were unanimously adopted:

Resolved, That we, the members of the Convention of Superintendents of the High Schools of the State, respectfully represent that we fully approve the plan of uniting the High Schools with the University by the method proposed, viz., that the High Schools shall prepare pupils in Orthography, Arithmetic, English Grammar, Geography, Physiology, United States History, Algebra, Geometry, Latin Grammar, Cæsar and Virgil, which shall admit them to the Freshman class without the necessity of preparing them in the study of Greek; and that the study of the advanced Mathematics be considered an equivalent for the additional amount of Greek now required for admission.

Resolutions of Superintendents and Principals (1873).

Resolved, That Mr. Gow present the above resolution to the Trustees of the University, at their meeting in June, as the expression of our views.

When these resolutions were presented to the Faculty and Trustees of the University, the following action was taken by the Board of Trustees:

Ordered by the Board of Trustees of Indiana University, that the minimum standard of admission to the Freshman class in the University, shall be a creditable examination in Orthography, Reading, Geography, English Grammar, United States History, Composition, Word Analysis, Physiology, Algebra, Geometry, Latin Grammar, Latin Prose Composition, Cæsar and Virgil, or their equivalents.

Action of the Board of Trustees.

Second, in order to bring the University into closer connection with the High Schools of the State, we recommend the following plan, viz., a certificate from certain High Schools (the schools to be hereafter named by the State Board of Education) of a satisfactory examination sustained in the Preparatory Course, will entitle the bearer to admittance to our Freshman class. And no one will be admitted as a student in the University (except those admitted to select studies), without such certificate from the authorities of the High Schools, the High School of Bloomington being named among the number.

Indiana University

Effects of the omission of Greek from entrance requirements.

Dr. Wylie, in his *History of Indiana University* (p. 78), says: "The part of this arrangement that Greek should not be required for entrance into the Freshman class was quite an innovation, and was regarded by many scholars and literary institutions throughout the State with great disfavor, and as lowering the college standard and a step downward and backward. No evil seems, however, to have resulted from it; the professor of Greek, the late Professor Ballantine, found that in a year after the change had been made he had the scholars as far advanced as under the old arrangement. This may be ascribed to the better and more uniform training in elementary instruction under the Professor himself than the pupil had under different instructors, some better and some worse, and each having his own peculiarities."

In the University catalogue for the year 1875 there appears the following report of the Faculty to the State Board of Education, showing the results of the recent changes—a report which deserves to be quoted in full:

Report of the Faculty to State Board of Education (1875).

The want of a proper adjustment of the High Schools of the State to the Colleges had been long and deeply felt. After much discussion in State, Collegiate and High School Associations, upon the recommendation of the Convention of Superintendents of Public Schools, held in the City of Indianapolis in the spring of 1873, the State Board of Education recommended and the Trustees of Indiana State University adopted a modification in the Collegiate course of study. This change was made for the purpose of uniting, harmonizing and completing the school system of Indiana. Middle education is the problem of the age. Where shall students be prepared for college? This is the real question. It is proposed to make the High Schools the middle schools of Indiana, and thus filling the vacuum before existing between the district schools and the University. To perfect this union, it was determined that the study of Greek should be commenced in the Freshman year, and continued through the four years of the college course, thus making the whole amount of Greek equal to that of both the preparatory and collegiate Greek taught in the best institutions in the land. To compensate for this preparatory Greek, transferred to the collegiate course, Higher Algebra, Geometry, Sentential Analysis and Physiology were placed in the preparatory course, and made requisites for admission to the University. This change, while it abates nothing from the extent of thoroughness of the usual curriculum, both preparatory and collegiate, is of the greatest importance, as it unites together and harmonizes all the sections of the public schools of

Relation to School System

the State into one complete system. The student can now pass directly from the primary, through the intermediate grades and High Schools, to the University, without delay or interruption. He is not now required, after completing his High School course, to spend, as heretofore, two years in some preparatory school or academy, in order to bring up his Greek, and fit himself for the Freshman class.

As this modification aimed to make the High Schools of the State preparatory schools for the State University, it was also provided that the work done in the High Schools, which had attained the proper grade, should be recognized and credited by the University. Hence, applicants presenting certificates from the Superintendents of those High Schools, which are commissioned by the State Board of Education, certifying that they had completed the preparatory studies, should be admitted to the Freshman class, without further examination. All applicants not thus furnished with certificates were to be examined by the Superintendent and Principal of the High School of Bloomington. “Initiatory examinations;

These examinations are conducted in writing, and are very thorough. They embrace ten questions upon each of the studies in the preparatory course; and a high grade in each is required for admission.

The time has been too short, only eighteen months having elapsed since its adoption, to test fully the wisdom and feasibility of the present plan. Thus far, however, the results have been favorable. In 1873, one hundred and nine applied for admission to the University; of whom fifty passed satisfactory examinations, and were admitted on the certificate of the Superintendent and Principal of the High School of Bloomington. Fifty-nine, having failed to pass satisfactory examinations, were rejected. In 1874, there were fewer rejections; as the terms of admission and the high grade of scholarship required, had become more generally known. “Results;

Of the twenty-one High Schools commissioned by the State Board of Education to prepare and examine students for the State University, only a very few have sent students. Greensburg has sent three; Evansville, two; New Albany, two; Peru, one, and Bloomington, twenty-six. The larger part of these twenty-six had come from other sections of the State to Bloomington, to prepare for college. All the others, who have been admitted to the Freshman class, have been examined by the Superintendent and Principal of the High School of Bloomington.

The effect upon the High Schools of the State has been very beneficial. They have been inspired with greater zeal and energy in the work of education, and the standard of scholarship has been elevated. The most of the High Schools which have not already been commissioned to prepare students for the University, are striving to reach that grade which will entitle them to that honor. The failure to send students to the University was not for the want of a disposition to do so,

Indiana University

on the part of the officers of the High Schools. These have generally regarded it an honor to receive a commission from the State Board, and have cordially coöperated to make the plan a success.

“The effect upon the standard of scholarship in the University;

The grade of scholarship of the students of the University has been greatly advanced. In accuracy, thoroughness, comprehensiveness, and maturity of mind and culture, the Freshman class is nearly equal to the Sophomore of former years; and the same may be said of the higher classes. It is gratifying to every lover of sound learning, to witness the vigor of thought and breadth of information, with which they grapple with subjects presented for their investigation. Their command of the English language and its resources is also of a high order.

“Classical Course;

Since the change has been made by which Greek is begun in the Freshman year, the number of students taking the classical course has greatly increased. Formerly one-half of the Freshman class were scientific; now nine-tenths are classical. Such, according to present indications, will continue to be the result of the present arrangements. Instead of lowering the standard of education, the present plan has greatly elevated it; and instead of the ancient classics being dishonored and ignored, they are now better taught, made popular, and greatly honored. Nor do we deem it too much to say, that classical education has been greatly benefited by the recent arrangements.

“The number of students.”

While there has been no diminution in the number of students, but on the contrary, a steady increase, yet the number in attendance is less by one hundred per cent. probably, than it would have been under the old regime, several causes having combined to produce this result:

1. The complete separation of the preparatory from the collegiate department has diminished the aggregate number of students. No student, in the preparatory department, is permitted to recite in any of the college classes, and no student in the select course in college is allowed to recite in classes belonging to the preparatory department. This complete isolation of the two departments cuts off a considerable number of irregulars, who desire to recite in preparatory and collegiate studies at the same time. This was allowed in this University some years ago, and is still in vogue in most of the colleges in the West.

2. This arrangement tends to diminish numbers, in the second place, since the preparatory students do not meet in the University chapel for prayers each morning with the students of the collegiate and professional grade; nor do the two departments intermingle, as they do in most Western institutions, in which students of the preparatory course mingle indiscriminately with those of collegiate grade, and recite to the same professors. Many prefer institutions where such irregularity prevails.

Relation to School System

3. The rigidity of the initiatory examinations, and the thoroughness of scholarship required for admission to the University tends also to lessen the number of students. The sifting process is now applied at the door of admission to the University, instead of being postponed, and too charitably applied, during the collegiate course. The custom of most of the colleges in the State has been to admit students upon an oral and very superficial examination, leaving their subsequent standing to be determined by their success in their studies. This course of necessity produces irregularity, lowers the grade of scholarship, and leads to many difficulties.

The State University now admits only those who pass satisfactory examinations, and are up in all their studies. This arrangement, while it has introduced order, regularity and system, and elevated the standard of scholarship, has diminished the number, which otherwise would have attended the University. Nearly one hundred applicants for admission to the Freshman class in the last two years have been rejected.

4. The elevation of the standard of scholarship leads some to prefer other institutions where college honors are more easily won. The grade of recitations requisite for graduation from one class to another higher, is seventy per cent. on the general average, and in no one study must the student fall below fifty per cent. A student who fails to reach this standard falls back into the next lower class. Some who have thus failed, have gone to other colleges, rather than to go back into the lower classes, as they could there go on with their class, and graduate a year sooner than at the State University. As, therefore, it might have been reasonably expected, the number of students in attendance is probably one hundred per cent. less than it would have been, had the old order and regulations continued. But what is lost in quantity is more than made up in quality. Yet there has been no decrease in the number of students, as has been incorrectly stated, but on the contrary, the increase has been regular, as the catalogues of the last five years will show:

In the year 1870-1, aggregate number.....	301
In the year 1871-2, aggregate number.....	358
In the year 1872-3, aggregate number.....	368
In the year 1873-4, aggregate number.....	371
In the year 1874-5, thus far in the year.....	389

The number of students at Bloomington, not counting those of the Medical Department, is as follows:

Indiana University

1870-1 (including Normal Class).....	301
1871-2 (Normal Class abolished).....	268
1872-3, aggregate number	264
1873-4, aggregate number ...:	268
1874-5, aggregate number	282

It is the aim of the Faculty and Trustees to do work of the highest grade and order, making thorough scholars and elevating the standard of scholarship, and when this is secured, numbers will not be wanting; but the popular sentiment has, from the beginning, judged the merits of institutions of learning by the size of the crowd that attends them, not taking into account discipline, thoroughness of scholarship, and training; as if it were the sole business of a college to gain numbers and to graduate a crowd instead of scholars.

The present plan we believe to be working well for the interests of education in Indiana, and, if it were comprehended, it would not only be approved, but highly commended by the people. It rests with the educators and friends of education in Indiana, whether the new measures adopted by the University will soon become what it aspires to be, the head and crown of the public school system; a University not only in name, but in reality, ranking among the very first in the land, an honor to the State, and a source of pride to all her citizens.

- CYRUS NUTT, President.
- T. A. WYLIE, Professor of Natural Philosophy.
- R. OWEN, Professor of Natural Science.
- D. KIRKWOOD, Professor of Mathematics.
- E. BALLANTINE, Professor of Greek.
- J. THOMPSON, Professor of Civil Engineering.
- A. ATWATER, Professor of Latin.
- G. W. HOSS, Professor of English Literature.
- S. P. MORRISON, Assistant Professor of English Literature.
- T. C. VAN NÜYS, Professor of Chemistry.

This report was accompanied by the following circular of the Faculty:

To the Superintendents of the Public Schools, and County Superintendents:

The founders of this Commonwealth, in the original Constitution of Indiana, provided for a system of Free Public Schools, to include in regular gradation the district and intermediate schools and a State University. The same wise and liberal

Circular of the
Faculty, 1875.

Relation to School System

provision is sanctioned in the present Constitution, while the laws of the State recognize the institution at Bloomington, Monroe County, as the State University.

Although the State University and the graded schools by the above constitutional and legislative provisions form one and the same system of public instruction, they have not, until recently, harmoniously coöperated. A plan for adjusting the University course of study to that of the High Schools was very maturely considered by the State Board of Education, by a convention of superintendents of public schools, and by the Trustees and Faculty of the State University; and, as the result, the classical course was enlarged to include all preparatory Greek, and the mathematical and scientific courses correspondingly diminished; the preparatory Latin and the excluded mathematics and science being incorporated in the High School course, which is as follows, viz.: Orthography, arithmetic, geography, English grammar, algebra (both elementary and higher), geometry (four books), physiology, history of the United States, Latin grammar, Latin reader, Latin prose composition, two books of Cæsar, and two books of Virgil, or their equivalents in Latin.

All High Schools in the State which are prepared to teach the above named branches and possess the other qualifications prescribed by the State Board of Education are entitled to a commission to prepare students for the State University, and to grant certificates of proficiency in the above studies, which shall entitle the holder to admission to the Freshman class of the University without further examination. This commission also authorizes the superintendent to examine any person who may apply, and to grant a certificate, if the applicant is found thoroughly proficient in all the studies of the Preparatory Course. The trouble and expense of a journey to Bloomington may thereby be in some cases avoided.

It is earnestly requested that notice be given throughout the section of the State in the vicinity of each designated High School, at what time applications may be made for examination, and that the President of the University be duly notified of the results of these examinations.

This system may not be wholly satisfactory to all of the friends of the public schools in Indiana, but it certainly has great merit; and shall it not be faithfully sustained and its provisions executed, until an opportune moment for its amendment shall arrive?

The State University, chief public school of the State, may not be free from defects, but it is progressive, and it will seek to know the demands of popular education in Indiana and to meet and satisfy these fully, expecting in return to be cordially sustained and liberally supported.

A. ATWATER, Secretary.

CYRUS NUTT,
President of the Faculty.

Bloomington, Indiana, April 15, 1875.

Indiana University

Number of Com-
missioned High
Schools.

The following table shows the development of the system of Commis-
sioned High Schools in Indiana from its inception in 1874 until the present
time:

<i>Year.</i>	<i>No. of Schools.</i>	<i>Year.</i>	<i>No. of Schools.</i>
1874.....	21	1889.....	100
1875.....	27	1890.....	107
1876.....	17	1891.....	108
1877.....	28	1892.....	110
1878.....	29	1893.....	107
1879.....	30	1894.....	112
1880.....	33	1895.....	118
1881.....	21	1896.....	123
1882.....	33	1897.....	130
1883.....	38	1898.....	143
1884.....	34	1899.....	156
1885.....	41	1900.....	158
1886.....	83	1901.....	177
1887.....	85	1902.....	176
1888.....	99	1903.....	191

GRADUATE SCHOOL

The first advanced degrees for work done in course in Indiana University were granted in 1882. In the catalogue for that year we find the announcement of the first definite scheme for graduate degrees, as follows: Requirements
for advanced
degrees in
1882.

FOR MASTERS' DEGREES

1. Any graduate of this University, as Bachelor of Arts, Letters, or Science, who subsequently completes a course of study of not less than two years in any reputable professional school of Theology, Law, Medicine, Literature, Music, Advanced Science, or the Mechanic Arts, on presenting to the Faculty of this University satisfactory evidence that he has thus completed any of the professional courses named, and that he has maintained a good character, may receive from the University the Master's Degree of the same name as the Bachelor's Degree he has already received.

2. Any graduate of this University, or of any similar and equal institution, who does not pursue a professional course as above described, may receive from this University a Master's Degree, corresponding to his Bachelor's Degree, at the expiration of three years from the date of graduation; provided, he gives evidence of good character and completes a course of study fairly equivalent to any of the professional courses above named under the direction of the Faculty of this University, either in residence at the University or in private, or partly in residence and partly in private. The satisfactoriness of the work to be determined by an examination of each candidate by the Faculty of this University, and by the presentation on his part of a creditable thesis on some theme prescribed by this Faculty. Provided, further, that the three years herein required may be reduced to two, if the entire time is spent by the candidate in residence at this University, or under the immediate direction of its Faculty.

Indiana University

FOR DEGREE OF DOCTOR OF PHILOSOPHY

The degree of Doctor of Philosophy may be received by the graduate of this University, or of any other institution of like character and equal rank, five years after graduation; provided, the candidate, in addition to the requirements for the Master's Degree, as above recited, shall still further pursue studies under the direction of the Faculty of this University, pass satisfactory examinations in the same, present in print a satisfactory thesis upon some prescribed or accepted subject, embodying original work, and maintain a good character. Provided, further, that the five years herein required may be reduced to three, if the entire time is spent in residence at this University, or under the immediate direction of its Faculty.

Modifications of
these require-
ments, 1885-87.

In 1885 and 1886 it was further required that "A copy of each thesis presented for a Master's degree must be deposited in the University Library." In 1885, it was stipulated that "The degree of Doctor of Philosophy will not be given as an honorary degree, and it will be given to no one who has not obtained prominence as a special student in some department of learning." In 1886 the time requirement for the degree of Doctor of Philosophy was altogether omitted, and the last part of the stipulation just mentioned was modified so as to read as follows: "It will, farther, not be given as a result of any examinations or of any course of study alone, but only on evidence of original work actually done, by some person who has achieved prominence as a special student in some department of learning."

It appears that at first not all the departments of the University were prepared to offer instruction of a graduate character. In the catalogue for 1885 we read: "Students holding a degree from Indiana University, or from any college having similar requirements, may select for themselves a course of advanced work, in any one or more departments of the University which may be able to provide for them. Facilities for such advanced work are offered in most departments of the University, especially in the Departments of Mathematics, Chemistry and Biology."

In the following year the latter part of this announcement was modified to read as follows: "Special courses, leading to the Master's degree (M.A., M.S.), will be arranged to meet the needs of each individual student. The advantages offered in the University for special advanced or original

Graduate School

work are now very great, and it is the aim of those in control of the affairs of the University to make it the center of such work in the State in all departments within its scope." In 1887 the following explanation also was added: "As a rule, no degree of any sort will be given by the University to any person who has not, at some time, been a matriculated student in residence at the University. It is not desired to create at the University an 'examining board' to certify to the value of work done elsewhere." As thus modified and enlarged, this announcement regarding the character of the graduate instruction appears also in the catalogues for 1888 and 1889. Since 1886 the degree of Master of Science has not been granted.

In 1887, in the same year in which the degree of Bachelor of Arts was made the only baccalaureate degree conferred by the University, the requirements for the graduate degrees were newly defined as follows:

Requirements
for advanced
degrees in 1887.

MASTER OF ARTS

Any graduate of this University, or of any similar institution, may receive from this University the degree of Master of Arts (A.M.) upon the completion of a course of advanced study, of not less than one year, in residence at the University, under the direction of the Faculty, the value of the work to be determined by an examination of each candidate, and by the presentation of a satisfactory thesis on some theme prescribed or accepted by the Faculty; but graduates of this University may, in special cases, be excused from residence though not from examination at the University.

Any graduate of this University of three years' standing, who has completed the course of study in a reputable professional school, on presenting to the Faculty of this University a creditable non-professional thesis, with satisfactory evidence that he has maintained a good character, may receive from this University the degree of Master of Arts.

DOCTOR OF PHILOSOPHY

The degree of Doctor of Philosophy (Ph.D.) may be received by the graduate of this University, or of any other institution of similar character and rank, upon the completion of an advanced course of study of not less than three years, at least one of which must be spent in residence at this University, the value of the work done to be shown by a final examination and by the presentation of a satisfactory thesis in print upon some prescribed or accepted subject embodying original work,

Indiana University

Subsequent
modifications.

The requirement regarding evidence of good character was omitted after 1888.

In 1890 it was provided that the work for the Master's degree be done not under the direction of the Faculty, as hitherto, but "under the direction and supervision of the professor in charge of the Department in which studies are carried on," and the work for the Doctor's degree had also to be done "under the direction and supervision of the appropriate member of the Faculty." This provision was only in line with the increasing tendency in the University at this time toward specialization. In the same year the rule that candidates for the Master's degree might in some cases be excused from residence, providing they were graduates of the University, was guarded by the additional provision that "graduates from other institutions will in no case be thus excused."

The more definite influence of the major subject system upon the plan of graduate instruction began to be felt in 1891. The Master's degree now required "the successful completion of three full courses of study occupying at least one year of three daily recitations, or the equivalent thereof, in residence at the University, such courses to be chosen under the advice of the head of the Department in which the major part of the work is to be done, and to be subject to the approval of the general Faculty."

In 1893 provision was made, moreover, that "If at any time during the year an undergraduate has completed the requirements for graduation, a written statement to this effect is given him by the President of the University, and his work for the remainder of the year may be counted toward his higher degree."

The number of graduate students registered and the degrees granted in successive years have been as follows:

Graduate School

Year	Number of Graduate Students		Number of Degrees Conferred		
	In Residence	In Absence	M.S.	A.M.	Ph.D.
1880-1881.....	1
1881-1882.....	1	..	3
1882-1883.....	2	..	2	4	1
1883-1884.....	2	..	1	..	2
1884-1885.....	1	..	3	4	1
1885-1886.....	6	..	3	10	2
1886-1887.....	8	5	1
1887-1888.....	5	6	..
1888-1889.....	9	19	..	7	2
1889-1890.....	12	29	..	14	..
1890-1891.....	19	17	..	16	2
1891-1892.....	28	24	..	17	2
1892-1893.....	22	23	..	16	1
1893-1894.....	47	11	..
1894-1895.....	49	15	..
1895-1896.....	62	14	..
1896-1897.....	65	13	..
1897-1898.....	84	14	..
1898-1899.....	77	15	..
1899-1900.....	69	11	..
1900-1901.....	69	21	..
1901-1902.....	82	18	..
1902-1903.....	82	19	..
Totals			12	250	14

Numbers of graduate students and degrees, 1880-1903.

Organization of the Graduate School, 1904.

A Committee on Advanced Degrees was first appointed in 1894. Recently (March, 1904), in order to emphasize the facilities offered by the University for work of an advanced nature, a Graduate School has been organized. The requirements for the degree of Master of Arts and of Doctor of Philosophy are thus set forth in the catalogue for 1904:

MASTER OF ARTS

The degree of Master of Arts may be conferred upon graduates of this University, or of any other institution of the same standing, upon the completion in residence of fifteen hours per term, carried during at least one entire college year. Thirty of the

Indiana University

Present requirements for advanced degrees.

total of forty-five hours must be in one department, or in closely allied departments. Fifteen hours must be distinctly graduate in character.

The Master's degree may be conferred upon graduates of this University upon the completion in absence of fifteen hours per term, or their equivalent, carried during at least two full years under the direction of the Faculty, hours of private work done in absence being estimated at one-half the credit value of work done at the University.

Professional studies are not accepted for this degree, but research work on professional subjects may be accepted at the option of the professor in charge of the major subject.

A thesis may be required at the option of the professor in charge of the major subject.

DOCTOR OF PHILOSOPHY.

The degree of Doctor of Philosophy may be conferred upon graduates of this University, or of any institution of similar character and rank, upon the completion of an advanced course of study of not less than three years. In exceptional cases, on the recommendation of the professor in charge of the major subject and with the concurrence of the Committee on Advanced Degrees, part of this time may be spent in study at other universities.

The course of study for the degree of Doctor of Philosophy must be pursued under the direction of a committee consisting of the heads of the Departments in which the work is done, and its value shall be determined by a final examination and by the presentation of a satisfactory thesis embodying original work upon some prescribed or accepted subject. In each case a detailed statement, which must be endorsed by the professor in charge of the major work, must be submitted to the Committee on Advanced Degrees not later than May 10th of the year in which the candidate presents himself for examination.

The thesis of every candidate for the degree of Doctor of Philosophy must be presented to the Committee on Advanced Degrees on or before the first day of June of the year in which he proposes to take the degree. The thesis must be endorsed by the head of the Department as being in its final form and ready for the press. Examinations of each candidate for this degree will be conducted before a committee consisting of all the instructors under whom graduate work has been taken. If the candidate is recommended for the degree, five printed copies of the thesis shall be deposited in the library before the degree is conferred.

Formal application for the degree of Master of Arts must be filed with the Dean at least three months before the time when the degree is to be given. Formal application for the degree of Doctor of Philosophy must be on file at least one year before the candidate is admitted to examination.

SCHOOL OF LAW

A School of Law has existed at two distinct periods at Indiana University, from 1842 to 1877, and from 1889 until the present time. Dr. Wylie says: "The organization of the Law School was agitated in 1835, if not sooner, early in the administration of the first President of the University. The earliest attempt to organize it as a Department of the University must have been some time between 1835 and 1837. A loose scrap of paper containing a note which the writer probably intended to transfer to the minutes has escaped destruction, on which is the following:

Steps toward
organization of
a Law School,
1835-41.

"Resolved, That in the opinion of the Board, a professorship of law should be established, to be connected with the college.

"That the law term should consist of four months, from December 1st to March 31st.

"That the salary of the professor shall be \$300, to be paid as other salaries of the college officers, and that he also be entitled to dispose of lecture tickets for his own benefit, the price of which shall not exceed \$10 per term.

"Resolved, That the Board now proceed to the election of said professor.

"Mr. Foster (who was a trustee from 1835 to 1838) was appointed teller, and on counting the votes it appeared that Isaac Blackford was unanimously elected professor. There is no further trace of Judge Blackford's professorship. From some notes which had been taken from the old record book of the College, destroyed in the fire of 1883, mention is made of Charles Lewis having been chosen professor of law, September 20, 1837. We have no further notice of Mr. Lewis.

"At the first meeting of the board, after the College had been made a University, the following appeared on record in its proceedings under

Indiana University

date of September 25, 1838: 'On motion of Mr. [John] Law the Board proceeded to the election of a professor of law. The result of the election was that the Hon. Miles G. Eggleston was unanimously elected.' Mr. Eggleston declined, owing to circumstances over which he had no control. Application was then made to several distinguished jurists, but no one was found willing to accept. The matter was then dropped till 1841, when Gen. Tilghman A. Howard was elected, and a very urgent letter was sent by the Board requesting his acceptance. General Howard, however, declined this earnest request. About a year after this the names of several distinguished jurists were presented to the Board. Of this number David McDonald, who was a resident of Bloomington and a Judge of the Circuit Court, was duly elected, and on the following day his letter of acceptance was received."¹

Its first announcement,
1842.

We read in the first announcement of the Law School, in the catalogue for 1842, that "In establishing this Department, the design of the Board of Trustees is (to use their own language), 'Nothing less than the building up of a Law School, that shall be inferior to none west of the Mountains; one in which the student will be so trained that he shall never, in the attorney, forget the scholar and the gentleman'. It will be the object of the Professor to furnish a complete course of legal education to gentlemen intending for the bar in any of the United States. Persons applying for admission as students will not be examined touching their literary attainments. But no one will be admitted who does not produce satisfactory testimonials of his good moral character. The sessions will, in all respects, be the same as in other branches of the University. The course of study will occupy four sessions [at this time there were two sessions each year]. The students will be divided into two classes—Junior and Senior. Such, however, as have elsewhere made sufficient progress in the study of law, may, if they prefer, be at once admitted to the Senior Class. And gentlemen not wishing to study municipal law as a profession, may enter the Junior Class for instruction in that part of the course which relates to international, constitutional and commercial law."

Instruction in this Department was in general given by means of recitations on prescribed text-books, and by lectures. A moot court was held,

¹Wylie, *Indiana University* (1890), pp. 88-89.

School of Law

also, in which the students of both classes were exercised in the preparation of pleadings, rules of practice, forms of record entries, and discussion of legal questions. At first this moot court was held every Saturday, but from 1874 it was convened four times a week.

The changes from time to time in the course of instruction in the Law Department may be seen in the following table of text-books, showing the time during which each of these books was in regular use:¹

Changes in the course of instruction, 1842-76.

JUNIOR CLASS

Blackstone's Commentaries, 1842-8, 1850-1, 1853-76.
Story's Commentaries on the Constitution, 1842-5.
Chitty on Contracts, 1842-8.
Stephen on Pleading, 1842-8, 1850-1, 1853-76.
Kent's Commentaries, 1842-8, 1850-1, 1853-61, 1871-6.
Smith on Contracts, 1850-1, 1853-61.
Parsons on Mercantile Law, 1862.
Smith or Parsons on Contracts, 1863-5.
Metcalf on Contracts, 1869-70.
Parsons on Contracts, 1871-76.

SENIOR CLASS

Kent's Commentaries, 1842-8, 1850-1, 1853-61.
Chitty on Bills, 1842-8.
Chitty on Pleading, 1842-8, 1850-1, 1853-4.
Starkie's Evidence, 1842-4.
Story's Equity Pleading, 1842.
Mitford's Equity Pleading, 1843-8, 1850-1, 1853-61.
Greenleaf's Evidence, 1845-8, 1850-1, 1853-76.
Adams's Equity, 1855-65.
Indiana Revised Statutes of 1852 (selections with reference to practice in the State Courts, in Civil and Criminal cases), 1855-61.
Williams on Real Property, 1862-70.
Bicknell's Practice and the Code, 1871-6.
Washburn on Real Property, 1871-6.
Story's Equity, 1871-6.

¹The University catalogue for 1849 is missing; in the catalogue for 1852 no list of text-books is given; also in the catalogue for 1877, which contains the announcement of the suspension of the Law Department in that year, no such list is given.

Indiana University

Students were also recommended to procure certain books in addition to the text-books, as follows:

Williams on Personal Property, 1873-5.

Sedgwick on Statutory Construction, 1873-6.

May on Insurance, 1874-6.

Cooley on Constitutional Limitations, 1874-6.

Benjamin on Personal Property, 1876.

Suspension of
the Law School,
1877-89; its re-
vival in 1889.

In 1877 the Law Department of the University closed its doors because of legislative action cutting down the salaries of professors to such a point that competent men could no longer be secured. For twelve years the Department was out of existence; but at a meeting in March, 1889, the Board of Trustees made provision for its reëstablishment in the next academic year with a two years' course. Regular instruction was contemplated in the following subjects: "The first, or Junior year, is devoted to the study of the law of real and personal property, contracts, negotiable instruments, criminal law, the law of bailments, and domestic relations. The second, or Senior year, is devoted to the study of equity jurisprudence, pleading evidence, the law of torts, constitutional law, federal jurisprudence and practice, and pleading and practice under codes."

Development
since 1889.

During the first year of the reopening of the Law Department, instruction was given during the Fall and Winter terms only, but thereafter the terms were made to correspond to the three terms in other Departments of the University. Beginning with 1901 the course in law has covered three years instead of two. In 1903 a fourth term of ten weeks was added, beginning the day after Commencement and ending early in the month of September. This is designed to "enable those who are compelled to remain out of the School during the Fall and Winter terms to make up a portion of their work missed during those terms."

The Law Department has undergone a steady development since its reorganization, so that it now constitutes a School of Law, with three professors, one associate professor, and three non-resident lecturers, besides numbering on its Faculty eight professors from other Departments of the University, representing regular instruction in history and political science, Roman law, economics and social science, medical jurisprudence, and debating and public speaking. In place, moreover, of the original

School of Law

weekly moot court, there are now two regular practice courts, the Third Year Practice Court (Indiana University Circuit Court), which meets once a week, and the University Supreme Court, which convenes as often as may be required by the business before it, the members of the Faculty of the School of Law acting as judges. Appeals are taken and writs of error prosecuted from the Third Year Practice Court. Besides these two



SCHOOL OF LAW—A CORNER OF THE LAW LIBRARY

regular practice courts, club courts also are organized for the discussion of legal questions by the students of each class.

Applicants for admission to the School of Law must be at least eighteen years of age; and since 1899 the requirement of scholarship for admission, except in the case of special students, has been the same as for admission to the Departments of Liberal Arts. Before that time the applicant was

Requirements
for admission.

Indiana University

required to satisfy the Faculty by standing an examination that he was prepared profitably to undertake the work of the Department, special emphasis being laid on his ability to use good English.

Combined course
in Arts and Law.

With the beginning of the academic year 1905, there will be offered to students in the Departments of Liberal Arts a combined course with law



SCHOOL OF LAW—ANOTHER PART OF THE LAW LIBRARY

as special major subject, leading to the degree of A.B. at the end of four years. The course contemplates the completion of two full years of academic work before the commencement of the law studies. During the third and fourth years the student taking the combined course will be required to do ten hours a week work in law, and five hours in prescribed

School of Law

and elective subjects in the Departments of Liberal Arts. The A.B. degree with law as the major subject will admit the holder to the third-year class of the School of Law, and enable him to complete the law course, with the degree LL.B., in one year. Students of the University whose major subject is other than that of law, are permitted after the completion of



SCHOOL OF LAW—MOOT COURT ROOM

their Freshman year to take one year of law on the A.B. course. They are thus enabled, after graduation, to complete the law course in two years.

The subjects offered in the Law Department in the first year of its reorganization in 1889 have already been mentioned. The following table shows the development of the course of instruction in this Department from 1890 to the present time. In this table the larger figures indicate the

Course of instruction, 1889-1903.

Indiana University

number of hours per week, and the index figures show the terms of the year—
whether first, second or third—in which the respective subjects were offered.
Hyphenated figures (e.g. 1-3) indicate that the subject was offered through-
out the three terms.

SUBJECTS OFFERED IN LAW DEPARTMENT

	'90	'91	'92	'93	'94	'95	'96	'97	'98	'99	1900	'01	'02	'03
Agency	2 ³	5 ¹	5 ¹	2 ²	5 ²	5 ²	5 ²	5 ³
Bankruptcy	1 ³
Bills and Notes	5 ³	5 ³	5 ³	1 ³	5 ³	5 ³	5 ³	5 ³	5 ²	5 ²	4 ³
Blackstone	5 ²⁻³	2 ¹⁻²
Carriers and Bailments...	5 ²	5 ²	5 ²	5 ²	2 ¹	2 ¹⁻²	5 ²	4 ²
Code Pleading } and Practice }	5 ¹	5 ¹⁻³	5 ¹⁻³	5 ¹	5 ¹⁻³	5 ¹⁻²	3 ¹⁻²	2 ¹	2 ¹	3 ²	5 ¹	5 ¹	5 ¹	5 ¹
Common Law Procedure	5 ¹	5 ¹	1 ³	2 ¹	5 ²	5 ³	5 ³	5 ³	5 ³	5 ³	5 ²
Constitutional Law.....	5 ¹	5 ¹	5 ¹	..	2 ³	2 ³	2 ³	2 ²	2 ²	4 ³	4 ²⁻³	3 ²⁻³	5 ³	5 ³
Contracts.....	5 ²⁻³	5 ¹⁻³	5 ¹⁻³	5 ¹⁻³	5 ¹⁻³	5 ¹⁻³	5 ¹	5 ¹	5 ¹	5 ¹	3 ¹	3 ¹⁻²	5 ¹	5 ¹
Criminal Law } and Procedure }	5 ³	5 ³	5 ³	3 ³	3 ³	3 ³	3 ³	5 ³	5 ³	5 ³	5 ¹	5 ¹	5 ¹	5 ¹
Damages	2 ³
Elementary Law.....	5 ¹	5 ¹	5 ¹	5 ¹	5 ¹	5 ¹	5 ¹	3 ¹	3 ¹	3 ¹	3 ¹	3 ¹	3 ¹	..
Equity Jurisprudence ...	5 ¹	5 ¹	5 ¹	5 ¹	5 ¹	5 ¹	5 ¹	5 ¹	5 ¹	5 ¹	5 ¹⁻³	5 ¹⁻³	5 ²	5 ¹
Equity Pleading } and Practice }	1 ¹⁻³	3 ²	3 ²	3 ¹	2 ²	2 ²	2 ²	3 ²
Evidence, I.....	5 ²	5 ²	5 ²	4 ²	4 ²	4 ²	4 ²	5 ²	5 ²	5 ²	5 ¹⁻³	5 ¹⁻³	3 ¹⁻²	5 ²
Evidence, II.....	5 ³
Federal Procedure.....	1 ¹	1 ¹	1 ¹
Guaranty and Suretyship	2 ³	2 ³	2 ³	2 ³	2 ³
History of English Law	5 ¹	5 ³
Indiana University } Circuit Court }	1 ¹⁻³	1 ¹⁻³	1 ¹⁻³	1 ¹⁻³	1 ¹⁻³	1 ¹⁻³
Indiana Pleading } and Practice }	1 ¹⁻³	1 ¹⁻³	1 ¹⁻³	3 ¹⁻³
Indiana Probate Law	2 ¹⁻³	2 ¹⁻³	2 ¹⁻³
International Law	5 ²	5 ²	5 ²	2 ³	2 ³	2 ³	2 ³	2 ³	2 ³	2 ³	2 ³	2 ³
Insurance	2 ²	2 ²	2 ²	3 ²	3 ²	3 ²	3 ²
Judgments	2 ²	2 ²	5 ³	..
Justice Practice.....	1 ¹	1 ¹	1 ²	1 ¹

School of Law

SUBJECTS OFFERED IN LAW DEPARTMENT—CONTINUED

	'90	'91	'92	'93	'94	'95	'96	'97	'98	'99	1900	'01	'02	'03
Legal Ethics	5 ³
Medical Jurisprudence..	1 ¹	1 ¹	1 ¹
Moot Court, I.....	1 ¹⁻³	1 ¹⁻³	1 ¹⁻³	1 ¹⁻³	1 ¹⁻³	1 ¹⁻³	1 ¹⁻³	1 ¹⁻³	1 ¹⁻³	1 ¹⁻³	1 ¹⁻³	1 ¹⁻³
Moot Court, II	1 ¹⁻³	1 ¹⁻³	1 ¹⁻³	1 ¹⁻³	1 ¹⁻³
Mortgages.....	4 ²
Negligence	2 ¹	2 ¹	2 ¹	2 ¹	2 ¹	3 ¹
Parliamentary Law	1 ¹⁻³	1 ¹	1 ¹	3 ¹
Partnership	2 ²	2 ²	2 ²	2 ²	2 ²
Patent Law and } Trade Marks }	1 ³	1 ³	1 ³
Persons and Do- } mestic Relations }	5 ³	5 ³	3 ²	2 ³	2 ³	2 ³	2 ³	2 ¹	2 ¹	2 ¹	3 ¹	3 ¹	3 ³	2 ²
Personal Property.....	..	5 ²⁻³	2 ² 5 ³	5 ²	5 ²	5 ²	5 ²	3 ²	3 ²	3 ¹	3 ¹	2 ¹	3 ¹	2 ²
Private Corporations	5 ³	5 ³	5 ³	5 ³	5 ³	5 ³	5 ³	5 ³	5 ³	5 ³	5 ¹⁻²	5 ¹⁻²	5 ¹	5 ²
Public Corporations	5 ²	5 ²	4 ²	5 ³	5 ³	5 ²	5 ³
Quasi-Contracts	5 ³
Real Property.....	5 ²	5 ²	5 ²	5 ²	5 ²	5 ²	5 ²	5 ¹	5 ¹	5 ¹	5 ¹⁻³	5 ²⁻³	5 ¹	5 ¹
Roman Law	1 ¹
Sales of Personal } Property }	5 ²	5 ²	5 ²	5 ³	5 ³	5 ³	5 ³
Torts	5 ³	5 ³	5 ³	..	3 ³	3 ³	3 ³	5 ³	5 ³	5 ³	5 ¹	5 ¹	5 ¹	5 ¹
Trusts	3 ³	3 ³	3 ³	5 ³	5 ³	5 ³	5 ³
University Su- } preme Court }	1 ¹⁻³	1 ¹⁻³	1 ¹⁻³	1 ¹⁻³	1 ¹⁻³	1 ¹⁻³
Wills and Adminis- } tration of Estates }	5 ²	5 ²	5 ²	1 ²	1 ²⁻³	1 ²⁻³	1 ²⁻³	2 ³	2 ³	1 ²	4 ³	5 ³	5 ³	5 ³

SCHOOL OF MEDICINE

Movement to
establish a
School of Medi-
cine, 1870.

In the annual reports of the Board of Trustees for 1870 and 1871, mention is made, among the wants of the University, of another professional department, that of Medicine, in which tuition shall be free for all. "Then Indiana, with her excellent common schools, her Graded and High Schools, her Normal College at Terre Haute, her Agricultural and Mechanical College at Lafayette, and her State University, embracing the College of Sciences and Arts, the College of Law, the College of Medicine, and that of Military Science, would have her system of education complete, and equal to that of any other State in the Union. Then no young men or women need leave their own State in order to secure the best liberal and professional educations in any vocation they may select. Indiana owes this to herself and her sons and daughters. Her children should not be dependent upon other commonwealths for what she, herself, is abundantly able to furnish."

Indiana Medical
College made the
Medical Depart-
ment of Indiana
University,
1871.

At a meeting of the Board in 1871, the Indiana Medical College, located at Indianapolis, was made the Medical Department of Indiana University, and the annual announcement of this college was incorporated for the first time in the University catalogue for 1872. Instruction was offered in surgery, obstetrics, diseases of women and children, principles and practice of medicine, pathology and clinical medicine, chemistry and toxicology, physiology, diseases of the eye, ear and nasal passage, materia medica and therapeutics, medical jurisprudence, descriptive and surgical anatomy. Lectureships were also established on the special branches of diseases of the nervous system, on comparative anatomy and medical botany, and on medical jurisprudence.

School of Medicine

In the study of anatomy an abundance of material for dissection was furnished at cost. Clinics were held twice each week at the City Hospital at Indianapolis. The Bobbs Free Dispensary also, which was under the control of the Faculty and located in the College building, furnished a great number and variety of interesting cases. The City Dispensary, at which the greater portion of the medical charity of the city is furnished, was located conveniently near and was under the superintendency of a member of the Faculty of this Department. At least one hour each day was devoted to clinical instruction.

The requirements for graduation in this Department were as follows:

Candidates for graduation must furnish proof of good moral character, that they have studied the science for three years under the instruction of a competent preceptor, and that they have attended two full courses of lectures in a medical college of good reputation, the last of which must have been in this Department. On such proof, and after satisfactory examination in the several branches of study, the candidate will be entitled to the degree of Doctor of Medicine.

Four years of reputable practice considered equivalent to attendance upon a first course of lectures.

The connection, however, of the Indiana Medical College with the University was little more than nominal and of no particular advantage to either side. From 1870 tuition had been free in all departments of the University. On this account the Board of Trustees seemed to feel in the case of the Medical Department, as in that of the Law Department a year later, that to undertake to continue its maintenance would require an expenditure beyond the means at their disposal. Accordingly in 1876, after continuing for five years, the connection of the Indiana Medical College with the University was terminated by mutual consent. The graduates of the Department during this period have not been accounted alumni of the University.

The connection discontinued, 1876.

In 1891 a Medical Preparatory Course was established under the general direction of the professors of chemistry and zoölogy. This course of four years, leading to the degree of A.B., was provided for students who expected afterwards to take up the study of medicine. The major study contained work from both these Departments, and as collateral work courses

Medical Preparatory Course, 1891-1902.

Indiana University

in botany and physics were also required. Students completing this course were enabled to enter with advanced standing in the three years' course of most medical colleges.

The Premedical Course, as thus planned, was continued through 1895. From 1896 until 1902 this course was under the direction of the Department of Chemistry, and embodied simply certain suggestions for a scheme of study which met the University requirements for graduation, with chemistry as the major subject, and at the same time formed a suitable preparation for students who intended later to study medicine. The plan of grouping together certain studies with zoölogy or chemistry as a major subject, although it enabled gradnates of the University to get one year of credit in reputable medical colleges for undergraduate work, yet failed to meet the needs of an increasing body of students who looked forward to Medicine as a career. Consequently, in the fall of 1903, a Department of Anatomy was established, and a substantial increase was made in the equipment for the work in physiology. The situation, however, was not relieved. It was found that a large number of students were intending to study medicine in medical colleges outside the State. Accordingly in November, 1903, in accordance with the charter rights of the University, a College of Medicine was organized, to be known as the Indiana University School of Medicine. In the fall of 1904 the full work of the first two years will be offered. Only the first two years of the medical course are provided for at present. The School of Medicine as thus planned will be represented by Departments of Anatomy, Physiology, and Chemistry, and will include also work in other departments of the University in neurology and embryology.

Indiana University School of Medicine established, 1903.

Combined course in Arts and Medicine.

A combined course in Arts and Medicine is now provided for, which is an integral part of the University curriculum. Requirements for admission to this course are the same as to any other Department of the University, and are practically identical with the minimum entrance requirements demanded by the Association of American Medical Colleges.

Following is given a tabular conspectus of the combined course leading to the collegiate degree of Bachelor of Arts in Medicine, and giving the student who completes it third-year standing in any medical school of the State and in many medical schools outside the State:

School of Medicine

FIRST YEAR

<i>Fall Term</i>	<i>Winter Term</i>	<i>Spring Term</i>
English. 2 hrs.	English..... 4 hrs.	English..... 4 hrs.
German 5 hrs.	German 5 hrs.	German 5 hrs.
Physics 3 hrs.	Physics. 3 hrs.	Physics..... 3 hrs.
Trigonometry 5 hrs.	Elective 3 hrs.	Elective 3 hrs.

SECOND YEAR

Zoölogy 5 hrs.	Zoölogy 5 hrs.	Botany 5 hrs.
General Chemistry.. 5 hrs.	Qualitative Analysis 5 hrs.	Qualitative Analysis 5 hrs.
French 3 hrs.	French 3 hrs.	French 3 hrs.
Elective 2 hrs.	Elective 2 hrs.	Hypnotism and Sug- gestion 3 hrs.

THIRD YEAR

Anatomy10 hrs.	Anatomy10 hrs.	Histology10 hrs.
Organic Chemistry. 5 hrs.	Physiological Chem- istry 5 hrs.	Physiological Chem- istry 5 hrs.

FOURTH YEAR

Anatomy 5 hrs.	Physiology 5 hrs.	Surgical Anatomy .. 5 hrs.
Physiology 5 hrs.	Bacteriology..... 3 hrs.	Physiology 5 hrs.
Toxicology 3 hrs.	Neurology 2 hrs.	Bacteriology..... 5 hrs.
Neurology..... 2 hrs.	Embryology..... 5 hrs.	

For the electives provided for during the first two years, the student is recommended to take courses in anthropology, drawing, general biology, French, Greek, history, hygiene, philosophy, and laboratory work in physics.

SUMMER SESSION

A Summer School organized, 1890; made a Summer Session, 1900.

The Indiana University Summer School was organized in the summer of 1890 for the purposes of extending to those who are occupied during the school year the advantages of advanced instruction in certain Departments, aided by the libraries, laboratories and other facilities for study connected with the University. The policy of the University in presenting thorough courses of study in each Department instead of multiplying short unrelated courses, was followed in this school. In the Summer School the instruction was given by members of the University Faculty, the buildings and apparatus of the University were at the disposal of the school, credit was given for the work done, and a general supervision over the school was maintained by the University authorities. Nevertheless, the Summer School remained a private venture, the instructors being remunerated solely from the fees paid. Subsequently, in 1900 the University assumed full control of this work, and the Summer School gave place to the Summer Session. The instruction now given in the Summer Session is an integral part of the University work. Under the new arrangement it has been found possible to offer a greater number and variety of courses, and the instruction is given for the most part by the heads of the respective Departments.

Purpose of the Summer Session.

The purpose of the Summer Session remains the same as that of the Summer School. It is the aim of the Session to present thorough courses which in quality of instruction and grade of work done are equivalent to those offered in the regular University terms. Some of the courses of instruction have been specially arranged for the purpose of aiding those

Summer Session

who teach, or wish to prepare themselves to teach, in high schools, academies and other schools. Methods of teaching are treated incidentally also in other courses. Since 1899 the session has been six weeks in length.

The development of the course of instruction in the Summer Session may be seen from the following table:

Courses of instruction in the Summer Session.

NUMBER OF COURSES OFFERED IN EACH SUBJECT IN SUMMER SESSIONS

DEPARTMENTS.	'90	'91	'92	'93	'94	'95	'96	'97	'98	'99	1900	'01	'02	'03
Greek	1	2
Latin	1	4	3	3	3	3	3	3	3	4
Romance Languages	2	4	5	2	2	3	3	3
Germanic Languages	2	4	3	3	5	4	4	5	4	4
English	4	4	4	3	5	7	5	6	6	5	6	6	6	6
History and Political Science	3	3	3	3	4	3	4	4	5	4
Economics and Social Science	1	..	3	3	3	3
Philosophy	1	1	..	1	..	1	1	5	3	4	4
Pedagogy (now Education)	3	2	3	3	3	3	5	4	5
Mathematics	7	6	7	4	3	7	8	5	8	8	6	8	8	8
Mechanics and Astronomy	1	1	1	4	4	5
Physics	3	5	5	..	1	1	2	2	3	5	3	4	4	6
Chemistry	3	4	4	..	1	2	3	6	4	4	3	3	3	7
Geology	1	1	..	1	2	4	4	4
Zoölogy	3	4	4	1	1	2	2	3	3
Botany	3	1	1	..	5	4	3	..	1	3
Nature Study	1	3	1	3

The School of Law began in 1897 to offer work in connection with the Summer School in the form of such special courses as were applied for. In 1900 summer instruction in this Department became regularly organized as a part of the course of the Summer Session. The general plan followed was to give instruction in law in any course offered in the regular University session, providing a sufficient number of students applied for it. The following table shows the scope of the work offered in the successive years

Work in the School of Law.

Indiana University

from 1900 through 1902; each course was given daily throughout the term of six weeks:

Elementary Law, 1900.
Domestic Relations, 1900.
Criminal Law, 1900-1902.
Personal Property, 1900.
Insurance, 1900.
Agency, 1900.
Partnership, 1900.
Bills and Notes, 1900, 1901.
Pleading and Practice, 1900-1902.
Contracts, 1901, 1902.
Equity, 1901, 1902.
Evidence, 1901.
Torts, 1901.

Summer term
of the School
of Law.

Beginning with the year 1903, there has been a Summer term of ten weeks in the School of Law, in which there are offered such courses as are given in the other terms of the School. In the Summer Session of 1903 the following courses were offered, the number in parenthesis indicating the number of hours a week:

First Year Courses—

Criminal Law and Procedure (5).
Elementary Law: Blackstone (5).
Common Law Pleading (5).

Second and Third Year Courses—

Equity Jurisprudence (5).
Code Pleading (5).
Personal Injuries (5).
Criminal Evidence (5).
Third Year Practice Court (2).

BIOLOGICAL STATION

The Indiana University Biological Station arose out of a desire to afford students in connection with the Department of Zoölogy the advantage of field work, during the summer months, at an inland biological observatory.



INDIANA UNIVERSITY BIOLOGICAL STATION — WINONA LAKE, INDIANA

In November, 1894, the Trustees of the University indorsed plans submitted to them for a biological station, and authorized the use, for this purpose, of the apparatus of the zoölogical laboratories. This important step was taken in the adoption of the following recommendation: "That Dr. Eigenmann be permitted to use the zoölogical apparatus for a summer school of zoölogy either at or away from the University, he being responsible to the University for such apparatus." Subsequent steps are described as

Organization of
the Biological
Station.

Indiana University

follows, in an article in *Science* for December 22, 1899, by Professor C. H. Eigenmann, the founder of the Station:

Its purpose.

"The Biological Station of Indiana University was planned with a well-defined object in view, the study of the variation of the nonmigratory vertebrates in some unit of environment. The Station was to be located on a lake which would present circumscribed boundaries within which the conditions were supposed to be nearly uniform at any time and from season to season. Here large numbers of the nonmigratory vertebrates were to



BIOLOGICAL STATION—LECTURE ROOM

be collected, their characteristics tabulated and compared with similar series from other lakes. We were, in short, to conduct a statistical inquiry into evolution. For the work in hand many of the lakes were available. Our location was therefore determined by the finding of an old boathouse suitable for a laboratory on the shore of Turkey Lake. For the first year the Trustees of the University granted the use of apparatus of the Zoölogical Department, provided the Station would in no way be an expense to the University. After the first year the Trustees provided generously for the permanent equipment of the Station. To help defray expenses a number

Biological Station

of courses of instruction were offered for a few students. It was expected that there would be about ten in the party the first year, but there were nineteen."

The work of the first summer resulted in a hydrographic map of the lake, a meteorological report, a description of the physical features of the lake, and reports on the characteristics of its inhabitants. These lines of work were continued in subsequent years.

In 1899 the Biological Station removed to Winona Lake. In readiness for its first year in this location, two buildings were erected on the lake-front by the Winona Assembly and Summer School, and were presented to the Station. These buildings are each 25x45 feet, and two stories high. An artesian well, situated between the laboratories, furnishes a supply of 5,000 gallons of water a day. The Station owns boats, nets, sounding and temperature apparatus, glassware, etc. Microscopes and other apparatus needed are moved to the Station from the University at the opening of each summer session. The laboratories will accommodate a hundred students, and the attendance is restricted to this number.

Removed to
Winona Lake,
1899.

At the Biological Station the following courses have been offered, in the years indicated:

Courses of in-
struction at the
Biological Sta-
tion.

Courses in Zoölogy—

General Zoölogy, 1895-1903.

The Lake Fauna, 1895-1903.

Embryology (including Segmentation, Morphogenesis, Histogenesis, and Histology), 1895-1903.

Special Investigation, 1895-1902.

General Problems in Biology, 1898, 1899, 1901-1903.

Courses in Neurology—

Neurology, 1901-1903.

Gross Anatomy of the Nervous System, 1901-1903.

Advanced Neurology, 1903.

Courses in Botany—

Elementary Botany, 1897-1903.

General Botany, 1898, 1899.

Advanced Botany, 1902, 1903.

Microscopic Botany, 1898.

Indiana University

Courses in Botany (continued)—

- Morphology of Algæ, 1899, 1900.
- Comparative Morphology of Archegoniates, 1899.
- Vegetable Histology, 1899, 1900.
- Research, 1899, 1900.
- Advanced Work in Ecology, 1901.
- Laboratory and Field Work on Plant Relations, 1901.
- Lectures on Plant Relations, 1901.
- Relations of Plants to Insects, 1901.

Courses in Bacteriology—

- General Bacteriology, 1899, 1900.
- Bacteriology—Laboratory Practice, 1899, 1900.
- Advanced Bacteriology, 1899, 1900.
- Lectures—Selected Topics, 1899, 1900.
- Research, 1899, 1900.

A course of ten lectures by Prof. C. F. Hodge, of Clark University, on the point of view of Nature Study was given in 1902.

DEPARTMENTS NOW DISCONTINUED

After the death of President Wylie in 1851, the Board of Trustees of the University was entirely reorganized. At one of their first meetings, namely, on April 14, of the next year, the new Board made provision for the adoption of each of the following measures, "as calculated to render the University more useful and more popular:"

1. A course of Agricultural Chemistry, to be commenced at such seasons of the year as may be agreed upon as most convenient and suitable. At this time of excitement and inquiry as to improvements in agriculture, it will be wise in this University to take the lead in establishing a course of instruction which lies at the very basis of all agricultural improvement.

Resolutions of
the Board of
Trustees, 1852.

2. A Normal Seminary consisting of departments for males and for females. There is no measure in regard to the State University more urgently required by public opinion than this. Through this department the common school system of the State will be brought into connection and sympathy with the University.

3. Theoretical and practical engineering, as connected with the Mathematical Department. The numerous public works now in process of construction render civil engineering a most important branch of University education, and it can not be doubted that instruction by an able and accomplished mathematician, in this important branch, together with practical illustrations in the field, would meet one of the present demands of public education in Indiana, and add a new class of valuable students to the University.

4. The adoption of regular graduation for that class of students who take what is denominated a Scientific course. It has been subject of complaint, that proper provision has not been made by our colleges to encourage that class of students who do not complete a full course of classical reading. In order to induce that class to

Indiana University

continue in the University until they shall have completed a prescribed course in Mathematics and Philosophy, it is recommended that a Diploma be conferred upon them, on the completion of a course of studies, to be prescribed by the Faculty, and that the same formalities be observed as in the conferring of the regular degrees now known in the University.

AGRICULTURAL DEPARTMENT

The Agricultural
Department,
1853-69.

In accordance with the terms of these provisions, in the year 1853 there was established an Agricultural Department of the University. This Department continued in existence for six years. The work of instruction embraced "Natural philosophy and chemistry, both organic and inorganic, including an account of nutrition, growth, and respiration, in the vegetable and animal economy, and analysis of soils and manures, ores, marls, etc., as connected with agriculture. The course also includes Geology."

In 1862, under acts of Congress, public lands were appropriated to the several States for the endowment of agricultural colleges. By an act, approved March 6, 1865, the General Assembly of Indiana accepted and claimed the benefits of the provisions of the acts of Congress and obligated itself to establish such an institution as was therein contemplated.

During this time the friends of the University were making a strong effort to have the Agricultural College located at Bloomington in connection with the University, and land and apparatus to the value of \$400,000 were pledged to the State by the citizens of Monroe County. During the summer of 1864, President Nutt delivered an urgent address in support of this plan in fifteen counties of central and southern Indiana.¹ By an act of the General Assembly, however, approved May 6, 1869, the State accepted donations made by Mr. John Purdue and other citizens of Tippecanoe County, and the college contemplated and thus provided for was located in Tippecanoe County under the name and style of "Purdue University," where it has remained as the State school of agriculture and mechanic arts. Thus was definitely defeated any hope of maintaining a distinct Agricultural Department in connection with the State University.

¹For the text of this address, see the University catalogue for 1866.

Departments Now Discontinued

NORMAL DEPARTMENT AND MODEL SCHOOLS

In accordance with the provisions of the Board of Trustees already referred to, the announcement was made in the catalogue for 1852 of the proposed establishment of a "Normal Department in connection with the University, with a male and female Model School as schools of practice." From the catalogue for 1857 the following description of the work is extracted:

Normal Department established, 1853.

This Department is designed to prepare young men for the profession of teaching. Through it, the University designs to afford its aid in carrying forward the great scheme of public education, thus making itself an ally of the general school system of the State.

Lectures are given embracing the following subjects: Education, its nature and design; physical education; intellectual education; moral education; æsthetical education; the history of education; an examination of the powers of the mind, especially with reference to receiving and communicating knowledge; schoolhouse architecture, including school furniture, grounds, etc.; organization and classification of schools; graded schools; the proper incentives for the school; rewards and punishments; modes of teaching different subjects; the office of teacher, his duties to himself, his school, and the public; duty of the State in reference to educating its citizens; the educational policy of Indiana.

It is intended, in this course of lectures, to present, as nearly as may be, the whole duty of the teacher, and to point out such modes of school discipline and management as shall assist the young teacher in preparing for his great work. The members of this Department are also required to write on various topics connected with education, and to discuss, in form of debate, such subjects as may be assigned by the Professor.

As auxiliary to the training of the Normal Class, the Board of Trustees have fitted up a room in one of the college buildings, and established a model school, under a teacher who has been trained in a Normal School, in order to present to the eye of the learner a common school, as nearly perfect as possible, in its order, arrangement, and modes of teaching; and also as a school of practice, in which to exercise and test the young teacher's ability and tact.

The course of lectures on the theory and practice of teaching commences on the first day of May, and continues during the Summer term of the University. The student designing to qualify himself for teaching is, however, permitted to pursue any of the studies of the literary or scientific course, and may with profit enter the University at the opening of any term, as may suit his convenience.

Indiana University

In addition to the course of lectures on didactics, the student must pass an examination on the following subjects, in order to entitle him to a diploma from the University, as a qualified professional teacher, viz.: reading, writing, linear drawing, mental and written arithmetic, bookkeeping, geography, with outline maps and the use of the globes, English grammar and composition, algebra, geometry, mensuration, surveying, natural philosophy, chemistry, human physiology, history (United States and general), history of English literature, Constitution of the United States and of Indiana, and vocal music.

Suspended in
1856.

“The resolution of the Board to establish a separate Female Department of the Normal School was rescinded in August, 1853. Not long after, a resolution was passed to make the Monroe County Female Seminary, then under the care of Mrs. E. J. McFerson, its accomplished Principal, the Female Normal Seminary of the University. This resolution was never carried into effect. After the resignation of Professor Read in 1856 the Normal Department was discontinued, and in the following year the model school. The model school was hard to manage. The pay of the teachers was insufficient; hence it was impossible to retain competent instructors. It had a change of teachers nearly every year of its existence.”¹

Its revival
in 1865.

If we may judge from its history, this Department seems not to have had a very successful career. In 1865 an attempt was made to revive it, and in the catalogue for that year we find the following announcement:

The Normal Department of Indiana University has been recently reorganized, under the charge of Mr. D. E. Hunter, Superintendent of the Graded Schools of Bloomington, aided by members of the Faculty. Mr. Hunter, from long experience in conducting common and graded schools, is eminently qualified for this Department. It is intended to form a Normal class at the beginning of each term of the University, to which, for a small fee, the students, and other persons of both sexes, who desire to prepare themselves thoroughly for the practice of the noble and useful profession of teaching, will be admitted.

It is the design of this Department to furnish teachers, who shall achieve the highest degree of success in their profession, and that the University may thus contribute its aid in carrying forward the great school system of the State.

There will also be held in connection with this Department, a Normal Institute, beginning on the first Monday of August and continuing three weeks.

¹Wylie, *Indiana University* (1890), pp. 60-61.

Departments Now Discontinued

No students were enrolled, however, and the Normal Department does not again come to life until 1869. It is worth noting that at this time the instruction in the theory and practice of teaching was put into the hands of the former Superintendent of Public Instruction for the State, Prof. G. W. Hoss, A.M. Several students were enrolled in this and the following year, after which the Department seems completely to have passed out of existence, except in so far as its place was taken in later years by the present Department of Education. The establishing of the State Normal School at Terre Haute, in 1865, was doubtless a factor in putting an end to the attempt to maintain a Normal Department in connection with the State University.

Final discontinuance, except for present Department of Education.

ENGINEERING

The third of the provisions named above was for instruction in Engineering. Instruction in this subject was given from 1853 to 1858 in connection with the Departments of Mathematics and Chemistry. Civil engineering had been offered as a special study, however, from the year 1841. Mechanical instruction of this sort then shared for a time the same fate as did the work in agriculture. In this earlier period of its existence, the "School of Theoretical and Practical Engineering" proposed, "besides the collegiate course in mathematics and natural philosophy, to afford instruction in the theory of roads, railroads, canals, and bridges, the laws of heat and steam, theory and construction of the steam engine, and topographical surveying."

Early work in Engineering (1841-58).

The work in engineering was revived in 1870 in connection with instruction in military science. In this year it was announced that "a class in Civil Engineering, recently formed, is acquiring information likely to be of important service, as well as in great demand, while our prosperous State continues her work of internal improvement." From 1870 to 1874 we have a distinct "Department of Military Science and Civil Engineering." The engineering feature of this Department included instruction "in practical surveying, in mechanical drawing, in the theory and the construction of bridges, railroads, turnpikes, etc., and in architectural mechanics."

Department of Military Science and Civil Engineering (1870-74).

"It so happened," says Professor Wylie, "that many of the students of the military class, who lived at a considerable distance from the College,

Indiana University

found it very inconvenient to attend the drill, and obtained permission to withdraw. While the military ardor was thus weakened, the zeal of the students took a new direction; the class of civil engineering was enlarged, and soon the military feature of Colonel Thompson's professorship became less and less prominent, while engineering, mechanical drawing, the construction of bridges, practical surveying, etc., became more and more popular."¹

Accordingly, the military features of this Department entirely disappeared, and from 1874 to 1876 instruction was given only in civil engineering, in which scientific students were required to attend daily recitations. From this time on, both the theoretical and the practical work of this Department has been undertaken by the Department of Mathematics, in conjunction later with the Department of Mechanics and Astronomy, and the Department of Physics. As was the case with the work in agriculture, the founding of Purdue University as a State school, in 1869, was doubtless an important contributory factor in the decline of engineering as a separate department.

Continuance of engineering in present Departments.

MILITARY DEPARTMENT

Instruction in military science was given at three different periods in the history of the University, namely, in 1841 and 1842, again in 1861, and again from 1869 to 1874. In the first and third of these periods, military instruction was auxiliary to the work in civil engineering. During the earliest period we find, under the heading of "Military Exercises," the following announcement:

Military exercises, 1841-42.

At such seasons as the weather permits, a portion of the students are instructed by the Professor of Civil Engineering [Lieutenant (later General) Jacob Ammen] (himself a graduate, and formerly an Assistant Professor at West Point) in Military Exercises. The hour of drill is after recitation hours [every afternoon in the week except Saturday and Sunday] and attendance, on the part of the students, is voluntary. Arms have been furnished by the Government.

After the resignation of Lieutenant Ammen in 1842, the military exercises were soon discontinued. But in the first year of President Nutt's

¹Wylie, *Indiana University* (1890), pp. 78-79.

Departments Now Discontinued

administration (1861), there was organized among the students of the University a company known as the "University Cadets." The following account is given of the purpose and scope of this organization: "As appropriate physical exercise is essential to health, and some knowledge of military tactics is not only desirable, but necessary for the complete education of young men, the students of the University have the opportunity of regular Military Drill, under competent instructors, in a company composed of students, called the University Cadets." This organization does not seem to have lasted beyond this one year.

In 1869 a distinct Military Department was organized, and arrangements were made for instruction in "Military Science, also for drill in the school of the soldier—company and battalion." In this Department, "tactics, outpost duty, military engineering, and the science of war" were also to be taught. Arms and accoutrements for infantry and artillery drill were obtained, and Major-General Eli Long was detailed by the President of the United States as Military Professor in the University. After a few months General Long, much to the regret of the Faculty, was relieved from duty by the War Department. The Trustees, however, secured for the next year the services of Colonel James Thompson, formerly an instructor at West Point, who, as professor of military science and civil engineering, carried on this Department until 1874, after which year the military features were discontinued.

Military Department, 1869-74.

III

Bibliography

“FOR BOOKS ARE NOT ABSOLUTELY DEAD THINGS; BUT DOE CONTAIN A POTENCIE OF LIFE IN THEM TO BE AS ACTIVE AS THAT SOULE WAS WHOSE PROGENY THEY ARE; NAY, THEY DO PRESERVE AS IN A VIOLL THE PUREST EFFICACIE AND EXTRACTION OF THAT LIVING INTELLECT THAT BRED THEM. I KNOW THEY ARE AS LIVELY, AND AS VIGOROUSLY PRODUCTIVE, AS THOSE FABULOUS DRAGONS TEETH; AND BEING SOWN UP AND DOWN, MAY CHANCE TO SPRING UP ARMED MEN. AND YET ON THE OTHER HAND, UNLESS WARINESSE BE US'D, AS GOOD ALMOST KILL A MAN AS KILL A GOOD BOOK; WHO KILLS A MAN KILLS A REASONABLE CREATURE, GODS IMAGE; BUT HEE WHO DESTROYES A GOOD BOOK, KILLS REASON IT SELFE, KILLS THE IMAGE OF GOD AS IT WERE IN THE EYE. MANY A MAN LIVES A BURDEN TO THE EARTH; BUT A GOOD BOOKE IS THE PRETIUS LIFE-BLOOD OF A MASTER SPIRIT, IMBALM'D AND TREASUR'D UP ON PURPOSE TO A LIFE BEYOND LIFE.”—MILTON.

PUBLICATIONS OF PRESENT FACULTY

*.*The following list of the publications of the present members of the Faculty of the University is fairly complete, except for newspaper articles, which have been excluded. So far as possible, the entries have been arranged in chronological order of publication.

All degrees received by members of the Faculty from this University are given with the year in which conferred. The omission of the date in connection with a degree indicates that it was conferred by some other institution.

ROBERT JUDSON ALEY, A.B. (1888), A.M. (1890), Ph.D. Professor of Mathematics.

1. A practical education. *In University Press, I*, p. 5. (Dec., 1888.)

2. Science in the Schools. *In University Press, II*, pp. 18-19. (March, 1889.)

3. Mathematics in the preparatory schools. *In Proc. Indiana Col. Asso.*, 1889, pp. 46-50. (Dec., 1889.)

4. Scales of notation. *In University Press, III*, pp. 2-3. (Dec., 1890.)

5. Preparation for teaching. *In University Press, III*, p. 18. (March, 1891.)

6. Modern synthetic geometry versus Euclid. *In Science, XX*, pp. 297-298. (Dec., 1892.)

7. Some old arithmetics. *In The Student, A Journal of Education, III*. (Feb., March, April, 1893.)

8. Bibliography of the history of geometry, also a list of mathematical periodicals. *In Am. Math. Mo.*, I, pp. 42-47. (Feb., 1894.)

9. Daniel Kirkwood: biography and bibliography. *In Am. Math. Mo.*, I, pp. 141-149. (May, 1894.)

10. Indiana University and her president. *In Indiana Sch. Jour.*, XXXIX, pp. 320-323. (June, 1894.)

11. Review of Robert Harris's 'Plane geometrical drawing.' *In Inland Educator, I*, p. 266. (Nov., 1895.)

12. Review of J. A. McLellan and John Dewey's 'The psychology of number.' *In Inland Educator, I*, pp. 320-321. (Dec., 1895.)

13. High school mathematical teaching and text-books. *In Inland Educator, I*, pp. 334-338. (Jan., 1896.)

14. Review of George C. Edward's 'Elements of geometry.' *In Inland Educator, II*, p. 54. (Feb., 1896.)

15. Review of W. W. Beman and D. E. Smith's 'Plane and solid geometry.' *In Inland Educator, II*, pp. 55-56. (Feb., 1896.)

16. Review of W. W. R. Ball's 'A primer of the history of mathematics.' *In Inland Educator, II*, p. 117. (March, 1896.)

17. Daniel Kirkwood. *In Indiana Sch. Jour.*, XLI, pp. 170-177. (March, 1896.)

18. Review of Levi L. Conant's 'The number concept.' *In Inland Educator, II*, pp. 174-175. (April, 1896.)

19. Review of A. E. Hornbrook's 'Concrete geometry.' *In Educ. Rev.*, XI, pp. 505-506. (May, 1896.)
20. Review of H. A. Wood's 'Short cuts in arithmetic.' *In Inland Educator*, II, p. 234. (June, 1896.)
21. Sketch of Judge D. D. Banta. *In Inland Educator*, II, pp. 267-268. (June, 1896.)
22. Review of Frank H. Hall's 'The Werner arithmetic for third and fourth grades.' *In Inland Educator*, II, p. 349. (July, 1896.)
23. Review of E. S. Crawley's 'Elements of plane and spherical trigonometry.' *In Inland Educator*, III, p. 227. (Nov., 1896.)
24. Review of Arthur Lefevre's 'Number and its algebra.' *In Inland Educator*, III, p. 227. (Nov., 1896.)
25. Review of Florian Cojori's 'A history of elementary mathematics.' *In Inland Educator*, IV, p. 54. (Feb., 1897.)
26. A device for extracting the square root of certain surd quantities. *In Am. Math. Mo.*, IV, pp. 204-208. (Sept., 1897.)
27. Contributions to the geometry of the triangle. Philadelphia, 1897. Pp. 32, 1 plate.
28. Note on Charles Smith's definition of multiplication. *In Proc. Indiana Acad. Sci.* for 1897, p. 103.
29. Collinear sets of three points connected with the triangle. *In Proc. Indiana Acad. Sci.* for 1897, pp. 103-111.
30. Counting. *In Indiana Sch. Jour.*, XLII, pp. 783-785. (Dec., 1897.)
31. Note on Angel's method of inscribing regular polygons. *In Proc. Indiana Acad. Sci.* for 1898, pp. 92-93.
32. Concurrent sets of three lines connected with the triangle. *In Proc. Indiana Acad. Sci.* for 1898, pp. 93-100.
33. A new triangle and some of its properties. *In Proc. Indiana Acad. Sci.* for 1898, pp. 89-91.
34. Review of Samuel E. Harwood's 'Notes on method in arithmetic.' *In Inland Educator*, V, p. 301. (Jan., 1898.)
35. The elective system. *In Jour. of Education*, XLVII, pp. 4-5. (Jan. 6, 1898.)
36. The high school curriculum. *In Inland Educator*, VI, pp. 14-18. (Feb., 1898.)
37. Review of M. A. Bailey's 'Comprehensive arithmetic.' *In Inland Educator*, VI, p. 32. (Feb., 1898.)
38. History of arithmetic. *In Inland Educator*, VI, pp. 79-80. (March, 1898.)
39. Reasons for failure in arithmetic. *In Inland Educator*, VI, p. 127. (April, 1898.)
40. Algebra and geometry as a help to arithmetic. *In Inland Educator*, VI, pp. 168-169. (May, 1898.)
41. Review of Fletcher Durell's 'The new school algebra.' *In Inland Educator*, VI, pp. 169-170. (May, 1898.)
42. Review of W. W. Speer's arithmetics. *In Inland Educator*, VI, p. 210. (June, 1898.)
43. No royal road to mathematics. *In Inland Educator*, VI, p. 254. (July, 1898.)
44. Liliwati and the hour-glass. *In Inland Educator*, VI, pp. 254, 255. (July, 1898.)
45. Christopher Dock. *In Inland Educator*, VII, pp. 4-8, 58-61. (August, Sept., 1898.)
46. The history of arithmetic. *In Inland Educator*, VII, pp. 20-21, 72-73, 124-125, 169, 226-227, 269-270; VIII, pp. 28-29, 84, 132-133, 183, 226-227, 279; IX, pp. 26, 78-79, 126, 170-171, 216, 269; X, pp. 23, 82, 131, 183, 219, 267. *In Educator-Journal*, I, pp. 34-35. (August, 1898, to Sept., 1900.)
47. Review of A. Jones's 'The science

- of arithmetic.' *In* *Inland Educator*, VII, p. 73. (Sept., 1898.)
48. Some suggestions on arithmetic. *In* *Inland Educator*, VII, pp. 71-72. (Sept., 1898.)
49. Compound numbers. *In* *Inland Educator*, VII, p. 126. (Oct., 1898.)
50. Review of J. B. Shewalter's 'Solution book.' *In* *Inland Educator*, VII, p. 170. (Nov., 1898.)
51. Fourth institute arithmetic. *In* *Inland Educator*, VII, pp. 169-170. (Nov., 1898.)
52. Review of G. E. Fisher and I. J. Schwatt's 'Text-book of algebra with exercises.' *In* *Inland Educator*, VII, p. 227. (Dec., 1898.)
53. Percentage. *In* *Inland Educator*, VII, p. 227. (Dec., 1898.)
54. Review of E. C. Hewett's 'The Rand-McNally arithmetics.' *In* *Inland Educator*, VII, pp. 227-228. (Dec., 1898.)
55. A proposed notation for the geometry of the triangle. *In* *Proc. Indiana Acad. Sci.* for 1899, pp. 86-87.
56. Some circles connected with the triangle. *In* *Proc. Indiana Acad. Sci.* for 1899, pp. 88-89.
57. The point P and some of its properties. *In* *Proc. Indiana Acad. Sci.* for 1899, pp. 90-93.
58. Squaring the circle. *In* *Inland Educator*, VII, pp. 271-272. (Jan., 1899.)
59. Review of J. H. Walsh's arithmetics. *In* *Inland Educator*, VII, pp. 270-271. (Jan., 1899.)
60. Review of Augustus De Morgan's 'Study and difficulties of mathematics.' *In* *Inland Educator*, VIII, p. 29. (Feb., 1899.)
61. Review of Henry Goldman's 'The arithmachinist.' *In* *Inland Educator*, VIII, p. 85. (March, 1899.)
62. The difference between arithmetic and algebra. *In* *Inland Educator*, VIII, pp. 84-85. (March, 1899.)
63. Review of Hermann Schubert's 'Esays and recreations.' *In* *Inland Educator*, VIII, p. 133. (April, 1899.)
64. The equation in arithmetic. *In* *Inland Educator*, VIII, p. 183. (May, 1899.)
65. Some large numbers. *In* *Inland Educator*, VIII, p. 184. (May, 1899.)
66. The order of signs in arithmetic. *In* *Inland Educator*, VIII, p. 228. (June, 1899.)
67. Apparatus in rural schools. *In* *Indiana Sch. Jour.*, XLIV, pp. 331-334. (June, 1899.)
68. Review of J. W. Cook and N. Cropsy's 'The Indiana arithmetics.' *In* *Inland Educator*, IX, pp. 27, 79-80, 127, 171-172. (August to Nov., 1899.)
69. Review of John Graham's 'The farmer's and mechanic's assistant and companion; or a new system of decimal arithmetic.' *In* *Inland Educator*, IX, p. 79. (Sept., 1899.)
70. Preparation for teaching arithmetic. *In* *Inland Educator*, IX, pp. 126-127. (Oct., 1899.)
71. Short cuts. *In* *Inland Educator*, IX, 217, pp. 269-270.; X, 23-24, 82-83, 131-132, 183-184, 222, 270. (Dec., 1899, to July, 1900.)
72. Some properties of the symmedian point. *In* *Proc. Indiana Acad. Sci.* for 1900, pp. 85-88.
73. Note on McGinnis's universal solution. *In* *Proc. Indiana Acad. Sci.* for 1900, pp. 88-90.
74. The beginning of the century. *In* *Inland Educator*, X, p. 24. (Feb., 1900.)
75. How to make mathematics interesting. *In* *Inland Educator*, X, pp. 84-85. (March, 1900.)
76. Review of D. E. Smith's 'The teaching of elementary mathematics.' *In* *Inland Educator*, X, p. 222. (June, 1900.)
77. Review of Karl Fink's 'A brief history of mathematics.' *In* *Inland Educator*, X, p. 271. (July, 1900.)
78. Review of J. T. Fairchild's 'Solu-

- tion book.' *In Educator-Journal*, I, p. 36. (August, 1900.)
79. Review of W. W. Rupert's 'Famous geometrical theorems and problems.' *In Educator-Journal*, I, p. 37. (August, 1900.)
80. Review of John S. Mackay's 'Arithmetic.' *In Educator-Journal*, I, pp. 79-80. (Sept., 1900.)
81. Review of John F. Downey's 'Higher algebra.' *In Educator-Journal*, I, pp. 79-80. (Sept., 1900.)
82. Augustus DeMogan. *In Educator-Journal*, I, p. 78. (Sept., 1900.)
83. Explanation in arithmetic work. *In Educator-Journal*, I, pp. 78-79. (Sept., 1900.)
84. John J. Sylvester. *In Educator-Journal*, I, pp. 125-126. (Oct., 1900.)
85. Definitions in mathematics. *In Educator-Journal*, I, pp. 126-127. (Oct., 1900.)
86. Joseph L. Lagrange. *In Educator-Journal*, I, p. 176. (Nov., 1900.)
87. Problem solving. *In Educator-Journal*, I, pp. 177-178. (Nov., 1900.)
88. Graphical representation. *In Educator-Journal*, I, pp. 219-220. (Dec., 1900.)
89. Sir Isaac Newton. *In Educator-Journal*, I, pp. 219-220. (Jan., 1901.)
90. Karl Frederick Gauss. *In Educator-Journal*, I, pp. 274-276. (Feb., 1901.)
91. René DesCartes. *In Educator-Journal*, I, pp. 380-381. (March, 1901.)
92. Incommensurable number. *In Educator-Journal*, I, p. 424. (April, 1901.)
93. Benjamin Pierce. *In Educator-Journal*, I, pp. 479-480.
94. Arthur Caley. *In Educator-Journal*, I, pp. 525-526. (June, 1901.)
95. William Chauvenet. *In Educator-Journal*, II, p. 20. (Sept., 1901.)
96. Counting. *In Educator-Journal*, II, pp. 21-22. (Sept., 1901.)
97. George Bruce Halsted. *In Educator-Journal*, II, p. 80. (Oct., 1901.)
98. Greater accuracy. *In Educator-Journal*, II, p. 80. (Oct., 1901.)
99. Proof of the elementary rules by casting out the 9's. *In Educator-Journal*, II, pp. 126-127. (Nov., 1901.)
100. Graphs, an appendix to Wells's 'Essentials of algebra.' Boston, 1901. Pp. 359-367.
101. Graphs, a monograph. Boston, 1902. Pp. iv, 21.
102. Arithmetic. *In Educator-Journal*, II, p. 175. (Dec., 1901.)
103. More thought. *In Educator-Journal*, II, pp. 175-176. (Dec., 1901.)
104. Review of Arthur F. Griffith's 'The easy and speedy reckoner.' *In Educator-Journal*, II, p. 176. (Dec., 1901.)
105. Review of T. Sundara Row's 'Geometric exercises in paper folding.' *In Educator-Journal*, II, p. 178. (Dec., 1901.)
106. Some obsolete arithmetical subjects. *In Educator-Journal*, II, p. 234. (Jan., 1902.)
107. Review of E. S. Loomis's 'How to attack an exercise in geometry.' *In Educator-Journal*, II, p. 280. (Feb., 1902.)
108. Review of Frank H. Hall's 'How to teach arithmetic.' *In Educator-Journal*, II, pp. 280-281. (Feb., 1902.)
109. Better results in arithmetic. *In Educator-Journal*, II, pp. 331-332. (March, 1902.)
110. Some curiosities of the digits. *In Educator-Journal*, II, p. 332. (March, 1902.)
111. Review of Egbert More's 'The trisection of an angle.' *In Educator-Journal*, II, p. 402. (April, 1902.)
112. Abridged multiplication. *In Educator-Journal*, II, p. 402. (April, 1902.)
113. Preparation for teaching high school mathematics. *In Educator-Journal*, II, pp. 448-450. (May, 1902.)
114. A peculiar number. *In Educator-Journal*, II, p. 451. (May, 1902.)

116. Greatest common divisor. *In* Educator-Journal, II, p. 497-498. (June, 1902.)
117. How to make a table of squares. *In* Educator-Journal, III, p. 17. (Sept., 1902.)
118. Division and partition. *In* Educator-Journal, III, p. 72. (Oct., 1902.)
119. Review of W. P. Morgan's 'Teacher's manual for the Indiana advanced arithmetic.' *In* Educator-Journal, III, p. 72. (Oct., 1902.)
120. Review of David Hilbert's 'The foundations of geometry.' *In* Educator-Journal, III, p. 73. (Oct., 1902.)
121. The metric system. *In* Educator-Journal, III, p. 113. (Nov., 1902.)
122. Circulating decimals. *In* Educator-Journal, III pp. 162, 214-215. (Dec., 1902, and Jan., 1903.)
123. Ratio and proportion. *In* Educator-Journal, III, p. 214. (Jan., 1903.)
124. Involvement. *In* Educator-Journal, III, pp. 392-393. (May, 1903.)
125. Review of W. E. Chancellor's 'Graded arithmetics.' *In* Educator-Journal, III, p. 431. (June, 1903.)
126. Review of O. L. Kelso's 'Arithmetic for high schools.' *In* Educator-Journal, III, p. 431. (June, 1903.)
127. Factoring. *In* Educator-Journal, IV, p. 76. (Oct., 1903.)
128. Counting. *In* Educator-Journal, IV, pp. 76-77. (Oct., 1903.)
129. Ways of paying a bill in a distant city. *In* Educator-Journal, IV, pp. 127-128. (Nov., 1903.)
130. The new elementary arithmetic. Revision. (Joint author with O. L. Kelso.) New York, 1903. Pp. x, 276.
131. The new advanced arithmetic. Revision. (Joint author with O. L. Kelso.) New York, 1903. Pp. xiii, 327-334.
132. Editorials. *In* Educator-Journal, 3 to 4 pages in each issue, beginning with Vol. IV, Sept., 1903.
133. The essentials of algebra. (Joint author with D. A. Rothrock.) New York, 1904.
-
- FRANK MARION ANDREWS, A.B. (1894), A.M. (1895), B.A.M., Ph.D. Assistant Professor of Botany.
1. Development of the embryo sac of *Jeffersonia diphylla*. *In* Bot. Gaz. XX.
 2. Karyokinesis in *Magnolia* and *Liriodendron* with special reference to the behavior of the chromosomes. *In* Beihefte z. Botan. Centralblatt, XI, pp. 734-742.
 3. Ueber die Wirkung der Centrifugalkraft auf Pflanzen. *In* Jahrb. f. wissens. Botanik, XXXVIII, pp. 1-40.
-
- JOSHUA WILLIAM BEEDE, Ph.D. Instructor in Geology.
1. The McPherson Equus beds. (Joint author with E. Haworth.) *In* Univ. Geol. Surv. Kansas, II, pp. 287-296; 1 plate, 1 map. (1897.)
 2. The stratigraphy of Shawnee county (Kansas). *In* Trans. Kansas Acad. Sci. XV, pp. 27-34. (1898.)
 3. McPherson Equus beds. Revised. *In* Trans. Kansas Acad. Sci. XV, pp. 104-110. 1 plate, 1 map. (1898.)
 4. Notes on Kansas physiography. *In* Trans. Kansas Acad. Sci., XV, pp. 114-120; 4 plates. (1898.)
 5. New corals from the Kansas carboniferous. *In* Kansas Univ. Quart., VII, pp. 180-181; 1 plate. (1898.)
 6. Variation of external appearance and internal characters of *Spirifer camera-tus* Morton. *In* Kansas Univ. Quart., VII, pp. 103-105; 2 plates. (April, 1898.)
 7. Notes on *Campophyllum torquium* Owen, and a new variety of *Monopteris gibbosa* Meek and Worthen. *In* Kansas

Univ. Quart., VII, pp. 187-190. 1 plate (July, 1898.)

8. Preliminary notice on the correlation of the Meek and Marcou section at Nebraska City, Nebraska, with the Kansas coal measures. *In* Kansas Univ. Quart., VII, pp. 231-233. (Oct., 1898.)

9. Description of some new forms of *Pseudomonotis* from the upper coal measures of Kansas. *In* Kansas Univ. Quart., VIII, pp. 79-84. 2 plates. (April, 1899.)

10. New fossils from the Kansas coal measures. *In* Kansas Univ. Quart., VIII, pp. 123-130. 2 plates. (July, 1899.)

11. New and little known Pelecypods from the coal measures. (Joint author with Austin F. Rogers.) *In* Kansas Univ. Quart., VIII, pp. 131-134; 1 plate. (July, 1899.)

12. On the correlation of the coal measures of Kansas and Nebraska. *In* Trans. Kansas Acad. Sci., XVI, pp. 70-84. (1899.)

13. The coal in western Atchison county. *In* A. C. H. S. Bull., VI, pp. 9-10. (1899.)

14. Two new crinoids from the Kansas carboniferous. *In* Kansas Univ. Quart., X, pp. 21-24; 1 plate. (Jan., 1900.)

15. Carboniferous invertebrates, Foraminifera to Pelecypods. *In* Univ. Geol. Surv. Kansas, VI, pp. 1-187; 22 plates. (1900.)

16. Reconnaissance in the Blue valley Permian. *In* Kansas Univ. Quart., IX, pp. 191-202; 1 map. (1900.)

17. The age of the Kansas-Oklahoma red-beds. *In* Amer. Geol., XXVIII, pp. 46-47. (1901.)

18. Permian Fauna of central United States, Part I. *In* Trans. Kansas Acad. Sci., XVII, pp. 185-190; 2 plates. (1901.)

19. New fossils from the upper carboniferous of Kansas. *In* Kansas Univ. Sci. Bull., XI, pp. 147-153; 1 plate. (Sept., 1902.)

20. Invertebrate paleontology of the red-

beds. *In* Adv. Bull. Geol. Surv. Oklahoma Territory, I, pp. 1-11; 1 plate. (April, 1902.)

21. Fauna of the Shawnee formation, Wabauunsee formation and the Cottonwood limestone. *In* Kansas Univ. Sci. Bull., I, pp. 163-181. (Sept., 1902.)

22. Cottonwood Falls folio, geological atlas of the United States. (Joint author with Charles S. Prosser.) *In* U. S. Geol. Surv. (In press.)

23. Kansas coal-measures faunal studies; lower coal measures. (Joint author with Austin F. Rogers.) *In* Kansas Univ. Sci. Bull. (In press.)

JOHN ANDREW BERGSTRÖM, Ph.D., Professor of Pedagogy.

1. Review of Mettier's 'Aural vertigo (Meniere's disease).' (*Jour. Nerv. Ment. Dis.* 1891, XVI, p. 19.) *In* Am. Jour. Psych., V, p. 102. (Oct., 1892.)

2. Experiments upon physiological memory by means of the interference of associations. *In* Am. Jour. Psych., V, pp. 356-369. (April, 1893.)

3. Review of Schumann's 'Ueber die Unterschiedsempfindlichkeit für kleine Zeitgrößen.' (*Zeitschrift f. Psych. u. Phys. der Sinnesorgane*, II, p. 294.) *In* Am. Jour. Psych., V, p. 102. (1893.)

4. Review of Epstein's 'Die logischen Principien der Zeitmessung.' *In* Am. Jour. Psych., V, p. 102. (1893.)

5. Review of J. J. Van Biervliet's 'La mémoire.' *In* Am. Jour. Psych., VI, p. 308. (1894.)

6. An experimental study of some of the conditions of mental activity. *In* Am. Jour. Psych., VI, pp. 247-274. (Jan., 1894.)

7. The relation of the interference to the practice effect of an association. *In* Am. Jour. Psych., VI, pp. 433-442. (June, 1894.)

8. Review of Fridtjuf Berg's 'Pedagogiska biblioteket i Stockholm,' and of N. G. W. Lagerstedt's 'Katalog öfver pedagogiska biblioteket i Stockholm.' *In* Ped. Sem. III, p. 163. (1894.)

9. Review of N. G. W. Lagerstedt's 'Åtgärder mot öfveranstängning vid de högre skolorna i Tyskland.' (*In* Verdandi, 1894.) *In* Ped. Sem., III, p. 163. (1894.)

10. Review of G. E. Müller and F. Schumann's 'Experimentelle Beiträge zur Untersuchung des Gedächtnisses,' (*Zeitschr. f. Psych. u. Phys. d. Sinnesorgane*, VI, p. 299.) *In* Am. Jour. Psych., IV, p. 299. (Jan., 1894.)

11. Review of Emil Kræpelin's 'Ueber die Beeinflussung einfacher psychischer Vorgänge durch einige Arzneimittel.' *In* Am. Jour. Psych., VI, p. 301. (1894.)

12. Review of Dr. Emanuel Rosenbaum's 'Warum müssen wir schlafen? Eine neue Theorie des Schlafes.' *In* Am. Jour. Psych., VI, p. 307. (1894.)

13. School hygiene. Translation of Dr. Ludwig Kotelmann's 'Ueber Schulgesundheitspflege. (Joint author with Edward Conradi.) Syracuse, N. Y. 1899. Pp. 391.

14. Review of Nicholas Alechseff's 'Reactionszeiten bei Durchgangsbeobachtungen.' (*Phil. Stud.*, XVI, p. 60.) *In* Psych. Rev., VII, p. 526. (1900.)

15. A type of pendulum chronoscope and attention apparatus. *In* Psych. Rev., XII, pp. 483-489. (Sept., 1900.)

16. A magnet registration key. *In* Psych. Rev., VII, pp. 612-614. (Nov., 1900.)

17. A new type of ergograph, with a discussion of ergographic experimentation. *In* Am. Jour. Psych., XIV, pp. 246-276. (1903.)

MARY BIDWELL BREED, Ph.D. Assistant Professor of Chemistry, and Dean of Women.

1. On phenolphthalein and methylorange as indicators. *In* Journal of Franklin Institute. (April, 1893.)

2. The atomic weight of palladium. (Joint author with Edward H. Keiser.) *In* Am. Chem. Jour., 1894.

3. The action of magnesium on aliphatic alcohols and a new method of preparing allylene. *In* Journal of Franklin Institute, 1895.

4. The polybasic acids of mesitylene. Bryn Mawr Monographs, No. 1. (1901.)

ALFRED MANSFIELD BROOKS, A.M. Associate Professor of the History of Art.

1. Decoration of school rooms. *In* Inland Educator, IX, pp. 272-274 (Jan., 1900); also *in* Indiana Sch. Jour., XLV, pp. 29-32. (Jan., 1900.)

2. Architecture: Greek, Roman, Byzantine, Romanesque and Gothic. *In* Progress, No. 3, pp. 155-189. (1901.)

3. The study of art in universities. *In* Education, XXI, pp. 364-371. (Feb., 1901.)

4. On the teaching of art in universities. *In* Proc. Western Drawing Teachers' Asso. for 1903.

5. Review of Charles Holroyd's 'Michael Angelo Buonarroti.' *In* Dial, 1904.

6. Review of William Bayne's 'Sir David Wilkie.' *In* Dial, 1904.

7. Review of Arthur B. Chamberlain's 'Thomas Gainsborough.' *In* Dial, 1904.

OLIVER W. BROWN, A.M. (1896). Assistant Professor of Chemistry.

1. Solubility and boiling point. *In* Jour. Phys. Chem., I, p. 784. (1897.)

2. Distribution of mercuric chloride between toluene and water. *In* Jour. Phys. Chem., II, p. 51. (1898.)

3. Preparation of potassium persele-nate. (Joint author with L. M. Dennis.) *In Jour. Amer. Chem. Soc.*, XXIII, p. 358. (1901.)

4. Efficiency of the nickel-plating tank. *In Trans. Amer. Electrochem. Soc.*, IV, pp. 83-99. (1903.)

ELMER BURRITT BRYAN, A.B. (1893). Pro-fessor of Educational and Social Psy-chology.

1. School hygiene. *In Indiana Sch. Jour.*, XLIV, pp. 393-396. (July, 1899.)

2. School diseases. *In Indiana Sch. Jour.*, XLIV, pp. 465-469. (August, 1899.)

3. The hygiene of instruction. *In In-diana Sch. Jour.*, XLIV, pp. 533-536. (Sept., 1899.)

4. The care of the senses. *In Indiana Sch. Jour.*, XLIV, pp. 593-594. (Oct., 1899.)

5. Child life. *In Indiana Sch. Jour.*, XLIV, p. 649. (Nov., 1899.)

6. Nascent stages and arrested devel-opment. *In Pedagogical Seminary*, VII, pp. 357-396. (Oct., 1900.)

7. The Philippine situation. *In Edu-cator-Journal*, IV, pp. 215-217. (Jan., 1904.)

WILLIAM LOWE BRYAN, A.B. (1884), A.M. (1886), Ph.D. President of the Uni-versity.

1. Psychology at Indiana University. *In Am. Jour. of Psych.*, III, pp. 283-284. (April, 1890.)

2. On the development of voluntary motor ability. *In Am. Jour. of Psych.*, V, pp. 125-204. (Nov., 1892.)

3. Auditory and visual memory in school children. *In Proc. Internat. Educ. Asso.* for 1893, pp. 779-781.

4. Child study, systematic and unsys-tematic. *In Proc. N. E. A.* for 1895, pp. 412-418.

5. On the methods and results of child study. Article in Johnson's Encyclopædia.

6. Science and education. *In Proc. N. E. A.* for 1895, pp. 161-165.

7. Scientific and non-scientific methods of child study. *In Proc. N. E. A.* for 1896, pp. 856-860.

8. Studies on the physiology and psy-chology of the telegraphic language. (With Noble Harter.) *In Psych. Rev.* IV, pp. 27-53. (Jan., 1897.)

9. Hygiene of motor development. *In Proc. N. E. A.* for 1897, pp. 279-280.

10. Report of special committee on the organization of a committee on school hy-giene. *In Proc. N. E. A.* for 1897, pp. 327-328.

11. Plato the teacher; being selections from the Apology, Euthydemus, Protagoras, Symposium, Phædrus, Republic, and Phædo of Plato. Edited with introduction and notes. (Joint author with Mrs. Charlotte Lowe Bryan.) New York, 1897. Pp. xli, 454.

12. The Republic of Plato. With studies for teachers. (Joint author with Mrs. Charlotte Lowe Bryan.) New York, 1898. Pp. 313.

13. Studies on the telegraphic lan-guage. The acquisition of a hierarchy of habits. (Joint author with Noble Harter.) *In Psych. Rev.* VI, pp. 345-375. (July, 1899.)

14. Science in the daily press. (Joint author with Ernest H. Lindley.) *In Sci-ence*, N. S., XI, p. 74. (1900.)

15. An arithmetical prodigy. (Joint author with E. H. Lindley.) *In Proc. Am. Psych. Assoc.* for 1900. *In Psych. Rev.*, VII, p. 135. (1900.)

16. The case of Arthur Griffith, arith-metical prodigy. (Joint author with E. H.

Lindley.) *In* Compte rendu du Congrès International de Psychologie tenu à Paris, 1900, p. 178.

17. Theory and practice. President's address, American Psychological Association, St. Louis meeting, December, 1903. *In* Psych. Rev., XI, pp. 71-82. (March, 1904.)

LEWIS NATHANIEL CHASE, Ph.D. Assistant Professor of English.

1. The English heroic play: a critical description of the rhymed tragedy of the Restoration. New York, 1903. Pp. vii, 250.

WILBUR ADELMAN COGSHALL, A.M. (1903). Assistant Professor of Astronomy.

1. November meteors. *In* Pop. Astron., VII, pp. 71-74. (Jan., 1899.)

2. Double-star measures. *In* Astro. Jour., XX, pp. 173-178.

3. Double-star measures. *In* Astro. Jour., XXI.

4. Double-star measures. *In* Astro. Jour., XXII, pp. 1-9.

5. Double-star measures. (Joint author with John A. Miller. *In* Astro. Jour., XXIII, pp. 167-169. (Sept., 1903.)

6. Double-star measures. (Joint author with John A. Miller.) *In* Astro. Jour., XXIV, pp. 15-16. (1904.)

7. Double-stars discovered at Lowell Observatory. *In* Astro. Jour. (In press.)

8. Double-star measures. (Joint author with J. A. Miller.) *In* Astronomische Nachrichten, CLXI. (In press.)

EDGAR ROSCOE CUMINGS, Ph.D. Assistant Professor of Geology.

1. Sections and thickness of the Lower Silurian formations on West Canada creek and in the Mohawk valley. (Joint author

with C. S. Prosser.) *In* 15th Ann. Rep. State Geol. New York, pp. 619-659; 13 plates and 3 text-figures. (1897.)

2. Lower Silurian system of eastern Montgomery county, New York. *In* Bull. New York State Museum, No. 34, VII, pp. 419-468; 4 plates; 4 maps. (1900.)

3. On the Waldron fauna at Tarr Hole, Indiana. *In* Proc. Indiana Acad. Sci. for 1899, pp. 174-176. (1900.)

4. The stream gradients of the lower Mohawk valley. *In* Proc. Indiana Acad. Sci. for 1899, pp. 176-178. (1900.)

5. Notes on the Ordovician rocks of southern Indiana. *In* Proc. Indiana Acad. Sci. for 1900, pp. 200-215. (1901.)

6. Some developmental stages of *Orthothes minutus* n. sp. *In* Proc. Indiana Acad. Sci. for 1900, pp. 216-218. (1901.)

7. *Orthothes minutus* n. sp. from the Salem limestone of Harrodsburg, Indiana. *In* Am. Geol., XXVII, pp. 147-149; 1 plate. (March, 1901.)

8. The use of Bedford as a formational name. *In* Jour. of Geol., IX, pp. 232-233. (1901.)

9. A section of the upper Ordovician at Vevay, Indiana. *In* Am. Geol., XXVIII, pp. 361-381; 2 plates. (Dec., 1901.)

10. A revision of the bryozoan genera *Dekayia* *Dekayella* and *Heterotrypa* of the Cincinnati group. *In* Am. Geol., XXIX, pp. 197-217; 4 plates. (April, 1902.)

11. A quantitative study of variation in the fossil brachiopod *Platystrophia lynx*. (Joint author with Abram V. Mauck.) *In* Am. Jour. Sci., XIV, pp. 9-16; 2 plates; 1 textfigure. (July, 1902.)

12. The morphogenesis of *Platystrophia*. A study of the evolution of a Paleozoic brachiopod. *In* Am. Jour. Sci., XV, pp. 1-48, 121-136; 27 text-figures. (Jan., Feb., 1903.)

13. Review of E. J. Conklin's 'The embryology of a brachiopod, *Terebratulina sep-*

tentrionalis, Couthouy.' *In Am. Nat.*, XXXVII, No. 434, pp. 121-122. (Feb., 1903.)

14. Review of E. S. Morse's 'Observations on living Brachiopoda.' *In Am. Nat.*, XXXVII, No. 434, pp. 122-123. (Feb., 1903.)

15. Review of Naohide Yatsu's 'On the development of *Lingula anatina*.' *In Am. Nat.*, XXXVII, No. 434, pp. 123-124. (Feb., 1903.)

16. Review of Naohide Yatsu's 'Notes on the histology of *Lingula anatina* Bruguiere.' *In Am. Nat.*, XXXVII, No. 434, p. 124. (Feb., 1903.)

17. Development of some Paleozoic Bryozoa. *In Am. Jour. Sci.*, XVII, pp. 49-78; 83 textfigures. (Jan., 1904.)

LOUIS SHERMAN DAVIS, A.B. (1891), A.M. (1892), Ph.D. Associate Professor of Chemistry.

1. Ueber die Alkaloide der Samen von *Lupinus Augustifolius* und *Lupinus Albus*. *In Archiv d. Pharm.*, pp. 85. (1897.)

2. The qualitative analysis of inorganic bodies. (Joint author with Robert E. Lyons.) Anderson, Ind., 1897. Pp. 210.

3. A manual of toxicological analysis. (Joint author with R. E. Lyons.) Anderson, Ind., 1899. Pp. 112.

4. The qualitative analysis of inorganic bodies. Revised edition. (Joint author with R. E. Lyons.) Anderson, Ind., 1900. Pp. 151.

5. A manual of general chemistry. Chicago, 1904. Pp. 400; 92 plates.

SCHUYLER COLFAX DAVISSON, A.B. (1890), A.M. (1892), D. Sc. Associate Professor of Mathematics.

1. Die geodätische Linie der Mannigfaltigkeit $ds^2 = dx^2 + \sin^2 x \cdot dy^2 + dz^2$. Tübingen, 1900. Pp. 26.

CARL H. EIGENMANN, A.B. (1886), A.M. (1887), Ph.D. (1889). Professor of Zoölogy and Director of Biological Station.

1. A review of the American Eleotridinæ. (Joint author with Morton W. Fordice. *In Proc. Acad. Nat. Sci. Phila.* for 1885, VIII, pp. 55-80.

2. Notes on skeletons of Etheostomatinæ. (Joint author with David Starr Jordan.) *In Proc. U. S. Nat. Mus.* for 1885, VIII, pp. 68-72.

3. A catalogue of the fishes of Bean Blossom creek, Monroe county, Indiana. (Joint author with M. W. Fordice.) *In Proc. Acad. Nat. Sci., Phila.* for 1886, pp. 233-252.

4. A review of the genera and species of Diodontidæ found in American waters. *In Ann. N. Y. Acad. Sci.*, III, pp. 297-311. (1885.)

5. A review of the American Gasterosteidæ. *In Proc. Acad. Nat. Sci. Philadelphia* for 1886, pp. 233-252.

6. A review of the Gobiidæ of North America. (Joint author with D. S. Jordan.) *In Proc. U. S. Nat. Mus.* for 1886, IX, pp. 477-518.

7. Folk-lore of a German village. *In Current, V*, No. 124. (1886.)

8. A review of the Chaetodontidæ of North America. (Joint author with Jennie E. Horning.) *In Ann. N. Y. Acad. Sci.* III, pp. 1-18. (1887.)

9. Notes on the specific names of certain North American fishes. *In Proc. Acad. Nat. Sci., Phila.* for 1887, pp. 295-296.

10. A review of the North American species of the genera *Lagodon*, *Archosargus*, and *Diplodus*. (Joint author with Elizabeth G. Hughes.) *In Proc. U. S. Nat. Mus.* for 1887, X, pp. 65-74.

11. Description of a new species of *Ophichthys* (*Ophichthys retropinnis*), from Pensacola, Fla. *In Proc. U. S. Nat. Mus.* for 1887, X, p. 116.

12. Notes on a collection of fishes sent by Mr. C. C. Leslie from Charleston, S. C. (Joint author with D. S. Jordan.) *In Proc. U. S. Nat. Mus.* for 1887, X, pp. 269-270.
13. A list of the American Gobiidæ and Callionymidæ, with notes on the specimens contained in the Museum of Comparative Zoölogy, at Cambridge, Mass. (Joint author with Rosa Smith Eigenmann.) *In Proc. California Acad. Sci.*, 2d ser., I, pp. 51-78. (Jan. 25, 1888.)
14. South American Nematognathi. (Joint author with R. S. Eigenmann.) *In Am. Nat.* XXIII, pp. 647-649. (July, 1888.)
15. Preliminary notes on South American Nematognathi. I. (Joint author with R. S. Eigenmann.) *In Proc. California Acad. Sci.*, 2d ser., I, pp. 119-172. (July 18, 1888.)
16. Notes on some California fishes, with descriptions of two new species. (Joint author with R. S. Eigenmann.) *In Proc. U. S. Nat. Mus.* for 1888, XI, pp. 463-466.
17. *Cyprinodon californiensis*, Girard. (Joint author with R. S. Eigenmann.) *In W. Am. Sci.*, V, pp. 3-4. (Sept., 1888.)
18. Description of a new species of *Cyprinodon*. (Joint author with R. S. Eigenmann.) *In California Acad. Sci.*, 2d ser., I, p. 270. (Jan. 8, 1889.)
19. On the development of California food fishes. *In Am. Nat.* XXIII, pp. 107-110. (March, 1889.)
20. Preliminary descriptions of new species and genera of Characinidæ. (Joint author with R. S. Eigenmann.) *In W. Am. Sci.*, VI, pp. 7-8. (April, 1889.)
21. Description of new Nematognathoid fishes from Brazil. (Joint author with R. S. Eigenmann.) *In W. Am. Sci.*, VI, pp. 8-10. (April, 1889.)
22. Preliminary notes on South American Nematognathi. II. (Joint author with R. S. Eigenmann.) *In Proc. California Acad. Sci.*, 2d ser., II, pp. 28-56. (Aug. 18, 1889.)
23. On the phosphorescent spots of *Porichthys margaritatus*. (Joint author with R. S. Eigenmann.) *In W. Am. Sci.*, VI, pp. 32-34. (May, 1889.)
24. Contributions from the San Diego Biological Laboratory. I. (Joint author with R. S. Eigenmann.) *In W. Am. Sci.*, VI, pp. 44-47. (June, 1889.)
25. Contributions from the San Diego biological laboratory. II. On the genesis of the color-cells of fishes. *In W. Am. Sci.*, VI, pp. 45-46. (July, 1889.)
26. Notes from the San Diego biological laboratory. I. The fishes of Cortez Banks. (Joint author with R. S. Eigenmann.) *In W. Am. Sci.*, VI, pp. 123-132. (Oct., 1889, issued Nov. 9, 1889.)
27. A review of the Sciaenidæ of America and Europe. (Joint author with D. S. Jordan.) *In Ann. Rep. Comm. Fish and Fisheries for 1886*, pp. 343-451, 4 plates. (1889.)
28. Notes from the San Diego biological laboratory. II. (Joint author with R. S. Eigenmann.) *In W. Am. Sci.*, VI, pp. 147-151. (Nov., 1889.)
29. A review of the Erythrininæ. (Joint author with R. S. Eigenmann.) *In Proc. California Acad. Sci.*, 2d ser., II, pp. 100-116; 1 plate. (Nov. 8, 1889.)
30. A revision of the edentulous genera of Curimatinae. (Joint author with R. S. Eigenmann.) *In Ann. N. Y. Acad. Sci.*, IV, pp. 1-32. (Nov., 1889.)
31. On the genus *Clevelandia*. *In Am. Nat.*, XXIII, pp. 916-918. (Oct., 1889.)
32. The development of *Micrometrus aggregatus*, one of the viviparous surf-perches. *In Am. Nat.* XXIII, pp. 923-927. (Oct., 1889.)
33. Additions to the fauna of San Diego.

- (Joint author with R. S. Eigenmann.) *In* Proc. California Acad. Sci., 2d ser., III, pp. 1-24. (March 24, 1890.)
34. The evolution of the catfishes. *In* Zool., I, pp. 10-15. (1890.)
35. Description of a fossil species of Sebastodes. *In* Zool., I, p. 16. (1890.)
36. On the egg membranes and micropyle of some osseous fishes. *In* Bull. Mus. Comp. Zool., XIX, pp. 129-154, 3 plates. (March, 1890.)
37. The barracuda. *In* Zool., I, pp. 55-56. (1890.)
38. The Point Loma blind fish and its relatives. *In* Zool., I, pp. 65-72. 2 plates.
39. Charles Harvey Bollman. *In* W. Am. Sci., VII, pp. 5-6. (1890.)
40. The coloration of fishes. *In* W. Am. Sci., p. 35. (1890.)
41. The food fishes of California fresh waters. *In* Rep. State Board Fish Comm. California for 1890, pp. 53-65.
42. A revision of the South American Nematognathi or Catfishes. (Joint author with R. S. Eigenmann.) *In* Occasional papers California Acad. Sci., I, pp. 1-508, figures, map. (July, 1890.)
43. Descriptions of new species of Sebastodes. (Joint author with R. S. Eigenmann.) *In* Proc. California Acad. Sci., 2d ser., III, pp. 36-38. (May 28, 1890.)
44. A review of the genera and species of Serranidae found in the waters of America and Europe. (Joint author with D. S. Jordan.) *In* Bull. U. S. Fish Comm., VIII, pp. 329-441; 20 plates. (1890.)
45. On the precocious segregation of the sex cells in *Micrometrus aggregatus* Gibbons. *In* Jour. Morph., V, pp. 480-492; 1 plate. (1891.)
46. A catalogue of the fresh-water fishes of South America. (Joint author with R. S. Eigenmann.) *In* Proc. U. S. Nat. Mus., XIV, pp. 1-18. (1891.)
47. On the genesis of the chromatophores in fishes. *In* Am. Nat., XXV, pp. 112-118; 4 plates. (Feb., 1891.)
48. The spawning season of San Diego fishes. *In* Am. Nat., XXV. (June, 1891.)
49. *Cottus beldingi*, sp. nov. (Joint author with R. S. Eigenmann.) *In* Am. Nat., XXV, pp. 1132-1133. (Dec., 1891.)
50. A new Diodont. *In* Am. Nat., XXV, p. 1133. (Dec., 1891.)
51. A catalogue of the fishes of the Pacific coast of America north of Cerros Island. (Joint author with R. S. Eigenmann.) *In* Ann. N. Y. Acad. Sci., VI, pp. 349-358. (June, 1892.)
52. The fishes of San Diego. *In* Proc. U. S. Nat. Mus. for 1892, XV, pp. 123-178; 9 plates.
53. *Branchiostoma elongatum* Sundevall, at San Diego. *In* Am. Nat. XXVI, p. 70. (Jan., 1892.)
54. On the presence of an operculum in the Aspredinidae. *In* Am. Nat., XXVI, p. 70. (Jan., 1892.) Abstract *in* Proc. Indiana Acad. Sci. for 1891, p. 175.
55. The Percopsidae on the Pacific slope. *In* Science for 1892, p. 233.
56. Recent additions to the fauna of California. (Joint author with R. S. Eigenmann.) Abstract *in* Indiana Acad. Sci. for 1891, pp. 159-161. (1892.)
57. New fishes from Western Canada. (Joint author with R. S. Eigenmann.) *In* Am. Nat., XXVI, pp. 961-964. (Nov., 1892.)
58. The continuity of the germ plasm in vertebrates. *In* Proc. Indiana Acad. Sci. for 1891, pp. 169-172. (1892.)
59. The eyes of blind fishes. Abstract *in* Proc. Indiana Acad. Sci. for 1891, p. 175. (1892.)
60. Biological stations. *In* Proc. Indiana Acad. Sci. for 1891, pp. 172-175. (1892.)
61. Preliminary description of new fishes from the Northwest. (Joint author

with R. S. Eigenmann.) *In Am. Nat.*, XXVII, pp. 151-154. (Feb., 1893.)

62. On the occurrence of the spiny box-fish (genus *Chilomycterus*) on the coast of California. *In Proc. U. S. Nat. Mus.* for 1892, XV, p. 485; 1 plate. (1892.)

63. Catalogue of the fresh-water fishes of Central America and Southern Mexico. *In Proc. U. S. Nat. Mus.* for 1893, XVI, pp. 53-60. (1893.)

64. Preliminary note on the relationship of the species usually united under the generic name *Sebastes*. (Joint author with C. H. Beeson.) *In Am. Nat.*, XXVII, pp. 668-671. (July, 1893.)

65. Early stages in the development of *Cymatogaster*. *In Proc. Indiana Acad. Sci.* for 1892, pp. 58-62. (1893.)

66. Explorations in Western Canada. Abstract *in Indiana Acad. Sci.* for 1892, p. 56. (1893.)

67. Local variations. Abstract *in Proc. Indiana Acad. Sci.* for 1892, p. 81. (1893.)

68. A revision of the American Cichlidae. (Joint author with William L. Bray.) *In Ann. New York Acad. Sci.*, VII, pp. 607-624. (Jan., 1894.)

69. Notes on some South American fishes. *In Ann. N. Y. Acad. Sci.*, VII, pp. 625-637. (Feb., 1894.)

70. On the viviparous fishes of the Pacific coast of North America. *In Bull. U. S. Fish Comm.* for 1892, pp. 381-478; 27 plates. (1894.)

71. Results of explorations in Western Canada and Northwestern United States. *In Bull. U. S. Fish Comm.* for 1894, pp. 101-132; 4 plates. (July 7, 1894.)

72. Biological survey of Indiana: Zoölogy. *In Indiana Acad. Sci.* for 1893, pp. 67-76. (Aug., 1894.)

73. The effect of environment on the mass of local species. *In Proc. Indiana Acad. Sci.* for 1893, pp. 226-229. (Aug., 1894.)

74. A revision of the fishes of the sub-family *Sebastinae* of the Pacific coast of America. (Joint author with C. H. Beeson.) *In Proc. U. S. Nat. Mus.*, XVII, pp. 375-404. (1894.)

75. The fishes of Indiana. Report of the Indiana State Biological Survey. (Joint author with C. H. Beeson.) *In Proc. Indiana Acad. Sci.* for 1893, pp. 76-108. (1894.)

76. The fishes of Indiana. Reprinted from *Proc. Indiana Acad. Sci.* for 1893. *In Rep. Indiana State Fish Comm.* for 1894, pp. 40-64.

77. Names and locations of Indiana streams. *In Rep. State Fish Comm. Indiana* for 1894, pp. 65-79.

78. *Leuciscus balteatus* (Richardson). A study in variation. *In Am. Nat.*, XXIX, pp. 10-25; 5 plates. (Jan., 1895.) Also, *in Proc. Indiana Acad. Sci.* for 1894, pp. 87-99. (Oct., 1895.)

79. Development of sexual organs in *Cymatogaster*. *In Proc. Indiana Acad. Sci.* for 1894, p. 138. (Oct., 1895.)

80. A new biological station and its aim. *In Proc. Indiana Acad. Sci.* for 1894, pp. 34-35. (Oct., 1895.)

81. First report of the Indiana University biological station. *In Proc. Indiana Acad. Sci.* for 1895, pp. 203-296. Plates. (Feb., 1896.) Editor, and author of papers on 'Turkey lake as a unit of environment,' 'Plankton,' 'The fishes,' 'The Testudinata,' 'The study of variation.'

82. The bearing of the origin and differentiation of the sex cells in *Cymatogaster* on the idea of the continuity of the germ plasma. *In Am. Nat.*, XXX, pp. 265-271. (April, 1896.)

83. Sex-differentiation in the viviparous teleost *Cymatogaster*. *In Archiv f. Entwickelungsmechanik*, IV, pp. 125-179; 6 plates. (April, 1896.) Abstract *in Trans. Am. Micro. Soc.* XVII, pp. 172-173.

- 83a. Steindachneria. *In* Am. Nat. XXXI, pp. 158-159.
84. Viviparous fishes. *In* Overland Monthly. (1898.)
- 84a. The Amblyopsidae, the blind fish of America. *In* Rep. British Assoc. for 1897, pp. 685-686. (1898.)
85. The origin of cave faunas. Abstract *in* Indiana Acad. Sci. for 1897, pp. 229-230. (1898.)
86. The Amblyopsidae and eyes of blind fishes. Abstract *in* Proc. Indiana Acad. Sci. for 1897, pp. 220-231. (1898.)
87. A new blind fish. Abstract *in* Indiana Acad. Sci. for 1897, p. 231. (1898.)
88. A case of convergence. *In* Science, N. S., IX, No. 217, 280-282. (Feb., 1899.); also *in* Proc. Indiana Acad. Sci. for 1898, pp. 247-257. (1899.)
89. Biological stations. *In* Indiana Woman for April, 1898.
90. The Indiana University Biological Station. *In* Science, N. S., IX, pp. 925-929. (Dec. 22, 1899.) Also *in* Inland Educator for 1900, pp. 61-65. Figures.
91. Plans for the new buildings of the Biological Station. *In* Proc. Indiana Acad. Sci. for 1898, pp. 55-58. (1899.)
92. Explorations in the caves of Missouri and Kentucky. *In* Proc. Indiana Acad. Sci. for 1898, pp. 58-61. (1899.)
93. The blind fishes of North America. *In* Pop. Sci. Mo., LVI, pp. 473-486. (Feb., 1899.)
94. The eyes of the blind vertebrates of North America. I. The eyes of the Amblyopsidae. Archiv f. Entwicklungsmechanik, VIII, pp. 545-617; 5 plates. (March, 1899.)
95. Notes on the blind fishes. *In* Science, N. S., IX, p. 370. (March 10, 1899.)
96. Preliminary notes upon the arrangement of rods and cones in the retina of fishes. (Joint author with George Hansell.) *In* Proc. Indiana Acad. Sci. for 1898, p. 239. (1899.)
97. Degeneration in the eyes of the Amblyopsidae, its plan, process and causes. *In* Proc. Indiana Acad. Sci. for 1898, pp. 239-241. (1899.)
98. The ear and the hearing of the blind fishes. (Joint author with Albert C. Yoder.) *In* Proc. Indiana Acad. Sci. for 1898, pp. 242-247; 2 plates. (1899.)
99. Chologaster agassizii and its eyes. Abstract *in* Proc. Indiana Acad. Sci. for 1898, p. 251. (1899.)
100. The eye of Typhlomolge from the artesian wells of San Marcos, Texas. Abstract *in* Proc. Indiana Acad. Sci. for 1898, p. 251. (1899.)
101. The eyes of Typhlotriton spelæus. (Joint author with W. A. Denny.) Abstract *in* Proc. Indiana Acad. Sci. for 1898, pp. 252-253. (1899.)
102. The blind rat of Mammoth cave. (Joint author with James Rollin Slonaker.) *In* Proc. Indiana Acad. Sci. for 1898, pp. 253-257. Figures. (1899.)
- 102a. Cave animals, their character, origin and their evidence for or against the transmission of acquired characters. *In* Science, N. S., X, p. 883. (Dec. 15, 1899.)
103. The blind fishes. *In* Biol. Lectures Marine Biol. Lab. of Woods Hole for 1899, pp. 113-126. (1900.)
104. The mosaic of single and twin cones in the retina of fishes. (Joint author with George Daniel Shafer.) *In* Am. Nat., XXXIV, pp. 10-118; 1 plate. (Feb., 1900.)
105. Degeneration in the eyes of the cold-blooded vertebrates of the North American caves. *In* Science, N. S., XI, pp. 492-503. Figures. (March 30, 1900.)
106. The structure of blind fishes. *In* Pop. Sci. Mo., LVII, pp. 49-58. (May, 1900.)
107. The eyes of blind vertebrates of North America. II. The eyes of Typhlomolge rathbuni Stejneger. *In* Trans. Am. Mic. Soc., XXI, pp. 49-60; 2 plates. (May, 1900.)

108. Causes of degeneration in blind fishes. *In* Pop. Sci. Mo., LVII, pp. 397-407. (August, 1900.)
109. Some cases of saltatory variation. (Joint author with Ulysses Cox.) *In* Science, N. S., XII, p. 300. (Aug. 24, 1900.)
110. A contribution to the fauna of the caves of Texas. *In* Science, N. S., XII, p. 301. (Aug. 24, 1900.)
111. Sobre alguns peixes de São Paulo, Brazil. (Joint author with Allen A. Norris.) *In* Revista do Museu Paulista, IV, pp. 349-362. (1900.)
112. Degeneration in the eyes of the cold-blooded vertebrates of the North American caves. *In* Proc. Indiana Acad. Sci. for 1899, pp. 31-46. Illustrations. (1900.)
113. Convergent evolution as illustrated by the blind lizard Rhineura. *In* Science, N. S., XII, p. 302. (Aug., 1900.)
114. The development of the eyes in the blind-fish Amblyopsis. *In* Science, N. S., XII, p. 302. (Aug. 24, 1900.)
115. The eyes of the cave salamander Typhlotriton. *In* Science, N. S., XII, p. 302. (Aug. 24, 1900.)
116. The development of the Conger eel. *In* Science, N. S., XII, pp. 401-402. (Sept. 14, 1900.)
117. The eyes of the blind vertebrates of North America. III. The structure and ontogenic degeneration of the eyes of the Missouri cave salamander. (Joint author with Winfield Augustus Denny.) *In* Biol. Bull. II, pp. 33-40; 1 plate. (Oct., 1900.)
118. Description of a new cave salamander, *Spelerpes stejneri*, from the caves of Southwestern Missouri. *In* Trans. Am. Mic. Soc., XXII, pp. 189-192; 2 plates. (1900.) Abstract *in* Proc. Indiana Acad. Sci. for 1900, pp. 167. (1901.)
119. Some cases of saltatory variation. (Joint author with U. S. Cox.) *In* Am. Nat., XXXV, pp. 33-38. (Jan., 1901.)
120. *Bergiaria*. (Joint author with Allen A. Norris.) *In* Com. Mus. Nac. Buenos Aires, I, p. 272. (March 18, 1901.)
121. Unilateral coloration with a bilateral effect. (Joint author with Clarence Kennedy.) *In* Science, XIII, pp. 828-830. (1901.)
122. Description of a new oceanic fish found off southern New England. *In* Bull. U. S. Fish Com., XXI, p. 35. (1901.) Abstract *in* Proc. Indiana Acad. Sci. for 1900, p. 166. (1901.)
123. The egg and development of the Conger eel. *In* Bull. U. S. Fish Com., XXI, pp. 37-44. Illustrations. (1901.) Abstract *in* Proc. Indiana Acad. Sci. for 1900, pp. 165-166. (1901.)
124. Investigations into the history of the young *Squeteague*. *In* Bull. U. S. Fish Comm., XXI, pp. 45-51. Illustrations. (1901.) Abstract *in* Proc. Indiana Acad. Sci. for 1900, p. 166. (1901.)
125. The *Leptocephalus* of the American eel and other American *Leptocephali*. (Joint author with Clarence Hamilton Kennedy.) *In* Bull. U. S. Fish Comm., XXI, pp. 81-92. Illustrations. (1901.) Abstract *in* Science, N. S. XIV, p. 631. (Oct. 25, 1901.)
126. The mounting of the remains of *Megalonyx jeffersoni* from Henderson, Ky. *In* Proc. Indiana Acad. Sci. for 1900, p. 166. (1901.)
127. The solution of the eel question. *In* Trans. Am. Mic. Soc., XXIII, pp. 5-18; 4 plates. (May, 1902.)
128. The physical basis of heredity. *In* Pop. Sci. Mo., LXI, pp. 32-44. Illustrations. (May, 1902.)
- 128a. The blind fish of Cuba. *In* Science, N. S. XVI, p. 347. (Aug. 29, 1902.)
129. The Carnegie institution. *In* Science, N. S., XVI, pp. 792-793. (Nov. 14, 1902.)
130. The eyes of the blind vertebrates of

North America. IV. The eyes of *Rhinenra floridana*. *In Proc. Washington Acad. Sci.*, IV, pp. 533-538; 3 plates. (Sept., 1902.) Abstracts *in Proc. Indiana Acad. Sci.* for 1901, p. 107 (1902), and *in Science*, N. S. XIV, p. 631. (Oct. 25, 1901.)

131. The history of the eye of Amblyopsis. Abstracts *in Proc. Indiana Acad. Sci.* for 1901, pp. 101-106 (1902); *in Science*, N. S. XIV, p. 631 (Oct. 25, 1901); and *in Science*, N. S. XV, pp. 523-524 (April 4, 1902.)

132. Zoölogical miscellany. *In Proc. Indiana Acad. Sci.* for 1901, pp. 107-113. (1902.)

133. The solution of the eel problem. *In World Today*, IV, pp. 478-482. (April, 1903.)

134. In search of blind fishes in Cuba. *In World Today*, V, pp. 1129-1136. Illustrations. (Sept., 1903.)

135. Auf der Suche nach blinden Fischen in Cuba. *In Die Umschau*, VII, pp. 365-367. (May 2, 1903.)

136. Variation notes. (Joint author with C. H. Kennedy.) *In Biol. Bull.*, IV, pp. 227-230. (April, 1903.)

137. Report on the freshwater fishes of Western Cuba. *In Bull. U. S. Fish Comm.* for 1902, pp. 211-236; 4 plates. (July, 1903.)

138. The water supply of Havana, Cuba. *In Science*, N. S., XVIII, pp. 281-282. (Aug. 28, 1893); and *in Proc. Indiana Acad. Sci.* for 1902, pp. 65-67. (1903.)

139. On a collection of fishes from Paraguay with a synopsis of the American genera of Cichlids. (Joint author with C. H. Kennedy.) *In Proc. Acad. Sci., Phila.* for 1903, pp. 497-537. (Sept., 1903.)

140. Some new genera of South American fresh-water fishes and new names for some old genera. *In Smithsonian Misc. Colls.*, XLV, pp. 144-148. (Dec., 1903.)

141. The eyes of the blind vertebrates of North America. V. The history of the eye

of Amblyopsis from the beginning of its development to its disintegration in old age. *In E. L. Mark anniversary volume*, pp. 167-204; plates xii-xv. (1904.) Abstract *in Proc. Indiana Acad. Sci.* for 1901, pp. 101-105.

ARTHUR LEE FOLEY, A.B. (1890), A.M. (1891). Ph.D. Professor of Physics.

1. The surface tension of liquids. *In Proc. Indiana Acad. Sci.* for 1895, pp. 67-75.

2. Surface tension of liquids. *In Phys. Rev.*, III, No. 5, pp. 381-386. (March-April, 1896.)

3. Arc spectra. *In Electrical Eng.*, XXIV. (Sept. 16, 1897.)

4. Arc spectra. *In Proc. A. A. A. S.*, XLVI, pp. 93-94. (1897.)

5. Arc spectra. *In Phys. Rev.*, V, No. 8, pp. 129-151; 5 plates. (Sept., 1897.)

6. Variations in the spectrum of the open and closed electric arc. *In Proc. Indiana Acad. Sci.* for 1897, pp. 95-97.

7. Electrolytic nature of the electric arc. *In Proc. Indiana Acad. Sci.* for 1897, pp. 100-103.

8. The spectrum of cyanogen. *In Proc. Indiana Acad. Sci.* for 1897, pp. 97-100.

9. X-ray transparency. *In Proc. Indiana Acad. Sci.* for 1898, pp. 74-75.

10. Diamond fluorescence. *In Proc. Indiana Acad. Sci.* for 1899, pp. 94-95.

11. Review of Cojori's 'History of physics.' *In Phys. Rev.*, XIII, No. 5, pp. 315-316. (May-June, 1899.)

12. Diamond-glass fluorescence. *In Science*, XIII, pp. 732-734. (1901.)

13. A method of measuring the absolute dilation of mercury. *In Proc. Indiana Acad. Sci.* for 1900, p. 99.

14. An improved Wehnelt interrupter. *In Proc. Indiana Acad. Sci.* for 1900, pp. 97-98.

15. A modified Wehnelt interrupter. *In Elec. World and Eng.*, XXXIX, pp. 373-374. (March 1, 1902.)

16. On the use of nickel in the core of a Marconi magnetic detector. *In Proc. Indiana Acad. Sci.* for 1903.

17. A remarkable distribution of carbon on the bulb of a 'Hylö' incandescent lamp. *In Proc. Indiana Acad. Sci.* for 1903.

18. On the use of manganese dioxide in the generation of oxygen from potassium-chlorate. (Joint author with R. R. Ramsey.) *In Proc. Indiana Acad. Sci.* for 1903.

19. On the use of nickel in the core of a Marconi magnetic detector. *In Phys. Rev.*, XVIII, pp. 349-354. (May, 1904.)

20. A remarkable distribution of the carbon deposit on the bulb of a 'Hylö' incandescent lamp. *In Science* for 1904.

21. A peculiar deposit of carbon on the bulb of a 'Hylö' lamp. *In Elec. World and Eng.* for 1904.

22. A modified magnetic detector. *In Elect. World and Eng.* for 1904. (In press.)

SAMUEL BANNISTER HARDING, A.B. (1890),
Ph.D. Junior Professor of European
History.

1. American history, 1781-1829. (Syllabus of the university extension department of the University of the State of New York.) Albany, N. Y., 1892. Pp. 61.

2. The 'minimum' principle in the tariff of 1828, and its recent revival. *In Annals Am. Acad. Pol. and Soc. Sci.*, VI, July, pp. 100-116. (1895.) Published separately as No. 153 of the publications of Am. Acad. of Pol. and Soc. Sci.

3. Party struggles over the first Pennsylvania constitution. *In Ann. Rep. Am. Hist. Asso.* for 1894, pp. 371-402. (1895.)

4. The contest over the ratification of the federal constitution in the state of

Massachusetts. (Harvard historical studies, No. 2.) New York, 1896. Pp. vi, 194.

5. Review of Edward Channing and Albert B. Hart's 'Guide to the study of American history.' *In Inland Educator*, III, pp. 315-317. (Jan., 1897.)

6. Greek gods, heroes, and men; a primer of the mythology and history of the Greeks. (Joint author with Mrs. Caroline H. Harding.) Chicago, 1897. Pp. vi, 195; illustrated.

7. The city of the seven hills; a book of stories from the history of ancient Rome. (Joint author with Mrs. Caroline H. Harding.) Chicago, 1898. Pp. 274; illustrated. Revised edition, 1902, pp. 268.

8. The story of the Middle Ages. Chicago, 1901. Pp. 224; illustrated.

9. Missouri party struggles in the Civil War period. *In Ann. Rep. Am. Hist. Asso.* for 1900, I, pp. 85-103. (1901.)

10. Review of Lewis Einstein's 'The Italian Renaissance in England.' *In Am. Hist. Rev.*, VIII, pp. 124-126. (Oct., 1902.)

11. Review of George M. Wrong's 'The British nation; a history.' *In Am. Hist. Rev.*, IX, pp. 348-350. (Jan., 1904.)

12. Essentials in mediæval and modern history. (In consultation with Albert Bushnell Hart.) New York, 1904. Pp. about 500; illustrations and maps. (In press.)

13. Life of George R. Smith, founder of Sedalia, Mo. Privately printed, 1904. Pp. about 400; illustrated. (In press.)

CHARLES M. HEPBURN, A.M., LL.B. Professor of Law.

1. The historical development of code pleading in America and England. Cincinnati, 1897. Pp. xvi, 318.

2. A selection of cases and statutes on the principles of code pleading. With notes. Cincinnati, 1899. Pp. xxxvi, 651.

AMOS SHARTLE HERSHEY, Ph.D. Associate Professor of European History and Politics.

1. Die Kontrolle über die Gesetzgebung in den Vereinigten Staaten von Nord Amerika. Heidelberg, 1894. Pp. 72.

2. The recognition of Cuban belligerency. *In Ann. Am. Acad. Pol. and Soc. Sci.*, VII, pp. 450-461. (May, 1896.) Published separately as No. 175 of the publications of the Am. Acad. Pol. and Soc. Sci.

3. Intervention and the recognition of Cuban independence. *In Ann. Am. Acad. Pol. and Soc. Sci.*, XI, pp. 353-381. (May, 1898.) Published separately as No. 228 of the publications of the Am. Acad. Pol. and Soc. Sci.

4. Higher education in Indiana. *In Normal Vidette*, VII, pp. 113-119; illustrated. (April, 1900.)

5. The Venezuelan affair in the light of international law. *In Am. Law Reg.*, N. S., XLII, pp. 249-268. (May, 1903.)

6. The importance of dates and maps in the teaching and study of history, or the location of events in time and space. *In Educator-Journal*, IV, pp. 113-118. (Nov., 1903.)

7. The Panama question. *In Green Bag*, XVI, pp. 265-267. (April, 1904.)

8. Some questions in international law arising from the Russo-Japanese war: I. Failure to declare war and violation of Korean neutrality. *In Green Bag*, XVI, (May, 1904.)

9. Some questions in international law arising from the Russo-Japanese war: II. The Hay note and Chinese neutrality. *In Green Bag*, XVI, (June, 1904.)

HORACE ADDISON HOFFMAN, A.B. (1881), A.M. Professor of Greek.

1. The religious and ethical views of

.Eschylus. *In Indiana University Bulletin*, March, 1888.

2. The study of man through language and literature. *In Proc. Indiana Coll. Asso.* for 1889.

3. A catalogue of the fishes of Greece, with notes on the names now in use and those employed by classical authors. (Joint author with David Starr Jordan.) *In Proc. Acad. Nat. Sci. Philadelphia*, August 17, 1892.

HAROLD WHETSTONE JOHNSTON, L.H.D. Professor of Latin.

1. The Roman commonwealth. Chicago, 1891. Pp. 25.

2. M. Tulli Ciceronis orationes et epistolae selectae. Selected orations and letters of Cicero with historical introduction, an outline of the Roman constitution, notes, excursuses, vocabulary, and index. Chicago, 1892. Pp. 814.

3. Revision of C. M. Lowe and J. T. Ewing's 'Caesar's Gallic war.' Chicago, 1894. Pp. 542.

4. Latin manuscripts. Chicago, 1897. Pp. 130; illustrated.

5. A collection of examples illustrating the metrical licenses of Vergil. Chicago, 1898. Pp. 54.

6. The teaching of Vergil. Chicago, 1898. Pp. 16.

7. Review of Macmillan's 'Latin dictionary.' *In School Rev.*, VI, pp. 136-7. (Feb., 1898.)

8. Cicero's orations and letters. (Joint author with F. W. Sanford, A.M.) Chicago, 1899. Pp. 797.

9. Review of Gudeman's 'Latin literature of the Empire.' *In School Review*, VIII, pp. 179-180. (March, 1899.)

10. The teaching of second-year Latin, with prefatory note by W. G. Hale. Chicago, 1901. Pp. 16.

11. The Roman name. Chicago, 1901. Pp. 16.
12. The teaching of Latin in the second year. *In School Review*, X, pp. 69-76. (Jan., 1902.)
13. The private life of the Romans. Chicago, 1903. Pp. 344; illustrated.
14. Caesar's Gallic war. (Joint author with F. W. Sanford, A.M.) Boston, 1904.

ALBERT FREDERICK KUERSTEINER, Ph.D.
Professor of Romance Languages.

1. Review of J. A. Pérez Bonalde's 'El Kuerbo por Edgar Allan Poe, Tradukzion direkta del Inglés.' *In Le Maître Phonétique*, X, pp. 146-147. (Aug., 1895.)
2. Note sur l'e mnét. *In Le Maître Phonétique*, X, pp. 154-155. (Sept., 1895.)
3. Apuntes sobre la pronunciación castellana. *In Le Maître Phonétique*, XI, pp. 217-221. (Dec., 1896.)
4. Review of B. Roettger's 'Die Altfranzösischen Lautgesetze in Tabellen.' *In Le Maître Phonétique*, XII, pp. 84-85. (March, 1897.)
5. Review of Peter E. Traub's 'The Spanish verb, with an introduction on Spanish pronnciation.' *In Mod. Lang. Notes*, XVIII, pp. 182-184. (June, 1903.)

EUGENE LESER, Ph.D. Assistant Professor
of German.

1. Fehler und Lücken in der Li Sermon saint Bernart benannten Predigtsammlung. Nebst einem lexikalischen Anhang. Sondershausen, 1887. Pp. 119.
2. *Parler français comme une vache espagnole.* *In Mod. Lang. Notes*, IX, p. 224.
3. Modern French *gêne* = Old French *gchine* (from *gchir*.) *In Mod. Lang. Notes*, X, pp. 168-169.
4. Review of J. T. Hatfield's 'Gæthe's

Hermann und Dorothea.' *In Jour. Ger. Phil.*, III, pp. 380-383. (1901.)

ERNEST HIRAM LINDLEY, A.B. (1893), A.M. (1894). Ph.D. Professor of Psychology and Philosophy.

1. Review of Theodore Kæs's (a) 'Beiträge zur Kenntniss des Reichthums der Grosshirnrinde des Menschen an markhaltigen Nervenfasern'; (b) 'Ueber den Markfasergehalt der Grosshirnrinde eines 1¼ jährigen männlichen Kindes'; (c) 'Ueber Grosshirnrindenmasse und über Anordnung der Markfasersysteme in der Rinde des Menschen, zugleich ein Beitrag zur Frage: Un terscheidet sich die Rinde des Kulturmenschen von den niederen Racen in Bezug auf Kaliber, Reichthum und Anordnung der markhaltigen Nervenfasern?' *In Am. Jour. Psych.*, VII, pp. 281-284. (Jan., 1896.)
2. A preliminary study of some of the motor phenomena of mental effort. *In Am. Jour. Psych.*, VII, pp. 491-517. (July, 1896.)
3. Some mental automatisms. (Joint author with G. E. Partridge.) *In Ped. Sem.*, V, pp. 41-60. (July, 1897.)
4. A study of puzzles, with special reference to the psychology of mental adaptation. *In Am. Jour. Psych.*, VIII, pp. 431-493. (July, 1897.)
5. Ueber Arbeit und Ruhe. *In Psychologische Arbeiten*, herausg. von E. Kræpelin. Heidelberg, III, 3 Heft, pp. 481-534.
6. Child study in Germany. *In Indiana Sch. Jour.*, XLIV, pp. 159-160. (March, 1899.)
7. Science in the daily press. (Joint author with William L. Bryan.) *In Science*, N. S. XI, p. 74. (1900.)
8. An arithmetical prodigy. (Joint author with W. L. Bryan.) *In Proc. Am. Psych. Asso.*, New Haven, 1900. *In Psych. Rev.*, VII, p. 135. (1900.)

9. The case of Arthur Griffith, arithmetical prodigy. (Joint author with W. L. Bryan.) *In* Comte rendu du IV^e Congrès International de Psychologie tenu à Paris, 1900, p. 178.

10. Review of J. H. Leuba's (a) 'The state of death' (*Am. Jour. Psych.*, XIV, pp. 133-145); (b) 'Introduction to a psychological study of religion' (*Monist*, XI, pp. 195-225); (c) 'The contents of religious consciousness' (*Monist*, XI, pp. 536-573); (d) 'Religion, its impulses and its ends' (*Monist*, 1902-03). *In* *Am. Jour. Religious Psych. and Educ.*, I. (May, 1904.)

ROBERT EDWARD LYONS, A.B. (1889), A.M. (1890), Ph.D. Professor of Chemistry.

1. A method for the estimation of albumin in urine. (Joint author with T. C. Van Nüys.) *In* *Am. Chem. Jour.* XII, pp. 1-17. (1890.)

2. Carbon di-oxide in the urine. (Joint author with T. C. Van Nüys.) *In* *Am. Chem. Jour.*, XIV, pp. 14-20. (1892.)

3. Die Phenylverbindungen von Schwefel, Selen und Tellur. Heidelberg, 1894. Pp. 40.

4. Ueber Diphenylselenide und einige Derivate desselben. (Joint author with F. Krafft.) *In* *Ber. d. Deutsch. Chem. Ges.*, XXVII, pp. 1760-1768. (1894.)

5. Ueber Diphenyltellurid und ein Verfahren zur Darstellung von Sulphiden, Seleniden und Telluriden. (Joint author with F. Krafft.) *In* *Ber. d. Deutsch. Chem. Ges.* XXVII, pp. 1768-1773. (1894.)

6. The effect of grape sugar upon the composition of certain fat producing bacteria. *In* *Proc. Indiana Acad. Sci.* for 1895, pp. 85-88.

7. Ueber Diphenylselenon, $C_6H_5_2 \cdot SeO_2$. $C_6H_5_2$. (Joint author with F. Krafft.) *In* *Ber. d. Deutsch. Chem. Ges.* XXIX, pp. 424-429. (1896.)

8. The qualitative analysis of inorganic bodies. (Joint author with L. S. Davis.) *Anderson, Ind.*, 1897. Pp. 210.

9. Analyses of certain Indiana shales and fire clays. (Assisted by O. W. Brown.) *In* *Ann. Rep. State Geologist for 1898*, pp. 68, 69, 114, 115, 130, 134.

10. A manual toxicological analysis. (Joint author with L. S. Davis.) *Anderson, Ind.*, 1899. Pp. 112, and color plate.

11. The qualitative analysis of inorganic bodies. (Joint author with L. S. Davis.) *Anderson, Ind.*, 1900. Second edition, pp. 151.

12. Analyses of certain Indiana mineral waters. *In* *Ann. Rep. of State Geologist for 1901*, pp. 70, 76, 83.

13. The quantitative determination of selenium in organic compounds. (Joint author with F. L. Shinn.) *In* *Jour. Am. Chem. Soc.*, XXIV, pp. 1085-1094 (1902); also in *Zeits. f. anal. Chem.*, XLII, pp. 659-661. (1902.)

14. Review of William Dodge Frost's 'Laboratory guide in elementary bacteriology.' Second edition. *In* *Jour. Am. Chem. Soc.*, XXIV, pp. 595-596. (1902.)

15. Analyses of certain Indiana coals. (Assisted by F. C. Mathers.) *In* *Ann. Rep. of State Geologist for 1903*.

16. Analyses of certain Indiana limestones and limes. (Assisted by F. C. Mathers.) *In* *Annual Report of State Geologist, 1903*.

17. Review of R. H. Aders Plimmer's 'Chemical changes and products resulting from fermentations.' *In* *Jour. Am. Chem. Soc.*, XXVI, pp. 113. (1904.)

VERNON FREEMAN MARSTERS, A.M. Professor of Geology.

1. Triassic traps of Nova Scotia, with notes on other intrusives of Pictou and An-

Moenkhaus] — Bibliography: Present Faculty

tigonish counties, Nova Scotia. *In Am. Geol.*, V, pp. 140-145. (1890.)

2. On certain camptonite dikes near Whitehall, Washington county, N. Y. (Joint author with J. F. Kemp.) *In Am. Geol.*, IV, pp. 97-102. (1889.)

3. The trap dikes of the Lake Champlain region. (Joint author with J. F. Kemp.) *In Bull. U. S. Geol. Surv.*, No. 107, pp. 11-62. (1893.)

4. Geologic literature of Indiana stratigraphic and economic. (Joint author with E. M. Kindle.) *In Proc. Indiana Acad. Sci.* for 1893. (1894.)

5. Camptonites and other intrusives of Lake Memphramagog. *In Am. Geol.*, XVI, pp. 25-39; 1 map. (1895.)

6. Aids in teaching physical geography. *In Proc. Indiana Acad. Sci.* for 1899, pp. 54-60; 1 pl. (1900.)

7. Topography and geography of Bean Blossom valley, Monroe county, Indiana. *In Proc. Indiana Acad. Sci.* for 1901, pp. 222-237; 4 figures, 6 plates. (1902.)

JOHN ANTHONY MILLER, A.B. (1890), Ph. D. Professor of Mechanics and Astronomy.

1. A trigonometry for beginners. New York, 1896. Pp. vii, 147; 67 plates.

2. An infinite system of forms satisfying the requirements of Hilbert's law. *In Proc. Indiana Acad. Sci.* for 1897, pp. 80-84.

3. The Leonids of 1898. *In Proc. Indiana Acad. Sci.* for 1898, pp. 151-153. 1 plate.

4. A linear relation between certain of Klein's X-functions and Sigma-functions of lower division value. *In Proc. Indiana Acad. Sci.* for 1898, pp. 154-157.

5. Meteor showers. *In Inland Educator*, VII, pp. 147-151; 2 plates. (Nov., 1898.)

6. The perseids of 1898. *In Pop. Astron.*, VII, p. 406; 1 plate. (Sept., 1899.)

7. Kirkwood observatory. *In Pub. Ast. Soc. of the Pacific*, XIII, pp. 139-140; 1 plate.

8. Meteor showers. *In Inland Educator*, IX, pp. 116-121. (Oct., 1899.)

9. The Leonids of 1900. *In Proc. Indiana Acad. Sci.* for 1900, pp. 73-74.

10. The Kirkwood observatory of Indiana University. *In Proc. Indiana Acad. Sci.* for 1901, pp. 85-87.

11. Inorganic nature study: the sky. *In Teachers' Journal*, III, pp. 20-21, 75-77, 121-124, 235-241, 273-276, 384-416. 14 plates.

12. Photographic observations of comet c 1902. *In Proc. Indiana Acad. Sci.* for 1902, p. 80.

13. Double-star measures. *In Astro. Jour.*, XXIII, pp. 167-169. (Sept., 1903.)

14. Double-star measures. *In Astro. Jour.*, XXIV, pp. 15-16. (1904.)

15. Measures of new double stars, selected from the Leipzig A. G. catalogue. *In Astronomische Nachrichten*, CLXI. (1904.)

16. Concerning certain elliptic functions of square rank. *In Am. Jour. Math.*, XXVI. (In press.)

WILLIAM J. MOENKHAUS, A.B. (1894), A.M. (1895), Ph.D. Associate Professor of Physiology.

1. Variation in the color-pattern of *Etheostoma caprodes*. (Abstract.) *In Proc. Indiana Acad. Sci.* for 1893, pp. 231-232.

2. Some cases of mimicry in fishes. *In Proc. Indiana Acad. Sci.* for 1894, p. 86.

3. Variation of North American fishes. I. The variation of *Etheostoma caprodes* Rafinesque. *In Am. Nat.*, XXVIII, pp. 641-658; 4 plates. (August, 1894.)

4. Notes on a collection of fishes from Dubois county, Indiana. *In Proc. Indiana Acad. Sci. for 1895*, pp. 159-162.

5. Variation of North American fishes. II. The variation of *Etheostoma caprodes* Rafinesque in Turkey lake and Tippecanoe lake. *In Proc. Indiana Acad. Sci. for 1895*, pp. 278-296; 9 figures.

6. Material for the study of the variation of *Etheostoma caprodes* Rafinesque and *Etheostoma nigrum* Rafinesque in Turkey lake and Tippecanoe lake. *In Proc. Indiana Acad. Sci. for 1897*, pp. 207-228; 6 figures.

7. Contribuição para o conhecimento das aranhas de S. Paulo. *In Revista do Museu Paulista*, III, pp. 77-112. 1 plate. (1898.)

8. The spinning of the egg-sac in *Lycosa*. *In Proc. Indiana Acad. Sci. for 1901*, pp. 113-114.

9. Experiments in the hybridization of fishes. (Abstract.) *In Proc. Indiana Acad. Sci. for 1901*, p. 114.

10. An aberrant *Etheostoma*. *In Proc. Indiana Acad. Sci. for 1901*, pp. 115-116.

11. The individuality of the maternal and paternal chromosomes in the hybrid between *Fundulus heteroclitus* and *Menidia notata*. (Abstract.) *In Proc. Indiana Acad. Sci. for 1902*, p. 111.

12. An extra pair of appendages modified for copulatory purposes in *Cambarus viridis*. *In Proc. Indiana Acad. Sci. for 1902*, pp. 111-112; 2 figures.

13. Description of a new darter from Tippecanoe Lake. *In Bull. U. S. Fish Com.*, XXII, pp. 397-398; 1 figure. (August, 1903.)

14. The development of the hybrids between *Fundulus heteroclitus* and *Menidia notata* with especial reference to the behavior of the maternal and paternal chromosomes. *In Amer. Jour. Anat.*, III, pp. 29-67; 4 plates. (1904.)

EDWARD PAYSON MORTON, A.M., Assistant Professor of English.

1. A lesson in English from a recent novel. *In Inland Educator*, II, pp. 150-152. (April, 1896.)

2. Shakespeare in the seventeenth century. *In Jour. Ger. Phil.*, I, pp. 31-44. (1897.)

3. Review of Myra Reynolds's 'The treatment of nature in English poetry from Pope to Wordsworth.' *In Jour. Ger. Phil.*, I, pp. 262-263. (1897.)

4. Review of Francis Turner Palgrave's 'Landscape in poetry from Homer to Tennyson.' *In Mod. Lang. Notes*, XII, pp. 414-417. (Nov., 1897.)

5. Review of Oscar Kuhns's 'The treatment of nature in Dante's *Divina Commedia*.' *In Mod. Lang. Notes*, XII, p. 495-498. (Dec., 1897.)

6. Goldsmith's 'Vicar of Wakefield.' Chicago, 1898. Pp. xxv, 254.

7. Shakespeare's 'Julius Cæsar.' Chicago, 1900. Pp. xxvi, 131.

8. Ruskin's 'Pathetic fallacy,' and Keats's treatment of nature. *In Poet Lore*, XII, 58-70. (Jan.-March, 1900.)

9. A method of teaching metrics. *In Mod. Lang. Notes*, XV, pp. 193-202. (April, 1900.)

10. Review of Mark Harvey Liddell's 'An introduction to the scientific study of poetry.' *In Mod. Lang. Notes*, XVII, pp. 431-434. (Nov., 1902.)

11. Chaucer's Identical rhymes. *In Mod. Lang. Notes*, XVIII, pp. 73-74. (March, 1903.)

12. Shakespeare's 'Twelfth Night.' New York, 1903. Pp. xiii, 179.

13. Review of Raymond Macdonald Alden's 'English verse.' *In Mod. Lang. Notes*, XVIII, pp. 174-176. (June, 1903.)

14. Review of Joseph Bickersteth Mayor's 'A handbook of modern English metre.' *In Mod. Lang. Notes*. (In press.)

CHARLES ALFRED MOSEMILLER, A.B. (1890),
Assistant Professor of Romance Lan-
guages.

1. Concerning the etymology of the French word *son* (=bran). *In Mod. Lang. Notes*, XVIII, p. 224. (Nov., 1903.)

2. The origin of the French word *canneberge*. *In Mod. Lang. Notes*, XIX, pp. 46-47. (Feb., 1904.)

—

DAVID MYERS MOTTIER, A.B. (1891), A.M.
(1892), Ph.D., Professor of Botany.

1. Notes on the apical growth of liverworts. *In Bot. Gaz.*, XVI, p. 141. 1 plate. (1891.)

2. On the archegonium and the apical growth of the stem in *Tsuga canadensis* and *Pinus sylvestris*. *In Bot. Gaz.*, XVII, p. 141; 1 plate. (1892.)

3. On the development of the embryo-sac of *Arisæma triphyllum*. *In Bot. Gaz.*, XVII, p. 258; 1 plate. (1892.)

4. The phylogeny of ferns. A review of J. Bretland Farmer's 'On the embryogeny of *Angiopteris evecta* Hoffm.' (*Ann. Bot.*, VI, p. 265.) *In Bot. Gaz.*, XVIII, p. 106. (1893.)

5. On the embryo-sac and embryo of *Senecio aureus*. *In Bot. Gaz.*, XVIII, pp. 245-253; 2 plates. (1893.)

6. Development of the embryo-sac of *Acer rubrum*. *In Bot. Gaz.*, XVIII, pp. 375-377; 1 plate. (1893.)

7. Contributions to the life-history of *Notothylas*. *In Ann. Bot.*, VIII, pp. 391-402; 3 plates. (1894.)

8. Contributions to the embryology of the Ranunculaceæ. *In Bot. Gaz.*, XX, pp. 241-248, 296-304; 4 plates. (1895.)

9. Beiträge zur Kenntniss der Kerntheilung in den Pollenmutterzellen einiger

Dikotylen und Monokotylen. *In Jahrb. für wiss. Bot.*, XXX, pp. 169-204; 6 plates. (1897.)

10. Ueber das Verhalten der Kerne bei der Entwicklung des Embryosacks und die Vorgänge bei der Befruchtung. *In Jahrb. für wiss. Bot.*, XXXI, pp. 125-158; 3 plates. (1897.)

11. Ueber den zweiten Theilungsschritt in Pollenmutterzellen. (Joint author with Edouard Strasburger.) *In Ber. der Deutsch. Bot. Gesellschaft*, XV, pp. 327-332; 1 plate. (1897.)

12. Ueber die Chromosomenzahl bei der Entwicklung der Pollenkörner von *Allium*. *In Ber. der Deutsch. Bot. Gesellschaft*, XV, p. 474. (1897.)

13. Das Centrosom bei *Dictyota*. *In Ber. der Deutsch. Bot. Gesellschaft*, XVI, pp. 123-128. (1898.)

14. The centrosome in cells of the gametophyte of *Marchantia*. *In Proc. Indiana Acad. Sci.* for 1898.

15. Endosperm haustoria of *Lilium candidum*. *In Proc. Indiana Acad. Sci.* for 1898.

16. Nuclear division in vegetative cells. *In Proc. Indiana Acad. Sci.* for 1898.

17. The effect of centrifugal force upon the cell. *In Ann. Bot.*, XIII, pp. 325-361; 1 plate. (1899.)

18. Nuclear and cell division in *Dictyota dichotoma*. *In Ann. Bot.*, XIV, pp. 163-192; 2 plates. (1900.)

19. A practical laboratory guide for the first year in botany. Bloomington, Ind., 1902.

20. The behavior of the chromosomes in the spore mother-cells of higher plants and the homology of the pollen and embryo-sac mother cells. *In Bot. Gaz.*, XXXV, pp. 250-282; 4 plates. (1903.)

21. The development of the spermatozoid of *Chara*. *In Ann. Bot.*, XVIII; 1 plate. (1904.)

22. Further studies on anomalous di-

cotyledonous plants. *In Proc. Indiana Acad. Sci.* for 1904.

23. Fecundation in plants. Washington, 1904.

BURTON DORR MYERS, M.D. Associate Professor of Anatomy.

1. The Chiasma of the toad (*Bufo lentiginosus*) and of some other vertebrates. *In Zeitschrift f. Morphologie u. Anthropologie*, III, pp. 183-207; 2 plates. (1901.)

2. Beitrag zur Kenntniss des Chiasmata und der Commissuren am Boden des dritten Ventrikels. *In Archiv f. Anat. u. Physiologie* for 1902, Anatomische Abth., pp. 32; 15 plates.

3. Fixation of tissues by injection. *In Jour. App. Micr.* for Nov., 1903.

4. Review of Gerrish's 'Text-book of anatomy.' *In Johns Hopkins Bull.* for April, 1903.

5. Review of Karl Camillo Schneider's 'Lehrbuch der vergleichenden Histologie der Thiere.' *In Science*, Sept. 25, 1903.

JOHN SCHOLTE NOLLEN, Ph.D. Professor of German.

1. Goethes Götze von Berlichingen auf der Bühne. Leipzig, 1893. Pp. 134.

2. Review of Elias J. MacEwan's translation of Freytag's 'Technique of the drama.' *In Dial*, XVIII, pp. 77-79. (Feb., 1895.) Also *In Mod. Lang. Notes*, X, pp. 76-77. (Feb., 1895.)

3. Review of Louis P. Betz's 'Heine in Frankreich.' *In Mod. Lang. Notes*, X, pp. 441-443. (Nov., 1895.)

4. Heinrich von Kleist's 'Prinz Friedrich von Homburg.' Boston, 1899. Pp. lxxii, 172.

5. Review of A. B. Faust's 'Heine's prose.' *In Mod. Lang. Notes*, XV, pp. 103-108. (Feb., 1900.)

6. Notes on the modern drama: Ibsen and Hauptmann. *In Faculty Corner*, Grinnell, pp. 47-64. (1901.)

7. Heine and Wilhelm Müller. *In Mod. Lang. Notes*, XVII, pp. 207-218, 261-276. (April, May, 1902.)

8. Kritisches und Prinzipielles zu Wolffs 'Jugendlustspielen von Heinrich von Kleist.' *In Jour. Ger. Phil.*, IV, pp. 483-519. (1902.)

9. Review of R. M. Meyer's 'Grundriss der neueren deutschen Litteraturgeschichte.' *In Mod. Lang. Notes*, XVII, pp. 391-395. (June, 1902.)

10. College and university in the middle west. *In Iowa College Circulars*, II, pp. 1-10. (Oct., 1902.)

11. Elective studies and courses in secondary schools. *In Iowa College Circulars*, II, pp. 47-59. (Dec., 1902.)

12. Review of Edward Stockton Meyer's 'Franz Grillparzer's Der Traum ein Leben.' *In Mod. Lang. Notes*, XVIII, pp. 122-124. (April, 1903.)

13. A chronology and practical bibliography of modern German literature. Chicago, 1903. Pp. 118.

14. Outline history of modern German literature, introductory to the texts of the 'Lake' German series. Chicago, 1903. Pp. 122.

15. German poems, 1800-1850. Chicago, 1904.

16. Review of John G. Robertson's 'A history of German literature.' *In Mod. Lang. Notes*, XIX, pp. 17-20. (Jan., 1904.)

17. Schiller's poems. New York, 1904.

CARL WILHELM FERDINAND OSTHAUS, A.M. (1890). Associate Professor of German.

1. Review of Hager's 'Freytag's Aus dem Staat Friedrichs des Grossen.' *In Mod. Lang. Notes*, V, pp. 301-303. (May, 1890.)

2. Gerstäcker's 'Germelshausen.' With introduction and English notes. Boston, 1891. Pp. vii, 56.

3. Eichendorff's 'Aus dem Leben eines Taugenichts.' With introduction and English notes. Boston, 1892. Pp. ix, 176.

4. Review of Carruth's 'Schiller's Wilhelm Tell.' *In Jour. Ger. Phil.*, II, pp. 125-126. (1898.)

5. Ein litterarischer Vandalismus? (Erwiderung). *In Pädagogische Monatshefte*, I, pp. 8-10. (March, 1900.)

6. Abridged editions of modern German authors. Reviews of nine different novels. *In Jour. Ger. Phil.*, IV, pp. 248-259. (1902.)

7. Where empire and republic meet. *In Western Camera Notes*, IV pp. 221-225; 5 plates. (Sept., 1903.)

8. Revision of Mary A. Frost's edition of Scheffel's 'Trompeter von Säckingen,' with introduction and notes. New York, 1904.

ROY HENDERSON PERRING, A.B. (1894),
A.M. (1896). Instructor in German.

1. An English criticism of Schiller's 'Robbers.' *In Germ. Amer. Ann. N. S.*, I, pp. 304-315. (June, 1903.)

ROLLA ROY RAMSEY, A.B. (1895), A.M.
(1898), Ph.D. Assistant Professor of
Physics.

1. A photographic study of electrolytic cells. *In Phys. Rev.*, IV, pp. 189-190; 1 plate. (1899.)

2. Eine photographische Unternehmung elektrolytischer Zellen. *In Physikalische Zeitschrift*, I, p. 269. (1900.)

3. The effect of gravity and pressure on electrolytic cells. *In Phys. Rev.*, XIII, pp. 1-30; 17 plates, 9 tables. (1901.)

4. Die Wirkung von Schwere und Druck auf die elektrolytischen Vorgänge. *In Physikalische Zeitschrift*, III, pp. 177-182; 4 tables. (1902.)

5. The change of volume in chalk and cadmium cells and its relation to change of electromotive force due to pressure. *In Phys. Rev.*, XVI, pp. 105-111; 1 plate, 3 tables. (1903.)

WILLIAM A RAWLES, A.B. (1884), A.M.
(1895), Ph.D. Junior Professor of Political
Economy.

1. The government of the people of the State of Indiana. Philadelphia, 1897. Pp. vi, 172. 12 plates.

2. Centralizing tendencies in the administration of Indiana. New York, 1903. Pp. 336.

GEORGE LOUIS REINHARD, LL.D. Professor
of Law and Dean of the School of Law.

1. Indiana criminal law. Cincinnati, 1879. Pp. xxii, 523.

2. Judicial opinions and decisions as judge of Indiana Appellate court. *In Indiana App. Ct. Rep.*, I-XVII. (1891-1897.)

3. Agency. A treatise on the law of principal and agent. Indianapolis, 1903. Pp. cxi, 656.

4. The right to practice law. *In Proc. Indiana State Bar Assn.* for 1902, pp. 129-151.

5. American law schools and the teaching of law. *In Green Bag*, XV. (March, 1904.)

DAVID ANDREW ROTHROCK, A.B. (1892),
A.M. (1893), Ph.D. Associate Professor
of Mathematics.

1. Invariants of the finite continuous groups of the plane. *In Am. Math. Mo.*, V, pp. 249-264. (Nov., 1898.)

2. Point invariants of the Lie groups. *In Proc. Indiana Acad. Sci.* for 1898, pp. 119-135.

3. Differential invariants derived from point invariants. *In Proc. Indiana Acad. Sci.* for 1898, pp. 135-147.

4. An algebra for high schools. (Joint author with R. J. Aley.) New York, 1904. (In press.)

MARTIN WRIGHT SAMPSON, A.M. Professor of English.

1. Milton's lyric and dramatic poems. New York, 1901. Pp. 1, 345.

2. Webster's 'Duchess of Malfy,' and 'The white devil.' Boston, 1904.

3. About 250 to 300 reviews and articles in *Critic*, *Dial*, *Anglia*, *Outlook*, *Nation*, *Modern Language Quarterly*, *Journal of Germanic Philology*, etc.

GUIDO HERMANN STEMPEL, A.M. Associate Professor of Comparative Philology.

1. Sein und haben. *In Germania*, III, pp. 132-135. (June 1, 1891.)

2. Review of Charles F. Johnson's 'English words.' *In School and College*, I, pp. 255-256. (April, 1892.)

3. Review of Emil Trechmann's 'A short historical grammar of the German language, translated and adapted from Professor Behaghel's *Deutsche Sprache*.' *In Academy*, VII, pp. 308-309. (June, 1892.)

4. Wilhelm Müller. *In Germania*, VI, 14-18. (May, 1894.)

5. Review of Charles Sears Baldwin's 'The inflections and syntax of the *Morte d'Arthur*.' *In Dial*, XVIII, p. 25. (Jan. 1, 1895.)

6. Review of Francis B. Gummere's 'Old English ballads.' *In Dial*, XVIII, p. 87. (Feb. 1, 1895.)

7. Review of Alfred M. Williams's 'Studies in folk-song and popular poetry.' *In Dial*, XVIII, pp. 182-183. (March 16, 1895.)

8. Review of Oliver Farrar Emerson's 'The history of the English language.' *In School Rev.*, III, pp. 229-233. (April, 1895.)

9. Review of Edward S. Joynes's 'Schiller's *Maria Stuart*.' *In Educ. Rev.*, X, pp. 499-500. (Dec., 1895.)

10. Review of Walter W. Skeat's 'The student's Chaucer.' *In School Rev.*, V. (Oct., 1897.)

11. Review of Hermann B. Boisen's 'Preparatory book of German prose.' *In Alumnus*, I, No. 2, pp. 32-33. (Nov., 1898.)

12. Review of Caroline H. Harding and Samuel B. Harding's 'Greek gods, heroes, and men.' *In Alumnus*, I, No. 2, p. 33. (Nov., 1898.)

13. Review of Carl Osthaus's 'Eichendorff's *Aus dem Leben eines Taugenicht's*.' *In Alumnus*, I, No. 2, p. 34. (Nov., 1898.)

14. Review of Caroline H. Harding and Samuel B. Harding's 'The city of the seven hills.' *In Alumnus*, I, No. 3, pp. 35-36. (Feb., 1898.)

15. Review of Harold W. Johnston's 'Latin manuscripts.' *In Alumnus*, I, No. 3, pp. 36-37. (Feb., 1898.)

16. Review of Edward P. Morton's 'Goldsmith's *The Vicar of Wakefield*.' *In Alumnus*, I, No. 4, pp. 24-25. (May, 1899.)

17. Questions, etc., and a bibliography. Contributed to Marsh and Royster's 'Teachers' manual for the study of English classics.' Chicago, 1902. Pp. 95.

18. The Yale bicentennial and comparative philology. Review of Hanns Oertel's 'Lectures on the study of language'; E. Washburn Hopkins's 'India old and new,' and 'The great epic of India'; E. P. Morris's 'On principles and methods in Latin syntax.' *In Dial*, XXXIII, pp. 92-94. (Aug. 16, 1902.)

HENRY THEW STEPHENSON, B.S., A.B.
Assistant Professor of English.

1. The Elizabethan play-house. *In Inland Educator*, X, pp. 158-164; 2 plates. (May, 1900.)
2. Patroon Van Volkenberg: A tale of old Manhattan in the year sixteen hundred and ninety-nine. Indianapolis, 1900. Pp. 380. Illustrated.
3. The fickle wheel: A tale of Elizabethan London. Indianapolis, 1901. Pp. 380. Illustrated.
4. Elizabethan London: A topographical description. (In press.)
5. Elizabethan manners and customs. (In preparation.)

ULYSSES GRANT WEATHERLY, Ph.D. Pro-
fessor of Economics and Social Science.

1. Louis VI, the founder of the French monarchy. Hamilton, N. Y., 1891. Pp. 27.
2. A miniature European state: Liechtenstein. *In Cornell Magazine*, VI, pp. 205-208. (March, 1894.)
3. Comparative politics. Albany, N. Y., 1895. Pp. 39.
4. Review of Herbert Tuttle's 'History of Prussia under Frederick the Great, 1756-1757.' *In Am. Hist. Rev.*, II, pp. 145-148.
5. The relation of history and geography. *In Indiana Sch. Jour.*, XLII, pp. 226-251. (April, 1897.)
6. Recent books on historical method. *In Inland Educator*, V, pp. 247-249. (Dec., 1897.)
7. Review of Georges Pariset's 'L'état et les églises en Prusse sous Frédéric Guillaume I, 1715-1740.' *In Am. Hist. Rev.*, III, pp. 352-355. (Jan., 1898.)
8. History in the high school. *In Inland Educator*, VI, pp. 261-262. (July, 1898.)

9. Review of Godefroy Cavaignac's 'La formation de la Prusse contemporaine, 1808-1813.' *In Am. Hist. Rev.*, IV, pp. 149-151. (Oct., 1898.)

10. Stein's German policy at the Congress of Vienna. *In Ann. Rep. Am. Hist. Asso. for 1900*, I, pp. 521-534. (1901.)

11. Why charities ought to be organized. *In Indiana Bull. Char. and Corr.*, June, 1902, pp. 91-92.

JAMES ALBERT WOODBURN, A.B. (1876),
A.M. (1885), Ph.D. Professor of Amer-
ican History and Politics.

1. The race problem in the South. *In Indiana Student*. (Nov., 1885.)
2. Government by the people. *In Indiana Student*. (Nov., 1886.)
3. The Johns Hopkins University. *In Indiana Student*. (Jan., 1887.)
4. Needed changes in the school law of Indiana. *In Indiana Sch. Jour.* (Feb., 1888.)
5. The slave trade. A series of articles on the recent slave trade of the Mohammedans in Central Africa. *In United Presbyterian*. (Jan., Feb., 1888.)
6. Review of Sir Henry Maine's 'Lectures on international law delivered before the University of Cambridge.' *In Christian Union*. (June 27, 1889.)
7. The study of history; an article on the study of history in America suggested by the proceedings of the 6th annual session of the American Historical Association at Washington, D. C., Dec., 1889. *In Christian Union*. (Jan. 9, 1890.)
8. The speaker and the quorum. An essay on the notable decision of Hon. Thomas B. Reed, Speaker of the House of Representatives, Feb., 1890. *In Indiana Student*. (March, 1890.)
9. Chautauqua; the growth of its summer school. *In Christian Union*. (Aug. 21, 1890.)

10. History of higher education in Indiana. Washington, 1891. Bureau of Education, Circulars of Information, No. 1. Pp. 200.
11. States made from colonies. *In* Chautauquan. (Dec., 1891.)
12. States made from territories. *In* Chautauquan. (Feb., 1892.)
13. Causes of the American Revolution. *In* Johns Hop. Univ. Studies, X, pp. 557-616. (Dec., 1892.)
14. Select orations of Burke and Webster, with introduction and notes. (Joint author with C. W. Hodgkin.) Boston, 1892. Pp. 583.
15. The historical significance of the Missouri Compromise. *In* Ann. Rept. Am. Hist. Asso. for 1893, pp. 251-297.
16. The study of politics in American colleges. *In* Am. Jour. of Pol. (May, 1894.)
17. American political orations, re-edited with historical notes. 4 vols. New York, 1896.
18. The tariff in legislation. *In* Chautauquan. (April, 1896.)
19. The Monroe doctrine and some of its applications. *In* Chautauquan. (Feb., 1896.)
20. To what extent may undergraduate students of history be trained in the use of the sources. *In* Ann. Rep. Am. Hist. Asso. for 1897, pp. 45-49.
21. France in the American Revolution. *In* Chautauquan. (June, 1897.)
22. The American Revolution, 1763-1783, being the chapters and passages relating to America from Lecky's history of England in the 18th century. Edited with bibliographical and historical notes. New York, 1898. Pp. xviii, 518.
23. The making of the Constitution: a syllabus for Madison's Journal. Chicago, 1898. Pp. 41.
24. Washington's foreign policy and the Philippines. *In* Independent, L. (Oct. 27, 1898.)
25. Our plighted word and the Philippines. *In* Independent, L. pp. 1381-1383. (Nov. 17, 1898.)
26. The American republic and its government: an analysis of the government of the United States with a consideration of its fundamental principles and of its relations to the States and Territories. New York, 1902. Pp. iv, 410.
27. Political parties and party problems in the United States: a sketch of American party history and of the development and operations of party machinery, together with a consideration of certain party problems in their relation to political morality. New York, 1902. Pp. ix, 314.
28. Party politics in Indiana during the Civil War. *In* Ann. Rep. Am. Hist. Assoc. for 1902, I, pp. 225-251.
29. Review of U. B. Phillip's 'Georgia and state rights.' *In* Am. Hist. Rev., VIII, pp. 785-786. (July, 1903.)
30. Review of Lecky's 'Leaders of public opinion in Ireland.' *In* Am. Hist. Rev., IX, pp. 375-377. (Jan., 1904.)
31. Review of William Henry Smith's 'A political history of slavery.' *In* Am. Hist. Rev., IX, pp. 285-289. (Jan., 1904.)

PUBLICATIONS OF FORMER FACULTY

**In the following list the attempt has been made to gather together the publications of former members of the Faculty up to the times when their connections with Indiana University ceased. The list is made as complete as the difficulty of the task and the time at the disposal of the compilers will permit; but it is realized that there must be many omissions, both of names of authors and of titles of publications, which the list as planned should include.

EDWIN GEORGE BALDWIN, M.A. Instructor in Latin, 1898-1899.

1. The laws of the twelve tables: text and translation. Bloomington, Ind., 1899. Pp. 8.
-

ELISHA BALLANTINE, D.D., LL.D. Professor of Mathematics, 1854-1856; Professor of Greek, 1856-1863; 1867-1878. Acting President, 1884; Vice President, 1884-1886. Died March 31, 1886, at Bloomington, Ind.

1. Christ, His own witness; or the words of Jesus concerning Himself. New York, 1877.

2. Old age; two discourses delivered at Bloomington, Ind. Bloomington, Ind., 1879. Pp. 22.
-

DAVID DEMAREE BANTA, Dean of the School of Law, 1890-96. *See Alumni list.*

EARL BARNES, Professor of European History, 1889-90. *See Alumni list.*

CHARLES HENRY BEESON, Tutor in Latin, 1894-95; Instructor in Latin, 1895-96. *See Alumni list.*

SANFORD BELL, Assistant Professor of Pedagogy, 1898-1900. *See Alumni list.*

GEORGE AUGUSTUS BICKNELL, A.B., LL.B., LL.D. (1864). Professor of Law, 1861-70.

1. Commentary on bankrupt law. New York, 1841.
 2. About 250 judicial decisions, as judge of the Second (Indiana) Judicial Circuit (1852-76).
 3. Bicknell's civil practice. Pp. 700, 2d edition, 1871.
 4. Bicknell's criminal practice. Pp. 500, 2d edition, 1871.
-

ERNEST LUDLOW BOGART, A.M., Ph.D. Assistant Professor of Economics and Social Science, 1898-1900. Now Professor of Economics and Sociology, Oberlin College, Oberlin, Ohio.

1. Financial procedure in the State legislatures. *In Ann. Am. Acad. Soc. Pol. Sci.*, VIII, pp. 236-253. (Sept., 1896.)
2. Geschichte der Volkspartei in den Vereinigten Staaten von Nord-Amerika. *In Jahrbücher für Nationalökonomie und Statistik*, LXVII, pp. 577-624. (Oct., 1896.)
3. Die Finanzverhältnisse der Einzelstaaten in den Vereinigten Staaten von Nord-Amerika. Jena, 1897. Pp. xiii, 157.

4. Die Geschichte der Nationalschuld der Vereinigten Staaten von Nord-Amerika. *In* Jahrbücher für Nationalökonomie und Statistik, LXX, pp. 66-88. (Jan., 1898.)

5. Housing of the working people in Yonkers. *In* Economic Studies of Am. Econ. Assoc., III, pp. 373-347. (Oct., 1898.)

6. Public employment bureaus in the United States and Germany. *In* Quart. Jour. Econ., XIV, pp. 341-377. (May, 1900.)

7. Ten or twelve review articles in Political Science Quarterly, Annals of the American Academy, and Jahrbücher für Nationalökonomie.

RICHARD GAUSE BOONE, Ph.D. Professor of Pedagogics, 1886-1893. Now editor of 'Education.'

1. Education in the United States. New York, 1889. Pp. xii, 402.

2. History of education in Indiana. New York, 1892. Pp. xi, 454.

3. Results under an elective system. *In* Educ. Rev., IV, 53-73, 142-156; 16 tables. (June, Sept., 1892.)

JOHN CASPER BRANNER, Professor of Geology, 1885-91. *See* Alumni list.

JAMES RAY McCORKLE BRYANT, Professor of Law, 1856-1861. Died Feb. 25, 1866.

1. A baccalaureate address to the graduating class of the Law Department of Indiana University, March 24, 1858. Bloomington, Ind., 1858. Pp. 19.

DOUGLAS HOUGHTON CAMPBELL, Ph.D. Professor of Botany, 1888-1891. Now Professor of Botany, Leland Stanford Junior University, Stanford University, Cal.

1. The Botanical Institute at Tübingen. *In* Bot. Gaz. for Jan., 1888.

2. The staining of the living nuclei. *In* Untersuchungen aus dem Bot. Inst. zu Tübingen. (1888.)

3. A meeting of the German Botanical Society. *In* Bot. Gaz. for June, 1888.

4. The paraffin imbedding process in botany. *In* Bot. Gaz. for June, 1888.

5. The systematic position of the Rhizocarpeæ. *In* Bull. Tor. Bot. Club for Oct., 1888.

6. Report of the Cleveland meetings of the Botanical Club of the A. A. A. S. *In* Torrey Bull. for Oct., 1888.

7. The development of *Pilularia globulifera*. *In* Ann. of Bot., II, No. 3. (1888.)

8. Einige Notizen über die Keimung von *Marsilia aegyptaca*. *In* Berichte der Deut. Bot. Gesell. for Dec., 1888.

9. On the affinities of the Filicineæ. *In* Bot. Gaz. for Jan., 1890.

10. Studies in cell-division. *In* Bull. Tor. Bot. Club for March, 1890.

11. Elements of structural and systematic botany. New York, 1890.

12. Contributions to the life-history of Isoetes. *In* Ann. Bot., V, pp. 231-258; 6 plates. (1891.)

13. Notes on the apical growth in the roots of *Osmunda* and *Botrychium*. *In* Bot. Gaz., XVI, pp. 37-42; 1 plate. (1891.)

JOHN ROGERS COMMONS, A.M. Professor of Economics and Social Science, Indiana University, 1892-1895. Now Assistant Secretary, National Civic Federation, New York City.

1. The Christian minister and sociology. *In* Lend a Hand, VIII, p. 117. (Feb., 1892.)

2. Proportional representation. *In* Ann. Am. Acad. Pol. Sci., II, pp. 700-707. (March, 1892.)

3. Natural monopolies and protection. *In* Quar. Jour. Econ., VI, pp. 479-484. (July, 1892.)

4. How to abolish the gerrymander. *In Rev. of Rev.*, VI, p. 541. (Dec., 1892.)

5. The church and poverty in cities. *In Charities Rev.*, II, pp. 347-356. (May, 1893.)

6. The distribution of wealth. New York, 1893. Pp. x, 258.

7. Social reform and the church. New York, 1894. Pp. x, 176.

8. State supervision for cities. *In Ann. Am. Acad. Pol. Sci.*, V, pp. 865-881. (May, 1895.)

9. Progressive individualism. *In Am. Mag. Civics*, VI, pp. 561-574. (June, 1895.)

10. Taxation in Chicago and Philadelphia. *In Jour. Pol. Econ.*, III, pp. 434-460. (Sept., 1895.)

JOHN MERLE COULTER, President of the University and Professor of Botany, 1891-93. *See Alumni list.*

RICHARD HEATH DABNEY, Ph.D. Professor of History, 1886-89.

1. The causes of the French revolution. New York, 1888. Pp. x, 297.

WILLIAM MITCHELL DAILY, D.D., LL.D. President of the University, 1853-59. *See Alumni list.*

GEORGE FLAVEL DANFORTH, Ph.B. Librarian, 1898-1903. Bloomington, Ind.

1. Catalogue of the Barnes reference library, Cornell University. Ithaca, N. Y., 1897.

2. United States catalog, books in print, 1899. Bloomington, Ind., 1900. Pp. 1112.

3. Quarterly bibliography of books reviewed in leading periodicals. Bloomington,

Ind., vol. 1 (1902), pp. 207; vol. II (in press).

FLETCHER BASCOM DRESSLAR, Instructor in Psychology, Sept.-Dec., 1892. *See Alumni list.*

FRANK DREW, Instructor in Philosophy, 1895-96. *See Alumni list.*

FRANK ALBERT FETTER, Professor of Economics and Social Science, 1895-98. *See Alumni list.*

SAMUEL GARNER, Professor of Romance Languages, 1882-1887. Now Professor of Romance Languages, U. S. Naval Academy, Annapolis, Md.

1. Review of Julius Siede's 'Syntaktische Eigentümlichkeiten der Umgangssprache weniger gebildeter Pariser.' *In Mod. Lang. Notes*, I, pp. 73-75. (1886.)

2. A much needed reform. *In Mod. Lang. Notes*, I, pp. 52-53. (1886.)

3. Report on Romania. *In Am. Jour. Philol.*, VII, No. 1. (1886.)

4. The gerundial construction in the Romanic languages. *In Mod. Lang. Notes*, II, pp. 109-117. (1887.)

CHARLES HENRY GILBERT, Professor of Zoölogy, 1888-1891. *See Alumni list.*

OLIVER EDMUNDS GLENN, Instructor in Mathematics, 1902-1903. *See Alumni list.*

EDWARD HOWARD GRIGGS, Instructor in English, 1889-90; Associate Professor of English, 1890-91; Professor of General Literature, 1891-93. *See Alumni list.*

BAYNARD RUSH HALL, Principal of Indiana Seminary, 1824-1828; Professor of Ancient Languages, 1828-1831. Died Jan. 23, 1863, at Brooklyn, N. Y.

1. Righteousness the safe-guard and glory of a nation; a sermon preached in the Representative Hall, at Indianapolis, Indiana, December 31, 1826. Pp. 23.

2. Something for everybody. New York, 1846. Pp. viii, 223.

3. The new purchase; or early years in the far West. 1st ed., New York, 1843. Vol. I, pp. 300; vol. II, pp. 316. 2d ed., New Albany, Ind., 1855. Pp. v, 471.

LAUNCELOT MINOR HARRIS, Ph.D. Instructor in English, 1893-94; Assistant Professor of English, 1894-96. Now Professor of English, College of Charleston. Charleston, S. C.

1. The Creoles of New Orleans. *In* Southern Collegian for 1896.

MARTIN LUTHER HOFFMAN, Instructor in Mathematics, 1896-97. *See* Alumni list.

WALTER RALEIGH HOUGHTON, Principal of the Preparatory Department, 1873-84. *See* Alumni list.

JOSEPH HENRY HOWARD, Assistant Professor of Latin, 1894-1901. *See* Alumni list.

GEORGE MAXWELL HOWE, Instructor in German, 1893-95. *See* Alumni list.

ERNEST WILSON HUFFCUT, LL.B., Professor of Law, 1890-92. Now Dean of the School of Law, Cornell University, Ithaca, N. Y.

1. English in the preparatory schools. (Monographs on education.) Boston, 1892. Pp. 28.

JEREMIAH WHIPPLE JENKS, Ph.D. Professor of Economics and Social Science, 1889-1891. Now Professor of Political Economy and Politics, Cornell University, Ithaca, N. Y.

1. Road legislation for the American state. *In* Monog. Am. Econ. Assoc. (May, 1889.)

2. The development of the whiskey trust. *In* Pol. Sci. Quart. for June, 1889.

3. The economic outlook: review of David A. Wells's 'Recent economic changes.' *In* Dial for Dec., 1889.

4. Trusts and the people. *In* Statesman for Dec., 1889.

5. Review of Yeijiuro Ono's 'The industrial transition in Japan' (Monograph of Am. Econ. Asso.). *In* Pol. Sci. Quart. for 1890.

6. The needs of the farmer. *In* Western Home and Farm for Dec., 1890.

7. Review of Theodor Hertzka's 'Freiland.' *In* Pol. Sci. Quart. for Dec., 1890.

8. Schoolbook legislation. *In* Pol. Sci. Quart. for March, 1891.

9. Die Trusts in den Vereinigten Staaten von Amerika. *In* Jahrb. f. Nationalök. u. Stat. for Jan., 1891.

10. Review of J. N. Keynes's 'The scope and method of economic science.' *In* Pol. Sci. Quart. for June, 1891.

11. Land transfer reform. *In* Ann. Am. Acad. Pol. Soc. Sci. for June, 1891.

12. The university extension movement in Indiana. *In* Book Notes for May, 1891.

HANS CARL GÜNTHER VON JAGEMANN, Ph.D. Professor of Germanic Languages and Philology, 1885-1889. Now Professor of Germanic Philology, Harvard University, Cambridge, Mass.

1. On the relation of the Anglo-Norman vowel system to the Norman words in

- English. *In* Trans. Am. Philol. Asso., XV, pp. 66-87. (1884.)
2. On the genitive in old French. *In* Proc. Mod. Lang. Asso., I. (1884.)
 3. On the genitive in old French. *In* Trans. Mod. Lang. Asso. of Am., I, pp. 64-83. (1884-1885.)
 4. On the use of English in teaching foreign languages. *In* Trans. Mod. Lang. Asso. of Am., I, pp. 216-226. (1884-1885.)
 5. On the etymology of *inveigle*. *In* Mod. Lang. Notes, I, pp. 18. (1886.)
 6. Review of E. Courtonne's 'Langue Internationale Néo-Latine.' *In* Mod. Lang. Notes, I, pp. 38-39. (1886.)
 7. Review of E. Pillissier's 'French roots and their families.' *In* Mod. Lang. Notes, I, p. 125. (1886.)
 8. Review of R. Kleinpaul's 'Menschen und Völkernamen.' *In* Science, VII, pp. 403-404. (1886.)
 9. Review of Jean Roemer's 'Origin of the English people and the English language.' *In* Dial for Feb., 1887; also *in* Mod. Lang. Notes for March, 1888.
 10. Review of Balg's 'Comparative glossary of the Gothic language.' *In* Mod. Lang. Notes for April, 1888.
 11. Fouqué's Undine; a new edition, with notes and vocabulary. New York, 1889.
-
- DAVID STARR JORDAN, LL.D. Professor of Biology, 1879-1885; President of the University, 1885-1891. Now President of Leland Stanford Junior University, Stanford University, Cal.
1. The colors of vegetation. *In* Am. Nat., VII, pp. 65-70. (1873.)
 2. Hoof-rot in sheep. *In* Prairie Farmer, 1873.
 3. A popular key to the birds, reptiles, batrachians, and fishes of the Northern United States, east of the Mississippi River. (Joint author with Balfour H. Van Vleck.) Appleton, Wis. Pp. 100. (1874.)
 4. The flora of Penikese island. *In* Am. Nat., VIII, pp. 193-187. (1874.)
 5. A key to the higher algæ of the Atlantic coast between Newfoundland and Florida. *In* Am. Nat., VIII, pp. 398-403, 479-493. (1874.)
 6. The Sisco of lake Tippecanoe. *In* Am. Nat., IX, pp. 135-138. (1875.)
 7. The Sisco of lake Tippecanoe and its relatives. *In* Rep. Geol. Surv. Indiana for 1876.
 8. A synopsis of the fishes to be looked for in Indiana. *In* Rep. Geol. Surv. Indiana for 1876.
 9. The genus *Pomoxys* Rafinesque. (Joint author with Herbert Edson Copeland.) *In* Proc. Acad. Nat. Sci. Philadelphia, XXVIII, pp. 68-71. (1876.)
 10. Concerning the fishes of the Ichthyologia Ohiensis. *In* Bull. Buffalo Soc. Nat. Hist., 1876, pp. 91-97. (1876.)
 11. Manual of the vertebrates of the Northern United States, including the district east of the Mississippi river and north of North Carolina and Tennessee, exclusive of marine species. Chicago, 1876.
 12. Johnny darters. (Joint author with H. E. Copeland.) *In* Am. Nat., X, pp. 335-341. (1876.)
 13. The sand-darter. (Joint author with H. E. Copeland.) *In* Am. Nat., XI, pp. 86-88. (1877.)
 14. List of fishes of Indiana. (Joint author with Charles Henry Gilbert.) *In* Indiana Farmer, Jan. 17, 1877.
 15. A story of a stone. *In* St. Nicholas, Feb. 1877.
 16. Check-list of the fishes of the fresh waters of North America. (Joint author with H. E. Copeland.) *In* Bull. Buffalo Soc. Nat. Hist., II, pp. 33-164. (1877.)
 17. On the fishes of Northern Indiana. *In* Proc. Acad. Nat. Sci. Philadelphia, XXIX, pp. 42-82. (1877.)

18. On the genera of North American fresh-water fishes. (Joint author with C. H. Gilbert.) *In Proc. Acad. Nat. Sci. Philadelphia*, XXIX, pp. 83-104. (1877.)
19. A partial synopsis of the fishes of Upper Georgia. *In Ann. Lyc. Nat. Hist., New York*, XI, pp. 307-377. (1877.)
20. Contributions to North American ichthyology, I. Review of Rafinesque's 'Memoirs on North American fishes.' *In Bull. U. S. Nat. Mus.*, IX, p. 53. (1877.)
21. Contributions to North American ichthyology, II. A. Notes on Cottidæ, Etheostomatidæ, Percidæ, Centrarchidæ, etc., with revisions of genera and descriptions of new or little known species. B. Synopsis of the Siluridæ of the United States. *In Bull. U. S. Nat. Mus.*, X, p. 116. (1877.)
22. On *Lagochila*, a new genus of catostomoid fishes. (Joint author with Alenbert Winthrop Brayton.) *In Proc. Acad. Nat. Sci., Phila.*, XXIX, pp. 280-283. (1877.)
23. On the distribution of fresh-water fishes. *In Am. Nat.*, XI, pp. 607-613. (1877.)
24. On the distribution of fresh-water fishes of the United States. *In Ann. N. Y. Acad. Sci.*, I, pp. 92-120. (1878.)
25. A catalogue of the fishes of Illinois. *In Illinois Lab. Nat. Hist.*, II. (1878.)
26. Catalogue of the fishes of Indiana. *In 27th Ann. Rep. Indiana State Board of Agr.* for 1877, XIX. (1878.)
27. Manual of the vertebrates of the Northern United States, including the district east of the Mississippi river and north of North Carolina and Tennessee, exclusive of marine species. Second edition, revised and enlarged. Chicago, 1878. Pp. 407.
28. Contributions to North American ichthyology, based primarily on the collections of the U. S. Nat. Mus. III. (Joint author with A. W. Brayton.) A. On the distribution of the fishes of the Alleghany region of South Carolina, Georgia, and Tennessee, with descriptions of new or little known species. B. A synopsis of the family Catostomidæ. *In Bull. U. S. Nat. Mus.*, XII, p. 237. (1878.)
29. Notes on a collection of fishes from Clackamas river, Oregon. *In Proc. U. S. Nat. Mus.*, I, pp. 69-119. (1878.)
30. Notes on a collection of fishes from the Rio Grande at Brownsville, Texas. *In Bull. U. S. Geol. Surv. Ter.*, IV, pp. 397-406. (1878.)
31. A catalogue of the fishes of the fresh waters of North America. *In Bull. U. S. Geol. Surv. Ter.*, IV, pp. 407-442. (1878.)
32. Notes on a collection of fishes from the Rio Grande at Brownsville, Texas, continued. *In Bull. U. S. Geol. Surv. Ter.*, IV, pp. 663-667.
33. Report on the collection of fishes made by Dr. Elliott Coues, U. S. A., in Dakota and Montana, during the seasons of 1873 and 1874. *In Bull. U. S. Geol. Surv.*, IV, pp. 777-799. (1878.)
34. Report on the fishes collected during the years 1875, 1876, and 1877, in California and Nevada. (Joint author with Henry W. Henshaw.) *In Rep. Geol. Surv. W. 100th Mer.*, for 1878. Appendix K, pp. 187-200.
35. Notes on the fishes of Beaufort Harbor, North Carolina. (Joint author with C. H. Gilbert.) *In Proc. U. S. Nat. Mus.*, I, 365-388. (1879.)
36. Notes on certain typical specimens of American fishes in the British Museum and in the Muséum d'Histoire Naturelle at Paris. *In Proc. U. S. Nat. Mus.*, II, pp. 218-226. (1880.)
37. Description of new species of North American fishes. *In Proc. U. S. Nat. Mus.*, II, pp. 235-241. (1880.)
38. Notes on a collection of fishes obtained in the streams of Guanajuato, and in Chapala lake, Mexico, by Prof. A. Dugès.

In Proc. U. S. Nat. Mus., II, pp. 298-301. (1880.)

39. Manual of the vertebrates of the Northern United States, including the district east of the Mississippi river and north of North Carolina and Tennessee, exclusive of marine species. Third edition, revised and enlarged. Chicago, 1880, p. 406.

40. Notes on a collection of fishes from East Florida, obtained by Dr. J. A. Henshall. *In Proc. U. S. Nat. Mus.*, III, pp. 17-21. (1880.)

41. Notes on a collection of fishes from St. John's river, Florida, obtained by Mr. A. H. Curtiss. *In Proc. U. S. Nat. Mus.*, III, p. 22. (1880.)

42. Notes on a collection of fishes from San Diego, California. (Joint author with C. H. Gilbert.) *In Proc. U. S. Nat. Mus.*, III, pp. 23-34. (1880.)

43. Description of a new flounder (*Xystreureys lolepis*) from Santa Catalina island, California. (Joint author with C. H. Gilbert.) *In Proc. U. S. Nat. Mus.*, III, pp. 34-36. (1880.)

44. Description of a new ray (*Platyrrhina triseriata*) from the coast of California. (Joint author with C. H. Gilbert.) *In Proc. U. S. Nat. Mus.*, III, pp. 36-38. (1880.)

45. Description of a new species of rock cod (*Sebastichthys serriceps*) from the coast of California. (Joint author with C. H. Gilbert.) *In Proc. U. S. Nat. Mus.*, III, pp. 38-40. (1880.)

46. On the occurrence of *Cephaloscyllium laticeps* (Duméril) Gill on the coast of California. (Joint author with C. H. Gilbert.) *In Proc. U. S. Nat. Mus.*, III, pp. 40-42. (1880.)

47. On the oil shark of Southern California (*Galeorhinus galeus*). (Joint author with C. H. Gilbert.) *In Proc. U. S. Nat. Mus.*, III, pp. 42-43. (1880.)

48. Description of a new flounder (*Pleuronichthys verticalis*) from the coast

of California, with notes on other species. (Joint author with C. H. Gilbert.) *In Proc. U. S. Nat. Mus.*, III, pp. 49-51. (1880.)

49. Notes on sharks from the coast of California. (Joint author with C. H. Gilbert.) *In Proc. U. S. Nat. Mus.*, III, pp. 51-52. (1880.)

50. On the generic relations of *Platyrrhina exasperata*. (Joint author with C. H. Gilbert.) *In Proc. U. S. Nat. Mus.*, III, p. 53. (1880.)

51. Description of a new species of *Sebastichthys* (*Sebastichthys miniatus*) from Monterey Bay, California. (Joint author with C. H. Gilbert.) *In Proc. U. S. Nat. Mus.*, III, pp. 70-73. (1880.)

52. Description of a new species of rockfish (*Sebastichthys carnatus*) from the coast of California. (Joint author with C. H. Gilbert.) *In Proc. U. S. Nat. Mus.*, III, pp. 73-75. (1880.)

53. Description of a new species of ray (*Raja stellulata*) from Monterey, California. (Joint author with C. H. Gilbert.) *In Proc. U. S. Nat. Mus.*, pp. 133-135. (1880.)

54. Description of new species of *Xiphister* and *Apodichthys*, from Monterey, California. (Joint author with C. H. Gilbert.) *In Proc. U. S. Nat. Mus.*, III, pp. 135-140. (1880.)

55. Description of two new species of *Sebastichthys* (*Sebastichthys entomelas* and *Sebastichthys rhodochloris*) from Monterey Bay, California. (Joint author with C. H. Gilbert.) *In Proc. U. S. Nat. Mus.*, III, pp. 142-146. (1880.)

56. Description of a new Agonoid fish (*Brachyopsis xyosternus*) from Monterey Bay, California. (Joint author with C. H. Gilbert.) *In Proc. U. S. Nat. Mus.*, III, pp. 152-154. (1880.)

57. Description of a new flounder (*Hippoglossoides exilis*) from the coast of California. (Joint author with C. H. Gil-

bert.) *In Proc. U. S. Nat. Mus.*, III, pp. 154-156. (1880.)

58. Description of a new species of ray (*Raia rhina*) from the coast of California. (Joint author with C. H. Gilbert.) *In Proc. U. S. Nat. Mus.*, III, pp. 251-253. (1880.)

59. Description of two new species of fishes (*Ascelichthys rhodorus* and *Scytalina cerdale*) from Neah Bay, Washington territory. (Joint author with C. H. Gilbert.) *In Proc. U. S. Nat. Mus.*, III, pp. 264-268. (1880.)

60. Description of two new species of Scopeloid fishes (*Sudis ringens* and *Myctophum crenulare*) from Santa Barbara Channel, California. (Joint author with C. H. Gilbert.) *In Proc. U. S. Nat. Mus.*, III, pp. 273-276. (1880.)

61. Description of two new species of flounders (*Parophrys ischyryus* and *Hippoglossoides elassodon*) from Puget Sound. (Joint author with C. H. Gilbert.) *In Proc. U. S. Nat. Mus.*, III, pp. 276-280. (1880.)

62. Description of seven new species of Sebastoid fishes from the coast of California. (Joint author with C. H. Gilbert.) *In Proc. U. S. Nat. Mus.*, III, pp. 287-298. (1880.)

63. Description of a new Embiotocoid (*Abeona aurora*) from Monterey, California, with notes on a related species. (Joint author with C. H. Gilbert.) *In Proc. U. S. Nat. Mus.*, III, pp. 299-301. (1880.)

64. Description of a new flounder (*Platysomatichthys stomias*) from the coast of California. (Joint author with C. H. Gilbert.) *In Proc. U. S. Nat. Mus.*, III, pp. 301-303. (1880.)

65. Description of a new Embiotocoid fish (*Cymatogaster rosaceus*) from the coast of California. (Joint author with C. H. Gilbert.) *In Proc. U. S. Nat. Mus.*, III, pp. 303-305. (1880.)

66. Description of a new species of deep-water fish (*Ichthys lockingtoni*) from

the coast of California. (Joint author with C. H. Gilbert.) *In Proc. U. S. Nat. Mus.*, III, pp. 305-308. (1880.)

67. Description of a new Embiotocoid fish (*Ditrema atripes*) from the coast of California. (Joint author with C. H. Gilbert.) *In Proc. U. S. Nat. Mus.*, III, pp. 320-322. (1880.)

68. Description of a new Scorpaenoid fish (*Sebastichthys maliger*) from the coast of California. (Joint author with C. H. Gilbert.) *In Proc. U. S. Nat. Mus.*, III, pp. 322-324. (1880.)

69. Notes on a forgotten paper of Dr. Ayres, and its bearing on the nomenclature of the Cyprinoid fishes of the San Francisco markets. *In Proc. U. S. Nat. Mus.*, III, pp. 325-327. (1880.)

70. Notes on *Sema* and *Dacentrus*. *In Proc. U. S. Nat. Mus.*, III, p. 327. (1880.)

71. Description of a new Scorpaenoid fish (*Sebastichthys proriger*) from Monterey Bay, California. (Joint author with C. H. Gilbert.) *In Proc. U. S. Nat. Mus.*, III, pp. 327-329. (1880.)

72. Description of a new Agonoid (*Agonus vulsus*) from the coast of California. (Joint author with C. H. Gilbert.) *In Proc. U. S. Nat. Mus.*, III, pp. 330-332. (1880.)

73. Description of a new species of Hemirhamphus (*Hemirhamphus rosæ*) from the coast of California. (Joint author with C. H. Gilbert.) *In Proc. U. S. Nat. Mus.*, III, pp. 335-336. (1880.)

74. Description of a new species of Notidanoid shark (*Hexanchus corinus*) from the Pacific coast of the United States. (Joint author with C. H. Gilbert.) *In Proc. U. S. Nat. Mus.*, III, pp. 352-355. (1880.)

75. Scientific names of the black bass. *In Forest and Stream*, Nov. 28, 1880, p. 340. (Reprinted in Henshall's 'Book of the black bass.')

76. Description of a new species of

Nemichthys (*Nemichthys avocetta*) from Puget Sound. (Joint author with C. H. Gilbert.) *In Proc. U. S. Nat. Mus.*, III, 409-410. (1881.)

77. Description of a new species of *Paralepis* (*Paralepis coruscans*) from the Straits of Juan de Fuca. (Joint author with C. H. Gilbert.) *In Proc. U. S. Nat. Mus.*, pp. 411-413. (1881.)

78. List of the fishes of the Pacific coast of the United States, with a table showing the distribution of the species. (Joint author with C. H. Gilbert.) *In Proc. U. S. Nat. Mus.*, III, pp. 452-458. (1881.)

79. On the generic relations of *Belone exilis* Grd. (Joint author with C. H. Gilbert.) *In Proc. U. S. Nat. Mus.*, III, p. 459. (1881.)

80. Notes on a collection of fishes from Utah Lake. (Joint author with C. H. Gilbert.) *In Proc. U. S. Nat. Mus.*, III, pp. 459-465. (1881.)

81. Description of a new species of rock fish (*Sebastichthys chrysomelas*) from the coast of California. (Joint author with C. H. Gilbert.) *In Proc. U. S. Nat. Mus.*, III, p. 465. (1881.)

82. Description of a new species of *Caranax* (*Caranax beani*) from Beaufort, North Carolina. *In Proc. U. S. Nat. Mus.*, III, pp. 486-488. (1881.)

83. Observations on the salmon of the Pacific. (Joint author with C. H. Gilbert.) *In Am. Nat.*, XV, pp. 177-186. (1881.)

84. Check-list of duplicates of fishes from the Pacific coast of North America, distributed by the Smithsonian Institution in behalf of the U. S. Nat. Mus. (Joint author with Pierre Louis Jouy.) *In Proc. U. S. Nat. Mus.*, IV, pp. 1-18. (1881.)

85. Notes on the fishes of the Pacific coast of the United States. (Joint author with C. H. Gilbert.) *In Proc. U. S. Nat. Mus.*, IV, p. 29-70. (1881.)

86. Description of *Sebastichthys mystinus*. (Joint author with C. H. Gilbert.)

In Proc. U. S. Nat. Mus., IV, pp. 70-72. (1881.)

87. Description of a new species of *Ptychochilus* (*Ptychochilus harfordi*) from Sacramento river. (Joint author with C. H. Gilbert.) *In Proc. U. S. Nat. Mus.*, IV, pp. 72-73. (1881.)

88. Note on *Raia inornata*. (Joint author with C. H. Gilbert.) *In Proc. U. S. Nat. Mus.*, IV, pp. 73-74. (1881.)

89. Story of a salmon. *In Pop. Sci. Mo.*, XIX, pp. 1-6. (1881.)

90. On the movements of plants. Review of Darwin's 'Power of movement in plants.' *In Dial*, March, 1881.

91. Notes on a collection of fishes made by Lieut. Henry E. Nichols, U. S. N., on the west coast of Mexico, with descriptions of new species. (Joint author with C. H. Gilbert.) *In Proc. U. S. Nat. Mus.*, IV, pp. 225-233. (1881.)

92. List of fishes collected by Lieut. Henry E. Nichols, U. S. N., in the Gulf of California, and on the west coast of Lower California, with descriptions of four new species. (Joint author with C. H. Gilbert.) *In Proc. U. S. Nat. Mus.*, IV, pp. 273-279. (1882.)

93. Description of thirty-three new species of fishes from Mazatlan, Mexico. (Joint author with C. H. Gilbert.) *In Proc. U. S. Nat. Mus.*, IV, pp. 338-365. (1882.)

94. Description of a new species of *Pomadasy*s from Mazatlan, with a key to the species known to inhabit the Pacific coasts of tropical America. (Joint author with C. H. Gilbert.) *In Proc. U. S. Nat. Mus.*, IV, pp. 383-388. (1882.)

95. Description of a new species of *Xenichthys* (*Xenichthys xenurus*) from the west coast of Central America. (Joint author with C. H. Gilbert.) *In Proc. U. S. Nat. Mus.*, IV, p. 454. (1882.)

96. Descriptions of five new species of fishes from Mazatlan, Mexico. (Joint

author with C. H. Gilbert.) *In Proc. U. S. Nat. Mus.*, IV, pp. 458-463. (1882.)

97. Ascent of the Matterhorn. *In Our Continent*, Nov. 2, 1882.

98. Description of four new species of sharks from Mazatlan, Mexico. (Joint author with C. H. Gilbert.) *In Proc. U. S. Nat. Mus.*, V, pp. 102-110. (1882.)

99. Description of a new shark (*Carcharias lamiella*) from San Diego, California. (Joint author with C. H. Gilbert.) *In Proc. U. S. Nat. Mus.*, V, pp. 110-111. (1882.)

100. Bull-trout and Pompano. *In Forest and Stream*, April 20, 1882.

101. Darwin. *In Dial*, May 2, 1882.

102. Review of Huxley's 'Science and culture.' *In Dial*, May 9, 1882.

103. Descriptions of nineteen new species of fishes from the Bay of Panama. (Joint author with C. H. Gilbert.) *In Bull. U. S. Fish Comm.*, I, pp. 306-335. (1882.)

104. Some ichthyological terms. *In Forest and Stream*, Aug. 20, 1882.

105. The air we breathe. Review of Tyndall's 'Floating matter in the air.' *In Dial*, Sept., 1882, pp. 90-93.

106. Description of a new Cyprinodont (*Zygonectes inurus*) from southern Illinois. (Joint author with C. H. Gilbert.) *In Proc. U. S. Nat. Mus.*, V, pp. 143-144. (1882.)

107. Description of a new species of Uranidea (*Uranidea pollicaris*) from Lake Michigan. (Joint author with C. H. Gilbert.) *In Proc. U. S. Nat. Mus.*, V, pp. 222-223. (1882.)

108. Notes on fishes observed about Pensacola, Florida, and Galveston, Texas, with description of new species. (Joint author with C. H. Gilbert.) *In Proc. U. S. Nat. Mus.*, V, pp. 241-307. (1882.)

109. Description of a new species of Blenny (*Isesthes gilberti*) from Santa Barbara, California. *In Proc. U. S. Nat. Mus.*, V, pp. 349-351. (1882.)

110. Description of a new species of Con-

don (*Condon serrifer*) from Boca Soledad, Lower California. (Joint author with C. H. Gilbert.) *In Proc. U. S. Nat. Mus.*, V, pp. 351-352. (1882.)

111. Catalogue of the fishes collected by Mr. John Xantus at Cape San Lucas, which are now in the United States National Museum, with descriptions of eight new species. (Joint author with C. H. Gilbert.) *In Proc. U. S. Nat. Mus.*, V, pp. 353-371. (1882.)

112. List of fishes collected by Mr. John Xantus at Colima, Mexico. (Joint author with C. H. Gilbert.) *In Proc. U. S. Nat. Mus.*, V, pp. 371-372. (1882.)

113. List of fishes collected at Panama by Capt. John M. Dow, now in the United States National Museum. (Joint author with C. H. Gilbert.) *In Proc. U. S. Nat. Mus.*, V, pp. 373-378. (1882.)

114. List of a collection of fishes made by Mr. L. Belding, near Cape San Lucas, Lower California. (Joint author with C. H. Gilbert.) *In Proc. U. S. Nat. Mus.*, V, pp. 378-381. (1882.)

115. List of fishes collected at Panama by Rev. Mr. Rowell, now preserved in the United States National Museum. (Joint author with C. H. Gilbert.) *In Proc. U. S. Nat. Mus.*, V, pp. 381-382. (1882.)

116. Descriptions of two new species of fishes (*Sebastichthys umbrosus* and *Citharichthys stigmæus*) collected at Santa Barbara, California, by Andrea Larco. *In Proc. U. S. Nat. Mus.*, V, pp. 410-412. (1882.)

117. The Gasper-Gou. *In Forest and Stream*, Oct. 5, 1882, p. 192.

118. A review of the Siluroid fishes found on the Pacific coast of tropical America, with descriptions of three new species. (Joint author with C. H. Gilbert.) *In Bull. U. S. Fish Comm.*, II, pp. 34-54. (1882.)

119. List of fishes collected at Mazatlan, Mexico, by C. H. Gilbert. (Joint author with C. H. Gilbert.) *In Bull. U. S. Fish Comm.*, II, pp. 105-108. (1882.)

120. List of fishes collected at Panama

- by C. H. Gilbert. (Joint author with C. H. Gilbert.) *In* Bull. U. S. Fish Comm., II, pp. 109-111. (1882.)
121. Description of a new species of Goby (*Gobiosoma ios*) from Vancouver's island. (Joint author with C. H. Gilbert.) *In* Proc. U. S. Nat. Mus., V, pp. 437-438. (1882.)
122. The blue-back trout (*Salvelinus oquassa*). *In* Forest and Stream, Dec., 1882, p. 389.
123. Dr. Henshall's scientific nomenclature again. *In* Am. Angler, Dec. 16, 1882, p. 391.
124. The nomenclature of our birds. Review of the Coues check-list. *In* Dial, Dec., 1882, pp. 165-167.
125. Report on the fishes of Ohio. *In* Rep. Geol. Surv. Ohio, sec. IV, vol. IV, pp. 735-1002. (1882.)
126. On certain neglected generic names of Lacépède. (Joint author with C. H. Gilbert.) *In* Proc. U. S. Nat. Mus., V, pp. 570-576. (1883.)
127. On the synonymy of the genus *Bothus Rafinesque*. (Joint author with C. H. Gilbert.) *In* Proc. U. S. Nat. Mus., V, pp. 576-577. (1883.)
128. Description of a new species of *Artedius* (*Artedius fenestralis*) from Puget Sound. (Joint author with C. H. Gilbert.) *In* Proc. U. S. Nat. Mus., V, pp. 577-579. (1883.)
129. Description of a new species of *Urophophus* (*U. asterias*) from Mazatlan and Panama. (Joint author with C. H. Gilbert.) *In* Proc. U. S. Nat. Mus., V, pp. 579-580. (1883.)
130. Notes on a collection of fishes from Charleston, South Carolina, with descriptions of three new species. (Joint author with C. H. Gilbert.) *In* Proc. U. S. Nat. Mus., V, pp. 580-620. (1883.)
131. List of fishes now in the museum of Yale College, collected by Prof. Frank H. Bradley at Panama, with descriptions of three new species. (Joint author with C. H. Gilbert.) *In* Proc. U. S. Nat. Mus., V, pp. 620-632. (1883.)
132. Description of two new species of fishes (*Myrophis vafer* and *Chloroscombrus orqueta*) from Panama. (Joint author with C. H. Gilbert.) *In* Proc. U. S. Nat. Mus., V, pp. 645-647. (1883.)
133. Description of a new eel (*Sidera castanea*) from Mazatlan, Mexico. (Joint author with C. H. Gilbert.) *In* Proc. U. S. Nat. Mus., V, pp. 647-648. (1883.)
134. On the nomenclature of the genus *Ophichthys*. (Joint author with C. H. Gilbert.) *In* Proc. U. S. Nat. Mus., V, pp. 648-651. (1883.)
135. Striped bass or rock-fish. *In* Forest and Stream, Jan. 4, 1883, p. 450.
136. New methods of anatomical dissection. Review of Wilder and Gage's 'Anatomical technology as applied to the domestic cat.' *In* Dial, Jan., 1883, pp. 202-203.
137. Contributions to North American ichthyology, based primarily on the collections of the U. S. National Museum. IV. A synopsis of the fishes of North America. (Joint author with C. H. Gilbert.) *In* Bull. U. S. Nat. Mus., XVI, p. 1145. (1883.)
138. Notes on the nomenclature of certain North American fishes. (Joint author with C. H. Gilbert.) *In* Proc. U. S. Nat. Mus., VI, pp. 110-111. (1883.)
139. Description of two new species of fishes (*Aprion ariommus* and *Ophidium beani*) from Pensacola, Florida. (Joint author with C. H. Gilbert.) *In* Proc. U. S. Nat. Mus., VI, pp. 142-144. (1883.)
140. A review of the American *Caranginae*. (Joint author with C. H. Gilbert.) *In* Proc. U. S. Nat. Mus., VI, pp. 198-207. (1883.)
141. Note on the genera of *Petromyzontidae*. (Joint author with C. H. Gilbert.) *In* Proc. U. S. Nat. Mus., VI, p. 208. (1883.)

142. Description of a new Murænid eel (*Sidera chleavastes*) from the Galapagos islands. (Joint author with C. H. Gilbert.) *In Proc. U. S. Nat. Mus.*, VI, pp. 208-210. (1883.)
143. Description of a new species of *Rhinobatus* (*Rhinobatus glaucostigma*) from Mazatlan, Mexico. (Joint author with C. H. Gilbert.) *In Proc. U. S. Nat. Mus.*, VI, pp. 210-211. (1883.)
144. List of fishes collected in the Clear Fork of the Cumberland, Whitley county, Kentucky, with descriptions of three new species. (Joint author with Joseph Swain.) *In Proc. U. S. Nat. Mus.*, VI, pp. 248-251. (1883.)
145. Notes on American fishes, preserved in the museums of London, Paris, Berlin, and Copenhagen. *In Proc. Acad. Nat. Sci., Phila.*, XXXV, pp. 281-293. (1883.)
146. Review of Boulenger's 'Catalogue of Batrachia gradientia in the British Museum.' *In Science*, II, pp. 810. (1883.)
147. Sketch of Felipe Poey. *In Pop. Sci. Mo.*, XXV, pp. 547-552. (1884.)
148. Some gossip about Darwin. *In Am. Nat.*, XVIII, p. 108. (1884.)
149. The beginning of life. Review of G. Hilton Scribner's 'Where did life begin?' *In Science*, III, p. 264. (1884.)
150. Review of Yarrow's check-list of North American reptilia and batrachia. *In Science*, III, p. 264. (1884.)
151. The fishes of the Florida Keys. *In Bull. U. S. Fish Comm.*, IV, pp. 77-80. (1884.)
152. Proposed propagation of catfish as a food-fish. *In Bull. U. S. Fish Comm.*, IV, p. 292. (1884.)
153. Notes on fishes improperly included in the fauna of the United States. *In Proc. Acad. Nat. Sci. Phila.*, XXXVI, pp. 99-103. (1884.)
154. A review of the species of the genus *Calamus*. (Joint author with C. H. Gilbert.) *In Proc. U. S. Nat. Mus.*, VII, pp. 14-24. (1884.)
155. Descriptions of ten new species of fishes from Key West, Florida. (Joint author with C. H. Gilbert.) *In Proc. U. S. Nat. Mus.*, VII, pp. 24-32. (1884.)
156. Note on *Caranx ruber* and *Caranx bartholomæi*. (Joint author with C. H. Gilbert.) *In Proc. U. S. Nat. Mus.*, VII, pp. 32-33. (1884.)
157. Notes on a collection of fishes from Pensacola, Florida, obtained by Silas Stearns, with descriptions of two new species (*Exocætus volador* and *Gnathypops mystacinus*.) *In Proc. U. S. Nat. Mus.*, VII, pp. 33-40. (1884.)
158. Notes on *Ælurichthys eydouxii* and *Porichthys porosissimus*. *In Proc. U. S. Nat. Mus.*, VII, pp. 40-41. (1884.)
159. List of fishes from Egmont Key, Florida, in the museum of Yale College, with description of two new species. *In Proc. Acad. Nat. Sci., Phila.*, XXXVI, pp. 42-46. (1884.)
160. The Canadian sea trout (*Salvelinus fontinalis immaculatus*). *In Am. Field*, July, 1884.
161. The rainbow trout (*Salmo gairdneri irideus*). *In Forest and Stream*, July, 1884.
162. Note on *Calamus proridens*, a new species of *Calamus*. (Joint author with C. H. Gilbert.) *In Proc. U. S. Nat. Mus.*, VII, p. 150. (1884.)
163. Descriptions of Scaroid fishes from Havana and Key West, including five new species. (Joint author with J. Swain.) *In Proc. U. S. Nat. Mus.*, VII, pp. 81-102. (1884.)
164. List of fishes collected at Key West, Florida, with notes and descriptions. *In Proc. U. S. Nat. Mus.*, VII, pp. 81-102. (1884.)
165. An identification of the figures of fishes in Catesby's 'Natural history of Carolina, Florida, and the Bahama islands.' *In*

Proc. U. S. Nat. Mus., VII, pp. 190-199. (1884.)

166. Notes on fishes collected by D. S. Jordan at Cedar Keys, Florida. (Joint author with J. Swain.) *In Proc. U. S. Nat. Mus.*, VII, pp. 230-234. (1884.)

167. List of fishes observed in the St. John's river at Jacksonville, Florida. (Joint author with Seth Eugene Meek.) *In Proc. U. S. Nat. Mus.*, VII, pp. 235-237. (1884.)

168. Notes on fishes collected at Guaymas, Mexico, by Mr. H. V. Emeric, with a description of *Gobiosoma histrio*, a new species. *In Proc. U. S. Nat. Mus.*, VII, pp. 260-261. (1884.)

169. A review of the American species of marine Mugilidæ. (Joint author with J. Swain.) *In Proc. U. S. Nat. Mus.*, VII, pp. 261-275. (1884.)

170. A review of the species of the genus *Hæmulon*. (Joint author with J. Swain.) *In Proc. U. S. Nat. Mus.*, VII, pp. 281-317. (1884.)

171. List of fishes collected in the vicinity of New Orleans by Dr. R. W. Shufeldt, U. S. A. *In Proc. U. S. Nat. Mus.*, VII, pp. 318-322. (1884.)

172. List of fishes collected in lake Jessup and Indiana river, Florida, by Mr. R. E. Earll, with descriptions of two new species. *In Proc. U. S. Nat. Mus.*, VII, pp. 322-324. (1884.)

173. A review of the American species of *Epinephelus* and related genera. (Joint author with J. Swain.) *In Proc. U. S. Nat. Mus.*, VII, pp. 358-410. (1884.)

174. A review of the species *Lutjaninæ* and *Hoplopagrînæ* found in American waters. (Joint author with J. Swain.) *In Proc. U. S. Nat. Mus.*, VII, pp. 427-474. (1884.)

175. Description of four new species of *Cyprinidæ* in the United States National Museum. (Joint author with S. E. Meek.)

In Proc. U. S. Nat. Mus., VII, pp. 474-477. (1884.)

176. Description of four new species of *Pœcilichthys* in the United States National Museum. *In Proc. U. S. Nat. Mus.*, VII, pp. 477-480. (1884.)

177. Description of *Sciæna sciera*, a new species of *Sciæna* from Mazatlan and Panama. (Joint author with C. H. Gilbert.) *In Proc. U. S. Nat. Mus.*, VII, p. 480. (1884.)

178. Description of *Zygonectes zonifer*, a new species of *Zygonectes* from Nashville, Georgia. (Joint author with S. E. Meek.) *In Proc. U. S. Nat. Mus.*, VII, p. 482. (1885.)

179. Description of three new species of fishes (*Prionotus stearnsi*, *Prionotus ophryas*, and *Anthias vivanus*) collected at Pensacola by Mr. Silas Stearns. (Joint author with J. Swain.) *In Proc. U. S. Nat. Mus.*, VII, pp. 541-545. (1885.)

180. Supplementary notes on North American fishes. *In Proc. U. S. Nat. Mus.*, VII, pp. 545-548. (1885.)

181. Description of a new species of *Hybognathus* (*Hybognathus hayi*) from Mississippi. *In Proc. U. S. Nat. Mus.*, VII, pp. 548-550. (1885.)

182. List of fishes collected in Iowa and Missouri in August, 1884, with descriptions of three new species. (Joint author with S. E. Meek.) *In Proc. U. S. Nat. Mus.*, VIII, pp. 1-17. (1885.)

183. A review of the American species of flying fishes (*Exocætus*). (Joint author with S. E. Meek.) *In Proc. U. S. Nat. Mus.*, VIII, 44-67. (1885.)

184. Notes on skeletons of *Etheostomatinae*. (Joint author with C. H. Eigenmann.) *In Proc. U. S. Nat. Mus.*, VIII, pp. 68-72. (1885.)

185. Note on the scientific name of the yellow perch, the striped bass, and other North American fishes. *In Proc. U. S. Nat. Mus.*, VIII, pp. 72-73. (1885.)

186. Note on Mr. Garman's paper on the American salmon and trout. *In Proc. U. S. Nat. Mus.*, VIII, pp. 81-83. (1885.)

187. Identification of the species of Cyprinidæ and Catostomidæ, described by Dr. Charles Girard in *Proc. Acad. Nat. Sci., Phila.*, 1856. *In Proc. U. S. Nat. Mus.*, VIII, pp. 118-127. (1885.)

188. On the *Etheostoma variatum* of Kirtland. *In Proc. U. S. Nat. Mus.*, VIII, pp. 163-165. (1885.)

189. Note on *Epinephelus nigritus*. *In Proc. U. S. Nat. Mus.*, VIII, pp. 208-209. (1885.)

190. A catalogue of the fishes known to inhabit the waters of North America north of the Tropic of Cancer, with notes on the species discovered in 1883 and 1884. Washington: Government Printing Office, Oct., 1885. (Also *in Rep. U. S. Fish Comm.*, XIII, pp. 789-973.) (1885.)

191. A list of the fishes known from the Pacific coast of tropical America, from the Tropic of Cancer to Panama. *In Proc. U. S. Nat. Mus.*, VIII, pp. 361-394. (1885.)

192. Note on some Linnæan names of American fishes. *In Proc. U. S. Nat. Mus.*, VIII, pp. 394-396. (1885.)

193. The habits and the value for food of the American channel catfish (*Ictalurus punctatus*, Rafinesque.) *In Bull. U. S. Fish Comm.*, V, p. 34. (1885.)

194. Notes on fishes observed in Lake Superior. *In Bull. U. S. Fish Comm.*, V, pp. 191-192. (1885.)

195. The mountain or salmon trout of Oregon. *In Bull. U. S. Fish Comm.*, V, p. 310. (1885.)

196. The fisheries and fishery industries of the United States. Prepared through the coöperation of the Commissioner of Fisheries and the Superintendent of the Tenth Census, by George Brown Goode, Assistant Director of the U. S. National Museum, and a staff of associates. Section 1, Natural history of useful aquatic animals, with an

atlas of 227 plates. Washington: Government Printing Office, 1884 (Feb., 1885). Pp. 895. (Discussions of fresh-water fishes, chiefly by David S. Jordan; of Pacific coast fishes, in collaboration with C. H. Gilbert.)

197. A manual of the vertebrates of the eastern United States, including the region east of the Mississippi river and north of the northern boundary of North Carolina and Tennessee, exclusive of marine species. Fourth edition, revised and enlarged. Chicago, 1885.

198. The standard natural history, III, 110-173. (Part relating to soft-rayed fishes.) Boston, 1885.

199. List of fishes collected in Arkansas, Indian Territory, and Texas, in September, 1884, with notes and descriptions. (Joint author with C. H. Gilbert.) *In Proc. U. S. Nat. Mus.*, IX, pp. 1-25. (1886.)

200. Notes on fishes collected at Beaufort, North Carolina, with a revised list of the species known from that locality. *In Proc. U. S. Nat. Mus.*, IX, pp. 25-30. (1886.)

201. List of fishes collected at Havana, Cuba, in December, 1883, with notes and descriptions. *In Proc. U. S. Nat. Mus.*, IX, pp. 31-55. (1886.)

202. A review of the genera and species of Julidinae found in American waters. (Joint author with Elizabeth G. Hughes.) *In Proc. U. S. Nat. Mus.*, IX, pp. 56-70. (1886.)

203. Notes on some fishes collected at Pensacola, by Mr. Silas Stearns, with descriptions of one new species (*Chaetodon aya*). *In Proc. U. S. Nat. Mus.*, IX, pp. 225-229. (1886.)

204. A review of the American species of Tetraodontidæ. (Joint author with Charles L. Edwards.) *In Proc. U. S. Nat. Mus.*, IX, pp. 230-247. (1886.)

205. Rafinesque. *In Pop. Sci. Mo.*, XXIX, pp. 212-221. (1886.)

206. A review of the American species of the genus *Prionotus*. (Joint author with Elizabeth G. Hughes.) *In Proc. U. S. Nat. Mus.*, IX, pp. 327-338. (1886.)
207. A review of the American species of *Belonidæ*. (Joint author with W. For-dice.) *In Proc. U. S. Nat. Mus.*, IX, pp. 339-361. (1886.)
208. A review of Seeley's 'The fresh-water fishes of Europe.' *In Dial*, June, 1886, pp. 34-35.
- 208a. The duty of the scholar towards the community, being the baccalaureate address delivered to the graduating class of 1886 of Indiana University, Richmond, Ind., 1886. Pp. 19.
209. A review of the 'A. O. U. code and check-list of North American birds.' *In Auk*, July, 1886, pp. 393-398.
210. Description of six new species of fishes from the Gulf of Mexico, with notes on other species. (Joint author with B. W. Evermann.) *In Proc. U. S. Nat. Mus.*, IX, pp. 466-476. (1886.)
211. A review of the *Gobiidæ* of North America. (Joint author with C. H. Eigenmann.) *In Proc. U. S. Nat. Mus.*, IX, pp. 466-476. (1886.)
212. Notes on typical specimens of fishes described by Cuvier and Valenciennes, and preserved in the Musée d'Histoire Naturelle in Paris. *In Proc. U. S. Nat. Mus.*, IX, pp. 525-546. (1886.)
213. Ulrich von Hutten. *In Current*, Dec. 4 and 11, 1886.
214. The origin of the fittest. A review of Professor E. D. Cope's 'Origin of the fittest.' *In Dial*, March, 1887.
215. Thoreau and John Brown. *In Current*, April, 1887.
216. A preliminary list of the fishes of the West Indies. *In Proc. U. S. Nat. Mus.*, IX, pp. 554-608. (1887.)
217. Note on *Polynemus californiensis* of Thominot. *In Proc. U. S. Nat. Mus.*, X, p. 332. (1887.)
218. The food-fishes of Indiana. (Joint author with B. W. Evermann.) *In Rep. Dept. Agr. Indiana for 1886*. (1887.)
219. A review of the flounders and soles (*Pleuronectidæ*) of America and Europe. (Joint author with David Kopp Goss.) *In Rep. U. S. Fish Comm. for 1886*, pp. 225-342; pl. i-ix. (1887.)
220. A review of the sciænoid fishes of America and Europe. (Joint author with C. H. Eigenmann.) *In Rep. U. S. Fish Comm. for 1886*, pp. 343-351; pl. i-iv. (1887.)
221. Science sketches. Chicago, 1887. Pp. 261.
222. The dispersion of fresh-water fishes. *In 'Science sketches,' pp. 82-132*. (1887.)
223. Darwin. *In 'Science sketches,' pp. 171-195*. (1887.)
224. The evolution of the college curriculum. *In 'Science sketches,' pp. 228-260*. (1887.)
225. Notes on a collection of fishes sent by Mr. Charles C. Leslie from Charleston, S. C. (Joint author with C. H. Eigenmann.) *In Proc. U. S. Nat. Mus.*, X, pp. 269-270. (1887.)
226. Description of a new species of *Thalassophryne* (*Thalassophryne dowi*) from Punta Arenas and Panama. (Joint author with C. H. Gilbert.) *In Proc. U. S. Nat. Mus.*, X, p. 388. (1887.)
227. Note on the 'Analysis de la Nature' of Rafinesque. *In Proc. U. S. Nat. Mus.*, X, pp. 480-481. (1887.)
228. Description of a new species of *Callionymus* (*Callionymus bairdi*) from the Gulf of Mexico. *In Proc. U. S. Nat. Mus.*, X, pp. 501-502. (1887.)
229. Description of a new species of *Xyrichthys* (*Xyrichthys jessiae*) from the Gulf of Mexico. *In Proc. U. S. Nat. Mus.*, X, p. 698. (1887.)
230. Description of two new species of fishes from South America (*Mycteroperca xenarcha*; *Cristiceps eigenmanni*). *In*

Proc. Acad. Nat. Sci. Phila., XXXIX, pp. 387-388. (1887.)

231. Note on *Achirus lorentzi*. In Proc. Acad. Nat. Sci., Phila., XXXIX, pp. 389-391. (1887.)

232. The fisheries and fishery interests of the United States. By George Brown Goode and a staff of associates. Section II. A geographical review of the fishery industries and fishing communities for the year 1880. Pp. 787. Washington, 1887 (issued January, 1888). (Part on fisheries of California, Oregon and Washington, by Jordan and Gilbert.)

233. Description of a new species of *Ethiostoma* (*E. longimana*) from James river, Virginia. In Proc. Acad. Nat. Sci., Phila., XI, p. 179. (1888.)

234. On the generic name of the tunny. In Proc. Acad. Nat. Sci., Phila., XI, p. 180. (1888.)

235. The *octroi* at Issoir: a city made rich by taxation. In Pop. Sci. Mo., XXXIII, pp. 433-456. (Reprinted in 'Science sketches,' 2d ed., pp. 181-223, as 'The fate of Iceodorum.') (1888.)

236. Science sketches. Second edition. Chicago, 1888. Pp. 276.

237. Silas Stearns. In Forest and Stream, Sept. 27, 1888.

238. A manual of the vertebrate animals of the northern United States, including the district north and east of the Ozark mountains, south of the Laurentian hills, north of the southern boundary of Virginia, and east of the Missouri river, inclusive of marine species. Fifth edition, entirely rewritten and much enlarged. Chicago, 1888. Pp. 375.

239. Darwinism: A brief account of the Darwinian theory of the origin of species. Chicago, 1888. Pp. 63.

240. On the occurrence of the Great Lake trout (*Salvelinus namaycush*) in the waters of British Columbia. In Proc. U. S. Nat. Mus., XI, p. 58. (1888.)

241. The Spanish missions in California. In Cornell Review, Oct., 1888.

242. List of fishes collected by Alphonse Forrer about Mazatlan, with descriptions of two new species. In Proc. U. S. Nat. Mus., XI, pp. 329-334. (1888.)

243. Descriptions of fourteen species of fresh-water fishes collected by the U. S. Fish Commission in the summer of 1888. In Proc. U. S. Nat. Mus., XI, pp. 351-363; pl. xliii-xlv. (1888.)

244. List of fishes now in the United States National Museum, collected in Nicaragua by Dr. Louis F. H. Birt. In Proc. U. S. Nat. Mus., XI, pp. 411-416. (1888.)

245. List of fishes collected at Green Turtle Cay in the Bahamas by Charles L. Edwards, with descriptions of three new species. (Joint author with Charles Harvey Bollman.) In Proc. U. S. Nat. Mus., XI, pp. 549-553. (1889.)

246. Studies of insect life. A review of Sir John Lubbock's 'The senses, instincts, and intelligence of animals.' In Dial, March, 1889.

247. Description of new species of fish collected at the Galapagos islands and along the coast of the United States of Colombia, 1887-1888. In Proc. U. S. Nat. Mus., XII, pp. 149-183. (1889.)

248. A catalogue of fishes collected at Port Castries, Saint Lucia, by the steamer Albatross. In Proc. U. S. Nat. Mus., XII, pp. 645-652. (1889.)

249. Report of explorations made by the U. S. Fish Commission during the summer of 1889, in Colorado and Utah, with an account of the fishes found in each river basin examined. In Bull. U. S. Fish Comm., IX, pp. 1-40. (1889.)

250. Report of an exploration of the waters of the Yellowstone Park made under the direction of the U. S. Fish Commission. In Bull. U. S. Fish Comm., IX, pp. 41-63. (1889.)

251. Description of the yellow-finned

trout of Twin Lakes, Colorado (*Salmo mykiss macdonaldi*). (Joint author with B. W. Evermann.) *In Proc. U. S. Nat. Mus.*, XII, pp. 453-454. (1889.)

252. A review of the flounders and soles (*Pleuronectidæ*) of America and Europe. (Joint author with D. K. Goss.) *In Rep. U. S. Fish Comm. for 1886*, XIV, pp. 225-342; 9 plates. (1889.)

253. A review of the species of *Seranidæ* found in the waters of America and Europe. (Joint author with C. H. Eigenmann.) *In Rep. U. S. Fish Comm. for 1886*, XIV, pp. 343-351; 4 plates. (1889.)

254. Report of explorations made during the summer and autumn of 1888, in the Alleghany region of Virginia, North Carolina, and Tennessee, and in western Indiana, with an account of the fishes found in each of the river basins of those regions. *In Bull. U. S. Fish Comm.*, VIII, pp. 97-173, plates xiii-xv. (1889.)

255. A list of fishes collected in the harbor of Bahia, Brazil, by the U. S. Fish Commission steamer *Albatross*. *In Proc. U. S. Nat. Mus.*, XIII, pp. 313-336. (1890.)

256. Description of a new darter (*Etheostoma tippecanoe*) from the Tippecanoe river, Indiana. (Joint author with B. W. Evermann.) *In Proc. U. S. Nat. Mus.*, XIII, pp. 3-4.

257. List of fishes collected in the waters of southern Florida by Dr. James A. Henshall, under the direction of the U. S. Fish Commission. *In Bull. U. S. Fish Comm. for 1890*, VIII, pp. 371-379. (1890.)

258. Notes on fishes of the genera *Agosia*, *Algansea*, and *Zophendum*. *In Proc. U. S. Nat. Mus.*, XIII, pp. 287-288. (1890.)

259. Science in the high school. *In Pop. Sci. Mo.*, XXVI, pp. 721-727. (1890.)

260. Evolution and the distribution of animals. *In Pop. Sci. Mo.*, XVII, pp. 313-322, 505-513. (1890.)

261. The fishes of the Yellowstone Park. *In Zoö*, I, pp. 38-40. (1890.)

262. On the fishes described in Müller's supplemental volume to the *Systema Naturæ* of Linnæus. *In Proc. Acad. Nat. Sci., Phila.*, XLII, pp. 48-50. (1890.)

263. Relations of temperature to vertebræ among fishes. *In Proc. U. S. Nat. Mus.*, XIV, pp. 107-120. (1890.)

264. The colors of letters. *In Pop. Sci. Mo.*, XXXIX, pp. 367-373. (1891.)

265. The story of a strange land. *In Pop. Sci. Mo.*, XL, p. 447. (1891.)

266. The Sunapee trout (*Salvelinus alpinus aureolus*). *In Forest and Stream*, Jan., 1891.

267. A review of the Labroid fishes of America and Europe. *In Rep. U. S. Fish Comm. for 1887*, XV, 599-699. (1891.)

GUSTAF E. KARSTEN, Ph.D. Professor of Romance Languages, 1886-1890; Professor of Germanic languages, 1890-1903. Now Instructor in German, Cornell University, Ithaca, N. Y.

1. Speech unities and their roll in sound change. Paper read before the Mod. Lang. Asso. of Am. at Philadelphia, Dec. 30, 1887.

2. Final *f* in French *soif*, *bief*, etc. *In Mod. Lang. Notes*, III, pp. 85-88. (1888.)

3. Dantesca. Osservazioni su alquanti passaggi della Divina Commedia. *In Mod. Lang. Notes*, III, pp. 119-123. (1888.)

4. The origin of the suffix *re* in French. *In Mod. Lang. Notes*, III, pp. 187-188. (1888.)

5. Review of Neumann's 'Die romanische Philologie'; Körting's 'Encyclopædie und Methodologie der romanischen Philologie'; Gröber's 'Grundriss der romanischen Philologie.' *In Mod. Lang. Notes*, III, No. 5. (1888.)

6. Review of the chief scientific works on Romance philology published in America. *In Litteraturblatt f. german. und roman. Philol. for 1888*. No. 6.

7. The third annual Neuphilologentag at Dresden, Germany. *In Mod. Lang. Notes*, III, 241-244. (1888.)

8. Secretary's report on the work done in the Phonetic Section of Mod. Lang. Asso. of Am. *In Trans. Mod. Lang. Asso. Am.* for 1889.

9. The origin and etymology of the name *America*. *In Mod. Lang. Notes* for 1889.

10. Review of J. Ferrette's 'Ecriture fonétique.' *In Viotor's Phonetische Studien*, Marburg, Germany, for 1889.

11. Review of R. J. Lloyd's 'Phonetic attraction.' *In Phonetische Studien* for 1889.

12. The Journal of Germanic Philology (editor). Bloomington, Ind. Vols. I-V. (1897-1902.)

13. Fauststudien. *In Philologische Studien*, 1896.

14. On the Hildebrandslied. *In Jour. Ger. Phil.*, I, No. 1. (1897.)

CYRUS AMBROSE KING, Instructor in Botany, 1900-1902. See Alumni list.

JOHN STERLING KINGSLEY, Professor of Zoölogy, 1887-1889. Now Professor of Biology, Tufts College, Mass.

1. The development of the compound eye of Crangon. *In Jour. of Morph.*, I, pp. 49-69; 1 plate. (1887.)

2. The embryology of Crangon. *In Bull. Essex Inst.*, XVIII, pp. 60; 2 plates. (1887.)

3. Editor of the 'Standard natural history.' 6 vols.

DANIEL KIRKWOOD, LL.D. Professor of Mathematics, 1856-1886. Died 1895 at Riverside, Cal.

1. A new analogy in the periods and

rotation of planets. *In Am. Jour. Sci. and Arts*, 2d ser., IX, pp. 359-397. (1850.)

2. Law of rotation of planets. *In Am. Jour. Sci. and Arts*, 2d ser., XI, pp. 394-398. (1851.)

3. On Saturn's rings. *In Am. Jour. Sci. and Arts*, 2d ser., XI, pp. 109-110. (1851.)

4. On certain analogies in the solar system. *In Am. Jour. Sci. and Arts*, 2d ser., XIV, pp. 210-219. (1852.)

5. The lunar world. *In Southern Presbyterian Review*, Oct., 1854.

6. An aurora of 1859. *In Am. Jour. Sci. and Arts*, 2d ser., XXVIII, pp. 396-389. (1859.)

7. Propositions relating to a particular curve. *In Runkle's Math. Mo.*, I. (1859.)

8. Distances and magnitudes of the fixed stars. *In Literary Record*, I. (1859.)

9. On the nebular hypothesis. *In Am. Jour. Sci. and Arts*, 2d ser., XXX, pp. 161-181. (1860.)

10. Instances of nearly commensurable periods in the solar system. *In Runkle's Math. Mo.*, II. (1860.)

11. The asteroids. *In Literary Record*, II. (1860.)

12. The meteors of July 13, 1846. *In Literary Record*, II. (1860.)

13. The new planets. *In New Englander*, XVIII. (1860.)

14. November meteors, 1860. *In Am. Jour. Sci. and Arts*, 2d ser., XXXI, p. 169. (1861.)

15. Astronomical discoveries. *In Literary Record*, III. (1861.)

16. On the probable existence of undiscovered planets. *In Literary Record*, III. (1861.)

17. Solar phenomena. *In New Englander*, XIX. (1861.)

18. Articles contributed to *Indiana School Journal* as mathematical editor from 1859 to 1863.

19. Orbits of binary stars. *In Am. Jour. Sci. and Arts*, 2d ser., XXXVII, p. 233. (1864.)
20. Harmonies of the solar system. *In Am. Jour. Sci. and Arts*, 2d ser., XXXVIII, pp. 1-18. (1864.)
21. Planetary distances. *In Am. Jour. Sci. and Arts*, 2d ser., XXXIX, pp. 55-59. (1865.)
22. On the theory of meteors. *In Proc. A. A. A. S.* for 1866, pp. 8-14.
23. The November meteors. *In Iowa Instructor and School Journal*, VII.
24. The aurora borealis of Feb. 20, 1866. *In Iowa Instructor and School Journal*, VII.
25. Meteoric astronomy. Philadelphia, 1867.
26. Asteroids and minor planets. *In Indiana Sch. Jour.*, XII. (1867.)
27. Meteor of July, 1867. *In Am. Jour. Sci. and Arts*, 2d ser., XLIV, p. 288. (1867.)
28. The meteors of Nov. 12, 1867. *In Mo. Notices Royal Ast. Soc.*, XXVIII, p. 33. (1868.)
29. Meteors of November 12-14, 1868. *In Proc. Am. Philos. Soc.*, X.
30. Comets of 1812 and 1845. *In Am. Jour. Sci. and Arts*, 2d ser., XLVIII, pp. 255-258. (1869.)
31. Periods of meteoric rings. *In Am. Jour. Sci. and Arts*, 2d ser., XLIX, p. 429. (1869.)
32. On the nebular hypothesis and the approximate commensurability of the planetary periods. *In Mo. Notices Royal Ast. Soc.*, XXIX, pp. 96-102. (1869.)
33. The meteors of Nov. 13-14. *In Mo. Notices Royal Ast. Soc.*, XXIX, pp. 62-63. (1869.)
34. On certain harmonies of the solar system. *In Danville Quart. Rev.* (1869.)
35. On comets and meteors. *In Proc. Am. Philos. Soc.*, XI, pp. 215-220. (1869.)
36. Asteroids between Jupiter and Mars. *In Proc. Am. Philos. Soc.*, XI. (1869.)
37. Periodicity of sun-spots. *In Proc. Am. Philos. Soc.*, XI, pp. 94-102. (1869.)
38. Periodicity of certain planetary rings. *In Proc. Am. Philos. Soc.*, XI. (1869.)
39. On comets and meteors, 1st paper. *In Scientific Opinion*, March 23, 1870.
40. On comets and meteors, 2d paper. *In Scientific Opinion*, March 30, 1870.
41. Mass of asteroids between Mars and Jupiter. *In Am. Jour. Sci. and Arts*, 3d ser., I, p. 71. (1871.)
42. Sun-spots of 1843. *In Am. Jour. Sci. and Arts*, 3d ser., I, p. 275. (1871.)
43. Testimony of the spectroscope on nebular hypothesis. *In Am. Jour. Sci. and Arts*, 3d ser., II, pp. 155-156. (1871.)
44. On the formation and primitive structure of the solar system. *In Proc. Am. Philos. Soc.*, XII, pp. 163-167. (1871.)
45. Sidereal systems. *In Our Monthly*, III. (1871.)
46. Astro-meteorology. *In Pop. Sci Mo.*, I, pp. 335-339. (1872.)
47. Mean motions of Jupiter, Saturn, Uranus, and Neptune. *In Amer. Jour. Sci. and Arts*, 3d ser., III, pp. 208-209. (1872.)
48. Meteors of April 30-May 1. *In Am. Jour. Sci. and Arts*, 3d ser., IV, pp. 52-53. (1872.)
49. Certain relations between the mean motions of the perihelia of Jupiter, Saturn, Uranus, and Neptune. *In Am. Jour. Sci. and Arts*, 3d ser., IV, pp. 225-226. (1872.)
50. The antiquity of man. *In Scientific American*. (1872.)
51. On the disintegration of comets. *In Nature*, VI, p. 148. (June 20, 1872.)
52. Meteors of April 30-May 1. *In Nature*, VI. (August 8, 1872.)
53. On some remarkable relations between the mean motions of Jupiter, Saturn, Uranus and Neptune. *In Proc. Am. Philos. Soc.*, XII, pp. 435-436. (1872.)

54. Changes in celestial scenery. *In Our Monthly*, IV. (1872.)
55. Total eclipses of the sun. *In Our Monthly*, IV. (1872.)
56. Comets and meteors. Philadelphia, 1873. Pp. 97.
57. Meteors of November 14th. *In Am. Jour. Sci. and Arts*, 3d ser., VI, p. 392. (1873.)
58. Biela's comet. *In Nature*, VIII, pp. 4-5. (May 1, 1873.)
59. On the meteors of January 2d. *In Proc. Am. Philos. Soc.*, XIII, pp. 501-502. (1873.)
60. Solution of a problem. *In Analyst*, I. (1874.)
61. On the relative positions of the asteroidal orbits. *In Analyst*, I. (1874.)
62. Distribution of the asteroids. *In Proc. A. A. A. S.* for 1875, pp. 74-77.
63. Relations between the motions of some of the minor planets. *In Mo. Not. Royal Ast. Soc.*, XXXV, pp. 62-63. (1875.)
64. Meteors of Nov. 14. *In Nature*, XII, pp. 85-86. (June 3, 1875.)
65. Reminiscences of William Lenhart, Esq. *In Analyst*, II. (1875.)
66. Mars and its satellites. *In Pop. Sci. Mo.*, XI, p. 706-709. (Oct., 1877.)
67. The meteors of Dec. 21, 1876. *In Indiana Sch. Jour.*, XXII, pp. 75-76. (1877.)
68. Satellites of Mars and the nebular hypothesis. *In Am. Jour. Sci. and Arts*, 3d ser., XIV, pp. 327-328. (1877.)
69. On eight meteoric fireballs seen in the United States from July, 1876, to Feb., 1877. *In Proc. Am. Philos. Soc.*, XVI, pp. 590-596. (1877.)
70. Ages of the sun and fixed stars. *In Proc. Am. Philos. Soc.*, XVI, pp. 622-625. (1877.)
71. The eclipse of July 29, 1878. *In Indiana Sch. Jour.*, XXIII. (1878.)
72. November meteors. *In Am. Jour. Sci. and Arts*, 3d ser., XV, p. 76. (1878.)
73. Solar and sidereal heat. *In Am. Jour. Sci. and Arts*, 3d ser., XV, pp. 291-293. (1878.)
74. The meteors of August 11, 1878. *In Analyst*, V. (1878.)
75. Aerolitic epoch of Nov. 12-13. *In Proc. Am. Philos. Soc.*, XVII, pp. 339-341. (1878.)
76. Cosmogony of LaPlace. *In Proc. Am. Philos. Soc.*, XVIII, pp. 324-326. (1879.)
77. Meteoric fireballs seen in U. S. during the year ending March 31, 1879. *In Proc. Am. Philos. Soc.*, XVIII, pp. 239-246. (1879.)
78. The great southern comet of 1880. *In Indiana Sch. Jour.*, XXV, p. 449. (1880.)
79. On the variation in the length of the day. *In Analyst*, VII. (1880.)
80. On the origin of planets. *In Proc. Am. Philos. Soc.*, XIX, p. 15. (1880.)
81. The meteors of Nov. 13-15. *In Pop. Sci. Mo.*, XVIII, pp. 542-544. (Feb., 1881.)
82. November meteors. *In Indiana Sch. Jour.*, XXVI, p. 543. (1881.)
83. On the limit of planetary stability. *In Analyst*, VIII. (1881.)
84. Astronomical panics. *In Pop. Sci. Mo.*, XXI, pp. 182-186. (June, 1882.)
85. The August meteors. *In Sidereal Messenger*, I, pp. 141-143. (Oct., 1882.)
86. The relative ages of planets, comets and meteors. *In Science*, II, p. 12. (1883.)
87. Some facts in the early history of Indiana University. *In Indiana Sch. Jour.*, XXVIII, pp. 503-504. (1883.)
88. A large meteor. *In Sidereal Messenger*, II. (1883.)
89. The zone of asteroids and the rings of Saturn. *In Proc. Am. Philos. Soc.*, XXI, pp. 263-266. (1883.)
90. The comet of 1812 and 1883. *In Pop. Sci. Mo.*, XXIV, pp. 488-491. (Feb., 1884.)

91. On temporary stars. *In Science*, IV, p. 291. (1884.)
92. Note on a meteor. *In Sidereal Messenger*, II. (1884.)
93. Temporary stars. *In Proc. A. A. A. S.* for 1884, p. 78.
94. The limit of stability of nebulous planets. *In Proc. Am. Philos. Soc.*, XXII, pp. 104-113. (1884.)
95. New telescopes and their prospective relations. *In Indiana Sch. Jour.*, XXX, pp. 495-497. (1885.)
96. The limits of stability of the solar system. *In Sidereal Messenger*, IV, pp. 65-78. (April, 1885.)
97. Recently discovered asteroids. *In Sidereal Messenger*, IV, pp. 114-116. (May, 1885.)
98. The comet of 1866 and the meteors of Nov. 14. *In Sidereal Messenger*, IV, pp. 228-230. (Oct., 1885.)
99. Commensurability of motions. *In Sidereal Messenger*, IV, pp. 257-259. (Nov., 1885.)
100. The comet of 1866 and the meteors of Nov. 14. *In Proc. Am. Philos. Soc.*, XXII, pp. 424-428. (1885.)
101. Appleton's Annual American Encyclopædia. Articles on astronomy, from beginning to 1885.
102. The comets of 1812-I, and 1846-IV. *In Sidereal Messenger*, V, pp. 13-14. (Jan., 1886.)
103. The Biela meteors. *In Sidereal Messenger*, V, p. 29. (Jan., 1886.)
104. About comets. *In Indiana Sch. Jour.*, XXXII, pp. 459-460. (1887.)
105. Origin of comets. *In Am. Jour. Sci. and Arts*, 3d ser., XXXIII, p. 50. (1887.)
106. Note on the origin of comets. *In Sidereal Messenger*, VI, pp. 77-78. (Feb., 1887.)
107. Distribution of the minor planets. *In Sidereal Messenger*, VI, p. 116. (March, 1887.)
108. The eccentricities and inclinations of the asteroidal orbits. *In Sidereal Messenger*, VI, pp. 169-170. (May, 1887.)
109. The relation of aerolites to shooting stars. *In Sidereal Messenger*, VI, pp. 248-250. (Sept., 1887.)
110. Relation of aerolites to shooting stars. *In Proc. Am. Philos. Soc.*, XXIV, pp. 111-112. (1887.)
111. Biela's comet and the large meteors of Nov. 27-30. *In Proc. Am. Philos. Soc.*, XXIV, pp. 242-243. (1887.)
112. The asteroids. Philadelphia, 1888. Pp. 60.
113. Notes on the progress of astronomy. *In Sidereal Messenger*, VII, pp. 29-30. (Jan., 1888.)
114. The relation of the short period comets to the zone of asteroids. *In Sidereal Messenger*, VII, p. 95. (Feb., 1888.)
115. On the inclination of asteroids. *In Sidereal Messenger*, VII, pp. 177-179. (May, 1888.)
116. Note on 279th asteroid. *In Sidereal Messenger*, VIII, pp. 83-84. (Feb., 1889.)
117. On the inclination of the asteroids. *In Sidereal Messenger*, VIII, pp. 305-307. (Aug., 1889.)
118. Notes on the densities of the planets. *In Proc. Ast. Soc. Pacific*, II, pp. 1-3. (Jan., 1890.)
119. On the similarity of certain orbits in the zone of asteroids. *In Proc. Ast. Soc. Pacific*, II, pp. 48-49. (Feb., 1890.)
120. On the possible existence of fireballs and the meteors in the stream of the Bielids. *In Proc. Am. Philos. Soc.*, XXVII.
121. On the inclination of the asteroids. *In Proc. Am. Philos. Soc.*, XXVII.
122. The origin of gaps in the zone of asteroids. *In Sidereal Messenger*, X, pp. 194-196. (April, 1891.)
123. Groups of asteroids. *In Sidereal Messenger*, XI, pp. 785-789. (Oct., 1892.)

124. The mutual relations between the orbits of certain asteroids. *In Proc. Am. Philos. Soc.*, XXX, pp. 269-270. (1892.)

125. The development of the solar system. *In Sidereal Messenger*, p. 94. (June, 1893.)

126. Holme's comet: its probable relation to the zone of asteroids. *In Sidereal Messenger*, XII, pp. 182-183. (Feb., 1893.)

127. The Leonids, or meteors of Nov. 13. *In Sidereal Messenger*, XII, pp. 386-390. (May, 1893.)

128. Relations between the mean motions of Jupiter, Saturn, and certain minor planets. *In Sidereal Messenger*, XII, pp. 302-303. (April, 1893.)

129. Tuttle's comet and the Perseids or August meteors. *In Sidereal Messenger*, XII, pp. 789-792. (Nov., 1893.)

CHARLES TOBIAS KNIPP, Instructor in Physics, 1893-1900; Assistant Professor, 1900-1903. *See Alumni list.*

JOHN HIRAM LAFHROP, LL.D. President of the University, 1859-60. Died, 1866, at Columbia, Mo.

1. Inaugural address, as fourth president of Indiana University. Indianapolis, 1861. Pp. 32.

THOMAS McCABE, Ph.D., Professor of Germanic Languages and Literature, 1889-1890. Died Feb. 22, 1891, at Bryn Mawr, Pa.

1. The Geste of Auberi le Bourgoing. *In Trans. Mod. Lang. Asso. for 1889*, IV, No. 1.

2. Review of Super's 'Preparatory French reader.' *In Mod. Lang. Notes*, IV, pp. 26-27. (1889.)

3. Arsène Darmesteter; an obituary. *In Mod. Lang. Notes*, IV, p. 95. (1889.)

4. Review of Gröber's 'Grundriss der Römischen Philologie.' *In Nation*, for May 9, 1889.

5. Review of C. Fontaine's 'Les Poètes français du XIXme siècle.' *In Mod. Lang. Notes*, V, p. 108. (1890.)

DAVID McDONALD, Professor of Law, 1841-1852.

1. Address on the study of law, delivered in the chapel of Indiana University, Dec. 5, 1842. Bloomington, Ind., 1843. Pp. 22.

2. Treatise on the justices of the peace and constables in Indiana. Cincinnati, 1857. Pp. 1063.

3. Many judicial opinions, *in Reports for the U. S. courts for the 7th circuit.*

JOHN ERNST MATZKE, Ph.D. Professor of Romance Languages, 1890-1891. Now Professor of Romanic Languages, Leland Stanford Junior University, Stanford University, Cal.

1. The historical Hernani. *In Mod. Lang. Notes*, VI, pp. 37-41. (1891.)

2. Some remarks on the development of *et* in the Romance languages. *In Mod. Lang. Notes*, VI, pp. 136-139. (1891.)

3. Study of the versification and rimes in Hugo's Hernani. *In Mod. Lang. Notes*, VI, pp. 168-171. (1891.)

4. Victor Hugo's Hernani, with introduction and English notes. Boston, 1891. Pp. 228.

HAMILTON BYRON MOORE, Instructor in English, 1898-1901; Assistant Professor, 1901-1903. *See Alumni list.*

SARAH PARKE MORRISON, Adjunct Professor of English Literature, 1873-75. See Alumni list.

JOHN FLESHER NEWSOM, Instructor in Geology, 1894-96; Assistant Professor, 1896-99. See Alumni list.

CYRUS NUTT, D.D., LL.D. President of the University, 1860-1875. Died Aug. 24, 1875, at Bloomington, Ind.

1. Baccalaureate sermon to the graduating class of the Indiana State University, June 23, 1861. Indianapolis, 1861. Pp. 25.

2. Baccalaureate sermon to the graduating class of Indiana University, 1862. Cincinnati, 1862.

3. Baccalaureate sermon to the graduating class of Indiana University, 1863. Cincinnati, 1863.

4. Prayer gauge; a sermon. Cincinnati, 1874. Pp. 19.

RICHARD OWEN, LL.D. Professor of Natural Philosophy and Chemistry, 1863-1867; Professor of Natural Science and Chemistry, 1867-1879. Died March 25, 1890, at New Harmony, Ind.

1. Report on geological survey of Wisconsin, Iowa, and Minnesota. (Joint author with David Dale Owen.) Philadelphia, 1852. Pp. xxxviii, 638.

2. Key to the geology of the globe. Boston, 1857. Pp. 256.

3. Report on a geological reconnaissance of Indiana, made during the years 1859, and 1860, under the direction of the late David Dale Owen. Indianapolis, 1862. Pp. xvi, 368.

4. On quaternary rock salt deposits in

Louisiana. *In* Trans. St. Louis Acad. Sci., II, pp. 250-252. (1868.)

5. Remarks on E. W. Hilgard's 'Geological history of the Gulf of Mexico.' *In* Am. Nat., V, pp. 522-523. (1871.)

6. Contribution to physiographic and dynamical geology, involving the discussion of terrestrial magnetism. *In* Proc. A. A. A. S., XX, pp. 208-216. (1872.)

7. Arkansas geological formations. *In* Macfarlane's Geological R. R. Guide for 1879, p. 206.

8. The law of land-forming on our globe. *In* Proc. A. A. A. S., XXIX, pp. 437-446. (1881.)

9. On the unification of geological nomenclature. *In* Science, II, pp. 438-440. (1881.)

10. Résumé d'un rapport sur l'unification de la nomenclature géologique. *In* Congrès Géol. Internat., Compte Rendu, 2d session, pp. 623-626. Boulogne, 1882.

11. Contribution to seismology. (Abstract.) *In* Proc. A. A. A. S., XXXI, pp. 329-336. (1883.)

12. Law of fracture or fissuring, applied to inorganic and organic matter. *In* Proc. A. A. A. S., XXXI, pp. 337-344. (1883.)

13. The earth's orographic framework; its seismology and geology. *In* Proc. A. A. A. S., XXXII, pp. 253-256. (1884.)

14. The continental type, or normal orography and geology of continents. *In* Proc. A. A. A. S., XXXII, pp. 256-260. (1884.)

15. British earthquakes and their seismic relations. (Abstract.) *In* Proc. A. A. A. S., XXXIII, pp. 438-443. (1885.)

16. Arkansas (in part). *In* Macfarlane's Geol. R. R. Guide, 2d edition, for 1890, pp. 406-407.

FREDERICK AUSTIN OGG, Instructor in History, 1902-1903. See Alumni list.

GEORGE JAMES PIERCE, Assistant Professor of Botany, 1896-1897. Now Associate Professor of Plant Physiology, Leland Stanford Junior University, Stanford University, Cal.

1. Certain changes in the pith cells, preliminary to the formation of cavities in the stems of grasses. *In Proc. Indiana Acad. Sci.* for 1896.

2. The microscopic examination of certain drinking waters. (Joint author with F. M. Andrews and A. C. Life.) *In Proc. Indiana Acad. Sci.* for 1896.

3. Review of F. W. Keeble's paper, 'Observations on the Loranthaceæ of Ceylon.' *In Bot. Gaz.*, August, 1896.

JAMES P PORTER, Instructor in Psychology, 1900-1903. *See Alumni list.*

ERNEST WILLIAM RETTGER, Instructor in Mathematics, 1898-1900. *See Alumni list.*

HERBERT GILSON REDDICK, Instructor in Chemistry, 1897-1899. *See Alumni list.*

RUFUS BYRAM RICHARDSON, Ph.D. Professor of Greek, 1880-1882. Recently director of American School of Classical Studies, Athens, Greece. New York City.

1. Andersonville. *In New Englander.* (1881.)

EDWARD ALSWORTH ROSS, Professor of Economics, 1891-1892. Now Professor of Sociology, University of Nebraska, Lincoln, Neb.

1. Turning toward Nirvana. *In Arena*, IV, pp. 736-743. (Nov., 1891.)

2. Sinking funds. *In Pub. Am. Econ. Asso.*, VII, p. 106. (1892.)

3. A new canon of taxation. *In Pol. Sci. Quart.*, VII, pp. 585-597. (Dec., 1892.)

EDWARD EARNEST RUBY, Tutor in Greek, 1897-98; Tutor in French, 1898-99; Instructor in French, 1901-1902. *See Alumni list.*

HARRY FLETCHER SCOTT, Tutor in Latin, 1899. Now Associate Instructor in Latin, University High School, Chicago.

1. Revision of J. D. S. Riggs's 'In Latinum.' Chicago, 1899.

JAMES R. SLONAKER, Ph.D. Instructor in Zoology, 1896-1899. Now Assistant Professor of Physiology, Leland Stanford Junior University, Stanford University, Cal.

1. A comparative study of the point of acute vision in the vertebrates. *In Am. Nat.*, XXX, pp 24-32. (Jan., 1896.)

2. A comparative study of the area of acute vision in the vertebrates. *In Jour. of Morph.*, XIII, pp. 445-502. (May, 1897.)

3. The fovea. *In Proc. Indiana Acad. Sci.* for 1896, pp. 304-310.

4. A method of preserving the eye for sectioning, or for demonstrating the area of acute vision. *In Jour. Applied Microscopy*, I, p. 18. (Feb., 1896.)

5. The eye of the Mammoth Cave rat. *In Proc. Indiana Acad. Sci.* for 1898, pp. 255-257.

WILLIAM WESLEY SPANGLER, Librarian, 1880-1893. *See Alumni list.*

EDGAR HOWARD STURTEVANT, Tutor in Latin, 1895-98; Instructor, 1901-1902. See Alumni list.

JOSEPH SWAIN, Instructor in Zoölogy and Mathematics, 1883-85; Professor of Mathematics, 1886-91; President of the University, 1893-1902. See Alumni list.

FREDERICK WILSON TRUSCOTT, Instructor in German, 1891-93. See Alumni list.

ALBERT BRENNUS ULREY, Instructor in Zoölogy, 1892. See Alumni list.

THOMAS CARLTON VAN NÜYS, M.D. Professor of Chemistry, 1874-1895.

1. Analysis of water from the deep wells in Indianapolis. *In* Rep. Indiana Board of Health for 1883.

2. Apparatus for the estimation of carbonic acid in the air. *In* Amer. Chem. Jour., VIII, pp. 190, 315. (1886.)

3. Estimation of carbonic acid in the air. (Joint author with B. F. Adams, Jr.) *In* Amer. Chem. Jour., IX, p. 64. (1887.)

4. Chemical analysis of healthy and diseased urine. Philadelphia, 1888. Pp. 188; 39 cuts.

5. A method for the estimation of albumin in urine. (Joint author with R. E. Lyons.) *In* Amer. Chem. Jour., XII, pp. 336-352. (1890.)

6. Suggestions to teachers of science or mathematics in the high school. *In* Proc. Indiana Acad. Sci., 1891, p. 6.

7. Carbon di-oxide in the urine. (Joint author with R. E. Lyons.) *In* Amer. Chem. Jour., XIV, p. 14. (1892.)

8. Analysis of certain Indiana mineral waters. *In* Rep. State Geol. of Indiana for 1901, pp. 71, 80, 93, 151.

ARTHUR BURNHAM WOODFORD, Ph.D. Associate Professor of Social Science and Economics and Instructor in History, 1885-1886; Professor of Social Science and Economics, 1886-1889. Now Instructor, Hopkins Grammar School, New Haven, Conn.

1. Recent economic discussion. Review of books and pamphlets by Denslow, Ely, Ingram and others. *In* Dial, Nov., 1888.

2. Review of Karl Marx's 'Capital.' *In* Dial, March, 1889.

3. Review of Marshall's 'Principles of economics,' Vol. I. *In* Dial, Oct., 1891.

ANDREW WYLIE, D.D. President of the University, 1829-1851. Died Nov. 11, 1851, at Bloomington, Ind.

1. An English grammar. Washington, Pa., 1817.

2. Religion and state, not church and state; a sermon delivered July 4, 1830, at Bloomington, Ind. Bloomington, Ind., 1830. Pp. 16.

3. A discourse delivered before the Indiana Historical Society. Indianapolis, 1831. Pp. 26.

4. An address delivered at Bloomington, Oct. 29, 1829. Indianapolis, 1833. Pp. 30.

5. An address delivered to the graduates in Indiana College. Bloomington, Ind., 1833.

6. Baccalaureate delivered at the fifth commencement of Indiana College, September 24, 1834. Bloomington, Ind., 1834. Pp. 11.

7. An eulogy on Lafayette. Cincinnati, 1835. Pp. 32.

8. The propriety of retaining Greek and Roman classics in their place as a part of study necessary in the course of a liberal

education. An address delivered at Crawfordsville, Ind., July, 1838. Bloomington, Ind., 1838.

9. Address to the citizens of Monroe county and to the members of the County Lyceum. Bloomington, Ind., 1840. Pp. 26.

10. Sectarianism is heresy. Bloomington, Ind., 1840. Pp. 132.

11. Baccalaureate, addressed to the senior class of Indiana University, at the late commencement, September, 1841. Bloomington, Ind., 1841. Pp. 24.

12. Baccalaureate, addressed to the senior class, on the day of commencement, 1843. Bloomington, Ind., 1843. Pp. 19.

13. Baccalaureate, addressed to the senior class of Indiana University, at the late commencement, September, 1845. Bloomington, Ind., 1845. Pp. 18.

14. Baccalaureate, addressed to the senior class of 1846, of Indiana University, Bloomington, Ind., 1846. Pp. 22.

15. Baccalaureate, addressed to the senior class of Indiana University, at the late commencement, September, 1847. Bloomington, Ind., 1847. Pp. 22.

16. Baccalaureate, addressed to the senior class of Indiana University, at the late commencement, August, 1850. Bloomington, Ind., 1850. Pp. 23.

17. The individual; a baccalaureate delivered to the class of seniors at the commencement of the Indiana University, Aug. 13, 1851. Indianapolis, 1851. Pp. 24.

18. Numerous sermons and translations from Plato. *In Equator*.

THEOPHILUS ADAM WYLIE, LL.D. Professor of Natural Philosophy, 1837-1852; 1854-1886; Emeritus Professor of Natural Philosophy, 1886-95. Died June 9, 1895, at Bloomington, Ind.

1. Baccalaureate discourse to the graduating class of Indiana University, 1859. Indianapolis, 1859. Pp. 30.

2. Andrew Wylie, D.D., first President of Indiana University. *In Indiana Sch. Jour.*, XIII. pp. 175-186. (May, 1868.)

PETER A. YODER, Instructor in Chemistry, 1894-96. *See Alumni list*.

PUBLICATIONS OF ALUMNI

**The list which follows is intended to include all books, pamphlets and articles (other than newspaper articles) published by alumni and students of Indiana University; but persons connected with the University only by the receipt of an honorary degree have been omitted from this list. Degrees conferred by this University are indicated by adding the year in which conferred; where the year is not given, it is to be understood that the degree was taken elsewhere.

BENJAMIN FRANKLIN ADAMS, JR., A.B. (1883). Bloomington, Ind.

1. Analysis of oölitic limestone (buff and blue) from Dunn & Dunn's quarry. *In* Rep. Indiana Geol. Surv. for 1881, pp. 32-33.
2. Estimation of carbonic acid in the air. (Joint author with T. C. Van Nüys.) *In* Am. Chem. Jour., IX, p. 64.

ROBERT JUDSON ALEY, A.B. (1888), A.M. (1890), Ph.D. *See* Faculty list.

FRANK MARION ANDREWS, A.B. (1894), A.M. (1895), Ph.D. *See* Faculty list.

CHARLES ELLSWORTH ATKINSON, A.B. (1897). Kokomo, Ind.

1. Why study music? *In* College Index for 1892.
2. Christ in his sanctum sanctorum. 1903. Pp. 18; 1 plate.
3. Spirit life. *In* Christ. Advoc. for 1904.
4. Upon what rests the stability of truth? Pp. 100. (In press.)

SAMUEL WEIR AXTELL, LL.B. (1874). Hoopeston, Ill.

1. The secret told, a text-book of psychic healing. Hoopeston, Ill. Pp. 250.
 2. Know thyself, from a mental science standpoint. Hoopeston, Ill. Pp. 70.
-

ORLAN FRANKLIN BAKER, LL.B. (1864). Died Sept. 9, 1888, at Vincennes, Ind.

1. The primitive dwellers; a history of the population, aboriginal and colonial.
 2. Annals of Vincennes.
-

DAVID DEMAREE BANTA, B.S. (1855); LL.B. (1857); LL.D. Dean of the School of Law, Indiana University, 1890-1896. Died April 9, 1896, at Bloomington, Ind.

1. A historical sketch of Johnson county, Indiana. Chicago, 1881. Pp. 170.
2. Making a neighborhood; an address delivered at the Shiloh reunion, May 26, 1887. Franklin, Ind. Pp. 49.
3. The Indiana Seminary. *In* T. A. Wylie's 'Indiana University, its history from 1820 to 1900,' pp. 5-37.
4. A history of the Presbyterian church of Franklin, Ind.

GEORGE BANTA, A.B. (1876). Menasha, Wis.

1. Flying leaves: being a collection of poems, stories, articles, etc., of various members of the Banta and Pleasants families. Menasha, Wis. Pp. 300.

EARL BARNES, A.B. (1890), M.S. Professor of European History, Indiana University, 1889-1890. Now editor and lecturer, Philadelphia, Pa.

1. Studies in education. First series. Stanford University, 1896-1897. Pp. 400.
2. Sheldon's studies in American history. (Joint author with Mary Sheldon Barnes.) Boston, 1898 (Revised edition). Pp. x, 433.
3. Studies in education. Second series. Philadelphia, 1902. Pp. 400.

FRED HENRY BATMAN, A.B. (1901). Chicago.

1. Pneumococcal bronchiolitis (capillary bronchitis). (Joint author with C. P. Clark.) *In Jour. of Infectious Diseases*, I, pp. 229-235. (March 19, 1904.)

CHARLES ORVILLE BECHTOL, A.B. (1898), M.D. Huntington, Ind.

1. An easily detachable plaster-of-paris cast. *In Jour. Am. Med. Asso.*, Sept. 5, 1903.

CHARLES HENRY BEESON, A.B. (1893), A.M. (1895). Tutor in Latin, Indiana University, 1894-95; Instructor in Latin, 1895-96. Now teacher of Latin, High School, Peoria, Ill.

1. Second Latin book (Intercollegiate

Latin series.) (Joint author with Frank J. Miller.) Chicago, 1902. Pp. 644.

2. Second Latin book. (Text edition.) (Joint author with Frank J. Miller.) Chicago, 1902. Pp. 178.

SANFORD BELL, A.B. (1899), A.M. (1900). Assistant Professor of Pedagogy, Indiana University, 1898-1900. Now Professor of Education, University of Colorado, Boulder, Colo.

1. Methods of observing children. *In Child-Study Mo.*, III, pp. 578-584. (April, 1898.)
2. A study of the teacher's influence. *In Ped. Sem.*, VII, pp. 492-525. (Dec., 1900.)
3. An educational object-lesson. *In Ped. Sem.*, IX, pp. 237-247. (June, 1902.)
4. A preliminary study of the emotion of love between the sexes. *In Am. Jour. Psych.*, XIII, pp. 325-354. (July, 1902.)
5. The significance of activity in child life. *In Independent*, LIV, pp. 911-914. (April 16, 1903.)
6. An introductory study in the psychology of foods. *In Am. Jour. Psych.*, 1904.

LEE FENT BENNETT, A.B. (1898). Professor of Geology and Mineralogy, Northern Indiana Normal School, Valparaiso, Ind.

1. Four comparative cross sections of the Knobstone group in Indiana. *In Proc. Indiana Acad. Sci. for 1897*, pp. 258-262; 1 plate.
2. Notes on the eastern escarpment of the Knobstone formation in Indiana. *In Proc. Indiana Acad. Sci. for 1898*, pp. 283-287; 1 plate.
3. Head-waters of Salt creek in Porter county, Ind. *In Proc. Indiana Acad. Sci. for 1899*, pp. 164-166; 1 plate.

4. Rocks and minerals. Valparaiso, 1903. Pp. 83.

WILLIS STANLEY BLATCHLEY, A.B. (1887), A.M. (1891). State Geologist of Indiana, Indianapolis.

1. On the American species of the genus *Umbra*. *In Proc. Phila. Acad. Sci.* for 1885, pp. 12-13.

2. A review of the species of the genus *Pimephales*. *In Proc. Phila. Acad. Sci.* for 1885, pp. 63-71.

3. On the genus *Aphredoderus*. *In Proc. Phila. Acad. Sci.* for 1885, pp. 136-137.

4. A gnatcatcher's strategy. *In Audubon Magazine*, March, 1888.

5. Some Indiana Acrididæ. *In Canadian Ent.*, XXIII, pp. 74-81, 98-100 (1891); XXIV, pp. 28-34 (1892); XXVI, pp. 217-222, 241-245 (1894); XXX, pp. 54-64 (1898).

6. Notes on the batrachians and reptiles of Vigo county, Ind. I. *In Jour. Cincinnati Soc. Nat. Hist.*, XIV, pp. 23-35. (1891.)

7. Entomologizing in Mexico. *In Ent. News*, pp. 111-114, 131-134. (1892.)

8. *Cnicus discolor* as an insect trap. *In Canadian Ent.*, pp. 310-311. (1892.)

9. The Gryllidæ of Indiana. *In Proc. Indiana Acad. Sci.* for 1892, pp. 126-144.

10. A catalogue of the butterflies known to occur in Indiana. *In 17th Ann. Rep. Indiana Dept. Geol. and Nat. Hist.* for 1893, pp. 365-408.

11. Some new Locustidæ from Indiana. *In Canadian Ent.*, XV, pp. 89-93. (1893.)

12. On a collection of batrachians and reptiles from Mount Orizaba, Mexico, with descriptions of two new species. *In Proc. U. S. Nat. Mus.*, XVI, pp. 37-42. (1893.)

13. The Locustidæ of Indiana. *In Proc. Indiana Acad. Sci.* for 1893, pp. 92-153.

14. The Blattidæ of Indiana. *In Proc. Indiana Acad. Sci.* for 1893, pp. 153-165.

15. Notes on the winter insect fauna of Vigo county, Indiana. *In Psyche*, June, 1895, pp. 247-250; August, 1895, pp. 267-270; Sept., 1895, pp. 279-283; Feb., 1896, pp. 336-340; May, 1896, pp. 379-381; July, 1896, pp. 399-401; Oct., 1896, pp. 434-437; Dec., 1896, pp. 455-458.

16. A preliminary report on the clays and clay industries of the coal bearing counties of Indiana. *In 20th Ann. Rep. Indiana Dept. Geol. and Nat. Res.* for 1895, pp. 23-185, 4 plates. (1896.)

17. Insects in general and the Orthoptera of Indiana in particular. *In Trans. Indiana Hort. Soc.* for 1896, pp. 1-23.

18. How plants and animals spend the winter. *In Pop. Sci. Mo.*, LI, pp. 496-507. (Feb., 1897.)

19. The natural resources of Indiana. *In 21st Ann. Rep. Indiana Dept. Geol. and Nat. Res.* for 1896, p. 1-25. (1897.)

20. The petroleum industry in Indiana. *In 21st Ann. Rep. Indiana Dept. Geol. and Nat. Res.* for 1896, pp. 27-96, 1 plate, 1 map. (1897.)

21. Indiana caves and their fauna. *In 21st Ann. Rep. Indiana Dept. Geol. and Nat. Res.* for 1896, pp. 122-212, 9 plates. (1897.)

22. A catalogue of the uncultivated ferns and fern allies and the flowering plants of Vigo county, Indiana. *In 21st Ann. Rep. Indiana Dept. Geol. and Nat. Res.* for 1896, pp. 577-708. (1897.)

23. Notes on some phanerogams new or rare to the State. *In Proc. Indiana Acad. Sci.* for 1897, pp. 130-143.

24. Review of Samuel H. Scudder's 'Revision of the Melanopli.' *In Canadian Ent.*, March, 1898.

25. Two new Melanopli from Les Cheneaux Islands, Michigan. *In Psyche*, April, 1898, pp. 195-197.

26. The geology of Lake and Porter counties, Indiana. *In 22d Ann. Rep. Indi-*

- ana Dept. Geol. and Nat. Res. for 1897, pp. 25-104, 1 map. (1898.)
27. The clays and clay industries of northwestern Indiana. *In* 22d Ann. Rep. Indiana Dept. Geol. and Nat. Res. for 1897, pp. 106-153, 1 plate. (1898.)
28. The petroleum industry in Indiana in 1897. *In* 22d Ann. Rep. Indiana Dept. Geol. and Nat. Res. for 1897, pp. 155-181. (1898.)
29. Gleanings from nature. Indianapolis, 1899. Pp. 348. Illustrated.
30. The natural resources of Indiana. *In* 24th Ann. Rep. Indiana Dept. Geol. and Nat. Res. for 1899, pp. 3-40. (1900.)
31. Notes on the batrachians and reptiles of Vigo county, Indiana. II. *In* 24th Ann. Rep. Indiana Geol. and Nat. Res. for 1900, pp. 537-552.
32. On the species of *Nemobius* known to occur in Indiana. *In* Psyche, IX, pp. 51-54. (1900.)
33. Portland cement; its history, uses, composition, process of manufacture, methods of testing, etc. *In* 25th Ann. Rep. Indiana Dept. Geol. and Nat. Res. for 1900, pp. 1-30, 4 plates. (1901.)
34. The lakes of northern Indiana and their associated marl deposits. (Joint author with Geo. H. Ashley.) *In* 25th Ann. Rep. Indiana Dept. Geol. and Nat. Res. for 1900, pp. 31-121. Illustrated. (1901.)
35. Oölite and oölitic stone for Portland cement manufacture. *In* 25th Ann. Rep. Indiana Dept. Geol. and Nat. Res. for 1900, pp. 322-330, 1 plate. (1901.)
36. The petroleum industry in Indiana in 1900. *In* 25th Ann. Rep. Indiana Dept. Geol. and Nat. Res. for 1900, pp. 481-527. (1901.)
37. On a small collection of batrachians and reptiles, with descriptions of two new species. *In* 25th Ann. Rep. Indiana Dept. Geol. and Nat. Res. for 1900, pp. 759-763. (1901.)
38. What the teacher of science can do to make the teaching of science in secondary schools more popular. *In* Proc. Nat. Educ. Assoc. for 1901, pp. 777-784.
39. A nature-wooting at Ormond by the sea. Indianapolis, 1902. Pp. 245. Illustrated.
40. The mineral waters of Indiana. *In* 26th Ann. Rep. Indiana Dept. Geol. and Nat. Res. for 1901, pp. 1-158, 19 plates. (1902.)
41. The petroleum industry in Indiana in 1901. *In* 26th Ann. Rep. Indiana Dept. Geol. and Nat. Res. for 1901, pp. 303-331. (1902.)
42. Gold and diamonds in Indiana. *In* 27th Ann. Rep. Indiana Dept. Geol. and Nat. Res. for 1902, pp. 11-47, 4 plates, 2 maps. (1903.)
43. The orthoptera of Indiana. *In* 27th Ann. Rep. Indiana Dept. Geol. and Nat. Res. for 1902, pp. 123-471. Illustrated. (1903.)
44. The petroleum industry in Indiana in 1903. *In* 27th Ann. Rep. Indiana Dept. Geol. and Nat. Res. for 1902, pp. 571-576. (1903.)
45. On some mollusca known to occur in Indiana. A supplementary paper to Call's catalogue. (Joint author with L. E. Daniels.) *In* 27th Ann. Rep. Indiana Dept. Geol. and Nat. Res. for 1902, pp. 517-628. Illustrated. (1903.)
46. The petroleum industry in Indiana in 1903. *In* 28th Ann. Rep. Indiana Dept. Geol. and Nat. Res. for 1903, pp. 73-209. (1904.)
47. The lime industry in Indiana in 1903. *In* 28th Ann. Rep. Indiana Dept. Geol. and Nat. Res., 1903, pp. 211-257. (1904.)
48. The Indiana of Nature: its evolution. *In* Proc. Indiana Acad. Sci. for 1903. (In press.)

EUGENE WILLIAM BOHANNON, A.B. (1890),
A.M. (1892). President State Normal
School, Duluth, Minn.

1. Plato and education. *In* Indiana
Sch. Jour., XXXIV, pp. 535-542. (July,
1889.)

2. Peculiar and exceptional children.
In Ped. Sem., IV, pp. 3-60. (Oct., 1896.)

3. The only child in a family. *In* Ped.
Sem., V, pp. 475-496. (April, 1898.)

4. The undue emphasis of method. *In*
Indiana Sch. Jour., XLIV, pp. 1-16. (Jan.,
1899.)

MARIE BOISEN. *See* Mrs. Morton C. Brad-
ley.

CHARLES HARVEY BOLLMAN, A.B. (1889).
Died July 13, 1889, at Waycross, Ga.

1. Notes on a collection of fishes from
the Allegheny river. (Joint author with B.
W. Evermann.) *In* New York Acad. Sci.
for 1886, pp. 335-340.

2. A list of fishes observed in the vi-
cinity of Brookville, Franklin county, Indi-
ana. *In* Bull. Brookville Soc. Nat. Hist.
for 1886, pp. 1-11.

3. Preliminary descriptions of ten new
North American Myriapods. *In* Am. Nat.,
XXI, pp. 81-82. (Jan., 1887.)

4. Notes on North American Litho-
biidæ and Scutigeraidæ, with description of
new species. *In* Proc. U. S. Nat. Mus. for
1887, pp. 255-266.

5. Descriptions of new genera and
species of Myriapods. *In* Ent. Amer., II,
pp. 225-228. (1887.)

6. Notes on North American Julidæ.
In Ann. New York Acad. Sci. for 1887,
pp. 25-44.

7. Some new species of Myriapods. *In*
Ann. New York Acad. Sci. for 1887.

8. List of Myriapods of Bloomington,
Ind. *In* Ann. New York Acad. Sci. for 1887.

9. Notes on a collection of fishes from
the Escambia river, with description of a
new species of *Zygonectes*. *In* Proc. U. S.
Nat. Mus. for 1886. (1887.)

10. New North American Myriapods.
In Ent. Amer., III, pp. 81-83. (1887.)

11. New genus and species of Polydes-
mida. *In* Entomologica Americana, III, pp.
45-46. (June, 1887.)

12. Notes upon a collection of Myria-
poda from East Tennessee. *In* Ann. New
York Acad. Nat. Sci. for 1888, pp. 106-112.

13. A preliminary list of the Myriapoda
of Arkansas. *In* Ent. Amer., IV, pp. 1-8.
(1888.)

14. List of fishes collected at Green Tur-
tle Cay in the Bahamas, by Charles L. Ed-
wards. (Joint author with David Starr Jordan.)
In Proc. U. S. Nat. Mus. for 1888, pp.
549-553.

15. Description of a new species of in-
sect, *Fontaria pulchella*, from Strawberry
Plains, Jefferson county, Tenn. *In* Proc. U.
S. Nat. Mus. for 1888, p. 316.

16. Notes on a collection of Myriapoda
from Cuba. *In* Proc. U. S. Nat. Mus. for
1888, pp. 335-338.

17. Notes on a collection of Myriapoda
from Mossy Creek, Tenn., with a descrip-
tion of a new species. *In* Proc. U. S. Nat.
Mus. for 1888, pp. 339-342.

18. Notes upon some Myriapods belong-
ing to the U. S. National Museum. *In*
Proc. U. S. Nat. Mus. for 1888, pp. 403-410.

19. Scientific results of explorations by
the U. S. Fish Commission Steamer Alba-
tross. No. IV. Descriptions of a new species
of fishes collected at the Galapagos Islands
and along the coast of the United States
of Colombia, 1887-1888. *In* Proc. U. S. Nat.
Mus. for 1889, p. 149.

20. Notes on a collection of Myriapods
from the Bermuda islands. *In* Proc. Acad.
Nat. Sci. Philadelphia for 1889, pp. 127-129.

21. A report upon the fishes of Kala-

mazoo, Calhoun and Antrim counties. Michigan. *In* Bull. U. S. Fish Comm. for 1890.

22. The Myriapoda of North America. *In* Bull. U. S. Nat. Mus. No. 46, Washington, 1893. Pp. 210. (Edited by L. M. Underwood.)

LEWIS BOLLMAN, A.B. (1831), LL.B. (1846). Died Sept. 3, 1888, at Bloomington, Ind.

1. The State University of Indiana; the causes of its want of prosperity considered. Indianapolis, 1882. Pp. 37.

MARIE (BOISEN) BRADLEY (Mrs. Morton C. Bradley), A.B. (1900), A.M. (1900). New York City.

1. Editor of 'The Arbutus' (Senior class annual, Indiana University). Bloomington, Ind., 1900. Pp. 288.

EDITH CLEMENTINE BRAMHALL, A.B. (1895), Ph.D. Professor of History, Rockford College, Rockford, Ill.

1. The origin of the temporal privileges of crusaders. *In* Am. Jour. Theol., V, pp. 279-292. (April, 1901.)

2. The early Christian persecutions. (Joint author with D. C. Munro.) *In* Univ. Penn. Translations and Reprints, IV, No. 1.

3. Review of Ed. Heyck's 'Die Kreuzzüge und das heilige Land.' *In* Am. Jour. Theol., V. (Oct., 1901.)

JOHN CASPER BRANNER, Ph.D. (1885), LL.D. Professor of Geology, Indiana University, 1885-91. Now Professor of Geology, Leland Stanford Junior University, Stanford University, Cal.

1. The course and growth of the fibro-

vascular bundles in palms. *In* Proc. Am. Phil. Soc. for 1884. XXI, pp. 459-483. 12 figures.

2. The pororóca or bore of the Amazon. *In* Science, IV, pp. 488-492. (Nov. 28, 1884.) Published as separate, with additional notes. Boston, 1885. 4 figures.

3. Rock inscriptions in Brazil. *In* Am. Nat., XVIII, pp. 1187-1192. 2 figures, 3 plates. (Dec., 1884.) The separates contain also pp. 1192a and 1192b.

4. Preliminary report of observations upon insects injurious to cotton, orange, and sugar-cane in Brazil. *In* U. S. Dept. of Agr., Division of Entomology, Bulletin No. 4, pp. 63-69. (1884.) The same report reprinted as a separate, Boston, 1884.

5. The Batrachichthys. *In* Science, III, p. 376. 1 figure. (March 28, 1884.)

6. Flexible sandstone. *In* Am. Nat., XVIII, p. 927. (Sept., 1884.)

7. Inscrições em rochedos do Brazil. Translated by Dr. João Baptista Regueira Costa and published by the Instituto Archeologico e Geographico Pernambucano. 4 plates. Pernambuco, Brazil, 1885.

8. Glaciation of the Lackawanna valley. *In* Proc. A. A. A. S. for 1885, XXXIV, pp. 212-214. Abstract *in* Science, VI, pp. 221-222. (1885.)

9. The reputation of the lantern-fly. *In* Am. Nat., XIX, pp. 835-838. 1 plate. (Sept., 1885.)

10. A Gitiranabóia. *In* Liberal Mineiro. Ouro Preto, Brazil. (Dec. 19, 1885.)

11. Cotton in the Empire of Brazil; the antiquity, methods and extent of its cultivation, together with statistics of exportation and home consumption. Dept. of Agr. Special Report No. 8. Pp. 79. (1885.)

12. Cotton caterpillars in Brazil. Appendix V, pp. 49-54. Fourth Rep. U. S. Entomological Comm. on cotton worm and boll worm. (1885.)

13. Glaciation of the Wyoming and Lackawanna valleys. *In* Proc. Am. Phil.

- Soc. for 1886, XXIII, pp. 337-357, 2 maps. Abstract *in Science*, VIII, p. 422. (1886.)
14. Geographical and geological exploration in Brazil. *In Am. Nat.*, XX, pp. 687-690. (August, 1886.)
15. Notes upon a native Brazilian language. *In Proc. A. A. A. S. for 1886*, XXXV, pp. 329-330. (1886.)
16. The thickness of the ice in north-eastern Pennsylvania during the glacial epoch. *In Am. Jour. of Sci.*, CXXXII, pp. 362-366. (Nov., 1886.)
17. Geological map of Indiana, colored according to the scheme of the International Congress of Geologists, 2 ft.x4 ft. Indianapolis, 1886.
18. The railways of Brazil. *In Railway Age*, XII, pp. 470-473. (July 8, 1887.) Reprinted with notes and additions. 26 pp., 2 maps. Chicago, 1887.
19. Annual report of the geological survey of Arkansas for 1887. Pp. 15. (1887.)
20. Additional notes on the lantern-fly of Brazil. *In Trans. New York Acad. Sci. for 1887*, VII, pp. 66-68.
21. Notes on the glacial striæ observed in the Lackawanna-Wyoming region. *In Lackawanna Inst. Hist. and Sci.*, I, pp. 19-27. Scranton, Pa., 1887.
22. Topographical map in ten-foot contours of a portion of the Lackawanna valley between Scranton and Carbondale, Lackawanna county, in the Northern Anthracite coal field; scale 1600'= $1''$. Preliminary topographical map, Lackawanna valley sheets Nos. I and II. *In Ann. Rep.*, 2d Geol. Surv. Pennsylvania for 1886. (1887.)
23. The so-called gold and silver mines of Arkansas; an official report to Governor S. P. Hughes. *In Engineering and Mining Journal*, N. Y., August 18, 1888.
24. Notes on the fauna of the islands of Fernando de Noronha. *In Am. Nat.*, XXII, pp. 861-871, 2 figures. (Oct., 1888.)
25. Notes on the *Botocúdis* and their ornaments. *In Proc. Am. Phil. Soc. for 1888*, XXVI, pp. 171-173; 10 figures.
26. The Cretaceous and Tertiary geology of the Sergipe-Alagôas basin of Brazil. *In Trans. Am. Phil. Soc. for 1888*, XVI, pp. 369-434, 5 plates, 10 figures.
27. On the manufacture of Portland cement. *In Ann. Rep. Geol. Surv. Arkansas for 1888*, II, chap. xxix, pp. 291-302.
28. Introduction to 'The Neozoic geology of Southwestern Arkansas.' *In Ann. Rep. Geol. Surv. Arkansas for 1888*, II, pp. xi-xiv.
29. Administrative report and introduction to 'Geology of Western Central Arkansas.' *In Ann. Rep. Geol. Surv. Arkansas for 1888*, I, pp. xv-xxxi.
30. Preface to 'Geology of the coal regions.' *In Ann. Rep. Geol. Surv. Arkansas for 1888*, III, pp. vii-x.
31. Glaciation; its relation to the Lackawanna-Wyoming valley. *In Lackawanna Inst. Hist. and Sci.*, I, pp. 3-18; 4 plates. Scranton, Pa., 1888.
32. Arkansas gold and silver mines; an official report to Governor S. P. Hughes in reply to certain charges. *In Engineering and Mining Jour.*, XLVI, pp. 325-327. (Oct. 20, 1888.)
33. Arkansas state weather service. Appendix V to the *Ann. Rep. Chief Signal Officer*, 1888, pp. 72-75. (1889.)
34. The geology of Fernando de Noronha. *In Am. Jour. Sci.*, XXXVII, pp. 145-161, map, 7 figures. (Feb., 1889.)
35. The convict island of Brazil—Fernando de Noronha. *In Pop. Sci. Mo.*, XXXV, pp. 33-40. (May, 1889.)
36. The age and correlation of the Mesozoic rocks of the Sergipe-Alogôas basin of Brazil. *In Proc. A. A. A. S. for 1889*, XXXVII, pp. 187-188.
37. The age of the crystalline rocks of Arkansas. *In Proc. A. A. A. S. for 1889*, XXXVII, p. 188.

38. The peridotite of Pike county, Arkansas. (Joint author with R. N. Brackett.) *In Am. Jour. Sci.*, CXXXVIII, pp. 50-56; 1 figure, 1 plate. (1889.) Reprinted *in Ann. Rep. Geol. Surv. Arkansas for 1890*, vol. II, pp. 378-391; 1 figure, 1 plate. Abstract *in Proc. A. A. A. S. for 1889*, XXXVII, pp. 188-189; also *in Neues Jahrbuch f. Mineralogie for 1893*, pp. 500-501.
39. Analyses of Fort Smith clay shales. *In Brick, Tile and Pottery Gazette*, X, p. 114. (June, 1889.)
40. Building stones of Arkansas. *In Stone*, II, pp. 92-93. (Oct., 1889.)
41. Geology of Arkansas. Abstract of a lecture delivered at Pine Bluff, Arkansas. *In Minutes State Teachers' Asso. Arkansas for 1889*, pp. 34-38.
42. Professor Hartt in Brazil. *In Cornell Mag.*, Ithaca, N. Y., II, pp. 186-192. (Feb., 1890.)
43. The training of a geologist. *In Am. Geologist*, V, pp. 147-160. (March, 1890.)
44. The æolian sandstone of Fernando de Noronha. *In Am. Jour. Sci.*, CXXXIX, pp. 247-257, 8 figures. (April, 1890.)
45. Geologia de Fernando de Noronha. No. 36 of the *Revista do Instituto Archaeologico e Geographico Pernambucano*. Pernambuco, Brazil, 1890. Pp. 21; 1 map, 7 plates.
46. The relation of the state and national geological survey to each other, and to the geologists of the country. *In Am. Geol.*, VI, pp. 295-309. (Nov., 1890.) *In Science*, XVI, pp. 120-123. (August, 1890.) Also *in Proc. A. A. A. S. for 1891*, XXXIX, pp. 219-237.
47. The pororôca or bore of the Amazon. *In Pop. Sci. Mo.*, XXXVIII, pp. 208-215. (Dec., 1890.)
48. A preliminary report upon the bauxite deposits of Arkansas, with locations and analyses. *In Bien. Rep. State Comm. Mines, Mfrs. and Agr. for 1893-94*, pp. 119-126; also *in Bien. Rep. of the same for 1895-96*, pp. 105-112.
49. Bauxite in Arkansas. *In Am. Geol.*, VII, pp. 181-183. (March, 1891.) *In Science*, XVII, p. 171. (March 27, 1891); also *in Engineering and Mining Jour.*, LI, p. 114. (1891.)
50. Introduction to 'The geology of Washington county' (Arkansas). *In Ann. Rep. Geol. Surv. Arkansas for 1888*, IV, pp. xi-xiv.
51. A list of the plants of Arkansas. (Joint author with F. V. Coville.) *In Ann. Rep. Geol. Surv. Arkansas for 1888*, IV, pp. 152-242.
52. Preface to 'The geology of Crowley's Ridge.' *In Ann. Rep. Geol. Surv. Arkansas for 1889*, II, pp. xi-xix.
53. Preface to 'Manganese; its uses, ores and deposits.' *In Ann. Rep. Geol. Surv. Arkansas for 1890*, I, pp. xxiii-xxvii.
54. Preface to 'The igneous rocks of Arkansas.' *In Ann. Rep. Geol. Surv. Arkansas*, II, pp. xi-xv. (1891.)
55. Analyses of Hot Springs waters. *In Rep. Supt. Hot Springs Reserv. to Sec. of Interior*, pp. 9-16. (1891.)
56. David Starr Jordan, LL.D. A biographical notice. *In Delta Upsilon Quart.*, IX, pp. 195-198. (May, 1901.)
57. The mineral waters of Arkansas. *In Ann. Rep. Geol. Surv. Arkansas for 1891*, I, pp. 144, map.
58. The cotton industry in Brazil. *In Pop. Sci. Mo.*, XI, pp. 666-674. (1892.)
59. The training of a geologist. San Francisco, 1892. 3d ed. 19 pp.
60. Preface to 'Whetstones and the Nodules of Arkansas.' *In Ann. Rep. Geol. Surv. Arkansas for 1890*, III, pp. xv-xviii.
61. Preface to 'The iron deposits of Arkansas.' *In Ann. Rep. Geol. Surv. Arkansas for 1892*, I, p. xi.
62. The lip and ear ornaments of the

Botocúds. *In* Pop. Sci. Mo., XLIII, pp. 753-757, 5 figures. (Oct., 1893.)

63. The supposed glaciation of Brazil. *In* Jour. Geology, I, pp. 753-772, illus. (1893.)

64. Preface to 'Marbles and other limestones.' *In* Ann. Rep. Geol. Surv. Arkansas for 1890, IV, pp. xvii-xxi.

65. Observations upon the erosion in the hydrographic basin of the Arkansas river above Little Rock. *In* Wilder Quarter-Century Book, pp. 325-337. Ithaca, N. Y. 1893. Also separate, Ithaca, N. Y., 1893.

66. The coal fields of Arkansas. *In* Mineral Resources of the U. S. for 1892, pp. 303-306, 1 figure. (1893.)

67. Proverbs from the Portugese. *In* the Overland Monthly, 2d ser., XXI, pp. 501-503. (May, 1893.)

68. Elevations in the State of Arkansas. *In* Ann. Rep. Geol. Surv. Arkansas for 1891, II, pp. 77-152, 2 figures. (1894.)

69. Observations upon the erosion in the hydrographic basin of the Arkansas river above Little Rock. *In* Ann. Rep. Geol. Surv. Arkansas for 1891, II, pp. 153-166. (1894.)

70. Magnetic observations and meridian monuments established in Arkansas. *In* Ann. Rep. Geol. Surv. Arkansas for 1891, II, pp. 167-176, 10 figures. (1894.)

71. Introduction to Sampson's 'Preliminary list of the Mollusca of Arkansas.' *In* Ann. Rep. Geol. Surv. Arkansas for 1891, II, pp. 179-180. (1894.)

72. Introduction to Meek's 'Catalogue of the fishes of Arkansas.' *In* Ann. Rep. Geol. Surv. Arkansas for 1891, II, pp. 216-220. (1894.)

73. Bibliography of the geology of Arkansas. *In* Ann. Rep. Geol. Surv. Arkansas for 1891, II, pp. 319-340. (1894.)

74. Introduction to and translation of the political constitutions of Brazil. *In* The Convention Manual of the Sixth New York State Constitutional Convention, 1894. Part 2, III, pp. 57-138.

75. Preface to 'The Tertiary geology of Southern Arkansas.' *In* Ann. Rep. Geol. Surv. Arkansas for 1892, II, pp. xiii-xiv. (1894.)

76. Report on road making materials in Arkansas. *In* U. S. Dept. Agr., Office of Road Inquiry, Bulletin No. 4. (1894); also *in* 4th Bien. Rep. Bureau of Mines, Mfrs. and Agr. (of Arkansas) for 1895-96, pp. 90-101. Also *in* 5th Bien. Rep. of that bureau for 1897-98, pp. 131-141.

77. The geological survey of Arkansas. *In* Jour. Geology, II, pp. 826-836. (1894.)

78. Os gres eolios de Fernando de Noronha. *In* Instituto Archeologico e Geographico Pernambucano, 8 figures. Pernambuco, Brazil, 1894.

79. Syllabus of lectures on economic geology. (Joint author with John F. Newsum.) Palo Alto, 1895. Pp. 282.

80. Great mountain railways. (Joint author with John H. Means.) *In* Chautauquan, July, 1895, pp. 426-433.

81. Report upon the condition of the geological survey of Arkansas. Appendix to Bien. Mess. of Gov. Wm. M. Fishback to General Assembly of Arkansas, pp. 26-33 (1895).

82. Decomposition of rocks in Brazil. *In* Bull. Geol. Soc. Am., VII, pp. 255-314; 5 plates, 6 figures. (1895-96.)

83. Thickness of the Paleozoic sediments in Arkansas. *In* Am. Jour. Sci., II, pp. 229-236, 8 figures. (Sept., 1896.)

84. The phosphate deposits of Arkansas. *In* Trans. Am. Inst. Mining Engineers for 1896, XXVI, pp. 580-598, map. (1896.)

85. Bibliography of clays and the ceramic arts. *In* Bull. 143 U. S. Geol. Surv., 114 pp., 2961 titles. (1896.)

86. Review of F. H. King's 'The soil.' *In* Jour. Geol., IV, p. 243. (1896.)

87. The decomposition of rocks in Brazil. *In* Jour. Geol., IV, pp. 630-631. (1896.)

88. On the size of geological publications. *In Jour. Geol.*, IV, pp. 214-217. (1896.)
89. A supposta glaciação do Brazil. *In Revista Brasileira*, VI, pp. 49-55, 106-113. (April, 1896.)
90. The study of science. (Part of a lecture delivered at the Mount Tamalpais Military Academy.) *In Overland Monthly*, Oct., 1896.
91. Abstract of F. Kater's 'Oldest fossiliferous beds of the Amazon region.' *In Jour. Geol.*, IV, pp. 975-976. (1896.)
92. Review of the proceedings of the Indiana Academy of Sciences, geological subjects. *In Jour. Geol.*, IV, p. 981. (1896.)
93. Geological map of Arkansas. Scale 80 mi.=1". (1896.)
94. Note on 'O fim da criação, pelo Visconde do Rio Grande.' *In Revista Brasileira*, August 1897, pp. 254-255, Rio de Janeiro, Brazil; also *in Anuario do Rio Grande do Sul*, 1898, pp. 261-265, Porto Alegre (Brazil), 1897.
95. Bacteria and the decomposition of rocks. *In Am. Jour. Sci.*, CLIII, pp. 438-442 (1897), and as separate; abstract *in Neues Jahr. f. Mineralogie*, II, Referate, 84. (1899.)
96. The cement materials of southwest Arkansas. *In Trans. American Inst. Mining Engineers for 1897*, XXVII, pp. 42-63, 6 figures. Also separate, 22 pp., map, and illustrations.
97. Reply to criticism of R. T. Hill on 'The cement materials of southwest Arkansas.' *In Trans. Am. Inst. Mining Engineers for 1897*, XXVII, pp. 945-946.
98. The bauxite deposits of Arkansas. *In Jour. Geol.*, V, pp. 263-289, 2 plates, 2 figures. (April-May, 1897.) Also as separate with 10 pp. additional matter, Chicago, 1897.
99. The Red River and Clinton monoclinal. (Joint author with J. F. Newsom.) *In Am. Geologist*, XX, pp. 1-13, 1 map, 3 figures. (July, 1897.)
100. Protection for American colleges. *In Nation*, May 27, 1897, p. 395.
101. The introduction of new terms in geology. *In Science*, V, pp. 912-913; VI, pp. 133-134. (June 11 and July 23, 1897.)
102. Mineral wealth of Arkansas. *In Engineering and Mining Jour.*, August 7, 1897, p. 153.
103. Geology in its relations to topography. *In Proc. Am. Soc. Civil Engineers for 1897*, XXIII, No. 8, pp. 473-495, 1 plate, 16 figures.
104. Introduction to Ashley's 'Geology of the Paleozoic area of Arkansas south of the Novaculite region.' *In Proc. Am. Phil. Soc. for 1897*, XXXVI, pp. 217-220.
105. The former extension of the Appalachians across Mississippi, Louisiana, and Texas. *In Am. Jour. Sci.*, CLIV, pp. 357-371, 2 figures. (November, 1897.) Abstract *in Rep. British Asso. for Advanc. Science*, Toronto meeting, 1897, pp. 643-644; *in Annales de Géographie*, 7me Année, pp. 245-246 (Sept. 15, 1898); *in Nature* LVII, p. 70 (Nov. 18, 1897); also *in Jour. Geol.*, V, pp. 759-760 (Oct.-Nov., 1897.)
106. Review of T. C. Hopkin and C. E. Siebenthal's 'The Bedford Oolitic limestone of Indiana,' published in 21st Ann. Rep. State Geologist Indiana. *In Jour. Geol.*, V, pp. 529-531. (July-August, 1897.)
107. Reviews of the 'Unpublished reports of the Comissão Geologica do Brazil,' published in the Boletim do Museu Paraense. *In Jour. Geol.*, V, pp. 756-757. (Oct.-Nov., 1897.)
108. Review of Kater's 'Devonian fauna of the Rio Maecurú,' published in the Boletim do Museu Paraense. *In Jour. Geol.*, V, pp. 757-758. (1897.)
109. Geology in its relations to topography (with discussion). *In Proc. Am. Soc. Civil Engineers*, XXXIX, pp. 53-95, 18 plates. (June, 1898.)

110. On the origin of certain siliceous rocks. (Joint author with O. A. Derby.) *In Jour. Geol.*, VI, pp. 366-371. (May-June, 1898.) Abstract *in Neues Jahrb. f. Mineralogie*, I, p. 408. (1900.)
111. A geologist's impression (of the Grand Canyon of the Colorado, and Black Crater, Flagstaff, Arizona). *In Land of Sunshine Mag.*, IX, pp. 149-152, illustrated. (August, 1898.)
112. The Spanish University of Salamanca. *In Maryville Coll. Monthly for 1898*, Maryville, Tenn.
113. Syllabus of elementary geology. Stanford University, 1898. Pp. 300; 69 plates.
114. Review of J. Geikie's 'Earth sculpture.' *In Science*, N. S., VIII, pp. 957-959. (1898.)
115. Some old French place names in the state of Arkansas. *In Mod. Lang. Notes*, XIV, No. 2, pp. 65-80. (Feb., 1899.)
116. The recent ascent of Itambé. *In Nat'l Geog. Mag.*, X, p. 183. (1899.)
117. Notes upon the Sao Paulo sheet of the Comissão Geographica e Geologica de São Paulo. *In Revista Brasileira*, Rio de Janeiro, 1899; republished in the Cidade de Santos, Santos, Brazil, January 10, 1900.
118. The São Paulo sheet of the topographic survey of the São Paulo, Brazil. *In Jour. Geol.*, VII, pp. 788-789. (1899.)
119. The manganese deposits of Bahia and Minas, Brazil. *In Trans. Am. Inst. Mining Engineers*, XXIX, pp. 756-770, 5 figures. (Sept., 1899.)
120. The stone reef at the mouth of Rio Grande do Norte. (Joint author with C. E. Gilman.) *In Am. Geol.*, XXIV, pp. 342-344, 2 figures. (Dec., 1899.)
121. A recife de pedra na foz do Rio Grande do Norte. (Joint author with C. E. Gilman.) Traduzido por Dr. Alfredo de Carvalho. *In Revista do Rio Grande do Norte*, 1900, Nos. 1, 2, Natal, pp. 267-271. (Jan. and Feb., 1900.)
122. Note upon John M. Clarke's 'The Upper Silurian fauna of the Rio Trombetas, State of Pará, Brazil,' and 'Devonian mollusca of the State of Pará, Brazil,' published in *Archivos do Museu Nacional*, X, pp. 1-48, 49-174. *In Journal of Geology*, VII, pp. 813-814. (Dec., 1899.)
123. Gold in Brazil. *In Mineral Industry*, VIII, p. 281. (1900.)
124. Diamonds in Brazil. *In Mineral Industry*, VIII, pp. 221-222. (1900.)
125. Ants as geologic agents in the tropics. *In Jour. Geol.*, VIII, pp. 151-153, 3 figures. (Feb.-March, 1900.)
126. The oil-bearing shales of the coast of Brazil. *In Trans. Am. Inst. Mining Engineers for 1900*, vol. XXX, pp. 537-554. Illustrated, map. Review *in Neues Jahrb. f. Mineralogie*, II, pp. 267-268. (1901.) Abstract *in Engineering and Mining Jour.*, LXX, pp. 308-309. (Sept. 15, 1900.)
127. Syllabus of economic geology. (Joint author with J. F. Newsom.) Stanford University, 1900. 2d ed. Pp. viii, 368, 141 figures.
128. Review of G. D. Harris and A. C. Veatch's 'A preliminary report on the geology of Louisiana.' *In Jour. Geol.*, VIII, pp. 177-179. (April-May, 1900.)
129. Two characteristic geologic sections on the northeast coast of Brazil. *In Proc. Washington Acad. Science for 1900*, II, pp. 185-201; 3 plates, 5 figures.
130. Beach cusps. *In Jour. Geol.* VIII, pp. 481-484, 3 figures. (Sept.-Oct., 1900.)
131. The zinc and lead region of North Arkansas. *In Ann. Rep. Geol. Survey Arkansas*, vol. V. Little Rock, Dec., 1900. Pp. xiv, 395; 38 plates, 92 figures, atlas of 7 sheets.
132. Review of F. W. Simonds's 'A record of the geology of Texas, etc.' *In Jour. Geol.*, IX, p. 91. (1901.)
133. Review of Henri Carpentier's 'Géologie et minéralogie appliquées. (Paris,

1900.) *In Jour. Geol.*, IX, pp. 198-199. (Feb.-March, 1901.)

134. Os recifes de grés do Rio Formoso, Brazil. *In Revista do Instituto Archeologico e Geographico Pernambucano*, No. 54, pp. 131-136. Illustrated. (1901.)

135. The origin of travertine falls. *In Science*, XIV, pp. 184-185. (August, 1901.)

136. The zinc and lead deposits of North Arkansas. *In Trans. Am. Inst. Mining Engineers*, vol. XXXI, pp. 572-603; 27 illustrations. Republished *in Lead and Zinc News of St. Louis, Mo.*, II, Nov. 4, 1901, pp. 4-6, Nov. 11, 1901, pp. 4-6, Nov. 18, 1901, pp. 4-6, Nov. 25, 1901, pp. 4-5. Abstract *in Engineering and Mining Jour.*, Nov. 30, 1901, pp. 718-719. 1 figure.

137. Editorial upon giant ripples. *In Jour. Geol.*, IX, pp. 535-536. (Sept.-Oct., 1901.)

138. Apontamentos sobre a fauna das Ilhas de Fernando de Noronha. Publicação do Instituto Archeologico e Geographico Pernambucano. Pernambuco, 1901. Pp. 14; 2 figures.

139. Depressions and elevations of the southern archipelagoes of Chile. Translation (with introduction) of a paper by Francisco Vidal Gormaz in the *Revista Nueva of Santiago de Chile*, 1901. Translation and introduction. *In Scottish Geog. Mag.*, XVIII, pp. 14-24, 1 map. (Jan., 1902.)

140. Notes upon the surface geology of Rio Grande do Sul, Brazil. By James E. Mills. Edited from his letters. *In Am. Geol.*, XXIX, pp. 126-127. (Feb., 1902.)

141. The occurrence of fossil remains of mammals in the interior of the States of Pernambuco and Alagoas, Brazil. *In Am. Jour. Sci.*, CLXIII, pp. 133-137, 1 map, 1 plate. (Feb., 1902.)

142. Geology of the northeast coast of Brazil. *In Bull. Geol. Soc. America*, Rochester, XIII, pp. 41-98; 16 figures, 9 plates.

143. The palm trees of Brazil. *In Pop. Sci. Mo.*, LX, pp. 386-412; 25 figures.

144. Discussion of Eric Hedburg's paper on 'The Missouri and Arkansas zinc region.' *In Trans. Am. Inst. Mining Engineers*, XXXI, pp. 1013-1014.

145. The phosphate rocks of Arkansas. (Joint author with J. F. Newsom.) *In Bull.* 74, Arkansas Agr. Exper. Station, pp. 59-123; 23 figures, 15 analyses. (Sept., 1902.)

146. Syllabus of a course of lectures on elementary geology. 2d ed. Stanford University, 1902. Pp. 370. 100 figures, 25 plates.

147. The Carnegie institution. *In Science*, Oct. 3, 1902. N. S., XVI, pp. 527-528.

148. Bibliography of the geology, mineralogy, and paleontology of Brazil. (1288 titles.) Published by the Bibliotheca Nacional de Rio Janeiro, Brazil. (1902.)

149. Geologia elementar. (An elementary treatise on geology for the use of Brazilian students. Published in Portuguese.) Rio de Janeiro, 1902. Pp. 256; 264 figures, 15 plates.

150. Biographical notice of James E. Mills. *In Bull. of the Geol. Soc. of Am.*, XIV. (1904.) (In press.)

JAMES RONALD BRANSON, A.B. (1903), Indianapolis, Ind.

1. Editor of 'The Arbutus' (Senior class annual, Indiana University). Bloomington, Ind., 1903. Pp. 287.

WILLIAM L BRAY, A.B. (1893), Ph.D. Associate Professor in charge of School of Botany, University of Texas, Austin, Tex.

1. Revision of the South American Cichlidae. (Joint author with C. H. Eigen-

- mann.) *In Ann. New York Acad. Sci.*, VII, pp. 607-637. (Jan., 1894.)
2. Synopsis of North American Amaranthaceæ. (Joint author with E. B. Uline.) *In Bot. Gaz.*, XIX, pp. 267-272, 313-320; XX, pp. 155-161; 337-344, 449-453. (July, August, 1894; April, August, Oct., 1895.)
3. The geographical distribution of the Frankeniaceæ considered in connection with their general relationship. *In Jahrb. f. system., Pflanzengeschichte u. Pflanzengeographie*, XXIV, pp. 395-418. (1897.)
4. On the relation of the flora of the Lower Sanoran zone in North America to that of the arid zones of Chili and Argentine. *In Bot. Gaz.*, XXVI, pp. 121-147. (August, 1898.)
5. Texas as a field for botanical study. *In the Univ. of Texas Record*, I, pp. 153-171. (April, 1899.)
6. The relation of plant physiology to the other sciences. Translation of an address by Dr. Julius Wiesner. *In Ann. Rep. Smithsonian. Inst. for 1898*, pp. 427-444. (1900.)
7. The relation of the North American flora to that of South America. *In Science*, XII, pp. 709-716. (Nov., 1900.)
8. Botany in the high school. *In Bulletin No. 1 of Committee of Affiliated Schools, Univ. of Texas*, pp. 55-61. (Feb., 1901.)
9. Destruction of timber by the Galveston storm. *In Forester*, VII, pp. 53-56. (March, 1901.)
10. Texas forests and the problem of forest management for the long-leaf pine lands. *In Forester*, VII, pp. 131-138. (June, 1901.)
11. The ecological relation of the vegetation of Western Texas. *In Bot. Gaz.*, XXXII, pp. 99-123, 195-217, 262-291; 24 text figures. (Aug., Sept., Oct., 1901.)
12. Forest management by the Kirby Lumber Company. *In University of Texas Record*, V, pp. 36-45. (April, 1903.)
13. The tissues of some plants of the Sotol region. *In Bull. Tor. Bot. Club*, XXX, pp. 621-633, 10 text figures. (Nov., 1903.)
14. Forest conditions and forest resources in Texas. *In Bull. U. S. Dept. Agriculture, Bureau of Forestry*. Numerous maps and plates. (In press.)
15. Relation of the timber covering the Edwards plateau in Texas to water supply. (A report now in hands of editor of Bureau of Forestry, U. S. Dept. Agriculture.) 10 plates.
16. The vegetation of the Sotol country. (Bulletin of University of Texas.) (1904.)
-
- OLIVER W BROWN, A.M. (1896). *See Faculty list.*
-
- ELMER BURRITT BRYAN, A.B. (1893). *See Faculty list.*
-
- WILLIAM LOWE BRYAN, A.B. (1884), A.M. (1886), Ph.D. *See Faculty list.*
-
- ROBERT CLARKSON BROOKS, A.B. (1896), Ph.D. Instructor in Economics, Cornell University, Ithaca, N. Y.
1. The Merchants' Municipal Committee of Boston. *In Municipal Affairs*, I, pp. 1-508. (Sept., 1897.)
2. Review of W. T. Stead's 'Satan's invisible world displayed.' *In Municipal Affairs*, II, pp. 304-306. (June, 1898.)
3. Review of Gustav Herzfeld's 'Gross New York, eine Studie zur Einverleibungsfrage.' *In Municipal Affairs*, III, pp. 351-352. (June, 1899.)
4. The three-class election system in Prussian cities. *In Municipal Affairs*, III, pp. 396-433. (Sept., 1899.)
5. Review of 'A municipal program.' (H. E. Deming and others, editors). *In Mu-*

municipal Affairs, IV, pp. 235-238. (March, 1900.)

6. Political clubs in Prussian cities. *In* Municipal Affairs, IV, pp. 375-384. (June, 1900.)

7. A bibliography of municipal administration and city conditions. New York, 1897. Pp. ix, 224. Second edition, revised and enlarged, New York, 1901. Pp. 346.

8. Translation of Karl Bücher's 'Die wirtschaftlichen Aufgaben der modernen Stadtgemeinde.' *In* Municipal Affairs, VI, pp. 167-179. (June, 1902.)

9. Review of Charles Zeublin's 'American municipal progress.' *In* Charities, X, pp. 185-186. (Feb., 1903.)

10. Review of S. N. Patten's 'Theory of prosperity.' *In* Philos. Rev. XII, pp. 689-690. (Dec., 1903.)

PERCY BENTLEY BURNET, A.B. (1884), A.M. (1887). Professor of Modern Languages, Iowa College, Grinnell, Iowa.

1. French-English and English-French dictionary. (Joint author with A. J. Edgren.) New York, 1901. Pp. xvi, 1252.

2. La Familia de Alvareda. New York, 1901. Pp. iv, 196 (30 pages of notes.)

3. Spanish grammar. Chicago, 1902. Pp. iii, 135.

4. Review of M. M. Ramsey's 'Lo Esencial del Lenguaje Castellano.' *In* Mod. Lang. Notes, Dec., 1902.

BESSIE BUSHING. *See* Mrs. Douglas Clay Ridgeley.

AMOS WILLIAM BUTLER, A.B. (1894), A.M. (1900). Secretary Indiana State Board of Charities, Indianapolis.

1. The birds of Franklin county, Ind. *In* Atlas of Franklin County, Indiana, etc. (Chicago, 1882), pp. 11-12.

2. Ornithological notes from Brook-

ville, Ind. *In* Jour. Cin. Soc. Nat. Hist., V, pp. 192-193. (1882.)

3. Local weather lore. *In* Am. Meteor. Jour., I, pp. 313-317. (Dec., 1884.) Abstract *in* Proc. A. A. A. S., XXXIII, pp. 609-613. (1884.)

4. Hibernation of the lower vertebrates. *In* Am. Nat., XIX, pp. 37-40. (1885.) Abstract *in* Proc. A. A. A. S., XXXIII, pp. 543-545. (1885.)

5. The habits of some Arvicolinæ. (Joint author with Edgar R. Quick.) *In* Am. Nat., XIX, pp. 113-118. (Feb., 1885.) Abstract *in* Proc. A. A. A. S., XXXIII, pp. 539-542. (1884.)

6. The sacrificial stone of San Juan Teotihuacan. *In* American Antiquarian, pp. 149-152. (May, 1885.) Abstract *in* Proc. A. A. A. S., XXXIII, pp. 601-603. (1884.)

7. Observations on faunal changes. *In* Bull. No. 1, Brookville Society of Nat. Hist., 1885, pp. 5-13. Reprinted *in* Ornithologist and Oölogist, X, p. 32. (1885.)

8. Land and fresh-water mollusca observed in Franklin county. (Joint author with D. R. Moore.) *In* Bull. No. 1, Brookville Soc. of Nat. Hist., 1885, pp. 41-44.

9. Observations on the muskrat. *In* Am. Nat., XIX, pp. 1044-1055. (Nov., 1885.) Abstract *in* Proc. A. A. A. S., XXXIV, pp. 324-329. (1885.)

10. The remains at San Juan Teotihuacan. Abstract *in* Proc. A. A. A. S., XXXIV, pp. 418-420. (1885.)

11. A list of the birds observed in Franklin county, Indiana. *In* Bull. No. 2, Brookville Soc. of Nat. Hist., pp. 12-39. (1886.)

12. Meadow mice in Southeastern Indiana. *In* Hoosier Naturalist, I, pp. 144-145. (April, May, 1886.)

13. The periodical Cicada in Southeastern Indiana. *In* Bull. No. 12, U. S. Dept. Agriculture, pp. 24-31. (1886.) Abstract *in* Proc. A. A. A. S., XXXIV, pp. 328-329. (1885.)

14. The cerulean warbler. *In* Ornithologist and Oölogist, IX, pp. 27-28. (1884.)
15. Zoölogical miscellany. *In* Jour. Cin. Soc. Nat. Hist., pp. 261-266. (Jan., 1887.)
16. Zoölogical miscellany—some notes on Indiana amphibians and reptiles. *In* Jour. Cin. Soc. Nat. Hist., pp. 147-150. (Oct., 1887.)
17. Zoölogical miscellany. *In* Jour. Cin. Soc. Nat. Hist., pp. 214-216. (Jan., 1888.)
18. Notes on the range of the prothonotary warbler in Indiana. *In* Ornithologist and Oölogist, XIII, pp. 33-34. (March, 1888.)
19. On a new subspecies of *Ammodramus sandwichensis* from Mexico. *In* Auk, V, pp. 264-266. (July, 1888.)
20. A catalogue of the birds of Indiana. *In* Proc. Indiana Hort. Soc., appendix C, pp. 1-135. (1890.)
21. Our birds and what they do for the farmer. *In* Rep. State Board of Agric. Indiana for 1890, pp. 113-125.
22. Notes on the range and habits of the Carolina parakeet. *In* Auk, IX, pp. 49-56. (Jan., 1892.)
23. Our smaller mammals and their relation to horticulture. *In* Trans. Indiana Hort. Soc. for 1891, pp. 117-123.
24. Contributions to Indiana Herpetology. No. 3. *In* Jour. Cin. Soc. Nat. Hist. for 1892, pp. 169-179. (1892.)
25. Some notes concerning the evening grosbeak. *In* Auk, IX, pp. 238-247. (July, 1892.)
26. On Indiana shrews. *In* Proc. Indiana Acad. Sci. for 1891, pp. 161-163.
27. Notes on Indiana birds. *In* Proc. Indiana Acad. Sci. for 1891, pp. 164-166.
28. Further notes on the evening grosbeak. *In* Auk, I, pp. 155-157. (April, 1893.)
29. The range of the crossbills in the Ohio valley, with notes on their unusual occurrence in summer. *In* Proc. Indiana Acad. Sci. for 1892, pp. 63-72; *in* Am. Nat., XXVIII, pp. 136-146 (Feb., 1894); *in* Papers presented to the World's Congress of Ornithology (1893), Chicago, 1896, pp. 47-58.
30. The fruit lands of southeastern Indiana. *In* Trans. Indiana Hort. Soc. for 1893, pp. 56-61.
31. Bibliography of Indiana ornithology. *In* Proc. Indiana Acad. Sci. for 1893, pp. 108-116.
32. Notes on Indiana birds. *In* Proc. Indiana Acad. Sci. for 1893, pp. 116-120.
33. Bibliography of Indiana mammals. (Joint author with B. W. Evermann.) *In* Proc. Indiana Acad. Sci. for 1893, pp. 120-124.
34. Preliminary list of Indiana mammals. *In* Proc. Indiana Acad. Sci. for 1893, pp. 124-139.
35. Notes on the birds of 1894. *In* Proc. Indiana Acad. Sci. for 1894, pp. 73-80.
36. The mammals of Indiana. *In* Proc. Indiana Acad. Sci. for 1894, pp. 81-86.
37. An orchard talk. *In* Trans. Indiana Hort. Soc. for 1895, pp. 149-152.
38. With the birds of Winona. *In* Indiana Synod, II, pp. 78-80. (Dec., 1895.)
39. Notes on the birds of 1894. *In* Oölogist, pp. 73-80. (1895.)
40. Indiana—a century of changes in the aspects of nature (President's address.) *In* Proc. Indiana Acad. Sci. for 1895, pp. 31-42; *in* Inland Educator, II, pp. 313-318. (July, 1896.) Reprint *in* Studies in Indiana Geography, Terre Haute, 1897, pp. 72-81.
41. Additional notes on Indiana birds. *In* Proc. Indiana Acad. Sci. for 1895, pp. 162-168.
42. From wilderness to civilization. *In* Proc. Indiana Hort. Soc. for 1896, pp. 19-29.
43. The bobolink (*Dolichonyx oryziv-*

- orus) in Indiana. *In Proc. Indiana Acad. Sci.* for 1896, pp. 227-243.
44. Some additions to the Indiana bird list, with other notes. *In Proc. Indiana Acad. Sci.* for 1896, pp. 244-246.
45. Some Indiana crow roosts. *In Proc. Indiana Acad. Sci.* for 1897, pp. 175-178.
46. Notes on Indiana heronries. *In Proc. Indiana Acad. Sci.* for 1897, pp. 201-202.
47. The recent occurrence of the raven in Indiana. *In Proc. Indiana Acad. Sci.* for 1897, pp. 201-202.
48. The birds of Indiana. *In 22d Rep. Indiana State Geologist* for 1897, pp. 515-1187.
49. Brunnich's murre (*Uria lomvia*), an addition to the birds of Indiana. *In Proc. Indiana Acad. Sci.* for 1897, pp. 180-183.
50. The unusual occurrence of Brunnich's murre (*Uria lomvia*) far inland, with notes on other rare birds. *In Auk*, XIV, pp. 197-200. (April, 1897.)
51. Bird life in Indiana. *In Trans. Indiana Hort. Soc.* for 1898, pp. 30-38.
52. Life in the forest—Mammals. *In Nature and Art*, I, Chicago, pp. 53-57. (Feb., 1898.)
53. State care of dependent children in Indiana. *In Ohio Bull. of Char. and Cor.*, June, 1899, pp. 5-9; *in Indiana Bull. Char. and Cor.*, June, 1899, pp. 8-12.
54. The value of horticulture to our public institutions. *In Trans. Indiana Hort. Soc.* for 1899, pp. 119-124; *in Indiana Bull. of Char. and Cor.*, March, 1900, pp. 10-16.
55. Notes on Indiana birds. *In Proc. Indiana Acad. Sci.* for 1899, pp. 149-151.
56. Development of the reformatory idea in Indiana. Read before the Local Council of Women, Indianapolis, 1899. Printed for general distribution by the Indiana Reformatory, pp. 12. Republished in *Ohio Bull. Char. and Cor.*, March, 1900, pp. 21-30.
57. Advantages and disadvantages of the present system of public care of the poor. Read before Indiana Trustees' Association, Dec. 27, 1899. *In Indiana Bull. Char. and Cor.*, March, 1900, pp. 2-10.
58. Facts about the operation of the new poor relief laws. *In Proc. Sixth Annual Meeting Indiana State Board of Commerce*, Feb., 1900, pp. 1-26; *in Bull. No. 10, Indiana Bureau of Statistics*, March, 1900, pp. 8-14; *in Eighth biennial report Indiana Bureau of Statistics*, 1900, pp. 289-297.
59. The condition and needs of our jails. From *Proc. Indiana State Conference of Char. and Cor.*, 1899. *In Indiana Bull. Char. and Cor.*, June, 1900, pp. 20-25.
60. Saving the children. *In Proc. Nat. Conf. Char. and Cor.* for 1901, pp. 204-213.
61. A notable factor of social degeneration. Vice-presidential address, Section of Anthropology. *In Proc. A. A. S.*, for 1901, L, pp. 337-353. Reprinted for general distribution in England by the Lancashire and Cheshire Society for the Permanent Care of the Feeble-minded, pp. 10. Also *in Science*, N. S., XIV, pp. 444-453. (Sept. 20, 1901); and *in Indiana Bull. Char. and Cor.*, Dec., 1901, pp. 17-27.
62. State visitation of children. *In Proc. Illinois Conf. of Char.*, 1901, pp. 14-19.
63. Education and crime. *In Ad. and Proc. Nat. Edu. Asso.*, Detroit, Mich., 1901, pp. 560-564; also *in Ann. Rep. Supt. of Pub. Inst.*, for 1901, p. 13-20.
64. State supervision and administration—the experience in Indiana. *In Proc. Nat. Conf. Char. and Cor.* for 1902, pp. 144-146.
65. The prevention of crime. *In Proc. Minnesota State Conf. Char. and Cor.* for 1902, pp. 61-68.
66. Report of committee on discharged prisoners. *In Proc. Nat. Pris. Asso.*, 1902, pp. 283-323. Reprinted for general distri-

bution by the Indiana Boys' School, 1903, pp. 44.

67. County and municipal corrections. *In Proc. Nat. Conf. Char. and Cor. for 1903*, pp. 392-400; extract *in Indiana Bull. Char. and Cor.*, Dec., 1903, pp. 4-7.

68. Child problems and their treatment. From *Proc. Ohio State Conf. Char. and Cor. for 1903*. *In Ohio Bull. Char. and Cor.*, XIX, pp. 75-81. (Dec., 1903.)

69. Conditions affecting the distribution of birds in Indiana. (Contributions from the Zoological Laboratory, Indiana University, No. 37.) *In Proc. Indiana Acad. Sci. for 1903*.

70. Ethnology. Article *in Encyclopedia Americana*, VII. (1904.)

71. The success of an Indiana experiment. *In Ann. Am. Acad. Pol. Soc. Sci.*, XXIII, pp. 202-204. (March, 1904.)

RICHARD ELLSWORTH CALL, A.B. (1890), A.M. (1891). Curator, Children's Museum, Brooklyn Institute of Arts, Brooklyn.

1. On the quaternary and recent Mollusca of the Great Basin, with descriptions of new forms. *In U. S. Geol. Surv. Bull.* II, pp. 355-420. (1884.)

2. Memoranda on a collection of fishes from the Ozark region of Missouri. *In Proc. Davenport Acad. Nat. Sci.*, V, p. 73. (1887.)

3. Description of new Unios from the Ozark region of Missouri. *In Proc. U. S. Nat. Mus. for 1889*, X, pp. 498-500, 2 plates.

4. On a new Post-Pleiocene Linnæid from California. *In Am. Geol.*, I, p. 146. (1888.) *In Proc. Iowa Acad. Sci. for 1889*, p. 17.

5. On the gross anatomy of *Campeoloma*. *In Am. Nat.*, for 1889. *In Proc. Iowa Acad. Sci. for 1889*, p. 16.

6. On the ferns of the Ozark region

of Missouri. *In Proc. Iowa Acad. Sci. for 1889*, pp. 15-16.

7. The parvus group of Unionidæ. *In Proc. Iowa Acad. Sci. for 1889*, pp. 45-51.

8. The geology of Crowley's Ridge, Arkansas. *In Proc. Iowa Acad. Sci. for 1889*, pp. 52-53.

9. The chemistry of soils. *In Northwest*, VII, No. 404, p. 11; VI, No. 410, p. 7.

10. The geology of eastern Arkansas. *In Proc. Iowa Acad. Sci. for 1889*, pp. 87-95.

11. The life and writings of Rafinesque. (Publications Filson Club, Louisville, Ky., vol. X.) Louisville. 1895. Pp. 227.

12. Sketch of the life, the ichthyologic work, and the ichthyologic bibliography of Rafinesque. *In Rafinesque-Schmaltz's 'Ichthyologia Ohiensis'* (Cleveland, 1899). Pp. 175.

JAMES MORTON CALLAHAN, A.B. (1894), A.M. (1895), Ph.D. Professor of History and Political Science, University of West Virginia, Morgantown, W. Va.

1. Outlines of physiology. Chicago, 1890. Pp. 50.

2. Outlines of civil government. Chicago, 1890. Pp. 48.

3. Outlines of United States history (with notes). Chicago, 1891. Pp. 60.

4. Outlines of geography. Chicago, 1891. Pp. 51.

5. Outlines and experiments in botany. Chicago, 1892. Pp. 53.

6. Outlines and experimental work in physiology. Boston, 1892. Pp. 121.

7. A guide to actual work in practical physiology. Chicago, 1893. Pp. 108.

8. The agreement of 1817—Reduction of naval forces on the American lakes. *In Ann. Rep. Am. Hist. Assoc. for 1895*, pp. 369-392. (1896.)

9. The northern lake frontier during the Civil War. *In Ann. Rep. Am. Hist. Assoc. for 1896*, I, pp. 337-359. (1897.)

10. Cuba and Anglo-American relations. *In Ann. Rep. Am. Hist. Assoc. for 1897, I, pp. 195-215. (1898.)*

11. Review of Jesse Macy's 'The English constitution.' *In Citizen for July 1898.*

12. The neutrality of the American Lakes, and Anglo-American relations. Baltimore, 1898. Pp. 199.

13. Diplomatic relations of the Confederate States with England (1861-1865). *In Ann. Rep. Am. Hist. Assoc. for 1898, pp. 267-283. (1899.)*

14. Cuba and international relations. Baltimore, 1899. Pp. 503.

15. American relations in the Pacific and the Far East. Baltimore, 1901. Pp. 177.

16. Great heroes and leaders. New York, 1901. Pp. 250.

17. Central America and the American foreign policy. Washington, 1902. Pp. 25.

18. Confederate archives. *In South Atlantic Quarterly for 1903, pp. 14.*

19. The American expansion policy. Baltimore, 1904. Pp. 350.

20. Introduction to American foreign policy. I. The Monroe Doctrine and inter-American relations. 1904. Pp. 300.

21. The United States and Canada: A study in international history. Pp. 275.

JOHN WESLEY CARR, A.B. (1885), A.M. (1890). Superintendent of Schools, Anderson, Ind.

1. The province of the supervisor. *In Proc. Nat. Edu. Asso. for 1897, pp. 235-236.*

2. Course of study for pupils who can not complete high school work. *In Proc. Nat. Edu. Asso. for 1899, pp. 378-379.*

3. Response to address of welcome at Charleston, S. C. *In Proc. Nat. Edu. Asso. for 1900, pp. 52-54.*

4. Does Indiana need additional Normal School facilities? (In conjunction with R. A. Ogg and C. M. McDaniel.) *In Rep.*

Indiana Town and City Superintendents' Asso. for 1902.

5. Best methods of electing school boards. *In Proc. Nat. Edu. Asso. for 1903, pp. 159-161.*

6. The school curriculum. *In Proc. Nat. Edu. Asso. for 1903, p. 263.*

7. Educational progress in Indiana. *In Proc. Nat. Edu. Asso. for 1903, pp. 798-800.*

8. Teaching of religion in the public schools. *In Proc. Nat. Educ. Assoc. for 1903, p. 361.*

9. Percentage of boys leaving high school. *In Proc. Nat. Educ. Assoc. for 1903, p. 798.*

10. Moral and religious training of children in the public schools. *In Proc. Religious Edu. Asso. for 1903.*

11. Moral instruction in the Anderson public schools. *In Proc. Religious Edu. Asso. for 1904.*

12. Course of instruction in morals. *In New York Sch. Jour.*

13. A permanent teaching profession. *In New York Sch. Jour.*

WILLIAM DAVIS CHAMBERS, A.B. (1898). Teacher, Muncie, Ind.

1. Mid-winter science. *In Educator-Journal, III, p. 294. (Jan., 1903.)*

2. Mid-winter science—iron and steel. *In Educator-Journal, III, pp. 344-345. (April, 1903.)*

OSCAR CHRISMAN, A.B. (1888), A.M. (1893), Ph.D. Professor of Paidology, Ohio University, Athens, Ohio.

1. The hearing of children. *In Ped. Sem., II, pp. 397-441. (Dec., 1893.)*

2. Secret language of children. *In Science, XXII, pp. 303-305; XXIII, pp. 18-19. (Dec. 1, 1893, and Jan. 12, 1894.)*

3. Child-study, a new department of education. *In Forum, XVI, pp. 728-736. (Feb., 1894.)*

4. The science of the child. *In* South Dakota Educator, VII, pp. 11-12.
5. Vertical writing. *In* Texas Sch. Jour. for 1894.
6. Contribution to a symposium on child-study. *In* Interstate Sch. Rev. for June, 1894, p. 225.
7. One year with a little girl. *In* Edu. Rev., IX, pp. 52-71. (Jan., 1895.)
8. Paidologie, Entwurf zu einer Wissenschaft des Kindes. Inaugural Dissertation der philosophischen Fakultät der Universität Jena zur Erlangung der Doktorwürde. Jena, 1896. Pp. 96.
9. 'Children's secret language. *In* Child-Study Mo., II, pp. 202-210. (Sept., 1896.)
10. How a story affected a child. *In* Child-Study Mo., II, pp. 650-661. (April, 1897.)
11. The hearing of school children. *In* North-Western Mo., VIII, pp. 31-35. (July 1897.)
12. Child-study in Texas. *In* Child-Study Mo., III, pp. 287-289. (Nov., 1897.) (Rep. Child-Study Section Texas State Teachers' Asso., held at Waco, June 29-July 2, 1897.)
13. Motor control: Its place in the physical and psychical life of the child. *In* State Normal Mo., X, pp. 3-4. (Oct., 1897.)
14. The secret language of children. *In* North-Western Mo., VIII, pp. 187-193, 375-379, 649-651. (Oct., 1897, Jan. and June, 1898.)
15. Exceptionals. *In* State Normal Mo., X, pp. 51-52. (Jan., 1898.)
16. Religious ideas of a child. *In* Child-Study Mo., III, pp. 516-528. (Jan., 1898.)
17. Results of child-study. *In* Education, XVIII, pp. 323-332. (Feb., 1898.)
18. How to use the library. *In* Western College Mag., XIX, pp. 502-505. (March, 1898.)
19. Paidology, the science of the child. *In* Educ. Rev., XV, pp. 269-284. (March, 1898.)
20. The secret language of childhood. *In* Century, LVI, pp. 54-58. (May, 1898.)
21. Religious periods of child-growth. *In* Educ. Rev., XVI, pp. 40-48. (June, 1898.)
22. Review of Nathan Oppenheim's 'Development of the child.' *In* Educ. Rev., XVI, pp. 279-282. (Oct., 1898.)
23. Child and parent. *In* North-Western Mo., IX, pp. 135-138, 180-183. (Nov. and Dec., 1898.)
24. Opening remarks as president of the Kansas Society for Child-Study. *In* Child-Study Mo., IV, pp. 451-452. (Feb., 1899.)
25. Editorial for the Child-Study Department. *In* North-Western Mo., IX, pp. 275-276. (Feb., 1899.)
26. The pubescent period. *In* Education, XIX, pp. 342-347. (Feb., 1899.)
27. Child and teacher. *In* Jour. Ped., XII, pp. 112-125. (May, 1899.)
28. Courses of study for Normal Schools. *In* Arena, XXII, pp. 56-60. (July, 1899.)
29. Outline in Paidology—the child among ancient peoples. Arranged for the 'Study Outlines for Clubs,' prepared by the Educational Committee of the National Congress of Mothers, 1900.
30. Review of Stuart H. Rowe's 'The physical nature of the child and how to study it.' *In* Educ. Rev., XIX, pp. 87-89. (Jan., 1900.)
31. Evolution and definition of Paidology. *In* Paidology, I, pp. 2-20. (July, 1900.)
32. The science of the child. *In* Quart. Rep. Nat. Cong. of Mothers, I, pp. 35-46. (Sept., 1900.)
33. Review of Millicent Washburn Shinn's 'Notes on the development of a child.' *In* Educ. Rev., II, pp. 192-184. (Sept., 1900.)
34. One child's disposition toward the

opposite sex. *In* Paidology, I, pp. 106-112. (Oct., 1900.)

35. Bibliography of Paidology. *In* Paidology, I, pp. 206-226. (Jan., 1901.)

36. Education of the home-woman. *In* Paidology, I, pp. 303-333. (April, 1901.)

37. Editor of 'Paidology, the Science of the Child.' A magazine devoted to the scientific and practical study of children. Published quarterly. Volume I, 1900-1901.

38. Education for the home. *In* Arena, XXX, pp. 401-409. (Oct., 1903.)

39. The department of Paidology in Ohio University. *In* Jour. Childhood and Adolescence, III, pp. 50-56. (Jan., 1904.)

CHARLES PATTON CLARK, A.B. (1901).
Student, Rush Medical College, Chicago.

1. Pneumococcal Bronchiolitis (capillary bronchitis). (Joint author with F. H. Batman.) *In* Jour. of Infectious Diseases, I, pp. 229-235. (March 19, 1904.)

HOWARD WALTON CLARK, A.B. (1896), A.M. (1902). Preparator in Zoölogy, Field Columbian Museum, Chicago.

1. The flora of Eagle Lake and vicinity. *In* Proc. Indiana Acad. Sci. for 1901, pp. 128-192. 7 plates.

HALBY EVAN COBLENTZ, A.B. (1894), A.M.
Teacher of English, South Division High School, Milwaukee.

1. The blank verse of Matthew Arnold's 'Sohrab and Rustum.' *In* Poet-Lore VII, pp. 497-505. (Oct., 1895.)

2. A Rime-Index to the parent cycle of the York mystery plays and of a portion of the Woodkirk 'Conspiracio et Captio.' *In* Pub. Mod. Lang. Asso., X, pp. 487-557.

3. Irving's Life of Goldsmith. Edited with notes and questions. Boston, 1904. Pp. xxix, 296.

WILBUR ADELMAN COGSHALL, A.M. (1903).
See Faculty list.

EDWARD CONRADI, A.B. (1897), A.M. (1898). Fellow in Clark University, Worcester, Mass.

1. School hygiene. Translation of Dr. Ludwig Kotelmann's 'Ueber Schulgesundheitspflege.' (Joint author with J. A. Bergström.) Syracuse, N. Y., 1899. Pp. 391.

2. Children's interests in words, slang, stories, etc. *In* Ped. Sem., X, pp. 359-404.

JAMES B. COOK, A.B. (1890). Died July 19, 1895, at Brookville, Ind.

1. The sugar trust. *In* Statesman for 1890.

JOHN MERLE COULTER, Ph.D. (1884). President of Indiana University and Professor of Botany, 1891-93. Now head of the Department of Botany and Professor of Morphology, University of Chicago.

1. Botany of the U. S. Geological Survey of Montana, Idaho, Wyoming, and Utah. Pp. 747-792. (April, 1873.)

2. Synopsis of the flora of Colorado. (Joint author with T. C. Porter.) *In* the U. S. Geological and Geographical Survey of Territories. Misc. publication No. 4. 180 pages. Washington. (March, 1874.)

3. A partial list of the flora of Jefferson county, Indiana. *In* Geological Survey of Indiana for 1874, pp. 230-273. (Dec., 1874.)

4. Relations of the scientific to the practical in botany. *In* Trans. Indiana Hort. Soc. for 1881, pp. 29-39. (Dec., 1880.)

5. Catalogue of the plants of Indiana. (Joint author with C. R. Barnes.) Crawfordsville, Indiana, 1881. Pp. 38.

6. The native flora of Indiana. *In*

Trans. Indiana Hort. Soc. for 1882, pp. 70-78. (Dec., 1881.)

7. Development of a dandelion flower. *In* Am. Nat., XVII, pp. 1211-1217. (Dec., 1883.)

8. Some lessons in botany. The seed; germination, or the seed in action; the root. *In* Indiana Farmer. (1884.)

9. Manual of the botany of the Rocky Mountain region. New York, 1885. Pp. xvi, 452.

10. Pollen spores of *Tradescantia virginica*. (Joint author with J. N. Rose.) *In* Bot. Gaz., XI, pp. 10-14. (Jan., 1886.)

11. Sketch of Edmond Boissier. *In* Bot. Gaz., XI, pp. 39-40. (Feb., 1886.)

12. Revision of North American *Hypericaceæ*. *In* Bot. Gaz., XI, pp. 78-88, 106-112. (April, May, 1886.)

13. *Primula cusickiana* Gray. *In* Bot. Gaz., XI, p. 91. (April, 1886.)

14. Synopsis of North American pines. (Joint author with J. N. Rose.) *In* Bot. Gaz., XI, pp. 256-262, 302-309. (Oct., Nov., 1886.)

15. Some notes on *Hypericum*. *In* Bot. Gaz., XI, pp. 275-276. (Oct., 1886.)

16. Notes on *Umbelliferae* of the Eastern United States. (Joint author with J. N. Rose.) *In* Bot. Gaz., XII, (1887.)

17. Some western plants. *In* Bot. Gaz., XII, p. 252. (Oct., 1887.)

18. Evolution in the plant kingdom. *In* Proc. Indiana Acad. Sci. for 1887, pp. 322-335.

19. Revision of North American *Umbelliferae*. (Joint author with J. N. Rose.) Washington, 1888. Pp. 144. 9 plates.

20. Continuity of protoplasm. *In* Bot. Gaz., XIV, pp. 82-83. (March, 1889.)

21. Some notes on *Hypericum*. *In* Bot. Gaz., XIV, p. 200. (August, 1889.)

22. Notes on North American *Umbelliferae*. (Joint author with J. N. Rose.) *In* Bot. Gaz., XIV, pp. 274-284 (Nov., 1889); XV, pp. 259-261 (Oct., 1890).

23. Manual of the botany of the Northern United States. (Joint author with Asa Gray and Sereno Watson.) New York, 1889. Pp. 760. 25 plates.

24. A new genus of *Umbelliferae*. (Joint author with J. N. Rose.) *In* Bot. Gaz., XV, pp. 15-16. (Jan., 1890.)

25. A revision of North American *Cornaceæ*. (Joint author with W. H. Evans.) *In* Bot. Gaz., XV, pp. 30-39, 86-97. (Feb., April, 1890.)

26. Sketch of Charles C. Parry. *In* Bot. Gaz., XV, pp. 66-68. (March, 1890.)

27. *Penicillium* and corrosive sublimate. *In* Bot. Gaz., XV, pp. 69-70. (March, 1890.)

28. Geographical distribution of North American *Umbelliferae*. *In* Proc. A. A. A. S., XXXIX, pp. 292-298. (August, 1890.)

29. *Pithecolobium texense*. *In* Bot. Gaz., XV, pp. 269-270. (Oct., 1890.)

30. *Actinella texana*. (Joint author with J. N. Rose.) *In* Bot. Gaz., XVI, pp. 27-28. (Jan., 1891.)

31. New or noteworthy *Compositæ* from Guatemala. *In* Bot. Gaz., XVI, pp. 95-102. (April, 1891.)

32. Some new *Solanaceæ* from Guatemala. *In* Bot. Gaz., XVI, pp. 144-145. (May, 1891.)

33. Practical education. Indianapolis, 1891. Pp. 16.

34. The future of systematic botany. *In* Proc. A. A. A. S., XI, pp. 3-14. (August, 1891.)

35. The future of systematic botany. *In* Bot. Gaz., XVI, pp. 243-254. (Sept., 1891.)

36. Botany and horticulture. *In* Trans. Indiana Hort. Soc. for 1891, pp. 30-33. (Dec., 1891.)

37. Sketch of Sereno Watson. *In* Bot. Gaz., XVII, pp. 137-141. (May, 1892.)

38. Some new North American plants. (Joint author with E. M. Fisher.) *In* Bot. Gaz., XVII, pp. 348-353. (Nov., 1892.)

39. *Sullivantia hapemani*. *In Bot. Gaz.*, XVII, p. 421. (Dec., 1892.)
40. Notes on North American Umbelliferae. (Joint author with J. N. Rose.) *In Bot. Gaz.*, XVIII, pp. 54-56. (Feb., 1893.)
41. Preliminary revision of North American species of *Cactus*, *Anhalonium*, and *Lophophora*. *In Contrib. U. S. Nat. Herbarium*, III, pp. 91-132. (March, 1894.)
42. Botany of Western Texas. *In Contrib. U. S. Nat. Herbarium*, II, p. 588. (1891, 1892, 1894.)
43. Formulæ for life histories. *In Bot. Gaz.*, XX, pp. 31-32. (Jan., 1895.)
44. New or noteworthy Compositæ from Guatemala. *In Bot. Gaz.*, XX, pp. 41-54. (Feb., 1895.)
45. Musineon of Rafinesque. (Joint author with J. N. Rose.) *In Bot. Gaz.*, XX, pp. 258-260. (June, 1895.)
46. The botanical work of the government. *In Bot. Gaz.*, XX, pp. 264-268. (June, 1895.)
47. The botanical outlook. Lincoln, 1895. Pp. 28.
48. *Deanea*, a new genus of Umbelliferae from Mexico. (Joint author with J. N. Rose.) *In Bot. Gaz.*, XX, pp. 372-373. (August, 1895.)
49. Preliminary revision of the North American species of *Echinocactus*, *Cereus*, and *Opuntia*. *In U. S. Nat. Herbarium*, III, IV, pp. 355-462. (Dec., 1895.)
50. Plants in their environment. Chicago, 1896. Pp. 12.
51. Review of 'Missouri Botanical Garden, 7th Annual report.' *In Bot. Gaz.*, XXII, pp. 59-60. (July, 1896.)
52. Review of E. Warming's 'Lehrbuch der ökologischen Pflanzengeographie.' *In Bot. Gaz.*, XXII, pp. 173-175. (August, 1896.)
53. Review of Mitford Freeman's 'The bamboo garden.' *In Bot. Gaz.*, XXII, pp. 177-178. (August, 1896.)
54. Review of N. L. Britton and A. Brown's 'An illustrated flora of the northern United States, Canada and the British possessions.' *In Bot. Gaz.*, XXII, pp. 269-270; XXIV, pp. 120-121; XXVI, pp. 281-282. (Sept., 1896; Aug., 1897; Oct., 1898.)
55. Evolution. Chicago, 1897. Pp. 14.
56. Notes on the fertilization and embryogeny of Conifers. *In Bot. Gaz.*, XXIII, pp. 40-43. (Jan., 1897.)
57. Review of W. P. Hiern's 'Catalogue of the African plants collected by Dr. F. Welwitsch.' *In Bot. Gaz.*, XXIII, pp. 210-211. (March, 1897.)
58. Review of W. J. Beal's 'Grasses of North America.' *In Bot. Gaz.*, XXIII, pp. 212-213. (March, 1897.)
59. Review of J. C. Willis's 'A manual and dictionary of the flowering plants and ferns.' *In Bot. Gaz.*, XXIII, pp. 213-214. (March, 1897.)
60. Revision of *Lilæopsis*. (Joint author with J. N. Rose.) *In Bot. Gaz.*, XXIV, pp. 47-49. (July, 1897.)
61. Review of Asa Gray's 'Synoptical flora of North America.' *In Bot. Gaz.*, XXIV, pp. 121-122. (August, 1897.)
62. Review of M. Gürke's 'Plantæ Europaeae.' *In Bot. Gaz.*, XXIV, p. 122. (August, 1897.)
63. Review of A. W. Chapman's 'Flora of the southern United States.' *In Bot. Gaz.*, XXIV, p. 123. (August, 1897.)
64. Review of M. W. Morley's 'A few familiar flowers.' *In Bot. Gaz.*, XXIV, p. 124. (August, 1897.)
65. Review of 'Cytologische Studien aus dem Bonner botanischen Institut,' by E. Strasburger, W. J. Osterhout, and others. *In Bot. Gaz.*, XXIV, pp. 216-220. (Sept., 1897.)
66. Review of C. C. Curtis's 'A text book of general botany.' *In Edu. Rev. for 1898.*
67. Review of J. R. Green's 'A manual of botany.' *In Bot. Gaz.*, XXV, pp. 62-63. (Jan., 1898.)

68. Review of W. W. Bailey's 'Botanical note book.' *In Bot. Gaz.*, XXV, pp. 63-64. (Jan., 1898.)
69. Notes on *Lilæopsis*. (Joint author with J. N. Rose.) *In Bot. Gaz.*, XXV, pp. 53-54. (Jan., 1898.)
70. Contribution to the life history of *Ranunculus*. *In Bot. Gaz.*, XXV, pp. 73-88. (Feb., 1898.)
71. Review of Mrs. L. L. Wilson's 'Nature study in elementary schools.' *In Botanical Gazette*, XXV, pp. 209-210. (March, 1898.)
72. Review of H. Christ's 'Die Farnkräuter der Erde.' *In Bot. Gaz.*, XXV, pp. 283-284. (April, 1898.)
73. Review of C. H. Clark's 'A laboratory manual in practical botany.' *In Bot. Gaz.*, XXV, pp. 367-368. (May, 1898.)
74. The origin of Gymnosperms and the seed habit. *In Bot. Gaz.*, XXVI, pp. 153-168. (Sept., 1898.) Also *in Science*, VIII, pp. 377-385. (Sept., 1898.)
75. Review of C. R. Barnes's 'Plant life.' *In Bot. Gaz.*, XXVI, pp. 280-281. (Oct., 1898.)
76. Review of 'Missouri Botanical Garden, 9th annual report.' *In Bot. Gaz.*, XXVI, pp. 282-283. (Oct., 1898.)
77. Review of Th. Durand and H. Schinz's 'Conspectus Floræ Africæ.' *In Bot. Gaz.*, XXVI, pp. 283-284. (Oct., 1898.)
78. Review of A. Schneider's 'A guide to the study of lichens.' *In Bot. Gaz.*, XXVI, pp. 284-285. (Oct., 1898.)
79. Review of G. F. Atkinson's 'Elementary botany.' *In Bot. Gaz.*, XXVI, pp. 440-441. (Dec., 1898.)
80. Plant relations. New York, 1899. Pp. vii, 266. 214 plates.
81. Plant structures. New York, 1899. Pp. vii, 348. 289 plates.
82. Review of A. Engler's 'Monographien afrikanischer Pflanzenfamilien und Gattungen.' *In Bot. Gaz.*, XXVII, pp. 72-73. (Jan., 1899.)
83. Review of S. H. Vine's 'An elementary text-book of botany.' *In Bot. Gaz.*, XXVII, pp. 141-142. (Feb., 1899.)
84. Review of D. Grecescu's 'Conspectus floræ Romainei.' *In Bot. Gaz.*, XXVII, pp. 142-143. (Feb., 1899.)
85. Review of I. Urban's 'Symbolæ Antillanæ seu fundamenta floræ Indiæ occidentalis.' *In Bot. Gaz.*, XXVII, p. 143. (Feb., 1899.)
86. Review of G. F. Atkinson's 'Elementary botany.' *In Sch. Rev.*, Feb., 1896, pp. 114-115.
87. Review of Gibb E. Hughes's 'The making of a daisy.' *In Bot. Gaz.*, XXVII, pp. 217-218. (March, 1899.)
88. Review of Alice M. Davidson's 'Californian plants in their homes.' *In Bot. Gaz.*, XXVII, p. 218. (March, 1899.)
89. Review of D. H. Campbell's 'Lectures on the evolution of plants.' *In Bot. Gaz.*, XXVII, p. 219. (March, 1899.)
90. Plant societies. *In Pratt Institute Mo.*, May, 1899, 172-173.
91. Review of F. L. Parson's 'How to know the ferns.' *In Bot. Gaz.*, XXVII, p. 484. (June, 1899.)
92. Review of J. M. Lawson's 'A text-book on botany.' *In Bot. Gaz.*, XXVII, 484-485. (June, 1899.)
93. Review of Alice Lounsberry's 'A guide to the wild flowers.' *In Bot. Gaz.*, XXVIII, p. 72. (July, 1899.)
94. Review of Maud Going's 'Field, forest, and wayside flowers.' *In Bot. Gaz.*, XXVIII, p. 72. (July, 1899.)
95. Review of Edw. Knobel's 'The grasses, sedges, and rushes of the northern United States.' *In Bot. Gaz.*, XXVIII, p. 72-73. (July, 1899.)
96. The origin of the leafy sporophyte. *In Bot. Gaz.*, XXVIII, pp. 46-59. (July, 1899.)
97. Review of Engler and Prantl's 'Die natürlichen Pflanzenfamilien.' *In Bot. Gaz.*, XXVIII, pp. 217-218. (Sept., 1899.)

98. The proper use of science by the pulpit. *In Amer. Jour. Theology*, III, pp. 641-653. (Oct., 1899.)
99. Analytical key to flowering plants. New York, 1900. Pp. 93.
100. A synopsis of Mexican and Central American Umbelliferae. (Joint author with J. N. Rose.) *In Proc. Wash. Acad. Sci.*, I, pp. 111-159. 10 plates. (Jan., 1900.)
101. Review of L. H. Bailey's 'Cyclopedia of American horticulture.' Vols. I-IV. *In Bot. Gaz.*, XXIX, pp. 282-283; XXX, p. 277; XXXI, p. 436; XXXIII, pp. 467-468. (April, Oct., 1900; June, 1901; June, 1902.)
102. Review of G. F. Atkinson's 'Lessons in botany.' *In Bot. Gaz.*, XXIX, p. 358. (May, 1900.)
103. A pattern flower. *In Nature and Art*, VIII, pp. 2-7. 1 plate. (June, 1900.)
104. Review of Harriet L. Keeler's 'Our native trees.' *In Bot. Gaz.*, XXX, pp. 132-133. (August, 1900.)
105. Review of Neltje Blanchan's 'Nature's garden.' *In Bot. Gaz.*, XXX, pp. 132-133. (August, 1900.)
106. Review of Alice Lounsbury's 'A guide to the trees.' *In Bot. Gaz.*, XXX, pp. 132-133. (August, 1900.)
107. Review of D. H. Scott's 'Studies in fossil botany.' *In Bot. Gaz.*, XXX, pp. 352-354. (Nov., 1900.)
108. Morphology of Gymnosperms. (Joint author with C. J. Chamberlain.) New York, 1901. Pp. x, 188. 10 plates.
109. The polity of the Y. M. C. A. Chicago, 1901. Pp. 16.
110. The student Y. M. C. A. as it relates to the entire association movement. Chicago, 1901. Pp. 14.
111. Plant studies. New York, 1901. Pp. ix, 387. 336 plates.
112. Review of J. Percival's 'Agricultural botany; theoretical and practical.' *In Bot. Gaz.*, XXXI, pp. 67-68. (Jan., 1901.)
113. Review of L. H. Bailey's 'Botany, an elementary text-book for schools.' *In Bot. Gaz.*, XXXI, pp. 129-130. (Feb., 1901.)
114. Some problems in education. *In Educator-Journal*, I, pp. 405-407, 459-460. (April, May, 1901.)
115. Review of W. L. Jepson's 'A flora of western middle California.' *In Bot. Gaz.*, XXXI, pp. 435-436. (June, 1901.)
116. Review of Charles Mohr's 'Plant life of Alabama.' *In Bot. Gaz.*, XXII, pp. 371-372. (Nov., 1901.)
117. Review of N. L. Britton's 'Manual of the flora of the northern states and Canada.' *In Bot. Gaz.*, XXXII, pp. 426-427. (Dec., 1901.)
118. Organic evolution as illustrated by plants. Chicago, 1902. Pp. 20.
119. Review of D. H. Campbell's 'A university text-book of botany.' *In Bot. Gaz.*, XXXIV, pp. 67-68. (July, 1902.)
120. Review of A. Schnedier's 'Powdered vegetable drugs.' *In Bot. Gaz.*, XXXV, pp. 60-61. (Jan., 1903.)
121. Review of H. Kraemer's 'A course in botany and pharmacognosy.' *In Bot. Gaz.*, XXXV, pp. 60-61. (Jan., 1902.)
122. The embryology of *Zamia*. (Joint author with C. J. Chamberlain.) *In Bot. Gaz.*, XXXV, pp. 184-195. (March, 1903.)
123. Morphology of Angiosperms. (Joint author with C. J. Chamberlain.) New York, 1903. Pp. x, 348. 113 plates.

EDWIN COOK CRAMPTON, LL.B. (1889).
Associate Editor, on editorial staff of
West Publishing Co. and Keefe-Davison
Co., St. Paul, Minn.

1. Articles on: False pretenses; false personation; fixtures; forcible entry and detainer; grand jury; health; and infants. *In Century Edition, American Digest of Law.* (1900-1901.)

2. Articles on: Lis pendens; licenses

to enter on land; life estates; remainders; reversions; powers; supervision of the power of alienation; poor; religious societies; postponement; principal and agent; stipulations; subscriptions; recording written instruments; records, registers. *In* Abbott's New York Cyclopedic Digest. (1901-1903.)

3. Articles on: Account; action or suit for cancellation of written instruments; bill of review; drainage; discovery and inspection; election of officers; equity; eminent domain; highways; new trial; garnishment; attachment; reformation of instruments; intoxicating liquors; injunction; rescission of contracts. *In* Illinois Cyclopedic Digest. (1902-1903.)

4. Articles on: Accounting; accounts stated and open accounts; agency; arbitration and award; attorneys and counselors; appeal and review; alteration of instruments; writs of assistance; arrest and binding over; auction and auctioneers; appearance; attachment; bail in civil actions; bail in criminal proceedings; breach of marriage promise; brokers; bridges; canals, cancellation of written instruments; confession of judgment; clerks of courts; contracts; conflict of laws; contempt; continuance and postponement; discovery and inspection; equity; eminent domain. *In* Current Law for 1903-1904.

NELSON KENDALL CROWE, A.B. (1851), A.M. (1854). Clintonville, Pa.

1. A history of the freedmen's mission of the Reformed Presbyterian church.

ELLWOOD P CUBBERLEY, A.B. (1891), A.M. Associate Professor of Education, Leland Stanford Jr. University. Stanford University, Cal.

1. Determinative mineralogy. Vincennes, 1895. Pp. xx, 200.

2. School organization. *In* Edu. Rev., XIII, pp. 163-171. (1897.)

3. Report of the public schools of San Diego, Cal., with courses of study. San Diego, 1897. Pp. 199; illustrated.

4. Report of the public schools of San Diego, Cal. San Diego, 1898. Pp. 15.

5. Courses of study for the public schools of San Francisco. San Francisco, 1900. Pp. 311.

6. A proposed act permitting of the consolidation of rural schools, rural supervision, and the transportation of pupils. *In* West. Jour. Educ., V, pp. 3-11; VIII, pp. 180-186. (1900, 1903.)

7. Syllabus of school management. Boston, 1901. Pp. 19.

8. The school situation in San Francisco. *In* Educ. Rev., XXI, pp. 364-383. (1901.)

9. A state tax for high schools. *In* West. Jour. Educ., VII, pp. 604-607. (1902.)

10. Our country school problem. *In* West. Jour. Educ., VIII, pp. 278-282. (1903.)

11. Consolidation of schools and transportation of pupils. *In* West. Jour. Educ., VIII, p. 80. (June, 1903.)

12. Syllabus of lectures on the history of education in Europe. New York, 1902. Pp. 302; 7 charts; 7 maps; 39 illustrations.

GEORGE ADAMS CUSTER, LL.B. (1897). Logansport, Ind.

1. Legal counselor and form book. (Joint author with Charles A. Hawkins.) Logansport, Ind., 1901. Pp. 645.

WILLIAM MITCHELL DAILY, A.B. (1836), D.D. (1851), LL.D. President of the University, 1853-59. Died Feb. 5, 1877, at New Orleans, La.

1. Funeral discourse delivered in the

chapel of Indiana University, Nov. 13, 1851, over the remains of the late Rev. Andrew Wylie, President of Indiana University. Indianapolis, 1852. Pp. 20.

2. Inaugural address as President of Indiana University, August 2, 1854. Indianapolis, 1854. Pp. 20.

3. The heroic man: a baccalaureate to the graduating class of the Indiana University at the commencement of 1855. Bloomington, Ind., 1855. Pp. 22.

4. Our banner: a baccalaureate to the graduating class of Indiana University, 1856. Bloomington, Ind., 1856. Pp. 22.

5. Zaph-nath Pa-a-ne-ah: a baccalaureate to the graduating class of Indiana University, 1857. Bloomington, Ind., 1857. Pp. 24.

6. Urim and Thummim: a baccalaureate to the graduating class of Indiana University, 1858. Bloomington, Ind., 1858. Pp. 23.

CHARLES GIDEON DAVIS, A.B. (1898), Ph.D.
Instructor in German, University of Illinois, Urbana, Ill.

1. Die Substantiva auf *ling* im achtzehnten Jahrhundert. Strassburg, 1903. Pp. 49.

LOUIS SHERMAN DAVIS, A.B. (1891), A.M. (1892), Ph.D. See Faculty list.

SCHUYLER COLFAX DAVISSON, A.B. (1890), A.M. (1892), Sc.D. See Faculty list.

ALONZO ALVIN DELARME, A.B. (1887), A.M. (1890). Pastor First Baptist Church, Paterson, N. J.

1. History of the First Baptist Church of Norristown, Pa. Philadelphia, 1897. Pp. 229. 20 plates.

JOHN FRANKLIN DILLON, B.S. (1874), LL.B. (1876). Pierre, S. D.

1. Pleading and practice in Dakota.

J. B. DOLAN, Student (1896-1897).

1. Temperature of Turkey Lake (Ind.). *In Proc. Indiana Acad. Sci.* for 1895, pp. 235-239.

WILLIAM COLUMBUS DRAPER, B.S. (1867), Trinidad, Col.

1. Esmeralda, and other stories. Trinidad, Colo., 1902. Pp. 120; 3 illustrations.

FLETCHER BASCOM DRESSLAR, A.B. (1889), A.M. (1892), Ph.D. Assistant Professor of Pedagogy, University of California, Berkeley, Cal.

1. A review of the genus *Semotilus*. (Joint author with E. P. Bicknell.) *In Proc. Acad. Nat. Sci. Phila.* for 1885.

2. A review of the mackerels (*Scombrinae*) of America and Europe. (Joint author with Bert Fesler.) *In Bull. U. S. Fish Comm.* for 1887.

3. Fatigue. *In Ped. Sem.*, II, pp. 102-106. (June, 1892.)

4. A sketch of old schoolhouses. *In Ped. Sem.*, II, pp. 115-125. (June, 1892.)

5. Some influences which affect the rapidity of voluntary movement. *In Am. Jour. Psych.*, IV, pp. 514-527. (August, 1892.)

6. On facial vision and the pressure sense of the drum of the ear. *In Am. Jour. Psych.*, V, pp. 344-350. (April, 1893.)

7. A new illusion for touch and an explanation for the illusion of displacement of certain cross lines in vision. *In Am. Jour. Psych.*, VI, pp. 275-276.

8. A new and simple method for counting

paring the perception of rate of movement in the direct and indirect fields of vision. *In Am. Jour. Psych.*, VI, p. 312.

9. Psychology of touch. *In Am. Jour. Psych.*, VI, pp. 50-54.

10. Outline for a study of habit-degeneration. *In Teachers' Handbook for Children*, published by Illinois Society for Child-Study, I, pp. 21-23. (May, 1895.)

11. Preparation for history in the grades. *In Normal Exponent for 1895*.

12. The new psychology and its pedagogical significance. *In Proc. California Teachers' Asso. for Dec.*, 1895.

13. Experiments in psychology. *In Overland Mo. for Aug.-Dec.*, 1896, and Feb.-June, 1897.

14. Education in Hawaii. *In Educ. Rev.*, XV, pp. 50-54. (Jan., 1898.)

15. Genetic psychology. *In Northwest-ern Mo.*, IX, pp. 355-358. (April, 1899.)

16. Guessing, as influenced by number preferences. *In Pop. Sci. Mo.*, LIV, pp. 781-786. (April, 1899.)

FRANK DREW, A.B. (1890), A.M. (1891), Ph.D. Instructor in Philosophy, Indiana University, 1895-96. Now Professor of Psychology, State Normal School, Worcester, Mass.

1. Field notes on the birds of San Juan county, Colorado. *In Bull. Nuttall Ornith. Club*, VI. (1881.)

2. On the vertical range of birds in Colorado. *In Auk*, II. (1885.)

3. Adenoids in children. *In Ped. Sem.*, II, pp. 307-309. (March, 1893.)

4. Love poems of college students. *In Ped. Sem.*, II, pp. 504-505. (Dec., 1893.)

5. Attention, experimental and critical. *In Am. Jour. Psych.*, VII, pp. 533-572. (July, 1896.)

JOHN WALTER DUNN, A.B. (1897). County Superintendent of Schools, Knox, Ind.

1. The Starke County (Ind.) Child Study Association. *In Child-Study Mo.*, V, No. 1. (May, 1899.)

CHARLES LINCOLN EDWARDS, B.S. (1886), A.M. (1887), Ph.D. Professor of Natural History, Trinity College, Hartford, Conn.

1. The relation of pectoral muscles in birds to the power of flight. *In Am. Nat.*, XX, pp. 25-29. (Jan., 1886.)

2. A review of the American species of the Tetraodontidæ. (Joint author with David Starr Jordan.) *In Proc. U. S. Nat. Mus. for 1886*, p. 232.

3. The influence of warmth upon the irritability of frogs' muscle and nerve. *In Studies from Biol. Lab. Johns Hopkins University*.

4. An expression of animal sympathy. *In Am. Nat.*, XXI, p. 1129. (Dec., 1887.)

5. Winter roosting colonies of crows. *In Am. Jour. Psych.*, I, pp. 436-459. (May, 1888.)

6. Notes on the embryology of *Mulleria Agassizii*. Sel., a Holthurian common at Green Turtle Cay, Bahamas. *In Johns Hopkins University Circular*, VIII, p. 37. (1889.)

7. Folk-lore of the Bahama negroes. *In Am. Jour. Psych.*, II, pp. 519-542. (August, 1889.)

8. Beschreibung einiger neuen Copepoden und eines neuen copepoden-ähnlichen Krebses, *Leuckartella paradoxa*. *In Archiv f. Naturgeschichte*, Jahrg. 57, Bd. I, p. 35. (1891.)

9. Some tales from Bahama folk-lore. *In Jour. of Am. Folk-Lore*, IV, pp. 47-54. (1891.)

10. Some tales from Bahama folk-lore.

Fairy tales. *In* Jour. of Am. Folk-Lore, IV, pp. 247-252. (1891.)

11. Bahama songs and stories. *In* Memoirs of the Am. Folk-Lore Soc., III, p. 111. (1895.)

12. Notes on the biology of *Phrynosoma cornutum* Harlan. *In* Zool. Anzeiger, No. 498. (1896.)

13. Variation and regeneration in *Synapta inherens*. *In* Science, N. S., XI, p. 178.

14. Animal myths, and their origin. (Address as president of the American Folk-Lore Society.) *In* Jour. of Am. Folk-Lore Soc., XIII. (Jan.-March, 1900.)

15. The lower temperature limits of incubation for the egg of the common fowl. *In* Science, N. S., XII, pp. 310-311. (August 24, 1900.)

16. Contributions from the biological laboratory of the department of Natural History, Trinity College, Hartford, Conn. Under the direction of C. L. Edwards.

17. The physiological zero and the index of development from the egg of the domestic fowl, *Gallus domesticus*. A contribution to the subject of the influence of temperature on growth. *In* Am. Jour. of Physiology, VI, pp. 351-397. (Feb., 1902.) Abstract *in* Science, N. S., XV, pp. 521-522. (April 4, 1902.)

18. A note on *Phrynosoma*. *In* Science, N. S., XVII, pp. 826-827. (May 22, 1903.)

ROSA (SMITH) EIGENMANN (Mrs. Carl H Eigenmann.) Student, 1880-1882.

1. *On the occurrence of a species of *Cremnobates* at San Diego, California. *In* Proc. U. S. Nat. Mus. for 1880, III, pp. 147-149.

2. *Description of a new gobioid fish (*Othonops eos*) from San Diego, California.

*Titles marked * appeared under the name Rosa Smith.

In Proc. U. S. Nat. Mus. for 1881, IV, pp. 19-21.

3. *Description of a new species of *Gobiesox* (*Gobiesox rhessodon*) from San Diego, California. *In* Proc. U. S. Nat. Mus. for 1881, IV, pp. 140-141.

4. *Notes on a collection of fishes from Johnston's Island, including descriptions of five new species. (Joint author with Joseph Swain.) *In* Proc. U. S. Nat. Mus. for 1882, V, pp. 119-143.

5. *On the life coloration of the young of *Pomacentrus rubicundus*. *In* Proc. U. S. Nat. Mus. for 1882, V, pp. 652-653.

6. *Description of a new species of *Uranidea* (*Uranidea rhothea*) from Spokane River, Washington Territory. *In* Proc. U. S. Nat. Mus. for 1882, V, pp. 347-348.

7. *The life colors of *Cremnobates integripinnis*. *In* Proc. U. S. Nat. Mus. for 1883, VI, pp. 216-217.

8. *Notes on the occurrence of *Gasterosteus williamsoni* Grd., in an artesian well at San Bernardino, California. *In* Proc. U. S. Nat. Mus. for 1883, VI, p. 217.

9. *Notes on the fishes of Todos Santos Bay, Lower California. *In* Proc. U. S. Nat. Mus. for 1883, VI, pp. 232-236.

10. *Description of a new species of *Squalius*. *In* Proc. California Acad. Sci. for 1884.

11. *Notes on fishes collected at San Cristobal, Lower California, by Mr. Charles H. Townsend, Assistant, U. S. Fish Commission. *In* Proc. U. S. Nat. Mus. for 1885, VII, pp. 551-553.

12. *The fishes of San Diego, California. A list in two parts. *In* W. Am. Sci. for 1885, pp. 45-47, 53-55. (July, August, 1885.)

13. *On the occurrence of a new species of *Rhinoptera* (*R. encenadæ*) in Todos Santos Bay, Lower California. *In* Proc. U. S. Nat. Mus. for 1886, IX, p. 220.

14. *On *Tetraodon setosus*. *In* Bull.

- California Acad. Sci., II, No. 6, pp. 155-156. (Nov. 13, 1886.)
15. A chapter on sharks. *In* Golden Era for August, 1887.
16. A chapter on sting rays. *In* Golden Era for Sept., 1887, pp. 489-490.
17. Charles L. McKay. *In* W. Am. Sci. for 1887, pp. 189-191.
18. Women in science. *In* W. Am. Sci. for 1887, pp. 230-236.
19. A list of the American Gobiidæ and Callionymidæ, with notes on the specimens contained in the Museum of Comparative Zoölogy, at Cambridge, Mass. (Joint author with Carl H. Eigenmann.) *In* Proc. California Acad. Sci., 2d ser., I, pp. 51-78. (Jan. 25, 1888.)
20. South American Nematognathi. (Joint author with C. H. Eigenmann.) *In* Am. Nat., XXIII, pp. 647-649. (July, 1888.)
21. Preliminary notes on South American Nematognathi. I. (Joint author with C. H. Eigenmann.) *In* Proc. California Acad. Sci. 2d ser., I, pp. 119-172. (July, 1888.)
22. *Cyprionodon californiensis*, Girard. (Joint author with C. H. Eigenmann.) *In* W. Am. Sci., V, pp. 3-4. (Sept., 1888.)
23. Description of a new species of *Cyprinodon*. (Joint author with C. H. Eigenmann.) *In* California Acad. Sci., 2d ser., I, p. 270. (Jan. 8, 1889.)
24. Notes on some California fishes, with descriptions of two new species. (Joint author with C. H. Eigenmann.) *In* W. Am. Sci., VI, pp. 7-8. (April, 1889.)
25. Preliminary notes on South American Nematognathi. II. (Joint author with C. H. Eigenmann.) *In* Proc. California Acad. Sci., 2d ser., II, pp. 28-56. (August 18, 1889.)
26. On the phosphorescent spots of *Porichthys margaritatus*. (Joint author with C. H. Eigenmann.) *In* W. Am. Sci., VI, pp. 32-34. (May, 1889.)
27. Contributions from the San Diego Biological Laboratory. I. (Joint author with C. H. Eigenmann.) *In* W. Am. Sci., VI, pp. 44-47. (June, 1889.)
28. Notes from the San Diego Biological Laboratory. The fishes of Cortes Banks. (Joint author with C. H. Eigenmann.) *In* W. Am. Sci., VI, pp. 123-132. (Oct., 1889.)
29. Notes from the San Diego Biological Laboratory. II. (Joint author with C. H. Eigenmann.) *In* W. Am. Sci., VI, pp. 147-151. (Nov., 1889.)
30. A review of the Erythrinina. (Joint author with C. H. Eigenmann.) *In* Proc. California Acad. Sci., 2d ser., II, pp. 100-116. 1 plate. (Nov. 8, 1889.)
31. A revision of the edentulous genera of Curimatina. (Joint author with C. H. Eigenmann.) *In* Ann. New York Acad. Sci., IV, pp. 1-32. (Nov., 1889.)
32. Description of a new species of *Euprotomierus*. *In* Proc. California Acad. Sci., 2d ser., III. (1890.)
33. New California fishes. *In* Am. Nat. for 1890, pp. 153-156.
34. Additions to the fauna of San Diego. (Joint author with C. H. Eigenmann.) *In* Proc. California Acad. Sci., 2d ser., III, pp. 1-25. (March 24, 1890.)
35. A revision of the South American Nematognathi or catfishes. (Joint author with C. H. Eigenmann.) *In* Occasional papers, Proc. California Acad. Sci., I, pp. 1-508, plates, map. (July, 1890.)
36. Descriptions of new species of Sebastodes. (Joint author with C. H. Eigenmann.) *In* Proc. California Acad. Sci., 2d ser., III, pp. 36-38. (May 28, 1890.)
37. A catalogue of the fresh-water fishes of South America. (Joint author with C. H. Eigenmann.) *In* Proc. U. S. Nat. Mus. for 1891, XIV, pp. 1-81.

38. A catalogue of the fishes of the Pacific coast of America north of Cerros island. (Joint author with C. H. Eigenmann.) *In* Ann. New York Acad. Sci., VI, pp. 349-358. (June, 1892.)

39. Recent additions to the fauna of California. (Joint author with C. H. Eigenmann.) Abstract *in* Proc. Indiana Acad. Sci. for 1891, pp. 159-161.

40. New fishes from Western Canada. (Joint author with C. H. Eigenmann.) *In* Am. Nat., XXVI, pp. 961-964. (Nov., 1892.)

41. Preliminary description of new fishes from the Northwest. (Joint author with C. H. Eigenmann.) *In* Am. Nat., XXVII, pp. 151-154. (Feb., 1893.)

WILLIAM HARRIS ELSON, A.B. (1895).
Superintendent of Schools, Grand Rapids, Michigan.

1. Outlines of masterpieces of American literature. Boston, 1893. Pp. 22.

2. The necessity of stimulating the child's full mental power in kindergarten work. *In* Kindergarten Magazine, X, pp. 357-363. (Feb., 1898.)

BARTON WARREN EVERMANN, B.S. (1886),
A.M. (1888), Ph.D. (1891). Assistant
in charge Division of Scientific Inquiry,
Bureau of Fisheries, Washington, D. C.

1. California bird notes. *In* Ornithologist and Oölogist, VI, p. 7. (March, 1881.)

2. Least titmouse, its nesting habits in California. *In* Ornithologist and Oölogist, VI, p. 19. (May, 1881.)

3. Large clutches of eggs. *In* Ornithologist and Oölogist, VI, p. 40. (July, 1881.)

4. Unusual nesting site of the chewink. *In* Ornithologist and Oölogist, VI, p. 61. (Oct., 1881.)

5. Animal analysis. Chicago, 1882. Pp. iv, 123.

6. The road-runner. *In* Ornithologist and Oölogist, VI, p. 85. (Jan., 1882.)

7. American barn owl, *Aluco flammeus americanus* (Aud.) Ridgw. *In* Ornithologist and Oölogist, VII, pp. 97-98, 109-110. (March, April, 1882.)

8. Bluebirds' eggs. *In* Ornithologist and Oölogist, VII, p. 147. (August, 1882.)

9. American barn owl, further notes. *In* Ornithologist and Oölogist, VII, pp. 166-167. (Oct., 1882.)

10. The black-crested fly-catcher. *In* Ornithologist and Oölogist, VII, pp. 169-170, 177-179. (Nov., Dec., 1882.)

11. Bird notes from Bloomington, Indiana. *In* Ornithologist and Oölogist, VIII, pp. 27-28. (April, 1883.)

12. A review of the species of Gerres found in American waters. (Joint author with Seth E. Meek.) *In* Proc. Acad. Nat. Sci. Phila. for 1883, pp. 116-124.

13. Bird migration. *In* American Field, XXI, pp. 544-545. (1884.)

14. Arrivals of birds at Camden, Indiana, 1884. *In* Ornithologist and Oölogist, IX, p. 74. (June, 1884.)

15. List of fishes collected in Harvey and Cowley counties, Kansas. (Joint author with Morton W. Fordice.) *In* Proc. Acad. Nat. Sci. Phila. for 1885, p. 412; also *in* Bull. Washburn College Lab. Nat. Hist., I, pp. 184-186. (July, 1886.)

16. A list of the birds observed in Ventura county, California. *In* Auk, III, pp. 86-94, 179-186. (Jan., Feb., 1886.)

17. Birds observed in Ventura county, California. *In* Pacific Science Mo., I, pp. 77-89. (Jan., 1886.)

18. A list of birds observed at Pensacola, Florida. *In* Ornithologist and Oölogist, II, pp. 81-83, 97-98. (June, July, 1886.)

19. Notes on a collection of fishes from the Monongahela River. (Joint author with

- Charles H. Bollman.) *In Proc. New York Acad. Sci. for 1886*, pp. 335-340.
20. Descriptions of six new species of fishes from the Gulf of Mexico, with notes on other species. (Joint author with David Starr Jordan.) *In Proc. U. S. Nat. Mus. for 1886*, pp. 466-476.
21. A list of the fishes observed in the vicinity of Brookville, Franklin county, Indiana. *In Bull. 2, Brookville Soc. Nat. Hist. for 1886*, pp. 1-11.
22. A revision of the American species of the genus *Gerres*. (Joint author with S. E. Meek.) *In Proc. Acad. Nat. Sci., Phila.*, for 1886, pp. 256-272.
23. The food fishes of Indiana. (Joint author with D. S. Jordan.) *In Rep. Indiana State Board of Agriculture for 1886*, pp. 156-173.
24. The yellow-billed magpie. *In Am. Nat.*, XX, pp. 607-611. (July, 1886.)
25. A day with the birds of a Hoosier swamp. *In Ornithologist and Oölogist*, II, pp. 99-101. (July, 1886.)
26. Some rare Indiana birds. *In Am. Nat.*, XXI, pp. 290-291. (March, 1887.)
27. Bird migration. *In Pop. Sci. Mo.*, XXXI, pp. 803-810. (April, 1887.)
28. Birds of Monroe county, Indiana. *In Hoosier Naturalist*, II, pp. 137-145. (May, 1887.)
29. An addition to the list of birds of Monroe county, Indiana. *In Hoosier Naturalist*, II, p. 164. (June, 1887.)
30. The occurrence in Indiana of the star-nosed mole. *In Am. Nat.*, XXII, p. 359. (April, 1888.)
31. Ornithology from a railroad train. (Joint author with Oliver P. Jenkins.) *In Ornithologist and Oölogist*, XIII, pp. 65-69. (May, 1888.)
32. Notes on Indiana fishes. (Joint author with O. P. Jenkins.) *In Proc. U. S. Nat. Mus. for 1888*, pp. 43-57.
33. Description of eighteen new species of fishes from the Gulf of California. (Joint author with O. P. Jenkins.) *In Proc. U. S. Nat. Mus. for 1888*, pp. 137-158.
34. Birds of Carroll county, Indiana. *In Auk*, V, pp. 344-351, 22-30. (Oct., 1888; Jan., 1889.)
35. The wood ibis in Indiana. *In Auk*, VI, pp. 186-187. (April, 1889.)
36. Description of the yellow-finned trout of Twin Lakes, Colorado. (Joint author with D. S. Jordan.) *In Proc. U. S. Nat. Mus. for 1889*, pp. 453-454. (1890.)
37. Description of a new species of fish from the Tippecanoe river, Indiana. (Joint author with D. S. Jordan.) *In Proc. U. S. Nat. Mus. for 1890*, pp. 3-4.
38. Report upon a collection of fishes made at Guaymas, Sonora, Mexico, with descriptions of new species. (Joint author with O. P. Jenkins.) *In Proc. U. S. Nat. Mus. for 1891*, pp. 121-165; 2 plates.
39. A reconnaissance of the streams and lakes of western Montana and northwestern Wyoming. *In Bull. U. S. Fish Comm. for 1891 (1892)*, pp. 3-60; 27 plates.
40. A report upon investigations made in Texas in 1891. *In Bull. U. S. Fish Comm. for 1891 (1892)*, pp. 61-90, 9 plates.
41. Two-Ocean Pass. *In Proc. Indiana Acad. Sci. for 1892*, pp. 29-34; 1 plate.
42. The work of the U. S. Fish Commission steamer Albatross in the North Pacific and Bering Sea in 1892. *In Proc. Indiana Acad. Sci. for 1892*, pp. 56-57.
43. The ptarmigan of the Aleutian Islands. *In Proc. Indiana Acad. Sci. for 1892*, pp. 78-81.
44. The work of the United States Fish Commission and its relation to the farmer. *In Rep. Indiana Fish Comm. for 1893-94*, pp. 15-25.
45. Description of a new sucker, *Pantosteus jordani*, from the upper Missouri Basin. *In Bull. U. S. Fish Comm. for 1892 (1893)*, pp. 51-56, 1 plate.
46. The fishes of Texas and the Rio Grande Basin, considered chiefly with ref-

erence to their geographic distribution. (Joint author with William C. Kendall.) *In Bull. U. S. Fish Comm. for 1892 (1894)*, pp. 57-126, 31 plates.

47. The ichthyologic features of the Black Hills region. *In Proc. Indiana Acad. Sci. for 1892*, pp. 73-78.

48. Bibliography of Indiana mammals. (Joint author with Amos W. Butler.) *In Proc. Indiana Acad. Sci. for 1893 (1894)*, pp. 120-124.

49. A preliminary list of Indiana mammals. (Joint author with A. W. Butler.) *In Proc. Indiana Acad. Sci. for 1893 (1894)*, pp. 124-139.

50. Notes on the fur-seal rookeries of the Pribilof Islands, July 18 to 31, 1892. *In Proc. Tribunal of Fur Seal Arbitration at Paris, 1893, VII*, pp. 264-273.

51. The investigation of rivers and lakes with reference to the fish environment. *In Bull. U. S. Fish Comm. for 1893*, pp. 69-73.

52. A skeleton of Steller's sea cow. *In Science*, p. 59. (Feb., 1893.)

53. Report upon the advisability of establishing a fish-hatching station in the State of Tennessee. *In Senate Mis. Doc. No. 52, 53d Cong., 2d Sess.*, pp. 1-3. (Jan., 1894.)

54. Report upon the advisability of establishing fish-hatchery stations at suitable points in Wyoming and the states of South Dakota, Iowa and Nebraska. *Senate Mis. Doc. No. 53, 53d Cong., 2d Sess.*, pp. 1-5. (Jan., 1894.)

55. The salmon fisheries of the Columbia River Basin. (Joint author with Charles H. Gilbert.) *Senate Mis. Doc. No. 200, 53d Cong., 2d Sess.*, pp. 1-55, 13 plates. (August, 1894.)

56. A report upon investigations in the Columbia River Basin, with descriptions of four new species of fishes. (Joint author with C. H. Gilbert.) *In Bull. U. S. Fish Comm. for 1894*, pp. 153-207; 13 plates.

57. A list of the species of fishes known from the vicinity of Neosho, Missouri. (Joint author with W. C. Kendall.) *In Bull. U. S. Fish Comm. for 1894 (1895)*, pp. 469-472.

58. The fishes of the Colorado Basin. (Joint author with Cloudsley Rutter.) *In Bull. U. S. Fish Comm. for 1894 (1895)*, pp. 473-486.

59. Recent investigations concerning the redbfish, *Oncorhynchus nerka*, at its spawning grounds in Idaho. (Joint author with J. T. Scovell.) *In Proc. Indiana Acad. Sci. for 1895*, pp. 131-134.

60. The fishes of the Missouri Basin. (Joint author with J. T. Scovell.) *In Proc. Indiana Acad. Sci. for 1895*, pp. 126-138.

61. Two-Ocean Pass. *In Pop. Sci. Mo., XLVII*, pp. 175-186; with plates. (June, 1895.)

62. In the Sawtooth Mountains. *In American Angler, XXV*, p. 285. (Oct., 1895.)

63. The whitefishes of North America. (Joint author with Hugh M. Smith.) *In Rep. U. S. Fish Comm. for 1894 (1896)*, pp. 283-324; 18 plates.

64. An annotated list of the fishes known from the state of Vermont. (Joint author with W. C. Kendall.) *In Rep. U. S. Fish Comm. for 1894 (1896)*, pp. 579-604.

65. Report upon the fishes of the Missouri River Basin. (Joint author with Ulysses O. Cox.) *In Rep. U. S. Fish Comm. for 1894 (1896)*, pp. 325-429.

66. Description of a new species of pipefish, *Siphostoma scovelli*, from Texas. (Joint author with W. C. Kendall.) *In Proc. U. S. Nat. Mus. for 1895 (1896)*, p. 113.

67. A preliminary report upon salmon investigations in Idaho in 1894. *In Bull. U. S. Fish Comm. for 1895 (1896)*, pp. 253-284.

68. The fishes of the Neuse River Basin.

- (Joint author with U. O. Cox.) *In Bull. U. S. Fish Comm. for 1895 (1896)*, pp. 303-310.
69. Description of a new species of shad (*Alosa alabamæ*) from Alabama. *In Rep. U. S. Fish Comm. for 1895 (1896)*, pp. 203-205.
70. A check-list of the fishes and fish-like vertebrates of North and Middle America. (Joint author with D. S. Jordan.) *In Rep. U. S. Fish Comm. for 1895 (1896)*, pp. 207-584.
71. The fishes of North and Middle America. (Joint author with D. S. Jordan.) *Bull. 47, U. S. Nat. Mus., Part I*, pp. lx, 1240 (1896); *Part II*, pp. xxx, 1241-2183 (1898); *Part III*, pp. xxix, 2183a-3136 (1898); *Part IV*, pp. ci, 3137-3313, 392 plates (1900).
72. Indian River and its fishes. (Joint author with Barton A. Bean.) *Senate Doc. 46, 54th Cong., 2d Sess.*, pp. 5-26; 37 plates. Also *in Rep. U. S. Fish Comm. for 1896*, pp. 223-262; 36 plates.
73. The opah (*Lampris luna*) in Monterey Bay. *In Recreation, IV*, p. 41. (Jan., 1896.)
74. Two-Ocean Pass. *In Inland-Educator, II*, pp. 299-306; 5 plates. (July, 1896.)
75. Something about snipes. *In Recreation, V*, p. 147. (Sept., 1896.)
76. Review of E. T. D. Chambers's 'The ouananiche and its Canadian environment.' *In American Angler, XXVI*, pp. 359-360. (Oct.-Nov., 1896.)
77. In the Sawtooth Mountains. *In Recreation, V*, pp. 135-137, 196-197, 252-253. (Sept., Oct., Nov., 1896.)
78. Idaho grouse. *In Recreation, V*, p. 274.
79. The mountain lion (*Felis concolor*). *In Recreation, V*, p. 332, 1 plate. (Dec., 1896.)
80. How many kinds of bears are there in this country? *In Recreation, V*, pp. 322-323. (Dec., 1896.)
81. Trouting in Klamath Lakes. *In Recreation, V*, p. 336. (Dec., 1896.)
82. Report on the fish and fisheries of the coastal waters of Florida. *In Senate Doc. No. 100, 54th Cong., 2d Sess.*, 1897, pp. 1-80; also *in Rep. U. S. Fish Comm. for 1896 (1897)*, pp. 263-342.
83. A report upon salmon investigations in the headwaters of the Columbia River, in the state of Idaho, in 1895. *In Bull. U. S. Fish Comm. for 1896*, pp. 149-202, 6 plates.
84. U. S. Fish Commission investigations at Crater Lake. *In Mazama, I*, pp. 230-238. (1897.)
85. The fish fauna of Florida. *In Bull. U. S. Fish Comm. for 1897*, pp. 201-208; also *in Recreation, XII*, pp. 292-295 (April, 1900); and *in Southern Sportsman, II*, pp. 9-14 (Jan., 1899).
86. A report upon salmon investigations in the Columbia River Basin and elsewhere on the Pacific coast in 1896. (Joint author with S. E. Meek. *In Bull. U. S. Fish Comm. for 1897*, pp. 15-84; 8 plates.
87. Review of Florence A. Merriam's 'A-birding on a broncho.' *In Recreation, VI*, p. 290. (April, 1897.)
88. Review of David Starr Jordan's 'Science Sketches.' *In Recreation, VI*, p. 290. (April, 1897.)
89. Review of W. Furneaux's 'Life in pond and stream.' *In Recreation, VI*, p. 291. (April, 1897.)
90. Review of Frank Cramer's 'The method of Darwin.' *In Recreation, VI*, p. 291. (April, 1897.)
91. Review of Nathaniel Lord Britton and Addison Brown's 'An illustrated flora of the northern United States, Canada and the British Possessions, I.' *In Inland Educator, IV*, p. 251. (June, 1897.)
92. Lake trout from Montana. *In Recreation, VII*, pp. 54-55. (July, 1897.)

93. Catfish in Louisiana. *In Recreation*, VII, p. 56. (July, 1897.)
94. Trout culture in Montana. *In Recreation*, VII, pp. 140. (August, 1897.)
95. White and yellow perch. *In Recreation*, VII, p. 178, 494. (Sept., Dec., 1897.)
96. Descriptions of new or little known genera and species of fishes from the United States. (Joint author with W. C. Kendall.) *In Bull. U. S. Fish Comm. for 1897* (1898), pp. 125-133; 4 plates.
97. Notes on fishes collected by E. W. Nelson on the Tres Marias Islands and in Sinaloa and Jalisco, Mexico. *In Proc. Biol. Soc. Wash.*, XII, pp. 1-3. (Jan., 1898.)
98. Crater Lake. *In Recreation*, VIII, pp. 18-20; 2 illustrations. (Jan., 1898.)
99. Note on the Columbia sturgeon. *In Recreation*, VIII, p. 301. (April, 1898.)
100. Crater Lake to be a national park. *In Recreation*, VIII, p. 396. (May, 1898.)
101. The teaching of biology in the public schools. *In Plant World*, I, pp. 119-122. (May, 1898.)
102. The teaching of biology in the public schools. *In Inland-Educator*, VI, pp. 141-143. (May, 1898.)
103. Review of Nathaniel Lord Britton and Addison Brown's 'An illustrated flora of the northern United States, Canada and the British Possessions, II.' *In Inland-Educator*, VI, p. 180. (May, 1898.)
104. Note on the Loch Leven trout. *In Recreation*, VIII, p. 465. (June, 1898.)
105. Key to the species of *Lucius*. *In Recreation*, IX, p. 207. (Sept., 1898.)
106. Artificial key to the families of true fishes or Teleostei of North and Middle America. (Joint author with D. S. Jordan.) *In Bull. 47, U. S. Nat. Mus.*, pp. 2875-2890. (1898.)
107. Report on investigations by the U. S. Fish Commission in Mississippi, Louisiana, and Texas in 1897. *In Rep. U. S. Fish Comm. for 1898* (1899), pp. 285-310; 29 plates.
108. Check-list of the fishes of Florida. (Joint author with W. C. Kendall.) *In Rep. U. S. Fish Comm. for 1899*, pp. 35-103.
109. Descriptions of new genera and species of fishes from Puerto Rico. (Joint author with Millard C. Marsh.) *In Rep. U. S. Fish Comm. for 1899*, pp. 351-362.
110. Something about Porto Rico. *In Inland-Educator*, pp. 7-10; 5 illustrations. (August, 1899.)
111. Review of S. Reynolds Hale's 'Our garden.' *In Recreation*, XI, p. 234. (Sept., 1899.)
112. Review of Albert Gardner Robinson's 'Porto Rico to-day.' *In Recreation*, XI, p. 322. (Oct., 1899.)
113. Review of Sir Edward Grey's 'Fly fishing.' *In Recreation*, XI, p. 322. (Oct., 1899.)
114. A note on *Roccus lineatus*, *Roccus chrysops*, and *Morone interrupta*. *In Recreation*, XI, pp. 287-288. (Oct., 1899.)
115. The ling and other fishes of Lake Chelan, Washington. *In Recreation*, XI, pp. 371-372. (Nov., 1899.)
116. Note on a specimen of the wolf-fish, *Alepisaurus æsculapias*. *In Recreation*, XI, p. 373. (Nov., 1899.)
117. Review of Frederic A. Ober's 'Puerto Rico and its resources.' *In Recreation*, XI, p. 397. (Nov., 1899.)
118. Review of David Starr Jordan's 'Manual of vertebrates.' *In Recreation*, XI, p. 397. (Nov., 1899.)
119. Description of two new species of darters from Lake Maxinkuckee, Indiana. *In Rep. U. S. Fish Comm. for 1899* (1900), pp. 363-367; 1 plate.
120. Investigations of the aquatic resources and fisheries of Porto Rico by the United States Fish Commission steamer Fish Hawk in 1899. *In Bull. U. S. Fish Comm. for 1900*, pp. 1-350; 52 plates, 112 figures.
121. The fishes of Porto Rico. (Joint

- author with M. C. Marsh.) *In Bull. U. S. Fish Comm. for 1900*, pp. 51-350; 164 plates.
122. Some observations concerning species and sub-species. *In Science, N. S., XI*, pp. 451-455. (March, 1900.)
123. Review of William Dinwiddie's 'Puerto Rico.' *In Recreation, XII*, p. 399. (May, 1900.)
124. The United States Fish Commission. *In Current Encyclopedia, I*, pp. 457-461; 6 illustrations. (Oct., 1901.)
125. Investigations of the United States Fish Commission steamer Albatross. *In Current Encyclopedia, I*, pp. 689-693; 3 illustrations. (Dec., 1901.)
126. Bait minnows. *In Rep. New York Forest, Fish and Game Comm. for 1900 (1902)*, pp. 307-352; 16 text-figures and colored plates of 12 species.
127. Notes on the fishes and mollusks of Chautauqua Lake, New York. (Joint author with Edmund L. Goldsborough.) *In Rep. New York Forest, Fish and Game Comm. for 1900 (1902)*, pp. 357-366; 1 plate.
128. Notes on the fishes of Lake Ontario. (Joint author with W. C. Kendall.) *In Rep. N. Y. Forest, Fish and Game Comm. for 1900 (1902)*, pp. 479-488.
129. Summary of the scientific results of the Fish Commission expedition to Porto Rico. *In Bull. U. S. Fish Comm. for 1900 (1902)*, XI-XV, First Part.
130. General report on the investigations in Porto Rico of the United States Fish Commission steamer Fish Hawk in 1899. *In Bull. U. S. Fish Comm. for 1900 (1902)*, pp. 1-26, Part 1.
131. List of species of fishes known to occur in the Great Lakes or their connecting waters. *In Bull. U. S. Fish Comm. for 1901 (1902)*, pp. 95-96.
132. A report on fishes collected in Mexico and Central America, with notes and descriptions of five new species. (Joint author with E. L. Goldsborough.) *In Bull. U. S. Fish Comm. for 1901 (1902)*, pp. 137-159; 8 text-figures.
133. Notes on the fishes and mollusks of Lake Chautauqua, New York. (Joint author with E. L. Goldsborough.) *In Rep. U. S. Fish Comm. for 1901 (1902)*, pp. 169-175.
134. Notes on the fishes of Lake Ontario. (Joint author with W. C. Kendall.) *In Rep. U. S. Fish Comm. for 1901 (1902)*, pp. 209-216.
135. An annotated list of the fishes known to occur in Lake Champlain and its tributary waters. (Joint author with W. C. Kendall.) *In Rep. U. S. Fish Comm. for 1901 (1902)*, pp. 217-226.
136. An annotated list of the fishes known to occur in the St. Lawrence River. (Joint author with W. C. Kendall.) *In Rep. U. S. Fish Comm. for 1901 (1902)*, pp. 227-240.
137. Description of a new species of shad (*Alosa ohioensis*) with notes on other food-fishes of the Ohio River. *In Rep. U. S. Fish Comm. for 1901 (1902)*, pp. 273-288; 6 plates.
138. The fishes and fisheries of the Hawaiian Islands. (Joint author with D. S. Jordan.) *In Rep. U. S. Fish Comm. for 1901 (1902)*, pp. 353-499; 7 plates.
139. Preliminary report on the investigations of the fishes and fisheries of the Hawaiian Islands. (Joint author with D. S. Jordan.) *In House Doc. No. 249, 57th Cong., 1st Sess.*, pp. 1-33. (Jan., 1902.)
140. Lopho, the quail. *In Harper's Mo., CIV*, pp. 487-492. (Feb., 1902.)
141. Facts about the eel. *In Recreation, XVI*, p. 222. (March, 1902.)
142. Lake Mashipacong. *In Recreation, XVI*, pp. 291-293. (April, 1902.)
143. Nature study and nature study books. *In Recreation, XVI*, p. 317. (April, 1902.)

144. Porto Rico, its fishes and fisheries. (Joint author with M. C. Marsh.) *In* Current Encyclopedia, II, pp. 1274-1279; 8 text-illustrations. (April, 1902.)
145. The feeding habits of the coot and other water birds. *In* Osprey, I, pp. 57-64. (April, 1902.)
146. American food and game fishes: a popular account of all the species found in America north of the Equator, with keys for ready identification, life histories, and methods of capture. (Joint author with D. S. Jordan.) New York, 1902. Pp. 1, 573; 10 colored plates, 63 photographic plates, and 220 text-figures.
147. Notes on some Mexican fishes. (Joint author with E. L. Goldsborough.) *In* Science, N. S., XV, pp. 746-749. (May, 1902.)
148. A new species of shad from the Ohio River. *In* Forest and Stream, LVIII, pp. 408-409; 6 plates. (May, 1902.)
149. Strange fishes of the deep sea. *In* The World To-day, II, pp. 1398-1406; 18 plates. (June, 1902.)
150. A new species of shad. *In* Sports Afield, XXIX, pp. 63-66; 3 plates. (July, 1902.)
151. Fishes of the Great Lakes. *In* Sports Afield, XXIX, p. 70. (July, 1902.)
152. The mystery of the salmon. *In* Outing, pp. 562-568. (August, 1902.)
153. Pike, pickerel, muscalonge. *In* Forest and Stream, LIX, p. 193. (Sept., 1902.)
154. The big trees of California. *In* Sports Afield, XXIX, p. 272. (Sept., 1902.)
155. Some strange ocean fishes. (Joint author with M. C. Marsh.) *In* World To-day, III, pp. 1800-1805, 10 plates. (Sept., 1902.)
156. Hawaiian Island fisheries. *In* Sports Afield, XXIX, p. 273. (Sept., 1902.)
157. Water the birds. *In* Country Life in America, III, pp. 17-19. (Nov., 1902.)
158. Nerka, the blueback salmon. *In* World To-day, III, pp. 2221-2228; 9 plates. (Dec., 1902.)
159. Descriptions of new genera and species of fishes from the Hawaiian Islands. (Joint author with D. S. Jordan.) *In* Bull. U. S. Fish Comm. for 1902 (1903), pp. 161-208.
160. Descriptions of a new genus and two new species of fishes from the Hawaiian Islands. (Joint author with D. S. Jordan.) *In* Bull. U. S. Fish Comm., for 1902 (1903), pp. 209-210.
161. The cutthroat trout and its relatives. *In* Country Life in America, IV, p. 130; 1 illustration. (June, 1903.)
162. The United States Bureau of Fisheries. *In* Pacific Fisherman II, pp. 16-18; 3 plates. (Jan., 1904.)
163. The fishes and other aquatic resources of the Hawaiian Islands. (Joint author with D. S. Jordan.) *In* Bull. U. S. Fish Comm. for 1903 (1904); 73 colored plates, 300 lithographs and text-figures.
164. Preliminary report of the Alaska Salmon Commission. (Joint author with D. S. Jordan.) *In* House Doc. No. 477, 58th Cong., 2d Sess., pp. 1-37. (Jan., 1904.)
165. The native fishermen of Hawaii. *In* Outing, XLIII, pp. 660-667; 7 illustrations.
166. Modesty itself, the brown towhee. *In* Recreation, XX, pp. 277-279; 1 plate. (April, 1904.)
167. Statistics of the fisheries of the Middle Atlantic States. *In* Rep. U. S. Fish Comm. for 1902, pp. 433-540. (1903.)
168. Report of the Division of Statistics and Methods of the Fisheries. *In* Rep. U. S. Fish Comm. for 1903, pp. 101-122. (1904.)
169. The Bureau of Fisheries. *In* Nat. Geog. Mag., XV, pp. 191-212; 14 illustrations. (May, 1904.)

BERT FESLER, A.B. (1889). Duluth, Minn.

1. A review of the mackerels (*Scombrinae*) of America and Europe. (Joint author with Fletcher B. Dresslar.) *In Bull. U. S. Fish Comm.* for 1887.

FRANK ALBERT FETTER, A.B. (1891), Ph.D.
Professor of Economics and Social Science, Indiana University, 1895-1898.
Now Professor of Political Economy and Finance, Cornell University.

1. Versuch einer Bevölkerungslehre, Jena, 1894. Pp. 105.

2. History of the city of Peru, Indiana. *In History of Miami county*, (Chicago, 1887), pp. 362-392.

3. Theories of value and deferred payments. *In Ann. Am. Acad. Pol. and Soc. Sci.*, V, pp. 882-896. (May, 1895.)

4. The gold reserve, its functions and its maintenance. *In Pol. Sci. Quart.*, XI, pp. 237-247. (June, 1896.)

5. Review of Julius Lehr's 'Produktion und Consumption.' *In Pol. Sci. Quart.*, XI, p. 336. (June, 1896.)

6. Review of F. W. Taussig's 'Wages and capital.' *In Pol. Sci. Quart.*, XII, p. 146. (March, 1897.)

7. The improvement of methods of poor relief in Indiana. *In Bull. Indiana State Board of Charities.* (June, 1898.)

8. The essay of Malthus: a centennial review. *In Yale Rev.*, VII, p. 153. (August, 1898.)

9. Review of John Davidson's 'Bargain theory of wages.' *In Pol. Sci. Quart.*, XIII, p. 556. (Sept., 1898.)

10. Politics in the charitable institutions of the Pacific coast. *In Proc. Nat. Conf. Char. and Cor.* for 1899.

11. Social progress and race degenera-

tion. *In Forum*, XXVIII, p. 228. (Oct., 1899.)

12. Recent discussion of the capital concept. *In Quart. Jour. Econ.*, XV, pp. 1-45. (Nov., 1900.)

13. The next decade of economic theory. *In Pub. Am. Econ. Asso.*, Third series, II, pp. 236-246. (Feb., 1901.)

14. The passing of the old rent concept. *In Quart. Jour. Econ.*, XV, pp. 416-445. (May, 1901.)

15. Public subsidies to private charities. *In Proc. Nat. Conf. Char. and Cor.* for 1901, p. 118.

16. An American economist (J. B. Clark). *In Internat. Mo.* (July, 1901.)

17. The maps, diagrams, data, and statistical tables on housing conditions in Chicago (about 100 pages). *In Report of the City Homes Association on Tenement Conditions in Chicago.* Chicago, 1901.

18. The subsidizing of private charities. *In Am. Jour. Soc.*, VII, p. 359. (Nov., 1901.)

19. Review of A. H. Gibson's 'Natural economy.' *In Jour. Pol. Econ.*, X, p. 289. (March, 1902.)

20. Review of E. A. Ross's 'Social control.' *In Charities*, VIII, p. 213. (March, 1902.)

21. Review of E. von Böhm-Bawerk's 'Einige strittige Fragen der Capitalstheorie.' *In Pol. Sci. Quar.*, XVII, p. 169. (March, 1902.)

22. Editor of 'Papers and proceedings of the 14th annual meeting of the American Economic Association.' New York, 1902. Pp. 400. (*Pub. Am. Econ. Asso.*, 3d ser., III, No. 1.)

23. The roundabout process in the interest theory. *In Quar. Jour. Econ.*, XVII, pp. 163-180. (Nov., 1902.)

24. Review of G. B. Lockwood's 'The New Harmony communities.' *In Jour. Pol. Econ.*, XI, p. 175. (Dec., 1902.)

25. Review of I. Broome, 'The last days of the Ruskin community.' *In Jour. Pol. Econ.*, XI, p. 177. (Dec., 1902.)

26. Editor of 'Papers and proceedings of the 15th annual meeting of the American Economic Association.' New York, 1903. Pp. 298. (Pub. Am. Econ. Asso., 3d ser., IV, No. 1.)

27. Taxation in the American States in 1902. *In Legislative Bull. New York State Library*, No. 19, p. 785. (1903.)

28. The relations between rent and interest. Paper read at the sixteenth annual meeting of the Am. Econ. Assoc., Dec., 1903. *In Pub. Am. Econ. Assoc.* 3d ser., V, pp. 176-198. (Feb., 1904.) Reprint, with discussion, 74 pp. (April, 1904.)

29. Taxation in the American States in 1903. *In Legis. Bull. N. Y. State Library* for May, 1904.

30. Editor of 'Papers and proceedings of the 16th annual meeting of the American Economic Association.' Part I. New York, 1904. Pp. 250. (Pub. Am. Econ. Assoc., 3d ser., V, No. 1.)

31. Editor of 'Papers and proceedings of the 16th annual meeting of the American Economic Association.' Part II. New York, 1904. Pp. 210. (Pub. Am. Econ. Assoc., 3d ser., V, No. 2.)

32. Principles of economies, with applications to practical problems. New York, 1904. About 500 pp. (In press.)

GUY HARLAND FITZGERALD, A.B. (1896),
M.D. Albuquerque, N. M.

1. Etiology of appendicitis. *In Cleveland Medical Gaz.* for 1901.

2. The Southwest for pulmonary tuberculosis. *In Cleveland Med. Jour.*, X. (March, 1902.)

3. Avoidable causes of mortality in tuberculosis in the Southwest. *In Cleveland Med. Jour.*, for Nov., 1903.

ARTHUR LEE FOLEY, A.B. (1890), A.M.
(1891), Ph.D. See Faculty list.

MORTON WILLIAM FORDICE, B.S. (1886).
Russellville, Ind.

1. A review of the American Stromatoidæ. *In Proc. Acad. Nat. Sci. Philadelphia*, for 1884, pp. 311-317.

2. A review of the American Eleotridinæ. (Joint author with C. H. Eigenmann.) *In Proc. Acad. Nat. Sci. Philadelphia* for 1885, pp. 66-80.

3. A catalogue of the fishes of Bean Blossom Creek, Monroe county, Indiana. (Joint author with C. H. Eigenmann.) *In Proc. Acad. Nat. Sci. Philadelphia*, for 1885, pp. 410-411.

4. List of fishes collected in Harvey and Cowley counties, Kansas. (Joint author with Barton W. Evermann.) *In Proc. Acad. Nat. Sci. Philadelphia*, for 1885, p. 412.

5. Some Kansas fishes. (Joint author with B. W. Evermann.) *In Bull. Washburn College Nat. Hist.* for 1885.

6. A review of the North American species of Petromyzontidæ. (Joint author with David Starr Jordan.) *In Ann. Acad. Nat. Sci. N. Y.*, for 1886.

7. A review of the American species of Bellonidæ. (Joint author with D. S. Jordan.) *In Proc. U. S. Nat. Mus.*, IX, pp. 338-361. (1886.)

8. A review of the sturgeons (Acipenseridæ) of North America. (Joint author with Philip H. Kirsch.) *In Proc. Acad. Nat. Sci. Philadelphia*, for 1889, pp. 245-257.

FINLEY MILLIGAN FOSTER, A.B. (1876),
Ph.D. Clergyman, New York.

1. The witnessing church. New York, 1890. Pp. 233.
2. A plea for the old church. New York, 1896. Pp. 44.

JOHN MITCHELL FOSTER, A.B. (1871). Pastor Second Reformed Presbyterian Church, Boston, Mass.

1. Review of S. L. Loomis's 'Modern cities.' *In* Christian Statesman. (Sept., 1888.)
2. Reformation principles. Cincinnati, 1890. Pp. 448.
3. Review of Elisha Mulford's 'The nation.' *In* Christian Statesman. (Sept., 1890.)
4. Distinctive principles of the Covenanters. Boston, 1892. Pp. 56.
5. Our triple foe. Boston, 1892. Pp. 48.
6. Romanism: The evil and its remedy. Boston, 1892. Pp. 64.
7. Principles of the covenanters. *In* Our Day (Boston) for March, 1894, pp. 102-113.
8. Christ the king. Boston, 1895. Pp. 448.
9. Secret societies and the state. *In* Arena, XIX, pp. 229-240. (Feb., 1898.)
10. Review of James Bryce's 'The American commonwealth.' *In* Christian Statesman. (June, 1900.)
11. Review of A. J. Gordon's 'The Holy Spirit in missions.' *In* Olive Tree. (1900.)
12. Review of R. W. Thompson's 'The papacy and the civil power.' *In* Am. Citizen. (April, 1901.)
13. Review of James Bryce's 'The Holy Roman Empire of the Germans.' *In* Am. Citizen. (March, 1901.)

14. Review of Josiah Strong's 'The new era.' *In* Christian Statesman. (June, 1901.)

15. Review of Stephen L. Baldwin's 'Foreign missions of the Protestant Church.' *In* Olive Tree. (Dec., 1901.)
16. Ten lectures on Romanism. *In* Am. Citizen. (Boston.)
17. One hundred lectures on the Christian state. *In* Christian Statesman. (Pittsburg, Pa.)
18. Twenty lectures on foreign missions. *In* Olive Tree. (New York.)
19. Fifty addresses on the Messiah's kingdom. *In* Midland. (Chicago.)
20. Review of Harlan P. Beach's 'The geography and atlas of Protestant missions.' *In* Olive Tree. (Feb., 1904.)
21. Review of Josiah Strong's 'Twentieth century cities.' *In* Midland.
22. Review of A. T. Pierson's 'Evangelistic work.' *In* Christian Nation.

JOHN WATSON FOSTER, A.B. (1855), LL.D.
Washington, D. C.

1. Coffee cultivation in Mexico, Agricultural Department. (1876.)
2. International awards and national honor. Washington, 1886.
3. Visit to foreign mission lands, Pres. bd., New York, 1895.
4. Bering Sea arbitration. *In* No. Am. Rev., CLXI, pp. 693-702. (Dec., 1895.)
5. Biography of Matthew Watson Foster. New York, 1896. Pp. 86.
6. The Viceroy Li Hung Chang. *In* Century, LII, pp. 560-571. (August, 1896.)
7. The Hawaiian Islands. *In* Nat. Geog. Mag., for Nov., 1899.
9. Rank of ambassadors. *In* Columbia Univ. Pub., for Dec., 1899.
10. A century of American diplomacy. Boston, 1900. Pp. i-xiii, 495.

11. A foreign sovereign in an American court. *In* Yale Law Jour., May, 1900.

12. A permanent method of arbitration. *In* Independent, LII, pp. 1420-1422. (June 14, 1900.)

13. The right of missionaries to protection. *In* Rev. of Revs., August, 1900.

14. The great chinese viceroy and diplomat. *In* Internat. Mo., II, pp. 584-596. (Nov., 1900.)

15. Reciprocity treaties and the Senate. *In* Independent, LII, p. 2899.

16. La Doctrina de Monroe. *In* Bull. Am. Republics, Dec., 1900.

17. The United States, *is* or *are*? *In* New York Sat. Rev., May 4, 1901.

18. The Clayton-Bulwer treaty. *In* Independent, LIII, pp. 1167-1171. (May, 1901.)

19. Latin-American constitutions and revolutions. *In* Jour. Am. Sci., Nov., 1901.

20. Treaty making power under the Constitution. *In* Yale Law Jour., Dec., 1901.

21. The New Mexico. *In* Nat. Geo. Mag., Jan., 1902.

22. Canada and the Monroe Doctrine. *In* Independent, LIV, pp. 721-723. (March 27, 1902.)

23. Pan-American diplomacy. *In* Atl. Mo., LXXXIX, pp. 482-491. (April, 1902.)

24. Gifts from foreign governments: Art. 1, Sec. 9, Cl. 8, U. S. Constitution. *In* Columbia Univ. Pub., Dec., 1902.

25. American diplomacy in the Orient. Boston, 1903. Pp. i-xiv, 498.

26. The Canadian boundary. *In* Nat. Geo. Mag., March, 1903.

27. Porfirio Diaz: Soldier and statesman. *In* Internat. Quar., VIII, pp. 342-353. (Dec., 1903.)

28. The Alaskan Boundary Tribunal. *In* Nat. Geo. Mag., Jan., 1904.

29. What the United States has done for international arbitration. *In* Green Bag, March, 1904.

ADDISON LUTHER FULWIDER, A.B. (1895).
Principal of High School, Jacksonville, Ill.

1. History in the high school. *In* Inland-Educator, VI, pp. 100-104. (April, 1898.)

2. Relative value of history. *In* Proc. Illinois State Teachers' Assn., Dec., 1899.

CHARLES HENRY GILBERT, M. S. (1882),
Ph.D. (1883). Professor of Zoölogy,
Indiana University, 1888-1891. Now
Professor of Zoölogy, Leland Stanford
Junior University, Stanford University,
Cal.

1. List of fishes of Indiana. (Joint author with David Starr Jordan.) *In* Indiana Farmer, Jan. 17, 1877.

2. On the genera of North American fresh-water fishes. (Joint author with D. S. Jordan.) *In* Proc. Acad. Nat. Sci. Philadelphia, XXIX, pp. 83-104.

3. Notes on the fishes of Beaufort Harbor, North Carolina. (Joint author with D. S. Jordan.) *In* Proc. U. S. Nat. Mus., I, pp. 365-388. (1878.)

4. Notes on a collection of fishes from San Diego, California. (Joint author with D. S. Jordan.) *In* Proc. U. S. Nat. Mus., III, pp. 23-34. (1880.)

5. Description of a new flounder (*Xystreurus liolepis*) from Santa Catalina Island, California. (Joint author with D. S. Jordan.) *In* Proc. U. S. Nat. Mus., III, pp. 34-36. (1880.)

6. Description of a new ray (*Platyrrhina triseriata*) from the coast of California. (Joint author with D. S. Jordan.) *In* Proc. U. S. Nat. Mus., III, pp. 36-38. (1880.)

7. Description of a new species of rock cod (*Sebastichthys sericeus*) from the coast of California. (Joint author with

- D. S. Jordan.) *In Proc. U. S. Nat. Mus.*, III, pp. 40-42.
8. On the occurrence of *Cephaloscyllium laticeps* (Duméril) Gill on the coast of California. (Joint author with D. S. Jordan.) *In Proc. U. S. Nat. Mus.*, III, pp. 40-42. (1880.)
9. On the oil shark of Southern California (*Galeorhinus galeus*). (Joint author with D. S. Jordan.) *In Proc. U. S. Nat. Mus.*, III, pp. 42-43. (1880.)
10. Description of a new flounder (*Pleuronichthys verticalis*) from the coast of California, with notes on other species. (Joint author with D. S. Jordan.) *In Proc. U. S. Nat. Mus.*, III, pp. 49-51. (1880.)
11. Notes on sharks from the coast of California. (Joint author with D. S. Jordan.) *In Proc. U. S. Nat. Mus.*, III, pp. 51-52. (1880.)
12. On the generic relations of *Platyrrhina exasperata*. (Joint author with D. S. Jordan.) *In Proc. U. S. Nat. Mus.*, III, p. 53. (1880.)
13. Description of a new species of *Sebastichthys* (*Sebastichthys miniatus*) from Monterey Bay, California. (Joint author with D. S. Jordan.) *In Proc. U. S. Nat. Mus.*, III, pp. 70-73. (1880.)
14. Description of a new species of rockfish (*Sebastichthys carnatus*) from the coast of California. (Joint author with D. S. Jordan.) *In Proc. U. S. Nat. Mus.*, III, pp. 73-75. (1880.)
15. Description of a new species of ray (*Raia stellulata*) from Monterey, California. (Joint author with D. S. Jordan.) *In Proc. U. S. Nat. Mus.*, III, pp. 133-135. (1880.)
16. Descriptions of new species of *Xiphister* and *Apodichthys*, from Monterey, California. (Joint author with D. S. Jordan.) *In Proc. U. S. Nat. Mus.*, III, pp. 135-140. (1880.)
17. Descriptions of two new species of *Sebastichthys* (*Sebastichthys entomelas* and *Sebastichthys rhodochloris*) from Monterey Bay, California. (Joint author with D. S. Jordan.) *In Proc. U. S. Nat. Mus.*, III, pp. 142-146. (1880.)
18. Description of a new Agonoid fish (*Brachyopsis xyosternus*) from Monterey Bay, California. (Joint author with D. S. Jordan.) *In Proc. U. S. Nat. Mus.*, III, pp. 152-154. (1880.)
19. Description of a new flounder (*Hippoglossoides exilis*) from the coast of California. (Joint author with D. S. Jordan.) *In Proc. U. S. Nat. Mus.*, III, pp. 154-156. (1880.)
20. Description of a new species of ray (*Raia rhina*) from the coast of California. (Joint author with D. S. Jordan.) *In Proc. U. S. Nat. Mus.*, III, pp. 251-253. (1880.)
21. Descriptions of two new species of fishes (*Ascelichthys rhodorus* and *Seytalina cerdale*) from Neah Bay, Washington Territory. (Joint author with D. S. Jordan.) *In Proc. U. S. Nat. Mus.*, III, pp. 264-268. (1880.)
22. Descriptions of two new species of Scopeloid fishes (*Sudis ringens* and *Myctophum crenulare*) from Santa Barbara Channel, California. (Joint author with D. S. Jordan.) *In Proc. U. S. Nat. Mus.*, III, pp. 273-276. (1880.)
23. Descriptions of two new species of flounders (*Parophrys ischyryrus* and *Hippoglossoides ellassodon*) from Puget Sound. (Joint author with D. S. Jordan.) *In Proc. U. S. Nat. Mus.*, III, pp. 276-280. (1880.)
24. Description of seven new species of Sebastoid fishes from the coast of California. (Joint author with D. S. Jordan.) *In Proc. U. S. Nat. Mus.*, III, pp. 287-298. (1880.)
25. Description of a new Embiotocoid (*Abeona aurora*) from Monterey, California, with notes on a related species. (Joint author with D. S. Jordan.) *In Proc. U. S. Nat. Mus.*, III, pp. 299-301. (1880.)

26. Description of a new flounder (*Platysomatischthys stomias*) from the coast of California. (Joint author with D. S. Jordan.) *In Proc. U. S. Nat. Mus.*, III, pp. 301-303. (1880.)
27. Description of a new Embiotocoid fish (*Cymatogaster rosaceus*) from the coast of California. (Joint author with D. S. Jordan.) *In Proc. U. S. Nat. Mus.*, III, pp. 303-305. (1880.)
28. Description of a new species of deep-water fish (*Icichthys lockingtoni*) from the coast of California. (Joint author with D. S. Jordan.) *In Proc. U. S. Nat. Mus.*, III, pp. 305-308. (1880.)
29. Description of a new Embiotocoid fish (*Ditrema atripes*) from the coast of California. (Joint author with D. S. Jordan.) *In Proc. U. S. Nat. Mus.*, III, pp. 320-322. (1880.)
30. Description of a new Scorpaenoid fish (*Sebastichthys maliger*) from the coast of California. (Joint author with D. S. Jordan.) *In Proc. U. S. Nat. Mus.*, III, pp. 322-324. (1880.)
31. Description of a new Scorpaenoid fish (*Sebastichthys proriger*) from Monterey Bay, California. (Joint author with D. S. Jordan.) *In Proc. U. S. Nat. Mus.*, III, pp. 327-329. (1880.)
32. Description of a new Agonoid (*Agonus vulsus*) from the coast of California. (Joint author with D. S. Jordan.) *In Proc. U. S. Nat. Mus.*, III, pp. 330-332. (1880.)
33. Description of a new species of Hemirhamphus (*Hemirhamphus rosae*) from the coast of California. (Joint author with D. S. Jordan.) *In Proc. U. S. Nat. Mus.*, III, pp. 335-336. (1880.)
34. Description of a new species of Notidanoid shark (*Hexanchus corinus*) from the Pacific coast of the United States. (Joint author with D. S. Jordan.) *In Proc. U. S. Nat. Mus.*, III, pp. 352-355. (1880.)
35. Description of a new species of Nemichthys (*Nemichthys avocetta*) from Puget Sound. (Joint author with D. S. Jordan.) *In Proc. U. S. Nat. Mus.*, III, pp. 409-410. (1881.)
36. Description of a new species of Paralepis (*Paralepis coruseans*) from the Straits of Juan de Fuca. (Joint author with D. S. Jordan.) *In Proc. U. S. Nat. Mus.*, III, pp. 411-413. (1881.)
37. List of the fishes of the Pacific coast of the United States, with a table showing the distribution of the species. (Joint author with D. S. Jordan.) *In Proc. U. S. Nat. Mus.*, III, pp. 452-458. (1881.)
38. On the generic relations of *Belone exilis*. (Joint author with D. S. Jordan.) *In Proc. U. S. Nat. Mus.*, III, p. 459. (1881.)
39. Notes on a collection of fishes from Utah Lake. (Joint author with D. S. Jordan.) *In Proc. U. S. Nat. Mus.*, III, pp. 359-465. (1881.)
40. Description of a new species of rock-fish (*Sebastichthys chrysomelas*) from the coast of California. (Joint author with D. S. Jordan.) *In Proc. U. S. Nat. Mus.*, III, p. 465. (1881.)
41. Observations on the salmon of the Pacific. (Joint author with D. S. Jordan.) *In Am. Nat.*, XV, pp. 177-186. (1881.)
42. Notes on the fishes of the Pacific coast of the United States. (Joint author with D. S. Jordan.) *In Proc. U. S. Nat. Mus.*, IV, pp. 29-70. (1881.)
43. Description of *Sebastichthys mystinus*. (Joint author with D. S. Jordan.) *In Proc. U. S. Nat. Mus.*, IV, pp. 70-72. (1881.)
44. Description of a new species of Ptychochilus (*Ptychochilus harfordi*) from Sacramento River. (Joint author with D. S. Jordan.) *In Proc. U. S. Nat. Mus.*, IV, pp. 72-73. (1881.)
45. Note on *Raia inornata*. (Joint author with D. S. Jordan.) *In Proc. U. S. Nat. Mus.*, IV, pp. 73-74. (1881.)

46. Notes on a collection of fishes made by Lieut. Henry E. Nichols, U. S. N., on the west coast of Mexico, with descriptions of new species. (Joint author with D. S. Jordan.) *In Proc. U. S. Nat. Mus.*, IV, pp. 225-233. (1881.)
47. List of fishes collected by Lieut. Henry E. Nichols, U. S. N., in the Gulf of California, and on the west coast of Lower California, with descriptions of four new species. (Joint author with D. S. Jordan.) *In Proc. U. S. Nat. Mus.*, IV, pp. 273-279. (1882.)
48. Descriptions of thirty-three new species of fishes from Mazatlan, Mexico. *In Proc. U. S. Nat. Mus.*, IV, pp. 338-365. (1882.)
49. Descriptions of a new species of Pomadasys from Mazatlan, with a key to the species known to inhabit the Pacific coast of tropical America. (Joint author with D. S. Jordan.) *In Proc. U. S. Nat. Mus.*, IV, pp. 383-388. (1882.)
50. Description of a new species of Xenichthys (*Xenichthys xenurus*) from the west coast of Central America. (Joint author with D. S. Jordan.) *In Proc. U. S. Nat. Mus.*, IV, p. 454. (1882.)
51. Description of five new species of fishes from Mazatlan, Mexico. (Joint author with D. S. Jordan.) *In Proc. U. S. Nat. Mus.*, IV, pp. 458-463. (1882.)
52. Description of four new species of sharks from Mazatlan, Mexico. (Joint author with D. S. Jordan.) *In Proc. U. S. Nat. Mus.*, V, pp. 102-110. (1882.)
53. Description of a new shark (*Carcharias lamiella*) from San Diego, California. (Joint author with D. S. Jordan.) *In Proc. U. S. Nat. Mus.*, V, pp. 110-111. (1882.)
54. Descriptions of nineteen new species of fishes from the Bay of Panama. (Joint author with D. S. Jordan.) *In Bull. U. S. Fish Comm.*, I, pp. 306-335. (1882.)
55. Description of a new Cyprinodont (*Zygonectes inurus*) from southern Illinois. (Joint author with D. S. Jordan.) *In Proc. U. S. Nat. Mus.*, V, pp. 143-144. (1882.)
56. Description of a new species of Uranidea (*Uranidea pollicaris*) from Lake Michigan. (Joint author with D. S. Jordan.) *In Proc. U. S. Nat. Mus.*, V, pp. 222-223. (1882.)
57. Notes on fishes observed about Pensacola, Florida, and Galveston, Texas, with descriptions of new species. (Joint author with D. S. Jordan.) *In Proc. U. S. Nat. Mus.*, V, pp. 241-307. (1882.)
58. Description of a new species of Conodon (*Conodon serrifer*) from Boca Soledad, Lower California. (Joint author with D. S. Jordan.) *In Proc. U. S. Nat. Mus.*, V, pp. 351-352. (1882.)
59. Catalogue of the fishes collected by Mr. John Xantus at Cape San Lucas, which are now in the United States National Museum, with descriptions of eight new species. (Joint author with D. S. Jordan.) *In Proc. U. S. Nat. Mus.*, V, pp. 353-371. (1882.)
60. List of fishes collected by Mr. John Xantus at Colima, Mexico. (Joint author with D. S. Jordan.) *In Proc. U. S. Nat. Mus.*, V, pp. 371-372. (1882.)
61. List of fishes collected at Panama by Capt. John M. Dow, now in the United States National Museum. (Joint author with D. S. Jordan.) *In Proc. U. S. Nat. Mus.*, V, pp. 373-378. (1882.)
62. List of a collection of fishes made by Mr. L. Belding, near Cape San Lucas, Lower California. (Joint author with D. S. Jordan.) *In Proc. U. S. Nat. Mus.*, V, pp. 378-381. (1882.)
63. List of fishes collected at Panama by Rev. Mr. Rowell, now preserved in the United States National Museum. (Joint author with D. S. Jordan.) *In Proc. U. S. Nat. Mus.*, V, pp. 381-382. (1882.)
64. Descriptions of two new species of fishes (*Sebastichthys umbrosus* and *Citharichthys stigmæus*) collected at Santa Bar-

bara, California, by Andrea Larco. (Joint author with D. S. Jordan.) *In Proc. U. S. Nat. Mus.*, V, pp. 410-412. (1882.)

65. A review of the Siluroid fishes found on the Pacific coast of tropical America, with descriptions of three new species. (Joint author with D. S. Jordan.) *In Bull. U. S. Fish Comm.*, II, pp. 34-54. (1882.)

66. List of fishes collected at Mazatlan, Mexico, by Charles H. Gilbert. (Joint author with D. S. Jordan.) *In Bull. U. S. Fish Comm.*, II, pp. 105-108. (1882.)

67. List of fishes collected at Panama by C. H. Gilbert. (Joint author with D. S. Jordan.) *In Bull. U. S. Fish Comm.*, II, pp. 109-111. (1882.)

68. Description of a new species of Goby (*Gobiosoma ios*) from Vancouver's Island. (Joint author with D. S. Jordan.) *In Proc. U. S. Nat. Mus.*, V, pp. 437-438. (1882.)

69. List of fishes observed at Punta Arenas, on the Pacific coast of Central America. *In Bull. U. S. Fish Comm.*, II, p. 112. (1882.)

70. On certain neglected generic names of Lacépède. *In Proc. U. S. Nat. Mus.*, V, pp. 570-576. (1883.)

71. On the synonymy of the genus *Bothus* Rafinesque. (Joint author with D. S. Jordan.) *In Proc. U. S. Nat. Mus.*, V, pp. 576-577. (1883.)

72. Description of a new species of *Artedius* (*Artedius fenestralis*) from Puget Sound. (Joint author with D. S. Jordan.) *In Proc. U. S. Nat. Mus.*, V, pp. 577-579. (1883.)

73. Description of a new species of *Urolophus* (*Urolophus asterias*) from Mazatlan and Panama. (Joint author with D. S. Jordan.) *In Proc. U. S. Nat. Mus.*, V, pp. 579-580. (1883.)

74. Notes on a collection of fishes from Charleston, South Carolina, with descriptions of three new species. (Joint author

with D. S. Jordan.) *In Proc. U. S. Nat. Mus.*, V, pp. 580-620. (1883.)

75. List of fishes now in the museum of Yale College, collected by Prof. Frank H. Bradley at Panama, with description of three new species. (Joint author with D. S. Jordan.) *In Proc. U. S. Nat. Mus.*, V, pp. 630-632. (1883.)

76. Descriptions of two new species of fishes (*Myrophis vafer* and *Chloroscombrus orqueta*) from Panama. (Joint author with D. S. Jordan.) *In Proc. U. S. Nat. Mus.*, V, pp. 645-647. (1883.)

77. Description of a new eel (*Sidera castanea*) from Mazatlan, Mexico. (Joint author with D. S. Jordan.) *In Proc. U. S. Nat. Mus.*, V, pp. 647-648. (1883.)

78. On the nomenclature of the genus *Ophichthys*. (Joint author with D. S. Jordan.) *In Proc. U. S. Nat. Mus.*, V, pp. 648-651. (1883.)

79. Contributions to North American ichthyology, based primarily on the collections of the U. S. Nat. Mus., IV. A synopsis of the fishes of North America. (Joint author with D. S. Jordan.) *In Bull. U. S. Nat. Mus.*, XVI, 1145 p. (1883.)

80. Notes on the nomenclature of certain North American fishes. (Joint author with D. S. Jordan.) *In Proc. U. S. Nat. Mus.*, VI, pp. 110-111. (1883.)

81. Description of two new species of fishes (*Aprion ariomnus* and *Ophidium beani*) from Pensacola, Florida. (Joint author with D. S. Jordan.) *In Proc. U. S. Nat. Mus.*, VI, pp. 142-144. (1883.)

82. A review of the American Caranginae. (Joint author with D. S. Jordan.) *In Proc. U. S. Nat. Mus.*, VI, pp. 188-208. (1883.)

83. Note on the genera of *Petromyzontidae*. (Joint author with D. S. Jordan.) *In Proc. U. S. Nat. Mus.*, VI, p. 268. (1883.)

84. Description of a new Murænoïd eel

(*Sidera chlevastes*) from the Galapagos Islands. (Joint author with D. S. Jordan.) *In Proc. U. S. Nat. Mus.*, VI, pp. 208-210. (1883.)

85. Description of a new species of *Rhinobatus* (*Rhinobatus glaucostigma*) from Mazatlan, Mexico. (Joint author with D. S. Jordan.) *In Proc. U. S. Nat. Mus.*, VI, pp. 210-211. (1883.)

86. A list of fishes collected in the east fork of White River, Indiana, with descriptions of two new species. *In Proc. U. S. Nat. Mus.*, VII, pp. 199-205. (1884.)

87. Notes on the fishes of Switz City Swamp, Greene county, Indiana. *In Proc. U. S. Nat. Mus.*, VII, pp. 206-210. (1884.)

88. Descriptions of three new fishes from Kansas. *In Proc. U. S. Nat. Mus.*, VII, pp. 512-514. (1884.)

89. Notes on the fishes of Kansas. *In Bull. Washburn Col. Lab. Nat. Hist.*, I, pp. 10-16. (1884.)

90. A review of the species of the genus *Calamus*. (Joint author with D. S. Jordan.) *In Proc. U. S. Nat. Mus.*, VII, pp. 14-24. (1884.)

91. Descriptions of ten new species of fishes from Key West, Florida. (Joint author with D. S. Jordan.) *In Proc. U. S. Nat. Mus.*, VII, pp. 24-32. (1884.)

92. Note on *Caranx ruber* and *Caranx bartholomæi*. (Joint author with D. S. Jordan.) *In Proc. U. S. Nat. Mus.*, VII, pp. 32-33. (1884.)

93. Note on *Calamus proridens*, a new species of *Calamus*. (Joint author with D. S. Jordan.) *In Proc. U. S. Nat. Mus.*, VII, p. 150. (1884.)

94. Description of *Sciæna sciæra*, a new species of *Sciæna* from Mazatlan and Panama. (Joint author with D. S. Jordan.) *In Proc. U. S. Nat. Mus.*, VII, p. 480. (1884.)

95. Second series of notes on the fishes of Kansas. *In Bull. Washburn Col. Lab. Nat. Hist.*, I, pp. 97-99. (1885.)

96. The fisheries and fishery industries of the United States, prepared through the coöperation of the Commissioner of Fisheries and the Superintendent of the Tenth Census, by George Brown Goode, Assistant Director of the U. S. National Museum, and a staff of associates. Section I. Natural history of useful aquatic animals, with an atlas of 227 plates. Washington: Government Printing Office, 1884. (Feb., 1885.) Pp. 895. (Discussions of fresh-water fishes, chiefly by D. S. Jordan; of Pacific coast fishes, in collaboration with C. H. Gilbert.)

97. Third series of notes on Kansas fishes. *In Bull. Washburn Col. Lab. Nat. Hist.*, I, pp. 207-211. (1886.)

98. List of fishes collected in Arkansas, Indian Territory, and Texas, in September, 1884, with notes and descriptions. (Joint author with D. S. Jordan.) *In Proc. U. S. Nat. Mus.*, IX, pp. 1-25. (1886.)

99. Descriptions of new and little known Etheostomoids. *In Proc. U. S. Nat. Mus.*, X, pp. 47-64. (1887.)

100. Description of a new species of *Thalassophryne* (*Thalassophryne dowi*) from Punta Arenas and Panama. (Joint author with D. S. Jordan.) *In Proc. U. S. Nat. Mus.*, X, p. 388. (1887.)

101. Description of a new species of *Bathymaster* from Puget Sound and Alaska. *In Proc. U. S. Nat. Mus.*, XI, p. 554. (1888.)

102. A list of fishes from a small tributary of the Poteau river, Scott county, Arkansas. *In Proc. U. S. Nat. Mus.*, XI, pp. 609-610. (1888.)

103. The fisheries and fishery interests of the United States, by George Brown Goode and a staff of associates. Section II. A geographical review of the fishery industries and fishing communities for the year 1880. Pp. 787. Washington, 1887. (Part on fisheries of California, Oregon, and Washington, by D. S. Jordan and C. H. Gilbert.)

104. Notes on the occurrence of Gillich-

thys y-cauda at San Diego, California. *In Proc. U. S. Nat. Mus.*, XI, p. 363. (1889.)

105. Report upon certain investigations relating to the planting of oysters in Southern California. *In Bull. U. S. Fish Comm.*, IX, pp. 95-98; 3 maps, 34 plates. (1889.)

106. Report of explorations made in Alabama during 1889, with notes on the fishes of the Tennessee, Alabama, and Escambia rivers. *In Bull. U. S. Fish Comm.*, IX, pp. 143-159. (1889.)

107. Scientific results of explorations by the U. S. Fish Commission steamer Albatross. No. XII. A preliminary report on the fishes collected by the steamer Albatross on the Pacific coast of North America during the year 1889, with descriptions of twelve new genera and ninety-two new species. *In Proc. U. S. Nat. Mus.*, XIII, pp. 49-126. (1890.)

108. Description of a new species of *Etheostoma* (*E. micropterus*) from Chihuahua, Mexico. *In Proc. U. S. Nat. Mus.*, XIII, pp. 289-290. (1890.)

109. Scientific results of explorations by the U. S. Fish Commission steamer Albatross. No. XIX. A supplementary list of fishes collected at the Galapagos Islands and Panama, with descriptions of one new genus and three new species. *In Proc. U. S. Nat. Mus.*, XIII, pp. 449-455. (1890.)

110. Scientific results of explorations by the U. S. Fish Commission steamer Albatross. No. XXI. Descriptions of Apodal fishes from the tropical Pacific. *In Proc. U. S. Nat. Mus.*, XIV, pp. 347-352. (1891.)

111. Scientific results of explorations by the U. S. Fish Commission steamer Albatross. No. XXII. Descriptions of thirty-four new species of fishes collected in 1888 and 1889, principally among the Santa Barbara Islands and the Gulf of California. *In Proc. U. S. Nat. Mus.*, XIV, pp. 539-566. (1891.)

112. Report on the fishes of the Death Valley expedition collected in Southern Cal-

ifornia and Nevada in 1891, with descriptions of new species. *In North American Fauna*, No. 7, pt. II, pp. 229-234, pl. v-vi. (1893.)

113. Note on the wall-eyed pollack (*Polachius chalcogrammus fucensis*) of Puget Sound. (Joint author with D. S. Jordan.) *In Proc. U. S. Nat. Mus.*, XVI, pp. 315-316. (1893.)

114. A report upon investigations in the Columbia River Basin, with descriptions of four new species. (Joint author with Barton Warren Evermann.) *In Bull. U. S. Fish Comm.*, XIV, pp. 169-207, pl. xvi-xxv. (1894.) Also issued as part of Sen. Misc. Doc. 200, Fifty-third Congress, 2d Ses.

115. Notes on fishes from the basin of the Mackenzie River in British America. *In Bull. U. S. Fish Comm.*, XIV, pp. 23-25. (1894.)

116. Description of a new species of ribbon-fish. (*Trachypterus rex-salmonorum*) from San Francisco. (Joint author with D. S. Jordan.) *In Proc. California Acad. Sci.*, 2d ser., IV, pp. 144-146. (1894.)

117. List of fishes inhabiting Clear Lake, California. (Joint author with D. S. Jordan.) *In Bull. U. S. Fish Comm.*, XIV, pp. 139-140. (1894.)

118. The ichthyological collections of the steamer Albatross during the years 1890-1891. *In Rep. U. S. Fish Comm. for 1893*, pp. 393-476, pl. xx-xxxv.

119. Report on the fishes dredged in deep water near the Hawaiian Islands, with descriptions and figures of twenty-three new species. (Joint author with Frank Cramer.) *In Proc. U. S. Nat. Mus.*, XIX, pp. 403-435, pl. xxxv-xlviii. (1897.)

120. Descriptions of twenty-two new species of fishes collected by the steamer Albatross of the United States Fish Commission. *In Proc. U. S. Nat. Mus.*, XIX, pp. 437-457, pl. xlix-lv. (1897.)

121. The fishes of the Klamath Basin. *In*

Bull. U. S. Fish Comm., XVII, pp. 1-13. (1897.)

122. Notes on a collection of fishes from the Colorado Basin in Arizona. (Joint author with Norman Bishop Scofield.) *In Proc. U. S. Nat. Mus.*, XX, pp. 487-499; pl. xxxvi-xxxix. (1898.)

123. The fishes of Bering Sea. *In* 'Report of Fur Seal Investigations, 1896-1897,' Part III, sec. xviii, pp. 433-492, pl. xlii-lxxv. (1898.)

124. On the occurrence of *Caulolepis longidens* Gill, on the coast of California. *In Proc. U. S. Nat. Mus.*, XXI, pp. 565-566. (1899.)

125. Report on fishes obtained by the steamer Albatross in the vicinity of Santa Catalina Island and Monterey Bay. *In Rep. U. S. Fish Comm. for 1898*, pp. 25-29, pl. i-ii.

126. Results of the Branner-Agassiz expedition to Brazil. III. The fishes. *In Proc. Washington Acad. Sci.*, II, pp. 161-183, pl. ix. (1900.)

127. The fishes of Panama Bay. (Joint author with Edwin Chapin Starks.) *In Proc. California Acad. Sci.*, IV, pp. 304, pl. xxxiii. (1904.)

128. Notes on fishes of the Pacific coast of North America. *In Proc. California Acad. Sci.*, 1904.

129. Deep-sea fishes of the Hawaiian Islands. *In Bull. U. S. Fish Comm.*, 1904.

OLIVER EDMUNDS GLENN, A.B. (1902), A.M. (1903). Instructor in Mathematics, Indiana University, 1902-1903. Now Harrison Fellow, University of Pennsylvania, Philadelphia.

1. The existence theorem; a comparison of the proofs of Gauss and Cayley. *In Proc. Indiana Acad. Sci. for 1903*, p. 75.

2. Method of transvection in the actual coefficients. *In Am. Math. Mo.*, XI, p. 10. (March, 1904.)

3. Motion of a particle on the helix surface. *In Proc. Indiana Acad. Sci. for 1903*, pp. 75-79.

WILLIAM EXHARD GOLDEN, A.B. (1888), A.M. (1889). Teacher of English in the Polytechnic Preparatory School, Brooklyn, N. Y.

1. A brief history of the English drama. New York, 1890. Pp. 227.

2. Hearts, a one-act comedy. New York, 1901.

DAVID KOPP GOSS, A.B. (1887), Principal of the American College, Strassburg, Germany.

1. A review of the American species of *Hemirhamphus*. (Joint author with Seth E. Meek.) *In Proc. Acad. Nat. Sci. Philadelphia for 1884*, pp. 221-226.

2. A review of the American species of the genus *Trachynotus*. (Joint author with S. E. Meek.) *In Proc. Acad. Nat. Sci. Philadelphia for 1884*, pp. 121-129.

3. A review of the flounders and soles of America and Europe. (Joint author with David Starr Jordan.) *In Rep. U. S. Fish Comm. for 1886*. pp. 225-342; 9 plates.

EDWARD HOWARD GRIGGS, A.B. (1889), A.M. (1890). Lecturer, Montclair, N. J.

1. The new humanism. Philadelphia, 1899. Pp. 239.

2. A book of meditations. Philadelphia, 1902.

NATHAN KIRK GRIGGS, LL.B. (1867). Lincoln, Neb.

1. The lilies. A collection of sacred songs. Chicago.

2. Griggs' collection. A collection of sacred songs. Chicago.

3. Voices of the winds series: (a) Croonings of the winds—12 lullabies. (b) Sighings of the winds—12 love songs. (c) Moanings of the winds—12 sorrow songs. (d) Rumbings of the winds—12 bass songs. (e) Sportings of the winds—12 negro songs. (f) Windings of the winds—12 sundry songs. Chicago.

4. Lyrics of the lariat. Volume of poems. Chicago.

5. Hell's canyon. Illustrated poem. Chicago.

FRANK SCHMIDT GRIMSLEY, A.B. (1899).
Milwaukee.

1. Editor of 'The Arbutus' (Senior class annual, Indiana University). Bloomington, Ind., 1899. Pp. 247.

RAYMOND LAWRENCE HALL, A.B. (1904).
Kentland, Ind.

1. Editor of 'The Arbutus' (Senior class annual, Indiana University). Bloomington, Ind., 1904. Pp. 312.

CLAUDE McDONALD HAMILTON, A.B. (1898).
New York City.

1. Editor of 'The Arbutus' (Senior class annual, Indiana University). Bloomington, Ind., 1898. Pp. 255.

JAMES HENRY HAMILTON, A.M. (1894),
Ph.D. Head worker, University Settlement, New York City.

1. Syracuse water supply. *In* Municipal Affairs, IV, pp. 60-70. (March, 1900.)

2. School finance. *In* Jour. of Ped. (March, 1900.)

3. History of the leisure class. *In* Jour. of Ped. (March, 1900.)

4. Review of Patten's 'History of English.' *In* Jour. of Ped. (March, 1900.)

5. Review of Conrad's 'American colleges.' *In* Jour. of Ped. (March, 1900.)

6. The neglected principle in civic reform. *In* Am. Jour. Soc., V, pp. 746-760. (May, 1900.)

7. Reviews of different authors *in* Am. Jour. Soc. and Jour. Pol. Econ.

8. Educational aspects of savings. *In* Jour. Pol. Econ.

9. The place of the service tax in modern finance. *In* Jour. Pol. Econ., VIII, pp. 303-326.

10. Savings and savings institutions. New York, 1902. Pp. 436.

11. Savings banks vs. commercial banks. *In* Ann. Am. Acad. Pol. and Soc. Sci., XI, pp. 44-53.

ESTHER (ALLERDICE) HARDING (Mrs. William Fletcher Harding), A.B. (1892).
Died March 12, 1902, at Indianapolis, Ind.

1. Lucindy listens. Verse. *In* St. Nicholas, XXVI, p. 551. (May, 1899.)

CAROLINE HIRST (BROWN) HARDING (Mrs. Samuel Bannister Harding), A.B. (1890).
Bloomington, Ind.

1. Greek gods, heroes, and men: a primer of the mythology and history of the Greeks. (Joint author with Samuel B. Harding.) Chicago, 1897. Pp. vi, 195. Illustrated.

2. The city of the seven hills: a book of stories from the history of ancient Rome. (Joint author with Samuel B. Harding.) Chicago, 1898. Pp. 274. (Revised edition, 1902, pp. 268.) Illustrated.

SAMUEL BANNISTER HARDING, A.B. (1890),
Ph.D. See Faculty list.

WILLIAM FLETCHER HARDING, A.B. (1893),
Ph.M. Washington, D. C.

1. State bank of Indiana. *In Jour. Pol. Econ.*, IV, pp. 1-36. (Dec., 1895.)

CHARLES HARRIS, A.B. (1879), Ph.D. Professor of German, Adelbert College, Cleveland, Ohio.

1. German composition. Boston, 1890. Pp. vi, 143.

2. German lessons. Boston, 1892. Pp. vi, 192.

3. German reader. New York, 1895. Pp. viii, 356.

4. Wichert's 'An der Majorsecke.' New York, 1895. Pp. 41.

5. Goethe's poems, selected and edited, Boston, 1899. Pp. xvii, 286.

6. Lessing's 'Hamburgische Dramaturgie,' abridged and edited. New York, 1901. Pp. xl, 356.

7. Review of Gerhart Hauptmann's tragi-comedy, 'Der rote Hahn.' *In Nation*, LXXIII, p. 490. (Dec. 26, 1901.)

8. Review of Ompteda's novels. *In Nation*, LXXIV, p. 128. (Feb. 13, 1902.)

9. Review of Hermann Sudermann's 'Es lebe das Leben.' *In Nation*, LXXIV, p. 169. (Feb. 27, 1902.)

10. Baedeker and the modern guide-book. *In Bookman*, XVII, p. 495. (July, 1903.)

11. Gerhart Hauptmann. *In Mod. Lang. Notes*, XIX, p. 33. (Feb., 1904.)

THOMAS LEGRAND HARRIS, A.B. (1892),
A.M. (1895). Sheridan, Ind.

1. The evolution of the college curricu-

lum in the United States. Indianapolis, 1892. (Magazine article.)

2. The Trent affair and relations with England at the beginning of the Civil War. Indianapolis, 1896. Pp. 288.

NOBLE HARTER, A.B. (1895), A.M. (1896).
Superintendent of Schools, Warsaw, Indiana.

1. Studies in the physiology and psychology of the telegraphic language. (Joint author with William Lowe Bryan.) *In Psych. Rev.*, IV, pp. 27-54. 8 plates.

2. Studies on the telegraphic language—the acquisition of a hierarchy of habits. (Joint author with W. L. Bryan.) *In Psych. Rev.*, VI, pp. 345-375; 2 plates.

SAMUEL ERNEST HARWOOD, A.B. (1876),
A.M. (1892). Professor of Mathematics in Southern Illinois Normal School, Carbondale, Ill.

1. Harwood's writing speller. Carbondale, Ill., 1879.

2. Heredity and the school. *In Pub. Sch. Jour.*, XIII, p. 260. (Jan., 1894.)

3. Typical plans for teaching number ideas: the idea six. *In Pub. Sch. Jour.*, XIV, p. 151. (Nov., 1894.)

4. Plan for teaching number symbols. *In Pub. Sch. Jour.*, XIV, p. 206. (Dec., 1894.)

5. Conscious analysis of the learning process. *In Pub. Sch. Jour.*, XIV, p. 340. (Feb., 1895.)

6. Some vital questions in education. *In School News*, 1895-1896. The introduction (Oct., 1895). The center of the school course (Nov., 1895). Adjustment of mental and manual exercises (Dec., 1895). The one or the many (Jan., 1896). Sex in education (Feb., 1896). Interest and duty

(March, 1896). The child and the race (April, 1896). Religion and the school (June, 1896). The school and the home (July, 1896). Shall the school prepare one for his calling or for living? (Sept., 1896.)

7. Happiness and the school. *In Inland Educator*, II, p. 256. (June, 1896.)

8. Homesick in heaven. *In Inland Educator*, III, p. 69. (Sept., 1896.)

9. Closer organization of the [Illinois] school system. *In School News*, 1896. A state board of education (Nov.). County and township institutes (Dec.). The township system (Jan.). Examinations and certificates (Feb.).

10. Notes on method in arithmetic. *Terre Haute*, 1897. Pp. 68.

11. Method in reading. *In School News*, XI, 1898-1899. The outline presented (Sept., 1898). The language group (Oct., 1898). Purposes in reading (Nov., 1898). Uses of definitions (Dec., 1898). Questionable devices (Jan., 1899). Steps in the process (Feb., 1899). A second-grade lesson (March, 1899). Classifying reading exercises (April, 1899). To be kept in mind (June, 1899).

12. Some relations of form and number. *In School News*. (Jan., 1900.)

13. The attitude of the school toward reforms in the English language. *In Intelligence*. (Jan., 1903.)

PAUL LELAND HAWORTH, A.B. (1899),
A.M. (1901). Instructor in History,
Teachers' College, Columbia University,
New York City.

1. The professor's scar (story). *In Outing*, XXXVI, pp. 161-165. (May, 1900.)

2. Negro disfranchisement in Louisiana. *In Outlook*, LXXI, pp. 163-166. (May 17, 1902.)

3. The skee tournament at Ishpeming

(story). *In Youth's Companion*, LXXVII, pp.1-2. (New Year's number for 1903.)

4. Bread upon the waters (story). Accepted by *Youth's Companion*.

5. The dog sledge mail (story). Accepted by *Youth's Companion*.

6. Articles on topics in biography and American history, about 150,000 words. *In New International Encyclopaedia*.

7. Tholocco Sam's canoe fight (story). Accepted by the Success Co. for a new magazine, the name of which has not yet been announced.

8. Frederick the Great and the revolted thirteen colonies. *In Am. Hist. Rev.*, April, 1904.

9. Historical note continuing an article on a proposed change in the method of electing the President, written in 1884 by Senator J. B. Doolittle. To appear in the *Pol. Sci. Quart.*

THOMAS J. HEADLEE, A.B. 1902. Teacher,
Rensselaer, Ind.

1. Discussion of botany requirements as outlined by the college entrance examination board of the Middle States and Maryland. *In Proc. Central Asso. Math. and Sci. Teachers*, for Nov., 1903.

2. Ecology of the mussels of Winona Lake. *In Proc. Indiana Acad. Sci.* for 1904. 2 plates.

NORVAL CHASE HEIRONIMUS, A.B. (1895).
Principal Central Grammar School,
Richmond, Indiana.

1. Type studies in American history for grammar grades. *Missouri Compromise*, Richmond, Ind., 1898. Pp. 39. Stamp act, Richmond, Ind., 1899. Pp. 38. Louisiana purchase, Richmond, Ind., 1900. Pp. 36. Colonial life, Richmond, Ind., 1901. Pp. 60.

ROBERT HESSLER, A.B. (1890), A.M. (1893), M.D. Logansport, Ind.

1. Railroad migrants among Indiana plants. *In* *Indiana Farmer*, XXIII, No. 34, p. 1. (August, 1888.)

2. Notes on a rare form of brain tumor, Psammoma. *In* *Indiana Med. Jour.* for April, 1892.

3. The preparation of microscopical sections. *In* *Indiana Med. Jour.* for Jan., 1893.

4. An extreme case of parasitism. *In* *Am. Nat.*, XXVII, pp. 346-352. (April, 1893.)

5. The adventitious plants of Fayette county, Ind. *In* *Proc. Indiana Acad. Sci.* for 1893, p. 258.

6. A case of Norway itch. (The first reported American case.) *In* *Medical News*, Philadelphia, LXII, p. 517.

7. The flora of lake Cicott and lake Maxinkuckee, Ind. *In* *Proc. Indiana Acad. Sci.* for 1896, pp. 116-129.

8. Thyroid medication. *In* *Indiana Med. Jour.*, XIV, pp. 431-435. (June, 1896.)

9. Epilepsy and erysipelas. (The use of Erysipelas antitoxin.) *In* *Jour. Am. Med. Assn.*, XXX, p. 1157. (May, 1898.)

10. Lymphadenoma or Hodgkin's disease. *In* *Indiana Med. Jour.* for July, 1898.

11. Blastomycetic dermatitis. (The fifth known case.) *In* *Indiana Med. Jour.*, XVII, p. 48. (August, 1898.)

12. Mosquitos and malaria. *In* *Proc. Indiana Acad. Sci.* for 1900, pp. 74-81.

13. Featherbeds and colds. *In* *Indiana Med. Jour.* for August, 1901.

14. Redreaming dreams. *In* *Psych. Rev.*, VIII, pp. 606-609. (Nov., 1901.)

15. The mineral waters of Indiana. *In* *Trans. Indiana State Med. Soc.* for 1902, p. 365.

16. The medicinal properties of Indiana

mineral waters. *In* 26th Ann. Rep. Indiana State Geologist, p. 159-224.

17. Cold and 'colds.' *In* *Proc. Indiana Acad. Sci.* for 1903.

18. Myxedema. Notes on two cases. *In* *Indiana Med. Jour.* for June, 1904.

19. Dust—A neglected factor in the production of ill health. *In* *Trans. Indiana State Med. Assn.* for 1904.

MARTIN LUTHER HOFFMAN, A.B. (1885), Auburn, Ind.

1. A review of the American species of the genus *teuthis*. (Joint author with Seth E. Meek.) *In* *Proc. U. S. Nat. Mus.* for 1884, pp. 227-231.

CYRUS LAURON HOOPER, Ph.B. (1887), A.M. (1888). Instructor in English in the North-West Division High School, Chicago.

1. A Cloverdale skeleton. New York, 1889. Pp. 170.

2. XXth century Shakespeare. Julius Cæsar. Edited with an introduction and notes. Chicago, 1901. Pp. 153.

3. XXth century Shakespeare. Macbeth. Edited with an introduction and notes. Chicago, 1902. Pp. 155.

4. XXth century Shakespeare. Hamlet. Edited with an introduction and notes. Chicago, 1902. Pp. 208.

5. Gee-boy. Chicago, 1903. Pp. 271.

6. XXth century Shakespeare. As You Like It. Edited with an introduction and notes. Chicago, 1904. (In press.)

7. Lamb's literary motive. Introduction to The Village Press's edition de luxe of 'A dissertation upon roast pig.' Chicago, 1904. (In press.)

8. Introduction to The Village Press's edition de luxe of William Morris's 'Hollow land.' Chicago, 1904. (In press.)

ADELIA ROBERTS HORNBOOK, A.B. (1893), A.M. (1894). Principal of the University Academy, Chicago.

1. The pedagogical value of number forms. *In Educ. Rev.*, III, pp. 467-480. (May, 1893.)

2. Laboratory methods of teaching mathematics in secondary schools. New York, 1895. Pp. 16.

3. Concrete geometry for beginners. New York, 1896. Pp. 201.

4. An experiment in Latin teaching. *In Education*. (Dec., 1896.)

5. Geometry under the laboratory method. *In Indiana Sch. Jour.*, XLII, pp. 141-147. (March, 1897.)

6. The laboratory method again. *In Indiana Sch. Jour.*, XLII, pp. 512-516. (August, 1897.)

7. Hornbrook's primary arithmetic. New York, 1898. Pp. 252.

8. Hornbrook's grammar school arithmetic. New York, 1900. Pp. 416.

9. Key to Hornbrook's arithmetics. New York, 1901. Pp. 116.

JENNIE E HORNING. *See* Mrs. Francis Marion Walters.

WALTER RALEIGH HOUGHTON, A.B. (1871), A.M. (1873). Principal of the Preparatory Department, Indiana University, 1873-1884. Now Principal of High School, Connersville, Ind.

1. A history of American politics. Indianapolis, 1883. Pp. x, 550.

2. Rules of etiquette and home culture. Chicago, 1884.

3. The lives of Blaine and Logan. Chicago, 1884.

4. New reversible political map and United States map combined. (A conspectus of the history of political parties and the Federal government.) Chicago, 1888.

JOSEPH HENRY HOWARD, A.B. (1888), A.M. (1890), Ph.D. Assistant Professor of Latin, 1894-1901. Now Professor of Latin, University of South Dakota, Vermillion, S. D.

1. Case usage in Petronius' satires. Leland Stanford Jr. University, 1902. Pp. 95.

2. The quantitative reading of Latin verse. Chicago, 1898. Pp. 30.

GEORGE MAXWELL HOWE, A.B. (1894), Ph. D. Instructor in German, 1893-1895. Now Instructor in German, Cornell University, Ithaca, N. Y.

1. The artificial palate. One way of making it and of keeping its records. *In Jour. Eng. and Ger. Philo.*, V, pp. 77-82. (Sept., 1903.)

2. German prose composition based on Storm's 'Immensee.' New York, 1904. Pp. vi, 64.

ELIZABETH GREEN HUGHES, A.B. (1875), M.S. (1886). Teacher, Stanford University, Cal.

1. A review of the genera and species of Julidinae found in American waters. (Joint author with D. S. Jordan.) *In Proc. U. S. Nat. Mus.* for 1886, pp. 56-70.

2. A review of the American species of the genus *Prionotus*. (Joint author with D. S. Jordan.) *In Proc. U. S. Nat. Mus.* for 1886, pp. 327-338.

3. A review of the genera *Archosargus*, *Lagodon*, and *Diplodus* with definitions of related genera. (Joint author with C. H. Eigenmann.) *In Proc. U. S. Nat. Mus.* for 1886.

- OLIVER PEEBLES JENKINS, M.S. (1886), Ph.D. (1889). Professor of Physiology, Leland Stanford Junior University, Stanford University, Cal.
1. Natural science in the elementary schools. *In* Educational Weekly, Indianapolis, IV, Nos. 16, 17. (1885.)
 2. Notes on the fishes of Beaufort Harbor, North Carolina. *In* Johns Hopkins Circulars, V, p. 11. (1885.)
 3. List of fishes collected in Vigo county, Indiana, in 1885 and 1888. *In* Hoosier Naturalist, II, pp. 93-96. (1887.)
 4. Notes on Indiana fishes. (Joint author with Barton Warren Evermann.) *In* Proc. U. S. Nat. Mus. for 1888, pp. 43-57. (1888.)
 5. Ornithology from a railroad train. (Joint author with B. W. Evermann.) *In* Ornithologist and Oölogist, XIII, pp. 65-70. (1888.)
 6. Physiology in the college curriculum. *In* Addresses and Proc. Indiana College Asso., 14th Ann. Sess., pp. 39-46. (1890.)
 7. Description of eighteen new species of fishes from the Gulf of California. (Joint author with B. W. Evermann.) *In* Proc. U. S. Nat. Mus. for 1888, pp. 137-158. (1889.)
 8. Report on a collection of fishes made at Guaymas, Sonora, Mexico, with descriptions of new species. (Joint author with B. W. Evermann.) *In* Proc. U. S. Nat. Mus. for 1891, pp. 121-165, 17 plates. (1891.)
 9. The Hopkins Seaside Laboratory. *In* Zoe, IV, No. 1; 26 plates. (1893.)
 10. Primary lessons in human physiology. Indianapolis, 1896. Pp. 211. 2d ed., rev.
 11. Advanced lessons in human physiology. Indianapolis, 1896. Pp. 318. 2d ed., rev.
 12. Suggestions in nature study in the primary grades. Stanford University, Cal., 1896. Pp. 29.
 13. Nature study. *In* School Report of Oakland, Cal., for 1896-97, pp. 1-44.
 14. The passing of Plato. Address at the sixth annual commencement, Leland Stanford Junior University, May 26th. Stanford University, Cal., 1897. Pp. 23.
 15. Nature study. *In* School Report of Oakland, Cal., for 1897-98, pp. 15-34. (Supplement to article in Report of 1896-97.)
 16. Plan of report of subcommittee on nature study. *In* Overland Monthly, XXXI, No. 183; Educational Department, II, No. 9. (1898.)
 17. Lessons in nature study. (Joint author with Vernon Lyman Kellogg.) *In* West. Jour. of Educ. A series of articles running through the years 1899-1900.
 18. Lessons in nature study. (Joint author with V. L. Kellogg.) San Francisco, 1900. Pp. 196.
 19. Description of new species of fishes from the Hawaiian Islands belonging to the families of Labridæ and Scaridæ. *In* Bull. U. S. Fish Comm. for 1899, pp. 45-65, 22 plates. (August 30, 1900.)
 20. Description of fifteen new species of fishes from the Hawaiian Islands. *In* Bull. of the U. S. Fish Comm. for 1899, pp. 187-404, 16 plates. (June 3, 1901.)
 21. The rate of the nervous impulse in certain mollusca. (Joint author with Anton Julius Carlson.) *In* Am. Jour. Physiology, VIII, pp. 251-268. (1903.)
 22. Report on collections of fishes made in the Hawaiian Islands, with descriptions of new species. *In* Bull. U. S. Fish Comm., for 1902, p. 417, 54 plates. (Sept. 23, 1903.)
 23. The rate of the nervous impulse in the ventral cord of certain worms. (Joint author with A. J. Carlson.) *In* Jour. Comp. Neurology, XIII, No. 4. (Dec., 1903.)

24. Physiological evidence of the fluidity of the conducting substance in the pedal nerves of the slug, *Ariolimax columbianus*. (Joint author with A. J. Carlson.) *In Jour. of Comp. Neurology and Psychology*. (1904.)

25. Description of a new species of *Ranzania* from the Hawaiian Islands. *In Proc. California Acad. Sci.*, 2d ser., V, pp. 779-784, 1 plate.

26. Notes on the fauna of Beaufort, North Carolina. The fishes. *In Studies from the Biological Laboratory, Johns Hopkins Univ.*, IV, p. 83.

FRED BATES JOHNSON, A.B. (1902), Superintendent of Schools, Carlisle, Ind.

1. Editor of 'The Arbutus' (Senior class annual, Indiana University). Bloomington, Ind., 1902. Pp. 283.

MANSON ULVAIN JOHNSON, A.B. (1890), A.M. (1892). Anderson, Ind.

1. The cotton-seed oil trust. *In Lit. Rev.*, July, 1899.

2. The tariff as viewed from a taxation standpoint. Indianapolis, 1891. Pp. 525.

NEWTON CARR JOHNSON, A.B. (1897), A.M. (1898). Dean of Normal Department, Oakland City College. Oakland City, Ind.

1. Habits of work and methods of study of high school pupils in some cities in Indiana. *In School Review*, V, pp. 257-277, 11 plates. (May, 1899.)

FRANK LEONARD JONES, A.B. (1898). Ex-State Superintendent Public Instruction, Indianapolis. South Bend, Ind.

1. 20th biennial report of the Indiana

State Superintendent of Public Instruction. Indianapolis, 1900. Pp. 800.

2. The rural schools. Indianapolis, 1900. Pp. 125.

3. 21st biennial report of the Indiana State Superintendent of Public Instruction. Indianapolis, 1902. Pp. 870.

JESSIE (KNIGHT) JORDAN (Mrs. David Starr Jordan), A.B. (1890). Stanford University, Cal.

1. Red letter days: The Canyon of the Colorado. *In Land of Sunshine*, IX, p. 123. (1898.)

CHANCEY JUDAY, A.B. (1896), A.M. (1897). Acting Professor of Biology, University of Colorado, Boulder, Colo.

1. Hydrographic map of Turkey Lake, Indiana. *In Proc. Indiana Acad. Sci.* for 1895.

2. The plankton of Turkey Lake. *In Proc. Indiana Acad. Sci.* for 1896, pp. 287-296; 1 map.

3. The plankton of Winona Lake. *In Proc. Indiana Acad. Sci.* for 1902, pp. 120-133; 2 plates.

4. The diurnal movement of plankton crustacea. *In Trans. Wisconsin Acad. Sci., Arts, and Letters.* (In press.)

5. The plankton of Lake Maxinkuckee in 1899. *In Bull. U. S. Fish Comm.* (In press.)

WILLIAM HENRY KELLY, A.B. (1894), Winamac, Ind.

1. Editor of 'The Arbutus' (Senior class annual, Indiana University). Bloomington, Ind., 1894. Pp. 120.

OSCAR LYNN KELSO, B.S. (1884), A.M. (1890). Professor of Mathematics, Indiana State Normal School, Terre Haute, Ind.

1. Arithmetic for high schools, academies and normal schools. New York, 1903, Pp. x, 274.

2. Revision of Cook-Cropsey series of arithmetics. (Joint author with Robert J. Aley.) New York, 1904. Elementary book, pp. xi, 276. Advanced book, pp. xiii, 327.

3. Some contributions to geometry. *In* Add. and Proc. Indiana College Asso. for 1900, pp. 29-36.

4. The relations of mathematics to the sciences in the High School. *In* Proc. State Sci. Teachers' Asso. for 1900, pp. 62-69.

5. Some errors in teaching arithmetic. *In* New York Teachers' Monographs. (To be published.)

CLARENCE HAMILTON KENNEDY, A.B. (1902), A.M. (1903). Scientific Assistant U. S. Bureau of Fisheries, Washington, D. C.

1. Unilateral coloration with a bilateral effect. (Joint author with C. H. Eigenmann.) *In* Science, XIII, pp. 828-830. (May, 1901.)

2. The Leptocephalus of the American eel and other American Leptocephali. (Joint author with C. H. Eigenmann.) *In* Bull. U. S. Fish Comm. for 1901, pp. 81-92.

3. Variation notes. (Joint author with C. H. Eigenmann.) *In* Biol. Bull., IV, pp. 227-230. (April, 1903.)

4. A list of the dragonflies of Winona Lake. *In* Proc. Indiana Acad. Sci. for 1903, pp. 159-164. (1903.)

5. A new diagnostic character for the species of the genus *Argia*. *In* Proc. Indiana Acad. Sci. for 1902, pp. 164-169, 2 plates. (1903.)

6. On a collection of fishes from Paraguay, with a synopsis of the American genera of Cichlids. (Joint author with C. H. Eigenmann.) *In* Proc. Acad. Sci. Philadelphia for 1903, pp. 497-537. (Sept., 1903.)

WALTER McCULLOUGH KERN, A.B. (1896). Superintendent of Schools, Columbus, Neb.

1. Editor of 'The Nebraska Teacher,' published at Lincoln, Neb.

EDWARD MARTIN KINDLE, A.B. (1893), Ph.D. Assistant Geologist, U. S. Geol. Survey. New Haven, Conn.

1. Geologic literature of Indiana, stratigraphic and economic. (Joint author with V. F. Marsters.) *In* Proc. Indiana Acad. Sci. for 1893, pp. 156-191.

2. The South American cat-fishes belonging to Cornell University. *In* Ann. N. Y. Acad. Sci., VI, pp. 249-256. (1893.)

3. A note on rock flexure. *In* Proc. Indiana Acad. Sci. for 1894, pp. 49-50.

4. Dip of the Keokuk rocks at Bloomington, Indiana. *In* Proc. Indiana Acad. Sci. for 1894, pp. 52-53.

5. Preliminary list of the birds of Brown county, Indiana. *In* Proc. Indiana Acad. Sci. for 1894, pp. 68-73.

6. The whetstone and grindstone rocks of Indiana. *In* 20th Ann. Rept. Indiana Dept. of Geol. and Nat. Res. for 1896, pp. 329-368, with geologic map.

7. The relation of the fauna of the Ithaca group to the faunas of the Portage and Chemung. *In* Bull. Am. Pal., II, No. 6, pp. 1-54; 1 plate. (1896.)

8. On some Paleozoic fossils from Baffinland. *In* Am. Jour. Sci., LII, pp. 455-456. (1896.)

9. Pleistocene fossils from Baffinland

and Greenland. *In Science*, N. S., V, pp. 91-93. (1897.)

10. A catalogue of the fossils of Indiana, accompanied by a bibliography of the literature relating to them. *In* 22d Ann. Rept. Indiana Dept. of Geol. and Nat. Res. for 1898, pp. 407-514.

11. The Devonian and Lower Carboniferous faunas of southern Indiana and central Kentucky. *In* Bull. Am. Pal., No. 12, pp. 1-112. (1889.)

12. The Devonian fossils and stratigraphy of Indiana. *In* 25th Ann. Rept. Geol. Nat. Res. of Indiana for 1900, pp. 530-758; 31 plates.

13. Geological maps of southern Indiana limestones (Salem sheet and Corydon sheet). (Joint author with G. H. Ashley.) *In* 27th Rep. Indiana Geol. Surv. for 1901 and 1902.

14. The Niagara rocks of Hamilton county, Indiana. *In* Am. Jour. Sci., XIV, pp. 221-224. (July, 1902.)

15. The Niagara domes of northern Indiana. *In* Am. Jour. Sci., XV, 459-468; 4 plates. (June, 1903.)

16. The Niagara stratigraphy and paleontology of northern Indiana. *In* 28th Ann. Rep. Indiana Geol. Surv., 30 plates. (Not yet issued.)

17. The fossil faunas of the Devonian and Lower Carboniferous of Virginia, West Virginia and Kentucky. (Joint author with H. S. Williams.) *In* Bull. U. S. Geol. Surv. 1904. (Not yet published.)

18. The folio of the Watkins Glen quadrangle. (Joint author with H. S. Williams.) *In* U. S. Geol. Survey. (Not yet published.)

CYRUS AMBROSE KING, A.B. (1893), Ph.D. Instructor in Botany, 1900-1902. Now teacher of Botany in the DeWitt Clinton High School, New York City.

1. Explosive discharge of antherozooids

in Conocephalum. *In* Torreyia for April, 1903, pp. 60-61.

2. Observations on the cytology of Aroiospora pulchra, Thaxter. *In* Trans. Boston Soc. Nat. Hist. for Nov., 1903, pp. 211-245; 5 plates.

PHILIP HENRY KIRSCH, A.B. (1888), A.M. (1889), Ph.D. (1893). Died Sept. 8, 1900, at El Paso, Texas.

1. Notes on a collection of fishes from the Rio Gila at Fort Thomas, Ariz., obtained by Lieut. W. L. Carpenter, U. S. A. *In* Proc. U. S. Nat. Mus. for 1888.

2. A review of the American species of thread-fins (Polynemidæ). *In* Ann. New York Acad. Nat. Hist. for 1890.

3. A review of the sturgeons (Acipenseridæ) of North America. (Joint author with Morton W. Fordice.) *In* Proc. Acad. Nat. Sci. Philadelphia for 1889, pp. 245-257.

OTTO PAUL KLOPSCH, A.B. (1896). Superintendent of schools, Mascoutah, Ill.

1. Editor of 'The Arbutus' (Senior class annual, Indiana University). Bloomington, Ind., 1896. Pp. 239.

CHARLES TOBIAS KNIPP, A.B. (1894), A.M. (1896), Ph.D. Instructor in Physics, 1893-1900; Assistant Professor, 1900-1903, Indiana University. Now Assistant Professor of Physics, University of Illinois, Urbana, Ill.

1. A new form of make and break. *In* Am. Jour. Sci., V, pp. 283-284. (1898.)

2. Surface tension of water above 100° C. *In* Phys. Rev., XI, pp. 129-154. (Sept., 1900.)

3. The use of the bicycle wheel in illustrating the principles of the gyroscope. *In* Phys. Rev., XII, pp. 43-46. (Jan., 1901.)

4. An automatic temperature regulator. *In Phys. Rev.*, XII, pp. 47-49. (Jan., 1901.)

5. On the density and surface tension of liquid air. *In Phys. Rev.*, XIV, pp. 75-82. (Feb., 1902.)

6. A method for maintaining intermediate temperatures. *In Phys. Rev.*, XV, pp. 125-126. (August, 1902.)

HENRY HIGGINS LANE, A.M. (1903). Assistant in Zoölogy, University of Chicago, Chicago.

1. The green heron (*Ardea virescens*). *In Birds and Nature*, May, 1902. 1 full-page plate in color.

2. The solitary sandpiper (*Totanus solitarius*). *In Birds and Nature*, Oct., 1902.

3. The ovarian structures of the viviparous blind fishes, *Lucifuga* and *Stygicola*. *In Biol. Bull.*, VI, pp. 38-54; 2 plates. (Dec., 1903.)

ALEXANDER DOWNING LEMON, B.S. (1858), LL.B. (1859). San Francisco, Cal.

1. The union of the States must be maintained. Bedford, Indiana, 1861. Pp. 10.

2. Reconstruction of the States. Bedford, Indiana, 1868. Pp. 12.

3. An address in support of the election of Samuel J. Tilden for President of the United States. San Francisco, Cal., 1876. Pp. 12.

4. Fourth of July Centennial address. San Diego, Cal., 1876. Pp. 10.

5. Prison reforms, and libraries for penal institutions. Phoenix, Ariz., 1883. Pp. 8.

6. An address on the silver question and bi-metallism. San Francisco, Cal., 1895. Pp. 15.

WILLIAM HARRISON LEMON, A.B. (1854), Ph.D. Lawrence, Kansas.

1. Evidence of pre-glacial man, in Greene county, Indiana. Papers to Smithsonian Inst. (1856.)

2. The valley of the Ghor, and the Noachian deluge. 1859. Pp. 200.

3. Olam Haba, or the world arrested at the theism of the Jews. 1882. Pp. 240.

4. Gisdubar, the pre-Adamite man. 1886. Pp. 180.

5. Bichloride of gold, or the skeleton in the closet. 1890. Pp. 200.

6. Ithuriel, or the legend of Eros; a romance of eschatology. 1903. Pp. 450.

JESSE LEWIS, A.B. (1901). Professor of History and Civics, State Normal School, Mayville, N. D.

1. A topical analysis of American history and government. Chicago, 1902. Pp. 185.

2. The educational value of history. *In Quar. Bull. State Normal School*, Mayville, N. D.

ERNEST HIRAM LINDLEY, A.B. (1893), A.M. (1894), Ph.D. See Faculty list.

CLARENCE GUY LITTELL, A.B. (1903).

1. The birds of Winona Lake (summer). *In Proc. Indiana Acad. Sci.* for 1902; reprinted *in Indiana Univ. Bull.*, I, No. 4, pp. 41-72; 27 figures (Nov., 1903).

ISAAC ANDERSON LOEB, A.B. (1890), I.L.B. Chicago, Ill.

1. The Jewess of the Apocrypha. Chicago, 1901.

2. Editor of 'The Independent Order Free Sons of Israel.' I (1903), II (1904). Chicago.

ROBERT EDWARD LYONS, A.B. (1889), A.M. (1890), Ph.D. See Faculty list.

JEFFERSON MCANNELLY, LL.B. (1872). Ft. Collins, Colo.

1. A guide to administrators, executors, and guardians. Fort Collins, Colo., 1886. Pp. 60.

AMANDA MCCOMB, A.M. (1900). Teacher High School, South Bend, Ind.

1. The development of the karyokinetic spindle in vegetative cells of higher plants. *In Bull. Tor. Bot. Club*, XXVII, pp. 451-459, 2 plates. (August, 1900.)

WILLIAM HARRISON MACE, A.M. (1889), Ph.D. Professor of History, Syracuse University, Syracuse, N. Y.

1. A series of articles in *Indiana Sch. Jour.*, Indianapolis, 1888-1890.

2. A series on method in history. *In Inter-State Sch. Rev.*, Danville, Ill., 1891-1892.

3. The organization of historical material. *In Papers Am. Hist. Asso.*, V, pp. 143-161; abstract in *Ann. Rep. Am. Hist. Asso.* for 1890, pp. 103-107. (1891.)

4. Review of G. P. Fisher's 'The colonial era.' *In Sch. Rev.* for 1893.

5. A series of five syllabi on American history. Albany, N. Y. 1892-1897.

6. A working manual of American history. Syracuse, 1895.

7. Method in history for teachers and students. Boston, 1897. Pp. xvii, 306.

8. Des ältern Pitt, Beziehungen zur amerikanischen Revolution. Jena, 1897.

9. The central defect of the normal school. *In Educ. Rev.*, XXI, pp. 132-139. (Feb., 1901.)

10. The method of the last course in history in the high school. *In Jour. Ped.* for 1901.

11. Political history in the elementary school. *In Elementary School Teacher* for 1904.

12. Graduate work and a school of education. *In Michigan Alumnus* for 1904.

13. Review of Frank McMurry's 'Special method in history.' *In Educ. Rev.*, XXVII, pp. 203-205. (Feb., 1904.)

DUDLEY ODELL MCGOVNEY, A.B. (1901). Cambridge, Mass.

1. Civil government in the Philippines. Chicago, 1904. Pp. xi, 209.

2. The navigation acts as applied to European trade. *In Am. Hist. Rev.*, IX, pp. 725-734. (July, 1904.)

CHARLES LESLIE MCKAY, B.S. (1881). Drowned April 19, 1883, near Cape Constantine, Alaska.

1. A review of the genera and species of the family Centrarchidæ, with a description of one new species. *In Proc. U. S. Nat. Mus.* for 1881, pp. 87-93.

ADAM MCMAHAN, A.B. (1889), A.M. (1892), M.D. Lafayette, Ind.

1. Membranous ententis. *In Trans. Indiana State Med. Soc.* for 1899, pp. 77-87.

2. Treatment of infantile convulsions. *In New York Med. Jour.*, LXXXVI, p. 461. (March, 1903.)

JEROME FEE McNEIL, B.S. (1886). Teacher, Richmond, Ind.

1. Description of twelve new species of Myriapoda, chiefly from Indiana. *In Proc. U. S. Nat. Mus.* for 1886.

2. Revision of the Truxalinae of North America. *In Proc. Davenport Acad. Sci.*, VI, pp. 179-274; 6 plates. (1897.)

3. Hopkins-Stanford Galapagos expedition, IV, Orthoptera. *In Proc. Washington Acad. Sci.*, III, pp. 487-506. (Nov., 1901.)

GEORGE WASHINGTON MARTIN, Ph.D. (1892). Professor of Biology, Vanderbilt University, Nashville, Tenn.

1. The organology of Aster and Solidago. *In Bot. Gaz.*, XVII, p. 5; 1 plate.

2. The embryology of Aster and Solidago. *In Bot. Gaz.*, XVII, p. 6; 1 plate.

3. The Floridæ. Indianapolis, 1894. Pp. 3.

4. Indiana Academy of Science. *In Indiana Sch. Jour.* for Dec., 1895, pp. 66-67.

5. Biology in secondary schools. Rochester, 1900. Pp. iii, 8.

6. The secondary school and preparation for citizenship. Nashville, 1901. Pp. 10.

WILLIAM ALEXANDER PARSONS MARTIN, A.B. (1846), A.M. (1849), D.D., LL.D. President University of Wuchong, Wuchong, China.

1. Account of an overland journey from Peking to Shanghai made in February and March, 1866. *In Jour. Roy. Asiat. Soc. North China branch*, N. S. III, p. 26. (1866.)

2. On the style of Chinese epistolary composition. *In Jour. Roy. Asiat. Soc. North China branch*, N. S. XI, p. 113. (1877.)

3. Report on the system of public instruction in China. (U. S. Education Bureau, Circulars of Information, No. 1.) Washington, 1877. Pp. 28.

4. Three systems of the religions of China. *In New Englander*, XXVIII, p. 223. (1877.)

5. Editor of 'The Peking Scientific Magazine' (Chinese). 1875-78.

6. The Chinese: their education, philosophy and letters. New York, 1881. Pp. viii, 319.

7. Mathematical physics (Chinese). 1885.

8. Tonquin; or the French in Annam. *In New Englander*, XLV, p. 665. (1886.)

9. The advisability or the reverse of endeavoring to convey western knowledge to the Chinese through the medium of their own language. (Joint author with others.) *In Jour. Roy. Asiat. Soc. North China branch*, N. S. XXI, p. 1. (1887.)

10. The Lusiad: the epic of the opening of the east. *In New Englander*, LIII, p. 542. (1890.)

11. Does China menace the world? *In Forum*, X, pp. 433-441. (Dec., 1890.)

12. As the Chinese see us. *In Forum*, X, pp. 678-688. (Feb., 1891.)

13. America's duty to China. *In John H. Barrow's 'The World's Parliament of Religions'* (Chicago, 1893), II, pp. 1137-1144.

14. The Chinese (Hanleii papers). 1st ser., Shanghai, 1880; 2d ser., Shanghai and London, 1894.

15. Editor of 'Science Monthly' (Chinese), 1897-98.

16. A cycle of Cathay; or China south and north, with personal reminiscences. New York, 1896. Pp. 464.

17. The fall of Peking. *In Independent*, LII, pp. 2419-2421. (Oct. 11, 1900.)

18. The siege of Peking. *In Nat. Geog. Mag.*, XII, p. 53. (Feb., 1901.)

19. The poetry of the Chinese. *In No.*

Am. Rev., CLXXII, pp. 853-862. (June, 1901.)

20. Li Hung Chang. *In* Independent, LIII, pp. 2686-2688. (Nov. 14, 1901.)

21. The lore of Cathay; or, the intellect of China. New York, 1901. Pp. iv, 480.

22. History of the classic ages of China.

23. Les vestiges d'un droit international dans l'ancienne Chine. *In* Revue de Droit Internationale.

24. Natural theology and evidences of Christianity (Chinese). Reprinted in numerous editions in China and Japan.

25. Natural Philosophy (Chinese). 7 vols. "This work contained the first formal treatise on chemistry and the first regular course of physics ever published in the Chinese language."

26. Translations into Chinese of Wheaton's 'International law,' De Marten's 'Guide diplomatique,' Woolsey's 'International law,' and Bluntschli's 'Le droit international codifié.'

JAMES RARIDEN MEEK, A.B. (1897). Principal of High School, Durango, Colo.

1. Editor of 'The Arbutus' (Senior class annual, Indiana University). Bloomington, Ind., 1897. Pp. 287.

SETH EUGENE MEEK, B.S. (1884), M.S. (1886), Ph.D. (1891). Assistant Curator of Zoölogy, Field Columbian Museum, Chicago.

1. A review of the species of Gerres found in American waters. (Joint author with Barton Warren Evermann.) *In* Proc. Acad. Nat. Sci. Philadelphia for 1883, pp. 116-124.

2. Note on the genus *Anguilla*. *In* Bull. U. S. Fish Comm. for 1883, p. 430.

3. A review of the American species of *Scomberomorus*. (Joint author with R.

G. Newland.) *In* Proc. Acad. Nat. Sci. Philadelphia for 1883, pp. 219-232.

4. A review of the genus *Sphyræna*. (Joint author with R. G. Newland.) *In* Proc. Acad. Nat. Sci. Philadelphia for 1884, pp. 67-75.

5. A review of the American species of *Hemirhamphus*. (Joint author with D. K. Goss.) *In* Proc. Acad. Nat. Sci. Philadelphia for 1884, pp. 221-235.

6. Notes on a collection of anchovies from Havana and Key West, with an account of a new species (*Stolephorus eurystole*) from Woods Hole, Mass. (Joint author with Joseph Swain.) *In* Proc. Acad. Nat. Sci. Philadelphia for 1884, pp. 34-46.

7. A review of the American species of the genus *Synodus*. *In* Proc. Acad. Nat. Sci. Philadelphia for 1884, pp. 130-136.

8. A review of the American species of the genus *Trachynotus*. (Joint author with D. K. Goss.) *In* Proc. Acad. Nat. Sci. Philadelphia for 1884, pp. 121-129.

9. Note on the Cuban eel. *In* Bull. U. S. Fish Comm. for 1884, p. 111.

10. List of fishes collected in the St. John's river at Jacksonville, Fla. (Joint author with David Starr Jordan.) *In* Bull. U. S. Fish Comm., 1884, p. 233-237.

11. Description of *Zygonectes zonifer*, a new species of *Zygonectes* from Nashville, Ga. (Joint author with D. S. Jordan.) *In* Proc. U. S. Nat. Mus. for 1884, pp. 526-627.

12. Description of a new species of *Hypobopsis* (*Hypobopsis montanus*). *In* Proc. U. S. Nat. Mus. for 1884, pp. 526-527.

13. Description of four new species of Cyprinidæ. (Joint author with D. S. Jordan.) *In* Proc. U. S. Nat. Mus. for 1884, pp. 474-477.

14. Notes on the pipe fishes of Key West, Fla., with descriptions of two new species. (Joint author with Joseph Swain.) *In* Proc. U. S. Nat. Mus. for 1884, pp. 237-239.

15. List of fishes collected in Iowa and Missouri, in August, 1884, with descriptions of three new species. (Joint author with D. S. Jordan.) *In Proc. U. S. Nat. Mus.* for 1885, pp. 1-17.
16. A review of the American species of flying fishes. (Joint author with D. S. Jordan.) *In Proc. U. S. Nat. Mus.* for 1885, pp. 44-67.
17. A review of the American genera and species of Batrachidæ. (Joint author with E. A. Hall.) *In Proc. Acad. Nat. Sci. Philadelphia* for 1885, pp. 52-62.
18. A review of the American species of the genus *Scorpæna*. (Joint author with R. G. Newland.) *In Proc. Acad. Nat. Sci. Phila.* for 1885, pp. 394-403.
19. A review of the genus *Esox*. (Joint author with R. G. Newland.) *In Proc. Acad. Nat. Sci. Philadelphia* for 1885, pp. 367-375.
20. A revision of the American species of the genus *Gerres*. (Joint author with B. W. Evermann.) *In Proc. Acad. Nat. Sci. Philadelphia* for 1886, pp. 256-272.
21. A note on the lamprey of Cayuga Lake. *In Ann. New York Acad. Sci.* for 1886, pp. 285-289.
22. Note on *Elagatis bipinnulatus*. (Joint author with C. H. Bollman.) *In Proc. Acad. Nat. Sci. Philadelphia* for 1889, pp. 42-44.
23. Report on the explorations made in Missouri and Arkansas during 1889, with an account of the fishes observed in each of the river basins examined. *In Bull. U. S. Fish Comm.* for 1889, pp. 113-141.
24. Note on *Ammocætes branchialis*. *In Am. Nat.*, XXIII, pp. 640-642. (1890.)
25. The native food fishes of Iowa. *In Proc. Iowa Acad. Sci.* for 1890, pp. 68-76.
26. Report on the fishes of Iowa based on observations and collections made during 1889, 1890 and 1891. *In Bull. U. S. Fish Comm.* for 1890, pp. 217-248.
27. The fishes of the Cedar river basin. *In Iowa Acad. Sci.* for 1891, pp. 1-8.
28. A catalogue of the fishes of Arkansas. *In Ann. Rept. Arkansas State Geol.* for 1891, pp. 215-276.
29. A description of *Etheostoma pagei*. *In Am. Nat.*, XXVIII, p. 957. (1894.)
30. A new *Cambarus* (*Cambarus faxonii*) from Arkansas. *In Am. Nat.*, XXVIII, pp. 1042-1043, 1 plate. (1894.)
31. Report of investigations respecting the fishes of Arkansas conducted during 1891, 1892 and 1893, with a synopsis of previous explorations in the same State. *In Bull. U. S. Fish Comm.* for 1894, pp. 67-94.
32. Notes on the fishes of western Iowa and eastern Nebraska. *In Bull. U. S. Fish Comm.* for 1894, pp. 133-138.
33. Description of a new species of *Gobiesox* (*Gobiesox muscarum*). (Joint author with C. J. Pierson.) *In Proc. California Acad. Sci.* for 1895, pp. 571-573.
34. A list of fishes and mollusks collected in Arkansas and the Indian Territory in 1894. *In Bull. U. S. Fish Comm.* for 1895, pp. 341-349.
35. Salmon investigations in the Columbia river basin and elsewhere on the Pacific coast in 1896. (Joint author with B. W. Evermann.) *In Bull. U. S. Fish Comm.* for 1897, pp. 15-84.
36. A list of fishes and reptiles obtained by the Field Columbian Museum East African Expedition to Somali-land in 1896. *In Field Col. Mus. Pub.*, Zoöl. Series, I, pp. 163-184. (1897.)
37. Notes on a collection of cold-blooded vertebrates from the Olympic mountains. *In Field Col. Mus. Pub.*, Zoöl. Series, I, pp. 225-236. (1899.)
38. Notes on a collection of fishes and amphibians from Muskoka and Gull lakes. *In Field Col. Mus. Pub.*, Zoöl. Series, I, pp. 307-311. (1899.)
39. Contribution to the ichthyology of

Mexico. *In* Field Col. Mus. Pub., Zoöl. Series III, pp. 63-128, 18 plates. (1902.)

40. The growth and variation of fishes. *In* Birds and Nature, VIII, pp. 84-89. (1900.)

41. The geological succession of fishes. *In* Birds and Nature, VIII, pp. 133-139. (1900.)

42. The geographical distribution of fishes. *In* Birds and Nature, VIII, pp. 161-164. (1900.)

43. Notes on a collection of cold-blooded vertebrates from Ontario. (Joint author with H. W. Clark.) *In* Field Col. Mus. Pub., Zoöl. Series, III, pp. 131-140. (1902.)

44. Contribution to museum technique. *In* Am. Nat., XXXVI, pp. 53-62. (Jan., 1902.)

45. Review of D. S. Jordan and B. W. Evermann's 'American game and food fishes.' *In* Am. Nat., XXXVI, pp. 557-558. (August, 1903.)

46. Distribution of fresh-water fishes in Mexico. *In* Am. Nat., XXXVII, pp. 771-784. (Nov., 1903.)

47. The fresh-water fishes of Mexico. *In* Field Col. Mus. Pub., Zoöl. Series, V, pp. 1-300. (In press.)

OSCAR MARION MEYNCKE, A.B. (1896).
Brookville, Ind.

1. The flora of Franklin county, Indiana. *In* Bulletins Nos. 1-2, Brookville Soc. Nat. Hist.

2. The study of the bird's nest. *In* Teachers' Jour. Also *in* Nature Study Mo.

GEORGE MOREY MILLER, A.B. (1892), A.M.
Assistant Professor of Rhetoric and English Literature, University of Cincinnati, Cincinnati, Ohio.

1. The agitation about English. *In* Proc. Mod. Lang. Asso. of Ohio, pp. 46-57. (1898-1899.)

2. The dramatic element in the popular ballad. *In* Univ. Cincinnati Bull., No. 19, Series II, Vol. II, pp. viii, 35. (1904.)

JOHN ANTHONY MILLER, A.B. (1890), Ph.D.
See Faculty list.

KATE MILNER. *See* Mrs. Albert Rabb.

GEORGE ELBERT MITCHELL, A.B. (1898).
Teacher of Science, High School, Rensselaer, Ind.

1. Note on the aberrant follicles in the ovary of *Cymatogaster*. *In* Proc. Indiana Acad. Sci. for 1898, pp. 229-232, 1 plate. (1899.)

WILLIAM J MOENKHAUS, A.B. (1894),
A.M. (1895), Ph.D. *See* Faculty list.

HAMILTON BYRON MOORE, A.M. (1901).
Instructor in English, Indiana University, 1898-1901; Assistant Professor, 1901-1903. Now Instructor in English, Manual Training High School, Indianapolis.

1. Dickens's 'The tale of two cities.' Edited with introduction and notes. Boston, 1901.

2. Thackeray's 'Henry Esmond.' Edited with introduction and notes. Boston, 1904.

WALTER PIETY MORGAN, A.M. (1900).
Assistant Professor of Mathematics, Indiana State Normal School, Terre Haute, Ind.

1. Teachers' manual for Cook and Cropsey arithmetics. Terre Haute, Ind., 1902. Pp. 302.

SARAH PARKE MORRISON, A.B. (1869), A.M. (1871). Adjunct Professor of English Literature, Indiana University, 1873-75. Knightstown, Ind.

1. I'm coming home, song. (Sheet music.) St. Louis, 1888. Pp. 5.

2. A monody to a father's memory. Cambridge, Mass., 1891. Pp. 49, 1 plate.

3. Among ourselves: to a mother's memory. Vol. I, Out of North Carolina. Pp. 170, 6 plates. Vol. II, Catherine and her surroundings. Pp. 214, 5 plates. Plainfield, Ind., 1901 and 1902.

WILLIAM LAGRANGE MORRISON, A.B. (1888). Superintendent of Schools, Scottsburg, Ind.

1. A review of the American species of Priacanthidae or big-eyes. *In Proc. Acad. Nat. Sci. Philadelphia* for 1889.

CHARLES ALFRED MOSEMILLER, A.B. (1890).
See Faculty list.

DAVID MYERS MOTTIER, A.B. (1891), A.M. (1892), Ph.D. See Faculty list.

ARTHUR LEROY MURRAY, A.B. (1901).
Teacher, Muncie, Ind.

1. Editor of 'The Arbutus' (Senior class annual, Indiana University). Bloomington, Ind., 1901. Pp. 250.

EDWIN MANSON NEHER, A.B. (1901), S.B.
Student, Rush Medical College, Chicago.

1. The eye of *Palaemonetes antrorum*. *In Proc. Indiana Acad. Sci.* for 1902.

ROBERT NEWLAND, A.B. (1887). Teacher in High School, Denver, Colo.

1. A review of the American species of the genus *Scorpæna*. (Joint author with S. E. Meek.) *In Proc. Acad. Nat. Sci. Philadelphia* for 1885, pp. 294-403.

2. A review of the species of the genus *Esox*. (Joint author with S. E. Meek.) *In Proc. Acad. Nat. Sci. Philadelphia* for 1885, pp. 52-62.

ADELAIDE (PERRY) NEWSOM (Mrs. John F. Newsom), A.B. (1894). Stanford University, Cal.

1. Editor of 'The Arbutus' (Senior class annual, Indiana University). (Joint editor with Clarence Arthur Zaring). Bloomington, Ind., 1895. Pp. 240.

JOHN FLESHER NEWSOM, A.B. (1891), Ph.D. Instructor in Geology, Indiana University, 1894-96; Assistant Professor, 1896-99. Now Associate Professor of Mining, Leland Stanford Junior University, Stanford University, Cal.

1. Syllabus of lectures on economic geology. (Joint author with J. C. Branner.) Stanford University, 1895. Pp. 282.

2. A relief map of Arkansas. *In Proc. Indiana Acad. Sci.*, for 1895, p. 56.

3. A geological section across southern Indiana from Hanover to Vincennes. *In Proc. Indiana Acad. Sci.*, for 1897, pp. 250-253.

4. The Knobstone group in the region of New Albany, Indiana. *In Proc. Indiana Acad. Sci.* for 1897, pp. 253-256.

5. The Red River and Clinton monoclines, Arkansas. (Joint author with J. C. Branner.) *In Am. Geol.*, XX, pp. 1-13, map, 3 plates. (1897.)

6. Notes on the distribution of the Knobstone group in Indiana. (Joint author with J. A. Price.) *In Proc. Indiana Acad. Sci.* for 1898, pp. 289-297. Map.

7. The effect of sea barriers upon ultimate drainage. *In Jour. of Geol.*, VII, pp. 445-451, 4 figures. (1899.)

8. Syllabus of economic geology. (Joint author with J. C. Branner.) Stanford University, 1900. 2d ed. Illustrated. Pp. viii, 368.

9. Drainage of southern Indiana. *In Journal of Geology*, X, pp. 166-181, map. (1902.)

10. The phosphate rocks of Arkansas. (Joint author with J. C. Branner.) *In Bull. 74 Arkansas Agr. Exp. Sta.*, 1 plate, 23 figures. (1902.)

11. A natural gas explosion near Waldron, Indiana. *In Jour. of Geol.*, X, pp. 803-814, 5 figures. (1902.)

12. A geologic and topographic section across southern Indiana, from Hanover to Vincennes, with a discussion of the Knobstone group in the State of Indiana. *In 26th Ann. Rep. Indiana Dept. Geol. and Nat. Hist.*

13. Review of Davies's 'A treatise on metalliferous minerals and mining.' *In Engineering and Mining Jour.*, June 6, 1903, pp. 863-864.

ALLEN ANSON NORRIS, A.B. (1902). Superintendent of Schools, Syracuse, Indiana.

1. Studies in the life of St. Paul. (Joint author with Chas. O. Davis.) Bloomington, Ind., 1898.

2. Sabre alguns peixes de São Paulo, Brazil. (Joint author with C. H. Eigenmann.) *In Revista do Museu Paulista*, IV, pp. 349-362. (1900.)

3. Maps of Winona, Pike, and Center Lakes. *In Proc. Indiana Acad. Sci.* for 1901. (1902.)

4. Lists of Mollusca of Pike, Winona and Center Lakes, Kosciusko county, Ind. *In Proc. Indiana Acad. Sci.* for 1901. (1902.)

REUBEN EDSON NYSWANDER, A.B. (1901). Magnetic Observer, U. S. Coast and Geodetic Survey, Washington, D. C.

1. A modified Wehnelt interrupter. (Joint author with A. L. Foley.) *In Electrical World and Engineer*, XXXIX, pp. 373-374. (March 1, 1902.)

2. The lunar diurnal variation as obtained at the Cheltenham magnetic observatory from a single complete lunation during February, 1903. (Abstract.) (Joint author with L. A. Bauer.) *In Terrestrial Magnetism and Atmospheric Electricity*, VIII, pp. 144-146. (Sept., 1903.)

FREDERIC AUSTIN OGG, A.M. (1900). Instructor in History, 1902-1903. Now Graduate student, Harvard University, Cambridge, Mass.

1. Geography from Homer to Columbus. *In Chautauquan*, XXXII, pp. 473-478. (Feb., 1901.)

2. Jay's treaty and the slavery interests of the United States. *In Ann. Rep. Am. Hist. Assoc.* for 1901, pp. 273-298. (1902.)

3. On the literary decline of history. *In Dial*, XXXII, pp. 233-235. (April 1, 1902.)

4. Slav and Saxon. *In Chautauquan*, XXXVI-XXXVII. (Oct., 1902-June, 1903.)

5. The proportion of city and country population in the United States. *In World's Work*, V, pp. 3003-3005. (Jan., 1903.)

6. Indian money in the New England colonies. *In New Eng. Mag.*, XXVII, pp. 749-760. (Feb., 1903.)

7. German interests and tendencies in South America. *In* World's Work, V, pp. 3168-3170. (March, 1903.)

8. Coins and coinage in the New England colonies. *In* New Eng. Mag., XXVIII, pp. 739-752. (Aug., 1903.)

9. The Pope and the Italian nation. *In* Chautauquan, XXXVIII, pp. 14-19. (Sept., 1903.)

10. The opening of the Mississippi: a struggle for supremacy in the American interior. New York, 1904. Pp. viii, 656.

11. Review of Willis Fletcher Johnson's 'A century of expansion.' *In* Dial, XXXVI, pp. 47-48. (Jan. 16, 1904.)

12. Paper money in the New England colonies. *In* New Eng. Mag., XXIX, pp. 772-783. (Feb., 1904.)

13. Newspaper satire during the American Revolution. *In* New Eng. Mag., XXX, pp. 366-376. (May, 1904.)

14. Review of William Garrott Brown's 'The foe of compromise, and other essays.' *In* Dial, XXXVI, pp. 323-324. (May 16, 1904.)

EDWARD CHARLES O'DONNELL, A.B. (1890).
Mitchell, Ind.

1. The Standard Oil Trust. *In* Statesman for 1890.

CARL WILHELM FERDINAND OSTHAUS, A.M. (1890). *See* Faculty list.

HENRY ALLISON PARSONS, LL.B. (1864).
Kansas City, Kansas.

1. The rise and fall of nations. Kansas City, 1878. Pp. 28.

2. Abridged history of Greece from the earliest times to the present dynasty. Kansas City, 1904. Pp. 149.

ROY HENDERSON PERRING, A.B. (1894),
A.M. (1896). *See* Faculty list.

ADELAIDE PERRY. *See* Mrs. John F. Newsum.

BURR HARRISON POLK, LL.B. (1857). Died
May 15, 1886, at Lincoln, Neb.

1. The big American caravan in Europe. (Letters republished in book form.)

JAMES P PORTER, A.B. (1898), A.M. (1901). Instructor in Psychology, Indiana University, 1900-1902. Now Instructor in Psychology, Clark University, Worcester, Mass.

1. The psychology of the English sparrow. *In* Am. Jour. Psych., XV. (April, 1904.)

WILLIAM HENRY PYLE, A.B. (1898). Superintendent City Schools, Vandalia, Ill.

1. Nature study in the country schools, Vandalia, Ill., 1901. Pp. 22.

KATE (MILNER) RABB (Mrs. Albert Rabb),
A.B. (1886), A.M. (1888). Indianapolis, Ind.

1. Indiana in fiction. *In* Kate Field's Washington for May, 1892.

2. A Kentucky 'Harut.' *In* New York Ledger for March 5, 1892.

3. The whitecaps. *In* Worthington's Mag. for Jan., 1893.

4. To him who waits. *In* Interior for June 15, 1893.

5. Björnson and Ibsen. *In* Dominion Illustrated Mo. for Sept., 1893.

6. Mikado tea. *In* Kate Field's Washington for Sept. 27, 1893.
7. Lias. *In* Worthington's Mag. for Nov., 1893.
8. The things which are Cæsar's. *In* Once a Week for March 3, 1894.
9. A bit of Sèvres. *In* Kate Field's Washington for August 29, 1894.
10. The snub. *In* Lippincott's Mag. for Oct., 1894.
11. At the institute. *In* N. Y. Sch. Jour. for July 13, 1895.
12. Claude Matthews. *In* Leslie's Weekly for May 23, 1895.
13. The destruction of a theory. *In* Kate Field's Washington for Jan. 12, 1895.
14. National epics. Chicago, 1896. Pp. 398.
15. A municipal experiment. *In* Leslie's Weekly for May 13, 1897.
16. The pilgrim and the palmer. *In* Interior for May 16, 1897.
17. Dido. *In* Self Culture for April, 1898.
18. A club election. *In* Designer for Sept., 1898.
19. The Boer boy. Philadelphia, 1900. Pp. 348.
20. The romance of a co-ed. *In* Delin-eator for Nov., 1900.
21. The institute at Glendean. *In* De-lineator for May, 1901.
22. A letter from O. W. Holmes. *In* St. Nicholas for March, 1902.
23. Miss Petrie's avocation. *In* Atlan. Mo. for July, 1902.
24. Hyacinths. *In* Leslie's Weekly for August 7, 1902.
25. The plateau of fatigue. *In* Atlan. Mo. for Jan., 1903.
26. By grace of Linnæus. *In* Delin-eator for June, 1903.
27. The new hunting. *In* Atlan. Mo. for Jan., 1904.
- ROLLA ROY RAMSEY, A.B. (1895), A.M. (1898), Ph.D. *See* Faculty list.
- RICHARD RATHBUN, M.S. (1883), D.Sc. Assistant Secretary of the Smithsonian Institution in charge of the U. S. National Museum. Washington, D. C.
1. On the Devonian Brachiopoda of Ereré, Province of Pará, Brazil. *In* Bull. Buffalo Soc. of Nat. Sci. for 1874, I, No. 4, pp. 236-261, plates viii-x.
2. Morgan expedition, 1870, Chas. Fred. Hartt, in charge. Preliminary report on the Cretaceous lamellibranchs collected in the vicinity of Pernambuco, Brazil. *In* Proc. Boston Soc. Nat. Hist. for 1874, XVII, pp. 241-256.
3. The geological commission of Brazil. Additions to the Echinoid fauna of Brazil. *In* Amer. Jour. Sci. and Arts, 3d series, XV, pp. 82-84. (1878.)
4. The Devonian Brachiopoda of the Province of Pará, Brazil. *In* Proc. Boston Soc. Nat. Hist. for 1878, XX, pp. 14-39.
5. Notes on the coral reefs of the Island of Itaparica, Bahia, and of Parahyba do Norte. *In* Proc. Boston Soc. Nat. Hist. for 1878, XX, pp. 39-41.
6. Observações sobre a Geologia aspecto do Ilha de Itaparica, na Bahia de Todos os Santos. *In* Archivos do Museu Nacional do Rio de Janeiro, III, pp. 159-183. (1878.)
7. Sketch of Professor C. F. Hartt. *In* Pop. Sci. Mo., XIII, pp. 231-235, with portrait as frontispiece. (June, 1878.)
8. Sketch of the life and scientific work of Prof. Charles Fred. Hartt. *In* Proc. Boston Soc. Nat. Hist. for 1878, XIX, pp. 338-364. Reprinted. New Haven, 1879. Pp. 38.
9. A list of the Brazilian echinoderms, with notes on their distribution, etc. *In*

Trans. Connecticut Acad. of Arts and Sciences for 1879, V, pp. 139-158.

10. List of marine invertebrata from the New England coast, distributed by the United States Commission of Fish and Fisheries. Series I. (Distributed in fifty sets, put up by Mr. Richard Rathbun, under the direction of Prof. A. E. Verrill. 1879.) *In Proc. U. S. Nat. Mus. for 1879, II, pp. 227-232.*

11. List of the dredging stations of the United States Fish Commission from 1871 to 1879, inclusive, with temperature and other observations. Arranged for publication by Sanderson Smith and Richard Rathbun. *In Ann. Rep. Commissioner of Fish and Fisheries for 1879, pp. 1-43.*

12. Prof. Hartt on the Brazilian sandstone reefs. *In Am. Nat., XIII, pp. 347-358. (June, 1879.)*

13. Review of O. A. Derby's 'The geology of the Lower Amazonas.' *In Am. Jour. of Sci. and Arts, 3d series, XVII, pp. 464-468. (June, 1879.)*

14. Brazilian corals and coral reefs. *In Am. Nat., XIII, pp. 539-551, one text figure. (Sept., 1879.)*

15. Review of O. A. Derby's 'The geology of the Diamantiferous region of the Province of Paraná, Brazil.' (Proc. American Phil. Soc., May 16, 1879.) *In Am. Jour. of Sci. and Arts, 3d series, XVIII, pp. 310, 311. (Oct., 1879.)*

16. The littoral marine fauna of Provincetown, Cape Cod, Massachusetts. *In Proc. U. S. Nat. Mus. for 1880, III, pp. 116-133.*

17. List of marine invertebrates, mainly from the New England coast, distributed by the United States National Museum. Series II. *In Proc. U. S. Nat. Mus. for 1881, IV, pp. 298-303.*

18. List of marine invertebrates from the New England coast, distributed by the United States National Museum. Series

III. Educational Series. *In Proc. U. S. Nat. Mus. for 1881, IV, pp. 304-307.*

19. The giant squid. *In St. Nicholas, VIII, pp. 266-270, 5 plates. (Feb., 1881.)*

20. Dredging stations of the United States Fish Commission Steamer Fish Hawk, Lieut. Z. L. Tanner commanding, for 1880, 1881, and 1882, with temperature and other observations. *In Bull. U. S. Fish Comm. for 1882, II, pp. 119-131.*

21. Notes on the shrimp and prawn fisheries of the United States. *In Bull. U. S. Fish Comm. for 1882, II, pp. 139-152.*

22. The American initiative in methods of deep-sea dredging. *In Science, IV, pp. 54-57. (1884.)*

23. American appliances for deep-sea investigation. *In Science, IV, pp. 146-151, 225-229, 400-404, with numerous text illustrations. (1884.)*

24. Annotated list of the described species of parasitic Copepoda (Siphonostoma) from American waters contained in the United States National Museum. *In Proc. U. S. Nat. Mus. for 1884, VII, pp. 483-492.*

25. Collection of economic crustaceans, worms, Echinoderms and sponges. (Great international fisheries exhibition, London, 1883; exhibit of U. S. of America.) *In Bull. U. S. Nat. Mus. for 1884, No. 27, pp. 107-137.*

26. Descriptive catalogue of the collection illustrating the scientific investigation of the sea and fresh waters. (Great international fisheries exhibition, London, 1883; exhibit of U. S. of America.) *In Bull. U. S. Nat. Mus. for 1884, No. 27, pp. 511-622.*

27. Notes on the decrease of lobsters. *In Bull. U. S. Fish Comm. for 1884, IV, pp. 421-426.*

28. Crustaceans, worms, radiates and sponges. *In The fisheries and fishery industries of the United States, prepared through the co-operation of the Commissioner of Fisheries and the Superintendent of the*

Tenth Census by George Brown Goode, Assistant Director of the U. S. National Museum, and a staff of associates. Section I. Natural history of aquatic animals. Part V, pp. 759-850, plates cclx-cclxxvii. Washington, Government Printing Office, 1884.

29. Reports on the Department of Marine Invertebrates in the U. S. National Museum for years 1883-1892, inclusive. By Richard Rathbun, curator. *In* Annual Reports of the Board of Regents of the Smithsonian Institution, showing the operations, expenditures and condition of the Institution for the several years. Washington, Government Printing Office, various dates.

30. Report upon the Echini collected by the United States Fish Commission Steamer Albatross, in the Caribbean Sea and Gulf of Mexico, January to May, 1884. *In* Proc. U. S. Nat. Mus. for 1885, VIII, pp. 83-89.

31. Report upon the Echini collected by the U. S. Fish Commission Steamer Albatross in the Gulf of Mexico from January to March, 1885. *In* Proc. U. S. Nat. Mus. for 1885, VIII, pp. 606-620.

32. Notice of a collection of stalked crinoids made by the Steamer Albatross in the Gulf of Mexico and Caribbean Sea, 1884 and 1885. *In* Proc. U. S. Nat. Mus. for 1885, VIII, pp. 628-635.

33. Catalogue of the collection of recent Echini in the United States National Museum (corrected to July 1, 1886). *In* Proc. U. S. Nat. Mus. for 1886, IX, pp. 255-293.

34. Descriptions of parasitic copepods belonging to the genera Pandarus and Chondracanthus. *In* Proc. U. S. Nat. Mus. for 1886, IX, pp. 310-324, plates v-xi.

35. Notes on lobster culture. *In* Bull. U. S. Fish Comm. for 1886, VI, pp. 17-32.

36. Catalogue of the species of corals belonging to the genus Madrepora, contained in the United States National Museum. *In* Proc. U. S. Nat. Mus. for 1887, X, pp. 10-19.

37. Annotated catalogue of the species of Porites and Synaræa in the United

States National Museum, with a description of a new species of Porites. *In* Proc. U. S. Nat. Mus. for 1887, X, pp. 354-366, plates xv-xix.

38. Descriptions of the species of Heliaster (a genus of starfishes) represented in the U. S. National Museum. *In* Proc. U. S. Nat. Mus. for 1887, X, pp. 440-449, plates xxiii-xxvi.

39. Descriptions of new species of parasitic copepods, belonging to the genera Trebius, Perissopus, and Lernanthropus. *In* Proc. U. S. Nat. Mus. for 1887, X, pp. 559-571, plates xxix-xxxv.

40. The fishing grounds of North America. Edited by Richard Rathbun. *In* The fisheries and fishery industries of the United States, prepared through the co-operation of the Commissioner of Fisheries and the Superintendent of the Tenth Census by George Brown Goode, Assistant Secretary of the Smithsonian Institution, and a staff of associates. Section III, pp. vii-xviii, 5-154, 49 charts. Washington, Government Printing Office, 1887.

41. Ocean temperatures of the Eastern coast of the United States, with thirty-two charts. *In* The fisheries and fishery industries of the United States, prepared through the co-operation of the Commissioner of Fisheries and the Superintendent of the Tenth Census by George Brown Goode, Assistant Secretary of the Smithsonian Institution, and a staff of associates. Section III, pp. 155-238, 32 plates. Washington, Government Printing Office, 1887.

42. The crab, lobster, crayfish, rock lobster, shrimp and prawn fisheries. *In* The fisheries and fishery industries of the United States, prepared through the co-operation of the Commissioner of Fisheries and the Superintendent of the Tenth Census by George Brown Goode, Assistant Secretary of the Smithsonian Institution, and a staff of associates. Section V. History and methods of the fisheries. II. Part XXI, pp.

627-841, plates cclxvi-cclv. Washington, Government Printing Office, 1887.

43. Results of investigations by the schooner *Grampus* on the Southern mackerel grounds in the spring of 1887. (Joint author with D. E. Collins and T. H. Bean.) *In Bull. U. S. Fish Comm. for 1887*, VII, pp. 217-267.

44. The transplanting of lobsters to the Pacific Coast of the United States. *In Bull. U. S. Fish Comm. for 1888*, VIII, pp. 453-472, plate lxxi.

45. Reports upon the inquiry respecting food fishes and the fishing grounds. *In Ann. Reports U. S. Commission of Fish and Fisheries. Reports of the Commissioner for years 1888-1889, inclusive.* Washington, Government Printing Office, various dates.

46. The United States Fish Commission. Some of its work. *In Century Mag.*, XLIII, pp. 679-697, 19 text figures. (1892.)

47. Jerome Henry Kidder. *In Bull. Philos. Soc. of Washington*, XI, pp. 480-488. (1892.)

48. Report of the joint commission of the United States and Great Britain relative to the preservation of the fisheries in waters contiguous to the United States and Canada, under agreement of December 6, 1892, by Richard Rathbun, representative on behalf of the United States, and William Wakeham, representative on behalf of Great Britain. Transmitted to the Congress of the United States by the President, under date of February 24, 1897. Washington, D. C. Government Printing Office, 1897, pp. 178.

49. A review of the fisheries in the contiguous waters of the State of Washington and British Columbia. *In Report of the U. S. Commissioner of Fish and Fisheries for 1899*, pp. 251-350, plates viii-xvi.

50. Reports upon the condition and progress of the U. S. National Museum during the years ending June 30, 1899, 1900, 1901, and 1902, by Richard Rathbun, Assistant

Secretary of the Smithsonian Institution, in charge of the U. S. National Museum. *In Annual Reports of the Board of Regents of the Smithsonian Institution, showing the operations, expenditures and condition of the Institution for the years ending June 30, 1899, 1900, 1901, and 1902.* Reports of the U. S. National Museum. Washington. Government Printing Office, various dates.

WILLIAM A RAWLES, A.B. (1884), A.M. (1895), Ph.D. *See Faculty list.*

ALBERT B REAGAN, A.M. (1903). Teacher, Indian Service.

1. Jamez vocabulary. *In Rep. U. S. Bureau Ethnology.* Pp. 14.

2. Grammar treatise of the Jamez language. *In Rep. U. S. Bureau Ethnology.* Pp. 18.

3. Jamez—open and secret. *In Rep. U. S. Bureau Ethnology.* Pp. 60, 22 plates.

4. The Apache pole game. *In Rep. U. S. Bureau Ethnology*; also *in Proc. Indiana Acad. Sci. for 1902.* Pp. 14; 26 plates.

5. The Apache Indians, their manners, customs, etc. *In Rep. U. S. Bureau Ethnology*, pp. 120, 40 plates.

6. The Jamez-Albuquerque region, N. M. *In Proc. Indiana Acad. Sci. for 1902*; also *in Am. Geol.*, Feb., 1903. Pp. 45, 8 plates.

7. The Jamez coal fields. *In Proc. Indiana Acad. Sci. for 1902.* Pp. 3.

8. The Apache stick game. *In Rep. U. S. Bureau Ethnology*; also *in Proc. Indiana Acad. Sci. for 1903.*

9. Age of the lava flows of the plateau region. *In Am. Geol.*, XXXII, pp. 170-177. (Sept., 1903.)

10. Geology of the Fort Apache region,

Arizona. *In Proc. Indiana Acad. Sci.* for 1903; also *in Am. Geol.*, XXXII, pp. 295-358, 5 plates. (Nov., 1903.)

11. Age of the Aubrey limestone. *In Proc. Indiana Acad. Sci.* for 1903. Pp. 5.

12. The fossils of the Upper Red Wall of Arizona, compared with those of the Kansas coal-measures. *In Proc. Indiana Acad. Sci.* for 1903. Pp. 3.

13. Some fossils from the Upper Red Wall of Arizona. *In Proc. Indiana Acad. Sci.* for 1903. Pp. 14, 1 plate.

14. Geology of Monroe county, Indiana, North of Latitude of Bloomington. *In Proc. Indiana Acad. Sci.* for 1903. Pp. 20.

15. The Apache medicine disk. *In Proc. Indiana Acad. Sci.* for 1903; *in Proc. A. A. A. S.* for 1903. Pp. 2, 1 plate.

16. Some paintings from one of the Estufas at Jemez, N. M. *In Proc. Indiana Acad. Sci.* for 1903; also *in Proc. A. A. A. S.* for 1903. Pp. 2, 6 plates.

HERBERT GILSON REDDICK, A.B. (1887),
A.M. (1898). Indianapolis, Ind.

1. The snakes of Turkey Lake. *In Proc. Indiana Acad. Sci.* for 1895, pp. 261-262.

WILLIAM ALLAN REED, A.B. (1898). Governor of Lepanto-Bontoc, P. I.

1. The Negritos of Zambales. Manila, 1904. Pp. xii, 65; 80 plates.

ERNEST WILLIAM RETTGER, A.B. (1893),
Ph.D. Instructor in Mathematics, Indiana University, 1898-1900. Now Professor of Mathematics, Missouri State Normal School, Warrensburg, Mo.

1. Note on the projective group. *In*

Proc. Am. Acad. Sci. for 1898, XXXIII, pp. 491-499.

2. On Lie's theory of continuous groups. *In Am. Jour. Math.* for 1899.

LEO FREDERICK RETTGER, A.B. (1896), A.M. (1897), Ph.D. Instructor in charge of Bacteriology, Yale University, New Haven, Conn.

1. Septicæmia in young chickens. *In New York Med. Jour.*, May, 1900, p. 803, and Feb., 1901, p. 267.

2. The liberation of volatile sulphide from milk on heating. *In Am. Jour. Physiol.*, VI, p. 450. (1902.)

3. The formation of film on heated milk. *In Am. Jour. Physiol.*, VII, p. 325. (1902.)

4. Experimental observations on pancreatic digestion and the spleen. *In Am. Jour. Physiol.*, VII, p. 387. (1902.)

5. An experimental study of the chemical products of bacillus coli communis and bacillus lactis aerogenes. *In Am. Jour. Physiol.*, VIII, p. 284. (1903.)

6. Mucin as a bacterial product. *In Jour. Med. Research*, X, p. 101. (1903.)

7. On the spore germination of bacillus subtilis and bacillus megatherium. *In Centralbl. für Bakt. Par. und Infek.*, XXXIII. (1903.)

8. A contribution to the study of pathogenic yeasts. *In Centralbl. für Bakt. Par. und Infek.* (1904.) (In press.)

BESSIE (BUSHING) RIDGELEY (Mrs. Douglas Clay Ridgeley), A.B. (1893).

1. Annelids of Turkey Lake. *In Proc. Indiana Acad. Sci.* for 1895, p. 241.

DOUGLAS CLAY RIDGELEY, A.B. (1893).
Professor of Geography, Illinois State
Normal University.

1. A preliminary report on the physical features of Turkey Lake, with hydrographic map. (Joint author with J. P. Dolan and Chancey Juday.) *In Proc. Indiana Acad. Sci.* for 1895, pp. 216-239.

2. The school excursion and the school museum as aids in the teaching of geography. *In Normal Sch. Quar.*, Series 2, No. 11, pp. 1-16.

3. Alexis Everett Frye's 'Grammar school geography.' *In Jour. of Geography*, I, pp. 341-342. (Sept., 1902.)

ROBERT RIDGWAY, M.S. (1884). Curator of
Birds, U. S. National Museum, Brook-
land, D. C.

1. The belted kingfisher again. *In Am. Nat.*, III, pp. 53-54. (March, 1869.)

2. Notices of certain obscurely known species of American birds. *In Proc. Acad. Nat. Sci. Phila.* for 1869, XXI, pp. 125-135.

3. A true story of a pet bird. *In Am. Nat.*, III, pp. 309-312. (August, 1869.)

4. A new classification of the North American Falconidæ, with descriptions of three new species. *In Proc. Acad. Nat. Sci. Phila.* for 1870, XXII, pp. 138-150.

5. Relationship of the American white-fronted owl. *In Am. Nat.*, VI, pp. 283-285. (May, 1872.)

6. New birds in southern Illinois. *In Am. Nat.*, VI, pp. 430-431. (July, 1872.)

7. On the occurrence of a near relation of *Aegiothus flavirostris*, at Waltham, Mass. *In Am. Nat.*, VI, pp. 433-434. (July, 1872.)

8. On the occurrence of *Setophaga picta* in Arizona. *In Am. Nat.*, VI, p. 436. (July, 1872.)

9. Notes on the vegetation of the lower

Wabash valley. I. The forests of the bottom lands. *In Am. Nat.*, VI, pp. 658-665. (Nov., 1872.)

10. Notes on the vegetation of the lower Wabash valley. II. Peculiar features of the bottom lands. *In Am. Nat.*, VI, pp. 724-732. (Dec., 1872.)

11. On the relation between color and geographical distribution in birds, as exhibited in melanism and hyperchromism. *In Am. Jour. Sci.*, IV, pp. 454-460 (Dec., 1872); V, pp. 39-44 (Jan., 1873).

12. Notes on the vegetation of the lower Wabash valley. III. The woods and prairies of the upland portions. *In Am. Nat.*, VII, pp. 154-157. (March, 1873.)

13. Descriptions of the type specimen of *Pyrranga roseogularis* Cabot. *In Ibis*, III, p. 126; 3 plates. (April, 1873.)

14. The prairie birds of southern Illinois. *In Am. Nat.*, VII, pp. 195-203. (April, 1873.)

15. Description of *Centronyx ochrocephalus* Aiken. *In Am. Nat.*, VII, p. 237. (April, 1873.)

16. The relation between the color and geographical distribution of birds. *In Am. Nat.*, VII, pp. 548-555. (Sept., 1873.)

17. On some new forms of American birds. *In Am. Nat.*, VII, pp. 602-619. (Oct., 1873.)

18. Notes on the bird fauna of the Salt Lake valley and the adjacent portion of the Wasatch Mountains. *In Bull. Essex Inst.* for Nov., 1873, V, pp. 168-173.

19. The birds of Colorado. *In Bull. Essex Inst.* for Nov., 1873, V, pp. 174-195.

20. On some new forms of American birds. *In Bull. Essex Inst.* for Dec., 1873, V, pp. 194-201.

21. Catalogue of the ornithological collection in the Museum of the Boston Society of Natural History. Part II, Falconidæ. *In Proc. Boston Soc. Nat. Hist.* for Dec., 1873, XVI, pp. 43-72.

22. Revision of the Falconine genera *Micrastur*, *Geranospiza* and *Rupornis*, and the Strigine genus *Glaucidium*. *In Proc. Boston Soc. Nat. Hist. for Dec., 1873*, XVI, pp. 73-106.
23. The grouse and quails of North America, discussed in relation to their variation with habitat. *In Forest and Stream*, I, pp. 289-290. (Dec., 1873.)
24. A history of North American birds. (Joint author with S. F. Baird and T. M. Brewer.) Boston, 1874. Vol. I, pp. i-xxvii, 1-596; 6 cuts; 26 plates. Vol. II, pp. 1-590; 6 cuts; 29 plates. Vol. III, pp. 1-560; 1 cut; 7 plates.
25. Letter to the editor of *Forest and Stream* concerning the question, argued pro and con by various correspondents, as to whether snakes hiss. *In Forest and Stream*, I, p. 327. (Jan., 1874.)
26. The nomenclature of American game birds. *In Forest and Stream*, III, pp. 210-211, 226-227. (Jan., 1874.)
27. Catalogue of the birds ascertained to occur in Illinois. *In Ann. Lyc. Nat. Hist., New York, for January, 1874*, pp. 364-394.
28. Notes upon American water birds. *In Am. Nat.*, VIII, pp. 108-111. (Feb., 1874.)
29. Why and how does the ruffed grouse drum? *In American Sportsman*, III, p. 322. (Feb., 1874.)
30. The lower Wabash valley, considered in its relation to the faunal districts of the eastern region of North America; with a synopsis of its avian fauna. *In Proc. Boston Soc. Nat. Hist. for 1874*, XVI, pp. 304-332.
31. Description of *Hydrochelidon cucopetra*, from a specimen taken at Lake Koshkonong, Wisconsin. *In Am. Nat.*, VIII, p. 189. (March, 1874.)
32. On local variations in the notes and nesting habits of birds. *In Am. Nat.*, VIII, pp. 197-201. (April, 1874.)
33. Two rare owls from Arizona. *In Am. Nat.*, VIII, pp. 239-240. (April, 1874.)
34. A remarkable peculiarity of *Centrocercus urophasianus*. *In Am. Nat.*, VIII, p. 240. (April, 1874.)
35. The dodo. *In Forest and Stream*, II, p. 244. (May, 1874.)
36. Notice of a species of tern new to the Atlantic coast of North America. *In Am. Nat.*, VIII, p. 433. (July, 1874.)
37. Birds new to the North American fauna. *In Am. Nat.*, VIII, pp. 434-435. (July, 1874.)
38. Discovery of a burrowing owl in Florida. *In Am. Sportsman*, IV, p. 216; 1 plate. (July, 1874.)
39. Description of a new bird from Colorado. *In Am. Sportsman*, IV, p. 241. (July, 1874.)
40. Opinion (requested by editor) as to question whether the excessive abundance of grasshoppers in Kansas, etc., has any connection with the decrease in number of game birds in the same districts. *In Am. Sportsman*, IV, p. 249. (July, 1874.)
41. Story of a wild goose. *In Am. Sportsman*, IV, pp. 258-259. (July, 1874.)
42. An unusually large wild goose. *In Am. Sportsman*, IV, p. 274. (August, 1874.)
43. Breeding ground of white pelicans at Pyramid Lake, Nevada. *In Am. Sportsman*, IV, p. 289. (August, 1874.)
44. Game birds and grasshoppers. A reply to Vix. *In Am. Sportsman*, IV, p. 356. (Sept., 1874.)
45. Concerning a 'strange bird' described by a correspondent in a preceding number. *In Forest and Stream*, III, p. 85. (Sept., 1874.)
46. The snow goose. *In Am. Nat.*, VIII, pp. 636-637. (Oct., 1874.)
47. List of birds observed at various localities contiguous to the Central Pacific Railroad, from Sacramento, California to

- Salt Lake Valley, Utah. *In* Bull. Essex Inst. for Oct., 1874, VI, pp. 169-174; Jan., 1875, VII, pp. 10-40.
48. A contribution to the sparrow war. *In* Am. Sportsman, III, p. 161. (Dec., 1874.)
49. Concerning the so-called English sparrow, *Passer domesticus*. *In* Forest and Stream, III, p. 309. (Dec., 1874.)
50. Note on *Sterna longipennis*, Nordmann. *In* Am. Nat., IX, pp. 54-55. (Jan., 1875.)
51. A heronry in the Wabash bottoms. *In* Am. Sportsman, V, pp. 312-313. (Feb., 1875.)
52. Big trees. *In* Am. Sportsman, V, pp. 321-322; 337; 353-354; 367-370. (Feb. 20 to March 13, inc., 1875.)
53. Snow birds and little owls. *In* Am. Sportsman, V, p. 393. (March, 1875.)
54. On *Nisus cooperi* (Bonaparte) and *N. gundlachi* (Lawrence). *In* Proc. Acad. Nat. Sci. Phila. for 1875, pp. 78-88.
55. On the Buteonine subgenus *Craxirex* Gould. *In* Proc. Acad. Nat. Sci. Phila. for 1875, pp. 89-119.
56. More about the Florida burrowing owl. *In* Rod and Gun, VI, p. 7. (April, 1875.)
57. Notice of a very rare hawk. *In* Rod and Gun, VI, p. 65. (May, 1875.)
58. A monograph of the genus *Leucosticte*, or gray-crowned purple finches. *In* Bull. U. S. Geol. and Geog. Surv. Terr. for May, 1875, No. 2, 2d series, pp. 51-82.
59. Outlines of a natural arrangement of the Falconidæ. (Read before the Philosophical Society of Washington, April, 1875.) *In* Bull. U. S. Geol. and Geog. Surv. Terr. for June, 1875, No. 4, 2d series, pp. 1-17, plates xi-xviii.
60. Nesting of the worm-eating warbler. *In* Forest and Stream, I, pp. 10-12. (July, 1875.)
61. The sparrow hawk or American kestrel. *In* Rod and Gun, VI, p. 109. (July, 1875.)
62. Description of a new wren from Florida. *In* Am. Nat., IX, p. 469. (August, 1875.)
63. First impressions of the bird fauna of California, and general remarks on western ornithology. *In* Sci. Mon., I, pp. 2-13. (Oct., 1875.)
64. Our native trees. The tulip tree, *Liriodendron tulipifera*. *In* Field and Forest, I, pp. 49-53. (Dec., 1875.)
65. Studies of the American Falconidæ. Monograph of genus *Micrastur*. *In* Proc. Acad. Nat. Sci., Phila., for 1875, pp. 470-502, figures i-ix.
66. Second thoughts on the genus *Micrastur*. *In* Ibis, VI, pp. 1-5. (Jan., 1876.)
67. The genus *Glaucidium*. *In* Ibis, VI, pp. 11-17, 1 pl. (Jan., 1876.)
68. Studies of the American Falconidæ. Monograph of the *Polybori*. *In* Bull. U. S. Geol. and Geog. Surv. Terr. for February, 1876, No. 6, 2d series, pp. 451-473; plates xxii-xxvi.
69. Studies of the American Falconidæ. *In* Bull. U. S. Geol. and Geog. Surv. Terr. for April, 1876, II, No. 2, pp. 91-182; plates xxx-xxxii.
70. Ornithology of Guadeloupe (Ile de Guadalupe) Island, based on notes and collections made by Dr. Edward Palmer. *In* Bull. U. S. Geol. and Geog. Surv. Terr. for April, 1876, II, No. 2, pp. 183-195.
71. Notes on the genus *Helminthophaga*. *In* Ibis, VI, pp. 166-171. (April, 1876.)
72. Regarding *Buteo vulgaris* in North America. *In* Bull. Nutt. Orn. Club for April, 1876, I, pp. 32-39.
73. Maximum length of the black snake. *In* Forest and Stream, VI, p. 318. (June, 1876.)
74. Giant pear trees. *In* Forest and Stream, VI, p. 337. (June, 1876.)
75. Notes on the catalpa. *Catalpa big-*

nonioides. *In* Field and Forest, II, pp. 27-29. (August, 1876.)

76. The black snake again. *In* Forest and Stream, VII, p. 20. (August, 1876.)

77. On geographical variation in *Dendroca palmarum*. *In* Bull. Nutt. Orn. Club, for Sept., 1876, I pp. 81-87.

78. Sexual, individual and geographical variation in the genus *Leucosticte*. *In* Field and Forest, II, pp. 37-43. (September, 1876.)

79. The little cypress swamp of Indiana. *In* Field and Forest, II, pp. 93-96. (Dec., 1876.)

80. Ornithology. *In* U. S. Geol. Surv. w. 40th Parallel, IV, part III, pp. 303-670. Washington, Government Printing Office, 1877.

81. On geographical variation in *Turdus migratorius*. *In* Bull. Nutt. Orn. Club, for Jan., 1877, II, pp. 8-9.

82. Mrs. Maxwell's Colorado museum. *In* Field and Forest, II, pp. 195-198; 208-214. (May and June, 1877.)

83. Mrs. Maxwell's Colorado museum. Additional notes. *In* Field and Forest, III, p. 11. (July, 1877.)

84. The birds of Guadalupe Island, discussed with reference to the present genesis of species. *In* Bull. Nutt. Orn. Club for July, 1877, II, pp. 58-66.

85. Description of a new wren of the Tres Marias Islands. *In* Bull. Nutt. Orn. Club, for Jan., 1878, III, pp. 10-11.

86. Three additions to the avifauna of North America. *In* Bull. Nutt. Orn. Club, for Jan., 1878, III, pp. 37-38.

87. Eastward range of *Chondestes grammaca*. *In* Bull. Nutt. Orn. Club, for Jan., 1878, III, pp. 43-44.

88. Studies of the American Herodiones. Part I. Synopsis of the American genera of Ardeidae and Ciconiidae; including descriptions of three new genera and a monograph of the genus *Ardea*, Linnæus. *In* Bull. U.

S. Geol. and Geog. Surv. Terr., for Feb., 1878, IV, pp. 219-251.

89. On a new humming bird (*Atthis ellioti*), from Guatemala. *In* Proc. U. S. Nat. Mus., for 1878, I, pp. 8-10.

90. Notes on some of the birds of Calaveras county, California, and adjoining localities. *In* Bull. Nutt. Orn. Club, for April, 1878, III, pp. 64-68.

91. Song birds of the West. *In* Harper's Mag., LVI, pp. 857-880, 19 wood cuts. (May, 1878.)

92. A review of the American species of the genus *Scops*, Savigny. *In* Proc. U. S. Nat. Mus. for August, 1878, I, sig. 1, pp. 85-117.

93. Notes on birds observed at Mount Carmel, southern Illinois, in the spring of 1878. *In* Bull. Nutt. Orn. Club for Oct., 1878, III, pp. 162-166.

94. Editor of 'Notes on the ornithology of southern Texas, being a list of birds observed in the vicinity of Fort Brown, Texas, from February, 1876 to June, 1878.' By James C. Merrill, Assistant Surgeon, U. S. Army. *In* Proc. U. S. Nat. Mus. for Oct., 1878, I, pp. 118-173.

95. Descriptions of several new species and geographical races of birds contained in the collection of the United States National Museum. *In* Proc. U. S. Nat. Mus. for Dec., 1878, I, pp. 247-252.

96. Description of two new species of birds from Costa Rica, and notes on other rare species from that country. *In* Proc. U. S. Nat. Mus. for Dec., 1878, I, pp. 252-255.

97. Editor of 'A partial list of the birds of central California.' By L. Belding, of Stockton. *In* Proc. U. S. Nat. Mus. for March, 1879, I, pp. 388-449.

98. Descriptions of new species and races of American birds, including a synopsis of the genus *Tyrannus*, Cuvier. *In* Proc. U. S. Nat. Mus. for April 1879, I, pp. 466-486.

99. Portion of letter to Mr. Geo. B. Grinnell in relation to the bird afterward described as *Seiurus neivus notabilis*. *In* Forest and Stream, XII, p. 307. (May, 1879.)
100. On the use of trinomials in zoölogical nomenclature. *In* Bull. Nutt. Orn. Club for July, 1879. IV, pp. 129-134.
101. On a new species of *Peucea* from southern Illinois and central Texas. *In* Bull. Nutt. Orn. Club for Oct., 1879, IV, pp. 218-222.
102. Note on *Helminthophaga gunnii*, Gibbs. *In* Bull. Nutt. Orn. Club for Oct., 1879, IV, pp. 233-234.
103. Henslow's bunting (*Coturniculus henslowi*) near Washington. *In* Bull. Nutt. Orn. Club for Oct., 1879, IV, p. 238.
104. On six species of birds new to the fauna of Illinois, with notes on other rare Illinois birds. *In* Bull. Nutt. Orn. Club for June, 1880, V, pp. 30-32.
105. On current objectionable names of North American birds. *In* Bull. Nutt. Orn. Club for Jan., 1880, V, pp. 36-38.
106. Note on *Peucea illinoensis*. *In* Bull. Nutt. Orn. Club for Jan., 1880, V, p. 52.
107. Late breeding of the blue grosbeak. *In* Bull. Nutt. Orn. Club for Jan., 1880, V, p. 53.
108. Description of an unusual (?) plumage of *Buteo harlani*. *In* Bull. Nutt. Orn. Club for Jan., 1880, V, pp. 58-59.
109. Revisions of nomenclature of certain North American birds. *In* Proc. U. S. Nat. Mus. for March, 1880, III, pp. 1-16.
110. Notes on the American vultures (*Sarcorhamphidæ*), with special reference to their generic nomenclature. *In* Bull. Nutt. Orn. Club for April, 1880, V, pp. 77-84.
111. Description of the adult plumage of *Hierofalco gyrfalco obsoletus*. *In* Bull. Nutt. Orn. Club for April, 1880, V, pp. 92-95.
112. The northern waxwing (*Ampelis garrulus*) in southern Illinois. *In* Bull. Nutt. Orn. Club for April, 1880, V, p. 118.
113. Note concerning the capture of a specimen of the greenfinch (*Ligurinus chloris*) at Lowville, Lewis county, New York. *In* Bull. Nutt. Orn. Club for April, 1880, V, p. 119.
114. On the supposed identity of *Ardea occidentalis*, Aud., and *A. wurdemanni*, Baird. *In* Bull. Nutt. Orn. Club for April, 1880, V, pp. 123-124.
115. On the moult of the bill, or parts of its covering in certain *Alcidæ*. *In* Bull. Nutt. Orn. Club for April, 1880, V, pp. 126, 127.
116. On *Rallus longirostris*, Bodd., and its geographical races. *In* Bull. Nutt. Orn. Club for July, 1880, V, pp. 138-140.
117. On *Macrohæphus griseus* (Gmel.) and *M. scotopæceus* (Say). *In* Bull. Nutt. Orn. Club for July, 1880, V, pp. 156-160.
118. On a new Alaskan sandpiper. *In* Bull. Nutt. Orn. Club for July, 1880, V, pp. 160-163.
119. *Scops flammeola* in Colorado. *In* Bull. Nutt. Orn. Club for July, 1880, V, p. 185.
120. The little brown crane (*Grus fraterculus*, Cassin). *In* Bull. Nutt. Orn. Club for July, 1880, V, pp. 187-188.
121. A catalogue of the birds of North America. *In* Proc. U. S. Nat. Mus. for August, 1880, III, pp. 163-246.
122. Description of the eggs of the Caspian tern (*Sterna caspia*). *In* Bull. Nutt. Orn. Club for October, 1880, V, pp. 221-223.
123. Note on *Helminthophaga cincinnatensis*, Langdon. *In* Bull. Nutt. Orn. Club for Oct., 1880, V, pp. 237-238.
124. Catalogue of the *Trochilidæ* in the collection of the United States National Museum. *In* Proc. U. S. Nat. Mus. for Oct., 1880, III, pp. 308-320.
125. Nomenclature of North American

- birds, chiefly contained in the U. S. Nat. Mus. Washington, Government Printing Office. (1881.)
126. Swainson's warbler in Texas. *In Bull. Nutt. Orn. Club*, VI, pp. 54-55. (Jan., 1881.)
127. Southern range of the raven on the Atlantic Coast of the United States. *In Bull. Nutt. Orn. Club*, VI, p. 118. (April, 1881.)
128. An unaccountable migration of the red-headed woodpecker. *In Bull. Nutt. Orn. Club*, VI, pp. 120-122. (April, 1881.)
129. The Caspian tern in California. *In Bull. Nutt. Orn. Club*, VI, p. 124. (April, 1881.)
130. A hawk new to the United States. *In Forest and Stream*, XVI, p. 206. (April 14, 1881.)
131. On a duck new to the North American fauna. *In Proc. U. S. Nat. Mus. for 1881*, IV, pp. 22-24.
132. On *Amazilia yucatanensis* (Cabot) and *A. cerviniventris*, Gould. *In Proc. U. S. Nat. Mus. for 1881*, IV, pp. 25-26.
133. A catalogue of the birds of Illinois. *In Bull. Illinois State Laboratory of Natural History for May, 1881*, pp. 164-208.
134. A review of the genus *Centurus*, Swainson. *In Proc. U. S. Nat. Mus. for 1881*, IV, pp. 93-119.
135. List of species of Middle and South American birds not contained in the United States National Museum. *In Proc. U. S. Nat. Mus. for 1881*, IV, pp. 165-203.
136. On a tropical hawk to be added to the North American fauna. *In Bull. Nutt. Orn. Club*, VI, pp. 207-214. (Oct., 1881.)
137. List of special desiderata among North American birds. *In Proc. U. S. Nat. Mus. for 1881*, IV, pp. 207-223.
138. On an apparently new heron from Florida. *In Bull. Nutt. Orn. Club*, VII, pp. 1-6. (Jan., 1882.)
139. Notes on some birds observed near Wheatland, Knox County, Indiana, in the spring of 1881. *In Bull. Nutt. Orn. Club*, VII, pp. 15-23. (Jan., 1882.)
140. On the generic name of *Helminthophaga*. *In Bull. Nutt. Orn. Club*, VII, pp. 53-54. (Jan., 1882.)
141. The great black-backed gull (*Larus marinus*) from a new locality. *In Bull. Nutt. Orn. Club*, VII, p. 60. (Jan., 1882.)
142. Correction of an erroneous identification of *Milvulus tyrannus* for *M. forficatus*. *In Ornithologist and Oölogist*, VI, p. 93. (Feb., 1882.)
143. Catalogue of Old World birds in the United States National Museum. *In Proc. U. S. Nat. Mus. for 1882*, IV, pp. 317-333.
144. Notes on some Costa Rican birds. *In Proc. U. S. Nat. Mus. for 1882*, IV, pp. 333-337.
145. Description of the adult female of *Falco peregrinus pealei*. *In Ibis*, VI, pp. 294-298. (April, 1882.)
146. Description of a new flycatcher and supposed new petrel from the Sandwich Islands. *In Proc. U. S. Nat. Mus. for 1882*, IV, pp. 337-338.
147. Description of a new owl from Porto Rico. *In Proc. U. S. Nat. Mus. for 1882*, IV, pp. 366-371.
148. Descriptions of two new thrushes from the United States. *In Proc. U. S. Nat. Mus. for 1882*, IV, pp. 374-379.
149. On two recent additions to the North American bird fauna, by L. Belding. *In Proc. U. S. Nat. Mus. for 1882*, IV, pp. 414-415.
150. Descriptions of several new races of American birds. *In Proc. U. S. Nat. Mus. for 1882*, V, pp. 9-15.
151. On the genera *Harporhynchus*, Cabanis, and *Methriopterus*, Reichenbach, with a description of a new genus of *Mimina*. *In Proc. U. S. Nat. Mus. for 1882*, V, pp. 43-46.
152. Notes on the native trees of the

- lower Wabash and White River valleys, in Illinois and Indiana. *In Proc. U. S. Nat. Mus. for 1882, V, pp. 49-88.*
153. Critical remarks on the tree creepers (Certhia) of Europe and North America. *In Proc. U. S. Nat. Mus. for 1882, V, pp. 111-116.*
154. Description of some new North American birds. *In Proc. U. S. Nat. Mus. for 1882, V, pp. 343-346.*
155. On a collection of birds from the Hacienda 'La Palma,' Gulf of Nicoya, Costa Rica. By C. C. Nutting. With critical notes by R. Ridgway. *In Proc. U. S. Nat. Mus. for 1882, V, pp. 382-409.*
156. Distribution of the fish crow (*Corvus ossifragus*). *In Bull. Nutt. Orn. Club, VII, p. 250. (Oct., 1882.)*
157. Birds new to or rare in the District of Columbia. *In Bull. Nutt. Orn. Club, VII, p. 253. (Oct., 1882.)*
158. List of additions to the catalogue of North American birds. *In Bull. Nutt. Orn. Club, VII, pp. 254-258. (Oct., 1882.)*
159. On Le Conte's bunting (*Coturniculus lecontei*) and other birds observed in southeastern Illinois. *In Bull. Nutt. Orn. Club, VIII, p. 58. (Jan., 1883.)*
160. The scissor-tail (*Milvulus forficatus*) at Norfolk, Va. *In Bull. Nutt. Orn. Club, VIII, p. 59. (Jan., 1883.)*
161. On some remarkable points of relationship between the American kingfishers. *In Bull. Nutt. Orn. Club, VIII, p. 59. (Jan., 1883.)*
162. Geographical variation in size among certain Anatidæ and Gruidæ. *In Bull. Nutt. Orn. Club, VIII, p. 62. (Jan., 1883.)*
163. Corrections. *In Ornithologist and Oölogist, VIII, p. 13. (Feb., 1883.)*
164. Catalogue of a collection of birds made in the interior of Costa Rica, by Mr. C. C. Nutting. *In Proc. U. S. Nat. Mus. for 1883, V, pp. 493-502.*
165. Description of a new warbler from the islands of Santa Lucia, West Indies. *In Proc. U. S. Nat. Mus. for 1883, V, pp. 525-526.*
166. Description of a supposed new plover, from Chili. *In Proc. U. S. Nat. Mus. for 1883, V, pp. 526-527.*
167. Catalogue of a collection of birds made at various points along the western coast of lower California, north of Cape St. Eugenio. By L. Belding. Edited by R. Ridgway. *In Proc. U. S. Nat. Mus. for 1883, V, pp. 527-532.*
168. Catalogue of a collection of birds made near the southern extremity of the peninsula of Lower California. By L. Belding. Edited by R. Ridgway. *In Proc. U. S. Nat. Mus. for 1883, V, pp. 532-550.*
169. On the genus *Tantalus* Linn., and its allies. *In Proc. U. S. Nat. Mus. for 1883, V, pp. 550-551.*
170. Catalogue of the aquatic and fish-eating birds exhibited by the United States National Museum at the Great International Fisheries Exhibition, London, 1883. Washington, Government Printing Office, 1883. Pp. 1-46.
171. Description of a new petrel from Alaska. *In Proc. U. S. Nat. Mus. for 1883, V, pp. 656-658.*
172. Descriptions of some birds, supposed to be undescribed, from the Commander Islands and Petropaulovski, collected by Dr. Leonhard Stejneger, U. S. Signal Service. *In Proc. U. S. Nat. Mus. for 1883, VI, pp. 90-96.*
173. Notes on the black racer. *In Forest and Stream, XXI, p. 63. (August 23, 1883.)*
174. On the probable identity of *Motacilla ocularis* Swinhoe and *M. amurensis* Seeböhm, with remarks on a supposed species, *M. blakistoni* Seeböhm. *In Proc. U. S. Nat. Mus. for 1883, VI, pp. 144-147.*
175. Notes on some rare species of Neotropical birds. *In Ibis, I, pp. 399-401. (Oct., 1883.)*

176. Letters to the editors concerning the U. S. National Museum exhibit of aquatic and fish-eating birds at the London International Fisheries Exhibition. *In Ibis*, I, pp. 548-580. (Oct., 1883.)

177. Descriptions of some new birds from Lower California. *In Proc. U. S. Nat. Mus. for 1883*, VI, pp. 154-156.

178. *Anthus cervinus* (Pallas) in Lower California. *In Proc. U. S. Nat. Mus. for 1883*, VI, pp. 156-157.

179. Note on *Merula confinis* (Baird). *In Proc. U. S. Nat. Mus. for 1883*, VI, pp. 158-159.

180. Additions and corrections to the list of native trees of the Lower Wabash. *In Bot. Gaz.*, VIII, pp. 345-352. (Dec. 1883.)

181. Report on the department of birds, U. S. National Museum. *In Ann. Rep. U. S. Nat. Mus. for 1882, 1883*, pp. 13-17.

182. Note on *Zenaidura yucatanensis* Lawr. *In Auk*, I, p. 96. (Jan., 1884.)

183. On a new *Carpodectes* from southwestern Costa Rica. *In Ibis*, II, for Jan., 1884, pp. 27-28, pl. 2.

184. Notes on three Guatemalan birds. *In Ibis*, II, for Jan., 1884, pp. 43-45.

185. List of birds found at Guaymas, Sonora, in December and April, 1883. By L. Belding. (Edited by R. Ridgway.) *In Proc. U. S. Nat. Mus. for Jan., 1884*, VI, pp. 343-344.

186. Second catalogue of a collection of birds made near the southern extremity of Lower California. By L. Belding. (Edited by R. Ridgway.) *In Proc. U. S. Nat. Mus. for Jan., 1884*, VI, pp. 344-352.

187. Notes on some Japanese birds related to North American species. *In Proc. U. S. Nat. Mus. for Jan., April, 1884*, VI, pp. 368-371.

188. *Ortyx virginianus* not in Arizona. *In Forest and Stream*, XXII, p. 124. (March 13, 1884.)

189. The water birds of North America. (Joint author with S. F. Baird and T. M.

Brewer.) *In Memoirs of the Museum of Comparative Zoölogy at Harvard College*, Vol. XII. (Issued in continuation of the publications of the geological survey of California.) Boston, 1884. Vol. I, pp. i-xi, 1-537; Vol. II, pp. 1-552.

190. Remarks concerning *Phalacrocorax violaceus* and *P. v. resplendens*. *In Auk*, I, p. 165. (April, 1884.)

191. Remarks concerning two Central American species commonly referred to the genus *Compsothlypis* cabanis. *In Auk*, I, p. 169. (April, 1884.)

192. Descriptions of some new North American birds. *In Proc. Biol. Soc. Wash.*, II, 1885 (author's edition distributed April 10, 1884), pp. 89-95.

193. Description of a new American kingfisher. *In Proc. Biol. Soc. Wash.*, II, 1885 (author's edition published April 10, 1884), pp. 95-96.

194. Note on *Psaltriparus grindae*, Belding. *In Proc. Biol. Soc. Wash.*, II, 1885 (author's edition published April 10, 1884), pp. 96.

195. Note on the generic name *Calodromus*. *In Proc. Biol. Soc. Wash.*, II, 1885 (author's edition published April 10, 1884), p. 97.

196. Southern limit of quail and grouse. *In Forest and Stream*, XXII, p. 243. (April 24, 1884.)

197. On a collection of birds from Nicaragua. By Charles C. Nutting. Edited by R. Ridgway. *In Proc. U. S. Nat. Mus. for April, 1884*, VI, pp. 24-26.

198. On some Costa Rican birds, with descriptions of several supposed new species. *In Proc. U. S. Nat. Mus. for April, 1884*, VI, pp. 410-415.

199. A review of the American crossbills (*Loxia*) of the *L. curvirostra* type. *In Proc. Biol. Soc. Wash.*, II, 1885 (author's edition published April 28, 1884), pp. 101-107.

200. Note on the *Anas hyperboreus*.

- Pall., and *Anser albatrus*, Cass. *In Proc. Biol. Soc. Wash.*, II, 1885 (author's edition published April 28, 1884), pp. 107-108.
201. Remarks on the type specimens of *Muscicapa fulvifrons*, Girard, and *Mitrephorus pallescens*, Coues. *In Proc. Biol. Soc. Wash.*, II, 1885 (author's edition published April 28, 1884), pp. 108-110.
202. Note regarding the earliest name for *Carpodacus hæmorrhous* (Wagler). *In Proc. Biol. Soc. Wash.*, II, 1885 (author's edition published April 28, 1884), pp. 110-111.
203. Note concerning the correct specific name of *Cypselus saxatilis* Woodhouse. *In Auk*, I, p. 230, footnote. (July, 1884.)
204. Remarks upon the close relationship between the white and scarlet ibises (*Eudocimus albus* and *E. ruber*).
205. Note on *Astur atricapillus striatulus*. *In Auk*, I, pp. 252-253. (July, 1884.)
206. On the possible specific identity of *Buteo cooperi* Cass. with *B. harlani* Aud. *In Auk*, I, p. 254. (July, 1884.)
207. Probable breeding of the red cross-bill (*Loxia curvirostra americana*) in central Maryland. *In Auk*, I, p. 292. (July, 1884.)
208. The probable breeding place of *Passerulus princeps*. *In Auk*, I, pp. 292-293. (July, 1884.)
209. Note on *Selasphorus torridus* Salvin. *In Proc. U. S. Nat. Mus.* for July, 1884, VII, p. 14.
210. *Melanetta fusca* (Linn.) in Alaska. *In Proc. U. S. Nat. Mus.* for July, 1884, VII, p. 68.
211. Description of a new snow bunting from Alaska. *In Proc. U. S. Nat. Mus.* for July, 1884, VII, pp. 68-70.
212. On a collection of birds made by Messrs. J. E. Benedict and W. Nye, of United States Fish Commission Steamer Albatross. *In Proc. U. S. Nat. Mus.* for Sept., 1884, VII, pp. 172-180.
213. Description of a new species of the field sparrow from New Mexico. *In Proc. U. S. Nat. Mus.* for 1884, VII, p. 254.
214. Another Kirtland's warbler from Michigan. *In Auk*, I, p. 389. (Oct., 1884.)
215. Note concerning bird exhibit of the U. S. National Museum at the New Orleans Exposition. *In Auk*, I, p. 403. (Oct., 1884.)
216. Note relative to extent of bird collection in the U. S. National Museum. *In Auk*, I, pp. 403-404. (Oct., 1884.)
217. On a new species of coot from the West Indies. *In Proc. U. S. Nat. Mus.* for Oct., 1884, VII, p. 358.
218. The bird collection of the U. S. National Museum. *In Science*, IV, p. 497. (Nov. 28, 1884.)
219. Grouse and mallard plumage. *In Forest and Stream*, XXIX, p. 463. (Jan. 5, 1885.)
220. Extract from letter to the editor concerning the name, etc., of *Spizella wortheni*. *In Ornithologist and Oölogist*, X, p. 24. (Feb., 1885.)
221. Description of some new species of birds from Cozumel Island, Yucatan. *In Proc. Biol. Soc. Wash.*, III, 1886 (author's edition published Feb. 20, 1885), pp. 21-24.
222. Description of a new race of the red-shouldered hawk from Florida. *In Proc. U. S. Nat. Mus.* for Feb., 1885, VII, p. 514.
223. On two hitherto unnamed sparrows from the coast of California. *In Proc. U. S. Nat. Mus.* for Feb., 1885, pp. 516-578.
224. The European sparrow. *In American Field*, XXIII, p. 295. (March 28, 1885.)
225. On *Buteo harlani* (Aud.) and *B. cooperi* Cass. *In Auk*, II, pp. 165-166. (April, 1885.)
226. Remarks on the California vulture (*Pseudogryphus californianus*). *In Auk*, II, pp. 167-169. (April, 1885.)

227. Note on *Sarcorhamphus æquatorialis* Sharpe. *In Auk*, II, pp. 169-171. (April, 1885.)
228. Review of Gurney's 'List of the diurnal birds of prey.' *In Auk*, II, pp. 203-205. (April 1885.)
229. Where did it come from? *In Forest and Stream*, XXIV, p. 204. (April 9, 1885.)
230. On *Æstrelata fisheri* and *Æ. defilipiana*. *In Proc. U. S. Nat. Mus.* for May, 1885, VIII, pp. 17-18.
231. *Icterus cucullatus*, Swainson, and its geographical variations. *In Proc. U. S. Nat. Mus.* for March, 1885, VIII, pp. 18-19.
232. Description of a new species of *Contopus* from tropical America. *In Proc. U. S. Nat. Mus.* for May, 1885, VIII, p. 21.
233. Note on the *Anser leucopareius* of Brandt. *In Proc. U. S. Nat. Mus.* for May, 1885, VIII, pp. 21-22.
234. Description of a new warbler from Yucatan. *In Proc. U. S. Nat. Mus.* for May, 1885, VIII, p. 23.
235. Description of two new birds from Costa Rica. *In Proc. U. S. Nat. Mus.* for May, 1885, VIII, pp. 23-24.
236. Description of three supposed new honey creepers from the Lesser Antilles, with a synopsis of the species of the genus *Certhiola*. *In Proc. U. S. Nat. Mus.* for May, 1885, VIII, pp. 25-30.
237. On *Cathartes burrovianus*, Cassin, and *C. urubitinga*, Pelzeln. *In Proc. U. S. Nat. Mus.* for May, 1885, VIII, pp. 34-36.
238. On *Onychotes gruberi*. *In Proc. U. S. Nat. Mus.* for May, 1885, VIII, pp. 36-38.
239. Remarks on the type specimens of *Buteo oxypterus*, Cassin. *In Proc. U. S. Nat. Mus.* for May, 1885, VIII, pp. 75-77.
240. Description of a new species of boat-billed heron from Central America. *In Proc. U. S. Nat. Mus.* for June, 1885, VIII, pp. 93-94.
241. Description of a new hawk from Cozumel. *In Proc. U. S. Nat. Mus.*, for June, 1885, VIII, pp. 94-95.
242. On *Peucaea mexicana* (Lawr.), a sparrow new to the United States. *In Proc. U. S. Nat. Mus.* for June, 1885, VIII, pp. 98-99.
243. A review of the American golden warblers. *In Proc. U. S. Nat. Mus.* for Sept., 1885, VIII, pp. 348-350.
244. Some emended names of North American birds. *In Proc. U. S. Nat. Mus.* for Sept., 1885, VIII, pp. 354-356.
245. Description of a new cardinal grosbeak from Arizona. *In Auk*, II, pp. 343-345. (Oct., 1885.)
246. *Helminthophila leucobronchialis*. *In Auk*, II, pp. 259-363. (Oct., 1885.)
247. On *Junco cinereus* (Swains.) and its geographical races. *In Auk*, II, pp. 363-364. (Oct., 1885.)
248. A new petrel for North America. *In Auk*, II, pp. 386-387. (Oct., 1885.)
249. Description of an apparently new species of *Dromococcyx* from British Guiana. *In Proc. U. S. Nat. Mus.* for Oct., 1885, VIII, p. 559.
250. Catalogue of a collection of birds made on the islands of Cozumel, Yucatan, by the naturalists of the U. S. Fish Commission Steamer Albatross, Capt. Z. L. Tanner commanding. *In Proc. U. S. Nat. Mus.* for Oct., 1885, VIII, pp. 560-583.
251. Report on the department of birds, U. S. National Museum, 1883. *In Ann. Rep. Smithsonian Institution for 1883* (1885), pp. 220-225.
252. Report on the department of birds, U. S. National Museum, 1884. *In Ann. Rep. Smithsonian Institution* (Report of U. S. National Museum) for 1884 (1885), pp. 143-155.
253. On the proper name of the prairie hen. *In Auk*, III, pp. 132-133. (Jan., 1886.)
254. The scissor-tail flycatcher. (Milv-

- lus forficatus) at Key West. *In Auk*, III, p. 134. (Jan., 1886.)
255. The vernacular name of *Plectrophenax hyperboreus*. *In Auk*, III, p. 135. (Jan., 1886.)
256. Arizona quail. *In Forest and Stream*. (Jan. 14, 1886.)
257. Birds and bonnets. *In Forest and Stream*, XXVI, p. 5. (Jan. 28, 1886.)
258. Is the dodo an extinct bird? *In Science*, VII, p. 190. (Feb. 26, 1886.)
259. Water birds of North America. 'A few corrections' rectified. *In Auk*, III, pp. 266-268. (April, 1886.)
260. *Tringa damacensis* (Horsf.) in Alaska; a sandpiper new to the North American fauna. *In Auk*, III, p. 275. (April, 1886.)
261. Discovery of the breeding place of McKay's snowflake (*Plectrophenax hyperboreus*.) *In Auk*, III, pp. 276-277. (April, 1886.)
262. On two abnormally colored specimens of the bluebird (*Sialia sialis*). *In Auk*, III, pp. 282-283. (April, 1886.)
263. Note announcing departure of the Fish Commission steamer Albatross on a scientific cruise among the Bahamas and other islands of the West Indies. *In Auk*, III, p. 286. (April, 1886.)
264. On the glaucous gull of Bering Sea and contiguous waters. *In Auk*, III, pp. 330-331. (July, 1886.)
265. A nomenclature of colors for naturalists, and compendium of useful knowledge for ornithologists. Boston, 1886. Pp. 1-129; 17 plates.
256. Description of new species of oyster-catcher from the Galapagos Islands. *In Auk*, III, p. 331. (July, 1886.)
267. Preliminary descriptions of some new species of birds from southern Mexico, in the collection of the Mexican Geographical and Exploring Commission. *In Auk*, III. (July, 1886.)
268. Descriptions of two new species of birds supposed to be from the interior of Venezuela. *In Auk*, III, p. 333. (July, 1886.)
269. Description of a new species of elf owl from Socorro Island, western Mexico. *In Auk*, III, pp. 333-334. (July, 1886.)
270. Description of a new genus of Oceanitidæ. *In Auk*, III, p. 334. (July, 1886.)
271. Description of four new species of birds from the Bahama Islands. *In Auk*, III, pp. 334-337. (July, 1886.)
272. Description of a new genus of Tyrannidæ from Santo Domingo. *In Auk*, III, p. 382. (July, 1886.)
273. Remarks concerning certain corrections of alleged errors in 'Water birds of North America.' *In Auk*, III, pp. 403-404. (July, 1886.)
274. Descriptions of some new species of birds, supposed to be from the interior of Venezuela. *In Proc. U. S. Nat. Mus.* for Sept. 17, 1886, IX, pp. 92-94.
275. On *Æstelata sandwichensis* Ridgw. *In Proc. U. S. Nat. Mus.* for Sept. 17, 1886, IX, pp. 95-96.
276. Catalogue of the animals collected by the Geographical and Exploring Commission of the Republic of Mexico. By Fernando Ferrari-Perez, Chief of the Natural History Section. II. Birds. By F. Ferrari-Perez. With descriptions of five new species, and critical remarks on others of greater or less rarity or interest, by Robert Ridgway. *In Proc. U. S. Nat. Mus.* for Oct., 1886, IX, pp. 130-182.
277. Description of the young and first plumage of *Sterna fuliginosa*. *In Auk*, III, pp. 433-434. (Oct., 1886.)
278. Description of a new species of the genus *Empidonax* from Guatemala. *In Ibis*, IV, pp. 459-460. (Oct., 1886.)
279. On *Empidochanes fuscatus* (Max.) and *Empidonax brunneus*, Ridgw. *In Ibis*, IV, pp. 460-461. (Oct., 1886.)

280. On the species of the genus *Empidonax*. *In* *Ibis*, IV, pp. 461-468. (Oct., 1886.)
281. Description of a melanistic specimen of *Buteo latissimus* (Wils.). *In* *Proc. U. S. Nat. Mus.* for Oct., 1886, IX, pp. 248-249.
282. Report on the department of birds, U. S. National Museum, Jan. 1 to June 30, 1885. *In* *Ann. Rep. Smithsonian Institution* (Report of U. S. National Museum) for 1885 (1886), pp. 85-91.
283. A singularly marked specimen of *Sphyrapicus thyroideus*. *In* *Auk*, IV, pp. 75-76. (Jan., 1887.)
284. Description of a recently new oystercatcher (*Hainatopus galapagoensis*) from the Galapagos Islands. *In* *Proc. U. S. Nat. Mus.* for Feb., 1887, IX, pp. 325-326.
285. Description of a new subspecies of *Cyclorhis* from Yucatan. *In* *Proc. U. S. Nat. Mus.* for Feb., 1887, IX, p. 519.
286. Description of a new species of *Myiarchus*, presumably from the Orinoco district of South America. *In* *Proc. U. S. Nat. Mus.* for Feb., 1887, IX, p. 520.
287. On a probable hybrid between *Dryobates nuttalli* (Gamb.) and *D. pubescens gairdnerii* (Aud.). *In* *Proc. U. S. Nat. Mus.* for Feb., 1887, IX, pp. 521-522.
288. Description of an apparently new species of *Picolaptes*, from the lower Amazon. *In* *Proc. U. S. Nat. Mus.* for Feb., 1887, IX, p. 523.
289. Description of a new plumed part-ridge from Sonora. *In* *Forest and Stream*, XXVIII, p. 106. (March 3, 1887.)
290. List of birds found breeding within the corporate limits of Mt. Carmel, Illinois. *In* *Bull. Ridgway Orn. Club* for April, 1887, pp. 26-35.
291. The imperial woodpecker (*Campephilus imperialis*) in northern Sonora. *In* *Auk*, IV, p. 161. (April, 1887.)
292. The coppery-tailed trogon (Trogon ambiguus) breeding in southern Arizona. *In* *Auk*, IV, pp. 161-162. (April, 1887.)
293. Description of a new species of *Cotinga* from the Pacific Coast of Costa Rica. *In* *Proc. U. S. Nat. Mus.* for April, 1877, X, pp. 1-2.
294. Description of a new form of *Spindalis* from the Bahamas. *In* *Proc. U. S. Nat. Mus.* for April, 1887, X, p. 3.
295. Description of the adult female of *Carpodectes antoniae*, Zeledon, with critical remarks, notes on habits, etc., by José C. Zeledon. *In* *Proc. U. S. Nat. Mus.* for April, 1877, X, p. 20.
296. Feathered songsters. Great western bird center. A list of the birds found breeding within the corporate limits of Mt. Carmel, Illinois. *In* *Mount Carmel Register*, April 28, 1887.
297. Description of a new species of *Porzana* from Costa Rica. *In* *Proc. U. S. Nat. Mus.* for July, 1887, Vol. X, p. 111.
298. Notes on *Ardea wuerdemanni* Baird. *In* *Proc. U. S. Nat. Mus.* for July, 1887, X, pp. 112-115.
299. Trogon ambiguus breeding in Arizona. *In* *Proc. U. S. Nat. Mus.* for July, 1887, p. 147.
300. Description of a new plumed part-ridge from Sonora. *In* *Proc. U. S. Nat. Mus.* for July, 1887, X, p. 148-150.
301. Description of a new genus of Dendrocolapline bird from the lower Amazon. *In* *Proc. U. S. Nat. Mus.* for July, 1887, X, p. 151.
302. Description of a new species of *Phacellodomus* from Venezuela. *In* *Proc. U. S. Nat. Mus.* for July, 1887, X, p. 152.
303. Clarke's nutcracker (*Picicorvus columbianus*) in the Bristol Bay region, Alaska. *In* *Auk*, IV, p. 255. (July, 1887.)
304. Clarke's nutcracker from the Kowak River, Alaska. *In* *Auk*, IV, p. 256. (July, 1887.)
305. Yellow-headed blackbird (*Xantho-*

- cephalus xanthocephalus) in Maine. *In* Auk, IV, p. 256. (July, 1887.)
306. Note on *Spizella monticola ochracea* Brewst. *In* Auk, IV, pp. 258-259. (July, 1887.)
307. Letter to the editor concerning the supposed breeding plumage of *Podiceps occidentalis* Lawrence. *In* Ibis, V, pp. 261-262. (July, 1887.)
308. Description of two new species of Kaup's genus *Megascops*. *In* Proc. U. S. Nat. Mus. for Aug., 1887, X, pp. 267-268.
309. Description of two new races of *Pyrhuloxia sinuata* Bonap. *In* Auk, IV, p. 347. (Oct., 1887.)
310. On the correct subspecific title of Baird's wren (No. 719b, A. O. U. check-list). *In* Auk, IV, pp. 249-250. (Oct., 1887.)
311. A correction. *In* Ornithologist and Oölogist, XII, p. 192. (Nov., 1887.)
312. Description of a new *Muscisaxicola*, from Lake Titicaca, Peru. *In* Proc. U. S. Nat. Mus. for Nov., 1887, X, p. 430.
313. On *Phrygilus gayi* (Eyd. and Gerv.) and allied species. *In* Proc. U. S. Nat. Mus. for Nov., 1887, X, pp. 431-435.
314. Spencer Fullerton Baird. (In memoriam.) *In* Auk, V, pp. 1-14. (Jan., 1888.)
315. Notes on some type-specimens of American Troglydytidæ in the Lafresnaye collection. *In* Proc. Bost. Soc. Nat. Hist. for March, 1888, XXIII, pp. 383-388.
316. Description of a new *Tityra* from western Mexico. *In* Auk, V, p. 263. (July, 1888.)
317. A review of the genus *Dendrocincla* Gray. *In* Proc. U. S. Nat. Mus. for 1888, X, pp. 32, 488-497.
318. Remarks on *Catharus berlepschi* Lawr. *In* Proc. U. S. Nat. Mus. for August, 1888, p. 504.
319. Descriptions of some new species and subspecies of birds from Middle America. *In* Proc. U. S. Nat. Mus. for August, 1888, X, pp. 505-510.
320. Note on the generic name *Uropsila*, Sc. and Salv. *In* Proc. U. S. Nat. Mus. for August 1888, X, p. 511.
321. Descriptions of new species and genera of birds from the lower Amazon. *In* Proc. U. S. Nat. Mus. for August, 1888, X, pp. 529-548.
322. A review of the genus *Psittacula* of Brisson. *In* Proc. U. S. Nat. Mus. for August, 1888, X, pp. 529-548.
323. Catalogue of a collection of birds made by Mr. Chas. H. Townsend, on islands in the Caribbean Sea and in Honduras. *In* Proc. U. S. Nat. Mus. for August, 1888, pp. 572-597.
324. Charles Wickliffe Beckham: Obituary. *In* Auk, V, pp. 445-446. (Oct., 1888.)
325. Supplementary remarks on the genus *Psittacula* Brisson. *In* Auk, V, pp. 460-462. (Oct., 1888.)
326. Description of a new *Psaltriparus* from southern Arizona. *In* Proc. U. S. Nat. Mus. for Oct., 1888, X, p. 697.
327. Description of a new western subspecies of *Accipiter velox* (Wilson), and subspecific diagnosis of *A. cooperi mexicanus* (Swains). *In* Proc. U. S. Nat. Mus. for Nov., 1888, XI, p. 92.
328. Note on *Æstelrelata sandwichensis* Ridgw. *In* Proc. U. S. Nat. Mus. for Nov., 1888, XI, p. 104.
329. Description of a new pigeon from Guayaquil, Ecuador. *In* Proc. U. S. Nat. Mus. for Nov., 1888, XI, p. 112.
330. Description of the adult male of *Acanthidops bairdi*. *In* Proc. U. S. Nat. Mus. for March, 1889, XI, p. 196.
331. Spring notes on migratory birds. *In* Forest and Stream, XXXII, p. 420 (Jan. 13, 1889.)
332. Notes on Costa Rican birds, with descriptions of seven new species and sub-

species and one new genus. *In Proc. U. S. Nat. Mus. for Sept., 1889, XI, pp. 537-546.*

333. Report on the department of birds, U. S. National Museum, for 1885-1886. *In Ann. Rep. Smithsonian Institution (Report of U. S. Nat. Mus.), for 1885-1886 (1889), pp. 153-162.*

334. The ornithology of Illinois. Part I, Descriptive catalogue. *In Nat. Hist. Survey of Illinois. Springfield, Ill. Vol. I, pp. viii, 520, 22 plates (1889); vol. II, pp. 282, 22 plates (1895).*

335. *Buteo brachyurus* and *B. fuliginosus*. *In Auk, VII, p. 90. (Jan., 1890.)*

336. Intergradation between *Zonotrichia leucophrys* and *Z. intermedia*, and between the latter and *Z. gambeli*. *In Auk, VII, p. 96. (Jan., 1890.)*

337. A chart of standard colors. *In Garden and Forest, III, pp. 22-23. (Jan. 3, 1890.)*

338. A review of the genus *Xiphocolaptes* of Lesson. *In Proc. U. S. Nat. Mus. for Feb., 1890, XII, pp. 1-20.*

339. A review of the genus *Sclerurus* of Swainson. *In Proc. U. S. Nat. Mus. for Feb., 1890, XII, pp. 21-31.*

340. Scientific results of explorations by the U. S. Fish Commission Steamer *Albatross*. (Published by permission of Hon. Marshall McDonald, U. S. Commissioner of Fisheries.) No. I—Birds collected on the Galapagos Islands in 1888. *In Proc. U. S. Nat. Mus. for Feb., 1890, XII, p. 101-128.*

341. Scientific results of explorations by the U. S. Fish Commission Steamer *Albatross*. (Published by permission of Hon. Marshall McDonald, Commissioner of Fisheries.) No. II—Birds collected on the Island of Santa Lucia, West Indies, the Abrolhos Islands, Brazil, and at the Straits of Magellan, in 1887-1888. *In Proc. U. S. Nat. Mus. for Feb., 1890, XII, pp. 129-139.*

342. A northern station for *Quercus lyrata*. *In Garden and Forest, III, p. 129. (March 12, 1890.)*

343. Review of Salvin and Godman's 'Biologia Centrali-Americana—Aves.' *In Auk, VII, pp. 189-195. (April, 1890.)*

344. Harlan's hawk a race of the red-tail, and not a distinct species. *In Auk, VII, p. 205. (April, 1890.)*

345. Further notes on the genus *Xiphocolaptes* of Lesson. *In Proc. U. S. Nat. Mus. for July, 1890, XIII, pp. 47-48.*

346. *Junco hyemalis shufeldti* in Maryland. *In Auk, VII, p. 289. (July, 1890.)*

347. A yellow-crowned *Regulus calendula*. *In Auk, VII, p. 292. (July, 1890.)*

348. Review of Allen's 'Birds from Quito.' *In Auk, VII, pp. 380-381. (Oct., 1890.)*

349. Review of Allen's 'Birds collected in Bolivia.' *In Auk, VII, pp. 381-382. (Oct., 1890.)*

350. Review of Allen's 'The genus *Cyclorhis*.' *In Auk, VII, pp. 382-384. (Oct., 1890.)*

351. Review of Allen's 'Descriptions of new South American birds.' *In Auk, VII, pp. 384-385. (Oct., 1890.)*

352. Review of Allen's 'Individual and seasonal variation in the genus *Elainea*.' *In Auk, VII, pp. 385-386. (Oct., 1890.)*

353. Review of Allen's 'The Maximilian types of South American birds.' *In Auk, VII, pp. 386-387. (Oct., 1890.)*

354. Observations on the Farallon rail (*Porzana jamaicensis coturniculus* Baird). *In Proc. U. S. Nat. Mus. for Nov., 1890, XIII, pp. 309-311.*

355. Report on the department of birds U. S. National Museum, for 1887-1888. *In Ann. Rep. Smithsonian Institution (Report of U. S. Nat. Mus.) for 1888 (1890), pp. 145-150.*

356. *Falco dominicensis* Gmel. versus *Falco sparverioides* Vig. *In Auk, VIII, pp. 113-114. (Jan., 1891.)*

357. A new name necessary for *Selasphorus floresii* Gould. *In Auk, VIII, p. 114. (Jan., 1891.)*

358. Note on the alleged occurrence of *Trochilus heloisæ* (Less. and DeLatt.) within the North American limits. *In Auk*, VIII, p. 115. (Jan., 1891.)
359. *Cistothorus marianæ* (i. e. *C. griseus*), *Buteo lineatus alleni*, and *Syrnium nebulosum alleni*, in South Carolina.
360. Fulvous tree duck in Missouri. *In Forest and Stream*, XXXVI, p. 435. (June S. 1891.)
361. List of birds collected on the Bahama Islands by the naturalists of the Fish Commission Steamer Albatross. *In Auk*, VIII, pp. 333-339. (Oct., 1891.)
362. Description of a new species of whippoorwill from Costa Rica. *In Proc. U. S. Nat. Mus.* for Oct., 1891, pp. 465-466.
363. Notes on some birds from the interior of Honduras. *In Proc. U. S. Nat. Mus.* for Oct., 1891, XIV, pp. 467-471.
364. Notes on some Costa Rican birds. *In Proc. U. S. Nat. Mus.* for Oct., 1891, XIV, pp. 473-478.
365. Note on *Pachyrhamphus albinucha*, Burmeister. *In Proc. U. S. Nat. Mus.* for Oct., 1891, XIV, pp. 479-480.
366. Description of two supposed new forms of *Thamnophilus*. *In Proc. U. S. Nat. Mus.* for Oct., 1891, XIV, p. 481.
367. Description of a new sharp-tailed sparrow from California. *In Proc. U. S. Nat. Mus.* for Oct., 1891, XIV, pp. 483-484.
368. Notes on the genus *Sittasomus* of Swainson. *In Proc. U. S. Nat. Mus.* for Oct., 1891, XIV, pp. 507-510.
369. Directions for collecting birds. *In Part A of Bull. U. S. Nat. Mus.*, No. 39, 1891.
370. Report on the department of birds, U. S. National Museum, for 1888-1889. *In Ann. Rep. Smithsonian Institution* (Report of U. S. Nat. Mus.), for 1888-1889 (1891), pp. 357-361.
371. Report on the department of birds, U. S. National Museum, for 1889-1890. *In Ann. Rep. Smithsonian Institution* (Report of the U. S. National Museum) for 1889-1890 (1891), pp. 195-198.
372. *Zonotrichia albicollis* in California. *In Auk*, IX, p. 302. (July, 1892.)
373. Spring arrivals at Washington, D. C. *In Auk*, IX, pp. 307-308. (July, 1892.)
374. The humming birds. *In Rep. U. S. Nat. Mus.* for 1890 (published July, 1892), pp. 253-383, plates i-xlvi.
375. Descriptions of two new forms of *Basileuterus rufifrons* from Mexico. *In Proc. U. S. Nat. Mus.* for July, 1892, XV, p. 119.
376. The systematic position of humming-birds. Reply to Dr. Shufeldt's 'Discussion.' *In Pop. Sci. News*, XXVI, pp. 164-165. (Nov., 1892.)
377. Shufeldt on the anatomy of the humming birds and swifts. *In Am. Nat.*, XXVI, pp. 1040-1041. (Dec., 1892.)
378. Nocturnal songsters, and other bird-notes. *Science*, XX, pp. 343-344. (Dec. 16, 1892.)
379. Report on the department of birds, U. S. Nat. Mus. for 1890-1891. *In Ann. Rep. Smithsonian Institution* (Report of U. S. Nat. Mus.), for 1890-1891 (1892), pp. 207-211.
380. Destruction of crows during the recent cold spell. *In Science*, XXI, p. 77. (Feb. 10, 1893.)
381. On the local segregation of trees. *In Garden and Forest*, VI, pp. 148-149. (March 29, 1893.)
382. The American plane tree. *In Meehan's Monthly*, for May, 1893, pp. 69-70.
383. Description of two supposed new species of swifts. *In Proc. U. S. Nat. Mus.* for June, 1893, XVI, pp. 43-44.
384. Age of guano deposits. *In Science*, XXI, p. 360. (June, 1893.)
385. Description of a supposed new species of *Odontophorus* from southern Mexico. *In Proc. U. S. Nat. Mus.* for July, 1893, XVI, pp. 469-470.
386. Remarks concerning the type-spec-

imen of *Malacoptila fuliginosa* Ridgway, described on pp. 572-573 of the same paper by Charles W. Richmond. *In Proc. U. S. Nat. Mus.* for Oct., 1893, XVI, p. 513.

387. Descriptions of some new birds collected on the islands of Aldabra and Assumption, northwest of Madagascar, by Dr. W. L. Abbot. *In Proc. U. S. Nat. Mus.* for Oct., 1893, XVI, pp. 597-600.

388. Remarks on the avian genus *Myiarchus*, with special reference to *M. yucatanensis* Lawrence. *In Proc. U. S. Nat. Mus.* for Oct., 1893, XVI, pp. 605-608.

389. On a small collection of birds from Costa Rica. *In Proc. U. S. Nat. Mus.* for Oct., 1893, XVI, pp. 609-614.

390. Scientific results of explorations by the U. S. Fish Commission Steamer *Albatross*. (Published by permission of Hon. Marshall McDonald, Commissioner of Fisheries.) No. XXVII—Catalogue of a collection of birds made in Alaska by Mr. C. H. Townsend during the cruise of the U. S. Fish Commission Steamer *Albatross*, in the summer and autumn of 1888. *In Proc. U. S. Nat. Mus.* for Nov., 1893, XVI, pp. 663-665.

391. A revision of the genus *Formicarius* Boddaert. *In Proc. U. S. Nat. Mus.* for Nov., 1893, Vol. XVI, pp. 667-686.

392. Description of a new storm petrel from the coast of western Mexico. *In Proc. U. S. Nat. Mus.* for Nov., 1893, XVI, pp. 687-688.

393. Report on the department of birds, U. S. Nat. Mus. for 1891-1892. *In Ann. Rep. Smithsonian Institution* (Report of U. S. Nat. Mus.) for 1891-1892 (1893), pp. 147-152.

394. Note on *Rougetius aldabranus*. *In Auk*, XI, p. 74. (Jan., 1894.)

395. Description of a new *Geothlypis* from Brownsville, Texas. *In Proc. U. S. Nat. Mus.* for Feb., 1894, XVI, pp. 691-692.

396. On geographical variation in *Sialia*

mexicana Swainson. *In Auk*, XI, pp. 145-160. (April, 1894.)

397. Description of *Pipilo orizabæ* Cox. *In Auk*, XI, p. 161. (April, 1894.)

398. *Picicorvus* an untenable genus. *In Auk*, XI, p. 179. (April, 1894.)

399. Geographical versus sexual variations in *Oreortyx pictus*. *In Auk*, XI, pp. 193-197, 6 plates. (July, 1894.)

400. *Colinus virginianus cubanensis* not a Florida bird. *In Auk*, XI, p. 324. (Oct., 1894.)

401. We, also, take exceptions. *In Nidologist*, II, p. 29. (Oct., 1894.)

402. Descriptions of twenty-two new species of birds from the Galapagos Islands. *In Proc. U. S. Nat. Mus.* for Nov., 1894, XVII, pp. 357-370.

403. Descriptions of some new birds from Aldabra, Assumption, and Gloriosa Islands, collected by Dr. W. L. Abbott. *In Proc. U. S. Nat. Mus.*, for Nov., 1894, XVII, pp. 371-373.

404. Additional notes of the trees of the lower Wabash Valley. *In Proc. U. S. Nat. Mus.* for Jan., 1895, XVII, pp. 409-421, 5 plates.

405. Letter to the editor concerning nearly total annihilation of bluebirds in the District of Columbia by the "blizzard" of February 7-9, 1895. *In Christian Register*, for May, 1895, p. 301.

406. On Fisher's petrel (*Æstrelata fisheri*). *In Auk*, XII, pp. 319-322, pl. lv. (October, 1895.)

407. On the correct subspecific names of the Texan and Mexican screech owls. *In Auk*, XII, pp. 389-390. (Oct., 1895.)

408. *Junco phænotus* Wagler, not *J. cinereus* (Swainson). *In Auk*, XII, p. 391. (Oct., 1895.)

409. Nesting of the duck hawk in trees. *In Nidologist*, III, pp. 42-44. (Dec., 1895.)

410. A manual of North American birds. Philadelphia, 1887. Pp. i-xi; 1-631; 123 plates. Second edition revised, with new

preface and appendix. Philadelphia, 1896. Pp. i-xiii; 1-653; 123 plates.

411. Description of a new species of ground warbler from eastern Mexico. *In Proc. U. S. Nat. Mus. for April, 1896, XVIII, pp. 119-120.*

412. Preliminary descriptions of some new birds from the Galapagos archipelago. *In Proc. U. S. Nat. Mus. for April, 1896, XVIII, pp. 293-294.*

413. Letter to the editor and publisher of *The Nidologist* concerning his contemplated return to California. *In Nidologist, III, p. 99. (May, 1896.)*

414. Description of a new subspecies of the genus *Peucedramus*, Coues. *In Proc. U. S. Nat. Mus. for May, 1896, XVIII, p. 441.*

415. Characters of a new American family of Passerine birds. *In Proc. U. S. Nat. Mus. for June, 1896, XVIII, pp. 449-450.*

416. On birds collected by Dr. W. L. Abbot in the Seychelles, Amirantes, Gloriosa, Assumption, Aldabra and adjacent islands, with notes on habits, etc., by the collector. *In Proc. U. S. Nat. Mus. for June, 1896, XVIII, pp. 509-546.*

417. Description of *Oceanodroma macrodactyla* (Bryant). *In Cat. Birds, Brit. Mus. for 1896, XXV, p. 351.*

418. Description of *Oceanodroma socorroensis* Townsend. *In Cat. Birds Brit. Mus. for 1896, XXV, p. 352.*

419. Description of *Oceanodroma tristrami* Stejneger. *In Cat. Birds Brit. Mus. for 1896, XXV, pp. 354-355.*

420. Results of comparison of a specimen of *Æstelrelata affinis* (Buller) with the type of *Æ. gularis* (Peale) and *Æ. fisheri* Ridgway. *In Cat. Birds Brit. Mus. for 1896, XXV, p. 415.*

421. Comparative characters of *Æstelrelata fisheri* Ridgway and *Æ. gularis* (Peale). *In Cat. Birds Brit. Mus. for 1896, XXV, pp. 415-4-6.*

422. Description of *Æstelrelata longiro-*

tris Stejneger. *In Cat. Birds Brit. Mus. for 1896, XXV, p. 418.*

423. Letter to Dr. G. Brown Goode concerning the writer's opinion of the services to ornithology of the eminent ornithologist, Dr. P. L. Sclater. *In Bull. U. S. Nat. Mus. for 1896, No. 49, pp. xviii-xix.*

424. List of private collections of birds containing over 1,000 specimens which have been presented at various times to the U. S. Nat. Mus. *In Rep. U. S. Nat. Mus. for 1893-4, pp. 48-49. (1896.)*

425. *Melopelia leucoptera* in Osceola county, Florida. *In Auk, XIV, pp. 88-89. (Jan., 1897.)*

426. Note on *Junco annectens* Baird and *J. ridgwayi* Mearns. *In Auk, XIV, p. 94. (Jan., 1897.)*

427. Correct nomenclature of the Texas cardinal. *In Auk, XIV, p. 95. (Jan., 1897.)*

428. *Dendroica cærulea* vs. *Dendroica rara*. *In Auk, XIV, p. 97. (Jan., 1897.)*

429. Birds of the Galapagos archipelago. *In Proc. U. S. Nat. Mus. for 1897, XIX, pp. 459-670.*

430. Where Junco roosts. *In Bull. Wilson Orn. Chapt. Agassiz Assn. for May, 1897, pp. 25-26.*

431. Description of the nest and eggs of Bachman's warbler. *In Auk, XIV, pp. 309-310. (July, 1897.)*

432. An earlier name for *Ammodramus lecontei*. *In Auk, XIV, p. 320. (July, 1897.)*

433. On the status of *Lanius robustus* Baird as a North American bird. *In Auk, XIV, p. 323. (July, 1897.)*

434. Review of Chapman's 'Bird Life.' *In Auk, XIV, pp. 336-338. (July, 1897.)*

435. Remarks concerning *Megascops pinosus* Nelson and Palmer. *In Biol. Cent. Amer. Aves., III, p. 17. (Nov., 1897.)*

436. An amateur's experiment. *In Garden and Forest for 1897, pp. 504-507.*

437. Birds of the Galapagos Islands. *In* Am. Nat., XXXII, pp. 386-389. (May, 1898.)
438. Descriptions of supposed new genera, species and subspecies of American birds. I. Fringillidæ. *In* Auk, XV, pp. 223-230. (July, 1898.)
439. New species of American birds. II. Fringillidæ (continued). *In* Auk, XV, pp. 319-324. (Oct., 1898.)
440. Description of new species of humming bird from Arizona. *In* Auk, XV, pp. 325-326. (Oct., 1898.)
441. Hemithraupis. A correction. *In* Auk, XV, pp. 330-331. (Oct., 1898.)
442. The home of the ivory-bill. *In* Osprey, III, pp. 35-36. (Nov., 1898.)
443. New species of American birds. Fringillidæ (continued). *In* Auk, XVI, pp. 35-37. (Jan., 1897.)
444. On the genus *Astragalinus cabanis*. *In* Auk, XVI, pp. 79-80. (Jan., 1899.)
445. On the generic name *Aimophila* versus *Peucea*. *In* Auk, XVI, pp. 80-81. (Jan., 1899.)
446. A fraud—look out for him. *In* Osprey, III, p. 94. (Feb., 1899.)
447. New species of American birds. IV. Fringillidæ (concluded). *In* Auk, XVI, pp. 254-256. (July, 1899.)
448. New species of American birds. V. Corvidæ (concluded). *In* Auk, XVII, pp. 27-29. (Jan., 1900.)
449. New species of American birds. VI. Fringillidæ (supplement). *In* Auk, XVII, pp. 29-30. (Jan., 1900.)
450. Concerning the use of scientific names. *In* Condor, II, p. 41. (March, 1900.)
451. Song birds of Europe and America. *In* Bird-Lore, II, pp. 69-75. (June, 1900.)
452. Description of *Buteo borealis socorroensis*. *In* Biol. Cent. Amer. Aves, for Nov., 1900, III, p. 64.
453. New birds of the families Tanageridæ and Icteridæ. *In* Proc. Wash. Acad. Sci. for April, 1901, III, pp. 149-155.
454. Descriptions of three new birds of the families Mniotiltidæ and Corvidæ. *In* Auk, XIX, pp. 69-70. (Jan., 1902.)
455. The birds of North and Middle America. Part I. Washington, 1901, pp. i-xxx, 1-715, 19 plates. Part II. Washington, 1902, pp. i-xx, 1-834, 22 plates.
456. The elf owl in California. *In* Condor, IV, pp. 18-19. (Jan., 1902.)
457. Review of Pycraft's 'Classification of the Falconiformes.' *In* Science, N. S., XVII, pp. 509-511. (March, 1903.)
458. *Leophophanes* vs. *Bæolophus*. *In* Auk, XX, p. 308. (July, 1903.)
459. Descriptions of new genera, species and subspecies of American birds. *In* Proc. Biol. Soc. Wash. for Sept., 1903. Vol. XVI, pp. 105-111.

DAVID ANDREW ROTHROCK, A.B. (1892),
A.M. (1893), Ph.D. *See* Faculty list.

EDWARD EARNEST RUBY, A.B. (1897), A.M.
Tutor in Greek, 1897-1898; Tutor in
French, 1898-1899; Instructor in
French, 1901-1902. Now Professor of
Latin, Whitman College, Walla Walla,
Wash.

1. Register of graduates of the Indiana University, including advanced and honorary degrees. Third edition. Bloomington, Ind., 1901. Pp. 112.

2. The catalogue of the Phi Delta Theta fraternity. Seventh edition. Chicago, 1904. Pp. xvi, 650; 1 plate.

HENRY WOLDMAN RUOFF, A.B. (1890),
D.C.L.

1. Origin of the family; ethical duties of the home; the home and the state; the

home in literature. Chapters contributed to 'Our Home.' Springfield, Mass., 1898. Pp. 98.

2. The century book of facts. Springfield, 1899. Pp. 688; 8 plates.

3. Woman during the Dark Ages; woman under medieval institutions; the dawn of woman's power. Chapters contributed to 'Woman.' Springfield, 1900. Pp. 121; 17 plates.

4. Leaders of men. Springfield, 1901. Pp. 695; 33 plates.

5. The capitals of the world. Springfield, 1902. Vol. I, pp. 414; vol. II, pp. 532; 800 plates.

6. Universal manual of ready reference. Springfield, 1904. Vol. I, pp. 741; 5 plates.

7. One hundred immortals. New York. (In press.)

NEWELL SANDERS, B.S. (1873). Chattanooga, Tenn.

1. Wendell Sanders. 1893. Pp. 112; 37 plates.

THOMAS E SANDERS, A.B. (1895). Superintendent of Schools, Batesville, Ark. (After July 1, 1904, Editor Progressive Teacher.)

1. Opening exercises for schools. Batesville, Ark., 1901. Pp. 150.

2. A guide to the study of literature in our schools. Batesville, Ark., 1903. Pp. 56.

3. Students' and teachers' aid to the study of civil government. Batesville, Ark., 1904. Pp. 136.

WILLIAM FRANCIS LEWIS SANDERS, A.B. (1873). Teacher in High School, Connersville, Ind.

1. The English sentence, a treatise on

(24)

grammar and analysis, with diagrams. Connersville, Ind., 1891. Pp. 269.

GEORGE L SCHERGER, A.B. (1894), Ph.D. Professor of History, Armour Institute of Technology, Chicago.

1. The evolution of modern liberty. New York, 1904. Pp. xiv, 284.

JOHN ANDREW SHAFER, A.B. (1894), A.M. (1895). Valparaiso, Ind.

1. Hygiene of school architecture. *In* Inland Educator, III, pp. 311-312 (Jan., 1897); IV, pp. 20-23 (Feb., 1897); IV, pp. 75-78 (March, 1897).

JOHN WILKES SHEPHERD, A.B. (1896), A.M. (1898). Professor of Chemistry, Chicago Normal School, Chicago, Ill.

1. The determination of methane, carbon monoxide, and hydrogen by explosion in technical gas analysis. (Joint author with W. A. Noyes.) *In* Jour. Am. Chem. Soc., XX, pp. 343-348.

EVERETT SHEPARDSON, A.B. (1890), A.M. (1892.) Assistant Professor of Psychology and Pedagogy, Los Angeles State Normal, Los Angeles, Cal.

1. Should fairy stories and folk tales be used in first and second grades? *In* Los Angeles State Normal Exponent, IV, pp. 150-158. (Jan., 1896.)

FREDERICK LAFAYETTE SHINN, A.B. (1901), A.M. (1902). Assistant in Physical Chemistry, University of Wisconsin, Madison, Wis.

1. The quantitative determination of selenium in organic compounds. (Joint au-

thor with R. E. Lyons.) *In Jour. Am. Chem. Soc.*, XXIV, pp. 1087-1093.

2. On double and triple thiocyanates of caesium, cobalt, and silver. (Joint author with H. L. Wells.) *In Am. Chem. Jour.*, XXIX, pp. 474-478.

CLAUDE E. SIEBENTHAL. Student, 1890-93.
Assistant, U. S. Geological Survey,
Washington, D. C.

1. The geology of Dallas county, Arkansas. *In Ann. Rept. Arkansas Geol. Surv.* for 1891, II, pp. 279-318. (1894.)

2. The Bedford oölitic limestone of Indiana. (Joint author with T. C. Hopkins.) *In 21st Ann. Rept. Dept. Geol. and Nat. Res. of Indiana for 1896*, pp. 291-413. (1897.)

3. The Bedford oölitic limestone. *In 19th Ann. Rept. U. S. Geol. Surv.*, pt. VI (continued), pp. 292-296. (1898.)

4. The Bedford oölitic limestone. *In Mineral Industry for 1898*, vol. VIII, pp. 479-482. (1899.)

5. The coal deposits of Indiana. (Joint author with W. S. Blatchley, G. H. Ashby, and others.) *In 23d Ann. Rept. Dept. Geol. and Nat. Res. of Indiana for 1898*, pp. 1-1741. (1899.)

6. Review of 24th annual report of the Department of Geology and Natural Resources of Indiana. *In Jour. Geol.*, VIII, pp. 475-477. (1900.)

7. On the use of the term Bedford limestone. *In Jour. Geol.*, IX, pp. 234-235. (1901.)

8. Review of 25th annual report of the Department of Geology and Natural Resources of Indiana. *In Jour. Geol.*, IV, pp. 354-356. (1901.)

9. Review of William Battle Phillips's 'Texas Petroleum.' *In Jour. Geol.*, IX, pp. 637-638. (1901.)

10. The Silver Creek hydraulic lime-

stone of southeastern Indiana. *In 25th Ann. Rept. Dept. Geol. and Nat. Res. of Indiana*, pp. 331-389; pls. xiii-xiv, figs. lxxi-lxxii. (1901.)

11. The Indiana oölitic industry in 1900. *In 25th Ann. Rept. Dept. Geol. and Nat. Res. of Indiana*, pp. 390-393. (1901.)

FRANK DARIUS SIMONS, A.B. (1895), M.S.
Assistant Chemist, Bureau Internal
Revenue, U. S. Treasury Department,
Washington, D. C.

1. The action of certain bodies on the digestive ferments. *In Jour. Am. Chem. Soc.*, XIX, pp. 744-754.

2. Detection of caramel in spirits and vinegar. (Joint author with C. A. Crampton.) *In Jour. Am. Chem. Soc.*, XXI, pp. 355-358.

3. Detection of foreign coloring matter in spirits. (Joint author with C. S. Crampton.) *In Jour. Am. Chem. Soc.*, XXII, pp. 810-813. 1 plate.

4. Synthetic chemicals under the War Revenue Act. (Joint author with C. A. Crampton.) *In Am. Jour. Phar.*, LXXII, p. 107.

VESTO MALVIN SLIPHER, A.B. (1901), A.M.
(1902). Assistant in charge of Lowell
Observatory, Flagstaff, Ariz.

1. Spectrograms of Jupiter. *In Pop. Ast.*, No. 101, pp. 1-4; 2 plates. (Jan., 1903.)

2. The spectroscopic binary β Scorpii. *In Lowell Observatory Bull.*, No. 1, p. 4. (June, 1903.)

3. A spectrographic investigation of the rotation velocity of Venus. *In Ast. Nach.*, Nos. 3891-3892, pp. 35-52. (August, 1903.)

4. On the efficiency of the spectrograph for investigating planetary rotations

and on the accuracy of the inclination method of measurement. Tests on the rotation of the planet Mars. *In Lowell Observatory Bull.*, No. 4, pp. 19-23. (August, 1903.)

5. Variable velocity of λ Scorpii in the line of sight. *In Lowell Observatory Bull.*, No. 4, p. 23. (August, 1903.)

FREDERICK MILLER SMITH, A.B. (1899). Associate Editor *Woman's Home Companion*, New York City.

1. Thoreau. *In Critic*, XXXVII, pp. 60-67. (July, 1900.)

2. The literary aspirant again. *In Critic*, XXXIX, pp. 270-272. (Sept., 1901.)

3. Christine: a serial novelette. *In Ladies' Home Journal*. (Nov., 1901-Feb., 1902.) Illustrated.

4. Review of Robert Louis Stevenson's 'Essays.' *In Poet-Lore*, XIV, pp. 70-83. (Oct., 1902.)

5. The trilemma of Albertine. *In Woman's Home Companion*, 1903-1904.

ROSA SMITH. *See Mrs. Carl H. Eigenmann.*

WILLIAM WESLEY SPANGLER, A.B. (1880), B.S. (1880), A.M. (1886.) Librarian, 1881-1893. Auburn Junction, Ind.

1. Genealogy of the Weyer family in Germany. Bloomington, Ind., 1886.

SAMUEL EDWIN SPARLING, A.B. (1892). Ph.D. Assistant Professor of Political Science, University of Wisconsin, Madison, Wis.

1. Municipal history and present organization of Chicago. *In Bull. Univ. of Wisconsin*, Madison, 1898. Pp. 188.

2. The small city and the model charter. *In Proc. Nat. Municipal League for 1899*, pp. 15.

3. Uniform accounting for cities. *In Proc. Nat. Municipal League for 1899*, pp. 15.

4. Uniform accounting for Wisconsin cities. *In Bull. League of Wisconsin Municipalities*, No. 3, 1899.

5. Notes on municipal government. (League of Wisconsin Municipalities.) *In Ann. Am. Acad. Pol. and Soc. Sci.*, XIII, pp. 269-270. (1899.)

6. Review of Frank Parson's 'The City for the people.' *In Municipal Affairs*, IV, pp. 405-406. (1900.)

7. Notes on municipal government. *In Ann. Am. Acad. Pol. and Soc. Sci.*, XIV, pp. 116-117. (1901.)

8. Responsible county government. *In Pol. Sci. Quart.*, XVI, pp. 437-449. (1901.)

9. State boards of control. *In Ann. Am. Acad. Pol. and Soc. Sci.*, XVII, pp. 74-91. (1901.)

10. Syllabus on municipal government. *In Pub. Nat. Municipal League. Second Report of Committee on Instruction in Municipal Government in American Educational Institutions*, June, 1902.

11. Chicago's voters' league. *In Outlook*, LXXI, pp. 495-498. (June, 1902.)

12. Municipal history and organization of Chicago. *In Bull. No. 29. Pol. Sci. Series. University of Wisconsin.*

13. Municipal conditions in Wisconsin. *In Ann. Am. Acad. Pol. and Soc. Sci.* (Feb., 1904.)

14. An American Political Science Association. *In Review of Reviews*, XXIX, pp. 212-213. (Feb., 1904.)

15. The work of the league of Wisconsin municipalities. *In Proc. Mich. Pol. Sci. Asso.*, Feb., 1904.

16. History of the league of Wisconsin municipalities. *In Iowa Hist. Rev.*, April, 1904.

17. Editor of 'The Municipality,' a monthly journal devoted to the discussion of municipal questions. In its fourth year.

WILLIAM MCKENDREE SPRINGER, A.B.
(1858), A.M. (1861), LL.D. Wash-
ington, D. C.

1. The telegraph monopoly. *In* No. Am. Rev., CXXXII, pp. 369-382. (April, 1881.)

2. Gold and silver: what shall the ratio be? *In* No. Am. Rev., CLV, pp. 4-6. (July, 1892.)

3. Why the Democrats should elect the next President. *In* Arena, VI, pp. 198-201. (July, 1892.)

4. How to revise the tariff. *In* No. Am. Rev., CLVI, pp. 127-135. (Feb., 1893.)

5. The financial muddle. (Joint author with J. Sterling Morton and Henry W. Cannon.) *In* No. Am. Rev., CLX, pp. 129-156. (Feb., 1895.)

EDWIN DILLER STARBUCK, A.B. (1890),
Ph.D. Assistant Professor of Educa-
tion, Leland Stanford Jr. University,
Stanford University, Cal.

1. A study of conversion. *In* Am. Jour. Psych., VIII, pp. 268-308. (Jan., 1897.)

2. Some aspects of religious growth. *In* Am. Jour. Psych., IX, pp. 70-124. (Oct., 1897.)

3. Child study and its possibilities as a science. *In* Northwestern Mo., IX, pp. 358-362. (March-April, 1899.)

4. The psychology of religion. With an introduction by Professor William James. London, 1899. Pp. xx, 423.

WARDER W STEVENS, LL.B. (1867). Salem,
Ind.

1. Swine husbandry. Indianapolis,
1899. Pp. 200.

2. History of Washington county, Ind.
1904. Pp. 600. (In press.)

ELMER BRYAN STEWART, A.B. Pastor
Third United Presbyterian Church, Chi-
cago.

1. The tithe. Chicago, 1903. Pp.
xxii, 82.

2. The tithe covenant plan for financ-
ing the Kingdom of Christ. Chicago, 1903.
Pp. 15.

JOHN CHARLES STONE, A.B. (1897), A.M.
(1897). Associate Professor of Mathe-
matics, State Normal School, Ypsilanti,
Mich.

1. Algebra by correspondence. (Joint
author with E. A. Lyman.) Chicago, 1902.
Pp. 100.

2. Geometry by correspondence. (Joint
author with E. A. Lyman.) Chicago, 1902.
Pp. 100.

3. Monograph on teaching arithmetic.
Boston, 1903. Pp. 25.

4. Southworth-Stone arithmetic. (Joint
author with G. S. Southworth.) Boston,
1904. Book I, pp. 184; book II, pp. 237;
book III, pp. 287.

5. Monograph on method in geometry.
Boston, 1904. Pp. 36.

EDGAR HOWARD STURTEVANT, A.B. (1898),
Ph.D. Tutor in Latin, 1895-1898, In-
structor in Latin, 1901-1902. Now
Acting Assistant Professor of Latin,
University of Missouri, Columbia, Mo.

1. Contraction in the case forms of the

Latin *io* and *ia* stems, and of *deus*, *is*, and *idem*. Chicago, 1902. Pp. 36.

2. Latin *rs* from *rss*. *In* *Clas. Rev.*, XVIII, 1904.

JOSEPH SWAIN, B.L. (1883), M.S. (1895), LL.D. Instructor in Mathematics and Zoölogy, Indiana University, 1883-1885; Professor of Mathematics, 1886-1891; President of the University, 1893-1902. Now President of Swarthmore College, Swarthmore, Pa.

1. Notes on a collection of fishes from Johnston's Island, including descriptions of five new species. (Joint author with Rosa Smith.) *In* *Proc. Nat. Mus.*, V, pp. 119-143. (1882.)

2. A review of the Syngnathinæ of the United States, with a description of one new species. *In* *Proc. U. S. Nat. Mus.*, V, pp. 307-315. (Aug. 15, 1882.)

3. A review of the species of *Stolephorus*, found on the Atlantic coast of the United States. *In* *Bull. U. S. Fish Comm.* for 1882, II, pp. 55-57. (Oct. 6, 1882.)

4. A review of Swainson's genera of fishes. *In* *Proc. Acad. Nat. Sci. Philadelphia* for 1882, pp. 272-284.

5. An identification of the species of fishes described in Shaw's *General Zoölogy*. *In* *Proc. Acad. Nat. Sci. Philadelphia* for 1882. Pp. 303-309.

6. A review of the genus *Noturus*, with a description of one new species. (Joint author with George B. Kalb.) *In* *Proc. U. S. Nat. Mus.*, V, pp. 638-644. (May 23, 1883.)

7. List of fishes collected in the Clear Fork of the Cumberland, Whitley county, Kentucky, with description of three new species. (Joint author with David Starr Jordan.) *In* *Proc. U. S. Nat. Mus.*, VI, pp. 248-251. (Nov. 27, 1883.)

8. Description of a new species of *Hadropterus* (*Hadropterus scierus*) from southern Indiana. *In* *Proc. U. S. Nat. Mus.*, VI, p. 252. (Nov. 27, 1883.)

9. Descriptions of Scaroid fishes from Havana and Key West, Fla., including five new species. (Joint author with D. S. Jordan.) *In* *Proc. U. S. Nat. Mus.*, VII, pp. 81-102. (July 1, 1884.)

10. Notes on fishes collected by D. S. Jordan, Cedar Keys, Fla. (Joint author with D. S. Jordan.) *In* *Proc. U. S. Nat. Mus.*, VII, pp. 230-234. (August 5, 1884.)

11. Notes on the pipe-fishes of Key West, Fla., with description of *Siphostoma McKayi*, a new species. (Joint author with Seth E. Meek.) *In* *Proc. U. S. Nat. Mus.*, VII, pp. 237-239. (August 5, 1884.)

12. A review of the American species of marine *Mugilidæ*. (Joint author with D. S. Jordan.) *In* *Proc. U. S. Nat. Mus.*, VII, pp. 261-275. (August 22, 1884.)

13. A review of the species of the genus *Hæmulon*. (Joint author with D. S. Jordan.) *In* *Proc. U. S. Nat. Mus.*, VII, pp. 281-317. (August 28, 1884.)

14. A review of the American species of *Epinephalus* and related genera. (Joint author with D. S. Jordan.) *In* *Proc. U. S. Nat. Mus.*, VII, pp. 358-410. (1884.)

15. A review of the species of *Lutjaninæ* and *Hoplopagriniæ* found in American waters. (Joint author with D. S. Jordan.) *In* *Proc. U. S. Nat. Mus.*, VII, pp. 427-474. (Sept. 19, 1884.)

16. Inaugural address at Indiana University, 1893. Published by Indiana University, July, 1893.

17. The State University. *In* 17th *Bien. Rep. Sup. Pub. Inst.*, Dec. 27, 1893, p. 111.

18. What should the high school do for the graduate of the elementary schools? *In* *Proc. Nat. Educ. Asso.* for 1896, pp. 362-363.

19. University ideals at Stanford. *In* Proc. Nat. Educ. Asso. for 1897, pp. 366-373.

20. College entrance requirements. *In* Proc. Nat. Educ. Asso. for 1899, pp. 630, 827.

21. The State University. *In* Proc. Nat. Educ. Asso. for 1900, p. 106.

22. State aid to higher education in Europe and America. *In* Proc. Nat. Educ. Asso. for 1900, p. 457.

23. Inaugural address at Swarthmore College. Published by Swarthmore College, Dec., 1902, pp. 457-463.

24. Address to Alumni of Swarthmore College, 1903. Published by Swarthmore College, July, 1903, pp. 1-8.

Numerous other short papers and addresses published in various years.

10. Articles on pedagogy. *In* Indiana Sch. Jour. monthly from 1890-1899; articles in school journals, at various times, on pedagogical subjects.

FREDERICK WILSON TRUSCOTT, A.B. (1891), A.M. (1892), Ph.D. Instructor in German, 1891-1893. Now Professor of Germanic Languages and Literature, West Virginia University, Morgantown, W. Va.

1. Laplace's essay on probabilities. (Joint translator with F. L. Emory.) New York, 1902. Pp. iv, 196.

2. Wildenbruch's Kinderthränen. New York, 1904. Pp. iii, 90. 2 plates. (In press.)

ARNOLD TOMPKINS, A.B. (1889), A.M. (1892), Ph.D. Principal of the Chicago Normal School, Chicago.

1. A graded course of study. Franklin, Ind., 1883. Pp. iii, 242.

2. The philosophy of teaching. Boston, 1895. Pp. xii, 280.

3. The philosophy of school management. Boston, 1895. Pp. xiv, 222.

4. The relation of sociology and pedagogy. *In* Am. Jour. Soc. for Nov., 1895.

5. Literary interpretations. Boston, 1896. Pp. vi, 204.

6. The science of discourse. Boston, 1897. Pp. xiv, 252.

7. Review of Vincent's 'The social mind and education.' *In* Am. Jour. Soc. (1897.)

8. Herbart's philosophy and his educational theory. *In* Educ. Rev., XVI, pp. 233-243. (Oct., 1898.)

9. Review of J. O. Quantz's 'Problems in the psychology of reading.' *In* Educ. Rev., XVI, pp. 513-517. (Dec., 1898.)

ALBERT BRENNUS ULREY, A.B. (1892), A.M. (1893). Instructor in Zoölogy, 1892-1894. Now Professor of Biology University of Southern California, Los Angeles, Cal.

1. A review of the Embiotocidæ. (Joint author with Carl H. Eigenmann.) *In* Proc. Indiana Acad. Sci. for 1891, p. 176 (abstract); *in* Bull. U. S. Fish Comm. for 1892, pp. 381-400.

2. Notes on the American bittern (*Botaurus lentiginosus*). *In* Ornithologist and Oölogist, XVII, pp. 76-77. (May, 1892.)

3. The fishes of Wabash county. *In* Proc. Indiana Acad. Sci. for 1893, pp. 229-231.

4. Preliminary descriptions of some South American Characinidæ. *In* Am. Nat., XXVIII, pp. 610-611. (July, 1894.)

5. On some South American Characinidæ. *In* Proc. Indiana Acad. Sci. for 1893, p. 226. (Abstract.)

6. On the occurrence of Kirtland's warbler in Indiana. *In Proc. Indiana Acad. Sci.* for 1894, p. 224.

7. Contributions to the biological survey of Wabash county. *In Proc. Indiana Acad. Sci.* for 1895, pp. 147-148.

8. Birds of Wabash county. *In Proc. Indiana Acad. Sci.* for 1895, pp. 148-159.

9. On the increasing abundance of the opossum (*Didelphis virginiana*) in Northern Indiana. *In Proc. Indiana Acad. Sci.* for 1896, p. 279.

10. The South American Characinidae collected by Charles F. Hartt. *In Ann. New York Acad. Sci.*, VIII, pp. 257-300. (Jan., 1895.)

11. On the occurrence of the Russian thistle (*Salsola kali tragus*) in Wabash county. *In Proc. Indiana Acad. Sci.* for 1896, p. 224.

12. Notes on the embryology of *Paragordius (Gordius) varius* (Leidy). *In Proc. Indiana Acad. Sci.* for 1897, pp. 232-233.

BENJAMIN VAIL, JR., A.B. (1878). Washington, D. C.

1. The poet's tribute to Garfield. Cambridge, Mass.

JAMES M. VAN HOOK, A.B. (1899), A.M. (1900). Plant Pathologist, Ohio Agricultural Experiment Station, Wooster, Ohio.

1. Notes on the division of the cell and nucleus in liverworts. *In Bot. Gaz.*, XXX, pp. 394-399; 1 plate. (Dec., 1900.)

2. Pink rot, an attendant of apple scab. (Joint author with J. Craig.) *In Cornell Univ. Agr. Exp. Sta. Bull.*, No. 207, pp. 161-171; 5 figures, 2 plates.

3. Diseases of ginseng. *In Cornell Univ. Agr. Exp. Sta. Bull.*, 25 figures. (1904.)

JOSEPH H VORIS, A.B. (1896). Teacher of Biology, High School, Evansville, Ind.

1. Material for the study of the variation of *Pimephales notatus* (Rafinesque), in Turkey Lake and in Shoe and Tippecanoe lakes. *In Proc. Indiana Acad. Sci.* for 1898, pp. 233-239.

FRANCIS MARION WALTERS, A.B. (1887), A.M. (1891). Professor of Chemistry, Missouri State Normal School, Warrensburg, Mo.

1. The elements of physiology. Columbia, Mo., 1902. Pp. 198.

JENNIE E. (HORNING) WALTERS (Mrs. Francis Marion Walters). Student, 1886-1888. Warrensburg, Mo.

1. A review of the American genera and species of *Chaetodontidae*. (Joint author with C. H. Eigenmann.) *In Ann. Acad. Nat. Sci.*, New York, for 1887, pp. 1-18.

ALDRED SCOTT WARTHIN, A.B. (1888), M.D., Ph.D. Professor of Pathology and Director of the Pathological Laboratory, University of Michigan, Ann Arbor.

1. Scheme for the systematic study of medical cases. Ann Arbor, 1892. Pp. 16.

2. Additional notes on the diazo-reaction. *In Med. News*, 1893. Pp. 12.

3. Some physiologic effects of music in hypnotized subjects. *In Med. News*, 1894. Pp. 13.

4. Accentuation of the pulmonary second sound an important sign in the diagnosis of pericarditis. *In Med. News*, 1895. Pp. 15.

5. Report of a case of ectopic gestation associated with tuberculosis of the

tubes, placenta, and fetus. *In Med. News*, 1896. Pp. 16. 2 plates.

6. Hypoleucoctosis in acute tuberculosis. *In Med. News*, 1896. Pp. 8.

7. Fibrolipoma of the kidney. *In Jour. Path. and Bact.*, 1897, pp. 404-411. 2 plates.

8. The diagnosis of primary sarcoma of the pleura from the cells found in the pleuritic exudate. *In Med. News*, 1897. Pp. 16, 5 plates.

9. Some experimental investigations as to the effects of the administration of yeast nuclein upon the leucocytes. *In New York Med. Jour.* for 1897. Pp. 45.

10. Practical pathology. Ann Arbor, 1897. Pp. 150.

11. The minute pathology of acute hæmorrhagic pancreatitis associated with multiple fat-necrosis. *In Phila. Med. Jour.* for 1898. Pp. 19. 1 plate.

12. A primary polymorphous-cell sarcoma of the nose. *In New York Med. Jour.* for 1899. Pp. 18.

13. The statistics of fifty autopsies on tuberculosis subjects. Usual localizations of tuberculosis. *In Med. News*, 1899. Pp. 16.

14. The pathology of the Pacinian corpuscle. (Prize essay.) *In Phila. Med. Jour.* for 1899. Pp. 20, 9 plates.

15. Multiple primary carcinoma. *In Jour. Am. Med. Assoc.* for 1899. Pp. 20.

16. The coexistence of carcinoma and tuberculosis of the mammary gland. *In Am. Jour. Med. Sci.* for 1899. Pp. 11, 1 plate.

17. A case of primary adenocarcinoma of the gallbladder with secondaries in both adrenals, melanosis of skin (Addison's disease?), vitiligo, and hypertrophy of the pancreas. *In Phila. Med. Jour.* for 1900. Pp. 28.

18. Multiple traumatic hemorrhage of the liver associated with multiple pulmonary emboli of liver-cells and giant cells re-

sembling bone-marrow cells. *In Med. News* for 1900. Pp. 31; 1 plate.

19. Accessory adrenal body in the broad ligament. *In Am. Jour. Obstet.*, 1900. Pp. 9, 2 plates.

20. Adenoma of both adrenals in the new-born, associated with retrogressive changes in the adrenals of Marchand. *In Archives of Pediatrics*, 1901. Pp. 16; 2 plates.

21. A case of endothelioma of the lachrymal gland (myxo-chondro-endothelioma cylindromatodes), with an analysis of previously reported cases of lachrymal gland tumors. *In Archives of Ophthalmology*, 1901. Pp. 20; 2 plates.

22. Multiple primary neoplasms in one individual. *In Phila. Med. Jour.* for 1901. Pp. 7.

23. Disappearing tumors. (Joint author with W. A. Spitzler.) *In Med. News* for 1901. Pp. 14.

24. A contribution to the normal histology and pathology of the hemolymph glands. *In Jour. Boston Soc. of Med. Sci.* for 1901. Pp. 22. *In Jour. Med. Research*, 1901, pp. 3-25.

25. The normal histology of the human hemolymph glands. *In Am. Jour. Anat.*, I, pp. 63-79.

26. Section on 'The voluntary muscles, tendons, tendon-sheaths and bursæ.' *In Am. Textbook of Path.* Philadelphia, 1901. Pp. 724-745.

27. The changes produced in the hemolymph glands of the sheep and goat by splenectomy, hemolytic poisons and hemorrhage. *In Jour. Med. Research*, for 1902. *In Vaughan Festschrift*, 1903, pp. 21; 15 plates.

28. Are the hemolymph nodes organs sui generis? *In Trans. Chicago Pathol. Soc.* for 1902, pp. 151-174.

29. The pathology of pernicious anæmia, with special reference to the changes

occurring in the hemolymph nodes. *In Am. Jour. Med. Sci.* for 1902, pp. 45, 7 plates.

30. Translator and editor of Ziegler's 'German pathology.' New York, 1903. Pp. 760; 586 figures.

31. A contribution to the casuistry of placental and congenital tuberculosis. (Joint author with D. M. Cowie.) *In Jour. of Infectious Diseases*, 1904, pp. 140-169.

32. A clinical and pathological study of two cases of splenic anæmia, with early and late stages of cirrhosis. (Joint author with G. Dock.) *In Am. Jour. Med. Sci.* for 1904. Pp. 32, 10 plates.

33. The development of hemolymph nodes in adipose tissue. *In Trans. Philadelphia Pathol. Soc.* for 1904.

34. Editor department of pathology, Reference Handbook of Medical Sciences, 2d edition, New York, 1900-1904. Author of numerous articles for same.

JOSHUA HOWE WATTS, A.B. (1857), Santa Cruz de Vojoa, Honduras.

1. Banana culture in Central America. *In Self-Culture Mag.*, for May, 1900.

LYDIA WHITAKER, A.B. (1900). Teacher of Latin, Terre Haute, Ind.

1. The prophet of St. Pierre. New York, 1904. Pp. 200. 6 plates.

JOHN EDWARD WILEY, A.B. (1885), A.M. (1889), LL.B. (1891). Anderson, Ind.

1. The tornado (a story).
2. Books and reading for pupils.

HOWARD LAFAYETTE WILSON, A.B. (1889), A.M. (1891). Teacher of Literature and General History, State Normal School, River Falls, Wis.

1. President Buchanan's proposed intervention in Mexico. *In Am. Hist. Rev.*, V, pp. 687-701. (July, 1900.)

2. The function of the high school. *In South Dakota Educator*, XV, pp. 43-47. (March, 1902.)

3. Intervention in Mexico. (1904.) Pp. xii, 250. (In press.)

JOHN BENJAMIN WISELY, A.B. (1890), A.M. (1891). Head of Department of Grammar and Composition, Indiana State Normal School, Terre Haute, Ind.

1. Studies in the science of English grammar. Terre Haute, Ind., 1895. Pp. 185.

2. A new English grammar. Terre Haute, Ind., 1896. Pp. 227.

3. Language for the grades. Terre Haute, Ind., 1896-1903. Pp. 237.

CLARK WISSLER, A.B. (1897), A.M. (1899), Ph.D. Assistant Curator in Department of Ethnology, American Museum of Natural History. Assistant in Anthropology, Columbia University, New York City.

1. Interest of children in the reading work of the elementary schools. *In Ped. Sem.*, V, pp. 523-541. (April, 1898.)

2. The diffusion of the motor impulse. (Joint author with N. R. Richardson.) *In Psych. Rev.*, VII, pp. 29-38. (Jan., 1900.)

3. The correlation of mental and physical tests. Monograph supplement to the *Psych. Rev.*, No. 16, New York, 1901. Pp. 62.

4. The growth of boys: correlation for the annual increments. *In Am. Anthropologist*, V, pp. 81-88.

5. Decorative and symbolic art of the Dakotas. *In Proc. International Cong. Americanists*, for 1902. New York. Pp. 10, 2 plates. (In press.)

6. Development of the decorative and symbolic art of the Sioux. *In* Bull. Am. Mus. Nat. Hist. for 1904, pp. 250, 40 plates. (In press.)

JOHN ANDERSON WOOD, A.B. (1897), A.M. (1901). Superintendent of Schools, La Porte, Ind.

1. High school statistics. (Joint author with W. H. Sanders.) *In* Rep. Subcommittee to Indiana Town and City Superintendents' Assoc. for 1899, pp. 28-62.

2. Relations of the schools to growing disregard of authority. *In* Indiana Sch. Jour., XLIV, pp. 189-198. (April, 1899.)

3. Use of pictures in teaching geography. *In* Bull. Am. Bureau of Geography, for Dec., 1900, p. 309; *in* Educ. Jour. for Oct. and Nov., 1901, pp. 71 and 118; *in* N. Y. Teachers' Monographs, for June, 1903.

4. Work books. *In* Teachers' Jour., II, p. 554. (June, 1903.)

5. Heating, ventilating and fuel for school buildings. La Porte, Ind., 1903. Pp. 40.

JAMES ALBERT WOODBURN, A.B. (1876), A.M. (1885), Ph.D. *See* Faculty list.

WILLIAM THEODORE WYLIE, A.B. (1848). Sparta, Ill.

1. Lessons and papers for the school and family.

2. Editor of 'The Christian Giver.'

ALBERT HENRY YODER, A.B. (1893). Professor of Pedagogy University of Washington, Seattle, Wash.

1. The study of the boyhood of great men. *In* Ped. Sem., III, pp. 134-156. (Oct., 1894.)

2. Investigations in pubescence. *In*

Trans. Illinois Soc. for Child-Study, II, pp. 81-84.

3. Pubescence. *In* North Western Mo., VIII, pp. 592-600.

4. Editor of Journal of Childhood and Adolescence, 3 volumes, 114 issues.

5. Incurrigibles. *In* Jour. Childhood and Adolescence, II, pp. 22-54.

6. Mouth-breathing. *In* Jour. Childhood and Adolescence, II, pp. 255-263.

7. Discussion on psychology of puberty and adolescence by Dr. Colin Scott. *In* Proc. Nat. Educ. Assoc. for 1897, p. 951.

8. Sex differentiation in relation to secondary education. *In* Proc. Nat. Educ. Assoc. for 1903, pp. 785-790.

9. Numerous short reviews of pedagogical literature. *In* Jour. of Childhood and Adolescence.

PETER A. YODER, A.B. (1894), A.M. (1896), Ph.D. Associate Professor of Chemistry, University of Utah.

1. Ueber Dehydroschleimsäure: eine neue Darstellungsmethode, sowie verschiedene Salze und Ester derselben. Dissertation. Göttingen, 1901. Pp. 63; 1 plate.

2. A new centrifugal soil elutriator. (Preliminary report.) *In* Proc. Fifth International Congress of Applied Chemistry, Sec. VII, pp. 9-21, 4 plates.

3. A new centrifugal soil elutriator. *In* Bull. Utah Agri. Exp. Sta. (1901). 13 plates. (In press.)

4. Some observations on farming in Germany. *In* 5th An. Rep. Utah Farmers' Institutes, for 1901, pp. 82-92.

CLARENCE ARTHUR ZARING, A.B. (1895), LL.B. (1896).

1. 'The Arbutus' (Senior class annual, Indiana University). (Joint editor with Adelaide Perry Newsom). Bloomington, Ind., 1895. Pp. 240.

LD
2518
A2

THE LIBRARY
UNIVERSITY OF CALIFORNIA
Santa Barbara

STACK COLLECTION

THIS BOOK IS DUE ON THE LAST DATE
STAMPED BELOW.

~~JAN 8 1968~~

UC SOUTHERN REGIONAL LIBRARY FACILITY



A 000 911 252 5

1994 6 21 11.4

