

TECHNICAL MANUAL  
OPERATOR'S MANUAL  
FOR  
ARMY RC-12 P AIRCRAFT  
NSN 1510-01-370-0805  
AND  
ARMY RC-12Q AIRCRAFT  
NSN 1510-01-417-0137

WARNING DATA	
TABLE OF CONTENTS	
INTRODUCTION	
DESCRIPTION OPERATION	
AVIONICS	
MISSION EQUIPMENT	
OPERATING LIMITS AND RESTRICTIONS	
WEIGHT/BALANCE AND LOADING	
PERFORMANCE DATA <b>P</b>	
PERFORMANCE DATA <b>Q</b>	
NORMAL PROCEDURES	
EMERGENCY PROCEDURES	
REFERENCES	
ABBREVIATIONS AND TERMS	
ALPHABETICAL INDEX	

Distribution Statement A: Approved for public release;  
Distribution is unlimited.

HEADQUARTERS  
DEPARTMENT OF THE ARMY  
31 December 1998

\*This manual supersedes TM 1-1510-224-10, dated 16 May 1997, including all changes.

FE00D970278 C

## WARNING PAGE

Personnel performing operations, procedures, and practices which are included or implied in this technical manual shall observe the following warnings. Disregard of these warnings and precautionary information can cause serious injury or loss of life.

## NOISE LEVELS

Sound pressure levels in this aircraft during some operating conditions exceed the Surgeon General's hearing conservation criteria, as defined in TB MED 501. Hearing protection devices, such as the aviator helmet or ear plugs, shall be worn by all personnel in and around the aircraft during its operation.

## STARTING ENGINES

Operating procedures or practices defined in this technical manual must be followed correctly. Failure to do so may result in personal injury or loss of life.

Exposure to exhaust gases shall be avoided since exhaust gases are an irritant to eyes, skin, and respiratory system.

## HIGH VOLTAGE

High voltage is a potential hazard around AC inverters, ignition exciter units, and strobe beacons.

## USE OF FIRE EXTINGUISHERS IN CONFINED AREAS

Monobromotrifluoromethane (CF<sub>3</sub>Br) is very volatile, but is not easily detected by its odor. Although non toxic, it must be considered to be about the same as other refrigerants and carbon dioxide, causing danger to personnel primarily by reduction of oxygen available for proper breathing. During operation of the fire extinguisher, ventilate personnel areas with fresh air. The liquid shall not be allowed to come into contact with the skin, as it may cause frostbite or low temperature burns because of its very low boiling point.

## VERTIGO

The strobe beacon lights should be turned off during flight through clouds to prevent sensations of vertigo, as a result of reflections of the light on the clouds.

## CARBON MONOXIDE

When smoke, suspected carbon monoxide fumes, or symptoms of lack of oxygen (hypoxia) exist, all personnel shall immediately don oxygen masks, and activate the oxygen system.

## FUEL AND OIL HAN LING

Turbine fuels and lubricating oils contain additives which are poisonous and readily absorbed through the skin. Do not allow them to remain on skin.

## SERVICING AIRCRAFT

When conditions permit, the aircraft shall be positioned so that the wind will carry fuel vapors away from all possible sources of ignition. The fueling unit shall maintain a distance of 20 feet between unit and filler point. A minimum of 10 feet shall be maintained between fueling unit and aircraft.

Prior to refueling, the hose nozzle static ground wire shall be attached to the grounding lugs that are located adjacent to filler openings.

### **SERVICING BATTERY**

Improper service of the nickel-cadmium battery is dangerous and may result in both bodily injury and equipment damage. The battery shall be serviced in accordance with applicable manuals by qualified personnel only.

### **CORROSIVE BATTERY ELECTROLYTE (POTASSIUM HYDROXIDE).**

Wear rubber gloves, apron, and face shield when handling batteries. If potassium hydroxide is spilled on clothing, or other material, wash immediately with clean water. If spilled on personnel, immediately start flushing the affected area with clean water. Continue washing until medical assistance arrives.

### **JET BLAST**

Occasionally, during starting, excess fuel accumulation in the combustion chamber causes flames to be blown from the exhausts. This area shall be clear of personnel and flammable materials.

### **RADIOACTIVE MATERIAL**

Instruments contained in this aircraft may contain radioactive material (TB 55-1510-314-25). These items present no radiation hazard to personnel unless seal has been broken due to aging or has accidentally been broken. If seal is suspected to have been broken, notify Radioactive Protective Officer.

### **RF BURNS**

Do not stand near the antennas when they are transmitting.

### **OPERATION OF AIRCRAFT ON GROUND**

At all times during a towing operation, be sure there is an authorized person in the cockpit to operate the brakes.

Personnel should take every precaution against slipping or falling. Make sure guard rails are installed when using maintenance stands.

Engines shall be started and operated only by authorized personnel. Reference AR 95-1.

Ensure that landing gear control handle is in the DN position.

TECHNICAL MANUAL

No. 1-1510-224-10

HEADQUARTERS  
DEPARTMENT OF THE ARMY  
WASHINGTON, DC 31 December 1998

OPERATOR'S MANUAL FOR  
ARMY RC-12P AIRCRAFT NSN 1510-01-370-0805 AND  
ARMY RC-12Q AIRCRAFT NSN 1510-01-417-0137

REPORTING ERRORS AND RECOMMENDING IMPROVEMENTS

You can help Improve this manual. If you find any mistakes or If you know of any way to Improve the procedures, please let us know. Mail your letter, DA Form 2028 (Recommended Changes to Publications and Blank Forms), or DA Form 2028-2 located In the back of this manual direct to: Commander, U.S. Army Aviation and Missile Command ATTN: AMSAM-MMC-LS-LP, Redstone Arsenal, AL 35898-5230. A reply will be furnished to you. You may also send In your comments electronically to our e-mail address; ls-lp@redstone.army.mil or by fax 256-842-6546/DSN 788-6546. Instructions for sending an electronic 2028 may be found at the back of this manual Immediately preceding the hard copy 2028.

DISTRIBUTION STATEMENT A: Approved for public release; distribution is unlimited.

TABLE OF CONTENTS

	Page
CHAPTER 1 INTRODUCTION.....	1-1
CHAPTER 2 AIRCRAFT AND SYSTEMS DESCRIPTION AND OPERATION.....	2-1
Section I. Aircraft.....	2-1
Section II. Emergency Equipment .....	2-26
Section III. Engines and Related Systems.....	2-27
Section IV. Fuel System .....	2-41
Section V. Flight Controls.....	2-48
Section VI. Propellers.....	2-52
Section VII. Utility Systems .....	2-55
Section VIII. Heating, Ventilation, Cooling, and Environmental Control System .....	2-65
Section IX. Electrical Power Supply and Distribution System.....	2-70
Section X. Lighting .....	2-82
Section XI. Flight Instruments .....	2-85
Section XII. Servicing, Parking, and Mooring.....	2-94
CHAPTER 3 AVIONICS .....	3-1
Section I. General .....	3-1
Section II. Communications .....	3-2
Section III. Navigation .....	3-21
Section IV. Radar and Transponder.....	3-80

\*This manual supersedes TM 1-1510-224-10, dated 16 May 1997, including all changes.



CHAPTER 4 MISSION EQUIPMENT ..... 4-1

    Section I. Mission Avionics ..... 4-1

    Section II. Aircraft Survivability Equipment ..... 4-4

CHAPTER 5 OPERATING LIMITS AND RESTRICTIONS ..... 5-1

    Section I. General ..... 5-1

    Section II. System Limits ..... 5-1

    Section III. Power Limits ..... 5-8

    Section IV. Loading Limits ..... 5-9

    Section V. Airspeed Limits, Maximum and Minimum ..... 5-10

    Section VI. Maneuvering Limits ..... 5-10

    Section VII. Environmental Restrictions ..... 5-12

    Section VIII. Other Limitations ..... 5-13

    Section IX. Required Equipment for Various Conditions of Flight ..... 5-13

CHAPTER 6 WEIGHT / BALANCE AND LOADING ..... 6-1

    Section I. General ..... 6-1

    Section II. Weight and Balance ..... 6-1

    Section III. Fuel/Oil ..... 6-7

    Section IV. Center of Gravity ..... 6-9

    Section V. Cargo Loading ..... 6-9

    Section VI. Survivability Equipment ..... 6-11

CHAPTER 7 PERFORMANCE DATA P ..... 7-1

CHAPTER 7A PERFORMANCE DATA Q ..... 7A-1

CHAPTER 8 NORMAL PROCEDURES ..... 8-1

    Section I. Mission Planning ..... 8-1

    Section II. Operating Procedures and Maneuvers ..... 8-1

    Section III. Instrument Flight ..... 8-26

    Section IV. Flight Characteristics ..... 8-26

    Section V. Adverse Environmental Conditions ..... 8-28

    Section VI. Crew Duties ..... 8-32

CHAPTER 9 EMERGENCY PROCEDURES ..... 9-1

    Section I. Aircraft Systems ..... 9-1

APPENDIX A REFERENCES ..... A1

APPENDIX B ABBREVIATIONS AND TERMS ..... B-1

INDEX ..... INDEX-1

## CHAPTER 1 INTRODUCTION

### 1-1. GENERAL

These instructions are for use by the operator(s). They apply to the RC-12P and RC-12Q aircraft.

### 1-2. WARNINGS, CAUTIONS, AND NOTES.

Warnings, cautions, and notes are used to emphasize important and critical instructions. Explanatory examples are as follows:

#### WARNING

**An operating procedure, practice, etc., which, if not correctly followed, could result in personal injury or loss of life.**

#### CAUTION

**An operating procedure, practice, condition, or statement, which if not strictly observed, could result in damage to or destruction of equipment, loss of mission effectiveness, or long term health hazards to personnel.**

#### NOTE

**An operating procedure, condition, etc., which is essential to highlight.**

### 1-3. DESCRIPTION.

This manual contains the best operating instructions and procedures for the RC-12P and RC-12Q aircraft under most circumstances. The observance of limitations, performance, and weight/balance data provided is mandatory. The observance of procedures is mandatory except when modification is required because of multiple emergencies, adverse weather, terrain, etc. Basic flight principles are not included. THIS MANUAL SHALL BE CARRIED IN THE AIRCRAFT DURING ALL FLIGHTS.

The RC-12P and RC-12Q are pressurized, low wing, all metal aircraft and are powered by two turboprop engines. The RC-12Q aircraft is distinguished by the large SATCOM radome located on top of the fuselage.

*a. RC-12P P* Basic Mission Statement. The basic mission of the aircraft is radio reconnaissance.

*b. RC-12Q Q* Basic Mission Statement. The basic mission of the aircraft is Direct Air to Satellite Relay

(DASR) communications.

### 1-4. APPENDIX A, REFERENCES.

Appendix A is a listing of official publications, cited within this manual, which are applicable to and available for flight crews.

### 1-5. APPENDIX B, ABBREVIATIONS AND TERMS.

Appendix B is a listing of abbreviations and terms used throughout this manual.

### 1-6. INDEX.

The index lists, in alphabetical order, titled paragraphs, figures, and tables contained in this manual.

### 1-7. ARMY AVIATION SAFETY PROGRAM.

Reports necessary to comply with the safety program are prescribed in AR 385-40.

### 1-8. DESTRUCTION OF ARMY MATERIEL TO PREVENT ENEMY USE.

For information concerning destruction of Army materiel to prevent enemy use, refer to TM 750-244-1-5.

### 1-9. FORMS AND RECORDS.

Army aviators flight record and aircraft maintenance records which are to be used by crew members are prescribed in DA PAM 738-751 and weight and balance manual TM 55-1500-342-23.

### 1-10. EXPLANATION OF CHANGE SYMBOLS.

Except as noted in this paragraph, changes to text and tables, including new material on added pages, are indicated by a vertical line in the outer margin extending close to the entire area of the material affected.

#### NOTE

**Exception: pages with emergency markings, which consist of black diagonal lines around three edges, may have the vertical line or change symbol placed along the inner margins.**

A miniature pointing hand symbol is used to denote a change to an illustration. However, a vertical line in the outer margin, rather than miniature pointing hands, is utilized when there have been extensive changes made to an illustration. Symbols show current changes only. Change symbols are not utilized to indicate changes in the following:

a. Introductory material.

b. Indexes and tabular data where the change cannot be identified.

c. Blank space resulting from the deletion of text, an illustration or a table.

d. Correction of minor inaccuracies, such as spelling, punctuation, relocation of material, etc., unless correction changes the meaning of instructive information and procedures.

#### 1-11. SERIES AND EFFECTIVITY CODES.

Designator symbols such as **P** (RC-12P) and **Q** (RC-12Q) are used in conjunction with-text contents, text headings and illustration titles to show limited effectivity of the material. If applicable, a designator symbol may follow a text heading or illustration title to indicate proper effectivity, unless the material applies to all series and configurations within the manual. If the material applies to all series and configurations, no designator symbols will be used. Note, however, that Chapter 7 **P** applies only to the RC-12P, while Chapter 7A **Q** applies only to the RC-12Q. Designator symbols will not used in these chapters other than within the chapter title. Designator symbols will precede procedural steps in Chapters 8 and 9, if applicable.

#### 1-12 AIRCRAFT DESIGNATION SYSTEM.

The designation system prescribed by AR 70-50 is used in aircraft designations as follows:

##### EXAMPLE RC-12P

R - Modified mission symbol (Reconnaissance)

C - Basic mission and type symbol (Cargo)

12 - Design number

P - Series symbol

#### 1-13. USE OF WORDS SHALL, SHOULD, AND MAY.

Within this technical manual the word "shall" is used to indicate a mandatory requirement. The word "should" is used to indicate a nonmandatory but preferred method of accomplishment. The word "may" is used to indicate an acceptable method of accomplishment.

#### 1-14. PLACARD ITEMS.

Where applicable, placarded items (switches, controls, etc.) are shown, throughout this manual, in boldface capital letters.

## CHAPTER 2 AIRCRAFT AND SYSTEMS DESCRIPTION AND OPERATION

### Section I. AIRCRAFT

#### 2-1. INTRODUCTION.

The purpose of this chapter is to describe the aircraft and its systems and controls which contribute to the physical act of operating the aircraft. It does not contain descriptions of avionics or mission equipment covered elsewhere in this manual. This chapter also contains the emergency equipment installed. This chapter is not designed to provide instructions on the complete mechanical and electrical workings of the various systems; therefore, each is described only in enough detail to make comprehension of that system sufficiently complete to allow for safe and efficient operation.

#### 2-2. GENERAL

The RC-12P and RC-12Q are pressurized, low wing, all metal aircraft and are powered by two PT6A-67 turboprop engines (fig. 2-1 and 2-2). The aircraft have all-weather capability. Distinguishable features of the aircraft are the slender, streamlined engine nacelles, four-bladed propellers, aft rotating boom antenna, mission antennas, wing tip pods, stabilons, T-tail, and a ventral fin below the empennage. The RC-12Q aircraft is distinguished by the large SATCOM radome located on top of the fuselage.

*a. RC-12P Basic Mission.* The basic mission of the aircraft is radio reconnaissance.

*b. RC-12Q Basic Mission.* The basic mission of the aircraft is Direct Air to Satellite Relay (DASR) communications.

Cabin entrance is made through a stair-type door aft of the wing on the left side of the fuselage (fig. 2-1 and 2-2). The interior configuration of the aircraft is shown in figure 2-3 and 2-4.

#### 2-3. DIMENSIONS.

Overall aircraft dimensions are shown in figure 2-5.

#### 2-4. GROUND TURNING RADIUS.

Minimum ground turning radius of the aircraft is shown in figure 2-6.

#### 2-5. MAXIMUM WEIGHTS.

*a. Takeoff.* Maximum gross takeoff weight is 16,500 pounds.

*b. Landing.* Maximum gross landing weight is 15,675 pounds.

*c. Maximum Ramp Weight.* Maximum ramp weight is 16,620 pounds.

*d. Maximum Zero Fuel Weight.* Maximum zero fuel weight is 13,100 pounds.

#### 2-6. EXHAUST AND PROPELLER DANGER AREAS.

Exhaust and propeller danger areas to be avoided by personnel while aircraft engines are being operated on the ground are depicted in figure 2-7. Distance to be maintained with engines operating at idle are also shown. Temperature and velocity of exhaust gases at varying locations aft of the exhaust stacks are shown for maximum power. The danger area extends to 40 feet aft of the exhaust stack outlets. Distance to be maintained with engines operating at idle and propeller danger areas are also shown.

#### 2-7. LANDING GEAR SYSTEM.

The retractable tricycle landing gear is electrically controlled and hydraulically actuated. The landing gear are extended and retracted by a hydraulic power pack, located in the left wing center section, forward of the main spar. The power pack consists primarily of a hydraulic pump, a 28 VDC motor, a gear selector valve and solenoid, a two section fluid reservoir, filter screens, a gear-up pressure-switch and a low fluid level sensor. Engine bleed air, regulated to 18 to 20 PSI, is plumbed into the power pack reservoir and the system fill reservoir to prevent cavitation of the pump. The fluid level sensor activates an amber caution annunciator, placarded **HYD FLUID LOW**, located on the caution/advisory annunciator panel, whenever the fluid level in the power pack. is low. The annunciator is tested by pressing the **HYD FLUID SENSOR TEST** switch located on the pilot's subpanel (fig. 2-8).

Power for the hydraulic power pack is supplied through the landing gear motor relay and a 60-ampere circuit breaker located under the floorboard forward of the main spar. The motor relay is energized by power furnished through the 2-ampere **LANDING GEAR CONTROL** circuit breaker located on the overhead circuit breaker panel (fig. 2-9). The power pack motor is protected by a time delay module which senses operation voltage through a 5-ampere circuit breaker. Both are located beneath the aisleway floorboards, forward of the main spar. Landing

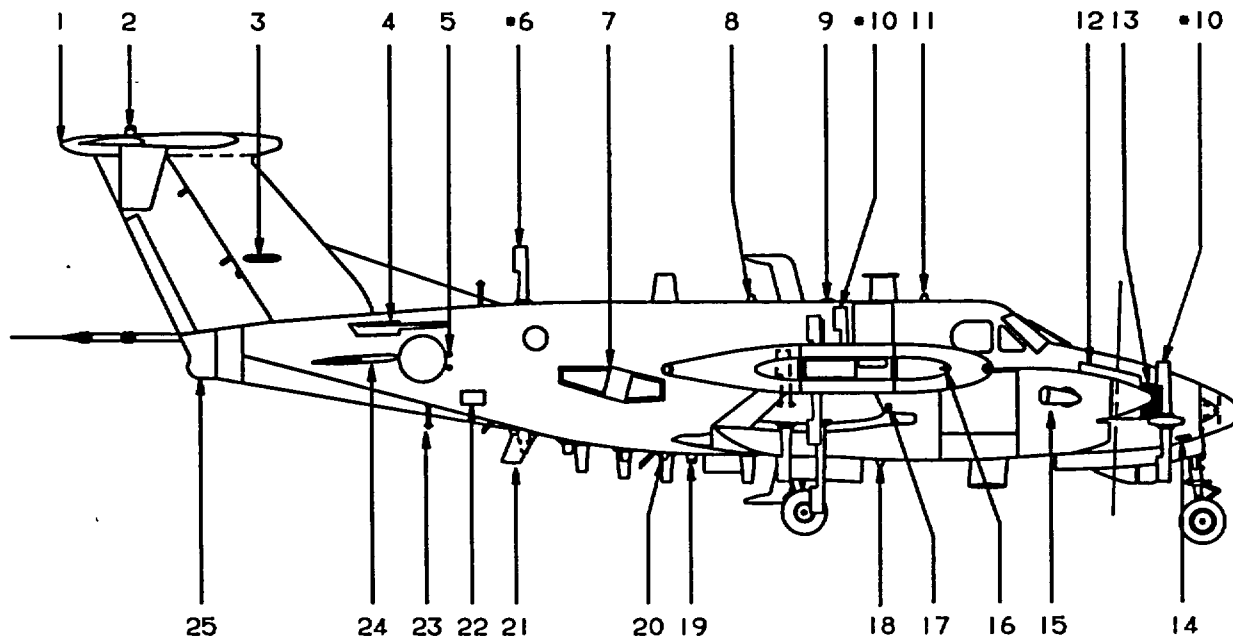

- |  |  |
|--|--|
| <ul style="list-style-type: none"> <li>1. Tall Navigation Light</li> <li>2. Strobe Beacon (Upper)</li> <li>3. VOR/Localizer Antenna</li> <li>4. Stroke</li> <li>5. Static Air Ports</li> <li>*6. Low Band Monopole</li> <li>7. Chaff/Flare Dispenser</li> <li>8. Transponder Antenna</li> <li>9. Global Positioning System Antenna</li> <li>*10. Low Band Dipole Antenna</li> <li>11. TACAN Antenna (Upper)</li> <li>12. Nose Avionics Compartment Access Door</li> <li>13. Air Conditioner Condenser Air Inlet</li> </ul> | <ul style="list-style-type: none"> <li>14. Pilot Tube</li> <li>15. Exhaust Stock</li> <li>16. Navigation Light</li> <li>17. Ice Light</li> <li>18. AN/APR-39 Blade Antenna</li> <li>19. Strobe Beacon (Lower)</li> <li>20. TACAN Antenna (Lower)</li> <li>21. VHF Communications Receiver #2 Antenna</li> <li>22. Oxygen System Servicing Door</li> <li>23. AN/APR-44 Antenna</li> <li>24. Stabilon</li> <li>25. Guardrail Dual Data Link Antenna</li> </ul> |
|--|--|

\* Provisions Only

A94FE00D0010 C

Figure 2-1. General Exterior Arrangement - Right Side, (Sheet 1 of 6) P

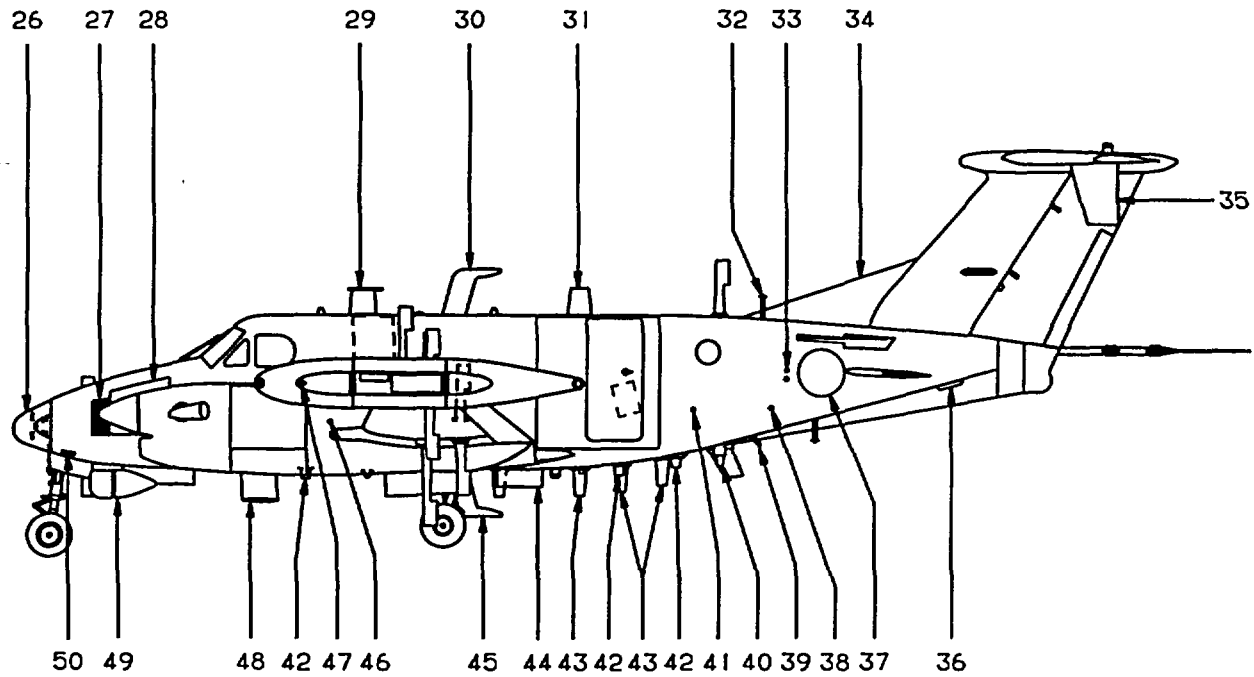

- |  |  |
|--|--|
| 26. Radome   | 39. Relief Tube Drain                                |
| 27. Air Conditioner Condenser Air Outlet             | 40. UHF/Transponder Antenna                          |
| 28. Nose Avionics Compartment Access Door            | 41. Emergency Light                                  |
| 29. VHF-FM (SINCGARS) Antenna                        | 42. High Band Intercept Dipole (3 Blades)            |
| 30. Low/Mid Band Vertical Bent Blade (Upper)         | 43. High Band Vertical Antenna (6 Blades)            |
| 31. VHF/UHF Communications Antenna                   | 44. Strobe Beacon Light Shield                       |
| 32. AN/APR-44 Antenna                                | 45. Low/Mid Band Vertical Bent Blade Antenna (Lower) |
| 33. Static Air Ports                                 | 46. Ice Light  |
| 34. Dorsal Fin                                       | 47. Navigation Light                                 |
| 35. Taillet  | 48. High Band Vertical/Horizontal Antenna            |
| 36. Lightning Sensor System Antenna                  | 49. Guardrail Dual Data Link Antenna                 |
| 37. P-Band Antenna                                   | 50. Pittot Tube                                      |
| 38. Emergency Locator Transmitter Switch Access Door |  |

A94FE00D0011 C

Figure 2-1. General Exterior Arrangement - Left Side, (Sheet 2 of 6) P

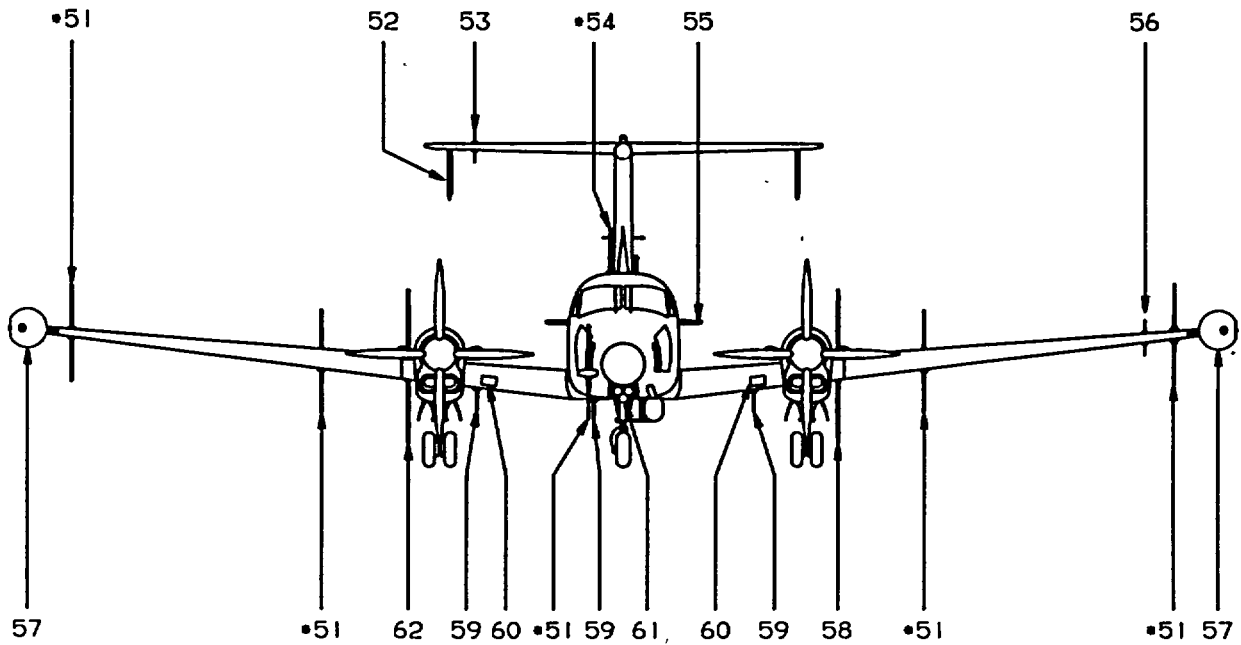

- \*51. Low Bond Dipole Antenna
- 52. Taillet
- 53. High Band CTT Dipole (Transmit)
- \*54. HF Extended Band Antenna
- 55. Stabilon DF Horizontal Loop Antenna
- 56. CTT High Bond Dipole Antenna (Receive)
- 57. DF/ELINT Pod
- 58. Mid Band Dipole Antenna
- 59. High Band Vertical Antenna
- 60. Bleed Air Heat Exchanger Air Inlet
- 61. Landing/Taxi Lights
- 62. Low Bond Intercept Dipole

\* Provisions Only

A94FE00D0012 C

Figure 2-1. General Exterior Arrangement - Front, (Sheet 3 of 6) P

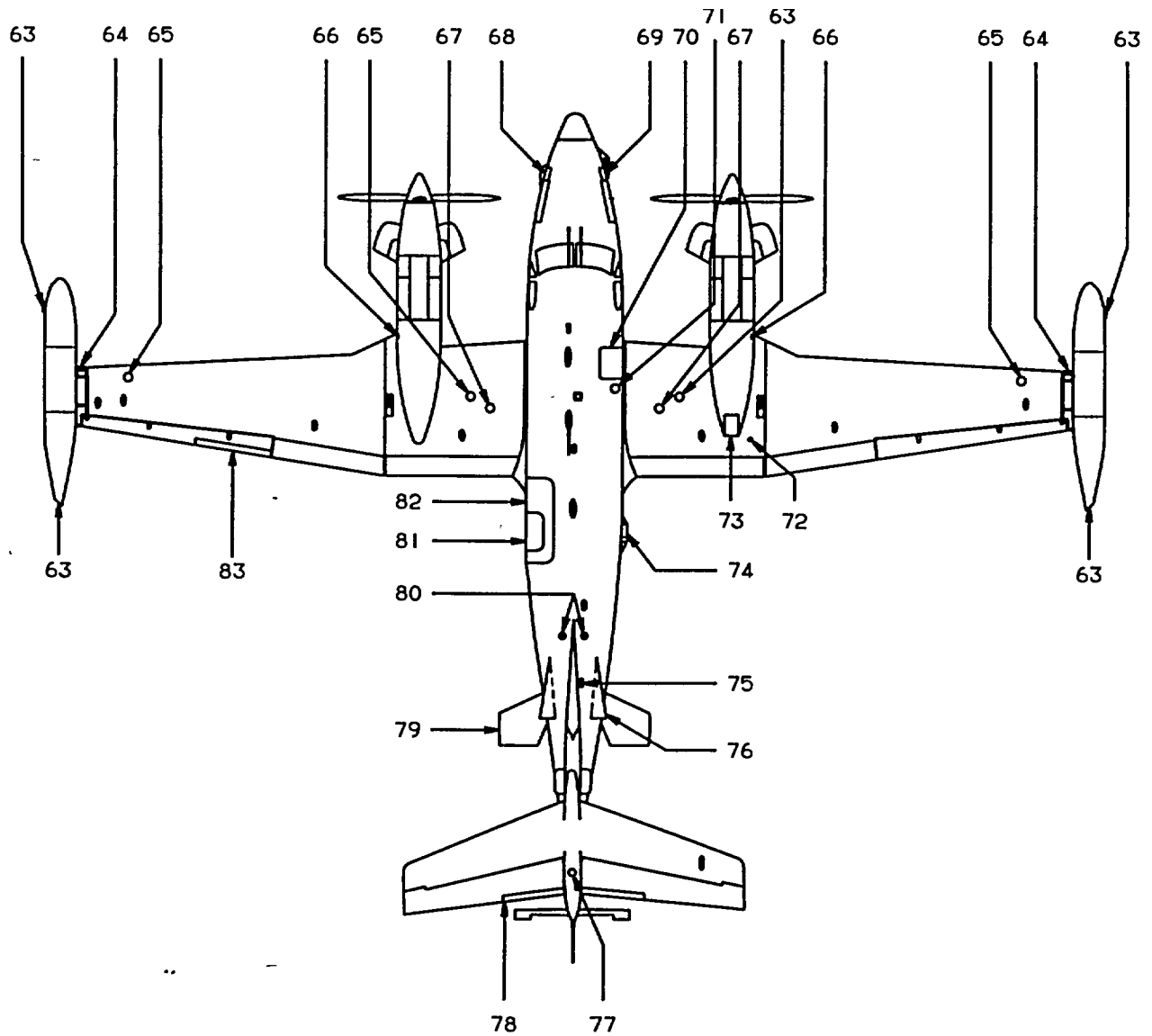

- |  |   |
|--|---|
| 63. AN/APR-39 Antenna                    | 73. Chaff Dispenser                       |
| 64. Recognition Light                    | 74. Chaff/Flare Dispenser                 |
| 65. Fuel Filler Cap                      | 75. Emergency Locator Transmitter Antenna |
| 66. Ice Light                            | 76. Stroke                                |
| 67. Auxiliary Fuel Tank Gage             | 77. Strobe Beacon (Upper)                 |
| 68. Air Conditioner Condenser Air Outlet | 78. Elevator Trim Tab                     |
| 69. Air Conditioner Condenser Air Inlet  | 79. Stabilon (DF Horizontal Loop Antenna) |
| 70. Emergency Exit Hatch                 | 80. AN/APR-44 Antennas                    |
| 71. Emergency Light                      | 81. Entrance Door                         |
| 72. Flare/Chaff Dispenser Safety Switch  | 82. Cargo Door                            |
|  | 83. Aileron Trim Tab                      |

**A9FE000013 C**

Figure 2-1. General Exterior Arrangement - Top, (Sheet 4 of 6) P



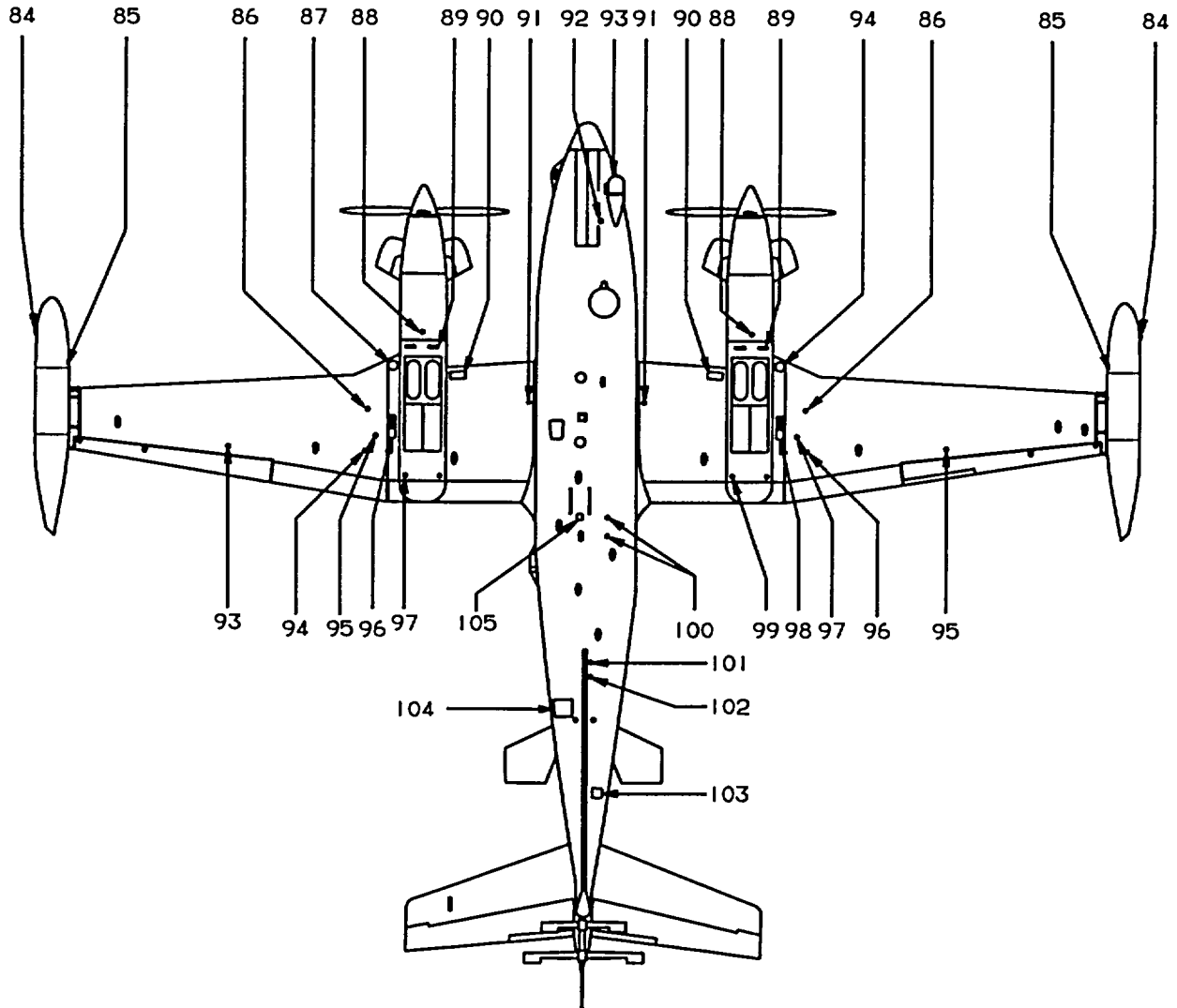

- |   |  |
|---|--|
| 84. Navigation Light                    | 95. Outboard Wing Fuel Sump Drain                      |
| 85. DF/ELINT Pod                        | 96. Ram Heated Fuel Vent                               |
| 86. Leading Edge Fuel Tank Drain        | 97. Recessed Fuel Vent                                 |
| 87. DC External Power Receptacle        | 98. Three Phase Inverter Cooling Air Outlet            |
| 88. Firewall Fuel Filter Drain          | 99. Engine Oil Vent                                    |
| 89. Strainer Drain                      | 100. Antenna Deice System Boot Hold-down Ejector Tubes |
| 90. Bleed Air Heat Exchanger Air Outlet | 101. Oxygen Regulator Vent                             |
| 91. Extended Range Fuel System Drain    | 102. Aft Compartment Drain                             |
| 92. Hydraulic Reservoir Drain           | 103. Lightning Sensor System Antenna                   |
| 93. Guardrail Dual Data Link Antenna    | 104. Tailcone Access Door                              |
| 94. AC External Power Receptacle        | 105. Strobe Beacon                                     |

**A94FE00D0014 C**

Figure 2-1. General Exterior Arrangement - Bottom, (Sheet 5 of 6) P

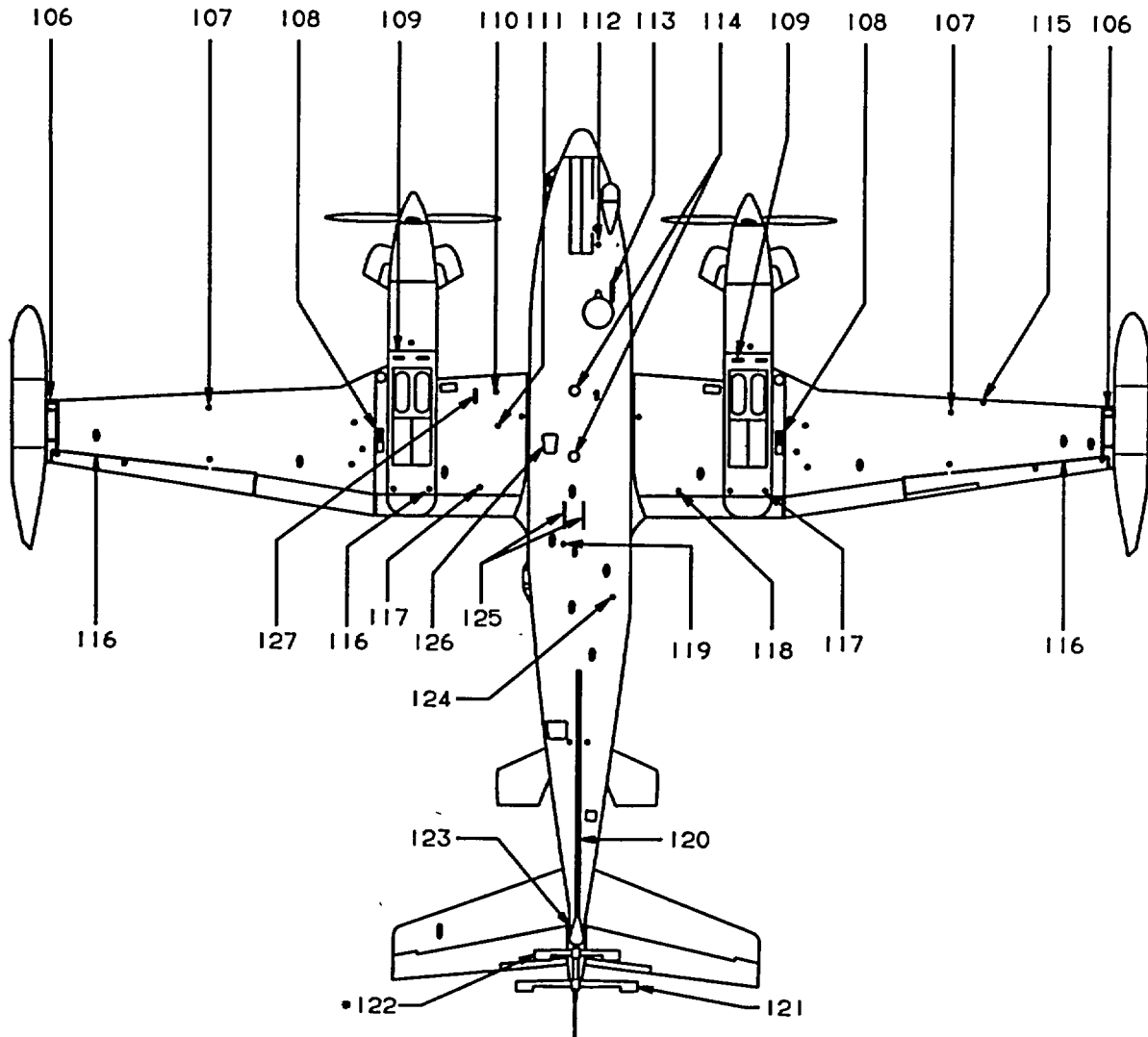

- |  |  |
|--|--|
| 106. Recognition Light                         | 117. Gravity Fuel Line Drain                   |
| 107. Tiedown Ring                              | 118. Wing Jack Pod                             |
| 108. Three Phase Inverter Cooling Air Intake   | 119. Surface Deice System Ejector Exhaust      |
| 109. Standby Fuel Pump Drain                   | 120. Ventral Fin                               |
| 110. Battery Ram Air Vent                      | 121. Mtd-bond Vertical Rotating Dipole Antenna |
| 111. Battery Drain                             | *122. Low-band Rotating Dipole Antenna         |
| 112. Nose Jack Pod                             | 123. Aft Guardrail Dual Data Link Antenna      |
| 113. Marker Beacon Antenna                     | 124. Relief Tube Drain                         |
| 114. Radio Altimeter Antenna                   | 125. Strobe Beacon Light Shields               |
| 115. Stall Warning Vane                        | 126. ADF Antenna                               |
| 116. Outboard Wing Fuel Vent (In Aileron Cove) | 127. Air Data Probe                            |

\* Provisions Only

A94FE00D0015 C

Figure 2-1. General Exterior Arrangement - Bottom, - Continued (Sheet 6 of 6) P

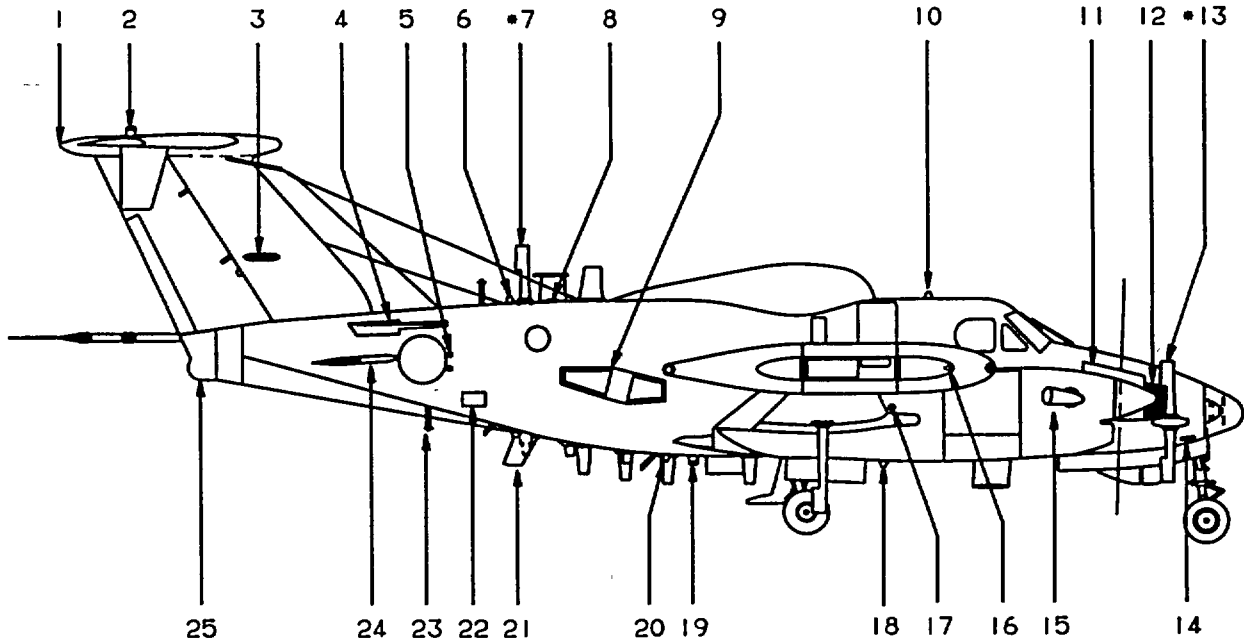

- |   |   |
|---|---|
| <ul style="list-style-type: none"> <li>1. Tall Navigation Light</li> <li>2. Strobe Beacon (Upper)</li> <li>3. VOR/Localizer Antenna</li> <li>4. Stroke</li> <li>5. Static Atr Ports</li> <li>6. TACAN Antenna (Upper)</li> <li>*7. Low Bond Monopole</li> <li>8. Global Positioning System Antenna</li> <li>9. Chaff/Flare Dispenser</li> <li>10. Transponder Antenna</li> <li>11. Nose Avionics Compartment Access Door</li> <li>12. Atr Conditioner Condenser Air Inlet</li> <li>13. Low Bond Dipole Antenna</li> </ul> | <ul style="list-style-type: none"> <li>14. Pitot Tube</li> <li>15. Exhaust Stock</li> <li>16. Navigation Light</li> <li>17. Ice Light</li> <li>18. AN/APR-39 Blade Antenna</li> <li>19. Strobe Beacon (Lower)</li> <li>20. TACAN Antenna (Lower)</li> <li>21. VHF Communications Receiver #2 Antenna</li> <li>22. Oxygen System Servicing Door</li> <li>23. AN/APR-44 Antenna</li> <li>24. Stabilon'</li> <li>25. Guardrail Dual Data Link Antenna</li> </ul> |
|---|---|

\* Provisions Only

FE02D97027 C

Figure 2-2. General Exterior Arrangement - Right Side, (Sheet 1 of 6) Q

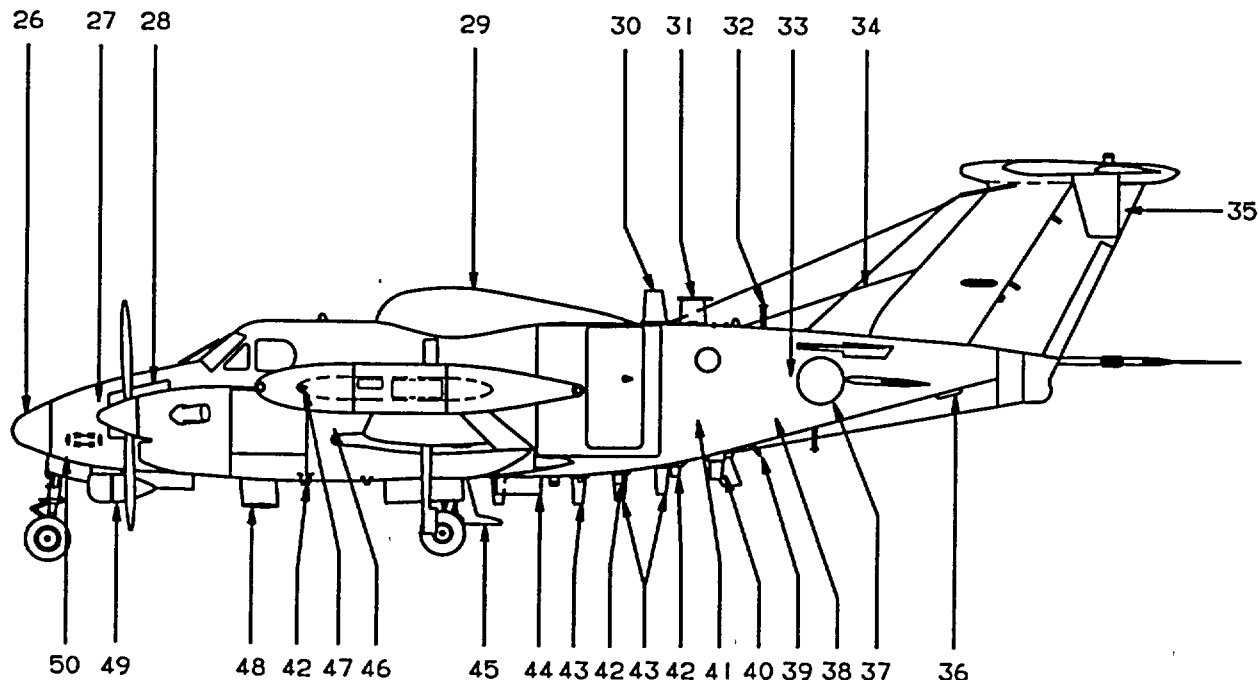

- |  |  |
|--|--|
| 26. Radome   | 39. Relief Tube Drain                                |
| 27. Air Conditioner Condenser Air Outlet             | 40. UHF/Transponder Antenna                          |
| 28. Nose Avionics Compartment Access Door            | 41. Emergency Light                                  |
| 29. SATCOM Antenna Radome                            | 42. High Band Intercept Dipole (3 Blades)            |
| 30. VHF/UHF Communications Antenna                   | 43. High Band Vertical Antenna (6 Blades)            |
| 31. VHF-FM (.SINCGARS) Antenna                       | 44. Strobe Beacon Light Shield                       |
| 32. AN/APR-44 Antenna                                | 45. Low/Mid Band Vertical Bent Blade Antenna (Lower) |
| 33. Static Air Ports                                 | 46. Ice Light  |
| 34. Dorsal Fin                                       | 47. Navigation Light                                 |
| 35. Taillet  | 48. High Band Vertical/Horizontal Antenna            |
| 36. Lightning Sensor System Antenna                  | 49. Guardrail Dual Data Link Antenna                 |
| 37. P-Bond Antenna                                   | 50. Pitot Tube                                       |
| 38. Emergency Locator Transmitter Switch Access Door |  |

FE02D970280 C

Figure 2-2. General Exterior Arrangement - Left Side, (Sheet 2 of 6) Q

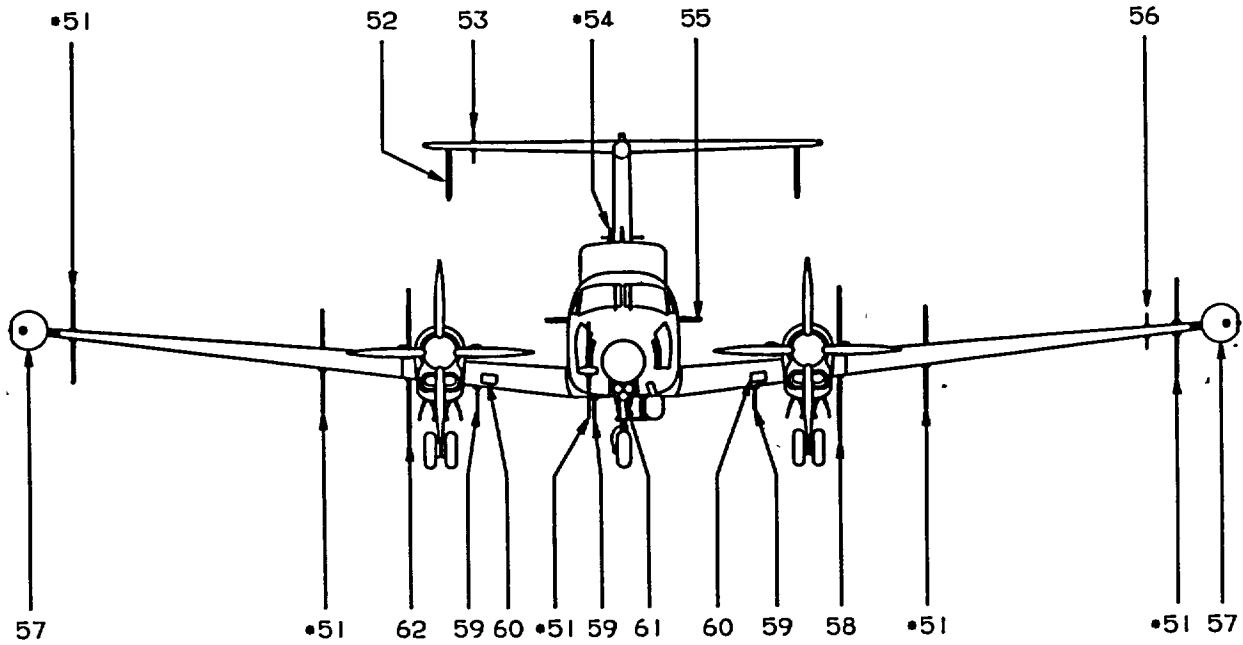

- \*51. Low Bond Dipole Antenna
- 52. Taillet
- 53. High Band CTT Dipole (Transmit)
- \*54. HF Extended Bond Antenna
- 55. Stabilon DF Horizontal Loop Antenna
- 56. CTT High Bond Dipole Antenna (Receive)
- 57. DF/ELINT Pod
- 58. Mtd Bond Dipole Antenna
- 59. High Bond Vertical Antenna
- 60. Bleed Air Heat Exchanger Air Inlet
- 61. Landing/Taxi Lights
- 62. Low Bond Intercept Dipole

\* Provisions Only

FE02D970281 C

Figure 2-2. General Exterior Arrangement - Front, (Sheet 3 of 6) Q



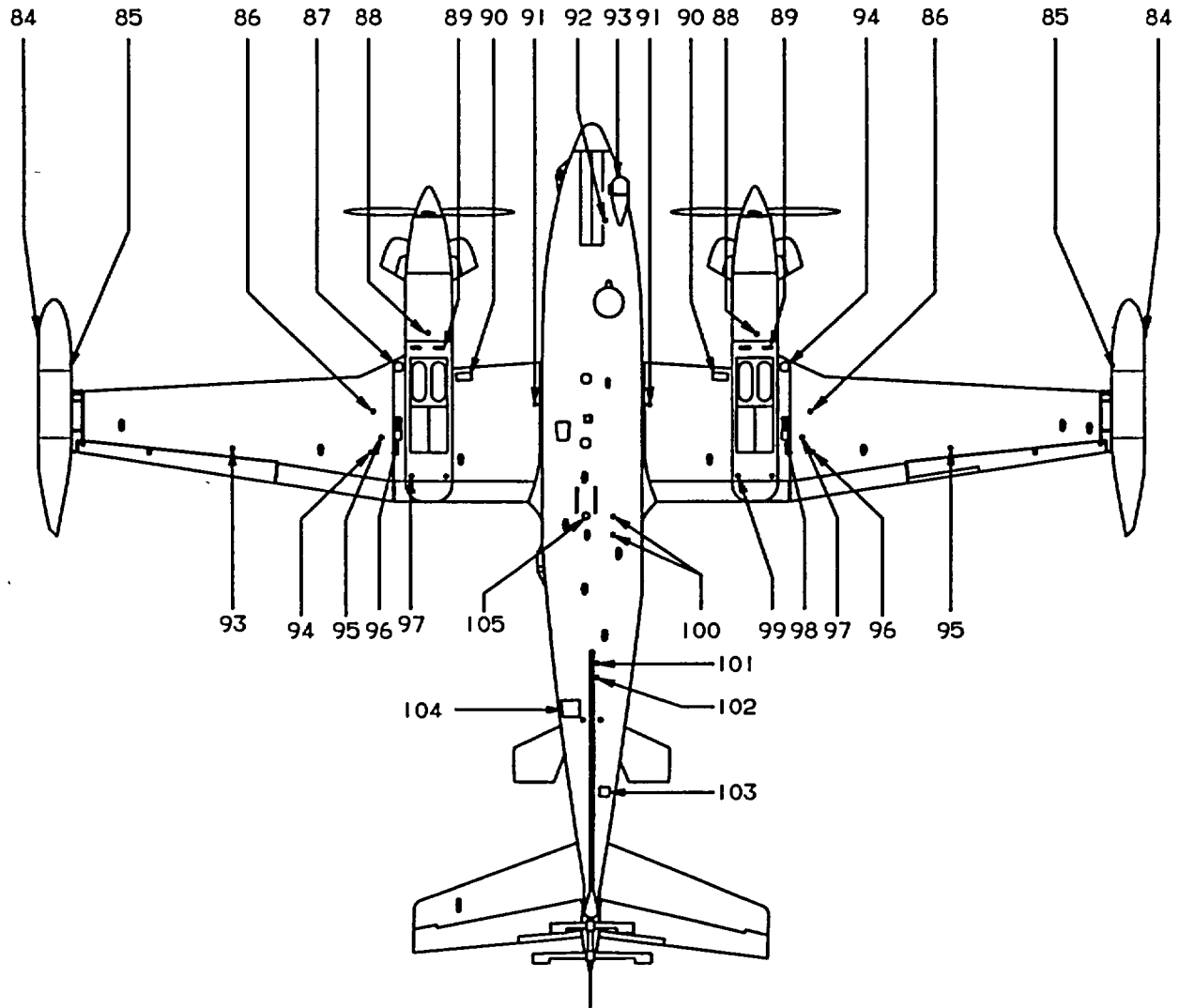

- |   |  |
|---|--|
| 84. Navigation Light                    | 95. Outboard Wing Fuel Sump Drain                      |
| 85. DF/ELINT Pod                        | 96. Ram Heated Fuel Vent                               |
| 86. Leading Edge Fuel Tank Drain        | 97. Recessed Fuel Vent                                 |
| 87. DC External Power Receptacle        | 98. Three Phase Inverter Cooling Air Outlet            |
| 88. Firewall Fuel Fitter Drain          | 99. Engine Oil Vent                                    |
| 89. Strainer Drain                      | 100. Antenna Deice System Boot Hold-down Elector Tubes |
| 90. Bleed Air Heat Exchanger Air Outlet | 101. Oxygen Regulator Vent                             |
| 91. Extended Range Fuel System Drain    | 102. Aft Compartment Drain                             |
| 92. Hydraulic Reservoir Drain           | 103. Lightning Sensor System Antenna                   |
| 93. Guardrail Dual Data Link Antenna    | 104. Tailcone Access Door                              |
| 94. AC External Power Receptacle        | 105. Strobe Beacon                                     |

**A94FE00D0014 C**

Figure 2-2. General Exterior Arrangement - Bottom, (Sheet 5 of 6) Q

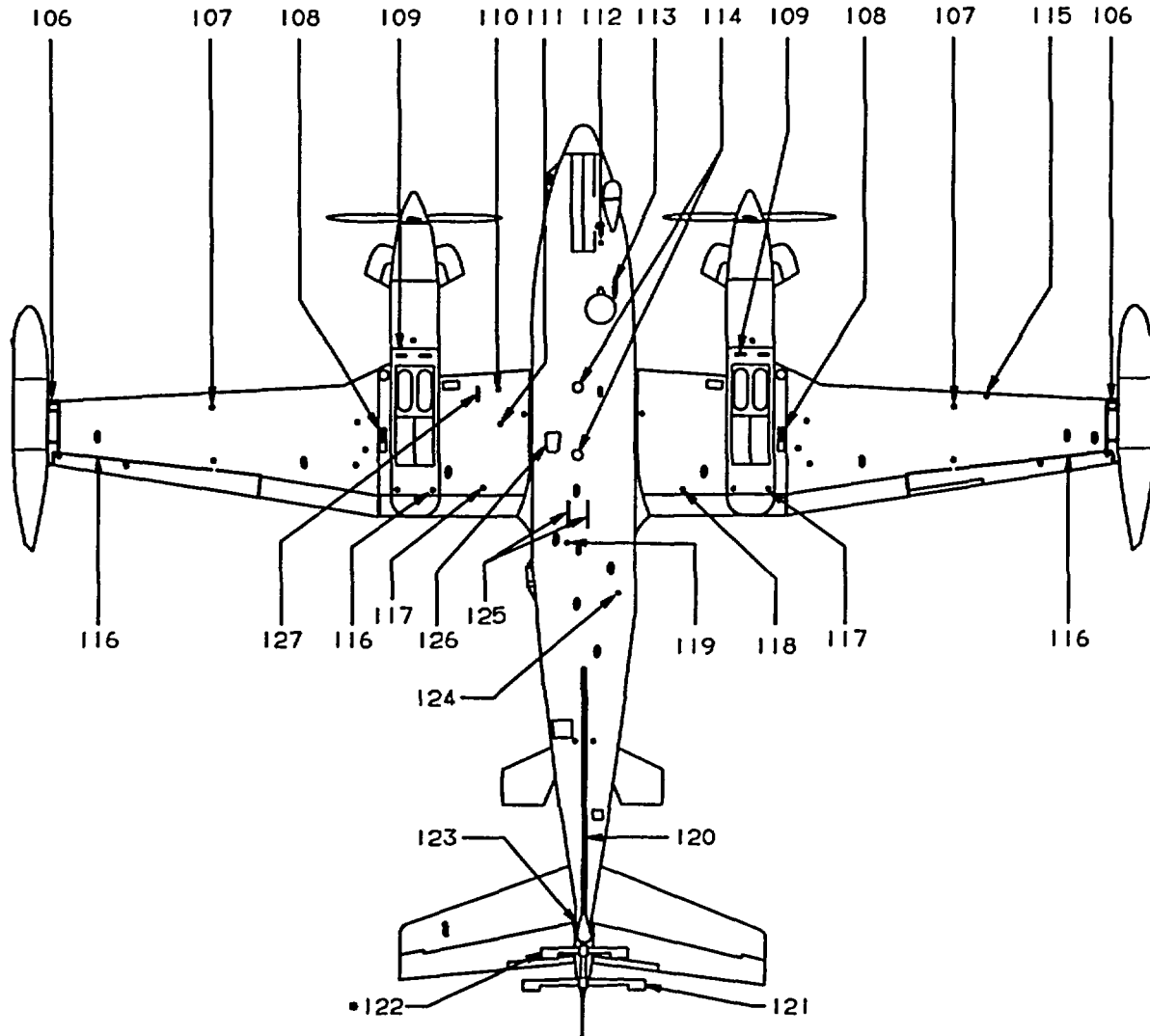

- |  |  |
|--|--|
| 106. Recognition Light                         | 117. Gravity Fuel Line Drain                   |
| 107. Tiedown Ring                              | 118. Wing Jack Pod                             |
| 108. Three Phase Inverter Cooling Air Intake   | 119. Surface Deice System Ejector Exhaust      |
| 109. Standby Fuel Pump Drain                   | 120. Ventral Fin                               |
| 110. Battery Ram Air Vent                      | 121. Mid-band Vertical Rotating Dipole Antenna |
| 111. Battery Drain                             | 122. Low-bond Rotating Dipole Antenna          |
| 112. Nose Jock Pad                             | 123. Art Guardrail Dual Data Link Antenna      |
| 113. Marker Beacon Antenna                     | 124. Relief Tube Drain                         |
| 114. Radio Altimeter Antenna                   | 125. Strobe Beacon Light Shields               |
| 115. Stall Warning Vane                        | 126. ADF Antenna                               |
| 116. Outboard Wing Fuel Vent (In Aileron Cove) | 127. Air Data Probe                            |
- \* Provisions Only

A94FE00D0015 C

Figure 2-2. General Exterior Arrangement - Bottom, - Continued (Sheet 6 of 6) Q



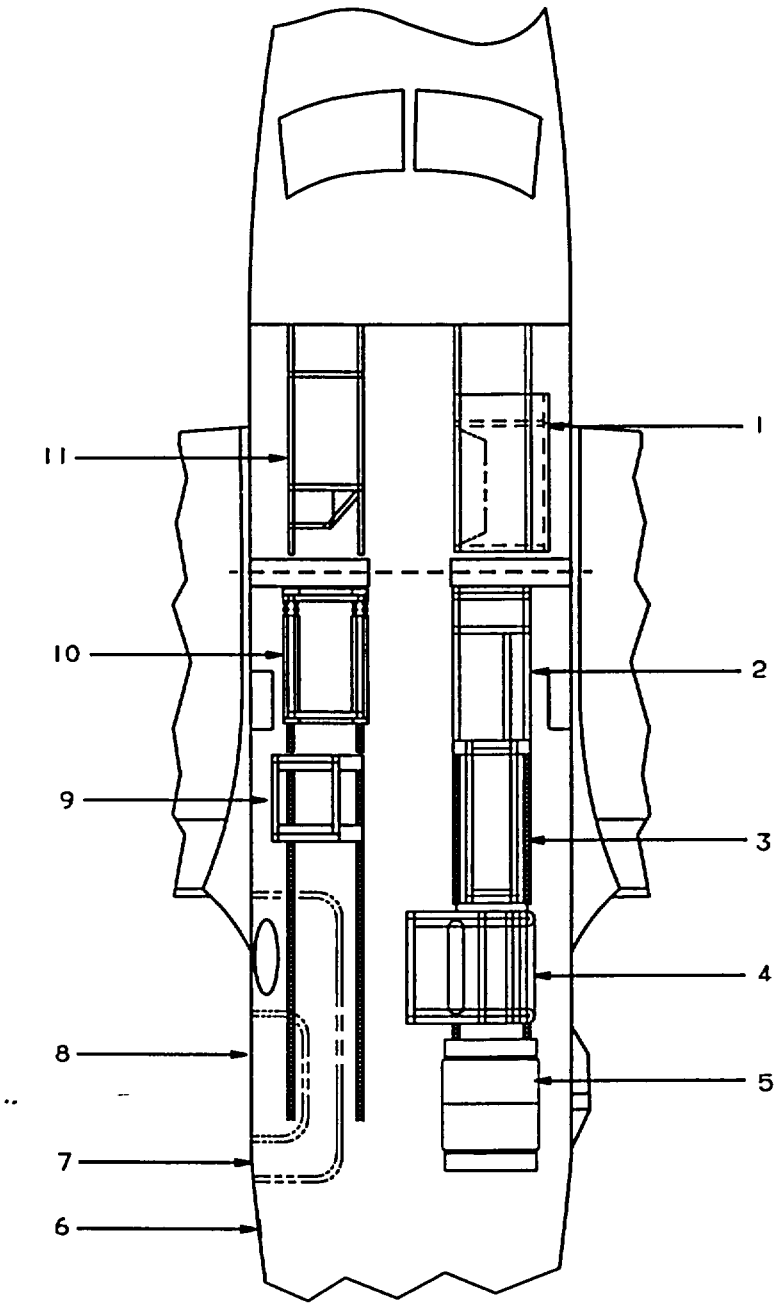

- 1. Mission Rock A1
- 2. Mission Rock A3
- 3. Mission Rock A5
- 4. Mission Rock A7
- 5. Chemical Toilet
- 6. Relief Tube

- 7. Cargo Door
- 8. Cabin Door
- 9. Mission Rock A6
- 10. Mission Rock A2
- 11. Mission Rock A4

A95E00D0275 C

Figure 2-3. General Interior Arrangement, P

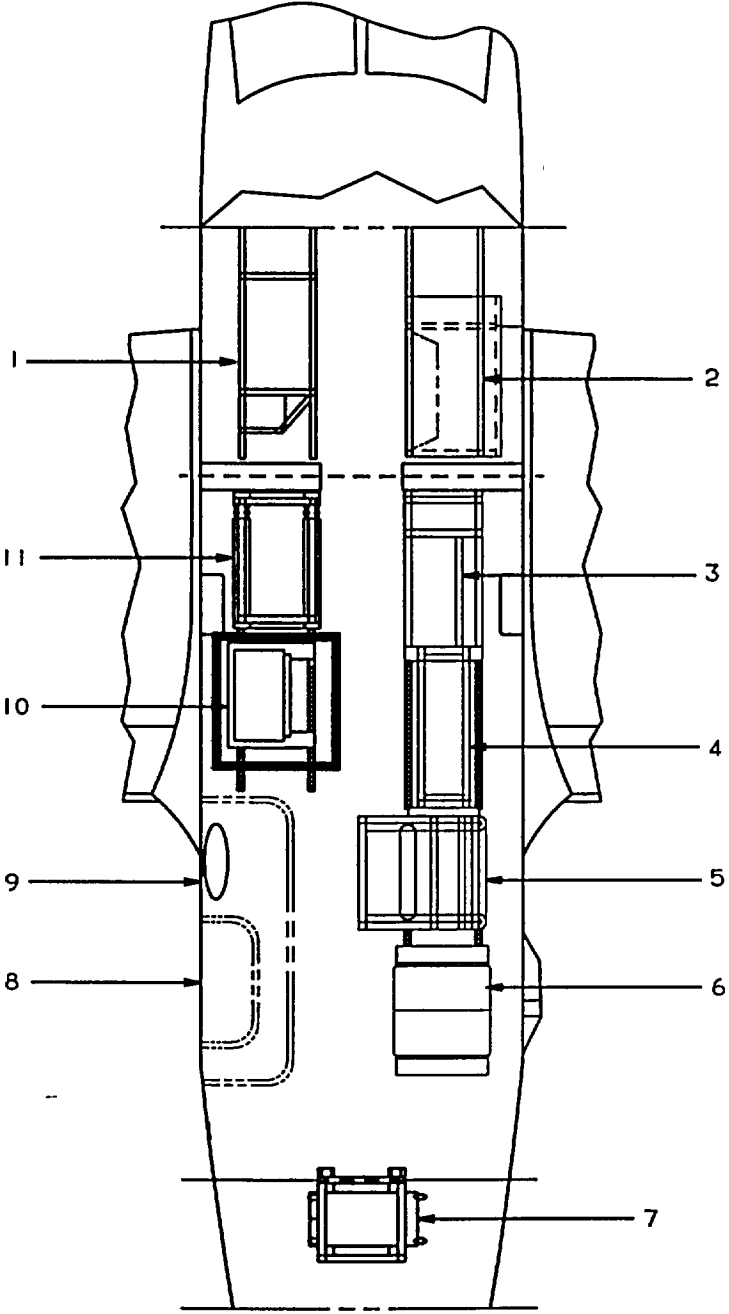

- 1. Mission Rack A4
- 2. Mission Rack A1
- 3. Mission Rack A3
- 4. Mission Rack A5
- 5. Mission Rack A7
- 6. Chemical Toilet

- 7. Mission Rack A8
- 8. Cabin Door
- 9. Cargo Door
- 10. Mission Rack A6
- 11. Mission Rack A2

FE02D970285 C

Figure 2-4. General Interior Arrangement, Q

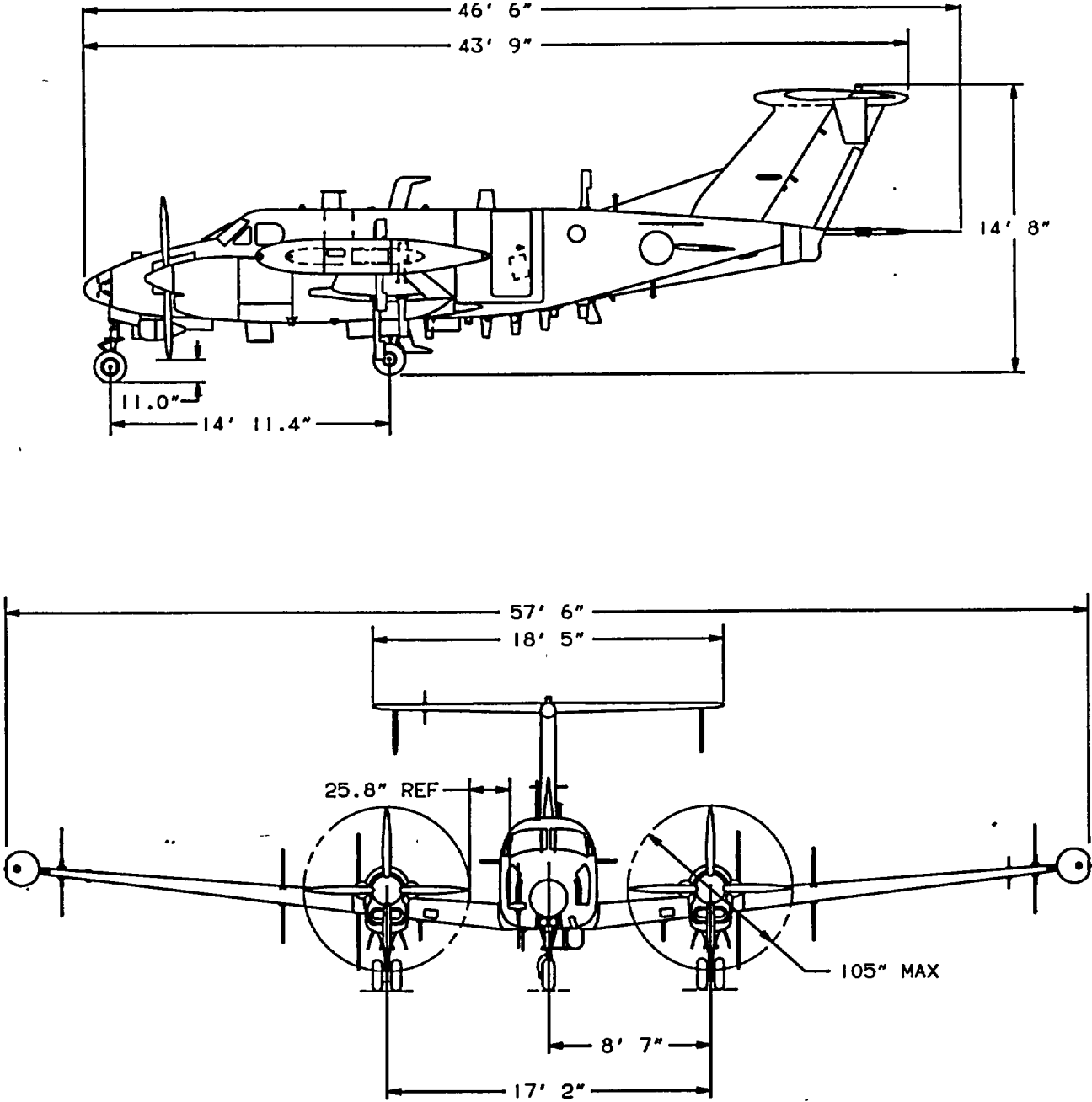

A94FE000017

Figure 2-5. Principal Dimensions

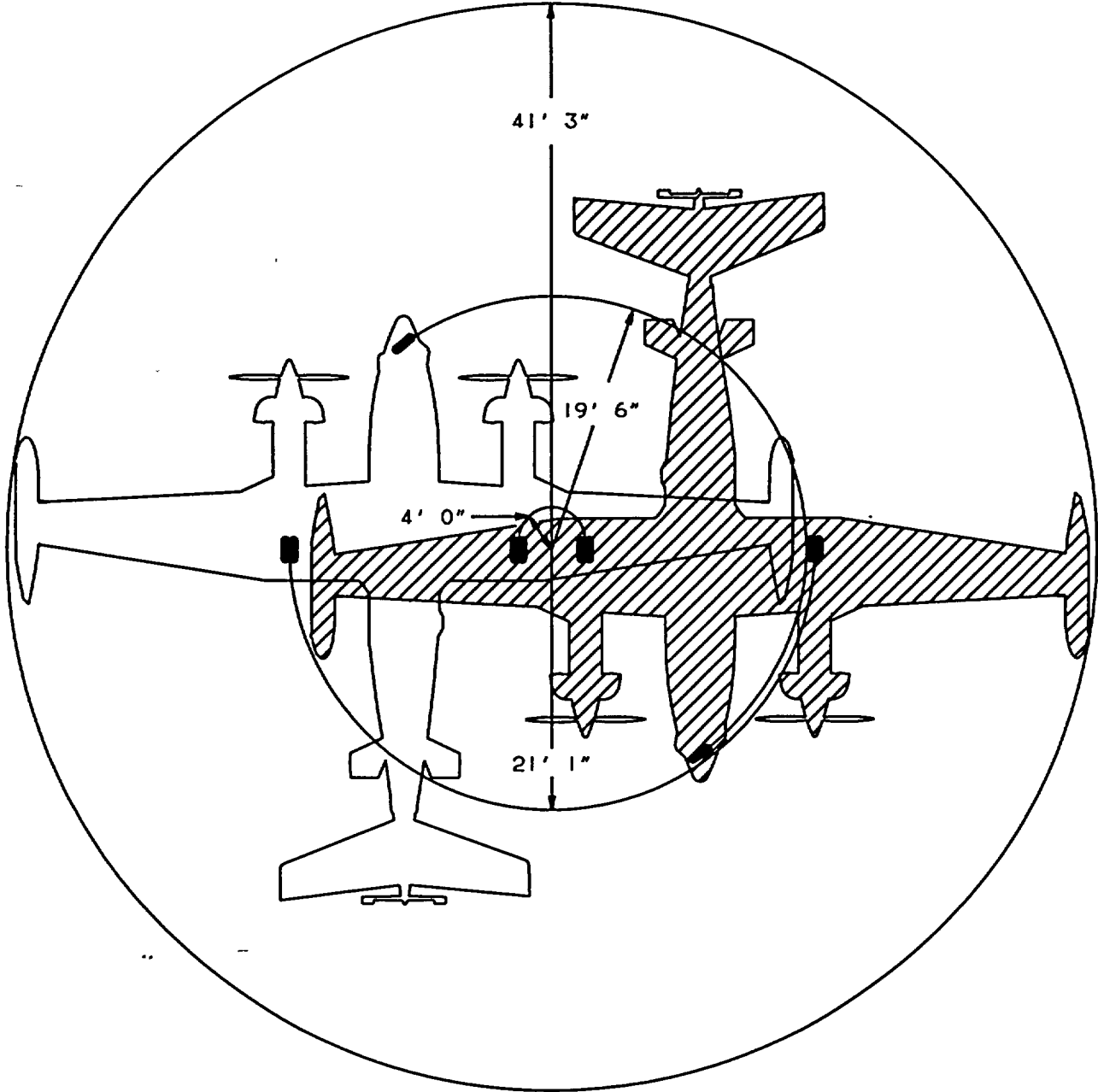

RADIUS FOR INSIDE GEAR.....	4 FEET
RADIUS FOR NOSE WHEEL.....	19 FEET 6 INCHES
RADIUS FOR OUTSIDE GEAR.....	21 FEET 1 INCH
RADIUS FOR WINGTIP.....	41 FEET 3 INCHES

TURNING RADII ARE PREDICATED ON THE USE OF DIFFERENTIAL BRAKING ACTION AND DIFFERENTIAL POWER. ACTUAL TURNING RADII DEPEND ON SURFACE CONDITIONS AND PILOT TECHNIQUE.

**A94FE00D0018 C**

Figure 2-6. Ground Turning Radius

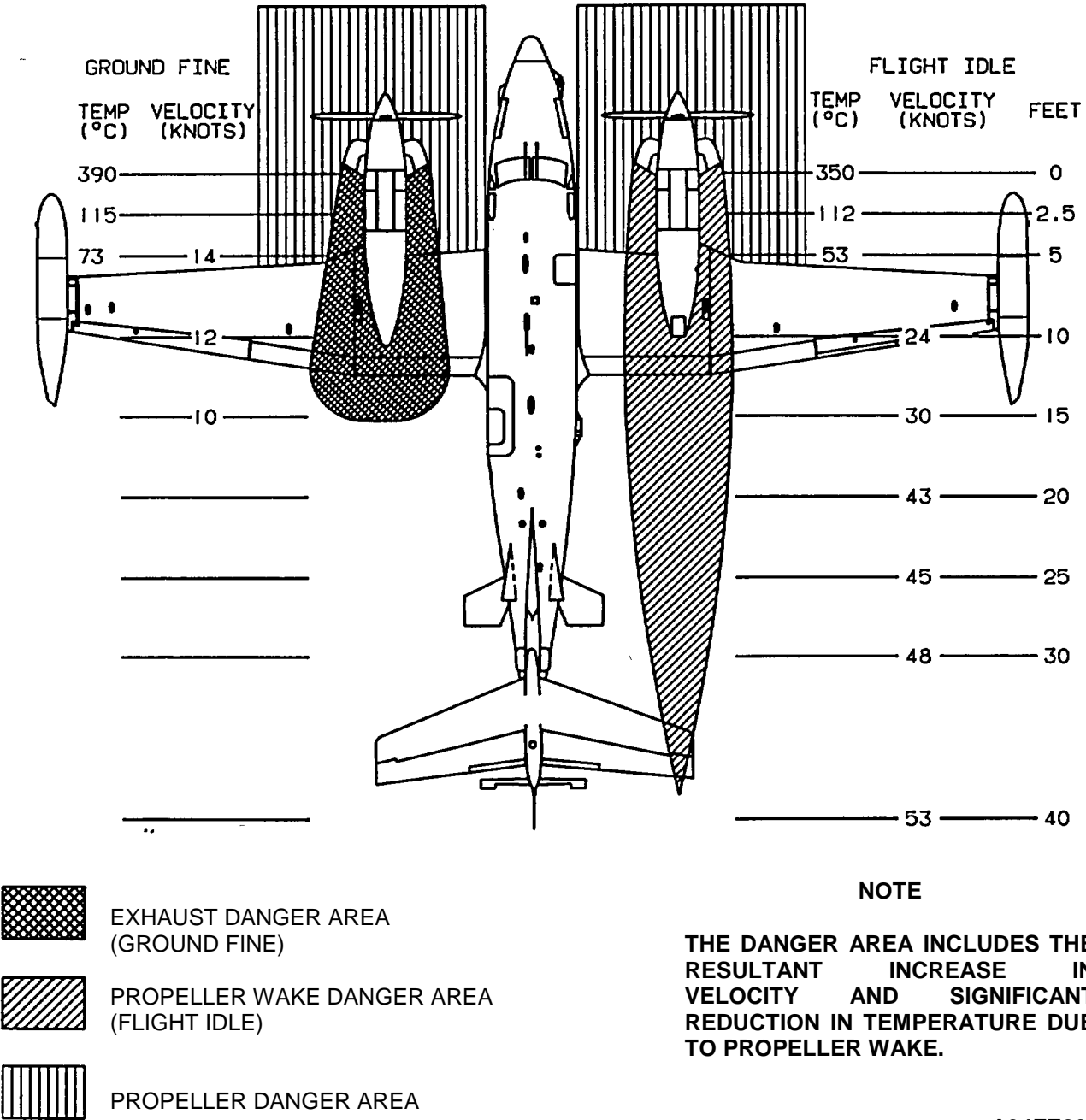

A94FE00D0019 C

Figure 2-7. Exhaust and Propeller Danger Areas

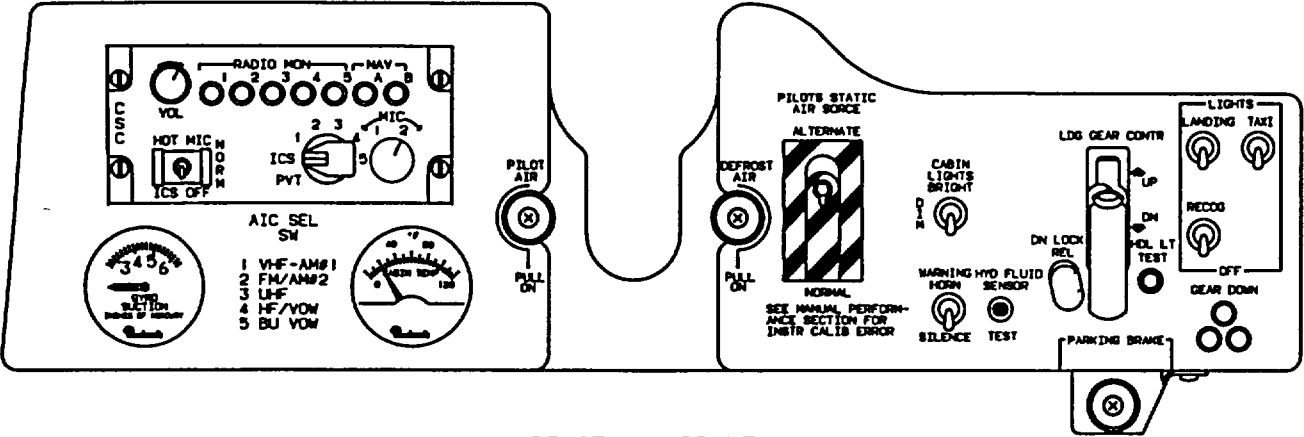

PILOT'S SUBPANEL

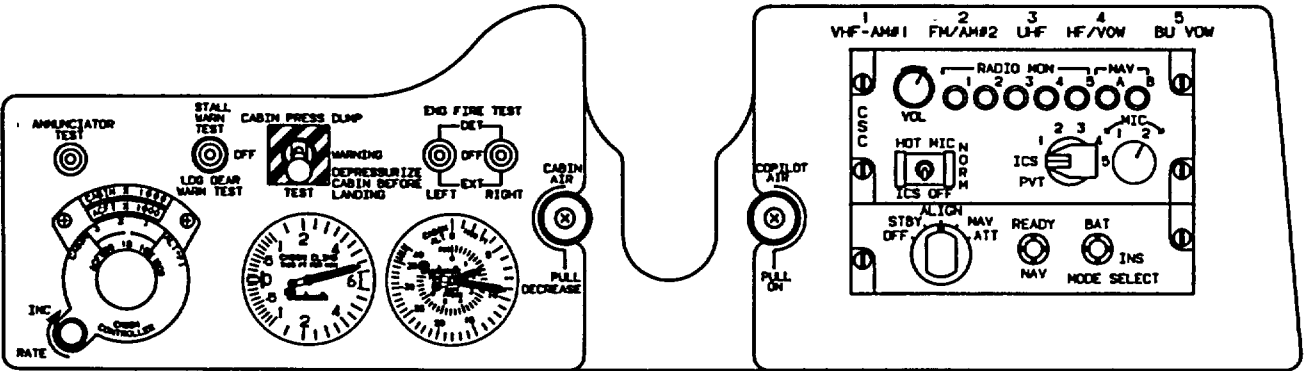

COPILOT'S SUBPANEL

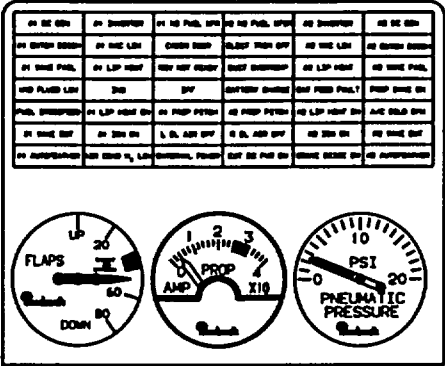

CENTER SUBPANEL

AP015207 C

Figure 2-8. Subpanels

gear extension or retraction is normally accomplished in 6 to 7 seconds. Voltage to the power pack is terminated after the fully extended or retracted position is reached. If electrical power has not terminated within 14 seconds, a relay and 2-ampere landing gear circuit breaker will open, and electrical power to the system power pack will be interrupted.

The landing gear system utilizes folding braces, called drag legs, that lock into place when the gear are fully extended. The nose landing gear actuator incorporates an internal down lock to hold the gear in the fully extended position. The two main landing gear are held in the fully extended position by mechanical hook and pin locks. The landing gear are held in the up position by hydraulic pressure. The pressure is controlled by the power pack pressure switch and an accumulator that is precharged with nitrogen to 800 ±50 psi. Gear doors are opened and closed through a mechanical linkage connected to the landing gear. The nose wheel steering mechanism is automatically centered and the rudder pedals relieved of the steering load when the landing gear are retracted. Air-oil type shock struts, filled with compressed nitrogen and hydraulic fluid, are incorporated with the landing gear.

*a. Landing Gear Control Switch.* Landing gear system operation is controlled by a manually actuated, wheel-shaped switch, placarded **LDG GEAR CONTR UP DN**, on the pilot's subpanel (fig. 2-8). The control switch and associated relay circuits are protected by a 2-ampere circuit breaker, placarded **LANDING GEAR CONTROL**, located on the overhead circuit breaker panel (fig. 2-9).

*b. Landing Gear Down Position Indicator Lights.* Visual indication of landing gear position is provided by three individual green **GEAR DOWN** position indicator lights located on the pilot's subpanel. Testing of the indicator lights is accomplished by pressing the annunciator test switch. The circuit is protected by a 5-ampere circuit breaker, placarded **LANDING GEAR IND**, on the overhead circuit breaker panel (fig. 2-9).

*c. Landing Gear Position Warning Lights.* Two parallel-wired red indicator lights, located in the **LDG GEAR CONTROL** switch handle, illuminate to show that the gear is in transit or unlocked. The red indicator lights in the handle also illuminate when the landing gear warning horn is actuated. Both red indicator lights indicate the same warning conditions, but two are provided for a failsafe indication in case one bulb burns out. The circuit is protected by a 5-ampere circuit breaker, placarded **LANDING GEAR IND**, on the overhead circuit breaker panel (fig. 2-9).

*d. Landing Gear Warning Indicator Light Test Switch.* A test switch, placarded HDL LT TEST, is located in the pilot's subpanel (fig. 2-8). When this test switch is pressed, failure of the landing gear handle to illuminate red indicates two defective bulbs or a circuit fault. The circuit is protected by a 5-ampere circuit breaker, placarded **LANDING GEAR HORN**, on the overhead circuit breaker panel (fig. 2-9).

*e. Landing Gear Warning System.* The landing gear warning system is provided to warn the pilot that the landing gear is not down and locked during specific flight regimes. Various warning modes result, depending upon the position of the flaps.

At airspeeds above 140 KIAS, with flaps in the **UP** or **APPROACH** position and either or both **POWER** levers retarded below approximately 84% N<sub>1</sub>, the landing gear switch handle annunciator will illuminate. The horn is automatically silenced by an altitude sensing switch, provided to silence the landing gear warning horn when above 12,500 feet. This prevents the horn from sounding above 12,500 feet when either **POWER** lever is pulled back, provided the flaps are at the approach position or above.

At airspeeds below 140 KIAS, with flaps in the **UP** or **APPROACH** positions and either or both **POWER** levers retarded below approximately 84% N<sub>1</sub>, the warning horn will sound and the landing gear switch handle indicator lights will illuminate. The horn can be silenced by moving the **WARNING HORN SILENCE** switch, located adjacent to the landing gear switch handle, to the up position. However, the annunciators in the landing gear switch handle cannot be cancelled. The gear warning silence switch is a magnetically held switch. Once actuated it will stay in the up position until both **POWER** levers are advanced above 86% N<sub>1</sub>, and/or airspeed increases above approximately 153 KIAS.

In either case (airspeeds above or below 140 KIAS), the landing gear warning system will be rearmed if both power levers are advanced above 86% N<sub>1</sub>.

With the landing gear retracted and flaps beyond the **APPROACH** position, the warning horn and landing gear switch handle annunciators will be activated regardless of the power setting. The horn cannot be silenced in this case, until either the landing gear is lowered or the flaps are retracted to the **UP** or **APPROACH** position.

*f. Landing Gear Warning Horn Test Switch.* The warning horn and gear handle indicator lights can be tested by placing the switch, placarded **STALL WARN: TEST OFF LDG GEAR WARN TEST**, to the **LDC GEAR WARN TEST** position (fig. 2-8). The gear handle warning lights will illuminate, and the warning horn will sound. Releasing the **LDG GEAR WARN TEST** switch to the **OFF** position will extinguish the gear handle indicator lights and silence the warning horn. The landing gear

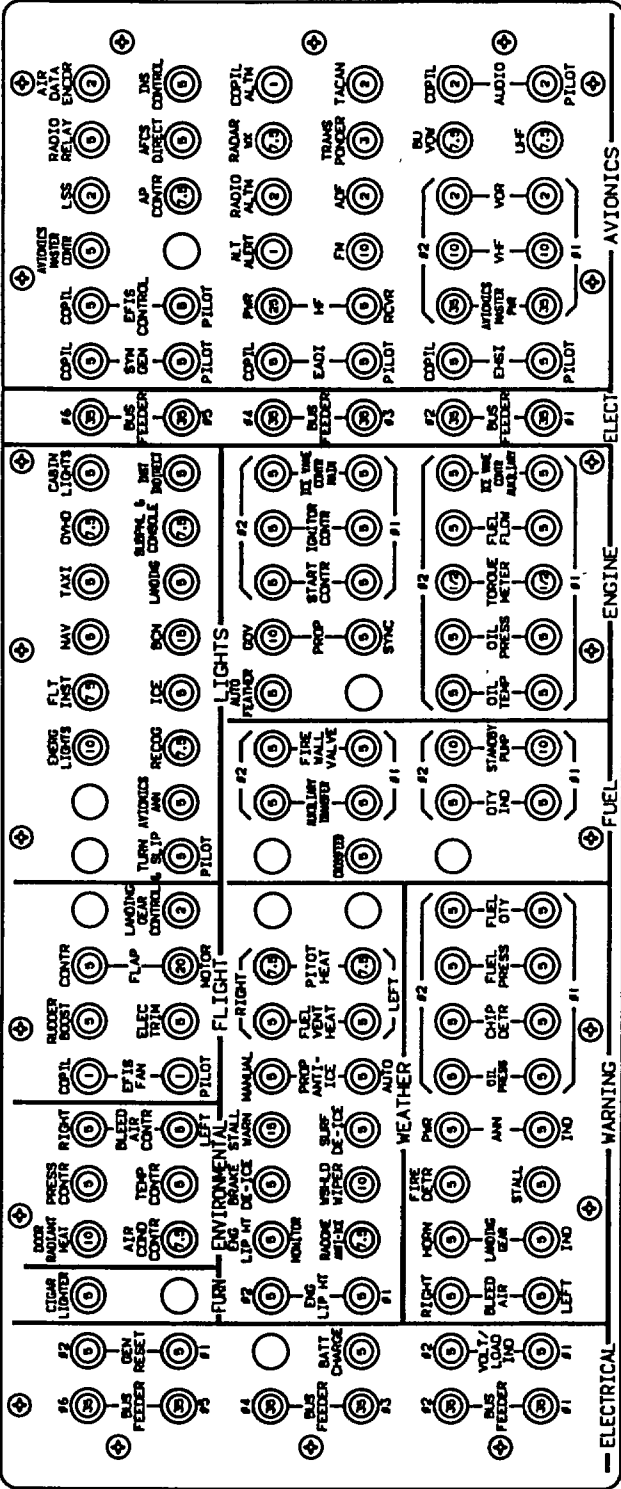

Figure 2-9. Overhead Circuit Breaker Panel

A94FE00D0020



warning horn circuit is protected by a 5-ampere circuit breaker, placarded LANDING GEAR HORN, located on the overhead circuit breaker panel (fig. 2-9).

*g. Landing Gear Safety Switches.* A safety switch on each main landing gear shock strut controls the operation of various aircraft systems that function only during flight or only during ground operation. These switches are mechanically actuated whenever the main landing gear shock struts are extended (normally after takeoff) or compressed (normally after landing). The safety switch on the right main landing gear strut deactivates the landing gear control circuits, cabin pressurization circuits, and the flight hour meter when the shock strut is compressed. This switch also activates a downlock hook, preventing the landing gear from being raised while the aircraft is on the ground. The hook, which unlocks automatically after takeoff, can be manually overridden by pressing down on the red button, placarded **DN LOCK REL**, located adjacent to the landing gear handle (fig. 2-8). If the override is used, the landing gear warning horn will sound intermittently and two parallel-wired red indicator lights, located in the landing gear control switch handle, will illuminate, provided the **BATTERY** switch is on. The safety switch on the left main landing gear strut activates the left and right engine ambient air shut-off valves when the strut is extended.

*h. Landing Gear Alternate Extension.*

**WARNING**

**After an emergency landing gear extension has been made, do not move any landing gear controls or reset any switches or circuit breakers until the aircraft is on jacks. The failure may have been in the gear-up circuit, which could cause the gear to retract while the aircraft is on the ground.**

**If for any reason the three green GEAR DOWN indicator lights do not illuminate (e.g., in case of an electrical system failure), continue pumping until sufficient resistance is felt to ensure that the gear is down and locked. Do not stow the hand pump handle. Stowing the handle will release hydraulic pressure. If the three GEAR DOWN indicator lights are not illuminated, the landing gear downlocks may not be engaged and hydraulic pressure may be the only thing holding the landing gear down.**

An extension lever, placarded **LANDING GEAR ALTERNATE EXTENSION**, is located on the floor between the crew seats. Manually pumping the lever lowers the landing gear. The hydraulic pump, which is utilized to manually lower the gear, is located under the floor.

To engage the system, pull the **LANDING GEAR CONTROL** circuit breaker, located on the overhead circuit breaker panel (fig. 2-9), and ensure that the **LDG GEAR CONTR** handle is in the **DN** position. Remove the extension lever from the securing clip and pump the lever up and down until the three green **GEAR DOWN** indicator lights illuminate. As the handle is moved, hydraulic fluid is drawn from the hand pump suction port of the power pack and routed through the hand pump pressure port to the actuators. After an alternate extension of the landing gear, ensure that the extension lever is in the full down position prior to stowing the lever in the retaining clip. When the lever is stowed, an internal relief valve is actuated to relieve the hydraulic pressure in the pump.

After a practice alternate extension, stow the extension lever, reset the **LANDING GEAR CONTROL** circuit breaker, and retract the gear in the normal manner with the landing gear control handle.

*i. Tires.* The aircraft is equipped with dual 22 x 6.75 x 10, 10 ply rated, tubeless rim-inflation tires on each main gear and a 22 x 6.75 x 10, 8 ply rated, tubeless tire on the nose wheel.

*j. Nose Wheel Steering System.* The aircraft is maneuvered on the ground by the nose wheel steering system. Direct linkage from the rudder pedals (fig. 2-10) to the nose wheel steering linkage allows the nose wheel to be turned 12° to the left of center or 14° to the right. When rudder pedal steering is augmented by main wheel braking action, the nose wheel can be deflected up to 48° either side of center. Shock loads which would normally be transmitted to the rudder pedals are absorbed by a spring mechanism in the steering linkage. Retraction of the landing gear automatically centers the nose wheel and disengages the steering linkage from the rudder pedals.

*k. Wheel Brake System.* The main wheels are equipped with multiple-disc hydraulic brakes, actuated by master cylinders attached to the toe brake sections of the rudder pedals. Brake fluid is supplied to the system from a reservoir in the nose compartment. Braking is permitted from either set of rudder pedals. No emergency brake system is provided. Repeated application of brakes with insufficient cooling time between applications will cause a loss of braking efficiency, and may cause brake failure, wheel failure, tire blowout, or destruction of wheel assembly by fire.

**2-8. PARKING BRAKE.**

Dual parking brake valves are installed below the cockpit floor. Both valves can be closed simultaneously by pressing both brake pedals in either cockpit position to build up pressure, then pulling out the handle, placarded

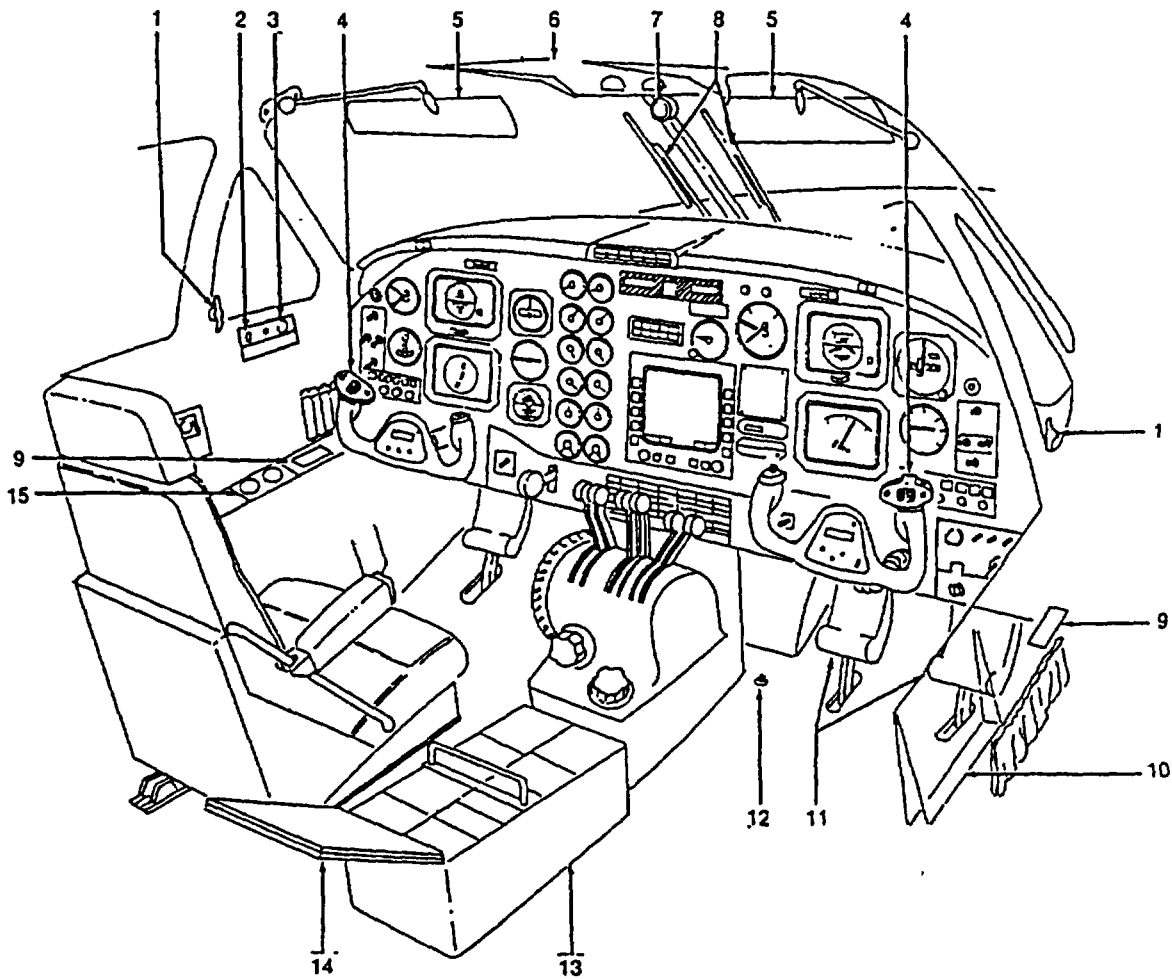

**NOTE:  
COPILOT SEAT REMOVED FOR CLARITY**

- |   |  |
|---|--|
| <ol style="list-style-type: none"> <li>1. Storm Window Lock</li> <li>2. Cigarette Lighter</li> <li>3. Free Air Temperature Gage</li> <li>4. Control Wheel</li> <li>5. Sun Visor</li> <li>6. Overhead Circuit Breaker Panel, Overhead Control Panel, and Fuel Management Panel</li> <li>7. Magnetic Compass</li> </ol> | <ol style="list-style-type: none"> <li>8. Windshield Wiper</li> <li>9. Oxygen Regulator Control Panel</li> <li>10. Mission Control Panel</li> <li>11. Rudder Pedals</li> <li>12. Foot-Operated Microphone Switch</li> <li>13. Pedestal Extension</li> <li>14. Assist Step</li> <li>15. Oxygen System Pressure Gages</li> </ol> |
|---|--|

A938C00C0078

Figure 2-10. Cockpit

**PARKING BRAKE** on the pilot's subpanel (fig. 2-8). Pulling the handle full out sets the check valves in the system and any pressure being applied by the toe brakes is maintained. The parking brake is released when the brake handle is pushed in. The parking brake may be set from either the pilot's or copilot's position. The parking brake shall not be set during flight.

## 2-9. ENTRANCE AND EXIT PROVISIONS.

### NOTE

**Two keys are provided in the loose tools and equipment bag. Both keys fit the locks on the cabin door, emergency hatch, tailcone access door, and the right and left nose avionics compartment doors.**

#### a. Cabin Door.

### CAUTION

**Structural damage may occur if more than one person is present on the airstair cabin door at one time. The door is weight limited to 300 pounds.**

An airstair cabin door (fig. 2-11), hinged at the bottom, provides a stairway for normal and emergency entrance and exit. In the closed position, the door becomes an integral part of the cargo door. The cabin door is provided with steps, two of which fold flat against the door in the closed position. A step folds down over the door sill when the door opens to provide a platform (step) for door seal protection. A plastic-encased cable provides a handhold and support for the door in the open position and a convenience for closing the door from inside. A hydraulic damper permits the door to lower gradually during opening. A rubber seal around the door seals the pressure vessel while the aircraft is in flight. The door locking mechanism is operated by either of the two mechanically interconnected handles, one inside and the other outside the door. When either handle is rotated, three rotating cam-type latches on either side of the door capture posts mounted on the cargo door. A button adjacent to the door handle must be depressed before the handle can be rotated to open the door. A bellows behind the button is inflated when the aircraft is pressurized to prevent accidental unlatching and/or opening of the door. A placard adjacent to the window instructs the operator that the safety lock arm is in position around the bellows shaft which indicates a properly locked door. Pushing the red button adjacent to the window will illuminate the inside door mechanism. A **CABIN DOOR** annunciator on the caution/l advisory panel will illuminate if the door is not closed and all latches fully locked. The cabin door opening is 21.5 inches wide by 50.0 inches high.

#### b. Cargo Door. A swing-up cargo door

(fig. 2-11), hinged at the top, provides access for loading cargo or bulky items. The cargo door opening is 52.0 inches wide by 52.0 inches high. After initial opening force is applied gas springs will completely open the cargo door automatically. The door is counterbalanced and will remain in the open position. A door support rod is used to hold the door in the open position, and to aid in overcoming the pressure of the gas spring assemblies when closing the door. Once closed, the gas springs apply a closing force to assist in latching the door. A rubber seal around the door seals the pressure vessel while in flight. The door locking mechanism is operated only from inside the aircraft, and is operated by two handles, one in the bottom forward portion of the door and the other in the upper aft portion of the door. When the upper aft handle is operated per placard instructions, cam-type latches (two on the forward side of the door and two on the aft side) rotate, capturing posts mounted on the fuselage side of the door opening. The bottom handle, when operated per placard instructions, actuates four pin-lug latches across the bottom of the door. A button on the upper aft handle must be pressed before the handle can be released to open or latch the door. A latching lever on the bottom handle must be lifted to release the handle before the lower latches can be opened. These act as additional aids in preventing accidental opening or unlatching of the door. The cabin and cargo doors are equipped with dual sensing circuits to provide the crew with remote indication of cabin/cargo door security. An annunciator, placarded **CABIN DOOR**, will illuminate if the cabin or cargo door is open and the **BATTERY** switch is on. If the **BATTERY** switch is off, the annunciator will illuminate only if the cabin door is not securely closed and latched. The cabin/cargo door sensing circuit receives power from the hot battery bus.

### CAUTION

**When operating the cargo door, ensure that the cabin door is closed and locked. Operating the cargo door while the cabin door is open may damage the door hinge and adjacent structure.**

#### (1) Opening the cargo door.

### CAUTION

**To prevent damage to the mechanism, avoid side loading of the gas springs.**

1. Handle access door (lower forward corner of door) - Unfasten and open.
2. Handle - Lift hook and move to **OPEN** position.

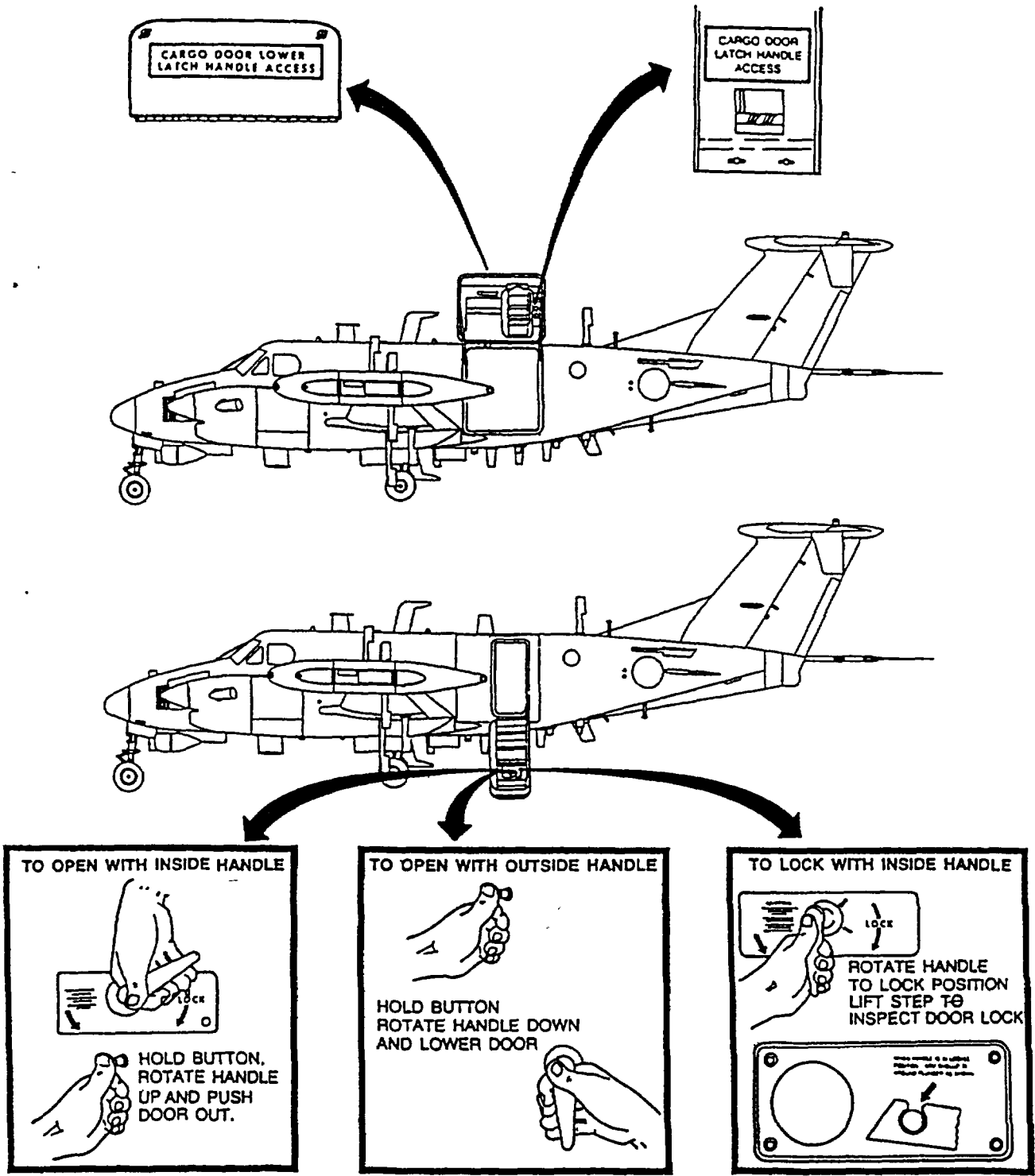

Figure 2-11. Cabin and Cargo Doors

3. Handle access door - Secure.
4. Handle access door (upper aft corner of door) - Unfasten and open.
5. Handle - Press button and lift to OPEN position, then latch in place.
6. Handle access door - Secure.
7. Door support rod - Attach one end to cargo door ball stud (on forward side of door).
8. Support rod detent pin - Check in place.
9. Cabin door sill step - Push out and allow cargo door to swing open. Gas springs will automatically open the door.
10. Door support rod - Attach free end to ball stud on forward fuselage door frame.

(2) *Closing the cargo door.*

**CAUTION**

**To prevent damage to the mechanism, avoid side loading of the gas springs.**

1. Door support rod - Detach from fuselage door frame ball stud, then firmly grasp free end of rod while exerting downward force to overcome the pressure of gas spring assemblies, then remove support rod from door as gas spring assemblies pass the over-center position.
2. Cargo door - Pull closed, using finger hold cavity in fixed cabin door step.
3. Handle access door (upper aft corner of door) - Unfasten and open.
4. Handle - Press button and pull handle down until it latches in closed position.
5. handle access door - Secure.
6. Handle access door (lower forward corner of door) - Unfasten and open.
7. Handle - Move to full forward position.
8. Safety hook - Check locked in position by pulling aft on handle.
9. handle access door - Secure.

*c. Cabin Door Annunciator.* As a safety precaution, two flashing yellow MASTER CAUTION

annunciators in the glare shield and a steadily illuminated **CABIN DOOR** amber caution annunciator on the caution/advisory panel indicate the cabin door is not closed and locked. This circuit is protected by the two 5-ampere circuit breakers, placarded ANN PWR and ANN IND, located on the overhead circuit breaker panel (fig. 2-9).

*d. Cabin Emergency Exit Hatch.* The cabin emergency hatch, placarded **EXIT<sup>o</sup>-PULL**, is located on the right cabin sidewall just aft of the copilot's seat. The hatch may be released from the inside with a pull-down handle. A flush-mounted, pull out handle allows the hatch to be released from the outside. The hatch is of the non-hinged plug type which removes completely from the frame when the latches are released. The hatch can be key locked from the inside to prevent opening from the outside. The inside handle will unlatch the escape hatch, whether or not it is locked, by overriding the locking mechanism. The keylock should be unlocked prior to flight to allow removal of the escape hatch from the outside in the event of an emergency. The key remains in the lock when the hatch is locked and can be removed only when the hatch is unlocked. The key slot is in the vertical position when the hatch is unlocked. Removal of the key from the lock before flight assures the pilot that the hatch can be removed from the outside if necessary.

## 2-10. WINDOWS.

*a. Cockpit Windows.* The pilot and copilot have side windows, a windshield, and storm windows, which provide visibility from the cockpit. The storm windows may be opened on the ground or during unpressurized flight.

*b. Cabin Windows.* The outer cabin windows, constructed of two-ply stretched acrylic, are of the pressure type and are an integral part of the pressure vessel. The windows have flaps which may be removed to permit visibility or installed to black out the windows.

## 2-11. SEATS.

*a. Pilot's and Copilot's Seats.* The controls for vertical height adjustment and fore and aft travel are located under each seat. The forward and aft adjustment handle is located beneath the lower front inboard corner of each seat. Pulling up on the handle allows the seat to move fore or aft. The height adjustment handle is located beneath the lower front outboard corner of each seat. Pulling up on the handle allows the seat to move up and down. Both seats have adjustable headrests and armrests which will raise and lower for access to the cockpit. Handholds on either

side of the overhead panels and a fold-away protective pedestal step are provided for pilot and copilot entry into the cockpit. For the storage of maps and the operator's manual, pilot's and copilot's seats have an inboard-slanted, expandable pocket affixed to the lower portion of the seat back. Pocket openings are held closed by shock cord tension (fig. 2-12).

b. *Pilot's and Copilot's Seat Belts and Shoulder Harnesses.* The pilot's and copilot's seats are each equipped with a lap-type seat belt and shoulder harness

connected to an inertia reel. The shoulder harness belt is of the Y configuration with the single strap being contained in an inertia reel attached to the base of the seatback. The two straps are worn with one strap over each shoulder and fastened by metal loops into the seat belt buckle. The inertia reel keeps the harness snug but will allow normal movement required during flight operations. The inertia reel is designed with a locking device that will secure the harness in the event of sudden forward movement or an impact action.

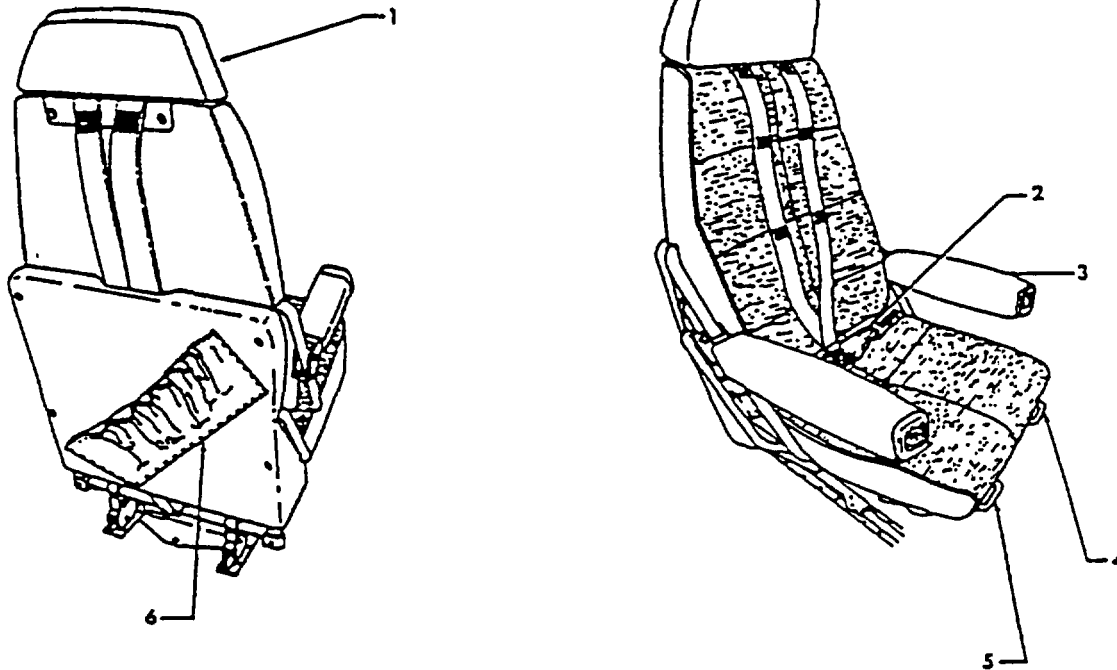

AF 004764

1. Adjustable Headrest
2. Seatbelt/Shoulder Harness Buckle
3. Moveable Armrest
4. Seat Height Adjustment (Pilot), Height And Adjustment (Copilot)
5. Sea Fore And Aft Adjustment (Pilot), Height And Adjustment (Copilot)
6. Expandable Map Pocket

Figure 2-12. Pilot's and Copilot's Seats

**Section II. EMERGENCY EQUIPMENT****2-12. DESCRIPTION.**

The equipment covered in this section includes all emergency equipment, except that which forms part of a complete system. For example, landing gear system, etc. Chapter 9 describes the operation of emergency exits and location of all emergency equipment.

**2-13. FIRST AID KITS.**

Three first aid kits are included in the survival kit.

**2-14. HAND-OPERATED FIRE EXTINGUISHER.****WARNING**

Repeated or prolonged exposure to high concentrations of monobromotrifluoro-methane (CF<sub>3</sub>Br) or decomposition products should be avoided. The liquid shall not be allowed to come into contact with the skin, as it may cause frost bite or low

**temperature burns because of its very low boiling point.**

One hand-operated fire extinguisher is mounted below the pilot's seat and a second extinguisher is located in the left cabin sidewall, aft of the cabin door. They are of the monobromotrifluoromethane (CF<sub>3</sub>Br) type. Each extinguisher is charged to a pressure of 150 to 170 PSI and emits a forceful stream. Use an extinguisher with care within the limited area of the cabin to avoid severe splashing.

**NOTE**

**Engine fire extinguisher systems are described in Section III.**

**2-15. SURVIVAL RAFTS AND KITS.**

Tie-down provisions for three survival rafts and kits are provided just aft of the toilet on the right side of the aft cabin area.

### Section III. ENGINES AND RELATED SYSTEMS

#### 2-16. ENGINES.

The aircraft is powered by two PT6A-67 turboprop engines, rated at 1200 SHP each (fig. 2-13). Each engine is equipped with a hydraulically controlled, reversible, constant-speed, four-bladed, full-feathering propeller. The engines are reverse-flow free turbines, and each employs a four-stage axial compressor and a single-stage centrifugal compressor in combination, driven by the gas generator turbine. The gas generator turbine and the two power turbines are in line and have opposite rotations. The power turbines are connected through planetary reduction gearing to a flanged propeller shaft. The oil tank, filler cap and dipstick are an integral part of the engine.

The ram air supply enters the lower portion of the nacelle and is drawn in through the aft protective screens. The air is then routed into the compressor. After the air is compressed, it is forced into the annular combustion chamber and mixed with fuel that is sprayed in through 14 nozzles mounted around the gas generator case. A capacitance discharge ignition unit and two spark igniter plugs are used to start combustion. After combustion, the exhaust passes through the compressor turbine and two stages of power turbines, then is routed through two exhaust ports near the front of the engine. A pneumatic fuel control system schedules fuel flow to maintain power set by the gas generator POWER lever (fig. 2-14). The accessory drive at the aft end of the engine provides power to drive the fuel pumps, fuel control, oil pump, refrigerant compressor (right engine), starter/generator, and the tachometer generator. The reduction gearbox forward of the power turbine provides gearing for the propeller and drives the propeller tachometer generator, the propeller overspeed governor, and the propeller primary governor.

#### 2-17. ENGINE COMPARTMENT COOLING.

The forward engine compartment, including the accessory section, is cooled by air which enters around the exhaust stack cutouts and through the gap between the propeller spinner and forward cowling, and exhausts through louvers in the upper forward and aft cowling.

#### 2-18. AIR INDUCTION SYSTEMS - GENERAL.

Each engine and oil cooler receives ram air ducted from separate air inlets located within the lower section of the forward nacelle. Induction system components protect the power plant from icing and reduce the possibility of foreign object damage.

#### 2-19. FOREIGN OBJECT DAMAGE CONTROL.

The engine has an integral air inlet screen designed to obstruct objects large enough to damage the compressor.

#### 2-20. ENGINE ICE PROTECTION SYSTEMS.

a. *Inertial Separator.* An inertial separation system is built into each engine air inlet to prevent moisture particles from entering the engine inlet plenum under icing conditions. A movable vane and a bypass door are lowered into the airstream when operating in visible moisture at 5 °C or colder, by energizing electrical actuators with the switches, placarded **#1** and **#2 ICE VANE CONTROL - ON**, located on the overhead control panel (fig. 2-15). The system incorporates an electrical back-up system which operates identically to the main system. The back-up ice vane system is controlled by two switches placarded **#1** and **#2 ICE VANE POWER SELECT - MAIN - STANDBY**, located on the overhead control panel (fig. 2-15). If the main system fails, placing the switch in the **STBY** position will allow use of the back-up system. Electrical protection is provided through two 5-ampere circuit breakers placarded **ICE VANE CONTR MAIN** and **ICE VANE CONTR AUXILIARY**, located on the overhead circuit breaker panel.

b. *Engine Ice Protection Systems Operation.* The vane deflects the ram airflow slightly downward to introduce a sudden turn in the airflow to the engine. Because of their greater momentum the particles continue undeflected and are discharged overboard.

Once the ice vane system is actuated, the extended position of the vane and bypass door is indicated by green annunciators, placarded **#1 VANE EXT** and **#2 VANE EXT**, located on the caution/advisory panel. If for any reason the vane(s) do not attain the selected position within 33 seconds, an amber **#1 VANE FAIL** and/or **#2 VANE FAIL** annunciator(s) illuminates on the caution/ advisory panel. In this event, the appropriate **#1** or **#2 ICE VANE POWER SELECT** switch should be placed in the **STBY** position. Once the vane is successfully positioned, using the standby (STBY) system, the amber annunciator(s) will extinguish and the applicable green **#1 VANE EXT** or **#2 VANE EXT** annunciator(s) will illuminate.

c. *Engine Anti-Ice System.*

(1) *Air inlet.* A small duct, which faces into the exhaust flow in the left exhaust stack of each engine, diverts a small portion of the engine exhaust gases to the engine air inlet lip. The gases are circulated through the engine air inlet lip and then exhausted through a duct in the right exhaust stack. The continuous flow of hot engine exhaust gases heats the engine air inlet lip, preventing the formation of ice. Two switches, placarded **ENG INLET LIP HEAT #1** and **#2** (located on the overhead control panel, fig. 2-15), operate solenoid valves in the lip heat



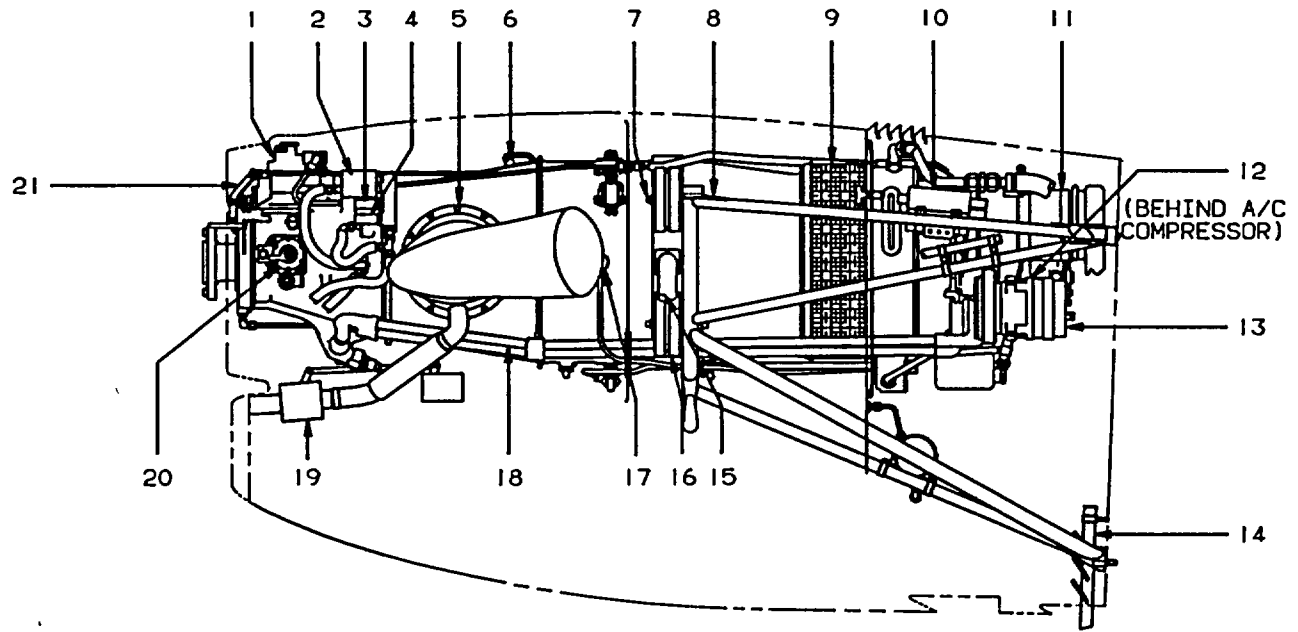

- |   |   |
|---|---|
| 1. Prop Governor                            | 13. Atr Conditioner Compressor (#2 Engine Only) |
| 2. Torque Transmitter                       | 14. Drain Manifold                              |
| 3. Pressure Switch (High)                   | 15. Bleed Air Line                              |
| 4. Pressure Switch (Low)                    | 16. Engine Mount Isolator                       |
| 5. Exhaust Duct                             | 17. Spark Igniter Plug (Behind Exhaust Stock)   |
| 6. TGT Wire Harness                         | 18. Oil Scavenge Tubes                          |
| 7. Engine Mount Isolator Bolt               | 19. Engine Inlet Heat Shutoff Valve             |
| 8. Engine Mount Truss Assembly              | 20. Overspeed Governor                          |
| 9. Engine Air Intake Screen                 | 21. Prop Reverse Linkage Lever                  |
| 10. Ignition Exciter                        |   |
| 11. Starter-Generator                       |   |
| 12. Fuel Boost Pump (Behind A/C Compressor) |   |

A9FE0000022 C

Figure 2-13. Engine (Sheet 1 of 2)

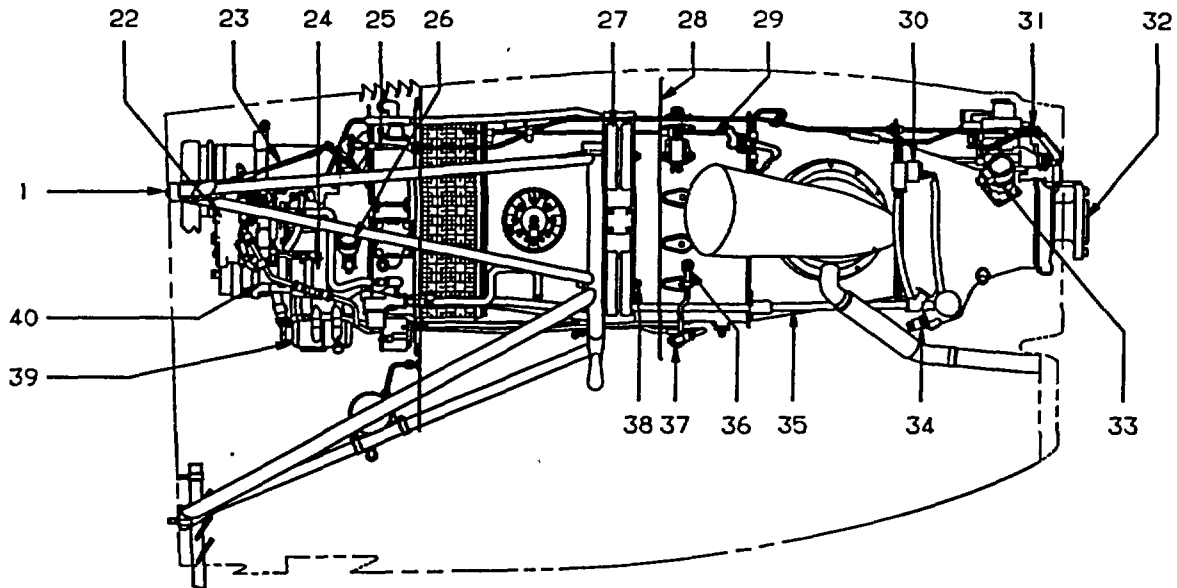

- |     |                                    |     |  |
|-----|------------------------------------|-----|--|
| 22. | Fuel Control Unit                  | 33. | Tach Generator (Prop. N2)                          |
| 23. | Fuel Control Unit Interconnect Rod | 34. | Chip Detector                                      |
| 24. | Fuel Pump                          | 35. | Pressure OIL Transfer Tube                         |
| 25. | Prop Interconnect Linkage (Aft)    | 36. | Spark Igniter Plug                                 |
| 26. | Oil Pressure Transducer            | 37. | Fuel Flow Divider                                  |
| 27. | Engine Mount Isolator              | 38. | Engine Mount Isolator Bolt                         |
| 28. | Fireseat                           | 39. | Oil-to-Fuel Heater                                 |
| 29. | Trim Thermocouple                  | 40. | Tach Generator<br>(Gas Generator, N <sub>1</sub> ) |
| 30. | Rudder Boost Sensor                | 41. | Engine Truss Mounting Bolt                         |
| 31. | Prop Interconnect Linkage (Fore)   |     |  |
| 32. | Prop Short                         |     |  |

A94FE00D0023 C

Figure 2-13. Engine (Sheet 2 of 2)

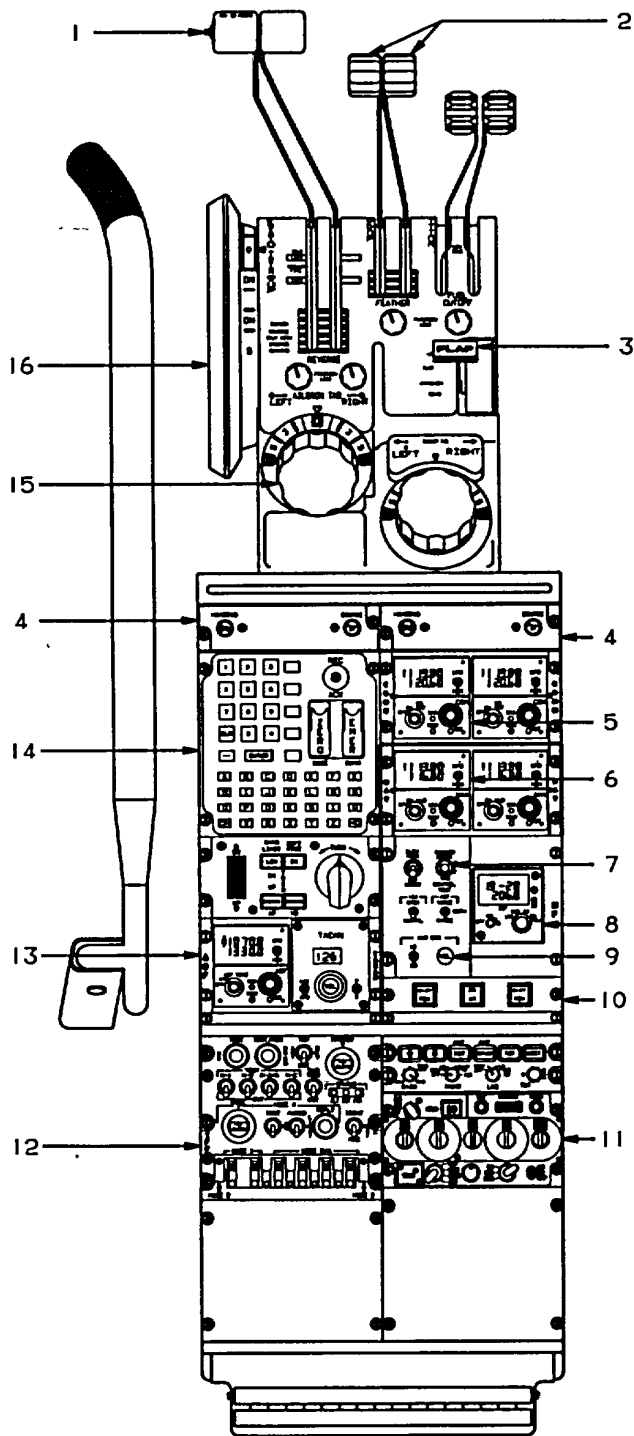

1. Go-Around Switch
2. Propeller Lovers
3. Flop Control Switch
4. EHSI Remote Heading/Course Panel
5. #1 VHF Transceiver Control Unit
6. #1 VHF Navigation Receiver Control Unit
7. Rudder Boost/Yaw Control Test Switch
8. HF Transceiver Control Unit
9. Marker Beacon Volume Control
10. VHF-FM/VHF-AM Transceiver Selector Panel
11. UHF Transceiver Control Unit
12. Transponder (IFF)
13. ADF Receiver Control Unit
14. Aircraft Survivability Equipment/  
Avionics Control System (ASE/ACS)  
Keyboard Unit (KU)
15. Aileron Trim Control
16. Elevator Trim Control

A93FE00D0089 C

Figure 2-14. Control Pedestal and Pedestal Extension (Sheet 1 of 2)

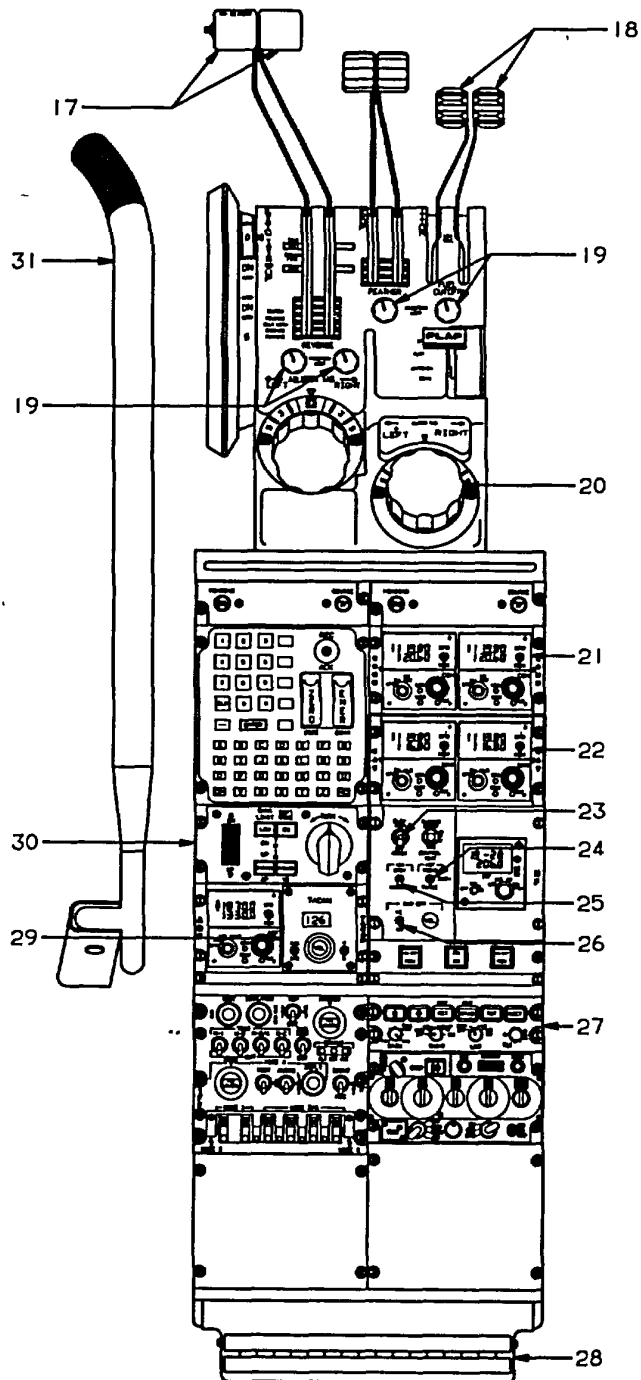

- 17. Power Levers
- 18. Condition Levers
- 19. Friction Lock Knobs
- 20. Rudder Trim Control
- 21. #2 VHF Transceiver Control Unit
- 22. #2 VHF Navigation Receiver Control Unit
- 23. Elevator Trim Switch
- 24. ADF Receiver Voice/Range Switch
- 25. UHF Transceiver Normal/Standby Switch
- 26. Marker Beacon High-Low Sensitivity Switch
- 27. Weather Radar/Lightning Sensor System Control Panel
- 28. Assist Step
- 29. TACAN Control Unit
- 30. Autopilot Controller
- 31. Landing Gear Alternate Extension Pump Handle

A93E00D008 C

Figure 2-14. Control Pedestal and Pedestal Extension (Sheet 2 of 2)

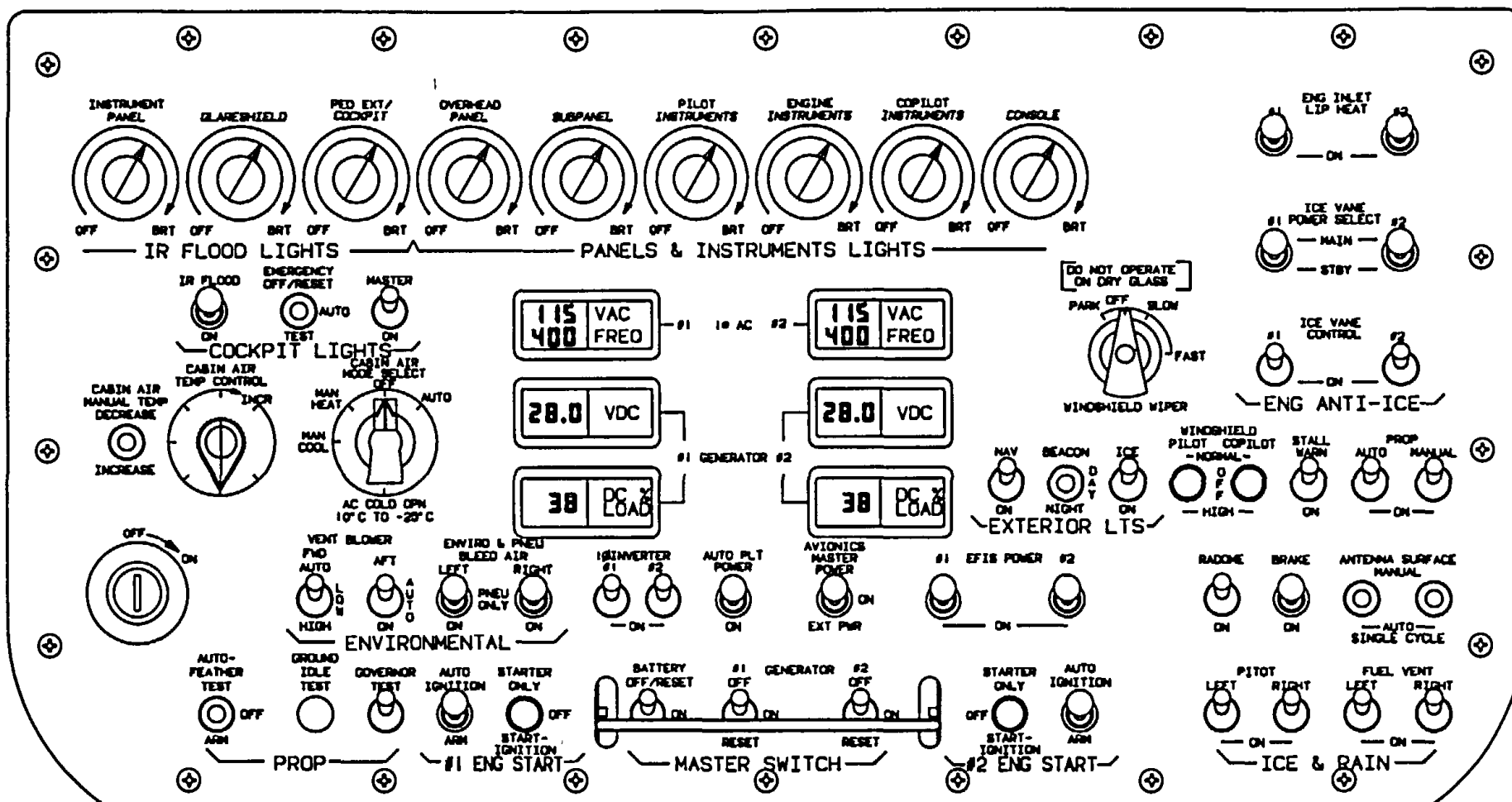

A94FE00D0024 C

Figure 2-15. Overhead Control Panel

exhaust plumbing. These valves control the flow of hot exhaust gasses to the inlet air lip assemblies.

(2) *Fuel heater.* An oil-to-fuel heat exchanger, located in the engine accessory case, operates continuously and automatically to heat the fuel sufficiently to prevent ice from collecting in the fuel control unit.

## 2-21.-ENGINE FUEL CONTROL SYSTEM.

a. *Description.* The basic fuel system for each engine consists of an engine driven fuel pump, a fuel control unit, a fuel flow divider, a dual fuel manifold, fourteen fuel nozzles, and a purge system. The fuel purge system forces residual fuel from the manifolds to the combustion chamber where it is consumed.

b. *Fuel Control Unit.* The fuel control unit is mounted on the accessory case of the engine. The unit is a hydro-pneumatic metering device which determines the proper fuel flow schedule required for the engine to produce the amount of power requested by the relative position of the associated **POWER** lever. The control of developed engine power is accomplished by adjusting the engine gas generator ( $N_1$ ) speed.  $N_1$  speed is controlled by varying the amount of fuel injected into the combustion chamber through the fuel nozzles. Engine shutdown is accomplished by moving the appropriate **CONDITION** lever to the full aft **FUEL CUTOFF** position, which shuts off the fuel supply.

## 2-22. POWER LEVERS.

### CAUTION

**Moving the POWER lever below the flight idle gate without the associated engine running may result in damage to the reverse mechanism linkage.**

The two **POWER** levers are located on the control pedestal (fig. 2-14), and are placarded **POWER**. These levers regulate power in the reverse, idle, and forward ranges, operating so that forward movement increases engine power. Power control is accomplished through adjustment of the  $N_1$  speed governor in the fuel control unit. Power is increased when  $N_1$  RPM is increased. The **POWER** levers also control propeller reverse pitch. Distinct movement (pulling up and then aft on the **POWER** lever) by the pilot is required for operation in the ground fine and reverse ranges. Forward lever travel range is designated **INCR** (increase), supplemented by an arrow pointing forward. Lever travel range is marked **IDLE**, **LIFT**, **GROUND FINE**, **LIFT**, and **REVERSE**. A placard below the lever slots reads: CAUTION - REVERSE ONLY WITH ENGINES RUNNING.

## 2-23. CONDITION LEVERS.

The two **CONDITION** levers are located on the control pedestal (fig. 2-14). Each lever starts and stops the fuel supply, and controls the idle speed for its respective engine. The levers have three placarded positions: **FUEL CUTOFF**, **LOW IDLE**, and **HIGH IDLE**. In the **FUEL CUTOFF** position, the **CONDITION** lever controls the cutoff function of its engine-mounted fuel control unit. From **LOW IDLE** to **HIGH IDLE**, they control the governors of the fuel control units to establish minimum fuel flow levels. **LOW IDLE** position sets the fuel flow rate to attain 60 to 62% minimum  $N_1$ , and **HIGH IDLE** position sets the rate to attain 71 to 73% minimum  $N_1$ . The **POWER** lever for the corresponding engine can select  $N_1$  from the respective idle setting, up to maximum power. An increase in low idle  $N_1$ , will be experienced at high field elevation.

## 2-24. FRICTION LOCK KNOBS.

Friction drag of the engine and propeller control levers is adjusted, as applicable, by four friction lock knobs. The friction lock knobs, placarded **FRICTION LOCK**, are located on the control pedestal (fig. 2-14). One knob is below the propeller levers, one is below the **CONDITION** levers, and two are below the **POWER** levers. When a knob is rotated clockwise, friction is increased, opposing movement of the affected lever as set by the pilot. Counterclockwise rotation of the knob will decrease friction, thus permitting free and easy lever movement.

## 2-25. ENGINE FIRE DETECTION SYSTEM.

a. *Description.* A fire detection system (fig. 2-16) is installed to provide an immediate warning in the event of a fire or overtemperature in each engine compartment. The main element of the system is a temperature sensing tube, which is routed continuously throughout each engine compartment and terminates in a responder unit. The responder unit is mounted in the accessory area on the upper left hand engine mount truss, just forward of the engine firewall. The responder unit contains two sets of contacts: a set of integrity switch contacts, for continuity test functions of the fire detection circuitry; and a set of alarm switch contacts, which complete the circuit to activate the fire warning system when the detector (sensor tubing) senses an overtemperature condition in critical areas around the engine. The detector is dual functioning and responds to overall "average" temperature, or a highly localized "discrete" temperature, caused by flames or hot gases. Both the average and discrete temperatures are preset, and cannot be adjusted in the field.

The sensor tubing consists of an outer tube that is filled with an inert gas, and an inner core that is filled with an active gas. The gases within the tube form a pressure barrier that keeps the contacts of the responder integrity

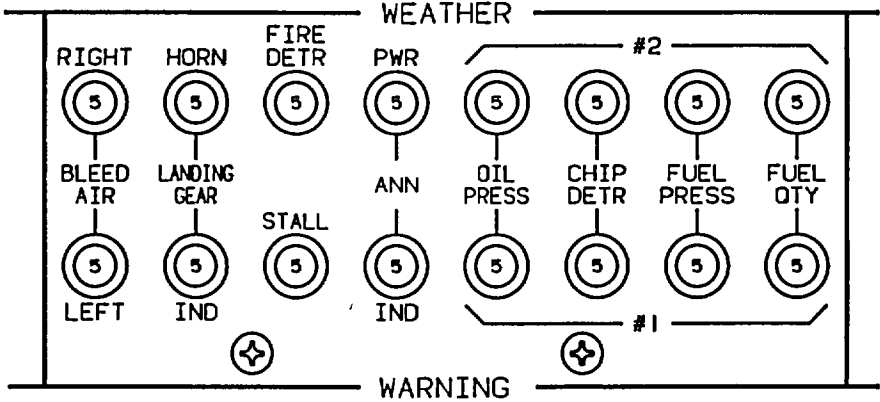

DETAIL A

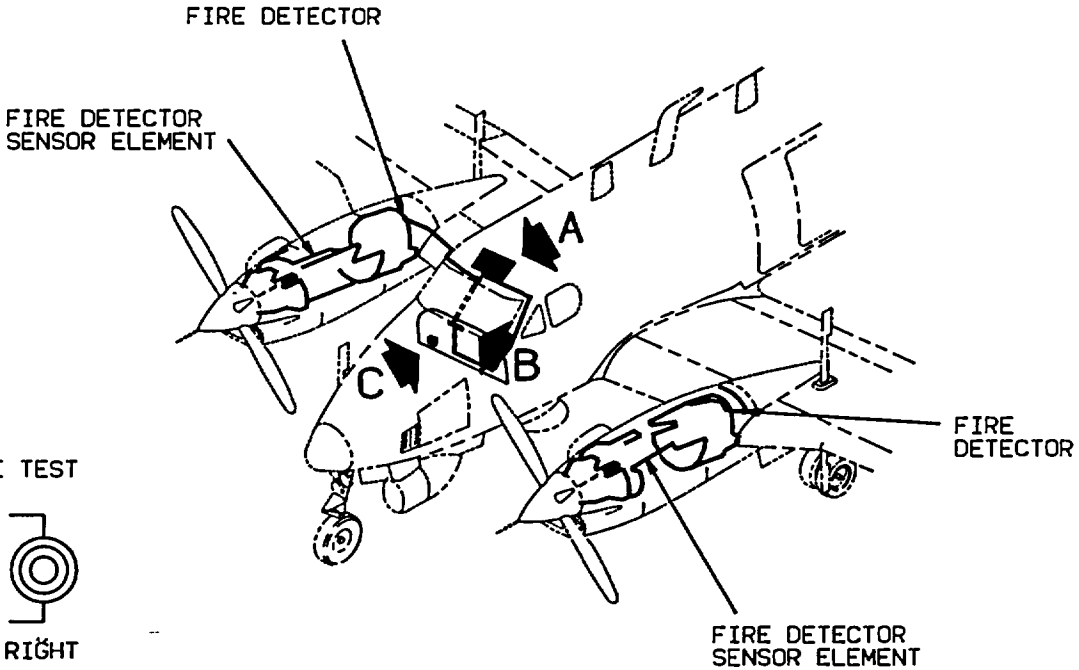

DETAIL C



DETAIL B

AP015212 C

Figure 2-16. Engine Fire Detection System

switch closed for fire alarm continuity test functions. As the temperature around the sensing cable increases, the gases within the tube to expand. When the pressure from the expanding gases reaches a preset point, the contacts of the responder alarm switch close, activating the respective fire warning system.

b. *Warning System.* The fire warning system consists of two lenses, placarded **#1 FIRE PULL and #2 FIRE PULL**, located in the T handles below the glareshield, two **MASTER WARNING** annunciators located in opposite sides of the glareshield, and a responder unit with a sensor in each engine compartment. If the sensor develops a leak, the loss of gas pressure allows the integrity switch to open and signal a lack of sensor integrity.

c. *Testing.* Testing system integrity, availability of power, and the proper operation of the annunciators (**#1 and #2 FIRE PULL and MASTER WARNING**) is accomplished by two switches located on the copilot's subpanel. The switches are placarded **ENG FIRE TEST, DET - OFF - EXT, LEFT, RIGHT**. When either the **LEFT** or **RIGHT** switch is placed in the **DET** position, electrical current flows from a 5-ampere circuit breaker, placarded **FIRE DETR**, located on the overhead circuit breaker panel, through the engine fire detector circuitry to the integrity switch contacts in the respective responder unit, causing the respective annunciators to illuminate. If the circuit breaker is open, the system will not operate during a test, or activate the annunciators if the detector cable senses an overtemperature condition. The system may be tested either before, after, or during flight as desired.

**2-26. ENGINE FIRE EXTINGUISHER SYSTEM.**

a. *Description.* The engine fire extinguisher system (fig. 2-17) consists of a supply cylinder, an explosive squib, and a valve located in each of the main gear wheel wells. A gage calibrated in PSI is provided on each supply cylinder for determining the level of charge. The extinguishing agent charge level should be checked during each preflight. When fired, the explosive squib opens the valve, releasing all of the pressurized extinguishing agent into a plumbing network. The plumbing network terminates in spray nozzles, strategically located in the probable fire areas of the engine compartment, which distribute the extinguishing agent.

b. *Operation.* Fire control T handles used to

arm the extinguisher system are centrally located on the instrument panel, immediately below the glareshield (fig. 2-18). These controls receive power from the hot battery bus. The fire detector system will indicate an engine fire by illuminating the **MASTER WARNING** annunciators on the glareshield and the respective **#1 or #2 FIRE PULL** annunciators in the fire control T handles. Pulling the fire control T handle will electrically arm the extinguisher system and close the firewall shutoff valve for that particular engine. This will cause the annunciator in the **PUSH TO EXTINGUISH** switch and the respective **#1 or #2 FUEL PRESS** annunciator on the warning annunciator panel to illuminate. Pressing the lens of the **PUSH TO EXTINGUISH** fire switch will fire the squib, expelling all the agent in the cylinder at one time. A hinged plastic guard covers the **PUSH TO EXTINGUISH** fire switch to prevent inadvertently actuating the fire extinguish switch squib circuit. The respective caution annunciator, **#1 and #2 EXTGH DISCH** on the caution/advisory annunciator panel and the **MASTER CAUTION** annunciator on the glareshield will illuminate and remain illuminated, regardless of the master switch position, until the squib is replaced.

c. *Testing.* The test switches, located on the copilot's subpanel (fig. 2-8), are placarded **ENG FIRE TEST, DET - OFF - EXT, LEFT and RIGHT**, and provide a test of the fire detection and extinguisher circuitry. When either of the switches is placed in the **EXT** position, the corresponding **PUSH TO EXTINGUISH, SQUIB OK, and EXTGH DISCH** annunciators should illuminate. The system may be tested either before, after, or during flight as desired.

A gage, calibrated in PSI, is mounted on each extinguishing agent supply cylinder. The gage indicates the level of charge and should be checked during preflight (table 2-1).

**2-27. OIL SUPPLY SYSTEM.**

**CAUTION**

**Maximum allowable oil consumption is one quart in 5 hours of engine operation.**

a. The engine oil tank is integral with the air-inlet casting located forward of the accessory gearbox. Oil for

Table 2-1. Engine Fire Extinguisher Gage Pressure

TEMP °C	-40	-29	-18	-06	04	16	27	38	48
	190	220	250	290	340	390	455	525	605
PSI	to	to	to	to	to	to	to	to	to
	240	275	315	365	420	480	550	635	730

BT2D194





DETAIL A

#1 DC GEN	#1 INVERTER	#1 NO FUEL XFEED	#2 NO FUEL XFEED	#2 INVERTER	#2 DC GEN
#1 EXTGN DISCH	#1 NAC LOW	EASTN OOR	ELECT TRIM OFF	#2 NAC LOW	#2 EXTGN DISCH
#1 YAW FAIL	#1 LTP HEAT	REV NOT READY	LOCT OVERTEMP	#2 LTP HEAT	#2 YAW FAIL
HYD FLUID LOW	INS	IFE	BATTERY CHARGE	BAT FEED FLT	PROP BIND ON
FUEL CROSSFEED	#1 LTP HEAT ON	L PROP PITCH	R PROP PITCH	#2 LTP HEAT ON	ICE COLD GEN
#1 YAW EXTEND	#1 LGN ON	L BL AIR OFF	R BL AIR OFF	#2 LGN ON	#2 YAW EXTEND
#1 AUTOFEATHER NR COND NL LOW	EXTERNAL POWER	EXT DC ON	BRAKE DEICE ON	#2 AUTOFEATHER	

DETAIL B

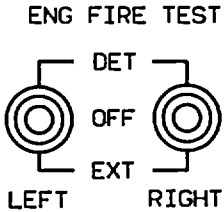
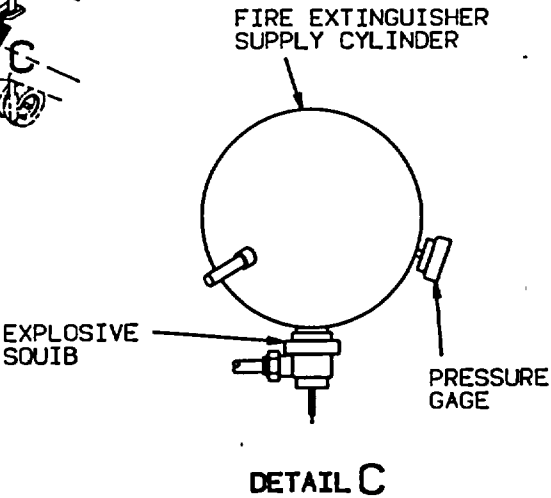
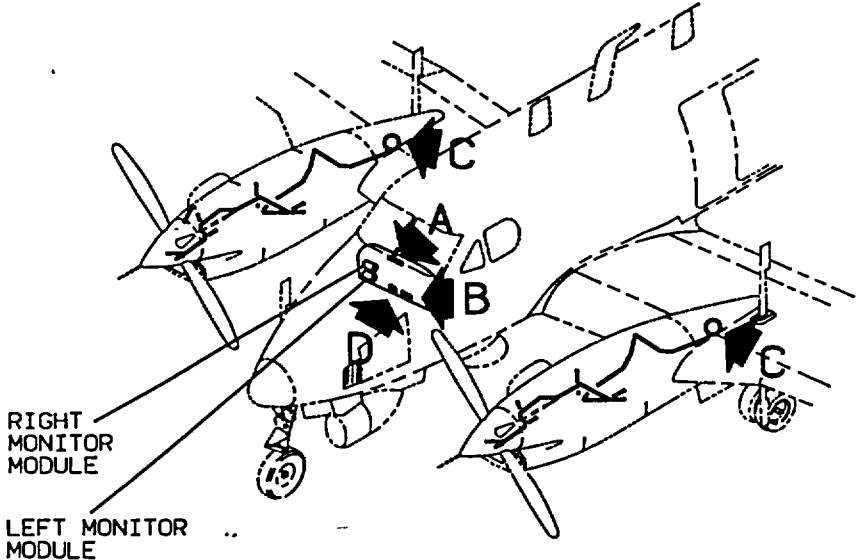

DETAIL D

AP015213 C

Figure 2-17. Engine Fire Extinguisher System

propeller operation and lubrication of the reduction gearbox and engine bearings is supplied by an external line from the high pressure pump. Two scavenge lines return oil to the tank from the propeller reduction gearbox. A noncongealing, external oil cooler keeps the engine oil temperature within operating limits. The capacity of each engine oil tank is 2.5 U.S. gallons. The total system capacity for each engine, which includes the oil tank, oil cooler, lines, etc., is approximately 3.5 U.S. gallons. The oil level is indicated by a dipstick attached to the oil filler cap. Oil grade, specifications, and servicing points are described in Section XII, Servicing.

b. The oil system of each engine is coupled to an oil cooler unit (radiator) of fin-and-tube design. The oil cooler unit, located in the lower aft nacelle below the engine air intake, is the only airframe mounted part of the oil system. Each oil cooler incorporates a thermal bypass valve which assists in maintaining oil at the proper temperature range for engine operation.

## 2-28. ENGINE IGNITION SYSTEM.

a. *Description.* The basic ignition system for each engine consists of a solid state ignition exciter unit, two igniter plugs, two shielded ignition cables, pilot controlled ignition and engine start switches, and the auto ignition switches (fig. 2-15). Placing either **ENG START** switch to **START - IGNITION** position will cause the respective engine to motor and igniter plugs to spark, igniting the fuel/air mixture sprayed into the combustion chamber by the fuel nozzles. The ignition system is activated for ground and air starts, but is switched off after combustion light up.

b. *Ignition and Engine Starter Switches.* Two three-position toggle switches, placarded **#1** or **#2 ENG START**, are located on the overhead control panel (fig. 2-15). These switches will initiate starter motoring and ignition in the **START IGNITION** position, or will motor the engine in the **STARTER ONLY** position. The **START IGNITION** switch position completes the starter circuit for engine rotation, energizes the igniter plugs for fuel combustion, and activates the respective **#1 IGN ON** or **#2 IGN ON** annunciator on the annunciator panel. In the center position the switch is OFF. Two 5-ampere circuit breakers on the overhead circuit breaker panel, placarded **IGNITOR CONTR #1** and **#2**, protect ignition circuits. Two 5-ampere circuit breakers on the overhead circuit breaker panel, placarded **START CONTR #1** and **#2**, protect starter control circuits (fig. 2-9).

## 2-29. AUTO IGNITION SYSTEM.

If armed, the auto ignition system automatically energizes both igniter plugs of either engine, should an accidental flameout occur. The system is not essential to normal engine operation, but is used to reduce the possibility of power loss due to icing or other conditions.

Each engine has a separate auto ignition control switch (fig. 2-15) and a green annunciator, placarded **#1 IGN ON** or **#2 IGN ON**, on the annunciator panel. Auto ignition is accomplished by energizing both igniter plugs in each engine.

### NOTE

**The system should be turned OFF during extended ground operation to prolong the life of the igniter plugs.**

a. *Auto Ignition Switches.* Two switches located on the overhead control panel (fig. 2-15), each placarded **-AUTO IGNITION - ARM**, control the auto ignition systems. The ARM position initiates a readiness mode for the auto ignition system of the corresponding engine. The system is disarmed when in the off position. Each circuit is protected by the corresponding **START CONTR #1** or **#2**, 5-ampere circuit breaker on the overhead circuit breaker panel (fig. 2-9).

b. *Auto Ignition Annunciators.* If an armed auto ignition system changes from a ready condition to an operating condition (energizing the igniter plugs in the engine) the corresponding engine's green annunciator will illuminate. The annunciator is placarded **#1 IGN ON** or **#2 IGN ON** and indicates that the igniters are energized. The auto ignition system is triggered from a ready condition to an operating condition when engine torque drops below approximately 20%. Therefore, when an auto ignition system is armed, the igniters will be energized continuously during the time when an engine is operating at a level below approximately 20% torque. The auto ignition annunciators are protected by the 5-ampere **IGNITOR CONTR #1** or **#2** circuit breakers, located on the overhead circuit breaker panel (fig. 2-9).

## 2-30. ENGINE STARTER-GENERATORS.

One starter-generator is mounted on the accessory drive section of each engine. Each starter-generator is able to function either as a starter or as a generator. In the starter-function, 28 volts DC is required to power rotation. In the generator function, each unit is capable of 400 amperes DC output. When the starting function is selected, the starter control circuit receives power through the respective 5-ampere **START CONTR** circuit breaker on the overhead circuit breaker panel (fig. 2-9), from either the aircraft battery or an external power source. When the generating function is selected, the starter-generator provides electrical power.

## 2-31. ENGINE INSTRUMENTS.

The engine instruments are arranged vertically near the center of the instrument panel (fig. 2-18).

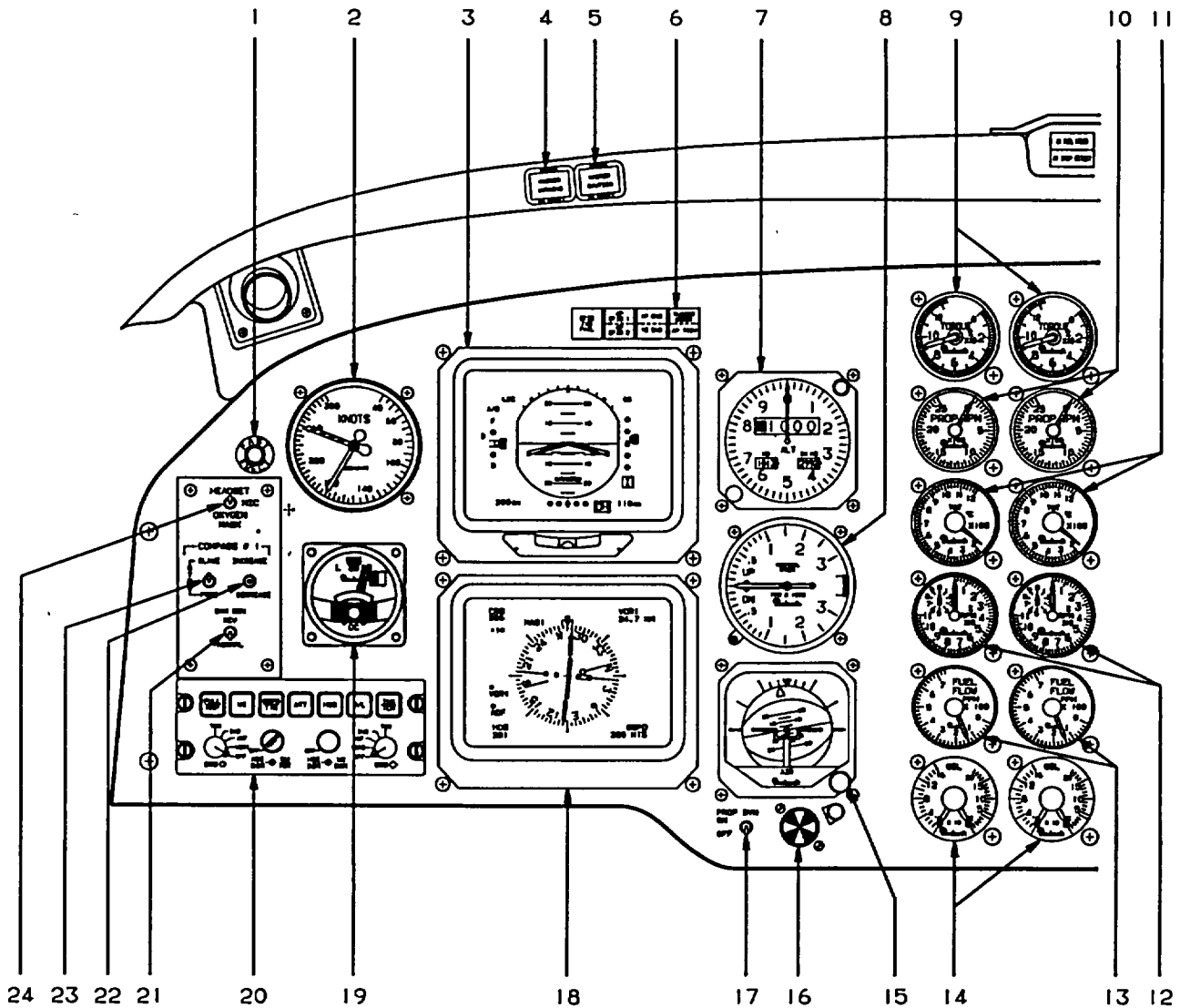

- |  |   |
|--|---|
| <ol style="list-style-type: none"> <li>1. Vertical Gyro Fast Erect Switch</li> <li>2. Airspeed Indicator</li> <li>3. Electronic Attitude Director Indicator</li> <li>4. Master Warning Annunciator</li> <li>5. Master Caution Annunciator</li> <li>6. EFIS/Autopilot/Rudder Boost Annunciators</li> <li>7. Pilot's Barometric Altimeter Indicator</li> <li>8. Vertical Speed Indicator</li> <li>9. Torquemeters</li> <li>10. Propeller Tachometers</li> <li>11. Turbine Gas Temperature Indicators</li> <li>12. Gas Generator Tachometers</li> </ol> | <ol style="list-style-type: none"> <li>13. Fuel Flow Indicators</li> <li>14. Oil Temperature/Pressure Indicators</li> <li>15. Standby Attitude Indicator</li> <li>16. Propeller Synchroscope</li> <li>17. Propeller Synchrophaser Switch</li> <li>18. Electronic Horizontal Situation Indicator</li> <li>19. Turn-and-Slip Indicator</li> <li>20. EFIS Display Controller</li> <li>21. Symbol Generator Reversionary Switch</li> <li>22. Compass Heading Increase/Decrease Switch</li> <li>23. Compass Slave/Free Switch</li> <li>24. Microphone Headset/Oxygen Mask Selector Switch</li> </ol> |
|--|---|

A94FE00D0025 C

Figure 2-18. Instrument Panel (Sheet 1 of 2)

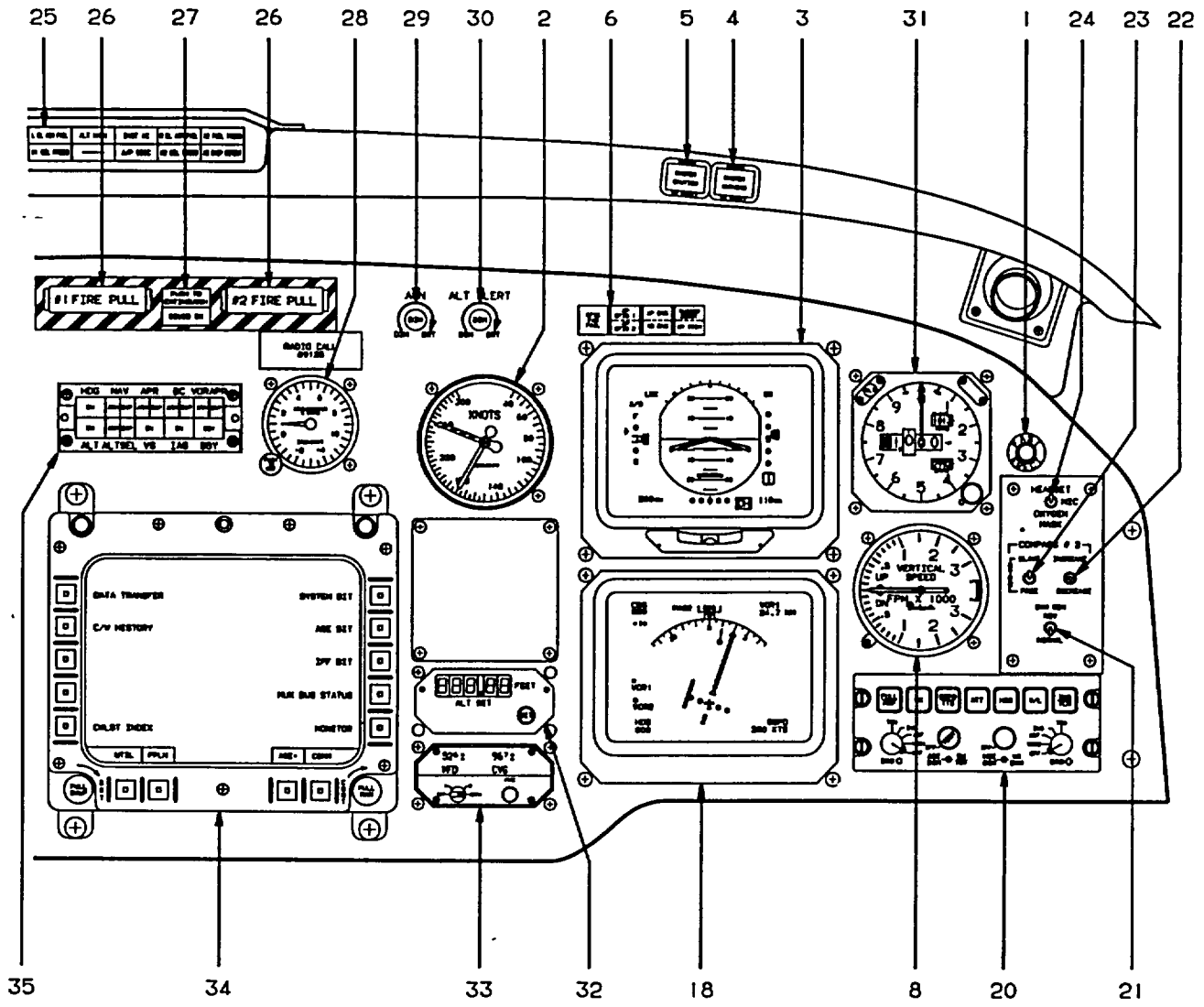

- 25. Warning Annunciator Panel
- 26. Fire Pull Handle
- 27. Fire Extinguisher Switch/Squib OK Annunciator
- 28. Accelerometer
- 29. Annunciator Lights Brightness Control (Autopilot/EFIS/Rudder Boost Only)
- 30. Altitude Select Controller Brightness Control
- 31. Copilot's Barometric Altimeter
- 32. Altitude Preselector
- 33. DME/TACAN Indicator
- 34. Multifunction Display (ASE/ACS)
- 35. Flight Director/Autopilot Mode Selector

A93FE00D0090 C

Figure 2-18. Instrument Panel (Sheet 2 of 2)

a. *Turbine Gas Temperature Indicators.* The two TGT gages on the instrument panel are calibrated in degrees Celsius (fig. 2-18). Each gage is connected to thermocouple probes located in the hot gases between the turbine wheels. The gages indicate the temperature present between the compressor turbine and a power turbine for the corresponding engine.

b. *Engine Torquemeters.* The two torquemeters on the instrument panel indicate torque applied to the propeller shaft of the respective engine (fig. 2-18). Each gage shows torque in percent of maximum using two percent graduations and is actuated by an electrical signal from a torque transmitter mounted on the reduction gearbox which senses engine internal torque pressure. The torquemeters are protected by individual 0.5-ampere circuit breakers, placarded **TORQUE METER #1** or **#2**, on the overhead circuit breaker panel (fig. 2-9).

c. *Turbine Tachometers.* The two tachometers on the instrument panel indicate compressor turbine RPM ( $N_1$ ) for the respective engine (fig. 2-18). These indicators register turbine RPM as a percentage of maximum gas generator RPM. Each instrument is slaved to a tachometer generator attached to the

respective engine.

d. *Oil Pressure/Oil Temperature Indicators.* The two gages on the instrument panel indicate oil pressure in PSI and oil temperature in °C (fig. 2-18). Oil pressure is taken from the delivery side of the main oil pressure pump. Warning annunciators, placarded **#1 OIL PRESS** and **#2 OIL PRESS**, are located in the warning annunciator panel. Oil temperature is transmitted by a thermal sensor unit which senses the temperature of the oil as it leaves the delivery side of the oil pressure pump. Each gage is connected to pressure and temperature transmitters installed on the respective engine. Both instruments are protected by 5-ampere circuit breakers, placarded **OIL PRESS** and **OIL TEMP #1** or **#2**, on the overhead circuit breaker panel (fig. 2-9).

e. *Fuel Flow Indicators.* Two gages on the instrument panel (fig. 2-18) indicate the rate of flow for consumed fuel as measured by sensing units coupled into the fuel supply lines of the respective engines. The fuel flow indicators are calibrated in increments of hundreds of pounds per hour. Both circuits are protected by 5-ampere circuit breakers, placarded **FUEL FLOW #1** or **#2**, on the overhead circuit breaker panel (fig. 2-9).

#### Section IV. FUEL SYSTEM

##### 2-32. FUEL SUPPLY SYSTEM.

The engine fuel supply system (fig. 2-19) consists of two identical systems sharing a common fuel management panel (fig. 2-20) and fuel crossfeed plumbing (fig. 2-21). Each main fuel system consists of five interconnected wing tanks and a nacelle tank. Each auxiliary fuel system consists of one tank located between the nacelle and the fuselage. A fuel transfer pump is located within each auxiliary tank. Additionally, the system has an engine-driven boost pump, a standby fuel pump located within each nacelle tank, a fuel heater (engine oil-to-fuel heat exchanger unit), a tank vent system, a tank vent heating system, and interconnecting wiring and plumbing. Total fuel tank capacity is shown in table 2-2. Gravity feed fuel flow is shown in figure 2-22.

a. *Engine-Driven Boost Pumps.*

##### CAUTION

**Engine operation using only the engine-driven primary (high pressure)**

**fuel pump without standby pump or engine-driven boost pump fuel pressure is limited to 10 cumulative hours. This condition is indicated by illumination of either the #1 or #2 FUEL PRESS warning annunciator and the simultaneous illumination of both MASTER WARNING annunciators. All time in this category shall be entered on DA Form 2408-13-1 for the attention of maintenance personnel.**

A gear-driven boost pump mounted on each engine supplies fuel under pressure to the inlet of the engine-driven primary high-pressure pump for engine starting and all normal operations. Either the engine-driven boost pump or electric standby pump is capable of supplying sufficient pressure to the engine-driven primary high-pressure pump and thus maintaining normal engine operation.

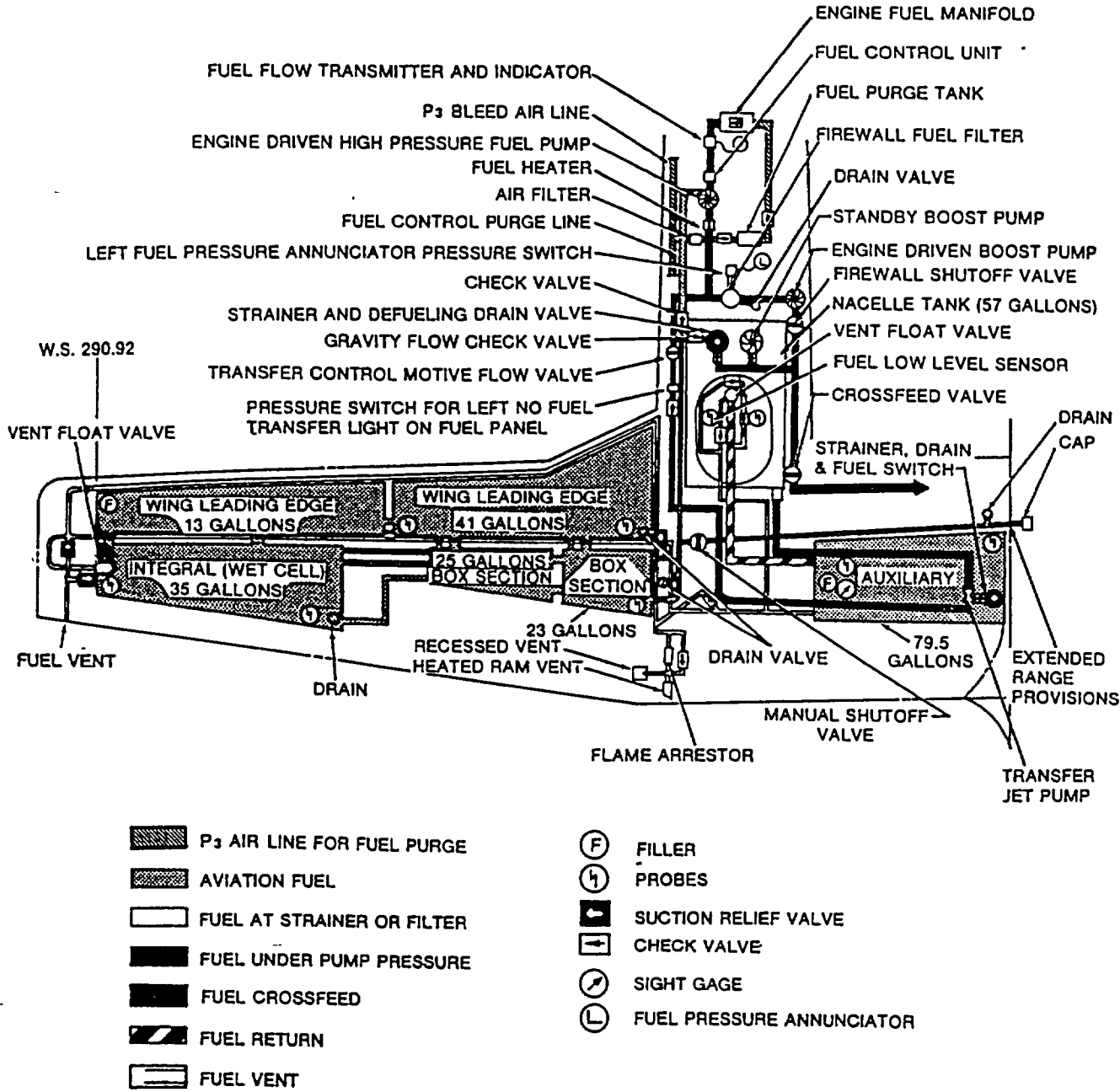

NOTE: QUANTITIES SHOWN ARE BLADDERS ONLY AND DO NOT ACCOUNT FOR INTERCONNECT PLUMPING.

TOTAL PER MAIN	195 GAL
TOTAL PER AUX	79.5 GAL
TOTAL AIRCRAFT	549 GAL
USESABLE AIRCRAFT	540 GAL

AP13025

Figure 2-19. Fuel System Schematic

Table 2-2. Usable Fuel Quantity Data

	TANKS	NUMBER	GALLONS
LEFT ENGINE	Main Tanks	6	192
	Auxiliary Tank	1	78
RIGHT ENGINE	Main Tanks	6	192
	Auxiliary Tank	1	78
*TOTALS		14	540

\*Unusable fuel quantity not included in totals.

BT06332

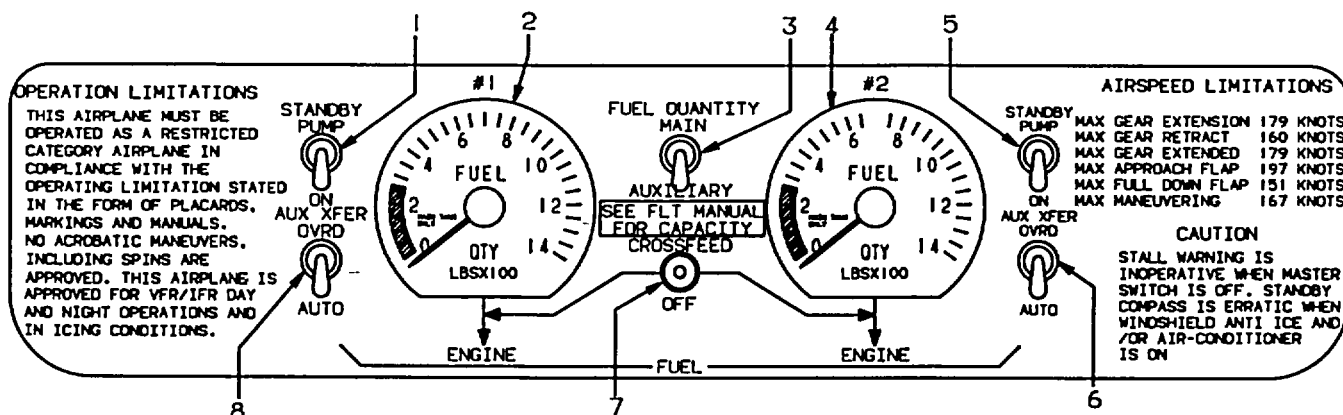

- |   |   |
|---|---|
| 1. Standby Pump Switch (#1 Engine)                            | 5. Standby Pump Switch (#2 Engine)                |
| 2. Fuel Quantity Indicator (#1 Engine)                        | 6. Auxiliary Transfer Override Switch (#2 Engine) |
| 3. Fuel Quantity Main/Auxiliary Gaging System Selector Switch | 7. Crossfeed Switch                               |
| 4. Fuel Quantity Indicator (#2 Engine)                        | 8. Auxiliary Transfer Override Switch (#1 Engine) |

A93FE00D0092 C

Figure 2-20. -Fuel Management Panel

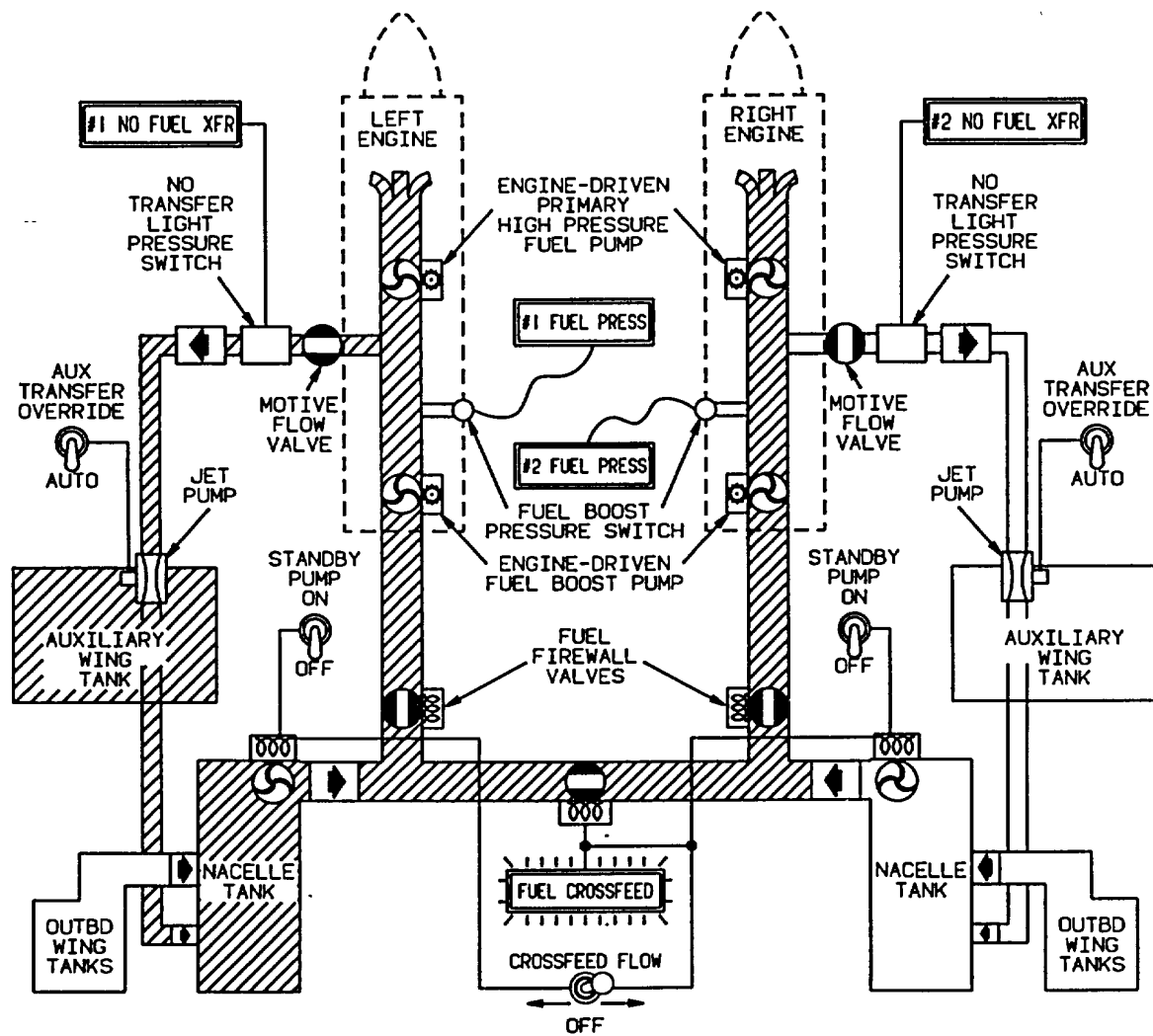

**NOTE**  
 BOTH STANDBY PUMP SWITCHES WILL BE OFF DURING CROSSFEED OPERATION.

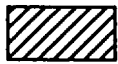
 PRESSURIZED FUEL FLOW FROM LEFT WING TANKS

**NOTE**  
 THE ENGINE-DRIVEN PRIMARY (HIGH PRESSURE) FUEL PUMP IS LIMITED TO 10 HOURS OF OPERATION THROUGHOUT ITS TBO PERIOD WITHOUT STANDBY FUEL PUMP OR ENGINE-DRIVEN BOOST PUMP FUEL PRESSURE.

**NOTE**  
 DIAGRAM SHOWS TYPICAL FUEL CROSSFEED SITUATION WITH LEFT WING FUEL SYSTEM SUPPLYING BOTH ENGINES (ALL BOOST AND STANDBY PUMPS OPERABLE). FOR SELECTION OF RIGHT WING FUEL FOR CROSSFEED REVERSE CROSSFEED SWITCH POSITION. EITHER CONFIGURATION WILL SUPPLY EITHER ENGINE DURING SINGLE-ENGINE OPERATION. FUEL WILL NOT CROSS TRANSFER BETWEEN TANK SYSTEMS.

AP015231 C

Figure 2-21. Crossfeed Fuel Flow



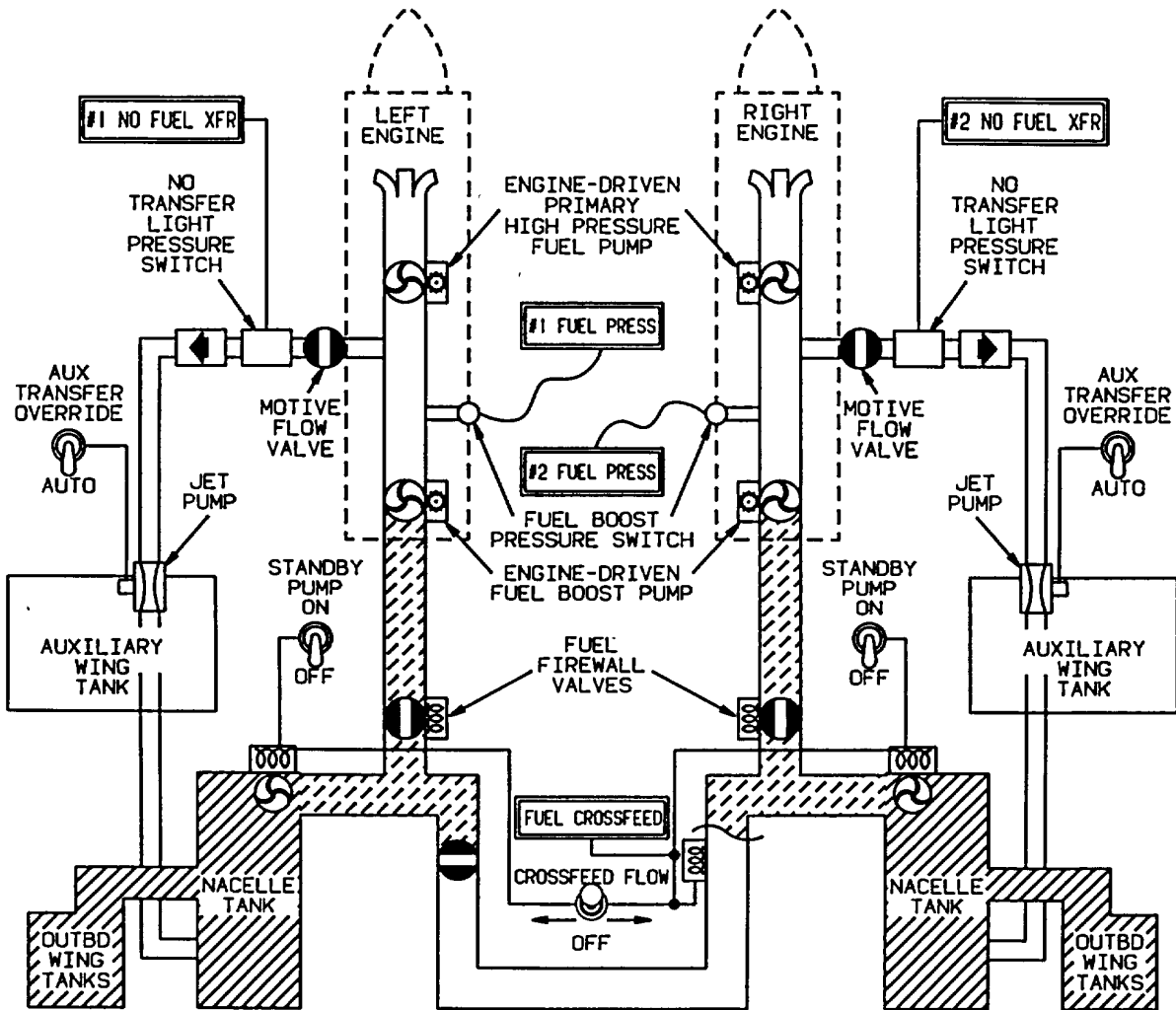

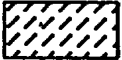
 GRAVITY FEED FUEL FLOW  
 SUCTION LIFT

**NOTE**  
 IF AN ENGINE DRIVEN BOOST PUMP FAILS, PRESSURE CAN BE MAINTAINED BY PLACING THE RESPECTIVE STANDBY PUMP SWITCH TO ON.

**NOTE**  
 THE ENGINE-DRIVEN PRIMARY (HIGH PRESSURE) FUEL PUMP IS LIMITED TO 10 HOURS OF OPERATION, THROUGHOUT ITS TBO PERIOD, WITHOUT STANDBY FUEL PUMP OR ENGINE-DRIVEN BOOST PUMP FUEL PRESSURE.

**NOTE**  
 THE SYSTEM WILL SUCTION LIFT FUEL ONLY TO ITS RESPECTIVE ENGINE DRIVEN BOOST PUMP, I.E., LEFT OR RIGHT. FUEL WILL NOT GRAVITY FEED THROUGH THE CROSSFEED SYSTEM.

FE02D  
 980395AA C

Figure 2-22. Gravity Feed Fuel Flow

b. *Standby Fuel Pumps.* A submerged, electrically-operated standby fuel pump, located within each nacelle tank, serves as a backup unit for the engine-driven boost pump. The standby pumps are switched off during normal system operations. A standby fuel pump will be operated during crossfeed operation to pump fuel from one nacelle tank to the opposite engine. The correct pump is automatically selected when the **CROSSFEED** switch is activated. Each standby fuel pump has an inertia switch included in the power supply circuit. When subjected to a 5 to 6 g shock loading, as in a crash situation, the inertia switch will remove electrical power from the standby fuel pumps. The standby fuel pumps are protected by two 10-ampere circuit breakers placarded **STANDBY PUMP #1** or **#2**, located on the overhead circuit breaker panel (fig. 2-9), and four 5-ampere circuit breakers (two each in parallel) on the hot battery bus.

c. *Fuel Transfer Pumps.* The auxiliary tank fuel transfer system automatically transfers the fuel from the auxiliary tank to the nacelle tank without pilot action. Motive flow to a jet pump mounted in the auxiliary tank sump is obtained from the engine fuel plumbing system downstream from the engine driven boost pump and routed through the transfer control motive flow valve. The motive flow valve is energized to the open position, by the control system, to transfer auxiliary fuel to the nacelle tank to be consumed by the engine during the initial portion of the flight. When an engine is started, pressure at the engine driven boost pump closes a pressure switch, which, after a 30 to 50 second time delay to avoid depletion of fuel pressure during starting, energizes the motive flow valve. When auxiliary fuel is depleted, a low level float switch de-energizes the motive flow valve after a 30 to 60 second time delay. This time delay function prevents cycling of the motive flow valve due to sloshing fuel. If the motive flow valve or the associated control circuitry fails, the loss of motive flow pressure when there is still fuel remaining in the auxiliary fuel tank is sensed by a pressure switch which illuminates a caution annunciator placarded **#1 NO FUEL XFR** or **#2 NO FUEL XFR**. During engine start, the pilot should note that the **NO FUEL XFR** annunciator extinguishes 30 to 50 seconds after engine start. The **NO FUEL XFR** annunciator will not illuminate if auxiliary tanks are empty. A manual override is incorporated as a backup for the automatic transfer system. Manual override is initiated by placing the **AUX XFER** switch, located in the fuel management panel, to the **OVRD** position. This will energize the transfer control motive flow valve. The transfer systems are protected by 5-ampere circuit breakers, placarded **AUXILIARY TRANSFER #1** or **#2**, located on the overhead circuit breaker panel (fig. 2-9).

#### NOTE

**In turbulence or during maneuvers, the NO FUEL XFR annunciators may momentarily illuminate after the auxiliary fuel has completed transfer.**

d. *Fuel Gaging System.* Fuel quantity is measured by a capacitance type fuel gaging system. Two fuel gages, one for the left and one for the right fuel system, read fuel quantity in pounds. A maximum of 3% error may be encountered in each system; however, the system is compensated for fuel density changes due to temperature excursions. In addition to the fuel gages, amber **#1 NAC LOW** or **#2 NAC LOW** annunciators on the caution/advisory annunciator panel illuminate when there is approximately 30 minutes (approximately 58 gallons) of fuel per engine remaining (on standard day, at sea level, maximum cruise power consumption rate).

#### NOTE

**The low fuel annunciators are level-sensing volumetric devices and are not compensated for fuel density, attitude, fuel flow, etc.**

The fuel gaging system is protected by individual 5-ampere circuit breakers placarded **QTY IND** and **FUEL QTY, #1** and **#2**, located on the overhead circuit breaker panel (fig. 2-9). A mechanical spiral float gage (fig. 2-23) is installed in each auxiliary fuel tank to provide an indication of fuel level when servicing the tank. The gage is installed on the auxiliary fuel tank cover, adjacent to the filler neck. A small sight window in the upper wing skin permits observation of the gage.

e. *Fuel Management Panel.* The fuel management panel is located overhead in the cockpit between the pilot and copilot. It contains the fuel gages, standby fuel pump switches, crossfeed valve switch, fuel gaging system control switch, and transfer control switches.

(1) *Fuel gaging system control switch.* A switch on the fuel management panel (fig. 2-20) placarded **FUEL QUANTITY, MAIN - AUXILIARY**, controls the fuel gaging system. When the switch is in the **MAIN** position, the fuel gages read the total fuel quantity in the left and right main fuel systems. When the switch is in the **AUXILIARY** position, the fuel gages read the fuel quantity in the left and right auxiliary tanks only.

(2) *Standby fuel pump switches.* Two switches, placarded **STANDBY PUMP - ON**, located on the fuel management panel (fig. 2-20), individually control a submerged fuel pump located in the corresponding nacelle tank. During normal aircraft operation both switches should be **OFF**, so long as the engine-driven fuel pumps are operative.

**NOTE**

Both **STANDBY PUMP** switches shall be **OFF** during crossfeed operation. The loss of fuel pressure due to failure of an engine-driven boost pump will illuminate the **MASTER WARNING** annunciators on the glareshield, and will illuminate the respective **#1 FUEL PRESS** or **#2 FUEL PRESS** annunciator on the warning annunciator panel. Turning on the **STANDBY PUMP** will extinguish the **FUEL PRESS** annunciator. The **MASTER WARNING** annunciators must be manually reset.

is placarded for fuel system selection with a simplified diagram on the overhead fuel control panel. Place the **STANDBY PUMP** switches in the off position when crossfeeding. A lever lock switch, placarded **CROSSFEED**, is moved from the center **OFF** position to the left or to the right, depending on direction of fuel flow. This opens the crossfeed valve and energizes the standby pump on the side from which crossfeed is desired. During crossfeed operation with firewall fuel valve closed, auxiliary tank fuel will not crossfeed. When the crossfeed mode is energized, a green **FUEL CROSSFEED** annunciator on the caution/advisory panel will illuminate. Crossfeed system operation is described in Chapter 9. The crossfeed valve is protected by a 5-ampere circuit breaker, placarded **CROSSFEED**, located on the overhead circuit breaker panel (fig. 2-9).

(3) *Fuel transfer control switches.* Two switches on the fuel management panel (fig. 2-20), placarded **AUX XFER OVRD - AUTO**, individually control operation of the fuel transfer pumps. During normal operation both switches are in **AUTO**, which allows the system to be automatically actuated. If either transfer system fails to operate, the fault condition is indicated by the **MASTER CAUTION** annunciators on the glareshield and a steadily illuminated amber **#1 NO FUEL XFR** or **#2 NO FUEL XFR** annunciator on the caution annunciator panel.

(4) *Fuel crossfeed switch.* The fuel crossfeed valve is controlled by a 3-position switch located on the fuel management panel (fig. 2-20), placarded **CROSSFEED - OFF**. Under normal flight conditions the switch is left in the **OFF** position. During emergency-single engine operation, it may become necessary to supply fuel to the operative engine from the fuel system on the opposite side. The crossfeed system

f. *Firewall Shutoff Valves.*

**CAUTION**

**Do not use the fuel firewall shutoff valve to shut down an engine, except in an emergency. The engine-driven high-pressure fuel pump obtains essential lubrication from fuel flow. When an engine is operating, this pump may be severely damaged (while cavitating) if the firewall valve is closed before the CONDITION lever is moved to the FUEL CUTOFF position.**

The fuel system incorporates a fuel line shutoff valve mounted aft of each engine firewall. The firewall shutoff valves close when the fire extinguisher T-handles on the instrument panel are pulled out. The firewall shutoff valves receive electrical power from the main buses, and also from the hot battery bus which is connected directly to the battery. The valves are protected by 5-ampere circuit breakers, placarded **FIREWALL VALVE #1** and **#2**, on the overhead circuit breaker panel (fig. 2-9).

g. *Fuel Tank Sump Drains.* A sump drain wrench is provided in the aircraft loose tools to simplify draining a small amount of fuel from the sump drain.

(1) There are five sump drains and one filter drain in each wing (table 2-3).

(2) An additional drain for the extended range fuel system line extends through the bottom of the wing center section adjacent to the fuselage. Any time the

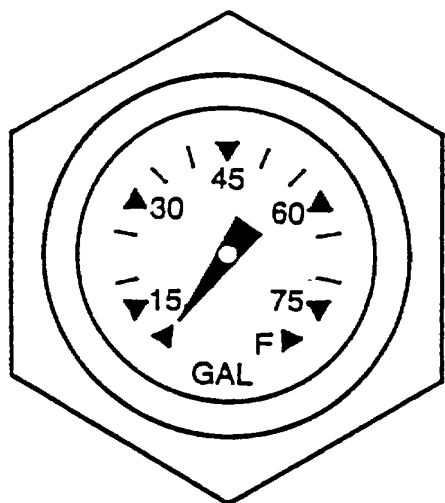

AP010909

Figure 2-23. Auxiliary Fuel Tank Fuel Gage

extended range system is in use, of the preflight inspection includes draining a small amount of fuel from this drain to check for fuel contamination. Whenever the extended range system is removed from the aircraft and the fuel line is capped off in the fuselage, the remaining fuel in the line shall be drained.

*h. Fuel Purge System.* Each engine is provided with a fuel purge system. The system is designed to ensure that any residual fuel in the fuel manifolds is consumed during engine shutdown. During engine operation, compressor discharge air is routed through a filter and check valve, pressurizing a small air tank mounted on the engine truss. On engine shutdown the pressure differential between the air tank and fuel manifolds causes air to be discharged from the air tank, through a check valve, and into manifolds, out through the nozzles and into the combustion chamber. The fuel forced into the combustion chamber is consumed, causing a momentary rise in engine TGT.

*i. Fuel Vent System.* Each fuel system is vented through two ram vents located in the underside of the wing adjacent to the nacelle, and a secondary vent, located in the aileron cove near the wing tip. To prevent icing of the vent system, one vent is recessed into the wing and the other ram vent protrudes out from the wing and contains a heating element. The vent line at the nacelle contains an inline flame arrester.

*j. Engine Oil-to-Fuel Heat Exchanger.* An engine oil-to-fuel heat exchanger, one located on each

engine accessory case, operates continuously during engine operation to heat fuel delivered to the engine to prevent the freezing of water which the fuel may contain 3h1.Fuel System Management.

*k. Fuel Transfer System.* When the auxiliary tanks are filled, they will be used first. During transfer of auxiliary fuel, which is automatically controlled, the nacelle tanks are maintained full. A check valve in the gravity feed line from the outboard wing prevents reverse fuel flow. Normal gravity transfer of the main wing fuel into the nacelle tanks will begin when auxiliary fuel is exhausted. The system will gravity feed fuel only to its respective nacelle tank, i.e., left or right (fig. 2-22). Fuel will not gravity feed through the crossfeed system.

*l. Operation With Failed Engine-Driven Boost Pump or Standby Pump.* Two pumps in each fuel system provide inlet head pressure to the engine-driven primary high-pressure fuel pump. If crossfeed is used, a third pump (the standby fuel pump from the opposite system) will supply the required pressure. Operation under this condition will result in an unbalanced fuel load, as fuel from one system will be supplied to both engines while all fuel from the system with the failed engine-driven and standby boost pumps will remain unused.

**2-33. FERRY FUEL SYSTEM.**

Provisions are installed for connection to long range fuel cells.

Table 2-3. Fuel Sump Drain Locations

NUMBER	DRAINS	LOCATION
1	Leading Edge Tank	Outboard of nacelle, underside of wing
1	Integral Tank	Underside of wing, forward of aileron
1	Firewall Fuel Filter	Underside of cowling forward of firewall
1	Sump Strainer	Bottom center of nacelle forward of wheel well
1	Gravity Feed Line	Aft of wheel well
1	Auxiliary Tank	At wing root, just forward of flap
1	Extended Range	Outboard of fuselage on underside of wing center section

BT001965

## Section V. FLIGHT CONTROLS

### 2-34. FLIGHT CONTROL SYSTEM.

The aircraft's primary flight control system consists of conventional rudder, elevator, and aileron control surfaces. These surfaces are manually operated from the cockpit through mechanical linkage using a control wheel for the ailerons and elevators, and adjustable rudder/brake pedals for the rudder. Both the pilot and copilot have flight controls. Trim control for the rudder, elevators, and ailerons is accomplished through a manually actuated cable-drum system for each set of control surfaces. The autopilot has provisions for controlling the position of the ailerons, elevators, elevator trim tab, and rudder.

### 2-35. CONTROL WHEELS.

Elevator and aileron control surfaces are operated by manually actuating either the pilot's or copilot's control wheel (fig. 2-24). A control wheel is installed on each side of the instrument panel. Switches are installed in the outboard grip of each wheel to operate the elevator trim tabs. A microphone switch, **CHAFF DISPENSE** switch, and an autopilot/yaw damp/electric trim disconnect switch are also installed in the outboard grip of each control wheel. A **FLARE DISPENSE** switch is installed on top of the inboard grip of each control wheel. A transponder ident switch is installed on the forward side of the inboard grip of each control wheel. Installed in the center of each control wheel is a digital electric clock. A map light switch, and TCS (touch control steering) switch are located adjacent to each digital clock.

### 2-36. RUDDER SYSTEM.

*a. Rudder Pedals.* Aircraft rudder control and nose wheel steering is accomplished by actuation of the rudder pedals from either the pilot's or copilot's station (fig. 2-10). The rudder pedals may be individually adjusted, forward or aft, to provide adequate leg room for the pilot and copilot. Adjustment is accomplished by depressing the lever alongside the rudder pedal arm and moving the pedal, forward or aft, until the locking pin engages in the selected position.

*b. Yaw Damper System.* A yaw damper system is provided to aid the pilot in maintaining directional stability and increase ride comfort. The system may be used at any altitude, but is required for flight above 17,000 feet. It must be deactivated for takeoff and landing. The yaw damper system is a part of the autopilot. The system is controlled by a **YAW DAMP** switch located on the autopilot control panel. Operating instructions for this system are contained in Chapter 3.

*c. Rudder Boost System.* The rudder boost system is a torque sensing, linear actuating system. The system utilizes a pressure transducer on each engine to

sense engine torque oil pressure, a stability augmentation computer to monitor torque levels, and a rudder servo to apply boost to aid the pilot.

The stability augmentation computer monitors torque levels and airspeed to determine if boost is required. The level of boost is proportional to the difference in torque between each engine and inversely proportional to airspeed. Boost commences at approximately 50% torque differential and increases to maximum at 100% torque differential. The level of boost available is inversely proportional to airspeed such that maximum rudder boost is obtained at 100% differential and low airspeed (80 knots), while no rudder boost is available at high airspeeds (above 180 knots).

The rudder boost system is controlled by a switch, placarded **RUDDER BOOST - OFF - YAW CONTROL TEST**, located on the pedestal extension (fig. 2-14). The rudder boost system is powered through a 5-ampere circuit breaker, placarded **RUDDER BOOST**, located on the overhead circuit breaker panel (fig. 2-9).

### 2-37. FLIGHT CONTROL LOCKS.

#### CAUTION

**Remove control locks before towing the aircraft or starting engines. Serious damage could result in the steering linkage if towed by a tug with the rudder lock installed.**

Positive locking of the rudder, elevator and aileron control surfaces, and engine controls (**POWER** levers, **PROP** levers, and **CONDITION** levers) is provided by a removable lock assembly (fig. 2-25) consisting of two pins, and an elongated U-shaped strap interconnected by a chain. Installation of the control locks is accomplished by inserting the U-shaped strap around the aligned control levers from the copilot's side; then the aileron/elevator locking pin is inserted through a guide hole in the top of the pilot's control column assembly. The rudder is held in a neutral position by an L-shaped pin which is installed through a guide hole in the floor aft of the pilot's rudder pedals. The rudder pedals must be centered to align the hole in the rudder bellcrank with the guide hole in the floor. Remove the locks in reverse order (rudder pin, control column pin, and power control clamp).

### 2-38. TRIM TABS.

Trim tabs are provided for all flight control surfaces. These tabs are manually actuated, and mechanically controlled by a cable-drum and jack-screw actuator system

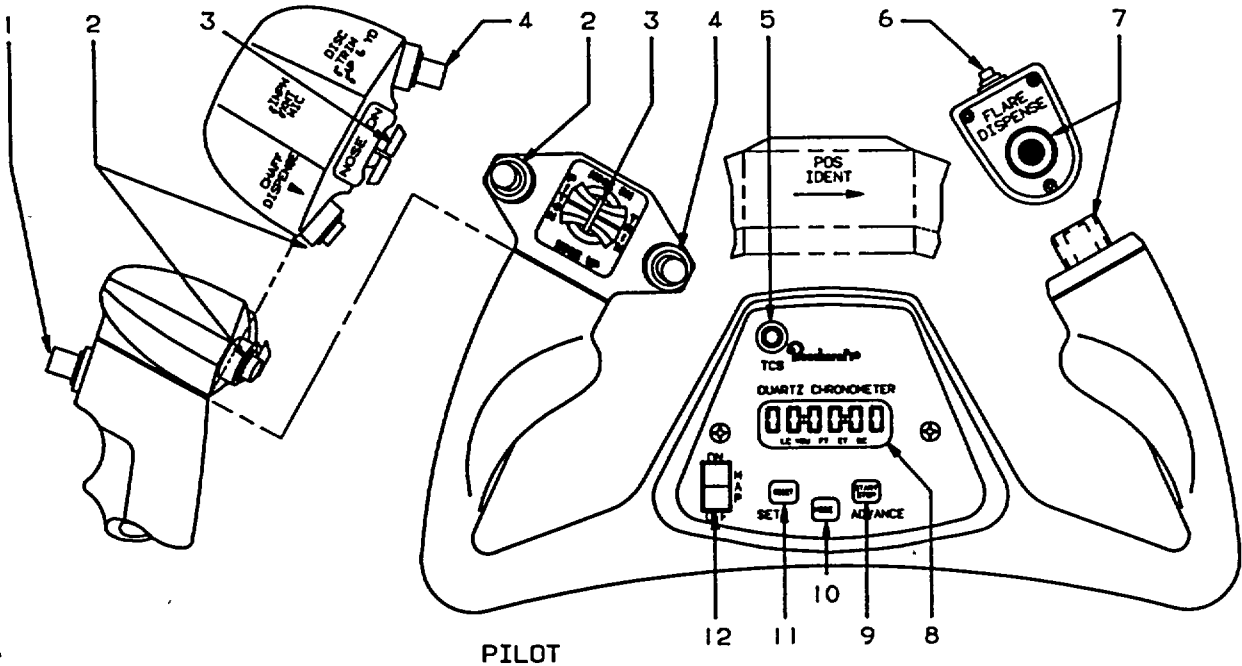

- |   |  |
|---|--|
| 1. Microphone Switch  | 7. Flare Dispense Switch                 |
| 2. Chaff Dispense Switch                                    | 8. Chronometer Digital Display           |
| 3. Electric Elevator Trim Switches                          | 9. Chronometer Start/Stop/Advance Switch |
| 4. Autopilot/Yaw Damper/<br>Electric Trim Disconnect Switch | 10. Chronometer Mode Switch              |
| 5. Touch Control Steering Switch                            | 11. Chronometer Set/Reset Switch         |
| 6. Transponder Ident Switch                                 | 12. Map Light Switch                     |

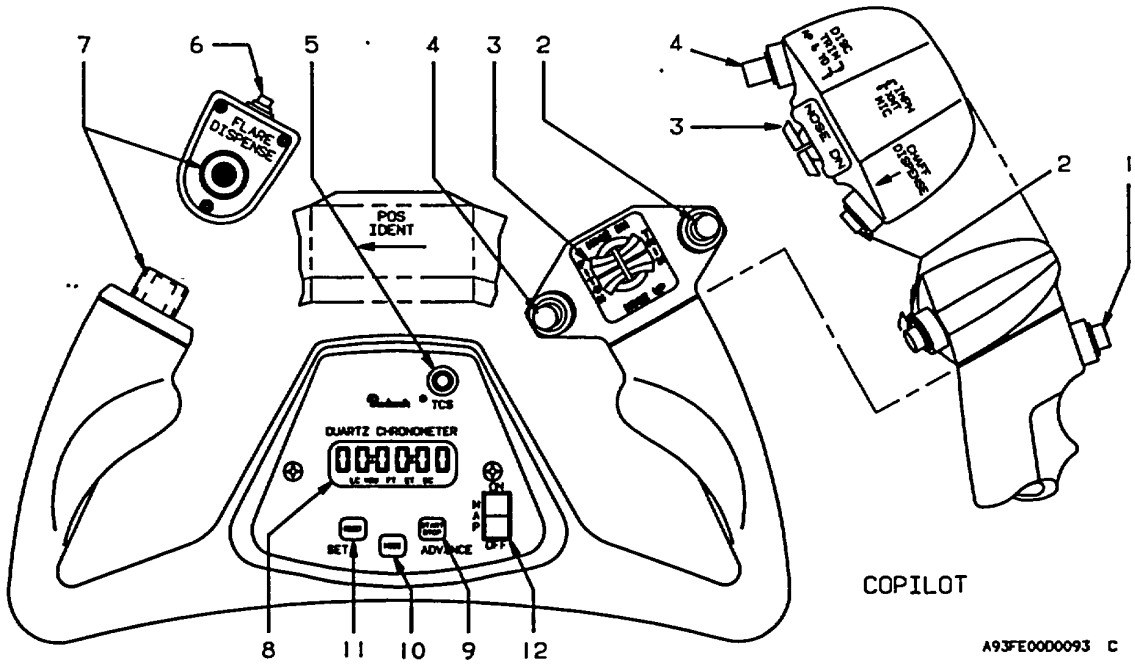

A93FE000093 C

Figure 2-24. Control Wheels

(except the right aileron tab, which is of the fixed, bendable type). Elevator and aileron trim tabs incorporate neutral, non-servo action, i.e., as the elevators or ailerons are displaced from the neutral position, the trim tab maintains an as-adjusted position. The rudder trim tab incorporates anti-servo action, i.e., as the rudder is displaced from the neutral position the trim tab moves in the same direction as the control surface. This action increases control pressure as the rudder is deflected from the neutral position.

a. *Elevator Trim Tab Control.* The elevator trim tab control wheel, placarded **PITCH TRIM, DN - UP**, is located on the left side of the control pedestal and controls a trim tab on each elevator (fig. 2-14). The amount of elevator tab deflection, in units from a neutral setting, is indicated by a position arrow.

b. *Electric Elevator Trim.* The electric elevator trim system is controlled by an **ELEV TRIM - OFF/RESET** switch located on the pedestal extension (fig. 2-14), dual element thumb switches on the control wheels (fig. 2-24), a trim disconnect switch on each control wheel, and a 5 ampere circuit breaker placarded **ELEC TRIM**, located on the overhead circuit breaker panel (fig. 2-9). The **ELEV TRIM - OFF/RESET** switch must be in the **ELEV TRIM** (on) position to operate the system. The dual element thumb switch is moved forward for trimming nose down and aft for nose up.

When released, and the switch returns to the center (off) position. Any activation of the trim system through the copilot's trim switch can be overridden by activation of the pilot's switch. Simultaneously operating the pilot's and copilot's switches in opposing directions results in the pilot having priority. An annunciator placarded **ELEC TRIM OFF** on the caution/advisory annunciator panel indicates failure or disconnect of the electric trim system.

A preflight check of the switches should be accomplished before flight by moving the switches individually on both control wheels. No one switch alone should operate the system; operation of elevator trim should occur only by movement of pairs of switches on each control wheel. The trim system disconnect is a bi-level pushbutton momentary-type switch, located on the outboard grip of each control wheel. Depressing the switch to the first of two levels disconnects the autopilot and yaw damp system, and the second level disconnects the electric trim system. The system can be reset by moving the **ELEV TRIM** switch toggle on the pedestal (fig. 2-14) to **OFF/RESET** position, then back to **ELEV TRIM**.

c. *Aileron Trim Tab Control.* The aileron trim tab control, placarded **AILERON TRIM - LEFT, RIGHT**, located on the control pedestal, adjusts the aileron trim tab

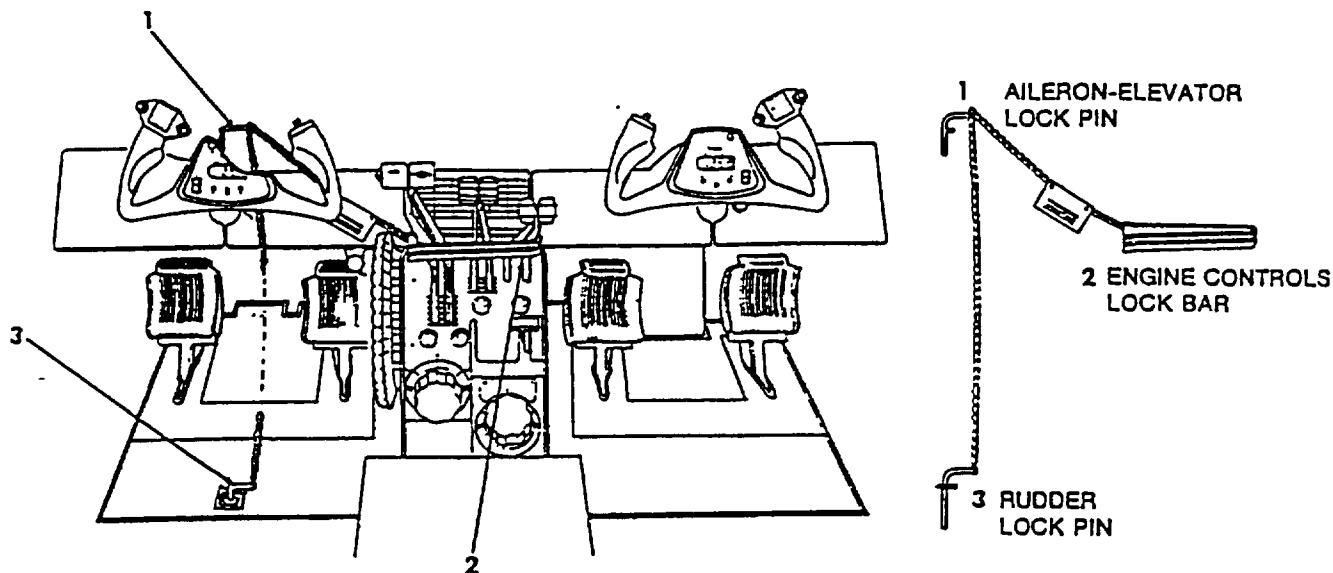

AP013028

Figure 2-25. Control Locks

(fig. 2-14). The amount of aileron tab deflection from a neutral setting, as indicated by a position indicator, is relative only and is not in degrees.

*d. Rudder Trim Tab Control.* The rudder trim tab control knob, placarded **RUDDER TAB LEFT, RIGHT**, located on the control pedestal, controls adjustment of the rudder trim tab (fig. 2-14). The amount of rudder tab deflection, in units from a neutral setting, is indicated by a position indicator.

## 2-39. WING FLAPS.

The slot-type wing flaps are electrically operated and consist of two sections for each wing. These sections extend from the inboard end of each aileron to the junction of the wing and fuselage. During extension or retraction, the flaps are operated as a single unit, with each section actuated by a separate jackscrew actuator. The actuators are driven through flexible shafts by a single reversible electric motor.)Wing flap position is indicated in percent of travel by a flap position indicator on the center subpanel. Full flap extension and retraction time is approximately 11 seconds. The flap control switch is located on the control pedestal. No emergency wing flap actuation system is provided. With flaps extended beyond the **APPROACH** position, the landing gear warning horn will sound, unless the landing gear is down and locked. The circuit is protected by a 20-ampere circuit breaker, placarded **FLAP MOTOR**, located on the overhead circuit breaker panel (fig. 2-9).

*a. Wing Flap Control Switch.* Flap operation is controlled by a three-position switch with a flap-shaped

handle on the control pedestal (fig. 2-14). The handle of this switch is placarded **FLAP**. Switch positions are placarded: **FLAP - UP - APPROACH** and **DOWN**. The amount of extension of the flaps is established by the position of the flap switch as follows: **UP - 0%**, **APPROACH - 40%**, and **DOWN 100%**. Limit switches, mounted on the right inboard flap, establish the flap travel. The flap control switch, limit switch, and relay circuits are protected by a 5-ampere circuit breaker, placarded **FLAP CONTR**, located on the overhead circuit breaker panel (fig. 2-9). Intermediate flap positions between **UP** and **APPROACH** cannot be selected. For intermediate flap positions between **APPROACH** and **DOWN**, the **APPROACH** position acts as an off position. To return the flaps to any position between full **DOWN** and **APPROACH** place the flap switch to **UP** and when desired flap position is obtained, return the switch to **APPROACH** detent. To return the flaps to full **UP**, place the flap switch to the **UP** detent position. To return the flaps to **APPROACH**, move the flap switch to the **UP** position and then to the **APPROACH** detent position. In the event that any two adjacent flap sections extend 3 to 5 degrees out of phase with the other, a safety mechanism is provided to discontinue power to the flap motor.

*b. Wing Flap Position Indicator.* Flap position in percent of travel from 0 percent (**UP**) to 100 percent (**DOWN**) is shown on an indicator, placarded **FLAPS**, located on the center subpanel (fig. 2-8). The approach and full down flap positions are 14 and 35 degrees, respectively. The flap position indicator is protected by a 5-ampere circuit breaker, placarded **FLAP CONTR**, located on the overhead circuit breaker panel (fig. 2-9).

## Section VI. PROPELLERS

### 2-40. DESCRIPTION.

A four-blade aluminum propeller is installed on each engine. The propeller is full feathering, constant speed, variable-pitch, counterweighted, and reversible; and is controlled by engine oil pressure through single action, engine driven propeller governors. The propeller is flange mounted to the engine shaft. Centrifugal counterweights, assisted by a feathering spring, move the blades toward the low RPM (high pitch) position and into the feathered position. Governor boosted engine oil pressure moves the propeller to the high RPM (low pitch) hydraulic stop and reverse position. The propeller has no low RPM (high pitch) stops; this allows the blades to feather after engine shutdown. Low pitch propeller position is determined by the low pitch stop, which is a mechanically actuated, hydraulic stop. Ground fine and reverse blade angles are controlled by the **POWER** levers in the ground fine and reverse range. Both manual and automatic propeller feathering systems

### 2-41. FEATHERING PROVISIONS.

are provided. Manual feathering is accomplished by pulling the corresponding **PROP** lever aft, past a friction detent. To unfeather, the **PROP** lever is pushed forward into the governing range. The automatic feathering system senses loss of torque and feathers an unpowered propeller. Feathering springs feather the propeller when it is not turning.

*a. Automatic Feathering.* The automatic feathering system provides a means of immediately dumping oil from the propeller servo to enable the feathering spring and counterweights to start feathering the blades in the event of an engine failure. Although the system is armed by a switch on the overhead control panel (fig. 2-15), placarded **AUTOFEATHER TEST - OFF - ARM**, the completion of the arming phase occurs when both **POWER** levers are advanced above 89% NI, at which time both annunciators on the caution/advisory



annunciator panel indicate a fully armed system. The annunciator panel annunciators are green and placarded # 1 **AUTOFEATHER** (left engine) and # 2 **AUTOFEATHER** (right engine). The system will remain inoperative as long as either **POWER** lever is retarded below approximately the 89% N<sub>1</sub> position, unless **TEST** position of the autofeather switch is selected to disable the **POWER** lever limit switches. The system is designed for use only during takeoff or landing, and should be turned off when establishing cruise climb. During takeoff or landing, should the torque for either engine drop to an indication between 19 13%, the autofeather system for the opposite engine will be disarmed. Disarming is confirmed when the **AUTOFEATHER** annunciator of the opposite engine becomes extinguished. If torque drops further, to a reading between 13 and 7%, oil is dumped from the servo of the affected propeller, allowing a feathering spring to move the blades into the feathered position. Feathering also causes the **AUTOFEATHER** annunciator of the feathered propeller to extinguish. At this time, both the # 1 **AUTOFEATHER** and # 2 **AUTOFEATHER** annunciators are extinguished, the propeller of the defective engine has feathered, and the propeller of the operative engine has been disarmed from autofeathering capability. Only manual feathering control remains for the second propeller.

b. *Propeller Autofeather Arm/Off/Test Switch.* A switch placarded **AUTOFEATHER TEST - OFF - ARM**, located on the overhead control panel (fig. 2-15), is provided for arming and disarming the system and for selection of the **TEST** function. The **TEST** position of the switch checks the readiness of the autofeather system below 89% N<sub>1</sub>.

c. *Autofeather Annunciators.* Autofeather annunciators consist of two green annunciators on the caution/advisory annunciator panel, placarded # 1 **AUTOFEATHER** and # 2 **AUTOFEATHER**. When illuminated, the annunciators indicate that the autofeather system is armed. Both annunciators will be extinguished if either propeller has been feathered or if the system is disarmed by retarding a **POWER** lever. Autofeather circuits are protected by a 5-ampere circuit breaker, placarded **AUTO FEATHER**, located on the overhead circuit breaker panel (fig. 2-9).

#### 2-42. PROPELLER GOVERNORS.

A constant speed governor and an overspeed governor control propeller RPM. The constant speed governor, mounted on top of the reduction housing, controls the propeller through its entire range. The propeller control lever controls the propeller by means of this governor. If the constant speed governor should malfunction and request more than 1700 RPM, the overspeed governor cuts in at 1802 RPM and dumps oil

from the propeller to keep the RPM from exceeding approximately 1802 RPM. A solenoid, actuated by the **GOVERNOR TEST** switch, located on the overhead control panel (fig. 2-15), is provided for resetting the overspeed governor to approximately 1540 to 1580 RPM for test purposes. If the propeller sticks or moves too slowly during a transient condition, causing the propeller governor to act too slowly to prevent an overspeed condition, the power turbine governor, contained within the constant speed governor housing, acts as a fuel topping governor. When the propeller reaches 106% of selected N<sub>2</sub> RPM, the power turbine governor limits the fuel flow to the gas generator, reducing N<sub>1</sub> RPM, which in turn prevents the propeller from exceeding approximately 1802 RPM. During operation in the reverse range, the power turbine governor is reset to approximately 95% of propeller RPM before the propeller reaches a negative pitch angle. This ensures that engine power is limited, allowing a propeller RPM of somewhat less than that of the constant speed governor setting to be maintained. The constant speed governor, therefore, will always sense an underspeed condition and direct oil pressure to the propeller servo piston to permit propeller operation in beta and reverse ranges.

#### 2-43. LOW PITCH STOP.

Low pitch propeller position is determined by a mechanically-monitored hydraulic low pitch stop. The propeller servo piston is connected by four spring-loaded sliding rods to the beta collar, mounted behind the propeller. A carbon brush block riding in the beta collar transfers the movement of the collar through the propeller reversing lever to the beta valve of the governor. The initial forward motion of the beta valve from its rigged position blocks off the flow of oil to the propeller. Further motion dumps the oil from the propeller into the reduction gear box sump. A mechanical stop limits the forward motion of the beta valve. Rearward movement of the beta valve from its rigged position does not affect normal propeller control. When the propeller is rotating at a speed lower than that selected on the governor, the governor pump provides oil pressure to the servo piston, decreasing pitch of the propeller blades until the feedback of motion from the beta collar pulls the beta valve into a position blocking the supply of oil to the propeller, thus preventing further pitch changes.

#### 2-44. GROUND FINE.

##### CAUTION

**Propeller speeds below 1000 RPM are not authorized, unless the propeller is feathered.**

Lifting the **POWER** levers and moving them aft past the flight idle stop will place the **POWER** levers into the ground fine position. Approximately half way back to the

ground fine gate, a mechanical linkage at the propeller governor will begin to bleed Py air from the fuel control unit, provided the **PROP** levers are positioned to the minimum RPM position. This results in a decrease in both engine N<sub>1</sub>, torque, and propeller RPM. With the **POWER** levers at the ground fine gate, engine N<sub>1</sub> should be within the range of 62% to 67%, and propeller RPM should not be less than 1000 RPM.

## 2-45. PROPELLER SYNCHROPHASER.

*a. Description.* The propeller synchrophaser matches left and right propeller RPM as well as propeller phase relationship. This phase relationship is designed to decrease cabin noise, and is not adjustable in flight. A toggle switch, placarded **PROP SYN - ON - OFF**, installed adjacent to the synchroscope on the pilot's instrument panel (fig. 2-18), turns the system on/off.

Signal pulses occurring once per revolution of the propeller are obtained from magnetic pickups (located in the front of the engine on the deice brush mounting bracket) when the target (mounted on the aft side of the spinner bulkhead) passes the magnetic pickup. The signal pulses are sent to a control box installed forward of the pedestal. The control box receives these signal pulses and compares them for pulse rate and relative position. Differences in pulse rate and/or propeller position cause the control box to vary the voltage in the primary governor coil, which in turn increases propeller speed until the correct speed and phasing are obtained.

A governor coil increases the speed set by the propeller control lever, but never decreases the speed set by the control lever. The maximum synchrophaser range is approximately 20 RPM. This limited range prevents either propeller from losing more than a limited RPM if the other propeller is feathered with the synchrophaser **ON**.

There is no master or slave engine in this system. There is a limited range for synchronizing, called the "holding -range". There is a maximum RPM differential (capture range), at which the synchrophaser, when turned on, will begin to synchronize the propellers. For this reason the propellers should be manually synchronized before turning the synchrophaser on.

### NOTE

**If the synchrophaser is ON but does not adjust properly, the synchrophaser has reached the limit of its range. Turn the system OFF, manually adjust the propeller RPM into synchronization, then turn the synchrophaser ON.**

The propeller synchrophaser may be used on takeoff at the pilot's option.

*b. Synchrophaser Control Box.* The control box, located forward of the pedestal, converts pulse rate differences into correction commands. Differences in pulse rate, and/or propeller position, cause the control box to vary the voltage in the primary governor coil, which in turn increases propeller speed until the correct speed and phasing are obtained. The system is protected by a 5-ampere circuit breaker placarded **PROP SYNC**, located on the overhead circuit breaker panel (fig. 2-9).

*c. Synchroscope.* The propeller Synchroscope, located on the pilot's instrument panel, provides an indication of synchronization of the propellers. If the right propeller is operating at a higher RPM than the left, a black and white cross pattern spins in a clockwise direction. Left, or counterclockwise, rotation indicates a higher RPM of the left propeller. This instrument aids the pilot in obtaining complete synchronization of the propellers.

## 2-46. PROPELLER LEVERS.

Two **PROP** levers on the control pedestal (fig. 2-14), placarded **PROP**, are used to regulate propeller speeds. Each lever controls a primary governor, which acts to regulate propeller speeds within the normal operational range. The full forward position of the levers is placarded **TAKEOFF, LANDING, AND REVERSE - HIGH RPM**. The full aft position of the levers is placarded **FEATHER**. When a lever is placed at **HIGH RPM**, the propeller may attain a static RPM of 1700 depending upon **POWER** lever position. As a lever is moved aft, passing through the propeller governing range, but stopping at the feathering detent, the propeller RPM will correspondingly decrease to the lowest limit (approximately 1200 RPM). Moving a **PROP** lever aft past the detent into **FEATHER** will feather the propeller.

## 2-47. PROPELLER REVERSING.

### CAUTION

**Do not move the POWER levers below the flight idle gate unless the engine is running. Damage to the reverse linkage mechanisms will occur.**

**Propeller reversing on deteriorating surfaces may cause engine FOD and propeller erosion from reversed airflow.**

### CAUTION

**Consideration should be given to not reversing propellers when operating in snow or dusty conditions, to prevent obscuring the pilot's vision.**

The engine **POWER** levers actuate an engine mounted cambox which is connected to the engine fuel control unit (FCU) and the propeller reversing cable. The cambox is arranged so that the reversing cable is not affected by **POWER** lever movement forward of the idle stop. When the **POWER** levers are lifted over the reversing detent and moved rearward, the reversing cable is pulled aft. This action resets the beta valve rearward, allowing the governor to pump more oil into the propeller, thus moving the blades through the ground fine range toward reverse pitch. As the blades move, the mechanical feedback collar is moved forward. This movement is transmitted by a carbon block on the end of

the reversing lever to the beta valve, causing it to move forward. As the **POWER** levers are moved further rearward (into the striped area), the propeller blades are moved further toward the reverse pitch stop, and the FCU is reset to increase engine speed.

#### 2-48. PROPELLER TACHOMETERS.

Two tachometers on the instrument panel register propeller speed in hundreds of RPM (fig. 2-18). Each indicator is slaved to a tachometer-generator unit attached to the corresponding engine, installed on the reduction gearbox.

### Section VII. UTILITY SYSTEMS

#### 2-49. DEFROSTING SYSTEM.

a. *Description.* The defrosting system is an integral part of the heating and ventilation system. The system consists of two warm air outlets connected by ducts to the heating system. One outlet is just below the pilot's windshield and the other is just below the copilot's windshield. A push-pull control placarded **DEFROST AIR**, on the pilot's subpanel, manually controls airflow to the windshield. When the control is pulled out, defrosting air is ducted to the windshield. As the control is pushed in, there is a corresponding decrease in airflow.

#### b. *Automatic Operation.*

1. **VENT BLOWER** switches As required.
2. **CABIN AIR MODE SELECT** switch **AUTO**.
3. **CABIN AIR TEMP CONTROL** rheostat As required.
4. **CABIN AIR, COPILOT AIR, PILOT AIR,** and **DEFROST AIR** controls As required.

c. *Manual Operation.* If the automatic temperature control should fail to operate, the temperature of defrost air and cabin air can be controlled manually by setting the **CABIN AIR MODE SELECT** switch to the **MAN COOL** position, then using the **CABIN AIR MANUAL TEMP** switch to set the desired temperature. This control is located on the overhead control panel (fig. 2-15). Use the following procedure for manual operation:

1. **PILOT** and **COPILOT AIR** controls In.
2. **CABIN AIR** and **DEFROST AIR** controls - Out
3. **CABIN AIR MODE SELECT** switch - **MAN COOL**.
4. Cold air outlets As required.
5. **CABIN AIR MANUAL TEMP** switch - As required.

#### 2-50. SURFACE DEICING SYSTEM.

a. *Description.* Ice accumulation is removed from each inboard and outboard wing leading edge, both horizontal stabilizers, stabilons, and taillets by the flexing of deice boots which are pneumatically actuated. Bleed air is used to supply air pressure to inflate the deice boots, and to supply vacuum through the ejector system. A pressure regulator protects the system from over inflation. When the system is not in operation, a distributor valve keeps the boots held down by vacuum supplied through the ejector system.

#### CAUTION

**Operation of the surface deice system in ambient temperatures below -40°C can cause permanent damage to the deice boots.**

**NOTE**

**Under conditions where one bleed air source is inoperative, sufficient bleed air pressure for deice boot inflation may not be available. Prior to deice boot inflation, check the regulated bleed air pressure gage for a minimum of 16 PSI. If insufficient pressure exists, increasing engine N<sub>1</sub> and/or decreasing aircraft altitude - will increase bleed air pressure.**

b. *Operation.***WARNING**

**To ensure adequate bleed air pressure to the deice boots, do not simultaneously actuate surface and antenna deice systems in the manual mode.**

(1) Deice boots are intended to remove ice after it has formed rather than prevent ice formation. For the most effective deicing operation, allow at least 1/2 inch of ice to form on the boots before attempting ice removal. Very thin ice may crack and cling to the boots instead of shedding.

**WARNING**

**Never cycle the system rapidly. This may cause the ice to accumulate outside the contour of the inflated boots and prevent ice removal.**

(2) A two position deice switch on the overhead control panel, placarded SURFACE, controls the deicing operation. The switch is spring loaded to return to the off position from SINGLE CYCLE AUTO or MANUAL. When the SINGLE CYCLE AUTO position is selected, the distributor valve opens to inflate the wing boots. After an inflation period of approximately 6 seconds, an electronic timer switches the distributor to deflate the wing boots and a 4 second inflation begins in the horizontal stabilizer, stabilon, and taillet boots. When these boots have inflated and deflated, the cycle is complete.

(3) If the switch is held in the MANUAL position, the boots will inflate simultaneously and remain inflated until the switch is released. The switch will return to the off position when released. After the cycle, the boots will remain in the vacuum hold down condition until again actuated by the switch.

(4) Either engine is capable of providing sufficient bleed

air for all requirements of the surface deice system. Check valves in the bleed air and vacuum lines prevent backflow through the system during single engine operation. Regulated pressure is indicated on a gage, placarded **PNEUMATIC PRESSURE**, located on the center subpanel.

**2-51. ANTENNA DEICING SYSTEM.**

a. *Description.* The antenna deicing system removes or prevents ice accumulation on the mission antennas. Pressure regulated bleed air is used to supply pressure to inflate the boots. To assure operation of the system in the event of failure of one engine, a check valve is incorporated in the bleed air line from each engine to prevent loss of pressure through the compressor of the inoperative engine. Inflation and deflation phases are controlled by distributor valves.

**WARNING**

**To ensure adequate bleed air pressure to the deice boots, do not simultaneously actuate surface and antenna deice systems in the manual mode.**

**NOTE**

**Under conditions where one bleed air source is inoperative, sufficient bleed air pressure for deice boot inflation may not be available. Prior to deice boot inflation, check PNEUMATIC PRESSURE gage for a minimum of 16 PSI. If insufficient pressure exists, increasing engine N<sub>1</sub> and/or decreasing aircraft altitude will increase bleed air pressure.**

b. *Antenna Deice System Switch.* The antenna deice system is controlled by a switch, placarded **ANTENNA, MANUAL SINGLE CYCLE AUTO**, located on the overhead control panel (fig. 2-15). The switch is spring loaded to return to the off position from the **SINGLE CYCLE AUTO** or **MANUAL** position. When the switch is set to the **SINGLE CYCLE AUTO** position, the system will run through one timed inflation/deflation cycle. When the switch is held in the **MANUAL** position the boots will inflate and remain inflated until the switch is released.

c. *Operation.* Deice boots are intended to remove ice after it has formed rather than prevent ice formation. For the most effective deicing operation, allow at least 1/8 to 1/4 inch of ice to form on the boots before attempting removal. Very thin ice may crack and cling to the boots instead of shedding.

**WARNING**

**Never cycle the system rapidly, this may cause the ice to accumulate outside the contour of the inflated boots and prevent ice removal.**

**2-52. FORWARD GUARDRAIL DUAL DATA LINK ANTENNA RADOME ANTI-ICE.**

The forward guardrail dual data link (GDDL) antenna radome anti-ice system utilizes engine bleed air to prevent the formation of ice on the radome. The system is controlled by a switch, placarded **RADOME - ON**, located on the overhead control panel (fig. 2-15). The circuit is protected by a 7.5-ampere circuit breaker, placarded **RADOME ANTI-ICE**, located on the overhead circuit breaker panel (fig. 2-9).

**2-53. PROPELLER ELECTRIC DEICE SYSTEM.**

*a. Description.* The propeller electric deice system includes electrically heated deice boots, slip rings and brush block assemblies, a timer for automatic operation, ammeter, circuit breakers for left and right propeller and control circuit protection, and two switches located on the overhead control panel (fig. 2-15), for automatic or manual control of the system.

*b. Automatic Operation.* The two position switch located on the overhead control panel, placarded **PROP AUTO - ON**, is provided to activate the automatic system. When the switch is placed to the **ON** position, the timer diverts power through the brush block and slip ring to all heating elements on one propeller. Subsequently, the timer then diverts power to all heating elements on the other propeller for the same length of time. This cycle will continue as long as the switch is in the **ON** position. The system utilizes a metal foil type single heating element, energized by DC voltage. The timer switches every 90 seconds, resulting in a complete cycle in approximately 3 minutes.

*c. Manual Operation.* The manual propeller deice system is provided as a backup to the automatic system. The spring-loaded control switch located on the overhead control panel, placarded **PROP - MANUAL - ON**, controls the manual override relay. When the switch is held in the **ON** position, the automatic timer is overridden, and power is supplied to the heating elements of both propellers simultaneously. The switch is of the momentary type and must be held in position for approximately 90 seconds to dislodge ice from the propeller surface. Repeat this procedure as required to avoid significant buildup of ice, which will result in a loss of performance, vibration, and impingement of ice upon the fuselage. The propeller deice ammeter will not indicate a load while the propeller deice system is being

utilized in the manual mode. However, each aircraft loadmeter will indicate an approximate 10% increase in load while the manual propeller deice system is operating.

**2-54. PITOT HEAT SYSTEM.****CAUTION**

**Pitot heat should not be used for more than 15 minutes while the aircraft is on the ground. Overheating may damage the heating elements.**

Heating elements are installed in both pitot masts, located on the nose. Each heating element is controlled by an individual switch, placarded **PITOT, LEFT, RIGHT** and **ON**, located on the overhead control panel (fig. 2-15). Circuit protection is provided by the two 7.5-ampere circuit breakers, placarded **PITOT HEAT**, on the overhead circuit breaker panel (fig. 2-9). The true airspeed temperature probe heat control circuit is also protected by these circuit breakers. If either left or right pitot heat is on, the true airspeed temperature probe heat will be on.

**2-55. STALL WARNING HEAT SYSTEM.****CAUTION**

**Heating elements protect the stall warning lift transducer vane and face plate from ice. However, a buildup of ice on the wing may change or disrupt the airflow and prevent the system from accurately indicating an imminent stall.**

The lift transducer is equipped with anti-icing capability on both the mounting plate and the vane. The heat is controlled by a switch, located on the overhead control panel, placarded **STALL WARN**. The level of heat is minimal for ground operation, but is automatically increased for flight operation through the landing gear safety switch. Circuit protection is provided by a 15-ampere circuit breaker, placarded **STALL WARN**, on the overhead circuit breaker panel (fig. 2-9).

**2-56. STALL WARNING SYSTEM.**

The stall warning system consists of a transducer, a lift computer, warning horn, and a test switch. Angle of attack is sensed by aerodynamic pressure on the lift transducer vane located on the left wing leading edge (fig. 2-1 and 2-2). When a stall is imminent, the output of the transducer activates a stall warning horn. The system has preflight test capability through the use of a switch placarded **STALL WARN TEST OFF LDG GEAR WARN TEST** on the copilot's subpanel (fig. 2-8).

Holding this switch in the **STALL WARN TEST** position actuates the warning horn by moving the transducer vane. The circuit is protected by the 5-ampere circuit breaker, placarded **STALL**, located on the overhead circuit breaker panel (fig. 2-9).

## 2-57. BRAKE DEICE SYSTEM.

*a. Description.* The brake deice system may be used in flight with gear retracted or extended, or on the ground. When the brake deice system is activated, hot air is diffused by means of a manifold assembly over the brake discs on each wheel. Manual and automatic controls are provided. There are two primary occasions which require brake deicing. The first is when an aircraft has been parked in a freezing atmosphere, allowing the brake systems to become contaminated by freezing rain, snow, or ice, and the aircraft must be moved or taxied. The second occasion is during flight through icing conditions, when brake assemblies which are presumed to be frozen, which must be thawed prior to landing to avoid possible tire damage and loss of directional control. Hot air for the brake deice system comes from the compressor stage of both engines. Hot air is obtained by means of a solenoid valve attached to the bleed air system which serves both the surface deice system and the pneumatic systems operation.

*b. Operation.* A switch located on the overhead control panel (fig. 2-15), placarded **BRAKE - ON**, controls the solenoid valve by routing power through a control module box under the aisle way floorboards. The system is protected by a 5-ampere circuit breaker on the overhead circuit breaker panel (fig. 2-9), placarded **BRAKE DE-ICE**. A 10-minute timer limits operation to avoid excessive wheel well temperatures when the landing gear is retracted. The control module also contains a circuit to the green **BRAKE DEICE ON** annunciator, and has a resetting circuit interlocked with the gear uplock switch. When the system is activated, the **BRAKE DEICE ON** annunciator should be monitored and the control switch selected off after the annunciator extinguishes, otherwise, on the next gear extension, the system will restart without pilot action. The control switch should also be selected off if deice operation fails to self-terminate after approximately 10 minutes. If the automatic timer has terminated brake deice operation after the last retraction of the landing gear, the landing gear must be extended in order to obtain further operation of the system.

(1) The **L BL AIR FAIL** or **R BL AIR FAIL** annunciator may momentarily illuminate during simultaneous operation of the surface and brake deice systems at low  $N_1$  speeds. If the annunciators immediately extinguish, they may be disregarded.

(2) During certain ambient conditions, use of the brake deice system may reduce available engine power, and during flight will result in a TGT rise of approximately 20°C. Applicable performance charts should be consulted before brake deice system use. If specified power cannot be obtained without exceeding limits, the brake deice system must be selected off until after takeoff is completed. TGT limitations must also be observed when setting climb and cruise power. The brake deice system is not to be operated above 15°C ambient temperature. During periods of simultaneous brake deice and surface deice operation, maintain 85%  $N_1$  or higher. If inadequate pneumatic pressure is developed for proper surface deice boot inflation, select the brake deice system off. Both sources of pneumatic bleed air must be in operation during brake deice system use. Select the brake deice system off during single engine operation.

## 2-58. FUEL SYSTEM ANTI-ICING.

*a. Description.* An oil-to-fuel heat exchanger, located in each engine accessory case, operates continuously and automatically to heat the fuel sufficiently to prevent freezing of any water in the fuel. No controls are involved. Three external fuel vents are provided on each wing. One is recessed to prevent ice formation, the second is flush mounted so that no ice can collect upon it, and the third is electrically heated. Heating is controlled by two toggle switches located on the overhead control panel, placarded **FUEL VENT, LEFT, RIGHT** and **ON** (fig. 2-15). They are protected by two 5-ampere circuit breakers, placarded **FUEL VENT HEAT, LEFT, and RIGHT**, located on the overhead circuit breaker panel (fig. 2-9).

### CAUTION

**To prevent overheat damage to electrically heated anti-ice jackets, the FUEL VENT heat switches should not be turned ON unless cooling air will soon pass over the jackets.**

*b. Normal Operation.* For normal operation, switches for the fuel vent anti-ice circuits are turned **ON** as required during the **BEFORE TAKEOFF** procedures.

## 2-59. WINDSHIELD ELECTROTHERMAL ANTI-ICE SYSTEM.

*a. Description.* Both the pilot's and copilot's windshields are provided with an electrothermal anti-ice system. Each windshield is part of an independent electrothermal anti-ice system. Each system is comprised of the windshield assembly with heating wires sandwiched between glass panels, a temperature

sensor attached to the glass, an electrothermal controller, two relays, a control switch, and two circuit breakers. Two switches, placarded **WINDSHIELD, PILOT, NORMAL - OFF - HIGH**, and **WINDSHIELD, COPILOT, NORMAL - OFF - HIGH**, located on the overhead control panel (fig. 2-15), control system operation. Each switch controls one electrothermal windshield system. The circuits of each system are protected by a 5-ampere circuit breaker and a 50-ampere circuit breaker, which are not accessible to the flight crew.

### CAUTION

**To help prevent windshield cracking, windshield heat should be placed in the NORMAL position for at least 15 minutes prior to using the HIGH position.**

*b. Normal Operation.* Two levels of heat are provided through the three position switches, placarded **NORMAL** in the aft position, **OFF** in the center position, and **HIGH** after lifting the switch over a detent and moving it to the forward position. In the **NORMAL** position, heat is provided for the major portion of each windshield. In the **HIGH** position, heat is provided at a higher watt density to a smaller portion of the windshield. The lever lock switch feature prevents inadvertent switching to the **HIGH** position during system shutdown.

## 2-60. PRESSURIZATION SYSTEM.

*a. Description.* A mixture of engine bleed air and ambient air is available for cabin pressurization at a rate of approximately 10 to 17 pounds per minute. The flow control unit of each engine controls bleed air from the engine to make it usable for pressurization, by mixing ambient air with the bleed air, depending upon aircraft altitude and ambient temperature. On takeoff, excessive pressure bumps are prevented by landing gear safety switch actuated solenoids incorporated in the flow control units. These solenoids, through a time delay, stage the input of ambient air flow by allowing ambient air flow introduction through the left flow control unit first, then four seconds later allowing ambient air flow through the right flow control unit.

*b. Pressure Differential.* The pressure vessel is designed for a normal working pressure differential of 6.5 PSI, which will provide a cabin pressure altitude of 8,000 feet at an aircraft altitude of 29,700 feet, and a cabin pressure altitude of 10,000 feet at an aircraft altitude of 34,000 feet.

*c. Pressurization Controller.* The pressurization controller, located on the copilot's subpanel (fig. 2-8),

provides a display of the selected altitude, an altitude selector, and a rate control selector. The cabin and aircraft altitude display is a mechanically coupled dial. The outer scale, (**CABIN ALT**) of the display, indicates the selected cabin altitude. The inner scale (**ACFT ALT**) indicates the corresponding altitude at which the maximum differential pressure would occur. The indicated value on each scale is read as placarded, **ALT - FT X 1000**. The rate control selector, placarded **RATE INC**, regulates the rate at which cabin pressure ascends or descends to the selected altitude. The rate change selected may be from 200 to 2000 feet per minute.

*d. Cabin Rate-of-Climb Indicator.* An indicator, placarded **CABIN CLIMB**, is located on the copilot's subpanel (fig. 2-8). It is calibrated in thousands of feet per minute change in cabin altitude.

*e. Cabin Altitude Indicator.* An indicator, placarded **CABIN ALT**, is located on the copilot's subpanel (fig. 2-8). The longer needle indicates aircraft altitude in thousands of feet on the outside dial. The shorter needle indicates pressure differential in PSI on the inner dial. Maximum differential is  $6.5 \pm 10$  PSI.

*f. Outflow Valve.* A pneumatically operated outflow valve, located in the aft pressure bulkhead, maintains the selected cabin altitude and rate-of-climb commanded by the cabin rate-of-climb and altitude controller. As the aircraft climbs, the controller modulates the outflow valve to maintain a selected cabin rate of climb and increases the cabin differential pressure until the maximum cabin pressure differential is reached. At a cabin altitude of 12,500 feet, a pressure switch mounted on the back of the overhead control panel completes a circuit to illuminate a red **ALT WARN** warning annunciator, to warn of operation requiring oxygen.

*g. Safety Valve.* Before takeoff, the safety valve is open with equal pressure between the cabin and the outside air. The safety valve closes upon lift off if the **CABIN PRESS DUMP** switch, located on the copilot's subpanel (fig. 2-8), is in the pressurize mode. The safety valve, adjacent to the outflow valve, provides pressure relief in the event of an outflow valve failure. The safety valve is also used as a dump valve. The safety valve is opened by vacuum, which is controlled by a solenoid valve operated by the **CABIN PRESS DUMP** switch. It is wired through the right landing gear safety switch. If either of these switches is open, or if the vacuum source or electrical power is lost, the safety valve will close to atmosphere except at maximum pressure differential of  $6.5 \pm 10$  PSI. A negative pressure relief diaphragm is also incorporated into

the outflow and safety valves to prevent outside atmospheric pressure from exceeding cabin pressure during rapid descent.

*h. Drain.* A drain in the outflow valve static control line is provided for removal of accumulated moisture. The drain is located behind the lower sidewall upholstery access panel in the baggage section of the aft compartment.

*i. Flow Control Unit.* A flow control unit, located forward of the firewall in each engine nacelle, controls bleed air flow and the mixing of ambient air to make up the total air flow to the cabin for pressurization, heating, and ventilation. An integral electric solenoid firewall shutoff valve is controlled by the **ENVIRO & PNEU BLEED AIR** valve switches on the overhead control panel (fig. 2-15). A solenoid, operated by the right landing gear safety switch, controls the introduction of ambient air to the cabin upon takeoff. Both the ambient air flow control valve and the bleed air flow control valve are motor driven.

The unit receives bleed air from the engine into an ejector which draws ambient air into the venturi of the nozzle. The mixed air is then forced into the bleed air line routed to the cabin.

Bleed air flow is controlled automatically. When the aircraft is on the ground, circuitry from the landing gear safety switch prevents ambient air from entering the flow control unit to provide maximum heating. The bleed air firewall shutoff valve in the control unit is a spring-loaded bellows-operated valve that is held in the open position by bleed air pressure. When the electric solenoid is shut off, or when bleed air diminishes on engine shutdown (in both cases the pressure to the firewall shutoff valve is cut off), the firewall valve closes.

## 2-61. OXYGEN SYSTEM.

*a. Description.* The oxygen system (fig. 2-26) is provided primarily as an emergency system; however, the system may also be used to provide supplemental (first aid) oxygen. Two 70 cubic-foot capacity oxygen supply cylinders, charged with aviator's breathing oxygen, are installed in the unpressurized portion of the aircraft behind the aft pressure bulkhead. The pilot's and copilot's positions are equipped with diluter demand type regulators, which automatically mix the proper amount of oxygen for a given amount of air at altitude. A first aid oxygen mask is also provided in the cabin. Oxygen system pressure is shown by two gages, placarded **OXYGEN SUPPLY PRESSURE**, located on

the pilot's and copilot's oxygen regulator control panels. Two pressure reducers, located in the unpressurized portion of the aircraft behind the aft bulkhead, lower the pressure in the system to 400 PSI, and route oxygen to the regulator control panels. Both cylinders are interconnected, allowing refilling to be accomplished through a single filler valve located in the aft right side of the fuselage exterior. A pressure gage is mounted in conjunction with the filler valve, and each cylinder has a pressure gage. Table 2-4 shows oxygen flow planning rates vs. altitude. Table 2-5 shows oxygen duration capacities of the system in liters per minute (LPM) per mask at normal temperature and pressure, dry (NTPD).

*b. Regulator control panels.*

### WARNING

**The rapid loss of oxygen pressure when the aircraft is above 12,500 feet is a valid cause for alarm. Should this condition arise, descend as rapidly as possible to an altitude which does not require the use of oxygen.**

### CAUTION

**When the oxygen system is not in use, the diluter control lever should be left in the 100% OXYGEN position to prevent regulator contamination.**

Each regulator control panel contains a blinker-type flow indicator, a 500 PSI pressure gage, a red emergency pressure control lever placarded **EMERGENCY - NORMAL - TEST MASK**, a white diluter control lever placarded **100% OXYGEN - NORMAL OXYGEN**, and a green supply control lever placarded **ON - OFF**. The diluter control lever selects either normal or 100% oxygen when the emergency pressure control lever is in the **NORMAL** position.

The emergency pressure control lever has three positions. Two positions control oxygen consumption for the individual using oxygen, and the remaining position serves for testing hose and mask integrity. In the **EMERGENCY** position, the control lever causes 100% oxygen to be delivered at a safe, positive pressure. In the **NORMAL** position, the lever allows delivery of normal or 100% oxygen, depending upon the selection of the diluter control lever. In the **TEST MASK** position, 100% oxygen at positive pressure is delivered to check hose and mask integrity.



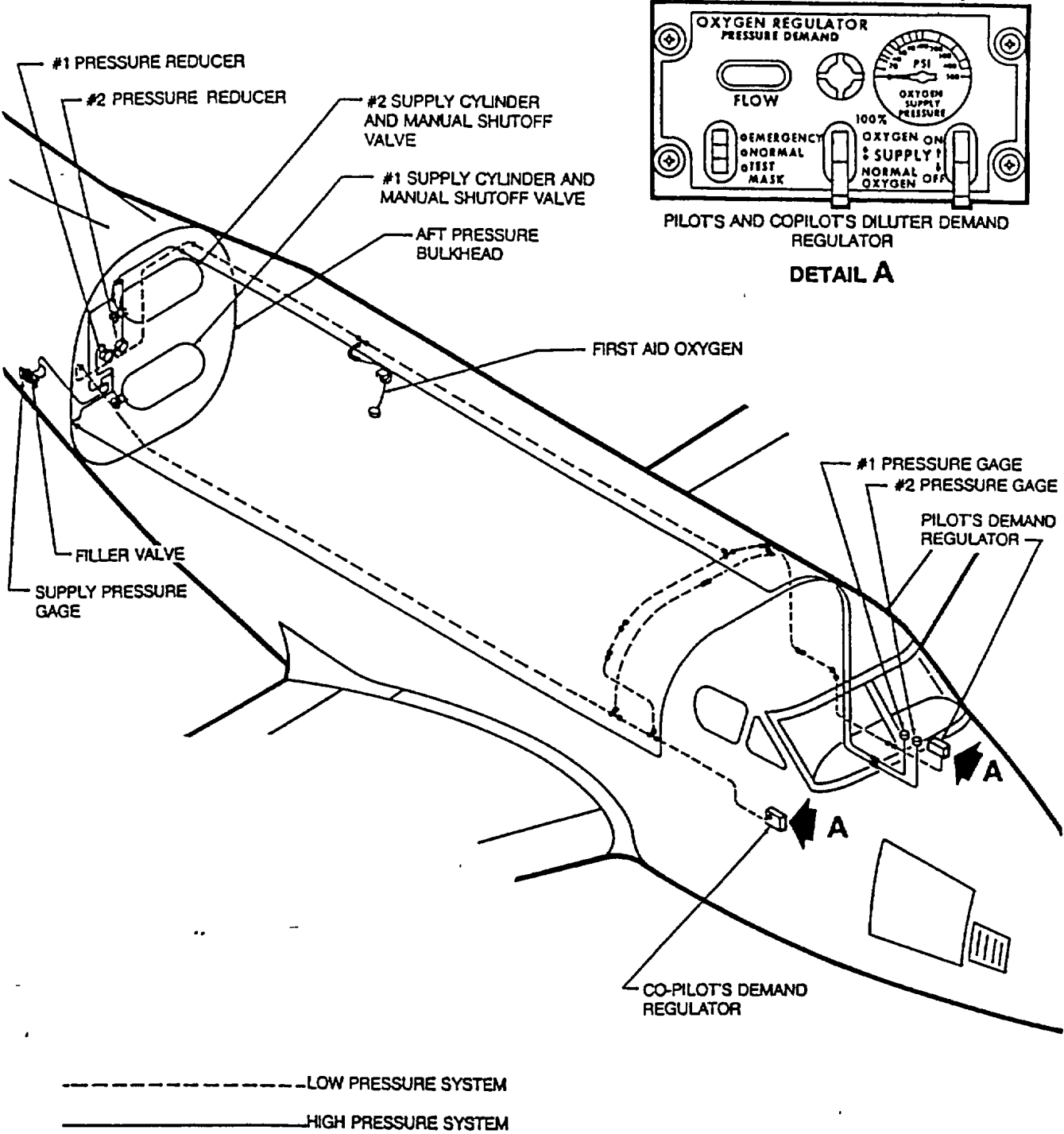

Figure 2-26. Oxygen System

AP006599

Table 2-4. Oxygen Flow Planning Rates Vs Altitude  
(All Flows in LPM Per Mask at NTPD)

CABIN PRESSURE ALTITUDE IN FEET	CREW MASK NORMAL(DILUTER DEMAND) (1)	CREW MASK 100% (1)	PASSENGER MASK
35,000	-0-(2)	3.1	3.7 (3)
34,000	-0-(2)	3.4	3.7 (3)
33,000	-0-(2)	3.7	3.7 (3)
32,000	-0-(2)	3.9	3.7 (3)
31,000	-0-(2)	4.2	3.7 (3)
30,000	-0-(2)	4.4	3.7 (3)
29,000	-0-(2)	4.7	3.7 (3)
28,000	-0-(2)	5.0	3.7 (3)
27,000	-0-(2)	5.3	3.7 (3)
26,000	-0-(2)	5.6	3.7 (3)
25,000	-0-(2)	5.9	3.7
24,000	-0-(2)	6.2	3.7
23,000	-0-(2)	6.6	3.7
22,000	-0-(2)	6.9	3.7
21,000	-0-(2)	7.2	3.7
20,000	3.6	7.6	3.7
19,000	3.9	7.9	3.7
18,000	4.2	8.3	3.7
17,000	4.5	8.7	3.7
16,000	4.8	9.1	3.7
15,000	5.1	9.5	3.7
14,000-	5.4	10.0	3.7
13,000	5.8	10.4	3.7
12,00	6.1	10.9	3.7
11,000	6.5	11.3	3.7
10,000	6.9	11.9	3.7

NOTES:

(1) Based on minute volume of 20 LPM-BTPS (Body Temperature and Pressure Saturated).

(2) Use 100% oxygen above 20,000 feet.

(3) Not recommended for other than emergency descent use above 25,000 feet.

If average climb or descent flows are desired, add the values between altitudes and divide by the number of values used.

For example, to determine the average rate for a uniform descent between 25,000 feet and 15,000 feet perform the following:

$$5.9 + 6.2 + 6.6 + 6.9 + 7.2 + 7.6 + 3.9 + 4.2 + 4.5 + 4.8 + 5.1 \div 11 = 5.7 \text{ LPM}$$

This method is preferred over averaging the extremes as some flow characteristics vary in such a way as to yield an incorrect answer.

**NOTE**

Check to ensure that the **OXYGEN SUPPLY PRESSURE** gage registers adequate pressure before each flight. When oxygen is in use, a check of the supply pressure should be made at intervals during flight, to note the quantity available and to approximate the supply duration. Outside temperature is reduced as altitude is increased. Oxygen cylinders thus cooled by temperature change will show a pressure drop. This type of drop in pressure will rise again upon return to a lower or warmer altitude.

The 500 PSI oxygen pressure gage provided on the oxygen control panels should never indicate over 400 PSI. If the pressure exceeds 400 PSI, a malfunction of the pressure reducer is likely. Whenever oxygen is inhaled, a blinkervane slides into view within the flow indicator window, showing that oxygen is being released. When oxygen is exhaled, the blinker vane vanishes from view.

c. *Oxygen masks.*

**WARNING**

Pure oxygen will support combustion. Do not smoke while oxygen is in use.

Oxygen masks for the pilot and copilot are provided. To connect a mask into the oxygen system, connect the line attached to the mask to the flexible hose which is attached to the cockpit sidewall. The microphone in the oxygen mask is connected to the audio system through the pilot's or copilot's headset/oxygen mask microphone selector switch, located on the instrument panel (fig. 2-18). To test mask and hose integrity, place the supply control lever on the regulator control panel to the **ON** position, put on and adjusts the mask, select **TEST MASK** position, and check for leaks.

If any symptoms occur suggestive of the onset of hypoxia, immediately set the emergency pressure control lever to the **EMERGENCY** position and descend below 10,000 feet. Whenever carbon monoxide or other noxious gas is present or suspected, set the diluter control lever to 100% oxygen and continue breathing oxygen until the danger is past.

d. *Normal Operation.* Oxygen pressure is maintained at all times to the regulator control panels if the cylinder shut-off valves are open and if there is pressure in the cylinders. Each individual places the supply lever (green) on the regulator control panel to the **ON** position, and the diluter lever (white) to the **NORMAL OXYGEN** position.

e. *Emergency Operation.* For emergency operation, the affected crew member selects the **EMERGENCY**

Table 2-5. Oxygen Duration In Minutes 140 Cubic Foot System

	CABIN PRESSURE ALTITUDE	CREW MASK CONDITION	TOTAL FLOW LPM-NTPD	DURATION IN MINUTES (1)
TWO MAN CREW	35,000	100%	6.3	512.1
	31,000	100%	8.4	384.0
	25,000	100%	11.8	273.3
	20,000	100%	15.2	212.2
	20,000	NORMAL	7.2	448.0
	15,000	100%	19.0	169.7
	15,000	NORMAL	10.2	316.2
	10,000	100%	23.8	135.5
TWO MAN CREW PLUS ONE PASS	10,000	NORMAL	13.8	233.7
	35,000	100%	10.0	323
	31,000	100%	12.1	266.6
	25,000	100%	15.5	208.1
	20,000	100%	18.9	170.7
	20,000	NORMAL	10.9	295.9
	15,000	100%	22.7	142.1
	15,000	NORMAL	13.9	232.1
10,000	100%	27.5	117.3	
	10,000	NORMAL	17.5	184.3

(1) For 100% capacity of usable oxygen, 3,226 L.

position of the emergency pressure control lever (red) on his regulator control panel. This selection provides 100% oxygen at a positive pressure, regardless of the position of the diluter control lever.

*f. First Aid Operation.* A first aid oxygen mask is installed in the aft cabin area as a supplemental or emergency source of oxygen. The mask is stowed behind an overhead cover, placarded **FIRST AID OXYGEN - PULL**. Removing the cover allows the mask to drop out of the container, exposing a manual control valve, which releases oxygen to the mask when placed in the **ON** position. After using the mask, the manual valve in the container must be turned **OFF** before stowing the mask and replacing the cover.

*g. Oxygen Duration Examples.*

(1) *Example one.*

(a) *Wanted.* Duration in minutes of oxygen at 100% capacity.

(b) *Known.* Two man crew plus one passenger, cabin pressure altitude = 15,000 feet, crew masks, normal, 100% capacity.

(c) *Method.* Find "two man crew plus one pass # line (table 2-5), move right then down to 15,000 "normal", read 232.1 minutes.

(2) *Example two.*

(a) *Wanted.* Duration of oxygen for previous example data at 84% of capacity.

(b) *Known.* 232.1 minutes duration at 100%, 84% capacity, total aircraft flow = 13.9 LPM.

(c) *Method.* Multiply 232.1 X 0.84 = 194.9 minutes, or multiply 3,226 X 0.84 = 2709.8, divide by 13.9 LPM = 194.9 minutes.

(3) *Example three.*

(a) *Wanted.* Duration of oxygen for complement at other cabin pressure altitude, at less than 100% capacity.

(b) *Known.* Cylinder at 84% capacity, 100% capacity = 3,226 L, cabin pressure altitude = 21,000 feet.

1 crew mask = LPM (100%), 1 passenger mask = LPM

(c) *Method.* Multiply 3,226 L X 0.84 = 2,709.8 L. Multiply 2 crew X 7.2 LPM = 14.4 LPM. Multiply 1 passenger X 3.7 LPM, add 14.4 LPM crew plus 3.7 LPM passenger = 18.1 LPM. Divide 2,709.8 L by 18.1 LPM = 149.7 minutes.

*h. Oxygen Cylinder Capacity Example Problem.* Oxygen cylinder capacity is determined by using figure 2-27.

(1) *Example one.*

(a) *Wanted.* Percent of capacity at known pressure and temperature and pressure when temperature decreases.

(b) *Known.* Pressure = 1,600 PSIG stabilized cylinder temperature is estimated at 200C, decreased stabilized cylinder temperature is estimated at -30°C.

(c) *Method.* Enter 1600 PSIG, move up to 200C line, move right to 84% then move left on 84% line to -300C line, and move down to 1250 PSIG.

(2) *Example two.*

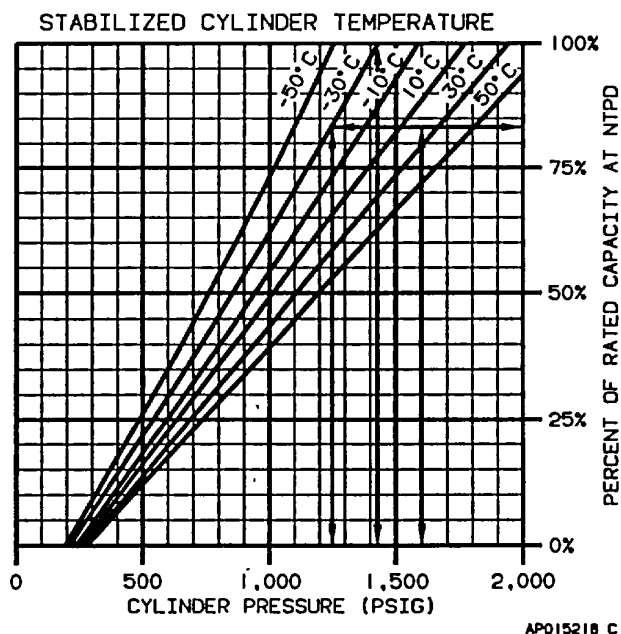

Figure 2-27. Oxygen Cylinder Capacity

(a) *Wanted.* 100% capacity pressure at known temperature.

(b) *Known.* Temperature = -30°C.

(c) *Method.* Move left along 100% line to -30°C line and move down to 1420 PSIG.

## 2-62. WINDSHIELD WIPERS.

*a. Description.* Two electrically-operated windshield wipers are provided for use at all flight speeds. A rotary switch (fig. 2-15) placarded **WINDSHIELD WIPER**, located on the overhead control panel, selects mode of windshield wiper operation. An information placard above the switch states: **DO NOT OPERATE ON DRY GLASS.** Function positions of the switch, as read clockwise, are placarded: **PARK - OFF - SLOW - FAST.** When the switch is held in the spring-loaded **PARK** setting, the blades will return to their normal inoperative position on the glass, then, when released, the switch will return to the **OFF** position, terminating windshield wiper operation. The **FAST** and **SLOW** switch positions are separate operating speed settings for wiper operation. The windshield wiper circuit is protected by one 10-ampere circuit breaker, placarded **WSHLD WIPER**, located on the overhead circuit breaker panel (fig. 2-9).

### CAUTION

**Do not operate windshield wipers on dry glass. Such action can damage the linkage as well as scratch the windshield glass.**

*b. Normal Operation.* To start, turn **WINDSHIELD WIPER** switch to **FAST** or **SLOW** speed, as desired. To stop, turn the switch to the **PARK** position and release. The blades will return to their normal inoperative position and stop. Turning the switch only to the **OFF** position will stop the windshield wipers, without returning them to the normal inactive position.

## 2-63. FERRY CHAIR.

For ferry purposes, a forward facing chair is provided that may be attached to the floor tracks at fuselage station 211.87.

## 2-64. CIGARETTE LIGHTERS AND ASH TRAYS.

The pilot and copilot have individual cigarette lighters and ash trays mounted in escutcheons outboard of their seats. The cigarette lighters are protected by a 5-ampere circuit breaker, placarded **CIGAR LIGHTER**, on the overhead circuit breaker panel (fig. 2-9).

## 2-65. CHEMICAL TOILET.

*a. Description.* A side-facing chemical toilet which can also be used as an additional seat is installed in the aft cabin area. Two hinged-lid half-sections must be raised to gain access to the toilet. Waste is stored within a removable container located below the seat in the cabinet assembly. This non-flushing system uses a dry chemical preparation to deodorize the stored waste. A toilet tissue dispenser is contained in a slide-out compartment on the forward side of the toilet cabinet. A box of disposable waste container liners and a box of chemical deodorant packets are also stored in the cabinet.

*b. Operation.* During use, a removable throwaway plastic liner is attached to the waste container. After use, dry chemical deodorant obtained from the storage cabinet is deposited on the waste and the hinged lid sections are closed over the cavity. After each flight, the waste container must be removed, emptied, relined, and replaced in the cabinet. Consumable toilet items should be resupplied as needed.

## 2-66. SUN VISORS.

### CAUTION

**When adjusting the sun visors, grasp only by the top metal attachment to avoid damage to the plastic shield.**

Individual sun visors are provided for the pilot and copilot (fig. 2-10). Each visor is manually adjustable. When not needed as a sun shield, each visor may be rotated to a position flush with the top of the cockpit so that it does not obstruct view through the windows.

## 2-67. RELIEF TUBE.

The relief tube is located immediately aft of the cargo door on the left side of the fuselage.

## Section VIII. HEATING, VENTILATION, COOLING, AND ENVIRONMENTAL CONTROL SYSTEM

### 2-68. HEATING SYSTEM.

Warm air for heating the cockpit and mission equipment compartment and for defrosting the windshield is provided by bleed air from both engines. Engine bleed air is combined with ambient air in the heating and pressurization flow control unit in each engine nacelle. If the mixed bleed air is too warm for cockpit comfort, it is cooled by being routed through an air-to-air heat exchanger located in the forward portion of each inboard wing. If the mixed bleed air is not too warm, the air-to-air heat exchangers are bypassed. The mixed bleed air is then ducted to a mixing plenum, where it is mixed with cabin recirculated air. The warm air is then ducted to the cockpit outlets, windshield defroster outlets, and floor outlets in the mission equipment compartment. The environmental system is shown in figure 2-28.

a. *Bleed Air Flow Control Unit.* A bleed air flow control unit, located forward of the firewall in each engine nacelle, controls the flow of bleed air and the mixing of ambient air to make up the total airflow to the cabin for heating, windshield defrosting, pressurization, and ventilation. The unit is electronically controlled with an integral electric solenoid firewall shutoff valve, controlled by the bleed air switches located on the overhead control panel (fig. 2-15), and a normally open solenoid valve operated by the right landing gear safety switch.

b. *Pneumatic Bleed Air Shutoff Valve.* A pneumatic shutoff valve is provided in each engine nacelle to control the flow of bleed air to the surface, antenna, and brake deice systems. These valves are controlled by the bleed air valve switches located on the overhead control panel (fig. 2-15).

c. *Bleed Air Valve Switches.* The bleed air flow control unit shutoff valve and pneumatic bleed air shutoff valves are controlled by two **LEFT** and **RIGHT** switches placarded **ENVIRO & PNEU BLEED AIR - PNEU ONLY - ON**, located on the overhead control panel (fig. 2-15). When set to the **ON** position, both the environmental flow control unit shutoff valve and the pneumatic shutoff valve are open; when set to the **PNEU ONLY** position, the environmental flow control unit shutoff valve is closed, and the pneumatic bleed air valve is open; in the **ENVIRO & PNEU** position, both are closed. For maximum cooling on the ground, turn the bleed air valve switches to the **PNEU ONLY** position.

d. *Cabin Temperature Mode Selector Switch.* A switch placarded **CABIN AIR MODE SELECT - OFF**

- **AUTO - AC COLD OPN 10°C to -25°C - MAN COOL - MAN HEAT**, located on the overhead control panel, controls cockpit and mission avionics compartment heating and air conditioning. When the cabin temperature mode selector switch is set to the **AUTO** position, the heating and air conditioning systems are automatically controlled. Control signals from the temperature control box are transmitted to the bleed air heat exchanger bypass valves. Here, the temperature of the air flowing to the cabin is regulated by the bypass valves controlling the amount of air bypassing the heat exchangers. When the temperature of the cabin air has reached the temperature setting of the cabin temperature control rheostat, the automatic temperature control allows hot air to bypass the air-to-air exchangers, admitting hot air into the cabin. When the bypass valves are in the fully closed position, allowing no air to bypass the heat exchangers, the air conditioner begins to operate, providing additional cooling. When the cabin temperature mode selector switch is set to the **A/C COLD OPN** position, the air conditioning system is in continuous operation. The cabin temperature control rheostat, in conjunction with the cabin temperature control sensor, provides regulation of cockpit and mission equipment compartment temperature. Bleed air heat is added as required to maintain the temperature selected by the cabin temperature control rheostat.

e. *Cabin Temperature Control Rheostat.* A control knob placarded **CABIN AIR TEMP CONTROL - INCR**, located on the overhead control panel (fig. 2-15), provides regulation of cabin temperature when the cabin temperature mode selector switch is set to the **AUTO** or the **AC COLD OPN** position. A temperature sensing unit in the cabin, in conjunction with the setting of the cabin temperature control rheostat, initiates a heat or cool command to the temperature controller for the desired cockpit or mission equipment compartment environment.

f. *Manual Temperature Control Switch.* A switch placarded **CABIN AIR MANUAL TEMP - DECREASE - INCREASE**, located on the overhead control panel (fig. 2-15), controls cockpit and mission equipment compartment temperature with the cabin temperature mode selector switch set to the **MAN HEAT** or **MAN COOL** position. The manual temperature control switch controls the cockpit and avionics equipment temperature by providing a means of manually changing the amount that the bleed air bypass valves are opened. To increase cabin temperature, the switch is held to the **INCR** position. To decrease cabin temperature, the switch is held to the **DECR** position. Approximately 30 seconds, per valve, is required to drive the bypass valves to the fully open or fully closed position. Only one valve moves at a time.

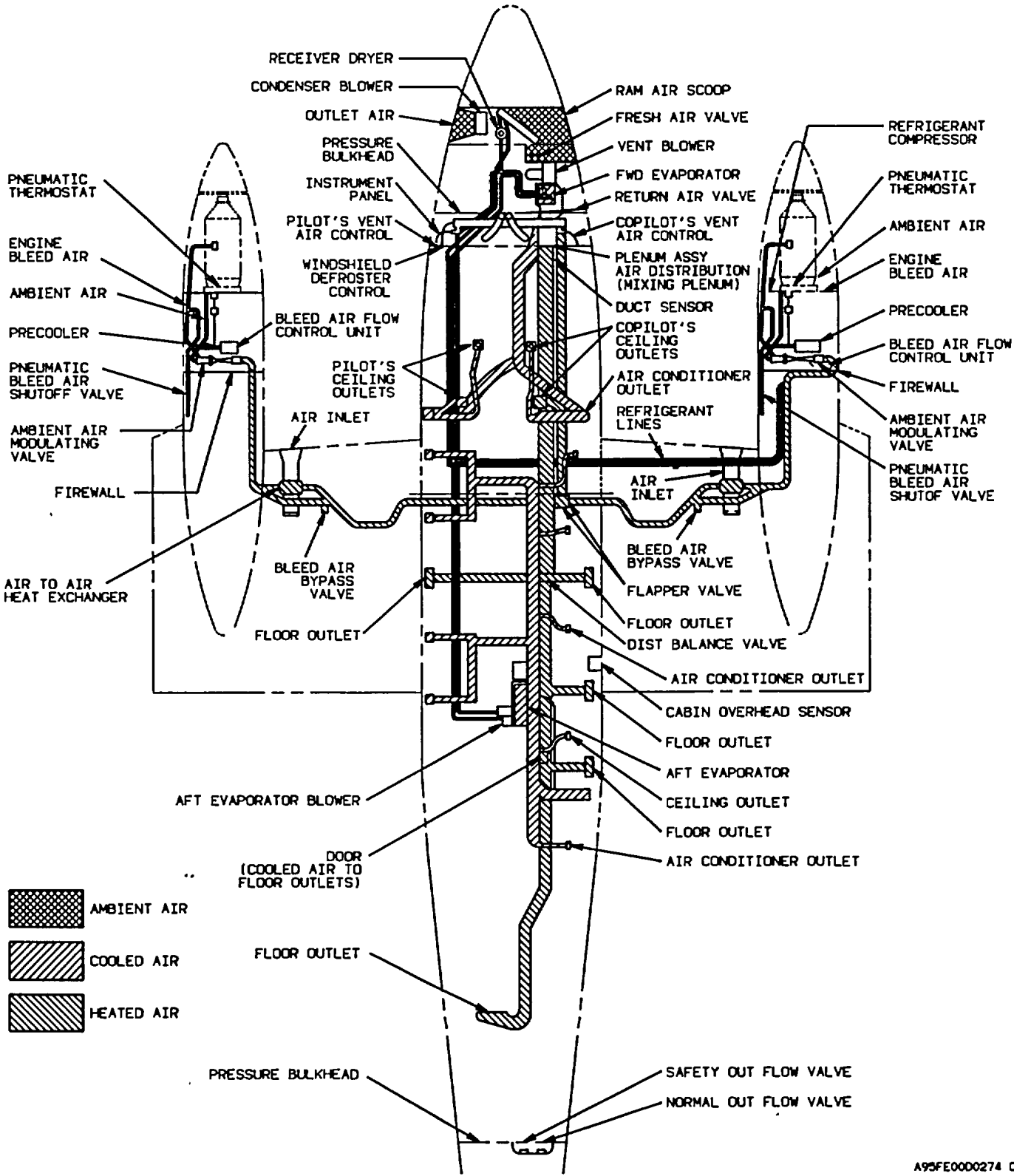

A93FE000274 C

Figure 2-28. Environmental System

*g. Forward Vent Blower Switch.* The forward vent blower is controlled by a switch placarded **VENT BLOWER FWD - AUTO - LOW - HIGH**, located on the overhead control panel (fig. 2-15). In the **AUTO** position, the fan will run at low speed. The forward vent blower will not operate when the cabin temperature mode selector switch is set to the **OFF** position.

*h. Aft Vent Blower Switch.* The aft vent blower is controlled by the switch placarded **VENT BLOWER AFT - AUTO - ON**, located on the overhead control panel (fig. 2-15). The single speed blower operates automatically through the  $N_1$  switch when the aft vent blower switch is placed in the **AUTO** position. The blower operates continuously when the switch is placed in the **ON** position with the air conditioner compressor operating. In the **OFF** position, the blower will not operate.

(1) *Automatic heating mode.*

1. **BLEED AIR** valve switches - **ON**, **LEFT** and **RIGHT**.
2. **CABIN AIR TEMP MODE SELECT** switch - **AUTO**.
3. **CABIN AIR TEMP CONTROL** rheostat - As required.
4. **CABIN, PILOT, COPILOT**, and **DEFROST AIR** knobs - As required.

(2) *Manual heating mode.*

1. **BLEED AIR** valve switches - **ON**, **LEFT** and **RIGHT**.
2. **CABIN AIR TEMP MODE SELECT** switch - **MAN HEAT**.
3. **VENT BLOWER** switches - As required.
4. **CABIN AIR MANUAL TEMP** switch - As required.
5. **CABIN, PILOT, COPILOT**, and **DEFROST AIR** knobs - As required.

(3) *Cargo door radiant heat.* A radiant heat panel is provided inside the cargo door to provide supplemental heating in the aft cabin area. The heat panel is operating whenever the cabin temperature mode switch is in the manual heat mode, or in the automatic mode with the temperature control system in the heat mode.

## 2-69. AIR CONDITIONING SYSTEM.

*a. Description.* Cabin air conditioning is provided by a refrigerant-gas, vapor-cycle refrigeration system (fig. 2-28). The system consists of a belt-driven engine-mounted compressor, installed on the # 2 engine accessory section, refrigerant plumbing, N<sub>1</sub> speed switch, high and low pressure protection switches, condenser coil, condenser underpressure switch, condenser blower, forward and aft evaporators, receiver-dryer, expansion valve, and a bypass valve. The plumbing from the compressor is routed through the right inboard wing leading edge to the fuselage and then forward to the condenser coil, receiver-dryer, expansion valve, bypass valve, and forward evaporator, which are located in the nose of the aircraft. A 7.5-ampere circuit breaker, placarded **AIR COND CONTR**, located on the overhead circuit breaker panel (fig. 2-9), protects the compressor clutch circuit.

(1) *Forward evaporator.* The forward evaporator and blower supplies airflow for the cockpit, forward ceiling outlets, and forward floor outlets. The forward evaporator blower has a high speed, which can be selected by setting the **VENT BLOWER FWD** switch, located on the overhead control panel (fig. 2-15), to the **HIGH** position. The forward vent blower is protected by a circuit breaker located on the DC power distribution panel, located beneath the aisleway.

(2) *Aft evaporator.* The aft evaporator and blower are located in the fuselage center aisle equipment bay, aft of the rear spar. Environmental air is circulated through the evaporator in either manual or automatic control modes. The rear evaporator supplies airflow for the aft ceiling outlets, rear floor outlets, and toilet compartment. The rear evaporator blower is protected by a circuit breaker located on the DC power distribution panel, located beneath the aisleway.

(3) *High and low pressure limit switches.* High and low pressure limit switches are provided to prevent compressor operation beyond operational limits. When the low or high pressure switches are activated, compressor operation will be terminated. When compressor operation has been terminated by limit switch activation, the system should be thoroughly checked before returning it to service.

(4) *Thermal sense switch.* A thermal sense switch is installed on the forward evaporator. This sense switch actuates a hot gas bypass valve which bypasses a portion of the refrigerant from the forward evaporator, thereby preventing icing of the evaporator.

(5) *Condenser blower.* A vane-axial blower draws air through the condenser when the aircraft is on the ground. The blower is protected by a 50-ampere circuit breaker located beneath the aisleway. When the cabin temperature mode selector switch is set to the **AC COLD**



**OPN** position during ground operation, the condenser blower will be off initially, and will remain off until compressor discharge pressure equals the pressure setting of the blower control high pressure switch. The blower will remain in operation until system pressure drops to equal the setting of the blower control low pressure switch.

(6) *Air conditioning cold operation bypass valve.* Selecting the **AC COLD OPN** mode on the **CABIN AIR MODE SELECT** switch (fig. 2-15) permits the operation of the air conditioning system by overriding the refrigerant low pressure switch. This allows the air conditioning system to operate in the manual mode. The operational life of the compressor will be decreased by five hours each time the air conditioning system is started below 10°C using this mode (**AC COLD OPN**). If the air conditioning system has been operating in the normal mode during flight, and decreasing ambient temperatures make it necessary to switch to the AC cold operation mode, there will be no degradation in the mean time between failure for the compressor.

(7) *Air conditioner cold operation.* The air conditioner cold operation mode is provided to allow the air conditioner to operate in the event of a hot cabin and an outside air temperature of less than 10°C. At an OAT of less than 10°C, a green advisory annunciator placarded **AC COLD OPN**, located on the caution/advisory annunciator panel will illuminate. This advises the crew that if air conditioning is required, the **CABIN AIR MODE SELECT** switch must be in the **AC COLD OPN** position. This causes the air conditioner compressor to run continuously and the temperature controller to operate the bypass valve.

*b. Normal Operation.*

(1) *Automatic cooling mode.*

1. **BLEED AIR** valve switches - **ON**, **LEFT** and **RIGHT**.
2. **CABIN AIR MODE SELECT** switch - **AUTO**.
3. **CABIN AIR TEMP CONTROL** rheostat - As required.
4. **CABIN, PILOT, COPILOT**, and **DEFROST AIR** knobs - As required.

(2) *Manual cooling mode.*

1. **BLEED AIR** valve switches **ON**, **LEFT** and **RIGHT**.

**NOTE**

**For maximum cooling on the ground, set the BLEED AIR valve switches to the PNEU ONLY position.**

2. **CABIN AIR MODE SELECT** switch - **MAN COOL**.

(3) *Air conditioning cold operation mode.* (Used if ambient temperature is between 10°C and -25°C.)

**NOTE**

**Setting the cabin temperature mode selector switch to the AC COLD OPN position at ambient temperatures below -25°C may cause the air conditioning system to exceed the compressor low pressure limit setting, terminating compressor operation and thereby rendering the system inoperative for the remainder of the flight.**

1. **BLEED AIR** valve switches - **ON**, **LEFT** and **RIGHT**.
2. **CABIN AIR MODE SELECT** switch - **AC COLD OPN**.
3. **CABIN AIR TEMP CONTROL** rheostat - As required.
4. **CABIN, PILOT, COPILOT**, and **DEFROST** air knobs - As required.

**2-70. UNPRESSURIZED VENTILATION.**

Ventilation is provided by two sources. One source is through the bleed air heating system in both the pressurized and unpressurized mode. The second source of ventilation is obtained from ram air which enters the condenser section in the nose and passes through a check valve in the vent blower plenum. The check valve closes during pressurized operation. Ventilation from this source is in the unpressurized mode only, with the **CABIN PRESS DUMP** switch in the **DUMP** position. The check valve closes during pressurized operation. Ram air ventilation is distributed through the main ducting system to all outlets. Ventilation air, ducted to each individual eyeball cold air outlet, can be directionally controlled by moving the ball in the socket. Volume is regulated by twisting the outlet to open or close the valve.

**2-71. ENVIRONMENTAL CONTROLS.**

An environmental control section on the overhead control panel (fig. 2-15) provides for automatic or manual control of the system. This section contains all the major controls of the environmental system, including bleed air valve switches, forward and aft vent blower switches, manual temperature switch for control of the heat exchanger valves, a cabin temperature level control, and the cabin temperature mode selector switch for selecting automatic heating/ cooling or manual heating/cooling.

*a. Heating Mode.*

- (1) *If the cockpit is too cold:*

1. **PILOT** and **COPILLOT AIR** knobs - As required.
2. **DEFROST AIR** knob - As required.
3. **CABIN AIR** knob - Pull out in small increments. Allow 3 to 5 minutes after each adjustment for system to stabilize.

(2) *If the cockpit is too hot:*

1. **CABIN AIR** knob - As required.
2. **PILOT** and **COPILLOT AIR** knobs - In as required.
3. **DEFROST AIR** knob - In as required.

b. *Cooling Mode:*

(1) *If the cockpit is too cold:*

1. **PILOT** and **COPILLOT AIR** knob - In as required.
2. **DEFROST AIR** knob - In as required.
3. Overhead cockpit outlets As required.

(2) *If the cockpit is too hot:*

1. **PILOT** and **COPILLOT AIR** knobs - Out as required.
2. **CABIN AIR** knob - Close in small increments. Allow 3 - 5 minutes after each adjustment for system to stabilize. If **CABIN AIR** knob is completely closed before obtaining satisfactory cockpit comfort, it may be necessary to place the **AFT VENT BLOWER** switch in the **ON** position to activate the aft evaporator and recirculate cabin air.

c. *Automatic Mode Control.* When the **AUTO** mode is selected on the **CABIN AIR MODE SELECT** switch, the heating and air conditioning systems are automatically controlled. When the temperature of the cabin has reached the selected setting, the automatic temperature control allows heated air to bypass the air-to-air exchangers in the wing center section. The warm bleed air is mixed with the cooled air. The rear evaporator picks up recirculated cabin air only.

When the automatic control drives the environmental system from a heat mode to a cooling mode, the bypass valves close. When the left bypass valve reaches a fully closed position, the refrigeration system will begin cooling, provided the right engine N, speed is above

65%. When the bypass valve is opened to a position approximately 30° from full open, the refrigeration system will turn off.

The **CABIN AIR TEMP CONTROL** provides regulation of the temperature level in the automatic mode. A temperature sensing unit in the cabin, in conjunction with the control setting, initiates a heat or cool command to the temperature controller for desired cockpit and cabin environment.

d. *Manual Mode Control.* With the **CABIN AIR MODE SELECT** switch in the **MAN HEAT** or **MAN COOL** position, regulation of the cabin temperature is accomplished manually with the **CABIN AIR MANUAL TEMP** switch.

(1) In the **MAN HEAT** mode, the automatic system is overridden and the system is controlled by opening and closing the bleed air bypass valves (two) **CABIN AIR MANUAL TEMP - INCREASE - DECREASE** switch. To increase cabin temperature, hold the switch in the **INCREASE** position; to decrease cabin temperature, hold the switch in the **DECREASE** position. Allow approximately 30 seconds per valve to drive the bypass valves to the fully open or fully closed position. Only one valve moves at a time.

(2) With the **CABIN AIR MODE SELECT** switch in the **MAN COOL** position, the automatic temperature control system is bypassed. When the left bypass valve reaches a fully closed position, the refrigeration system will begin cooling, provided the right engine N, speed is above 65%. When the bypass valve is opened to a position approximately 30° from full open, the refrigeration system will turn off. Hold the **CABIN AIR MANUAL TEMP** switch in **DECREASE** position for approximately one minute to fully close air-to-air heat exchanger bypass valves.

(3) Bleed air entering the cabin is controlled by **LEFT** and **RIGHT** bleed air valve switches placarded **ENVIRO & PNEU BLEED AIR - PNEU ONLY - ON**. When the switch is in the **ON** position, the environmental flow control unit and the pneumatic valve are open. When the switch is in the **PNEU ONLY** position, the environmental flow control unit is closed and the pneumatic bleed air valve is open. In the **ENVIRO & PNEU BLEED AIR** position, both are closed. For maximum cooling on the ground, turn the bleed air valve switches to the **PNEU ONLY** position.

(4) The forward vent blower is controlled by the switch placarded **VENT BLOWER FWD - AUTO - LOW - HIGH**. The **HIGH** and **LOW** positions regulate the blower to two speeds of operation. In the **AUTO** position, the fan will run at low speed except when the

**CABIN AIR MODE SELECT** switch is placed in the **OFF** position. In the **OFF** position, the blower will not operate.

(5) The aft vent blower is controlled by the switch placarded **VENT BLOWER AFT - AUTO - ON**. The single speed blower operates automatically through

the  $N_1$  speed switch when the aft vent blower switch is placed in the **AUTO** position. The blower operates continuously when the switch is placed in the **ON** position with the air conditioner compressor running. In the **OFF** position, the blower will not operate.

## Section IX. ELECTRICAL POWER SUPPLY AND DISTRIBUTION SYSTEM

### 2-72. DESCRIPTION.

The aircraft employs both direct current (DC) and alternating current (AC) electrical power. The DC electrical power supply (fig. 2-29 and 2-30) is the basic power system energizing most aircraft circuits. Electrical power is used to start the engines, power the landing gear and flap motors, operate the standby fuel pumps, ventilation blower, lights, and electronic equipment. AC power is obtained from the DC power system through inverters. The single phase AC power system is shown in figure 2-32, and the three phase AC power system is shown in figure 2-33. The three sources of DC power consist of one 20 cell 34-ampere/hour battery and two 400-ampere startergenerators. DC power may be applied to the aircraft through an external power receptacle on the underside of the right wing, just outboard of the nacelle. The startergenerators are controlled by generator control units. The output of each generator passes through a cable to the respective generator bus. Other buses distribute power to aircraft DC loads, deriving power from the generator buses. The generators are paralleled to balance the DC loads between the two units. When one of the generating systems is not on line, and no fault exists, all aircraft DC requirements may be supplied by either the other on-line generating system or by an external power source. The generator system is designed to allow cross starting of the other engine. When one generator is on line, all current limiters are bypassed while starting the other engine. Most DC distribution buses are connected to both generator buses but have isolation diodes to prevent power crossfeed between the generating systems, when connection between the generator buses is lost. Thus, when either generator is lost because of a ground fault, the operating generator will supply power for all aircraft DC loads except those receiving power from the inoperative generator's bus, which cannot be crossfed. When a generator is not operating, reverse current and over-voltage protection is automatically provided. Two inverters operating from DC power produce the required single-phase AC power. Three phase AC electrical power for the inertial navigation system and mission avionics is supplied by two DC powered three phase mission inverters (fig. 2-33, 2-34, and 2-35).

The mission AC/DC power cabinet (fig. 2-36) is located in the mission rack, aft of the copilot's seat. AC power may be applied through an external power receptacle located on the underside of the left wing, just outboard of the engine nacelle.

### 2-73. DC POWER SUPPLY.

One nickel-cadmium battery furnishes DC power when the engines are not operating. This 24-volt 34-ampere/hour battery, located in the right wing center section, is accessible through a panel on the top of the wing. DC power is produced by two engine-driven 28 volt, 400-ampere starter-generators. Controls and indicators associated with the DC supply system are located on the overhead control panel (fig. 2-15) and consist of a single battery switch, two generator switches, two DC digital voltmeters, and two DC digital loadmeters.

a. *Battery Switch.* A switch, placarded **BATTERY - OFF/RESET - ON** (fig. 2-15), is located on the overhead control panel under the **MASTER SWITCH** (gang bar). The **BATTERY** switch controls DC power to the aircraft bus system through the battery relay, and must be **ON** to allow external power to enter aircraft circuits. When the **MASTER SWITCH** (gang bar) is placed aft, the **BATTERY** switch is forced **OFF**.

#### NOTE

**With battery or external power removed from the aircraft electrical system due to fault, power cannot be restored to the system until the BATTERY switch is moved to OFF/RESET, then ON.**

b. *Generator Switches.* Two switches (fig. 2-15), placarded **GENERATOR # 1** and **# 2** are located on the overhead control panel. These switches control electrical power from the designated generator to paralleling circuits and the bus distribution system. Switch positions are placarded **RESET**, **ON**, and **OFF**. **RESET** is forward (springloaded back to ON), **ON** is center, and **OFF** is aft. When a generator is removed from the aircraft electrical system, due either to fault or from placing the **GENERATOR** switch in the **OFF** position, the affected unit cannot have its output restored to aircraft use until the **GENERATOR** switch is moved to **RESET**, then **ON**.

c. *Master Switch.* All electrical current may be shut off using the **MASTER SWITCH** gang bar (fig.

2-15) which extends above the battery and generator

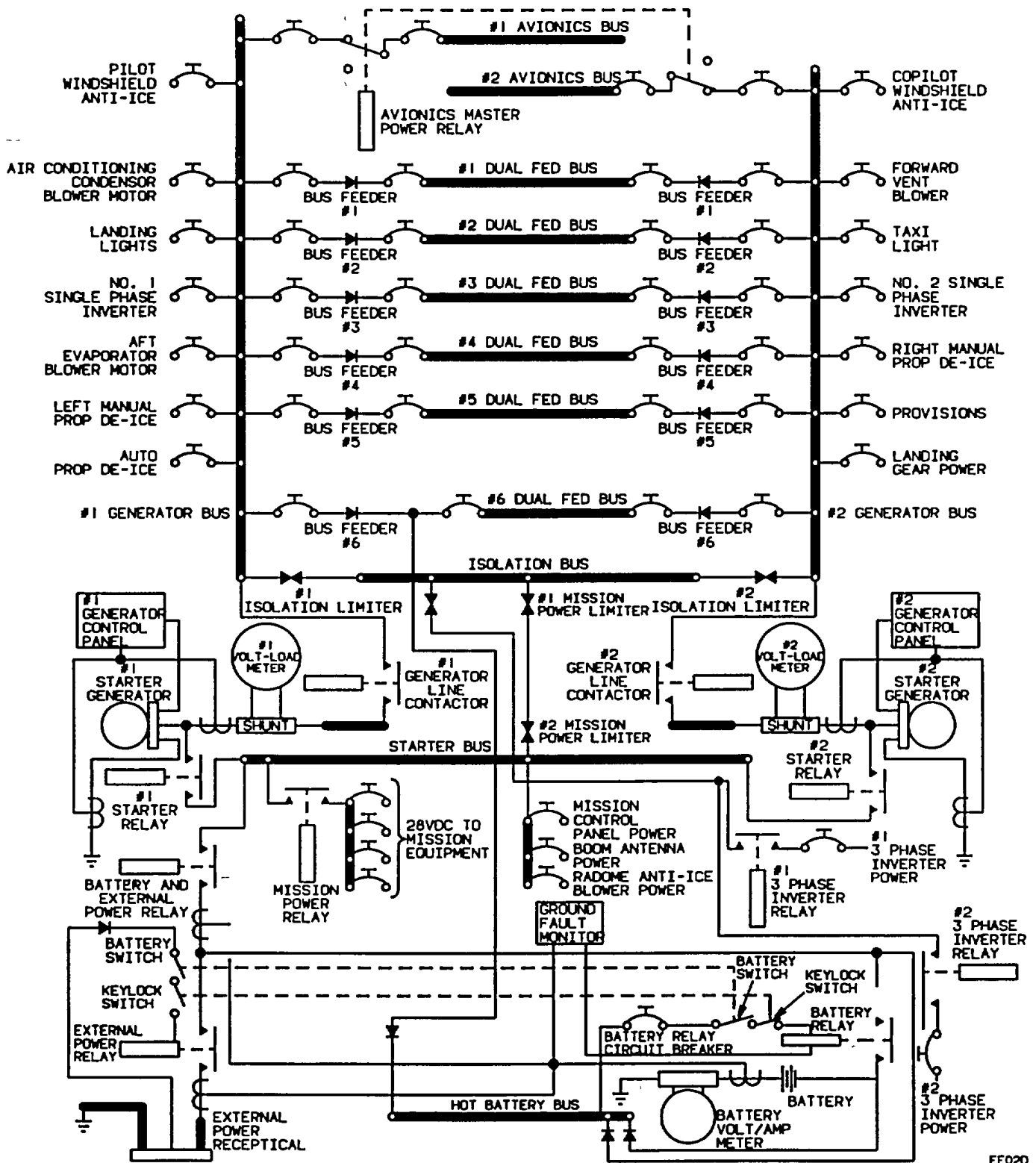

FE02D 980398AA

Figure 2-29. DC Electrical System

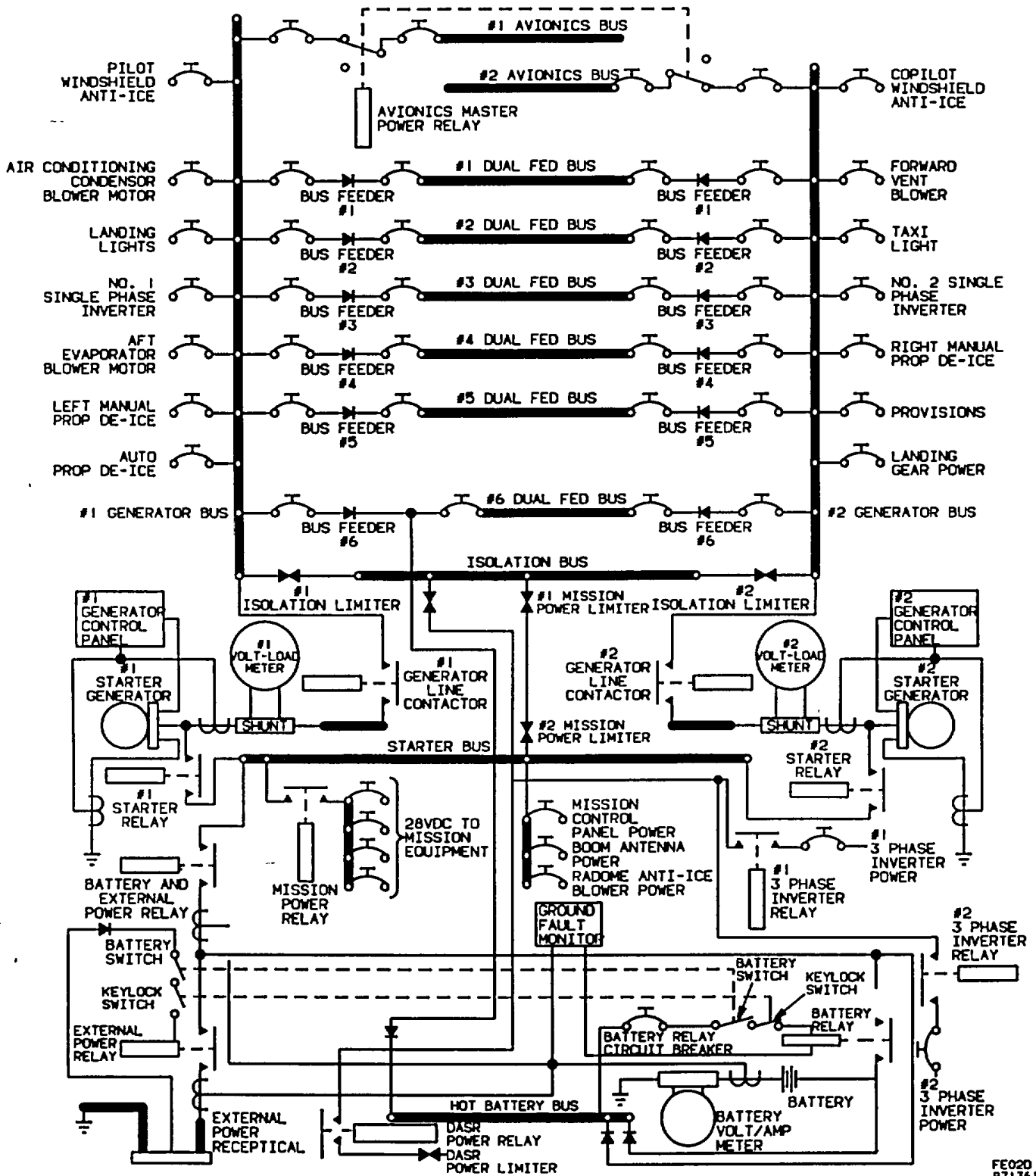

FE020  
971361AA

Figure 2-30. DC Electrical System

TACAN TRANSPONDER ADF FM	<p><b>#1 AVIONICS BUS</b></p> HF RCVR AP CONTR AFCS DIRECT INS CONTROL	VHF #1 VOR #1 UHF PILOT AUDIO
HF PWR VHF #2 VOR #2 BU VOW	<p><b>#2 AVIONICS BUS</b></p> COPILO AUDIO COPILO ALTM RADAR WX RADIO ALTM	ALT ALERT LSS RADIO RELAY AIR DATA ENCDR
#1 VOLT/LOAD IND LEFT BLEED AIR WARN LANDING GEAR IND STALL WARNING ANN IND #1 OIL PRESS WARN	<p><b>#1 DUAL FED BUS</b></p> #1 CHIP DETR #1 FUEL PRESS WARN #1 FUEL QTY WARN #1 FUEL QTY IND #1 STANDBY PUMP #1 OIL TEMP	#1 OIL PRESS #1 FUEL FLOW #1 ICE VANE CONTROL, AUXILIARY PILOT EHSI
#2 VOLT/LOAD IND RIGHT BLEED AIR WARN LANDING GEAR HORN FIRE DETR ANN PWR #2 OIL PRESS WARN	<p><b>#2 DUAL FED BUS</b></p> #2 CHIP DETR #2 FUEL PRESS WARN #2 FUEL QTY WARN #2 FUEL QTY IND #2 STANDBY PUMP #2 OIL TEMP	#2 OIL PRESS #2 FUEL FLOW #2 ICE VANE CONTROL, AUXILIARY COPILO EHSI
BATT CHARGE #1 ENG LIP HT RADOME ANTI-ICE WSHLD WIPER SURF DE-ICE PROP ANTI-ICE AUTO	<p><b>#3 DUAL FED BUS</b></p> LEFT FUEL VENT HEAT LEFT PITOT HEAT CROSSFEED #1 AUXILIARY TRANSFER #1 FIREWALL VALVE PROP SYNC	#1 START CONTR #1 IGNITOR CONTR #1 ICE VANE CONTR, MAIN PILOT EADI

BT03571

Figure 2-31. DC Electrical System Busses (Sheet 1 of 2)

<p>#2 ENG LIP HT ENG LIP HT MONITOR BRAKE DE-ICE STALL WARN HEAT PROP ANTI-ICE, MANUAL RIGHT FUEL VENT HEAT</p>	<p><b>#4 DUAL FED BUS</b> RIGHT PITOT HEAT #2 AUXILIARY TRANSFER #2 FIREWALL VALVE AUTO FEATHER PROP GOV TEST #2 START CONTR</p>	<p>#2 IGNITOR CONTR #2 ICE VANE CONTR, MAIN COPIE EADI HF PWR</p>
<p>AIR COND CONTR TEMP CONTR LEFT BLEED AIR CONT PILOT EFIS FAN ELEC TRIM FLAP MOTOR</p>	<p><b>#5 DUAL FED BUS</b> LANDING GEAR CONTROL AVIONICS ANN RECOG LIGHTS ICE LIGHTS BCN LIGHTS LANDING LIGHTS</p>	<p>SUBPANEL &amp; CONSOLE LIGHTS INST INDIRECT LIGHTS PILOT SYM GEN PILOT EFIS CONTROL PILOT TURN &amp; SLIP</p>
<p>CIGAR LIGHTER DOOR RADIANT HEAT PRESS CONTR RIGHT BLEED AIR CONTR COPIE EFIS FAN RUDDER BOOST</p>	<p><b>#6 DUAL FED BUS</b> FLAP CONTR EMERG LIGHTS FLT INST LIGHTS NAV LIGHTS TAXI LIGHTS OVHD LIGHTS</p>	<p>CABIN LIGHTS COPIE SYM GEN COPIE EFIS CONTROL AVIONICS MASTER CONTR</p>
<p>CRYPTO HOLD #2 ENGINE FIRE EXT #1 ENGINE FIRE EXT BATTERY RELAY</p>	<p><b>HOT BATTERY BUS</b> CABIN LIGHT TRANSPONDER (KIT-1C) #2 FIREWALL FUEL VALVE #1 FIREWALL FUEL VALVE</p>	<p>#2 STANDBY PUMP #1 STANDBY PUMP CABIN/CARGO DOOR SENSING CIRCUIT</p>
<p>MISSION DC POWER RELAY #1 ENGINE START RELAY BATTERY/EXTERNAL POWER RELAY MISSION CONTROL PANEL BOOM ANTENNA POWER</p>	<p><b>STARTER BUS</b> #2 3 0 INVERTER POWER RELAY #2 ENGINE START RELAY #1 3 0 INVERTER POWER RELAY RADOME ANTI-ICE BLOWER</p>	

BT03570

Figure 2-31. DC Electrical System Busses (Sheet 2 of 2)

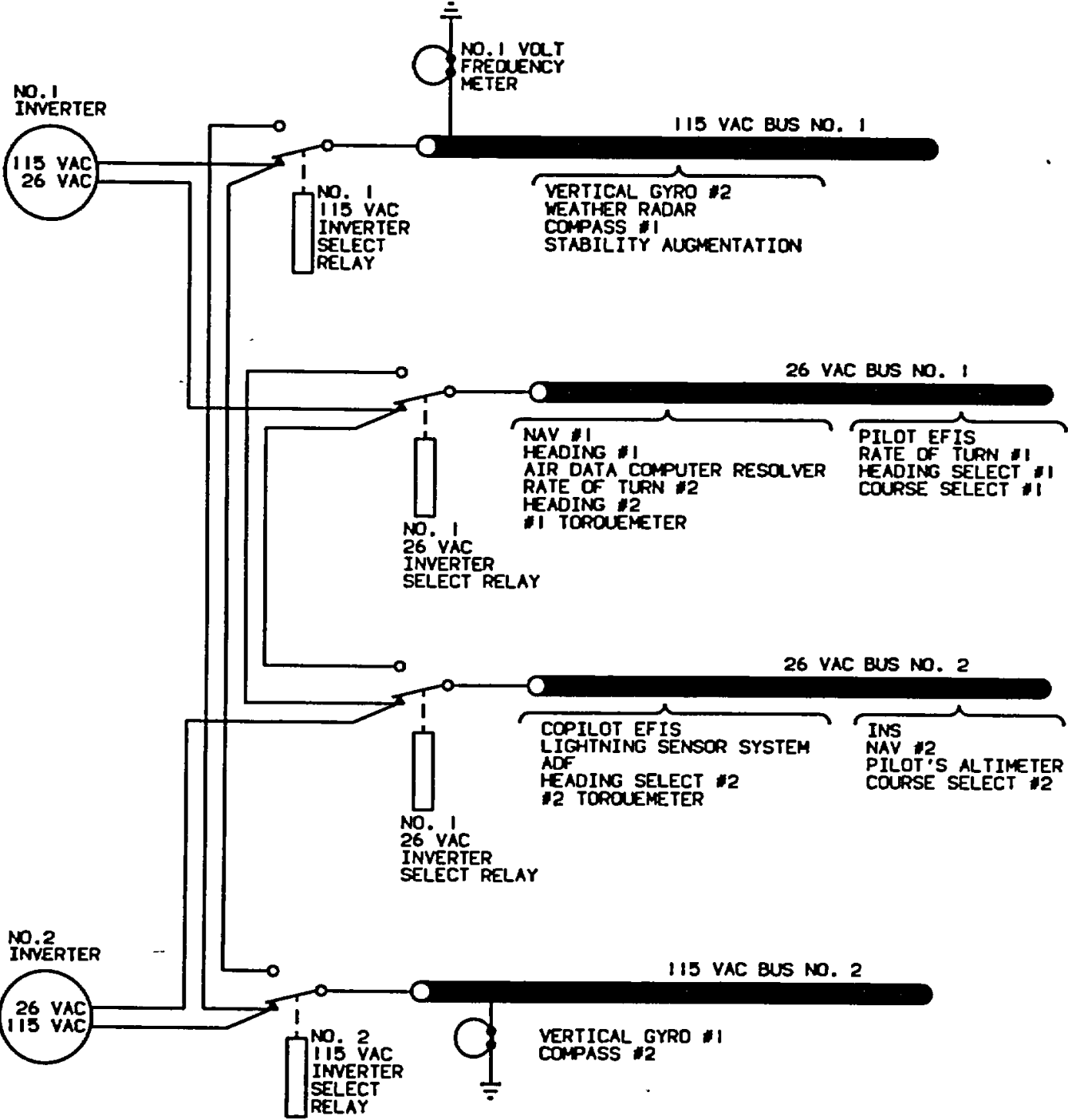

AP015236 C

Figure 2-32. Single Phase AC Electrical System



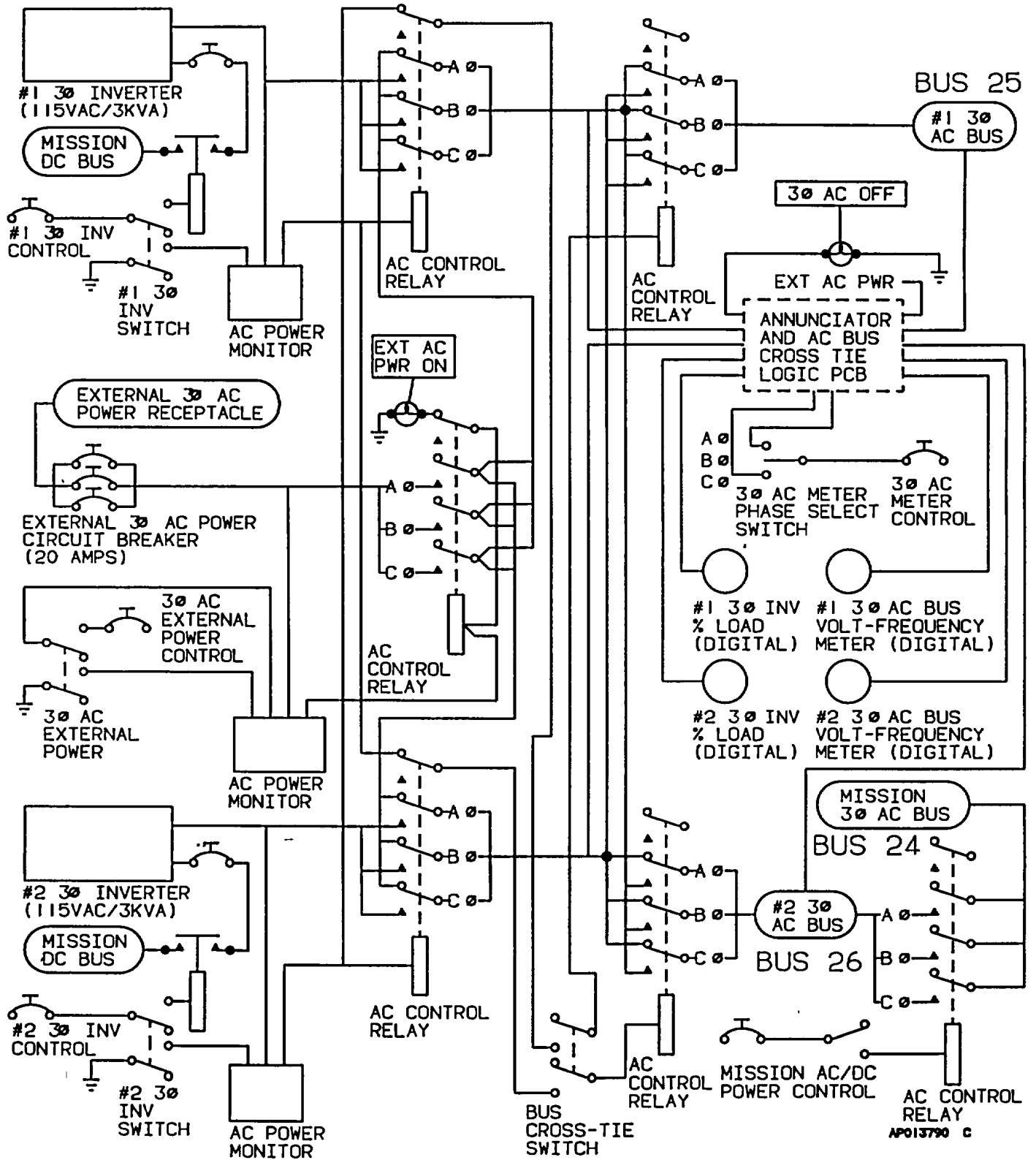
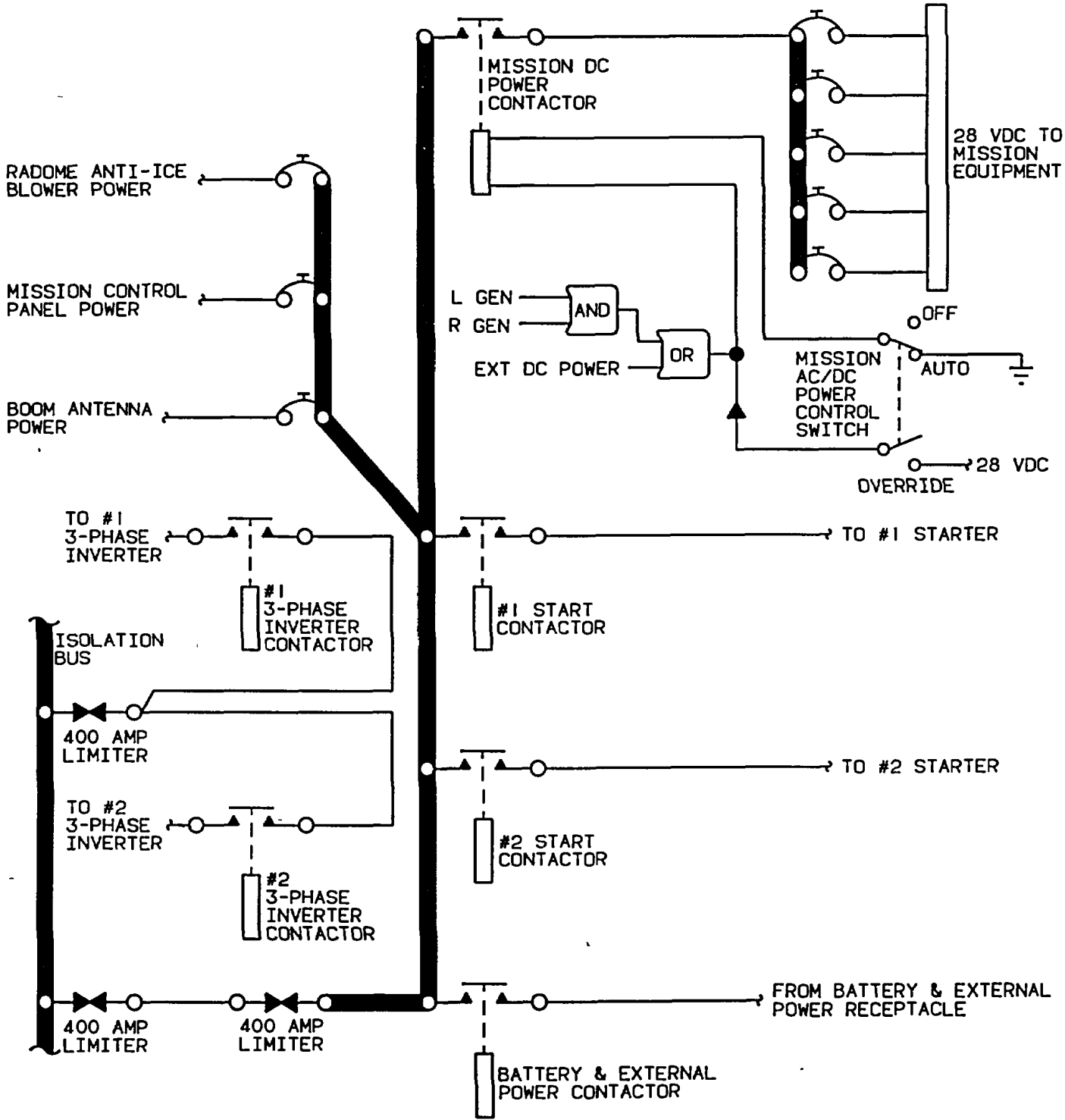
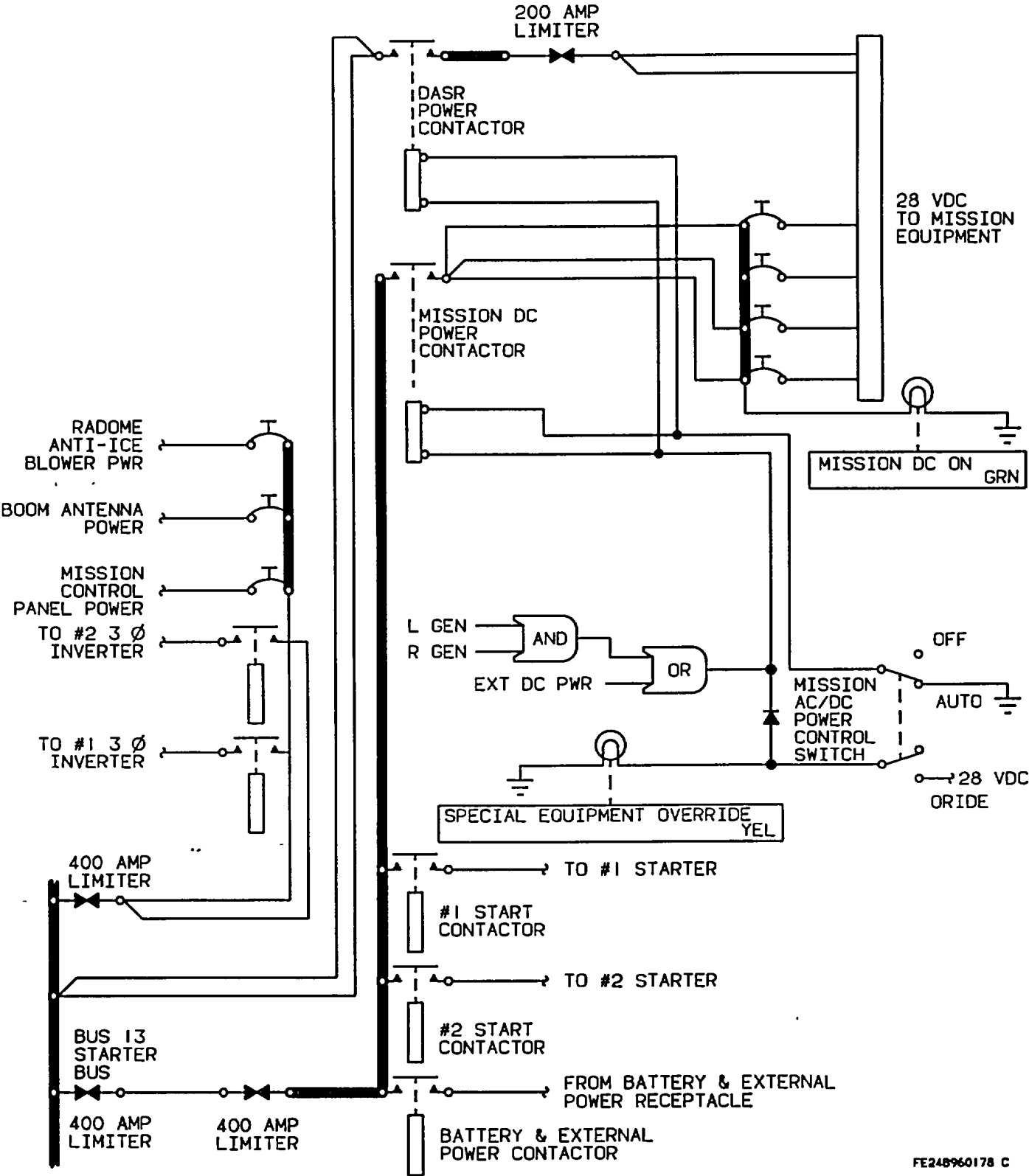

Figure 2-33. Three Phase AC Electrical System



A94FE0200890 C

Figure 2-34. Mission Equipment DC Power System P



FE248960178 C

Figure 2-35. Mission Equipment DC Power System

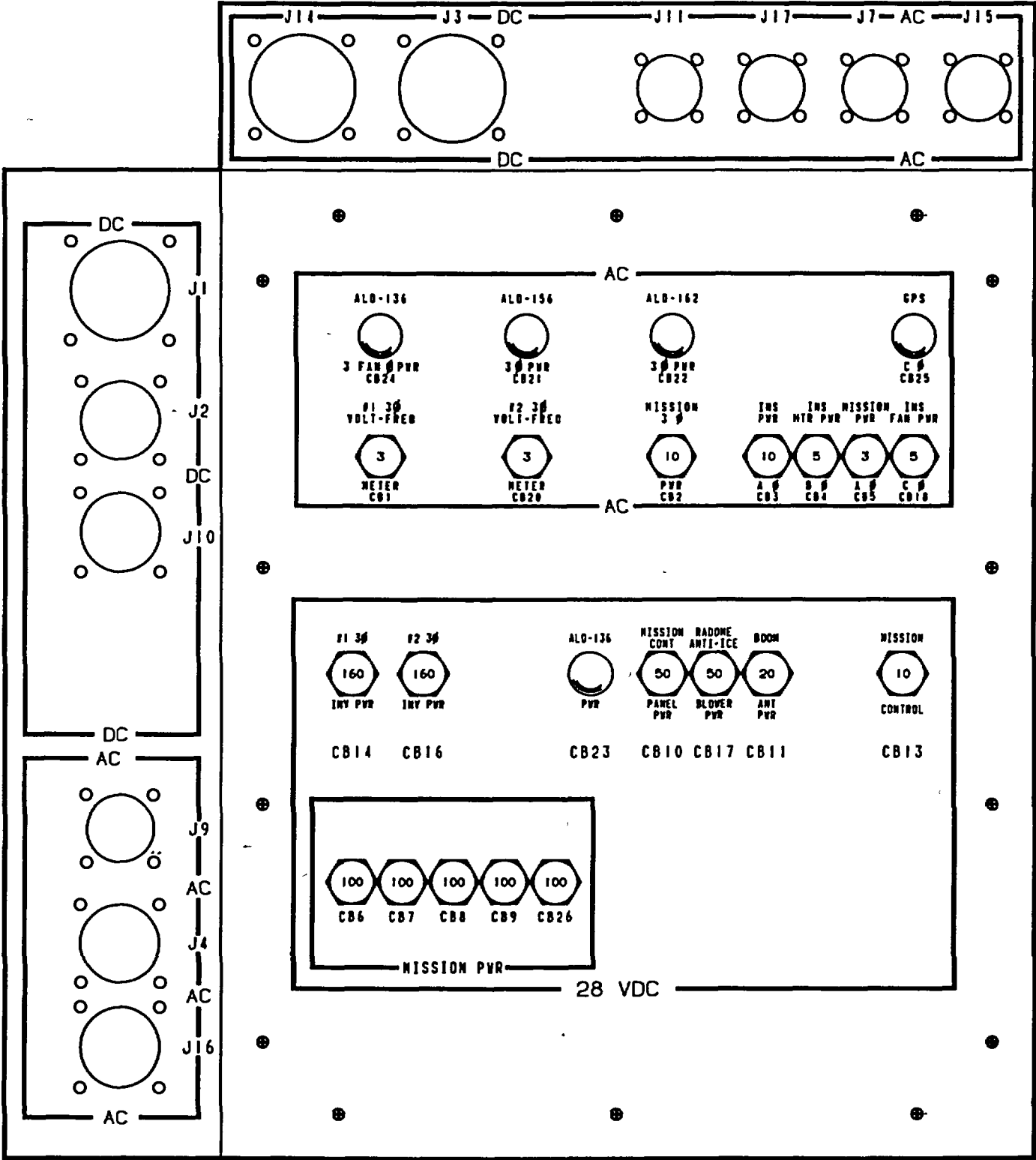

AP015219 C

Figure 2-36. Mission AC/DC Power Cabinet

switches. The **MASTER SWITCH** (gang bar) is moved forward when a battery or generator switch is turned on. When moved aft, the bar positions each switch to the **OFF** position.

d. *DC Load and Voltmeters.* Four digital meters, located on the overhead control panel (fig. 2-15), display voltage readings and show the rate of current usage from the left and right generating systems. The two loadmeters indicate output amperage as a percent of rated capacity from the respective generator. Current consumption is indicated as a percentage of total output amperage capacity for the generating system being monitored. The two voltmeters indicate bus voltage for the respective generating system.

e. *Battery Volt/Ammeter.* The mission control panel (fig. 4-1), located in the fuselage sidewall adjacent to the copilot's seat, incorporates a digital volt/ ammeter that displays available battery voltage and amperage. Minimum battery voltage for engine starting is 22 VDC.

f. *Battery Charge Monitor.* Nickel-cadmium battery overheating will cause the battery charge current to increase if thermal runaway is imminent. The aircraft has a charge-current sensor which will detect a charge current. The charge current system senses battery current through a shunt in the negative lead of the battery. Any time the battery charging current exceeds approximately 7 amperes for 6 seconds or longer, the amber **BATTERY CHARGE** annunciator and the **MASTER CAUTION** annunciator will illuminate. Following a battery engine start, the caution annunciator will illuminate approximately six seconds after the generator switch is placed in the **ON** position. The annunciator will normally extinguish within two to five minutes, indicating that the battery is approaching a full charge. The time interval will increase if the battery has a low state of charge, the battery temperature is very low, or if the battery has previously been discharged at a very low rate (i.e., battery operation of radios or lights for prolonged periods). The caution annunciator may also illuminate for short intervals after landing gear and/or flap operation. If the caution annunciator should illuminate during normal steady-state cruise, this indicates that conditions exist that may cause a battery thermal runaway. If this occurs, the battery current should be monitored using the battery ammeter. If battery current continues to increase, the battery is in thermal runaway and should be selected **OFF** and may be turned back **ON** only for gear and flap extension and approach to landing.

g. *Generator Out Warning Annunciators.* Two caution/advisory annunciator panel fault annunciators inform the pilot when either generator is not delivering current to the aircraft DC bus system. These

annunciators are placarded # 1 **DC GEN** and # 2 **DC GEN**. Illumination of the two **MASTER CAUTION** annunciators and either fault annunciator indicates that either the identified generator has failed or voltage is not sufficient to keep it connected to the power distribution system.

#### **CAUTION**

**The GPU shall be adjusted to regulate at 28 ±.2 volts. The GPU shall be capable of producing 1000 amperes for 5 seconds, 500 amperes for 2 minutes, and 300 amperes continuously.**

h. *DC External Power Source.* External DC power can be applied to the aircraft through an external power receptacle on the underside of the right wing, just outboard of the engine nacelle (fig. 2-1 and 2-2). The receptacle is installed inside of the wing structure and is accessible through a hinged access panel. DC power is supplied through the DC external power plug, through the external power relay, directly to the battery bus. Turn off all external power while connecting the power cable to or removing it from the external power supply receptacle. The holding coil circuit of the relay is energized by the external power source when the **BATTERY** switch is in the **ON** position. The GPU shall be adjusted to regulate at 28 volts maximum to prevent damage to the aircraft battery. The **EXTERNAL POWER** annunciator indicates that the DC external power plug is connected. The **EXT DC PWR ON** annunciator indicates that external power is connected to the aircraft DC bus.

i. *Security Keylock Switch.* The aircraft has a security keylock switch (fig. 2-15) installed on the overhead control panel, placarded **OFF - ON**. The switch is connected to the battery relay circuit and must be **ON** when energizing the **BATTERY MASTER SWITCH**. The key cannot be removed from the lock when in the **ON** position.

j. *Circuit Breakers.* The overhead circuit breaker panel (fig. 2-9) contains circuit breakers for most aircraft systems. The circuit breakers on the panel are grouped into areas which are placarded as to their general function. A DC power distribution panel is mounted beneath the aisleway, forward of the main spar. This panel contains higher current rated circuit breakers and is not accessible to the flight crew under normal conditions.

#### **2-74. AC POWER SUPPLY.**

a. *Single Phase AC Power Supply.* AC power for the aircraft is supplied by inverter units, numbered # 1 and # 2 (fig. 2-32), which obtain operational current from

the DC power system. Both inverters are rated at 750 volt-amperes and provide single phase output only. Each inverter provides 115 volts, 26 volts, and 400 Hz AC output. The inverters are protected by circuit breakers mounted on the DC power distribution panel mounted beneath the floor. Controls and indicators of the AC power system are located on the overhead control panel and on the caution/advisory annunciator panel.

(1) *AC power WARNING/CAUTION annunciators.* Illumination of the two **MASTER CAUTION** annunciators, and the illumination of the **# 1 INVERTER** and/or **# 2 INVERTER** caution annunciator indicates inverter failure.

(2) *Instrument AC annunciator.* A red **INST AC** warning annunciator, will illuminate if all instrument AC buses fail.

(3) *Inverter control switches.* Two switches, placarded **1 $\phi$  INVERTER # 1** and **# 2** on the overhead control panel (fig. 2-15), control the single-phase AC inverters.

b. *Volt-Frequency Meters.* Two digital volt-frequency meters (fig. 2-15) are mounted on the overhead control panel. These meters provide continuous monitoring of voltage and frequency on each 115 VA. bus. Normal bus conditions will be indicated by a reading of 115 VA. and 400 Hz on each meter.

c. *Three Phase AC Power Supply.* Three phase AC electrical power (fig. 2-33) for operation of the inertial navigation system and mission avionics is supplied by two DC-powered 3000 volt-ampere solid state three phase inverters.

(1) *Three phase inverter control switches.* Two three-position switches, placarded **# 1 IN RESET - ON -OFF** and **# 2 IN RESET -ON -OFF**, located on the mission control panel (fig. 4-1), control three phase inverter operation.

(2) *Three phase volt/frequency meters.* Two digital three-phase volt/frequency meters, mounted on the mission control panel (fig. 4-1), monitor and display the voltage and frequency outputs of the three phase inverters.

(3) *Three phase loadmeters.* Two digital three-phase loadmeters, mounted on the mission control panel (fig. 4-1), monitor inverter output level.

(4) *Three phase AC off annunciator.* An annunciator placarded **3 $\phi$  AC OFF**, located on the mission annunciator panel (fig. 4-1), indicates a problem with one of the three phase AC power busses.

(5) *Three phase AC external power.* External three phase AC power for operation of the inertial navigation system or mission equipment can be applied to the aircraft through an external power receptacle located on the underside of the left wing just outboard of the engine nacelle (fig. 2-1 and 2-2). The receptacle is installed inside the wing structure, accessible through a hinged access panel. The AC electrical system is automatically isolated from the external power source if the external power is over or under voltage, over or under frequency, or has an improper phase sequence.

(a) *External AC power annunciator.* The annunciator placarded **EXT AC PWR ON**, located on the mission annunciator panel (fig. 4-1), indicates that external AC power is connected to the 3 phase busses. The **EXTERNAL POWER** annunciator in the advisory annunciator panel indicates that an AC GPU plug is mated to the AC external power receptacle.

(b) *External AC power control switch.* The switch placarded **EXT PWR -RESET -ON -OFF**, located on the mission control panel (fig. 4-1), controls application of three phase AC power to the aircraft.

## Section X. LIGHTING

## 2-75. EXTERIOR LIGHTING.

Exterior lighting (fig. 2-37) consists of a navigation light on the aft end of the aft portion of the vertical stabilizer; one standard navigation light on the outside of each wing tip pod; two strobe beacons, one on top of the horizontal stabilizer (directly above the vertical stabilizer) and one on the underside of the fuselage section; dual landing lights and a taxi light mounted on the nose gear assembly; a recognition light located in the outboard leading edge of each wing; two ice lights, one light flush mounted in each nacelle positioned to illuminate along the leading edge of each outboard wing; and emergency exit lights aft of the escape hatch and aft of the cabin door.

*a. Navigation Lights.* The navigation lights are protected by the 5-ampere circuit breaker placarded **NAV** on the overhead circuit breaker panel (fig. 2-9). Control of the lights is provided by the switch placarded **NAV - ON**, located on the overhead control panel (fig. 2-15).

*b. Strobe Beacons.* The strobe beacons are dual intensity units. They are protected by the 15-ampere circuit breaker placarded **BCN** on the overhead circuit breaker panel (fig. 2-9). Control of the lights is provided by a switch located on the overhead control panel placarded **BEACON - DAY - NIGHT** (fig. 2-15). Placing the switch in the **DAY** position will activate the high intensity white section of the strobe lights for greater visibility during daylight operation. Placing the switch in the **NIGHT** position activates the lower intensity red portion of the strobe lights.

*c. Recognition Lights.* The recognition lights are operated by the two-position switch placarded **RECOG**, located in the pilot's subpanel. The lights provide a very bright, steady illumination. They are protected by a 7.5-ampere circuit breaker, located on, the overhead circuit breaker panel (fig. 2-9).

*d. Landing/Taxi Lights.* Dual landing lights and a single taxi light are mounted on the nose gear assembly. The lights are controlled by the switches placarded **LANDING** and **TAXI**, located on the pilot's subpanel. The landing light circuit is protected by the 5-ampere circuit breaker placarded **LANDING**, located on the overhead circuit breaker panel (fig. 2-9). The taxi light circuit is protected by a 5-ampere circuit breaker placarded **TAXI**, located on the overhead circuit breaker panel (fig. 2-9). Landing/Taxi lights are automatically turned off when the landing gear is retracted. The landing lights and taxi light power circuits are protected by 35-ampere and 15-ampere circuit breakers, respectively, located on the DC power distribution panel beneath the aisleway forward of the main spar.

*e. Ice Lights.* The ice lights circuit is protected by a 5-ampere circuit breaker placarded **ICE** on the overhead circuit breaker panel (fig. 2-9). Control of the lights is provided by a switch placarded **ICE - ON** on the overhead control panel (fig. 2-15).

## 2-76. INTERIOR LIGHTING.

Lighting systems are installed for use by the pilot and copilot. The lighting systems in the cockpit are provided with intensity controls on the overhead control panel. A switch placarded **MASTER - ON**, located on the overhead control panel in the **COCKPIT LIGHTS** section (fig. 2-15), provides overall control for all engine instrument lights, pilot's and copilot's instrument lights, overhead panel lights, and subpanel lights. The switch placarded **IR FLOOD ON**, located on the overhead control panel (fig. 2-15), provides overall control for instrument panel, glareshield, and pedestal extension/cockpit lights.

*a. Cockpit Lighting.*

(1) *Utility lights.* Two utility lights are located on the cockpit overhead to provide additional instrument panel lighting, as required. The lights are protected by the 7.5-ampere **FLT INST** circuit breaker, located on the overhead circuit breaker panel (fig. 2-9). Variable light intensity, for both lights is provided through the **INSTRUMENT PANEL** rheostat, located in the **IR FLOOD LIGHTS** switch section, on the overhead control panel. Individual intensity control is provided by a switch placarded **BRT - DIM OFF**, located on each utility light.

(2) *Glareshield lights.* Lights are mounted in the glareshield overhang along the top edge of the instrument panel, providing overall instrument panel IR illumination. The circuit is protected by a 5-ampere circuit breaker placarded **INST INDIRECT** on the overhead circuit breaker panel (fig. 2-9). Control is provided by the rheostat switch placarded **GLARESHIELD** on the overhead control panel, located in the **IR FLOOD LIGHTS** switch section (fig. 2-15). Turning the control clockwise from **OFF**, illuminates the lights and increases their brilliance.

(3) *Flood light.* A single overhead cockpit flood light is installed. This light provides overall IR illumination of the entire cockpit area. The circuit is protected by a 7.5-ampere circuit breaker placarded **FLT INST**, located on the overhead circuit breaker panel (fig. 2-9). Control is provided by the rheostat/switch, placarded **PED EXT/COCKPIT**, located in the **IR FLOOD LIGHTS** switch section of the overhead control panel (fig. 2-15). Turning the control clockwise from **OFF**, illuminates the light and increases its brilliance.

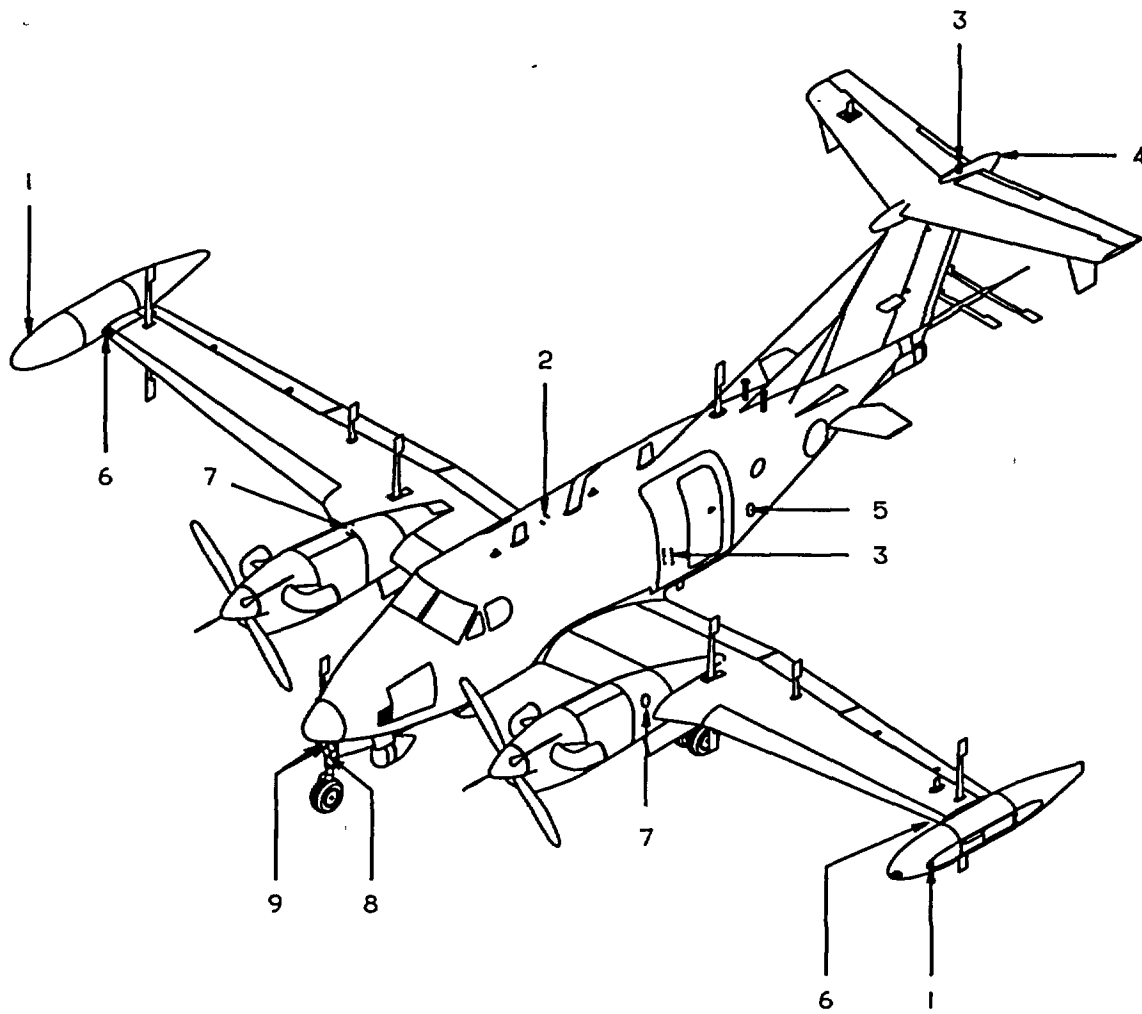

1. Wing Navigation Light
2. Emergency Light (Right Side)
3. Strobe Beacon
4. Tail Navigation Light
5. Emergency Light (Left side)
6. Recognition Light
7. Ice Light
8. Taxi Light
9. Landing Lights

A94FE00D0026 C

Figure 2-37. Exterior Lighting



(4) *Flight instrument lights.* Each individual flight instrument contains internal lamps for illumination. The circuit is protected by the 7.5-ampere circuit breaker placarded **FLT INST**, located on the overhead circuit breaker panel (fig. 2-9). Control is provided by the two rheostat switches placarded **PILOT INSTRUMENTS** and **COPILOT INSTRUMENTS**, located on the overhead control panel (fig. 2-15). Turning the control clockwise from **OFF**, illuminates the lights and increases their brilliance.

(5) *Engine instrument lights.* Each individual engine instrument contains internal lamps for illumination. The circuit is protected by the 7.5-ampere circuit breaker placarded **FLT INST** on the overhead circuit breaker panel (fig. 2-9). Control is provided by the rheostat switch placarded **ENGINE INSTRUMENTS** on the overhead control panel (fig. 2-15). Turning the control clockwise from **OFF**, illuminates the lights and increases their brilliance.

(6) *Overhead panel lights.* Lamps illuminating the overhead circuit breaker, control, and fuel management panels are protected by the 7.5-ampere circuit breaker, placarded **OVHD** on the overhead circuit breaker panel (fig. 2-9). Control is provided by the rheostat switch placarded **OVERHEAD PANEL**, located on the overhead control panel (fig. 2-15). Turning the control clockwise from **OFF**, illuminates the lights and increases their brilliance.

(7) *Subpanel and console lights.* Lights on the pilot's and copilot's subpanels, console edge-lighted panels, mission control panel, and pedestal extension panels are protected by the 7.5-ampere circuit breaker, placarded **SUBPNL & CONSOLE** on the overhead circuit breaker panel (fig. 2-9). Control is provided by two rheostat switches placarded **SUBPANEL** and **CONSOLE** on the overhead control panel (fig. 2-15). Turning the controls clockwise from **OFF**, illuminates the lights and increases their brilliance.

(8) *Free air temperature light.* Two post lights are mounted adjacent to the outside air temperature gage on the left cockpit sidewall. The circuit is protected by the 7.5-ampere circuit breaker placarded **FLT INST** on the overhead circuit breaker panel (fig. 2-9). Control is provided by a pushbutton switch adjacent to the gage. Light intensity is not adjustable.

#### b. Cabin Lighting.

(1) *Threshold and spar cover lights.* A threshold light is installed just above floor level on the left side of the cabin, just inside the cabin door. A spar cover

light is installed on the left side of the sunken aisle, immediately aft of the main spar cover. Both circuits are protected by a 5-ampere circuit breaker located in the battery box, and are connected to the emergency battery bus. Both lights are controlled by a switch mounted adjacent to the threshold light. If the lights are illuminated, closing the cabin door will automatically extinguish them.

(2) *Cabin aisle lights.* Three cabin aisle lights are installed in the cabin aisle. Control is provided by the **CABIN LIGHTS BRIGHT - DIM** switch located on the pilot's subpanel.

(3) *Cabin utility lights.* A utility light is located adjacent to each overhead flood light in the cabin area. The utility lights are individually controlled by the rheostat switch placarded **OFF - ON - BRT**, located on the back of each light. A momentary **ON** switch is located in the center of the rheostat. The light is capable of producing a red or white spotlight by adjusting a diaphragm, located in front of the light. To remove the light from the stationary position, pull down on the light. The light is connected to the light housing by an 11 inch coiled cord that extends to approximately 50 inches. Power for the utility lights is provided through the 5-ampere circuit breaker placarded **CABIN LIGHTS**, on the overhead circuit breaker panel.

(4) *Cabin door latching mechanism light.* A light is provided to check the cabin door latching mechanism. It is controlled by a red pushbutton switch located adjacent to the round observation window, which is just above the second step.

## 2-77. EMERGENCY LIGHTING SYSTEM.

An independent battery-operated emergency lighting system is installed. The system is actuated automatically by shock, such as a forced landing. It provides adequate lighting inside and outside the fuselage to permit the occupants to read instruction placards and locate exits. An inertia switch, when subjected to a 2 G (minimum) shock will illuminate the interior lights in the cockpit, forward and aft cabin areas, exterior lights aft of the emergency exit, and aft of the cabin door. The battery power source is automatically recharged by the aircraft electrical system.

a. *Emergency Lighting System Operation.* An emergency lights override switch, located on the overhead control panel (fig. 2-15), is provided to turn the system off if it is accidentally actuated. The switch is placarded **EMERGENCY OFF/RESET - AUTO - TEST**. Should the system accidentally actuate, the emergency lights will illuminate. Placing the switch in the momentary **OFF/RESET** position will extinguish the lights. To test the system, place the switch in the momentary **TEST** position. The lights should illuminate. Moving the switch to the **OFF/RESET** position will turn the system off and reset it. The switch is normally in the **AUTO** position.

Section XI. FLIGHT INSTRUMENTS

2-78. PITOT SYSTEM.

The pitot system (fig. 2-38) provides ram air pressure for the airspeed indicators and air data computer. The pitot system consists of two pitot masts (one located on each side of the lower portion of the nose), and associated plumbing. The pitot masts are protected from ice formation by internal electric heating elements.

2-79. STATIC AIR SYSTEM.

a. *Description.* The static system (fig. 2-38) provides static air pressure for the pilot's and copilot's airspeed indicators, copilot's altimeter, air data computer, and pilot's and copilot's vertical speed indicators. The static air pressure ports are located on the right and left sides of the aft fuselage exterior skin.

b. *Alternate Static Air Source.* An alternate static air line, which terminates just aft of the rear pressure bulkhead, provides a source of static air for the pilot's instruments in the event of source failure from the pilot's static air line. A control on the pilot's subpanel placarded

**PILOTS STATIC AIR SOURCE, NORMAL** or **ALTERNATE** air source by a two position selector valve. The valve is secured in the **NORMAL** position by a spring clip.

2-80. TURN-AND-SLIP INDICATOR.

A turn-and-slip indicator is installed on the pilot's side of the instrument panel (fig. 2-18). This indicator is gyroscopically operated and electrically powered through a 5-ampere circuit breaker placarded **TURN & SLIP**, located on the overhead circuit breaker panel (fig. 2-9).

2-81. AIRSPEED INDICATORS.

Two identical airspeed indicators are installed separately on the pilot's and copilot's sides of the instrument panel (fig. 2-18). These indicators require no electrical power for operation. The indicator dials are calibrated in knots from 40 to 300. A striped pointer automatically displays the maximum allowable airspeed at a given aircraft altitude.

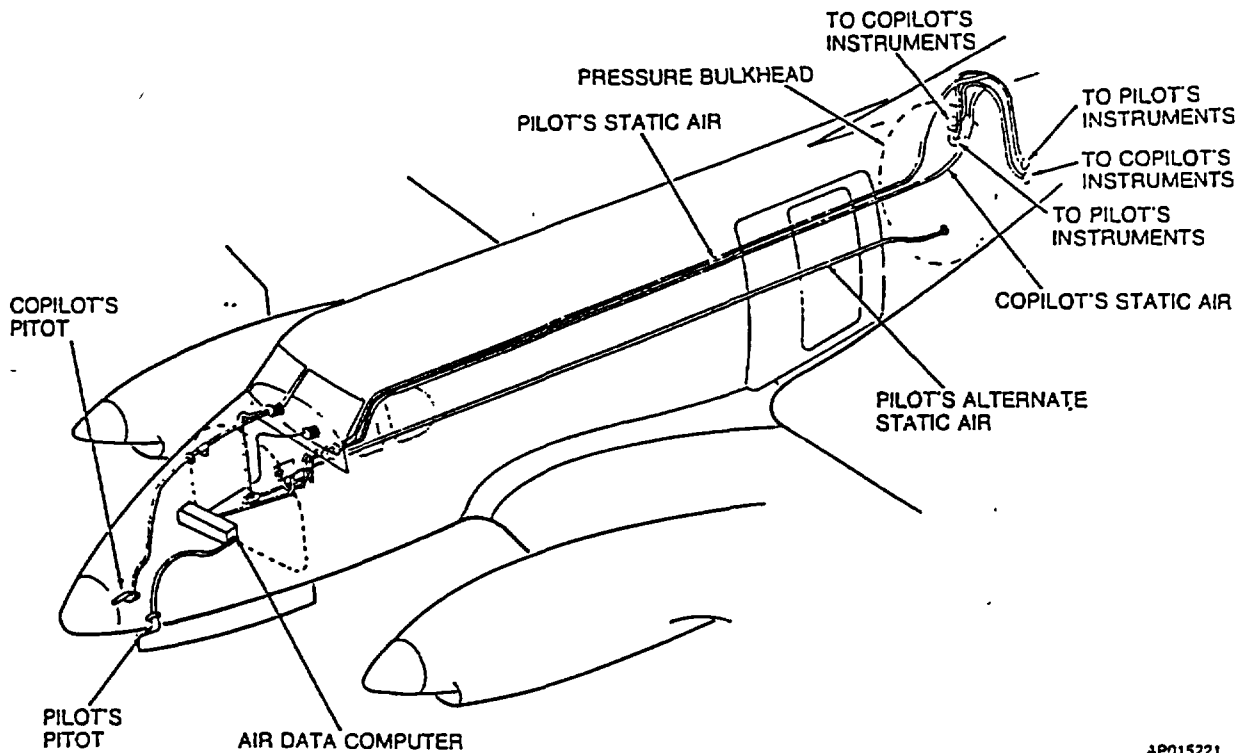

AP015221

Figure 2-38. Pitot and Static System

**2-82. COPILOT'S BAROMETRIC ALTIMETER.**

a. *Description.* The copilot's barometric altimeter (fig. 2-39), provides an indication of the aircraft's pressure altitude above sea level.

b. *Controls, Indicators, and Functions.*

(1) *Altitude indicator needle.* Used in conjunction with altitude scale to display aircraft altitude in hundreds of feet.

(2) *Barometric pressure counter-drum indicator (millibars).* Indicates barometric pressure in millibars that has been set by the barometric pressure setting knob.

(3) *Barometric pressure counter-drum indicator (Inches of mercury).* Indicates barometric pressure in inches of mercury that has been set by the barometric pressure setting knob.

(4) *Barometric pressure setting knob.* Used to manually set barometric pressure displayed in the IN HG and MB windows.

(5) *Counter-drum altitude display.* Indicates aircraft altitude in tens of thousands, thousands, and hun-

dreds of feet above sea level.

(6) *Altitude scale.* Used in conjunction with altitude indicator needle to indicate aircraft altitude in hundreds of feet. Subdivided into 20 foot increments.

**NOTE**

**If the altimeter does not read within 70 feet of field elevation, when the correct local barometric setting is used, the altimeter needs calibration or internal failure has occurred. An error of greater than 70 feet also nullifies use of the altimeter for IFR flight.**

**2-83. STANDBY ATTITUDE INDICATOR.**

An air-driven standby attitude indicator is located on the pilot's instrument panel (fig. 2-18).

a. *Standby Attitude Indicator Controls, Indicators, and Functions (fig. 2-40).*

(1) *Bank angle scale and pointer.* The moveable bank angle pointer indicates aircraft bank angle by moving around a fixed bank angle scale.

(2) *Pitch angle scale.* Aircraft pitch angle may be read under the symbolic miniature aircraft on a vertical pitch angle scale located on the attitude sphere.

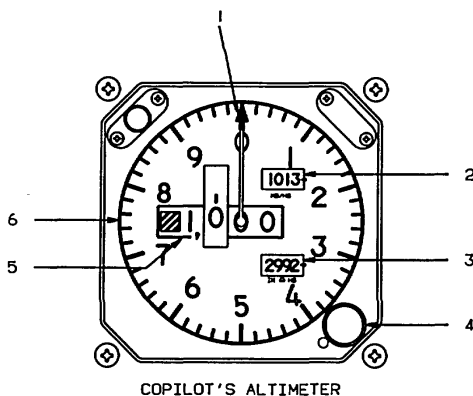

- 1. Altitude Indicator Needle
- 2. Barometric Pressure Counter-Drum Indicator Window (Millibars)
- 3. Barometric Pressure Counter-Drum Indicator Window (Inches of Mercury)
- 4. Barometric Pressure Setting Knob
- 5. Counter-Drum Altitude Display
- 6. Altitude Scale

A93FE00D0095 C

Figure 2-39. Copilot's Barometric Altimeter

(3) *Horizon bar.* The horizon bar displays aircraft pitch and roll attitude with respect to the earth's horizon.

(4) *Pitch adjustment knob.* This knob is used to vertically adjust the symbolic miniature aircraft for changes in the aircraft's level flight pitch attitude.

(5) *Symbolic miniature aircraft.* Aircraft pitch and roll attitudes are displayed by the relationship between the fixed miniature aircraft symbol and the movable attitude sphere.

(6) *Eyelid display.* The eyelid display surrounds the attitude sphere to provide a positive attitude identification. When the aircraft is in an upright position the upper (blue) eyelid is located next to the upper (blue) half of the attitude sphere, while the lower (brown) eyelid display is located next to the lower (brown) half of the attitude sphere. Thus the eyelid display maintains the proper ground-sky relationship, regardless of the position of the sphere, to aid in recovery from unusual attitudes.

**2-84. VERTICAL SPEED INDICATORS.**

Vertical speed indicators are installed separately on the pilot's and copilot sides of the instrument panel (fig. 2-18).

They indicate the rate at which the aircraft ascends or descends based on changes in atmospheric pressure. The indicator is a direct reading pressure instrument requiring no electrical power for operation.

**2-85. ACCELEROMETER.**

An accelerometer, located on the instrument panel, registers and records positive and negative G loads imposed on the aircraft. One hand moves in the direction of the G load being applied while the other two (one for positive G loads and one for negative g loads), follow the indicating pointer to its maximum travel. The recording pointers remain at the respective maximum travel positions of the G's being applied, providing a record of maximum G loads encountered. Depressing the push-to-reset knob at the lower left corner of the instrument allows the recording pointers to return to the normal position.

**2-86. FREE AIR TEMPERATURE (FAT) GAGE.**

The free air temperature gage, mounted outboard of the pilot's seat (fig. 2-10), indicates free air temperature in degrees celsius.

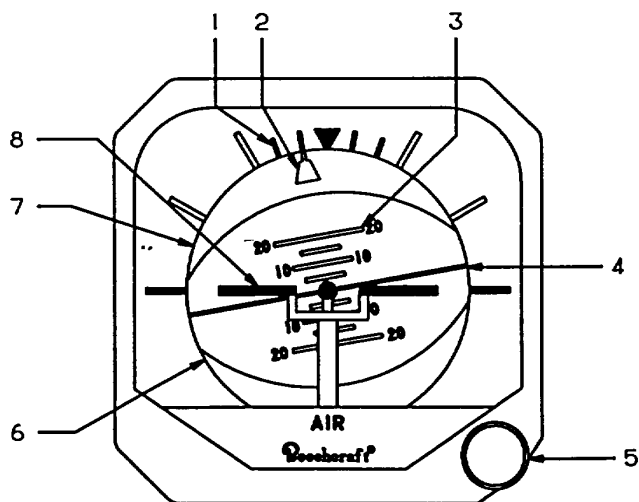

- 1. Bank Angle Scale
- 2. Bank Angle Pointer
- 3. Pitch Angle Scale
- 4. Horizon Bar
- 5. Pitch Adjustment Knob
- 6. Lower Eyelid Display
- 7. Upper Eyelid Display
- 8. Symbolic Miniature Aircraft

A93E00D0094 C

Figure 2-40. Standby Attitude Indicator

**2-87. STANDBY MAGNETIC COMPASS.**

**WARNING**

**Inaccurate indications on the standby magnetic compass will occur while windshield heat, radome anti-ice, air conditioning, or EFIS are being used or the sunvisors are in the front position.**

The standby magnetic compass (fig. 2-10), located below the overhead control panel, is used in the event of failure of the compass system, and for instrument cross check. Readings should be taken only during level flight since errors may be introduced by turning or acceleration. A compass correction chart, indicating deviation factors, is located on the magnetic compass.

**2-88. MISCELLANEOUS INSTRUMENTS.**

*a. Warning Annunciator Panel.* The warning annunciator panel, located near the center of the instrument panel below the glareshield (fig. 2-18 and 2-41), contains red fault annunciators. Illumination of a red fault annunciator signifies the existence of a hazardous

condition requiring pilot attention. Table 2-6 lists the red fault annunciators, and the causes for their illumination.

*b. Caution/Advisory Annunciator Panel.* The caution advisory annunciator panel, located on the center subpanel (fig. 2-8 and 2-42), contains the caution/advisory annunciators. The amber caution annunciators signify a condition requiring pilot attention. A green advisory annunciator indicates a functional condition. Table 2-7 lists the caution/advisory annunciators and their cause for illumination.

*c. Mission Annunciator Panel.* The mission annunciator panel, located on the right cockpit sidewall (fig. 4-1), contains mission equipment annunciators and some annunciators which involve flight operations. Table 2-8 lists the mission annunciators and their cause for illumination.

*d. Autopilot/EFIS/Rudder Boost Remote Annunciator Panel.* Two autopilot/EFIS/rudder boost remote annunciator panels are provided (one located above the pilot's and one above the copilot's EADI, fig. 2-43), to advise the pilot and copilot of certain autopilot, EFIS, and rudder boost functions, and to select which EFIS is providing information to the autopilot. The functions of this panel are as follows:

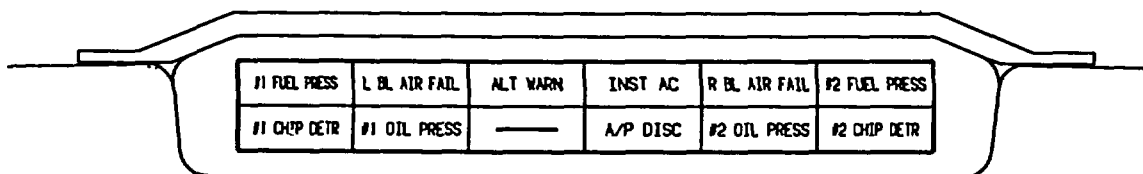

AP01522 C

Figure 2-41. Warning Annunciator Panel

#1 DC GEN	#1 INVERTER	#1 NO FUEL XFR	#2 NO FUEL XFR	#2 INVERTER	#2 DC GEN
#1 EXTGH DISCH	#1 NAC LOW	CABIN DOOR	ELEC TRIM OFF	#2 NAC LOW	#2 EXTGH DISCH
#1 VANE FAIL	#1 LIP HEAT	REV NOT READY	DUCT OVERTEMP	#2 LIP HEAT	#2 VANE FAIL
HYD FLUID LOW	INS	IFF	BATTERY CHARGE	BAT FEED FAULT	PROP SYNC ON
FUEL CROSSFEED	#1 LIP HEAT ON	#1 PROP PITCH	#2 PROP PITCH	#2 LIP HEAT ON	A/C COLD OPN
#1 VANE EXT	#1 IGN ON	L BL AIR OFF	R BL AIR OFF	#2 IGN ON	#2 VANE EXT
#1 AUTOFEATHER	AIR COND N, LOW	EXTERNAL POWER	EXT DC PWR ON	BRAKE DEICE ON	#2 AUTOFEATHER

AP015223 C

Figure 2-42. Caution/Advisory Annunciator Panel

Table 2-6. Warning Annunciator Panel Legend

WARNING ANNUNCIATOR		
NOMENCLATURE	COLOR	CAUSE FOR ILLUMINATION
#1 FUEL PRESS	RED	Fuel pressure failure on left side
L BL AIR FAIL	RED	Left bleed air warning line has melted or failed, indicating possible leak of No. 1 engine bleed air
ALT WARN	RED	Cabin altitude exceeds 12,500 feet
INST AC	RED	No 26 VAC
R BL AIR FAIL	RED	Right bleed air warning line has melted or failed, indicating possible leak of No. 2 engine bleed air
#2 FUEL PRESS	RED	Fuel pressure failure on right side
#1 CHIP DETR	RED	Contamination of No. 1 engine oil detected
#1 OIL PRESS	RED	Oil pressure failure on left side
A/P DISC	RED	Autopilot has disengaged
#2 OIL PRESS	RED	Oil pressure failure on right side
#2 CHIP DETR	RED	Contamination of No. 2 engine oil detected

BT00103

Table 2-7. Caution/Advisory Annunciator Panel Legend

CAUTION/ADVISORY ANNUNCIATOR		
NOMENCLATURE	COLOR	CAUSE FOR ILLUMINATION
#1 DC GEN	Yellow	No. 1 engine generator off the line
#1 INVERTER	Yellow	No. 1 inverter inoperative
#1 NO FUEL XFR	Yellow	Auxiliary fuel tank on side of No. 1 engine not transferring fuel into nacelle tank
#2 NO FUEL XFR	Yellow	Auxiliary fuel tank on side of No. 2 engine not transferring fuel into nacelle tank
#2 INVERTER	Yellow	No. 2 inverter inoperative
#2 DC GEN	Yellow	No. 2 engine generator off the line
#1 EXTGH DISCH	Yellow	No. 1 engine fire extinguisher discharged
#1 NAC LOW	Yellow	No. 1 engine has 30 minutes fuel remaining at sea level, maximum cruise power consumption rate
CABIN DOOR	Yellow	Cabin/cargo door open or not secure
ELEC TRIM OFF	Yellow	Electric trim switch has been turned off, or electric trim monitor has detected a trim fault and turned trim off.
#2 NAC LOW	Yellow	No. 2 engine has 30 minutes fuel remaining at sea level, maximum cruise power consumption rate
#2 EXTGH DISCH	Yellow	No. 2 engine fire extinguisher discharged
#1 VANE FAIL	Yellow	No. 1 engine ice vane malfunction. Ice vane has not attained proper position.
#1 LIP HEAT	Yellow	Failure of No. 1 lip heat valve to conform to selected position or in transit
REV NOT READY	Yellow	Propeller levers are not in the high RPM, low pitch position, with the landing gear extended
DUCT OVERTEMP	Yellow	Excessive bleed air temperature in environmental heat ducts
#2 LIP HEAT	Yellow	Failure of No. 2 lip heat valve to conform to selected position or in transit
#2 VANE FAIL	Yellow	No. 2 engine ice vane malfunction. Ice vane has not attained proper position
HYD FLUID LOW	Yellow	Fluid level in power pack is low
INS	Yellow	Inertial navigation system's cooling fan is off or an INS malfunction that annunciates INS FAIL on MFD.
IFF	Yellow	Transponder fails to reply to a valid mode 4 interrogation
BATTERY CHARGE	Yellow	Charge rate on battery exceeds 7 amps
BAT FEED FAULT	Yellow	Ground fault detected in battery external power line
PROP SYNC ON	Yellow	Synchrophaser turned on with landing gear extended
FUEL CROSSFEED	Green	Crossfeed valve open
#1 LIP HEAT ON	Green	No. 1 engine air scoop heat is on
#1 PROP PITCH	Yellow	No. 1 propeller is below the flight idle stop
#2 PROP PITCH	Yellow	No. 2 propeller is below the flight idle stop
#2 LIP HEAT ON	Green	No. 2 engine air scoop heat is on
A/C COLD OPN	Green	Air conditioner is operating in cold mode, or ambient temperatures require switching to cold mode if air conditioner operation is to be continued
#1 VANE EXT	Green	No. 1 ice vane extended
#1 IGN ON	Green	No. 1 engine ignition/start switch on, No. 1 engine autoignition switch armed and engine torque below 20 percent
L BL AIR OFF	Green	Left environment bleed air valve closed
R BL AIR OFF	Green	Right environmental bleed air valve closed
#2 IGN ON	Green	No. 2 engine ignition/start switch on, No. 2 engine autoignition switch armed and engine torque below 20 percent
#2 VANE EXT	Green	No. 2 ice vane extended
#1 AUTOFEATHER	Green	No. 1 autofeather armed
AIR COND N <sub>1</sub> LOW	Green	No. 2 engine RPM too low for air conditioning load
EXTERNAL POWER	Green	External power connector plugged in
EXT DC PWR/ON	Green	External DC power is on
BRAKE DEICE ON	Green	Brake deicing system is on
#2 AUTOFEATHER	Green	No. 2 autofeather armed

BT00104

(1) *EFIS FAN FAIL annunciator light (amber).*  
Illumination indicates failure of EFIS cooling fan.

(2) *Autopilot EFIS selector switch and indicator.* An alternate-action pushbutton switch placarded **AP EFIS 1** (green) and **AP EFIS 2** (amber) on the pilot's side of the instrument panel and **AP EFIS 1** (amber) and **AP EFIS 2** (green) on the copilot's side (indicator only), allows selection of information from **EFIS # 1** or **EFIS # 2** for controlling the autopilot.

(3) *Autopilot/yaw damper annunciator light.* A split annunciator light (green) placarded **AP ENG** and **YD ENG**, illuminates to indicate that the autopilot and/or yaw damper is engaged.

(4) *Rudder boost/autopilot trim annunciator.* The upper half of this split annunciator, placarded **RUDDER BOOST** (amber), illuminates to indicate that the rudder boost has failed. The lower half of the annunciator, placarded **AP TRIM** (amber), illuminates to indicate that the autopilot trim has run longer than 5 to 8 seconds.

Table 2-8. Mission Control Panel Annunciator Legend

MISSION ANNUNCIATOR		
NOMENCLATURE	COLOR	CAUSE FOR ILLUMINATION
CRYPTO ALERT	Yellow	Security equipment is holding cipher key when aircraft's wheels are down and TWTA INTLK DEFEAT toggle switch on mission status panel is set to OFF position.
CALL	Yellow	A request for VOW communication is being received by mission equipment.
3 φ AC OFF	Yellow	Loss of three-phase AC power from either mission inverter if 3 0 AC CONTROL BUS CROSS TIE switch is set to OFF. Indicates a loss of three-phase AC power from both mission inverters if 3 0 AC CONTROL BUS CROSS TIE switch is set to ON.
CABIN OVERTEMP	Yellow	Cabin area containing mission equipment is overheating.
MISSION POWER	Yellow	No power to mission equipment.
RADOME HOT	Yellow	Overtemperature condition inside IDL nose radome.
ELINT LEFT	Yellow	Left ELINT power supply failure.
SPCL EQPT OVRD	Yellow	Aircraft's normal +28 VDC source has been overridden to provide remaining +28 VDC power sources to mission equipment. Enabled when MISSION CONTROL switch is set to ORIDE position.
ELINT RIGHT	Yellow	Right ELINT power supply failure.
ANT MALF	Yellow	Tail boom antenna is not in proper position as set by ANT ORIDE switch or landing gear uplock switch.
NO INS UPDATE	Yellow	No INS update data from either TACAN, data link, or GPS to aircraft's INS equipment
WOW DEFEAT	Yellow	Indicates that WOW OVERRIDE switch is in the ON Position.
LB PS OVERTEMP	Yellow	Overtemperature condition in low band receiver power supply.
ASE SILENT	Yellow	Transmitting elements of ASE are in passive mode.
LB PS FAULT	Yellow	Failure in low band receiver power supply.
ANT STOWED	Green	Tail boom antenna is in horizontal stowed position.
ANT OPERATE	Green	Tail boom antenna is in vertical operating position.
RADOME HEAT	Green	IDL nose radome deicer is on. Enabled by RADOME anti-ice switch on overhead control panel.
MISSION AC ON	Green	Three-phase AC power is being applied to mission inverter #2 AC bus. Enabled when 3 φ AC CONTROL #2 INV switch is in ON position, or when #2 INV switch is in OFF position and BUS CROSS TIE switch is in ON/AUTO position and #1 INV switch is in ON position.
INS UPDATE	Green	INS update is received by aircraft's INS equipment from either TACAN, data link, or GPS.
MISSION DC ON	Green	+28 VDC power is applied to mission equipment. Enabled by MISSION CONTROL switch.
WAVE GUIDE	Green	IDL waveguides are pressurized.
EXT AC PWR ON	Green	AC power source is connected and applied to aircraft.

BT00105



e. *Annunciator System General.* In the frontal view, the annunciator panels present rows of small opaque rectangular annunciators. Word printing on the respective indicator identifies the monitored function, situation, or fault condition, but it cannot be read until the annunciator is illuminated. Blank annunciators (no word printing) are non-functioning annunciators. The bulbs of all annunciator panels are tested by activating the **ANNUNCIATOR TEST** switch, located on the copilot's subpanel near the caution/advisory panel. The system is protected by the 5-ampere circuit breakers placarded **ANN PWR** and **ANN IND** on the overhead circuit breaker panel (fig. 2-9). The annunciators are dimmed when the **MASTER** light switch is **ON** and the pilot's flight instrument lights are illuminated. The annunciators are automatically reset to maximum brightness if:

- (1) Both generators are not producing power (or turned **OFF**) with **MASTER SWITCH ON**.
- (2) The **INSTRUMENT PANEL** light switch is rotated clockwise.
- (3) The **MASTER** light switch is off.
- (4) The **MASTER** light switch is **ON** and the **PILOT INSTRUMENTS** light switch is **OFF**.

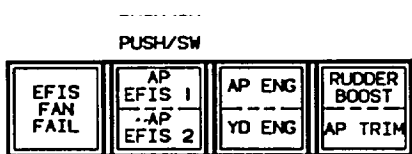

**NOTE**

AP EFIS 1 AND AP EFIS 2 IS A PUSHBUTTON SWITCH ON PILOT'S SIDE ONLY.

AP015464 C

Figure 2-43. Autopilot/EFIS/Rudder Boost Remote Annunciator Panel

f. *Master Warning Annunciators (red).* Two **MASTER WARNING** annunciators, one located on each side of the glareshield (fig. 2-18), are provided to alert the crew of a hazardous condition. Any time a warning annunciator illuminates, the **MASTER WARNING** annunciator will flash, and will remain flashing until the **MASTER WARNING** annunciator is reset. If a new condition occurs, the annunciator will be reactivated, and the applicable annunciator panel annunciator(s) will illuminate.

g. *Master Caution Annunciators (amber).* Two **MASTER CAUTION** annunciators, one located on each side of the glareshield, adjacent to the **MASTER WARNING** annunciator (fig. 2-18), are provided to alert the crew of a situation requiring the crews attention. Whenever a caution annunciator illuminates, the **MASTER CAUTION** annunciator will flash, and remain flashing until the **MASTER CAUTION** annunciator is reset. If a new condition occurs, the annunciator will be reactivated and the appropriate annunciator(s) will illuminate.

h. *Clocks.*

(1) *Description.* A digital quartz chronometer is mounted in the center of both control wheels (fig. 2-24). Each quartz chronometer is a five-function clock/timer that is controlled by three pushbutton switches, located directly below the six-digit liquid crystal display.

(2) *Operation.* The **MODE** button is pressed to select the desired mode of operation. The mode annunciator is displayed above the mode identifiers, and advances to indicate each of the following modes:

- LC** - Local Time
- ZU** - Zulu or Greenwich Mean Time
- FT** - Trip or Flight Timer
- ET** - Elapsed Time
- DC** - Downcounter with Alarm

(3) *Local time mode (LC).* Press the **MODE** button to advance the annunciator to **LC**. To set the hour, press the **RST** button once, then press and hold the **ADV** button until the correct hour is displayed. To set minutes, press the **RST** button again, then press and hold the **ADV** button until the correct minute is displayed. Press the **SET** button once to display and hold the selected time. Press the **ST - SP** button to resume clock operation and/or synchronize the display with a selected time standard.

(4) *Zulu or Greenwich mean time mode*

(ZU). Press the **MODE** button to advance the annunciator to **ZU** and set time as for local time shown above. Minutes and seconds do not need to be reset if local time is correctly set. Press the **RST** button to display minutes/ seconds, then press again to activate the complete display.

When changing time zones, the hour may be changed as above. It is not necessary to change the minutes/seconds. Press the **RST** button twice to return to the full time display.

(5) *Trip/flight timer mode (FT)*. Press the **MODE** button to advance the annunciator to **FT**. Press the **ST-SP** button and verify that the display shows zero. The timer will activate at takeoff and stop at touchdown. To prevent an accidental reset of flight time, the clock cannot be manually reset during flight.

(6) *Elapsed time mode (ET)*. Press the **MODE** button to advance the annunciator to **ET**. Press the **RST** button to set the time display to zero. Press the **ST-SP** button one time. To stop the counting, press the **ST-SP** button a second time. Ending time will be displayed until

the **RST** button is pressed to clear the display. The clock may be used in other modes and the elapsed time display will remain until cleared by pressing the **RST** button. If the timer is counting when the **RST** button is pressed, the display will reset to zero and the count will begin again from zero.

(7) *Downcounter mode (DC)*. Press the **MODE** button to advance the annunciator to **DC**. Press the **SET** button twice to reset the hour display to zero. Press and hold the **ADV** button until the desired hour is displayed. Press the **SET** button, again, to reset the minute display to zero. Press and hold the **ADV** button until the desired minute is displayed. Press the **SET** button, again, to reset the seconds display to zero. Press and hold the **ADV** button until the desired second is displayed. Press the **SET** button, again, to arm the counter. Press the **ST - SP** button to begin countdown. When the countdown reaches zero, the display will flash for approximately one minute and then reset. The countdown may also be reset at any time by pressing the **ST - SP** button.

## Section XII. SERVICING, PARKING, AND MOORING

### 2-89. GENERAL.

The following paragraphs include the procedures necessary to service the aircraft except lubrication. The lubrication requirements of the aircraft are covered in the aircraft maintenance manual. Tables 2-9, 2-10, 2-11, and 2-12 are used for identification of fuel, oil, etc. used to service the aircraft. The servicing instructions provide procedures and precautions necessary to service the aircraft. Figure 2-44 shows servicing location points.

### 2-90. FUEL HANDLING PRECAUTIONS.

Table 2-2, Fuel Quantity Data, lists the capacity of the fuel tanks in the aircraft. Service the fuel tanks after each flight to keep moisture out of the tanks and to keep the bladder type cells from drying out.

Table 2-9. Approved Military Fuels, Oil, Fluids, and Unit Capacities

SYSTEM	SPECIFICATION	CAPACITY
Fuel	MIL-T-83133 (JP-8)	540 U.S. Gals. Usable
Engine Oil	MIL-L-23699	10 U.S. Quarts per engine
Hydraulic Brake System	MIL-H-5606	1 U.S. Pint
Oxygen System	MIL-O-27210	140 Cubic Feet
Toilet Chemical	Monogram DG-19	3 Ounces

BT03858

Table 2-10. Approved Fuels

SOURCE	PRIMARY OR STANDARD FUEL	ALTERNATE FUEL		
US MILITARY FUEL NATO Code No.	JP-8 (MIL-T-83133) NATO F-34	JP-5 (MIL-T-5624) NATO F-44 (High Flash Type)	JP-4 (MIL-T-5624) NATO F-40 (Wide Cut Type)	
COMMERCIAL FUEL (ASTM-D-1655) American Oil Co. Atlantic Refining Co. B.P. Trading Co. Caltex Petroleum Corp. Cities Service Co. Continental Oil Co. EXXON Co. USA Gulf Oil Mobil Oil Phillips Petroleum Pure Oil Co.  Richfield Oil Co. Shell Oil  Sinclair Standard Oil Co. of California Standard Oil Co. of Ohio Standard Oil Co. of Kentucky Texaco Union Oil FOREIGN FUEL Belgium Canada Denmark France Germany Greece Italy Netherlands Norway Portugal Turkey United Kingdom (Britain)	JET A-1  American Jet Fuel Type A-1 Arcojet A-1 BP A.T.K. Caltex Jet A-1  Conoco Jet-60 EXXON Turbo Fuel 1-A Gulf Jet A-1 Mobil Jet A-1  Purejet Turbine Fuel Type A-1 Richfield Turbine Fuel A-1 Aeroshell Turbine Fuel 650  Superjet Fuel A-1 Chevron TF-1  Jet A-1 Kerosene Standard JF A-1  Avjet K-58 76 Turbine Fuel  CAN/CGSB 3.23/Jet A-1  D. Eng RD 2494	JET A  American Jet Fuel Type A Arcojet A  Turbine Type A Conoco Jet-50 EXXON Turbo Fuel A Gulf Jet A Mobil Jet A Philjet A-50 Purejet Turbine Fuel Type A  Richfield Turbine Fuel A Aeroshell Turbine Fuel 640  Superjet Fuel A  Jet A Kerosene Standard JF A  Avjet K-40  NATO F-44  3-6P-24e  UTL-9130-007/UTL9130-010  AMC-143 D. Eng RD 2493  D. Eng RD 2498	JET B  Arcojet B BP A.T.G. Caltex Jet-B  Conoco Jet JP-4 EXXON Turbo Fuel 4 Gulf Jet B Mobil Jet B Philjet JP-4  Aeroshell Turbine Fuel JP-4  Chevron JP-4  Standard JF B  Avjet JP-4 Union JP-4 NATO F-40 BA-PF-2B 3GP-22F JP-4 MIL-T-5624 AIR 3407A VTL-9130-006 JP-4 MIL-T-5624 AA-M-C-1421 JP-4 MIL-T-5624 JP-4 MIL-T-5624 JP-4 MIL-T-5624 D. Eng RD 2454	

**NOTE**

Anti-icing and Biocidal Additive for Commercial Turbine Engine Fuel The fuel system icing inhibitor shall conform to MIL-L-27686. The additive provides anti-icing protection and also functions as a biocide to kill microbial growths in aircraft fuel systems. Icing inhibitor conforming to MIL-L-27686 shall be added to commercial fuel, not containing an icing inhibitor, during refueling operations, regardless of ambient temperatures. Refueling operations shall be accomplished in accordance with accepted procedures.

BT05517

Table 2-11. Standard, Alternate, and Emergency Fuels

ENGINE	ARMY STANDARD FUEL	ALTERNATE TYPE	EMERGENCY FUEL	
			TYPE	*MAX HOURS
PT6A	MIL-T-83133 Grade JP-8	MIL-T-5624 Grade JP-4/5 MIL-T-5624 Grade JP-4	MIL-G-5572 Any AV Gas	150

\* Maximum operating hours with indicated fuel between engine overhauls (TBO).

BT03859

Table 2-12. Recommended Fluid Dilution Chart

AMBIENT TEMPERATURE (°F)	PERCENT DEFROSTING FLUID BY VOLUME	PERCENT WATER BY VOLUME	FREEZING POINT OF MIXTURE (°F) (APPROXIMATE)
30° and above	20	80	10°
20°	30	70	0°
10°	40	60	-15°
0°	45	55	-25°
-10°	50	50	-35°
-20°	55	45	-45°
-30°	60	40	-55°

1. Use anti-icing and deicing fluid (MIL-A-8243 or commercial fluids).
2. Heat Mixture to a temperature of 82° to 93°C (180° to 200°F).

BT00201

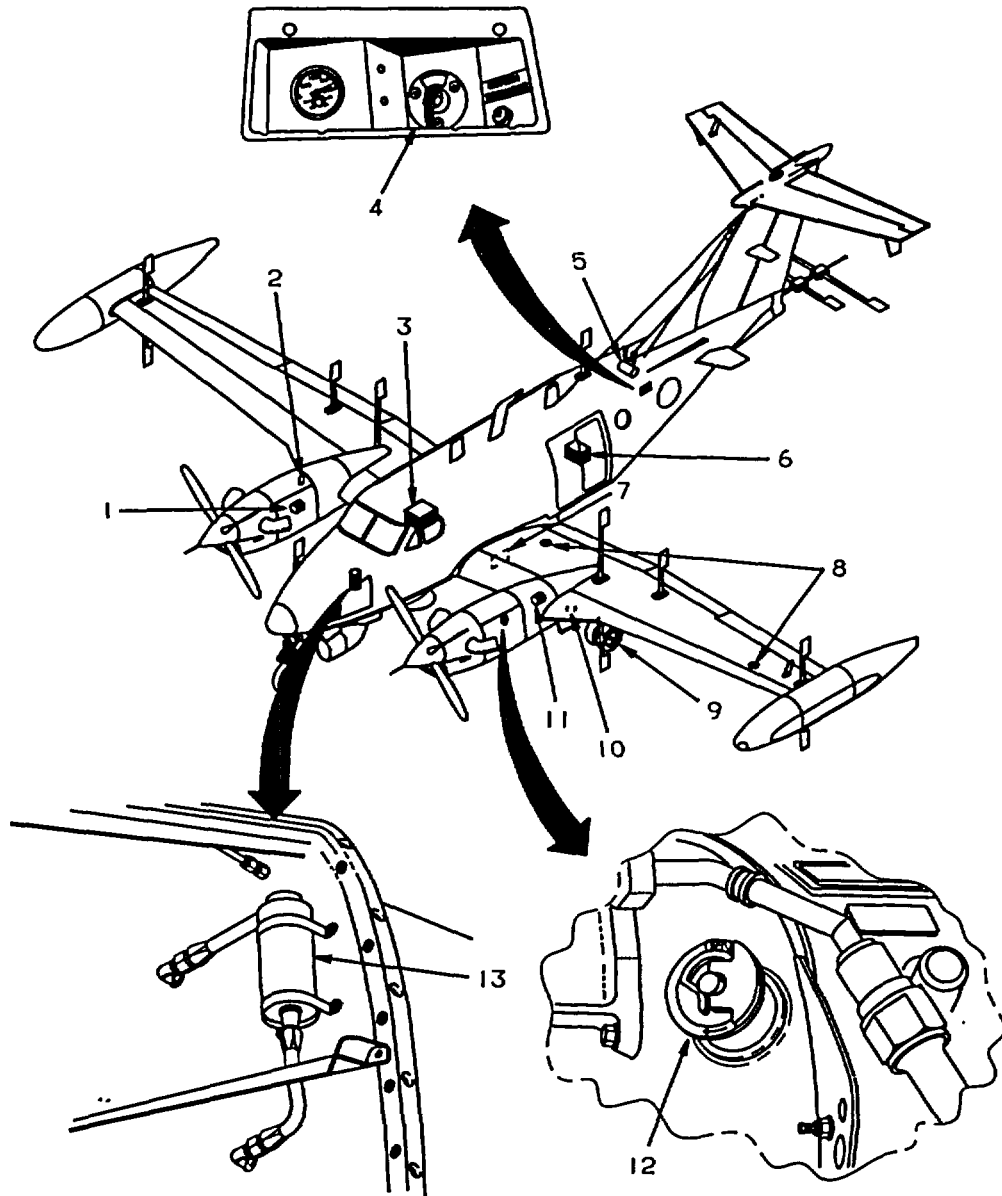

- |  |  |
|--|--|
| <ul style="list-style-type: none"> <li>1. Air Conditioning Compressor</li> <li>2. DC External Power Receptacle</li> <li>3. Battery 24 VDC</li> <li>4. Oxygen System Filler</li> <li>5. Oxygen Cylinders 2<br/>(70 CU Ft Bottles)</li> <li>6. Chemical Toilet</li> <li>7. Landing Gear Hydraulic Reservoir</li> <li>8. Fuel Filler Cops<br/>(Typical Left and Right)</li> </ul> | <ul style="list-style-type: none"> <li>9. Landing Gear Tires<br/>(Typical Left, Right, and Nose Gear)</li> <li>10. AC External Power Receptacle</li> <li>11. Engine Fire Extinguisher<br/>(Typical Left and Right)</li> <li>12. Engine Oil Filler Cap<br/>(Typical Left and Right)</li> <li>13. Wheel Brake Fluid Reservoir</li> </ul> |
|--|--|

A94FE000027 C

Figure 2-44. Servicing Locations

**WARNING**

During warm weather, open fuel caps slowly to prevent being sprayed with fuel. Care should be taken to prevent cuts or abrasions while inspecting the exhaust or turbine area of engines that have been operated on aviation gasoline. The exhaust deposits can cause lead poisoning.

**CAUTION**

Proper procedures for handling aircraft fuels cannot be overstressed. Clean, fresh fuel shall be used and the entrance of water into the fuel storage or aircraft fuel system must be kept to a minimum.

When conditions permit, the aircraft shall be positioned so that the wind will carry the fuel vapors away from all possible sources of ignition. The fueling vehicle shall be positioned to maintain a minimum distance of 10 feet from any part of the aircraft, while maintaining a minimum distance of 20 feet between the fueling vehicle and the fuel filler point.

a. Shut off unnecessary electrical equipment in the aircraft, including radar and radar equipment. The master switch may be left on, to monitor fuel quantity gages, but shall not be moved during the fueling operation. Do not allow operation of any electrical tools, such as drills or buffers, in or near the aircraft during fueling.

b. Keep fuel servicing nozzles free of snow, water, and mud at all times.

c. Carefully remove snow, water, and ice from the aircraft fuel filler cap area before removing the filler cap (fig. 2-44). Remove only one aircraft tank filler cap at any one time, and replace each one immediately after the servicing operation is completed.

d. Wipe all frost from fuel filler necks before servicing the aircraft.

e. Drain water from fuel tanks, filter cases, and pumps prior to first flight of the day. Preheat, when required, to ensure free fuel drainage.

f. Avoid dragging the fueling hose where it can damage the soft, flexible surface of the deice boots.

g. Observe **NO SMOKING** precautions.

h. Prior to transferring fuel, ensure that the hose is grounded to the aircraft.

i. Wash off spilled fuel immediately.

j. Handle the fuel hose and nozzle cautiously to avoid damaging the wing skin.

k. Do not conduct fueling operations within 100 feet of energized airborne radar equipment or within 300 feet of energized ground radar equipment installations.

l. Wear only nonsparking shoes near aircraft or fueling equipment, as shoes with nailed soles or metal heel plates can be a source of sparks.

**WARNING**

Prior to removing the fuel tank filler cap, the hose nozzle static ground wire shall be attached to the grounding sockets located adjacent to the filler opening.

**2-91. FILLING FUEL TANKS.**

Fill tanks as follows:

1. Attach bonding cables to aircraft.
2. Attach bonding cable from hose nozzle to ground socket adjacent to fuel tank being filled.

**CAUTION**

**Do not insert fuel nozzle completely into fuel cell due to possible damage to bottom of fuel cell. Nozzle should be supported and inserted straight down to prevent damage to the antisiphon valve.**

3. Remove fuel tank filler cap and fill main tank before filling corresponding auxiliary tanks.
4. Secure applicable fuel tank filler cap. Make sure latch tab on cap is pointed aft.
5. Disconnect bonding cables from aircraft.

**2-92. DRAINING MOISTURE FROM FUEL SYSTEM.**

Twelve (12) fuel drains are installed (plus two drains for the ferry fuel system, when installed) to remove sediment from the fuel system.

**2-93. FUEL TYPES.**

Approved fuel types are as follows:

- a. Army Standard Fuels. Army standard fuel is JP-8.
- b. Alternate Fuels. Army alternate fuels are JP-4 and JP-5.
- c. Emergency Fuel. Avgas is an emergency fuel and subject to a 150 hour time limit.

**2-94. USE OF FUELS.**

Fuel is used as follows:

a. *Fuel limitations.* Fuel limitations are outlined in Chapter 5. For the purpose of recording, fuel mixtures shall be identified as to the major component of the mixture, except when the mixture contains leaded gasoline. The use of emergency fuels will be entered in the FAULTS/REMARKS column of DA Form 2408-13-1, Aircraft Maintenance and Inspection Record, noting the type of fuel, additives, and duration of operation.

b. *Use of Kerosene Fuels.* The use of kerosene fuels (JP-5 type) in turbine engines dictates the need for observance of special precautions. Both ground starts and air restarts at low temperature may be more difficult due to low vapor pressure. Kerosene fuels having a freezing point of -40°C (-40°F), limit the maximum altitude of a mission to 28,000 feet under standard day conditions.

c. *Mixing of Fuels in Aircraft Tanks.* When changing from one type of authorized fuel to another, for example JP-4 to JP-5, it is not necessary to drain the aircraft fuel system before adding the new fuel.

d. *Fuel Specifications.* Fuels having the same NATO code number are interchangeable. Jet fuels conforming to ASTM D-1655 specification may be used when MIL-T-5624 fuels are not available. This usually occurs during cross-country flights where aircraft using NATO F-44 (JP-5) are refueling with NATO F-40 (JP-4) or commercial ASTM type B fuels. Whenever this condition occurs, the engine operating characteristics may change in that lower operating temperature, slower acceleration, lower engine speed, easier starting, and shorter range may be experienced. The reverse is true when changing from F-40 (JP-4) fuel to F-44 (JP-5) or Commercial ASTM Type A-I fuels. Most commercial turbine engines will operate satisfactorily on either kerosene or JP-4 type fuel. The difference in specific gravity may possibly require fuel control adjustments; if so, the recommendations of the manufacturers of the engine and airframe are to be followed.

**2-95. SERVICING OIL SYSTEM.**

An integral oil tank occupies the cavity formed between the accessory gearbox housing and the compressor inlet case on the engine. The tank has a calibrated oil dipstick and an oil drain plug. Avoid spilling oil. Any oil spilled must be removed immediately. Use a cloth moistened in solvent to remove oil. Overfilling may cause a discharge of oil through the accessory gearbox breather during engine operation, until a satisfactory level is reached. Service oil system as follows:

1. Open access door on upper cowling to gain access to oil filler cap and dipstick.

**CAUTION**

**A cold oil check is unreliable. If possible, check oil within 10 minutes after engine shutdown. If over 10 minutes have elapsed, motor the engine for 40 seconds, then check. If over 10 hours have elapsed, start the engine and run for 2 minutes, then check. Add oil as required. Do not overfill.**

2. If oil level is over 2 quarts low, motor or run engine as required, and service as necessary.
3. Remove oil filler cap.
4. Insert clean funnel, with screen incorporated, into filler neck.
5. Replenish with oil to within 1 quart below **MAX** mark or **MAX COLD** on dipstick (cold engine). Fill to **MAX** or **MAX HOT** (hot engine).
6. Check oil filler cap for damaged preformed packing, general condition and locking.

**CAUTION**

**Ensure that oil filler cap is correctly installed and securely locked to prevent loss of oil and possible engine failure.**

7. Install and secure oil filler cap.
8. Check for any oil leaks.

**2-96. SERVICING THE HYDRAULIC SYSTEM.**

- a. *Servicing Hydraulic Brake System Reservoir.*

1. Gain access to brake hydraulic system reservoir.

2. Remove brake reservoir cap and fill reservoir to washer on dipstick with hydraulic fluid.
3. Install brake reservoir cap.

*b. Servicing Hydraulic Landing Gear System.*

Servicing the hydraulic landing gear extension/ retraction system consists of maintaining the correct fluid level and maintaining the correct accumulator precharge. The accumulator is located in the reservoir access area and is charged to 800 ±50 PSI using bottled nitrogen. A charging gage is mounted on the accumulator. A reservoir, located just inboard of the left nacelle and forward of the main spar, has a lid with a dipstick attached marked **FLUID TEMP 0°F, 50°F, 100°F**. Add MIL-H-5606 hydraulic fluid (consumable materials list) as required to fill the system, corrected for temperature.

## 2-97. INFLATING TIRES.

Inflate tires as follows:

- a. Inflate nose wheel tires to a pressure between 55 and 60 PSI.
- b. Inflate main wheel tires to a pressure between 73 and 77 PSI.

## 2-98. SERVICING THE CHEMICAL TOILET.

The toilet should be serviced during routine ground maintenance of the aircraft following every usage. The waste storage container should be removed, emptied, its disposable plastic liner replaced, and the container replaced in the toilet cabinet. Toilet paper, waste container plastic liners, and dry chemical deodorant packets should also be resupplied within the toilet cabinet as needed.

## 2-99. SERVICING THE AIR CONDITIONING SYSTEM.

Servicing the air conditioning system consists of checking and maintaining the correct refrigerant level, compressor oil level, belt tension and condition, system leak detection, and replacement of the evaporator air filters. It is imperative that maintenance of the air conditioning system, except for filter replacement, be accomplished only by qualified refrigerant system technicians.

## 2-100. ANTI-ICING, DEICING, AND DEFROSTING TREATMENT.

### NOTE

**Do not apply anti-icing, deicing, and defrosting fluid to exposed aircraft surfaces if snow is expected. Melting snow will dilute the defrosting fluid and form a slush mixture which will freeze in place and become difficult to remove.**

The aircraft is protected in subfreezing weather by spraying the surfaces (to be covered with protective covers) with defrosting fluid. Spraying defrosting fluid on aircraft surfaces before installing protective covers will permit protective covers to be removed with a minimum of sticking. To prevent freezing rain and snow from blowing under protective covers and diluting the fluid, ensure that protective covers are fitted tightly. As a deicing measure, keep exposed aircraft surface wet with fluid for protection against frost.

Use undiluted anti-icing, deicing, and defrosting fluid (MIL-A-8243) to treat aircraft surfaces for protection against freezing rain and frost. Spray aircraft surface sufficiently to wet area, but without excessive drainage. A fine spray is recommended to prevent waste. Use diluted, hot fluid to remove ice accumulations.

a. Remove frost or ice accumulations from aircraft surfaces by spraying with diluted anti-icing, deicing, and defrosting fluid mixed in accordance with Table 2-12.

b. Spray diluted, hot fluid in a solid stream (not over 15 gallons per minute). Thoroughly saturate aircraft surface and remove loose ice. Keep a sufficient quantity of diluted, hot fluid on aircraft surface coated with ice, to prevent liquid layer from freezing. Diluted, hot fluid should be sprayed at a high pressure, but not exceeding 300 PSI.

c. When facilities for heating are not available and it is deemed necessary to remove ice accumulations from aircraft surfaces, undiluted defrosting fluid may be used. Spray undiluted defrosting fluid at 15 minute intervals to assure complete coverage. Removal of ice accumulations using undiluted defrosting fluid is expensive and slow.

d. If tires are frozen to ground, use undiluted defrosting fluid to melt ice around tire. Move aircraft as soon as tires are free.

### NOTE

**Do not apply anti-icing, deicing, and defrosting fluid to exposed aircraft surfaces if snow is expected. Melting snow will dilute the defrosting fluid and form a slush mixture which will freeze in place and become difficult to remove.**



**2-101. APPLICATION OF EXTERNAL POWER.****CAUTION**

**Before connecting the power cables from the external power source to the aircraft, ensure that the GPU is not touching the aircraft at any point. Due to the voltage drop in the cables, the two ground systems will be of different potentials. Should they come in contact while the GPU is operating, arcing could occur. Turn off all external power while connecting the power cable to, or removing it from, the external power supply receptacle. Be certain that polarity of the external power source is the same as that of the aircraft before it is connected. Minimum GPU requirements are as follows: 400-amperes, 28V continuous output DC and 115V, 3 phase, 400 cycle, 3 KVA continuous output AC.**

An external power source is often needed to supply the electric current required to properly ground service the aircraft electrical equipment and to facilitate starting the aircraft's engines. An external DC power receptacle is installed on the underside of the right wing, just outboard of the engine nacelle. An external AC power receptacle is installed on the underside of the left wing, just outboard of the engine nacelle.

**2-102. SERVICING OXYGEN SYSTEM.**

The oxygen system furnishes breathing oxygen to the pilot, copilot, and first aid position. The oxygen cylinder location is shown in figure 2-26.

*a. Oxygen System Safety Precautions.***WARNING**

**Keep fire and heat away from oxygen equipment. Do not smoke while working with or near oxygen equipment, and take care not to generate sparks with carelessly handled tools when working on the oxygen system.**

(1) Keep oxygen regulators, cylinders, gages, valves, fittings, masks, and all other components of the oxygen system free of oil, grease, gasoline, and all other readily combustible substances. The utmost care shall be exercised in servicing, handling, and inspecting the oxygen system.

(2) Do not allow foreign matter to enter oxygen lines.

(3) Never allow electrical equipment to come into contact with the oxygen cylinder.

(4) Never use oxygen from a cylinder without first reducing its pressure through a regulator.

*b. Replenishing Oxygen System.*

1. Remove oxygen access door on outside of aircraft (fig. 2-26).
2. Remove protective cap on oxygen system filler valve.
3. Attach oxygen hose from oxygen servicing unit to filler valve.

**WARNING**

**If the oxygen system pressure is below 200 PSI, do not attempt to service system. Make an entry on DA Form 2408-13-1.**

4. Ensure that supply cylinder shutoff valves on aircraft are open.
5. Slowly adjust valve position so that pressure increases at a rate not to exceed 200 PSIG per minute.
6. Close pressure regulating valve on oxygen servicing unit when pressure gage on oxygen system indicates pressure obtained using the Oxygen System Servicing Pressure Chart (fig. 2-45).

**NOTE**

**To compensate for loss of aircraft cylinder pressure as the oxygen cools to ambient temperature after recharging, the cylinder should be charged initially to approximately 10% over prescribed pressure. Experience will determine what initial pressure should be used to compensate for the subsequent pressure loss upon cooling. A complete recharge will create substantial heating.**

The final stabilized cylinder pressure should be adjusted for ambient temperature per figure 2-45.

7. Disconnect oxygen hose from oxygen servicing unit and filler valve.
8. Install protective cap on oxygen filler valve.
9. Install oxygen access door.

**2-103. GROUND HANDLING.**

Ground handling covers all the essential information concerning movement and handling of the aircraft while on

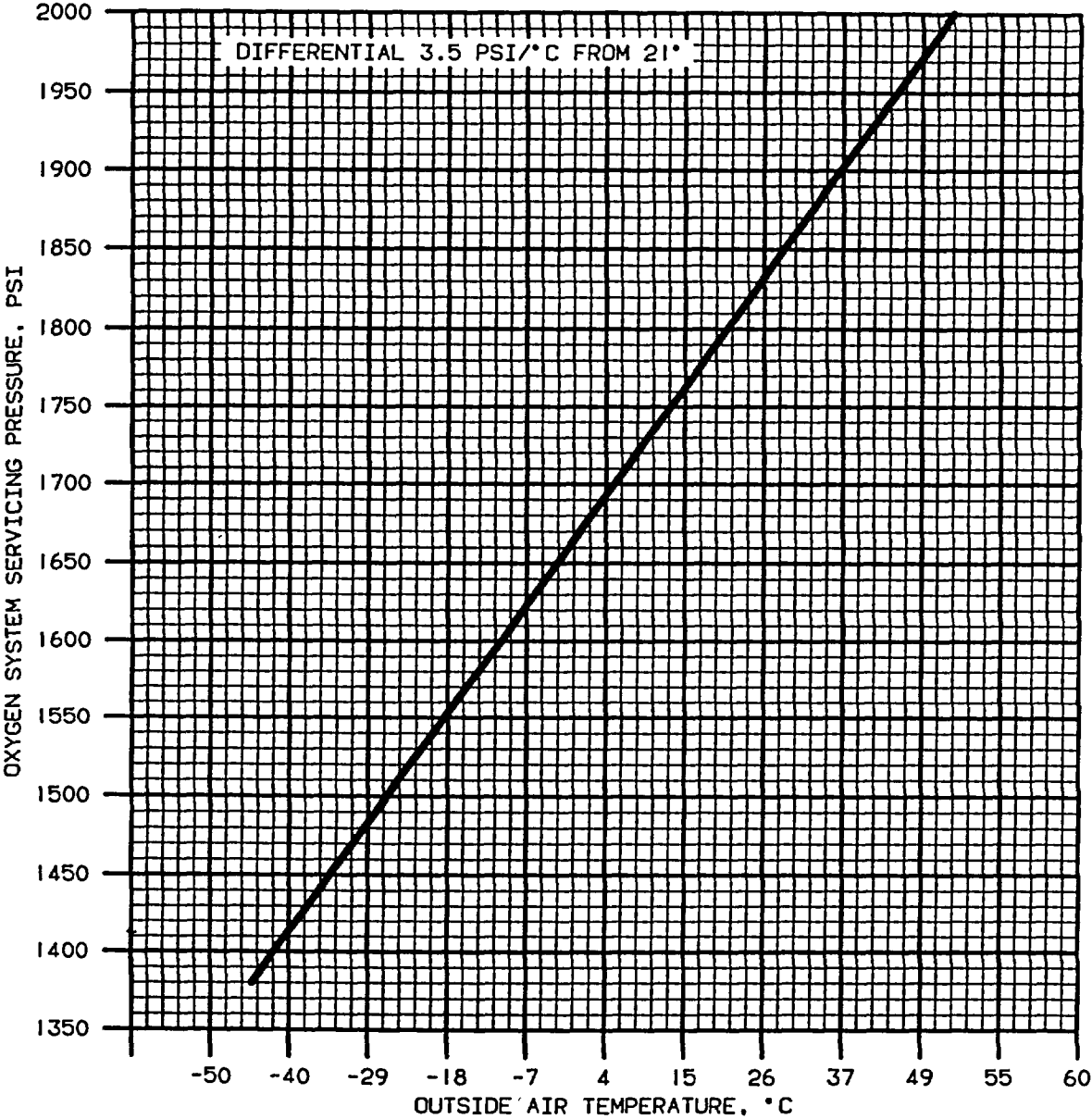

A95BW02C0491 C

Figure 2-45. Oxygen System Servicing Pressure

the ground. The following paragraphs give, in detail, the instructions and precautions necessary to accomplish ground handling functions. Parking, covers, ground handling, and towing equipment are shown in figure 2-46.

*a. General Ground Handling Procedure.* Accidents resulting in injury to personnel and damage to equipment can be avoided or minimized by close observance of existing safety standards and recognized ground handling procedures. Carelessness or insufficient knowledge of the aircraft or equipment being handled can be fatal. The applicable technical manuals and pertinent directives should be studied for familiarization with the aircraft, its components, and the ground handling procedures applicable to it, before attempting to accomplish ground handling.

*b. Ground Handling Safety Practices.* Aircraft equipped with turboprop engines require additional maintenance safety practices. The following list of safety practices should be observed at all times to prevent possible injury to personnel and/or damaged or destroyed aircraft:

(1) Keep intake air ducts free of loose articles such as rags, tools, etc.

(2) Stay clear of exhaust outlet areas.

(3) During ground runup, ensure the brakes are firmly set.

(4) Keep area fore and aft of propellers clear of maintenance equipment.

(5) Do not operate engines with flight control surfaces in the locked position.

(6) Do not attempt towing or taxiing of the aircraft with flight control surfaces in the locked position.

(7) When high winds are present, do not unlock the control surfaces until prepared to properly operate them.

(8) Do not operate engines while towing equipment is attached to the aircraft, or while the aircraft is tied down.

(9) Check the nose wheel position. Unless it is in the centered position, avoid operating the engines at high power settings.

(10) Hold control surfaces in the neutral position when the engines are being operated at high power settings.

(11) When moving the aircraft, do not push on propeller deicing boots. Damage to the heating elements may result.

*c. Moving Aircraft on Ground.* Aircraft on the ground shall be moved in accordance with the following:  
(1) Taxiing. Taxiing shall be in accordance with chapter 8.

### CAUTION

**When the aircraft is being towed, a qualified person must be in the pilot's seat to maintain control by use of the brakes. When towing, do not exceed nose gear turn limits (fig. 2-47). Avoid short radius turns, and always keep the inside or pivot wheel turning during the operation. Do not tow aircraft with rudder locks installed, as severe damage to the nose steering linkage can result. When moving the aircraft backwards, do not apply the brakes abruptly. Tow the aircraft slowly, avoiding sudden stops, especially over snowy, icy, rough, soggy, or muddy terrain. In arctic climates, the aircraft must be towed by the main gears, as an immense breakaway load, resulting from ice, frozen tires, and stiffened grease in the wheel bearings may damage the nose gear.**

**Do not tow or taxi aircraft with deflated shock struts.**

(2) *Towing.* Towing lugs are provided on the upper torque knee fitting of the nose strut. When it is necessary to tow the aircraft with a vehicle, use the vehicle tow bar. Never exceed the turn limit arrows displayed on the placard located on the nose gear assembly (fig. 2-47). In the event towing lines are necessary, use towing lugs on the main landing gear. Use towing lines long enough to clear nose and/or tail by at least 15 feet. This length is required to prevent the aircraft from overrunning the towing vehicle or fouling the nose gear.

*d. Ground Handling Under Extreme Weather Conditions.* Extreme weather conditions necessitate particular care in ground handling of the aircraft. In hot, dry, sandy, desert conditions, special attention must be devoted to finding a firmly packed parking and towing area. If such areas are not available, steel mats or an equivalent solid base must be provided for these purposes. In wet, swampy areas, care must be taken to avoid bogging down the aircraft. Under cold, icy, arctic conditions, additional mooring is required, and added precautions must be taken to avoid skidding during towing operations.

### 2-104. PARKING.

Parking is defined as the normal condition under which the aircraft will be secured while on the ground. This condition may vary from the temporary expedient of setting

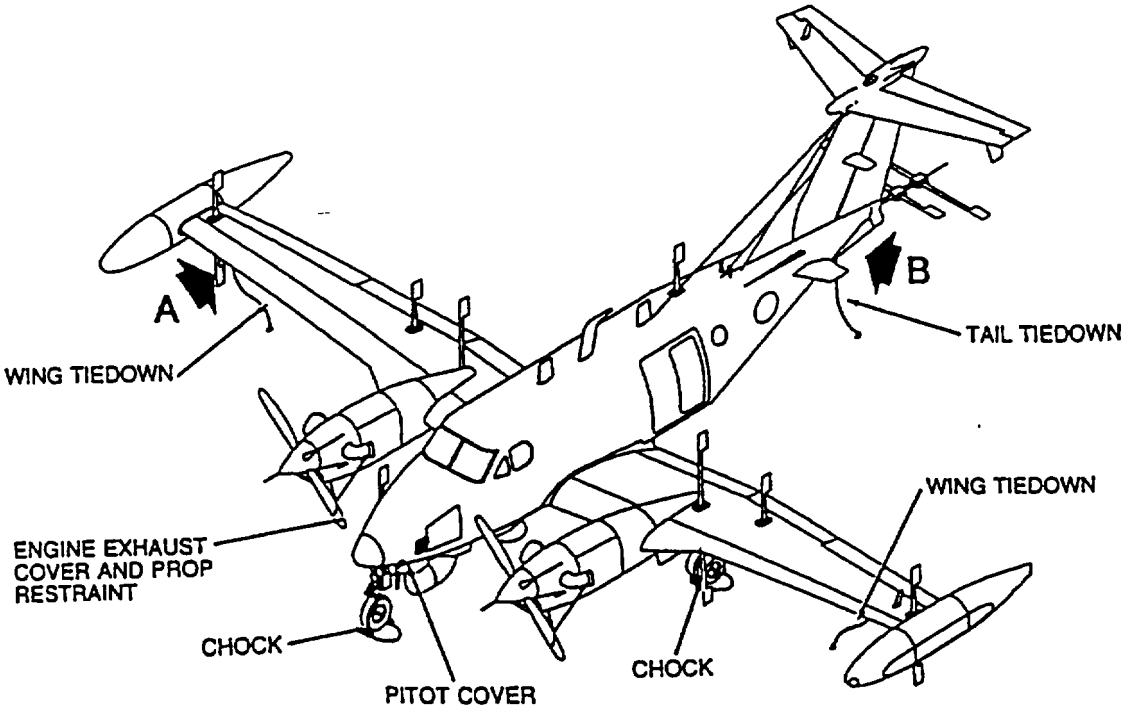
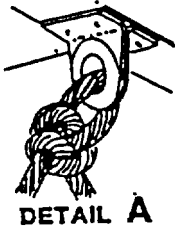
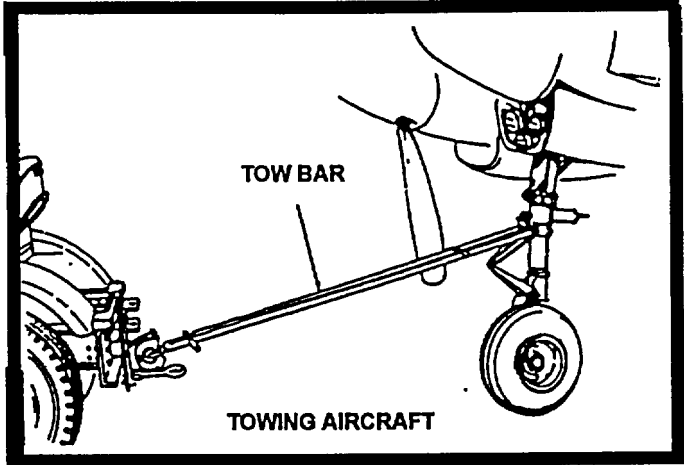

fe02d981921aa

Figure 2-46. Parking, Covers, Ground Handling, and Towing Equipment

the parking brake and chocking the wheels to the more elaborate mooring procedures described under Mooring. The proper steps for securing the aircraft must be based on the time the aircraft will be left unattended, the aircraft weight, the expected wind direction and velocity, and the anticipated availability of ground and air crews for mooring and/or evacuation. When practical, head the aircraft into the wind, especially if strong winds are forecast or if it will be necessary to leave the aircraft overnight. Set the parking brake and chock the wheels securely. Following engine shutdown, position and engage the control locks.

**NOTE**

**Cowlings and loose equipment will be suitably secured at all times when left in an unattended condition.**

a. The parking brake system for the aircraft incorporates two lever-type valves, one for each wheel brake. Both valves are closed simultaneously by pulling out the parking brake handle. Operate the parking brake as follows:

1. Depress both brakes.
2. Pull parking brake handle out. This will cause the parking brake valves to lock the hydraulic fluid under pressure in the parking

brake system, thereby retaining braking action.

3. Release brake pedals.

**CAUTION**

**Do not set parking brakes when the brakes are hot, during freezing ambient temperatures. Allow brakes to cool before setting parking brakes.**

4. To release the parking brakes push in on the parking brake handle.

b. The control lock (fig. 2-25) holds the engine and propeller control levers in a secure position. The elevator, rudder, and ailerons are secured in a neutral position. Install the control locks as follows:

1. With engine and propeller control levers in secure position, slide lock around the aligned control levers.
2. Install elevator and aileron lockpin through pilot's control column to lock control wheel.
3. Install rudder lock pin through floor

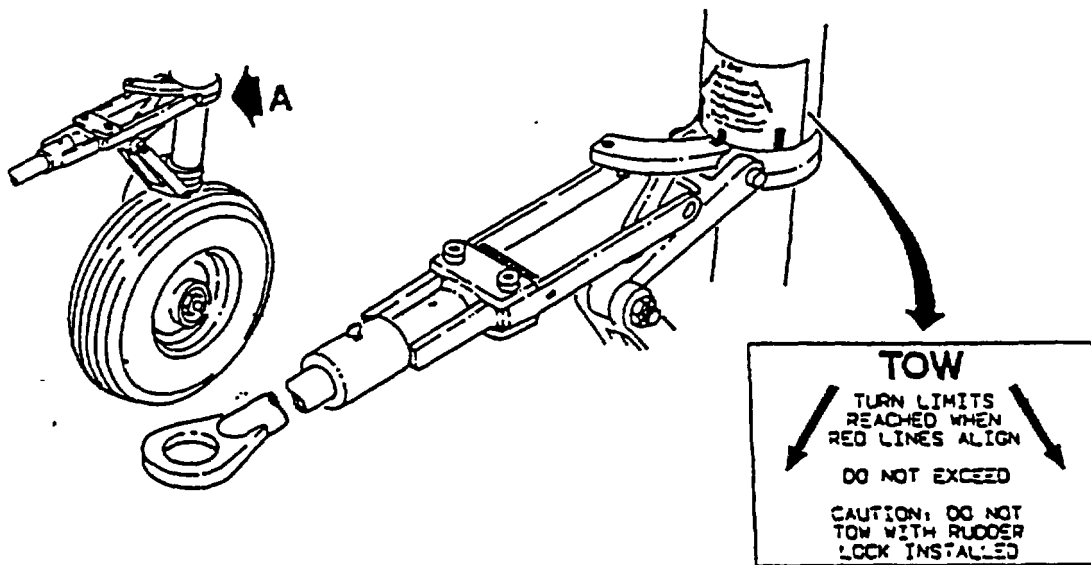

**DETAIL A**

AP015221

Figure 2-47. Towing Turn Limits

This will necessitate turning the aircraft after the first passing.

12. After high winds, inspect aircraft for visible

signs of structural damage and for evidence of damage from flying objects. Service nose shock strut and reconnect battery.

## CHAPTER 3 AVIONICS

### Section I. GENERAL

#### 3-1. INTRODUCTION.

Except for mission avionics, this chapter covers all avionics equipment installed in the RC-12P and RC-12Q aircraft. It provides a brief description of the equipment, the technical characteristics, and locations. It covers systems and controls, and provides the proper techniques and procedures to be employed when operating the equipment. For more detailed operational information consult the vendor manuals that accompany the aircraft loose tools.

#### 3-2. AVIONICS EQUIPMENT CONFIGURATION.

The aircraft avionics covered consists of three groups of electronic equipment. The communication group consists of the intercom system, UHF transceivers (2, HAVEQUICK), VHF-FM transceiver (SINCGARS), VHF-AM transceivers (2), HF transceiver, and an emergency locator transmitter (ELT). The navigation group consists of VOR/localizer/glideslope/marker beacon receivers (2), automatic direction finder receiver (ADF), inertial navigation system (INS), TACAN receiver, a global positioning system (GPS), a radio altimeter system, a gyromagnetic compass system, an electronic flight instrument system (EFIS), and a digital integrated flight control system. The transponder and radar group consists of a weather radar, lightning sensor system, transponder, and a servoed encoding altimeter indicator. The transponder and radar group includes an identification, position, emergency tracking system, and a radar and lightning sensor system to locate potentially dangerous weather areas. For additional operational details to operate equipment controlled by aircraft survivability equipment/avionics control system (ASE/ACS) refer to Chapter 4.

#### 3-3. POWER SOURCE.

*a. DC Power.* DC power for the avionics equipment is provided from four sources: the aircraft battery, left and right generators, and external power. Power is routed through two 50-ampere circuit breakers to the avionics power relay, which is controlled by the AVIONICS MASTER POWER switch, located on the overhead control panel (fig. 2-15). Individual system circuit breakers and the associated avionics buses are shown in figure 2-9.

(1) *AVIONICS MASTER POWER switch.* A switch placarded **AVIONICS MASTER POWER ON EXT PWR**, located on the overhead control panel controls power to the # 1 and # 2 avionics buses.

(a) *Off.* In the aft (off) position, power from the 5-ampere circuit breaker placarded **AVIONICS**

**MASTER PWR**, located on the overhead circuit breaker panel (fig. 2-9), energizes the avionics relay, removing power from the avionics buses.

(b) *ON.* With the switch in the **ON** (center) position, the avionics power relay is de-energized and power is applied through the 35-ampere **AVIONICS MASTER PWR # 1** and **# 2** circuit breakers to the individual avionics circuit breakers on the overhead circuit breaker panel (fig. 2-9).

#### NOTE

**If the AVIONICS MASTER POWER switch fails to operate, power to the individual avionics circuit breakers can be provided by pulling the 5-ampere circuit breaker, placarded AVIONICS MASTER CONTR, located on the overhead circuit breaker panel (fig. 2-9).**

(c) *External power (EXT PWR).* When the switch is in the **EXT PWR** (forward) position, external power may be applied to the avionics buses. The avionics system is automatically isolated from **DC GPU** power. Setting the **AVIONICS MASTER POWER** switch to the **EXT PWR** position allows avionics isolation from **DC GPU** power to be overridden, de-energizing the avionics power relay, and applying power to the avionics equipment from the **DC GPU**.

*b. Single-Phase AC Power.* Two static inverters supply 400 Hz single-phase 115 volt and 26 volt AC electrical power to the avionics equipment. During normal operation, the **# 1** inverter supplies 115 volts AC and 26 volts AC power to the # 1 avionics systems and the **# 2** inverter supplies AC power to the # 2 avionics system.

If either inverter fails, the total single-phase AC electrical load is shifted to the remaining inverter automatically unless a ground fault exists. Either inverter is capable of supplying the entire AC electrical load. AC power from the inverters is routed through fuses located in the nose avionics compartment. The single phase inverters are controlled by two switches placarded **# 1** and **# 2 1 $\phi$  INVERTER - ON**, located on the overhead control panel (fig. 2-15).

*c. Three-Phase AC Power.* Three phase AC electrical power for operation of the inertial navigation system and mission avionics is supplied by two 3000 volt-ampere, solid state, three phase inverters. The three phase

inverters are controlled by two three-position switches placarded **3 $\phi$  AC CONTROL, # 1** and **# 2 INV, RESET**

- **ON - OFF**, located on the mission control panel (fig. 4-1).

## Section II. COMMUNICATIONS

### 3-4. COMMUNICATIONS EQUIPMENT GROUP DESCRIPTION.

The communications equipment group consists of an intercom system connected to individual audio control panels for the pilot and copilot which interface with VHF, UHF, BU VOW, VHF-FM, and HF transceivers, and provide reception of audio from VOR, localizer, marker beacon, TACAN/DME, and ADF receivers.

### 3-5. MICROPHONES, SWITCHES, AND JACKS.

Boom and oxygen mask microphones can be utilized in the aircraft.

*a. Control Wheel Microphone Switches.* The pilot and copilot are each provided with bi-level microphone switches placarded **MIC, INTPH - XMIT**, located behind the outboard handgrip of their respective control wheels (fig. 2-24). When the control wheel microphone switches are depressed to the first level (**INTPH** position), voice audio signals from the respective microphone are routed to the intercom system (the position of the transmitter-intercom selector switch is disregarded).

When the control wheel microphone switches are depressed to the second level (**XMIT** position), voice audio signals from the respective microphone are routed to the transmitter selected by the transmitter-intercom selector switch (located on the respective audio control panel, fig. 3-1).

*b. Cockpit Floor Foot-Operated Microphone Switches.* The pilot and copilot are each provided with a foot-operated microphone switch, placarded **MIC**, located on the cockpit floor, forward of their respective seat positions.

Depressing the foot-operated microphone switches routes audio signals to the device selected by the transmitter-intercom selector switch located on the respective audio control panel (fig. 3-1).

*c. Microphone Jack Selector Switches.* Two switches, placarded **MIC, HEADSET OXYGEN MASK**, located on the left and right sides of the instrument panel (fig. 2-18), provide a means of selecting which microphone jack is connected to the audio system. When the pilot's or copilot's switch is set to the **HEADSET** position, the headset jack is connected to the respective audio system. When set to the **OXYGEN MASK** position,

the oxygen mask jack is connected to the respective audio system.

### 3-6. AUDIO CONTROL PANELS.

*a. Description.* Separate identical audio control panels (fig. 3-1), located on the left and right subpanels (fig. 2-8), are provided for the pilot and copilot. Each audio control panel is powered by its respective 2-ampere circuit breaker placarded **AUDIO PILOT** or **AUDIO COPILO**, located on the overhead circuit breaker panel (fig. 2-9).

*b. VHF-FM/VHF-Alternate Communication Switch Panel.* An alternate communication switch panel with three alternate-action (push on, push off) switches, located on the pedestal extension (fig. 3-2), allows position 2 of the audio control panel transmitter-selector switch to be connected to an alternate transmitter.

(1) *VHF-FM/VHF-AM alternate communication selector switch.* The center alternate-action (push on, push off) alternate communication switch is placarded **FM, AM**. When the switch is depressed, either **FM** or **AM** will be illuminated. When the switch is set to the **FM** position, position number 2 of the transmitter selector switch (audio control panel, fig. 3-1) and number 2 radio monitor control will be connected to the VHF-FM (SINCGARS) transceiver for both transmit and receive functions. When the switch is set to the **AM** position, position number 2 of the transmitter selector switch (audio control panel, fig. 3-1) and the number 2 radio monitor control will be connected to the VHF-AM number 2 transceiver for both transmit and receive functions.

(2) *Pilot's and copilot's alternate communication monitor switch.* The pilot and copilot are each provided with an alternate action (push on, pull off) alternate communication monitor switch, located on the left side (pilot's switch) or right side (copilot's switch), of the alternate communication switch panel (pedestal extension, fig. 2-14). Both switches have illuminated placarding which reads **MON, ON - OFF**. When the switch is depressed, either **ON** or **OFF** will be illuminated. When either of the switches is set to **ON** and the center switch is set to **FM**, the VHF-AM number 2 audio will be heard in addition to the FM audio. The FM audio cannot be monitored when the center switch is set to **AM**. The monitored audio volume will not be controlled by the number two radio monitor control.



c. Audio Control Panel (fig. 3-1), Controls and Functions.

(1) Master volume control. The master volume control, placarded **VOL**, controls audio volume to individual headsets.

(2) Transceiver audio monitor controls. The transceiver audio monitor controls, placarded **RADIO MON, 1** through **5**, are used to select which transceiver's received audio will be heard in the pilot's or copilot's respective headset, and its volume. These controls are of the push on, pull off type. Clockwise rotation of a control increases audio volume to headset.

(a) **RADIO MON 1**. Connects user's headset to audio from VHF-AM transceiver number 1.

(b) **RADIO MON 2**. Connects user's headset to audio from VHF-AM transceiver number 2, or VHF-FM (SINCGARS) transceiver, as selected by the FM/AM alternate communication selector switch.

(c) **RADIO MON 3**. Connects user's headset to audio from # 1 UHF transceiver.

(d) **RADIO MON 4**. Connects user's headset to audio from HF or VOW transceivers.

(e) **RADIO MON 5**. Connects user's headset to audio from # 2 UHF transceiver (BU VOW).

(3) Navigation receiver audio monitor controls. The navigation receiver audio monitor controls, placarded **RADIO MON, A** and **B**, are used to select which navigation receiver's audio will be heard in the pilot's or copilot's respective headset, and its volume. These controls are of the push on, pull off type. Clockwise rotation of a control increases audio output to headset.

(a) **NAV A**. Connects user's headset to audio from **VOR # 1**, **VOR # 2**, and marker beacon number 1.

(b) **NAV B**. Connects user's headset to audio from TACAN, marker beacon # 2, and ADF receivers.

(4) Microphone impedance selector switch. The microphone impedance selector switch, placarded **MIC, 1, 2**, allows selection of impedance to match microphone being used. Select **MIC 1** position for 5 ohm microphones, and **MIC 2** position for 150 ohm microphones.

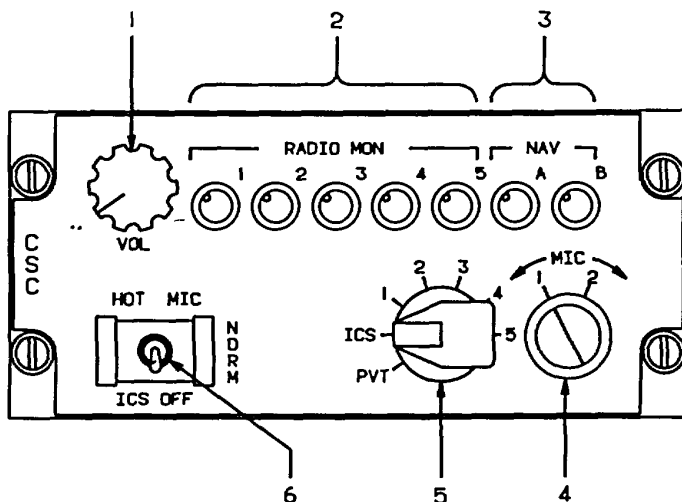

1. Master Volume Control
2. Transceiver Audio Monitor Controls
3. Navigation Receiver Audio Monitor Controls
4. Microphone Impedance Selector Switch
5. Transmitter-Intercom Selector Switch
6. Intercom Mode Selector Switch

A93FE00D0096 C

Figure 3-1. Audio Control Panel

(5) *Transmitter-intercom selector switch.* The transmitter-intercom selector switch, placarded **PVT**, ICS, 1 5, is used to select which transceiver the microphone is connected to when the user's control wheel microphone switch is depressed to the second level or the respective cockpit floor microphone switch is depressed, and routes the selected transceiver's received audio to the headset, regardless of the whether transceiver audio monitor control is on or off.

(a) *PVT.* This position is not used in this installation.

(b) *ICS.* Selects intercom system. Intercom will be activated when control wheel microphone switch is depressed to the first or second level, or when cockpit floor microphone switch is depressed.

(c) *Position 1.* Selects VHF-AM # 1 transceiver.

(d) *Position 2.* Selects VHF-FM (SINCGARS) transceiver or VHF-AM # 2 transceiver depending upon the position of the **AM/FM** alternate communication selector switch (pedestal extension, fig. 2-14.

(e) *Position 3.* Selects # 1 UHF transceiver.

(f) *Position 4.* Selects HF transceiver or VOW transceiver.

(g) *Position 5.* Selects # 2 UHF transceiver (BU VOW).

(6) *Intercom mode selector switch.* The three-position intercom mode selector switch, placarded **HOT MIC, NORM, ICS OFF**, controls the operating mode of the intercom system.

(a) *HOT MIC.* Microphone will be continuously connected to intercom system except when transmitter-intercom selector switch is set to a transceiver, and control wheel microphone switch is depressed to the second level, or cockpit floor microphone switch is depressed.

(b) *NORM.* Microphone will be connected to intercom system only when the control wheel microphone switch is depressed to the first level. If the transmitter-selector switch is set to the ICS position, the intercom will also be activated when the control wheel microphone switch is depressed to the second level.

(c) *ICS OFF.* Deactivates intercom system.

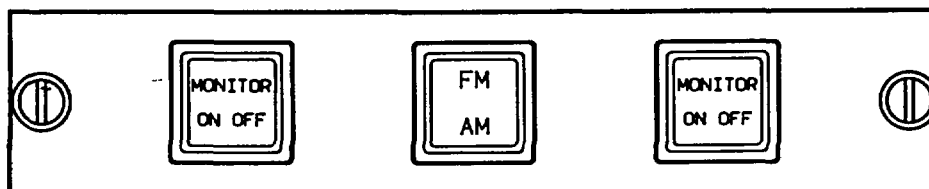

AP01565 C

Figure 3-2. VHF-FM/VHF/AM Alternate Communication Switch Panel

d. *Normal Operation.*

(1) *Turn-on procedure:*

1. **BATTERY** switch (overhead control panel, fig. 2-15) - ON.
2. **AVIONICS MASTER POWER** switch (overhead control panel, fig. 2-15) - ON.

(2) *Receiver operating procedure:*

1. Master **VOL** control - Adjust as required.
2. Receiver **RADIO MON** controls (audio control panel, fig. 3-1) - ON and adjust as required.

(3) *Transceiver operating procedure:*

1. Transmitter-intercom selector switch -Set to desired transceiver.
2. **MIC** selector switch (instrument panel, fig. 2-18) - **HEADSET** or **OXYGEN MASK**.
3. Control wheel microphone switch - Depress to **XMIT** (second level), or depress cockpit floor **MIC** switch to transmit.

(4) *Intercommunication procedure:*

1. **MIC** selector switch (instrument panel, fig. 2-18) - **HEADSET** or **OXYGEN MASK**.
2. Intercom mode selector switch (fig. 3-1) - **NORM** or **HOT MIC**.
3. If **HOT MIC** is selected - Speak into microphone.
4. If **NORM** is selected - Depress control wheel microphone switch to first level (**XMIT**) and speak into microphone.

e. Shutdown Procedure. **AVIONICS MASTER POWER switch - Off.**

**3-7. UHF TRANSCEIVER (AN/ARC-164, HAVE QUICK II).**

a. *Description.* The UHF transceiver, located on the left equipment rack, is a line-of-sight radio transceiver which provides transmission and reception of amplitude modulated (AM) signals in the ultra high frequency range of 225.000 to 399.975 MHz for a distance range of up to

100 miles. Channel selection is spaced at 0.025 MHz. A separate receiver is incorporated to provide monitoring capability for the UHF guard frequency (243.0 MHz). UHF audio output is applied to the audio panel where it is routed to the headsets. This system provides for secure communications through interfacing with a voice security system. A frequency hopping, or anti-jam mode is also available. The UHF transceiver is powered through a 7.5-ampere circuit breaker placarded **UHF**, located on the overhead circuit breaker panel (fig. 2-9). The UHF radio can be controlled in either of two ways. Control is selected by means of the **164 STBY/NORMAL** switch (pedestal extension, fig. 2-14). When **NORMAL** is selected, control is by means of the aircraft survivability equipment/avionics control system (ASE/ACS). When **STBY** is selected, control is by means of the UHF transceiver control panel (fig. 3-3) located on the pedestal extension.

**NOTE**

**The preset channel selector and manual frequency selectors are inoperative when the mode selector switch is set to the GD position. The receiver-transmitter will be set to the emergency frequency only.**

b. *Standby UHF Control Panel (fig. 3-3), Controls and Functions.* This unit provides standby control, when the **164 STBY/NORMAL** switch located on the pedestal extension (fig. 2-14) is set to the STBY position.

(1) *TOD/Hundreds/AJ switch.*

(a) *Position T.* The T position is a momentary spring-return position enabling input of time of day (TOD), or for an emergency clock start.

(b) 2,3. The 2 or 3 position may be used to select the 100's digit of the desired frequency in the normal mode, or the 100's digit of the word of day (WOD) element for the anti-jam (AJ) mode, and indicates units digit of frequency (0 through 9) in MHz.

(c) A. The A position is used to select the AJ mode of operation.

(2) *Preset channel selector switch.* Selects one of 20 preset channels when mode selector switch is set to PRE.

(3) *Tens digit frequency selector knob and indicator.* Selects tens digit of frequency (0 through 9).

(4) *CHAN indicator.* Displays selected preset channel number.

(5) *Units digit frequency selector knob and indicator.* Selects units digit of frequency (0 through 9).

(6) *SET switch.* Activates the circuitry to store the selected frequency in the selected preset channel memory.

(7) *Tenths digit frequency selector knob and indicator.* Selects tenths digit of frequency (0 through 9).

(8) *MEMORY indicator.* Displays the operating frequency when **READ** switch is depressed.

(9) *Hundredths digit frequency selector knob and indicator.* Selects hundredths digit of frequency (0 through 9).

(10) *READ switch.* When depressed, **MEMORY** indicator will display operating frequency.

(11) *Squelch switch.* The squelch switch, placarded **ON - SQ - OFF**, enables and disables squelch circuits of the main receiver.

(12) *Mode selector switch.* Selects mode of frequency selection.

(a) *GD.* The main receiver and transmitter are automatically tuned to the guard frequency, and the

guard receiver is disabled.

(b) *PRE.* Frequency is selected using the preset channel selector switch. Also used when programming the preset channels.

(c) *MAN.* Frequency is manually selected using the frequency selector switches.

(13) *Volume control.* Adjusts audio output volume to headsets.

(14) *Function selector switch.* Selects operating mode.

(a) *OFF.* Shuts down equipment.

(b) *MAIN.* Enables main receiver and main transmitter.

(c) *BOTH.* Enables main receiver, main transmitter, and guard receiver.

(d) *ADF.* Not used in this installation.

(15) *TONE switch.* When depressed, the TONE switch transmits time of day (TOD), followed by a 1020 Hz tone on the selected frequency. When used in conjunction with the T-2-3-A switch, it starts the TOD clock.

1. TOD/Hundreds/AJ Switch
2. Preset Channel Selector Switch
3. Tens Digit Frequency Selector and Indicator
4. Preset Channel Indicator
5. Units Digit Frequency Selector and Indicator
6. Set Switch
7. Tenths Digit Frequency Selector Knob and Indicator
8. Memory Indicator
9. Hundredths Digit Frequency Selector Knob and Indicator
10. Read Switch
11. Squelch Switch
12. Mode Selector
13. Volume Switch
14. Function Selector Switch
15. Tone Switch

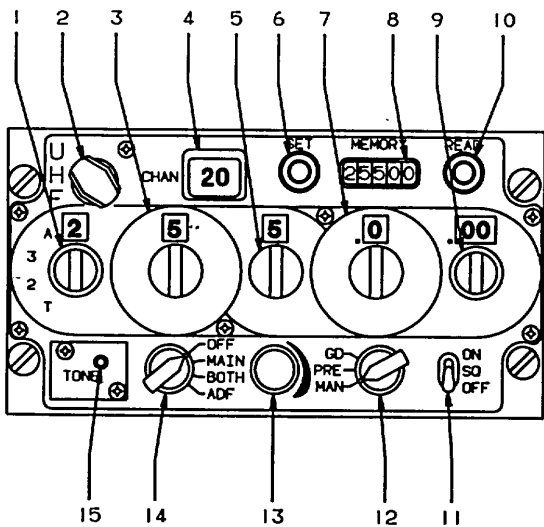

Figure 3-3. UHF Transceiver

A93FE00D0097 C

When not in the AJ mode, it operates as a tone transmission switch only.

c. *Standby Operation.* Normal operation using the aircraft survivability equipment/ avionics control system (ASE/ACS) is described in chapter 4.

(1) *Turn on procedure:*

1. **AVIONICS MASTER POWER** switch (overhead control panel, fig. 2-15) - **ON**.
2. UHF transceiver 164 **STBY/NORMAL** switch (pedestal extension, fig. 2-14) - **STBY**.
3. Function select switch - **MAIN BOTH** position, as required.

**NOTE**

**If function selector is at MAIN setting, only the normal UHF communications will be received. If selector is at BOTH position, emergency communications on the guard channel and normal UHF communications will both be received.**

(2) *Transceiver operating procedure.*

1. Transmitter-intercom selector switch (audio control panel, fig. 3-1) - 3.
2. Microphone switch - Depress to transmit.

(3) *Preset channel selection.*

1. Function selector switch - MAIN.
2. Mode selector switch - PRE.
3. Manual frequency selector switches - Set frequency to be placed into memory.
4. Preset channel selector switch - Set desired channel number.
5. SET switch - Depress.

**3-8. VOICE SECURITY SYSTEM TSECIKY-58 (COMPLETE PROVISIONS ONLY).**

Complete provisions only are provided for a TSEC/ KY-58 voice security system. This system provides secure (ciphered) two-way voice communications for the pilot and copilot in conjunction with the # 1 UHF, VHF-FM (SINC-GARS), and # 2 (BU VOW) transceivers. The system will

be located in the left equipment rack behind the pilot. System circuits are protected by the UHF, VHF-FM, and BU VOW circuit breakers on the overhead circuit breaker panel (fig. 2-9).

**3-9. BACK-UP VOICE ORDER WIRE (BU VOW) (AN/ARC-1 64).**

A transceiver identical in type and performance to the UHF transceiver (fig. 3-3) is located on the left equipment rack, to serve as a back-up voice order wire. The transceiver can only be controlled by the ASE/ACS. Standby control is not available. The transceiver is selected on the audio control panel (fig. 3-1) by transmitter-intercom selector switch position number 5 and by radio audio monitor control number 5. This set provides for secure communications through interfacing with a voice security system. The back-up voice order wire set is protected by the 7 1/2-ampere **BU VOW** circuit breaker in the overhead circuit breaker panel (fig. 2-8). The back-up voice order wire shares an antenna mounted on the aircraft belly with the transponder (fig. 2-1 and 2-2).

**3-10. VHF COMMUNICATIONS TRANSCEIVERS (VHF-22B).**

a. *Introduction.* The VHF communications transceivers (fig. 3-4), provide airborne VHF communications on 1360 channels from 118.00 through 151.975 MHz, and are operated by two CTL-22 transceiver control units, located on the pedestal extension (fig. 2-14).

The solid-state transceiver includes capture-effect automatic squelch to help prevent missed radio calls, plus audio leveling and response shaping to ensure audio quality. Transmitter sidetone comes from detected transmitter signal, and is therefore a reliable check of transmission quality. Each VHF transceiver is powered through its respective circuit breaker, placarded VHF # 1 or VHF # 2, located on the overhead circuit breaker panel (fig. 2-9).

b. VHF Transceiver Operating Controls (VHF-22B). All operating controls for the transceivers are located on the CTL-22 transceiver control units and on the FM/AM alternate communication switch panel (pedestal extension, fig. 2-14).

(1) *Active frequency display.* Displays the active frequency (frequency to which the transceiver is tuned) and diagnostic messages.

(2) *Transfer/memory switch.* This switch is a three-position spring-loaded toggle switch placarded XFRI MEM, which when held to the XFR position, causes the preset frequency to be transferred up to the active display and the transceiver to be returned. The previously active frequency will become the new preset frequency and will

be displayed in the lower window. When this switch is held to the **MEM** position, one of the six stacked memory frequencies will be loaded into the preset display. Successive pushes will cycle the six memory frequencies through the display ( 2,3,4,5,6,1,2,3 ).

(3) *Store switch.* This switch, placarded **STO**, allows up to six preset frequencies to be selected and entered into the control unit's memory. After presetting the frequency to be stored, push the **STO** switch. The upper window displays the channel number of available memory (CH 1 through CH 6) while the lower window continues to display the frequency to be stored. For approximately 5

seconds, the **MEM** switch may be used to advance through the channel numbers without changing the preset display. Push the **STO** switch a second time to commit the preset frequency to memory in the selected location. After approximately 5 seconds, the control will return to normal operation.

(4) *Tuning knobs.* Two concentric tuning knobs control the preset or active frequency displays. The larger knob changes the three digits to the left of the decimal point in 1-MHz steps. The smaller knob changes the two digits to the right of the decimal point in 50-kHz steps (or in 25-kHz steps for the first two steps after the direction

of rotation has been reversed). The numbers will roll over at the upper and lower frequency limits.

(5) *Active switch.* The active switch, placarded **ACT**, enables the tuning knobs to directly tune the VHF transceiver, when depressed and held for two seconds. The bottom window will display dashes and the upper window will continue to display the active frequency. Pushing the **ACT** switch a second time will return the control unit to the normal two-display mode.

(6) *Test switch.* This switch placarded **TEST** initiates the transceiver self-test diagnostic routine. (Selftest is active only when the **TEST** switch is pressed.)

(7) *Light sensor.* This built-in light sensor automatically controls display brightness.

(8) *Volume control.* The volume control is concentric with the power and mode switch.

(9) *Power and mode switch.* The power and mode switch contains three detented positions. The **ON** and **OFF** positions switch system power. **SQ OFF** position disables the receiver squelch circuits.

(10) *Annunciators.* The transceiver control unit contains a **MEM** (memory) and a **TX** (transmit) annunciator. The **MEM** annunciator illuminates whenever a preset

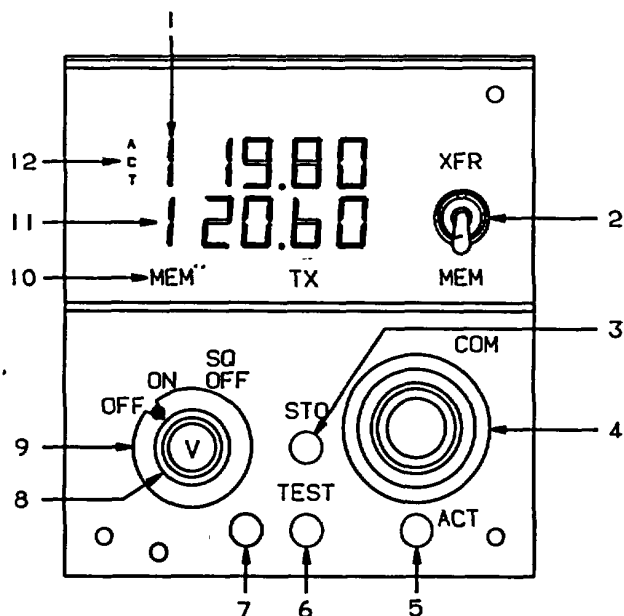

1. Active Frequency Display
2. Transfer/Memory Switch
3. Store Switch
4. Tuning Knobs
5. Active Switch
6. Test Switch
7. Light Sensor
8. Volume Control
9. Power and Mode Switch
10. Annunciators (MEM, TX)
11. Preset Frequency Display
12. Compare Annunciator

A93FD00D0098 C

Figure 3-4. VHF Communications Transceiver Control Unit

frequency is being displayed in the lower window. The TX annunciator illuminates whenever the transceiver is transmitting.

(11) *Preset frequency display.* Displays the preset (inactive) frequency and diagnostic messages.

(12) *Compare* annunciator. An annunciator placarded **ACT** momentarily illuminates when frequencies are being changed. The **ACT** annunciator flashes if the actual radio frequency to which the transceiver is tuned is not identical to the frequency shown in the active frequency display.

c. *Operating Procedures.* The frequencies displayed on the transceiver control unit show only five of the six digits. The sixth digit is always a zero (when the fifth digit is a 0 or 5) or a 5 (when the fifth digit is a 2 or 7), therefore, the sixth digit does not need to be displayed.

#### NOTE

**It is possible that erroneous operation could occur without a fault indication. It is the responsibility of the pilot to detect such an occurrence by continually assessing the reasonableness of operation as displayed on the associated transceiver control unit and by the quality of received signals and transmissions.**

(1) *Equipment turn-on.* The transceiver and the control unit are turned on by rotating the power and mode switch on the transceiver control unit to the ON position. When the transceiver is first turned on it sounds a brief tone while the microprocessor checks its own memory. If there is a memory defect the tone continues, indicating that the transceiver can neither receive nor transmit. After the memory check, the transceiver control unit will display the same active and preset frequencies that were present when the equipment was last turned off.

#### NOTE

**If two short 800-Hz tones are heard, the transceiver has detected an internal fault. Push the TEST switch on the transceiver control unit to initiate self-test and display the fault code. Adjust the volume and perform a quick squelch test by setting the power and mode switch on the transceiver control unit to SQ OFF and adjusting the volume level with background noise. After a comfortable listening level has been established, return the power and mode switch to the ON position. All background noise should disappear unless a station or aircraft is transmitting on the active frequency.**

(2) *Frequency selection.* Frequency selection is made using either the frequency select knobs, or the

**XFR/MEM** (transfer/memory recall) switch. Rotation of either frequency select knob increases or decreases the frequency in the preset frequency display. The larger, outer knob changes the frequency in 1-MHz increments (the number to the left of decimal point). The smaller, inner knob changes the frequency in 50-kHz increments when first rotated, or in 25-kHz increments for the first two increments after the direction of rotation is reversed.

After the desired frequency is set into the preset frequency display, it can be transferred to the active frequency display by momentarily setting the **XFR/MEM** switch to **XFR**. At the same time that the preset frequency is transferred to the active display, the previously active frequency is transferred to the preset display. A short audio tone is applied to the audio system to indicate that the active frequency has been changed, and the active (ACT) annunciator on the control will flash while the transceiver is tuning to the new frequency.

#### NOTE

**The active (ACT) annunciator continuing to flash indicates that the transceiver is not tuned to the frequency displayed in the active display.**

The transceiver control unit's memory permits storing up to six preset frequencies. Once stored, these frequencies can be recalled to the preset display by positioning the XFR/MEM switch to the **MEM** position. The storage location (**CH 1** through **CH 6**) for the recalled frequency is displayed in the active frequency display while the **XFR/ MEM** switch is held in the **MEM** position. All six stored frequencies can be displayed one at a time in the preset display by repeatedly positioning the **XFR/MEM** switch to the **MEM** position. After the desired stored frequency has been recalled to the preset display, it can be transferred to the active display by momentarily positioning the **XFR/ MEM** switch to the **XFR** position.

During normal operation, all frequency selections and revisions are done in the preset frequency display. However, the active frequency can be selected directly as described in the following paragraph.

#### (3) *Direct active frequency selection.*

The active frequency can be selected directly with the frequency select knobs by pushing the ACT switch for about 2 seconds. The active frequency selection mode is indicated by dashes appearing in the preset display. Also, the ACT annunciator will flash as the frequency select knobs are turned to indicate that the transceiver is being returned.

**NOTE**

The ACT annunciator continuing to flash after the frequency has been selected indicates that the transceiver is not tuned to the frequency displayed in the active display.

To return to the preset frequency selection mode, push the ACT switch again for about 2 seconds. As a safety feature, the transceiver control unit switches to the active frequency selection mode when a frequency select knob is operated while the STO, TEST, or XFR/MEM switches are actuated.

(4) *Frequency storage.* To program the memory, select the frequency in the preset frequency display using the frequency select knobs and push the STO switch once. One of the channel numbers (CH 1 through CH 6) will appear in the active display for approximately 5 seconds. During this time the channel number can be changed without changing the preset frequency by momentarily positioning the XFR/MEM switch to the MEM position. After the desired channel number has been selected, push the STO switch again to store the frequency.

**NOTE**

When storing a frequency, the second actuation of the STO switch must be done within 5 seconds after selecting the channel number or the first actuation of the STO switch. If more than 5 seconds elapse, the control will revert to the normal modes of operation and the second store command will be interpreted as the first store command.

After a frequency has been stored in memory, it will remain there until changed by using the STO switch. Memory is retained even when the unit is turned off for an extended period of time.

(5) *Stuck microphone switch.* Each time the push-to-talk switch is depressed, the microprocessor in the transceiver starts a 2-minute timer. (The TX annunciator on the transceiver control unit will be illuminated when-ever the transmitter is transmitting.) If the transmitter is still transmitting at the end of 2 minutes, the microprocessor turns it off. Most intentional transmissions last much less than 1 minute; a 2-minute transmission is most likely the result of a stuck microphone switch. This timing feature protects the ATC channel from long-term interference.

When it turns off the transmitter, the microprocessor switches the transceiver to receive operation. A stuck microphone switch will prevent you from hearing received

Table 3-1. VHF Communications Transceiver Fault Codes

CODE	INTERPRETATION
00	No fault found
01	5 V dc below limit
02	5 V dc above limit
03	12 V do below limit
04	1 2 V dc above limit
05	Synthesizer not locked
07 -	Noise squelch open without signal
08	Noise squelch not open with signal
12	BCD frequency code invalid
13	2-out-of-5 frequency code invalid
14	Serial message invalid
15	Frequency out of range
16	Forward power below limit
17	Transmitter temperature excessive
21	Tuning voltage out of limit at highest receive frequency
22	Tuning voltage out of limit at 118 MHz
23	Local oscillator output below limit
24	No-signal AGC voltage too high
25	Inadequate AGC voltage increase with RF signal
26	Reflected RF power above limit
27	Transmitter timed out



signals, or the two warning beeps. The microprocessor then waits until the push-to-talk switch opens to sound the two beeps.

To transmit for more than 2 minutes, release the microphone switch briefly and then press it again. The 2-minute timer resets and starts a new count each time the microphone switch is pressed.

(6) *Over-temperature protection.* The microprocessor regularly monitors the temperature of the transmitter. If the transmitter gets too hot during a transmission, the microprocessor will stop the transmission, and the sidetone will cease. When the microphone switch is released, you will hear two beeps. (Press the **TEST** switch on the transceiver control unit to observe the fault code.) As long as the temperature remains above the limit, the microprocessor will not respond to a normal push of the microphone switch. If you must transmit, however, you can override the protection by rapidly keying the microphone switch twice, holding it on the second push. The shutdown temperature is 160°C (320°F).

(7) *Self-test.* An extensive self-test diagnostic routine can be initiated in the transceiver by pushing the TEST switch on the transceiver control unit. The control unit will modulate the active and preset display intensity from minimum to maximum to announce that self-test is in progress. Several audio tones will be heard from the audio system while the self-test routine is being executed. At the completion of the self-test program, the transceiver control unit will usually display dashes in the active display, and 00 in the preset display. This indicates normal operation. If any out-of-limit condition is found, the transceiver control unit will display **DIAG** (diagnostic) in the active display and a 2-digit fault code in the preset display. Record any fault codes displayed to help the service technician locate the problem. Refer to table 3-1 for a description of the self-test fault codes that can be displayed on the transceiver control unit. (The **TEST** switch must be pushed before any fault code can be displayed.)

### 3-11. HF COMMUNICATIONS TRANSCEIVER (KHF-950).

a. Description. The HF communications transceiver (fig. 3-5), provides long-range voice communications within the frequency range of 2.0000 to 29.9999 MHz (280,000 possible frequencies). The unit can employ either amplitude modulation (AM) or upper sideband (USB) modulation. (Lower sideband (LSB) modulation has not been enabled in this installation.) The HF system consists of a control display unit located on the pedestal extension, a receiver/exciter, a power amplifier/antenna coupler, a bus adapter, and an antenna. The system is powered through a 25-ampere circuit breaker placarded **HF PWR** and a

5-ampere circuit breaker placarded HF RCV, located on the overhead circuit breaker panel (fig. 2-9).

b. HF Transceiver Control-Display Unit Controls and Functions.

(1) *Digital display.* The digital display provides frequency, mode, and operational status information. The upper area of the display shows a two digit channel number when in the program mode, followed by a dash and the first one or two digits of the operating frequency (with the emission mode selector switch set to the **USB** or **AM** position). Transmitter operation (**TX**) is shown at the right end of this display. The lower line of the display shows the last four digits of the operating frequency (with the emission mode selector switch set to the **USB** or **AM** position).

(2) *Light sensor.* A light sensor located to the right of the display senses ambient light conditions and adjusts display brightness accordingly.

(3) *Store switch.* A momentary push button switch placarded **STO**, is used to store in memory the displayed data when programming preset channels. When the **STO** switch is pressed simultaneously with a microphone transmit switch, a 1000 Hz operator attention tone will be transmitted (required by some Canadian radiotelephone stations).

(4) *Frequency/channel selector knob.* The frequency/channel selector knob (inner concentric with the emission mode selector switch) allows the pilot to set channels and frequencies, and serves as a clarifier control in sideband mode. Depressing the control knob causes the flashing cursor on the display to move to the digit that the pilot desires to change. Each time the control is depressed, the cursor moves forward to the next digit. The digit at the cursor position is changed by rotating the channel/ frequency selector knob.

(5) *Emission mode selector switch.* The emission mode switch, placarded **LSB**, **USB**, **AM**, and **TEL (A3J)**. (concentric with the frequency/selector knob) is used to select the operating mode of the HF transceiver.

(6) *Squelch control.* A knob placarded SQ (outer concentric with the off/volume control knob) provides a variable squelch threshold control. This control is used to help reduce background noise when a signal is not being received.

(7) *On, off, volume control.* A knob placarded OFF, VOL (inner concentric with the squelch knob) is used to turn the transceiver on and off, and adjust volume. Clockwise rotation from the detent applies power to the

system. Further clockwise rotation increases audio output level.

c. *Frequency Selection.* The HF system has two methods of frequency selection: direct tuning mode and channel mode.

(1) *Direct tuning mode.* In the direct tuning mode the desired frequency is set into the display using the frequency/channel selector knob, and stored in memory. Only simplex operation is allowed while operating in the direct tuning mode.

(2) *Channel mode.* When the HF control unit is in the channel mode, channels and their respective frequencies are changed using the frequency/channel selector knob. Frequencies in the channel mode are stored with channel number, emission mode (USB or AM), and transmit and receive frequency.

(a) *Simplex operation.* The operator programs the same frequency for receive and transmit. The simplex function is used by air traffic control, **ARINC**, and others.

(b) *Semi-duplex.* In semi-duplex operation the operator programs two different frequencies, one for transmit and one for receive. The semi-duplex function is

used by maritime radiotelephone network (public correspondence) stations.

d. *HF Communications Transceiver Operation.*

(1) Direct frequency tuning operation (simplex only).

1. Emission mode selector switch - **USB** or **AM**.
2. Frequency/channel selector switch Turn knob until a flashing 0 appears in the display. HF system is now in direct tuning mode.
3. Frequency/channel selector switch Depress repeatedly until cursor is at digit to be changed.

**NOTE**

The first one or two digits (MHz) of the frequency are shown on the upper right portion of the display, while the last four digits (kHz) of the frequency are displayed on the bottom of the display.

4. Frequency/channel selector switch - Turn knob until desired number has

1. Digital Display
2. Light Sensor
3. Store Switch
4. Frequency/Channel Selector Knob
5. Emission Mode Selector Switch
6. Squelch Control
7. On, Off, Volume Control

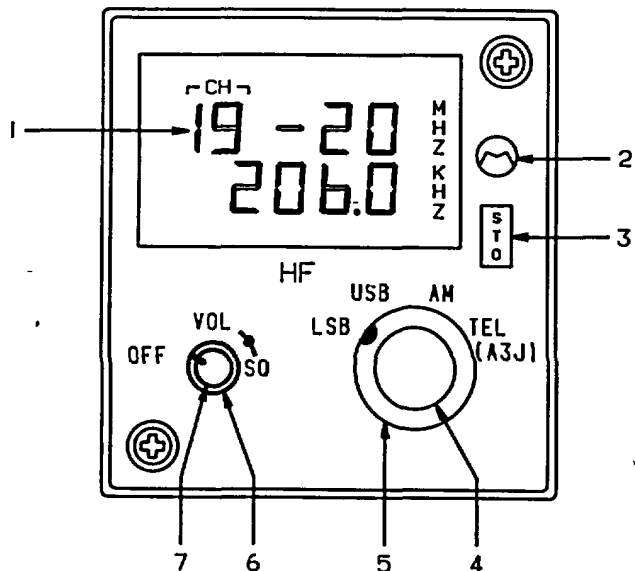

A93FE0D0099 C

Figure 3-5. HF Communications Transceiver Control Unit

been selected. The 0 in channel display will become blank.

5. Continue moving cursor and changing digits until desired frequency appears in display.
6. Frequency/channel selector switch Stow cursor by depressing repeatedly until no digit is left flashing.

**NOTE**

**Keying the microphone momentarily will also stow the cursor.**

7. Antenna coupler - Tune by keying radio momentarily. During antenna coupler tuning process, TX on display will flash and frequency numbers will be blank.
8. When TX annunciator stops flashing and frequency reappears, antenna tuning cycle is complete and radio is ready to transmit on the selected frequency.

**NOTE**

**Always key the radio after selecting a new frequency to initiate antenna tuning. Otherwise poor reception or failure to hear a ground station which is calling you may be experienced.**

(2) *Programming simplex preset channels.*

1. Emission mode selector switch - **USB** or **AM**.
2. Frequency/channel selector switch - Depress repeatedly until channel number is flashing.
3. Frequency/channel selector switch - Twist to select desired channel number. Previously programmed receive frequency associated with that channel number will appear in display.
4. Frequency/channel selector switch - Depress repeatedly until cursor is at digit to be changed.

**NOTE**

**The first one or two digits (MHz) of the frequency are shown on the upper right portion of the display, while the last four digits (kHz) of the frequency are displayed on the bottom of the display.**

5. Frequency/channel selector switch - Twist knob until desired number has

been selected. A flashing dash will appear to right of channel number to indicate that transceiver is in program mode.

6. Continue moving cursor and changing digits until desired frequency appears in display.

**NOTE**

**The program mode may be exited at any time and the previously stored frequency returned by keying the microphone.**

7. Store switch - Depress to store frequency in receive portion of memory. TX annunciator will flash to indicate that memory is ready to receive transmit frequency.
8. Store switch - Depress a second time to store frequency in the transmit portion of the memory if entering a simplex frequency.
9. If entering a semi-duplex frequency, use frequency/channel selector switch to set transmit frequency in display.
10. Store switch - Depress to enter transmit frequency into memory. Cursor will stow and flashing dash will disappear to indicate that HF control-display unit is no longer in program mode.
11. Antenna coupler - Tune by keying radio momentarily. During antenna coupler tuning process, TX on display will flash and frequency numbers will be blank.
12. When TX annunciator stops flashing and frequency reappears, antenna tuning cycle is complete and transceiver is ready to transmit on the selected frequency.

**NOTE**

**Always key radio after selecting a new frequency to initiate antenna tuning. Otherwise poor reception or failure to hear a ground station which is calling you may be experienced.**

(3) *Programming semi-duplex preset channels.*

1. Emission mode selector switch - **USB** or **AM**.
2. Frequency/channel selector switch - Depress repeatedly until channel number is flashing

3. Frequency/channel selector switch - Twist to select desired channel number. Previously programmed receive frequency associated with that channel number will appear in the display.
4. Frequency/channel selector switch - Depress repeatedly until cursor is at the digit to be changed.

**NOTE**

**The first one or two digits (MHz) of the frequency are shown on the upper right portion of the display, while the last four digits (kHz) of the frequency are displayed on the bottom of the display.**

5. Frequency/channel selector switch - Twist knob until desired number has been selected. A flashing dash will appear to right of channel number to indicate that transceiver is in program mode.
6. Continue moving cursor and changing digits until desired frequency appears in display.

**NOTE**

**The program mode may be exited at any time and the previously stored frequency returned by keying the microphone.**

7. Store switch - Depress to store frequency in receive portion of memory. TX annunciator will flash to indicate that memory is ready to receive transmit frequency.
8. Frequency/channel selector switch - Depress repeatedly until cursor is at the digit to be changed.

**NOTE**

**The first one or two digits (MHz) of the frequency are shown on the upper right portion of the display, while the last four digits (kHz) of the frequency are displayed on the bottom of the display.**

9. Frequency/channel selector switch - Turn knob until desired number has been selected. A flashing dash will appear to right of channel number to indicate that transceiver is in program mode.
10. Continue moving cursor and changing digits until desired transmit frequency

appears in display.

**NOTE**

**The program mode may be exited at any time and the previously stored frequency returned by keying the microphone.**

11. Store switch - Depress a second time to store frequency in transmit portion of memory. Cursor will stop and flashing dash will disappear to indicate that HF control-display unit is no longer in program mode.
12. Antenna coupler- Tune by keying radio momentarily. During antenna coupler tuning process, TX on display will flash and frequency numbers will be blank.
13. When TX annunciator stops flashing and frequency reappears, antenna tuning cycle is complete and transceiver is ready to transmit on selected frequency.

e. *Clarifier Operation.* A clarifier function is provided by the control-display unit which allows the operator to make small adjustments to the receive frequency when operating in the channel mode (simplex or semi-duplex) in the USB mode. The clarifier is not normally used in the AM mode and cannot be used with the emission mode selector switch in the A3J position. The clarifier helps eliminate unnatural sounds associated with SSB transmission as a result of off-frequency ground station transmissions. Operate clarifier as follows:

1. Frequency/channel selector switch - Depress repeatedly until last digit of receive frequency is flashing.
2. Frequency/channel selector switch - Rotate to increase or decrease last digit of receive frequency by one increment.
3. Received audio quality - Monitor. If reception does not improve sufficiently, try additional changes in last digit.

**NOTE**

**If transmission is made while using clarifier, transmission will be on the originally selected frequency. The dash to the right of the channel number will not flash and the transceiver will not be in the program mode.**

4. To exit clarifier mode, depress store switch or return last digit to original frequency selection.

*f. Maritime Radiotelephone Network Channel Operation.* The memory of the control-display unit has all 176 ITU (International Telecommunications Union) public correspondence channels programmed permanently into its memory. Operation in this mode is as follows:

1. Emission mode selector switch - A3J.
2. Frequency/channel selector switch - Depress repeatedly until channel number is flashing.
3. Frequency/channel selector switch - Turn to select desired channel number.
4. Frequency/channel selector switch - Depress repeatedly until cursor is at digit to be changed.
5. Frequency/channel selector switch - Turn knob until desired number has been selected.

**NOTE**

There are only two cursor positions for the ITU channel number. The hundreds position also controls the thousands position. For example, if the displayed channel number is 1204, the cursor could be moved to the 12 but not the 1. With the cursor in the 12 position, turning the frequency/channel selector one step counter-clockwise will change the 12 to an 8, while another step in the same direction will change 8 to a 6. This is consistent with the actual channel numbers.

6. Antenna coupler - Tune by keying radio momentarily. During antenna coupler tuning process, TX on display will flash and frequency numbers will be blank.
7. When TX annunciator stops flashing and frequency reappears, antenna tuning cycle is complete and transceiver is ready to transmit on selected frequency.

**NOTE**

Always key the microphone after selecting a new frequency to initiate antenna tuning. Otherwise poor reception or failure to hear a ground station which is calling you may be experienced.

Before keying the microphone to talk, depress the store (STO) switch momentarily. This will allow monitoring of the transmit frequency to see if another aircraft is calling the same ground station.

Some Canadian public correspondence stations require the reception of a 1,000 Hz signal from an aircraft calling the station before it will answer. This signal may be sent by keying the radio and then simultaneously depressing the store (STO) switch.

**3-12. VHF-FM TRANSCEIVER (AN/ARC-201A(V), SINGGARS).**

*a. Description.* The single channel ground and airborne radio system (SINGGARS, AN/ARC-201A(V)) provides VHF-FM radio communications. The frequency range is 30 to 87.975 MHz. The system provides for secure communications through interfacing with a voice security system. The system is protected by a 10-ampere circuit breaker placarded FM, located on the overhead circuit breaker panel (fig. 2-9).

Control of the VHF-FM transceiver is provided by the aircraft survivability equipment/avionics control system (ASE/ACS).

- b. Normal Operation.*

**NOTE**

Some operations in the VHF-FM transceiver require several seconds to accomplish. While these operations are active, the TUNING legend (multifunction display, fig. 4-2), will be displayed and some bezel buttons will become inactive until tuning is complete.

- (1) *Turn-on procedure.*

1. **BATTERY** switch (overhead control panel, fig. 2-15) - **ON**.
2. **AVIONICS MASTER POWER** switch (overhead control panel, fig. 2-15) - **ON**.
3. Transmitter-intercom selector switch (audio control panel, fig. 3-1) - 2.
4. **FM/AM** alternate communication selector switch (pedestal extension, fig. 2-14) - As required.
5. **D** mode selector switch (multifunction display, fig. 4-2) - Depress to select **COMM** control page.

**NOTE**

**On power-up, the transceiver is put into the self-test mode for approximately 30 seconds. During this period, the legend TUNING is displayed adjacent to L1 on the COMM control page and at the top center of this page and the transceiver will not respond to operator inputs.**

(2) *COMM control page.* The **COMM** control page shows the status of the **VHF-FM** and has a frequency list. Radio name, mode of operation, selected channel and frequency (or hopset number/**AJ NET** number), and plain/ cipher indications are presented. Two arrows indicate which transceiver each pilot has selected with the transmitter-intercom selector switch (audio control panel, fig. 3-1).

**NOT INST** - The aircraft is configured for the equipment but it is not installed.

**FAIL** - The equipment has failed.

**Blank - No** legend at the bezel switch indicates that the aircraft is not configured for the equipment.

**NOTE**

**The following definitions apply to the legend adjacent to the bezel switches:**

If L1 line selection switch is depressed with the scratch-pad empty:

The **FM** frequency list will be displayed in the box in the center of the multifunction display (MFD).

The **HOPSET/LOCKSET** list will be displayed in the box in the center of the MFD if the frequency hopping mode is active.

The legend at R4 will change to **FM FREQ.**

The legend at R5 will change to **2-FM SETUP.**

If the VHF-FM transceiver is in the single channel mode and valid data is scratchpadded, depressing L1 will cause the transceiver to be returned and the display at L1 to be updated to reflect the scratchpadded data. Valid data is:

A channel (1 through 20, or C or E).

A frequency (30.000 to 87.975 with leading and trailing zeroes and decimal points optional).

An identifier (1 through 6 alphanumeric characters, beginning with an alpha but excluding E, C, C plus 1 through 6, and P).

Identifiers are valid only if they exist in the frequency list.

If the VHF-FM is in the frequency hopping mode and valid data is scratchpadded, depressing L1 will cause the transceiver to be returned and the display at L1 to be

updated to reflect the scratchpadded data. Valid data is:

A **HOPSET** channel (0 through 6 or an M).

A **HOPSET** number (3 digit number).

An identifier (1 through 6 alphanumeric characters, beginning with an alpha but excluding E, C, C plus 1 through 6).

**HOPSET** and identifier entries are valid only if they exist in the hopset list.

**NOTE**

**Hopset channel 0 is processed and displayed as an M channel.**

1 *Displayed data at L1.* The first line of text at L1 is **2-FM** followed by an ICS select arrow if the radio has been selected by the transmitter-intercom selector switch (audio control panel, fig. 3-1). The text **CIPH** and a fill number is displayed to the right of the ICS select arrow if the cipher mode has been selected.

The second line of text at L1 can read:

Channel number/frequency followed by an optional identifier.

**E** (for emergency)/I followed by 40.5, followed by an optional identifier.

**Net** channel number/ followed by a **FH** followed by the net number in the frequency hopping mode.

**M/** followed by a frequency if the radio is tuned to a frequency list or if the cipher fill number/status is changed after the radio is tuned.

The third line of text (L1) may contain one of the following messages in the following priority:

**FAIL** - The radio has failed one of several tests.

**EMER** - The emergency tune function has been selected using the **KU EMER** switch.

**TUNING** - The ARC-201 is tuning and L1 is inoperative.

**NO TSEC** - The **FH** or **FH/M** mode is selected and a **TSEC** variable has not been stored into permanent memory.

(3) *2-FM SETUP* page. The **2-FM SETUP** page allows the operator to set up the VHF-FM transceiver. On power-up, the transceiver is put into the self-test mode for approximately 30 seconds. During this period, the legend **TUNING** is displayed adjacent to L1 on the **COMM** control page and at the top center of this page and the transceiver will not respond to operator inputs.

(a) *SC (single channel)* mode. The data at the top center of the page is:

Top line - **2-FM SETUP**

Second line - Currently tuned preset channel, frequency, and plain/cipher indication plus identifier

Third line - **FAIL**, **EMER**, or **TUNING** if appropriate

1 L1. Successive depressions of L1 will cause the mode to change from **SC** to **FH** to **FH/M**, with the active mode boxed.

2 L5. In SC mode, this function is a normal clock function.

If the scratchpad is blank, depressing R5 will change the display of time stored in the transceiver. If time is not available from the transceiver, the display remains blank. If valid data is scratchpadded, the data will be displayed adjacent to L5 and sent to the transceiver.

Valid time data is day (0 through 99), hours (0 through 23), and minutes (0 through 59). Data fields not entered are considered zero.

3 R1. Successive depressions of R1 will change the squelch from **OFF** to **ON**, with the active mode boxed.

4 R2. Successive depressions of R2 will cause the frequency offset for the selected preset channel to change from 0 to +5 to +10 to -10 to -5, with the active offset boxed. The offset selected for a preset channel is stored with that preset channel.

**NOTE**

**When the EMER switch on the keyboard unit (KU) is activated, 40.5 MHz is tuned, squelch is set to ON, and the function keys on the 2-FM AM/FM page are disabled.**

(b) *FH (frequency hopping mode)*. This mode is the member versus master/controller mode of the frequency hopping mode of the VHF-FM transceiver. The data at the top center of the page is:

Top line - **2-FM SETUP**.

Second line - The currently selected **FH** channel, the text **NET**, and the **NET** number.

Third line - Displays **FAIL**, **EMER**, **TUNING**, or **NO TSEC** if appropriate.

The display formats vary somewhat depending upon whether the aircraft is on the ground or in the air.

1 On the ground.

A L1. Second depressions of L1 will cause the mode to change from **SC** to **FH** to **FHIM**, with the active mode boxed.

**NOTE**

**If a TRANSEC variable has not been loaded, the text NO TSEC appears on the third line of text at the top center of the display.**

B L2. The **ERF RCV** key is used to initiate reception of frequency hopping data from the **NET** controller's radio. The received data is then stored in the member radio. Depressing L2 causes the legend to be boxed. If an **ERF** is received while the **ERF RCV** mode is active, the text at L2 will change to **STORE HSET** or **STORE LSET**, followed by the **HSET** or **LSET** data that was received. Depressing L2 will store the **LSET** in its channel or the **HSET** data in the channel entered in the scratchpad (valid entry is 1 through 6) and added to the **HSET/LSET** list. If the received data is bad, the text **BAD** is displayed next to L2. If the retrieval/storage of data is unsuccessful for some other reason, the text **ERROR** is displayed.

C L3. Function key L3 of the 2-FM **SETUP** page (FH format) is the **HSET TUNE** function key. This function key allows tuning of a hopset while on the **2-FM SETUP** page. Pressing L3 with a valid channel number (1-6, **O** or **M** (**O** is processed the same as an **M**)) that contains a hopset will cause the radio to be tuned to the entered channel. If a channel number is entered which does not contain a valid hopset and L3 is pressed, a scratchpad error. will occur.

**NOTE**

**The displayed HSET channel is the one that is used for LATE ENTRY.**

D L4. The **LSET CH** key is used to display lockset data associated with a particular LSET channel. If the scratchpad is empty, depressing L4 will cause the current displayed LSET channel and code to be blanked from the display. If a valid **LSET** channel is scratchpadded, depressing L4 will cause the scratchpadded

channel and its **LSET** code to be displayed. Valid **LSET** channels are I through 6. Other possible messages are **ERROR** and **NO LSET** (no **LSET** loaded for that channel).

e L5. In **FH** mode, this function is used to time **FH** operations. If the scratchpad is blank, depressing L5 will change the display of time stored in the transceiver. If time is not available from the transceiver, the display remains blank. If valid data is scratchpadded, the data will be displayed adjacent to L5 and sent to the transceiver. Valid time data is day (0 through 99), hours (0 through 23), and minutes (0 through 59). Data fields not entered are considered zero.

f R1. Depressing R1 will cause the legend at R1 to be boxed and the transceiver to be put into the **LATE NET E** (entry) mode. The late net mode can be used to re-synchronize the radio if communication has been lost due to drifting of the clock.

g R3. The function key R3 of the **2-FM SETUP** page (**FH** format) is the **CLEAR** function key. Pressing R3 with a valid hopset (1-6) or lockset (L1-L8) channel number in the scratch pad will cause the associated hopset or lockset to be cleared from the radio.

h R5. R5 is used to store hopsets and locksets from a fill device into the transceiver. When depressed, the legend at R5 will be boxed and will load the **HSET** or **LSET** channel entered into the scratchpad with the data from the fill device. Valid **HSET** entries are 1 through 6 or H1 through H6. Valid **LSET** entries are L1 through L6 or the single character L. **ERROR** or **BAD** can be displayed for unsuccessful or bad fill attempts.

2 In the air. The legend at R4 and R5 will be blanked in 66 air because the **TSEC FILL** and **FILL** function is only available when the aircraft is on the ground.

(c) *FH/M* (frequency hopping - master mode). This mode is the master/controller versus the member mode of the frequency hopping mode of the VHF-FM transceiver. The data at the top center of the page is:

Top line - **2-FM SETUP**

Second line - The currently selected **FH** channel; and the text **NET** and the net number

Third line - **CONTROL** or **CONTROL/NO TSEC**, but can read **FAIL**, **EMER**, or **TUNING** if appropriate. The display formats vary somewhat depending upon whether the aircraft is on the ground or in the air.

1 On the ground.

a L1. Successive depressions of L1 will cause the mode to change from **SC** to **FH** to **FHIM**, with the active mode boxed.

The differences between the **FH/M** and **FH** mode display formats are:

**FH/M** mode - L2 allows the operator to send (versus receive) frequency hopping data

R1 (**LATE NET**) - Blanked.

**NOTE**

**If a TRANSEC variable has not been loaded, the text NO TSEC will appear on the third line of text at the top center of the display.**

b L2. The **ERF SEND** key is used to initiate transmission of frequency hopping data from the NET controller's radio. When data is in the scratchpad and L2 is depressed, the text **SENDING HSET CH X** or **SENDING LSET CH X** (where X is the **HSET** or **LSET** channel in the scratchpad) is displayed. Valid scratchpad data is I through 6, H1 through H6, or L1 through L8. The sending legend is displayed for 12 seconds or until the radio has finished sending.

2 In the air. The on-ground and in-air display formats for the **FH/M** mode are the same except that the legends **TSEC FILL** (R4) and **FILL** (R5) keys are blanked (these functions are not available in flight).

c. **FM FREQ** List Page. The FM frequency list page is accessed by depressing R4 on the **COMM** control page when **FM FREQ** is displayed at R4. This page is used to enter/delete preset frequencies and hopsets/locksets for the **VHF-FM** transceiver. On power-up, all data displayed in the frequency list box (right side of the display) at shutdown is recalled, and the hopset/lockset information stored in the radio is recalled and displayed in the hopset/ lockset box (left side of the display). Leading zeroes and zeroes in the hundredths and thousandths position are not displayed.

(1) **ADD NET** function key. Function key L1 of the **UHF** frequency list page is the add net function key. The **ADD NET** key is used to add data to the **AJ NET** list. Entering valid data in the scratchpad and pressing L1 causes the data in the scratchpad to be entered into the **AJ NET** list. Valid data consists of a valid net channel (1-20) followed by a valid net number (1 to 5 digits with an optional decimal point whose final form will be in the



range 00.000-99.975 with the last two digits being 00, 25, 50, or 75), and/or a valid plain/cipher command (a P or a space or C plus a 1-6), and/or a valid identifier (1-6 alphanumeric characters, beginning with an alpha but excluding E, C, C plus 1 through 6, and P). Examples of valid entries are as follows:

(a) When 1 357 C3 ANET is scratchpadded and R1 is pressed, AJ NET code 35.7 is entered into the **AJ NET** list as preset 1 with an identifier of **ANET**. When tuned, this net is ciphered with fill 3.

(b) When 2 35725 **CENTAG** is scratchpadded and R1 is pressed, AJ NET code 35.725 is entered into the **AJ NET** list as preset 2 with an identifier of **CENTAG**.

(2) Delete (DEL) NET function key. Function key L2 of the UHF frequency list page is the **DEL NET** function key. The **DEL NET** key is used to delete data from the net list. Entering valid data in the scratchpad and pressing L2 causes the net code, plain/cipher mode, and fill data and identifier associated with the scratchpad entry to be deleted. Valid data consists of a valid channel (1-20). Several channels can be deleted at once by following the procedure described in paragraph c(4).

(3) ADD. When the VHF-FM transceiver is in the single channel mode, this key is used to add information to the single channel frequency list. Scratchpadding valid data and depressing R1 will cause the scratchpadded data to be entered into the frequency list.

Valid data consists of a valid channel (1 through 20 or C or E) followed by a valid frequency (30.000 through 87.975 with leading and trailing zeroes and decimal points optional) and/or a valid plain/cipher command (a P or a space or C plus a 1 through 6) and/or a valid identifier (1 through 6 alphanumeric characters, beginning with an alpha but excluding E, C, C plus 1 through 6, and P).

(4) DEL. This key is used to delete channel (preset) data from the frequency list. Scratchpadding valid data and depressing R2 will cause the frequency, plain/cipher mode and fill data, and identifier for the scratchpadded channels to be deleted.

Valid channels for the VHF-FM transceiver are I through 20 or C or E.

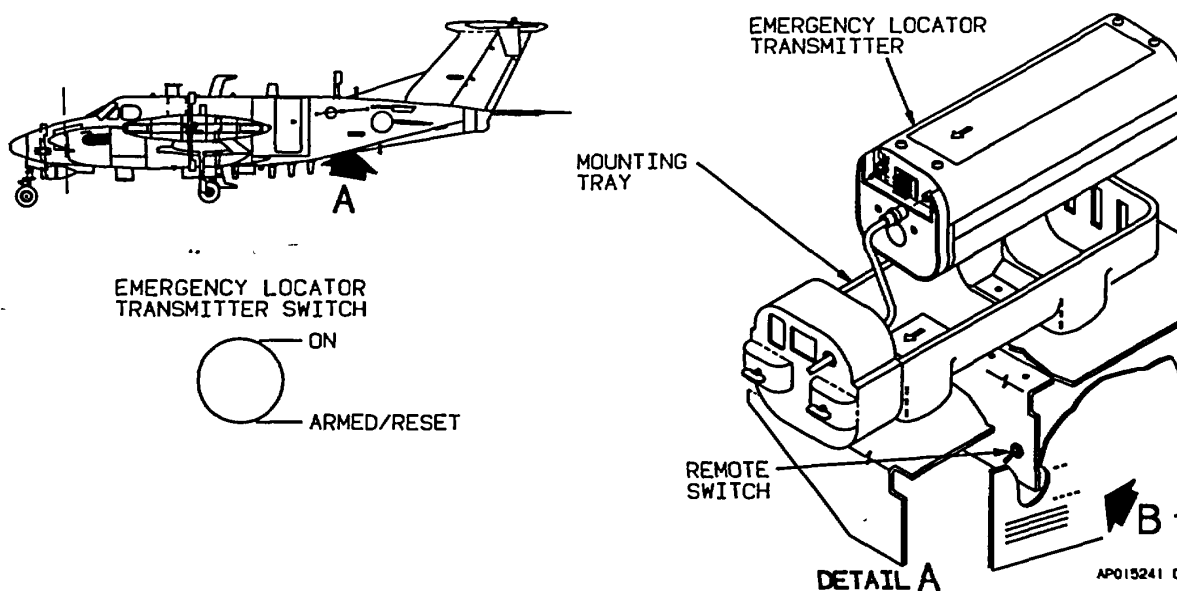

FOR AVIATION EMERGENCY USE ONLY  
 UNLICENSED OPERATION UNLAWFUL  
 OPERATION IN VIOLATION OF FCC  
 RULES SUBJECT TO FINE OR LICENSE  
 REVOCATION  
 DETAIL B

Figure 3-6. Emergency Locator Transmitter

**NOTE**

Several channels can be deleted at once by scratchpadding several channel numbers with a space between them. Scratchpadding 1 4 and depressing R2 will cause data in channels 1 and 4 to be deleted. Scratchpadding 1-4 and depressing R2 will cause data in channels 1 through 4 to be deleted.

**3-13. EMERGENCY LOCATOR TRANSMITTER (ELT 110-4).**

a. *Description* An automatic or manually activated emergency locator transmitter (ELT, fig. 3-6), is located in the left side of the aft fuselage. The associated antenna is mounted on top of the aft fuselage. An access hole with spring-loaded cover is located in the fuselage skin adjacent to the transmitter, enabling a downed pilot to manually initiate or terminate operation, or reset the ELT to an armed mode. The transmitter contains a G switch which automatically activates the transmitter following a velocity change of 3.5 feet per second. When activated, the ELT will radiate Omnidirectional radio frequency signals on the international distress frequencies of 121.5 and 243.0 MHz. The radiated signal is modulated with an audio swept tone. Internal batteries provide transmitter operation for a

minimum of 50 hours at -200C.

b. *Remote Switch and Functions.* The remote switch is accessible through a small (finger-size) spring loaded door, located on the left side of the aft fuselage. The remote switch is placarded **ON ARMED/RESET**.

(1) ON. Initiates emergency signal transmissions for test or for emergency purposes.

(2) ARMED/RESET. Used to **ARM** the **ELT** or reset it after an accidental activation.

c. *Normal Operation.* During normal operation the remote switch is in the down (ARMED/RESET) position.

d. *Emergency Operation.* The ELT may be manually activated by moving the remote switch to the up (ON) position.

e. *Resetting the ELT.* If the ELT is activated accidentally it will need to be reset. Do this by moving the remote switch up to the ON position and holding it there for one second, then immediately rocking it down to the ARMED/RESET position, then releasing the switch.

**Section III. NAVIGATION****3-14. NAVIGATION EQUIPMENT GROUP DESCRIPTION.**

The navigation equipment group provides the pilot and copilot with instrumentation required to establish and maintain an accurate flight course and position, and to make an approach on instruments under Instrument Meteorological Conditions (IMC). The navigation configuration includes equipment for determining attitude, position, destination range and bearing, heading reference, and ground speed.

**3-15. DIGITAL INTEGRATED FLIGHT CONTROL SYSTEM (SPZ-4500).**

The digital integrated flight control system (fig. 3-7), provides flight director guidance, autopilot, yaw damper, and trim functions.

The digital integrated flight control system is an integrated fail passive autopilot/flight director/air data system which has a full complement of horizontal and vertical flight guidance modes:

Radio guidance modes

Inertial navigation system tracking

Air data oriented vertical modes

The pilot can couple either the left or right electronic flight instrument system (EFIS) to the single automatic flight control system for control of the aircraft. The flight control computer provides digital processing of heading, navigation, and air data information to satisfy the pilot's requirements. The data is presented to the pilots on the altitude indicator and the electronic flight instrument system (EFIS).

The flight control system displays heading, course, radio bearing, pitch and roll attitude, barometric altitude, selected alert altitude, radio altitude, short and long range navigation, course deviation, glideslope deviation, to-from indication, TACAN distance and course indications, and VOR- DME distance information. Display of weather radar and lightning sensor system information on the electronic horizontal situation indicators (EHSI) is also provided.

Lighted annunciators denote selected flight mode, altitude alert, decision height, and go-around mode (on EADI's only) engagement. Pitch and roll steering commands are displayed on the electronic attitude director indicators (EADI).

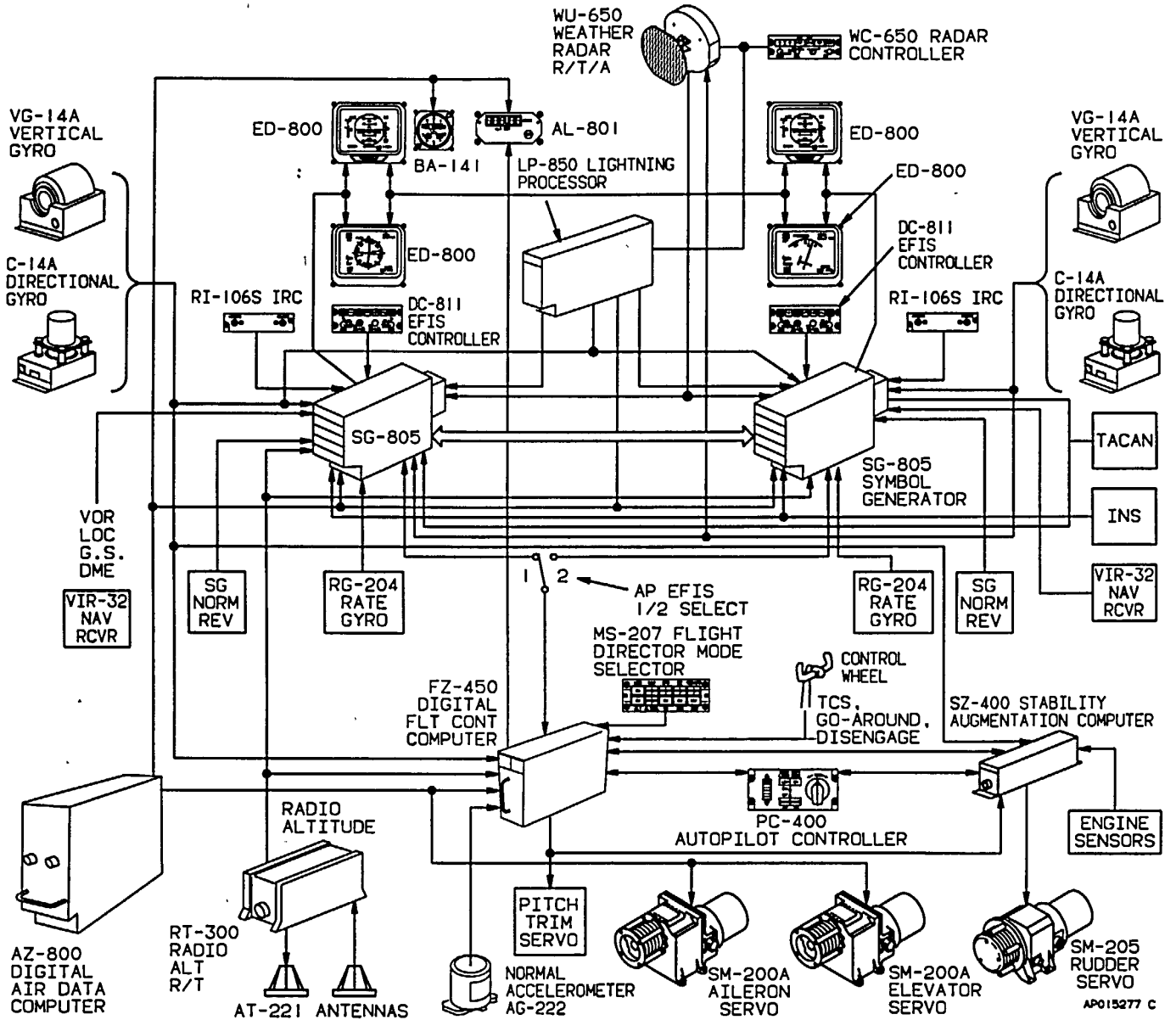

Figure 3-7. Integrated Flight Control System Block Diagram

The pilot's and copilot's symbol generators are the focal point of information flow in the systems. The symbol generator converts information to video and deflection formats required by the EADI and EHSI displays, and provides analog steering information to the flight director/autopilot interfaces.

When engaged and coupled to the flight director commands, the digital integrated flight control system will control the aircraft using the same commands displayed on the EADI. When engaged and not coupled to the flight director commands, manual pitch and roll commands may be inserted using the touch control steering (TCS) switch on the pilot's or copilot's respective control wheel or the autopilot pitch wheel and turn knob located on the pedestal extension.

### 3-16. ATTITUDE AND HEADING REFERENCE SYSTEM.

The attitude and heading reference system consists of the vertical gyros (VG-14A), directional gyros (C-14A), dual remote compensator (CS-412), flux valves (FX-220), and the inertial navigation system (INS).

The vertical gyros provide the digital flight control system, electronic flight instrument system, and weather radar antenna with pitch and roll information.

The inertial navigation system, when selected for display on the EFIS, also provides inputs to the flight control computer.

The directional gyros, with the flux valve and compensator, provide stabilized magnetic north referenced heading information for use by the digital flight control computer, electronic flight instrument system, INS, and mission equipment.

### 3-17. AIR DATA SYSTEM (ADZ-800).

The air data system consists of the digital air data computer (AZ-800), pilot's barometric altimeter (BA-141), and the altitude preselector (AL-801).

The digital air data computer is a microprocessor-based digital computer which accepts both analog and digital inputs, performs digital computations, and supplies both digital and analog outputs. It receives both pitot and static pressure for computing standard air data functions. Altitude preselect data is input from the altitude preselector. Information from the digital air data computer is sent to the pilot's barometric altimeter indicator, transponder, flight director/autopilot, INS, and GPS.

### 3-18. ELECTRONIC FLIGHT INSTRUMENT SYSTEM (EFIS).

*a. Description.* The electronic flight instrument system consists of the pilot's and copilot's electronic attitude

director indicators (EADI) and electronic horizontal situation indicators (EHSI) display units (ED-800), symbol generators (SG-805), display controllers (DC-811), and instrument remote controllers (RI-106S).

The EFIS electronic displays present pitch and roll attitude, heading, course orientation, flight path commands, radio altitude, weather radar and lightning sensor system presentations, and mode and source annunciations.

#### *b. Electronic Flight Instrument System (EFIS) Preflight Test.*

##### **NOTE**

**For this test to be valid, the AUTO PLT POWER switch must be on and the radio altimeter must be on.**

1. **TEST** switch (display controller, fig. 2-18) - Depress and verify the following:
2. **EADI**
  - a. Radio altimeter - Stews to 100 ±10 feet.
  - b. **DH** display replaced with dashes.
  - c. Marker beacon - All three annunciators will be in view.
  - d. **HDG** and **ATT** annunciators appear.
  - e. **ATT FAIL** annunciator appears.
  - f. Pitch and roll command cue - Out of view.
  - g. Caution and warning flags - All will be in view.
  - h. **FD FAIL** will appear momentarily and then be replaced in the left center of the display by the word **TEST** to indicate that flight director mode selector lamp test is good.
3. **EHSI** - **DTRK**, **NM**, **GSPD**, and **HDG** displays replaced with dashes.
4. AP disconnect horn sounds after 5-7 seconds.

Preflight test of the composite mode will cause the same results as the above test, except the digital heading readout will be replaced with a red FAIL indication, and the expanded localizer scale and pointer will be removed.

##### **NOTE**

**A localizer frequency must be tuned on both NAV receivers to annunciate ILS comparator monitor.**

**NOTE**

**Test is inhibited during glideslope capture.**

**3-19. DISPLAY CONTROLLER (DC-811).**

a. *Description.* The display controller (fig. 3-8), enables each pilot to control formatting on his respective EHSI and EADI, and to select the source of navigation, attitude, and heading information.

b. *Display Controller Controls, Indicators, and Functions:*

(1) *Full/map pushbutton selector switch.* The **FULL/MAP** pushbutton selector switch is a multiple function switch that allows selecting the format of the EHSI. When power is first applied to the EFIS, the EHSI will display a full 360 degree compass mode. Depressing the **FULL/MAP** switch once will change the display to a 90 degree heading arc with a large course pointer. Depressing the switch again selects a 90 degree heading arc display with a navigation map display that is dependant upon the selected navigation source.

(2) *Weather pushbutton selector switch.* The weather pushbutton selector switch, placarded **WX**, is used to select weather radar and lightning sensor system data

to be displayed on the partial compass heading arc display or the map display on the EHSI. If the EHSI is in the full compass mode, depressing the **WX** switch will change the display to the partial compass mode and display weather radar returns and lightning sensor system data. Depressing the switch again will remove the weather radar returns and lightning sensor system data from the display.

(3) *Ground speed/time-to-go pushbutton selector switch.* The groundspeed/time-to-go pushbutton selector switch, placarded **GSPD/TITG**, is used to select whether groundspeed or time to go will be displayed on the lower right corner of the EHSI. **GSPD/TTG** data is always INS data if the INS is functioning. The **GSPD/TTG** field will be blank unless the INS is the selected navigation source. If the INS is not functioning, the **GSPD/TTG** field will be dashed.

(4) *Attitude pushbutton selector switch.* The attitude pushbutton selector switch, placarded **ATT** is used to select whether attitude source 4# (vertical gyro # 1), attitude source # 2 (vertical gyro # 2), or attitude source # 3 (inertial navigation system) will provide pitch and roll information to the respective EFIS. Each depression of the switch changes the attitude source and the respective EADI.

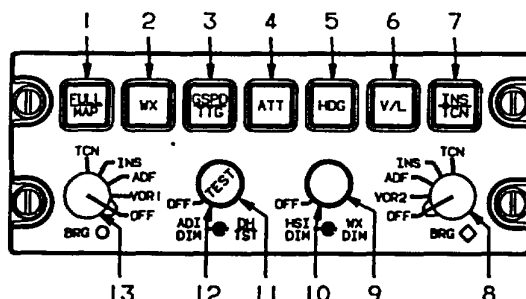

1. Full/Half Arc/Map Pushbutton Selector Switch
2. Weather Pushbutton Selector Switch
3. Groundspeed/Time-to-Go Pushbutton Selector Switch
4. Attitude Source Pushbutton Selector Switch
5. Heading Source Pushbutton Selector Switch
6. VOR/Localizer Pushbutton Selector Switch
7. INS/TACAN Pushbutton Selector Switch
8. Double-Needle Pointer Bearing Source Selector Switch
9. Weather Radar Dim Control
10. EHSI Dim Control
11. Decision Height Setting Control and EFIS Test Switch
12. EADI Dim Control
13. Single-Needle Pointer Bearing Source Selector Switch

A9FE0D0I00 C

Figure 3-8. Display Controller

**NOTE**

**The attitude display on the EADI will power up to the previously selected attitude source.**

(5) *Heading pushbutton selector switch.* The heading pushbutton selector switch, placarded **HDG**, is used to select whether gyro-magnetic compass system # 1 or # 2 will supply heading information to the respective EHSI. Each depression of the switch will cause the display on the EHSI to alternate between **MAG1** and **MAG2**, unless the **SLAVE/FREE** switch is set to **FREE**, then **DG1** or **DG2** will be displayed.

(6) *VOR/localizer pushbutton selector switch.* The VOR/localizer pushbutton selector switch, placarded **V/L**, is used to select which **VHF** navigation receiver will provide information to the respective **EFIS**. Each depression of the switch alternates the navigation source display on the EHSI between **VOR1** or **VOR2**, or **ILS1** or **ILS2**, depending upon whether a **VOR** or localizer frequency has been selected on the respective VHF navigation receiver control panel.

The VOR/localizer switch may be used to activate the preview mode on the EHSI if:

INS is displayed on the EHSI as the navigation source

LNAV flight director mode annunciator is displayed on the EADI

System is powered-up using the primary on-side VHF navigation receiver.

The preview mode may be cancelled by depressing the V/L switch.

(7) *INS/TACAN pushbutton selector switch.* The inertial navigation system/**TACAN** pushbutton selector switch, placarded **INS/TCN**, is used to select whether the **INS** or **TACAN** will provide information to the EFIS. Each depression of the switch will alternate the navigation source annunciator on the EHSI between **INS** and **TCN**.

(8) *Double-needle pointer bearing source selector switch.* The double-needle pointer bearing source selector switch, located on the lower right side of the display controller, is used to select which navigation information sources will provide information to the double-needle bearing pointer.

(a) *OFF.* Removes double-needle pointer from the EHSI.

(b) *VOR2.* Double-needle pointer receives bearing information from # 2 VHF navigation receiver.

(c) *ADF.* Double-needle pointer receives bearing information from ADF navigation receiver.

(d) *INS.* Double-needle pointer receives bearing information from the inertial navigation system.

(e) *TCN.* Double-needle pointer receives bearing information from TACAN navigation receiver.

(9) *Weather radar dim control.* Control of the intensity of the weather radar display on the EHSI is accomplished by a control knob placarded **WX DIM**, which is an inner concentric knob with the **HSI DIM** knob.

The **WX DIM** control dims only the raster on the EHSI which contains the weather radar information. If the EHSI is in the composite mode with the EADI, the **WX DIM** control is used to dim the attitude sphere.

(10) *EHSI dim control.* Control of the intensity of the raster and stroke writing on the EHSI is accomplished by a control knob placarded **HSI DIM**, which is an outer concentric knob with the **WX DIM** knob. Turning the knob counterclockwise to the **OFF** position will cause the EHSI to become blank and the composite mode to be displayed on the EADI.

(11) *Decision height setting control and EFIS test switch.*

(a) *Decision height setting control.* The decision height setting control, placarded **DH/TEST**, is an inner concentric knob with the **ADI DIM** knob. Rotating the **DH** knob allows setting the decision height display on the EADI in 10-foot increments from 200 to 990 feet, and in 5 foot increments from 0 to 200 feet. By rotating the **DH** knob completely counterclockwise to the **OFF** position, the decision height display may be removed from the EADI.

(b) *EFIS test switch.* Depressing the EFIS test switch, placarded **TEST**, will cause the EFIS displays to enter a test mode. In the test mode, flags and cautions are presented along with a test of the radio altimeter. Observe the following after depressing the **TEST** switch:

**NOTE**

A complete test of the EFIS is only functional on the ground. Radio altimeter test is functional at all times except during glideslope **CAP/ TRK**.

Course select, heading select, **DH** set, DME distance, and **GSPD/TTG** digital displays are replaced by amber dashes.

**ATT** and **HDG** displays are flagged.

All pointers and scales are flagged.  
 All heading related markers and pointers are removed.  
 Flight control computer standby mode is activated.

(12) *EADI dim control* Control of the intensity of the raster and stroke writing on the EADI is accomplished by a control knob placarded **ADI DIM**, which is an outer concentric which is an outer concentric knob with the **DH SET/TEST** knob. Turning the knob counterclockwise to the **OFF** position will cause the EADI to become blank and the composite mode to be displayed on the EHSI.

(13) *Single-needle pointer bearing source selector switch.* The single-needle pointer bearing source selector switch, located on the lower left side of the display controller, is used to select which navigation information sources will provide information to the single-needle bearing pointer.

(a) *TCN.* Single-needle pointer receives bearing information from TACAN navigation receiver.

(b) *INS.* Single-needle pointer receives bearing information from the inertial navigation system.

(c) *ADF.* Single-needle pointer receives bearing information from ADF navigation receiver.

(d) *VOR1.* Single-needle pointer receives bearing information from # 1 VHF navigation receiver.

(e) *OFF.* Removes single-needle pointer from the EHSI.

### 3-20. ELECTRONIC ATTITUDE DIRECTOR INDICATOR (EADI).

a. *Description.* The EADI (fig. 3-9), combines a sphere-type attitude display with lateral and vertical computed steering signals to provide commands required to intercept and maintain a desired flightpath. The EADI provides the following display information:

- Attitude display
- Flight director command cue
- Flight director mode annunciations
- Vertical deviation
- Expanded localizer
- Radio altitude with rising runway display
- Decision height setting and annunciations

- Marker beacon annunciations
- Air data command
- Rate of turn
- Reversionary annunciations
- Flags
- Comparison monitors

b. EADI Controls, Indicators, and Functions (fig. 3-9).

(1) *Attitude source annunciator.* The selected attitude source will be displayed on the **EADI** if it is other than the normal source for that instrument. Possible annunciations are **ATT1** (vertical gyro # 1), **ATT2** (vertical gyro # 2), or **ATT3** (inertial navigation system). As other attitude sources are selected, they will be annunciated in white. When the pilot's and copilot's attitude sources are the same, the annunciation will be amber.

(2) *Lateral mode capture annunciator.* Flight director mode capture is annunciated on the EADI in green. Possible annunciations are approach (**APR**), localizer (**LOC**), long-range navigation (**LNAV**), heading (**HDG**), and navigation (**NAV**).

(3) *Attitude sphere.* The attitude sphere moves with respect to the symbolic aircraft reference to display pitch and roll attitude.

(4) *Roll attitude pointer.* Roll attitude pointer indicates aircraft roll attitude with respect to the roll attitude scale.

(5) *Roll attitude scale.* The roll attitude scale indicates aircraft bank angle in degrees with respect to a moving pointer.

(6) *Vertical mode arm annunciator.* Flight director vertical mode arming is annunciated on the EADI in white. Possible annunciations are altitude select (**ASEL**) and glideslope (**GS**).

(7) *Vertical mode capture annunciator.* Flight director vertical mode capture is annunciated on the **EADI** in green. Possible annunciations are glideslope (**GS**), vertical speed (**VS**), indicated airspeed (**IAS**), altitude (**ALT**), and go-around (**GA**).

(8) *Pitch attitude scale.* The pitch attitude scale has white reference marks in 5 degree increments.

(9) *Horizon line.* The horizon line is affixed to the sphere and remains parallel to the earth's surface.

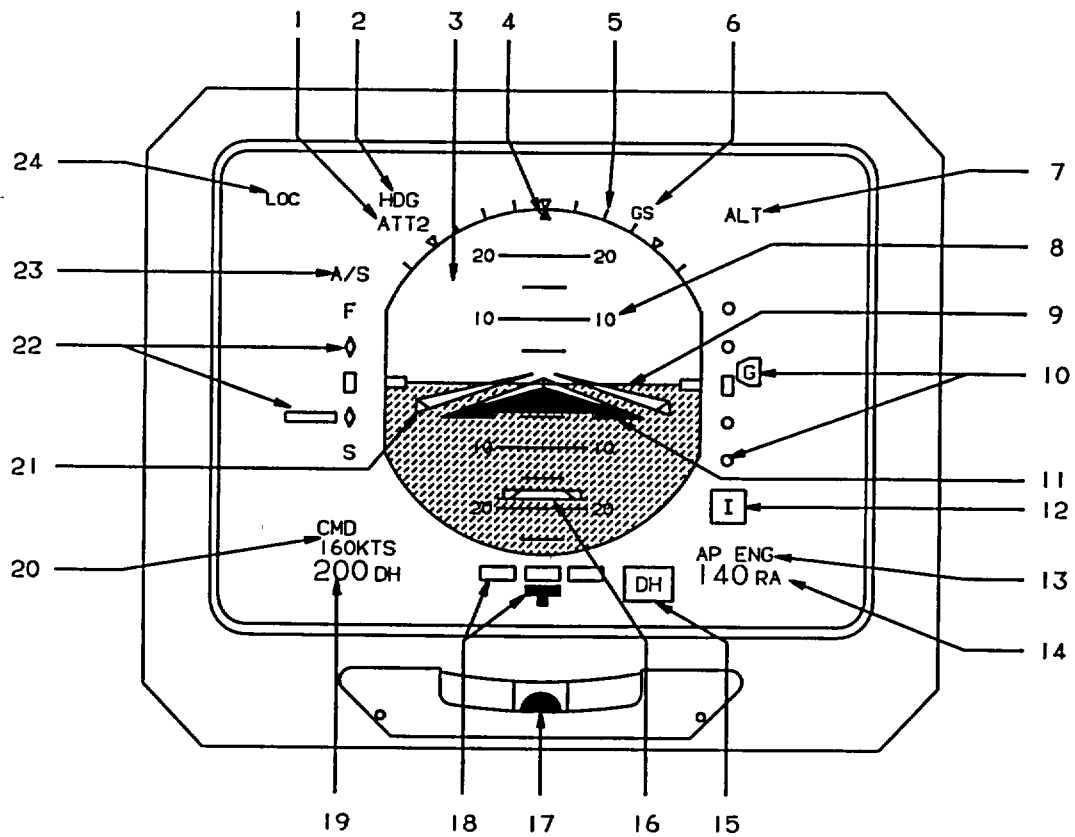

- |  |  |
|--|--|
| 1. Attitude Source Annunctor                   | 13. Autopilot Engagement Annunciator                     |
| 2. Lateral Mode Capture Annunciator            | 14. Radio Altitude Display                               |
| 3. Attitude Sphere                             | 15. Decision Height Annunciator                          |
| 4. Roll Attitude Pointer                       | 16. Resting Runway Radio Altitude Display                |
| 5. RoLL Attitude Scale                         | 17. Inclinator   |
| 6. Vertical Mode Annunciator                   | 18. Expanded Localizer or Rate-of-Turn Pointer and Scale |
| 7. Vertical Mode Capture Annunctor             | 19. Decision Height Display                              |
| 8. Pitch Attitude Scale                        | 20. Air Data Command Display                             |
| 9. Horizon Line                                | 21. Pitch and RoLL Command Cue                           |
| 10. GLideslope Pointer, Annunctor, and Scale - | 22. Fast/Slow Deviation Pointer and Scale                |
| 11. Aircraft Symbol                            | 23. Fast/Slow Source Annunciator                         |
| 12. Marker Beacon Annunctor                    | 24. Lateral Mode Arm Annunctor                           |

A93FE00D0101 C

Figure 3-9. Electronic Attitude Director Indicator (EADI)



(10) *Glideslope deviation pointer, annunciator, and scale.* The glideslope deviation pointer shows aircraft deviation from the center of the glideslope beam. The G annunciator on the glideslope deviation pointer indicates that the information being presented is glideslope deviation. Deviation from the center of the glideslope beam is measured by the glideslope scale. The distance between two dots is equal to a 0.35 degree deviation. The glideslope display will not be present on the EADI unless a valid ILS frequency has been tuned.

(11) *Aircraft symbol.* The aircraft symbol serves as a stationary representation of the aircraft. Aircraft pitch and roll attitudes are displayed by the relationship between the fixed miniature aircraft and the movable attitude sphere. The inverted V shaped miniature aircraft symbol is flown to align with the flight director command cue in order to satisfy the commands of the selected flight director mode.

(12) *Marker beacon annunciator.* Reception of a marker beacon signal is indicated on the EADI by the illumination of the appropriate marker beacon annunciator. Possible annunciations are outer marker (O, blue), middle marker (M, amber), and inner marker (I, white).

(13) *Autopilot engagement annunciator.* Autopilot engagement is indicated on the EADI by an annunciator placarded AP ENG (green).

(14) *Radio altitude display.* Radio altitude is presented by a four-digit display from -20 feet to 2500 feet above ground level (AGL). Radio altitude is displayed in blue numbers followed by RA in white letters. Display resolution between 200 and 2500 feet AGL is in 10-foot increments. Display resolution below 200 feet AGL is in 5-foot increments. The radio altitude display will disappear from the EADI when radio altitude is above 2500 feet AGL.

(15) *Decision height annunciator.* When radio altitude is less than 100 feet above the selected decision height, a white box will appear adjacent to the radio altitude display. When the aircraft is at or below decision height an amber DH annunciator will be illuminated inside the white decision height display box on the EADI.

(16) *Rising runway radio altitude display.* A miniature rising runway symbol displays absolute altitude reference above the terrain. The rising runway appears at 200 AGL and contacts the aircraft symbol at touchdown.

(17) *Inclinometer.* The inclinometer provides the pilot with a display of aircraft slip or skid for coordinating turns.

(18) *Expanded localizer or rate-of-turn pointer and scale.* When the flight director navigation source is other than a localizer frequency, rate-of-turn is displayed by a pointer and scale on the EADI. A standard rate turn (3 degrees per second) is indicated when the turn needle is deflected until the needle covers the left or right rate-of-turn scale mark. When the flight director navigation source is a localizer frequency, the rate-of-turn pointer and scale display will become an expanded localizer pointer and scale display. The expanded localizer pointer receives raw localizer data from the navigation receiver. The expanded localizer pointer becomes an extremely sensitive reference indicator of aircraft position with respect to the center of the localizer course. From the center of the expanded localizer scale to the left or right scale index mark equals 33 feet deviation from the center of the localizer course.

#### NOTE

**When back course (BC) has been selected on the flight director, or when the selected course is more than 90 degrees from aircraft heading, expanded localizer deviation will automatically be reversed to provide proper sensing with respect to the localizer centerline, and amplification will be reduced by one half.**

(19) *Decision height display.* Decision height is displayed on the EADI by a three-digit display in blue numbers followed by DH in white letters. Decision heights may be set into the display by the decision height setting control on the respective display controller. Decision heights in the 0 to 200 foot range are set into the display in 5-foot increments. Decision heights in the 200 to 990 foot range are set into the display in 10-foot increments.

(20) *Air data command display.* Flight director air data command modes are vertical speed (VS) or indicated air speed (IAS). When an air data command mode has been selected on the flight director mode selector panel, the command reference will appear on the EADI in blue numbers below CMD in white letters. The autopilot pitch wheel on the autopilot control panel is used to change the air data command reference number when operating in the VS or IAS mode. When a vertical mode other than VS or IAS is selected, the air data command display will disappear from the EADI.

(21) *Pitch and roll command cue.* The flight director pitch and roll command cue displays the computed commands required to capture and maintain a desired flight path. The inverted V shaped miniature aircraft symbol is flown to align with the flight director command cue in order to satisfy the commands of the selected flight director mode. The cue will be removed from view if an invalid

Table 3-2 Comparison Monitor Symbols and Mismatch Levels

Compared Signals	Displayed Symbol	Mismatch Level
1. Pitch Attitude	PIT	60
2. Roll Attitude	ROL	6°
** 3. Heading	HDG	6°
* 4. Localizer	LOC	40 mV (. 1/2 dot)
* 5. Glideslope	GS	50 mV (. 1 dot)
6. Pitch & Roll Attitude	ATT	50 mV
* 7. Localizer & Glideslope	ILS	50 mV (.1 dot)

\* These comparisons are only active during flight director localizer and glideslope capture with both NAV receivers tuned to LOC frequency.  
 \*\* If the compared heading sources are not the same (both MAG or TRU), the comparison monitor is disabled.

BT03839

condition occurs in either flight director pitch or roll command. The cue is displayed on the side coupled to the flight director only, and reflects the flight director mode selected by the flight director mode selector panel.

(22) *Fast/slow pointer and scale.* The fast/slow pointer and scale provide a display of deviation from relative approach speed information provided by the lift computer. The information provided to the indicator is for an approach speed of approximately 1.3 times V<sub>0</sub>. The display

play is removed from the EADI when flaps are extended to the full down position.

(23) *Fast/slow source annunciator.* The fast/slow source annunciator (white) displays A/S.

(24) *Lateral mode arm annunciators.* Lateral mode arm function is annunciated on the EADI in white. Possible annunciations are NAV, APR, LOC, and BC.

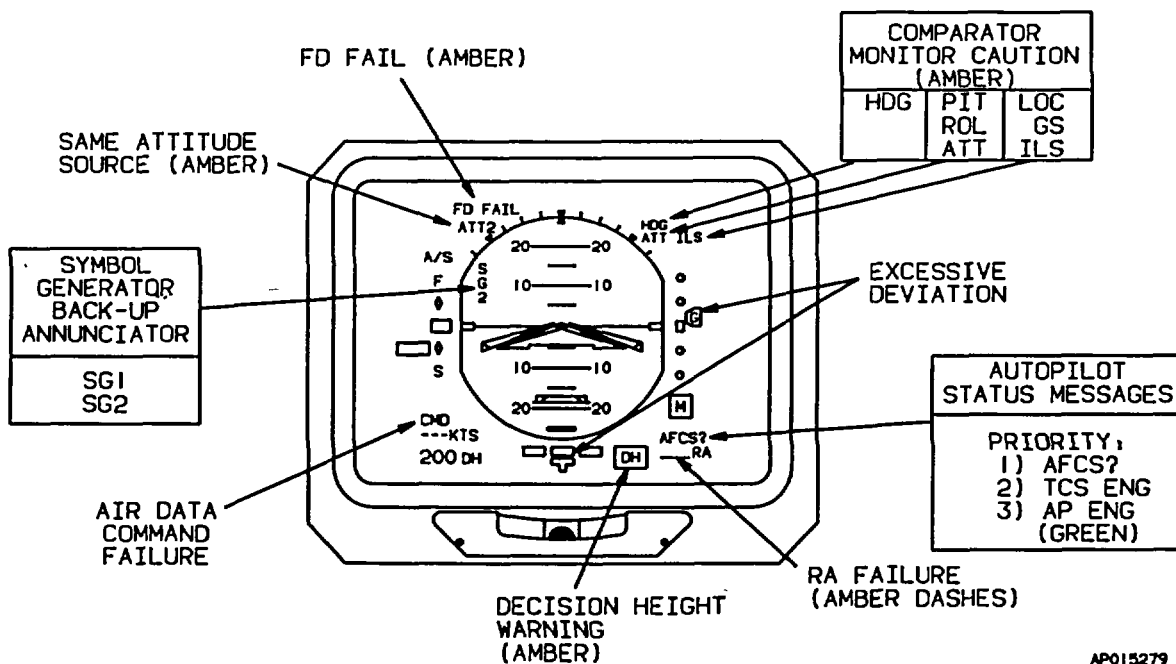

AP015279 C

Figure 3-10. EADI Caution Annunciators (Amber)

c. EADI Amber Caution and Failure annunciators (fig. 3-10).

(1) *Same attitude source.* There is no attitude source annunciated if the pilot and copilot are using their normal attitude sources. Selecting other attitude sources causes the new source to be annunciated in white. If the pilot and copilot have selected the same attitude source, that attitude source will be annunciated in amber on both EADI's.

(2) *Comparison monitor.* The comparison monitor compares selected pilot and copilot input data in the symbol generator. If the difference between the data exceeds predetermined levels, the out-of-tolerance symbol will be displayed. Table 3-2 shows comparison monitor symbols and miscompare levels.

**NOTE**

**When the compared pitch and roll attitude or glideslope and localizer signals are out of tolerance, a combined symbol (ATT or ILS) is displayed.**

(3) *Radio altitude failure.* Radio altitude failure is indicated by amber dashes replacing the numerical altitude value, and the removal of the rising runway

altitude display from the EADI, if present.

(4) *Decision height warning.* If a **DH** potentiometer is open, or during self test, amber dashes will replace numerical values of decision height display.

(5) *Autopilot status messages.* The following messages may appear for autopilot status. They will replace the autopilot engage (AP ENG) annunciator:

- (a) AP ENG. Autopilot engaged.
- (b) AFCS? Autopilot wraparound signal failure.

(c) TCS ENG. Touch control steering is engaged.

(6) *Flight director failure.* In the event of a flight director failure, an amber FD FAIL warning will be displayed on the EADI.

(7) *Air data command failure.* If an air data flight director mode has been selected, and the air data computer fails, amber dashes will replace the numerical values in the air data command display.

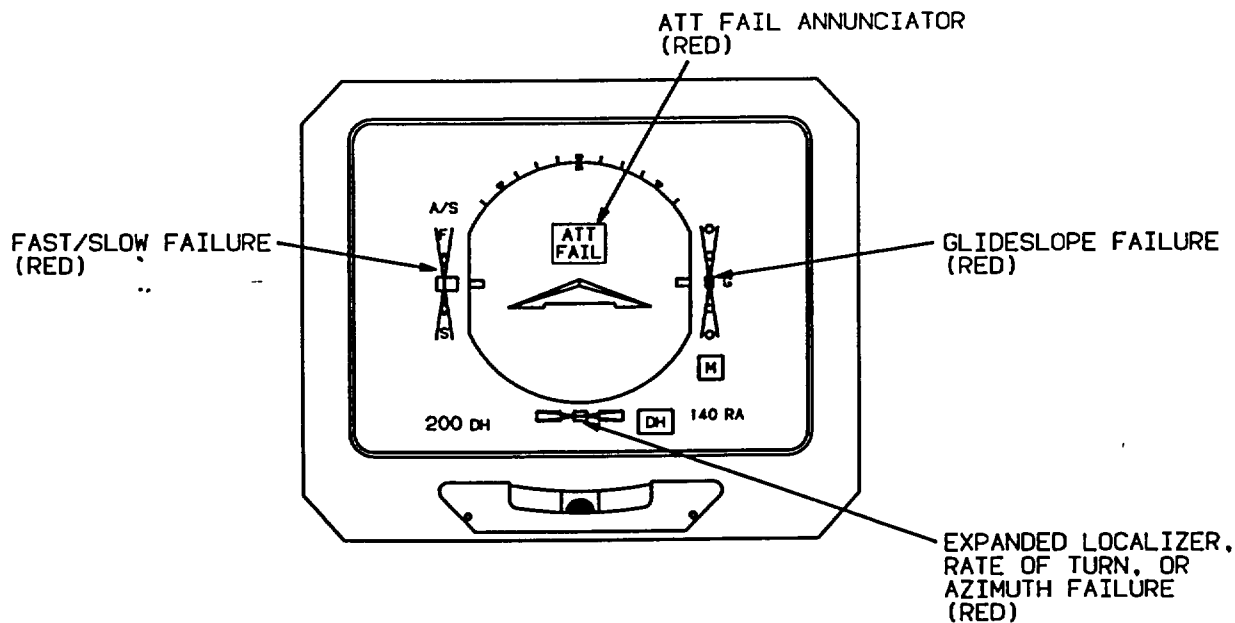

AP015280 C

Figure 3-11. EADI Failure Annunciations (Red)

(8) *Common symbol generator.* When in the reversionary mode and one symbol generator is driving both the pilot's and copilot's display tubes, an amber reversionary warning is given to indicate the information source.

d. EADI Red Failure Annunciations (fig. 3-11).

(1) *Attitude failure.* If the attitude display, pitch scale, or roll pointer fail, they will be removed from the display, the attitude sphere will become blue, and a red ATT FAIL will be displayed on the EADI.

(2) *Glideslope, expanded localizer, and rate-of-turn failures.* If the glideslope, expanded localizer, or rate-of-turn system fails, the pointer will be removed and a red X will be drawn through the scale. The letter G will remain at the zero deviation position to identify invalid glideslope information.

(3) *Internal failure.* If an internal failure occurs within the display system itself, the display will be blank. A failure of the input/output processor will be indicated by a red X centered on the display with a SG FAIL annunciated (fig. 3-12).

**3-21. ELECTRONIC HORIZONTAL SITUATION INDICATOR (EHSI).**

a. *Description.* The electronic horizontal situation indicator (fig. 3-13), combines several displays to provide a map-like display of aircraft position. The indicator displays aircraft displacement relative to a VOR or TACAN radial, inertial navigation system guidance, and localizer and glideslope beam. The EHSI provides the following full and partial compass display information:

- (1) Full compass displays Heading
- Course selection
- Course or azimuth deviation
- Distance
- Groundspeed
- To/from
- Desired track
- Bearing

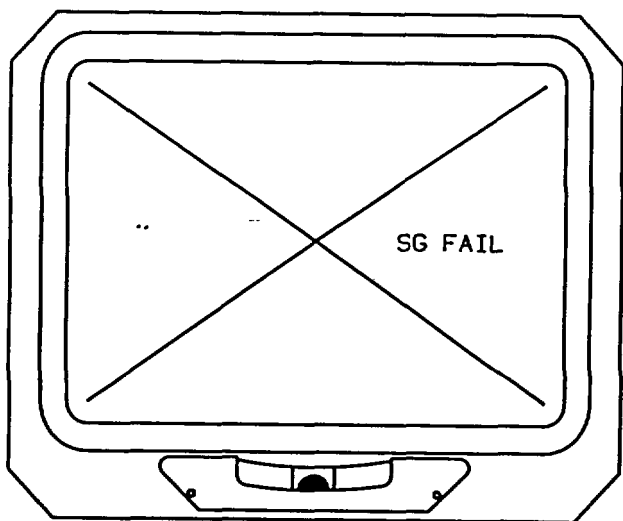

**NOTE**  
**SG FAIL IS AMBER ON THE EHSI.**

AP015281 C

Figure 3-12 EADI Input/Output Processor Failure Indications



Heading selection  
 Glideslope deviation  
 Time-to-go  
 Heading and navigation source annunciators  
 Heading synchronization

(2) *Partial compass displays.*

Weather radar

Lightning sensor system data

Navigation map

b. *EHSI Controls, Indicators, and Functions (fig. 3-13).*

(1) *Course/desired track display.* The course (**CRS**)/desired track (**DTRK**) display provides a digital digital readout of the course selected by the course pointer (yellow) or the desired track when navigation with information supplied by the INS. Course (**CRS**) or desired track (**DTRK**) are displayed in white letters with the numerical course displayed in yellow.

(2) *Single-needle bearing pointer.* The single-needle bearing pointer (blue circle) indicates the relative bearing to the selected navaid. The navigation source is indicated by the single-needle pointer source annunciator. When the bearing pointer navigation source is invalid or a localizer frequency has been chosen, the bearing pointer will be removed from the display.

(3) *Heading source annunciator.* The heading source annunciator will display **MAG1** or **MAG2** when slaved or **DG1** or **DG2** when free, to show which gyrocompass system is providing heading information to the **EHSI**.

(4) *Heading marker.* The notched blue heading marker is positioned on the heading dial by the respective heading selection knob on the remote instrument controller panel, which is located on the pedestal extension (fig. 2-14). Once set to the desired heading, the heading marker will maintain its position on the heading dial. The difference between the heading marker and the lubber line index is the amount of heading select error applied to the flight director computer. In heading mode, the EADI pitch and roll command cue will display the proper bank commands to turn to and maintain this selected heading. Pulling on the heading select knob (pedestal extension, fig. 2-14) will set the heading marker to aircraft heading.

(5) *Lubber line.* Aircraft heading is read from the heading dial under the lubber line.

(6) *Double-needle bearing pointer.* The double-needle bearing pointer (green diamond) indicates the relative bearing to the selected navaid. The navigation source is indicated by the double-needle pointer source annunciator. When the bearing pointer navigation source is invalid or a localizer frequency has been chosen, the bearing pointer will be removed from the display.

(7) *DME hold annunciator.* Illumination of the amber DME hold (**H**) annunciator indicates that hold has been selected on the VOR navigation receiver control panel that is supplying navigation information to the respective EHSI.

(8) *Navigation source annunciator.* The navigation source that is being used by the EHSI is indicated by the illumination of a navigation source annunciator. Possible annunciations are **VOR1**, **VOR2**, **ILS1**, **ILS2**, **TCN**, and **INS**. All the annunciations are white, except **INS** which is annunciated in blue to show that it is a long range navigation system. The navigation source will annunciate amber if the pilot and copilot select the same navigation source. The navigation source will annunciate amber if the pilot has selected **VOR2** or if the copilot has selected **VOR1**.

(9) *Distance display.* The distance display indicates the distance in nautical miles to the selected DME station or INS waypoint. When short range navigation information is being used the distance will be displayed in a 0 to 399.9 nautical mile format. When long range navigation (INS) information is being used the distance will be displayed in a 0 to 3999 nautical mile format.

DME distance is supplied to the EFIS by channels # 1 and # 2 of the three channel TACAN/DME unit. Channel # 1 provides the TACAN distance data when TACAN is the selected navigation source or DME distance data when **NAV1** is the selected navigation source. Channel # 2 provides distance data when **NAV2** is the selected navigation source.

(10) *Preview course pointer navigation source annunciator.* The preview course pointer navigation source annunciator displays which navigation source is being used by the preview course pointer.

(11) *Glideslope deviation pointer, annunciator, and scale.* The glideslope deviation pointer shows aircraft deviation from the center of the glideslope beam. The G annunciator on the glideslope deviation pointer indicates that the information being presented is glideslope deviation. Deviation from the center of the glideslope beam is measured by the glideslope scale. The distance between two dots is equal to a 0.35 degree deviation. The glideslope display will not be present on the EHSI unless a valid ILS frequency has been tuned.

(12) *Course deviation bar.* The course deviation bar represents the centerline of the selected VOR, localizer, or TACAN course, or inertial navigation system (INS) track. The aircraft symbol pictorially shows the aircraft's position in relation to the selected course or track.

(a) *VOR/TACAN.* When the selected navigation source is a VOR or TACAN station each dot on either side of the aircraft symbol represents a 5 degree deviation from the centerline of the course. When the selected navigation source is a localizer, each dot represents a 1 degree deviation from the centerline of the course. When the selected navigation source is the INS, each dot represents 3.75 nautical miles of cross track deviation.

(b) *Back course (BC).* When back course (BC) mode has been selected, or when a localizer frequency has been tuned and the selected course is more than 90 degrees from aircraft heading, course deviation will automatically reverse to provide proper deviation sensing with respect to the course centerline. The course deviation bar always indicates the location of the course centerline relative to the nose of the aircraft.

(13) *Groundspeed or time-to-go display.* Depressing the **GSPD/TTG** button on the display control panel will cause groundspeed or time-to-go to alternately be displayed. **GSPD/TTG** information is always referenced to the active INS waypoint.

(14) *To-from indicator.* An arrowhead (white triangular box) in the center of the EHSI indicates whether the selected course is to or from the station or waypoint. The to-from annunciator will be removed from view during localizer operation.

(15) *Aircraft symbol.* The aircraft symbol provides a quick visual cue as to the aircraft's position with respect to the selected course and aircraft heading.

(16) *Preview course pointer.* A preview course pointer (magenta) is provided to enable the pilot to preview data prior to its use.

The preview course pointer will be displayed if:

**INS** is displayed as the navigation source on the EHSI.

**LNAV** is the lateral capture mode (green) displayed on the **EADI**.

Selection of V/L or TCN on the display controller after the above two conditions have been met.

The preview course pointer may be rotated around the heading dial using the remote course knob on the remote instrument control panel, located on the pedestal extension (fig. 3-14). Each time the preview course pointer position is changed on the heading dial with the remote course knob, the EHSI digital course display will show the preview course in magenta for 5 seconds, or until the course is changed again.

The preview course deviation bar will respond to VOR, localizer, and TACAN signals as appropriate.

Once the previewed navigation source is valid, if the approach mode (for localizer or ILS) or VOR approach mode (for VOR or TACAN) has been selected on the flight director mode selector, the appropriate **LOC**, **ILS**, or **NAV** annunciator will be illuminated on the EADI.

When the flight director determines that the capture point for the previewed mode has been reached, it will transition the flight director from **LNAV** mode to the capture mode of the previewed navigation source. The preview course pointer will then be removed and the standard course pointer will be slewed to the previewed selected course.

(17) *Course pointer.* The course pointer (yellow) is positioned on the rotating heading dial by a remote course knob on the remote heading/course control panel, located on the pedestal extension (fig. 2-12). The course pointer is set to a magnetic bearing that coincides with the desired VOR or TACAN radial, or localizer course. Once set, the course pointer maintains its position on the rotating heading dial to provide a continuous readout of course error to the flight director computer. Pulling out on the remote course knob (pedestal extension, fig. 2-14), will rotate the course pointer to center the course deviation bar.

When long range navigation (INS) is selected, the course pointer becomes a desired track pointer. The desired track pointer will be positioned on the rotating heading dial by the INS.

(18) *Heading display.* The heading display is a digital readout of the heading selected by the blue heading marker. The display is placarded HDG (white) with blue numerals.

(19) *Double-needle bearing pointer source annunciator.* This annunciator displays the navigation source supplying information to the double-needle bearing pointer (green). This display is marked by a green diamond with the navigation source displayed in white letters. Possible annunciations are **ADF**, **VOR2**, **INS**, and **TCN**.

(20) *Single-needle bearing pointer source annunciator.* This annunciator displays the navigation source supplying information to the single-needle bearing pointer (blue). This display is marked by a blue circle with

the navigation source displayed in white letters. Possible annunciations are **ADF**, **VOR1**, **INS**, and **TCN**.

(21) *Weather radar tilt angle display.* The weather radar tilt angle display (green) shows the angle that the weather radar antenna is tilted upward or downward from level in degrees plus or minus.

(22) *Weather radar mode annunciator.* The weather radar mode annunciator indicates the operating mode of the radar system. Possible annunciations in the full compass format of the EHSI are **TX** (magenta) and **WX** (amber). **TX** indicates that the radar is transmitting but not being displayed. **WX** indicates a weather radar system failure. Possible annunciations in the partial compass format are standby (**STBY**), test (**TEST**), weather detection (**WX**), rain echo attenuation compensation technique (**RCT**), ground mapping (**GMAP**), and fail (**FAIL**). All partial compass annunciations are green except FAIL, which is amber.

(23) *Weather radar target alert and variable gain annunciator.* The green **TGT** annunciator indicates that the target alert function of the weather radar has been selected. The amber **VAR** annunciator indicates that variable gain has been selected.

(24) *Lightning sensor system mode annunciator*

The lightning strike sensor system mode annunciator indicates the operating mode of the lightning sensor system. Possible annunciations are **LX**, **LX/F**, **LX/S**, **LX/T**, **LX/H**, **LX/1**, **LX/C**, **LX/L**, and **LXMN**. All annunciations are green except **LX/F** and **LXMN** which are amber. These mode annunciators are described in the lightning sensor system paragraph in this chapter.

(25) *Compass system synchronization annunciator.* The compass synchronization system annunciator indicates the state of the compass system in the slaved mode. The bar represents commands to the compass gyro to slew to the indicated direction (+ for increased heading and 0 for decreased heading). Compass synchronization annunciation will be removed during the compass free gyro mode. If the cross-side compass display has been selected, the synchronization annunciator will be removed.

c. *EHSI Partial Compass Format (fig. 3-15).* The partial compass mode displays a 90-degree arc of the compass card. The following additional features are available during partial compass operation:

(1) *Range rings.* Range rings are displayed to aid in the use of radar returns and position of nav aids. The outer range ring is the compass card boundary and represents the selected range on the radar. Range annunciation

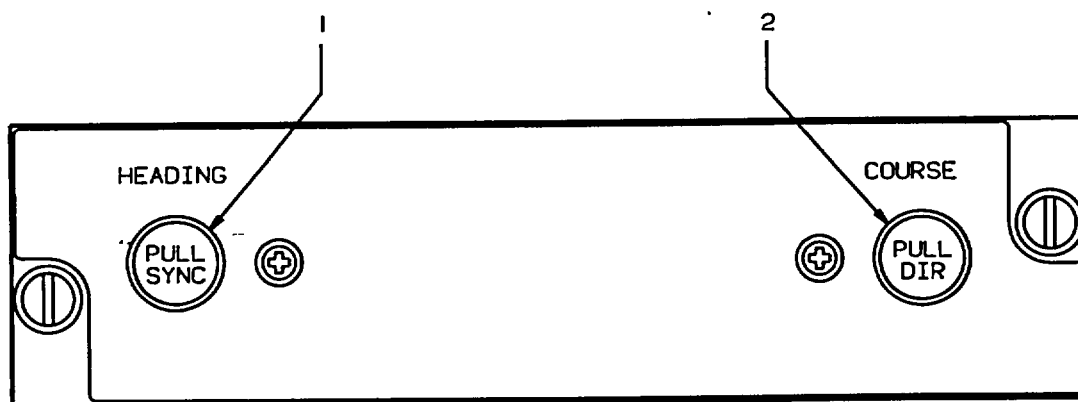

- 1. Heading Knob
- 2. Course Knob

A93FE00D0103 C

Figure 3-14. Flight Director Remote Heading/Course Control Panel "



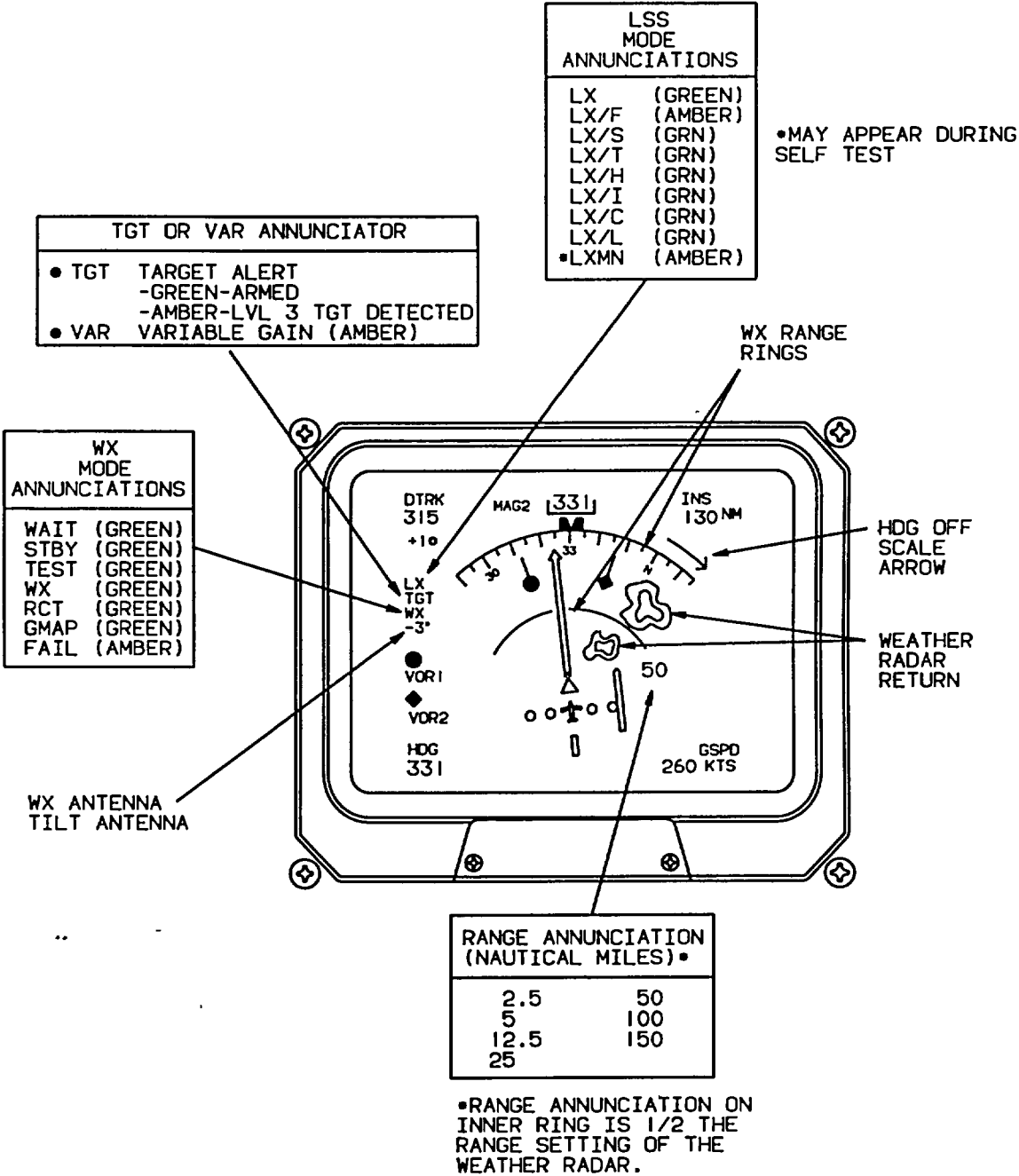

NOTE:  
OFF-SCALE ARROW INDICATES THE SHORTEST DISTANCE TO THE HEADING MARKER

AP01522 C

Figure 3-15. EHSI Partial Compass Format Unique Indications

on the inner ring represents one-half the range setting of the weather radar.

(2) *Navaid position.* Navaid position may be selected for display during map mode. Source of navaid position markers is selected and annunciated in conjunction with the associated bearing source and is color coded.

(3) *Weather.* Weather radar information may be displayed in the partial compass mode.

(4) *Off scale arrow.* When the heading marker is rotated out of view (off scale) an arrow on the compass arc is provided to indicate the shortest direction of the heading marker.

d. *EHSI Short Range Navigation (SRN) Map Mode* (fig. 3-16). Map mode is selected by depressing the **FULL/MAP** pushbutton selector switch on the display controller until the EHSI is in the **MAP** mode.

When the map mode has been selected, the following will occur:

The course pointer and course deviation bar displays will be removed.

Both bearing pointers will be removed.

A full-scale navigation deviation display and deviation bar will be present on the bottom of the EHSI

display. This will show the position of the aircraft with respect to the selected course.

The map mode deviation display functions as a simple, fixed-card course deviation indicator for VOR or TACAN data. As long as the aircraft is headed within 90 degrees of the selected course or selected radial, and as long as the to-from annunciation is correct, the course deviation indicator (CDI) will be directional; otherwise, it will display reverse sensing and the techniques required for reverse sensing will apply.

When the navigation source is a localizer, and the aircraft has a heading greater than 90 degrees to the selected inbound localizer course, the CDI will reverse polarity, but will remain directional.

When VOR or TACAN stations are shown on the EFIS map, a solid or dashed course line is drawn through the selected navigation source. The solid line represents the selected inbound course to the station. The dashed line represents the selected outbound radial from the station. If TACAN has been selected as the NAV source, the identifier will be displayed adjacent to the navaid symbol. Cross-side navaid identifiers are not available.

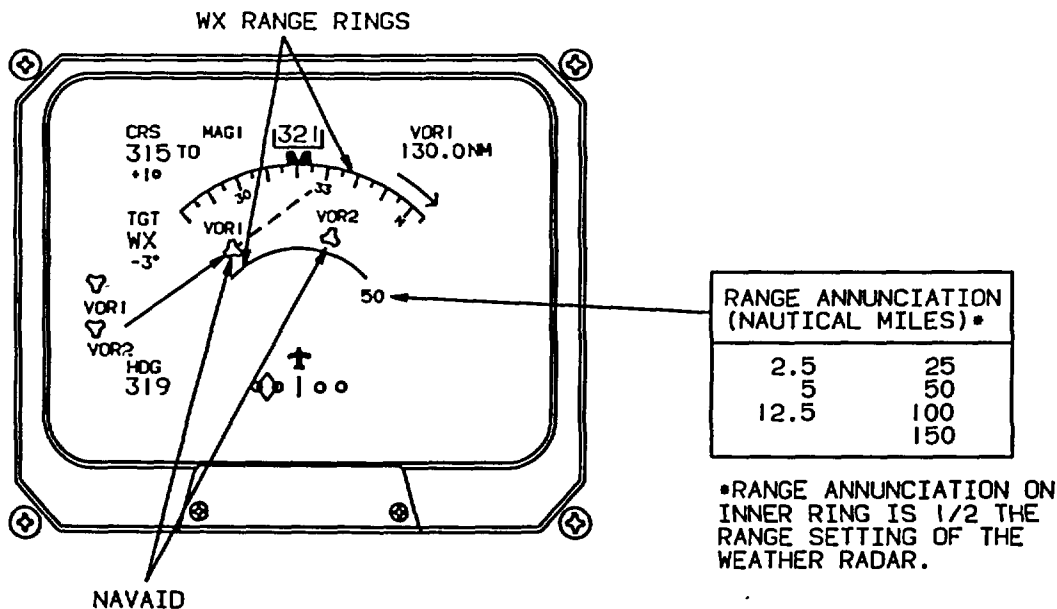

Figure 3-16. EHSI Partial Compass VOR Map Mode

If the VOR or TACAN stations are out of range of the EFIS map, either a solid magenta or dashed magenta line will appear if within the 90 degree arc. A solid magenta line with an arrow indicates the inbound course to the station. A dashed magenta line indicates the outbound radial.

e. *EHSI Long Range Navigation (LRN) Multiple Waypoint Map Mode.* The EFIS can display multiple waypoints from a long range navigation (INS) system (fig. 3-17).

With the INS programmed for multiple waypoints, and the weather radar range set to a range allowing display of multiple waypoints, selecting the MAP mode will permit up to six (6) to be displayed on the EHSI.

When the map mode has been selected, the following will occur:

The course pointer and course deviation bar displays will be removed.

Both bearing pointers will be removed.

The multiple waypoints will appear on the EHSI.

Each waypoint will be identified by a number between 00 and 09.

The waypoint to which the aircraft is flying will be

magenta, with all other waypoints in white.

If the EFIS is receiving valid TACAN, VOR information, and DME distance, the nav aids for the two VOR or TACAN stations will be available for display on the EFIS. The blue nav aid will be VOR1 (**NAV1**) and the green nav aid will be VOR2 (**NAV2**).

The EHSI can display up to six LRN waypoints and two VOR station nav aid symbols at the same time. This assumes that all waypoints are within the selected weather radar range, and all are within the limits of the heading display of the EHSI in the map mode.

The specific functions of the multiple-waypoint map mode are as follows:

(1) *Desired track.* The desired track annunciator and a digital readout of the desired track from past waypoint to the next waypoint are shown in the upper left corner of the EHSI.

(2) *To-from annunciator.* The to-from display is located to the right of the desired track digital readout. It shows TO when the aircraft is flying to the waypoint.

f. *EHSI Weather Radar Displays.*

(1) Target alert annunciator (all formats).

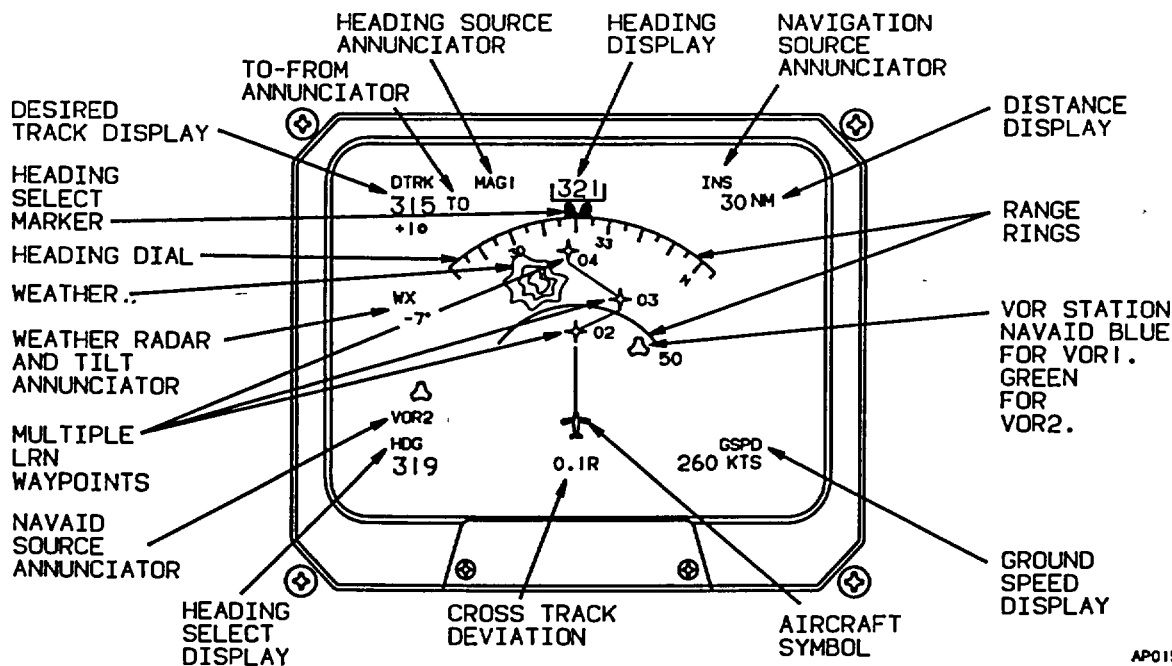

AP015406 C

Figure 3-17. EHSI Multiple Waypoint Map Mode (LRN)

When target alert is selected on the weather radar controller, **TGT** in green is displayed on the EHSI. If a level 3 weather radar return is detected within 7.5 degrees of aircraft heading, but beyond the selected radar range, the annunciator will change **TGT** to amber.

(2) *Range ring and annunciator.* The range ring and annunciator is displayed only when **WX**, **NAV**, and **NAV/WX** format is selected. The range is selected on the weather radar controller. One-half the selected range is annunciated in white beside the half range ring. If weather radar range control is not available, the range default value will be 50 nautical miles.

(3) *Weather radar modes.* Weather radar mode is annunciated on the EHSI.

(4) *Weather radar return display.* Weather radar (**WX**) mode, weather radar information is displayed (table 3-3).

(5) *Lightning sensor system display.* Three levels of lightning activity are displayed using a white lightning symbol. A magenta lightning symbol is used to, annunciate activity at an unknown range.

g. *EHSI Amber Caution or Failure Annunciations (fig. 3-18).*

(1) *Same compass source or navigation source.* When both the pilot and copilot select the same compass or navigation source, the source annunciators will be amber.

(2) *Cross-switched navigation sources.* If the pilot selects the copilot's navigation source (**VOR2**) or if the copilot selects the pilot's navigation source (**VOR1**), the annunciator will be amber to indicate cross-switched navigation sources. If both the pilot and copilot select TACAN as the navigation source, TCN will be annunciated in amber.

(3) *DME hold.* When DME is set in the hold position, an amber H is displayed to the left of the numerical DME readout.

(4) *Waypoint annunciations.* An amber **WPT** annunciation from the long range navigation system (**INS**) is displayed to indicate waypoint passage.

(5) *Cautions due to failures of DME, GSPD, or TTG.* When distance measuring equipment (**DME**), groundspeed (**GSPD**), or time-to-go (**TTG**) systems fail, the digital displays will be replaced by amber dashes. If **NAV1** distance information is not available due to TACAN selection, an amber **N/A** will appear in the distance position.

**NOTE**

**If one pilot selects TCN but the other pilot selects NAV1 navigation source, the pilot with the NAV1 data will have an N/A in the distance display. If TCN is deselected, distance data will return to the NAV1 distance display.**

(6) *Target alerts.* Weather radar target alerts are annunciated on the EHSI. A green TGT annunciation indicates an armed condition, while an amber TGT indicates an alert condition.

(7) *Course select and heading select.* Failure of course or heading select signals will cause these displays to be replaced by amber dashes. They are also dashed when the heading display is invalid.

(8) *Weather radar failure.* Failure of the weather radar system is indicated on the EHSI by **WX FAILURE** (amber).

h. *EHSI Red failure annunciations (fig. 3-19).*

(1) *Heading failure.* A failure of the heading system results in the removal of bearing annunciators, bearing pointers, course deviation pointer, and course scale. The digital course readout and digital heading readout will be dashed, and a red **HDG FAIL** will be displayed.

(2) *Course deviation or glideslope deviation failure.* Failure of course or glideslope deviation systems will result in the removal of course and glideslope pointers and a red X will be drawn through the scale. The letter G will appear at the zero deviation position of the glideslope scale to identify the invalid information.

Table 3-3. Weather Radar Return Levels

Return	WX	GMAP
Level 1	Green	Cyan
Level 2	Yellow	Yellow
Level 3	Red	Magenta
Level 4	Magenta	---
RCT	Blue	---

BT03840

**3-22. EADI AND EHSI COMPOSITE DISPLAY.**

If an EADI or EHSI display unit fails, a composite attitude and navigation format (fig. 3-20), may be displayed on the remaining display. Selection of the composite mode is made by turning the applicable **DIM** control to **OFF**. As in normal EADI and EHSI presentations, all elements are not displayed at the same time. The presence or absence of each display element is determined by flight phase, navigation radio tuning, selected flight director mode, absolute altitude, etc. The failure, caution, and warning annunciations function is much the same as for the normal display mode.

**NOTE**

The composite mode deviation display functions as a simple fixed-card course deviation indicator (CDI) for VOR/TACAN data. As long as the aircraft is headed within 90 degrees of the selected course or selected radial, and as long as the to-from annunciation is correct, the course deviation pointer is directional; otherwise, it will display reverse sensing and the techniques

required for reverse sensing will apply.

When a localizer has been tuned, and the aircraft has a heading greater than 90 degrees to the selected inbound localizer course, the course deviation indicator (CDI) will reverse sensing so that normal front course corrections will apply.

**3-23. DIGITAL FLIGHT CONTROL SYSTEM (DFZ-450).**

The digital flight control system consists of the following components:

- Flight Control Computer (FZ-450).
- Stability Augmentation Computer (SZ-400).
- Autopilot Controller (PC-400).
- Flight Director Mode Selector (MS-207).
- Rudder Servo (SM-205).
- Elevator and Aileron Servos (SM-200).
- Elevator Trim Tab Servo

a. *Flight Control Computer (FZ-450).* The flight control computer provides fail-passive operation of flight director, autopilot, and pitch trim. Fail-passive operation is achieved through the use of comparator monitor

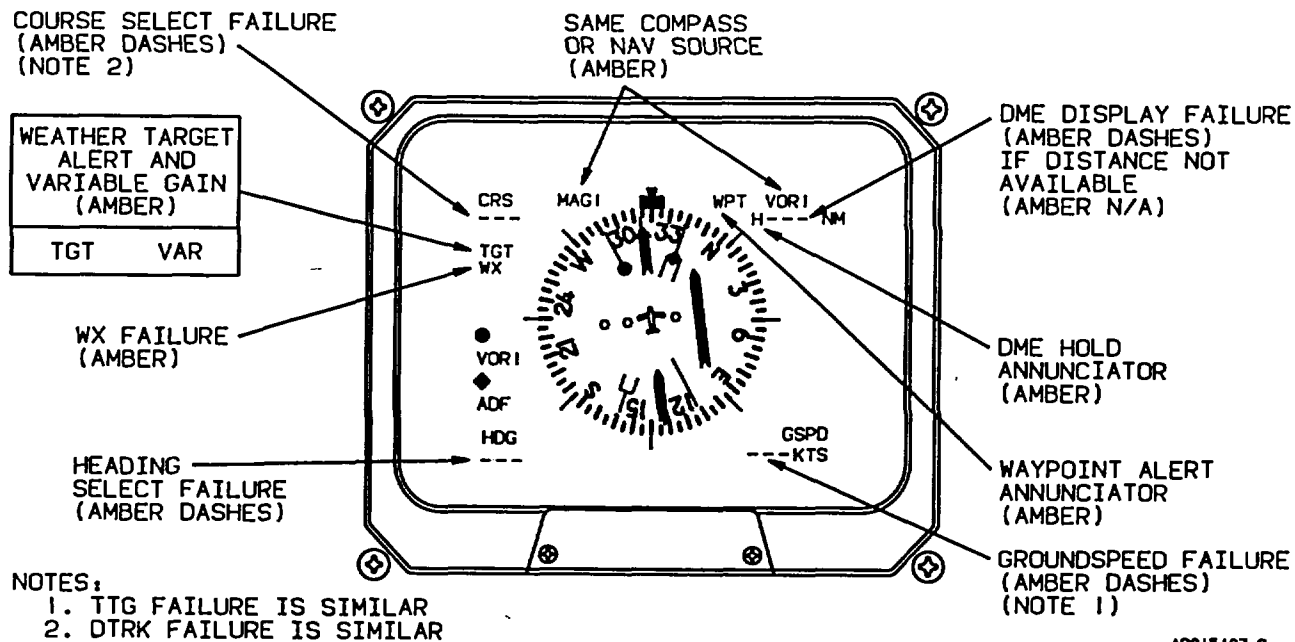

Figure 3-18. EHSI Caution Annunciators (Amber)

circuits on vertical gyros, and servo command outputs. Servo command outputs from a computed servo model in all three axes are compared to actual commands. If the difference between commands exceeds a certain threshold value, the flight control computer is disconnected from the servos. Normal flight control computer functions are computed based on the vertical and directional gyros selected with the respective EFIS display controllers.

b. *Flight Control Computer/Autopilot Mode Annunciation.* Flight control computer/autopilot operating modes are annunciated on the flight director mode selector and on each electronic attitude director indicator (EADI). The flight director command bars, on the coupled side's EADI, reflect the selected mode. The navigation sensor used for the selected modes is chosen with the display controller (DC-811) and annunciated on the EHSI.

c. *Autopilot Self-Disconnection Fault Messages.* The pilot can investigate the cause of an inflight autopilot disconnection by depressing the **SBY** button on the flight director mode selector for more than 5 seconds. The altitude preselector display will be disconnected from the digital air data computer and connected to the autopilot. A numerical fault code will appear on the altitude preselector display. Table 3-4

provides an explanation of fault codes. Subsequent pushes on the **SBY** switch on the flight director mode selector will yield additional fault codes or dashes, which indicate the end of the error code log. When the dashes appear in the display, the altitude preselector display will again be reconnected to the digital air data computer. Fault messages are displayed as a letter code followed by a three digit number. Ignore the last digit of the number, which will be a zero.

If the autopilot was disconnected as a result of the fault, depressing the **AP DISC** button on the control wheel will allow the autopilot to be re-engaged, provided the failure no longer exists.

d. *Digital Flight Control System Performance/Operating Limits.* Table 3-5 contains the digital flight control system performance and operating limits.

e. *Yaw Damper.* The yaw damper computer provides basic yaw damper functions with or without the autopilot. When the autopilot is engaged turn coordination is active. Yaw damper mode is active when either the **YD** or **AP ENGAGE** button on the autopilot controller is selected.

f. *Rudder Boost.* The yaw damper computer also provides rudder assist (boost) in the event of an engine failure. The amount of assist provided is

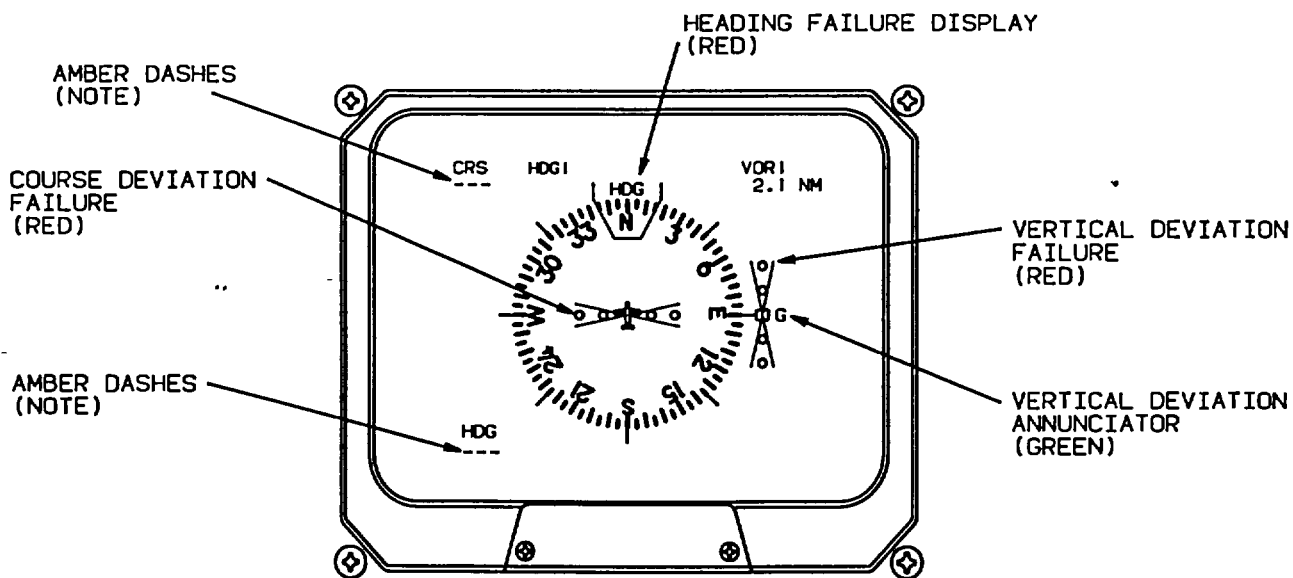

AP015408 C

NOTE:  
 IN THE EVENT OF HEADING FAILURE. THE COURSE SCALE AND RED X WILL NOT BE DISPLAYED AND THE CRS AND HDG READOUTS WILL INDICATE AMBER DASHES.

Figure 3-19. EHSI Failure Annunciators (Red)

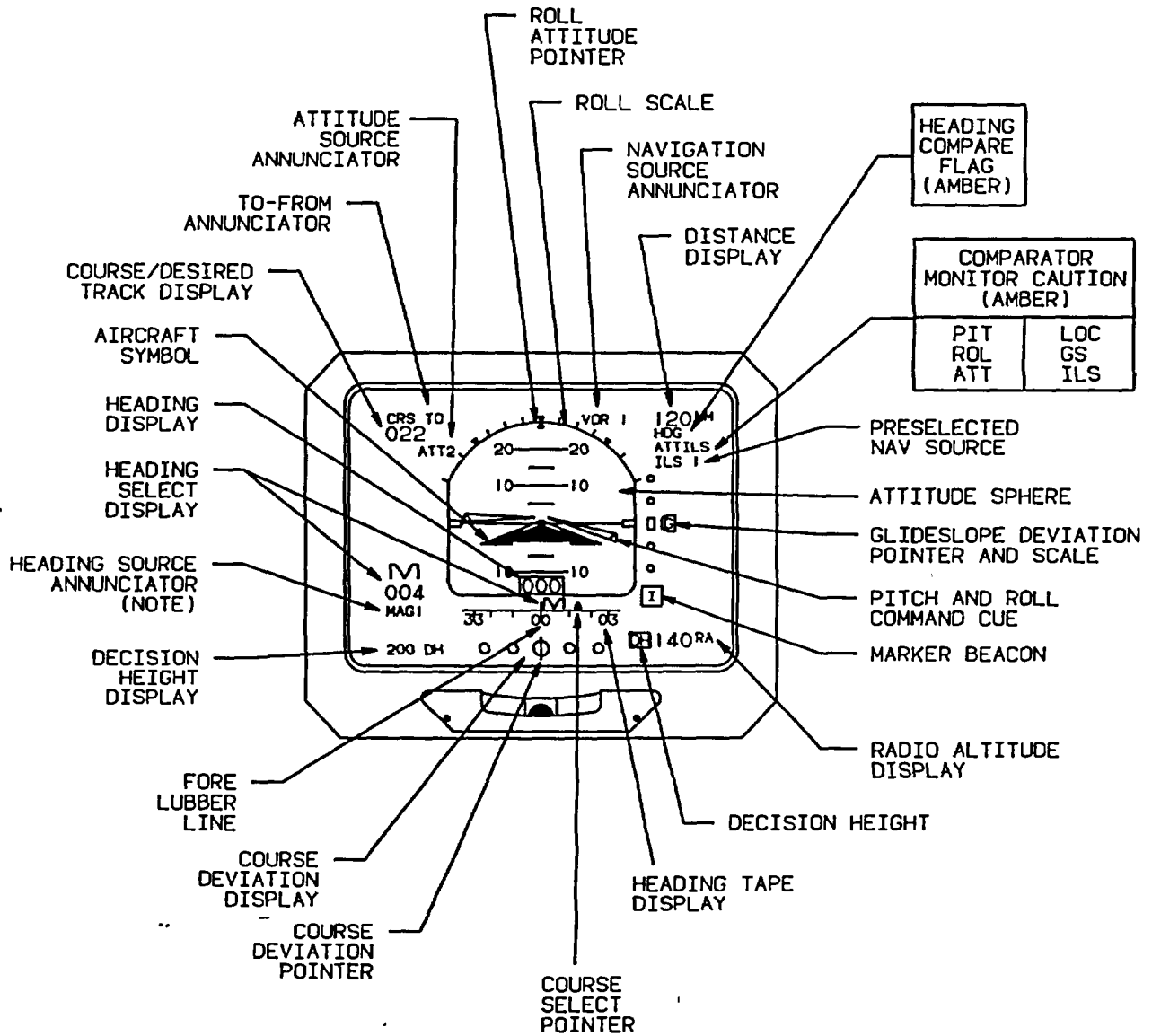

NOTE:  
 WHEN AIR DATA COMMAND MODES ARE SELECTED THE HEADING SOURCE ANNUNCIATOR IS REMOVED.  
 CANCELING THE AIR DATA COMMAND CAUSES THE HEADING SOURCE ANNUNCIATOR TO REAPPEAR.  
 AP015409 C

Figure 3-20. EADI/EHSI Composite Display

Table 3-4. Digital Flight Control System Error Codes

<b>FZ-450 Error Codes</b>	
Err 00 Processor Reset/Lost Processor	Err 35 Trim Test Fail
01 +15 Volt DC Fail	36 Lateral Accelerometer Fail
02 -15 Volt DC Fail	50 Aircraft ID Fail
03 -5 Volt DC Fail	51 Abbreviated Trim Test Fail
04 +10 Volt DC Fail	52 DG Fail
05 LVC Monitor Fail	53 Hardware Fail
06 Sawtooth Monitor Fail	54 VG No. 1 Fail
07 26 VAC Reference Fail	55 VG No. 2 Fail
08 Watchdog Monitor Fail	56 Pitch Current Monitor Fail
09 Interrupt Register Fail	57 Roll Current Monitor Fail
10 A/D End-Around Fail	59 Vertical
11 EEPROM Full	Gyro Comparison Fail
12 PROM Checksum Fail	60 Pitch Servo Loop Fail
13 RAM Read/Write Fail	61 Roll Servo Loop Fail
14 CPU Register Fail	63 Servo Fail
15 CPU Instruction Set Fail	64 Excessive
16 RAM Continuous Fail	Lateral Acceleration
17 Essential RAM Checksum Fail	65 Pitch Trim Fail
18 Continuous	66 Excessive
A/D and D/A Test Fail	Vertical Acceleration
19 Continuous PROM Test Fail	67 Excessive Roll Rate
20 Ticket Fail	68 Wrong Trim Polarity
21 CPU Fail	69 RG Valid Fail
30 Pitch Magnitude	70 26 VAC Cross-side
Rate Limiter Fail	Reference Fail
31 Roll Magnitude	71 AP Disconnect PB Fail
Rate Limiter Fail	72 Turn Knob Detent Fail
33 Roll Torque Fail	73 Manual Trim Input Fail
34 Pitch Torque Fail	

BT0341



Table 3-5. Digital Flight Control System Limits (Sheet 1 of 3)

Mode	Control or Sensor	Parameter	Value
Yaw Damper	Yaw Engage	Engage Limit	Up to 45° left or right bank
Autopilot Engage	A/P Engage	Engage Limit	Roll: Up to ± 15° Pitch: Up to ± 20°
Basic Autopilot	Touch Control Steering (TCS)	Roll Control Limit Pitch Control Limit	Roll: Up to ± 32° Pitch: Up to ± 20°
	Turn Knob	Roll Angle Limit Roll Rate Limit	± 30° ± 5.5° /sec
	Pitch Wheel	Pitch Angle Limit	± 20° pitch
	Heading Hold	Roll Angle Limit	Less than 6° and no roll mode selected
Heading Select	Heading SEL knob on HIS or remote slew knob on console	Roll Angle Limit Roll Rate Limit	± 25° ± 3.0°/sec
VOR or VORAPR	Course Knob, NAV Receiver and DME Receiver	<u>Capture</u> Beam Angle Intercept (HDG SEL)	Up to ± 90°
		Roll Angle Limit	± 25°
		Roll Rate Limit	± 5° /sec VORAPR ± 3° /sec VOR
		Course Cut Limit at Capture	± 30° course
		Capture Point	Function of beam, beam rate, course error, and DME distance. Maximum trip point is 175 mV. Minimum trip point is 30 mV.
		<u>On Course</u> Roll Angle Limit	± 13°
		Crosswind Correction	Up to ± 45° course error in VOR, ± 30° in VORAPR
LOC or APR or BC	Course Knob and NAV Receiver and	<u>Over Station</u> Course Change Roll Angle Limit Roll Rate Limit	Up to ± 30° ± 17° ± 3° /sec
		<u>LOC Capture</u> Beam Intercept	Up to ± 90°
		Roll Angle Limit Roll Rate Limit	± 25° ± 5.5° /sec

Table 3-5. Digital Flight Control System Limits (Sheet 2 of 3)

Mode	Control or Sensor	Parameter	Value
LOC or APR or BC (cont)	Radio Altimeter	Capture Point	Function of beam rate and course error. Maximum trip point is 200 mV. Minimum trip point is 60 mV.
	GS Receiver, Air Data Computer and Radio Altimeter	NAV On Course Roll Angle Limit Crosswind Correction Limit	± 13° of roll ± 30° of course error
Gain Programming		Starts at 1200 ft radio altitude, gain reduction = 1 to 0.4	
Glideslope Capture Beam Capture		Function of beam and beam rate.	
Pitch Command Limit		± 10°	
Glideslope Damping Pitch Rate Limit Gain Programming		Vertical Acceleration f (TAS) Starts at 1200 ft radio altitude, gain reduction = 1 to 0.08.	
GA	Control Switch on Wheel	Fixed Pitch-Up, Command Wings Level	8° pitch up
Pitch Sync ALT Hold	TCS Switch on Wheel	Pitch Altitude Command	± 20° maximum
	AIR Data Computer	ALT Hold Engage Range	0 to 41,000 ft
VS Hold	Air Data Computer	ALT Hold Engage Error	± 30 ft
		Pitch Limit	+ 20
		Pitch Rate Limit	f (TAS)
		VERT Speed Engage Range	0 to ± 6000 ft/min
IAS Hold	Air Data Computer	VERT Speed Hold Engage Error	± 100 ft/min
		Pitch Limit	± 20°
		Pitch Rate Limit	f (TAS)
		IAS Engage Range	80 to 400 knots
IAS Hold	Air Data Computer	IAS Hold Engage Error	± 5 knots
		Pitch Limit	± 20°
		Pitch Rate Limit	f (TAS)

dependent upon airspeed and engine power differential. The boost function is armed when the rudder boost switch located on the pedestal extension is set to the **RUDDER BOOST** position.

g. *Autopilot Controller (PC-400)*. The autopilot controller (fig. 3-21), provides a means of engaging/disengaging the autopilot and yaw damper as well as manually controlling the autopilot through the turn knob and pitch wheel. Whenever the autopilot is engaged, it will fly basic roll and pitch hold or the selected lateral or vertical flight director modes.

(1) *Pitch wheel*. Rotating the pitch wheel with the autopilot engaged will result in a change in pitch attitude proportional to the amount of rotation and in the direction of wheel movement. Movement of the pitch wheel cancels only altitude hold (**ALT HOLD**) or altitude select capture (**ALT SEL CAP**). With the vertical modes of vertical speed (**VS**) or indicated air speed (**IAS**) selected on the mode selector, rotation of the pitch wheel will change the respective air data command vertical mode reference (with autopilot engaged or disengaged) which is displayed on the EADI. **VS** or **IAS** modes may be cancelled by pressing the mode button on the mode selector panel. Movement of the pitch wheel has no effect with the autopilot coupled to the glideslope.

(2) *Bank limit switch-indicator*. The **BANK LIMIT** switch provides a lower maximum bank angle while in the heading select mode. Depressing the bank limit switch-indicator will illuminate the **LOW** indicator on the switch face. Depressing the switch again will cause the **LOW** indicator to be extinguished and the autopilot to return to normal bank limits. The lower bank limit is inhibited and the **LOW** indicator will be extinguished during **NAV** mode captures. If heading select is again engaged, **LOW** will again be illuminated on the bank limit switch-indicator.

(3) *Soft ride switch-indicator*. The **SOFT RIDE** mode provides reduced pitch and roll autopilot gains while still maintaining stability in rough air. This mode may be used with any flight director mode, but should only be selected **ON** in turbulence. Depressing the **SOFT RIDE** switch-indicator will cause the **ON** indicator to illuminate on the switch face.

(4) *Turn knob*. Rotation of the turn knob out of the detent results in a roll command. The roll angle is proportional and in the direction of turn knob rotation. The turn knob must be in the detent (center position) before the autopilot can be engaged. Rotation of the turn knob cancels any other previously selected lateral mode.

(5) *Yaw damper switch-indicator*. Depressing the yaw damper (**YD**) switch will engage the yaw damper and illuminate the **ENGAGE** indicator on the switch face. With the autopilot (**AP**) and yaw damper (**YD**) engaged, depressing the yaw damper switch-indicator will engage or disengage the yaw damper only (the autopilot will remain engaged).

(6) *Autopilot switch-indicator*. Depressing the autopilot (**AP**) switch-indicator will engage the autopilot and yaw damper simultaneously, and will illuminate the **AP** and **YD ENGAGE** indicators on the switch face. The autopilot may be engaged with the aircraft in any reasonable attitude. With no flight director modes selected, the autopilot will roll the aircraft to a wings level attitude upon engagement.

h. *Flight Director Mode Selector (MS-207)*. The flight director mode selector (fig. 3-22), provides all mode selection except go-around, which is initiated by the go-around switch located on the left power lever (fig. 2-14). The flight director command bars on the EADI provide integrated pitch and roll guidance to satisfy the selected mode. The top row of illuminated switch-indicators contains the lateral modes, and the bottom

Table 3-5. Digital Flight Control System Limits (Sheet 3 of 3)

Mode	Control or Sensor	Parameter	Value
ALT Preselect	Air Data Encoding	Preselect Capture Range	0 to 41,000 ft
	Altimeter and Altitude Preselect Controller	Maximum Gravitation Force During Capture Maneuver	± 0.20 g
		Pitch Limit	± 20°
Rudder Boost	Engine Sensors, Air Data	Pitch Rate Limit Rudder Force	f (TAS) f (Engine torque differential) f (IAS)

BT03842

row contains the vertical modes. The split light switch-indicators illuminate amber for armed conditions and green for captured conditions. Mode status is annunciated on both EADI's. If more than one lateral or vertical mode is selected, the flight director system automatically arms and captures the submode.

(1) *Heading mode switch-indicator.* Depressing the heading mode switch-indicator, placarded HDG, will illuminate the **ON** indicator on the face of the switch and will command the flight control computer to follow the inputs of the heading marker located on the heading dial of the coupled EHSI.

(2) *Navigation mode switch-indicator.* Depressing the navigation mode switch-indicator, placarded **NAV**, will cause the flight control computer to arm, capture, and track the navigation signal (**VOR**, **LOC**, **TACAN**, or **LNAV**) which has been selected as the navigation source for the EFIS. When approach (**APR**) has been selected, the navigation (**NAV**) select switch-indicator will annunciate lateral tracking status.

(3) *Approach mode switch-indicator.* Depressing the approach mode switch-indicator, placarded **APR**, will select the appropriate gains to arm and capture the lateral navigation signal for localizer (**LOC**) and vertical navigation signals for the glideslope. Except for an ILS, when approach is selected, the **NAV**

switch will annunciate the appropriate arm or capture condition.

(4) *Back course mode switch-indicator.* Depressing the back course mode switch-indicator, placarded **BC**, will command the flight control computer to track the localizer back course, and will illuminate the **ARM** or **CAP** indicators on the switch face as appropriate.

(5) *VOR approach mode switch-indicator.* Depressing the VOR approach switch-indicator, placarded **VOR APR**, will select the appropriate gains for capturing and tracking a VOR during the approach phase of flight, and will illuminate the **ARM** and **CAP** indicators on the switch face when appropriate.

(6) *Standby mode switch-indicator.* Depressing the standby mode switch-indicator, placarded **SBY**, will remove all the selected flight director modes, forcing the command bars to be removed from the EADI, and will illuminate the **SBY** indicator located on the switch face.

(7) *Indicated airspeed hold mode switch-indicator.* Depressing the indicated airspeed hold mode switch-indicator, placarded **IAS**, will command the system to maintain the current indicated airspeed or to allow a new

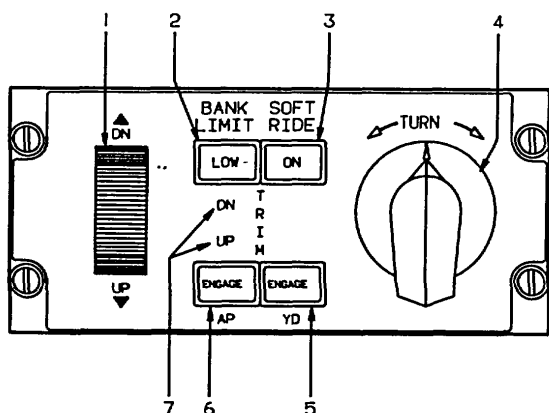

1. Pitch Wheel
2. Bank Limit Switch-Indicator
3. Soft Ride Switch-Indicator
4. Turn Knob
5. Yaw Damper Switch-Indicator
6. Autopilot Switch-Indicator
7. Trim Annunciators

A93FE00D0104 C

Figure 3-21. Autopilot Controller

indicated airspeed to be selected with either the autopilot pitch wheel or by using the touch control steering switch on the control wheel. When operating in the **IAS** mode the **ON** indicator located on the face of the switch will be illuminated and the target airspeed will be displayed on the EADI.

(8) *Vertical speed hold mode switch-indicator.* Depressing the vertical speed hold mode switch-indicator, placarded **VS**, will command the system to maintain the current vertical speed or to allow a new vertical speed to be selected with either the autopilot pitch wheel or by using the touch control steering switch on the control wheel. When operating in the **VS** mode the **ON** indicator located on the face of the switch will be illuminated and the target vertical speed will be displayed on the EADI.

(9) *Altitude preselect mode switch-indicator.* Depressing the altitude preselect mode switch-indicator, placarded **ALT SEL**, will command the flight control computer to arm and capture and maintain the altitude displayed on the altitude preselector (fig. 3-23). When operating in the **ALT SEL** mode the **ARM** or **CAP** indicators located on the switch face will be illuminated as appropriate.

(10) *Altitude hold mode switch-indicator.* Depressing the altitude hold mode switch-indicator,

placarded **ALT**, commands the flight control computer to hold the current altitude, and will illuminate the **ON** indicator located on the face of the switch. Capturing the altitude displayed on the altitude preselector will also cause the system to maintain that altitude.

i. *Control-Wheel Mounted Autopilot Disconnection Switches.* A bi-level autopilot/electric trim/yaw damper disconnect switch, placarded **DISC - AP & YD - TRIM**, is mounted on each control wheel (fig. 2-24). Depressing the switch to the first level will disconnect the autopilot and the yaw damper. Depressing the switch to the second level will also disconnect the electric elevator trim.

j. *Touch Control Steering (TCS).* A control-wheel mounted touch control steering switch (fig. 2-24), placarded **TCS**, allows the pilot to manually change aircraft attitude, altitude, vertical speed, or airspeed without disengaging the autopilot. The **TCS** switch is held depressed while the aircraft is maneuvered to the new attitude, altitude, vertical speed, or airspeed. When the switch is released, the autopilot will automatically synchronize to the vertical mode. If an air data mode (**IAS** or **VS**) has been selected, the selected value will be synchronized to the current value when the switch is released.

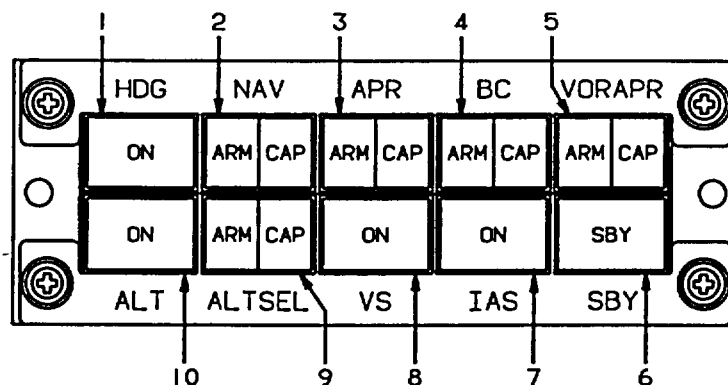

1. Heading Mode Switch-Indicator
2. Navigation Mode Switch-Indicator
3. Approach Mode Switch-Indicator
4. Back Course Mode Switch-Indicator
5. VOR Approach Mode Switch-Indicator
6. Standby Mode Switch-Indicator
7. Indicated Airspeed Hold Mode Switch-Indicator
8. Vertical Speed Hold Switch-Indicator
9. Altitude Preselect Mode Switch-Indicator
10. Attitude Hold Mode Switch-Indicator

A93FE00D106 C

Figure 3-22. Flight Director Mode Selector

k. *Go-Around Switch.* A pushbutton switch located on the left power lever (fig. 2-14), placarded **GO AROUND**, activates the flight control system go-around mode when depressed. Go-around mode will disengage the autopilot, command a wings-level 7 degree nose-up attitude, and engage the yaw damper.

l. *Rudder Boost/Yaw Control Test Switch.* A three-position toggle switch located on the pedestal extension (fig. 2-14), placarded **RUDDER BOOST - OFF - YAW CONTROL TEST**, arms the rudder boost system and is used to test for correct operation of the stability augmentation computer.

m. *Autopilot EFIS Select Switch.* A pushbutton switch-indicator located above the pilot's EADI, placarded **AP EFIS 1** and **AP EFIS 2**, selects which side's symbol generator will provide inputs to the flight control computer.

n. *Symbol Generator Reversionary Switch.*

**WARNING**

**Placing the pilot and co-pilot reversionary switches to the REV position on the SYM GEN switch will cause the blanking of all four EFIS display screens.**

A symbol generator reversionary toggle switch (fig. 2-18), placarded **SYM GEN, REV - NORMAL**, is located on the left and right sides of the instrument panel. In the event of a known or suspected symbol generator failure, placing the symbol generator reversionary switch to the **REV** position connects the corresponding EFIS system to the cross-side symbol generator. In the reversionary position, the opposite side symbol generator provides all the information to both (all four) displays. Additionally, the opposite display controller controls all of the display functions.

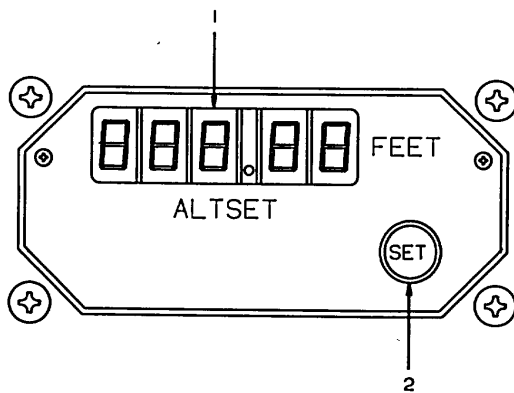

1. Attitude Display
2. Altitude Selector Knob

A93FE00D0105 C

Figure 3-23. Altitude Preselector

**NOTE**

If the **SYM GEN** reversionary switch is moved to the **REV** position with the autopilot/flight director selected to that side, the flight director modes will disengage.

Table 3-6 shows which flight director modes are reset by the EFIS when sources are changed.

**NOTE**

When **ATT** is selected, the autopilot will disengage.

*o. Automatic flight control system - Check as follows:*

1. Altitude alerter - Check as follows:

**NOTE**

Pause for a few seconds between each step to allow time for proper indications.

- a. Altitude preselector - Set to more than 1000 feet above altitude set on pilot's altimeter. Pilot's altimeter altitude alert annunciator light should be extinguished.
- b. Pilot's altimeter barometric set knob - Slowly increase pilot's altimeter setting.
- c. Altitude alerter annunciator and horn - Verify that altitude alerter annunciator on pilot's altimeter illuminates and altitude alerter horn sounds when pilot's altimeter reading is approximately 1000 feet from value set on altitude select controller.
- d. Pilot's altimeter - Reset to field elevation.
- e. Altitude preselector - Reset to field elevation.
- f. Pilot's altimeter barometric set knob

- Slowly increase pilot's altimeter setting.
- g. Altitude alerter annunciator and horn - Verify that the altitude alerter annunciator on pilot's altimeter illuminates and altitude alerter horn sounds when altimeter reading is approximately 250 feet from value set on altitude alert controller.
- h. Pilot's altimeter - Reset to field elevation.
2. Flight director - Check as follows:
  - a. **SBY** pushbutton switch-indicator (flight director mode selector - Depress for at least 5 to 8 seconds and verify the following indications:
    - (1) Flight director mode selector - Annunciators illuminate.
    - (2) Autopilot controller - Annunciators illuminate.
    - (3) Altitude select controller - All 8's illuminate.
    - (4) Pilot's altimeter altitude alerter annunciator - Illuminates.
    - (5) EADI - **FD FAIL** (amber) will be annunciated.
  - b. After **SBY** pushbutton switch-indicator has been held depressed for 5 to 8 seconds verify that:
    - (1) AP TRIM annunciator - Illuminates.
    - (2) Autopilot disconnect horn - Sounds.
  - c. **SBY** pushbutton switch-indicator - Release.
  - d. **FD** and **ATT** annunciations on the EADI - Check extinguished.
3. Autopilot - Check as follows:
  - a. Autopilot trim annunciators - Check extinguished.
  - b. **TURN** knob - Center.
  - c. **ELEV TRIM** switch - Check on.

Table 3-6. Flight Director Modes Reset when EFIS Sources Change

Selection Action	FD Modes Reset
V/L or INS/TCN	Navigation
HDG	Lateral
ATT	All modes

BT03843

**NOTE**

The control wheel must be held at mid-travel due to ballast in the elevator. The autopilot will disconnect during pitch wheel check due to the heavy nose down force if the control wheel is not off the forward stop.

- d. Control wheel - Move to mid-travel.
  - e. **AP ENGAGE** switch-indicator (autopilot controller) - Depress to engage autopilot and yaw damper. Check that **AP ENGAGE** and **YD ENGAGE** switch-indicators on autopilot controller and remote annunciators on instrument panel are illuminated.
4. Autopilot overpower check - Check as follows:
- a. Rudder pedals - Overpower slowly.
  - b. Control wheel - Overpower slowly in both directions.

**WARNING**

If the autopilot or yaw damper disengages during the overpower test, the system is considered non-operative and should not be used. The elevator trim system must not be forced beyond the limits which are indicated on the elevator trim indicator.

5. Elevator trim follow-up - Check as follows:
- a. Control wheel - Move aft of mid-travel. Trim wheel should run nose down after approximately 3 seconds. **TRIM DN** annunciator (autopilot controller) should illuminate after approximately 6 to 8 seconds, and **AP TRIM** annunciator (instrument panel) should illuminate after approximately 15 seconds.
  - b. Control wheel - Move forward of mid-travel. Trim wheel should run nose up after approximately 3 seconds. **TRIM UP** annunciator (autopilot controller) check illuminated after approximately 6 to 8 seconds. **AP TRIM** annunciators (instrument panel) check illuminated after approximately 15 seconds.
6. **AP & YD/TRIM DISC** switch (control wheel) - Depress to first level. Check that autopilot and yaw damper disengage, **AP ENGAGE** and **YD**

**ENGAGE** switch-indicators on the autopilot controller and remote annunciators above the EADI's flash 5 times.

- 7. Control wheel - Hold to mid-travel.
- 8. **AP ENGAGE** switch - Re-engage.
- 9. Turn knob - Check that elevator control trim wheel follows in each applied direction, then center.
- 10. Pitch wheel - Check that trim responds to pitch wheel movements. (**UP TRIM** and **DN TRIM** annunciators may illuminate.)
- 11. Heading marker - Center and engage **HDG**. Check that control wheel follows a turn in each direction.
- 12. **GO AROUND** button (left power lever) - Depress. Check that **AP** disengages and **FD** commands a wings level, 7 degrees nose up attitude. Check GA annunciator on EADI illuminates. Yaw damper should automatically engage and **YD ENGAGE** switch-annunciator should be illuminated on the autopilot controller and the remote annunciators above the EADI's should be illuminated.
- 13. **RUDDER BOOST/YAW CONTROL TEST** switch (pedestal extension) - **TEST**. Check the **RUDDER BOOST** annunciator above the EADI's illuminates, yaw damper disengages, **YD ENGAGE** switch-indicator on the autopilot controller extinguishes, and the **YD ENGAGE** remote annunciators above the EADI's flash 5 times.

**WARNING**

If the **SBY** annunciator on the flight director mode selector does not illuminate within 10 seconds after the avionics master switch is turned on, the autopilot has failed self-test and is considered inoperative and should not be used.

**CAUTION**

Do not force the elevator trim system beyond the limits which are indicated on the **ELEVATOR** trim tab indicator.

- 14. **YD ENGAGE** pushbutton switch-indicator (autopilot controller) - Depress while holding rudder boost/yaw control test switch in **TEST**. Yaw damper should not engage.



15. **RUDDER BOOST/YAW CONTROL TEST** switch - **RUDDER BOOST**. Check **RUDDER BOOST** annunciator extinguished.
16. Electric elevator trim - Check.
- ELEV TRIM** switch - On.
  - Pilot and copilot trim switches - Check operation.

**WARNING**

Operation of the electric trim system should occur only by movement of pairs of switches. Any movement of the elevator trim wheel while depressing only one switch element indicates a trim system malfunction. The electric elevator trim control switch must then be turned OFF and flight conducted by operating the elevator trim wheel manually. Do not use autopilot.

- Pilot and copilot trim switches - Check individual element for no movement of trim, then check proper operation of both elements.
- Pilot trim switches - Check that pilot switches override copilot switches while trimming in opposite directions, and trim moves in direction commanded by pilot.
- Pilot or copilot trim switches - Check trim disconnects while activating pilot or copilot trim disconnect switches.
- ELEV TRIM** switch - **OFF** then on (**ELEC TRIM OFF** annunciator extinguishes).

p. *Digital Flight Control System Modes of Operation.*

(1) *Heading hold mode (wings level).* The basic lateral mode of the autopilot is heading hold. Heading hold mode is defined as:

Autopilot engaged  
No lateral flight director mode selected  
Bank angle less than 6 degrees

If the above conditions are satisfied, the autopilot will roll the aircraft to a wings level attitude. When the aircraft's bank angle is less than 3 degrees for 10 seconds, the heading hold mode is automatically

engaged. The heading hold mode is not annunciated on the EADI as it is the default lateral mode when no other lateral steering mode is selected. Autopilot engagement is annunciated on the EADI.

(2) *Roll hold mode.* The autopilot will recognize the roll hold mode as being operational when:

No lateral flight director mode has been selected  
The aircraft's bank angle is greater than 6 degrees, but less than 35 degrees '  
The autopilot is engaged

When the above conditions have been satisfied, the autopilot will maintain the desired bank angle. With the autopilot engaged, bank angles up to 35 degrees can be established using the turn knob. If touch control steering (TCS) was used to initiate the roll, bank angles up to 35 degrees can be maintained and **TCS ENG** will be annunciated on the EADI.

(3) *Heading select mode.* The heading select mode is used to intercept and maintain a magnetic heading. The mode is selected with the HDG switch-indicator on the flight director mode selector panel (fig. 3-22). Heading mode selection is annunciated by a green HDG annunciator on the EADI. The heading marker is set on the heading dial of the EHSI by means of the instrument remote controller (pedestal extension, fig. 2-14). When operating in the heading mode the flight control computer provides inputs to the pitch and roll command cue on the EADI to command a turn to the heading selected by the heading marker located on the EHSI. Heading mode signal gain is a function of airspeed. Bank angle limit is 25 degrees in the heading select mode.

Heading select mode is cancelled by:

Capture of any other lateral steering mode  
Selecting go-around mode  
Selecting standby mode  
**EFIS 1/2** reversionary selection  
**NAV, ATT, or HDG** reversionary selections

(4) *VOR (NAV) mode.* The VOR mode provides for automatic intercept, capture, and tracking of a selected VOR radial, using the selected navigation source displayed on the EHSI. The navigation source displayed on the EHSI is a function of the VOR/localizer (**V/L**) pushbutton selector switch located on the display controller (fig. 3-8). Prior to engaging the VOR (**NAV**)

mode, perform the following:

1. VOR navigation receiver control panel - Set desired VOR frequency.
2. **V/L** pushbutton selector switch (display controller) - Depress to select **VOR1** or **VOR2**.
3. Course pointer (EHSI) - Set desired course on heading dial.
4. Heading marker (EHSI) - Set desired intercept heading for selected course.

With the aircraft outside the normal capture range of the VOR signal (typically, course deviation indicator on EHSI off course by more than 2 dots), engage the **NAV** switch-indicator on the flight director mode selector. **HDG** switch-indicator on the flight director mode selector panel will illuminate **ON**, and the **NAV** switch-indicator will annunciate **ARM**. **HDG** (green) and **VOR ARM** (white) will also be annunciated on the EADI. The flight control computer is now armed to capture the VOR signal, and is generating a roll command to fly the heading select mode.

When reaching the lateral beam sensor trip point, the system will automatically drop the heading select mode and will switch to the VOR capture phase. The EADI will display the following indications:

**VOR** annunciator (white) will extinguish.

**HDG** annunciator (green) will extinguish.

**NAV** (green) will be annunciated and will be enclosed in a white box for 5 seconds to indicate the capture phase.

The heading pushbutton switch-indicator on the autopilot/flight director mode selector will extinguish and the **NAV** pushbutton switch-indicator will switch from **ARM** to **CAP**.

The flight control computer will generate the proper roll command to capture and track the selected VOR radial.

Course select error signal is established by the heading selected by the course pointer on the EHSI. This signal represents the difference between the actual aircraft heading and the desired course. The course error signal is then sent from the symbol generator to the flight control computer.

The radio deviation signal is routed from the navigation receiver to the symbol generator and flight control computer. The signal is lateral gain programmed in the flight control computer.

The lateral gain programming is performed as a function of DME distance to the station (if available), true airspeed, and barometric altitude. This gain programming adjusts for the aircraft going toward or away from the VOR station.

#### NOTE

**If possible, avoid using DME hold or having N/A as a distance display annunciation during VOR capture and tracking. When in this condition the flight control computer cannot use DME distance for gain programming.**

When flying a VOR intercept, the optimum intercept angle is less than 45 degrees. When the aircraft satisfies VOR track conditions, the course error signal is removed from the lateral steering command. This leaves radio deviation, roll attitude, and lateral acceleration to track the VOR signal, and to compensate for beam standoff in the presence of a crosswind. The system will automatically compensate for a crosswind of up to 45 degrees course error.

As the aircraft approaches the VOR station, it will enter a zone of unstable radio signals (zone of confusion). This zone radiates upward from the station in the shape of a truncated cone. In this area, the radio signal becomes highly erratic and it is desirable to remove it from the roll command. The overstation sensor monitors entry into the zone of confusion and removes radio deviation from the roll command.

The system also uses the collocated DME signal (if available) to adjust tracking gains.

When over the VOR station, the system will accept and follow a course change of up to 30 degrees.

(5) *VOR approach mode.* The set-up procedure for the VOR approach mode is the same as for VOR tracking, except the **VORAPR** pushbutton switch-indicator on the mode selector panel is depressed instead of the **NAV** switch-indicator. **ARM** will be annunciated by the **VORAPP** switch-indicator on the mode selector panel and **APR** will be displayed in white on the EADL.

The flight control computer will now apply the gains appropriate for a VOR approach. Upon capture of the selected course, the VOR APP mode selector switch will annunciate capture (**CAP**), and **APR** will be annunciated on the EADI in green.

(6) *TACAN navigation and approach mode.* TACAN navigation and approaches are accomplished in a similar manner to VOR navigation and approaches. Prior to engaging the mode, perform the following:

1. TACAN navigation receiver control panel - Set desired channel.
2. **INS/TCN** pushbutton selector switch (display controller) - Depress to select **TCN**.
3. Course pointer (EHSI) - Set desired course on heading dial.

4. Heading marker (EHSI) - Set desired intercept heading for selected course.
5. Flight director mode selector panel - Select **NAV** for TACAN navigation or **APR** for a TACAN approach. The EADI will annunciate **NAV** arm and capture when appropriate.

The flight control system will perform the capture and tracking as described for VOR navigation and approaches.

(7) *Inertial navigation system (INS) steering mode.* Operation in the INS steering mode is similar to operation in the NAV mode, with the following differences:

Instead of using course error and radio deviation from the symbol generator, a composite lateral steering command from the INS through the symbol generator is used.

Lateral steering command gain is programmed in the INS.

**LNAV** is annunciated on the EADI.

Desired track is selected by the INS.

When the **NAV** pushbutton switch-indicator on the flight director mode selector panel is depressed, **LNAV** will annunciate in green on the EADI. The flight command computer will use the INS-supplied steering commands to track the desired course. Bank angle limit is 22 degrees.

**LNAV** mode is cancelled by:

Depressing the **NAV** pushbutton indicator-selector switch on the flight director mode selector panel.

Selecting go-around mode - Selecting standby mode

Selecting an alternate **ATT**, **HDG**, or **NAV** source on the display controller.

(8) *Preview and transition mode.* A preview course pointer (magenta) is provided to enable the pilot to preview data prior to its use. The flight control computer can be commanded to automatically transition from tracking the INS to tracking one of the short range navigation (**SRN**) sources (VOR, localizer, or TACAN). One use for this feature is to transition from tracking the INS to an approach using VOR, localizer, or TACAN.

Set-up for preview course pointer mode is as follows:

1. **INS/TACAN** pushbutton selector switch (display controller) - **INS**.
2. **NAV** pushbutton selector switch (flight director mode selector panel) - Depress **NAV** to capture and track

**INS** track.

3. EADI - Observe that **LNAV** (green) is displayed.
4. Selection of **V/L** or **TCN** on the display controller after the above three conditions have been met.

The preview course deviation bar will respond to VOR, localizer, and TACAN signals as appropriate.

Once the previewed navigation source is valid, if the approach mode (for localizer, ILS, or TACAN) or VOR approach mode (for VOR) has been selected on the flight director mode selector, the appropriate **LOC**, **ILS**, or **NAV** annunciator will be illuminated on the EADI.

When the flight director determines that the capture point for the previewed mode has been reached, it will transition the flight director from **LNAV** mode to the capture mode of the previewed navigation source. The preview course pointer will then be removed and the standard course pointer will be slewed to the previewed selected course.

#### NOTE

**Since INS and TACAN are selected with the same display controller pushbutton switch, it is possible to inadvertently reselect the INS as the navigation source rather than preview the TACAN navigation source.**

(9) *Localizer (NAV) mode.* The localizer mode provides for automatic intercept, capture, and tracking of a front course localizer beam. Prior to mode engagement, perform the following:

1. VHF navigation receiver control panel - Set desired localizer frequency.
2. **V/L** pushbutton selector switch (display controller) - Depress to select **LOC1** or **LOC2**.
3. Course pointer (EHSI) - Set inbound course on heading dial.
4. Heading marker (EHSI) - Set desired intercept heading for course interception.

The EHSI will display the relative position of the aircraft to the center of the localizer beam and the desired inbound course. With the heading marker set, the heading select mode can be used to perform the intercept. Outside the normal capture range of the localizer signal (between one and two dots on the EHSI), depressing the **NAV** or

**APR** pushbutton switch on the flight director mode selector will cause the EADI to annunciate **LOC** and **GS** in white and **HDG** in green. The aircraft will then be flying the desired heading intercept and the system will be armed for automatic localizer and glideslope beam capture.

With the aircraft approaching the selected course interception, the lateral beam sensor (LBS) is monitoring localizer beam deviation, beam rate, and true airspeed. At the computed time, the LBS will trip and capture the localizer signal. The flight control computer will drop the heading select mode and generate the proper roll command to bank the aircraft toward the localizer beam center. When the LBS trips, the EADI will display **LOC** in green. **LOC** will be enclosed in a white box for 5 seconds.

If both radio altitude and glideslope deviation are valid, distance is calculated using radio altitude and glideslope deviation data. If only radio altitude is valid, distance is first estimated for capture. It is assumed that an approach to the runway is being made without glideslope, and distance is calculated based on radio altitude only. If radio altitude information is not valid, distance is estimated as a function of glideslope deviation and true airspeed. If neither radio altitude nor glideslope data is valid, distance is estimated as a function of true airspeed and time.

The glideslope mode is cancelled by:

- Depressing **NAV** or **APR** pushbutton switch-indicator on the flight director mode selector.
- Selecting a VOR frequency on the selected VHF navigation receiver control panel.
- Selecting go-around mode.
- Selecting standby mode.
- Selecting back course mode.
- Coupling flight control computer to the cross-side EFIS.
- Selecting an alternate **ATT**, **HDG**, or **NAV** source on the display controller.

When the aircraft satisfies the localizer track conditions, the course error signal is removed from the lateral steering command. This leaves radio deviation, roll attitude, and lateral acceleration to track the localizer signal, and to compensate for localizer beam standoff in the presence of a crosswind. The system will automatically compensate for a crosswind of up to 45 degrees course error.

(10)Back course mode. The back course mode (BC) provides for automatic intercept, capture and

tracking of the back course localizer signal. When flying a back course localizer approach, glideslope capture is automatically inhibited. The back course mode is set up and flown exactly like a front course localizer approach, with the following differences:

Back course (**BC**) is selected on the flight director mode selector.

With the aircraft outside the normal back course localizer capture limits, the EADI will annunciate **BC** in white and **HDG** in green.

At back course capture, the EADI will annunciate **BC** in green (**BC** will be enclosed in a white box for 5 seconds).

When the back course mode has been selected on the flight director mode selector, logic in the flight control computer was established to internally reverse the polarity of the course error and localizer signals, and provide expanded localizer display on the EADI. Also a gain change takes place in the computer when **BC** has been selected, since the aircraft is closer to the localizer transmitter by the length of the runway plus 1000 feet. At back course capture, the flight control computer will generate a roll command to capture and track the back course localizer signal.

The back course mode is cancelled by:

- Depressing the **BC** pushbutton switch-indicator on the flight director mode selector
- Selecting a VOR frequency on the selected VHF navigation receiver control panel
- Selecting go-around mode
- Selecting standby mode
- Selecting heading mode
- Coupling flight control computer to the cross-side EFIS
- Selecting an alternate **ATT**, **HDG**, or **NAV** source on the display controller.

(11)ILS approach mode. The ILS approach mode provides for automatic intercept, capture, and tracking of the front course localizer and glideslope signals. This allows flying a fully coupled ILS approach. Set-up for the ILS approach mode is as follows:

1. VHF navigation receiver control panel - Set desired localizer frequency.
2. **V/L** pushbutton selector switch (display controller) - Depress to select **LOC1** or **LOC2**.
3. Course pointer (EHSI) - Set inbound course on heading dial.

4. Heading marker (EHSI) - Set desired intercept heading for course interception.

The EHSI will now display the relative position of the aircraft to the center of the localizer beam and the desired inbound course. With the heading marker set for intercept, the heading select mode can be used to perform the intercept. Outside the normal capture range of the localizer signal (between one and two dots on the EHSI), depressing the APR pushbutton switch on the flight director mode selector will cause the EADI to announce LOC in white and HDG in green. The aircraft will now be flying the desired heading intercept and the system will be armed for automatic localizer beam capture.

With the aircraft approaching the selected course interception, the lateral beam sensor (LBS) is monitoring localizer beam deviation, beam rate, and true airspeed. At the computed time, the LBS will trip and capture the localizer signal. The flight control computer will drop the heading select mode and generate the proper roll command to bank the aircraft toward the localizer beam center. When the LBS trips, the EADI will display LOC in green. LOC will be enclosed in a white box for 5 seconds.

The glideslope portion of the approach mode is used for the automatic intercept, capture, and tracking of the glideslope beam. The beam is used to guide the aircraft down to the runway in a linear descent. Typical glideslope beam angles vary between 2 and 3 degrees, depending on terrain. When the glideslope mode is used as the vertical portion of the approach, it allows the pilot to fly a fully coupled ILS approach. The mode is interlocked, so that glideslope capture is inhibited until localizer capture has occurred.

As the aircraft approaches the glideslope beam, the vertical beam sensor monitors true airspeed, vertical speed, and glideslope deviation to determine the correct capture point. At glideslope capture, the computer drops any other vertical mode that was in use, and automatically generates a pitch command to smoothly track the glideslope beam. Gain programming is performed on the glideslope signal to compensate for the aircraft closing on the glideslope transmitter and beam convergence caused by the directional properties of the glideslope antenna. Glideslope programming is normally accomplished as a function of radio altitude and vertical speed. If the radio altimeter is not valid, glideslope gain programming is accomplished as a function of preset height- above-the-runway estimates and run-down as a function of true airspeed.

The ILS approach mode is cancelled by:

Depressing **NAV** or **APR** pushbutton switch-indicator on the flight director mode selector.

Selecting a VOR frequency on the selected VHF

navigation receiver control panel.

Selecting go-around mode.

Selecting standby mode.

Selecting back course mode.

Coupling flight control computer to the cross-side EFIS.

Selecting an alternate **ATT**, **HDG**, or **NAV** source on the display controller.

When the aircraft satisfies the localizer track conditions, the course error signal is removed from the lateral steering command. This leaves radio deviation, roll attitude, and lateral acceleration to track the localizer signal, and to compensate for localizer beam standoff in the presence of a crosswind. The system will automatically compensate for a crosswind of up to 45 degrees course error.

*(12)Pitch attitude hold mode.* The pitch attitude hold mode is the basic vertical flight director mode. It is activated when a flight director lateral (roll) mode is selected without an accompanying vertical (pitch) mode. There is no annunciation for pitch hold mode although the basic **AP ENG** annunciation is available. The pitch command on the EADI provides the pilot with a pitch reference corresponding to the pitch attitude existing at the moment the lateral mode was selected. This pitch reference can be changed with the touch control steering (**TCS**) switch located on the control wheels. The reference pitch attitude can also be changed as a function of the pitch wheel on the autopilot controller when the autopilot is engaged. Pitch attitude hold mode may be cancelled by selecting any vertical mode or the automatic capture of a vertical mode.

*(13)Vertical speed hold mode.* The vertical speed hold mode is used to automatically maintain the aircraft at a selected vertical speed reference. To initiate the mode, the aircraft is maneuvered to the desired climb or descent attitude to establish the vertical speed reference, then the mode is engaged by depressing the **VS** pushbutton switch-indicator on the flight director mode selector. The reference vertical speed can be changed by pushing the touch control steering (**TCS**) switch on the control wheel and maneuvering the aircraft to a new vertical speed reference and then releasing the switch. The vertical speed reference can also be changed by the use of the pitch wheel on the autopilot controller.

When the vertical speed mode is engaged, **VS** (green) will be annunciated on the EADI, and the vertical speed target will be displayed in the lower left corner of the EADI. When the vertical speed reference is changed by using the pitch wheel on the autopilot controller, the EADI's will indicate the commanded vertical speed reference. Actual aircraft vertical speed will be displayed on the vertical speed indicator. Selecting vertical speed (**VS**) will reset all previously selected vertical modes.

Vertical speed mode may be cancelled by:

- Depressing the VS pushbutton switch-indicator on the flight director mode selector.
- Selecting another vertical mode.
- Selecting the go-around mode.
- Selecting the standby mode.
- Coupling to the cross-side EFIS.
- Selecting an alternate ATT source on the display controller.

(14) Indicated airspeed hold mode.

Activation of the IAS pushbutton indicator-selector switch on the flight director mode selector automatically commands the flight director to maintain the present indicated airspeed. The referenced airspeed can be changed by depressing the touch control steering (TCS) switch on the control wheel, maneuvering the aircraft to a new indicated airspeed, then releasing the TCS switch. The airspeed reference can also be changed by using the pitch wheel on the autopilot controller. When the airspeed mode is engaged, IAS (green) will be annunciated on the EADI, and the indicated airspeed target will be displayed in the lower left corner of the EADI. Actual aircraft indicated airspeed will be displayed on the airspeed indicator. When the indicated airspeed hold mode is selected, all previously selected vertical modes will be reset.

The indicated airspeed mode may be cancelled by:

- Depressing the IAS pushbutton switch-indicator on the flight director mode selector
- Selecting another vertical mode
- Selecting go-around
- Coupling to the cross-side EFIS

(15) *Altitude hold mode.* The altitude hold mode is a vertical flight director mode which is used to maintain a barometric altitude reference. The vertical command for altitude hold is displayed on the flight director pitch command cue on the EADI. To select altitude hold, depress the ALT pushbutton switch-indicator located on the flight director mode selector, while operating in any lateral mode. The ALT (green) annunciator will be illuminated on the EADI while altitude hold mode is active. The vertical axis of the flight director will maintain the barometric altitude at the time of mode engagement. The reference altitude may be change by depressing the touch control steering (TCS) switch on the control wheel, maneuvering the aircraft to

the desired altitude, then releasing the TCS switch.

The altitude hold mode can be cancelled by:

- Moving the pitch wheel on the autopilot controller.
- Depressing the ALT pushbutton switch-indicator on the flight director mode selector.
- Selecting any other vertical mode.
- Coupling to the cross-side EFIS.
- Selecting an alternate ATT source on the display controller.

(16) *Altitude preselect mode.* The altitude preselect (ALT SEL) mode is used in conjunction with another vertical mode to achieve automatic capture, flare, and level-off onto a preselected altitude. The ALT SEL mode is armed by depressing the ALT SEL pushbutton switch-indicator on the flight director mode selector. The desired altitude is entered into the altitude preselector display window using the SET knob.

When armed, the ALT SEL mode is annunciated on the EADI. Vertical speed hold mode (VS HOLD), indicated airspeed hold (IAS), or pitch hold can be used to fly to the selected altitude. When reaching the bracket altitude, the system automatically switches to the ALT SEL CAP mode and the previous pitch mode is cancelled. A command is then generated to asymptotically capture the selected altitude. The ALT SEL mode is cancelled in altitude hold (ALT) or after glideslope capture. ALT SEL capture is annunciated on the EADI by a green ASEL at the vertical capture annunciation location. To indicate the transition to capture, ASEL will be enclosed in a white box for 5 seconds.

The aircraft will remain in the ALT SEL capture mode until the following conditions exist simultaneously:

- ALT error is less than 25 feet
- ALT rate is less than 5 feet per second

At this time, the altitude select (ALT SEL) mode will be dropped and the system will be placed in the altitude hold (ALT) mode.

The ALT SEL CAP mode will be dropped and the ALT SEL ARM mode will be automatically reselected following an ALT SEL knob motion or a pitch wheel actuation.

Perform the following steps to fly to a preselected altitude using the altitude select mode (ALT SEL):

1. Set selected altitude on altitude preselector.
2. Select pitch hold, **VS**, or **IAS** mode descend or ascend toward selected altitude.
3. Depress **ALT SEL** pushbutton switch-indicator on flight director mode selector panel. **ALT SEL** mode is now armed.

The altitude flare point (**ALT SEL CAP**) is a nonlinear function, dependent upon vertical speed and distance to the selected altitude.

4. **ALT SEL** capture is dropped and **ALT HOLD** is automatically engaged.

The **ALT SEL** capture submode is cancelled by:

Moving the **ALT SET** knob on the altitude preselector.

Moving the pitch wheel on the autopilot controller.

Selecting on or captured any other vertical mode.

Coupling to the cross-side EFIS.

Selecting an alternate ATT source on the display controller.

(17) *Go-around mode (wings level)*. The go-around mode is normally used to transition from an approach to a climb when a missed approach has occurred. Go-around mode is selected by depressing the go-around switch located on the left power lever. With go-around selected, all flight director modes are cancelled, and the autopilot is disengaged. The pilot will see a wings level command and a 7-degree climb angle will be presented on the EADI. When go-around is selected, the autopilot will automatically disengage, and the yaw damper will automatically engage.

### 3-24. VHF NAVIGATION RECEIVERS (VIR-32).

*a. Introduction.* The VHF navigation receivers (fig. 3-24), provide 200 50-kHz spaced VOR/localizer channels from 108.00 through 117.95 MHz, 40 glide slope channels automatically paired with localizer channels, and a marker beacon receiver. The digital navigation receiver provides VOR, LOC, and GS deviation outputs, high and low level flag signals, magnetic bearing to the station, to/from information, marker beacon lamp signals, and VOR and marker beacon audio outputs. The navigation receivers are powered through the 2-ampere **VOR #1** and **VOR #2** circuit breakers, located on the overhead circuit breaker panel (fig. 2-9).

*b. VHF Navigation Receiver Control Unit Controls and Functions.* All operating controls for the navigation receiver are located on the CTL-32 navigation receiver control unit (fig. 3-24). The VHF navigation receiver control unit also controls the DME function of the TACAN when it is operated in DME mode.

(1) *Active frequency display.* The active frequency (frequency to which the receiver is tuned) and diagnostic messages are displayed in the upper window.

(2) *Transfer/memory switch.* This switch is a 3-position spring-loaded toggle switch placarded **XFR/MEM**, which, when held to the **XFR** position, causes the preset frequency to be transferred up to the active display and the receiver to be retuned. The previously active frequency will become the new preset frequency and will be displayed in the lower window. When this switch is held to the **MEM** position, one of the four stacked memory frequencies will be loaded into the preset display. Successive pushes will cycle the four memory frequencies through the display.

(3) *Store switch.* This switch, placarded **STO**, allows up to four preset frequencies to be selected and entered into the control unit's memory. After presetting the frequency to be stored, the **STO** switch should be pushed. The upper window displays the channel number of available memory channel (CH 1 through CH 4) while the lower window continues to display the frequency to be stored. For approximately 5 seconds, the **MEM** switch may be used to advance through the channel numbers without changing the preset display. The **STO** switch is pushed a second time to commit the preset frequency to memory in the selected location. After approximately 5 seconds, the control will return to normal operation.

(4) *Tuning knobs.* Two concentric tuning knobs control the preset or active frequency displays. The larger knob changes the three digits to the left of the decimal point in 1-MHz steps. The smaller knob changes the two digits to the right of the decimal point in 0.05 MHz steps. The two frequency select switches are independent of each other so that the upper and lower rollover of the 0.1 MHz digit will not cause the 1.0 MHz digit to change.

(5) *Active switch.* The active switch, placarded **ACT**, enables the tuning knobs to directly tune the receiver when depressed and held for two seconds. The bottom window will display dashes and the upper window will continue to display the active frequency. Pushing the **ACT** switch a second time will return the control unit to the normal 2-display mode.

(6) *Test switch.* This switch, placarded **TEST**, initiates the receiver self-test diagnostic routine. (Self-test is active only when the **TEST** switch is pressed.)

(7) *Light sensor.* This built-in light sensor automatically controls display brightness.

(8) *Volume control.* The volume control is concentric with the power and mode switch.

(9) *Power and mode switch.* The power and mode switch contains three detented positions placarded **OFF**, **ON**, and **HLD**. The **ON** and **OFF** position switches system power. The hold (**HLD**) position allows the navigation receiver frequency to be changed while holding the DME in its present frequency.

(10) *Annunciators.* The receiver control unit contains **MEM** (memory) and **RMT** (remote) annunciators. The **MEM** annunciator illuminates whenever a preset frequency is being displayed in the lower window. The **RMT** annunciator is not used in this installation.

(11) *Preset frequency display.* The preset (inactive) frequency and diagnostic messages are displayed in the lower window.

(12) *Compare annunciator.* An annunciator placarded **ACT** momentarily illuminates when frequencies are being changed. The **ACT** annunciator flashes if the actual radio frequency which the receiver is tuned to is not identical to the frequency shown in the

active frequency display.

c. *Operating Procedures.*

**WARNING**

**It is not practical to provide monitoring for all conceivable system failures and, it is possible that erroneous operation could occur without a fault indication. It is the responsibility of the pilot to detect such an occurrence by means of cross-checks with redundant or correlated information available in the cockpit.**

(1) Equipment turn-on. The VIR-32 receiver and the CTL-32 NAV control are turned on as follows:

1. **BATTERY** switch (overhead control panel, fig. 2-9) - **ON**.
2. **AVIONICS MASTER POWER** switch (overhead control panel, fig. 2-9) - **ON** or **EXT PWR** as required.
3. EFIS power switches (2, overhead control panel, fig. 2-9) - **ON**.

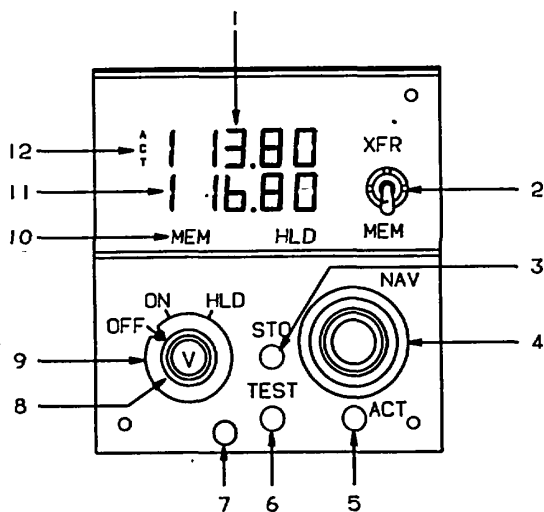

1. Active Frequency Display
2. Transfer/Memory Switch
3. Store Switch
4. Tuning Knobs
5. Active Switch
6. Test Switch
7. Light Sensor
8. Volume Control
9. Power and Mode Switch
10. Annunciators (**MEM**, **RMT**, **HLD**)
11. Preset Frequency Display
12. Compare Annunciator

A93FE00D0107 C

Figure 3-24. VHF Navigation Receiver Control Unit



4. Power and mode switch (fig. 3-25) - **ON.**

After power is applied, the control unit displays the same active and preset frequencies that were present when the equipment was last turned off.

(2) Frequency selection. Frequency selection is made using either the frequency select knobs, or the **XFR/MEM** (transfer/memory recall switch). Rotation of either frequency select knob increases or decreases the frequency in the preset frequency display. The larger, outer knob changes the frequency in 1-MHz increments (number to the left of decimal point). The smaller, inner knob changes the frequency in 0.05 MHz increments. After the desired frequency is set in the preset frequency display, it can be transferred to the active frequency display by momentarily setting the **XFR/MEM** switch to **XFR**. At the same time that the preset frequency is transferred to the active display, the previously active frequency is transferred to the preset display. The **ACT** annunciator on the control unit flashes while the receiver is tuning to the new frequency.

**NOTE**

**The ACT annunciator continuing flashing indicates that the receiver is not tuned to the frequency displayed in the active display.**

The control unit has memory that permits storing up to four preset frequencies. Once stored, these frequencies can be recalled to the preset display by positioning the **XFR/MEM** switch to the **MEM** position. The storage location (**CH 1** through **CH 4**) for the recalled frequency is displayed in the active frequency display while the **XFR/MEM** switch is held in the **MEM** position. All four stored frequencies can be displayed one at a time in the preset display by repeatedly positioning the **XFR/MEM** switch to the **MEM** position. After the desired stored frequency has been recalled to the preset display, it can be transferred to the active display by momentarily positioning the **XFR/MEM** switch to the **XFR** position.

During normal operation, all frequency selections and revisions are accomplished in the preset frequency display. However, the active frequency can be selected directly as described in the direct active frequency selection paragraph.

(3) Direct active frequency selection. The active frequency can be selected directly with the frequency select knobs by pushing the **ACT** switch for about 2 seconds. The active frequency selection mode is indicated by dashes appearing in the preset display. Also, the **ACT** annunciator will flash as the frequency select knobs are turned to indicate that the receiver is being retuned.

**NOTE**

**The ACT annunciator continuing flashing indicates that the receiver is not tuned to the frequency displayed in the active display.**

To return to the preset frequency selection mode, push the **ACT** switch again for about 2 seconds. As a safety feature, the control unit automatically switches to the active frequency selection mode when a frequency select knob is operated while the **STO**, **TEST**, or **XFR/MEM** switches are actuated.

(4) Frequency storage. Up to four preset frequencies can be stored in memory in the control unit for future recall. To program the memory, select the frequency in the preset frequency display using the frequency select knobs and push the **STO** switch once. One of the channel numbers (**CH 1** through **CH 4**) will appear in the active display for approximately 5 seconds. During this time, the channel number can be changed, without changing the preset frequency, by momentarily positioning the **XFR/MEM** switch to the **MEM** position. After the desired channel number has been selected, push the **STO** switch again to store the frequency.

**NOTE**

**When storing a frequency the second actuation of the STO switch must be done within 5 seconds after selecting the channel number or the first actuation of the STO STO switch. If more than 5 seconds elapse, the control will revert to the normal modes of operation and the second store command will be interpreted as the first store command.**

After a frequency has been stored in memory, it will remain there until changed by using the **STO** switch. Memory is retained even when the unit is turned off for an extended period of time.

*d. Self-Test.* During self-test, the VIR-32 provides VOR, ILS, and marker beacon test outputs. The following paragraphs provide the procedures required and the results to be expected when performing the self-test.

(1) *VOR Self-Test*

1. Tuning knobs (**NAV** control unit) - Select a VOR frequency.

**NOTE**

**A specific frequency is not required for the test. Also, a signal on the frequency will not interfere with the self-test.**

2. VOR/localizer pushbutton selector switch (display controller, fig. 3-8) - Select **VOR1** or **VOR2**, as required.

3. Single-needle bearing pointer source selector switch (display controller, fig. 3-8) - **VOR1**.
4. Double-needle bearing pointer source selector switch (display controller, fig. 3-8) - **VOR2**.
5. Course knob (HSI) - Rotate until course pointer indicates approximately 0 degrees.
6. **TEST** switch (**NAV** control unit) - Depress and hold.
7. **NAV** flag on the HSI will come into view. After approximately 2 seconds the flag will go out of view, the HSI course deviation bar will approximately center, and a TO indication will appear. The bearing pointers will indicate approximately a 0-degree magnetic bearing. The VIR-32 will return to normal operation after approximately 15 seconds, even if the **TEST** switch is held.

(2) *ILS (Localizer and Glide Slope) Self-*

*Test.*

1. Tuning knobs (**NAV** control unit) - Select a localizer frequency.

**NOTE**

**A specific frequency is not required for the test. Also, a signal on the frequency will not interfere with the self-test.**

2. **TEST** switch (**NAV** control unit) - Depress and hold.
3. HSI - **NAV** and **GS** (glide slope) flags will come into view. After approximately 3 seconds, the flags will go out of view, the HSI course deviation bar will deflect right approximately 2/3 of full scale and the glide slope pointer will deflect down approximately 2/3 of full scale.
4. The VIR-32 will return to normal operation after approximately 15 seconds, even if the **TEST** switch is held.

(3) *Marker beacon self-test.* The marker beacon assembly is tested automatically when the self-test is actuated and either a VOR or localizer frequency is selected. Proper operation of the marker beacon assembly is indicated when all three marker indicators are displayed on the EADI. A 30 Hz tone will also be present in the marker beacon audio output.

- e. *Marker beacon audio.* Marker beacon audio

generally associated with an ILS, must be source selected by the **NAV A** or **B** audio selector switches located on the audio control panel. Sensitivity selection for marker beacon audio is accomplished by a toggle switch placarded **MKR BCN HI-LO**, and audio volume is controlled by a knob placarded **VOL** (both are located on the pedestal extension, fig. 2-14).

- f. *Diagnostic display.*

**NOTE**

**The diagnostic routines are intended as an extension of the self-test capability. The pilot should first observe the deviation indicators and associated flags for the proper self-test responses. If a fault condition exists, the problem may be verified in more detail by the diagnostics.**

An extensive self-test diagnostic routine is also initiated in the VIR-32 NAV receiver by pushing the **TEST** switch on the **NAV** control unit. The **NAV** control unit will modulate the active and preset display intensity from minimum to maximum to annunciate the self-test is in progress. If a fault condition existed prior to actuating self-test, the **NAV** control unit will display the diagnostic code associated with the fault for approximately 2 seconds immediately after the **TEST** switch is pressed (the code will appear in the preset display). If a fault is detected during self-test, that fault code will also be displayed on the NAV control unit along with the word '**DIAG**', '**FLAG**', or four dashes ('----'): in the active display. The four dashes will be displayed along with the code '00' indicating that no faults have been found. '**FLAG**' will be displayed along with a 2-digit code when something is abnormal but a failure has not occurred (i.e. low signal level, etc). '**DIAG**' is displayed along with a code to indicate a failure has been detected in the VIR-32. Completion of self-test is indicated when either the normal frequency displays or a fault code is displayed on the **NAV** control. A partial list of diagnostic and fault codes is provided in table 3-7. (The **TEST** switch must be pushed before any fault code can be displayed.)

**3-25. ADF RECEIVER (ADF-60).**

a. *Introduction.* The ADF receiver (fig. 3-25), provides aural reception of signals from a selected ground station and indicates relative bearing to that station. The ground station must be within the frequency range of 190 to 1749.5 kHz. The ADF receiver has three functional modes of operation. In the antenna (**ANT**) mode the ADF receiver functions as an aural receiver, providing only an aural output of the received signal. In automatic direction

finder (**ADF**) mode it functions as an automatic direction finder receiver in which relative bearing to the station is presented on an associated bearing indicator, and an aural output of the received signal is provided. The tone (**TONE**) mode provides a 1000-Hz aural output tone when a signal is being received to identify keyed continuous wave (CW) signals. The **ADF** receiver is powered through a 2-ampere circuit breaker placarded **ADF**, located on the overhead circuit breaker panel (fig. 2-9).

b. *ADF Control Unit Operating Controls, Indicators, and Functions.* All operating controls for the **ADF** receiver are located on the **ADF** control unit (fig. 3-25).

(1) *Active frequency display.* The active frequency (frequency to which the **ADF** receiver is tuned) and diagnostic messages are displayed in the upper window.

(2) *Transfer/memory switch.* This switch is a 3-position spring-loaded toggle switch placarded **XFR/MEM**, which, when held to the **XFR** position,

causes the preset frequency to be transferred up to the active display and the **ADF** receiver to be retuned. The previously active frequency will become the new preset frequency and will be displayed in the lower window. When this switch is held to the **MEM** position, one of the four stacked memory frequencies will be loaded into the preset display. Successive pushes will cycle the four memory frequencies through the display.

(3) *Store switch.* This switch, placarded **STO**, allows up to four preset frequencies to be selected and entered into the control unit's memory. After presetting the frequency to be stored, push the **STO** switch. The upper window displays the channel number of available memory (**CH 1** through **CH 4**); the lower window continues to display the frequency to be stored. For approximately 5 seconds, the **MEM** switch may be used to advance through the channel numbers without changing the preset display. Push the **STO** switch a second time to commit the preset frequency to memory in the selected location. After

Table 3-7. VHF Navigation Receiver Fault Codes

CODE	INCORPORATION	COMMENT
00	No fault found	
02	RAM test failed	Unit unusable (μP problem)
03	No serial data to unit	Unit unusable (CTL problem)
04	No serial freq word	Unit unusable (CTL problem)
05	Invalid NAV freq	CTL may be tuned to DME channel
06	Microprocessor fault	Unit unusable
09	Microprocessor fault	Unit unusable
10	Microprocessor fault	Unit unusable
11	AID fault	Unit unusable
12	AID failed accuracy test	Unit unusable
13	+13 V dc power supply fault	Unit unusable
14	-13 V dc power supply fault	Unit unusable
15	VOR sin 0 / GS D/A fault	VOR/LOC unusable
16	VOR cos 0 /GS D/A fault	VOR/GS unusable
17	VOR smo unlocked	VOR receiver imperative
18	VOR AFC not locked	VOR unusable (no rf signal)
19	Low 30 Hz reference signal	VOR unusable
20	Low 30 Hz variable signal	VOR unusable
21	400 Hz pwr supply unusable	VOR OBI and OBS unusable
22	OBI sin out of tolerance	VOR OBI and OBS unusable
23	OBI cos out of tolerance	VOR OBI and OBS unusable
24	OBS return out of tolerance	VOR OBS unusable
25	LOC smo unlocked	LOC receiver inoperative
26	LOC signal level low	LOC unusable
27	LOC dev out of tolerance	LOC dev unreliable
28	GS smo unlocked	GS receiver inoperative
29	GS signal too low	GS unusable
30	GS dev out of tolerance	GS dev unreliable
32	Marker beacon fault	Observe marker lamps for fault

BT03844

approximately 5 seconds, the control will return to normal operation.

(4) *Tuning knobs.* Two concentric tuning knobs control the preset or active frequency displays. The larger knob changes the 1,000's and 100's kHz digit. The smaller knob changes the 10's, units, and tenths kHz digits. Each detent of the larger knob changes the frequency in the display in 100-kHz steps. Each detent of the smaller knob changes the frequency in the display in 1 kHz steps, with the exception that the first two detent positions following a change in rotational direction of the knob will cause a 0.5 kHz change in frequency. Rapid rotation of the smaller knob will cause frequency changes greater than 1-kHz as a function of rate of rotation. Frequencies roll over at the upper and lower limits. The two tuning knobs are independent of each other in that the upper and lower limit rollover of the 10-kHz digit will not cause the 100-kHz digit to change.

(5) *Active switch.* The active switch, placarded **ACT**, enables the tuning knobs to directly tune the ADF receiver when depressed and held for two seconds. The bottom window will display dashes and the upper window will continue to display the active frequency. Pushing the **ACT** switch a second time will

return the control unit to the normal two-display mode.

(6) *Test switch.* This switch, placarded **TEST**, initiates the receiver self-test diagnostic routine. (Self-test is active only when the **TEST** switch is pressed.)

(7) *Light sensor.* This built-in light sensor automatically controls display brightness.

(8) *Volume control.* The volume control is concentric with the power and mode switch.

(9) *Power and mode switch.* The power and mode switch contains four detented positions placarded **OFF**, **ANT**, **ADF**, and **TONE**. The **OFF** position removes system power. Selecting **ANT**, **ADF**, or **TONE** position applies power to the ADF system and establishes the system mode of operation.

(10) *Annunciators.* The receiver control unit contains a **MEM** (memory) and a **RMT** (remove) annunciator. The **MEM** annunciator illuminates whenever a preset frequency is being displayed in the lower window. The **RMT** annunciator is not used in this installation.

(11) *Preset frequency display.* The preset (inactive) frequency and diagnostic messages are displayed in the lower window.

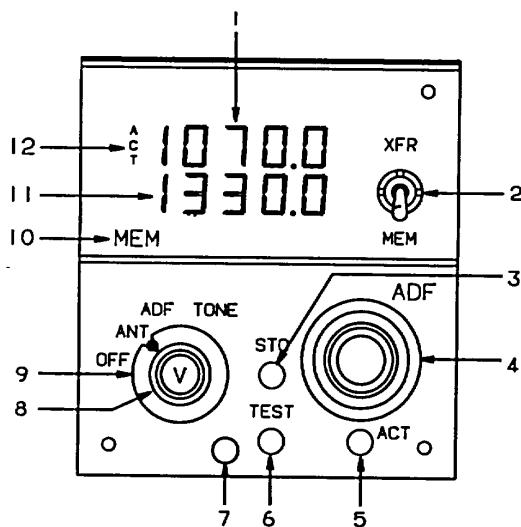

1. Active Frequency Display
2. Transfer/Memory Switch
3. Store Switch
4. Tuning Knobs
5. Active Switch
6. Test Switch
7. Light Sensor
8. Volume Control
9. Power and Mode Switch
10. Annunciators (**MEM**)
11. Preset Frequency Display
12. Compare Annunciator

A93FE00D0108 C

Figure 3-25. ADF Control Unit

(12) *Compare annunciator.* An annunciator placarded **ACT** momentarily illuminates when frequencies are being changed. The **ACT** annunciator flashes if the actual radio frequency which the receiver is tuned to is not identical to the frequency shown in the active frequency display.

c. *Operating Procedures.*

**WARNING**

**It is not practical to provide monitoring for all conceivable system failures and, it is possible that erroneous operation could occur without a fault indication. It is the responsibility of the pilot to detect such an occurrence by means of cross-checks with redundant or correlated information available in the cockpit.**

(1) *Equipment turn on.* The ADF receiver and the control unit are turned on by rotating the power and mode switch on the ADF control unit to the **ANT**, **ADF**, or **TONE** position. After power is applied, the control unit displays the same active and preset frequencies that were present when the equipment was last turned off.

(2) *Frequency selection.* Frequency selection is made using either the frequency select knobs or the **XFR/MEM** (transfer/memory recall switch).

For future developments, the control unit has a normal frequency range of 190.00 to 1799.5 kHz. However, when used with the ADF-60, the upper frequency is limited to 1749.5 kHz. Rotation of either frequency select knob increases or decreases the frequency in the preset frequency display. The larger outer knob changes the frequency in 1000-kHz and 100-kHz increments (first and second numbers from the left). The smaller inner knob changes the frequency in 10's, units, and tenths kHz increments (third, fourth, and fifth numbers from the left). After the desired frequency is set in the preset frequency display, it can be transferred to the active frequency display by momentarily setting the **XFR/MEM** switch to **XFR**. At the same time that the preset frequency is transferred to the active display, the previously active frequency is transferred to the preset display. The **ACT** annunciator on the control flashes while the receiver is tuning to the new frequency.

**NOTE**

**If the ACT annunciator continues flashing, it indicates that the receiver is not tuned to the frequency displayed in the active display.**

The ADF control unit has a memory that permits storing up to four preset frequencies. Once stored, these frequencies can be recalled to the preset display by positioning the **XFR/MEM** switch to the **MEM** position. The storage location (**CH 1** through **CH 4**) for the recalled frequency is displayed in the active frequency display while the **XFR/MEM** switch is held in the **MEM** position. All four stored frequencies can be displayed one at a time in the preset display by repeatedly positioning the **XFR/MEM** switch to the **MEM** position. After the desired stored frequency has been recalled to the preset display, it can be transferred to the active display by momentarily positioning the **XFR/MEM** switch to the **XFR** position. During normal operation, all frequency selections and revisions are done in the preset frequency display. However, the active frequency can be selected directly as described in the following paragraph.

(3) *Direct active frequency selection.* The active frequency can be selected directly with the frequency select knobs by pushing the **ACT** switch for 2 seconds. The active frequency selection mode is indicated by dashes appearing in the preset display. The **ACT** annunciator will flash as the frequency select knobs are turned to indicate that the transceiver is being retuned.

**NOTE**

**If the ACT annunciator continues flashing, it indicates that the receiver is not tuned to the frequency displayed in the active display.**

To return to the preset frequency selection mode, push the **ACT** switch again for 2 seconds. As a safety feature, the ADF receiver control unit automatically switches to the active frequency selection mode when a frequency select knob is operated while the **STO**, **TEST**, or **XFR/MEM** switches are actuated, or the memory recall inputs to the control are grounded.

(4) *Frequency storage.* Up to four preset frequencies can be stored in the memory in the ADF receiver control unit for future recall. To program the memory, select the frequency in the preset frequency display using the frequency select knobs and push the **STO** switch once. One of the channel numbers (**CH 1** through **CH 4**) will appear in the active display for approximately five seconds. During this time the channel number can be changed without changing the preset frequency by momentarily positioning the **XFR/MEM** switch to the **MEM** position. After the desired channel number has been selected, push the **STO** switch again to store the frequency.

**NOTE**

When storing a frequency, the second actuation of the **STO** switch must be done within 5 seconds after selecting the channel number or the first actuation of the **STO** switch. If more than 5 seconds elapse, the control will revert to the normal modes of operation and the second store command will be interpreted as the first store command.

After a frequency has been stored in memory, it will remain there until changed by using the **STO** switch. Memory is retained even when the unit is turned off for an extended period of time.

*d. Normal Operation.*

1. Power and mode switch - **ANT**, **ADF**, or **TONE** (BFO).
2. Tuning knobs - Set desired frequency.
3. **ANT** function - Position power and mode switch to **ANT**. Select **ADF** on audio system and adjust volume.
4. **ADF** function - Position power and mode switch to **ADF**. Bearing pointer will indicate relative bearing to tuned station.

**NOTE**

When the **ADF** system is not receiving a reliable signal, bearing pointer will be removed from view. The **ADF** bearing pointer may momentarily blank during station crossings because of signal loss.

5. **TONE** function - Position power and mode switch to **TONE** (BFO). A 1000-Hz tone will identify keyed CW stations.

(1) *Self-test.*

1. Power and mode switch - **ADF**.
2. Tuning knobs - Tune a nearby NDB, compass locator, or broadcast station.
3. **TEST** switch - Depress. Bearing pointer will rotate 90 degrees from the previous valid indication. Release **TEST** switch and verify that the bearing pointer returns to previous valid indication.

**NOTE**

If the signal received is weak or of poor quality, bearing pointer rotation will be slow.

ADF receiver fault codes are listed in table 3-8.

**3-26. TACAN/DME SYSTEM (AN/ARN-154).**

*a. Description.* The TACAN/DME system (fig. 3-26) operates in conjunction with TACAN and VORTAC ground stations to provide distance, groundspeed, time to station, and bearing to station. The TACAN/DME system electronically converts elapsed time to distance by measuring the length of time between the transmission of a radio signal to a selected DME/TACAN station and the reception of the reply signal. The distance is measured on a slant from the aircraft to the ground station and is commonly referred to as slant-range distance. Slant range approximates actual ground distance. The difference between slant-range distance and ground distance is smallest at low altitude and long range, and greatest when in close proximity to the selected ground station. The system is capable of tracking the range of up to four stations and the bearing of two stations simultaneously. The system will operate on any one of 252 preselected frequencies (126 X mode and 126 Y mode channels). Course deviation, bearing to station, and distance to TACAN or VORTAC stations are displayed on the EHSI. Distance, time to station, bearing,

Table 3-8. ADF Receiver Fault Codes

CODE	INTERPRETATION
00	No faults
02	RAM test failed (test failed at power-up)
03	No serial sync block received
04	No serial data block received for more than 2 seconds
05	Transponder label received in first block
06	I/O port 1 failure
07	I/O port 2 failure
08	Illegal ADF frequency
09	Serial input failed or stuck low
10	ADF not lock in ADF mode

BT03845

station identifier, and groundspeed may be displayed on the TACAN digital display. The TACAN/DME also provides distance information to the inertial navigation system (INS). The system is protected by a 2-ampere circuit breaker placarded **TACAN**, located on the overhead circuit breaker panel (fig. 2-9).

b. *TACAN Control Unit Controls and Functions* (fig. 3-26).

(1) *TACAN channel display.* Indicates selected channel.

(2) *X-Y mode selector switch.* Selects either X or Y mode.

(3) *Volume control (inner concentric knob).* Turns system on. Volume control is inoperative in this installation.

(4) *Channel selector (outer concentric knob).* Rotation allows selection of desired TACAN channel.

(5) *Air-to-air/air-to-ground mode selector switch.* Allows selection of air-to-air or air-to-ground mode of operation.

c. *TACAN/DME Display Unit Controls and Functions* (fig. 3-27).

(1) *Display.* Displays distance to station, bearing to station, groundspeed, time to station, and station identifier, depending on the page being viewed.

(2) *PAGE pushbutton selector switch.* When the mode selector switch is in the **NAV 1** or **NAV 2** position, depressing the **PAGE** pushbutton selector switch will alternate the lower right portion of the display between distance to station and groundspeed. When the mode selector switch is set to **BOTH**, the **PAGE** pushbutton selector switch will alternate the left and right lower displays between bearing to station and station identifier.

(3) *Mode selector switch.*

(a) *OFF.* Turns system off/on.

(b) *NAV 1.* Selects information for display from the TACAN/DME unit as selected by the # 1 VHF navigation receiver or TACAN control unit, depending upon whether either pilot has selected **TACAN** on EFIS display controller.

(c) *NAV 2.* Selects information for display from the TACAN/DME unit as selected by the # 2 VHF navigation receiver.

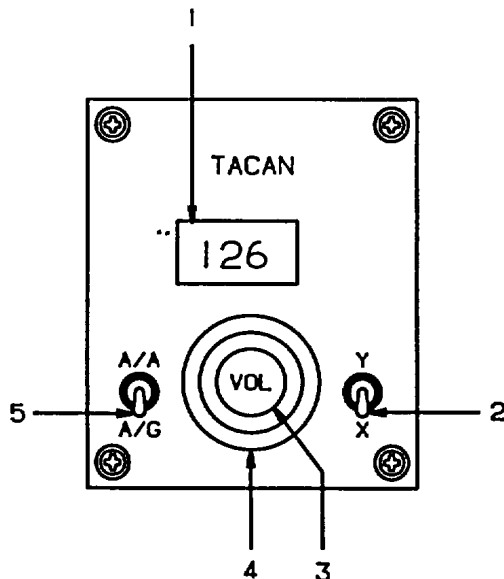

1. Channel Display
2. X-Y Mode Selector Switch
3. Volume Control (Inner Concentric Knob)
4. Channel Selector (Outer Concentric Knob)
5. Air-to-Air/Air-to-Ground Mode Selector Switch

A93FE00D0109 C

Figure 3-26. TACAN/DME Control Unit

(d) BOTH. Selects information for display from the TACAN/DME unit as selected by both the # 1 and # 2 VHF navigation receivers.

d. Normal Operation.

(1) Turn-on procedure.

1. **BATTERY** switch **ON**.
2. **AVIONICS MASTER POWER** switch **ON**.
3. **INS/TCN** pushbutton selector switch (display control panel, fig. 3-8) Select **TCN**.
4. Mode selector switch (TACAN indicator, fig. 3-27) Select operating mode.
5. **VOL** control (TACAN control unit, fig. 3-26) Rotate clockwise from detent to adjust volume.

The TACAN/DME indicator will run a display segment text and then scroll from right to left and display **IND** in the upper left corner of the display and the software version number in the upper right corner of the display for approximately 3 seconds. **TCN** will be displayed in the

lower left corner and the software version will be displayed on the lower right corner of the display for approximately 3 seconds. After the three seconds **SELF TEST PASS** or **SELF TEST FAIL** (with a fail message number) will be displayed.

**NOTE**

The fail message number indicates the circuit which has failed. Always note the fail message number prior to system shutdown.

(2) TACAN *air-to-ground navigation procedure*. After turn-on procedure proceed as follows:

1. **X-Y** mode selector switch (TACAN control unit, fig. 3-26) As required.
2. Air-to-air/air-to-ground switch **A/G**.
3. Channel selector knob Select desired channel.

(3) TACAN *air-to-air ranging*. Air-to-air ranging may be accomplished between two airborne aircraft when each is equipped with an appropriate TACAN system. Air-to-air ranging is activated by placing the two-position mode selector switch on each aircraft's respective

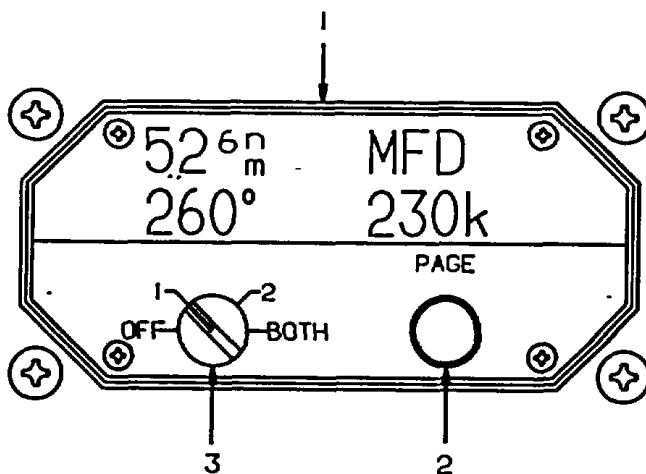

1. Display
2. Page Pushbutton Switch
3. Mode Selector Switch

A93FE00D0110 C

Figure 3-27 TACAN/DME Display Unit



TACAN control unit in the **A/A** position and tuning to channels that are 63 channels apart from each other (such as channel 20 and channel 83). The **X/Y** mode switches will have to both be in the **X** or **Y** mode position.

### 3-27. INERTIAL NAVIGATION SYSTEM.

*a. Description.* The inertial navigation system (INS) is a self-contained navigation and attitude reference system. It is aided by (but not dependent upon) data obtained from the global positioning system (GPS), TACAN, encoding altimeter data, and heading information from the gyromagnetic compass system. The position and attitude information computed by the INS is supplied to the automatic flight control system, the electronic flight instrument system (EFIS), and to mission equipment. The INS provides a visual display of present position data in universal transverse mercator (UTM) coordinates or conventional geographic (latitude-longitude) coordinates during all phases of flight. When approaching the point selected for a leg switch, a WPT will be displayed on both EHSI's and "waypoint alert" will be displayed on the multifunction display (MFD) informing the pilot of an imminent automatic leg switch or the need to manually insert course change data. The INS may be manually updated for precise aircraft present position accuracy by flying over a reference point of known coordinates. The INS may be updated automatically by the TACAN system or the GPS. Altitude information is automatically inserted into the INS computer by an encoding altimeter whenever the INS is operational.

The INS consists of a navigation unit (NU), mode selector unit (MSU), and a battery unit (BU).

The aircraft survivability equipment/avionics control system (ASE/ACS) keyboard (fig. 4-3) provides a means for entering data into the INS and displaying navigation and system status information. Refer to chapter 4 for a complete description and operating instructions for the ASE/ACS.

The INS system receives AC power from a 10-ampere **INS PWR**, a 5-ampere **INS HTR POWER**, and a 5-ampere **INS FAN PWR** circuit breaker, located on the mission power cabinet. The INS system receives DC power from a 5-ampere **INS CONTROL** circuit breaker located on the overhead circuit breaker panel (fig. 2-9).

(1) *Navigation unit.* The navigation unit (NU) contains an inertial reference unit (IRU), a digital computer unit (DCU), and an inertial reference unit electronics (IRUE). All INS attitude, navigation, and steering information is determined in the NU.

(a) *Inertial reference unit.* The inertial reference unit (IRU) is a gyro-stabilized platform and

gimbal assembly which is electronically controlled to provide a local horizontal azimuth reference regardless of aircraft attitude.

(b) *Battery unit.* The battery unit (BU) provides auxiliary DC power to initiate INS turn-on and to supply essential power to maintain INS operation should 115 volt primary power be interrupted after INS turn-on. The battery unit will sustain operation of the INS for 15 minutes.

(c) *Inertial reference unit electronics.* The inertial reference unit electronics (IRUE) includes power circuits, temperature control circuits, and circuits required for interface between the inertial reference unit (IRU), computer, mode selector unit (MSU), aircraft survivability equipment/avionics control system (ASE/ACS), battery unit, and for malfunction warning signals.

*b. Controls, Indicators, and Functions, INS Mode Selector Unit (fig. 3-28).*

(1) *READY NAV lamp.* The READY NAV (ready to navigate) lamp illuminates when high-accuracy alignment status of the INS has been attained. When alignment has been accomplished with the mode selector set to **ALIGN**, the ready NAV lamp will remain illuminated until NAV is selected. The READY NAV lamp will illuminate momentarily during transition from state 9 to 8 and when alignment is accomplished with the mode selector at the NAV position.

(2) *BAT lamp.* The battery (BAT) lamp illuminates only when the INS has automatically shut down due to low battery unit voltage. The INS will automatically shut down before the battery unit is completely discharged. A shutdown due to low battery unit voltage can only occur while the INS is operating on battery unit power. The INS operates on battery power for a short period during coarse leveling (alignment state 8). If the battery unit charge is below the required minimum level during this period, the INS will shut down and the BAT lamp will illuminate to indicate the reason.

(3) *Mode selector knob.* The mode selector knob controls the operating modes of the INS. The knob must be pulled out for rotation across mechanical stops between **STBY** and **ALIGN** and between NAV and ATT.

(a) *OFF.* Deactivates INS.

(b) *STBY.* The standby (**STBY**) position is used only during ground operation. Setting the mode selector to **STBY** from **OFF**:

Starts fast warm-up in the navigation unit (NU).

Cages the inertial reference unit (IRU) to the orientation of the aircraft.

Starts the gyro wheels spinning.

Activates the computer so information can be entered.

When STBY is selected from any other position, the IRU is not caged but operates the same as during the attitude mode of operation.

(c) **ALIGN**. The alignment (**ALIGN**) position is used only during ground operation while the aircraft is parked. Setting the mode selector to **ALIGN** from **STBY** will start automatic INS alignment, providing that the fast warm-up heaters have shut off. Fine alignment will not be started until present position has been inserted. The computer automatically cycles through leveling alignment. The **ALIGN** position can be selected from the **OFF** position, but leveling will not be started until the fast warm-up heaters have shut off. Moving the mode selector from NAV will not downmode the INS but will allow automatic shutdown if an overtemperature is detected.

(d) **NAV**. The navigation (**NAV**) position is used to command entry into the navigation mode after automatic alignment is completed. The **NAV** position

must be selected before moving the aircraft. The INS will automatically sequence through standby and alignment operation to the navigation mode when the **NAV** position is selected from the **STBY** position, providing that present position is inserted and the aircraft is parked.

This position is also used to shorten the time in **STBY** if stored heading is valid and to bypass the battery test in state 8.

(e) **ATT**. The attitude (**ATT**) position is used to provide only INS attitude signals. This position shuts down the computer so that navigation and steering signals are not provided. The **ATT** position can be selected from any other position. Once the **ATT** position is selected, INS alignment is lost and the INS must be realigned before the navigation mode of operation can again be used.

c. **INS Modes of Operation**. The INS can be operated in four modes: Standby (**STBY**), Align, navigation (**NAV**), attitude (**ATT**). When the INS is turned on it will (under normal conditions) proceed through the **STBY** and **ALIGN** modes and enter the **NAV** mode, where it will remain until it is downmoded at the end of the flight. The only exception will be in the event of a malfunction, in which case the INS will be shut down or placed in the

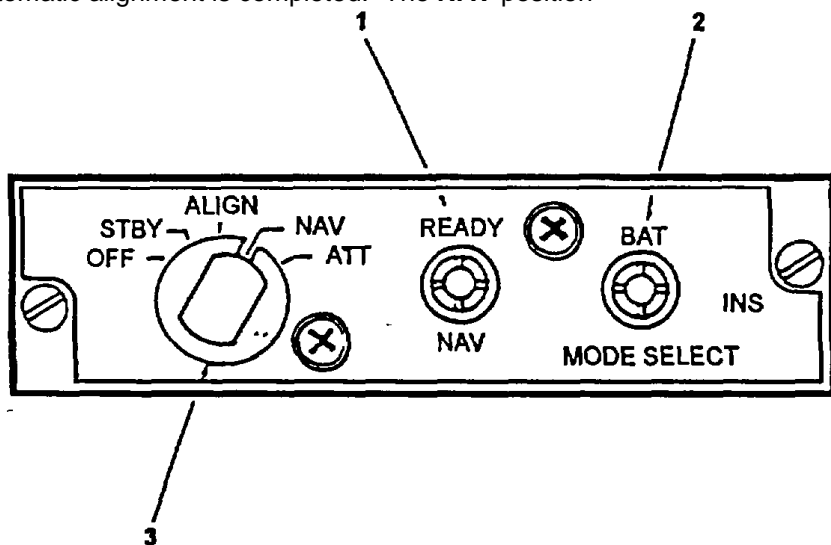

- 1. READY NAV Lamp
- 2. BAT Lamp
- 3. MODE Selector

AP006413

Figure 3-28. INS Mode Selector

**ATT** mode. In the **ATT** mode, the computer is turned off and the INS will only provide attitude signals.

(1) *Standby mode.* The characteristics of the standby mode vary, depending upon whether the INS is being turned on or is being downmoded from **NAV**, **ALIGN**, or **ATT**. During standby mode the alignment state number is 9.

(a) *Standby mode (INS being turned on).* If the INS is being turned on by setting the mode selector to **STBY**, the navigation unit is brought up to operating temperature by fast warm-up heaters and the gyro wheels are brought up to speed. The INS platform is caged to the aircraft axes and all instrument warning lamps controlled by the INS indicate warning.

(b) *Standby mode (INS being downmoded).* If the INS is being downmoded from a higher mode by setting the mode selector switch to **STBY**, the INS platform retains its alignment with local horizontal, and all instrument flags controlled by the INS except **ATTITUDE** and **PLATFORM HEADING** flags, will indicate warning.

**NOTE**

**Present position, waypoint coordinates, and TACAN station data can be inserted into the INS while in the standby mode.**

(2) *Alignment mode.* In the alignment (**ALIGN**) mode the INS computer progresses through a series of submodes called alignment states.

(a) *Alignment state 8.* During alignment state 8, the INS platform is aligned to local horizontal and the INS battery is tested. Attitude warnings are removed at the beginning of state 8, but all other instrument flags controlled by the INS continue to indicate warnings. The battery unit is tested during the first 12 seconds of this state. The INS spends a minimum of 51 seconds in state 8.

During the transition of state 8 to state 7, the heading is set to the stored value. If this value compares favorably with magnetic heading plus magnetic variation, the status will remain unchanged. If the comparison is unfavorable, the status will be set invalid, and the system must be upmoded to **NAV** before a heading may be stored.

**NOTE**

**Present position must be loaded before the system will progress from state 8 to state 7.**

(b) *Alignment states 7 and 6.* The primary function of states 7 and 6 is to refine the

relationship between the INS platform and true north. This function continues unchanged throughout both states and 7. In state 6 the INS compares the latitude of the loaded present position with the latitude it has computed as part of the alignment process, and it uses the results of this comparison (with other information) to update certain self-calibration data. During these states it is possible to enter the navigation mode if the stored heading is valid. Entry to **NAV** will immediately follow the setting of the mode selector to **NAV**. The alignment will be entirely dependent upon the stored values regardless of the length of time in states 7 or 6.

(c) *Alignment states 5 through 0.* Entry into alignment state 5 indicates that normal or standard accuracy alignment is complete. The **NAV** mode may be selected at any time after entry into this mode, but for precision inertial accuracies, the alignment should be allowed to progress until the **READY NAV** lamp is illuminated, and preferably to alignment state 2 or 1. A standard accuracy alignment takes about 20 minutes, while a high accuracy alignment requires about 45 minutes.

Alignment states 4 through 0 indicate continuing operating of the self calibration process begun in alignment states 6 and 5. In addition, automatic calibration data for the azimuth gyro is now available. If the INS is left in **ALIGN**, the self-calibration data will continue to be refined and the alignment state will decrease toward 0.

(3) *Navigation mode.* In the navigation (**NAV**) mode, all navigation data is computed and available for display. All warning flags controlled by the INS will disappear from view. The INS depends on its own inertial instruments for all position and velocity data. The present position computed by the INS can be updated by TACAN, GPS, data link, or manually when the aircraft passes over a known position reference.

(4) *Attitude mode.* In the attitude (**ATT**) mode, the computer is shut down and no navigation information is available. The **ATT** mode is entered at the discretion of the pilot if navigation and/or steering data signals become unreliable. Attitude signals and platform heading outputs continue to be available. The **NAV** mode can only be reentered from the **ATT** mode after the system has been realigned. Alignment can take place only on the ground.

(5) *Pattern steering using INS.* Pattern steering provides a box or straight line pattern which may be used to fly the aircraft in a specific pattern. The pattern will originate at the current TO waypoint. The length of the base leg, true bearing of the pattern, offset distance of the return leg, and direction of the turns are loaded into the computer via the ASE/ACS. Should the operator specify a zero offset distance for the return leg, the direction of the turns will alternate at each end of the pattern.

A waypoint change to 00 will cause the computer to enter the pattern steering mode. The coordinates for waypoints 1, 2, 3, and 4 will be saved and replaced with computed waypoints for the pattern. Waypoints 0 and 4 will be the initial point (IP) for the pattern. The differences between the pattern steering mode and the normal steering mode are:

Automatic leg switching will occur when directly over the destination waypoint.

Leg switching can only be accommodated automatically. If MAN leg changing was specified on the INS SETUP page, the aircraft will continue on the same path with a flashing WAYPOINT ALERT lamp until leg changing is changed to AUTO on the MFD.

The approach to the base or return legs will be at 90 degrees versus the normal approach of 45 degrees.

The program is designed to overfly all waypoints with a minimum of overshoot, provided sufficient distance to the return leg has been entered. When coupled to the autopilot, up to three maximum bank turns may be commanded while performing the 180 degree return.

The pattern steering mode is exited when the operator inserts a valid non 00 leg switch command. The original set of four waypoint coordinates will be returned to their former location.

*d. Normal Operating Procedures.*

*(1) Preflight procedure.*

1. GPU Connected.
2. **BATTERY** switch **ON**.
3. Overhead and mission panel switches Set as follows:
  - a. Aircraft **#1** and **#2** **INVERTER** switches **ON**.
  - b. **AUTO PLT POWER** switch **ON**.
  - c. **AVIONICS MASTER POWER** switch **EXT PWR**.
- d. **#1** and **#2** **EFIS POWER** switches **ON**.
- e. **#1** and **#2** three phase inverter switches **RESET/ON**.
- f. **BUS CROSS TIE** switch **AUTO**.
- g. **ATT** pushbutton selector switch (display controller) Depress as required.
- h. Autopilot **EFIS 1/2** switch **EFIS 1**.

4. INS - Align as follows:
  - a. Mode switch B (MFD) Depress to select **FPLN** page.
  - b. **NAV SETUP** (R5) Depress.
  - c. **INS SETUP** (R5) Depress.
  - d. INS mode selector **STBY**. (Text at L1 will be blank until INS mode selector is placed in **STBY**. Then, last align and last known text will appear.)

**NOTE**

**An advisory message ALIGN POSITION NOT ENTERED will appear.**

INS malfunction codes are shown in table 3-9. INS action codes and recommended actions are shown in table 3-10.

- e. Present position Enter by one of the following methods:
  - ( 1 ) To accept **LAST ALIGN** coordinates, SKPD 1, then depress L1.
  - ( 2 ) To accept **LAST KNOWN** coordinates, SKPD 2, then depress L1.
  - ( 3 ) SKPD in alignment coordinates, then depress L1.

**NOTE**

**When L1 is depressed INS LOADING will appear at the top of the MFD and L1 text changes to ALIGN = X.DD.MM.SS.Y.DD.MM.SS and ALIGN STATE 9. It takes 6 to 8 minutes for the program to load.**

Valid alignment data for LAT/LONG is X.DD.MM.SS.T Y.DDD.MM.SS.T, where:

X = Latitude hemisphere (N or S)

DD = Degrees of latitude (0 90)

MM = Minutes of latitude or longitude

SS = Seconds (0 59)

T = Tenths of seconds (0 9)

Y = Longitude hemisphere (E or W)

DDD = Degrees of longitude

ZZ = UTM zone

Valid alignment data for UTM is ZZ.KKK-  
.MMM.KKKK.MMM, where:

KKK = Easting kilometers

Table 3-9. INS Malfunction Codes

MALF CODE	FAILED TEST	MODES OF OPERATION	RECOMMENDED ACTION CODE
10	Invalid heading	ALIGN	04
11	GR/CS program pin connected in error	ALIGN	01
12	Canned altitude profile in use (input altitude invalid)	ALIGN, NAV	05
13	Y velocity change	NAV	02
14	X velocity change	NAV	02
15	Torque limited	ALIGN, NAV	02
16	Invalid pitch and roll	ALIGN, NAV	05
17	Invalid magnetic heading	ALIGN, NAV	05
18	Excessive saturation time	ALIGN	04
20	Bearing to waypoint	ALIGN, NAV	03
22	Bearing to waypoint	ALIGN, NAV	03
23	Drift angle	ALIGN, NAV	03
24	Steering converter	ALIGN, NAV	03
25	True heading converter	ALIGN, NAV	03
26	XTK converter	ALIGN, NAV	03
27	Tick mark too fast	STBY	01
31	Ground speed	NAV	02
32	Memory parity	STBY, ALIGN, NAV	02
33	Azimuth stabilization loop	ALIGN, NAV	01
34	Inner roll stabilization loop	ALIGN, NAV	01
35	Pitch stabilization loop	ALIGN, NAV	01
36	Accelerometer loop	ALIGN, NAV	01
37	Z platform overtemperature	NAV	01
38	XY platform overtemperature	NAV	01
40	Heading error	ALIGN	04
42	Drift angle 45'	NAV	02
44	Azimuth gyro drift rate	ALIGN	02
45	Gym scale factor or loaded altitude	ALIGN	04
47	15-second loop	NAV	02
49	Fix measurement too large	NAV	02
51	Excessive wind	ALIGN, NAV	05
54	incomplete conversation from UTM to L/L	STBY, ALIGN, NAV	05
57	XY platform rotation rate	ALIGN	02
59	600 Millisecond loop	STBY, ALIGN, NAV	02
60	X or Y sample and hold change	ALIGN	04
62	XY platform rotation rate	NAV	02
63	DCU self-checks	STBY, ALIGN, NAV	02

BT03846

KKKK = Northing Kilometers

MMM = Northing or easting meters

**NOTE**

**Zero is assumed for meters, minutes, and seconds.**

Table 3-11 provides a datum cross reference.

5. INS mode selector **ALIGN**. Place the mode selector to **ALIGN** when the **INS LOADING** message goes out.

(2) *INS BIT check.*

1. **UTIL** on MFD Depress.
2. **SYSTEM BIT** (R1) Depress.
3. BIT check Conduct on installed equipment as required. Before conducting the **INS BIT**, check that the INS is in align state 8 or lower. Before INS is placed in the NAV mode of operation, set up the EHSI for an interface check by performing the following:
  - a. INS on EHSI Select by depressing **INS/TCN** on EFIS display controller.
  - b. INS Select on single needle bearing source selector switch on EFIS display controller.
4. INS (R2) Depress. Check indications as follows:
5. **NAV** on flight director mode selector Select:
  - a. MFD **INS BATT**, **INS FAIL**, and **WAYPOINT ALERT CWA** annunciators (3) illuminated.
  - b. EHSI INS needle 30 degrees right of lubber line and course deviation bar displaced right

followed by INS needle centering and course deviation bar displaced left. Check **WPT** alert annunciator illuminated.

- c. Aircraft caution/advisory annunciator panel Amber **INS** annunciator light illuminated.
- d. INS mode controller Green **READY** light and red **BATT** light illuminated.
- e. Mission annunciator panel Green **INS UPDATE** and amber **NO INS UPDATE** annunciator lights illuminated.
- f. After 15 seconds the text **COMPLETE** or any **ACTION** or **MALFUNCTION** codes will be displayed. If **ACTION** or **MALFUNCTION** codes are displayed they may have been cleared by the **BIT** test and the display is showing what was previously there. The only way to ensure that they are cleared is to conduct another **BIT** and the text **COMPLETE** appears.

(3) *Waypoints/flight plan.*

1. Waypoint list Build as follows:
  - a. Mode switch B Depress to select **FLIGHT PLAN** page.
  - b. **WPT LIST** (R4) Depress. WPT numbers 10 59 are shown. The **WPT** select window surrounds a **WPT** line.
  - c. Waypoint string (line number, **WPT ID**, and **LAT/LONG** coordinates) Enter into scratchpad.
  - d. **ADD/SEL** (R1) Depress to load **WPT** into system.

Table 3-10. *INS Action Codes and Recommended Actions*

Code	Recommended Action
01	Shut down INS.
02	Watch for degradation (NAV). During ground operation, downmode to STBY and restart alignment
03	INS may be used for navigation. One or more analog outputs are not functioning properly. Check 26 VAC circuit breakers. HSI and autopilot.
04	Downmode to STBY and restart alignment (ground operation only).
05	Correct problem in interfacing system (could be INS). Will not seriously affect performance.

BT04138

2. Flight plan Build as follows:

- a. **WPT** numbers Enter into scratchpad in order of desired use (up to nine) or box desired **WPTs** with **PREV** (R2) or **NEXT** (R3) and depress **LOAD SCRATCH PAD** (L5).
- b. **ROUTES** (R5) Depress.
- c. Route Select 1st, 2nd, or 3rd to enter **WPT** numbers by depressing the appropriate line button to store the **WPTS** as a route.
- d. Route Select route to use as the active **FPLN** and depress the adjacent line button to box it.
- e. **NEW FPLN** (L1) Depress to activate the **FPLN**.

- h. Offset distance in NM Enter into scratchpad.
- i. L4 line selection switch Depress to enter **OFFSET**.

5. Waypoint move Program as follows:

- a. Mode switch B Depress to select **FLIGHT PLAN** page.
- b. R5 line selection switch Depress to select **NAV SETUP** page.
- c. True bearing Enter into scratchpad.
- d. R1 line selection switch Depress to enter **BEARING**.
- e. Range in NM Enter into scratchpad.
- f. R2 line selection switch Depress to enter **RANGE**.

3. TACAN list Build as follows:

- a. Mode switch B Depress to select **FLIGHT PLAN** page.
- b. **NAV SETUP** (R5) Depress.
- c. **INS SETUP** (R5) Depress.
- d. **TACAN LIST** (R4) Depress.
- e. TACAN station information (list number, ID, channel number, latitude/longitude, and station elevation) Enter into scratchpad.
- f. R1 line selection switch Depress to load into system.
- g. TACAN stations to be used for updating Enter into scratchpad.
- h. R4 line selection switch Depress to select **TACAN SELECT**.

(4) *Navigation Information.*

4. Pattern steering mode Program as follows:

- a. Mode switch B Depress to select **FLIGHT PLAN** page.
- b. R5 line selection switch Depress to select **NAV SETUP** page.
- c. True bearing Enter into scratchpad.
- d. L1 line selection switch Depress to enter **BEARING**.
- e. Leg length in NM Enter into scratchpad.
- f. L2 line selection switch Depress to enter **LEG LENGTH**.
- g. L3 line selection switch Depress to select **LEFT** or **RIGHT**.

- 1. B mode selector switch Depress to select **FLIGHT PLAN** page.
- 2. L4 line selector switch Depress to select **NAV DATA** information box. The following information is provided in the **NAV DATA** box:
  - (a) *Present position.* The present position (**PRESENT POS**) display shows the actual latitude and longitude coordinates of the point on the earth's surface directly below the aircraft at any given instant.
  - (b) *Navigation status.* The navigation status display (**NAV STATUS**) shows the alignment status of the INS by a number (1 through 9).
  - (c) *Ground track angle.* The ground track angle (**TRK**) is the clockwise angle from true north to an imaginary line on the earth's surface connecting successive points over which the aircraft has flown (ground track).
  - (d) *Wind direction and wind speed.* Wind direction and wind speed are shown in the TRU WIND display. Wind direction is the clockwise angle from

Table 3-11. Datum Cross Reference

DATUM	LOCAL GEODETIC SYSTEM	SPHEROID	FLATNESS COEFFICIENT	RELATIVE RADIUS
30	ORD SURVEY OF GB 1936	AIRY	29932	7563
3	AUSTER GEODETIC 1966	AUS NATL	29825	8160
4	BUKIT RIMPAH	BESSEL	29915	7397
6	DJAKARTA	BESSEL	29915	7397
11	G. SEGARA	BESSEL	29915	7397
39	TIMBALAI	BESSEL	29915	7397
40	TOKYO	BESSEL	29915	7397
44	SD TOKYO SPECIAL	BESSEL	29915	7397
10	GUAM 1963	CLARKE 1866	29498	8206
21	LUZON	CLARKE 1866	29498	8206
25	N AMER 1927 CONUS	CLARKE 1866	29498	8206
26	N AMER 1927 ALA & CAN	CLARKE 1866	29498	8206
43	SD LUZON SPECIAL	CLARKE 1866	29498	8206
1	ADINDAN	CLARKE 1880	29346	8249
2	ARC 1950	CLARKE 1880	29346	8349
19	LIBERIA 1964	CLARKE 1880	29346	8249
22	MERCHICH	CLARKE 1880	29346	8249
24	NIGERIA-MINNA	CLARKE 1880	29346	8249
16	INDIAN	EVEREST	30080	7276
42	SD-MGRS INDIAN SPEC	EVEREST	30080	7276
5	CAMP AREA ASTRO	INTERNATIONAL	29700	8388
7	EUROPEAN 1950	INTERNATIONAL	29700	8388
8	GEODETIC DATUM 1949	INTERNATIONAL	29700	8388
13	HERAT NORTH	INTERNATIONAL	29700	8388
14	HJORSEY 1955	INTERNATIONAL	29700	8388
15	HU-TSU-SHAN	INTERNATIONAL	29700	8388
27	OLD HAWAIIAN-MAUI	INTERNATIONAL	29700	8388
28	OLD HAWAIIAN-OAHU	INTERNATIONAL	29700	8388
27	OLD HAWAIIAN-KAUAI	INTERNATIONAL	29700	8388
31	QORNOQ	INTERNATIONAL	29700	8388
33	S AMER-PROVIN 1956	INTERNATIONAL	29700	8388
34	S AMER-CORREGO ALEGRE	INTERNATIONAL	29700	8388
35	S AMER-CAMPO INCHAUSPE	INTERNATIONAL	29700	8388
36	S AMER-CHUA ASTRO	INTERNATIONAL	29700	8388
37	S AMER-YACARE	INTERNATIONAL	29700	8388
38	TANANARIVE OBSERV 192	INTERNATIONAL	29700	8388
17	IRELAND (ERIE) 1965	MODIFIED AIRY	29932	7340
18	KERAU-MALAYAN REV TRI	MODIFIED EVRST	30080	7304
46	WGS 72	WGS 72	29826	8135
9	GHANA	WGS 84	29826	8137
12	G. SERINDUNG	WGS 84	29826	8137
23	MONTJONG LOWE	WGS 84	29826	8137
32	SIERRA LEONE 1960	WGS 84	29826	8137
41	VOIROL	WGS 84	29826	8137
45	SD, WGS 84 SPECIAL	WGS 84	29826	8137
47	WGS (DEFAULT DATUM)	WGS 84	29826	8137

BT03848



true north to the wind velocity vector. Wind speed (knots) is the velocity of the wind with respect to a point on the earth's surface. Zero wind speed and direction will be displayed when there is no true airspeed input.

(e) *Desired track.* The desired track angle (**DES TRK**) is the clockwise angle from true north to an imaginary line on the earth's surface connecting successive points over which flight is desired (desired track). The line describes the great circle course between two successive waypoints, and is further defined by the intersection of a plane and the earth's surface when the plane passes through the two successive waypoints and the center of the earth.

(f) *True heading.* The true heading (**TRU HDG**) display is the clockwise angle from true north to the aircraft centerline.

(g) *Track angle error.* The track angle error (**TRK ERR**) display is the angle between the aircraft's actual ground track and the desired track, or the angular difference between ground track angle and the desired track angle. Track angle error is left when the actual track angle is less than the desired track angle and right when the actual track angle is greater than the desired track angle.

(h) *Drift angle.* Drift angle (**DFT ANG**) is the angle between the airplane centerline and ground track or the angular difference between the true heading and ground track angle. Drift angle is right when ground track angle is greater than true heading and left when ground track angle is less than true heading.

(i) *Cross track deviation.* Cross track deviation (**XTRK DEV**) is the shortest distance between the aircraft's present position and the desired track. Cross track deviation is left when the present position is left of the desired track and right when present position is right of the desired track.

1. LS line selection switch Depress. If the scratchpad is empty, present position and **NAV STATUS** will be displayed. If a single valid waypoint number is scratchpadded, the time and distance to that waypoint will be continuously displayed. If two valid waypoint numbers between 1 and 9 are scratchpadded, the time and distance between those two waypoints will be continuously displayed.

(5) *INS operation.*

1. INS mode selector **NAV** when desired nav status is achieved.
2. B mode selector switch Depress to call up **FLIGHT PLAN** page.
3. R5 line selector switch Depress to call up **NAV SETUP** page.
4. R5 line selector switch Depress to call up **INS SETUP** page.
5. L3 line selector switch Depress to **select LEG CHANGES** to **AUTO** or **MAN**.
6. R2 line selector switch Depress to select roll limit **OFF** or **ON**.
7. R3 line selector switch Depress to select **AUTO MIXING** mode: **TACAN**, **DL**, **GPS**, or **OFF**.

(6) *INS update.*

1. R5 line selection switch Depress to select **INS UPDATE STATUS** page.
2. Valid waypoint number or coordinates Enter into scratchpad and depress L1. Update box will be displayed for approximately 30 seconds. The data within the box will show:

The scratchpadded coordinates or those associated with the scratchpadded waypoint.

The current **NAV** status number.

The difference between the scratchpadded waypoint/coordinates and the INS position when the update button was depressed. This difference is displayed in nautical miles and tenths if **LAT/LONG** is selected, and in kilometers and tenths if UTM is selected.

3. To accept the INS update Depress L1 (**UPDATE ACCEPT**).
4. To reject the INS update Depress L2 (**UPDATE REJECT**).

(7) *INS stored heading procedure.* An accurate INS heading and the local magnetic variation will be stored in the computer memory by performing the stored heading shut-down procedure. This will allow the INS to be ready for the next flight in a shorter time period.

**NOTE**

Stored heading alignments may not be completed back to back. Once a stored heading alignment has been performed, the next alignment must be a normal alignment.

(a) *Stored heading shut down.*

1. Come to a complete stop in desired aircraft parking position.
2. Wait for **STORED HEADING** to appear in the advisory box on the MFD. This will take approximately 5 minutes.
3. INS mode selector **OFF**.

**NOTE**

After completion of the stored heading shutdown the aircraft must not be moved until the stored heading alignment is complete.

If more than a week elapses prior to the next alignment, a stored heading alignment should not be attempted.

(b) *Stored heading alignment.* This procedure may be done before or after starting the engines. If prior to engine start (GPU), the complete procedure must be done before engaging the starter switch to ensure the data is not dropped from the INS due to power drop.

1. INS mode selector **STBY**.
2. B mode selector switch Depress to call up **FPLN** page.
3. R5 line selector switch Depress to call up **NAV SETUP** page.
4. R5 line selector switch Depress to call up **INS SETUP** page.
5. Valid alignment data Enter into scratchpad "2" for last known as long as it reflects the correct present position coordinates.
6. L1 Depress to enter position.

7. INS mode selector **NAV** (after **INS LOADING** light goes out).
8. Wait for completion of alignment. This will take 7 to 8 minutes. This can be confirmed by noting that the **ALIGN STATE** legend at L1 of the **INS SETUP** page has disappeared.

**NOTE**

Do not move the aircraft until the alignment is complete.

**3-28. GLOBAL POSITIONING SYSTEM (AN/ASN-149 ((B)3)).**

a. *Description.* The GPS is used to provide updated position information to the inertial navigation system and to mission equipment. The GPS system consists of a receiver-processor, an antenna electronics unit, and an antenna. The GPS is controlled by the aircraft survivability equipment/avionics control system (ASE/ACS).

b. *GPS Normal Operation.*

(1) *Turn-On Procedure.*

1. **BATTERY** switch (overhead control panel, fig. 2-15) **ON**.
2. **AVIONICS MASTER POWER** switch (overhead control panel, fig. 2-15) **ON**.
3. **# 1 3φAC** inverter control switch (mission control panel, fig. 4-1) **RESET**, then **ON**.
4. A mode selection switch (multifunction display, fig. 4-2) Depress to select **UTILITY** page.
5. B mode selection switch (multifunction display, fig. 4-2) Depress to select **FLIGHT PLAN** page.
6. R5 line selection switch Depress to select **NAV SETUP** page.
7. R4 line selection switch Depress to select **GPS SETUP** page.

**NOTE**

On the **GPS SETUP** page, data fields are filled with dashes if data is unavailable from the GPS or if the data is invalid.

**CAUTION**

A run-off error sometimes occurs in these receivers. The following procedures should be used when loading crypto keys (GUV or CVW): After key loading and once the receiver indicates FOM 1 or 2, the operator should cycle the receiver to **INIT** and then back to **NAV**. This action resets the corrupted data and will recover normal operations. Note that this is a peacetime environment solution.

(2) *GPS initialization mode.* Successive depressions of RI will cause the GPS mode to toggle from **NAV** to **INIT**, with the active mode boxed. Normally, on power-up, a BIT runs for approximately 30 seconds, followed by the nav legend automatically being boxed and the legend **QUICK**, **NORMAL**, or **COLD** (indicating start-up mode) being displayed to the right of the text at L5. Valid year data is 1 or two digits in the range 0 through 99. If GPS data displayed is not correct, depress RI to select **INIT** and correct data as follows:

(a) *GPS position data insertion.*

1. If position is not correct, enter position data into the scratchpad.

Valid position data is X.DD.MM.SS.T Y.DDD.MM.SS.T, where:

X = Latitude Hemisphere (N or S)

DD = Degrees of Latitude (0 90)

MM = Minutes of Latitude or Longitude

SS = Seconds (0059)

T = Tenths of Seconds (0 9)

Y = Longitude Hemisphere (E or W)

DDD = Degrees of Longitude

**NOTE**

**Zero is assumed for minutes and seconds if not entered.**

**If INS is in NAV, its position and altitude will be sent to the GPS in INIT and displayed next to LI.**

2. L1 line selection switch Depress.

With valid data in the scratchpad and GPS in the INIT mode, depressing LI will cause the scratchpadded data to be displayed to the right of the text at L1.

(b) *GPS altitude data insertion.*

1. If altitude data is in error, enter valid altitude data into scratchpad.
2. L2 line selection switch Depress.

With valid data in the scratchpad and GPS in the INIT mode, depressing L2 will cause the scratchpadded data to be displayed to the right of the text at L2. Valid altitude data is 1 thru 5 digits with a range of 0 99999.

**NOTE**

**The units of altitude for GPS are feet MSL.**

(c) *GPS time data insertion.*

1. If time data is in error, enter valid UTC time data into scratchpad.
2. L3 line selection switch Depress.

With a valid time entered in the scratchpad and GPS in the **INIT** mode, depressing L3 will cause the scratchpadded data to be displayed to the right of the text at L3. Valid time is HH MM SS, where:

HH = Hour of the day (0 23)

MM = Minutes after the hour (0 59)

SS = Seconds after the minute (0 59)

**NOTE**

**Zero is assumed for minutes and seconds if not entered.**

3. Day of year (**DOY**) data insertion.
4. Enter valid day of year (**DOY**) data into scratchpad.
5. L4 line selection switch Depress.

With a day of the year (**DOY**) entered in the scratchpad and GPS in the **INIT** mode, depressing L4 will cause the scratchpadded data to be displayed to the right of the text at LA. Valid day of the year data is 1 through 3 digits in the range of 1 through 365.

(d) *Year data insertion.*

1. If year is wrong, enter valid year data into scratchpad.
2. L5 line selection switch Depress. With a year entered in the scratchpad and GPS in the INIT mode,

depressing L5 will cause the scratchpadded to be displayed to the right of the text at L5. Valid year data is 1 or 2 digits in the range 0 through 99.

(3) *GPS quick start-up mode.* The **QUICK** start-up mode is the mode which is normally automatically selected by the ASE/ACS. When the **QUICK** start-up mode is complete, the **QUICK** legend below the **NAV INIT** text is removed to cue the crew that the GPS is ready for normal navigation. The transition from **QUICK** start to navigate mode occurs when 3 or more satellites are being tracked and the figure of merit is less than 9.

Figure of merit (**FOM**) is a single digit from 1 to 9. It represents estimated position error (**EPE**) in feet as follows:

- FOM = 1, then EPE < 82
- FOM = 2, then EPE < 164
- FOM = 3, then EPE < 246
- FOM = 4, then EPE < 328
- FOM = 5, then EPE < 642
- FOM = 6, then EPE < 1640
- FOM = 7, then EPE < 3280
- FOM = 8, then EPE < 16404
- FOM = 9, then EPE > 16404

(4) *GPS normal start-up mode.* If there is a large difference between the initial GPS position and the INS alignment position (approximately 54 NM or larger), the ASE/ACS selects the **NORMAL** start-up mode. When autoselected, the legend **NORMAL** appears below the text **NAV INIT** and the ASE/ACS will place the GPS in the **INIT** mode; send the INS latitude, longitude, and datum to the GPS; and reselect the **NAV** mode. When the **NORMAL** start-up mode is complete, the **NORMAL** legend below the **NAV INIT** text is removed to cue the crew that the GPS is ready for normal navigation. The transition from **NORMAL** start to navigate mode occurs when 3 or more satellites are being tracked and the figure of merit is less than 9.

(5) *GPS cold start-up mode.* If the GPS almanac data is more than 5000 hours old, the GPS initiates a **COLD** start-up mode. When this happens, the legend **COLD** will appear below the text **NAV INIT** and the GPS will initiate a search for a good satellite to download almanac data (this process can take up to 13 minutes). The total time to complete the **COLD** start-up is totally dependent on satellite visibility. If **COLD** start-up is initiated and satellite number 14 (the first in the search sequence) is visible and good, the whole almanac downloading and start-up sequence should be completed in less than 20 minutes. When the **COLD** start-up mode is complete, the **COLD** legend below the **NAV INIT** text is

removed to cue the crew that the GPS is ready for normal navigation. The transition from **COLD** start to navigate mode occurs when 3 or more satellites are being tracked and the figure of merit is less than 9.

(6) *Map datum entry.* With a local map datum entered in the scratchpad and GPS in the **INIT** mode, depressing R2 will cause the scratchpadded data to be displayed to the left of the text at R2. A valid datum is any number from 1 through 47 except 20. Datum cross reference is shown in table 3-11. Map datum default is 47.

**3-29. CHALS USE OF GPS AND INS.**

a. *CHALS Concept.* CHALS (Communications High Accuracy Airborne Location System), is an emitter location system that provides timely, high accuracy locations required for targeting and to support emitter associations and battlefield situation assessment. CHALS provides this capability through coherent processing of differential doppler (DD) and time difference of arrival (TDOA) information received at a ground facility from the aircraft. CHALS receivers aboard the aircraft will receive and digitize emitter signals. The data will be transmitted over the data link to the GR/CS integrated processing facility (IPF). There, CHALS processors will perform the required computations to produce accurate emitter locations. The precise navigation required is provided by the inertial navigation system (INS) and the global positioning system (GPS). GPS also provides the primary means of time synchronizing the CHALS receivers (signal conditioners or SC's) aboard the aircraft. A backup for the GPS is provided by the data link. The resultant emitter reports will be sent to GR/CS by CHALS.

b. *GPS (and INS) Involvement.* The accurate and timely navigation (position and velocity) is provided by integrating an INS with a GPS, and integrating both (through a series of intermediaries) with a CHALS ground based navigation processor (NP). The SC, data link, and CHALS HSSP (high speed signal processor) form the communication link. The critical airborne interfaces for CHALS navigation and time synchronization include the following:

(1) *INS to GPS and CHALS:*

- Acceleration
- Velocity
- Position
- Altitude

(2) *GPS to CHALS:*

Time mark pulse (time synchronization)

TM/covariance data block (time, TM time, covariance)

Navigation data block (position, velocity, and time)

Status data block (status including DOP's and FOMN)

Error state vector data block (9 element ESV, time)

**Section IV. RADAR AND TRANSPONDER**

**3-30. RADAR AND TRANSPONDER EQUIPMENT GROUP DESCRIPTION.**

The radar and transponder group consists of a weather radar, lightning sensor system, transponder, and encoding altimeter indicator. The transponder and radar group includes an identification, position, emergency tracking system, and a radar and lightning sensor system to locate potentially dangerous weather areas.

**3-31. WEATHER RADAR SYSTEM (WC-650).**

The weather radar system is a light weight, X-band digital radar with alphanumeric designed for weather detection and analysis and ground mapping. The radar system is controlled from the radar control panel (fig. 3-29), located on the pedestal extension (fig. 2-14). Radar information is displayed on the pilot's and copilot's EHSI.

**NOTE**

The weather radar may display false echoes and spikes on all ranges when the VHF-FM (SINCGARS) transceiver is transmitting.

The primary purpose of the system is to detect storms along the flight path and give the pilot a color visual indication of their rainfall intensity. After proper evaluation, the pilot can chart a course to avoid these storm areas.

Figure 3-30 depicts a typical EFIS weather test pattern (120 degree scan).

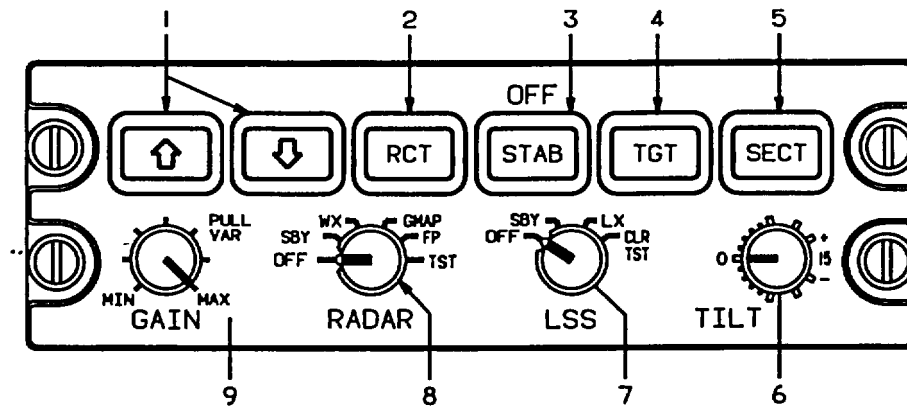

1. Range Switches
2. Rain Echo Attenuation Compensation Technique Pushbutton Selector Switch
3. Attitude Stabilization Pushbutton Selector Switch
4. Target Alert Pushbutton Selector Switch
5. Sector Scan Angle Pushbutton Selector Switch
6. Antenna Tilt Angle Control
7. Lightning Sensor System Mode Selector Switch
8. Radar System Mode Selector Switch
9. Radar Receiver Gain Control

A93FE00D0111 C

Figure 3-29. Weather Radar/Lightning Sensor System Control Panel

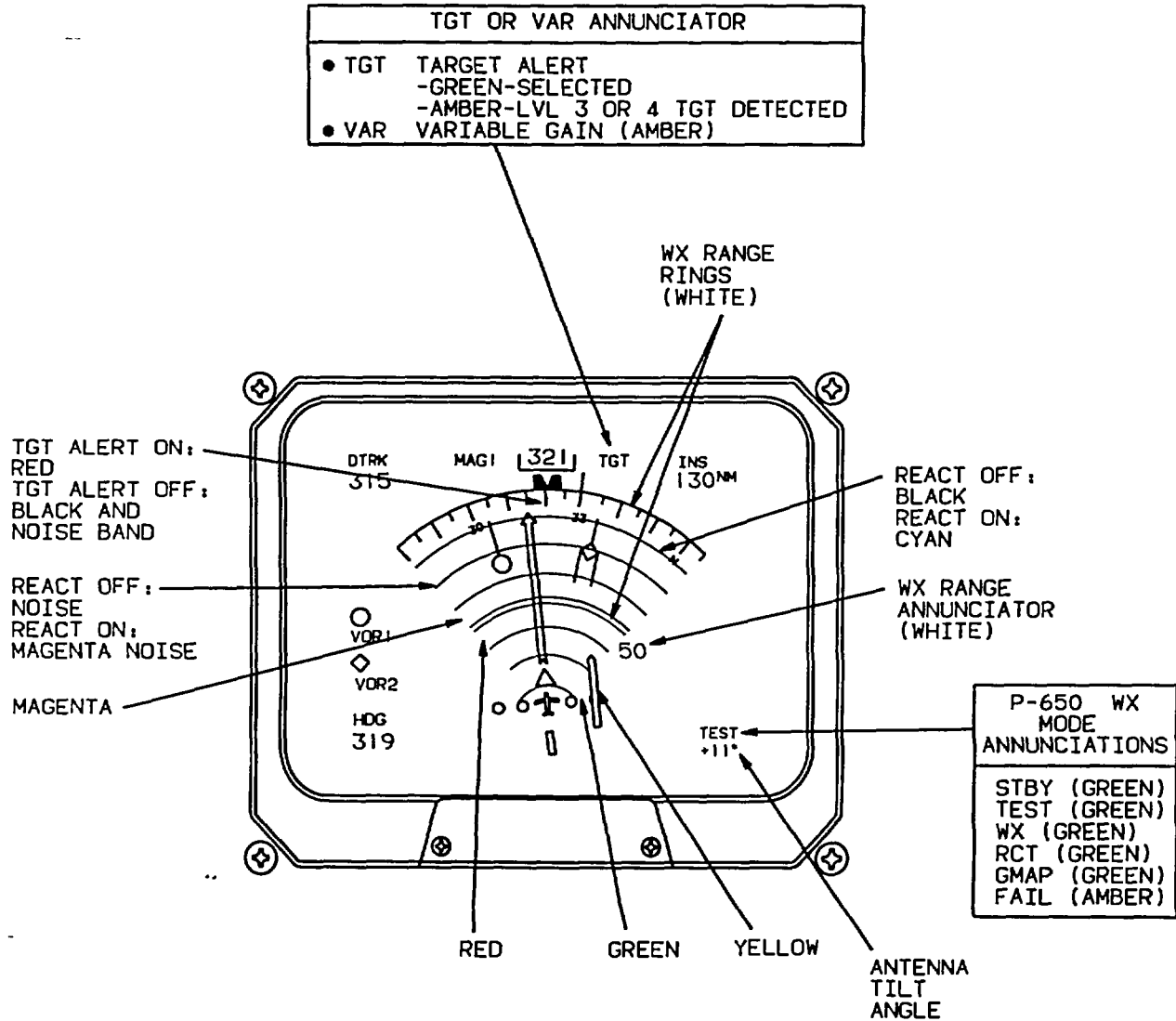

AP015410 C

Figure 3-30. EFIS Weather Test Pattern (Typical, 120-Degree Scan)

**WARNING**

The system performs only the functions of weather detection or ground mapping. It should not be used nor relied upon for proximity warning or anti-collision protection.

Output power is radiated during test mode.

**CAUTION**

If the radar system is to be operated in any mode other than standby while the aircraft is on the ground: Direct the nose of the aircraft so that the antenna scan sector is free of large metallic objects such as hangars or other aircraft for a distance of 100 feet (30 meters).

Do not operate during refueling of aircraft or defueling operation within 100 feet (30 meters).

Do not operate if personnel are standing too close to the 270-degree forward sector of the aircraft (fig. 3-31).

**Operating personnel should be familiar with FAA AC 20-68B.**

In the weather detection mode, precipitation intensity levels are displayed in four colors, contrasted against a deep black background. Areas of very heavy rainfall will appear in magenta, heavy rainfall in red, less severe in yellow, light rain in green, and little or no rainfall in black (background). The correlation of precipitation intensity and the color of displayed weather is shown in table 3-12.

Range marks with identifying numerics, displayed in white, are provided to facilitate evaluation of storm cells.

Selection of the ground mapping (**GMAP**) function will cause system parameters to be optimized to improve resolution and enhance identification of small targets at short range. The reflected signal from ground surfaces will be displayed as magenta, yellow, or cyan (most to least reflective).

a. *Radar Control Panel Controls, Indicators, and Functions:*

(1) *Range switches.* Two momentary-contact pushbutton switches (placarded with an up arrow on the left switch, and a down arrow on the right), are used to select the operating range of the radar (and the lightning

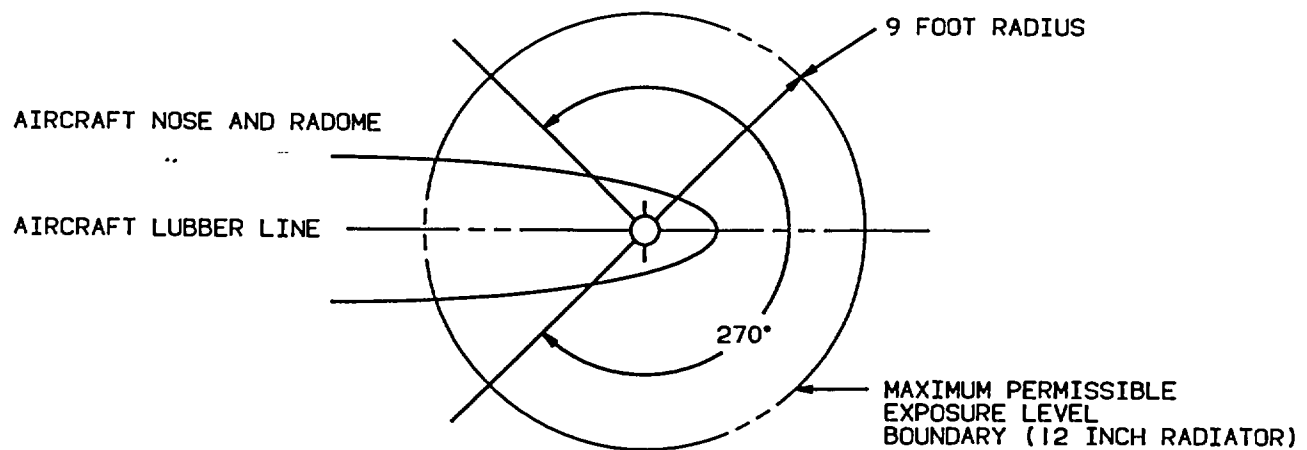

AP015276 C

Figure 3-31. Maximum Permissible Exposure Level

sensor system). By depressing the switches, ranges of 5, 10, 25, 50, 100, 200, and 300 nautical miles with corresponding range marks may be selected. Ranges of 600 and 1200 nautical miles are available if the radar system mode selector switch is in the **FP** position.

(2) Rain echo attenuation compensation technique pushbutton selector switch. The rain echo attenuation compensation technique (**REACT**) pushbutton selector switch, placarded **RCT**, is used to enable or disable the **REACT** function of the radar system. When the **RCT** mode has been activated, receiver gain is automatically adjusted according to received signal strength. When receiver is in calibrated range, displayed colors are as in weather mode. When calibration range is exceeded, background will be in blue for the affected areas. Signals in the uncalibrated range will be displayed as a level three (red). **REACT** mode may be activated in all radar ranges. When activated, **RCT** will be annunciated on the EHSI.

(3) Attitude stabilization pushbutton selector switch. The alternate-action, attitude stabilization pushbutton selector switch, placarded **STAB** is used to enable or disable attitude stabilization of the radar image. When stabilization is selected off, an **OFF** annunciator above the **STAB** switch will illuminate.

(4) Target alert pushbutton selector switch. The alternate-action, target alert pushbutton selector switch, placarded **TGT** is used to enable or disable the radar target alert feature. When the target alert function has been selected, **TGT** (green) will be annunciated on the EHSI. When the target alert feature has been

selected, the area beyond the selected range and 7.5 degrees on either side of aircraft heading is monitored for radar returns of level 3 (red) or greater. If a level 3 or greater return is detected and triggers the system, **TGT** will be annunciated in amber on the EHSI. Target alert is selectable in all but the 300 nautical-mile range.

(5) Sector scan angle pushbutton selector switch. The alternate-action, sector scan angle pushbutton selector switch is used to select either the normal 14 looks per minute 120-degree scan or the faster update 28 looks per minute 60-degree sector scan.

(6) Antenna tilt angle control. The rotary antenna tilt angle control, placarded **TILT**, is used to select the angle of the antenna beam with relation to earth plane. Clockwise rotation tilts the beam upward from 0 to 15 degrees. Counterclockwise rotation tilts the beam downward from 0 to 15 degrees. The scale range between +5 degrees and -5 degrees is expanded for ease of use.

(7) Lightning sensor system mode selector switch.

(a) **OFF**. Disables lightning sensor system.

(b) **STBY**. In the standby (**STBY**) mode, lightning data is not displayed. However, the receiving and processing equipment is active and lightning strikes are being counted and accumulated.

(c) **LX**. The **LX** mode is the normal working mode of the lightning sensor system. Lightning strikes are collected, processed, and displayed.

Table 3-12. Video Integrated Processor VS Aircraft Radar Return Levels

Display Level	Rainfall Rate (mm/Hr)	Rainfall Rate (inches/Hr)	Video Integrated Processor (VIP) Categorizations			Maximum Calibrated Range (NM)
			Storm Category	VIP Level	Rainfall Rate (mm/Hr) (Inches/Hr)	
4 (Magenta)	Greater than 52	Greater than 2.1	Extreme	6	Greater than 125 (5)	175
			Intense	5	50-125 (2-5)	
3 (Red)	Greater than 12-52	Greater than 0.5-2.1	Very Strong	4	25-50 (1-2)	175
			Strong	3	12-25 (0.5-1)	
2 (Yellow)	4-12	0.17-0.5	Moderate	2	2.5-12 (0.1-0.5)	175
1 (Green)	1-4	0.04-0.17	Weak	1	0.25-2.5 (0.01-0.1)	175
0 (Black)	Less than 1	Less than 0.04				-

BT03849



(d) *CLR/TST*. When clear/test is selected, all memory of past strikes and symbols are erased. After 3 seconds the system enters the test mode.

In the test mode, simulated lightning signals are fed into the test loop in the antenna and a lightning strike is simulated-at a bearing of 45 degrees at 25 nautical miles. A lightning alert is also generated along the outermost range ring at a bearing of 45 degrees. This simulated strike will progress in severity through level three within 15 seconds of entry into the test mode. If the mode selector is left in the **CLR/TST** mode, the alert and strike symbols will reduce in severity and disappear. The lightning rate symbol will disappear after approximately 2 minutes.

#### NOTE

**The lightning sensor system antenna is used in this test, and as a result, any real lightning activity that occurs while the test is in operation may also be displayed.**

(8) Radar system mode selector switch.

(a) *OFF*. Turns the radar system off.

(b) *SBY*. Places the radar system in standby. This is a ready state with the antenna scan stopped, the transmitter inhibited, and the memory erased. **STBY** will be displayed on the EHSI.

(c) *WX*. Selecting **WX** places the radar system in the weather detection mode. **WX** (green) will be annunciated on the EHSI. The system is fully operational and all internal parameters are set for enroute weather detection. Automatic or variable gain control may be used. Radar display levels are depicted in four colors as described in figure 3-31. If **WX** is selected prior to the expiration of the initial system warm-up period (approximately 45 seconds), **WAIT** (green) will be annunciated on the EHSI. In wait mode, the transmitter and antenna scan is inhibited and the memory is erased. Upon completion of the warm-up period, the system will automatically switch to **WX** mode.

(d) *GMAP*. Selecting **GMAP** places the radar system in the ground mapping mode. The system is fully operational and all internal parameters are set to enhance returns from the ground and reduce returns from weather targets.

#### CAUTION

**Weather type targets are not calibrated when the radar is in the GMAP mode. Because of this, the pilot should not use the GMAP mode for weather detection.**

As a constant reminder that **GMAP** has been selected, the **GMAP** legend is displayed and the color scheme is changed to cyan, yellow, and magenta. Cyan represents the least reflective return, yellow is a moderate return, and magenta is a strong return. If ground mapping is selected prior to the expiration of the warm-up period (approximately 45 seconds), a white **WAIT** legend will be displayed. In the **WAIT** mode, the transmitter and antenna scan will be inhibited and the memory is erased. Upon completion of the warm-up period, the system will automatically switch to the **GMAP** mode.

(e) *FP*. Selection of the *FP* position places the radar system in the flight plan mode permitting the display of navigation data on the EFIS with radar data omitted. This position allows an extended MAP display range (up to 1200 nautical miles) to be selected for navigation data.

(f) *TEST*. Selection of **TEST** position selects test mode and puts a test pattern on the screen to verify system operation. **TEST** will be annunciated on the EHSI in the radar mode field. **TEST** mode is inhibited when system is in forced standby mode.

(g) *Radar receiver gain control*. This control (placarded **GAIN, MIN MAX**) is used to adjust receiver gain when gain is variable. Pulling out on gain control makes gain control variable. A fully automatic gain control is provided when the gain control is in the preset (pushed in) position.

b. *Weather Radar Normal Operation*. Radar turn-on procedure.

1. Radar system mode selector switch **OFF**.
2. Radar receiver gain control Preset (pushed in) position.
3. Antenna tilt angle control +15 degrees.
4. Weather (**WX**) pushbutton selector switch (display controller) Depress to select weather display mode on the EHSI.
5. Radar mode selector switch **SBY** or **TEST**.

**NOTE**

**When power is first applied, the radar will be in the WAIT mode for 45 seconds to allow the magnetron to warm up.**

*c. Weather Radar Modes of Operation.*

(1) *Standby mode.* When **SBY** has been selected with the radar system mode selector switch, the radar antenna will be stowed in a tilt-up position and will be neither scanning nor transmitting. Standby should be selected any time it is desirable to keep power on the system without transmitting.

(2) *Forced standby.* Provisions are included in the weather radar controller to place the system into the forced standby mode when the radar is operating and weight is on the aircraft's wheels. The forced standby mode is a safety feature that stops the radar from transmitting on the ground to eliminate the microwave radiation hazard. In the forced standby mode, the transmitter and antenna scan are both inhibited and the memory erased.

Forced standby may be overridden (restoring normal operation) by simultaneously depressing both range switches on the radar control panel.

(3) *Weather detection mode.* Normal weather detection mode is selected by placing the radar system mode selector switch to the **WX** position, and selecting **WX** on the display controller. To assist the pilot in categorizing storms, the radar receiver gain is calibrated in the **WX** mode with the **GAIN** control in the preset position. The radar is not calibrated when variable gain is being used. Calibration is restored if rain echo attenuation compensation technique (**RCT**) or target alert (**TGT**) is selected. In the weather detection mode precipitation is displayed in five levels as black, green, yellow, red, and magenta.

In order to permit the user to interpret the display, targets are displayed in various colors. Each color represents a specific target intensity. The relationship between the colors on the display and the national weather service video integrated processor (VIP) level is shown in table 3-12. Rain echo attenuation compensation technique may be used in the **WX** mode to compensate for the attenuation of the radar signal as it passes through a storm. It does this by increasing or decreasing the gain of the receiver as weather is detected. Depressing the **RCT** pushbutton switch on the weather radar selects and deselects the rain echo attenuation compensation technique (**REACT**) circuitry and selects and deselects the blue field display which indicates that the receiver is at maximum gain and the reference levels are at final values. Any returns detected beyond this point are displayed as magenta. (Selecting **RCT** prevents variable gain from operating.)

(4) *Ground mapping mode.* Ground mapping mode is selected by setting the radar system mode selector switch to the **GMAP** position. The **TILT** control is then used to tilt the antenna down until the desired amount of terrain is displayed. The degree of tilt-down will depend upon the aircraft altitude and the selected range. In the **GMAP** mode the receiver characteristics are altered to provide equalization of ground-target reflection versus range. As a result, leaving the gain control in the depressed (preset) position will generally provide the desired mapping display. However, the pilot may desire to decrease the gain manually by selecting manual gain control and rotating the **GAIN** control. With experience, the pilot will develop the ability to interpret the color display patterns that indicate water regions, coast lines, hilly or mountainous regions, cities, or even large structures.

(5) *Fault monitoring.* Critical functions in the receiver/transmitter/antenna are continuously monitored.

### 3-32. LIGHTNING SENSOR SYSTEM (LSZ-850).

#### **WARNING**

**The lightning sensor system is to be used for hazardous weather avoidance, not weather penetration.**

The lightning sensor system (LSS) is used to detect and locate areas of lightning activity within a 100 nautical mile radius around the aircraft. The system provides the operator with a visual display of the position and rate of occurrence of the lightning activity on the EHSI. The lightning sensor system detects both visible and high energy invisible electromagnetic and electrostatic discharges (lightning) indicating areas of turbulent activity. After evaluating the LSS display, and its relation to precipitation as indicated by the weather radar display, the operator can effectively plan the proper course to avoid hazardous weather. The lightning sensor system consists of a receiver/processor, an antenna, a mode selector switch (located on the radar control panel, fig. 3-29), and the pilot's and copilot's EHSI. The system is powered by a 2-ampere circuit-breaker placarded LSS, located on the overhead circuit breaker panel (fig. 2-9). Because the system is a passive device (it does not transmit), it can be operated safely on the ground. Weather in all directions around the aircraft may be monitored, even before starting engines.

*a. Lightning Sensor System Mode Selector Switch (fig. 3-29).*

(1) *OFF.* Disables lightning sensor system.

(2) *SBY.* In the standby (**SBY**) mode, lightning data is not displayed. However, the receiving and processing equipment is active and lightning strikes are being counted and accumulated.

(3) *LX*. The **LX** mode is the normal working mode of the lightning sensor system. Lightning strikes are collected, processed, and displayed.

(4) *CLR/TST*. When clear/test is selected, all memory of past strikes and symbols are erased. After 3 seconds the system enters the test mode.

In the test mode, simulated lightning signals are fed into the test loop in the antenna and a lightning strike is simulated at a bearing of 45 degrees at 25 nautical miles. A lightning alert is also generated along the outermost range ring at a bearing of 45 degrees. This simulated strike will progress in severity through level three within 15 seconds of entry into the test mode. If the mode selector is left in the **CLR/TST** mode, the alert and strike symbols will reduce in severity and disappear. The lightning rate symbol will disappear after approximately 2 minutes.

**NOTE**

**The lightning sensor system antenna is used in this test, and as a result, any real lightning activity that occurs while the test is in operation may also be displayed.**

*b. Lightning Sensor System Display.* The LSS shows areas of lightning activity on the EHSI with symbols. Each lightning symbol represents the center of a circular area with a radius of nine nautical miles. Three different lightning symbols are used to represent three different rates of occurrence of the lightning within each 18 nautical-mile diameter circle. The lightning rate symbols represent the lightning rates-of-occurrence during the last two minutes. The symbol's location on the display represents the average position of the lightning that has occurred during the last two minutes inside each 18 nautical-mile diameter area. Lightning may -not be occurring at the center of the symbol. Because it is easier for the LSS to detect lightning at close distances than at far distances, the number of lightning strokes required for each rate symbol is adjusted for distance to the storm. Figure 3-32 shows the number of strokes required for each symbol versus range to the storm. Figure 3-33 shows the three rate-of-occurrence symbols.

*c. Lightning Alert System.* It is possible to see a lightning flash visually, and see no change in the display. This is normal, because, unless one of the rate thresholds are crossed, there will be no change in the symbol, other than a slight position update. The lightning alert function shows the operator that the unit is operational, and shows real-time lightning activity. The lightning alert function places a magenta rate-one symbol near the outer range mark of the display, at the proper bearing, for each lightning flash (fig. 3-33). The lightning alert symbol is displayed for five seconds, and gives the operator confidence that the system is functional even

though there may be no change in the white lightning rate symbols. It is also an indicator of real-time activity.

*d. Lightning Sensor System Mode Annunciations.* The following mode annunciations may appear on the EHSI display.

(1) *LX/F (amber)*. Indicates that self-test has detected a fault.

(2) *LX/S (green)*. Indicates that the system is in the standby (SBY) mode.

(3) *LX/CL (green)*. Indicates that the system is in the clear (**CLR**) mode. This annunciator will appear for approximately 3 seconds after the **CLR/TEST** mode has been selected. After this time the mode annunciator will switch to LX/T.

(4) *LX/T (green)*. Indicates that the system is in the test (**TST**) mode. This annunciator may be replaced with LXMN.

(5) *LXmn (amber)*. In the **CLR/TST** mode an amber **LXmn** will be displayed, where mn is a two digit failure code. Table 3-13 explains these codes.

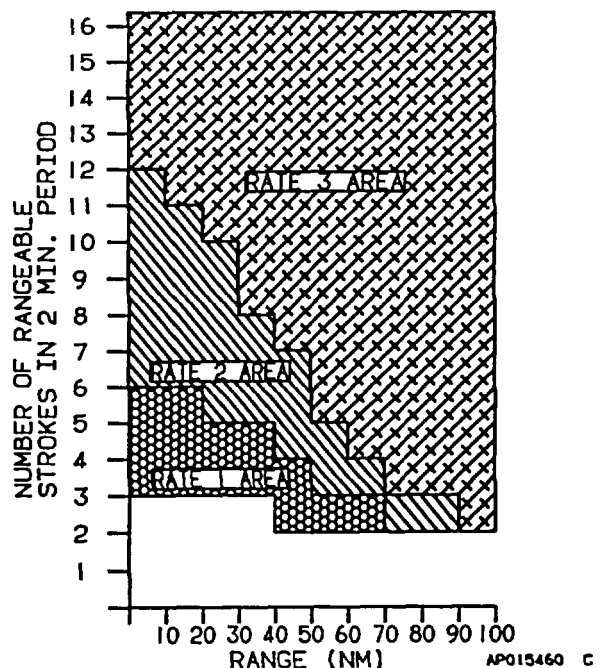

Figure 3-32. Lightning Strokes Required per Symbol vs. Range to Storm

(6) *LX/I (green)*. Indicates that the receiver is inhibited by the XMIT INH input during transmission by communications transmitters. No lightning may be received during this condition.

(7) *LH/H (green)*. Indicates that heading input has been deselected by the HDG VALID input.

(8) *LX/C (green)*. Indicates that the system is in the self-calibration mode. This will revert to the selected mode approximately 10 seconds after power has been applied.

(9) *LX/L (green)*. The number of computed lightning rate symbols exceeds the capability of the display system.

(10) *LX (green)*. Indicates that the system is in the normal operating mode.

**NOTE**

**If two or more of the above situations are true at the same time, the annunciation which is highest on the above list will be displayed.**



NOTE: EACH RATE SYMBOL REPRESENTS THE CENTER OF AN 18-MILE DIAMETER AREA OF LIGHTNING ACTIVITY.

AP015461 C

Figure 3-33. Lightning Rate of Occurrence Symbols

e. *Self Calibration Mode*. During approximately the first 8 seconds after power is applied, the system performs a self-calibration process to cancel out variations in antenna gain and cable loss (**LX/C** will be displayed on the EHSI). As soon as this is complete, the letter **C** will be removed from the display. If strong interfering signals outside the aircraft, or equipment malfunction prevent the calibration of the system, it will revert to preset calibration factors, in which case the **C** will not be removed from the display. In this case the operator should select the **TST** mode and evaluate the test display. Interference signals can be caused by other systems on the aircraft, by adjacent ground installations such as power transformers, or by nearby aircraft. If sources outside the aircraft cause the **C** to remain displayed, they will not be present after takeoff, and the LSS mode selector switch should be switched to **OFF** and set back to the LX mode to force recalibration for greater accuracy. If the **C** display persists after takeoff, **TST** mode should be selected again to re-evaluate the system.

f. *Self-Test*.

1. Range switches (radar control panel, fig. 3-29) Select range of 50 nautical miles or greater.
2. Lightning sensor system (LSS) mode selector switch (radar control panel) **CLR/TST**. Verify that all lightning rate symbols are erased from display.

**NOTE**

**After 3 or 4 seconds, simulated lightning test pulses are sent to the display.**

3. Verify that a rate symbol is displayed at 25 nautical miles, at 45 degrees to right of center. This symbol will take approximately 5 to 7 seconds to build up.

**NOTE**

**This time will be extended to approximately 15 seconds if TST is selected immediately from OFF, due to lightning processor initialization.**

The symbol's range may vary by as much as 5 nautical miles if strong local interference is present.

4. Verify that a magenta lightning alert symbol is displayed at maximum selected range, at 45 degrees right of center. This must remain on display for 3 to 7 seconds.
5. To restart the test, switch to **LX** mode and back to **CLR/TST** mode.

If the power-on test or the on line built-in test equipment detects a fault, either prior to or during the operation of self test, the system will switch the displayed mode symbol to an amber LX/F. A special fault message may be obtained by switching to the CLR/TST mode. In the CLR/ TST mode an amber LXmn will be displayed, where mn is a failure code that may be interpreted according to table 3-13.

g. *Lightning Sensor System Normal Operation.*

1. **LSS** mode selector switch (radar control panel) **LX**
2. Range switches (radar control panel) - Set desired range.

**NOTE**

**If radar system mode selector switch is set to OFF, LSS range will revert to 50 nautical miles.**

**3-33. TRANSPONDER SET (APX-100).**

a. Description. The transponder system receives, decodes, and responds to interrogations from air traffic

control (ATC) radar to allow aircraft identification, altitude reporting, position tracking, and emergency tracking. The system receives a frequency of 1030 MHz and transmits preset coded reply pulses on a frequency of 1090 MHz at a minimum peak power of 200 watts. The range of the system is limited to line-of-sight. The transponder system consists of a combined receiver/transmitter/control panel (fig. 3-34) located in the pedestal extension; a pair of remote switches, one in each control wheel; and two antennas, located on the underside and top of the fuselage. The system is protected by the 3-ampere TRANSPONDER, and 35-ampere AVIONICS MASTER PWR NO. 1 circuit breakers on the overhead circuit breaker panel (fig. 2-9).

b. *Transponder Controls, Indicators, and Functions (fig. 3-34).*

(1) *TEST-GO indicator.* Illuminates to indicate successful completion of built-in-test (BIT).

(2) *TEST/MON/NO GO indicator.* Illuminates to indicate system malfunction or interrogation by a ground station.

(3) *ANT switch.* Selects desired antenna for signal input.

Table 3-13. *Lightning Sensor System Failure Codes*

LX FAIL CODE (mn)	HARDWARE/FIRMWARE FAILURE
00	No LX system failure (not displayed)
01	Power supply out-of-tolerance
02	Invalid configuration
03	Reserved
04	Data Processor RAM failure
05	Data Processor Checksum failure
06	Data Processor shared RAM failure
07	Reserved
08	Reserved
09	I/O Processor RAM failure.
0A	I/O Processor Checksum failure
0B	I/O Processor shared RAM failure
0C	HN out-of-range
0D	Hw out-of-range
0E	Reserved
0F	HNLF out-of-range
10	HwLF out-of-range
11	ELF out-of-range
12	No data from antenna

BT03847

- (a) *TOP*. Selects upper antenna.
  - (b) *DIV*. Selects diverse (both) antennas.
  - (c) *BOT*. Selects lower antenna.
- (4) *RAD TEST-OUT switch*. Enables reply to **TEST** mode interrogations from test set.
- (5) *MASTER control*. Selects system operating mode.
- (a) *OFF*. Deactivates system.
  - (b) *STBY*. Activates system warm-up (standby) mode.
  - (c) *NORM*. Activates normal operating mode.
  - (d) *EMER*. Transmits emergency reply code.
- (6) *STATUS ANT indicator*. Illuminates to indicate the **BIT** or **MON** fault is caused by high VSWR in antenna.

- (7) *STATUS KIT*. Illuminates to indicate the **BIT** or **MON** fault is caused by external computer.
- (8) *STATUS ALT indicator*. Illuminates to indicate the **BIT** or **MON** fault is caused by the altitude digitizer.
- (9) *IDENT - MIC - OUT*. Selects source of aircraft identification signal.
  - (a) *IDENT*. Activates transmission of identification pulse (**IP**).
  - (b) *MIC*. Enables either control wheel **POS IDENT** switch to activate transmission of ident signal from transponder.
  - (c) *OUT*. Disallows outgoing signal.
- (10) *MODE 4 reply indicator light*. Illuminates to indicate a reply has been made to a valid Mode 4 interrogation.
- (11) *MODE 4 AUDIO OUT switch*. Selects monitor mode for mode 4 operation.
  - (a) *AUDIO*. Enables sound and sight monitoring of mode 4 operation.

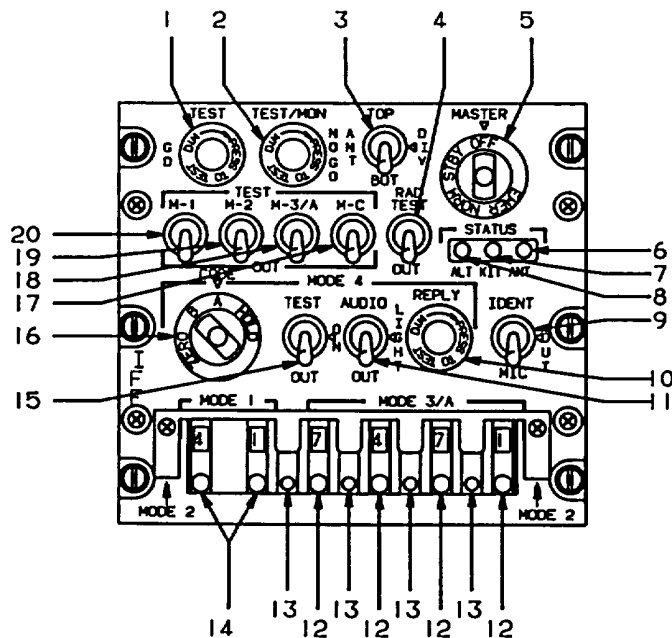

1. TEST-GO Indicator
2. TEST/MON. NO GO Indicator
3. ANTenna Switch
4. RAD TEST-OUT Switch
5. MASTER Control
6. STATUS ANT Indicator
7. STATUS KIT Indicator
8. STATUS ALT Indicator
9. IDENT MIC-OUT Switch
10. MODE 4 REPLY Indicator
11. MODE 4 AUDIO-LIGHT-OUT Switch
12. MODE 3/A Code Selectors
13. MODE 2 Code Selectors
14. MODE 1 Code Selectors
15. MODE 4 TEST-ON-OUT Switch
16. MODE 4 Code Selector
17. M-C TEST Switch
18. M-3/A TEST Switch
19. M-2 TEST Switch
20. M-1 TEST Switch

A93FE00D112 C

Figure 3-34. Transponder Control Panel

(b) *LIGHT*. Enables monitoring **REPLY** indicator for mode 4 operation.

(c) *OUT*. Deactivates monitor mode.

(12) *MODE 3/A code selectors*. Select desired reply codes for mode 3/A operation.

(13) *MODE 2 code selectors*. Select desired reply codes for mode 2 operation. The cover over mode select switches must be slid forward to display the selected mode 2 code.

(14) *MODE 1 code selectors*. Select desired reply codes for mode 1 operation.

(15) *MODE 4 TEST-ON-OUT switch*. Selects test mode of Mode 4 operation.

(a) *TEST*. Activates built-in-test of mode 4 operation.

(b) *ON*. Activates mode 4 operation.

(c) *OUT*. Disables mode 4 operation.

(16) *MODE 4 code control*. Selects preset mode 4 code.

(17) *M-C, M-3A, M-2, and M-1 switches*. Select test or reply mode of respective codes.

(a) *TEST*. Activates self-test of selected code. Transponder can also reply.

(b) *ON*. Activates normal operation.

(c) *OUT*. Deactivates operation of selected code.

(18) *POS IDENT pushbutton (control wheels, fig. 2-24)*. When pressed, activates transponder identification reply.

c. *Transponder Normal Operation.*

(1) *Turn-on procedure*: MASTER switch STBY. Depending on type of receiver installed, **TEST/MON NO GO** indicator may illuminate. Disregard this signal.

(2) *Test procedure*:

**NOTE**

**Make no checks with the master switch in EMER, or with M-3/A codes 7600 or 7700 without first obtaining authorization from the interrogating station(s).**

1. Allow set two minutes to warm up.
2. Select codes assigned for use in modes 1 and 3/A by depressing and releasing the pushbutton for each switch until the desired number appears in the proper window.
3. Lamp indicators Operate press-to-test feature.
4. M-1 switch Hold in **TEST**. Observe no annunciators illuminate.
5. M-1 switch Return to **ON**.
6. Repeat steps 4 and 5 for the **M-2, M-3/A** and **M-C** mode switches.
7. **MASTER** control **NORM**.
8. **MODE 4** code control - **A**. Set a code in external computer.
9. **MODE 4 AUDIO OUT** switch **OUT**.

(3) *Modes 1, 2, 3/A, and/or 4 operating*

*procedure:*

**NOTE**

If the external security computer is not installed, a **NO GO** annunciator will illuminate any time the Mode 4 switch is moved out of the **OFF** position.

1. **MASTER** control **NORM**.
2. **M-1, M-2, M-3/A, and/or MODE 4 ON-OUT** switches **ON**. Actuate only those switches corresponding to required codes. The remaining switches should be left in **OUT** position.
3. **MODE 1** code selectors Set (if applicable).
4. **MODE 3/A** code selectors Set (if applicable).
5. **MODE 4** code control Set (if required).
6. **MODE 4** REPLY indicator Monitor to determine when transponder set is replying to SIF interrogation.
7. **MODE 4 AUDIO OUT** switch Set (as required to monitor mode 4 interrogations and replies).
8. **MODE 4** audio and/or indicator Listen and/or observe (for mode 4 interrogations and replies).

9. **IDENT-MIC-OUT** switch Press to **IDENT** momentarily.
10. **MODE 4 TEST-ON-OUT** switch **TEST**.
11. Observe that the **TEST GO** annunciator illuminates.
12. **MODE 4 TEST-ON-OUT** switch **ON**.
13. **ANT** switch **BOT**.
14. Repeat steps 4, 5 and 6. Observe that **TEST GO** indicator illuminates.
15. **TOP-DIV-BOT-ANT** switch **TOP**.
16. Repeat step 14.
17. **TOP-DIV-BOT-ANT** switch **DIV**.
18. Repeat step 14.
19. When possible, obtain the cooperation of an interrogating station to exercise the **TEST** mode. Execute the following steps:
20. **RAD TEST-OUT** switch **RAD TEST**.
21. Obtain verification from interrogating station that **TEST MODE** reply was received.
22. **RAD TEST-OUT** switch **OUT**.

(4) *Transponder set identification-position operating procedure:* The transponder set can make identification-position replies while operating in code Modes 1, 2, and/or 3/A, in response to ground station interrogations. This type of operation is initiated by the operator as follows:

1. Modes 1, 2 and/or 3/A **ON**, as required.
2. **IDENT-OUT-MIC** switch Press momentarily to **IDENT**, when directed.

#### NOTE

Holding circuits within the transponder receiver-transmitter will transmit identification-position signals for 15 to 30 seconds. This is normally sufficient time for ground control to identify the aircraft's position. During the 15 to 30 second period, it is normal procedure to acknowledge via the aircraft communications set that identification/ position signals are being generated.

Set any of the **M1, M2, M3/A, M-C**, or **MODE 4** switches to **OUT** to inhibit transmission of replies in undesired modes.

With the **IDENT-OUT-MIC** switch set to the **MIC** position, the **POS IDENT** button on either control wheel must be depressed to transmit identification pulses.

#### (5) *Shutdown procedure:*

1. To retain Mode 4 code in external computer during a temporary shutdown:
2. **MODE 4 CODE** switch Rotate to **HOLD**.
3. Wait 15 seconds.
4. **MASTER** control **OFF**.
5. To zeroize the Mode 4 code in the external computer, turn **MODE 4 CODE** switch to **ZERO**.
6. **MASTER** control **OFF**. This will automatically zeroize external computer unless codes have been retained (step 1 above).

### 3-34. PILOT'S BAROMETRIC ALTIMETER INDICATOR (BA-141).

The pilot's barometric altimeter indicator (fig. 3-35), is a servoed unit which displays altitude information from the air data computer. Altitude is displayed by a 10,000 foot counter, a 1000 foot counter, a 100 foot counter, and a single needle pointer (coupled with the 100 foot counter) which indicates hundreds of feet on a circular scale in 20 foot increments. Below an altitude of 10,000 feet, a diagonal striped symbol will appear on the 10,000 foot counter. The barometric pressure knob allows ground supplied altimeter setting to be manually set. Altimeter setting is displayed in inches of mercury and millibars on barometric counters.

#### a. *Controls, Indicators and Functions.*

(1) *Failure warning flag.* The failure warning flag, placarded **OFF**, comes into view when the error between the altitude displayed and the signal received is too great, the air data computer goes invalid, or the barometric altimeter loses primary power. Pilot's Barometric Altimeter Indicator

(2) *Altitude alert annunciator.* The altitude alert annunciator, placarded **ALT**, is illuminated when aircraft is within 1000 feet of preselected altitude during capture maneuver and extinguishes when aircraft is within 250 feet of preselected altitude. After capture, annunciator will



illuminate if aircraft departs more than 250 feet from the selected altitude.

(3) *Altitude scale.* Used in conjunction with altitude indicator needle to indicate aircraft altitude in hundreds of feet. Subdivided into 20 foot increments.

(4) *Barometric pressure counter-drum indicator (inches of mercury).* Indicates barometric pressure in inches of mercury that has been set by the barometric pressure setting knob.

(5) *Barometric pressure counter-drum indicator (millibars).* Indicates barometric pressure in millibars that has been set by the barometric pressure setting knob.

(6) *Barometric pressure setting knob.* Used to manually set barometric pressure displayed in the MB pressure window.

(7) *Altitude indicator needle.* Used in conjunction with altitude scale to display aircraft altitude in hundreds of feet.

(8) *Counter-drum altitude display.* Indicates aircraft altitude in tens of thousands, thousands, and hundreds of feet above sea level.

b. *Altimeter Operating Procedure.*

1. Barometric pressure setting knob Set desired altimeter setting.
2. Failure warning flag Check not visible.
3. Altitude indicator needle Check operation.

**NOTE**

**If the altimeter does not read within 70 feet of field elevation, when the correct local barometric setting is used, the altimeter needs calibration or internal failure has occurred. An error of greater than 70 feet also nullifies use of the altimeter for IFR flight.**

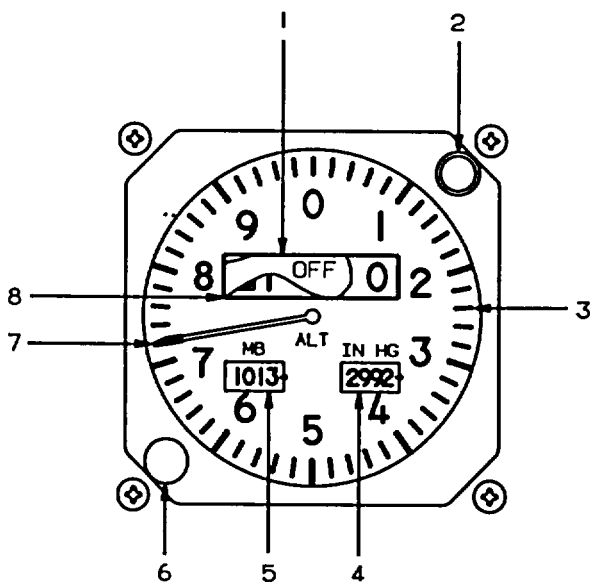

1. Failure Warning Flag
2. Altitude Alert Annunciator
3. Altitude Scale
4. Barometric Pressure Counter-Drum Indicator Window (Inches of Mercury)
5. Barometric Pressure Counter-Drum Indicator Window (Millibars)
6. Barometric Pressure Setting Knob
7. Altitude Indicator Needle
8. Counter-Drum Altitude Display

A93FE00D0113 C

Figure 3-35. Pilot's Barometric Altimeter Indicator

## CHAPTER 4

## MISSION EQUIPMENT

## Section I. MISSION AVIONICS

## 4-1. MISSION CONTROL PANEL.

a. *Description.* The mission control panel (fig. 4-1), mounted on the copilot's sidewall, consists of three sections. The top section contains the mission caution/advisory annunciator panel. The annunciator panel incorporates all mission annunciators along with three aircraft system annunciators (**CABIN OVERTEMP**, **NO INS UPDATE**, and **INS UPDATE**). The center section contains a digital DC volt/ammeter, digital AC volt/frequency meters (2), and AC digital load meters (2). The bottom section contains the mission equipment control switches and the mission equipment circuit breakers.

b. *Mission Control Panel Controls, Indicators, and Functions.*

(1) *Mission annunciator panel* Mission annunciator panel functions are described in table 2-8.

(2) *Battery voltmeter.* A liquid crystal display indicator placarded **VDC**, which indicates aircraft battery voltage.

(3) *Battery ammeter.* A liquid crystal display indicator placarded **AMPS**, which indicates aircraft battery current.

(4) *AC volt-frequency meters.* Two liquid crystal display meters, placarded **VAC FREQ** indicate the voltage and frequency output of the # 1 and # 2 three-phase inverters respectively. The meters indicate the voltage and -frequency of either the **A**, **B**, or **C** phase of the inverters, depending on the position of the **METERS** switch.

(5) *AC loadmeters.* Two liquid crystal display meters placarded **AC% LOAD**, indicate the load in percent on the # 1 and # 2 three-phase inverters respectively. The meters indicate the load on either the **A**, **B**, or **C** phase of the inverters, depending on the position of the **METERS** switch.

(6) *Rotating boom antenna operating position control switch.* The rotating boom antenna operating position control switch, placarded **ANT ORIDE**, **OPR POS** **AUTO ROTATE**, allows overriding antenna operating position on the ground or automatic operation. The

antenna normally rotates to a vertical position when the landing gear is retracted and automatically rotates to a horizontal position when the landing gear is extended. Moving the switch to the **OPR POS** allows rotation of the antenna to the vertical position while on the ground.

(7) *Mission equipment control switch.* The mission equipment control switch, placarded **MISSION CONTROL ORIDE - AUTO - OFF** controls power to the mission equipment.

(a) *ORIDE.* The **ORIDE** (override) position is used to apply AC and DC power to the mission equipment when one generator has failed and the aircraft is not operating on external power.

(b) *AUTO.* The **AUTO** (automatic) position applies AC and DC power to the mission equipment. Power is automatically removed from the mission equipment if a generator fails, and the aircraft is not operating on external power.

(c) *OFF.* The **OFF** position removes power from the mission equipment.

(8) *Radio altimeter switch.* The radio altimeter switch, placarded **RADIO ALT ON**, **OFF**, controls operation of the radio altimeter system. This switch allows turning off the radio altimeter system to reduce radio emissions from the aircraft.

(9) *ELINT power switch.* The **ELINT** power switch, placarded **ELINT ON OFF**, controls power to the **ELINT** mission equipment.

(a) *ON.* Applies power to the **ELINT** mission equipment.

(b) *OFF.* Removes power from the **ELINT** mission equipment.

(10) *COMINT power switch.* The **COMINT** power switch, placarded **COMINT ON OFF**, controls power to the CHALS, lowband, and remaining mission equipment.

(a) *ON.* Applies power to the CHALS, lowband, and remaining mission equipment.

(b) *OFF.* Removes power from the CHALS, lowband, and remaining mission equipment.

(b) *OFF*. Removes power from the CHALS, lowband, and remaining mission equipment.

**WARNING**

**When the GRFA transmit (XMIT) mode is selected the GRFA will transmit RF energy, regardless of the position of the WOW switch. The position of the WOW switch only determines the level of power that will be radiated by the GRFA.**

(11) *Weight-on-wheels override switch*. The weight-on-wheels override switch is placarded **WOW OVERRIDE ON OFF**. A weight-on-wheels sensor provides an indication to the Guardrail Radio Frequency Assembly (GRFA) of whether the aircraft is on the ground (**WOW** active) or airborne (**WOW** inactive). When **WOW** is active, modes which would cause RF energy to be radiated by the GRFA are physically reduced to radiate RF energy at the low power level when **TRANSMIT** mode is selected through the MFD.

(a) *ON*. Overrides the **WOW** sensor and allows the operator to transmit RF energy at the high power level while the aircraft is on the ground.

(b) *OFF*. Turns off the override function of the **WOW** sensor, preventing the GRFA from transmitting RF energy at the high power level while the aircraft is on the ground.

(12) *Three-phase AC bus cross tie switch*. The three-phase AC bus cross tie switch, placarded **3φ AC CONTROL BUS CROSS TIE ON/AUTO OFF**, controls the AC bus cross tie.

(a) *ON/AUTO*. In the **ON/AUTO** position the AC busses will automatically be connected if an inverter fails.

(b) *OFF*. In the **OFF** position the AC busses will not be connected (no cross-tie).

(13) *Three-phase AC inverter control switches*. Two three-phase AC inverter control switches, placarded **3φ AC CONTROL # 1** and **# 2 INV RESET ON OFF**, control operation of the three-phase inverters.

(a) *RESET*. When an inverter is off-line due either to a fault or to placing the inverter switch to the **OFF** position, the affected unit cannot have its output restored until the inverter switch is moved to the spring loaded **RESET ON** position.

(b) *ON*. **ON** position selects inverter operation.

(c) *OFF*. **OFF** position turns off inverter.

(14) *Three-phase AC external power switch*. The three-phase AC external power switch, placarded **3φ AC CONTROL EXT PWR - RESET - ON - OFF**, controls application of external three-phase AC power to the aircraft.

(a) *RESET*. The AC external power switch must be moved to the spring loaded **RESET** position, then to the **ON** position to bring AC external power on line.

(b) *ON*. **ON** position applies AC external power to the three-phase busses through the AC external power receptacle under the left wing.

(c) *OFF*. **OFF** position removes AC external power from the three-phase busses.

(15) *Three-phase AC meter switch*. The three phase meters switch, placarded **METERS Aφ - Bφ - Cφ** controls which phase of the three-phase inverters is being measured by the AC voltage, frequency, and loadmeters.

(16) *ASE control switch*. The ASE control switch, placarded **ASE SILENT NORM OFF**, controls operation of the ASE.

(a) *SILENT*. When the **SILENT** position is selected, the transmitting elements of the ASE are placed in a passive mode.

(b) *NORM*. The **NORM** position allows normal ASE operation.

(c) *OFF*. The **OFF** position removes power from ASE equipment. When the **ASE** control switch is set back to **NORM**, the originally selected mode will again become active.

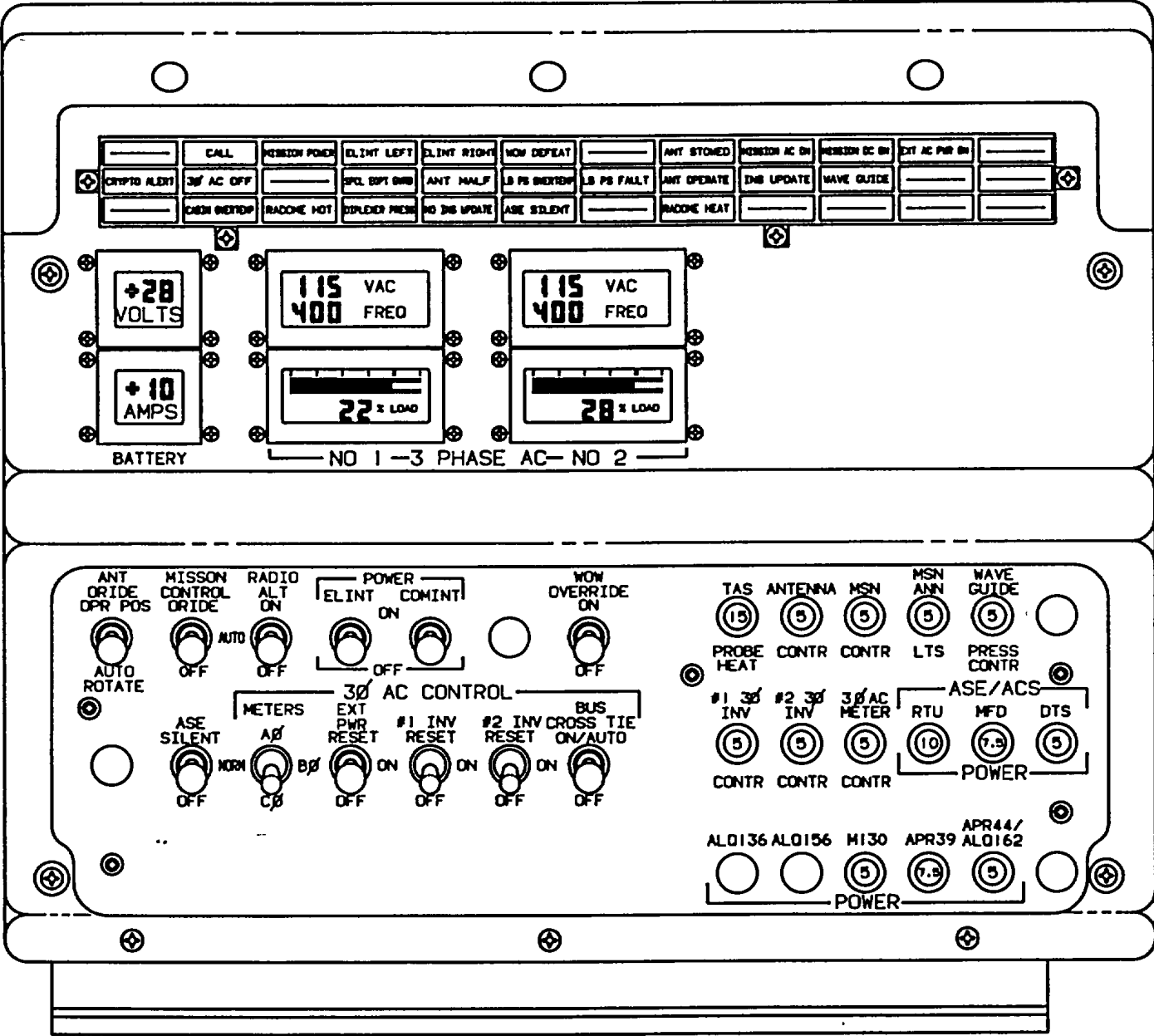

FE000  
980399AA C

Figure 4-1. Mission Control Panel

## Section II. AIRCRAFT SURVIVABILITY EQUIPMENT

### 4-2. M-130 FLARE AND CHAFF DISPENSING SYSTEM.

*a. Description.* The M-130 flare and chaff dispensing system provides effective survival countermeasures against radar guided weapons systems and infrared seeking missile threats. The system consists of two dispenser assemblies with payload module assemblies, two control wheel mounted chaff dispensing switches and two control wheel mounted flare dispensing switches, and associated wiring. The system is controlled by the aircraft survivability equipment/avionics control system (ASE/ACS) keyboard, located on the control pedestal extension (fig. 2-14). The flare and chaff dispensing system is powered by a 5-ampere circuit breaker, placarded **M130** located on the mission control panel (fig. 4-1).

#### WARNING

**Right engine nacelle dispenser is for chaff only.**

(1) *Dispenser assemblies.* Two interchangeable dispenser assemblies are mounted on the aircraft. One is located in the aft portion of the right nacelle and the other is mounted on the right side of the fuselage. The dispenser in the nacelle is used for chaff only while the dispenser mounted on the fuselage can be used for either flares or chaff. The selector switch (placarded **C-F**) on the dispenser can be set for either chaff or flares. The unit also contains the sensor for the flare detector and the sequencing mechanism. The dispenser assembly breech plate has the electrical contact pins which fire the impulse cartridges.

(2) *Payload module assemblies.* A removable payload module assembly is provided for each dispenser assembly. Each payload module has 30 chambers which will accept either flares or chaff. Flares or chaffs are loaded into the rear-end (studded end) of the payload module, and secured in place by a retaining plate.

(3) *Flare detector.* The flare detector is provided to ensure that a flare is burning when it is ejected from the dispenser payload module. If the initial flare fails to ignite, the detector automatically fires another flare within 75 milliseconds. If the second flare fails to ignite, the detector will fire a third flare. If the third flare ignition is not detected, the detector will not fire another flare until the system is activated again by pressing the **FLARE DISPENSE** switch.

(4) *Internal safety switch.* The internal safety switch (with safety pin and yellow flag), mounted on the

right rack behind the copilot, prevents firing of chaff or flares when the safety pin is inserted. The safety pin shall be removed only while the aircraft is in flight or during test of the system.

(5) *Control wheel mounted flare dispenser switches.* Two pushbutton switches placarded **FLARE DISPENSE**, one located on the top right portion of the pilot's control wheel and the other located on the top left portion of the copilot's control wheel, activate the flare dispensing system when pressed. Depressing either one of the switches will fire a flare from the dispenser payload module each time it is pressed. If a **FLARE DISPENSE** switch is held down, it will dispense a flare every 2.3 seconds until all flares are expended.

(6) *Control wheel mounted chaff dispense switches.* Two pushbutton switches placarded **CHAFF DISPENSE**, one located on the top left portion of the pilot's control wheel and the other located on the top right portion of the copilot's control wheel, activate the chaff dispensing system when pressed.

(7) *Wing mounted safety switch.* A wing mounted safety switch (with safety pin and red flag), located on top of the right wing, just aft of the nacelle, prevents the firing of chaff or flares when the pin is inserted. This safety pin shall be inserted while the aircraft is on the ground and removed prior to flight or during system test.

(8) *Ammunition for dispenser.* Ammunition for the system consists of countermeasure chaff M1 and countermeasure flares M206. An impulse cartridge M796, fits into the base of either the flare or chaff and is electrically initiated to eject flares or chaff from the dispenser payload module.

(a) *Countermeasure chaff M1.* These units consist of a plastic case 8 inches in length and 0.97 inches square. The base of the chaff case is flanged to provide one-way assembly into the dispenser payload module. The chaff consists of aluminum coated fiberglass strands.

(b) *Countermeasure flare M206.* These units consist of an aluminum case 8 inches in length and 0.97 inches square. The base of the flare is flanged to provide one-way assembly into the payload module. The flare material consists of a magnesium and teflon composition. A preformed packing is required in the base of the flare unit prior to inserting the impulse cartridge.

(c) *Impulse cartridge M796.* This cartridge fits into the base of either the flare or chaff and is electrically initiated to eject flares or chaff from the dispenser payload module.

b. *Normal Operation.*

**NOTE**

**The fairing should be removed from the fuselage if the aircraft is to be flown with the flare dispenser assembly removed.**

(1) *General.* At the present time surface-to-air intermediate range guided missiles launched against the aircraft must be visually detected by the aircraft crew. Crew members must ensure visual coverage over the ground area where a missile attack is possible. The aircraft radar warning system will only alert the pilot and copilot when the aircraft is being tracked by radar-guided antiaircraft weapons systems. It will not indicate the firing of weapons against the aircraft.

(2) *Crew responsibilities.* The pilot, or designated crew member, is responsible for removing the safety pin from the right wing before flight, and for replacing it immediately after flight. The pilot is responsible for removing the safety pin and arming the system, after the aircraft is airborne, and before landing, he is responsible for re-inserting the safety pin and selecting **SAFE** on the MFD. While airborne, the pilot and copilot are responsible for scanning the terrain for missile threats. When either pilot recognizes a missile launch, they will press the **FLARE DISPENSE** button to eject flares.

**WARNING**

**Aircraft must be in flight to dispense flares.**

(3) *Conditions for firing.* The dispenser system should not be fired unless a missile launch is observed or radar guided weapons systems are detected and locked on. If a system malfunction is suspected, aircraft commander may authorize attempts to dispense flares or chaff as a test in a non-hostile area.

(4) *Firing procedure.*

(a) *Flares.* Upon observing a missile launch the pilot or copilot (whoever sights the launch first) will fire a flare. If more than one missile launch is observed, the firing sequence should be continued until the aircraft has cleared the threat area.

(b) *Chaff.* Upon receiving an alert from the aircraft radar warning system, the pilot or copilot will fire the chaff and initiate an evasive maneuver. The number of burst/salvo and number of salvo/program and their intervals is established by training doctrine and will

be set on the MFD prior to takeoff (refer to TM 9-1095-206-13 & P for procedures on setting programmer). If desired, the operator may override the programmed operational mode and fire chaff countermeasures manually by selecting **MANUAL** on the MFD and pressing the dispenser switch.

(c) *Firing responsibility.* When the pilot or copilot observe a missile launch or radar warning indication, they will fire flares or chaff as required and assume command of the dispenser system. The other pilot must be advised that a missile launch has been observed or a radar warning signal has been received, and announcement made that flares or chaff have been fired.

**4-3. SYSTEM DAILY PREFLIGHT/RE-ARM TEST.**

The following test procedures shall be conducted prior to the first flight of each day and prior to each re-arming of the M-130 dispensers. Notify AVUM (aviation unit maintenance) if any improper indications occur during the tests.

**WARNING**

**Ensure payload module is not connected to dispenser assembly at any time during the following test procedure.**

a. *Flare Dispenser (Right Fuselage) - Preliminary Procedure.*

1. Flare dispenser assembly **C-F** selector switch **F** (flare).
2. M-91 test set Obtain and ensure that **TEST SEQUENCE** switch is in the **START/HOME** position.
3. Clean dust, foreign particles, or moisture from breech and mounting plate of dispenser.
4. Connect base plate of test set to breech of dispenser assembly. Secure both mounting studs uniformly, using 5/32-inch hexagonal wrench provided in test set carrying case.
5. Obtain test set power cable from loose tools and connect cable between exterior connection J1 (28V DC) on aircraft fuselage above trailing edge of wing and aircraft power +28V DC (J1) of test set.
6. Remove safety pins from on right equipment rack aft of copilot's seat, and on top skin of right wing.
7. Provide aircraft power to M-130 system by

resetting the **M-130 POWER** circuit breaker.

8. **ASE** mode select switch on multifunction display (MFD, fig. 4-2) Depress to call up **ASE** control page.
9. L3 line selector switch Depress to set **DISPENSER** to **ARM**.
10. R5 line selector switch Depress to call up **ASE SETUP** page.

b. *Flare Dispenser System Test Procedure.*

1. **ASE** mode selector switch Depress to return to **ASE** control page.
2. Reinstall safety pins one at a time. **PWR FAIL** shall appear below **DISPENSER** on **MFD**.
3. Remove safety pins and verify **DISPENSER** is set to **ARM** on **MFD**.

**NOTE**

When the test set is installed on the dispenser assembly and 28 volts DC aircraft power has been applied, the sequencer switch inside of dispenser assembly resets, making an audible sound as it rotates. There will be no such sound if the sequencer switch has been previously reset or if switch is in position 12 or 24.

On test set, **TS PWR ON** annunciator (clear) illuminates and remains illuminated throughout the test sequence until aircraft power to test set (via test set power cable) is disconnected or shut off.

4. Perform the following operations on the M-91 test set:
  - a. Press to test remaining three annunciators on test set. Each annunciator will illuminate.

**NOTE**

Replace any annunciator that does not illuminate when pressed. If none of the indicating annunciators illuminate, return test set to **AVUM** (aviation unit maintenance).

- b. Rotate **TEST SEQUENCE** switch **TS RESET** position. No visual indication will occur.
- c. Rotate **TEST SEQUENCE** switch clockwise to **SV SELF TEST** position. **STRAY VOLTAGE** annunciator (red) will illuminate.

- d. Rotate **TEST SEQUENCE** switch clockwise to **TS RESET** position. **STRAY VOLTAGE** annunciator (red) will extinguish.
- e. Rotate **TEST SEQUENCE** switch clockwise to **STRAY VOLT** position. **STRAY VOLTAGE** annunciator (red) should not illuminate.
- f. Rotate **TEST SEQUENCE** switch clockwise to **SYS NOT RESET** position. **SYS NOT RESET** annunciator (amber) should not illuminate. If annunciator illuminates, press and release **MANUAL SYSTEM RESET** switch and **SYS NOT RESET** annunciator should extinguish.

**NOTE**

When the **MANUAL SYSTEM RESET** switch is pressed and released, and 28 volts DC power has been applied, the sequencer switch inside the dispenser assembly resets, making an audible sound as it rotates. If the sequencer switch has been previously reset or if the switch is in position 12 or 24, there will be no such sound.

- g. Rotate **TEST SEQUENCE** switch clockwise to next position, **DISP COMP**.
5. Press either **FLARE DISPENSE** switch once. For each depression the **FLARE** counter on DCP should count down in groups of three.
6. On MFD, depress L5 repeatedly until text reads **RIPPLE FIRE ARMED**. Within 7 seconds, depress a **FLARE DISPENSE** switch. Flare counter shall count down to 00 and **ALL FLARES EXPENDED** shall be displayed on MFD. **DISPENSE COMPLETE** lamp (green) on test set shall be illuminated.

**NOTE**

**DISPENSER COMP** lamp may fail to illuminate during the previous step due to improper connection between the base plate and breech plate. If this happens, remove and reinstall base plate to ensure proper connection and repeat **FLARE DISPENSE** tests. If this still does not result in proper operation, verify the C-F selector switch is in the **F** position.

7. Perform the following operations on the M-91 test set:

- a. Rotate **TEST SEQUENCE** switch counterclockwise to **SYS NOT RESET** position. **SYS NOT RESET** annunciator (amber) will illuminate. **DISPENSER COMPLETE** annunciator (green) will remain illuminated.
- b. Reset **FLARE** counter to 30. **ALL FLARES EXPENDED** shall not be displayed. Do not depress **MANUAL SYSTEM RESET** switch.

**NOTE**

When the **MANUAL SYSTEM RESET** switch is pressed and released, and 28 volts DC power is being applied, the sequencer switch inside the dispenser assembly resets, making an audible sound as it rotates. If the sequencer switch has been previously reset or if the switch is in position 12 or 24, there will be no such sound.

- c. Rotate **TEST SEQUENCE** switch counterclockwise to **STRAY VOLT** position. **STRAY VOLTAGE** annunciator (red) should not illuminate.
- d. Rotate **TEST SEQUENCE** switch counterclockwise to **START/HOME** position.

**NOTE**

When the **TEST SEQUENCE** switch is turned to the **START/HOME** position, the **DISPENSER COMPLETE** annunciator will extinguish, the **STRAY VOLTAGE** annunciator will illuminate, and then will extinguish when passing through the **TS RESET** position.

8. Remove M-91 test set from right fuselage dispenser assembly.

*c. Chaff Dispenser (Right Nacelle) - Preliminary Procedure.*

1. **C-F** selector switch on dispenser **C** (chaff).
2. Set **TEST SEQUENCE** switch on test set to **START/HOME** position.
3. Clean dust, foreign particles, or moisture from breech and mounting plate of dispenser.

4. Connect M-91 test set to breech assembly of right nacelle dispenser assembly. Secure both mounting studs uniformly tight using ball hexagonal key screwdriver provided in test set carrying case.
5. Obtain test set power cable from loose tools and connect cable between exterior connection J1 (28V DC) on aircraft fuselage above trailing edge of wing and aircraft power +28V DC (J1) of test set.
6. Remove safety pins from right equipment rack aft of copilot's seat, and on top skin of right wing.
7. Provide aircraft power to system by resetting **M-130 POWER** circuit breaker.
8. ASE mode select switch (multifunction display, fig. 4-2) Depress to call up **ASE** control page.
9. L3 line selector switch Depress to set **DISPENSER** to **ARM**.
10. L4 line selector switch Depress to set **CHAFF** to **MAN**.
11. R5 line selector switch Depress to call up **ASE SETUP** page.
12. ASE/ACS keyboard unit (fig. 4-3) Key in 30 (30 will be displayed in scratchpad on MFD), then depress line select switch R1 to set **CHAFF COUNT** to 30.

**NOTE**

When the test set is installed on the dispenser assembly and 28 volts DC aircraft power is being applied, the sequence switch inside the dispenser assembly resets, making an audible sound as it rotates. There will be no such sound if the sequencer switch has been previously reset or if switch is in position 12 or 24.

*d. Chaff Dispenser (Right Nacelle) System Test Procedure.*

1. ASE mode selector switch Depress to return to the ASE control page.
2. Reinstall safety pins one at a time. PWR FAIL shall appear below **DISPENSER** on MFD.
3. Remove the safety pins and verify **DISPENSER** is set to **ARM** on MFD.



**NOTE**

On test set, **TS PWR ON** annunciator (clear) illuminates and remains illuminated throughout the test sequence until aircraft power to test set (via test set power cable) is disconnected or shut off.

4. Perform the following operations on the M-91 test set:
  - a. Press to test all four annunciators on test set. Each annunciator will illuminate.

**NOTE**

Replace any annunciator that does not illuminate when pressed. If none of the indicating annunciators illuminate, return test set to AVUM (aviation unit maintenance).

- b. Rotate **TEST SEQUENCE** switch clockwise to **TS RESET** position. No visual indication will occur.
- c. Rotate **TEST SEQUENCE** switch clockwise to **SV SELF TEST** position. **STRAY VOLTAGE** annunciator (red) will illuminate.
- d. Rotate **TEST SEQUENCE** switch clockwise to next position, **TS RESET**. **STRAY VOLTAGE** annunciator (red) will extinguish.
- e. Rotate **TEST SEQUENCE** switch clockwise to next position, **STRAY VOLT**. **STRAY VOLTAGE** annunciator (red) should not illuminate.
- f. Rotate **TEST SEQUENCE** switch clockwise to next position, **SYS NOT RESET**. **SYS NOT RESET** annunciator (amber) should not illuminate. If annunciator illuminates, press and release **MANUAL SYSTEM RESET** switch and **SYS NOT RESET** annunciator should then extinguish.

**NOTE**

When the **MANUAL SYSTEM RESET** switch is pressed and released, and 28 volts DC power is being applied, the sequencer switch inside the dispenser assembly resets, making an audible sound as it rotates. If the sequencer switch has been previously reset or if the switch is in position 12 or 24, there will be no such sound.

- g. Rotate **TEST SEQUENCE** switch clockwise to next position, **DISP COMPL**.
- h. Press pilot's **CHAFF DISPENSER** switch once. Press copilot's **CHAFF DISPENSER** switch once. On MFD, for each depression, **CHAFF** counter should count down by an increment of one.
  - i. On MFD, depress L3 line selector switch until **PRGM** appears.
  - j. Depress pilot's **CHAFF DISP** switch once. On MFD, number shown on **CHAFF** counter should decrease by one.
  - k. On MFD, depress line select switch L4 to set **CHAFF** to **PRGM**.
  - l. Depress copilot's **CHAFF DISP** switch once. On MFD, **CHAFF** counter will read 29 minus **SALVO COUNT** multiplied by **BURST COUNT** as displayed on **ASE** setup page.
- m. Repeatedly depress a **CHAFF DISP** switch until **CHAFF** counter reads 00 and **LL CHAFF EXPENDED** is displayed on MFD. The **DISPENSE COMPLETE** lamp (green) on test set shall be illuminated.

**NOTE**

The **DISPENSER COMP** lamp may fail to illuminate during the previous step due to improper connection between the base plate and breechplate. If this happens, remove and reinstall base plate to ensure proper connection and repeat **CHAFF DISPENSE** tests. If this still does not result in proper operation, verify the **C-F** selector switch is in the **C** position.

5. Perform the following operations on the M-91 test set:
  - a. Rotate **TEST SEQUENCE** switch counterclockwise to **SYS NOT RESET** position. **SYS NOT RESET** annunciator (amber) will illuminate.
  - b. Press and release **MANUAL SYSTEM RESET** switch. **SYS NOT RESET** annunciator (amber) will extinguish and **DISPENSE COMPLETE** lamp: will remain illuminated.
  - c. Reset the **CHAFF** counter to 30. **ALL CHAFF EXPENDED** shall not be displayed on MFD. Do not depress

**MANUAL SYSTEM RESET** switch.

**NOTE**

When the **MANUAL SYSTEM RESET** switch is pressed and released, and 28 volts DC power is being applied, the sequencer switch inside the dispenser assembly resets, making an audible sound as it rotates. If the sequencer switch has been previously reset or if the switch is in position 12 or 24, there will be no such sound.

- d. Rotate **TEST SEQUENCE** switch counterclockwise to **STRAY VOLT** position. **STRAY VOLTAGE** annunciator (red) should not illuminate.
- e. Rotate **TEST SEQUENCE** switch counterclockwise to **START/HOME** position.

**NOTE**

When turning the **TEST SEQUENCE** switch to the **OFF** position, the **DISPENSER COMPLETE** annunciator will extinguish, the **STRAY VOLTAGE** annunciator will illuminate and then will extinguish when the **OFF** position is reached.

6. Install safety pins.
7. Disconnect test set power cable.
8. Remove M-91 test set from dispenser assembly and restore in carrying case along with power cable and hexagonal wrench.
9. On MFD, depress L3 until **SAFE** appears.
10. Reset **CHAFF** counter to 30.
11. Disconnect aircraft power by pulling 5-ampere **M130** circuit breaker located on mission control panel (fig. 4-1).
12. Proceed immediately to ammunition loading procedures.

**4-4. AMMUNITION.**

- a. *Ammunition Loading Procedure.*

**WARNING**

Only one shipping container is to be opened at a time. If a shipping container has been opened and only partially emptied, the remaining contents will be secured in the container with an appropriate type of packaging material or filler to adequately prevent jostling. All munitions in storage must be in their original shipping containers.

1. Place payload module assembly on work bench in approved safe area so that the retaining plate is facing up.
2. Remove retaining plate by unscrewing two retaining bolts.
3. Insert one flare (or chaff) at a time into each chamber of payload module.
4. Remove plastic dust cap from each chaff or flare.

**CAUTION**

Prior to insertion of an impulse cartridge, be sure there is a preformed packing in the flare cartridge. (There will be no preformed packing in chaff cartridges.) Reinstall any preformed packing that is inadvertently removed with dustcap. The loading of impulse cartridges into a flare or chaff shall be accomplished one at a time.

5. Insert one impulse cartridge into each flare (or chaff).
6. Install retainer plate assembly by screwing the two retainer bolts into payload module.

**WARNING**

The system must have been tested to ensure that there is no stray voltage and all aircraft power must be removed from the system prior to loading the payload module.

7. MFD - Bring up **ASE** page and depress L3 to change dispenser to **SAFE**.
8. On right equipment rack, ensure safety pins

and flag assemblies are installed.

9. Slide payload module assembly into dispenser assembly and secure two stud bolts, using 5/32-inch hexagonal wrench.

b. *Ammunition Unloading Procedure.*

**WARNING**

All aircraft power to the dispenser system must be turned off prior to removal of payload module from dispenser assembly. Safety pin flag shall be installed on the right equipment rack prior to landing and the safety pin flag shall be installed in the wing-mounted safety switch immediately after landing.

1. MFD Bring up **ASE** page and depress L3 to change dispenser to **SAFE**.
2. Assure safety pin and flag are inserted in right equipment rack and in wing mounted safety switch.

**WARNING**

If there is an indication that a misfire occurred, notify emergency ordnance disposal personnel for disposition and disposal.

3. Remove module from dispenser assembly by unscrewing two stud bolts with a 5/32inch hexagonal wrench and slide dispenser assembly out.
4. Remove retaining plate from payload module by unscrewing two retaining bolts.
5. Remove expended and unexpended impulse cartridges and flares (or chaff) from payload module.
6. Repack unexpended items in original containers and return to stores.

**NOTE**

Cracking of the chaff cartridge case upon firing is not unusual. This does not effect performance of the item and should not be reported as a malfunction.

**4-5. RADAR SIGNAL DETECTING SET (AN/ APR-39(V)1).**

**CAUTION**

To prevent damage to the receiver detector crystals, assure that the AN/APR-39(V)1 antennas are at least 60 meters from active ground radar antennas or 6 meters from active airborne radar antennas. Allow an extra margin for new, unusual, or high power antennas.

The radar signal detecting set indicates the relative position of search radar stations. The radar signal detecting set is controlled through the aircraft survivability equipment/ avionics control system (ASE/ACS). Audio warning signals are applied to the pilot's and copilot's headsets. The radar signal detecting set is protected by the 7.5-ampere circuit breaker placarded **APR39**, located on the mission control panel (fig. 4-1). The associated antennas are shown in figure 2-1. For operating instructions, refer to TM 11-5841-283-20.

**4-6. RADAR SIGNAL DETECTING SET (AN/ APR-39(V)2).**

**CAUTION**

To prevent damage to the receiver detector crystals, assure that the AN/APR-39(V)2 antennas are at least 60 meters from active ground radar antennas or 6 meters from active airborne radar antennas. Allow an extra margin for new, unusual, or high power antennas.

The radar signal detecting set indicates the relative position of search radar emitters. Through graphic symbology, the type of tracking radar emitters may be identified. Unknown emitter origins are also depicted. Audio warning signals are applied to the pilot's and copilot's headsets. The radar signal detecting set is controlled through the aircraft survivability equipment/avionics control system (ASE/ ACS). The radar signal detecting set is protected by the 7.5-ampere circuit breaker placarded APR39, located on the mission control panel (fig. 4-1). The associated antennas are shown in figure 2-1 or 2-2. Complete operating instructions are to be obtained from the appropriate manuals.

**4-7. DATA TRANSFER SYSTEM.**

The data transfer system allows the crew to retrieve mission data from the programmable cartridge and to store mission data back to the programmable cartridge.

Operation of the system is through the aircraft survivability equipment/avionics control system (ASE/ACS). Depressing L1 when the **UTILITY** page is displayed will call up the **DATA TRANSFER** page.

**4-8. AIRCRAFT SURVIVABILITY EQUIPMENT/ AVIONICS CONTROL SYSTEM (ASE/ACS).**

The aircraft survivability equipment/avionics control system (ASE/ACS) consists of a multifunction display (MFD), a keyboard unit (KU), and a remote terminal unit (RTU). The ASE/ACS is the primary way that the flight crew interfaces with the following systems:

UHF Transceiver (AN/ARC/164), (two each)

VHF-FM (SINCGARS, AN/ARC-201A)

Inertial Navigation System

Global Positioning System

Voice Security System (KY-58)

Flare and Chaff Dispenser System (M-130)

Radar Signal Detecting Set (AN/APR-39(V)1)

Radar Signal Detecting Set (AN/APR-39(V)2)

Radar Warning Receiver (AN/APR-44(V)3)

Prime Mission Equipment Intercommunications Control Panels (2 each, C-499/AIC)

For operation of the Aircraft Survivability Equipment/ Avionics Control System (ASE/ACS) refer to latest Operator's Manual for the Aircraft Survivability Equipment/ Avionics Control System (ASE/ACS) for the RC-12 Guardrail/Common Sensor Aircraft.

## CHAPTER 5 OPERATING LIMITS AND RESTRICTIONS

### Section I. GENERAL

#### 5-1. PURPOSE.

This chapter identifies or refers to all important operating limits and restrictions that shall be observed during ground and flight operations.

#### 5-2. GENERAL.

The operating limitations set forth in this chapter are the direct result of design analysis, tests, and operating experiences. Compliance with these limits will allow the pilot to safely perform the assigned missions and to derive maximum utility from the aircraft. Limits concerning maneuvers, weight, and center of gravity are also covered in this chapter.

#### 5-3. EXCEEDING OPERATIONAL LIMITS.

Anytime an operational limit is exceeded, an appropriate entry shall be made on DA Form 2408-13-1. Entry shall state what limit or limits were exceeded, range, time beyond limits, and any additional data that would aid maintenance personnel in the maintenance action that may be required.

#### 5-4. MINIMUM CREW REQUIREMENTS.

The minimum crew required for aircraft operation is two pilots. Additional crewmembers as required, will be added at the discretion of the commander, in accordance with pertinent Department of the Army regulations.

### Section II. SYSTEM LIMITS

#### 5-5. INSTRUMENT MARKINGS.

Instruments which display operating limitations are illustrated in figure 5-1. The operating limitations are color coded on the instrument faces. Color coding of each instrument is explained in the illustration.

#### 5-6. INSTRUMENT MARKING COLOR CODES.

Operating limitations and ranges are illustrated by the colored markings which appear on the dial faces of engine, flight, and utility system instruments. Red markings indicate the limit above or below which continued operation is likely to cause damage or shorten life. The green markings indicate the safe or normal range of operation. The yellow markings indicate the range when special attention should be given to the operation covered by the instrument. Operation is permissible in the yellow range, but should be avoided. White markings on the airspeed indicator denote the flap operating range. The blue marking on the airspeed indicator denotes best rate of climb with one engine inoperative, at maximum gross weight, maximum forward c.g., sea level standard day conditions.

#### 5-7. PROPELLER LIMITATIONS.

The maximum propeller overspeed limit is 1870 RPM (transient, 20 seconds maximum). Propeller speeds above 1700 RPM indicate failure of the constant speed governor. Propeller speeds above 1802 RPM indicates failure of both the constant speed and overspeed governors.

#### 5-8. STARTER LIMITATIONS.

The starters are limited to an operating period of 40 seconds **ON**, then 15 minutes **OFF**, 40 seconds **ON**, then 30 minutes **OFF**. Contact maintenance personnel for assistance if no engine start occurs during cycle noted in this paragraph.

#### 5-9. AUTOPILOT LIMITATIONS.

a. An autopilot preflight check must be conducted and found satisfactory prior to each flight on which the autopilot is to be used.

b. A pilot must be seated in the pilot's seat at the flight controls with the seat belt fastened when the autopilot is in operation.

c. Operation of the autopilot and yaw damper is prohibited during takeoff and landing, and below 200 feet above terrain. Maximum speed for autopilot operation is 248 KIAS to 11,500 feet, then 0.472 Mach to 35,000 feet.



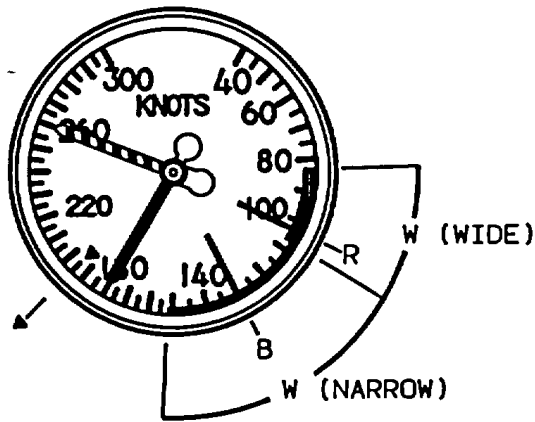

### AIRSPEED P



RC-12P

R/W  248 KIAS MAXIMUM  $V_{mo}$  (.472 MACH)

NOTE  
MAXIMUM ALLOWABLE AIRSPEED (RED STRIPED) POINTER IS SELF ADJUSTING WITH ALTITUDE

- R  103 KIAS MINIMUM SINGLE-ENGINE CONTROL SPEED ( $V_{mca}$ )
- B  130 KIAS ONE-ENGINE INOPERATIVE BEST RATE-OF-CLIMB ( $V_{yse}$ )
- W  83-151 KIAS FULL FLAP OPERATING RANGE
- W  197 KIAS MAXIMUM APPROACH FLAP EXTENSION SPEED



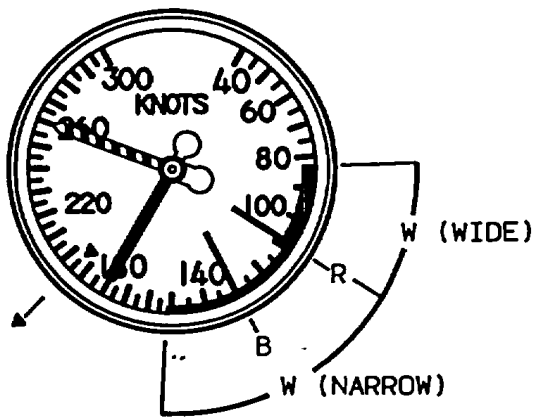

### AIRSPEED C



RC-12Q

R/W  248 KIAS MAXIMUM  $V_{mo}$  (.472 MACH)

NOTE  
MAXIMUM ALLOWABLE AIRSPEED (RED STRIPED) POINTER IS SELF ADJUSTING WITH ALTITUDE

- R  108.5 KIAS MINIMUM SINGLE-ENGINE CONTROL SPEED ( $V_{mca}$ )
- B  130 KIAS ONE-ENGINE INOPERATIVE BEST RATE-OF-CLIMB ( $V_{yse}$ )
- W  83-151 KIAS FULL FLAP OPERATING RANGE
- W  197 KIAS MAXIMUM APPROACH FLAP EXTENSION SPEED

COLOR CODES	
R = RED	B = BLUE
G = GREEN	W = WHITE
Y = YELLOW	BK = BLACK

FE05C971723

Figure 5-1. Instrument Markings (Sheet 1 of 5)

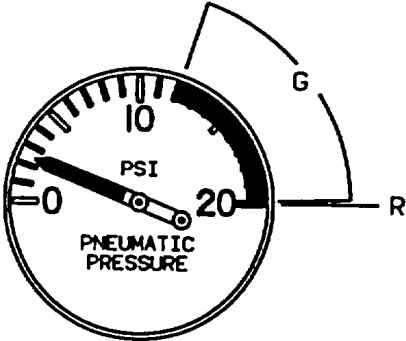

PNEUMATIC PRESSURE

- G [Black Box] 12-20 PSI NORMAL OPERATING RANGE
- R [Black Box] 20 PSI MAXIMUM

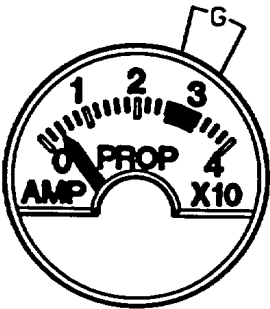

PROPELLER DEICER AMMETER

- G [Black Box] 26-32 AMPERES NORMAL OPERATION

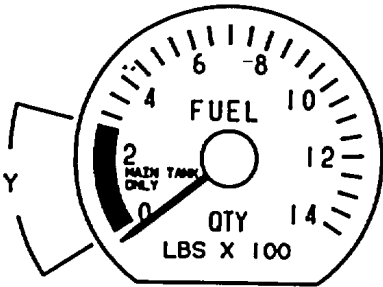

FUEL QUANTITY

- Y [Black Box] 0-265 LBS NO TAKEOFF RANGE

COLOR CODES	
R = RED	B = BLUE
G = GREEN	W = WHITE
Y = YELLOW	BK = BLACK

FE05C971724

Figure 5-1. Instrument Markings (Sheet 2 of 5)

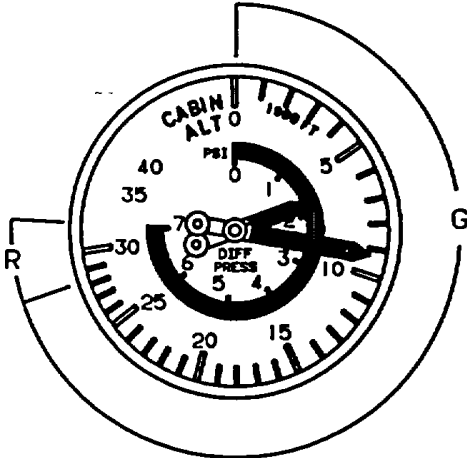

### CABIN ALTIMETER AND DIFFERENTIAL PRESSURE

- G  0-6.5 PSI NORMAL RANGE
- R  6.5 PSI MAXIMUM

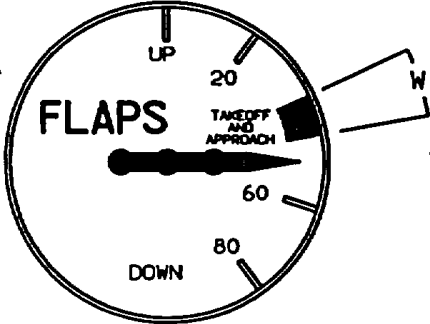

### FLAP POSITION INDICATOR

- W  40% TAKEOFF AND APPROACH

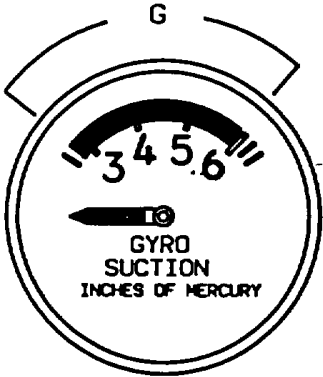

### GYRO SUCTION

- G  2.8 TO 5.9 INCHES OF MERCURY  
NORMAL OPERATING RANGE

COLOR CODES	
R = RED	B = BLUE
G = GREEN	W = WHITE
Y = YELLOW	BK = BLACK

Figure 5-1. Instrument Markings (Sheet 3 of 5)



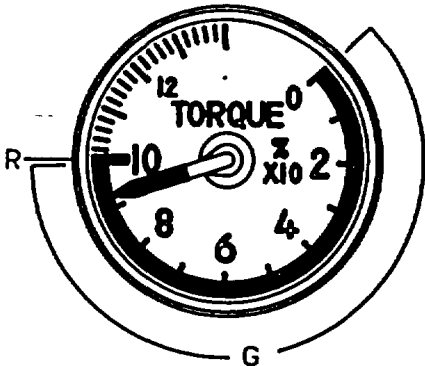

TORQUE

- G [Black Box] 0 - 100% NORMAL OPERATING RANGE
- R [Black Box] 100% MAXIMUM

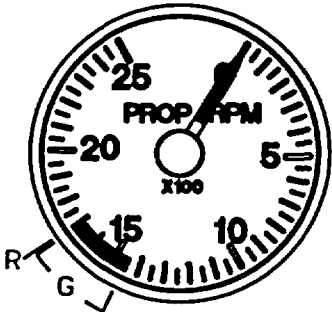

PROPELLER TACHOMETER

- G [Black Box] 1450 - 1700 RPM NORMAL OPERATING RANGE
- R [Black Box] 1700 RPM MAXIMUM

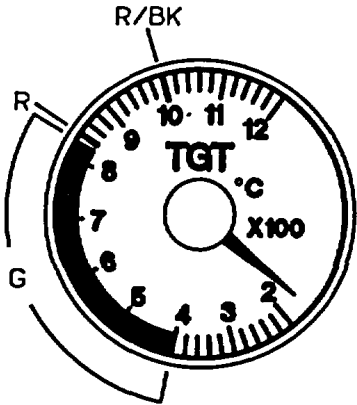

TURBINE GAS TEMPERATURE

- G [Black Box] 400 - 830°C NORMAL OPERATING RANGE
- R [Black Box] 840°C MAXIMUM TAKEOFF
- R/BK [Black Box] 1000°C MAXIMUM STARTING (5 SECONDS)

COLOR CODES	
R = RED	B = BLUE
G = GREEN	W = WHITE
Y = YELLOW	BK = BLACK

FE05C971726

Figure 5-1. Instrument Markings (Sheet 4 of 5)

TURBINE TACHOMETER (N<sub>1</sub> SPEED)

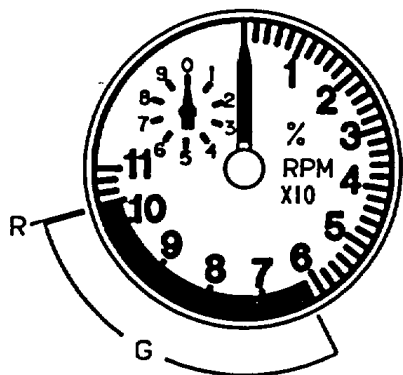

- G [ ] 62 - 104% NORMAL OPERATING RANGE
- R [ ] 104% MAXIMUM

OIL TEMPERATURE AND PRESSURE  
OIL TEMPERATURE SCALE

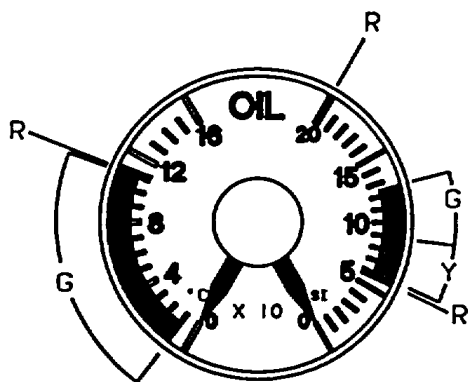

- G [ ] 10 - 105°C NORMAL OPERATING RANGE
- R [ ] 105°C MAXIMUM

OIL PRESSURE SCALE

- R [ ] 60 PSI MINIMUM
- Y [ ] 60 - 90 PSI 54% TORQUE MAXIMUM
- G [ ] 90 - 135 PSI NORMAL OPERATING RANGE
- R [ ] 200 PSI MAXIMUM STARTING WITH COLD OIL

NOTE: ± 10 PSI FLUCTUATIONS ARE ACCEPTABLE

COLOR CODES	
R = RED	B = BLUE
G = GREEN	W = WHITE
Y = YELLOW	BK = BLACK

Figure 5-1. Instrument Markings (Sheet 5 of 5)

**5-10. FUEL SYSTEM LIMITS.****NOTE**

Aviation gasoline (AVGAS) contains a form of lead which has an accumulative adverse effect on gas turbine engines. The lowest octane AVGAS available (less lead content) should be used. If any AVGAS is used, the total operating time must be entered on DA Form 240813-1. Operating time on AVGAS is computed on the basis of quantity used and average consumption.

*a. Operating Limits.*

(1) Operation with FUEL PRESS annunciator light illuminated is limited to 10 hours.

Log time (duration) FUEL PRESS light is illuminated on DA Form 2408-13-1.

(2) Crossfeed of AVGAS to an engine with a failed engine-driven boost pump is not authorized. Crossfeed of AVGAS to an engine with a failed engine-driven boost pump will result in less than minimum fuel pressure to the high pressure pump on that side.

(3) Takeoff torque may not be attainable during operations with AVGAS.

(4) AVGAS operation is limited to 150 hours.

(5) Crossfeed fuel will not be available from the side with an inoperative standby boost pump.

(6) The use of AVGAS requires the standby boost pumps to be used during all operations above 15,000 feet.

(7) Operation with JP-4 requires the use of standby pumps above 30,000 feet.

*b. Fuel Management.* Auxiliary tanks will not be filled for flight unless the main tanks are full. Maximum allowable fuel imbalance is 300 lbs. Do not take off if fuel quantity gages indicate in yellow arc (less than 265 lbs. of fuel in each main tank). Crossfeed only during single engine operation.

**CAUTION**

JP-8 fuel per MIL-T-5624 has anti-icing additive per MIL-I-27686 blended in the fuel at the refinery and no further treatment is necessary. Some fuel suppliers blend in anti-icing additive, in their storage tanks. Prior to refueling, check with the fuel supplier to determine if fuel has been blended. To assure proper concentration by volume of fuel on board, blend only enough additive for the unblended fuel.

*c. Fuel System Anti-Icing.* Icing inhibitor conforming to MIL-I-27686 will be added to commercial fuel, not containing an icing inhibitor, during fueling operations, regardless of ambient temperatures. The additive provides anti-icing protection and also functions as a biocide to kill microbiological growth in the aircraft fuel system.

**5-11. LANDING GEAR CYCLING AND BRAKE DEICE LIMITATIONS.**

*a. Hydraulic Landing Gear.* While conducting training operations, the landing gear cyclic rate shall not exceed 5 complete (extension and retraction) cycles equally spaced in a 20 minute period, without allowing a 10 to 15 minute interval between the 20 minute time groupings. It is suggested the cycle rate should not exceed 10 cycles equal spaced in one (1) hour. This rate is to keep the power pack motor operations within an intermittent duty class.

*b. Brake Deice.* The following limitations apply to the brake deice system:

(1) The brake deice system shall not be operated at ambient temperatures above 15°C.

(2) The brake deice system shall not be operated longer than 10 minutes (one timer cycle) with the landing gear retracted. If operation does not automatically terminate approximately 10 minutes after gear retraction, turn the **BRAKE** deice switch off.

(3) Maintain 85%  $N_1$  or higher during simultaneous operation of the brake deice and surface deice systems. If adequate pneumatic pressure cannot be provided for simultaneous operation of the brake deice and surface deice systems, turn off the brake deice system.

(4) The brake deice system shall be turned off during single engine operation, in order to maintain an adequate supply of systems pneumatic bleed air.

**5-12. PITOT HEAT LIMITATIONS.**

*a.* Pitot heat should not be used for more than 15 minutes while the aircraft is on the ground.

Section III. POWER LIMITS

5-13. ENGINE LIMITATIONS.

CAUTION

Observe limitations found in table 5-1 during operation of this aircraft, equipped with two Pratt and Whitney of Canada, Ltd, PT6A-67 engines. Each column is a separate limitation. The limits presented do not necessarily occur simultaneously. Whenever operating limits are exceeded, the pilot should record the value and duration of the condition encountered, in the aircraft log. Operation of the engines is monitored by instruments, with reference to the operating limits marked on the face of each instrument.

Engine operation using only the engine-driven fuel pump without boost pump fuel pressure is limited to 10 cumulative hours. All time in this category shall be entered on DA Form 240813-1 for the attention of maintenance personnel.

Table 5-1. Engine Operating Limitations

OPERATING CONDITION	TORQUE % (1)	MAXIMUM OBSERVED TGT°C	GAS GENERATOR RPM N <sub>1</sub> %	PROP RPM N <sub>2</sub>	OIL PRESS PSI (10)	OIL TEMP °C	
						(2)	(3)
STARTING	--	1000(4)	--	--	200 (max)	-40 (min)	
LOW IDLE	--	750(5)	62 (min)	1000 (min)	60 (min)	-40 to 110	
HIGH IDLE	--	--	(6)	1000 (min)	--	--	
TAKEOFF (5 MIN.)	100	840	104	1700	90 to 135	10 to 110	
MAX. CONT.	100	830	104	1700	90 to 135	10 to 105	
MAX. CRUISE and	(7) (9)	810	104	(9)	90 to 135	10 to 105	
MAX CLIMB	(9)	810	104	(9)	90 to 135	10 to 105	
NORMAL CRUISE and	(7) (9)	800	104	(9)	90 to 135	10 to 105	
NORMAL CLIMB	(9)	800	104	(9)	90 to 135	10 to 105	
MAX REVERSE	75	760	88	1650	90 to 135	10 to 105	
TRANSIENT	138(8)	870(8)	104	1870(8)	40 (min) 200 (max) (8)	-40 to 110	

NOTES:

The limits presented do not necessarily occur simultaneously. Whenever operation limits are exceeded the pilot will record the value and duration of the condition encountered on DA Form 2408-13-1.

- (1) Torque limit applies within range of 1000 to 1700 propeller RPM (N<sub>2</sub>). Below 1000 RPM, torque is limited to 54%.
- (2) An engine oil temperature of 74° C to 80° C is recommended.
- (3) Oil temperature limits are -40° C to 105° C. However, temperatures of up to 110° C are permitted for a maximum time of 10 minutes.
- (4) These values are time limited to 5 seconds
- (5) High TGT at ground idle may be corrected by reducing accessory load and/or increasing N<sub>1</sub> RPM.
- (6) At approximately 72% N<sub>1</sub>.
- (7) Cruise torque values shall be set per Chapter 7. Operating engines during cruise at higher torque values than those listed in chapter 7 will reduce engine life.
- (8) These values are time limited to 20 seconds.
- (9) Torque limited to 94% when operating at 1500 RPM (N<sub>2</sub>). Torque limited to 83% when operating at 1700 RPM (N<sub>2</sub>)-
- (10) Oil Pressures below 90 PSI are undesirable. Under emergency conditions, a lower oil pressure limit of 60 PSI is permissible at reduced power, not to exceed 54% torque.

**CAUTION**

Use of aviation gasoline is time-limited to 150 hours of operation during any Time-Between-Overhaul (TBO) period. It may be used in any quantity with primary or alternate fuel.

**5-14. OVERTEMPERATURE AND OVERSPEED LIMITATIONS.**

a. Whenever limiting temperatures, listed in the Engine Operating Limitations chart (table 5-1), are exceeded and cannot be controlled by retarding the power levers, the engine will be shut down and a landing made as soon as possible.

b. During engine starting the temperatures and time limits listed in the Engine Operating Limitations chart (table 5-1) must be observed. When these limits are exceeded, the incident will be entered as an engine discrepancy in the appropriate maintenance forms. It is particularly important to record the amount and duration of over temperature.

c. Whenever the prescribed engine overspeed limit or engine RPM operating limit is exceeded, the incident must be reported as an engine discrepancy in the appropriate maintenance forms. It is particularly

important to record the maximum percent of RPM registered by the tachometer, and the duration of overspeed.

d. Continued engine operation above 810°C will reduce engine life.

**5-15. POWER DEFINITIONS FOR ENGINE OPERATIONS.**

The following definitions describe the engine power ratings.

a. *Takeoff Power.* The maximum power permissible, limited to periods of five minutes duration.

b. *Maximum Continuous Power.* Maximum continuous power is the highest power rating not limited by time. Use of this rating is intended for emergency situations at the discretion of the pilot.

**5-16. GENERATOR LIMITS.**

Maximum generator load is limited for flight and variable during ground operations. Observe the limits shown in table 5-2 during ground operation.

Table 5-2. Generator Load Limits

GENERATOR LOAD	MINIMUM GAS GENERATOR RPM - N <sub>1</sub>
0 to 95%	65%
95 to 100%	70%

**Section IV. LOADING LIMITS**

**5-17. CENTER OF GRAVITY LIMITATIONS.**

Center of gravity limits and instructions for computation of the center of gravity are contained in Chapter 6. The center of gravity range will remain within limits, providing the aircraft loading is accomplished according to instructions in Chapter 6.

**5-18. WEIGHT LIMITATIONS.**

**WARNING**

The ability to experience loss of engine power and successfully stop, continue the takeoff, or climb, before or after gear retraction is not assured for all conditions. Thorough mission planning must be accomplished prior to takeoff by analysis of maximum takeoff weight permitted by takeoff distance, accelerate-stop, positive one engine inoperative climb at lift off, accelerate-go, takeoff climb gradient, and climb performance. This data will describe performance capabilities for critical mission decisions.

Max. Ramp Weight - 16,620 lbs

Max. Takeoff Weight - 16,500 lbs.  
 Max. Landing Weight - 15,675 lbs  
 Max. Zero Fuel Weight - 13,100 lbs

#### 5-19. CABIN AIRSTAIR DOOR WEIGHT LIMITATION.

The maximum weight that may be placed on the steps of the cabin airstair door is 300 pounds.

### Section V. AIRSPEED LIMITS, MAXIMUM AND MINIMUM

#### 5-21. AIRSPEED LIMITATIONS.

All placarded airspeeds, and airspeed indicator readings contained in procedures, text, and illustrations throughout this Operator's Manual are given as indicated airspeed (IAS) unless otherwise noted.

#### 5-22. MAXIMUM ALLOWABLE AIRSPEED.

Refer to Flight Envelope Chart (fig. 5-2) to determine limiting airspeeds at maximum gross weight under various conditions. The maximum allowable airspeed is 248 KIAS below 11,500 feet, and  $M_{mo}$  of 0.472 Mach as indicated by the maximum allowable airspeed pointer (red striped) between 11,500 feet to 35,000 feet.

#### 5-23. LANDING GEAR EXTENSION/EXTENDED SPEED.

The airspeed limit for extending the landing gear and for flight with the landing gear extended is 179 KIAS.

#### 5-20. TOILET WEIGHT LIMITATION.

The maximum weight of a person occupying the toilet during takeoff or landing shall not exceed 238 pounds.

#### 5-24. LANDING GEAR RETRACTION SPEED.

The airspeed limit for retracting the landing gear is 160 KIAS.

#### 5-25. WING FLAP EXTENSION SPEEDS.

The airspeed limit for **APPROACH** extension (40%) of the wing flaps is 197 KIAS. The airspeed limit for full **DOWN** extension (100%) of the wing flaps is 151 KIAS. If wing flaps are extended above these speeds, the flaps or their operating mechanisms may be damaged.

#### 5-26. MINIMUM SINGLE ENGINE CONTROL AIRSPEED ( $V_{MCA}$ ).

The minimum single engine control airspeed ( $V_{MCA}$ ) at sea level standard conditions is 103 KIAS **P** or 108.5 KIAS **Q**.

#### 5-27. MAXIMUM DESIGN MANEUVERING SPEED.

The maximum design maneuvering speed is 167 KS.

### Section VI. MANEUVERING LIMITS

#### 5-28. MANEUVERS.

- a. The following maneuvers are prohibited.
  - (1) Spins.
  - (2) Aerobatics of any kind.
  - (3) Abrupt maneuvers above 167 KIAS.
  - (4) Any maneuver which results in a positive load factor of 3.02G's or a negative load factor of 1.21 g's with wing flaps in up or approach; or a positive load factor of 2.0 g's, or 0 g's with flaps down.

- b. Recommended turbulent air penetration airspeed is 150 KIAS.

#### 5-29. BANK AND PITCH LIMITS.

- a. Bank limits are 60° left or right
- b. Pitch limits are 30° above or below the horizon.

# FLIGHT ENVELOPE (16,500 LBS)

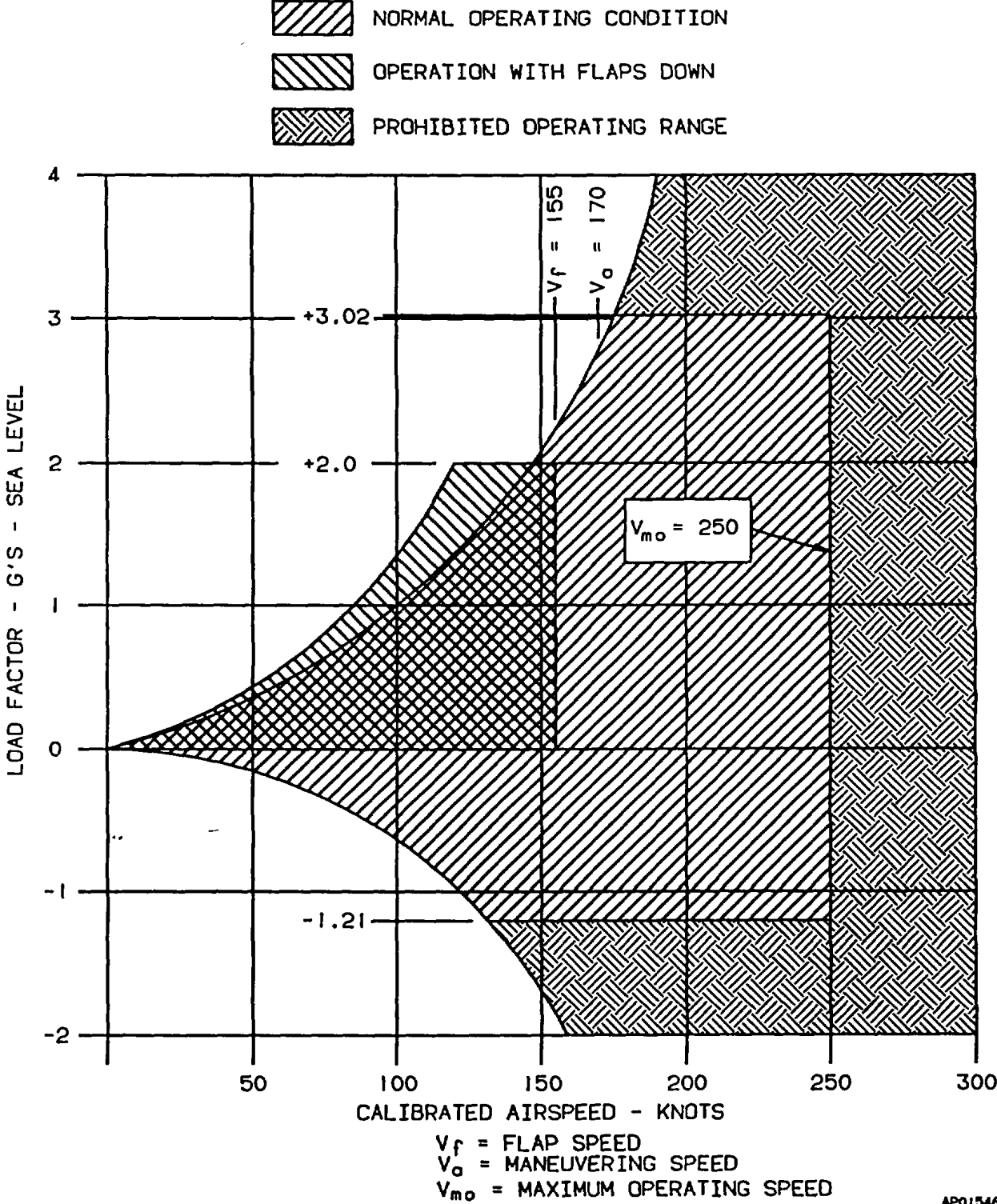

Figure 5-2. Flight Envelope

## Section VII. ENVIRONMENTAL RESTRICTIONS

### 5-30. ALTITUDE LIMITATIONS.

The maximum altitude that the aircraft may be operated at is 35,000 feet. When operating with inoperative yaw dam the altitude limit is 17,000 feet **P** and 12,000 feet **Q**.

### 5-31. TEMPERATURE LIMITS.

a. The aircraft shall not be operated when the ambient temperatures are warmer than ISA +37°C at sea level to 25,000 feet, or ISA +31°C above 25,000 feet.

b. The ice vanes shall be extended for operations in ambient temperatures of 5° C or below when flight free of visible moisture cannot be assured.

c. Minimum free air temperature for operation of deicing boots shall be -40°C .

d. Many components of the RC-12P/Q Primary Mission Equipment (PME) are classified as Commercial Off The Shelf (COTS). The maximum storage limit of COTS equipment is 65°C (149°F). If an aircraft is sitting in the sun and the outside temperature reaches 55°C (131°F), the cabin temperature could reach 82°C (180°F). Under these conditions, measures must be taken to lower the cabin temperature or damage could result.

### 5-32. FLIGHT UNDER IMC (INSTRUMENT METEOROLOGICAL CONDITIONS).

This aircraft is qualified for operation in instrument meteorological conditions.

### 5-33. TYPICAL ICING LIMITATIONS.

#### WARNING

**While in icing conditions, if there is an unexplained 30% increase of torque needed to maintain airspeed in level flight, a cumulative total of two or more inches of ice accumulation on the wing, an unexplained decrease of 15 knots IAS, or an unexplained deviation between pilot's and copilot's airspeed indicators, the icing environment should be exited as soon as practicable. Ice accumulation on the pitot tube assemblies could cause a complete loss of airspeed indication.**

The following conditions indicate a possible accumulation of ice on the pitot tube assemblies and

unprotected aircraft surfaces. If any of these conditions are observed, the icing environment should be exited as soon as practicable.

a. Total ice accumulation of two inches or more on the wing surfaces. Determination of ice thickness can be accomplished by summing the estimated ice thickness on the wing prior to each pneumatic boot deice cycle (e.g. four cycles of minimum recommended 1/2-inch accumulation).

b. A 30 percent increase in torque per engine required to maintain a desired airspeed in level flight (not to exceed 85 percent torque) when operating at recommended holding speed.

c. A decrease in indicated airspeed of 15 knots after entering the icing condition (not slower than 1.4 power off stall speed) if maintaining original power setting in level flight. This can be determined by comparing preicing condition entry speed to the indicated speed after a surface and antenna deice cycle is completed.

d. Any variations from normal indicated airspeed between the pilot's and copilot's airspeed indicators.

### 5-34. SEVERE ICING LIMITATIONS.

#### WARNING

**Severe icing may result from environmental conditions outside of those for which the aircraft is certificated. Flight in freezing rain, freezing drizzle, or mixed icing conditions (supercooled liquid water and ice crystals) may result in a buildup on protective surfaces exceeding the capability of the ice protection system, or may result in ice forming aft of these protected surfaces. This ice may not shed using ice protection systems, and may seriously degrade the performance and controllability of the aircraft.**

a. During flight, severe icing conditions that exceed those for which the aircraft is certificated shall be determined by the following visual cues. If one or more of these visual cues exist, immediately request priority handling from air traffic control to facilitate a route or an altitude change to exit the icing conditions:

(1) Unusually extensive ice accreted on the frame in areas not normally observed to collect ice.

(2) Accumulation of ice on the upper (or lower, as appropriate) surface of the wing aft of the protected area.



(3) Accumulation of ice on the propeller spinner farther aft than normally observed.

b. Since the autopilot may mask tactile cues that indicate adverse changes in handling characteristics, use of the autopilot is prohibited when any of the visual cues specified above exist, or when unusual lateral trim requirements or autopilot trim warnings are encountered while the aircraft is in icing conditions.

**NOTE**

**All icing detection lights must be operative prior to flight into icing conditions at night. This supersedes any relief provided by the master minimum equipment list (MMEL) or equivalent.**

**5-35. CROSSWIND LIMITATIONS.**

**WARNING**

**Landing with wind conditions in excess of the demonstrated crosswind component may result in damage to the aircraft. This should only be attempted during emergency situations.**

The maximum demonstrated crosswind component is 20 knots at 90 degrees. Landing the aircraft in a crab will impose side loads on the landing gear and should be recorded on DA Form 2408-13-1. Refer to Chapter 8 for crosswind landing techniques.

**5-36. OXYGEN REQUIREMENTS.**

a. Oxygen requirements will be in accordance with AR95-1.

b. Oxygen system data/duration tables are found in Chapter 2.

**5-37. CABIN PRESSURE LIMITS.**

Maximum cabin differential pressure is 6.5 PSI.

**5-38. CRACKED CABIN WINDOW/WINDSHIELD.**

If a crack occurs in any side window or windshield, aircraft operation is limited to 25,000 feet or less and cabin pressurization of 4.0 PSI or less as required to complete the flight. The aircraft shall not be flown again until maintenance actions are conducted unless proper authorization is obtained for a ferry flight to a location where a maintenance action can be performed.

If a crack develops in any side window or windshield in flight, refer to Chapter 9, Emergency Procedures.

**Section VIII. OTHER LIMITATIONS**

**5-39. MAXIMUM DESIGN SINK RATE.**

The maximum design landing sink rate is 500 feet per minute, with a normal flare initiated just prior to touchdown.

**5-40. INTENTIONAL ENGINE OUT SPEED.**

Intentional inflight engine cuts below the safe one engine inoperative speed ( $V_{SSE}=115$  KIAS **P**,  $V_{SSE}=120$  KIAS **Q**) are prohibited.

**5-41. LANDING ON UNPREPARED RUNWAY.**

**CAUTION**

**Except in an emergency, propellers should be moved out of reverse below 40 knots to minimize propeller blade erosion, and during crosswind to minimize stress imposed on propellers, engines, and airframe. Care must be exercised when reversing on runways with loose sand or dust on the surface. Flying gravel will damage propeller blades and dust may impair the pilot's forward visibility at low aircraft speeds.**

The aircraft has demonstrated landings on hard, smooth runways. Hard braking, i.e., skidding tires while operating on other than smooth runways, can result in damage to the landing gear. Operations from unimproved runways (rocks, potholes, mud, deteriorated surfaces) are prohibited. When landing on other than dry surfaces, use discretionary propeller reverse to stop the aircraft on the available runway.

**Section IX. REQUIRED EQUIPMENT FOR VARIOUS CONDITIONS OF FLIGHT****5-42. REQUIRED EQUIPMENT LISTING.**

a. A Required Equipment for Various Conditions of Flight listing (table 5-3), is provided to enable the pilot to identify those systems/components required for flight. For the sake of brevity, the listing does not include obviously required items such as wings, rudder, flaps, engines, landing gear, etc. It is important to note that ALL ITEMS WHICH ARE RELATED TO THE AIRWORTHINESS OF THE AIRCRAFT AND NOT INCLUDED ON THE LIST ARE AUTOMATICALLY REQUIRED TO BE OPERATIVE.

b. It is the final responsibility of the pilot to determine whether the lack of, or inoperative status of a piece of equipment on the aircraft will limit the conditions under which the aircraft may be operated.

(1) The remarks and/or exceptions column provides for explicit information or reference.

(2) Numbered items indicate the number of items required for flights by AR 95-1.

c. The pilot is responsible for exercising the necessary operational control to assure that no aircraft is flown with multiple items inoperative, without first determining that any interface or interrelationship between inoperative systems or components will not result in a degradation in the level of safety and/or cause an undue increase in crew workload.

d. The exposure to additional failures during continued operation with inoperative systems or components must also be considered in determining that an acceptable level of safety is being maintained. The list may not deviate from requirements of the Operator's Manual limitations section, emergency procedures or safety of flight messages.

Table 5-3. Required Equipment Listing

SYSTEM and/or COMPONENT	VFR DAY					Remarks and/or Exceptions
	VFR NIGHT					
	IFR DAY					
	IFR NIGHT					
	ICING CONDITIONS					
<b>ELECTRICAL POWER</b>						
AC Volts/Frequency Meter	2	2	2	2	2	
Battery	1	1	1	1	1	
Battery Charge Annunciator	1	1	1	1	1	
DC Generator	2	2	2	2	2	
DC Generator Annunciator	2	2	2	2	2	One may be inoperative provided corresponding loadmeter is monitored.
DC Load Meter	2	2	2	2	2	One may be inoperative provided operating generator loadmeter is monitored.
Inverter	2	2	2	2	2	
Inverter Warning Annunciator	1	1	1	1	1	May be inoperative provided both inverters are operative.
DC Voltmeter	2	2	2	2	2	One may be inoperative provided corresponding loadmeter and generator warning light is monitored.
<b>ENVIRONMENTAL</b>						
Bleed Air Fail Annunciators	2	2	2	2	2	
Altitude Warning Annunciator (Cabin)	1	1	1	1	1	May be inoperative provided aircraft remains unpressurized.
Cabin Rate of Climb Indicator	1	1	1	1	1	Cabin altitude remains in accordance with AR # 95-1.
Differential Pressure/Cabin Altitude Indicator	1	1	1	1	1	
Duct Overtemp Annunciator	1	1	1	1	1	
Outflow Valve	1	1	1	1	1	
Pressurization Controller	1	1	1	1	1	
Safety Valve	1	1	1	1	1	
Bleed Air Shutoff Valve	2	2	2	2	2	
<b>FIRE PROTECTION</b>						
Engine Fire Detector System Including Annunciators	2	2	2	2	2	
Engine Fire Extinguishers	2	2	2	2	2	

Table 5-3. Required Equipment Listing - (Cont'd)

SYSTEM and/or COMPONENT	VFR DAY					Remarks and/or Exceptions	
	VFR NIGHT						
	IFR DAY						
	IFR NIGHT						
	ICING CONDITIONS						
<b>FLIGHT CONTROLS</b>							
Flap Position Indicator	1	1	1	1	1	May be inoperative provided that the flap travel is visually inspected prior to takeoff.	
Flap System	1	1	1	1	1		
Stall Warning Horn	1	1	1	1	1		
Trim Tab Position Indicator (Rudder, Aileron, Elevator)	3	3	3	3	3		
Yaw Damp System	1	1	1	1	1	May be inoperative for flight at and below 17,000 feet.	
Rudder Boost System	1	1	1	1	1		
<b>FUEL</b>							
Engine Driven Boost Pump	2	2	2	2	2	Both required for operation on aviation gasoline above 15,000 feet.	
Fuel Crossfeed System Including Annunciator	1	1	1	1	1		
Standby Fuel Boost Pump	2	2	2	2	2		
Fuel Pressure Annunciator	2	2	2	2	2		
Fuel Quantity Indicating System Including Annunciators	2	2	2	2	2		
Firewall Fuel Shutoff System Including Annunciators	2	2	2	2	2		
Jet Transfer Pump	2	2	2	2	2		Required if aux tanks contain fuel.
Motive Flow Valve	2	2	2	2	2		Required if aux tanks contain fuel.
Fuel Flow Indicator	2	2	2	2	2		One may be inoperative provided fuel quantity gages are operative.
<b>ICE AND RAIN PROTECTION</b>							
Antenna Deice System	0	0	0	0	1	Four annunciators must be operative.	
Alternate Static Air Source	1	1	1	1	1		
Engine Auto Ignition and Annunciators	2	2	2	2	2		
Engine Ice Vane System	2	2	2	2	2		
Engine Inlet Lip Heat Indicator	0	0	0	0	2		
Heated Fuel Vent	2	2	2	2	2		
Heated Windshield (Left)	0	0	0	0	1		Right side may be inoperative.
Pitot Heat (Left)	1	1	1	1	2		Right side must be operative during icing conditions.
Pneumatic Pressure Indicator	0	0	1	1	1		

Table 5-3. Required Equipment Listing - (Cont'd)

SYSTEM and/or COMPONENT	VFR DAY					Remarks and/or Exceptions
	VFR NIGHT					
	IFR DAY					
	IFR NIGHT					
	ICING CONDITIONS					
Propeller Deicer System	0	0	0	0	1	
Stall Warning Heater	0	0	0	0	1	
Surface Deicer System	0	0	0	0	1	
Wing Ice Light	0	1	0	1	1	
<b>LANDING GEAR</b>						
Landing Gear Position Indicator Lights	3	3	3	3	3	One of the three may be inoperative provided gear handle light is monitored.
Landing Gear Handle Light	1	1	1	1	1	
Landing Gear Aural Warning	1	1	1	1	1	
Landing Gear Hydraulic Power Pack	1	1	1	1	1	
Brake Deice Shutoff Valve	2	2	2	2	2	
Hydraulic Fluid Low Annunciator	1	1	1	1	1	
Emergency Extension Hand Pump	1	1	1	1	1	
<b>LIGHTS</b>						
Cockpit and instrument Lighting System	0	1	0	1	0	Lights must illuminate all instruments and controls.
Cabin Door Annunciator	1	1	1	1	1	
Landing Lights	0	1	0	1	0	
Position Lights	0	3	0	3	0	
Anti-collision Light System	1	1	1	1	1	System will be operated in accordance with AR 95-1.
<b>NAVIGATION INSTRUMENTS</b>						
Airspeed Indicator (Left)	1	1	1	1	2	Right side must be operative during icing conditions.
Altimeter	2	2	2	2	2	
Magnetic Compass	1	1	1	1	1	
Outside Air Temperature Gage	1	1	1	1	1	
Standby Attitude Indicator	1	1	1	1	1	
Turn and Slip Indicator	1	1	1	1	1	
Vacuum System	1	1	1	1	1	
Electronic Flight Instrument System	0	1	2	2	2	During IFR day, IFR night, or icing conditions, one EFIS display is required at the pilot and copilot station.
<b>OXYGEN</b>						
Oxygen System	1	1	1	1	1	

Table 5-3. Required Equipment Listing - (Cont'd)

SYSTEM and/or COMPONENT	VFR DAY					Remarks and/or Exceptions
	VFR NIGHT					
	IFR DAY					
	IFR NIGHT					
	ICING CONDITIONS					
Oxygen Masks	2	2	2	2	2	
<b>PROPELLERS</b>						
<i>Autofeather System Including Annunciators</i>	1	1	1	1	1	Annunciators may be inoperative.
Propeller Reversing System	2	2	2	2	2	
Propeller Governor Test Switch	1	1	1	1	1	
Propeller Overspeed Governor	2	2	2	2	2	
Propeller Pitch Annunciators	2	2	2	2	2	
<b>ENGINE INDICATIONS</b>						
TGT Indicator	2	2	2	2	2	
Tachometer (Gas Generator)	2	2	2	2	2	
Tachometer (Propeller)	2	2	2	2	2	
Torque Indicator	2	2	2	2	2	
<b>ENGINE OIL</b>						
Chip Detector System Including Annunciators	2	2	2	2	2	
Oil Pressure	2	2	2	2	2	
Oil Temperature Indicator	2	2	2	2	2	
Oil Pressure Annunciator	2	2	2	2	2	
<b>NOTE</b>						
The above equipment list does not include all specific flight instruments and communications/navigation equipment required by FAR Parts 91 and 135 Operating Requirements.						

B701221

## CHAPTER 6 WEIGHT/BALANCE AND LOADING Section I. GENERAL

### 6-1. EXTENT OF COVERAGE.

Sufficient data has been provided so that, knowing the basic weight and moment of the aircraft, any combination of weight and balance can be computed.

### 6-2. CLASS.

Army model RC-12P and RC-12Q mission equipment aircraft are in Weight and Balance Class 1. When operating in a passenger/cargo configuration, the aircraft weight and balance classification becomes a Class 2. Additional directives governing weight and balance

classifications 1 and 2 aircraft forms and records are contained in AR 95-1, TM 55-1500-342-23, and DA PAM 738-751.

### 6-3. AIRCRAFT COMPARTMENTS AND STATIONS.

The aircraft is separated into two compartments associated with loading. These compartments are the cockpit and the cabin. Figure 6-1 shows the general description of aircraft compartments.

## Section II. WEIGHT AND BALANCE

### 6-4. PURPOSE.

The data to be inserted on weight and balance charts and forms are applicable only to the individual aircraft, the serial number of which appears on the title page of the booklet entitled WEIGHT AND BALANCE DATA supplied by the aircraft manufacturer and on the various forms and charts which remain with the aircraft. The charts and forms referred to in this chapter may differ in nomenclature and arrangement from time to time, but the principles on which they are based will not change.

forms. All charts, including one sample Weight and Balance Clearance Form F, if applicable, are completed at time of delivery. This record is the basic weight and balance data of the aircraft at delivery. All subsequent changes in weight and balance are compiled by the weight and balance technician.

### 6-5. CHARTS AND FORMS.

The standard system of weight and balance control requires the use of several different charts and forms.

### 6-7. CHART C - BASIC WEIGHT AND BALANCE RECORD, DD FORM 365-3.

Chart C is a continuous history of the basic weight and moment resulting from structural and equipment changes made in service. At all times, the last weight and moment/ 100 entry is considered the current weight and balance status of the basic aircraft.

Within this chapter, the following are used:

1. Chart C - Basic Weight and Balance Record, DD Form 365-3.
2. Form F - Weight and Balance Clearance, DD Form 365-4 (Tactical).

### 6-8. WEIGHT AND BALANCE CLEARANCE, DD FORM 365-4 (TACTICAL).

Refer to TM 55-1500-342-23 for DD Form 365-4 instructions. Refer to table 6-1 through 6-5 for weight and balance data.

### 6-6. RESPONSIBILITY.

The aircraft manufacturer inserts all aircraft identifying data on the title page of the booklet entitled WEIGHT AND BALANCE DATA and on the various charts and

AIRCRAFT DIAGRAM

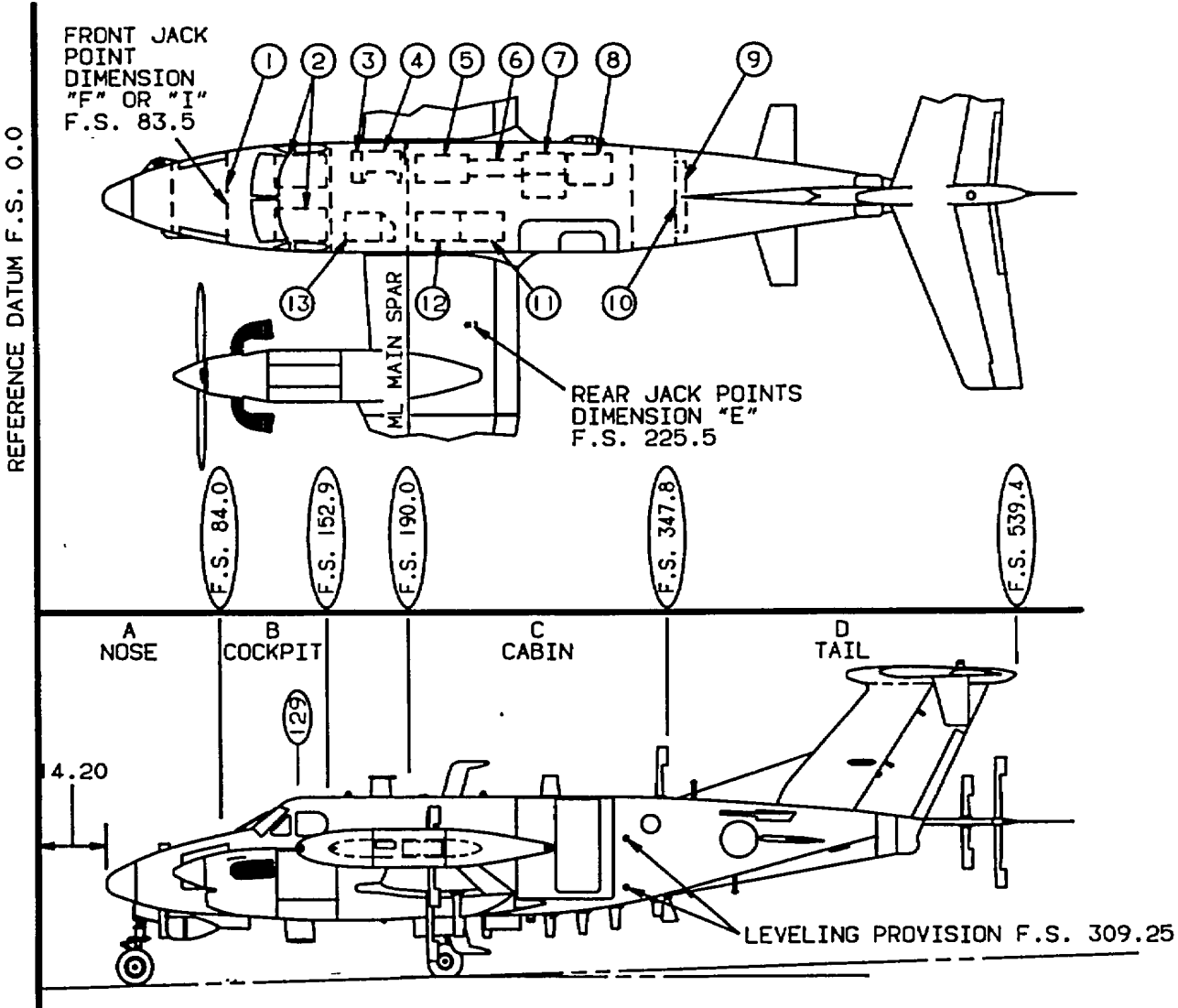

- ① AVIONICS COMPARTMENT
- ② PILOT AND COPILOT SEATS
- ③ MISSION AC DC POWER CABINET
- ④ EQUIPMENT RACK - A1
- ⑤ EQUIPMENT RACK - A3
- ⑥ EQUIPMENT RACK - A5
- ⑦ EQUIPMENT RACK - A7
- ⑧ LAVATORY
- ⑨ AVIONICS SHELVES AND OXYGEN BOTTLES
- ⑩ SURVIVAL KITS (3)
- ⑪ EQUIPMENT RACK - A6
- ⑫ EQUIPMENT RACK - A2
- ⑬ EQUIPMENT RACK - A4

A95FE0000272 C

Figure 6-1. Aircraft Compartments and Stations



AIRCRAFT DIAGRAM

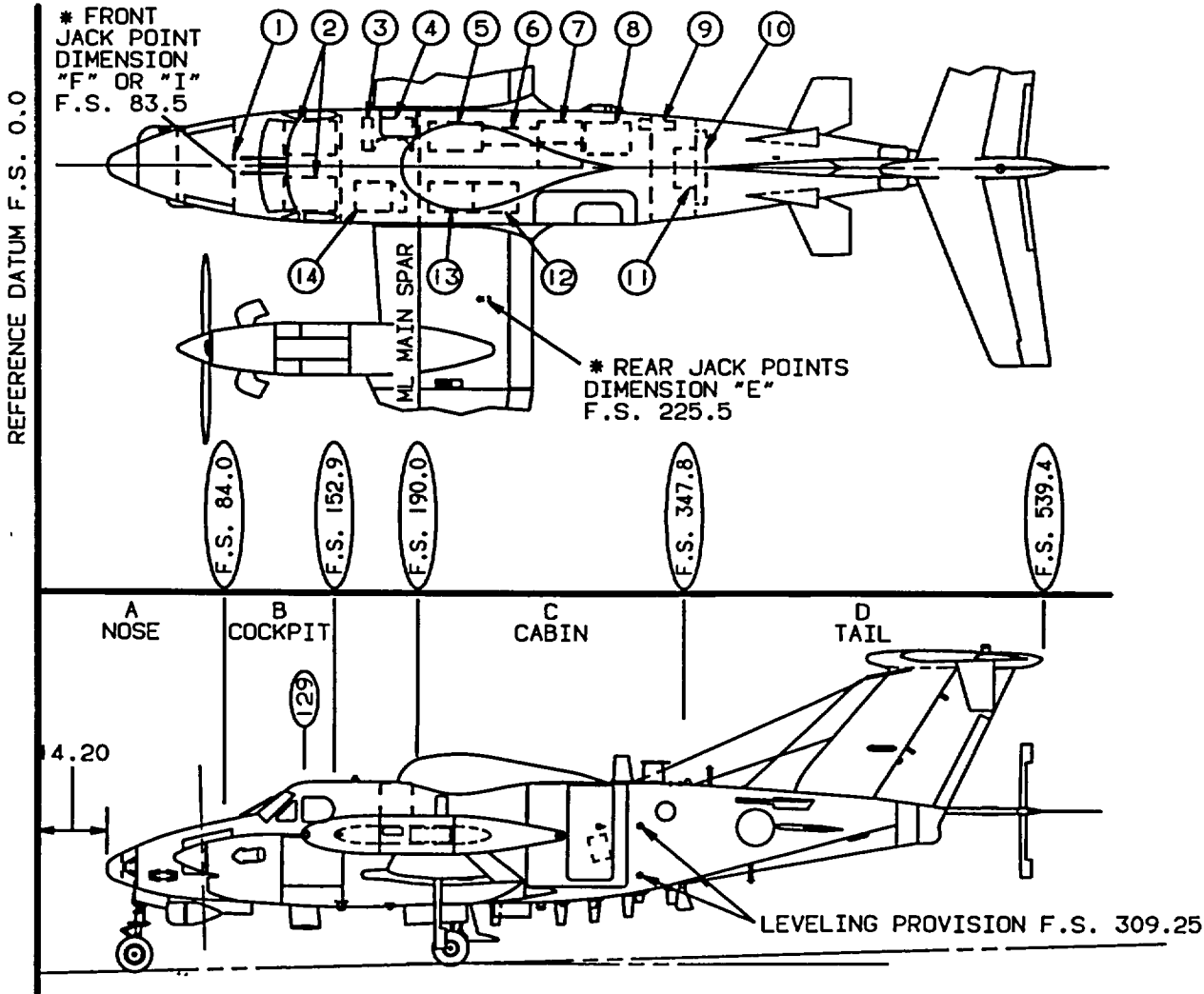

- ① AVIONICS COMPARTMENT
- ② PILOT AND COPILOT SEATS
- ③ MISSION AC DC POWER CABINET
- ④ EQUIPMENT RACK - A1
- ⑤ EQUIPMENT RACK - A3
- ⑥ EQUIPMENT RACK - A5
- ⑦ EQUIPMENT RACK - A7
- ⑧ LAVATORY
- ⑨ SURVIVAL KITS (3)
- ⑩ AVIONICS SHELVES AND OXYGEN BOTTLES
- ⑪ EQUIPMENT RACK - A8
- ⑫ EQUIPMENT RACK - A6
- ⑬ EQUIPMENT RACK - A2
- ⑭ EQUIPMENT RACK - A4

FE060970491 C

Figure 6-2. Aircraft Compartments and Stations ©

Table 6-1. Occupants - Useful Loads, Weights, and Moments

WEIGHT	CREW	LAVATORY
	F.S. 129	F.S. 292
	Moment/100	
80	103	234
90	116	263
100	129	292
110	142	321
120	155	350
130	168	380
140	181	409
150	194	438
160	206	467
170	219	496
180	232	526
190	245	555
200	258	584
210	271	613
220	284	642
230	297	672
240	310	701
250	323	730

BT03867

Table 6-2. Survivability Equipment - Weights and Moments

ITEM	WEIGHT	MOM1100
NACELLE DISPENSER (F.S. 214.7)	10	21
Chaff Cartridges (30)		
FUSELAGE DISPENSER (F.S. 288.6)	10	29
Chaff Cartridges (30)		
Flare Cartridges (30)	13	37

BT03866

Table 6-3. Useful Load Weights and Moments  
Usable Fuel, 6.4 to 6.8 LB/GAL

GALLON	6.4 LB/GAL		6.5 LB/GAL		6.6 LB/GAL		6.7 LB/GAL		6.8 LB/GAL	
	WEIGHT	MOMENT	WEIGHT	MOMENT	WEIGHT	MOMENT	WEIGHT	MOMENT	WEIGHT	MOMENT
		100		100		100		100		100
10	64	99	65	100	66	102	67	103	68	105
20	128	197	130	200	132	203	134	206	136	209
30	192	305	195	310	198	314	201	319	204	324
40	256	423	260	430	264	436	268	443	272	450
50	320	542	325	550	330	559	335	567	340	576
60	384	662	390	672	396	683	402	693	408	703
70	448	782	455	794	462	807	469	819	476	831
80	512	904	520	918	528	932	536	948	544	960
90	576	1023	585	1039	594	1055	603	1071	612	1087
100	640	1142	650	1160	660	1178	670	1196	680	1214
110	704	1260	715	1280	726	1300	737	1319	748	1339
120	768	1379	780	1400	792	1422	804	1443	816	1465
130	832	1496	845	1519	858	1543	871	1568	884	1589
140	896	1616	910	1640	924	1665	938	1690	952	1715
150	960	1734	975	1761	990	1788	1005	1815	1020	1842
160	1024	1852	1040	1881	1056	1910	1072	1939	1088	1968
170	1088	1971	1105	2002	1122	2033	1139	2064	1156	2095
180	1152	2090	1170	2122	1188	2155	1206	2188	1224	2221
190	1216	2209	1235	2244	1254	2279	1273	2313	1292	2348
200	1280	2328	1300	2365	1320	2401	1340	2437	1360	2473
210	1344	2447	1365	2486	1388	2524	1407	2562	1428	2600
220	1408	2567	1430	2607	1452	2647	1474	2687	1496	2727
230	1472	2686	1495	2728	1518	2770	1541	2812	1564	2854
240	1536	2806	1560	2850	1584	2894	1608	2938	1632	2982
250	1600	2926	1625	2971	1650	3107	1675	3063	1700	3109
260	1664	3045	1690	3093	1716	3140	1742	3188	1768	3238
270	1728	3164	1755	3213	1782	3263	1809	3312	1838	3381
280	1792	3283	1820	3334	1848	3386	1876	3437	1904	3488
290	1856	3402	1885	3455	1914	3508	1943	3562	1972	3615
300	1920	3521	1950	3576	1980	3631	2010	3686	2040	3741
310	1984	3641	2015	3698	2046	3754	2077	3811	2108	3868
320	2048	3760	2080	3819	2112	3878	2144	3936	2176	3995
330	2112	3880	2145	3940	2178	4001	2211	4062	2244	4123
340	2176	3999	2210	4062	2244	4124	2278	4178	2312	4249
350	2240	4119	2275	4184	2310	4248	2345	4312	2380	4376
360	2304	4244	2340	4310	2376	4377	2412	4443	2448	4509
370	2368	4365	2405	4434	2442	4502	2479	4570	2516	4638
380	2432	4489	2470	4560	2508	4630	2546	4700	2584	4770
384	2458	4540	2498	4610	2534	4680	2573	4752	2611	4823
400	2560	4748	2600	4822	2640	4896	2680	4970	2720	5043
410	2624	4879	2665	4955	2708	5031	2747	5107	2788	5182
420	2688	5009	2730	5087	2772	5166	2814	5244	2856	5321
430	2752	5140	2795	5220	2838	5300	2881	5380	2924	5460
440	2816	5270	2860	5353	2904	5435	2948	5517	2992	5598
450	2880	5401	2925	5485	2970	5569	3015	5654	3060	5737
460	2944	5531	2990	5618	3036	5704	3082	5790	3128	5876
470	3008	5662	3055	5750	3102	5839	3149	5927	3196	6014
480	3072	5793	3120	5883	3168	5973	3218	6064	3264	6155
490	3138	5923	3185	6016	3234	6108	3283	6200	3332	6292
500	3200	6054	3250	6148	3300	6243	3350	6337	3400	6431
510	3264	6184	3315	6281	3368	6377	3417	6474	3468	6571
520	3328	6315	3380	6413	3432	6512	3484	6610	3536	6708
530	3392	6445	3445	6546	3498	6647	3551	6747	3604	6847
540	3456	6576	3510	6679	3564	6781	3618	6884	3672	6987
542	3468	6602	3523	6705	3577	6808	3631	6910	3686	7014

BT01942

Table 6-4. Useful Load Weights and Moments  
Usable Fuel 6.9 to 7.1 LB/GAL

GALLON	6.9 LB/GAL		7.0 LB/GAL		7.1 LB/GAL	
	WEIGHT	MOMENT 100	WEIGHT	MOMENT 100	WEIGHT	MOMENT 100
10	69	107	70	108	71	110
20	138	212	140	215	142	218
30	207	329	210	334	213	338
40	276	457	280	463	284	470
50	345	583	350	592	355	600
60	414	713	420	724	426	734
70	483	843	490	855	497	868
80	552	974	560	988	568	1002
90	621	1103	630	1119	639	1135
100	690	1232	700	1250	710	1268
110	759	1359	770	1378	781	1398
120	828	1487	840	1508	852	1530
130	897	1612	910	1636	923	1659
140	966	1740	980	1765	994	1791
150	1035	1869	1050	1896	1065	1923
160	1104	1997	1120	2026	1136	2055
170	1173	2126	1190	2157	1207	2187
180	1242	2254	1260	2286	1278	2319
190	1311	2383	1330	2417	1349	2452
200	1380	2509	1400	2546	1420	2582
210	1449	2638	1470	2676	1491	2715
220	1518	2767	1540	2807	1562	2847
230	1587	2896	1610	2938	1633	2980
240	1656	3026	1680	3070	1704	3114
250	1725	3155	1750	3200	1775	3246
260	1794	3284	1820	3331	1846	3379
270	1863	3410	1890	3460	1917	3509
280	1932	3539	1960	3591	1988	3642
290	2001	3668	2030	3721	2059	3774
300	2070	3796	2100	3851	2130	3906
310	2139	3925	2170	3982	2201	4039
320	2206	4054	2240	4113	2272	4171
350	2277	4184	2310	4244	2343	4305
340	2346	4311	2380	4374	2414	4436
350	2415	4440	2450	4505	2485	4569
360	2484	4575	2520	4642	2556	4708
370	2553	4706	2590	4774	2627	4843
380	2622	4840	2660	4910	2698	4980
384	2650	4893	2688	4964	2726	5035
400	2760	5117	2800	5193	2840	5267
410	2829	5258	2870	5336	2911	5411
420	2898	5401	2940	5478	2982	5556
430	2967	5540	3010	5621	3053	5701
440	3036	5682	3080	5763	3124	5845
450	3105	5823	3150	5906	3195	5992
460	3174	5962	3220	6049	3266	6135
470	3243	6104	3290	6191	3337	6281
480	3312	6245	3360	6336	3408	6424
490	3381	6385	3430	6477	3479	6570
500	3450	6526	3500	6620	3550	6715
510	3519	6666	3570	6764	3621	6861
520	3588	6807	3640	6905	3692	7004
530	3657	6948	3710	7048	3763	7149
540	3726	7088	3780	7192	3834	7295
542	3740	7117	3794	7220	3848	7323

**Section III. FUEUOIL**

**6-9. FUEL LOAD.**

Fuel loading imposes a restriction on the amount of load which can be carried. The required fuel must first be determined, then that weight subtracted from the total weight of crew and fuel. Weight up to and including the remaining allowable capacity can be subtracted directly from the weight of crew and fuel. As the fuel load is increased, the loading capacity is reduced. Figure 6-2 depicts the density variation of aviation fuel.

FUEL TYPE .....	SPECIFIC WEIGHT
JP-4 .....	6.5 lb/gal
JP-5 .....	6.8 lb/gal
JP-8 .....	6.7 lb/gal

*b. Oil Data.* Total oil weight is 52 pounds and is included in the basic weight of the aircraft.

**6-10. FUEL AND OIL DATA.**

*a. Usable Fuel Moment Tables.* Fuel Moment Tables 6-3 and 6-4 show usable fuel moments/100 for US gallons (or pounds) for fuel specific weights ranging from 6.4 to 7.1 pounds per gallon. Fuel moments should be determined by entering the table by fuel weight and using the column which represents the specific weight of the fuel being used.

The full tank usable fuel weight will vary depending upon fuel specific weight. The fuel quantity is calibrated for correct indication using JP-5 or JP-8. When using other fuels multiply the indicated fuel in pounds by 0.99 for JP-4 or by 0.98 for aviation gasoline.

Figure 6-2 is provided to show the general range of specific weights to be expected with the change in fuel temperature. Specific weight will vary between different lots of the same type of fuel at the same temperature by as much as 0.5 pounds per gallon. The following approximate fuel specific weights at 15 degrees Celsius may be used for most mission planning.

*Table 6-5. Center of Gravity Limits (Landing Gear Down) Restricted Category*

<b>WEIGHT CONDITION</b>	<b>FORWARD CG LIMIT</b>	<b>AFT CG LIMIT</b>
16,500 LBS (MAXIMUM TAKE-OFF)	188.7	195.1
15,675 LBS (MAXIMUM LANDING)	186.7	195.1
13,100 LBS (MAXIMUM ZERO FUEL)	180.3	195.1
12,600 LBS OR LESS	179.0	195.1

**NOTE:**  
The moment/100 for retraction of the landing gear is -61.6. Loadings based on wheels-down condition which fall within the limiting moments in the table, will be satisfactory for flight with landing gear retracted.

BT05792

DENSITY VARIATION OF AVIATION FUEL  
BASED ON AVERAGE SPECIFIC GRAVITY

FUEL	AVERAGE SPECIFIC GRAVITY
JET A (JP-5) (JP-8) AND JET A1	0.819 AT 15°C
JET B (JP-4)	0.764 AT 15°C
AV GAS GRADE 100/130	0.706 AT 15°C

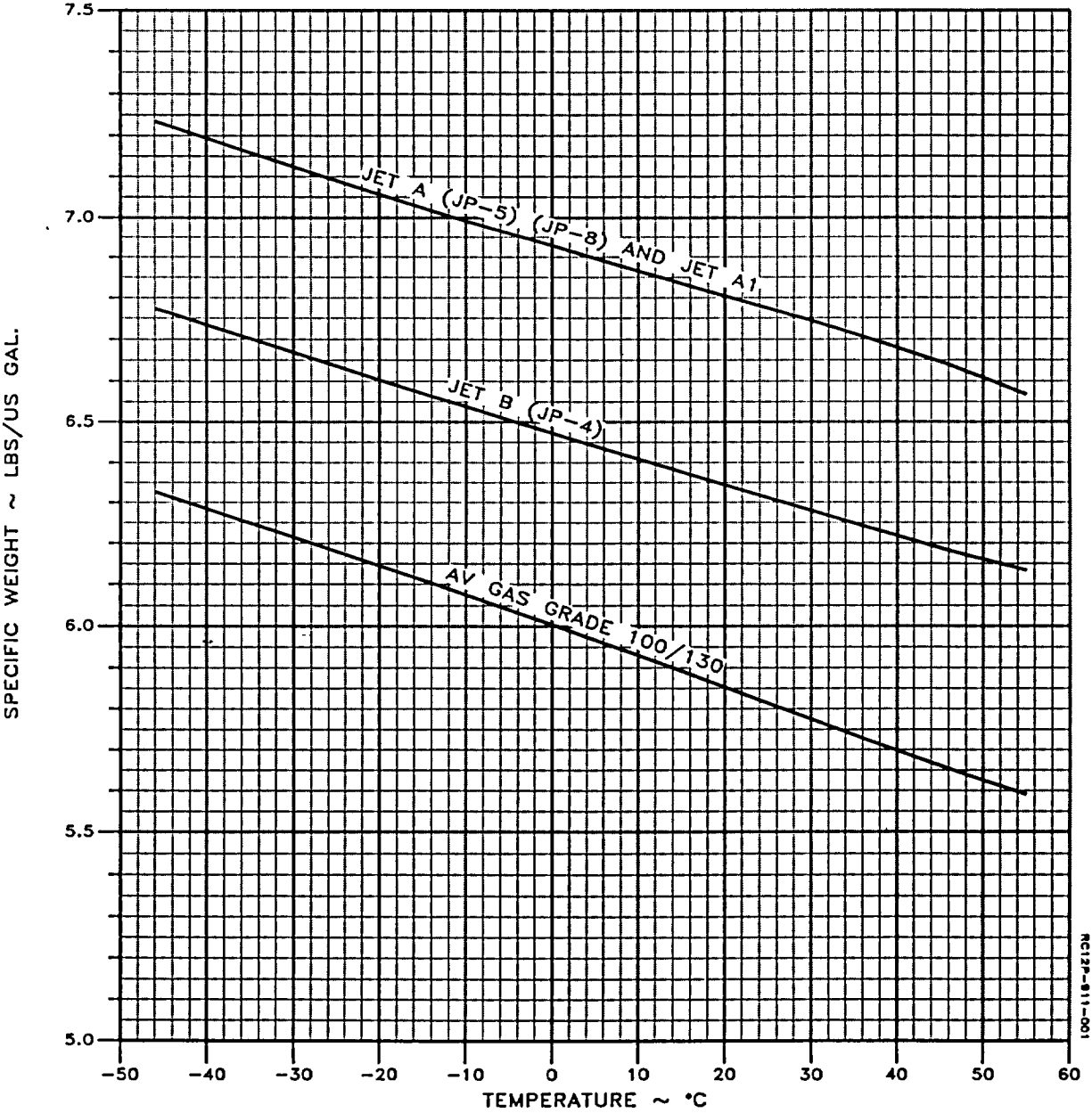

Figure 6-3. Density Variation of Aviation Fuel

## Section IV. CENTER OF GRAVITY

### 6-11. CENTER OF GRAVITY LIMITATIONS.

#### WARNING

**When mission gear is removed the forward center of gravity limit is easily exceeded.**

Center of gravity limitations are expressed in ARM inches which refers to a positive measurement from the aircraft's reference datum. The forward CG limit at 12,600 lbs., or less, is 179.0 ARM inches. The forward-sloping CG limit line is a straight line from 12,600

lbs. to 16,500 lbs, ending at fuselage station 188.7. At 16,500 lbs., or less, the aft CG limit is 195.1 ARM inches. The Center of Gravity Loading Diagram (fig. 6-3) is designed to establish forward and aft CG limitations. When mission gear is removed it may be necessary to add removable ballast or baggage in the aft baggage compartment.

## Section V. CARGO LOADING

### 6-12. LOAD PLANNING.

The basic factors to be considered in any loading situation are as follows:

a. Cargo shall be arranged to permit access to all emergency equipment and exits during flight.

b. Floorboard structural capacity shall be considered in the loading of heavy or sharp-edged containers and equipment. Shorings shall be used to distribute highly condensed weights evenly over the cargo areas. Use of the floor seat tracks to support loads is encouraged where possible.

c. All cargo shall be adequately secured to prevent damage to the aircraft, other cargo, or the item itself.

### 6-13. LOADING PROCEDURE.

#### NOTE

**The cabin airstair door is weight limited to a maximum of 300 pounds to prevent possible structural damage.**

Loading of cargo is accomplished through the cabin door (21.5 in. X 49.0 in.) or the cargo door (52.0 in. X 52.0 in.).

### 6-14. SECURING LOADS.

All cargo shall be secured with restraints strong enough to withstand the maximum force exerted in any direction. The maximum force can be determined by multiplying the weight of the cargo item by the applicable load factor. These established load factors (the ratio between the total force and the weight of the cargo item) are 1.5 to the side and rear, 3.0 up, 6.6 down, and 9.0 forward. SURVIVABILITY EQUIPMENT.

## Section VI. SURVIVABILITY EQUIPMENT

### 6-15. FLARE AND CHAFF DISPENSERS.

Refer to table 6-2 for flare and chaff dispenser weight and balance data.

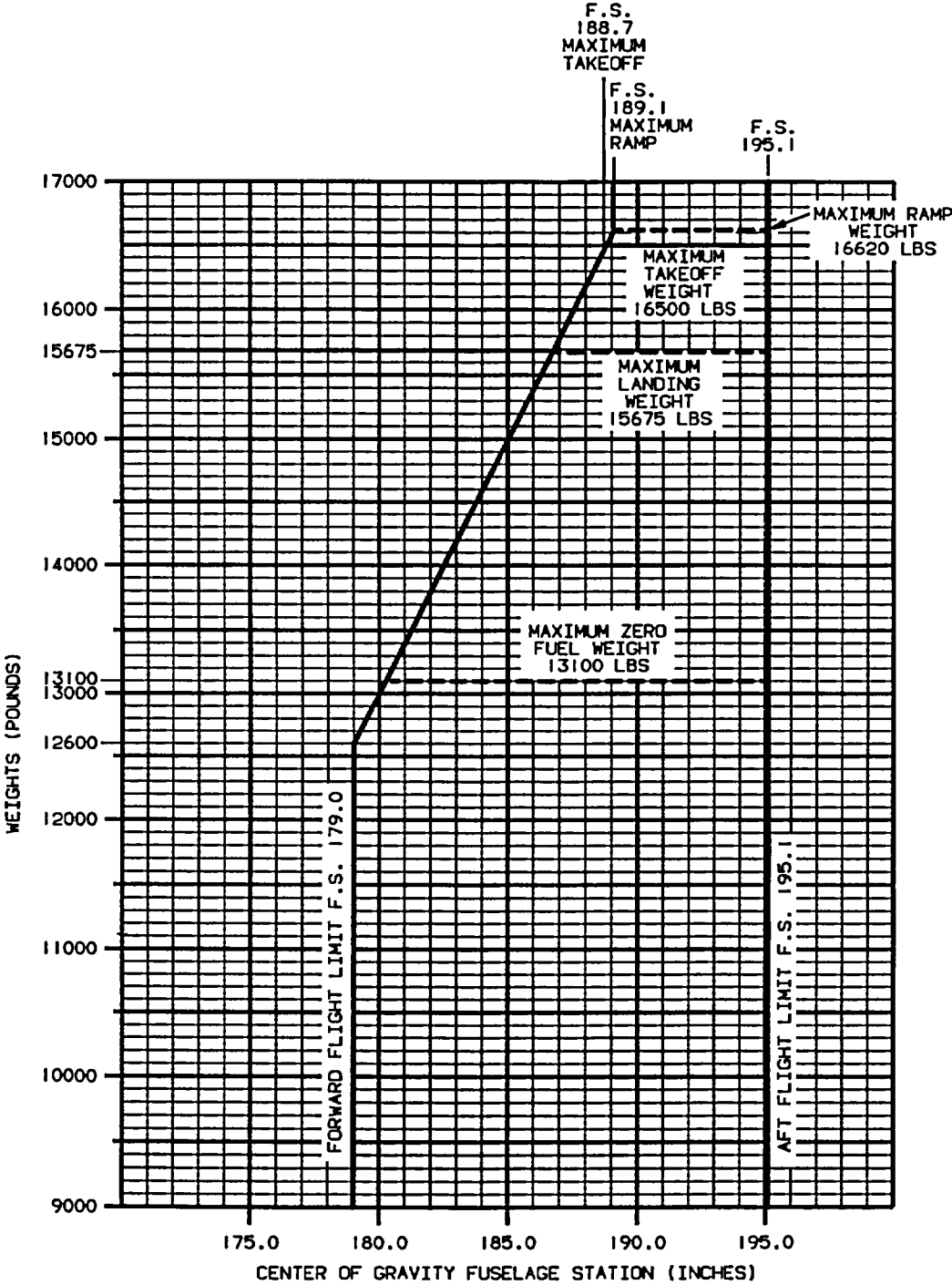

A95FE06D0273 C

Figure 6-4. Center of Gravity Loading Diagram



## CHAPTER 7 PERFORMANCE DATA **P**

### 7-1. INTRODUCTION TO PERFORMANCE.

#### NOTE

**Chapter 7 contains performance data for the model RC-12P aircraft. Refer to Chapter 7A for RC-12Q performance data.**

The graphs and tables in this chapter present performance information for takeoff, climb, flight planning, and landing at various parameters of weight, power, altitude, and temperature. Examples explaining appropriate use are provided for performance graphs.

#### NOTE

**All flight performance data are based on JP-4 fuel. The change in fuel flow and other power/ torque data when using JP-5, JP-8, aviation gasoline, or any other approved fuel is insignificant. The only exceptions are figures 7-51, 7-63, 7-72, 7-81, 7-82, 7-83, 7-84, and 7-85 which address aircraft range and endurance when the fuel density is approximately 6.7 pounds per gallon.**

### 7-2. HOW TO USE GRAPHS.

1. All airspeeds and references to airspeeds in this chapter are indicated airspeeds unless otherwise noted.
2. A reference line indicates where to begin following the guidelines. Always project to the reference line first, then follow the guidelines to the next item by maintaining the same proportional distance between the guideline above and the guideline below the projected line. For instance, if the projected line intersects the reference line in the ratio of 30% down/70% up between the guidelines, then maintain this same 30%/70% relationship between the guidelines all the way to the next item.
3. The Airspeed Calibration Normal System Takeoff Ground Roll graph was used to obtain V1 and VR indicated airspeeds (IAS). All other indicated airspeeds (except stall speeds) were obtained by using the Airspeed Calibration Normal System graph.
4. The associated conditions define the specific conditions from which performance parameters have been determined. They are not intended to

be used as instructions; however, performance values determined from graphs can only be achieved if the specified conditions exist.

5. The graphs assume that the full amount of usable fuel is available for all approved flight conditions.
6. Notes have been provided to approximate performance with the ice vanes extended. The effect will vary, depending upon airspeed, temperature, and altitude.

### 7-3. PERFORMANCE ILLUSTRATIONS, GRAPHS, AND TABLES.

#### *a. Takeoff Path Profile - One Engine Inoperative.*

(1) *Description.* The Takeoff Path Profile One Engine Inoperative illustration (fig. 7-1) describes the nomenclature of the various segments of a takeoff and climbout with one engine inoperative from brake release to 1500 feet AGL.

(2) *Purpose.* This figure provides a schematic profile of a one engine inoperative takeoff, from brake release to 1500 feet AGL, to help the pilot visualize the process and to show where each segment begins and ends.

#### *b. Airspeed Calibration Normal System, 1 Takeoff Ground Roll.*

(1) *Description.* The Airspeed Calibration Normal System, Takeoff Ground Roll graph (fig. 7-2) depicts the relationship between indicated airspeed and calibrated airspeed for the normal aircraft static air source during the takeoff ground roll.

(2) *Purpose.* This graph is used to determine calibrated airspeed for a given indicated airspeed. Data is provided for up and approach flap settings with the gear down. The indicated airspeed values on this graph assume zero instrument error.

#### *c. Airspeed Calibration Normal System.*

(1) *Description.* The Airspeed Calibration Normal System graph (fig. 7-3) depicts the relationship between indicated airspeed and calibrated airspeed for the normal aircraft static air source during flight.

(2) *Purpose.* This graph is used to determine calibrated airspeed for a given indicated airspeed using the

normal aircraft static air system. The data is shown on two graphs. One graph is for airspeeds between 80 and 200 knots with lines for flaps down with gear down, flaps approach with gear down, and flaps approach with gear up. The other graph is for airspeeds between 100 and 250 knots with lines for flaps up with gear down and flaps up with gear up. The indicated airspeed values on this graph assume zero instrument error.

*d. Altimeter Correction Normal System.*

(1) *Description.* The Altimeter Correction Normal System graph (fig. 7-4) provides the altitude correction to be made to the altimeter reading when the normal aircraft static source is being used.

(2) *Purpose.* This graph is used to determine altimeter correction factors to be added to indicated altitude for flaps settings of up, approach, and down at various indicated airspeeds to find true pressure altitude for a given indicated pressure altitude. The indicated airspeed values on this graph assume zero instrument error.

*e. Airspeed Calibration Alternate System.*

(1) *Description.* The Airspeed Calibration Alternate System graph (fig. 7-5) depicts the relationship between indicated airspeed and calibrated airspeed for the alternate aircraft static air source.

(2) *Purpose.* This graph is used to determine calibrated airspeed for a given indicated airspeed using the alternate aircraft static air system.

*f. Altimeter Correction Alternate System.*

(1) *Description.* The Altimeter Correction Alternate System graph (fig. 7-6) provides the altitude correction to be made to the altimeter reading when the alternate aircraft static air source is being used.

(2) *Purpose.* This graph is used to determine altimeter correction factors to be added or subtracted to indicated altitude for a given indicated airspeed and pressure altitude.

*g. Indicated Outside Air Temperature Correction.*

(1) *Description.* The Indicated Outside Air Temperature Correction graph (fig. 7-7) provides temperature corrections to be made to indicated free air temperature to obtain true free air temperature.

(2) *Purpose.* This graph is used to determine the correction factor which must be added to the reading on

the free air temperature gage to obtain true free air temperature at a given calibrated airspeed and pressure altitude. The graph assumes standard day (ISA) conditions.

*h. ISA Conversion.*

(1) *Description.* The ISA Conversion graph (fig. 7-8) allows conversion to ISA.

(2) *Purpose.* This graph is used to convert to ISA, given free air temperature in degrees Celsius and pressure altitude in feet.

*i. Fahrenheit to Celsius Temperature Conversion.*

(1) *Description.* The Fahrenheit to Celsius Temperature Conversion graph (fig. 7-9) depicts the relationship between temperature in degrees Fahrenheit and degrees Celsius.

(2) *Purpose.* This graph is used to convert from degrees Fahrenheit to degrees Celsius or degrees Celsius to degrees Fahrenheit.

*j. Static Take-off Power at 1700 RPM, Ice Vanes Retracted or Extended.*

(1) *Description.* The Static Take-off Power at 1700 RPM, Ice Vanes Retracted or Extended graphs (fig. 7-10 and 7-11) depict the power which must be available for takeoff without exceeding engine limitations.

(2) *Purpose.* These graphs are used to determine static take-off power available at 1700 RPM for a given free air temperature in degrees Celsius and field pressure altitude in feet. One graph is provided for ice vanes retracted and the other for ice vanes extended. Torque will increase with increasing airspeed.

*k. Wind Components.*

(1) *Description.* The Wind Components graph (fig. 7-12) allows conversion of wind direction, wind speed, and angle between wind direction and flight path to headwind and crosswind speed components.

(2) *Purpose.* This graph is used to determine the headwind component and crosswind component in knots when the wind speed in knots and the angle between the wind direction and flight path in degrees are known.

*l. Maximum Take-off Weight Permitted by Enroute Climb Requirements.*

(1) *Description.* The Maximum Take-off Weight Permitted by Enroute Climb Requirements graph

(fig. 7-13) provides the one engine inoperative climb performance weight limit as a function of field pressure altitude and temperature.

(2) *Purpose.* This graph is used to determine the maximum weight at which the aircraft can take off and still meet the minimum one engine inoperative rate of climb capability, given field pressure altitude in feet and temperature in degrees Celsius. Refer to the Climb One Engine Inoperative graph for the actual climb capabilities applicable to the temperature and altitude being considered. For operation with ice vanes extended, reduce the weight determined from the graph by 1800 pounds.

*m. Maximum Take-off Weight Flaps Up To Achieve Positive One Engine Climb At Lift-off.*

(1) *Description.* The Maximum Take-off Weight to Achieve Positive One Engine Inoperative Climb at Liftoff Flaps Up graph (fig. 7-14) provides the one engine inoperative liftoff climb performance weight limit as a function of field pressure altitude and temperature.

(2) *Purpose.* This graph is used to determine the maximum weight at which the aircraft can take off with flaps up, have an engine failure, and be able to attain a positive rate of climb at liftoff, given field pressure altitude in feet and free air temperature in degrees Celsius. For operation with ice vanes extended, add 1700 feet to field pressure altitude before entering graph.

*n. Maximum Take-off Weight as Limited by Tire Speed Flaps Up.*

(1) *Description.* The Maximum Take-off Weight as Limited by Tire Speed Flaps Up graph (fig. 7-15) provides the takeoff tire speed weight limit as a function of field pressure altitude, temperature, and wind component.

(2) *Purpose.* This graph is used to determine the maximum weight at which the aircraft can take off and not exceed tire limitations, given free air temperature in degrees Celsius, field pressure altitude in feet, and head or tail wind component in knots.

*o. Take-off Speeds (KIAS) Flaps Up.*

(1) *Description.* The Take-off Speeds (KIAS) Flaps Up table (fig. 7-16) allows selection of the proper takeoff speeds for takeoff weight, pressure altitude, and temperature.

(2) *Purpose.* This table is used to determine  $V_1$ ,  $V_R$ ,  $V_2$ , and  $V_{50}$  For each takeoff, given free air temperature in degrees Celsius, field pressure altitude in feet, and takeoff gross weight in pounds.

*p. Take-off Flaps Up.*

(1) *Description.* The Take-off Distance Over 50 Foot Obstacle Flaps Up graph (fig. 7-17) depicts the relationship of takeoff distance to free air temperature, field pressure altitude, takeoff weight, runway gradient, and wind component.

(2) *Purpose.* This graph is used to determine the ground roll distance or the total distance required to take off and clear a 50 foot obstacle, given free air temperature in degrees Celsius, field pressure altitude in feet, aircraft takeoff weight in pounds, runway gradient in % up or down, and head or tail wind component in knots. For operation with ice vanes extended, increase total distance by 31%. Consult Maximum Take-off weight Flaps Up as limited by Tire Speed graph for possible tailwind prohibitions.

*q. Accelerate-Stop Flaps Up.*

(1) *Description.* The Accelerate-Stop Flaps Up graph (fig. 7-18) depicts the distance required to accelerate to decision speed ( $V_1$ ) then stop.

(2) *Purpose.* This graph is used to determine the total runway length required to accelerate to  $V_1$  (takeoff decision speed), set power levers to ground fine at  $V_1$ , then use maximum braking (without sliding tires) until the aircraft is stopped, given free air temperature in degrees Celsius, field pressure altitude in feet, takeoff weight in pounds, up or down runway gradient in %, and head or tail wind component in knots. For operations with ice vanes extended, increase distance by 7%. Maximum Take-Off Weight Flaps Up As Limited by Tire Speed graph for possible tailwind prohibitions.

*r. Accelerate-Go Flaps Up.*

(1) *Description.* The Accelerate-Go Distance Over 50 Foot Obstacle Flaps Up graph (fig. 7-19) depicts the total distance required to accelerate to takeoff airspeed, have an engine failure, then continue the takeoff until 50 feet above the runway.

(2) *Purpose.* This graph is used to determine the total distance required to accelerate to  $V_1$  (takeoff decision speed), have an engine failure, then continue the climb until 50 feet above the runway. For operation with ice vanes extended, increase distance by 35%. Consult Maximum Take-Off Weight Flaps Up As Limited by Tire Speed graph for possible tailwind prohibitions.

s. *Net Take-off Flight Path First Segment Flaps Up.*

(1) *Description.* The Net Take-off Flight Path First Segment Flaps Up graph (fig. 7-20) depicts the net climb gradient for the first segment of a one engine inoperative climb.

(2) *Purpose.* This graph is used to determine the climb gradient in % for a one engine inoperative climb from liftoff until the landing gear completes the retraction cycle, given free air temperature in degrees Celsius, field pressure altitude in feet, takeoff weight in pounds, and head or tail wind in knots. For operation with ice vanes extended, decrease net climb gradient by 1.2 percentage points.

t. *Net Take-off Flight Path Second Segment Flaps Up.*

(1) *Description.* The Net Take-off Flight Path Second Segment Flaps Up graph (fig. 7-21) depicts the net climb gradient for the second segment of a one engine inoperative climb.

(2) *Purpose.* This graph is used to determine the climb gradient in % for a one engine inoperative climb from completion of the landing gear retraction cycle, until reaching 500 feet above the runway, given free air temperature in degrees Celsius, field pressure altitude in feet, takeoff weight in pounds, and wind component in knots. For operation with ice vanes extended, decrease net climb gradient by 1.2 percentage points.

u. *Horizontal Distance From Reference Zero to Third Segment Climb Flaps Up.*

(1) *Description.* The Horizontal Distance from Reference Zero to Third Segment Climb Flaps Up graph (fig. 7-22) depicts the horizontal distance traveled to the third segment climb of a one engine inoperative climb.

(2) *Purpose.* This graph is used to determine the horizontal distance required for a one engine inoperative climb from a point 50 feet above the runway (reference zero) to a point where the third segment climb has been reached, given free air temperature in degrees Celsius, field pressure altitude in feet, takeoff weight in pounds, and head or tail wind component in knots. For operation with ice vanes extended, increase free air temperature by 11°C before entering graph.

v. *Maximum Take-off Weight to Achieve One engine Inoperative Climb at Liftoff Flaps Approach.*

(1) *Description.* The Maximum Take-off Weight to Achieve Positive One-engine Inoperative Climb

at Liftoff Flaps Approach graph (fig. 7-23) provides the one engine inoperative liftoff climb performance weight limit as a function of field pressure altitude and temperature.

(2) *Purpose.* This graph is used to determine the maximum weight at which the aircraft can take off and achieve a positive rate of climb after an engine failure at liftoff, given field pressure altitude in feet and free air temperature in degrees Celsius. For operation with ice vanes extended, add 1500 feet to field pressure altitude before entering graph.

w. *Maximum Take-off Weight as Limited by Tire Speed Flaps Approach.*

(1) *Description.* The Maximum Take-off Weight as Limited by Tire Speed Flaps Approach graph (fig. 7-24) provides the takeoff tire speed weight limit as a function of field pressure altitude, temperature, and wind component.

(2) *Purpose.* This graph is used to determine the maximum weight at which the aircraft can take off and not exceed tire limitations, given free air temperature in degrees Celsius, field pressure altitude in feet, and head or tail wind component in knots.

x. *Take-off Speeds Flaps Approach.*

(1) *Description.* The Take-off Speeds Flaps Approach table (fig. 7-25) allows selection of the proper takeoff speeds for takeoff weight, pressure altitude, and temperature.

(2) *Purpose.* This table is used to determine  $V_1$ ,  $V_R$ ,  $V_2$ , and  $V_{50}$  for each takeoff, given free air temperature in degrees Celsius, field pressure altitude in feet, and takeoff gross weight in pounds.

y. *Take-off Distance Flaps Approach.*

(1) *Description.* The Take-off Distance Over 50 Foot Obstacle Flaps Approach graph (fig. 7-26) depicts the relationship of takeoff distance to free air temperature, field pressure altitude, takeoff weight, runway gradient, and wind component.

(2) *Purpose.* This graph is used to determine the ground roll and total distance required to take off and clear a 50 foot obstacle, given free air temperature in degrees Celsius, field pressure altitude in feet, aircraft takeoff weight in pounds, runway gradient in % up or down, and head or tail wind component in knots. For operations with ice vanes extended, increase distance by 22%. Consult

Maximum Take-Off Weight Flaps Approach As Limited By Tire Speed graph for possible tailwind prohibitions.

*z. Accelerate Stop Flaps Approach.*

(1) *Description.* The Accelerate-Stop 7 Flaps Approach graph (fig. 7-27) depicts the distance required to accelerate to  $V_1$  (takeoff decision speed) then stop.

(2) *Purpose.* This graph is used to determine the total runway length required to accelerate to  $V_1$  (takeoff decision speed), set power levers to ground fine at  $V_1$ , then use maximum braking (without sliding tires) until the aircraft is stopped, given free air temperature in degrees Celsius, field pressure altitude in feet, takeoff weight in pounds, up or down runway gradient in %, and head or tail wind component in knots. For operation with ice vanes extended, increase distance by 5%. Consult Maximum Take-Off Weight Flaps Approach As Limited By Tire Speed graph for possible tailwind prohibitions.

*aa. Accelerate Go Flaps Approach.*

(1) *Description.* The Accelerate Go Distance Over 50 Foot Obstacle Flaps Approach graph (fig.7-28) depicts the total distance required to accelerate to takeoff airspeed, have an engine failure, then continue the takeoff until 50 feet above the runway.

(2) *Purpose.* This graph is used to determine the total distance required to accelerate to  $V_1$  (takeoff decision speed), have an engine failure, then continue the climb until 50 feet above the runway, given free air temperature in degrees Celsius, field pressure altitude in feet, takeoff weight in pounds, up or down runway gradient in %, and head or tail wind component in knots. For operation with ice vanes extended, increase distance by 35%. Consult Maximum Take-Off Weight Flaps Approach As Limited -By Tire Speed graph for possible tailwind prohibitions.

*ab. Net Take-off Flight Path First Segment Flaps Approach.*

(1) *Description.* The Net Take-off Flight Path First Segment Flaps Approach graph (fig. 7-29) depicts the net climb gradient for the first segment of a one engine inoperative climb.

(2) *Purpose.* This graph is used to determine the climb gradient in % for a one engine inoperative climb from liftoff until the landing gear completes the retraction cycle, given free air temperature in degrees Celsius, field pressure altitude in feet, takeoff weight in pounds, and head or tail wind in knots. For operation with ice vanes extended, decrease net climb gradient by 1.0 percentage point.

*ac. Net Take-off Flight Path Second Segment Flaps Approach.*

(1) *Description.* The Net Take-off Flight Path Second Segment Flaps Approach graph (fig. 7-30) depicts the net climb gradient for the second segment of a one engine inoperative climb.

(2) *Purpose.* This graph is used to determine the climb gradient in % for a one engine inoperative climb from completion of the landing gear retraction cycle, until reaching 500 feet above the runway, given free air temperature in degrees Celsius, field pressure altitude in feet, takeoff weight in pounds, and head or tail wind in knots. For operation with ice vanes extended, decrease net climb gradient by 1.0 percentage point.

*ad. Horizontal Distance from Reference Zero to Third Segment Climb Flaps Approach.*

(1) *Description.* The Horizontal Distance from Reference Zero to Third Segment Climb Flaps Approach graph (fig. 7-31) depicts the horizontal distance traveled to the third segment of a one engine inoperative climb.

(2) *Purpose.* This graph is used to determine the horizontal distance required for a one engine inoperative climb from a point 50 feet above the runway (reference zero) to a point where the third segment climb has been reached, given free air temperature in degrees Celsius, field pressure altitude in feet, takeoff weight in pounds, and head or tail wind component in knots. For operation with ice vanes extended, increase free air temperature by 11 °C before entering graph.

*ae. Close-in Take-off Flight Path.*

(1) *Description.* The Close-in Take-off Flight Path Flaps Approach graph (fig. 7-32) depicts the climb gradient required to clear an obstacle within 1000 feet of reference zero.

(2) *Purpose.* This graph is used to determine net climb gradient in % required to clear an obstacle of known height plus a desired margin of clearance, given the horizontal distance of the obstacle from reference zero in feet.

*af. Distant Take-off Flight Path.*

(1) *Description.* The Distant Take-off Flight Path Flaps Approach graph (fig. 7-33) depicts the climb gradient required to clear an obstacle within 2.4 nautical miles from reference zero.

(2) *Purpose.* This graph is used to determine net climb gradient in % required to clear an obstacle of

known height plus a desired margin of clearance, given the horizontal distance of the obstacle from reference zero in nautical miles.

*ag. Net Take-off Flight Path Third Segment.*

(1) *Description.* The Net Take-off Flight Path Third Segment graph (fig. 7-34) depicts the climb gradient for the third segment of a one engine inoperative climb.

(2) *Purpose.* This graph is used to determine the net climb gradient in % for a one engine inoperative climb from 500 feet above the runway to 1500 feet above the runway at VENR, given free air temperature in degrees Celsius, pressure altitude in feet, aircraft weight in pounds, and head or tail wind component in knots. For operation with ice vanes extended, decrease net climb gradient by 1.5 percentage points.

*ah. Climb Two Engine Flaps Up.*

(1) *Description.* The Climb Two Engine Flaps Up graph (fig. 7-35) depicts rate of climb for two engine operation.

(2) *Purpose.* This graph is used to determine the rate of climb in feet per minute and climb gradient in % for a two engine climb with flaps up, given free air temperature in degrees Celsius, pressure altitude in feet, and aircraft weight in pounds. For operation with ice vanes extended, rate of climb will be reduced by approximately 500 feet per minute.

*ai. Climb Two Engine Flaps Approach.*

(1) *Description.* The Climb Two Engine Flaps Approach graph (fig. 7-36) depicts rate of climb for two engine operation.

(2) *Purpose.* This graph is used to determine the rate of climb in feet per minute and climb gradient in % for a two engine climb with flaps approach, given free air temperature in degrees Celsius, pressure altitude in feet, and aircraft weight in pounds. For operation with ice vanes extended, rate of climb will be reduced by approximately 500 feet per minute.

*aj. Climb One Engine Inoperative.*

(1) *Description.* The Climb One Engine Inoperative graph (fig. 7-37) depicts the rate of climb to be expected in feet per minute at 130 knots for all aircraft weights with one propeller feathered, landing gear and flaps retracted, and maximum continuous power on the operating engine.

(2) *Purpose.* This graph is used to determine the rate of climb in feet per minute and climb gradient in % for a one engine inoperative climb with gear and flaps up, given free air temperature in degrees Celsius, pressure altitude in feet, and aircraft weight in pounds. For operation with ice vanes extended, rate of climb will be reduced by approximately 220 feet per minute.

*ak. Service Ceiling One Engine Inoperative.*

(1) *Description.* The Service Ceiling One Engine Inoperative graph (fig. 7-38) depicts the maximum pressure altitude at which the aircraft is capable of climbing at 50 feet per minute with one propeller feathered.

(2) *Purpose.* This graph is used to determine the maximum pressure altitude at which the aircraft is capable of climbing at 50 feet per minute with one propeller feathered, given free air temperature in degrees Celsius and aircraft weight in pounds. For operation with ice vanes extended, the service ceiling will be lowered by approximately 1800 feet.

*al. Time, Fuel, and Distance to Cruise Climb.*

(1) *Description.* The Time, Fuel, and Distance to Cruise Climb graph (fig. 7-39) depicts the time, fuel, and distance to cruise climb.

(2) *Purpose.* This graph is used to determine the time, fuel, and distance required to cruise climb, given the beginning and ending free air temperature in degrees Celsius, beginning and ending pressure altitude in feet, and the initial climb aircraft weight in pounds. To account for start, taxi, and takeoff add 120 pounds of fuel. For operation with ice vanes extended, add 150C to the actual FAT before entering the graph.

*am. Maximum Cruise Power at 1700 RPM.*

(1) *Description.* The Maximum Cruise Power at 1700 RPM tables (fig. 7-40 through 7-47) show fuel flow, airspeed, and torque for various flight conditions.

(2) *Purpose.* These tables are used to determine fuel flow per engine, total fuel flow, indicated airspeed, and true airspeed, given pressure altitude in feet, indicated free air temperature in degrees Celsius, free air temperature in degrees Celsius, aircraft weight in pounds, and torque per engine in percent. During operations with ice vanes extended, torque will decrease approximately 12%, fuel flow will decrease approximately 8%, and true airspeed will be reduced by approximately 15 knots.

*an. Maximum Cruise Speeds at 1700 RPM.*

(1) *Description.* The Maximum Cruise Speeds at 1700 RPM graph (fig. 7-48) depicts the relationship

between maximum cruise speed, pressure altitude, ISA condition, and aircraft weight in pounds. During operation with ice vanes extended, true airspeed will be reduced approximately 15 knots.

(2) *Purpose.* This graph is used to determine maximum cruise speed, given pressure altitude in feet and ISA condition, and aircraft weight in pounds. During operation with ice vanes extended, true airspeed will be reduced by approximately 15 knots.

*ao. Maximum Cruise Power At 1700 RPM.*

(1) *Description.* The Maximum Cruise Power At 1700 RPM graph (fig. 7-49) depicts the recommended torque setting to attain maximum cruise power.

(2) *Purpose.* This graph is used to determine the recommended torque setting for maximum cruise power, given indicated free air temperature in degrees Celsius, pressure altitude in feet, and aircraft weight in pounds. During operation with ice vanes extended, torque will decrease approximately 12%.

*ap. Fuel Flow at Maximum Cruise Power at 1700 RPM.*

(1) *Description.* The Fuel Flow at Maximum Cruise Power at 1700 RPM graph (fig. 7-50) depicts the fuel flow per engine in pounds per hour at maximum cruise power.

(2) *Purpose.* This graph is used to determine maximum cruise power fuel flow per engine given indicated free air temperature in degrees Celsius, pressure altitude in feet, and aircraft weight in pounds. During operation with ice vanes extended, fuel flow will decrease 8%.

*aq. Range-Profile --Maximum Cruise Power at 1700 RPM.*

(1) *Description.* The Range Profile Maximum Cruise Power at 1700 RPM graph (fig. 7-51) depicts range at maximum cruise power.

(2) *Purpose.* This graph is used to determine range in nautical miles for various fuel loads and fuel tank combinations, given pressure altitude in feet and true airspeed in knots. Range allows for start, taxi, and runup; includes cruise climb descent; and allows for 45 minutes reserve fuel at maximum range power. At 16,620 pounds ramp weight, the maximum zero fuel weight limitation of 13,100 pounds would be exceeded at fuel loading less than 3520 pounds.

*ar. Normal Cruise Power at 1500 RPM.*

(1) *Description.* The Normal Cruise Power at 1500 RPM tables (fig. 7-52 through 7-59) show fuel flow, airspeed, and torque for various flight conditions.

(2) *Purpose.* These tables are used to determine fuel flow per engine, total fuel flow, indicated airspeed, and true airspeed, given pressure altitude in feet, indicated free air temperature in degrees Celsius, free air temperature in degrees Celsius, aircraft weight in pounds, and torque per engine in percent. During operation with ice vanes extended, torque will decrease by approximately 12%, fuel flow will decrease by approximately 8%, and true airspeed will be reduced by approximately 15 knots.

*as. Normal Cruise Speeds at 1500 RPM.*

(1) *Description.* The Normal Cruise Speeds at 1500 RPM graph (fig. 7-60) depicts the relationship between normal cruise speed, pressure altitude, and ISA condition.

(2) *Purpose.* This graph is used to determine maximum cruise speed, given pressure altitude in feet, ISA condition, and aircraft weight in pounds. During operation with ice vanes extended, true airspeed will be reduced by approximately 15 knots

*at. Normal Cruise Power At 1500 RPM.*

(1) *Description.* The Normal Cruise Power at 1500 RPM graph (fig. 7-61) depicts the torque setting to attain normal cruise power.

(2) *Purpose.* This graph is used to determine the torque setting for normal cruise power, given indicated free air temperature in degrees Celsius or ISA, pressure altitude in feet, and aircraft weight in pounds.

*au. Fuel Flow at Normal Cruise Power at 1500 RPM.*

(1) *Description.* The Fuel Flow at Normal Cruise Power at 1500 RPM graph (fig. 7-62) depicts the fuel flow per engine in pounds per hour at normal cruise power.

(2) *Purpose.* This graph is used to determine normal cruise power fuel flow per engine, given indicated free air temperature, pressure altitude in feet, and aircraft weight in pounds. During operations with ice vanes extended, torque will decrease by approximately 12%.

*av. Range Profile Normal Cruise Power at 1500 RPM.*

(1) *Description.* The Range Profile Normal Cruise Power at 1500 RPM graph (fig. 7-63) depicts range at normal cruise power.

(2) *Purpose.* This graph is used to determine range in nautical miles for various fuel loads and fuel tank combinations, given pressure altitude in feet and true airspeed in knots. Range allows for start, taxi, and runup; includes cruise climb descent; and allows for 45 minutes reserve fuel at maximum range power. At 16,620 pounds ramp weight the maximum zero-fuel weight limitation of 13,100 pounds would be exceeded at fuel loading less than 3520.

*aw. Maximum Range Power at 1500 RPM.*

(1) *Description.* The Maximum Range Power at 1500 RPM tables (fig. 7-64 through 7-71) show fuel flow, airspeed, and torque for various flight conditions.

(2) *Purpose.* These tables are used to determine fuel flow per engine, total fuel flow, indicated airspeed, and true airspeed, given pressure altitude in feet, indicated free air temperature and free air temperature in degrees Celsius, aircraft weight in pounds, and torque per engine in percent. During operation with ice vanes extended, torque will decrease by approximately 10%. Fuel flow will decrease by approximately 5%, and true air speed will be reduced by approximately 10 knots.

*ax. Range Profile Maximum Range Power at 1500 RPM.*

(1) *Description.* The Range Profile Maximum Range Power at 1500 RPM graph (fig. 7-72) depicts range at maximum range power.

(2) *Purpose.* This graph is used to determine range in nautical miles for various fuel loads and fuel tank combinations, given pressure altitude in feet and true airspeed in knots. Range allows for start, taxi, and runup; includes cruise climb descent; and allows for 45 minutes reserve fuel at maximum range power. At 16,620 pounds ramp weight, the maximum zero fuel weight limitation of 13,100 pounds would be exceeded at fuel loading less than 3520 pounds.

*ay. Loiter Power at 1700 RPM.*

(1) *Description.* The Loiter Power at 1700 RPM tables (fig. 7-73 through 7-80) show fuel flow, airspeed, and torque for various flight conditions.

(2) *Purpose.* These tables are used to determine fuel flow per engine, total fuel flow, indicated airspeed, and true airspeed, given pressure altitude in feet, indicated free air temperature and free air temperature in degrees Celsius, aircraft weight in pounds, and torque per engine in percent. During operation with ice vanes

extended, torque, fuel flow, and true airspeed will remain approximately unchanged.

*az. Endurance Profile Loiter Power.*

(1) *Description.* The Endurance Profile Loiter Power at 1700 RPM graph (fig. 7-81) depicts endurance at loiter power allowing fuel for start, taxi, runup, cruise climb and descent, and 45 minutes fuel reserve.

(2) *Purpose.* This graph is used to determine endurance in hours for various fuel loads and fuel tank combinations, given pressure altitude in feet and true airspeed in knots. Endurance allows for start, taxi, and runup; includes cruise climb descent; and allows for 45 minutes reserve fuel at maximum range power. At 16,620 pounds ramp weight, the maximum zero fuel weight limitation of 13,100 pounds would be exceeded at fuel loading less than 3520 pounds.

*ba. Range Profile Full Main Tanks.*

(1) *Description.* The Range Profile Full Main Tanks graph (fig. 7-82) depicts range, allowing fuel for start, taxi, runup, cruise climb and descent, and 45 minutes fuel reserve.

(2) *Purpose.* This graph is used to determine range in nautical miles for full main tanks, given pressure altitude in feet and true airspeed in knots.

*bb. Endurance Profile Full Main Tanks.*

(1) *Description.* The Endurance Profile Full Main Tanks graph (fig. 7-83) depicts endurance, allowing fuel for start, taxi, runup, cruise climb and descent, and 45 minutes fuel reserve.

(2) *Purpose.* This graph is used to determine endurance in hours for full main tanks, given pressure altitude in feet and true airspeed in knots.

*bc. Range Profile Full Main and Aux Tanks.*

(1) *Description.* The Range Profile Full Main and Aux Tanks graph (fig. 7-84) depicts range, allowing fuel for start, taxi, runup, cruise climb and descent, and 45 minutes fuel reserve.

(2) *Purpose.* This graph is used to determine range in nautical miles for full main and aux tanks, given pressure altitude in feet and true airspeed in knots.

*bd. Endurance Profile Full Main and Aux Tanks.*

(1) *Description.* The Endurance Profile Loiter Power at 1700 RPM graph (fig. 7-85) depicts endurance,



allowing fuel for start, taxi, runup, cruise climb and descent, and 45 minutes fuel reserve.

(2) *Purpose.* This graph is used to determine endurance in hours for full main and aux tanks, given pressure altitude in feet and true airspeed in knots.

*be. One Engine Inoperative Max Cruise Power at 1700 RPM.*

(1) *Description.* The One Engine Inoperative Max Cruise Power at 1700 RPM tables (fig. 7-86 through 7-93) show fuel flow, airspeed, and torque for various flight conditions.

(2) *Purpose.* These tables are used to determine fuel flow per engine, total fuel flow, indicated airspeed, and true airspeed, given pressure altitude in feet, indicated free air temperature and free air temperature in degrees Celsius, aircraft weight in pounds, and torque per engine in percent. During operation with ice vanes extended, torque will decrease approximately 10%, fuel flow will decrease by approximately 6%, and true airspeed will be reduced by approximately 10 knots.

*bf. Time, Fuel, and Distance to Descend.*

(1) *Description.* The Time, Fuel, and Distance to Descend graph (fig 7-94) depicts the time, fuel, and distance to descend.

(2) *Purpose.* This graph is used to determine the time, fuel, and distance required to descend, given the beginning and ending pressure altitudes in feet.

*bg. Climb Balked Landing.*

(1) *Description.* The Climb Balked Landing graph (fig. 7-95) depicts rate of climb to be expected after a balked landing.

(2) *Purpose.* This graph is used to determine the rate of climb in feet per minute and climb gradient in percent, given the free air temperature in degrees Celsius, pressure altitude in feet, and aircraft weight in pounds. For operation with ice vanes extended, rate of climb will be reduced by approximately 300 feet per minute. Enter the graph at the pressure altitude from which a go-around would be initiated.

*bh. Normal Landing Distance Flaps Down.*

(1) *Description.* The Normal Landing Distance Flaps Down graph (fig. 7-96) depicts normal flaps down landing distance.

(2) *Purpose.* This graph is used to determine flaps down landing distance, given free air temperature in degrees Celsius, field pressure altitude, runway gradient in % up or down, and head or tail wind component in knots. The wind grids include factors of 50% for headwinds and 150% for tailwinds. Components of reported winds may therefore be used directly in the grids. Weight does not significantly affect landing distance.

*bi. Landing Distance Flaps Up.*

(1) *Description.* The Landing Distance Flaps Up graph (fig. 7-97) depicts landing distance with flaps up.

(2) *Purpose.* This graph is used to determine flaps up landing distance, given flaps down landing distance. Landing with flaps full down is normal procedure. Flaps up landings may produce tire speeds and/or brake energies that exceed limitation. To determine the flaps-up landing distance, read from the Normal Landing Distance Flaps Down graph, the landing distance appropriate to temperature, altitude, runway gradient, and wind. Enter the subject graph with the derived value, and read the flaps-up landing distance.

*bj. Landing Distance One Engine Inoperative Flaps Down.*

(1) *Description.* The Landing Distance One Engine Inoperative Flaps Down graph (fig. 7-98) depicts one engine inoperative landing distance.

(2) *Purpose.* This graph is used to determine one engine inoperative flaps down landing distance, given the flaps down normal landing distance. To determine the one engine inoperative landing distance, read from the Normal Landing Distance Flaps Down graph, the landing distance appropriate to temperature, altitude, runway gradient, and wind. Enter the subject graph with the derived value, and read the one engine inoperative landing distance.

**7-4. EXAMPLES.**

The following examples present calculations for flight time, block speed, and fuel required for a proposed flight from Billings, Montana, to Casper, Wyoming, at flight level 250, using the conditions listed below, except as noted. The desired takeoff weight is 16,000 pounds, if possible.

*a. Conditions. At Billings-Logan International (BIL):*

Free Air Temperature .....59°F  
 Field Elevation.....3649 feet<sup>1</sup>

Altimeter Setting..... 30.07 in. Hg  
 Wind..... 290 at 15 knots  
 Runway 34 Length ..... 5585 feet<sup>1</sup>  
 Gradient ..... 9% downhill<sup>1</sup>

<sup>1</sup>Source: DOD TERM USLIAAPVO1, 9 JAN 92.

Route of Trip: BIL - V19 - CPR

Route Segment Data: Table 7-1.

At Natrona County International (CPR):

Free Air Temperature..... 68°F  
 Field Elevation ..... 5348 feet<sup>4</sup>  
 Altimeter Setting..... 29.27 in. Hg  
 Wind..... 330° at 10 knots  
 Runway 30 Length ..... 8686 feet<sup>4</sup>  
 Gradient ..... 0.3% up<sup>4</sup>

<sup>4</sup>Source: DOD TERM USLIAPV03, 9 JAN 92.

*b. Fahrenheit to Celsius Temperature Conversion.*  
 Convert reported field temperatures at the departure and destination airports from Fahrenheit to Celsius using the Fahrenheit to Celsius Temperature Conversion graph (fig. 7-9). Enter the chart at the appropriate value on the °F scale, read up to the reference line and left to the corresponding value in °C.

Billings-Logan International 59°F..... 15°C  
 Natrona County International 68°F..... 20°C

*c. Pressure Altitude.* To determine the approximate pressure altitudes at origin and destination airports, add 1000 feet to field elevation for each 1.00 in. Hg that the reported altimeter setting value is below 29.92 in. Hg, and subtract 1000 feet for each 1.00 in. Hg above 29.92 in. Hg. Always subtract 1000 feet for each 1.00 in. Hg above 29.92 in. Hg, then multiply the answer by 1000 to find the

difference in feet between field elevation and pressure altitude.

Pressure Altitude at BIL:

29.92  
 $\frac{-30.07}{-0.15}$   
 -0.15 x 1000 feet = -150 feet

Field Elevation ..... 3649 feet  
 Pressure Altitude Correction..... -150 feet  
 Field Pressure Altitude ..... 3499 feet

Pressure Altitude at CPR:

29.92  
 $\frac{-29.27}{+0.65}$   
 0.65 x 1000 feet = 650 feet

Field Elevation ..... 5348 feet  
 Pressure Altitude Correction..... +650 feet  
 Field Pressure Altitude ..... 5998 feet

*d. Wind Components.* Determine the headwind (tailwind) and crosswind component for the selected runway. Compute the angle between the reported wind at Billings-Logan International of 290° and the selected runway heading of 340° to be 50°. Locate the line for 50° angle between wind direction and flight path on the graph. Trace along the 50° line and locate the reported wind speed of 15 knots (the point midway between the 10 and 20 knot wind speed lines). Read left to obtain the headwind component and down to obtain the crosswind component.

Headwind Component ..... 10 knots  
 Crosswind Component ..... 12 knots

Table 7-1. Route Segment Data2

ROUTE SEG-MENT	AVERAGE MAGNETIC COURSE	AVERAGE MAGNETIC VARIATION	DIS-TANCE NM	WIND AT FL 250 DIR.IKNOTS	FAT AT FL 250 °C	MEA FEET	FAT AT MEA °C	ALTIMETER SETTING IN. HG
BIL-SHR	117°	15°E	91 <sup>3</sup>	010°/45	-40	8000	0	29.97
SHR-CZI	139°	14°E	57	350°65	-40	9000	-4	29.60
CZI-CPR	161°	13°E	69 <sup>3</sup>	310°/50	-30	7600	0	29.48

<sup>2</sup>Source: DOD Low Altitude Enroute Chart L-9, 9 Jan 1992.

<sup>3</sup>Includes distance between airport and VORTAC, per DOD US IFR SUPPLEMENT, 9 JAN 1992.

e. *Takeoff Weight* The following examples illustrate the use of graphs which may restrict takeoff weight.

**NOTE**

**Do not exceed the maximum takeoff weight limitation of 16,500 pounds.**

(1) *Maximum takeoff weight as limited by tire speed.* Enter the graphs at 15°C, 3499 ft, 10 knots headwind component, and read:

Flaps Up ..... Exceeds Structural Limit of 16,500 lbs  
 Flaps Approach.... Exceeds Structural Limit of 16,500 lbs

(2) Maximum takeoff weight to achieve positive one-engine-inoperative climb at liftoff. Enter the graphs at 3499 feet pressure altitude, 15°C, and read:

Flaps Up ..... 16,500 lbs  
 Flaps Approach ..... 16,500 lbs

(3) *Maximum enroute weight for 50-ft/minute one-engine-inoperative climb.* To determine the maximum takeoff weight, the weight of the fuel used to reach the MEA is added to the maximum enroute weight obtained from the Service Ceiling - One Engine Inoperative graph (fig. 7-38). Use the Time, Fuel, and Distance to Cruise Climb graph (fig. 7-39) to determine the weight of the fuel used to climb. Use the Cruise Power tables to determine the weight of the fuel used to cruise to each MEA.

Enter the Service Ceiling - One Engine Inoperative graph (fig. 7-38) at the conditions for each enroute MEA. For example, enter the graph at the highest MEA altitude of 9000 feet, and trace right; enter again at the MEA FAT of -4°C, and trace up. Read the maximum enroute weight at the MEA at the intersection of the tracings.

Maximum enroute weight for 50-ft/min one-engine-inoperative climb:

8000 ft, 0°C.... Exceeds Structural Limit of 16,500 lbs  
 9000 ft, -4°C... Exceeds Structural Limit of 16,500 lbs  
 7600 ft, 0°C.... Exceeds Structural Limit of 16,500 lbs

Since these weights are all greater than the maximum takeoff weight limitation of 16,500 lbs, there is no additional limitation to meet enroute weight requirements. Anytime the value is less than 16,500 lbs, add the fuel required to climb, plus any fuel used in cruise before reaching each MEA, to determine the maximum allowable takeoff weight to meet the requirement for each route segment of the trip.

f. *Minimum Static Takeoff Power (Ice Vanes Retracted).* Enter the graph at 15°C FAT and 3499 feet pressure altitude:

Minimum Static Takeoff Power ..... 93.5%

g. *Takeoff Speeds.* Tables are provided for takeoff decision speed (VI), rotation speed (VR), takeoff safety speed (V2), and all-engines takeoff safety speed (VWs) In order to determine the takeoff speeds for 15°C FAT, 3499 feet pressure altitude, and 16,000 pounds takeoff weight, enter the tables at 2000 ft and 4000 ft pressure altitude, 100C and 20°C FAT, and 16,000 pounds takeoff weight, then interpolate to find the actual values for the specified conditions:

V<sub>1</sub>..... 116 KTS (flaps up), 108 KTS (flaps approach)  
 V<sub>R</sub> ..... 124 KTS (flaps up), 113 KTS (flaps approach)  
 V<sub>2</sub>..... 128 KTS (flaps up), 114 KTS (flaps approach)  
 V<sub>50</sub>..... 140 KTS (flaps up), 126 KTS (flaps approach)

h. *Minimum Field Length.* The following example illustrates the use of graphs which may restrict takeoff weight due to field length available under existing conditions.

(1) *Takeoff distance.* Enter the graphs at 15°C, 3499 feet pressure altitude, 16,000 pounds, 1.9% downhill runway gradient, and 10 knots headwind component, and obtain the following results:

Ground Roll (flaps up) ..... 3511 ft  
 Takeoff Distance (flaps up) ..... 4864 ft  
 Ground Roll (flaps approach) ..... 2909 ft  
 Takeoff Distance (flaps approach) ..... 3886 ft

(2) *Accelerate-stop distance.* Enter the graphs at 15°C, 3499 feet pressure altitude, 16,000 pounds, 1.9% downhill runway gradient, and 10 knots headwind component, and obtain the following results:

Accelerate-Stop Distance (flaps up)..... 5877 ft  
 Accelerate-Stop Distance (flaps approach)..... 4972 ft

(3) *Accelerate-go distance.* Enter the graphs at 15°C, 3499 feet pressure altitude, 16,000 pounds, 1.9% downhill runway gradient, and 10 knots headwind component, and obtain the following results:

Accelerate-Go Distance (flaps up) ..... 7172 ft  
 Accelerate-Go Distance (flaps approach) ..... 5069 ft

The minimum recommended runway length is the longest of the distances determined above for the selected flap

setting. The accelerate-go distance (flaps up) would exceed the available runway length, so a flaps-approach takeoff must be calculated if it is desired to allow for the accelerate-go distance (which is not a regulatory requirement, but a recommended practice).

*i. Takeoff Path One Engine Inoperative.* Graphs are provided to estimate the horizontal distance required to reach a height of 1500 feet, or the minimum climb gradient required to clear an obstacle along the takeoff flight path. If clearance of obstacles beyond the runway is required, these results may restrict takeoff weight accordingly.

The takeoff distance extends from brake release to reference zero, which is the point at which the aircraft is 50 feet above the runway. The net takeoff flight path begins at liftoff and consists of the following segments:

1. The first segment climb extends from liftoff to the point where the landing gear completes the retraction cycle. The airspeed is maintained at  $V_2$ .
2. The second segment climb begins at the end of the first segment and extends to 500 feet above the runway. The airspeed during the second segment is  $V_2$ .

3. The acceleration and flap retraction segment consists of an acceleration from  $V_2$  to  $V_{E,R}$  at a constant height of 500 feet. If a flaps approach takeoff was made, begin flap retraction at  $V_{ENR}$ .
4. The third segment climb begins when one engine-inoperative climb speed is reached and flaps are fully retracted at 500 feet, and extends to 1500 feet above the runway. Airspeed is maintained at  $V_{ENR}$  during this segment.

*j. Takeoff Path Profile (Flaps Approach, One Engine Inoperative).* The following examples illustrate the use of the flaps-approach takeoff path graphs. Enter the graphs at 15°C FAT, 3499 feet pressure altitude, 16,000 pounds takeoff weight, 1.9% downhill runway gradient, and a 10-knot headwind component.

(1) Example 1 close-in obstacle clearance:  
given:

Obstacle Height Above Aircraft at Brake Release..... 88 feet

Obstacle Distance from Brake Release ..... 16,294 feet

1. The obstacle horizontal distance from

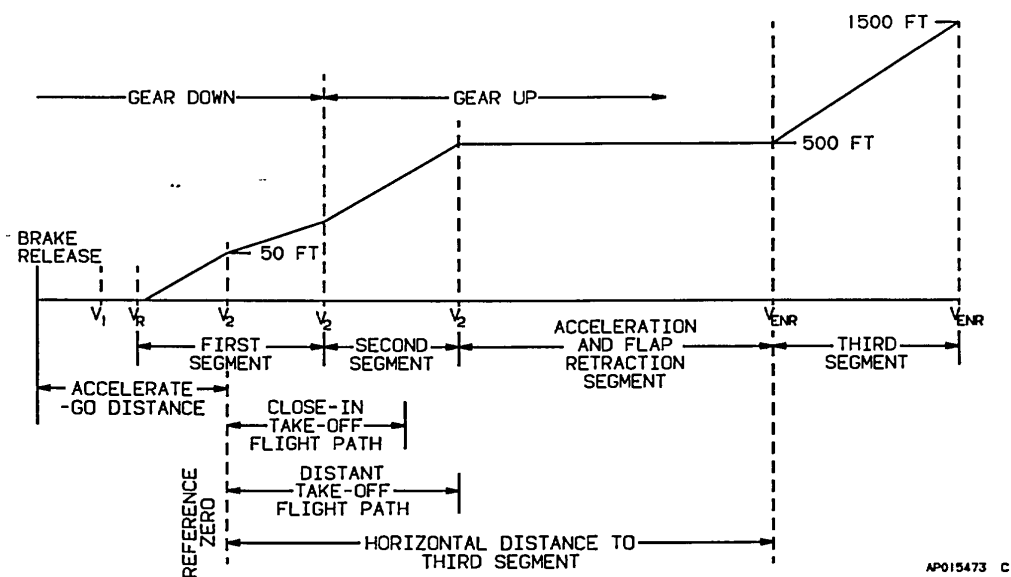

Figure 7-1. Takeoff Path Profile - One Engine Inoperative

reference zero equals the obstacle distance from brake release less the accelerate-go distance to 50 feet AGL (16,294 ft - 5069 ft) = 11,225 feet = 1.85 nautical miles.

2. Determine the total height required to clear the obstacle by adding to the obstacle height the decrease in aircraft altitude during the takeoff procedure due to a downhill runway gradient.

1.9% gradient 5069 ft = 96.3 feet = 96 feet

The total height required to clear the obstacle is:  
88 ft + 96 = 184 feet.

3. Obtain the required gradient to clear the obstacle from the Distant Takeoff Flight Path Graph using the obstacle distance from reference zero found in step 1, and the total height determined in step 2: 1.19%.
4. Read the scheduled net gradient of climb from the Net Takeoff Flight Path Second Segment Flaps Approach graph (fig. 7-30): 2.53%.

Thus, the calculations indicate that a takeoff weight of 16,000 pounds will result in a net climb gradient greater than that required to clear the obstacle, even if an engine should fail at the most critical takeoff point.

(2) *Example 2* Obstacle clearance above 500 feet: given:

Obstacle Height Above Aircraft at Brake Release..... 600 feet.  
Obstacle Distance from Brake Release..... 10.71 nm

1. Obtain the accelerate-go distance to 50 feet AGL ..... 5069 feet (0.83 nm).
2. Read the scheduled distance from the Horizontal Distance From Reference Zero To Third Segment Climb - Flaps Approach graph (fig. 7-31) ..... 5.07 nm.
3. Add the results of steps 1 and 2 to obtain total distance to start of third segment climb, (0.83 nm + 5.07 nm) = 5.9 nm.
4. Distance to obstacle from start of third segment climb is obtained by subtracting results of step 3 from 10.71 nm. (10.71 - 5.9) = 4.81 nm.
5. Add to the obstacle height above the aircraft at brake release any decrease in

aircraft altitude during the takeoff resulting from a downhill runway gradient.

The sum is the total height required to clear the obstacle:

(1.9% gradient / 100) x 5069 ft = 96.3 feet = 96 feet

The total height required to clear the obstacle is:  
600 ft + 96 ft = 696 feet.

6. Required climb gradient to clear obstacle is obtained using the following formula:

$$\% \text{ Gradient} = (\text{RH}) \times (\text{F}) / (\text{D})$$

Where:

RH = Required Height (in feet) above 500 feet  
F = A units conversion factor of 0.0165  
D = Distance (in nautical miles) to obstacle from start of third segment

Therefore:

$$\% \text{ Gradient} = (696 - 500) (0.0165) + 4.81 = 0.67\%$$

7. Obtain (from the Net Take-Off Flight Path Third Segment One-Engine Inoperative graph, fig. 7-34) the scheduled third segment net gradient of climb of 2.33%. Since this gradient exceeds the required gradient of 0.67%, the calculations indicate that the obstacle will be cleared at a takeoff weight of 16,000 pounds even if an engine should fail at the most critical takeoff point.

*k. Climb - Two Engines.* Enter the graphs at -4°C, 9000 feet pressure altitude, 15,500 pounds, and obtain the following results:

Climb - Two Engines (flaps up) ..... 2250 ft/min  
Climb Gradient ..... 11.3%  
Climb - Two Engines (flaps approach) ..... 2068 ft/min  
Climb Gradient ..... 3%

*l. Climb - One Engine Inoperative.* Enter the graph at -4°C, 9000 feet pressure altitude, 15,500 pounds, and obtain the following results:

Climb - One Engine Inoperative ..... 386 ft/min  
Climb Gradient ..... 2.1%.

m. *Flight Planning Example.* The following calculations provide information for flight planning. Calculations for flight time, block speed, and fuel requirements for the proposed flight are detailed below.

**NOTE**

**For example purposes, the differences between MSL altitudes and pressure altitudes have been ignored in MEA calculations.**

(1) *ISA conversion.* Enter the graph at the conditions indicated:

**BIL**

Pressure Altitude .....3499 feet  
 FAT ..... 15°C  
 ISA Condition.....ISA+7°C

**BIL-CZI**

Pressure Altitude .....25,000 feet  
 FAT .....-40°C  
 ISA Condition.....ISA-6°C

**CZI-CPR**

Pressure Altitude .....25,000 feet  
 FAT .....-30°C  
 ISA Condition.....ISA+5°C

**CPR**

Pressure Altitude .....5998 feet  
 FAT .....20°C  
 ISA Condition.....ISA+17°C

(2) *Time, fuel, and distance to cruise climb.* Enter the graph at 15°C, to 3499 feet pressure altitude, and to 16,000 pounds. Enter again at -40°C to 25,000 feet pressure altitude, and to 16,000 pounds. The following results are obtained:

Time to Climb ..... 22 - 2 = 20 min  
 Fuel to Climb ..... 392 - 50 = 342 lbs  
 Distance Traveled ..... 52 - 4 = 48 nm

(3) *Time fuel, and distance to descend.* Enter the graph at 25,000 feet, and enter again at 5998 feet, and find:

Time to Descend ..... 17 - 4 = 13 min  
 Fuel Used to Descend..... 206 - 58 = 148 lbs  
 Distance to Descend ..... 62 - 13 = 49 nm

(4) *Cruise weight (estimated).* For the following cruise segment examples, the estimated average cruise weight used was 15,600 pounds.

(5) *Cruise tables.* Enter the tables for Normal Cruise Power at 1500 RPM for ISA -10°C, ISA, and ISA +10°C, and read the cruise speeds for 24,000 feet and 26,000 feet at 16,000 pounds and 14,000 pounds. Interpolate between these speeds for 25,000-foot values. Refer to table 7-2 for the results.

Interpolate between the 25,000-foot speeds for ISA -6°C and ISA +5°C at 15,600 pounds.

Cruise True Airspeed (ISA -6C) .....257 knots  
 Cruise True Airspeed (ISA +5C) .....246 knots

Similar computations can be made to interpolate for cruise torque setting and fuel flow.

Cruise Torque (ISA-6°C) ..... 68.5%  
 Cruise Total Fuel Flow (ISA -6°C)..... 778 lbs/hr  
 Cruise Fuel Flow/Eng (ISA -6°C) ..... 389 lbs/hr  
 Cruise Torque (ISA+5°C) ..... 61.4%  
 Cruise Total Fuel Flow (ISA +5°C) ..... 716 lbs/hr  
 Cruise Fuel Flow/Eng (ISA +5°C)..... 358 lbs/hr

(6) *Cruise graphs.* In addition to the cruise performance presented in tabular form, data representing a cruise weight of 14,000 pounds is presented in graphical form for quick reference.

Table 7-2. Example Cruise True Airspeeds

ALT FEET	16,000 POUNDS			14,000 POUNDS		
	ISA - 10°C	ISA	ISA +10°C	ISA - 10C	ISA	ISA +10°C
24,000	261	253	242	267	260	250
25,000	259	250.5	238.5	265.5	258	248
26,000	257	248	235	264	256	246

BT05789

**NOTE**

**Use of these graphs for flight conditions other than 14,000 pounds gross weight may introduce errors.**

(a) *Cruise speeds.* Enter the Normal Cruise Speeds at 1500 RPM graph at 25,000 feet, and read the true airspeeds for ISA -6°C and ISA +5°C:

Cruise True Air Speed (ISA -6°C)..... 262 KTAS  
 Cruise True Air Speed (ISA +5°C)..... 254 KTAS

(b) *Cruise power setting.* Enter the Normal Cruise Power at 1500 RPM graph at 25,000 feet, and read the recommended torque settings for ISA -6°C (-34°C IFAT) and ISA +5°C (-25°C IFAT):

ISA -6°C (-350C IFAT)..... 70% torque per engine  
 ISA +50C (-250C IFAT) ..... 63% torque per engine

**NOTE**

**For flight planning, enter the Cruise Power graphs at the forecast ISA condition; for enroute power settings, enter the graphs at the actual IFAT.**

(c) *Cruise fuel flow.* Enter the Fuel Flow At Normal Cruise Power at 1500 RPM graph at 25,000 feet, and read the fuel flow for ISA -6°C IFAT) and ISA +5°C (-24°C IFAT):

ISA -6°C (-35°C IFAT)  
 Fuel Flow Per Engine..... 392 lbs/hr

Total Fuel Flow ..... 784 lbs/hr

ISA +5°C (-24°C IFAT)  
 Fuel Flow Per Engine ..... 359 lbs/hr

Total Fuel Flow ..... 718 lbs/hr

Time and fuel used were calculated at normal cruise power at 1500 RPM as follows:

Time = distance/ground speed  
 Fuel used = (time)(total fuel flow)

(7) *Flight planning results.* Refer to table 7-3 for an example of the flight planning procedure.

**NOTE**

**For flight planning, enter the Fuel Flow graphs at the forecast ISA condition; for enroute fuel flow, enter the graphs at the actual IFAT.**

Refer to table 7-4 for an example of the total flight planning results.

(a) *Reserve fuel.* Reserve Fuel is the amount of fuel required to fly at cruise altitude for 45 minutes at maximum range power. This example assumes the average cruise weight while using reserve fuel to be 15,000 pounds.

Enter the Maximum Range Power at 1500 RPM tables for ISA and for ISA +10°C and interpolate to find the total fuel flow for 25,000 feet at 16,000 pounds and 14,000 pounds. Interpolate between these values for 15,000 Table 7-3. Example Cruise Results

ROUTE SEGMENT	<sup>1</sup> DISTANCE NM	ESTIMATED GROUND SPEED KNOTS	<sup>2</sup> TIME AT CRUISE ALTITUDE MIN	<sup>3</sup> FUEL USED FOR CRUISE LBS
BIL-SHR	43	278	9.3	120.34
SHR-CZI	57	318	10.8	139.5
CZI-CPR	20	279	4.3	51.3
TOTAL	120	---	24.4	311.14

<sup>1</sup> Distance required to climb or descend has been subtracted from segment distance.

<sup>2</sup> Time =Distance divided by Ground Speed.

<sup>3</sup> Fuel Used =Distance divided by Ground Speed, multiplied by total Fuel Flow.

BT05790

pounds. In this example it is found that data is presented for MAXIMUM RANGE POWER at 1500 RPM for ISA and ISA +10°C at 24,000 feet and at 26,000 feet for 14,000 pounds, but not for 16,000 pounds. Consequently, it is not possible to determine a maximum range power torque, airspeed, or fuel flow for 15,000 pounds at 25,000 feet, since chart values may not be extrapolated. This means that either a lower altitude must be selected for the leg of the mission that would be using reserve fuel, or that the Normal Cruise Power At 1500 RPM values must be used to determine power setting and the reserve fuel requirement. If no values are presented for the given conditions in the Normal Cruise Power at 1500 RPM tables, either select a lower altitude, or use the maximum cruise power at 1700 RPM table values to determine power setting and the reserve fuel requirement. In this example it is found that data is presented for the mission conditions in the Normal Cruise Power at 1500 RPM tables, so that data can be used. Refer to table 7-5 for an example of the reserve fuel determination procedure.

(8) *Total fuel requirement.* Expected fuel usage + reserve fuel = total fuel requirement. (921 lbs) + (537 lbs) = 1458 lbs.

(9) *Zero-fuel weight limitation.* For this example, the following conditions were assumed:

- Ramp Weight ..... 16,120 lbs
- Weight of Usable Fuel on Board..... 3631 lbs
- Zero Fuel Weight = (16,120 - 3631) ..... 12,489 lbs
- Maximum Zero Fuel Weight (from Chapter 5)  
..... 13,100 lbs

Maximum zero fuel weight limitation will not be exceeded.

Anytime the zero fuel weight exceeds the maximum zero fuel weight limit, the excess weight must be offloaded from payload only (i.e., not from fuel). If desired, additional fuel may then be added. However, the foregoing calculations will remain unchanged only if the fuel added is equal in weight to the payload off-loaded, since only then will the ramp weight and takeoff weight remain the same as before.

n. *Range and Endurance.* Estimates of the effect of fuel load and power setting on aircraft range and endurance can be determined from the Range and Endurance Profile graphs. The range of a mission at normal cruise power can be determined by entering the Range Profile Normal Cruise Power graph at 25,000 feet, reading right to the anticipated fuel load and down to the resulting range. This chart indicates that a fuel load as low as 1500 pounds would be sufficient for the planned 217 nautical mile mission from Billings to Casper. The available range with full main and auxiliary tanks (3631 pounds) for a flight at 25,000 feet can be determined to be 1010 nautical miles. If additional range is required, either a higher altitude or a lower power setting could be selected. To determine the range with a maximum fuel load, enter the Range Profile Full Main and Aux Tanks graph (fig. 7-84) at 25,000 feet, read right to the desired power setting and down to the resulting range. This chart depicts that for a full-fuel mission, range can be increased from 1010 to 1081 nautical miles by reducing power to maximum range power.

The aircraft endurance can be determined from the various endurance profile graphs in a similar manner.

It should be noted that all of these graphs are based on standard day temperatures, and the range graphs are also based on zero wind. If forecast temperatures differ from standard values or if headwinds are expected, a more rigorous mission analysis should be accomplished.

o. *Landing Example.*

(1) *Weight.* The estimated landing weight is determined by subtracting the fuel usage expected for the trip from the ramp weight:

- Ramp Weight..... 16,120
- Fuel Usage Expected for Total Trip ..... (-)921 lbs
- Landing Weight ..... 15,199 lbs
- Maximum Landing Weight (Chapter 5) ..... 15,675 lbs

Anytime the maximum landing weight limitation would be exceeded, off-load the excess from useful load prior to

Table 7-4. Example Time, Fuel, and Distance

ITEM	TIME MIN	FUEL POUNDS	DISTANCE NM
Start, Runup, Taxi, and Takeoff Acceleration	0.0	120	0
Climb	20	342	48
Cruise	24.4	311	120
Descent	13.0	148	49
TOTAL	57.4	921	217

Block Speed: 217 NM Divided by 56.9 Minutes = 227 Knots.

BT05787



takeoff, or burn off the excess from excess fuel (i.e., not from reserve fuel) before landing.

(2) *Normal landing distance flaps down.* Enter the graph at 200C, 5998 feet, 15,199 pounds, 0.3% uphill runway gradient, 10 knots headwind component, and read the following:

Ground Roll..... 1857 ft  
 Total Distance Over 50-Foot Obstacle .....4702 ft

(3) *Abnormal landing distances.* The landing distances for one engine inoperative or flaps retracted can be determined as shown below.

Landing Distance - One Engine Inoperative - Flaps Down:

Enter the graph with the normal landing distance determined in paragraph (2) above and read the following:

Landing Distance - One Engine Inoperative - Over 50-Foot Obstacle - Flaps Down .....5834 feet  
 Landing Distance - Flaps Up:

Enter the graph with the normal landing distance of 4702 feet as determined in paragraph (2) above and a landing weight of 15,199 lbs, and read the following:

Flaps-Up Landing Distance Over 50-Foot Obstacle.....7138 feet  
 Approach Speed ..... 136 knots

(4) *Climb - balked landing.* Enter the graph at 20°C, 6400 feet (see note 2 on graph), 15,199 pounds, and read the following results:

Rate of climb..... 1444 ft/min  
 Climb Gradient.....9.6%

*p. Enroute Instrument Corrections.* Errors are introduced to measured airspeed and temperature readings as a result of the aircraft speed. For this example, it has been assumed that the aircraft is established in level cruise flight between CZI and CPR.

Pilot's Indicated Airspeed ..... 158 KIAS  
 Indicated Pressure Altitude ..... 25,000 feet  
 Indicated Free Air Temperature ..... -35°C

(1) *Airspeed calibration - normal system Graph.* Enter the flaps-up graph at the indicated airspeed value of 158 knots, read up reference line and trace left to obtain the following results:

Calibrated Airspeed.....161 knots

(2) *Altimeter correction - normal system Graph.* Enter the flaps-up graph at the indicated airspeed value of 158 knots, read up to the 25,000-foot reference line and trace left to obtain the following results:

Altimeter Correction..... +69 feet

Add this result to the indicated pressure altitude value of 25,000 feet to obtain the corrected altitude.

Actual Pressure Altitude ..... 25,061 feet

(3) *Indicated outside air temperature correction Graph.* Enter the graph at the calibrated airspeed value of 161 knots, read right to the actual pressure altitude of 25,051 feet and down to obtain the following result:

Temperature Correction ..... 5.2°C

Compute the free air temperature by subtracting the temperature correction of 5.20C from the indicated temperature of -350C to obtain:

Free Air Temperature ..... -40.2°C.

Table 7-5. Example Fuel Flow (lbs/hr)

WEIGHT POUNDS	ISA	ISA +5°C	ISA 10°C
16,000	744.0	-	686.0
15,000	745.0	716.25	687.5
14,000	746.0	-	689.0
Total Fuel Flow = 716.25 lbs/hr Reserve Fuel = 45 minutes x 716.25 lbs/hr =537 lbs			

BT06333

AIRSPEED CALIBRATION - NORMAL SYSTEM  
TAKE-OFF GROUND ROLL

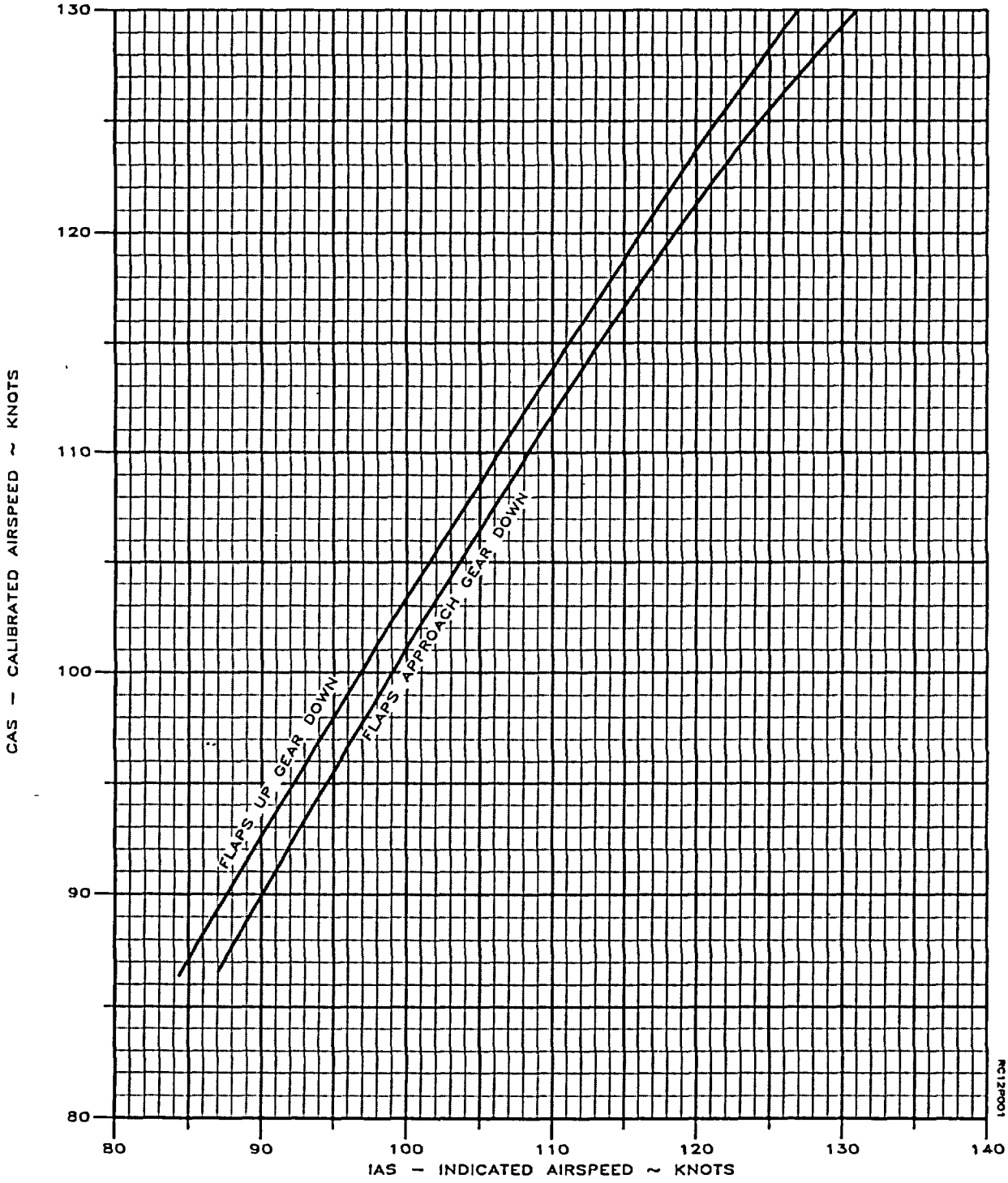

Figure 7-2. Airspeed Calibration - Normal System, Takeoff Ground Roll

AIRSPEED CALIBRATION - NORMAL SYSTEM

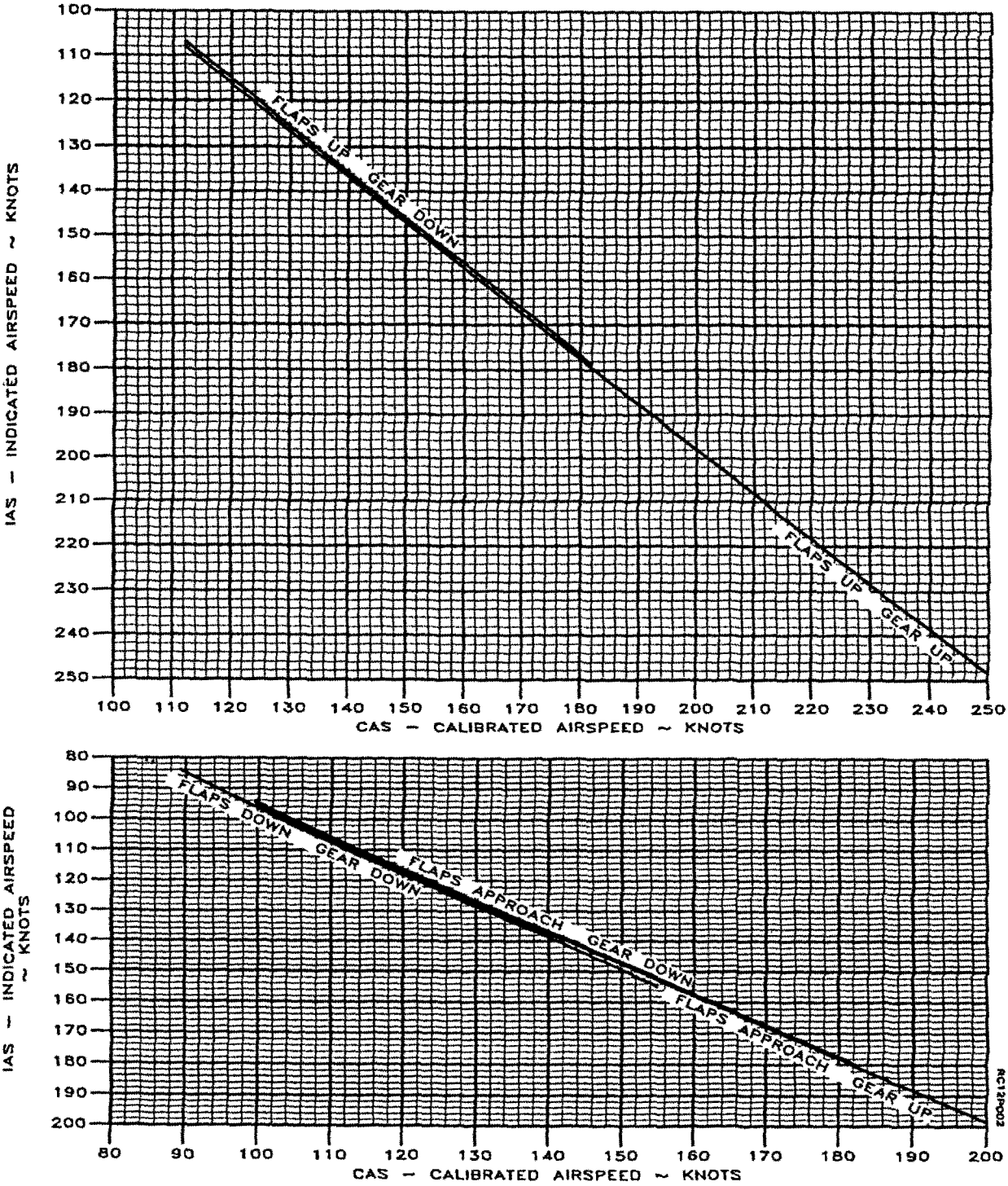

Figure 7-3. Airspeed Calibration - Normal System

ALTIMETER CORRECTION - NORMAL SYSTEM

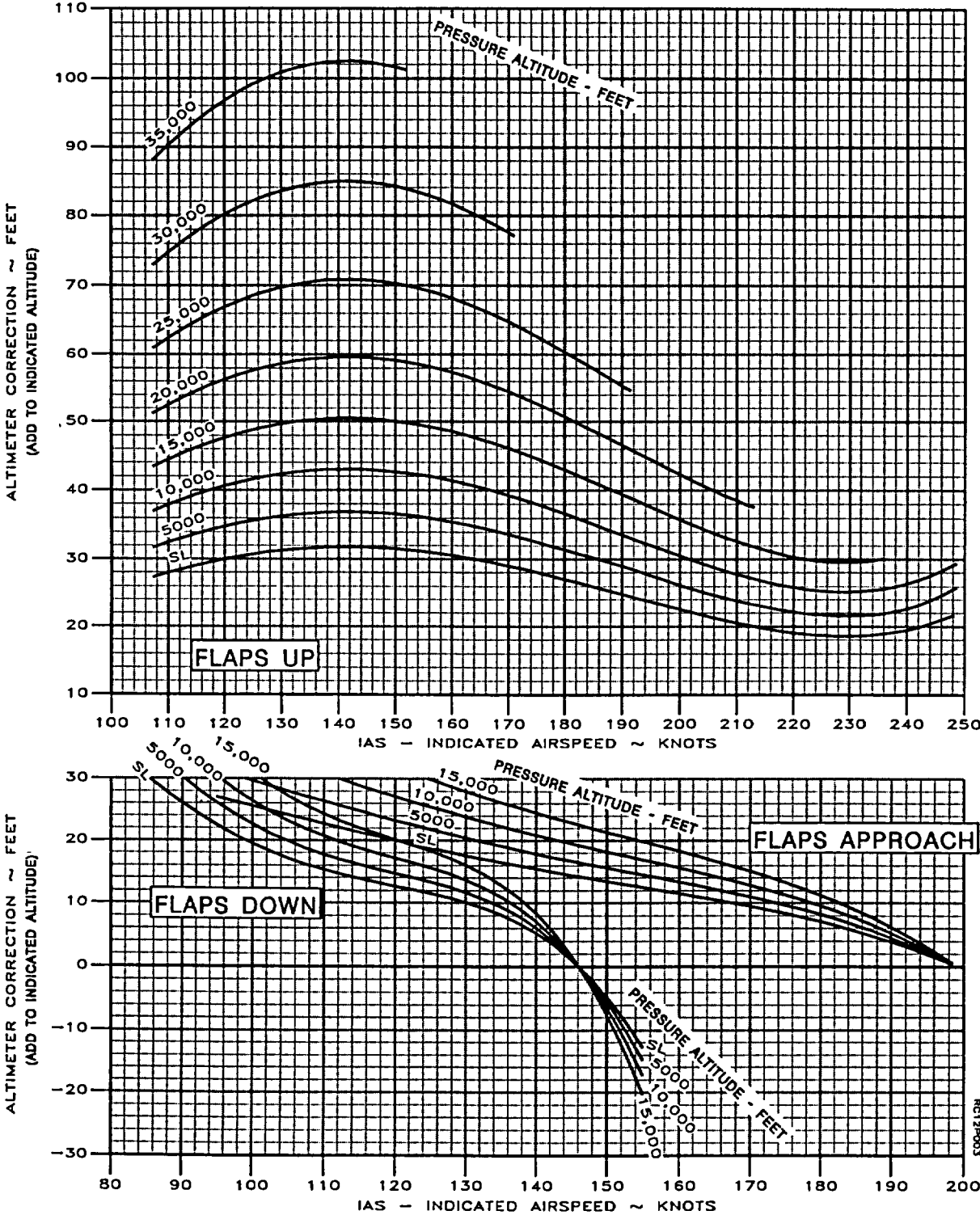

Figure 7-4. Altimeter Correction - Normal System

**AIRSPEED CALIBRATION - ALTERNATE SYSTEM  
APPLICABLE FOR ALL FLAP POSITIONS**

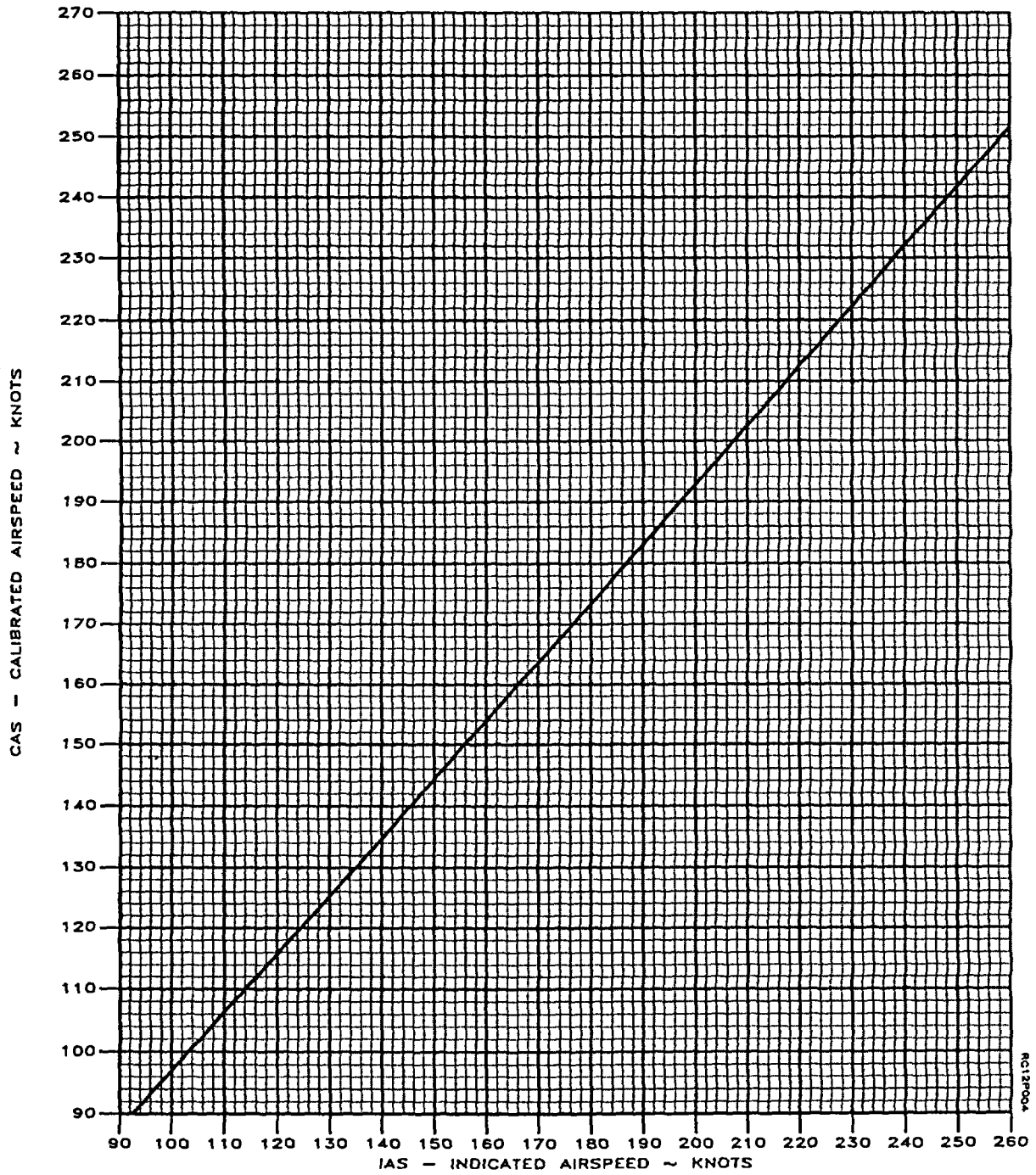

Figure 7-5. Airspeed Calibration - Alternate System

ALTIMETER CORRECTION - ALTERNATE SYSTEM  
APPLICABLE FOR ALL FLAP POSITIONS

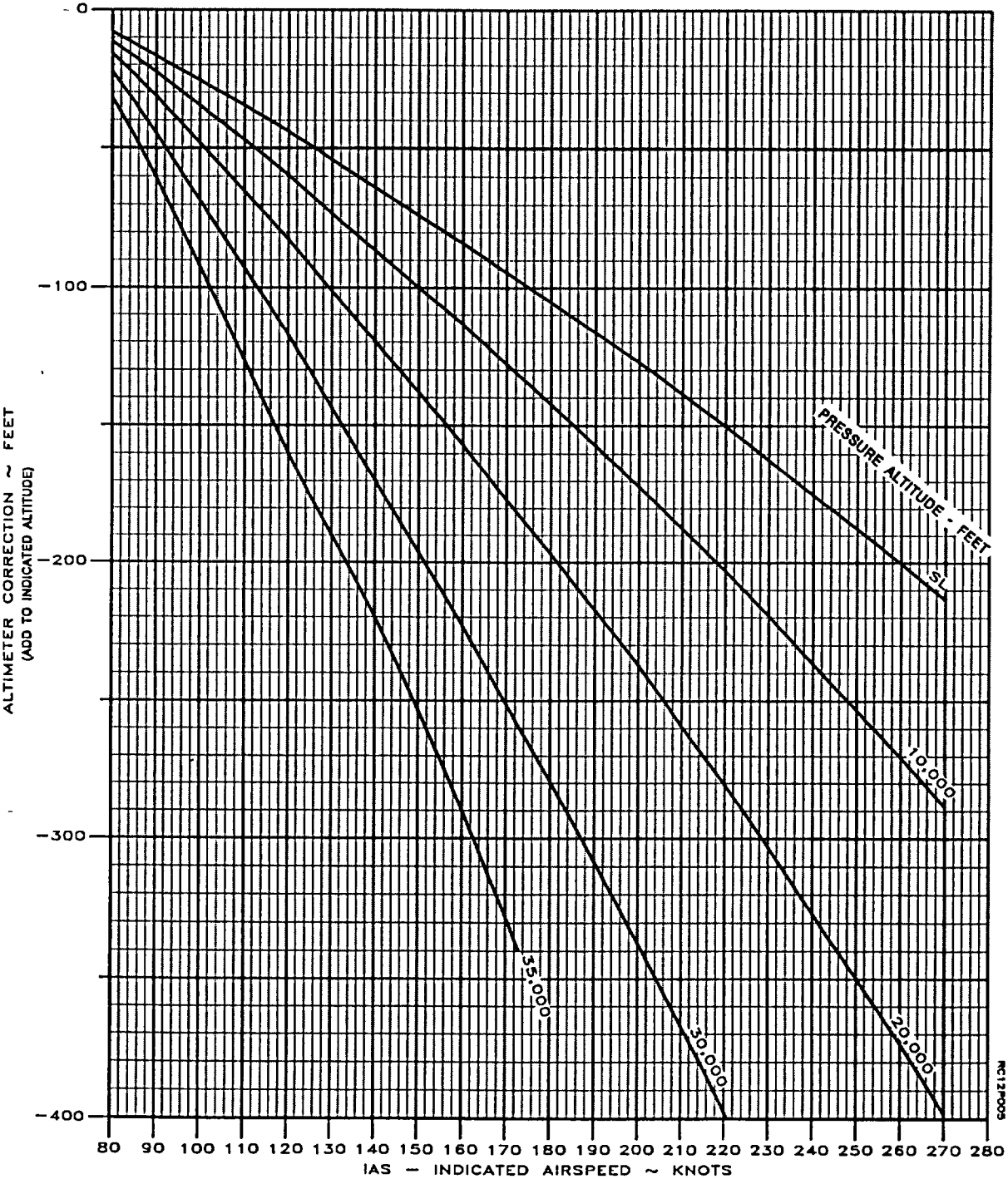

Figure 7-6. Altimeter Correction - Alternate System

### INDICATED OUTSIDE AIR TEMPERATURE CORRECTION STANDARD DAY (ISA)

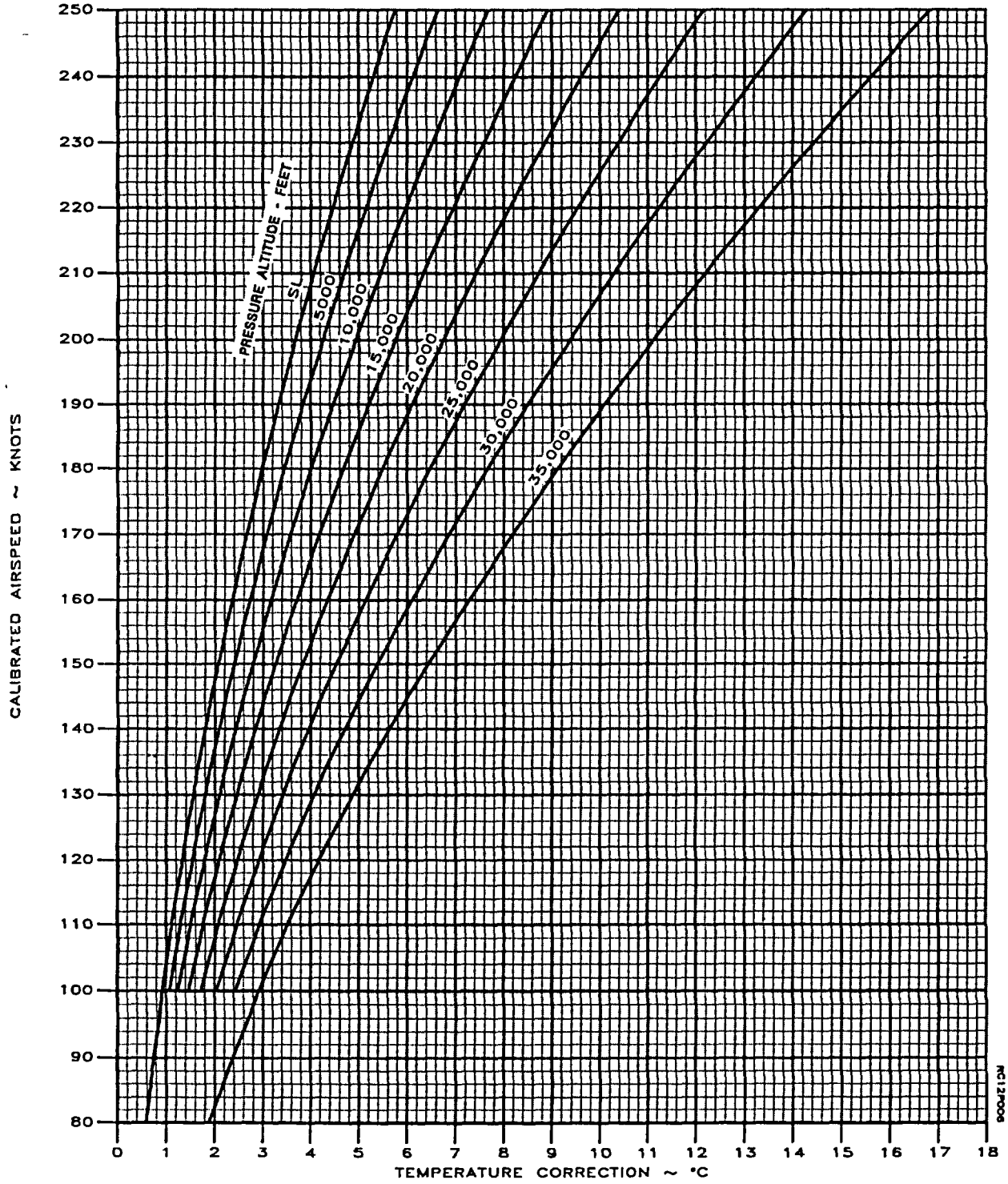
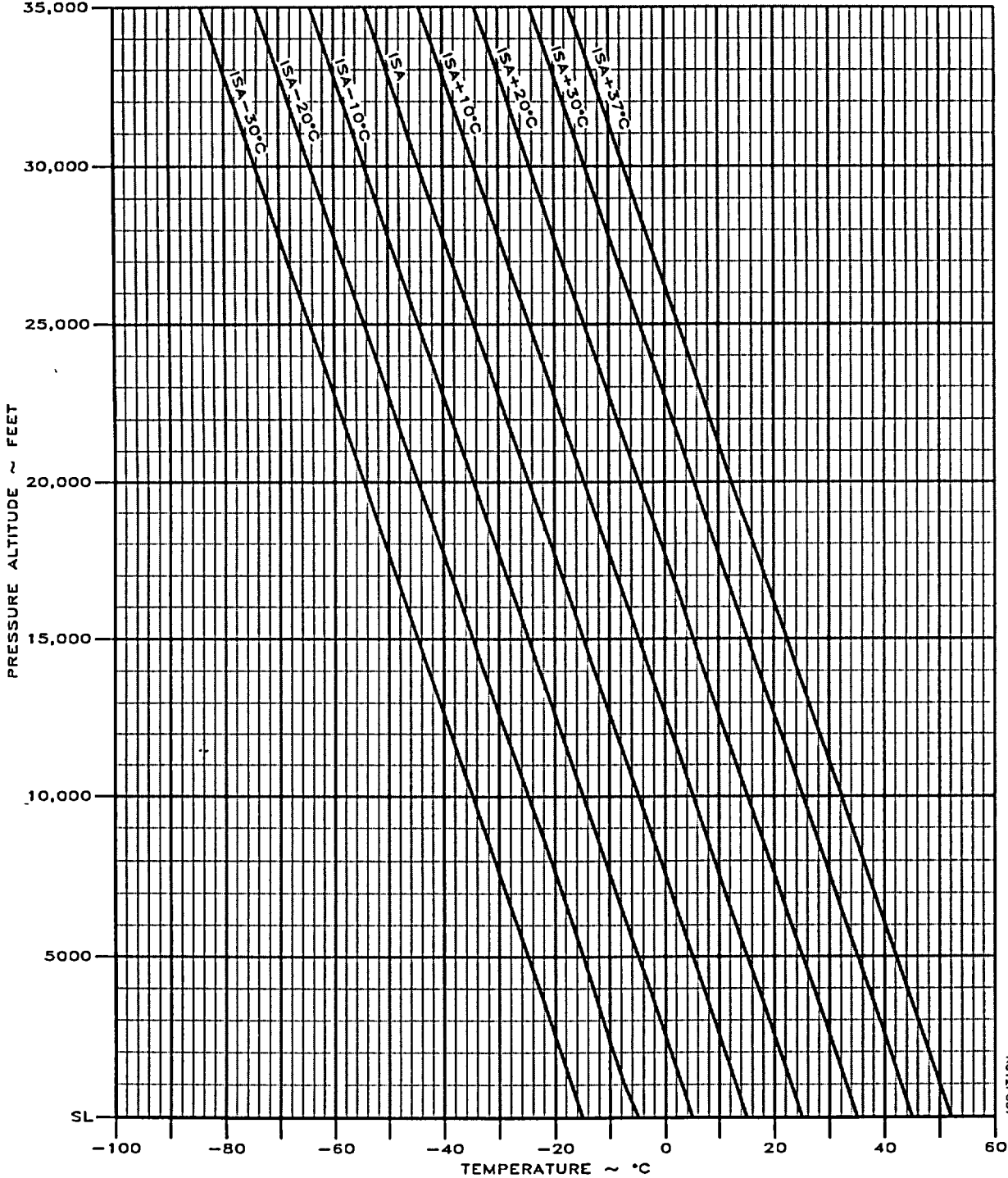

Figure 7-7. Indicated Outside Air Temperature Correction

ISA CONVERSION

PRESSURE ALTITUDE VERSUS FREE AIR TEMPERATURE



NC12P007

Figure 7-8. ISA Conversion



### FAHRENHEIT TO CELSIUS TEMPERATURE CONVERSION

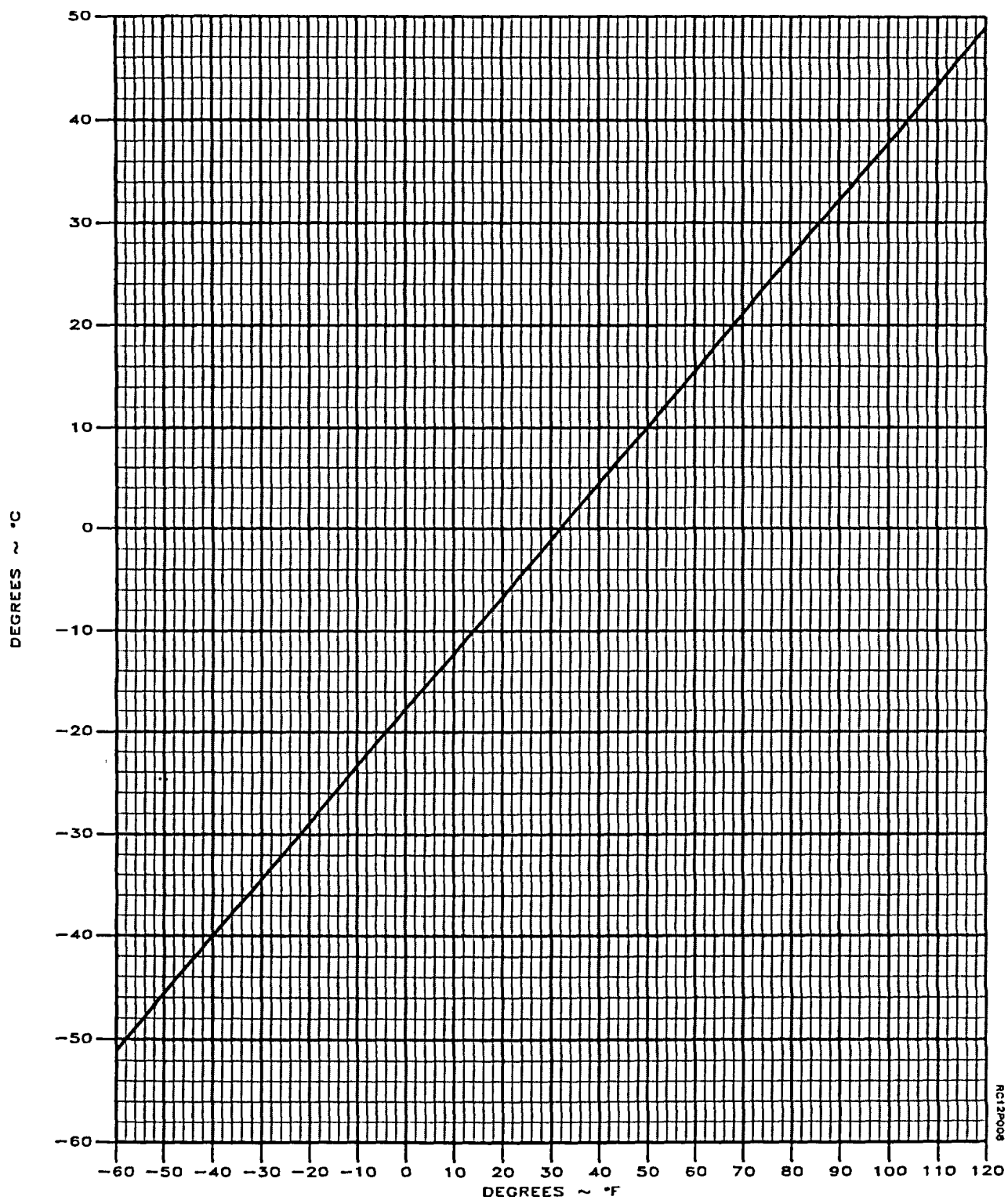

Figure 7-9. Fahrenheit to Celsius Temperature Conversion

STATIC TAKE-OFF POWER AT 1700 RPM  
WITH ICE VANES RETRACTED

EXAMPLE:  
FAT ..... 15°C  
FIELD PRESSURE ALTITUDE ..... 3499 FT  
TAKE-OFF POWER..... 93.5%5

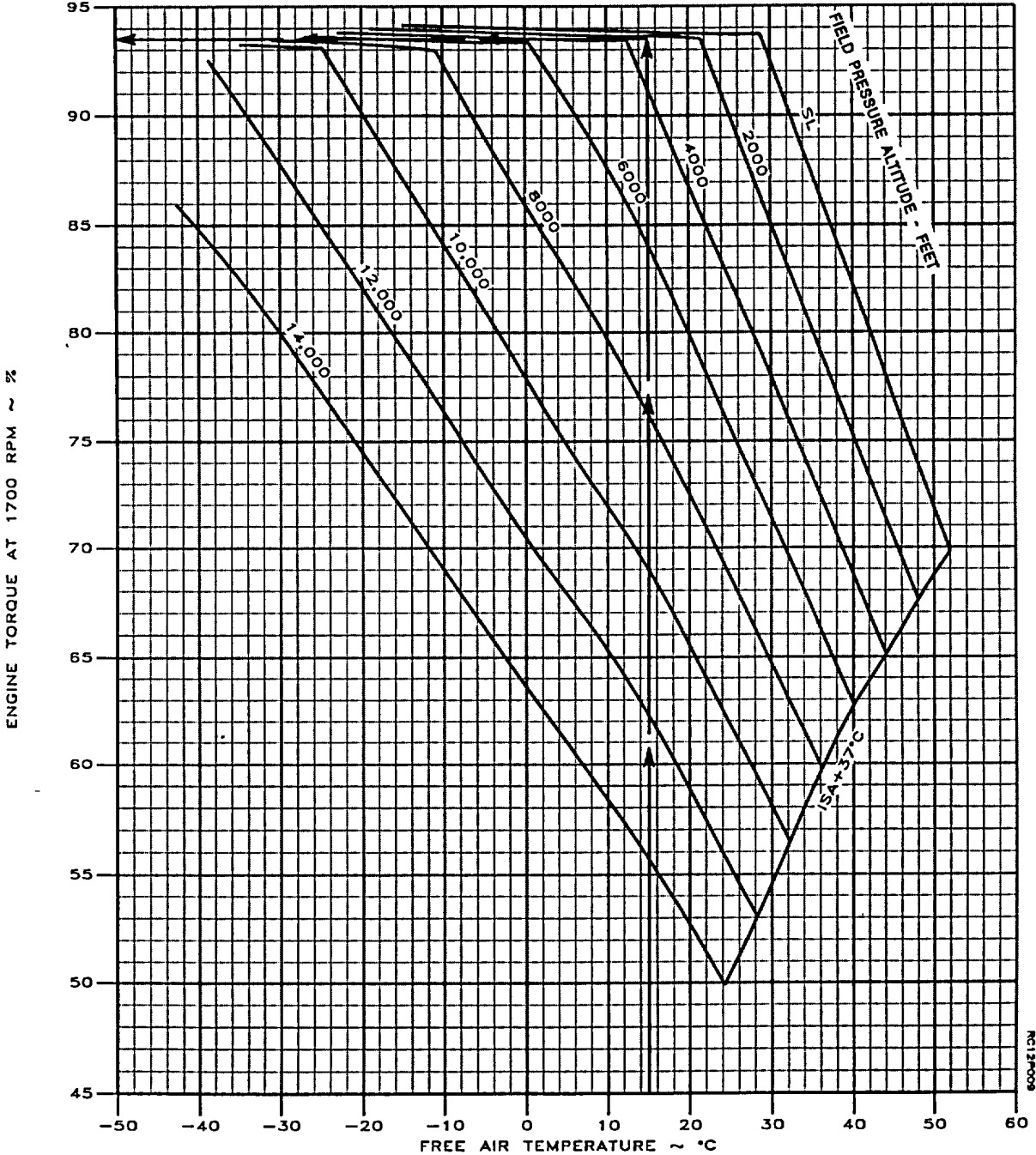

Figure 7-10. Static Take-off Power at 1700 RPM, Ice Vanes Retracted

STATIC TAKE-OFF POWER AT 1700 RPM  
WITH ICE VANES EXTENDED

EXAMPLE!  
FAT ..... 15°C  
FIELD PRESSURE ALTITUDE ..... 3499 FT  
TAKE-OFF POWER ..... 85.8 X

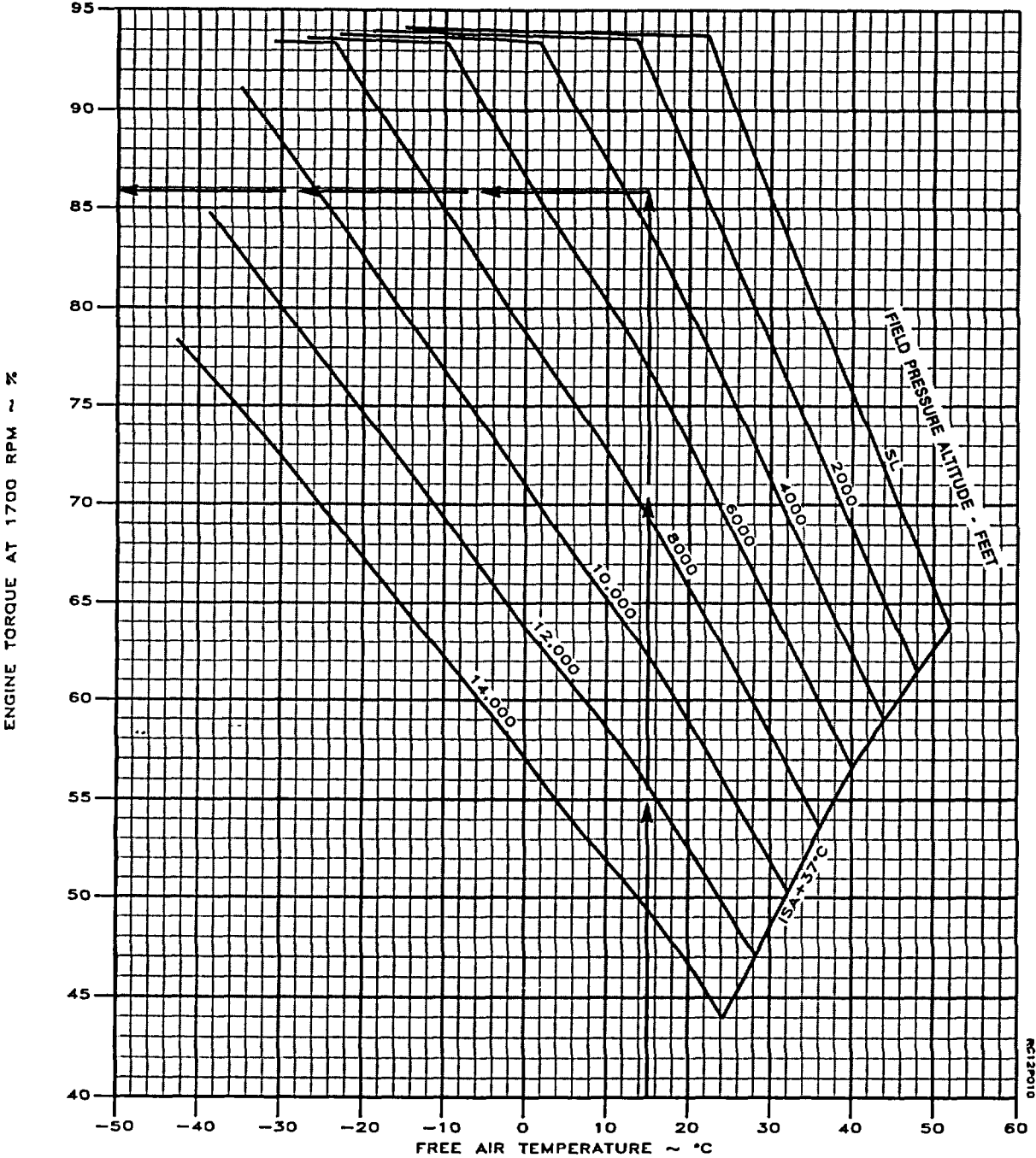

Figure 7-11. Static Take-off Power at 1700 RPM, Ice Vanes Extended

WIND COMPONENTS

EXAMPLE:  
 WIND SPEED ..... 15 KNOTS  
 ANGLE BETWEEN WIND DIRECTION  
 AND FLIGHT PATH ..... 50°  
 HEADWIND COMPONENT ..... 9.6 KNOT  
 CROSSWIND COMPONENT ..... 11.5 KNOT

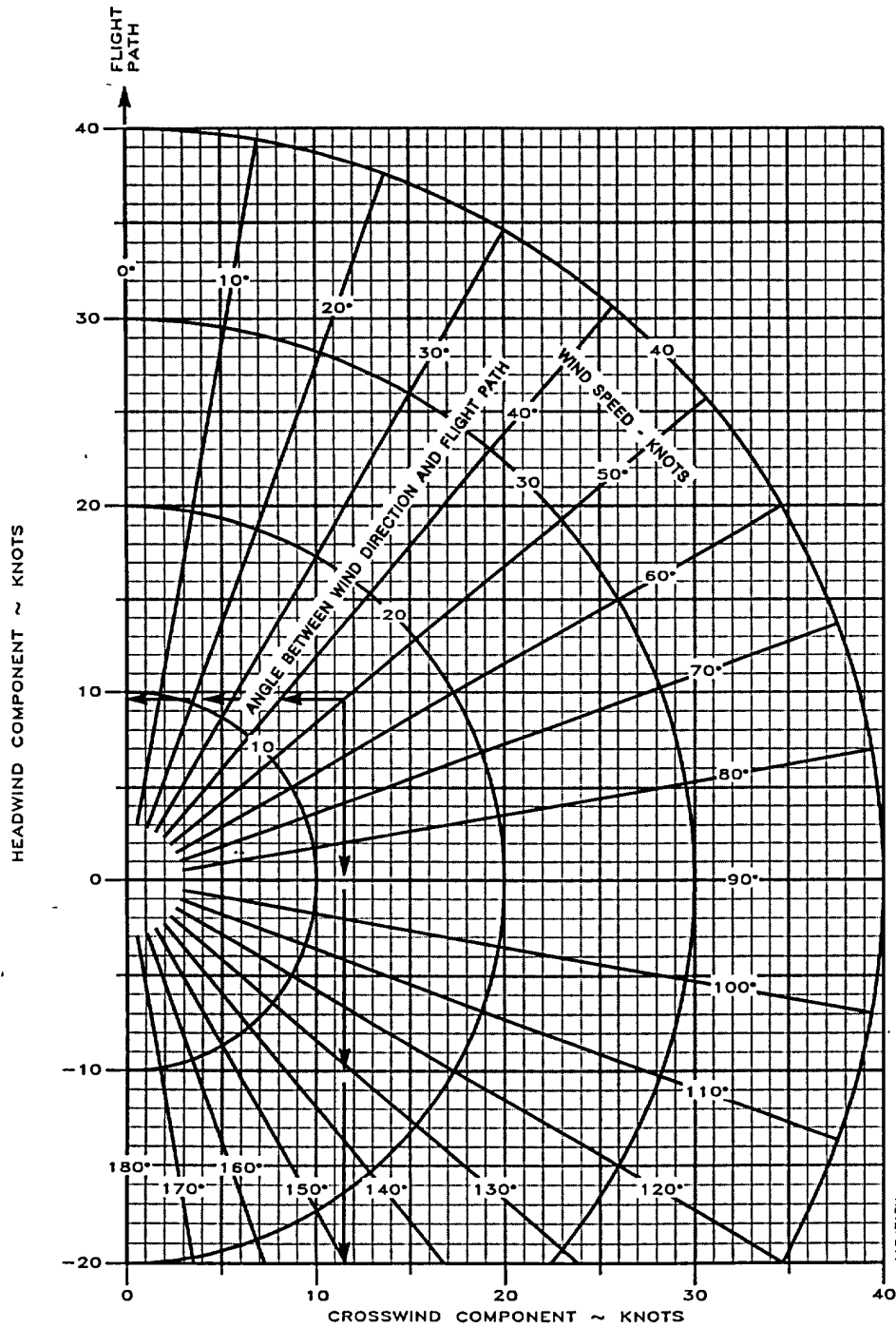

Figure 7-12. Wind Components

### MAXIMUM TAKE-OFF WEIGHT PERMITTED BY ENROUTE CLIMB REQUIREMENTS

ASSOCIATED CONDITIONS:  
 POWER..... MAXIMUM CONTINUOUS  
 INOPERATIVE PROPELLER..... FEATHERED  
 FLAPS..... UP  
 LANDING GEAR ..... UP

EXAMPLE:  
 FIELD PRESSURE ALTITUDE ..... 3499 FT  
 FAT ..... 15°C  
 TAKE-OFF WEIGHT ..... 16,500 LBS.

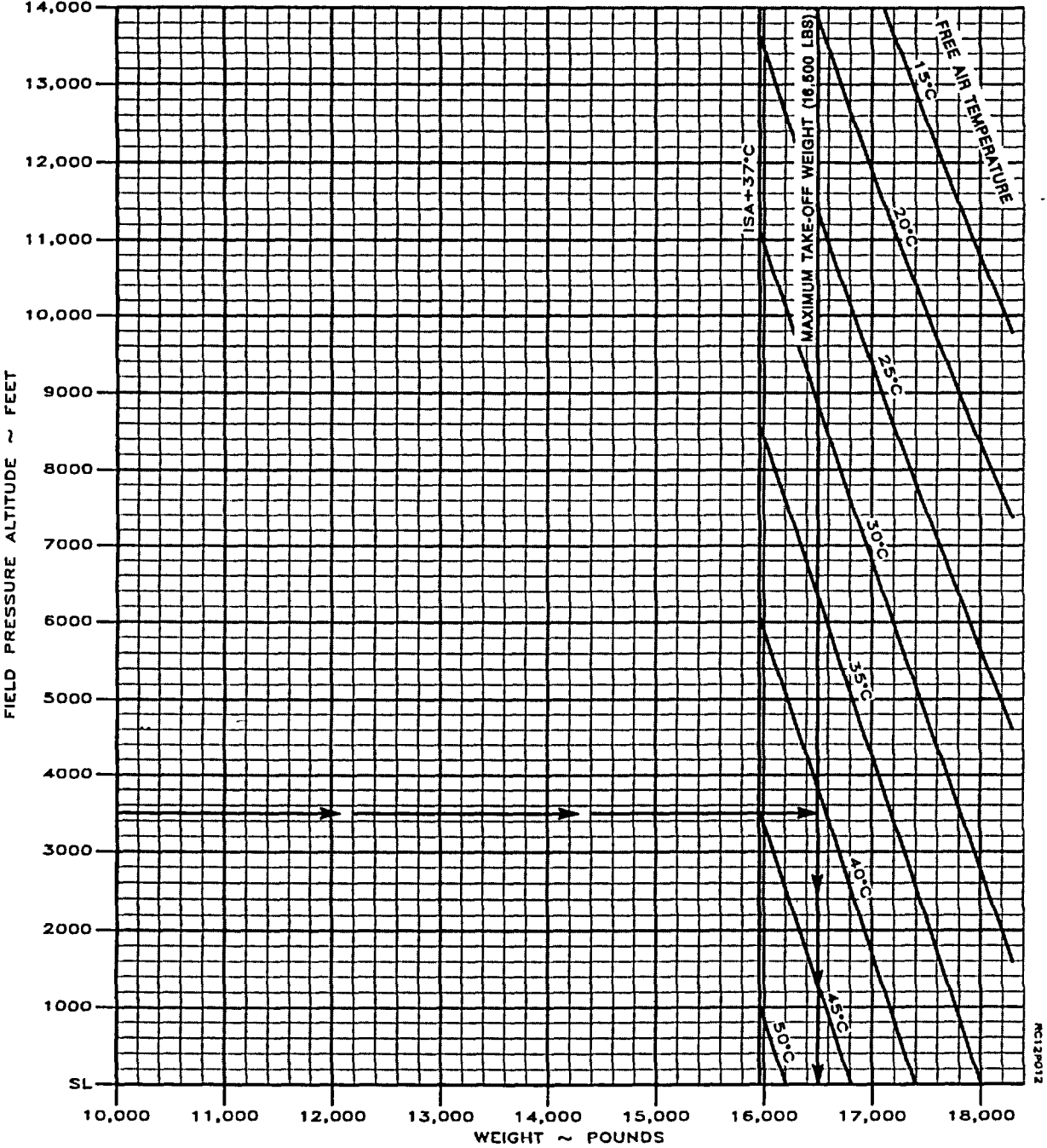

Figure 7-13. Maximum Take-off Weight Permitted by Enroute Climb Requirements

MAXIMUM TAKE-OFF WEIGHT - FLAPS UP  
TO ACHIEVE POSITIVE ONE-ENGINE-INOPERATIVE CLIMB AT LIFT-OFF

ASSOCIATED CONDITIONS:  
POWER..... TAKEOFF  
LANDING GEAR ..... DOWN  
INOPERATIVE PROPELLER..... FEATHERED

EXAMPLE:  
FIELD PRESSURE ALTITUDE ..... 3499 FT  
FAT ..... 15°C  
TAKE-OFF WEIGHT ..... 1 6,500 LE

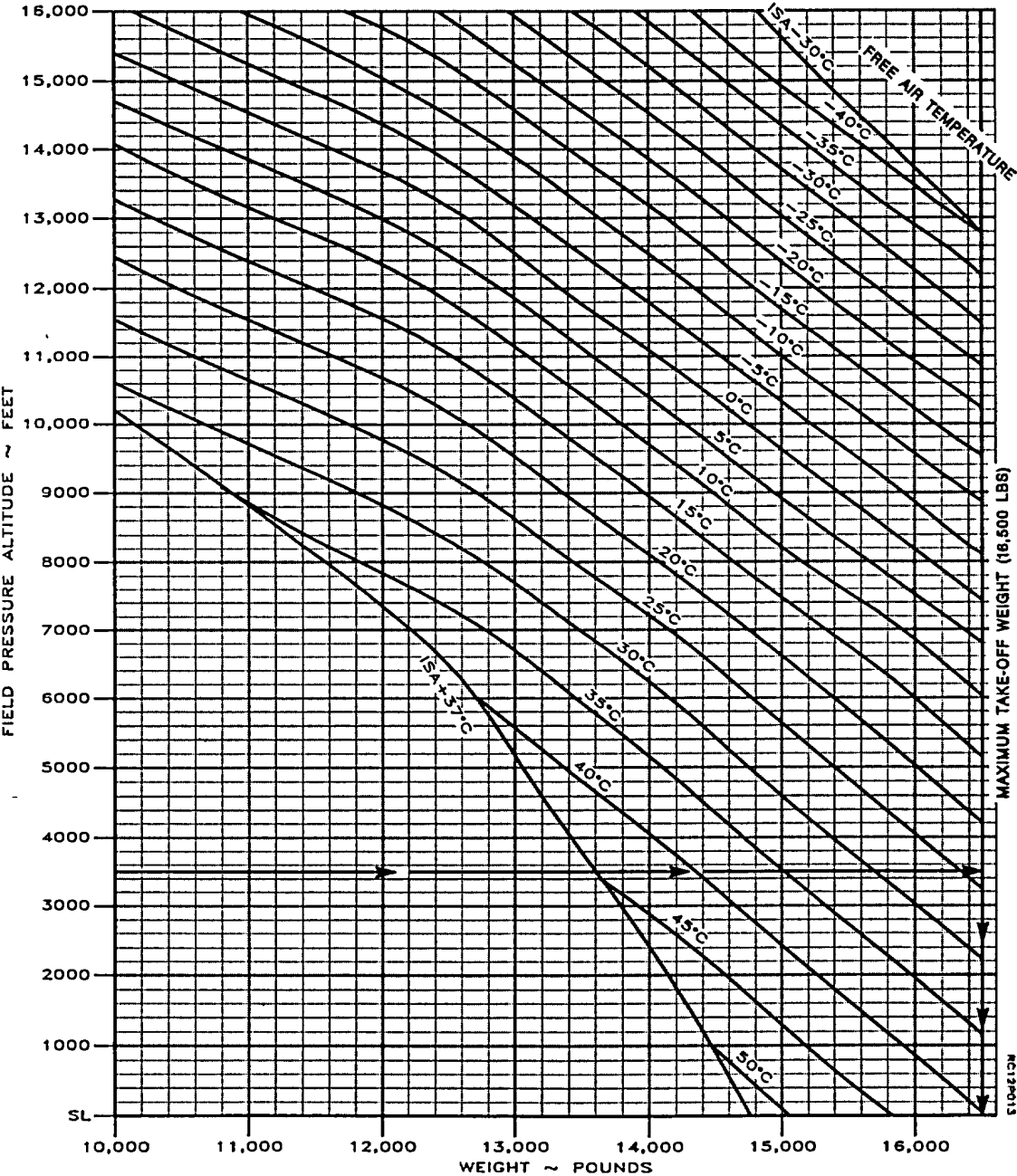

Figure 7-14. Maximum Take-off Weight to Achieve Positive One Engine Inoperative Climb at Liftoff - Flaps Up

**MAXIMUM TAKE-OFF WEIGHT - FLAPS UP  
AS LIMITED BY TIRE SPEED**

EXAMPLE:  
FAT .....15°C  
FIELD PRESSURE ALTITUDE .....3499 FT  
HEADWIND COMPONENT .....10 KTS  
WEIGHT.....EXCEEDS STRUCTURAL LIMIT  
.....OF 16.500 LBS.

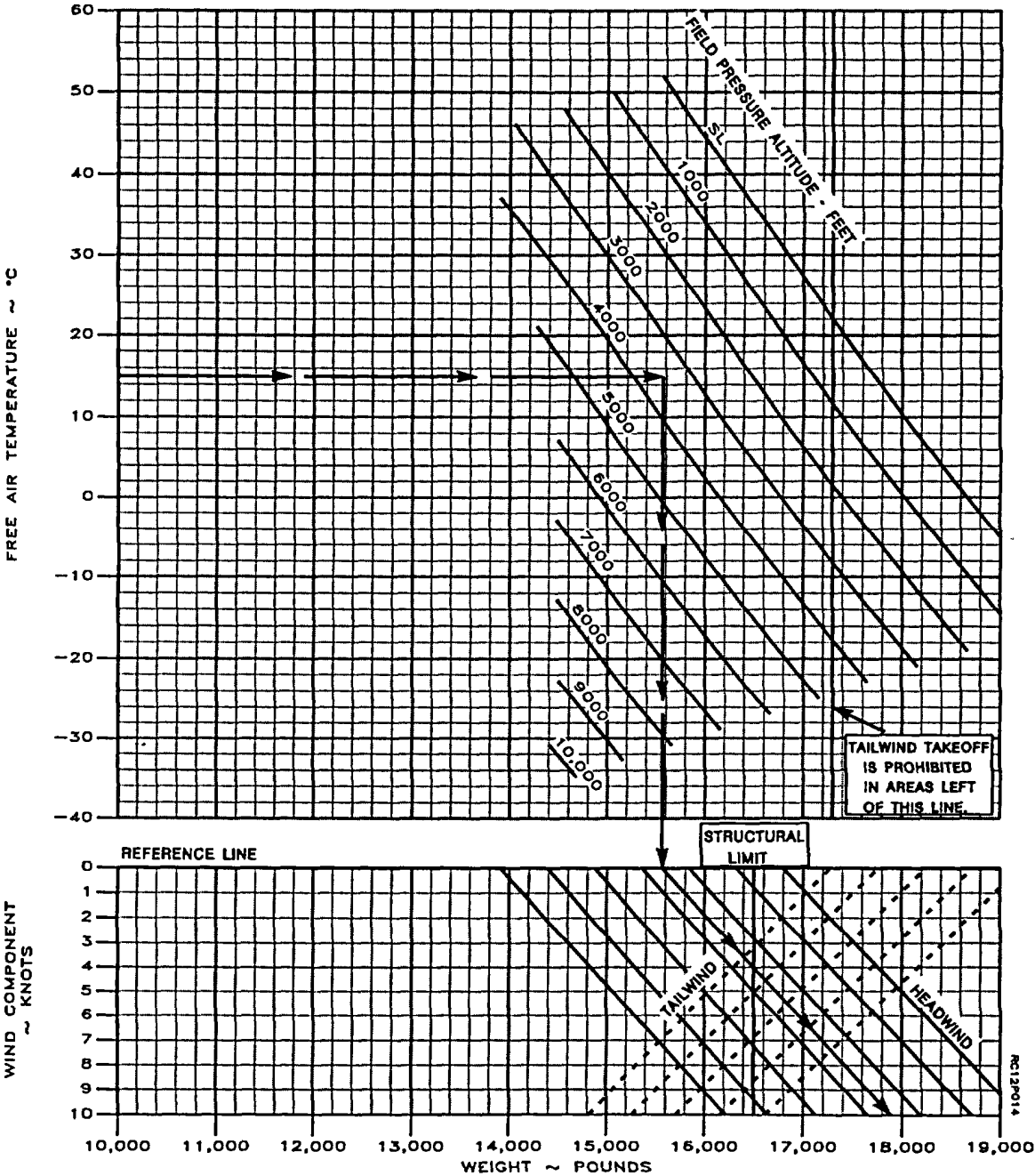

Figure 7-15. Maximum Take-off Weight as Limited by Tire Speed - Flaps Up

TAKE-OFF SPEEDS (KIAS) - FLAPS UP

		FREE AIR TEMPERATURE																											
PRESS. ALT (FT)	T/O WT (LBS)	-30°C				-10°C				0°C				10°				20°C				40°C				52°C			
		V <sub>1</sub>	V <sub>R</sub>	V <sub>2</sub>	V <sub>50</sub>	V <sub>1</sub>	V <sub>R</sub>	V <sub>2</sub>	V <sub>50</sub>	V <sub>1</sub>	V <sub>R</sub>	V <sub>2</sub>	V <sub>50</sub>	V <sub>1</sub>	V <sub>R</sub>	V <sub>2</sub>	V <sub>50</sub>	V <sub>1</sub>	V <sub>R</sub>	V <sub>2</sub>	V <sub>50</sub>	V <sub>1</sub>	V <sub>R</sub>	V <sub>2</sub>	V <sub>50</sub>	V <sub>1</sub>	V <sub>R</sub>	V <sub>2</sub>	V <sub>50</sub>
SL	16,500	118	124	130	144	118	124	130	143	118	125	130	143	118	125	130	143	118	125	130	143	118	127	130	141	118	128	130	140
	16,000	116	121	128	142	116	122	128	142	116	122	128	141	116	122	128	141	116	123	128	141	116	124	128	139	116	126	128	138
	15,000	114	116	124	139	114	117	124	139	114	117	124	138	114	118	124	138	114	118	124	138	114	119	124	138	114	121	124	135
	14,000	114	114	123	138	114	114	122	137	114	114	122	136	114	114	121	136	114	114	121	135	114	115	121	133	114	116	121	131
	13,000	114	114	123	140	114	114	123	138	114	114	122	138	114	114	122	137	114	114	122	137	114	114	120	133	114	114	118	130
	12,000	114	114	124	141	114	114	124	140	114	114	123	139	114	114	123	139	114	114	123	139	114	114	121	135	114	114	119	131
	11,000	114	114	124	143	114	114	125	142	114	114	124	141	114	114	124	141	114	114	124	141	114	114	122	136	114	114	120	133
	10,000	114	114	127	145	114	114	126	144	114	114	125	143	114	114	125	142	114	114	125	142	114	114	123	138	114	114	121	134
2000	16,500	118	124	130	143	118	125	130	143	118	125	130	143	118	126	130	142	118	126	130	142	118	128	130	140	118	129	130	138
	16,000	116	122	128	142	116	122	128	141	116	123	126	141	116	123	128	141	116	123	128	140	116	126	128	138	116	127	128	137
	15,000	114	117	124	139	114	118	124	138	114	118	124	138	114	118	124	138	114	118	124	137	114	121	135	114	122	124	134	134
	14,000	114	114	122	137	114	114	121	136	114	114	121	135	114	114	121	135	114	114	121	134	114	116	121	132	114	117	121	130
	13,000	114	114	123	139	114	114	122	137	114	114	122	137	114	114	122	136	114	114	121	136	114	114	119	131	114	114	117	128
	12,000	114	114	124	140	114	114	123	139	114	114	123	138	114	114	122	138	114	114	122	137	114	114	120	132	114	114	118	129
	11,000	114	114	125	142	114	114	124	141	114	114	124	140	114	114	123	139	114	114	123	139	114	114	121	134	114	114	119	130
	10,000	114	114	126	144	114	114	125	143	114	114	125	142	114	114	124	141	114	114	124	140	114	114	121	135	114	114	120	132
4000	16,500	118	125	130	143	118	126	130	142	118	126	130	142	118	126	130	142	118	127	130	141	118	129	130	139	118	129	130	137
	16,000	118	122	128	141	116	123	128	141	116	123	128	140	116	123	128	140	116	124	128	139	116	126	128	137	116	127	128	135
	15,000	114	117	124	138	114	118	124	138	114	118	124	137	114	119	124	137	114	119	124	136	114	122	124	134	114	123	124	132
	14,000	114	114	121	136	114	114	121	135	114	114	121	134	114	114	121	134	114	115	121	133	114	117	121	131	114	118	121	129
	13,000	114	114	122	137	114	114	122	136	114	114	121	136	114	114	121	135	114	114	120	133	114	114	118	129	114	114	117	126
	12,000	114	114	123	139	114	114	123	138	114	114	122	137	114	114	122	137	114	114	121	135	114	114	119	130	114	114	117	127
	11,000	114	114	124	141	114	114	123	139	114	114	123	139	114	114	123	138	114	114	122	136	114	114	119	131	114	114	118	128
	10,000	114	114	125	143	114	114	125	141	114	114	124	140	114	114	124	140	114	114	123	138	114	114	120	133	114	114	119	129
6000	16,500	118	125	130	142	118	128	130	142	118	126	130	142	118	127	130	141	118	128	130	140	118	129	130	137	---	---	---	---
	16,000	116	123	128	141	116	124	128	140	116	124	128	140	116	124	128	139	116	125	128	138	116	127	128	136	---	---	---	---
	15,000	114	118	124	138	114	119	124	137	114	119	124	137	114	120	124	136	114	121	124	135	114	122	124	133	---	---	---	---
	14,000	114	114	121	135	114	114	121	134	114	114	121	134	114	115	121	133	114	116	121	132	114	118	121	130	---	---	---	---
	13,000	114	114	122	136	114	114	121	135	114	114	121	135	114	114	120	133	114	114	119	131	114	114	117	127	---	---	---	---
	12,000	114	114	123	138	114	114	122	137	114	114	122	136	114	114	121	134	114	114	120	132	114	114	117	128	---	---	---	---
	11,000	114	114	124	140	114	114	123	138	114	114	123	137	114	114	122	136	114	114	121	134	114	114	118	129	---	---	---	---
	10,000	114	114	125	141	114	114	124	140	114	114	124	139	114	114	123	137	114	114	121	135	114	114	119	130	---	---	---	---
8000	16,500	118	126	130	142	118	126	130	141	118	127	130	141	118	128	130	140	118	129	130	139	118	129	130	136	---	---	---	---
	16,000	116	123	128	140	116	124	128	140	116	125	128	139	116	126	128	138	116	126	128	137	116	127	128	134	---	---	---	---
	15,000	114	119	124	137	114	119	124	137	114	120	124	136	114	121	124	135	114	122	124	134	114	123	124	131	---	---	---	---
	14,000	114	114	121	134	114	114	121	133	114	115	121	133	114	116	121	132	114	117	121	131	114	119	121	128	---	---	---	---
	13,000	114	114	121	135	114	114	120	134	114	114	120	132	114	114	119	130	114	114	118	129	114	114	117	125	---	---	---	---
	12,000	114	114	122	137	114	114	121	135	114	114	120	134	114	114	119	132	114	114	119	130	114	114	116	126	---	---	---	---
	11,000	114	114	123	138	114	114	122	137	114	114	121	135	114	114	120	133	114	114	119	131	114	114	117	127	---	---	---	---
	10,000	114	114	124	140	114	114	123	139	114	114	122	137	114	114	121	135	114	114	120	133	114	114	118	128	---	---	---	---

Figure 7A-16. Take-off Speeds (KIAS) - Flaps up (Sheet 1 of 2)



TAKE-OFF SPEEDS (KIAS) - FLAPS UP (Cont'd)

		FREE AIR TEMPERATURE																											
PRESS. ALT (FT)	T/O WT (LBS.)	-30°C				-10°C				0°C				10°				20°C				40°C				52°C			
		V <sub>1</sub>	V <sub>R</sub>	V <sub>2</sub>	V <sub>50</sub>	V <sub>1</sub>	V <sub>R</sub>	V <sub>2</sub>	V <sub>50</sub>	V <sub>1</sub>	V <sub>R</sub>	V <sub>2</sub>	V <sub>50</sub>	V <sub>1</sub>	V <sub>R</sub>	V <sub>2</sub>	V <sub>50</sub>	V <sub>1</sub>	V <sub>R</sub>	V <sub>2</sub>	V <sub>50</sub>	V <sub>1</sub>	V <sub>R</sub>	V <sub>2</sub>	V <sub>50</sub>	V <sub>1</sub>	V <sub>R</sub>	V <sub>2</sub>	V <sub>50</sub>
10,000	16,500	118	126	130	142	118	128	130	140	118	128	130	140	118	129	130	139	118	129	130	137	118	130	130	135	---	---	---	---
	16,000	116	124	128	140	116	125	128	139	116	126	128	138	116	126	128	137	116	127	128	136	116	128	128	133	---	---	---	---
	15,000	114	119	124	137	114	120	124	135	114	121	124	135	114	122	124	134	114	122	124	133	114	123	124	130	---	---	---	---
	14,000	114	114	114	133	114	116	121	132	114	116	121	131	114	117	121	131	114	118	121	130	114	119	121	127	---	---	---	---
	13,000	114	114	121	134	114	114	119	131	114	114	118	130	114	114	118	128	114	114	117	126	114	115	117	124	---	---	---	---
	12,000	114	114	121	136	114	114	120	133	114	114	119	131	114	114	118	129	114	114	117	128	114	114	115	124	---	---	---	---
	11,000	114	114	122	137	114	114	121	134	114	114	120	132	114	114	119	131	114	114	118	129	114	114	116	125	---	---	---	---
10,000	114	114	123	139	114	114	122	136	114	114	121	134	114	114	120	132	114	114	119	130	114	114	117	126	---	---	---	---	
12,000	16,500	118	127	130	141	118	128	130	139	118	129	130	138	118	129	130	137	118	129	130	136	118	130	130	134	---	---	---	---
	16,000	116	125	128	139	116	126	128	138	116	127	128	137	116	127	128	136	116	127	128	134	116	128	128	132	---	---	---	---
	15,000	114	120	124	136	114	121	124	134	114	122	124	134	114	123	124	133	114	123	124	131	114	124	124	129	---	---	---	---
	14,000	114	115	121	133	114	117	121	131	114	118	121	130	114	118	121	130	114	119	121	128	114	119	121	126	---	---	---	---
	13,000	114	114	120	132	114	114	118	129	114	114	117	127	114	114	117	126	114	114	117	125	114	115	117	123	---	---	---	---
	12,500	114	114	120	134	114	114	119	130	114	114	118	129	114	114	117	127	114	114	116	125	114	114	115	122	---	---	---	---
	11,000	114	114	121	135	114	114	120	132	114	114	119	130	114	114	118	128	114	114	117	127	114	114	115	123	---	---	---	---
10,000	114	114	122	137	114	114	120	133	114	114	119	131	114	114	119	130	114	114	118	128	114	114	116	124	---	---	---	---	
14,000	16,500	118	128	130	140	118	129	130	138	118	129	130	137	118	130	130	136	118	130	130	135	118	130	130	133	---	---	---	---
	16,000	116	126	128	138	116	127	128	136	116	127	128	135	116	127	128	134	116	128	128	133	116	128	128	131	---	---	---	---
	15,000	114	121	124	135	114	122	124	133	114	123	124	132	114	123	124	131	114	123	124	130	114	124	124	128	---	---	---	---
	14,000	114	116	121	131	114	118	121	130	114	118	121	129	114	119	121	128	114	119	121	127	114	120	121	125	---	---	---	---
	13,000	114	114	118	130	114	114	117	127	114	114	117	126	114	115	117	125	114	115	117	124	114	116	117	121	---	---	---	---
	12,000	114	114	119	131	114	114	118	128	114	114	117	127	114	114	116	125	114	114	115	124	114	114	115	120	---	---	---	---
	11,000	114	114	120	132	114	114	118	129	114	114	118	128	114	114	117	125	114	114	116	125	114	114	115	121	---	---	---	---
10,000	114	114	121	134	114	114	119	131	114	114	118	129	114	114	118	127	114	114	117	126	114	114	115	122	---	---	---	---	

BT05189

Figure 7A-16. Take-off Speeds (KIAS) - Flaps up (Sheet 2 of 2)

TAKE-OFF DISTANCE - FLAPS UP

ASSOCIATED CONDITIONS:

POWER.....STATIC TAKE-OFF POWER SET BEFORE BRAKE RELEASE.

VR. V50.....AS SCHEDULED IN TABLE OF TAKE-OFF SPEEDS.

LANDING GEAR.....RETRACTED AFTER LIFT-OFF

RUNWAY.....PAVED, DRY SURFACE

EXAMPLE-

FAT ..... 15C  
 FIELD PRESSURE ALTITUDE ..... 3499 FT  
 WEIGHT..... 16,000 LBS.  
 RUNWAY GRADIENT..... 1.9% DN  
 HEADWIND COMPONENT ..... 10 KTS  
 GROUND ROLL..... 3511 FT  
 TOTAL DISTANCE OVER 50-FT OBSTACLE ..... 4864 FT

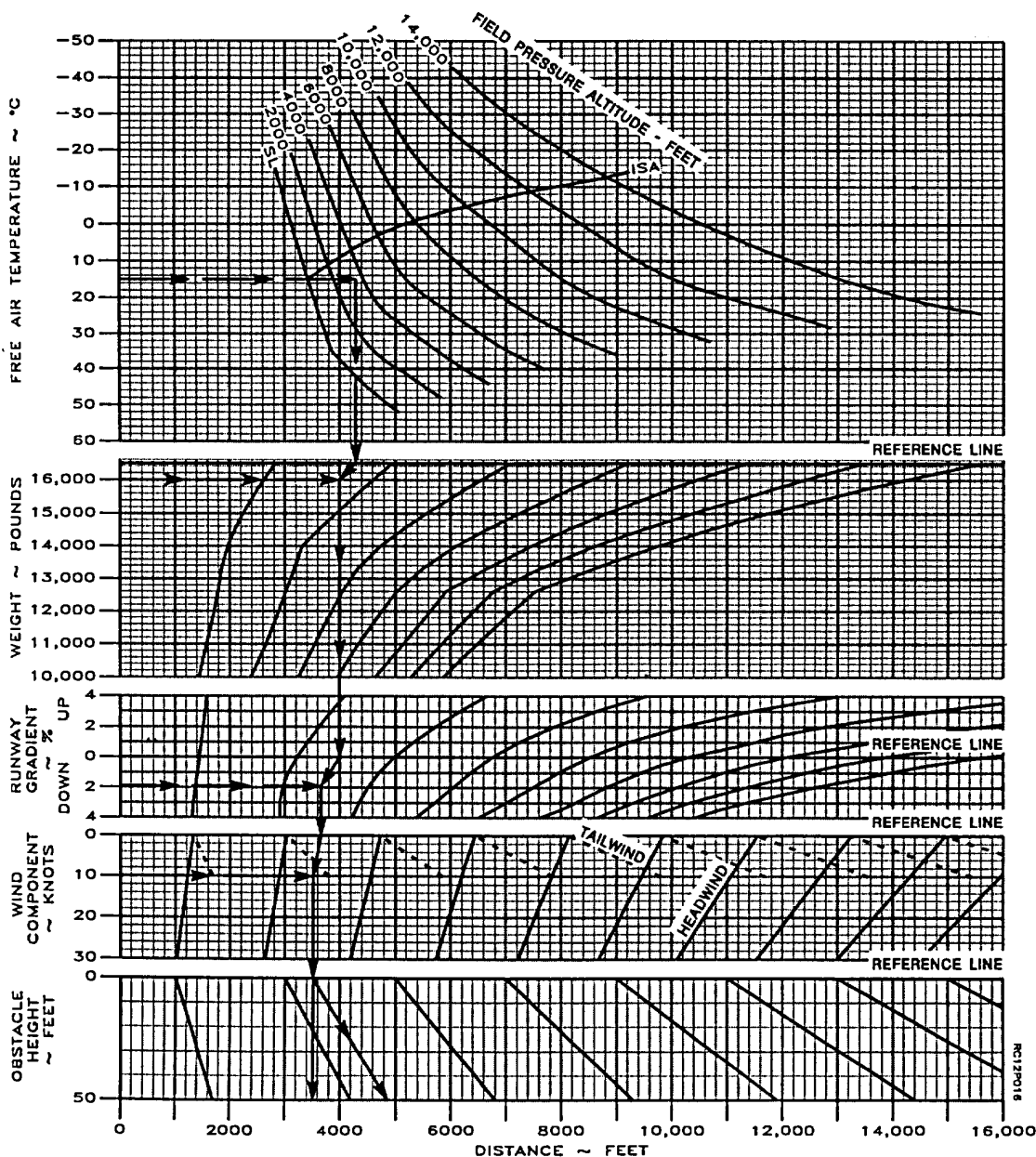

Figure 7-17. Take-off Distance Over 50 Foot Obstacle - Flaps Up

ACCELERATE-STOP - FLAPS UP

ASSOCIATED CONDITIONS:

POWER.....STATIC TAKE-OFF POWER SET BEFORE BRAKE RELEASE.  
 AUTOFEATHER.....ARMED  
 V1.....AS SCHEDULED IN TABLE OF TAKE-OFF SPEEDS.  
 POWER LEVERS.....GROUND FINE AT V1  
 BRAKING.....MAXIMUM WITHOUT SLIDING TIRES  
 RUNWAY.....PAVED. DRY SURFACE

EXAMPLE:

FAT ..... 15°C  
 FIELD PRESSURE ALTITUDE ..... 3499 FT  
 WEIGHT ..... 16,000 LBS  
 RUNWAY GRADIENT ..... 19% DN  
 HEADWIND COMPONENT ..... 10 KTS  
 ACCELERATE-STOP DISTANCE .. 5877 FT

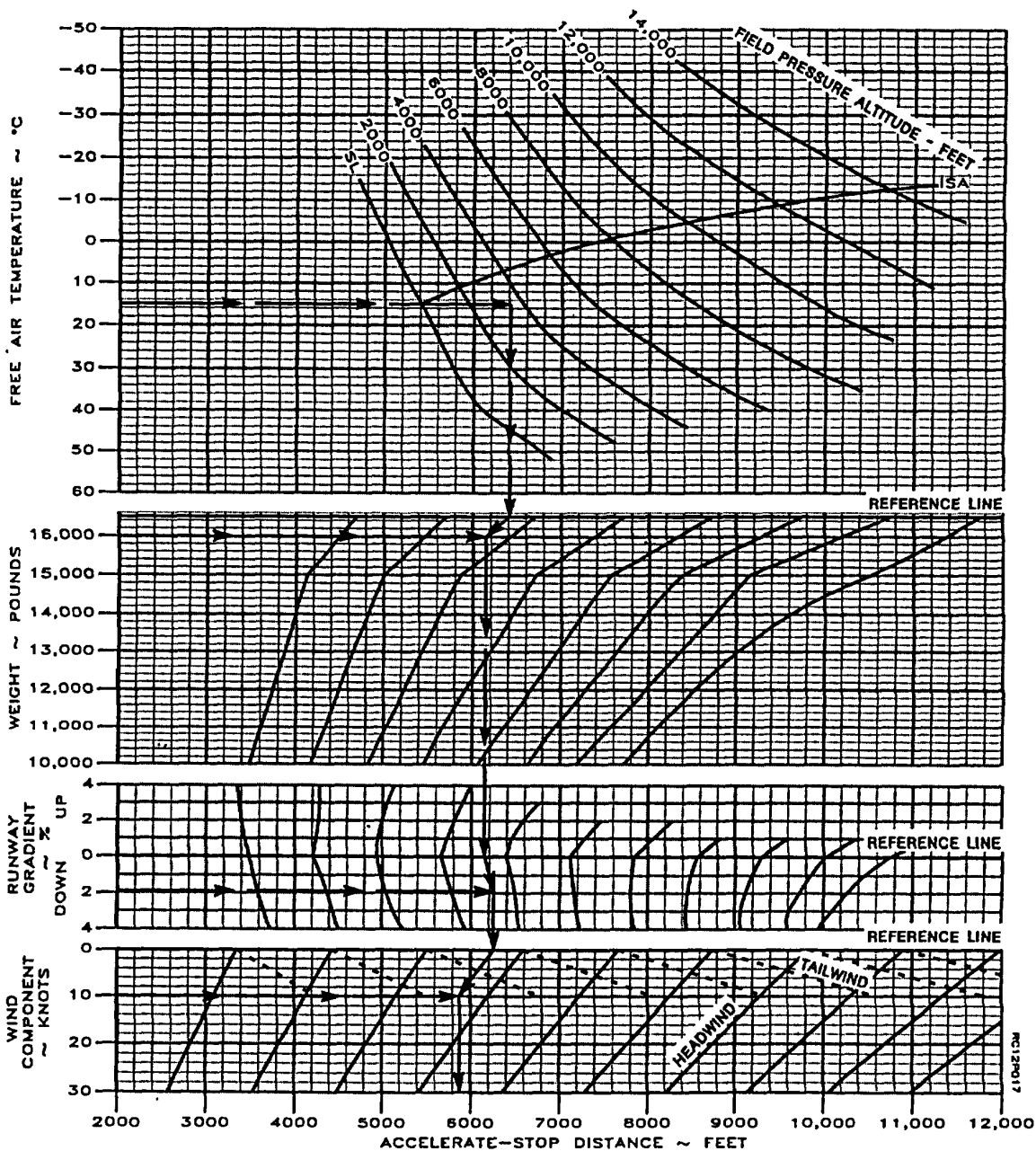

Figure 7-18. Accelerate Stop - Flaps Up

ACCELERATE- GO - FLAPS UP

ASSOCIATED CONDITIONS:

POWER.....STATIC TAKE-OFF POWER SET  
 BEFORE BRAKE RELEASE.  
 AUTOFEATHER.....ARMED  
 V1 AND V2.....AS SCHEDULED IN TABLE  
 OF TAKE-OFF SPEEDS.  
 LANDING GEAR.....RETRACTED AFTER LIFT-OFF  
 RUNWAY.....PAVED, DRY SURFACE

EXAMPLE:

FAT ..... 15°C  
 FIELD PRESSURE ALTITUDE ..... 3499 FT  
 WEIGHT..... 16,000 LBS  
 RUNWAY GRADINET ..... 1.9% DN  
 HEADWIND COMPONENT ..... 10 KTS  
 ACCELERATE-GO DISTANCE ..... 7172 FT

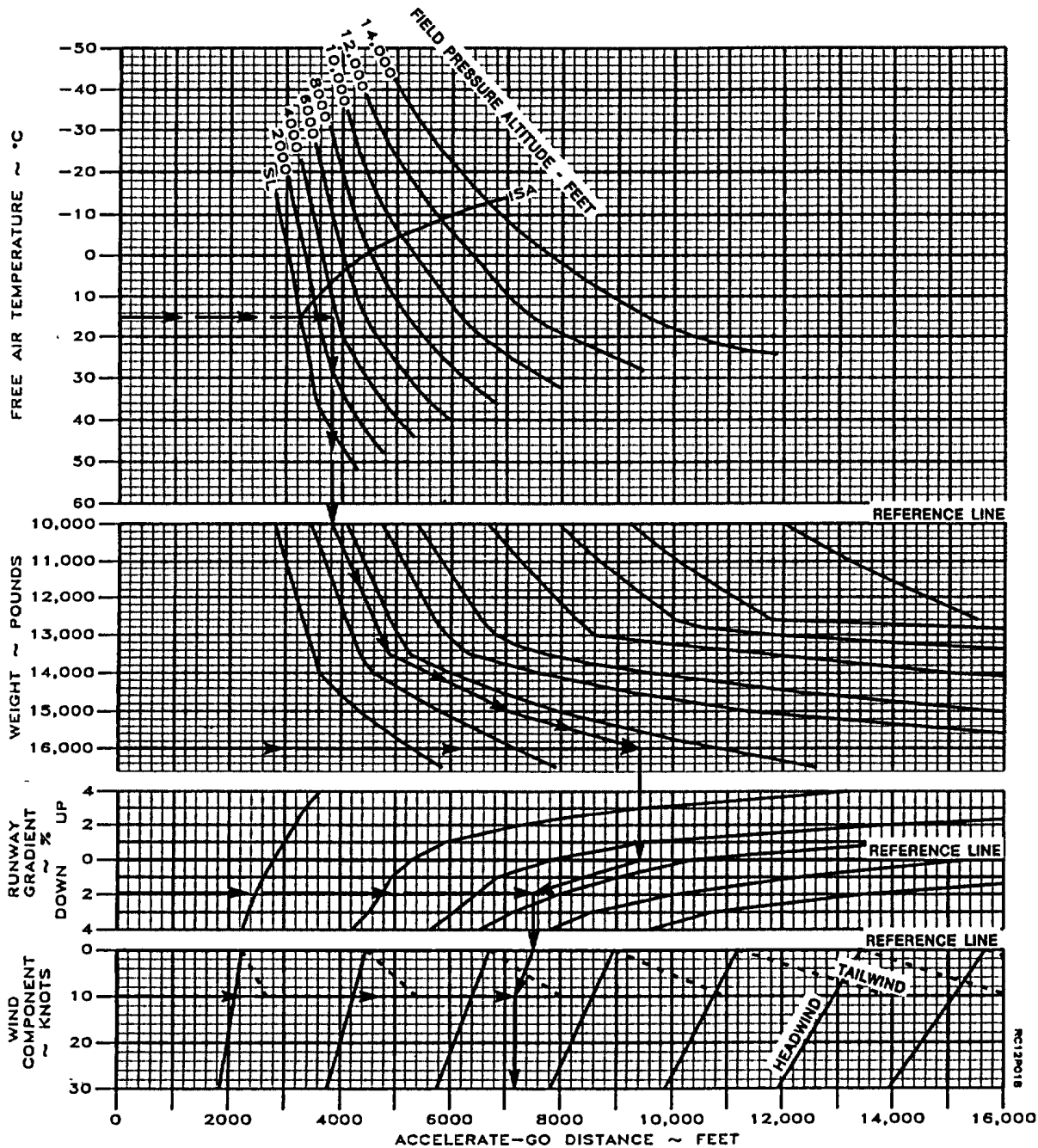

Figure 7-19. Accelerate-Go Distance Over 50 Foot Obstacle - Flaps Up

### NET TAKE-OFF FLIGHT PATH - FIRST SEGMENT - FLAPS UP ONE ENGINE INOPERATIVE

**ASSOCIATED CONDITIONS:**

POWER.....STATIC TAKE-OFF  
 .....POWER SET BEFORE  
 .....BRAKE RELEASE  
 INOPERATIVE PROPELLER...FEATHERED  
 LANDING GEAR.....DOWN  
 CLIMB SPEED.....V2

**EXAMPLE:**

FAT ..... 15°C  
 FIELD PRESSURE ALTITUDE ..... 3499 FT  
 WEIGHT.....16,000 LBS  
 HEADWIND COMPONENT ..... 10 KTS  
 NET CLIMB GRADIENT ..... 0.00

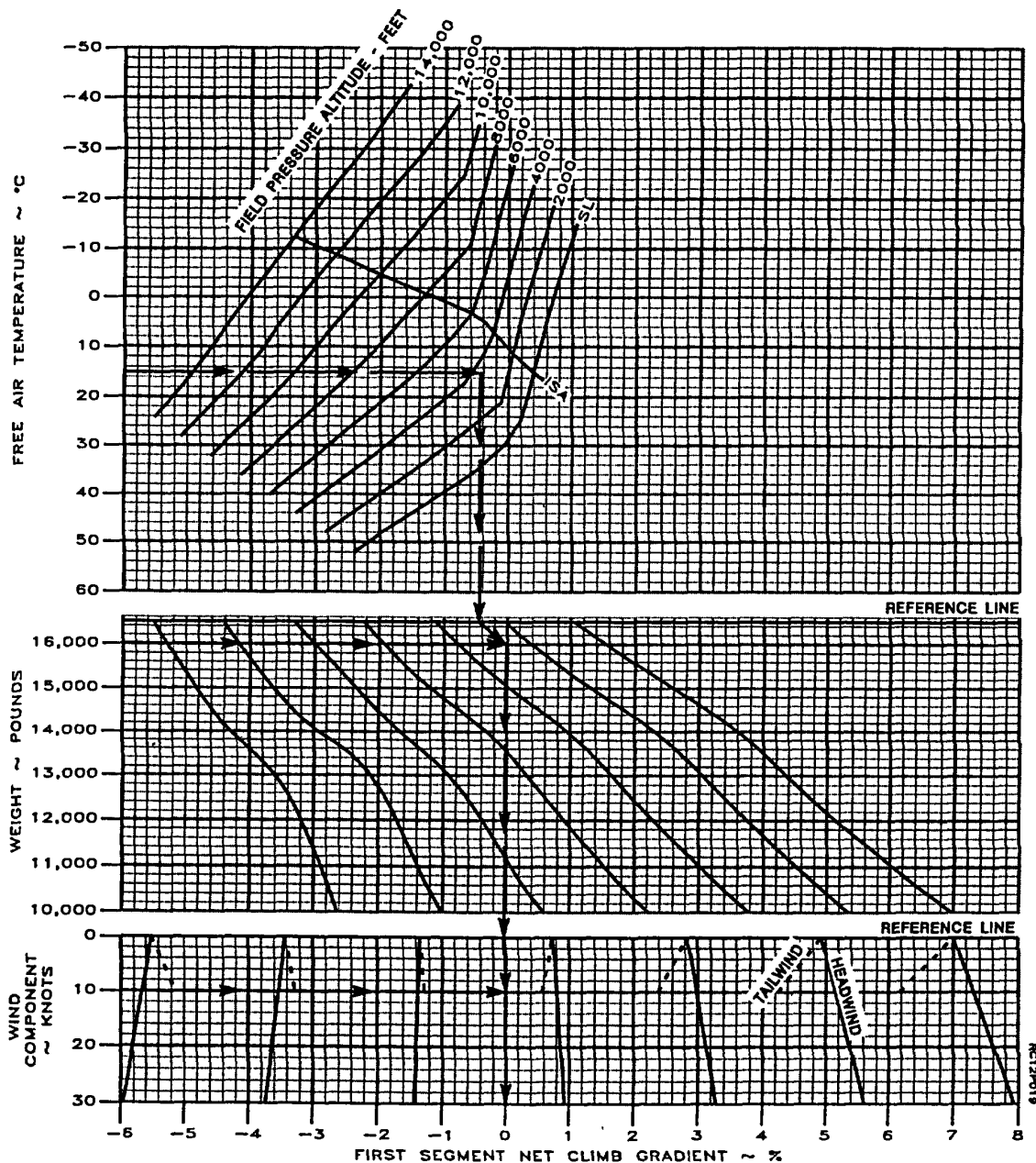

Figure 7-20. Net Take-off Flight Path - First Segment - Flaps Up

### NET TAKE-OFF FLIGHT PATH - SECOND SEGMENT - FLAPS UP ONE ENGINE INOPERATIVE

ASSOCIATED CONDITIONS:

POWER.....STATIC TAKE-OFF  
.....POWER SET BEFORE  
.....BRAKE RELEASE  
INOPERATIVE PROPELLER...FEATHERED  
LANDING GEAR.....UP  
CLIMB SPEED.....V2

EXAMPLE:

FAT ..... 15°C  
FIELD PRESSURE ALTITUDE ..... 3499 FT  
WEIGHT..... 6,000 LBS  
HEADWIND COMPONENT ..... 10 KTS  
NET CLIMB GRADIENT ..... 2.70 %

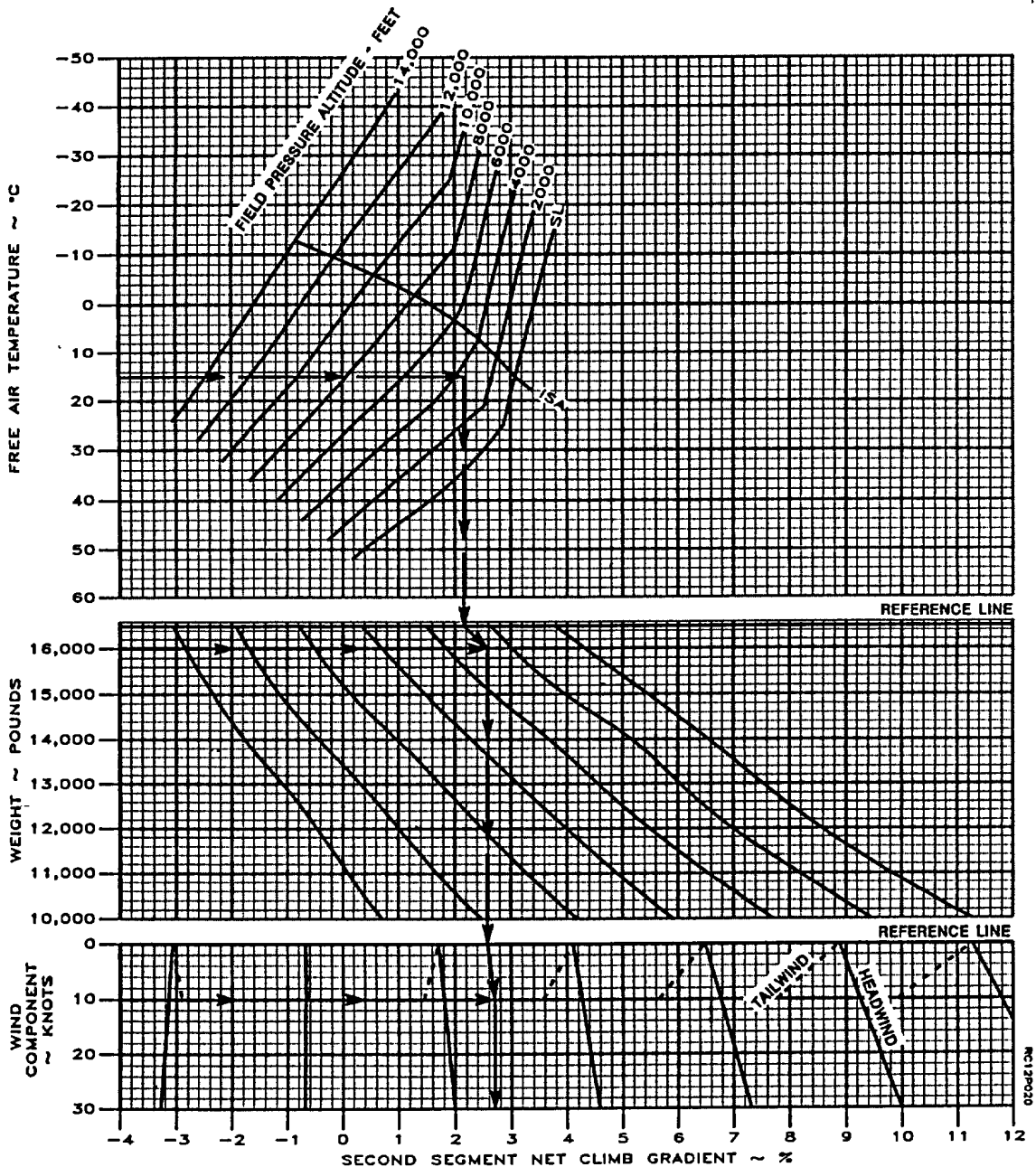

Figure 7-21. Net Take-off Flight Path - Second Segment - Flaps Up

**HORIZONTAL DISTANCE FROM REFERENCE ZERO  
TO THIRD SEGMENT CLIMB - FLAPS UP**

**ASSOCIATED CONDITIONS:**

POWER:  
TO 500 FT AOL.....STATIC TAKE-OFF  
POWER SET BEFORE  
BRAKE RELEASE.  
AT 500 FT AGL.....TAKEOFF  
AIRSPEED:  
TO 500 FT AGL .....V2  
AT 500 FT AL.....ACCELERATE TO VENR  
INOPERATIVE PROPELLER...FEATHERED  
LANDING GEAR .....RETRACTED AFTER LIFT-OFF

**EXAMPLE:**

FAT ..... 15°C  
FIELD PRESSURE ALTITUDE ..... 3499 FT  
WEIGHT ..... 16,000 LBS  
HEADWIND COMPONENT ..... 10 KTS  
DISTANCE ..... 3.23 NM

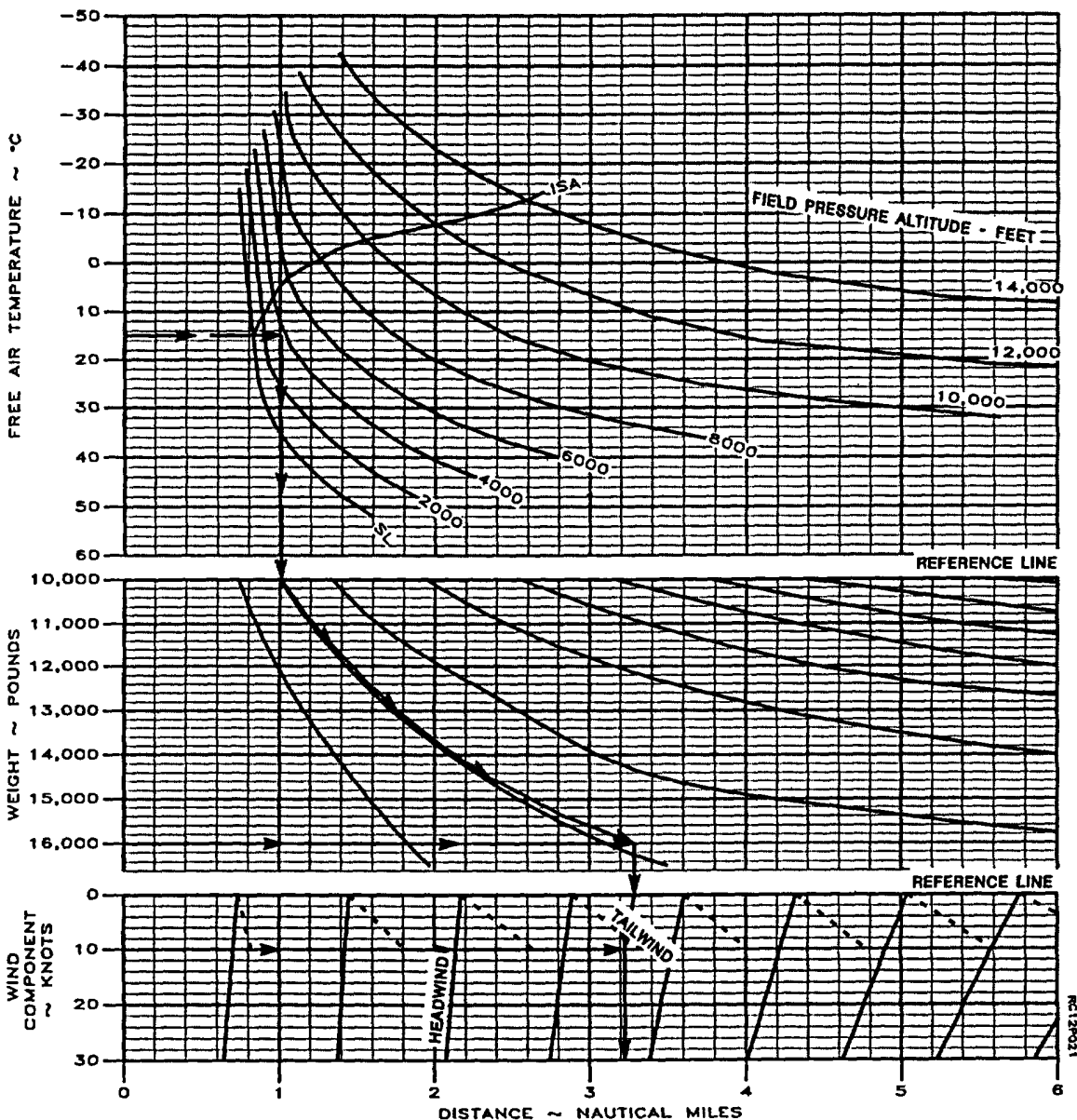

Figure 7-22. Horizontal Distance from Reference Zero to Third Segment Climb - Flaps Up

MAXIMUM TAKE-OFF WEIGHT - FLAPS APPROACH  
TO ACHIEVE POSITIVE ONE-ENGINE-INOPERATIVE CLIMB AT LIFT-OFF

ASSOCIATED CONDITIONS:  
POWER.....TAKEOFF  
LANDING GEAR .....DOWN  
INOPERATIVE PROPELLER...FEATHERED

EXAMPLE  
FIELD PRESSURE ALTITUDE ..... 3499 FT  
FAT ..... 15°C  
TAKE-OFF WEIGHT ..... 16,500 LBS

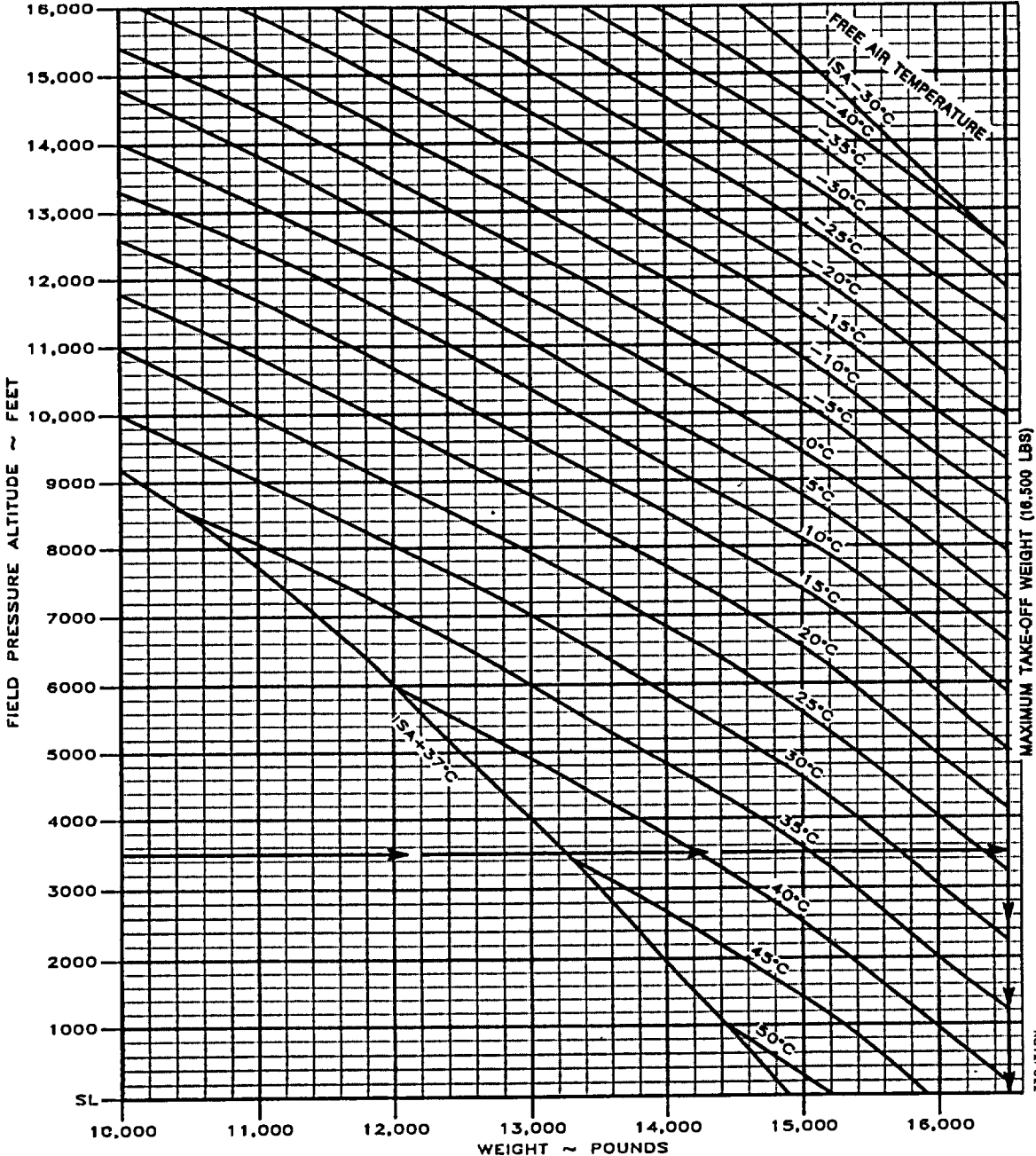

Figure 7-23. Maximum Take-off Weight to Achieve Positive One Engine Inoperative Climb at Liftoff - Flaps Approach



**MAXIMUM TAKE-OFF WEIGHT - FLAPS APPROACH  
AS LIMITED BY TIRE SPEED**

EXAMPLE:  
FAT ..... 15°C  
FIELD PRESSURE ALTITUDE ..... 3499 FT  
HEADWIND COMPONENT ..... 10 KTS  
WEIGHT ..... EXCEEDS STRUCTURAL LIMIT  
OF 16,500 LBS

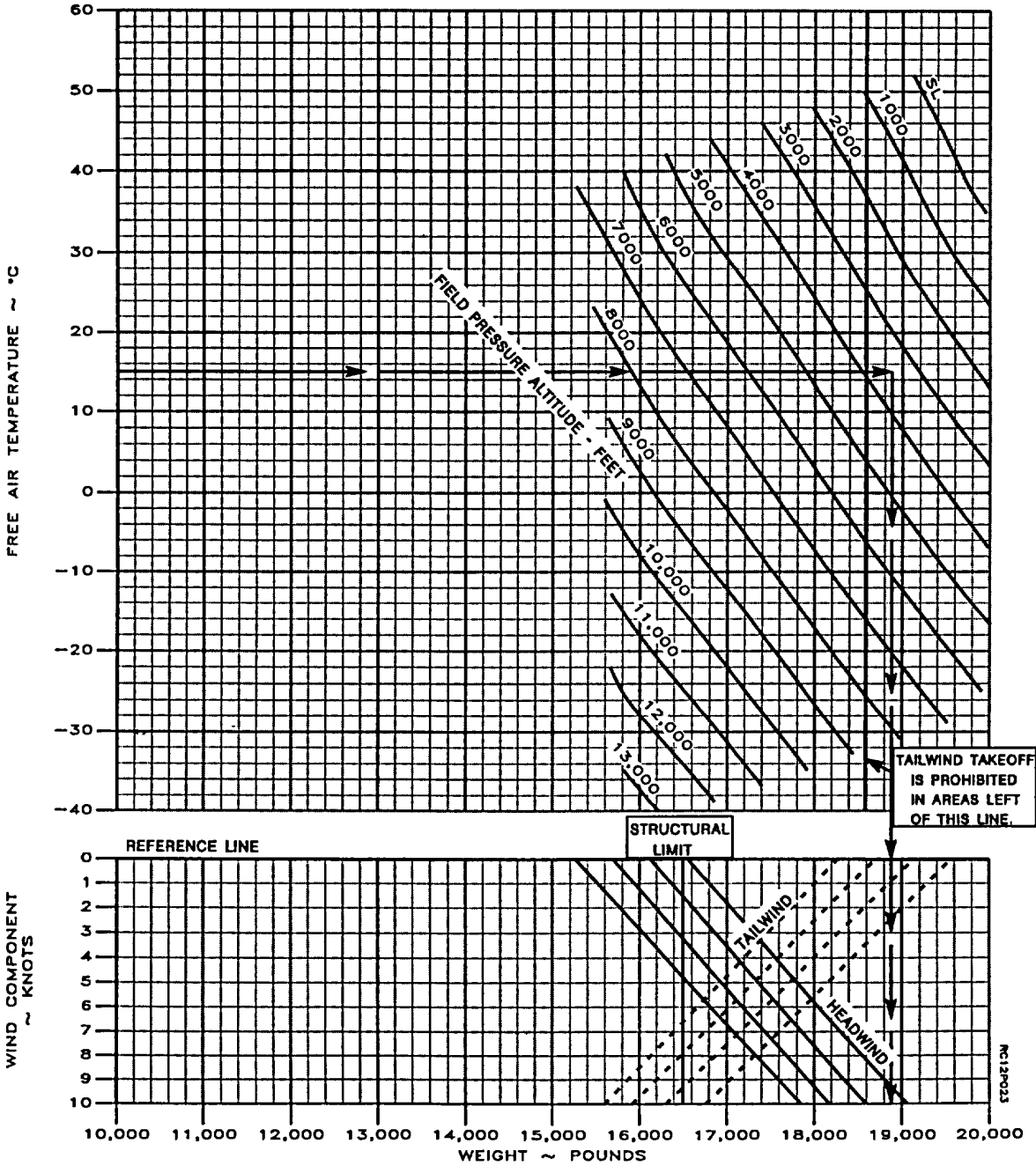

Figure 7-24. Maximum Take-off Weight as Limited by Tire Speed - Flaps Approach

TAKE-OFF SPEEDS (KIAS) - FLAPS APPROACH

		FREE AIR TEMPERATURE																											
PRESS. ALT (FT)	T/O WT (LBS)	-30°C				-10°C				0°C				10°				20°C				40°C				52°C			
		V <sub>1</sub>	V <sub>R</sub>	V <sub>2</sub>	V <sub>50</sub>	V <sub>1</sub>	V <sub>R</sub>	V <sub>2</sub>	V <sub>50</sub>	V <sub>1</sub>	V <sub>R</sub>	V <sub>2</sub>	V <sub>50</sub>	V <sub>1</sub>	V <sub>R</sub>	V <sub>2</sub>	V <sub>50</sub>	V <sub>1</sub>	V <sub>R</sub>	V <sub>2</sub>	V <sub>50</sub>	V <sub>1</sub>	V <sub>R</sub>	V <sub>2</sub>	V <sub>50</sub>	V <sub>1</sub>	V <sub>R</sub>	V <sub>2</sub>	V <sub>50</sub>
SL	16,500	110	113	116	129	110	114	116	129	110	114	116	129	110	114	116	128	110	114	116	128	110	116	116	127	110	116	116	125
	18,000	108	111	114	128	108	111	114	127	108	111	114	127	108	112	114	127	108	112	114	127	108	112	114	127	108	113	114	124
	15,000	108	110	115	129	108	110	114	128	108	110	114	127	108	110	114	127	108	110	113	126	108	110	112	123	108	110	111	121
	14,000	108	110	116	130	108	110	115	129	108	110	115	128	108	110	114	128	108	110	114	127	108	110	113	124	108	110	111	122
	13,000	108	110	116	132	108	110	116	130	108	110	116	130	108	110	115	129	108	110	115	129	108	110	113	126	108	110	112	123
	12,000	108	110	117	133	108	110	117	132	108	110	116	131	108	110	116	131	108	110	116	130	108	110	114	127	108	110	113	124
	11,000	108	110	118	135	108	110	118	133	108	110	117	133	108	110	117	132	108	110	117	132	108	110	115	128	108	110	113	125
	10,000	108	110	120	137	108	110	119	135	108	110	118	134	108	110	118	134	108	110	118	133	108	110	116	130	108	110	114	127
2000	16,500	110	113	116	129	110	114	116	128	110	114	116	128	110	114	116	128	110	115	116	128	110	116	116	126	110	116	116	124
	16,000	108	111	114	127	108	112	114	127	108	112	114	127	108	112	114	126	108	112	114	126	108	114	114	124	108	114	114	123
	15,000	108	110	114	125	108	110	114	127	108	110	113	126	108	110	113	126	108	110	113	125	108	110	111	121	108	111	111	120
	14,000	108	110	115	129	108	110	114	128	108	110	114	127	108	110	114	127	108	110	114	126	108	110	112	122	108	110	110	120
	13,000	108	110	116	130	108	110	115	129	108	110	115	129	108	110	115	128	108	110	115	128	108	110	112	123	108	110	111	121
	12,000	108	110	117	132	108	110	116	131	108	110	116	130	108	110	116	130	108	110	115	129	108	110	113	125	108	110	112	122
	11,000	108	110	118	133	108	110	117	132	108	110	117	132	108	110	117	131	108	110	116	131	108	110	114	126	108	110	112	123
	10,000	108	110	119	135	108	110	118	134	108	110	118	133	108	110	118	133	108	110	117	132	108	110	115	127	108	110	113	124
4000	18,500	110	114	116	128	110	114	116	128	110	115	116	128	110	115	118	127	110	116	116	127	110	116	116	125	110	116	116	122
	18,000	108	112	114	127	108	112	114	126	108	112	114	126	108	113	114	126	108	113	114	125	108	114	114	123	108	114	114	121
	15,000	108	110	114	127	108	110	113	126	108	110	113	125	108	110	113	125	108	110	112	123	108	111	111	120	108	111	111	118
	14,000	108	110	115	128	108	110	114	127	108	110	114	126	108	110	113	126	108	110	113	124	108	110	111	120	108	110	110	118
	13,000	108	110	115	129	108	110	115	128	108	110	115	128	108	110	114	127	108	110	113	125	108	110	111	121	108	110	110	119
	12,000	108	110	116	131	108	110	116	130	108	110	115	129	108	110	115	129	108	110	114	127	108	110	112	122	108	110	111	120
	11,000	108	110	117	132	108	110	117	131	108	110	116	131	108	110	118	130	108	110	115	128	108	110	113	124	108	110	111	121
	10,000	108	110	118	134	108	110	118	133	108	110	117	132	108	110	117	132	108	110	116	130	108	110	114	125	108	110	112	122
6000	16,500	110	115	116	128	110	115	116	127	110	115	116	127	110	116	116	127	110	116	116	126	110	116	116	123	---	---	---	---
	16,000	108	113	114	126	108	113	114	126	108	113	114	126	108	114	114	125	108	114	114	124	108	114	114	122	---	---	---	---
	15,000	108	110	113	126	108	110	113	125	108	110	113	124	108	110	112	123	108	110	111	121	108	111	111	119	---	---	---	---
	14,000	108	110	114	127	108	110	114	126	108	110	113	125	108	110	113	124	108	110	112	122	108	110	110	118	---	---	---	---
	13,000	108	110	115	128	108	110	114	127	108	110	114	127	108	110	113	125	108	110	112	123	108	110	110	119	---	---	---	---
	12,000	108	110	116	130	108	110	115	129	108	110	115	128	108	110	114	126	108	110	113	125	108	110	111	120	---	---	---	---
	11,000	108	110	117	131	108	110	116	130	108	110	118	129	108	110	115	128	108	110	114	126	108	110	112	122	---	---	---	---
	10,000	108	110	118	133	108	110	117	132	108	110	117	131	108	110	116	129	108	110	115	127	108	110	113	123	---	---	---	---
8000	16,500	110	115	116	127	110	115	116	126	110	116	116	126	110	116	116	126	110	116	116	125	110	116	116	122	---	---	---	---
	16,000	108	114	114	126	108	113	114	125	108	114	114	125	108	114	114	124	108	114	114	123	108	114	114	120	---	---	---	---
	15,000	108	110	113	125	108	110	112	124	108	110	111	122	108	110	111	121	108	111	111	120	108	110	111	117	---	---	---	---
	14,000	108	110	114	126	108	110	113	125	108	110	112	123	108	110	111	122	108	110	111	120	108	110	110	117	---	---	---	---
	13,000	108	110	114	127	108	110	114	126	108	110	113	124	108	110	112	123	108	110	111	121	108	110	110	118	---	---	---	---
	12,000	108	110	115	129	108	110	114	127	108	110	114	126	108	110	113	124	108	110	112	122	108	110	110	119	---	---	---	---
	11,000	108	110	116	130	108	110	115	129	108	110	114	127	108	110	114	125	108	110	113	124	108	110	111	120	---	---	---	---
	10,000	108	110	117	132	108	110	116	130	108	110	115	129	108	110	115	127	108	110	114	125	108	110	111	121	---	---	---	---

Figure 7-25. Take-off Speeds (KIAS) - Flaps Approach (Sheet 1 of 2)

TAKE-OFF SPEEDS (KIAS) - FLAPS APPROACH

		FREE AIR TEMPERATURE																															
PRESS. ALT (FT)	T/O WT (LBS)	-30°C				-10°C				0°C				10°				20°C				40°C				52°C							
		V <sub>1</sub>	V <sub>R</sub>	V <sub>2</sub>	V <sub>50</sub>	V <sub>1</sub>	V <sub>R</sub>	V <sub>2</sub>	V <sub>50</sub>	V <sub>1</sub>	V <sub>R</sub>	V <sub>2</sub>	V <sub>50</sub>	V <sub>1</sub>	V <sub>R</sub>	V <sub>2</sub>	V <sub>50</sub>	V <sub>1</sub>	V <sub>R</sub>	V <sub>2</sub>	V <sub>50</sub>	V <sub>1</sub>	V <sub>R</sub>	V <sub>2</sub>	V <sub>50</sub>	V <sub>1</sub>	V <sub>R</sub>	V <sub>2</sub>	V <sub>50</sub>				
10,000	16,500	110	115	116	127	110	116	116	126	110	116	116	125	110	116	116	124	110	116	116	123	110	116	116	120	110	116	116	120	---	---	---	---
	16,000	108	113	114	125	108	114	114	124	108	114	114	124	108	114	114	123	108	114	114	122	108	114	114	119	108	114	114	119	---	---	---	---
	15,000	108	110	112	124	108	110	111	122	108	111	111	120	108	111	111	120	108	111	111	119	108	111	111	119	108	111	111	116	---	---	---	---
	14,000	108	110	113	125	108	110	112	123	108	110	111	121	108	110	110	120	108	111	110	118	108	110	110	115	108	110	110	115	---	---	---	---
	13,000	108	110	114	126	108	110	112	124	108	110	112	122	108	110	111	121	108	110	110	119	108	110	110	116	108	110	110	116	---	---	---	---
	12,000	108	110	115	128	108	110	113	125	108	110	112	123	108	110	112	122	108	110	111	120	108	110	111	117	108	110	110	117	---	---	---	---
	11,000	108	110	115	129	108	110	114	126	108	110	113	125	108	110	112	123	108	110	112	121	108	110	112	118	108	110	110	118	---	---	---	---
	10,000	108	110	116	131	108	110	115	128	108	110	114	126	108	110	113	124	108	110	112	123	108	110	112	121	108	110	110	119	---	---	---	---
12,000	16,500	110	116	116	126	110	116	116	125	110	116	116	124	110	116	116	123	110	116	116	121	110	116	116	119	110	116	116	119	---	---	---	---
	16,000	108	114	114	125	108	114	114	123	108	114	114	122	108	114	114	121	108	114	114	120	108	114	114	117	108	114	114	117	---	---	---	---
	15,000	108	111	111	122	108	111	111	120	108	111	111	119	108	111	111	119	108	111	111	117	108	111	111	114	108	111	111	114	---	---	---	---
	14,000	108	110	112	123	108	110	111	120	108	110	110	119	108	110	110	118	108	110	110	116	108	110	110	113	108	110	110	113	---	---	---	---
	13,000	108	110	113	124	108	110	111	122	108	110	111	120	108	110	110	119	108	110	110	117	108	110	110	114	108	110	110	114	---	---	---	---
	12,500	108	110	114	126	108	110	112	123	108	110	111	121	108	110	111	120	108	126	110	118	108	110	110	115	108	110	110	115	---	---	---	---
	11,000	108	110	114	127	108	110	113	124	108	110	112	122	108	110	111	121	108	122	111	119	108	110	110	116	108	110	110	116	---	---	---	---
	10,000	108	110	115	128	108	110	114	125	108	110	113	124	108	110	112	122	108	118	111	121	108	110	110	117	108	110	110	117	---	---	---	---
14,000	16,500	110	116	116	125	110	116	116	123	110	116	116	122	110	116	116	121	116	116	116	120	110	116	116	118	110	116	116	118	---	---	---	---
	16,000	108	114	114	124	108	114	114	122	108	114	114	121	108	114	114	120	108	114	114	119	108	114	114	116	108	114	114	116	---	---	---	---
	15,000	108	111	111	120	108	111	111	119	108	111	111	118	108	111	111	117	108	111	111	116	108	111	111	113	108	111	111	113	---	---	---	---
	14,000	108	110	111	121	108	110	110	119	108	110	110	117	108	110	110	116	108	110	110	115	108	110	110	112	108	110	110	112	---	---	---	---
	13,000	108	110	112	122	108	110	110	120	108	110	110	118	108	110	110	117	108	110	110	116	108	110	110	113	108	110	110	113	---	---	---	---
	12,000	108	110	112	123	108	110	111	121	108	110	110	119	108	110	110	118	108	110	110	117	108	110	110	113	108	110	110	113	---	---	---	---
	11,000	108	110	113	125	108	110	112	122	108	110	111	120	108	110	110	119	108	110	110	118	108	110	110	114	108	110	110	114	---	---	---	---
	10,000	108	110	114	126	108	110	113	123	108	110	112	122	108	111	111	120	108	110	110	119	108	110	110	115	108	110	110	115	---	---	---	---

BT05190

Figure 7-25. Take-off Speeds (KIAS) - Flaps Approach (Sheet 2 of 2)

TAKE-OFF DISTANCE - FLAPS APPROACH

ASSOCIATED CONDITIONS:  
 POWER.....STATIC TAKE-OFF POWER SET  
 .....BEFORE BRAKE RELEASE.  
 VR. V50.....AS SCHEDULED IN TABLE  
 .....OF TAKE-OFF SPEEDS.  
 LANDING GEAR.....RETRACTED AFTER LIFT-OFF  
 RUNWAY.....PAVED. DRY SURFACE

EXAMPLE:  
 FAT ..... 15°C  
 FIELD PRESSURE ALTITUDE ..... 3499 FT  
 WEIGHT ..... 16,000 LBS  
 RUNWAY GRADIENT ..... 1.9% DN  
 HEADWIND COMPONENT ..... 10 KTS  
 GROUND ROLL ..... 2909 FT  
 TOTAL DISTANCE OVER  
 50-FT OBSTACLE ..... 3886 FT

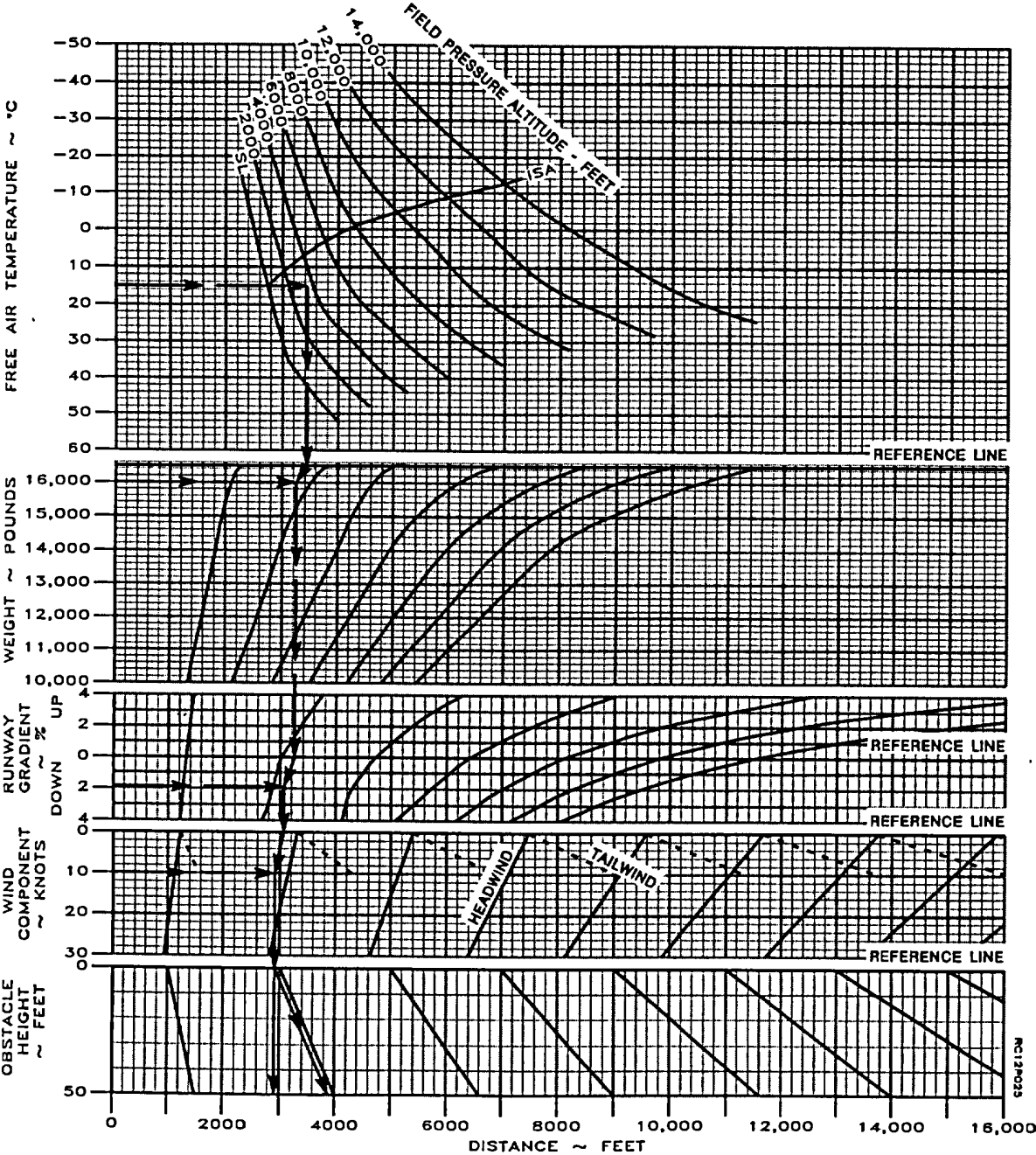

Figure 7-26. Take-off Distance Over 50 Foot Obstacle - Flaps Approach

ACCELERATE-STOP - FLAPS APPROACH

ASSOCIATED CONDITIONS:

POWER.....STATIC TAKE-OFF POWER SET BEFORE BRAKE RELEASE.  
 AUTOFEATHER.....ARMED  
 V<sub>1</sub>.....AS SCHEDULED IN TABLE OF TAKE-OFF SPEEDS.  
 POWER LEVERS.....GROUND FINE AT V<sub>1</sub>  
 BRAKING.....MAXIMUM WITHOUT SLIDING TIRES  
 RUNWAY.....PAVED. DRY SURFACE

EXAMPLE

FAT ..... 15°C  
 FIELD PRESSURE ALTITUDE ..... 3499 FT  
 WEIGHT ..... 16,000 LBS  
 RUNWAY GRADIENT ..... 1.9% DN  
 HEADWIND COMPONENT ..... 10 KTS  
 ACCELERATE-STOP DISTANCE .. 4972 FT,

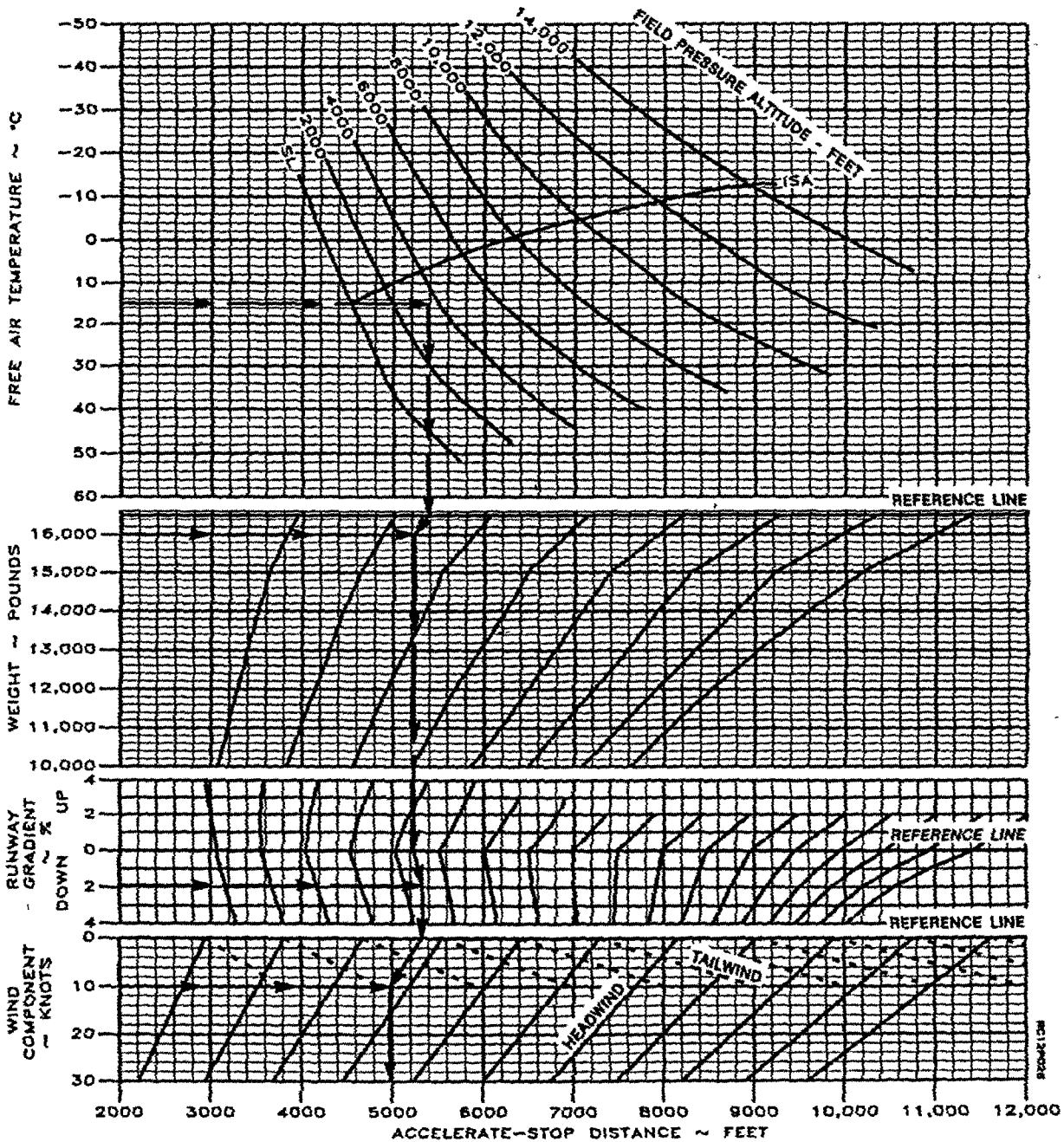

Figure 7-27. Accelerate Stop - Flaps Approach

### ACCELERATE-GO - FLAPS APPROACH

ASSOCIATED CONDITIONS:  
 POWER.....STATIC TAKE-OFF POWER SET BEFORE BRAKE RELEASE.  
 AUTOFEATHER.....ARMED  
 V<sub>1</sub> AND V<sub>2</sub>.....AS SCHEDULED IN TABLE OF TAKE-OFF SPEEDS.  
 LANDING GEAR.....RETRACTED AFTER LIFT-OFF  
 RUNWAY.....PAVED, DRY SURFACE

EXAMPLE:  
 FAT ..... 15°C  
 FIELD PRESSURE ALTITUDE FEET .... 3499 FT  
 WEIGHT..... 16,000 LBS  
 RUNWAY GRADIENT..... 1.9% DN  
 HEADWIND COMPONENT..... 10 KTS  
 ACCELERATE-GO DISTANCE ..... 5069 FT

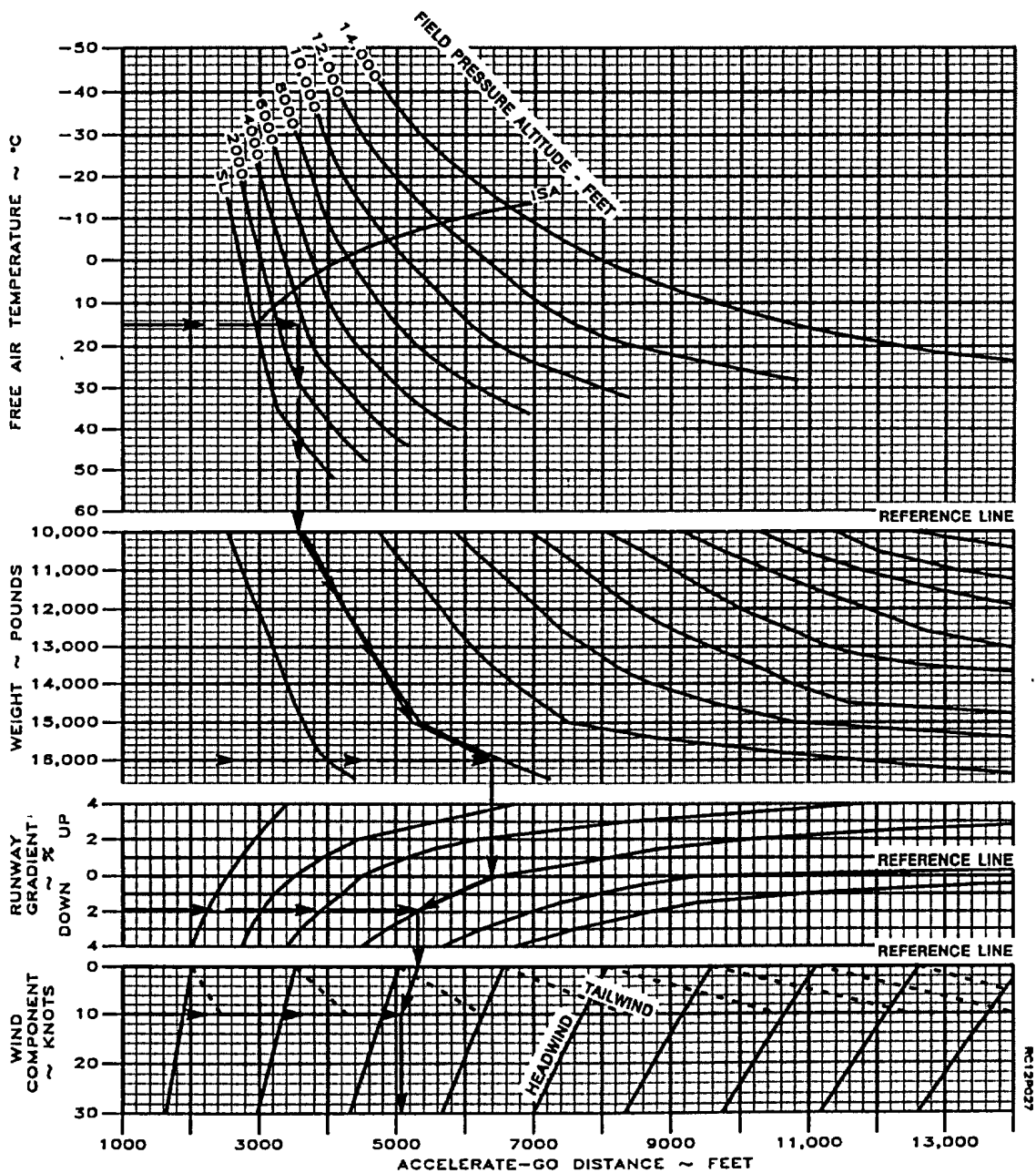

Figure 7-28. Accelerate-Go Distance Over 50 Foot Obstacle - Flaps Approach

**NET TAKE-OFF FLIGHT PATH - FIRST SEGMENT - FLAPS APPROACH  
ONE ENGINE INOPERATIVE**

**ASSOCIATED CONDITIONS:**

POWER.....STATIC TAKE-OFF  
POWER SET BEFORE  
BRAKE RELEASE  
INOPERATIVE PROPELLER...FEATHERED  
LANDING GEAR .....DOWN  
CLIMB SPEED ..... $V_2$

**EXAMPLE:**

FAT ..... 15°C  
FIELD PRESSURE ALTITUDE ..... 3499 FT  
WEIGHT ..... 16,000 LBS  
HEADWIND COMPONENT ..... 10 KTS  
NET CLIMB GRADIENT ..... .011 %

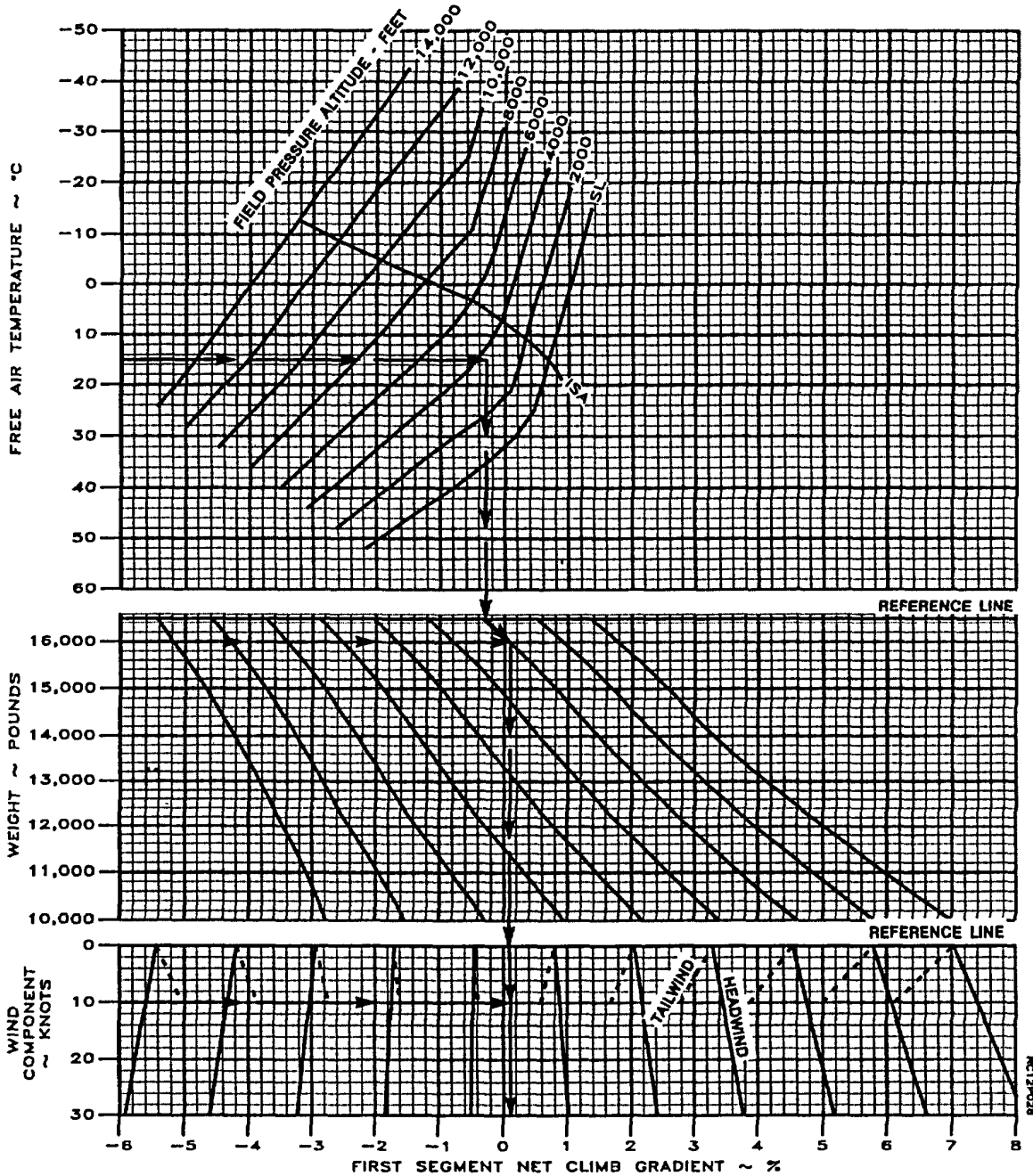

Figure 7-29. Net Take-off Flight Path - First Segment - Flaps Approach

### NET TAKE-OFF FLIGHT PATH - SECOND SEGMENT - FLAPS APPROACH ONE ENGINE INOPERATIVE

**ASSOCIATED CONDITIONS:**

POWER.....STATIC TAKE-OFF  
POWER SET BEFORE  
BRAKE RELEASE  
INOPERATIVE PROPELLER...FEATHERED  
LANDING GEAR .....UP  
CLIMB SPEED .....V<sub>2</sub>

**EXAMPLE:**

FAT ..... 15°C  
FIELD PRESSURE ALTITUDE ..... 3499 FT  
WEIGHT ..... 16,000 LBS  
HEADWIND COMPONENT ..... 10 KTS  
NET CLIMB GRADIENT ..... 2.53 %

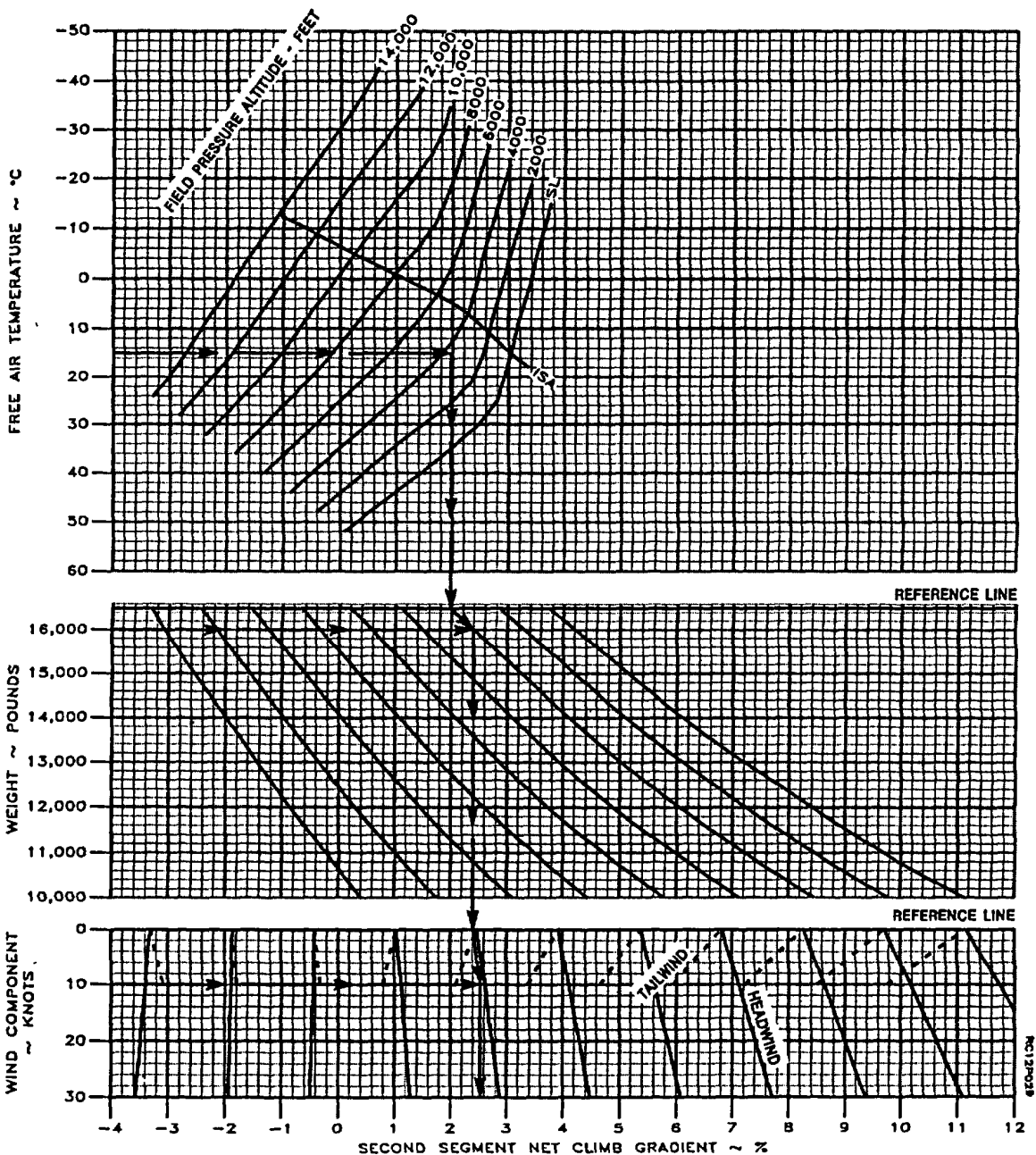

Figure 7-30. Net Take-off Flight Path - Second Segment - Flaps Approach





CLOSE-IN TAKE-OFF FLIGHT PATH

NOTE: TOTAL HEIGHT REQUIRED IS EQUAL TO TOTAL HEIGHT REQUIRED TO CLEAR OBSTACLE PLUS DESIRED MARGIN OF CLEARANCE.

EXAMPLE:  
 TOTAL HEIGHT REQUIRED .....70 FT  
 OBSTACLE DISTANCE FROM REFERENCE ZERO .....920 FT  
 NET CLIMB GRADIENT REQUIRED.....2.2%.

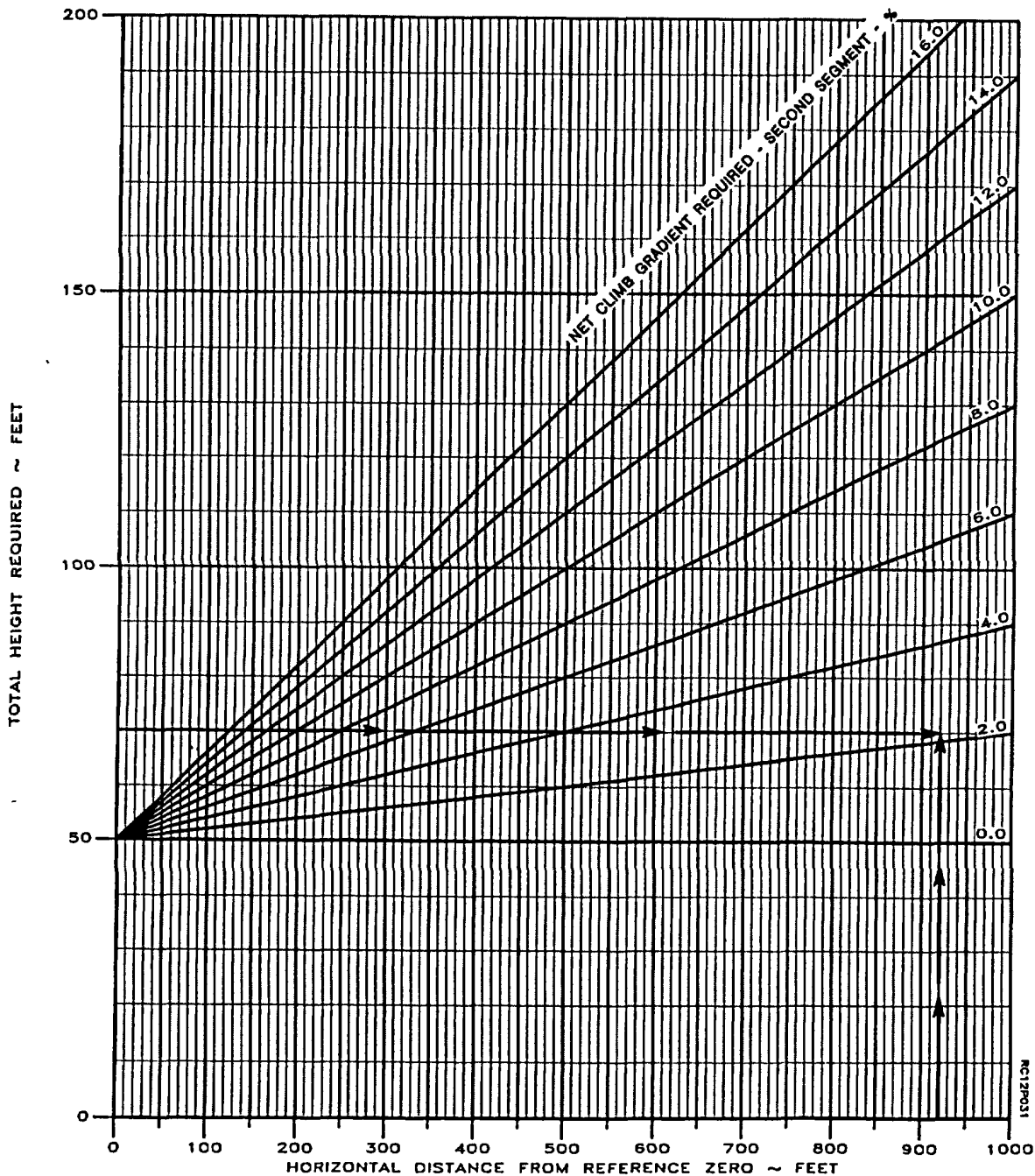

Figure 7-32. Close-in Take-off Flight Path - Flaps Approach

DISTANT TAKE-OFF FLIGHT PATH

NOTE: TOTAL HEIGHT REQUIRED IS EQUAL TO TOTAL HEIGHT REQUIRED TO CLEAR OBSTACLE PLUS DESIRED MARGIN OF CLEARANCE.

EXAMPLE:  
 TOTAL HEIGHT REQUIRED .....184 FT  
 OBSTACLE DISTANCE FROM  
 REFERENCE ZERO .....1.85 NM  
 NET CLIMB GRADIENT REQUIRED .....1.19%

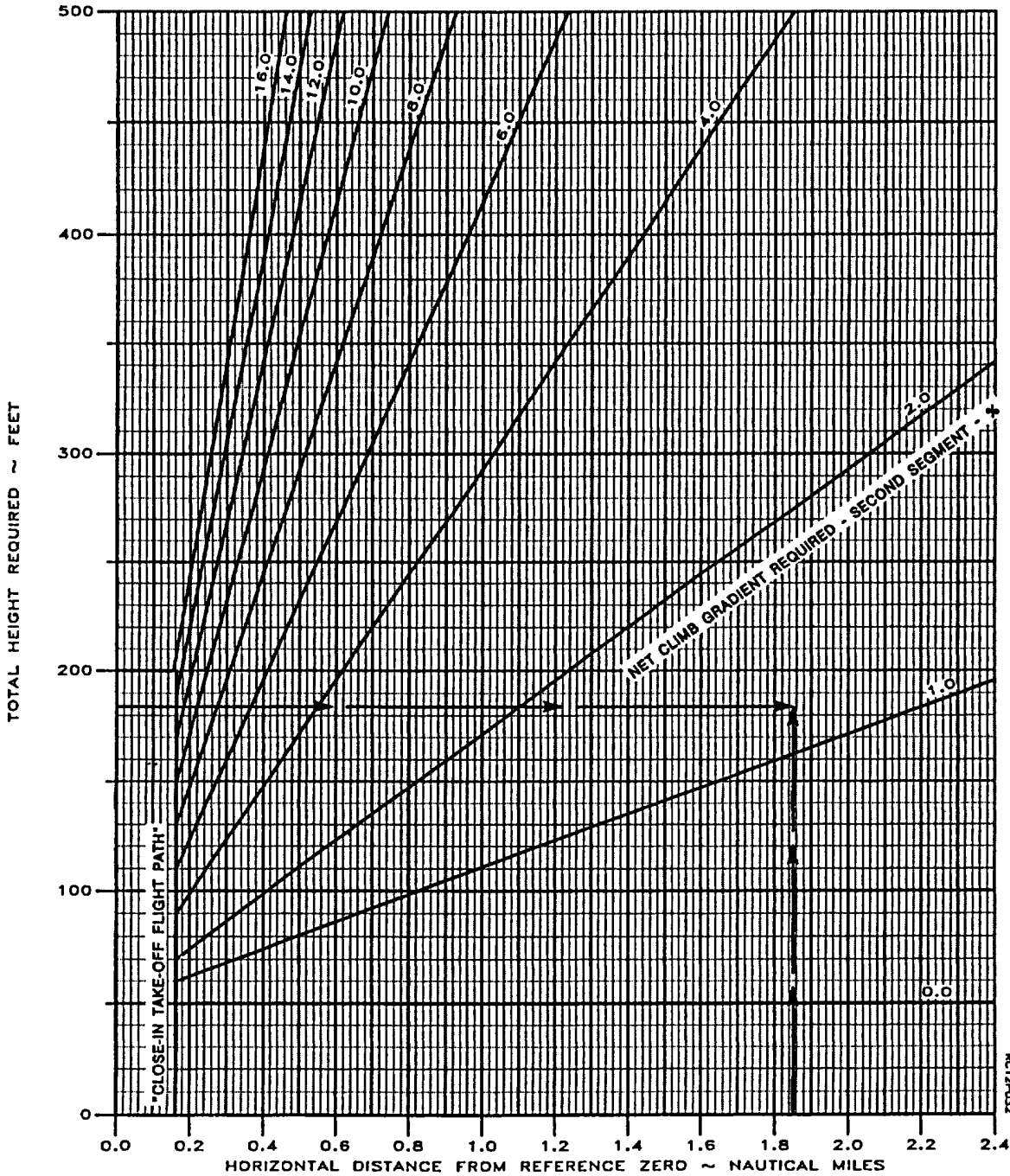

Figure 7-33. Distant Take-off Flight Path - Flaps Approach

### NET TAKE-OFF FLIGHT PATH - THIRD SEGMENT ONE ENGINE INOPERATIVE

**ASSOCIATED CONDITIONS:**

POWER..... MAXIMUM CONTINUOUS  
 INOPERATIVE PROPELLER ..... FEATHERED  
 LANDING GEAR ..... UP  
 FLAPS ..... UP  
 CLIMB SPEED ..... VENR

**EXAMPLE:**

FAT ..... 15°C  
 FIELD PRESSURE ALTITUDE ..... 3499 FT  
 WEIGHT ..... 16,000 LBS  
 HEADWIND COMPONENT ..... 10 KTS  
 NET CLIMB GRADIENT ..... 2.33 %

$V_{ENR} = 130$  KNOTS (ALL WEIGHTS)

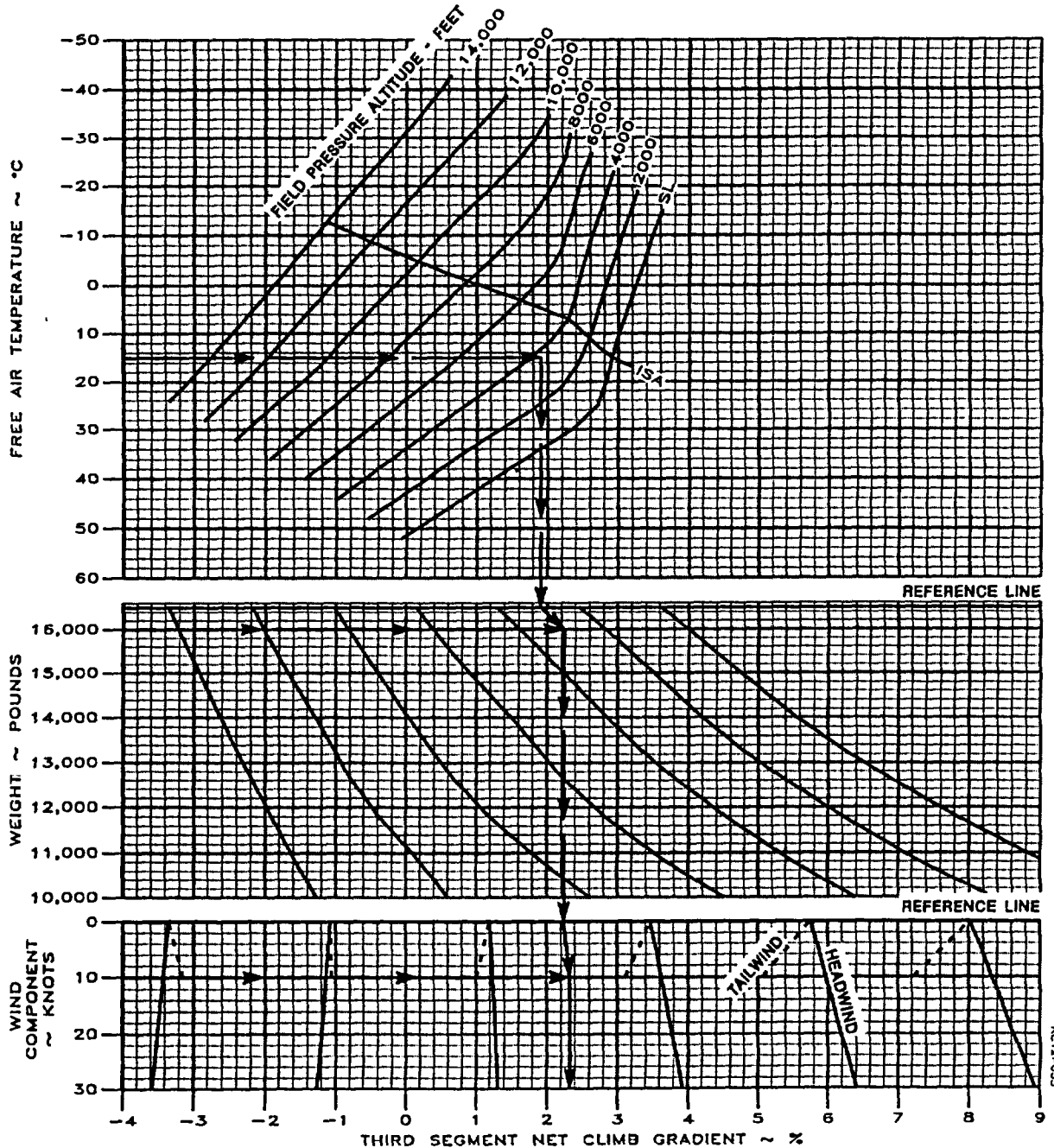

Figure 7-34. Net Take-off Flight Path - Third Segment

CLIMB - TWO ENGINES - FLAPS UP

ASSOCIATED CONDITIONS:  
POWER..... MAXIMUM CONTINUOUS  
LANDING GEAR ..... UP

EXAMPLE:  
FAT .....-4°C  
PRESSURE ALTITUDE.....9000 FT  
WEIGHT..... 15,500 LBS  
RATE-OF-CLIMB .....2250 FT/MIN  
CLIMB GRADIENT .....11.3 %

CLIMB SPEED = 135 KNOTS (ALL WEIGHTS)

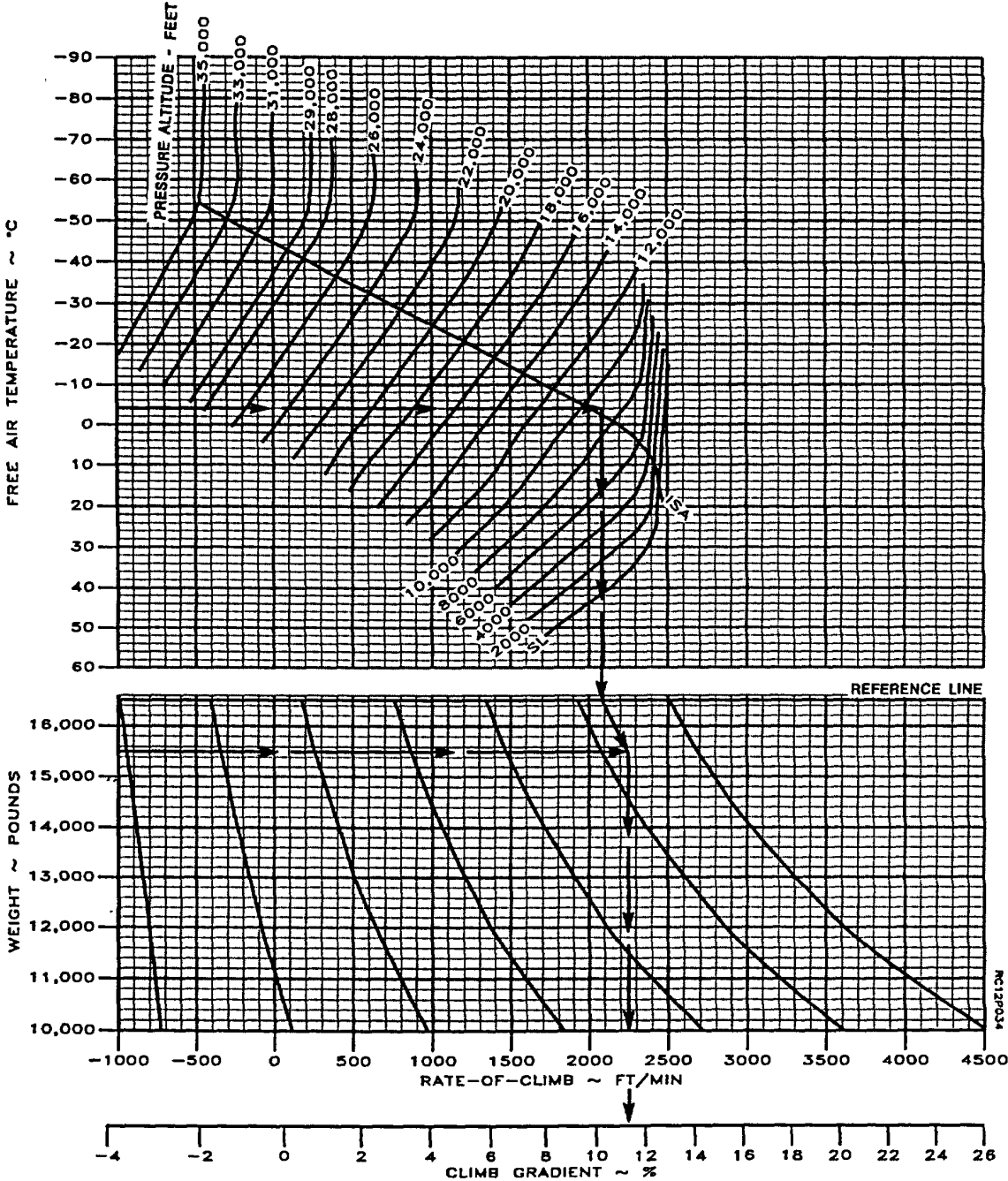

Figure 7-35. Climb - Two Engine - Flaps Up

CLIMB - TWO ENGINES - FLAPS APPROACH

ASSOCIATED CONDITIONS:

POWER..... MAXIMUM CONTINUOUS  
LANDING GEAR ..... UP

EXAMPLE:

FAT .....-4°C  
PRESSURE ALTITUDE.....9000 FT  
WEIGHT.....15,500 LBS  
RATE-OF-CLIMB.....2068 FT/MIN  
CLIMB GRADIENT .....10.3 %

CLIMB SPEED - 135 KNOTS (ALL WEIGHTS)

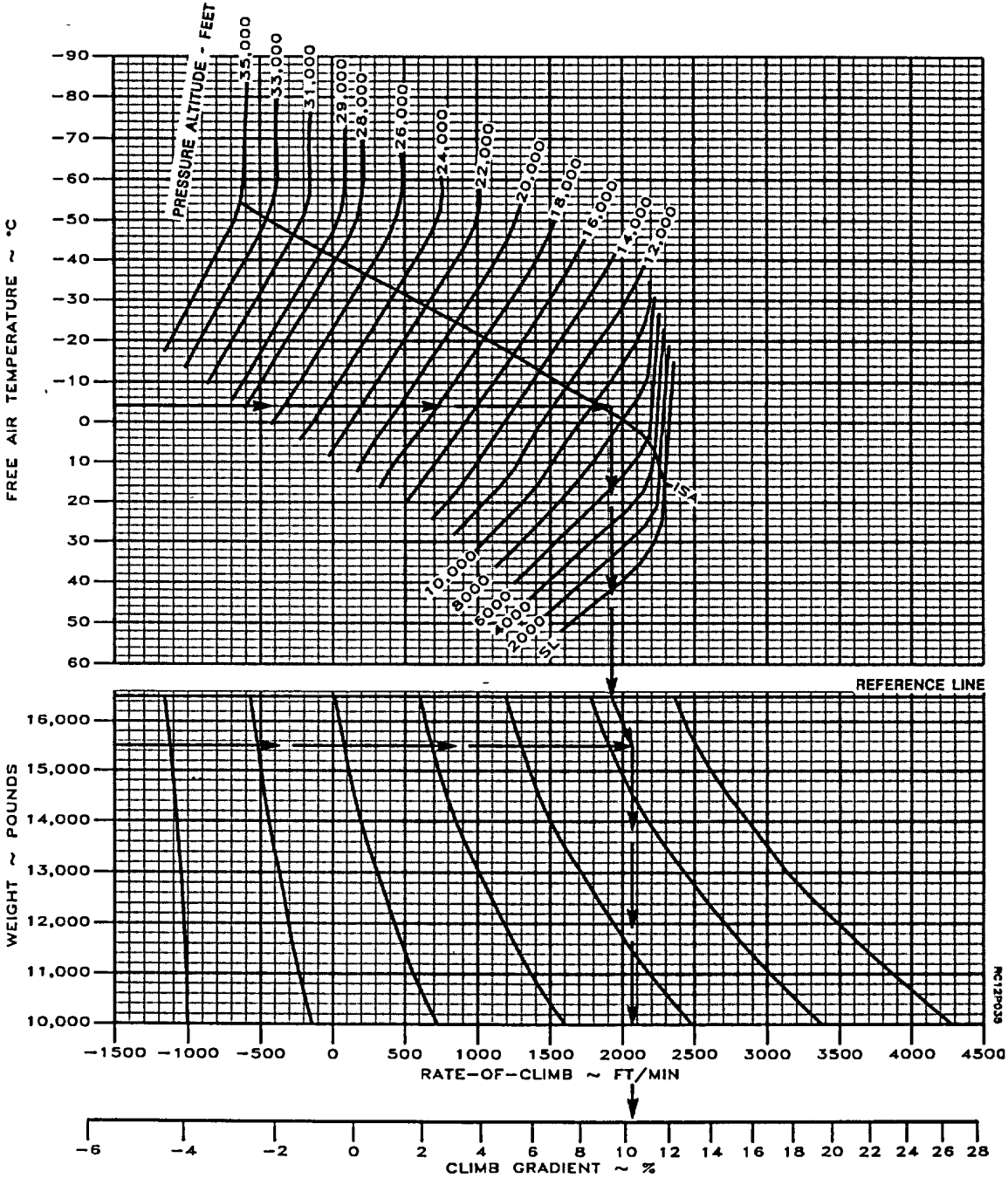

Figure 7-36. Climb - Two Engine - Flaps Approach

CLIMB - ONE ENGINE INOPERATIVE

ASSOCIATED CONDITIONS:

POWER.....MAXIMUM CONTINUOUS  
 FLAPS.....UP  
 LANDING GEAR.....UP  
 INOPERATIVE PROPELLER ....FEATHERED  
 CLIMB SPEED.....VYSE

EXAMPLE:

FAT .....-4°C  
 PRESSURE ALTITUDE.....9000 FT  
 WEIGHT.....15,500 LBS  
 RATE-OF-CLIMB.....386 FT/MIN  
 CLIMB GRADIENT .....2.1 %

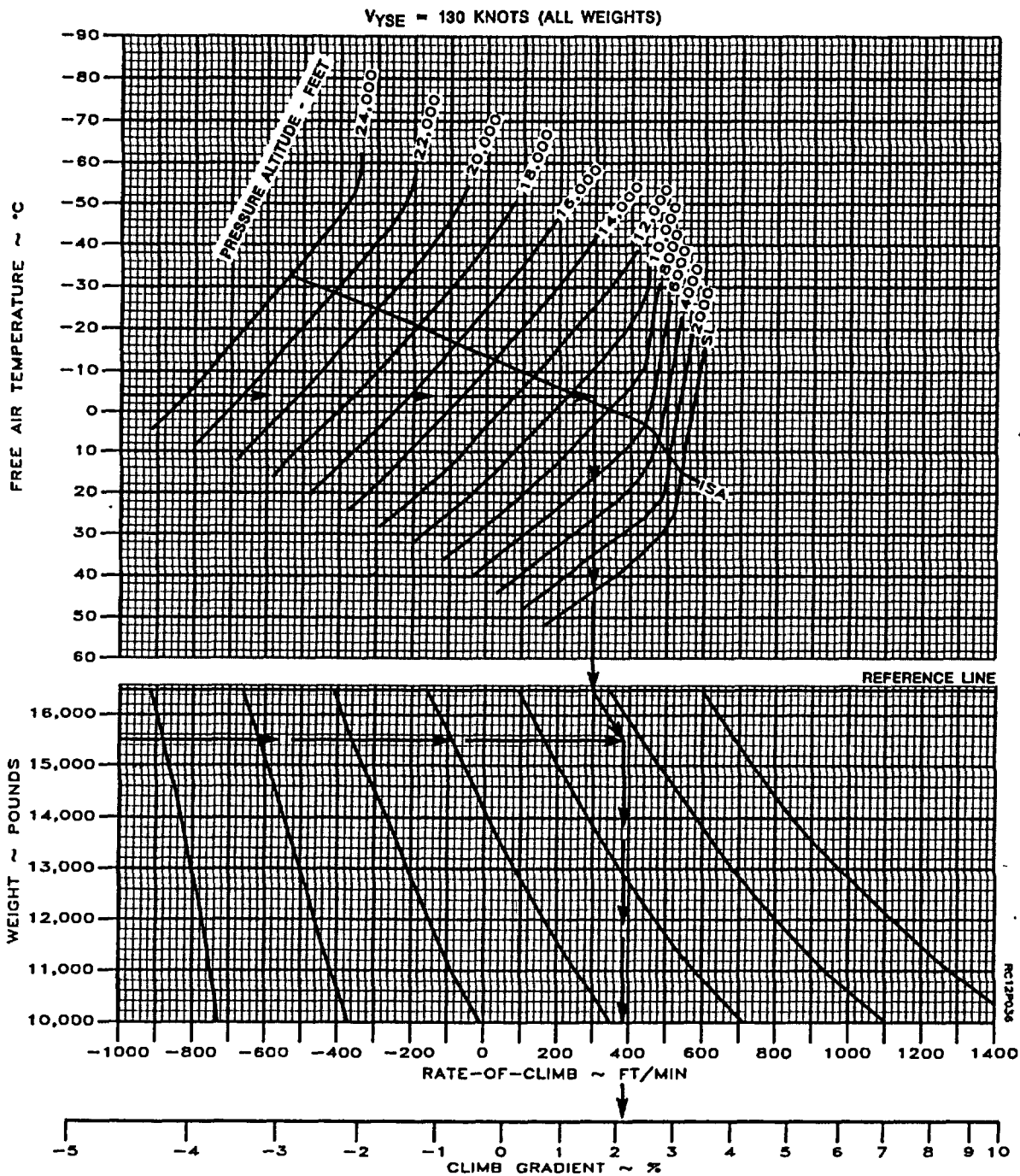

Figure 7-37. Climb - One Engine Inoperative

SERVICE CEILING - ONE ENGINE INOPERATIVE

ASSOCIATED CONDOITIONS:

POWER.....MAXIMUM CONTINUOUS
FLAPS.....UP
INOPERATIVE PROPELLER ....FEATHERED
LANDING GEAR.....UP

EXAMPLE:

FAT .....0°C
WEIGHT.....15,659 LBS
SERVICE CEILING.....12,647 FT

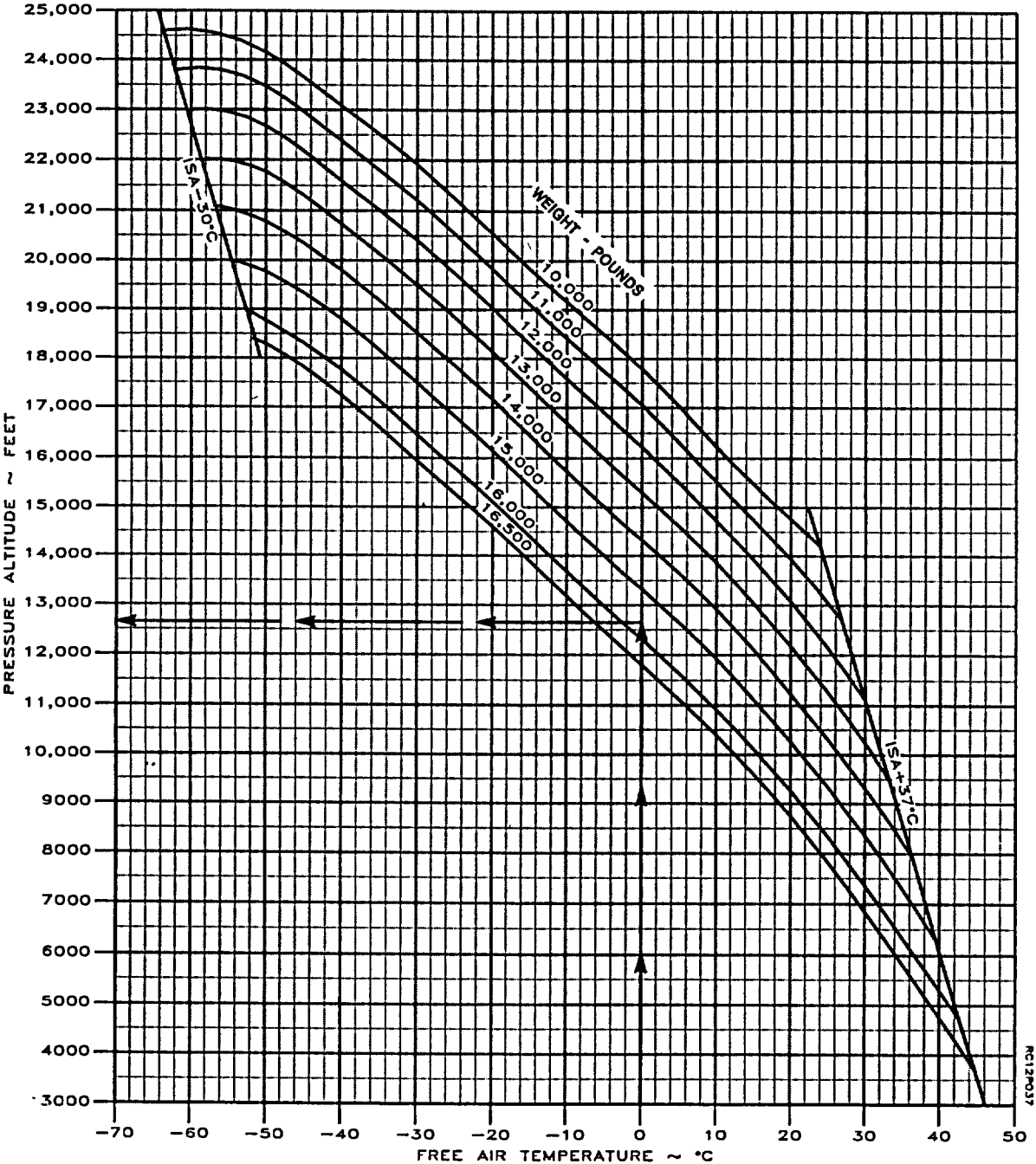

Figure 7-38. Service Ceiling - One Engine Inoperative



**TIME, FUEL, AND DISTANCE TO CRUISE CLIMB**

ASSOCIATED CONDITIONS:

PROPELLER SPEED ..... 1700 RPM  
 POWER..... NORMAL CLIMB

ALTITUDE - FEET	CLIMB SPEED - KNOTS
SL TO 10,000	135
10,000 TO 20,000	130
20,000 TO 25,000	125
25,000 TO 35,000	120

EXAMPLE:

FAT AT TAKEOFF ..... 15°C  
 FAT AT CRUISE ..... -40°C  
 AIRPORT PRESSURE ALTITUDE 3499 FT  
 CRUISE ALTITUDE ..... 25,000 FT  
 INITIAL CLIMB WEIGHT ..... 16,000 LBS  
 TIME TO CLIMB (22-2)..... 20 MIN  
 FUEL TO CLIMB (392-50) ..... 342 LBS  
 DISTANCE TO CLIMB (52-4) .... 48 NM

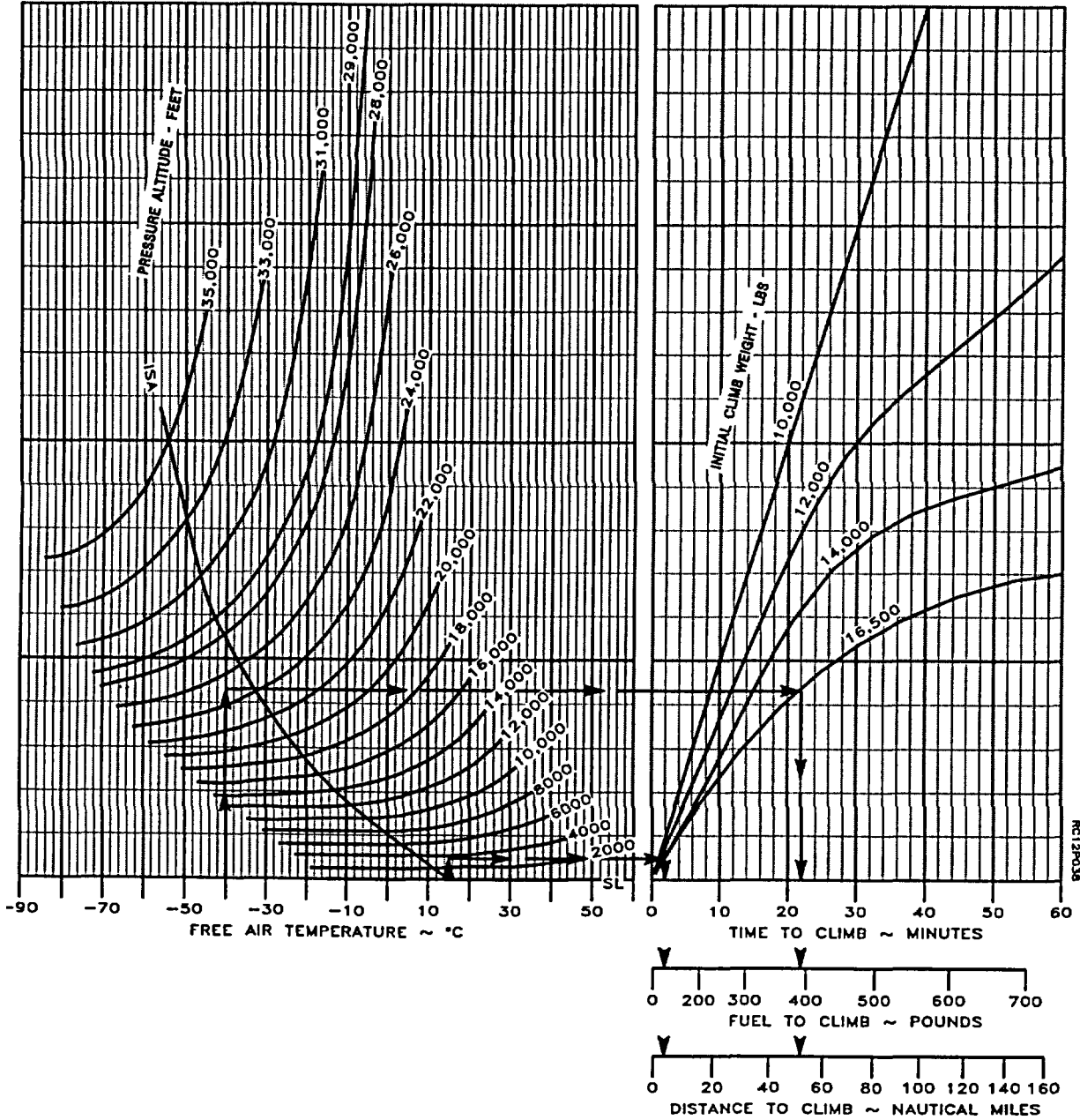

Figure 7-39. Time, Fuel, and Distance to Cruise Climb

**MAXIMUM CRUISE POWER  
1700 RPM  
ISA -30°C**

WEIGHT→			16,000 POUNDS					14,000 POUNDS				
PRESSURE ALTITUDE	IOAT	OAT	TORQUE PER ENGINE	FUEL FLOW PER ENGINE	TOTAL FUEL FLOW	IAS	TAS	TORQUE PER ENGINE	FUEL FLOW PER ENGINE	TOTAL FUEL FLOW	IAS	TAS
FEET	°C	°C	PERCENT	LBS/HR	LBS/HR	KTS	KTS	PERCENT	LBS/HR	LBS/HR	KTS	KTS
0	-11	-15	83	629	1258	231	220	83	628	1256	233	222
2000	-14	-19	83	610	1220	230	226	83	609	1218	232	227
4000	-18	-23	83	592	1184	230	232	83	592	1184	232	234
6000	-22	-27	83	576	1152	228	236	83	576	1152	230	238
8000	-25	-31	83	565	1130	227	242	83	564	1128	228	244
10,000	-29	-35	83	555	1110	225	247	83	555	1110	226	248
12,000	-33	-39	83	545	1090	222	251	83	544	1088	224	253
14,000	-37	-43	83	536	1072	220	257	83	535	1070	222	259
16,000	-40	-47	83	528	1056	218	262	83	528	1056	220	264
18,000	-44	-51	83	522	1044	216	268	83	521	1042	218	270
20,000	-48	-55	83	516	1032	214	273	83	515	1030	216	276
22,000	-51	-59	83	511	1022	212	279	83	511	1022	214	282
24,000	-55	-63	79	486	972	205	279	80	488	976	208	283
26,000	-59	-67	74	453	906	196	276	74	455	910	200	281
28,000	-64	-70	66	411	822	184	269	67	414	828	189	275
29,000	-66	-72	62	390	780	178	265	63	393	786	183	272
31,000	-70	-76	55	349	698	164	254	56	353	706	171	263
33,000	-75	-80	48	312	624	149	240	49	316	632	158	253
35,000	-79	-84	---	---	---	---	---	42	279	558	142	237

BT05210

**NOTE**

During operations with ice vanes extended, torque will decrease approximately 12%, fuel flow will decrease approximately 8%, and true airspeed will be reduced by approximately 15 knots.

*Figure 7-40. Maximum Cruise Power at 1700 RPM - ISA -30°C (Sheet 1 of 2)*

**MAXIMUM CRUISE POWER  
1700 RPM  
ISA -30°C**

WEIGHT→			12,000 POUNDS					10,000 POUNDS				
PRESSURE ALTITUDE	IOAT	OAT	TORQUE PER ENGINE	FUEL FLOW PER ENGINE	TOTAL FUEL FLOW	IAS	TAS	TORQUE PER ENGINE	FUEL FLOW PER ENGINE	TOTAL FUEL FLOW	IAS	TAS
FEET	°C	°C	PERCENT	LBS/HR	LBS/HR	KTS	KTS	PERCENT	LBS/HR	LBS/HR	KTS	KTS
0	-10	-15	83	628	1256	234	223	83	628	1256	235	224
2000	-14	-19	83	609	1218	233	229	83	609	1218	234	230
4000	-18	-23	83	591	1182	233	235	83	591	1182	234	236
6000	-22	-27	83	576	1152	231	239	83	575	1150	232	240
8000	-25	-31	83	564	1128	230	245	83	564	1128	231	246
10,000	-29	-35	83	554	1108	228	250	83	554	1108	229	251
12,000	-33	-39	83	544	1088	226	255	83	544	1088	227	256
14,000	-36	-43	83	535	1070	224	261	83	535	1070	225	262
16,000	-40	-47	83	528	1056	222	266	83	527	1054	223	268
18,000	-44	-51	83	521	1042	220	272	83	520	1040	222	274
20,000	-47	-55	83	515	1030	218	278	83	514	1028	219	280
22,000	-51	-59	83	510	1020	216	284	83	510	1020	218	286
24,000	-55	-63	80	488	976	211	286	80	489	978	213	289
26,000	-59	-67	75	456	912	203	285	75	457	914	205	288
28,000	-63	-70	67	416	832	192	280	68	418	836	195	284
29,000	-65	-72	64	395	790	187	277	64	397	794	190	281
31,000	-70	-76	57	356	712	176	270	57	359	718	179	276
33,000	-74	-80	50	320	640	164	262	51	323	646	169	269
35,000	-79	-84	43	282	564	150	250	44	286	572	156	260

BT05209

**NOTE**

During operations with ice vanes extended, torque will decrease approximately 12%, fuel flow will decrease approximately 8%, and true airspeed will be reduced by approximately 15 knots.

Figure 740. Maximum Cruise Power at 1700 RPM - ISA -30°C (Sheet 2 of 2)

**MAXIMUM CRUISE POWER  
1700 RPM  
ISA -20°C**

WEIGHT→			12,000 POUNDS					10,000 POUNDS				
PRESSURE ALTITUDE	IOAT	OAT	TORQUE PER ENGINE	FUEL FLOW PER ENGINE	TOTAL FUEL FLOW	IAS	TAS	TORQUE PER ENGINE	FUEL FLOW PER ENGINE	TOTAL FUEL FLOW	IAS	TAS
FEET	°C	°C	PERCENT	LBS/HR	LBS/HR	KTS	KTS	PERCENT	LBS/HR	LBS/HR	KTS	KTS
0	0	-5	83	630	1260	230	224	83	630	1260	232	225
2000	-4	-9	83	610	1220	230	229	83	610	1220	231	231
4000	-8	-13	83	593	1186	229	236	83	593	1186	231	237
6000	-12	-17	83	580	1160	227	240	83	580	1160	229	242
8000	-15	-21	83	568	1136	225	245	83	568	1136	226	246
10,000	-19	-25	83	558	1116	222	249	83	558	1116	224	251
12,000	-23	-29	83	547	1094	220	254	83	547	1094	222	256
14,000	-27	-33	83	538	1076	218	260	83	537	1074	220	262
16,000	-30	-37	83	529	1058	216	265	83	529	1058	218	268
18,000	-34	-41	83	523	1046	214	271	83	522	1044	216	274
20,000	-38	-45	83	518	1036	212	276	83	518	1036	214	279
22,000	-42	-49	79	489	978	204	276	79	489	978	207	279
24,000	-46	-53	74	459	918	197	275	74	460	920	200	279
26,000	-50	-57	69	429	858	188	272	69	430	860	192	277
28,000	-54	-60	63	397	794	178	267	64	399	798	183	274
29,000	-56	-62	61	382	764	173	264	61	384	768	178	272
31,000	-60	-66	54	348	696	161	255	55	351	702	168	265
33,000	-65	-70	48	312	624	145	240	49	316	632	155	255
35,000	---	---	---	---	---	---	---	42	279	558	139	238

BT05208

**NOTE**

During operations with ice vanes extended, torque will decrease approximately 12%, fuel flow will decrease approximately 8%, and true airspeed will be reduced by approximately 15 knots.

*Figure 7-41. Maximum Cruise Power at 1700 RPM - ISA -20°C (Sheet 1 of 2)*

**MAXIMUM CRUISE POWER  
1700 RPM  
ISA -20°C**

WEIGHT→			12,000 POUNDS					10,000 POUNDS				
PRESSURE ALTITUDE	IOAT	OAT	TORQUE PER ENGINE	FUEL FLOW PER ENGINE	TOTAL FUEL FLOW	IAS	TAS	TORQUE PER ENGINE	FUEL FLOW PER ENGINE	TOTAL FUEL FLOW	IAS	TAS
FEET	°C	°C	PERCENT	LBS/HR	LBS/HR	KTS	KTS	PERCENT	LBS/HR	LBS/HR	KTS	KTS
0	0	-5	83	630	1260	233	226	83	629	1258	234	227
2000	-4	-9	83	610	1220	233	232	83	609	1218	234	233
4000	-8	-13	83	592	1184	232	239	83	592	1184	233	240
6000	-11	-17	83	579	1158	230	243	83	579	1158	231	244
8000	-15	-21	83	568	1136	228	248	83	567	1134	229	249
10,000	-19	-25	83	557	1114	226	253	83	557	1114	227	254
12,000	-23	-29	83	547	1094	224	258	83	546	1092	225	260
14,000	-26	-33	83	537	1074	222	264	83	537	1074	223	265
16,000	-30	-37	83	529	1058	220	270	83	528	1056	222	272
18,000	-34	-41	83	522	1044	218	276	83	521	1042	220	278
20,000	-37	-45	83	517	1034	216	282	83	517	1034	217	284
22,000	-41	-49	79	490	980	209	282	79	490	980	211	285
24,000	-45	-53	75	461	922	202	282	75	462	924	205	285
26,000	-49	-57	70	431	862	195	281	70	432	864	197	285
28,000	-53	-60	64	400	800	186	279	65	401	802	189	283
29,000	-55	-62	62	385	770	182	277	62	386	772	185	282
31,000	-60	-66	56	353	706	172	273	56	355	710	176	278
33,000	-64	-70	50	319	638	161	265	50	321	642	166	272
35,000	-68	-74	43	283	566	148	253	44	287	574	154	263

BT05211

**NOTE**

**During operations with ice vanes extended, torque will decrease approximately 12%, fuel flow will decrease approximately 8%, and true airspeed will be reduced by approximately 15 knots.**

*Figure 7-41. Maximum Cruise Power at 1700 RPM - ISA -200C (Sheet 2 of 2)*

**MAXIMUM CRUISE POWER  
1700 RPM  
ISA -10°C**

WEIGHT→			16,000 POUNDS					14,000 POUNDS				
PRESSURE ALTITUDE	IOAT	OAT	TORQUE PER ENGINE	FUEL FLOW PER ENGINE	TOTAL FUEL FLOW	IAS	TAS	TORQUE PER ENGINE	FUEL FLOW PER ENGINE	TOTAL FUEL FLOW	IAS	TAS
FEET	°C	°C	PERCENT	LBS/HR	LBS/HR	KTS	KTS	PERCENT	LBS/HR	LBS/HR	KTS	KTS
0	10	5	83	633	1266	230	228	83	632	1264	232	229
2000	6	1	83	614	1228	230	234	83	614	1228	231	235
4000	2	-3	83	598	1196	227	238	83	597	1194	229	240
6000	-1	-7	83	583	1166	225	242	83	583	1166	227	244
8000	-5	-11	83	570	1140	223	247	83	570	1140	224	249
10,000	-9	-15	83	559	1118	220	252	83	559	1118	222	254
12,000	-13	-19	83	548	1096	218	257	83	548	1096	220	259
14,000	-16	-23	83	539	1078	216	263	83	539	1078	218	265
16,000	-20	-27	83	531	1062	214	269	83	530	1060	216	271
18,000	-24	-31	82	515	1030	210	272	82	516	1032	212	275
20,000	-28	-35	78	491	982	204	272	78	491	982	206	276
22,000	-32	-39	73	463	926	196	271	74	463	926	199	275
24,000	-36	-43	69	434	868	188	269	69	435	870	192	274
26,000	-40	-47	64	405	810	179	266	64	406	812	183	272
28,000	-44	-50	59	375	750	169	261	59	376	752	174	268
29,000	-46	-52	56	361	722	164	257	57	362	724	170	266
31,000	-51	-56	51	332	664	152	248	52	334	668	160	260
33,000	-55	-60	46	304	608	138	235	47	307	614	149	252
35,000	-59	-64	---	---	---	---	---	42	279	558	136	239

BT05222

**NOTE**

**During operations with ice vanes extended, torque will decrease approximately 12%, fuel flow will decrease approximately 8%, and true airspeed will be reduced by approximately 15 knots.**

*Figure 7-42. Maximum Cruise Power at 1700 RPM - ISA -10°C (Sheet 1 of 2)*

**MAXIMUM CRUISE POWER  
1700 RPM  
ISA -10°C**

WEIGHT→			12,000 POUNDS					10,000 POUNDS				
PRESSURE ALTITUDE	IOAT	OAT	TORQUE PER ENGINE	FUEL FLOW PER ENGINE	TOTAL FUEL FLOW	IAS	TAS	TORQUE PER ENGINE	FUEL FLOW PER ENGINE	TOTAL FUEL FLOW	IAS	TAS
FEET	°C	°C	PERCENT	LBS/HR	LBS/HR	KTS	KTS	PERCENT	LBS/HR	LBS/HR	KTS	KTS
0	10	5	83	632	1264	233	231	83	631	1262	234	232
2000	6	1	83	613	1226	233	237	83	613	1226	234	238
4000	2	-3	83	597	1194	230	241	83	597	1194	231	242
6000	-1	-7	83	582	1164	228	246	83	582	1164	229	247
8000	-5	-11	83	570	1140	226	251	83	569	1138	227	252
10,000	-9	-15	83	559	1118	224	256	83	558	1116	225	257
12,000	-12	-19	83	548	1096	222	261	83	548	1096	223	263
14,000	-16	-23	83	538	1076	220	267	83	538	1076	221	269
16,000	-20	-27	83	530	1060	218	273	83	530	1060	220	275
18,000	-24	-31	82	516	1032	215	277	82	516	1032	216	279
20,000	-27	-35	78	492	984	209	278	78	492	984	210	281
22,000	-31	-39	74	464	928	202	278	74	464	928	204	281
24,000	-35	-43	69	436	872	195	278	69	436	872	197	281
26,000	-39	-47	64	407	814	187	276	65	407	814	189	280
28,000	-44	-50	59	377	754	178	274	60	378	756	182	278
29,000	-46	-52	57	363	726	174	272	57	364	728	178	277
31,000	-50	-56	52	336	672	165	268	53	337	674	169	274
33,000	-54	-60	48	309	618	156	263	48	311	622	161	271
35,000	-58	-64	43	282	564	145	255	43	284	568	152	265

BT05223

**NOTE**

During operations with ice vanes extended, torque will decrease approximately 12%, fuel flow will decrease approximately 8%, and true airspeed will be reduced by approximately 15 knots.

Figure 7-42. Maximum Cruise Power at 1700 RPM - ISA -10°C (Sheet 2 of 2)

**MAXIMUM CRUISE POWER  
1700 RPM  
ISA**

WEIGHT→			16,000 POUNDS					14,000 POUNDS				
PRESSURE ALTITUDE	IOAT	OAT	TORQUE PER ENGINE	FUEL FLOW PER ENGINE	TOTAL FUEL FLOW	IAS	TAS	TORQUE PER ENGINE	FUEL FLOW PER ENGINE	TOTAL FUEL FLOW	IAS	TAS
FEET	°C	°C	PERCENT	LBS/HR	LBS/HR	KTS	KTS	PERCENT	LBS/HR	LBS/HR	KTS	KTS
0	20	15	83	632	1264	230	231	83	632	1264	231	233
2000	16	11	83	617	1234	228	236	83	617	1234	229	238
4000	12	7	83	602	1204	225	240	83	601	1202	227	242
6000	9	3	83	586	1172	223	245	83	586	1172	225	247
8000	5	-1	83	572	1144	221	250	83	572	1144	222	252
10,000	1	-5	83	559	1118	218	255	83	559	1118	220	257
12,000	-3	-9	83	548	1096	217	260	83	547	1094	219	263
14,000	-6	-13	83	540	1080	215	266	83	539	1078	217	268
16,000	-10	-17	80	512	1024	208	266	80	513	1026	211	269
18,000	-14	-21	75	483	966	201	266	76	483	966	204	269
20,000	-18	-25	71	458	916	194	266	72	458	916	197	270
22,000	-22	-29	67	432	864	187	264	68	433	866	190	269
24,000	-26	-33	63	407	814	179	262	64	408	816	183	268
26,000	-30	-37	59	381	762	170	259	59	382	764	175	266
28,000	-35	-40	54	354	708	160	253	55	356	712	166	262
29,000	-37	-42	52	341	682	155	249	53	342	684	162	259
31,000	-41	-46	47	314	628	142	239	48	316	632	151	253
33,000	-45	-50	---	---	---	---	---	43	291	582	140	243
35,000	-50	-54	---	---	---	---	---	39	265	530	125	228

BT05220

**NOTE**

**During operations with ice vanes extended, torque will decrease approximately 12%, fuel flow will decrease approximately 8%, and true airspeed will be reduced by approximately 15 knots.**

*Figure 7-43. Maximum Cruise Power at 1700 RPM - ISA (Sheet 1 of 2)*



**MAXIMUM CRUISE POWER  
1700 RPM  
ISA**

WEIGHT→			12,000 POUNDS					10,000 POUNDS				
PRESSURE ALTITUDE	IOAT	OAT	TORQUE PER ENGINE	FUEL FLOW PER ENGINE	TOTAL FUEL FLOW	IAS	TAS	TORQUE PER ENGINE	FUEL FLOW PER ENGINE	TOTAL FUEL FLOW	IAS	TAS
FEET	°C	°C	PERCENT	LBS/HR	LBS/HR	KTS	KTS	PERCENT	LBS/HR	LBS/HR	KTS	KTS
0	20	15	83	631	1262	233	234	83	631	1262	234	235
2000	16	11	83	616	1232	231	239	83	616	1232	232	240
4000	13	7	83	601	1202	228	243	83	601	1202	230	245
6000	9	3	83	585	1170	226	248	83	585	1170	227	250
8000	5	-1	83	571	1142	224	253	83	571	1142	225	255
10,000	1	-5	83	559	1118	222	259	83	558	1116	223	260
12,000	-2	-9	83	547	1094	220	265	83	547	1094	222	266
14,000	-6	-13	83	539	1078	218	270	83	539	1078	220	272
16,000	-10	-17	80	513	1026	213	272	80	513	1026	214	274
18,000	-14	-21	76	484	968	206	272	76	484	968	208	275
20,000	-18	-25	72	458	916	200	273	72	459	918	202	276
22,000	-22	-29	68	433	866	193	273	68	434	868	195	276
24,000	-26	-33	64	408	816	186	273	64	409	818	189	276
26,000	-30	-37	60	383	766	179	271	60	383	766	182	275
28,000	-34	-40	55	357	714	171	269	55	357	714	174	274
29,000	-36	-42	53	343	686	167	267	53	344	688	170	273
31,000	-40	-46	48	318	636	158	263	49	319	638	162	270
33,000	-44	-50	44	293	586	148	257	44	294	588	154	265
35,000	-49	-54	40	267	534	137	248	40	269	538	144	260

BT05221

**NOTE**

During operations with ice vanes extended, torque will decrease approximately 12%, fuel flow will decrease approximately 8%, and true airspeed will be reduced by approximately 15 knots.

Figure 743. Maximum Cruise Power at 1700 RPM - ISA (Sheet 2 of 2)

**MAXIMUM CRUISE POWER  
1700 RPM  
ISA +10°C**

WEIGHT→			16,000 POUNDS					14,000 POUNDS				
PRESSURE ALTITUDE	IOAT	OAT	TORQUE PER ENGINE	FUEL FLOW PER ENGINE	TOTAL FUEL FLOW	IAS	TAS	TORQUE PER ENGINE	FUEL FLOW PER ENGINE	TOTAL FUEL FLOW	IAS	TAS
FEET	°C	°C	PERCENT	LBS/HR	LBS/HR	KTS	KTS	PERCENT	LBS/HR	LBS/HR	KTS	KTS
0	30	25	83	637	1274	228	234	83	636	1272	230	235
2000	26	21	83	617	1234	226	238	83	616	1232	227	240
4000	23	17	83	599	1198	223	243	83	598	1196	225	244
6000	19	13	83	582	1164	221	247	83	582	1164	223	249
8000	15	9	83	569	1138	219	252	83	569	1138	221	254
10,000	11	5	83	561	1122	217	258	83	560	1120	219	260
12,000	7	1	81	537	1074	212	260	81	537	1074	215	263
14,000	4	-3	77	506	1012	205	260	77	506	1012	208	263
16,000	0	-7	73	476	952	198	259	73	477	954	201	263
18,000	-4	-11	69	448	896	191	258	69	449	898	194	263
20,000	-8	-15	65	424	848	184	257	65	424	848	188	262
22,000	-13	-19	61	399	798	176	255	61	400	800	180	261
24,000	-17	-23	57	375	750	168	252	57	375	750	173	259
26,000	-21	-27	53	351	702	159	247	53	352	704	165	256
28,000	-25	-30	49	328	656	149	241	50	330	660	156	253
29,000	-27	-32	47	317	634	143	237	48	318	636	152	250
31,000	-32	-36	43	293	586	128	222	44	296	592	142	243
33,000	-35	-40	---	---	---	---	---	40	272	544	129	231
35,000	----	----	---	---	---	---	---	---	---	---	---	---

BT05218

**NOTE**

**During operations with ice vanes extended, torque will decrease approximately 12%, fuel flow will decrease approximately 8%, and true airspeed will be reduced by approximately 15 knots.**

*Figure 7-44. Maximum Cruise Power at 1700 RPM - ISA +10°C (Sheet 1 of 2)*

**MAXIMUM CRUISE POWER  
1700 RPM  
ISA +10°C**

WEIGHT→			12,000 POUNDS					10,000 POUNDS				
PRESSURE ALTITUDE	IOAT	OAT	TORQUE PER ENGINE	FUEL FLOW PER ENGINE	TOTAL FUEL FLOW	IAS	TAS	TORQUE PER ENGINE	FUEL FLOW PER ENGINE	TOTAL FUEL FLOW	IAS	TAS
FEET	°C	°C	PERCENT	LBS/HR	LBS/HR	KTS	KTS	PERCENT	LBS/HR	LBS/HR	KTS	KTS
0	30	25	83	636	1272	231	237	83	635	1270	232	238
2000	26	21	83	616	1232	229	241	83	615	1230	230	242
4000	23	17	83	598	1196	227	246	83	598	1196	228	247
6000	19	13	83	582	1164	224	251	83	581	1162	226	252
8000	15	9	83	568	1136	223	256	83	568	1136	224	257
10,000	12	5	83	560	1120	221	262	83	560	1120	222	263
12,000	8	1	81	537	1074	216	265	81	538	1076	218	267
14,000	4	-3	77	507	1014	210	266	77	507	1014	212	268
16,000	0	-7	73	477	954	204	266	73	478	956	206	268
18,000	-4	-11	69	449	898	197	266	69	450	900	199	269
20,000	-8	-15	65	425	850	191	266	65	425	850	193	269
22,000	-12	-19	61	401	802	184	266	62	401	802	186	269
24,000	-16	-23	58	376	752	177	265	58	376	752	180	269
26,000	-20	-27	54	353	706	169	263	54	353	706	173	268
28,000	-24	-30	50	330	660	162	261	50	331	662	166	267
29,000	-26	-32	48	319	638	158	259	49	320	640	162	266
31,000	-30	-36	44	297	594	149	255	45	298	596	155	263
33,000	-35	-40	41	275	550	140	249	41	276	552	146	259
35,000	-39	-44	37	251	502	129	239	37	253	506	137	253

BT05219

**NOTE**

**During operations with ice vanes extended, torque will decrease approximately 12%, fuel flow will decrease approximately 8%, and true airspeed will be reduced by approximately 15 knots.**

*Figure 7-44. Maximum Cruise Power at 1700 RPM - ISA +10°C (Sheet 2 of 2)*

**MAXIMUM CRUISE POWER  
1700 RPM  
ISA +20°C**

WEIGHT→			16,000 POUNDS					14,000 POUNDS				
PRESSURE ALTITUDE	IOAT	OAT	TORQUE PER ENGINE	FUEL FLOW PER ENGINE	TOTAL FUEL FLOW	IAS	TAS	TORQUE PER ENGINE	FUEL FLOW PER ENGINE	TOTAL FUEL FLOW	IAS	TAS
FEET	°C	°C	PERCENT	LBS/HR	LBS/HR	KTS	KTS	PERCENT	LBS/HR	LBS/HR	KTS	KTS
0	40	35	83	640	1280	227	236	83	639	1278	228	238
2000	36	31	83	619	1238	224	240	83	618	1236	226	242
4000	33	27	83	600	1200	222	245	83	600	1200	224	247
6000	29	23	83	584	1168	219	250	83	584	1168	221	252
8000	25	19	81	560	1120	215	252	82	560	1120	217	255
10,000	21	15	78	531	1062	209	253	78	531	1062	212	256
12,000	17	11	74	500	1000	203	254	75	501	1002	206	257
14,000	13	7	69	468	936	195	251	70	469	938	198	255
16,000	9	3	65	439	878	187	250	65	440	880	190	254
18,000	5	-1	62	413	826	180	248	62	414	828	184	254
20,000	1	-5	58	387	774	172	246	58	388	776	176	252
22,000	-3	-9	54	364	728	163	242	54	365	730	169	250
24,000	-7	-13	50	341	682	154	238	51	342	684	161	247
26,000	-12	-17	47	320	640	145	231	47	321	642	153	244
28,000	-16	-20	43	300	600	133	221	44	302	604	144	239
29,000	-17	-22	---	---	---	---	---	43	292	584	140	236
31,000	-22	-26	---	---	---	---	---	39	271	542	128	226
33,000	---	---	---	---	---	---	---	---	---	---	---	---
35,000	---	---	---	---	---	---	---	---	---	---	---	---

BT05216

**NOTE**

**During operations with ice vanes extended, torque will decrease approximately 12%, fuel flow will decrease approximately 8%, and true airspeed will be reduced by approximately 15 knots.**

*Figure 7-45. Maximum Cruise Power at 1700 RPM - ISA +20°C (Sheet 1 of 2)*

**MAXIMUM CRUISE POWER  
1700 RPM  
ISA +20°C**

WEIGHT→			12,000 POUNDS					10,000 POUNDS				
PRESSURE ALTITUDE	IOAT	OAT	TORQUE PER ENGINE	FUEL FLOW PER ENGINE	TOTAL FUEL FLOW	IAS	TAS	TORQUE PER ENGINE	FUEL FLOW PER ENGINE	TOTAL FUEL FLOW	IAS	TAS
FEET	°C	°C	PERCENT	LBS/HR	LBS/HR	KTS	KTS	PERCENT	LBS/HR	LBS/HR	KTS	KTS
0	40	35	83	639	1278	229	239	83	639	1278	231	240
2000	37	31	83	618	1236	227	243	83	618	1236	228	245
4000	33	27	83	599	1198	225	248	83	599	1198	226	250
6000	29	23	83	583	1166	223	253	83	583	1166	224	255
8000	25	19	82	561	1122	219	257	82	561	1122	220	258
10,000	21	15	78	531	1062	214	258	78	532	1064	215	260
12,000	17	11	75	501	1002	208	259	75	501	1002	210	262
14,000	13	7	70	469	938	200	258	70	470	940	202	261
16,000	9	3	66	440	880	193	258	66	441	882	196	261
18,000	5	-1	62	414	828	187	258	62	415	830	189	261
20,000	1	-5	58	389	778	180	257	58	389	778	183	261
22,000	-3	-9	55	366	732	173	256	55	366	732	176	260
24,000	-7	-13	51	343	686	166	254	51	344	688	169	259
26,000	-11	-17	48	322	644	159	252	48	323	646	163	258
28,000	-15	-20	45	303	606	151	250	45	304	608	156	257
29,000	-17	-22	43	294	588	148	248	43	294'	588	153	257
31,000	-21	-26	40	274	548	139	243	40	275	550	145	254
33,000	-25	-30	36	252	504	129	235	37	254	508	137	249
35,000	-30	-34	33	231	462	115	221	33	233	466	128	242

BT05217

**NOTE**

**During operations with ice vanes extended, torque will decrease approximately 12%, fuel flow will decrease approximately 8%, and true airspeed will be reduced by approximately 15 knots.**

*Figure 7-45. Maximum Cruise Power at 1700 RPM - ISA +20°C (Sheet 2 of 2)*

**MAXIMUM CRUISE POWER  
1700 RPM  
ISA +30°C**

WEIGHT→			16,000 POUNDS					14,000 POUNDS				
PRESSURE ALTITUDE	IOAT	OAT	TORQUE PER ENGINE	FUEL FLOW PER ENGINE	TOTAL FUEL FLOW	IAS	TAS	TORQUE PER ENGINE	FUEL FLOW PER ENGINE	TOTAL FUEL FLOW	IAS	TAS
FEET	°C	°C	PERCENT	LBS/HR	LBS/HR	KTS	KTS	PERCENT	LBS/HR	LBS/HR	KTS	KTS
0	50	45	82	635	1270	223	236	82	635	1270	225	238
2000	46	41	80	606	1212	218	238	80	606	1212	220	240
4000	42	37	77	577	1154	214	240	77	577	1154	216	242
6000	39	33	75	548	1096	209	242	75	548	1096	211	244
8000	35	29	72	520	1040	203	243	73	520	1040	206	246
10,000	31	25	70	493	986	198	244	70	493	986	201	247
12,000	27	21	66	462	924	191	244	66	463	926	194	247
14,000	23	17	63	433	866	184	243	63	434	868	188	247
16,000	19	13	58	403	806	176	239	58	404	808	180	245
18,000	14	9	53	373	746	165	233	53	374	748	170	240
20,000	10	5	49	347	694	156	228	50	348	696	162	237
22,000	6	1	46	327	654	147	224	47	328	656	155	235
24,000	2	-3	43	307	614	137	216	44	308	616	147	231
26,000	-2	-7	---	---	---	---	---	41	290	580	139	227
28,000	-6	-10	---	---	---	---	---	39	273	546	129	220
29,000	-8	-12	---	---	---	---	---	37	264	528	124	215
31,000	---	---	---	---	---	---	---	---	---	---	---	---
33,000	---	---	---	---	---	---	---	---	---	---	---	---
35,000	---	---	---	---	---	---	---	---	---	---	---	---

BT05214

**NOTE**

During operations with ice vanes extended, torque will decrease approximately 12%, fuel flow will decrease approximately 8%, and true airspeed will be reduced by approximately 15 knots.

Figure 7-46. Maximum Cruise Power at 1700 RPM - ISA +30°C (Sheet 1 of 2)

**MAXIMUM CRUISE POWER  
1700 RPM  
ISA +30°C**

WEIGHT→			12,000 POUNDS					10,000 POUNDS				
PRESSURE ALTITUDE	IOAT	OAT	TORQUE PER ENGINE	FUEL FLOW PER ENGINE	TOTAL FUEL FLOW	IAS	TAS	TORQUE PER ENGINE	FUEL FLOW PER ENGINE	TOTAL FUEL FLOW	IAS	TAS
FEET	°C	°C	PERCENT	LBS/HR	LBS/HR	KTS	KTS	PERCENT	LBS/HR	LBS/HR	KTS	KTS
0	50	45	82	636	1272	227	240	82	636	1272	228	241
2000	46	41	80	606	1212	222	242	80	606	1212	223	243
4000	43	37	78	577	1154	218	244	78	577	1154	219	246
6000	39	33	75	549	1098	213	246	75	549	1098	214	248
8000	35	29	73	521	1042	208	248	73	521	1042	210	250
10,000	31	25	70	494	988	203	250	70	494	988	205	252
12,000	27	21	67	463	926	197	251	67	463	926	199	253
14,000	23	17	63	434	868	191	251	63	435	870	193	254
16,000	19	13	59	405	810	183	249	59	405	810	186	253
18,000	15	9	54	374	748	174	245	54	375	750	177	249
20,000	11	5	50	349	698	167	243	50	350	700	170	248
22,000	7	1	47	329	658	160	242	47	330	660	164	248
24,000	3	-3	44	309	618	153	240	44	309	618	158	247
26,000	-1	-7	42	291	582	146	238	42	291	582	152	246
28,000	-5	-10	39	275	550	140	236	39	276	552	146	246
29,000	-7	-12	38	266	532	136	234	38	268	536	142	245
31,000	-12	-16	35	248	496	126	227	35	250	500	135	242
33,000	-16	-20	32	228	456	114	214	32	231	462	126	236
35,000	-20	-24	---	---	---	---	---	29	211	422	116	227

BT05215

**NOTE**

**During operations with ice vanes extended, torque will decrease approximately 12%, fuel flow will decrease approximately 8%, and true airspeed will be reduced by approximately 15 knots.**

*Figure 7-46. Maximum Cruise Power at 1700 RPM - ISA +30°C (Sheet 2 of 2)*

**MAXIMUM CRUISE POWER  
1700 RPM  
ISA +37°C**

WEIGHT→			16,000 POUNDS					14,000 POUNDS				
PRESSURE ALTITUDE	IOAT	OAT	TORQUE PER ENGINE	FUEL FLOW PER ENGINE	TOTAL FUEL FLOW	IAS	TAS	TORQUE PER ENGINE	FUEL FLOW PER ENGINE	TOTAL FUEL FLOW	IAS	TAS
FEET	°C	°C	PERCENT	LBS/HR	LBS/HR	KTS	KTS	PERCENT	LBS/HR	LBS/HR	KTS	KTS
0	57	52	73	607	1214	213	228	74	607	1214	215	230
2000	53	48	72	577	1154	209	231	72	577	1154	211	233
4000	49	44	70	548	1096	205	233	70	548	1096	207	235
6000	45	40	68	522	1044	200	235	68	522	1044	203	238
8000	41	36	66	495	990	195	236	66	495	990	198	239
10,000	37	32	63	468	936	189	237	64	468	936	192	240
12,000	33	28	60	436	872	182	235	60	437	874	186	240
14,000	29	24	56	407	814	175	233	57	408	816	179	239
16,000	25	20	53	378	756	166	230	53	379	758	171	236
18,000	21	16	48	349	698	156	223	49	351	702	162	232
20,000	17	12	44	323	646	145	216	45	324	648	153	227
22,000	12	8	41	302	604	134	207	42	304	608	144	222
24,000	9	4	---	---	---	---	---	38	283	566	134	215
26,000	5	0	---	---	---	---	---	36	266	532	125	208
28,000	0	-3	---	---	---	---	---	34	252	504	114	198
29,000	-2	-5	---	---	---	---	---	33	243	486	103	184
31,000	---	---	---	---	---	---	---	---	---	---	---	---
33,000	---	---	---	---	---	---	---	---	---	---	---	---
35,000	---	---	---	---	---	---	---	---	---	---	---	---

BT05212

**NOTE**

**During operations with ice vanes extended, torque will decrease approximately 12%, fuel flow will decrease approximately 8%, and true airspeed will be reduced by approximately 15 knots.**

*Figure 7-47. Maximum Cruise Power at 1700 RPM - ISA +37°C (Sheet 1 of 2)*



**MAXIMUM CRUISE POWER  
1700 RPM  
ISA +37°C**

WEIGHT→			12,000 POUNDS					10,000 POUNDS				
PRESSURE ALTITUDE	IOAT	OAT	TORQUE PER ENGINE	FUEL FLOW PER ENGINE	TOTAL FUEL FLOW	IAS	TAS	TORQUE PER ENGINE	FUEL FLOW PER ENGINE	TOTAL FUEL FLOW	IAS	TAS
FEET	°C	°C	PERCENT	LBS/HR	LBS/HR	KTS	KTS	PERCENT	LBS/HR	LBS/HR	KTS	KTS
0	57	52	74	607	1214	217	232	74	607	1214	218	234
2000	53	48	72	577	1154	213	235	72	577	1154	215	237
4000	49	44	70	549	1098	209	238	70	549	1098	211	239
6000	45	40	68	522	1044	205	240	69	522	1044	206	242
8000	42	36	66	496	992	200	242	67	496	992	202	244
10,000	38	32	64	469	938	195	243	64	469	938	197	246
12,000	34	28	60	437	874	189	243	61	438	876	191	246
14,000	30	24	57	408	816	182	243	57	409	818	185	246
16,000	26	20	53	380	760	175	241	54	380	760	178	245
18,000	22	16	49	351	702	167	229	49	352	704	170	243
20,000	18	12	45	326	652	159	235	46	326	652	163	241
22,000	13	8	42	305	610	151	232	43	306	612	156	239
24,000	9	4	39	284	568	143	228	39	285	570	149	236
26,000	5	0	37	267	534	136	225	37	268	536	142	235
28,000	1	-3	35	254	508	129	222	35	255	510	137	235
29,000	-1	-5	34	247	494	125	221	34	249	498	134	235
31,000	-5	-9	32	231	462	116	212	32	233	466	127	232
33,000	-9	-13	---	---	---	---	---	29	215	430	118	224
35,000	-13	-17	---	---	---	---	---	26	196	392	106	212

BT05213

**NOTE**

**During operations with ice vanes extended, torque will decrease approximately 12%, fuel flow will decrease approximately 8%, and true airspeed will be reduced by approximately 15 knots.**

*Figure 7-47. Maximum Cruise Power at 1700 RPM - ISA +37°C (Sheet 2 of 2)*

MAXIMUM CRUISE SPEEDS  
1700 RPM  
WEIGHT: 14,000 LBS

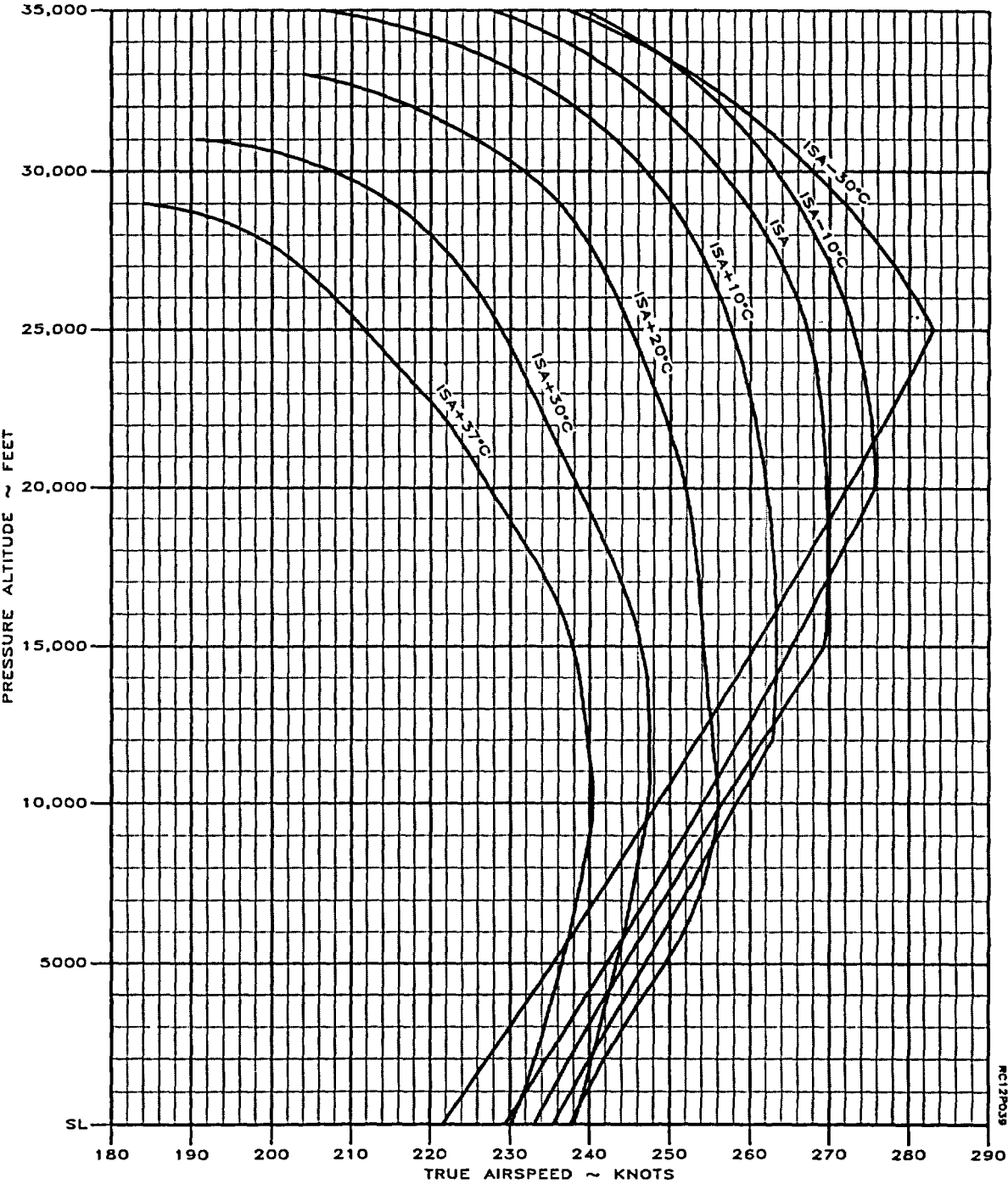

Figure 7-48. Maximum Cruise Speeds at 1700 RPM

MAXIMUM CRUISE POWER  
1700 RPM  
WEIGHT: 14,000 LBS

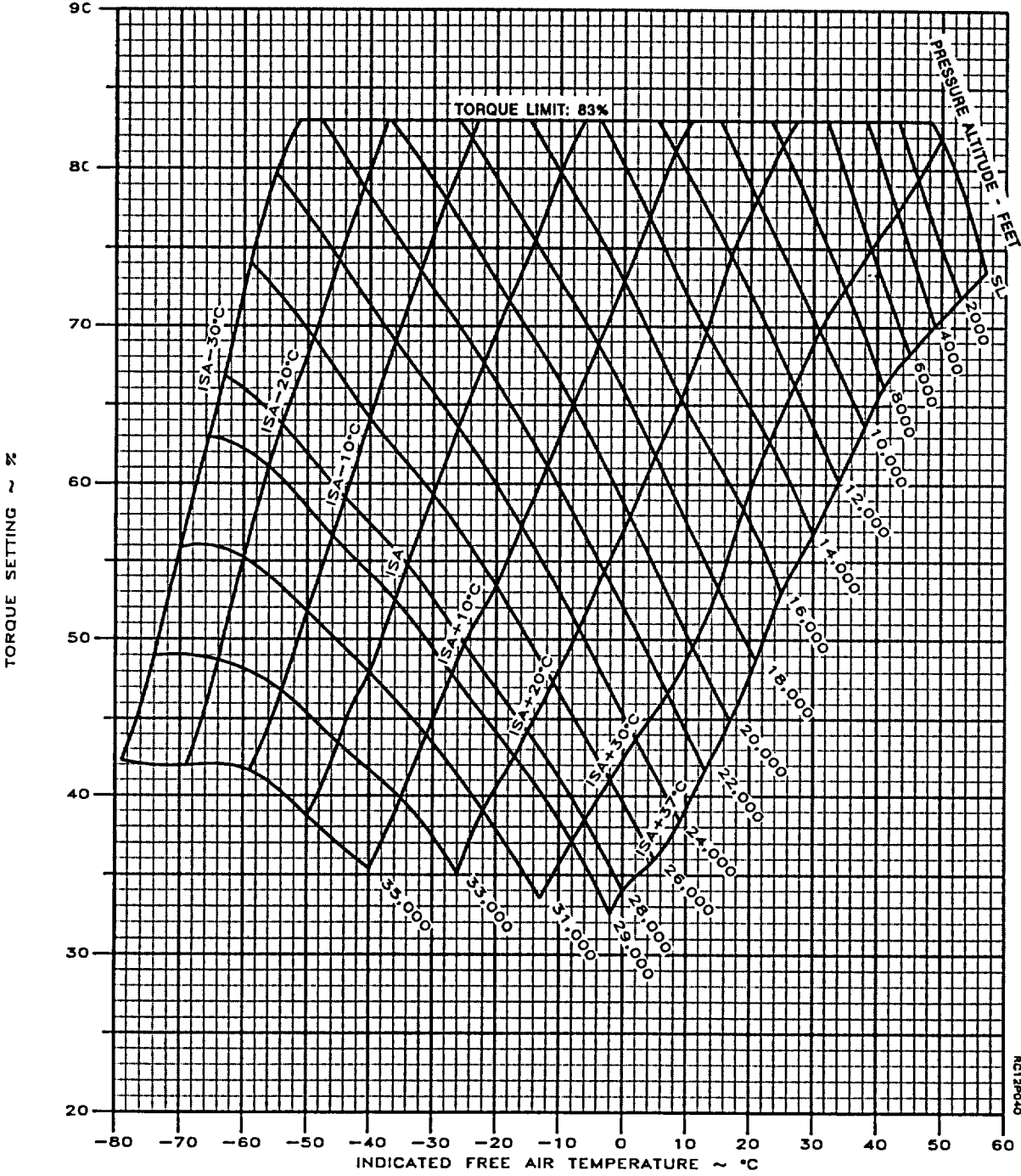

Figure 7-49. Maximum Cruise Power at 1700 RPM

FUEL FLOW AT MAXIMUM CRUISE POWER  
1700 RPM  
WEIGHT: 14,000 LBS

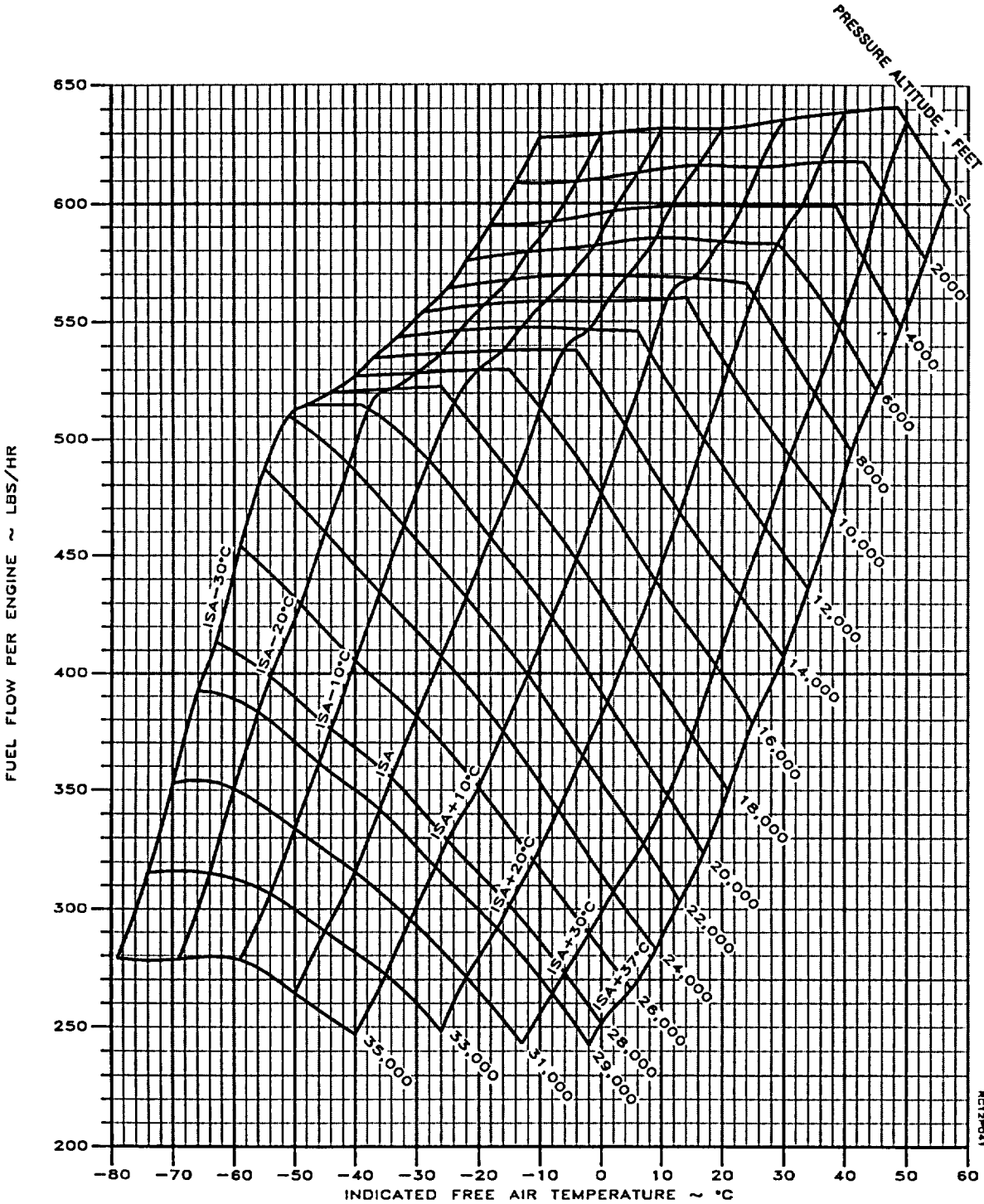

Figure 7-50. Fuel Flow at Maximum Cruise Power at 1700 RPM

RANGE PROFILE - MAXIMUM CRUISE POWER

ASSOCIATED CONDITIONS-  
WEIGHT ..... \*16.620 LBS BEFORE  
ENGINE START  
FUEL ..... AVIATION KEROSENE  
FUEL DENSITY ..... 6.7 LBS/GAL  
ICE VANES ..... RETRACTED

1700 RPM  
STANDARD DAY (ISA)  
ZERO WIND

EXAMPLE:  
PRESSURE ALTITUDE ..... 26,000 FT  
FUEL ..... 2572 LBS  
RANGE ..... 648 NM

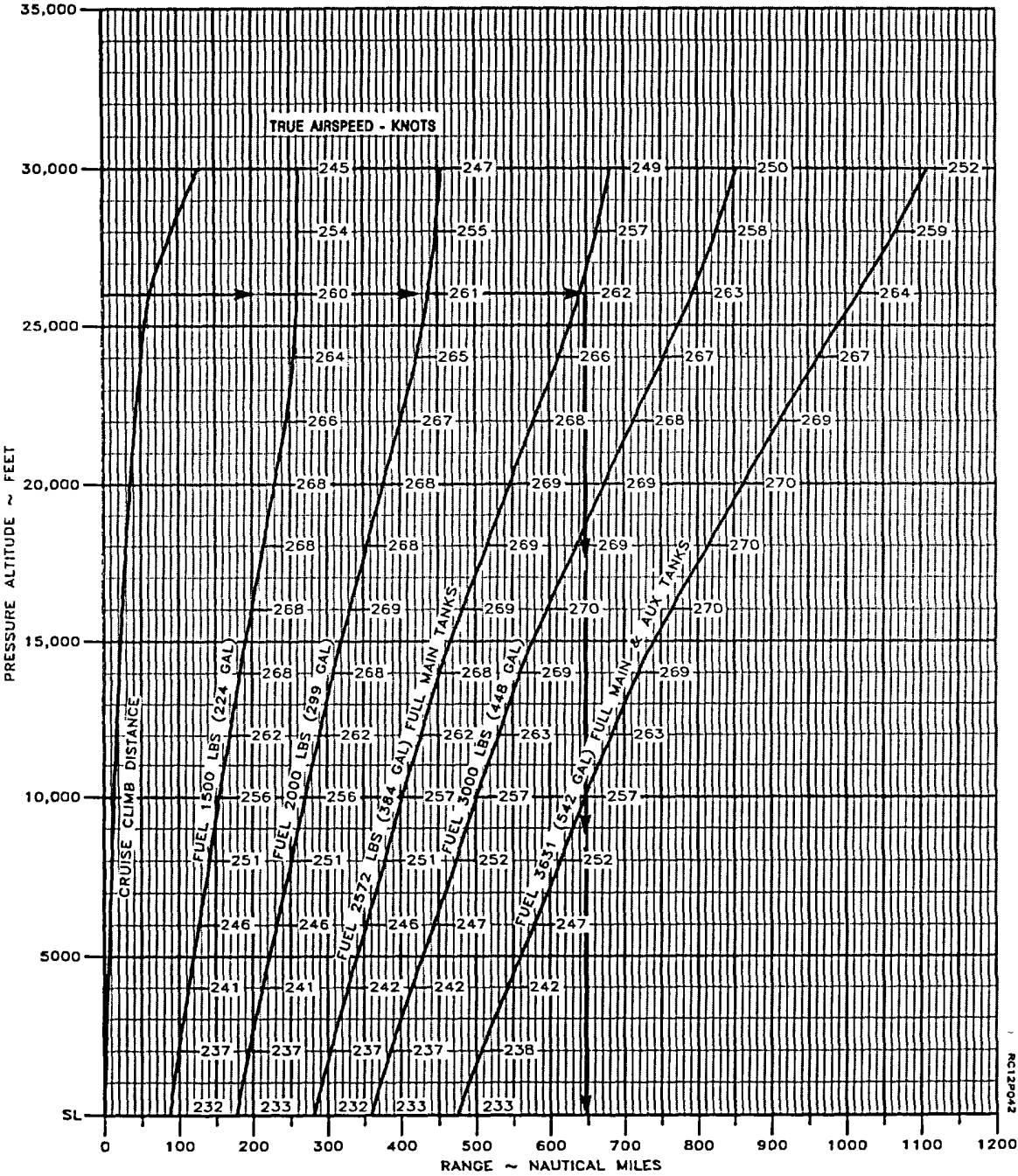

Figure 7-51. Range Profile - Maximum Cruise Power at 1700 RPM

**NORMAL CRUISE POWER  
1500 RPM  
ISA -30°C**

WEIGHT→			16,000 POUNDS					14,000 POUNDS				
PRESSURE ALTITUDE	IOAT	OAT	TORQUE PER ENGINE	FUEL FLOW PER ENGINE	TOTAL FUEL FLOW	IAS	TAS	TORQUE PER ENGINE	FUEL FLOW PER ENGINE	TOTAL FUEL FLOW	IAS	TAS
FEET	°C	°C	PERCENT	LBS/HR	LBS/HR	KTS	KTS	PERCENT	LBS/HR	LBS/HR	KTS	KTS
0	-10	-15	94	622	1244	234	223	94	622	1244	236	225
2000	-14	-19	94	604	1208	232	228	94	604	1208	234	229
4000	-18	-23	94	587	1174	231	232	94	587	1174	232	234
6000	-22	-27	94	572	1144	228	237	94	572	1144	230	238
8000	-25	-31	94	561	1122	227	242	94	560	1120	229	244
10,000	-29	-35	94	552	1104	225	247	94	551	1102	227	249
12,000	-33	-39	94	542	1084	223	252	94	541	1082	225	254
14,000	-37	-43	94	534	1068	220	257	94	533	1066	222	259
16,000	-40	-47	94	527	1054	218	262	94	526	1052	220	264
18,000	-44	-51	94	521	1042	215	267	94	520	1040	218	269
20,000	-48	-55	94	516	1032	213	272	94	515	1030	215	275
22,000	-52	-59	90	490	980	206	272	90	490	980	209	276
24,000	-56	-63	85	463	926	199	271	85	464	928	202	276
26,000	-60	-67	79	431	862	190	268	79	433	866	194	274
28,000	-64	-70	71	392	784	179	261	72	395	790	184	268
29,000	-66	-72	67	371	742	172	256	68	375	750	177	264
31,000	-71	-76	59	332	664	157	244	60	336	672	165	255
33,000	-76	-80	52	299	598	142	229	53	302	604	152	244
35,000	-79	-84	---	---	---	---	---	46	269	538	137	229

BT05239

**NOTE**

During operations with ice vanes extended, torque will decrease approximately 12%, fuel flow will decrease approximately 8%, and true airspeed will be reduced by approximately 15 knots.

Figure 7-52. Normal Cruise Power at 1500 RPM - ISA -30°C (Sheet 1 of 2)

**NORMAL CRUISE POWER  
1500 RPM  
ISA -30°C**

WEIGHT→			12,000 POUNDS					10,000 POUNDS				
PRESSURE ALTITUDE	IOAT	OAT	TORQUE PER ENGINE	FUEL FLOW PER ENGINE	TOTAL FUEL FLOW	IAS	TAS	TORQUE PER ENGINE	FUEL FLOW PER ENGINE	TOTAL FUEL FLOW	IAS	TAS
FEET	°C	°C	PERCENT	LBS/HR	LBS/HR	KTS	KTS	PERCENT	LBS/HR	LBS/HR	KTS	KTS
0	-10	-15	94	621	1242	237	226	94	621	1242	238	227
2000	-14	-19	94	603	1206	235	230	94	603	1206	236	231
4000	-18	-23	94	587	1174	233	235	94	586	1172	234	236
6000	-22	-27	94	572	1144	231	240	94	571	1142	233	241
8000	-25	-31	94	560	1120	231	246	94	560	1120	232	247
10,000	-29	-35	94	551	1102	228	251	94	551	1102	230	252
12,000	-33	-39	94	541	1082	226	256	94	541	1082	227	257
14,000	-36	-43	94	533	1066	224	261	94	533	1066	225	262
16,000	-40	-47	94	526	1052	222	266	94	526	1052	223	268
18,000	-44	-51	94	520	1040	219	271	94	519	1038	221	273
20,000	-48	-55	94	515	1030	217	277	94	514	1028	219	279
22,000	-51	-59	91	491	982	211	278	91	491	982	213	281
24,000	-55	-63	86	465	930	205	279	86	466	932	201	282
26,000	-59	-67	80	434	868	197	278	80	435	870	200	281
28,000	-61	-70	72	397	794	187	273	73	399	798	190	277
29,000	-66	-72	68	377	754	182	270	69	379	758	185	275
31,000	-70	-76	61	340	680	171	263	62	343	686	175	269
33,000	-74	-80	54	306	612	159	255	55	309	618	164	263
35,000	-79	-84	47	272	544	146	244	48	275	550	153	254

BT05240

**NOTE**

During operations with ice vanes extended, torque will decrease approximately 12%, fuel flow will decrease approximately 8%, and true airspeed will be reduced by approximately 15 knots.

Figure 7-52. Normal Cruise Power at 1500 RPM - ISA -30°C (Sheet 2 of 2)

**NORMAL CRUISE POWER  
1500 RPM  
ISA -20°C**

WEIGHT→			16,000 POUNDS					14,000 POUNDS				
PRESSURE ALTITUDE	IOAT	OAT	TORQUE PER ENGINE	FUEL FLOW PER ENGINE	TOTAL FUEL FLOW	IAS	TAS	TORQUE PER ENGINE	FUEL FLOW PER ENGINE	TOTAL FUEL FLOW	IAS	TAS
FEET	°C	°C	PERCENT	LBS/HR	LBS/HR	KTS	KTS	PERCENT	LBS/HR	LBS/HR	KTS	KTS
0	0	-5	94	625	1250	233	226	94	624	1248	234	227
2000	-4	-9	94	606	1212	231	230	94	605	1210	232	232
4000	-8	-13	94	589	1178	230	236	94	588	1176	232	238
6000	-12	-17	94	576	1152	227	240	94	576	1152	229	242
8000	-15	-21	94	565	1130	225	245	94	565	1130	227	247
10,000	-19	-25	94	555	1110	223	250	94	555	1110	225	252
12,000	-23	-29	94	545	1090	220	255	94	545	1090	222	257
14,000	-27	-33	94	536	1072	218	259	94	536	1072	220	262
16,000	-30	-37	94	529	1058	215	264	94	528	1056	218	267
18,000	-34	-41	93	517	1034	212	268	94	518	1036	214	271
20,000	-38	-45	90	495	990	206	269	90	496	992	209	273
22,000	-42	-49	84	467	934	198	268	85	468	936	202	272
24,000	-46	-53	79	439	878	191	267	80	440	880	194	271
26,000	-50	-57	73	407	814	181	263	74	409	818	186	269
28,000	-54	-60	67	374	748	170	256	67	376	752	176	264
29,000	-57	-62	63	357	714	164	252	64	359	718	171	261
31,000	-61	-66	57	327	654	152	242	58	329	658	160	254
33,000	-66	-70	51	297	594	137	227	52	300	600	148	245
35,000	-69	-74	---	---	---	---	---	46	271	542	134	231

BT05237

**NOTE**

During operations with ice vanes extended, torque will decrease approximately 12%, fuel flow will decrease approximately 8%, and true airspeed will be reduced by approximately 15 knots.

Figure 7-53. Normal Cruise Power at 1500 RPM - ISA -20°C (Sheet 1 of 2)



**NORMAL CRUISE POWER  
1500 RPM  
ISA -20°C**

WEIGHT→			12,000 POUNDS					10,000 POUNDS				
PRESSURE ALTITUDE	IOAT	OAT	TORQUE PER ENGINE	FUEL FLOW PER ENGINE	TOTAL FUEL FLOW	IAS	TAS	TORQUE PER ENGINE	FUEL FLOW PER ENGINE	TOTAL FUEL FLOW	IAS	TAS
FEET	°C	°C	PERCENT	LBS/HR	LBS/HR	KTS	KTS	PERCENT	LBS/HR	LBS/HR	KTS	KTS
0	0	-5	94	624	1248	235	229	94	624	1248	236	230
2000	-4	-9	94	605	1210	234	233	94	605	1210	235	234
4000	-8	-13	94	588	1176	233	239	94	587	1174	234	240
6000	-11	-17	94	575	1150	231	244	94	575	1150	232	245
8000	-15	-21	94	564	1128	228	248	94	564	1128	230	250
10,000	-19	-25	94	554	1108	226	253	94	554	1108	227	255
12,000	-23	-29	94	544	1088	224	259	94	544	1088	225	260
14,000	-26	-33	94	535	1070	222	264	94	535	1070	223	265
16,000	-30	-37	94	528	1056	219	269	94	528	1056	221	271
18,000	-34	-41	94	518	1036	216	274	94	518	1036	218	276
20,000	-38	-45	90	496	992	211	275	90	496	992	213	278
22,000	-42	-49	85	468	936	204	276	85	469	938	206	278
24,000	-46	-53	80	440	880	197	275	80	441	882	200	278
26,000	-50	-57	74	410	820	189	273	75	411	822	192	277
28,000	-54	-60	68	377	754	180	270	68	378	756	183	274
29,000	-56	-62	65	361	722	175	268	65	363	726	179	273
31,000	-60	-66	59	331	662	166	263	59	333	666	170	269
33,000	-64	-70	53	303	606	156	256	54	306	612	161	264
35,000	-69	-74	47	274	548	144	247	48	278	556	151	258

BT05238

**NOTE**

During operations with ice vanes extended, torque will decrease approximately 12%, fuel flow will decrease approximately 8%, and true airspeed will be reduced by approximately 15 knots.

Figure 7-53. Normal Cruise Power at 1500 RPM - ISA -20°C (Sheet 2 of 2)

**NORMAL CRUISE POWER  
1500 RPM  
ISA -10°C**

WEIGHT→			16,000 POUNDS					14,000 POUNDS				
PRESSURE ALTITUDE	IOAT	OAT	TORQUE PER ENGINE	FUEL FLOW PER ENGINE	TOTAL FUEL FLOW	IAS	TAS	TORQUE PER ENGINE	FUEL FLOW PER ENGINE	TOTAL FUEL FLOW	IAS	TAS
FEET	°C	°C	PERCENT	LBS/HR	LBS/HR	KTS	KTS	PERCENT	LBS/HR	LBS/HR	KTS	KTS
0	10	5	94	627	1254	232	229	94	627	1254	233	231
2000	6	1	94	610	1220	230	234	94	609	1218	232	236
4000	2	-3	94	594	1188	228	238	94	593	1186	229	240
6000	-1	-7	94	580	1160	225	243	94	579	1158	227	245
8000	-5	-11	94	568	1136	223	247	94	567	1134	225	249
10,000	-9	-15	94	557	1114	221	252	94	557	1114	223	254
12,000	-13	-19	94	547	1094	218	257	94	547	1094	220	259
14,000	-16	-23	94	538	1076	216	262	94	538	1076	218	264
16,000	-20	-27	92	517	1034	211	264	92	518	1036	213	267
18,000	-24	-31	87	488	976	204	264	87	488	976	206	267
20,000	-28	-35	83	465	930	197	264	83	465	930	200	268
22,000	-32	-39	78	440	880	190	263	79	440	880	193	268
24,000	-36	-43	74	414	828	182	261	74	415	830	186	267
26,000	-40	-47	68	386	772	173	257	69	387	774	178	264
28,000	-45	-50	62	355	710	162	249	63	356	712	168	259
29,000	-47	-52	59	340	680	156	245	60	342	684	163	255
31,000	-51	-56	54	312	624	143	234	54	315	630	152	248
33,000	-55	-60	---	---	---	---	---	49	290	580	141	240
35,000	-60	-64	---	---	---	---	---	45	266	532	128	226

BT05235

**NOTE**

During operations with ice vanes extended, torque will decrease approximately 12%, fuel flow will decrease approximately 8%, and true airspeed will be reduced by approximately 15 knots.

Figure 7-54. Normal Cruise Power at 1500 RPM - ISA -10°C (Sheet 1 of 2)

**NORMAL CRUISE POWER  
1500 RPM  
ISA -10°C**

WEIGHT→			12,000 POUNDS					10,000 POUNDS				
PRESSURE ALTITUDE	IOAT	OAT	TORQUE PER ENGINE	FUEL FLOW PER ENGINE	TOTAL FUEL FLOW	IAS	TAS	TORQUE PER ENGINE	FUEL FLOW PER ENGINE	TOTAL FUEL FLOW	IAS	TAS
FEET	°C	°C	PERCENT	LBS/HR	LBS/HR	KTS	KTS	PERCENT	LBS/HR	LBS/HR	KTS	KTS
0	10	5	94	626	1252	235	232	94	626	1252	236	233
2000	6	1	94	609	1218	233	237	94	608	1216	234	238
4000	2	-3	94	593	1186	231	242	94	593	1186	232	243
6000	-1	-7	94	579	1158	229	246	94	579	1158	230	248
8000	-5	-11	94	567	1134	226	251	94	567	1134	228	252
10,000	-9	-15	94	556	1112	224	256	94	556	1112	225	258
12,000	-12	-19	94	546	1092	222	261	94	546	1092	223	263
14,000	-16	-23	94	537	1074	219	266	94	537	1074	221	268
16,000	-20	-27	92	518	1036	215	269	92	518	1036	217	271
18,000	-24	-31	87	488	976	208	270	87	489	978	210	272
20,000	-28	-35	83	466	932	203	271	83	466	932	205	274
22,000	-32	-39	79	441	882	196	271	79	441	882	198	274
24,000	-36	-43	74	416	832	189	271	75	417	834	192	275
26,000	-40	-47	69	388	776	182	269	69	389	778	185	273
28,000	-44	-50	63	358	716	173	265	63	359	718	176	270
29,000	-46	-52	60	343	686	168	263	61	344	688	172	269
31,000	-50	-56	55	316	632	159	258	55	318	636	163	265
33,000	-54	-60	50	292	584	149	253	51	294	588	155	262
35,000	-59	-64	45	268	536	139	245	46	269	538	146	256

BT05236

**NOTE**

During operations with ice vanes extended, torque will decrease approximately 12%, fuel flow will decrease approximately 8%, and true airspeed will be reduced by approximately 15 knots.

Figure 7-54. Normal Cruise Power at 1500 RPM - ISA - 10°C (Sheet 2 of 2)

**NORMAL CRUISE POWER  
1500 RPM  
ISA - 10°C**

WEIGHT→			16,000 POUNDS					14,000 POUNDS				
PRESSURE ALTITUDE	IOAT	OAT	TORQUE PER ENGINE	FUEL FLOW PER ENGINE	TOTAL FUEL FLOW	IAS	TAS	TORQUE PER ENGINE	FUEL FLOW PER ENGINE	TOTAL FUEL FLOW	IAS	TAS
FEET	°C	°C	PERCENT	LBS/HR	LBS/HR	KTS	KTS	PERCENT	LBS/HR	LBS/HR	KTS	KTS
0	20	15	94	628	1256	230	232	94	627	1254	232	233
2000	16	11	94	613	1226	228	236	94	613	1226	230	238
4000	12	7	94	599	1198	226	241	94	598	1.196	228	243
6000	9	3	94	584	1168	223	245	94	583	1166	225	247
8000	5	-1	94	570	1140	221	250	94	569	1138	223	252
10,000	1	-5	94	558	1116	219	255	94	557	1114	221	257
12,000	-3	-9	94	544	1088	216	259	94	545	1090	218	262
14,000	-7	-13	89	514	1028	209	259	90	515	1030	211	262
16,000	-11	-17	85	486	972	202	259	85	486	972	205	262
18,000	-14	-21	80	459	918	195	258	81	459	918	198	262
20,000	-18	-25	76	435	870	188	258	76	436	872	191	262
22,000	-23	-29	72	410	820	180	256	72	411	822	184	261
24,000	-27	-33	67	385	770	172	253	68	386	772	177	260
26,000	-31	-37	62	359	718	163	248	63	360	720	168	256
28,000	-35	-40	57	333	666	152	240	58	334	668	159	251
29,000	-37	-42	55	320	640	146	235	55	322	644	154	248
31,000	-42	-46	50	295	590	131	221	51	298	596	144	241
33,000	-45	-50	---	---	---	---	---	46	275	550	132	230
35,000	---	---	---	---	---	---	---	---	---	---	---	---

BT05224

**NOTE**

During operations with ice vanes extended, torque will decrease approximately 12%, fuel flow will decrease approximately 8%, and true airspeed will be reduced by approximately 15 knots.

Figure 7-55. Normal Cruise Power at 1500 RPM - ISA (Sheet 1 of 2)

**NORMAL CRUISE POWER  
1500 RPM  
ISA**

WEIGHT→			12,000 POUNDS					10,000 POUNDS				
PRESSURE ALTITUDE	IOAT	OAT	TORQUE PER ENGINE	FUEL FLOW PER ENGINE	TOTAL FUEL FLOW	IAS	TAS	TORQUE PER ENGINE	FUEL FLOW PER ENGINE	TOTAL FUEL FLOW	IAS	TAS
FEET	°C	°C	PERCENT	LBS/HR	LBS/HR	KTS	KTS	PERCENT	LBS/HR	LBS/HR	KTS	KTS
0	20	15	94	627	1254	233	235	94	626	1252	234	236
2000	16	11	94	612	1224	231	239	94	612	1224	232	241
4000	13	7	94	598	1196	229	244	94	597	1194	230	245
6000	9	3	94	583	1166	227	249	94	582	1164	228	250
8000	5	-1	94	569	1138	224	254	94	569	1138	226	255
10,000	1	-5	94	557	1114	222	259	94	557	1114	223	260
12,000	-2	-9	94	545	1090	220	264	94	545	1090	221	266
14,000	-6	-13	90	515	1030	213	264	90	516	1032	215	266
16,000	-10	-17	85	487	974	207	265	85	487	974	209	267
18,000	-14	-21	81	460	920	200	265	81	460	920	203	268
20,000	-18	-25	77	436	872	194	266	77	436	872	196	269
22,000	-22	-29	72	411	822	188	265	72	412	824	190	269
24,000	-26	-33	68	387	774	181	265	68	388	776	183	269
26,000	-30	-37	63	361	722	173	263	63	362	724	176	267
28,000	-34	-40	58	336	672	165	259	59	337	674	169	265
29,000	-36	-42	56	323	646	160	257	56	324	648	165	264
31,000	-40	-46	51	300	600	151	253	52	301	602	157	261
33,000	-45	-50	47	277	554	142	246	47	278	556	148	257
35,000	-49	-54	42	254	508	131	237	43	256	512	139	251

BT05225

**NOTE**

During operations with ice vanes extended, torque will decrease approximately 12%, fuel flow will decrease approximately 8%, and true airspeed will be reduced by approximately 15 knots.

Figure 7-55. Normal Cruise Power at 1500 RPM - ISA (Sheet 2 of 2)

**NORMAL CRUISE POWER  
1500 RPM  
ISA +10°C**

WEIGHT→			16,000 POUNDS					14,000 POUNDS				
PRESSURE ALTITUDE	IOAT	OAT	TORQUE PER ENGINE	FUEL FLOW PER ENGINE	TOTAL FUEL FLOW	IAS	TAS	TORQUE PER ENGINE	FUEL FLOW PER ENGINE	TOTAL FUEL FLOW	IAS	TAS
FEET	°C	°C	PERCENT	LBS/HR	LBS/HR	KTS	KTS	PERCENT	LBS/HR	LBS/HR	KTS	KTS
0	30	25	94	633	1266	229	234	94	632	1264	230	236
2000	26	21	94	613	1226	226	238	94	613	1226	228	240
4000	23	17	94	596	1192	224	243	94	595	1190	226	245
6000	19	13	94	580	1160	221	248	94	580	1160	223	250
8000	15	9	94	567	1134	219	252	94	567	1134	221	254
10,000	11	5	89	534	1068	211	251	89	534	1068	214	254
12,000	7	1	85	506	1012	205	252	85	507	1014	208	255
14,000	3	-3	82	480	960	199	253	82	481	962	202	256
16,000	-1	-7	78	454	908	193	252	78	454	908	196	256
18,000	-5	-11	73	427	854	185	251	74	428	856	189	256
20,000	-9	-15	69	403	806	178	249	69	403	806	182	255
22,000	-13	-19	65	379	758	169	246	65	380	760	174	253
24,000	-17	-23	60	355	710	161	242	61	356	712	167	250
26,000	-21	-27	56	331	662	151	235	56	333	666	158	246
28,000	-26	-30	51	308	616	139	226	52	310	620	149	241
29,000	-28	-32	49	296	592	131	218	50	299	598	144	238
31,000	-32	-36	---	---	---	---	---	46	277	554	133	228
33,000	---	---	---	---	---	---	---	---	---	---	---	---
35,000	---	---	---	---	---	---	---	---	---	---	---	---

BT05226

**NOTE**

During operations with ice vanes extended, torque will decrease approximately 12%, fuel flow will decrease approximately 8%, and true airspeed will be reduced by approximately 15 knots.

Figure 7-56. Normal Cruise Power at 1500 RPM - ISA +10°C (Sheet 1 of 2)

**NORMAL CRUISE POWER  
1500 RPM  
ISA +10°C**

WEIGHT→			12,000 POUNDS					10,000 POUNDS				
PRESSURE ALTITUDE	IOAT	OAT	TORQUE PER ENGINE	FUEL FLOW PER ENGINE	TOTAL FUEL FLOW	IAS	TAS	TORQUE PER ENGINE	FUEL FLOW PER ENGINE	TOTAL FUEL FLOW	IAS	TAS
FEET	°C	°C	PERCENT	LBS/HR	LBS/HR	KTS	KTS	PERCENT	LBS/HR	LBS/HR	KTS	KTS
0	30	25	94	632	1264	232	237	94	632	1264	233	238
2000	26	21	94	612	1224	229	242	94	612	1224	231	243
4000	23	17	94	595	1190	227	246	94	595	1190	228	248
6000	19	13	94	579	1158	225	251	94	579	1158	226	253
8000	15	9	94	567	1134	223	256	94	566	1132	224	258
10,000	11	5	89	535	1070	215	256	89	535	1070	217	258
12,000	7	1	86	507	1014	210	258	86	508	1016	212	260
14,000	3	-3	82	481	962	205	259	82	481	962	206	261
16,000	0	-7	78	455	910	199	260	78	455	910	201	262
18,000	-4	-11	74	428	856	192	259	74	429	858	194	263
20,000	-8	-15	70	404	808	185	259	70	404	808	188	263
22,000	-12	-19	65	380	760	178	258	66	381	762	181	262
24,000	-16	-23	61	357	714	171	257	61	358	716	174	261
26,000	-21	-27	57	334	668	163	254	57	334	668	167	260
28,000	-25	-30	53	311	622	155	251	53	312	624	160	258
29,000	-27	-32	51	300	600	151	249	51	301	602	156	257
31,000	-31	-36	47	279	558	142	244	47	280	560	149	254
33,000	-35	-40	43	258	516	133	237	43	260	520	141	250
35,000	-40	-44	39	237	474	121	225	39	239	478	131	244

BT05227

**NOTE**

During operations with ice vanes extended, torque will decrease approximately 12%, fuel flow will decrease approximately 8%, and true airspeed will be reduced by approximately 15 knots.

Figure 7-56. Normal Cruise Power at 1500 RPM - ISA +10°C (Sheet 2 of 2)

**NORMAL CRUISE POWER  
1500 RPM  
ISA +20°C**

WEIGHT→			16,000 POUNDS					14,000 POUNDS				
PRESSURE ALTITUDE	IOAT	OAT	TORQUE PER ENGINE	FUEL FLOW PER ENGINE	TOTAL FUEL FLOW	IAS	TAS	TORQUE PER ENGINE	FUEL FLOW PER ENGINE	TOTAL FUEL FLOW	IAS	TAS
FEET	°C	°C	PERCENT	LBS/HR	LBS/HR	KTS	KTS	PERCENT	LBS/HR	LBS/HR	KTS	KTS
0	40	35	94	637	1274	227	236	94	636	1272	229	238
2000	36	31	94	616	1232	224	241	94	616	1232	226	242
4000	33	27	92	588	1176	220	243	92	588	1176	222	245
6000	29	23	88	557	1114	214	243	89	557	1114	216	246
8000	25	19	85	528	1056	208	244	85	528	1056	210	247
10,000	21	15	81	500	1000	202	245	82	500	1000	205	248
12,000	17	11	78	474	948	197	246	79	474	948	200	250
14,000	13	7	74	445	890	189	244	74	446	892	192	248
16,000	9	3	69	419	838	181	243	70	419	838	185	247
18,000	5	-1	66	394	788	174	241	66	395	790	179	247
20,000	1	-5	61	369	738	166	238	62	370	740	171	245
22,000	-4	-9	57	346	692	157	233	58	347	694	163	242
24,000	-8	-13	53	323	646	147	227	54	324	648	155	238
26,000	-12	-17	49	301	602	135	217	50	303	606	146	234
28,000	-16	-20	---	---	---	---	---	46	284	568	137	227
29,000	-18	-22	---	---	---	---	---	45	275	550	131	222
31,000	---	---	---	---	---	---	---	---	---	---	---	---
33,000	---	---	---	---	---	---	---	---	---	---	---	---
35,000	---	---	---	---	---	---	---	---	---	---	---	---

BT05228

**NOTE**

During operations with ice vanes extended, torque will decrease approximately 12%, fuel flow will decrease approximately 8%, and true airspeed will be reduced by approximately 15 knots.

Figure 7-57. Normal Cruise Power at 1500 RPM - ISA +20°C (Sheet 1 of 2)



**NORMAL CRUISE POWER  
1500 RPM  
ISA +20°C**

WEIGHT→			12,000 POUNDS					10,000 POUNDS				
PRESSURE ALTITUDE	IOAT	OAT	TORQUE PER ENGINE	FUEL FLOW PER ENGINE	TOTAL FUEL FLOW	IAS	TAS	TORQUE PER ENGINE	FUEL FLOW PER ENGINE	TOTAL FUEL FLOW	IAS	TAS
FEET	°C	°C	PERCENT	LBS/HR	LBS/HR	KTS	KTS	PERCENT	LBS/HR	LBS/HR	KTS	KTS
0	40	35	94	636	1272	230	239	94	636	1272	231	241
2000	37	31	94	615	1230	228	244	94	615	1230	229	245
4000	33	27	92	588	1176	223	247	93	589	1178	225	248
6000	29	23	89	557	1114	218	248	89	558	1116	219	250
8000	25	19	85	528	1056	213	249	85	529	1058	214	251
10,000	21	15	82	500	1000	207	251	82	501	1002	209	253
12,000	17	11	79	474	948	202	252	79	475	950	204	255
14,000	13	7	74	446	892	195	252	74	447	894	197	255
16,000	9	3	70	420	840	188	251	70	420	840	191	255
18,000	5	-1	66	395	790	182	251	66	396	792	185	255
20,000	1	-5	62	371	742	175	250	62	371	742	178	255
22,000	-3	-9	58	348	696	168	249	58	349	698	172	254
24,000	-7	-13	54	325	650	161	246	55	326	652	165	252
26,000	-11	-17	51	305	610	153	244	51	305	610	158	251
28,000	-15	-20	47	286	572	145	240	47	287	574	151	249
29,000	-17	-22	45	277	554	141	238	46	278	556	147	248
31,000	-21	-26	42	258	516	132	232	42	259	518	140	245
33,000	-26	-30	38	238	476	121	222	39	240	480	131	240
35,000	-29	-34	---	---	---	---	---	35	220	440	122	232

BT05229

**NOTE**

During operations with ice vanes extended, torque will decrease approximately 12%, fuel flow will decrease approximately 8%, and true airspeed will be reduced by approximately 15 knots.

Figure 7-57. Normal Cruise Power at 1500 RPM - ISA +20°C (Sheet 2 of 2)

**NORMAL CRUISE POWER  
1500 RPM  
ISA +30°C**

WEIGHT→			16,000 POUNDS					14,000 POUNDS				
PRESSURE ALTITUDE	IOAT	OAT	TORQUE PER ENGINE	FUEL FLOW PER ENGINE	TOTAL FUEL FLOW	IAS	TAS	TORQUE PER ENGINE	FUEL FLOW PER ENGINE	TOTAL FUEL FLOW	IAS	TAS
FEET	°C	°C	PERCENT	LBS/HR	LBS/HR	KTS	KTS	PERCENT	LBS/HR	LBS/HR	KTS	KTS
0	50	45	85	606	1212	216	229	86	606	1212	219	232
2000	46	41	83	577	1154	212	231	83	577	1154	214	234
4000	42	37	80	547	1094	207	233	81	547	1094	209	235
6000	38	33	77	518	1036	201	234	78	518	1036	204	237
8000	34	29	75	490	980	196	234	75	490	980	199	238
10000	30	25	72	462	924	190	235	72	463	926	193	239
12,000	26	21	69	438	876	185	236	70	438	876	188	240
14,000	22	17	67	414	828	179	236	67	415	830	183	241
16,000	18	13	63	388	776	171	234	63	389	778	176	240
18,000	14	9	57	359	718	160	227	57	360	720	166	235
20,000	10	5	52	331	662	150	219	53	333	666	157	230
22,000	6	1	49	311	622	140	213	49	312	624	149	226
24,000	2	-3	---	---	---	---	---	46	292	584	140	221
26,000	-2	-7	---	---	---	---	---	43	274	548	131	215
28,000	-6	-10	---	---	---	---	---	41	259	518	121	207
29,000	---	---	---	---	---	---	---	---	---	---	---	---
31,000	---	---	---	---	---	---	---	---	---	---	---	---
33,000	---	---	---	---	---	---	---	---	---	---	---	---
35,000	---	---	---	---	---	---	---	---	---	---	---	---

BT05230

**NOTE**

During operations with ice vanes extended, torque will decrease approximately 12%, fuel flow will decrease approximately 8%, and true airspeed will be reduced by approximately 15 knots.

Figure 7-58. Normal Cruise Power at 1500 RPM - ISA +30°C (Sheet 1 of 2)

**NORMAL CRUISE POWER  
1500 RPM  
ISA +30°C**

WEIGHT→			12,000 POUNDS					10,000 POUNDS				
PRESSURE ALTITUDE	IOAT	OAT	TORQUE PER ENGINE	FUEL FLOW PER ENGINE	TOTAL FUEL FLOW	IAS	TAS	TORQUE PER ENGINE	FUEL FLOW PER ENGINE	TOTAL FUEL FLOW	IAS	TAS
FEET	°C	°C	PERCENT	LBS/HR	LBS/HR	KTS	KTS	PERCENT	LBS/HR	LBS/HR	KTS	KTS
0	50	45	86	606	1212	220	233	86	607	1214	222	235
2000	46	41	83	577	1154	216	236	84	577	1154	218	237
4000	42	37	81	548	1096	211	237	81	548	1096	213	239
6000	38	33	78	519	1038	206	239	78	519	1038	208	241
8000	35	29	75	491	982	201	240	75	491	982	203	243
10,000	31	25	72	463	926	196	242	72	463	926	198	244
12,000	27	21	70	439	878	191	244	70	439	878	193	246
14,000	23	17	67	415	830	186	245	67	416	832	189	248
16,000	19	13	63	390	780	179	244	64	390	780	182	248
18,000	15	9	58	361	722	171	241	58	362	724	174	245
20,000	11	5	53	334	668	162	237	54	335	670	166	243
22,000	7	1	50	313	626	155	235	50	314	628	160	242
24,000	2	-3	47	293	586	148	232	47	293	586	153	240
26,000	-2	-7	44	276	552	141	230	44	276	552	147	239
28,000	-6	-10	41	261	522	134	227	42	262	524	141	238
29,000	-8	-12	40	253	506	130	225	41	254	508	138	238
31,000	-12	-16	37	236	472	120	216	38	238	476	130	234
33,000	-16	-20	---	---	---	---	---	34	219	438	121	227
35,000	-20	-24	---	---	---	---	---	31	200	400	110	216

BT05231

**NOTE**

During operations with ice vanes extended, torque will decrease approximately 12%, fuel flow will decrease approximately 8%, and true airspeed will be reduced by approximately 15 knots.

Figure 7-58. Normal Cruise Power at 1500 RPM - ISA +30°C (Sheet 2 of 2)

**NORMAL CRUISE POWER  
1500 RPM  
ISA +37°C**

WEIGHT→			16,000 POUNDS					14,000 POUNDS				
PRESSURE ALTITUDE	IOAT	OAT	TORQUE PER ENGINE	FUEL FLOW PER ENGINE	TOTAL FUEL FLOW	IAS	TAS	TORQUE PER ENGINE	FUEL FLOW PER ENGINE	TOTAL FUEL FLOW	IAS	TAS
FEET	°C	°C	PERCENT	LBS/HR	LBS/HR	KTS	KTS	PERCENT	LBS/HR	LBS/HR	KTS	KTS
0	57	52	77	582	1164	206	221	77	582	1164	208	223
2000	53	48	74	551	1102	201	222	75	551	1102	204	225
4000	49	44	72	521	1042	197	224	72	521	1042	199	227
6000	45	40	70	492	984	191	225	70	492	984	195	229
8000	41	36	67	465	930	186	226	68	465	930	190	230
10,000	37	32	65	439	878	181	226	65	439	878	185	231
12,000	33	28	63	415	830	176	227	63	416	832	180	233
14,000	29	24	61	392	784	170	227	61	393	786	175	233
16,000	25	20	57	367	734	162	225	58	368	736	168	232
18,000	21	16	52	338	676	151	217	53	340	680	159	227
20,000	16	12	47	310	620	139	207	48	312	624	148	220
22,000	13	8	---	---	---	---	---	44	291	582	139	214
24,000	8	4	---	---	---	---	---	41	270	540	127	204
26,000	---	---	---	---	---	---	---	---	---	---	---	---
28,000	---	---	---	---	---	---	---	---	---	---	---	---
29,000	---	---	---	---	---	---	---	---	---	---	---	---
31,000	---	---	---	---	---	---	---	---	---	---	---	---
33,000	---	---	---	---	---	---	---	---	---	---	---	---
35,000	---	---	---	---	---	---	---	---	---	---	---	---

BT05232

**NOTE**

During operations with ice vanes extended, torque will decrease approximately 12%, fuel flow will decrease approximately 8%, and true airspeed will be reduced by approximately 15 knots.

Figure 7-59. Normal Cruise Power at 1500 RPM - ISA +37°C (Sheet 1 of 2)

**NORMAL CRUISE POWER  
1500 RPM  
ISA +37°C**

WEIGHT→			12,000 POUNDS					10,000 POUNDS				
PRESSURE ALTITUDE	IOAT	OAT	TORQUE PER ENGINE	FUEL FLOW PER ENGINE	TOTAL FUEL FLOW	IAS	TAS	TORQUE PER ENGINE	FUEL FLOW PER ENGINE	TOTAL FUEL FLOW	IAS	TAS
FEET	°C	°C	PERCENT	LBS/HR	LBS/HR	KTS	KTS	PERCENT	LBS/HR	LBS/HR	KTS	KTS
0	57	52	77	582	1164	210	225	77	582	1164	212	227
2000	53	48	75	551	1102	206	228	75	552	1104	208	230
4000	49	44	73	521	1042	202	230	73	521	1042	204	232
6000	45	40	70	492	984	197	231	70	492	984	199	234
8000	41	36	68	465	930	193	233	68	465	930	195	236
10,000	37	32	65	439	878	188	235	66	440	880	190	238
12,000	33	28	64	416	832	183	237	64	416	832	186	240
14,000	30	24	61	393	786	178	238	61	393	786	181	242
16,000	26	20	58	368	736	172	237	58	369	738	175	242
18,000	21	16	53	341	682	164	234	54	341	682	168	239
20,000	17	12	49	313	626	155	230	49	314	628	159	236
22,000	13	8	45	292	584	147	226	45	293	586	152	233
24,000	9	4	41	271	542	138	220	42	272	544	144	230
26,000	5	0	39	255	510	130	216	39	256	512	138	228
28,000	1	-3	37	243	486	123	214	38	244	488	133	228
29,000	-1	-5	36	236	472	120	211	37	237	474	130	228
31,000	-5	-9	---	---	---	---	---	34	222	444	123	224
33,000	-9	-13	---	---	---	---	---	31	204	408	112	215
35,000	---	---	---	---	---	---	---	---	---	---	---	---

BT05234

**NOTE**

During operations with ice vanes extended, torque will decrease approximately 12%, fuel flow will decrease approximately 8%, and true airspeed will be reduced by approximately 15 knots.

Figure 7-59. Normal Cruise Power at 1500 RPM - ISA +37°C (Sheet 2 of 2)

NORMAL CRUISE SPEEDS  
1500 RPM  
WEIGHT: 14,000 LBS

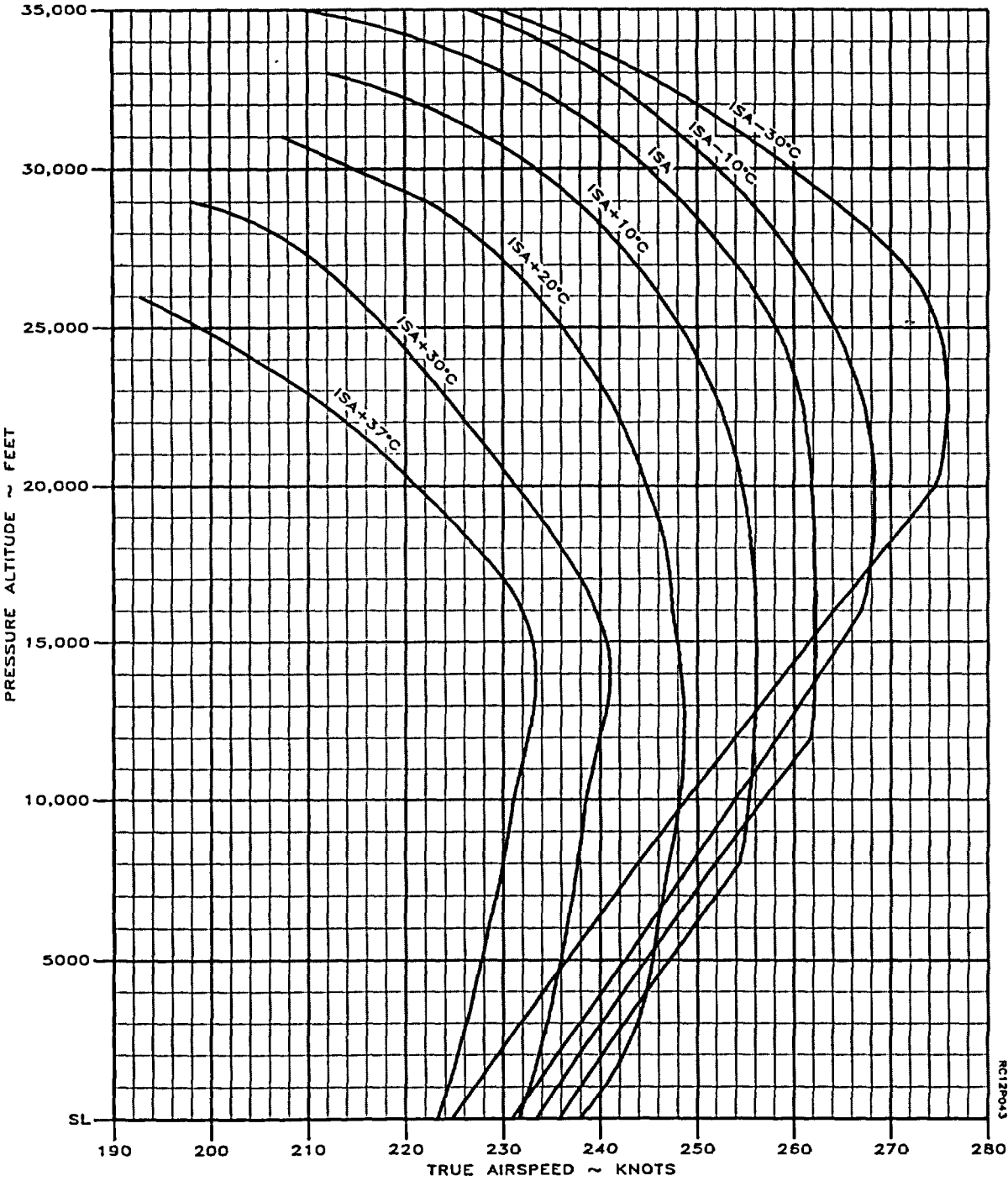

Figure 7-60. Normal Cruise Speeds at 1500 RPM

NORMAL CRUISE POWER  
1500 RPM  
WEIGHT: 14,000 LBS

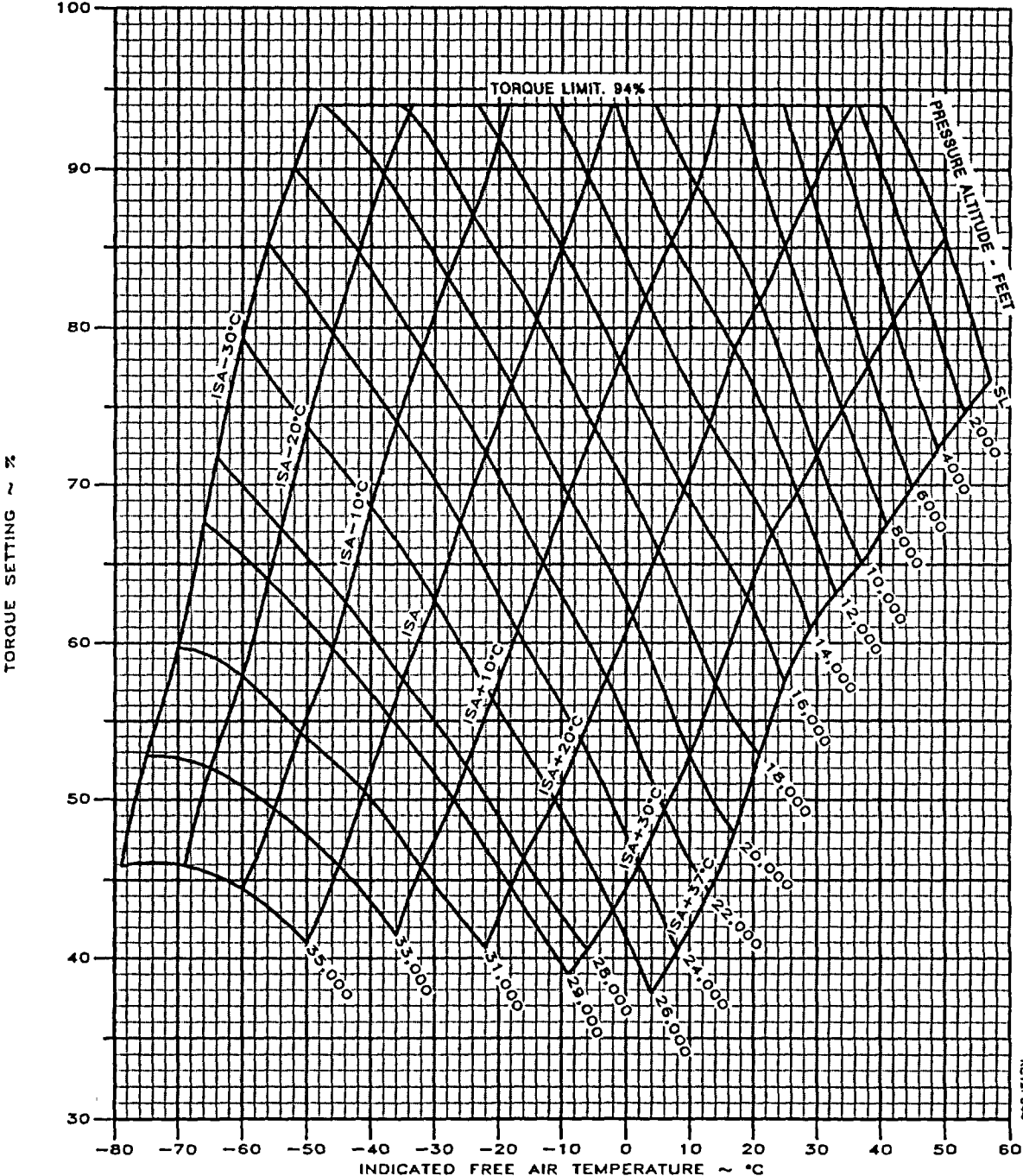

Figure 7-61. Normal Cruise Power at 1500 RPM

FUEL FLOW AT NORMAL CRUISE POWER  
1500 RPM  
WEIGHT: 14,000 LBS

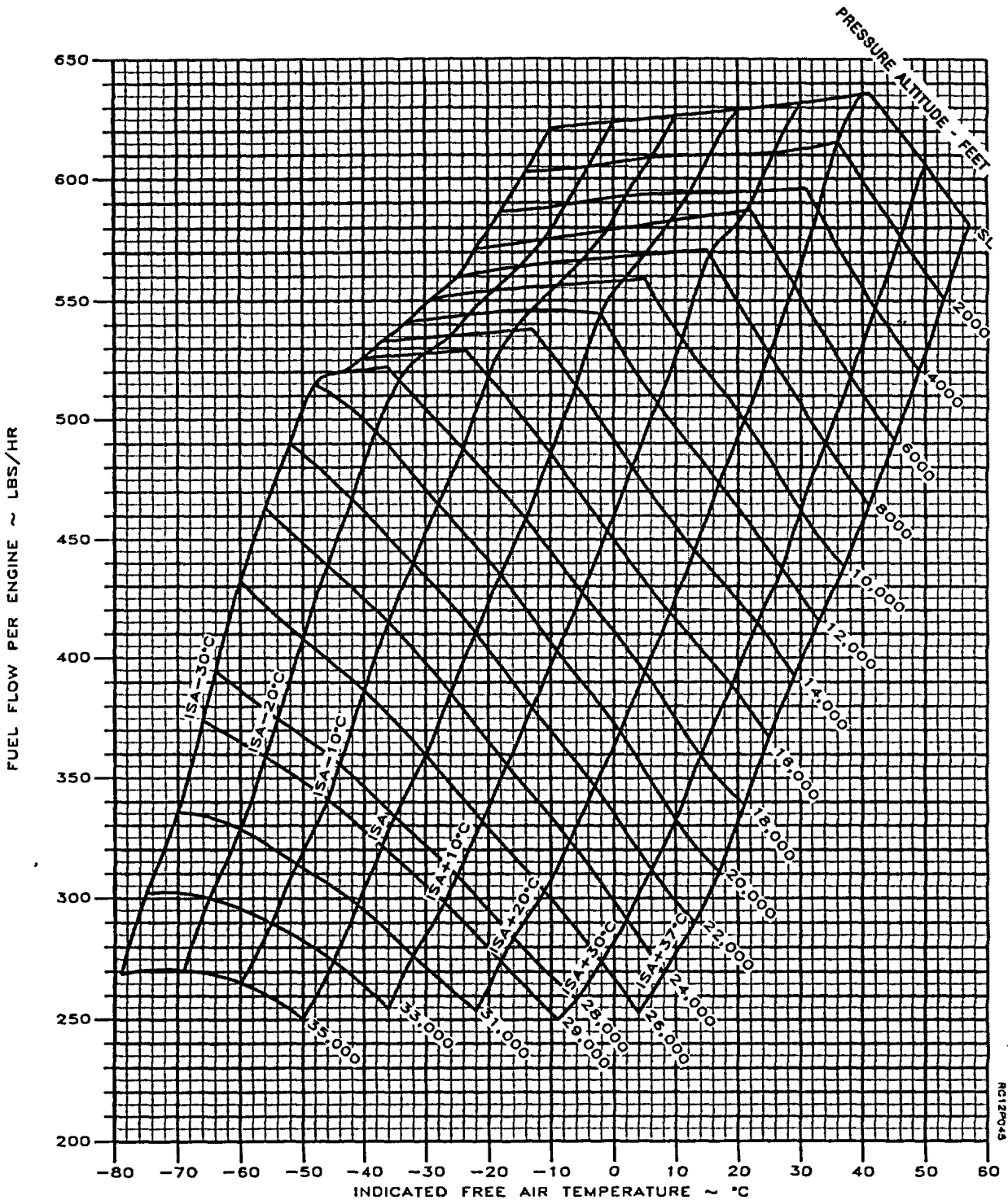

Figure 7-62. Fuel Flow at Normal Cruise Power at 1500 RPM



**RANGE PROFILE - NORMAL CRUISE POWER**

ASSOCIATED CONDITIONS:

WEIGHT..... \*16,620 LBS BEFORE  
ENGINE START  
FUEL..... AVIATION KEROSENE  
FUEL DENSITY.. 6.7 LBS/GAL  
ICE VANES..... RETRACTED

1500 RPM  
STANDARD DAY (ISA)  
ZERO WIND

EXAMPLE:

PRESSURE ALTITUDE..... 26,000 FT  
FUEL..... 2572 LBS  
RANGE..... 661 NM

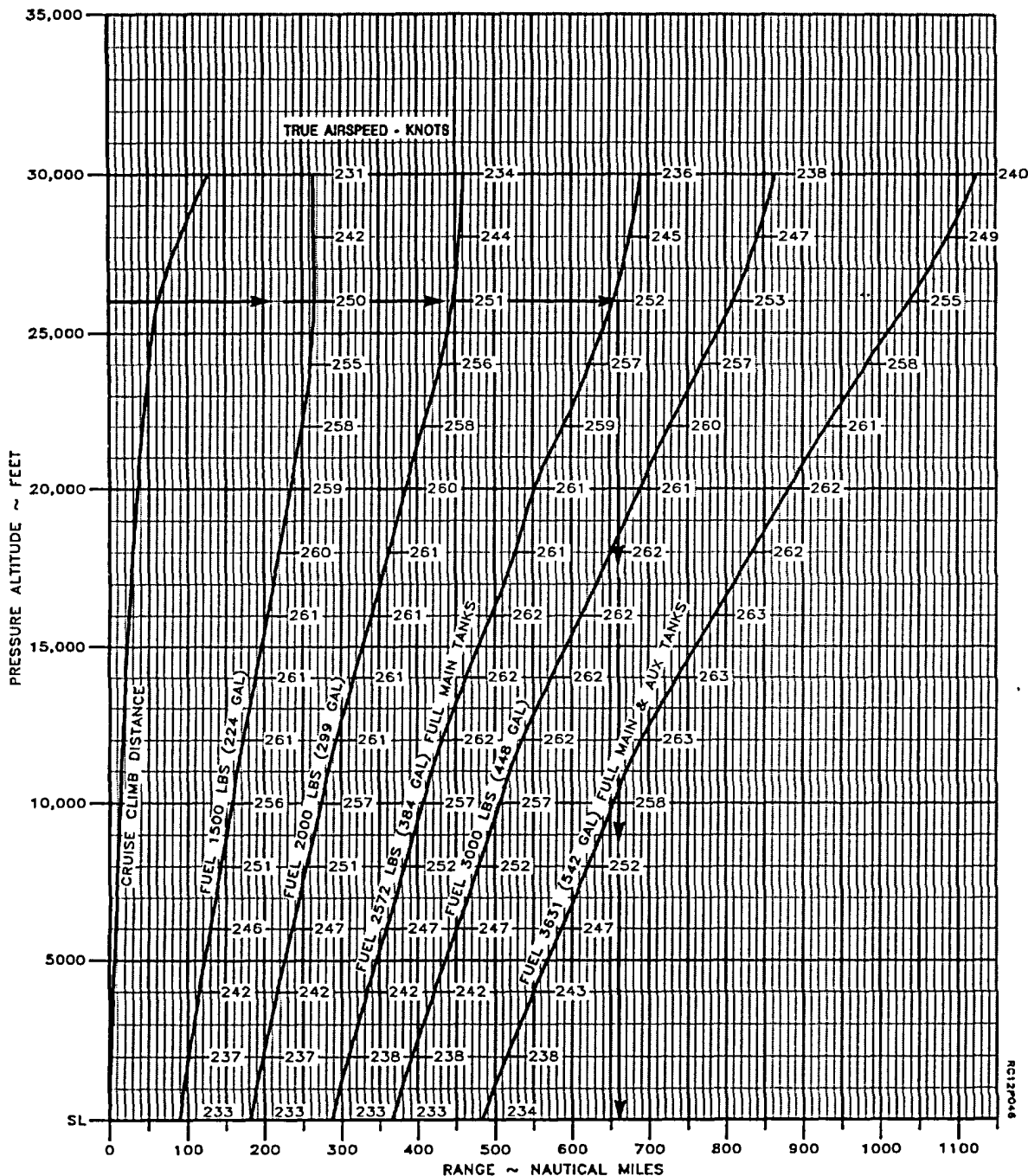

Figure 7-63. Range Profile - Normal Cruise Power at 1500 RPM

**MAXIMUM RANGE POWER  
1500 RPM  
ISA -30°C**

WEIGHT→			16,000 POUNDS					14,000 POUNDS				
PRESSURE ALTITUDE	IOAT	OAT	TORQUE PER ENGINE	FUEL FLOW PER ENGINE	TOTAL FUEL FLOW	IAS	TAS	TORQUE PER ENGINE	FUEL FLOW PER ENGINE	TOTAL FUEL FLOW	IAS	TAS
FEET	°C	°C	PERCENT	LBS/HR	LBS/HR	KTS	KTS	PERCENT	LBS/HR	LBS/HR	KTS	KTS
0	-11	-15	76	554	1108	212	203	71	536	1072	208	199
2000	-15	-19	72	519	1038	206	202	67	503	1006	202	199
4000	-19	-23	67	484	968	198	201	64	471	942	196	199
6000	-23	-27	64	453	906	192	200	61	440	880	190	198
8000	-27	-31	61	424	848	185	199	57	411	822	184	197
10,000	-31	-35	58	398	796	179	198	54	382	764	177	196
12,000	-35	-39	56	376	752	174	199	51	356	712	170	195
14,000	-39	-43	55	361	722	171	201	49	336	672	166	195
16,000	-43	-47	54	347	694	168	204	47	317	634	160	195
18,000	-47	-51	53	334	668	164	206	45	299	598	155	194
20,000	-51	-55	52	323	646	160	208	44	286	572	151	196
22,000	-54	-59	53	319	638	159	212	45	284	568	150	201
24,000	-58	-63	53	315	630	157	216	45	281	562	149	207
26,000	-62	-67	53	311	622	154	221	46	280	560	148	212
28,000	-66	-70	50	295	590	146	217	46	277	554	147	218
29,000	-68	-72	51	298	596	146	220	46	272	544	145	218
31,000	-71	-76	54	309	618	149	231	44	262	524	138	215
33,000	-76	-80	---	---	---	---	---	45	268	536	138	224
35,000	---	---	---	---	---	---	---	---	---	---	---	---

BT05241

**NOTE**

**During operations with ice vanes extended, torque will decrease approximately 10%, fuel flow will decrease approximately 5%, and true airspeed will be reduced by approximately 10 knots.**

*Figure 7-64. Maximum Range Power at 1500 RPM - ISA -30°C (Sheet 1 of 2)*

**MAXIMUM RANGE POWER  
1500 RPM  
ISA -30°C**

WEIGHT→			12,000 POUNDS					10,000 POUNDS				
PRESSURE ALTITUDE	IOAT	OAT	TORQUE PER ENGINE	FUEL FLOW PER ENGINE	TOTAL FUEL FLOW	IAS	TAS	TORQUE PER ENGINE	FUEL FLOW PER ENGINE	TOTAL FUEL FLOW	IAS	TAS
FEET	°C	°C	PERCENT	LBS/HR	LBS/HR	KTS	KTS	PERCENT	LBS/HR	LBS/HR	KTS	KTS
0	-11	-15	67	521	1042	205	196	63	508	1016	203	194
2000	-15	-19	64	490	980	200	197	61	478	956	198	195
4000	-19	-23	61	459	918	195	197	58	448	896	193	195
6000	-23	-27	58	430	860	189	197	56	420	840	188	196
8000	-27	-31	55	402	804	183	197	53	393	786	183	196
10,000	-31	-35	52	374	748	177	196	50	365	730	177	195
12,000	-35	-39	49	349	698	171	195	47	340	680	171	195
14,000	-39	-43	47	326	652	166	195	45	318	636	166	195
16,000	-43	-47	44	305	610	160	195	43	298	596	161	196
18,000	-47	-51	42	287	574	155	195	41	280	560	156	196
20,000	-51	-55	40	270	540	149	194	39	263	526	151	197
22,000	-55	-59	38	254	508	143	192	36	246	492	145	195
24,000	-59	-63	37	245	490	139	193	34	230	460	138	192
26,000	-63	-67	38	243	486	138	199	32	214	428	131	189
28,000	-67	-70	39	245	490	139	207	32	212	424	129	193
29,000	-68	-72	40	245	490	140	211	32	210	420	128	195
31,000	-72	-76	40	241	482	137	215	33	208	416	128	202
33,000	-76	-80	37	229	458	130	211	33	207	414	128	208
35,000	-80	-84	38	230	460	128	216	32	201	402	124	210

BT05242

**NOTE**

**During operations with ice vanes extended, torque will decrease approximately 10%, fuel flow will decrease approximately 5%, and true airspeed will be reduced by approximately 10 knots.**

Figure 7-64. Maximum Range Power at 1500 RPM - ISA -30°C (Sheet 2 of 2)

**MAXIMUM RANGE POWER  
1500 RPM  
ISA -20°C**

WEIGHT→			16,000 POUNDS					14,000 POUNDS				
PRESSURE ALTITUDE	IOAT	OAT	TORQUE PER ENGINE	FUEL FLOW PER ENGINE	TOTAL FUEL FLOW	IAS	TAS	TORQUE PER ENGINE	FUEL FLOW PER ENGINE	TOTAL FUEL FLOW	IAS	TAS
FEET	°C	°C	PERCENT	LBS/HR	LBS/HR	KTS	KTS	PERCENT	LBS/HR	LBS/HR	KTS	KTS
0	-1	-5	85	592	1184	222	216	76	561	1122	213	208
2000	-5	-9	80	553	1106	214	214	72	526	1052	207	207
4000	-9	-13	75	516	1032	206	213	68	492	984	200	206
6000	-13	-17	71	484	968	200	212	64	458	916	193	205
8000	-17	-21	67	454	908	193	211	61	427	854	186	204
10,000	-21	-25	64	427	854	187	211	57	399	798	180	203
12,000	-25	-29	62	401	802	181	211	54	373	746	174	203
14,000	-29	-33	60	381	762	176	212	52	352	704	169	203
16,000	-32	-37	58	364	728	172	213	51	334	668	164	204
18,000	-36	-41	57	350	700	168	215	49	319	638	160	206
20,000	-40	-45	55	337	674	164	216	48	307	614	157	208
22,000	-44	-49	55	329	658	161	220	48	300	600	155	212
24,000	-48	-53	54	322	644	157	223	48	292	584	152	215
26,000	-52	-57	52	306	612	150	219	48	287	574	149	219
28,000	-56	-60	51	301	602	145	220	46	278	556	145	220
29,000	-58	-62	52	307	614	146	226	45	271	542	131	218
31,000	-62	-66	---	---	---	---	---	44	266	532	137	219
33,000	-65	-70	---	---	---	---	---	47	277	554	139	231
35,000	---	---	---	---	---	---	---	---	---	---	---	---

BT05243

**NOTE**

**During operations with ice vanes extended, torque will decrease approximately 10%, fuel flow will decrease approximately 5%, and true airspeed will be reduced by approximately 10 knots.**

Figure 7-65. Maximum Range Power at 1500 RPM - ISA - 20°C (Sheet 1 of 2)

**MAXIMUM RANGE POWER  
1500 RPM  
ISA -20°C**

WEIGHT→			12,000 POUNDS					10,000 POUNDS				
PRESSURE ALTITUDE	IOAT	OAT	TORQUE PER ENGINE	FUEL FLOW PER ENGINE	TOTAL FUEL FLOW	IAS	TAS	TORQUE PER ENGINE	FUEL FLOW PER ENGINE	TOTAL FUEL FLOW	IAS	TAS
FEET	°C	°C	PERCENT	LBS/HR	LBS/HR	KTS	KTS	PERCENT	LBS/HR	LBS/HR	KTS	KTS
0	-1	-5	66	525	1050	203	197	58	497	994	194	190
2000	-5	-9	64	494	988	198	198	57	469	938	190	191
4000	-9	-13	61	464	928	192	198	55	442	884	186	192
6000	-13	-17	58	434	868	187	199	53	415	830	182	193
8000	-17	-21	55	405	810	181	198	51	389	778	177	194
10,000	-21	-25	52	377	754	174	197	48	363	726	172	194
12,000	-25	-29	49	350	700	168	196	46	338	676	167	194
14,000	-29	-33	46	326	652	162	195	43	314	628	161	194
16,000	-33	-37	44	306	612	157	195	41	294	588	156	194
18,000	-37	-41	42	287	574	151	195	39	276	552	151	194
20,000	-41	-45	40	273	546	147	196	37	259	518	146	194
22,000	-45	-49	40	266	532	145	200	35	244	488	140	193
24,000	-49	-53	40	261	522	144	204	34	230	460	135	193
26,000	-52	-57	41	256	512	142	209	33	222	444	132	195
28,000	-56	-60	41	251	502	140	213	33	217	434	130	198
29,000	-58	-62	41	249	498	139	216	33	215	430	129	201
31,000	-62	-66	40	243	486	136	218	34	214	428	129	208
33,000	-66	-70	38	231	462	129	215	34	211	422	128	213
35,000	-70	-74	39	234	468	127	221	32	202	404	122	212

BT05244

**NOTE**

**During operations with ice vanes extended, torque will decrease approximately 10%, fuel flow will decrease approximately 5%, and true airspeed will be reduced by approximately 10 knots.**

*Figure 7-65. Maximum Range Power at 1500 RPM - ISA - 20°C (Sheet 2 of 2)*

**MAXIMUM RANGE POWER  
1500 RPM  
ISA -10°C**

WEIGHT→			16,000 POUNDS					14,000 POUNDS				
PRESSURE ALTITUDE	IOAT	OAT	TORQUE PER ENGINE	FUEL FLOW PER ENGINE	TOTAL FUEL FLOW	IAS	TAS	TORQUE PER ENGINE	FUEL FLOW PER ENGINE	TOTAL FUEL FLOW	IAS	TAS
FEET	°C	°C	PERCENT	LBS/HR	LBS/HR	KTS	KTS	PERCENT	LBS/HR	LBS/HR	KTS	KTS
0	10	5	93	621	1242	229	226	89	608	1216	227	224
2000	6	1	87	581	1162	221	225	83	565	1130	218	222
4000	2	-3	82	543	1086	213	224	77	525	1050	209	220
6000	-2	-7	77	507	1014	206	222	72	488	976	202	218
8000	-6	-11	73	476	952	199	222	67	455	910	194	217
10,000	-10	-15	69	447	894	193	221	63	425	850	188	216
12,000	-14	-19	66	420	840	187	221	60	397	794	181	215
14,000	-18	-23	63	397	794	181	222	58	374	748	176	216
16,000	-22	-27	61	377	754	176	222	55	353	706	171	216
18,000	-26	-31	59	360	720	171	223	53	335	670	165	216
20,000	-30	-35	57	345	690	165	223	52	321	642	161	218
22,000	-34	-39	55	331	662	159	223	51	310	620	157	220
24,000	-38	-43	52	314	628	152	220	49	299	598	153	222
26,000	-42	-47	50	301	602	144	217	47	286	572	147	221
28,000	-46	-50	53	312	624	146	227	44	269	538	138	215
29,000	-47	-52	55	319	638	148	234	44	267	534	136	216
31,000	-52	-56	---	---	---	---	---	46	276	552	138	226
33,000	---	---	---	---	---	---	---	---	---	---	---	---
35,000	---	---	---	---	---	---	---	---	---	---	---	---

BT05245

**NOTE**

**During operations with ice vanes extended, torque will decrease approximately 10%, fuel flow will decrease approximately 5%, and true airspeed will be reduced by approximately 10 knots.**

*Figure 7-66. Maximum Range Power at 1500 RPM - ISA - 10°C (Sheet 1 of 2)*

**MAXIMUM RANGE POWER  
1500 RPM  
ISA -10°C**

WEIGHT→			12,000 POUNDS					10,000 POUNDS				
PRESSURE ALTITUDE	IOAT	OAT	TORQUE PER ENGINE	FUEL FLOW PER ENGINE	TOTAL FUEL FLOW	IAS	TAS	TORQUE PER ENGINE	FUEL FLOW PER ENGINE	TOTAL FUEL FLOW	IAS	TAS
FEET	°C	°C	PERCENT	LBS/HR	LBS/HR	KTS	KTS	PERCENT	LBS/HR	LBS/HR	KTS	KTS
0	9	5	79	572	1144	216	214	54	485	970	186	185
2000	5	1	75	539	1078	211	215	57	476	952	189	194
4000	1	-3	71	504	1008	204	214	57	455	910	188	198
6000	-3	-7	66	468	936	197	213	55	428	856	184	199
8000	-7	-11	62	434	868	189	211	53	402	804	179	200
10,000	-11	-15	57	402	804	182	209	50	374	748	173	200
12,000	-15	-19	54	373	746	175	208	47	347	694	167	199
14,000	-19	-23	51	349	698	169	208	44	323	646	161	198
16,000	-23	-27	48	327	654	163	207	42	300	600	155	198
18,000	-27	-31	46	307	614	158	207	39	279	558	149	196
20,000	-31	-35	44	292	584	153	208	37	263	526	144	196
22,000	-34	-39	44	283	566	151	211	36	251	502	141	198
24,000	-38	-43	43	274	548	148	214	36	242	484	138	201
26,000	-42	-47	42	264	528	144	217	36	235	470	136	205
28,000	-46	-50	42	256	512	141	220	35	228	456	134	209
29,000	-48	-52	41	250	500	138	219	35	225	450	133	211
31,000	-52	-56	38	237	474	130	215	35	219	438	130	215
33,000	-56	-60	38	233	466	126	216	34	213	426	126	217
35,000	-60	-64	39	240	480	127	226	32	204	408	121	215

BT05246

**NOTE**

**During operations with ice vanes extended, torque will decrease approximately 10%, fuel flow will decrease approximately 5%, and true airspeed will be reduced by approximately 10 knots.**

*Figure 7-66. Maximum Range Power at 1500 RPM - ISA -10°C (Sheet 2 of 2)*

**MAXIMUM RANGE POWER  
1500 RPM  
ISA**

WEIGHT→			16,000 POUNDS					14,000 POUNDS				
PRESSURE ALTITUDE	IOAT	OAT	TORQUE PER ENGINE	FUEL FLOW PER ENGINE	TOTAL FUEL FLOW	IAS	TAS	TORQUE PER ENGINE	FUEL FLOW PER ENGINE	TOTAL FUEL FLOW	IAS	TAS
FEET	°C	°C	PERCENT	LBS/HR	LBS/HR	KTS	KTS	PERCENT	LBS/HR	LBS/HR	KTS	KTS
0	20	15	89	607	1214	224	226	87	600	1200	224	226
2000	16	11	84	571	1142	216	224	83	566	1132	217	225
4000	12	7	79	538	1076	210	224	78	533	1066	211	225
6000	8	3	76	506	1012	203	224	74	500	1000	204	225
8000	4	-1	72	477	954	197	224	70	468	936	198	224
10,000	0	-5	69	448	896	191	224	67	439	878	191	224
12,000	-4	-9	66	420	840	185	223	64	412	824	186	224
14,000	-8	-13	63	396	792	178	223	60	385	770	179	223
16,000	-12	-17	60	372	744	172	222	57	363	726	173	223
18,000	-16	-21	57	352	704	165	221	55	344	688	168	224
20,000	-20	-25	54	333	666	158	218	53	326	652	162	223
22,000	-24	-29	52	318	636	151	216	50	309	618	155	222
24,000	-28	-33	52	314	628	148	219	47	292	584	148	219
26,000	-32	-37	54	319	638	149	228	45	277	554	141	216
28,000	-35	-40	56	327	654	150	237	45	277	554	138	220
29,000	-38	-42	---	---	---	---	---	46	279	558	138	224
31,000	-41	-46	---	---	---	---	---	48	286	572	139	234
33,000	---	---	---	---	---	---	---	---	---	---	---	---
35,000	---	---	---	---	---	---	---	---	---	---	---	---

BT05247

**NOTE**

**During operations with ice vanes extended, torque will decrease approximately 10%, fuel flow will decrease approximately 5%, and true airspeed will be reduced by approximately 10 knots.**

*Figure 7-67. Maximum Range Power at 1500 RPM - ISA (Sheet 1 of 2)*



**MAXIMUM RANGE POWER  
1500 RPM  
ISA**

WEIGHT→			12,000 POUNDS					10,000 POUNDS				
PRESSURE ALTITUDE	IOAT	OAT	TORQUE PER ENGINE	FUEL FLOW PER ENGINE	TOTAL FUEL FLOW	IAS	TAS	TORQUE PER ENGINE	FUEL FLOW PER ENGINE	TOTAL FUEL FLOW	IAS	TAS
FEET	°C	°C	PERCENT	LBS/HR	LBS/HR	KTS	KTS	PERCENT	LBS/HR	LBS/HR	KTS	KTS
0	20	15	86	593	1186	224	225	74	553	1106	211	213
2000	16	11	81	559	1118	217	225	73	530	1060	209	217
4000	12	7	76	523	1046	210	224	71	505	1010	205	219
6000	8	3	72	490	980	203	224	67	475	950	199	220
8000	4	-1	68	458	916	196	223	62	439	878	191	218
10,000	0	-5	63	424	848	188	221	58	405	810	183	215
12,000	-4	-9	59	393	786	181	219	53	374	748	176	213
14,000	-8	-13	56	367	734	175	219	50	346	692	169	212
16,000	-12	-17	53	345	690	169	219	47	322	644	163	211
18,000	-16	-21	50	325	650	164	219	44	301	602	157	210
20,000	-20	-25	48	307	614	159	219	42	282	564	152	210
22,000	-24	-29	47	295	590	155	221	40	268	536	147	211
24,000	-28	-33	45	282	564	150	223	39	256	512	143	213
26,000	-32	-37	43	266	532	144	221	38	244	488	139	214
28,000	-36	-40	40	251	502	136	217	37	235	470	136	217
29,000	-38	-42	39	245	490	133	216	36	231	462	134	218
31,000	-42	-46	38	238	476	128	216	35	220	440	129	218
33,000	-46	-50	39	241	482	127	223	32	207	414	122	214
35,000	-49	-54	41	247	494	128	232	31	199	398	116	212

BT05248

**NOTE**

**During operations with ice vanes extended, torque will decrease approximately 10%, fuel flow will decrease approximately 5%, and true airspeed will be reduced by approximately 10 knots.**

*Figure 7-67. Maximum Range Power at 1500 RPM - ISA (Sheet 2 of 2)*

**MAXIMUM RANGE POWER  
1500 RPM  
ISA +10°C**

WEIGHT→			16,000 POUNDS					14,000 POUNDS				
PRESSURE ALTITUDE	IOAT	OAT	TORQUE PER ENGINE	FUEL FLOW PER ENGINE	TOTAL FUEL FLOW	IAS	TAS	TORQUE PER ENGINE	FUEL FLOW PER ENGINE	TOTAL FUEL FLOW	IAS	TAS
FEET	°C	°C	PERCENT	LBS/HR	LBS/HR	KTS	KTS	PERCENT	LBS/HR	LBS/HR	KTS	KTS
0	30	25	83	592	1184	216	222	82	588	1176	217	223
2000	26	21	79	555	1110	210	221	78	552	1104	211	223
4000	22	17	75	522	1044	203	221	74	517	1034	205	223
6000	18	13	72	490	980	197	221	71	486	972	199	223
8000	14	9	67	459	918	190	220	67	457	914	192	222
10,000	10	5	63	431	862	182	218	63	427	854	185	221
12,000	6	1	60	404	808	176	217	60	402	804	179	221
14,000	2	-3	58	383	766	171	218	57	377	754	174	221
16,000	-2	-7	56	359	718	164	216	54	354	708	167	220
18,000	-6	-11	54	343	686	159	216	52	332	664	160	219
20,000	-10	-15	53	332	664	154	218	49	313	626	154	217
22,000	-14	-19	54	330	660	153	223	47	297	594	147	215
24,000	-18	-23	55	331	662	152	229	46	287	574	142	216
26,000	-22	-27	---	---	---	---	---	46	287	574	141	221
28,000	-26	-30	---	---	---	---	---	48	289	578	141	229
29,000	-27	-32	---	---	---	---	---	49	292	584	141	233
31,000	---	---	---	---	---	---	---	---	---	---	---	---
33,000	---	---	---	---	---	---	---	---	---	---	---	---
35,000	---	---	---	---	---	---	---	---	---	---	---	---

BT05249

**NOTE**

**During operations with ice vanes extended, torque will decrease approximately 10%, fuel flow will decrease approximately 5%, and true airspeed will be reduced by approximately 10 knots.**

*Figure 7-68. Maximum Range Power at 1500 RPM - ISA +10°C (Sheet 1 of 2)*

**MAXIMUM RANGE POWER  
1500 RPM  
ISA +10°C**

WEIGHT→			12,000 POUNDS					10,000 POUNDS				
PRESSURE ALTITUDE	IOAT	OAT	TORQUE PER ENGINE	FUEL FLOW PER ENGINE	TOTAL FUEL FLOW	IAS	TAS	TORQUE PER ENGINE	FUEL FLOW PER ENGINE	TOTAL FUEL FLOW	IAS	TAS
FEET	°C	°C	PERCENT	LBS/HR	LBS/HR	KTS	KTS	PERCENT	LBS/HR	LBS/HR	KTS	KTS
0	30	25	81	583	1166	217	223	80	579	1158	218	223
2000	26	21	77	547	1094	212	224	76	543	1086	212	224
4000	22	17	73	513	1026	206	224	72	508	1016	206	224
6000	18	13	70	481	962	200	224	68	475	950	200	224
8000	14	9	66	452	904	193	224	64	444	888	193	223
10,000	10	5	61	422	844	186	222	60	415	830	186	222
12,000	6	1	59	395	790	180	222	57	387	774	180	222
14,000	2	-3	56	371	742	175	223	54	361	722	174	222
16,000	-2	-7	53	348	696	169	223	51	337	674	168	221
18,000	-6	-11	51	327	654	164	223	48	315	630	162	221
20,000	-10	-15	48	307	614	157	221	45	295	590	156	221
22,000	-14	-19	45	289	578	150	219	43	279	558	151	220
24,000	-18	-23	42	272	544	144	218	40	263	526	146	220
26,000	-22	-27	39	254	508	135	213	38	246	492	139	218
28,000	-26	-30	38	245	490	130	213	36	232	464	133	216
29,000	-28	-32	39	245	490	130	216	35	225	450	130	215
31,000	-32	-36	40	246	492	129	222	32	211	422	123	212
33,000	-35	-40	41	252	504	130	232	32	205	410	118	213
35,000	-40	-44	---	---	---	---	---	32	206	412	117	219

BT05250

**NOTE**

During operations with ice vanes extended, torque will decrease approximately 10%, fuel flow will decrease approximately 5%, and true airspeed will be reduced by approximately 10 knots.

Figure 7-68. Maximum Range Power at 1500 RPM - ISA + 10°C (Sheet 2 of 2)

**MAXIMUM RANGE POWER  
1500 RPM  
ISA +20°C**

WEIGHT→			16,000 POUNDS					14,000 POUNDS				
PRESSURE ALTITUDE	IOAT	OAT	TORQUE PER ENGINE	FUEL FLOW PER ENGINE	TOTAL FUEL FLOW	IAS	TAS	TORQUE PER ENGINE	FUEL FLOW PER ENGINE	TOTAL FUEL FLOW	IAS	TAS
FEET	°C	°C	PERCENT	LBS/HR	LBS/HR	KTS	KTS	PERCENT	LBS/HR	LBS/HR	KTS	KTS
0	40	35	81	591	1182	213	222	78	579	1158	212	221
2000	36	31	76	553	1106	206	221	73	542	1084	205	220
4000	32	27	72	517	1034	199	220	70	507	1014	198	220
6000	28	23	68	481	962	191	218	66	474	948	192	219
8000	24	19	65	450	900	185	218	63	442	884	185	219
10,000	20	15	61	422	844	178	217	59	412	824	179	218
12,000	16	11	59	397	794	172	217	57	387	774	173	218
14,000	12	7	57	380	760	167	217	54	365	730	167	216
16,000	8	3	57	369	738	164	221	51	342	684	160	215
18,000	4	-1	57	358	716	161	224	49	327	654	155	216
20,000	0	-5	57	351	702	159	229	49	315	630	151	218
22,000	-4	-9	---	---	---	---	---	49	308	616	149	222
24,000	-8	-13	---	---	---	---	---	49	303	606	147	226
26,000	---	---	---	---	---	---	---	---	---	---	---	---
28,000	---	---	---	---	---	---	---	---	---	---	---	---
29,000	---	---	---	---	---	---	---	---	---	---	---	---
31,000	---	---	---	---	---	---	---	---	---	---	---	---
33,000	---	---	---	---	---	---	---	---	---	---	---	---
35,000	---	---	---	---	---	---	---	---	---	---	---	---

BT05252

**NOTE**

**During operations with ice vanes extended, torque will decrease approximately 10%, fuel flow will decrease approximately 5%, and true airspeed will be reduced by approximately 10 knots.**

*Figure 7-69. Maximum Range Power at 1500 RPM - ISA +20°C (Sheet 1 of 2)*

**MAXIMUM RANGE POWER  
1500 RPM  
ISA +20°C**

WEIGHT→			12,000 POUNDS					10,000 POUNDS				
PRESSURE ALTITUDE	IOAT	OAT	TORQUE PER ENGINE	FUEL FLOW PER ENGINE	TOTAL FUEL FLOW	IAS	TAS	TORQUE PER ENGINE	FUEL FLOW PER ENGINE	TOTAL FUEL FLOW	IAS	TAS
FEET	°C	°C	PERCENT	LBS/HR	LBS/HR	KTS	KTS	PERCENT	LBS/HR	LBS/HR	KTS	KTS
0	39	35	76	573	1146	211	221	74	566	1132	211	220
2000	36	31	72	536	1072	205	220	70	530	1060	205	220
4000	32	27	68	501	1002	199	220	67	496	992	199	221
6000	28	23	65	468	936	193	220	64	464	928	193	221
8000	24	19	61	437	874	187	220	61	433	866	188	221
10,000	20	15	58	408	816	181	220	57	404	808	182	221
12,000	16	11	56	384	768	176	221	55	378	756	177	222
14,000	12	7	52	358	716	168	219	51	354	708	170	221
16,000	8	3	49	333	666	161	216	48	331	662	164	220
18,000	4	-1	46	314	628	155	216	45	309	618	158	220
20,000	0	-5	44	295	590	149	215	42	288	576	151	218
22,000	-4	-9	42	278	556	143	213	40	269	538	145	216
24,000	-8	-13	41	267	534	139	215	37	251	502	138	214
26,000	-12	-17	40	259	518	135	217	35	236	472	132	213
28,000	-16	-20	40	255	510	132	221	34	224	448	127	212
29,000	-18	-22	40	254	508	131	223	32	217	434	123	210
31,000	-22	-26	---	---	---	---	---	32	212	424	120	213
33,000	-26	-30	---	---	---	---	---	33	211	422	119	218
35,000	---	---	---	---	---	---	---	---	---	---	---	---

BT05251

**NOTE**

**During operations with ice vanes extended, torque will decrease approximately 10%, fuel flow will decrease approximately 5%, and true airspeed will be reduced by approximately 10 knots.**

*Figure 7-69. Maximum Range Power at 1500 RPM - ISA +20°C (Sheet 2 of 2)*

**MAXIMUM RANGE POWER  
1500 RPM  
ISA +30°C**

WEIGHT→			12,000 POUNDS					10,000 POUNDS				
PRESSURE ALTITUDE	IOAT	OAT	TORQUE PER ENGINE	FUEL FLOW PER ENGINE	TOTAL FUEL FLOW	IAS	TAS	TORQUE PER ENGINE	FUEL FLOW PER ENGINE	TOTAL FUEL FLOW	IAS	TAS
FEET	°C	°C	PERCENT	LBS/HR	LBS/HR	KTS	KTS	PERCENT	LBS/HR	LBS/HR	KTS	KTS
0	50	45	89	615	1230	224	233	87	601	1202	222	231
2000	46	41	88	577	1154	217	233	77	557	1114	208	227
4000	42	37	81	542	1084	211	233	72	520	1040	200	225
6000	38	33	74	405	1010	197	229	67	482	964	192	223
8000	34	29	70	473	946	190	228	63	449	898	185	222
10,000	30	25	67	444	888	184	227	60	418	836	178	220
12,000	26	21	64	416	832	177	226	57	390	780	172	220
14,000	22	17	61	394	788	172	227	54	365	730	165	219
16,000	18	13	61	381	762	168	230	53	349	698	161	221
18,000	14	9	---	---	---	---	---	53	341	682	159	225
20,000	---	---	---	---	---	---	---	---	---	---	---	---
22,000	---	---	---	---	---	---	---	---	---	---	---	---
24,000	---	---	---	---	---	---	---	---	---	---	---	---
26,000	---	---	---	---	---	---	---	---	---	---	---	---
28,000	---	---	---	---	---	---	---	---	---	---	---	---
29,000	---	---	---	---	---	---	---	---	---	---	---	---
31,000	---	---	---	---	---	---	---	---	---	---	---	---
33,000	---	---	---	---	---	---	---	---	---	---	---	---
35,000	---	---	---	---	---	---	---	---	---	---	---	---

BT05253

**NOTE**

**During operations with ice vanes extended, torque will decrease approximately 10%, fuel flow will decrease approximately 5%, and true airspeed will be reduced by approximately 10 knots.**

*Figure 7-70. Maximum Range Power at 1500 RPM - ISA +30°C (Sheet 1 of 2)*

**MAXIMUM RANGE POWER  
1500 RPM  
ISA +30°C**

WEIGHT→			16,000 POUNDS					14,000 POUNDS				
PRESSURE ALTITUDE	IOAT	OAT	TORQUE PER ENGINE	FUEL FLOW PER ENGINE	TOTAL FUEL FLOW	IAS	TAS	TORQUE PER ENGINE	FUEL FLOW PER ENGINE	TOTAL FUEL FLOW	IAS	TAS
FEET	°C	°C	PERCENT	LBS/HR	LBS/HR	KTS	KTS	PERCENT	LBS/HR	LBS/HR	KTS	KTS
0	50	45	78	582	1164	213	225	74	567	1134	210	222
2000	46	41	71	537	1074	203	222	68	524	1048	201	219
4000	42	37	67	501	1002	196	221	64	489	978	194	219
6000	38	33	62	464	928	189	219	59	454	908	187	218
8000	34	29	58	431	862	182	218	56	423	846	181	217
10,000	30	25	55	401	802	175	217	53	393	786	175	217
12,000	26	21	52	373	746	169	217	51	367	734	170	218
14,000	22	17	49	347	694	163	216	48	342	684	165	218
16,000	18	13	47	326	652	157	215	45	317	634	157	216
18,000	14	9	45	313	626	152	216	41	296	592	150	213
20,000	10	5	45	301	602	149	219	38	275	550	143	211
22,000	6	1	44	289	578	145	221	37	260	520	138	211
24,000	2	-3	43	279	558	142	224	36	247	494	134	212
26,000	-2	-7	43	271	542	139	227	34	236	472	130	213
28,000	-6	-10	---	---	---	---	---	34	228	456	126	215
29,000	-8	-12	---	---	---	---	---	34	224	448	124	216
31,000	-12	-16	---	---	---	---	---	32	209	418	118	214
33,000	-16	-20	---	---	---	---	---	32	207	414	116	218
35,000	---	---	---	---	---	---	---	---	---	---	---	---

BT05254

**NOTE**

**During operations with ice vanes extended, torque will decrease approximately 10%, fuel flow will decrease approximately 5%, and true airspeed will be reduced by approximately 10 knots.**

*Figure 7-70. Maximum Range Power at 1500 RPM - ISA +30°C (Sheet 2 of 2)*

**MAXIMUM RANGE POWER  
1500 RPM  
ISA +37°C**

WEIGHT→			16,000 POUNDS					14,000 POUNDS				
PRESSURE ALTITUDE	IOAT	OAT	TORQUE PER ENGINE	FUEL FLOW PER ENGINE	TOTAL FUEL FLOW	IAS	TAS	TORQUE PER ENGINE	FUEL FLOW PER ENGINE	TOTAL FUEL FLOW	IAS	TAS
FEET	°C	°C	PERCENT	LBS/HR	LBS/HR	KTS	KTS	PERCENT	LBS/HR	LBS/HR	KTS	KTS
0	57	52	84	607	1214	214	230	84	607	1214	216	232
2000	53	48	82	577	1154	210	232	82	576	1152	217	236
4000	49	44	80	547	1094	211	235	79	534	1068	209	233
6000	45	40	78	511	1022	203	234	72	498	996	202	233
8000	41	36	72	478	956	196	232	71	463	926	194	230
10,000	37	32	72	451	902	191	233	65	436	872	190	232
12,000	33	28	66	424	848	185	233	60	405	810	176	227
14,000	29	24	65	403	806	180	234	58	380	760	170	227
16,000	25	20	60	378	756	166	230	56	362	724	166	229
18,000	21	16	55	349	698	156	224	55	344	688	166	231
20,000	17	12	50	323	646	145	216	---	---	---	---	---
22,000	12	8	47	302	604	134	207	---	---	---	---	---
24,000	8	4	42	280	560	115	185	---	---	---	---	---
26,000	---	---	---	---	---	---	---	---	---	---	---	---
28,000	---	---	---	---	---	---	---	---	---	---	---	---
29,000	---	---	---	---	---	---	---	---	---	---	---	---
31,000	---	---	---	---	---	---	---	---	---	---	---	---
33,000	---	---	---	---	---	---	---	---	---	---	---	---
35,000	---	---	---	---	---	---	---	---	---	---	---	---

BT05255

**NOTE**

**During operations with ice vanes extended, torque will decrease approximately 10%, fuel flow will decrease approximately 5%, and true airspeed will be reduced by approximately 10 knots.**

*Figure 7-71. Maximum Range Power at 1500 RPM - ISA +37°C (Sheet 1 of 2)*



**MAXIMUM RANGE POWER  
1500 RPM  
ISA +37°C**

WEIGHT→			12,000 POUND					10,000 POUNDS				
PRESSURE ALTITUDE	IOAT	OAT	TORQUE PER ENGINE	FUEL FLOW PER ENGINE	TOTAL FUEL FLOW	IAS	TAS	TORQUE PER ENGINE	FUEL FLOW PER ENGINE	TOTAL FUEL FLOW	IAS	TAS
FEET	°C	°C	PERCENT	LBS/HR	LBS/HR	KTS	KTS	PERCENT	LBS/HR	LBS/HR	KTS	KTS
0	57	52	84	599	1198	221	233	75	573	1146	209	224
2000	53	48	78	557	1114	214	232	71	537	1074	203	224
4000	49	44	73	519	1039	206	230	67	501	1002	197	224
6000	45	40	70	484	968	200	230	62	466	932	190	223
8000	41	36	61	443	886	185	224	56	425	850	181	219
10,000	37	32	57	411	822	177	222	52	393	786	173	217
12,000	33	28	54	381	762	170	221	49	364	728	167	217
14,000	29	24	51	354	708	164	220	46	339	678	161	216
16,000	25	20	49	334	668	159	220	44	314	628	155	215
18,000	21	16	48	320	640	156	223	42	296	592	150	216
20,000	17	12	48	309	618	160	229	40	280	560	146	217
22,000	13	8	46	292	584	153	227	39	267	534	141	218
24,000	9	4	44	280	560	148	227	37	254	508	137	218
26,000	4	0	---	---	---	---	---	31	223	446	122	204
28,000	0	-3	---	---	---	---	---	29	201	402	112	196
29,000	-2	-5	---	---	---	---	---	30	203	406	114	202
31,000	-5	-9	---	---	---	---	---	31	206	412	115	212
33,000	---	---	---	---	---	---	---	---	---	---	---	---
35,000	---	---	---	---	---	---	---	---	---	---	---	---

BT05256

**NOTE**

**During operations with ice vanes extended, torque will decrease approximately 10%, fuel flow will decrease approximately 5%, and true airspeed will be reduced by approximately 10 knots.**

*Figure 7-71. Maximum Range Power at 1500 RPM - ISA +37° C (Sheet 2 of 2)*

**RANGE PROFILE - MAXIMUM RANGE POWER**

ASSOCIATED CONDITIONS:  
 WEIGHT ..... \*16,620 LBS BEFORE  
 ENGINE START  
 FUEL ..... AVIATION KEROSENE  
 FUEL DENSITY . . 6.7 LBS/GAL  
 ICE VANES ..... RETRACTED

1500 RPM  
 STANDARD DAY (ISA)  
 ZERO WIND

EXAMPLE:  
 PRESSURE ALTITUDE ..... 26,000 FT  
 FUEL ..... 2572 LBS  
 RANGE ..... 686 NM

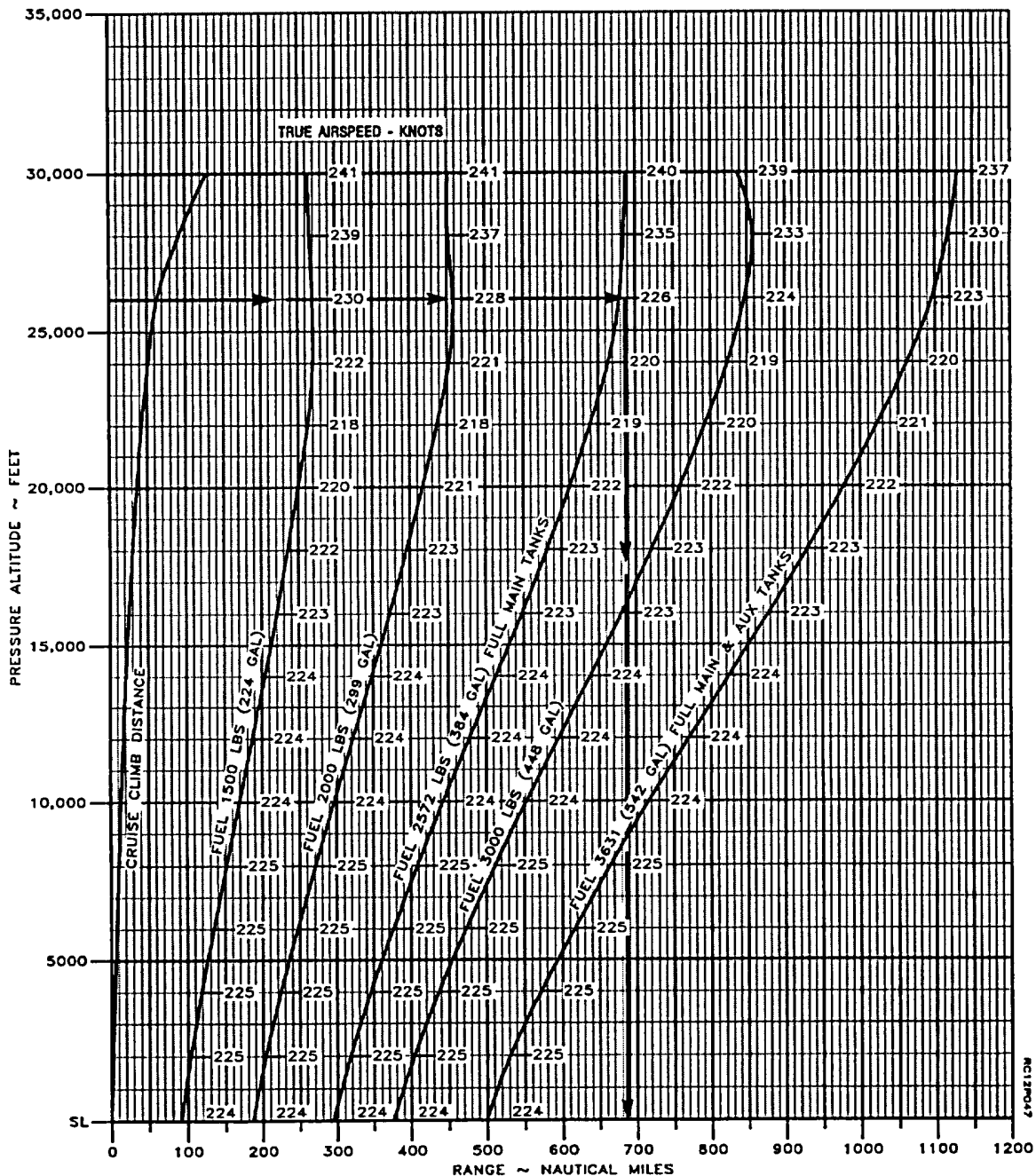

Figure 7-72. Range Profile - Maximum Range Power at 1500 RPM

**LOITER POWER  
1700 RPM  
ISA -30°C**

WEIGHT→			16,000 POUND					14,000 POUNDS				
PRESSURE ALTITUDE	IOAT	OAT	TORQUE PER ENGINE	FUEL FLOW PER ENGINE	TOTAL FUEL FLOW	IAS	TAS	TORQUE PER ENGINE	FUEL FLOW PER ENGINE	TOTAL FUEL FLOW	IAS	TAS
FEET	°C	°C	PERCENT	LBS/HR	LBS/HR	KTS	KTS	PERCENT	LBS/HR	LBS/HR	KTS	KTS
0	-14	-15	29	405	810	125	121	26	392	784	125	121
2000	-18	-19	29	387	774	125	125	26	374	748	125	125
4000	-21	-23	29	369	738	125	129	27	356	712	125	129
6000	-25	-27	30	353	706	125	132	27	339	678	125	132
8000	-29	-31	30	337	674	125	136	27	324	648	125	136
10,000	-33	-35	31	322	644	125	140	28	309	618	125	140
12,000	-37	-39	31	309	618	125	145	28	295	590	125	145
14,000	-41	-43	32	297	594	125	149	29	283	566	125	149
16,000	-45	-47	33	287	574	125	154	29	272	544	125	154
18,000	-48	-51	34	279	568	125	159	30	263	526	125	159
20,000	-52	-55	34	273	546	125	164	31	255	510	125	164
22,000	-56	-59	35	269	538	125	169	31	250	500	125	169
24,000	-60	-63	36	265	530	125	175	32	246	492	125	175
26,000	-63	-67	36	262	524	125	181	33	243	486	125	181
28,000	-67	-70	37	260	520	125	187	33	241	482	125	187
29,000	-69	-72	37	259	518	125	190	33	239	478	125	190
31,000	-73	-76	38	265	530	125	197	34	239	478	125	197
33,000	-77	-80	40	269	538	125	204	35	243	486	125	204
35,000	-80	-84	41	272	544	125	211	36	247	494	125	211

BT05257

Figure 7-73. Loiter Power at 1700 RPM - ISA -30°C (Sheet 1 of 2)

**LOITER POWER  
1700 RPM  
ISA -30°C**

WEIGHT→			12,000 POUND					10,000 POUNDS				
PRESSURE ALTITUDE	IOAT	OAT	TORQUE PER ENGINE	FUEL FLOW PER ENGINE	TOTAL FUEL FLOW	IAS	TAS	TORQUE PER ENGINE	FUEL FLOW PER ENGINE	TOTAL FUEL FLOW	IAS	TAS
FEET	°C	°C	PERCENT	LBS/HR	LBS/HR	KTS	KTS	PERCENT	LBS/HR	LBS/HR	KTS	KTS
0	-14	-15	24	381	762	125	121	22	372	744	125	121
2000	-18	-19	24	363	726	125	125	22	353	706	125	125
4000	-21	-23	24	345	690	125	129	22	335	670	125	129
6000	-25	-27	24	328	656	125	132	22	318	636	125	132
8000	-29	-31	25	312	624	125	136	23	302	604	125	136
10,000	-33	-35	25	297	594	125	140	23	287	574	125	140
12,000	-37	-39	25	283	566	125	145	23	273	546	125	145
14,000	-41	-43	26	271	542	125	149	24	260	520	125	149
16,000	-45	-47	26	259	518	125	154	24	249	498	125	154
18,000	-48	-51	27	250	500	125	159	24	239	478	125	159
20,000	-52	-55	28	241	482	125	164	25	230	460	125	164
22,000	-56	-59	28	235	470	125	169	25	223	446	125	169
24,000	-60	-63	29	229	458	125	175	26	216	432	125	175
26,000	-63	-67	29	226	452	125	181	27	212	424	125	181
28,000	-67	-70	30	224	448	125	187	27	209	418	125	187
29,000	-69	-72	30	222	444	125	190	27	208	416	125	190
31,000	-73	-76	31	221	442	125	197	28	206	412	125	197
33,000	-77	-80	31	221	442	125	204	28	205	410	125	204
35,000	-80	-84	32	225	450	125	211	29	207	414	125	211

BT0258

Figure 7-73. Loiter Power at 1700 RPM - ISA -300C (Sheet 2 of 2)

**LOITER POWER**  
**1700 RPM**  
**ISA -20°C**

WEIGHT→			16,000 POUND					14,000 POUNDS				
PRESSURE ALTITUDE	IOAT	OAT	TORQUE PER ENGINE	FUEL FLOW PER ENGINE	TOTAL FUEL FLOW	IAS	TAS	TORQUE PER ENGINE	FUEL FLOW PER ENGINE	TOTAL FUEL FLOW	IAS	TAS
FEET	°C	°C	PERCENT	LBS/HR	LBS/HR	KTS	KTS	PERCENT	LBS/HR	LBS/HR	KTS	KTS
0	-4	-5	29	407	814	125	124	26	394	788	125	124
2000	-7	-9	29	389	778	125	127	26	376	752	125	127
4000	-11	-13	29	372	744	125	131	27	358	716	125	131
6000	-15	-17	30	356	712	125	135	27	342	684	125	135
8000	-19	-21	31	341	682	125	139	27	327	654	125	139
10,000	-23	-25	31	327	654	125	143	28	312	624	125	143
12,000	-27	-29	32	313	626	125	148	29	299	598	125	148
14,000	-31	-33	33	301	602	125	152	29	286	572	125	152
16,000	-34	-37	33	291	582	125	157	30	275	550	125	157
18,000	-38	-41	34	284	568	125	162	30	267	534	125	162
20,000	-42	-45	35	277	554	125	168	31	260	520	125	168
22,000	-46	-49	35	272	544	125	173	32	254	508	125	173
24,000	-50	-53	36	268	536	125	179	32	250	500	125	179
26,000	-53	-57	37	266	532	125	185	33	246	492	125	185
28,000	-57	-60	37	264	528	125	192	34	244	488	125	192
29,000	-59	-62	38	265	530	125	195	34	243	486	125	195
31,000	-63	-66	39	269	538	125	202	34	242	484	125	202
33,000	-66	-70	41	275	550	125	209	36	247	494	125	209
35,000	-70	-74	40	271	542	117	205	37	252	504	125	217

BT05259

Figure 7-74. Loiter Power at 1700 RPM - ISA -200C (Sheet 1 of 2)

**LOITER POWER  
1700 RPM  
ISA -20°C**

WEIGHT→			12,000 POUND					10,000 POUNDS				
PRESSURE ALTITUDE	IOAT	OAT	TORQUE PER ENGINE	FUEL FLOW PER ENGINE	TOTAL FUEL FLOW	IAS	TAS	TORQUE PER ENGINE	FUEL FLOW PER ENGINE	TOTAL FUEL FLOW	IAS	TAS
FEET	°C	°C	PERCENT	LBS/HR	LBS/HR	KTS	KTS	PERCENT	LBS/HR	LBS/HR	KTS	KTS
0	-4	-5	23	382	764	125	124	21	372	744	125	124
2000	-7	-9	24	364	728	125	127	22	354	708	125	127
4000	-11	-13	24	346	692	125	131	22	336	672	125	131
6000	-15	-17	24	330	660	125	135	22	320	640	125	135
8000	-19	-21	25	314	628	125	139	23	304	608	125	139
10,000	-23	-25	25	300	600	125	143	23	289	578	125	143
12,000	-27	-29	26	286	572	125	148	23	275	550	125	148
14,000	-31	-33	26	273	546	125	152	24	262	524	125	152
16,000	-34	-37	27	262	524	125	157	24	251	502	125	157
18,000	-38	-41	27	253	506	125	162	25	241	482	125	162
20,000	-42	-45	28	245	490	125	168	25	233	466	125	168
22,000	-46	-49	29	239	478	125	173	26	226	452	125	173
24,000	-50	-53	29	234	468	125	179	26	220	440	125	179
26,000	-53	-57	30	230	460	125	185	27	216	432	125	185
28,000	-57	-60	30	227	454	125	192	27	213	426	125	192
29,000	-59	-62	30	226	452	125	195	28	211	422	125	195
31,000	-63	-66	31	223	446	125	202	28	208	416	125	202
33,000	-66	-70	32	224	448	125	209	28	207	414	125	209
35,000	-70	-74	33	229	458	125	217	29	209	418	125	217

BT05280

Figure 7-74. Loiter Power at 1700 RPM - ISA -20°C (Sheet 2 of 2)

**LOITER POWER  
1700 RPM  
ISA -10°C**

WEIGHT→			16,000 POUND					14,000 POUNDS				
PRESSURE ALTITUDE	IOAT	OAT	TORQUE PER ENGINE	FUEL FLOW PER ENGINE	TOTAL FUEL FLOW	IAS	TAS	TORQUE PER ENGINE	FUEL FLOW PER ENGINE	TOTAL FUEL FLOW	IAS	TAS
FEET	°C	°C	PERCENT	LBS/HR	LBS/HR	KTS	KTS	PERCENT	LBS/HR	LBS/HR	KTS	KTS
0	6	5	29	411	822	125	126	26	396	792	125	126
2000	3	1	29	394	788	125	130	26	379	758	125	130
4000	-1	-3	30	377	754	125	134	27	362	724	125	134
6000	-5	-7	30	362	724	125	138	27	346	692	125	138
8000	-9	-11	31	347	694	125	142	28	331	662	125	142
10,000	-13	-15	31	332	664	125	146	28	317	634	125	146
12,000	-17	-19	32	319	638	125	151	29	303	606	125	151
14,000	-20	-23	33	307	614	125	156	29	291	582	125	156
16,000	-24	-27	34	296	592	125	161	30	280	560	125	161
18,000	-28	-31	34	287	574	125	166	31	270	540	125	166
20,000	-32	-35	35	280	560	125	171	31	263	526	125	171
22,000	-36	-39	36	275	550	125	177	32	257	514	125	177
24,000	-39	-43	37	271	542	125	183	33	253	506	125	183
26,000	-43	-47	37	267	534	125	189	33	249	498	125	189
28,000	-47	-50	38	269	538	125	196	34	246	492	125	196
29,000	-49	-52	39	271	542	125	199	34	244	488	125	199
31,000	-52	-56	40	276	552	125	207	35	248	496	125	207
33,000	-56	-60	41	281	562	125	214	37	253	506	125	214
35,000	-60	-64	---	---	---	---	---	38	258	516	125	222

BT05261

Figure 7-75. Loiter Power at 1700 RPM - ISA -10°C (Sheet 1 of 2)

**LOITER POWER  
1700 RPM  
ISA -10°C**

WEIGHT→			12,000 POUND					10,000 POUNDS				
PRESSURE ALTITUDE	IOAT	OAT	TORQUE PER ENGINE	FUEL FLOW PER ENGINE	TOTAL FUEL FLOW	IAS	TAS	TORQUE PER ENGINE	FUEL FLOW PER ENGINE	TOTAL FUEL FLOW	IAS	TAS
FEET	°C	°C	PERCENT	LBS/HR	LBS/HR	KTS	KTS	PERCENT	LBS/HR	LBS/HR	KTS	KTS
0	6	5	23	383	766	125	126	21	373	746	125	126
2000	3	1	24	366	732	125	130	22	355	710	125	130
4000	-1	-3	24	349	698	125	134	22	338	676	125	134
6000	-5	-7	24	333	666	125	138	22	322	644	125	138
8000	-9	-11	25	318	636	125	142	23	306	612	125	142
10,000	-13	-15	25	303	606	125	146	23	292	584	125	146
12,000	-17	-19	26	290	580	125	151	23	278	556	125	151
14,000	-20	-23	26	277	554	125	156	24	266	532	125	156
16,000	-24	-27	27	266	532	125	161	24	254	508	125	161
18,000	-28	-31	28	256	512	125	166	25	244	488	125	166
20,000	-32	-35	28	248	496	125	171	26	236	472	125	171
22,000	-36	-39	29	242	484	125	177	26	229	458	125	177
24,000	-39	-43	30	237	474	125	183	27	224	448	125	183
26,000	-43	-47	30	232	464	125	189	27	219	438	125	189
28,000	-47	-50	31	229	458	125	196	28	215	430	125	196
29,000	-49	-52	31	227	454	125	199	28	213	426	125	199
31,000	-52	-56	31	225	450	125	207	28	210	420	125	207
33,000	-56	-60	32	229	458	125	214	29	209	418	125	214
35,000	-60	-64	33	233	466	125	222	30	212	424	125	222

BT05282

Figure 7-75. Loiter Power at 1700 RPM - ISA -10°C (Sheet 2 of 2)



**LOITER POWER  
1700 RPM  
ISA**

WEIGHT→			16,000 POUND					14,000 POUNDS				
PRESSURE ALTITUDE	IOAT	OAT	TORQUE PER ENGINE	FUEL FLOW PER ENGINE	TOTAL FUEL FLOW	IAS	TAS	TORQUE PER ENGINE	FUEL FLOW PER ENGINE	TOTAL FUEL FLOW	IAS	TAS
FEET	°C	°C	PERCENT	LBS/HR	LBS/HR	KTS	KTS	PERCENT	LBS/HR	LBS/HR	KTS	KTS
0	17	15	29	412	824	125	128	26	397	794	125	128
2000	13	11	30	398	796	125	132	27	382	764	125	132
4000	9	7	30	384	768	125	136	27	368	736	125	136
6000	5	3	31	370	740	125	140	28	353	706	125	140
8000	1	-1	32	356	712	125	145	28	339	678	125	145
10,000	-3	-5	32	340	680	125	149	29	325	650	125	149
12,000	-7	-9	33	325	650	125	154	29	310	620	125	154
14,000	-10	-13	34	312	624	125	159	30	297	594	125	159
16,000	-14	-17	34	300	600	125	164	31	285	570	125	164
18,000	-18	-21	35	291	582	125	169	31	274	548	125	169
20,000	-22	-25	35	283	566	125	175	32	266	532	125	175
22,000	-26	-29	36	278	556	125	181	32	260	520	125	181
24,000	-29	-33	37	273	546	125	187	33	255	510	125	187
26,000	-33	-37	38	273	546	125	194	34	251	502	125	194
28,000	-37	-40	39	276	552	125	200	35	250	500	125	200
29,000	-39	-42	40	278	556	125	204	35	252	504	125	204
31,000	-42	-46	41	282	564	125	211	36	255	510	125	211
33,000	-46	-50	42	288	576	125	219	37	259	518	125	219
35,000	-50	-54-	---	---	---	---	39	263	526	125	227	

BT05263

Figure 7-76. Loiter Power at 1700 RPM - ISA (Sheet 1 of 2)

**LOITER POWER  
1700 RPM  
ISA**

WEIGHT→			12,000 POUND					10,000 POUNDS				
PRESSURE ALTITUDE	IOAT	OAT	TORQUE PER ENGINE	FUEL FLOW PER ENGINE	TOTAL FUEL FLOW	IAS	TAS	TORQUE PER ENGINE	FUEL FLOW PER ENGINE	TOTAL FUEL FLOW	IAS	TAS
FEET	°C	°C	PERCENT	LBS/HR	LBS/HR	KTS	KTS	PERCENT	LBS/HR	LBS/HR	KTS	KTS
0	17	15	24	384	768	125	128	21	372	744	125	128
2000	13	11	24	368	736	125	132	22	357	714	125	132
4000	9	7	24	353	706	125	136	22	341	682	125	136
6000	5	3	25	339	678	125	140	23	326	652	125	140
8000	1	-1	25	324	648	125	145	23	312	624	125	145
10,000	-3	-5	26	310	620	125	149	23	297	594	125	149
12,000	-7	-9	26	296	592	125	154	24	284	568	125	154
14,000	-10	-13	27	284	568	125	159	24	271	542	125	159
16,000	-14	-17	28	271	542	125	164	25	259	518	125	164
18,000	-18	-21	28	260	520	125	169	25	248	496	125	169
20,000	-22	-25	29	251	502	125	175	26	239	478	125	175
22,000	-26	-29	29	245	490	125	181	26	232	464	125	181
24,000	-29	-33	30	239	478	125	187	27	226	452	125	187
26,000	-33	-37	30	235	470	125	194	28	221	442	125	194
28,000	-37	-40	31	231	462	125	200	28	217	434	125	200
29,000	-39	-42	31	230	460	125	204	28	215	430	125	204
31,000	-42	-46	32	231	462	125	211	29	213	426	125	211
33,000	-46	-50	33	235	470	125	219	30	214	428	125	219
35,000	-50	-54	34	238	476	125	227	31	217	434	125	227

BT05264

Figure 7-76. Loiter Power at 1700 RPM - ISA (Sheet 2 of 2)

**LOITER POWER  
1700 RPM  
ISA +10°C**

WEIGHT→			16,000 POUND					14,000 POUNDS				
PRESSURE ALTITUDE	IOAT	OAT	TORQUE PER ENGINE	FUEL FLOW PER ENGINE	TOTAL FUEL FLOW	IAS	TAS	TORQUE PER ENGINE	FUEL FLOW PER ENGINE	TOTAL FUEL FLOW	IAS	TAS
FEET	°C	°C	PERCENT	LBS/HR	LBS/HR	KTS	KTS	PERCENT	LBS/HR	LBS/HR	KTS	KTS
0	27	25	30	421	842	125	131	27	403	806	125	131
2000	23	21	30	404	808	125	134	27	386	772	125	134
4000	19	17	31	387	774	125	138	28	370	740	125	138
6000	15	13	32	371	742	125	143	28	355	710	125	143
8000	11	9	32	357	714	125	147	29	342	684	125	147
10,000	7	5	33	344	688	125	152	30	330	660	125	152
12,000	4	1	34	330	660	125	157	30	315	630	125	157
14,000	0	-3	34	317	634	125	162	31	302	604	125	162
16,000	-4	-7	35	305	610	125	167	31	289	578	125	167
18,000	-8	-11	35	294	588	125	173	32	279	558	125	173
20,000	-12	-15	36	286	572	125	178	32	270	540	125	178
22,000	-15	-19	37	282	564	125	184	33	264	528	125	184
24,000	-19	-23	38	281	562	125	191	34	258	516	125	191
26,000	-23	-27	39	281	562	125	198	35	257	514	125	198
28,000	-27	-30	40	283	566	125	205	36	258	516	125	205
29,000	-28	-32	41	284	568	125	208	36	258	516	125	208
31,000	-32	-36	42	288	576	125	216	37	260	520	125	216
33,000	-36	-40	---	---	---	---	---	38	263	526	125	224
35,000	---	---	---	---	---	---	---	---	---	---	---	---

BT05286

Figure 7-77. Loiter Power at 1700 RPM - ISA +10°C (Sheet 1 of 2)

**LOITER POWER  
1700 RPM  
ISA +10°C**

WEIGHT→			12,000 POUND					10,000 POUNDS				
PRESSURE ALTITUDE	IOAT	OAT	TORQUE PER ENGINE	FUEL FLOW PER ENGINE	TOTAL FUEL FLOW	IAS	TAS	TORQUE PER ENGINE	FUEL FLOW PER ENGINE	TOTAL FUEL FLOW	IAS	TAS
FEET	°C	°C	PERCENT	LBS/HR	LBS/HR	KTS	KTS	PERCENT	LBS/HR	LBS/HR	KTS	KTS
0	27	25	24	389	778	125	131	22	376	752	125	131
2000	23	21	24	371	742	125	134	22	359	718	125	134
4000	19	17	25	355	710	125	138	22	342	684	125	138
6000	15	13	25	340	680	125	143	23	327	654	125	143
8000	11	9	26	327	654	125	147	23	314	628	125	147
10,000	7	5	27	317	634	125	152	24	305	610	125	152
12,000	4	1	27	303	606	125	157	25	292	584	125	157
14,000	0	-3	28	289	578	125	162	25	278	556	125	162
16,000	-4	-7	28	276	552	125	167	25	265	530	125	167
18,000	-8	-11	29	265	530	125	173	26	253	506	125	173
20,000	-12	-15	29	256	512	125	178	26	244	488	125	178
22,000	-15	-19	30	249	498	125	184	27	237	474	125	184
24,000	-19	-23	30	243	486	125	191	28	230	460	125	191
26,000	-23	-27	31	238	476	125	198	28	224	448	125	198
28,000	-27	-30	32	236	472	125	205	29	220	440	125	205
29,000	-28	-32	32	236	472	125	208	29	218	436	125	208
31,000	-32	-36	33	238	476	125	216	30	218	436	125	216
33,000	-36	-40	34	240	480	125	224	31	220	440	125	224
35,000	-39	-44	35	242	484	125	232	31	221	442	125	232

BT05266

Figure 7-77. Loiter Power at 1700 RPM - ISA +10°C (Sheet 2 of 2)

**LOITER POWER**  
**1700 RPM**  
**ISA +20°C**

WEIGHT→			16,000 POUND					14,000 POUNDS				
PRESSURE ALTITUDE	IOAT	OAT	TORQUE PER ENGINE	FUEL FLOW PER ENGINE	TOTAL FUEL FLOW	IAS	TAS	TORQUE PER ENGINE	FUEL FLOW PER ENGINE	TOTAL FUEL FLOW	IAS	TAS
FEET	°C	°C	PERCENT	LBS/HR	LBS/HR	KTS	KTS	PERCENT	LBS/HR	LBS/HR	KTS	KTS
0	37	35	31	431	862	125	133	28	414	828	125	133
2000	33	31	31	412	824	125	137	28	398	796	125	137
4000	29	27	32	394	788	125	141	29	379	758	125	141
6000	25	23	32	376	752	125	145	29	362	724	125	145
8000	21	19	33	360	720	125	150	30	345	690	125	150
10,000	17	15	33	344	688	125	154	30	329	658	125	154
12,000	14	11	34	329	658	125	159	31	314	628	125	159
14,000	10	7	35	318	636	125	165	31	303	606	125	165
16,000	6	3	35	308	616	125	170	32	293	586	125	170
18,000	2	-1	36	298	596	125	176	32	282	564	125	176
20,000	-2	-5	37	293	586	125	182	33	274	548	125	182
22,000	-5	-9	38	289	578	125	188	34	269	538	125	188
24,000	-9	-13	39	286	572	125	195	35	265	530	125	195
26,000	-13	-17	40	285	570	125	202	36	263	526	125	202
28,000	-16	-20	41	286	572	125	209	36	262	524	125	209
29,000	-18	-22	42	289	578	125	213	37	262	524	125	213
31,000	-22	-26	---	---	---	---	---	38	265	530	125	220
33,000	---	---	---	---	---	---	---	---	---	---	---	---
35,000	---	---	---	---	---	---	---	---	---	---	---	---

BT05267

Figure 7-78. Loiter Power at 1700 RPM - ISA +20°C (Sheet 1 of 2)

**LOITER POWER  
1700 RPM  
ISA +20°C**

WEIGHT→			12,000 POUND					10,000 POUNDS				
PRESSURE ALTITUDE	IOAT	OAT	TORQUE PER ENGINE	FUEL FLOW PER ENGINE	TOTAL FUEL FLOW	IAS	TAS	TORQUE PER ENGINE	FUEL FLOW PER ENGINE	TOTAL FUEL FLOW	IAS	TAS
FEET	°C	°C	PERCENT	LBS/HR	LBS/HR	KTS	KTS	PERCENT	LBS/HR	LBS/HR	KTS	KTS
0	37	35	25	397	794	125	133	22	383	766	125	133
2000	33	31	25	381	762	125	137	23	366	732	125	137
4000	29	27	26	364	728	125	141	23	350	700	125	141
6000	25	23	26	349	698	125	145	24	335	670	125	145
8000	21	19	27	333	666	125	150	24	320	640	125	150
10,000	17	15	27	316	632	125	154	25	305	610	125	154
12,000	14	11	28	301	602	125	159	25	290	580	125	159
14,000	10	7	28	290	580	125	165	25	279	558	125	165
16,000	6	3	29	279	558	125	170	26	268	536	125	170
18,000	2	-1	29	269	538	125	176	26	257	514	125	176
20,000	-2	-5	30	260	520	125	182	27	248	496	125	182
22,000	-5	-9	30	253	506	125	188	28	240	480	125	188
24,000	-9	-13	31	247	494	125	195	28	233	466	125	195
26,000	-13	-17	32	243	486	125	202	29	227	454	125	202
28,000	-16	-20	33	242	484	125	209	29	224	448	125	209
29,000	-18	-22	33	241	482	125	213	30	224	448	125	213
31,000	-22	-26	34	242	484	125	220	30	223	446	125	220
33,000	-26	-30	35	243	486	125	229	31	224	448	125	229
35,000	-29	-34	---	---	---	---	---	32	224	448	125	237

BT05268

Figure 7-78. Loiter Power at 1700 RPM - ISA +20°C (Sheet 2 of 2)

**LOITER POWER  
1700 RPM  
ISA +30°C**

WEIGHT→			16,000 POUND					14,000 POUNDS				
PRESSURE ALTITUDE	IOAT	OAT	TORQUE PER ENGINE	FUEL FLOW PER ENGINE	TOTAL FUEL FLOW	IAS	TAS	TORQUE PER ENGINE	FUEL FLOW PER ENGINE	TOTAL FUEL FLOW	IAS	TAS
FEET	°C	°C	PERCENT	LBS/HR	LBS/HR	KTS	KTS	PERCENT	LBS/HR	LBS/HR	KTS	KTS
0	47	45	31	431	862	125	135	28	417	834	125	135
2000	43	41	32	414	828	125	139	28	400	800	125	139
4000	39	37	32	398	796	125	143	29	383	766	125	143
6000	35	33	33	381	762	125	148	29	366	732	125	148
8000	31	29	33	365	730	125	152	30	350	700	125	152
10,000	27	25	34	349	698	125	157	30	333	666	125	157
12,000	24	21	34	333	666	125	162	31	318	636	125	162
14,000	20	17	35	320	640	125	168	31	304	608	125	168
16,000	16	13	36	309	618	125	173	32	293	586	125	173
18,000	12	9	37	303	606	125	179	33	286	572	125	179
20,000	9	5	37	296	592	125	185	33	278	556	125	185
22,000	5	1	38	291	582	125	192	34	273	546	125	192
24,000	1	-3	39	287	574	125	198	35	268	536	125	198
26,000	-3	-7	40	288	576	125	205	36	264	528	125	205
28,000	-6	-10	---	---	---	---	---	37	264	528	125	213
29,000	---	---	---	---	---	---	---	---	---	---	---	---
31,000	---	---	---	---	---	---	---	---	---	---	---	---
33,000	---	---	---	---	---	---	---	---	---	---	---	---
35,000	---	---	---	---	---	---	---	---	---	---	---	---

BT05269

Figure 7-79. Loiter Power at 1700 RPM - ISA +30°C (Sheet 1 of 2)

**LOITER POWER  
1700 RPM  
ISA +30°C**

WEIGHT→			12,000 POUND					10,000 POUNDS				
PRESSURE ALTITUDE	IOAT	OAT	TORQUE PER ENGINE	FUEL FLOW PER ENGINE	TOTAL FUEL FLOW	IAS	TAS	TORQUE PER ENGINE	FUEL FLOW PER ENGINE	TOTAL FUEL FLOW	IAS	TAS
FEET	°C	°C	PERCENT	LBS/HR	LBS/HR	KTS	KTS	PERCENT	LBS/HR	LBS/HR	KTS	KTS
0	47	45	26	405	810	125	135	23	392	784	125	135
2000	43	41	26	387	774	125	139	24	376	752	125	139
4000	39	37	26	370	740	125	143	24	359	718	125	143
6000	35	33	27	353	706	125	148	24	342	684	125	148
8000	31	29	27	336	672	125	152	25	325	650	125	152
10,000	27	25	27	320	640	125	157	25	309	618	125	157
12,000	24	21	28	305	610	125	162	25	293	586	125	162
14,000	20	17	28	291	582	125	168	26	279	558	125	168
16,000	16	13	29	279	558	125	173	26	268	536	125	173
18,000	12	9	29	271	542	125	179	27	259	518	125	179
20,000	9	5	30	263	526	125	185	27	250	500	125	185
22,000	5	1	31	257	514	125	192	28	243	486	125	192
24,000	1	-3	32	251	502	125	198	29	237	474	125	198
26,000	-3	-7	32	247	494	125	205	29	232	464	125	205
28,000	-6	-10	33	244	488	125	213	30	228	456	125	213
29,000	-8	-12	33	243	486	125	217	30	227	454	125	217
31,000	-12	-16	34	244	488	125	225	31	224	448	125	225
33,000	-15	-20	---	---	---	---	---	31	225	450	125	233
35,000	---	---	---	---	---	---	---	---	---	---	---	---

BT06270

Figure 7-79. Loiter Power at 1700 RPM - ISA +30°C (Sheet 2 of 2)



**LOITER POWER  
1700 RPM  
ISA +37°C**

WEIGHT→			16,000 POUND					14,000 POUNDS				
PRESSURE ALTITUDE	IOAT	OAT	TORQUE PER ENGINE	FUEL FLOW PER ENGINE	TOTAL FUEL FLOW	IAS	TAS	TORQUE PER ENGINE	FUEL FLOW PER ENGINE	TOTAL FUEL FLOW	IAS	TAS
FEET	°C	°C	PERCENT	LBS/HR	LBS/HR	KTS	KTS	PERCENT	LBS/HR	LBS/HR	KTS	KTS
0	54	52	31	431	862	125	136	28	417	834	125	136
2000	50	48	31	414	828	125	140	28	399	798	125	140
4000	46	44	32	398	796	125	145	29	383	766	125	145
6000	42	40	33	382	764	125	149	29	367	734	125	149
8000	38	36	33	367	734	125	154	30	351	702	125	154
10,000	35	32	34	352	704	125	159	30	336	672	125	159
12,000	31	28	35	337	674	125	164	31	321	642	125	164
14,000	27	24	35	323	646	125	170	32	307	614	125	170
16,000	23	20	36	311	622	125	175	32	295	590	125	175
18,000	19	16	37	302	604	125	181	33	286	572	125	181
20,000	16	12	37	294	588	125	187	34	277	554	125	187
22,000	12	8	38	289	578	125	194	34	272	544	125	194
24,000	8	4	---	---	---	---	---	35	267	534	125	201
26,000	5	0	---	---	---	---	---	36	266	532	125	208
28,000	---	---	---	---	---	---	---	---	---	---	---	---
29,000	---	---	---	---	---	---	---	---	---	---	---	---
31,000	---	---	---	---	---	---	---	---	---	---	---	---
33,000	---	---	---	---	---	---	---	---	---	---	---	---
35,000	---	---	---	---	---	---	---	---	---	---	---	---

BT05271

Figure 7-80. Loiter Power at 1700 RPM - ISA +37°C (Sheet 1 of 2)

**LOITER POWER  
1700 RPM  
ISA +37°C**

WEIGHT→			12,000 POUND					10,000 POUNDS				
PRESSURE ALTITUDE	IOAT	OAT	TORQUE PER ENGINE	FUEL FLOW PER ENGINE	TOTAL FUEL FLOW	IAS	TAS	TORQUE PER ENGINE	FUEL FLOW PER ENGINE	TOTAL FUEL FLOW	IAS	TAS
FEET	°C	°C	PERCENT	LBS/HR	LBS/HR	KTS	KTS	PERCENT	LBS/HR	LBS/HR	KTS	KTS
0	54	52	25	404	808	125	136	23	393	786	125	136
2000	50	48	26	386	772	125	140	24	375	750	125	140
4000	46	44	26	369	738	125	145	24	358	716	125	145
6000	42	40	27	353	706	125	149	24	342	684	125	149
8000	38	36	27	338	676	125	154	25	326	652	125	154
10,000	35	32	28	323	646	125	159	25	311	622	125	159
12,000	31	28	28	307	614	125	164	26	296	592	125	164
14,000	27	24	29	293	586	125	170	26	282	564	125	170
16,000	23	20	29	281	562	125	175	26	269	538	125	175
18,000	19	16	30	272	544	125	181	27	260	520	125	181
20,000	16	12	30	263	526	125	187	28	251	502	125	187
22,000	12	8	31	257	514	125	194	28	244	488	125	194
24,000	8	4	31	251	502	125	201	29	237	474	125	201
26,000	5	0	32	246	492	125	208	29	232	464	125	208
28,000	1	-3	33	244	488	125	216	30	225	450	125	216
29,000	-1	-5	33	245	490	125	220	30	224	448	125	220
31,000	-5	-9	---	---	---	---	---	31	226	452	125	228
33,000	---	---	---	---	---	---	---	---	---	---	---	---
35,000	----	---	---	---	---	---	---	---	---	---	---	---

BT05272

Figure 7-80. Loiter Power at 1700 RPM - ISA +37°C (Sheet 2 of 2)

ENDURANCE PROFILE - LOITER POWER

ASSOCIATED CONDITIONS:  
WEIGHT.....\*16,620 LBS BEFORE  
ENGINE START  
FUEL.....AVIATION KEROSENE  
FUEL DENSITY..7 LBS/GAL  
ICE VANES.....RETRACTED

1700 RPM  
STANDARD DAY (ISA)

EXAMPLE:  
PRESSURE ALTITUDE.....26,000 FT  
FUEL.....2572 LBS  
ENDURANCE.....3.44 HRS

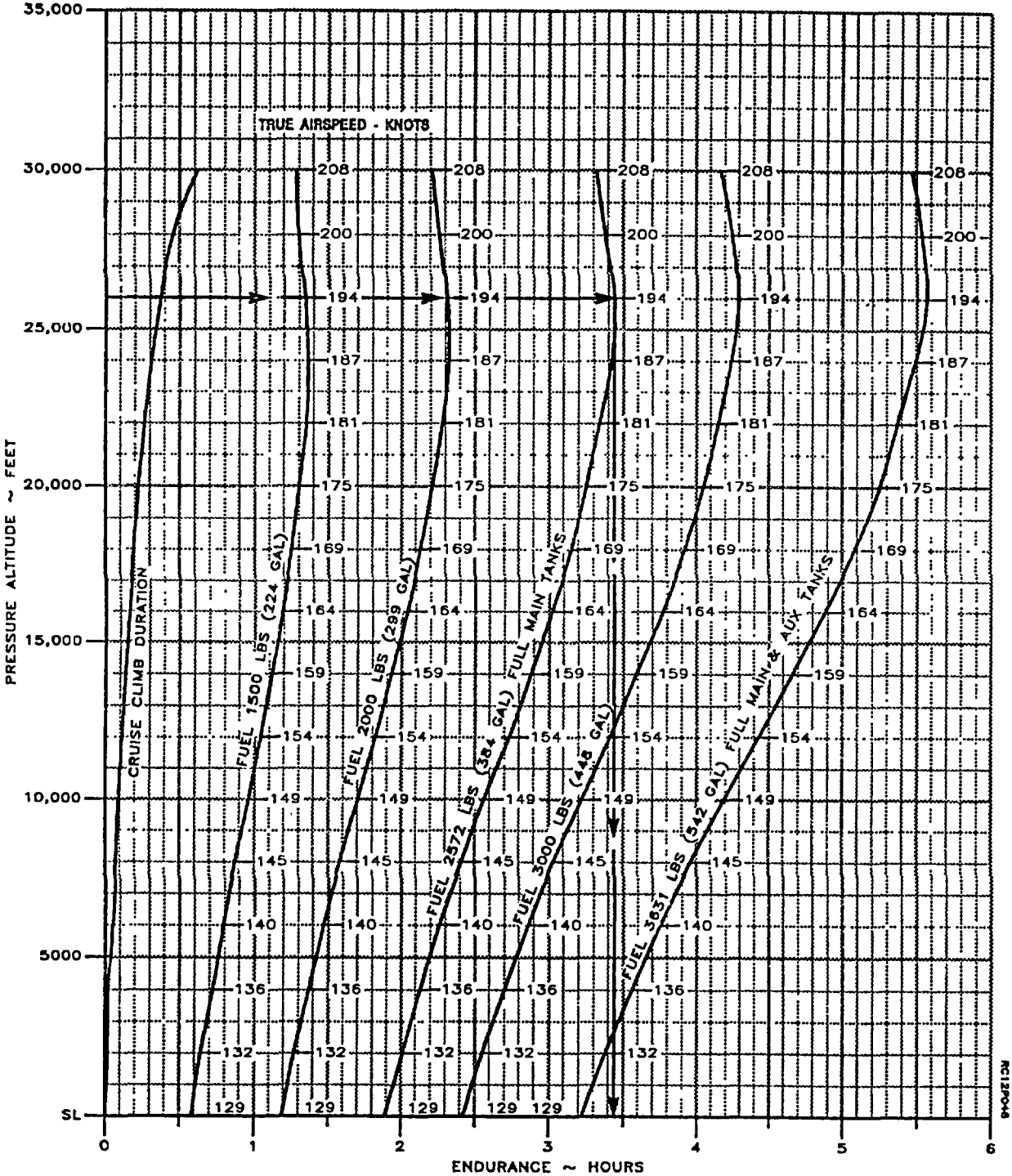

Figure 7-81. Endurance Profile - Loiter Power at 1700 RPM

**RANGE PROFILE - FULL MAIN TANKS**

**ASSOCIATED CONDITIONS:**  
 WEIGHT ..... 1.672 LBS BEFORE  
 ENGINE START  
 FUEL ..... AVIATION KEROSENE  
 FUEL DENSITY .. 6.7 LBS/GAL  
 ICE VANES ..... RETRACTED

**STANDARD DAY (19A)  
 ZERO WIND**

**EXAMPLE:**  
 PRESSURE ALTITUDE ..... 26,000 FT  
 RANGE @:  
 MAXIMUM CRUISE POWER... 641 NM  
 NORMAL CRUISE POWER..... 654 NM  
 MAXIMUM RANGE POWER.... 679 NM

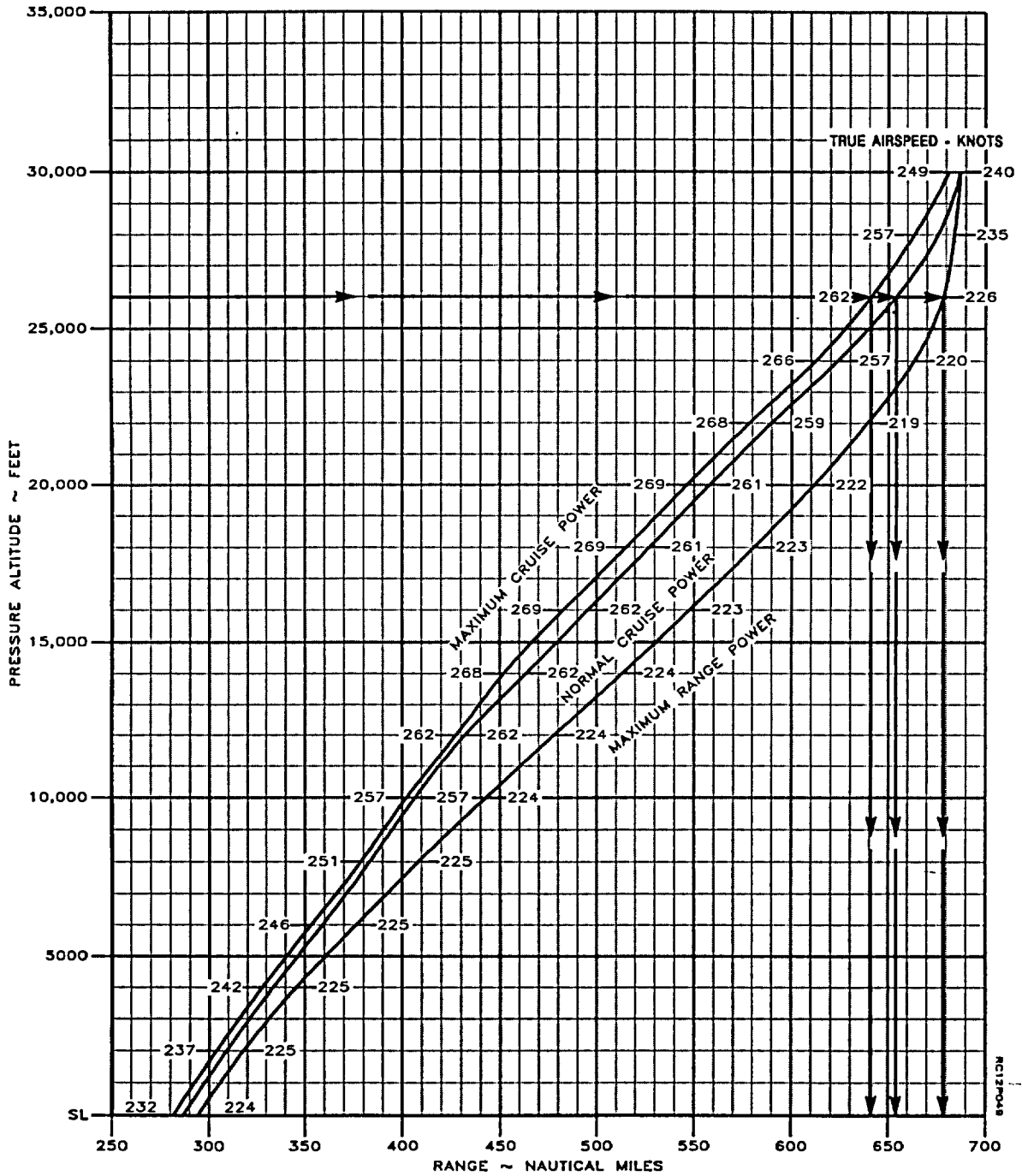

Figure 7-82. Range Profile - Full Main Tanks

ENDURANCE PROFILE - FULL MAIN TANKS

ASSOCIATED CONDITIONS:  
WEIGHT ..... 15,672 LBS BEFORE  
ENGINE START  
FUEL ..... AVIATION KEROSENE  
FUEL DENSITY . . 6.7 LBS/GAL  
ICE VANES ..... RETRACTED

STANDARD DAY (ISA)

EXAMPLE:  
PRESSURE ALTITUDE ..... 26,000 FT  
ENDURANCE @:  
MAXIMUM CRUISE POWER ... 2.59 HRS  
NORMAL CRUISE POWER ..... 2.72 HRS  
LOITER POWER ..... 3.44 HRS

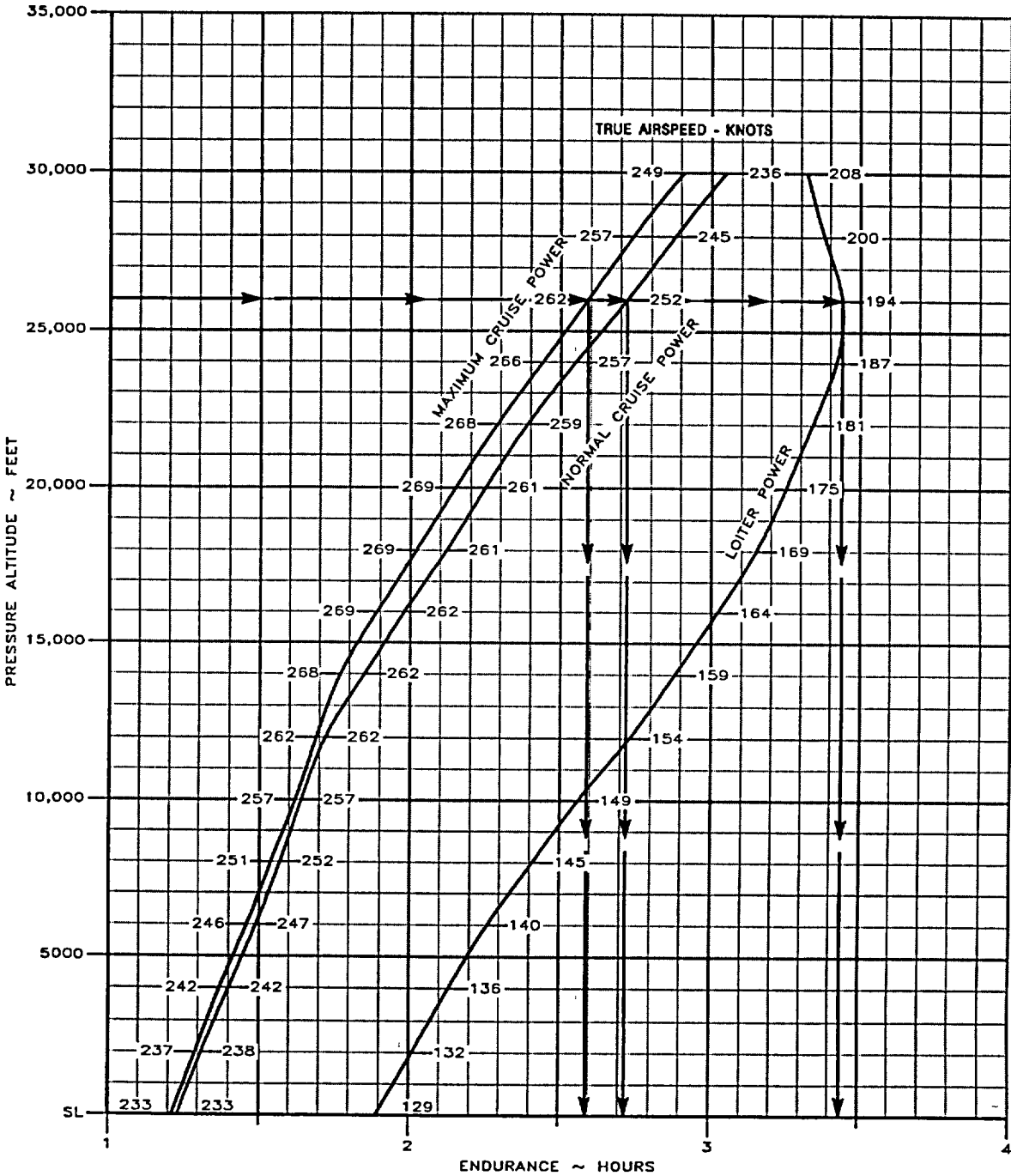

Figure 7-83. Endurance Profile - Full Main Tanks

RANGE PROFILE - FULL MAIN & AUX TANKS

ASSOCIATED CONDITIONS:  
WEIGHT ..... 16,620 LBS BEFORE  
ENGINE START  
FUEL ..... AVIATION KEROSENE  
FUEL DENSITY .. 6.7 LBS/GAL  
ICE VANES ..... RETRACTED

STANDARD DAY (ISA)  
ZERO WIND

EXAMPLE:  
PRESSURE ALTITUDE ..... 26,000 FT  
RANGE @:  
MAXIMUM CRUISE POWER... 1017 NM  
NORMAL CRUISE POWER..... 1038 NM  
MAXIMUM RANGE POWER.... 1096 NM

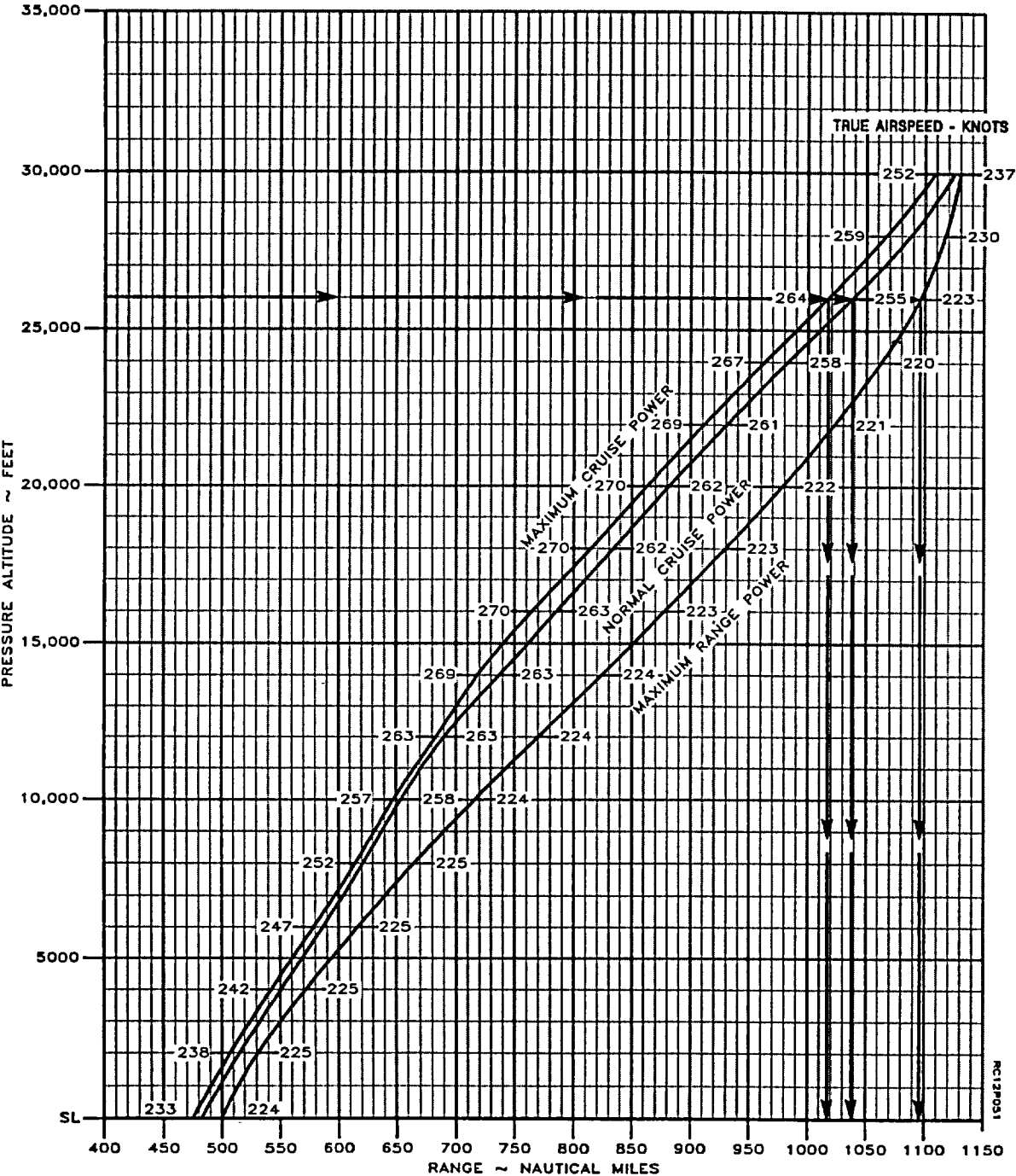

Figure 7-84. Range Profile - Full Main and Aux Tanks

ENDURANCE PROFILE - FULL MAIN & AUX TANKS

ASSOCIATED CONDITIONS:  
WEIGHT ..... 16,620 LBS BEFORE  
ENGINE START  
FUEL ..... AVIATION KEROSENE  
FUEL DENSITY . . 6.7 LBS/GAL  
ICE VANES ..... RETRACTED

STANDARD DAY (ISA)

EXAMPLE:  
PRESSURE ALTITUDE ..... 26,000 FT  
ENDURANCE @:  
MAXIMUM CRUISE POWER... 4.00 HRS  
NORMAL CRUISE POWER..... 4.21 HRS  
LOITER POWER ..... 5.57 HRS

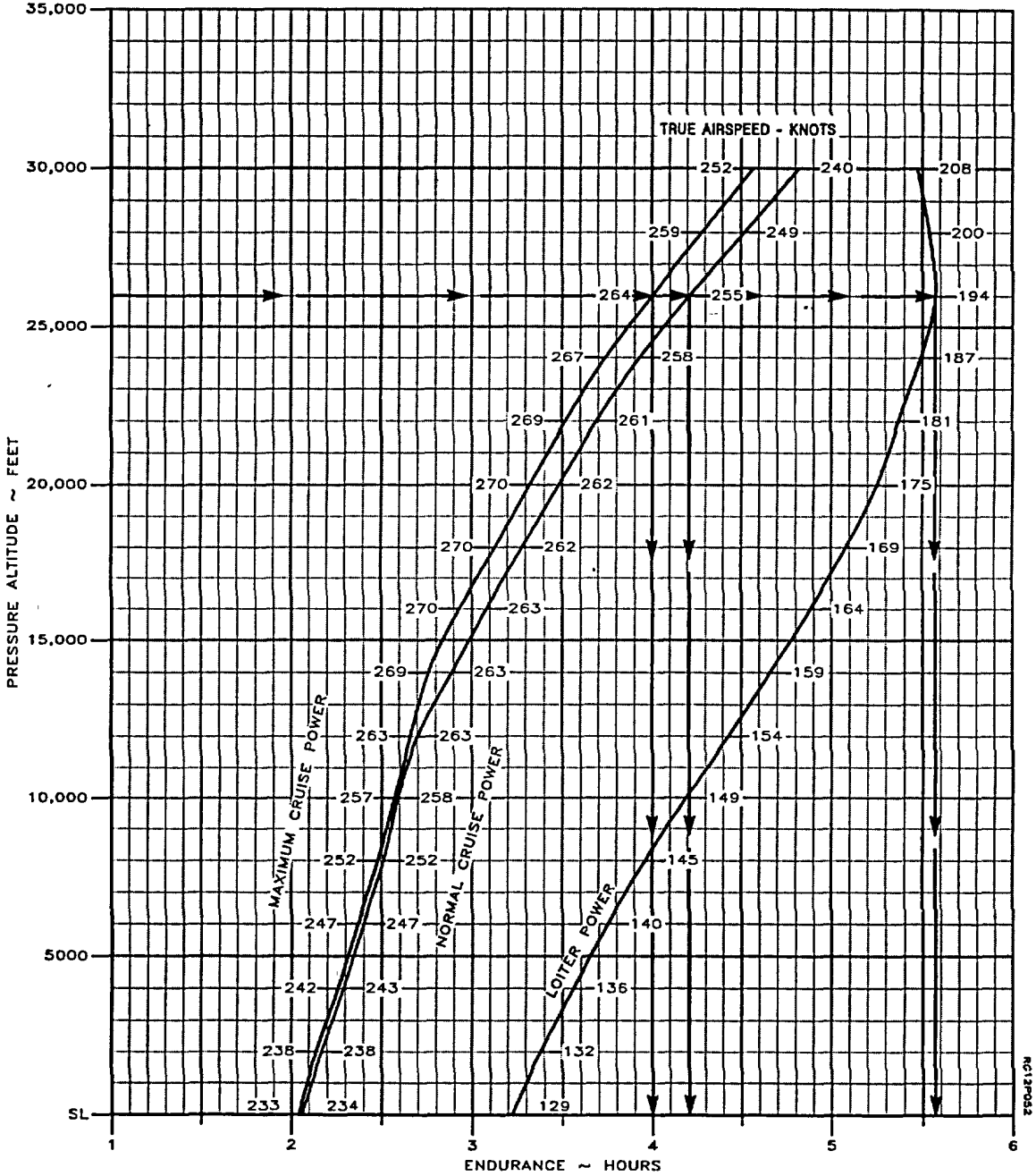

Figure 7-85. Endurance Profile - Full Main and Aux Tanks

**ONE-ENGINE-INOPERATIVE MAXIMUM CRUISE POWER  
1700 RPM  
ISA -30°C**

WEIGHT→			16,000 POUND					14,000 POUNDS				
PRESSURE ALTITUDE	IOAT	OAT	TORQUE PER ENGINE	FUEL FLOW PER ENGINE	TOTAL FUEL FLOW	IAS	TAS	TORQUE PER ENGINE	FUEL FLOW PER ENGINE	TOTAL FUEL FLOW	IAS	TAS
FEET	°C	°C	PERCENT	LBS/HR	LBS/HR	KTS	KTS	PERCENT	LBS/HR	LBS/HR	KTS	KTS
0	-13	-15	83	642	642	169	162	83	641	641	173	166
2000	-16	-19	83	622	622	167	165	83	621	621	172	170
4000	-20	-23	83	604	604	167	170	83	603	693	171	174
6000	-24	-27	83	591	591	164	172	83	590	590	170	178
8000	-28	-31	83	580	580	162	175	83	579	579	167	180
10,000	-32	-35	83	569	569	159	177	83	568	568	165	183
12,000	-36	-39	83	558	558	157	179	83	557	557	163	186
14,000	-40	-43	83	549	549	154	182	83	548	548	160	189
16,000	-44	-47	83	542	542	150	184	83	540	540	158	192
18,000	-47	-51	83	537	537	147	186	83	535	535	155	195
20,000	-51	-55	83	530	530	143	186	83	531	531	152	198
22,000	-56	-59	76	492	492	128	173	78	496	496	143	193
24,000	-59	-63	---	---	---	---	---	71	458	458	132	184
26,000	---	---	---	---	---	---	---	---	---	---	---	---
28,000	---	---	---	---	---	---	---	---	---	---	---	---
29,000	---	---	---	---	---	---	---	---	---	---	---	---
31,000	---	---	---	---	---	---	---	---	---	---	---	---
33,000	---	---	---	---	---	---	---	---	---	---	---	---
35,000	---	---	---	---	---	---	---	---	---	---	---	---

BT05277

**NOTE**

**During operations with ice vanes extended, torque will decrease approximately 10%, fuel flow will decrease approximately 6%, and true airspeed will be reduced by approximately 10 knots.**

Figure 7-86. One Engine Inoperative Max Cruise Power at 1700 RPM (Engine Anti-Ice Off) - ISA -300C (Sheet 1 of 2)



**ONE-ENGINE-INOPERATIVE MAXIMUM CRUISE POWER  
1700 RPM  
ISA -30°C**

WEIGHT→			12,000 POUND					10,000 POUNDS				
PRESSURE ALTITUDE	IOAT	OAT	TORQUE PER ENGINE	FUEL FLOW PER ENGINE	TOTAL FUEL FLOW	IAS	TAS	TORQUE PER ENGINE	FUEL FLOW PER ENGINE	TOTAL FUEL FLOW	IAS	TAS
FEET	°C	°C	PERCENT	LBS/HR	LBS/HR	KTS	KTS	PERCENT	LBS/HR	LBS/HR	KTS	KTS
0	-12	-15	83	640	640	177	170	83	640	640	180	172
2000	-16	-19	83	621	621	176	174	83	620	620	179	177
4000	-20	-23	83	603	603	175	178	83	602	602	178	181
6000	-24	-27	83	589	589	174	181	83	589	589	177	184
8000	-28	-31	83	578	578	171	184	83	577	577	175	188
10,000	-32	-35	83	567	567	169	188	83	567	567	173	191
12,000	-35	-39	83	557	557	167	191	83	556	556	171	195
14,000	-39	-43	83	547	547	165	194	83	546	546	169	199
16,000	-43	-47	83	539	539	163	198	83	539	539	167	203
18,000	-47	-51	83	534	534	161	202	83	533	533	165	207
20,000	-51	-55	83	530	530	158	205	83	529	529	163	210
22,000	-55	-59	78	498	498	151	203	79	500	500	157	210
24,000	-59	-63	73	462	462	143	199	73	465	465	150	207
26,000	-63	-67	66	422	422	132	191	67	426	426	141	203
28,000	-68	-70	58	380	380	118	178	59	384	384	131	195
29,000	-69	-72	---	---	---	---	---	56	365	365	125	191
31,000	-73	-76	---	---	---	---	---	50	328	328	113	179
33,000	---	---	---	---	---	---	---	---	---	---	---	---
35,000	---	---	---	---	---	---	---	---	---	---	---	---

BT05278

**NOTE**

**During operations with ice vanes extended, torque will decrease approximately 100%, fuel flow will decrease approximately 6%, and true airspeed will be reduced by approximately 10 knots.**

Figure 7-86. One Engine Inoperative Max Cruise Power at 1700 RPM (Ice Vanes Retracted) - ISA -30°C (Sheet 2 of 2)

**ONE-ENGINE-INOPERATIVE MAXIMUM CRUISE POWER  
1700 RPM  
ISA -20°C**

WEIGHT→			16,000 POUND					14,000 POUNDS				
PRESSURE ALTITUDE	IOAT	OAT	TORQUE PER ENGINE	FUEL FLOW PER ENGINE	TOTAL FUEL FLOW	IAS	TAS	TORQUE PER ENGINE	FUEL FLOW PER ENGINE	TOTAL FUEL FLOW	IAS	TAS
FEET	°C	°C	PERCENT	LBS/HR	LBS/HR	KTS	KTS	PERCENT	LBS/HR	LBS/HR	KTS	KTS
0	-3	-5	83	644	644	168	164	83	643	643	172	169
2000	-6	-9	83	625	625	167	168	83	624	624	172	173
4000	-10	-13	83	609	609	165	171	83	608	609	170	176
6000	-14	-17	83	595	595	162	174	83	594	594	168	179
8000	-18	-21	83	582	582	160	176	83	581	581	165	182
10,000	-22	-25	83	571	571	157	178	83	570	570	163	185
12,000	-26	-29	83	560	560	154	180	83	560	560	161	188
14,000	-30	-33	83	551	551	151	182	83	550	550	158	191
16,000	-34	-37	83	543	543	148	185	83	542	542	156	194
18,000	-38	-41	83	534	534	143	185	83	536	536	153	196
20,000	-42	-45	77	503	503	132	176	78	506	506	145	193
22,000	-45	-49	---	---	---	---	---	73	474	474	135	187
24,000	-50	-53	---	---	---	---	---	68	442	442	123	176
26,000	---	---	---	---	---	---	---	---	---	---	---	---
28,000	---	---	---	---	---	---	---	---	---	---	---	---
29,000	---	---	---	---	---	---	---	---	---	---	---	---
31,000	---	---	---	---	---	---	---	---	---	---	---	---
33,000	---	---	---	---	---	---	---	---	---	---	---	---
35,000	---	---	---	---	---	---	---	---	---	---	---	---

BT05279

**NOTE**

During operations with ice vanes extended, torque will decrease approximately 10%, fuel flow will decrease approximately 6%, and true airspeed will be reduced by approximately 10 knots.

Figure 7-87. One Engine Inoperative Max Cruise Power at 1700 RPM (Ice Vanes Retracted) - ISA -20°C (Sheet 1 of 2)

**ONE-ENGINE-INOPERATIVE MAXIMUM CRUISE POWER  
1700 RPM  
ISA -20°C**

WEIGHT→			12,000 POUND					10,000 POUNDS				
PRESSURE ALTITUDE	IOAT	OAT	TORQUE PER ENGINE	FUEL FLOW PER ENGINE	TOTAL FUEL FLOW	IAS	TAS	TORQUE PER ENGINE	FUEL FLOW PER ENGINE	TOTAL FUEL FLOW	IAS	TAS
FEET	°C	°C	PERCENT	LBS/HR	LBS/HR	KTS	KTS	PERCENT	LBS/HR	LBS/HR	KTS	KTS
0	-2	-5	83	642	642	176	172	83	642	642	179	175
2000	-6	-9	83	623	623	176	177	83	622	622	178	179
4000	-10	-13	83	607	607	174	180	83	606	606	177	183
6000	-14	-17	83	593	593	172	183	83	592	592	175	186
8000	-18	-21	83	581	581	170	186	83	580	580	173	190
10,000	-21	-25	83	570	570	167	190	83	569	569	171	193
12,000	-25	-29	83	559	559	165	193	83	558	558	169	197
14,000	-29	-33	83	549	549	163	196	83	548	548	167	201
16,000	-33	-37	83	541	541	161	200	83	540	540	165	205
18,000	-37	-41	83	535	535	159	204	83	534	534	163	209
20,000	-41	-45	79	508	508	152	202	79	509	509	157	209
22,000	-45	-49	74	477	477	145	199	75	478	478	151	207
24,000	-49	-53	69	445	445	137	195	70	447	447	144	205
26,000	-53	-57	64	413	413	127	188	64	416	416	137	201
28,000	-58	-60	57	377	377	1133	174	59	382	382	128	195
29,000	-59	-62	---	---	---	---	---	56	364	364	122	191
31,000	-63	-66	---	---	---	---	---	49	328	328	110	179
33,000	---	---	---	---	---	---	---	---	---	---	---	---
35,000	---	---	---	---	---	---	---	---	---	---	---	---

BT05280

**NOTE**

**During operations with ice vanes extended, torque will decrease approximately 10%, fuel flow will decrease approximately 6%, and true airspeed will be reduced by approximately 10 knots.**

Figure 7-87. One Engine Inoperative Max Cruise Power at 1700 RPM (Ice Vanes Retracted) - ISA -20°C (Sheet 2 of 2)

**ONE-ENGINE-INOPERATIVE MAXIMUM CRUISE POWER  
1700 RPM  
ISA -10°C**

WEIGHT→			16,000 POUND					14,000 POUNDS				
PRESSURE ALTITUDE	IOAT	OAT	TORQUE PER ENGINE	FUEL FLOW PER ENGINE	TOTAL FUEL FLOW	IAS	TAS	TORQUE PER ENGINE	FUEL FLOW PER ENGINE	TOTAL FUEL FLOW	IAS	TAS
FEET	°C	°C	PERCENT	LBS/HR	LBS/HR	KTS	KTS	PERCENT	LBS/HR	LBS/HR	KTS	KTS
0	8	5	83	650	650	167	167	83	649	649	172	171
2000	4	-1	83	631	631	166	170	83	630	630	171	175
4000	0	-3	83	614	614	163	172	83	613	613	168	178
6000	-4	-7	83	598	598	161	175	83	597	597	166	181
8000	-8	-11	83	584	584	158	177	83	583	583	164	183
10,000	-12	-15	83	571	571	155	179	83	570	570	161	186
12,000	-16	-19	83	560	560	152	181	83	559	559	159	189
14,000	-20	-23	83	552	552	149	184	83	551	551	156	192
16,000	-24	-27	80	529	529	142	181	81	532	532	151	193
18,000	-28	-31	76	502	502	130	173	77	505	505	144	190
20,000	-31	-35	---	---	---	---	---	73	479	479	136	186
22,000	-36	-39	---	---	---	---	---	68	448	448	125	177
24,000	---	---	---	---	---	---	---	---	---	---	---	---
26,000	---	---	---	---	---	---	---	---	---	---	---	---
28,000	---	---	---	---	---	---	---	---	---	---	---	---
29,000	---	---	---	---	---	---	---	---	---	---	---	---
31,000	---	---	---	---	---	---	---	---	---	---	---	---
33,000	---	---	---	---	---	---	---	---	---	---	---	---
35,000	---	---	---	---	---	---	---	---	---	---	---	---

BT05281

**NOTE**

During operations with ice vanes extended, torque will decrease approximately 10%, fuel flow will decrease approximately 6%, and true airspeed will be reduced by approximately 10 knots.

Figure 7-88. One Engine Inoperative Max Cruise Power at 1700 RPM (Ice Vanes Retracted) - ISA -10°C (Sheet 1 of 2)

**ONE-ENGINE-INOPERATIVE MAXIMUM CRUISE POWER  
1700 RPM  
ISA -10°C**

WEIGHT→			12,000 POUND					10,000 POUNDS				
PRESSURE ALTITUDE	IOAT	OAT	TORQUE PER ENGINE	FUEL FLOW PER ENGINE	TOTAL FUEL FLOW	IAS	TAS	TORQUE PER ENGINE	FUEL FLOW PER ENGINE	TOTAL FUEL FLOW	IAS	TAS
FEET	°C	°C	PERCENT	LBS/HR	LBS/HR	KTS	KTS	PERCENT	LBS/HR	LBS/HR	KTS	KTS
0	8	5	83	648	648	176	175	83	647	647	179	178
2000	4	1	83	629	629	174	179	83	629	629	177	182
4000	0	-3	83	612	612	172	182	83	611	611	175	185
6000	-4	-7	83	596	596	170	185	83	595	595	173	188
8000	-8	-11	83	582	582	168	188	83	581	581	171	192
10,000	-11	-15	83	569	569	166	192	83	569	569	169	195
12,000	-15	-19	83	558	558	163	195	83	558	558	167	199
14,000	-19	-23	83	550	550	161	199	83	549	549	165	203
16,000	-23	-27	82	534	534	158	200	82	535	535	162	206
18,000	-27	-31	78	507	507	152	199	78	508	508	157	206
20,000	-31	-35	74	481	481	146	198	75	482	482	152	206
22,000	-35	-39	69	451	451	138	194	70	453	453	145	204
24,000	-39	-43	64	421	421	128	188	65	423	423	138	201
26,000	-44	-47	59	390	390	117	178	60	394	394	130	196
28,000	-47	-50	---	---	---	---	---	55	364	364	121	190
29,000	-49	-52	---	---	---	---	---	52	350	350	116	186
31,000	-54	-56	---	---	---	---	---	47	320	320	103	172
33,000	---	---	---	---	---	---	---	---	---	---	---	---
35,000	---	---	---	---	---	---	---	---	---	---	---	---

BT05282

**NOTE**

**During operations with ice vanes extended, torque will decrease approximately 10%, fuel flow will decrease approximately 6%, and true airspeed will be reduced by approximately 10 knots.**

*Figure 7-88. One Engine Inoperative Max Cruise Power at 1700 RPM (Ice Vanes Retracted) - ISA -10°C (Sheet 2 of 2)*

**ONE-ENGINE-INOPERATIVE MAXIMUM CRUISE POWER  
1700 RPM  
ISA**

WEIGHT→			16,000 POUND					14,000 POUNDS				
PRESSURE ALTITUDE	IOAT	OAT	TORQUE PER ENGINE	FUEL FLOW PER ENGINE	TOTAL FUEL FLOW	IAS	TAS	TORQUE PER ENGINE	FUEL FLOW PER ENGINE	TOTAL FUEL FLOW	IAS	TAS
FEET	°C	°C	PERCENT	LBS/HR	LBS/HR	KTS	KTS	PERCENT	LBS/HR	LBS/HR	KTS	KTS
0	18	15	83	649	649	166	169	83	648	648	171	174
2000	14	11	83	633	633	164	171	83	632	632	169	177
4000	10	7	83	616	616	161	174	83	615	615	167	179
6000	6	3	83	500	600	159	176	83	599	599	164	182
8000	2	-1	83	585	585	156	178	83	584	584	162	185
10,000	-2	-5	83	572	572	153	180	83	571	571	159	188
12,000	-6	-9	82	553	553	148	180	83	556	556	156	190
14,000	-10	-13	77	521	521	138	175	78	525	525	149	188
16,000	-14	-17	---	---	---	---	---	74	496	496	142	184
18,000	-18	-21	---	---	---	---	---	70	470	470	133	180
20,000	-22	-25	---	---	---	---	---	66	443	443	122	171
22,000	---	---	---	---	---	---	---	---	---	---	---	---
24,000	---	---	---	---	---	---	---	---	---	---	---	---
26,000	---	---	---	---	---	---	---	---	---	---	---	---
28,000	---	---	---	---	---	---	---	---	---	---	---	---
29,000	---	---	---	---	---	---	---	---	---	---	---	---
31,000	---	---	---	---	---	---	---	---	---	---	---	---
33,000	---	---	---	---	---	---	---	---	---	---	---	---
35,000	---	---	---	---	---	---	---	---	---	---	---	---

BT05283

**NOTE**

**During operations with ice vanes extended, torque will decrease approximately 10%, fuel flow will decrease approximately 6%, and true airspeed will be reduced by approximately 10 knots.**

*Figure 7-89. One Engine Inoperative Max Cruise Power at 1700 RPM (Ice Vanes Retracted) - ISA (Sheet 1 of 2)*

**ONE-ENGINE-INOPERATIVE MAXIMUM CRUISE POWER  
1700 RPM  
ISA**

WEIGHT→			12,000 POUNDS					10,000 POUNDS				
PRESSURE ALTITUDE	IOAT	OAT	TORQUE PER ENGINE	FUEL FLOW PER ENGINE	TOTAL FUEL FLOW	IAS	TAS	TORQUE PER ENGINE	FUEL FLOW PER ENGINE	TOTAL FUEL FLOW	IAS	TAS
FEET	°C	°C	PERCENT	LBS/HR	LBS/HR	KTS	KTS	PERCENT	LBS/HR	LBS/HR	KTS	KTS
0	18	15	83	647	647	175	177	83	647	647	178	180
2000	14	11	83	631	631	173	181	83	631	631	176	183
4000	10	7	83	615	615	171	184	83	614	614	174	187
6000	6	3	83	598	598	168	187	83	598	598	172	190
8000	2	-1	83	583	583	166	190	83	583	583	170	194
10,000	-1	-5	83	570	570	164	193	83	570	570	168	198
12,000	-5	-9	83	558	558	162	197	83	558	558	166	201
14,000	-9	-13	79	527	527	156	196	79	528	528	160	201
16,000	-13	-17	75	498	498	150	194	75	500	500	155	201
18,000	-17	-21	71	473	473	143	193	72	474	474	149	200
20,000	-21	-25	67	447	447	136	190	68	449	449	144	200
22,000	-25	-29	63	420	420	128	185	64	423	423	137	198
24,000	-30	-33	59	393	393	118	178	60	397	397	130	195
26,000	-33	-37	---	---	---	---	---	56	370	370	122	190
28,000	-37	-40	---	---	---	---	---	51	343	343	113	182
29,000	-40	-42	---	---	---	---	---	49	329	329	107	177
31,000	---	---	---	---	---	---	---	---	---	---	---	---
33,000	---	---	---	---	---	---	---	---	---	---	---	---
35,000	---	---	---	---	---	---	---	---	---	---	---	---

BT05285

**NOTE**

**During operations with ice vanes extended, torque will decrease approximately 10%, fuel flow will decrease approximately 6%, and true airspeed will be reduced by approximately 10 knots.**

*Figure 7-89. One Engine Inoperative Max Cruise Power at 1700 RPM (Ice Vanes Retracted) - ISA (Sheet 2 of 2)*

**ONE-ENGINE-INOPERATIVE MAXIMUM CRUISE POWER  
1700 RPM  
ISA +10°C**

WEIGHT→			16,000 POUNDS					14,000 POUNDS				
PRESSURE ALTITUDE	IOAT	OAT	TORQUE PER ENGINE	FUEL FLOW PER ENGINE	TOTAL FUEL FLOW	IAS	TAS	TORQUE PER ENGINE	FUEL FLOW PER ENGINE	TOTAL FUEL FLOW	IAS	TAS
FEET	°C	°C	PERCENT	LBS/HR	LBS/HR	KTS	KTS	PERCENT	LBS/HR	LBS/HR	KTS	KTS
0	28	25	83	653	653	164	170	83	652	652	170	175
2000	24	21	83	632	632	162	172	83	631	631	167	178
4000	20	17	83	613	613	159	175	83	612	612	165	181
6000	16	13	83	596	596	157	177	83	595	595	163	184
8000	12	9	83	584	584	154	179	83	583	583	160	187
10,000	8	5	78	548	548	144	174	79	551	551	153	184
12,000	4	1	74	517	517	134	168	76	521	521	147	183
14,000	0	-3	---	---	---	---	---	71	489	489	139	179
16,000	-4	-7	---	---	---	---	---	67	459	459	129	173
18,000	---	---	---	---	---	---	---	---	---	---	---	---
20,000	---	---	---	---	---	---	---	---	---	---	---	---
22,000	---	---	---	---	---	---	---	---	---	---	---	---
24,000	---	---	---	---	---	---	---	---	---	---	---	---
26,000	---	---	---	---	---	---	---	---	---	---	---	---
28,000	---	---	---	---	---	---	---	---	---	---	---	---
29,000	---	---	---	---	---	---	---	---	---	---	---	---
31,000	---	---	---	---	---	---	---	---	---	---	---	---
33,000	---	---	---	---	---	---	---	---	---	---	---	---
35,000	---	---	---	---	---	---	---	---	---	---	---	---

BT05284

**NOTE**

During operations with ice vanes extended, torque will decrease approximately 10%, fuel flow will decrease approximately 6%, and true airspeed will be reduced by approximately 10 knots.

Figure 7-90. One Engine Inoperative Max Cruise Power at 1700 RPM (Ice Vanes Retracted) - ISA +10°C (Sheet 1 of 2)



**ONE-ENGINE-INOPERATIVE MAXIMUM CRUISE POWER  
1700 RPM  
ISA +10°C**

WEIGHT→			12,000 POUNDS					10,000 POUNDS				
PRESSURE ALTITUDE	IOAT	OAT	TORQUE PER ENGINE	FUEL FLOW PER ENGINE	TOTAL FUEL FLOW	IAS	TAS	TORQUE PER ENGINE	FUEL FLOW PER ENGINE	TOTAL FUEL FLOW	IAS	TAS
FEET	°C	°C	PERCENT	LBS/HR	LBS/HR	KTS	KTS	PERCENT	LBS/HR	LBS/HR	KTS	KTS
0	28	25	83	652	652	173	179	83	651	651	176	182
2000	24	21	83	631	631	171	182	83	630	630	174	185
4000	20	17	83	611	611	169	185	83	611	611	172	189
6000	16	13	83	595	595	167	189	83	594	594	170	192
8000	13	9	83	582	582	165	192	83	581	581	168	196
10,000	9	5	80	553	553	159	191	80	555	555	164	196
12,000	5	1	76	523	523	154	191	77	525	525	159	197
14,000	1	-3	72	492	492	147	189	73	493	493	153	196
16,000	-3	-7	68	462	462	141	187	69	464	464	147	195
18,000	-8	-11	64	435	435	133	183	65	437	437	141	194
20,000	-12	-15	60	409	409	125	179	61	412	412	135	191
22,000	-16	-19	56	385	385	114	169	57	389	389	128	189
24,000	-19	-23	---	---	---	---	---	54	365	365	121	185
26,000	-24	-27	---	---	---	---	---	50	341	341	112	179
28,000	---	---	---	---	---	---	---	---	---	---	---	---
29,000	---	---	---	---	---	---	---	---	---	---	---	---
31,000	---	---	---	---	---	---	---	---	---	---	---	---
33,000	---	---	---	---	---	---	---	---	---	---	---	---
35,000	---	---	---	---	---	---	---	---	---	---	---	---

BT05286

**NOTE**

During operations with ice vanes extended, torque will decrease approximately 10%, fuel flow will decrease approximately 6%, and true airspeed will be reduced by approximately 10 knots.

Figure 7-90. One Engine Inoperative Max Cruise Power at 1700 RPM (Ice Vanes Retracted) - ISA +10°C (Sheet 2 of 2)

**ONE-ENGINE-INOPERATIVE MAXIMUM CRUISE POWER  
1700 RPM  
ISA +20°C**

WEIGHT→			16,000 POUNDS					14,000 POUNDS				
PRESSURE ALTITUDE	IOAT	OAT	TORQUE PER ENGINE	FUEL FLOW PER ENGINE	TOTAL FUEL FLOW	IAS	TAS	TORQUE PER ENGINE	FUEL FLOW PER ENGINE	TOTAL FUEL FLOW	IAS	TAS
FEET	°C	°C	PERCENT	LBS/HR	LBS/HR	KTS	KTS	PERCENT	LBS/HR	LBS/HR	KTS	KTS
0	38	35	83	656	656	163	171	83	655	655	168	177
2000	34	31	83	635	635	160	174	83	634	634	166	179
4000	30	27	81	606	606	155	173	82	608	608	162	181
6000	26	23	78	575	575	14	817	79	577	577	157	180
8000	22	19	75	544	544	141	167	76	547	547	151	179
10,000	18	5	71	512	512	130	160	72	516	516	145	177
12,000	14	11	---	---	---	---	---	69	485	485	137	174
14,000	10	7	---	---	---	---	---	63	450	450	124	163
16,000	---	---	---	---	---	---	---	---	---	---	---	---
18,000	---	---	---	---	---	---	---	---	---	---	---	---
20,000	---	---	---	---	---	---	---	---	---	---	---	---
22,000	---	---	---	---	---	---	---	---	---	---	---	---
24,000	---	---	---	---	---	---	---	---	---	---	---	---
26,000	---	---	---	---	---	---	---	---	---	---	---	---
28,000	---	---	---	---	---	---	---	---	---	---	---	---
29,000	---	---	---	---	---	---	---	---	---	---	---	---
31,000	---	---	---	---	---	---	---	---	---	---	---	---
33,000	---	---	---	---	---	---	---	---	---	---	---	---
35,000	---	---	---	---	---	---	---	---	---	---	---	---

BT05287

**NOTE**

During operations with ice vanes extended, torque will decrease approximately 10%, fuel flow will decrease approximately 6%, and true airspeed will be reduced by approximately 10 knots.

Figure 7-91. One Engine Inoperative Max Cruise Power at 1700 RPM (Ice Vanes Retracted) - ISA +20°C (Sheet 1 of 2)

**ONE-ENGINE-INOPERATIVE MAXIMUM CRUISE POWER  
1700 RPM  
ISA +20°C**

WEIGHT→			12,000 POUNDS					10,000 POUNDS				
PRESSURE ALTITUDE	IOAT	OAT	TORQUE PER ENGINE	FUEL FLOW PER ENGINE	TOTAL FUEL FLOW	IAS	TAS	TORQUE PER ENGINE	FUEL FLOW PER ENGINE	TOTAL FUEL FLOW	IAS	TAS
FEET	°C	°C	PERCENT	LBS/HR	LBS/HR	KTS	KTS	PERCENT	LBS/HR	LBS/HR	KTS	KTS
0	38	35	83	654	654	172	181	83	654	654	175	184
2000	34	31	83	633	633	170	184	83	633	633	173	187
4000	30	27	82	609	609	167	186	83	610	610	170	190
6000	26	23	80	579	579	162	186	80	580	580	166	191
8000	22	19	76	549	549	157	186	77	550	550	162	191
10,000	18	15	73	519	519	152	186	74	520	520	157	192
12,000	14	11	70	487	487	146	184	70	489	489	151	191
14,000	10	7	65	455	455	138	180	65	457	457	144	189
16,000	6	3	60	425	425	129	176	61	428	428	138	187
18,000	2	-1	57	399	399	120	170	58	403	403	132	185
20,000	-2	-5	---	---	---	---	---	54	377	377	125	181
22,000	-6	-9	---	---	---	---	---	51	354	354	117	177
24,000	-10	-13	---	---	---	---	---	47	331	331	108	170
26,000	---	---	---	---	---	---	---	---	---	---	---	---
28,000	---	---	---	---	---	---	---	---	---	---	---	---
29,000	---	---	---	---	---	---	---	---	---	---	---	---
31,000--	---	---	---	---	---	---	---	---	---	---	---	---
33,000	---	---	---	---	---	---	---	---	---	---	---	---
35,000	---	---	---	---	---	---	---	---	---	---	---	---

6T0528

**NOTE**

**During operations with ice vanes extended, torque will decrease approximately 10%, fuel flow will decrease approximately 6%, and true airspeed will be reduced by approximately 0 knots.**

Figure 7-91. One Engine Inoperative Max Cruise Power at 1700 RPM (Ice Vanes Retracted) - ISA +20°C (Sheet 2 of 2)

**ONE-ENGINE-INOPERATIVE MAXIMUM CRUISE POWER  
1700 RPM  
ISA +30°C**

WEIGHT→			16,000 POUNDS					14,000 POUNDS				
PRESSURE ALTITUDE	IOAT	OAT	TORQUE PER ENGINE	FUEL FLOW PER ENGINE	TOTAL FUEL FLOW	IAS	TAS	TORQUE PER ENGINE	FUEL FLOW PER ENGINE	TOTAL FUEL FLOW	IAS	TAS
FEET	°C	°C	PERCENT	LBS/HR	LBS/HR	KTS	KTS	PERCENT	LBS/HR	LBS/HR	KTS	KTS
0	47	45	75	625	625	151	161	76	627	627	159	170
2000	43	41	73	595	595	146	161	74	597	597	155	170
4000	39	37	71	565	565	139	158	72	568	568	150	170
6000	35	33	68	535	535	130	153	69	538	538	144	169
8000	32	29	---	---	---	---	---	67	508	508	138	167
10,000	28	25	---	---	---	---	---	63	476	476	129	162
12,000	---	---	---	---	---	---	---	---	---	---	---	---
14,000	---	---	---	---	---	---	---	---	---	---	---	---
16,000	---	---	---	---	---	---	---	---	---	---	---	---
18,000	---	---	---	---	---	---	---	---	---	---	---	---
20,000	---	---	---	---	---	---	---	---	---	---	---	---
22,000	---	---	---	---	---	---	---	---	---	---	---	---
24,000	---	---	---	---	---	---	---	---	---	---	---	---
26,000	---	---	---	---	---	---	---	---	---	---	---	---
28,000	---	---	---	---	---	---	---	---	---	---	---	---
29,000	---	---	---	---	---	---	---	---	---	---	---	---
31,000	---	---	---	---	---	---	---	---	---	---	---	---
33,000	---	---	---	---	---	---	---	---	---	---	---	---
35,000	---	---	---	---	---	---	---	---	---	---	---	---

BT05289

**NOTE**

During operations with- ice vanes extended, torque will decrease approximately 10%, fuel flow will decrease approximately 6%, and true airspeed will be reduced by approximately 10 knots.

Figure 7-92. One Engine Inoperative Max Cruise Power at 1700 RPM (Ice Vanes Retracted) - ISA +30°C (Sheet 1 of 2)

**ONE-ENGINE-INOPERATIVE MAXIMUM CRUISE POWER  
1700 RPM  
ISA +30°C**

WEIGHT→			12,000 POUNDS					10,000 POUNDS				
PRESSURE ALTITUDE	IOAT	OAT	TORQUE PER ENGINE	FUEL FLOW PER ENGINE	TOTAL FUEL FLOW	IAS	TAS	TORQUE PER ENGINE	FUEL FLOW PER ENGINE	TOTAL FUEL FLOW	IAS	TAS
FEET	°C	°C	PERCENT	LBS/HR	LBS/HR	KTS	KTS	PERCENT	LBS/HR	LBS/HR	KTS	KTS
0	48	45	76	628	628	165	176	77	629	629	168	179
2000	44	41	74	599	599	161	177	75	599	599	165	181
4000	40	37	72	569	569	156	177	73	570	570	161	182
6000	36	33	70	540	540	152	178	71	541	541	157	183
8000	32	29	67	511	511	147	177	68	512	512	152	184
10,000	28	25	64	480	480	141	176	65	481	481	147	184
12,000	24	21	61	449	449	134	173	62	451	451	142	183
14,000	20	17	58	420	420	126	169	58	422	422	136	181
16,000	16	13	53	389	389	114	159	54	393	393	128	178
18,000	12	9	---	---	---	---	---	49	362	362	118	170
20,000	8	5	---	---	---	---	---	45	336	336	109	163
22,000	---	---	---	---	---	---	---	---	---	---	---	---
24,000	---	---	---	---	---	---	---	---	---	---	---	---
26,000	---	---	---	---	---	---	---	---	---	---	---	---
28,000-	---	---	---	---	---	---	---	---	---	---	---	---
29,000	---	---	---	---	---	---	---	---	---	---	---	---
31,000	---	---	---	---	---	---	---	---	---	---	---	---
33,000	---	---	---	---	---	---	---	---	---	---	---	---
35,000	---	---	---	---	---	---	---	---	---	---	---	---

BT05292

**NOTE**

During operations with ice vanes extended, torque will decrease approximately 10%, fuel flow will decrease approximately 6%, and true airspeed will be reduced by approximately 10 knots.

Figure 7-92. One Engine Inoperative Max Cruise Power at 1700 RPM (Ice Vanes Retracted) - ISA +300C (Sheet 2 of 2)

**ONE-ENGINE-INOPERATIVE MAXIMUM CRUISE POWER  
1700 RPM  
ISA +37°C**

WEIGHT→			16,000 POUNDS					14,000 POUNDS				
PRESSURE ALTITUDE	IOAT	OAT	TORQUE PER ENGINE	FUEL FLOW PER ENGINE	TOTAL FUEL FLOW	IAS	TAS	TORQUE PER ENGINE	FUEL FLOW PER ENGINE	TOTAL FUEL FLOW	IAS	TAS
FEET	°C	°C	PERCENT	LBS/HR	LBS/HR	KTS	KTS	PERCENT	LBS/HR	LBS/HR	KTS	KTS
0	54	52	66	597	597	135	147	67	598	598	146	159
2000	50	48	---	---	---	---	---	66	569	569	143	159
4000	46	44	---	---	---	---	---	64	540	540	138	160
6000	42	40	---	---	---	---	---	62	512	512	133	159
8000	38	36	---	---	---	---	---	60	482	482	125	154
10,000	---	---	---	---	---	---	---	---	---	---	---	---
12,000	---	---	---	---	---	---	---	---	---	---	---	---
14,000	---	---	---	---	---	---	---	---	---	---	---	---
16,000	----	---	---	---	---	---	---	---	---	---	---	---
18,000	----	---	---	---	---	---	---	---	---	---	---	---
20,000	---	---	---	---	---	---	---	---	---	---	---	---
22,000	---	---	---	---	---	---	---	---	---	---	---	---
24,000	---	---	---	---	---	---	---	---	---	---	---	---
26,000	---	---	---	---	---	---	---	---	---	---	---	---
28,000	---	---	---	---	---	---	---	---	---	---	---	---
29,000	---	---	---	---	---	---	---	---	---	---	---	---
31,000	---	---	---	---	---	---	---	---	---	---	---	---
33,000	----	---	---	---	---	---	---	---	---	---	---	---
35,000	---	---	---	---	---	---	---	---	---	---	---	---

BT05290

**NOTE**

During operations with ice vanes extended, torque will decrease approximately 10%, fuel flow will decrease approximately 6%, and true airspeed will be reduced by approximately 10 knots.

Figure 7-93, One Engine Inoperative Max Cruise Power at 1700 RPM (Ice Vanes Retracted) - ISA +37°C (Sheet 1 of 2)

**ONE-ENGINE-INOPERATIVE MAXIMUM CRUISE POWER  
1700 RPM  
ISA +37°C**

WEIGHT→			12,000 POUNDS					10,000 POUNDS				
PRESSURE ALTITUDE	IOAT	OAT	TORQUE PER ENGINE	FUEL FLOW PER ENGINE	TOTAL FUEL FLOW	IAS	TAS	TORQUE PER ENGINE	FUEL FLOW PER ENGINE	TOTAL FUEL FLOW	IAS	TAS
FEET	°C	°C	PERCENT	LBS/HR	LBS/HR	KTS	KTS	PERCENT	LBS/HR	LBS/HR	KTS	KTS
0	55	52	68	600	600	154	166	68	600	600	159	171
2000	51	48	67	570	570	151	168	67	571	571	156	174
4000	47	44	65	541	541	147	169	66	542	542	153	176
6000	43	40	63	514	514	143	170	64	515	515	150	177
8000	39	36	61	485	485	138	169	62	487	487	145	178
10,000	35	32	58	455	455	131	167	59	457	457	140	177
12,000	31	28	55	423	423	123	316	56	426	426	134	175
14,000	26	24	51	393	393	112	153	52	397	397	127	173
16,000	23	20	---	---	---	---	---	49	368	368	119	168
18,000	19	16	---	---	---	---	---	44	338	338	108	158
20,000	---	---	---	---	---	---	---	---	---	---	---	---
22,000	---	---	---	---	---	---	---	---	---	---	---	---
24,000	---	---	---	---	---	---	---	---	---	---	---	---
26,000	---	---	---	---	---	---	---	---	---	---	---	---
28,000	---	---	---	---	---	---	---	---	---	---	---	---
29,000	---	---	---	---	---	---	---	---	---	---	---	---
31,000	---	---	---	---	---	---	---	---	---	---	---	---
33,000	---	---	---	---	---	---	---	---	---	---	---	---
35,000	---	---	---	---	---	---	---	---	---	---	---	---

BT05291

**NOTE**

During operations with ice vanes extended, torque will decrease approximately 10%, fuel flow will decrease approximately 6%, and true airspeed will be reduced by approximately 10 knots.

Figure 7-93. One Engine Inoperative Max Cruise Power at 1700 RPM (Ice Vanes Retracted) - ISA +37°C (Sheet 2 of 2)

**TIME, FUEL, AND DISTANCE TO DESCEND**

ASSOCIATED CONDITIONS:

POWER..... ASI REQUIRED TO DESCEND  
 AT 1500 FT/MIN  
 LANDING GEAR ..... UP  
 FLAPS ..... UP

EXAMPLE:

INITIAL ALTITUDE.....25,000 FT  
 FINAL ALTITUDE.....5998 FT  
 TIME TO DESCEND (17-4) .....153 MIN  
 FUEL TO DESCEND (206-558) .....148 LBS  
 DISTANCE TO DESCEND (62-13) .....49 NM

DESCENT SPEED:  $M_{MO}$  OR 200 KNOTS, WHICHEVER IS LESS.

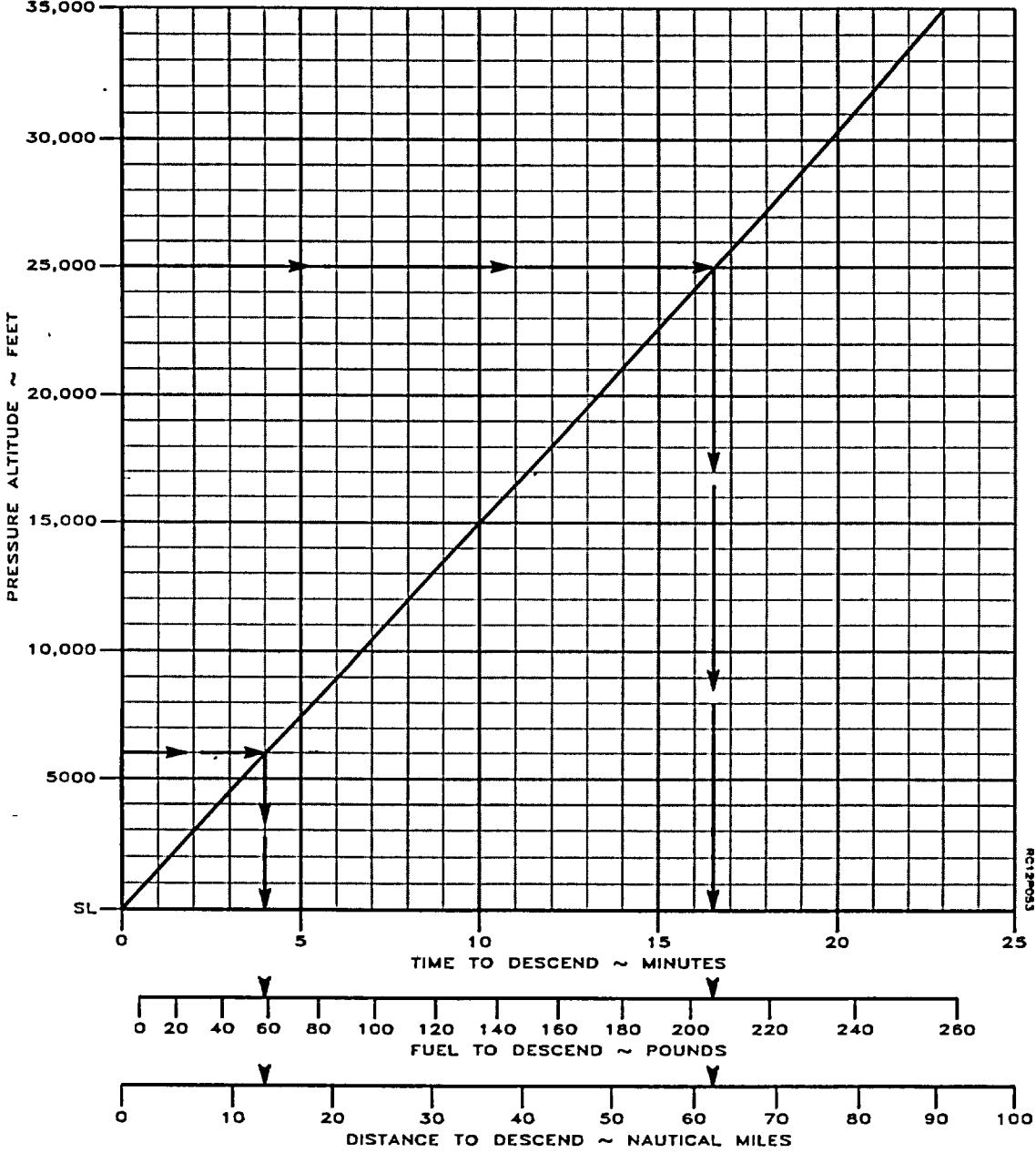

Figure 7-94. Time, Fuel, and Distance to Descend



**CLIMB - BALKED LANDING**

ASSOCIATED CONDITIONS:  
 POWER..... TAKEOFF  
 FLAPS..... DOWN  
 LANDING GEAR..... DOWN

EXAMPLE:  
 FAT .....20C  
 PRESSURE ALTITUDE .....6400 FT  
 WEIGHT.....15,199 LBS  
 RATE-OF-CMB.....1444 FT/MIN  
 CLIMB GRADIENT.....9.6 X

CUMS SPEED: 111 KNOTS (ALL WEIGHTS)

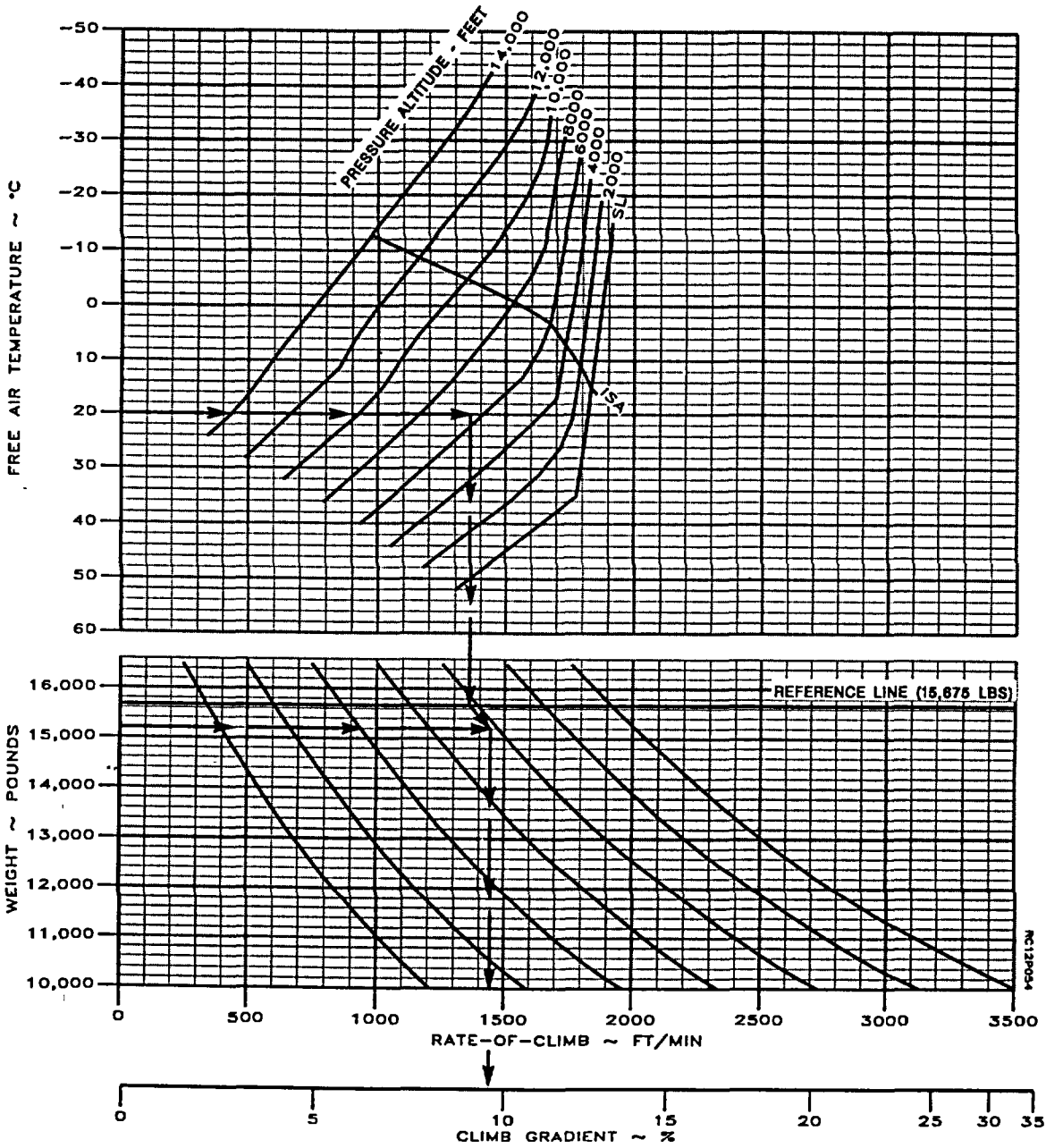

Figure 7-95. Climb - Balked Landing

**NORMAL LANDING DISTANCE - FLAPS DOWN**

ASSOCIATED CONDITIONS:

POWER.....RETARDED TO MAINTAIN 500 FT/MIN ON FINAL APPROACH  
 RUNWAY .....PAVED, DRY SURFACE  
 POWER LEVERS.....GROUND FINE AT TOUCHDOWN  
 BRAKING .....MAXIMUM WITHOUT SLIDING TIRES  
 OBSTACLE HEIGHT.....50 FT

EXAMPLE:

FAT .....20°C  
 FIELD PRESSURE ALTITUDE .....5998 FT  
 RUNWAY GRADIENT .....0.3% UP  
 HEADWIND COMPONENT .....10 KTS  
 GROUND ROLL.....1857 FT  
 TOTAL DISTANCE OVER 50-FT OBSTACLE .....4702 FT

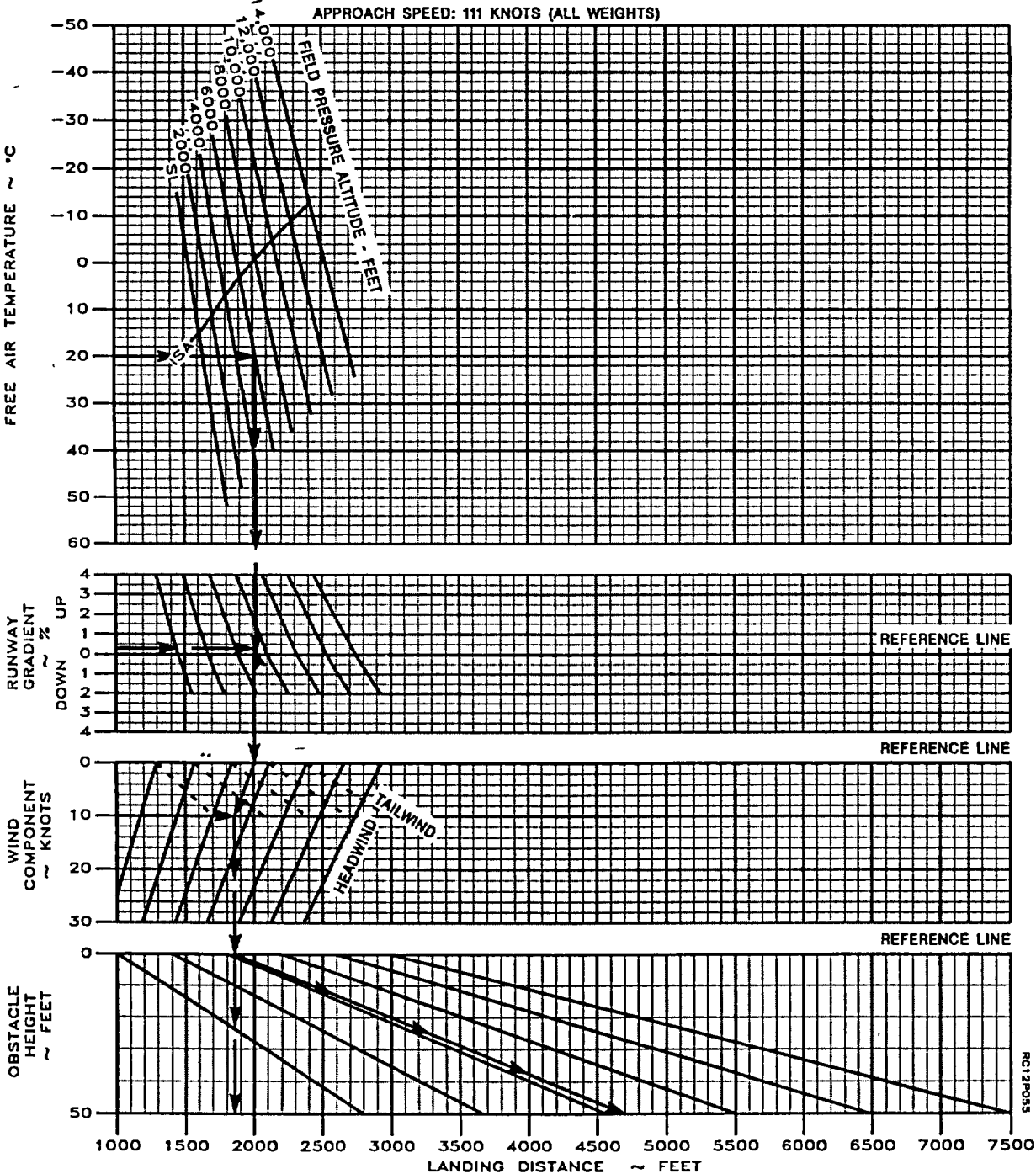

Figure 7-96. Normal Landing Distance - Flaps Down

**LANDING DISTANCE - FLAPS UP**

ASSOCIATED CONDITIONS:

POWER..... RETARDED TO MAINTAIN  
 500 FT/MIN ON FINAL  
 APPROACH  
 RUNWAY ..... PAVED, DRY SURFACE  
 APPROACH SPEED ..... KIAS AS TABULATED  
 POWER LEVERS..... GROUND FINE AT  
 TOUCHDOWN  
 BRAKING ..... MAXIMUM WITHOUT  
 SLIDING TIRES  
 OBSTACLE HEIGHT..... 50 FT

EXAMPLE:

FLAPS-DOWN NORMAL LANDING DISTANCE 4702 FT  
 LANDING WEIGHT ..... 15,199 LBS  
 FLAPS-UP LANDING DISTANCE..... 7138 FT  
 APPROACH SPEED..... 136 KTS

WEIGHT ~POUNDS	APPROACH SPEEDS ~KNOTS
15,675	138
15,000	135
14,000	131
13,000	127
12,000	122
11,000	117
10,000	111

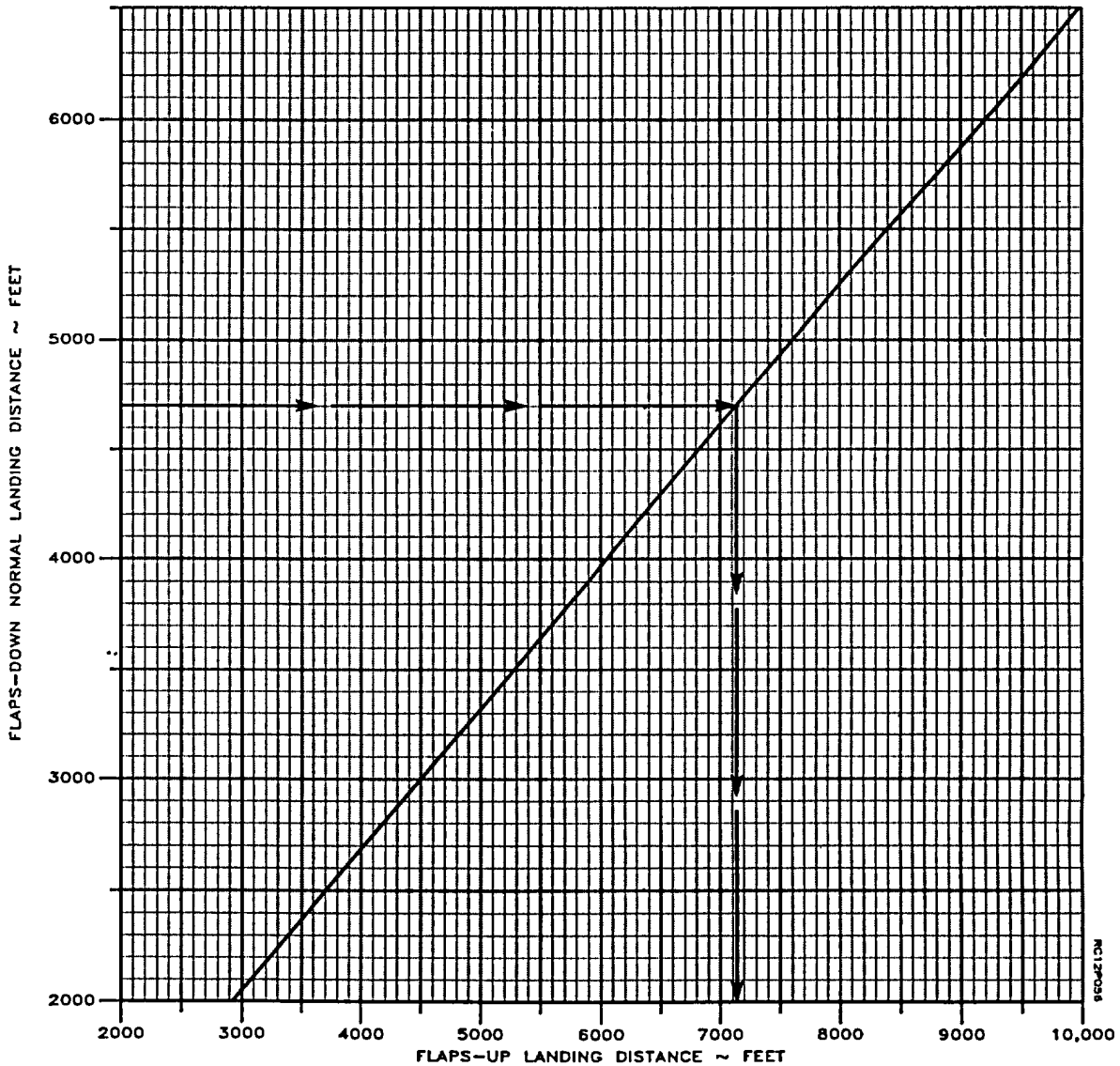

Figure 7-97. Normal Landing Distance - Flaps Up

**LANDING DISTANCE - ONE ENGINE INOPERATIVE**

**FLAPS DOWN**

APPROACH SPEED: 111 KNOTS (ALL WEIGHTS)

ASSOCIATED CONDITIONS:

POWER.....RETARDED TO MAINTAIN  
500 FT/MIN ON FINAL  
APPROACH

PROPELLER CONTROL

INOPERATIVE ENGINE ..... FEATHERED  
RUNWAY .....PAVED. DRY SURFACE

POWER LEVERS:

OPERATIVE ENGINE..GROUND FINE AT  
TOUCHDOWN

OBSTACLE HEIGHT.....50 FT

EXAMPLE:

FLAPS-DOWN NORMAL LANDING DISTANCE.....4702 FT  
ONE-ENGINE-INOPERATIVE LANDING DISTANCE .5834 FT

*Figure 7-98. Landing Distance - One Engine Inoperative - Flaps Down*

## CHAPTER 7A

## PERFORMANCE DATA E

## 7A-1. INTRODUCTION TO PERFORMANCE.

**NOTE**

**Chapter 7A contains performance data for the model RC-12Q aircraft. Refer to Chapter 7 for the RC-12P performance data.**

The graphs and tables in this chapter present performance information for takeoff, climb, flight planning, and landing at various parameters of weight, power, altitude, and temperature. Examples explaining appropriate use are provided for performance graphs.

**NOTE**

**All flight performance data are based on JP-4 fuel. The change in fuel flow and other power/ torque data when using JP-5, JP-8, aviation gasoline, or any other approved fuel is insignificant. The only exceptions are figures 7A-51, 7A-63, 7A-72, 7A-81, 7A-82, 7A-83, 7A-84, and 7A-85 which address aircraft range and endurance when the fuel density is approximately 6.7 pounds per gallon.**

## 7A-2. HOW TO USE GRAPHS.

1. All airspeeds and references to airspeeds in this chapter are indicated airspeeds unless otherwise noted.
2. A reference line indicates where to begin following the guidelines. Always project to the reference line first, then follow the guidelines to the next item by maintaining the same proportional distance between the guideline above and the guideline below the projected line. For instance, if the projected line intersects the reference line in the ratio of 30% down/70% up between the guidelines, then maintain this same 30%/70% relationship between the guidelines all the way to the next item.
3. The Airspeed Calibration - Normal System - Takeoff Ground Roll graph was used to obtain VI and VR indicated airspeeds (IAS). All other indicated airspeeds (except stall speeds) were obtained by using the Airspeed Calibration - Normal System graph.
4. The associated conditions define the specific conditions from which performance parameters

have been determined. They are not intended to

be used as instructions; however, performance values determined from graphs can only be achieved if the specified conditions exist.

5. The graphs assume that the full amount of usable fuel is available for all approved flight conditions.
6. Notes have been provided to approximate performance with the ice vanes extended. The effect will vary, depending upon airspeed, temperature, and altitude.

## 7A-3. PERFORMANCE ILLUSTRATIONS, GRAPHS, AND TABLES.

*a. Takeoff Path Profile - One Engine Inoperative.*

(1) *Description.* The Takeoff Path Profile - One Engine Inoperative illustration (fig. 7A-1) describes the nomenclature of the various segments of a takeoff and climbout with one engine inoperative from brake release to 1500 feet AGL.

(2) *Purpose.* This figure provides a schematic profile of a one engine inoperative takeoff, from brake release to 1500 feet AGL, to help the pilot visualize the process and to show where each segment begins and ends.

*b. Airspeed Calibration - Normal System, Takeoff Ground Roll.*

(1) *Description.* The Airspeed Calibration - Normal System, Takeoff Ground Roll graph (fig. 7A-2) depicts the relationship between indicated airspeed and calibrated airspeed for the normal aircraft static air source during the takeoff ground roll.

(2) *Purpose.* This graph is used to determine calibrated airspeed for a given indicated airspeed. Data is provided for up and approach flap settings with the gear down. The indicated airspeed values on this graph assume zero instrument error.

*c. Airspeed Calibration - Normal System.*

(1) *Description.* The Airspeed Calibration - Normal System graph (fig. 7A-3) depicts the relationship between indicated airspeed and calibrated airspeed for the normal aircraft static air source during flight.

(2) *Purpose.* This graph is used to determine calibrated airspeed for a given indicated airspeed using the

normal aircraft static air system. The data is shown on two graphs. One graph is for airspeeds between 80 and 200 knots with lines for flaps down with gear down, flaps approach with gear down, and flaps approach with gear up. The other graph is for airspeeds between 100 and 250 knots with lines for flaps up with gear down and flaps up with gear up. The indicated airspeed values on this graph assume zero instrument error.

*d. Altimeter Correction - Normal System.*

(1) *Description.* The Altimeter Correction - Normal System graph (fig. 7A-4) provides the altitude correction to be made to the altimeter reading when the normal aircraft static source is being used.

(2) *Purpose.* This graph is used to determine altimeter correction factors to be added to indicated altitude for flaps settings of up, approach, and down at various indicated airspeeds to find true pressure altitude for a given indicated pressure altitude. The indicated airspeed values on this graph assume zero instrument error.

*e. Airspeed Calibration - Alternate System.*

(1) *Description.* The Airspeed Calibration - Alternate System graph (fig. 7A-5) depicts the relationship between indicated airspeed and calibrated airspeed for the alternate aircraft static air source.

(2) *Purpose.* This graph is used to determine calibrated airspeed for a given indicated airspeed using the alternate aircraft static air system.

*f. Altimeter Correction - Alternate System.*

(1) *Description.* The Altimeter Correction - Alternate System graph (fig. 7A-6) provides the altitude correction to be made to the altimeter reading when the alternate aircraft static air source is being used.

(2) *Purpose.* This graph is used to determine altimeter correction factors to be added or subtracted to indicated altitude for a given indicated airspeed and pressure altitude.

*g. Indicated Outside Air Temperature Correction.*

(1) *Description.* The Indicated Outside Air Temperature Correction graph (fig. 7A-7) provides temperature corrections to be made to indicated free air temperature to obtain true free air temperature.

(2) *Purpose.* This graph is used to determine the correction factor which must be added to the reading on the free air temperature gage to obtain true free air temperature at a given calibrated airspeed and pressure

altitude. The graph assumes standard day (ISA) conditions.

*h. ISA Conversion.*

(1) *Description.* The ISA Conversion graph (fig. 7A-8) allows conversion to ISA.

(2) *Purpose.* This graph is used to convert to SA, given free air temperature in degrees Celsius and pressure altitude in feet.

*i. Fahrenheit to Celsius Temperature Conversion.*

(1) *Description.* The Fahrenheit to Celsius Temperature Conversion graph (fig. 7A-9) depicts the relationship between temperature in degrees Fahrenheit and degrees Celsius.

(2) *Purpose.* This graph is used to convert from degrees Fahrenheit to degrees Celsius or degrees Celsius to degrees Fahrenheit.

*j. Static Take-off Power at 1700 RPM, Ice Vanes Retracted or Extended.*

(1) *Description.* The Static Take-off Power at 1700 RPM, Ice Vanes Retracted or Extended graphs (fig. 7A-10 and 7A-11) depict the power which must be available for takeoff without exceeding engine limitations.

(2) *Purpose.* These graphs are used to determine static take-off power available at 1700 RPM for a given free air temperature in degrees Celsius and field pressure altitude in feet. One graph is provided for ice vanes retracted and the other for ice vanes extended. Torque will increase with increasing airspeed.

*k. Wind Components.*

(1) *Description.* The Wind Components graph (fig. 7A-12) allows conversion of wind direction, wind speed, and angle between wind direction and flight path to headwind and crosswind speed components.

(2) *Purpose.* This graph is used to determine the headwind component and crosswind component in knots when the wind speed in knots and the angle between the wind direction and flight path in degrees are known.

*l. Maximum Take-off Weight Permitted by Enroute Climb Requirements.*

(1) *Description.* The Maximum Take-off Weight Permitted by Enroute Climb Requirements graph

(fig. 7A-13) provides the one engine inoperative climb performance weight limit as a function of field pressure altitude and temperature.

(2) *Purpose.* This graph is used to determine the maximum weight at which the aircraft can take off and still meet the minimum one engine inoperative rate of climb capability, given field pressure altitude in feet and temperature in degrees Celsius. Refer to the Climb - One Engine Inoperative graph for the actual climb capabilities applicable to the temperature and altitude being considered. For operation with ice vanes extended, reduce the weight determined from the graph by 1800 pounds.

*m. Maximum Take-off Weight To Achieve Positive One Engine Climb At Lift-off - Flaps Up.*

(1) *Description.* The Maximum Take-off Weight to Achieve Positive One Engine Inoperative Climb at Liftoff - Flaps Up graph (fig. 7A-14) provides the one engine inoperative liftoff climb performance weight limit as a function of field pressure altitude and temperature.

(2) *Purpose.* This graph is used to determine the maximum weight at which the aircraft can take off with flaps up, have an engine failure, and be able to attain a positive rate of climb at liftoff, given field pressure altitude in feet and free air temperature in degrees Celsius. For operation with ice vanes extended, add 1700 feet to field pressure altitude before entering graph.

*n. Maximum Take-off Weight as Limited by Tire Speed - Flaps Up.*

(1) *Description.* The Maximum Take-off Weight as Limited by Tire Speed - Flaps Up graph (fig. 7A-15) provides the takeoff tire speed weight limit as a function of field pressure altitude, temperature, and wind component.

(2) *Purpose.* This graph is used to determine the maximum weight at which the aircraft can take off and not exceed tire limitations, given free air temperature in degrees Celsius, field pressure altitude in feet, and head or tail wind component in knots.

*o. Take-off Speeds (KIAS) - Flaps Up.*

(1) *Description.* The Take-off Speeds (KIAS) - Flaps Up table (fig. 7A-16) allows selection of the proper takeoff speeds for takeoff weight, pressure altitude, and temperature.

(2) *Purpose.* This table is used to determine  $V_1$ ,  $V_R$ ,  $V_2$ , and  $V_{50}$ . For each takeoff, given free air

temperature in degrees Celsius, field pressure altitude in feet, and takeoff gross weight in pounds.

*p. Take-off - Flaps Up.*

(1) *Description.* The Take-off Distance Over 50 Foot Obstacle - Flaps Up graph (fig. 7A-17) depicts the relationship of takeoff distance to free air temperature, field pressure altitude, takeoff weight, runway gradient, and wind component.

(2) *Purpose.* This graph is used to determine the ground roll distance or the total distance required to take off and clear a 50 foot obstacle, given free air temperature in degrees Celsius, field pressure altitude in feet, aircraft takeoff weight in pounds, runway gradient in % up or down, and head or tail wind component in knots. For operation with ice vanes extended, increase total distance by 33%. Consult Maximum Take-off weight - Flaps Up -as limited by Tire Speed graph for possible tailwind prohibitions.

*q. Accelerate-Stop - Flaps Up.*

(1) *Description.* The Accelerate-Stop - Flaps Up graph (fig. 7A-18) depicts the distance required to accelerate to decision speed ( $V_1$ ) then stop.

(2) *Purpose.* This graph is used to determine the total runway length required to accelerate to  $V_1$  (takeoff decision speed), set power levers to ground fine at  $V_1$ , then use maximum braking (without sliding tires) until the aircraft is stopped, given free air temperature in degrees Celsius, field pressure altitude in feet, takeoff weight in pounds, up or down runway gradient in %, and head or tail wind component in knots. For operations with ice vanes extended, increase distance by 7%. Consult Maximum Take-Off Weight - Flaps Up As Limited by Tire Speed graph for possible tailwind prohibitions.

*r. Accelerate-Go - Flaps Up.*

(1) *Description.* The Accelerate-Go Distance Over 50 Foot Obstacle - Flaps Up graph (fig.7A-19) depicts the total distance required to accelerate to takeoff airspeed, have an engine failure, then continue the takeoff until 50 feet above the runway.

(2) *Purpose.* This graph is used to determine the total distance required to accelerate to  $V_1$  (takeoff decision speed), have an engine failure, then continue the climb until 50 feet above the runway. For operation with ice vanes extended, increase distance by 35%. Consult Maximum Take-Off Weight - Flaps Up As Limited by Tire Speed graph for possible tailwind prohibitions.

s. *Net Take-off Flight Path - First Segment - Flaps Up.*

(1) *Description.* The Net Take-off Flight Path - First Segment - Flaps Up graph (fig. 7A-20) depicts the net climb gradient for the first segment of a one engine inoperative climb.

(2) *Purpose.* This graph is used to determine the climb gradient in % for a one engine inoperative climb from liftoff until the landing gear completes the retraction cycle, given free air temperature in degrees Celsius, field pressure altitude in feet, takeoff weight in pounds, and head or tail wind in knots. For operation with ice vanes extended, decrease net climb gradient by 1.2 percentage points.

t. *Net Take-off Flight Path - Second Segment - Flaps Up.*

(1) *Description.* The Net Take-off Flight Path - Second Segment - Flaps Up graph (fig. 7A-21) depicts the net climb gradient for the second segment of a one engine inoperative climb.

(2) *Purpose.* This graph is used to determine the climb gradient in % for a one engine inoperative climb from completion of the landing gear retraction cycle, until reaching 500 feet above the runway, given free air temperature in degrees Celsius, field pressure altitude in feet, takeoff weight in pounds, and wind component in knots. For operation with ice vanes extended, decrease net climb gradient by 1.3 percentage points.

u. *Horizontal Distance From Reference Zero to Third Segment Climb - Flaps Up.*

(1) *Description.* The Horizontal Distance from Reference Zero to Third Segment Climb - Flaps Up graph (fig. 7A-22) depicts the horizontal distance traveled to the third segment climb of a one engine inoperative climb.

(2) *Purpose.* This graph is used to determine the horizontal distance required for a one engine inoperative climb from a point 50 feet above the runway (reference zero) to a point where the third segment climb has been reached, given free air temperature in degrees Celsius, field pressure altitude in feet, takeoff weight in pounds, and head or tail wind component in knots. For operation with ice vanes extended, increase free air temperature by 12aC positive before entering graph.

v. *Maximum Take-off Weight to Achieve One-engine Inoperative Climb at Liftoff - Flaps Approach.*

(1) *Description.* The Maximum Take-off Weight to Achieve Positive One-engine Inoperative Climb at Liftoff - Flaps Approach graph (fig. 7A-23) provides the one engine inoperative liftoff climb

performance weight limit as a function of field pressure altitude and temperature.

(2) *Purpose.* This graph is used to determine the maximum weight at which the aircraft can take off and achieve a positive rate of climb after an engine failure at liftoff, given field pressure altitude in feet and free air temperature in degrees Celsius. For operation with ice vanes extended, add 1500 feet to field pressure altitude before entering graph.

w. *Maximum Take-off Weight as Limited by Tire Speed - Flaps Approach.*

(1) *Description.* The Maximum Take-off Weight as Limited by Tire Speed - Flaps Approach graph (fig. 7A-24) provides the takeoff tire speed weight limit as a function of field pressure altitude, temperature, and wind component.

(2) *Purpose.* This graph is used to determine the maximum weight at which the aircraft can take off and not exceed tire limitations, given free air temperature in degrees Celsius, field pressure altitude in feet, and head or tail wind component in knots.

x. *Take-off Speeds - Flaps Approach.*

(1) *Description.* The Take-off Speeds - Flaps Approach table (fig. 7A-25) allows selection of the proper takeoff speeds for takeoff weight, pressure altitude, and temperature.

(2) *Purpose.* This table is used to determine  $V_1$ ,  $V_R$ ,  $V_2$ , and  $V_{50}$  for each takeoff, given free air temperature in degrees Celsius, field pressure altitude in feet, and takeoff gross weight in pounds.

y. *Take-off Distance - Flaps Approach.*

(1) *Description.* The Take-off Distance Over 50 Foot Obstacle - Flaps Approach graph (fig. 7A-26) depicts the relationship of takeoff distance to free air temperature, field pressure altitude, takeoff weight, runway gradient, and wind component.

(2) *Purpose.* This graph is used to determine the ground roll and total distance required to take off and clear a 50 foot obstacle, given free air temperature in degrees Celsius, field pressure altitude in feet, aircraft take-off weight in pounds, runway gradient in % up or down, and head or tail wind component in knots. For operations with ice vanes extended, increase distance by 28%. Consult



Maximum Take-Off Weight - Flaps Approach As Limited By Tire Speed graph for possible tailwind prohibitions.

*z. Accelerate Stop - Flaps Approach.*

(1) *Description.* The Accelerate-Stop - Flaps Approach graph (fig. 7A-27) depicts the distance required to accelerate to V1 (takeoff decision speed) then stop.

(2) *Purpose.* This graph is used to determine the total runway length required to accelerate to V1 (take-off decision speed), set power levers to ground fine at VI, then use maximum braking (without sliding tires) until the aircraft is stopped, given free air temperature in degrees Celsius, field pressure altitude in feet, takeoff weight in pounds, up or down runway gradient in %, and head or tail wind component in knots. For operation with ice vanes extended, increase distance by 6%. Consult Maximum Take-Off Weight - Flaps Approach As Limited By Tire Speed graph for possible tailwind prohibitions.

*aa. Accelerate Go - Flaps Approach.*

(1) *Description.* The Accelerate Go Distance Over 50 Foot Obstacle - Flaps Approach graph (fig.7A-28) depicts the total distance required to accelerate to takeoff airspeed, have an engine failure, then continue the takeoff until 50 feet above the runway.

(2) *Purpose.* This graph is used to determine the total distance required to accelerate to VI (takeoff decision speed), have an engine failure, then continue the climb until 50 feet above the runway, given free air temperature in degrees Celsius, field pressure altitude in feet, takeoff weight in pounds, up or down runway gradient in %, and head or tail wind component in knots. For operation with ice vanes extended, increase distance by 35%. Consult Maximum Take-Off Weight - Flaps Approach As Limited By Tire Speed graph for possible tailwind prohibitions.

*ab. Net Take-off Flight Path - First Segment -Flaps Approach.*

(1) *Description.* The Net Take-off Flight Path -First Segment - Flaps Approach graph (fig. 7A-29) depicts the net climb gradient for the first segment of a one engine inoperative climb.

(2) *Purpose.* This graph is used to determine the climb gradient in % for a one engine inoperative climb from liftoff until the landing gear completes the retraction cycle, given free air temperature in degrees Celsius, field pressure altitude in feet, takeoff weight in pounds, and head or tail wind in knots. For operation with ice vanes extended, decrease net climb gradient by 1.1 percentage points.

*ac. Net Take-off Flight Path - Second Segment - Flaps Approach.*

(1) *Description.* The Net Take-off Flight Path -Second Segment - Flaps Approach graph (fig. 7A-30) depicts the net climb gradient for the second segment of a one engine inoperative climb.

(2) *Purpose.* This graph is used to determine the climb gradient in % for a one engine inoperative climb from completion of the landing gear retraction cycle, until reaching 500 feet above the runway, given free air temperature in degrees Celsius, field pressure altitude in feet, takeoff weight in pounds, and head or tail wind in knots. For operation with ice vanes extended, decrease net climb gradient by 1.2 percentage points.

*ad. Horizontal Distance from Reference Zero to Third Segment Climb - Flaps Approach.*

(1) *Description.* The Horizontal Distance from Reference Zero to Third Segment Climb - Flaps Approach graph (fig. 7A-31) depicts the horizontal distance traveled to the third segment of a one engine inoperative climb.

(2) *Purpose.* This graph is used to determine the horizontal distance required for a one engine inoperative climb from a point 50 feet above the runway (reference zero) to a point where the third segment climb has been reached, given free air temperature in degrees Celsius, field pressure altitude in feet, takeoff weight in pounds, and head or tail wind component in knots. For operation with ice vanes extended, increase free air temperature by 12°C before entering graph.

*ae. Close-in Take-off Flight Path.*

(1) *Description.* The Close-in Take-off Flight Path - Flaps Approach graph (fig. 7A-32) depicts the climb gradient required to clear an obstacle within 1000 feet of reference zero.

(2) *Purpose.* This graph is used to determine net climb gradient in % required to clear an obstacle of known height plus a desired margin of clearance, given the horizontal distance of the obstacle from reference zero in feet.

*af. Distant Take-off Flight Path.*

(1) *Description.* The Distant Take-off Flight Path - Flaps Approach graph (fig. 7A-33) depicts the climb gradient required to clear an obstacle within 2.4 nautical miles from reference zero.

(2) *Purpose.* This graph is used to determine net climb gradient in % required to clear an obstacle of

known height plus a desired margin of clearance, given the horizontal distance of the obstacle from reference zero in nautical miles.

*ag. Net Take-off Flight Path - Third Segment.*

(1) *Description.* The Net Take-off Flight Path -Third Segment graph (fig. 7A-34) depicts the climb gradient for the third segment of a one engine inoperative climb.

(2) *Purpose.* This graph is used to determine the net climb gradient in % for a one engine inoperative climb from 500 feet above the runway to 1500 feet above the runway at VENR, given free air temperature in degrees Celsius, pressure altitude in feet, aircraft weight in pounds, and head or tail wind component in knots. For operation with ice vanes extended, decrease net climb gradient by 1.5 percentage points.

*ah. Climb - Two Engine - Flaps Up.*

(1) *Description.* The Climb - Two Engine - Flaps Up graph (fig. 7A-35) depicts rate of climb for two engine operation.

(2) *Purpose.* This graph is used to determine the rate of climb in feet per minute and climb gradient in % for a two engine climb with flaps up, given free air temperature in degrees Celsius, pressure altitude in feet, and aircraft weight in pounds. For operation with ice vanes extended, rate of climb will be reduced by approximately 500 feet per minute.

*ai. Climb - Two Engine - Flaps Approach.*

(1) *Description.* The Climb - Two Engine - Flaps Approach graph (fig. 7A-36) depicts rate of climb for two engine operation.

(2) *Purpose.* This graph is used to determine the rate of climb in feet per minute and climb gradient in % for a two engine climb with flaps approach, given free air temperature in degrees Celsius, pressure altitude in feet, and aircraft weight in pounds. For operation with ice vanes extended, rate of climb will be reduced by approximately 500 feet per minute.

*aj. Climb - One Engine Inoperative.*

(1) *Description.* The Climb - One Engine Inoperative graph (fig. 7A-37) depicts the rate of climb to be expected in feet per minute at 130 knots for all aircraft weights with one propeller feathered, landing gear and flaps retracted, and maximum continuous power on the operating engine.

(2) *Purpose.* This graph is used to determine the rate of climb in feet per minute and climb gradient in % for a one engine inoperative climb with gear and flaps

up, given free air temperature in degrees Celsius, pressure altitude in feet, and aircraft weight in pounds. For operation with ice vanes extended, rate of climb will be reduced by approximately 220 feet per minute.

*ak. Service Ceiling - One Engine Inoperative.*

(1) *Description.* The Service Ceiling - One Engine Inoperative graph (fig. 7A-38) depicts the maximum pressure altitude at which the aircraft is capable of climbing at 50 feet per minute with one propeller feathered.

(2) *Purpose.* This graph is used to determine the maximum pressure altitude at which the aircraft is capable of climbing at 50 feet per minute with one propeller feathered, given free air temperature in degrees Celsius and aircraft weight in pounds. For operation with ice vanes extended, the service ceiling will be lowered by approximately 1900 feet.

*al. Time, Fuel, and Distance to Cruise Climb.*

(1) *Description.* The Time, Fuel, and Distance to Cruise Climb graph (fig. 7A-39) depicts the time, fuel, and distance to cruise climb.

(2) *Purpose.* This graph is used to determine the time, fuel, and distance required to cruise climb, given the beginning and ending free air temperature in degrees Celsius, beginning and ending pressure altitude in feet, and the initial climb aircraft weight in pounds. To account for start, taxi, and takeoff add 120 pounds of fuel. For operation with ice vanes extended, add 17°C to the actual FAT before entering the graph.

*am. Maximum Cruise Power at 1700 RPM.*

(1) *Description.* The Maximum Cruise Power at 1700 RPM tables (fig. 7A-40 through 7A-47) show fuel flow, airspeed, and torque for various flight conditions.

(2) *Purpose.* These tables are used to determine fuel flow per engine, total fuel flow, indicated air-speed, and true airspeed, given pressure altitude in feet, indicated free air temperature in degrees Celsius, free air temperature in degrees Celsius, aircraft weight in pounds, and torque per engine in percent. During operations with ice vanes extended, torque will decrease approximately 12%, fuel flow will decrease approximately 8%, and true airspeed will be reduced by approximately 15 knots.

*an. Maximum Cruise Speeds at 1700 RPM.*

(1) *Description.* The Maximum Cruise Speeds at 1700 RPM graph (fig. 7A-48) depicts the relationship

between maximum cruise speed, pressure altitude, ISA condition, and aircraft weight in pounds. During operation with ice vanes extended, true airspeed will be reduced approximately 15 knots.

(2) *Purpose.* This graph is used to determine maximum cruise speed, given pressure altitude in feet and ISA condition, and aircraft weight in pounds. During operation with ice vanes extended, true airspeed will be reduced by approximately 15 knots.

*ao. Maximum Cruise Power At 1700 RPM.*

(1) *Description.* The Maximum Cruise Power At 1700 RPM graph (fig. 7A-49) depicts the recommended torque setting to attain maximum cruise power.

(2) *Purpose.* This graph is used to determine the recommended torque setting for maximum cruise power, given indicated free air temperature in degrees Celsius, pressure altitude in feet, and aircraft weight in pounds. During operation with ice vanes extended, torque will decrease approximately 12%.

*ap. Fuel Flow at Maximum Cruise Power at 1700 RPM.*

(1) *Description.* The Fuel Flow at Maximum Cruise Power at 1700 RPM graph (fig. 7A-50) depicts the fuel flow per engine in pounds per hour at maximum cruise power.

(2) *Purpose.* This graph is used to determine maximum cruise power fuel flow per engine given indicated free air temperature in degrees Celsius, pressure altitude in feet, and aircraft weight in pounds. During operation with ice vanes extended, fuel flow will decrease 8%.

*aq. Range Profile Maximum Cruise Power at 1700 RPM.*

(1) *Description.* The Range Profile Maximum Cruise Power at 1700 RPM graph (fig. 7A-51) depicts range at maximum cruise power.

(2) *Purpose.* This graph is used to determine range in nautical miles for various fuel loads and fuel tank combinations, given pressure altitude in feet and true airspeed in knots. Range allows for start, taxi, and run up; includes cruise climb descent; and allows for 45 minutes reserve fuel at maximum range power. At 16,620 pounds ramp weight, the maximum zero fuel weight limitation of 13,100 pounds would be exceeded at fuel loading less than 3520 pounds.

*ar. Normal Cruise Power at 1500 RPM.*

(1) *Description.* The Normal Cruise Power at 1500 RPM tables (fig. 7A-52 through 7A-59) show fuel flow, airspeed, and torque for various flight conditions.

(2) *Purpose.* These tables are used to determine fuel flow per engine, total fuel flow, indicated airspeed, and true airspeed, given pressure altitude in feet, indicated free air temperature in degrees Celsius, free air temperature in degrees Celsius, aircraft weight in pounds, and torque per engine in percent. During operation with ice vanes extended, torque will decrease by approximately 12%, fuel flow will decrease by approximately 8%, and true airspeed will be reduced by approximately 15 knots.

*as. Normal Cruise Speeds at 1500 RPM.*

(1) *Description.* The Normal Cruise Speeds at 1500 RPM graph (fig. 7A-60) depicts the relationship between normal cruise speed, pressure altitude, and ISA condition.

(2) *Purpose.* This graph is used to determine maximum cruise speed, given pressure altitude in feet, ISA condition, and aircraft weight in pounds. During operation with ice vanes extended, true airspeed will be reduced by approximately 15 knots.

*at. Normal Cruise Power At 1500 RPM.*

(1) *Description.* The Normal Cruise Power at 1500 RPM graph (fig. 7A-61) depicts the torque setting to attain normal cruise power.

(2) *Purpose.* This graph is used to determine the torque setting for normal cruise power, given indicated free air temperature in degrees Celsius or ISA, pressure altitude in feet, and aircraft weight in pounds. During operations with ice vanes extended, torque will decrease by approximately 12%.

*au. Fuel Flow at Normal Cruise Power at 1500 RPM.*

(1) *Description.* The Fuel Flow at Normal Cruise Power at 1500 RPM graph (fig. 7A-62) depicts the fuel flow per engine in pounds per hour at normal cruise power.

(2) *Purpose.* This graph is used to determine normal cruise power fuel flow per engine, given indicated free air temperature, pressure altitude in feet, and aircraft weight in pounds. During operations with ice vanes extended, fuel flow will decrease by approximately 8%.

*av. Range Profile Normal Cruise Power at 1500 RPM.*

(1) *Description.* The Range Profile Normal Cruise Power at 1500 RPM graph (fig. 7A-63) depicts range at normal cruise power.

(2) *Purpose.* This graph is used to determine range in nautical miles for various fuel loads and fuel tank combinations, given pressure altitude in feet and true airspeed in knots. Range allows for start, taxi, and runup; includes cruise climb descent; and allows for 45 minutes reserve fuel at maximum range power. At 16,620 pounds ramp weight the maximum zero-fuel weight limitation of 13,100 pounds would be exceeded at fuel loading less than 3520.

*aw. Maximum Range Power at 1500 RPM.*

(1) *Description.* The Maximum Range Power at 1500 RPM tables (fig. 7A-64 through 7A-71) show fuel flow, airspeed, and torque for various flight conditions.

(2) *Purpose.* These tables are used to determine fuel flow per engine, total fuel flow, indicated airspeed, and true airspeed, given pressure altitude in feet, indicated free air temperature and free air temperature in degrees, Celsius, aircraft weight in pounds, and torque per engine in percent. During operation with ice vanes extended, torque will decrease by approximately 10%. Fuel flow will decrease by approximately 5%, and true air speed will be reduced by approximately 10 knots.

*ax. Range Profile Maximum Range Power at 1500 RPM.*

(1) *Description.* The Range Profile Maximum Range Power at 1500 RPM graph (fig. 7A-72) depicts range at maximum range power.

(2) *Purpose.* This graph is used to determine range in nautical miles for various fuel loads and fuel tank combinations, given pressure altitude in feet and true airspeed in knots. Range allows for start, taxi, and runup; includes cruise climb descent; and allows for 45 minutes reserve fuel at maximum range power. At 16,620 pounds ramp weight, the maximum zero fuel weight limitation of 13,100 pounds would be exceeded at fuel loading less than 3520 pounds.

*ay. Loiter Power at 1700 RPM.*

(1) *Description.* The Loiter Power at 1700 RPM tables (fig. 7A-73 through 7A-80) show fuel flow, airspeed, and torque for various flight conditions.

(2) *Purpose.* These tables are used to determine fuel flow per engine, total fuel flow, indicated airspeed, and true airspeed, given pressure altitude in feet, indicated free air temperature and free air

temperature in degrees Celsius, aircraft weight in pounds, and torque per engine in percent. During operation with ice vanes extended, torque, fuel flow, and true airspeed will remain approximately unchanged.

*az. Endurance Profile Loiter Power.*

(1) *Description.* The Endurance Profile Loiter Power at 1700 RPM graph (fig. 7A-81) depicts endurance at loiter power allowing fuel for start, taxi, runup, cruise climb and descent, and 45 minutes fuel reserve.

(2) *Purpose.* This graph is used to determine endurance in hours for various fuel loads and fuel tank combinations, given pressure altitude in feet and true airspeed in knots. Endurance allows for start, taxi, and runup; includes cruise climb descent; and allows for 45 minutes reserve fuel at maximum range power. At 16,620 pounds ramp weight, the maximum zero fuel weight limitation of 13,100 pounds would be exceeded at fuel loading less than 3520 pounds.

*ba. Range Profile Full Main Tanks.*

(1) *Description.* The Range Profile Full Main Tanks graph (fig. 7A-82) depicts range, allowing fuel for start, taxi, runup, cruise climb and descent, and 45 minutes fuel reserve.

(2) *Purpose.* This graph is used to determine range in nautical miles for full main tanks, given pressure altitude in feet and true airspeed in knots.

*bb. Endurance Profile Full Main Tanks.*

(1) *Description.* The Endurance Profile Full Main Tanks graph (fig. 7A-83) depicts endurance, allowing fuel for start, taxi, runup, cruise climb and descent, and 45 minutes fuel reserve.

(2) *Purpose.* This graph is used to determine endurance in hours for full main tanks, given pressure altitude in feet and true airspeed in knots.

*bc. Range Profile Full Main and Aux Tanks.*

(1) *Description.* The Range Profile Full Main and Aux Tanks graph (fig. 7A-84) depicts range, allowing fuel for start, taxi, runup, cruise climb and descent, and 45 minutes fuel reserve.

(2) *Purpose.* This graph is used to determine range in nautical miles for full main and aux tanks, given pressure altitude in feet and true airspeed in knots.

*bd. Endurance Profile Full Main and Aux Tanks.*

(1) *Description.* The Endurance Profile Loiter Power at 1700 RPM graph (fig. 7A-85) depicts endurance, allowing fuel for start, taxi, runup, cruise climb and descent, and 45 minutes fuel reserve.

(2) *Purpose.* This graph is used to determine endurance in hours for full main and aux tanks, given pressure altitude in feet and true airspeed in knots.

*be. One Engine Inoperative Max Cruise Power at 1700 RPM.*

(1) *Description.* The One Engine Inoperative Max Cruise Power at 1700 RPM tables (fig. 7A-86 through 7A-93) show fuel flow, airspeed, and torque for various flight conditions.

(2) *Purpose.* These tables are used to determine fuel flow per engine, total fuel flow, indicated airspeed, and true airspeed, given pressure altitude in feet, indicated free air temperature and free air temperature in degrees Celsius, aircraft weight in pounds, and torque per engine in percent. During operation with ice vanes extended, torque will decrease approximately 10%, fuel flow will decrease by approximately 6%, and true airspeed will be reduced by approximately 10 knots.

*bf. Time, Fuel, and Distance to Descend.*

(1) *Description.* The Time, Fuel, and Distance to Descend graph (fig 7A-94) depicts the time, fuel, and distance to descend.

(2) *Purpose.* This graph is used to determine the time, fuel, and distance required to descend, given the beginning and ending pressure altitudes in feet.

*bg. Climb Balked Landing.*

(1) *Description.* The Climb Balked Landing graph (fig. 7A-95) depicts rate of climb to be expected after a balked landing.

(2) *Purpose.* This graph is used to determine the rate of climb in feet per minute and climb gradient in percent, given the free air temperature in degrees Celsius, pressure altitude in feet, and aircraft weight in pounds. For operation with ice vanes extended, rate of climb will be reduced by approximately 300 feet per minute. Enter the graph at the pressure altitude from which a go-around would be initiated.

*bh. Normal Landing Distance Flaps Down.*

(1) *Description.* The Normal Landing Distance Flaps Down graph (fig. 7A-96) depicts normal flaps down landing distance.

(2) *Purpose.* This graph is used to determine flaps down landing distance, given free air temperature in degrees Celsius, field pressure altitude, runway gradient in % up or down, and head or tail wind component in knots. The wind grids include factors of 50% for headwinds and 150% for tailwinds. Components of reported winds may therefore be used directly in the grids. Weight does not significantly affect landing distance.

*bi. Landing Distance Flaps Up.*

(1) *Description.* The Landing Distance Flaps Up graph (fig. 7A-97) depicts landing distance with flaps up.

(2) *Purpose.* This graph is used to determine flaps up landing distance, given flaps down landing distance. Landing with flaps full down is normal procedure. Flaps up landings may produce tire speeds and/or brake energies that exceed limitation. To determine the flaps-up landing distance, read from the Normal Landing Distance Flaps Down graph, the landing distance appropriate to temperature, altitude, runway gradient, and wind. Enter the subject graph with the derived value, and read the flaps-up landing distance.

*bj. Landing Distance One Engine Inoperative Flaps Down.*

(1) *Description.* The Landing Distance One Engine Inoperative Flaps Down graph (fig. 7A-98) depicts one engine inoperative landing distance.

(2) *Purpose.* This graph is used to determine one engine inoperative flaps down landing distance, given the flaps down normal landing distance. To determine the one engine inoperative landing distance, read from the Normal Landing Distance Flaps Down graph, the landing distance appropriate to temperature, altitude, runway gradient, and wind. Enter the subject graph with the derived value, and read the one engine inoperative landing distance.

**7A-4. EXAMPLES.**

The following examples present calculations for flight time, block speed, and fuel required for a proposed flight from Billings, Montana, to Casper, Wyoming, at flight level 250, using the conditions listed below, except as noted. The desired takeoff weight is 16,000 pounds, if possible.

a. *Conditions.* At Billings-Logan International (BIL):  
 Free Air Temperature..... 59°F  
 Field Elevation..... 3649 feet<sup>1</sup>  
 Altimeter Setting..... 07 in. Hg  
 Wind ..... 290 at 15 knots  
 Runway 34 Length ..... 5585 feet<sup>1</sup>  
 Gradient..... 1.9% downhill<sup>1</sup>

<sup>1</sup>Source: DOD TERM USLIAAPVOI, 9 JAN 92.

Route of Trip: BIL - V19 - CPR

Route Segment Data: Table 7A-1.

At Natrona County International (CPR):

Free Air Temperature ..... 68°F  
 Field Elevation ..... 5348 feet<sup>4</sup>  
 Altimeter Setting ..... 29.27 in. Hg  
 Wind..... 330° at 10 knots  
 Runway 30 Length..... 8686 feet<sup>4</sup>  
 Gradient..... 0.3% up<sup>4</sup>

<sup>4</sup>Source: DOD TERM USLIAPV03, 9 JAN 92.

b. *Fahrenheit to Celsius Temperature Conversion.*  
 Convert reported field temperatures at the departure and destination airports from Fahrenheit to Celsius using the Fahrenheit to Celsius Temperature Conversion graph (fig. 7A-9). Enter the chart at the appropriate value on the °F scale, read up to the reference line and left to the corresponding value in °C.

Billings-Logan International 59°F ..... 15°C  
 Natrona County International 68°F ..... 20°C

c. *Pressure Altitude.* To determine the approximate pressure altitudes at origin and destination airports, add 1000 feet to field elevation for each 1.00 in.

Hg that the reported altimeter setting value is below 29.92 in. Hg, and subtract 1000 feet for each 1.00 in. Hg above 29.92 in. Hg. Always subtract 1000 feet for each 1.00 in. Hg above 29.92 in. Hg, then multiply the answer by 1000 to find the difference in feet between field elevation and pressure altitude.

Pressure Altitude at BIL:

29.92  
-30.07  
 -0.15  
 -0.15 x 1000 feet = -150 feet

Field Elevation..... 3649 feet  
 Pressure Altitude Correction ..... -150 feet  
 Field Pressure Altitude ..... 3499 feet

Pressure Altitude at CPR:

29.92  
 -29.27  
 +0.65  
 0.65 x 1000 feet = 650 feet

Field Elevation..... 5348 feet  
 Pressure Altitude Correction ..... +650 feet  
 Field Pressure Altitude ..... 5998 feet

d. *Wind Components.* Determine the headwind (tailwind) and crosswind component for the selected runway. Compute the angle between the reported wind at Billings-Logan International of 290° and the selected runway heading of 340° to be 50°. Locate the line for 50° angle between wind direction and flight path on the graph. Trace along the 50° line and locate the reported wind speed of 15 knots (the point midway between the 10 and 20 knot wind speed lines). Read left to obtain the headwind component and down to obtain the crosswind component. Headwind Component 10 knots

Table 7A-1. Route Segment Data<sup>2</sup>

ROUTE SEGMENT	AVERAGE MAGNETIC COURSE	AVERAGE MAGNETIC VARIATION	DISTANCE NM	WIND AT FL 250 DIR./KNOTS	FAT AT FL 250 °C	MEA FEET	FAT AT MEA °C	ALTIMETER SETTING IN. HG
BIL-SHR	117°	15°E	91 <sup>3</sup>	010°/45	-40	8000	0	29.97
SHR-CZI	139°	14°E	57	350°/65	-40	9000	-4	29.60
CZI-CPR	161°	13°E	69 <sup>3</sup>	310°/50	-30	7600	0	29.48

<sup>2</sup>Source: DOD Low Altitude Enroute Chart L-9, 9 Jan 1992.

<sup>3</sup>Includes distance between airport and VORTAC, per DOD US IFR SUPPLEMENT, 9 JAN 1992.

Crosswind Component ..... 12 knots  
 e. *Takeoff Weight.* The following examples illustrate the use of graphs which may restrict takeoff weight.

**NOTE**

**Do not exceed the maximum takeoff weight limitation of 16,500 pounds.**

(1) Maximum takeoff weight as limited by tire speed. Enter the graphs at 150C, 3499 ft, 10 knots headwind component, and read:

Flaps Up .....Exceeds Structural Limit of 16,500 lbs  
 Flaps Approach Exceeds Structural Limit of 16,500 lbs

(2) *Maximum takeoff weight to achieve positive one-engine-inoperative climb at liftoff.* Enter the graphs at 3499 feet pressure altitude, 15°C, and read:

Flaps Up . ..... 16,500 lbs  
 Flaps Approach ..... 16,500 lbs

(3) *Maximum enroute weight for 50-ft/ minute one-engine-inoperative climb.* To determine the maximum takeoff weight, the weight of the fuel used to reach the MEA is added to the maximum enroute weight obtained from the Service Ceiling - One Engine Inoperative graph (fig. 7A-38). Use the Time, Fuel, and Distance to Cruise Climb graph (fig. 7A-39) to determine the weight of the fuel used to climb. Use the Cruise Power tables to determine the weight of the fuel used to cruise to each MEA.

Enter the Service Ceiling - One Engine Inoperative graph (fig. 7A-38) at the conditions for each enroute MEA. For example, enter the graph at the highest MEA altitude of 9000 feet, and trace right; enter again at the MEA FAT of -4°C, and trace up. Read the maximum enroute weight at the MEA at the intersection of the tracings.

Maximum enroute weight for 50-ft/min one-engine-inoperative climb:

8000 ft, 0°C            Exceeds Structural Limit of 16,500 lbs  
 9000 ft, -4°C           Exceeds Structural Limit of 16,500 lbs  
 7600 ft, 0°C            Exceeds Structural Limit of 16,500 lbs

Since these weights are all greater than the maximum takeoff weight limitation of 16,500 lbs, there is no additional limitation to meet enroute weight requirements. Anytime the value is less than 16,500 lbs, add the fuel required to climb, plus any fuel used in cruise before reaching each MEA, to determine the maximum allowable takeoff weight to meet the requirement for each route segment of the trip.

f. *Minimum Static Takeoff Power (Ice Vanes Retracted).* Enter the graph at 150C FAT and 3499 feet pressure altitude:

Minimum Static Takeoff Power .....93.5%

g. *Takeoff Speeds.* Tables are provided for takeoff decision speed ( $V_1$ ), rotation speed ( $V_R$ ), takeoff safety speed ( $V_2$ ), and all-engines takeoff safety speed ( $V_{50}$ .)

In order to determine the takeoff speeds for 15°C FAT, 3499 feet pressure altitude, and 16,000 pounds takeoff weight, enter the tables at 2000 ft and 4000 ft pressure altitude, 10°C and 20°C FAT, and 16,000 pounds takeoff weight, then interpolate to find the actual values for the specified conditions:

$V_1$ ..... 116 KTS (flaps up), 108 KTS (flaps approach)  
 $V_R$  .... 124 KTS (flaps up), 113 KTS (flaps approach)  
 $V_2$ ..... 128 KTS (flaps up), 114 KTS (flaps approach)  
 $V_{50}$ .... 140 KTS (flaps up), 126 KTS (flaps approach)

h. *Minimum Field Length.* The following example illustrates the use of graphs which may restrict takeoff weight due to field length available under existing conditions.

(1) *Takeoff distance.* Enter the graphs at 15°C, 3499 feet pressure altitude, 16,000 pounds, 1.9% downhill runway gradient, and 10 knots headwind component, and obtain the following results:

Ground Roll (flaps up)..... 3602 ft  
 Takeoff Distance (flaps up)..... 5167 ft  
 Ground Roll (flaps approach)..... 2960 ft  
 Takeoff Distance (flaps approach)..... 4150 ft

(2) *Accelerate-stop distance.* Enter the graphs at 15°C, 3499 feet pressure altitude, 16,000 pounds, 1.9% downhill runway gradient, and 10 knots headwind component, and obtain the following results:

Accelerate-Stop Distance (flaps up) ..... 5924 ft  
 Accelerate-Stop Distance (flaps approach) ..... 5047 ft

(3) *Accelerate-go distance.* Enter the graphs at 15°C, 3499 feet pressure altitude, 16,000 pounds, 1.9% downhill runway gradient, and 10 knots headwind component, and obtain the following results:

Accelerate-Go Distance (flaps up).....7419 ft  
 Accelerate-Go Distance (flaps approach).....5389 ft

The minimum recommended runway length is the longest of the distances determined above for the selected flap





1. The obstacle horizontal distance from reference zero equals the obstacle distance from brake release less the accelerate-go distance to 50 feet AGL (16,294 ft - 5389 ft) = 10,905 feet = 1.79 nautical miles.
2. Determine the total height required to clear the obstacle by adding to the obstacle height the decrease in aircraft altitude during the takeoff procedure due to a downhill runway gradient.

1.9% gradient 5389 ft = 102.4 feet = 102 feet

The total height required to clear the obstacle is: 88 ft + 102 = 190 feet.

3. Obtain the required gradient to clear the obstacle from the Distant Takeoff Flight Path Graph using the obstacle distance from reference zero found in step 1, and the total height determined in step 2: 1.29%.
4. Read the scheduled net gradient of climb from the Net Takeoff Flight Path Second Segment Flaps Approach graph (fig. 7A-30) 2.32%.

Thus, the calculations indicate that a takeoff weight of 16,000 pounds will result in a net climb gradient greater than that required to clear the obstacle, even if an engine should fail at the most critical takeoff point.

(2) *Example 2 Obstacle clearance above 500 feet: given: Obstacle Height Above Aircraft at Brake Release 600 feet.*

Obstacle Distance from Brake Release ..... 10.71 nm

1. Obtain the accelerate-go distance to 50 feet AGL ..... 5389 feet (0.89 nm)
2. Read the scheduled distance from the Horizontal Distance From Reference Zero To Third Segment Climb Flaps Approach graph (fig. 7A-31) 5.65 nm.
3. Add the results of steps 1 and 2 to obtain total distance to start of third segment climb, (0.89 nm + 5.65 nm) = 6.54 nm.
4. Distance to obstacle from start of third segment climb is obtained by subtracting results of step 3 from 10.71 nm. (10.71 - 6.54) = 4.17 nm.
5. Add to the obstacle height above the aircraft at brake release any decrease in aircraft altitude during the takeoff resulting from a downhill runway gradient.

The sum is the total height required to clear the obstacle:

$$(1.9\% \text{ gradient} / 100) \times 5389 \text{ ft} = 102.4 \text{ feet} = 102 \text{ feet}$$

The total height required to clear the obstacle is: 600 ft + 102 ft = 702 feet.

6. Required climb gradient to clear obstacle is obtained using the following formula:

$$\% \text{ Gradient} = (\text{RH}) \times (\text{F}) / (\text{D})$$

Where:

RH = Required Height (in feet) above 500 feet

F = A units conversion factor of 0.0165

D = Distance (in nautical miles) to obstacle from start of third segment

Therefore:

$$\% \text{ Gradient} = (702 / 500) (0.0165) + 4.17 = 0.80\%$$

7. Obtain (from the Net Take-Off Flight Path Third Segment One-Engine Inoperative graph, fig. 7A-34) the scheduled third segment net gradient of climb of 2.07%. Since this gradient exceeds the required gradient of 0.80, the calculations indicate that the obstacle will be cleared at a takeoff weight of 16,000 pounds even if an engine should fail at the most critical takeoff point.

k. *Climb Two Engines.* Enter the graphs at -4°C, 9000 feet pressure altitude, 15,500 pounds, and obtain the following results:

Climb Two Engines (flaps up) ..... 2237 ft/min  
 Climb Gradient ..... 11.3%  
 Climb Two Engines (flaps approach) .... 2053 ft/min  
 Climb Gradient ..... 10.7%

l. *Climb One Engine Inoperative.* Enter the graph at -4°C, 9000 feet pressure altitude, 15,500 pounds, and obtain the following results:

Climb One Engine Inoperative ..... 358 ft/min  
 Climb Gradient ..... 2.0%

m. Flight Planning *Example*. The following calculations provide information for flight planning. Calculations for flight time, block speed, and fuel requirements for the proposed flight are detailed below.

Time to Climb ..... 23 - 2 = 21 min  
 Fuel to Climb ..... 400 - 57 = 343 lbs  
 Distance Traveled ..... 55 - 5 = 50 nm

**NOTE**

**For example purposes, the differences between MSL altitudes and pressure altitudes have been ignored in MEA calculations.**

(3) *Time fuel, and distance to descend*. Enter the graph at 25,000 feet, and enter again at 5998 feet, and find:

Time to Descend ..... 17 - 4 = 13 min  
 Fuel Used to Descend ..... 208 - 60 = 148 lbs  
 Distance to Descend ..... 61 - 13 = 49 nm

(1) *ISA conversion*. Enter the graph at the conditions indicated:

BIL  
 Pressure Altitude ..... 3499 feet  
 FAT ..... 15°C  
 ISA Condition ..... ISA +7°C

BIL-CZI  
 Pressure Altitude ..... 25,000 feet  
 FAT ..... -40°C  
 ISA Condition ..... ISA -6°C

CZI-CPR  
 Pressure Altitude ..... 25,000 feet  
 FAT ..... -30°C  
 ISA Condition ..... ISA +5°C

CPR  
 Pressure Altitude ..... 5998 feet  
 FAT ..... 20°C  
 ISA Condition ..... ISA +17°C

(4) *Cruise weight (estimated)*. For the following cruise segment examples, the estimated average cruise weight used was 15,600 pounds.

(5) *Cruise tables*. Enter the tables for Normal Cruise Power at 1500 RPM for ISA -10°C, ISA, and ISA +10°C, and read the cruise speeds for 24,000 feet and 26,000 feet at 16,000 pounds and 14,000 pounds. Interpolate between these speeds for 25,000-foot values. Refer to table 7A-2 for the results.

Interpolate between the 25,000-foot speeds for ISA -6°C and ISA +5°C at 15,600 pounds.

Cruise True Airspeed (ISA -6°C) ..... 255 knots  
 Cruise True Airspeed (ISA +5°C) ..... 245 knots

Similar computations can be made to interpolate for cruise torque setting and fuel flow.

Cruise Torque (ISA -6°C) ..... 68.5%  
 Cruise Total Fuel Flow (ISA -6°C) ..... 778 lbs/hr  
 Cruise Fuel Flow/Eng (ISA -6°C) ..... 389 lbs/hr  
 Cruise Torque (ISA +5°C) ..... 61.4%  
 Cruise Total Fuel Flow (ISA +5°C) ..... 716 lbs/hr  
 Cruise Fuel Flow/Eng (ISA +5°C) ..... 358 lbs/hr

(2) *Time, fuel, and distance to cruise climb*. Enter the graph at 15°C, to 3499 feet pressure altitude, and to 16,000 pounds. Enter again at -40°C to 25,000 feet pressure altitude, and to 16,000 pounds. The following results are obtained:

(6) *Cruise graphs*. In addition to the cruise performance presented in tabular form, data representing a cruise weight of 14,000 pounds is presented in graphical form for quick reference.

Table 7A-2. Example Cruise True Airspeeds

ALT FEET	16,000 POUNDS			14,000 POUNDS		
	ISA - 10°C	ISA	ISA +10°C	ISA - 10°C	ISA	ISA +10°C
24,000	260	251	240	266	259	249
25,000	257.5	248.5	237	264.5	257	247
26,000	255	246	234	263	255	245

BT085

**NOTE**

**Use of these graphs for flight conditions other than 14,000 pounds gross weight may introduce errors.**

(a) *Cruise speeds.* Enter the Normal Cruise Speeds at 1500 RPM graph at 25,000 feet, and read the true airspeeds for ISA -60C and ISA +5°C:

Cruise True Air Speed (ISA -6°C)..... 261 KTAS  
 Cruise True Air Speed (ISA +5°C)..... 252 KTAS

(b) *Cruise power setting.* Enter the Normal Cruise Power at 1500 RPM graph at 25,000 feet, and read the recommended torque settings for ISA -6°C (-34°C IFAT) and ISA +5°C (-24°C IFAT):

ISA -6°C (-34°C IFAT) ..... 69% torque per engine  
 ISA +5°C (-24°C IFAT) ..... 62% torque per engine

**NOTE**

**For flight planning, enter the Cruise Power graphs at the forecast ISA condition; for enroute power settings, enter the graphs at the actual IFAT.**

(c) *Cruise fuel flow.* Enter the Fuel Flow At Normal Cruise Power at 1500 RPM graph at 25,000 feet, and read the fuel flow for ISA -6°C (-34°C IFAT) and ISA +5°C (-24°C IFAT):

ISA -6°C (-34°C IFAT)

Fuel Flow Per Engine..... 392 lbs/hr  
 Total Fuel Flow..... 784 lbs/hr

ISA +5°C (-24°C IFAT)

Fuel Flow Per Engine..... 359 lbs/hr  
 Total Fuel Flow..... 718 lbs/hr

Time and fuel used were calculated at normal cruise power at 1500 RPM as follows:

Time = distance/ground speed  
 Fuel used = (time)(total fuel flow)

(7) *Flight planning results.* Refer to table 7A-3 for an example of the flight planning procedure.

**NOTE**

**For flight planning, enter the Fuel Flow graphs at the forecast ISA condition; for enroute fuel flow, enter the graphs at the actual IFAT. Refer to table 7A-4 for an example of the total flight planning results.**

(a) *Reserve fuel.* Reserve Fuel is the amount of fuel required to fly at cruise altitude for 45 minutes at maximum range power. This example assumes the average cruise weight while using reserve fuel to be 15,000 pounds.

Enter the Maximum Range Power at 1500 RPM tables for ISA and for ISA +10°C and interpolate to find the total fuel flow for 25,000 feet at 16,000 pounds and 14,000 pounds. Interpolate between these values for 15,000

Table 7A-3. Example Cruise Results

ROUTE SEGMENT	<sup>1</sup> DISTANCE	ESTIMATED GROUND SPEED	<sup>2</sup> TIME AT CRUISE ALTITUDE	<sup>3</sup> FUEL USED FOR CRUISE
	NM	KNOTS	MIN	LBS
BIL-SHR	42	276	9.1	118.4
SHR-CZI	57	316	10.8	140.3
CZI-CPR	18	278	3.9	46.4
TOTAL	117	---	23.8	305.1

1 Distance required to climb or descend has been subtracted from segment distance.

2 Time =Distance divided by Ground Speed.

3 Fuel Used =Distance divided by Ground Speed, multiplied by total Fuel Flow.

BT0D883

pounds. In this example it is found that data is presented for MAXIMUM RANGE POWER at 1500 RPM for ISA and ISA +10°C at 24,000 feet and at 26,000 feet for 14,000 pounds, but not for 16,000 pounds. Consequently, it is not possible to determine a maximum range power torque, airspeed, or fuel flow for 15,000 pounds at 25,000 feet, since chart values may not be extrapolated. This means that either a lower altitude must be selected for the leg of the mission that would be using reserve fuel, or that the Normal Cruise Power At 1500 RPM values must be used to determine power setting and the reserve fuel requirement. If no values are presented for the given conditions in the Normal Cruise Power at 1500 RPM tables, either select a lower altitude, or use the maximum cruise power at 1700 RPM table values to determine power setting and the reserve fuel requirement. In this example it is found that data is presented for the mission conditions in the Normal Cruise Power at 1500 RPM tables, so that data can be used. Refer to table 7A-5 for an example of the reserve fuel determination procedure.

(8) *Total fuel requirement.* Expected fuel usage + reserve fuel = total fuel requirement. (916 lbs) + (537 lbs) = 1453 lbs.

(9) *Zero-fuel weight limitation.* For this example, the following conditions were assumed:

Ramp Weight ..... 16,120 lbs  
 Weight of Usable Fuel on Board ..... 3631 lbs  
 Zero Fuel Weight = (16,120 - 3631)..... 12,489 lbs  
 Maximum Zero Fuel Weight (from Chapter 5)  
 ..... 13,100 lbs

Maximum zero fuel weight limitation will not be exceeded.

Anytime the zero fuel weight exceeds the maximum zero fuel weight limit, the excess weight must be off-loaded from payload only (i.e., not from fuel). If desired, additional fuel may then be added. However, the foregoing calculations will remain unchanged only if the fuel added is equal in weight to the payload off-loaded, since only then will the ramp weight and takeoff weight remain the same as before.

n. *Range and Endurance.* Estimates of the effect of fuel load and power setting on aircraft range and endurance can be determined from the Range and Endurance Profile graphs. The range of a mission at normal cruise power can be determined by entering the Range Profile - Normal Cruise Power graph at 25,000 feet, reading right to the anticipated fuel load and down to the resulting range. This chart indicates that a fuel load as low as 1500 pounds would be sufficient for the planned 217 nautical mile mission from Billings to Casper. The available range with full main and auxiliary tanks (3631 pounds) for a flight at 25,000 feet can be determined to be 997 nautical miles. If additional range is required, either a higher altitude or a lower power setting could be selected. To determine the range with a maximum fuel load, enter the Range Profile - Full Main and Aux Tanks graph (fig. 7A-84) at 25,000 feet, read right to the desired power setting and down to the resulting range. This chart depicts that for a full-fuel mission, range can be increased from 997 to 1060 nautical miles by reducing power to maximum range power.

The aircraft endurance can be determined from the various endurance profile graphs in a similar manner.

It should be noted that all of these graphs are based on standard day temperatures, and the range graphs are also based on zero wind. If forecast temperatures differ from standard values or if headwinds are expected, a more rigorous mission analysis should be accomplished.

o. *Landing Example.*

(1) *Weight.* The estimated landing weight is determined by subtracting the fuel usage expected for the trip from the ramp weight:

Ramp Weight..... 16,120  
 Fuel Usage Expected for Total Trip .....(-)916 lbs  
 Landing Weight ..... 15,204 lbs  
 Maximum Landing Weight (Chapter 5) .. 15,675 lbs

Anytime the maximum landing weight limitation would be exceeded, off-load the excess from useful load prior to

Table 7A-4. Example Time, Fuel, and Distance

ITEM	TIME	FUEL	DISTANCE
	MIN	POUNDS	NM
Start, Runup, Taxi, and Takeoff Acceleration	0.0	120	0
Climb	21	343	49
Cruise	23.8	305	117
Descent	13.0	148	51
TOTAL	57.8	916	217
Block Speed: 217 NM Divided by 57.8 Minutes = 225 Knots.			

takeoff, or burn off the excess from excess fuel (i.e., not from reserve fuel) before landing.

(2) Normal landing distance flaps down. Enter the graph at 20°C, 5998 feet, 15,204 pounds, 0.3% uphill runway gradient, 10 knots headwind component, and read the following:

Ground Roll ..... 1857 ft  
 Total Distance Over 50-Foot Obstacle ..... 4702 ft

(3) Abnormal landing distances. The landing distances for one engine inoperative or flaps retracted can be determined as shown below.

Landing Distance - One Engine Inoperative - Flaps Down:

Enter the graph with the normal landing distance determined in paragraph (2) above and read the following:

Landing Distance - One Engine Inoperative - Over 50-Foot Obstacle - Flaps Down ..... 5834 feet

Landing Distance - Flaps Up:

Enter the graph with the normal landing distance of 4702 feet as determined in paragraph (2) above and a landing weight of 15,204 lbs, and read the following:

Flaps-Up Landing Distance Over 50-Foot Obstacle ..... 7138 feet  
 Approach Speed ..... 136 knots

(4) Climb balked landing. Enter the graph at 20°C, 6400 feet (see note 2 on graph), 15,204 pounds, and read the following results:

Rate of climb ..... 1423 ft/min  
 Climb Gradient ..... 9.6%

p. Enroute Instrument Corrections. Errors are introduced to measured airspeed and temperature readings as a result of the aircraft speed. For this example, it has been assumed that the aircraft is established in level cruise flight between CZI and CPR.

Pilot's Indicated Airspeed ..... 158 KIAS  
 Indicated Pressure Altitude ..... 25,000 feet  
 Indicated Free Air Temperature ..... -35°C

(1) Airspeed calibration normal system Graph. Enter the flaps-up graph at the indicated airspeed value of 158 knots, read up reference line and trace left to obtain the following results:

Calibrated Airspeed ..... 161 knots

(2) Altimeter correction normal system Graph. Enter the flaps-up graph at the indicated airspeed value of 158 knots, read up to the 25,000-foot reference line and trace left to obtain the following results:

Altimeter Correction ..... +69 feet

Add this result to the indicated pressure altitude value of 25,000 feet to obtain the corrected altitude.

Actual Pressure Altitude ..... 25,061 feet

(3) Indicated outside air temperature correction Graph. Enter the graph at the calibrated airspeed value of 161 knots, read right to the actual pressure altitude of 25,051 feet and down to obtain the following result:

Temperature Correction ..... 5.2°C

Compute the free air temperature by subtracting the temperature correction of 5.2°C from the indicated temperature of -35°C to obtain:

Free Air Temperature ..... -40.2°C.

Table 7A-5. Example Fuel Flow (lbs/hr)

WEIGHT POUNDS	ISA	ISA +5°C	ISA 10°C
16,000	744.0	---	686.0
15,000	745.0	716.25	687.5
14,000	746.0	---	689.0
Total Fuel Flow = 716.25 lbs/hr Reserve Fuel = 45 minutes x 716.25 lbs/hr = 537 lbs			

AIRSPEED CALIBRATION - NORMAL SYSTEM  
TAKE-OFF GROUND ROLL

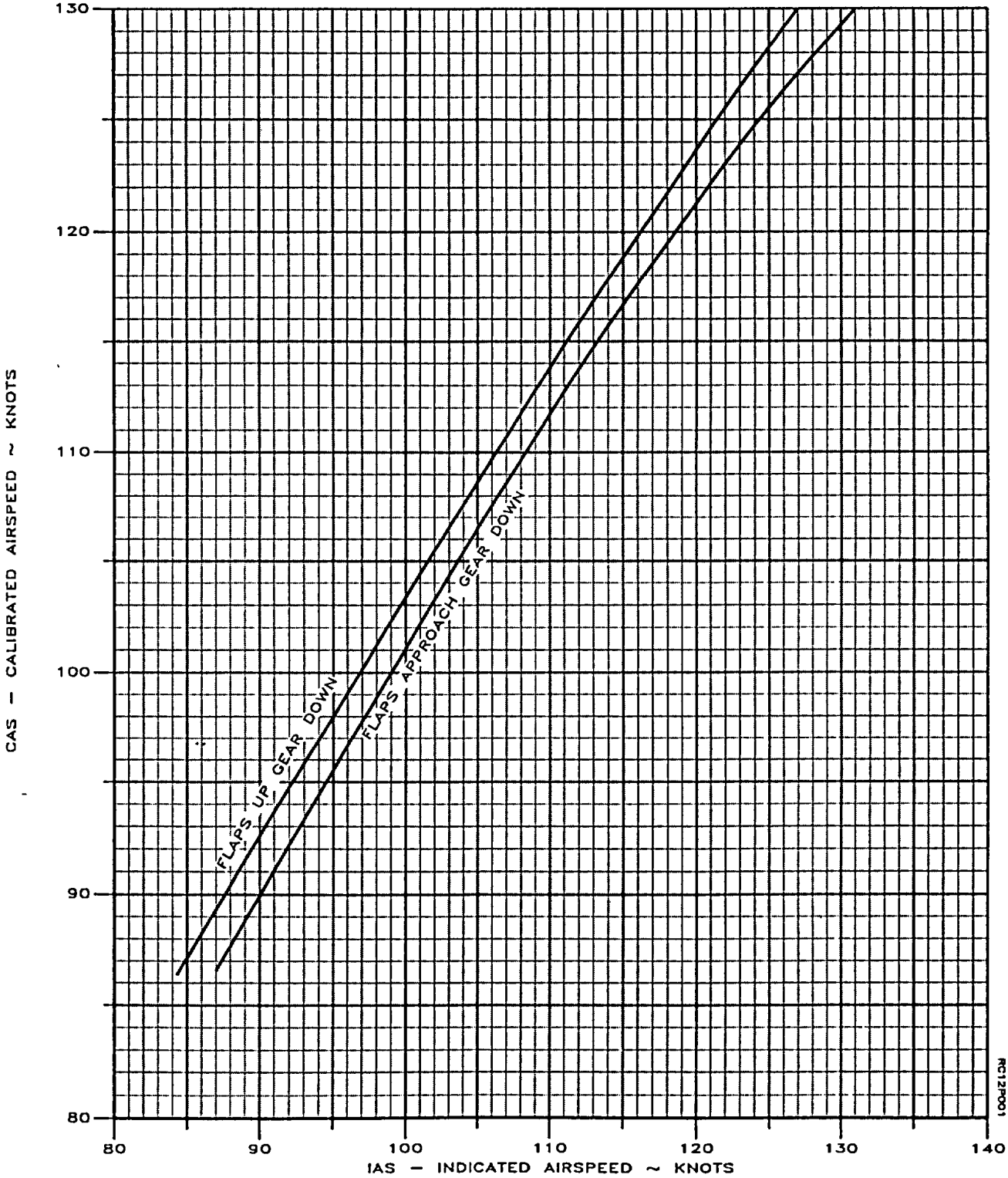

Figure 7A-2. Airspeed Calibration - Normal System, Takeoff Ground Roll

AIRSPED CALIBRATION - NORMAL SYSTEM

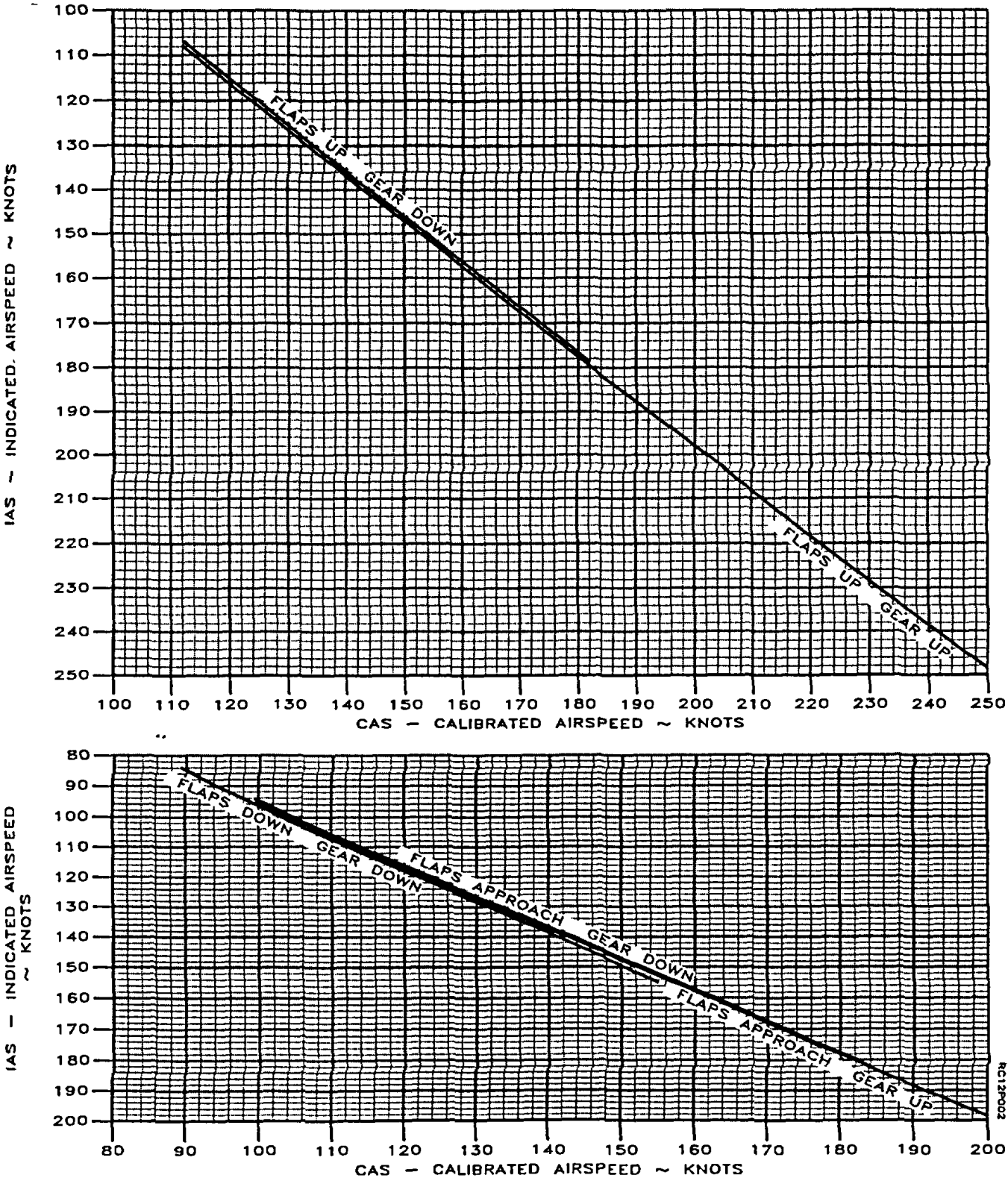

Figure 7A-3. Airspeed Calibration - Normal System

ALTIMETER CORRECTION - NORMAL SYSTEM

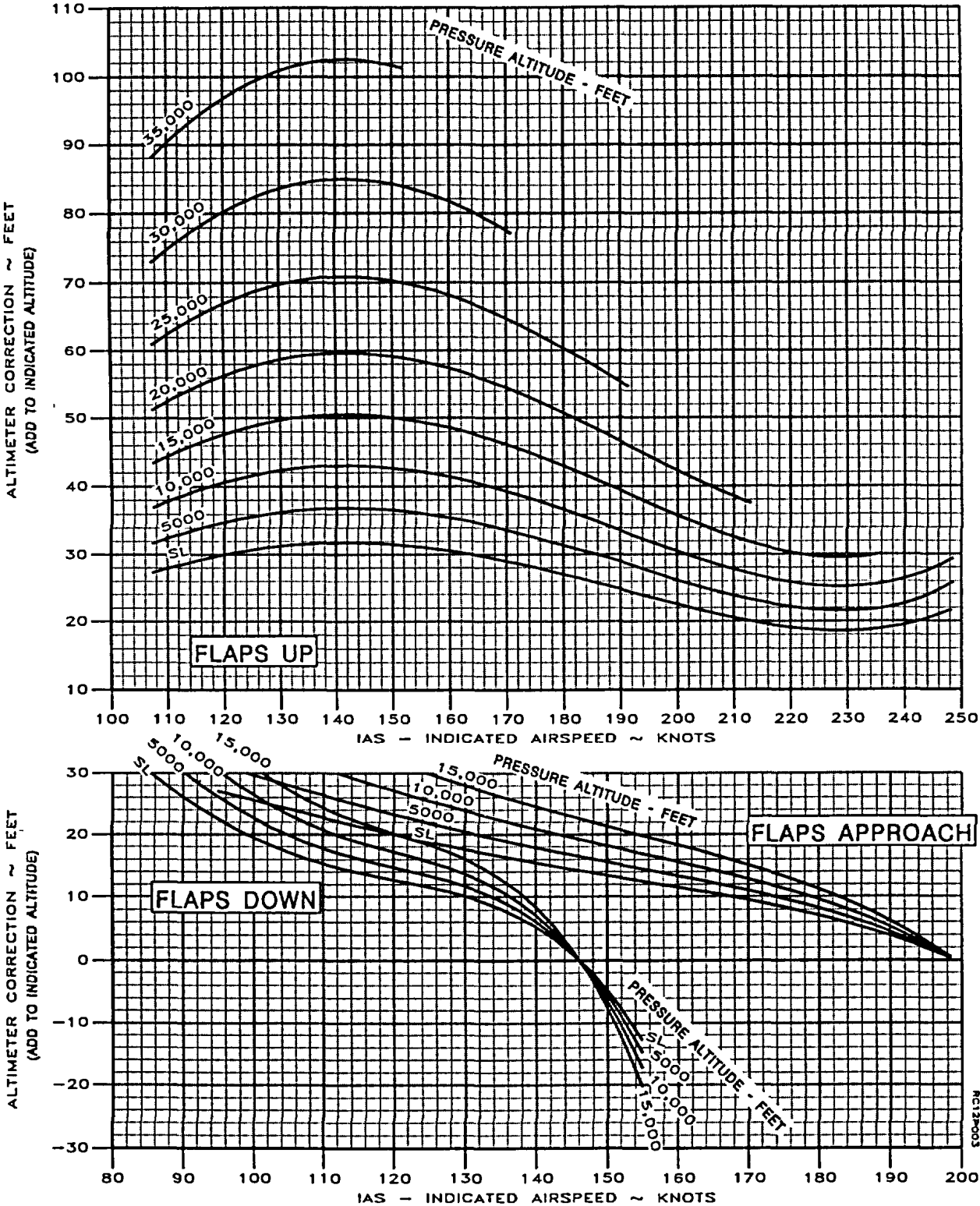

Figure 7A-4. Altimeter Correction - Normal System



AIRSPEED CALIBRATION - ALTERNATE SYSTEM  
APPLICABLE FOR ALL FLAP POSITIONS

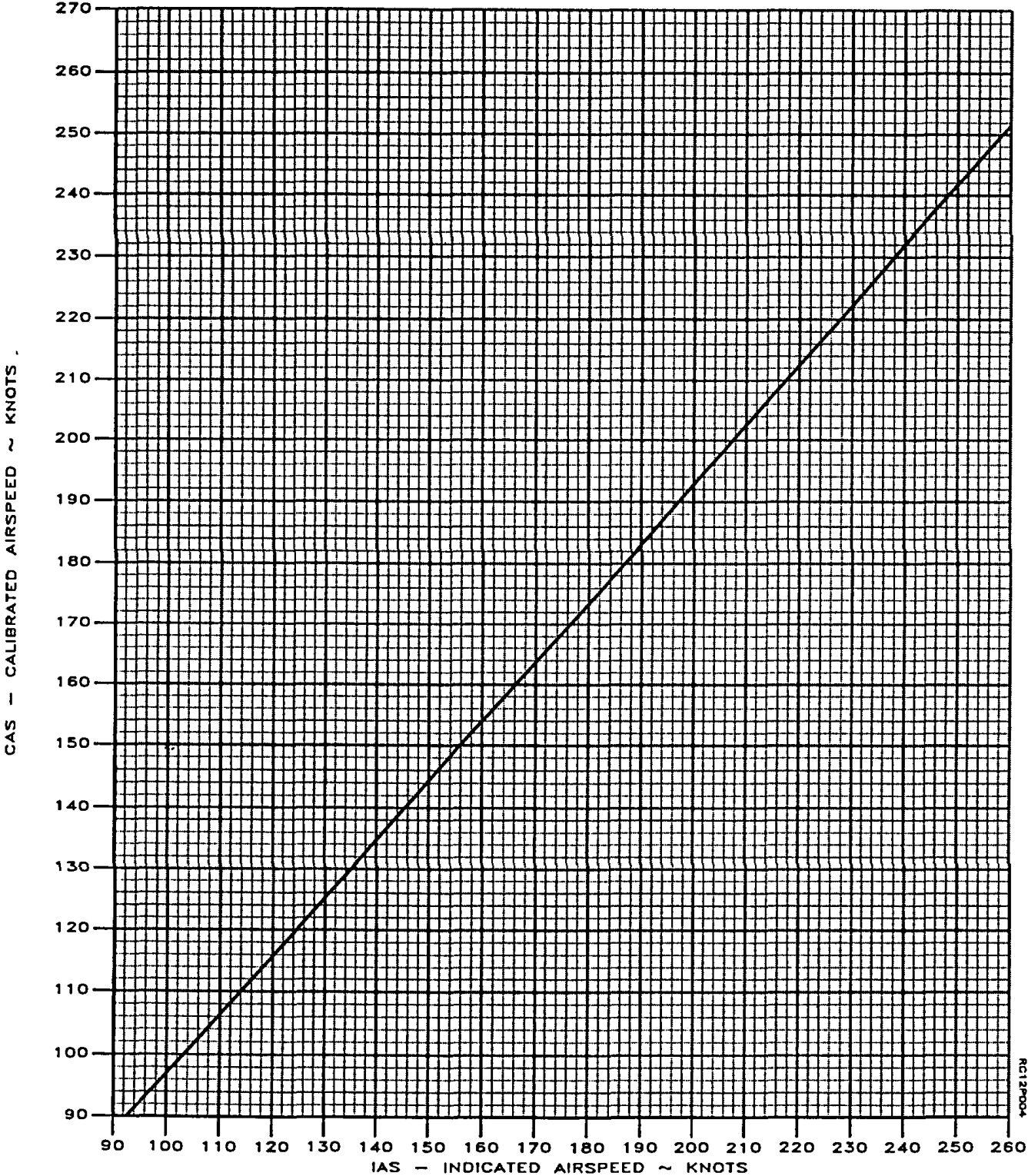

Figure 7A-5. Airspeed Calibration - Alternate System

ALTIMETER CORRECTION - ALTERNATE SYSTEM  
APPLICABLE FOR ALL FLAP POSITIONS

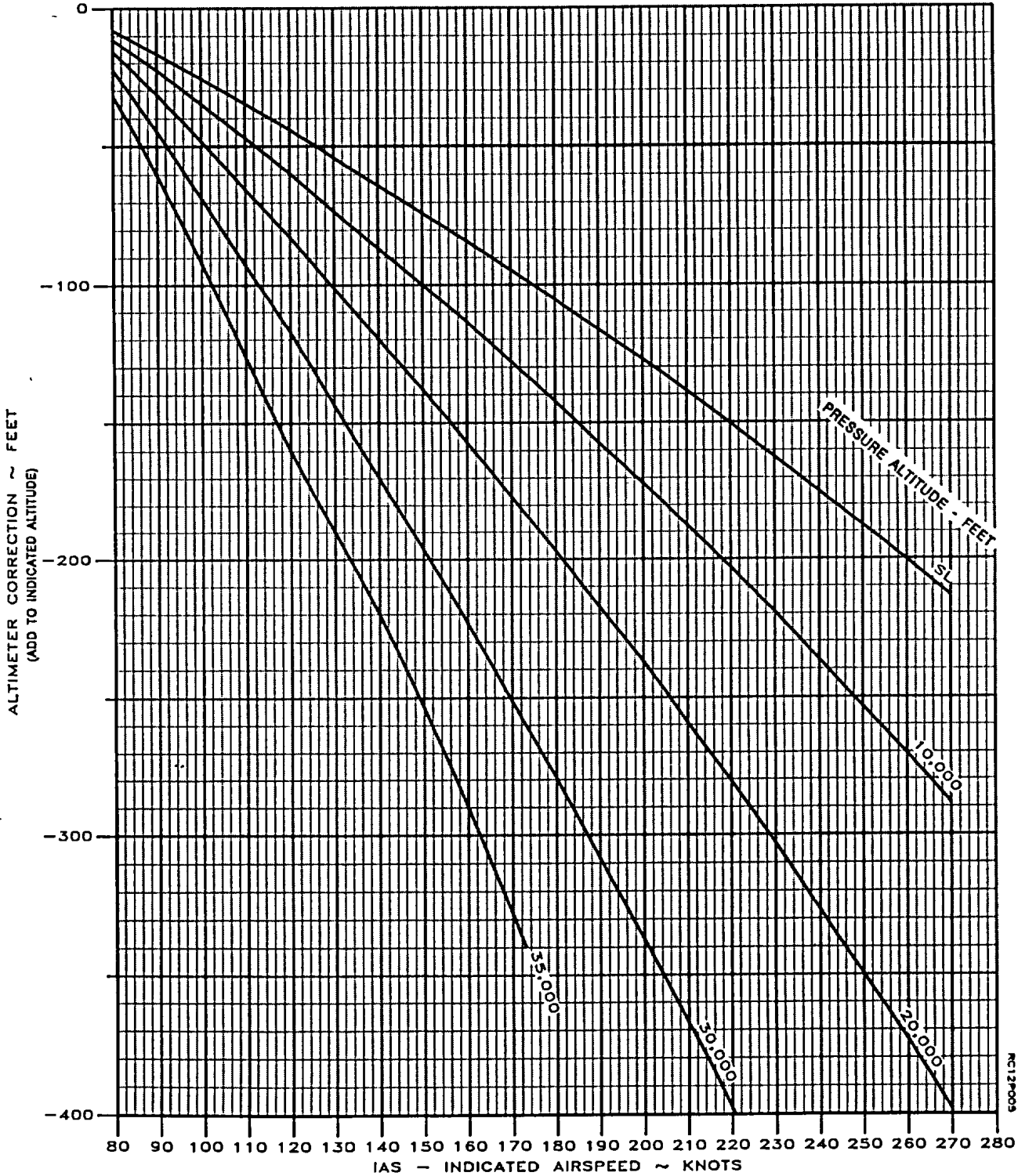

Figure 7A-6. Altimeter Correction - Alternate System

INDICATED OUTSIDE AIR TEMPERATURE CORRECTION  
STANDARD DAY (ISA)

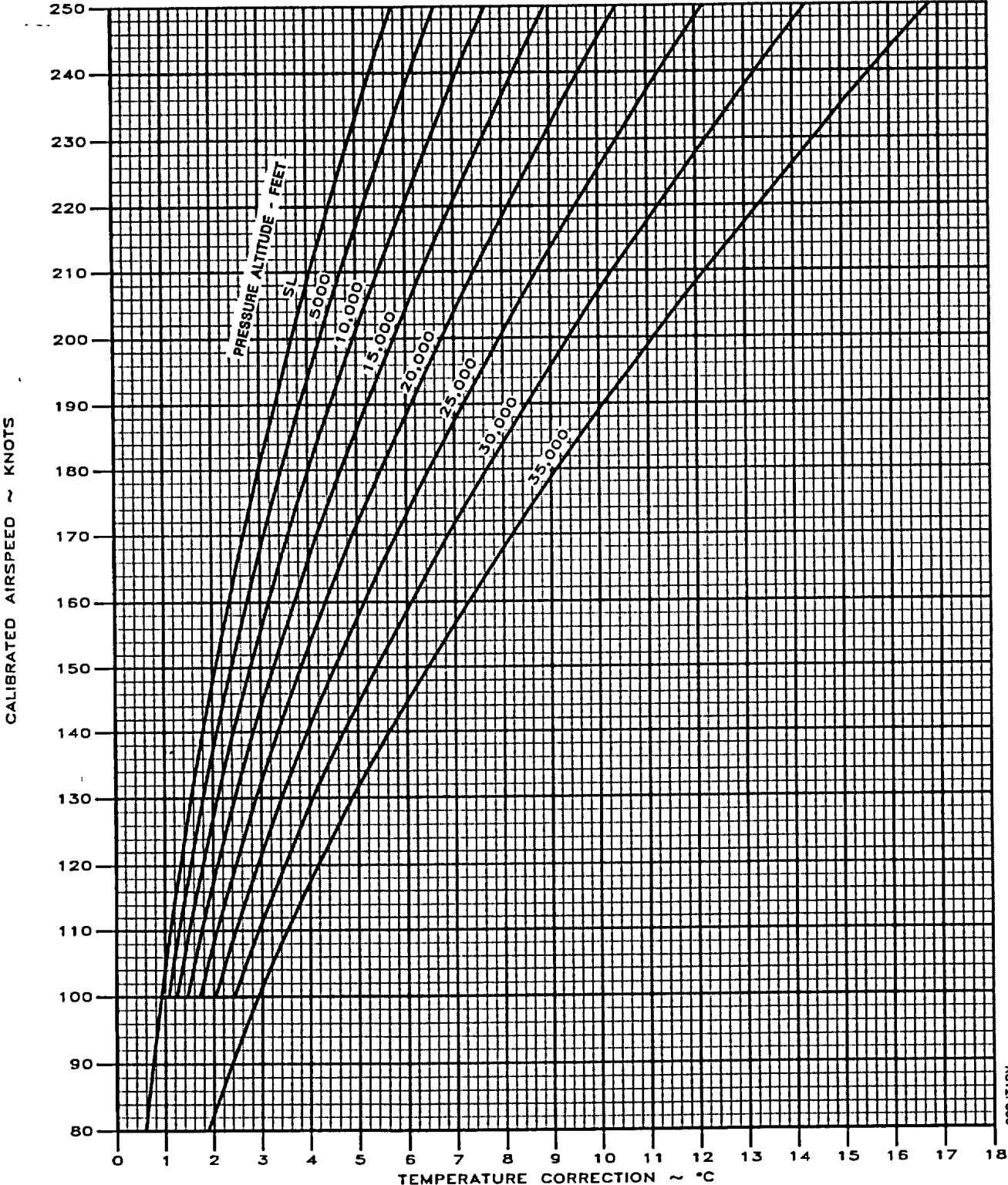
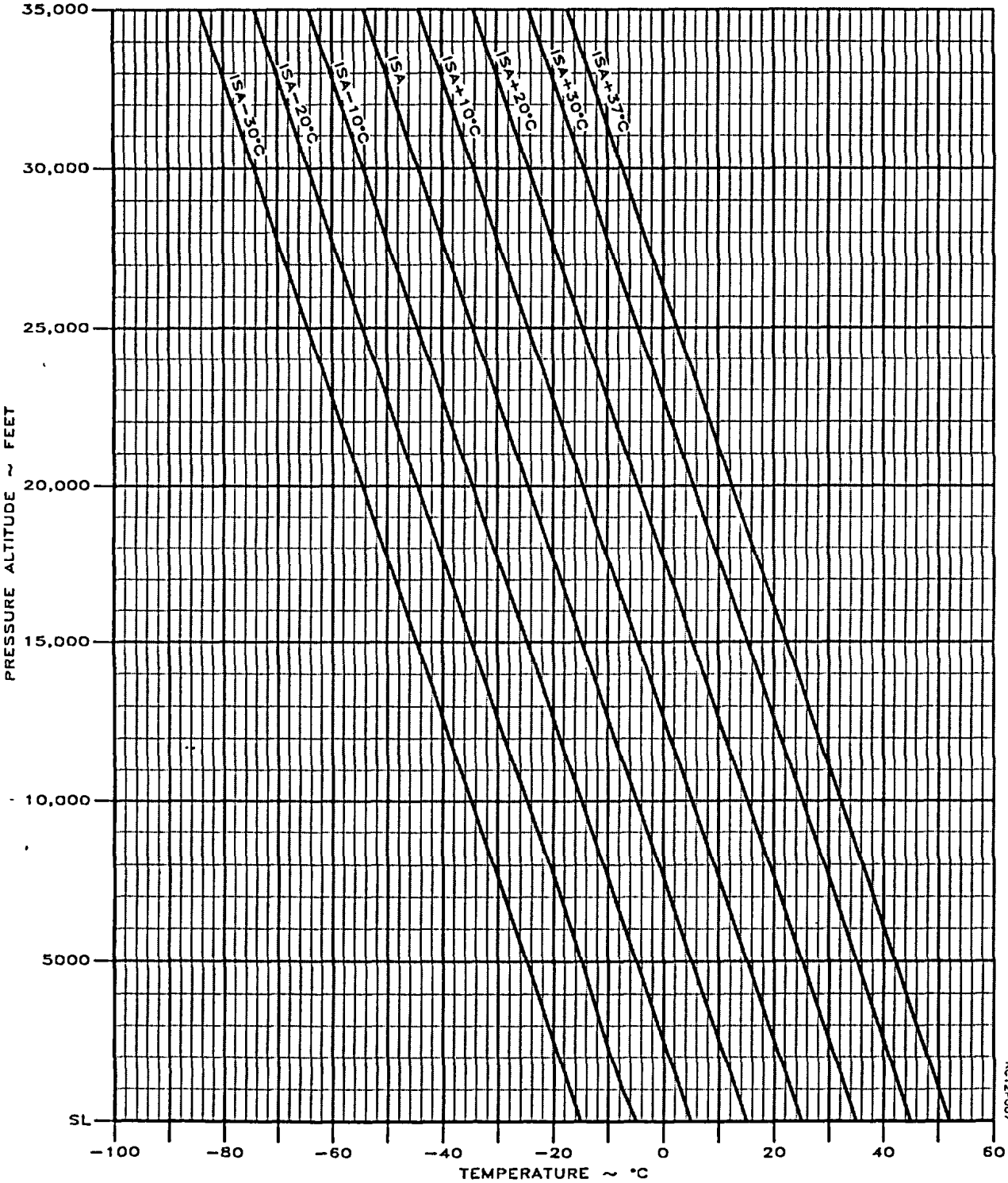

Figure 7A-7. Indicated Outside Air Temperature Correction

ISA CONVERSION

PRESSURE ALTITUDE VERSUS FREE AIR TEMPERATURE



RC129007

Figure 7A-8. ISA Conversion

FAHRENHEIT TO CELSIUS TEMPERATURE CONVERSION

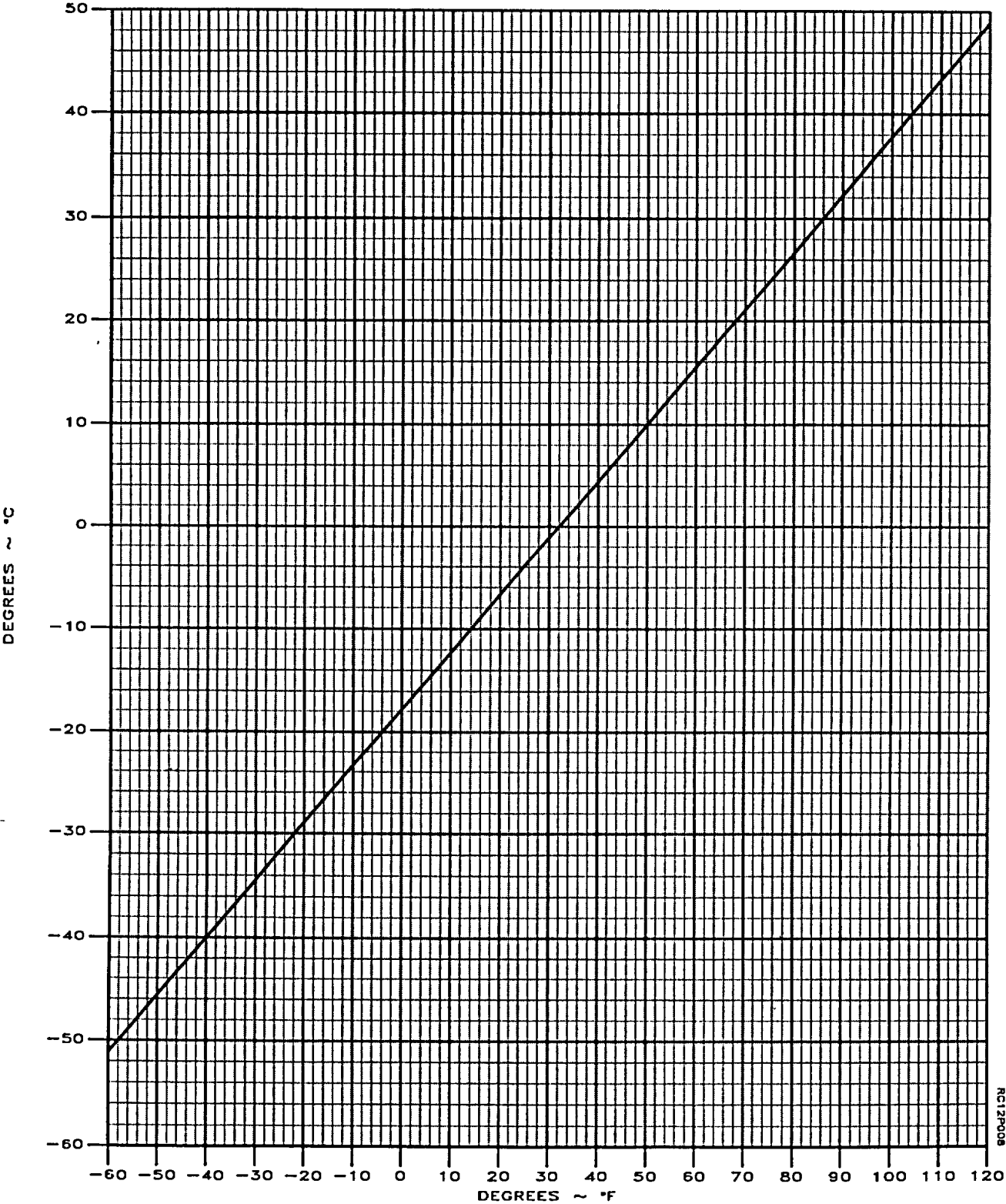

Figure 7A-9. Fahrenheit to Celsius Temperature Conversion

STATIC TAKE-OFF POWER AT 1700 RPM  
WITH ICE VANES RETRACTED

EXAMPLE  
FAT .....15°C  
FIELD PRESSURE ALTITUDE .....3499 FT  
TAKE-OFF POWER.....93.5%

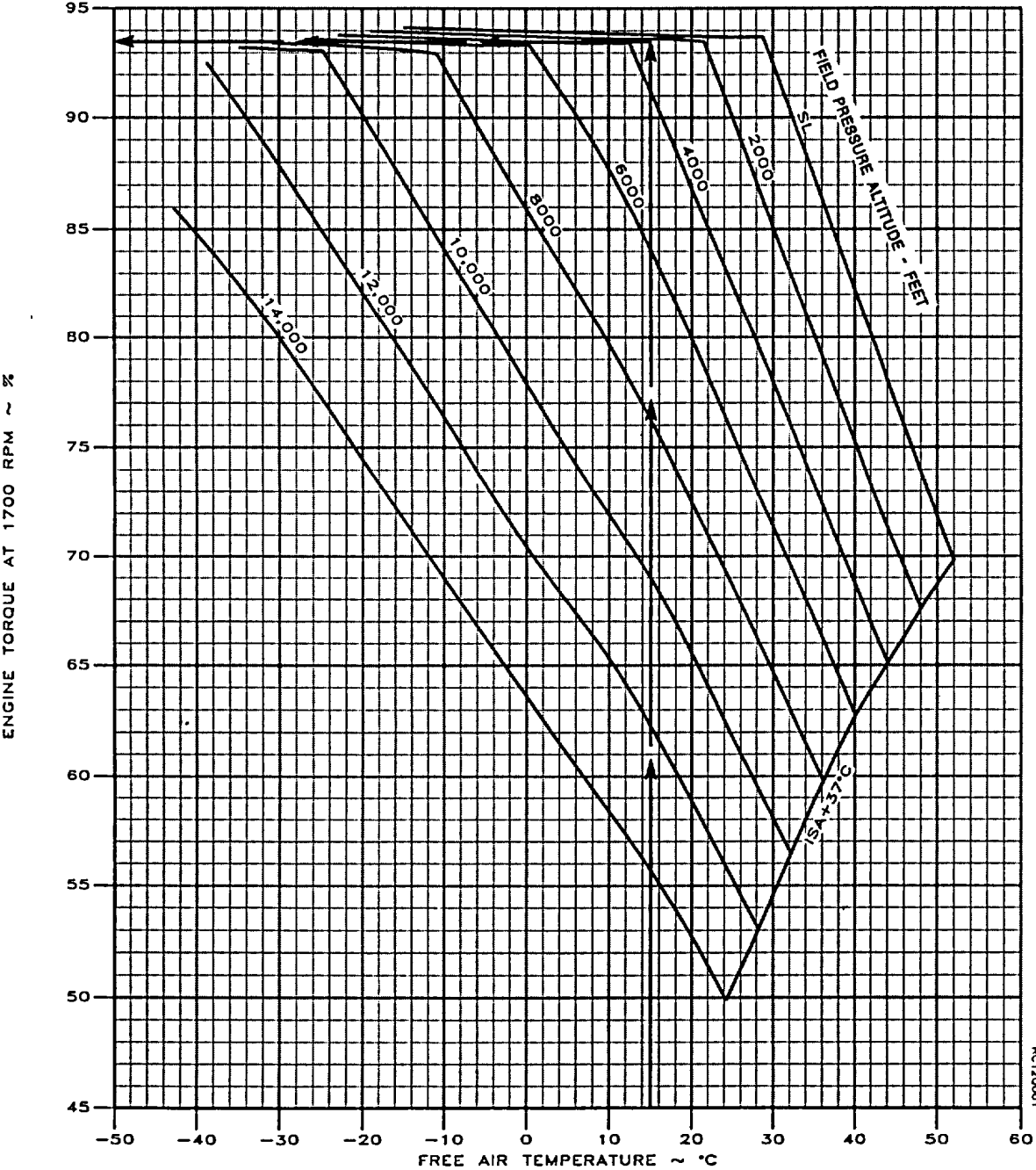

Figure 7A-10. Static Take-off Power at 1700 RPM, Ice Vanes Retracted

STATIC TAKE-OFF POWER AT 1700 RPM  
WITH ICE VANES EXTENDED

EXAMPLE:  
FAT .....15°C  
FIELD PRESSURE ALTITUDE .....3499 FT  
TAKE-OFF POWER.....85.8 %

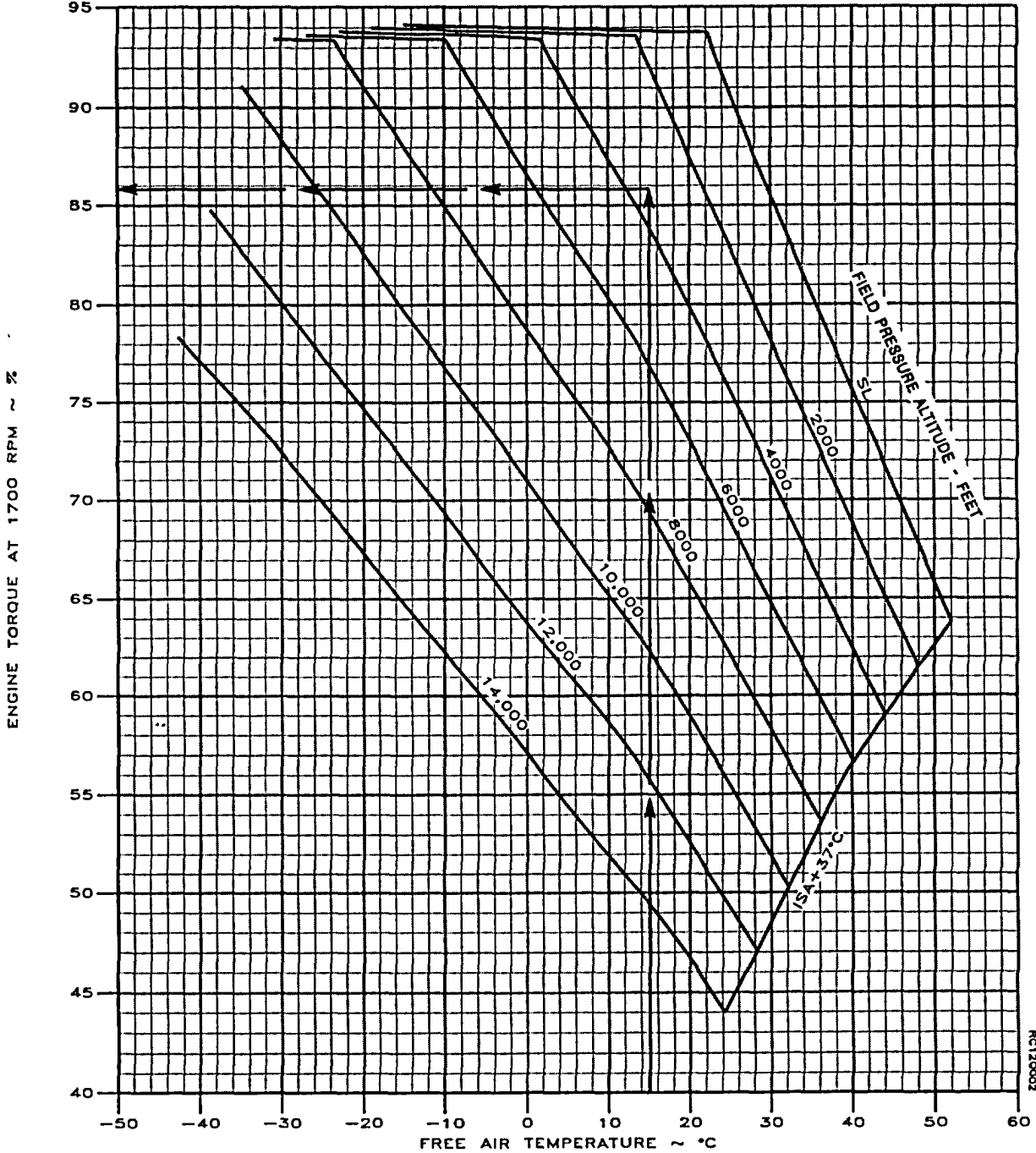

Figure 7A-11. Static Take-off Power at 1700 RPM, Ice Vanes Extended

WIND COMPONENTS

EXAMPLE:  
WIND SPEED..... 15 KNOTS  
ANGLE BETWEEN WIND DIRECTION  
AND FLIGHT PATH..... 50°  
HEADWIND COMPONENT ..... 9.6 KNOT  
CROSSWIND COMPONENT ..... 11.5 KNO

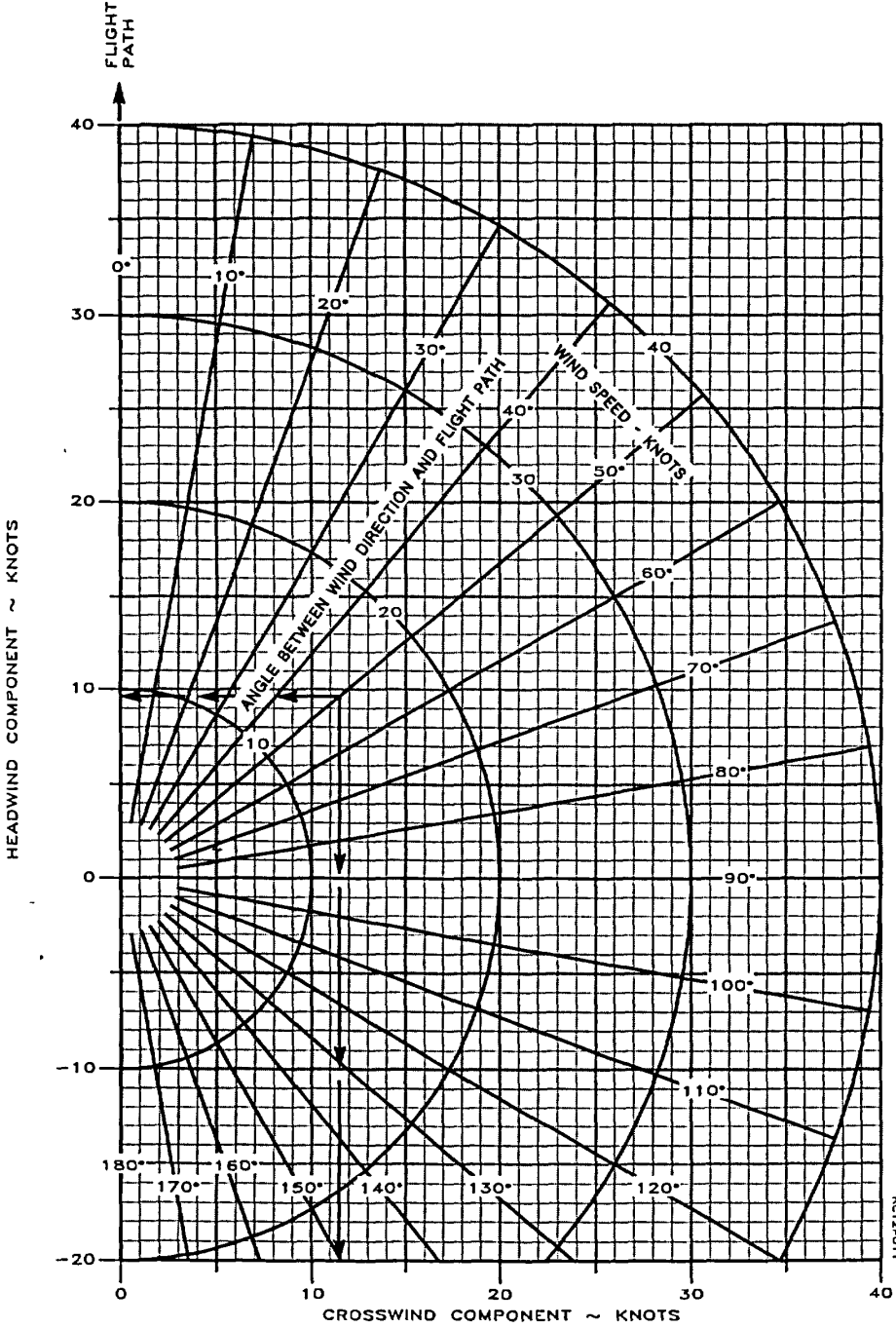

Figure 7A-12. Wind Components



### MAXIMUM TAKE-OFF WEIGHT PERMITTED BY ENROUTE CLIMB REQUIREMENTS

ASSOCIATED CONDITIONS:  
POWER..... MAXIMUM CONTINUOUS  
INOPERATIVE PROPELLER..... FEATHERED  
FLAPS..... UP  
LANDING GEAR..... UP

EXAMPLE:  
FIELD PRESSURE ALTITUDE..... 3499 FT  
FAT..... 15°C  
TAKE-OFF WEIGHT..... 16,500 LBS

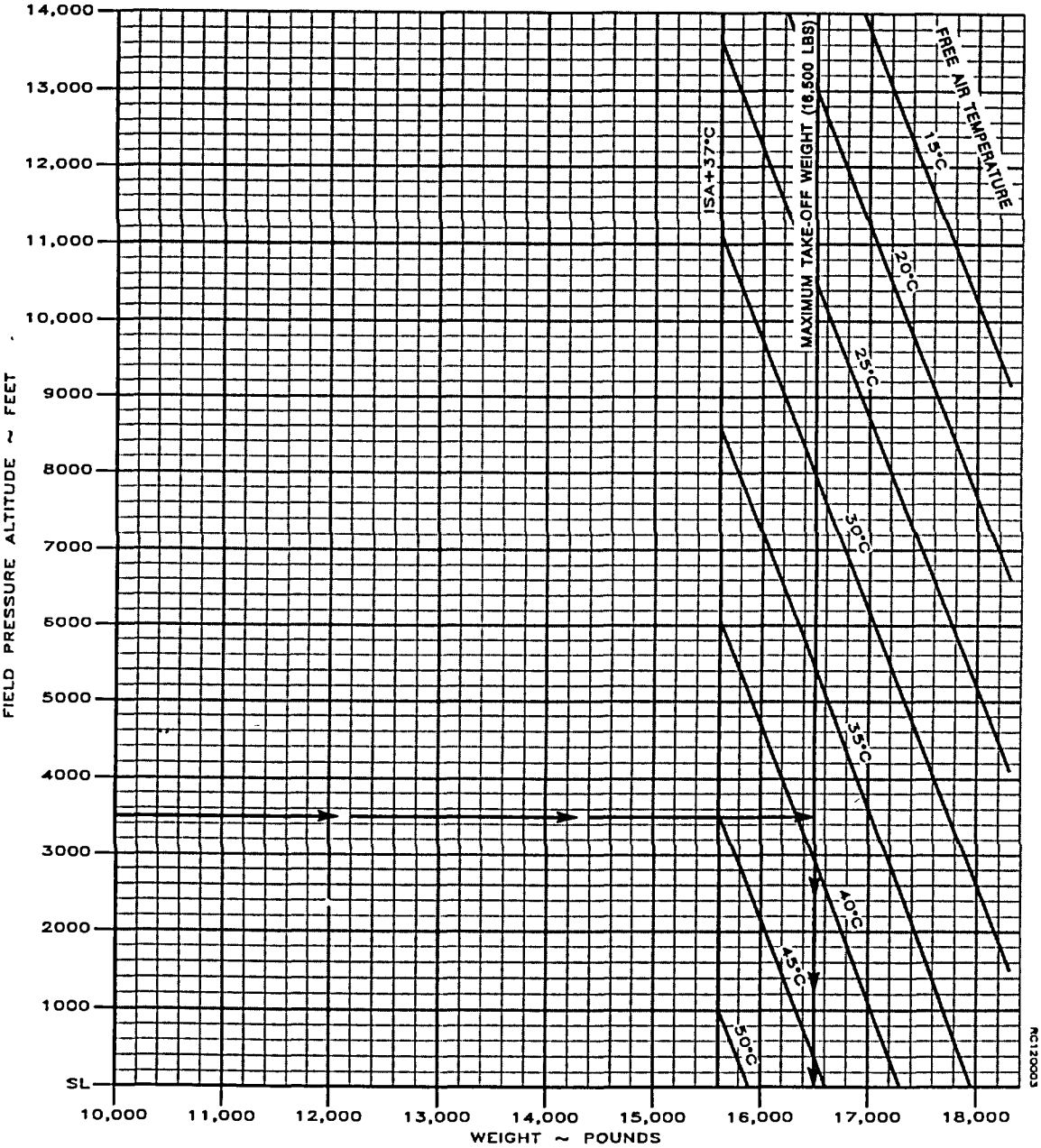

Figure 7A-13. Maximum Take-off Weight Permitted by Enroute Climb Requirements

**MAXIMUM TAKE-OFF WEIGHT - FLAPS UP  
TO ACHIEVE POSITIVE ONE-ENGINE-INOPERATIVE CLIMB AT LIFT-OFF**

ASSOCIATED CONDITIONS:

POWER.....TAKEOFF  
LANDING GEAR.....DOWN  
INOPERATIVE PROPELLER.....FEATHERED

EXAMPLE:

FIELD PRESSURE ALTITUDE ..... 3499 FT  
FAT ..... 15°C  
TAKE-OFF WEIGHT ..... 16,500 LBS

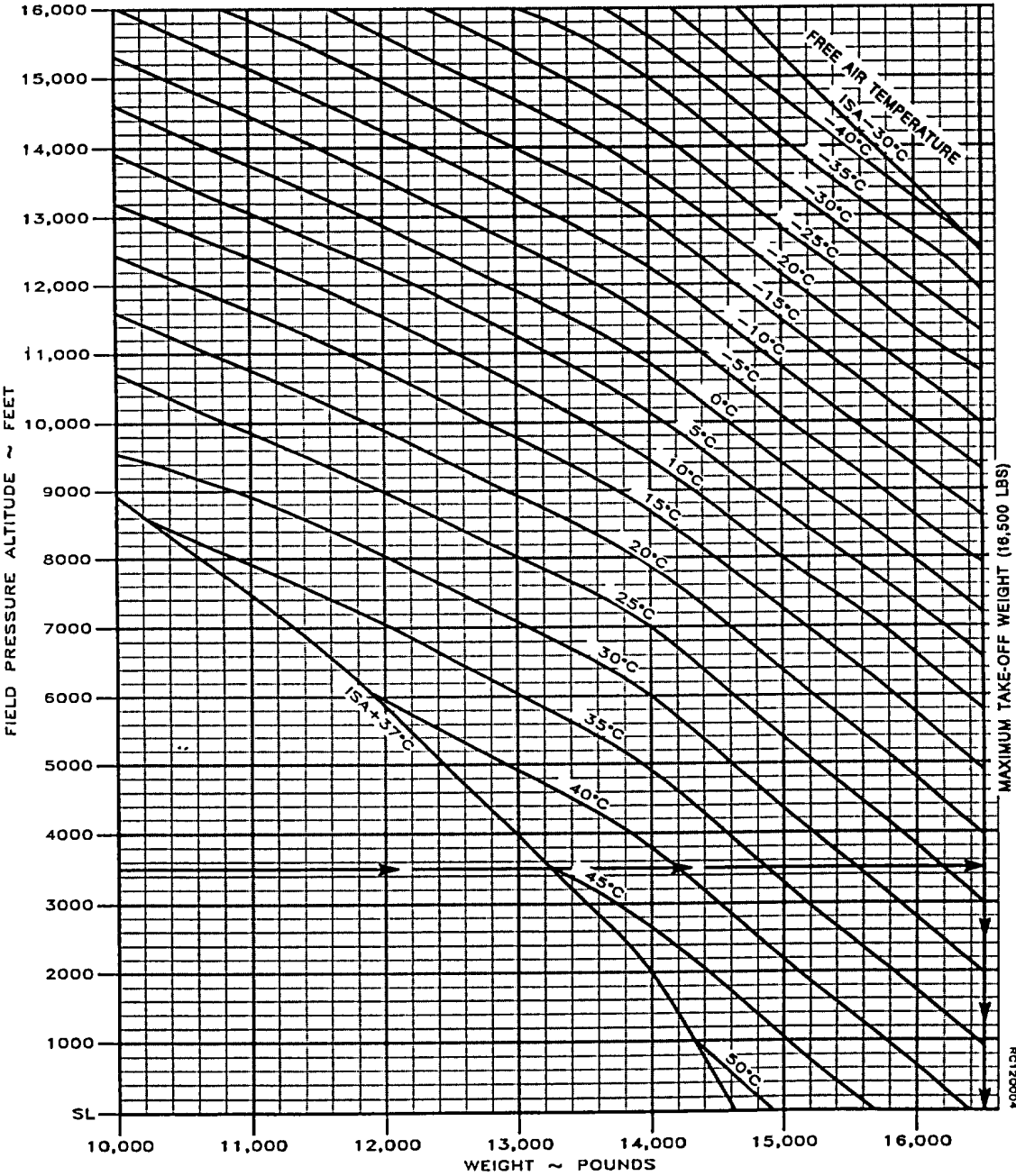

Figure 7A-14. Maximum Take-off Weight to Achieve Positive One Engine Inoperative Climb at Liff-off - Flaps Up

**MAXIMUM TAKE-OFF WEIGHT - FLAPS UP  
AS LIMITED BY TIRE SPEED**

EXAMPLE:  
FAT .....15°C  
FIELD PRESSURE ALTITUDE .....3499 FT  
HEADWIND COMPONENT .....10 KTS  
WEIGHT .....EXCEEDS STRUCTURAL LIMIT  
OF 16,500 LBS

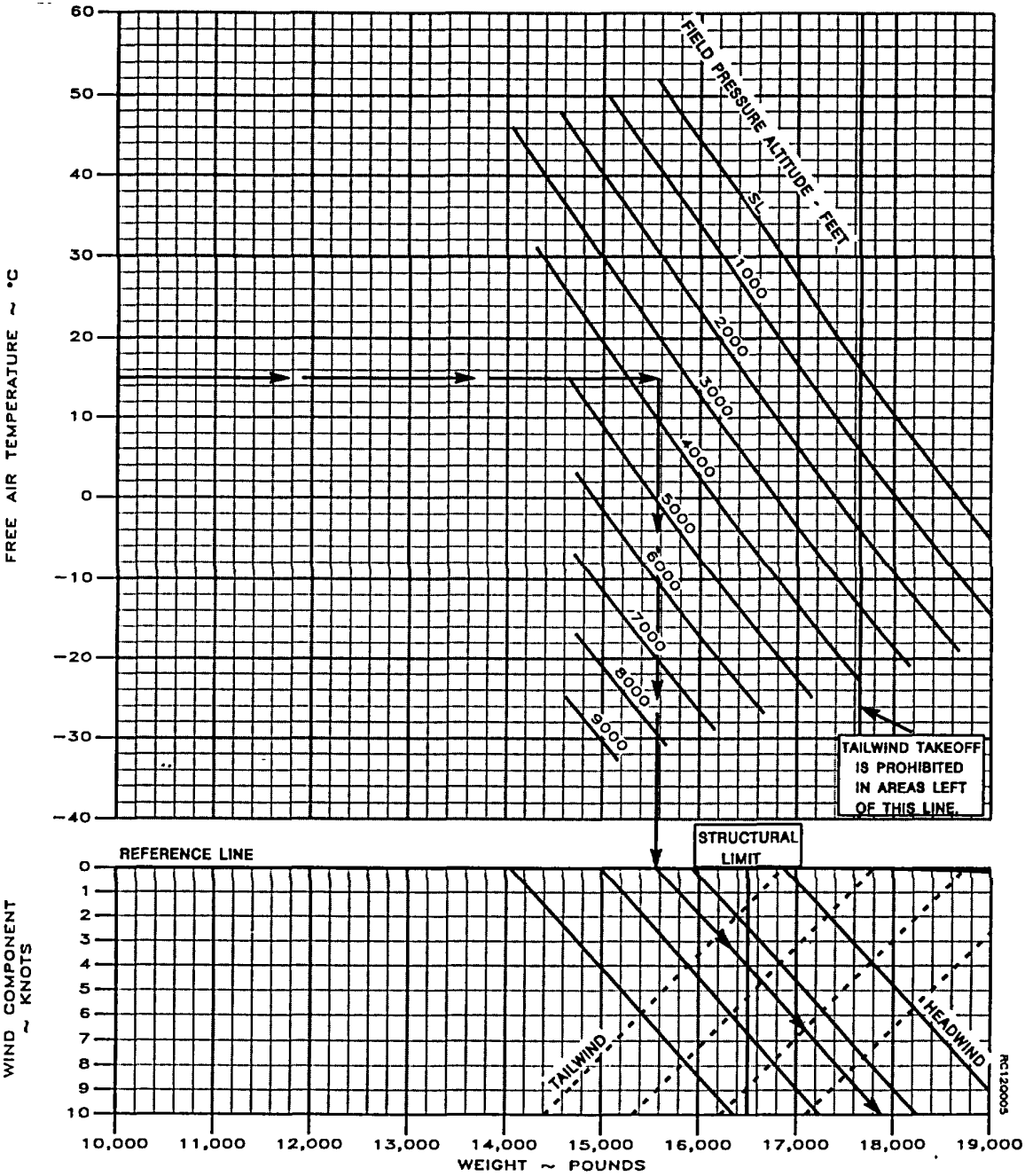

Figure 7A-15. Maximum Take-off Weight as Limited by Tire Speed - Flaps Up

TAKE-OFF SPEEDS (KIAS) - FLAPS UP

		FREE AIR TEMPERATURE																											
PRESS. ALT (FT)	T/O WT (LBS)	-30°C				-10°C				0°C				10°				20°C				40°C				52°C			
		V <sub>1</sub>	V <sub>R</sub>	V <sub>2</sub>	V <sub>50</sub>	V <sub>1</sub>	V <sub>R</sub>	V <sub>2</sub>	V <sub>50</sub>	V <sub>1</sub>	V <sub>R</sub>	V <sub>2</sub>	V <sub>50</sub>	V <sub>1</sub>	V <sub>R</sub>	V <sub>2</sub>	V <sub>50</sub>	V <sub>1</sub>	V <sub>R</sub>	V <sub>2</sub>	V <sub>50</sub>	V <sub>1</sub>	V <sub>R</sub>	V <sub>2</sub>	V <sub>50</sub>	V <sub>1</sub>	V <sub>R</sub>	V <sub>2</sub>	V <sub>50</sub>
SL	16,500	118	124	130	144	118	124	130	143	118	125	130	143	118	125	130	143	118	125	130	143	118	127	130	141	118	128	130	140
	16,000	116	121	128	142	116	122	128	142	116	122	128	141	116	122	128	141	116	123	128	141	116	124	128	139	116	126	128	138
	15,000	114	116	124	139	114	117	124	139	114	117	124	138	114	118	124	138	114	118	124	138	114	119	124	138	114	121	124	135
	14,000	114	114	123	138	114	114	122	137	114	114	122	136	114	114	121	136	114	114	121	135	114	115	121	133	114	116	121	131
	13,000	114	114	123	140	114	114	123	138	114	114	122	138	114	114	122	137	114	114	122	137	114	114	120	133	114	114	118	130
	12,000	114	114	124	141	114	114	124	140	114	114	123	139	114	114	123	139	114	114	123	138	114	114	121	135	114	114	119	131
	11,000	114	114	124	143	114	114	125	142	114	114	124	141	114	114	124	141	114	114	124	140	114	114	122	136	114	114	120	133
	10,000	114	114	127	145	114	114	126	144	114	114	125	143	114	114	125	142	114	114	125	142	114	114	123	138	114	114	121	134
2000	16,500	118	124	130	143	118	125	130	143	118	125	130	143	118	126	130	142	118	126	130	142	118	128	130	140	118	129	130	138
	16,000	116	122	128	142	116	122	128	141	116	123	126	141	116	123	128	141	116	123	128	140	116	126	128	138	116	127	128	137
	15,000	114	117	124	139	114	118	124	138	114	118	124	138	114	118	124	138	114	118	124	137	114	121	135	114	122	124	134	
	14,000	114	114	122	137	114	114	121	136	114	114	121	135	114	114	121	135	114	114	121	134	114	116	124	132	114	117	121	130
	13,000	114	114	123	139	114	114	122	137	114	114	122	137	114	114	122	136	114	114	121	136	114	114	119	131	114	114	117	128
	12,000	114	114	124	140	114	114	123	139	114	114	123	138	114	114	122	138	114	114	122	137	114	114	120	132	114	114	118	129
	11,000	114	114	125	142	114	114	124	141	114	114	124	140	114	114	123	139	114	114	123	139	114	114	121	134	114	114	119	130
	10,000	114	114	126	144	114	114	125	143	114	114	125	142	114	114	124	141	114	114	124	140	114	114	121	135	114	114	120	132
4000	16,500	118	125	130	143	118	126	130	142	118	126	130	142	118	126	130	142	118	127	130	141	118	129	130	139	118	129	130	137
	16,000	118	122	128	141	116	123	128	141	116	123	128	140	116	123	128	140	116	124	128	139	116	126	128	137	116	127	128	135
	15,000	114	117	124	138	114	118	124	138	114	118	124	137	114	119	124	137	114	119	124	136	114	122	124	134	114	123	124	132
	14,000	114	114	121	136	114	114	121	135	114	114	121	134	114	114	121	134	114	115	121	133	114	117	121	131	114	118	121	129
	13,000	114	114	122	137	114	114	122	136	114	114	121	136	114	114	121	135	114	114	120	133	114	114	118	129	114	114	117	126
	12,000	114	114	123	139	114	114	123	138	114	114	122	137	114	114	122	137	114	114	121	135	114	114	119	130	114	114	117	127
	11,000	114	114	124	141	114	114	123	139	114	114	123	139	114	114	123	138	114	114	122	136	114	114	119	131	114	114	118	128
	10,000	114	114	125	143	114	114	125	141	114	114	124	140	114	114	124	140	114	114	123	138	114	114	120	133	114	114	119	129
6000	16,500	118	125	130	142	118	128	130	142	118	126	130	142	118	127	130	141	118	128	130	140	118	129	130	137	---	---	---	---
	16,000	116	123	128	141	116	124	128	140	116	124	128	140	116	124	128	139	116	125	128	138	116	127	128	136	---	---	---	---
	15,000	114	118	124	138	114	119	124	137	114	119	124	137	114	120	124	136	114	121	124	135	114	122	124	133	---	---	---	---
	14,000	114	114	121	135	114	114	121	134	114	114	121	134	114	115	121	133	114	116	121	132	114	118	121	130	---	---	---	---
	13,000	114	114	122	136	114	114	121	135	114	114	121	135	114	114	120	133	114	114	119	131	114	114	117	127	---	---	---	---
	12,000	114	114	123	138	114	114	122	137	114	114	122	136	114	114	121	134	114	114	120	132	114	114	117	128	---	---	---	---
	11,000	114	114	124	140	114	114	123	138	114	114	123	137	114	114	122	136	114	114	121	134	114	114	118	129	---	---	---	---
	10,000	114	114	125	141	114	114	124	140	114	114	124	139	114	114	123	137	114	114	121	135	114	114	119	130	---	---	---	---
8000	16,500	118	126	130	142	118	126	130	141	118	127	130	141	118	128	130	140	118	129	130	139	118	129	130	136	---	---	---	---
	16,000	116	123	128	140	116	124	128	140	116	125	128	139	116	126	128	138	116	126	128	137	116	127	128	134	---	---	---	---
	15,000	114	119	124	137	114	119	124	137	114	120	124	136	114	121	124	135	114	122	124	134	114	123	124	131	---	---	---	---
	14,000	114	114	121	134	114	114	121	133	114	115	121	133	114	116	121	132	114	117	121	131	114	119	121	128	---	---	---	---
	13,000	114	114	121	135	114	114	120	134	114	114	120	132	114	114	119	130	114	114	118	129	114	114	117	125	---	---	---	---
	12,000	114	114	122	137	114	114	121	135	114	114	120	134	114	114	119	132	114	114	119	130	114	114	116	126	---	---	---	---
	11,000	114	114	123	138	114	114	122	137	114	114	121	135	114	114	120	133	114	114	119	131	114	114	117	127	---	---	---	---
	10,000	114	114	124	140	114	114	123	139	114	114	122	137	114	114	121	135	114	114	120	133	114	114	118	128	---	---	---	---

Figure 7A-16. Take-off Speeds (KIAS) - Flaps up (Sheet 1 of 2)

TAKE-OFF SPEEDS (KIAS) - FLAPS UP (Cont'd)

		FREE AIR TEMPERATURE																															
PRESS. ALT (FT)	T/O WT (LBS)	-30°C				-10°C				0°C				10°				20°C				40°C				52°C							
		V <sub>1</sub>	V <sub>R</sub>	V <sub>2</sub>	V <sub>50</sub>	V <sub>1</sub>	V <sub>R</sub>	V <sub>2</sub>	V <sub>50</sub>	V <sub>1</sub>	V <sub>R</sub>	V <sub>2</sub>	V <sub>50</sub>	V <sub>1</sub>	V <sub>R</sub>	V <sub>2</sub>	V <sub>50</sub>	V <sub>1</sub>	V <sub>R</sub>	V <sub>2</sub>	V <sub>50</sub>	V <sub>1</sub>	V <sub>R</sub>	V <sub>2</sub>	V <sub>50</sub>	V <sub>1</sub>	V <sub>R</sub>	V <sub>2</sub>	V <sub>50</sub>				
10,000	16,500	118	126	130	142	118	128	130	140	118	128	130	140	118	129	130	139	118	129	130	137	118	129	130	137	118	130	130	135	---	---	---	---
	16,000	116	124	128	140	116	125	128	139	116	126	128	138	116	126	128	137	116	127	128	136	116	127	128	136	116	128	128	133	---	---	---	---
	15,000	114	119	124	137	114	120	124	135	114	121	124	135	114	122	124	134	114	122	124	133	114	122	124	133	114	123	124	130	---	---	---	---
	14,000	114	114	114	133	114	116	121	132	114	116	121	131	114	117	121	131	114	118	121	130	114	119	121	127	114	119	121	127	---	---	---	---
	13,000	114	114	121	134	114	114	119	131	114	114	118	130	114	114	118	128	114	114	117	126	114	115	117	124	114	115	117	124	---	---	---	---
	12,000	114	114	121	136	114	114	120	133	114	114	119	131	114	114	118	129	114	114	117	128	114	114	117	128	114	114	115	124	---	---	---	---
	11,000	114	114	122	137	114	114	121	134	114	114	120	132	114	114	119	131	114	114	118	129	114	114	118	129	114	114	116	125	---	---	---	---
10,000	114	114	123	139	114	114	122	136	114	114	121	134	114	114	120	132	114	114	119	130	114	114	119	130	114	114	117	126	---	---	---	---	
12,000	16,500	118	127	130	141	118	128	130	139	118	129	130	138	118	129	130	137	118	129	130	136	118	130	130	134	118	130	130	134	---	---	---	---
	16,000	116	125	128	139	116	126	128	138	116	127	128	137	116	127	128	136	116	127	128	134	116	128	128	132	116	128	128	132	---	---	---	---
	15,000	114	120	124	136	114	121	124	134	114	122	124	134	114	123	124	133	114	123	124	131	114	124	124	129	114	124	124	129	---	---	---	---
	14,000	114	115	121	133	114	117	121	131	114	118	121	130	114	118	121	130	114	119	121	128	114	119	121	126	114	119	121	126	---	---	---	---
	13,000	114	114	120	132	114	114	118	129	114	114	117	127	114	114	117	126	114	114	117	125	114	115	117	123	114	115	117	123	---	---	---	---
	12,500	114	114	120	134	114	114	119	130	114	114	118	129	114	114	117	127	114	114	116	125	114	114	115	122	114	114	115	122	---	---	---	---
	11,000	114	114	121	135	114	114	120	132	114	114	119	130	114	114	118	128	114	114	117	127	114	114	117	127	114	114	115	123	---	---	---	---
10,000	114	114	122	137	114	114	120	133	114	114	119	131	114	114	119	130	114	114	118	128	114	114	118	128	114	114	116	124	---	---	---	---	
14,000	16,500	118	128	130	140	118	129	130	138	118	129	130	137	118	130	130	136	118	130	130	135	118	130	130	133	118	130	130	133	---	---	---	---
	16,000	116	126	128	138	116	127	128	136	116	127	128	135	116	127	128	134	116	128	128	133	116	128	128	131	116	128	128	131	---	---	---	---
	15,000	114	121	124	135	114	122	124	133	114	123	124	132	114	123	124	131	114	123	124	130	114	124	124	128	114	124	124	128	---	---	---	---
	14,000	114	116	121	131	114	118	121	130	114	118	121	129	114	119	121	128	114	119	121	127	114	120	121	125	114	120	121	125	---	---	---	---
	13,000	114	114	118	130	114	114	117	127	114	114	117	126	114	115	117	125	114	115	117	124	114	116	117	121	114	116	117	121	---	---	---	---
	12,000	114	114	119	131	114	114	118	128	114	114	117	127	114	114	116	125	114	114	115	124	114	114	115	120	114	114	115	120	---	---	---	---
	11,000	114	114	120	132	114	114	118	129	114	114	118	128	114	114	117	125	114	114	116	125	114	114	116	125	114	114	115	121	---	---	---	---
10,000	114	114	121	134	114	114	119	131	114	114	118	129	114	114	118	127	114	114	117	126	114	114	117	126	114	114	115	122	---	---	---	---	

BT05189

Figure 7A-16. Take-off Speeds (KIAS) - Flaps up (Sheet 2 of 2)

TAKE-OFF DISTANCE - FLAPS UP

ASSOCIATED CONDITIONS:

POWER.....STATIC TAKE-OFF POWER SET BEFORE BRAKE RELEASE.  
 $V_R$ ,  $V_{50}$ .....AS SCHEDULED IN TABLE OF TAKE-OFF SPEEDS.  
 LANDING GEAR .....RETRACTED AFTER LIFT-OFF  
 RUNWAY .....PAVED, DRY SURFACE

EXAMPLE:

FAT .....15°C  
 FIELD PRESSURE ALTITUDE .....3499 FT  
 WEIGHT.....16,000 LBS  
 RUNWAY GRADIENT .....1.9% DN  
 HEADWIND COMPONENT.....10 KTS  
 GROUND ROLL.....3602 FT  
 TOTAL DISTANCE OVER 50-FT OBSTACLE .....5167 FT

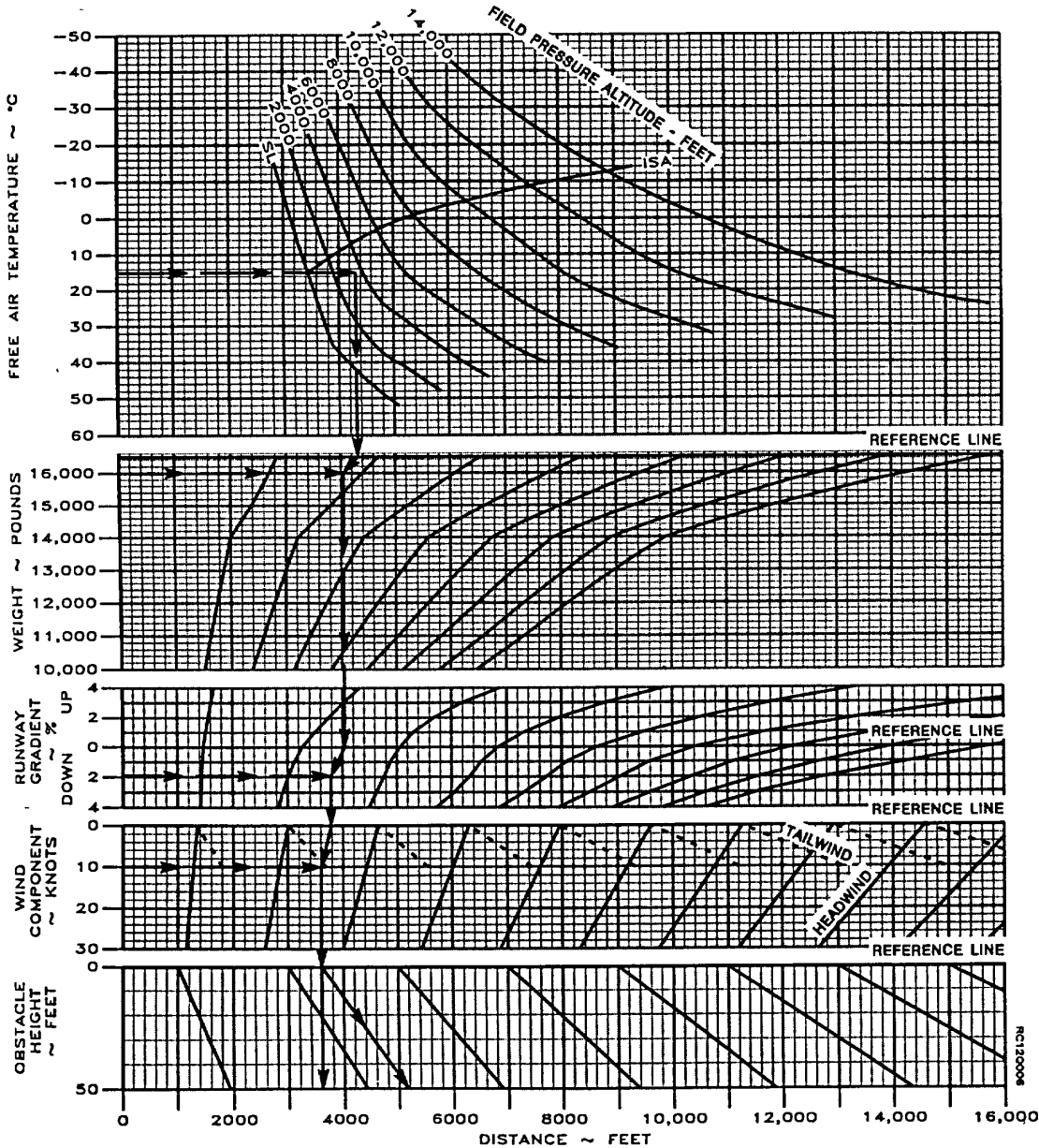

Figure 7A-17. Take-off Distance Over 50 Foot Obstacle - Flaps Up

**ACCELERATE-STOP - FLAPS UP**

ASSOCIATED CONDITIONS:

POWER.....STATIC TAKE-OFF POWER SET  
 BEFORE BRAKE RELEASE.  
 AUTOFEATHER..... ARMED  
 V<sub>1</sub>..... AS SCHEDULED IN TABLE  
 OF TAKE-OFF SPEEDS.  
 POWER LEVERS ..... GROUND FINE AT V<sub>1</sub>  
 BRAKING.....MAXIMUM WITHOUT SLIDING TIRES  
 RUNWAY ..... PAVED. DRY SURFACE

EXAMPLE:

FAT .....15°C  
 FIELD PRESSURE ALTITUDE .....3499 FT  
 WEIGHT.....16,000 LBS  
 RUNWAY GRADIENT .....1.9% DN  
 HEADWIND COMPONENT.....10 KTS  
 ACCELERATE-STOP DISTANCE.....5924 FT

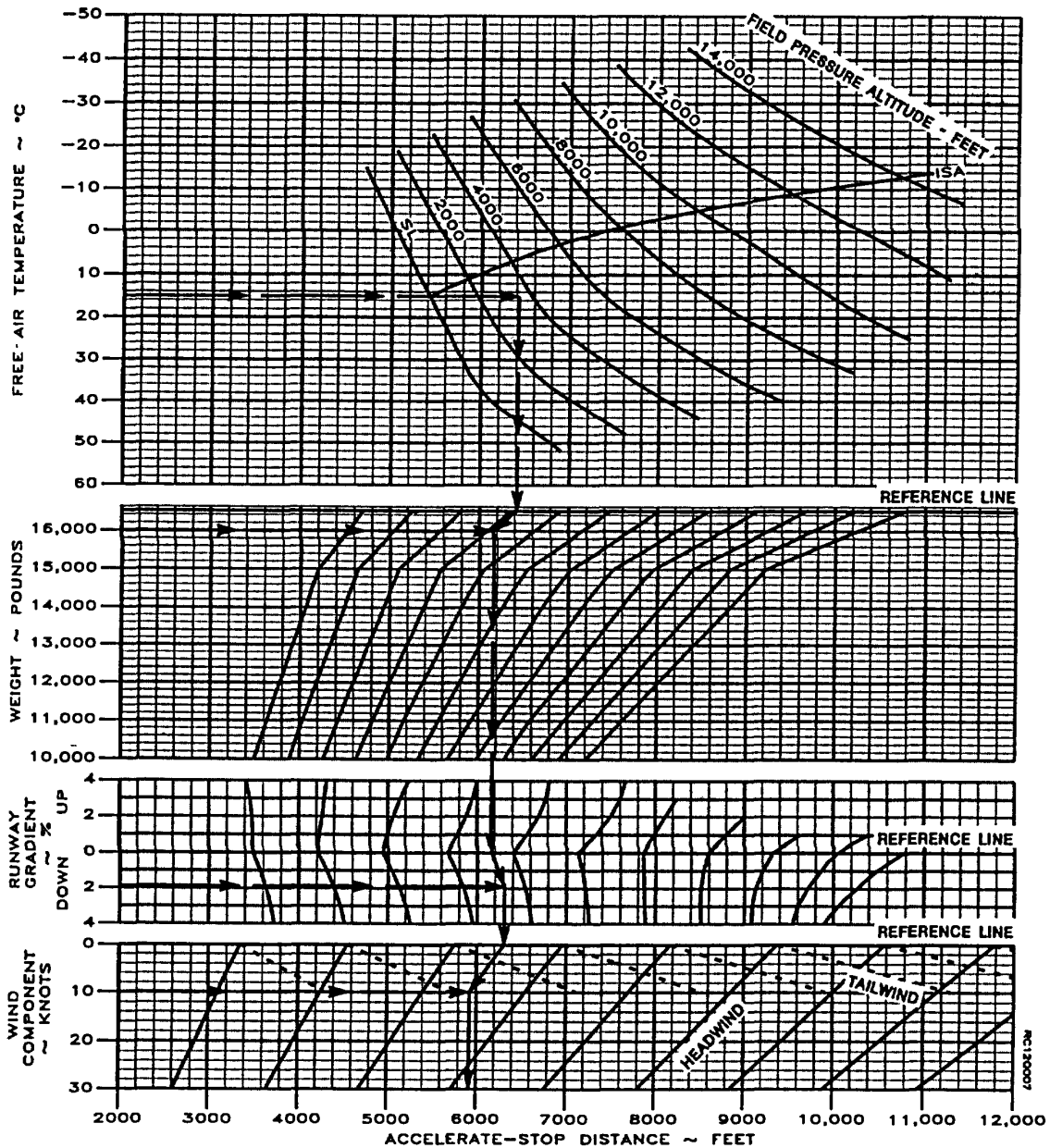

Figure 7A-18. Accelerate Stop - Flaps Up

ACCELERATE-GO - FLAPS UP

ASSOCIATED CONDITIONS:

POWER..... STATIC TAKE-OFF POWER SET BEFORE BRAKE RELEASE.  
 AUTOFEATHER..... ARMED  
 V<sub>1</sub> AND V<sub>2</sub>..... AS SCHEDULED IN TABLE OF TAKE-OFF SPEEDS.  
 LANDING' GEAR ..... RETRACTED AFTER LIFT-OFF  
 RUNWAY ..... PAVED, DRY SURFACE

EXAMPLE:

FAT ..... 15°C  
 FIELD PRESSURE ALTITUDE ..... 3499 FT  
 WEIGHT ..... 16,000 LBS  
 RUNWAY GRADIENT ..... 1.9% DN  
 HEADWIND COMPONENT ..... 10 KTS  
 ACCELERATE-GO DISTANCE ..... 7419 FT

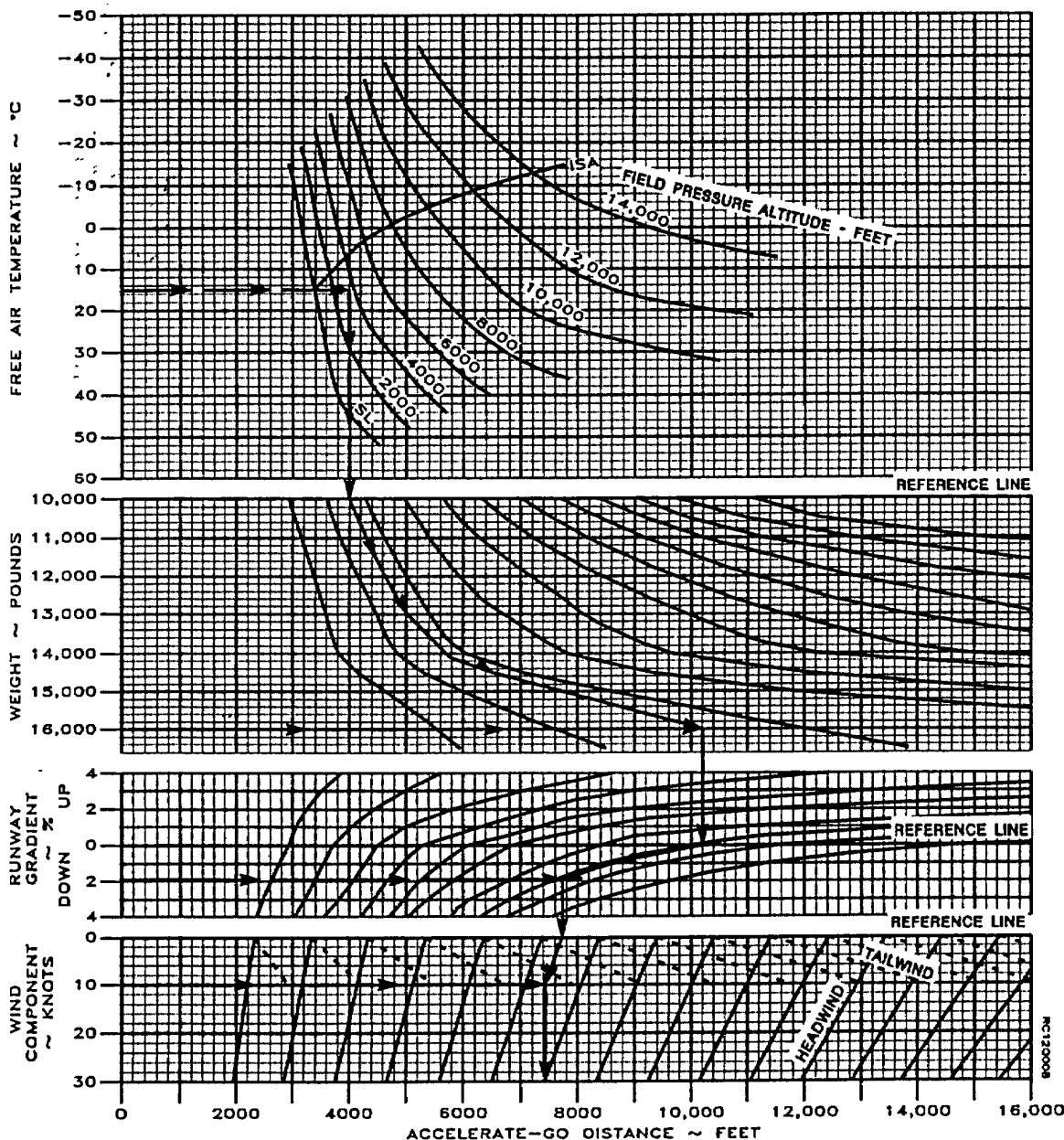

Figure 7A-19. Accelerate-Go Distance Over 50 Foot Obstacle - Flaps Up



### NET TAKE-OFF FLIGHT PATH - FIRST SEGMENT - FLAPS UP ONE ENGINE INOPERATIVE

ASSOCIATED CONDITIONS:

POWER.....STATIC TAKE-OFF  
 POWER SET BEFORE  
 BRAKE RELEASE  
 INOPERATIVE PROPELLER ....FEATHERED  
 LANDING GEAR .....DOWN  
 CLIMB SPEED ..... $V_2$

EXAMPLE:

FAT 15°C  
 FIELD PRESSURE ALTITUDE 3499 FT  
 WEIGHT 16,000 LBS  
 HEADWIND COMPONENT 10 KTS  
 NET CLIMB GRADIENT -0.16 %

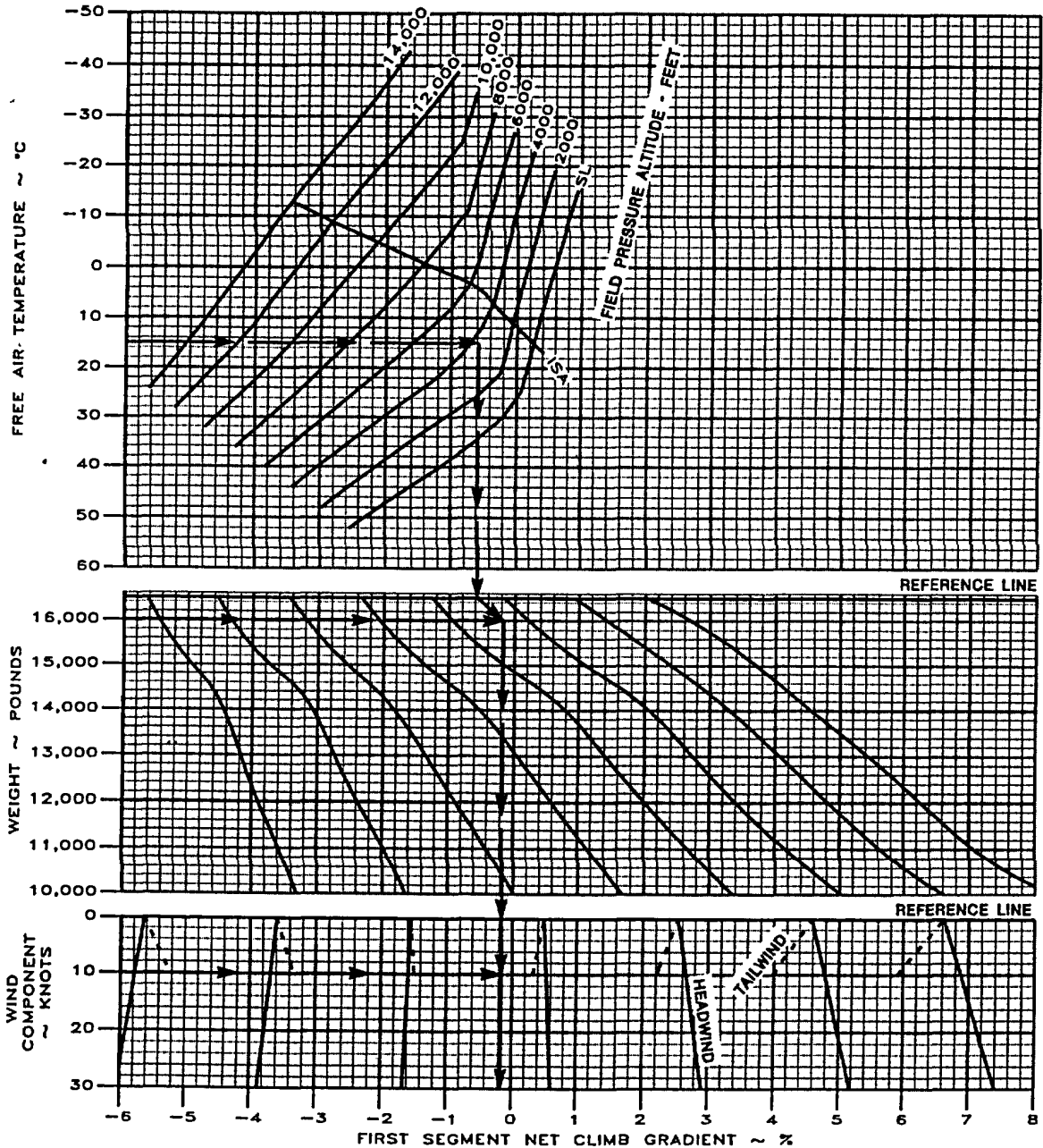

Figure 7A-20. Net Take-off Flight Path - First Segment - Flaps Up

**NET TAKE-OFF FLIGHT PATH - SECOND SEGMENT - FLAPS UP  
ONE ENGINE INOPERATIVE**

ASSOCIATED CONDITIONS:

POWER.....STATIC TAKE-OFF  
 POWER SET BEFORE  
 BRAKE RELEASE  
 INOPERATIVE PROPELLER ....FEATHERED  
 LANDING GEAR .....UP  
 CLIMB SPEED .....V<sub>2</sub>

EXAMPLE:

FAT 15°C  
 FIELD PRESSURE ALTITUDE 3499 FT  
 WEIGHT 16,000 LBS  
 HEADWIND COMPONENT 10 KTS  
 NET CLIMB GRADIENT 2.58%

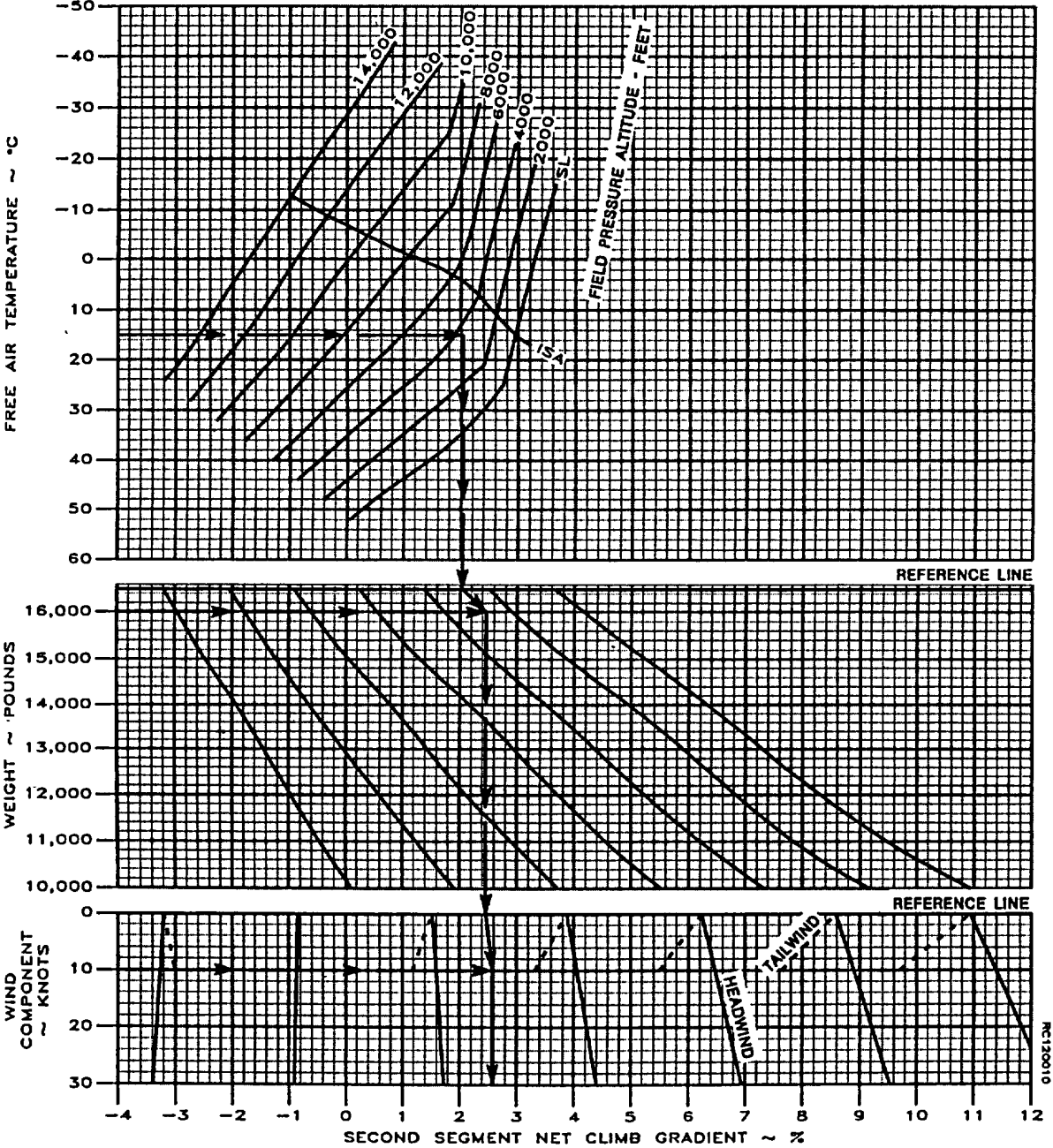

Figure 7A-21. Net Take-off Flight Path - Second Segment - Flaps Up



MAXIMUM TAKE-OFF WEIGHT - FLAPS APPROACH  
TO ACHIEVE POSITIVE ONE-ENGINE-INOPERATIVE CLIMB AT LIFT-OFF

ASSOCIATED CONDITIONS:  
POWER.....TAKEOFF  
LANDING GEAR .....DOWN  
INOPERATIVE PROPELLER .....FEATHERED

EXAMPLE:  
FIELD PRESSURE ALTITUDE ..... 3499 FT  
FAT ..... 15°C  
TAKE-OFF WEIGHT..... 16,500 LBS

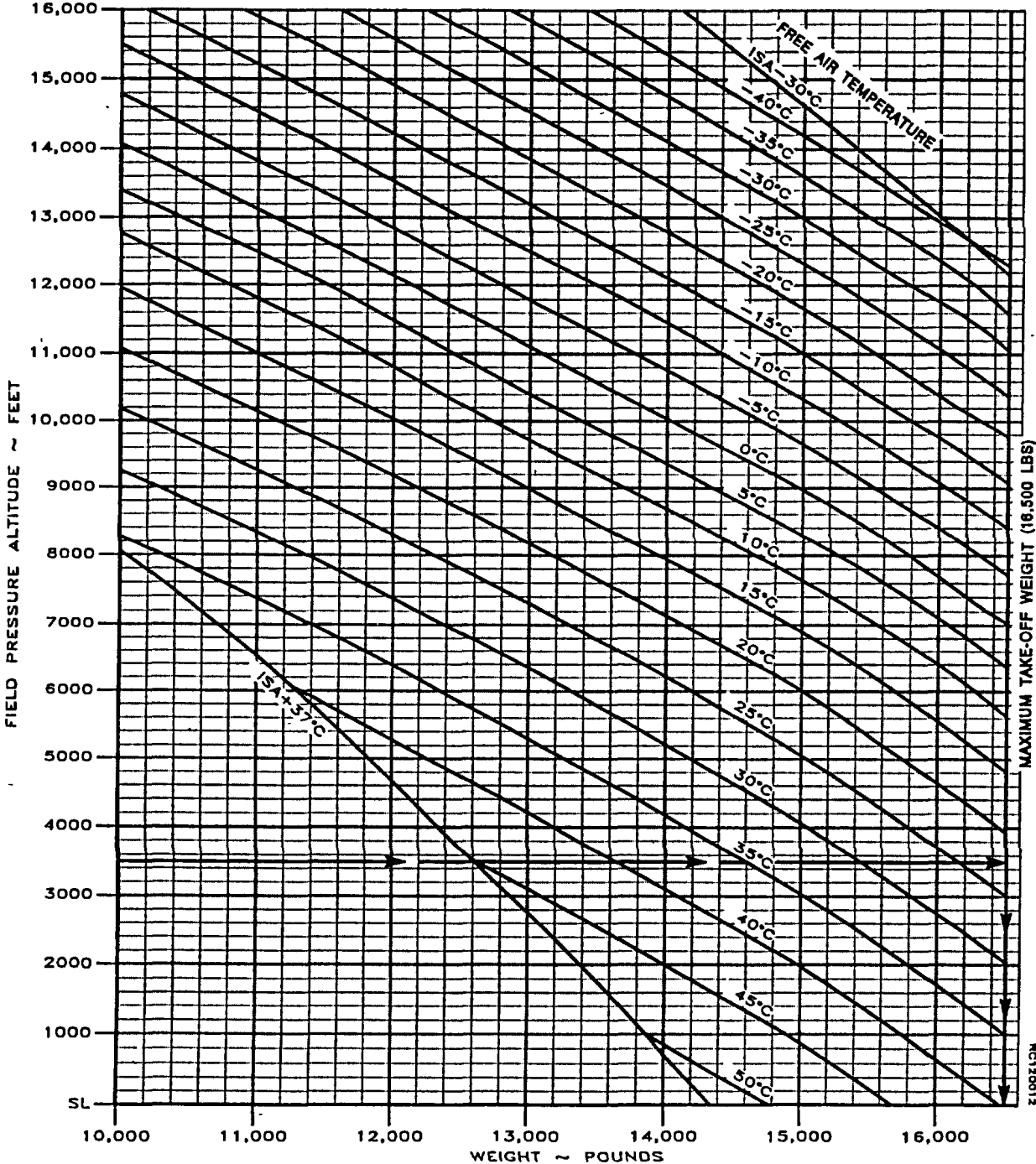

Figure 7A-23. Maximum Take-off Weight to Achieve Positive One Engine Inoperative Climb at Liftoff - Flaps Approach

**MAXIMUM TAKE-OFF WEIGHT - FLAPS APPROACH  
AS LIMITED BY TIRE SPEED**

EXAMPLE:  
FAT ..... 15°C  
FIELD PRESSURE ALTITUDE ..... 3499 FT  
HEADWIND COMPONENT ..... 10 KTS  
WEIGHT ..... EXCEEDS STRUCTURAL LIMIT  
OF 16,500 LBS

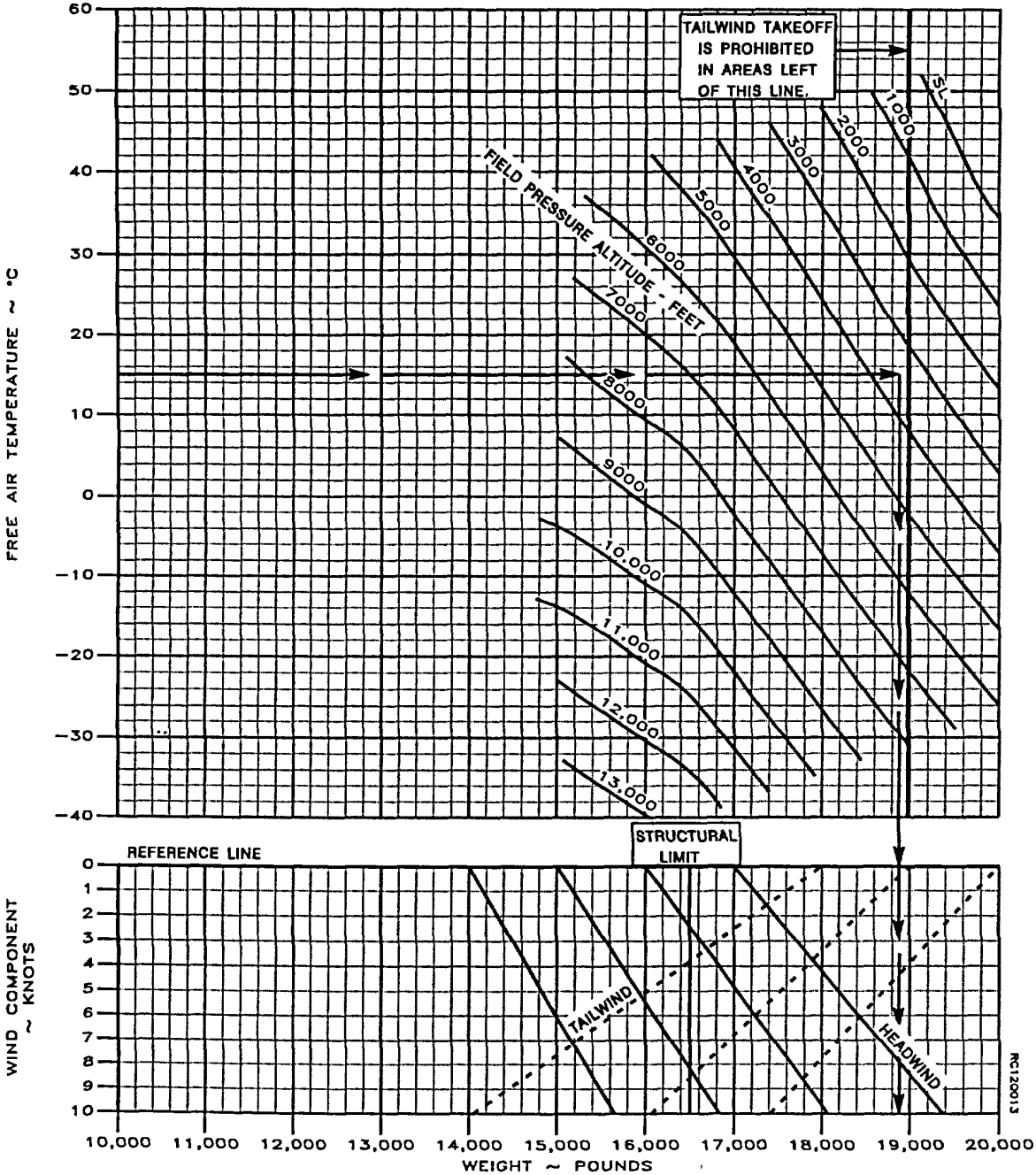

Figure 7A-24. Maximum Take-off Weight as Limited by Tire Speed - Flaps Approach

TAKE-OFF SPEEDS (KIAS) - FLAPS APPROACH

		FREE AIR TEMPERATURE																											
PRESS. ALT (FT)	T/O WT (LBS)	-30°C				-10°C				0°C				10°				20°C				40°C				52°C			
		V <sub>1</sub>	V <sub>R</sub>	V <sub>2</sub>	V <sub>50</sub>	V <sub>1</sub>	V <sub>R</sub>	V <sub>2</sub>	V <sub>50</sub>	V <sub>1</sub>	V <sub>R</sub>	V <sub>2</sub>	V <sub>50</sub>	V <sub>1</sub>	V <sub>R</sub>	V <sub>2</sub>	V <sub>50</sub>	V <sub>1</sub>	V <sub>R</sub>	V <sub>2</sub>	V <sub>50</sub>	V <sub>1</sub>	V <sub>R</sub>	V <sub>2</sub>	V <sub>50</sub>	V <sub>1</sub>	V <sub>R</sub>	V <sub>2</sub>	V <sub>50</sub>
SL	16,500	110	113	116	129	110	114	116	129	110	114	116	129	110	114	116	128	110	114	116	128	110	116	116	127	110	116	116	125
	18,000	108	111	114	128	108	111	114	127	108	111	114	127	108	112	114	127	108	112	114	127	108	112	114	127	108	113	114	124
	15,000	108	110	115	129	108	110	114	128	108	110	114	127	108	110	114	127	108	110	113	126	108	110	112	123	108	110	111	121
	14,000	108	110	116	130	108	110	115	129	108	110	115	128	108	110	114	128	108	110	114	127	108	110	113	124	108	110	111	122
	13,000	108	110	116	132	108	110	116	130	108	110	116	130	108	110	115	129	108	110	115	129	108	110	113	126	108	110	112	123
	12,000	108	110	117	133	108	110	117	132	108	110	116	131	108	110	116	131	108	110	116	130	108	110	114	127	108	110	113	124
	11,000	108	110	118	135	108	110	118	133	108	110	117	133	108	110	117	132	108	110	117	132	108	110	115	128	108	110	113	125
	10,000	108	110	120	137	108	110	119	135	108	110	118	134	108	110	118	134	108	110	118	133	108	110	116	130	108	110	114	127
2000	16,500	110	113	116	129	110	114	116	128	110	114	116	128	110	114	116	128	110	115	116	128	110	116	116	126	110	116	116	124
	16,000	108	111	114	127	108	112	114	127	108	112	114	127	108	112	114	126	108	112	114	126	108	114	114	124	108	114	114	123
	15,000	108	110	114	125	108	110	114	127	108	110	113	126	108	110	113	126	108	110	113	125	108	110	111	121	108	111	111	120
	14,000	108	110	115	129	108	110	114	128	108	110	114	127	108	110	114	127	108	110	114	126	108	110	112	122	108	110	110	120
	13,000	108	110	116	130	108	110	115	129	108	110	115	129	108	110	115	128	108	110	115	128	108	110	112	123	108	110	111	121
	12,000	108	110	117	132	108	110	116	131	108	110	116	130	108	110	116	130	108	110	115	129	108	110	113	125	108	110	112	122
	11,000	108	110	118	133	108	110	117	132	108	110	117	132	108	110	117	131	108	110	116	131	108	110	114	126	108	110	112	123
	10,000	108	110	119	135	108	110	118	134	108	110	118	133	108	110	118	133	108	110	117	132	108	110	115	127	108	110	113	124
4000	18,500	110	114	116	128	110	114	116	128	110	115	116	128	110	115	118	127	110	116	116	127	110	116	116	125	110	116	116	122
	18,000	108	112	114	127	108	112	114	126	108	112	114	126	108	113	114	126	108	113	114	125	108	114	114	123	108	114	114	121
	15,000	108	110	114	127	108	110	113	126	108	110	113	125	108	110	113	125	108	110	112	123	108	111	111	120	108	111	111	118
	14,000	108	110	115	128	108	110	114	127	108	110	114	126	108	110	113	126	108	110	113	124	108	110	111	120	108	110	110	118
	13,000	108	110	115	129	108	110	115	128	108	110	115	128	108	110	114	127	108	110	113	125	108	110	111	121	108	110	110	119
	12,000	108	110	116	131	108	110	116	130	108	110	115	129	108	110	115	129	108	110	114	127	108	110	112	122	108	110	111	120
	11,000	108	110	117	132	108	110	117	131	108	110	116	131	108	110	118	130	108	110	115	128	108	110	113	124	108	110	111	121
	10,000	108	110	118	134	108	110	118	133	108	110	117	132	108	110	117	132	108	110	116	130	108	110	114	125	108	110	112	122
6000	16,500	110	115	116	128	110	115	116	127	110	115	116	127	110	116	116	127	110	116	116	126	110	116	116	123	---	---	---	---
	16,000	108	113	114	126	108	113	114	126	108	113	114	126	108	114	114	125	108	114	114	124	108	114	114	122	---	---	---	---
	15,000	108	110	113	126	108	110	113	125	108	110	113	124	108	110	112	123	108	110	111	121	108	111	111	119	---	---	---	---
	14,000	108	110	114	127	108	110	114	126	108	110	113	125	108	110	113	124	108	110	112	122	108	110	110	118	---	---	---	---
	13,000	108	110	115	128	108	110	114	127	108	110	114	127	108	110	113	125	108	110	112	123	108	110	110	119	---	---	---	---
	12,000	108	110	116	130	108	110	115	129	108	110	115	128	108	110	114	126	108	110	113	125	108	110	111	120	---	---	---	---
	11,000	108	110	117	131	108	110	116	130	108	110	118	129	108	110	115	128	108	110	114	126	108	110	112	122	---	---	---	---
	10,000	108	110	118	133	108	110	117	132	108	110	117	131	108	110	116	129	108	110	115	127	108	110	113	123	---	---	---	---
8000	16,500	110	115	116	127	110	115	116	126	110	116	116	126	110	116	116	126	110	116	116	125	110	116	116	122	---	---	---	---
	16,000	108	114	114	126	108	113	114	125	108	114	114	125	108	114	114	124	108	114	114	123	108	114	114	120	---	---	---	---
	15,000	108	110	113	125	108	110	112	124	108	110	111	122	108	110	111	121	108	111	111	120	108	110	111	117	---	---	---	---
	14,000	108	110	114	126	108	110	113	125	108	110	112	123	108	110	111	122	108	110	111	120	108	110	110	117	---	---	---	---
	13,000	108	110	114	127	108	110	114	126	108	110	113	124	108	110	112	123	108	110	111	121	108	110	110	118	---	---	---	---
	12,000	108	110	115	129	108	110	114	127	108	110	114	126	108	110	113	124	108	110	112	122	108	110	110	119	---	---	---	---
	11,000	108	110	116	130	108	110	115	129	108	110	114	127	108	110	114	125	108	110	113	124	108	110	111	120	---	---	---	---
	10,000	108	110	117	132	108	110	116	130	108	110	115	129	108	110	115	127	108	110	114	125	108	110	111	121	---	---	---	---

Figure 7-25. Take-off Speeds (KIAS) - Flaps Approach (Sheet 1 of 2)

**TAKE-OFF SPEEDS (KIAS) - FLAPS APPROACH**

		FREE AIR TEMPERATURE																											
PRESS. ALT (FT)	T/O WT (LBS)	-30°C				-10°C				0°C				10°				20°C				40°C				52°C			
		V <sub>1</sub>	V <sub>R</sub>	V <sub>2</sub>	V <sub>50</sub>	V <sub>1</sub>	V <sub>R</sub>	V <sub>2</sub>	V <sub>50</sub>	V <sub>1</sub>	V <sub>R</sub>	V <sub>2</sub>	V <sub>50</sub>	V <sub>1</sub>	V <sub>R</sub>	V <sub>2</sub>	V <sub>50</sub>	V <sub>1</sub>	V <sub>R</sub>	V <sub>2</sub>	V <sub>50</sub>	V <sub>1</sub>	V <sub>R</sub>	V <sub>2</sub>	V <sub>50</sub>	V <sub>1</sub>	V <sub>R</sub>	V <sub>2</sub>	V <sub>50</sub>
10,000	16,500	110	115	116	127	110	116	116	126	110	116	116	125	110	116	116	124	110	116	116	123	110	116	116	120	---	---	---	---
	16,000	108	113	114	125	108	114	114	124	108	114	114	124	108	114	114	123	108	114	114	122	108	114	114	119	---	---	---	---
	15,000	108	110	112	124	108	110	111	122	108	111	111	120	108	111	111	120	108	111	111	119	108	111	111	116	---	---	---	---
	14,000	108	110	113	125	108	110	112	123	108	110	111	121	108	110	110	120	108	111	110	118	108	110	110	115	---	---	---	---
	13,000	108	110	114	126	108	110	112	124	108	110	112	122	108	110	111	121	108	110	110	119	108	110	110	116	---	---	---	---
	12,000	108	110	115	128	108	110	113	125	108	110	112	123	108	110	112	122	108	110	111	120	108	110	110	117	---	---	---	---
	11,000	108	110	115	129	108	110	114	126	108	110	113	125	108	110	112	123	108	110	112	121	108	110	110	118	---	---	---	---
10,000	108	110	116	131	108	110	115	128	108	110	114	126	108	110	113	124	108	110	112	123	108	110	110	119	---	---	---	---	
12,000	16,500	110	116	116	126	110	116	116	125	110	116	116	124	110	116	116	123	110	116	116	121	110	116	116	119	---	---	---	---
	16,000	108	114	114	125	108	114	114	123	108	114	114	122	108	114	114	121	108	114	114	120	108	114	114	117	---	---	---	---
	15,000	108	111	111	122	108	111	111	120	108	111	111	119	108	111	111	119	108	111	111	117	108	111	111	114	---	---	---	---
	14,000	108	110	112	123	108	110	111	120	108	110	110	119	108	110	110	118	108	110	110	116	108	110	110	113	---	---	---	---
	13,000	108	110	113	124	108	110	111	122	108	110	111	120	108	110	110	119	108	110	110	117	108	110	110	114	---	---	---	---
	12,500	108	110	114	126	108	110	112	123	108	110	111	121	108	110	111	120	108	126	110	118	108	110	110	115	---	---	---	---
	11,000	108	110	114	127	108	110	113	124	108	110	112	122	108	110	111	121	108	122	111	119	108	110	110	116	---	---	---	---
10,000	108	110	115	128	108	110	114	125	108	110	113	124	108	110	112	122	108	118	111	121	108	110	110	117	---	---	---	---	
14,000	16,500	110	116	116	125	110	116	116	123	110	116	116	122	110	116	116	121	116	116	116	120	110	116	116	118	---	---	---	---
	16,000	108	114	114	124	108	114	114	122	108	114	114	121	108	114	114	120	108	114	114	119	108	114	114	116	---	---	---	---
	15,000	108	111	111	120	108	111	111	119	108	111	111	118	108	111	111	117	108	111	111	116	108	111	111	113	---	---	---	---
	14,000	108	110	111	121	108	110	110	119	108	110	110	117	108	110	110	116	108	110	110	115	108	110	110	112	---	---	---	---
	13,000	108	110	112	122	108	110	110	120	108	110	110	118	108	110	110	117	108	110	110	116	108	110	110	113	---	---	---	---
	12,000	108	110	112	123	108	110	111	121	108	110	110	119	108	110	110	118	108	110	110	117	108	110	110	113	---	---	---	---
	11,000	108	110	113	125	108	110	112	122	108	110	111	120	108	110	110	119	108	110	110	118	108	110	110	114	---	---	---	---
10,000	108	110	114	126	108	110	113	123	108	110	112	122	108	111	111	120	108	110	110	119	108	110	110	115	---	---	---	---	

BT05190

Figure 7-25. Take-off Speeds (KIAS) - Flaps Approach (Sheet 2 of 2)

TAKE-OFF DISTANCE - FLAPS APPROACH

ASSOCIATED CONDITIONS:

POWER.....STATIC TAKE-OFF POWER SET BEFORE BRAKE RELEASE.  
 VR.  $V_{50}$ .....AS SCHEDULED IN TABLE OF TAKE-OF SPEEDS.  
 LANDING GEAR .....RETRACTED AFTER LIFT-OFF  
 RUNWAY .....PAVED, DRY SURFACE

EXAMPLE

FAT ..... 15°C  
 FIELD PRESSURE ALTITUDE ..... 3499 FT  
 WEIGHT..... 16,000 LB  
 RUNWAY GRADIENT ..... 1.9% DN  
 HEADWIND COMPONENT..... 10 KTS  
 GROUND ROLL..... 2960 FT  
 TOTAL DISTANCE OVER 50-FT OBSTACLE..... 4150 FT

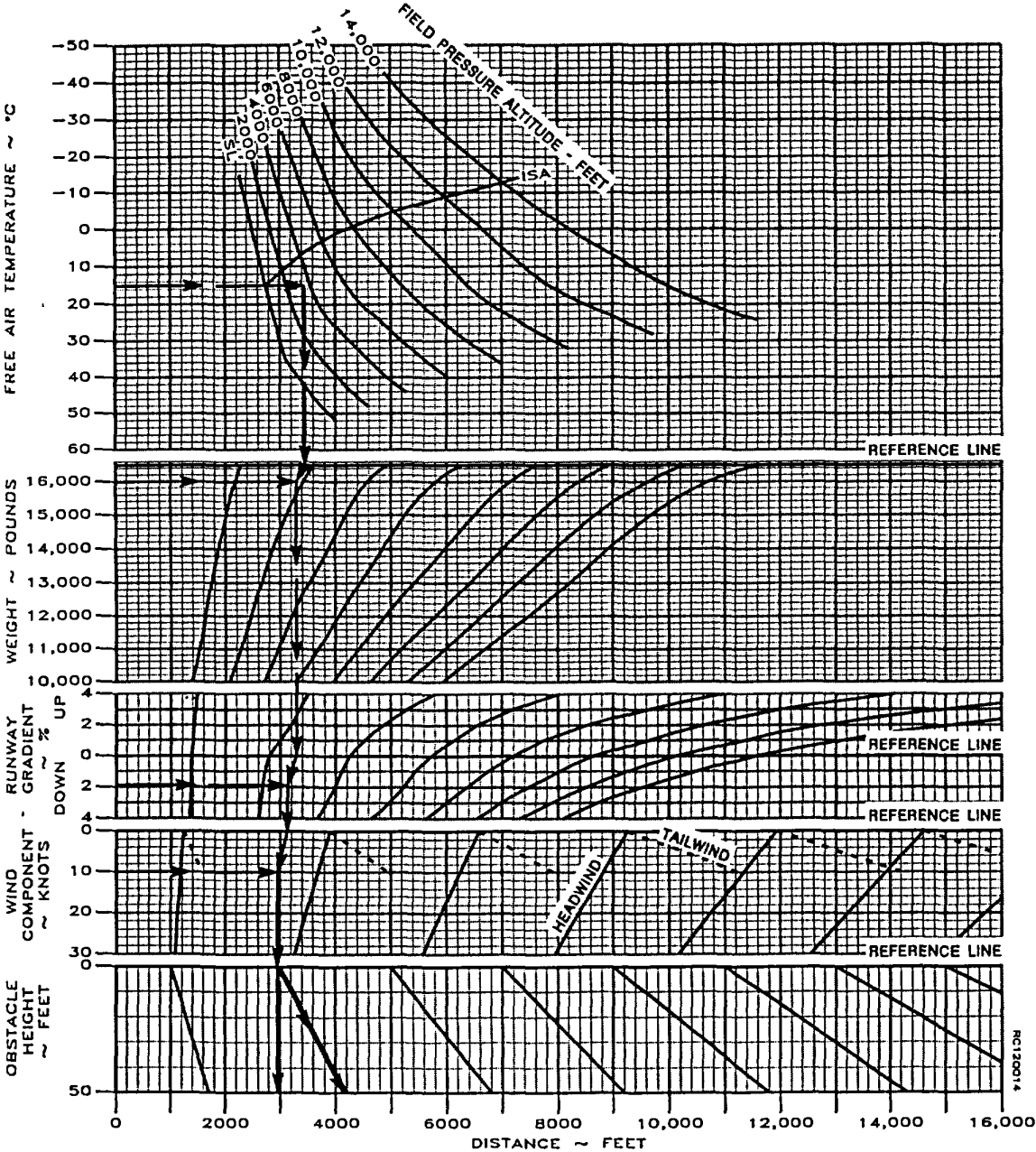

Figure 7A-26. Take-off Distance Over 50 Foot Obstacle - Flaps Approach



ACCELERATE-STOP - FLAPS APPROACH

ASSOCIATED CONDITIONS:

POWER.....STATIC TAKE-OFF POWER SET  
 BEFORE BRAKE RELEASE.  
 AUTOFEATHER ARMED  
 $V_1$  .....AS SCHEDULED IN TABLE  
 OF TAKE-OFF SPEEDS.  
 POWER LEVERS .....GROUND FINE AT  $V_1$   
 BRAKING .....MAXIMUM WITHOUT SLIDING TIRES  
 RUNWAY .....PAVED, DRY SURFACE

EXAMPLE:

FAT ..... 15°C  
 FIELD PRESSURE ALTITUDE ..... 3499 FT  
 WEIGHT ..... 16,000 LBS  
 RUNWAY GRADIENT ..... 1.9% DN  
 HEADWIND COMPONENT ..... 10 KTS  
 ACCELERATE-STOP DISTANCE ..... 5047 FT

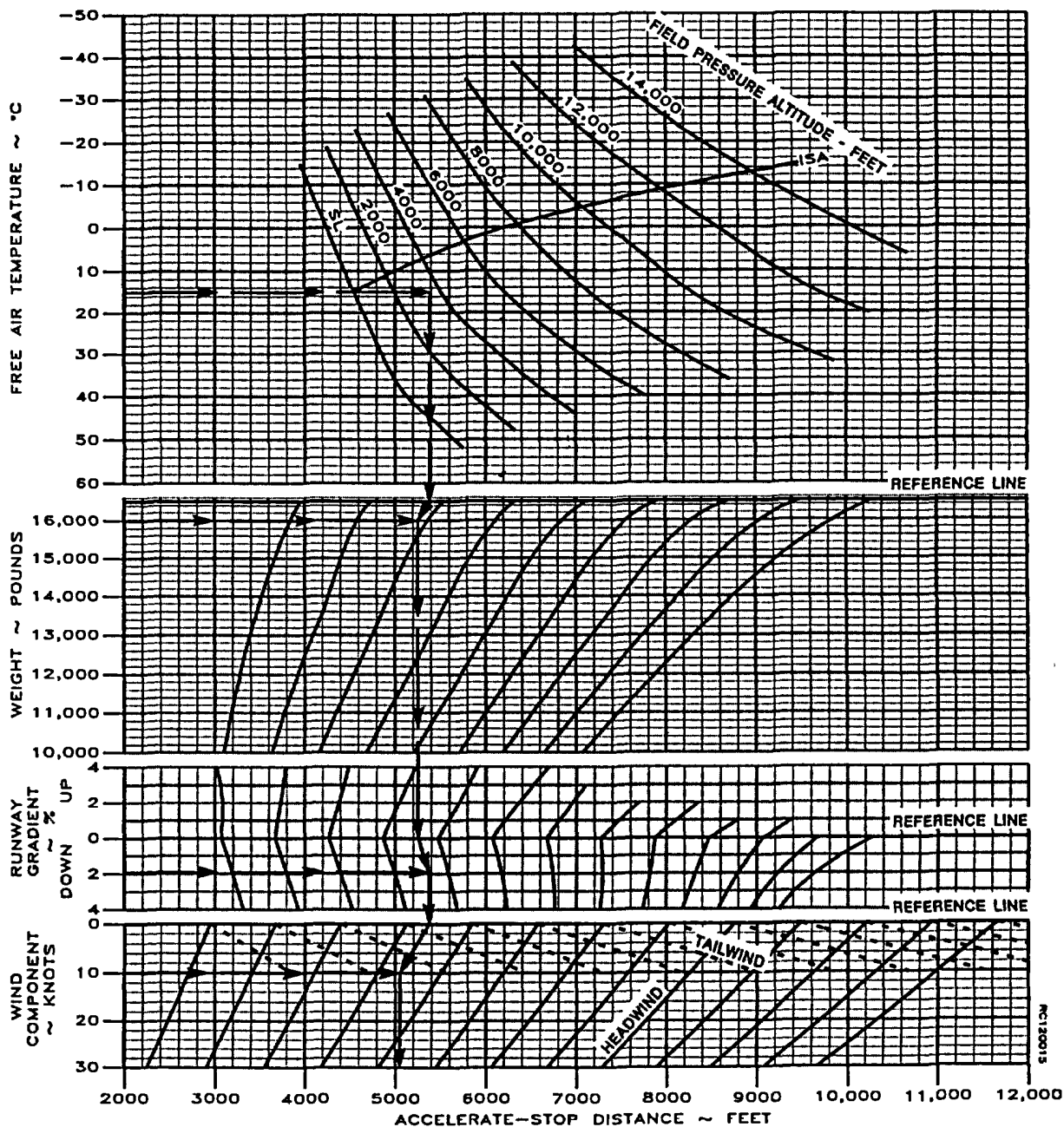

Figure 7A-27. Accelerate Stop - Flaps Approach

ACCELERATE-GO - FLAPS APPROACH

ASSOCIATED CONDITIONS:

POWER.....STATIC TAKE-OFF POWER SET BEFORE BRAKE RELEASE.  
 AUTOFEATHER.....ARMED  
 V<sub>1</sub> AND V<sub>2</sub>.....AS SCHEDULED IN TABLE OF TAKE-OFF SPEEDS.  
 LANDING GEAR .....RETRACTED AFTER LIFT-OFF  
 RUNWAY .....PAVED. DRY SURFACE

EXAMPLE:

FAT ..... 15°C  
 FIELD PRESSURE ALTITUDE FEET .... 3499 FT  
 WEIGHT ..... 16,000 LBS  
 RUNWAY GRADIENT ..... 1.9% DN  
 HEADWIND COMPONENT..... 10 KTS  
 ACCELERATE-GO DISTANCE..... 5389 FT

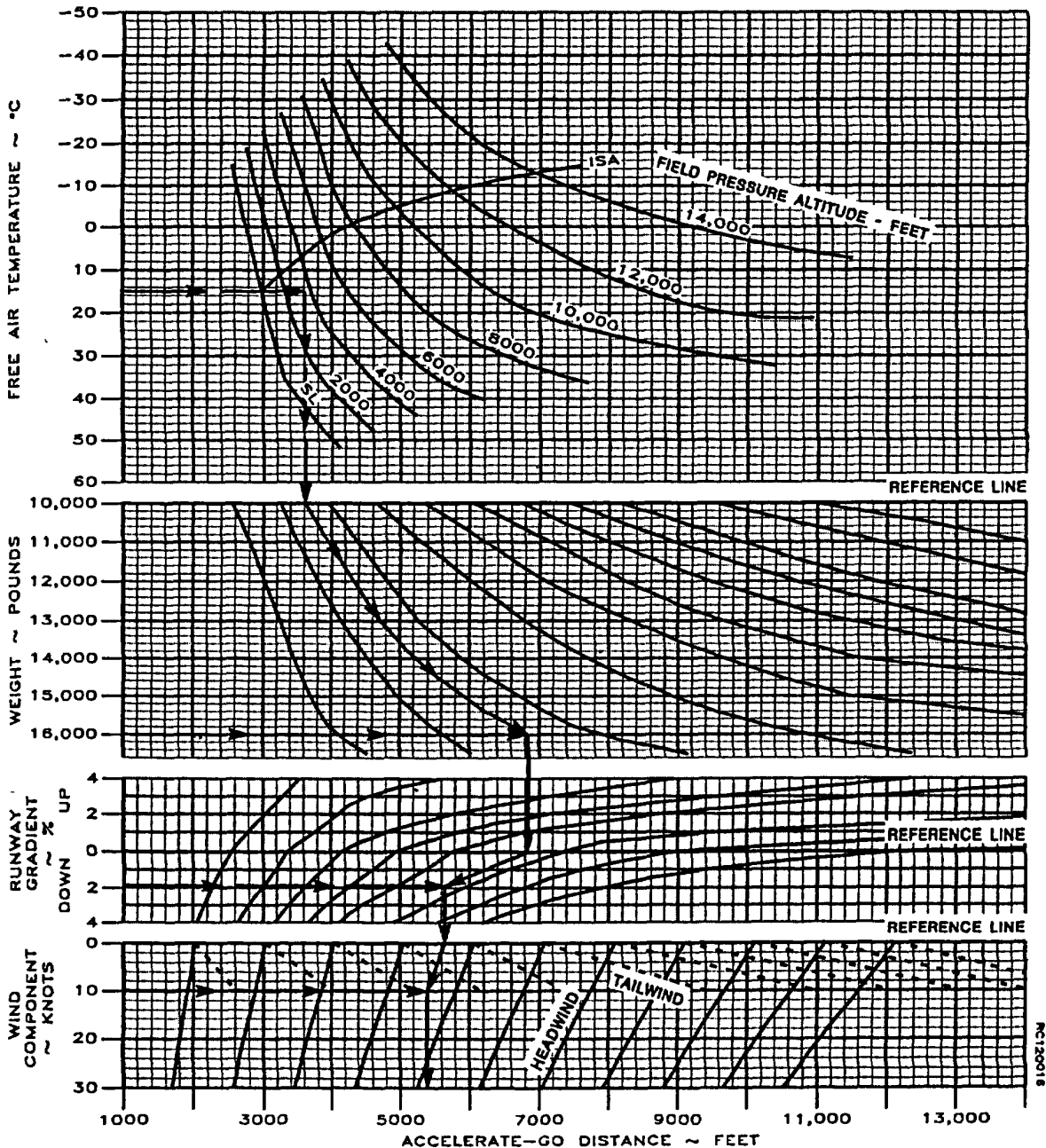

Figure 7A-28. Accelerate-Go Distance Over 50 Foot Obstacle - Flaps Approach

NET TAKE-OFF FLIGHT PATH - FIRST SEGMENT - FLAPS APPROACH

ONE ENGINE INOPERATIVE

ASSOCIATED CONDITIONS:

POWER ..... STATIC TAKE-OFF  
 POWER SET BEFORE  
 BRAKE RELEASE  
 INOPERATIVE PROPELLER ..... FEATHERED  
 LANDING GEAR ..... DOWN  
 CLIMB SPEED ..... V2

EXAMPLE:

FAT ..... 15°C  
 FIELD PRESSURE ALTITUDE ..... 3499 FT  
 WEIGHT ..... 16,000 LBS  
 HEADWIND COMPONENT ..... 10 KTS  
 NET CLIMB GRADIENT ..... -0.06 %

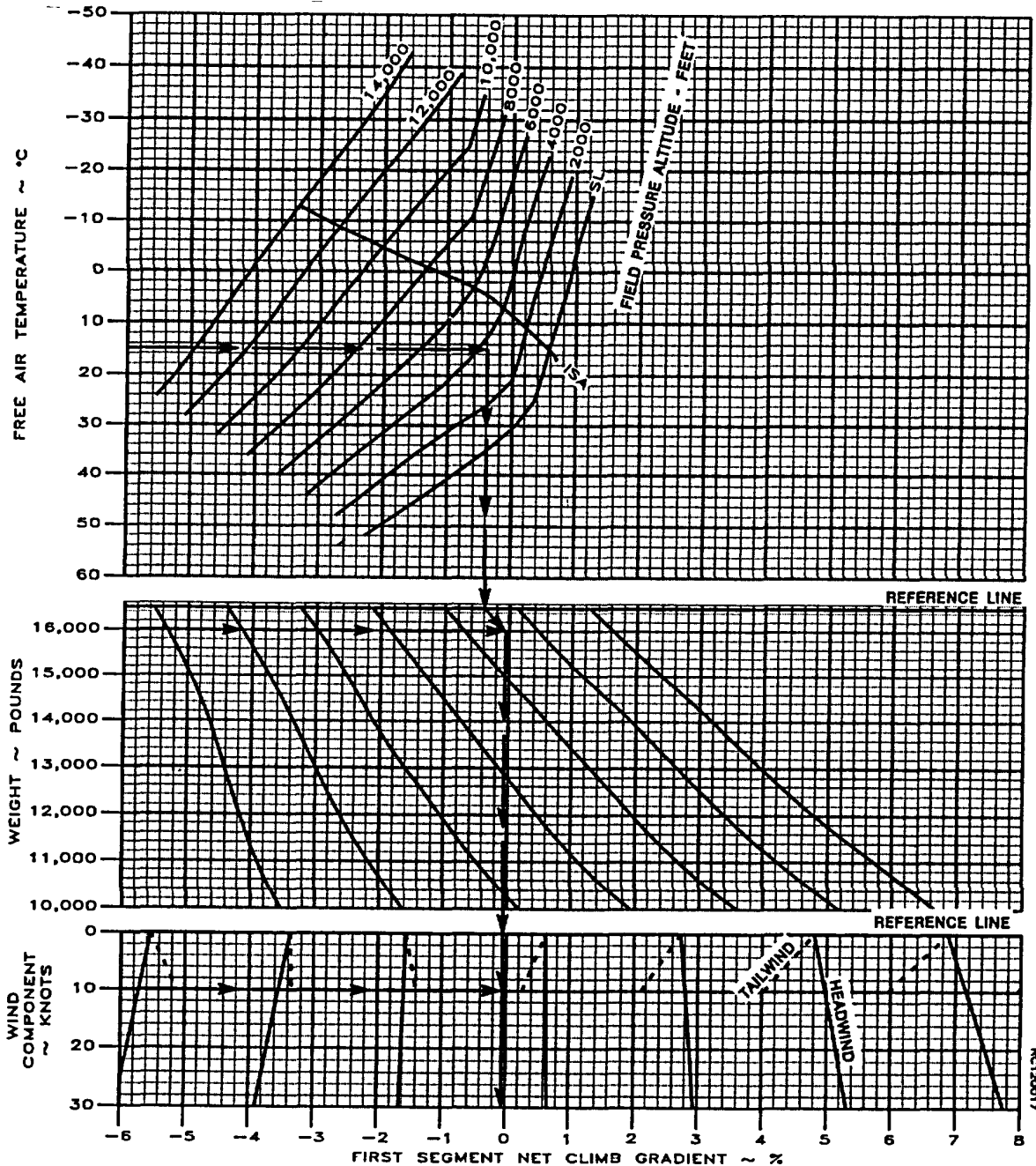

Figure 7A-29. Net Take-off Flight Path - First Segment - Flaps Approach

NET TAKE-OFF FLIGHT PATH - SECOND SEGMENT - FLAPS APPROACH

ONE ENGINE INOPERATIVE

ASSOCIATED CONDITIONS:

POWER ..... STATIC TAKE-OFF  
 ..... POWER SET BEFORE  
 ..... BRAKE RELEASE  
 INOPERATIVE PROPELLER ..... FEATHERED  
 LANDING GEAR ..... UP  
 CLIMB SPEED ..... V2

EXAMPLE:

FAT ..... 15°C  
 FIELD PRESSURE ALTITUDE ..... 3499 FT  
 WEIGHT ..... 16,000 LBS  
 HEADWIND COMPONENT ..... 10 KTS  
 NET CLIMB GRADIENT ..... 2.32%

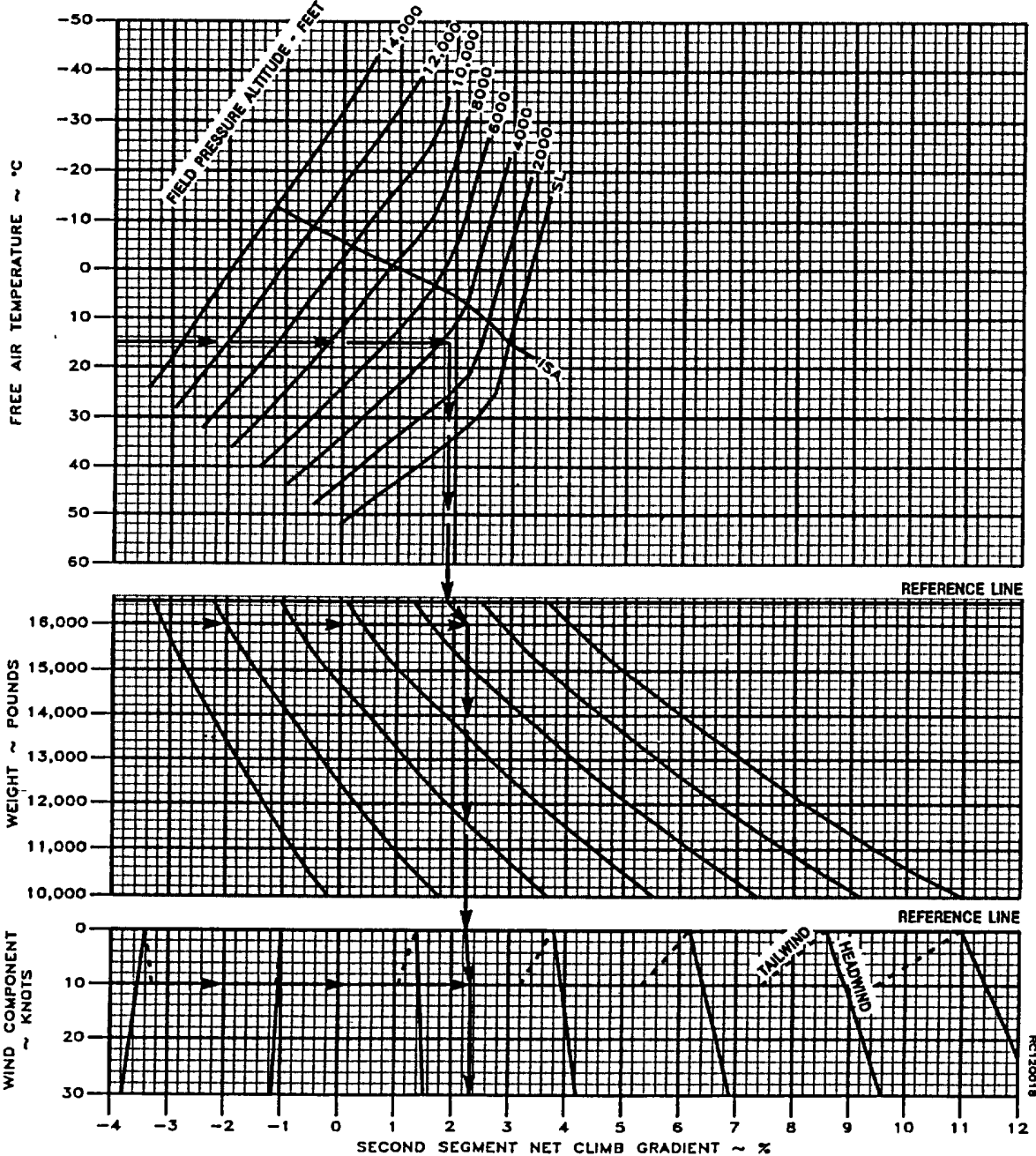

Figure 7A-30. Net Take-off Flight Path - Second Segment - Flaps Approach

### HORIZONTAL DISTANCE FROM REFERENCE ZERO TO THIRD SEGMENT CLIMB - FLAPS APPROACH

**ASSOCIATED CONDITIONS:**

**POWER:**  
 TO 500 FT AGL ..... STATIC TAKE-OFF  
 ..... POWER SET BEFORE  
 ..... BEFORE BRAKE.  
 AT 500 FT AGL ..... TAKEOFF

**AIRSPPEED:**  
 TO 500 FT AGL ..... V2  
 AT 500 FT AGL ..... ACCELERATE TO VENR  
 INOPERATIVE PROPELLER ..... FEATHERED  
 LANDING GEAR ..... RETRACTED AFTER LIFT-OFF

**EXAMPLE:**

FAT ..... 15°C  
 FIELD PRESSURE ALTITUDE ..... 3499 FT  
 WEIGHT ..... 16,000 LBS  
 HEADWIND COMPONENT ..... 10 KTS  
 DISTANCE ..... 5.65 NM

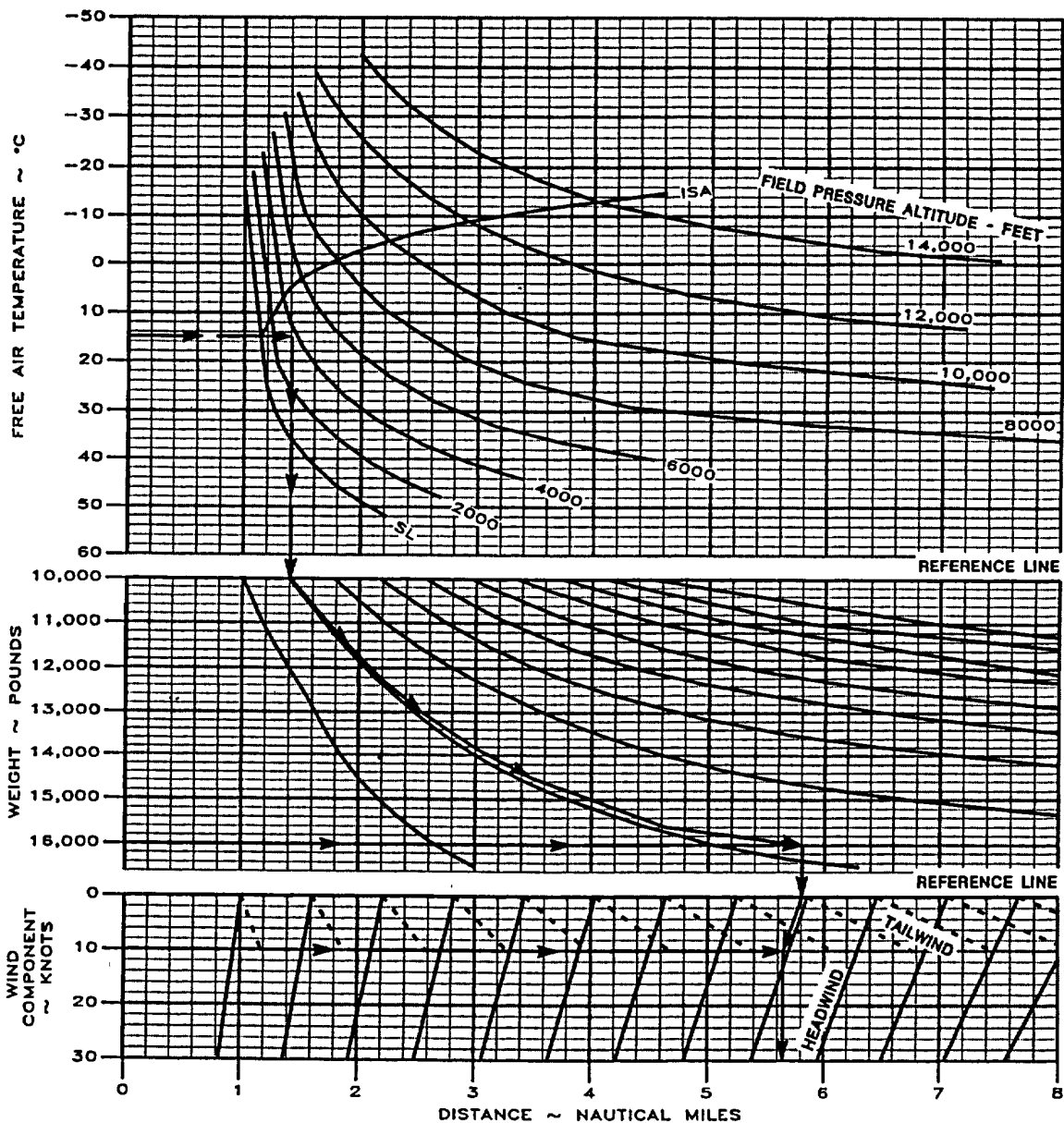

Figure 7A-31. Horizontal Distance from Reference Zero to Third Segment Climb - Flaps Approach

CLOSE-IN TAKE-OFF FLIGHT PATH

NOTE: TOTAL HEIGHT REQUIRED IS EQUAL TO TOTAL HEIGHT REQUIRED TO CLEAR OBSTACLE PLUS DESIRED MARGIN OF CLEARANCE.

EXAMPLE: TOTAL HEIGHT REQUIRED .....70 FT  
OBSTACLE DISTANCE FROM REFERENCE ZERO .....920 FT  
NET CLIMB GRADIENT REQUIRED .....2.2%.

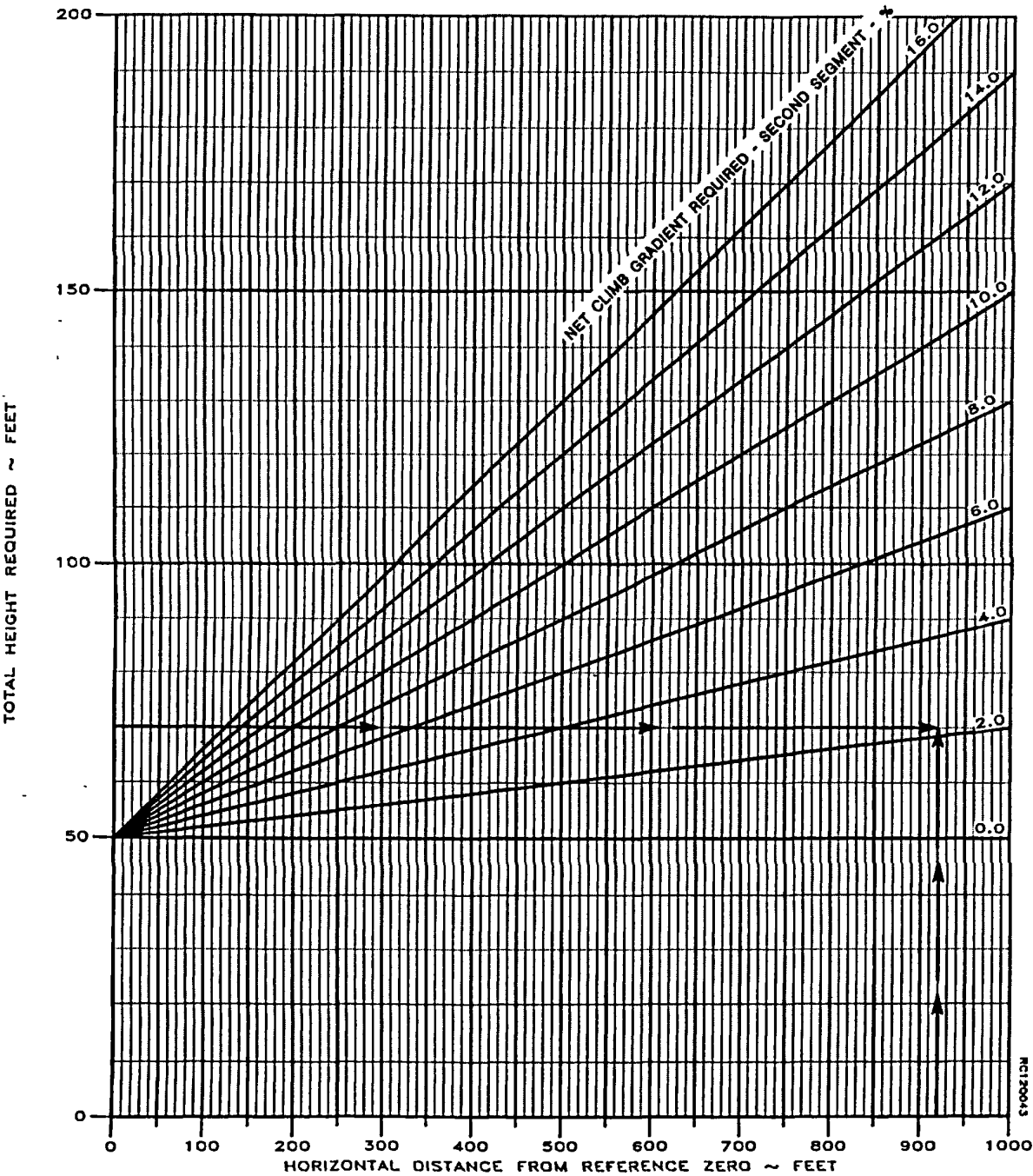

Figure 7A-32. Close-in Take-off Flight Path - Flaps Approach

DISTANT TAKE-OFF FLIGHT PATH

NOTE: TOTAL HEIGHT REQUIRED IS EQUAL TO TOTAL HEIGHT REQUIRED TO CLEAR OBSTACLE PLUS DESIRED MARGIN OF CLEARANCE.

EXAMPLE:  
 TOTAL HEIGHT REQUIRED ..... 190 FT  
 OBSTACLE DISTANCE FROM  
 REFERENCE ZERO ..... 1.79 NM  
 NET CLIMB GRADIENT REQUIRED ..... 1.29%

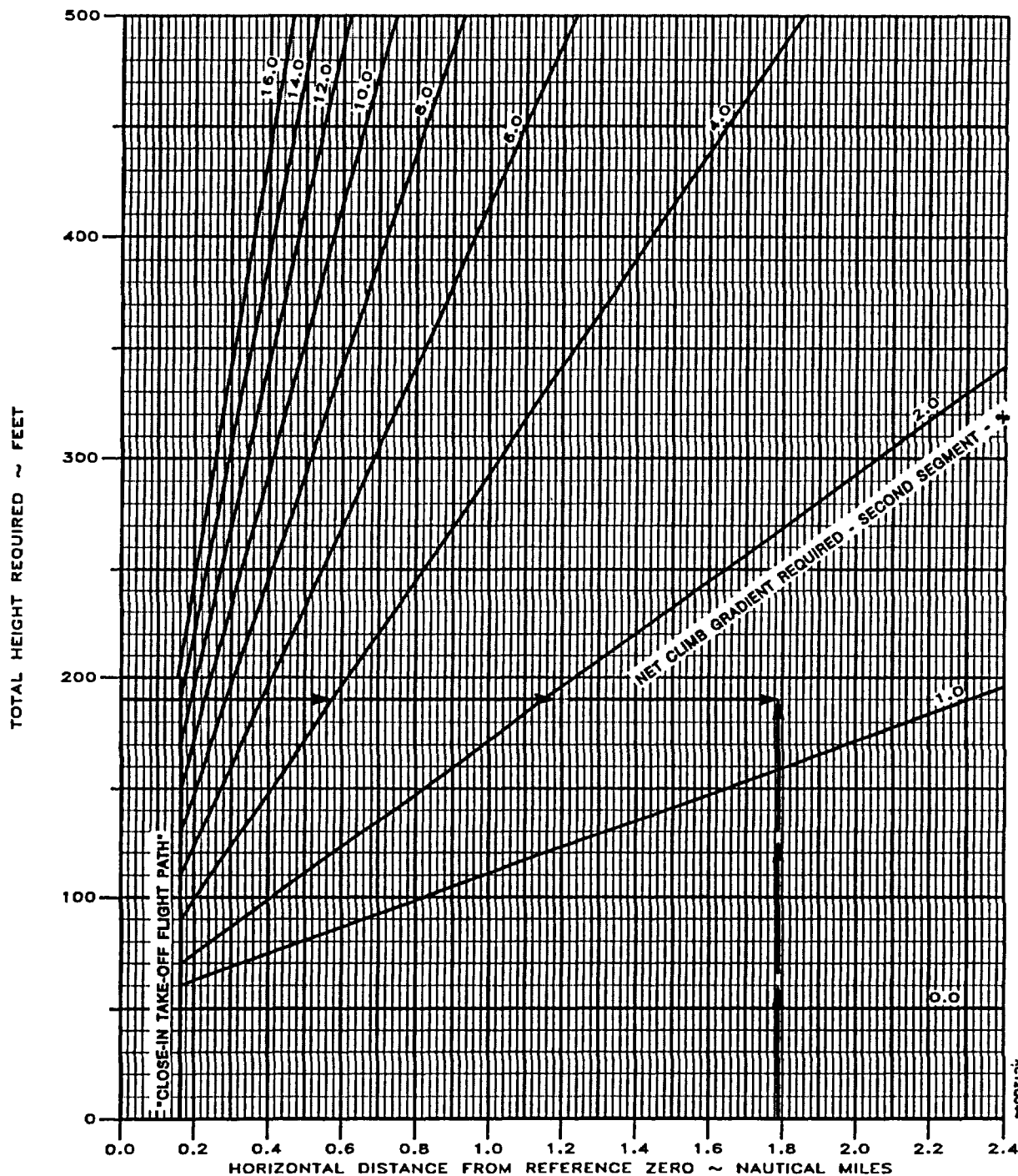

Figure 7A-33. Distant Take-off Flight Path - Flaps Approach

NET TAKE-OFF FLIGHT PATH - THIRD SEGMENT

ONE ENGINE INOPERATIVE

ASSOCIATED CONDITIONS:

POWER ..... MAXIMUM CONTINUOUS  
 INOPERATIVE PROPELLER ..... FEATHERED  
 LANDING GEAR ..... UP  
 FLAPS ..... UP  
 CLIMB SPEED ..... VENR

EXAMPLE:

FAT ..... 15°C  
 FIELD PRESSURE ALTITUDE ..... 3499 FT  
 WEIGHT ..... 16,000 LBS  
 HEADWIND COMPONENT ..... 10 KTS  
 NET CLIMB GRADIENT ..... 2.07%

VENR = 130 KNOTS (ALL WEIGHTS)

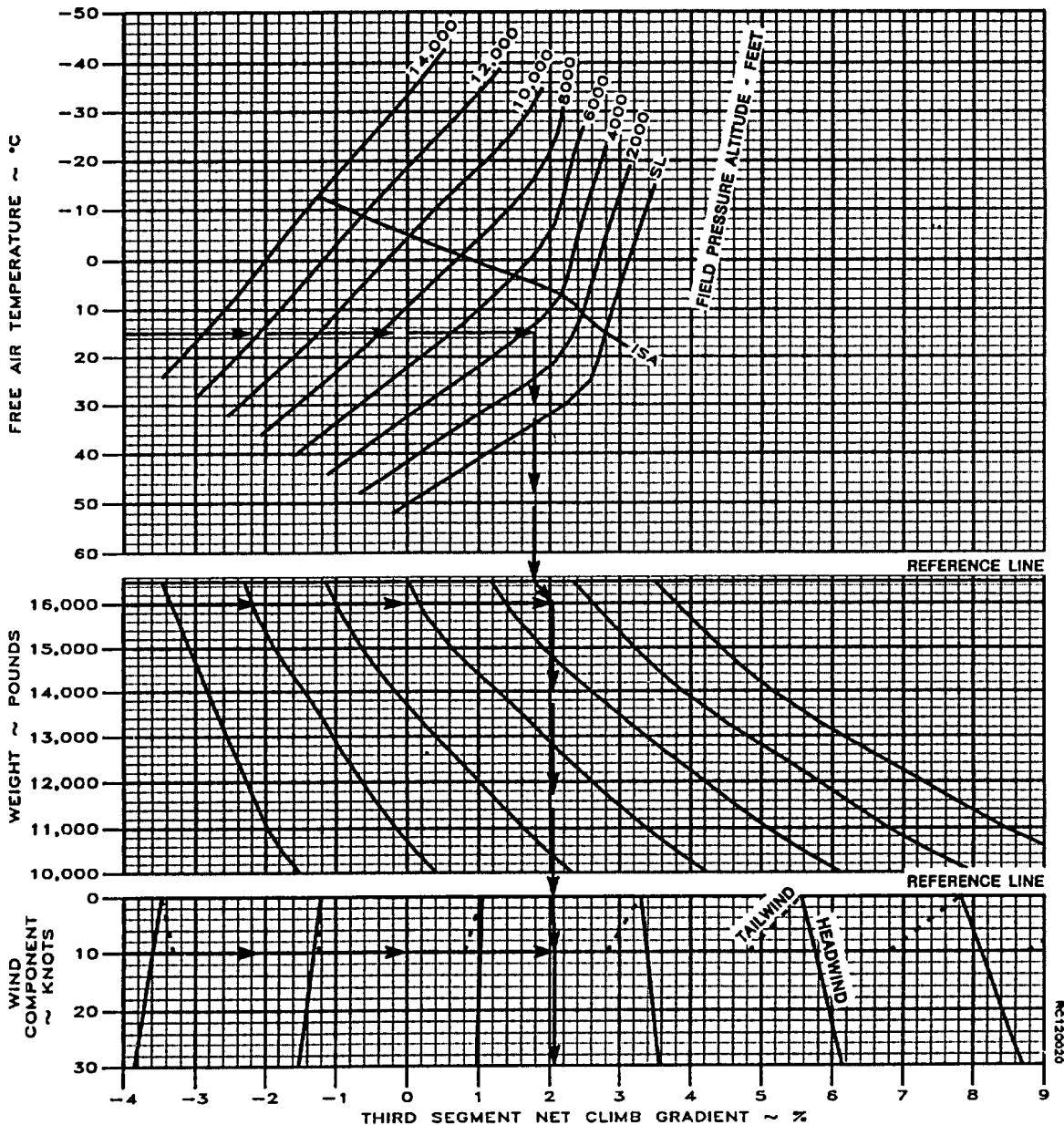

Figure 7A-34. Net Take-off Flight Path - Third Segment



CLIMB - TWO ENGINES - FLAPS UP

ASSOCIATED CONDITIONS:

POWER ..... MAXIMUM CONTINUOUS  
 LANDING GEAR ..... UP

EXAMPLE:

FAT ..... -4°C  
 PRESSURE ALTITUDE ..... 9000 FT  
 WEIGHT ..... 15,500 LBS  
 RATE-OF-CLIMB ..... 2237 FT/MIN  
 CLIMB GRADIENT ..... 11.3 %

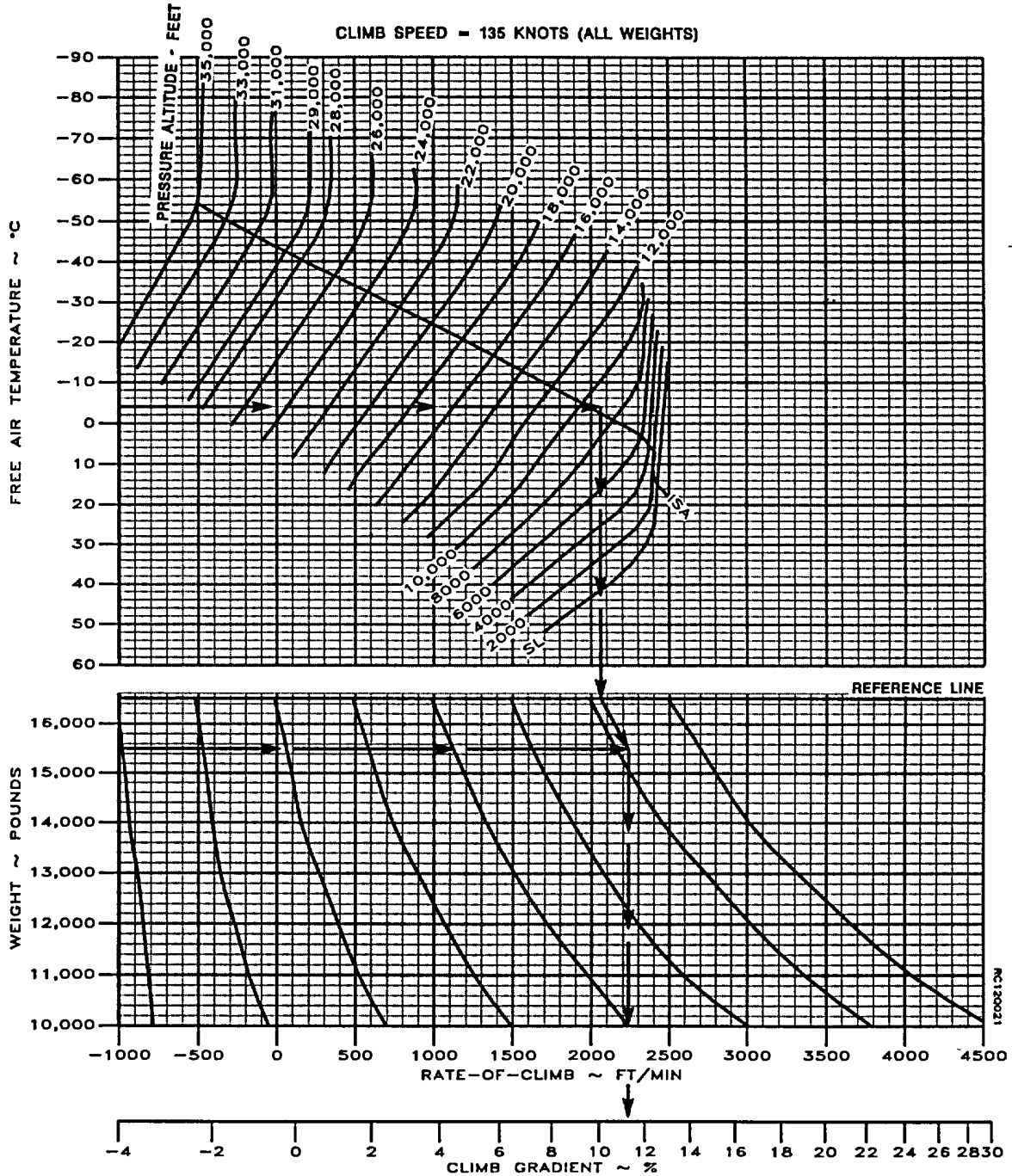

Figure 7A-35. Climb - Two Engines - Flaps Up

CLIMB - TWO ENGINES - FLAPS APPROACH

ASSOCIATED CONDITIONS

POWER ..... MAXIMUM CONTINUOUS  
 LANDING GEAR ..... UP

EXAMPLE:

FAT ..... -4°C  
 PRESSURE ALTITUDE ..... 9000 FT  
 WEIGHT ..... 15,500 LBS  
 RATE-OF-CLIMB ..... 2053 FT/MIN  
 CLIMB GRADIENT ..... 10.7 %

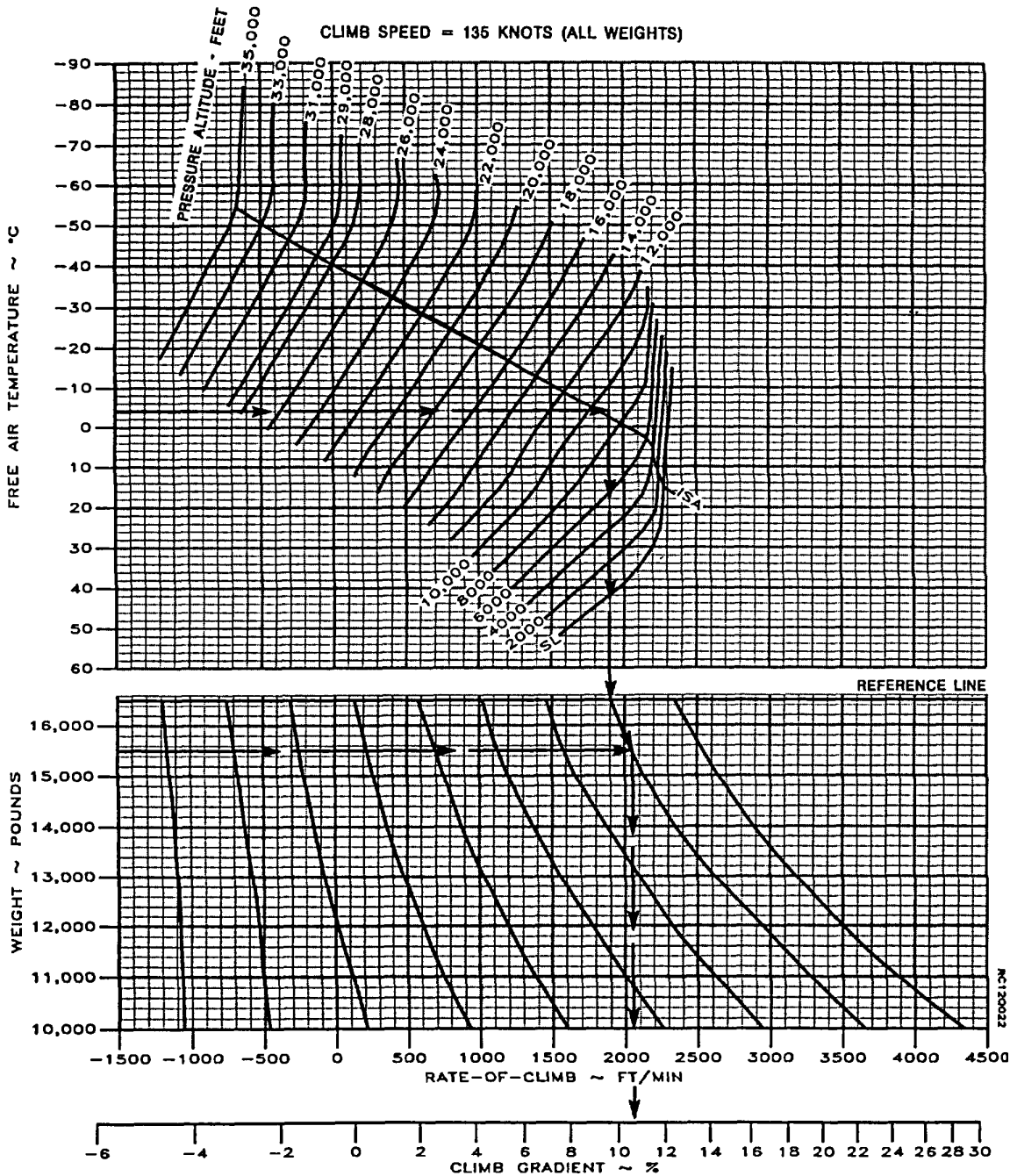

Figure 7A-36. Climb - Two Engines - Flaps Approach

CLIMB - ONE ENGINE INOPERATIVE

ASSOCIATED CONDITIONS:

POWER ..... MAXIMUM CONTINUOUS  
 FLAPS ..... UP  
 LANDING GEAR ..... UP  
 INOPERATIVE PROPELLER ..... FEATHERED  
 CLIMB SPEED ..... VYSE

EXAMPLE:

FAT ..... -4°C  
 PRESSURE ALTITUDE ..... 9000 FT  
 WEIGHT ..... 15,500 LBS  
 RATE-OF-CLIMB ..... 358 FT/MIN  
 CLIMB GRADIENT ..... 2.0 %

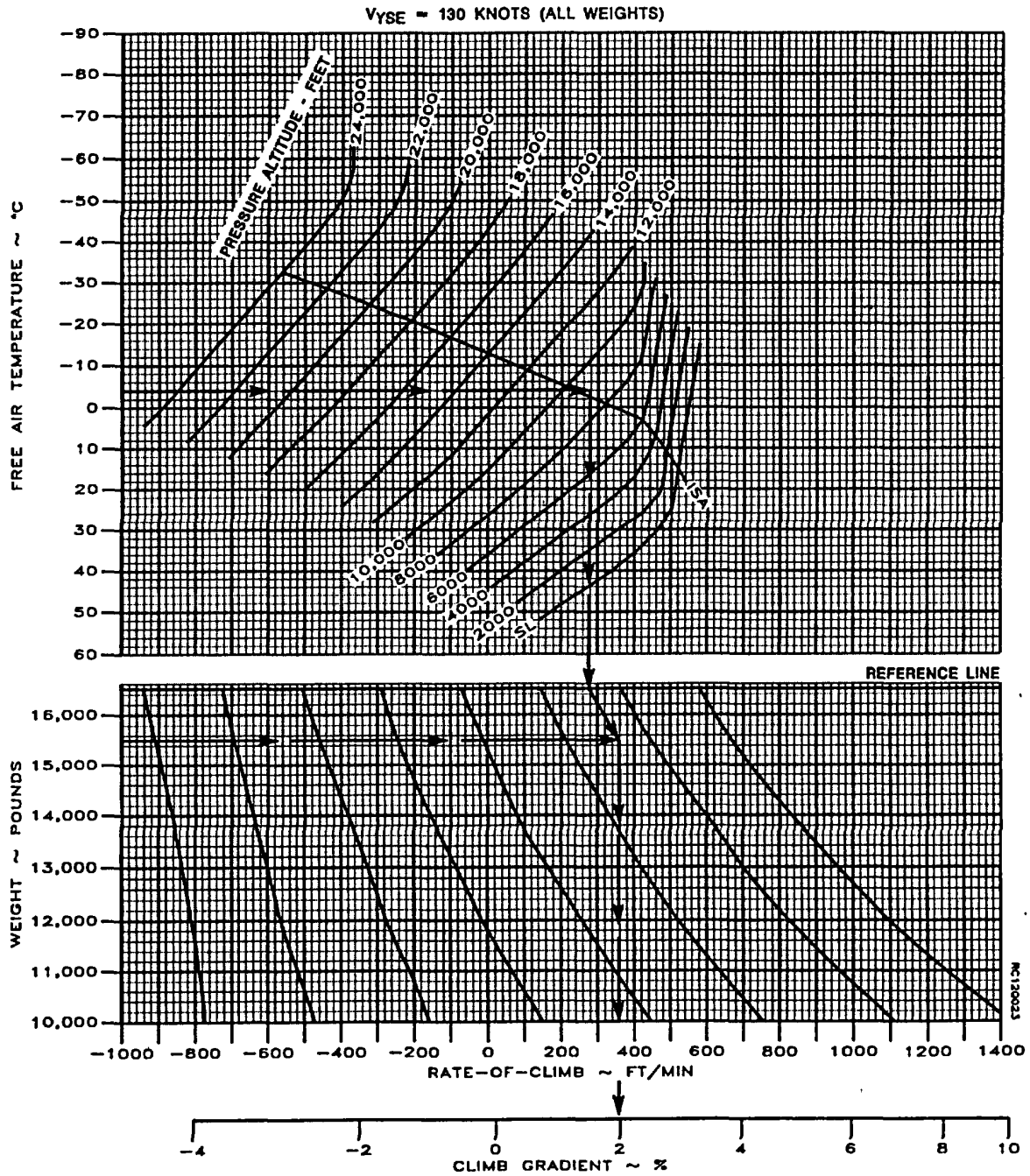

Figure 7A-37. Climb - One Engine Inoperative

SERVICE CEILING - ONE ENGINE INOPERATIVE

ASSOCIATED CONDITIONS:  
POWER ..... MAXIMUM CONTINUOUS  
FLAPS ..... UP  
INOPERATIVE PROPELLER ..... FEATHERED  
LANDING GEAR ..... UP

EXAMPLE:  
FAT ..... 0°C  
WEIGHT ..... 5,659 LBS  
SERVICE CEILING ..... 12,369 FT

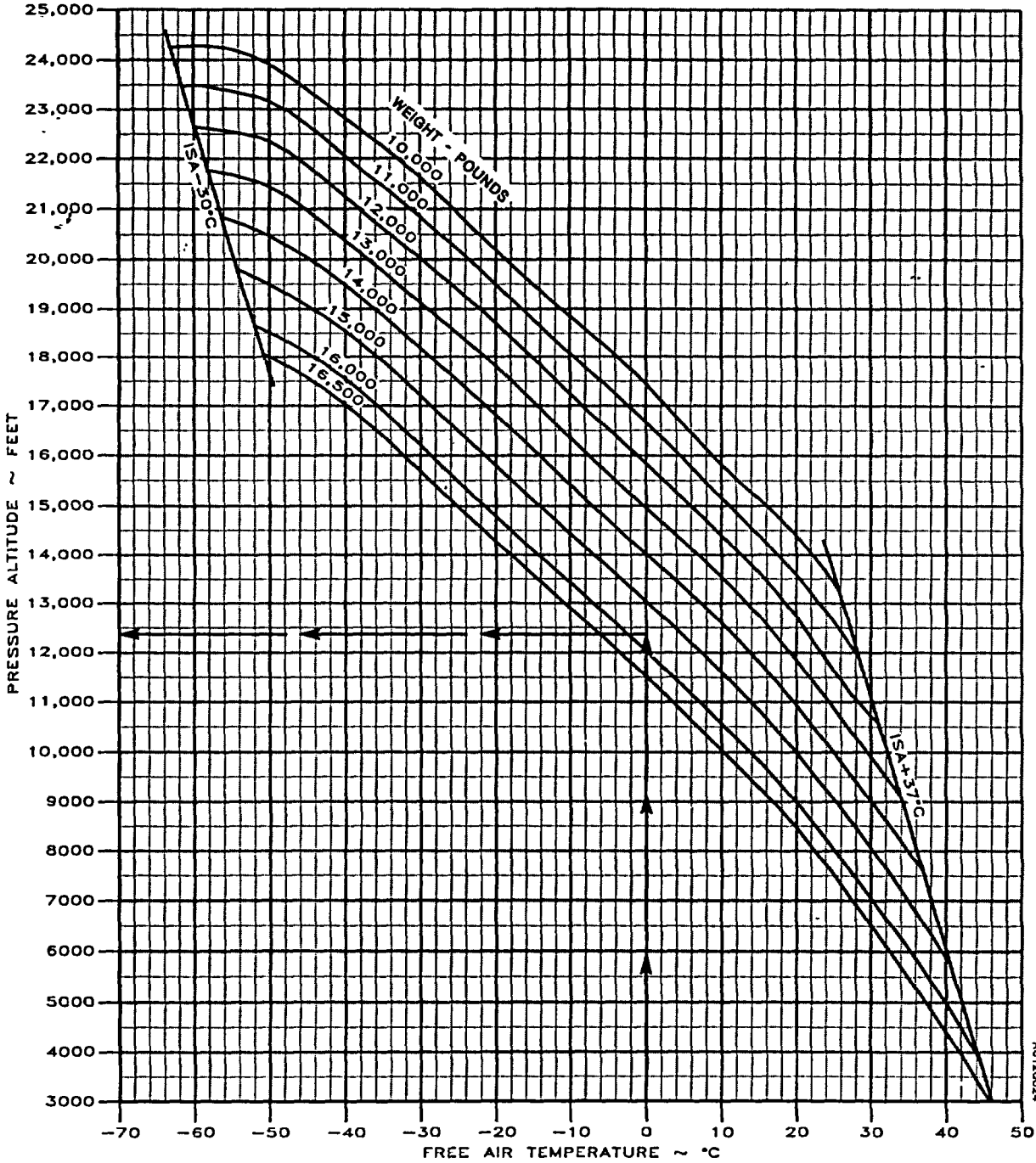

Figure 7A-38. Service Ceiling - One Engine Inoperative

**TIME, FUEL, AND DISTANCE TO CRUISE CLIMB**

ASSOCIATED CONDITIONS:

PROPELLER SPEED..... 1700 RPM  
 POWER ..... NORMAL CLIMB

EXAMPLE:

FAT AT TAKEOFF ..... 15°C  
 FAT AT CRUISE ..... -40°C  
 AIRPORT PRESSURE ALTITUDE..... 3499 FT  
 CRUISE ALTITUDE ..... 25,000 FT  
 INITIAL CLIMB WEIGHT..... 16,000 LBS  
 TIME TO CLIMB (23-2) ..... 21 MIN  
 FUEL TO CLIMB (400-57)..... 343 LBS  
 DISTANCE TO CLIMB (54-5)..... 49 NM

ALTITUDE-FEET	CLIMB SPEED-KNOTS
SL TO 10,000	135
10,000 TO 20,000	130
20,000 TO 25,000	125
25,000 TO 35,000	120

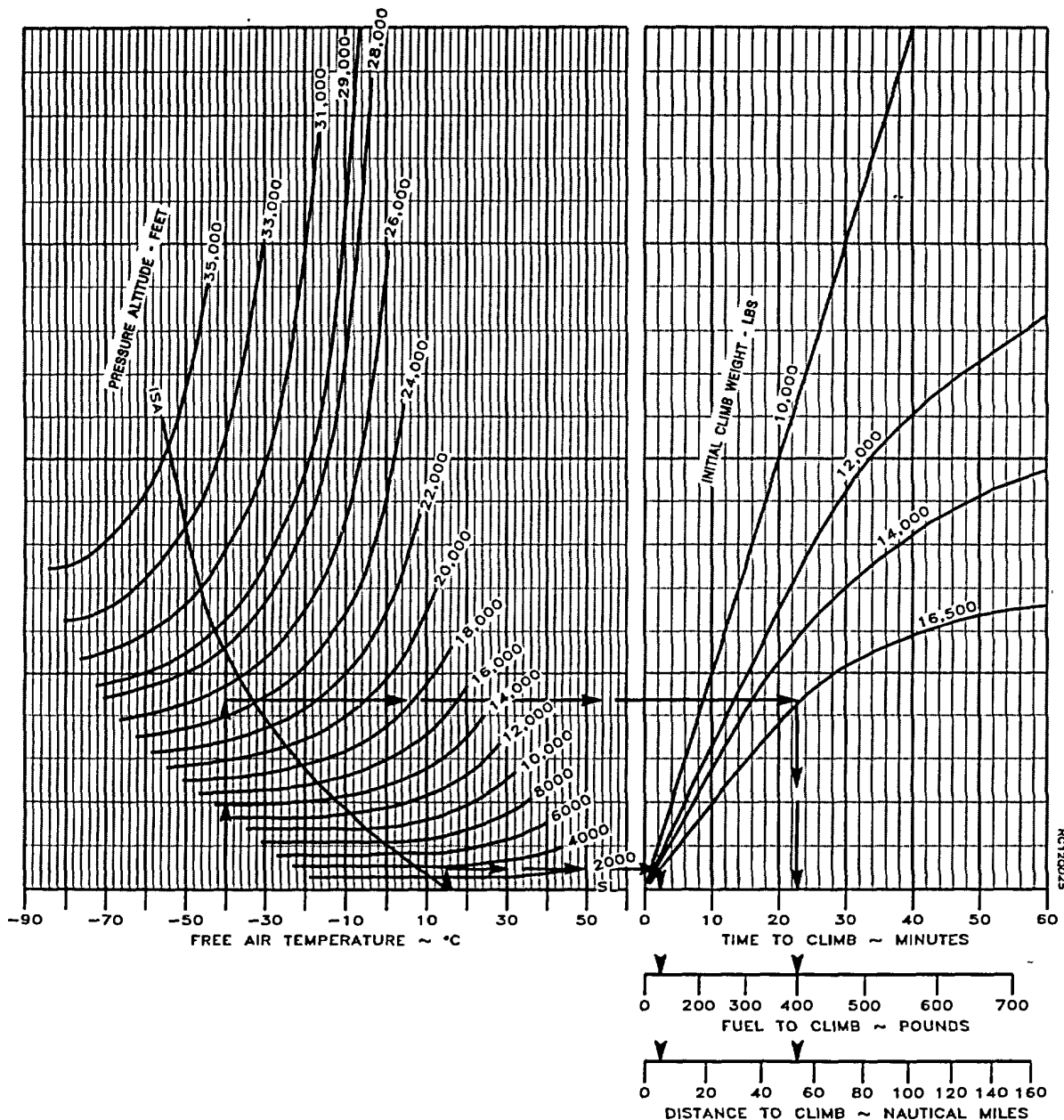

Figure 7A-39. Time, Fuel, and Distance to Cruise Climb

**MAXIMUM CRUISE POWER  
1700 RPM  
ISA -30°C**

WEIGHT→			12,000 POUNDS					10,000 POUNDS				
PRESSURE ALTITUDE	IFAT	FAT	TORQUE PER ENGINE	FUEL FLOW PER ENGINE	TOTAL FUEL FLOW	IAS	TAS	TORQUE PER ENGINE	FUEL FLOW PER ENGINE	TOTAL FUEL FLOW	IAS	TAS
FEET	°C	°C	PERCENT	LBS/HR	LBS/HR	KTS	KTS	PERCENT	LBS/HR	LBS/HR	KTS	KTS
0	-10	-15	83	627	1254	233	222	83	627	1254	234	223
2000	-14	-19	83	608	1216	232	228	83	608	1216	233	229
4000	-18	-23	83	590	1180	232	234	83	590	1180	233	235
6000	-22	-27	83	574	1148	230	238	83	574	1148	231	240
8000	-25	-31	83	562	1124	229	244	83	562	1124	230	245
10,000	-29	-35	83	553	1106	227	249	83	552	1104	228	250
12,000	-33	-39	83	542	1084	225	254	83	542	1084	226	256
14,000	-37	-43	83	533	1066	223	260	83	533	1066	224	261
16,000	-40	-47	83	526	1052	221	265	83	526	1052	223	267
18,000	-44	-51	83	519	1038	219	271	83	519	1038	221	273
20,000	-48	-55	83	513	1026	217	277	83	513	1026	219	279
22,000	-51	-59	83	509	1018	215	283	83	508	1016	217	285
24,000	-55	-63	80	488	976	210	285	80	489	978	212	288
26,000	-59	-67	74	456	912	202	284	75	457	914	204	287
28,000	-63	-70	67	416	832	192	279	68	418	836	195	283
29,000	-65	-72	64	395	790	186	276	64	397	794	189	281
31,000	-70	-76	57	356	712	175	269	57	358	716	179	275
33,000	-74	-80	50	320	640	163	261	51	323	646	168	268
35,000	-79	-84	43	282	564	149	249	44	286	572	156	259

BT0586816

**NOTE**

During operations with ice vanes extended, torque will decrease approximately 12%, fuel flow will decrease approximately 8%, and true airspeed will be reduced by approximately 15 knots.

Figure 7A-40. Maximum Cruise Power at 1700 RPM - ISA -30°C (Sheet 1 of 2)

**MAXIMUM CRUISE POWER  
1700 RPM  
ISA -30°C**

WEIGHT→			16,000 POUNDS					14,000 POUNDS				
PRESSURE ALTITUDE	IFAT	FAT	TORQUE PER ENGINE	FUEL FLOW PER ENGINE	TOTAL FUEL FLOW	IAS	TAS	TORQUE PER ENGINE	FUEL FLOW PER ENGINE	TOTAL FUEL FLOW	IAS	TAS
FEET	°C	°C	PERCENT	LBS/HR	LBS/HR	KTS	KTS	PERCENT	LBS/HR	LBS/HR	KTS	KTS
0	-11	-15	83	628	1256	230	219	83	627	1254	232	221
2000	-14	-19	83	609	1218	229	225	83	608	1216	231	226
4000	-18	-23	83	591	1182	229	231	83	590	1180	231	233
6000	-22	-27	83	575	1150	227	235	83	575	1150	229	237
8000	-26	-31	83	563	1126	226	241	83	563	1126	228	243
10,000	-29	-35	83	553	1106	224	246	83	553	1106	225	247
12,000	-33	-39	83	543	1086	221	250	83	542	1084	223	252
14,000	-37	-43	83	534	1068	219	255	83	534	1068	221	258
16,000	-40	-47	83	527	1054	217	261	83	526	1052	219	263
18,000	-44	-51	83	520	1040	215	267	83	519	1038	218	269
20,000	-48	-55	83	514	1028	213	272	83	514	1028	215	275
22,000	-51	-59	83	510	1020	211	278	83	509	1018	213	281
24,000	-55	-63	79	486	972	204	278	80	487	974	207	282
26,000	-60	-67	73	452	904	195	275	74	454	908	199	280
28,000	-64	-70	66	410	820	184	268	67	413	826	188	274
29,000	-66	-72	62	389	778	177	263	63	392	784	182	271
31,000	-71	-76	55	348	696	163	252	56	353	706	170	262
33,000	-75	-80	48	312	624	147	237	49	315	630	156	251
35,000	-80	-84	40	272	544	122	207	42	279	558	141	235

BT0586815

**NOTE**

During operations with ice vanes extended, torque will decrease approximately 12%, fuel flow will decrease approximately 8%, and true airspeed will be reduced by approximately 15 knots.

Figure 7A-40. Maximum Cruise Power at 1700 RPM - ISA -30°C (Sheet 2 of 2)

**MAXIMUM CRUISE POWER  
1700 RPM  
ISA -20°C**

WEIGHT→			16,000 POUNDS					14,000 POUNDS				
PRESSURE ALTITUDE	IFAT	FAT	TORQUE PER ENGINE	FUEL FLOW PER ENGINE	TOTAL FUEL FLOW	IAS	TAS	TORQUE PER ENGINE	FUEL FLOW PER ENGINE	TOTAL FUEL FLOW	IAS	TAS
FEET	°C	°C	PERCENT	LBS/HR	LBS/HR	KTS	KTS	PERCENT	LBS/HR	LBS/HR	KTS	KTS
0	0	-5	83	629	1258	229	223	83	629	1258	231	224
2000	-4	-9	83	609	1218	229	228	83	609	1218	230	230
4000	-8	-13	83	592	1184	229	235	83	591	1182	230	236
6000	-12	-17	83	578	1156	226	239	83	578	1156	228	241
8000	-15	-21	83	567	1134	224	244	83	566	1132	225	245
10,000	-19	-25	83	556	1112	221	248	83	556	1112	223	250
12,000	-23	-29	83	546	1092	219	253	83	545	1090	221	255
14,000	-27	-33	83	536	1072	217	259	83	536	1072	219	261
16,000	-30	-37	83	528	1056	215	264	83	527	1054	218	267
18,000	-34	-41	83	521	1042	213	270	83	520	1040	215	273
20,000	-38	-45	83	517	1034	211	275	83	516	1032	213	278
22,000	-42	-49	79	489	978	204	275	79	489	978	206	279
24,000	-46	-53	74	459	918	196	274	74	460	920	199	278
26,000	-50	-57	69	429	858	187	271	69	430	860	191	276
28,000	-54	-60	63	397	794	177	266	64	399	798	182	273
29,000	-56	-62	60	381	762	172	263	61	383	766	177	271
31,000	-60	-66	54	348	696	160	254	55	351	702	167	264
33,000	-65	-70	48	314	622	144	238	49	315	630	154	253
35,000	-69	-74	---	---	---	---	---	42	279	558	137	236

BT0586813

**NOTE**

**During operations with ice vanes extended, torque will decrease approximately 12%, fuel flow will decrease approximately 8%, and true airspeed will be reduced by approximately 15 knots.**

*Figure 7A-41. Maximum Cruise Power at 1700 RPM - ISA -20°C (Sheet 1 of 2)*



**MAXIMUM CRUISE POWER  
1700 RPM  
ISA -20°C**

WEIGHT→			12,000 POUNDS					10,000 POUNDS				
PRESSURE ALTITUDE	IFAT	FAT	TORQUE PER ENGINE	FUEL FLOW PER ENGINE	TOTAL FUEL FLOW	IAS	TAS	TORQUE PER ENGINE	FUEL FLOW PER ENGINE	TOTAL FUEL FLOW	IAS	TAS
FEET	°C	°C	PERCENT	LBS/HR	LBS/HR	KTS	KTS	PERCENT	LBS/HR	LBS/HR	KTS	KTS
0	0	-5	83	628	1256	232	225	83	628	1256	233	226
2000	-4	-9	83	608	1216	232	231	83	608	1216	233	232
4000	-8	-13	83	591	1182	232	238	83	590	1180	233	239
6000	-11	-17	83	578	1156	229	242	83	577	1154	230	243
8000	-15	-21	83	566	1132	227	247	83	566	1132	228	248
10,000	-19	-25	83	556	1112	225	252	83	555	1110	226	253
12,000	-23	-29	83	545	1090	223	257	83	545	1090	224	259
14,000	-26	-33	83	535	1070	221	263	83	535	1070	222	265
16,000	-30	-37	83	527	1054	219	269	83	527	1054	221	271
18,000	-34	-41	83	520	1040	217	275	83	520	1040	219	277
20,000	-37	-45	83	516	1032	215	281	83	515	1030	217	283
22,000	-41	-49	79	490	980	209	282	79	490	980	211	284
24,000	-45	-53	74	461	922	202	282	75	461	922	204	284
26,000	-49	-57	69	431	862	194	280	70	432	864	197	284
28,000	-53	-60	64	400	800	186	278	64	401	802	189	282
29,000	-55	-62	61	385	770	181	276	62	386	772	185	281
31,000	-60	-66	56	353	706	172	271	56	355	710	176	277
33,000	-64	-70	50	319	638	160	264	50	321	642	165	271
35,000	-68	-74	43	282	564	147	251	44	286	572	154	262

BT0586814

**NOTE**

During operations with ice vanes extended, torque will decrease approximately 12%, fuel flow will decrease approximately 8%, and true airspeed will be reduced by approximately 15 knots.

Figure 7A-41. Maximum Cruise Power at 1700 RPM - ISA -20°C (Sheet 2 of 2)

**MAXIMUM CRUISE POWER  
1700 RPM  
ISA -10°C**

WEIGHT→			16,000 POUNDS					14,000 POUNDS				
PRESSURE ALTITUDE	IFAT	FAT	TORQUE PER ENGINE	FUEL FLOW PER ENGINE	TOTAL FUEL FLOW	IAS	TAS	TORQUE PER ENGINE	FUEL FLOW PER ENGINE	TOTAL FUEL FLOW	IAS	TAS
FEET	°C	°C	PERCENT	LBS/HR	LBS/HR	KTS	KTS	PERCENT	LBS/HR	LBS/HR	KTS	KTS
0	10	5	83	631	1262	229	227	83	631	1262	231	229
2000	6	1	83	613	1226	229	233	83	612	1224	231	235
4000	2	-3	83	596	1192	226	237	83	596	1192	228	239
6000	-2	-7	83	582	1164	224	242	83	581	1162	226	243
8000	-5	-11	83	569	1138	222	246	83	568	1136	224	248
10,000	-9	-15	83	558	1116	219	251	83	557	1114	221	253
12,000	-13	-19	83	547	1094	217	256	83	546	1092	219	258
14,000	-16	-23	83	537	1074	215	262	83	537	1074	217	264
16,000	-20	-27	83	529	1058	213	267	83	529	1058	215	270
18,000	-24	-31	82	515	1030	209	271	82	516	1032	212	274
20,000	-28	-35	78	491	982	203	271	78	491	982	206	275
22,000	-32	-39	73	463	926	195	270	74	463	926	198	274
24,000	-36	-43	69	434	868	187	268	69	435	870	191	273
26,000	-40	-47	64	405	810	178	265	64	406	812	183	271
28,000	-44	-50	59	375	750	168	259	59	376	752	174	267
29,000	-46	-52	56	360	720	163	256	57	362	724	169	265
31,000	-51	-56	51	332	664	151	247	52	334	668	159	259
33,000	-55	-60	46	304	608	136	232	47	307	614	148	250
35,000	-59	-64	---	---	---	---	---	42	278	556	134	237

BT0586811

**NOTE**

**During operations with ice vanes extended, torque will decrease approximately 12%, fuel flow will decrease approximately 8%, and true airspeed will be reduced by approximately 15 knots.**

*Figure 7A-42. Maximum Cruise Power at 1700 RPM - ISA -10°C (Sheet 1 of 2)*

**MAXIMUM CRUISE POWER  
1700 RPM  
ISA -10°C**

WEIGHT→			12,000 POUNDS					10,000 POUNDS				
PRESSURE ALTITUDE	IFAT	FAT	TORQUE PER ENGINE	FUEL FLOW PER ENGINE	TOTAL FUEL FLOW	IAS	TAS	TORQUE PER ENGINE	FUEL FLOW PER ENGINE	TOTAL FUEL FLOW	IAS	TAS
FEET	°C	°C	PERCENT	LBS/HR	LBS/HR	KTS	KTS	PERCENT	LBS/HR	LBS/HR	KTS	KTS
0	10	5	83	630	1260	232	230	83	630	1260	233	231
2000	6	1	83	612	1224	232	236	83	611	1222	233	237
4000	2	-3	83	595	1190	230	240	83	595	1190	231	241
6000	-1	-7	83	581	1162	227	245	83	580	1160	228	246
8000	-5	-11	83	568	1136	225	250	83	568	1136	226	251
10,000	-9	-15	83	557	1114	223	255	83	557	1114	224	256
12,000	-13	-19	83	546	1092	221	260	83	546	1092	222	262
14,000	-16	-23	83	537	1074	219	266	83	536	1072	221	268
16,000	-20	-27	83	528	1056	217	272	83	528	1056	219	274
18,000	-24	-31	82	516	1032	214	277	82	516	1032	216	279
20,000	-27	-35	78	491	982	208	278	78	492	984	210	280
22,000	-31	-39	74	463	926	201	278	74	464	928	203	280
24,000	-35	-43	69	435	870	194	277	69	436	872	196	280
26,000	-39	-47	64	406	812	186	276	65	407	814	189	279
28,000	-44	-50	59	377	754	178	273	60	378	756	181	278
29,000	-46	-52	57	363	726	174	271	57	364	728	177	276
31,000	-50	-56	52	336	672	165	267	53	337	674	169	274
33,000	-54	-60	47	309	618	155	262	48	311	622	160	270
35,000	-58	-64	43	282	564	144	253	43	284	568	151	264

BT058812

**NOTE**

During operations with ice vanes extended, torque will decrease approximately 12%, fuel flow will decrease approximately 8%, and true airspeed will be reduced by approximately 15 knots.

Figure 7A-42. Maximum Cruise Power at 1700 RPM - ISA -10°C (Sheet 2 of 2)

**MAXIMUM CRUISE POWER  
1700 RPM  
ISA**

WEIGHT→			16,000 POUNDS					14,000 POUNDS				
PRESSURE ALTITUDE	IFAT	FAT	TORQUE PER ENGINE	FUEL FLOW PER ENGINE	TOTAL FUEL FLOW	IAS	TAS	TORQUE PER ENGINE	FUEL FLOW PER ENGINE	TOTAL FUEL FLOW	IAS	TAS
FEET	°C	°C	PERCENT	LBS/HR	LBS/HR	KTS	KTS	PERCENT	LBS/HR	LBS/HR	KTS	KTS
0	20	15	83	631	1262	229	230	83	630	1260	230	232
2000	16	11	83	616	1232	227	235	83	615	1230	229	237
4000	12	7	83	601	1202	224	239	83	600	1200	226	241
6000	9	3	83	585	1170	222	244	83	584	1168	224	246
8000	5	-1	83	571	1142	220	249	83	570	1140	222	251
10,000	1	-5	83	558	1116	218	254	83	557	1114	219	256
12,000	-3	-9	83	546	1092	216	259	83	545	1090	218	262
14,000	-6	-13	83	538	1076	214	265	83	538	1076	216	267
16,000	-10	-17	80	512	1024	207	266	80	513	1026	210	269
18,000	-14	-21	75	483	966	200	265	75	483	966	203	269
20,000	-18	-25	71	458	916	193	265	72	458	916	197	269
22,000	-22	-29	67	432	864	186	263	68	433	866	190	268
24,000	-26	-33	63	407	814	178	261	64	407	814	182	267
26,000	-30	-37	59	381	762	169	257	59	382	764	174	265
28,000	-35	-40	54	354	708	159	251	55	356	712	165	261
29,000	-37	-42	52	341	682	154	247	52	342	684	161	258
31,000	-41	-46	47	314	628	141	236	48	316	632	150	251
33,000	-45	-50	---	---	---	---	---	43	291	582	139	241
35,000	-50	-54	---	---	---	---	---	39	264	528	123	224

BT058689

**NOTE**

**During operations with ice vanes extended, torque will decrease approximately 12%, fuel flow will decrease approximately 8%, and true airspeed will be reduced by approximately 15 knots.**

*Figure 7A-43. Maximum Cruise Power at 1700 RPM - ISA (Sheet 1 of 2)*

**MAXIMUM CRUISE POWER  
1700 RPM  
ISA**

WEIGHT→			12,000 POUNDS					10,000 POUNDS				
PRESSURE ALTITUDE	IFAT	FAT	TORQUE PER ENGINE	FUEL FLOW PER ENGINE	TOTAL FUEL FLOW	IAS	TAS	TORQUE PER ENGINE	FUEL FLOW PER ENGINE	TOTAL FUEL FLOW	IAS	TAS
FEET	°C	°C	PERCENT	LBS/HR	LBS/HR	KTS	KTS	PERCENT	LBS/HR	LBS/HR	KTS	KTS
0	20	15	83	630	1260	232	233	83	630	1260	233	234
2000	16	11	83	615	1230	230	238	83	615	1230	231	239
4000	13	7	83	600	1200	228	243	83	599	1198	229	244
6000	9	3	83	584	1168	225	247	83	584	1168	227	249
8000	5	-1	83	570	1140	223	252	83	569	1138	224	254
10,000	1	-5	83	557	1114	221	258	83	557	1114	223	259
12,000	-2	-9	83	545	1090	219	263	83	545	1090	221	265
14,000	-6	-13	83	537	1074	218	269	83	537	1074	219	271
16,000	-10	-17	80	513	1026	212	271	80	513	1026	214	273
18,000	-14	-21	76	483	966	205	272	76	484	968	207	274
20,000	-18	-25	72	458	916	199	272	72	459	918	201	275
22,000	-22	-29	68	433	866	193	272	68	434	868	195	275
24,000	-26	-33	64	408	816	186	272	64	409	818	188	275
26,000	-30	-37	60	383	766	178	270	60	383	766	181	275
28,000	-34	-40	55	356	712	170	268	55	357	714	174	273
29,000	-36	-42	53	343	686	166	266	53	344	688	170	272
31,000	-40	-46	48	318	636	157	261	49	319	638	162	269
33,000	-44	-50	44	292	584	147	255	44	294	588	153	265
35,000	-49	-54	39	267	534	136	246	40	268	536	144	259

BT0586810

**NOTE**

**During operations with ice vanes extended, torque will decrease approximately 12%, fuel flow will decrease approximately 8%, and true airspeed will be reduced by approximately 15 knots.**

*Figure 7A-43. Maximum Cruise Power at 1700 RPM - ISA (Sheet 2 of 2)*

**MAXIMUM CRUISE POWER  
1700 RPM  
ISA +10°C**

WEIGHT→			16,000 POUNDS					14,000 POUNDS				
PRESSURE ALTITUDE	IFAT	FAT	TORQUE PER ENGINE	FUEL FLOW PER ENGINE	TOTAL FUEL FLOW	IAS	TAS	TORQUE PER ENGINE	FUEL FLOW PER ENGINE	TOTAL FUEL FLOW	IAS	TAS
FEET	°C	°C	PERCENT	LBS/HR	LBS/HR	KTS	KTS	PERCENT	LBS/HR	LBS/HR	KTS	KTS
0	30	25	83	635	1270	227	233	83	635	1270	229	235
2000	26	21	83	615	1230	225	237	83	615	1230	227	239
4000	22	17	83	597	1194	223	242	83	597	1194	224	243
6000	19	13	83	581	1162	220	246	83	581	1162	222	248
8000	15	9	83	568	1136	218	251	83	567	1134	220	253
10,000	11	5	83	559	1118	216	257	83	559	1118	218	259
12,000	7	1	81	536	1072	212	259	81	537	1074	214	262
14,000	3	-3	77	506	1012	205	259	77	506	1012	207	262
16,000	-1	-7	73	476	952	198	258	73	477	954	201	262
18,000	-5	-11	69	448	896	190	257	69	449	898	194	262
20,000	-9	-15	65	424	848	183	256	65	424	848	187	261
22,000	-13	-19	61	399	798	175	254	61	400	800	180	260
24,000	-17	-23	57	374	748	167	251	57	375	750	172	258
26,000	-21	-27	53	351	702	158	246	53	352	704	164	255
28,000	-25	-30	49	328	656	148	239	50	329	658	156	251
29,000	-27	-32	47	316	632	142	234	48	318	636	151	249
31,000	-31	-36	35	248	496	125	225	44	296	592	141	241
33,000	-36	-40	---	---	---	---	---	40	272	544	128	229
35,000	---	---	---	---	---	---	---	---	---	---	---	---

BT058687

**NOTE**

**During operations with ice vanes extended, torque will decrease approximately 12%, fuel flow will decrease approximately 8%, and true airspeed will be reduced by approximately 15 knots.**

*Figure 7A-44. Maximum Cruise Power at 1700 RPM - ISA +10°C (Sheet 1 of 2)*

**MAXIMUM CRUISE POWER  
1700 RPM  
ISA +10°C**

WEIGHT→			16,000 POUNDS					14,000 POUNDS				
PRESSURE ALTITUDE	IFAT	FAT	TORQUE PER ENGINE	FUEL FLOW PER ENGINE	TOTAL FUEL FLOW	IAS	TAS	TORQUE PER ENGINE	FUEL FLOW PER ENGINE	TOTAL FUEL FLOW	IAS	TAS
FEET	°C	°C	PERCENT	LBS/HR	LBS/HR	KTS	KTS	PERCENT	LBS/HR	LBS/HR	KTS	KTS
0	30	25	83	634	1268	230	236	83	634	1268	231	237
2000	26	21	83	614	1228	228	240	83	614	1228	229	242
4000	23	17	83	596	1192	226	245	83	596	1192	227	246
6000	19	13	83	580	1160	224	250	83	580	1160	225	251
8000	15	9	83	567	1134	221	255	83	567	1134	223	257
10,000	11	5	83	558	1116	220	261	83	558	1116	221	262
12,000	8	1	81	537	1074	216	264	81	538	1076	217	266
14,000	4	-3	77	507	1014	210	265	77	507	1014	211	267
16,000	0	-7	73	477	954	203	265	73	478	956	205	268
18,000	-4	-11	69	449	898	197	265	69	450	900	199	268
20,000	-8	-15	65	425	850	190	265	65	425	850	192	269
22,000	-12	-19	61	400	800	183	265	62	401	802	186	269
24,000	-16	-23	58	376	752	176	264	58	376	752	179	268
26,000	-20	-27	54	352	704	169	262	54	353	706	172	267
28,000	-24	-30	50	330	660	161	260	50	331	662	165	266
29,000	-26	-32	48	319	638	157	258	48	320	640	162	265
31,000	-30	-36	44	297	594	149	254	45	298	596	154	262
33,000	-35	-40	41	274	548	139	247	41	276	552	146	258
35,000	-39	-44	36	251	502	127	237	37	253	506	136	252

BT058688

**NOTE**

**During operations with ice vanes extended, torque will decrease approximately 12%, fuel flow will decrease approximately 8%, and true airspeed will be reduced by approximately 15 knots.**

*Figure 7A-44. Maximum Cruise Power at 1700 RPM - ISA +10°C (Sheet 2 of 2)*

**MAXIMUM CRUISE POWER  
1700 RPM  
ISA +20°C**

WEIGHT→			16,000 POUNDS					14,000 POUNDS				
PRESSURE ALTITUDE	IFAT	FAT	TORQUE PER ENGINE	FUEL FLOW PER ENGINE	TOTAL FUEL FLOW	IAS	TAS	TORQUE PER ENGINE	FUEL FLOW PER ENGINE	TOTAL FUEL FLOW	IAS	TAS
FEET	°C	°C	PERCENT	LBS/HR	LBS/HR	KTS	KTS	PERCENT	LBS/HR	LBS/HR	KTS	KTS
0	40	35	83	639	1278	226	235	83	638	1276	227	237
2000	36	31	83	618	1236	223	239	83	617	1234	225	241
4000	33	27	83	599	1198	221	244	83	598	1196	223	246
6000	29	23	83	583	1166	219	249	83	582	1164	220	251
8000	25	19	81	560	1120	214	252	81	560	1120	217	254
10,000	21	15	78	531	1062	209	253	78	531	1062	211	255
12,000	17	11	74	500	1000	202	253	75	500	1000	205	256
14,000	13	7	69	468	936	194	251	70	469	938	197	254
16,000	9	3	65	439	878	186	249	65	440	880	190	253
18,000	5	-1	62	413	826	179	247	62	414	828	183	253
20,000	1	-5	58	387	774	171	244	58	388	776	176	251
22,000	-3	-9	54	364	728	163	241	54	365	730	168	249
24,000	-7	-13	50	341	682	153	236	51	342	684	160	246
26,000	-12	-17	47	319	638	143	229	47	321	642	152	242
28,000	-16	-20	43	299	598	131	218	44	302	604	143	238
29,000	-17	-22	38	266	532	135	233	43	292	584	139	234
31,000	-22	-26	35	248	496	125	225	39	271	542	126	223
33,000	---	---	---	---	---	---	---	---	---	---	---	---
35,000	---	---	---	---	---	---	---	---	---	---	---	---

BT058685

**NOTE**

**During operations with ice vanes extended, torque will decrease approximately 12%, fuel flow will decrease approximately 8%, and true airspeed will be reduced by approximately 15 knots.**

*Figure 7A-45. Maximum Cruise Power at 1700 RPM - ISA +20°C (Sheet 1 of 2)*



**MAXIMUM CRUISE POWER  
1700 RPM  
ISA +20°C**

WEIGHT→			12,000 POUNDS					10,000 POUNDS				
PRESSURE ALTITUDE	IFAT	FAT	TORQUE PER ENGINE	FUEL FLOW PER ENGINE	TOTAL FUEL FLOW	IAS	TAS	TORQUE PER ENGINE	FUEL FLOW PER ENGINE	TOTAL FUEL FLOW	IAS	TAS
FEET	°C	°C	PERCENT	LBS/HR	LBS/HR	KTS	KTS	PERCENT	LBS/HR	LBS/HR	KTS	KTS
0	40	35	83	638	1276	229	238	83	637	1274	230	239
2000	36	31	83	617	1234	226	243	83	616	1232	227	244
4000	33	27	83	598	1196	224	247	83	597	1194	225	249
6000	29	23	83	582	1164	222	253	83	581	1162	223	254
8000	25	19	82	560	1120	218	256	82	561	1122	220	258
10,000	21	15	78	531	1062	213	258	78	532	1064	215	260
12,000	17	11	75	501	1002	207	259	75	501	1002	209	261
14,000	13	7	70	469	938	200	258	70	470	940	202	260
16,000	9	3	66	440	880	193	257	66	441	882	195	260
18,000	5	-1	62	414	828	186	257	62	415	830	189	260
20,000	1	-5	58	389	778	179	256	58	389	778	182	260
22,000	-3	-9	55	366	732	172	255	55	366	732	176	259
24,000	-7	-13	51	343	686	165	253	51	343	686	169	259
26,000	--11	-17	48	322	644	158	251	48	323	646	162	258
28,000	-15	-20	45	303	606	151	249	45	304	608	156	256
29,000	-17	-22	43	294	588	147	247	43	294	588	152	256
31,000	-21	-26	40	273	546	138	242	40	275	550	145	253
33,000	-25	-30	36	252	504	127	233	37	254	508	136	241
35,000	-30	-34	32	230	460	114	218	33	233	466	127	241

BT058686

**NOTE**

**During operations with ice vanes extended, torque will decrease approximately 12%, fuel flow will decrease approximately 8%, and true airspeed will be reduced by approximately 15 knots.**

*Figure 7A-45. Maximum Cruise Power at 1700 RPM - ISA +20°C (Sheet 2 of 2)*

**MAXIMUM CRUISE POWER  
1700 RPM  
ISA +30°C**

WEIGHT→			16,000 POUNDS					14,000 POUNDS				
PRESSURE ALTITUDE	IFAT	FAT	TORQUE PER ENGINE	FUEL FLOW PER ENGINE	TOTAL FUEL FLOW	IAS	TAS	TORQUE PER ENGINE	FUEL FLOW PER ENGINE	TOTAL FUEL FLOW	IAS	TAS
FEET	°C	°C	PERCENT	LBS/HR	LBS/HR	KTS	KTS	PERCENT	LBS/HR	LBS/HR	KTS	KTS
0	50	45	82	635	1270	223	236	82	635	1270	224	238
2000	46	41	79	606	1212	218	238	80	606	1212	220	240
4000	42	37	77	577	1154	213	239	77	577	1154	215	242
6000	38	33	75	548	1096	208	241	75	548	1096	210	244
8000	35	29	72	520	1040	203	242	72	520	1040	205	245
10,000	31	25	69	493	986	197	243	70	493	986	200	247
12,000	27	21	66	462	924	190	243	66	462	924	194	247
14,000	23	17	62	433	866	183	242	63	434	868	187	246
16,000	19	13	58	403	806	175	238	58	404	808	179	244
18,000	14	9	53	373	746	164	232	53	374	748	170	239
20,000	10	5	49	347	694	155	227	50	348	696	161	236
22,000	6	1	46	327	654	146	222	47	328	656	154	233
24,000	2	-3	43	306	612	136	214	44	308	616	146	230
26,000	-2	-7	---	---	---	---	---	41	290	580	138	225
28,000	-6	-10	---	---	---	---	---	38	273	546	128	218
29,000	-8	-12	---	---	---	---	---	37	264	528	122	212
31,000	---	---	---	---	---	---	---	---	---	---	---	---
33,000	---	---	---	---	---	---	---	---	---	---	---	---
35,000	---	---	---	---	---	---	---	---	---	---	---	---

BT058683

**NOTE**

**During operations with ice vanes extended, torque will decrease approximately 12%, fuel flow will decrease approximately 8%, and true airspeed will be reduced by approximately 15 knots.**

*Figure 7A-46. Maximum Cruise Power at 1700 RPM - ISA +30°C (Sheet 1 of 2)*

**MAXIMUM CRUISE POWER  
1700 RPM  
ISA +30°C**

WEIGHT→			12,000 POUNDS					10,000 POUNDS				
PRESSURE ALTITUDE	IFAT	FAT	TORQUE PER ENGINE	FUEL FLOW PER ENGINE	TOTAL FUEL FLOW	IAS	TAS	TORQUE PER ENGINE	FUEL FLOW PER ENGINE	TOTAL FUEL FLOW	IAS	TAS
FEET	°C	°C	PERCENT	LBS/HR	LBS/HR	KTS	KTS	PERCENT	LBS/HR	LBS/HR	KTS	KTS
0	50	45	82	635	1270	226	239	82	636	1272	227	241
2000	46	41	80	606	1212	222	242	80	606	1212	223	243
4000	43	37	78	577	1154	217	244	78	577	1154	218	245
6000	39	33	75	548	1096	212	246	75	549	1098	214	248
8000	35	29	73	521	1042	207	248	73	521	1042	209	250
10,000	31	25	70	494	988	202	249	70	494	988	204	252
12,000	27	21	66	463	926	196	250	67	463	926	198	252
14,000	23	17	63	434	868	190	250	63	435	870	192	253
16,000	19	13	59	405	810	183	248	59	405	810	185	252
18,000	15	9	54	374	748	174	245	54	375	750	177	249
20,000	11	5	50	349	698	166	243	50	350	700	170	247
22,000	7	1	47	329	658	160	241	47	330	660	164	247
24,000	3	-3	44	309	618	153	239	44	309	618	157	246
26,000	-1	-7	41	291	582	146	237	42	291	582	151	245
28,000	-5	-10	39	275	550	139	235	39	275	550	145	245
29,000	-7	-12	38	266	532	135	233	38	268	536	142	244
31,000	-12	-16	35	248	496	125	225	35	250	500	134	241
33,000	-15	-20	---	---	---	---	---	32	231	462	126	235
35,000	-20	-24	---	---	---	---	---	29	211	422	115	225

BT058684

**NOTE**

**During operations with ice vanes extended, torque will decrease approximately 12%, fuel flow will decrease approximately 8%, and true airspeed will be reduced by approximately 15 knots.**

*Figure 7A-46. Maximum Cruise Power at 1700 RPM - ISA +30°C (Sheet 2 of 2)*

**MAXIMUM CRUISE POWER  
1700 RPM  
ISA +37°C**

WEIGHT→			16,000 POUNDS					14,000 POUNDS				
PRESSURE ALTITUDE	IFAT	FAT	TORQUE PER ENGINE	FUEL FLOW PER ENGINE	TOTAL FUEL FLOW	IAS	TAS	TORQUE PER ENGINE	FUEL FLOW PER ENGINE	TOTAL FUEL FLOW	IAS	TAS
FEET	°C	°C	PERCENT	LBS/HR	LBS/HR	KTS	KTS	PERCENT	LBS/HR	LBS/HR	KTS	KTS
0	57	52	73	607	1214	212	227	74	607	1214	214	230
2000	53	48	72	577	1154	208	230	72	577	1154	211	232
4000	49	44	70	548	1096	204	232	70	548	1096	206	235
6000	45	40	68	522	1044	199	234	68	522	1044	202	237
8000	41	36	66	495	990	194	235	66	495	990	197	239
10,000	37	32	63	467	934	189	236	64	468	936	192	240
12,000	33	28	60	436	872	181	234	60	437	874	185	239
14,000	29	24	56	407	814	174	232	57	437	874	185	239
16,000	25	20	53	378	756	165	228	53	379	758	170	236
18,000	21	16	48	349	698	155	222	49	350	700	162	231
20,000	17	12	44	323	646	144	214	45	324	648	152	226
22,000	12	8	41	302	604	132	204	42	304	608	143	221
24,000	9	4	---	---	---	---	---	38	283	566	133	213
26,000	4	0	---	---	---	---	---	36	266	532	123	206
28,000	---	---	---	---	---	---	---	---	---	---	---	---
29,000	---	---	---	---	---	---	---	---	---	---	---	---
31,000	---	---	---	---	---	---	---	---	---	---	---	---
33,000	---	---	---	---	---	---	---	---	---	---	---	---
35,000	---	---	---	---	---	---	---	---	---	---	---	---

BT05868

**NOTE**

**During operations with ice vanes extended, torque will decrease approximately 12%, fuel flow will decrease approximately 8%, and true airspeed will be reduced by approximately 15 knots.**

*Figure 7A-47. Maximum Cruise Power at 1700 RPM - ISA +37°C (Sheet 1 of 2)*

**MAXIMUM CRUISE POWER  
1700 RPM  
ISA +37°C**

WEIGHT→			12,000 POUNDS					10,000 POUNDS				
PRESSURE ALTITUDE	IFAT	FAT	TORQUE PER ENGINE	FUEL FLOW PER ENGINE	TOTAL FUEL FLOW	IAS	TAS	TORQUE PER ENGINE	FUEL FLOW PER ENGINE	TOTAL FUEL FLOW	IAS	TAS
FEET	°C	°C	PERCENT	LBS/HR	LBS/HR	KTS	KTS	PERCENT	LBS/HR	LBS/HR	KTS	KTS
0	57	52	74	607	1214	216	232	74	607	1214	218	233
2000	53	48	72	577	1154	213	235	72	577	1154	214	236
4000	49	44	70	549	1098	208	237	70	549	1098	210	239
6000	45	40	68	522	1044	204	239	69	522	1044	206	241
8000	42	36	66	495	990	200	241	67	496	992	201	244
10,000	38	32	64	468	936	194	243	64	469	938	197	245
12,000	34	28	60	437	874	188	243	61	437	874	190	246
14,000	30	24	57	408	816	182	242	57	409	818	184	246
16,000	26	20	53	380	760	174	241	54	380	760	177	245
18,000	22	16	49	351	702	166	238	49	352	704	170	242
20,000	17	12	45	325	650	158	234	46	326	652	162	240
22,000	13	8	42	305	610	151	231	42	305	610	155	238
24,000	9	4	39	284	568	142	227	39	285	570	148	236
26,000	5	0	36	267	534	135	223	37	268	536	142	234
28,000	1	-3	35	254	508	128	221	35	255	510	136	234
29,000	-1	-5	34	247	494	124	219	34	248	496	134	234
31,000	-5	-9	31	231	462	114	210	32	233	466	126	231
33,000	-9	-13	---	---	---	---	---	29	215	430	117	223
35,000	-13	-17	---	---	---	---	---	26	196	392	105	209

BT058682

**NOTE**

**During operations with ice vanes extended, torque will decrease approximately 12%, fuel flow will decrease approximately 8%, and true airspeed will be reduced by approximately 15 knots.**

*Figure 7A-47. Maximum Cruise Power at 1700 RPM - ISA +37°C (Sheet 2 of 2)*

MAXIMUM CRUISE SPEEDS  
1700 RPM  
WEIGHT: 14,000 LBS

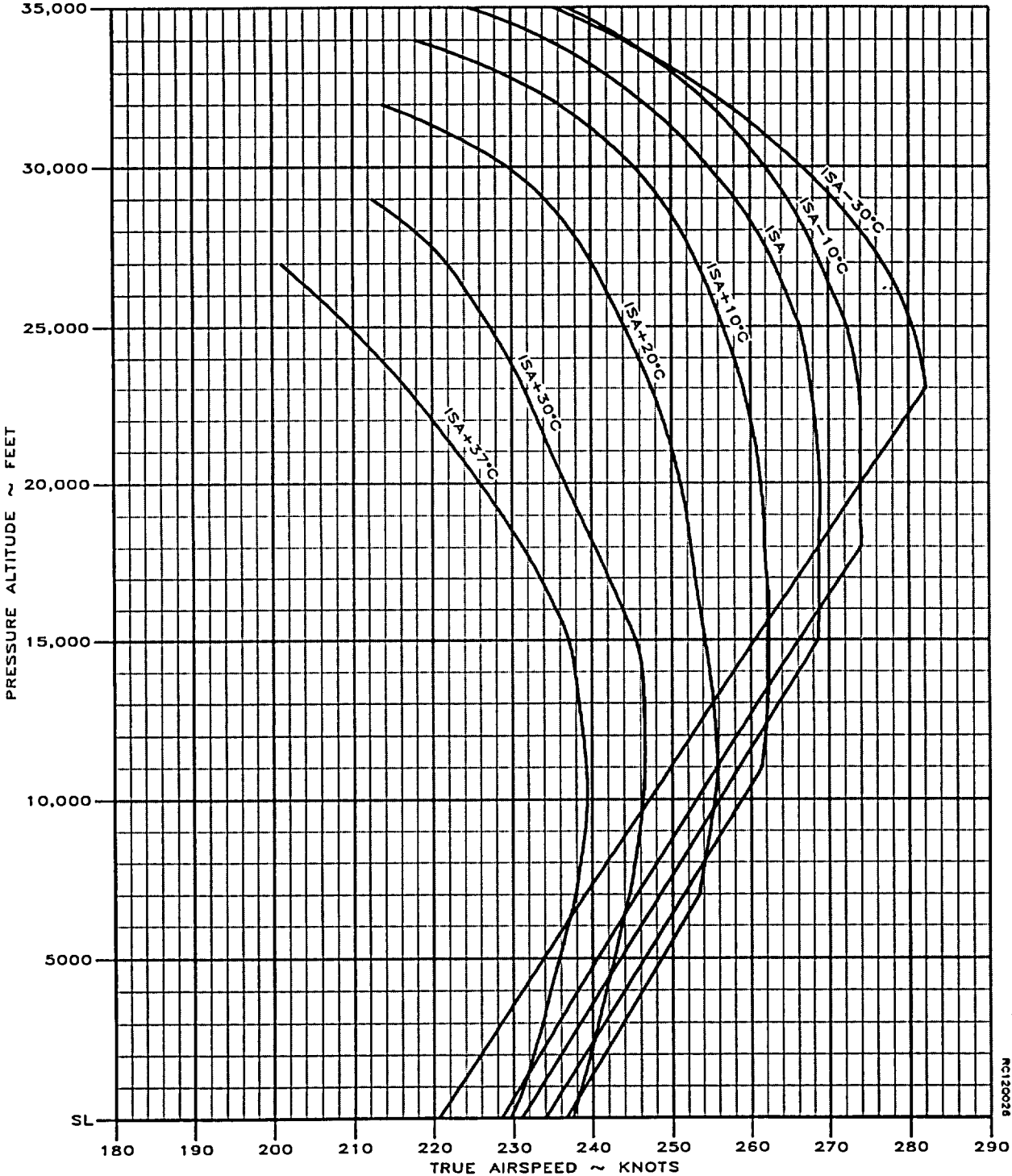

Figure 7A-48. Maximum Cruise Speeds at 1700 RPM

MAXIMUM CRUISE POWER  
1700 RPM  
WEIGHT: 14,000 LBS

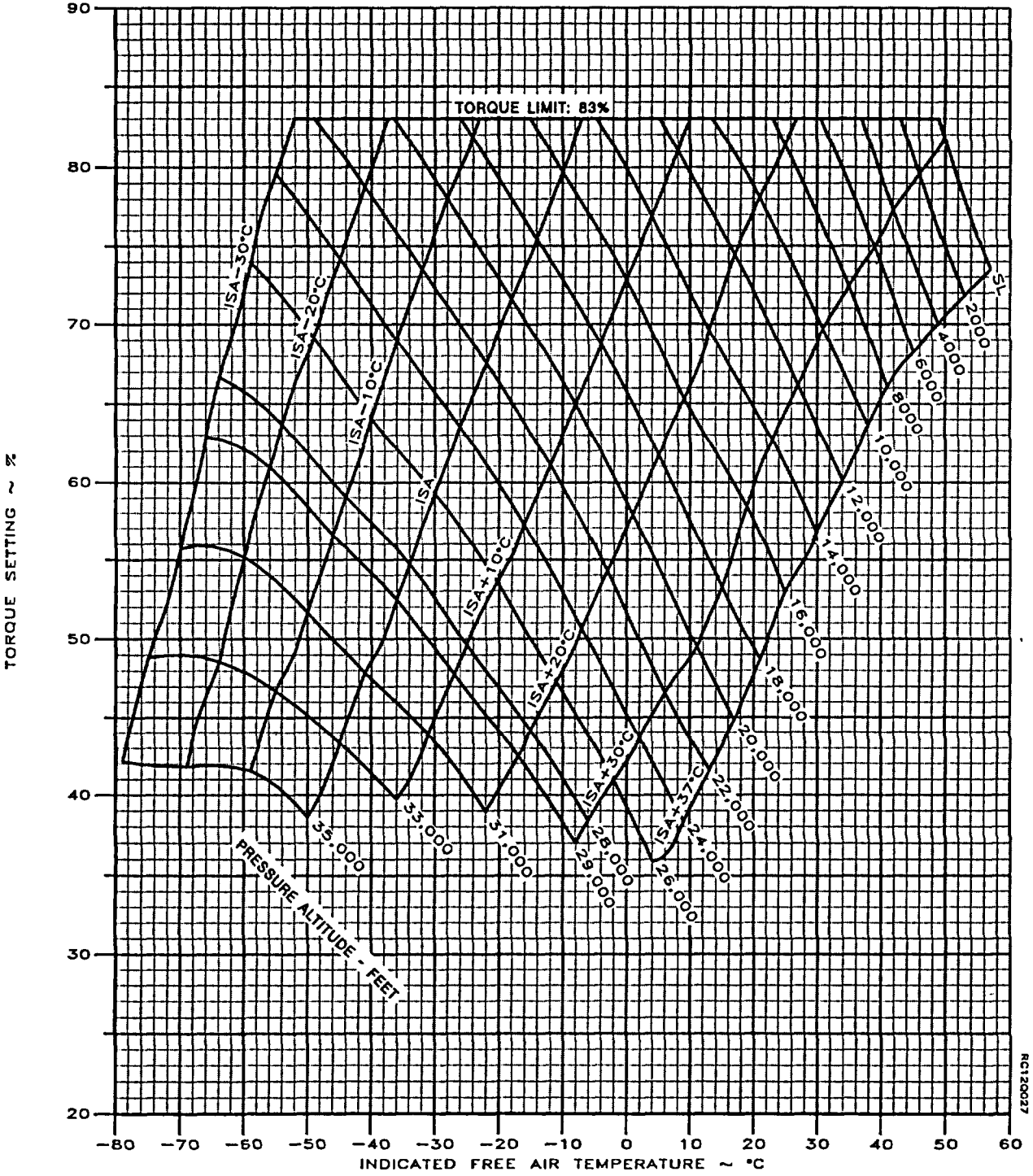

Figure 7A-49. Maximum Cruise Power at 1700 RPM

FUEL FLOW AT MAXIMUM CRUISE POWER  
1700 RPM  
WEIGHT: 14,000 LBS

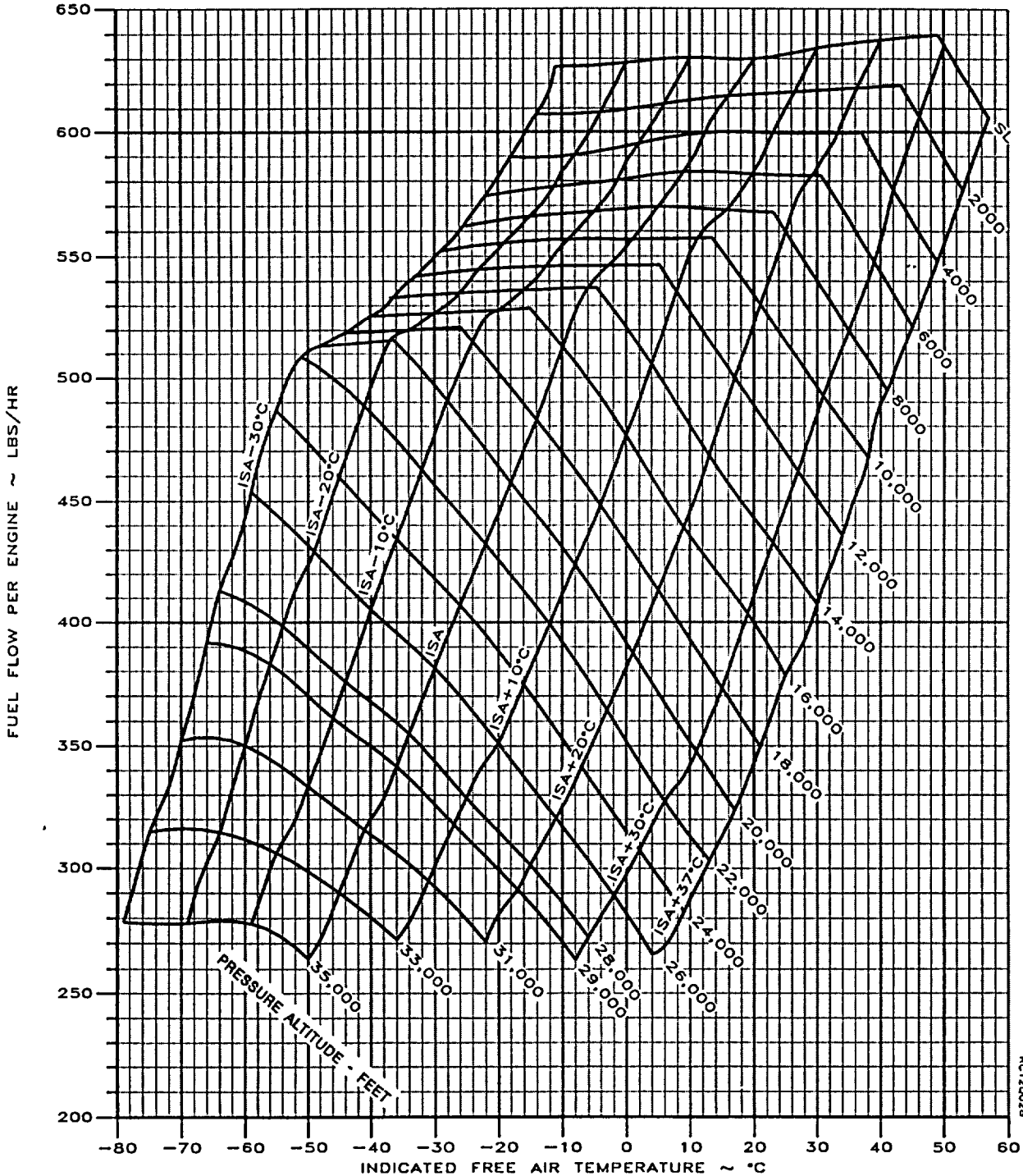

Figure 7A-50. Fuel Flow at Maximum Cruise Power at 1700 RPM



**RANGE PROFILE - MAXIMUM CRUISE POWER**

ASSOCIATED CONDITIONS:

WEIGHT ..... 16.620 LBS BEFORE  
ENGINE START  
FUEL ..... AVIATION KEROSENE  
FUEL DENSITY..... 6.7 LBS/GAL  
ICE VANES ..... RETRACTED

1700 RPM

**STANDARD DAY (ISA)  
ZERO WIND**

EXAMPLE:

PRESSURE ALTITUDE.....26.000 FT  
FUEL..... 2572 LBS  
RANGE .....628 NM

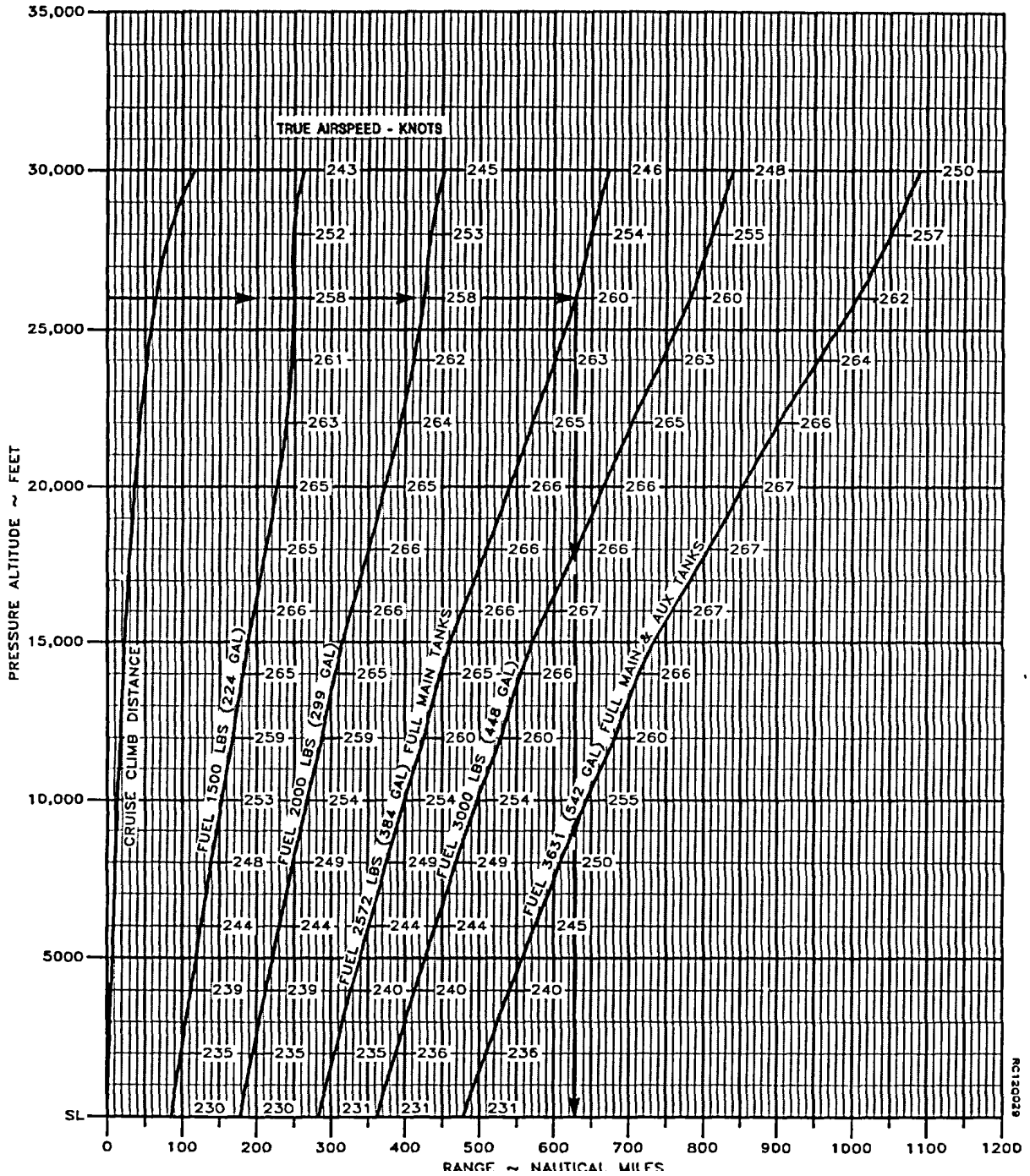

Figure 7A-51. Range Profile - Maximum Cruise Power at 1700 RPM

**NORMAL CRUISE POWER  
1500 RPM  
ISA -30°C**

WEIGHT→			16,000 POUNDS					14,000 POUNDS				
PRESSURE ALTITUDE	IFAT	FAT	TORQUE PER ENGINE	FUEL FLOW PER ENGINE	TOTAL FUEL FLOW	IAS	TAS	TORQUE PER ENGINE	FUEL FLOW PER ENGINE	TOTAL FUEL FLOW	IAS	TAS
FEET	C°	C°	PERCENT	LBS/HR	LBS/HR	KTS	KTS	PERCENT	LBS/HR	LBS/HR	KTS	KTS
0	-10	-15	94	620	1240	233	222	94	620	1240	235	224
2000	-14	-19	94	602	1204	231	227	94	602	1204	233	228
4000	-18	-23	94	586	1172	230	231	94	585	1170	231	233
6000	-22	-27	94	571	1142	227	236	94	570	1140	229	237
8000	-25	-31	94	559	1118	226	241	94	558	1116	228	243
10,000	-29	-35	94	550	1100	224	246	94	549	1098	226	248
12,000	-33	-39	94	540	1080	222	251	94	539	1078	224	253
14,000	-37	-43	94	532	1064	219	255	94	531	1062	221	258
16,000	-40	-47	94	525	1050	217	260	94	524	1048	219	263
18,000	-44	-51	94	519	1038	214	265	94	518	1036	217	268
20,000	-48	-55	94	514	1028	212	271	94	513	1026	214	273
22,000	-52	-59	90	490	980	205	271	90	490	980	208	275
24,000	-56	-63	85	463	926	198	270	85	464	928	202	275
26,000	-60	-67	79	431	862	189	267	79	433	866	193	273
28,000	-64	-70	71	392	784	178	260	72	395	790	183	267
29,000	-66	-72	66	370	740	171	255	68	374	748	177	263
31,000	-71	-76	59	332	664	156	242	60	335	670	164	253
33,000	-76	-80	51	298	596	140	226	53	302	604	151	243
35,000	-80	-84	---	---	---	---	---	46	269	538	135	227

BT0588915

**NOTE**

During operations with ice vanes extended, torque will decrease approximately 12%, fuel flow will decrease approximately 8%, and true airspeed will be reduced by approximately 15 knots.

Figure 7A-52. Normal Cruise Power at 1500 RPM - ISA -30°C (Sheet 1 of 2)

**NORMAL CRUISE POWER  
1500 RPM  
ISA -30°C**

WEIGHT→			12,000 POUNDS					10,000 POUNDS				
PRESSURE ALTITUDE	IFAT	FAT	TORQUE PER ENGINE	FUEL FLOW PER ENGINE	TOTAL FUEL FLOW	IAS	TAS	TORQUE PER ENGINE	FUEL FLOW PER ENGINE	TOTAL FUEL FLOW	IAS	TAS
FEET	C°	C°	PERCENT	LBS/HR	LBS/HR	KTS	KTS	PERCENT	LBS/HR	LBS/HR	KTS	KTS
0	-10	-15	94	620	1240	236	225	94	619	1238	237	226
2000	-14	-19	94	602	1204	234	229	94	601	1202	235	231
4000	-18	-23	94	585	1170	233	234	94	585	1170	234	235
6000	-22	-27	94	570	1140	231	239	94	570	1140	232	240
8000	-25	-31	94	558	1116	230	245	94	558	1116	231	246
10,000	-29	-35	94	549	1098	227	249	94	548	1096	229	251
12,000	-33	-39	94	539	1078	225	254	94	539	1078	227	256
14,000	-37	-43	94	531	1062	223	260	94	531	1062	225	261
16,000	-40	-47	94	524	1048	221	265	94	524	1048	222	267
18,000	-44	-51	94	518	1036	218	270	94	517	1034	220	272
20,000	-48	-55	94	513	1026	216	276	94	512	1024	218	278
22,000	-51	-59	90	491	982	211	278	91	491	982	213	280
24,000	-55	-63	86	465	930	204	278	86	465	930	207	281
26,000	-59	-67	80	434	868	197	277	80	435	870	199	280
28,000	-64	-70	72	397	794	187	272	73	399	798	190	277
29,000	-66	-72	68	377	754	181	269	69	379	758	185	274
31,000	-70	-76	61	339	678	170	262	61	342	684	174	268
33,000	-74	-80	54	305	610	158	254	55	309	618	164	262
35,000	-79	-84	47	272	544	145	243	48	275	550	152	253

BT056916

**NOTE**

During operations with ice vanes extended, torque will decrease approximately 12%, fuel flow will decrease approximately 8%, and true airspeed will be reduced by approximately 15 knots.

Figure 7A-52. Normal Cruise Power at 1500 RPM - ISA -30°C (Sheet 2 of 2)

**NORMAL CRUISE POWER  
1500 RPM  
ISA -30°C**

WEIGHT→			16,000 POUNDS					14,000 POUNDS				
PRESSURE ALTITUDE	IFAT	FAT	TORQUE PER ENGINE	FUEL FLOW PER ENGINE	TOTAL FUEL FLOW	IAS	TAS	TORQUE PER ENGINE	FUEL FLOW PER ENGINE	TOTAL FUEL FLOW	IAS	TAS
FEET	C°	C°	PERCENT	LBS/HR	LBS/HR	KTS	KTS	PERCENT	LBS/HR	LBS/HR	KTS	KTS
0	0	-5	94	623	1246	232	225	94	623	1246	233	226
2000	-4	-9	94	604	1208	230	229	94	604	1208	231	231
4000	-8	-13	94	587	1174	229	235	94	586	1172	230	236
6000	-12	-17	94	574	1148	226	239	94	574	1148	238	241
8000	-15	-21	94	563	1126	224	244	94	563	1126	226	246
10,000	-19	-25	94	553	1106	222	249	94	553	1106	224	251
12,000	-23	-29	94	543	1086	219	253	94	543	1086	221	256
14,000	-27	-33	94	534	1068	217	258	94	534	1068	219	261
16,000	-30	-37	94	527	1054	214	263	94	526	1052	217	266
18,000	-34	-41	93	517	1034	211	268	94	518	1036	214	271
20,000	-38	-45	89	495	990	205	268	90	495	990	208	272
22,000	-42	-49	84	467	934	198	267	85	467	934	201	272
24,000	-46	-53	79	438	876	190	266	80	439	878	194	271
26,000	-50	-57	73	407	814	180	262	74	408	816	185	268
28,000	-54	-60	66	373	746	169	255	67	375	750	175	263
29,000	-57	-62	63	357	714	163	250	64	359	718	170	260
31,000	-61	-66	57	326	652	151	240	58	329	658	159	253
33,000	-66	-70	51	297	594	135	224	52	300	600	147	243
35,000	-70	-74-	---	---	---	---	---	46	271	542	132	228

BT0588913

**NOTE**

During operations with ice vanes extended, torque will decrease approximately 12%, fuel flow will decrease approximately 8%, and true airspeed will be reduced by approximately 15 knots.

Figure 7A-53. Normal Cruise Power at 1500 RPM - ISA -20°C (Sheet 1 of 2)

**NORMAL CRUISE POWER  
1500 RPM  
ISA -30°C**

WEIGHT→			12,000 POUNDS					10,000 POUNDS				
PRESSURE ALTITUDE	IFAT	FAT	TORQUE PER ENGINE	FUEL FLOW PER ENGINE	TOTAL FUEL FLOW	IAS	TAS	TORQUE PER ENGINE	FUEL FLOW PER ENGINE	TOTAL FUEL FLOW	IAS	TAS
FEET	C°	C°	PERCENT	LBS/HR	LBS/HR	KTS	KTS	PERCENT	LBS/HR	LBS/HR	KTS	KTS
0	0	-5	94	622	1244	234	228	94	622	1244	235	229
2000	-4	-9	94	604	1208	233	232	94	603	1206	234	233
4000	-8	-13	94	586	1172	231	237	94	586	1172	232	238
6000	-11	-17	94	573	1146	230	243	94	573	1146	231	244
8000	-15	-21	94	562	1124	227	247	94	562	1124	229	249
10,000	-19	-25	94	552	1104	225	252	94	552	1104	227	254
12,000	-23	-29	94	542	1084	223	257	94	542	1084	225	259
14,000	-26	-33	94	533	1066	221	263	94	533	1066	222	264
16,000	-30	-37	94	526	1052	218	268	94	525	1050	220	270
18,000	-34	-41	94	518	1036	216	273	94	518	1036	217	275
20,000	-38	-45	90	496	992	210	275	90	496	992	212	277
22,000	-42	-49	85	468	936	204	275	85	468	936	206	278
24,000	-46	-53	80	440	880	197	275	80	441	882	199	278
26,000	-50	-57	74	409	818	189	273	74	410	820	191	276
28,000	-54	-60	68	377	754	179	269	68	378	756	183	273
29,000	-56	-62	65	361	722	175	267	65	362	724	178	272
31,000	-60	-66	59	331	662	165	262	59	333	666	169	268
33,000	-64	-70	53	303	606	155	255	54	306	612	160	263
35,000	-69	-74	47	274	548	143	246	48	277	554	150	257

8T0588614

**NOTE**

During operations with ice vanes extended, torque will decrease approximately 12%, fuel flow will decrease approximately 8%, and true airspeed will be reduced by approximately 15 knots.

Figure 7A-53. Normal Cruise Power at 1500 RPM - ISA -200C (Sheet 2 of 2)

**NORMAL CRUISE POWER  
1500 RPM  
ISA -30°C**

WEIGHT→			16,000 POUNDS					14,000 POUNDS				
PRESSURE ALTITUDE	IFAT	FAT	TORQUE PER ENGINE	FUEL FLOW PER ENGINE	TOTAL FUEL FLOW	IAS	TAS	TORQUE PER ENGINE	FUEL FLOW PER ENGINE	TOTAL FUEL FLOW	IAS	TAS
FEET	C°	C°	PERCENT	LBS/HR	LBS/HR	KTS	KTS	PERCENT	LBS/HR	LBS/HR	KTS	KTS
0	10	5	94	626	1252	231	228	94	625	1250	233	230
2000	6	1	94	608	1216	229	233	94	608	1216	231	235
4000	2	-3	94	592	1184	227	238	94	592	1184	229	239
6000	-1	-7	94	578	1156	224	242	94	577	1154	226	244
8000	-5	-11	94	566	1132	222	246	94	565	1130	224	248
10,000	-9	-15	94	555	1110	220	251	94	555	1110	222	253
12,000	-13	-19	94	545	1090	217	256	94	545	1090	219	258
14,000	-16	-23	94	536	1072	215	261	94	536	1072	217	263
16,000	-20	-27	92	517	1034	210	263	92	518	1036	212	266
18,000	-24	-31	87	488	976	203	263	87	488	976	206	266
20,000	-28	-35	83	465	930	196	263	83	465	930	200	267
22,000	-32	-39	78	440	880	189	262	79	440	880	193	267
24,000	-36	-43	74	414	828	181	260	74	415	830	185	266
26,000	-40	-47	68	385	770	172	255	69	387	774	177	263
28,000	-45	-50	62	354	708	160	248	63	356	712	167	257
29,000	-47	-52	59	339	678	154	243	60	341	682	162	254
31,000	-51	-56	53	312	624	141	232	54	314	628	151	247
33,000	-55	-60	---	---	---	---	---	49	290	580	140	238
35,000	-60	-64	---	---	---	---	---	44	266	532	126	223

BT0586911

**NOTE**

During operations with ice vanes extended, torque will decrease approximately 12%, fuel flow will decrease approximately 8%, and true airspeed will be reduced by approximately 15 knots.

Figure 7A-54. Normal Cruise Power at 1500 RPM - ISA -10°C (Sheet 1 of 2)

**NORMAL CRUISE POWER  
1500 RPM  
ISA -30°C**

WEIGHT→			12,000 POUNDS					10,000 POUNDS				
PRESSURE ALTITUDE	IFAT	FAT	TORQUE PER ENGINE	FUEL FLOW PER ENGINE	TOTAL FUEL FLOW	IAS	TAS	TORQUE PER ENGINE	FUEL FLOW PER ENGINE	TOTAL FUEL FLOW	IAS	TAS
FEET	C°	C°	PERCENT	LBS/HR	LBS/HR	KTS	KTS	PERCENT	LBS/HR	LBS/HR	KTS	KTS
0	10	5	94	625	1250	234	231	94	624	1248	235	232
2000	6	1	94	607	1214	232	236	94	607	1214	233	237
4000	2	-3	94	591	1182	230	241	94	591	1182	231	242
6000	-1	-7	94	577	1154	228	245	94	577	1154	229	247
8000	-5	-11	94	565	1130	225	250	94	565	1130	227	252
10,000	-9	-15	94	555	1110	223	255	94	554	1108	225	257
12,000	-13	-19	94	544	1088	221	260	94	544	1088	222	262
14,000	-16	-23	94	535	1070	219	265	94	535	1070	220	267
16,000	-20	-27	92	518	1036	214	269	92	518	1036	216	271
18,000	-24	-31	87	488	976	208	269	87	489	978	210	271
20,000	-28	-35	83	466	932	202	270	83	466	932	204	273
22,000	-32	-39	79	441	882	196	270	79	441	882	198	274
24,000	-36	-43	74	416	832	189	270	75	417	834	191	274
26,000	-40	-47	69	388	776	181	268	69	389	778	184	273
28,000	-44	-50	63	358	716	172	264	63	359	718	175	270
29,000	-46	-52	60	343	686	167	262	61	344	688	171	268
31,000	-50	-56	55	316	632	158	257	55	317	634	163	264
33,000	-55	-60	50	292	584	149	251	51	293	586	154	261
35,000	-59	-64	45	268	536	138	243	46	538	538	145	255

BT0586912

**NOTE**

During operations with ice vanes extended, torque will decrease approximately 12%, fuel flow will decrease approximately 8%, and true airspeed will be reduced by approximately 15 knots.

Figure 7A-54. Normal Cruise Power at 1500 RPM - ISA -10°C (Sheet 2 of 2)

**NORMAL CRUISE POWER  
1500 RPM  
ISA -30°C**

WEIGHT→			16,000 POUNDS					14,000 POUNDS				
PRESSURE ALTITUDE	IFAT	FAT	TORQUE PER ENGINE	FUEL FLOW PER ENGINE	TOTAL FUEL FLOW	IAS	TAS	TORQUE PER ENGINE	FUEL FLOW PER ENGINE	TOTAL FUEL FLOW	IAS	TAS
FEET	C°	C°	PERCENT	LBS/HR	LBS/HR	KTS	KTS	PERCENT	LBS/HR	LBS/HR	KTS	KTS
0	20	15	94	626	1252	229	231	94	625	1250	231	232
2000	16	11	94	612	1224	227	235	94	611	1222	229	237
4000	12	7	94	597	1194	225	240	94	597	1194	227	242
6000	9	3	94	582	1164	222	244	94	581	1162	224	246
8000	5	-1	94	568	1136	220	249	94	568	1136	222	251
10,000	1	-5	94	556	1112	218	254	94	555	1110	220	256
12,000	-3	-9	94	544	1088	215	258	94	544	1088	217	261
14,000	-7	-13	89	514	1028	208	258	90	515	1030	211	261
16,000	-11	-17	85	485	970	201	258	85	486	972	204	261
18,000	-15	-21	80	459	918	194	257	81	459	918	197	261
20,000	-19	-25	76	435	870	187	256	76	435	870	191	261
22,000	-23	-29	72	410	820	179	254	72	411	822	184	260
24,000	-27	-33	67	385	770	171	251	68	386	772	176	259
26,000	-31	-37	62	359	718	162	246	63	360	720	168	255
28,000	-35	-40	57	332	664	150	238	58	334	668	158	250
29,000	-37	-42	54	320	640	144	233	55	322	644	153	247
31,000	-42	-46	49	294	588	129	217	50	298	596	143	239
33,000	-46	-50	---	---	---	---	---	46	274	548	130	228
35,000	---	---	---	---	---	---	---	---	---	---	---	---

BT058899

**NOTE**

During operations with ice vanes extended, torque will decrease approximately 12%, fuel flow will decrease approximately 8%, and true airspeed will be reduced by approximately 15 knots.

Figure 7A-55. Normal Cruise Power at 1500 RPM - ISA (Sheet 1 of 2)



**NORMAL CRUISE POWER  
1500 RPM  
ISA -30°C**

WEIGHT→			12,000 POUNDS					10,000 POUNDS				
PRESSURE ALTITUDE	IFAT	FAT	TORQUE PER ENGINE	FUEL FLOW PER ENGINE	TOTAL FUEL FLOW	IAS	TAS	TORQUE PER ENGINE	FUEL FLOW PER ENGINE	TOTAL FUEL FLOW	IAS	TAS
FEET	C°	C°	PERCENT	LBS/HR	LBS/HR	KTS	KTS	PERCENT	LBS/HR	LBS/HR	KTS	KTS
0	20	15	94	625	1250	232	234	94	625	1250	233	235
2000	16	11	94	619	1222	230	239	94	610	1220	232	240
4000	13	7	94	596	1192	228	243	94	596	1192	229	244
6000	9	3	94	581	1162	226	248	94	581	1162	227	249
8000	5	-1	94	567	1134	224	253	94	567	1134	225	254
10,000	1	-5	94	555	1110	221	258	94	555	1110	223	259
12,000	-2	-9	94	544	1088	219	263	94	543	1086	220	265
14,000	-6	-13	90	515	1030	213	264	90	515	1030	214	266
16,000	-10	-17	85	486	972	206	264	85	487	974	208	267
18,000	-14	-21	81	459	918	200	265	81	460	920	202	267
20,000	-18	-25	77	436	872	194	265	77	436	872	196	268
22,000	-22	-29	72	411	822	187	265	72	412	824	190	268
24,000	-26	-33	68	387	774	180	264	68	387	774	183	268
26,000	-30	-37	63	361	722	172	262	63	362	724	176	267
28,000	-34	-40	58	336	672	164	258	58	336	672	168	264
29,000	-36	-42	56	323	646	160	256	56	324	648	164	263
31,000	-41	-46	51	299	598	151	251	52	301	602	156	260
33,000	-45	-50	47	277	554	141	245	47	278	556	148	256
35,000	-49	-54	42	254	508	130	235	43	256	512	138	250

BT0586910

**NOTE**

During operations with ice vanes extended, torque will decrease approximately 12%, fuel flow will decrease approximately 8%, and true airspeed will be reduced by approximately 15 knots.

Figure 7A-55. Normal Cruise Power at 1500 RPM - ISA (Sheet 2 of 2)

**NORMAL CRUISE POWER  
1500 RPM  
ISA -30°C**

WEIGHT→			16,000 POUNDS					14,000 POUNDS				
PRESSURE ALTITUDE	IFAT	FAT	TORQUE PER ENGINE	FUEL FLOW PER ENGINE	TOTAL FUEL FLOW	IAS	TAS	TORQUE PER ENGINE	FUEL FLOW PER ENGINE	TOTAL FUEL FLOW	IAS	TAS
FEET	C°	C°	PERCENT	LBS/HR	LBS/HR	KTS	KTS	PERCENT	LBS/HR	LBS/HR	KTS	KTS
0	30	25	94	631	1262	228	233	94	631	1262	229	235
2000	26	21	94	612	1224	225	238	94	611	1222	227	232
4000	22	17	94	594	1188	223	242	94	594	1188	225	244
6000	19	13	94	579	1158	220	246	94	578	1156	222	249
8000	15	9	94	566	1132	218	251	94	565	1130	220	253
10,000	11	5	89	534	1068	210	250	89	534	1068	213	253
12,000	7	1	85	506	1012	205	251	85	507	1014	207	254
14,000	3	-3	82	480	960	199	252	82	480	960	202	255
16,000	-1	-7	78	453	906	192	251	78	454	908	195	255
18,000	-5	-11	73	427	854	185	250	74	428	856	188	255
20,000	-9	-15	69	402	804	177	248	69	403	806	181	254
22,000	-13	-19	65	379	758	168	245	65	380	760	174	252
24,000	-17	-23	60	355	710	160	240	61	356	712	166	249
26,000	-21	-27	56	331	662	149	234	56	332	664	157	245
28,000	-26	-30	51	307	614	137	223	52	310	620	148	239
29,000	-28	-32	49	296	592	129	215	50	298	596	143	236
31,000	-32	-36	---	---	---	---	---	46	277	554	131	226
33,000	---	---	---	---	---	---	---	---	---	---	---	---
35,000	---	---	---	---	---	---	---	---	---	---	---	---

**NOTE**

During operations with ice vanes extended, torque will decrease approximately 12%, fuel flow will decrease approximately 8%, and true airspeed will be reduced by approximately 15 knots.

*Figure 7A-56. Normal Cruise Power at 1500 RPM - ISA +10C (Sheet 1 of 2)*

**NORMAL CRUISE POWER  
1500 RPM  
ISA -30°C**

WEIGHT→			12,000 POUNDS					10,000 POUNDS				
PRESSURE ALTITUDE	IFAT	FAT	TORQUE PER ENGINE	FUEL FLOW PER ENGINE	TOTAL FUEL FLOW	IAS	TAS	TORQUE PER ENGINE	FUEL FLOW PER ENGINE	TOTAL FUEL FLOW	IAS	TAS
FEET	C°	C°	PERCENT	LBS/HR	LBS/HR	KTS	KTS	PERCENT	LBS/HR	LBS/HR	KTS	KTS
0	30	25	94	630	1260	231	236	94	630	1260	232	237
2000	26	21	94	611	1222	228	241	94	610	1220	230	242
4000	23	17	94	593	1186	226	245	94	593	1186	227	247
6000	19	13	94	578	1156	224	250	94	577	1154	225	252
8000	15	9	94	565	1130	222	255	94	565	1130	223	257
10,000	11	5	89	535	1070	215	255	89	535	1070	217	257
12,000	7	1	86	507	1014	210	257	86	508	1016	211	259
14,000	3	-3	82	481	962	204	258	82	481	962	206	261
16,000	0	-7	78	454	908	198	259	78	455	910	200	262
18,000	-4	-11	74	428	856	191	259	74	428	856	194	262
20,000	-8	-15	70	404	808	185	258	70	404	808	187	262
22,000	-12	-19	65	380	760	178	257	66	381	762	181	262
24,000	-16	-23	61	357	714	170	256	61	357	714	174	261
26,000	-21	-27	57	333	666	163	253	57	334	668	167	259
28,000	-25	-30	53	311	622	155	250	53	312	624	159	257
29,000	-27	-32	51	300	600	150	248	51	301	602	156	256
31,000	-31	-36	46	279	558	142	242	47	280	560	148	253
33,000	-35	-40	43	258	516	132	235	43	259	518	140	248
35,000	-40	-44	38	237	474	119	223	39	239	478	131	242

BT058698

**NOTE**

During operations with ice vanes extended, torque will decrease approximately 12%, fuel flow will decrease approximately 8%, and true airspeed will be reduced by approximately 15 knots.

Figure 7A-56. Normal Cruise Power at 1500 RPM - ISA +10°C (Sheet 2 of 2)

**NORMAL CRUISE POWER  
1500 RPM  
ISA -30°C**

WEIGHT→			16,000 POUNDS					14,000 POUNDS				
PRESSURE ALTITUDE	IFAT	FAT	TORQUE PER ENGINE	FUEL FLOW PER ENGINE	TOTAL FUEL FLOW	IAS	TAS	TORQUE PER ENGINE	FUEL FLOW PER ENGINE	TOTAL FUEL FLOW	IAS	TAS
FEET	C°	C°	PERCENT	LBS/HR	LBS/HR	KTS	KTS	PERCENT	LBS/HR	LBS/HR	KTS	KTS
0	40	35	94	635	1270	226	235	94	635	1270	228	237
2000	36	31	94	615	1230	223	240	94	614	1228	225	241
4000	32	27	92	588	1176	219	242	92	588	1176	221	244
6000	29	23	88	557	1114	213	243	89	557	1114	215	245
8000	25	19	85	528	1056	207	244	85	528	1056	210	246
10,000	21	15	81	500	1000	202	244	82	500	1000	204	247
12,000	17	11	78	473	946	196	245	79	474	948	199	249
14,000	13	7	74	445	890	188	243	74	446	892	192	248
16,000	9	3	69	418	836	181	242	70	419	838	185	247
18,000	5	-1	65	393	786	173	240	66	394	788	178	246
20,000	1	-5	61	369	738	165	236	62	370	740	170	244
22,000	-4	-9	57	346	692	156	232	58	347	694	162	241
24,000	-8	-13	53	323	646	146	225	54	324	648	154	237
26,000	-12	-17	49	301	602	133	214	50	303	606	145	232
28,000	-16	-20	---	---	---	---	---	46	284	568	135	225
29,000	-18	-22	---	---	---	---	---	44	274	548	130	220
31,000	---	---	---	---	---	---	---	---	---	---	---	---
33,000	---	---	---	---	---	---	---	---	---	---	---	---
35,000	---	---	---	---	---	---	---	---	---	---	---	---

BT058895

**NOTE**

During operations with ice vanes extended, torque will decrease approximately 12%, fuel flow will decrease approximately 8%, and true airspeed will be reduced by approximately 15 knots.

Figure 7A-57. Normal Cruise Power at 1500 RPM - ISA +20°C (Sheet 1 of 2)

**NORMAL CRUISE POWER  
1500 RPM  
ISA -30°C**

WEIGHT→			12,000 POUNDS					10,000 POUNDS				
PRESSURE ALTITUDE	IFAT	FAT	TORQUE PER ENGINE	FUEL FLOW PER ENGINE	TOTAL FUEL FLOW	IAS	TAS	TORQUE PER ENGINE	FUEL FLOW PER ENGINE	TOTAL FUEL FLOW	IAS	TAS
FEET	C°	C°	PERCENT	LBS/HR	LBS/HR	KTS	KTS	PERCENT	LBS/HR	LBS/HR	KTS	KTS
0	40	35	94	634	1268	229	238	94	634	1268	230	240
2000	36	31	94	614	1228	227	243	94	614	1228	228	244
4000	33	27	92	588	1176	223	246	93	589	1178	224	248
6000	29	23	89	557	1114	217	247	89	557	1114	219	249
8000	25	19	85	528	1056	212	249	85	529	1058	214	251
10,000	21	15	82	500	1000	207	250	82	500	1000	208	252
12,000	17	11	79	474	948	201	252	79	475	950	203	254
14,000	13	7	74	446	892	195	251	74	446	892	197	254
16,000	9	3	70	420	840	188	251	70	420	840	190	254
18,000	5	-1	66	395	790	181	251	66	396	792	184	254
20,000	1	-5	62	371	742	174	249	62	371	742	178	254
22,000	-3	-9	58	348	696	167	248	58	349	698	171	253
24,000	-7	-13	54	325	650	160	245	54	326	652	164	252
26,000	-11	-17	50	304	608	152	243	51	305	610	157	250
28,000	-16	-20	47	286	572	144	239	47	287	574	150	248
29,000	-17	-22	45	276	552	140	237	46	278	556	147	247
31,000	-21	-26	42	257	514	131	230	42	259	518	139	244
33,000	-26	-30	38	237	474	119	219	39	220	440	121	231
35,000	-29	-34	---	---	---	---	---	35	220	440	121	231

BT058896

**NOTE**

During operations with ice vanes extended, torque will decrease approximately 12%, fuel flow will decrease approximately 8%, and true airspeed will be reduced by approximately 15 knots.

Figure 7A-57. Normal Cruise Power at 1500 RPM - ISA +20°C (Sheet 2 of 2)

**NORMAL CRUISE POWER  
1500 RPM  
ISA -30°C**

WEIGHT→			16,000 POUNDS					14,000 POUNDS				
PRESSURE ALTITUDE	IFAT	FAT	TORQUE PER ENGINE	FUEL FLOW PER ENGINE	TOTAL FUEL FLOW	IAS	TAS	TORQUE PER ENGINE	FUEL FLOW PER ENGINE	TOTAL FUEL FLOW	IAS	TAS
FEET	C°	C°	PERCENT	LBS/HR	LBS/HR	KTS	KTS	PERCENT	LBS/HR	LBS/HR	KTS	KTS
0	50	45	85	606	1212	216	229	85	606	1212	218	231
2000	46	41	83	577	1154	211	231	83	577	1154	214	233
4000	42	37	80	547	1094	206	232	80	547	1094	209	235
6000	38	33	77	518	1036	201	233	78	518	1036	203	236
8000	34	29	75	490	980	195	234	75	490	980	198	237
10,000	30	25	72	462	924	189	234	72	463	926	193	238
12,000	26	21	69	438	876	184	235	70	438	876	188	239
14,000	22	17	67	414	828	178	235	67	415	830	182	240
16,000	18	13	63	388	776	170	232	63	389	778	175	239
18,000	14	9	57	358	716	159	225	57	360	720	165	234
20,000	10	5	52	331	662	148	218	53	333	666	156	229
22,000	6	1	49	311	622	138	210	49	312	624	148	225
24,000	2	-3	---	---	---	---	---	46	292	584	139	219
26,000	-2	-7	---	---	---	---	---	43	274	548	130	213
28,000	---	---	---	---	---	---	---	---	---	---	---	---
29,000	---	---	---	---	---	---	---	---	---	---	---	---
31,000	---	---	---	---	---	---	---	---	---	---	---	---
33,000	---	---	---	---	---	---	---	---	---	---	---	---
35,000	---	---	---	---	---	---	---	---	---	---	---	---

BT058693

**NOTE**

During operations with ice vanes extended, torque will decrease approximately 12%, fuel flow will decrease approximately 8%, and true airspeed will be reduced by approximately 15 knots.

Figure 7A-58. Normal Cruise Power at 1500 RPM - ISA +300C (Sheet 1 of 2)

**NORMAL CRUISE POWER  
1500 RPM  
ISA -30°C**

WEIGHT→			12,000 POUNDS					10,000 POUNDS				
PRESSURE ALTITUDE	IFAT	FAT	TORQUE PER ENGINE	FUEL FLOW PER ENGINE	TOTAL FUEL FLOW	IAS	TAS	TORQUE PER ENGINE	FUEL FLOW PER ENGINE	TOTAL FUEL FLOW	IAS	TAS
FEET	C°	C°	PERCENT	LBS/HR	LBS/HR	KTS	KTS	PERCENT	LBS/HR	LBS/HR	KTS	KTS
0	50	45	86	606	1212	220	233	86	607	1214	221	234
2000	46	41	83	577	1154	216	235	84	577	1154	217	237
4000	42	37	81	548	1096	211	237	81	548	1096	212	239
6000	38	33	78	519	1038	206	238	78	1038	1038	208	240
8000	34	29	75	491	982	201	240	75	491	982	203	242
10,000	31	25	72	463	926	195	241	72	463	926	197	244
12,000	27	21	70	438	876	191	243	70	439	878	193	246
14,000	23	17	67	415	830	186	244	67	416	832	188	248
16,000	19	13	63	389	778	179	244	63	390	780	182	247
18,000	15	9	58	361	722	170	240	58	361	722	173	244
20,000	11	5	53	334	668	162	216	54	335	670	166	242
22,000	7	1	50	313	626	155	234	50	314	628	159	241
24,000	2	-3	46	293	586	147	231	47	293	586	152	239
26,000	-2	-7	44	275	550	140	228	44	276	552	146	238
28,000	-6	-10	41	261	522	133	225	42	262	524	140'	237
29,000	-8	-12	40	253	506	129	223	41	254	508	137	237
31,000	-12	-16	37	236	472	118	214	38	238	476	130	233
33,000	-16	-20	---	---	---	---	---	34	219	438	120	225
35,000	-20	-24	---	---	---	---	---	31	199	398	109	213

8T058094

**NOTE**

During operations with ice vanes extended, torque will decrease approximately 12%, fuel flow will decrease approximately 8%, and true airspeed will be reduced by approximately 15 knots.

Figure 7A-58. Normal Cruise Power at 1500 RPM - ISA +30°C (Sheet 2 of 2)

**NORMAL CRUISE POWER  
1500 RPM  
ISA -30°C**

WEIGHT→			16,000 POUNDS					14,000 POUNDS				
PRESSURE ALTITUDE	IFAT	FAT	TORQUE PER ENGINE	FUEL FLOW PER ENGINE	TOTAL FUEL FLOW	IAS	TAS	TORQUE PER ENGINE	FUEL FLOW PER ENGINE	TOTAL FUEL FLOW	IAS	TAS
FEET	C°	C°	PERCENT	LBS/HR	LBS/HR	KTS	KTS	PERCENT	LBS/HR	LBS/HR	KTS	KTS
0	56	52	76	582	1164	205	220	77	582	1164	208	223
2000	53	48	74	551	1102	201	222	75	551	1102	203	225
4000	49	44	72	521	1042	196	223	72	521	1042	199	226
6000	45	40	70	492	984	191	224	70	492	984	194	228
8000	41	36	67	465	930	186	225	67	465	930	189	229
10,000	37	32	65	439	878	180	226	65	439	878	184	230
12,000	33	28	63	415	830	175	226	63	416	832	179	232
14,000	29	24	61	392	784	169	226	61	393	786	174	232
16,000	25	20	57	367	734	161	223	57	367	734	167	231
18,000	21	16	52	338	676	150	216	53	339	678	158	226
20,000	16	12	47	309	618	137	204	48	311	622	147	219
22,000	13	8	---	---	---	---	---	44	290	580	138	212
24,000	8	4	---	---	---	---	---	40	270	540	126	202
26,000	---	---	---	---	---	---	---	---	---	---	---	---
28,000	---	---	---	---	---	---	---	---	---	---	---	---
29,000	---	---	---	---	---	---	---	---	---	---	---	---
31,000	---	---	---	---	---	---	---	---	---	---	---	---
33,000	---	---	---	---	---	---	---	---	---	---	---	---
35,000	---	---	---	---	---	---	---	---	---	---	---	---

BT05869

**NOTE**

During operations with ice vanes extended, torque will decrease approximately 12%, fuel flow will decrease approximately 8%, and true airspeed will be reduced by approximately 15 knots.

Figure 7A-59. Normal Cruise Power at 1500 RPM - ISA +370C (Sheet 1 of 2)



**NORMAL CRUISE POWER  
1500 RPM  
ISA -30°C**

WEIGHT→			12,000 POUNDS					10,000 POUNDS				
PRESSURE ALTITUDE	IFAT	FAT	TORQUE PER ENGINE	FUEL FLOW PER ENGINE	TOTAL FUEL FLOW	IAS	TAS	TORQUE PER ENGINE	FUEL FLOW PER ENGINE	TOTAL FUEL FLOW	IAS	TAS
FEET	C°	C°	PERCENT	LBS/HR	LBS/HR	KTS	KTS	PERCENT	LBS/HR	LBS/HR	KTS	KTS
0	57	52	77	582	1164	210	225	77	582	1164	212	227
2000	53	48	75	551	1102	206	227	75	552	1104	208	229
4000	49	44	73	521	1042	201	229	73	521	1042	203	231
6000	45	40	70	492	984	197	231	70	492	984	199	233
8000	41	36	68	465	930	192	233	68	465	930	194	235
10,000	37	32	65	439	878	187	234	66	440	880	190	237
12,000	33	28	63	416	832	183	236	64	416	832	185	239
14,000	29	24	61	393	786	178	237	61	393	786	181	241
16,000	26	20	58	368	736	171	237	58	368	736	175	241
18,000	21	16	53	340	680	163	233	54	341	682	167	239
20,000	17	12	49	313	626	154	229	49	314	628	159	235
22,000	13	8	45	292	584	146	224	45	293	586	152	233
24,000	9	4	41	271	542	137	219	42	272	544	144	229
26,000	5	0	39	255	510	129	215	39	255	510	137	227
28,000	1	-3	37	243	486	122	212	38	244	488	132	227
29,000	-1	-5	36	236	472	118	209	37	237	474	129	227
31,000	-5	-9	34	222	444	122	223	34	222	444	122	223
33,000	-9	-13	---	---	---	---	---	31	204	408	111	213
35,000	---	---	---	---	---	---	---	---	---	---	---	---

BT058692

**NOTE**

During operations with ice vanes extended, torque will decrease approximately 12%, fuel flow will decrease approximately 8%, and true airspeed will be reduced by approximately 15 knots.

Figure 7A-59. Normal Cruise Power at 1500 RPM - ISA +370C (Sheet 2 of 2)

**NORMAL CRUISE SPEEDS**

**1500 RPM**

**WEIGHT: 14,000 LBS**

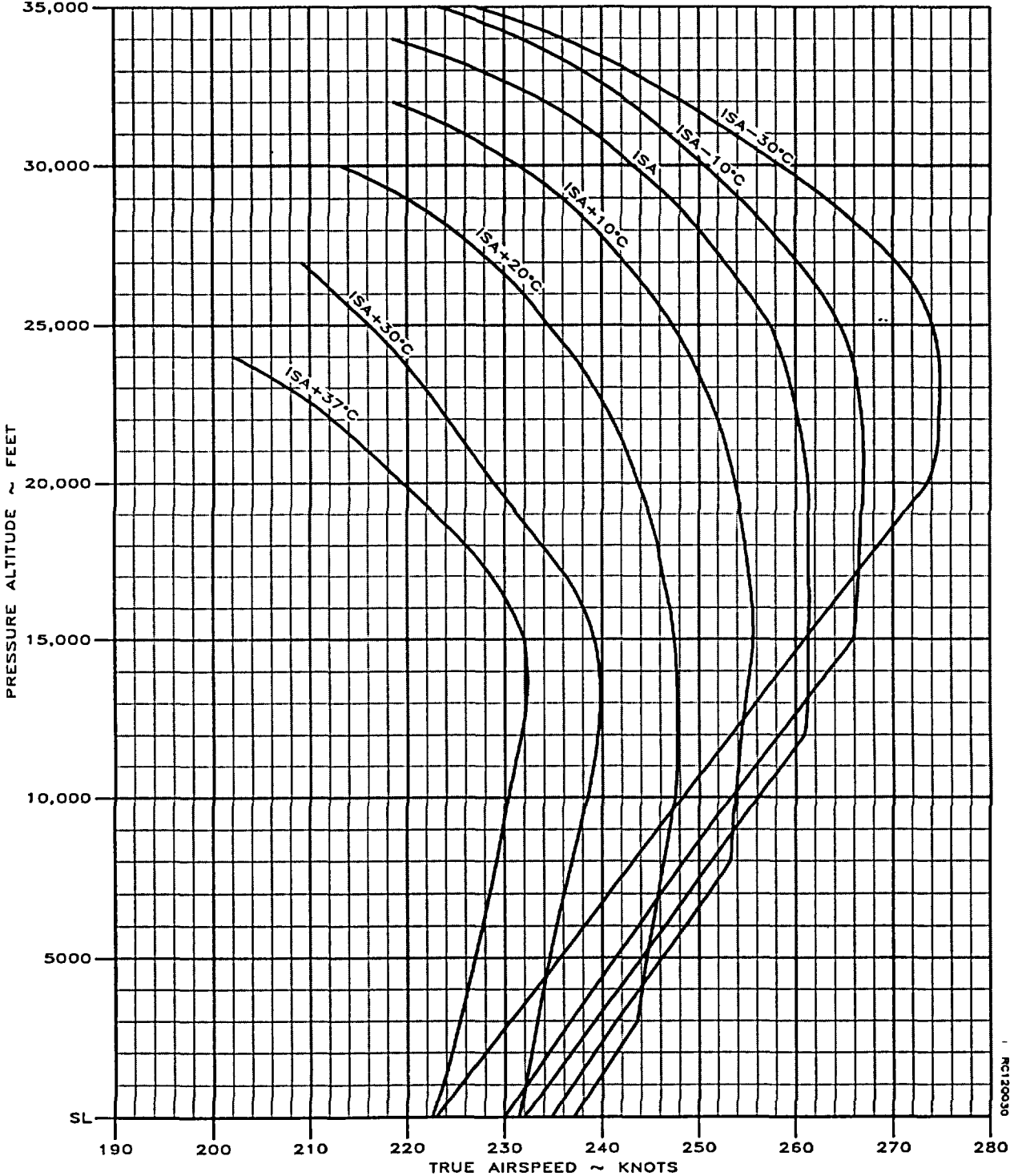

Figure 7A-60. Normal Cruise Speeds at 1500 RPM

NORMAL CRUISE POWER  
1500 RPM  
WEIGHT: 14,000 LBS

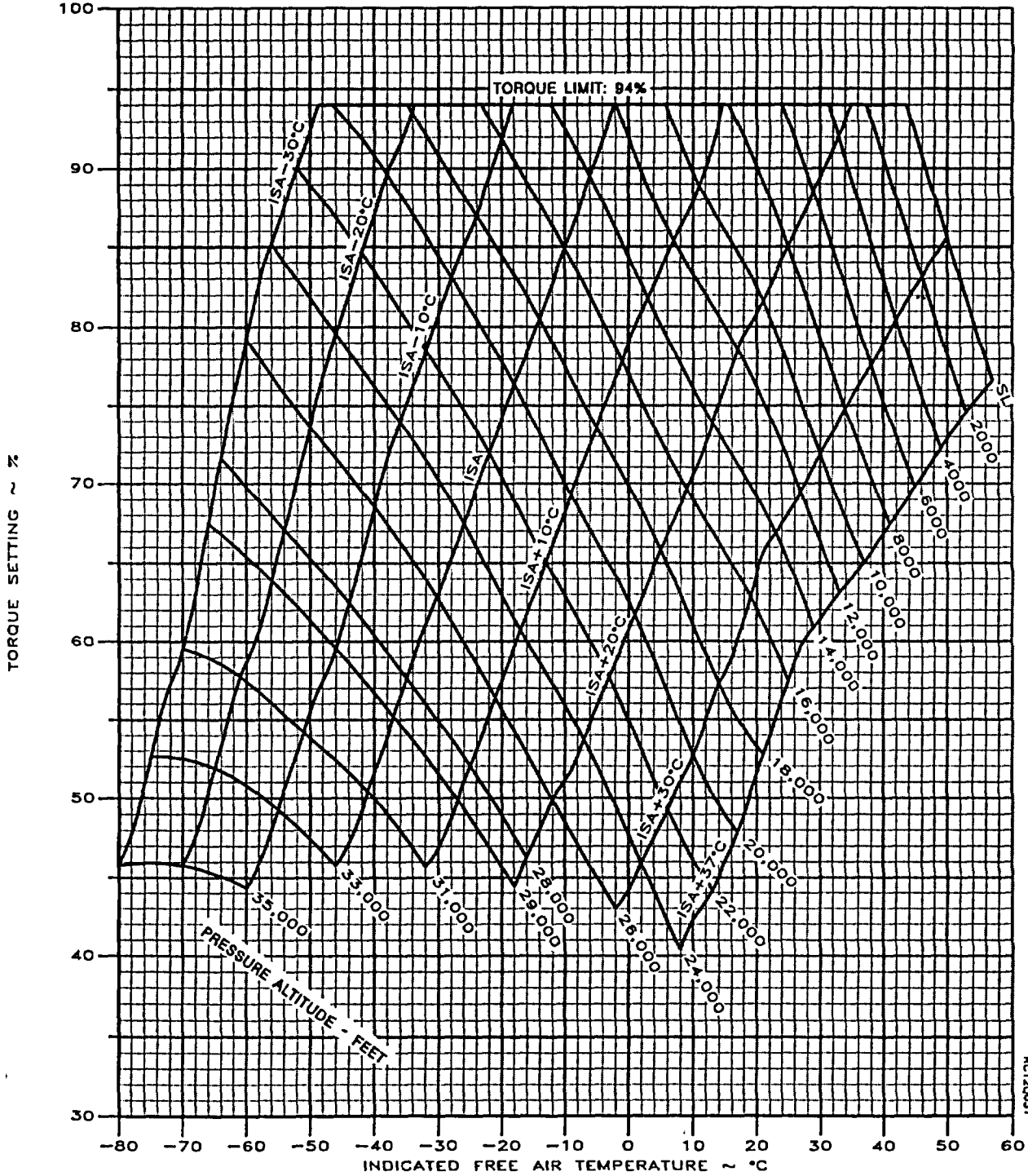

Figure 7A-61. Normal Cruise Power at 1500 RPM

FUEL FLOW AT NORMAL CRUISE POWER  
11500 RPM i  
WEIGHT: 14,000 LBS

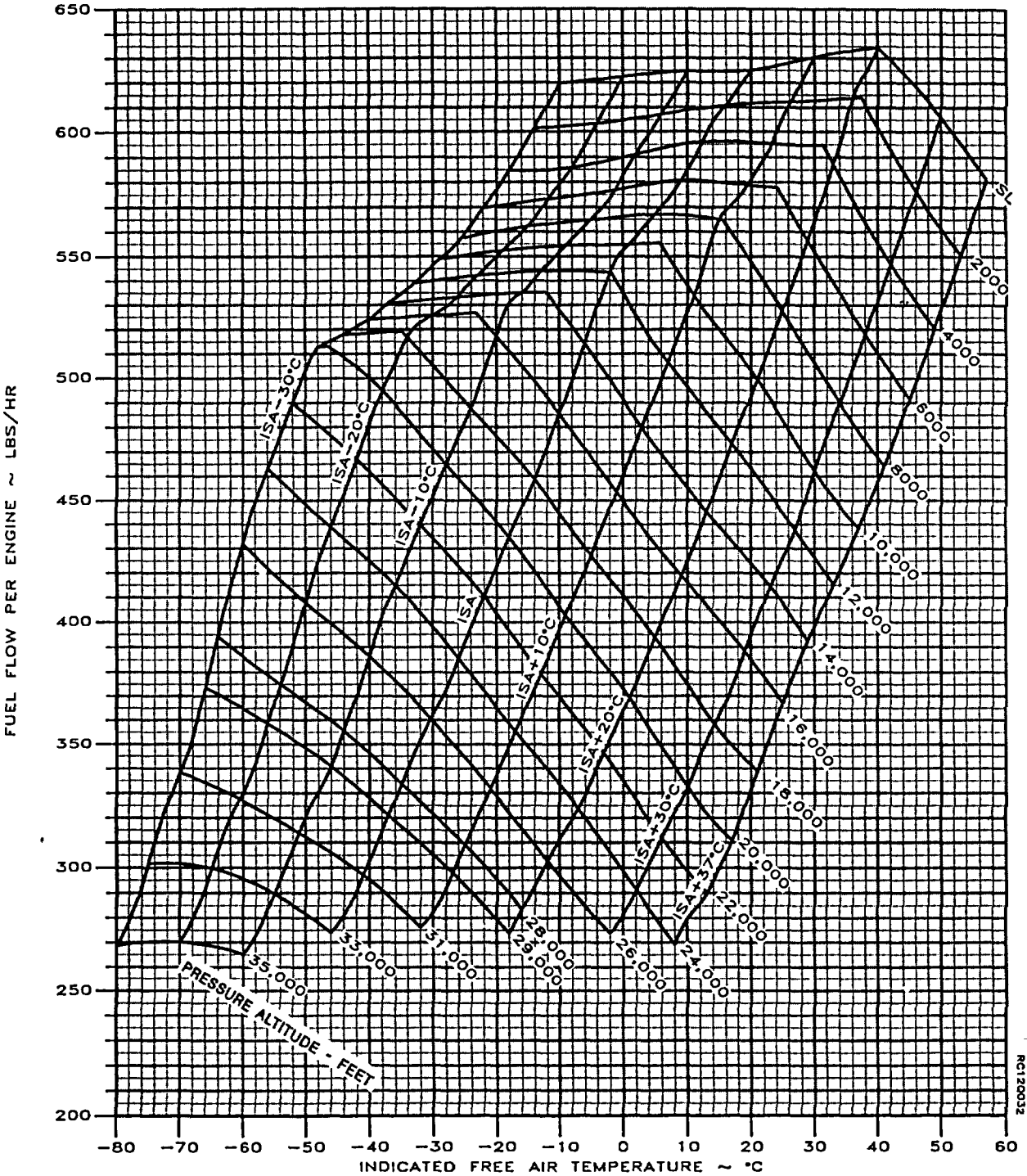

Figure 7A-62. Fuel Flow at Normal Cruise Power at 1500 RPM

**RANGE PROFILE - NORMAL CRUISE POWER**

ASSOCIATED CONDITIONS:

WEIGHT ..... \*16,620 LBS BEFORE  
ENGINE START  
FUEL ..... AVIATION KEROSENE  
FUEL DENSITY ..... 6.7 LBS/GAL  
ICE VANES ..... RETRACTED

1500 RPM

STANDARD DAY (ISA)  
ZERO WIND

EXAMPLE:

PRESSURE ALTITUDE ..... 26000 FT  
FUEL ..... 2572 LBS  
RANGE ..... 637 NM

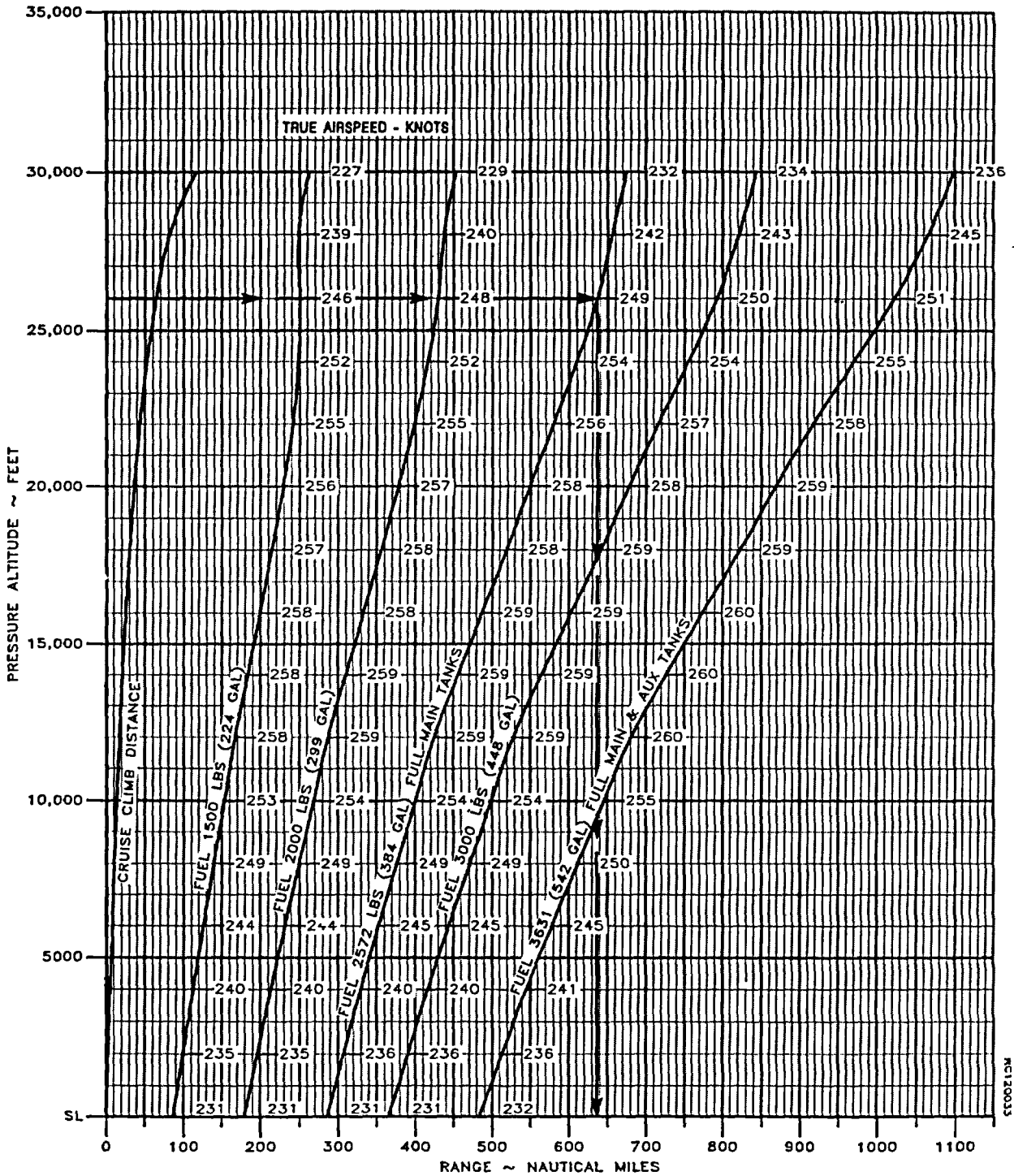

Figure 7A-63. Range Profile - Normal Cruise Power at 1500 RPM

**NORMAL CRUISE POWER  
1500 RPM  
ISA -30°C**

WEIGHT→			16,000 POUNDS					14,000 POUNDS				
PRESSURE ALTITUDE	IFAT	FAT	TORQUE PER ENGINE	FUEL FLOW PER ENGINE	TOTAL FUEL FLOW	IAS	TAS	TORQUE PER ENGINE	FUEL FLOW PER ENGINE	TOTAL FUEL FLOW	IAS	TAS
FEET	C°	C°	PERCENT	LBS/HR	LBS/HR	KTS	KTS	PERCENT	LBS/HR	LBS/HR	KTS	KTS
0	-11	-15	76	556	1112	212	203	71	537	1074	208	199
2000	-15	-19	72	521	1042	205	202	68	504	1008	202	199
4000	-19	-23	68	486	972	198	200	64	472	944	196	198
6000	-23	-27	64	455	910	192	200	61	441	882	190	198
8000	-27	-31	61	425	850	185	198	57	410	820	183	196
10,000	-31	-35	58	399	798	179	198	54	383	766	176	195
12,000	-35	-39	57	379	758	175	199	51	358	716	170	194
14,000	-39	-43	56	363	726	171	202	49	337	674	165	195
16,000	-43	-47	55	350	700	168	204	47	318	636	160	195
18,000	-47	-51	54	338	676	165	207	46	302	604	155	195
20,000	-51	-55	53	327	654	161	208	45	290	580	151	197
22,000	-54	-59	53	322	644	159	213	45	287	574	150	202
24,000	-58	-63	54	318	636	157	217	46	284	568	150	207
26,000	-62	-67	53	313	626	155	221	47	283	566	149	213
28,000	-66	-70	51	299	598	147	217	47	280	560	147	218
29,000	-68	-72	52	302	604	147	221	46	273	546	144	217
31,000	-71	-76	55	315	630	150	233	45	266	532	138	217
33,000	-76	-80	---	---	---	---	---	46	273	546	139	225
35,000	---	---	---	---	---	---	---	---	---	---	---	---

BT0687115

**NOTE**

During operations with ice vanes extended, torque will decrease approximately 10%, fuel flow will decrease approximately 5%, and true airspeed will be reduced by approximately 10 knots.

Figure 7A-64. Maximum Range Power at 1500 RPM - ISA -30°C (Sheet 1 of 2)

**NORMAL CRUISE POWER  
1500 RPM  
ISA -30°C**

WEIGHT→			12,000 POUNDS					10,000 POUNDS				
PRESSURE ALTITUDE	IFAT	FAT	TORQUE PER ENGINE	FUEL FLOW PER ENGINE	TOTAL FUEL FLOW	IAS	TAS	TORQUE PER ENGINE	FUEL FLOW PER ENGINE	TOTAL FUEL FLOW	IAS	TAS
FEET	C°	C°	PERCENT	LBS/HR	LBS/HR	KTS	KTS	PERCENT	LBS/HR	LBS/HR	KTS	KTS
0	-11	-15	67	522	1044	205	196	64	509	1018	202	193
2000	-15	-19	64	491	982	200	197	61	479	958	198	195
4000	-19	-23	61	460	920	194	197	59	449	898	193	195
6000	-23	-27	58	430	860	189	197	56	421	842	188	196
8000	-27	-31	55	402	804	183	196	53	393	786	182	196
10,000	-31	-35	52	374	748	177	195	50	366	732	176	195
12,000	-35	-39	49	349	698	171	195	47	341	682	171	195
14,000	-39	-43	47	326	652	165	194	45	319	638	166	195
16,000	-43	-47	44	304	608	159	194	43	298	596	161	195
18,000	-47	-51	42	286	572	154	193	41	280	560	156	196
20,000	-51	-55	40	270	540	149	193	39	263	526	151	196
22,000	-55	-59	38	254	508	142	191	37	247	494	145	195
24,000	-59	-63	38	247	494	139	194	34	231	462	138	192
26,000	-63	-67	39	246	492	139	200	32	216	432	131	189
28,000	-66	-70	40	248	496	140	208	32	213	426	129	193
29,000	-68	-72	40	248	496	140	212	33	212	424	129	196
31,000	-72	-76	40	242	484	137	215	33	210	420	128	202
33,000	-76	-80	38	231	462	130	211	33	209	418	128	208
35,000	-80	-84	38	233	466	129	217	32	202	404	124	209

BT05871168

**NOTE**

During operations with ice vanes extended, torque will decrease approximately 10%, fuel flow will decrease approximately 5%, and true airspeed will be reduced by approximately 10 knots.

Figure 7A-64. Maximum Range Power at 1500 RPM - ISA -300C (Sheet 2 of 2)

**NORMAL CRUISE POWER  
1500 RPM  
ISA -30°C**

WEIGHT→			16,000 POUNDS					14,000 POUNDS				
PRESSURE ALTITUDE	IFAT	FAT	TORQUE PER ENGINE	FUEL FLOW PER ENGINE	TOTAL FUEL FLOW	IAS	TAS	TORQUE PER ENGINE	FUEL FLOW PER ENGINE	TOTAL FUEL FLOW	IAS	TAS
FEET	C°	C°	PERCENT	LBS/HR	LBS/HR	KTS	KTS	PERCENT	LBS/HR	LBS/HR	KTS	KTS
0	-1	-5	86	594	1188	222	216	78	565	1130	214	209
2000	-5	-9	80	555	1110	214	214	73	529	1058	207	208
4000	-9	-13	76	518	1036	206	213	69	494	988	201	207
6000	-13	-17	72	486	972	200	212	65	461	922	194	206
8000	-17	-21	68	457	914	194	212	61	429	858	187	204
10,000	-21	-25	65	429	858	187	211	58	400	800	180	203
12,000	-25	-29	62	404	808	182	211	55	375	750	174	203
14,000	-29	-33	60	383	766	177	212	53	354	708	169	203
16,000	-32	-37	59	367	734	172	214	51	336	672	165	205
18,000	-36	-41	58	353	706	168	216	50	322	644	161	206
20,000	-40	-45	56	340	680	164	217	49	310	620	157	209
22,000	-44	-49	56	332	664	161	220	49	302	604	155	212
24,000	-48	-53	54	322	644	157	222	48	295	590	152	215
26,000	-52	-57	52	307	614	149	218	48	290	580	150	219
28,000	-56	-60	52	306	612	146	222	47	279	558	144	219
29,000	-58	-52	54	313	626	148	228	45	271	542	140	217
31,000	-62	-66	---	---	---	---	---	45	270	540	137	220
33,000	-65	-70	---	---	---	---	---	48	282	564	140	232
35,000	---	---	---	---	---	---	---	---	---	---	---	---

BT0587113

**NOTE**

During operations with ice vanes extended, torque will decrease approximately 10%, fuel flow will decrease approximately 5%, and true airspeed will be reduced by approximately 10 knots.

Figure 7A-65. Maximum Range Power at 1500 RPM - ISA -20°C (Sheet 1 of 2)



**NORMAL CRUISE POWER  
1500 RPM  
ISA -30°C**

WEIGHT→			12,000 POUNDS					10,000 POUNDS				
PRESSURE ALTITUDE	IFAT	FAT	TORQUE PER ENGINE	FUEL FLOW PER ENGINE	TOTAL FUEL FLOW	IAS	TAS	TORQUE PER ENGINE	FUEL FLOW PER ENGINE	TOTAL FUEL FLOW	IAS	TAS
FEET	C°	C°	PERCENT	LBS/HR	LBS/HR	KTS	KTS	PERCENT	LBS/HR	LBS/HR	KTS	KTS
0	-1	-5	67	527	1054	203	198	59	499	998	195	190
2000	-5	-9	64	496	992	198	198	57	471	942	191	191
4000	-9	-13	61	466	932	192	199	55	443	886	186	192
6000	-13	-17	58	436	872	187	199	53	416	832	182	193
8000	-17	-21	55	407	814	181	198	51	390	780	177	194
10,000	-21	-25	52	378	756	174	197	48	364	728	172	194
12,000	-25	-29	49	352	704	169	197	46	339	678	166	194
14,000	-29	-33	46	328	656	162	196	43	315	630	161	194
16,000	-33	-37	44	307	614	157	195	41	294	588	155	194
18,000	-37	-41	42	289	578	152	195	39	277	554	151	194
20,000	-41	-45	41	275	550	147	196	37	260	520	146	194
22,00G	-45	-49	41	269	538	146	200	35	244	488	140	192
24,000	-49	-53	41	263	526	144	205	34	231	462	135	192
26,000	-52	-57	41	258	516	142	209	33	224	448	132	195
28,000	-56	-60	41	254	508	141	214	33	219	438	130	199
29,000	-58	-62	41	251	502	140	216	33	217	434	129	202
31,000	-62	-66	40	244	488	135	218	34	215	430	129	208
33,000	-66	-70	38	232	464	128	214	34	213	426	128	214
35,000	-70	-74	39	238	476	128	221	33	204	408	123	213

BT0587114

**NOTE**

During operations with ice vanes extended, torque will decrease approximately 10%, fuel flow will decrease approximately 5%, and true airspeed will be reduced by approximately 10 knots.

Figure 7A-65. Maximum Range Power at 1500 RPM - ISA -20°C (Sheet 2 of 2)

**NORMAL CRUISE POWER  
1500 RPM  
ISA -30°C**

WEIGHT→			16,000 POUNDS					14,000 POUNDS				
PRESSURE ALTITUDE	IFAT	FAT	TORQUE PER ENGINE	FUEL FLOW PER ENGINE	TOTAL FUEL FLOW	IAS	TAS	TORQUE PER ENGINE	FUEL FLOW PER ENGINE	TOTAL FUEL FLOW	IAS	TAS
FEET	C°	C°	PERCENT	LBS/HR	LBS/HR	KTS	KTS	PERCENT	LBS/HR	LBS/HR	KTS	KTS
0	10	5	93	622	1244	229	226	89	609	1218	226	224
2000	6	1	87	582	1164	221	225	83	566	1132	226	224
4000	2	-3	82	545	1090	213	224	77	526	1052	209	222
6000	-2	-7	77	509	1018	206	223	72	490	980	202	218
8000	-6	-11	73	478	956	199	222	68	457	914	194	217
10,000	-10	-15	70	449	898	193	221	64	427	854	188	216
12,000	-14	-19	67	422	844	187	221	61	399	798	182	215
14,000	-18	-23	64	400	800	181	222	58	376	752	176	216
16,000	-22	-27	62	379	758	176	222	56	356	712	171	216
18,000	-26	-31	60	362	724	171	223	54	337	674	165	216
20,000	-30	-35	58	347	694	165	223	52	324	648	161	218
22,000	-34	-39	55	331	662	158	222	51	313	626	158	220
24,000	-38	-43	52	314	628	150	218	50	301	602	153	222
26,000	-42	-47	51	307	614	145	218	47	287	574	146	220
28,000	-46	-50	54	318	636	148	229	44	271	542	148	215
29,000	-47	-52	56	324	648	149	235	45	272	544	137	217
31,000	-52	-56	---	---	---	---	---	47	281	562	139	227
33,000	---	---	---	---	---	---	---	---	---	---	---	---
35,000	---	---	---	---	---	---	---	---	---	---	---	---

BT0587111

**NOTE**

During operations with ice vanes extended, torque will decrease approximately 10%, fuel flow will decrease approximately 5%, and true airspeed will be reduced by approximately 10 knots.

Figure 7A-66. Maximum Range Power at 1500 RPM - ISA -10°C (Sheet 1 of 2)

**NORMAL CRUISE POWER  
1500 RPM  
ISA -30°C**

WEIGHT→			12,000 POUNDS					10,000 POUNDS				
PRESSURE ALTITUDE	IFAT	FAT	TORQUE PER ENGINE	FUEL FLOW PER ENGINE	TOTAL FUEL FLOW	IAS	TAS	TORQUE PER ENGINE	FUEL FLOW PER ENGINE	TOTAL FUEL FLOW	IAS	TAS
FEET	C°	C°	PERCENT	LBS/HR	LBS/HR	KTS	KTS	PERCENT	LBS/HR	LBS/HR	KTS	KTS
0	9	5	79	575	1150	217	215	54	488	976	187	185
2000	5	1	76	542	1084	211	215	58	481	962	191	195
4000	1	-3	72	507	1014	205	215	58	458	916	189	199
6000	-3	-7	66	469	938	197	213	56	431	862	184	200
8000	-7	-11	62	435	870	189	211	53	404	808	179	200
10,000	-11	-15	58	403	806	182	209	50	376	752	173	200
12,000	-15	-19	54	375	750	175	208	47	349	698	167	199
14,000	-19	-23	51	350	700	169	208	45	324	648	161	198
16,000	-23	-27	49	329	658	164	208	42	301	602	155	197
18,000	-27	-31	47	309	618	158	207	39	280	560	149	196
20,000	-31	-35	45	295	590	154	208	37	263	526	144	196
22,000	-34	-39	45	285	570	151	212	37	253	506	141	199
24,000	-38	-43	44	276	552	148	214	36	245	490	139	202
26,000	-42	-47	43	266	532	145	217	36	236	472	136	205
28,000	-46	-50	42	257	514	141	219	36	230	460	134	209
29,000	-48	-52	41	251	502	138	218	35	227	454	133	212
31,000	-52	-56	38	238	476	130	214	35	221	442	130	215
33,000	-56	-60	38	237	474	127	217	34	215	430	127	217
35,000	-60	-64	40	244	488	128	227	32	203	406	119	213

BT0587112

**NOTE**

During operations with ice vanes extended, torque will decrease approximately 10%, fuel flow will decrease approximately 5%, and true airspeed will be reduced by approximately 10 knots.

Figure 7A-66. Maximum Range Power at 1500 RPM - ISA -10°C (Sheet 2 of 2)

**NORMAL CRUISE POWER  
1500 RPM  
ISA -30°C**

WEIGHT→			16,000 POUNDS					14,000 POUNDS				
PRESSURE ALTITUDE	IFAT	FAT	TORQUE PER ENGINE	FUEL FLOW PER ENGINE	TOTAL FUEL FLOW	IAS	TAS	TORQUE PER ENGINE	FUEL FLOW PER ENGINE	TOTAL FUEL FLOW	IAS	TAS
FEET	C°	C°	PERCENT	LBS/HR	LBS/HR	KTS	KTS	PERCENT	LBS/HR	LBS/HR	KTS	KTS
0	20	15	89	607	1214	223	225	88	602	1204	224	226
2000	16	11	84	572	1144	216	224	82	566	1132	216	224
4000	12	7	80	539	1078	209	224	78	534	1068	210	225
6000	8	3	76	507	1014	203	223	74	500	1000	204	224
8000	4	-1	72	477	954	197	224	71	469	938	197	224
10,000	0	-5	69	448	896	190	223	67	441	882	192	224
12,000	-4	-9	66	422	844	184	223	64	412	824	185	223
14,000	-8	-13	63	396	792	178	222	61	387	774	179	223
16,000	-12	-17	60	373	746	171	221	58	365	730	173	224
18,000	-16	-21	57	353	706	165	220	55	344	688	167	223
20,000	-20	-25	54	334	668	157	217	53	327	654	161	223
22,000	-24	-29	52	320	640	151	216	50	310	620	154	221
24,000	-28	-33	53	319	638	149	221	47	292	584	147	217
26,000	-32	-37	55	325	650	150	229	45	279	558	140	215
28,000	-36	-40	---	---	---	---	---	46	281	562	139	221
29,000	-38	-42	---	---	---	---	---	47	284	568	139	225
31,000	-41	-46	---	---	---	---	---	49	291	582	140	235
33,000	---	---	---	---	---	---	---	---	---	---	---	---
35,000	---	---	---	---	---	---	---	---	---	---	---	---

BT058719

**NOTE**

During operations with ice vanes extended, torque will decrease approximately 10%, fuel flow will decrease approximately 5%, and true airspeed will be reduced by approximately 10 knots.

Figure 7A-67. Maximum Range Power at 1500 RPM - ISA (Sheet 1 of 2)

**NORMAL CRUISE POWER  
1500 RPM  
ISA -30°C**

WEIGHT→			12,000 POUNDS					10,000 POUNDS				
PRESSURE ALTITUDE	IFAT	FAT	TORQUE PER ENGINE	FUEL FLOW PER ENGINE	TOTAL FUEL FLOW	IAS	TAS	TORQUE PER ENGINE	FUEL FLOW PER ENGINE	TOTAL FUEL FLOW	IAS	TAS
FEET	C°	C°	PERCENT	LBS/HR	LBS/HR	KTS	KTS	PERCENT	LBS/HR	LBS/HR	KTS	KTS
0	20	15	86	594	1188	223	225	75	556	1112	212	214
2000	16	11	81	559	1118	216	224	73	533	1066	209	217
4000	12	7	77	527	1054	210	225	71	508	1016	206	220
6000	8	3	72	491	982	203	223	68	475	950	199	220
8000	4	-1	68	459	918	196	223	63	440	880	191	217
10,000	0	-5	63	425	850	188	221	58	406	812	183	215
12,000	-4	-9	59	395	790	181	220	54	375	750	176	213
14,000	-8	-13	56	369	738	175	219	50	347	694	169	212
16,000	-12	-17	53	346	692	169	219	47	323	646	163	211
18,000	-16	-21	51	327	654	164	219	45	302	604	157	211
20,000	-20	-25	49	309	618	159	220	42	284	568	152	210
22,00C	-24	-29	47	296	592'	154	221	41	270	540	147	211
24,000	-28	-33	45	282	564	150	222	39	257	514	143	213
26,000	-32	-37	43	267	534	143	220	38	246	492	140	215
28,000	-36	-40	40	252	504	136	217	37	237	474	136	217
29,000	-38	-42	39	246	492	132	215	36	232	464	134	218
31,000	-42	-46	39	241	482	128	217	35	221	442	128	217
33,000	-46	-50	40	245	490	128	224	33	209	418	122	214
35,000	-49	-54	42	252	504	129	234	32	201	402	116	213

BT0587110

**NOTE**

During operations with ice vanes extended, torque will decrease approximately 10%, fuel flow will decrease approximately 5%, and true airspeed will be reduced by approximately 10 knots.

Figure 7A-67. Maximum Range Power at 1500 RPM - ISA (Sheet 2 of 2)

**NORMAL CRUISE POWER  
1500 RPM  
ISA -30°C**

WEIGHT→			16,000 POUNDS					14,000 POUNDS				
PRESSURE ALTITUDE	IFAT	FAT	TORQUE PER ENGINE	FUEL FLOW PER ENGINE	TOTAL FUEL FLOW	IAS	TAS	TORQUE PER ENGINE	FUEL FLOW PER ENGINE	TOTAL FUEL FLOW	IAS	TAS
FEET	C°	C°	PERCENT	LBS/HR	LBS/HR	KTS	KTS	PERCENT	LBS/HR	LBS/HR	KTS	KTS
0	30	25	83	592	1184	216	221	82	588	1176	217	222
2000	26	21	79	555	1110	209	221	78	553	1106	211	222
4000	22	17	75	522	1044	203	221	74	517	1034	204	222
6000	18	13	71	489	978	196	220	71	486	972	198	223
8000	14	9	68	461	922	190	220	67	457	914	192	222
10,000	10	5	64	432	864	182	217	63	427	854	184	220
12,000	6	1	61	405	810	175	217	60	401	802	178	220
14,000	2	-3	59	383	766	170	217	57	377	754	173	220
16,000	-2	-7	56	360	720	163	215	55	355	710	167	220
18,000	-6	-11	54	344	688	158	215	52	332	664	160	218
20,000	-10	-15	54	336	672	155	218	49	314	628	153	216
22,000	-14	-19	55	334	668	153	223	47	299	598	147	215
24,000	-18	-23	56	336	672	153	230	46	291	582	143	217
26,000	-22	-27	---	---	---	---	---	47	291	582	142	222
28,000	-26	-30	---	---	---	---	---	49	294	588	142	230
29,000	---	---	---	---	---	---	---	---	---	---	---	---
31,000	---	---	---	---	---	---	---	---	---	---	---	---
33,000	---	---	---	---	---	---	---	---	---	---	---	---
35,000	---	---	---	---	---	---	---	---	---	---	---	---

BT058717

**NOTE**

During operations with ice vanes extended, torque will decrease approximately 10%, fuel flow will decrease approximately 5%, and true airspeed will be reduced by approximately 10 knots.

Figure 7A-68. Maximum Range Power at 1500 RPM - ISA +10°C (Sheet 1 of 2)

**MAXIMUM RANGE POWER  
1500 RPM  
ISA +10°C**

WEIGHT→			12,000 POUNDS					10,000 POUNDS				
PRESSURE ALTITUDE	IFAT	FAT	TORQUE PER ENGINE	FUEL FLOW PER ENGINE	TOTAL FUEL FLOW	IAS	TAS	TORQUE PER ENGINE	FUEL FLOW PER ENGINE	TOTAL FUEL FLOW	IAS	TAS
FEET	°C	°C	PERCENT	LBS/HR	LBS/HR	KTS	KTS	PERCENT	LBS/HR	LBS/HR	KTS	KTS
0	30	25	81	583	1166	217	223	80	578	1156	217	223
2000	26	21	77	547	1094	211	223	76	543	1086	211	223
4000	22	17	73	513	1026	205	223	72	507	1014	205	223
6000	18	13	70	481	962	199	223	68	474	948	199	223
8000	14	9	66	452	904	193	223	65	446	892	193	224
10,000	10	5	62	422	844	186	222	60	416	832	186	222
12,000	6	1	59	396	792	180	222	57	388	776	180	222
14,000	2	-3	56	372	744	175	223	54	362	724	174	222
16,000	-2	-7	54	349	698	169	223	51	338	676	168	221
18,000	-6	-11	51	327	654	163	222	48	316	632	162	221
20,000	-10	-15	48	308	616	156	221	46	297	594	157	221
22,000	-14	-19	45	289	578	150	219	43	280	560	151	221
24,000	-18	-23	42	271	542	143	216	40	262	524	145	219
26,000	-22	-27	40	255	510	135	213	38	246	492	139	218
28,000	-26	-30	39	247	494	131	213	36	232	464	132	216
29,000	-28	-32	39	248	496	130	217	35	225	450	129	214
31,000	-32	-36	40	249	498	129	223	33	214	428	123	213
33,000	-36	-40	---	---	---	---	---	32	208	416	118	213
35,000	-40	-44	---	---	---	---	---	33	209	418	117	219

BT058718

**NOTE**

**During operations with ice vanes extended, torque will decrease approximately 10%, fuel flow will decrease approximately 5%, and true airspeed will be reduced by approximately 10 knots.**

Figure 7A-68. Maximum Range Power at 1500 RPM - ISA +10°C (Sheet 2 of 2)

**MAXIMUM RANGE POWER  
1500 RPM  
ISA +20°C**

WEIGHT→			16,000 POUNDS					14,000 POUNDS				
PRESSURE ALTITUDE	IFAT	FAT	TORQUE PER ENGINE	FUEL FLOW PER ENGINE	TOTAL FUEL FLOW	IAS	TAS	TORQUE PER ENGINE	FUEL FLOW PER ENGINE	TOTAL FUEL FLOW	IAS	TAS
FEET	°C	°C	PERCENT	LBS/HR	LBS/HR	KTS	KTS	PERCENT	LBS/HR	LBS/HR	KTS	KTS
0	40	35	82	594	1188	213	222	78	580	1160	211	220
2000	36	31	77	553	1106	205	220	74	544	1088	205	220
4000	32	27	72	516	1032	198	219	70	507	1014	198	219
6000	28	23	69	485	970	192	219	66	473	946	191	218
8000	24	19	65	452	904	184	217	62	441	882	184	217
10,000	20	15	62	423	846	178	216	59	412	824	178	217
12,000	16	11	59	398	796	172	216	57	388	776	173	217
14,000	12	7	58	385	770	168	218	54	364	728	166	215
16,000	8	3	58	373	746	165	221	51	344	688	159	214
18,000	4	-1	58	362	724	162	225	49	327	654	155	215
20,000	0	-5	58	356	712	160	230	49	318	636	152	218
22,000	-4	-9	---	---	---	---	---	49	311	622	149	222
24,000	-8	-13	---	---	---	---	---	50	306	612	147	227
26,000	---	---	---	---	---	---	---	---	---	---	---	---
28,000	---	---	---	---	---	---	---	---	---	---	---	---
29,000	---	---	---	---	---	---	---	---	---	---	---	---
31,000	---	---	---	---	---	---	---	---	---	---	---	---
33,000	---	---	---	---	---	---	---	---	---	---	---	---
35,000	---	---	---	---	---	---	---	---	---	---	---	---

BT058715

**NOTE**

During operations with ice vanes extended, torque will decrease approximately 10%, fuel flow will decrease approximately 5%, and true airspeed will be reduced by approximately 10 knots.

*Figure 7A-69. Maximum Range Power at 1500 RPM - ISA +20°C (Sheet 1 of 2)*



**MAXIMUM RANGE POWER  
1500 RPM  
ISA +20°C**

WEIGHT→			12,000 POUNDS					10,000 POUNDS				
PRESSURE ALTITUDE	IFAT	FAT	TORQUE PER ENGINE	FUEL FLOW PER ENGINE	TOTAL FUEL FLOW	IAS	TAS	TORQUE PER ENGINE	FUEL FLOW PER ENGINE	TOTAL FUEL FLOW	IAS	TAS
FEET	°C	°C	PERCENT	LBS/HR	LBS/HR	KTS	KTS	PERCENT	LBS/HR	LBS/HR	KTS	KTS
0	39	35	76	574	1148	211	220	74	567	1134	211	220
2000	36	31	72	536	1072	204	220	70	530	1060	205	220
4000	32	27	68	501	1002	198	219	67	496	992	199	220
6000	28	23	65	468	936	192	220	64	464	928	193	220
8000	24	19	62	438	876	186	220	60	433	866	187	221
10,000	20	15	58	408	816	180	219	57	404	808	181	221
12,000	16	11	56	384	768	175	220	55	378	756	176	221
14,000	12	7	52	357	714	167	217	51	355	710	170	221
16,000	8	3	49	336	672	161	217	48	331	662	163	219
18,000	4	-1	46	313	626	154	215	45	308	616	157	218
20,000	0	-5	44	295	590	148	214	42	287	574	151	217
22,000	-4	-9	42	279	558	142	213	40	270	540	145	216
24,000	-8	-13	41	269	538	139	215	38	254	508	139	215
26,000	-12	-17	41	262	524	136	218	35	237	474	132	212
28,000	-16	-20	41	258	516	133	221	33	223	446	126	210
29,000	-18	-22	41	257	514	132	224	33	218	436	123	210
31,000	-22	-26	---	---	---	---	---	33	214	428	120	213
33,000	-26	-30	---	---	---	---	---	33	215	430	120	220
35,000	-29	-34	---	---	---	---	---	34	217	434	120	228

BT058716

**NOTE**

During operations with ice vanes extended, torque will decrease approximately 10%, fuel flow will decrease approximately 5%, and true airspeed will be reduced by approximately 10 knots.

*Figure 7A-69. Maximum Range Power at 1500 RPM - ISA +20°C (Sheet 2 of 2)*

**MAXIMUM RANGE POWER  
1500 RPM  
ISA +30°C**

WEIGHT→			16,000 POUNDS					14,000 POUNDS				
PRESSURE ALTITUDE	IFAT	FAT	TORQUE PER ENGINE	FUEL FLOW PER ENGINE	TOTAL FUEL FLOW	IAS	TAS	TORQUE PER ENGINE	FUEL FLOW PER ENGINE	TOTAL FUEL FLOW	IAS	TAS
FEET	°C	°C	PERCENT	LBS/HR	LBS/HR	KTS	KTS	PERCENT	LBS/HR	LBS/HR	KTS	KTS
0	50	45	85	606	1212	216	229	85	603	1206	217	230
2000	46	41	83	577	1154	211	231	78	559	1118	208	227
4000	42	37	80	547	1094	206	232	73	521	1042	200	225
6000	38	33	74	507	1014	197	219	68	483	966	192	223
8000	34	29	59	433	866	182	218	64	451	902	185	222
10,000	30	25	67	447	894	184	228	60	421	842	178	221
12,000	26	21	64	419	838	177	227	57	393	786	172	220
14,000	22	17	62	397	794	172	227	54	367	734	166	219
16,000	18	13	62	384	768	169	231	53	351	702	161	221
18,000	14	9	---	---	---	---	---	53	344	688	159	225
20,000	---	---	---	---	---	---	---	---	---	---	---	---
22,000	---	---	---	---	---	---	---	---	---	---	---	---
24,000	---	---	---	---	---	---	---	---	---	---	---	---
26,000	---	---	---	---	---	---	---	---	---	---	---	---
28,000	---	---	---	---	---	---	---	---	---	---	---	---
29,000	---	---	---	---	---	---	---	---	---	---	---	---
31,000	---	---	---	---	---	---	---	---	---	---	---	---
33,000	---	---	---	---	---	---	---	---	---	---	---	---
35,000	---	---	---	---	---	---	---	---	---	---	---	---

BT058713

**NOTE**

During operations with ice vanes extended, torque will decrease approximately 10%, fuel flow will decrease approximately 5%, and true airspeed will be reduced by approximately 10 knots.

*Figure 7A-70. Maximum Range Power at 1500 RPM - ISA +30°C (Sheet 1 of 2)*

**MAXIMUM RANGE POWER  
1500 RPM  
ISA +30°C**

WEIGHT→			12,000 POUNDS					10,000 POUNDS				
PRESSURE ALTITUDE	IFAT	FAT	TORQUE PER ENGINE	FUEL FLOW PER ENGINE	TOTAL FUEL FLOW	IAS	TAS	TORQUE PER ENGINE	FUEL FLOW PER ENGINE	TOTAL FUEL FLOW	IAS	TAS
FEET	°C	°C	PERCENT	LBS/HR	LBS/HR	KTS	KTS	PERCENT	LBS/HR	LBS/HR	KTS	KTS
0	50	45	79	584	1168	213	225	74	568	1136	209	222
2000	46	41	72	539	1078	203	222	68	524	1048	200	219
4000	42	37	67	503	1006	196	221	64	490	980	194	219
6000	38	33	63	466	932	189	219	60	455	910	187	218
8000	34	29	59	433	866	182	218	56	423	846	181	217
10,000	30	25	56	404	808	176	218	53	394	788	175	217
12,000	26	21	53	376	752	170	217	51	367	734	170	217
14,000	22	17	50	349	698	163	216	48	342	684	164	217
16,000	18	13	47	327	654	157	215	44	316	632	157	214
18,000	14	9	46	315	630	153	216	41	295	590	149	212
20,000	10	5	45	303	606	149	219	39	278	556	144	212
22,000	6	1	45	292	584	146	222	37	263	526	139	212
24,000	2	-3	44	283	566	143	225	36	248	496	134	212
26,000	-2	-7	---	---	---	---	---	35	238	476	130	214
28,000	-6	-10	---	---	---	---	---	34	230	460	126	215
29,000	-8	-12	---	---	---	---	---	34	227	454	125	217
31,000	-12	-16	---	---	---	---	---	33	212	424	119	215
33,000	---	---	---	---	---	---	---	---	---	---	---	---
35,000	---	---	---	---	---	---	---	---	---	---	---	---

BT058714

**NOTE**

During operations with ice vanes extended, torque will decrease approximately 10%, fuel flow will decrease approximately 5%, and true airspeed will be reduced by approximately 10 knots.

*Figure 7A-70. Maximum Range Power at 1500 RPM - ISA +30°C (Sheet 2 of 2)*

**MAXIMUM RANGE POWER  
1500 RPM  
ISA +37°C**

WEIGHT→			16,000 POUNDS					14,000 POUNDS				
PRESSURE ALTITUDE	IFAT	FAT	TORQUE PER ENGINE	FUEL FLOW PER ENGINE	TOTAL FUEL FLOW	IAS	TAS	TORQUE PER ENGINE	FUEL FLOW PER ENGINE	TOTAL FUEL FLOW	IAS	TAS
FEET	°C	°C	PERCENT	LBS/HR	LBS/HR	KTS	KTS	PERCENT	LBS/HR	LBS/HR	KTS	KTS
0	56	52	76	582	1164	205	220	77	582	1164	208	223
2000	53	48	74	551	1102	201	222	75	551	1102	203	225
4000	49	44	72	521	1042	196	223	72	521	1042	199	226
6000	45	40	70	492	984	191	224	70	492	984	194	228
8000	41	36	67	465	930	186	225	67	465	930	189	229
10,000	37	32	65	439	878	180	226	65	439	878	184	230
12,000	33	28	63	415	830	175	226	61	406	812	176	227
14,000	29	24	61	392	784	169	226	58	383	766	170	228
16,000	---	---	---	---	---	---	---	---	---	---	---	---
18,000	---	---	---	---	---	---	---	---	---	---	---	---
20,000	---	---	---	---	---	---	---	---	---	---	---	---
22,000	---	---	---	---	---	---	---	---	---	---	---	---
24,000	---	---	---	---	---	---	---	---	---	---	---	---
26,000	---	---	---	---	---	---	---	---	---	---	---	---
28,000	---	---	---	---	---	---	---	---	---	---	---	---
29,000	---	---	---	---	---	---	---	---	---	---	---	---
31,000	---	---	---	---	---	---	---	---	---	---	---	---
33,000	---	---	---	---	---	---	---	---	---	---	---	---
35,000	---	---	---	---	---	---	---	---	---	---	---	---

BT05871

**NOTE**

During operations with ice vanes extended, torque will decrease approximately 10%, fuel flow will decrease approximately 5%, and true airspeed will be reduced by approximately 10 knots.

Figure 7A-71. Maximum Range Power at 1500 RPM - ISA +37°C (Sheet 1 of 2)

**MAXIMUM RANGE POWER  
1500 RPM  
ISA +37°C**

WEIGHT→			12,000 POUNDS					10,000 POUNDS				
PRESSURE ALTITUDE	IFAT	FAT	TORQUE PER ENGINE	FUEL FLOW PER ENGINE	TOTAL FUEL FLOW	IAS	TAS	TORQUE PER ENGINE	FUEL FLOW PER ENGINE	TOTAL FUEL FLOW	IAS	TAS
FEET	°C	°C	PERCENT	LBS/HR	LBS/HR	KTS	KTS	PERCENT	LBS/HR	LBS/HR	KTS	KTS
0	57	52	77	582	1164	210	225	77	582	11164	212	227
2000	53	48	75	551	1102	206	227	75	552	1104	208	229
4000	49	44	72	519	1038	200	228	67	502	1004	197	249
6000	45	40	68	483	966	194	227	63	467	934	190	223
8000	41	36	62	445	890	185	224	57	426	852	181	219
10,000	37	32	58	412	824	177	222	53	394	788	173	218
12,000	33	28	54	382	764	170	220	49	364	728	167	216
14,000	29	24	51	356	712	164	220	46	338	676	161	215
16,000	25	20	49	336	672	159	220	44	316	632	155	215
18,000	21	16	48	321	642	155	223	42	296	592	149	215
20,000	17	12	47	308	616	152	226	40	282	564	146	217
22,000	13	8	---	---	---	---	---	39	269	538	141	218
24,000	9	8	---	---	---	---	---	38	257	514	137	219
26,000	5	0	---	---	---	---	---	33	232	464	126	209
28,000	---	---	---	---	---	---	---	---	---	---	---	---
29,000	---	---	---	---	---	---	---	---	---	---	---	---
31,000	---	---	---	---	---	---	---	---	---	---	---	---
33,000	---	---	---	---	---	---	---	---	---	---	---	---
35,000	---	---	---	---	---	---	---	---	---	---	---	---

BT058712

**NOTE**

During operations with ice vanes extended, torque will decrease approximately 10%, fuel flow will decrease approximately 5%, and true airspeed will be reduced by approximately 10 knots.

Figure 7A-71. Maximum Range Power at 1500 RPM - ISA +37°C (Sheet 2 of 2)

RANGE PROFILE - MAXIMUM RANGE POWER

ASSOCIATED CONDITIONS:

WEIGHT ..... 16.620 LBS BEFORE ENGINE START
FUEL ..... AVATION KEROSENE
FUEL DENSITY..... 6.7 LBS/GAL
ICE VANES ..... RETRACTED
1500 RPM
STADARD DAY (ISA)
ZERO WIND

EXAMPLE:

PRESSURE ALTITUDE.....26.000 FT
FUEL.....2572 LBS
RANGE .....658 NM

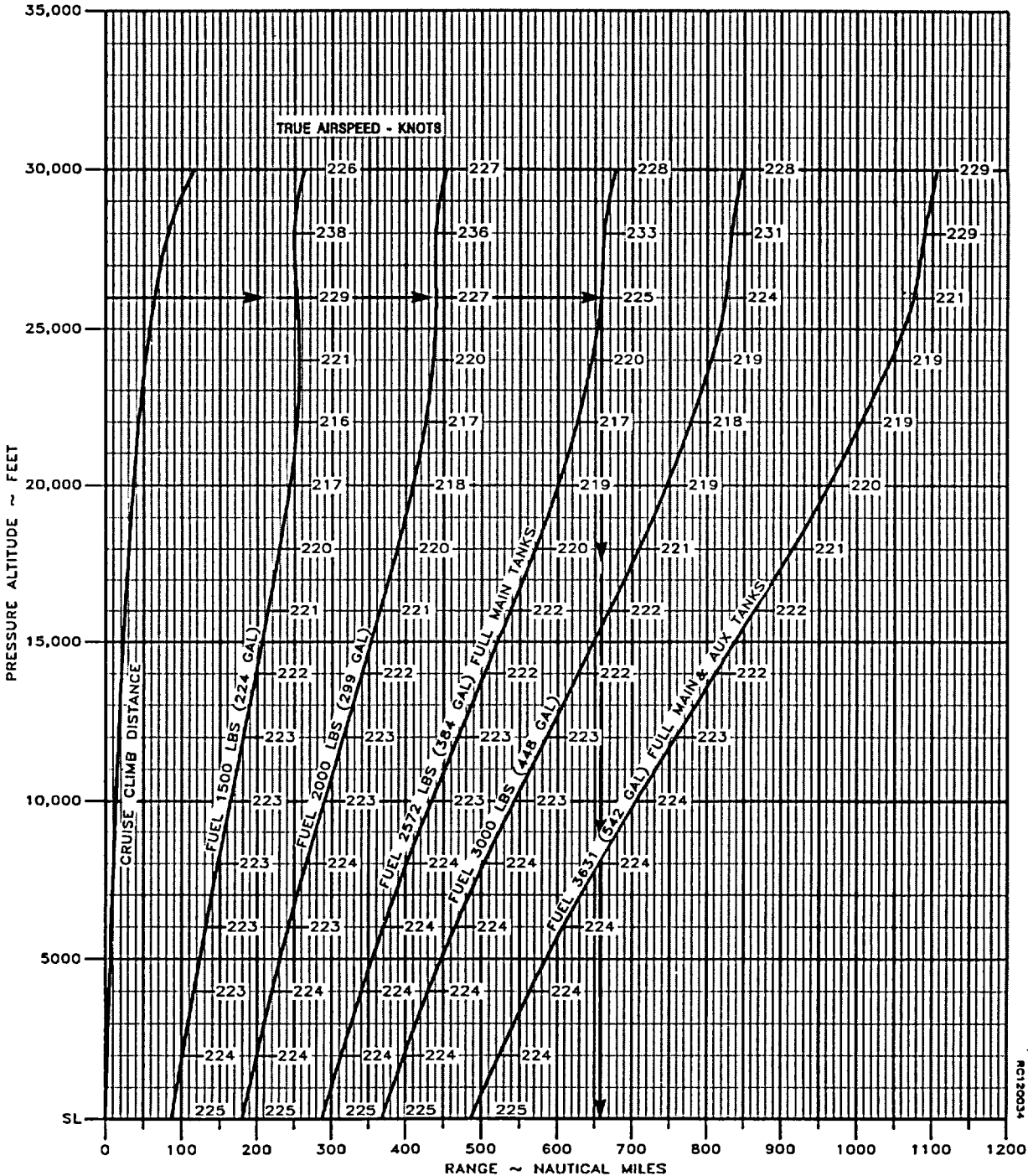

Figure 7A-72. Range Profile - Maximum Range Power at 1500 RPM

**MAXIMUM RANGE POWER  
1700 RPM  
ISA -30°C**

WEIGHT→			16,000 POUNDS					14,000 POUNDS				
PRESSURE ALTITUDE	IFAT	FAT	TORQUE PER ENGINE	FUEL FLOW PER ENGINE	TOTAL FUEL FLOW	IAS	TAS	TORQUE PER ENGINE	FUEL FLOW PER ENGINE	TOTAL FUEL FLOW	IAS	TAS
FEET	°C	°C	PERCENT	LBS/HR	LBS/HR	KTS	KTS	PERCENT	LBS/HR	LBS/HR	KTS	KTS
0	-14	-15	29	406	812	125	121	26	394	788	125	121
2000	-18	-19	29	388	776	125	125	27	375	750	125	125
4000	-21	-23	30	371	742	125	129	27	358	716	125	129
6000	-25	-27	30	354	708	125	132	27	341	682	125	132
8000	-29	-31	31	339	678	125	136	28	326	652	125	136
10,000	-33	-35	31	324	648	125	140	28	311	622	125	140
12,000	-37	-39	32	311	622	125	145	29	297	594	125	145
14,000	-41	-43	33	299	598	125	149	29	285	570	125	149
16,000	-45	-47	33	289	578	125	154	30	274	548	125	154
18,000	-48	-51	34	281	562	125	159	30	265	530	125	159
20,000	-52	-55	35	275	550	125	164	31	257	514	125	164
22,000	-56	-59	35	271	542	125	169	32	253	506	125	169
24,000	-60	-63	36	267	534	125	175	32	248	496	125	175
26,000	-63	-67	37	265	530	125	181	33	245	490	125	181
28,000	-67	-70	37	262	524	125	187	33	243	486	125	187
29,000	-69	-72	38	262	524	125	190	34	242	484	125	190
31,000	-73	-76	39	268	536	125	197	35	242	484	125	197
33,000	-77	-80	40	272	544	125	204	36	246	492	125	204
35,000	-80	-84	---	---	---	---	---	37	250	500	125	211

BT0586715

Figure 7A-73. Loiter Power at 1700 RPM - ISA -30°C (Sheet 1 of 2)

**MAXIMUM RANGE POWER  
1700 RPM  
ISA -30°C**

WEIGHT→			12,000 POUNDS					10,000 POUNDS				
PRESSURE ALTITUDE	IFAT	FAT	TORQUE PER ENGINE	FUEL FLOW PER ENGINE	TOTAL FUEL FLOW	IAS	TAS	TORQUE PER ENGINE	FUEL FLOW PER ENGINE	TOTAL FUEL FLOW	IAS	TAS
FEET	°C	°C	PERCENT	LBS/HR	LBS/HR	KTS	KTS	PERCENT	LBS/HR	LBS/HR	KTS	KTS
0	1-14	-15	24	383	766	125	121	22	373	746	125	121
2000	-18	-19	24	364	728	125	125	22	355	710	125	125
4000	-21	-23	24	346	692	125	129	22	337	674	125	129
6000	-25	-27	25	330	660	125	132	23	320	640	125	132
8000	-29	-31	25	314	628	125	136	23	304	608	125	136
10,000	-33	-35	25	299	598	125	140	23	289	578	125	140
12,000	-37	-39	26	285	570	125	145	24	275	550	125	145
14,000	-41	-43	26	272	544	125	149	24	262	524	125	149
16,000	-45	-47	27	261	522	125	154	24	251	502	125	154
18,000	-48	-51	27	252	504	125	159	25	241	482	125	159
20,000	-52	-55	28	243	486	125	164	25	232	464	125	164
22,000	-56	-59	29	237	474	125	169	26	225	450	125	169
24,000	-60	-63	29	232	464	125	175	26	218	436	125	175
26,000	-63	-67	30	229	458	125	181	27	215	430	125	181
28,000	-67	-70	30	226	452	125	187	27	212	424	125	187
29,000	-69	-72	30	225	450	125	190	28	210	420	125	190
31,000	-73	-76	31	224	448	125	197	28	208	416	125	197
33,000	-77	-80	32	225	450	125	204	29	208	416	125	204
35,000	-80	-84	33	228	456	125	211	29	210	420	125	211

BT0586716

Figure 7A-73. Loiter Power at 1700 RPM - ISA -30°C (Sheet 2 of 2)



**MAXIMUM RANGE POWER  
1700 RPM  
ISA -20°C**

WEIGHT→			16,000 POUNDS					14,000 POUNDS				
PRESSURE ALTITUDE	IFAT	FAT	TORQUE PER ENGINE	FUEL FLOW PER ENGINE	TOTAL FUEL FLOW	IAS	TAS	TORQUE PER ENGINE	FUEL FLOW PER ENGINE	TOTAL FUEL FLOW	IAS	TAS
FEET	°C	°C	PERCENT	LBS/HR	LBS/HR	KTS	KTS	PERCENT	LBS/HR	LBS/HR	KTS	KTS
0	-4	-5	29	409	818	125	124	26	395	790	125	124
2000	-7	-9	29	391	782	125	127	27	378	756	125	127
4000	-11	-13	30	374	748	125	131	27	360	720	125	131
6000	-15	-17	30	358	716	125	135	27	344	688	125	135
8000	-19	-21	31	343	686	125	139	28	329	658	125	139
10,000	-23	-25	32	329	658	125	143	28	314	628	125	143
12,000	-27	-29	32	315	630	125	148	29	300	600	125	148
14,000	-31	-33	33	303	606	125	152	30	288	576	125	152
16,000	-34	-37	34	293	586	125	157	30	277	554	125	157
18,000	-38	-41	35	286	572	125	162	31	269	538	125	162
20,000	-42	-45	35	279	558	125	168	32	262	524	125	168
22,000	-46	-49	36	275	550	125	173	32	257	514	125	173
24,000	-50	-53	37	271	542	125	179	33	252	504	125	179
26,000	-53	-57	37	268	536	125	185	33	249	498	125	185
28,000	-57	-60	38	266	532	125	192	34	246	492	125	192
29,000	-59	-62	38	268	536	125	195	34	245	490	125	195
31,000	-63	-66	40	273	546	125	202	35	246	492	125	202
33,000	-66	-70	41	278	556	125	209	36	251	502	125	209
35,000	-70	-74	---	---	---	---	---	37	256	512	125	217

BT0586713

Figure 7A-74. Loiter Power at 1700 RPM - ISA -20°C (Sheet 1 of 2)

**MAXIMUM RANGE POWER  
1700 RPM  
ISA -20°C**

WEIGHT→			12,000 POUNDS					10,000 POUNDS				
PRESSURE ALTITUDE	IFAT	FAT	TORQUE PER ENGINE	FUEL FLOW PER ENGINE	TOTAL FUEL FLOW	IAS	TAS	TORQUE PER ENGINE	FUEL FLOW PER ENGINE	TOTAL FUEL FLOW	IAS	TAS
FEET	°C	°C	PERCENT	LBS/HR	LBS/HR	KTS	KTS	PERCENT	LBS/HR	LBS/HR	KTS	KTS
0	-4	-5	24	384	768	125	124	22	374	748	125	124
2000	-7	-9	24	366	732	125	127	22	356	712	125	127
4000	-11	-13	24	348	696	125	131	22	338	676	125	131
6000	-15	-17	25	332	664	125	135	23	321	642	125	135
8000	-19	-21	25	316	632	125	139	23	306	612	125	139
10,000	-23	-25	26	302	604	125	143	23	291	582	125	143
12,000	-27	-29	26	288	576	125	148	24	277	554	125	148
14,000	-31	-33	27	275	550	125	152	24	264	528	125	152
16,000	-34	-37	27	264	528	125	157	25	253	506	125	157
18,000	-38	-41	28	255	510	125	162	25	243	486	125	162
20,000	-42	-45	28	247	494	125	168	26	235	470	125	168
22,000	-46	-49	29	241	482	125	173	26	228	456	125	173
24,000	-50	-53	30	236	472	125	179	27	222	444	125	179
26,000	-53	-57	30	232	464	125	185	27	218	436	125	185
28,000	-57	-60	31	229	458	125	192	28	215	430	125	192
29,000	-59	-62	31	228	456	125	195	28	213	426	125	195
31,000	-63	-66	31	226	452	125	202	29	211	422	125	202
33,000	-66	-70	32	227	454	125	209	29	210	420	125	209
35,000	-70	-74	33	232	464	125	217	30	212	424	125	217

BT0586714

Figure 7A-74. Loiter Power at 1700 RPM - ISA -20°C (Sheet 2 of 2)

**MAXIMUM RANGE POWER  
1700 RPM  
ISA -10°C**

WEIGHT→			16,000 POUNDS					14,000 POUNDS				
PRESSURE ALTITUDE	IFAT	FAT	TORQUE PER ENGINE	FUEL FLOW PER ENGINE	TOTAL FUEL FLOW	IAS	TAS	TORQUE PER ENGINE	FUEL FLOW PER ENGINE	TOTAL FUEL FLOW	IAS	TAS
FEET	°C	°C	PERCENT	LBS/HR	LBS/HR	KTS	KTS	PERCENT	LBS/HR	LBS/HR	KTS	KTS
0	6	5	29	412	824	125	126	26	398	796	125	126
2000	3	1	30	396	792	125	130	27	381	762	125	130
4000	-1	-3	30	379	758	125	134	27	364	728	125	134
6000	-5	-7	31	364	728	125	138	28	348	696	125	138
8000	-9	-11	31	349	698	125	142	28	333	666	125	142
10,000	-13	-15	32	334	668	125	146	29	319	638	125	146
12,000	-17	-19	33	321	642	125	151	29	305	610	125	151
14,000	-20	-23	33	309	618	125	156	30	293	586	125	156
16,000	-24	-27	34	298	596	125	161	31	282	564	125	161
18,000	-28	-31	35	289	578	125	166	31	272	544	125	166
20,000	-32	-35	36	282	564	125	171	32	265	530	125	171
22,000	-36	-39	36	277	554	125	177	32	259	518	125	177
24,000	-39	-43	37	273	546	125	183	33	255	510	125	183
26,000	-43	-47	38	270	540	125	189	34	251	502	125	189
28,000	-47	-50	39	272	544	125	196	34	248	496	125	196
29,000	-49	-52	39	274	548	125	199	35	247	494	125	199
31,000	-52	-56	41	279	558	125	207	36	252	504	125	207
33,000	-56	-60	42	285	570	125	214	37	257	514	125	214
35,000	-60	-64	---	---	---	---	---	38	261	522	125	222

BT0586711

Figure 7A-75. Loiter Power at 1700 RPM - ISA -10°C (Sheet 1 of 2)

**MAXIMUM RANGE POWER  
1700 RPM  
ISA -10°C**

WEIGHT→			12,000 POUNDS					10,000 POUNDS				
PRESSURE ALTITUDE	IFAT	FAT	TORQUE PER ENGINE	FUEL FLOW PER ENGINE	TOTAL FUEL FLOW	IAS	TAS	TORQUE PER ENGINE	FUEL FLOW PER ENGINE	TOTAL FUEL FLOW	IAS	TAS
FEET	°C	°C	PERCENT	LBS/HR	LBS/HR	KTS	KTS	PERCENT	LBS/HR	LBS/HR	KTS	KTS
0	6	5	24	385	770	125	126	22	375	750	125	126
2000	3	1	24	368	736	125	130	22	357	714	125	130
4000	-1	-3	24	351	702	125	134	22	340	680	125	134
6000	-5	-7	25	335	670	125	138	23	324	648	125	138
8000	-9	-11	25	320	640	125	142	23	308	616	125	142
10,000	-13	-15	26	305	610	125	146	23	294	588	125	146
12,000	-17	-19	26	292	584	125	151	24	280	560	125	151
14,000	-20	-23	27	279	558	125	156	24	268	536	125	156
16,000	-24	-27	28	268	536	125	161	25	256	512	125	161
18,000	-28	-31	28	258	516	125	166	25	246	492	125	166
20,000	-32	-35	29	250	500	125	171	26	238	476	125	171
22,000	-36	-39	29	244	488	125	177	27	231	462	125	177
24,000	-39	-43	30	239	478	125	183	27	226	452	125	183
26,000	-43	-47	31	235	470	125	189	28	221	442	125	189
28,000	-47	-50	31	231	462	125	196	28	217	434	125	196
29,000	-49	-52	31	230	460	125	199	28	215	430	125	199
31,000	-52	-56	32	228	456	125	207	29	213	426	125	207
33,000	-56	-60	33	232	464	125	214	29	212	424	125	214
35,000	-60	-64	34	237	474	125	222	30	216	432	125	222

BT0586712

Figure 7A-75. Loiter Power at 1700 RPM - ISA -10°C (Sheet 2 of 2)

**MAXIMUM RANGE POWER  
1700 RPM  
ISA**

WEIGHT→			16,000 POUNDS					14,000 POUNDS				
PRESSURE ALTITUDE	IFAT	FAT	TORQUE PER ENGINE	FUEL FLOW PER ENGINE	TOTAL FUEL FLOW	IAS	TAS	TORQUE PER ENGINE	FUEL FLOW PER ENGINE	TOTAL FUEL FLOW	IAS	TAS
FEET	°C	°C	PERCENT	LBS/HR	LBS/HR	KTS	KTS	PERCENT	LBS/HR	LBS/HR	KTS	KTS
0	17	15	29	414	828	125	128	27	399	798	125	128
2000	13	11	30	400	800	125	132	27	384	768	125	132
4000	9	7	31	386	772	125	136	28	370	740	125	136
6000	5	3	31	372	744	125	140	28	355	710	125	140
8000	1	-1	32	357	714	125	145	29	341	682	125	145
10,000	-3	-5	33	342	684	125	149	29	327	654	125	149
12,000	-7	-9	33	327	654	125	154	30	312	624	125	154
14,000	-10	-13	34	314	628	125	159	31	299	598	125	159
16,000	-14	-17	35	302	604	125	164	31	287	574	125	164
18,000	-18	-21	35	293	586	125	169	32	276	552	125	169
20,000	-22	-25	36	285	570	125	175	32	268	536	125	175
22,000	-26	-29	37	280	560	125	181	33	262	524	125	181
24,000	-29	-33	37	275	550	125	187	34	257	514	125	187
26,000	-33	-37	39	276	552	125	194	34	253	506	125	194
28,000	-37	-40	40	280	560	125	200	35	254	508	125	200
29,000	-39	-42	41	281	562	125	204	36	255	510	125	204
31,000	-42	-46	42	285	570	125	211	37	258	516	125	211
33,000	-46	-50	---	---	---	---	---	38	262	524	125	219
35,000	---	---	---	---	---	---	---	---	---	---	---	---

BT058679

Figure 7A-76. Loiter Power at 1700 RPM - ISA (Sheet 1 of 2)

**MAXIMUM RANGE POWER  
1700 RPM  
ISA**

WEIGHT→			12,000 POUNDS					10,000 POUNDS				
PRESSURE ALTITUDE	IFAT	FAT	TORQUE PER ENGINE	FUEL FLOW PER ENGINE	TOTAL FUEL FLOW	IAS	TAS	TORQUE PER ENGINE	FUEL FLOW PER ENGINE	TOTAL FUEL FLOW	IAS	TAS
FEET	°C	°C	PERCENT	LBS/HR	LBS/HR	KTS	KTS	PERCENT	LBS/HR	LBS/HR	KTS	KTS
0	17	15	24	386	772	125	128	22	374	748	125	128
2000	13	11	24	370	740	125	132	22	359	718	125	132
4000	9	7	25	356	712	125	136	23	343	686	125	136
6000	5	3	25	341	682	125	140	23	328	656	125	140
8000	1	-1	26	327	654	125	145	23	314	628	125	145
10,000	-3	-5	26	312	624	125	149	24	300	600	125	149
12,000	-7	-9	27	299	598	125	154	24	286	572	125	154
14,000	-10	-13	27	285	570	125	159	25	273	546	125	159
16,000	-14	-17	28	273	546	125	164	25	262	524	125	164
18,000	-18	-21	28	262	524	125	169	26	250	500	125	169
20,000	-22	-25	29	253	506	125	175	26	241	482	125	175
22,000	-26	-29	30	247	494	125	181	27	235	470	125	181
24,000	-29	-33	30	242	484	125	187	28	228	456	125	187
26,000	-33	-37	31	237	474	125	194	28	223	446	125	194
28,000	-37	-40	31	234	468	125	200	29	219	438	125	200
29,000	-39	-42	32	232	464	125	204	29	218	436	125	204
31,000	-42	-46	33	235	470	125	211	29	215	430	125	211
33,000	-46	-50	34	238	476	125	219	30	218	436	125	219
35,000	-50	-54	35	242	484	125	227	31	221	442	125	227

BT0586710

Figure 7A-76. Loiter Power at 1700 RPM - ISA (Sheet 2 of 2)

**MAXIMUM RANGE POWER  
1700 RPM  
ISA +10°C**

WEIGHT→			16,000 POUNDS					14,000 POUNDS				
PRESSURE ALTITUDE	IFAT	FAT	TORQUE PER ENGINE	FUEL FLOW PER ENGINE	TOTAL FUEL FLOW	IAS	TAS	TORQUE PER ENGINE	FUEL FLOW PER ENGINE	TOTAL FUEL FLOW	IAS	TAS
FEET	°C	°C	PERCENT	LBS/HR	LBS/HR	KTS	KTS	PERCENT	LBS/HR	LBS/HR	KTS	KTS
0	27	25	30	423	846	125	131	27	406	812	125	131
2000	23	21	31	406	812	125	134	28	389	778	125	134
4000	19	17	31	390	780	125	138	28	372	744	125	138
6000	15	13	32	373	746	125	143	29	357	714	125	143
8000	11	9	33	358	716	125	147	29	344	688	125	147
10,000	7	5	33	346	692	125	152	30	332	664	125	152
12,000	4	1	34	332	664	125	157	31	317	634	125	157
14,000	0	-3	35	318	636	125	162	31	304	608	125	162
16,000	-4	-7	35	307	614	125	167	32	291	582	125	167
18,000	-8	-11	36	296	592	125	173	32	281	562	125	173
20,000	-12	-15	37	288	576	125	178	33	272	544	125	178
22,000	-15	-19	38	284	568	125	184	34	266	532	125	184
24,000	-19	-23	39	284	568	125	191	34	261	522	125	191
26,000	-23	-27	40	284	568	125	198	35	260	520	125	198
28,000	-27	-30	41	286	572	125	205	36	261	522	125	205
29,000	-28	-32	41	287	574	125	208	37	262	524	125	208
31,000	-32	-36	43	291	582	125	216	38	264	528	125	216
33,000	-36	-40	---	---	---	---	---	39	267	534	125	224
35,000	---	---	---	---	---	---	---	---	---	---	---	---

BT058677

Figure 7A-77. Loiter Power at 1700 RPM - ISA +10°C (Sheet 1 of 2)

**MAXIMUM RANGE POWER  
1700 RPM  
ISA +10°C**

WEIGHT→			12,000 POUNDS					10,000 POUNDS				
PRESSURE ALTITUDE	IFAT	FAT	TORQUE PER ENGINE	FUEL FLOW PER ENGINE	TOTAL FUEL FLOW	IAS	TAS	TORQUE PER ENGINE	FUEL FLOW PER ENGINE	TOTAL FUEL FLOW	IAS	TAS
FEET	°C	°C	PERCENT	LBS/HR	LBS/HR	KTS	KTS	PERCENT	LBS/HR	LBS/HR	KTS	KTS
0	27	25	24	391	782	125	131	22	378	756	125	131
2000	23	21	25	374	748	125	134	22	361	722	125	134
4000	19	17	25	357	714	125	138	23	344	688	125	138
6000	15	13	26	342	684	125	143	23	329	658	125	143
8000	11	9	26	330	660	125	147	24	316	632	125	147
10,000	7	5	27	319	638	125	152	25	307	614	125	152
12,000	4	1	28	305	610	125	157	25	294	588	125	157
14,000	0	-3	28	291	582	125	162	25	280	560	125	162
16,000	-4	-7	29	278	556	125	167	26	267	534	125	167
18,000	-8	-11	29	267	534	125	173	26	255	510	125	173
20,000	-12	-15	30	258	516	125	178	27	246	492	125	178
22,000	-15	-19	30	251	502	125	184	27	239	478	125	184
24,000	-19	-23	31	245	490	125	191	28	232	464	125	191
26,000	-23	-27	32	240	480	125	198	29	226	452	125	198
28,000	-27	-30	32	239	478	125	205	29	222	444	125	205
29,000	-28	-32	33	240	480	125	208	29	221	442	125	208
31,000	-32	-36	34	241	482	125	216	30	222	444	125	216
33,000	-36	-40	35	243	486	125	224	31	223	446	125	224
35,000	-39	-44	35	246	492	125	232	32	225	450	125	232

BT058678

Figure 7A-77. Loiter Power at 1700 RPM - ISA +10°C (Sheet 2 of 2)



**MAXIMUM RANGE POWER  
1700 RPM  
ISA +20°C**

WEIGHT→			16,000 POUNDS					14,000 POUNDS				
PRESSURE ALTITUDE	IFAT	FAT	TORQUE PER ENGINE	FUEL FLOW PER ENGINE	TOTAL FUEL FLOW	IAS	TAS	TORQUE PER ENGINE	FUEL FLOW PER ENGINE	TOTAL FUEL FLOW	IAS	TAS
FEET	°C	°C	PERCENT	LBS/HR	LBS/HR	KTS	KTS	PERCENT	LBS/HR	LBS/HR	KTS	KTS
0	37	35	31	433	866	125	133	28	417	834	125	133
2000	33	31	32	414	828	125	137	29	400	800	125	137
4000	29	27	32	395	790	125	141	29	381	762	125	141
6000	25	23	33	378	756	125	145	29	364	728	125	145
8000	21	19	33	362	724	125	150	30	347	694	125	150
10,000	17	15	34	346	692	125	154	30	331	662	125	154
12,000	14	11	34	331	662	125	159	31	316	632	125	159
14,000	10	7	35	320	640	125	165	32	305	610	125	165
16,000	6	3	36	310	620	125	170	32	295	590	125	170
18,000	2	-1	36	300	600	125	176	33	284	568	125	176
20,000	-2	-5	37	295	590	125	182	33	276	552	125	182
22,000	-5	-9	38	292	584	125	188	34	271	542	125	188
24,000	-9	-13	39	289	578	125	195	35	268	536	125	195
26,000	-13	-17	40	287	574	125	202	36	265	530	125	202
28,000	-16	-20	41	290	580	125	209	37	265	530	125	209
29,000	-18	-22	---	---	---	---	---	37	265	530	125	213
31,000	-22	-26	---	---	---	---	---	38	268	536	125	220
33,000	---	---	---	---	---	---	---	---	---	---	---	---
35,000	---	---	---	---	---	---	---	---	---	---	---	---

BT058675

Figure 7A-78. Loiter Power at 1700 RPM - ISA +20°C (Sheet 1 of 2)

**MAXIMUM RANGE POWER  
1700 RPM  
ISA +20°C**

WEIGHT→			12,000 POUNDS					10,000 POUNDS				
PRESSURE ALTITUDE	IFAT	FAT	TORQUE PER ENGINE	FUEL FLOW PER ENGINE	TOTAL FUEL FLOW	IAS	TAS	TORQUE PER ENGINE	FUEL FLOW PER ENGINE	TOTAL FUEL FLOW	IAS	TAS
FEET	°C	°C	PERCENT	LBS/HR	LBS/HR	KTS	KTS	PERCENT	LBS/HR	LBS/HR	KTS	KTS
0	37	35	25	400	800	125	133	23	385	770	125	133
2000	33	31	26	383	766	125	137	23	369	738	125	137
4000	29	27	26	367	734	125	141	24	352	704	125	141
6000	25	23	27	351	702	125	145	24	337	674	125	145
8000	21	19	27	334	668	125	150	25	323	646	125	150
10,000	17	15	28	318	636	125	154	25	307	614	125	154
12,000	14	11	28	303	606	125	159	25	292	584	125	159
14,000	10	7	29	292	584	125	165	26	281	562	125	165
16,000	6	3	29	281	562	125	170	26	270	540	125	170
18,000	2	-1	30	271	542	125	176	27	259	518	125	176
20,000	-2	-5	30	262	524	125	182	27	250	500	125	182
22,000	-5	-9	31	255	510	125	188	28	242	484	125	188
24,000	-9	-13	32	250	500	125	195	29	235	470	125	195
26,000	-13	-17	32	246	492	125	202	29	230	460	125	202
28,000	-16	-20	33	244	488	125	209	30	227	454	125	209
29,000	-18	-22	34	244	488	125	213	30	227	454	125	213
31,000	-22	-26	34	245	490	125	220	31	226	452	125	220
33,000	-26	-30	35	247	494	125	229	32	227	454	125	229
35,000	-29	-34	---	---	---	---	---	32	228	456	125	237

BT058676

Figure 7A-78. Loiter Power at 1700 RPM - ISA +20°C (Sheet 2 of 2)

**MAXIMUM RANGE POWER  
1700 RPM  
ISA +30°C**

WEIGHT→			16,000 POUNDS					14,000 POUNDS				
PRESSURE ALTITUDE	IFAT	FAT	TORQUE PER ENGINE	FUEL FLOW PER ENGINE	TOTAL FUEL FLOW	IAS	TAS	TORQUE PER ENGINE	FUEL FLOW PER ENGINE	TOTAL FUEL FLOW	IAS	TAS
FEET	°C	°C	PERCENT	LBS/HR	LBS/HR	KTS	KTS	PERCENT	LBS/HR	LBS/HR	KTS	KTS
0	47	45	31	433	866	125	135	28	419	838	125	135
2000	43	41	32	416	832	125	139	29	402	804	125	139
4000	39	37	32	400	800	125	143	29	385	770	125	143
6000	35	33	33	383	766	125	148	30	368	736	125	148
8000	31	29	34	367	734	125	152	30	352	704	125	152
10,000	27	25	34	351	702	125	157	31	335	670	125	157
12,000	24	21	35	335	670	125	162	31	320	640	125	162
14,000	20	17	36	322	644	125	168	32	306	612	125	168
16,000	16	13	36	311	622	125	173	32	295	590	125	173
18,000	12	9	37	305	610	125	179	33	288	576	125	179
20,000	9	5	38	298	596	125	185	34	281	562	125	185
22,000	5	1	39	294	588	125	192	35	275	550	125	192
24,000	1	-3	39	290	580	125	198	35	270	540	125	198
26,000	-3	-7	---	---	---	---	---	36	267	534	125	205
28,000	-6	-10	---	---	---	---	---	37	267	534	125	213
29,000	---	---	---	---	---	---	---	---	---	---	---	---
31,000	---	---	---	---	---	---	---	---	---	---	---	---
33,000	---	---	---	---	---	---	---	---	---	---	---	---
35,000	---	---	---	---	---	---	---	---	---	---	---	---

BT058673

Figure 7A-79. Loiter Power at 1700 RPM - ISA +30°C (Sheet 1 of 2)

**MAXIMUM RANGE POWER  
1700 RPM  
ISA +30°C**

WEIGHT→			12,000 POUNDS					10,000 POUNDS				
PRESSURE ALTITUDE	IFAT	FAT	TORQUE PER ENGINE	FUEL FLOW PER ENGINE	TOTAL FUEL FLOW	IAS	TAS	TORQUE PER ENGINE	FUEL FLOW PER ENGINE	TOTAL FUEL FLOW	IAS	TAS
FEET	°C	°C	PERCENT	LBS/HR	LBS/HR	KTS	KTS	PERCENT	LBS/HR	LBS/HR	KTS	KTS
0	47	45	26	406	812	125	135	24	395	790	125	135
2000	43	41	26	389	778	125	139	24	378	756	125	139
4000	39	37	27	372	744	125	143	24	361	722	125	143
6000	35	33	27	355	710	125	148	25	344	688	125	148
8000	31	29	27	338	676	125	152	25	327	654	125	152
10,000	27	25	28	322	644	125	157	25	311	622	125	157
12,000	24	21	28	307	614	125	162	26	295	590	125	162
14,000	20	17	29	293	586	125	168	26	281	562	125	168
16,000	16	13	29	281	562	125	173	27	270	540	125	173
18,000	12	9	30	273	546	125	179	27	261	522	125	179
20,000	9	5	31	265	530	125	185	28	252	504	125	185
22,000	5	1	31	259	518	125	192	28	246	492	125	192
24,000	1	-3	32	254	508	125	198	29	239	478	125	198
26,000	-3	-7	33	249	498	125	205	30	234	468	125	205
28,000	-6	-10	33	247	494	125	213	30	231	462	125	213
29,000	-8	-12	34	246	492	125	217	31	230	460	125	217
31,000	-12	-16	35	248	496	125	225	31	227	454	125	225
33,000	-15	-20	---	---	---	---	---	32	229	458	125	233
35,000	---	---	---	---	---	---	---	---	---	---	---	---

BT058674

Figure 7A-79. Loiter Power at 1700 RPM - ISA +30°C (Sheet 2 of 2)

**MAXIMUM RANGE POWER  
1700 RPM  
ISA +37°C**

WEIGHT→			16,000 POUNDS					14,000 POUNDS				
PRESSURE ALTITUDE	IFAT	FAT	TORQUE PER ENGINE	FUEL FLOW PER ENGINE	TOTAL FUEL FLOW	IAS	TAS	TORQUE PER ENGINE	FUEL FLOW PER ENGINE	TOTAL FUEL FLOW	IAS	TAS
FEET	°C	°C	PERCENT	LBS/HR	LBS/HR	KTS	KTS	PERCENT	LBS/HR	LBS/HR	KTS	KTS
0	54	52	31	433	866	125	136	28	418	836	125	136
2000	50	48	32	416	832	125	140	29	401	802	125	140
4000	46	44	32	400	800	125	145	29	385	770	125	145
6000	42	40	33	384	768	125	149	30	369	738	125	149
8000	38	36	34	369	738	125	154	30	353	706	125	154
10,000	35	32	34	354	708	125	159	31	339	678	125	159
12,000	31	28	35	339	678	125	164	32	323	646	125	164
14,000	27	24	36	325	650	125	170	32	309	618	125	170
16,000	23	20	36	313	626	125	175	33	297	594	125	175
18,000	19	16	37	304	608	125	181	33	288	576	125	181
20,000	16	12	38	296	592	125	187	34	279	558	125	187
22,000	12	8	39	292	584	125	194	35	274	548	125	194
24,000	8	4	---	---	---	---	---	35	269	538	125	201
26,000	---	---	---	---	---	---	---	---	---	---	---	---
28,000	----	----	---	---	---	---	---	---	---	---	---	---
29,000	---	---	---	---	---	---	---	---	---	---	---	---
31,000	---	---	---	---	---	---	---	---	---	---	---	---
33,000	---	---	---	---	---	---	---	---	---	---	---	---
35,000	---	---	---	---	---	---	---	---	---	---	---	---

BT05867

Figure 7A-80. Loiter Power at 1700 RPM - ISA +37°C (Sheet 1 of 2)

**MAXIMUM RANGE POWER  
1700 RPM  
ISA +37°C**

WEIGHT→			12,000 POUNDS					10,000 POUNDS				
PRESSURE ALTITUDE	IFAT	FAT	TORQUE PER ENGINE	FUEL FLOW PER ENGINE	TOTAL FUEL FLOW	IAS	TAS	TORQUE PER ENGINE	FUEL FLOW PER ENGINE	TOTAL FUEL FLOW	IAS	TAS
FEET	°C	°C	PERCENT	LBS/HR	LBS/HR	KTS	KTS	PERCENT	LBS/HR	LBS/HR	KTS	KTS
0	54	52	26	405	810	125	136	24	395	790	125	136
2000	50	48	26	388	776	125	140	24	377	754	125	140
4000	46	44	27	371	742	125	145	24	360	720	125	145
6000	42	40	27	355	710	125	149	25	344	688	125	149
8000	38	36	28	340	680	125	154	25	328	656	125	154
10,000	35	32	28	325	650	125	159	26	313	626	125	159
12,000	31	28	29	309	618	125	164	26	298	596	125	164
14,000	27	24	29	295	590	125	170	26	284	568	125	170
16,000	23	20	29	283	566	125	175	27	271	542	125	175
18,000	19	16	30	274	548	125	181	27	262	524	125	181
20,000	16	12	31	265	530	125	187	28	253	506	125	187
22,000	12	8	31	259	518	125	194	29	246	492	125	194
24,000	8	4	32	253	506	125	201	29	240	480	125	201
26,000	5	0	33	249	498	125	208	30	235	470	125	208
28,000	1	-3	33	248	496	125	216	30	229	458	125	216
29,000	-1	-5	---	---	---	---	---	31	227	454	125	220
31,000	-5	-9	---	---	---	---	---	31	229	458	125	228
33,000	---	---	---	---	---	---	---	---	---	---	---	---
35,000	---	---	---	---	---	---	---	---	---	---	---	---

BT058672

Figure 7A-80. Loiter Power at 1700 RPM - ISA +37°C (Sheet 2 of 2)

ENDURANCE PROFILE - LOITER POWER

ASSOCIATED CONDITIONS:

WEIGHT ..... 16.620 LBS BEFORE  
ENGINE START  
FUEL ..... AVIATION KEROSENE  
FUEL DENSITY..... 6.7 LBS/GAL  
ICE VANES ..... RETRACTED

1700 RPM  
STANDARD DAY (ISA)

EXAMPLE:

PRESSURE ALTITUDE.....26,000 FT  
FUEL.....2572 LBS  
ENDURANCE .....3.34 HRS

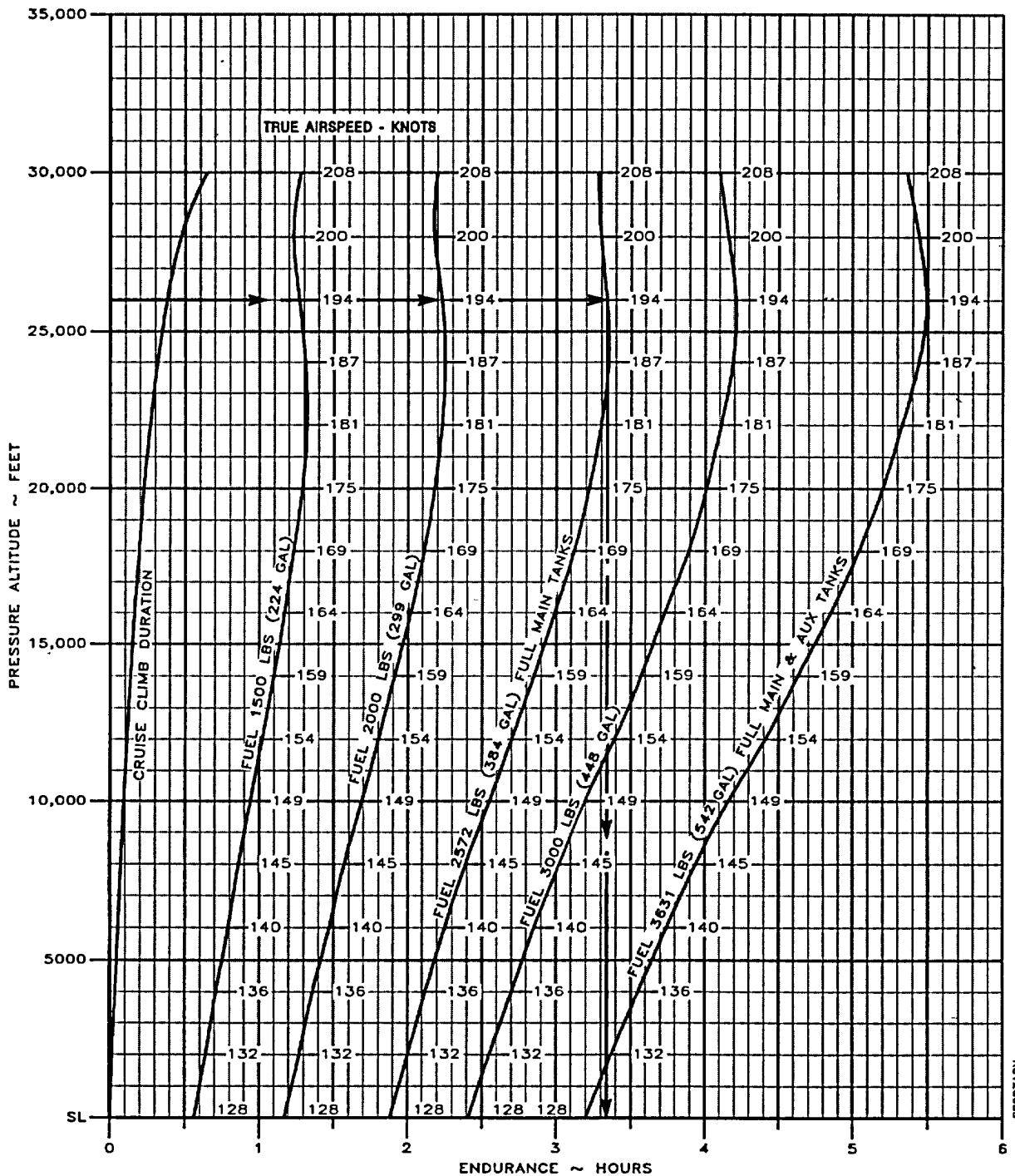

Figure 7A-81. Endurance Profile - Loiter Power at 1700 RPM

**RANGE PROFILE - FULL MAIN TANKS**

ASSOCIATED CONDITIONS:

WEIGHT ..... 15672 LBS BEFORE  
 ENGINE START  
 FUEL ..... AVIATION KEROSENE  
 FUEL DENSITY..... 6.7 LBS/GAL  
 ICE VANES ..... RETRACTED

**STANDARD DAY (ISA)**

**ZERO WIND**

EXAMPLE:

PRESSURE ALTITUDE .....26,000 FT  
 RANGE @:  
 MAXIMUM CRUISE 0POWER...650 NM  
 NORMAL CRUISE POWER.....661 NM  
 MAXIMUM RANGE POWER .....700 NM

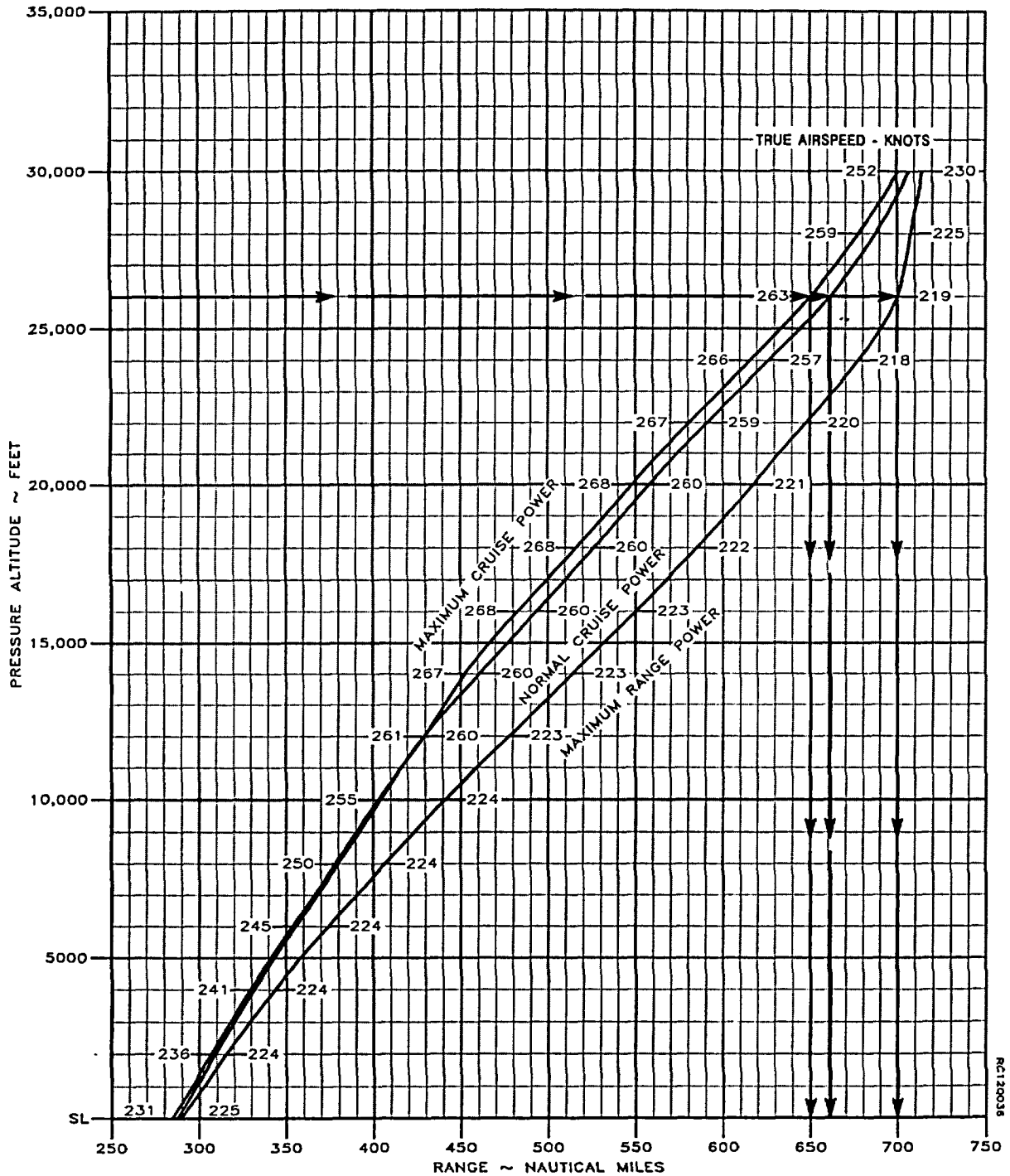

Figure 7A-82. Range Profile - Full Main Tanks



ENDURANCE PROFILE - FULL MAIN TANKS

ASSOCIATED CONDITIONS:

WEIGHT ..... 15.672 LBS BEFORE ENGINE START  
FUEL ..... AVIATION KEROSENE  
FUEL DENSITY..... 6.7 LBS/GAL  
ICE VANES ..... RETRACTED

STANDARD DAY (ISA)

EXAMPLE:

PRESSURE ALTITUDE .....26,000 FT  
ENDURANCE @:  
MAXIMUM CRUISE POWER.....2.61 HRS  
NORMAL CRUISE POWER.....2.73 HRS  
LOITER POWER.....3.56 HRS

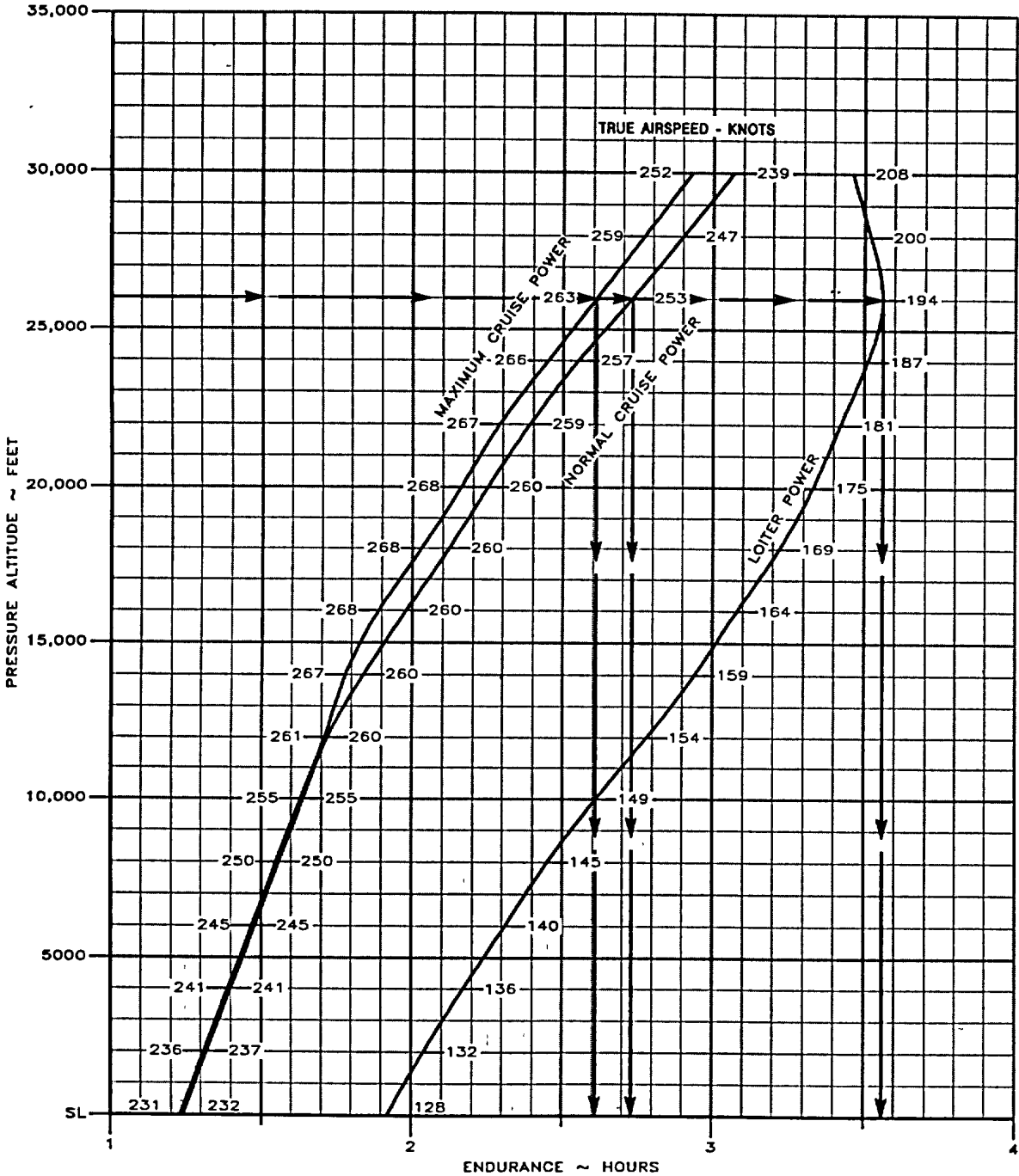

Figure 7A-83. Endurance Profile - Full Main Tanks

**RANGE PROFILE - FULL MAIN & AUX TANKS**

ASSOCIATED CONDITIONS:

WEIGHT ..... 16,620 LBS BEFORE  
 ENGINE START  
 FUEL ..... AVIATION KEROSENE  
 FUEL DENSITY..... 6.7 LBS/GAL  
 ICE VANES ..... RETRACTED

**STANDARD DAY (ISA)**

**ZERO WIND**

EXAMPLE:

PRESSURE ALTITUDE .....26,000 FT  
 RANGE @:  
 MAXIMUM CRUISE POWER.....1005 NM  
 NORMAL CRUISE POWER.....1023 NM  
 MAXIMUM RANGE POWER .....1075 NM

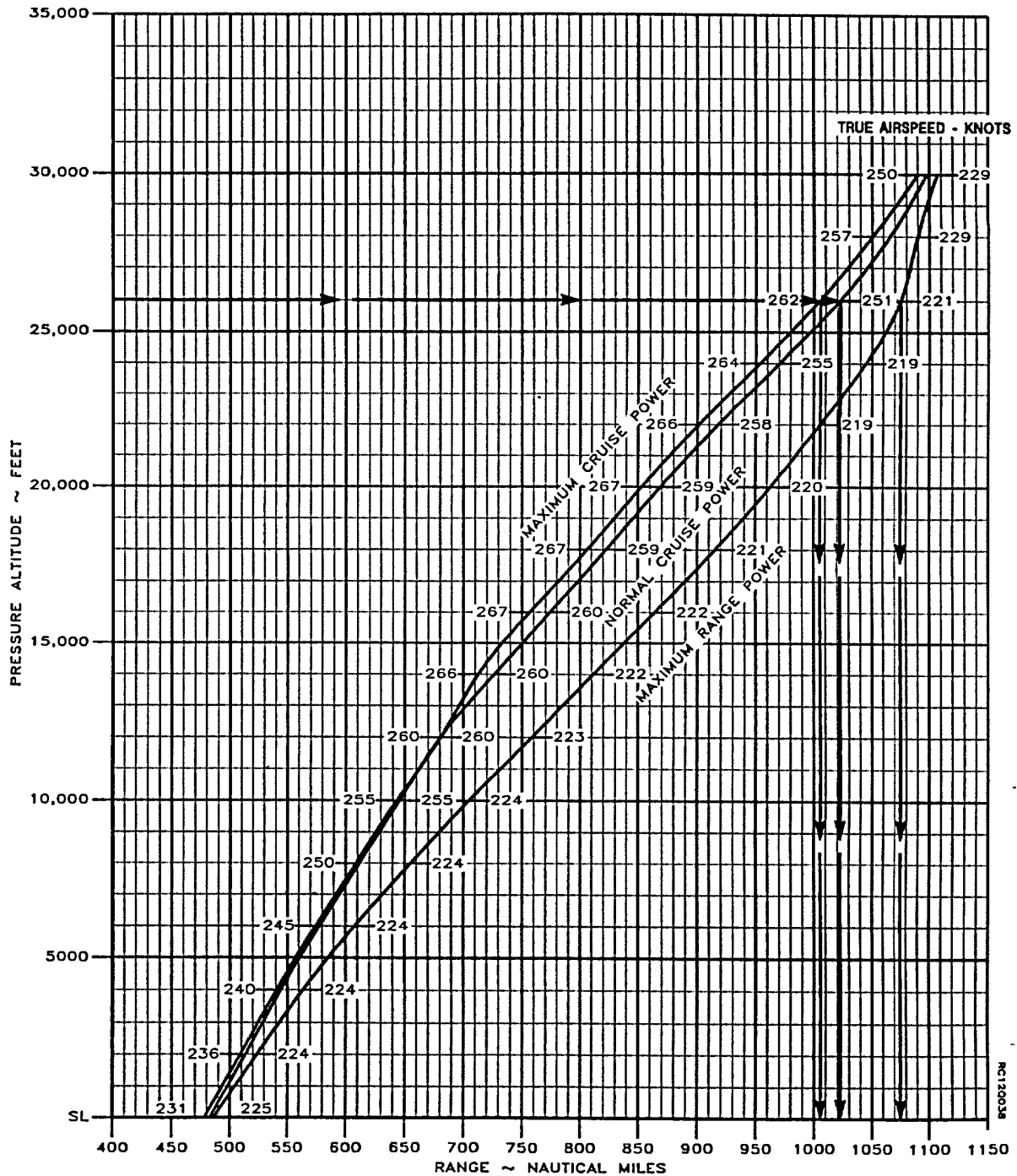

Figure 7A-84. Range Profile - Full Main and Aux Tanks

ENDURANCE PROFILE - FULL MAIN & AUX TANKS

ASSOCIATED CONDITIONS:

WEIGHT ..... 16,620 LBS BEFORE ENGINE START  
FUEL ..... AVIATION KEROSENE  
FUEL DENSITY..... 6.7 LBS/GAL  
ICE VANES ..... RETRACTED

STANDARD DAY (18A)

EXAMPLE:

PRESSURE ALTITUDE .....26,000 FT  
ENDURANCE @:  
MAXIMUM CRUISE POWER.....3.99 HRS  
NORMAL CRUISE POWER.....4.20 HRS  
LOITER POWER.....5.49 HRS

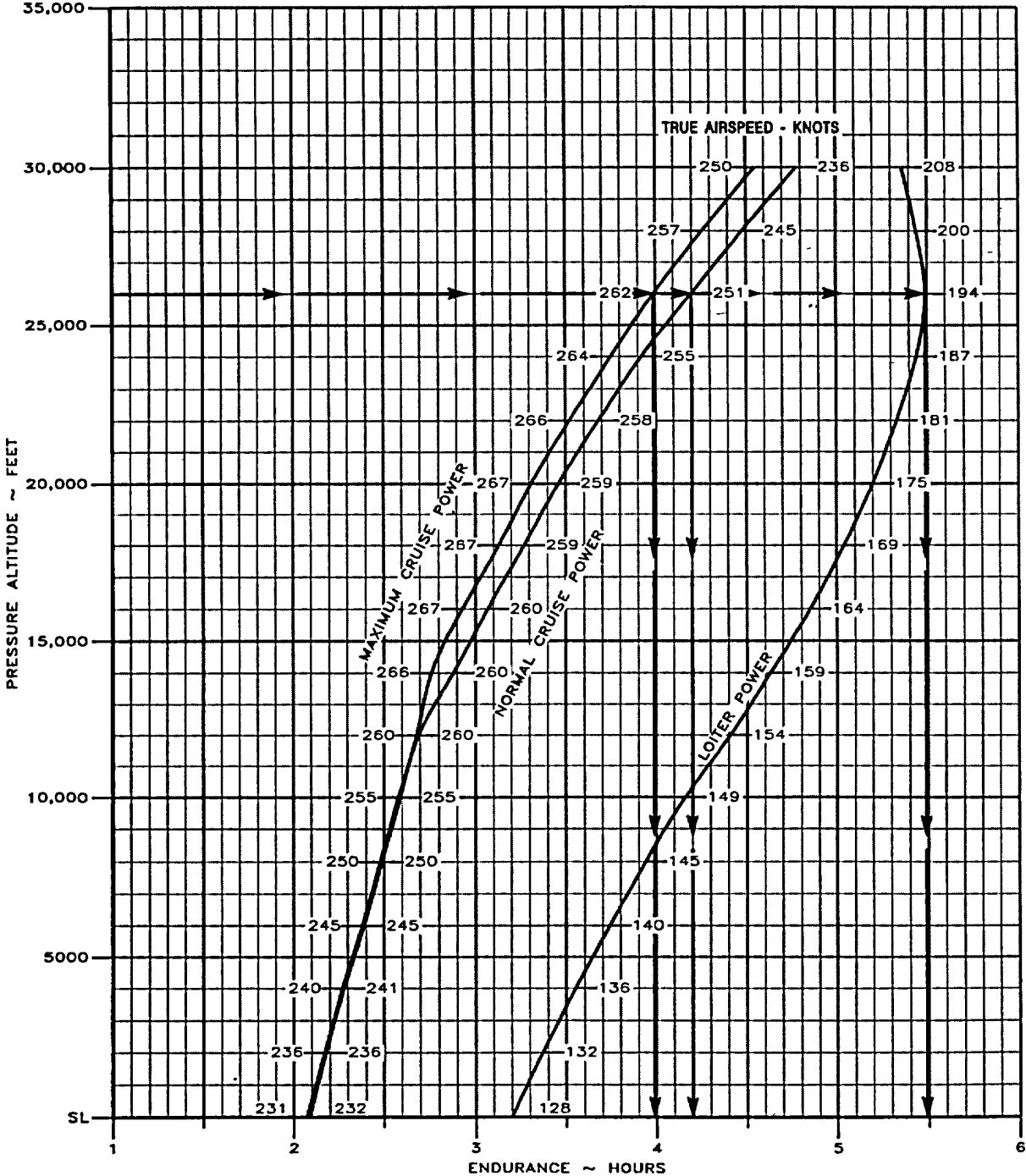

Figure 7A-85. Endurance Profile - Full Main and Aux Tanks

**MAXIMUM RANGE POWER  
1700 RPM  
ISA -30°C**

WEIGHT→			12,000 POUNDS					10,000 POUNDS				
PRESSURE ALTITUDE	IFAT	FAT	TORQUE PER ENGINE	FUEL FLOW PER ENGINE	TOTAL FUEL FLOW	IAS	TAS	TORQUE PER ENGINE	FUEL FLOW PER ENGINE	TOTAL FUEL FLOW	IAS	TAS
FEET	°C	°C	PERCENT	LBS/HR	LBS/HR	KTS	KTS	PERCENT	LBS/HR	LBS/HR	KTS	KTS
0	-12	-15	83	639	639	175	168	83	639	639	178	170
2000	-16	-19	83	620	620	174	172	83	619	619	177	174
4000	-20	-23	83	601	601	173	176	83	601	601	176	176
6000	-24	-27	83	588	588	171	179	83	587	587	174	182
8000	-28	-31	83	576	576	169	182	83	576	576	172	186
10,000	-32	-35	83	566	566	167	185	83	565	565	170	189
12,000	-35	-39	83	555	555	165	189	83	554	554	168	193
14,000	-39	-43	83	545	545	163	192	83	545	545	167	196
16,000	-43	-47	83	538	538	161	195	83	537	537	165	165
18,000	-47	-51	83	533	533	158	199	83	532	532	163	204
20,000	-51	-55	83	529	529	156	203	83	527	527	161	208
22,000	-55	-59	78	498	498	149	200	79	499	499	155	207
24,000	-59	-63	72	461	461	141	196	73	464	464	148	205
26,000	-63	-67	65	421	421	130	188	66	425	425	139	200
28,000	-68	-70	58	378	378	115	174	59	384	384	129	193
29,000	-69	-72	---	---	---	---	---	56	364	364	123	188
31,000	-74	-76	---	---	---	---	---	49	327	327	111	176
33,000	---	---	---	---	---	---	---	---	---	---	---	---
35,000	---	---	---	---	---	---	---	---	---	---	---	---

BT0587016

**NOTE**

During operations with ice vanes extended, torque will decrease approximately 10%, fuel flow will decrease approximately 6%, and true airspeed will be reduced by approximately 10 knots.

Figure 7A-86. One Engine Inoperative Max Cruise Power at 1700 RPM (Engine Anti-Ice Off) - ISA -30°C (Sheet 1 of 2)

**ONE-ENGINE INOPERATIVE:  
MAXIMUM CRUISE POWER  
1700 RPM  
ISA -30°C**

WEIGHT→			16,000 POUNDS					14,000 POUNDS				
PRESSURE ALTITUDE	IFAT	FAT	TORQUE PER ENGINE	FUEL FLOW PER ENGINE	TOTAL FUEL FLOW	IAS	TAS	TORQUE PER ENGINE	FUEL FLOW PER ENGINE	TOTAL FUEL FLOW	IAS	TAS
FEET	C°	C°	PERCENT	LBS/HR	LBS/HR	KTS	KTS	PERCENT	LBS/HR	LBS/HR	KTS	KTS
0	-13	-15	83	641	641	166	160	83	640	640	171	164
2000	-17	-19	83	621	621	165	163	83	620	620	170	168
4000	-20	-23	83	603	603	164	167	83	602	602	169	172
6000	-24	-27	83	590	590	162	170	83	589	589	168	175
8000	-28	-31	83	578	578	159	172	83	577	577	165	178
10,000	-32	-35	83	568	568	157	175	83	566	566	163	181
12,000	-36	-39	83	557	557	154	177	83	556	556	160	184
14,000	-40	-43	83	548	548	151	179	83	546	546	158	186
16,000	-44	-47	83	540	540	148	181	83	539	539	155	189
18,000	-48	-51	83	536	536	145	183	83	534	534	153	192
20,000	-52	-55	83	530	530	140	183	83	530	530	150	195
22,000	-55	-59	---	---	---	---	---	77	495	495	141	190
24,000	-60	-63	---	---	---	---	---	71	457	457	129	181
26,000	---	---	---	---	---	---	---	---	---	---	---	---
28,000	---	---	---	---	---	---	---	---	---	---	---	---
29,000	---	---	---	---	---	---	---	---	---	---	---	---
31,000	---	---	---	---	---	---	---	---	---	---	---	---
33,000	---	---	---	---	---	---	---	---	---	---	---	---
35,000	---	---	---	---	---	---	---	---	---	---	---	---

BT0587015

**NOTE**

During operations with ice vanes extended, torque will decrease approximately 10%, fuel flow will decrease approximately 6%, and true airspeed will be reduced by approximately 10 knots.

Figure 7A-86. One Engine Inoperative Max Cruise Power at 1700 RPM (Ice Vanes Retracted) - ISA -30°C (Sheet 2 of 2)

**ONE-ENGINE INOPERATIVE  
MAXIMUM CRUISE POWER  
1700 RPM  
ISA -20°C**

WEIGHT→			16,000 POUNDS					14,000 POUNDS				
PRESSURE ALTITUDE	IFAT	FAT	TORQUE PER ENGINE	FUEL FLOW PER ENGINE	TOTAL FUEL FLOW	IAS	TAS	TORQUE PER ENGINE	FUEL FLOW PER ENGINE	TOTAL FUEL FLOW	IAS	TAS
FEET	C°	C°	PERCENT	LBS/HR	LBS/HR	KTS	KTS	PERCENT	LBS/HR	LBS/HR	KTS	KTS
0	-3	-5	83	643	643	165	162	83	642	642	170	166
2000	-6	-9	83	624	624	164	166	83	623	623	169	171
4000	-10	-13	83	608	608	162	169	83	607	607	168	174
6000	-14	-17	83	594	594	160	171	83	592	592	166	177
8000	-18	-21	83	581	581	157	173	83	580	580	163	180
10,000	-22	-25	83	570	570	155	176	83	569	569	161	182
12,000	-26	-29	83	559	559	152	178	83	558	558	158	185
14,000	-30	-33	83	549	549	149	180	83	548	548	156	188
16,000	-34	-37	83	542	542	146	182	83	540	540	153	191
18,000	-38	-41	82	533	533	141	182	83	535	535	151	194
20,000	-41	-45	---	---	---	---	---	78	506	506	143	190
22,000	-45	-49	---	---	---	---	---	73	474	474	133	184
24,000	---	---	---	---	---	---	---	---	---	---	---	---
26,000	---	---	---	---	---	---	---	---	---	---	---	---
28,000	---	---	---	---	---	---	---	---	---	---	---	---
29,000	---	---	---	---	---	---	---	---	---	---	---	---
31,000	---	---	---	---	---	---	---	---	---	---	---	---
33,000	---	---	---	---	---	---	---	---	---	---	---	---
35,000	---	---	---	---	---	---	---	---	---	---	---	---

BT0587013

**NOTE**

During operations with ice vanes extended, torque will decrease approximately 10%, fuel flow will decrease approximately 6%, and true airspeed will be reduced by approximately 10 knots.

Figure 7A-87. One Engine Inoperative Max Cruise Power at 1700 RPM (Ice Vanes Retracted) - ISA -20°C (Sheet 1 of 2)

**ONE-ENGINE INOPERATIVE  
MAXIMUM CRUISE POWER  
1700 RPM  
ISA -20°C**

WEIGHT→			12,000 POUNDS					10,000 POUNDS				
PRESSURE ALTITUDE	IFAT	FAT	TORQUE PER ENGINE	FUEL FLOW PER ENGINE	TOTAL FUEL FLOW	IAS	TAS	TORQUE PER ENGINE	FUEL FLOW PER ENGINE	TOTAL FUEL FLOW	IAS	TAS
FEET	C°	C°	PERCENT	LBS/HR	LBS/HR	KTS	KTS	PERCENT	LBS/HR	LBS/HR	KTS	KTS
0	-2	-5	83	641	641	174	170	83	641	641	177	173
2000	-6	-9	83	622	622	173	175	83	621	621	176	177
4000	-10	-13	83	606	606	172	178	83	605"	605	175	181
6000	-14	-17	83	592	592	170	181	83	591	591	173	184
8000	-18	-21	83	579	579	167	184	83	579	579	171	188
10,000	-22	-25	83	568	568	165	187	83	567	567	169	191
12,000	-25	-29	83	557	557	163	191	83	557	557	167	195
14,000	-29	-33	83	548	548	161	194	83	547	547	165	198
16,000	-33	-37	83	540	540	159	198	83	539	539	163	203
18,000	-37	-41	83	534	534	157	201	83	533	533	161	206
20,000	-41	-45	79	508	508	150	200	79	509	509	156	206
22,000	-45	-49	74	477	477	143	197	74	478	478	149	205
24,000	-49	-53	69	445	445	135	192	69	447	447	142	202
26,000	-53	-57	63	412	412	125	185	64	415	415	135	199
28,000	-57	-60	---	---	---	---	---	58	381	381	126	193
29,000	-59	-62	---	---	---	---	---	55	363	363	120	188
31,000	-64	-66	---	---	---	---	---	49	328	328	107	176
33,000	---	---	---	---	---	---	---	---	---	---	---	---
35,000	---	---	---	---	---	---	---	---	---	---	---	---

BT0587014

**NOTE**

During operations with ice vanes extended, torque will decrease approximately 10%, fuel flow will decrease approximately 6%, and true airspeed will be reduced by approximately 10 knots.

Figure 7A-87. One Engine Inoperative Max Cruise Power at 1700 RPM (Ice Vanes Retracted) - ISA -20°C (Sheet 2 of 2)

**ONE-ENGINE INOPERATIVE  
MAXIMUM CRUISE POWER  
1700 RPM  
ISA -10°C**

WEIGHT→			16,000 POUNDS					14,000 POUNDS				
PRESSURE ALTITUDE	IFAT	FAT	TORQUE PER ENGINE	FUEL FLOW PER ENGINE	TOTAL FUEL FLOW	IAS	TAS	TORQUE PER ENGINE	FUEL FLOW PER ENGINE	TOTAL FUEL FLOW	IAS	TAS
FEET	C°	C°	PERCENT	LBS/HR	LBS/HR	KTS	KTS	PERCENT	LBS/HR	LBS/HR	KTS	KTS
0	7	5	83	649	649	164	164	83	648	648	170	169
2000	4	1	83	630	630	163	168	83	629	629	168	173
4000	0	-3	83	613	613	161	170	83	611	611	166	176
6000	-4	-7	83	597	597	158	172	83	596	596	164	178
8000	-8	-11	83	583	583	155	175	83	581	581	161	181
10,000	-12	-15	83	570	570	152	177	83	569	569	159	184
12,000	-16	-19	83	558	558	149	179	83	557	557	156	187
14,000	-20	-23	83	551	551	146	181	83	549	549	154	190
16,000	-24	-27	80	529	529	139	178	81	532	532	149	190
18,000	-27	-31	---	---	---	---	---	77	505	505	142	187
20,000	-32	-35	---	---	---	---	---	73	478	478	134	183
22,000	-36	-39	---	---	---	---	---	68	447	447	121	173
24,000	---	---	---	---	---	---	---	---	---	---	---	---
26,000	---	---	---	---	---	---	---	---	---	---	---	---
28,000	---	---	---	---	---	---	---	---	---	---	---	---
29,000	---	---	---	---	---	---	---	---	---	---	---	---
31,000	---	---	---	---	---	---	---	---	---	---	---	---
33,000	---	---	---	---	---	---	---	---	---	---	---	---
35,000	---	---	---	---	---	---	---	---	---	---	---	---

BT0587011

**NOTE**

During operations with ice vanes extended, torque will decrease approximately 10%, fuel flow will decrease approximately 6%, and true airspeed will be reduced by approximately 10 knots.

Figure 7A-88. One Engine Inoperative Max Cruise Power at 1700 RPM (Ice Vanes Retracted) - ISA -10°C (Sheet 1 of 2)



**ONE-ENGINE INOPERATIVE  
MAXIMUM CRUISE POWER  
1700 RPM  
ISA -10°C**

WEIGHT→			12,000 POUNDS					10,000 POUNDS				
PRESSURE ALTITUDE	IFAT	FAT	TORQUE PER ENGINE	FUEL FLOW PER ENGINE	TOTAL FUEL FLOW	IAS	TAS	TORQUE PER ENGINE	FUEL FLOW PER ENGINE	TOTAL FUEL FLOW	IAS	TAS
FEET	C°	C°	PERCENT	LBS/HR	LBS/HR	KTS	KTS	PERCENT	LBS/HR	LBS/HR	KTS	KTS
0	8	5	83	647	647	173	173	83	646	646	176	176
2000	4	1	83	628	628	172	177	83	627	627	175	180
4000	0	-3	83	611	611	170	180	83	610	610	173	183
6000	-4	-7	83	595	595	168	183	83	594	594	171	186
8000	-8	-11	83	581	581	166	186	83	580	580	169	190
10,000	-12	-15	83	568	568	164	189	83	567	567	167	193
12,000	-15	-19	83	557	557	161	192	83	556	556	165	197
14,000	-19	-23	83	549	549	159	196	83	548	548	163	201
16,000	-23	-27	82	534	534	156	198	82	535	535	160	204
18,000	-27	-31	78	507	507	150	197	78	508	508	155	204
20,000	-31	-35	74	481	481	144	195	74	482	482	150	203
22,000	-35	-39	69	451	451	136	191	70	453	453	143	201
24,000	-39	-43	64	420	420	126	185	65	423	423	136	198
26,000	-44	-47	59	389	389	114	175	60	393	393	128	194
28,000	-47	-50	---	---	---	---	---	55	364	364	119	187
29,000	-49	-52	---	---	---	---	---	52	349	349	114	183
31,000	---	---	---	---	---	---	---	---	---	---	---	---
33,000	---	---	---	---	---	---	---	---	---	---	---	---
35,000	---	---	---	---	---	---	---	---	---	---	---	---

BT0587012

**NOTE**

During operations with ice vanes extended, torque will decrease approximately 10%, fuel flow will decrease approximately 6%, and true airspeed will be reduced by approximately 10 knots.

Figure 7A-88. One Engine Inoperative Max Cruise Power at 1700 RPM (Ice Vanes Retracted) - ISA -10°C (Sheet 2 of 2)

**ONE-ENGINE INOPERATIVE  
MAXIMUM CRUISE POWER  
1700 RPM  
ISA**

WEIGHT→			16,000 POUNDS					14,000 POUNDS				
PRESSURE ALTITUDE	IFAT	FAT	TORQUE PER ENGINE	FUEL FLOW PER ENGINE	TOTAL FUEL FLOW	IAS	TAS	TORQUE PER ENGINE	FUEL FLOW PER ENGINE	TOTAL FUEL FLOW	IAS	TAS
FEET	C°	C°	PERCENT	LBS/HR	LBS/HR	KTS	KTS	PERCENT	LBS/HR	LBS/HR	KTS	KTS
0	18	15	83	648	648	163	166	83	647	647	169	171
2000	14	11	83	632	632	161	169	83	631	631	167	174
4000	10	7	83	615	615	159	171	83	614	614	165	177
6000	6	3	83	599	599	156	173	83	598	598	162	180
8000	2	-1	83	584	584	153	176	83	583	583	160	183
10,000	-2	-5	83	571	571	150	178	83	570	570	157	185
12,000	-6	-9	82	553	553	146	178	83	555	555	154	188
14,000	-10	-13	77	520	520	135	171	78	524	524	147	185
16,000	-14	-17	---	---	---	---	---	74	495	495	139	182
18,000	-18	-21	---	---	---	---	---	70	469	469	131	177
20,000	---	---	---	---	---	---	---	---	---	---	---	---
22,000	---	---	---	---	---	---	---	---	---	---	---	---
24,000	---	---	---	---	---	---	---	---	---	---	---	---
26,000	---	---	---	---	---	---	---	---	---	---	---	---
28,000	---	---	---	---	---	---	---	---	---	---	---	---
29,000	---	---	---	---	---	---	---	---	---	---	---	---
31,000	---	---	---	---	---	---	---	---	---	---	---	---
33,000	---	---	---	---	---	---	---	---	---	---	---	---
35,000	---	---	---	---	---	---	---	---	---	---	---	---

BT058709

**NOTE**

During operations with ice vanes extended, torque will decrease approximately 10%, fuel flow will decrease approximately 6%, and true airspeed will be reduced by approximately 10 knots.

Figure 7A-89. One Engine Inoperative Max Cruise Power at 1700 RPM (Ice Vanes Retracted) - ISA (Sheet 1 of 2)

**ONE-ENGINE INOPERATIVE  
MAXIMUM CRUISE POWER  
1700 RPM  
ISA**

WEIGHT→			12,000 POUNDS					10,000 POUNDS				
PRESSURE ALTITUDE	IFAT	FAT	TORQUE PER ENGINE	FUEL FLOW PER ENGINE	TOTAL FUEL FLOW	IAS	TAS	TORQUE PER ENGINE	FUEL FLOW PER ENGINE	TOTAL FUEL FLOW	IAS	TAS
FEET	C°	C°	PERCENT	LBS/HR	LBS/HR	KTS	KTS	PERCENT	LBS/HR	LBS/HR	KTS	KTS
0	18	15	83	646	646	173	175	83	646	646	176	178
2000	14	11	83	630	630	171	178	83	629	629	174	181
4000	10	7	83	614	614	169	181	83	613	613	172	185
6000	6	3	83	597	597	166	184	83	596	596	170	188
8000	2	-1	83	582	582	164	188	83	582	582	168	191
10,000	-1	-5	83	569	569	162	191	83	568	568	166	195
12,000	-5	-9	83	557	557	160	194	83	557	557	164	199
14,000	-9	-13	79	526	526	154	193	79	528	528	159	199
16,000	-13	-17	75	498	498	148	192	75	500	500	153	199
18,000	-17	-21	71	472	472	141	190	72	474	474	148	198
20,000	-21	-25	67	447	447	134	187	68	449	449	142	197
22,000	-25	-29	63	420	420	126	182	64	422	422	135	195
24,000	-30	-33	59	393	393	116	174	60	396	396	128	192
26,000	-33	-37	---	---	---	---	---	55	370	370	120	187
28,000	-37	-40	---	---	---	---	---	51	343	343	111	179
29,000	-40	-42	---	---	---	---	---	48	329	329	104	173
31,000	---	---	---	---	---	---	---	---	---	---	---	---
33,000	---	---	---	---	---	---	---	---	---	---	---	---
35,000	---	---	---	---	---	---	---	---	---	---	---	---

BT0587010

**NOTE**

**During operations with ice vanes extended, torque will decrease approximately 10%, fuel flow will decrease approximately 6%, and true airspeed will be reduced by approximately 10 knots.**

*Figure 7A-89. One Engine Inoperative Max Cruise Power at 1700 RPM (Ice Vanes Retracted) - ISA (Sheet 2 of 2)*

**ONE-ENGINE INOPERATIVE  
MAXIMUM CRUISE POWER  
1700 RPM  
ISA +10°C**

WEIGHT→			16,000 POUNDS					14,000 POUNDS				
PRESSURE ALTITUDE	IFAT	FAT	TORQUE PER ENGINE	FUEL FLOW PER ENGINE	TOTAL FUEL FLOW	IAS	TAS	TORQUE PER ENGINE	FUEL FLOW PER ENGINE	TOTAL FUEL FLOW	IAS	TAS
FEET	C°	C°	PERCENT	LBS/HR	LBS/HR	KTS	KTS	PERCENT	LBS/HR	LBS/HR	KTS	KTS
0	28	25	83	653	653	162	167	83	651	651	167	173
2000	24	21	83	631	631	159	170	83	630	630	165	176
4000	20	17	83	612	612	157	172	83	611	611	163	178
6000	16	13	83	595	595	154	175	83	594	594	161	181
8000	12	9	83	582	582	151	177	83	581	581	158	184
10,000	8	5	78	547	547	141	171	79	550	550	151	182
12,000	4	1	74	516	516	131	164	75	520	520	145	180
14,000	0	-3	---	---	---	---	---	71	488	488	137	176
16,000	-4	-7	---	---	---	---	---	67	458	458	127	169
18,000	---	---	---	---	---	---	---	---	---	---	---	---
20,000	---	---	---	---	---	---	---	---	---	---	---	---
22,000	---	---	---	---	---	---	---	---	---	---	---	---
24,000	---	---	---	---	---	---	---	---	---	---	---	---
26,000	---	---	---	---	---	---	---	---	---	---	---	---
28,000	---	---	---	---	---	---	---	---	---	---	---	---
29,000	---	---	---	---	---	---	---	---	---	---	---	---
31,000	---	---	---	---	---	---	---	---	---	---	---	---
33,000	---	---	---	---	---	---	---	---	---	---	---	---
35,000	---	---	---	---	---	---	---	---	---	---	---	---

BT058707

**NOTE**

During operations with ice vanes extended, torque will decrease approximately 10%, fuel flow will decrease approximately 6%, and true airspeed will be reduced by approximately 10 knots.

*Figure 7A-90. One Engine Inoperative Max Cruise Power at 1700 RPM (Ice Vanes Retracted) - ISA +10°C  
(Sheet 1 of 2)*

**ONE-ENGINE INOPERATIVE  
MAXIMUM CRUISE POWER  
1700 RPM  
ISA +10°C**

WEIGHT→			12,000 POUNDS					10,000 POUNDS				
PRESSURE ALTITUDE	IFAT	FAT	TORQUE PER ENGINE	FUEL FLOW PER ENGINE	TOTAL FUEL FLOW	IAS	TAS	TORQUE PER ENGINE	FUEL FLOW PER ENGINE	TOTAL FUEL FLOW	IAS	TAS
FEET	C°	C°	PERCENT	LBS/HR	LBS/HR	KTS	KTS	PERCENT	LBS/HR	LBS/HR	KTS	KTS
0	28	25	83	651	651	171	177	83	650	650	174	180
2000	24	21	83	629	629	169	180	83	629	629	172	183
4000	20	17	83	610	610	167	183	83	610	610	170	186
6000	16	13	83	593	593	165	186	83	593	593	168	190
8000	12	9	83	580	580	163	189	83	580	580	166	193
10,000	8	5	79	553	553	157	189	80	554	554	162	194
12,000	5	1	76	523	523	152	188	76	524	524	157	194
14,000	1	-3	72	491	491	145	187	72	493	493	151	194
16,000	-4	-7	68	462	462	139	184	69	464	464	145	193
18,000	-8	-11	64	435	435	131	181	65	437	437	139	191
20,000	-12	-15	60	409	409	123	176	61	412	412	133	189
22,000	-16	-19	56	384	384	111	165	57	388	388	126	186
24,000	-19	-23	---	---	---	---	---	53	364	364	119	182
26,000	-24	-27	---	---	---	---	---	50	341	341	110	176
28,000	---	---	---	---	---	---	---	---	---	---	---	---
29,000	---	---	---	---	---	---	---	---	---	---	---	---
31,000	---	---	---	---	---	---	---	---	---	---	---	---
33,000	---	---	---	---	---	---	---	---	---	---	---	---
35,000	---	---	---	---	---	---	---	---	---	---	---	---

BT068708

**NOTE**

**During operations with ice vanes extended, torque will decrease approximately 10%, fuel flow will decrease approximately 6%, and true airspeed will be reduced by approximately 10 knots.**

*Figure 7A-90. One Engine Inoperative Max Cruise Power at 1700 RPM (Ice Vanes Retracted) - ISA +10°C (Sheet 2 of 2)*

**ONE-ENGINE INOPERATIVE  
MAXIMUM CRUISE POWER  
1700 RPM  
ISA +20°C**

WEIGHT→			16,000 POUNDS					14,000 POUNDS				
PRESSURE ALTITUDE	IFAT	FAT	TORQUE PER ENGINE	FUEL FLOW PER ENGINE	TOTAL FUEL FLOW	IAS	TAS	TORQUE PER ENGINE	FUEL FLOW PER ENGINE	TOTAL FUEL FLOW	IAS	TAS
FEET	C°	C°	PERCENT	LBS/HR	LBS/HR	KTS	KTS	PERCENT	LBS/HR	LBS/HR	KTS	KTS
0	38	35	83	655	655	160	169	83	654	654	166	174
2000	34	31	83	634	634	158	171	83	633	633	164	177
4000	30	27	81	605	605	153	171	82	607	607	160	178
6000	26	23	78	574	574	146	168	79	577	577	155	178
8000	22	19	75	543	543	138	164	76	547	547	149	177
10,000	18	15	---	---	---	---	---	72	516	516	142	175
12,000	14	11	---	---	---	---	---	69	484	484	134	171
14,000	10	7	---	---	---	---	---	63	449	449	121	160
16,000	---	---	---	---	---	---	---	---	---	---	---	---
18,000	---	---	---	---	---	---	---	---	---	---	---	---
20,000	---	---	---	---	---	---	---	---	---	---	---	---
22,000	---	---	---	---	---	---	---	---	---	---	---	---
24,000	---	---	---	---	---	---	---	---	---	---	---	---
26,000	---	---	---	---	---	---	---	---	---	---	---	---
28,000	---	---	---	---	---	---	---	---	---	---	---	---
29,000	---	---	---	---	---	---	---	---	---	---	---	---
31,000	---	---	---	---	---	---	---	---	---	---	---	---
33,000	---	---	---	---	---	---	---	---	---	---	---	---
35,000	---	---	---	---	---	---	---	---	---	---	---	---

BT058706

**NOTE**

During operations with ice vanes extended, torque will decrease approximately 10%, fuel flow will decrease approximately 6%, and true airspeed will be reduced by approximately 10 knots.

Figure 7A-91. One Engine Inoperative Max Cruise Power at 1700 RPM (Ice Vanes Retracted) - ISA +20°C (Sheet 1 of 2)

**ONE-ENGINE INOPERATIVE  
MAXIMUM CRUISE POWER.  
1700 RPM  
ISA +20°C**

WEIGHT→			12,000 POUNDS					10,000 POUNDS				
PRESSURE ALTITUDE	IFAT	FAT	TORQUE PER ENGINE	FUEL FLOW PER ENGINE	TOTAL FUEL FLOW	IAS	TAS	TORQUE PER ENGINE	FUEL FLOW PER ENGINE	TOTAL FUEL FLOW	IAS	TAS
FEET	C°	C°	PERCENT	LBS/HR	LBS/HR	KTS	KTS	PERCENT	LBS/HR	LBS/HR	KTS	KTS
0	38	35	83	653	653	170	178	83	653	653	173	182
2000	34	31	83	632	632	168	181	83	632	632	171	185
4000	30	27	82	609	609	165	184	82	610	610	168	188
6000	26	23	79	578	578	160	184	80	580	580	164	189
8000	22	19	76	548	548	155	184	77	550	550	160	189
10,000	18	15	73	518	518	150	183	73	519	519	155	189
12,000	14	11	69	487	487	144	182	70	489	489	150	189
14,000	10	7	65	454	454	136	178	65	456	456	143	187
16,000	6	3	60	425	425	127	173	61	427	427	136	185
18,000	2	-1	57	398	398	118	166	58	402	402	130	183
20,000	-2	-5	---	---	---	---	---	54	376	376	123	179
22,000	-6	-9	---	---	---	---	---	50	353	353	115	174
24,000	-10	-13	---	---	---	---	---	47	330	330	105	166
26,000	---	---	---	---	---	---	---	---	---	---	---	---
28,000	---	---	---	---	---	---	---	---	---	---	---	---
29,000	---	---	---	---	---	---	---	---	---	---	---	---
31,000	---	---	---	---	---	---	---	---	---	---	---	---
33,000	---	---	---	---	---	---	---	---	---	---	---	---
35,000	---	---	---	---	---	---	---	---	---	---	---	---

BT068706

**NOTE**

During operations with ice vanes extended, torque will decrease approximately 10%, fuel flow will decrease approximately 6%, and true airspeed will be reduced by approximately 10 knots.

Figure 7A-91. One Engine Inoperative Max Cruise Power at 1700 RPM (Ice Vanes Retracted) - ISA +20°C (Sheet 2 of 2)

**ONE-ENGINE INOPERATIVE  
MAXIMUM CRUISE POWER  
1700 RPM  
ISA +30°C**

WEIGHT→			16,000 POUNDS					14,000 POUNDS				
PRESSURE ALTITUDE	IFAT	FAT	TORQUE PER ENGINE	FUEL FLOW PER ENGINE	TOTAL FUEL FLOW	IAS	TAS	TORQUE PER ENGINE	FUEL FLOW PER ENGINE	TOTAL FUEL FLOW	IAS	TAS
FEET	C°	C°	PERCENT	LBS/HR	LBS/HR	KTS	KTS	PERCENT	LBS/HR	LBS/HR	KTS	KTS
0	47	45	75	625	625	148	159	75	626	626	157	168
2000	43	41	73	595	595	143	158	74	597	597	153	168
4000	39	37	70	565	565	136	156	71	567	567	148	168
6000	36	33	---	---	---	---	---	69	538	538	142	167
8000	32	29	---	---	---	---	---	66	508	508	135	164
10,000	28	25	---	---	---	---	---	63	476	476	126	159
12,000	---	---	---	---	---	---	---	---	---	---	---	---
14,000	---	---	---	---	---	---	---	---	---	---	---	---
16,000	---	---	---	---	---	---	---	---	---	---	---	---
18,000	---	---	---	---	---	---	---	---	---	---	---	---
20,000	---	---	---	---	---	---	---	---	---	---	---	---
22,000	---	---	---	---	---	---	---	---	---	---	---	---
24,000	---	---	---	---	---	---	---	---	---	---	---	---
26,000	---	---	---	---	---	---	---	---	---	---	---	---
28,000	---	---	---	---	---	---	---	---	---	---	---	---
29,000	---	---	---	---	---	---	---	---	---	---	---	---
31,000	---	---	---	---	---	---	---	---	---	---	---	---
33,000	---	---	---	---	---	---	---	---	---	---	---	---
35,000	---	---	---	---	---	---	---	---	---	---	---	---

BT058703

**NOTE**

During operations with ice vanes extended, torque will decrease approximately 10%, fuel flow will decrease approximately 6%, and true airspeed will be reduced by approximately 10 knots.

Figure 7A-92. One Engine Inoperative Max Cruise Power at 1700 RPM (Ice Vanes Retracted) - ISA +30°C (Sheet 1 of 2)



**ONE-ENGINE INOPERATIVE  
MAXIMUM CRUISE POWER  
1700 RPM  
ISA +30°C**

WEIGHT→			12,000 POUNDS					10,000 POUNDS				
PRESSURE ALTITUDE	IFAT	FAT	TORQUE PER ENGINE	FUEL FLOW PER ENGINE	TOTAL FUEL FLOW	IAS	TAS	TORQUE PER ENGINE	FUEL FLOW PER ENGINE	TOTAL FUEL FLOW	IAS	TAS
FEET	C°	C°	PERCENT	LBS/HR	LBS/HR	KTS	KTS	PERCENT	LBS/HR	LBS/HR	KTS	KTS
0	48	45	76	627	627	162	173	76	628	628	166	178
2000	44	41	74	598	598	159	175	75	599	599	163	179
4000	40	37	72	569	569	154	175	73	570	570	159	180
6000	36	33	70	540	540	150	176	70	541	541	155	181
8000	32	29	67	510	510	145	175	68	511	511	150	182
10,000	28	25	64	479	479	139	174	65	481	481	145	181
12,000	24	21	61	448	448	132	171	62	450	450	140	180
14,000	20	17	57	419	419	124	166	58	422	422	134	179
16,000	16	13	53	388	388	111	156	54	392	392	127	176
18,000	12	9	---	---	---	---	---	49	361	361	116	168
20,000	8	5	---	---	---	---	---	45	335	335	106	159
22,000	---	---	---	---	---	---	---	---	---	---	---	---
24,000	---	---	---	---	---	---	---	---	---	---	---	---
26,000	---	---	---	---	---	---	---	---	---	---	---	---
28,000	---	---	---	---	---	---	---	---	---	---	---	---
29,000	---	---	---	---	---	---	---	---	---	---	---	---
31,000	---	---	---	---	---	---	---	---	---	---	---	---
33,000	---	---	---	---	---	---	---	---	---	---	---	---
35,000	---	---	---	---	---	---	---	---	---	---	---	---

BT08704

**NOTE**

**During operations with ice vanes extended, torque will decrease approximately 10%, fuel flow will decrease approximately 6%, and true airspeed will be reduced by approximately 10 knots.**

*Figure 7A-92. One Engine Inoperative Max Cruise Power at 1700 RPM (Ice Vanes Retracted) - ISA +30°C (Sheet 2 of 2)*

**ON E-ENGINE-INOPERATIVE  
MAXIMUM CRUISE POWER  
1700 RPM  
ISA +37°C**

WEIGHT→			16,000 POUNDS					14,000 POUNDS				
PRESSURE ALTITUDE	IFAT	FAT	TORQUE PER ENGINE	FUEL FLOW PER ENGINE	TOTAL FUEL FLOW	IAS	TAS	TORQUE PER ENGINE	FUEL FLOW PER ENGINE	TOTAL FUEL FLOW	IAS	TAS
FEET	C°	C°	PERCENT	LBS/HR	LBS/HR	KTS	KTS	PERCENT	LBS/HR	LBS/HR	KTS	KTS
0	54	52	66	596	596	133	144	67	598	598	144	156
2000	50	48	---	---	---	---	---	66	568	568	140	157
4000	46	44	---	---	---	---	---	64	539	539	136	157
6000	42	40	---	---	---	---	---	62	511	511	131	156
8000	38	36	---	---	---	---	---	60	482	482	123	151
10,000	---	---	---	---	---	---	---	---	---	---	---	---
12,000	---	---	---	---	---	---	---	---	---	---	---	---
14,000	---	---	---	---	---	---	---	---	---	---	---	---
16,000	---	---	---	---	---	---	---	---	---	---	---	---
18,000	---	---	---	---	---	---	---	---	---	---	---	---
20,000	---	---	---	---	---	---	---	---	---	---	---	---
22,000	---	---	---	---	---	---	---	---	---	---	---	---
24,000	---	---	---	---	---	---	---	---	---	---	---	---
26,000	---	---	---	---	---	---	---	---	---	---	---	---
28,000	---	---	---	---	---	---	---	---	---	---	---	---
29,000	---	---	---	---	---	---	---	---	---	---	---	---
31,000	---	---	---	---	---	---	---	---	---	---	---	---
33,000	---	---	---	---	---	---	---	---	---	---	---	---
35,000	---	---	---	---	---	---	---	---	---	---	---	---

BT05870

**NOTE**

During operations with ice vanes extended, torque will decrease approximately 10%, fuel flow will decrease approximately 6%, and true airspeed will be reduced by approximately 10 knots.

Figure 7A-93. One Engine Inoperative Max Cruise Power at 1700 RPM (Ice Vanes Retracted) - ISA +37°C (Sheet 1 of 2)

**ONE-ENGINE INOPERATIVE  
MAXIMUM CRUISE POWER  
1700 RPM  
ISA +37°C**

WEIGHT→			12,000 POUNDS					10,000 POUNDS				
PRESSURE ALTITUDE	IFAT	FAT	TORQUE PER ENGINE	FUEL FLOW PER ENGINE	TOTAL FUEL FLOW	IAS	TAS	TORQUE PER ENGINE	FUEL FLOW PER ENGINE	TOTAL FUEL FLOW	IAS	TAS
FEET	C°	C°	PERCENT	LBS/HR	LBS/HR	KTS	KTS	PERCENT	LBS/HR	LBS/HR	KTS	KTS
0	54	52	68	599	599	152	164	68	600	600	157	169
2000	51	48	66	570	570	148	166	67	571	571	154	171
4000	47	44	65	541	541	145	167	65	542	542	151	174
6000	43	40	63	513	513	141	168	64	515	515	148	175
8000	39	36	61	485	485	136	167	62	487	487	143	176
10,000	35	32	58	454	454	129	164	59	457	457	138	175
12,000	31	28	54	422	422	121	159	55	425	425	132	173
14,000	27	24	---	---	---	---	---	52	396	396	125	170
16,000	23	20	---	---	---	---	---	48	367	367	117	165
18,000	19	16	---	---	---	---	---	44	337	337	106	156
20,000	---	---	---	---	---	---	---	---	---	---	---	---
22,000	---	---	---	---	---	---	---	---	---	---	---	---
24,000	---	---	---	---	---	---	---	---	---	---	---	---
26,000	---	---	---	---	---	---	---	---	---	---	---	---
28,000	---	---	---	---	---	---	---	---	---	---	---	---
29,000	---	---	---	---	---	---	---	---	---	---	---	---
31,000	---	---	---	---	---	---	---	---	---	---	---	---
33,000	---	---	---	---	---	---	---	---	---	---	---	---
35,000	---	---	---	---	---	---	---	---	---	---	---	---

BT058702

**NOTE**

**During operations with ice vanes extended, torque will decrease approximately 10%, fuel flow will decrease approximately 6%, and true airspeed will be reduced by approximately 10 knots.**

*Figure 7A-93. One Engine Inoperative Max Cruise Power at 1700 RPM (Ice Vanes Retracted) - ISA +37°C (Sheet 2 of 2)*

**TIME, FUEL, AND DISTANCE TO DESCEND**

ASSOCIATED CONDITIONS:

POWER.....AS REQUIRED TO DESCEND  
 AT 1500 FT/MIN

LANDING GEAR .....UP

FLAPS .....UP

EXAMPLE:

INITIAL ALTITUDE ..... 25,000 FT

FINAL ALTITUDE..... 5998 FT

TIME TO DESCEND (17-4) ..... 13 MIN

FUEL TO DESCEND (208-60)..... 148 LBS

DISTANCE TO DESCEND (64-13)..... 51 NM

DESCENT SPEED:  $M_{MO}$  OR 200 KNOTS, WHICHEVER IS LESS.

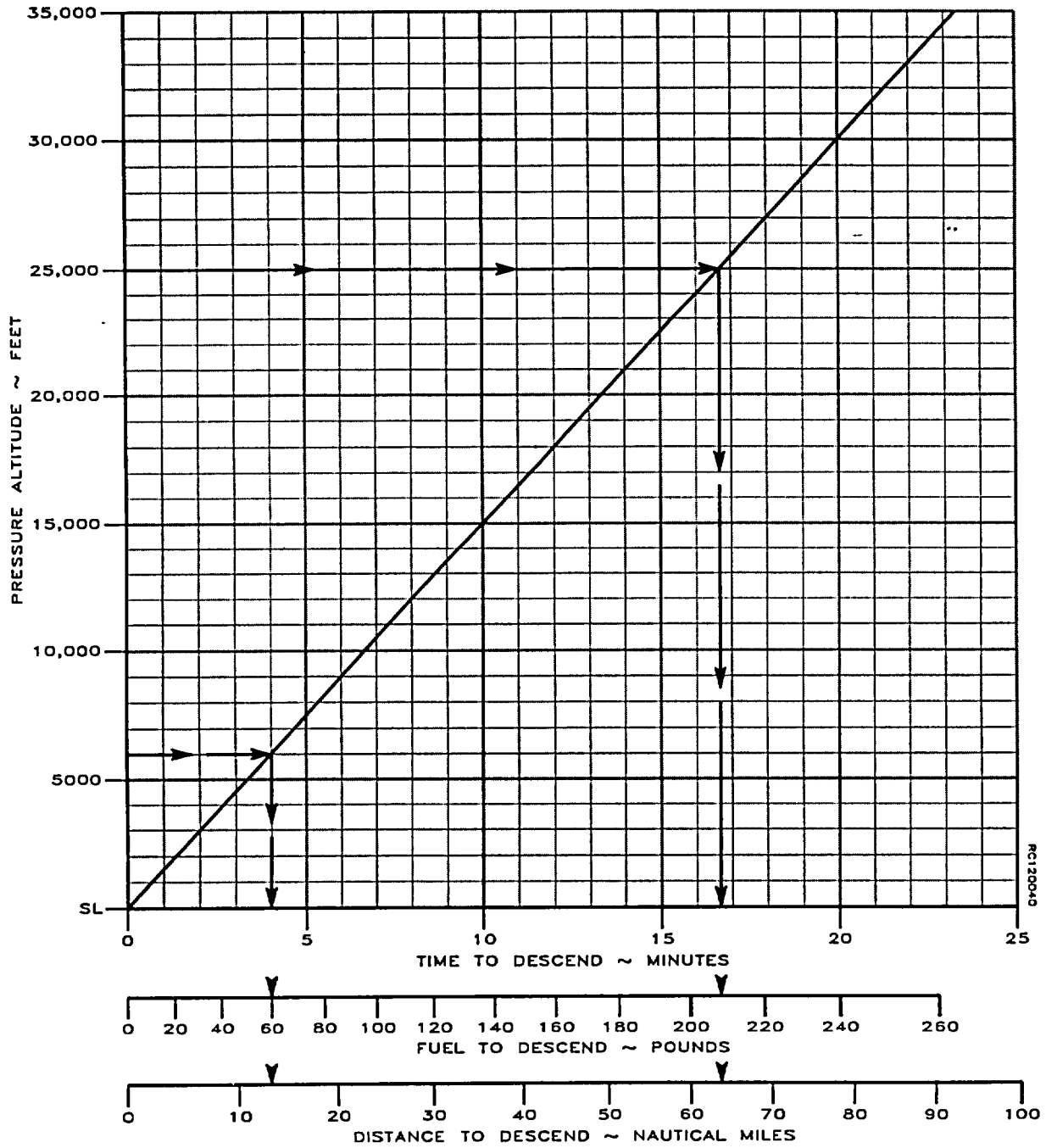

Figure 7A-94. Time, Fuel, and Distance to Descend

**CLIMB - BALKED LANDING**

ASSOCIATED CONDITIONS:  
 POWER.....TAKEOFF  
 FLAPS.....DOWN  
 LANDING GEAR.....DOWN

EXAMPLE:  
 FAT .....20°C  
 PRESSURE ALTITUDE.....6400 FT  
 WEIGHT.....15,204 LBS  
 RATE-OF-CLIMB.....1423 FT/MIN  
 CLIMB GRADIENT.....9.6 %

CLIMB SPEED: 111 KNOTS (ALL WEIGHTS)

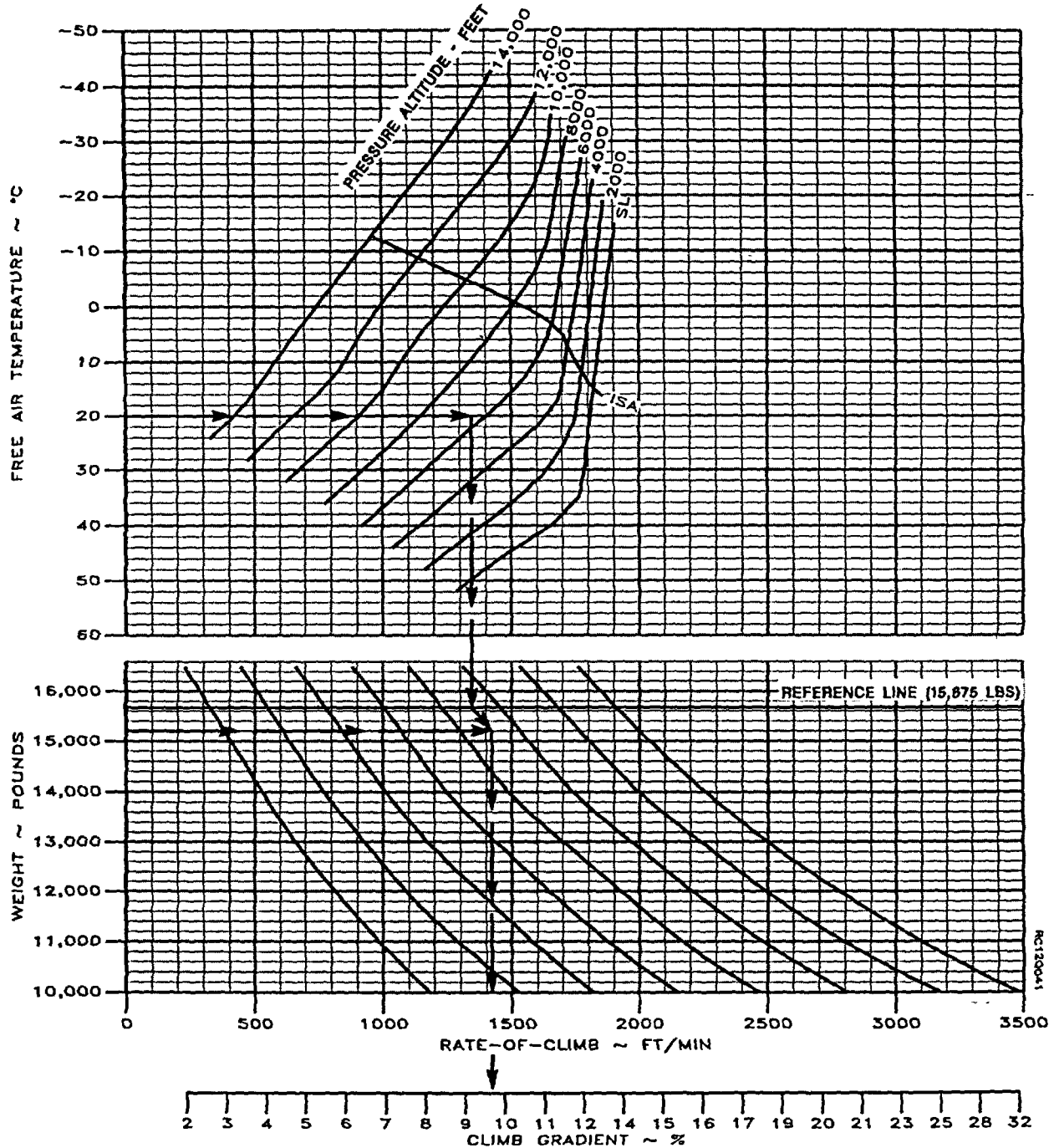

Figure 7A-95. Climb - Balked Landing

**NORMAL LANDING DISTANCE - FLAPS DOWN**

ASSOCIATED CONDITIONS:

POWER..... RETARDED TO MAINTAIN 500  
 FT/MIN ON FINAL APPROACH  
 RUNWAY ..... PAVED, DRY SURFACE  
 POWER LEVERS .... GROUND FINE AT TOUCHDOWN  
 BRAKING ..... MAXIMUM WITHOUT SLIDING  
 TIRES  
 OBSTACLE HEIGHT 50 FT

EXAMPLE:

FAT .....20°C  
 FIELD PRESSURE ALTITUDE.....5998 FT  
 RUNWAY GRADIENT .....0.3%UP  
 HEADWIND COMPONENT .....10 KTS  
 GROUND ROLL.....1857 FT  
 TOTAL DISTANCE OVER  
 50-FT OBSTACLE .....4702 FT

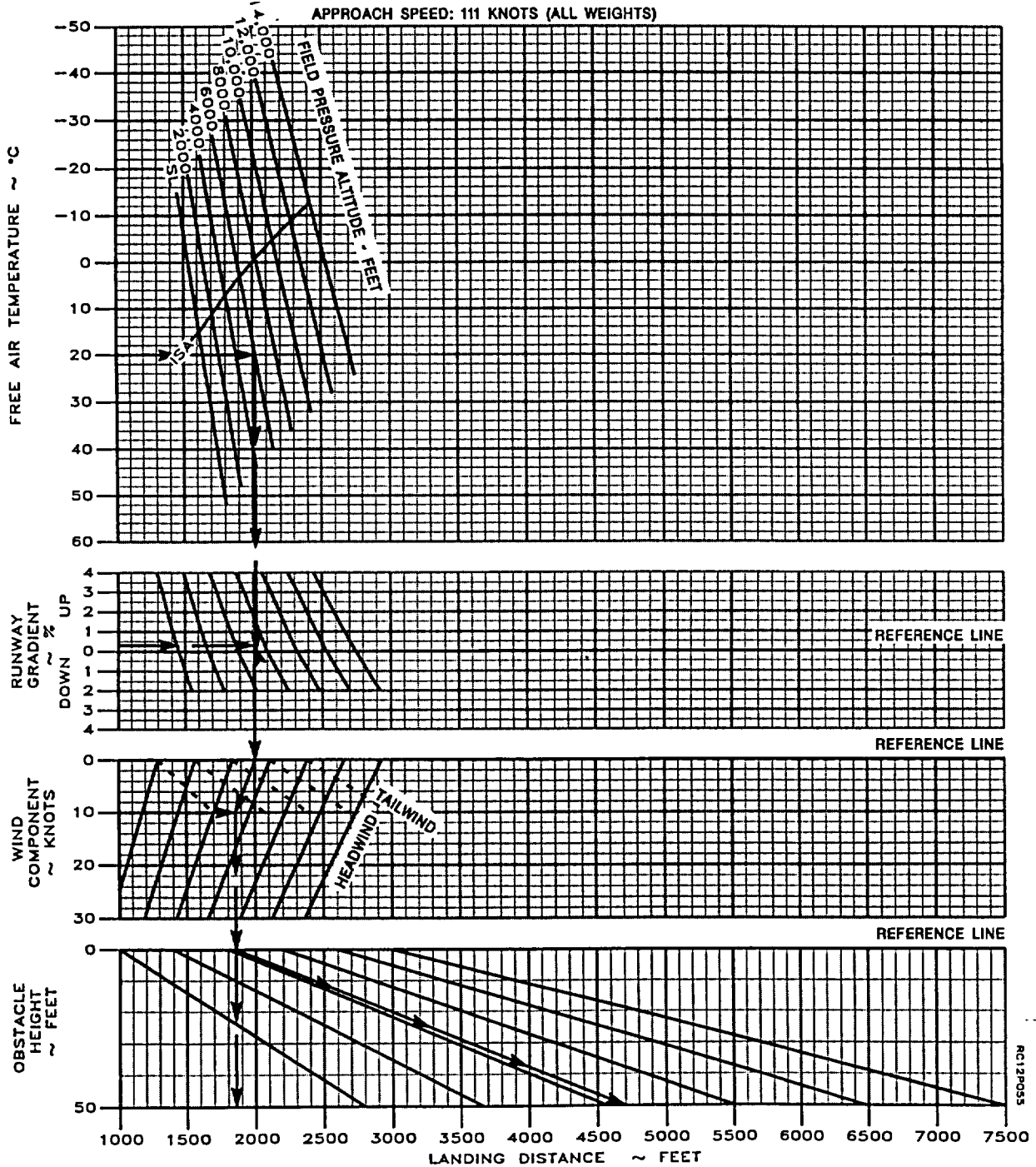

Figure 7A-96. Normal Landing Distance - Flaps Down

**LANDING DISTANCE - FLAPS UP**

ASSOCIATED CONDITIONS:

POWER ..... RETARDED TO MAINTAIN  
 500 FT/MIN ON FINAL  
 APPROACH  
 RUNWAY ..... PAVED DRY SURFACE  
 APPROACH SPEED ..... KIAS AS TABULATED  
 POWER LEVERS ..... GROUND FINE AT  
 TOUCHDOWN  
 BRAKING ..... MAXIMUM WITHOUT  
 SLIDING TIRES  
 OBSTACLE HEIGHT ..... 50 FT

EXAMPLE:

FLAPS-DOWN NORMAL LANDING DISTANCE .4702 FT  
 LANDING WEIGHT ..... 15,204 LBS  
 FLAPS-UP LANDING DISTANCE ..... 7158 FT  
 APPROACH SPEED ..... 136 KTS

WEIGHT	APPROACH SPEEDS
~ POUNDS	~ KNOTS
15,675	158
15,000	135
14,000	13
13,000	127
12,000	122
11,000	117
10,000	111

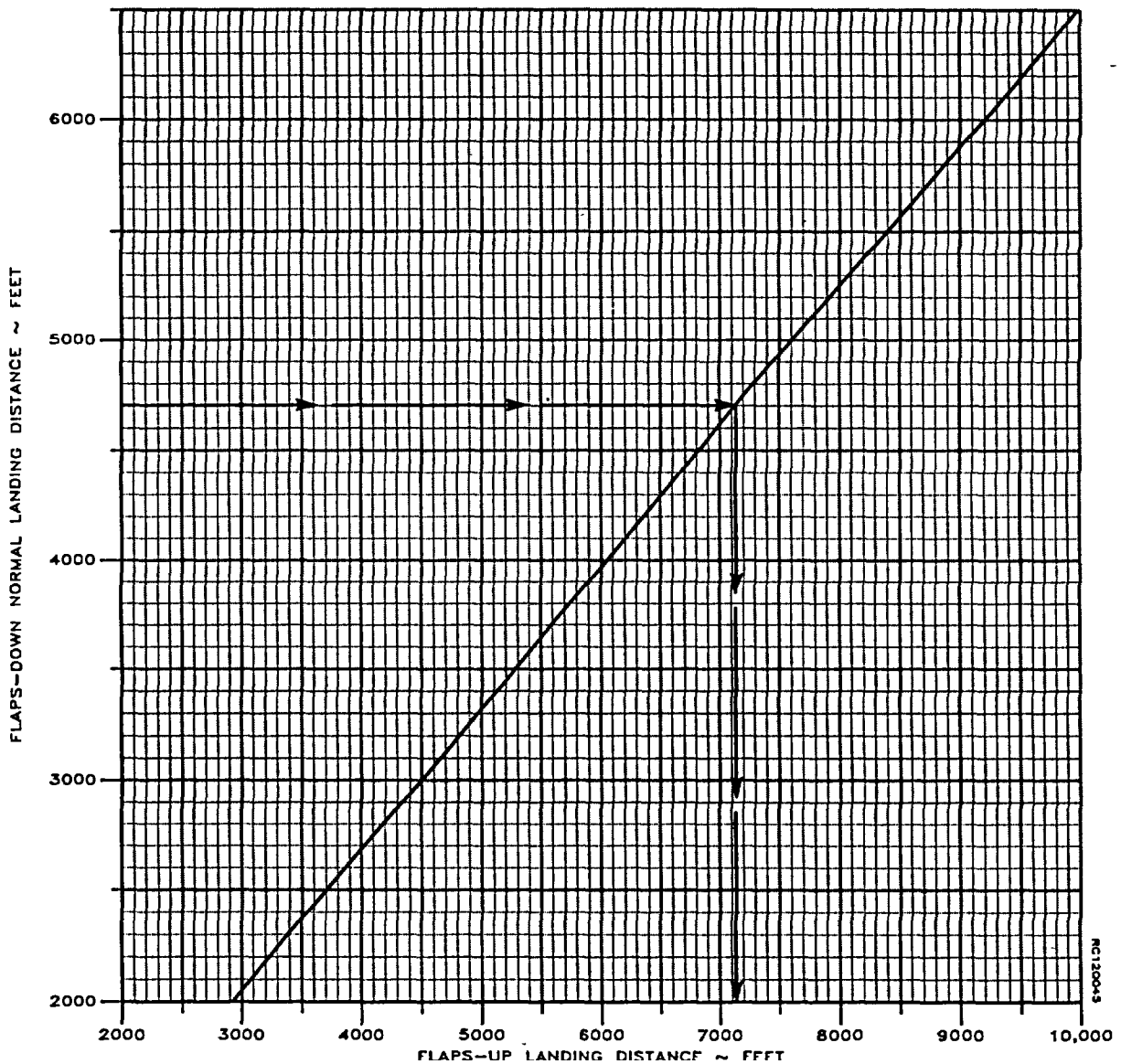

Figure 7A-97. Normal Landing Distance - Flaps Up

### LANDING DISTANCE - ONE ENGINE INOPERATIVE FLAPS DOWN

APPROACH SPEED: 111 KNOTS (ALL WEIGHTS)

ASSOCIATED CONDITIONS:

POWER..... RETARDED TO MAINTAIN  
500 FT/MIN ON FINAL  
APPROACH  
PROPELLER CONTROL:

INOPERATIVE ENGINE ..... FEATHERED  
RUNWAY ..... PAVED, DRY SURFACE

POWER LEVERS:  
OPERATIVE ENGINE ..... GROUND FINE AT  
TOUCHDOWN

OBSTACLE HEIGHT ..... 50 FT

EXAMPLE:

FLAPS-DOWN NORMAL LANDING DISTANCE 4702 FT  
ONE-ENGINE-INOPERATIVE LANDING DISTANCE  
..... 5834 FT

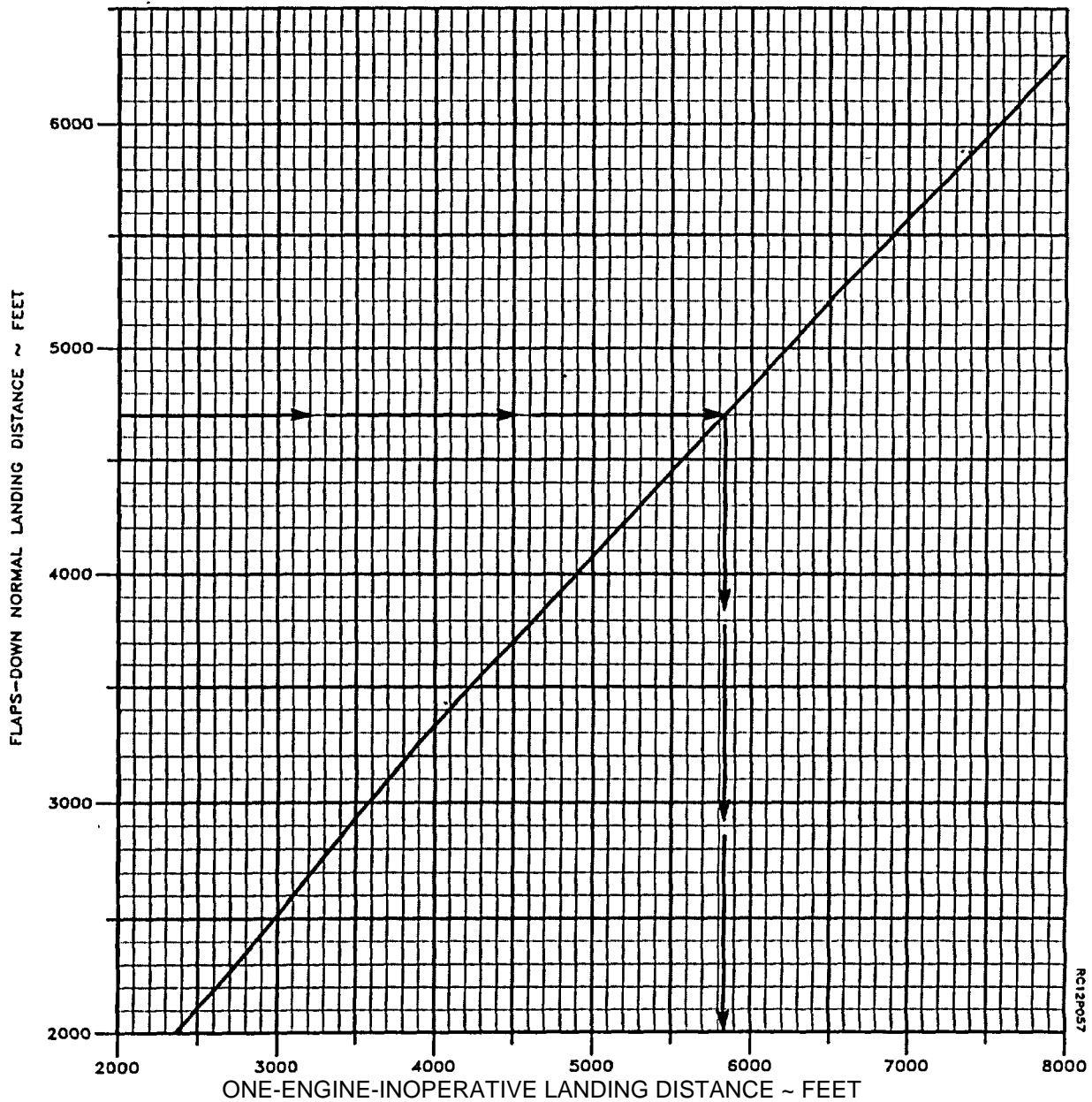

RC12P057

Figure 7A-98. Landing Distance - One Engine Inoperative - Flaps Down



## CHAPTER 8 NORMAL PROCEDURES

### Section I. MISSION PLANNING

#### 8-1. MISSION PLANNING.

Mission planning begins when the mission is assigned and extends to the preflight check of the aircraft. It includes, but is not limited to, checks of operating limits and restrictions; weight, balance, and loading; performance; publications; flight plan; and crew briefings. The pilot in command shall ensure compliance with the contents of this manual that are applicable to the mission.

#### 8-2. AVIATION LIFE SUPPORT EQUIPMENT (ALSE).

All aviation life support equipment required for the mission shall be checked.

#### 8-3. CREW DUTIES/RESPONSIBILITIES.

The minimum crew required to fly the aircraft is a pilot and a copilot.

*a. Pilot.* The pilot in command is responsible for all aspects of mission planning, preflight, and operation of the aircraft. The pilot also will assign duties and functions to all other crewmembers as required. Prior to, or during the preflight check, the pilot will brief the crew on items pertinent to the mission; e.g., performance data, monitoring of instruments, communications, emergency procedures, taxi, and loading operations.

*b. Copilot.* The copilot must be familiar with the pilot in command duties and will assist the pilot as directed.

#### 8-4. CREW BRIEFING.

A crew briefing shall be conducted in accordance with Aircrew Coordination Training Requirements and Unit Standard Operating Procedures.

### Section II. OPERATING PROCEDURES AND MANEUVERS

#### 8-5. OPERATING PROCEDURES AND MANEUVERS.

This section deals with normal procedures and includes all steps necessary for safe and efficient operation of the aircraft from the time a preflight begins until the flight is completed and the aircraft is parked and secured. Unique feel, characteristics, and reaction of the aircraft during various phases of operation, and the techniques and procedures used for taxiing, takeoff, climb, etc., are described, including precautions to be observed. Only the duties of the minimum crew necessary for the actual operation of the aircraft are included. For operation of avionics equipment, refer to the operating handbooks that accompany the aircraft loose tools.

#### 8-6. SYMBOLS DEFINITION.

Items which apply only to night or only to instrument flying shall have an N or an I, respectively, immediately preceding the check to which it is pertinent. The symbol O shall be used to indicate if installed or available. Those duties which are the responsibility of the copilot, will be indicated by a circle around the step number i.e., (4) STARTER and IGN SYS circuit breakers In. The symbol star ★ indicates that a detailed procedure for the step is located in the performance section of the condensed checklist. The symbol asterisk \* indicates that performance of step is mandatory for all thru-flights. In addition to thru-flight, the asterisked steps in this checklist

may be used for combat/tactical operations when authorized by the commander. The asterisk applies only to checks performed prior to takeoff. Placarded items such as switches and controllables appear in boldface, capital letters.

#### 8-7. CHECKLIST.

Normal procedures are given primarily in checklist form and are amplified as necessary in accompanying paragraph form when a detailed description of a procedure or maneuver is required. The condensed version of the amplified checklist is contained in the Operator's and Crewmember's Checklist, TM 1-1510-224-CL. To provide for easier cross referencing, the procedural steps are numbered to coincide with the corresponding numbered steps in this manual.

#### 8-8. PREFLIGHT CHECK.

The pilot's walkaround and interior checks are outlined in the following procedures. The preflight check is not intended to be a detailed mechanical inspection. The steps that are essential for safe aircraft operation are included.

#### 8-9. BEFORE EXTERIOR CHECK.

1. GPU Connect as required.

- \*2. Publications Check DA Forms 2408-12, -13, -14, and -18, DD Form 365-4, locally required forms and publications, and availability of operator's manual (-10) and checklist (-CL).
- ★3. Oxygen system - Check that oxygen quantity is sufficient for the entire mission, that crew masks operate normally, and that the diluter selector is set at 100%.
  - a. **OXYGEN SUPPLY PRESSURE** gages Check.
  - b. **SUPPLY** control lever (green) **ON**.
  - c. Diluter control lever - **100% OXYGEN**.
  - d. **EMERGENCY** control lever (red) Set to **TEST MASK** position while holding mask directly away from face, then return to **NORMAL**.
  - e. Oxygen mask Put on and adjust.
  - f. **EMERGENCY** pressure control lever Set to **TEST MASK** position and check mask for leaks, then return lever to **NORMAL**.
  - g. **FLOW** indicator Check. During inhalation blinker appears, during exhalation blinker disappears. Repeat a minimum of 3 times.
  - h. Oxygen masks Remove and store.
- \*4. Flight controls - Unlock and check.
- \*5. PARKING BRAKE - Set.

**CAUTION**

**The elevator trim system shall not be forced past the limits which are shown on the PITCH TRIM indicator scale.**

- 6. Elevator trim - Set to 0 (neutral).

**CAUTION**

**Do not cycle LDG GEAR CONTR handle on the ground.**

- \*7. Gear - **DN**.
- \*8. Keylock switch - **ON**.

- \*9. Weather radar - **OFF**.
- ★10. Fuel pumps/crossfeed operation Check as follows:
  - a. **FIRE PULL** handles Pull.
  - b. **STANDBY PUMP** switches **ON**.
  - c. **BATTERY** switch **ON**.
  - d. **# 1** and **# 2 FUEL PRESS** warning annunciators - Illuminated.
  - e. **FIRE PULL** handles In.
  - f. **# 1** and **# 2 FUEL PRESS** warning annunciators Extinguished.
  - g. **STANDBY PUMP** switches **STANDBY PUMP**.
  - h. **# 1** and **# 2 FUEL PRESS** warning annunciators Illuminated.
  - i. Crossfeed Check system operation by activating switch momentarily left then right, noting that **# 1** and **# 2 FUEL PRESS** warning annunciators extinguish and that the **FUEL CROSSFEED** advisory light illuminates as switch is energized.

**CAUTION**

**Extend the ice vanes during ground operation, to minimize foreign object damage (FOD) to the engine.**

- 11. Ice vane control switches Check as follows:
  - a. **ICE VANE POWER SELECT** switches (2) **STBY**.
  - b. **ICE VANE CONTROL** switches (2) Off.
- \*12. **BATTERY** switch **ON**.
- 13. Lighting and anti-ice/deice systems Check as required. Check shall include position lights, recognition lights, landing/taxi light, wing ice lights, beacons, emergency lights, pitot tubes, heated fuel vents, stall warning vane, true airspeed temperature probe, and interior lights, then off. Check ice vanes retracted.

**NOTE**

The **EMERGENCY** lights override switch should be placed in the **TEST** position and the emergency lights (5) checked for illumination and intensity. A dim light indicates a weak battery pack. At the completion of the check, the switch must be cycled from the **TEST** position to the **OFF/RESET** position and then placed in **AUTO**.

- \*14. **FUEL** gages Check fuel quantity and gage operation.
- 15. **HYD FLUID SENSOR TEST** switch Check as follows:
  - a. **HYD FLUID SENSOR TEST** switch Depress and hold. Check **HYD FLUID LOW** annunciator light illuminates.
  - b. **HYD FLUID SENSOR TEST** switch Release. Check that annunciator light extinguishes.
- 16. Engine fire protection system Check as follows:
  - a. **ENG FIRE TEST** switches Hold switches to **DET** position, check that **FIRE PULL** handle warning annunciators and **MASTER WARNING** annunciators illuminate.
  - b. **ENG FIRE TEST** switches Hold switches to **EXT** position, check that **SQUIB OK** and **EXTGH DISCH** annunciators and **MASTER CAUTION** annunciators illuminate.

**NOTE**

If **MASTER WARNING** annunciators are cancelled between tests, they may not re-illuminate.

- 17. Stall and gear warning system Check as follows:
  - a. **STALL WARN TEST** switch **TEST**. Check that warning horn sounds.
  - b. **LDG GEAR WARN TEST** switch **TEST**. Check that warning horn sounds and that the **LDG GEAR CONTR** handle warning lights illuminate.

- 18. GPU Check connected and DC voltage if steps 19 through 26 are to be performed.
- ★19. Overhead control panel switches Set as required: TM 1-1510-224-10
  - a. Aircraft # 1 and # 2 **INVERTER** switches **ON**.
  - b. **AUTO PLT POWER** switch **ON**.
  - c. **AVIONICS MASTER POWER** switch **EXT PWR**.
  - d. # 1 and # 2 **EFIS POWER** switches **ON**.
  - e. **ATT** pushbutton selector switch (display controller) Press as required.
  - f. Autopilot **EFIS 1/2** switch **EFIS 1**.
- ★20. Mission control panel switches Check and set as required:
  - a. Mission control panel circuit breakers - Check in.
  - b. **ANT ORIDE** switch **AUTO ROTATE**.
  - c. **MISSION CONTROL** switch As required.
  - d. **RADIO ALT** switch **ON**.
  - e. **ELINT/COMINT** switches (2) As required.
  - f. **WOW OVERRIDE - OFF**.
  - g. **BUS CROSS TIE** switch As required.
  - h. # 2 3-phase **INV** switch **RESET/ON**.
  - i. # 1 3-phase **INV** switch **RESET/ON**.
  - j. **EXT PWR** switches As required.
  - k. AC phase meter switch As required.
  - i. **ASE SILENT** switch **OFF**.
- ★21. **INS** - Align as required.
  - a. Mode switch B (MFD) Depress to select **FPLN** page.
  - b. **NAV SETUP** (R5) Depress.
  - c. **INS SETUP** (R5) Depress.
  - d. **INS** mode selector **STBY**. Text at LI will be blank until **INS** mode selector is placed in **STBY** or **ALIGN**. The 1. **LAST ALIGN** and 2. **LAST KNOWN** text will appear.
  - e. Present position Enter by one of these methods:

- (1) To accept **LAST ALIGN** coordinates, SKPD 1, then depress LI.
- (2) To accept **LAST KNOWN** coordinates, SKPD 2, then depress LI.
- (3) SKPD in alignment coordinates, then depress LI.
- (4) If using the Data Transfer System, load the present position by depressing **SETUP DATA L5** in the desired data set on **DATA TRANSFER** page.

**NOTE**

When L1 is depressed **INS LOADING** will appear at the top of the MFD and L1 text changes to **ALIGN = X.DD.MM.SS Y.DD.MM.SS** and **ALIGN STATE 9**. It takes 6 to 8 minutes for the program to load. Complete autopilot/flight director checks while waiting.

- f. When the **INS LOADING** message is extinguished Place the INS mode selector switch to **ALIGN**.

★22. Pilot's and copilot's **EFIS TEST** switches Depress. Verify the following indications:

a. EADI

- (1) Radio altimeter Slews to 100 +10 feet.
- (2) **DH** display Replaced with dashes.
- (3) Marker beacon annunciators Appear.
- (4) **HDG** and **ATT** annunciators Appear.
- (5) **ATT FAIL** annunciator Appears.
- (6) Pitch and roll command cue Out of view.
- (7) Caution and warning flags All will be in view.
- (8) **TEST** should appear in left center of display to indicate that flight director mode selector lamp test is good. **FD FAIL** will appear momentarily and be replaced by **TEST**.

b. EHSI **DTRK**, **NM**, **GSPD**, and **HDG** displays Replaced with dashes.

c. AP disconnect horn sounds after 5 to 7 seconds.

**NOTE**

**Preflight test of composite mode will cause same results as above test, except digital heading readout will be replaced with a red FAIL indication, and expanded localizer scale and pointer will be removed.**

A localizer frequency must be tuned on both **NAV** receivers to annunciate ILS comparator monitor. EFIS test is inhibited during glideslope capture.

- ★23. Automatic flight control system Check as follows:
  - a. Altitude alerter - Check as follows:

**NOTE**

**Pause for a few seconds between each step to allow time for proper indications.**

- (1) Altitude preselector Set to more than 1000 feet above altitude set on pilot's altimeter. Pilot's altimeter altitude alert annunciator light should be extinguished.
- (2) Pilot's altimeter barometric set knob Slowly increase pilot's altimeter setting.
- (3) Altitude alerter annunciator and horn Verify that altitude alerter annunciator on pilot's altimeter illuminates and altitude alerter horn sounds when pilot's altimeter reading is approximately 1000 feet from value set on altitude select controller.
- (4) Pilot's altimeter Reset to field elevation.
- (5) Altitude preselector Reset to field elevation.
- (6) Pilot's altimeter barometric set knob Slowly increase pilot's altimeter setting.
- (7) Altitude alerter annunciator and horn Verify that the altitude alerter annunciator on pilot's altimeter illuminates and altitude alerter horn sounds when altimeter reading is approximately 250 feet from value set on altitude alert controller.
- (8) Pilot's altimeter Reset to field elevation.

b. Flight director Check as follows:

- (1) **SBY** pushbutton switch-indicator (flight

director mode selector Depress for at least 5 to 8 seconds and verify the following indications:

- (a) Flight director mode selector Annunciators illuminate.
- (b) Autopilot controller Annunciators illuminate.
- (c) Altitude select controller All 8's illuminate.
- (d) Pilot's altimeter altitude alerter annunciator Illuminates.
- (e) EADI **FD FAIL** (amber) will be annunciated.

(2) After **SBY** pushbutton switch-indicator has been held depressed for 5 to 8 seconds verify that:

- (a) **AP TRIM** annunciator Illuminates.
- (b) Autopilot disconnect horn Sounds.

(3) **SBY** pushbutton switch-indicator Release.

(4) **FD** and **ATT** annunciations on the EADI Check extinguished.

c. Autopilot Check as follows:

- (1) Autopilot trim annunciators Check extinguished.
- (2) **TURN** knob Center.
- (3) **ELEV TRIM** switch Check on.

**NOTE**

**The control wheel must be held at mid-travel due to ballast in the elevator. The autopilot will disconnect during pitch wheel check due to the heavy nose down force if the control wheel is not off the forward stop.**

- (4) Control wheel Move to mid-travel.
- (5) **AP ENGAGE** switch-indicator (autopilot controller) Depress to engage autopilot and yaw damper. Check that **AP ENGAGE** and **YD ENGAGE** switch-indicators on autopilot controller and remote annunciators on instrument panel are illuminated.

d. Autopilot overpower check Check as follows:

- (1) Rudder pedals Overpower slowly.
- (2) Control wheel Overpower slowly in both directions.

**WARNING**

**If the autopilot or yaw damper disengages during the overpower test, the system is considered non-operative and should not be used. The elevator trim system must not be forced beyond the limits which are indicated on the elevator trim indicator.**

e. Elevator trim follow-up Check as follows:

- (1) Control wheel Move aft of mid-travel. Trim wheel should run nose down after approximately .3 seconds. **TRIM DN** annunciator (autopilot controller) should illuminate after approximately 6 to 8 seconds, and **AP TRIM** annunciator (instrument panel) should illuminate after approximately 15 seconds.

- (2) Control wheel Move forward of midtravel. Trim wheel should run nose up after approximately 3 seconds. **TRIM UP** annunciator (autopilot controller) check illuminated after approximately 6 to 8 seconds. **AP TRIM** annunciators (instrument panel) check illuminated after approximately 15 seconds.

f. **AP & YD/TRIM DISC** switch (control wheel) Depress to first level. Check that autopilot and yaw damper disengage, **AP ENGAGE** and **YD ENGAGE** switch-indicators on the autopilot controller and remote annunciators above the EADI's flash 5 times.

- g. Control wheel Hold to mid-travel.
- h. **AP ENGAGE** switch Re-engage.
- i. Turn knob Check that elevator control trim wheel follows in each applied direction, then center.
- j. Pitch wheel Check that trim responds to pitch wheel movements. (**TRIM UP** and **TRIM DN** annunciators may illuminate.)
- k. Heading marker Center and engage **HDG**. Check that control wheel follows a turn in each direction.
- l. **GO AROUND** button (left power lever) Depress. Check that AP disengages and **FD**

commands a wings level, 7 degrees nose up attitude. Check **GA** annunciator on EADI illuminates. Yaw damper should automatically engage and **YD ENGAGE** switch-annunciator should be illuminated on the autopilot controller and the remote annunciators above the EADI's should be illuminated.

- m. **RUDDER BOOST/YAW CONTROL TEST** switch (pedestal extension) **TEST**. Check the **RUDDER BOOST** annunciator above the EADI's illuminates, yaw damper disengages, **YD ENGAGE** switch-indicator on the autopilot controller extinguishes, and the **YD ENGAGE** remote annunciators above the EADI's flash 5 times.

**WARNING**

If the **SBY** annunciator on the flight director mode selector does not illuminate within 10 seconds after the avionics master switch is turned on, the autopilot has failed self-test and is considered inoperative and should not be used.

**CAUTION**

Do not force the elevator trim system beyond the limits which are indicated on the **ELEVATOR** trim tab indicator.

- n. **YD ENGAGE** pushbutton switch-indicator (autopilot controller) Depress while holding rudder boost/yaw control test switch in **TEST**. Yaw damper should not engage.
- o. **RUDDER BOOST/YAW CONTROL TEST** switch **RUDDER BOOST**. Check **RUDDER BOOST** annunciator extinguished.
- p. Electric elevator trim Check.
  - (1) **ELEV TRIM** switch On.
  - (2) Pilot and copilot trim switches Check operation.

**WARNING**

Operation of the electric trim system should occur only by movement of pairs of switches. Any movement of the elevator trim wheel while depressing only one switch element indicates a trim system malfunction. The electric elevator trim control switch must then

be turned **OFF** and flight conducted by operating the elevator trim wheel manually. Do not use autopilot.

- (3) Pilot and copilot trim switches Check individual element for no movement of trim, then check proper operation of both elements.
- (4) Pilot trim switches Check that pilot switches override copilot switches while trimming in' opposite directions, and trim moves in direction commanded by pilot.
- (5) Pilot or copilot trim switches Check trim disconnects while activating pilot or copilot trim disconnect switches.
- (6) **ELEV TRIM** switch **OFF** then on (**ELEC TRIM OFF** annunciator extinguishes).

- ★24. ASE/ACS Perform **BIT** checks as required.
  - a. **UTIL** on MFD Depress.
  - b. **SYSTEM BIT** (R1) Depress.

**NOTE**

Before conducting the **INS BIT** ensure mode selector is in **ALIGN** and align state is 8 or lower, but before mode selector is placed in **NAV**.

- c. **INS BIT** Perform as follows:
  - (1) **INS** Select on EHSI by depressing **INS/TCN** on display controller.
  - (2) **INS** Select on single needle bearing source selector switch on display controller.
  - (3) **UTIL** on MFD Depress.
  - (4) **SYSTEM BIT** (R1) Depress.
  - (5) **INS BIT** (R2) Depress.
  - (6) **NAV** on flight director mode selector Select.

- (7) Check indications as follows:
- (a) **MFD INS BATT, INS FAIL, and WAYPOINT ALERT CWA** annunciators (3) illuminated.
  - (b) EHSI INS needle 30 degrees right of lubber line and course deviation bar displaced right followed by INS needle centering and course deviation bar displaced left. Check WPT alert annunciator illuminated.
  - (c) Aircraft caution/advisory annunciator panel Amber **INS** annunciator light illuminated.
  - (d) INS mode controller Green **READY** light and red **BATT** light illuminated.
  - (e) Mission annunciator panel Green **INS UPDATE** annunciator light and amber **NO INS UPDATE** annunciator light illuminated.
  - (f) After 15 seconds the text **COMPLETE** or any active **ACTION** or **MALFUNCTION** codes will be displayed. If an action and malfunction code is displayed they may have been cleared by the **BIT** test. The only way to ensure that they are cleared is to conduct another **BIT** and the text **COMPLETE** appears.
- d. **ASE RTU, 2-FM, 3-UHF, 5-UHF, DTS, MFD KU, GPS, and ASE BIT** checks Conduct as required by depressing the appropriate line button.

**DATA** (L2) when the desired data set is TM 1-1510-224-10 boxed on the **DATA TRANSFER** page.

- b. Flight plan Build as follows:
  - (1) **WPT** numbers Enter into scratchpad in order of desired use (up to nine) or box desired **WPT's** and **PREV** (R2) or **NEXT** (R3) and depress **LOAD SCRATCH PAD** (L5).
  - (2) **ROUTES** (R5) Depress.
  - (3) Route Select 1st, 2nd, or 3rd to enter **WPT** numbers by depressing the appropriate line button to store the WPTs.
  - (4) Routes to use as the active **FPLN** Select and depress the adjacent line button to box it.
  - (5) **NEW FPLN** (L1) Depress to activate the **FPLN**.
- c. **TACAN** list Build as follows:
  - (1) Mode switch B Depress to select **FLIGHT PLAN** page.
  - (2) R5 line selection switch Depress to select **TACAN LIST** page.
  - (3) **TACAN** station information (list number, ID, channel number, latitude/ longitude, and station elevation) Enter into scratchpad.
  - (4) R1 line selection switch Depress to load into system.
  - (5) Or load **TACAN** list using the **DATA TRANSFER SYSTEM** by depressing **NAV DATA** (L1) on the **DATA TRANSFER** page.
  - (6) **TACAN** stations to be used for updating Select and enter into scratchpad.
  - (7) R4 line selection switch Depress to select **TACAN SELECT**.
- d. Pattern steering mode Program as follows:
  - (1) Mode switch B Depress-to select **FLIGHT PLAN** page.
  - (2) R5 line selection switch Depress to select **NAV SETUP** page.
  - (3) True bearing Enter into scratchpad.
  - (4) L1 line selection switch Depress to enter **BEARING**.

★25. ASE/ACS Program as required.

- a. Waypoint list Build as follows:
  - (1) Mode switch B Depress to select **FLIGHT PLAN** page.
  - (2) **WPT LIST** (R4) Depress. **WPT** numbers 10-59 are shown. The **WPT** select window surrounds a **WPT** line.
  - (3) Waypoint string (line number, **WPT ID**, and **LAT/LONG** coordinates) Enter into scratch pad.
  - (4) **ADD/SEL** (R1) Depress to load **WPT** into system.
  - (5) Or load waypoint list using the data transfer system by depressing **NAV**

- (5) Leg length in NM Enter into scratchpad.
- (6) L2 line selection switch Depress to enter **LEG LENGTH**.
- (7) L3 line selection switch Depress to select **LEFT** or **RIGHT**.
- (8) Offset distance in NM Enter into scratchpad.
- (9) L4 line selection switch Depress to enter **OFFSET**.

- e. Waypoint move mode Program as follows:
  - (1) True bearing Enter into scratchpad.
  - (2) R1 line selection switch Depress to enter **BEARING**.
  - (3) Range in NM Enter into scratchpad.
  - (4) R2 line selection switch Depress to enter **RANGE**.

★26. Avionics Check as follows:

- a. VHF comm (#1 and #2) Press **TEST** and observe the following:
  - (1) Normal Dashes displayed in active display and 00 in preset display.
  - (2) Fault Flag in active display and a two digit fault code in preset display.
- b. VHF navigation receivers (#1 and #2) Test as follows:
  - (1) VOR self test/marker beacon test:
    - (a) Tuning knobs (NAV control unit) Select a VOR frequency.
    - (b) VOR/localizer pushbutton selector switch (display controller) Select **VOR 1** or **VOR 2**.
    - (c) Single needle bearing pointer source selector switch (display controller) **VOR 1**.
    - (d) Double needle bearing pointer source selector switch (display controller) **VOR 2**.
    - (e) Course knob (EHSI) Rotate until pointer indicates 0 degrees.
    - (f) **TEST** switch (NAV control unit) Depress.
    - (g) **NAV** flag on the EHSI - Will come into view. After two seconds, the flag will go out of view, the EHSI

course deviation bar will center, and a TO indication will appear. The bearing pointers will indicate a 0 degree magnetic bearing. The VIR-32 will return to normal after 15 seconds.)

- (h) EHSI Check for three marker indications and listen for a 30 Hz tone on audio channel of NAV system.
- (2) ILS self test (NAV 1 and NAV 2):
  - (a) Tuning knobs (NAV control unit) Select a localizer frequency.
  - (b) **TEST** switch (NAV control unit) Depress.
  - (c) **NAV** and **GS** flags on EHSI Will come into view. After 3 seconds, the flags will go out of view, the EHSI course deviation bar will deflect right 2/3 full scale, and the glide slope pointer will deflect down 2/3 full scale.
  - (d) VIR-32 Will return to normal after 15 seconds.
- (3) ADF receiver test:
  - (a) Power and mode switch On.
  - (b) Tuning knobs Tune a nearby NDB, compass locator, or broadcast station.
  - (c) EFIS display controller Select **ADF** on single needle pointer bearing source selector switch.
  - (d) **TEST** switch Depress. Bearing pointer will rotate 90 degrees from previous indication. Release **TEST** switch and verify bearing pointer returns to previous indication.
- (4) TACAN/DME indicator system:
  - (a) TACAN/DME Will conduct a self test for 3 seconds after powerup. After 3 seconds, check for **SELF TEST PASS** or **SELF TEST FAIL** (with a fail message number).
- (5) Transponder (APX-100):
  - (a) **MASTER** switch **STBY**.



- (b) Warmup Allow two minutes.
- (c) Mode I and mode 3/A codes Set.
- (d) Lamp indicators Press to test.
- (e) Antenna switch Select **TOP**.
- (f) Mode selector **NORM**.
- (g) Modes 1, 2, 3/A, and C Hold to **TEST** and observe **GO** light.
- (h) Antenna switch Select **BOT** and repeat step (g).
- (i) Antenna switch Select **DIV** and repeat step (g).
- (j) Mode 4 Hold to **TEST** and observe **GO** light (if code has been set in external computer).

27. **BATTERY** switch As required.

28. Toilet Check condition.

29. Emergency equipment Check that all required emergency equipment is available and that fire extinguishers and first-aid kits have current inspection date.

O 30. Parachutes Check.

#### 8-10. FUEL SAMPLE AND OIL CHECK.

##### NOTE

**Fuel and oil quantity check may be performed prior to exterior check. During warm weather, open fuel cap slowly to prevent being sprayed by fuel under thermal pressure.**

- \*1. Fuel sample Check collective fuel sample from all drains for possible contamination. Thru-flight check is required only if aircraft has been refueled.

#### 8-11. EXTERIOR CHECK.

a. *Left Wing Area.* Check as follows (fig. 8-1):

1. Left wing Check.

- \*a. General condition Check.
- b. Flaps Check for full retraction (approximately 0.25 inch play) and skin damage, such as buckles, splits, dents, or distortion.
- c. Fuel sump drains Check for leaks.

- d. Aileron and movable trim tab Check security and trim tab rig.
- e. Outboard wing fuel vent (in aileron cove) Check free of obstruction.
- f. Static wicks (4) Check security and condition.
- g. Wing pod, navigation lights, and deice boots Check condition and pod tip latches closed.
- h. Recognition light Check condition.
- i. Outboard antennas Check condition.
- \*j. Main tank fuel and cap Check fuel level visually, condition of seal, and tap tight and properly installed.
- k. Outboard deice boot Check for secure bonding, cracks, loose patches, stall strip, and condition.
  - i. Stall warning vane Check freedom of movement.
- \*m. Tiedown Released.
- n. Inboard dipole antenna sets Check for security and cracks at mounting points.
  - Check bonding secure, boots free of cuts and cracks.
- o. Wing ice light Check condition.
- p. AC GPU access door Secured.
- q. Recessed and heated fuel vents Check free of obstructions.
- r. Inverter inlet and exhaust louvers Check free of obstructions.

2. Left main landing gear Check.

- \*a. Tires Check condition.
- b. Brake assembly Check.
- c. Brake deice assembly and bleed air hose Check for condition and security.
- \*d. Shock strut Check for signs-of leakage, minimum strut extension (5.5 inches), and that left and right strut extension is approximately equal.
- e. Torque links Check condition.
- f. Safety switch Check condition, wire, and security.
- g. Wheel, well, doors, and linkage Check

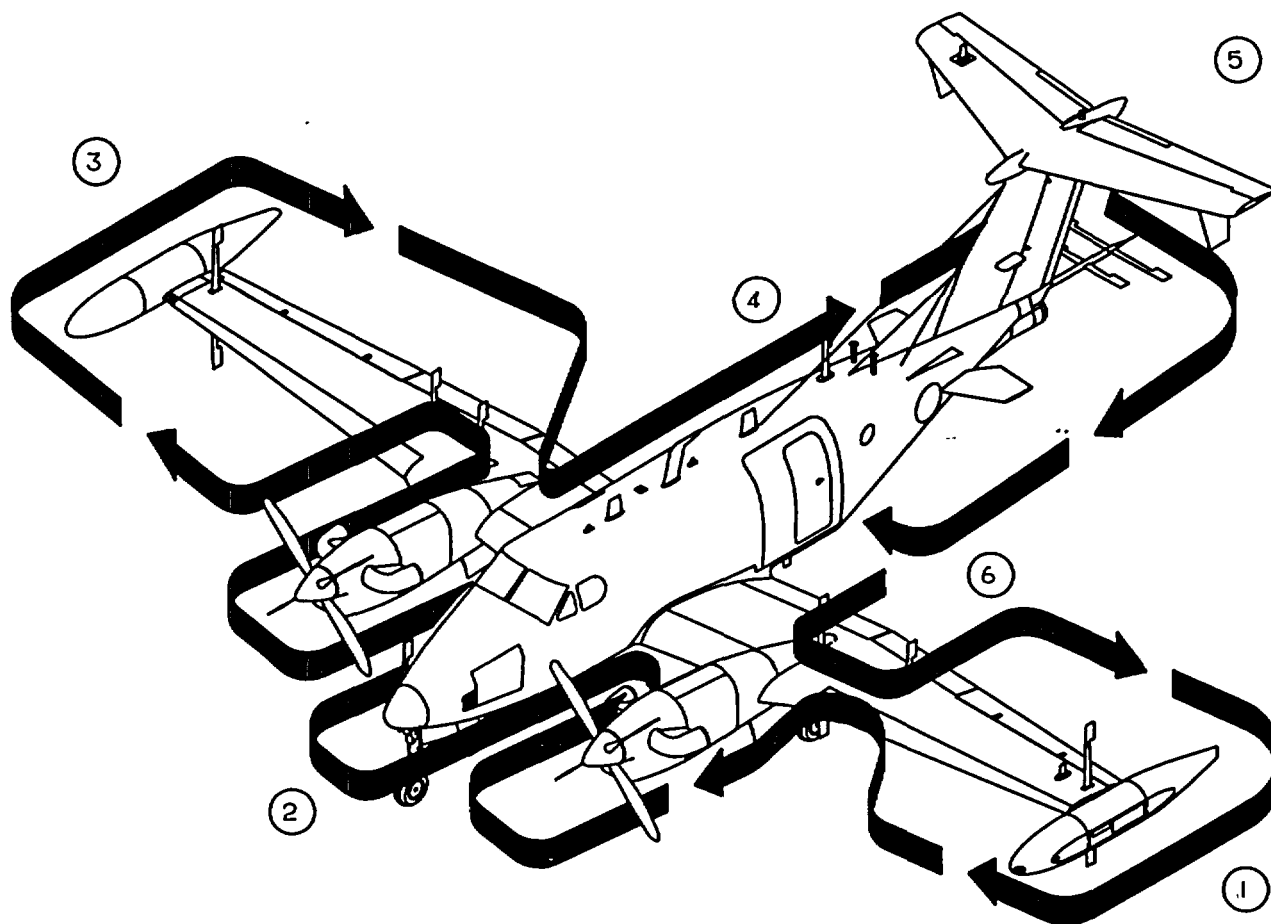

- AREA 1. LEFT WING LANDING GEAR. ENGINE, NACELLE. AND PROPELLER
- AREA 2. NOSE SECTION
- AREA 3. RIGHT WING LANDING GEAR, ENGINE. NACELLE, AND PROPELLER
- AREA 4. FUSELAGE. RIGHT SIDE
- AREA 5. EMPENNAGE
- AREA 6. FUSELAGE, LEFT SIDE

A94FE00D1004 C

Figure 8-1. Exterior Inspection

- for signs of leaks, broken wires, security, and condition.
  - \* h. Fuel sump drains (forward) Check for leaks.
- H\* 3. Fire extinguisher pressure Check pressure within limits (Chapter 2).
4. Left engine and propeller Check.

**CAUTION**

**A cold oil check is unreliable. Oil should be checked within 10 minutes after stopping engine. If more than 10 minutes have elapsed, motor engine for 40 seconds, then recheck. If more than 10 hours have elapsed, run engine for 2 minutes, then recheck. Add oil as required. Do not overfill.**

- \* a. Engine oil Check oil level, add as required, and oil cap secured.
  - b. Engine compartment, left side Check for fuel and oil leaks, security of cap, and condition. Check door secure.
  - c. Left upper cowl locks Locked.
  - d. Left exhaust stack Check for cracks and free of obstruction.
  - e. Propeller blades and spinner Check blade condition, security of spinner, and free propeller rotation.
  - \* f. Engine air inlets and ice vane Check free of obstruction and vane extended.
  - g. Right upper cowl locks Locked.
  - h. Right exhaust stack Check for cracks and free of obstructions.
  - i. Engine compartment, right side Check for fuel and oil leaks and condition. Check door secure.
5. Left wing center section Check.
- \* a. Auxiliary tank fuel, cap, and sight gage Check fuel level visually, condition of seal, and cap tight and properly installed.
  - b. Heat exchanger inlet and outlet Check for cracks and free of obstructions.
  - c. Deice boot Check.
  - \* d. Auxiliary tank fuel sump drain Check for leaks.

- e. Hydraulic reservoir vent and pump seal drain Check vent clear of obstructions, and that no excessive fluid is present.
  - f. Monopole antenna Check condition.
6. Fuselage underside Check.
- \* a. General condition Check for skin damage.
  - b. Antennas Check security, and condition.
- b. *Nose Section.* Check as follows:
1. Nose section Check.
    - \* a. General condition Check.
    - b. Free air temperature probe Check condition.
    - c. Avionics door, left side Check secure.
    - d. Air conditioner exhaust Check free of obstruction.
    - e. Data link antenna radome Check condition.
    - f. Wheel well condition Check for signs of leaks, broken wires, and condition.
    - g. Doors and linkage Check.
    - h. Nose gear turning stop Check condition.
    - \* i. Shock strut Check for signs of leakage and 3.0 inches minimum extension.
    - j. Torque links Check condition.
    - \* k. Tire Check condition.
      - l. Shimmy damper and linkage Check.
    - m. Landing and taxi lights Check for security and condition.
    - n. Pitot tubes Check free of obstruction.
    - o. Radome Check condition.
    - p. Windshields and wipers Check.
    - q. Air conditioner inlet Check free of obstructions.
    - r. Dipole antenna set Check for security and cracks at mounting points, bonding secure, and free of cuts and cracks.
    - s. Avionics door, right side Check secure.

c. *Right Wing Area. Check as follows:*

1. Right wing center section Check.
  - \* a. Auxiliary tank fuel, cap, and sight gage Check fuel level visually, condition of seal, and cap tight and properly installed.
  - b. Battery access panel Secure.
  - c. Battery exhaust louvers Check free of obstructions.
  - d. Heat exchanger outlet and inlet Check for cracks and free of obstruction.
  - e. Deice boot Check.
  - f. Battery compartment drain Check free of obstruction.
  - g. Battery ram air intake Check free of obstruction.
  - h. TAS probe Check condition and free of obstruction.
  - \* i. Auxiliary tank fuel sump drain Check for leaks.
  - j. Monopole antenna Check.
2. Right engine and propeller Check.

**CAUTION**

**A cold oil check is unreliable. Oil should be checked within 10 minutes after stopping engine. If more than 10 minutes have elapsed, motor engine for 40 seconds, then recheck. If more than 10 hours have elapsed, run engine for 2 minutes, then recheck. Add oil as required. Do not overfill.**

- \*a. Engine oil Check oil level, add as required, and oil cap secure.
- b. Engine compartment, left side Check for fuel and oil leaks, security of oil cap, and condition. Check door secure.
- c. Left upper cowl locks Locked.
- d. Left exhaust stack Check for cracks and free of obstruction.
- e. Propeller blades and spinner Check blade condition, security of spinner, and free propeller rotation.
- f. Engine air inlets and ice vane Check free of obstruction and ice vane extended.

- g. Right upper cowl locks Locked.
  - h. Right exhaust stack Check for cracks and free of obstruction.
  - i. Engine compartment, right side Check for fuel and oil leaks and condition. Check door secure.
3. Right main landing gear Check.
    - \* a. Tires Check condition.
    - b. Brake assembly Check. Also check brake deice assembly and bleed air hose for condition and security.
    - \* c. Shock strut Check for signs of leakage and minimum strut extension (5.5 inches) and that left and right strut extension is approximately equal.
    - d. Torque links Check condition.
    - e. Safety switch Check condition, wire, and security.
    - f. Wheel well, doors, and linkage Check for signs of leaks, broken wires, security, and condition.
    - \* g. Fuel sump drains (forward) Check for leaks.

H\* 4. Fire extinguisher pressure Check pressure within limits (Chapter 2).

## 5. Right wing Check.

- \* a. General condition Check.
- b. Recessed and heated fuel vents Check free of obstructions.
- c. Inverter inlet and exhaust louvers Check free of obstructions.
- d. DC GPU access door Secured.
- e. Inboard dipole antenna sets Check for security and cracks at mounting points, bonding secure, free of cuts and cracks.
- f. Wing ice light Check condition.
- g. Outboard deice boot Check for secure bonding, cracks, loose patches, stall strip, and condition.
- \* h. Tiedown Released.
- \* i. Main tank fuel and cap Check fuel level visually, condition of seal, and cap tight and properly installed.
- j. Outboard antennas Check condition.

- k. Recognition light Check condition.
- l. Wing pod, navigation lights, and deice boots Check condition and pod tip latches closed.
- m. Static wicks (4) Check security and condition.
- n. Aileron and trim tab Check security and condition.
- o. Outboard wing fuel vent (in aileron cove) Check free of obstruction.
- \*p. Fuel sump drains Check for leaks.
- q. Flaps Check for full retraction (approximately 0.25 inch play) and skin damage, such as buckles, splits, dents, or distortion.
- r. Chaff dispenser Check number of chaff cartridges in payload module and for security and safety pin removed.

d. *Fuselage Right Side. Check as follows:*

- 1. Fuselage right side Check.
  - \*a. General condition Check.
  - b. Emergency light Check condition.
  - c. M-130 test cap Secure.
  - d. Flare/chaff dispenser Check number of flares/chaff cartridges in payload module and for security.
  - e. Beacon Check condition.
  - f. Fuselage underside antennas Check condition.
  - g. Tailcone access door Check secured.
  - h. Static ports Check clear of obstructions.
    - i. P-band antenna Check condition.
    - j. Oxygen filler door Check secured.
  - k. APR-44 antennas Check condition.
    - i. Emergency locator transmitter antenna Check condition.
  - m. Stabilon and static wick Check condition.
  - e. Empennage. Check as follows:

**WARNING**

**Do not attempt takeoff if the possibility of ice accumulation on the horizontal stabilizer or elevator exists.**

- 1. Empennage Check.
  - \* a. General condition Check.
  - \* b. Vertical stabilizer, rudder, and trim tab Check condition.
  - c. Horizontal stabilizer, taillets, elevator, and trim tab Check condition.
  - d. Deice boots Check condition.
  - e. Elevator trim tab Verify 0 (neutral) position the elevator trim tab 0 (neutral) position is determined by observing that the trailing edge of the elevator trim tab aligns with the trailing edge of the elevator, while the elevator is resting against the downstops.

**NOTE**

**Any difference between the indicated position on the trim tab position indicator and the actual position of the elevator trim tab signifies an unairworthy condition which must be corrected prior to flight.**

- f. Static wicks (18) Check installed.
  - g. Position and beacon lights Check condition.
  - h. Navigation antennas Check security and condition.
  - i. Rotating boom dipole antenna Check condition and position.
  - j. Data link antenna radome Check condition.
- f. *Fuselage Left Side. Check as follows.*
- 1. Fuselage left side Check.
    - \*a. General condition Check.
    - b. Stabilon and static wick Check condition.
    - c. P-band antenna Check condition.
    - d. Static ports Check clear of obstruction.
    - e. **ELT-ARMED.**

- f. APR-44 antennas Check condition.
- g. Emergency light Check condition.
- h. Cabin door Check door seal and condition.
- i. Fuselage top side Check general condition and antennas.
- \*j. Chocks and tiedowns Check removed.

**\* 8-12. INTERIOR CHECK.**

1. Cargo/loose equipment Check secured.
- \* 2. Cabin/cargo doors Test and lock:
  - a. Cabin door Check closed and latched as follows:
    - (1) Safety arm and diaphragm plunger Check position (lift door step).
    - (2) Index marks on rotary cam locks (6) Check aligned with indicator windows.
  - b. Cargo door Check closed and latched as follows:
    - (1) Upper handle Check closed and latched. (Observe through cargo door latch handle access cover window.)
    - (2) Index marks on rotary cam locks (4) Check aligned with indicator windows.
    - (3) Lower pin latch handle Check closed and latched. (Observe through cargo door lower latch handle access cover window.)
    - (4) Carrier rod Check orange indicator aligned with orange stripe on carrier rod. (Observe through window, aft lower corner.)
  - c. **BATTERY** switch-**OFF**.
  - d. Cargo door Check closed and latched.
  - e. Cabin door Close but leave unlatched. Check **CABIN DOOR** annunciator light illuminated.
  - f. Cabin door Open. Check **CABIN DOOR** annunciator light extinguished.
  - g. **BATTERY** switch **ON**. Check **CABIN DOOR** annunciator light illuminated.
  - h. Cabin door Close and latch. Check

**CABIN DOOR** annunciator light extinguished.

**NOTE**

**The above procedures check both cargo and cabin door security provisions.**

3. Emergency exit Check secure and key removed.
4. Mission cooling ducts Check open and free of obstructions.
5. Flare/chaff dispenser preflight test Completed.
6. COMSEC keys Loaded as required.
7. Crew briefing As required.

**8-13. BEFORE STARTING ENGINES.**

- \* 1. Oxygen system -Set as required.
2. Circuit breakers Check in.
- \* 3. Overhead panel Check and set.
  - a. Light dimming controls As required.
  - b. Cockpit lights (3) As required.
  - c. **CABIN AIR MODE SELECT** switch **OFF**.
  - d. **ENG INLET LIP HEAT** switches **OFF**.
  - e. **ICE VANE POWER SELECT** switches (2) MAIN.
  - f. **ICE VANE CONTROL** switches (2) **ON**.
  - g. **ICE & RAIN** switches Off.
  - h. **EXTERIOR LTS** switches As required.
  - i. **# 1 and # 2 EFIS POWER** switches Off.
  - j. **AVIONICS MASTER POWER** switch As required.
  - k. **AUTO PLT POWER** switch Off.
  - l. **# 1 and # 2 INVERTER** switches As required.
  - m. Environmental switches As required.
  - n. **AUTOFEATHER** switch **OFF**.
  - o. **# 1 AUTO IGNITION** switch Off.
  - p. **# 1 ENG START** switch **OFF**.

- q. **BATTERY** switch - As required.
  - r. **GENERATOR** switches (2) - **OFF**.
  - s. **# 2 ENG START** switch - **OFF**.
  - t. **# 2 AUTO IGNITION** switch - Off.
- \* 4. Fuel panel switches - Check.
- a. **STANDBY PUMP** switches (2) - Off.
  - b. **AUX XFER** switches (2) - **AUTO**.
  - c. **CROSSFEED** switch - **OFF**.
5. Magnetic compass - Check for fluid, heading, and current correction card.

**CAUTION**

**Movement of the POWER levers below the flight idle gate with the engines not operating may result in bending and damage to control linkage.**

- \* 6. Pedestal controls - Set.
- a. **POWER** levers - **IDLE**.
  - b. **PROP** levers - **FEATHER**.
  - c. **CONDITION** levers - **FUEL CUTOFF**.
  - d. Flaps - As required.
- \* 7. Pedestal extension switches - Set.
- a. Avionics - As required.
  - b. **RUDDER BOOST** switch - On.
  - c. **ELEV TRIM** switch - On.
8. **LANDING GEAR ALTERNATE EXTENSION** pump handle - Stowed.
9. Free air temperature gage - Check. Note current reading.
10. Pilot's instrument panel - Check and set.
- a. **MIC** switch - **HEADSET**.
  - b. **GYRO** switch - **SLAVE**.
  - c. **SYM GEN REV** switch - **NORMAL**.
  - d. Flight instruments - Check instruments for protective glass, warning flags, and static readings.

- e. **PROP SYN** switch - **OFF**.
  - f. Engine instruments - Check instruments for protective glass and static readings.
11. Copilot's instrument panel - Check and set.
- a. Flight instruments - Check instruments for protective glass, warning flags, and static readings.
  - b. **MIC** switch - **HEADSET**.
  - c. **GYRO** switch - **SLAVE**.
  - d. **SYM GEN REV** switch - **NORMAL**.
12. Mission panel switches and circuit breakers - As required.
- a. **ANT ORIDE** switch - **AUTO ROTATE**.
  - b. **MISSION CONTROL** switch - **OFF**.
13. Subpanels - Check and set.
- a. **ENG FIRE TEST** switches (2) - **OFF**.
  - b. **CABIN PRESS DUMP** switch - **OFF**.
  - c. Pressurization controls - As required.
  - d. **LANDING, TAXI, and RECOG** light switches - **OFF**.
  - e. **LDG GEAR CONTR** switch - Recheck DN.
  - f. **CABIN LIGHTS** switch - As required.
  - g. **PILOTS STATIC AIR SOURCE** - **NORMAL**.

**CAUTION**

**Do not use alternate static source during takeoff and landing except in an emergency. Instruments will show a variation in airspeed and altitude when using alternate static source.**

14. **AC and DC GPU** - As required.
- \* 15. **BATTERY** switch - **ON**.
16. **DC** power - Check (22 VDC minimum for battery, 28 VDC maximum for GPU starts).
17. Annunciator panels - Test as follows:
- a. **ANNUNCIATOR TEST** switch - Hold to

**TEST** position. Check that annunciator panels, **FIRE PULL** handle annunciators, **MASTER CAUTION**, and **MASTER WARNING** annunciators are illuminated.

- b. **MASTER CAUTION** and **MASTER WARNING** annunciators Press and release. Both annunciators should extinguish.

**8-14. FIRST ENGINE START (BATTERY START).**

**NOTE**

Do not start engines until after the **INS** is placed into the **NAV** mode or **OFF**, as required.

Starting procedures are identical for both engines.

1. **INS - OFF**.
2. **EXTERIOR LTS** switches - As required.
3. Propeller area - Clear.
4. **ENG START** switch - **START-IGNITION**. **IGN ON** annunciator should illuminate and **FUEL PRESS** annunciator should extinguish.

**NOTE**

False fuel flow indications may be observed with the starter engaged and the **CONDITION** lever in **FUEL CUTOFF**.

**CAUTION**

If ignition does not occur within 10 seconds after moving **CONDITION** lever to **LOW IDLE**, initiate **Abort Start** procedure. If for any reason a starting attempt is discontinued, the entire starting sequence must be repeated after allowing the engine to come to a complete stop (15 minute minimum).

5. **CONDITION** lever (after **N<sub>1</sub>** **RPM** stabilizes above 13% minimum) - **LOW IDLE**.

**CAUTION**

Monitor **TGT** to avoid a hot start. If there is a rapid rise in **TGT**, be prepared to abort the start before limits are exceeded. During starting, the maximum allowable **TGT** is **1000° C** for 5 seconds. If this limit is exceeded, initiate **Abort Start** procedure and discontinue start. Enter the peak temperature and duration on **DA Form 2408-13-1**.

6. **TGT** and **N1** Monitor (**TGT** **1000° C** maximum).
7. Oil pressure Check (60 PSI minimum).
8. **ENG START** switch **OFF** after **TGT** peaks.
9. **CONDITION** lever **HIGH IDLE**. Monitor **TGT** as **CONDITION** lever is advanced.
10. **GENERATOR** switch **RESET**, then **ON**.

**\* 8-15. SECOND ENGINE START (BATTERY START).**

1. **GENERATOR DC LOAD** Verify less than 50%.
2. Propeller area Clear.
3. **ENG START** switch **START-IGNITION**. **IGN ON** annunciator should illuminate and **FUEL PRESS** annunciator should extinguish.
4. **CONDITION** lever (after **NI** **RPM** stabilizes above 13% minimum) **LOW IDLE**.
5. **TGT** and **NI** Monitor (**TGT** **1000° C** maximum).
6. Oil pressure Check (60 PSI minimum).
7. **ENG START** switch **OFF** after **TGT** peaks.
8. **CONDITION** levers **HIGH IDLE**. Monitor **TGT** as **CONDITION** lever is advanced.

**CAUTION**

Monitor oil temperature closely during ground operation with propellers in **FEATHER** due to lack of air flow over oil cooler.

9. **PROP** levers **HIGH RPM**.
10. **INVERTER** switches **ON**, check **INVERTER** annunciators off.



11. Current limiters Check as follows:
  - a. **BATTERY CHARGE** annunciator Check on. **BATTERY CHARGE** annunciator should extinguish within 5 minutes following a normal engine start on battery.
  - b. # 1 and # 2 INV annunciators Check extinguished. This procedure checks both 400 and 500 ampere current limiters that tie aircraft bus systems together.
12. **GENERATOR** switch **RESET**, then **ON**.

**NOTE**

To reset beacon light, turn off for approximately 5 seconds, then DAY or NIGHT. When voltage drops below approximately 20 volts, beacon light may become inoperative.

13. **BEACON** lights switch **OFF**, then as required.

**8-16. ABORT START PROCEDURE.**

1. **CONDITION** lever **FUEL CUTOFF**.
2. **ENG START** switch **STARTER ONLY**.
3. **TGT** Monitor for drop in temperature.
4. **ENG START** switch **OFF**.

**8-17. ENGINE CLEARING PROCEDURE.**

1. **CONDITION** lever **FUEL CUTOFF**.
2. **ENG START** switch **OFF** (15 minute minimum).
3. **ENG START** switch **STARTER ONLY**.
4. **ENG START** switch **OFF**.

**\* 8-18. FIRST ENGINE START (GPU START).**

**NOTE**

The engines must not be started until after the **INS** is placed into the **NAV** mode or **OFF** as required.

1. **INS** mode selector switch **OFF** or **NAV** as appropriate. After placing the mode switch to **NAV** (state 5 or less):
  - a. **FPLN** Depress.
  - b. **NAV SETUP** (R5) Depress.
  - c. **INS SETUP** (R5) Depress.

- d. **AUTO MIXING (R3)** Depress to **TACAN, DL, GPS**.
- e. **ROLL LIMIT (R2)** Depress to **ON** or **OFF**.
- f. **LEG CHANGES (L3)** Depress to **MAN** or **AUTO**.

2. **3φ AC CONTROL** switches, **#1 INV** and **#2 INV OFF**.
3. **EXTERIOR LTS** switches As required.
4. Propeller area Clear.
5. **ENG START** switch **START-IGNITION, IGN ON** annunciator should illuminate and **FUEL PRESS** annunciator should extinguish.

**NOTE**

False fuel flow indication may be observed with the starter engaged and the **CONDITION** lever in **FUEL CUTOFF**.

**CAUTION**

If ignition does not occur within 10 seconds after moving **CONDITION** lever to **LOW IDLE**, initiate Abort Start procedure. If for any reason a starting attempt is discontinued, the entire starting sequence must be repeated after allowing the engine to come to a complete stop (15 minute minimum).

6. **CONDITION** lever (after  $N_1$  RPM stabilizes above 13% minimum) **LOW IDLE**.

**CAUTION**

Monitor **TGT** to avoid a hot start. If there is a rapid rise in **TGT**, be prepared to abort the start before limits are exceeded. During engine start, the maximum allowable **TGT** is 1000° C for 5 seconds. If this limit is exceeded, initiate Abort Start procedure and discontinue start. Enter the peak temperature and duration on DA Form 2408-13-1.

7. **TGT** and  $N_1$  Monitor (**TGT** 1000°C maximum).
8. Oil pressure Check (60 PSI minimum).
9. **ENG START** switch **OFF** after **TGT** peaks.

10. **CONDITION** lever **HIGH IDLE**. Monitor **TGT** as **CONDITION** lever is advanced.
11. **DC GPU** disconnect As required.
12. **GENERATOR** switch **RESET** then **ON**, for second engine battery start.

**\* 8-19. SECOND ENGINE START (GPU START).**

1. Propeller area Clear.
2. **ENG START** switch **START-IGNITION**. **IGN ON** annunciator should illuminate and **FUEL PRESS** annunciator should extinguish.
3. **CONDITION** lever (after  $N_1$  RPM stabilizes above 13% minimum) **LOW IDLE**.
4. **TGT** and  $N_1$  Monitor (**TGT** 1000° C maximum).
5. Oil pressure Check (60 PSI minimum).
6. **ENG START** switch **OFF** after **TGT** peaks.

**CAUTION**

Monitor oil temperature closely during ground operation with propellers in **FEATHER** due to lack of air flow over oil cooler.

7. **AC and DC GPU** units Disconnect (check aircraft external power and mission external power annunciators extinguished).
8. **CONDITION** levers **HIGH IDLE**. Monitor **TGT** as **CONDITION** levers are advanced.
9. **PROP** levers **HIGH RPM**.
10. **#1** and **#2 INVERTER** switches **ON** Check **INVERTER** annunciators extinguished.
11. **GENERATOR** switch (1) **RESET**, then **ON**.
12. Current limiters Check as indicated:
  - a. **BATTERY CHARGE** annunciator Check on. **BATTERY CHARGE** annunciator should extinguish within 5 minutes following a normal engine start on battery.
  - b. **# 1** and **# 2 INV** annunciators Check extinguished. This procedure checks both 400 and 500 ampere current limiters that tie aircraft bus systems together.
13. **GENERATOR** switch **RESET**, then **ON**.

**NOTE**

To reset beacon light, turn **OFF** approximately 5 seconds, then **DAY** or **NIGHT**. When voltage drops below approximately 20 volts, the beacon light may become inoperative.

14. **BEACON** lights switch **OFF**, then as required.

**8-20. BEFORE TAXIING.**

- \* 1. **BRAKE** deice switch Check and set as required. Ensure both bleed air valves are open.
- \* 2. **CABIN AIR MODE** and **TEMP** controls Set as desired.

**NOTE**

For maximum cooling on the ground, turn the **PNEU & ENVIRO BLEED AIR valve switches** to **PNEU ONLY** position. Verify airflow is present from aft cockpit eyeball outlets to ensure sufficient cooling for mission equipment.

- H3. AC/DC power Check for:

- (1) AC frequency 394 to 406 Hz.
- (2) AC voltage 104 to 124 VAC.
- (3) DC voltage 28 to 28.5 VDC.

- \* 4. **AUTO PLT POWER** switch-**ON**.
- \* 5. **AVIONICS MASTER POWER** switch-**ON**.
- \* 6. **# 1** and **# 2 EFIS POWER** switches-**ON**.
- \* 7. Mission-panel Set as follows:
  - a. **3 $\phi$ AC CONTROL** switches, **#1 INV** and **#2 INV RESET- ON**.
  - b. **MISSION CONTROL** switch As required.
  - c. **ELINT/COMINT** switches (2) As required.

- H 8. Pilot's and copilot's **EFIS TEST** switches As required. (Refer to paragraph 8-9.)
- H 9. Automatic flight control system-Perform as required. (Refer to paragraph 8-9.)
- H 10. Avionics Check and set as required.
11. Weather radar/**LSS-SBY**.
12. Flaps Check.

13. Altimeters - Set and check.

**\* 8-21. TAXIING.**

Taxi speed can be effectively controlled by the use of power application and the use of the variable pitch propellers in the ground fine range with the **PROP** levers retarded to the **FEATHER** detent.

1. **PROP** levers As required.
2. Brakes Check.
3. Flight instruments Check for normal operation.

**8-22. ENGINE RUNUP.**

1. Mission control panel After receiving clearance from IPF set as instructed.
2. Propeller feathering Check by pulling **PROP** levers aft past detent to **FEATHER**. Check that each propeller feathers, then advance levers to **HIGH RPM** position.

H 3. Autofeather/auto ignition Check as follows:

- a. **AUTO IGNITION** switches ARM.
- b. **POWER** levers Approximately 25% torque.
- c. **AUTOFEATHER** switch Hold to TEST (both **AUTOFEATHER** annunciators illuminated).
- d. **POWER** levers Retard individually.

(1) At 13% to 19% torque Opposite **AUTOFEATHER** annunciator extinguished, **IGN ON** annunciator illuminated.

(2) At 7% to 13% torque Both **AUTOFEATHER** annunciators extinguished (propeller starts to feather).

**NOTE**

The **POWER** lever may have to be lifted and pulled towards the ground fine gate in order to attain the 7% to 13% torque.

**AUTOFEATHER** annunciators will illuminate and extinguish with each fluctuation of torque as the propeller feathers.

- (3) Return **POWER** lever to approximately 25% torque.
- e. Repeat above procedure with other engine.

- f. **POWER** levers **IDLE**.
- g. **AUTOFEATHER** switch **ARM**.
- h. **AUTO IGNITION** switches Off.

4. Overspeed governors and rudder boost Check as follows:

- a. Yaw damper **ENGAGE**. Observe **YD ENG** annunciator illuminated.
- b. **PROP GOVERNOR TEST** switch Hold to **PROP GOVERNOR TEST** position.
- c. Left **POWER** lever Increase until propeller stabilizes at 1540 to 1580 **RPM**.
- d. Release **PROP GOVERNOR TEST** switch Observe that propeller RPM increases.
- e. Left **POWER** lever Continue advancing. At approximately 50% torque differential, **YD ENG** annunciator should extinguish, and left rudder pedal should start to move forward. Increasing engine power should result in increased rudder pedal travel. (Observe torque and TGT limits.)
- f. Left **POWER** lever Slowly retard. Rudder pedal travel should decrease with decreasing power. The **YD ENG** annunciator may flicker as rudder boost system disengages.
- g. Yaw damper Re-engage yaw damper, and repeat steps b through f with other engine.

H 5. Primary governors Check as follows:

- a. **POWER** levers Set at 1500 RPM.
- b. Exercise propeller Move aft to detent, check propeller RPM 1150 ±50, then return to high RPM.

6. Engine anti-ice Check as follows:

- a. **ENG INLET LIP HEAT** switches (2) ON. Check # 1 and # 2 **LIP HEAT** caution advisory annunciator lights illuminated.
- b. # 1 and # 2 **LIP HEAT** advisory annunciator lights Check illuminated.

H 7. Anti-ice and deice systems Check as follows:

- a. **WINDSHIELD** anti-ice switches (2) **NORMAL** then **HIGH**. Check **PILOT** and **COPILOT** (individually) for loadmeter rise, then OFF.

- b. **AUTO PROP** deice switch **ON** (momentarily). Check for loadmeter rise.
- c. **MANUAL PROP** deice switch **ON** (momentarily). Check for loadmeter rise, then off.
- d. **SURFACE** deice switch **SINGLE CYCLE AUTO**. Check for drop in pneumatic pressure and wing deice boot inflation, and after 6 seconds for second drop in pneumatic pressure.
- e. **SURFACE** deice switch **MANUAL**. Check that surface boots inflate, and remain inflated, then off.
- f. **ANTENNA** deice switch **SINGLE CYCLE AUTO**. Check for drop in pneumatic pressure and that antenna deice boots inflate.
- g. **ANTENNA** deice switch **MANUAL**. Check that boots inflate, and remain inflated, then **OFF**.
- h. **RADOME** anti-ice switch **ON**. Check for loadmeter rise and pneumatic pressure drop then off.
- j. **L BL AIR OFF** annunciator Check extinguished.
- k. **L and R BL AIR FAIL** annunciators Check extinguished.
- l. **PNEUMATIC PRESSURE** gage/**GYRO SUCTION** gage Check in green arc.
- m. **CABIN CLIMB** indicator Check for descent indication within approximately 10 15 seconds, then release TEST switch.
- n. **LEFT PNEU & ENVIRO BLEED AIR** valve switch Off.
- o. Repeat steps i through m using the right bleed air valve.
- p. **CABIN PRESS** switch Set to pressure position (center).
- q. **CABIN ALT** controller Reset as required.
- r. Cabin pressurization **RATE** control Reset as required.
- s. **PNEU & ENVIRO BLEED AIR** valve switches (2) **ON**.

H 8. Pneumatics/vacuum/pressurization Check as follows:

- a. **PNEUMATIC PRESSURE** gage/**GYRO SUCTION** gage Check in green arcs.
- b. **CABIN ALT** controller Set 500 feet lower than field pressure altitude.
- c. Cabin pressurization **RATE** control Set to maximum.
- d. **ENVIRO & PNEU BLEED AIR** valve switches (2) ENVIRO & PNEU off.
- e. **PNEUMATIC PRESSURE** gage/**GYRO** suction gage Check. Pressure should drop to zero.
- f. **BL AIR FAIL OFF** annunciators (2) Check illuminated.
- g. **BL AIR FAIL** annunciators (2) Check illuminated.
- h. **CABIN PRESS** switch **TEST** (hold).
- i. **LEFT PNEU & ENVIRO BLEED AIR** valve switch **ON**.

**CAUTION**

If windshield anti-ice is needed prior to takeoff, use **NORMAL** setting for a minimum of 15 minutes prior to selecting **HIGH** temperature to provide adequate preheating and minimize effects of thermal shock.

9. **WINDSHIELD** anti-ice As required.

**WARNING**

Do not operate the weather radar set while personnel or combustible materials are within 18feet of the antenna reflector. When the weather radar set is operating, high-power radio frequency energy is emitted from the antenna reflector, which can have harmful effects on the human body and can ignite combustible materials. Do not operate radar in congested areas.

**CAUTION**

Do not operate the weather radar system in a confined space where the nearest metal wall is 50 feet from the antenna reflector. Scanning such surfaces within 50 feet of the antenna reflector may damage receiver crystals.

**NOTE**

The weather radar system should be tested before each flight during which the system is to be used.

H 10. Weather radar Test and set as required:

- a. **RADAR** mode selector switch **SBY**.
- b. **LSS** mode selector switch **SBY**.
- c. **WX** pushbutton selector switch (display controller) Depress. Observe that EHSI displays partial compass heading arc.

**WARNING**

The radar transmitter is radiating X band microwave energy when in the test (TST) mode.

- d. **RADAR** mode selector switch **TST**. Observe that **WX** mode annunciator on **EHSI** remain **STBY**.
- e. Range switches (radar control panel) Depress both switches simultaneously. Observe that **WX** mode annunciator on **EHSI** changes from **STBY** to **TEST**, and that magenta, red, yellow, and green are displayed. A green noise band will appear at the upper arc range marking.
- f. **RADAR** mode selector switch **SBY**, then as required.
- g. Range switches (radar control panel) Select 50 NM or greater.
- h. **LSS** mode selector switch **CLR TST**.
- i. **EHSI** Verify that a white lightning rate symbol appears at approximately 25 NM at 45 degrees right of center and a magenta lightning alert symbol is displayed at maximum selected range at 45 degrees right of center.

- j. **LSS** mode selector switch **SBY** or as required.

**NOTE**

While the aircraft's weight is on the wheels, the weather radar system is forced into the standby mode. This is a safety feature that prevents the radar from transmitting on the ground, to eliminate the microwave radiation hazard.

**\* 8-23. BEFORE TAKEOFF.**

- (1) **AUTOFEATHER** switch **ARM**.
- (2) **PNEU & ENVIRO BLEED AIR** valves (2) As required.

**CAUTION**

Do not use pitot heat more than 15 minutes while the aircraft is on the ground. Overheating may damage the heating elements.

- (3) **ICE & RAIN** switches As required. As a minimum, **PITOT**, **STALL WARN**, and **FUEL VENT** switches shall be **ON**.
- (4) Fuel panel Check fuel quantity and switch positions.
5. Flight and engine instruments Check for normal indications and **EFIS** display controller is set to desired setting.
- (6) **CABIN CONTROLLER** Set.
7. Annunciator panels Check (note indications).
8. Flaps As required.
9. Trim Set.
- (10) **ASE/ACS** Set.
- (11) Avionics Set.
12. Flight controls Check.
- H 13. Departure briefing (paragraph 8-52) Complete.

**\* 8-24. LINE UP.**

- (1) **ENG ANTI-ICE** switches As required.
- (2) Engine **AUTO IGNITION** switches **ARM**.
3. **PROP** levers **HIGH RPM**.

- (4) Altitude alerter Check. Set as required.
- (5) Transponder As required.
- 6. Lights As required.

**NOTE**

**Landing lights may be used for takeoff to assist in avoiding bird strikes and to make the aircraft more visible while operating in congested areas.**

**8-25. TAKEOFF.**

To aid in planning the takeoff and to obtain maximum aircraft performance, make full use of the information which affects takeoff, as shown in Chapter 7. The data shown is achieved by setting brakes, setting static takeoff power, and then releasing brakes. Normal takeoff may be modified by starting the takeoff roll prior to attaining takeoff power. This will result in a smoother takeoff, but will invalidate all subsequent field performance data.

a. *Normal Takeoff.* After the Line Up check is complete, smoothly apply power to the setting determined from the appropriate Static Takeoff Power at 1700 RPM chart. Release brakes and maintain directional control with nosewheel steering and rudder, while maintaining wings level with ailerons. The pilot should retain a light hold on the power levers through the takeoff and be ready to initiate abort procedures if required. The copilot should ensure that the **AUTOFEATHER** advisory lights are illuminated and monitor engine torque during the takeoff roll. As the aircraft accelerates, engine torque will increase, but should not exceed engine limits (torque or TGT). As the copilot calls VI, the pilot will remove his hand from the **POWER** levers. The copilot will call rotate at V, and the pilot will commence a smooth, positive aircraft rotation to an indicated pitch attitude of 7°. When two positive climb indications are observed, the landing gear will be retracted.

b. *Crosswind Takeoff.* Position the aileron control into the wind at the start of the takeoff roll to maintain a wings level attitude. Under strong crosswind conditions, leading with upwind power at the beginning of the takeoff roll will assist in maintaining directional control. As the nosewheel comes off the ground, the rudder is used as necessary to prevent turning (crabbing) into the wind. Rotate in a positive manner to keep from side-skipping as weight is lifted from the shock struts. To prevent damage to the landing gear, in the event that the aircraft were to settle back onto the runway, remain in slipping flight until well clear of the ground, then crab into the wind to continue a straight flight path.

c. *Minimum Run Takeoff.* Not applicable.

d. *Obstacle Clearance Climb.* Obtain performance data from Chapter 7 using field performance data.

**8-26. AFTER TAKEOFF.**

**WARNING**

**Immediately after takeoff, the pilot flying the aircraft should avoid adjusting controls located on the aft portion of the extended pedestal to preclude inducing spatial disorientation.**

With both engines operating, the aircraft will rapidly accelerate through V2. Allow the aircraft to continue accelerating to the two engine climb speed, or the cruise climb schedule, as applicable. Retract the flaps when safely airborne. The procedural steps are as follows:

- 1. Gear **UP**.
- 2. Flaps **UP**.
- 3. **LANDING LIGHTS** switch **OFF**.

**CAUTION**

**Turn windshield anti-ice to NORMAL when passing 10,000 feet AGL or prior to entering the freezing level (whichever comes first). Leave on until no longer required during descent for landing. High temperature may be selected as required after a minimum warm-up period of 15 minutes.**

- 4. **WINDSHIELD** anti-ice As required.

**8-27. CLIMB.**

Cruise climb is performed at a speed which provides a good rate-of-climb. Propellers should be kept at 1700 RPM. Lower propeller RPM will reduce the amount of cabin noise, but will degrade the aircraft climb performance. The following chart may be used as an airspeed schedule.

**NOTE**

**To increase visibility and safety when operating in high traffic, a climb speed of 160 KIAS to 10,000 feet MSL may be used.**

SL to 10,000 FEET .....	135 KIAS
10,000 to 20,000 FEET .....	130 KIAS
20,000 to 25,000 FEET .....	125 KIAS

25,000 to 35,000 FEET ..... 120 KIAS

#### NOTE

The maximum rate of climb performance is obtained by setting maximum continuous power and maintaining two-engine climb speed.

1. Climb power Set.
2. Propeller synchronization As required.
- (3) Yaw damper **ENGAGE** (required above 17,000 feet).
- (4) **BRAKE** deice As required.
- (5) **ICE VANE CONTROL** switches As required.
- (6) **STANDBY PUMP** switches As required (refer to Chapter 5).
- (7) Cabin pressurization Check. Adjust rate control knob so that cabin rate-of-climb equals one third of aircraft rate-of-climb.
8. Wings and center section Check for security and no fuel/oil leaks.
9. Flare/chaff dispenser safety pin Remove as required.
- (10) **ASE** As required.
- (11) **RADIO ALT** switch **OFF**.

#### 8-28. CRUISE.

Refer to Chapter 7 for airspeed, power settings, and fuel flow information. The following procedures are to be used for cruise configuration:

1. Power Set.
- (2) **ICE & RAIN** switches As required.
- (3) **AUTOFEATHER** As required.
- (4) Auxiliary fuel gages Monitor.
5. Altimeters Check.
6. Engine instrument indications Noted.
7. **RECOG** lights As required.

#### 8-29. DESCENT.

Descent from cruise altitude should normally be made by letting down at cruise airspeed with reduced power. (Refer to Chapter 7 for performance data.)

#### NOTE

Cabin altitude and rate-of-climb controller should be adjusted prior to starting descent.

If required to descend at a low airspeed (e.g., to conserve airspace or minimize turbulence), approach flaps and landing gear may be extended to increase the rate and angle of descent while maintaining the slower airspeed.

#### 8-30. DESCENT-ARRIVAL.

Refer to Chapter 7 for performance data. Perform the following checks prior to the final descent for landing:

#### WARNING

**Vmo may be easily exceeded when descending from high altitude. The pilot should frequently cross check the airspeed limit indicators to avoid exceeding Vmo. Exceeding V<sub>o</sub>, could result in structural failure and loss of airframe integrity.**

- (1) **CABIN CONTROLLER** Set.
- (2) **ICE & RAIN** switches As required.

#### CAUTION

**Set windshield anti-ice to NORMAL or HIGH as required well before descent into icing conditions or into warm moist air to aid in defogging. Turn off windshield anti-ice when descent is completed to lower altitudes and when heating is no longer required. This will preclude possible wind screen distortions.**

- (3) **WINDSHIELD** anti-ice As required.
4. **RECOG** lights On.
5. Altimeters Set to current altimeter setting.
- (6) **RADIO ALT** switch **ON**.
- (7) **ASE** As required.
- (8) **STANDBY PUMP** switches As required.
9. Flare/chaff dispenser safety pin Insert.
10. Avionics and **EFIS** display controller Set and check. Ensure **EFIS** displays match procedure to be flown.
- H 11. Arrival briefing (paragraph 8-53) Complete.

**8-31. BEFORE LANDING.**

1. **PROP SYN** switch - As required.
2. **PROP** levers - As required.
3. Flaps (below 197 KIAS) - **APPROACH**.
4. Gear (below 179 KIAS) - DN
5. **LANDING LIGHTS** switch - As required.
- (6) **AUTOFEATHER** switch - **ARM**.
- (7) **ICE VANE CONTROL** switches - As required.
- (8) **BRAKE** deice - As required.
- (9) **WOW OVERRIDE** switch - OFF.
- (10) **ANT STOWED** annunciator light - Check illuminated.

**8-32. LANDING.****CAUTION**

The maximum demonstrated crosswind component is 20 knots at 900. Landing the aircraft in a crab will impose side loads on the landing gear and should be recorded on DA Form 2408-13-1.

a. *Normal Landing.* Refer to Chapter 7 for performance data. When landing is assured:

1. Autopilot and yaw damper Disengage.
2. **GEAR DOWN** annunciators Check.
3. **PROP** levers **HIGH RPM**.

b. *Crosswind Landing.* Refer to Chapter 7 for recommended  $V_{ref}$  speed. Use the crab into the wind method to correct for drift during final approach. The crab is changed to a slip (aileron into wind and top rudder) to correct for drift during flare and touchdown. After landing, position ailerons as required to correct for crosswind effect. For crosswind exceeding the published limits, a combination slip and crab method at touchdown should be used.

c. *Soft Field Landing.* Not applicable.

**8-33. TOUCH AND GO/STOP AND GO LANDING.**

When a touch and go/stop and go landing is to be performed, the following procedures shall be used:

- (1) **PROP** levers - HIGH RPM.

- (2) Flaps - As required.
- (3) Trim - Set.
4. Power stabilized - Check 25% minimum.
5. Takeoff power - Set.

**8-34. GO-AROUND.**

When a go-around is commenced prior to the LANDING check, use power as required to climb to, or maintain, the desired altitude and airspeed. If the go-around is started after the LANDING check has been performed, apply maximum allowable power, retract the flaps to APPROACH, and simultaneously increase pitch attitude to stop the descent. Retract the landing gear after ensuring that the aircraft will not touch the ground. Accelerate to two engine climb airspeed, retracting flaps fully after attaining  $V_{ref}$

1. Power - Maximum allowable.
2. Gear - UP.
3. Flaps - UP.
4. **LANDING LIGHTS** switch - OFF.
5. Climb power - Set.
- (6) **BRAKE** deice - Off.

**8-35. AFTER LANDING.**

Complete the following procedures after the aircraft has cleared the runway:

1. **PROP** levers - Retard to **FEATHER** detent
- (2) **ICE VANE CONTROL** switches - **ON**.
- (3) Engine **AUTO IGNITION** switches - Off.
- (4) **ICE & RAIN** switches - Off.
5. Flaps - **UP**.
- (6) Radar/transponder - As required.
7. Lights - As required.
- (8) Mission control panel - Set as follows:
  - a. **RADIO ALT** switch - **OFF**.
  - b. **MISSION CONTROL ORIDE** switch - **OFF**.
  - c. **ELINT/COMINT** switches (2) - As required.
  - d. **ASE SILENT** switch - **OFF**.



**8-36. ENGINE SHUTDOWN.****NOTE**

To prevent sustained loads on rudder shock links, the aircraft should be parked with the nose gear centered.

1. **PARKING BRAKE** - Set.
2. **LANDING/TAXI LIGHTS** switches - **OFF**.
- (3) **INS** - **OFF**.
4. **BUS CROSS TIE** switch - **OFF**.
5. **CABIN AIR MODE** switch - **OFF**.
6. **FWD and AFT VENT BLOWER** switches - **AUTO**.
7. **AUTOFEATHER** switch - **OFF**.
8. Inverter switches (4) - Off.
9. **AUTO PLT POWER** switch - Off.
10. **# 1 and # 2 EFIS POWER** switches - Off.
11. **BRAKE** deice - Off.
12. Battery condition - Check.
13. **TGT** - Check stabilized for 1 minute prior to shutdown.
14. **POWER** levers - Flight **IDLE**.
15. **PROP** levers - **FEATHER**.

**CAUTION**

Monitor TGT during shutdown. If sustained combustion is observed, proceed immediately to Abort Start procedure.

16. **CONDITION** levers - **FUEL CUTOFF**.

17. Oxygen system - **OFF**.

**WARNING**

Do not turn exterior lights off until propeller rotation has stopped.

18. **COCKPIT LIGHTS** switches - Off.
19. **AVIONICS MASTER POWER** switch - Off.
20. **EXTERIOR LTS** - Off.
21. **MASTER SWITCH** - **OFF**.
22. Keylock switch - **OFF**.

**8-37. BEFORE LEAVING AIRCRAFT.****NOTE**

Brakes should be released after chocks are in place (ramp conditions permitting).

1. Wheels - Chocked.
2. **PARKING BRAKE** - As required.
3. Flight controls - Locked.
4. **STANDBY PUMP** switches - Off.
5. **COMSEC** - Zeroize as required.
6. Windows - As required.
7. Emergency exit lock - As required.
8. Aft cabin lights - **OFF**.
9. Door light - **OFF**.
10. Walk-around inspection - Complete.
11. Aircraft forms - Complete.
12. Aircraft - Check secured.

### Section III. INSTRUMENT FLIGHT

#### 8-38. GENERAL.

This aircraft is qualified for operation under instrument flight meteorological conditions. Handling characteristics, stability characteristics, and range are the same during instrument flight conditions as when under visual flight conditions.

#### 8-39. INSTRUMENT FLIGHT PROCEDURES.

Refer to FM 1-240, DOD FLIP, AR 95-1, and procedures described in this manual or applicable foreign regulations.

#### 8-40. INSTRUMENT TAKEOFF.

##### NOTE

**If the GO AROUND button is depressed to set a 7 degree takeoff command, the yaw damper will engage.**

Complete the normal checks prescribed in this chapter. Follow takeoff procedures dictated by local conditions.

#### 8-41. AUTOPILOT COUPLED APPROACHES.



The recommended airspeed for autopilot coupled approaches is 130 KIAS.

### Section IV. FLIGHT CHARACTERISTICS

#### 8-42. STALLS.

A warning in the form of light buffeting may be felt when approaching a stall. An aural warning is provided by the warning horn. The warning horn will begin to sound approximately 5 to 19 knots above power off stall speed, depending on aircraft configuration, altitude, and power. If correct stall recovery technique is used, very little altitude will be lost during the stall recovery. For the purpose of this section, the term power on means that both engines and propellers of the aircraft are operating normally and are responsive to pilot control. The term power off means that both engines are operating at idle power. During practice, enter power off stalls from normal glides. Enter power on stalls by smoothly increasing pitch attitude to a climb attitude obviously impossible for the aircraft to maintain, and hold that attitude until the stall occurs.

*a. Power On Stalls.* The power on stall attitude is very steep and, unless this high pitch attitude is maintained, the aircraft will generally settle or mush instead of stall. It is difficult to stall the aircraft inadvertently in any normal maneuver. A light buffet precedes the stall, and the first indication of approaching stall is generally a decrease in control effectiveness, accompanied by a tone from the stall warning horn. The stall itself is characterized by a rolling tendency if the aircraft is allowed to yaw. The proper use of rudder will minimize the tendency to roll. A slight pitching tendency will develop if the aircraft is held in the stall, resulting in the nose dropping slightly, then pitching up toward the horizon; this cycle is repeated until recovery is made. Control is regained very quickly with little altitude loss, providing the nose is not lowered excessively. Begin recovery with forward movement of the control wheel and a gradual return to level flight. The roll tendency caused by yaw is more pronounced in power on stalls, as is the pitching tendency.

*b. Power Off Stalls.* The roll tendency is considerably less pronounced in power off stalls (in any configuration), and is more easily prevented or corrected by adequate rudder and aileron control, respectively. The nose will generally drop straight through with some tendency to pitch up again if recovery is not made immediately. The Stall Speed graph (fig. 8-2) shows the indicated power off stall speeds with aircraft in various configurations. Altitude loss during a full stall may be as high as 1270 feet  or 1107 feet .

*c. Accelerated Stalls.* The aircraft gives noticeable stall warning in the form of buffeting when an accelerated stall occurs. The stall warning horn and buffet can be demonstrated in turns by applying excessive back pressure on the control wheel.

#### 8-43. SPINS.

Intentional spins are prohibited. If a spin is inadvertently entered, use the following recovery procedure:

##### WARNING

**Spin demonstrations have not been conducted. The recovery technique is based on the best available information.**

Perform the following three actions as nearly simultaneously as possible.

1. POWER levers - IDLE.
2. Apply full rudder opposite direction of spin rotation.
3. Push control wheel forward and neutralize ailerons.

STALL SPEEDS - POWER IDLE

EXAMPLE:  
WEIGHT ..... 11,000 LBS  
FLAPS ..... APPROACH  
ANGLE OF BANK ..... 30°  
STALL SPEED ..... RA7Q KIAS

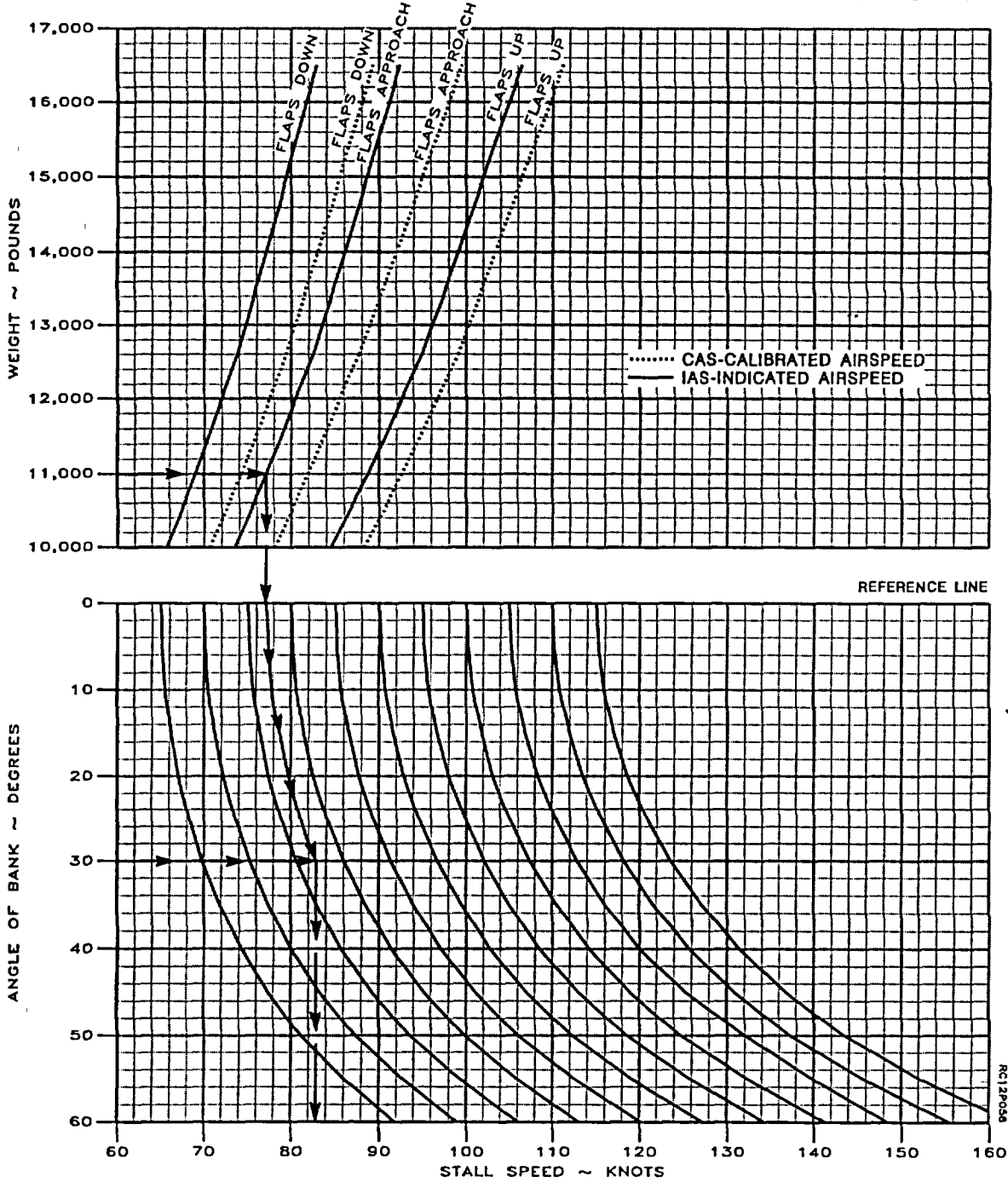

Figure 8-2. Stall Speeds - Power Idle

4. When rotation stops, neutralize rudder.

**WARNING**

**Do not pull out of the resulting dive too abruptly as this could cause excessive wing loads and a possible secondary stall.**

5. Pull out of dive by exerting a smooth, steady back pressure on control wheel, avoiding an accelerated stall and excessive aircraft stresses.

#### **8-44. MANEUVERING FLIGHT.**

Maneuvering speed (V.) is the maximum speed at which abrupt full control inputs can be applied without exceeding the design load on the aircraft as shown in Chapter 5. The data is based on 16,500 pounds and there are no additional restrictions below this weight. There are no unusual characteristics under accelerated flight.

#### **8-45. FLIGHT CONTROLS.**

The aircraft is stable under all normal flight conditions. Aileron, elevator, rudder, and trim tab controls function effectively throughout all normal flight conditions. Elevator

control forces are relatively light in the extreme aft CG (center of gravity) condition, progressing to moderately high with CG at the forward limit. Extending and retracting the landing gear causes only slight changes in control pressure. Control pressures resulting from changes in power settings or the repositioning of the wing flaps are not excessive in the landing configuration at the most forward CG. The minimum speed at which the aircraft can be fully trimmed is 106 KIAS (gear and flaps down, propellers at high RPM). Control forces produced by changes in speed, power setting, wing flap position and landing gear position are light and can be overcome with one hand on the control wheel. Trim tabs permit the pilot to reduce these forces to zero. During single engine operation, the rudder boost system aids in relieving the relatively high rudder pressures resulting from the large variation in power.

#### **8-46. LEVEL FLIGHT CHARACTERISTICS.**

All level flight characteristics are conventional throughout the level flight speed range.

### **Section V. ADVERSE ENVIRONMENTAL CONDITIONS**

#### **8-47. INTRODUCTION.**

The purpose of this section is to inform the pilot of the special precautions and procedures to be followed during the various weather conditions that may be encountered in flight. This section is primarily narrative; only those checklists that cover specific procedures characteristic of weather operations are included. The checklist in Section II provides for adverse environmental operations.

#### **8-48. COLD WEATHER OPERATIONS.**

**WARNING**

**To ensure adequate bleed air pressure to the deice boots, do not simultaneously actuate the surface and antenna deice systems in the manual mode.**

**CAUTION**

**Operation of the surface deice system in ambient temperatures below -40 °C can cause permanent damage to the deice boots.**

**NOTE**

**Under conditions where one bleed air source is inoperative, sufficient bleed air pressure for deice boot inflation may not be available. Prior to deice boot inflation, check the regulated bleed air pressure gage for a minimum of 16 PSI. If insufficient pressure exists, increasing engine N1 and/or decreasing aircraft altitude will increase bleed air pressure.**

Operational difficulties may be encountered during extremely cold weather, unless proper steps are taken prior to, or immediately after flight. All personnel should understand and be fully aware of the necessary procedures and precautions involved.

*a. Preparation For Flight.* Accumulations of snow, ice, or frost on aircraft surfaces will adversely affect takeoff distance, climb performance, and stall speed to a

dangerous degree. Such accumulations must be removed before flight. In addition to the normal exterior checks, following the removal of ice, snow, or frost, inspect wing and empennage surfaces to verify that these surfaces remain sufficiently cleared. Also, move all control surfaces to confirm full freedom of movement. Ensure that tires are not frozen to wheel chocks or to the ground. Use ground heaters, anti-ice solution, or brake deice to free frozen tires. When heat is applied to release tires, the temperature should not exceed 710 C (160° F). Refer to Chapter 2 for anti-icing, deicing, and defrosting treatment.

*b. Engine Starting.* When starting engines on ramps covered with ice, PROP levers should be in the **FEATHER** position to prevent the tires from sliding.

*c. Warm-Up and Ground Test.* Warm-up procedures and ground test are the same as those outlined in Section II.

*d. Taxiing.* Whenever possible, taxiing in deep snow, light weight dry snow, or slush should be avoided, particularly in colder FAT conditions. If it is necessary to taxi through snow or slush, do not set the parking brake when stopped. If possible, do not park the aircraft in snow or slush deep enough to reach the brake assemblies. Chocks or sandbags should be used to prevent the aircraft from rolling while parked. Before attempting to taxi, activate the brake deice system, and ensure that the bleed air valves are open and that the condition levers are in **HIGH IDLE**. An outside observer should visually check wheel rotation to ensure brake assemblies have been deiced.

*e. Before Takeoff.*

(1) If icing conditions are expected, activate all anti-ice systems before takeoff, allowing sufficient time for the equipment to become effective.

(2) If the possibility of ice accumulation on the horizontal stabilizer or elevator exists, takeoff shall not be attempted.

*f. Takeoff.* Takeoff procedures for cold weather operations are the same as for normal takeoff. Taking off with temperature at or below freezing, with water, slush, or snow on the runway, can cause ice to accumulate on the landing gear and can throw ice into the wheel well areas. Such takeoffs shall be made with brake deice on and with the ice vanes extended. Before flight into icing conditions, set the pilot and copilot **WINDSHIELD** anti-ice switches each to the **NORMAL** position.

*g. During Flight.*

(1) After takeoff from a runway covered with snow or slush, it is advisable to leave brake deice on to dislodge ice accumulated from the spray of slush or water. Monitor **BRAKE DEICE ON** annunciator for automatic termination of system operation and then turn the switch **OFF**. During flight, periodically exercise trim tabs and controls to prevent freezing. Ensure that anti-icing systems are activated before entering icing conditions. Do not activate the surface deice system until ice has accumulated at least 0.5 INCH. The propeller deice system operates effectively as an anti-ice system and it may be operated continuously in flight. If propeller imbalance due to ice does occur, it may be relieved by increasing RPM briefly, then returning to desired setting.

Ice vanes must be extended when operating in visible moisture or when freedom from visible moisture cannot be assured, at +50C FAT or less. Ice vanes are designed as an anti-ice system, not a deice system. After the engine air inlet screens are blocked, lowering the ice vanes will not rectify the condition.

(2) Stalling airspeeds will increase when ice has accumulated on the aircraft causing distortion of the wing airfoil. For the same reason, stall warning devices are not accurate and should not be relied upon. Keep a comfortable margin of airspeed above the normal stall airspeed. Maintain a minimum of 140 knots during sustained icing conditions to prevent ice accumulation on unprotected surfaces of the wing. In the event of windshield icing, reduce airspeed to 226 knots or below.

*h. Descent.* Use normal procedures in Section II. Brake deicing should be considered if moisture was encountered during previous ground operations or in flight, in icing conditions with gear extended.

*i. Landing.* Landing on an icy runway should be attempted only when absolutely necessary and should not be attempted unless the wind is within 10° of runway heading. Application of brakes without skidding the tires on ice is very difficult, due to the sensitive brakes. In order not to impair pilot visibility, use reverse thrust with caution when landing on a runway covered with snow or standing water. Use procedures in Section II for normal landing.

*j. Engine Shutdown.* Use normal procedures in Section II.

*k. Before Leaving Aircraft.* When the aircraft is parked outside on ice or in a fluctuating freeze-thaw temperature condition, use the following procedures in addition to the normal procedures in Section II. After wheel chocks are in place, release the brakes to prevent freezing.

Fill fuel tanks to minimize condensation, remove any accumulation of dirt and ice from the landing gear shock struts, and install protective covers to guard against possible collection of snow and ice.

#### **8-49. DESERT OPERATION AND HOT WEATHER OPERATION.**

Dust, sand, and high temperatures encountered during desert operation can sharply reduce the operational life of the aircraft and its equipment. The abrasive characteristics of dust and sand upon turbine blades and other moving parts of the aircraft and the destructive effect of heat upon the aircraft instruments will necessitate many hours of maintenance if basic preventive measures are not followed. In flight, the hazards of dust and sand will be difficult to escape, since dust clouds over a desert may be found at altitudes up to 10,000 feet. During hot weather operations, the principal difficulties encountered are high turbine gas temperatures (TGT) during engine starting, over-heating of brakes, and longer takeoff and landing distances due to the higher density altitudes encountered. In areas where high humidity is encountered, electrical equipment (such as communication equipment and instruments) will be subject to malfunction by corrosion, fungi, and moisture absorption by nonmetallic materials.

*a. Preparation For Flight.* Check the position of the aircraft in relation to other aircraft. Propeller blown sand can damage nearby aircraft. Check that the landing gear shock struts are free of dust and sand. Check the instrument panel and general interior for dust and sand accumulation. Open main entrance door and cockpit vent storm windows to ventilate the aircraft.

*b. Engine Starting.* Use normal procedures in Section II. Engine starting under conditions of high ambient temperatures may produce a higher than normal TGT during the start. Closely monitor TGT when the CONDITION lever is moved to the LOW IDLE position. If overtemperature tendencies are encountered, periodically move CONDITION lever to IDLE CUTOFF position periodically during acceleration of gas generator RPM (N1). Be prepared to abort the start before temperature limitations are exceeded.

*c. Warm-Up Ground Tests.* Use normal procedures in Section II.

*d. Taxiing.* Use normal procedures in Section II. When practical, avoid taxiing over sandy terrain to minimize propeller damage and engine deterioration that results from impingement of sand and gravel. During hot weather operation, use minimum braking action to prevent brake overheating.

*e. Takeoff.* Use normal procedures in Section II. Avoid taking off in the wake of another aircraft if the runway surface is sandy or dusty.

*f. During Flight.* Use normal procedures in Section II.

*g. Descent.* Use normal procedures in Section II.

*h. Landing.* Use normal procedures in Section II.

*i. Engine Shutdown.* Use normal procedures in Section II.

#### **CAUTION**

**If fuel tanks are completely filled during hot weather, fuel expansion may cause overflow, thereby creating a fire hazard.**

*j. Before Leaving Aircraft.* Use normal procedures in Section II. Take extreme care to prevent sand or dust from entering the fuel and oil system during servicing. During hot weather, release the brakes immediately after installing wheel chocks to prevent brake disc warpage.

#### **8-50. TURBULENCE AND THUNDERSTORM OPERATION.**

#### **CAUTION**

**Due to the comparatively light wing loading, control in severe turbulence and thunderstorms is critical. Since turbulence imposes heavy loads on the aircraft structure, make all necessary changes in aircraft attitude with the least amount of control pressures possible to avoid excessive loads on the aircraft structure.**

Thunderstorms and areas of severe turbulence should be avoided. However, if such areas are to be penetrated, it is necessary to counter rapid changes in attitude and accept major indicated altitude variations. Penetration should be at an altitude which provides adequate maneuvering margins as a loss or gain of several thousand feet of altitude may be expected. The recommended speed for penetration of severe turbulence is 150 KIAS. Constant pitch attitude and power settings are vital to proper flight technique. Establish recommended penetration speed and proper attitude prior to entering turbulent air to minimize most difficulties. False indications by the pressure instruments due to barometric pressure variations within the storm make the instruments unreliable. Maintaining a pre-established attitude will result in a fairly constant airspeed. Turn cockpit and

cabin lights on to minimize the blinding effects of lightning. Do not use autopilot altitude hold. Maintain constant power settings and pitch attitude regardless of airspeed or altitude indications. Concentrate on maintaining a level attitude by reference to the flight director/attitude indicator. Maintain original heading. Make no turns unless absolutely necessary.

## 8-51. ICE AND RAIN (TYPICAL).

### WARNING

**While in icing conditions, if there is an unexplained 30% increase of torque needed to maintain airspeed in level flight, a cumulative total of two or more inches of ice accumulation on the wing, an unexplained decrease of 15 knots IAS, or an unexplained deviation between pilot's and copilot's airspeed indicators, the icing environment should be exited as soon as practicable. Ice accumulation on the pitot tube assemblies could cause a complete loss of airspeed indication.**

*a. Typical Icing.* The following conditions indicate a possible accumulation of ice on the pitot tube assemblies and unprotected aircraft surfaces. If any of the following conditions are observed, the icing environment should be exited as soon as practicable:

(1) Total ice accumulation of two inches or more on the wing surfaces. Determination of ice thickness can be accomplished by summing the estimated ice thickness on the wing prior to each pneumatic boot deice cycle (e.g. four cycles of minimum recommended 1/2-inch accumulation).

(2) A 30 percent increase in torque per engine required to maintain desired airspeed in level flight (not to exceed 85 percent torque) when operating at recommended holding/loiter speed.

(3) A decrease in indicated airspeed of 15 knots after entering the icing condition (not slower than 1.4 power off stall speed) if maintaining original power setting in level flight. This can be determined by comparing pre-icing condition entry speed to the indicated speed after a surface and antenna deice cycle is completed.

(4) Any variations from normal indicated airspeed between the pilot's and copilot's airspeed indicators.

Icing occurs because of supercooled water vapor such as fog, clouds, or rain collecting on the aircraft surface. The most severe icing occurs on aircraft surfaces in visible moisture or precipitation with a true

outside air temperature between -5°C and +1°C; however, under some circumstances, dangerous icing conditions may be encountered with temperatures below -10°C. The surface of aircraft must be at a temperature of freezing or below for ice to stick. If severe icing conditions are encountered, ascend or descend to altitudes where these conditions do not prevail. If flight into icing conditions is unavoidable, proper use of aircraft anti-icing and deicing systems may minimize the problems encountered. Approximately 15 minutes prior to flight into temperature conditions which could produce frost or icing conditions, the pilot and copilot windshield anti-ice switches should be set at normal or high temperature position (after preheating) as necessary to eliminate windshield ice. Stalling airspeeds should be expected to increase when ice has accumulated on the aircraft causing distortion of the wing airfoil. For the same reason, stall warning devices are not accurate and should not be relied upon. Keep a comfortable margin of airspeed above the normal stall airspeed with ice on the aircraft. Maintain a minimum of 140 KNOTS during sustained icing conditions to prevent ice accumulation on unprotected surfaces of the wing. In the event of windshield icing, reduce airspeed to 226 KNOTS or below.

*b. Rain.* Rain presents no particular problems other than slippery runways, restricted visibility, and occasional incorrect airspeed indications.

*c. Taxiing.* Extreme care must be exercised when taxiing on ice, or slippery runways. Excessive use of either brakes or power may result in an uncontrollable skid.

*d. Takeoff.* Extreme care must be exercised during takeoff from ice or slippery runways. Excessive use of either brakes or power may result in an uncontrollable skid.

*e. Climb.* Keep aircraft attitude as flat as possible and climb with higher airspeed than usual, so that the lower surfaces of the aircraft will not be iced by flight at a high angle of attack.

### *f. Cruise Flight.*

(1) Prevention of ice formation is far more effective and satisfactory than attempts to dislodge the ice after it has formed. If icing conditions are inadvertently encountered, turn on the anti-icing systems prior to the first sign of ice formation.

(2) Do not operate deicer boots continuously. Allow at least 0.5 inch of ice on the wing deicer boots or 0.25 inch on the antenna deicer boots before activating to remove the ice. Continued flight in severe icing conditions should not be attempted. If ice forms on the wing area aft of the deicer boots, climb or descend to an altitude where conditions are less severe.

*g. Landing.* Extreme care must be exercised when landing on ice or slippery runways. Excessive use of either brakes or power may result in an uncontrollable skid. Ice accumulation on the aircraft will result in higher stalling airspeeds due to the change in aerodynamic characteristics and increased weight of the aircraft due to ice buildup. Approach and landing airspeeds must be increased accordingly.

**8-52. SEVERE ICING.**

*a.* The following weather conditions may be conducive to severe in-flight icing:

- (1) Visible rain at temperatures below zero degrees Celsius ambient air temperature.
- (2) Droplets that splash or splatter on impact at temperatures below zero degrees Celsius ambient air temperature.

*b.* The following procedures for exiting a severe icing environment are applicable to all flight phases from takeoff to landing.

- (1) Monitor the ambient air temperature. While severe icing may form at temperatures as cold as -18 degrees Celsius, increased vigilance is warranted at temperatures around freezing with visible moisture present.
- (2) Upon observing the visual cues specified

in the limitations section of this manual for the identification of severe icing conditions (reference paragraph 5-34), accomplish the following:

- (a) Immediately request priority handling from air traffic control to facilitate a route or an altitude change to exit the severe icing conditions in order to avoid extended exposure to flight conditions more severe than those for which the aircraft has been certificated.
- (b) Avoid abrupt and excessive maneuvering that may exacerbate control difficulties.
- (c) Do not engage the autopilot.
- (d) If the autopilot is engaged, hold the control wheel firmly and disengage the autopilot.
- (e) If an unusual roll response or uncommanded roll control movement is observed reduce the angle-of-attack.
- (f) Do not extend flaps during extended operation in icing conditions. Operations with flaps extended can result in a reduced angle-of-attack, with the possibility of ice forming on the upper surface further aft on the wing than normal, possibly aft of the protected area.
- (g) If the flaps are extended, do not retract them until the airframe is clear of ice.
- (h) Report these weather conditions to air traffic control.

**Section VI. CREW DUTIES.**

**\*8-53. DEPARTURE BRIEFING.**

**NOTE**

**The aircraft incorporates advanced technologies in regard to ASE/ACS and EFIS systems. Aviators should conduct thorough crew briefings prior to departures and arrivals to ensure that systems are set and understood.**

The following is a guide that should be used as applicable in accomplishing the required crew briefing prior to takeoff; however, if the crew has operated together previously (thru-flight) and the pilot is certain that the copilot understands all items of the briefing, the pilot may omit the briefing by stating "standard briefing" when the briefing is called for during the BEFORE TAKEOFF CHECK.

- 1. ATC clearance - Review.

- a. Routing.
- b. Initial altitude.
- 2. Departure procedure - Review.
- 3. Copilot duties - Review.
  - a. Adjust static power.
  - b. Monitor engine instruments.
  - c. Ensure **AUTOFEATHER** lights illuminated at 65 knots.
  - d. Call V1, ROTATE.
  - e. Call out engine malfunctions.
  - f. Tune/identify all nav/comm radios.
  - g. Make all radio calls.
  - h. Adjust transponder and radar as required.



i. Complete flight log during flight. Note altitudes and headings. Note departure time.

4. PPC - Review.

- a. Static power.
- b. V1.
- d. V2.
- C. Vr.
- e. Venr

**\*8-54. ARRIVAL BRIEFING.**

**NOTE**

**The aircraft incorporates advanced technologies in regard to ASEIACS and EFIS systems. Aviators should conduct thorough crew briefings prior to departures and arrivals to ensure that systems are set and understood.**

The following is a guide that should be used as applicable in accomplishing the required crew briefing prior to landing; however, if the crew has operated together previously (thru-flight) and the pilot is certain that the copilot understands all items of the briefing, the pilot may omit the briefing by stating "standard briefing" when the briefing is called for during the DESCENT-ARRIVAL CHECK.

1. Weather/altimeter setting.
2. Airfield/facilities - Review.
  - a. Field elevation.

- b. Runway length.
- c. Runway condition.
3. Approach procedure - Review.
  - a. Approach plan/profile.
  - b. ASE/ACS/EFIS - Set.
  - c. Altitude restrictions.
  - d. Missed approach.
    - (1) Point.
    - (2) Time.
    - (3) Intentions.
  - e. Decision height or MDA.
  - f. Lost communications.
4. Backup approach/frequencies.
5. Copilot duties - Review.
  - a. Nav/comm set-up.
  - b. Monitor altitude and airspeeds.
  - c. Monitor approach.
  - d. Call out visual/field in sight.
  6. Landing performance data - Review.
    - a. Approach speed.
    - b. Runway required.

## CHAPTER 9 EMERGENCY PROCEDURES

### Section I. AIRCRAFT SYSTEMS

#### 9-1. AIRCRAFT SYSTEMS.

This section describes the aircraft systems emergencies that may reasonably, be expected to occur and presents the procedures to be followed. Emergency procedures are given in checklist form when applicable. A condensed version of these procedures is contained in the Operator's and Crewmember's Checklist, TM 1-1510-224-CL. Emergency operation of avionics equipment is covered, when appropriate, in Chapter 3, Avionics, and is repeated in this section only if safety of flight is affected.

#### 9-2. IMMEDIATE ACTION EMERGENCY CHECKS.

Immediate action emergency items are underlined for your reference and shall be committed to memory.

##### NOTE

**The urgency of certain emergencies requires immediate action by the pilot. The most important single consideration is aircraft control. All procedures are subordinate to this requirement.**

#### 9-3. DEFINITION OF LANDING TERMS.

The term LAND AS SOON AS POSSIBLE is defined as landing at the nearest suitable landing area (e.g., open field) without delay. (The primary consideration is to ensure the survival of occupants.) The term LAND AS SOON AS PRACTICABLE is defined as landing at a suitable landing area. (The primary consideration is the urgency of the emergency.)

#### 9-4. EMERGENCY EXITS AND EQUIPMENT.

Emergency exits and equipment are shown in figure 9-1.

#### 9-5. EMERGENCY ENTRANCE.

Entry may be made through the cabin emergency hatch. The hatch may be released by pulling on its flush-mounted, pull-out handle, placarded EMERGENCY EXIT - PULL HANDLE TO RELEASE. The hatch is of the nonhinged, plug type, which removes completely from the frame when the latches are released. After the latches are released, the hatch may be pushed in.

#### 9-6. ENGINE MALFUNCTION.

a. *Flight Characteristics Under Partial Power Conditions.* There are no unusual flight characteristics

during single engine operation as long as airspeed is maintained at or above minimum control speed ( $V_{MC}$ ). The capability of the aircraft to climb or maintain level flight depends on configuration, gross weight, altitude, and free air temperature. Performance and aircraft control will improve by feathering the propeller of the inoperative engine, retracting the landing gear and flaps, and establishing the single engine best rate-of-climb speed ( $V_{Y_1}$ ).

b. *Engine Malfunction Prior To or At  $V_{MC}$ , (Abort).* If an engine should fail, or the crew determines that an abort is warranted prior to  $V_{MC}$  or at  $V_1$ , utilize the following procedures: -

1. POWER levers - GROUND FINE.
2. Braking - As required.
3. Reverse thrust - As required.

If insufficient runway remains for stopping, perform the following:

- (4) **CONDITION** levers - **FUEL CUTOFF.**
- (5) **FIRE PULL** handles - **Pull.**
- (6) **MASTER SWITCH** - **OFF.**

Single engine reversing should be used only with extreme caution.

c. *Engine Failure After  $V_{MC}$ .* If engine failure occurs after  $V_{MC}$ , continue the takeoff. Directional control can readily be maintained with rudder. Do not retard the throttle of the inoperative engine until the propeller has stopped rotating. To do so will deactivate the autofeather system, and the propeller may not feather. As the copilot calls "rotate", smoothly raise the nose of the aircraft to an indicated pitch attitude of 7°. After takeoff, verify two positive climb indications, then raise the landing gear.

Continue the climb at  $V_2$ . Do not retract the flaps if they are set to APPROACH for takeoff. Level the aircraft at an altitude of 500 feet above the airport field elevation. Accelerate to  $V_{Y_1}$ , then retract the flaps, if extended. After flap retraction is complete, reduce power on the operating engine to maximum continuous and continue the climb at  $V_{Y_1}$ .

Field performance data, as obtained from Chapter 7, is predicated on no power adjustments from the point of

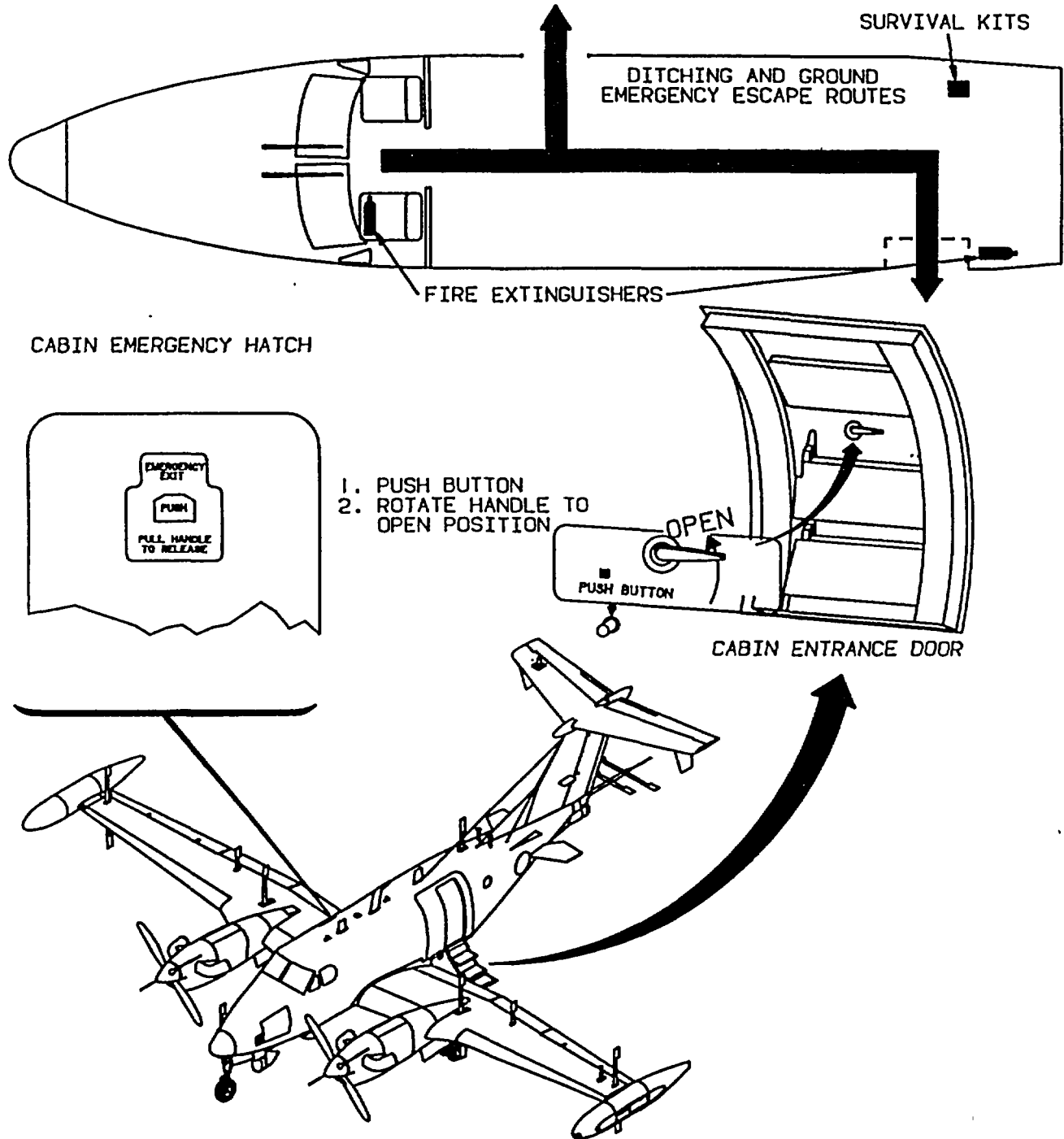

A94FE000034 C

Figure 9-1. Emergency Exits and Equipment

brake release to the power reduction at 500 feet. The Static Power Setting Chart in Chapter 7 permits a power setting that allows for normal torque increase during the takeoff roll and the ensuing climb. The static power is determined so that at some point during the climb to 500 feet, the torque or TGT will reach red line. (The TGT limit will only be reached on a minimum performance engine. A better than minimum engine will exhibit a positive TGT margin under these conditions.) Setting of a static power greater than that presented in Chapter 7 will result in an engine limit being exceeded prior to the aircraft reaching 500 feet, necessitating an unscheduled power adjustment. Setting of a static power less than that presented in Chapter 7 will result in insufficient power available and failure of the aircraft to attain scheduled performance.

1. Power - Maximum allowable.
2. Gear - UP (two positive climb indications).
3. Propeller - Verify feathered.
4. Flaps - UP after  $V_{enr}$ , (130 KIAS).
5. LANDING lights - OFF.
6. Engine cleanup - Perform.
7. Land as soon as practicable.

**NOTE**

**Holding up to 5 degrees of bank (1/2 ball width) toward the operating engine will assist in maintaining directional control and will improve aircraft performance.**

d. *Engine Malfunction During Flight.* If an engine malfunctions during flight, perform the following:

1. Autopilot/Yaw Damp - Disengage.
2. Power - As required.
3. Dead engine - Identify.
4. **POWER** lever (dead engine) - **IDLE**.
5. **PROP** lever (dead engine) - **FEATHER**.
6. Gear - As required.
7. Flaps - As required.
8. Engine Cleanup - Perform.
9. Power - Set for single engine cruise.
10. Land as soon as practicable.

e. *Engine Malfunction During Final Approach.* If an engine malfunctions during final approach (after (after LANDING CHECK) the propeller should not be manually feathered unless time and altitude permit or con-

ditions require it. Continue approach using the following procedure:

1. Power - As required.
2. Gear - **DN**.

f. *Engine Malfunction (Second Engine).* If the second engine fails, the airspeed to fly will depend upon whether or not a restart will be attempted, and whether or not the restart attempt will be accomplished with or without starter assist. If no restart is to be attempted, use maximum glide speed from figure 9-2 or 9-3. Perform the following procedure if the second engine fails during cruise flight.

1. Airspeed - As required.
2. **POWER** lever - **IDLE**.
3. **PROP** lever - As required.
4. Conduct engine restart procedure.

### 9-7. ENGINE SHUTDOWN IN FLIGHT.

If it becomes necessary to shut an engine down during flight, perform the following:

1. **POWER** lever - **IDLE**.
2. **PROP** lever - **FEATHER**.
3. **CONDITION** lever - **FUEL CUTOFF**.
4. Engine cleanup - **Perform**.

### 9-8. ENGINE CLEANUP.

The cleanup procedure to be used after engine malfunction, shutdown, or an unsuccessful restart is as follows:

- (1) **CONDITION** lever - **FUEL CUTOFF**.
- (2) Engine **AUTO IGNITION** switch - **Off**.
- (3) **AUTOFEATHER** switch - **OFF**.
- (4) **GENERATOR** switch - **OFF**.
- (5) Mission control switches - As required.
6. **PROP SYNC** switch - **OFF**.
- (7) **BRAKE** deice switch - **OFF**.

**9-9. ENGINE RESTART DURING FLIGHT (NO STARTER ASSIST).****CAUTION**

This procedure should be conducted only during an emergency and should not be practiced or demonstrated. This procedure will cause damage to the engine hot section.

**CAUTION**

The pilot should determine the reason for engine failure before attempting an airstart. Do not attempt an airstart if  $N_1$  indicates zero. Do not attempt engine airstarts above 25,000 ft. As engine accelerates to idle speed, it may become necessary to move the condition lever into FUEL CUTOFF in order to avoid an over temperature condition.

- (1) **POWER** lever - **IDLE**.
- (2) **PROP** lever - **HIGH RPM**.
- (3) **CONDITION** lever - **FUEL CUTOFF**.
- (4) **CABIN AIR MODE SELECT** switch - As required.
- (5) **FIRE PULL** handle - Push (**PUSH TO EXTINGUISH** annunciator extinguished).
- (6) Engine anti-ice - **Off**.
- (7) **GENERATOR** switch (inoperative engine) - **OFF**.
8. Airspeed - As required (140 kn6ts propeller windmilling, 190 knots propeller feathered).
9. Altitude - Below 25,000 feet.
10. Engine cleanup - Perform if engine restart is unsuccessful.
- (11) Engine  $N_1$  - Monitor (10% minimum, propeller feathered).

**NOTE**

$N_1$  may be increased by increasing airspeed.

- (12) **AUTO IGNITION** switch - **ARM**.
- (13) **CONDITION** lever - **LOW IDLE**.

14. Power - As required (after TGT peaks).
- (15) **GENERATOR** switch - **RESET**, then **ON**.
16. **PROP SYNC** switch - As required.
17. Electrical equipment - As required.
- (18) **CONDITION** lever - **HIGH IDLE**.
- (19) **CABIN AIR MODE SELECT** switch - As required.

**9-10. ENGINE RESTART DURING FLIGHT (USING STARTER).**

Engine restarts should only be attempted below 25,000 feet. If a restart is attempted, perform the following:

**CAUTION**

The pilot should determine the reason for engine failure before attempting an airstart. Do not attempt an airstart if  $N_1$  indicates zero.

Do not attempt engine airstarts above 25,000 feet. During engine acceleration to idle speed, it may become necessary to move the **CONDITION** lever into **FUEL CUTOFF** in order to avoid an over temperature condition.

- (1) **CABIN AIR MODE SELECT** switch - **OFF**.
- (2) **FWD VENT BLOWER** switch - **AUTO**.
- (3) **AUTO PLT POWER** switch - **Off**.

**WARNING**

Airstarts using the starter assist procedures will cause the momentary loss of all electronic flight instrument system (EFIS) data. The engine restart during flight (no starter assist procedure), or turning EFIS power off prior to a starter assisted restart, should normally be performed.

- (4) EFIS POWER switches (2) - **OFF** (if conditions permit).

**NOTE**

If EFIS power is turned off, aircraft attitude should be maintained by using outside visual references or the air driven standby attitude indicator and turn-and-slip indicator.

- (5) Radar - **SBY** or **OFF**.

- (6) **POWER** lever - **IDLE**.
- (7) **PROP** lever - **Low RPM**.
- (8) **CONDITION** lever - **FUEL CUTOFF**.
- (9) **FIRE PULL** handle - Push in (to extinguish annunciator).

**NOTE**

If conditions permit, reduce power on the operative engine to obtain a TGT of 700°C or less to reduce the possibility of exceeding TGT limit. Reduce electrical load to minimum consistent with flight conditions.

False fuel flow indications may be observed with the starter engaged and the **CONDITION** lever in **FUEL CUTOFF**.

- (10) **ENG START** switch - **START-IGNITION**. Check **IGN ON** annunciator illuminated.
- (11) **CONDITION** lever - **LOW IDLE**.
- (12) **ENG START** switch - **OFF** after **TOT** peaks.
- (13) **CONDITION** lever - **HIGH IDLE**.
- 14. **PROP** lever - As required.
- 15. **POWER** lever - As required.
- (16) Engine cleanup - Perform if engine restart is unsuccessful.
- (17) **GENERATOR** switch - **RESET**, then **ON**.
- (18) Engine **AUTO IGNITION** - As required.
- 19. **PROP SYNC** switch - As required.
- (20) **CABIN AIR MODE SELECT** switch - As required.
- (21) Electrical equipment - As required.

**9-11. MAXIMUM GLIDE.**

In the event of failure of both engines, maximum gliding distance is obtained by feathering both propellers to reduce propeller drag and by maintaining the appropriate airspeed with the gear and flaps up. Figure 9-2 or 9-3 gives the approximate gliding distances in relation to altitude. The procedure to follow in the event of failure of both engines is as follows:

- 1. Gear - **UP**.
- 2. Flaps - **UP**.

**WARNING**

Determine that procedures for restarting first and second failed engines are ineffective before feathering second engine propeller.

- 3. **PROP** levers - **FEATHERED**.
- 4. Airspeed - As required (fig. 9-2 or 9-3).

**9-12. SINGLE-ENGINE DESCENT/ARRIVAL.**

Perform the following procedure prior to the final descent for landing:

- (5) **CABIN CONTROLLER** - Set
- (6) **ICE & RAIN** switches - As required.
- 3. **RECOG** lights - **On**.

**NOTE**

Set windshield anti-ice to **NORMAL** or **HIGH** as required well before descent into icing conditions or into warm moist air to aid in defogging. Turn off windshield anti-ice when descent is completed to lower altitudes and when heating is no longer required. This will preclude possible wind screen distortions.

- (4) Windshield anti-ice - As required.
- (5) Radio altimeter - As required.
- 6. Altimeters - Set to current altimeter setting.
- (7) **ASE** - As required.
- 8. Flare/chaff dispenser safety pin - Insert.
- \* 9. Arrival briefing - Complete.

**NOTE**

When landing with one engine inoperative, maintain airspeed at a minimum of  $V_{yse}$  until landing is assured. A go-around after laps are fully extended may not be possible.

**9-13. SINGLE-ENGINE BEFORE LANDING.**

- 1. **PROP** lever - **HIGH RPM**.
- 2. Flaps - As required.
- 3. Gear - **DN**.
- 4. Landing lights - As required.

### MAXIMUM GLIDE DISTANCE STANDARD DAY (ISA)

**ASSOCIATED CONDITIONS;**

POWER.....BOTH ENGINES  
 INOPERATIVE  
 PROPELLERS .....FEATHERED  
 LANDING GEAR .....UP  
 FLAPS .....UP (0%)  
 AIRSPEED .....IAS AS TABULATED  
 WIND.....ZERO KNOTS

**EXAMPLE:**

HEIGHT ABOVE TERRAIN .....12,000 FT  
 WEIGHT .....13,500 LBS  
 MAXIMUM GLIDE DISTANCE .....22.1 NM  
 BEST GLIDE SPEED .....113 KIAS

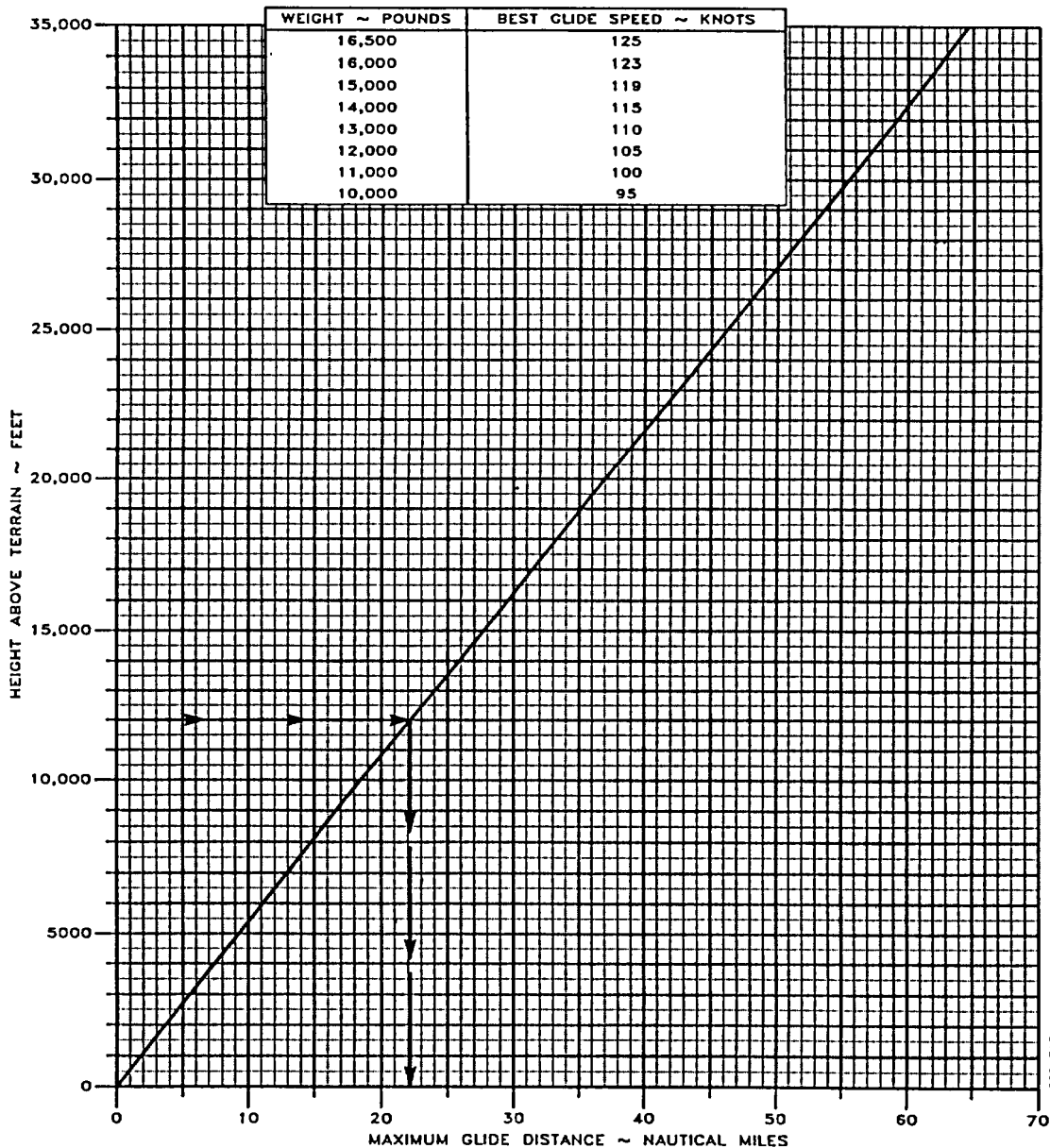

Figure 9-2. Maximum Glide Distance

**MAXIMUM GLIDE DISTANCE  
STANDARD DAY (ISA)**

**ASSOCIATED CONDITIONS:**

POWER..... BOTH ENGINES  
 INOPERATIVE  
 PROPELLERS ..... FEATHERED  
 LANDING GEAR ..... UP  
 LAPS ..... UP (0%)  
 AIRSPEED ..... IAS AS TABULATED  
 WIND..... ZERO KNOTS

**EXAMPLE:**

HEIGHT ABOVE TERRAIN ..... 12,000 FT  
 WEIGHT ..... 13,500 LBS  
 MAXIMUM GLIDE DISTANCE ..... 21.8 NM  
 BEST GLIDE SPEED ..... 13 KIAS

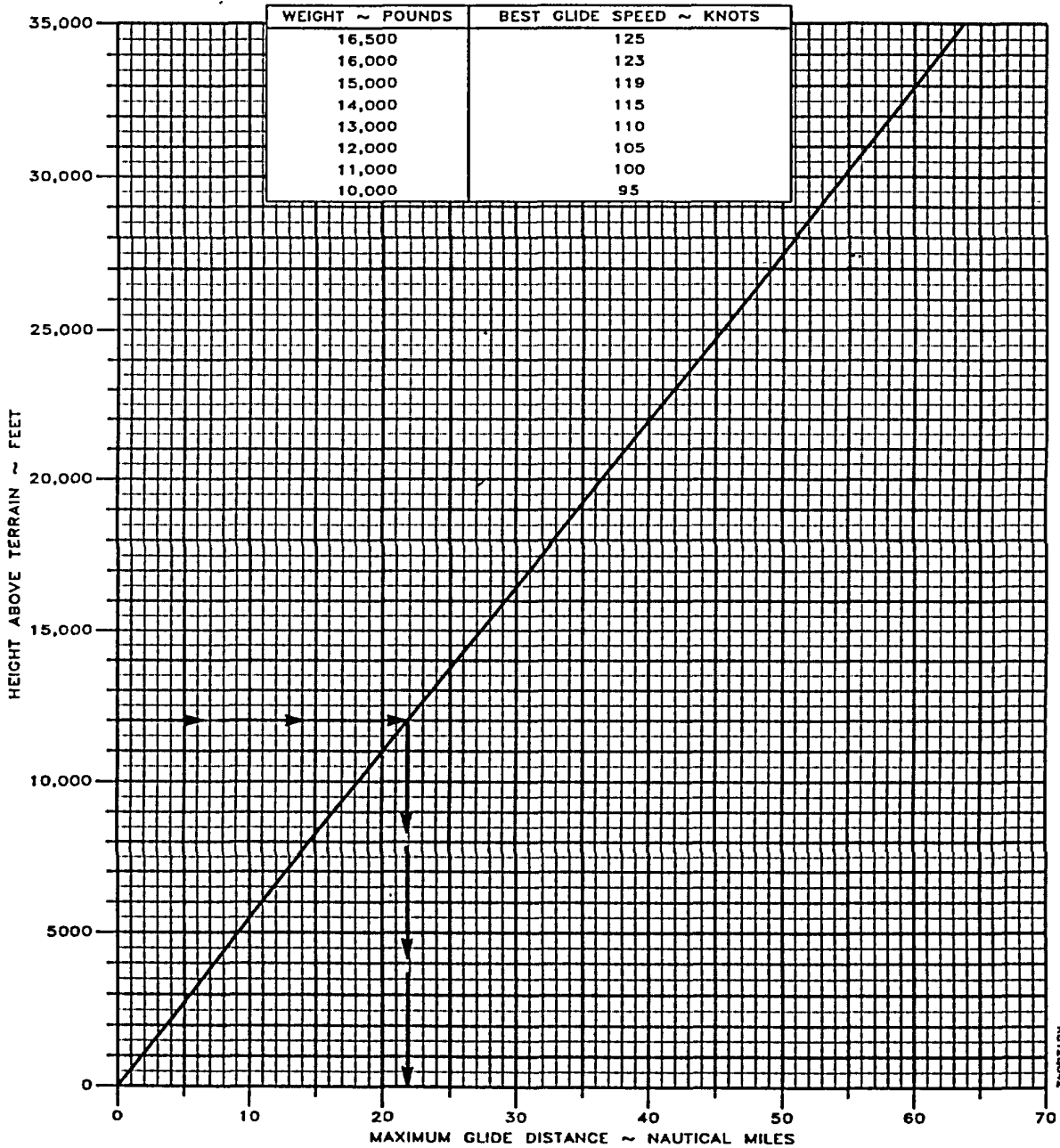

Figure 9-3. Maximum Glide Distance Q



5. Yaw damp - Off.
- (6) BRAKE deice switch - Off.

#### 9-14. SINGLE-ENGINE LANDING CHECK.

Perform the following procedure during final approach to runway.

1. Autopilot/yaw damp - Disengage.
2. GEAR DOWN lights - Check.
3. PROP lever (operative engine) - HIGH RPM.

#### NOTE

**To ensure constant reversing characteristics, the propeller control must be in the HIGH RPM position.**

4. Flaps - As required.

#### 9-15. SINGLE-ENGINE GO-AROUND.

The decision to go around must be made as early as possible. Elevator forces at the start of the go-around are very high, and a considerable amount of rudder control will also be required at low airspeeds. Retrim as required. If rudder application is insufficient, or applied too slowly, directional control cannot be maintained. If control difficulties are experienced, reduce power on the operating engine. Ensure the aircraft will not touch the ground before retracting the landing gear. Retract the flaps only as safe airspeed permits. Retract flaps to APPROACH position until  $V_{ref}$ , then UP. Perform single-engine go-around as follows:

1. Power - Maximum allowable.
2. Gear- UP.
3. Flaps - UP.
4. Airspeed -  $V_{ref}$ .
5. Landing lights - OFF.

#### 9-16. TWO ENGINES INOPERATIVE/OFF AIRFIELD LANDING.

#### NOTE

**With propellers feathered, there is less drag and the aircraft will have a tendency to overshoot the planned touchdown point.**

**When landing on rough terrain or unprepared surfaces, the landing gear will absorb landing energy during touchdown, if extended.**

Select landing gear up or down as best suits the conditions of the landing site. If gear-up, follow gear-up landing procedure. If gear-down, make a normal touchdown and use brakes as required.

#### 9-17. LOW OIL PRESSURE.

In the event of a low oil pressure indication, perform procedures as applicable:

1. Oil pressure below 90 PSI and above 60 PSI: Torque - As required (54% maximum).
2. Oil pressure below 60 PSI: Perform engine shutdown, or land as soon as practicable using minimum power to ensure safe arrival.

#### 9.18. L OR R CHIP DETR WARNING ANNUNCIATOR ILLUMINATED.

If the L CHIP DETR or R CHIP DETR warning annunciator illuminates, and safe single-engine flight can be maintained:

1. Perform engine shutdown.
2. Land as soon as practicable.

#### 9-19. DUCT OVERTEMP CAUTION ANNUNCIATOR ILLUMINATED.

Ensure the cabin floor outlets are open and unobstructed, then perform the following steps in sequence until the annunciator is extinguished. Allow approximately 30 seconds after each adjustment for the system temperature to stabilize. The over temperature condition is considered corrected at any point during the procedure that the annunciator extinguishes.

- (1) CABIN AIR control - In.
- (2) CABIN AIR MODE SELECT switch - AUTO.
- (3) CABIN AIR TEMP control - DECREASE.
- (4) FWD VENT BLOWER switch - HIGH.
- (5) CABIN AIR MODE switch - MAN COOL.
- (6) CABIN AIR MANUAL TEMP switch - DECREASE (hold).
- (7) LEFT ENVIRO & PNEU BLEED AIR valve switch - PNEU ONLY.
- (8) Light still illuminated after 30 seconds: LEFT ENVIRO & PNEU BLEED AIR valve switch - ON.
- (9) RIGHT ENVIRO & PNEU BLEED AIR valve switch - PNEU ONLY.

- (10) Light still illuminated after 30 seconds: RIGHT ENVIRO & PNEU BLEED AIR valve switch - ON.

**NOTE**

**If the DUCT OVERTEMP annunciator has not extinguished after completing the above procedure, the warning system has malfunctioned.**

**9-20. ENGINE ANTI-ICE FAILURE.**

Ice vane failure is indicated by the illumination of the amber # 1 or # 2 VANE FAIL caution annunciator lights. If the ice vanes fail to operate, perform the following:

- (1) ICE VANE POWER SELECT switch - STBY.
2. VANE FAIL annunciator - Check extinguished.

**9-21. ENGINE BLEED AIR SYSTEM MALFUNCTION.**

a. *BL AIR FAIL Annunciator Illuminated.* Steady illumination of the warning annunciator in flight indicates a possible ruptured bleed air line aft of the engine firewall. The annunciator will remain illuminated for the remainder of flight. Perform the following:

**NOTE**

**BLEED AIR FAIL annunciators may momentarily illuminate during simultaneous surface deice and brake deice operation at low N1 speed.**

- (1) BRAKE deice switch - Off.
- (2) TGT and torque - Monitor (note readings).
- (3) ENVIRO & PNEU BLEED AIR valve switch (affected side) - Off.

**NOTE**

**Brake deice on the affected side will not be available with bleed air valve switch off.**

- (4) Cabin pressurization - Check.

b. *Excessive Differential Pressure.* If cabin differential pressure exceeds 6.5 PSI, perform the following:

- (2) Cabin altitude and rate-of-climb controller - Select higher setting.

If condition persists:

- (3) **LEFT ENVIRO & PNEU BLEED AIR** valve switch - **PNEU ONLY (L BL AIR**

**OFF** annunciator illuminated).

If condition still persists:

- (3) **RIGHT ENVIRO & PNEU BLEED AIR** valve switch - **PNEU ONLY (R BL AIR OFF** annunciator illuminated).

If condition still persists:

4. Descend immediately.

If unable to descend:

5. Oxygen masks - On and 100%.
- (6) **CABIN PRESS** switch - **DUMP**.
- (7) **ENVIRO & PNEU BLEED AIR** valve switches - ON, if cabin heating is required.

**9-22. LOSS OF PRESSURIZATION (ABOVE 10,000 FEET).**

If cabin pressurization is lost when operating above 10,000 feet or the ALT WARN warning annunciator illuminates, perform the following:

1. Crew oxygen masks - On and 100%.
2. Descend as required.

**NOTE**

**Proper EFIS operation has been demonstrated at cabin altitudes of up to 12,500 feet.**

**9-23. CABIN DOOR CAUTION ANNUNCIATOR ILLUMINATED.**

Remain clear of cabin door and perform the following:

- (1) **ENVIRO & PNEU BLEED AIR** valve switches - **PNEU ONLY**.
2. Descend below 14,000 feet as soon as practicable.
3. Oxygen - As required.

**9-24. PROPELLER FAILURE (OVER 1802 RPM).**

If an overspeed condition occurs that cannot be controlled with the propeller lever or by reducing power, perform the following:

1. **POWER** lever (affected engine) - **IDLE**.
2. **PROP** lever - **FEATHER**.
3. **CONDITION** lever - As required.
- (4) .Engine cleanup - As required.

**9-25. FIRE.**

a. *Engine Fire.* The following procedures shall be performed in the event of engine fire.

(1) *Engine/nacelle fire during start or ground operations.* If engine/nacelle fire is identified during start or ground operation, perform the following:

1. **PROP** levers - **FEATHER.**
2. **CONDITION** levers - **FUEL CUT-OFF.**
3. **FIRE PULL** handle - Pull.

**CAUTION**

**If fire extinguisher has been used to extinguish an engine fire, do not attempt to restart, until maintenance personnel have inspected the aircraft and released it for flight**

4. **PUSH TO EXTINGUISH** switch -Push.
5. **MASTER SWITCH - OFF.**

(2) *Engine fire in flight (FIRE PULL handle light illuminated).* If an engine fire is suspected in flight, perform the following:

1. **POWER** lever (affected engine) -**IDLE.**
2. If **FIRE PULL** handle light is extinguished: Advance power.
3. If **FIRE PULL** handle light is still illuminated: Engine fire in flight procedures (identified) - Perform.

(3) *Engine fire in flight (identified).* If an engine fire occurs in flight, perform the following:

**CAUTION**

**Due to the possibilities of fire warning malfunctions, the fire should be visually identified before the engine is secured and the extinguisher actuated.**

1. **POWER** lever (affected engine) - **IDLE.**
2. **PROP** lever (affected engine) - **FEATHER.**

3. **CONDITION** lever (affected engine) -**FUEL CUTOFF.**

4. **FIRE PULL** handle - Pull.

5. Fire extinguisher - Actuate as required.

- (6) Engine cleanup - Perform.

b. *Fuselage Fire.* If a fuselage fire occurs, perform the following:

1. Fight the fire.
2. Land as soon as possible if fire continues.

c. *Wing Fire.* There is little that can be done to control a wing fire except to shut off fuel and electrical systems that may be contributing to the fire, or which could aggravate it. Diving and slipping the aircraft away from the burning wing may help. If a wing fire occurs, perform the following:

1. Perform engine shutdown on affected side.
2. Land as soon as possible.

d. *Electrical Fire.* Upon noting the existence or indications of an electrical fire, turn off all affected electrical circuits, if known. If electrical fire source is unknown, perform the following:

1. Crew oxygen - On and 100%.
- (2) **MASTER SWITCH - OFF** (visual conditions only).
- (3) All nonessential electrical equipment- Off.

**NOTE**

**With loss of DC electrical power, the aircraft will depressurize. All electrical instruments, with the exception of PROP RPM, N1 RPM, and TGT gages, will be inoperative.**

- (4) **BATTERY** switch - **ON.**
- (5) **GENERATOR** switches (individually) - **RESET**, then **ON.**
- (6) Circuit breakers - Check for indication of defective circuit.

**CAUTION**

**As each electrical switch is returned to ON, note loadmeter reading and check for evidence of fire.**

- (7) Essential electrical equipment- On (individually until fire source is isolated).

8. Land as soon as practicable.
- e. *Smoke and Fume Elimination.* To eliminate smoke and fumes from the aircraft, perform the following:
1. Crew oxygen - On and 100%.
  - (2) **ENVIRO & PNEU BLEED AIR** valve switches - **PNEU ONLY**.
  - (3) **FWD VENT BLOWER** switch - **AUTO**.
  - (4) **AFT VENT BLOWER** switch - **Off**.
  - (5) **CABIN AIR MODE SELECT** switch - **OFF**.
  - (6) If smoke and fumes are not eliminated: **CABIN PRESS** switch - **DUMP**.

**NOTE**

**Opening storm window' (after depressurizing) will facilitate smoke and fume removal.**

7. Engine instruments - Monitor.

**9-26. FUEL SYSTEM.**

a. *FUEL PRESS Warning Annunciator Illuminated.* Illumination of the # 1 or # 2 FUEL PRESS warning annunciator usually indicates failure of the respective engine-driven boost pump. Perform the following:

- (1) **STANDBY PUMP** switch - **ON**.
- (2) **FUEL PRESS** annunciator - Check extinguished.
- (3) FUEL PRESS annunciator still illuminated - Record unboosted time.
- (4) Monitor system for further abnormal indications.

b. *NO FUEL XFER Caution Annunciator Illuminated.* Illumination of a # 1 or # 2 **NO FUEL XFR** annunciator with fuel remaining in the respective auxiliary fuel tank indicates a failure of that automatic fuel transfer system. Proceed as follows:

- (1) AUX XFER switch (affected side) - **OVRD**.
- (2) Auxiliary fuel quantity - Monitor.
- (3) **AUX XFER** switch (after respective auxiliary fuel has completely transferred) - **AUTO**.

c. *Nacelle Fuel Leak.* If nacelle fuel leaks are evident, perform the following:

1. Engine shutdown (affected engine) - Perform.
  2. **FIRE PULL** handle - **Pull**.
  3. Land as soon as practicable.
- d. *Fuel Crossfeed.* For fuel crossfeed, perform the following:
- (1) **AUX XFER** switches - **AUTO**.

**NOTE**

**With the FIRE PULL handle pulled, the fuel in the auxiliary tank for that side will not be available (usable) for crossfeed.**

- (2) **STANDBY PUMP** switches - Off.
- (3) **CROSSFEED** switch - As required.
- (4) **FUEL- CROSSFEED** annunciator illuminated - Check.

**NOTE**

**With the FIRE PULL handle pulled, the FUEL PRESS annunciator will remain illuminated on the side supplying fuel.**

- (5) **FUEL PRESS** annunciator extinguished - Check.
- (6) Fuel quantity - Monitor.

e. *NAC LOW Annunciator Illuminated.* Illumination of the # 1 or # 2 **NAC LOW** caution annunciator indicates that the affected tank has approximately 30 minutes (58 gallons) of usable fuel remaining at sea level, at maximum cruise power consumption rate. Proceed as follows:

**WARNING**

**Failure of the fuel tank venting systems will prevent the fuel in the wing tanks from gravity feeding into the nacelle tank. Fuel vent system failure may be indicated by illumination of the # 1 or # 2 NAC LOW caution light with greater than 30 minutes of usable fuel indicated in the main tank fuel system. The total usable fuel remaining in the main fuel supply system with the low fuel caution light illuminated may be as little as 140 pounds, regardless of the total fuel quantity indicated. Continued flight may result in engine flameout due to fuel starvation.**

1. Land as soon as practicable.

**9-27. ELECTRICAL SYSTEM EMERGENCIES.**

a. *DC GEN Annunciator Illuminated.* When a DC GEN annunciator illuminates, perform the following:

- (1) **GENERATOR** switch - **OFF, RESET**, then **ON.**
- (2) **GENERATOR** switch (no reset) - **OFF.**
- (3) **MISSION CONTROL** switch - **ORIDE.**
- (4) Operating loadmeter - 100% maximum.

b. *Both DC GEN Annunciators Illuminated* (reset failed).

- (1) All nonessential equipment - Off.
- 2. Land as soon as practicable.

c. *Excessive Loadmeter Indication* (over 100%). If either loadmeter indicates over 100%, perform the following:

- (1) **BATTERY** switch - **OFF** (monitor loadmeter).
- (2) Loadmeter over 100% - Nonessential electrical equipment off.
- (3) Loadmeter under 100% - **BATTERY** switch **ON.**

d. *INVERTER Annunciator Illuminated.* When either # 1 or # 2 **INVERTER** annunciator illuminates, perform the following:

- (1) Affected **INVERTER** switch - Off.

e. *INST AC Annunciator Illuminated.*

**NOTE**

**Illumination of the, INST AC warning annunciator indicates that both 26 VAC circuits are inoperative.**

**The following systems will be affected:**

- NAV #1
- NAV #2
- Heading #2
- #1 torquemeter
- #2 torquemeter
- Pilot's EFIS
- Copilot's EFIS

INS

ADF

#1 rate of turn

#2 rate of turn

Air data computer

Under these conditions, power must be governed by indications of N, and TGT gages. Perform the following:

- 1. N, and TGT indications - Check.
- 2. Other engine instruments - Monitor.

f. *Circuit Breaker Tripped.* If a circuit breaker trips, perform the following:

- 1. Bus feeder breaker tripped - Do not reset.

**NOTE**

**Circuit breakers should not be reset more than once until the cause of circuit malfunction has been determined and corrected.**

- 2. Nonessential circuit - Do not reset.
- (3) Essential circuit - Reset once.

g. *BATTERY CHARGE Annunciator Illuminated.* If the **BATTERY CHARGE** caution annunciator illuminates during normal cruise flight, perform the following:

- (1) Battery ammeter - Check, note indication, and monitor for increasing load. If load continues to increase, turn battery switch OFF.
- (2) **BATTERY** switch - **OFF.**

**NOTE**

**The battery may be turned back ON only for gear and flap extension and approach to landing. Battery may be usable after a 15 - 20 minute cool down period.**

- (3) **BATTERY** switch (landing gear/flap extension only) - **ON.**

h. *AVIONICS MASTER POWER Switch Failure.* If the **AVIONICS MASTER POWER** switch fails to operate in the ON position, perform the following:

- (1) **AVIONICS MASTER CONTR** circuit breaker - Pull.

**NOTE**

The avionics power relay is normally hot. Pulling the AVIONICS MASTER CONTR circuit breaker will remove power to the relay, thus allowing electrical power to the associated busses.

i. *BAT FEED FAULT Annunciator Illuminated.* If the **BAT FEED FAULT** caution annunciator illuminates, perform the following:

- (1) **BATTERY** switch - **RESET**, then **ON**.

**9-28. EMERGENCY DESCENT.**

The following procedure assumes the structural integrity of the aircraft and smooth flight conditions. If structural integrity is in doubt, limit speed as much as possible, reduce rate of descent if necessary, and avoid high maneuvering loads. For emergency descent, perform the following:

1. **POWER** levers - **IDLE**.
2. **PROP** levers - **HIGH RPM**.
3. Flaps - **APPROACH**.
4. Gear - **DN**.
5. Airspeed - 179 KIAS (0.472 Mach) maximum.

**NOTE**

Windshield defogging may be required.

**9-29. FLIGHT CONTROL MALFUNCTIONS.**

Use the following procedures, as applicable, for flight control malfunctions.

a. *Autopilot, Emergency Disconnection.* The autopilot can be disengaged by any of the following methods:

1. Pressing the **AP & YD/RIM DISC** switch.
2. Pressing the **AP ENGAGE** pushbutton on the autopilot controller.
3. Pressing the **GO-AROUND** switch (yaw damper will remain on).
4. Pulling the **AP CONTR** and **AFCS DIRECT** circuit breakers.
5. Setting **AVIONICS MASTER POWER** switch to the off (aft) position.

6. Setting aircraft **MASTER SWITCH** to the **OFF** position.
7. Setting the **AUTO PLT** power switch to off position.

b. *Yaw Damp Emergency Disconnection.* The yaw damp can be disengaged by any of the following methods:

1. Pressing the **AP & YD/TRIM DISC** switch.
2. Pressing the **AP ENGAGE** pushbutton on the autopilot controller.
3. Setting the **RUDDER BOOST/YAW CONTROL TEST** switch to the **YAW CONTROL TEST** position.
4. Pulling the **AP CONTR** circuit breaker.
5. Pulling the **RUDDER BOOST** circuit breaker.
6. Setting **AVIONICS MASTER POWER** switch to the off (aft) position.
7. Setting aircraft **MASTER** switch to the **OFF** position.
8. Setting the **AUTO PLT** power switch to off.

c. *Unscheduled Rudder Boost Activation.* Rudder boost operation without a large variation of power between engines indicates a failure of the system. Perform the following:

1. **AP & YD/RIM DISC** switch - Disconnect and hold (hold to first level).
- (2) **RUDDER BOOST switch** - **OFF**.
3. **RUDDER BOOST** circuit breaker - Pull (provided that rudder boost does not deactivate).
4. **AP & YD/TRIM DISC** switch - Release.
- (5) Yaw damper - Reengage (if **RUDDER BOOST** circuit breaker is not pulled).

d. *Unscheduled Electric Trim.* In the event of unscheduled electric elevator trim, perform the following:

1. **ELEV TRIM** switch - **OFF**.
2. **ELEC TRIM** circuit breaker - Pull.

## 9-30. LANDING EMERGENCIES.

**WARNING**

Structural damage may exist after landing with brake, tire, or landing gear malfunctions. Under no circumstances shall an attempt be made to inspect the aircraft until jacks have been installed.

a. *Landing Gear Unsafe Indication.*

1. LDG GEAR CONTR switch - Check DN.
- (2) LANDING GEAR CONTROL and LANDING GEAR IND circuit breakers - Check in.
3. GEAR DOWN lights - Check illuminated. If indication remains unsafe:
4. Landing gear emergency extension - Perform.

**WARNING**

If for any reason the green GEAR DOWN lights do not illuminate (e.g., in case of an electrical system failure), continue pumping until sufficient resistance is felt to ensure that the gear is down and locked. Do not stow the LANDING GEAR ALTERNATE EXTENSION pump handle, but leave it in the full up position. The landing gear cannot be manually retracted in flight.

b. *Landing Gear Emergency Extension.*

1. Airspeed - Below 179 KIAS.
- (2) LANDING GEAR CONTROL circuit breaker - Pull.
3. LDG GEAR CONTR switch - DN.
4. LANDING GEAR ALTERNATE EXTENSION pump handle - Unstow.
5. LANDING GEAR ALTERNATE EXTENSION pump handle - Pump until the three green GEAR DOWN annunciators illuminate and red gear handle lights extinguish.
6. LANDING GEAR ALTERNATE EXTENSION pump handle - Stow (secure in clip).

c. *Gear-up Landing.*

1. Crew emergency briefing - Completed.
- (2) Loose equipment - Stowed.
- (3) ENVIRO & PNEU BLEED AIR valve switches - PNEU ONLY.
- (4) CABIN PRESS switch - DUMP.
- (5) Cabin emergency hatch- Remove and stow.
6. Seat belts and harnesses - Secured.
7. LANDING GEAR ALTERNATE EXTENSION pump handle - Stowed.
- (8) LANDING GEAR CONTROL circuit breaker - In.
9. Gear - UP.
- (10) Nonessential electrical equipment - Off.
11. Flaps - As required (DOWN for landing).

**NOTE**

Fly a normal approach to touchdown. Avoid touching down in a nose-high attitude.

Brakes may be used for reducing landing roll and for directional control.

12. POWER levers (runway assured) - IDLE.
13. PROP levers - FEATHER.
- (14) CONDITION levers - FUEL CUTOFF.
15. FIRE PULL handles - Pull.
- (16) MASTER SWITCH - OFF.

## 9-31. CRACK IN ANY SIDE WINDOW OR IN WINDSHIELD.

If it has been determined that a crack has developed in any side window or windshield:

1. Altitude - Maintain 25,000 feet or less.
- (2) Pressurization controller - Reset to maintain 4.0 PSI or less as required.

**NOTE**

Prior to next flight, maintenance actions are required. Refer to the Cracked Cabin Window/ Windshield limitations in Chapter 5. While inner-ply cracking is not a structural consideration requiring replacement, possible glass flaking from the damaged area could interfere with pilot vision.

Visibility through the windshield may be significantly impaired, windshield wipers could be damaged if used on dracked surface, and heating elements could be inoperative in the area of the crack.

### 9-32. DITCHING.

Landing should be made with full flaps and landing gear retracted. Refer to Table 9-1 for pilot, copilot and ferry chair occupant actions. Refer to figure 9-4 for body positions during ditching. Figure 9-5 shows sea swell information. Refer to FM 20-151 for techniques to be used during ditching. Table 9-1 lists the appropriate duties for crew and occupants for planned ditching and immediate ditching.

#### WARNING

**Do not unstrap from the seat until all motion stops. The possibility of injury and disorientation requires that evacuation not be attempted until the aircraft comes to a complete stop.**

- (1) Radio calls/transponder - As required.
- (2) Crew emergency briefing - As required.
- (3) **ENVIRO & PNEU BLEED AIR** valve switches - **PNEU ONLY**.
- (4) Cabin pressure switch - **DUMP**.
- (5) Cabin emergency hatch - Remove and stow.
6. Seat belts and harnesses - Secured.
7. Gear- UP.

8. Flaps - **DOWN**.

- (9) Nonessential electrical equipment- Off.
10. Approach - Normal, power on.
- (11) Emergency lights - As required.

### 9-33. BAILOUT.

When the decision has been made to abandon the air-craft in flight, the pilot will give the warning signal. Exit from the aircraft will be through the main entrance door, and in the departure sequence using the exit routes as indicated in figure 9-1. Proceed as follows if bailout becomes necessary:

1. Notify crew to prepare to bail out.
- (2) Distress message - Transmit.
- (3) **COMSEC; ZEROIZE**.
- (4) Transponder - 7700.
5. Flaps - **DOWN**.
6. Airspeed - 116 KIAS.
7. Trim - As required.
8. Autopilot - Engage.
- (9) Cabin pressure switch - **DUMP**.
10. Parachute - Attach to harness.
11. Cabin door - Open.
12. Abandon the aircraft.

## Section II. MISSION EQUIPMENT

Emergency procedures for mission equipment are included in Chapter 4.



BRACE POSITIONS

REAR FACING

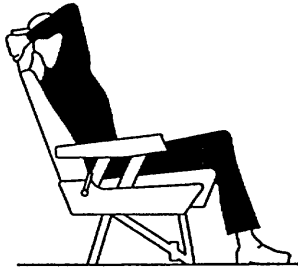

1. RAISE ARMS OVER SHOULDER.
2. GRIP THE TOP OF THE HEADREST. ELBOWS FIRMLY AGAINST HEAD.

IN AN EMERGENCY LANDING OR DITCHING SITUATION ASSUME ONE OF THE BRACING POSITIONS SHOWN.

1. REMOVE EYEGASSES AND SHARP ARTICLES FROM POCKETS.
2. FASTEN SEAT BELT TIGHT AND LOW ACROSS HIPS.
3. SEAT BACK UPRIGHT.

FRONT FACING AND COUCH

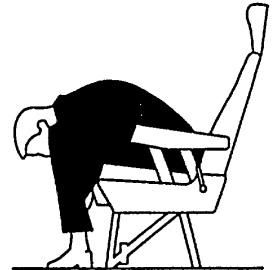

1. LEAN FORWARD AND AS FAR DOWN AS POSSIBLE.
2. CLASP HANDS FIRMLY UNDER LEGS.

A9058W09C0473 C

Figure 9-4. Ferry Chair Occupant Emergency Body Position

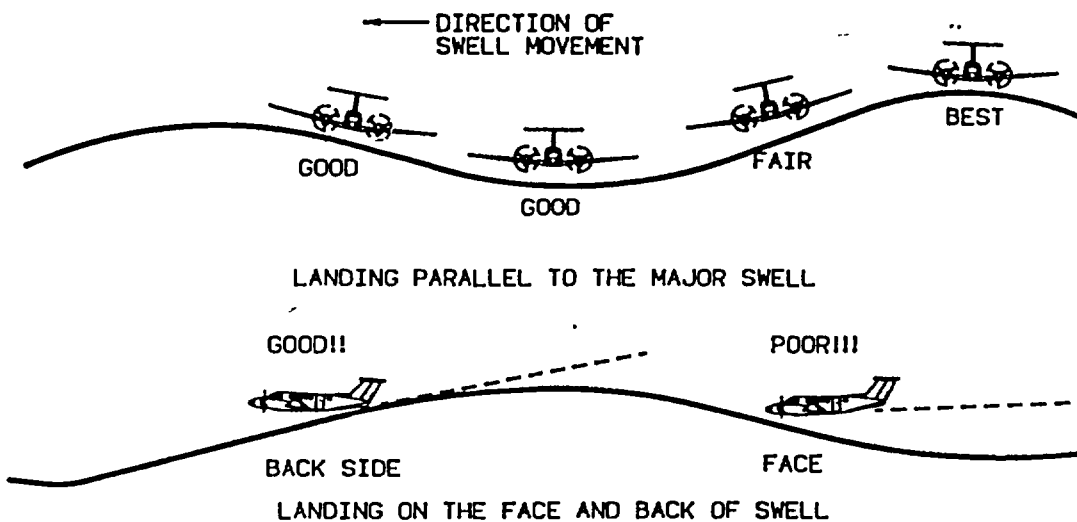

A958W09C0472 C

Figure 9-5. Wind Swell Ditch Heading Evaluation

## APPENDIX A REFERENCES

Reference information for the subject material contained in this manual can be found in the following publications:

AR 70-50	Designating and Naming Defense Equipment, Rockets, and Guided Missiles
AR 95-1	Army Aviation - General Provisions and Flight Regulations
AR 380-40	Safeguarding COMSEC Information
AR 385-40	Accident Reporting and Records
AR 700-26	Aircraft Designation System
DA PAM 738-751	Functional User's Manual for the Army Maintenance Management System - Aviation - (TAMMS-A)
FAR Part 91	General Operating and Flight Rules
FM 1-230	Meteorology for Army Aviators
FM 1-240	Instrument Flying and Navigation for Army Aviators
TB 55-9150-200-24	Engine and Transmission Oils, Fuels, and Additives for Army Aircraft
TB AVN 23-13	Anti-icing, Deicing, and Defrosting Procedures for Parked Aircraft
TB MED 501	Noise and Conservation of Hearing
TM 9-1095-206-13&P	Operator's Aviation Unit Maintenance and Aviation Intermediate Maintenance Manual (Including Repair Parts and Special Tools List) to Dispenser, General Purpose Aircraft: M-130
TM 11-5841-283-20	Organizational Maintenance Manual for Detection Set, Radar Signal AN/APR-39(V)1.
TM 11-5841-291-12	Operator and Organizational Maintenance Manual, Radar Warning System, AN/APR-44(V)1
TM 11-6140-203-14-2	Operator's Organizational, Direct Support, General Support and Depot Maintenance Manual Including Repair Parts and Special Tools List: Aircraft Nickel-Cadmium Batteries
TM 11-6940-214-12	Operator and Organization Maintenance Manual, Simulator, Radar Signal, SM-756/APR-44(V)
TM 55-410	Aircraft Maintenance, Servicing and Ground Handling Under Extreme Environmental Conditions
TM 55-1500-204-25/1	General Aircraft Maintenance Manual
TM 55-1500-314-25	Handling, Storage, and Disposal of Army Aircraft Components Containing Radioactive Materials
TM 55-1500-342-23	Army Aviation Maintenance Manual - Weight and Balance
TM 750-244-1-5	Procedures for the Destruction of Aircraft and Associated Equipment to Prevent Enemy Use
92-30109	Maintenance Manual
92-30110C	Continuous Inspection Procedures Manual

**APPENDIX B  
ABBREVIATIONS AND TERMS**

For the purpose of this manual, the following abbreviations and terms apply. See appropriate technical manuals for additional terms and abbreviations.

**B-1. AIRSPEED TERMINOLOGY.**

CAS	Calibrated airspeed is indicated airspeed corrected for position and instrument error	$V_{fe}$	Maximum flap extended speed is the highest speed permissible with wing flaps in a airspeed corrected for position
GS	Ground speed is the speed of the aircraft relative to the ground.	$V_{1c}$	Maximum landing gear extended speed is the maximum speed at which an aircraft can be safely flown with the landing gear extended
IAS	Indicated airspeed is the speed as shown on the airspeed indicator and assumes no instrument error.	$V_{10}$	craft can be safely flown with the landing gear extended. Maximum landing gear operating speed is the maximum
KT	Knots.	$V_{mca}$	speed at which the landing gear can be safely extended or retracted.
$M_{mo}$	Mach number. The ratio of true airspeed to the speed of sound.	$V_{mca}$	The minimum flight speed at which the aircraft is directionally controllable as determined in accordance with Federal Aviation Regulations.
$M_{mo}$	Maximum operating Mach number.		Aircraft Certification conditions include one engine becoming inoperative and propeller feathered; up to a 5° bank toward the operative engine; takeoff power on operative engine; landing gear up; flaps up; and most rearward CG. This speed has been demonstrated to provide satisfactory control above power off stall speed (which varies with weight, configuration , and flight attitude).
TAS	True airspeed is calibrated airspeed corrected for altitude, temperature, pressure, and compressibility effects.		
$V_1$	Takeoff decision speed		
$V_{50}$	Takeoff safety speed is the speed at 50 feet AGL (35 feet AGL with one engine inoperative).		
$V_a$	Maneuvering speed is the Maximum speed at which application of full available aerodynamic control will not overstress the aircraft.	$V_{mo}$	Maximum operating limit speed
$V_{enr}$	One engine inoperative enroute climb speed.	$V_r$	Rotation speed.
$V_f$	Design flap speed is the highest speed permissible at which wing flaps may be actuated.	$V_{ref}$	The indicated airspeed that the aircraft should be at when 50 feet above the runway in the landing configuration.

$V_s$	Power off stalling speed or the minimum speed at which the aircraft is controllable.	Pressure Altitude steady flight  SL	Indicated pressure altitude corrected for altimeter error.  Sea level.
$V_{so}$	Stalling speed or the minimum steady flight speed in the landing configuration.	Wind	The wind velocities recorded as variables in the charts of this manual are to be understood as the headwind or tailwind components of the actual winds at 50 feet above runway surface (tower winds).
$V_{ssc}$	The safe one-engine inoperative speed selected to provide a reasonable margin against the occurrence of an unintentional stall when making intentional engine cuts.	<b>B-3. POWER TERMINOLOGY.</b>	

$V_{yse}$	The best single-engine rate of climb speed.	Cruise Climb	Is the maximum power approved for normal climb. This power is torque or temperature (TGT) limited.
-----------	---	--------------	--

**B-2. METEOROLOGICAL TERMINOLOGY.**

Altimeter Setting	Barometric pressure corrected to sea level.	Ground Fine	The region of the power lever control which is aft of the idle stop and forward of reversing range where blade pitch angle and gas generator RPM can be changed.
°C °F	Degrees Celsius Degrees Fahrenheit.		
FAT	Free air temperature is the free air static temperature, obtained either from ground meteorological sources or From in-flight temperature indications adjusted for compressibility effects.	High Idle  Low Idle	Obtained by placing the condition lever in the HIGH IDLE position. Obtained by placing the condition lever in the LOW IDLE position.
Indicated Pressure Altitude	The number actually read from an altimeter when, the barometric scale (Kollsman window) has been set to 29.92 inches of mercury (1013 millibars).	Maximum Cruise Power  Maximum Power	Is the highest power rating for cruise and is not time limited.  The maximum power available from an engine for use during an emergency operation.
ISA	International Standard Atmosphere in which: Power	Normal Rated Climb	The maximum power available from an engine for continuous normal climb operations.
a.	The air is a dry perfect gas.		
b.	The temperature at sea level is 59 degrees Fahrenheit, 15 degrees Celsius.	Normal Rated Power	The maximum power available from an engine for continuous operation in cruise (with lower TGT limit than
c.	The pressure at sea level is 29.92 inches Hg.	normal rated climb power).	Obtained by lifting the power levers and moving them aft of the beta range.
d.	The temperature gradient from sea level to the altitude at which the temperature is -69.7 degrees Fahrenheit per foot and zero Fahrenheit above that altitude.	Reverse Thrust	

RPM	Revolutions Per Minute.		ential pressure from the outlets.
SHP	Shaft horsepower. The horsepower imparted to the propeller shaft.	Turbine Gas Temperature (TGT)	Two gages on the instrument panel indicate the temperature between the compressor and
Static Power	The power which must be available for takeoff without exceeding engine limitations.		

**B-5. GRAPH AND TABULAR TERMINOLOGY.**

Takeoff Power	The maximum power available from an engine for takeoff, limited to periods of five minutes duration.	AGL	Above ground level.
		Best Angle of Climb	The best angle-of-climb speed is the airspeed which delivers the greatest gain of altitude in the shortest possible horizontal distance with gear and flaps up.

**B-4. CONTROL AND INSTRUMENT TERMINOLOGY.**

Condition Lever (Fuel Shut-off Lever)	The fuel shut-off lever actuates a valve in the fuel control unit which controls the flow of fuel at the fuel control outlet and regulates the idle range from LOW to HIGH.	Best Rate of Climb	The best rate-of-climb speed is the airspeed which delivers the greatest gain of altitude in the shortest possible time with gear and flaps up.
NI Tachometer (Gas Generator RPM)	The tachometer registers the RPM of the gas generator with 100% representing a gas generator speed of 37,500 RPM.	Clean Configuration	Gear and flaps up.
Power Lever (Gas Generator N1 RPM)	This lever serves to modulate engine power from full reverse thrust to takeoff. The position for idle represents the lowest recommended level of power for flight operation.	Demonstrated Crosswind	The maximum 90° crosswind component for which adequate control of the aircraft during takeoff and landing was actually demonstrated during certification tests.
Propeller Control Lever (N2 RPM)	This lever requests the control to maintain RPM at a selected value and, in the maximum decrease RPM position, feathers the propeller.	Gradient	The ratio of the change in height to the horizontal distance, usually expressed in percent.
Propeller Governor	This Governor will maintain the selected propeller speed requested by the propeller control lever.	Landing Weight	The weight of the aircraft at landing touchdown.
Torquemeter	The torquemeter system determines the shaft output torque. Torque values are obtained by tapping into two outlets on the reduction gear case and recording the differ-	Maximum Zero Fuel Weight	Any weight above the value given must be loaded as fuel.
		MEA	Minimum Enroute Altitude.
		Ramp Weight	The gross weight of the aircraft before engine start. Included is the takeoff weight plus a fuel allowance for start, taxi, run-up and take-off ground roll to lift-off.
		Route Segment	A part of a route. Each end of that part is identified by a geographic location or a point at which a definite radio fix

	can be established.	Maximum Weight	The largest weight allowed by design, structural, performance or other limitations.
Service Ceiling	The altitude at which the maximum rate of climb of 100 feet per minute can be attained for existing aircraft weight.	Maximum Zero Fuel Weight	Any weight above the value must be loaded as fuel.
Takeoff Weight	The weight of the aircraft at lift-off from the runway.	Moment	A measure of the rotational tendency of a weight, about a specified line, mathematically equal to the product of the weight and the arm.

**B-6. WEIGHT AND BALANCE TERMINOLOGY.**

Approved Loading Envelope	-Those combinations of aircraft weight and center of gravity which define the limits beyond which loading is not approved.	Standard	Weights corresponding to the aircraft as offered with seating and interior, avionics, accessories, fixed ballast and other equipment specified by the manufacturer as composing a standard aircraft
Arm	The distance from the center of gravity of an object to a line about which moments are to be computed.	Station	The longitudinal distance from some point to the zero datum or zero fuselage station.
Basic Empty Weight	The aircraft weight with fixed ballast, unusable fuel, engine oil, engine coolant, hydraulic fluid, and in other respects as required by applicable regulatory standards.	Takeoff Weight	The weight of the aircraft at liftoff.
Center-of-Gravity	A point at which the weight of an object may be considered concentrated for weight and balance purposes.	Unusable Fuel	The fuel remaining after consumption of usable fuel.
CG Limits	CG limits are the extremes of movement which the CG can have without making the aircraft unsafe to fly. The CG of the loaded aircraft must be within these limits at takeoff, in the air, and on landing.	Usable Fuel	That portion of the total fuel which is available for consumption as determined in accordance with applicable regulatory standards.
Datum	A vertical plane perpendicular to the aircraft longitudinal axis from which fore and aft (usually aft) measurements are made for weight and balance purposes.	Useful Load	The difference between the aircraft ramp weight and basic empty weight.

**B-7. MISCELLANEOUS ABBREVIATIONS.**

	A/A	Air to air
	AAA	Anti-aircraft artillery
	AC current	Advisory circular, alternating
	ACCEL	Accelerometer, acceleration
Engine Oil	ACS	Avionics control system
	ACT	Active
Landing Weight	A/D	Analog to digital

ADC	Air data computer	BCD	Binary coded decimal
ADF	Automatic direction finder	BFO	Beat frequency oscillator
ADI	Attitude director indicator	BIT	Built-in test
AFC	Automatic frequency control	BOT	Bottom
AFCS	Automatic flight control system	BRG	Bearing
A/G	Air to ground	BU	Back-up, battery unit
AGC	Automatic gain control	CAP	Capture
AGL	Above ground level	CDI	Course deviation indicator
AI	Airborne interceptor	CDS	Control-display system
AJ	Anti-jam	CDU	Control-display unit
ALM	Almanac	CH	Channel
ALSE	Aviation life support equipment	CHAALS	Coherent high-accuracy airborne location system
ALT	Altitude	CIPH	Cipher
AM	Amplitude modulation	CKLST	Checklist
ANT	Antenna	CKW	Cryptokey weekly
AP, A/P	Autopilot	CLR	Clear
APPR	Approach	CMD	Command
ARINC	Aeronautical radio, inc.	COMM	Communications
AS, A/S	Airspeed	COMSEC	Communications security
ASE	Aircraft survivability equipment	CONFIG	Configuration
ASET	Aircraft survivability equipment training	CN	Carrier to noise
ATC	Air traffic control	CPU	Central processing unit
ATT	Attitude	CRS	Course
AUX	Auxiliary	CV	Crypto variable
AVGAS	Aviation gasoline	CW	Continuous wave
AVUM	Aviation unit maintenance	C/W	Caution/warning
AZ	Azimuth	CWA	Caution, warning, and advisory
BARO	Barometric	DA	Drift angle
BAT	Battery	DASR	Direct air to satellite relay
BC	Back course	D/A	Digital to analog
		DC	Direct current



DCU	Digital computer unit	EHSI	Electronic horizontal situation
DD	Differential doppler		indicator
DEG	Degrees	ELEV	Elevation
DEL	Delete	ELT	Emergency transmitter locator
DES TRK	Desired track	EMER	Emergency
DEV	Deviation	ENG	Engage
DFT ANG	Drift angle	EPE	Estimated position error
DG	Directional gyro	ERF	Electronic remote fill
DH	Decision height	ESV	Error state vector
DIAG	Diagnostic	ET	Elapsed time
DIR	Direct	EX LOC	Expanded localizer
DISP	Dispenser	EXT	External
DIST	Distance	FAA	Federal aviation administration
DIV	Diverse		
DL	Data link	FC	Frequency/code
DME	Distance measuring equipment	FCC	Flight control computer
DN	Down	FD, F/D	Flight director
DOP	Dilution of precision	FH	Frequency hopping
DOY	Day of the year	FH-M	Frequency hopping-master
DSCRM	Discriminate	FLIP	Flight information publications
DTRK	Desired track	FLT	Flight
DTS	Data transfer system	FM	Frequency modulation
DUR	Duration	FOD	Foreign object damage
E	East	FOM	Figure of merit
EADI	Electronic attitude director indicator	FP	Flight plan
ECCM	Electronic counter-countermeasure	FPLN	Flight plan
EEPROM	Electrically erasable/programmable read only memory	FR, FRM	From
EFIS	Electronic flight instrument system	FREQ	Frequency
		FS	Fuselage station
		FT	Foot or feet
		FT-LB	Foot-pounds
		FT/MIN	Feet per minute
		G	Glideslope

GA, G/A	Go-around	IRU	Inertial reference unit
GAL	Gallons	IRUE	Inertial reference unit elec- tronics
GMAP	Ground mapping		Kilohertz
GPS	Global positioning system	kHz	Keyboard unit
GPU	Ground power unit	KU	Left
GS, G/S	Glideslope	L	Latitude, lateral
GSPD	Ground speed	LAT	Pounds
GUK	Group unique key	LB	Light emitting diode
GUV	Group unique variable	LED	Left hand
HDG	Heading	LH	Localizer
HF	High frequency	LOC	Longitude
HOM	Homing	LONG	Long range navigation
HR	Hours	LRN	Line replaceable unit
HSET	Hopset	LRU	Lower sideband
HSI	Horizontal situation indicator	LSB	Lockout set
HSSP	High speed signal processor	LSET	Lightning sensor system
I	Inner marker	LSS	Line voltage compensation
ICS	Intercom system	LVC	Lightning sensor system
ID	Identification	LX	Magnetic
IDENT	Identification	MAG	Manual
IDL	Interoperable data link	MAN	Maximum
IFF	Identification, friend or foe	MAX	Minimum descent altitude
IFR	Instrument flight rules	MDA	Memory
ILS	Instrument landing system	MEM	Multifunction display
INIT	Initialize	MFD	Megahertz
INOP	Inoperative	MHz	Microphone
INS	Inertial navigation system	MIC	Minimum
INST	Installed	MIN	Mission
INSUFF	Insufficient	MIS	Middle marker
INTPH	Interphone	MM	Monitor
I/O	Input/output	MON	Missile
IP	Instructor pilot	MSL	Mode selector unit
IPF	Integrated processing facility	MSU	

MUX	Multiplex	PWR	Power
mV	Millivolt	R	Right
N	North	RA, R/A	Radio altimeter
N/A	Not applicable	RAD ALT	Radio altimeter
NAUT	Nautical	RAM	Random access memory
NAV	Navigation	RIC	Rate of climb
NDB	Non directional beacon	RCT	Rain echo attenuation com- pensation technique
NM	Nautical miles		
NOC	Navigation on course	RCV	Receive
NORM	Normal	RCVR	Receiver
NP	Navigation processor	REACT	Rain echo attenuation com- pensation technique
NTPD	Normal temperature and pressure, dry	RG	Rate gyroscope
NU	Navigation unit	RH	Right hand
OBI	Omni bearing indicator	RMI	Radio magnetic indicator
OBS	Omni bearing selector	ROL	Roll
OM	Outer marker	RPM	Revolutions per minute
OPER	Operate	RT	Receiver-transmitter
PATT	Pattern	R/T	Rate of turn
PB	Pushbutton	RTU	Remote terminal unit
PC	Programmable cartridge	RUD	Rudder
PIT	Pitch	S	South
PITCH SYNC	Pitch synchronization	SA	Surface to air
PM	Performance monitor	SA/A-S	Selective availability/anti- spoofing
POS	Position		
PPC	Performance planning card	SAM	Surface-to-air missile
PRE	Preset	SAT	Static air temperature
PREV	Previous	SATCOM	Sattelite communications
PROM	Programmable read-only memory	SBY	Standby
		SC	Signal conditioner, single channel
PSI	Pounds per square inch		
PSIG	Pounds per square inch gage	SEC	Seconds
		SEL	Select
PVT	Private	SG	Symbol generator

SID	Standard instrument departure	TTL	Tuned to localizer
SINCGARS	Single channel ground and airborne radio system	TX	Transmit
SPD	Speed	UHF	Ultra high frequency
SQ	Squelch	UNVER	Unverified
SRN	Short range navigation	USB	Upper sideband
SRU	Shop replaceable unit	UTIL	Utility
STBY	Standby	UTM	Universal transverse mercator
STO	Store	VAPP	VOR approach
SV	Space vehicle	VAR	Variation
SYNC	Synchronization	VBS	Vertical beam sensor
SYS	System	VER	Verified
TACAN	Tactical air navigation	VERT	Vertical
TBO	Time between overhauls	VFR	Visual flight rules
TCN	Tactical air navigation	VG	Vertical gyro
TCS	Touch control steering	VHF	Very high frequency
TDOA	Time difference of arrival	VIP	Video integrated processor
TEL	Telephone	VLD	Valid
TEMP	Temperature	VOL	Volume
TFOM	Time figure of merit	VOR	VHF omni range
TGT	Target, turbine gas temperature	VORTAC	Collocated VOR and TACAN station
THRT	Threat	VOW	Voice order wire
TOD	Time of day	VRT	Vertical
T/R	Transmit and receive	VS	Vertical speed
T/R+G	Transmit/receive + guard	VSI	Vertical speed indicator
TRK	Track	W	West
TRK ERR	Track error	WARN	Warning
TRU HDG	True heading	WOD	Word of the day
TS	Test set	WPT	Waypoint
TSEC	Transec	WR	Weather radar
TST	Test	WX	Weather radar
TTG	Time to go	XFR, XFER	Transfer
		XMIT	Transmit

XMTR  
XTRK DEV

Transmitter  
Cross track deviation

YD, Y/D

Yaw damper

INDEX

Subject	Paragraph, Figure, Table Number	Subject	Paragraph, Figure, Table Number
<b>A</b>			
Abort Start Procedure .....	8-16	Airspeed Calibration - Normal System, Takeoff Ground Roll <b>Q</b> .....	F 7A-2, 7A-3
AC Power Supply .....	2-75	Airspeed Indicators <b>Q</b> .....	2-82
Accelerate-Go Distance Over 50 Foot Obstacle - Flaps Approach <b>P</b> .....	F 7-28, 7-3	Airspeed Limitations .....	5-20
Accelerate-Go Distance Over 50 Foot Obstacle - Flaps Approach <b>Q</b> .....	F 7A-28, 7A-3	Alternate Static Air Source .....	2-80
Accelerate-Go Distance Over 50 Foot Obstacle - Flaps Up <b>P</b> .....	F 7-19, 7-3	Altimeter Correction - Alternate System <b>P</b> .....	F 7-6, 7-3
Accelerate-Go Distance Over 50 Foot Obstacle - Flaps Up <b>Q</b> .....	F 7A-19, 7A-3	Altimeter Correction - Alternate System <b>Q</b> .....	F 7A-6, 7A-3
Accelerated Stalls .....	8-42	Altimeter Correction - Normal System <b>P</b> .....	F 7-4, 7-3
Accelerate-Stop - Flaps Approach <b>P</b> .....	F 7-27, 7-3	Altimeter Correction - Normal System <b>Q</b> .....	F 7A-4, 7A-3
Accelerate-Stop - Flaps Approach <b>Q</b> .....	F 7A-27, 7A-3	Altimeter Operating Procedure .....	3-34
Accelerate-Stop - Flaps Up <b>P</b> .....	F 7-18, 7-3	Altitude Preselector .....	F 3-23
Accelerate-Stop - Flaps Up <b>Q</b> .....	F 7A-18, 7A-3	Altitude Limitations .....	5-30
Accelerometer .....	2-86	Ammunition .....	4-4
ADF Control Unit Operating Controls, Indicators, and Functions .....	F 3-25, 3-25	Ammunition Loading Procedure .....	4-4
ADF Receiver (ADF-60) .....	3-25	Ammunition Unloading Procedure .....	4-4
ADF Receiver Fault Codes .....	3-8	Annunciator System - General .....	2-89
Aft Vent Blower Switch .....	2-69	Antenna Deice System Switch .....	2-52
After Landing .....	8-35	Antenna Deicing System .....	2-52
After Takeoff .....	8-26	Anti-Icing, Deicing, and Defrosting Treatment .....	2-101
Aileron Trim Tab Control .....	2-39	Appendix A, References .....	1-4
Air Conditioning System .....	2-70	Appendix B, Abbreviations and Terms .....	1-5
Air Data System (ADZ-800) .....	3-17	Application of External Power .....	2-102
Air Induction Systems - General .....	2-18	Approved Fuels .....	2-10
Aircraft Compartments and Stations <b>P</b> .....	F 6-1, 6-3	Approved Military Fuels, Oil, Fluids, and Unit Capacities .....	2-9
Aircraft Compartments and Stations <b>Q</b> .....	F 6-2, 6-3	Army Aviation Safety Program .....	1-7
Aircraft Designation System .....	1-11	Arrival Briefing .....	8-54
Aircraft Survivability Equipment/Avionics Control System (ASE/ACS) .....	4-8	Attitude and Heading Reference System .....	3-16
Aircraft Systems .....	9-1	Audio Control Panel, Controls and Functions .....	3-6
Airspeed Calibration - Alternate System <b>P</b> .....	F 7-5, 7-3	Audio Control Panels .....	F 3-1, 3-6
Airspeed Calibration - Alternate System <b>Q</b> .....	F 7A-5, 7A-3	Auto Ignition Annunciators .....	2-29
Airspeed Calibration - Normal System <b>P</b> .....	F 7-3, 7-3	Auto Ignition Switches .....	2-29
Airspeed Calibration - Normal System <b>Q</b> .....	F 7A-3, 7A-3	Auto Ignition System .....	2-29
Airspeed Calibration - Normal System, Takeoff Ground Roll <b>P</b> .....	F 7-2, 7-3	Autofeather Annunciators .....	2-42
		Automatic Feathering .....	2-42
		Autopilot Controller (PC-400) .....	F 3-21, 3-23
		Autopilot Coupled Approaches .....	8-41
		Autopilot EFIS Select Switch .....	3-23
		Autopilot Emergency Disconnection .....	9-29

Subject	Paragraph, Figure, Table Number
Autopilot Limitations .....	5-9
Autopilot Self-Disconnection Fault Messages.....	3-23
Autopilot/EFIS/Rudder Boost Remote Annunciator Panel .....	F 2-43, 2-89
Auxiliary Fuel Tank Fuel Gage.....	F 2-23
Aviation Life Support Equipment (ALSE) .....	8-2
Avionics Equipment Configuration .....	3-2
AVIONICS MASTER POWER Switch Failure.....	9-27

**B**

Back-Up Voice Order Wire (BU VOW) (AN/ARC-164).....	3-9
Bailout. ....	9-33
Bank and Pitch Limits.....	5-29
BAT FEED FAULT Annunciator Illuminated .....	9-27
BATTERY CHARGE Annunciator Illuminated .....	9-27
Battery Charge Monitor. ....	2-74
Battery Switch .....	2-74
Battery Volt/Ammeter. ....	2-74
Before Exterior Check .....	8-9
Before Landing .....	8-31
Before Leaving Aircraft.....	8-37, 8-48, 8-49
Before Starting Engines .....	8-13
Before Takeoff.....	8-23, 8-48
Before Taxiing .....	8-20
BL AIR FAIL Annunciator Illuminated .....	9-21
Bleed Air Flow Control Unit.....	2-69
Bleed Air Valve Switches .....	2-69
Both DC GEN Annunciators Illuminated (reset failed).....	9-27
Brake Deice.....	5-11
Brake Deice System.....	2-58

**C**

Cabin Airstair Door Weight Limitation .....	5-19
Cabin Altitude Indicator .....	2-61
Cabin and Cargo Doors .....	F 2-11
Cabin Door .....	2-9
Cabin Door Annunciator.....	2-9
CABIN DOOR Caution Annunciator Illuminated .....	9-23
Cabin Emergency Exit Hatch .....	2-9
Cabin Lighting .....	2-77
Cabin Pressure Limits .....	5-37
Cabin Rate-of-Climb Indicator.....	2-61
Cabin Temperature Control Rheostat .....	2-69
Cabin Temperature Mode Selector Switch .....	2-69

Subject	Paragraph, Figure, Table Number
Cabin Windows.....	2-10
Cargo Door .....	2-9
Caution/Advisory Annunciator Panel.....	F 2-42, T 2-7, 2-89
Center of Gravity Limitations .....	5-17, 6-11
Center of Gravity Limits (Landing Gear Down) Restricted Category .....	6-5
Center of Gravity Loading Diagram.....	F 6-4
Chaff Dispenser (Right Nacelle) - Preliminary Procedure .....	4-3
Chaff Dispenser (Right Nacelle) System Test Procedure .....	4-3
CHALS Concept .....	3-29
CHALS Use of GPS and INS .....	3-29
Chart C - Basic Weight and Balance Record, DD Form 365-3 .....	6-7
Charts and Forms.....	6-5
Checklist.....	8-7
Chemical Toilet.....	2-66
Chip Detector Warning Annunciator Illuminated .....	9-18
Cigarette Lighters and Ash Trays.....	2-65
Circuit Breaker Tripped .....	9-27
Circuit Breakers .....	2-74
Clarifier Operation .....	3-11
Class.....	6-2
Climb .....	8-27, 8-51
Climb - Bailed Landing <b>P</b> .....	7-95, 7-3
Climb - Bailed Landing <b>Q</b> .....	F 7A-95, 7A-3
Climb - One Engine Inoperative <b>P</b> .....	F 7-37, 7-3
Climb - One Engine Inoperative <b>Q</b> .....	F 7A-37, 7A-3
Climb - Two Engine - Flaps Approach <b>P</b> .....	F 7-36, 7-3
Climb - Two Engine - Flaps Approach <b>Q</b> .....	7A-36, 7A-3
Climb - Two Engine - Flaps Up <b>P</b> .....	F 7-35, 7-3
Climb - Two Engine - Flaps Up <b>Q</b> .....	F 7A-35, 7A-3
Clocks.....	2-89
Close-in Take-off Flight Path - Flaps Approach <b>P</b> .....	F 7-32, 7-3
Close-in Take-off Flight Path - Flaps Approach <b>Q</b> .....	F 7A-32, 7A-3
Cockpit.....	F 2-10
Cockpit Floor Foot-Operated Microphone Switches.....	3-5
Cockpit Lighting .....	2-77
Cockpit Windows .....	2-10
Cold Weather Operations.....	8-48

Subject	Paragraph, Figure, Table Number
Communications Equipment Group Description .....	3-4
Comparison Monitor Symbols and Miscompare Levels .....	T 3-2
Condition Levers .....	2-23
Control Locks .....	F 2-25
Control Pedestal and Pedestal Extension.....	F 2-14
Control Wheel Microphone Switches .....	3-5
Control-Wheel Mounted Autopilot Disconnection Switches.....	3-23
Control Wheels.....	F 2-24, 2-36
Control, Indicators, and Functions, INS Mode Selector Unit .....	3-27
Cooling Mode: .....	2-72
Copilot's Barometric Altimeter.....	F 2-39, 2-83
Crack in Any Side Window or in Windshield .....	9-31
Cracked Cabin Window/Windshield.....	5-38
Crew Briefing.....	8-4
Crew Duties/Responsibilities.....	8-3
Crossfeed Fuel Flow .....	F 2-21
Crosswind Landing.....	8-32
Crosswind Limitations .....	5-35
Crosswind Takeoff .....	8-25
Cruise .....	8-28
Cruise Flight .....	8-51
<b>D</b>	
Data Transfer System .....	4-7
Datum Cross Reference.....	T 3-11
DC External Power Source .....	2-74
DC Electrical System <b>P</b> .....	F 2-29
DC Electrical System <b>Q</b> .....	F 2-30
DC Electrical System Busses.....	F 2-31
DC GEN Annunciator Illuminated .....	9-27
DC Load and Voltmeters.....	2-74
DC Power .....	3-3
DC Power Supply .....	2-74
Definition of Landing Terms .....	9-3
Defrosting System.....	2-50
Density Variation of Aviation Fuel .....	F 6-3
Departure Briefing .....	8-53
Descent .....	8-29, 8-48, 8-49
Descent-Arrival.....	8-30
Desert Operation and Hot Weather Operation.....	8-49
Destruction of Army Materiel to Prevent Enemy Use .....	1-8
Diagnostic Display.....	3-24

Subject	Paragraph, Figure, Table Number
Digital Flight Control System (DFZ-450) .....	3-23
Digital Flight Control System Error Codes .....	T 3-4
Digital Flight Control System Limits.....	T 3-5
Digital Flight Control System Modes of Operation .....	3-23
Digital Flight Control System Performance/Operating Limits .....	3-23
Digital Integrated Flight Control System (SPZ-4500) .....	3-15
Dimensions.....	2-3
Display Controller .....	F 3-8
Display Controller Controls, Indicators, and Functions: .....	3-19
Display Controller (DC-811) .....	3-19
Distant Take-off Flight Path:.....	7-3
Distant Take-off Flight Path-Flaps Approach <b>P</b> .....	F 7-33, 7-3
Distant Take-off Flight Path-Flaps Approach <b>Q</b> .....	F 7A-33, 7A-3
Ditching.....	T 9-1, 9-32
Draining Moisture From Fuel System.....	2-93
DUCT OVERTEMP Caution Annunciator Illuminated.....	9-19
<b>E</b>	
EADI Amber Caution and Failure Annunciators.....	3-20
EADI Caution Annunciators (Amber) .....	F 3-10
EADI and EHSI Composite Display.....	F 3-20, 3-22
EFIS Weather Test Pattern (Typical, 120 Degree Scan).....	F 3-30
EADI Controls, Indicators, and Functions .....	3-20
EADI Input/Output Processor Failure Indications .....	F 3-12
EADI Red Failure Annunciations.....	F 3-11, 3-20
EHSI Amber Caution or Failure Annunciations .....	3-21
EHSI Caution Annunciators (Amber) .....	F 3-18
EHSI Controls, Indicators, and Functions .....	F 3-21
EHSI Long Range Navigation (LRN) Multiple Waypoint Map Mode .....	3-21
EHSI Multiple Waypoint Map Mode (LRN).....	F 3-17
EHSI Partial Compass Format .....	F 3-21
EHSI Partial Compass Format Unique Indications .....	F 3-15
EHSI Partial Compass VOR Map Mode.....	F 3-16
EHSI Red Failure Annunciators .....	F 3-19, 3-21
EHSI Short Range Navigation (SRN) Map Mode .....	3-21
EHSI Weather Radar Displays .....	3-21



Subject	Paragraph, Figure, Table Number
Electric Elevator Trim .....	2-39
Electrical Fire.....	9-25
Electrical System Emergencies.....	9-27
Electronic Attitude Director Indicator (EADI) .....	F 3-9, 3-20
Electronic Flight Instrument System (EFIS) .....	3-18
Electronic Flight Instrument System (EFIS) Preflight Test.....	3-18
Electronic Horizontal Situation Indicator (EHSI) .....	F 3-13, 3-21
Elevator Trim Tab Control .....	2-39
Emergency Descent .....	9-28
Emergency Entrance.....	9-5
Emergency Exits and Equipment.....	F 9-1, 9-4
Emergency Lighting System .....	2-78
Emergency Lighting System Operation .....	2-78
Emergency Locator Transmitter (ELT 110-4).....	F 3-6, 3-13
Empennage .....	8-11
Endurance Profile - Full Main and Aux Tanks <b>P</b> .....	F 7-85, 7-3
Endurance Profile - Full Main and Aux Tanks <b>Q</b> .....	F 7A-85, 7A-3
Endurance Profile - Full Main Tanks <b>P</b> .....	F 7-83, 7-3
Endurance Profile - Full Main Tanks <b>Q</b> .....	F 7A-83, 7A-3
Endurance Profile - Loiter Power at 1700 RPM <b>P</b> .....	F 7-81, 7-3
Endurance Profile - Loiter Power at 1700 RPM <b>Q</b> .....	F 7A-81, 7A-3
Engine .....	F 2-13
Engine Anti-Ice Failure .....	9-21
Engine Anti-Ice System.....	2-20
Engine Bleed Air System Malfunction.....	9-21
Engine Cleanup.....	9-8
Engine Clearing Procedure .....	8
17	
Engine Compartment Cooling .....	2-17
Engine Driven Boost Pumps .....	2-32
Engine Failure After V1 .....	9-6
Engine Fire .....	9-25
Engine Fire Detection System.....	F 2-16, 2-25
Engine Fire Extinguisher Gage Pressure.....	T 2-1
Engine Fire Extinguisher System .....	F 2-17, 2-26
Engine Fuel Control System .....	2-21
Engine Ice Protection Systems .....	2-20
Engine Ice Protection Systems Operation .....	2-20

Subject	Paragraph, Figure, Table Number
Engine Ignition System.....	2-28
Engine Instruments .....	2-31
Engine Limitations .....	5-13
Engine Malfunction.....	9-6
Engine Malfunction During Final Approach.....	9-6
Engine Malfunction During Flight .....	9-6
Engine Malfunction Prior To or At V1 (Abort).....	9-6
Engine Malfunction (Second Engine).....	9-6
Engine Oil-to-Fuel Heat Exchanger.....	2-32
Engine Operating Limitations .....	T 5-1
Engine Restart During Flight (No Starter Assist).....	9-9
Engine Restart During Flight (Using Starter).....	9-10
Engine Runup .....	8-22
Engine Shutdown .....	8-36, 8-48, 8-49
Engine Shutdown in Flight.....	9-7
Engine Starter-Generators .....	2-30
Engine Starting.....	8-48, 8-49
Engine Torquemeters.....	2-31
Engine-Driven Boost Pumps .....	2-32
Engines.....	2-16
Entrance and Exit Provisions .....	2-9
Environmental Controls .....	2-72
Environmental System .....	F 2-28
Example Cruise Results <b>P</b> .....	T 7-3
Example Cruise Results <b>Q</b> .....	T 7A-3
Example Cruise True Airspeeds <b>P</b> .....	T 7-2
Example Cruise True Airspeeds <b>Q</b> .....	T 7A-2
Example Fuel Flow (lbs/hr)Cruise Results <b>P</b> .....	T 7-5
Example Fuel Flow (lbs/hr)Cruise Results <b>Q</b> .....	T 7A-5
Example Time, Fuel, and Distance <b>P</b> .....	T 7-4
Example Time, Fuel, and Distance <b>Q</b> .....	T 7A-4
Exceeding Operational Limits.....	5-3
Excessive Differential Pressure.....	9-21
Excessive Loadmeter Indication (over 100%).....	9-27
Exhaust and Propeller Danger Areas.....	F 2-7, 2-6
Explanation of Change Symbols .....	1-10
Extent of Coverage.....	6-1
Exterior Check .....	8-11
Exterior Inspection.....	F 8-1
Exterior Lighting.....	F 2-37, 2-76

Subject	Paragraph, Figure, Table Number
<b>F</b>	
Fahrenheit to Celsius Temperature Conversion <b>P</b>	F 7-9, 7-3
Fahrenheit to Celsius Temperature Conversion <b>Q</b>	F 7A-9, 7A-3
Feathering Provisions	2-42
Ferry Chair	2-64
Ferry Chair Occupant Emergency Body Position	F 9-4
Ferry Fuel System	2-34
Filling Fuel Tanks	2-92
Fire 9-25	
Firewall Shutoff Valves	2-32
First Aid Kits	2-13
First Aid Operation	2-62
First Engine Start (Battery Start)	8-14
First Engine Start (GPU Start)	8-18
Flare and Chaff Dispensers	6-15
Flare Dispenser (Right Fuselage) - Preliminary Procedure	4-3
Flare Dispenser System Test Procedure	4-3
Flight Characteristics Under Partial Power Conditions	9-6
Flight Control Computer (FZ-450)	3-23
Flight Control Computer/Autopilot Mode Annunciation	3-23
Flight Control Locks	2-38
Flight Control Malfunctions	9-29
Flight Control System	2-35
Flight Controls	8-45
Flight Director Mode Selector (MS-207)	F 3-22, 3-23
Flight Director Remote Heading/Course Control Panel	F 3-14
Flight Envelope	F 5-2
Flight Director Modes Reset when EFIS Sources Change	T 3-6
Flight Under IMC (Instrument Meteorological Conditions)	5-32
Flow Control Unit	2-61
FM FREQ List Page	3-12
Foreign Object Damage Control	2-19
Forms and Records	1-9
Forward Guardrail Dual Data Link Antenna Radome Anti-Ice	2-53
Forward Vent Blower Switch	2-69
Free Air Temperature (FAT) Gage	2-87

Subject	Paragraph, Figure, Table Number
Frequency Selection	3-11
Friction Lock Knobs	2-24
Fuel and Oil Data	6-10
Fuel Control Unit	2-21
Fuel Crossfeed	9-26
Fuel Flow at Maximum Cruise Power at 1700 RPM <b>P</b>	F 7-50, 7-3
Fuel Flow at Maximum Cruise Power at 1700 RPM <b>Q</b>	F 7A-50, 7A-3
Fuel Flow at Normal Cruise Power at 1500 RPM <b>P</b>	F 7-62, 7-3
Fuel Flow at Normal Cruise Power at 1500 RPM <b>Q</b>	F 7A-62, 7A-3
Fuel Flow Indicators	2-31
Fuel Gaging System	2-32
Fuel Handling Precautions	2-91
Fuel limitations	2-95
Fuel Load	6-9
Fuel Management	5-10
Fuel Management Panel	F 2-20, 2-32
FUEL PRESS Warning Annunciator Illuminated	9-26
Fuel Purge System	2-32
Fuel Sample and Oil Check	8-10
Fuel Specifications	2-95
Fuel Sump Drain Locations	T 2-3
Fuel Supply System	2-32
Fuel System	9-26
Fuel System Anti-Icing	2-59, 5-10
Fuel System Limits	5-10
Fuel System Management	2-33
Fuel Tank Sump Drains	2-32
Fuel System Schematic	F 2-19
Fuel Transfer Pumps	2-32
Fuel Transfer System	2-33
Fuel Types	2-94
Fuel Vent System	2-32
Fuselage Fire	9-25
Fuselage Left Side	8-11
Fuselage Right Side	8-11
<b>G</b>	
Gear-up Landing	9-30
General Exterior Arrangement <b>P</b>	F 2-1
General Exterior Arrangement <b>Q</b>	F 2-2
General Interior Arrangement <b>P</b>	F 2-3
General Interior Arrangement <b>Q</b>	F 2-4

Subject	Paragraph, Figure, Table Number
General Ground Handling Procedure .....	2-104
Generator Limits.....	5-16
Generator Load Limits.....	T 5-2
Generator Out Warning Annunciators.....	2-74
Generator Switches.....	2-74
Global Positioning System (AN/ASN-149 ((B)3)).....	3-28
Go-Around.....	8-34
Go-Around Switch .....	3-23
GPS (and INS) Involvement.....	3-29
GPS Normal Operation .....	3-28
Gravity Feed Fuel Flow .....	F 2-22
Ground Fine .....	2-45
Ground Handling .....	2-104
Ground Handling Safety Practices.....	2-104
Ground Handling Under Extreme Weather Conditions .....	2-104
Ground Turning Radius.....	F 2-6, 2-4
<b>H</b>	
Hand-Operated Fire Extinguisher .....	2-14
Heating Mode .....	2-72
Heating System .....	2-69
HF Communications Transceiver (KHF-950).....	3-11
HF Communications Transceiver Operation.....	3-11
HF Communications Transceiver Control Unit.....	F 3-5
HF Transceiver Control-Display Unit Controls and Functions .....	3-11
Horizontal Distance from Reference Zero to Third Segment Climb - Flaps Approach <b>P</b> .....	F 7-31, 7-3
Horizontal Distance from Reference Zero to Third Segment Climb - Flaps Approach <b>Q</b> .....	F 7A-31, 7A-3
Horizontal Distance From Reference Zero to Third Segment Climb - Flaps Up <b>P</b> .....	F 7-22, 7-3
Horizontal Distance From Reference Zero to Third Segment Climb - Flaps Up <b>Q</b> .....	F 7A-22, 7A-3
How to Use Graphs <b>P</b> .....	7-2
How to Use Graphs <b>Q</b> .....	7A-2
Hydraulic Landing Gear .....	5-11
<b>I</b>	
Ice .....	8-51
Ice and Rain (Typical) .....	8-51
Ice Lights .....	2-76

Subject	Paragraph, Figure, Table Number
Ignition and Engine Starter Switches .....	2-28
Immediate Action Emergency Checks .....	9-2
Index .....	1-6
Indicated Outside Air Temperature Correction <b>P</b> .....	F 7-7, 7-3
Indicated Outside Air Temperature Correction <b>Q</b> .....	F 7A-7, 7A-3
Inertial Navigation System.....	3-27
Inertial Separator .....	2-20
Inflating Tires .....	2-98
INS Action Codes and Recommended Actions .....	T 3-10
INS Malfunction Codes.....	T 3-9
INS Modes of Operation .....	3-27
INS Mode Selector .....	F 3-28
INST AC Annunciator Illuminated.....	9-27
Installation of Protective Covers.....	2-106
Instrument Flight Procedures .....	8-39
Instrument Marking Color Codes.....	5-6
Instrument Markings.....	F 5-1, 5-5
Instrument Panel .....	F 2-18
Instrument Takeoff .....	8-40
Integrated Flight Control System Block Diagram .....	F 3-7
Intentional Engine Out Speed .....	5-40
Interior Check .....	8-12
Interior Lighting.....	2-77
Introduction to Performance <b>P</b> .....	7-1
Introduction to Performance <b>Q</b> .....	7A-1
INVERTER Annunciator Illuminated.....	9-27
ISA Conversion <b>P</b> .....	F 7-8, 7-3
ISA Conversion <b>Q</b> .....	F 7A-8, 7A-3
<b>L</b>	
Landing.....	2-5, 8-32, 8-49, 8-51
Landing Distance - One Engine Inoperative - Flaps Down <b>P</b> .....	F 7-98, 7-3
Landing Distance - One Engine Inoperative - Flaps Down <b>Q</b> .....	F 7A-98, 7A-3
Landing Emergencies.....	9-30
Landing Gear Alternate Extension .....	2-7
Landing Gear Control Switch .....	2-7
Landing Gear Cycling and Brake Deice Limitations .....	5-11
Landing Gear Down Position Indicator Lights.....	2-7
Landing Gear Emergency Extension .....	9-30

Subject	Paragraph, Figure, Table Number
Landing Gear Extension/Extended Speed	5-23
Landing Gear Position Warning Lights	2-7
Landing Gear Retraction Speed	5-24
Landing Gear Safety Switches	2-7
Landing Gear System	2-7
Landing Gear Unsafe Indication	9-30
Landing Gear Warning Horn Test Switch	2-7
Landing Gear Warning Indicator Light	
Test Switch	2-7
Landing Gear Warning System	2-7
Landing On Unprepared Runway	5-41
Landing/Taxi Lights	2-76
Left Wing Area	8-11
Level Flight Characteristics	8-46
Lightning Alert System	3-32
Lightning Rate of Occurrence Symbols	F 3-33
Lightning Sensor System Display	3-32
Lightning Sensor System (LSZ-850)	3-32
Lightning Sensor System Failure Codes	T 3-13
Lightning Sensor System Mode Annunciations	3-32
Lightning Sensor System Mode Selector	
Switch	3-32
Lightning Sensor System Normal Operation	3-32
Lightning Strokes Required per Symbol vs.	
Range to Storm	F 3-32
Line Up	8-24
Load Planning	6-12
Loading Procedure	6-13
Loiter Power at 1700 RPM <b>P</b>	7-3
Loiter Power at 1700 RPM <b>Q</b>	7A-3
Loiter Power at 1700 RPM-ISA -30°C <b>P</b>	F 7-73
Loiter Power at 1700 RPM-ISA -30°C <b>Q</b>	F 7A-73
Loiter Power at 1700 RPM-ISA -20°C <b>P</b>	F 7-74
Loiter Power at 1700 RPM-ISA -20°C <b>Q</b>	F 7A-74
Loiter Power at 1700 RPM -10°C <b>P</b>	F 7-75
Loiter Power at 1700 RPM -10°C <b>Q</b>	F 7A-75
Loiter Power at 1700 RPM-ISA <b>P</b>	F 7-76
Loiter Power at 1700 RPM-ISA <b>Q</b>	F 7A-76
Loiter Power at 1700 RPM +10°C <b>P</b>	F 7-77
Loiter Power at 1700 RPM +10°C <b>Q</b>	F 7A-77
Loiter Power at 1700 RPM +20°C <b>P</b>	F 7-78
Loiter Power at 1700 RPM +20°C <b>Q</b>	F 7A-78
Loiter Power at 1700 RPM +30°C <b>P</b>	F 7-79
Loiter Power at 1700 RPM +30°C <b>Q</b>	F 7A-79
Loiter Power at 1700 RPM-ISA +37°C <b>P</b>	F 7-80

Subject	Paragraph, Figure, Table Number
Loiter Power at 1700 RPM-ISA +37°C <b>Q</b>	F 7A-80
Loss of Pressurization (Above 10,000 Feet)	9-22
Low Oil Pressure	9-17
Low Pitch Stop	2-44

**M**

M-130 Flare and Chaff Dispensing System	4-2
Maneuvering Flight	8-44
Maneuvers	5-28
Manual Mode Control	2-72
Manual Temperature Control Switch	2-69
Maritime Radiotelephone Network Channel	
Operation	3-11
Marker Beacon Audio	3-24
Master Caution Annunciators (amber)	2-89
Master Switch	2-74
Master Warning Annunciators (red)	2-89
Maximum Allowable Airspeed	5-22
Maximum Continuous Power	5-15
Maximum Cruise Power at 1700	
RPM <b>P</b>	F 7-49, 7-3
Maximum Cruise Power at 1700	
RPM <b>Q</b>	F 7A-49, 7A-3
Maximum Cruise Power At 1700	
RPM-ISA-30°C <b>P</b>	F 7-40
Maximum Cruise Power At 1700	
RPM-ISA-30°C <b>Q</b>	F 7A-40
Maximum Cruise Power At 1700	
RPM-ISA-20°C <b>P</b>	F 7-41
Maximum Cruise Power At 1700	
RPM-ISA-20°C <b>Q</b>	F 7A-41
Maximum Cruise Power At 1700	
RPM-ISA-10°C <b>P</b>	F 7-42
Maximum Cruise Power At 1700	
RPM-ISA-10°C <b>Q</b>	F 7A-42
Maximum Cruise Power At 1700	
RPM-ISA <b>P</b>	F 7-43
Maximum Cruise Power At 1700	
RPM-ISA <b>Q</b>	F 7A-43
Maximum Cruise Power At 1700	
RPM-ISA +10°C <b>P</b>	F 7-44
Maximum Cruise Power At 1700	
RPM-ISA +10°C <b>Q</b>	F 7A-44
Maximum Cruise Power At 1700	
RPM-ISA +20°C <b>P</b>	F 7-45
Maximum Cruise Power At 1700	
RPM-ISA +20°C <b>Q</b>	F 7A-45

Subject	Paragraph, Figure, Table Number
Maximum Cruise Power At 1700 RPM-ISA +30°C <b>P</b>	F 7-46
Maximum Cruise Power At 1700 RPM-ISA +30°C <b>Q</b>	F 7A-46
Maximum Cruise Power At 1700 RPM-ISA +37°C <b>P</b>	F 7-47
Maximum Cruise Power At 1700 RPM-ISA +37°C <b>Q</b>	F 7A-47
Maximum Cruise Speeds at 1700 RPM <b>P</b>	F 7-48, 7-3
Maximum Cruise Speeds at 1700 RPM <b>Q</b>	F 7A-48, 7A-3
Maximum Design Maneuvering Speed	5-27
Maximum Design Sink Rate	5-39
Maximum Glide	9-11
Maximum Glide Distance <b>P</b>	F 9-2
Maximum Glide Distance <b>Q</b>	F 9-3
Maximum Permissible Exposure Level	F 3-31
Maximum Ramp Weight	2-5
Maximum Range Power at 1500 RPM <b>P</b>	7-3
Maximum Range Power at 1500 RPM <b>Q</b>	7A-3
Maximum Range Power at 1500 RPM-ISA -30°C <b>P</b>	F 7-64
Maximum Range Power at 1500 RPM-ISA -30°C <b>Q</b>	F 7A-64
Maximum Range Power at 1500 RPM-ISA -20°C <b>P</b>	F 7-65
Maximum Range Power at 1500 RPM-ISA -20°C <b>Q</b>	F 7A-65
Maximum Range Power at 1500 RPM-ISA -10°C <b>P</b>	F 7-66
Maximum Range Power at 1500 RPM-ISA -10°C <b>Q</b>	F 7A-66
Maximum Range Power at 1500 RPM-ISA +10°C <b>P</b>	F 7-67
Maximum Range Power at 1500 RPM-ISA +10°C <b>Q</b>	F 7A-67
Maximum Range Power at 1500 RPM-ISA +20°C <b>P</b>	F 7-68
Maximum Range Power at 1500 RPM-ISA +20°C <b>Q</b>	F 7A-68
Maximum Range Power at 1500 RPM-ISA +30°C <b>P</b>	F 7-69
Maximum Range Power at 1500 RPM-ISA +30°C <b>Q</b>	F 7A-69
Maximum Range Power at 1500 RPM-ISA +30°C <b>P</b>	F 7-70
Maximum Range Power at 1500 RPM-ISA +30°C <b>Q</b>	F 7A-70

Subject	Paragraph, Figure, Table Number
Maximum Range Power at 1500 RPM-ISA +37°C <b>P</b>	F 7-71
Maximum Range Power at 1500 RPM-ISA +37°C <b>Q</b>	F 7A-71
Maximum Take-off Weight as Limited by Tire Speed - Flaps Approach <b>P</b>	F 7-24, 7-3
Maximum Take-off Weight as Limited by Tire Speed - Flaps Approach <b>Q</b>	F 7A-24, 7A-3
Maximum Take-off Weight as Limited by Tire Speed - Flaps Up <b>P</b>	F 7-15, 7-3
Maximum Take-off Weight as Limited by Tire Speed - Flaps Up <b>Q</b>	F 7A-15, 7A-3
Maximum Take-off Weight Permitted by Enroute Climb Requirements <b>P</b>	F 7-13, 7-3
Maximum Take-off Weight Permitted by Enroute Climb Requirements <b>Q</b>	F 7A-13, 7A-3
Maximum Take-off Weight to Achieve Positive One-engine Inoperative Climb at Liftoff - Flaps Approach <b>P</b>	F 7-23, 7-3
Maximum Take-off Weight to Achieve Positive One-engine Inoperative Climb at Liftoff - Flaps Approach <b>Q</b>	F 7A-23, 7A-3
Maximum Take-off Weight to Achieve Positive One-engine Inoperative Climb at Liftoff - Flaps Up <b>P</b>	F 7-14, 7-3
Maximum Take-off Weight to Achieve Positive One-engine Inoperative Climb at Liftoff - Flaps Up <b>Q</b>	F 7A-14, 7A-3
Maximum Weights	2-5
Maximum Zero Fuel Weight	2-5
Microphone Jack Selector Switches	3-5
Microphones, Switches, and Jacks	3-5
Minimum Crew Requirements	5-4
Minimum Run Takeoff	8-25
Minimum Single Engine Control Airspeed ( $V_{MCA}$ )	5-26
Minimum Static Takeoff Power (Ice Vanes Retracted) <b>P</b>	7-3
Minimum Static Takeoff Power (Ice Vanes Retracted) <b>Q</b>	7A-3
Miscellaneous Instruments	2-89
Mission Annunciator Panel	2-89
Mission Control Panel	F 4-1, 4-1
Mission Control Panel Annunciator Legend	T 2-8
Mission Control Panel Controls, Indicators, and Functions	4-1
Mission AC/DC Power Cabinet	F 2-31
Mission Equipment DC Power System <b>P</b>	F 2-34
Mission Equipment DC Power System <b>Q</b>	F 2-35

Subject	Paragraph, Figure, Table Number
Mission Planning .....	8-1
Mixing of Fuels in Aircraft Tanks .....	2-95
Mooring .....	2-107
Mooring Procedures for High Winds .....	2-107
Mooring Provisions .....	2-107
Mooring The Aircraft .....	F 2-48
Moving Aircraft on Ground .....	2-104

**N**

NAC LOW Annunciator Illuminated .....	9-26
Nacelle Fuel Leak <b>Q</b> .....	9-26
Navigation Equipment Group Description .....	3-14
Navigation Lights <b>P</b> .....	2-76
Net Take-off Flight Path - First Segment - Flaps Approach <b>Q</b> .....	F 7-29, 7-3
Net Take-off Flight Path - First Segment - Flaps Approach is <b>P</b> .....	F 7A-29, 7A-3
Net Take-off Flight Path - First Segment - Flaps Up <b>Q</b> .....	F 7-20, 7-3
Net Take-off Flight Path - First Segment - Flaps Up <b>P</b> .....	F 7A-20, 7A-3
Net Take-off Flight Path - Second Segment - Flaps Approach <b>Q</b> .....	F 7-30, 7-3
Net Take-off Flight Path - Second Segment - Flaps Approach <b>P</b> .....	F 7A-30, 7A-3
Net Take-off Flight Path - Second Segment - Flaps Up <b>Q</b> .....	F 7-21, 7-3
Net Take-off Flight Path - Second Segment - Flaps Up <b>P</b> .....	F 7A-21, 7A-3
Net Take-off Flight Path - Third Segment <b>Q</b> .....	F 7-34, 7-3
Net Take-off Flight Path - Third Segment <b>P</b> .....	F 7A-34, 7A-3
NO FUEL XFER Caution Annunciator Illuminated <b>Q</b> .....	9-26
Normal Cruise Power at 1500 RPM <b>P</b> .....	F 7-61, 7-3
Normal Cruise Power at 1500 RPM <b>Q</b> .....	F 7A-61, 7A-3
Normal Cruise Power At 1500 RPM-ISA -30C <b>P</b> .....	F 7-52
Normal Cruise Power At 1500 RPM-ISA -30C <b>Q</b> .....	F 7A-52
Normal Cruise Power At 1500 RPM-ISA -20C <b>P</b> .....	F 7-53
Normal Cruise Power At 1500 RPM-ISA -20C <b>Q</b> .....	F 7A-53
Normal Cruise Power At 1500 RPM-ISA -10°C <b>P</b> .....	F 7-54

Subject	Paragraph, Figure, Table Number
Normal Cruise Power At 1500 RPM-ISA -10°C <b>Q</b> .....	F 7A-54
Normal Cruise Power At 1500 RPM-ISA <b>P</b> .....	F 7-55
Normal Cruise Power At 1500 RPM-ISA <b>Q</b> .....	F 7A-55
Normal Cruise Power At 1500 RPM-ISA +10°C <b>P</b> .....	F 7-56
Normal Cruise Power At 1500 RPM-ISA +10°C <b>Q</b> .....	F 7A-56
Normal Cruise Power At 1500 RPM-ISA +20°C <b>P</b> .....	F 7-57
Normal Cruise Power At 1500 RPM-ISA +20°C <b>Q</b> .....	F 7A-57
Normal Cruise Power At 1500 RPM-ISA +30°C <b>P</b> .....	F 7-58
Normal Cruise Power At 1500 RPM-ISA +30°C <b>Q</b> .....	F 7A-58
Normal Cruise Power At 1500 RPM-ISA +37°C <b>P</b> .....	F 7-59
Normal Cruise Power At 1500 RPM-ISA +37°C <b>Q</b> .....	F 7A-59
Normal Cruise Speeds at 1500 RPM <b>P</b> .....	F 7-60, 7-3
Normal Cruise Speeds at 1500 RPM <b>Q</b> .....	F 7A-60, 7A-3
Normal Landing .....	8-32
Normal Landing Distance - Flaps Down <b>P</b> .....	F 7-96, 7-3
Normal Landing Distance - Flaps Down <b>Q</b> .....	F 7A-96, 7A-3
Normal Landing Distance - Flaps Up <b>P</b> .....	F 7-97, 7-3
Normal Landing Distance - Flaps Up <b>Q</b> .....	F 7A-97, 7A-3
Normal Takeoff .....	8-25
Nose Section .....	8-11
Nose Wheel Steering System .....	2-7

**O**

Obstacle Clearance Climb .....	8-25
Occupants - Useful Loads, Weights, and Moments .....	T 6-1
Oil Data .....	6-10
Oil Pressure/Oil Temperature Indicators .....	2-31
Oil Supply System .....	2-27
One Engine Inoperative Max Cruise Power at 1700 RPM <b>P</b> .....	7-3

Paragraph, Figure, Subject	Table Number
One Engine Inoperative Max Cruise Power at 1700 RPM <b>Q</b> .....	7A-3
One Engine Inoperative Max Cruise Power at 1700 RPM (Ice Vanes Retracted) - ISA -30°C <b>P</b> .....	F 7-86
One Engine Inoperative Max Cruise Power at 1700 RPM (Ice Vanes Retracted) - ISA -30°C <b>Q</b> .....	F 7A-86
One Engine Inoperative Max Cruise Power at 1700 RPM (Ice Vanes Retracted) - ISA -20°C <b>P</b> .....	F 7-87
One Engine Inoperative Max Cruise Power at 1700 RPM (Ice Vanes Retracted) - ISA -20°C <b>Q</b> .....	F 7A-87
One Engine Inoperative Max Cruise Power at 1700 RPM (Ice Vanes Retracted) - ISA -10°C <b>P</b> .....	F 7-88
One Engine Inoperative Max Cruise Power at 1700 RPM (Ice Vanes Retracted) - ISA -10°C <b>Q</b> .....	F 7A-88
One Engine Inoperative Max Cruise Power at 1700 RPM (Ice Vanes Retracted) - ISA <b>P</b> .....	F 7-89
One Engine Inoperative Max Cruise Power at 1700 RPM (Ice Vanes Retracted) - ISA <b>Q</b> .....	F 7A-89
One Engine Inoperative Max Cruise Power at 1700 RPM (Ice Vanes Retracted) - ISA +10°C <b>P</b> .....	F 7-90
One Engine Inoperative Max Cruise Power at 1700 RPM (Ice Vanes Retracted) - ISA +10°C <b>Q</b> .....	F 7A-90
One Engine Inoperative Max Cruise Power at 1700 RPM (Ice Vanes Retracted) - ISA +20°C <b>P</b> .....	F 7-91
One Engine Inoperative Max Cruise Power at 1700 RPM (Ice Vanes Retracted) - ISA +20°C <b>Q</b> .....	F 7A-91
One Engine Inoperative Max Cruise Power at 1700 RPM (Ice Vanes Retracted) - ISA +30°C <b>P</b> .....	F 7-92
One Engine Inoperative Max Cruise Power at 1700 RPM (Ice Vanes Retracted) - ISA +30°C <b>Q</b> .....	F 7A-92
One Engine Inoperative Max Cruise Power at 1700 RPM (Ice Vanes Retracted) - ISA +37°C <b>P</b> .....	F 7-93
One Engine Inoperative Max Cruise Power at 1700 RPM (Ice Vanes Retracted) - ISA +37°C <b>Q</b> .....	F 7A-93
Operating Limits .....	5-10
Operating Procedures and Maneuvers .....	8-5

Paragraph, Figure, Subject	Table Number
Operation With Failed Engine-Driven Boost Pump or Standby Pump .....	2-33
Outflow Valve .....	2-61
Overhead Circuit Breaker Panel .....	F 2-9
Overhead Control Panel .....	F 2-15
Overtemperature and Overspeed Limitations .....	5-14
Oxygen Cylinder Capacity .....	F 2-27, 2-62
Oxygen Duration Examples .....	2-62
Oxygen Duration In Minutes 140 Cubic Foot System .....	T 2-5
Oxygen Flow Planning Rates Vs Altitude .....	T 2-4
Oxygen Masks .....	2-62
Oxygen Requirements .....	5-36
Oxygen System .....	F 2-26, 2-62
Oxygen System Safety Precautions .....	2-103
Oxygen System Servicing Pressure .....	F 2-45

**P**

Parking .....	2-105
Parking Brake .....	2-8
Parking, Covers, Ground Handling, and Towing Equipment .....	F 2-46
Performance Illustrations, Graphs, and Tables <b>P</b> .....	7-3
Performance Illustrations, Graphs, and Tables <b>Q</b> .....	7A-3
Pilot. ....	8-3
Pilot's and Copilot's Seat Belts and Shoulder Harnesses .....	2-11
Pilot's and Copilot's Seats .....	F 2-12, 2-11
Pilot's Barometric Altimeter Indicator (BA-141) .....	F 3-35, 3-34
Pitot and Static System .....	F 2-38
Pitot Heat Limitations .....	5-12
Pitot Heat System .....	2-55
Pitot System .....	2-79
Placard Items .....	1-14
Pneumatic Bleed Air Shutoff Valve .....	2-69
Power Definitions for Engine Operations .....	5-15
Power Levers .....	2-22
Power Off Stalls .....	8-42
Power On Stalls .....	8-42
Power Source .....	3-3
Preflight Check .....	8-8
Preparation For Flight .....	8-48, 8-49
Pressure Differential .....	2-61

Paragraph, Figure, Subject	Table Number
Pressurization Controller.....	2-61
Pressurization System .....	2-61
Principal Dimensions.....	F 2-5
Propeller Autofeather Arm/Off/Test Switch .....	2-42
Propeller Electric Deice System.....	2-54
Propeller Failure (Over 1802 RPM).....	9-24
Propeller Governors .....	2-43
Propeller Levers .....	2-47
Propeller Limitations.....	5-7
Propeller Reversing.....	2-48
Propeller Synchrophaser.....	2-46
Propeller Tachometers.....	2-49
Purpose.....	5-1, 6-4

**R**

Radar and Transponder Equipment Group	
Description. ....	3-30
Radar Control Panel Controls, Indicators, and	
Functions:.....	3-31
Radar Signal Detecting Set (AN/APR-39(V)1).....	4-5
Radar Signal Detecting Set (AN/APR-39(V)2).....	4-6
Rain.....	8-51
Range Profile - Full Main Tanks <b>P</b> .....	F 7-82, 7-3
Range Profile - Full Main Tanks <b>Q</b> .....	F 7A-82, 7A-3
Range Profile - Full Main and Aux	
Tanks <b>P</b> .....	F 7-84, 7-3
Range Profile - Full Main and Aux	
Tanks <b>Q</b> .....	F 7A-84, 7A-3
Range Profile - Maximum Cruise Power at 1700	
RPM <b>P</b> .....	F 7-51, 7-3
Range Profile - Maximum Cruise Power at 1700	
RPM <b>Q</b> .....	F 7A-51, 7A-3
Range Profile - Maximum Range Power at 1500	
RPM <b>P</b> .....	F 7-72, 7-3
Range Profile - Maximum Range Power at 1500	
RPM <b>Q</b> .....	F 7A-72, 7A-3
Range Profile - Normal Cruise Power at 1500	
RPM <b>P</b> .....	F 7-63, 7-3
Range Profile - Normal Cruise Power at 1500	
RPM <b>Q</b> .....	F 7A-63, 7A-3
Recognition Lights.....	2-76
Recommended Fluid Dilution Chart .....	T 2-12
Regulator Control Panels .....	2-62
Relief Tube.....	2-68
Remote Switch and Functions .....	3-13
Replenishing Oxygen System.....	2-103
Required Equipment Listing.....	T 5-3, 5-42

Paragraph, Figure, Subject	Table Number
Resetting the.....	3-13
Responsibility.....	6-6
Right Wing Area.....	8-11
Route Segment Data <b>P</b> .....	T 7-1
Route Segment Data <b>Q</b> .....	T 7A-1
Rudder Boost.....	3-23
Rudder Boost System.....	2-37
Rudder Boost/Yaw Control Test Switch .....	3-23
Rudder Pedals .....	2-37
Rudder System .....	2-37
Rudder Trim Tab Control.....	2-39

**S**

Safety Valve.....	2-61
Seats.....	2-11
Second Engine Start (Battery Start) .....	8-15
Second Engine Start (GPU Start) .....	8-19
Securing Loads .....	6-14
Security Keylock Switch.....	2-74
Self Calibration Mode .....	3-32
Series and Effectivity Codes.....	1-11
Service Ceiling - One Engine	
Inoperative <b>P</b> .....	F 7-38, 7-3
Service Ceiling - One Engine	
Inoperative <b>Q</b> .....	F 7A-38, 7A-3
Servicing Hydraulic Brake System Reservoir .....	2-97
Servicing Hydraulic Landing Gear System .....	2-97
Servicing Locations.....	F 2-44
Servicing Oil System.....	2-96
Servicing Oxygen System.....	2-103
Servicing The Air Conditioning System .....	2-100
Servicing The Chemical Toilet.....	2-99
Servicing The Hydraulic System.....	2-97
Severe Icing.....	8-52
Severe Icing Limitations.....	5-34
Single-Engine Before Landing .....	9-13
Single-Engine Descent/Arrival .....	9-12
Single-Engine Go-Around.....	9-15
Single-Engine Landing Check .....	9-14
Single-Phase AC Power .....	3-3
Single Phase AC Electrical System.....	F 2-32
Single Phase AC Power Supply .....	2-75
Smoke and Fume Elimination.....	9-25
Soft Field Landing.....	8-32
Spins.....	8-43



Paragraph, Figure, Subject	Table Number
Stall Warning Heat System .....	2-56
Stall Warning System .....	2-57
Stalls .....	8-42
Stall Speed - Power Idle .....	F 8-2
Standard, Alternate, and Emergency Fuels .....	T 2-11
Standby Attitude Indicator. ....	F 2-40, 2-84
Standby Attitude Indicator Controls, Indicators, and Functions .....	2-84
Standby Fuel Pumps .....	2-32
Standby Magnetic Compass .....	2-88
Standby UHF Control Panel, Controls and Functions .....	3-7
Starter Limitations .....	5-8
Static Air System .....	2-80
Static Take-off Power at 1700 RPM, Ice Vanes Retracted <b>P</b> .....	F 7-10, 7-3
Static Take-off Power at 1700 RPM, Ice Vanes Retracted <b>Q</b> .....	F 7A-10, 7A-3
Static Take-off Power at 1700 RPM, Ice Vanes Extended <b>P</b> .....	F 7-11, 7-3
Static Take-off Power at 1700 RPM, Ice Vanes Extended <b>Q</b> .....	F 7A-11, 7A-3
Strobe Beacons .....	2-76
Subpanels .....	F 2-8
Sun Visors .....	2-67
Surface Deicing System .....	2-51
Survivability Equipment - Weights and Moments .....	T 6-2
Survival Rafts and Kits .....	2-15
Symbol Generator Reversionary Switch .....	3-23
Symbols Definition .....	8-6
Synchrophaser Control Box .....	2-46
Synchroscope .....	2-46
System Daily Preflight/Re-Arm Test .....	4-3

**T**

TACAN Control Unit Controls and Functions .....	3-26
TACAN Control Unit .....	F 3-26
TACAN Display Unit .....	F 3-27
TACAN/DME Display Unit Controls and Functions .....	3-26
TACAN/DME System (AN/ARN-154) .....	3-26
Takeoff .....	2-5, 8-25, 8-48, 8-49, 8-51
Take-off Distance Over Fifty Foot Obstacle - Flaps Approach <b>P</b> .....	F 7-26, 7-3
Take-off Distance Over Fifty Foot Obstacle - Flaps Approach <b>Q</b> .....	F 7A-26, 7A-3

Paragraph, Figure, Subject	Table Number
Take-off Distance Over Fifty Foot Obstacle - Flaps Up <b>P</b> .....	F 7-17, 7-3
Take-off Distance Over Fifty Foot Obstacle - Flaps Up <b>Q</b> .....	F 7A-17, 7A-3
Takeoff Path Profile - One Engine Inoperative <b>P</b> .....	F 7-1, 7-3
Takeoff Path Profile - One Engine Inoperative <b>Q</b> .....	F 7A-1, 7A-3
Takeoff Power .....	5-16
Take-off Speeds - Flaps Approach <b>P</b> .....	F 7-25, 7-3
Take-off Speeds - Flaps Approach <b>Q</b> .....	F 7A-25, 7A-3
Take-off Speeds - Flaps Up .....	F 7-16, 7-3
Take-off Speeds - Flaps Up .....	F 7A-16, 7A-3
Taxiing .....	8-21, 8-48, 8-49, 8-51
Temperature Limits .....	5-31
Three Phase AC Electrical System .....	F 2-33
Three Phase AC Power Supply .....	2-75
Three-Phase AC Power .....	3-3
Time, Fuel, and Distance to Cruise Climb <b>P</b> .....	F 7-39, 7-3
Time, Fuel, and Distance to Cruise Climb <b>Q</b> .....	F 7A-39, 7A-3
Time, Fuel, and Distance to Descend <b>P</b> .....	F 7-94, 7-3
Time, Fuel, and Distance to Descend <b>Q</b> .....	F 7A-94, 7A-3
Tires .....	2-7
Toilet Weight Limitation .....	5-20
Touch And Go/Stop and Go Landing .....	8-33
Touch Control Steering (TCS) .....	3-23
Towing Turn Limits .....	F 2-47
Transponder - Normal Operation .....	3-33
Transponder Control Panel .....	F 3-34
Transponder Controls, Indicators, and Functions .....	3-33
Transponder Set (APX-100) .....	3-33
Trim Tabs .....	2-39
Turbine Gas Temperature Indicators .....	2-31
Turbine Tachometers .....	2-31
Turbulence and Thunderstorm Operation .....	8-50
Turn-and-Slip Indicator .....	2-81
Two Engines Inoperative/Off Airfield Landing .....	9-16
Typical Icing Limitations .....	5-33

**Subject** **Paragraph, Figure, Table Number**

**Subject** **Paragraph, Figure, Table Number**

**U**

UHF Transceiver (AN/ARC-164, HAVE QUICK II) .....3-7  
 UHF Transceiver ..... F 3-3  
 Unpressurized Ventilation .....2-71  
 Unscheduled Electric Trim .....9-29  
 Unscheduled Rudder Boost Activation .....9-29  
 Usable Fuel Moment Tables .....6-10  
 Usable Fuel Quantity Data ..... T 2-2  
 Use of Fuels .....2-95  
 Use of Kerosene Fuels.....2-95  
 Use of Words Shall, Should, and May .....1-13  
 Useful Load Weights and Moments Usable  
     Fuel, 6.4 to 6.8 LB/GAL..... T 6-3  
 Useful Load Weights and Moments Usable  
     Fuel, 6.9 to 7.1 LB/GAL..... T 6-4

**V**

Vertical Speed Indicators .....2-85  
 VHF Communications Transceiver Control Unit. .... F 3-4  
 VHF Communications Transceivers (VHF-22B). .....3-10  
 VHF Communications Transceiver Fault Codes..... T 3-1  
 VHF Navigation Receiver Control Unit Controls  
     and Functions ..... F 3-24, 3-24  
 VHF Navigation Receivers (VIR-32) .....3-24  
 VHF Navigation Receiver Fault Codes ..... T 3-7  
 VHF Transceiver Operating Controls  
     (VHF-22B). .....3-10  
 VHF-FM Transceiver (AN/ARC-201A(V),  
     SINCGARS). .....3-12  
 VHF-FMNHF-AM Alternate Communication  
     Switch Panel..... F 3-2, 3-6  
 Video Integrated Processor VS Aircraft Radar  
     Return Levels ..... T 3-12  
 Voice Security System TSEC/KY-58 (Complete  
     Provisions Only) .....3-8

**W**

Warm-Up and Ground Test .....8-48, 8-49  
 Warning Annunciator Panel ..... F 2-41, T 2-6, 2-89  
 Warnings, Cautions, and Notes ..... 1-2  
 Weather Radar/Lightning Sensor System  
     Control Panel ..... F 3-29  
 Weather Radar Modes of Operation..... 3-31  
 Weather Radar Normal Operation ..... 3-31  
 Weather Radar Return Levels ..... T 3-3  
 Weather Radar System (WC-650)..... 3-31  
 Weight and Balance Clearance, DD Form  
     365-4 (TACTICAL) ..... 6-8  
 Weight Limitations..... 5-18  
 Wheel Brake System ..... 2-7  
 Wind Components **P** ..... F 7-12, 7-3  
 Wind Components **Q** ..... F 7A-12, 7A-3  
 Wind Swell Ditch Heading Evaluation..... F 9-5  
 Windows .....2-10  
 Windshield Electrothermal Anti-Ice System..... 2-60  
 Windshield Wipers ..... 2-63  
 Wing Fire..... 9-25  
 Wing Flap Control Switch ..... 2-40  
 Wing Flap Extension Speeds..... 5-25  
 Wing Flap Position Indicator ..... 2-40  
 Wing Flaps ..... 2-40

**Y**

Yaw Damp Emergency Disconnection ..... 9-29  
 Yaw Damper. .... 3-23  
 Yaw Damper System ..... 2-37

By Order of the Secretary of the Army:

DENNIS J. REIMER  
*General, United States Army*  
*Chief of Staff*

Official:

JOEL B. HUDSON  
*Administrative Assistant to the*  
*Secretary of the Army*  
05435

DISTRIBUTION STATEMENT: To be distributed in accordance with Initial Distribution Number (IDN) 313652, requirements for TM 1-1510-224-10.

The following format must be used if submitting an electronic 2028. The subject line must be exactly the same and all fields must be included; however only the following fields are mandatory: 1, 3, 4, 5, 6, 7, 8, 9, 10, 13, 15, 16, 17, and 27.

From: "Whomever" <whomever@avma27.army.mil>

To: <mpmt%avma28@st-louis-emh7.army.mil>

Subject: DA Form 2028

1. **From:** Joe Smith
2. Unit: home
3. **Address:** 4300 Park
4. **City:** Hometown
5. **St:** MO
6. **Zip:** 77777
7. **Date Sent:** 19-OCT-93
8. **Pub no:** 55-2840-229-23
9. **Pub Title:** TM
10. **Publication Date:** 04-JUL-85
11. Change Number: 7
12. Submitter Rank: MSG
13. **Submitter FName:** Joe
14. Submitter MName: T
15. **Submitter LName:** Smith
16. **Submitter Phone:** 123-123-1234
17. **Problem: 1**
18. *Page:* 2
19. *Paragraph:* 3
20. *Line:* 4
21. *NSN:* 5
22. *Reference:* 6
23. *Figure:* 7
24. *Table:* 8
25. *Item:* 9
26. *Total:* 123
27. **Text:**

This is the text for the problem below line 27.

RECOMMENDED CHANGES TO EQUIPMENT TECHNICAL PUBLICATIONS



THEN... JOT DOWN THE DOPE ABOUT IT ON THIS FORM. CAREFULLY TEAR IT OUT. FOLD IT AND DROP IT IN THE MAIL!

**SOMETHING WRONG** WITH THIS PUBLICATION?

FROM: (PRINT YOUR UNIT'S COMPLETE ADDRESS)

CDR, 1st Bn, 65th ADA  
ATTN: SP4 John Doe  
Key West, FL 33040

DATE SENT  
14 January 1979

PUBLICATION NUMBER

TM 9-1430-550-34-1

PUBLICATION DATE

7 Sep 72

PUBLICATION TITLE

Unit of Radar Set  
AN/MPQ-50 Tested at the HFC

BE EXACT. PIN-POINT WHERE IT IS

PAGE NO	PARA-GRAPH	FIGURE NO	TABLE NO
9-19		9-5	
21-2	step IC		21-2

SAMPLE

IN THIS SPACE TELL WHAT IS WRONG AND WHAT SHOULD BE DONE ABOUT IT:

"B" Ready Relay K11 is shown with two #9 contacts. That contact which is wired to pin 8 of relay K16 should be changed to contact #10.

Reads: Multimeter B indicates 600 K ohms to 9000 K ohms.

Change to read: Multimeter B indicates 600 K ohms minimum.

Reason: Circuit being checked could measure infinity. Multimeter can read above 9000 K ohms and still be correct.

NOTE TO THE READER:

*Your comments will go directly to the writer responsible for this manual, and he will prepare the reply that is returned to you. To help him in his evaluation of your recommendations, please explain the reason for each of your recommendations, unless the reason is obvious.*

*All comments will be appreciated, and will be given immediate attention. Handwritten comments are acceptable.*

*For your convenience, blank "tear out" forms, preprinted, addressed, and ready to mail, are included in this manual.*

PRINTED NAME, GRADE OR TITLE AND TELEPHONE NUMBER

SP4 John Doe, Autovon 222-222

SIGN HERE

RECOMMENDED CHANGES TO EQUIPMENT TECHNICAL PUBLICATIONS



THEN...JOT DOWN THE DOPE ABOUT IT ON THIS FORM. CAREFULLY TEAR IT OUT. FOLD IT AND DROP IT IN THE MAIL!

**SOMETHING WRONG WITH THIS PUBLICATION?**

FROM: (PRINT YOUR UNIT'S COMPLETE ADDRESS)

DATE SENT

PUBLICATION NUMBER

TM 1-1510-224-10

PUBLICATION DATE

31 December 1998

PUBLICATION TITLE

Operator's Manual for RC-12P  
And RC-12Q Aircraft

BE EXACT...PIN-POINT WHERE IT IS

PAGE  
NO

PARA-  
GRAPH

FIGURE  
NO

TABLE  
NO

IN THIS SPACE TELL WHAT IS WRONG  
AND WHAT SHOULD BE DONE ABOUT IT:

PRINTED NAME, GRADE OR TITLE, AND TELEPHONE NUMBER

SIGN HERE

DA FORM 2028-2  
1 JUL 79

PREVIOUS EDITIONS  
ARE OBSOLETE  
DRSTB-M Overprint 2, 1 Nov 80

P.S.--IF YOUR OUTFIT WANTS TO KNOW ABOUT YOUR  
RECOMMENDATION MAKE A CARBON COPY OF THIS  
AND GIVE IT TO YOUR HEADQUARTERS

AK2533  
8A

THIS AREA REPROTECTED LINE

FILL IN YOUR  
UNIT'S ADDRESS



FOLD BACK

DEPARTMENT OF THE ARMY

---

---

TEAR ALONG PERFORATED LINE

Commander  
U. S. Army Aviation and Missile Command  
ATTN: AMSAM-MMC-LS-LP  
Redstone Arsenal, AI 35898-5230

## The Metric System and Equivalents

### *Linear Measure*

1 centimeter = 10 millimeters = .39 inch  
 1 decimeter = 10 centimeters = 3.94 inches  
 1 meter = 10 decimeters = 39.37 inches  
 1 dekameter = 10 Meters = 32.8 feet  
 1 hectometer = 10 dekameters = 328.08 feet  
 1 kilometer = 10 hectometers = 3,280.8 feet

### *Weights*

1 centigram = 10 milligrams = .15 grain  
 1 decigram = 10 centigrams = 1.54 grains  
 1 gram = 10 decigram = 0.35 ounce  
 1 dekegram = 10 Grams = .35 ounce  
 1 hectogram = 10 dekagrams = 3.52 ounces  
 1 kilogram = 10 hectograms = 2.2 pounds  
 1 quintal = 100 kilograms = 220.46 pounds  
 1 metric ton = 10 quintals = 1.1 short tons

### *Liquid Measure*

1 centiliter = 10 milliliters = .34 fluid ounce  
 1 deciliter = 10 centiliters = 3.38 fluid ounces  
 1 liter = 10 deciliters = 33.81 fluid ounces  
 1 dekaliter = 10 liters = 2.64 gallons  
 1 hectoliter = 10 dekaliters = 27.42 gallons  
 1 kiloliter = 10 hectoliters = 264.18 gallons

### *Square Measure*

1 sq. centimeter = 100 sq millimeters = .155 sq. inch  
 1 sq. decimeter = 100 sq centimeters = 125.5 sq. inches  
 1 sq. meter (centare) = 100 sq decimeters = 10.76 sq. feet  
 1 sq. dekameter (are) = 1,076.4 sq. feet  
 1 sq. hectometer (hectare) = 100 sq. dekameters = 2.47 acres  
 1 sq. kilometer = 100 sq. hectometers = .386 sq. mile

### *Cubic Measure*

1 cu. centimeter = 1000 cu. millimeters = .06 cu. inch  
 1 cu. decimeter = 1000 cu. decimeters = 61.02 cu. inches  
 1 cu. meter = 1000 cu. decimeters = 35.31 cu. feet

## Approximate Conversion Factors

To change	To	Multiply by	To change	To	Multiply by
inches	centimeters	2.540	ounce-inches	newton-meters	.007062
feet	meters	.305	centimeters	inches	.394
yards	meters	.914	meters	feet	3.280
miles	kilometers	1.609	meters	yards	1.094
square inches	square centimeters	6.451	kilometers	miles	.621
square feet	square meters	.093	square centimeters	square inches	.155
square yards	square meters	.836	square meters	square feet	10.764
square miles	square kilometers	2.590	square meters	square yards	1.196
acres	square hectometers	.405	square kilometers	square miles	.386
cubic feet	cubic meters	.028	square hectometers	acres	2.471
cubic yards	cubic meters	.765	cubic meters	cubic feet	35.315
fluid ounces	milliliters	29.573	cubic meters	cubic yards	1.308
pints	liters	.473	milliliters	fluid ounces	.034
quarts	liters	.946	liters	pints	2.113
gallons	liters	3.785	liters	quarts	1.057
ounces	grams	28.349	liters	gallons	.264
pounds	kilograms	.454	grams	ounces	.035
short tons	metric tons	.907	kilograms	pounds	2.205
pound-feet	newton-meters	1.356	metric tons	short tons	1.102
pounds-inches	newton-meters	.11296			

### Temperature (Exact)

°F    Fahrenheit Temperature                      5/9 (after subtracting 32)                      Celsius Temperature                      °C





This fine document...

Was brought to you by me:



## [Liberated Manuals -- free army and government manuals](#)

Why do I do it? I am tired of sleazy CD-ROM sellers, who take publicly available information, slap “watermarks” and other junk on it, and sell it. Those masters of search engine manipulation make sure that their sites that sell free information, come up first in search engines. They did not create it... They did not even scan it... Why should they get your money? Why are not letting you give those free manuals to your friends?

I am setting this document FREE. This document was made by the US Government and is NOT protected by Copyright. Feel free to share, republish, sell and so on.

I am not asking you for donations, fees or handouts. If you can, please provide a link to [liberatedmanuals.com](http://liberatedmanuals.com), so that free manuals come up first in search engines:

<A HREF=<http://www.liberatedmanuals.com/>>Free Military and Government Manuals</A>

– Sincerely  
Igor Chudov  
<http://igor.chudov.com/>