

EO 5190

ELEMENTS OF MECHANISM.

ELEMENTS OF MECHANISM:

ELUCIDATING

THE SCIENTIFIC PRINCIPLES OF

THE

PRACTICAL CONSTRUCTION OF MACHINES.

FOR THE

USE OF SCHOOLS, AND STUDENTS IN MECHANICAL
ENGINEERING.

WITH NUMEROUS SPECIMENS OF MODERN MACHINES, REMARKABLE FOR
THEIR UTILITY AND INGENUITY.

BY T. BAKER, C.E.

Author of "Railway Engineering," "Land and Engineering Surveying," "Mensuration,"
"Principles and Practice of Statics and Dynamics," "Integration
of Differentials," &c. &c.

Illustrated by Two Hundred and Forty-three Engravings.



JOHN WEALE, 59, FLEET STREET, HOLBORN.

1852.

LONDON :
BRADBURY AND EVANS, PRINTERS, WHITEFRIARS.

INTRODUCTION.



IN the first part of this work will be found all the most approved elementary or simple parts of mechanism that the ingenuity of man has suggested, in the past and present age, for multiplying power—for increasing and diminishing speed—for changing the direction of motion—for producing straight from curvilinear motions, and *vice versa*—also irregular from regular motions, and *vice versa*. The several subjects are accompanied by the methods of calculating and comparing the powers, velocities, &c., of the different parts of each combination. The fundamental principles of these methods are derived from *Baker's Principles and Practice of Statics and Dynamics* in Mr. Weale's Series, with examples wrought out by common arithmetic; so that they may be understood without a knowledge of the higher branches of the mathematics. The more abstruse parts of the theory of variable motion are taken from *Professor Willis's Mechanism* (by the Professor's kind permission): to which great work, and to *Buchanan's* work on the

same subject,* I am indebted for the greater part of the elementary forms of mechanism, which are duly acknowledged in the course of the work.

In this part of the work, besides the elementary combinations, several complete machines, of the more simple kinds, are also described, either with or without reference to their specific purposes.

The engraving to Articles 9, 10, 12, 13, 22, 27, 30, 46, 58, 72, 73, 74, 75, 76, 83, 95, 120, 122, 127, and 141, and, in a few cases, a part of their accompanying descriptions, are taken from *Tomlinson's Mechanics* in the Series.

The second part treats generally of machines, and parts of machines, designed for specific purposes; a great many of which are of a novel and ingenious character, and made a conspicuous part in the mechanical department of the *Great Exhibition of 1851*.

The first part is divided into eight, and the second part into ten, chapters; of each of which it will be proper to say a little.

PART I.

In Chapter I. of this part are given, the definitions and fundamental principles of calculation, adapted to machinery.

* Buchanan on Mill Work and on Machinery and Tools, edited by George Rennie, F.R.S. Text in 8vo, and Plates in folio.

Chapter II. treats of the lever, link-work, cranks, and several of their combinations.

Chapter III. embraces the various combinations of wheel-work; the arrangement of the teeth of wheels; with the ingenious and expeditious method of forming the flanks of the teeth by the *Odontograph*, invented by *Professor Willis*.

Chapter IV. treats of the forms of gudgeons, couplings of axles, contrivances for the engagement and disengagement of machinery, &c. &c. The nature and theory of the pulley, and motion by means of wrapping connectors, as cords, straps, chains, &c., conclude this subject.

Chapter V. includes the most approved specimens of variable motion by the rolling contact of wheels.

In Chapter VI. various methods of producing intermittent and reciprocating motion are given.

Chapter VII. treats of the inclined plane, the screw, the wedge, and the camb, with several of their combinations.

In Chapter VIII. the arrangements of the escapements of clocks and watches, and the nature of the pendulum, are explained.

PART II.

In Chapter I. of this part the most approved regulators and accumulators of motion are described.

In Chapter II. are described various arrangements of mechanism for modifying motion, as to change a continuous reciprocating motion into a continuous circular motion, and the reverse; with the theory of parallel motion, as given by *Professor Willis* and *Mr. Hann*.

In Chapter III. are given the ordinary machines used in the common arts of construction, and for domestic purposes.

In Chapter IV. are described all the most approved hydraulic machines, from the common suction-pump to *Appold's centrifugal pump*, which was so conspicuous in the *Great Exhibition of 1851*; and the various kinds of water-wheels, including the turbine, with the methods of calculating their powers; also the most approved marine screw-propellers; with the theory of the motion of water in pipes, rivers, and open canals, &c.

In Chapter V. *Mr. Joseph Whitworth's* self-acting lathes, &c. &c., are described.*

Chapter VI. treats of machines for carding, spinning, flax-dressing, &c. &c.; most of which formed an attractive part of the *Great Exhibition of 1851*.

Chapter VII. describes the various mechanical arrangements of the steam-engine, with two specimens of novel machines of this kind.

* To *Mr. Whitworth*, thanks are due for his liberality and kindness.

In Chapter VIII. are given descriptions of machinery for refining sugar, &c.

Chapter IX. treats of the friction of machinery, and of labouring forces; with the nature of the resistance of friction on railways and common roads, &c. &c.

Chapter X. describes the process and mechanism for manufacturing brown salt-glazed stoneware and Bristol-ware, as practised at Vauxhall Pottery, by *Messrs. Singer, Green, and Co.**

A more complete detail of the several subjects will be found in the table of contents.

T. BAKER.

* To Mr. Green, thanks are due for his kind aid.

■

MAJAH SALAR JUNG BAHADUR

CONTENTS.

PART I.

CHAPTER I.

ELEMENTS OF MECHANISM.

	Page
Definitions of motion, &c.	1
On the use of machines in general	2
Elementary forms of mechanism	3
Velocity ratio	3

CHAPTER II.

THE LEVER AND LINK-WORK.

Lever of the first, second, and third order	7
The common steelyard	7
The compound lever	8—9
The weighing machine for turnpike roads, &c.	10
Oblique and bent levers	12
Link-work, cranks, &c.	13
The bent lever balance	15
To find the velocity ratio in link-work.	16

CHAPTER III.

WHEEL-WORK, PRODUCING MOTION BY ROLLING CONTACT.

	Page
Wheel-work, axes parallel	17
Teeth or cogs of wheels	18
Trains of wheels	18—19
Mill-work	20
Annular wheels	21
Angular velocity	21
Motion by rolling contact, axes not parallel.—Bevel gear . . .	23
The position of the axes of two bevel-wheels, and their radii being given, to construct the conical surfaces forming the wheels .	24
Crown wheels	25
Face-wheel and lantern	25
Bevel-gear, axes not meeting	25
Idle wheels.—Intermediate bevel-wheels	26
Marlborough wheels	26
Skew bevel-wheels	27
The rack and pinion	27

CHAPTER IV.

ON PITCH—THE TEETH OF WHEELS—GUDGEONS—COUPLINGS OF AXLES—HOOKE'S JOINT—FRICTION WHEELS—ENGAGEMENT AND DISENGAGEMENT OF MACHINERY—CONCENTRIC WHEELS.

On the pitch of wheels	29
On the teeth of wheels	31
The odontograph, or instrument to form the flanks of the teeth of wheels	32
Gudgeons	35
Coupling of horizontal axles	35
———— of vertical axles	36
Hooke's joint	36
—— double universal joint	37

CONTENTS.

xix

	Page
Friction wheels	37
The engagement and disengagement of machinery when in motion	37
The sliding pulley	38
Fast and loose pulleys	38
Fly-wheel coupling	39
Engagement of wheel revolving in opposite directions	39
Concentric wheels	40
Hour and minute hands of a clock or watch	40

**PULLEYS—PRODUCING MOTION BY WRAPPING CONTACT
BY MEANS OF CORDS—CHAINS, STRAPS, ETC.**

The pulley	41
The endless cord or band	41
Forms of pulleys	43
Gearing chains	44
Fixed and moveable pulleys	44
Tackles of pulleys	45
White's tackle	47
Guide pulleys	48
Wheel and axle with wrapping cords	49
The ratchet-wheel	50
The windlass and capstan	50
The Chinese windlass	51
Speed pulleys	52
Alternate cones	53
The face-wheel and roller	53
Variable velocities	54
_____ by an endless band	54
Fusees of a watch	55
Double fusee	55
Power and weight connected by oblique cords	56

CHAPTER V.

VARIABLE MOTION BY THE ROLLING CONTACT OF WHEELS.

	Page
To construct curves with elliptical projections, called lobes, to produce variable motion by rolling contact	58
Variable motion by lobed-toothed wheels	60
————— by an eccentric spur-wheel	60
Roßmar's wheels	61
The eccentric crown-wheel	61
Variable motion by sliding contact	63

CHAPTER VI.

INTERMITTENT AND RECIPROCATING MOTION BY WHEELS.

The Geneva stop	64
The mangle-motion	65
Mangle-rack	66
Reciprocating motion by a crown-wheel	66
————— by a double rack	67
The eccentric wheel	67
Note and example on the theory of the eccentric wheel	68
To equalise the velocity by link-work	69

CHAPTER VII.

THE INCLINED PLANE, THE SCREW, THE WEDGE, AND CAMB,
PRODUCING MOTION BY SLIDING.

The inclined plane, and examples	70
The wedge	71
Reciprocating motion by the wedge	72
The screw	72

CONTENTS.

xv

	Page
Theory of the screw and examples	73
Rectilinear motion by the screw	74
The rack and screw.—Nut screw	74
The differential screw	75
The endless screw and examples	76
The conical screw	77
Cams	78
To construct the camb	78
Various forms of cambs	79
The forge hammer	79

CHAPTER VIII.

ESCAPEMENTS, PENDULUMS, ETC.

Crown-wheel escapement	80
Anchor escapement	81
Lever escapement	81
The common pendulum	82

PART II.

CHAPTER I.

MECHANISM, AND PARTS OF MECHANISM, DESIGNED TO
EFFECT PROPOSED OBJECTS.

Regulators and accumulators of motion :—

The fly-wheel	84
The governor	85
The safety valve	87
The spring safety valve for high-pressure boilers	87

CHAPTER II.

MECHANISM FOR MODIFYING MOTION.

<i>To change a reciprocating motion into a continuous circular motion :—</i>	
Sun and planet wheels	Page 89
The lever of Lagarousse	90
<i>To change a continuous circular motion into a reciprocating rectilinear one.—Various methods</i>	
The spiral or solid camb	91
The swash-plate	92
Watt's parallel motion	92
_____ theory of	94
White's parallel motion	95

CHAPTER III.

MACHINES COMMONLY USED IN THE ARTS OF CONSTRUCTION,
AND FOR DOMESTIC PURPOSES.

The crab	96
The jib crane	96
The pile engine	98
The hand-jack	99
The patent excavator	99
Uncoupling for railways	101
The dredging machine	102
The drilling machine	104
The hand drill	104
Nasmyth's foot-drill	104
The common foot-lathe	105
Change-wheels	106
Punching-machine	108
Shears for cutting metal	108
The saw-mill	109
The smoke-jack	110
The common clock	110
The perambulator	112

CHAPTER IV.

PUMPS AND OTHER HYDRAULIC MACHINES.

	Page
The common suction-pump	113
The forcing pump	114
Forcing pump with an air-chamber	115
The double-acting pump	115
The fire-engine	116
The spiral pump	117
The screw of Archimedes	117
The hydraulic ram	118
The suction-ram	118
The chain-pump	119
Hydraulic belt	119
The centrifugal pump	119
Bramah's press	121
Hydrostatic press	122
Hydraulic press for lifting the tubular bridges	125
Water as a moving power	130
The undershot wheel	130
The overshot wheel	131
The breast wheel	131
Calculation of the power of water wheels	132
Barker's mill	133
Marine screw-propellers	134
Maudslay's feathering screw	136
The turbine water-wheel	139
Motion of water in pipes	144
Motion of water in rivers and open canals	144
Work performed by the sun's evaporation	145
Work of the great cataract of the river Niagara	146
Work or power of the tides	147

CHAPTER V.

SELF-ACTING LATHES FOR SLIDING, SCREWING, AND SURFACING;
ALSO SELF-ACTING PLANING, SHAPING, SLOTTING, PUNCHING,
AND SHEARING MACHINES.

	Page
Foot lathe for sliding, screwing, and surfacing	148
Self-acting lathe for sliding, screwing, and surfacing	151
Patent self-acting duplex lathe	151
Self-acting planing machine	158
Patent universal shaping machine	153
Large patent slotting machine	155
Punching and shearing machine	157
Large self-acting surfacing and screw-propeller lathe, made for her Majesty's Dockyard, Woolwich	157
Large lathe for turning railway wheels and other heavy work	161

CHAPTER VI.

MACHINES FOR CARDING, SPINNING. ETC.

Carding machine	161
Spinning machine	163
Flax machines	164
Fairbairn's patent riveting machine	170

CHAPTER VII.

THE STEAM ENGINE.

Mercurial steam-gauge for low-pressure boilers	173
————— high-pressure boilers	174
Watt's Indicator	175
Boilers and their appendages	177
The self-acting feeding apparatus	179
————— boiler feeder	180

CONTENTS.

xix

	Page
The slide-valves	181
General arrangements of different steam-engines	183
Oscillating engine	183
Improved pendulous high-pressure steam-engine	185

CHAPTER VIII.

MACHINERY FOR THE MANUFACTURING AND REFINING

SUGAR.

On the sugar cane	187
Schröder's patent evaporating disc pan	188
The blow-up pans	191
The filtering process	192
The decolouring cisterns	193
Boiling the liquid sugar in the vacuum pans	194
Sugar heaters	197
Sugar moulds	197
Patent manufactory of charcoal for refining sugar	197

CHAPTER IX.

ON THE FRICTION OF MACHINERY AND LABOURING

FORCES.

Friction on horizontal and inclined planes, with examples	200
The useful effect or modulus of a machine, with examples	202
The practical application of mechanism to the work of living agents with examples	203
Sources of labouring force and the work of living agents, with examples	205

	Page
Work in moving a carriage or railway train on a horizontal plane, with examples	207
Work in overcoming the joint resistances of friction and gravity on an inclined railway or common road	209
Mechanism for preventing collisions on railways	211
The super-elevation of exterior rail in railway curves	213
Table of super-elevation to be given to the exterior rail in curves	218

CHAPTER X.

ON THE PRODUCTION OF BROWN SALT-GLAZED STONE-WARE AND
BRISTOL-WARE.

Clay used for stone-ware	218
Iron runners	219
Pug-mills	220
Potter's wheel	221
Potter's kilns	223
Bristol glazed ware	224

ERRATA.

- Page 32, Art. 50, draw the curve m p so as to incline a little to the left, thus making the curve n m p represent the long italic f.*
- 70, 118, supply the letter C to the pulley in second figure.
- 71, 119, supply the letter D to the pulley in first figure.
- 91, 155, supply the pin C in the figure.
- 106, 173, supply the letter F to the frame that carries the screw E in the figure.

ELEMENTS OF MECHANISM.

PART I.

CHAPTER I.

DEFINITIONS OF MOTION.

1. *Motion* is the continual change of place of a body. When the body moves in a straight line it is said to have *rectilinear motion*; when it moves in a curved line it is called *curvilinear motion*; and when it moves backwards and forwards it is said to have *reciprocating motion*.

Motion may be also either *uniform or variable*. When the body moves over equal spaces in equal times, it is said to have *uniform motion*; but when it moves over unequal spaces in equal times, it is said to have *variable motion*.*

The *velocity* of a body is measured by the linear rate of motion of a point in the body; thus, if a body move uniformly over 10 feet per second, it is said to have a velocity of 10 feet per second. Therefore, when velocity is to be measured, we must have a given number of units of space passed over in a given unit of time: it is an established custom to take a foot for the unit of space, and a second for the unit of time, when treating of these subjects in a scientific manner.

2. *When a body moves uniformly the space it passes over is equal to the product of the velocity and time.*

* There are also *accelerated and retarded motions*; the most common cases of these motions may be seen in falling bodies, in the former case, and in bodies thrown directly upwards in the latter case.

For, if a body moves with a velocity of 6 feet per second, it will move over twice 6 feet, or 12 feet, in 2 seconds, and over thrice 6 feet in 3 seconds, and so on.

Or, generally, let v be the velocity of the body per second, t the time in seconds, and s the space or distance passed over, then

$$s = v \text{ times } t$$

$$\text{that is, } s = v t \quad (1)$$

which equation shows the relation of velocity, time, and space in uniform motion, any two of which being given the remaining one may be found by common algebraic transposition; thus,

$$t = \frac{s}{v} \quad 2)$$

$$v = \frac{s}{t} \quad (3)$$

Example 1.—The velocity of a body is 15 feet per second, in what time will it move over 100 yards?

Here $s = 100 \text{ yards} = 100 \times 3 = 300 \text{ feet}$, and $v = 15 \text{ feet}$; hence by equation (2),

$$t = \frac{s}{v} = \frac{300}{15} = 20 \text{ seconds.}$$

Ex. 2.—A locomotive engine moves with a velocity of 30 miles per hour; required its velocity per second.

Here $s = 30 \times 5280 = 158400 \text{ feet}$, and $t = 1 \text{ hour} = 3600 \text{ seconds}$; hence by equation (3),

$$v = \frac{158400}{3600} = 44 \text{ ft. per second.}$$

ON THE USE OF MACHINES IN GENERAL.

3. *Firstly.*—Machines are used for producing power or force greater than the strength of man or any other animal; as by the lever, crane, &c. *Secondly.*—For increasing or decreasing the velocity of motion; as by the lathe, smoke-jack, &c. *Thirdly.*—For prolonging the action of power, as in a clock or watch. *Fourthly.*—For changing the direction of motion; as by the windlass, the piston of the steam-engine, &c. *Fifthly.*—For reducing the time of labour; as in the case of locomotive engines on railways compared

with draught horses on common roads. And *Sixthly*.—For producing accuracy and quickness in the work required to be done; as in the case of lathe-work, which cannot be produced with perfect uniformity without the lathe. But instances of this kind may be produced without end; we shall therefore proceed to

4. *Parts of a Machine*.—These parts may be divided into three: *firstly*, the part which is subject to the action of the moving power, as the handle of a windlass, which may be called the *receiver* of work; *secondly*, the mechanism that communicates the work of the receiver to the work to be done, as the windlass and the rope coiling round it, which may be called *interposed mechanism* or *communicators* of work. And *thirdly*, the part which performs the required work, as the bucket, which is attached to the rope, and which may be called the *working part*, or *operator*.

5. The moving powers of machines may be divided into seven; *Firstly*, man and other animals. *Secondly*, the fall of water. *Thirdly*, the force of the wind. *Fourthly*, the descent of weights. *Fifthly*, the action of springs. *Sixthly*, the expansion of elastic fluids, as steam, air, &c. And *seventhly*, electricity and magnetism.

ELEMENTARY FORMS OF MECHANISM.

The Elementary Forms of Mechanism consist of the six *mechanical powers*.

1st.—*Levers*, producing motion by *Link-work* or *Jointed-rods*.

2nd.—*Wheels*, or *Wheels and Axles*, producing motion by rolling contact, or by teeth raised upon them.

3rd.—*Pulleys*, producing motion by wrapping contact, by means of *cords*, *straps*, or *chains*.

4th.—*Inclined Planes*; and 5th, *The Wedge*, producing motion by *sliding*, or *wedge-motions*.

6th.—*Screws*, also producing motion by *sliding* by the help of the lever, or some other of the mechanical powers.

VELOCITY RATIO.

6. In calculating the motion of the parts of a machine, *Professor Willis* and others have found it to be most convenient to compare their proportional velocities, or, in other

words, to find an expression for their *velocity ratio*. Thus, let the receiver of a machine move through a space of v feet, while its operator moves through v feet; then their velocity ratio is expressed by $\frac{V}{v}$; and, if P represent the power applied to the receiver, and w the weight moved by the operator; then

$$\frac{P's \text{ velocity}}{w's \text{ velocity}} = \frac{v}{v}$$

Example.—Let the velocity v of the receiver = 28 feet, and the velocity v of the operator = 4 feet in the same time; then

$$\frac{P's \text{ vel.}}{w's \text{ vel.}} = \frac{v}{v} = \frac{28}{4} = \frac{7}{1}$$

or, the power P of the receiver moves with seven times the velocity of the weight w moved by the operator, which is the velocity ratio in this case. Examples explaining this principle will be given in Art. 8, on the practical application of the lever.

We shall now proceed to compare the velocity and power of the receiver of work with the velocity and power of the operator of a machine, the form of the interposed mechanism or communicators being given.

CHAPTER II.

THE LEVER AND LINK-WORK.

7. We shall first take the lever AB , as presenting the most simple form of mechanism. Let the lever rest on the



fulcrum F , and let a power P be applied to the end A of the lever, which is called the *receiver*, to move the end B , which is called the *operator*; also let the power move the lever to the position $a b$; thus causing the weight w to ascend through the space $B b$ in the same time that the power descends through the space $A a$;

then, by the principle of Virtual Velocities, Art. 85, *Baker's Statics and Dynamics, Weale's Series,*

$$A a : B b :: A F : F B,$$

that is, P's vel. : W's vel. :: A F : F B,

$$\therefore \frac{P's \text{ vel.}}{W's \text{ vel.}} = \frac{A F}{F B}. \quad (1)$$

Also, when equilibrium takes place between the weight and power, we shall have by Art. 42, *Ibid.,*

$$P \times A F = W \times F B \quad (2)$$

that is, *the power multiplied by the length of its arm is equal to the weight multiplied by the length of its arm;—the former product is called the momentum of the power, and the latter the momentum of the weight.*

From equation (2). $\frac{W}{P} = \frac{A F}{F B} \quad (3)$

and by comparing equations (1) and (3) we shall have

$$\frac{P's \text{ vel.}}{W's \text{ vel.}} = \frac{W}{P} \quad (4)$$

that is, the velocity ratio, or $\frac{P's \text{ vel.}}{W's \text{ vel.}}$, is equal to the weight w divided by the power P , which is employed to raise the weight w , an equilibrium between the weight and power being supposed to exist.

8. *For the instruction of those students that are not accustomed to the use of mathematical equations, we shall give the following rules and examples, in which the magnitude of the power and weight, and the lengths of the arms of the lever, are given in numbers.*

RULE I.—The velocity ratio of the power P and the weight w is equal to the length of the arm $A F$ divided by the length of the arm $B F$. (See last figure.)

Example.—Let the arm $A F$ of the lever $A B$ be 36 inches, and the length of the arm $B F = 9$ inches; required the velocity ratio of the weight and power.

$$\frac{P's \text{ vel.}}{W's \text{ vel.}} = \frac{36}{9} = \frac{4}{1}$$

that is, the power's velocity is to the weight's velocity as 4 is to 1.—This is the *velocity ratio* in this case, which is much used in calculations relating to machinery, and is the same as would be given by equation (1) of the last article.

RULE II.—The velocity ratio of the power and weight is equal to the weight divided by the power.

Example.—Let the weight $w = 28$ cwt., and the power $P = 4$ cwt.; required the velocity ratio, an equilibrium being supposed to exist between the weight and the power?

$$\frac{P's \text{ vel.}}{w's \text{ vel.}} = \frac{28}{4} = \frac{7}{1},$$

that is, the velocity of the power P is to the velocity of the weight w as 7 is to 1.

Note.—In this example, $\frac{28}{4} = \frac{7}{1} = \frac{w}{P}$, or the weight to be raised divided by the power applied, is called "*the advantage gained by the lever*;" and the velocity ratio, or $\frac{P's \text{ vel.}}{w's \text{ vel.}} = \frac{7}{1}$, expresses the number of times that the velocity of the weight is contained in the velocity of the power, which quotients are equal; hence *the advantage gained by a machine is equal to the velocity of the power divided by the velocity of the weight raised*, which is called *the principle of virtual velocities*. *Mechanicians* define this principle by saying "what is gained in power is lost in speed." *This simple principle, abating friction, will apply to all machines*, however complicated, and this is the most simple aspect in which their motion can be viewed.

RULE III.—Also, when an equilibrium takes place on the lever, the product of power and the length of its arm is equal to the product of the weight and the length of its arm.

Or,—The power is to the weight inversely as the lengths of the arms of the lever on which they respectively act; hence, if any three of these four be given the other may be found.

Example.—The lengths of the arms of a lever are 36 and 3 inches, and a power of 2 cwt. acts at the end of the longer arm; what weight will it balance?

$$\begin{array}{cccc} \text{in.} & \text{in.} & \text{cwt.} & \text{cwt.} \\ 3 & : 36 & :: 2 & : 24, \end{array}$$

that is, the product of the power and the length of its arm is equal to the product of the weight and the length of its arm; thus,

$$2 \times 36 = 24 \times 3 = 72,$$

the *momentum of the power*, being equal to the *momentum of weight*, see equation (2); the lever in all these cases being supposed to be without weight.

9. There are commonly reckoned three kinds of levers, depending on the positions of the *points of application of the power* and the *weight* with respect to the fulcrum.

A *lever of the first kind* is represented by fig. I., in which the fulcrum *F* is situated between the power *P* and weight *w*. In a *lever of the second kind*, fig. II., the power *P* and the weight *w* act on the same side of the fulcrum *F*, the weight being between the fulcrum and the power.

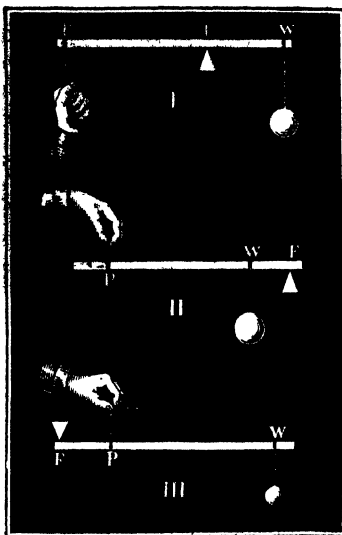

In a *lever of the third kind*, fig. III., the power *P* and the weight *w* act on the same side of the fulcrum *F*, as in the latter case, but the power, in this case, is between the fulcrum and the weight.

The velocity ratio, and the equations of equilibrium, equations (1), (2), and (4), Art. 7, apply to all the three kinds of levers, that is,

$$\frac{P's \text{ vel.}}{w's \text{ vel.}} = \frac{F w}{F P'}$$

$$\text{or, } \frac{P's \text{ vel.}}{w's \text{ vel.}} = \frac{w}{P} \text{ in case of equilibrium;}$$

$$\text{and } P \times F P = w \times F w.$$

10. *The Common Steelyard* is a useful application of the lever for finding the weights of bodies.—The beam of the steelyard is shown in the annexed figure; *c* is the fulcrum,

w the body (the weight of which is to be found) is suspended at the end s of the shorter arm, and the constant weight P is moved along the graduated arm till there shall be an equilibrium. Let it be assumed that the scale and heavy ball at

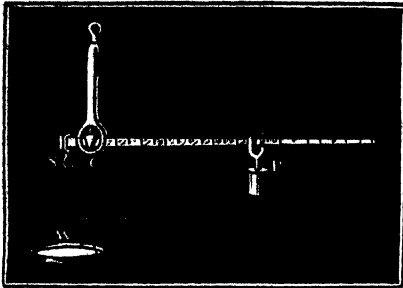

keep the lever in equilibrium or in a horizontal position when the load w and the weight P are removed, as is the case with some steelyards. Now, let w and P be applied to the steelyard so that they may balance each other; then $P \times CP = W \times CS$ or $w = \frac{P \times CP}{CS}$, therefore, when $CP = CS$, w will be $= P$, and when $CP = 2 CS$, w will be $= 2 P$, and so on. Therefore, if the longer arm of the lever be marked so that $c1, c2, c3, \&c.$ shall be equal to $s c, 2 s c, 3 s c, \&c.$, respectively; then, when P is at the 1st, 2nd, 3rd, $\&c.$, marks, the corresponding weights of w will be $P, 2 P, 3 P, \&c.$ Thus, if P be 1 lb., then w will be successively equal to 1, 2, 3, $\&c.$ pounds, when P is at the 1st, 2nd, 3rd, $\&c.$, marks on the longer arm of the steelyard. In the figure, P is shown at the twelfth mark on the longer arm, therefore, in this case, $w = 12 P$; and, if $P = 1$ lb., then $w = 12$ lbs.

11. When the power is required to be very great, and it is not convenient to construct a very long lever, a *compound lever*, or a *composition of levers*, is employed. In the composition of levers, in the annexed figure, the several levers $A B, B C, c D$, act perpendicularly one on another, the fulcrums, or centres of motion, of which are respectively $F, F',$ and F'' ; then by Art. 48, *Baker's Statics and Dynamics*, we shall

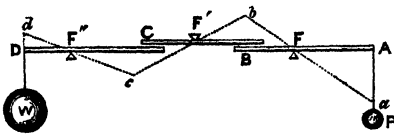

have, in case of equilibrium between the power P and weight w,

$$P : W :: FB \times F' C \times F'' D : FA \times F' B \times F'' C$$

$$\text{or, } \frac{W}{P} = \frac{FA \times F' B \times F'' C}{FB \times F' C \times F'' D} \quad (1)$$

Now, let the power P descend through the small space Δa , then the levers AB, BC, CD will respectively assume the positions $a b, b c, c d$, and we shall have the velocity ratio by equation (4), Art. 7, or by the principle of Virtual Velocities,

$$\frac{P's \text{ vel.}}{W's \text{ vel.}} = \frac{A's \text{ vel.}}{D's \text{ vel.}} = \frac{W}{P},$$

and by comparing this equation with equation (1), there results the velocity ratio, or

$$\frac{A's \text{ vel.}}{D's \text{ vel.}} = \frac{FA \times F' B \times F'' C}{FB \times F' C \times F'' D}, \quad (2)$$

Hence generally, *the velocity ratio of A and D, or of P and w, will be found by dividing the product of lengths of all the alternate arms of the levers beginning from P by the product of all the alternate arms beginning from w.*

12. A system or composition of levers may be conveniently arranged as in the annexed fig. Here, there are two of the

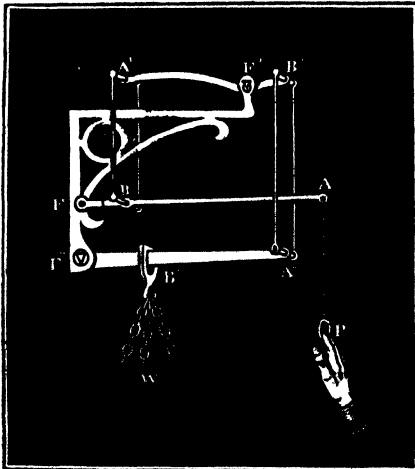

second kind, viz. ΔF and $\Delta'' F''$, and one of the first kind $\Delta' B'$, and we shall now consider the manner in which the power P is transmitted to the weight w . The power P , acting on the lever ΔF , produces a downward force at B , which acts through the link $B \Delta'$ on the arm $\Delta' F'$ of the second lever, which arm is therefore pulled down, thus causing the arm $F' B'$ to ascend, which acts by means of the link $B' \Delta''$ on the arm $\Delta'' F''$, which is therefore drawn upwards, causing the weight w (suspended at B'') to ascend; hence the velocity ratio of P and w , or of Δ and Δ'' , by the last Article, will be

$$\frac{P's \text{ vel.}}{w's \text{ vel.}} = \frac{\Delta F \times \Delta' F' \times \Delta'' F''}{F B \times F' B' \times F'' B''}, \text{ or, } = \frac{W}{P} \text{ in case of equilibrium.}$$

Example 1.—Let $\Delta F = 20$, $\Delta' F' = 16$, and $\Delta'' F'' = 18$ inches, also let $B F' = 2$, $B' F' = 2$, and $B'' F'' = 3$ inches; then, by equation (2), we shall have the velocity ratio, or

$$\frac{P's \text{ vel.}}{w's \text{ vel.}} = \frac{20 \times 16 \times 18}{2 \times 2 \times 3} = \frac{480}{1},$$

that is, the power's velocity is to the weight velocity as 480 is to 1; or the point Δ moves with 480 times the velocity of that of the point B'' ; and consequently, by the nature of virtual velocities, the weight w is 480 times the power P .

Ex. 2.—Let the power P be such as a man can exert, which is usually taken at 150 lb., what weight can he raise by the composition of levers in the last example?

Since the weight is 480 times the power, we shall have

$$w = 480 \times 150 = 72000 \text{ lb.} = 32 \text{ tons } 2 \text{ cwt. } 96 \text{ lb.}$$

The same result may be obtained from equation (1), Art. 11.

13. *The Weighing Machine* for turnpike-roads, &c., is formed of a composition of levers. It is chiefly used for weighing loaded wagons and other large weights. It consists of a wooden platform, placed over a pit made in the line of the road, and level with its surface; and so arranged as to move freely up and down without touching the walls of the pit. The levers on which the platform rests are four; viz., ΔF , $B F$, $C F$, and $D F$, all converging towards the centre F , and each moving on a fulcrum at Δ , B , C , D , securely fixed in each corner of the pit. The platform rests on its feet $a' c' d'$, which rests on steel points a, b, c, d . The four levers are supported at the point F , under the centre of the platform, by a long lever $G E$, resting on a steel fulcrum at E , while its

longer arm at *G* is connected with a rod, which is carried up into the turnpike-house, where it is attached to the shorter

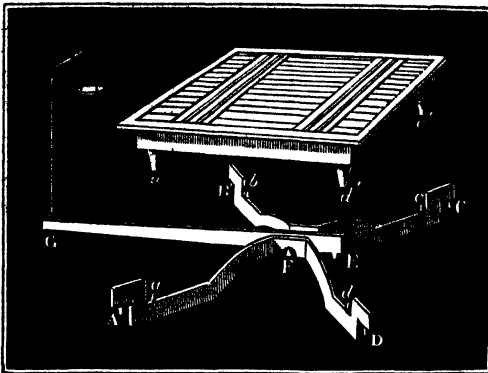

arm of another lever, while a scale,* suspended from the other arm, carries the counterpoise or power, the amount of which, of course, indicates the weight of the wagon on the platform.

Now, as the four levers *A*, *B*, *C*, *D*, are perfectly equal and similar, the effect of the weight distributed amongst them is the same as if the whole weight rested upon any one. In order, therefore, to ascertain the conditions of equilibrium, we need only consider one of these levers, such as *A F*. Suppose, then, the distance from *A* to *F* to be 10 times as great as that from *A* to *a*, a force of 1 lb. at *F* would balance 10 lb. at *a*, or on the platform. So, also, if the distance from *E* to *G* be 10 times greater than the distance from the fulcrum *E* to *F* a force of 1 lb., applied so as to raise up the end of the lever *G*, would counterpoise a weight of 10 lb. on *F*; therefore, as we gain 10 times the power by the first levers, and 10 times more by the lever *E G*, it is evident that a force of 1 lb. tending to raise *G*, would balance 100 lb. on the platform. If the weight of 10 lb. be placed in the opposite arm of the balance to which *G* is attached, this 10 lb. will express the value of 1000 lb. on the platform. When the platform is not loaded, the levers are counterpoised by a weight applied to the end of the last lever.

Note.—Equations (1) and (2), Art. 11, will apply generally to the use of the *Weighing Machine*, just described.

* Instead of a scale, a constant moveable weight is more commonly used, as in the steelyard.

THE OBLIQUE AND BENT LEVERS.

14. A lever AB , turning on the fulcrum F , is acted upon by the power P , and the weight w in the oblique directions PAS , wBT ; it is required to find the nature of the equilibrium between P and w , and their velocity ratio?

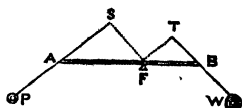

From F draw the perpendiculars FS , FT upon the respective directions of P and w ; then, by Art. 42 (2), *Baker's Statics and Dynamics*,

$$P \times FS = w \times FT, \quad (1)$$

$$\text{or, } \frac{w}{P} = \frac{FS}{FT}$$

Also, by Art. 86, *Ibid.*, the velocity ratio of P and w , estimated vertically, is

$$\frac{P's \text{ vel.}}{w's \text{ vel.}} = \frac{w}{P} = \frac{FS}{FT}. \quad (2)$$

From (1) and (2) it appears that P multiplied by the perpendicular from the fulcrum on its direction is equal to w multiplied by the perpendicular on its direction; and that the velocities of P and w are to each other as the same perpendiculars: both which positions are agreeable to the great principle of the equality of moments, Articles 85, 86, and 87. *Baker's Statics and Dynamics*.

Note.—Put $AF = a$, $BF = b$, the angle $S A F = \alpha$, and $T B F = \beta$; then, Art. 43, *Ibid.*, $P a \sin. \alpha = w b \sin. \beta$.

15. The law of equilibrium and velocity ratio, given in Art. 14, is equally true with respect to bent levers of any

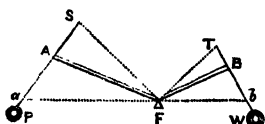

kind, as AFB , in the annexed fig.; for, instead of the straight lever, shown by the dotted line afb , we may conceive the rigid bent lever AFB to meet the directions of the forces P and w , and these forces to be transferred to its extremities A and B . Draw the perpendiculars FS , FT to the directions PAS , wBT of

the forces P and w respectively, and we shall have, as in the last Art.,

$$P \times FS = w \times FT,$$

$$\text{and } \frac{P's \text{ vel.}}{w's \text{ vel.}} = \frac{FS}{FT}.$$

16. When the arms FA , FB of the lever are perpendicular to the directions PA , wB , in which P and w act, that is, when PAF , wBF are right angles (see last fig.); then

$$P \times FA \times W \times FB,$$

$$\text{and } \frac{P's \text{ vel.}}{W's \text{ vel.}} = \frac{FA}{FB};$$

which is sufficiently evident from the two preceding Articles.

Example 1,—Let FS be = 2 feet, and FT = 1 foot, fig. to Art. 14, then, by equation (2), the velocity of P will be 2 times the velocity of w , that is,

$$\frac{P's \text{ vel.}}{w's \text{ vel.}} = \frac{FS}{FT} = \frac{2}{1}$$

Ex. 2.—Let the power $P=6$ cwt., the weight $w=18$ cwt., $FS = 3$ feet, and $FT = 1$ foot; then, by equation (1),

$$P \times FS = w \times FT$$

that is, $3 \times 6 = 1 \times 18$

both products being 18, as they obviously ought to be.

LINK-WORK, CRANKS, &c.

17. Rotatory motion may be communicated from an axis B to another axis D by the arms or cranks Bb , Dd (which are of equal lengths), and the link bd , which is equal to BD . If Bb be moved round the circle Bb , dD will always be a parallelogram, and therefore the angular velocities of Bb , Dd , will be always the same. When the cranks arrive at the positions Bs , Dt , the link bd will have the position st , the cranks and link being in this case all in what is called the *line of centres* $qBDt$, the link is now said to be

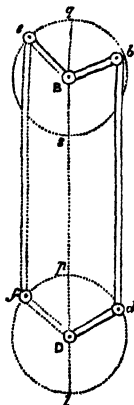

in one of its *dead points*, as the tension upon it has no effect in turning the crank, but generally the moving force of the machinery, to which the crank is attached, carries it beyond the dead point. It will also be seen that q and p are dead points which the cranks and link have to pass over in one revolution.

18. To remedy the inconvenience of dead points, the two cranks $B e$, $D f$, at right angles to $B b$, $D d$, respectively, and equal to them, with their connecting link $e f$, are frequently added to the system. The advantage of this arrangement is to give a constant and efficient moving force to drive round the cranks $D d$, $D f$, independent of any moving force in the machinery.

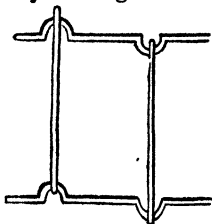

19. A second manner of avoiding the dead points may be gained by bending the two axes into loops or cranks, at right angles to one another, by which arrangement the planes of rotation of the two are separated, so that they can never come in contact; the same must be understood to be the case in Art. 17, as well as in the follow Art.

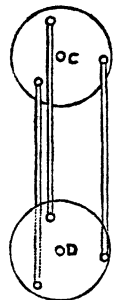

20. "The third method of passing the links over the dead points consists, like the latter, in employing two or more sets of arms and links, so disposed that only one set shall be passing the dead point at the same moment. In this method the axes c , d , are parallel, but not opposite; pins are fixed in the free side of each disc or wheel,* at equal distances from the centres of motion, and at equal angular distances from each other, and links each equal to the distance of the centres c , d , are joined to them, as shown in the annexed fig."—*Prof. Willis's Mechanism*, Art. 200.

21. In the annexed fig., the wheel or grindstone G has a continuous rotatory motion given to it by the crank $C B$, the connecting rod or link $C D$ and the foot-board or treadle $A D$, which last piece turns upon A as a centre, the rod $C D$ having joints at its extremities to connect it with the crank and foot-board. By pressing the foot, for an instant, upon $A D$, the wheel is turned by the crank,

* By this arrangement the links will pass one another without collision.

the moving force, thus communicated to the wheel, being sufficient to carry it round, passing both the dead points, till it arrives at its former position, when the pressure is again applied, and the rotation of the wheel is thus continued for any length of time required. The reciprocating, or up and down motion of the great beam of the steam engine turns, by means of its connecting rod, the crank of the fly-wheel, the moving force or *inertia* of which maintains continuous rotatory motion, in the same manner as in the wheel or grindstone, just described.

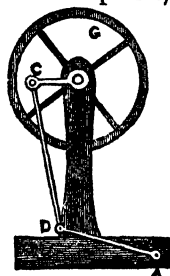

22. *The bent-lever balance* is a convenient form of scale, in which the weight is constant. It consists of a bent lever ABC , to one end of which a weight c is fixed, and to the other end A , a hook carrying a scale-pan w , in which the substance to be weighed is placed. This lever is moveable about an axis B . As the weight in w depresses the shorter arm BA , its leverage is constantly diminished, while that of the arm CB is constantly increased. When c counterpoises the weight, the division at which it settles on the graduated arc expresses its amount. The graduation of the instrument of course commences at the point where the index settles when there is no load in w . The scale-pan is then successively loaded with 1, 2, 3, &c., ounces or pounds, and the successive positions of the index marked on the arc.

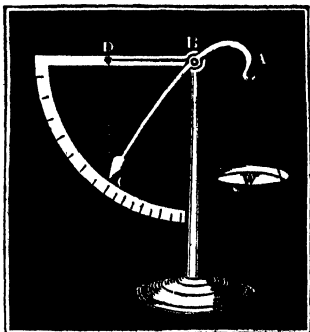

23. *Note.*—"One of the principal uses of the common lever is for raising large weights through small spaces, which is done by a series of short intermitting efforts. After the weight has been raised, it must be supported in its new position, until the lever is readjusted to repeat the action. The chief defect, therefore, of the lever is want of range and the means of supplying continuous motion. This defect could be supplied if the moving power could be enabled to move round the entire circle, and so continue to revolve for any length of time, still producing the due proportion of effect on the weight to be raised, or on

the resistance to be overcome. If, for instance, a weight is to be raised, there are many ways in which the action of the lever may be made continuous," which shall be shown in the following chapters.

TO FIND THE VELOCITY RATIO IN LINK-WORK.

24. "Let ΔP , BQ be two arms moving on fixed centres A and B respectively, and let them be connected by a link PQ ,

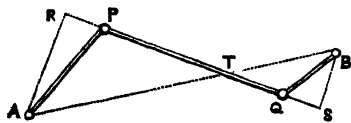

jointed to their extremities P and Q . Let ΔB , BS be perpendiculars from the centres upon the direction of the link PQ produced, if necessary ;"

and let the centres A and B be joined ; then ΔB is called the line of centres, and by *Prof. Willis's Mechanism*, Art. 32,

$$\text{ang. vel. of } \Delta P : \text{ang. vel. of } BQ :: BT : AT,$$

that is, the angular velocities of the arms ΔP , BQ are to each other inversely as the segments into which the link divides the line of centres ΔB .

Also, by *Art. 32, Cor. 1, Ibid.*,

$$\text{ang. vel. of } \Delta P : \text{ang. vel. of } BQ :: BS : AB,$$

that is, the angular velocities of the arms ΔP , BQ are inversely as the perpendiculars from their centres of motion upon the line of the link PQ .

These two proportions may be arranged in equations as follows :

$$\frac{\text{ang. vel. of } \Delta P}{\text{ang. vel. of } BQ} = \frac{BT}{AT}, \quad (1)$$

and

$$\frac{\text{ang. vel. of } \Delta P}{\text{ang. vel. of } BQ} = \frac{BS}{AB}. \quad (2)$$

CHAPTER III.

WHEEL-WORK.—PRODUCING MOTION BY ROLLING CONTACT—
AXES, PARALLELS.

25. Let **E** and **F** be two wheels or cylinders, in contact with each other, and respectively revolving on the parallel axes **A a**, **B b**; the sum of the radii of the two wheels being equal to the distance of the centres of their axes, and therefore the wheels will be in contact in all positions; and, if the wheel **E** be made to revolve, it will communicate motion to the wheel **F**, in a contrary direction, by the friction of their circumferences, which will obviously have the same velocity; therefore the number of times **F** revolves while **E** makes one revolution will be equal to the number of times the circumference of **F** is contained in that of **E**, or = the number of times the radius of **F** is contained in that of **E**. Let **R** and **r** be the radii of **E** and **F** respectively, and **N** = number of revolutions made by **F** while **E** makes one revolution; then

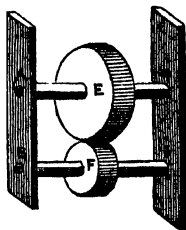

$$N = \frac{R}{r}$$

Example.—Let the radii of the wheels **E F** be respectively 10 and 4 inches; how many revolutions will **F** make while **E** makes one?

$$\text{Here } N = \text{number of revolutions} = \frac{R}{r} = \frac{10}{4} = 2\frac{1}{2}.$$

26. If motion is communicated by the wheel **E** to the wheel **F**, then **E** is called *the driver* and **F** *the follower*.

27. There are various methods by which the circumferences of wheels are made to act upon one another. Sometimes by the mere friction of their surfaces, the friction being increased by cutting the wood so that the grains of the opposed surfaces may run in opposite directions; in

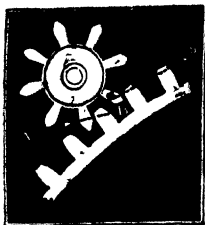

other cases the surfaces are covered with thick soft leather; but the most usual method of transmitting power in complex wheel-work is by means of *teeth* or *cogs*, raised on the surfaces of the wheels, as in the annexed fig. The term *teeth* is usually applied to the cogs on the surface of the large wheel, as B, and *leaves* to those on the surface of the small wheel, usually called a *pinion*, as a.—Wheels and pinions are usually made of cast-iron, each wheel and its teeth being of one piece.

28. When the teeth of wheels are engaged together, as in the fig., they are said to be *in gear*, but when disengaged *out of gear*.

29. The number of times the pinion revolves while the wheel makes one revolution will be evidently equal to the number of teeth in the wheel divided by the number of leaves in the pinion.—Let T = no. of teeth in the wheel, t = no. of leaves in the pinion, and N = no. of revolutions made by the pinion while the wheel makes one, or if R, r be the respective radii of the wheel and pinion; then

$$N = \frac{T}{t} = \frac{R}{r}$$

Example.—The number of teeth in a wheel is 48, the leaves in its pinion are 8; how often will the pinion turn round while the wheel turns once round?

$$\text{Here } N = \text{number of turns} = \frac{48}{8} = 6.$$

30. In a train of wheels, arranged as in the annexed fig., the conditions of equilibrium and velocity ratio are the same as in the train of levers in Art. 12, that is,

$$\frac{P's \text{ vel.}}{W's \text{ vel.}} = \frac{a \times e \times f}{b \times c \times d} = \frac{W}{P} \quad (1)$$

a, e, f being the radii of the wheels, and b, c, d the radii of the pinions; also,

$$W = \frac{P \times a \times e \times f}{b \times c \times d}. \quad (2)$$

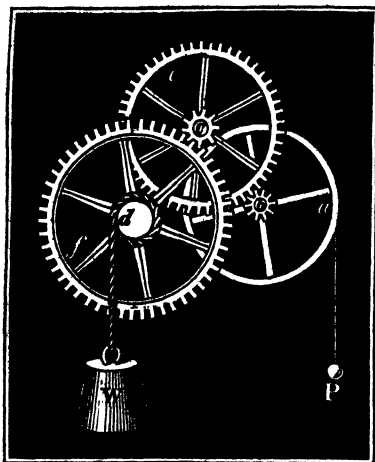

31. In the marginal train of wheels, let the wheel T drive the pinion t , which is fixed on the axis of the wheel T' ; let T' drive the pinion t' , which is fixed on the axis of the wheel T'' , which last wheel drives the pinion t'' ; let the number of teeth in the wheels and pinions be represented by the letters annexed to them, and let N = number of revolutions made by the pinion t'' while the wheel T makes one revolution; then we shall have, by *Art. 220, Prof. Willis's Mechanism,*

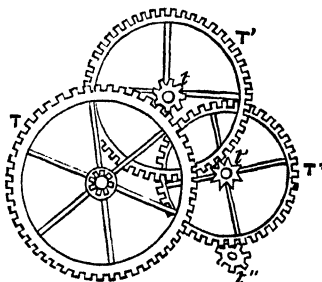

$$N = \frac{T \times T' \times T''}{t \times t' \times t''}$$

Hence it appears that *while the first driving-wheel makes one revolution, the number of revolutions made by the last*

follower in the train is equal to the product of the number of teeth in all the drivers, divided by the product of the number of teeth in all the followers; and this rule will hold for a greater or less number of drivers and followers, arranged as in the fig.

Example 1.—Let the radii of three wheels *a*, *e*, and *f* be respectively 16, 18, and 24 inches, and the radii of their pinions *b*, *c*, and *d* be 2, 2, and 3 inches respectively; required the velocity ratio of *p* and *w*, and the weight of the latter when the former is 1 cwt., in case of equilibrium.

By Art. 30, equation (1),

$$\frac{p\text{'s vel.}}{w\text{'s vel.}} = \frac{a \times e \times f}{b \times c \times d} = \frac{16 \times 18 \times 24}{2 \times 2 \times 3} = \frac{576}{1},$$

that is, *p*'s vel. is to *w*'s vel. as 576 is to 1; and consequently when *p* = 1 cwt., *w* = 576 cwt. = 28 tons, 16 cwt.

Ex. 2.—In a train of three wheels and their pinions, (see last fig.,) the number of teeth in the wheels are respectively 56, 64, and 96, and the number of leaves in the pinions respectively 8, 12, and 16; required the number of revolutions made by the last pinion while the first wheel turns once round?

$$\text{By Art. 31, } N = \frac{56 \times 64 \times 96}{8 \times 12 \times 16} = 224 = \text{number of revol.}$$

MILL-WORK.

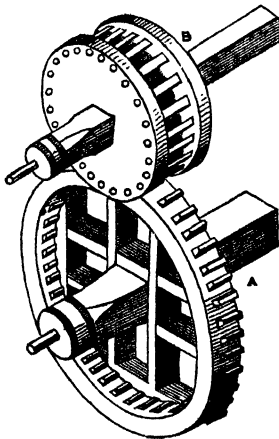

32. The subjoined fig. shows the construction of mill-work, and large machinery, previous to the introduction of cast-iron wheels. The wheel *A* is formed of wood, as shown in the fig.; equidistant mortices are pierced through the rim to insert the teeth or *cogs*, as they are called when made of separate pieces, which are also of well-seasoned hard wood. The pinion *B* is formed by inserting the extremities of small wooden cylinders into equidistant holes, in two parallel discs attached to its axis or shaft, thus forming a kind of cage, which is called a *lantern*, the

cylindrical teeth being called its *staves* or *rounds*. This construction is very strong, and the circular form of its staves gives it the advantage of a very smooth motion.—This kind of wheel and lantern is still very common in old mills.—

Prof. Willis's Mechanism, Art. 54.

33. "The above construction of a toothed wheel has been partly imitated in modern mill-work, for it is found that, if, in a pair of wheels, the teeth of one be of cast-iron and in the other of wood, that the pair work together with much less vibration and consequent noise, and that the teeth wear each other less than if both wheels of the pair had iron teeth. Hence, in the best modern engines, one wheel of every large sized pair has wooden cogs fitted in it, in the manner just described; only, instead of employing a wooden wheel to receive them, a cast-iron wheel with mortices in its rim is employed. Large wheels of the kind hitherto described, in which the teeth are placed radially on the circumference, whether the teeth be of one piece with the wheel or separate, are termed *spur-wheels*."—*Prof. Willis's Mechanism, Art. 55.*

ANNULAR WHEELS.

34. When wheels transmit motion to one another, as in the annexed fig., they are called annular wheels, the teeth in the large wheel being cut in the internal side of the annulus or rim; hence *the two axes revolve in the same direction*, whereas they revolve in *contrary directions* when the teeth are on the outside of the rim. The arrangement shown in the fig. is sometimes required in machinery.

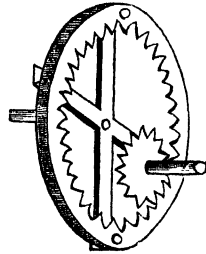

ANGULAR VELOCITY.

34A. Let RO be the radius of a wheel revolving round O as a centre; let OR move to the position OS in one second, then the length of the arc RS is the velocity of the point R of the wheel. Let a point m , one foot from the centre O , describe the arc mn , meeting OS in n ; then the length of

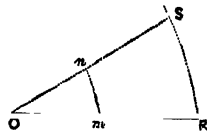

the arc $m n$ is the measure of the angular velocity of the wheel.

Let the length of the radius $R O = r$, $v =$ velocity of the point R , and $v =$ the angular velocity or measure of the arc $m n$; then by similar sectors,

$$r : v :: 1 : v,$$

$$\text{whence,} \quad r v = v. \quad (1)$$

$$\text{and} \quad v = \frac{v}{r}; \quad (2)$$

whence, by knowing the velocity of the circumference of a wheel, of which $R O$ is the radius, its angular velocity becomes known.

Also let $n =$ number of revolutions made by a wheel in a second or any other given time, and put $\pi = 3.1416 =$ semi-circumference of a circle the radius of which is unity; r , v and v representing the same things as before; then,

$$\text{circum. of wheel} = 2 \pi r,$$

$$\text{and vel. of circum. of wheel} = 2 n \pi r,$$

$$\text{that is, } v = 2 n \pi r, \quad (3)$$

$$\text{and } n = \frac{v}{2 \pi r} \quad (4)$$

But since $v = r v$ from equation (1), we shall have by substitution,

$$n = \frac{r v}{2 \pi r} = \frac{v}{2 \pi} \quad (5)$$

$$\text{and } v = 2 \pi n \quad (6)$$

See *Professor Willis's Principles of Mechanism*, Art. 11.

Example 1.—Let a wheel, the radius of which is 10 feet, have a velocity of 12 feet per second at its circumference; required its angular velocity?

In equation (2), by substituting 10 for r , and 12 for v , that is,

$$\text{vel. } v = \frac{v}{r} = \frac{12}{10} = 1\frac{1}{5} \text{ ft. per second.}$$

Ex. 2.—The driving-wheel of a locomotive engine, the radius of which is 3 feet, makes three revolutions in a second; required the rate of motion of the locomotive engine per hour in miles?

By equation (3) the velocity of the circumference of the wheel is

$$v = 2 \pi n r = 2 \times 3.1416 \times 3 \times 3 = 55.5488 \text{ feet per second ;}$$

hence the distance passed over by the wheel in 1 hour, or 3600 seconds, will be $55.5488 \times 3600 = 199975$ feet; which, being divided by 5280, the number of feet in a mile, gives $37\frac{9}{10}$ miles nearly.

Ex. 3.—The radius of a wheel is 8 feet, and its angular velocity 5 feet; required the velocity of its circumference?

Ans. 40 feet.

Ex. 4.—In a train of three wheels and their pinions, (see fig. to Art. 31) the number of teeth in the wheels τ τ' τ'' are respectively, 112, 128, and 96, and the number of leaves in the pinions t , t' , t'' are respectively 12, 8 and 14; required the number of revolutions made by the pinion t'' while the wheel τ turns once round, and the angular velocity of the pinion t'' when the velocity of the circumference of τ is 3 feet per second?

Ex. 5.—A locomotive engine moves at the rate of 60 miles per hour; required the number of revolutions made per second by the driving wheel of the engine, its radius being 3 feet; also the number of revolutions made by a common wheel of the same engine in the same time, its radius being 20 inches?

MOTION BY ROLLING CONTACT—AXES NOT PARALLEL.

35. If the two axes of rotation be not parallel, they will either meet, when prolonged, or not; these cases shall be considered separately.

BEVEL GEAR.

36. *Axes meeting when prolonged.*—Let the axes of rotation Bb , Cc meet, when prolonged, in A . On these axes two

right cones $A E d$, $A E f$, the vertices of which meet in A , are formed, touching each other in the line $A e E$. When the cone $A E d$ revolves on its axis $B b$, it will transmit a rotatory motion to the cone $A E f$ on its axis $C c$ by rolling contact. In practice thin frustums or frusta of the cones are used, as $d D e E$, $e F f F$.

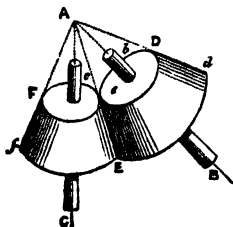

As these conical surfaces will evidently roll freely against each other, they will perform their rotations in the same manner as the cylindrical wheels in Art. 25, that is, if R and r be the radii of the frustums at any point where they are in contact, and N the number of revolutions made by $e F f F$ while $d D e E$ makes one revolution; then

$$N = \frac{R}{r} \text{ or } = \frac{\text{circum. } E d}{\text{circum. } F f'}$$

To maintain adhesional contact more firmly, the surface of one or both rollers may be covered with thick soft leather, but it is more common in practice to cut equidistant teeth on each surface, the outline of the teeth being directed to the common vertex A of the two cones $A D E$, $A E F$, as shown in the fig., $D E$, $E F$ being the wheels and B , C their axes.

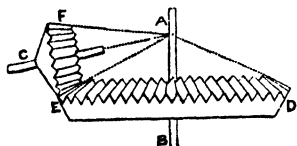

37. Wheels having their teeth cut, as in the fig., are called *bevel gear*; their mathematical principle was first laid down by Camus in 1766.

38. *The position of the axes of two bevel wheels, and their radii being given, to construct the conical surfaces forming the wheels.*

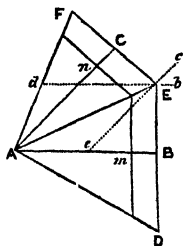

Let $A B$, $A C$ be the position of the two axes. Draw $d b$, $e c$ respectively parallel to $A B$, $A C$, and at distances equal to the radii of the wheels, let $d b$, $e c$ meet in E ; join $A E$, which is the line of contact of the two cones. Through E respectively perpendicular to $A B$, $A C$ draw the outer diameters $E D$, $E F$ of the two bevel wheels; join $A D$, $A F$; then $A D E$, $A E F$

will be sections of the required cones, from which any convenient breadths Bm , Cn may be taken for the thickness of the wheels.

CROWN WHEELS.

39. Rotation is transferred from one axis to another, which is at right angles to it, by means of a *crown-wheel*, as B , which gives motion to the wheel or pinion A . The teeth of the crown-wheel, it will be seen, are cut in the edge of the hoop, which forms its rim. This combination of wheels is much used in clocks and watches.

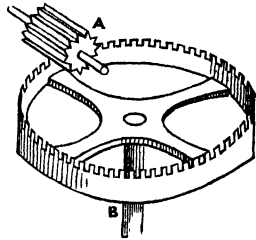

FACE-WHEEL AND LANTERN.

40. Also, when the axes of the wheels are at right angles to each other, and one of them is required to revolve much quicker than the other, the form of a cylindrical lantern was usually given to the less wheel, as A , the teeth of the large wheel, as B , being fixed in its face, hence the name "face-wheel."

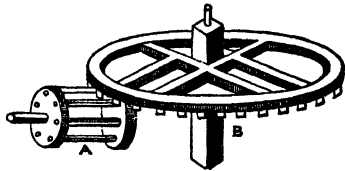

This arrangement of the wheel and pinion, as well as that in Art. 32, has long been, and still is, much used in old mills. For further information on this and like subjects, see *Prof. Willis's Principles of Mechanism*, Arts. 61, 62, and 63.

BEVEL-GEAR, AXIS NOT MEETING.

41. *Axis not meeting when prolonged.*—This case admits of solution by means of a third intermediate cone.

The position of two axes, which do not meet when prolonged, being given, to construct bevel-wheels to transmit rotatory motion from the one to the other.

Let Aa , Bb be the two axes, take a third line meeting the two axes, prolonged, if necessary, at any convenient points c and d respectively; and let another axis be formed in the direction of this third line to revolve between the other two axes. Now a pair of frustums e, f , of cones, having a

common vertex c ; and another pair of frustums g, h , having a common vertex D , will be thus formed, of which the frustums f, g are fixed on one axis c, D , which frustums will communicate motion by rolling contact from e to h , and teeth may be formed on the conical surfaces e, f, g, h , as in former cases. Moreover, it is obvious that the wheel h will transmit the same ratio of velocity to the wheel e as if they were in contact, and the equation in Art. 36 will equally apply in this case. It will be perceived

that in this case the wheels e and h revolve in the same direction.

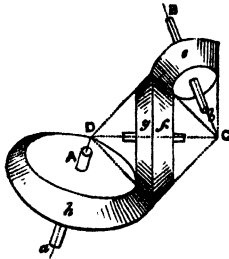

IDLE WHEELS.

42. A wheel placed between two other wheels, as that on the axis CD , between those on the axes Aa, Bb , is termed an *idle wheel*, whether the axes of the wheels are inclined to one another, as in the fig., or all parallel. An idle wheel, as appears from Art. 41, does not affect the velocity ratio of the two wheels with which it is in contact, but causes them to revolve in the same direction.

INTERMEDIATE BEVEL-WHEELS.

43. The axes of wheels, whether they be parallel or inclined to one another, may be made to revolve either in the same or opposite directions, according to the relative positions of the wheels. Thus, in the marginal fig., the intermediate bevel-wheels B and E , mounted on the same axis,

connect the driving-wheel A with the wheels C and D ; of which the wheel C revolves in the same direction as A ; and the wheel D in the contrary direction.

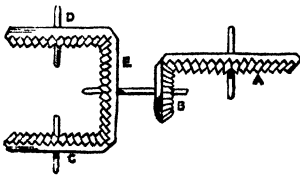

MARLBOROUGH WHEELS.

44. When the shafts of two wheels A and B , whether parallel or inclined, are so close together that the wheels cannot be placed with their teeth in contact without making

them too small, they may be fixed as shown in the annexed fig., so as to lie one behind the other, the connexion being formed by the idle wheel c, the thickness of which must be double that of the wheels it connects. This arrangement is used in the roller frames of spinning machinery.

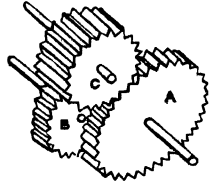

SKEW BEVEL-WHEELS.

45. When the axes of two wheels are inclined to each other, without meeting when prolonged, instead of an intermediate double bevel-wheel, as in Art. 41, the frustums, derived from the tangent cones of a pair of hyperboloids, may be employed. The direction of their teeth must be inclined to the base of the frustums, to enable them to come in contact. From the inclined position thus given to the teeth, wheels of this kind have obtained the name of *Skew Bevels*. These wheels are not much used on account of the difficulty of their construction.

For the method of forming skew bevel-wheels, and marking out the teeth upon them, see *Prof. Willis's Principles of Mechanism*, Arts. 47 and 67.

THE RACK AND PINION.

46. The combination, in the annexed fig., may be considered the connecting link between wheel-work and the lever, and is the most simple machine of the kind for producing a continuous vertical motion with great power. "In this machine the axis of motion *c c* forms the fulcrum of a lever whose longer arm *c A* is called the *winch*, and describes a complete circle; the shorter arm is repeated in the figure 8 times, forming the 8 leaves or teeth of the *pinion*, and there is always one of these employed in lifting by one of its teeth the *rack* *B C* to which the load or other resistance is applied. Thus, as soon as one of these short arms of the lever has done its work, another

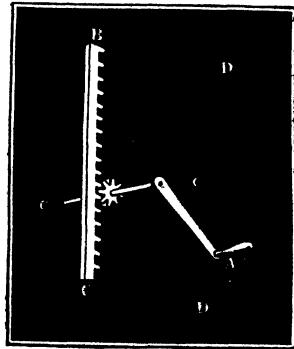

of these short arms of the lever has done its work, another

is ready to supply its place; and though each lifts the weight only through a very small space, the entire range is limited only by the length of the rack. But in lifting the weight through this range, the hand at *A* must describe altogether a space much greater, viz. in the proportion that the circumference *DAD* exceeds the height occupied by 8 teeth of the rack."

Let *R* = length of the winch *cA* = radius of the circle *DAD*, and *r* = radius of the pinion, *P* = power applied to the handle *A* of the winch, and *w* = weight raised by the rack *BC*; then, since the *P* and *w* act perpendicularly to the arms of the lever, formed by the winch and pinion, we shall have by Art. 16, in case of equilibrium,

$$P \times R = w \times r,$$

$$\text{or } w = \frac{P \times R}{r}.$$

Example.—Let *R* = length of the winch = 18 inches, *r* = radius of pinion = 2 inches, and *P* = 150 lb. = power that can be exerted by a strong man; required the weight *w* that can be raised by the rack and pinion?

$$\text{Here } w = \frac{P \times R}{r} = \frac{150 \times 18}{2} = 1350 \text{ lb.} = 12 \text{ cwt. 6 lbs.}$$

CHAPTER IV.

ON PITCH—THE TEETH OF WHEELS—GUDGEONS—COUPLINGS OF AXLES—HOOKE'S JOINT—FRICTION WHEELS—ENGAGEMENT AND DISENGAGEMENT OF MACHINERY—CONCENTRIC WHEELS.

47. The subjoined fig. represents portions of a driving-wheel and its pinion, with the teeth formed on them in the most usual manner; A and B the centres of the wheel and pinion respectively. The line A B joining the centres of the wheels is called the *line of centres*, and the two circles M T N, m t n are called the **PITCH CIRCLES**; these two circles touch each other upon the line of centres at T, their centres being the centres, and are respectively of the same diameters as those of cylinders, the rolling contact of which would be the same as that produced by the introduction of teeth. The pitch circles have always their radii proportional to the number of teeth in their respective wheels. The circumference of the pitch circle is divided into the same number of equal parts as the number of teeth required in the wheel; the length of one of these parts is called the *pitch of the teeth*, each part containing "the exact distance occupied by one complete *tooth and space*." The word *space*

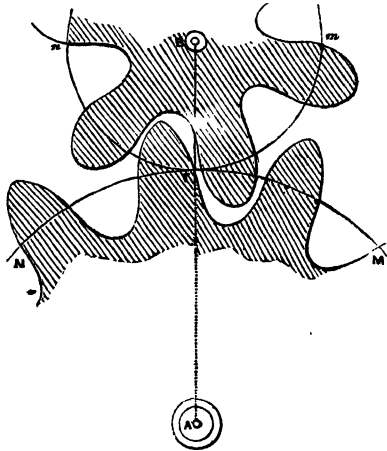

technically means an opening between any two consecutive teeth.

Let p = pitch of the teeth, n = number of teeth, d = diameter of the pitch circle, and $\pi = 3.1416$ = diameter of a circle to radius 1; then, both the following products are equal to the circumference of the pitch circle, and therefore equal to one another, that is,

$$\pi d = np;$$

from which equation, if any two of the three quantities p , d , n , be given, the third may be found; thus,

$$d = \frac{np}{\pi} \quad (1)$$

$$n = \frac{\pi d}{p} \quad (2)$$

$$\text{and } p = \frac{\pi d}{n} \quad (3)$$

Only a given number of standard values are used for p , or the pitch of the teeth, in cast-iron wheels; the values most commonly used are $\frac{1}{4}$, $\frac{3}{8}$, $\frac{1}{2}$, $\frac{5}{8}$, $\frac{3}{4}$, $1\frac{1}{8}$, $1\frac{1}{4}$, $1\frac{1}{2}$, 2, and 3 inches; and it rarely happens that any intermediate values of the pitch of the teeth are required. For machinery of less size, as clocks, watches, &c., the wheels are not cast, but cut out of discs of brass or steel by a cutting engine. In conical or bevel-wheels the pitch circle is the base of the frustum.

Example 1.—A spur-wheel is required to have 60 teeth; required the diameter of the *pitch circle*, the *pitch of the teeth* being 2 inches?

By equation, (1):

$$d = \frac{np}{\pi} = \frac{60 \times 2}{3.1416} = 38.196 \text{ inches, the diameter required.}$$

Ex. 2.—The diameter of the pitch circle is 24 inches, and the pitch of the teeth $1\frac{1}{4}$ in.; required the number of teeth in the wheel?

By equation, (2):

$$n = \frac{\pi d}{p} = \frac{3.1416 \times 24}{1\frac{1}{4}} = 60 = \text{number of teeth.}$$

Ex. 3.—A wheel is 61 inches in diameter and has 96 teeth; required the pitch of the teeth?

By equation, (3) :

$$p = \frac{\pi d}{n} = \frac{3.1416 \times 61}{96} = 2 \text{ inches, the pitch required.}$$

48. To find the number of teeth and diameter of the pitch circle by *Willis's Table*, Art. 73, *Prin. of Mechanism*.

Example 1.—A wheel has 21 teeth of 2-in. pitch; required the diameter of the pitch circle?

Here the factor, in the third column of the table, corresponding to the given pitch is .6366, which multiplied by 21 gives 13.35 inches, the diameter required.

Ex. 2.—The teeth of a wheel 4 ft. diameter are $1\frac{1}{4}$ in. pitch; required the number of teeth?

Here the factor, in the second column of the table, corresponding to the given pitch is 2.5132, which multiplied by 48, the diameter in inches, gives 120, the number of teeth required.

THE TEETH OF WHEELS.

49. The formation and arrangement of the teeth of wheels constitute an important and interesting branch of this subject, and many eminent mathematicians have therefore been led to investigate the nature of the curve which should form the flanks of the teeth of two wheels revolving in contact, so that the force may be conveyed from one wheel to another with a constant velocity ratio, and with the least friction or rubbing. The curves that have been found the most effectually to answer the required conditions are the *epicycloid* and the *involute of the circle*. Learned investigations on this subject are given in *Prof. Willis's Mechanism* and *Buchanan's Treatise on Machinery*; but as these curves are not easily described, and as the small portions of them, which are required in the length of a tooth of a wheel, will make so near an approach to an arc of a circle that the difference is practically imperceptible, these arcs are therefore now commonly used for the purpose, taking care to determine correctly the radius of curvature, and the position of the centre of the arc. For this purpose *Prof. Willis* has invented an instrument which he calls the *Odontograph*, or tooth-describer, by which the circular arcs for the flanks of the teeth of wheels are expeditiously described, and with sufficient accuracy for practical purposes.

This instrument is at present used in most of the best factories with complete success.

THE ODONTOGRAPH.

“The opposite figure represents the Odontograph exactly half the size of the original; but as it is merely formed out of a sheet of card-paper, this figure will enable any one to make it for use. The side NTM , which corresponds to the line Dg in the following figure, is straight, and the line TC makes an angle of exactly 75° with it, and corresponds to the radius AD of the wheel, the side NTM is graduated into a scale of half inches, each half-inch being divided into ten parts, and the half-inch divisions are numbered both ways from T .”

50. “One example will show the method of using this instrument. Let it be

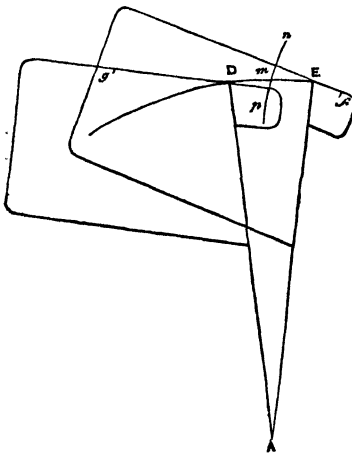

required to describe the form of a tooth for a wheel of 29 teeth, of 3 inches pitch. Describe from a centre A , an arc of the given pitch circle; and upon it set off DE , equal to the pitch, and bisected in m . Draw radial lines DA , EA . For the arc within the pitch circle apply the slant edge TC of the instrument to the radial line AD , placing its extremity D on the pitch circle, as in the figure. In the table headed, *Centers for the Flanks of Teeth*,

look down the column of 3 inch pitch, and opposite to 30 teeth, which is the nearest number to that required, will be found the number 49. The point g indicated on the drawing-board by the position of this number on the scale of equal parts, marked *Scale of Centers for the Flanks of Teeth*, is the center required, from which the arc mp must be drawn with the radius gm . The center for the arc mn , or face, which lies outside the pitch circle is formed in a manner precisely similar, by applying the slant edge of the instrument to the radial line EA . The number 21 obtained

THE ODONTOGRAPH.

TABLES SHOWING THE PLACE OF THE CENTERS UPON THE SCALES.

CENTERS FOR THE FLANKS OF TEETH,

Number of Teeth.	Pitch in Inches.							
	1	1 $\frac{1}{4}$	1 $\frac{1}{2}$	1 $\frac{3}{4}$	2	2 $\frac{1}{4}$	2 $\frac{1}{2}$	3
	13	129	160	193	225	257	289	321
14	69	87	104	121	139	156	173	208
15	49	62	74	86	99	111	123	148
16	40	50	59	69	79	89	99	191
17	34	42	50	59	67	75	84	101
18	30	37	45	52	59	67	74	89
20	25	31	37	43	49	56	62	74
22	22	27	33	39	43	49	54	65
24	20	25	30	35	40	45	49	59
26	18	23	27	32	37	41	46	55
30	17	21	25	29	33	37	41	49
40	15	18	21	25	28	32	35	42
60	13	15	19	22	25	28	31	37
80	12	...	17	20	23	26	29	35
100	11	14	22	25	28	34
150	...	13	16	19	21	24	27	32
Rack.	10	12	15	17	20	22	25	30

CENTERS FOR THE FACES OF TEETH.

12	5	6	7	9	10	11	12	15
15	...	7	8	10	11	12	14	17
20	6	8	9	11	12	14	15	18
30	7	9	10	12	14	16	18	21
40	8	...	11	13	15	17	19	23
60	...	10	12	14	16	18	20	25
80	9	11	13	15	17	19	21	26
100	18	20	22	...
150	14	16	19	21	23	27
Rack.	10	12	15	17	20	22	25	30

N.B. This figure is half the size of the original.

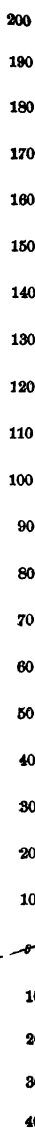

Scale of Centers for the Flanks of Teeth.

Centers for Faces of Teeth.

C

from the lower table, will indicate the position f of the required center upon the lower scale. In using the instrument, it is only necessary to recollect, that the scale employed and the point m always lie on the two opposite sides of the radial line to which the instrument is applied. The curve nmp is also true for an annular wheel of the same radius and number of teeth, n becoming the root and p the point of the teeth. For a rack, the pitch line DE becomes a right line, and DA , EA , perpendiculars to it, at a distance equal to the pitch.

Numbers for pitches not inserted in the tables may be obtained by direct proportion from the column of some other pitch: thus for 4-inch pitch, by doubling those of 2-inch, and for half-inch pitch by halving those of inch pitch. Also, no tabular numbers are given for twelve teeth in the upper table, because within the pitch circle their teeth are radial lines.*"—*Prof. Willis's Mechanism*, Arts. 142 and 143.

* "In fact, in the actual instrument I have inserted columns for $\frac{1}{4}$, $\frac{1}{2}$, $\frac{3}{4}$, 1 , $1\frac{1}{2}$, 2 , and $3\frac{1}{2}$ pitch, which are omitted in the fig. for want of room, and are indeed scarcely necessary, as the numbers are so easily obtained from the columns given.

It is unnecessary to have numbers corresponding to every wheel, for the error produced by taking those which belong to the nearest as directed, is so small as to be unappreciable in practice. I have calculated the amount and nature of these errors by way of obtaining a principle for the number and arrangement of the wheels selected. It is unnecessary to go at length into these calculations, which result from very simple considerations, but I will briefly state the results.

The difference of form between the tooth of one wheel and of another is due to two causes, (1) the difference of curvature, which is provided for in the Odontograph by placing the compasses at the different points of the scale of equal parts, (2) the variation of the angle DAE (fig. to Art. 50), which is met by placing the instrument upon the two radii in succession. The first cause is the only one with which these calculations are concerned. Now in 3 inch pitch the greatest difference of form produced by mere curvature in the portion of tooth which lies beyond the pitch circle, is only .04 inch between the extreme cases of a pinion of twelve and a rack, and in the acting part of the arc within the pitch circle is .1 inch, so that as all the other forms lie between these, it is clear that if we select only four or five examples for the outer side of the tooth and ten or twelve for the inner side, that we can never incur an error of more than the $\frac{1}{200}$ th of an inch in 3 inch pitch by always taking the nearest number in the manner directed, and a proportionably smaller error in smaller pitches. But to ensure this, the selected numbers should be so taken, that their respective forms shall lie between the extremes at equal distances. Now it appears that the variation of form is much greater among the teeth of small numbers than among the larger ones, and that in fact

GUDGEONS.

51. The circular portions of shafts or axles, upon which wheels revolve, are called *gudgeons*.

The gudgeons in cast-iron axles are simply parts, or the extremities, of the axles turned exactly circular in a lathe. The circular aperture, in which the gudgeons turn, are called *brasses*; which are made of a composition of copper and tin, and are very durable as well as not readily worn by the friction of the iron axles. The beams in which the brasses are fixed are called *bearings*.

52. When iron gudgeons are fixed in wooden axles the connection will be secured in the most durable manner by forming the gudgeon *g* with cross-flanges *a, b, c, d*, upon it; these flanges are let into the end of the wooden axle, by means of a mortise made for the purpose, the cross-flanges being wedge-shaped, and having the front edge thinner than the back, that it may be driven tightly into the end of the axle, which is bound with a strong iron hoop to prevent the gudgeon from slipping.

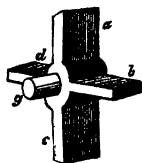

* 53. In vertical axles, whether of wood or cast-iron, the lower ends of the gudgeons (which have to support the weight of the axles, &c.) are made of a hemispherical form.

COUPLING OF HORIZONTAL AXLES.

54. When motion is to be conveyed by an axle to a considerable distance, or when the motion of a part of the axle is occasionally required to be discontinued, a *coupling* of the following form is commonly used. The axles *A* and *B* are terminated with circular heads *m* and *n*, on which projections and indentations are formed, so that the

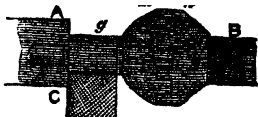

the numbers in the two following series are so arranged that the curves corresponding to them possess this required property.

For the outer side of the tooth, 12, 14, 17, 21, 26, 34, 47, 73, 148, Rack.

For the inner side, 12, 13, 14, 15, 16, 17, 19, 22, 26, 33, 46, 87, Rack.

Now these numbers, although strictly correct, would be very inconvenient and uncouth in practice if employed for a table like that in question, where convenience manifestly requires that the numbers, if not consecutive, should always proceed either by twos or fives, or by whole tens, and so on. They are only given as guides in the selection, and by comparing them with the actual table, their use in the formation of the first column will be evident."

former shall exactly fit into the latter, as shown in the fig. The gudgeon *g* of the axle *A* rests on its journal *c*; sometimes the axles on both sides of the coupling rest on journals. When the axles are required to be disengaged, one of them is moved in the direction of its length, till the projections of *m* be cleared of those of *n*.

Note. Various forms for the coupling of axles have been proposed, (See *Buchanan on Machinery*) but none of them have been found so efficient as the one here shown; for should the bearings yield slightly through any settlement of the building or other cause, this coupling will admit of the derangement, and still transmit the motion from one axle to another.

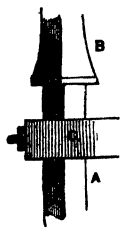

COUPLING OF VERTICAL AXLES.

55. Here *A* represents part of the under shaft or axle, *B* the lower end of the upper shaft, *c* the journal; the termination of *A* is made square, to correspond with which there is a socket formed in *B*, which answers the purpose of a coupling-box. The shaft *B* is disengaged by lifting it vertically with a lever.

Note. This is a very good and simple mode of coupling upright shafts. It is held together by the weight of the shaft *B*, together with that of the wheels that may be upon it, and is not apt to get loose in the socket, which is found to be the case when this kind of coupling is used for shafts lying horizontally. A great many other schemes for couplings have been introduced, for which see *Buchanan on Machinery*, but the one just described is considered the best.

HOOKE'S JOINT.

56. This joint, usually called *the universal joint*, furnishes another method of coupling axles, which are not exactly in the same direction, but which meet when prolonged. This joint has to a certain degree the property of being flexible in all directions. The two axles are *A a* and *B b*, the ends of which are formed like forks, which work on pivots at the extremities of a cross *c d c d*, as shown in the fig.; sometimes the pivots are fixed at right angles on the circumference of a hoop, or on the surface of a solid ball. The moving parts are evidently alike in all these cases.

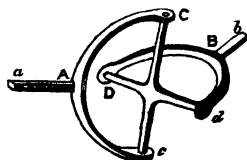

Note. This joint is sometimes used to transmit motion instead of bevel gear, where the angle of the shafts does not exceed 20 or 25 degrees, and where the number of their revolutions are to be the same; also where exact equality of motion is not required; for as the shafts

recede from a right line, its motion becomes irregular. In these cases this joint is much used for couplings; as it allows for the inaccuracy which arises from the settling of framing or the wearing of brasses, in which cases no irregularity of motion can arise to be hurtful in practice. In thrashing machines it is also used in the axles of the upper rollers, to allow them to rise and fall according to the varying thickness of the sheaves.

57. When Hooke's *double universal joint* is used, a much greater inclination of the shafts can be admitted; care, however, must be taken that the two shafts *A a*, *B b*, may meet when prolonged, and that the angles they make with the intermediate piece *C D* may be equal.

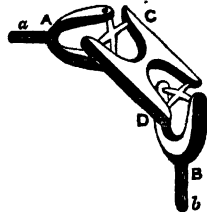

FRICITION WHEELS.

58. These wheels are used in delicate pieces of mechanism, where it is required to reduce the friction of the gudgeons of the wheels as far as possible.

Here the gudgeons of the large wheel rest between four friction wheels. As the large wheel revolves, its gudgeons communicate by rolling contact a slow motion to the four friction wheels, so that the friction is transferred to the gudgeons of the four friction wheels, thus greatly reducing the friction by the slowness of the motion of the friction wheels as well as by throwing the pressure of the rubbing surface on eight gudgeons instead of two.

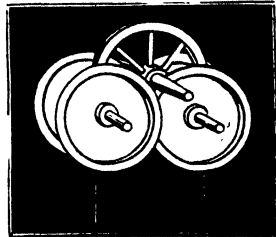

THE ENGAGEMENT AND DISENGAGEMENT OF MACHINERY WHEN IN MOTION.

59. In order to engage or disengage machinery when in motion, one of the wheels, instead of being fast to the axle, has a round bush like a loose pulley, and a clutch or bayonet, which connects it with its axle; thus the wheel *A* has a bush, and works on a round part of the shaft *B*; the clutch *D* slides on a square part *C* of the same axle, and is engaged or disengaged at pleasure, by means of the lever *E F*; when the teeth of the clutch *D* are thus

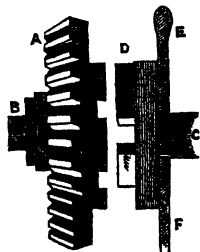

made to engage the corresponding teeth fixed on the side of the wheel A, then A and D revolve together.

60. Wheels are often disengaged and re-engaged by means of one of the bridges A B, which carries the end of the shaft nearest the wheel, the bridge A B acting as a lever having its fulcrum at B; the other end A is moveable, and is raised by applying a lever at C, and is held out of gear by a wedge or by a catch under the end of the bridge.

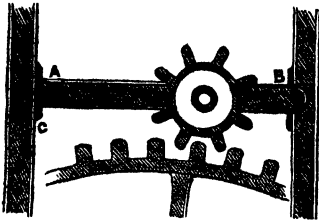

Note. When a machine is in motion, we may, with perfect safety, lift a wheel out of gear; but in throwing wheels into gear, when in motion, there is a great risk of breaking the teeth; it is nevertheless often done. The risk of breaking the teeth is much less when the wheel to be thrown into gear is previously set in motion by the hand, as the inertia of the wheel is obviously lessened.

61. *The Sliding Pulley** is one of the oldest schemes for engaging and disengaging a machine moved by a band or belt.

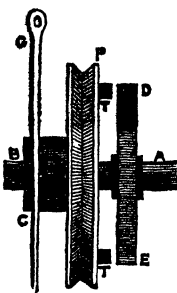

The pulley P, which gives motion to the machine, is not fixed on the axle A B, but has a hollow cylindrical bush made of metal, accurately fitted to the axle, so that it may revolve freely upon it, and slide a little backward and forward. In order to make the pulley P carry round the axle A B, there is a cross-piece or gland D E firmly fixed to it. On the side of the pulley towards the cross-piece D E, there is one or more teeth T, and when P is moved towards D E by the lever G C, the teeth lay hold of it, and thereby carry round the axle. By sliding it backwards, the teeth T are disengaged from D E, of course the pulley stops, and with it the machine to which it gives motion.

62. *Fast and Loose Pulleys.*—The pulley B is fixed to the axle A, and the pulley C, having a bush, is loose; the belt or band, which conveys the motion, may be shifted from one pulley to the other either by the hand or by a lever.

* The nature of the pulley is explained in the following chapter.

When running on the loose pulley c, the axle stands still; when on the fast pulley B, the axle revolves.

Note. This contrivance of the fast and loose pulleys is remarkable for its beautiful simplicity; the engagement or disengagement of the machinery is attended by no shock, and it is perhaps the most perfect thing yet invented for the purpose, in all cases where it can be applied. Its application in cotton-mills is now general, and the spinning mules were never found to give satisfaction until it was applied.

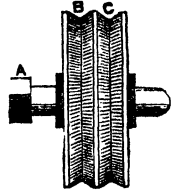

63. *Fly Wheel Coupling.*—The marginal figure represents a coupling, which is frequently used to convey motion from the fly-wheel shaft of a steam-engine; and is so contrived, that in case the fly should turn the wrong way, the mill-work remains at rest, and thus prevents accidents. This effect is produced by means of a joint c, on the arm B, resembling the joint of a carpenter's rule. When the fly-wheel turns the proper way, the arm D, on the end of the fly-shaft A, acts against the face of the arm B, on the mill-shaft F; and as the joint does not yield in that direction, the mill-shaft is carried round with the fly-shaft; but if, from any accident, the fly turns the wrong way, the arm D strikes the back of the arm B, the joint yields, and the mill remains at rest.

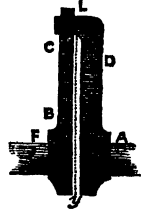

64. *Engagement of Wheels revolving in opposite directions.*—The two bevel-wheels A and B revolve loose upon bushes

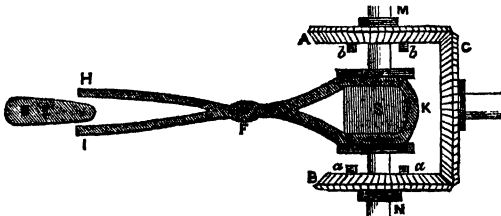

on the axle MN, and are driven in opposite directions by the bevel-wheel c; either of these wheels A B may be engaged with the axle MN by means of the sliding-piece s being raised or depressed by the double lever H F K L, which turns on the fulcrum F. The sliding-piece s being thus made to lay hold of the teeth a a or b b, the axle MN may be

respectively made to revolve in opposite directions. An excentric wheel or camb *E*, moved by the machinery, may be used to move the lever, and bring *A* and *B* alternately into gear.

CONCENTRIC WHEELS.

65. Two separate wheels *A* and *B* may revolve concentrically, that is, on the same axle; the

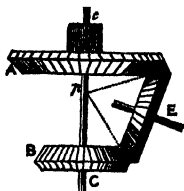

wheel *B* is fixed to the axle *c c*, and the wheel *A* to a tube or cannon *d*, which turns freely on *c c*, both *A* and *B* being turned by *E*, the three cones having a common apex *p*. It will be seen that *A* and *B* revolve in opposite directions; and since *E* is an idle wheel, the velocity

ratio of *B* to *A* will depend on their respective number of teeth.

66. *The Hour and Minute Hands of a Clock or Watch.*—

In this case the concentric wheels are required to revolve in the same direction, and four wheels are necessary. The wheel *E* is fixed to the axis *F*, and the wheel *f* to a cannon *c* revolving freely on the axis *F*. The minute hand *M* is fixed to the axis *F*, and the hour hand to the cannon *c*. The driving wheel communicates motion to the

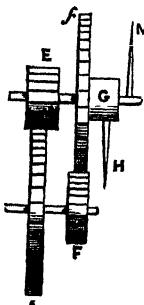

wheels *e* and *F*, which are fixed on the same axis, and *F* communicates to the cannon *c*. Let *E* have 12 teeth, *e* 36, *F* 10, and *f* 60; then, by Art. 30,

$$\frac{E's \text{ vel.}}{f's \text{ vel.}} = \frac{M's \text{ vel.}}{H's \text{ vel.}} = \frac{36 \times 40}{12 \times 10} = \frac{12}{1},$$

that is, the minute hand *M* makes 12 revolutions while the hour hand makes one.

Note. Various other numbers may be given to the teeth of the wheels to produce the same result; thus, if the wheels *E e* have equal numbers of teeth, the wheel *f* must have 12 times the number of the wheel *F*.

CHAPTER IV.

PULLEYS—PRODUCING MOTION BY WRAPPING CONTACT BY MEANS OF CORDS—CHAINS, STRAPS—ETC.

67. A *Pulley* is a small wheel AB moveable about an axis passing through its centre c ; in the circumference of the wheel is a groove to admit a rope or flexible chain. The pulley is called fixed or moveable, according as its axis is fixed or moveable. A force P drawing the cord $PABW$ causes the pulley to turn on its axis c , and draw up the weight w , attached to the other end of the cord, the weight w ascending through a space equal to the descent of the force or power P , and the space described by the circumference of the pulley being equal to the space descended by P .



68. An *Endless Cord* or *Band* passes round the fixed pulleys or wheels A and B (fig. 1), and when one of the wheels, as A , is turned round, motion is transmitted by the band to the wheel B . The circumferences of the wheels have the same velocity, since the band is in continued contact with both A and B ; therefore, if N be the number of revolutions made by the wheel B , and r its radius, n the number of revolutions made by the wheel A , and R its radius; then

$$\frac{N}{n} = \frac{R}{r} \quad (1)$$

or the number of revolutions, made by the wheel B , while A makes one revolution, (since in this case $n = 1$), will be

$$N = \frac{R}{r} \quad (2).$$

If the wheels be equal they will



Fig. 2.



Fig. 1.

revolve round in the same time; for if in equation (2), $R = r$, there results $N = 1$.

The band may be *direct*, as in fig. 1, or it may be *crossed*, as in fig. 2. In the former case the wheels A and B will both turn in the *same direction*, and in the latter case the wheels *a* and *b* turn in *opposite directions*.

69. When a thick band is passed over a wheel, its inner surface is compressed, while the outer surface is extended, the centre of the band alone remaining in the original state of tension; hence the radii of the wheels, to which rotation is imparted by the band, are extended by half the thickness of the band, which half thickness must be added to each of the radii in computing the number of revolutions. Let $t = \frac{1}{2}$ thickness of the band, then equations (1) and (2) become respectively,

$$\frac{N}{n} = \frac{R + t}{r + t} \quad (3) \quad N = \frac{R + t}{r + t} \quad (4).$$

Example 1.—A pulley A of 8 inches radius communicates rotatory motion to pulley B of 2 inches radius, by means of a thin band; how many revolutions will be made by B while A makes one revolution?

By equation (2), Art. 68,

$$N = \text{number of revolutions} = \frac{R}{r} = \frac{8}{2} = 4.$$

Ex. 2.—When the motion of the pulleys A and B, in the last example, is communicated by a cord 1 inch in thickness; required the number of revolutions made by B while A makes one revolution?

Here the $\frac{1}{2}$ thickness of cord $t = \frac{1}{2}$ inch must be added to each of the radii of the pulleys, whence by equation (4), Art. 69,

$$N = \text{number of revolutions} = \frac{R + t}{r + t} = \frac{8 + \frac{1}{2}}{2 + \frac{1}{2}} = \frac{17}{5} = 3\frac{2}{5},$$

which is $\frac{2}{5}$ of a revolution less than in *Ex. 1*, arising from the thickness of the cord.

Note. “Motion, communicated by cords, bands, or straps, is remarkably smooth, and free from noise and vibration, and on this account, as well as from the extreme simplicity of the method, it is always preferred to every other, unless the motion require to be conveyed in an exact ratio. As the communication of motion between the wheels and bands

is entirely maintained by the frictional adhesion between them, it may happen that it may occasionally fail through the band sliding on the pulley. This, if not excessive, is an advantageous property of the contrivance, because it enables the machinery to give way when unusual obstructions or resistances are opposed to it, and so prevents breakage and accident. For example, if the pulley to which motion is communicated were to be suddenly stopped, the driving pulley, instead of receiving the shock and transmitting it to the whole of the machinery in connexion with it, would slip round until the friction of the band upon the two pulleys had gradually destroyed its motion. But if motion is to be transmitted in an exact proportion, for example, such as is required in clock-work, where the hour hand must make one exact revolution while the minute-hand revolves exactly 12 times, bands are inapplicable; for supposing it practicable to make the pulleys in so precise a manner that their diameters should bear the exact proportion required, which it is not, this liability to slip would be fatal. But in all that large class of machinery in which an exact ratio is not required to be maintained in the communication of rotation, endless bands are always employed, and are capable of transmitting great forces."—*Prof. Willis's Mechanism*, Art. 178.

FORMS OF PULLEYS.

70. *The Form of the Pulley* on which an endless band is to act is of importance, since the adhesion of band to the pulley is thus greatly influenced.

Round bands of rope, catgut, &c., or even chains, require an angular groove, as A, into which they are forced by tension, and thus grasp the pulley more firmly.

When soft cords or bands are used, sharp short spikes are fixed round the bottom of the grooves, as in B; these spikes prevent the

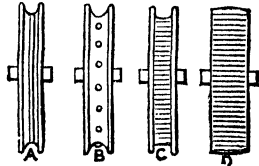

band from slipping, but at the same time gradually wear it out.

"If a tight flat belt run on a revolving cone, it will advance gradually towards the base of the cone, instead of sliding towards its point, as might be expected at first sight."—

"Advantage is taken of this curious property in forming the pulleys for straps, which are made in the form represented in the pulley D, which is a little swelled in the middle. This slight swelling is more effective in retaining the belt than if the pulley had been furnished with edges, as in C; and the form of D, besides its greater simplicity, enables the belt to be shifted easily off the pulley. In fact, when a pulley of the form C is used, the belt will generally make its way

to the top of one of the side disks, and remain there, or else be huddled up against one or other of them, but will never remain flat in the centre of the rim, if there be the slightest difference of the diameters of the two extremities of the cylinder. In order to bring the belt into contact with as much as possible of the circumference of the pulley, it is better to cross it, as in Art. 68, fig. 2, whenever the nature of the machinery will admit of so doing." — See *Prof. Willis's Mechanism*, Art. 181, where further information on these subjects may be obtained.

GEARING CHAINS.

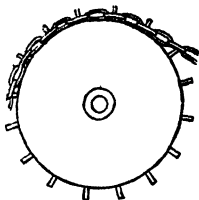

71. When a wheel is required to revolve uniformly, and presents such considerable resistance to motion as to cause straps or bands to slide upon it, gearing chains of various forms are used. The marginal fig. shows a wheel or pulley, (similar to the section B, fig. to Art. 70,) where the alternate links of the gearing chain lay hold of the spikes fixed in the circumference of the wheel.

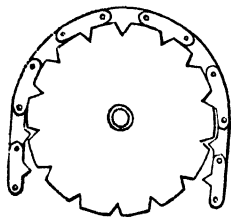

The lower fig. presents another form of the gearing chain, from *Hachette*, in which the links are riveted together, somewhat after the manner of a watch-chain, the links having pointed spikes or teeth, which enter the notches made on the edges of the wheel, and thus effectually prevent slipping.

FIXED AND MOVEABLE PULLEYS.

72. Pulleys are called fixed or moveable, according as their axes are *fixed* or *moveable*; thus, DC is a fixed pulley and BA a moveable one. In the annexed fig., it is evident that the rope PCDA BH must have the same tension throughout its length, and that this tension must be equal to the power P, and since the tensions of the two parts of the rope AD, BH are each equal to P, the weight w, suspended from the axis of the pulley AB, must be necessarily equal to 2P in case of equilibrium. If w with its pulley AB ascend

n feet, the cords AD , BH will each be shortened n feet; hence the rope CP will be lengthened $2n$ feet; that is,

$$P\text{'s vel.} = 2 \times w\text{'s vel.},$$

and it has been already shown that

$$2P = w.$$

TACKLES OF PULLEYS.

73. The same principle may be applied to a system or combination of pulleys, called a tackle, all drawn by one cord, passed over an equal number of fixed and moveable pulleys, called *blocks* of pulleys. In fig. 1, (next page) $P : w :: 1 : \text{number of parts of the cord passing over the moveable block}$. Therefore, since the number of parts of the cord going over the moveable block is 4, we shall have

$$P : w :: 1 : 4,$$

$$\text{or } 4P = w.$$

And generally, if the number of these parts of the cord be n , then

$$nP = w.$$

Also, on the same principle, in fig. 1,

$$P\text{'s vel.} = 4 \times w\text{'s vel.}$$

And generally, when the number of these parts of the cord is n , then

$$P\text{'s vel.} = n \times w\text{'s vel.}$$

74. In fig. 2, the weight, being sustained by 3 cords, is equal to 3 times the power; and generally, if the number of parts of the cord (passing over moveable pulleys) be n , then

$$(n + 1)P = w,$$

$$\text{and } P\text{'s vel.} = (n + 1)w.$$

75. In the pulleys hitherto described only one rope has been introduced; we have now to consider the effect of several distinct ropes in the same system. Pulleys containing



more than one rope are called *Spanish bartons*. Such a system is represented in fig. 8, containing two ropes. The tension of the rope $PBAD$ is evidently equal to the power; consequently the portions AB and AD must



Fig. 1.



Fig. 2.

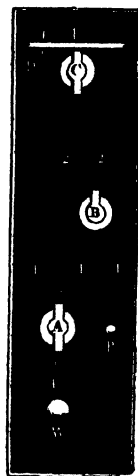

Fig. 3.

each sustain a portion of the weight equal to the power. The rope CB sustains the tensions of BP and BA , and therefore the tension of BCA must equal twice the power. The united tensions of the ropes which support the pulley A amount therefore to four times the power.

76. In the combination, fig. 4, a cord passes over the fixed pulley E , under the moveable pulley D , and is fixed to a hook at 1. Another cord is fixed at D , goes under the moveable pulley C ; and is fixed to the hook at 2; and so on.

From Art. 55,

the weight at $D = 2P$,

the weight at $C = 2 \times \text{wt. at } D = 2^2 P$,

the weight at $B = 2 \times \text{wt. at } C = 2^3 P$;

and if the number of moveable pulleys be n , then

$$2^n P = w$$

$$\text{and } P\text{'s vel.} = 2^n w\text{'s vel.}$$

Example.—Let the number of moveable pulleys be 4, as in the last fig., and the power 100 lb.; required the weight?

$$\begin{aligned} \text{In the equa. } 2^n P &= w, \\ \text{or, } 2^4 \times 100 &= 1600 \text{ lb.} = w. \end{aligned}$$

The tension of each of the strings in this system is shown by the numbers above the hooks, these tensions being P , $2P$, $4P$, &c.

Note. Although the power increases rapidly in this system, being doubled by the addition of every moveable pulley; this advantage over the common system is more than counterbalanced by the very limited range; since in the common blocks, the motion may be continued till the fixed and moveable block come into contact. But in this system the motion can only be continued till D and E come into contact, at which time the other pulleys will be far apart, because C rises only half as fast as D , B only one-fourth, and A only one-eighth as fast. Hence the longest possible range is but a small portion of the whole height occupied by the system, which accordingly entails a great waste of space, and is hardly of any practical use.

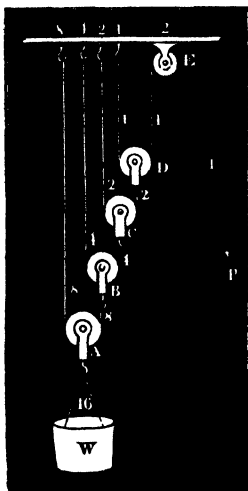

Fig. 4.

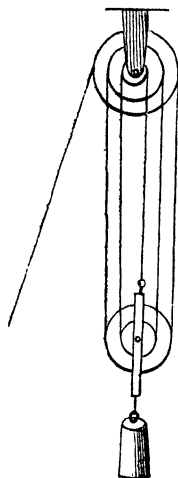

Fig. 5.

WHITE'S TACKLE. (Fig. 5.)

77. As the pulleys, in Art. 75, fig. 1, revolve with widely different velocities, according to the quantity of rope passing over them, thus producing an enormous inequality in the

wear of the axles, as well as different amounts of friction against the sides of the blocks; to remedy these defects, White's Tackle (from the inventor's name) was suggested; in which the pulleys were made to differ in size, in proportion to the quantity of rope to be passed over them: thus causing them to revolve all in the same time, the pulleys on the same block requiring no divisions between them. By tracing the different velocities of the rope on the blocks in figure 5, and by supposing the lower block to ascend one foot, it will be readily seen that the pulleys on the upper block, beginning with the least, throw off respectively 1, 3, 5, &c., feet of rope; while the corresponding pulleys in the lower block throw off 2, 4, 6, &c., feet, respectively. Therefore, the radii of the pulleys in the upper block must be proportioned as the numbers 1, 3, 5, &c., and the radii of those in the lower block as the numbers 2, 4, 6, &c., so that they may all revolve exactly in the same time. The pulleys in each block may, therefore, be all formed by cutting several grooves upon the face of one solid conical wheel; and by passing the rope successively over the grooves of such wheels, it would be thrown off in the same manner as if each groove were upon a separate pulley, and thus all the inequality of wearing and friction would be avoided, except the uniform friction at the axes of the two blocks, which would be comparatively small.

If the rope be tied to the upper block, the proportions of the radii of the grooves of the two blocks must be reversed.

Note. In these cases the effect of weights of the blocks and pulleys have not been noticed: in most cases it will be found that their weights act against the power, which is thus diminished according to the amount of these weights.

GUIDE PULLEYS.

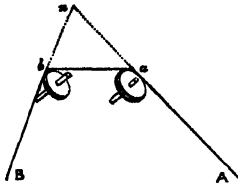

78. These pulleys are used to change the direction of the motion of cords or bands: thus a band moving in the direction Δn may have its path changed to the direction $n B$ by guide pulleys. When the lines of direction of the band meet in one point, n , one pulley will be sufficient, with its axis placed perpendicular to the plane of the two lines, Δn , $n B$, and the diameter of its groove made to touch these lines.

If this be not convenient, then two pulleys will be required, the positions of which are found as follows :

Draw a third line, $a b$, meeting the two former lines in any convenient points, a and b , and let this line be part of the path of the band. Fix, as before, guide pulleys at the intersections a and b , the axes of which must be respectively perpendicular to the plane of the two directions of the band.

79. "Let $A B$ be two pulleys, whose axes are neither parallel nor meeting in direction, and let the line $c d$ be the intersection of the two planes of these pulleys. In this line, assume any two convenient points c and d ; and in the plane of A , draw $c e, d f$, tangents to the opposite sides of this pulley; also in the plane of B , draw $c g, d h$, similarly tangents to the pulley B . This process gives the path of the endless band, $e c g h d f$, in which it may be retained by the guide pulley at c in the plane $e c g$, and another at d in the plane $f d h$."—See *Prof. Willis's Mechanism*, Art. 187.

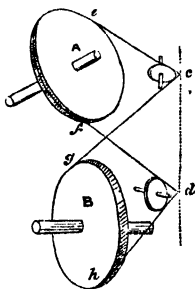

WHEEL AND AXLE WITH WRAPPING CORDS.

80. Let CA, CB be the radii of the wheel and axle, at the extremities of which the power and weight act; then ABC may be considered as a lever, the fulcrum of which is C ; and since the power P and the weight w , being suspended by cords, act perpendicularly to AC , we shall have by Art. 7, equa. (1) and (2)

$$\begin{aligned} P\text{'s vel.} &= \frac{AC}{BC} \\ w\text{'s vel.} &= \frac{BC}{AC} \end{aligned}$$

and $P \times AC = w \times BC$.

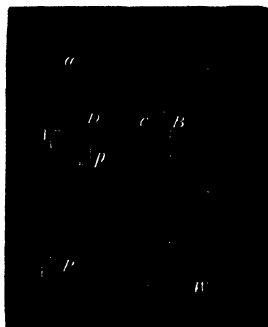

81. If the power p act in the direction ap , which cuts AC at right angles in D , then there will be an equilibrium when $p \times CD = w \times BC$.

82. When P and w sustain each other by means of a D

wheel and axle, the thickness of the rope by which they are sustained, if considerable, must be taken into account; that is, we must add half the thickness of the rope to each of the distances at which P and w act. Therefore, if R = radius of the wheel, r = radius of the axle, and $2t$ = thickness of the rope, then we shall have

$$\frac{P\text{'s vel.}}{w\text{'s vel.}} = \frac{R + t}{r + t}$$

$$\text{and } P \times (R + t) = w \times (r + t).$$

THE RACHET-WHEEL.

83. The *Ratchet-wheel* is a simple contrivance for preventing a wheel from turning except in one direction. A catch, c , plays into the teeth of the wheel A B , permitting it to revolve in the direction of c B , but preventing any recoil on the part of the weight, or resistance contrary to the direction of the power. This contrivance may be connected with other machinery by means of teeth, instead of cords, or the wheel and axle, as in the cases of the turnstiles of bridges, &c., where the number of turns of the ratchet-wheel is required to be registered.

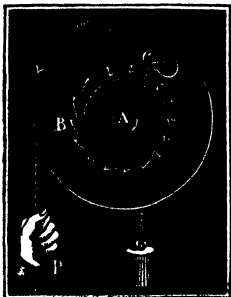

The equations of the velocity ratio and of equilibrium are the same in this case as in Art. 80.

THE WINDLASS AND CAPSTAN.

84. In the *windlass*, the power acts by means of a winch or handle fixed on the axle; the wheel, as in Articles 80 and 83, being removed, the rope coiling round the axle or barrel in the usual manner.

85. In the *capstan*, the axle is fixed in a vertical position, and the power is applied by means of handspikes or bars inserted into holes, made for that purpose in the axle, the rope coiling round the lower part of the axle, and uncoiling itself at the upper part, the axle being of a conical form, that the rope may be shifted upwards, when necessary.

In the *windlass*, the length of the handle, and in the

capstan the length of the handspikes, are the radii on which the power acts, the equations of the velocity ratio and of equilibrium being the same as in Art. 80.

THE CHINESE WINDLASS.

86. Let $A a$ be an axis to which are fixed two cylinders, B and C , nearly of the same diameter, and let a cord be coiled round B , passed under a pulley, D , and then brought back and coiled in the opposite direction round C . When the axis $A a$ revolves so as to cause the cord to move in the direction of the arrow, one end of the cord will be coiled round B , and the other uncoiled from C . Now let $R =$ radius of B , $r =$ radius of C , and $2\pi =$ circumference to radius $= 1$; then, while the axis makes one revolution, the cord on B will ascend $2\pi R$, and the cord on A will descend $2\pi r$; also the centre of the pulley D , and weight w , will ascend in the same time through half the difference moved by the ends of the cord on B and A ; that is, the space ascended by D will be $= \frac{2\pi(R-r)}{2} = \pi(R-r)$. If a handle be fixed to the

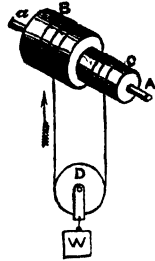

axis, $A a$, the length of which is l , and P be the power applied to the handle, then the circumference described by this power will be $2\pi l$; hence, by the equality of moments,

$$2\pi l \times P = \pi(R-r)w,$$

or, $w(R-r) = 2Pl.$

This equation of equilibrium is the same as would result if the weight were suspended from an axis $A a$ by a cord wrapped round a single cylinder of radius $= \frac{1}{2}(R-r)$.

Example.—Let $R = 3$ in., $r = 2\frac{1}{2}$ in., and the length of handle $l = 20$ in.; required the proportion of the weight w to the power P .

By the above equa., $w(3 - 2\frac{1}{2}) = 2P \times 20,$
 or, $\frac{1}{2}w = 40P,$
 or, $w = 80P,$

that is, the weight is 80 times the power, which is very great for so simple a machine.

Note. "This combination belongs to a class which has received the
n 2

same of *differential motions*, their object being to communicate a very slow motion to a body, or rather produce by a single combination such a velocity ratio between two bodies, that under the usual arrangement a considerable train of combinations would be required *practically* to reduce the velocity; for, theoretically, a simple combination will always answer the same purpose. Thus in the above machine, although theoretically a barrel with a radius $= \frac{1}{2}(R-r)$ would do as well as the double barrel, yet its diameter, in practice, would be so small as to make it useless from weakness. Whereas each barrel of the differential combination may be made as large and strong as we please. If a considerable extent of motion, however, be required, this contrivance becomes very troublesome, on account of the great quantity of rope which must be wound upon the barrels. For by one turn of the differential barrel, the space through which the weight is raised $= 2\pi(R-r)$, but the quantity of rope employed is the same as that which is coiled upon one barrel, and of that which is uncoiled from the other $= 4\pi(R+r)$. Now, in the equivalent simple barrel, the quantity of rope coiled is exactly equal to the space through which the weight is moved, and therefore in this case $= 2\pi(R-r)$, so that for a given extent of motion,

$$\frac{\text{rope for differential barrel}}{\text{rope for common barrel}} = 2 \frac{R+r}{R-r}$$

when $R-r$ is by hypothesis very small. This inconvenience has been sufficient to banish the contrivance from practice, for although it is represented in all mechanical books under the name of Chinese windlass, it is never used in practice.—See *Prof. Willis's Mechanism*, Art. 401.

SPEED PULLEYS.

87. *Speed pulleys* are used for changing the velocity of machinery, as in lathes, &c. A series of pulleys, gradually increasing in size, is mounted on an axle, and on the spindle of the lathe is a similar series, but placed in an opposite order, so that the same length of belt will work on every pair of opposite pulleys, according to the speed required.

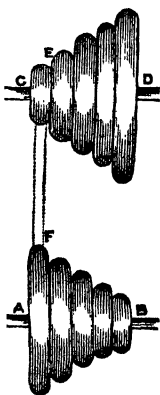

This contrivance is shown in the annexed fig., and may be applied to the spindle AB of a turning lathe; CD is part of a shaft made to revolve with a regular velocity. When a slow motion is required, the belt works at EF ; when a greater velocity is required, the belt is shifted, by pressing it to one side, to another pair of opposite pulleys. This contrivance is very simple in its construction, and is found of important practical use in the turning of various substances.

ALTERNATE CONES.

88. Instead of the opposite series of pulleys, two opposite cones, called alternate cones, are used, where a motion constantly varying is required. One of these cones gives motion to the other by a belt, as shown in the subjoined fig.; the belt is gradually moved by the machinery from one end of the cones towards the other. *A B* is the belt, *c* is the guide, which, receiving its motion from the machinery, traverses the belt with any velocity that the case may require.

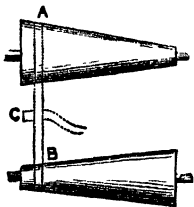

Note. It is usual in practice to make the two groups of speed pulleys, Art. 87, exactly alike, as well as the alternate cones, Art. 88, placing the small end of one set opposite to the large end of the other.

THE FACE-WHEEL AND ROLLER.

89. The face wheel and roller will produce the same effect as alternate cones, and are often used to obtain an adjustable velocity ratio by rolling contact. *A B* is the face-wheel, *B* the roller, the directions of their axes meeting one another. The edge of the roller, *c*, is covered with a narrow belt of soft leather to make it adhere more firmly to the face-wheel, and is so mounted on its axis that it can be made to slide at pleasure to different distances from the axis of the face-wheel. The roller *c*, with its axis, will therefore receive from *A B* a rotation by rolling contact, which may be varied to suit the required purpose. For further information on this subject, see *Prof. Willis's Mechanism*, Art. 480; and *Buchanan on Machinery*, Art. 423.

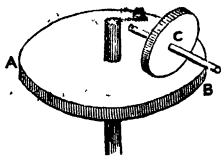

The velocity ratios, in Arts. 87, 88, may be found by Art. 67, by using the radii of the pulleys or those of the parts of the cones, with which the belt is in contact; and the velocity ratio in Art. 89 may be found by using the radius of the roller *c* and the adjusted radius on the face-wheel *A B*.

90. When a system of wheels and axles are continuously connected by bands or belts, instead of teeth, as in the figure to Art. 31, their relative number of revolutions or

velocity ratio may be found by the equation given in the article just referred to, whence the conditions of equilibrium may be at once deduced.

VARIABLE VELOCITIES.

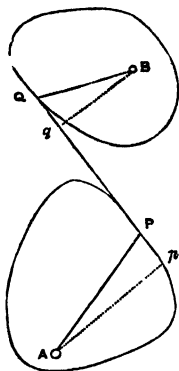

91. Let PQ be cord connecting the two excentric wheels or curves, the centres of motion of which are A and B ; then the cord PQ will be a common tangent to the two curves at P and Q ; let fall the perpendiculars Ap , Bq upon PQ prolonged, if necessary; then the velocity of the cord will be equal to the velocity of the points P and Q on the edges of the wheels or curves, and by *Prof. Willis's Mechanism*, Art. 38,

$$\frac{\text{ang. vel. of } AP}{\text{ang. vel. of } BQ} = \frac{Bq}{Ap'}$$

that is, *the angular velocities of the two wheels or curves are to each other inversely as the perpendiculars from their respective centres of motion upon their connecting cords.*

VARIABLE VELOCITY BY AN ENDLESS BAND.

92. When an indefinite number of variable rotations is required to be communicated from an axis A to another axis B , an endless band or cord pqc may be used. A is the axis of the driving pulley, the edge of which is curved so as to adapt to producing the required variable velocity; the follower B is a circular pulley fixed on its centre; the band passes under a *stretching pulley* c , having a weight suspended from it, which keeps the band continually stretched. Now, if the axis A revolve uniformly, in consequence of the varying radius of its pulley, a continually varying length of cord will pass to the pulley B , which will therefore have a variable motion, the variations of which will be repeated during every revolution

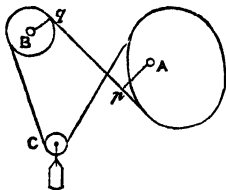

of the pulley on the axis A. Draw A p, B q perpendicular to the cord p q; then, by the last article—

$$\frac{\text{ang. vel. of A}}{\text{ang. vel. of B}} = \frac{B q}{A p}.$$

FUSEE OF A WATCH.

93. If the variable motion be required to extend to more than one complete revolution, it may be obtained by a spiral groove formed on the surface of one of the wheels, as in the fusee of a watch. The axes A a, B b are parallel; A a carries a solid pulley, called a fusee, upon the surface of which is a spiral groove; on the axis B b is mounted a plain cylinder; a cord or chain goes round the cylinder, and, extending to the fusee, winds round its spiral groove, the extremities of cord being fixed at the top of the fusee, and at the bottom of the cylinder. Now, when the cylinder is turned uniformly round, the fusee, by means of the cord, will be turned round in the same direction, the velocity ratio of the two axes will vary inversely as the perpendiculars from the respective axes upon the direction of the cord.



Note. In watches and other time-pieces a spiral spring is coiled round the axis B b within the cylinder, to give it rotatory motion, and that the varying force of the spring, as it uncoils itself, may be equalised, the cord or chain acts with greater leverage on the spiral of the fusee.

DOUBLE FUSEE.

94. If the fusee be required to communicate a variable reciprocating motion, it may be made double, as in the marginal fig., where A a is the axis of the fusee; two cords are fastened at the extremities of the two spirals of the fusees at A, a, and being coiled round the fusee in opposite directions, are respectively conducted to n, m, and attached to machinery, (not shown in the fig.) the two cords leaving the fusee at the same point. Now, when the axis A a revolves, the two cords will wrap and unwrap themselves upon and from the fusee, evidently leaving its surface always at the same point. If the axis of the fusee be turned

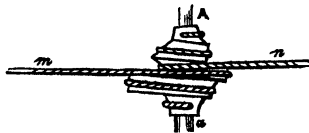

uniformly, it will gradually accelerate the motion of the cords, till they have reached the largest convolution of the fusee, and then gradually retard their motion till they reach the ends of the convolutions at A and a . The variable velocity ratio of the cords, in coiling from one end of the fusee to the other, will depend on the radii of the different points of its spiral.

Note. The double fusee is employed in this manner as part of the machinery of the self-acting mule of Mr. Roberts of Manchester.

WHEN THE POWER AND WEIGHT ARE CONNECTED BY
OBLIQUE CORDS.

95. A cord fixed at H passes under the moveable pulley B , and over the fixed pulley C , the power being applied at the

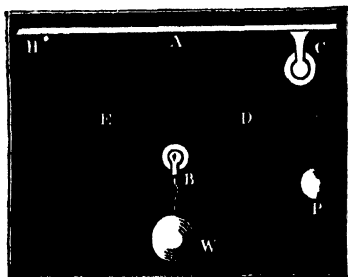

extremity of the cord. The weight w is suspended from the movable pulley B ; then

$$w = 2 P \cos. \frac{1}{2} H B C,$$

$$\text{whence } \frac{P's \text{ vel.}}{w's \text{ vel.}} = 2 \cos. \frac{1}{2} H B C.$$

Demonstration. Draw the vertical line $A B$, of such a length as to represent the weight w , and complete the parallelogram $A D B E$; then $B D$, $B E$, will represent the tensions of the cord, which are evidently each equal to the power P , \therefore all the sides of the parallelogram are equal. Now, conceive $E D$ to be joined, by a line not shown in the figure, then we shall have $P : w :: B D : A B :: \text{rad.} : 2 \cos. A B D$, because the angle $E D B$ is the complement of $A B D$; whence $w = 2 P \cos. A B D = 2 P \cos. \frac{1}{2} H B C$, and consequently $\frac{P's \text{ vel.}}{w's \text{ vel.}} = 2 \cos. \frac{1}{2} H B C$.

CHAPTER V.

VARIABLE MOTION BY THE ROLLING CONTACT OF WHEELS.

96. The elementary combinations of wheels, which form the subject of Chap. II., include those which are chiefly used in heavy machinery, required to move with a uniform velocity, and consequently with a uniform velocity ratio. Some of the combinations in Chap. III. are required to move with a uniform velocity, and others with a variable velocity by means of wrapping connectors. In the combinations that are here to be considered, either the velocity ratio, or the directional relation, or both, are made to vary, in a definite manner, which cannot in every case be obtained by means of wrapping connectors, as shown in the last chapter.

97. "Let $\Delta P M$, $a P$ be two similar and equal ellipses, of which s, H are the foci of former, and s one of the foci of the latter; and let the ellipses be placed in contact at any point P , situated at equal distances ΔP , $a P$, from the extremities Δ , a of their major axis, and draw $t P T$ the common tangent to the ellipses at P . Now, by the property of the ellipse, the tangent makes equal angles with the radii $s P$, $P H$; and because $\Delta P = a P$, and the ellipses are equal, the tangent makes the same angles with the radii $s P$, $P h$; whence the angles $T P H$, $t P s$ are equal, $s P H$ is a right line. Also $s P = s P$; therefore $s P + P H = s P + P H = \Delta M$ is a constant distance, whatever be the distance of the point of contact P , from the extremities of the axes major. If, therefore, the foci $H s$ be made centres of motion, and their distance equal to one of the major axes of the ellipses, the curves will roll together."

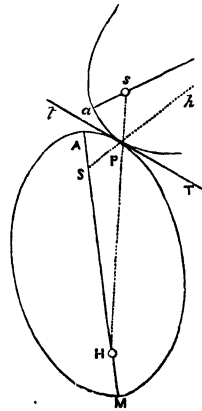

“The logarithmic spiral or ellipse round the focus appears to be only two rolling curves that admit of simple independent demonstrations of their possessing this property.”— See *Prof. Willis's Mechanism*, Art. 259.

98. “To employ rolling curves in practice. In fig. to Art. 97, let the upper curve (supposed to be completed) be the driver, and let it revolve in the direction from r to t ; then since the radius of contact $s p$ increases by this motion, and the corresponding radius $p h$ decreases, the edge of the driver will press against that of the follower, and so communicate a motion to it, of which the angular velocity ratio will be

$$\frac{p h}{s p}$$

But when the point m has reached m , the radii of contact in the driver will begin to diminish, and its edge to retire from that of the follower, so that the communication of motion will cease.”

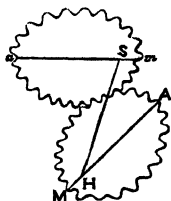

To maintain the motion, it will be necessary to furnish the edge of the driver with teeth to engage with similar teeth upon the corresponding edge of the follower, as in the annexed fig., and thus the communication of continuous variable motion will be maintained, the distance $h s$ being constantly $= A M = a m =$ axis major of each ellipse.

TO CONSTRUCT CURVES WITH ELLIPTICAL PROJECTIONS, CALLED LOBES, TO PRODUCE VARIABLE MOTION BY ROLLING CONTACT.

99. Let it be required to construct a set of three rolling curves of one, three, and four lobes respectively, from two convenient given distances, l and k , such that

$$a = \sqrt{n^2 k^2 + \frac{1}{4} l^2} + \frac{1}{2} l,$$

$$\text{and } b = \sqrt{n^2 k^2 + \frac{1}{4} l^2} - \frac{1}{2} l;$$

in which $a+b$ = major axis of the ellipse, $a-b$ = distance between its foci, and n = number of elliptical lobes.

For the use of those students that are not accustomed to

solve algebraic equations, these values of a and b may be determined by construction as follows.

“Describe the circle $\Delta K G$ with a diameter $= l$, and upon the tangent ΔD set off $\Delta C = k$, $\Delta E = 3k$, and $\Delta D = 4k$. Through the centre D of the circle draw $C C$, $E L$, and $D L$. The curve of one lobe will be an ellipse round the focus M , (see the following fig.) whose apsidal distances are $C F$ and $C G$, and the major axis consequently $= C F + C G$,” as shown in the preceding fig.

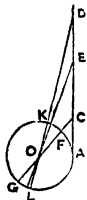

“For a curve of three lobes, first describe a semi-ellipse Q , with apsidal distances $e k$, $e l$, respectively equal to $E K$, $E L$; (see first fig.) and from e draw a sufficient number of radii $e 1$, $e 2$, $e 3$, &c., at equal angular distances.”

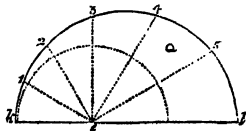

“To construct the three-lobed curve N , describe a circle round the centre e , which divide into six equal sectors, each one of which will contain half a lobe. Divide each sector

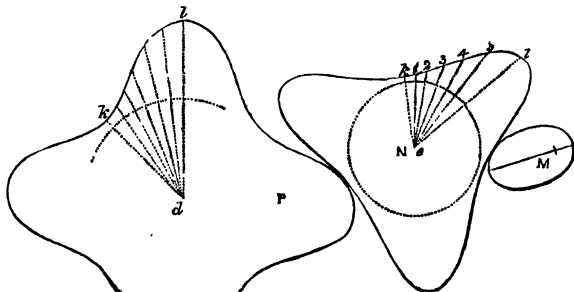

into as many equal angles as those of the semi-ellipse Q , and draw radii, upon which set off in order distances equal to the radii of the semi-ellipse Q , as indicated by the corresponding letters and figures. Through the points thus obtained, draw the curved edge of the semi-lobe, and this curve, repeated to right and left alternately, will complete the three-lobed curve.”

“To describe the four-lobed curve P , draw a semi-ellipse whose apsidal distances are $D K$, $D L$, (see first fig.) and proceed in a precisely similar manner as was done in the second fig. Q , dividing it and transferring its radials from the focus to the semi-lobe $d k l$ of the four-lobed curve P .”

“Any two of these curves will roll together, or, if two of them be made alike, the pair so obtained will roll together. The angular velocities of these rolling curves will be inversely as the segments into which the point of contact divides the line of centres.” See *Prof. Willis's Mechanism*, Arts. 260—268, where elaborate investigations of this and other important subjects may be seen.

VARIABLE MOTION BY LOBED-TOOTHED WHEELS.

100. The form of the wheels, in the marginal figure, are such as to fulfil the conditions of the constructions of the last article, teeth being formed all round the two plates to prevent their slipping, which is the method always adopted in practice; as in the *Cometarium*, and in the silk-mills, being an excellent method of obtaining a varying velocity ratio.

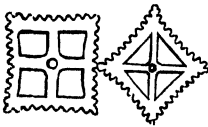

VARIABLE MOTION BY AN EXCENTRIC SPUR-WHEEL.

101. A method of producing a variable velocity ratio by means of spur-wheels, is shown in the annexed fig. The wheel, whose centre is A, turns on an excentric centre of motion B; D is a wheel required to revolve with a varying angular velocity, while A revolves with a uniform velocity round the excentric axle B; C is a pinion, the teeth of which are engaged with those of A and D, the centre of the pinion being carried by the links D C, A C, which rise and fall to suit the position of the excentric wheel A,

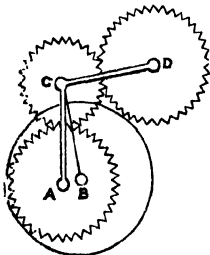

the links at the same time keeping the pinion C in gear. The dotted circle shows the range of the teeth of the excentric, which must be fixed to the extremity of its axis, to prevent the link A C from striking it in the course of its revolutions. “This combination, being wholly formed of spur-wheels, is one of the simplest modes of producing a varying angular velocity ratio.”

ROËMAR'S WHEELS.

102. "These wheels were invented by the celebrated astronomer Olaus Roëmar, to effect the varying motion of planetary machines. $\Delta a, B b$ are two parallel axes, of which the lower one is provided with a cone c , fluted into regular teeth like those of ordinary bevel-wheels, but occupying the surface of a much thicker frustum of the cone than usual. Opposite to this cone is fixed upon the axis Δa , a smooth frustum D , whose apex d is in the reverse direction, and this latter cone is so formed as just to clear the tops of the teeth of c . Upon the surface of D are fixed a series of teeth or pins, so arranged as to fall in succession between the teeth of c . By placing these pins at different distances from the apex d , we can obtain any velocity ratio we please between the extremes; for if R and r be the greatest and least radii of D , and R' and r' of c ; then the angular velocity ratio of c and D will vary between the limits of $\frac{R}{r'}$ and $\frac{r}{R'}$; the first being obtained by placing the pins close to the large end of D , and the second by fixing them at the small end; and when the pins are fixed in any intermediate position, an intermediate velocity ratio will be obtained."— See *Prof. Willis's Mechanism*, Art. 280.

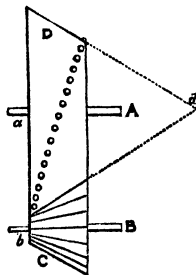

THE EXCENTRIC CROWN-WHEEL.

103. "If the axis be not parallel, a varying ratio of angular velocity may be obtained by the excentric crown-wheel. This was invented by Huygens, for the purpose of representing the motions of the planets in his Planetarium. ΔB is an axis, to the extremity of which is fixed a crown-wheel F , exactly similar to that represented in the figure to Art. 39, only that its centre of motion B is excentric to its circumference. This wheel is driven by a long cylindrical pinion $c D$, whose axis meets that of ΔB in direction, and is at right angles to it. Now, since the radius of contact of the pinion is constant,

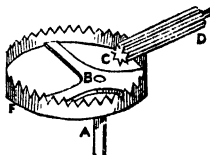

while the radius of contact of the hoop varies at different points of its circumference by virtue of its excentricity, it follows that the angular velocity ratio of the axes will vary."

"In Huygens's machine the pinion is the driver, and is supposed to revolve uniformly, but if the contrivance be adopted in other machines, the wheel or pinion may be made the driver, according to the law of the velocity required."—See *Prof. Willis's Mechanism*, Art. 281.

104. "Let H be the centre of motion of the crown-wheel, C the centre of its circumference; $CP = R$, $HP = r$, $HC = E$, and angle $MHP = \theta$; then, since the axis of the pinion is directed to H in the line of the excentric radius HP , the perimetral velocity of the pinion will be communicated to the radius in a direction perpendicular to it; and if ρ be the radius of the pinion, we shall have

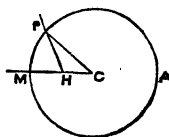

$$\frac{\text{pinion's ang. vel.}}{\text{crown-wheel's ang. vel.}} = \frac{r}{\rho}.$$

$$\text{But } R^2 = r^2 + E^2 \mp 2rE \cos. \theta,$$

$$\text{whence } r = \pm E \cos. \theta + R \sqrt{1 - \frac{E^2}{R^2} \sin.^2 \theta}.$$

Now in planetary machines E is small with respect to R ,

$$\therefore r = \pm E \cos. \theta + R.$$

And since the pinion revolves uniformly, the angular velocity of the crown-wheel is

$$\text{as } \frac{1}{r} \text{ as } \frac{1}{R \pm E \cos. \theta} \text{ as } R \mp E \cos. \theta \text{ nearly.}$$

But if MP were the elliptic orbit of a planet of which C is the centre, H the focus, HP the radius vector, and $AM = 2E$ the major axis, we should have the angular velocity of HP

$$\text{as } \frac{1}{HP^2} \text{ as } (R \mp E \cos. \theta)^2 \text{ as } R \mp 2E \cos. \theta \text{ nearly.}$$

By making, therefore the *excentric distance* CH of the crown-wheel equal to the *distance of the foci* of the elliptic orbit, the radius vector HP will revolve with an approximate representation of planetary motion, when the driving pinion

revolves uniformly." *Moreover, the contrivances here introduced are applicable to machinery generally, and on this account deserve to be studied.*—See *Prof. Willis's Mechanism*, Art. 282.

VARIABLE MOTION BY SLIDING CONTACT.

105. "The simplest mode of obtaining a varying angular velocity ratio, when the rotations are to be continued indefinitely in the same direction, is by the pin and slit; A *a*, B *b* are axes parallel in direction, but placed with their ends opposite to each other; A *a* is provided with an arm carrying a pin *d*, which enters and slides freely in a long straight slit, formed in a similar arm *b f*, which is fixed to the extremity of B *b*. If one of these axes revolves, it will transmit a rotation to the other with a varying velocity ratio; for the pin in revolving is continually changing its distance from the axis B."—See *Prof. Willis's Mechanism*, Art. 290, where the angular velocity ratio of the two axes is investigated.

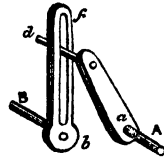

CHAPTER VI.

INTERMITTENT AND RECIPROCATING MOTIONS BY WHEELS.

106. This kind of motion is frequently required in some kinds of machinery; it may be readily produced with a pair of spur-wheels, by cutting away all the teeth of the driver A, except those between *m* and *n*; consequently when A revolves, it will cease to turn B while the plain part of its circumference is passing the line of centres, but will turn it every time the teeth between *m* and *n* come into action with the teeth of B. By properly proportioning the arc, which contains the teeth, with the plain arc, any required ratio of rest and motion, which can be included in one revolution, may be obtained.

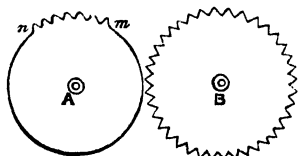

This arrangement is liable to objection, since there exists

a chance of the first tooth of A not exactly engaging with the teeth of B, causing the teeth of the two wheels to get jammed together; this defect, however, may be remedied in the following manner.

107. In the annexed figure, the follower B has its edge mn formed into an arc of a circle, the centre of which is the centre of the driver A: part of the circumference of the driver is a plain disk of a greater diameter than the pitched circle of its toothed portion. The plain edge of A runs past mn without touching it, but effectually preventing B from being moved from its position of rest, and thus ensures the meeting of a pin p , (fixed in A) with a guide-plate g , (fixed in B) which bring the teeth of the two wheels exactly into gear, after which B will make one revolution. The ratio of the times of rest and motion may be found as in the last article.

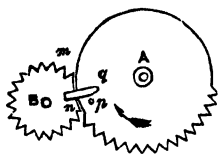

108. "A simple intermittent motion is effected by a pinion A, having one tooth p . This tooth will, in each revolution, pass a single tooth of the wheel B across the line of centres; but during the greatest part of its rotation will leave the wheel B undisturbed. To prevent the wheel B from continuing its motion by inertia through a greater space than this one tooth, a *detent* c may be employed. This turns freely upon its centre, and may be pressed by a weight or spring against the teeth. It will be raised as the inclined side of the tooth passes under it by the action of A, and will fall over into the next space, thus retaining the wheel in its position during the absence of the tooth p ."—See *Prof. Willis's Mechanism*, Art. 292.

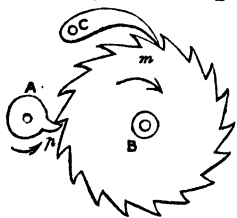

THE GENEVA STOP.

109. This is a still better arrangement for producing intermittent motion: it was first introduced into the mechanism of the Geneva watches, whence its name is derived.

"A is the driver which revolves continually in the same direction, B the follower which receives from it an intermittent motion, with long intervals of rest. For this purpose its circumference is notched alternately into arcs

of circles as db , concentric to the centre of A when placed opposite to it, and into square recesses, as shown in the figure. The circumference of A is a plain circular disk, very nearly of the same radius as the concave tooth which is opposed to it; this disk is provided with a projecting hatchet-shaped tooth, flanked by two hollows at s . When A revolves, no motion will be given to B so long as the plain edge is passing the line of centres, but at the same time the concave form of the tooth of B will prevent it from being moved. But when the hatched-shaped tooth has reached the square recess of B , its point will strike against the side of the recess at a , and carry B through the space of one tooth, so as to bring the next concave arc db opposite to the plain edge of the disk, which will retain it until another revolution has brought the hatchet into contact with the next recess bf .



Note. "The office of this contrivance in a Geneva watch is to prevent it from being over-wound, whence it is termed a *stop*; and for this purpose one of the teeth is made convex at gf . If A be turned round, the hatchet-tooth will pass the four notches in order, but after passing the fourth across the line of centres, the convex edge gf will prevent further rotation, so that in this state the combination serves to prevent an axis from being turned more than a certain number of times in the same direction. For the wheel A is attached to the axis which is turned by the key in winding, and the wheel B thus prevents the axis from being turned too far, so as to overstrain the spring. As the watch goes during the day, the axis of A revolves slowly in the opposite direction, carrying the stop-wheel with it by a similar intermittent motion."— See *Prof. Willis's Mechanism*, Arts. 293, 294.

THE MANGLE MOTION.

110. When a spur-wheel is acted upon by a pinion the axes move in opposite directions; but when an annular wheel is acted upon by a pinion the axes move in the same direction; and by combining a spur-wheel with an annular wheel the *mangle-wheel* is produced. The wheel $s k$ revolves on its centre c , pins or teeth a, n, m , are fixed concentric with c , these teeth are interrupted at f ; and B is a pinion,

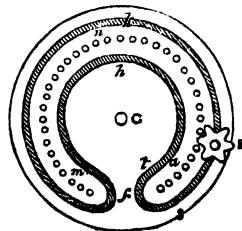

the teeth of which act upon the teeth of the wheel, and is fixed to the end of an axis to which a continuous motion is given, and this axis is capable of admitting a short motion towards *c*, by means of a slide or swing-frame; a pin projects from the centre of the pinion, and is guided by a groove *s B k f h t*, which is cut in the surface of the wheel concentric with the teeth upon it. Now, when the pinion is on the outside of the teeth, as in the fig., they will revolve in opposite directions; but when the interrupted portion *f* of the wheel comes to the pinion, the groove will guide the pinion from the outside to the inside of the teeth, and then the wheel will revolve in the same direction as the pinion, and this will continue until the opening *f* is again moved to the pinion, which will be carried out by the groove, and the motion will be again reversed.

Note. "The mangle-wheel, under all its forms, is a very practical and effective contrivance." "It derives its name from the first machine to which it was applied, but has since been very generally used in manufacturing mechanism."—See *Prof. Willis's Mechanism*, Arts. 315—319.

MANGLE-RACK.

111. "If the reciprocating piece move in a right line, as it very often does, then the mangle-wheel is transformed into

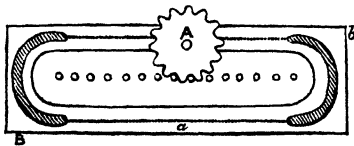

the *mangle-rack*. *B b* is the sliding piece, and *A* the driving pinion, the axis of which must have the power of shifting from *A* to *a*, through a space equal to its own

diameter to allow of the change from one side of the rack to the other, at each extremity of the motion."—See *Prof. Willis's Mechanism*, Art. 320.

RECIPROCATING MOTION BY A CROWN-WHEEL.

112. The interrupted teeth of a crown-wheel may be made

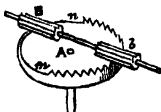

to engage themselves with the teeth of one pinion, and then quit it and engage with the teeth of another pinion, and so on alternately; the two sets being so disposed as to produce continuous reciprocating motion. "For example, *A a* is an axis which revolves continually in the same direction, *B b* an

RECIPROCATING MOTION.

axis to which is to be transmitted a few rotations to right and left alternately. This axis carries two pinions b and δ , and the first axis has a crown-wheel at its extremity, the teeth of which extend only over half its circumference, as from m to n ; these teeth will act upon those of δ , and cause the shaft $B\delta$ to revolve; when the last tooth n has quitted δ this rotation will cease, but at that moment the first tooth m will begin to act upon the pinion b , and turn it in the opposite direction."

Note. "This contrivance is manifestly faulty on account of the shock at each change of motion, and the danger of the teeth becoming entangled, so that I should hardly have thought it worth describing, were it not for the numerous similar forms that present themselves in the early history of machinery, more especially in the works of Ramelli, in which this principle is exhibited in a variety of forms."—See *Prof. Willis's Mechanism*, Art. 322.

RECIPROCATING MOTION BY A DOUBLE RACK.

113. "The marginal fig. shows the application of the same principle to a double rack, which deserves attention on account of the provision which is made to ensure the first engagement of each set of teeth.

Aa is a frame to which the reciprocating motion is to be given, B the driving pinion, which is made in the form of a lantern, and the teeth confined to about a quarter of its circumference.

These teeth act alternately upon a rack fixed on opposite sides of the frame, which thus receives a back-and-forward motion from the continued rotation of the pinion." The manner of ensuring the safe engagement of the teeth of the pinion with those of the two racks may be seen by inspecting the figure.—See *Prof. Willis's Mechanism*, Art. 323.

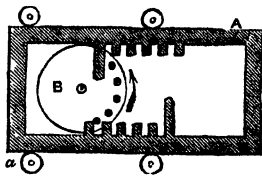

THE EXCENTRIC WHEEL.

114. To the different forms under which the arm and link appear, may be added this important piece of mechanism, which is commonly used to turn the slide valve of the steam engine. E is the centre and A the axis of the excentric wheel, which is always fixed to the axis of the fly-wheel of the steam engine; a hoop BDC embraces this wheel or pulley so as just to allow it to turn freely with its circle,

the hoop being generally of two pieces joined at B and C; a frame B F C connects the hoop with the extremity F of the bent lever F G H, which turns on the centre G. When E revolves on its excentric axis A, the frame B F C will be drawn alternately to the right and left, and the end F of the bent lever F G H will describe at every revolution two

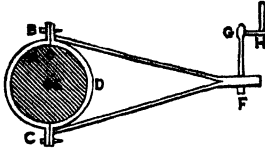

arcs of a circle; the reciprocating motion of F, thus produced, transmits a like kind of motion to the other end of the lever, to which the slide-valve of the engine is attached.

115. *Note.* "The excentric arm or crank, is by far the most simple mode of converting rotation into reciprocation, and it has the valuable property of beginning the motion in each direction gently, and again gradually retarding it so as to avoid jerks. Nevertheless the law of variation in the velocities is not always the best adapted to the requirements of mechanism; but the reciprocation is produced so simply, that it is often worth while to retain the crank, and correct the law of velocity by combining other pieces with it in a train. By trains of link-work very complex laws of motion may be derived from a uniformly revolving driver. This will be best illustrated by the following examples."—*Professor Willis.*

116. *Example 1.* "If the crank, instead of being fixed to the uniformly revolving axis, be carried by a second axis, and then two axes connected by one of the combinations at the beginning of this chapter, for the production of a varying velocity ratio, the inequality of the velocity in the reciprocating piece may be almost entirely got rid of. Thus let these two axes be connected by a pair of rolling curve-wheels, (Art. 100) let A_1 be the angular velocity of the first axis, A_2 the angular velocity of the second axis, upon which is also fixed the crank; let ρ be the radius of the crank, and θ the angle it makes with the path of the reciprocating piece; then, if v be the linear velocity of this piece, we have $v = \rho \sin. \theta A_2$, (by *Willis's Mechanism*, Art. 329) which is to be constant by hypothesis. Let r_1 , and r_2 be the radii of contact of the rolling curves, which connect the first and second axes respectively; then

$$\frac{A_2}{A_1} = \frac{r_1}{r_2} = \frac{c - r_2}{r_2},$$

c being the distance of the axes.

$$\therefore \frac{v}{A_1} = \frac{c - r_2}{r_2} \rho \sin. \theta = k,$$

k being a constant by hypothesis,

$$\text{whence } r_2 = \frac{c \rho \sin. \theta}{\rho \sin. \theta + k}$$

is the equation of the rolling curve of the second axis, whence that of the first may be found by *Willis's Mechanism*, Arts. 260 or 269.

Any contrivance, however, that produces two equal periods of

variation in the angular velocity in each revolution, will serve to correct the crank-follower sufficiently for practice. The rolling curves (Art. 100) are used in some silk-machinery; but their figure is not so completely formed upon principle.

117. *Ex. 2. To equalise the velocity by link-work.* The velocity of the reciprocating piece may be also nearly equalised by a train of link-work only. Thus, let A be

the axis of the crank Aa , which by means of a link ac transmits in the usual way a reciprocating motion to a point c , which travels in the line Ab between B and b ; a second link cd connects c with an arm Dd , moving on a centre D , and the motion of c between B and b thus move d between g and r ; so that the rotation of the crank Aa causes the arm Dd to reciprocate between the positions Dg and Dr . In any given position of this system draw perpendiculars Am , Dn from the centres of motion upon the links; then if A_1 , A_2 be the angular velocities of Aa , Dd respectively, and v the velocity of c , we have very nearly by *Willis's Mechanism*, Art. 329,

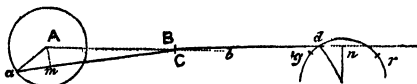

$A_1, Am = v = A_2, Dn;$

$$\therefore \frac{A_2}{A_1} = \frac{Am}{Dn}.$$

If Aa , Dd both reach the position perpendicular to the link at the same time, then Am , Dn will reach their maximum values together, and will increase and decrease together, so that the ratio $\frac{Am}{Dn}$ may

be made nearly constant; and thus, if Aa revolve uniformly, the reciprocating piece Dd will move in each direction with a velocity much more uniform than that of the piece c , which may either slide or may be fixed to a long arm so as to make Bb an arc of large radius; or the intermediate piece may be omitted, and ac connected by a single link; but this is not so good."—See *Prof. Willis's Mechanism*, Arts. 332, 333.

CHAPTER VII.

THE INCLINED PLANE, THE SCREW, THE WEDGE, AND CAMB
PRODUCING MOTION BY SLIDING.

118. *The Inclined Plane*, in mechanism, is considered as a smooth, perfectly hard, and inflexible surface; the iron rails on an ascending or descending gradient of a railway may be regarded as a plane of this kind.

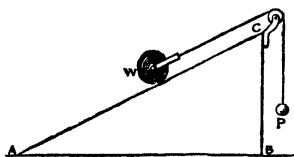

Let $A C$ be an inclined plane, $A B$ its horizontal base, $B C$ its height, and $B A C$ its angle of elevation; w a body sustained on the plane by the power P acting by the cord $w c P$ over a pulley at c , in the direction $w c$ parallel to the plane $A C$.

Then, by *Baker's Statics and Dynamics*, Art. 74,—

$$P : W :: B C : A C,$$

that is, $P : w ::$ the height of the plane : its length, or

$$P = \frac{W \times B C}{A C} \quad (1).$$

And, by the nature of virtual velocities, Art. 85. (5) *ibid.*

$$\frac{P's \text{ vel.}}{w's \text{ vel.}} = \frac{W}{P} = \frac{A C}{B C} \quad (2).$$

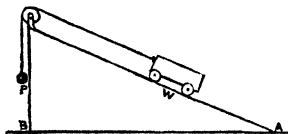

Example 1.—If a waggon, w , weighing three tons be drawn up an inclined plane $A C$, the length of the plane $A C$ being to its height $B C$ as 5 to 1, required the power P that will just balance the waggon on the plane?

By equation (1) :

$$P = \frac{W \times BC}{AC} = \frac{3 \times 1}{5} = \frac{3}{5} \text{ of a ton} = 12 \text{ cwt.}$$

A slight addition to this power to overcome the friction of the waggon-wheels would draw the waggon up the plane.

Note. This method of drawing waggons up steep inclined planes by stationary engines is much practised in mineral districts ; where the waggons also descend inclined planes, their speed being regulated by a windlass at the top of the plane.

Ex. 2. Required the power requisite to draw a train of carriages weighing 40 tons, up a railway gradient rising 1 foot in every 100 feet ?

$$\text{Here } P = \frac{W \times BC}{AC} = \frac{40 \times 1}{100} = \frac{2}{5} \text{ of a ton} = 8 \text{ cwt.}$$

119. When the power P acts over the pulley D , in the direction wD , which is not parallel to the inclined plane AC ; then, by *Baker's Statics and Dynamics*, Art. 73,

$$P : W :: \sin. BAC : \cos. CWD,$$

$$\text{whence } \frac{W}{P} = \frac{\cos. CWD}{\sin. BAC}.$$

And, by the nature of virtual velocities,

$$\frac{P's \text{ vel.}}{W's \text{ vel.}} = \frac{\cos. CWD}{\sin. BAC}.$$

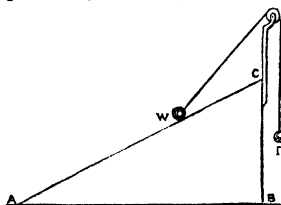

THE WEDGE.

120. *The wedge* may be considered as a moveable inclined plane, or rather as a double inclined plane, as the figure $A d B C$; besides its use in mechanism, it is also much used for separating bodies that are strongly bound or pressed together, as for cleaving timber, in which case it is urged by percussion. The force impressed by percussion, or a blow on the back of the wedge, has an effect incomparably greater than any mere pressure or force produced by machinery. If P be the force impressed on the back AB of

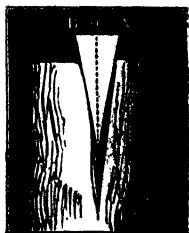

the wedge, and w the pressure on $A C$ or $B C$; then, by *Baker's Statics and Dynamics*, Art. 79,

$$P : W :: A B : A C,$$

$$\text{whence } \frac{W}{P} = \frac{A C}{A B}, \text{ (and by virt. vel.),}$$

$$\frac{P\text{'s vel.}}{W\text{'s vel.}} = \frac{A C}{A B} = \frac{d c}{A B} \text{ nearly,}$$

since the length of the wedge perpendicularly is nearly equal to its slant length, in all usual cases.

RECIPROCATING MOTION BY THE WEDGE.

121. Let $A B C$ be a wedge or inclined plane moveable along the horizontal plane $B C$, and $g g$ a bar constrained by guides $m n$, to move in the direction of its length only, and having a friction pulley at g . When the wedge is moved forward and backward, the rod $g g$ will rise and fall, and in pushing the wedge through its whole length $A B$ the rod will rise through a height equal to $A B$; whence, evidently, the velocity ratio, &c. may be estimated as in the last article.

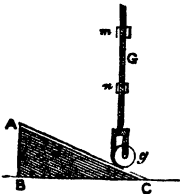

THE SCREW.

122. *The screw* is a spiral groove winding round a cylinder so as to cut all the lines drawn on its surface parallel to its axis at right angles. The screw is, therefore, nothing more than an inclined plane, wrapped round the surface of the cylinder, the base of the plane being equal to the circumference of the cylinder's base, and coinciding with it, and the height of the plane equal to the distance $A B$ between two of the threads.

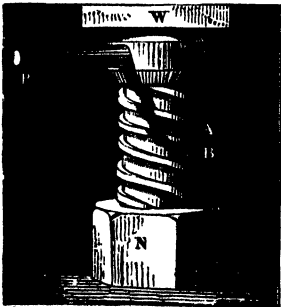

Since the screw is nothing more than an inclined plane $A B C$, unwrapped from the cylinder, (see the small fig.) the

base BC of the plane being equal to the circumference of the cylinder's base, and the height AB of the plane equal to the distance between two threads of the screw; and, since the power applied to the screw acts parallel to the base, we shall have, by Art. 75, *Statics and Dynamics*,

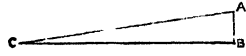

$$P : W :: AB : BC, \text{ or}$$

$P : W ::$ distance between two threads : circumference described by the power, which in this case is the circumference of the cylinder, to which the power P is supposed to be applied, the weight w resting on the top of the screw, as shown in the larger figure.

But when the power P is applied to the lever PW , then we shall have, by the same article

$$P : W :: AB : \text{the circumference described by } P. \\ :: d : 2 \pi r,$$

d being the distance between the threads, r the length of the lever PW , and $\pi =$ semi-circum. to rad. 1.

$$\text{whence } w = \frac{2 \pi r P}{d}, \quad (1),$$

$$\text{and } \frac{P\text{'s vel.}}{w\text{'s vel.}} = \frac{2 \pi r}{d} = \frac{\text{circum. described by } P}{\text{dist. between the threads}} \quad (2).$$

Note. Instead of considering the screw to raise a weight w by acting vertically, we may suppose it to be applied to produce a pressure w in any other direction, and the relation between P and w will be the same as that already shown.

Ex. The distance PW at which the power acts is 6 feet, and the distance between two of the threads of the screw is 2 inches; what weight will a man be able to raise, when he acts at P with a force of 150 lb.?

Here the power acts 72 inches from the centre, hence $2 \pi r = 2 \times 72 \times 3.1416 = 452.39$ inches = circumference described by the power; whence, by equa. (1)

$$w = \frac{452.39 \times 150}{2} = 33929\frac{1}{2} \text{ lb.}$$

RECTILINEAL MOTION BY THE SCREW.

123. *The Pin and Screw.* Let the cylinder kl , the axis of which is AB , have a spiral groove mno cut upon its surface, so as to represent the screw described in the last article; and let CD be a rod constrained to move parallel to AB , the rod having a pin at m to fit into the groove. Now, when the cylinder is turned on its axis, the pin will move in the groove and cause the rod to move in the direction of its length. The velocity ratio, &c. of the cylinder kl and the rod CD may be determined by the last article.



124. *The Rack and Screw.* Instead of a single pin m , let other pins bc also be fixed on the bar opposite the threads of the screw, which may be made triangular, without the least affecting the motion. We shall thus obtain the rack c and the screw s , and by turning the screw which is supposed to be fixed on its axis, a continuous rectilinear motion is given to the rack c , the teeth of which are made exactly to fit the threads of the screw.



Note. "This is the most ancient form in which the screw was employed. It appears to be that which was described by Pappus," in his *Moth. Col.*

125. *Nut and Screw.* "In most cases the piece which receives the action of the screw s , is formed with a hollow cavity, as N , within which are threads exactly fitting those of the screw s . The piece N is called the nut, and the hollow screw within it, the female screw."—See *Prof. Willis's Mechanism.*



THE SCREW PRESS.

126. The screw is frequently used where a great pressure is to be exerted through a small space. The figure to Art. 122 represents the screw press, where the solid screw AB works in the nut N , which is fixed; w is the weight to be raised, or substance to be pressed; the screw AB is moved round by the lever p , which is inserted into a hole in the screw. The power that can be exerted by this press is very considerable, as will be apparent from the example following Art. 122.

Note. It will be seen that we may increase the mechanical efficacy of

the screw, either by causing the power to move through a greater space by increasing the length of the lever, or by diminishing the thickness of the threads; thus, in the above example, if the distance between the threads were $\frac{1}{2}$ or $\frac{1}{4}$ of an inch, the other parts remaining the same, the efficacy of the machine would be respectively doubled or quadrupled. There is, however, a practical difficulty in diminishing the distance of the threads of the screw, for, as they become crowded into a small space, they become more delicate, and are apt to be torn off, under a considerable pressure, while by increasing the length of the lever, the machine becomes unwieldy: these objections have been entirely got rid of by the following ingenious arrangement.

THE DIFFERENTIAL SCREW.

127. This machine (invented by *Mr. John Hunter*) consists of two screws, CD and DE, having threads of different thicknesses. The larger screw

CD has a hollow or female screw formed within it exactly fitting the screw DE, which can only move in the direction of its length, and, therefore, when CD is turned round, DE screws into CD, which works in a female screw fixed in the frame AB. In one revolution of the lever L, the screw CD ascends a space equal to the distance of its exterior threads; and during the same time, the screw DE descends into the female screw, in CD, a space equal to the distance of its threads; consequently the point

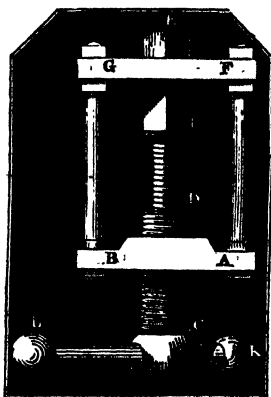

E will only ascend a space equal to the difference of the distances of the threads on CD and those on DE: let these distances be respectively c and c' , r = length of the lever LC, P = power applied at L, and w = weight at E; then by the nature of virtual velocities, &c.

$$\frac{P's \text{ vel.}}{w's \text{ vel.}} = \frac{2 \pi r}{c - c'} \quad (1),$$

$$\text{and } w = \frac{2 \pi r P}{c - c'} \quad (2).$$

Ex. Let the distances of the threads on CD and DE be respectively $\frac{5}{16}$ and $\frac{1}{4}$ of an inch, and let the length of the

lever LC be 60 in. and the power P applied at $L = 150$ lb.; required the weight w that can be raised at E , neglecting the friction of the screws?

By equa. (2):

$$w = \frac{2 \times 3.1416 \times 60 \times 150}{1\frac{5}{8} - \frac{1}{4}} = 904781 \text{ lb.} = 404 \text{ tons nearly.}$$

Note.—It will be found from equation (1) that the velocity ratio of the power and weight, or $\frac{P's \text{ vel.}}{w's \text{ vel.}} = \frac{6032}{1}$ nearly, which is the advantage, abating friction, gained by the machine.

Note. “In the usual method of applying [the differential or] Hunter's screw, the two threads are cut on different parts of the same cylinder. Upon these are placed nuts, which are capable of moving in the direction of their length, but are not allowed to turn round. It is clear, therefore, that, by turning the screw once round, the two nuts will be brought nearer together, or driven farther apart, according to the direction in which the screw is turned, through a space equal to the difference of the pitch of the two threads. In this way, Hunter's screw is well adapted to the purposes of a *micrometer screw*, because it admits of an indefinitely slow motion, without requiring exquisite workmanship in the thread. The uses of the screw in a micrometer have been noticed in our Introduction to the study of Natural Philosophy, p. 34.” —*Tomlinson's Mechanics.*

THE ENDLESS SCREW.

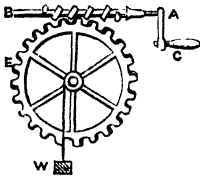

128. The endless screw AB is so combined with the wheel E and its axle that the threads of the screw may work in the teeth on the circumference of the wheel. Let $R =$ radius of the wheel, $\rho =$ radius of the axle, $r =$ length of the handle AC ; then by the nature of virtual vel., *Statics and Dynamics*,

$$\frac{P's \text{ vel.}}{w's \text{ vel.}} = \frac{2 \pi r R}{\rho} = \frac{W}{P}.$$

SCREWS, CAMBS, ETC.

129. *The endless screw* in the annexed figure presents a combination of still greater power, having three toothed wheels, two pinions and one axle, round which the rope sustaining the weight w coils. Let $d =$ distance between the threads of the screw, $r =$ length of the winch AC , r' , r'' , r''' the

respective radii of the wheels E, F, G, and ρ , ρ' , ρ'' , the radii of the respective pinions and axle, also P = power applied at A to raise w; then, by Art. 84, *Statics and Dynamics*,

$$P : W :: d \rho \rho' \rho'' : 2 \pi r r' r'' r''' ,$$

$$\text{whence } w = \frac{2 \pi r r' r'' r''' P}{d \rho \rho' \rho''} .$$

The velocity ratio may be determined from this equation, as in former cases.

Ex. 2.—If the endless screw be turned by a winch A C, the threads of the screw being distant half an inch each, the screw turns a toothed wheel E, the pinion of which turns another wheel F, the pinion of this another wheel G, and on the pinion or axle of which is sustained the weight w; now the radii of the wheels are each 18 inches, those of the pinions and axle each 2 inches, and the length of the winch A C = 22 inches; what weight will a man be able to sustain who acts at the handle of the winch with a force of 150 lb. ? From Art. 129,

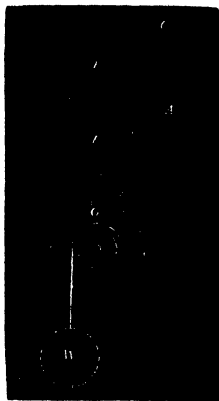

$$w = \frac{2 \times 3.1416 \times 22 \times 18 \times 18 \times 18 \times 150}{\frac{1}{2} \times 2 \times 2 \times 2} = 30,231,630 \text{ lb.}$$

$$= 13,496 \text{ tons nearly.}$$

THE CONICAL SCREW.

130. A method has been shown, in Art. 123, for giving a rectilinear motion to a bar by a screw, the axis of which and the bar are parallel; but, if the path of the bar be not parallel to the axis of the screw, it must be formed in a conical shape. "Thus, in the fig., A B is the axis, C E the sliding bar, e its pin, the path c d of whose acting extremity is in this case supposed to meet the axis. If this line c d generate a cone D by revolving round A B, the pin will always lie at the same depth in the groove excavated on the conical surface. Also, if the surface be developed, the groove ef will be the spiral of Archimedes."—See *Prof. Willis's Mechanism*, Art. 165.

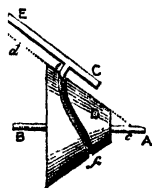

CAMBS.

131. These important parts of mechanism consist of a properly formed revolving plate, by which a reciprocating motion may be given to bars or lever, varying according to any required law.

“Thus, let A be the centre of motion of the comb-plate $nmpq$, BD a lever turning on the centre B , and furnished with a friction roller D , which rests upon the edge of the camb. Let Am be the least radius of the camb, and Ap the greatest, and let the radii gradually increase along the edge mnp , and decrease along the edge pqm . Then, if the camb revolve continually round, the roller D , by the action of the edge, will be pushed farther from the centre A , during the passage of mnp under it, and will return towards the centre during the passage of pqm ; the lever being supposed to be kept in contact with the edge by its weight or by a spring.” — See *Prof. Willis's Mechanism*, Art. 352.

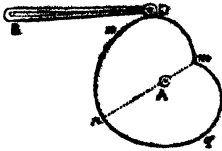

Note. A sliding-bar may be applied to the edge of the camb, as in Art. 121. In this manner a series of reciprocations may be given to the bar BD , and the velocity ratio of the bar to that of the camb can be made to vary according to any required law, by adjusting the shape of the edge of the plate. This may be set out by points, as in the following example.

132. “Let the velocity ratio vary so that when a series of points 1, 2, 3, 4, 5 in the circumference of the circle c shall have reached in order the point c , the pin or friction roller in the bar, or sliding piece, shall be moved to the corresponding positions I, II, III, IV, V. To each of the position points in the circumference of the circle draw

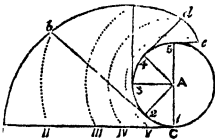

tangents, and with centre A draw circular arcs in order, each intersecting one of the position points I, II, III, &c., and the corresponding tangents, as at a, b, c, d, e ; thus is obtained a series of points through which, if a curve be drawn, it will be the camb required; for it is manifest, that if any point, as 3, of the circle be brought to c , the corres-

ponding point *c* of the curve will be moved to III, and thus the pin will be placed in its required position, and so for every other pair of positions."

133. If the camb-plate be required to produce more than one reciprocation to the lever or sliding piece in each revolution, its edge must be formed into a corresponding number of waves, as A, B, C.

134. If the sliding piece or lever is required to be raised gently, and let fall by its own weight, the edges or waves of the camb must terminate abruptly, as *a*, *b*, *c*.

135. If it be required that the pressure of the camb may produce both the upward and downward motion of the lever, the pin B of the lever BC may move in a groove formed in the surface of the camb A.

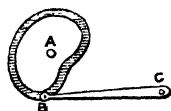
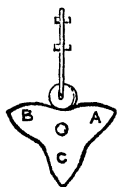

THE FORGE HAMMER.

136. If the lever is required to receive repeated lifts with intervals of rest, the camb becomes a set of teeth, as shown on the circumference of the wheel A; in this case the teeth are called *wipers* or *tappets*. Thus the *forge hammer* HFB, turning on the pivot or fulcrum F is depressed at its extremity B by the wipers, thus raising the head H of the hammer; but as soon as the wiper disengages itself from the end B of the lever, the hammer falls by its weight on the anvil or steady s; and as there are six wipers on the wheel A, the hammer will make a like number of strokes on the anvil for every revolution of the wheel.

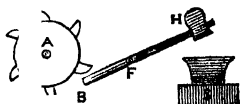

CHAPTER VIII.

ESCAPEMENTS, PENDULUMS, ETC.

IN this class of combinations called escapements, a revolving wheel produces reciprocation in its follower by acting alternately on two different pieces attached to it. These arrangements are used in clocks and watches, also in other machinery.

CROWN-WHEEL ESCAPEMENT.

137. "When the axes are at right angles the crown-wheel escapement is commonly employed. *A* is a revolving axis, to the extremity of which is fixed a crown-wheel with large saw-shaped teeth; *c c* the vibrating axis or *verge*. This

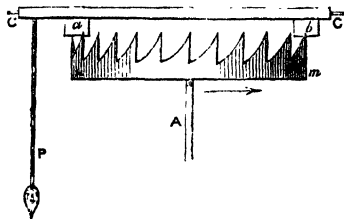

carries the two pieces or pallets *b* and *a*, which are set in planes making an angle with each other sufficient to allow of the escaping action. When the wheel revolves in the direction of the arrow, one of its teeth *n* pressing against the pallet *b* will turn the verge in

the same direction, until, by the circular motion of *A*, its extremity is lifted so high that the crown-wheel tooth passes under it, or, in other words, this tooth escapes from the pallet. By the same motion of the verge the pallet *a* is brought into a vertical plane, and the tooth *n* presses it in the contrary direction, and turns the verge back again until *n* escapes from under *a*, when a new tooth begins to act upon *b*, and so on. Thus the rotation of the crown-wheel produces the vibration of the verge and pendulum *P C*, the crown-wheel being the driver."

ANCHOR ESCAPEMENT.

138. This escapement is very commonly used when the axes of the wheel and verge are parallel. Here c is the centre of the wheel, D that of the escapement $A D B$. In the figure, a tooth a is represented as having just escaped from the pallet A , and a tooth b on the opposite side of the wheel has met the pallet B ; the pendulum (attached to the axis passing through D) will not stop here, but will advance a little further to the left, and so the slope of the pallet B will drive the tooth b back again a little, and thus produce the *recoil*, which may be observed very plainly in any common house clock with a seconds hand. The sloped faces of the pallets cause the teeth of the wheel to give them impulses in escaping, so as to maintain the motion of the pendulum. This kind of escapement is much the most common, and will probably never be superseded, as it is sufficiently accurate for ordinary purposes, and is very easy to make, since no particular form is required for the pallets. This escapement is said to have been invented by Dr. Hooke about 200 years ago.

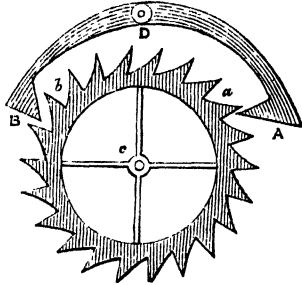

LEVER ESCAPEMENT.

139. "A very simple arrangement is shown in the annexed figure. The revolving wheel, of which the centre is A , has pins $a, b, c, \&c.$, and turns in the direction of the arrow; D is the verge, n, n the pallets; which are fixed against the face of an arm (or lever) $D n$, which lies parallel to the face of the wheel, and so far from it as to clear the tops of the pins. The pin a is shown in the act of pressing the pallet m , and therefore of depressing the arm; when this pin reaches n , it escapes from m and begins to act upon n , by which it raises the arm and escapes at the lower end of n , when the pin b begins to touch and depress the first pallet m , and so on."

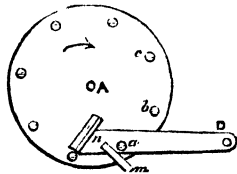

140. "In all these escapements the verge may be made the driver, and thus a reciprocating motion may be made to produce a rotation. The wheel will always revolve the contrary way to that in which it turns when itself drives."

THE COMMON PENDULUM.

141. The common pendulum is one of the simplest of scientific instruments, and also one of the most important; for by its means we are enabled, not only to measure time with precision, but to determine the variation of the force of gravity at different parts of the earth's surface.

"Any weight, attached to the end of a rod, wire, or flexible thread, and suspended from a fixed point P, may be said to constitute a pendulum. Its fundamental properties are first, to show, when at rest, the exact vertical, or the direction in which gravity acts (when used for this purpose, it is usually called a *plumb-line*); *secondly*, to oscillate in a vertical plane when drawn on one side, and then left to itself. If, for example, the pendulum PC be drawn aside to A and liberated, it will descend to c, and then ascend on the other side as far as B, describing an arc BC, nearly equal to the arc AC. From the point B it will again descend to c, and then ascend towards A, and so on, for a considerable time. When the weight is descending from A to c, the motion is accelerated, and in ascending from c to B it is retarded. The motion of the pendulum from A to B is called an *oscillation* or *vibration*. The *amplitude* of each vibration is measured by the arc AB in degrees and minutes. The *duration* of a vibration is the time of describing this arc. If the amplitude of the vibrations of the pendulum does not exceed a certain magnitude, the time of vibration will not sensibly vary, however the amplitude may vary. Thus the time of oscillation will be practically the same, whether the angle APC be 4° or 5° , 2° or 3° , or of so small a magnitude that the eye cannot distinguish it without the aid of a microscope. It is certainly remarkable that the pendulum should require as much time to describe an arc of $\frac{1}{10}$ th of a degree, as to describe one of 10 degrees. The reason, however, will be evident when we consider that the effect of gravity in

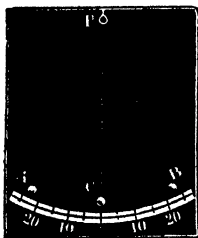

producing motion depends upon the obliquity of the line PA . In the position PC the force of gravity tends to keep the pendulum at rest; the impelling effect of the force of gravity is measured by the distance of the pendulum from this position; the greater this distance, the greater the average velocity of descent; and any increase of distance within a few degrees is exactly compensated by the increased speed of describing it."—*Tomlinson's Mechanics*.

142. To show the nature of the application of the pendulum to clocks, let PC (fig. to Art. 137) be a seconds pendulum vibrating on the axis CC of the verge. It will readily be seen, from what has been already shown, that at each double vibration of the pendulum, one tooth of the crown-wheel A is liberated and carried round; and, if there be 30 teeth in the wheel, it will exactly make one revolution in a minute. The slight impulses given by the teeth of the wheel to the pallets a and b , suffice to overcome the friction of the axle CC and the resistance of the air, which would otherwise destroy the motion of the pendulum.

PART II.



CHAPTER I.

MECHANISM AND PARTS OF MECHANISM DESIGNED TO EFFECT
PROPOSED OBJECTS.

IN the chapters of the preceding part of this work, the simple forms or elements of mechanism and small combinations of mechanism have been considered, in most cases without regard to the object to be effected; the method of classifying the different forms of which all mechanism must consist, and calculating the ratio velocities and powers of the combinations must necessarily occupy the first place in a work of this kind. It will now be proper to consider the most approved forms of mechanism exclusively with regard to objects to be effected. Machines, or parts of machines, specially designed to regulate motion, shall now be considered. The variable action of steam and the wind as prime movers, and, in some cases, the variable resistance of the work to be done, have called forth the necessity of those contrivances; since it is always desirable and often necessary, that the parts of machines should have a uniform and regular motion.

REGULATORS AND ACCUMULATORS OF MOTION.

THE FLY-WHEEL.

143. The nature of the motion of the fly-wheel has been already referred to at the end of Art. 21, but the marginal figure shows the usual manner of its application as a regulator of motion in the steam-engine. It consists of a large heavy metallic wheel EF , to which motion is given by the crank AB , which is fixed to the axle of the wheel at A ; to the other extremity B of the crank is attached *the connecting rod* BD , to which a reciprocating motion is given by

the great beam DC moving on the axle c . To the other end of the great beam (not shown in the fig.) is attached the piston rod of the steam-engine which gives the reciprocating motion to the beam.

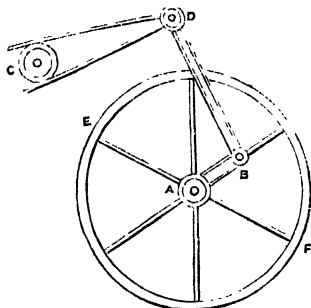

The fly-wheel is also an accumulator of motion, for when the impulsive force of the steam is greater than the resistance of the load, the surplus is imparted to the wheel, to which it gives a slight increase of speed; and owing to the great weight of the wheel, an increase of speed, which is scarcely sensible, absorbs an immense amount of moving force. When the impulse of the steam becomes less than the resistance, then the momentum or moving force of the wheel acts upon the load, and that part of the surplus force, which was previously imparted, is given back, and the wheel assists the piston in moving the load past the dead points, and when at the same time the steam is weakened by expansion. When the moving force is in excess, the fly-wheel absorbs the surplus; and when the moving force is deficient, the fly-wheel gives back what it has absorbed; thus producing a continual uniformity of motion.

THE GOVERNOR.

144. This is one of the most important regulators of the steam-engine as well as of other machinery. The arrangement usually adopted in the steam-engine is represented in the following figure. Two balls I, I , are attached to equal rods of iron HG, HG . The arrangement is composed of a series of jointed rods HF, EF , which play upon a vertical spindle CD , being fixed at H , but capable of sliding upon it at E . When the balls are separated so that the rods HG, HG become more divergent, the arms HF, HF open, and the pivots F, F separating, draw down the collar E , which slides upon the spindle; and on the contrary, when the balls approach each other, the arms HF, HF also approach each other, and the collar E is forced up. In the collar E is inserted the forked end K of the lever NLK . The end N of this lever

is connected, as shown in the fig., with the throttle-valve *t* of the steam-engine, and the proportion and position of the rods are so adjusted that when the balls descend to their lowest position, the throttle-valve becomes open; and when they separate it becomes gradually closed. A grooved

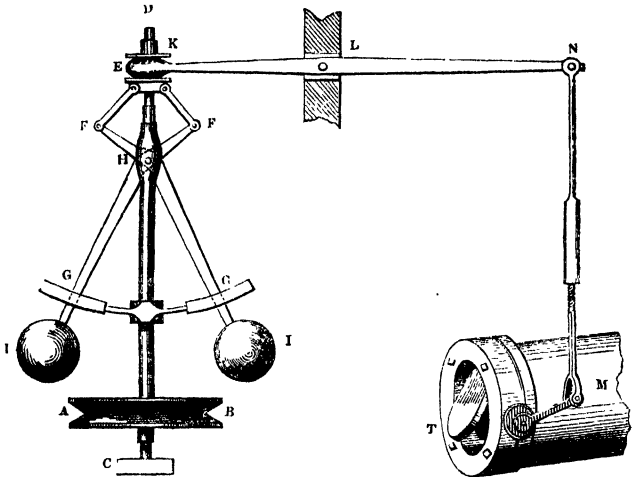

wheel *A B*, or oftener a toothed pinion, is fixed upon the axle of the spindle, which receives its motion from any convenient part of the machinery. Now, suppose the load of the engine to be suddenly diminished, or the force of the steam increased, then a momentary augmentation of speed will take place in the piston, and consequently an increased velocity will be imparted to the wheel *A B* and the balls of the governor; these balls will therefore fly further from the spindle *D C*, the fork *K* will be drawn down, the throttle valve *T* partially closed, and the supply of steam to the cylinder diminished. If, on the contrary, the load of the engine be increased, or the force of the steam diminished, the speed of the piston will be momentarily slackened, the velocity of the wheel *A B* will be diminished, the balls will descend and approach the spindle, the fork *K* will be raised, and the valve *T* be partially opened. In this manner the governor has the effect of admitting at all times to the cylinder just that portion of steam which is necessary to

give the piston its proper speed, the quantity being always proportioned to the load of the engine.

145. The annexed fig. shows another form of the governor, in which the rods $c g$, $c g$, have a common joint c in the vertical spindle $A a$, and are connected by the links $g s$, $g s$, with the sliding piece s which acts upon the throttle valve as in the last article, rotatory motion being given to the spindle $A a$ by the bevel-gear G .

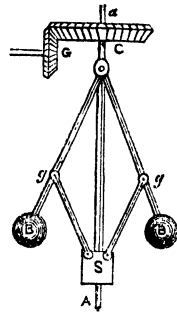

Note. The method of calculating the weight of the balls, &c., of the governor so that they may produce a given effect upon the lever of the throttle valve, is given in a clear manner in *Hann's Treatise on the Steam Engine*.

THE SAFETY VALVE.

146. The safety valve is for the purpose of preventing the bursting of steam-engine boilers by the elastic force of the steam. $A F$ is a graduated lever turning on F as a fulcrum, v is the valve, which is raised when the elastic force of the steam becomes too great for the pressure of the weight w , which presses down the valve by means of the lever $A F$.



THE SPRING SAFETY VALVE FOR HIGH-PRESSURE BOILERS.

147. In the following fig. is shown the safety valve for high-pressure engines. The valve is shown in its seat, its spindle s being pressed down at A by the lever $B A C$; C is a fixed pivot on which the lever turns; the pressure on the valve at A is produced by a nut at B , working upon a screw, which is attached to a spring balance L , the lower end of which is attached to a fixed point P . The nut at B may be turned so as to submit the valve to any pressure within the limit of the action of the spring-balance. An index and scale are attached to the balance, the scale being so divided as to express the number of pounds per square inch by which the valve is pressed upon its seat. Thus, if the nut B be turned until the index shows a pressure of 50 lb., then the force of the valve will be at the rate of 50 lb. per square

inch, and the steam will be confined in the boiler until it has attained that pressure; when the pressure exceeds that limit, the lever at B by the action of the steam on the valve,

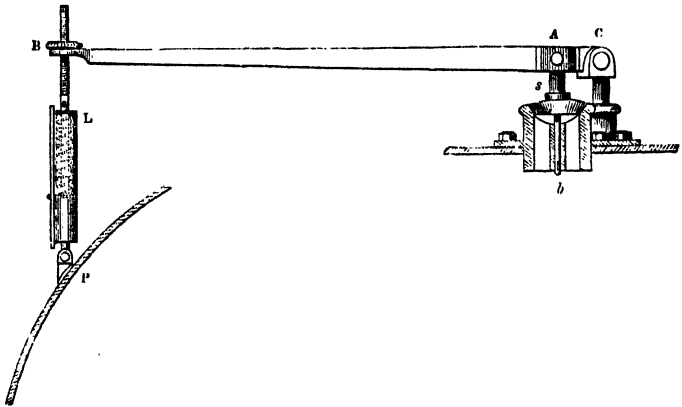

presses the nut upwards with a force greater than the strength of the spring, which will consequently be further compressed, the valve at the same time opening and allowing the escape of the steam.

148. There are various other arrangements in mechanism for regulating motion appended to the steam-engine, as the *boiler-feeder*, the *self-acting damper*, the *steam-gauge*, &c., which render that important engine completely self-acting; but these shall be hereafter described under the head of Steam Engine. The *pendulum* is also an important regulator of motion, but it has been already described in the chapter on escapements, with which it is particularly connected.

CHAPTER II.

MECHANISM FOR MODIFYING MOTION.

149. Since the production of motion by the moving power of machines, as the reciprocating action of the piston of the steam-engine, and the nature of the work required to be done, which sometimes requires regular circular motion, and sometimes motion varied according to a fixed law ; also since regular circular motion, as that produced by the water-wheel, is frequently required to be converted into reciprocating or some other varied motion ; there results a necessity for modifying these motions of the moving power to adapt them to the particular requirements of the arts and manufactures. Several methods of modifying motion have been already given in Chapters VI. VII. and VIII., where the methods of calculating the velocity ratios of the parts, and of constructing the particular forms of the mechanism, are given. Several other modes of modifying motion shall now be given, many of which are very ingenious, and more or less used in practice. They are chiefly taken from that excellent and scientific work on *Mechanism*, by Professor Willis.

TO CHANGE A RECIPROCATING MOTION INTO A CONTINUOUS CIRCULAR MOTION.

SUN AND PLANET WHEELS.

150. "This arrangement was invented by Watt as a substitute for the common crank, in converting the reciprocating motion of the great beam of the steam-engine into the circular motion of the fly-wheel. The rod *DB* has a toothed wheel *B* fixed to it, and the fly-wheel *FF*, has also a toothed wheel *A* fixed to its axis ; a

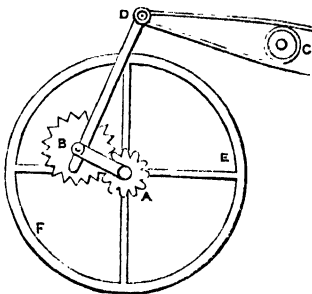

link AB serves to keep these wheels in gear. Now, when the beam CD (the centre of which is c) is in action, the link or arm AB will be made to revolve round the centre A just as a common crank would, but as the wheel B is attached to the rod DB , so as to prevent it from absolutely revolving on its own centre B , every part of its circumference is in turn presented to the wheel A , which thus receives a rotatory motion." In Watt's engine the wheels A and B were equal, and therefore the fly-wheel revolved twice as fast as the crank-arm.

THE LEVERS OF LAGAROUSSE.

151. *First Arrangement.* "Let A be the centre of motion of the lever BAa, D that of the ratchet wheel, and let the lever have two clicks ab, ac , jointed to its extremity a , and engaged with the opposite side of the wheel. When a is depressed, the click b will push the teeth, and the click c will slide over them; on the other hand, when a is raised, the click c will act upon the teeth, but b will now slip over them, so that whether a rise or fall the wheel is made to move in the direction of the arrow."

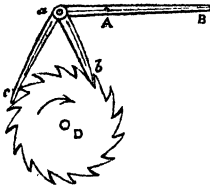

152. *Second Arrangement.* "Here A is the centre of motion of the lever BAa , and clicks ab, cd , are jointed at equal distances on each side of A . When a rises, the click ab slips over the teeth, and dc pushes them; but when a falls, the click pushes the teeth, and dc slips over them."

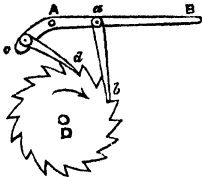

Note. Levers either of the latter kind with two clicks, or with a single click accompanied by a detent, are also employed to move racks.

TO CHANGE A CONTINUOUS CIRCULAR MOTION INTO A RECIPROCATING RECTILINEAR ONE.

153. "In the annexed figure, abc is a revolving piece or driver, which has three equal wipers or tappets, and the follower is a sliding bar and frame $DABC$ provided with two teeth or pallets A and B , on opposite sides of the centre of motion

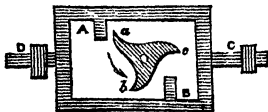

of the driver, which revolves in the direction of the arrow, and its wiper *a* is shown in the act of urging the follower to the left, by pressing against the side of the tooth *A*. Revolving a little farther in the same direction, *a* will by its circular motion escape from *A*, and at the same instant *b* will encounter *B*, and will urge it in the opposite direction until *b* in like manner escapes from it, when *c* will act upon *A*. In this way the rotation of *a b c* will produce the reciprocation of the frame."

154. In this arrangement the wheel *A*, the centre of motion of which is *a*, by means of the excentric revolving pin *c*, working in the slit of the arm *b d*, the centre of motion of which is *b*, gives it a reciprocating motion. This is the same combination as that of Art. 105, but that in this case the pin *c*, by revolving always on the same side of the centre *b*, produces reciprocation, while in Art. 105 the pin, having the centre *b* within its path, produces a rotation in the follower.



155. In the marginal figure, the slit is attached transversely to the bar *b*, which slides in the direction of its length, the wheel *c* revolving on its centre *a*, and carrying the pin *c* which acts in the slit. In this case it is easy to see that the law of motion is the same as in a crank with an infinite link.

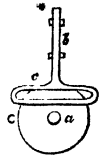

156. The sliding bar *c d* is connected with a frame, of which the two bars *e f*, *g h*, are parallel, and at right angles to the bar; *A* is a wheel the centre of which is *b*, and its centre of motion *a*. This combination is precisely the same as that in the last article, *a b* being the radial distance from the centre of motion *a*.

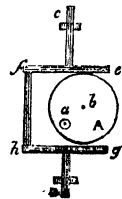

THE SPIRAL OR SOLID CAMB.

157. "If a single series of changes in velocity and direction be required, and which are too numerous to be included within a single rotation of a camb-plate, then the spiral or solid camb may be used. *A a* is the axis of the camb, on one extremity *a* of which a common screw is cut, which works in a nut in the frame of the machine, so that as the axis revolves it also travels endlong. *B* is the solid camb, *D* the roller of the follower whose path is *m d*, and which is

kept in contact with the camb by a weight or spring as usual. As the axis revolves the follower Dd will receive from it a motion in its path, the velocity and direction of which will be governed by the figure of the camb, as in Art. 131. But by means of the screw at a , the camb will be gradually carried endlong, so that at the completion of each revolution the same point of the camb will be no longer presented to the follower, as in Art. 131, in which the same cycle of changes is repeated in each revolution. On the contrary, the path traced by D on the surface of B will be a spiral or screw of the same pitch as that at a , and by properly shaping the comb, we can thus provide a series of changes that will extend through as many revolutions of the camb as the length of the camb contains the pitch of the screw a ."

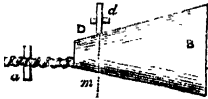

THE SWASH PLATE.

158. "E e is a revolving axis, G g a bar capable of sliding in the direction of its length, and having a friction roller at g ; a flat circular plate F is fixed to the extremity of the axis E e , but not perpendicular to it; the bar G g may be pressed into contact with the plate by a spring or weight. Now, if the plate were perpendicular to its axis, the rotation of the latter would communicate no motion to the bar, but the effect of the inclination is to communicate a reciprocating motion to the bar in the direction of its length, the quantity of which varies with the inclination of the plate to its axis; and if the plate be so attached to the axis as to admit of an adjustment of this inclination, a ready mode is obtained of adjusting the length of the excursions of the bar."—See *Prof. Willis's Mechanism*, Art. 359, where the law of motion of the bar G g is investigated.

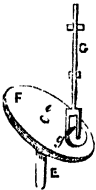

WATT'S PARALLEL MOTION.

159. This simple and beautiful arrangement of link-work was invented by the celebrated Watt, to convert the reciprocating circular motion of the extremity of the great beam of the steam-engine into a reciprocating rectilinear motion adapted to the piston rod.

Let the two equal rods CB and OD , connected by a third rod or link BD , move on their fixed centres C and O ; and

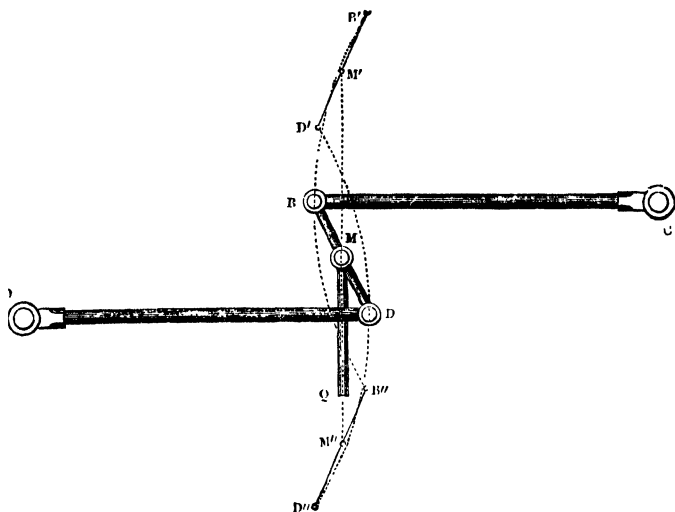

let M be the middle of the rod BD . Now, if CB be made to move on its centre C alternately upwards and downwards in the arc $B'B''$, which will cause OD to move alternately in the same manner in the arc $D'D''$, it will be found that the point M will ascend and descend in a line $M'M''$, which will not deviate sensibly from a vertical straight line. For when the point B is moved upwards to B' , the upper extremity of the rod BC is drawn a little to the *right*; and at the same time the extremity D to the rod OD , being moved to D' , is drawn a little to the *left*. When the extremity B descends to B'' , the extremity D descends to D'' ; thus the two extremities are again drawn, the one a little to the *right*, and the other a little to the *left*. It will be easily understood that while the ends of the rod BD are thus alternately made to move right and left, its middle point M will not sensibly deviate to the right nor to the left, but will move upwards and downwards in a line not sensibly varying from a vertical direction.

160. " The complete parallel motion, which is most

universally adopted in large steam-engines, is shown in the

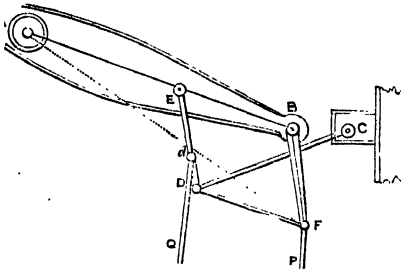

annexed fig. When so employed the beam of the engine becomes one of the radius rods of the system. AB is half this beam, of which the centre of motion is A . It has two links ED , BF , jointed to it, of which BF is termed

the *main-link*, and ED the *back-link*, and these are connected below by a third link DF , termed the *parallel-rod*, and equal to BE . The radius rod or *bridle-rod* CD is jointed to the end D of the back-link ED , and its centre C is fixed at a vertical distance below A equal to ED or BF . The length of the rods are so proportioned that F shall be the point to which the rectilinear motion is communicated, or *parallel-point* as it is termed."—See *Prof. Willis's Mechanism*, Art. 447, who deduces from a learned and abstruse investigation, the following simple equation exhibiting the proportions of the parts constituting the parallel motion.

$$AE^2 = CD \times DF,$$

$$\text{or } CD = \frac{AE^2}{DF} = \text{length of the radius rod.}$$

161. "Since the parts AE , ED , CD considered separately, form a system similar to the arrangement in Art. 159, it follows that if the proper point d between D and E be taken, an additional parallel motion is obtained; so that this form combines two parallel motions in one, and is commonly so employed in steam-engines, by suspending the great piston rod PF from F , and the air-pump rod da from d in the link ED ." The position of the point d is found from the following equation.

$$Dd = \frac{ED \cdot AE}{AE + CD}.$$

Note. If the system of link-work constituting the parallel motion be moved into all the positions it is capable of taking, the actual paths of the points F and d would be found to be, since the extent of the stroke

of the piston is small, curves in the shape of the figure 8; but the portion of the curves described, differ insensibly from right lines. See *Prof. Willis's Mechanism*, Arts. 441 to 452, where various other important investigations on the same subject are given. *Mr. Hann*, in his work on the *Steam-Engine*, has also given similar methods of constructing the parallel motion.

WHITE'S PARALLEL MOTION.

162. Toothed wheels are sometimes used in parallel motions; their action is necessarily not so smooth as that of Watt's, but on the other hand the rectilinear motion is strictly true, instead of being an approximation.

"A fixed annular wheel *D* has an axis of motion *A* at the centre of its pitch-line. An arm or crank *A B* revolves round this centre of motion, and carries the centre of a wheel *B*, whose pitch-line is exactly of half the diameter of the annular wheel *D*, with whose teeth it gears.

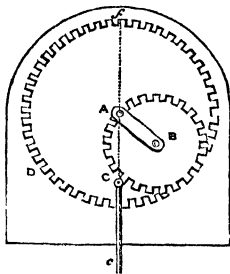

By the well-known property of the hypocycloid, any point *c* in the circumference of the pitch-line of *B* will describe a right line coinciding with a diameter of the annular pitch-circle. If then the extremity *c* of a rod *cc* be jointed to this wheel *B*, by a pin exactly coinciding with the circumference of its pitch-circle, the rotation of the arm *A B* will cause *c* to describe an exact straight line, *cf*, passing through the centre *A*."

Note. "Since $\Delta C = 2 \cos. B A C$, it is evident that the velocity ratio of *c* to *A B* is the same as in the common crank, and the motion produced on *c* is equal to that which would be given by a crank with a radius equal to $2 \Delta A B$, and in infinite link."

CHAPTER III.

MACHINES COMMONLY USED IN THE ARTS OF CONSTRUCTION
AND FOR DOMESTIC PURPOSES.

THE CRAB.

163. This machine is chiefly used for raising building materials to a great height. It is worked by two handles,

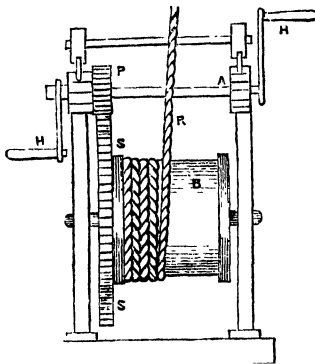

H H, which turn the axle A P, on which is fixed the pinion P, turning the spur-wheel s, on the axle of which is fixed the barrel or drum B; the rope R coils round this barrel, and passes over a pulley fixed upon the scaffolding to which the materials are to be raised. When very great weights are required to be raised, the power of this machine may be greatly increased by the addition of another spur-wheel and pinion. The re-

coiling of the machinery is usually prevented by a ratchet-wheel fixed on the axle A P.

Example.—Let the length of the winch of each of the handles H H be 18 inches, the radius of the pinion $p = 2$ inches, the radius of the spur-wheel $s = 20$ inches, and the radius of the barrel or drum $B = 8$ inches; required, the weight that can be raised by the crab when a continuous power of 150lb. is applied to the two handles?

By Art. 30, equa. (2) $w = \frac{150 \times 18 \times 20}{2 \times 8} = 3375 \text{ lb.},$
 $= 30 \text{ cwt.}, 15 \text{ lb.},$ the weight required.

THE JIB CRANE.

164. This machine is used for raising weights vertically by means of a rope or chain coiling round a barrel and

passing over a pulley or pulleys attached to a projecting arm, called the jib.

In the annexed figure, the jib jke rests as well as turns on an axle e , firmly fixed in masonry, and is also further supported by rollers. The handle h turns a pinion a , which turns the spur-wheel b ; a pinion on the axle of b turns the wheel c ; on the axle of the wheel c is a barrel, round which coils the chain p, p, p passing over two pulleys p, p ; the

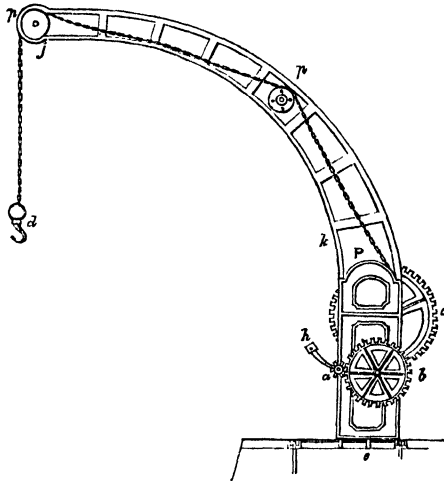

end of the chain has a hook d to lay hold of the weight which is to be raised. The barrel on the axle of the wheel c is furnished with a ratchet-wheel and detent. The crane admits of being turned round so as to bring the hook d over any object lying within its circular range, and after it is raised the whole machine may be turned round again, to deposit it at any other place within that range.

When the crane is not required to lift very great weights only one spur-wheel b is necessary, to the axle of which the barrel is fixed in this case.

Note.—This crane, which was patented by *Messrs. W. Fairbairn and Sons, Manchester*, affords an additional example of the extension of the tubular system in the light and elegant construction of its jib.

Example.—Let the length of the winch or handle h = 20 inches, the radius of the pinion a = 3 inches, the

radius of the wheel $b = 18$ inches, the radius of the pinion on the axle of $b = 4$ inches, the radius of the wheel $c = 24$ inches, and the radius of the barrel on the axle of $c = 8$ inches; required, the weight the crane will lift when a continuous power of 100lb. is applied to the winch?

$$\text{By Art. 30, equa. (2) } w = \frac{100 \times 20 \times 18 \times 24}{3 \times 4 \times 8} = 9000 \text{ lb.}$$

= 4 tons, 40 lb., the weight required.

THE PILE ENGINE.

165. This engine is used to drive piles into the ground for the support of the piers of bridges, or heavy walls,

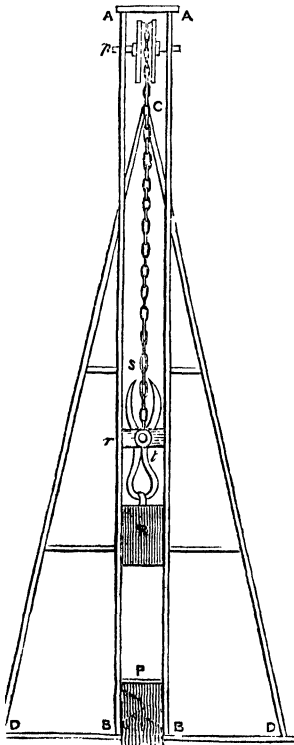

where the soil is not sufficiently firm to carry the structure. r is a heavy block of metal, usually about 10 cwt., called the *ram*, which being drawn up by a chain passing over the pulley p , falls by its own gravity upon the head of the pile P , and thus drives it into the ground. The ram is drawn up by a crab (described at the beginning of this Chapter), and at the end of the chain is a pair of nippers $s t$, which lay hold of the loop at the top of the ram; r is a heavy sliding piece fixed on the nippers, and when the ram is drawn up to near the top of the frame $A A B B$, the two forks s of the nippers are closed between the inclined stays $C D, C D$, thus causing the nippers to open below, which, releasing the loop, allows the ram to fall upon the head of the pile. The nippers are then allowed to fall by the

weight of the sliding piece r , and they are so contrived as to

fix themselves on the loop of the ram, which is thus prepared for another ascent. The height of the frame *A B* is usually from 20 to 30 feet. There are various other methods of constructing the pile engine, but the one just described is the most commonly used.

THE HAND JACK.

166. This machine is much used in raising large blocks of timber or stone through a short space, by builders; part of the case of the machine is open to show the wheel-work, &c. *H* is the handle, which turns the pinion *a* acting on the spur-wheel *c*; the pinion *b*, on the axle of *c*, acts upon the teeth of the rack *B R*, which is provided with a fork to lay hold of the beam or other material to be raised; and *D* is a detent to hold the rack as it is raised. The power of this machine may be calculated by Art. 30, equa. (2).

Example.—Let the length of the handle *H* = 20, the radius of the spur-wheel *c* = 15, and the radii of the pinions *a* and *b* each 2 inches; and let the power applied at *H* be 1 cwt.; then the power acting on the rack, that is, the

$$\text{power at R} = \frac{20 \times 15 \times 1 \text{ cwt.}}{2 \times 2} = 75 \text{ cwt.}$$

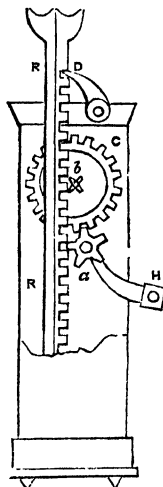

THE PATENT EXCAVATOR.*

167. This machine, originally an American invention, is capable of cutting and levelling earthwork for the making of railways and for other works, at a cost considerably below manual labour, and which has the additional advantage of saving much time. By the attendance of the engine-man and assistant, together with the labour of six men for carting away the removed earth, this machine, it is said, can be made to excavate 1500 cubic yards in twelve hours, at a cost of fuel of 12*s.* per diem. The cost of the machine is 1500*l.* Earthwork in England has generally been taken at 10*d.* to 1*s.* per cubic yard.

* See "Ensamles of Railway Making," royal 8vo.

This apparatus is a strong rectangular frame of wood, or other material, mounted upon wheels, supported, together with the machine, on a temporary railroad: at one end of this frame is a strong crane, consisting of a vertical shaft or pillar, with the jib supported by diagonal stays, or arms: to the end of the chain tackle is suspended a scoop, shovel, or scraper, made of strong boiler-plate iron, and consisting of two sides, end, and bottom, the edge of which latter is

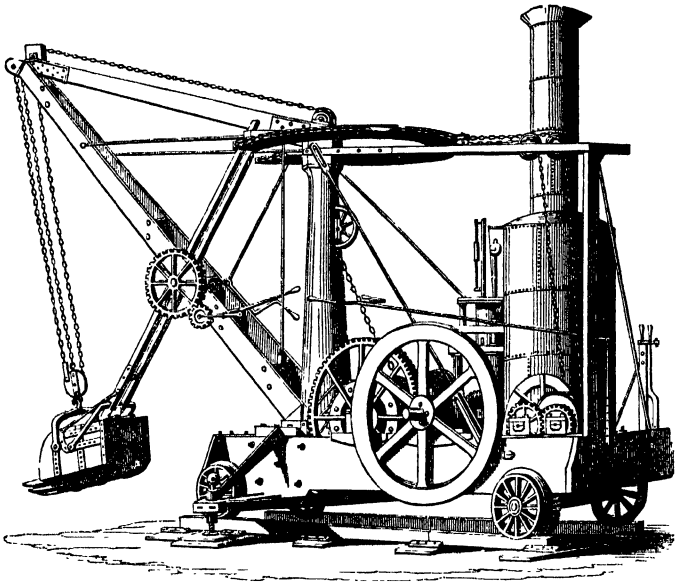

provided with four or more projecting points or cutters; and between these, and at their roots, is a steel edge, well tempered, so as to resist stone or other hard substance with which it may come in contact: the chain tackle is attached to the sides of the shovel, and passes over a pulley at the end of the jib, and over another pulley fixed on the top of the pillar or support of the crane, and from thence to the barrel, upon which it is made to coil. The periphery of the last-mentioned pulley is formed with indentations to receive the links of the chain, for the purpose of giving motion to the pulley, which has on its axis a bevel-wheel, taking into

and driving a similar wheel, upon the end of an inclined shaft, which shaft actuates certain machinery fixed to and supported by the diagonal arms of the crane. This machinery consists of a barrel, with other appurtenances, round which is passed a chain, with its ends attached to the opposite ends of a beam or arm, which is also fixed to the shovel or scraper. The crane is capable of being moved round, so as to turn the scoop, when elevated, either to the right or left, in a horizontal direction; for this purpose a "horse-shoe pulley," having a groove in its periphery, is affixed to the upper part of the crane: a chain, attached at each end to a transverse bar, passes round this pulley and over certain horizontal and vertical guide-pulleys, to a barrel, in such a manner that, by reversing the motion of the barrel, the jib of the crane can be turned either to the right or left. A steam engine is erected at one end of the rectangular frame, or platform, for the purpose of giving motion to the various parts of the apparatus. When commencing operation, the shovel, or scraper, is suspended by the chain tackle in a nearly vertical position, with the steel points towards the ground: by releasing the clicks, or catches, of the chain barrel, and applying the brake, the shovel will be lowered, and force itself, by its own weight, into the ground; then, by communicating motion to the chain barrel, the tackle will be raised, and, by means of the indented grooved pulley, motion will be given to the shaft which actuates the machinery on the diagonal arms, which, in its turn, will force forward the shovel into the ground. At the same time that this motion is going forward, the shovel, or scraper, is being raised or lifted up by the tackle, by which means the shovel has a double motion—a thrusting forward motion and a lifting motion. When the shovel has become filled, and attained its proper altitude, these motions stop, and the shovel being prevented from returning by the clicks, or catches, the other barrel is thrown into gear by means of a coupling or clutch-box, and the crane turned round so as to bring the shovel over the cart, or other place of deposit; and by certain arrangements it is turned up so as to empty itself, in which position it is again ready for another operation.

UNCOUPLING FOR RAILWAYS.

168. This apparatus was first used on the Taunus Railway, which, from its simplicity and efficiency, cannot be excelled.

It is attached to the hinder part of the tender *T*, and is used in case of emergency, as well as being constantly used at the stations, saving much trouble, and with less danger to engine-men, as they can disconnect at any speed or at any time, whether the engine and train are in motion or not. The

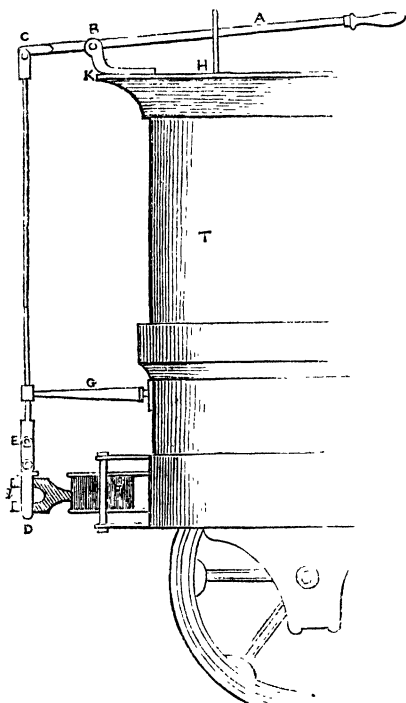

apparatus consists of a lever *A C*, moving on a fulcrum *B*, which rests on the tender at *K*; this lever is keyed at *C* to a rod *C E*, which is connected with a double eye and rod to the slightly conical pin *D*, going through the large double eye *d*, which is attached to the drag-spring *F* of the tender *T*; the links *E, E* are to admit the vibration of the drag-spring, which is always more or less stretched when the train is behind the tender; *G* is a guide, bolted upon the planking of the tender, to keep the pin *D* always in a right position; *H* is a standard or catch-plate screwed upon the tank to hold the

lever *A C* in its place. When it is found necessary to uncouple the engine, the lever *A C* is lifted out of the notch of the plate *H* and allowed to fall, by which the pin *D* is raised and the engine is immediately disengaged. This piece of mechanism was invented by Mr. Thorman, of Newcastle-on-Tyne.

THE DREDGING MACHINE.

This machine is used for raising sand, mud, and gravel from the bottoms of harbours and navigable rivers, for

the purpose of increasing their depth and improving their navigation.

169. The boat, or vessel that contains the dredging machine, by *Messrs. Summers and Co.*, is 90 feet long

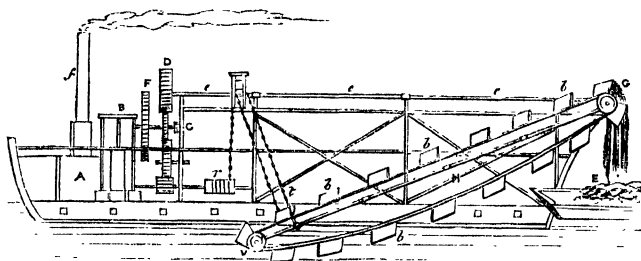

and 22 feet on deck. A section of the steam-engine, that works the dredging apparatus, is shown in the figure: A is the boiler, B the engine, &c., both of which are adapted to marine purposes. The endless chain $a\ b\ v\ b$ carries a series of buckets $b, b, b, \&c.$, which are attached to its alternate links. The chain passes over the toothed axle fixed on the wheel G, and a similar axle at v, which is near the bottom of the water when the machine is at work. The full buckets ascend on the upper side of the chain, and on passing G become inverted, emptying their contents into the small boat E. The buckets are perforated to let the water run out of them, and their top extremities are pointed to pierce the mud, sand, &c., at the bottom of the water. Motion is given to the fly F, and the wheels C and D, by the crank-shaft of the engine B, and communicated by the line of shafting e, e, e , to the wheel G by a pinion, not shown in the figure, and from thence to the buckets. The bucket-frame H, acting on the axle of the wheel G as a centre, is regulated to a proper depth in the water by the engine, by means of wheels which act upon the barrel r , and round which the chain of tackle t passes, as shown in the figure. The number of the buckets may be from 20 to 40, according to the depth of the water; each bucket is 26 inches wide, 16 inches broad, and 17 inches deep; and formed of the best plate-iron $\frac{3}{8}$ of an inch in thickness; also on the fronts, or pointed parts of the buckets, are fixed pieces of iron edged with steel, for the purpose of increasing the strength of that portion of the bucket, and the better adapting it for coming

in contact with hard materials. With an engine of 20-horse power this apparatus will lift, from a depth of 18 feet, about 110 tons of mud or clay per hour, or 160 tons of sand or gravel in the same time, but in very hard ground, intermixed with stones, no proper amount of quantity can be given.

THE DRILLING MACHINE.

170. Where great accuracy is required, the common method of drilling holes with the bow cannot be applied, especially where large holes are to be bored in metal. The portable drilling machine, shown in the margin, is a simple and useful contrivance, which may be driven either by hand, or by other machinery. Upon the bed *A* the standards *B, B* are firmly fixed, supporting the two bearings *c, c* of the drill-spindle *D d*, in which the drill *D* is fixed. The drill-spindle is turned round by the bevel wheels *a, b*, the former being fixed on the axle of the fly-wheel *F*, which is worked by the handle *H*.

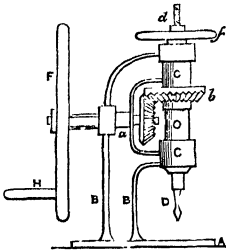

To give the drill the requisite vertical motion there is a small fly-wheel *f* working upon the screw *d* on the top of the spindle *D d*. This machine is one of *Mr. James Nasmyth's*.

THE HAND-DRILL.

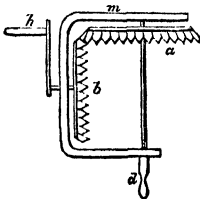

171. Where moderately heavy work is required to be done, and where the drill just described cannot be applied, the hand-drill may be advantageously used: motion is given to the machine by the handle *h*, through the bevel wheels *a, b*, to the drill *d*, the part *m* of the frame being placed against the breast of the operator.

NASMYTH'S FOOT-DRILL.

172. This machine is driven by the riggers or pulleys *b*, the one running loose while the other is fixed to the spindle for conveying the motion by means of the upper and lower sets of speed-pulleys *c*, the strap of which is shown by the

dotted lines. The motion is then carried at right angles to the drilling spindle *d* by the bevel wheels *e*. A moveable

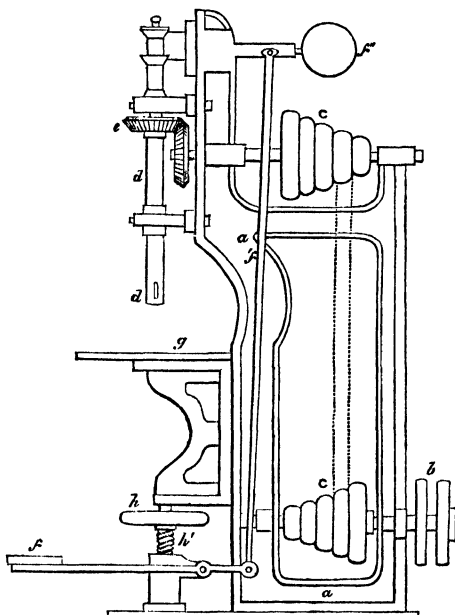

table *g*, for supporting the work to be drilled, is fixed in the frame *a*, in which it slides, and can be raised or lowered by the wheel *h* and screw *h'*, according to the size of the work. By means of the footboard *f* working as a lever on its fulcrum, the drilling-spindle is made to rise and fall; the pressure of the foot on the board causing the rod *f''* to rise, which, by the upper lever fixed to the frame of the machine, depresses the spindle *d* while it is revolving; as soon as the pressure is withdrawn, the counterbalance weight *f'''* causes the drill to ascend to its former position.

THE COMMON FOOT-LATHE.

173. This machine for turning metals or wood, by causing the material to revolve on central points, and be cut by a tool held by hand or fixed in a slide-rest, is by Messrs.

Whitworth. In the common foot-lathe, shown in the annexed figure, the cutting-tool is held by hand.

The axis or spindle $A B$, is called the mandril, and is made to revolve with considerable variation of speed by means of the speed-pulleys s, s' , which are connected by the band or

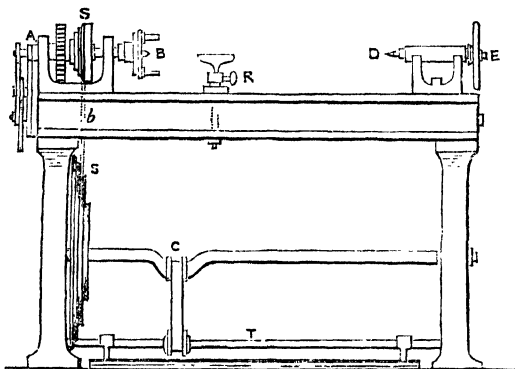

strap b , shown by the dotted lines. The frame F carries a pointed screw within the fixed female screw $D E$, the pointed screw is moved by the wheel E for the purpose of adjusting the distance $B D$ to the length of the bar, which is to be turned; the frame F can be moved lengthwise by unscrewing the nut which fixes it to the frame of the lathe. The cutting tool of the workman is supported by the rest R , which can also be moved lengthwise by unscrewing the nut which fixes it. The speed-pulleys s , which act as a fly-wheel, are made to revolve by the crank c , on pressure being applied by the foot of the workman to the treadle T . The bar of wood or iron to be turned is fixed between the points B and D , and is made to revolve with the spindle $A B$ by means of clutches, which lay hold of a small vice screwed upon the bar.

Note.—In Chap. V. are given detailed descriptions of self-acting and self-adjusting lathes, which are adapted to plain and circular turning, screw-cutting and boring. The method of arranging the mechanism, and making the calculations for cutting screws of any required pitch, shall next be given.

174. "*Change-wheels* are employed in lathes for cutting screws of any required pitch, and also in self-acting lathes.

The following figure represents the general arrangement of this mechanism; Λb is the spindle or mandril of the lathe; to which is united, in the usual way, a cylindrical rod ba , upon which the screw is to be cut. cc is a long screw revolving in bearings fixed to the frame of the lathe, and giving motion, by means of the nut n , to a sliding-table or *saddle*, upon which is clamped the pointed tool m , which is intended to cut the screw. Every revolution of the screw cc will therefore advance the tool m through the space of one pitch of its threads, and supposing the spindle Λa to revolve with the same velocity as the screw cc , the tool will trace upon the surface of ba a screw of exactly the same pitch as cc ; but, if Λa revolve with a less velocity than the screw cc , ba will have a greater pitch.

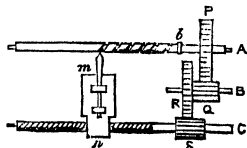

“ If Λa and cc be connected by a set of change-wheels p, s , we can, by properly choosing the numbers of teeth in these wheels, obtain any required pitch for the screw ba . Let B be an intermediate axle supported by the framework of the lathe, and either carrying an idle wheel, or two additional change-wheels q and r . Now the pitch of screws is commonly defined by stating the number of threads in the inch. Let the screw cc have n threads in the inch, and let the number of teeth in the wheels p, q, r and s be respectively represented by those letters; then one turn of cc advances

the tool m through the space of $\frac{1 \text{ inch}}{n}$ and one turn of Λa advances the tool through the space which corresponds to

$\frac{p \times r}{q \times s}$ turns of cc , (Art. 30) that is, through $\frac{p \times r}{q \times s \times n}$ inches.

The pitch of the screw Λa is therefore $\frac{q \times s \times n}{p \times r}$ threads in

the inch. Thus, by providing the proper change-wheels, a screw of any required pitch can be cut. The pitches usually cut upon these lathes extend from about 4 to 50 threads in the inch, and a set of twenty change-wheels will generally be suffi-

cient to supply all values required for $\frac{q \times s}{p \times r}$. These should

be arranged in a table, and the wheels corresponding to each

written opposite to them to save the trouble of computation during the work."

Example.—Let the numbers of teeth in the wheels P, Q, R and S be respectively 18, 12, 24 and 12; and let the screw C have 9 threads to the inch, or $n = 9$;

$$\text{then } \frac{Q \times S \times n}{P \times R} = \frac{12 \times 12 \times 9}{18 \times 24} = 3 \text{ threads in the inch.}$$

Note.—"If the apparatus, just described, be used for turning cylinders, instead of cutting screws, the arrangement will not essentially differ, for the motion by which a tool traces a cylinder is precisely the same as when it cuts a screw, only that the spiral thread is much closer. In a lathe for turning, the number of cuts will be from 50 to 1000 in an inch."

PUNCHING MACHINE.

175. This machine is used for making holes for the rivets that join iron plates together for the purpose of forming the boilers of steam-engines; for this purpose immense force is required to be exerted through a small space.

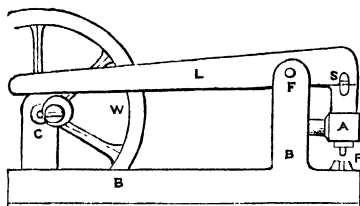

In this machine a heavy cast-iron lever L is used, having its fulcrum at F, in the strong standard B B; the shorter arm carries the punch P, the socket of which is S, and which is kept fast by the box A in which it slides. The longer arm of the lever L is raised by the camb C, and is on the same axis as the heavy fly-wheel W, which is moved by steam or any other efficient power.

SHEARS FOR CUTTING METAL.

176. In this machine L is a heavy cast-iron lever, moving on the fulcrum D; the camb C, revolving on the centre of motion A, acts upon the friction roller P, which is attached to the end of the longer arm of the lever; B, B are the edges of the shears, formed of strong steel plates to cut the metal, the lower of which is firmly fixed to the heavy block E; the weight of the longer arm D P keeps the friction wheel P in contact with the camb C, on the centre A of which is fixed a ponderous fly-wheel W. When the machine is in the position shown in the figure, the metal required to

be cut is placed between the edges B, B of the shears, and

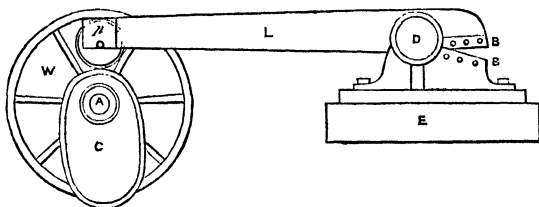

the camb *c* revolving, raises the end *p* of the lever, thus causing the edges of the shears to close and cut the metal.

SAW MILL.

177. The annexed figure explains the connection of the parts of a saw mill, though various other constructions of the same machine have been recently produced. "A is a

toothed wheel, which may be supposed to be driven either by a water wheel or a steam-engine, and its teeth are engaged with those of the smaller wheel B, on whose axis is fixed a crank *c* and an excentric *E*. The crank is connected by a link *c* with the saw frame *D*; this is fitted between guides, and therefore, when the crank revolves, receives a vertical oscillating motion. The timber *w* which is submitted to the action of the saw, is clamped to a carriage which moves on rollers *m*, *n* in a horizontal direction. While the saw

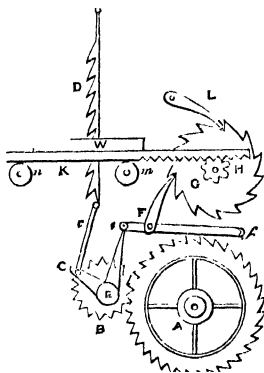

is in motion, as above described, the carriage and timber are made to advance in the following manner. The excentric *E* communicates an oscillating motion to the lever *ef* whose centre of motion is *f*; this lever carries a click *F*, which acts upon the teeth of the ratchet-wheel *G*, to which an intermittent rotation is thus given. Upon the axis of *G* is a pinion *H*, which, gearing with a rack fixed upon the wood-carriage, causes the latter to advance towards the saw with the same intermittent motion. This intermission is adjusted to the motion of the saw-frame, so that when the saw rises the wood shall advance; and when the saw descends, and there-

fore cuts the wood, shall remain at rest. The cut is made by the inclined position of the saw, the toothed edge of which is not vertical but slightly inclined forwards, so as to bring the teeth into successive action during the descent of the frame. The detent *L* serves to hold the ratchet-wheel, and therefore the wood-carriage, firm in its position during the cut.”—See *Prof. Willis's Mechanism*.

THE SMOKE JACK.

178. This machine is well known as being used in the kitchen to turn the spit.

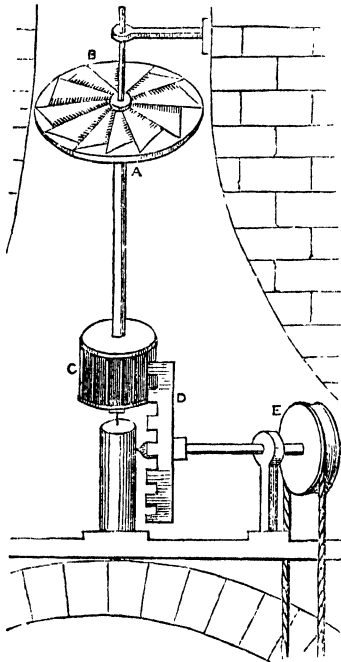

A B is a horizontal wheel in which vanes or sails are inclined to the horizon. The rarified air and smoke rushing up the chimney at *B*, strikes these sails, and causes the wheel to revolve together with the pinion *C*, which is on the same axis; *C* turns the face-wheel *D* and the pulley *E*, which are on the same axis; and *E* carries the chain or cord which turns the spit. The wheel *A B* must be placed in the straightest part of the chimney where the motion of the air is swiftest, and that the greater part of it may strike upon the sails. The force of this machine increases in proportion to the heat of the fire, and the consequent higher rarification of the air.

THE COMMON CLOCK.

179. This figure represents the arrangement of the wheel-work of a clock of the simplest kind. “The weight *w* is attached to the end of a cord, which is coiled round the barrel *A*. Upon the same axis as that of the barrel is fixed the toothed wheel *B*, and this wheel drives the pinion *b*, which

is fixed on the second axis *c b* of the train, which also carries a wheel *c*. This wheel drives a pinion *c* upon the third axis, and upon this axis is fixed a toothed wheel *D*, which is called an escapement or swing-wheel," (see Art. 138) one tooth of the wheel *D* escaping or passing the line of centres for every vibration of the pendulum *e' f'*, which is attached to the verge *e' d*, the pallets *d* on the verge being engaged with the teeth of the wheel *D*.

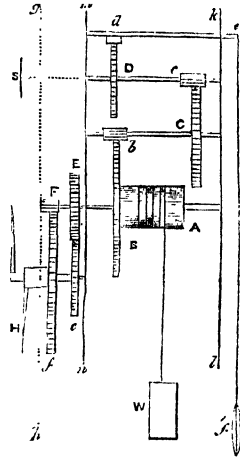

“Let the time of a vibration of the pendulum be *t* seconds, where *t* is a whole number or a fraction, and let the swing-wheel have *e* teeth, then the time of rotation of this wheel is $2te$. To take a simple case, let the pendulum vibrate seconds; therefore $t=1$, and if $e=30$, the swing-wheel will revolve in a minute; and if *B* have 48 teeth, $c=45$, the pinions *C* leaves each, and *x* the number of revolutions made by *A* while *D* makes one revolution, then

$$x = \frac{48 \times 45}{6 \times 6} = 60;$$

therefore *A* will revolve in one hour; and supposing the cord to be coiled about 16 times round the barrel *A*, the weight *w* in its descent will uncoil it and turn the barrel round, communicating motion to the entire train until the cord is completely uncoiled.

“This train of wheel-work is solely destined to the purpose of communicating the action of the weight to the pendulum in such a manner as to supply the loss of motion from friction and the resistance of the air. But besides this, the clock is required to indicate the hours and minutes by the rotation of two separate hands, and accordingly two other trains of wheel-work are employed for this purpose.” The train just described is generally contained in a frame consisting of two plates, shown edgewise as *k l, m n*, which are kept parallel and at the proper distance by three or four pillars, not shown in the diagram. Opposite holes are

drilled in these plates, which receive the pivots of the axes already described. But the axis which carries *A* and *B* projects through the plate, and other wheels *E* and *F*, are fixed to it. Below this axis and parallel to it, a stout pin or stud is fixed to the plate, and a tube revolves upon this stud, to one end of which is fixed the minute-hand *M*, and to the other a wheel *e* engaged with *E*. In our present clock *E* revolves in an hour, consequently the wheels *E* and *e* must be equal. A second and shorter tube is fitted upon the tube of the minute-hand so as to revolve freely, and this carries at one end the hour-hand *H*, and at the other a wheel *f*, which is driven by the pinion *F*; and because *f* must revolve in 12 hours, it must have 12 times as many teeth as *F*." For an elaborate work on clocks, &c., see Rudimentary Treatise on Clock and Watch making, by E. B. Denison, M.A.

THE PERAMBULATOR.

"This machine is used for measuring distances on roads, for settling disputes concerning the charges of the drivers of hack-carriages, and for other purposes. It consists principally of a wheel upon which it runs, and an index which shows the number of turns of the wheel reduced into miles, furlongs, poles and yards. The carriage or stock is made of wood, and is about three feet long. At one end is a handle for the person who uses it, and the other is furnished with brasses in which the axle of the wheel turns; this end of the stock has the central part removed, thus leaving two arms between which the wheel works. Upon the stock and just in front of the handle is the dial-plate with its two hands by which the distances are registered. The wheel is $8\frac{1}{4}$ feet or $\frac{1}{2}$ pole in circumference. Upon one end of the axis of this wheel is a small pinion which works into a similar pinion at the end of a rod which passes up the stock to the work beneath the dial-plate. Upon this rod is an endless screw, which turns once round for every revolution of the carriage-wheel of the perambulator. This screw works into a wheel of 80 teeth, which is consequently moved one tooth for every $\frac{1}{2}$ pole, and carries an index or hand making one revolution for 40 poles or 1 furlong. On the axis of this wheel is a pinion of 8 teeth, which works into a wheel of 40 teeth, and on the axis of this second wheel is a pinion of 10 teeth, which moves a wheel of 160 teeth. This last wheel carries another hand, which conse-

quently makes one revolution for 80 of the former. These hands are concentric like the hour and minute-hands of a clock. The first of these circles is divided into 220, and the second into 40, the respective numbers of yards and poles in a furlong; the figures on these circles are read off by the first-mentioned index. The third circle is divided into 80, the number of furlongs in 10 miles, and to this circle belongs the index attached to the wheel of 160 teeth. The distance moved over is shown by reading off the figures of the indices, or hands, and dividing the number shown by the last-named hand by 8, which gives the distance required in miles, furlongs, poles and yards. The instrument is furnished with a stop, so that after the distance is measured, the perambulator may be conveyed without the hands being altered. When about to commence a measurement, the wheel should be turned round until the first-mentioned hand points to 220 on the circle of yards, which may be called the zero of the instrument."—See *Perambulator*, *Penny Cyclopædia*.

CHAPTER IV.

PUMPS AND OTHER HYDRAULIC MACHINES.

THE COMMON SUCTION PUMP.

180. This machine, so well known in domestic establishments, is usually thus constructed. $A C$ is a cylindrical barrel, $A B$ a pipe having its lower end in water; v is a fixed valve opening upwards, and p is an air-tight piston, moveable by a handle or brake fixed to the rod, and having a valve v' opening also upwards. Now, let the piston p descend as low as it can, each valve being shut; then, when p ascends, there will be a vacuum in the barrel between A and C , and the valve v will be opened by the upward pressure of the air in the pipe $A B$, and the air will follow the piston and fill the empty space $A C$. The air in the pipe will thus become rarified, and hence the pressure of the air on the surface of the water at w will be greater than the pressure of the air in $A B$, and therefore the water will be forced a short distance up the pipe $A B$, till the equilibrium is restored.

On again depressing the piston, the valve v is closed, and the valve v' forced open (as in fig. 2), through which the air in Δc escapes. On raising the piston a second time more air rushes from ΔB , and the water in the pipe rises still higher. Thus, by alternately raising and depressing the piston, all the air will be drawn out of ΔB , and the water will rise up to the valve v . The piston being now raised water instead of air will open the valve v , and rush into the barrel, and, on lowering the piston, the water closes this valve v , thus preventing it from flowing back; at the same time the water forces open the valve v' and passes through it, so that the water is now both above and below the piston. This action being continued, the water will rise still higher above the piston, till it be discharged at the spout s .

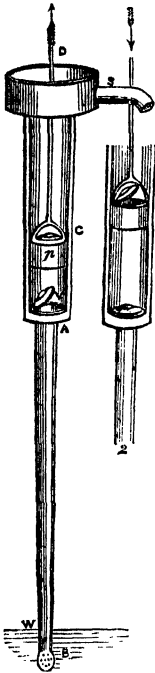

Note.—In this pump the height of the valve v above the water must not greatly exceed 30 feet; because the pressure of the atmosphere, in its rarest state, will not raise the water in a vacuum above that altitude.

THE FORCING PUMP.

181. In this machine ΔF is the suction tube, $\Delta B C$ the body of the pump, and $H K$ a tube ascending to any required height. The body of the pump is furnished with an air-tight solid piston or plunger $M N$, attached to the rod D , which is moved by a handle or brake, as in the last Article. At c and H are fixed valves opening upwards. Now, suppose the plunger D at its greatest depression, the valves closed, and the air in its natural state; then by the ascent of $M N$, the air in $\Delta C N M$ occupying a greater space, its elasticity will be diminished, and consequently the greater elasticity of the air in ΔF will open the valve at c , while the valve at H is kept closed by the elasticity of the external air; water will therefore rise in the suction

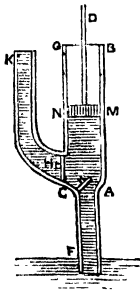

tube. On the descent of $M N$ from its greatest elevation, the increased elasticity of the air in the body of the pump will keep the valve at c closed and open that at H , whence air will escape. By similar ascents and descents of the piston the air will be expelled and water rise into the body of the pump. The descending piston will then press the water through the valve at H , which will close and prevent its return into the body of the pump. The ascents and descents of the piston, being thus continued, will raise the water to any required height in the pipe $H K$.

Note.—In this pump, $M N$ must not ascend higher than about 32 feet above the surface of the water at F .

FORCING PUMP WITH AN AIR-CHAMBER.

182. In the forcing pump just described, the stream is intermittent, since there is no force impelling it during the descent of the piston. One mode of remedying this is by making an interruption in the ascending tube, which is surrounded by an air-vessel T , in which, when the water has risen above z , the air above it is compressed, and by its elasticity forces the water up the pipe $z T$, the orifice of which is narrower than that of the air-chamber $P Q$, and therefore the quantity of water introduced during the descent of the piston will supply its discharge for the whole time of the stroke, producing a continued stream.

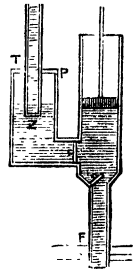

Note.—There is a great defect in the pump just described; for after it has been some time in action, the air in the chamber $P Q$ becomes absorbed into the water, so that it is found that at length nearly all the air has passed off with the water discharged from the pump. The defect of this pump is remedied by the following arrangement.

THE DOUBLE-ACTING PUMP.

183. This machine is simply a double-acting forcing pump. P is a solid piston, or plunger, attached to a rod which passes through an air-tight stuffing-box at R . On each side of the cylinder containing the piston are two pipes $a b, c d$. The water is drawn up $a b$ from the well, and forced up $c d$ to the reservoir. The valves A, B, C, D all rise in the same direction; and supposing the body of the pump to be filled with water, then by the raising of the piston the valves A

and *D* will be opened, while *c* and *B* will be kept shut by the pressure of the water on them; at the same time the water is forced by the piston through the valve *D*, and from thence up the pipe *c d*; while by the pressure of the external air the water rises up the pipe *a*, and pressing open the valve *A*, follows the ascending piston. But when the piston descends, the valves *A*, *D* will be closed, and *c*, *B* opened; the water in this case is forced through the valve *c* up the pipe *c d*; the water at the same time entering the cylinder by the valve *B*, follows the descending piston; and so on.



THE FIRE ENGINE.

184. This engine is a combination of two forcing pumps *E F*, *G H*, the pistons of which are *Q*, *Q'*, which force the water through two valves, opening inwards, into a large receiver or air-chamber *A B C D*. From the receiver proceeds a flexible tube *M L*, called a *hose*, of any required length, through

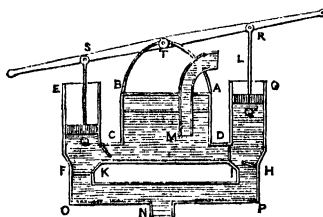

which the water is thrown and directed to any point. The pumps are worked by the lever *R T S*, the fulcrum of which is *T*, so that while the one piston ascends the other descends. The suction-pipe *N* supplies the water required to be raised. When the piston *Q'* is raised, the pump *G H* becomes filled, and the descent of *Q'* will cause the valve *H* to close, and force the water into the air-chamber through the valve *I*, while the water in the air-chamber will close the valve *K*. At the same time that *Q'* ascends, *Q* descending will force the water through the valve *K* into the air-chamber. By these means the air above the surface of the water in the chamber, becoming greatly compressed, will, by its elasticity, force the water to ascend through the hose *M L* with a great velocity.

Note.—There are various other arrangements in the parts of this machine, the chief of which is link-work, like the parallel motion, Art 160, attached to the lever *R S*, and the pistons *Q*, *Q'*, *S*, *Q*, to make them ascend and descend vertically. The same thing is also accomplished by

two segments of a spur-wheel, fixed on the lever, and acting on racks fixed on the pistons; both of which additions are improvements. But the general principle of the machine is the same as that just described.

THE SPIRAL PUMP.

185. This machine is usually formed by a spiral pipe of several convolutions in one plane, as in the annexed fig. The curved pipe is connected at its inner end, by a water-tight joint, to a vertical pipe $r p$, while the other end s receives, during each revolution, nearly equal quantities of air and water. This machine revolves on an axis (not shown in the fig.) passing through the end r of the pipe. "The outer end of the pipe is furnished with a spoon s , containing as much water as will half fill one of its coils. The water enters the pipe a little before the spoon has reached its highest position, the other half remaining full of air. This air communicates the pressure of the curved column of water to the preceding portion; and in this manner the effect of nearly all the water in the coiled wheel is united, and becomes capable of supporting the column of water, or rather water mixed with air, in the ascending pipe $r p$. The air nearest the joint at r is compressed into a space much smaller than that which it occupied at its entrance. The loss of power, supposing the machine well constructed, arises only from the friction of the water against the sides of the pipe with that of the wheel on its axis, and a small additional quantity of water on the side of the machine nearest the spoon s : and where a large quantity of water is to be raised to a moderate height, these sources of resistance may be rendered inconsiderable."—*Gregory's Mathematics for Practical Men.*

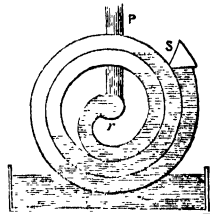

Note.—The spiral pump is usually called the *Zurich machine*, because it was invented, about 1746, by *Andrew Wirtz*, of Zurich. It has been employed with great success in various countries; and the late *Dr. Thomas Young* states, that he employed it advantageously for raising water 40 feet high.

186. *The Screw of Archimedes* is usually classed among machines for raising water, being somewhat similar in its action to the spiral pump just described. It chiefly consists of a pipe wound spirally round a cylinder, which is placed at

an inclination of from 30° to 45° to the horizon, and is capable of being turned on pivots. The lower end of the spiral pipe being immersed in the water to be raised, the water first descends into the pipe by its gravity; but the cylinder being turned, the water moves on in the pipe and at length issues at its upper end. Several circumstances tend to make this machine imperfect in its operation. The adjustments necessary to ensure a maximum of work are often difficult; besides, it seldom happens that the work done exceeds *a third* of the power applied; so that, notwithstanding its apparent ingenuity and simplicity, it is seldom used in modern times.

THE HYDRAULIC RAM.

187. The essential parts of this machine are shown in the marginal fig.; it may be advantageously employed where

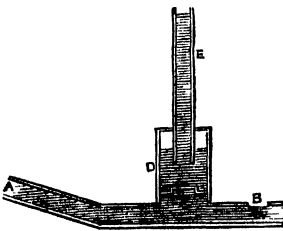

there is a large supply of water with only a small descent. The water running in the inclined pipe *A* acquires sufficient force to raise the heavy valve *B*, which immediately stops its further passage. The momentum which the water has acquired then forces a portion of it through the valve *c*, into the

air-vessel *D*. The condensed air in the upper part of *D* causes the water to rise in the pipe *E*, as long as the effect of the water in *A B* continues.

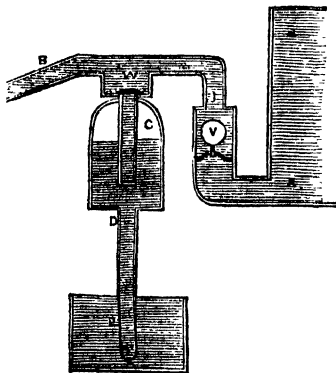

When the water in *A B* becomes settled, the valve *B* will open again by its own weight, and the current along *A B* will be renewed, until it again acquires sufficient force to close the valve *B*, open *c*, and repeat the operation.

THE SUCTION RAM.

188. In principle this machine is the same as the last. The water flows from the reservoir *A a* along the

pipe $A I W B$; v is a ball valve, which closes the opening I , when lifted up by the water; E is a well from which the water is to be raised by the pipe $E D W$, having valves at D and w , and an air-chamber C . The pressure of the water in the cistern $A a$ sustains a current in the pipe $A I W B$; and when the water has acquired a sufficient velocity, the valve v is raised, and the opening I closed: after which the water in the pipe $W B$ continues to be discharged at B , thus forming a vacuum in the pipe. The pressure of the external air then raises the water in the well E up the pipe $E D W$, thus opening the valves D and w ; the water is then discharged at B . When the current in the pipe $A I B$ is at rest, the valve v falls, and the current is renewed in the pipe $I W B$, the valve v again ascends, and so on as before.

THE CHAIN PUMP.

189. This machine is only used when water is required to be raised from 3 to 10 feet in height. It consists of a continuous chain passing over two pulleys (like the upper one in Art. 54), one placed vertically above the other, (the whole may be conceived by referring to the right-hand figure, Art. 50). The lower pulley is in the water to be raised, and the upper one at the required height, which is usually turned by a winch. The chain is furnished with leathern suckers acting as pistons, at from 8 to 10 inches apart, and these draw the water up a vertical pipe enclosing one side of the chain, when the upper pulley is turned round.

HYDRAULIC BELT.

190. This is an endless double band of woollen cloth, passing over two rollers, the lower part of the belt being immersed in water: it is driven with a velocity of not less than a thousand feet per minute, and the water contained between the two surfaces is carried up and discharged, as it passes over the upper roller, by the pressure of the band.

THE CENTRIFUGAL PUMP.

191. This very ingenious and powerful machine was invented by *Mr. Appold*, and its capabilities tested at the great Exhibition of 1851. It consists of a hollow disk, or cylinder, a section through the axis of which is shown at d , and a side view at D with curved vanes: the disk is 12 inches in diameter and 3 inches in width at the rim, with a

circular opening in the centre 6 inches in diameter, through which the water passes. This disk is enclosed on both sides, excepting the central opening, and is quite open all round the rim. The disk is placed vertically on an axle $p d$ passing through its centre; and on the end of this axle is fixed a pulley p for driving the disk with a strap from the gearing of a steam-engine, having a cylinder 9 inches in diameter and $2\frac{1}{4}$ feet stroke. In order to

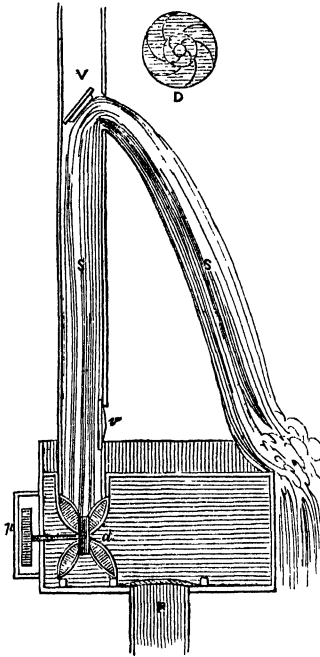

raise the water, the disk d is fixed at the bottom of a vertical trunk $s v$, which is 22 feet high, $7\frac{1}{2}$ feet broad, and one foot wide; at the bottom of this trunk is a tank to receive the water as it flows out of the valve v ; and there are other valves v , &c., at different heights in the trunk, according to the height the water may be required to be raised.

When in action at the Great Exhibition the water issued at the valve v , which is 10 feet above the disk, at the rate of about 2000 gallons per minute, and the disk was making from 800 to 1000 revolutions per minute; the capacity of the disk is about 345 cubic inches, or about $1\frac{1}{4}$ gallon.

192. While the one-foot disk is raising 8 tons of water $5\frac{1}{2}$ feet high per minute, there is no greater strain on any part of the pump than 160 lbs. on the six-inch drum within the disk; this strain is equal to a leverage of 3 inches. (See the results of various experiments on the following Table.) The pump will pass almost anything that is small enough to go through, there being no valves; a quantity of nut-galls (about half a gallon) were thrown into the one-foot pump all at once, when it was at full speed, and they passed through without breaking one.

Table of Mean Results of various Experiments with Mr. Appold's Centrifugal Pump.

No. of revolutions per minute of 6 in. drum and pump.	No. of gallons raised 5 feet 6 inches high per minute.	Equivalent in lbs. raised 1 foot high per minute.	Strain in lbs. on a drum of 4 ft. diameter driving one of 6 in. diameter, as measured by a dynamometer.	Equivalent strain on the steam engine rated in lbs., raised 1 foot high per minute.	Per centage of work done compared with power expended.
400	500	27,500	74	44,400	61·7
412	600	33,000	80	49,440	66·7
427	700	38,500	87	55,723	69·
440	800	44,000	94	62,010	70·9
453	900	49,500	100	67,950	72·8
474	1000	55,000	106	75,366	72·9
481	1100	60,500	113	81,479	74·2
495	1200	66,000	118	87,615	75·3
518	1300	71,500	121	94,017	76·
535	1400	77,000	126	101,115	76·1
563	1500	82,500	134	113,163	72·9
580	1600	88,000	138	120,060	73·3
595	1700	93,500	142	126,733	73·6
607	1800	99,000	150	136,575	72·5

Note.—This machine has lately been found more efficacious than any other hydraulic apparatus of like power, in the drainage of Soham Mere, in Cambridgeshire.

BRAMAH'S PRESS.

193. This machine has pistons fitted into the large and small cylinders A and B, which are connected together, as shown in the figure, there being a valve at c to admit the water from B to A. A pump piston in the cylinder B forces the water through the valve c into the cylinder A, and thus raises its piston. Now, let the diameter of the cylinder A = D inches, and that of the cylinder B = d inches; then the area of the piston in A = $\frac{1}{4} \pi D^2$, and the area of the pump-piston in B = $\frac{1}{4} \pi d^2$; therefore the areas are

$$\text{as } d^2 : D^2$$

$$\text{or as } 1 : \frac{D^2}{d^2}$$

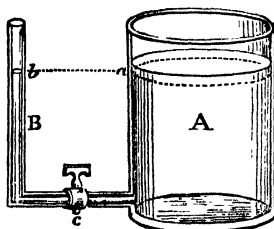

Now, if $D = 20$ inches and $d = \frac{1}{2}$ an inch; then

$$1 : \frac{D^2}{d^2} :: 1 : \left(\frac{20}{\frac{1}{2}}\right)^2 = 1600.$$

Therefore, if a force be applied to the pump-piston in B, it will produce an effect on that in A as 1 to 1600. Now, suppose the pump piston be pressed down by a lever with a force of 5 cwt.; then the large piston will ascend with a force of $1600 \times 5 = 8000$ cwt. = 400 tons.

This press has appeared in various forms and under various names, since its invention by the celebrated mechanic, *J. Bramah*, who obtained a patent for it in 1796. It has been extensively used for pressing goods of various kinds. Another of its most useful applications is to the testing of girders and beams of cast iron. Its latest and perhaps most remarkable duty is that of lifting the iron work of the tubular bridges *en masse* from the water level to their final altitude. Figures 1, 2, and 3, with their accompanying descriptions, will show their arrangements in their chief modern applications.

Fig. 1.

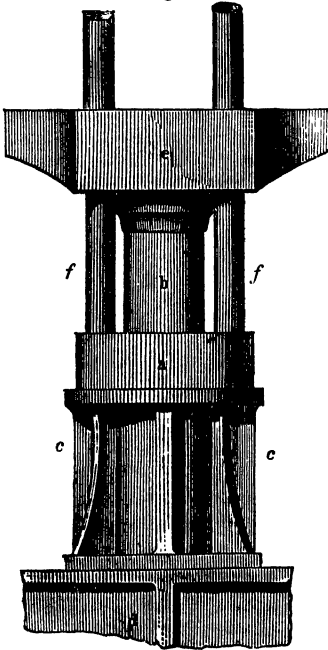

THE HYDROSTATIC, OR HYDRAULIC PRESS.

194. Hydrostatic presses consist essentially of two distinct parts, viz., the *press*, or machine in which the force acquired is applied, and the *pumping apparatus*, by which the water is forced into the press; these two parts of the entire machine being connected only by the pipe through which the water passes from one to the other. Of the accompanying figs., Nos. 1 and 2 show the main parts of the press, viz., the

cylinder, into which the water is admitted; the ram, or solid plunger or piston; and the cross-head by which the pressure at the end of the ram is distributed over a lengthened surface for use. The figures show the cylinder as supported in a frame upon girders, in a manner similar to that adopted in raising the tubes of the railway bridge recently erected at Conway.

Fig. 3 shows the section of a portable forcing-pump as commonly used for proving castings with the hydraulic press, for which purpose the press is applied horizontally, and mounted on an iron carriage for portability. But, however varied in arrangement for particular purposes, the pump and the press consist of the same essential parts, as follows: the pump comprises a cistern, or kind of pail, for containing the water, and into which a barrel descends nearly to the bottom. The barrel is fitted with a plunger, by working which the water is driven through a small tube or pipe into the press. The pump is furnished with a safety-valve, and also with a screw for letting off the water as required.

The press consists of a strong hollow cylinder of cast-iron, close at one end, and of a solid ram working through the other end, the water-pipe being inserted through the metal of the cylinder in a water-tight screwed aperture. Fig. 1 is an elevation of the press; fig. 2, a vertical section of the press, taken at right angles to the elevation: and fig. 3, a vertical section of a pump; *a* is the cast-iron cylinder; *b*, the ram; *c*, the casing or frame of the cylinder; *d d* are two cast-iron girders supporting the casing; *e* is the cast-iron cross-head;

Fig. 2.

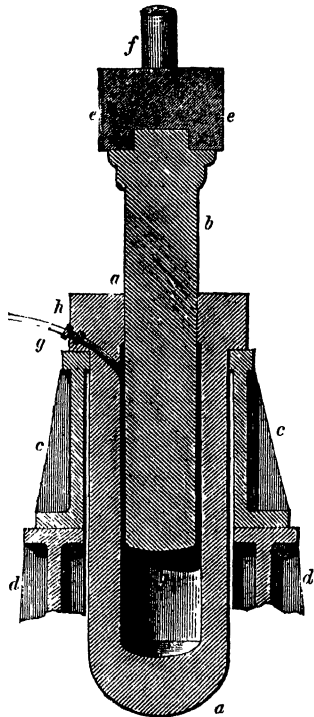

ff, two guide-rods; *g*, the water-pipe from the pump, with a lever-valve at *h*, by closing which the pressure will be retained, should the pipe burst. On fig. 3, *j* shows the other end of the water-pipe, which is at *i* screwed into a stuffing-box on the pump; *k* is the lever of the safety-valve *a'*, which is cylindrical, and finished with a conical end, which fits a seating of similar form; *l* is a standard

Fig. 3.

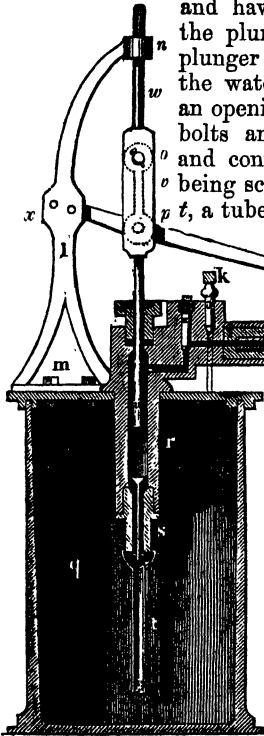

bolted at *m* to the cover of the cistern, and having an eye-boss at *n*, for guiding the plunger; *op* is a link pinned to the plunger; *q* is the pail or cistern for holding the water; *r*, the barrel passing through an opening in the cover, and fixed to it with bolts and nuts; *s*, the lower valve-seat, and conical three-sided valve, the former being screwed into the end of the barrel; *t*, a tube depending from the valve-seat *s*, and screwed upon it: this tube reaches nearly to the bottom of the cistern, and is perforated at the end with

minute apertures, through which the water is admitted without dirt or particles, which would injure the working of the pump; *u* is the plunger, which works through a stuffing-box on the top of the barrel, and is made with a slot at *v*, to receive the link *op*, which is pinned to it and also to the pump-handle; *w* is the plunger-rod, screwed into the upper end of the plunger; *y*, the pump-handle, jointed to the standard at *x*. During the

first part of the action of the pump, while no great pressure is yet produced, the handle is pinned to the outer of these holes, as it makes a larger stroke with the piston, and thus saves time: the pin is afterwards removed to the inner hole, to have all the advantage of the leverage. *z* is the upper or discharge valve, with a conical end: it is intro-

duced from the top, and covered with a short screw, which likewise regulates the lift of the valve. This valve is formed by being simply filed flat out of the round.

HYDRAULIC PRESS FOR LIFTING THE TUBULAR BRIDGES.

195. The most stupendous work to which the hydraulic press has been applied is that of lifting the massive portions of the Britannia and Conway tubular bridges to their positions; for which purpose the arrangements of the machinery shall be here described. For the purpose of forcing the water into the cylinders of these presses, two steam engines, each of 40-horse power, are employed. The cylinders of these engines are arranged horizontally, 17 inches in diameter, and 16 inches stroke. The piston-rods work through stuffing-boxes in both ends of the cylinder, and, being continued, form the pistons of the forcing-pumps. These pumps are $1\frac{1}{8}$ inch in diameter, and 16 inches stroke. The pipe for conveying the water into the cylinder is $\frac{1}{2}$ -inch bore, and $\frac{1}{4}$ -inch thick, so that its external diameter is 1 inch, made of wrought iron. The power applied to the pump is thus increased in the ratio of the areas of $1\frac{1}{8}$ to 20 inches, or as 1 to 355. If the full power of the engine, equal to that of 40 horses, were exerted, the available power thus produced in the press would equal the product of 355 and 40, or that of 14,200 horses. The actual work done by the one large press at one end of the tube, or the two smaller ones at the other, is of course equal to raising half the tube, or 900 tons. The power exerted by the head of the ram, 20 inches diameter, is thus equal to 2.25 tons, or 5040 lb. per circular inch.

The ends of the tubes, which were to be raised, were strengthened with massive frames of cast-iron fitted to the interior, and bolted to the plates of the tubes, and also to each other at the joints.

Figs. 1 and 2 represent the frames employed for this purpose. In fig. 1, A A are vertical side frames of cast iron, fitted to the inside of the plates, and bolted to them; B B are horizontal frames similarly secured, firmly bolted, and closely fitted to the vertical frames; c shows the manner in which other cross girders were connected with the vertical frames, for the purpose of connecting the chains. In the Conway tubes, two of these lifting frames were used at each end of the tube, one over the other. In the Britannia

tubes, three are employed, similarly arranged, one over the other, the ends of them fitting under deep notches or shoulders formed in the vertical frames, and firmly bolted thereto. By way of providing additional safety, two very

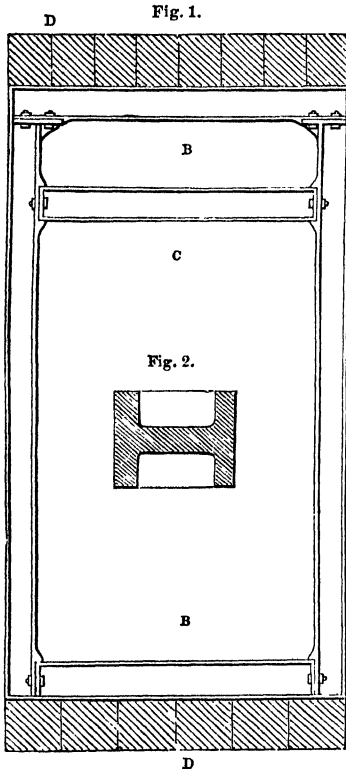

thick straps of wrought iron pass over the upper pair of cast-iron beams from a central point above, and descend in the inclined positions of the sides of the letter A into the bottom cells, where they are secured with strong wrought-iron keys. The vertical partitions forming the bottom cells are, for a length of from 8 to 12 feet at each end of each of the tubes, strengthened with thick cast-iron cheeks, or fitches, of the same width as the plates, 1 foot 9 inches; one of these cheeks being placed on each side of each of the vertical plates, and firmly bolted through. Fig. 2 shows a transverse section of one of the strengthening frames, A A, (fig. 1,) which are 12 in. deep, 15 in. wide over the face, 3 inches thick in the outer flange, and 2 inches in the inner one.

Figs. 3 and 4 show the combined arrangements for lifting the tubes of the Conway Bridge, with the hydraulic press, chains, &c., and the cast-iron lifting frames. Fig. 3 is a transverse section through the tube and front elevation of the press. Fig. 4 is a longitudinal section of the end of the tube and section through the middle of the press. Referring to these figures, we will describe first the parts which permanently belong to the construction of the tube and its connection with the tower, and afterwards the temporary

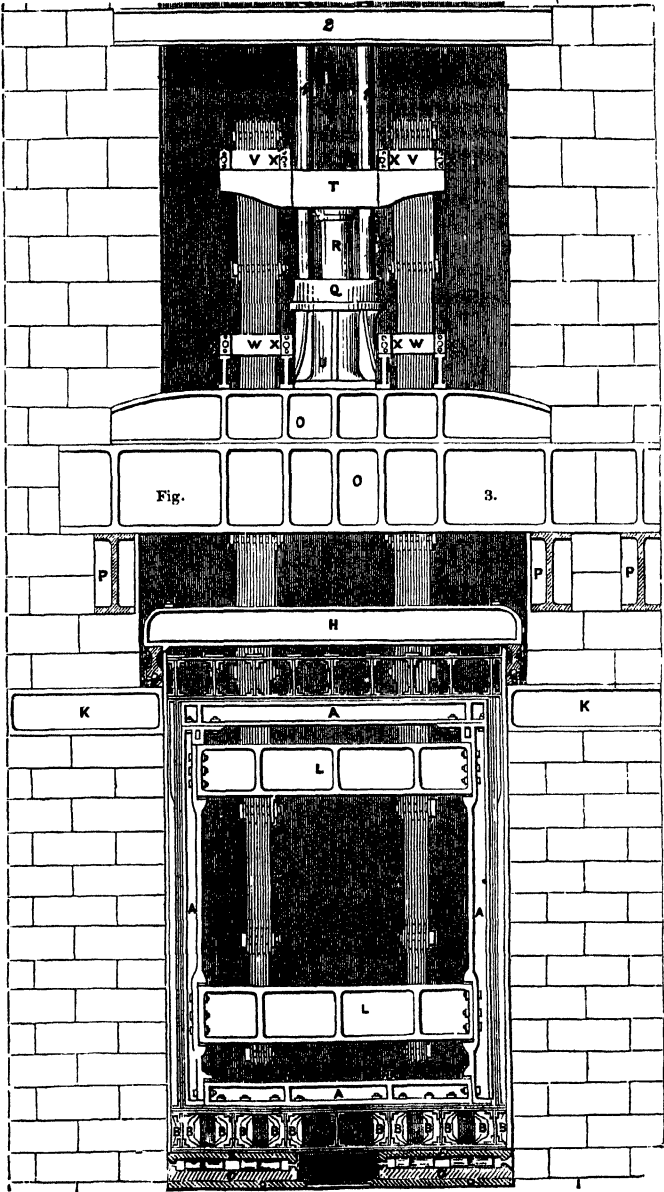

apparatus employed for the purpose of lifting the tube. *AA* are the two side and top and bottom beams of cast-iron, forming one of the sets of castings used to strengthen these parts of the tube, as already described. *BB* are the cast-iron flitches or cheeks bolted against the vertical plates forming the partitions of the lower cells. *CC*, the lower bed-plates of cast-iron, resting upon bearings of wood, *DD*. *EE*, cast-iron rollers, upon which *FF*, the bed-plates of the tube, rest, and are capable of longitudinal motion in either direction. The top of the tube is connected by strong wrought-iron bolts, *GG*, with a series of transverse cast-iron girders, *HH*. These girders are connected by sockets in their lower flanges, with two longitudinal girders, *II*, which are capable of longitudinal motion, as they rest upon spheres of gun-metal, as before mentioned, working in a groove on the upper surface of the bearing plates, *JJ*, which are fixed upon the projecting ends of transverse girders of cast-iron, *KK*. The temporary parts, introduced for the purpose of stiffening the ends of the tube during the raising, and also of connecting the lifting chains, are as follows:—*LL* are two pair of cast-iron girders, or lifting frames, fixed horizontally across each end of the tube, and bolted in recesses formed in the vertical casting frames *AA*. In the Britannia tubes three pairs of these girders were used, the upper and under ones for the purpose of attaching the lifting chains, and the intermediate one to assist in supporting the sides of the tube.

The lifting chains *MM* are formed in links with notches at one end of each alternate link, as shown at *NN*, fig. 4. These notches fit into corresponding ones on the lower flanges of the cross girders *LL*; and when these are bolted in their places the links are, as shown in fig. 4, held firmly between them.

The press by which these chains are drawn up, and the tube thus raised, is shown above the tube in the place in which it is first fixed, and which it occupies during the whole operation. In lifting the Conway tubes, each of the presses was supported upon a pair of double girders of cast-iron, marked *OO* in the figures, resting at the ends upon longitudinal girders, *PP*, built in the masonry. In lifting the Britannia tubes, however, wrought-iron girders are judiciously substituted for those of cast-iron. Each of these wrought-iron girders is composed of 12 plates of best iron, 2 feet in width and a full inch in thickness, firmly fastened together, so that the

girder consists of a well-connected mass of wrought-iron, having a transverse section 24 inches in depth and 12 inches in width. At the ends, these wrought-iron girders are supported upon cast-iron transverse girders, fixed upon benches formed in the masonry of the towers.

The press consists principally of four parts, viz., the cylinder *Q*, the ram or piston, *R*, the pipe, *s*, by which the water is introduced from the pumps, and the cross-head, *T*. The cylinder rests within a cast-iron jacket or casing, *U U*, supported upon the transverse girders, *o o*, already described. The forcing of the water into the cylinder causes the ram to rise, forcing up with it the cross-head, *T*. Upon the cross-head two pairs of clamps, *v v*, are fixed, which embrace the notched ends of the chain-links, and are screwed up tightly against them with screws, *x x*. These screws have cogged wheels, *Y*, fitted to their ends, and an intermediate pinion turned by a winch, *z*, gives motion to the wheels of the

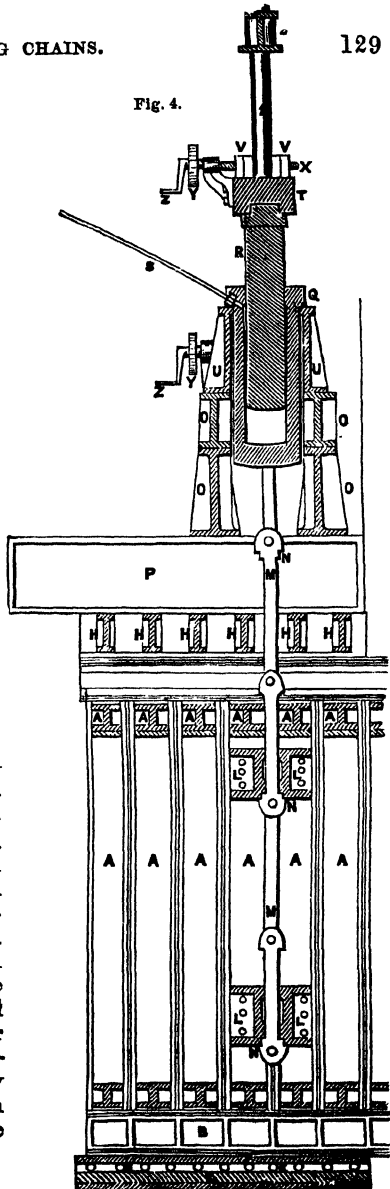

two screws. A similar arrangement of clamps and gearing is fixed below at *w w*. The action of the press is preserved in a true vertical direction by fixed guide-rods, *11*, secured above to a cross-girder, *Q*, and upon these rods the cross-head slides upward, as the action of the press continues.

The chains here represented are evidently highly important members of the apparatus, as any failure in them would, of course, involve the falling of the tube. Each set of links consists of eight and nine alternately, the eight being made somewhat thicker than the nine, so as to contain an equal total strength. Each link is 7 inches wide, about 1 inch thick, and exactly 6 feet in length between the centres of the eyes at the ends. They are manufactured by a process, for which a patent was granted, October 6, 1845, to Mr. Thomas Howard, of the King and Queen Iron Works, Rotherhithe, and entitled "improvements in rolling iron bars for suspension bridges and other purposes." By these improvements wrought-iron bars are rolled with the ends or heads of increased breadth in one entire piece, and chains thus manufactured are worthy of much greater confidence than those of which the links are made in separate bars and heads, and united by the uncertain process of welding. Besides the application of these chains to the lifting of the Conway and Britannia bridges, they are employed in the permanent construction of the large suspension bridge erected by Mr. W. T. Clarke over the Danube, at Pesh, and of the Russian bridge at Kieff, now in course of erection by Mr. Vignoles.

WATER AS A MOVING POWER.

196. The impulse of a current of water, and sometimes its weight and impulse jointly, are applied to give motion to machinery, as mills for grinding corn, and for innumerable other purposes. Commonly the impulse is applied obliquely to *float-boards* in a manner that may be at once comprehended by reference to the following figure, which represents

THE UNDERSHOT WHEEL.

197. This wheel requires a stream of about 1 yard wide, and from $1\frac{1}{2}$ to 2 feet deep, with a strong current to give it sufficient power to move the machinery of an ordinary corn-mill, the machinery of the mill being fixed to the axle of the wheel. The float-boards of the wheel, on which the water acts, are disposed around its circumference at an

angle of about 30° with the radii. *Poncelet* recommends the float-boards of the undershot wheel to be curved towards the direction of the current that the water may roll up their surfaces, and expend all its power upon them; this arrangement of the float-boards has been found by experiment to give the wheel nearly one-third more power than the ordinary form.

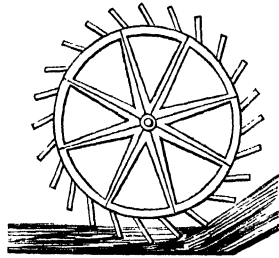

THE OVERSHOT WHEEL.

198. This wheel requires much less water to turn it than the undershot wheel. The water is conducted by a box or trough to the top of the wheel, as shown in the annexed figure, and falls into the buckets, which are fixed all round the rim of the wheel; the weight of the water in these buckets makes the right hand side of the wheel to be heavier than the left hand side; where the buckets, being turned upside down, are all empty, the wheel there-

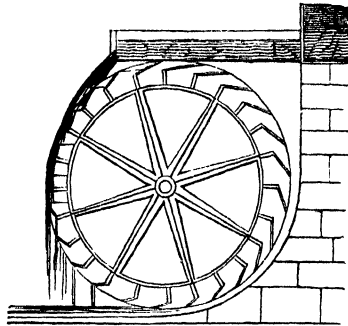

fore revolves in the direction of the descending water. It will be seen the leverage of those buckets at the extreme right of the wheel is the greatest, and those towards the top of the wheel, receiving the impulse of the water, have also considerable leverage, while those towards the bottom of the wheel, becoming gradually empty, have the least leverage.

THE BREAST WHEEL.

199. Where the fall of the water is too small for an overshot wheel, it is most advisable to employ a breast-wheel, which partakes somewhat of its properties; but its float-boards are formed like those of the undershot wheel,

and somewhat assimilated to buckets. The water meets the wheel at about half, and sometimes at about a third of its height, the water being considerably confined in the buckets by means of an arched channel fitting moderately close, but not so as to produce unnecessary friction. The form of this wheel may be easily conceived from this description, in conjunction with the drawing of the undershot wheel.

200. It has been found by experiment that a water-wheel performs the greatest quantity of work when the velocity of the water is $2\frac{1}{2}$ times that of the wheel, whence by *Baker's Statics and Dynamics*, Art. 259, the power of water (the velocity of which is given) striking the paddles or float-boards of wheel might be calculated; but the following method has been found in practice to be less complicated: for when a body descends from a given height, it is capable of raising a body of equal weight through the same height. Therefore, if water fall upon a wheel, the quantity of work which it is capable of performing, abating friction, is equal to the product of the weight of the water, and the height through which it descends; whether it falls upon the paddles of an undershot or a breast wheel, or into the buckets of an overshot wheel.

201. PROP.—Given the breadth a , and depth b , of a stream, its mean velocity v , in feet per minute, the height h , of the fall, and s = specific gravity of water; it is required to determine the horse power of the water-wheel, when the modulus of the machine is n th part of the work of the water, and U = units of work in a horse power.

Water descending per minute = abv cubic feet.

Weight of water in the same time = $abv s$ lb.

Hence work of water per minute. . = $abhvs$,

And the work of the wheel = $nabhvs$;

\therefore Horse-powers = $\frac{nabhvs}{U}$.

Ex. 1.—The breadth of a stream is 5 feet, depth = 3 feet, mean velocity 20 feet per minute, and height of the fall 25 feet; required the H-P of the water-wheel which performs $\frac{4}{5}$ of the work of the water, that is, $\frac{1}{5}$ of the work of the wheel is lost by friction?

$$\text{H.-power} = \frac{nabhvs}{U} = \frac{4 \times 5 \times 3 \times 20 \times 25 \times 62.5}{5 \times 33000} = 11\frac{4}{11}.$$

Ex. 2.—The section of a stream is 4 feet by 3, the mean velocity of the water 20 feet per minute, and the fall 30 feet; what is the H-P of the water-wheel, its modulus being $\frac{2}{3}$; and how many bushels of corn will the wheel grind in a day of 14 hours, one H-P being able to grind a bushel of corn per hour?

$$\text{H.-power} = \frac{n a b h v s}{v} = \frac{4 \times 4 \times 3 \times 20 \times 30 \times 62.5}{5 \times 33000} = 10\frac{1}{11}.$$

$$\therefore \text{bushels ground per day} = 10\frac{1}{11} \times 14 = 152\frac{8}{11}.$$

Ex. 3.—The section of a stream, the mean velocity, and fall of the water are the same as in the last example; how many cubic feet of water will the wheel raise to the height of 120 feet, the modulus of the machine being $\frac{2}{3}$ of the work of the water?

Put H = the height to which the water is pumped; then,
 Work of the wheel per minute = $n a b h v s$ units,
 „ of pumping 1 cubic foot of water = $\frac{H s}{s}$ „

$$\therefore \text{number of cubic feet pumped per min.} = \frac{n a b h v s}{\frac{H s}{s}} = \frac{n a b h v}{H};$$

which in number gives $\frac{\frac{2}{3} \times 4 \times 3 \times 20 \times 30}{120} = 40$

cubic feet.

BARKER'S MILL.

202. The construction of this machine is shown in the annexed fig., where CD is a vertical axis, moving on a pivot at D, and carrying the upper millstone *m*, and passing through an opening in the lower millstone C. Upon this axis is fixed a vertical tube TT, communicating with a horizontal tube AB: near to the extremities of which are two apertures A, B, in opposite directions. When water from the mill-stream, MN, is brought into the tube TT, it flows out of the apertures A, B, and by the reaction or counter-pressure of the issuing water the arm AB, and consequently the whole machine, is put in motion.

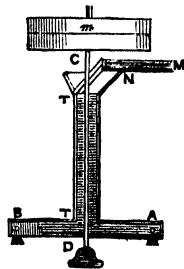

Note.—“ In order to understand more clearly how this motion is produced, let us suppose both the apertures to be shut, and the tube

TT filled with water to the top; then the apertures A, B , which are shut up, will be pressed outwards by a force equal to the weight of a column of water whose height is TT , and whose area is the area of the apertures. Every part of the tube AB sustains a similar pressure, but as these pressures are balanced by equal and opposite pressures, the arm AB is at rest. (See *Baker's Statics and Dynamics, Weale's Series, Art. 197*). By opening the aperture at A , however, the pressure at that place is removed, and consequently the arm is carried round by a pressure equal to that of a column TT acting upon an area equal to that of the aperture A . The same thing happens on the arm TB ; and these two pressures drive the arm AB round in the same direction. This apparatus may evidently be applied to drive any kind of machinery, by fixing a wheel or pulley upon the vertical axis CD ."—*Gregory's Mechanics*.

MARINE SCREW-PROPELLERS.

203. Screw-propellers for navigation, by means of steam power, have now become objects of importance to all nations: they are especially applicable for vessels of war, the machinery for propulsion being without the reach of gunshot. Screw-propellers, however variously they may be modified, all derive their power of propelling by being placed on an axis which is parallel to the keel, and by having threads or blades extending from the axis, which form segments of a helix or spiral, so that by causing the axis to revolve, the threads or blades worm their way through the water, much in the same way as a carpenter's screw inserts

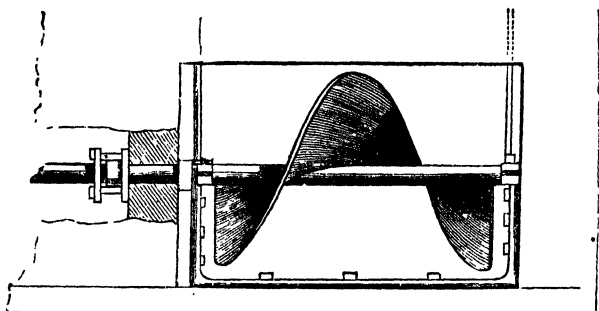

itself into a piece of wood; with the difference, in the case of the screw-propeller, of its making the water recede. Screw-propelling is not of recent invention; *M. Duquet* in 1727, and *Mr. Paucton* in 1768, both produced machinery of this kind; other inventions followed until a recent date.

When the "Archimedes" was first tried down the River

Thames in 1836, the shape of the screw was as represented in the woodcut, viz., a single thread of thin sheet iron, bent to fit sixteen wrought-iron arms fixed round the axis at equal distances so as to form a helix, or screw. This screw, from having only one thread of long pitch, viz., 45° , caused a great commotion in the water and a great deal of vibration in the stern of the vessel; so that on reaching Sheerness, the vessel was laid ashore, and portions of the iron plate taken off at equal intervals; but the effect was not improved. The form of the screw was then changed to a double one; and, finally, a series of experiments was made under the joint superintendence of Mr. Smith and Mr. Lloyd, by order of the Admiralty, with three and four-bladed screws, which ended in the adoption of the *two*-bladed screw. These experiments were tried in H.M. vessels "Dwarf" and "Rattler," after a speed had been produced in the "Dwarf" of $12\frac{1}{4}$ miles per hour with Mr. Rennie's three-bladed conoidal screw of cast-iron; being the greatest speed which had ever been obtained by the screw. The speed attained by the "Archimedes" was about nine knots per hour, which, taken as a first experiment, was a great performance. The "Archimedes" beat most of the fastest steamers then known, and made a voyage all round Great Britain, being a distance of 2096 nautical miles, in 237 hours 25 minutes, or nearly nine knots per hour the whole distance. The "Archimedes" afterwards went from Plymouth to Oporto in 69 hours, and returned from thence against strong headwinds and high seas in 88 hours, and the reports of some of the most eminent officers predicted all that has since been realised by the screw.

The use of three and four blades for screw-propellers was commenced by Baron Seguin, in 1792; by Fulton, in 1794; by Cartwright, in 1798; and Shorter, in 1802. But the first useful experiment was that of Samuel Brown, the inventor of the gas-vacuum engine, who applied a two and four bladed propeller to a vessel of 60 feet in length, and actually obtained, by means of a gas engine, a speed on the River Thames of from six to seven miles per hour. The success of the "Archimedes" led to the construction of the "Princess Royal" and the "Great Northern" passage vessel, and H.M. experimental vessels, "Bee" and "Rattler," the latter of which has been most successful, and has served as a model to most of the larger vessels which have been fitted with the screws in H.M. service; the adoption of

which in merchant vessels has greatly facilitated extended commerce. The form generally adopted for screw-propellers is as yet imperfect.

The dimensions of the "Archimedes" were—

Length	125 feet.
Breadth	21 feet 10 inches.
Burthen	232 tons.
Mean draft	9½ feet.
Area of midship section . . .	143 feet.
Area of screw	26 feet.
Power of engines	80 horse.

The dimensions of the screw were—

Diameter, 5 ft. 9 in.	} And made by means of two wheels and two pinions.
Length, 4 ft.	
Pitch, 8 ft.	
Angle of screw, 45°.	

The dimensions of the "Mermaid" or "Dwarf" were—

Length	130 feet.
Breadth	16 feet 6 inches.
Depth	9 feet.
Draft	5 feet 8 inches.
Burthen	164 tons.

The propeller consisted of three blades, with variable curves, approximating from the angles of 27° to 30°, and advancing 7 feet 6 inches per revolution. The diameter was 5 feet 10 inches, and the number of revolutions 160 per minute.

MAUDSLAY'S FEATHERING SCREW.

204. This screw is represented on the next page; the object sought to be obtained is, that the blades, whenever the vessel is put under canvas and the screw not required, should be placed in a direction parallel with the line of the keel, and so form as it were a portion of the dead-wood, as they cause considerable obstruction, if they be allowed to remain fixed in their position, or even though they be disconnected from the engine and allowed to revolve. In auxiliary sailing vessels not fitted with a trunk or aperture for raising the screw out of the water, this is particularly valuable; but it will also be found useful in men-of-war, by lessening the

1st. *In position for use as a propeller.*

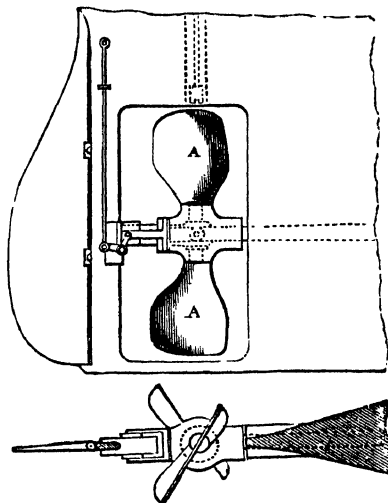

2nd. *In position for sailing under canvas alone.*

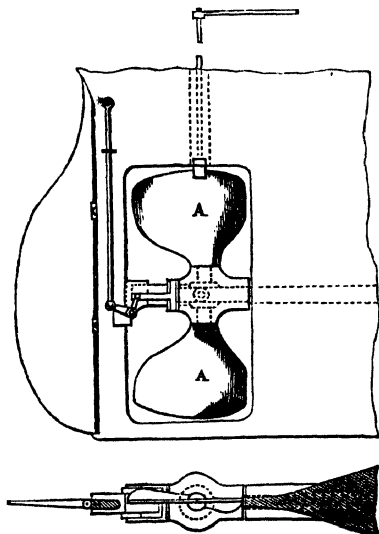

width of the trunk through which it has to rise, if this be desired; and also by the facility which it gives in emergencies, for placing a vessel quickly under canvas, or under steam, without requiring the aid of the crew.

205. "*The Diameter of the Screw* should in most cases be made as great as the draught of water will admit, and for running in smooth water its upper edge need not be more than a few inches below the surface. In the case of sea-going vessels, it is preferable to keep it $1\frac{1}{2}$ or 2 feet below the mean surface of the water."

206. *The Area of the Screw*. "By the area of the disk of the screw is understood the area of the circle described by its extreme diameter. When the area of the blades is spoken of, their actual oblique surface should always be specially distinguished from the plane projection of the resisting surface. This latter measurement, as representing the actual amount of surface directly employed in the propulsion of the vessel, is probably the most important of these areas."—*Murray on the Marine Engine, in Weale's Rudimentary Series*, p. 127.

207. Other patents were subsequently taken out, and

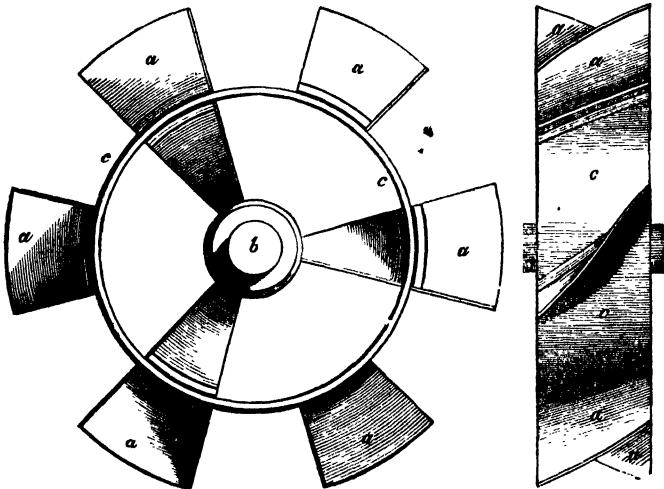

many experiments made. In 1838, Mr. Ericsson obtained a patent for a propeller consisting of six blades, *a a a a a a*, set

at equal distances round a cylinder concentric with the axis *b*: the blades and arms were segments of a screw.

THE TURBINE.

208. The horizontal water-wheel, called the Turbine, is among the most recently invented hydraulic machines, having been produced in a most efficient form in 1827, by *M. Fourneyron* after a series of experiments commencing in 1823, and it is now much used in France, Germany, and America. The water enters the centre of the wheel, and, diverging from thence in every direction, it then enters all the buckets simultaneously, and passes off at the external circumference of the wheel. The pressure with which the water acts upon the buckets of the revolving wheel is in

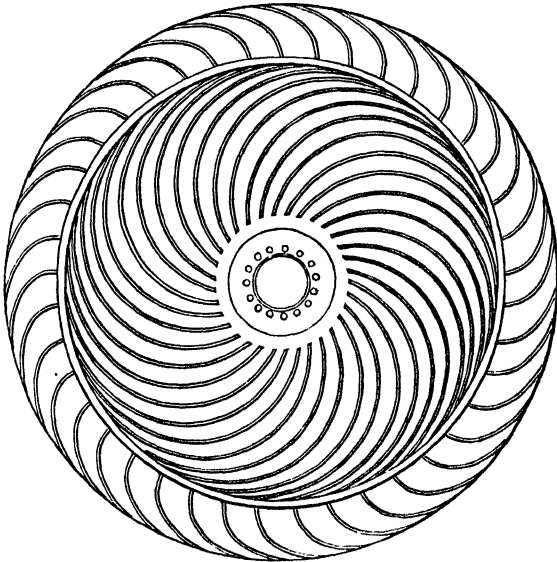

proportion to the vertical column of water, or height of the fall, and it is conducted into these buckets by fixed curved girders secured upon the platform within the circle of the revolving part of the machine. The accompanying fig. represents the wheel of the turbine with its buckets and conducting curved girders.

The influx of the water is regulated by a hollow cylindrical sluice, to which stops are fixed, which act together between guides, and are raised or lowered by screws that communicate with a governor, so that the opening of the sluice may be enlarged or reduced in proportion to the required velocity of the wheel. Turbines may be divided into high and low pressure machines. High-pressure turbines are adapted to hilly countries, where high falls of water may be commanded; in these cases the height of the column of water will compensate for the smallness of its volume, reservoirs being provided to keep up a constant supply. The low-pressure turbines produce great effect with a head of water of only nine inches, and are suitable for situations in which a large bulk of water flows with little fall. The results of an investigation by *MM. Arago, Prony, and others*, who were appointed by the French Académie des Sciences to report upon turbines, are as follows: (1.) That these wheels are applicable equally to great and to small falls of water. (2.) That they transmit a useful effect equal to from 70 to 78 per cent. of the absolute total moving force. (3.) That they will work at very different velocities, above or below that corresponding to the maximum effect, without the useful effect varying materially from that maximum. (4.) That they will work from one to two yards deep under water, without the proportion which the useful effect bears to the total force being sensibly diminished. (5.) In consequence of the last mentioned property, they utilise at all times the greatest possible proportion of power, as they may be placed below the lowest levels to which the water-surface sinks.

In 1844 *Mr. Boyden* designed a turbine of 75 horse-power for the Appleton Company at Lowell, Massachusetts, containing many new features never before suggested: its success was remarkable for a first attempt on so difficult a subject. Soon after *Mr. Boyden* designed and superintended the construction of three others of 200 horse-power each for the same company; the experiments on which proved their useful effect to be above 80 per cent. of the power expended, or about 3 per cent. more than previous results.

Figs. 1 and 2 represent a general plan and elevation of a turbine of 150 horse-power, constructed for the Lowell Company, from designs by *Mr. J. B. Francis*, and communicated by him to *Mr. Weale*; the diameter of the

water-wheel is 8 ft. 4 in., and operates under a fall of water of 13 ft.

The following references apply to both figures :

- a*, The masonry of the wheel-pit, faced with large blocks of granite backed with rubble masonry laid in hydraulic cement.
- b*, The sheet-iron pipe conducting the water to the turbine.
- c*, The throttle-gate, to shut the water off from the turbine, either for examination or repairs ; the apparatus for moving this gate is not represented.
- c'*, The leak-box for the purpose of collecting the leakage of the throttle-gate, and for carrying it off in a pipe when repairs are required on the wheel, &c.

Fig. 1.

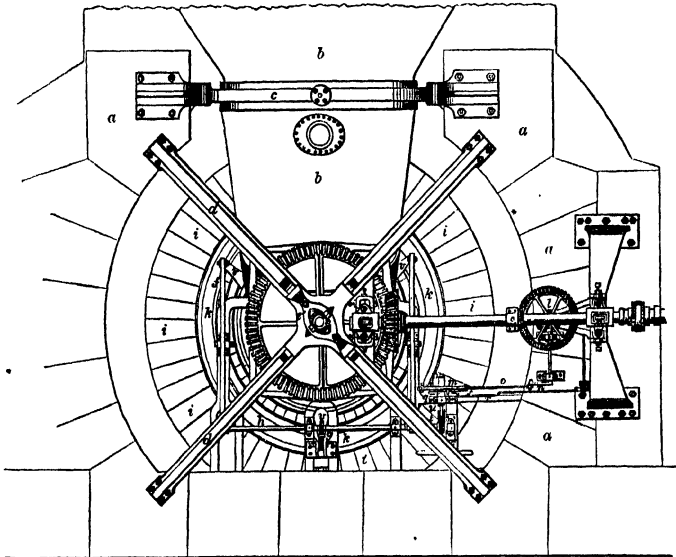

- d*, The cast-iron framing supporting the upright and horizontal shafts of the wheel.
- e*, The suspension-box, which is made to fit the corresponding parts of the upright shaft by a lining of soft metal, principally tin, which is melted and poured into the outer shell, the necks being in place.
- e'*, The gimbal.
- f*, Levers for moving the speed-gate.

Fig. 2.

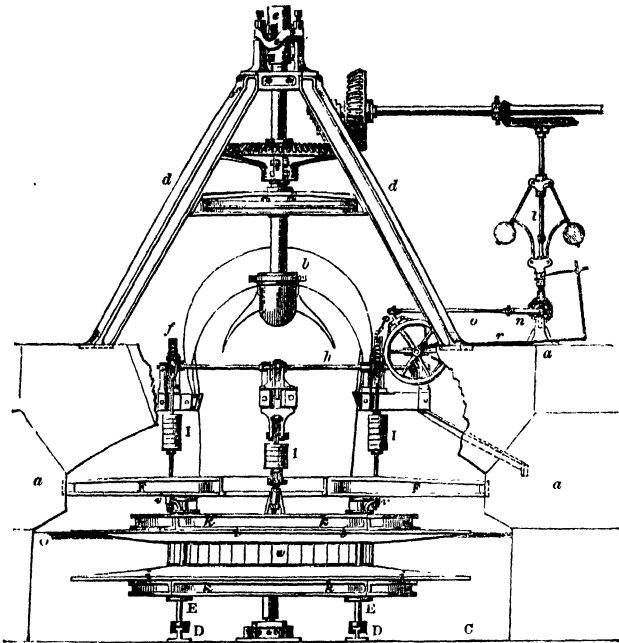

- g*, Rack for the same purpose.
h, Pinion-shaft for the purpose of moving the levers and rack.
i, Wooden staves of the diffuser.
k, Circular iron beams, to which the staves are fastened.
l, The governor.
m, The ratchet-wheel, fast on the worm-shaft.
n, The crank carrying the rocker.
o, Connecting rod.
p, The rocker carrying the palls.
r, The rod for moving the shield by the action of the governor.
s, The shield : when the governor is running at the speed intended, the shield protects the ratchet-wheel from the action of the palls : if the speed changes a small amount, only a few of the teeth of the ratchet-wheel are acted on at each vibration of the rocker ; if there is a great variation of speed, a much greater number of the teeth of the ratchet-wheel are acted on at each vibration ; the number of teeth exposed to be acted on is proportional to the variation of the governor-balls from their normal position.
t, The worm driving the pinion-shaft.
u, The worm-wheel fastened on to the pinion-shaft.

- v*, Brackets fastened to the speed-gate.
w, The wheel, carrying the floats of Russia sheet-iron, about $\frac{1}{8}$ th of an inch thick, grooved, tenoned, and riveted into the upper and lower rings of the wheel.
x, The speed-gate.
y, The disc, carrying the guides or leading curves of Russia sheet-iron, about $\frac{1}{16}$ th of an inch thick, tenoned and riveted into the disc.
z, The disc-pipe, supported by the adjusting screws at the top of the curb.
 A, The main shaft of the turbine.
 B, The step for steadying the bottom of the shaft, lined with case-hardened wrought iron; the pin in the bottom of the shaft is of cast steel.
 C, The timber floor of the wheel-pit, covered with 3-inch planks.
 D, Cast-iron beams, to distribute the weight on the columns over the timber floor.
 E, Column supporting the diffuser beams *k* and the beams F.
 F, Beams supporting the curb or acting as braces from the sides of the wheel-pit.
 G, The lower curb, of cast-iron: the outer surface is turned cylindrical, for the purpose of receiving properly the packing of the speed-gate.
 H, The upper curb, also of cast-iron, about $1\frac{1}{2}$ inch thick.
 I, Weights counterbalancing the weight of the speed-gate.

MOTION OF WATER IN PIPES, ETC.

209. To find the height to which the water will rise after any given stroke in the common pump, (fig. Art. 180.)

Let the water, after a given number of strokes, rise to P, in the pipe A B, and after the next stroke let it rise to *p*; (these points are not shown in the fig.) Put *h* = height of a column of water equivalent to the pressure of the air, A S = *a*, A P = *b*, *c* = *h* — P B, and B *p* = *x*; also put *k* = area of a section of the pipe A B, and *m k* = area of a section of the barrel AS. Now, let the piston be at A, then the elasticity of the air A P, together with the weight of the column of water B P, is equal to the pressure of the air, or is = column of water of the height *h*; hence

elasticity of air in AP = column of water above P = *c*;
 let the water rise to *p* after the next stroke, then

elasticity of air in *A p* = column of water above *p* = *c* — *x*.

Now, the air which filled the space A P, before the rise of the piston, will expand, after its ascent, and occupy the space *p S*; hence

density of air in AP : density of air in *p S* :: space *p S* : space AP.
 :: (*b* — *x*) *k* + *am k* : *b k*,
 :: *b* — *x* + *am* : *b*.

But the density of the air is proportional to its elastic force; hence

$$\begin{aligned} c-x : c :: b : b-x+ma; \text{ therefore} \\ bc = (c-x)(am+b-x), \text{ whence} \\ x^2 - (am+b+c)x + acm = 0; \end{aligned}$$

whence the value of x = rise of water due to one stroke, may be found.

210. *To find the velocity with which water is discharged from a reservoir of given height h , through a pipe of given length l , and diameter d .*

The experiments and investigations of M. Poncelet are considered strictly accurate: the limits of this work do not admit of their insertion here; the following is his formula for the velocity per second, all the dimensions being in feet.

$$v = 48 \sqrt{\frac{hd}{l+54d}}$$

Ex. 1.—Water is brought to supply Mentz from a reservoir 65 $\frac{3}{4}$ feet in height, by pipes 9, 843 feet in length, and 3 $\frac{3}{8}$ inches in diameter; required the velocity of the water per second.

First 3 $\frac{3}{8}$ in. = .2625 of a foot, and 65 $\frac{3}{4}$ = 65.6 feet, then

$$v = 48 \sqrt{\frac{hd}{l+54d}} = 48 \sqrt{\frac{65.6 \times .2625}{9843 + 54 \times .2625}} = 2 \text{ feet per}$$

second nearly.

Ex. 2.—In the last example, how much water will be discharged in 24 hours?

The area of the section of the pipe = .7854 \times (.2625)² = .0541 square feet, the quantity of water per second = 2 \times .0541 = .1082 cubic feet, and 24 hours = 86400 seconds; \therefore the quantity of water brought by the pipe in 24 hours will be

$$86400 \times .1082 = 9348\frac{1}{2} \text{ cubic feet.}$$

211.—*To determine the mean velocity with which water runs in rivers and open canals.*

The formula for this purpose is also derived from experiments, of which no less than 91 were made by Eytelwein on rivers and canals: the dimensions used by him are reduced to feet, and are the following:—

c = wet contour,

s = area of a section of the fluid,

$\frac{s}{c}$ = hydraulic mean depth,

g = force of gravity,

a = angle of inclination of surface of stream,

and v = mean velocity; then

$$v = \sqrt{\left(\frac{5.9}{3}\right)^2 g \cdot \frac{s}{c} \sin. a + \left(\frac{1}{100}\right)^2 - \frac{1}{100}} = \text{the velocity in feet.}$$

Note.—It has been proved that the greatest velocity is at the surface in the middle of the stream; from which it diminishes towards the bottom and sides, where the velocity is least.

WORK PERFORMED BY THE SUN'S EVAPORATION.

212. The heat of the sun is continually raising the temperature of the atmosphere, thus making it capable of absorbing water from the immense surface of the oceans and seas that surround the earth. The water, thus raised, forms clouds at various elevations above the earth's surface. The sudden cooling of the atmosphere, either by cold currents or by meteoric changes, precipitates these clouds in the form of rain; while the dews of night descend by the gradual cooling of the atmosphere, through the absence of the sun. The water, therefore, which thus falls, may be considered as the measure of the sun's evaporating power. In the torrid zone the annual fall of rain and dew amounts, at a medium, to about 100 inches in depth, and at the northern border of the temperate zone, as at Archangel, the medium fall of water is about 20 inches in depth; the mean of these depths is 60 inches, or 5 feet, which may be taken as the mean depth of water which descends upon the whole of the earth's surface. Now, if we take 900 feet as the mean

height from which this water falls in the form of rain and dew, there will result—

The work of the water falling on one square mile of the earth's surface per minute, through the agency of the sun's evaporation in horse powers, that is,

$$\text{H.P.} = \frac{27878.400 \times 5 \times 900 \times 62.5}{365 \times 24 \times 60 \times 33000} = 452.$$

See *Baker's Statics and Dynamics, Weale's Series*, Arts. 92 and 263.

Hence, the work thus done on the whole surface of the globe, taking its diameter at 8,000 miles, will be

$$\text{H.P.} = 8,000^2 \times 3.1416 \times 452 = 90,880,000,000.$$

Now, taking the united powers of all the steam-engines in the British Isles to be $2\frac{1}{2}$ millions of horse powers, and the united powers of all the steam-engines in all the other states of the world to be $3\frac{1}{2}$ millions of horse powers, thus giving for the steam engines of the whole world 6 millions of horse powers, which it is presumed is not far from the truth, at the present time (1851), we shall have the work due to the sun's evaporation somewhat more than 15,000 times the work of all the steam-engines in the world, supposing them to work continuously day and night. This comparison shows how insignificant the most stupendous works of man are to those of his CREATOR. Though only a very trifling part of this vast power is available for the purposes of moving machinery, yet it serves a still more important purpose in watering and invigorating the vegetation on the surface of the earth, and in producing the countless small streams up to large rivers, which diversify and spread health throughout creation, as well as supply immense facilities for inland navigation. Such is the stupendous and magnificent scale by which we must measure the mechanism of creation, and such the boundless power and beneficence of the GREAT CREATOR.

One of the immense results of the power of evaporation may here be given in the *Work of the Great Fall or Cataract of the River Niagara*.

213. This river, which discharges all the water issuing from the great central chain of lakes in North America, falls

with astonishing grandeur over a perpendicular rock 133 feet in height, in one unbroken sheet; the rapids above this fall extend several miles, making an addition of 200 feet to the height of the fall; the whole height of the fall is therefore 333 feet. It is calculated that 33 millions of tons of water are discharged, at an average, per hour by this fall; hence the work of the water per minute may be readily determined in horse powers, that is

$$\text{H. P.} = \frac{33000000 \times 2240 \times 333}{60 \times 33000} = 12,432,000.$$

This river is therefore (see last Art.) capable of performing more work than twice the work of all the steam-engines in the whole world.

WORK OR POWER OF THE TIDES.

214. Assuming the average height of the rise of the tides in the Atlantic and Pacific oceans to be 20 feet, which is probably less than the true average, and the united length of the coasts of these two oceans (which may be said to extend from pole to pole) including their windings, to be 100,000 miles, we shall thus have a body of water 100,000 miles in length raised to the height of 20 feet, and of a breadth varying according to the widths of the respective oceans. This vast power is immensely greater than that which results from the sun's evaporation; (Art. 212) and is due to the joint attraction of the sun and moon. A very small portion of this immense power is used for mechanical purposes, on account of its being inconveniently situated for that purpose; besides, the shores of these oceans are exposed to tempests, which would in most cases greatly damage or entirely destroy any machinery, which might under other circumstances be conveniently moved by the tide. There are, however, a few ponds, which are filled by the tide in convenient situations, for moving the machinery of corn mills, &c. Yet the rise of the tide is of immense importance in aiding the purposes of navigation, by its repeated flow into numerous rivers, harbours, bays, creeks, &c., which would otherwise in many cases be almost useless for this purpose. Besides, the continued agitation of the ocean by the tide diffuses the saline matter, derived

from some of the strata which forms part of its basin, equally throughout every part of its liquid mass; thus maintaining its waters in a perpetual state of salubrity, which would otherwise become stagnant, and in all probability so putrid as to be destructive to animal life. We may hence perceive another grand purpose of the GREAT CREATOR carried out by the agency of the tide for the continued renovation of nature, and of far greater importance than its use as a moving power for machinery, which the ingenuity of man by the agency of steam can produce in localities more convenient for his several requirements.

CHAPTER V.

SELF-ACTING LATHES FOR SLIDING, SCREWING, AND SURFACING;
ALSO SELF-ACTING PLANING, SHAPING, SLOTTING, PUNCHING,
AND SHEARING MACHINES.

215. THIS chapter will be chiefly occupied by the above-named highly-esteemed and ingenious machines of *Messrs. Joseph Whitworth & Co. of Manchester*; most of which formed a conspicuous part in the Machinery Department of the *Great Exhibition* of 1851. The original drawings and descriptions were communicated by *Messrs. W. & Co.* to *Mr. Weale*.

Foot Lathe for sliding, screwing, and surfacing. (Fig. 1.)

- A, Fast headstock with gearing.
- B, Moveable do. do.
- C, Centres.
- D, Bed and standards.
- E, Top slide-rest.
- F, Bottom do.
- G, Guide-screw.
- H, Change-wheels.
- J, Driving-pulley and crank.
- K, Treadle-motion, with anti-friction chains.
- α , The band for transmitting motion.

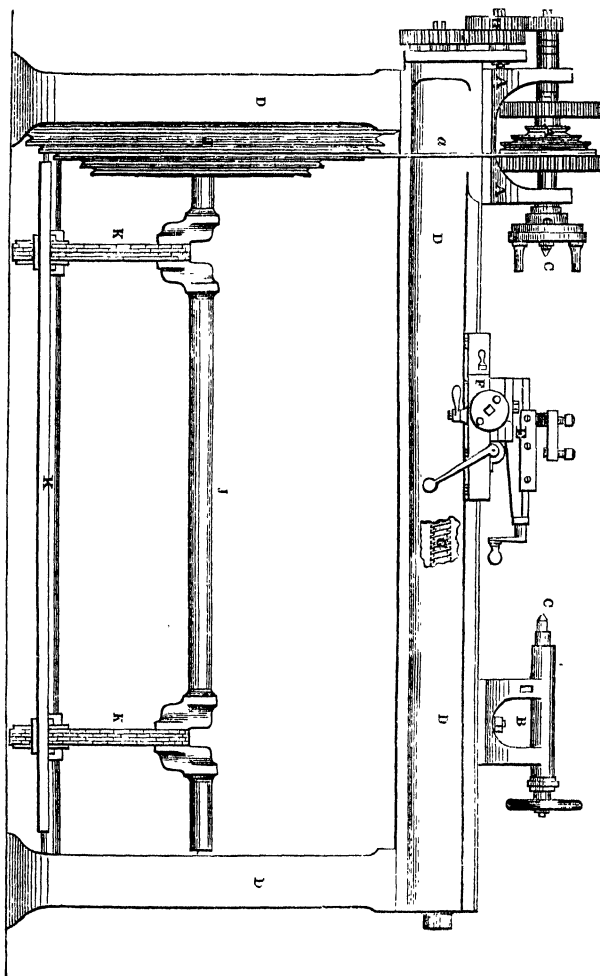

Fig. 1.—Front Elevation.

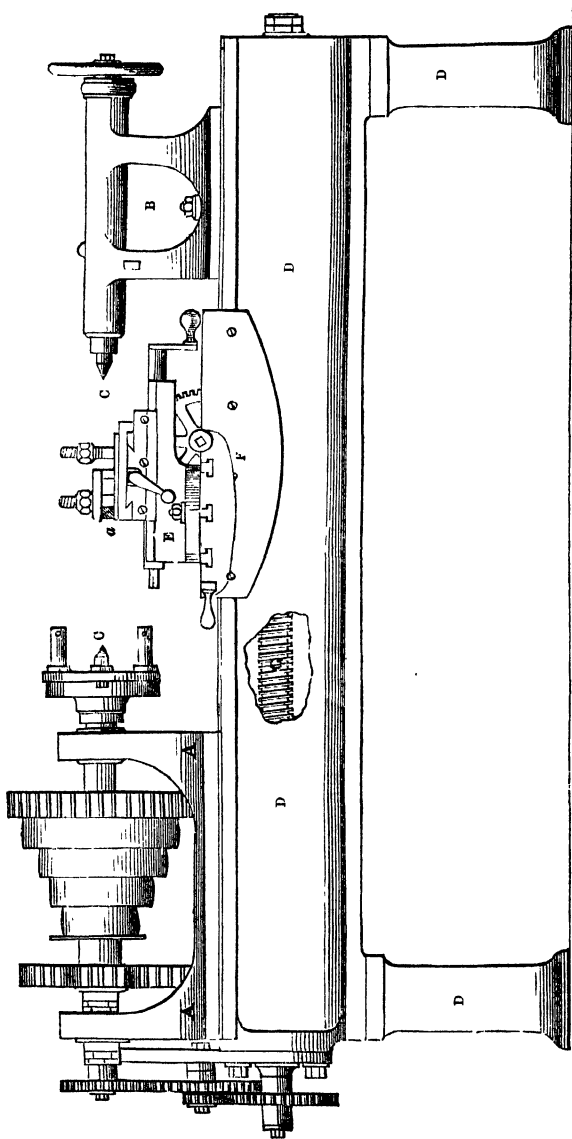

Fig. 2.—Front Elevation.

216. *Self-acting Lathe*, for sliding, screwing and surfacing, worked by power. (Fig. 2.)

- | | |
|-----------------------|--|
| A, Fast headstock. | F, Bottom rest, provided with a quick hand traverse. |
| B, Moveable do. | G, Guide-screw. |
| C, Centres. | H, Change-wheels. |
| D, Bed and standards. | a, The cutting tool. |
| E, Top slide-rest. | |

217. *Patent Self-acting Duplex Lathe*, for sliding, screwing and surfacing. The peculiarity in this lathe consists in the employment of a cutting tool at the back of the lathe in

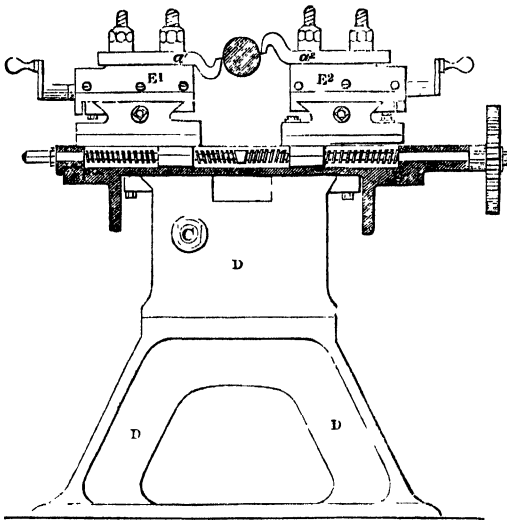

Fig. 3.—End Elevation.

addition and opposite to the tool in front, but in inverted positions to each other. The transverse forces are thus balanced, the work produced is more correct, and is accomplished in less time than by the ordinary lathe. (Fig. 3.)

- a¹, Tool in front.
 a², Inverted tool at back.
 D Bed and standard.
 E¹, and E², two compound slide-rests.
 F, A right and left screw for moving the two slide-rests, simultaneously, to and from the centre of the lathe.

The other parts of the lathe are the same as in the self-acting lathe, see fig. 2.

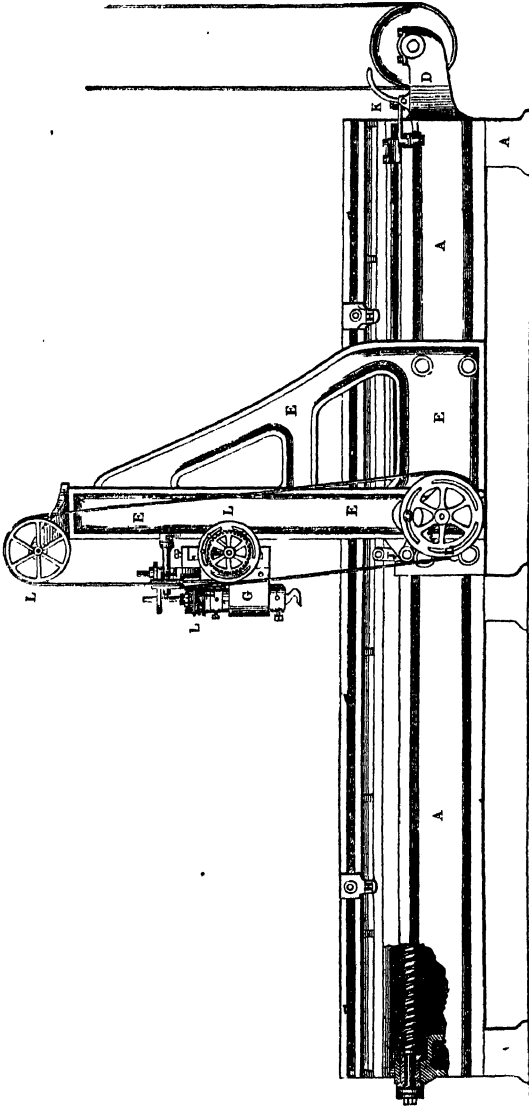

Fig. 4.—Side Elevation.

218. *Self-acting Planing Machine*, for horizontal, vertical, and angular planing. (Side elevation, Fig. 4.)

- A, Bed and standards.
- B, Guide-screw.
- C, The table, having a nut (not shown) taking into the guide screw, by which it is moved along the bed.
- D, The driving apparatus, which by being at the end of the bed is out of the workman's way.
- E, Uprights.
- F, Cross-slide.
- G, Reversing tool to plane both ways.
- H, Two stops which can be fixed at any distance apart, according to the desired traverse of the table.
- J, Lever upon which the stops H act.
- K, Rod and strap lever, by which the driving strap is shifted from one pulley to another, and the direction in which the table C moves, is changed.
- L, Band-pulleys, which transmit the motion of the lever J to the reversing tool, at the same time as the strap is shifted, and the tool is thus made to turn at each end of the work. The band-pulleys also impart self-acting motions to the tool in the transverse, vertical, and angular directions as required.

Note.—The same general arrangement of machine, with a fixed tool, to plane only one way, and the driving apparatus D, constructed to give to the table a quick return motion, is sometimes made. The tables of machines, which do not plane above 2 feet long, are moved by a crank.

219. *Patent Universal Shaping Machine*, particularly adapted for shaping levers, cranks, and connecting rods, also for work in general. (Fig. 5.)

- A, Bed grooved on the front side.
- B, Two tables for holding the work, adjustable vertically or horizontally.
- C, Headstock, made, when necessary, to slide along the bed A.
- D, Tool-slide, moves in a direction at right angles to the bed A.
- E, Tool-holder, fitted with a segment wheel and worm for planing hollow or internal curves.
- F, Spur-wheel and crank, which, as they revolve, give a reciprocating motion to the tool-slide, the extent of which is variable, being determined by the distance of the crank-pin from the centre of the crank.
- G, Central arbor, upon which is shaped circular work.
- H, Driving pulley on grooved shaft with pinion (not shown) taking into the wheel F.
- J, A screw of the length of the bed, taking into a nut on the under side of the headstock C, by which the latter is made to move along the bed.

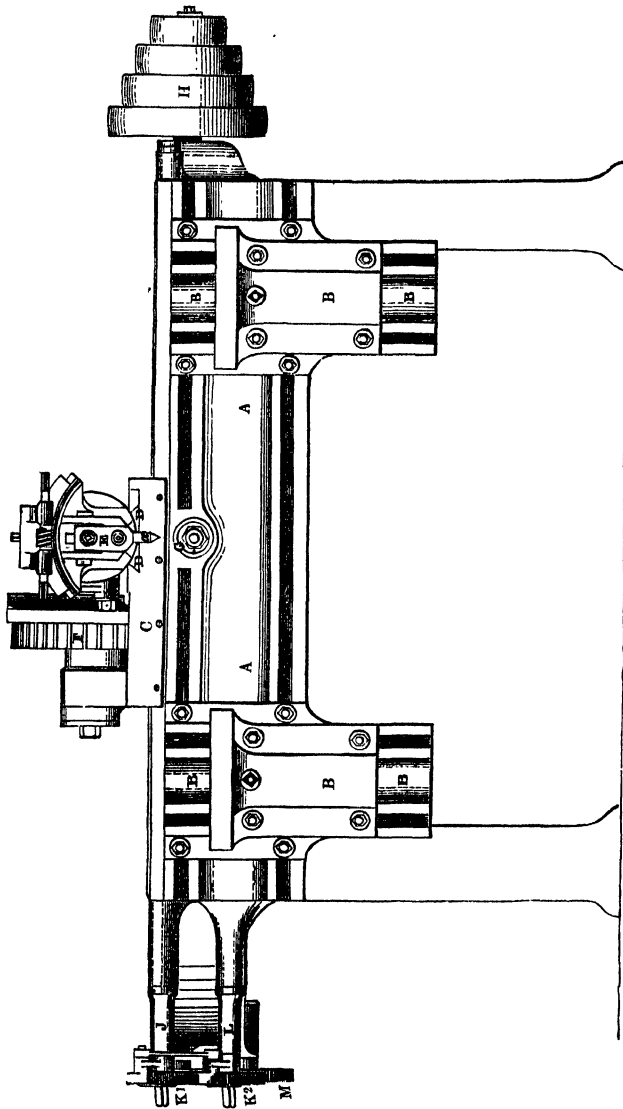

Fig. 5.—Front Elevation.

- K¹, Ratchet wheel on the end of the screw.
 L, A shaft passing through the bed, having at the end, not exposed, a worm which takes into a worm-wheel on the central arbor a.
 K², Ratchet-wheel on the end of the shaft L.
 M, A cam-wheel, which, at the return of the tool, actuates the ratchets K¹ and K².
 a, The cutting tool.

220. *Large Patent Slotting Machine.* (Fig. 6.)

- A, Main frame.
 B, Table for holding the work.
 C, Tool-slide, which in cutting moves slowly and uniformly downwards, and quickly in returning therefrom.
 D, Guide-screw, takes into a nut on the back of the tool-slide c.
 a, Bevil-wheel, keyed on end of guide-screw D.
 b c, Bevil pinions gearing in wheel a.

Fig. 6.

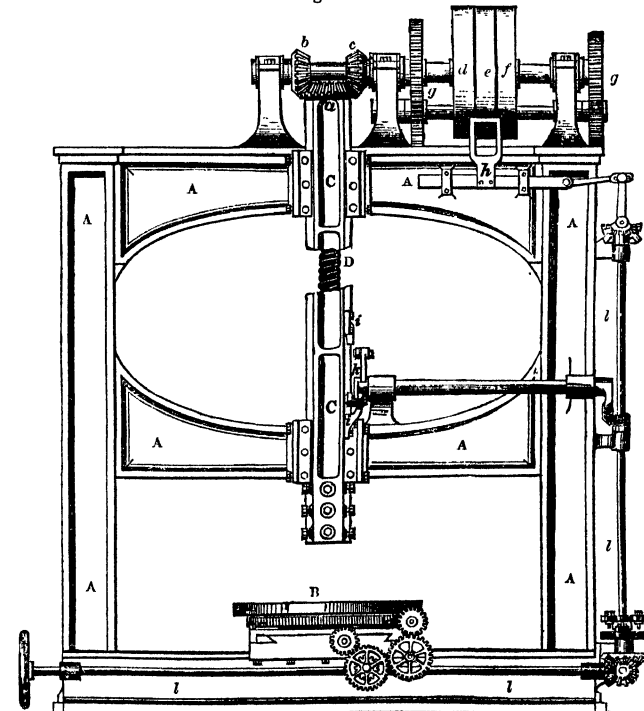
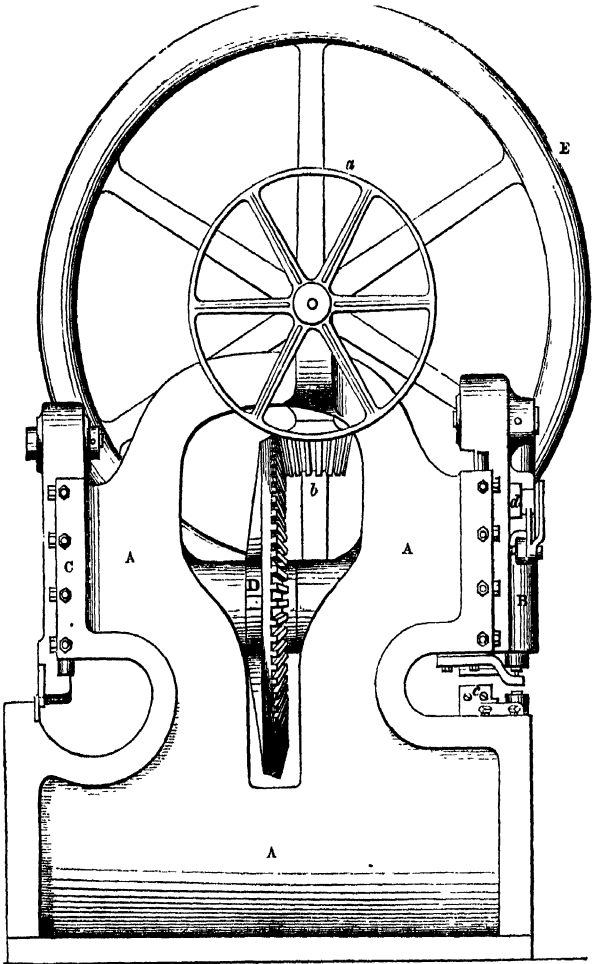

Fig. 7.



- d e f*, Strap pulleys, *d* being connected with pinion *b*, the other with pinion *c*, whilst the middle one, *e*, runs loosely.
- g*, A train of gearing which transmits motion from the pulley *f*, to the bevil pinion *c*.
- h*, Strap lever apparatus.
- i i*, Two stops, which can be fixed at any distance apart, according to the desired traverse of the tool-slide, *c*.
- k*, Lever upon which the stops *i i* act.
- ll*, Horizontal and vertical shafts for conveying motion from lever *k*, to the strap lever apparatus *h*, whereby the direction of motion of the tool-slide *c* is changed; the motion thus derived is also conveyed simultaneously to the table *B*, whereby self-acting circular and transverse motions may be imparted to it.

The smaller Patent Slotting Machines are fitted with an adjustable crank, and quick return motion similar to the "Patent Universal Shaping Machine."

Punching and Shearing Machine. (Fig. 7.)

- A, Main frame, made on the hollow principle.
- B, Vertical slide for punching, worked by eccentric and connecting rod not shown.
- C, Ditto, for shearing, worked in the same manner.
- D, Large wheel, keyed upon the eccentric shaft which passes through the frame (but is not shown).
- E, Fly-wheel.
- a*, Strap pulleys—fast and loose.
- b*, Bevil pinion gearing into wheel *D*.
- c*, Cross shears for cutting off bars of any length.
- d*, Is an incline bar worked by hand, for the purpose of lifting the punch without stopping the machine.

In the smallest machines the punching and shearing are both arranged upon the same side. The driving gear of larger machines is differently arranged to the above, but in other respects the same general arrangement prevails.

221. *Large Self-acting Surfacing and Screw-Propeller Lathe*, made for her Majesty's Dockyard, Woolwich, by Messrs. Francis Lewis & Sons, Manchester. (Figs. 8 and 9.)

- A, A strong cast-iron bed, planed 7 feet wide, and 20 feet long.
- B¹, Fast headstock.
- B², Moveable do.
- C C, Two carriages moveable longitudinal on bed having studs and pinions *ccc* to work in the rack *D*.
- E E, Two compound slide-rests.
- F F, Two large face-plates with external wheels at the back.

G G, Spindles, G² is hollow, and a moveable cylinder fitted therein, and is made to slide in and out by a screw attached to the hand wheel *h*.

H, Cone-strap pulley.

I, Pinion driving the wheel J, which is fixed on the longitudinal shaft.

K, So also are the pinions L L, which drive the face-plate F; these pinions are thrown in and out of gear, by levers projecting through the slots *m m* in the head stocks.

o o o, Driving studs.

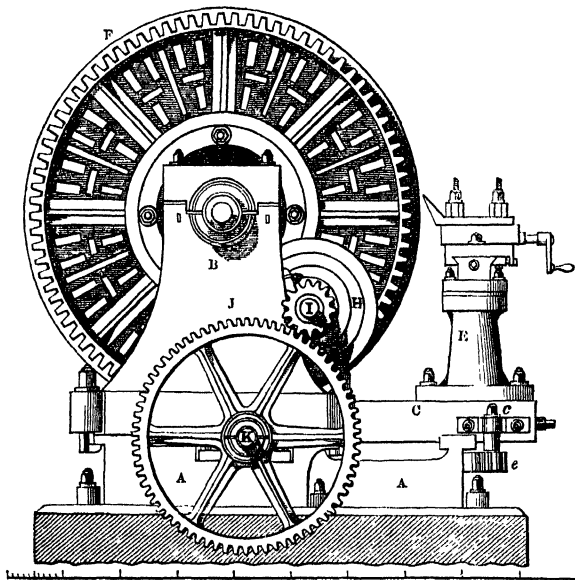

Fig. 8.—End Elevation.

The lathe will admit propellers up to 18 feet diameter, and will cut pitches varying from 8 feet to 20 feet. It is shown as set for cutting a propeller; the driving pulley being placed on the longitudinal shaft D, the motion is transmitted at one end to the face-plate, and simultaneously at the other to the slide rest. The change driving shafts *c*, afford a great variety of speeds, for ordinary boring and surfacing. It is unnecessary to state that a pit is formed between the fast headstock A, and the bed-plate G.

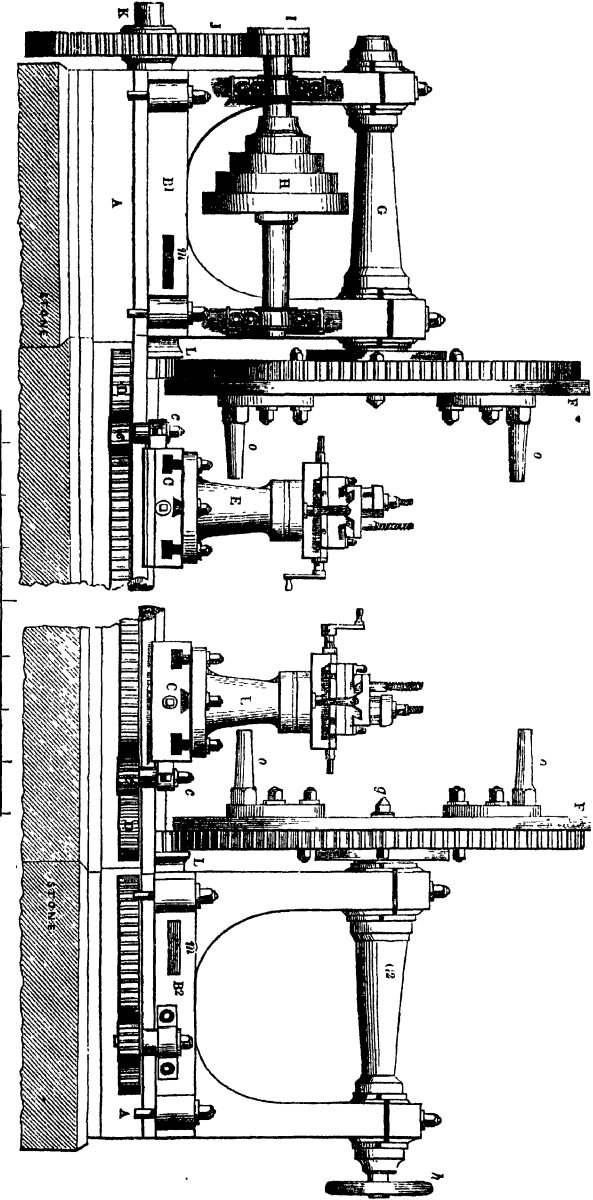

Fig. 9.—Front Elevation.

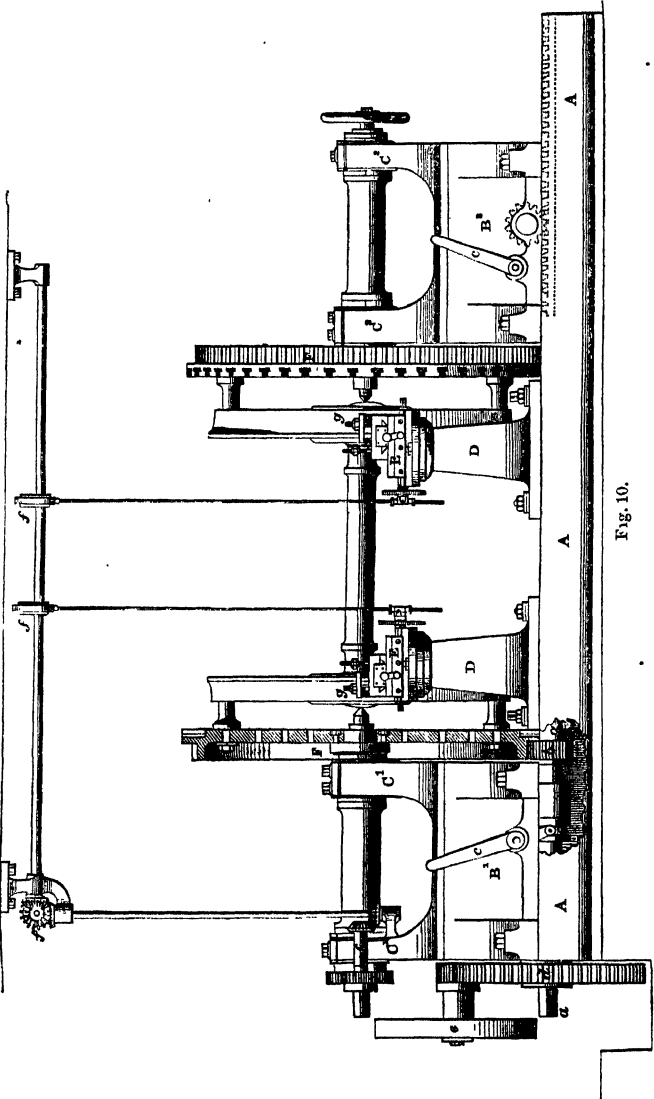

Fig. 10.

222. *Large Lathe for Turning Railway wheels, and other heavy work, by Messrs. Joseph Whitworth & Co. (Fig. 10.)*

- A, Heavy base-plate, extending throughout the length and breadth of lathe, planed and grooved on the upper side.
- B¹, B², Standards for carrying headstocks, B¹ being permanent, and B² moveable on the base plate, by means of the rack and pinion.
- C¹, Fast headstock.
- C², Moveable headstock, the centre in which can be moved out any distance, as in an ordinary poppet-head.
- DD, Standards for carrying slide-rests.
- E E, Compound slide-rests.
- F F, Two large face-plates, with external wheels at the back.
 - a, Longitudinal shaft.
 - b, Two pinions (one only shown,) keyed on shaft a, and gearing into the external wheels F F.
 - c, Clutches for disconnecting the pinions from the external wheels.
 - d, Spur gearing placed at the end of the lathe.
 - e, The strap pulley.
- ff, Apparatus for giving self-acting motion to the two compound slide-rests.
- g g, Represent the wheels to be turned on their axle.

CHAPTER VI.

MACHINES FOR CARDING, SPINNING, ETC.

CARDING MACHINE (GLOBE WORKS, ROCHDALE.)

223. This figure presents a single wool-carding engine, lap-machine, and self-acting feeder; the same, with condenser attached, intended to produce a number of endless cardings and slubbings, and dispense with the use of the billy machine and the hand required to work it.

Action of the Machine.—The wool is removed from the doffer of the first carding engine as usual, and is drawn by a pair of rollers fixed at the side of the frame through a revolving tube, which imparts an amount of false twist to the sliver. It is returned by a lower pair of rollers to the lap-machine in front of the engine, which is arranged to form a lap 16 inches in diameter and 4 inches wide. When the required length of sliver is wound on, notice is given by a

CARDING MACHINE.

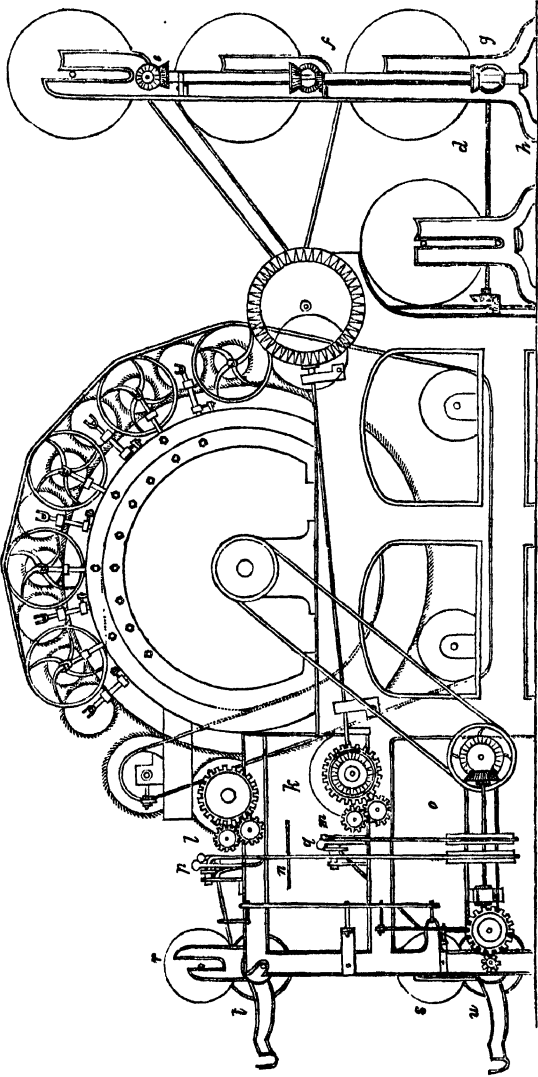

bell; and if not attended to, another movement doffs the lap, so as to ensure each one being the required length.

These narrower laps are placed side by side upon rods, so as to form four rows, *a, b, c, d*, each row being the whole width of the engine, which is turned off into the engine by the unlapping rollers *e, f, g, h*. Each sliver passes through a guide or reed as it enters the feeding rollers to keep it in its proper place. The quantity of sliver thus put up at the feeding end of the machine will last a whole day. The wool having passed through the engine, and being carded in the usual manner, is removed from the main cylinder by the condenser doffers *i, k*, which are provided with rings of cards, and alternate blank spaces, so that the wool which is left upon the cylinder by the top doffer is removed by the lower one. The stripper-rollers *l, m*, take the bands of wool from the doffers, after which they pass between the double endless twisting-straps *n, o*, in order to receive a degree of false twist, sufficient to enable them to carry forward to be spun. They then pass between the delivery-rollers *p, q*, to the bobbins *r, s*, on which they are lapped by the friction of contact with the drums *t, u*.

When the bobbins are fitted they are removed direct to the mule to be spun, where they are unlapped in a similar manner by drums.

The advantage of this system consists in a great economy of labour; three operations being entirely dispensed with, viz., feeding, slubbing, and piercing. With the addition of the self-feeding condenser, yarns are found to be more regular and level than those produced by the ordinary methods; a greater quantity of work is turned off; the threads are more nappy or oozy, which increases the felting quality in milling, causes a firmer texture in the cloth, and a corresponding fulness of bottom and richness of appearance when finished, not attained by the methods formerly in use.

Note. This machine was made and jointly invented by *Mr. J. Mason, of the Globe Works, Rochdale*. Its performance received high approbation at the Great Exhibition of 1851.

SPINNING MACHINE.

224. This machine was improved by *Mr. J. Mason* of the *Globe Works, Rochdale*, including *Mason and Collier's* patent collars or bearings for spindles, separating plates for the stubbings, and the break motion for readily stopping the

machine. This improvement is accomplished by making the collar in the lifting rail longer (shown, detached, in Fig. 2), and continuing it through the wheel B, and up the inside

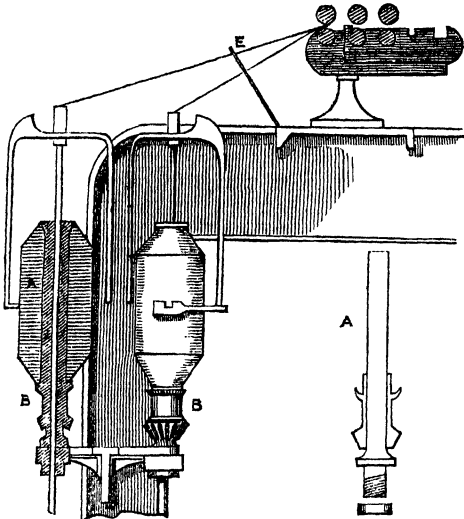

Fig. 1.

Fig. 2.

of the bobbin-barrel to the top of it, where the bearing of the barrel is shown at A, Figs. 1 and 2. The collars are chambered inside, so that the spindle fits only their ends, and they are firmly screwed to the lifting rail, the wheels and bobbins running loosely around them, as represented. The separating plates E prevent the broken threads becoming entangled with the other spindles.

FLAX MACHINES.

225. These machines were invented and patented by *Mr. Robert Plumber, of Newcastle-upon-Tyne*, and their performance was highly approved at the Great Exhibition of 1851. They consist of the following, 1st, a Rotatory Disc Scutching Machine for flax, hemp, &c., with straw holders, and with straw to scutch; 2nd, a Flax-breaking Machine, for flax-straw previous to being scutched; 3rd, a Flax-cutting Machine for preparing flax for the Cut-flax Heckling

Machine ; 4th, a Heckling Machine for dressing flax, hemp, &c., with flax-holders.

Fig. 1 represents the metal disc for scutching flax, with the brushes fitted to it.

Fig. 1.

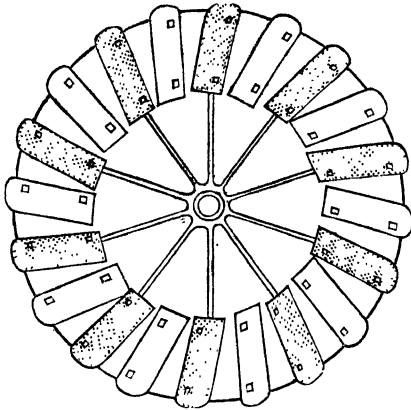
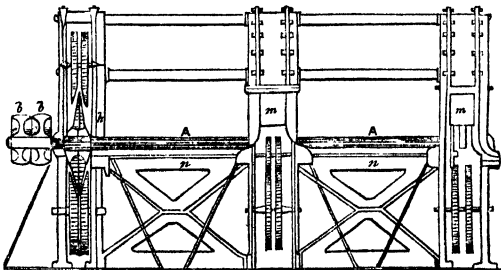

Fig. 2 represents a front elevation of the Rotatory Disc Scutching-mill. *A* is an axle having its bearings in an independent framing of metal, the upper portion being made open ; the metal pieces *m m* at the front end, being secured by bolts, can be readily removed for the purpose of changing

Fig. 2.



the brushes of the discs. The framing is stiffened by cross-pieces *n, n* ; by the pulleys *b b* a rotatory motion is imparted

to the axles. The top *i* of the scutching-board *h* is placed

Fig. 3.

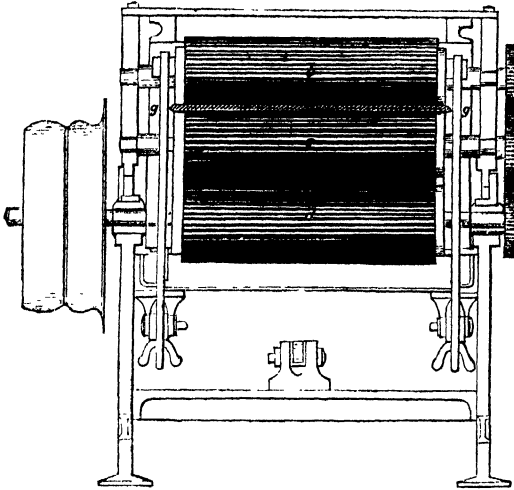

a little above the centre of the axle *A*. The heckle, or comb, is composed of steel wire.

Fig. 4.

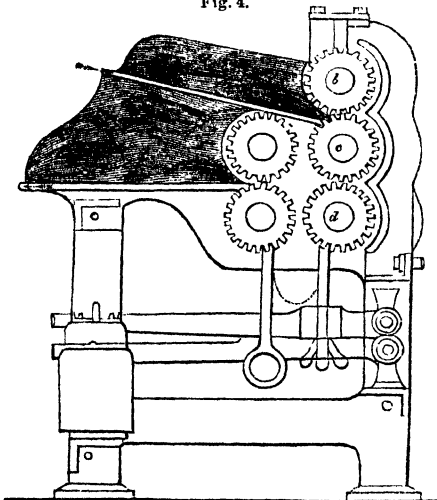
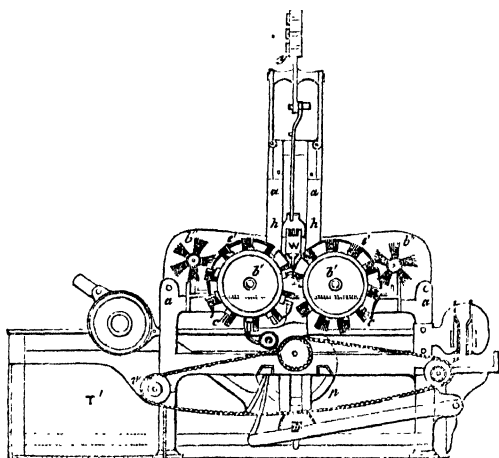

Fig. 3 is a front, and Fig. 4 is a side elevation of an improved Flax-breaking Machine. The letters *b*, *c*, and *d* are placed upon the grooved metal rollers, to which the flax is presented, and afterwards goes out, as seen in Fig. 4, by the direction of the arrows.

Figs. 5 and 6 represent a side and end elevation of the Double Cylinder Heckling Machine, adapted to dressing cut or short flax, in which elastic brushes are combined with rigid heckles. There are two revolving cylinders *b' b'*, mounted in a frame-work *a, a*; in their circumferences are sets of rigid heckles *c*, intermixed with the sets of elastic brushes *c, c* (in any way that may be deemed most advisable.) The cylinders *b', b'*, are also made to revolve in opposite directions, and the rows of brushes and heckles on one

Fig. 5.



cylinder are placed in alternating order in regard to those on the other cylinder, as before described. There are also loose stripping bars with guards, that, besides regulating the depth to which the heckles or brushes shall penetrate, doff, or throw down the tow from the brushes and heckles, and two small cylinders *b'', b''*, which are fitted with brushes for cleansing the working brushes and heckles *c, c*.

One of the cylinders *b'* may, if required, be made to oscillate by means of the link *h h*, which, as it rises and falls with

the lifter to which it is attached, moves the cylinder in a horizontal direction to and from the other cylinder; the bearings of the oscillating cylinder are made to slide, and attached by a rod to the radius arm by which the wheels k^3 , $l' m'$, and n' are kept in gear so as to answer the varying position of the oscillating cylinder. Motion is given to the rotating parts of the machine as in the one first described, but the holder is made to traverse or move forward in the trough, (which movement may also be applied to the brushing

Fig. 6.

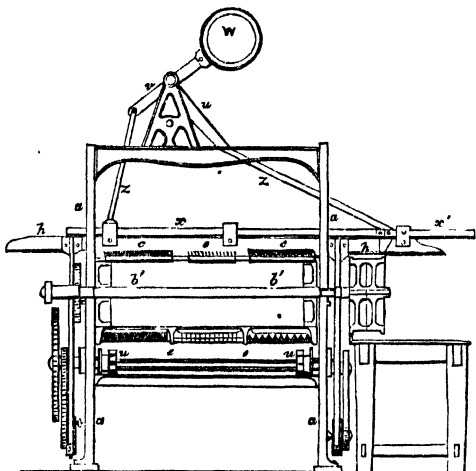

machine) by the combination of a bell-crank movement with the rising and falling motion of the trough, as will be hereafter described. The mechanism for lifting the trough h is shown in Fig. 6, and consists of a combination of pinions, wheels, camb, straps, pulleys and levers, such as are ordinarily used in heckling machines, and consequently well known. When the trough is raised, it pushes up a rod x , which is connected to the long arm of the bell-crank y , mounted on a standard fixed to the top of the framework a , when a weight w , which is attached to the opposite end of the arm, falls over, and causes the short arm of the bell-crank to pull in a rod z , which draws forward a finger-bar x' of the ordinary construction, to an extent sufficient to advance the holder the breadth of one set of heckles or

brushes. The tow and shive or dirt, thrown down from the heckles or brushes, are in this case received upon an endless chain of bars *t, t*, instead of the inclined grating represented in the machine first described, bars of which extend the whole length of the machine under the heckles and brushes, and are connected together by two side bands. The chain of bars revolves round two friction pulleys *v, v*, and takes into two pinions *u, u*; by means of which rotation is given to the chain from the same first mover by which the other parts of the machine are put in motion. The shive or dirt falls through between the bars upon the floor, while the tow is carried forward on the top of the bars, and delivered into the trough π' . To separate tow doffed from each set of heckles or brushes, the space between the endless chain of bars and the cylinders is divided by partitions into as many compartments as there are sets of heckles or brushes, (see Fig. 1), and the receiving trough π' is also divided into a corresponding number of compartments.

A cross-section of the holder of this machine is given in

Fig. 7.

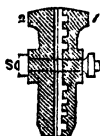

Fig. 8.

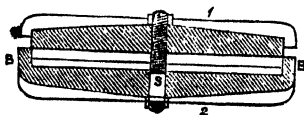

Fig. 7, and a longitudinal section in Fig. 8. It consists of two plates 1 and 2, connected transversely by a screw-bolt *s*, and having flanges *A, A* at their upper edges, by means of which they are supported in the trough *p*, Fig. 5. The plate 2 has two flanges *B, B*, one at each end, which come within the two flanges *A, A*, of the plate 1, and thereby confine the streak at the edges. The inner face of the plate 2 is planed perfectly true, and covered with felt, cloth, or some other soft or yielding material; but the plate 1 is formed on its inner face with flat beads, and flat grooves in alternate order, as shown in Fig. 7, so that the streak of flax or other material may be more firmly compressed between the plates without being unduly crimped. At their under edges the plates are chamfered off to admit the holder to come lower down. By this mode of construction, the pins or studs, ordinarily made use of to confine the outer edges of the

streaks, are dispensed with, and a greater breadth is obtained on which to spread the streaks, and the holder is also narrowed and rendered more easy to work.

FAIRBAIRN'S PATENT RIVETING MACHINE.

226. In this machine, for riveting boilers and other wrought-iron vessels, the moving slide and die are worked by a revolving camb upon an elbow joint, which gives a variable motion, and exerts the greatest force at the closing of the joint and the finishing of the rivet. The following figure represents this machine.

B is the boiler to be riveted, suspended by a hook which can be raised or lowered ; A, a large stem of malleable iron,

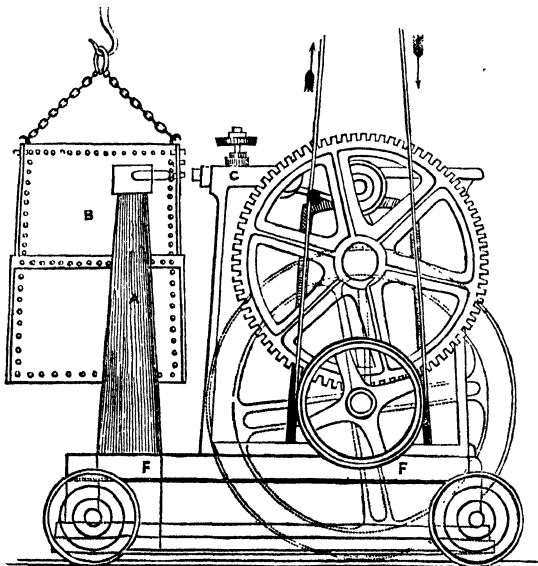

firmly fixed in an iron frame F, which makes the whole perfectly safe in the case of the dies coming in contact with a cold rivet, or any other hard substance. c is the slide moved by the camb ; in this slide are three dies corresponding with others in the stem A. By using the

centre die every description of flat or circular work can be riveted, and by selecting those on the sides it will rivet the corners, and thus complete vessels of almost every description. This machine is of a portable form, and can be moved on rails to suit the article suspended from the hook. This machine fixes in the firmest manner, and completes 8 rivets of $\frac{3}{4}$ -inch diameter in a minute, with the attendance of two men and two boys; whereas the average work that can be done by two riveters, with one "holder on" and a boy, is 40 $\frac{3}{4}$ -inch rivets per hour; the quantity done in the two cases being in the proportion of 40 to 480, or as 1 to 12, exclusive of the saving of one man's labour. The cylinder of an ordinary locomotive-engine boiler, $8\frac{1}{2}$ feet long and 3 feet diameter, can be riveted and the plates fitted completely by the machine in four hours; while, to execute the same work by hand, would require, with an extra man, twenty hours. The work produced by the machine is likewise of a superior kind to that made in the ordinary manner, the rivets being found stronger and the boilers more free from leakage. The riveting is performed without noise, and thus is almost entirely removed the constant deafening clamour of the boiler-maker's hammer.

CHAPTER VII.

THE STEAM-ENGINE.

227. The means by which steam produces mechanical action is almost invariably a piston, moveable in a hollow cylinder. The *piston* is a solid plug or disc, fitting the interior of the cylinder so exactly, as to prevent the steam from passing from the one side of it to the other; the piston having, at the same time, sufficient freedom of motion to allow it to play up and down in the cylinder, without any considerable loss of force from friction. The ends of the cylinder are closed by strong discs; one of which is cast with the cylinder, and forms part of it; the other, usually called the cap, is attached to the cylinder by screws and nuts, and so exactly fitted as to prevent the escape of the steam at the joints. Small apertures are provided at each

end of the cylinder, furnished with stoppers, called valves, by which the steam may be admitted, or allowed to escape, at pleasure. Now, it will be readily perceived that if a strong current of steam be admitted at one end of the cylinder, it will drive the piston to the other end; and if a current of steam be admitted at the other end, that which had been previously admitted being allowed to escape, the piston will be driven back again. This operation being continued, the piston will be alternately driven backward and forward within the cylinder, for any required length of time; and the force with which this is produced will depend on the force of the steam.

To give the action thus produced a mechanical effect, an appendage, called the *piston-rod*, is firmly fixed into the centre of the piston. This rod is turned exactly circular, and passes through a circular hole in the centre of the cap of the cylinder,—the hole being made to fit the rod so exactly, as not to let the steam escape, and to move, at the same time, so freely, as to require very little power to urge it.

It will be easily understood that, to attain this object, very great precision of form is necessary in the internal surface of the cylinder, and in the piston and its rod. The cylinder is made of cast-iron, but the internal surface of it, after being cast, is reduced to a perfectly cylindrical form, by a boring machine. (Art. 217.) The piston, which is flat at either side, and circular at its edge, to correspond with the cylinder, is made to fit the cylinder in steam-tight contact, and, at the same time, to move freely, by a variety of contrivances, which are minutely described in the *Third Edition of Tredgold on the Steam-Engine*. The hole through which the piston-rod plays in the cap of the cylinder, is surrounded by a packing of hemp, soaked in oil and tallow, which is pressed against the sides of the piston-rod; and in this way, whilst the motion is free, no steam escapes. The piston-rod thus partakes of the alternate motion which the piston itself receives, and conveys this motion to any object outside, with which it may be connected. This alternate motion, backwards and forwards, in a straight line, may be converted into any other kind of motion, by an infinite variety of mechanical contrivances, for the most important of which see Articles 143, 150, 159, 160, and 161. Various other important appendages of the steam-engine have been already described in Articles 144, 145, 146, and 147, as

regulators of its motion ; and in this place it will be proper to describe the following additional appendages of this important machine.

MERCURIAL STEAM-GAUGE FOR LOW-PRESSURE BOILERS.

228. This instrument is shown in the annexed figure. *c* is a tube, leading from that part of the boiler within which steam is contained ; *d* a stop-cock, to open or close the communication at pleasure ; *m b m* a siphon tube of iron, which extends to a height sufficiently great for a column of mercury, representing the pressure of steam in the boiler. At *M* and *m* are two small apertures, stopped by screws, which can be opened or closed at pleasure. The tube is filled through an opening at *R*, until the mercury shall flow through the holes at *M* and *m*. The opening *R* *M* and *m* are then closed, a small quantity of water having previously been let in at *R*, on the surface of the mercury at *M*. A float is placed on the top of the mercury in the longer leg of the siphon, from which a string is carried over the pulley *P*, to which a small index *s* is attached, which points to the divisions on a scale. Now, let the stop-cock be opened, and steam will flow from the boiler, and press upon the fluid in *G* ; and the column of mercury in the leg *M b* will be pressed down to some point, as *x*, and the column in the longer leg of the siphon will be raised to a point *x*, as much above *m* as *x* in the shorter leg is below *M*. As the mercury in the longer leg rises, it will raise the float, the counterpoise of

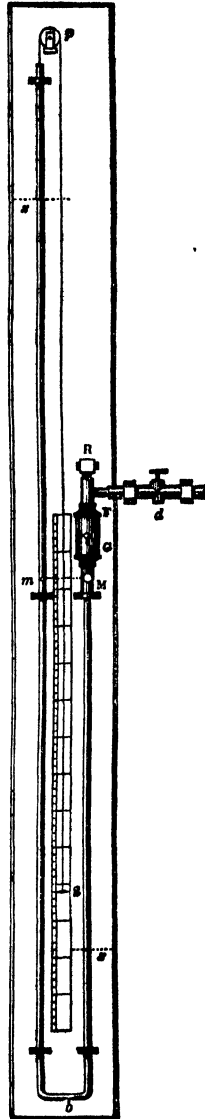

which, s , will of course descend; and the scale is so adjusted, that it indicates the height of the column of mercury from x in the shorter leg to x in the longer leg, which column balances the pressure of steam in the boiler, or, more correctly speaking, it balances the excess of the pressure of the steam in the boiler, above that of the atmosphere; in fact, the atmosphere, pressing through the open mouth of the tube upon the mercury in the longer leg, combines with the column of mercury xx in balancing the pressure of steam in the boiler. If, then, two inches of mercury be taken to express a pound per square inch, to which it is very nearly equal, such gauge will at once indicate the number of pounds per square inch by which the pressure of the steam in the boiler exceeds that of the atmosphere.

MERCURIAL STEAM-GAUGE FOR HIGH-PRESSURE BOILERS.

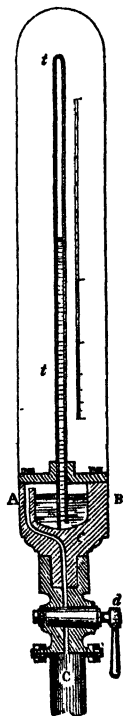

229. In high-pressure boilers, a mercurial gauge of the form shown in the preceding fig. would be inconvenient, owing to the great height of the column of mercury which would be necessary. In this case a gauge of another form is made use of, an example of which is shown in the annexed figure. Let $A B$ be a cistern of mercury; let t be a glass tube, open at the lower end and closed at the upper end, immersed in the mercury, and containing air in its ordinary state. When the stop-cock d is open, the steam from the boiler rushes through the passage c , and, pressing on the mercury in the cistern, will raise a column of mercury in the tube, by which the air in the tube will be compressed. When the air is compressed into half its original bulk, its pressure will be doubled; when it is compressed into one-third, its pressure will be increased in a three-fold proportion, and so on. The pressure of the steam, therefore, will be measured by the space into which it is able to compress the air in the tube. When great accuracy is required, a slight correction will have to be made for the column of mercury sustained in the tube, $\frac{1}{2}$ a lb. per square inch being added to the pressure

indicated by the compression of the air for every inch of mercury sustained in the tube. There are other gauges appended to the steam-engine, as the barometer-gauge, the siphon barometer-gauge, and the glass water-gauge, which are minutely described in the *Third Edition of Tredgold on the Steam-Engine*,—their principle being very nearly the same as those already described.

WATT'S INDICATOR.

230. Fig. 1 represents a front view in section, and fig. 2 a side elevation of this instrument. The rod attached to the piston plays through a collar at *a*. At *t* is a pencil-holder. At *s* is a screw, by which the instrument is inserted in a hole provided for it in the top of the cylinder. At *d* is a stop-cock, by which a communication may be opened or shut at pleasure between the indicator and the cylinder. The piston-rod of the indicator is surrounded by a spiral spring, the lower extremity of which is attached to the piston and the upper extremity to a fixed piece *a*, containing the hole through which the piston-rod plays. When the piston rises, the spring is compressed; and when it falls, the spring is extended. The spring is *in equilibrio* when the piston is at the middle of the cylinder, and the space through which it rises and falls is, from the known properties of this species of spring, proportional to the force which presses the piston upwards or downwards. When both extremities of the cylinder are open to the atmosphere, the spring is at rest, and the piston in the middle of the cylinder; but when steam is allowed to pass from the cylinder to the indicator, by opening the stop-cock *d*, such steam will press the piston

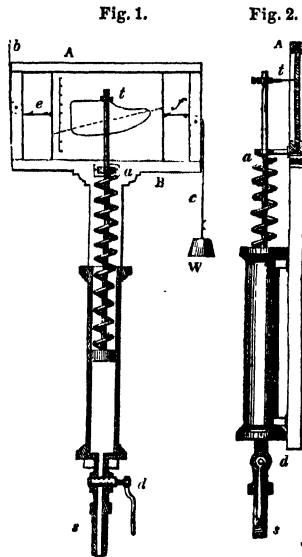

upwards, and compress the spring with a force equal to the excess of the pressure of the steam above that of the atmosphere. When, on the other hand, a vacuum is produced in the cylinder by the condensation of the steam, the same vacuum will be produced under the piston in the indicator, and the piston will be forced downwards by the excess of the pressure of the atmosphere above that of the uncondensed vapour in the cylinder.

“If an index were placed near the extremity of the piston-rod t , the pencil, ascending and descending on this index, would indicate by the space through which it would ascend the excess of the pressure of the steam over that of the atmosphere, and by the space through which it would descend, the excess of the pressure of the atmosphere over that of the uncondensed vapour. Both spaces added together, or the entire play of the piston, would, therefore, indicate the excess of the pressure of the steam above the pressure of the uncondensed vapour which resists it, and would, therefore, indicate the effective force of the piston, exclusive of friction.

“But as the piston of the indicator would be in rapid and continued motion, it would not be easy to observe and record the limits of its play, and still more difficult to note the rapidity of its motion. An ingenious expedient was therefore contrived to enable the engine itself to record these effects, which converted the indicator into a self-registering instrument. A small square frame AB was constructed, the breadth of which was somewhat greater than the extreme play of the piston of the indicator. In it was placed a card, capable of sliding in a horizontal direction in grooves: a string e was fastened to the side of the card, and, passing under a pulley, was carried upwards towards b , and attached to some part of the machinery which rises and falls with the piston of the engine. Another string f was attached to the other side of the card, and carried over a pulley and fixed to a small weight w . When the piston rises, the string e is drawn to the left, the card drawn in the same direction, and the weight w rises. When the piston falls, the weight w , acting on the string f , draws the card to the right; thus, as the piston rises and falls, the card is drawn alternately through a certain space left and right. Now, suppose the steam to be admitted above the piston, to press it down, this steam presses the indicator of the piston up, and the pencil t , passing on the card, would, if the card were at rest, mark

upon it a straight line, the length of which will indicate the pressure of the steam; but as the card is drawn from left to right while the piston falls, the pencil will describe upon it a curve (as in fig. 1), by the combined effects of the vertical motion of the pencil and the horizontal motion of the card. When the piston has reached the bottom of the cylinder, and the upper exhausting valve is opened, a vacuum is produced in the cylinder, which vacuum extends to the indicator, the piston of which, therefore, descends, the pencil t descending at the same time and at the same rate. While this takes place the card is moved from right to left, and a corresponding curve is described by the pencil, the curvation of which will indicate the suddenness with which the vacuum is produced, as well as its degree of perfection. From what has been stated, it will appear that in a single ascent and descent of the piston, or in one stroke, as it is called, a curve will be formed on the card, which will exhibit not only the entire effect of the steam acting on one side against the uncondensed vapour on the other, but will show the entire character of its progressive action at every point of the stroke."

There are various other arrangements in mechanism for regulating motion appended to the steam-engine, as the governor, safety-valves, &c., already described in articles 144, 145, 146, and 147, which, with those described in the following articles, render this important machine completely self-acting.

BOILERS AND THEIR APPENDAGES.

231. The cross section of a waggon boiler is shown in fig. 1, and the longitudinal section of the same boiler is shown in fig. 2. The same letters refer to the corresponding parts in the two figures; " a is the grate supporting the burning fuel; b and b' represent the flue which encompasses the boiler; e, e are the gauge-cocks; s is the steam-pipe which leads from the boiler to the cylinder; $g p$ is the safety-valve, the pressure upon which may be regulated by the sliding-weight g , the lever $g p$ being fixed on a pivot at p . The spindle of the valve is attached to it at i ; h is a fork to keep the lever $g p$ in its position. The weight g produces an effect at i , which is in the proportion of $g p$ to $i p$: thus, if $g p$ be three times $i p$, then 10lbs. suspended at g will produce a pressure of $3 \times 10 = 30$ lbs. at i . The

opening which appears immediately above the valve is the end of a discharge-pipe for conducting away the steam which escapes from the safety-valve. When the pressure of the steam in the boiler exceeds the pressure produced by the weight on the safety-valve, the latter will be raised, steam will escape around it, and issue through the waste pipe. Sometimes this steam is allowed to escape into the atmosphere, and sometimes it is conducted into the cistern of water by which the boiler is supplied, where it is condensed, and has the effect of raising the temperature of the water. By this means a portion of the heat, which would otherwise have been wasted, is carried back to the boiler. The internal safety-valve is represented at *xyz*. This valve presses at *n* within the boiler, and is drawn

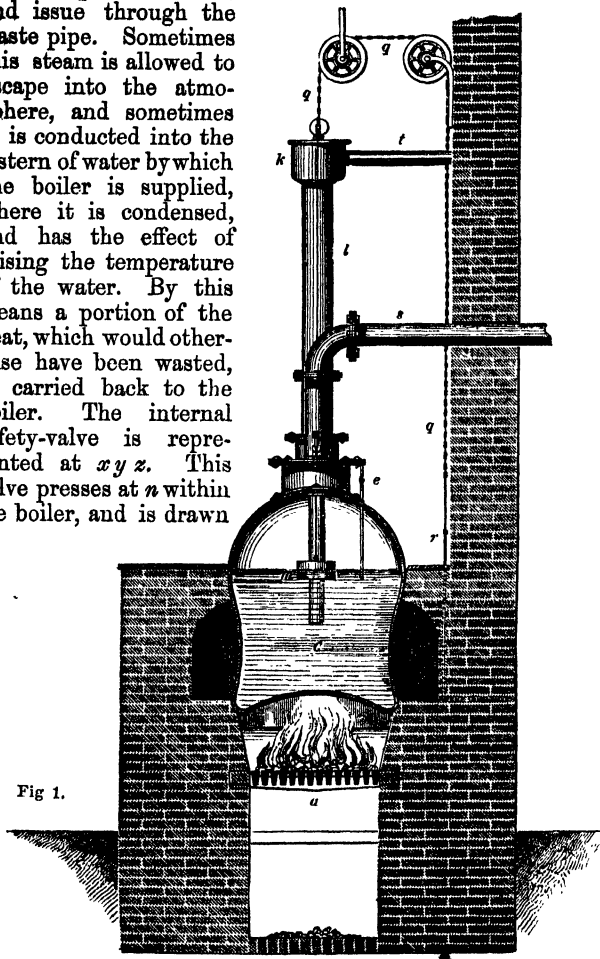

Fig 1.

up into its seat by the end of the lever x ; y is the pivot which supports the lever, and a weight suspended at z draws it upwards. When a vacuum is produced in the boiler by the condensation of the steam, the pressure of the external atmosphere forces the valve n open, and the air enters and fills the boiler."

Fig. 2.

THE SELF-ACTING FEEDING APPARATUS.

232. This is shown at $w u v k$; "a tube l is attached to the top of the boiler, and descends within it to a point below the level at which the water should stand. The pressure of the steam within the boiler, acting upon the water, supports a column of water in the tube l ; on the surface of this water at o rests a float, attached to a chain g , which passes over two pulleys shown in fig. 1, and which, descending from the second

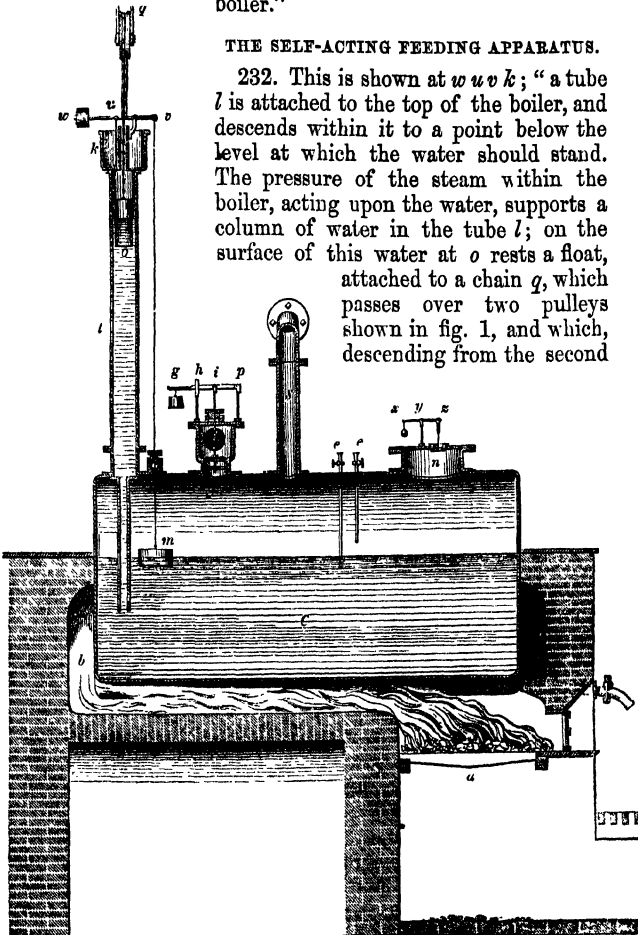

pulley, is attached to a rod r , which supports the damper. This chain, as it rises and falls, raises and lowers the damper, and opens or closes, more or less, the flue across which the damper passes.—When the pressure of the steam within the boiler is unduly augmented, the column of water it supports in l rises; with it rises the float o , and consequently the damper r falls, contracts the flue, diminishes the draft, mitigates the heat of the furnace, and thus lessens the evaporation in the boiler. When, on the other hand, the evaporation in the boiler does not proceed fast enough, the pressure of the steam in it is unduly diminished, and the column of water it supports in the tube l is lowered; the float o falls, and the damper r rises; the opening of the flue is enlarged, the draft increased, the furnace acquires additional heat, thus augmenting the evaporation. In this manner the varying demands of the engine on the boiler are supplied by the varying power of the furnace—the wants of the engine producing the requisite effect on the boiler.”

THE SELF-ACTING BOILER FEEDER.

233. “The float m , fig. 2, rests on the surface of the water within the boiler; a wire attached to it passes, steam-tight, through a collar in the top of the boiler, and is fastened to the end v of a lever, which is balanced by a weight w at the opposite end; a rod is attached at u to the lever, which descends to the bottom of the small hole in the hot water cistern k , and is attached to a valve at the bottom of this cistern, which opens upwards. When u rises, this valve is opened; when it is pressed down, the valve is closed. The cistern k is supplied by a small pump, called the *hot water pump*, which draws water from a reservoir receiving the discharge from the condenser of the engine, as thrown out by the air-pump.—This water is thus pumped by the engine itself into the cistern k , and a waste-pipe is provided for the discharge of so much of it as is not consumed by the boiler.—When the water in the boiler begins to be exhausted, the level falls, and with it the float m ; this draws down the end v of the lever, and raises u , by which the valve o is opened, and the water from the cistern k allowed to descend by the tube l ; and this continues until the level of the water in the boiler is raised to the proper point; the float m is raised with it, and the end v of the lever also

raised, and the valve *o* closed." In this manner the water in the boiler is always sustained at a proper height.

"All these arrangements will be still more clearly understood by means of the following figure, which represents the waggon boiler with all its appendages in perspective. The grate and a part of the flues are made visible by the removal of a portion of the masonry in which the boiler is set. The interior of the boiler is also shown by cutting off one half of its roof."

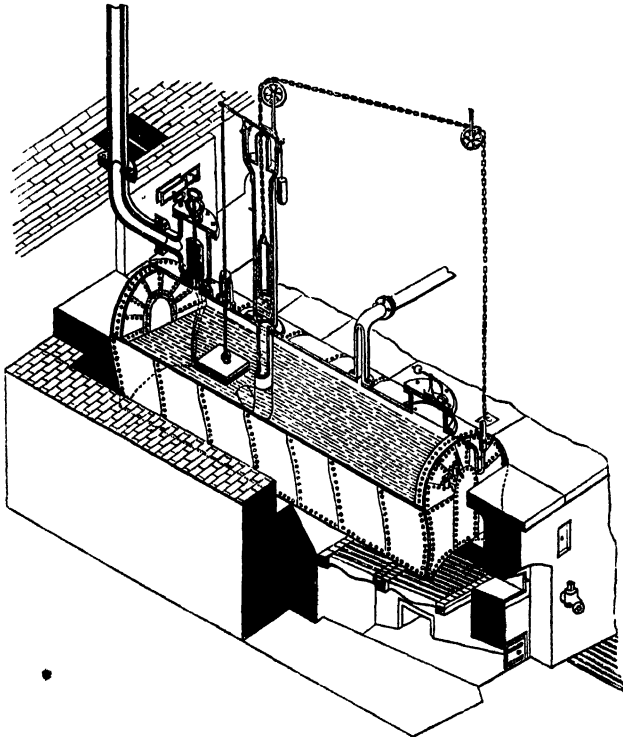

284. *The Slide-Valves.* — "In the following figures, page 182, are represented the most usual forms of slide-valves.

Fig. 1 represents in section the cylinder, piston, and slide: *s* is the mouth of the steam-pipe coming from the boiler;

e is the pipe leading to the condenser; *t* is the rod which is attached to the slide, moving through a stuffing-box *m*. This slide is represented in longitudinal section, separately, in fig. 3, and in transverse section in fig. 4. In the position of the slide represented in fig. 1, the steam passing from the boiler enters at *s*, and passes to the bottom of the cylinder through the opening *b*, and acts below the piston, causing it

Fig. 1.

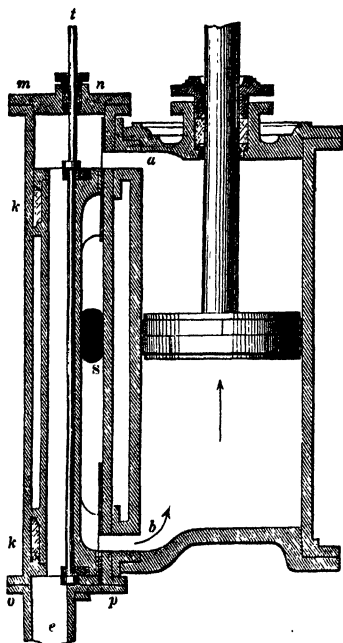

Fig. 2.

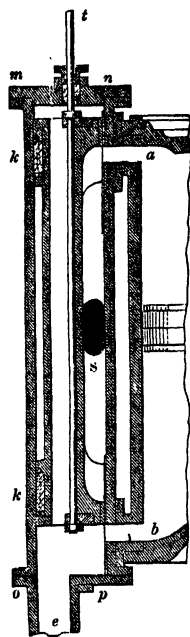

Fig. 3.



Fig. 4.



to ascend. The steam which was above the piston escapes through the opening at *a*, and descending through a longitudinal opening in the slide behind the mouth of the steam pipe, finds its way to the pipe *e*, and through that to the condenser.

When the piston has reached the top of the cylinder, the slide will have been moved to the position represented in fig. 2. The steam now entering at *s* passes through the opening *a* into the cylinder above the piston, while the steam which was below it escapes through the opening *b* and the pipe *c* to the condenser.

The form of the valve from which it derives its name of D-valve is represented in fig. 4. The longitudinal opening through which the steam descends then appears in section of a semicircular form. The packing at the back of the slide is represented at *k*; this is pressed against the surface of the valve-box.

235. The general arrangement of the several parts of the steam-engine already described in Articles 143, 144, 145, 146, 147, 150, 159, 160, 227, 228, 229, 230, 231, 232, 233, and 234, so as to constitute the double-acting stationary engine, as constructed by *Messrs. Fairbairn and Co., of Manchester*, and generally used in manufactories, is fully described in *Lardner's Rudimentary Treatise on the Steam Engine, Weale's Series*.—*The Cornish Pumping-engine and the High-pressure Engine*, are described in *W. Pole's* works on those subjects.—See also the *Rudimentary Treatise on the Marine Engine, by R. Murray, C.E., Weale's Series*, and *J. Sewell's Rudimentary Treatise on the Locomotive Engine in the same Series*. The object of this work being chiefly to treat of the purely mechanical arrangements of the several appendages of this important machine, without entering into the details of the chemical properties of steam, which will be found amply discussed in the works above referred to; and, to conclude this chapter, two steam-engines of a novel, ingenious, and economical construction, shall be described, which received high approbation at the *Great Exhibition* of 1851. (See pages 184, 185, 186.)

OSCILLATING ENGINE.

236. This engine is chiefly indebted to Mr. Penn for its elegant simplicity and its present perfection of workmanship and arrangement. It need hardly be explained that this engine derives its name from its cylinders "oscillating" upon hollow axes or trunnions, through which the steam is admitted to, and withdrawn from, the cylinders; the piston-rod by this means accommodates itself to the motion of the crank without the *parallel motion* being required. This construction has now been proved as applicable to ocean

steamers as to small boats on rivers; it also appears to be well adapted for driving the screw-propeller; and on account of the small space that its machinery occupies it is frequently made portable for agricultural and various other uses.

The annexed figure shows an engine of this kind, in which the number of working parts are greatly reduced when compared with the engines just described; thus rendering it

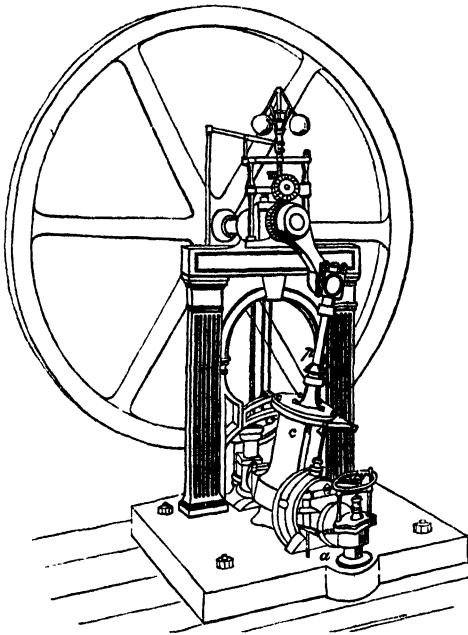

very simple and less liable to get out of repair. It is well adapted for working threshing machines, saw-mills, corn-mills, &c. The power may be communicated by a leather band over a pulley fixed on the axle of the fly-wheel, or by means of a spur-wheel and pinion. Here *p* is the piston, acting on the crank which is fixed to the axle of the fly-wheel; *c* the oscillating cylinder, to which the steam is admitted through the hollow axle *a*, and withdrawn through a similar hollow axle at the opposite side of the cylinder.

All modern marine engines have double cylinders, acting upon cranks which are inclined to one another. This is necessary for the purpose of passing the axle of the paddle-wheels or screw-shaft over the dead points, as the fly-wheel in engines of this kind is inadmissible.

MESSRS. WILLIAM JOYCE AND CO.'S IMPROVED PENDULOUS
HIGH-PRESSURE STEAM-ENGINE.

237. The principal advantages of this engine are its great simplicity and economy of fuel. The cylinder is inverted, and oscillates on its trunnions after the manner of a pendulum, and the piston-rod is connected direct to the crank-pin without the intervention of cross-heads, connecting-rods, &c. From the great simplicity of this engine there is no risk of derangement; its being composed of so few parts causes the

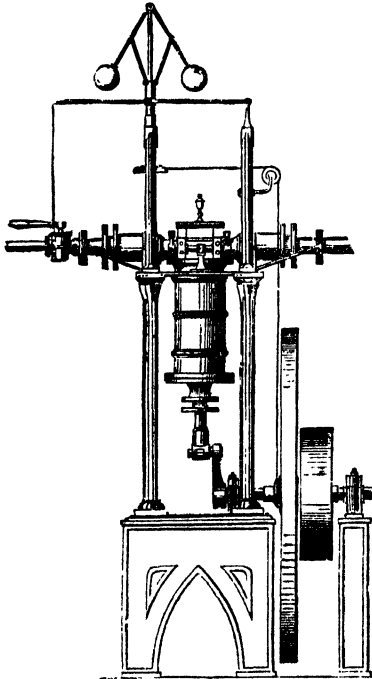

friction to be reduced to the smallest possible amount. The accompanying cuts represent a front and side view of the engine.

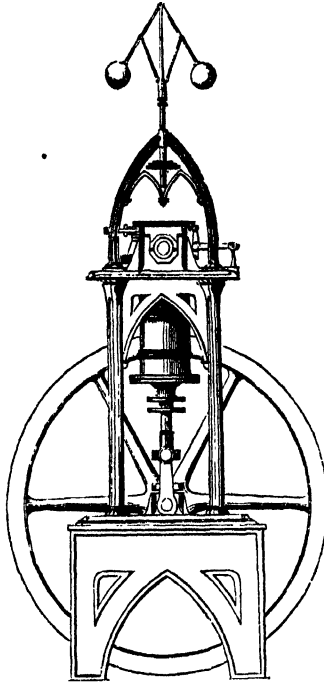

For extended information on these important subjects see the *Third Edition of Tredgold on the Steam-Engine.*

CHAPTER VIII.



MACHINERY FOR MANUFACTURING AND REFINING SUGAR.

238. Sugar is the sweet or saccharine constituent of vegetables, in all of which it is found in greater or lesser quantities. It occurs most abundantly in the sugar-cane, and next to this in the beetroot and maple. The sugar obtained from these three vegetables has the peculiar property of crystallising in oblique prisms. Sugar also occurs, though less abundantly, in ripe grapes, dates, figs, pears, and other fruits, the crystals of which are called *decrepit*, or not *truly* formed; and its sweetening power is only about three-fifths of that from the sugar-cane, &c. There are also the sugar of manna, milk, mushrooms, &c., which may be called animal substances. The sugar of commerce consists of oxygen, carbon, and hydrogen, in about the following proportions in 100 parts, as given by *Gay Lussac*, &c.

Oxygen	50 $\frac{1}{2}$
Carbon	42 $\frac{1}{2}$
Hydrogen	7
	100

239. The sugar-cane (*Arundo saccharifera*, or sugar-bearing reed) varies in height from 8 to 15 and even 20 feet, and is from 1 to 2 inches in diameter at the bottom of the stem, which is of a green hue, changing to yellow as it ripens, and divided by circular joints about 3 inches apart. The cane is brittle, with flat pointed leaves of 3 or 4 feet in length, which fall off as the plant advances to maturity. It is found in a wild state in the tropical parts of America and the West India islands; also in the tropical parts of Asia and Africa, though less abundantly. When the canes are ripe, they are cut and carried to the mill-house, and crushed by a machine composed chiefly of rollers, between which the canes are passed. The crushed cane is then boiled, and the

juice is drawn from the boiler, then evaporated and clarified, and separated from the molasses, being now of a brown colour, and in large broad crystals; in this state it is imported from the West Indies in hogsheads. There are annually imported into the United Kingdom upwards of 6,000,000 cwts. of unrefined sugar, about three-quarters of which come from British possessions.

SCHRODER'S PATENT EVAPORATING DISC-PAN.

240. Schroder's patent pan, lately introduced with great success into the West Indies, for evaporating saccharine solutions and liquids at a temperature not exceeding 180°



PERSPECTIVE VIEW

Fahrenheit, and may be worked by hand or other motive power, is shown in perspective in the annexed engraving.

This invention is patented in the United Kingdom and British Colonies, France, Holland, Belgium, Cuba, &c.

It has the property of evaporating syrups and other

liquids at a temperature under 180° Fahrenheit, at which degree sugar cannot carbonise.

Evaporation is as rapid as by the vacuum-pan, while the expense, including the royalty, is about 100%.

Every part of the machine is open to view, and from its extreme simplicity can be cleaned, or any accidental injury repaired, by a common workman.

If the machine is worked as a substitute for the tache,

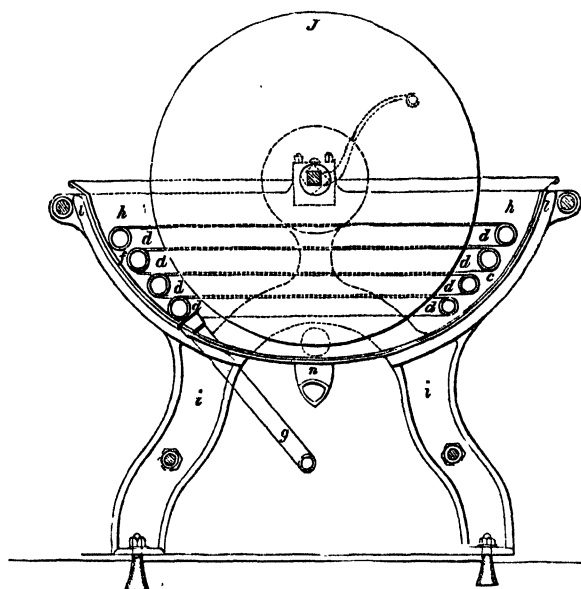

CROSS SECTION

the economy of fuel will be obvious, when contrasted with other modes of evaporation.

The whole weight of the revolving discs being supported upon centre-bearings, the revolution of the evaporating surfaces is effected with slight exertion or expense of power, and the contact of the atmosphere, combined with the rapidity of condensation, produces a large, hard-grained sugar, not to be surpassed by any other mode yet employed.

A reference to the drawings will show the operation of the machine, which may be simply described. The man, or

steam power, turns the battery of discs, *J*, which exposes the liquid or syrup that adheres to them to atmospheric evaporation; the condensed water from the steam pipes runs into the condensing chamber, from which it can be returned into the boiler at a temperature a little below 180° Fahrenheit. When the syrup is cooked, the elevation of the lever-handle, *n*, discharges the contents of the pan. The plan and cross sections will show the disposition of the steam-pipes; but any other modification can be adopted that suits the purchaser.

References to the cross and longitudinal sections and plan of SCHRODER'S patent pan.

- a*, Steam-pipe from boiler.
- b*, Stop-cock in steam-pipe.
- c*, Branch pipe distributing steam to *d*, *d*, *d*, *d*.

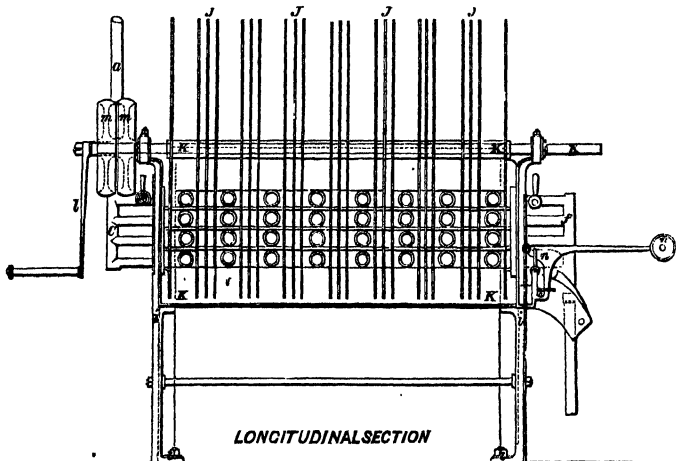

- d, d, d, d*, Four tiers of pipes containing steam.
- e*, Stop-cock for shutting off steam from top coil of pipes when required.
- f*, Branch pipe for letting off condensed water from *d, d, d, d*.
- g*, Pipe leading to Condenser box (not shown) which prevents steam from blowing through the pipes, but allows the condensed water freely to pass off, either by returning to the Steam Boiler or to waste.
- h*, Pan.

- i*, Frame carrying ditto with tie rods.
j, The Patent Evaporating Discs.
k, Spindle supporting ditto with pieces to regulate the distance between discs.
l, Winch-handle for turning discs.

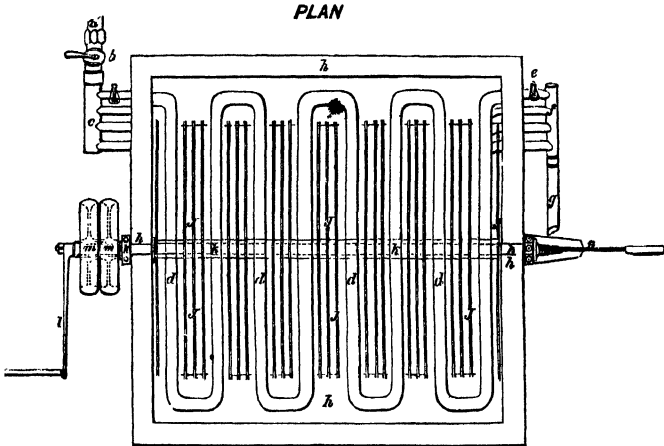

- m m*, Live and dead pulleys for driving discs by power.
n, Loaded Valve for discharging pan, with lever and links to carry it.
o, Conduit for the above.

THE BLOW-UP PANS.

241. The first process the raw sugar undergoes, preparatory to refining it, is melting or dissolving it in the blow-up pans, as they are called. These pans are large cylindrical copper vessels, about 8 or 9 feet in diameter and 5 feet deep; into which steam is introduced by means of pipes coiled round within the vessels to dissolve the sugar, which thence becomes a dark, thick, viscous liquid; as yet the earthy impurities, and part of the molasses, which are always present in raw sugar, are unremoved; a small portion of lime-water being admitted to the liquid sugar, and constant stirring with long slender rods being applied to assist the process of liquefaction. This process is so simple that it may be easily understood without an illustration. The blow-up pans are generally rectangular, 6 or

7 feet long, 3 or 4 feet wide, and 3 feet deep, with perforated copper pipes near the bottom, through the holes of which steam is blown into the sugar.

THE FILTERING PROCESS.

242. When the raw sugar has been sufficiently dissolved in the blow-up pans, just described, it is allowed to run

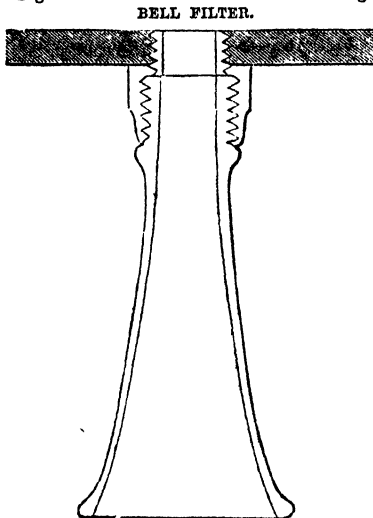
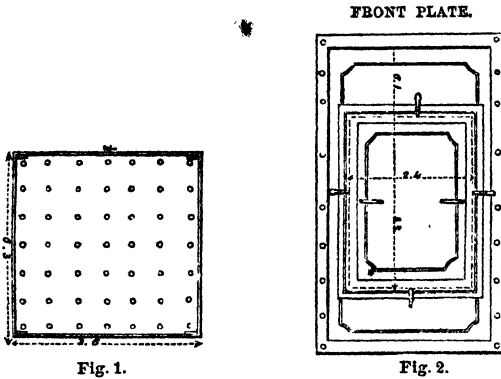

from the blow-up pans to the filters, which are placed in a lower room. The filters are cast-iron vessels in the form of chests, about 7 feet in height, 4 feet broad, and $3\frac{1}{2}$ feet in width. Fig. 1 is a section, fig. 2 a front elevation, which is furnished with a door for the arrangement of the filtering bags; and fig. 3 is another kind of filtering vessel, called a bell-filter. At the top of each filtering vessel is a shallow chamber, in which the liquid sugar is first received, and in the bottom of which are several circular holes (shown in fig. 1); below these holes are suspended several stout canvas bags, from 5 to 6 feet long and 2 feet wide. Into these bags the melted sugar flows, and strains gradually through the bags, in a transparent stream of a slightly red colour. Each filtering vessel contains from 40 to 50 of these bags, in which are retained all the impurities, already referred to in the last article, with the exception of the colouring matter, which is removed by another process. The bags, when they become clogged with impurities, are taken out of the filtering vessels and completely cleansed in the yard of the refining establishment.

CHARCOAL FILTERS OR CISTERNS.

243. Preparatory to describing these cisterns, which are 12 to 18 feet high, and 3 to 4 feet diameter, we must first inform the reader that at the bottoms of the filtering vessels is formed a false floor of laths. This false floor is completely covered with a strong woollen cloth, on which a layer of powdered animal charcoal, or bone-black, as it is commonly called, is laid, of about 12 to 18 feet in thickness. The liquid sugar flows from the filter-bags upon the charcoal, and in a short time distils through the layer of charcoal and the cloth lath-work beneath it, and is thence carried off by pipes, having now become a transparent and nearly colourless liquid, through the operation of the charcoal-filter. Thus the heavy impurities of the liquid are got rid of by means of the canvas bags, described in the last Article, and the colouring matter disappears by the charcoal-filter just described. This last process is of too simple a character to require illustration by drawings.

The charcoal, after about a week's use, becomes completely filled with impurities, which are soon removed by burning it in retorts in another part of the refining establishment. The charcoal then becomes as good as before

and though it wastes in a slight degree, the power of charcoal can never be destroyed, the same charcoal having been reburned and used in the same establishment, it is said, for upwards of 20 years.

BOILING THE LIQUID SUGAR IN THE VACUUM-PANS.

244. These pans are circular, dome-covered, air-tight copper vessels, as represented in the opposite engraving: each pan is furnished with pipes, valves, and taps for the various purposes of allowing the air to be drawn off by the air-pump, for admitting steam to the pan, for testing the temperature of the liquid, &c., &c.

The saccharine liquor, after passing through the charcoal filter, is pumped into these pans. Steam is next admitted by a pipe at the bottom of the pans into a space below the liquid sugar, and also by several other pipes to the interior of the fluid mass, which is thus brought to a boiling state at a temperature little higher than that of a blood-heat: such is the well-known effect of the vacuum created in the pan. That a more perfect evaporation of the liquid sugar may be effected, it is made to flow through large iron pipes (shown in the engraving), each containing several small tubes, which further tend to condense the steam and maintain the vacuum. As this process of evaporation goes on, the crystals of sugar are formed in the pans. For the purpose of testing the state of the sugar in the pans, each of them is furnished with a glass pipe and thermometer, showing the state of the steam inside, and an index by which the progress of the evaporation of the liquor may be determined. By these means, and finally by means of the proof-rod, which penetrates to the interior of the pan, by means of valves, without disturbing the vacuum, the efficacy or inefficacy of the boiling is determined; and it is then, as the case may be, either submitted to further boiling, or at once drawn out of the pan for the next process.

Note.—Formerly the liquid sugar was boiled in large open pans over a fire, at a temperature of above 240° of Fahrenheit, but by the greatest care in boiling the sugar was injured by this high temperature, and crystallisation could only be partially obtained. This great defect was remedied by the invention of the vacuum-pan, just described, by Mr. Howard, about forty years ago, who patented his invention, by which he realized upwards of £40,000.

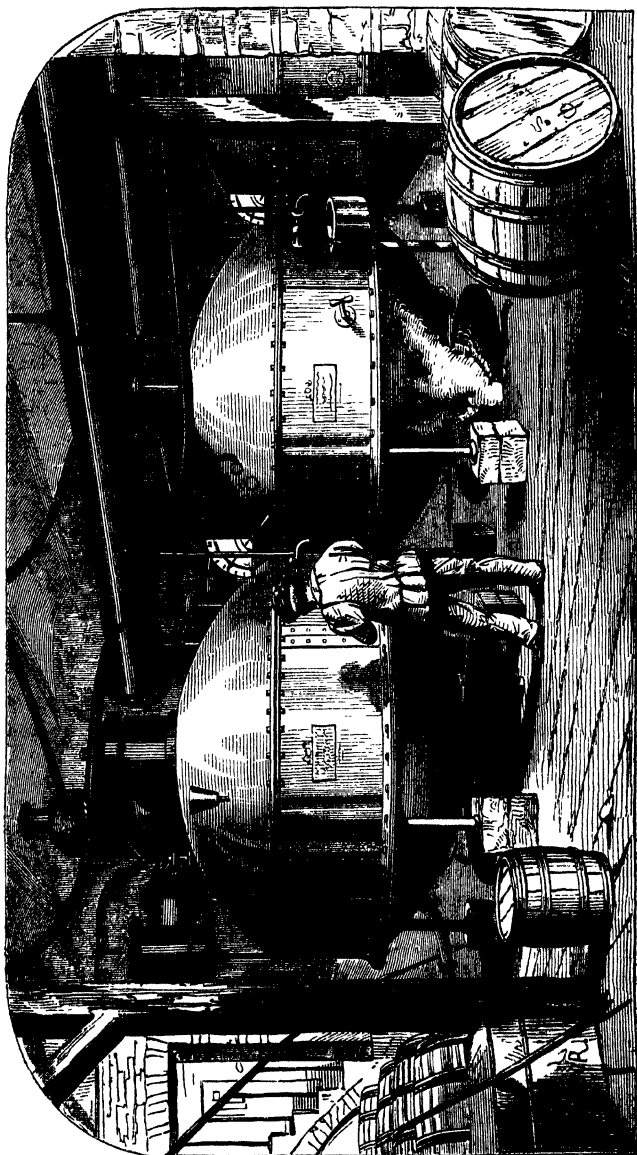

VACUUM-PANS.

ELEVATION and SECTION of RETORTS and SHAFT.

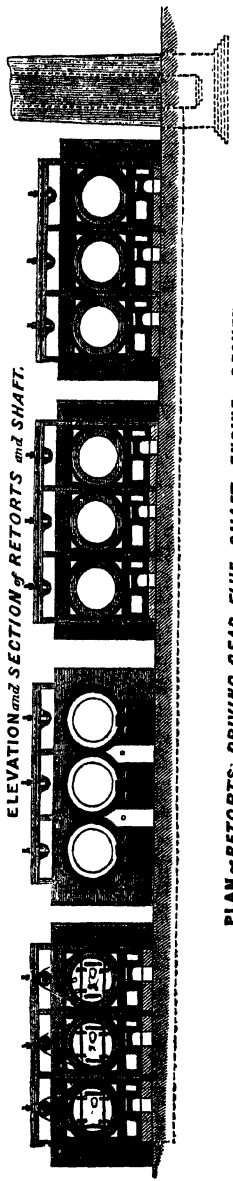

PLAN of RETORTS; DRIVING GEAR FLUE-SHAFT. ENGINE and BOILER.

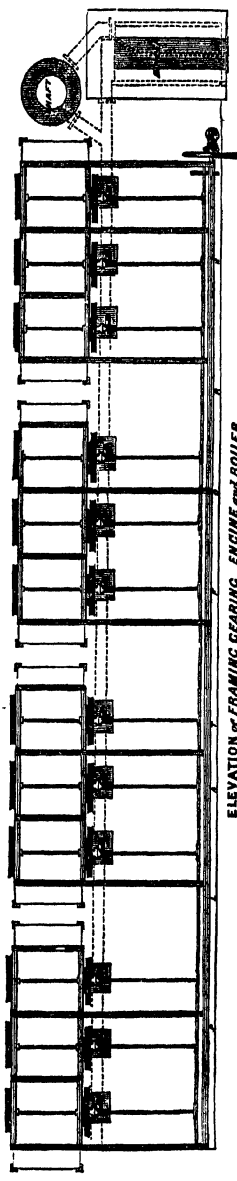

ELEVATION of FRAMING GEARING ENGINE and BOILER.

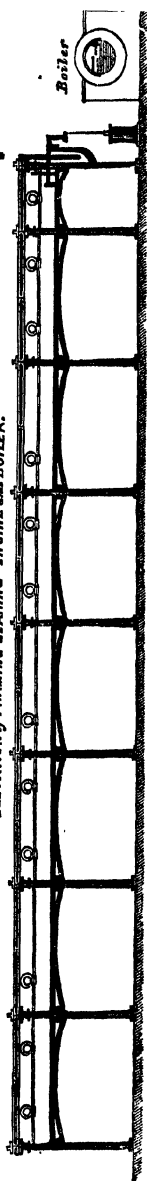

ARRANGEMENT OF TWELVE CYLINDER RETORTS.

SUGAR-HEATERS.

245. The process in the vacuum-pans being finished, the crystallised sugar is now transferred to the heating vessels, or sugar-heaters, for the purpose of giving it greater consistency. Heaters are simply semi-elliptical cast-iron pans, with a copper lining—the steam is admitted between.

THE MOULDS.

246. The moulds are vessels nearly of a conical shape, placed on their vertices. Their mean dimensions are about 2 feet in length and 6 or 7 inches in diameter at the larger end, which is open. The liquid sugar is poured into these moulds, and after remaining in the mould about two days, and then undergoing the final operations of “washing and brushing off,” as they are called, the sugar-loaf, so well-known in commerce, is completed; it having only now to be folded in paper and dried in a room heated to a high temperature by means of iron-pipes, through which the surplus steam from the boiler passes.

Note.—The cost of loaf or refined sugar seldom exceeds that of brown or unrefined sugar by more than 20 per cent. This result is due to the great improvements in the process and machinery by *C. E. Howard, Esq.*, in 1812, and subsequently by others; previous to which the cost of refining was not less than from 40 to 50 per cent.

PATENT MANUFACTORY OF CHARCOAL FOR REFINING SUGAR.

247. The opposite engravings show the elevation, section, and plan of revolving retorts for burning animal or bone charcoal, for refining sugar; also elevations and plan of the appended steam-engine and machinery, the nature of which may be readily seen from the engravings. By these arrangements very superior charcoal for the sugar-refiner's purpose is obtained, as well as greater economy in producing it. This system of retorts, &c., was recently patented by *James Bowman, Esq.*, who transferred his patent to *George Torr, Esq.*, animal charcoal, ivory black, and ammonia manufacturer, London, whose son now possesses the sole right of using these valuable improvements.

side ELEVATION

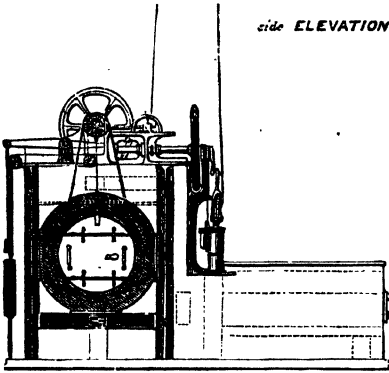

end ELEVATION

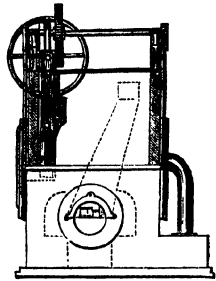

PLAN

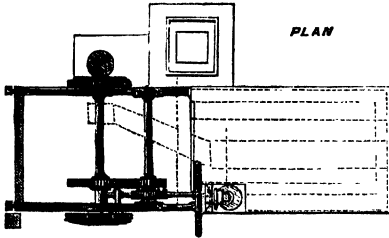

ARRANGEMENT FOR ONE RETORT.

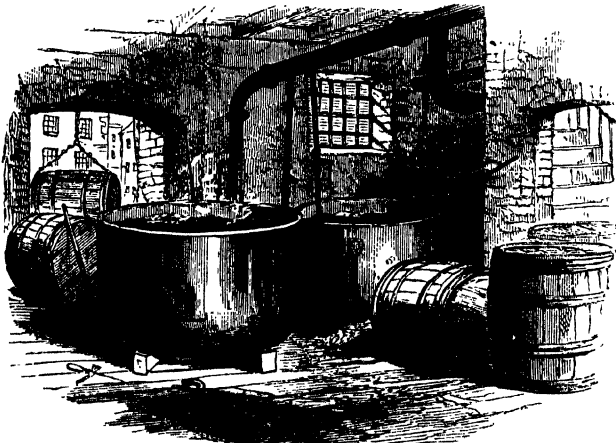

CYLINDRICAL VESSEL AND PIPE.

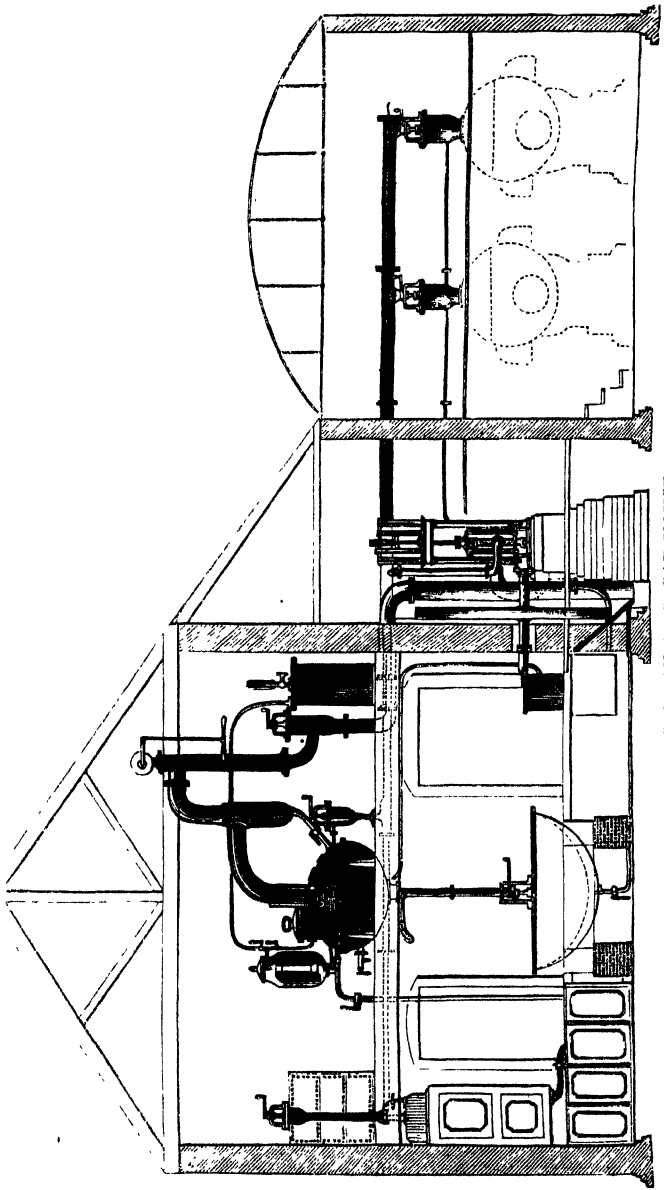

SECTION OF SUGAR HOUSE.

CHAPTER IX.



ON THE FRICTION OF MACHINERY, AND LABOURING FORCES.

248. IN the investigations of the problems in equilibrium the surfaces of bodies have been assumed to be perfectly smooth; but, in practice, all bodies are found to be more or less rough, and therefore the results that have been deduced will be more or less modified by the effects of this roughness, which produces a retarding force called friction. It has been found by experiment that this retarding force or resistance, on a given surface, is a certain proportional part of the weight of the body moved, and that it is not affected by the rate of motion, nor by the extent of the rubbing surface. Thus, if the weight w rest on the horizontal plane AB , and it be drawn horizontally by a weight F attached to a cord passing over a pulley P , then the weight F , which is just sufficient to draw w along the plane, will measure the friction of w on the plane. If w be 1 ton, then, in the case of well-made, smooth Macadamised road, the resistance of friction is found to be about $\frac{1}{30}$ of the whole load, or F is about 75 lbs. to the ton; so that a horse drawing 1 ton along such a road, must pull with a force of 75 lbs.; which is called the traction of the horse. In the case of a railway, where the friction is probably the smallest in all ways, being about $\frac{1}{80}$ of the weight, therefore, if w be 1 ton, then F will be



$$\frac{w}{280} = 8 \text{ lbs.}, \text{ and if } \frac{1}{n} = \frac{1}{280}, \text{ then, generally, } F \text{ will be } = \frac{w}{n}.$$

The fractions $\frac{1}{30}$ and $\frac{1}{80}$ are called the co-efficients of friction.

249. *If the inclination of the plane, on which a body is moved, is small, as on the ascending and descending gradients of railways, and the ascents and descents of common roads, the pressure on the plane will evidently be very*

nearly equal to the weight of the body; hence the resistance produced by friction may be calculated with sufficient accuracy after the manner explained in the last article.

250. Now, let P = power requisite to draw a weight w , including its friction, along a plane with a rise of h feet in 100 feet, Q = power requisite to draw w along the plane exclusive of friction, and let the friction F be $= \frac{w}{n} = an$ part of the weight; required the relation between P and w .

By Art 118. $Q : w :: h : 100 ;$

$$\text{whence } Q = \frac{h w}{100};$$

$$\text{but } P = Q + F = \frac{h w}{100} + \frac{w}{h} = \frac{h n + 100}{100 n} w \quad (1)$$

$$\therefore w = \frac{100 n P}{h n + 100} \quad (2)$$

Ex. 1. If a train of 30 tons be moved along a level railway, what power will be required to overcome the resistance of friction at the rate of 8lbs. per ton, or $\frac{1}{280}$ of the weight?

Here the required power P is equal to the resistance of friction, that is, by Art. 248,

$$P = F = \frac{w}{n} = \frac{30 \times 2240}{280} = 240 \text{ lbs.},$$

$$\text{or, } P = 8 w = 8 \times 30 = 240 \text{ lbs.}$$

Ex. 2.—The gradient of a railway rises 2 feet in 100; what power will be required to draw a train of 50 tons up the gradient, the co-efficient of friction being $\frac{1}{280}$ or $n = 280$?

By equa. (1), Art. 250,

$$P = \frac{h n + 100}{100 n} w = \frac{5 \times 280 + 100}{100 \times 280} \times 50 \times 2240 = 2640 \text{ lbs.}$$

Ex. 3. The ascent of a turnpike-road is 5 feet in 100; what power will be requisite to draw a load of 6 tons thereon, the co-efficient of friction being $\frac{1}{24}$ or $n = 24$?

$$\text{Here } P = \frac{h n + 100}{100 n} W = \frac{5 \times 24 + 100}{100 \times 24} 6 \times 2240 = 1232 \text{ lbs.} = 11 \text{ cwt.}$$

Note.—The powers resulting from these three examples are just sufficient to balance the load and the friction; therefore a small addition must be made to each of these powers to put the train or carriage in motion.

THE USEFUL EFFECT OR MODULUS OF A MACHINE.

251. The useful effect or modulus of a machine is, the fraction which expresses the value of the work compared with the power applied, which is expressed by unity. Thus, if a machine only perform $\frac{2}{3}$ of the work applied to it, in this case $\frac{1}{3}$ of the work or power applied is lost by friction, and $\frac{2}{3}$ is called the modulus of the machine. The work that is thus lost depends on the nature and extent of the rubbing surfaces. The work thus lost in the screw, the inclined chain-pump, &c., is very great. The following is a table of the moduli of several machines in which the friction is considerable, with examples of their application.

Screw press	$\frac{1}{3}$
Endless screw	$\frac{1}{2}$
Inclined chain-pump	$\frac{2}{5}$
Upright chain-pump	$\frac{1}{2}$
Bucket-wheel	$\frac{3}{5}$
Pumps for draining mines	$\frac{2}{3}$
Crab for raising materials	$\frac{4}{5}$

Ex. 1. The distance $P W$ at which the power acts is 6 feet (see fig. to Art. 122) and the distance between two of the threads of the screw is 2 inches; what pressure will a man be able to exert with the screw-press when he acts at P with a force of 150 lbs., the useful effect of the machine being only $\frac{1}{3}$ of the power applied, as per table?

By equa. (1), Art. 122, in conjunction with the table,

$$\text{pressure} = w = \frac{2 \pi r P}{d} \times \frac{1}{3} = \frac{2 \times 3.1416 \times 72 \times 150}{2 \times 3} =$$

$$11309\frac{2}{3} \text{ lbs.} = 5 \text{ tons, } 109\frac{2}{3} \text{ lbs.}$$

Ex. 2.—Let the length of the winch of each of the handles HH be 18 inches (see fig to Art. 163) the radius

of the pinion $P = 2$ inches, the radius of the spur-wheel $S = 20$ inches, and the radius of the barrel or drum $B = 8$ inches; required, the weight that can be raised by the crab when a continuous power of 150 lbs. is applied to the two handles, the useful effect being as per table.

By equa. (2) Art. 30, and the table,

$$w = \frac{150 \times 18 \times 20 \times 4}{2 \times 8 \times 5} = 2700 \text{ lbs.}$$

Ex. 3.—A power of 150 lbs. is applied to the winch which turns the axle of an inclined chain-pump; what weight of water will this power raise, the length of the winch being 20 inches and the radius of the axle 4 inches?

By the property of the lever, or wheel and axle, in conjunction with the table,

$$4w = \frac{2}{3} \times 20 \times P;$$

$$\text{whence } w = \frac{\frac{2}{3} \times 20 \times 150}{4} = 300 \text{ lbs.}$$

Ex. 4.—The piston of a steam-engine draws the rod of a pump for draining a mine with a force of 6 tons; what weight of water will be raised by the piston?

Here the engine is supposed to act with a lever with equal arms; hence by the table,

$$w = \frac{2}{3} P = \frac{2}{3} \times 6 = 4 \text{ tons.}$$

THE PRACTICAL APPLICATION OF MECHANISM TO THE WORK OF LIVING AGENTS,

(*The friction of the machinery not being considered*).

In applying the principles already laid down, to estimate and compare the different kinds of work performed under different circumstances, it becomes necessary to have a distinct measure or unit of work by which the various results can be estimated and compared.

252. *The English unit of work is the power necessary to raise one pound through a space of one foot.* Thus, if one pound be raised one foot either by a living agent or by a machine, then one unit of work has been performed; if 1 lb. be raised 5 feet, then 5 units of work have been performed;

if 4 lbs. be raised 6 feet, then $4 \times 6 = 24$ units of work have been performed, and so on. *Hence the units of work performed are measured by product of the weight of the body in pounds, and the space or height in feet through which it is raised*; also, pressures or resistances of every kind, in whatever direction they are exerted, may be expressed in pounds, and therefore measured by the unit of work here described.

Ex. 1.—How many units are required to raise a corf of coals of 5 cwt. from a pit, the depth of which is 60 fathoms?

Weight of coals in pounds = $112 \times 5 = 560$ lbs. ;

Depth of pit in feet = $60 \times 6 = 360$ feet ;

\therefore the units of work required = $560 \times 360 = 201,600$.

Ex. 2.—The ram of a pile-engine weighs 9 cwt., and it has a fall of 21 feet; required the units of work exerted in raising the ram?

Units of work = $9 \times 112 \times 21 = 21,168$.

Ex. 3.—How many units of work will be required to pump 6000 cubic feet of water from a mine, the depth of which is 80 fathoms?

A cubic foot of water weighs $62\frac{1}{2}$ lbs. ; hence,

weight of water = $62\frac{1}{2} \times 6000 = 375,000$;

\therefore units of work = $375,000 \times 80 \times 6 = 180,000,000$.

Ex. 4.—A horse moving at the rate of 3 miles an hour, draws a bucket of water weighing 100 lbs. out of a well, by means of a rope passing over a pulley; required the units of work done per minute.

Space passed over per minute = $\frac{5280 \times 3}{60} = 264$;

\therefore units of work per minute = $264 \times 100 = 26,400$.

Ex. 5.—How much labouring force will be required to raise 1000 gallons of water from a well, the depth of which is 50 fathoms?

Ex. 6.—How many units of work will be performed by a man descending a mine 50 fathoms deep, and drawing up a weight of 140 lbs. over a fixed pulley, the man's weight being supposed slightly to exceed the given weight?

Ans. 42,000lbs.

SOURCES OF LABOURING FORCE AND THE WORK OF LIVING AGENTS.

·253. The chief sources of labouring force are *animals*, including *man, water, wind, and steam*: the labouring force or work of animals varies according to the manner in which they exert their strength, and it is estimated by *the number of units of work* which they can raise, or move by drawing, or by pressure in any direction, in one minute. The following table shows the amount of effective work that can be performed by several of the most common living agents.

Work done per minute.

Duration of labour, eight hours per day.	
Horse-power	33,000 units.*
A man turning a winch	2,600 „
—— drawing horizontally	3,200 „
—— raising materials with a pulley	1,600 „
—— throwing earth to height of 5 feet	560 „

Examples of manual power.

Ex. 1.—How many tons of earth will a man raise in eight hours working with a winch, (wheel and axle,) from a mine 20 fathoms deep?

Here the time of work is $8 \times 60 = 480$ minutes, hence
 Units of work per day . . . = 2600×480 (see table);
 Units of work in raising 1 ton }
 to the height of 20 fathoms, } = $2240 \times 20 \times 6$;
 or 120 feet }

\therefore Number of tons raised . . = $\frac{2600 \times 480}{2240 \times 20 \times 6} = 4.64$.

Ex. 2.—How many cubic feet of earth of 100lbs. per foot, will a man throw to the height of 5 feet in a day of eight hours?

$$\text{No. c. ft.} = \frac{560 \times 60 \times 8}{100 \times 5} = 537\frac{3}{5}.$$

* This is the number of units of work assigned by Watt to a horse, but by recent experiments it has been found to be considerably too much, $\frac{2}{3}$ of which, or 22,000, is considered to be the work of a horse of average strength; however, the number given in the table is still retained by engineers as the number of units of a horse's power.

Ex. 3.—How many tons of earth will a man raise with a single pulley in a day of eight hours, from a mine 80 feet in depth?

$$\text{No. of tons} = \frac{1600 \times 60 \times 8}{2240 \times 80} = 4\frac{2}{7}$$

Examples of horse-power.

Ex. 4.—How many horse-powers will it require to raise five cwt. of coals per minute from a mine 100 fathoms deep?

Weight of coals raised per minute = $5 \times 112 = 560$ lbs ;

Depth of mine in feet = $6 \times 100 = 600$ feet ;

∴ units of work per minute . . = $560 \times 600 = 336,000$.

Now a horse does 33,000 units of work per minute (see table, Art. 253) ;

$$\therefore \text{Horse-powers or } H = \frac{336,000}{33,000} = 10\frac{2}{11}$$

Ex. 5.—How many horse-powers will be required to lift 10,000 cubic feet of water per hour, from a mine 80 fathoms deep?

Weight of water = $62\frac{1}{2} \times 10,000$ lbs. ;

Depth of mine . = 6×80 feet ;

$$\therefore \text{units of work per min.} = \frac{62\frac{1}{2} \times 10,000 \times 6 \times 80}{60},$$

$$\text{and } H = \frac{62\frac{1}{2} \times 10,000 \times 6 \times 80}{60 \times 33,000} = 151\frac{1}{3}.$$

Ex. 6.—How many cubic feet of water will an engine of 10 horse-powers raise per hour, from a mine 80 fathoms deep?

Ex. 7.—Required the number of cubic feet of water which an engine of 60 horse-powers will raise per hour, from a mine 80 fathoms deep, supposing $\frac{1}{3}$ of the work to be lost by friction.

Ex. 8.—A forge hammer weighing five cwt. makes sixty lifts of 2 feet each in one minute ; what is the horse-power of the engine that moves the hammer?

WORK IN MOVING A CARRIAGE OR RAILWAY TRAIN
ON A HORIZONTAL PLANE.

254. When a locomotive engine commences its motion, its power exceeds the resistance, and therefore the speed of the engine continues to increase until the resistance becomes equal to the power of the engine, then the speed of the train will be uniform, which is commonly called a steady speed, or the greatest or maximum speed, the work destroyed by the resistance being now exactly equal to the power exerted by the locomotive engine. The same may be said of all other machines; and it is on this principle that the following investigations are made.

255. By Art. 248, the friction on a horizontal plane is $\frac{w}{n}$, or the n th part of the weight w of the carriage or train; $\frac{1}{n}$ being the coefficient of friction; therefore the whole resistance to motion on the plane is also $= \frac{w}{n}$. Let P = power or units of work required to move the train, s = space in feet moved over in the time t in minutes, and Π = number of horse-powers in P ; then $P = 33,000 \Pi$ = units of work or pounds moved one foot in one minute, and $\frac{s}{t}$ = feet moved in one minute by the weight $\frac{w}{n}$, whence $\frac{w}{n} \times \frac{s}{t}$ = units of work required in moving the carriage or train;

$$\therefore P = 33,000 \Pi = \frac{w}{n} \times \frac{s}{t};$$

$$\text{whence } \Pi = \frac{w s}{33,000 n t} \quad (\text{A})$$

In railway calculations of this kind w and s are usually given in tons and miles, which are to be reduced to pounds and feet by multiplying them respectively by 2240 and 5280; also n is most commonly = 280; if, therefore, we substitute 2240 w for w , 5280 s for s , and 280 for n , in equa. (A), we shall have after reduction,

$$H = \frac{128 w s}{100 t} = \frac{5 w s}{4 t} \text{ very nearly} \quad (1)$$

$$\text{whence } w = \frac{4 H t}{5 s} \quad (2)$$

$$s = \frac{4 H t}{5 w} \quad (3)$$

$$\text{and } t = \frac{5 w s}{4 H} \quad (4)$$

in which equations w = weight in tons, and s = space or distance in miles.

Ex. 1.—Required the horse-power (H) of a locomotive engine, which moves with a steady speed of 50 miles per hour, on a level railway, the weight of the train being 45 tons, and the friction $\frac{1}{80}$ of the weight of the train, the resistance of the air not being considered.

By equa. (1),

$$H = \frac{5 w s}{4 t} = \frac{5 \times 45 \times 50}{4 \times 60} = 47 \text{ horse-powers.}$$

Ex. 2.—An engine of 40 H moves with a steady speed of 35 miles per hour on a level railway; required the weight of the train, the friction being as usual.

By equa. (2),

$$w = \frac{4 H t}{5 s} = \frac{4 \times 40 \times 60}{5 \times 35} = 54\frac{6}{7} \text{ tons.}$$

Ex. 3.—In what time will an engine of 50 H , moving a train of 60 tons, complete a distance of 40 miles?

By equa. (4),

$$t = \frac{5 w s}{4 H} = \frac{5 \times 60 \times 40}{4 \times 50} = 60 \text{ min.} = 1 \text{ hour.}$$

Ex. 4.—How many miles per hour will a train of 40 tons be drawn by an engine of 35 H ?

By equa. (3),

$$s = \frac{4 H t}{5 w} = \frac{4 \times 35 \times 60}{5 \times 40} = 42 \text{ miles.}$$

Ex. 5.—If four horses draw a load of 6 tons two miles per hour, on a road of which the co-efficient of friction is $\frac{1}{20}$, how many units of work will each horse perform?

By transposing equa. (A), and putting u instead of 33,000, we shall have

$$u = \frac{ws}{ntH} = \frac{6 \times 2240 \times 2 \times 5280}{20 \times 60 \times 4} = 29,568 \text{ units of work.}$$

Ex. 6.—What must be the effective H of a locomotive engine, which moves with a uniform speed of 50 miles per hour, on a level railway, the weight of the train being 30 tons, and the friction as usual? *Ans.* $31\frac{1}{4} H$.

Ex. 7.—In what time will a locomotive engine of 50 H , which moves a train of 135 tons, complete a journey of 80 miles on a level rail?

Ex. 8.—At what rate per hour will a train of 100 tons be drawn by an engine of 50 H on a level rail?

Ex. 9.—The maximum speed of a locomotive engine of 50 H is 40 miles per hour on a level rail; required the weight of the train.

WORK IN OVERCOMING THE JOINT RESISTANCES OF FRICTION AND GRAVITY ON AN INCLINED RAILWAY OR COMMON ROAD.

256. Let P = power and w = weight in pounds of a carriage or train, and h = rise of the inclined plane in every 100 feet of its length; then, by Art. 250, equa. (1), $P = \frac{100 + hn}{100n}w$; and let H , s and t respectively represent the horse-powers, space in feet, and time required in moving the weight $\frac{100 + hn}{100n}w$, as in the last article; then $P = 33,000 H =$ units of work in pounds, and $\frac{s}{t}$ = feet moved in one minute by the weight $\frac{100 + hn}{100n}w$; whence $\frac{100 + hn}{100n}w \times \frac{s}{t} =$ units of work required in moving the weight, which must be equal to the units of work in the power; ,

$$\therefore P = 33,000 H = \frac{100 + hn}{100n}w \times \frac{s}{t};$$

$$\text{whence } H = \frac{(100 + hn)sw}{33,000 + 100nt} \quad (A)$$

Now, let w = weight moved in tons and s = space or distance moved in miles, as usually given in railway calculations; then $w = 2240 w$, and $s = 5280 s$; these values being substituted in equa. (A), and n being taken = 280 as in the last article, there will result, after reduction,

$$H = \frac{256 (5 + 14 h) w s}{1000 t} = \frac{(5 + 14 h) w s}{4 t} \text{ nearly} \quad (1)$$

$$\text{whence } w = \frac{4 t H}{(5 + 14 h) s} \quad (2)$$

$$s = \frac{4 t H}{(5 + 14 h) w} \quad (3)$$

$$t = \frac{(5 + 14 h) w s}{4 H} \quad (4)$$

$$\text{and } h = \frac{4 t H - 5 w s}{14 w s} \quad (5)$$

Note.—In all these equations h must be taken negatively, when the weight or train descends the plane; in which case gravity assists the moving power. It also appears that when h is negative and equal $\frac{5}{14}$ of a foot, then no power is required to move the train; for the value of H vanishes, since in this case $5 + 14 h$ becomes = 0, the train descending the railway gradient by gravity alone.

Ex. 1.—A train of 40 tons ascends a railway gradient, rising 2 feet in 100, with a uniform speed of 15 miles per hour; required the H of the locomotive engine, the friction being as usual.

By equa. (1), Art. 256,

$$H = \frac{(5 + 14 h) w s}{4 t} = \frac{(5 + 14 \times 2) \times 40 \times 15}{4 \times 60} = \frac{33 \times 40 \times 15}{4 \times 60} \\ = 82\frac{1}{2} \text{ horse-powers.}$$

Ex. 2.—Required the H , as in the last example, when the weight of the train is 60 tons, the rise 1 in 200 or $\frac{1}{2}$ in 100, and the rate of motion 30 miles per hour. *Ans.* 90 H .

Ex. 3.—An engine of 75 H ascends a gradient, rising $\frac{3}{4}$ in 100, with a uniform speed of 20 miles per hour; required the weight of the train.

By equa. (2),

$$w = \frac{4 t H}{(5 + 14 h) s} = \frac{4 \times 60 \times 75}{(5 \times 14 \times \frac{3}{4}) \times 20} = 58\frac{3}{4} \text{ tons.}$$

Ex. 4.—A train of 120 tons descends a gradient, rising $\frac{1}{4}$ in 100, with a uniform speed of 50 miles per hour; what is the H exerted by the engine?

Here h must be negative, because the train descends the gradient; hence,

By equa. (1),

$$H = \frac{(5 - 14h) s w}{4 t} = \frac{(5 - 14 \times \frac{1}{4}) \times 50 \times 620}{4 \times 60} = 37\frac{1}{2} H.$$

Ex. 5.—A train of 50 tons ascends a railway gradient, having a rise of 1 in 600; what is the speed per hour of the engine when its horse-power is 40?

By equa. (3) the speed is found to be $26\frac{2}{11}$ miles per hour.

Ex. 6.—At what rate per hour will a train of 50 tons be drawn by an engine of 60 H up a gradient rising 1 in 800?

Ex. 7.—An engine of 40 H draws a train of 50 tons, with a uniform speed of $25\frac{1}{2}$ miles per hour up a gradient; required the rise per cent. of the gradient.

By equa. (5) the rise of the gradient is found to be nearly $\frac{1}{6}$ per cent.

The following arrangement of mechanism is to prevent violent collisions of trains on railways, by *Lewis Gompertz, Esq., of Kennington Oval*, (Mechanical Department of the *Great Exhibition of 1851*.)

In the annexed engraving is represented merely the lower parts of the first and last carriages of two trains. Fig. 1 is the first carriage of the one train, and fig. 2 the last of the other, the arrangement being such that, by means of the curved lever M and the friction-roller T , a violent collision of the trains is avoided, fig. 1 turning off the rails upon the adjoining line, though without of itself regaining the line from which it is thus driven off. The wheels A, B, C, D of fig. 1 are contrived so as to admit of simultaneous horizontal rotation, each turning on a long axle above it, in sockets E, F, G, H , which are fixed in the bed of the carriage. The wheels are compelled to turn parallel to each other by the following means:— R is a plate at the bottom of the carriage, to which it is only attached by means of the frames E, F, G, H of the wheels; each of these frames has an upright pin, shown projecting near to E, F, G , and H . The plate R holding all these pins, causes all the wheels to turn alike at the same time. In order, then, to cause them to turn when required, the curved lever M is attached to the wheel B , and

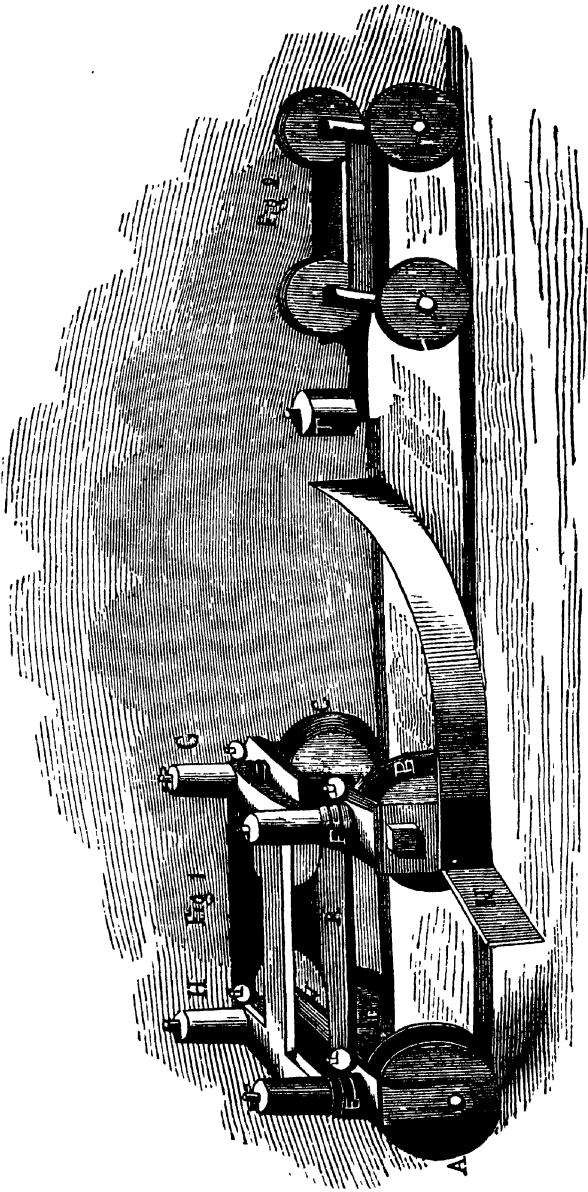

ARRANGEMENT OF MECHANISM TO PREVENT COLLISIONS.

projecting far before the carriage, the part *M* being curved one way and the part *N* the reverse. The last carriage of the opposite train has a roller *T*, on the reverse side to the lever *M*, and supposing these two carriages to meet, the roller *T* will strike the lever *M*, turning the wheels *A, B, C, D* horizontally, so that the carriage will be lifted off the rails and pass laterally to the other rails, it being prevented from going too far by the part of the lever *N*, which turns the wheels right again without actually replacing them on the rails, a spring being used to keep the wheels steady. This plan has only been used in a model of two carriages, but it is judged applicable to a whole train, and as collisions frequently take place, not only in meeting, but in overtaking, the shock is consequently less sudden and more easily counteracted. It will be readily perceived that only the first carriage of the one train and the last of the other need be thus provided; besides, the operation would be greatly assisted if the flanges of the wheels of fig. 1 were not so large as they are usually made.

THE SUPER-ELEVATION OF THE EXTERIOR RAIL IN
RAILWAY CURVES. •

257. The super-elevation of the exterior rail, or the rail on the convex side of the line, in railway curves, the radii of which are within certain limits, is rendered absolutely necessary to counteract the centrifugal force produced by the velocity of the train, since all moving bodies have a tendency to continue their motion in a direct line. From this cause the railway train is impelled towards the exterior rail, and would finally leave the rails, were it not prevented by the conical inclination of the tire and the flanges of the wheels.

258. PROP.—*To determine the centrifugal force of a railway train, or that portion of the weight of the train, which makes it tend to leave the curve.*

Let *v* = velocity of the train per second, *R* = radius of the curve, *F* = centrifugal force, and *g* force of gravity at the earth's surface; also let *w* = weight of the train; then, by Art. 277, *Baker's Statics and Dynamics*,

$$F = \frac{w v^2}{g R}.$$

Ex. 1.—When *R* = $\frac{1}{2}$ a mile = 2640 feet, *v* = velocity =

30 miles per hour = 44 feet per second, and $g = 32\frac{1}{2}$ feet = velocity of a body falling from rest, at the end of a second; then

$$F = \frac{w \times 44^2}{32\frac{1}{2} \times 2640} = \frac{22}{9651} w = \text{nearly } \frac{1}{44} w;$$

that is, the force that urges the train to quit the curve is $\frac{1}{44}$ of its whole weight, in this case.

Ex. 2.—When $v = 60$ miles per hour = 88 feet per second, and R the same as in example 1; then,

$$F = \frac{w \times 88^2}{32\frac{1}{2} \times 2640} = \text{nearly } \frac{1}{11} w;$$

that is, the force, in this case, is $\frac{1}{11}$ of the weight of the train. Hence it may be perceived how extremely dangerous high velocities are in curves of small radius.

259. This great amount of centrifugal force, in curves of small radius, would be very much increased by the high velocities, which some are sanguine enough to expect as likely to be attained on railways; since this force varies as

$$\frac{v^2}{R} \text{ or as } v^2$$

for the same curve: thus, for a velocity of 120 miles per hour, on a curve of $\frac{1}{3}$ of a mile radius, we shall have

$$f = \frac{w \times 176^2}{32\frac{1}{2} \times 2640} = \frac{1}{11} w;$$

that is, the centrifugal force is, in this case, more than $\frac{1}{3}$ of the whole weight of the train; while for curves of 1 mile radius, which are very common in railways, $f = \frac{1}{11} w$, or nearly $\frac{1}{2}$ of the weight of the train. It must, therefore, be evident that a velocity of 120 miles per hour, or even one of 90 miles per hour, must be extremely dangerous, especially on an embanked curve, should any accident throw the train off the line, which is often the case with the present velocities. Moreover, the resistance of the air, which varies as v^2 , must be considerably augmented by high winds opposed to the direction of a train of these great velocities; while its engine would require a power greatly superior to those now in use.

260. This force, except in curves of very small radius, is

counteracted by the conical inclination of the tire of the wheels, each pair of which is firmly fixed on the axle which turns with them; the inclination of the tire is commonly about $\frac{1}{2}$ an inch in the whole breadth of the wheel, which is $3\frac{1}{2}$ inches. This inclination of the tire with the lateral play of the flanges of the two wheels of $\frac{1}{2}$ an inch on each side, and the centrifugal force urging the train towards the exterior rail, when moving in a curve, increase the diameter of the outer wheel, and diminish that of the inner one, which causes the train to roll on conical surfaces, thus necessarily producing a centripetal force to counteract the tendency of the train to leave the curve. However, in curves of very small radius, the centrifugal force is not sufficiently counteracted by the centripetal force thus generated, the centre of which last-named force is the vertex of the cone, of which the increased and diminished diameters of the wheels are sections. The amount, therefore, of this centripetal force shall be determined in the following—

261. PROP.—*The velocity of the train, the gauge of the rails, the radius of the wheels, and the inclination of their tire being given, to determine the centripetal force generated by the conical inclination of the tire of the wheels of the train, and by the centrifugal force impelling the train outwards.*

Let d = mean diameter of the wheels of the train, δ = increment, and consequently the decrement which the diameters of the exterior and interior wheels respectively receive, through the conjoined action of the centrifugal force and the inclination of the tire; then under these circumstances the respective diameters of the exterior and interior wheels will be

$$d + \delta \text{ and } d - \delta;$$

also, if R = radius of a circle which the centre of a carriage would describe in consequence of the inclination of the tire of the wheels, and b = breadth of the road or gauge of the rails: then $R + \frac{1}{2}b$, and $R - \frac{1}{2}b$ are radii which would be described respectively by the exterior and interior wheels; and by similar triangles,

$$d + \delta : d - \delta :: R' + \frac{1}{2}b : R' - \frac{1}{2}b;$$

$$\text{whence } d : \delta :: 2R' : b,$$

$$\text{and } R' = \frac{bd}{2\delta}.$$

Or, if $\frac{1}{n}$ = inclination of the tire, and Δ deviation of the wheels, then,

$$\delta = \frac{2 \Delta}{n},$$

and, by substitution,

$$R' = \frac{b d n}{4 \Delta}.$$

Now v and w representing the velocity and weight of the train, as in Art. 258, the centripetal force corresponding to the radius R' will be

$$F' = \frac{w v^2}{g R'},$$

or, by substituting the value of R' ,

$$F' = \frac{4 w v^2 \Delta}{b d g n}.$$

262. PROP.—*To determine the deviation of the wheels, and the radius of the curve, when the centrifugal and centripetal forces, in Art. 258 and 261, just balance each other.*

Because the forces F and F' act in contrary directions, they will hold each other in equilibrium when they become equal, and the train will cease to have a tendency to quit the curve; this will take place when

$$\frac{w v^2}{g R} = \frac{w v^2}{g R'}$$

$$\text{OR, } R = R'.$$

Also, by Art. 258 and 261,

$$\frac{w v^2}{g R} = \frac{4 w v^2 \Delta}{b d g n};$$

$$\text{whence } \Delta = \frac{b d n}{4 R};$$

which is the deviation requisite to produce an equilibrium between the centripetal and centrifugal forces of the train. And, since $R = R'$, the vertex of the imaginary cone, of

which the increased and diminished diameters of the wheels are sections, will coincide with the centre of the curve, there will consequently be no dragging on the wheel on either of the rails.

If in $R' = \frac{bdn}{4\Delta}$, $d = 3$ feet, $b = 4$ feet $8\frac{1}{2}$ inches $= 4.7$ feet = breadth of the narrow gauge, $\frac{1}{n} = \frac{1}{7}$, and $\Delta = \frac{1}{3}$ of an inch, the radius of curvature corresponding to this deviation, when the two forces are in equilibrium, will be

$$R' = \frac{bdn}{4\Delta} = 4.7 \times 3 \times 7 \div 4 \times \frac{1}{3} \times \frac{1}{12} = 888 \text{ feet.}$$

But, since an accidental depression of the exterior rail might cause the flange of the wheel to rub the rail on that side, it would be advisable, for the sake of greater safety, to limit the value of R' to not less than 1200 or 1500 feet. Moreover, in curves of less than 1500 feet radius, it will at once appear that a super-elevation of the exterior rail will be absolutely necessary to counteract the excess of the centrifugal above the centripetal force.

263. PROP. — *To determine the super-elevation of the exterior rail in railway curves of less than 1200 or 1500 feet radius; the same things being given as in the preceding proposition.*

Let x = super-elevation of the exterior rail; then, since b = breadth of the way, the inclination of the plane on which the train moves $= \frac{x}{b}$ to rad. = 1, and hence the gravity of the train will impel it to the interior rail with the force

$$R'' = \frac{Wx}{b}.$$

This force, together with the centrifugal force, resulting from the deviation of the train to exterior rail of the curve, must hold the centrifugal force in equilibrium; therefore, from Articles 258 and 261, there will result

$$\frac{Wx}{b} + \frac{WV^2}{gR'} = \frac{WV^2}{gR};$$

whence $x = \frac{bV^2}{g} \left(\frac{1}{R} - \frac{1}{R'} \right),$

which is the formula for the super-elevation of the exterior rail, and due to *Pambour*; who, by solving it for some of the usual cases, produces the following

TABLE OF THE SUPER-ELEVATION TO BE GIVEN TO THE EXTERIOR RAIL IN CURVES.

Designation of the Waggon and the Way.	Radius of the Curve in Feet.	Super-elevation to be given to the Rail in Inches, the Velocity of the motion in Miles per hour being:—		
		10 Miles.	20 Miles.	30 Miles.
Waggon with wheels 3 feet in diameter.	250	1.14	5.60	12.99
Gauge of way, 4.7 feet	500	0.57	2.83	6.5
Play of the waggons on the way, 1 inch.	1000	0.29	1.43	3.30
Inclination of the tire of the wheels, 1 in 7.	2000	0.15	0.71	1.65
	3000	0.10	0.47	1.10
	4000	0.07	0.36	0.83
	5000	0.06	0.28	0.66

The correctness of the above results is pretty generally conceded. It must, however, be considered, that it is extremely difficult, if not impossible, to realise in practice the precise conditions and proportions determined by these important formulæ; as accidental depressions and enlargements of gauge of part of the rails, as well as many other matters that cannot be subjected to calculation, will unavoidably derange these results.

CHAPTER X.

ON THE PRODUCTION OF BROWN SALT, GLAZED STONE-WARE AND BRISTOL WARE, AS MANUFACTURED AT MESSRS. SINGER AND GREEN'S POTTERY, VAUXHALL.

(MECHANICAL DEPARTMENT OF THE GREAT EXHIBITION OF 1851.)

IN laying before our readers the manufacture of stone pottery, we will commence from the pit in which the clay is dug, and proceed through its different stages until fit for the market.

264. The best clay for stone-ware is obtained from Dorsetshire, and is taken from the same pits as the clay used in Staffordshire for fine white and other wares; the

top stratum of the pit is a sandy clay, with fine particles of grit, and is used to a very large extent for the stone drain pipes so universally approved in house drainage; the second stratum is a clay of the same quality, only free from sand and grit, and is used for general pottery ware by the Vauxhall and Lambeth manufacturers. Other clays of a somewhat similar quality are obtained from Devonshire, and mixed with the Dorsetshire clays in proportions suitable to the articles for which they are required. The clay is dug from the pits in large balls, about 30lb. in weight, and are sold to the potters 70 balls to the ton, and shipped through the different agents from Poole.

No. 1.

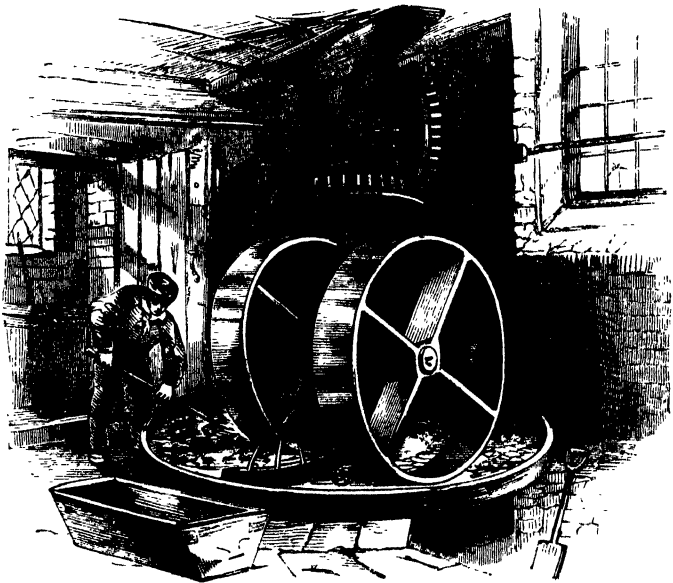

265. When thoroughly dry, the balls are broken and passed under *iron-runners*, as shown in sketch No. 1., with a bed plate of gratings, to allow the clay, as it becomes ground sufficiently small, to pass through the openings of the gratings.

To the upright shaft of the runners are attached two

scrapers, projecting as far as the rim of the bed plate, the one is continually spreading the clay over the gratings to allow the fine clay to pass through, and the other follows, collecting the coarser particles, and is so placed as to bring them again under the runners.

The ground clay is then mixed with water and other ingredients, as may be required, by a man working it with his feet, and passed through pugmills, as shown in sketch No. 2.

No. 2.



266. *Pugmills* are generally formed of iron cylinders, some straight, some slightly tapering, averaging in size about 4 ft. high, and 22 in. in diameter. Some are also of wood as in the accompanying illustration.

An upright shaft or axis revolves in the cylinder, from which knives radiate in all directions, somewhat resembling the form of a screw, and projecting to within one inch of the side of the cylinder.

The clay being put into the mill, is gradually compressed,

and worked by the knives, which, being placed, as above described, in the form of a screw, press it to the bottom of the mill, and through a small hole, where it is discharged, cut off, and placed in a bin appropriate for the purpose.

The clay is then ready for the potter, but before being used it undergoes a process of slapping or wedging, as shown on the right-hand side of sketch No. 3.

No. 3.

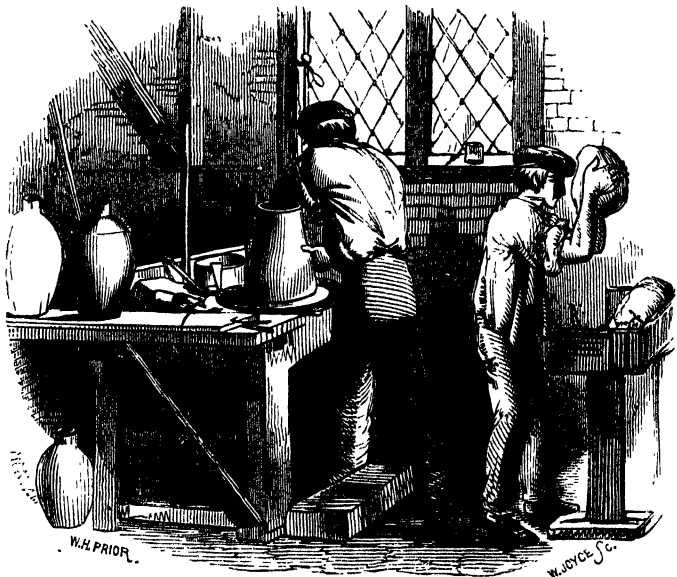

POTTER'S WHEEL.

Wedging consists in tearing or cutting clay into pieces by wire, and striking them together again, with a force sufficient to make them adhere; this is repeated twenty or thirty times, by which process the clay becomes well intermingled; it is then made into balls of a size sufficiently large for the article required to be made, and the potter works from the solid lump of clay, bottles, jars, &c., as shown in sketch No. 3.

267. There are two kinds of *potter's-wheels*, one for small goods, where the man generally sits to his work: it consists

of an upright iron shaft, the lower point of which turns in a socket, and the upper is fixed in a broad wooden disc; near the top, the shaft passes through a socket attached to the frame-work of the wheel; on the shaft are a series of speed-pulleys, by which the speed of the shaft can be increased or lessened as circumstances require. This shaft is driven by a fly-wheel, from which an endless belt passes to the speed-pulleys, and is turned generally by a boy.

268. For larger goods the man stands to his work, and the wheel is formed, as in sketch No. 3, of a pair of cog-wheels, the one on the perpendicular shaft on which the potter forms his goods, the other on a horizontal shaft, on which is also a fly-wheel and handle turned by a boy.

As the wheel revolves, the potter dashes his lump of clay on the disc; he then slips his hands frequently in water to allow the clay easily to pass through them, and pressing it with both hands, it gradually assumes an irregular conical form; he then presses it flat again, by which operation he expels any air-bubbles that may be in it; the boy then lessens the speed of the wheel, and the potter forms his ball of clay into the article required.

269. The vessel is then taken to the lathe room, where it is allowed to dry gradually, until it arrives at a certain point called the green state, when it is put upon a lathe, the rough outside surface taken off by a sharp tool, and afterwards by a smooth one, formed of a piece of flat steel called a burnisher. Figures and handles, &c., are also attached to vessels in the green state.

Being finished, the articles are then placed on stillions round the kilns or ovens, the heat of which evaporates all moisture from them, and leaves them perfectly dry and ready for the burning.

270. Vessels made as above described, are all of a round shape; anything out of the round is generally formed in moulds made from plaster of Paris. The mould is in two halves, which are filled with cakes of clay and joined together, the cakes of clay being made of a thickness sufficient to the size of the article; the plaster absorbs the water from the body thus moulded, which shrinks from it, and in half an hour after being filled, the two halves of the mould can be taken from the vessel thus formed.

THE KILNS. (No. 4.)

271. The kilns are generally of a circular form, varying from 9 ft. to 14 ft. in diameter, and from 10 ft. to 18 ft. high. The fire holes from five to eight in number, according to the size of the kiln pass through the thickness of the brickwork, and are placed at regular distances from each other.

No. 4.

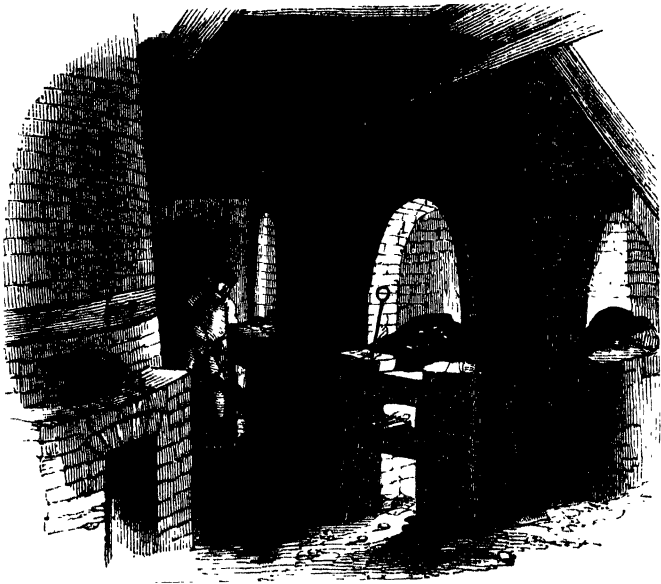

KILNS.

For brown salt glazed stone-ware, the inside of the kilns is generally formed of square boxes, made of fire-clay lumps, in which small goods are placed; these boxes are built up about half the height of the kiln, and the top is filled by placing larger goods on each other.

When filled, the doorway is bricked up, and fire applied to the furnaces.

The heat is gradually increased from the time of lighting, till the ware is found to be properly burnt, when a quantity

of salt is thrown into the top, by means of iron cups attached to long handles, used for the purpose; the salt, being evaporated, deposits itself on the exposed body of the ware, and gives it a bright brown appearance.

The inside, before being put into the kiln is lined with a coating of liquid glaze, prepared from glass, clay, stone, &c., in proportions necessary to the heat to which the goods are burnt, and suitable to the body on which it has to be placed.

A 12 ft. kiln can be worked once every week, as it generally takes two days filling, two days and nights burning, two days cooling, and one day emptying. It requires about $3\frac{1}{4}$ tons of coals to burn it, and will hold on an average, from 35% to 45% worth of stone-ware goods, the contents varying in value according to the articles with which it may be filled.

BRISTOL GLAZED WARE.

272. The Bristol glazed ware, so called from having been first manufactured by the Bristol potters, is an article made

No. 5.

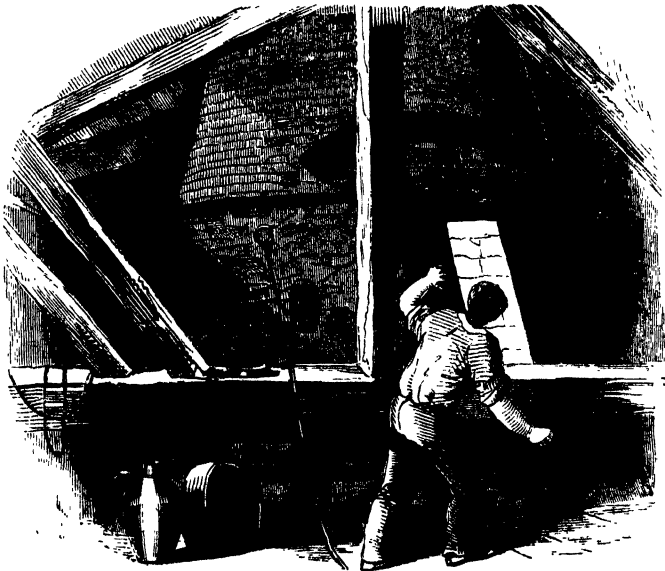

from the same clays as salt glazed stone-ware, and is generally preferred through its being more highly glazed, better finished and more pleasing to the eye, and the mode of burning is such as to preserve the goods from being damaged by the fire, not being exposed, as in the salt glazed kilns to the direct action of the fire.

The vessels, when ready for the kilns, are immersed in a liquid glaze, and instead of being placed on each other, as in the stone-kilns, are burned in close saggars, or boxes made of fire-clay, so as to prevent the flame of the fire reaching them. The kiln (No. 5.), which is on a somewhat different principle to the stone-kiln, is then fired until the glaze on the vessels becomes melted.

During the process of burning, the man in attendance continually looks into the kiln, through sight-holes, in order to see whether the fires are burning alike, and thus keeping an equality of heat through his kiln; when he considers it nearly finished, he draws trials through a hole in the doorway, until he finds the glaze melted and bright, which shows him the kiln is finished.

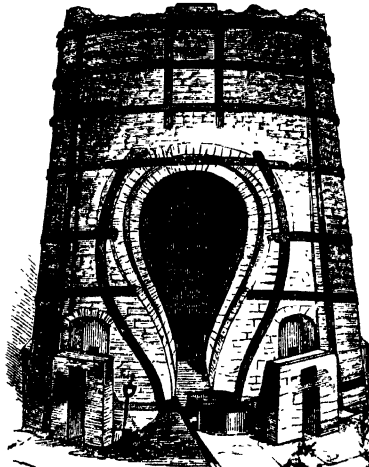

FURNACE.



LONDON :
BRADBURY AND EVANS, PRINTERS, WHITEFRIARS.

*In one Volume large 8vo, with 13 Plates, Price One Guinea,
in half-morocco binding,*

MATHEMATICS

FOR

PRACTICAL MEN:

BEING

A COMMON-PLACE BOOK

OF

PURE AND MIXED MATHEMATICS,

DESIGNED CHIEFLY FOR THE USE OF

CIVIL ENGINEERS, ARCHITECTS, AND SURVEYORS.

BY OLINTHUS GREGORY, LL.D., F.R.A.S.

THIRD EDITION, REVISED AND ENLARGED.

BY HENRY LAW,

CIVIL ENGINEER.

In octavo, price 9s. extra cloth boards,

THE

STUDENT'S GUIDE

TO THE

PRACTICE OF DESIGNING, MEASURING, AND VALUING

ARTIFICERS' WORKS;

CONTAINING

DIRECTIONS FOR TAKING DIMENSIONS, ABSTRACTING THE SAME,
AND BRINGING THE QUANTITIES INTO BILL;

WITH

TABLES OF CONSTANTS,

And copious memoranda for the valuation of labour and materials in the respective trades of bricklayer and slater, carpenter and joiner, sawyer, stone-mason, plasterer, smith and ironmonger, plumber, painter and glazier, paper-hanger.

Thirty-Eight Plates and Woodcuts.

M. W. A. B. S. A. L. A. R. J. U. N. G. B. A. H. A. L. U. R.

THE MEASURING, ETC. EDITED BY

EDWARD DOBSON, ARCHITECT AND SURVEYOR.

SECOND EDITION.

WITH THE ADDITIONS ON DESIGN,

By E. LACY GARBETT, ARCHITECT,

Author of "Rudimentary Treatise on the Principles of Design in Architecture." In Two Vols.

LONDON: JOHN WEALE, 59, HIGH HOLBORN.

NEW [AND PERMANENT] LIST OF WORKS

PUBLISHED BY

JOHN WEALE, 59, HIGH HOLBORN, LONDON.

SERIES OF RUDIMENTARY WORKS

FOR THE USE OF BEGINNERS.

1856.

1. CHEMISTRY, by Prof. Fownes, F.R.S., including Agricultural Chemistry, for the use of Farmers. 4th edition 1s.
2. NATURAL PHILOSOPHY, by Charles Tomlinson. 2nd edition 1s.
3. GEOLOGY, by Lieut.-Col. Portlock, F.R.S., &c. 2nd edition 1s. 6d.
- 4, 5. MINERALOGY, by D. Varley, 2 vols. 2nd edition 2s.
6. MECHANICS, by Charles Tomlinson. 2nd edition 1s.
7. ELECTRICITY, by Sir William Snow Harris, F.R.S. 3rd edition 1s. 6d.
- 8, 9, 10. MAGNETISM, by the same, 3 vols. 3s. 6d.
- 11, 11* ELECTRIC TELEGRAPH, History of the, by E. Highton, C.E., double Part 2s.
12. PNEUMATICS, by Charles Tomlinson. 2nd edition 1s.
- 13, 14, 15. CIVIL ENGINEERING, by Henry Law, C.E., 3 vols.; and 15* Supplement 4s. 6d.
16. ARCHITECTURE (Orders of), by W. H. Leeds. 2nd edition 1s.
17. ARCHITECTURE (Styles of), by T. Bury, Architect. 2nd edition, with additional cuts 1s. 6d.
- 18, 19. ARCHITECTURE (Principles of Design in), by E. L. Garbett, Architect, 2 vols. 2s.
- 20, 21. PERSPECTIVE, by G. Pyne, Artist, 2 vols. 3rd edition 2s.
22. BUILDING, Art of, by E. Dobson, C.E. 2nd edition 1s.
- 23, 24. BRICK-MAKING, TILE-MAKING, &c., Art of, by the same, 2 vols. 2s.
- 25, 26. MASONRY AND STONE-CUTTING, Art of, by the same, with illustrations of the preceding, in 16 4to. atlas plates 2s.
- 27, 28. PAINTING, Art of, or a GRAMMAR OF COLOURING, by George Field, Esq., 2 vols. 2s.
29. DRAINING DISTRICTS AND LANDS, Art of, by G. R. Dempsey, C.E. 1s.
30. DRAINING AND SEWAGE OF TOWNS AND BUILDINGS, Art of, by G. R. Dempsey, C.E. 1s. 6d.
31. WELL-SINKING AND BORING, Art of, by G. R. Burnell, C.E. 2nd edition 1s.
32. USE OF INSTRUMENTS, Art of the, by J. F. Heather, M.A. 3rd edition 1s.
33. CONSTRUCTING CRANES, Art of, by J. Glynn, F.R.S., C.E. 1s.
34. STEAM ENGINE, Treatise on the, by Dr. Lardner 1s.
35. BLASTING ROCKS AND QUARRYING, AND ON STONE, Art of, by Lieut.-Gen. Sir J. Burgoyne, K.C.B., R.E. 2nd edition 1s.

RUDIMENTARY WORKS.

36, 37, 38, 39. DICTIONARY OF TERMS used by Architects, Builders, Civil and Mechanical Engineers, Surveyors, Artists, Ship-builders, &c., 4 vols.	4s.
40. GLASS-STAINING, Art of, by Dr. M. A. Gessert	1s.
41. PAINTING ON GLASS, Essay on, by E. O. Fromberg	1s.
42. COTTAGE BUILDING, Treatise on, 2nd edition	1s.
43. TUBULAR AND GIRDER BRIDGES, and others, Treatise on, more particularly describing the Britannia and Conway Bridges, with Experiments	1s.
44. FOUNDATIONS, &c., Treatise on, by E. Dobson, C.E.	1s.
45. LIMES, CEMENTS, MORTARS, CONCRETE, MASTICS, &c., Treatise on, by Geo. R. Burnell, C.E.	1s.
46. CONSTRUCTING AND REPAIRING COMMON ROADS, Treatise on the Art of, by H. Law, C.E.	1s.
47, 48, 49. CONSTRUCTION AND ILLUMINATION OF LIGHTHOUSES, Treatise on the, by Alan Stevenson, C.E., 3 vols.	3s.
50. LAW OF CONTRACTS FOR WORKS AND SERVICES, Treatise on the, by David Gibbons, Esq.	1s.
51, 52, 53. NAVAL ARCHITECTURE, Principles of the Science, Treatise on, by J. Peake, N.A., 3 vols.	3s.
54. MASTING, MAST-MAKING, AND RIGGING OF SHIPS, Treatise on, by R. Kipping, N.A.	1s. 6d.
55, 56. NAVIGATION, Treatise on: THE SAILOR'S SEA-BOOK.—How to keep the log and work it off—Latitude and longitude—Great Circle Sailing—Law of Storms and Variable Winds; and an Explanation of Terms used, with coloured illustrations of Flags, 2 vols.	2s.
57, 58. WARMING AND VENTILATION, Treatise on the Principles of the Art of, by Chas. Tomlinson, 2 vols.	2s.
59. STEAM BOILERS, Treatise on, by R. Armstrong, C.E.	1s.
60, 61. LAND AND ENGINEERING SURVEYING, Treatise on, by T. Baker, C.E., 2 vols.	2s.
62. RAILWAY DETAILS, Introductory Sketches of, by R. M. Stephenson, C.E.	1s.
63, 64, 65. AGRICULTURAL BUILDINGS, Treatise on the Construction of, on Motive Powers, and the Machinery of the Steading; and on Agricultural Field Engines, Machines, and Implements, by G. H. Andrews, 3 vols.	3s.
66. CLAY LANDS AND LOAMY SOILS, Treatise on, by Prof. Donaldson, A.E.	1s.
67, 68. CLOCK AND WATCH-MAKING, AND ON CHURCH CLOCKS, Treatise on, by E. B. Denison, M.A., 2 vols.	2s.
69, 70. MUSIC, Practical Treatise on, by C. C. Spencer, 2 vols.	2s.
71. PIANO-FORTE, Instruction for Playing the, by the same	1s.
72, 73, 74, 75. RECENT FOSSIL SHELLS, Treatise (A Manual of the Mollusca) on, by Samuel P. Woodward, and illustrations, 4 vols.	4s.
76, 77. DESCRIPTIVE GEOMETRY, Treatise on, by J. F. Heather, M.A., 2 vols.	2s.
77*. ECONOMY OF FUEL, Treatise on, particularly with reference to Reverberatory Furnaces for the Manufacture of Iron and Steam Boilers, by T. S. Prideaux, Esq.	1s.

RUDIMENTARY WORKS.

- 78, 79. STEAM AS APPLIED TO GENERAL PURPOSES AND LOCOMOTIVE ENGINES, Treatise on, by J. Sewell, C.E., 2 vols. 2s.
- 79* RUDIMENTARY WORK ON PHOTOGRAPHY, containing full instructions in the Art of producing Photographic Pictures on any material and in any colour; and also Tables of the Composition and Properties of the Chemical Substances used in the several Photographic Processes. By Dr. H. Halleur, of Berlin. Translated from the German, by the advice of Baron A. von Humboldt, by Dr. Strauss 1s.
- 80, 81. MARINE ENGINES, AND ON THE SCREW, &c., Treatise on, by R. Murray, C.E., 2 vols. 2s.
- 80*, 81*. EMBANKING LANDS FROM THE SEA, the Practice of, treated as a Means of Profitable Employment of Capital, by John Wiggins, F.G.S., Land Agent and Surveyor, 2 vols. 2s.
- 82, 82*. POWER OF WATER, AS APPLIED TO DRIVE FLOUR-MILLS, Treatise on the, by Joseph Glynn, F.R.S., C.E. 2s.
83. BOOK-KEEPING, Treatise on, by James Haddon, M.A. 1s.
- 82**, 83*. COAL GAS, Practical Treatise on the Manufacture and Distribution of, by Samuel Hughes, C.E., 3 vols. 3s.
- 83**. CONSTRUCTION OF LOCKS, Treatise on the, with illustrations . . . 1s. 6d.
- 83 bis. PRINCIPLES OF THE FORMS OF SHIPS AND BOATS, by W. Bland, Esq. 1s.
84. ARITHMETIC, Elementary Treatise on, the Theory, and numerous Examples for Practice, and for Self-Examination, by Prof. J. R. Young 1s. 6d.
- 84*. KEY to the above, by Prof. J. R. Young 1s. 6d.
85. EQUATIONAL ARITHMETIC: Questions of Interest, Annuities, and General Commerce, by W. Hipsley, Esq. 1s.
- 86, 87. ALGEBRA, Elements of, for the use of Schools and Self-Instruction, by James Haddon, M.A., 2 vols. 2s.
- 88, 89. GEOMETRY, Principles of, by Henry Law, C.E., 2 vols. 2s.
90. GEOMETRY, ANALYTICAL, by James Hann 1s.
- 91, 92. PLANE AND SPHERICAL TRIGONOMETRY, Treatises on, by the same, 2 vols. 2s.
93. MENSURATION, Elements and Practice of, by T. Baker, C.E. 1s.
- 94, 95. LOGARITHMS, Treatise on, and Tables for facilitating Astronomical, Nautical, Trigonometrical, and Logarithmic Calculations, by H. Law, C.E., 2 vols. 2s.
96. POPULAR ASTRONOMY, Elementary Treatise on, by the Rev. Robert Main, M.R.A.S. 1s.
97. STATICS AND DYNAMICS, Principles and Practice of, by T. Baker, C.E. 1s.
- 98, 98*. MECHANISM, AND PRACTICAL CONSTRUCTION OF MACHINES, Elements of, by the same, 2 vols, 2s.
- 99, 100. NAUTICAL ASTRONOMY AND NAVIGATION, Theory and Practice of, by H. W. Jeans, R.N.C., Portsmouth, 2 vols. 2s.
101. DIFFERENTIAL CALCULUS, by W. S. B. Woolhouse, F.R.A.S. 1s.
102. INTEGRAL CALCULUS, by Homersham Cox, M.A. 1s.
103. INTEGRAL CALCULUS, Collection of Examples of the, by James Hann 1s.
104. DIFFERENTIAL CALCULUS, Collection of Examples of the, by J. Haddon, M.A. 1s.
105. ALGEBRA, GEOMETRY, AND TRIGONOMETRY, First Mnemonical Lessons in, by the Rev. Thomas Pennington Kirkman, M.A. 1s. 6d.

 RUDIMENTARY WORKS.

NEW SERIES OF EDUCATIONAL WORKS;

OR

Volumes intended for Public Instruction and for Reference :

THE public favour with which the Rudimentary Works on scientific subjects have been received induces the Publisher to commence a New Series, somewhat different in character, but which, it is hoped, may be found equally serviceable. The DICTIONARIES of the MODERN LANGUAGES are arranged for facility of reference, so that the English traveller on the Continent and the Foreigner in England may find in them an easy means of communication, although possessing but a slight acquaintance with the respective languages. They will also be found of essential service for the desk in the merchant's office and the counting-house, and more particularly to a numerous class who are anxious to acquire a knowledge of languages so generally used in mercantile and commercial transactions.

The want of small and concise GREEK and LATIN DICTIONARIES has long been felt by the younger students in schools, and by the classical scholar who requires a book that may be carried in the pocket; and it is believed that the present is the first attempt which has been made to offer a complete Lexicon of the Greek Language in so small a compass.

In the volumes on ENGLAND, GREECE and ROME, it is intended to treat of History as a Science, and to present in a connected view an analysis of the large and expensive works of the most highly valued historical writers. The extensive circulation of the preceding Series on the pure and applied Sciences amongst students, practical mechanics, and others, affords conclusive evidence of the desire of our industrious classes to acquire substantial knowledge, when placed within their reach; and this has induced the hope that the volumes on History will be found profitable not only in an intellectual point of view, but, which is of still higher importance, in the social improvement of the people; for without a knowledge of the principles of the English constitution, and of those events which have more especially tended to promote our commercial prosperity and political freedom, it is impossible that a correct judgment can be formed by the mass of the people of the measures best calculated to increase the national welfare, or of the character of men best qualified to represent them in Parliament; and this knowledge becomes indispensable in exact proportion as the elective franchise may be extended and the system of government become more under the influence of public opinion.

The scholastic application of these volumes has not been overlooked, and a comparison of the text with the examinations for degrees given, will show their applicability to the course of historic study pursued in the Universities of Cambridge and London.

- | | | |
|-------|---|---------|
| 1, 2. | CONSTITUTIONAL HISTORY OF ENGLAND, 2 vols., by W. D. Hamilton | 2s. |
| 3, 4. | ————— DOWN TO VICTORIA, by the same | 2s. |
| 5. | OUTLINE OF THE HISTORY OF GREECE, by the same | 1s. |
| 6. | ————— TO ITS BECOMING A ROMAN PROVINCE, by the same | 1s. 6d. |
| 7. | OUTLINE HISTORY OF ROME | 1s. |
| 8. | ————— TO THE DECLINE | 1s. 6d. |

NEW LIST OF WORKS.

RUDIMENTARY WORKS.

- 9, 10. A CHRONOLOGY OF CIVIL AND ECCLESIASTICAL HISTORY, LITERATURE, SCIENCE, AND ART, from the earliest time to a late period, 2 vols., by Edward Law. 2s.
11. GRAMMAR OF THE ENGLISH LANGUAGE, for use in Schools and for Private Instruction, by Hyde Clarke, Esq., D.C.L. 1s.
- 12, 13. DICTIONARY OF THE ENGLISH LANGUAGE. A new and compressed Dictionary of the English Tongue, as Spoken and Written, including above 100,000 words, or 50,000 more than in any existing work, and including 10,000 additional Meanings of Old Words, 2 vols. in 1, by the same 3s. 6d.
14. GRAMMAR OF THE GREEK LANGUAGE, by H. C. Hamilton 1s.
- 15, 16. DICTIONARY OF THE GREEK AND ENGLISH LANGUAGES, by H. R. Hamilton, 2 vols. in 1 2s.
- 17, 18. ————— ENGLISH AND GREEK LANGUAGES, 2 vols. in 1, by the same 2s.
19. GRAMMAR OF THE LATIN LANGUAGE 1s.
- 20, 21. DICTIONARY OF THE LATIN AND ENGLISH LANGUAGES 2s.
- 22, 23. ————— ENGLISH AND LATIN LANGUAGES 1s. 6d.
24. GRAMMAR OF THE FRENCH LANGUAGE, by Dr. Strauss, late Lecturer at Besançon 1s.
25. DICTIONARY OF THE FRENCH AND ENGLISH LANGUAGES, by A. Elwes 1s.
26. ————— ENGLISH AND FRENCH LANGUAGES, by the same 1s. 6d.
27. GRAMMAR OF THE ITALIAN LANGUAGE, by the same 1s.
- 28, 29. DICTIONARY OF THE ITALIAN, ENGLISH, AND FRENCH LANGUAGES, by the same 2s.
- 30, 31. ————— ENGLISH, FRENCH, AND ITALIAN LANGUAGES, by the same 2s.
- 32, 33. ————— FRENCH, ITALIAN, AND ENGLISH LANGUAGES, by the same 2s.
34. GRAMMAR OF THE SPANISH LANGUAGE, by the same 1s.
- 35, 36. DICTIONARY OF THE SPANISH AND ENGLISH LANGUAGES, by the same 2s.
- 37, 38. ————— ENGLISH AND SPANISH LANGUAGES, by the same 2s.
39. GRAMMAR OF THE GERMAN LANGUAGE, by Dr. Strauss 1s.
40. CLASSICAL GERMAN READER, from the best Authors, by the same 1s.
- 41, 42, 43. DICTIONARIES OF THE ENGLISH, GERMAN, AND FRENCH LANGUAGES, by N. E. S. A. HAMILTON, 3 vols. 3s.
- 44, 45. DICTIONARY OF THE HEBREW AND ENGLISH AND ENGLISH AND HEBREW LANGUAGES, containing all the new Biblical and Rabbinical words, 2 vols. (together with the Grammar, which may be had separately for 1s.), by Dr. Bresslau, Hebrew Professor 7s.

SUPPLEMENTARY TO THE SERIES.

DOMESTIC MEDICINE ; or complete and comprehensive Instructions for Self-aid by simple and efficient Means for the Preservation and Restoration of Health ; originally written by M^r. Raspail, and now fully translated and adapted to the use of the British public. 1s. 6d.

7*. GALVANISM, by Sir William Snow Harris	1s. 6d.
62. RAILWAYS, being vol. ii.	1s.
75*. Supplement to RECENT and FOSSIL SHELLS	1s. 6d.
78*. Rudimentary Treatise on LOCOMOTIVE ENGINES	1s.
79*. Atlas to the preceding; examples of the several Engines in detail, 4to	3s. 6d.
82***. On WATER WORKS for the Supply of Towns, 3 vols.	3s.
86, 87*. Key to the ELEMENTS OF ALGEBRA	1s. 6d.
101*. On WEIGHTS AND MEASURES OF ALL NATIONS	1s. 6d.

THE WORK ON

BRIDGES OF STONE, IRON, TIMBER,
AND WIRE.

In 4 Vols., bound in 3, described in the larger Catalogue of Publications; to which the following is the Supplement, now completed, entitled

SUPPLEMENT TO "THE THEORY, PRACTICE, AND
ARCHITECTURE OF BRIDGES OF STONE, IRON,
TIMBER, WIRE, AND SUSPENSION,"

In one large 8vo volume, with explanatory Text and 68 Plates, comprising details and measured dimensions, in Parts as follows:—

Part I.	6s.
„ II.	6s.
„ III.	6s.
„ IV.	10s.
„ V. & VI.	20s.

Bound in half-morocco, uniform with the larger work, price 2*l.* 10*s.*, or in a different pattern at the same price.

LIST OF PLATES.

Cast-iron girder bridge, Ashford, Rye and Hastings Railway.	Mr. Fairbairn's hollow-girder bridge at Blackburn.
Details, ditto.	Waterford and Limerick Railway truss bridge.
Elevation and plan of truss of St. Mary's Viaduct, Cheltenham Railway.	Hollow-girder bridge over the River Medlock.
Iron road bridge over the Railway at Chalk Farm. ;	Railway bridge over lagunes of Venice.

BRIDGES OF STONE, &C.

- Viaduct at Beangency, Orleans and Tours Railway.
- Oblique cast-iron bridge, on the system of M. Polonceau, over the Canal St. Denis.
- Blackwall Extension Railway, Commercial Road bridge.
- Ditto, enlarged elevation of outside girders, with details.
- Ditto, details.
- Ditto, ditto, and sections.
- Ditto, ditto, ditto.
- Richmond and Windsor main line, bridge over the Thames.
- Ditto, details.
- Ditto, ditto, and sections.
- Orleans and Bordeaux Railway bridge.
- Ditto, sections and details.
- Rouen and Havre Railway timber bridge.
- Ditto, details.
- Ditto, ditto, and sections.
- Viaduct of the Valley of Malauncey, near Rouen.
- Hoop-iron suspension bridge over the Seine at Suresne, department de la Seine.
- Hoop-iron suspension foot bridge at Abainville.
- Suspension bridge over the Douro, iron wire suspension cables.
- Ditto, details.
- Glasgow and South-Western Railway bridge over the water of Ayr.
- Ditto, sections and details.
- Plan of the cities of Ofen and Pesth.
- Sections and soundings of the River Danube.
- Longitudinal section of framing.
- No. 1 coffer-dam.
- Transverse framing of coffer-dam.
- Sections of Nos. 2 and 3 of coffer-dam.
- Plan of No. 3 coffer-dam and ice-breakers.
- Plan and elevation of the construction of the scaffolding, and the manner of hoisting the chains.
- Line of soundings,—dam longitudinal sections.
- Dam sections.
- Plan and elevation of the Pesth suspension bridge.
- Elevation of Nos. 2 and 3 coffer-dams.
- End view of ditto.
- Transverse section of No. 2 ditto.
- Transverse section of coffer-dam, plan of the 1st course, and No. 3 pier.
- Vertical section of Nos. 2 and 3 piers, showing vertical bond-stones.
- Vertical cross section of ditto.
- Front elevation of Nos. 2 and 3 piers.
- End elevation of ditto.
- Details of chains.—Ditto.
- Ditto and plan of nut, bolt, and retaining-links.
- Plan and elevation of roller-frames.
- Elevation and section of main blocks for raising the chains.
- Ditto, longitudinal section of fixture pier, showing tunnel for chains.
- Plan and elevation of retaining-plates, showing machine for boring holes for retaining-bars.
- Retaining link and bar.
- Longitudinal plan and elevation of cast-iron beam with truss columns.
- Longitudinal elevation and section of trussing, &c.
- Plan of pier at level of footpath.
- Detail of cantilevers for supporting the balconies round the towers.
- Elevation and section of cantilevers.
- Detail of key-stone & Hungarian arms.
- Front elevation of toll-houses and wing walls.
- Longitudinal elevation of toll-house, fixture pier, wing wall, and pedestal.
- Vertical section of retaining-piers.
- Section at end of fixture pier, showing chain-holes.
- Lamp and pedestal at entrance of bridge.
- Lamp and pedestal at end of wing walls.

Separately sold from the above in a volume, price half-bound in morocco £1. 12s.

An ACCOUNT, with Illustrations, of the SUSPENSION BRIDGE ACROSS the RIVER DANUBE, BY WILLIAM TIERNEY CLARK, C. E., F. R. S.

With Forty Engravings.

GREAT EXHIBITION BUILDING.

The BUILDING erected in HYDE PARK for the
GREAT EXHIBITION of the WORKS of
INDUSTRY of ALL NATIONS, 1851:

Illustrated by 28 large folding Plates, embracing plans, elevations, sections, and details, laid down to a large scale from the working drawings of the Contractors, Messrs. FOX, HENDERSON, and Co., by CHARLES DOWNES, Architect; with a scientific description by CHARLES COWPER, C.E.

In 4 Parts, royal quarto, now complete, price £1. 10s.,
 or in cloth boards, lettered, price £1. 11s. 6d.

* * This work has every measured detail so thoroughly made out as to enable the Engineer or Architect to erect a construction of a similar nature, either more or less extensive.

SIR JOHN RENNIE'S WORK

ON THE

**THEORY, FORMATION, AND CONSTRUCTION
 OF BRITISH AND FOREIGN HARBOURS.**

Copious explanatory text, illustrated by numerous examples, 2 Vols., very neat
 in half-morocco, £18

The history of the most ancient maritime nations affords conclusive evidence of the importance which they attached to the construction of secure and extensive Harbours, as indispensably necessary to the extension of commerce and navigation, and to the successful establishment of colonies in distant parts of the globe.

To this important subject, and more especially with reference to the vast extension of our commerce with foreign nations, the attention of the British Government has of late years been worthily directed; and as this may be reasonably expected to enhance the value of any information which may add to our existing stock of knowledge in a department of Civil Engineering as yet but imperfectly understood, its contribution at the present time may become generally useful to the Engineering Profession.

The Plates are executed by the best mechanical Engravers; the Views finely engraved under the direction of Mr. Pye: all the Engineering Plates have dimensions, with every explanatory detail for professional use.

In octavo, cloth boards, price 9s.

HYDRAULIC FORMULÆ, CO-EFFICIENTS, AND TABLES,

For finding the Discharge of Water from Orifices, Notches, Weirs, Short Tubes, Diaphragms, Mouth-pieces, Pipes, Drains, Streams, and Rivers.

BY JOHN NEVILLE,

ARCHITECT AND C. E., MEMBER ROYAL IRISH ACADEMY, MEMBER INST. C. E. IRELAND, MEMBER GEOLOGICAL SOC. IRELAND, COUNTY SURVEYOR OF LOUTH, AND OF THE COUNTY OF THE TOWN OF DROGHEDA.

This work contains above 150 different hydraulic formulæ (the Continental ones reduced to English measures), and the most extensive and accurate Tables yet published for finding the mean velocity of discharge from triangular, quadrilateral, and circular orifices, pipes, and rivers; with experimental results and coefficients;—effects of friction; of the velocity of approach; and of curves, bends, contractions, and expansions;—the best form of channel;—THE DRAINAGE EFFECTS OF LONG AND SHORT WEIRS, AND WEIR-BASINS;—extent of back-water from weirs; contracted channels;—catchment basins;—hydrostatic and hydraulic pressure;—water-power, &c.

TREDGOLD ON THE STEAM ENGINE.

Published in 74 Parts, price 2s. 6d. each, in 4to, illustrated by very numerous engravings and wood-cuts, a new and much extended edition, now complete in 3 vols. bound in 4, in elegant half-morocco, price Nine Guineas and a Half.

THE STEAM ENGINE,

IN ITS PROGRESSIVE AND PRESENT STATE OF IMPROVEMENT;

Practically and amply elucidating, in every detail, its modifications and applications, its duties and consumption of fuel, with an investigation of its principles and the proportions of its parts for efficiency and strength; including examples of British and American recently constructed engines, with details, drawn to a large scale.

The well-known and highly appreciated Treatise, Mr. TREDGOLD'S national Work on the STEAM ENGINE, founded on scientific principles and compiled from the practice of the best makers—showing also easy rules for construction, and for the calculation of its power in all cases—has commanded a most extensive sale in the several English editions, and in Translations on the Continent. These editions being *now out of print*, the proprietor has been induced to

TREDGOLD ON THE STEAM ENGINE.

enlarge and extend the present edition by practical examples of all kinds, with the most recent improvements in the construction and practical operations of the steam engine both at home and abroad.

The work is divided into the sections named below, either of which may be *purchased separately*: working engineers will be thus enabled to select those portions which more especially apply to the objects upon which they may be respectively employed.

Several scientific men, extensively and practically employed, have contributed original and really practical papers of the utmost utility; by which the value of this extended edition is much increased. A copious INDEX for reference is added.

DIVISION A. Locomotive Engines, 41 plates and 55 wood-cuts, complete, making Vol. I. In half-morocco binding, price £2. 12s. 6d.

DIVISION B. Marine Engines, British and American, numerous plates and wood-cuts, making Vol. II.; bound in 2 vols. half-morocco, price £3. 13s. 6d.

DIVISION C to G. making Vol. III., and completing the work, comprising Stationary Engines, Pumping Engines, Engines for Mills, and several examples of Boilers employed in the British Steam Navy; in half-morocco, price £3. 13s. 6d.

LIST OF PLATES.

DIVISION A.—LOCOMOTIVE ENGINES.

Elevation of the 8-wheeled locomotive engine and tender, the IRON DUKE, on the Great Western Railway.

Longitudinal section of ditto.

Plan, ditto.

Transverse sections, ditto.

Details of ditto: transverse section through working gear, transverse section and end view of tender; plan and section of feed-pump; plan and elevation of hand-pump; details of inside framing, centre axle, driving axle-box, regulation-valve, centre-beam stay, &c.

Elevation of Crampton's patent locomotive engine and tender.

Longitudinal section of ditto.

Plan of ditto.

Transverse sections of ditto.

Elevation of the PYRAMON 6-wheeled goods' engine on the Great Western Railway.

Half-plan of the working gear of ditto.

Elevation of a portion of the working gear of ditto.

Diagrams, by J. Sewell, L. E., of resistances per ton of the train; and portion of engines of the class of the

GREAT BRITAIN locomotive, including tender, with various loads and at various velocities; also of the additional resistance in lbs. per ton of the train, when the engine is loaded, to be added to the resistance per ton of the engine and tender when unloaded.

Side and front elevation of an express carriage engine, introduced on the Eastern Counties Railway by James Samuel, C. E., Resident Engineer.

Longitudinal and cross section of ditto.

Plan of ditto; with plan and section of cylinders, details and sections, piston full size.

Elevation of the outside-cylinder tank engine made by Sharpe Brothers & Co., of Manchester, for the Manchester and Birmingham Railway.

Section of cylinder and other parts, and part elevation of ditto.

Longitudinal section of ditto.

Plan of ditto.

Transverse sections of both ends, with sectional parts.

Mr. Edward Woods' experiments on the several sections of old and modern

TREGGOLD ON THE STEAM ENGINE.

- valves of locomotive engines,—viz. fig. 1. stroke commences; fig. 2, steam-port open; fig. 3, steam-port open; fig. 4, steam-port open; fig. 5, stroke completed, steam cut off, exhaustion commences; fig. 6, stroke commences; fig. 7, steam-port full open; fig. 8, steam cut off; fig. 9, exhaustion commences; fig. 10, steam completed.
- Ditto, drawn and engraved to half-size: fig. 1, old valve, $\frac{1}{4}$ -inch lap; fig. 2, $\frac{3}{8}$ -inch lap; fig. 3, $\frac{3}{4}$ -inch lap; fig. 4, $\frac{7}{8}$ -inch lap, Gray's patent; fig. 5, 1-inch lap.
- Elevation of a six-wheeled locomotive engine and tender, No. 15, constructed by Messrs. Tayleur, Vulcan Foundry, Warrington, for the Caledonian Railway.
- Longitudinal section of ditto.
- Plan of ditto, engine and tender, with cylindrical part of boiler removed.
- Elevations of fire-box, section of fire-box, section of smoke-box, of ditto.
- Elevations and sectional parts of ditto.
- Sectional parts, half-plan of working gear, ditto.
- Elevation of Messrs. Robert Stephenson and Co.'s six-wheeled patent locomotive engine and tender.
- Longitudinal section of ditto.
- Plan and details of Stephenson's patent engine.
- Section of fire-box, section of smoke-box, front and back elevations of the same.
- Plan of a six-wheeled engine on the Birmingham and Shrewsbury Railway, constructed by Messrs. Bury, Curtis, and Kennedy, Liverpool.
- Longitudinal section of ditto.
- Sectional elevation of the smoke-box, & Sectional elevation of the fire-box of ditto.
- Elevation of the locomotive engine and tender, PLEWS, adapted for high speeds, constructed by Messrs. R. & W. Hawthorn, of Newcastle-upon-Tyne, for the York, Newcastle, and Berwick Railway Company.
- Longitudinal section of ditto. This section is through the fire-box, boiler, and smoke-box, showing the tubes, safety-valve, whistles, steam and blast pipes, &c.
- Plan of ditto.
- Plan of the working gear, details, &c.

Forty-one plates and fifty-five wood engravings.

DIVISION B.—MARINE ENGINES, &C.

- Two plates, comprising figures 1, 2, and 3, Properties of Steam.
- Plan of H. M. screw steam frigate DAUNTLESS, constructed by Robert Napier, Esq.
- Longitudinal elevation and transverse section of ditto.
- Longitudinal section at A B on plan, longitudinal section at C D on plan of ditto.
- Engines of H. M. steam ship TERRIBLE, constructed by Messrs. Maudslay, Sons, and Field, on the double-cylinder principle. Longitudinal sections of engines.
- Transverse section and end view of ditto.
- Transverse section through boilers of ditto.
- Plan of engines, showing also bunkers, paddles, &c.
- Oscillating engines of the Peninsular and Oriental Company's steam vessel ARIEL, constructed by John Penn and Sons. Longitudinal section.
- Section at engines of ditto.
- Section at boiler of ditto.
- Plan at boiler of ditto.
- Section at air-pump, and at cylinder.
- Annular cylinder engines of the iron steam vessels PRINCESS MARY and PRINCESS MAUDE, constructed by Maudslay, Sons, and Field. Longitudinal section.
- Transverse section at engines of ditto.
- Section at boilers of ditto.
- Plan of engines of ditto, showing bunkers, paddles, &c.
- Plan of engines of H. M. steam vessel SMOOM, constructed by James Watt & Co., of London and Soho.

TREGOLD ON THE STEAM ENGINE.

- Longitudinal section of the **SIMOOM**.
 Cross section of ditto.
 Engine of the **RED ROVER**, side view and plan.
 Longitudinal section of ditto.
 Cross sections of ditto.
 Sheer draught and plans of vessel.
 Plan of the engine of H. M. steam frigate **PHENIX**.
 Longitudinal section of engine of ditto.
 Cross section of ditto.
 Engine of the **RUBY** steam vessel, elevation and plan.
 Sheer draught and plan of vessel.
 Plan of engine of the **WILBERFORCE**, Hull and London packet.
 Cross section of ditto and vessel.
 Longitudinal section of engines of ditto.
 Elevation of engines of ditto.
 Engines of the **BERENICE**, Hon. E. I. Co.'s steam vessel.
 Section of ditto.
 Sheer draught and plan, stern view, and body plan of vessel.
 View of the **BERENICE**, whilst at sea.
 Boilers of H. M. ships **HERMES**, **SPITFIRE**, and **FIREFLY**.
 Kingston's valves, as fitted on board sea-going vessels for blow-off injection, and hand-pump sea valves.
 Boilers of H. M. steam vessel **AFRICAN**.
 Morgan's paddle-wheels, as fitted in H. M. S. **MEDEA**.
 Side elevation of ditto.
 Plans of upper and lower decks of ditto.
 Sheer draught and profile of ditto.
 Morgan and Seaward's paddle-wheels, comparatively.
 Positions of a float of a radiating paddle-wheel in a vessel in motion, and positions of a float of a vertically acting wheel in a vessel in motion.
 Cycloidal paddle-wheels.
 Sailing of steamers in five points from courses.
 Experimental steaming and sailing of the **CALEDONIA**, **VANGUARD**, **ASIA**, and **MEDEA**.
 Engines of H. M. steam ship **MEGERA**.
 Engine of the steam boat **NEW WORLD**.
- T. F. Secor & Co., Engineers, New York. Elevation and section.
 Elevations of cylinder and crank ends.
 Steam cylinders, plans, and sections.
 Details.
 Several sections of details.
 Details and sections.
 Details of parts.
 Plans and sections of condenser, bed-plates, air-pump bucket, &c.
 Details and sections, injection valves.
 Details, plan and elevation of beams, &c.
 Details, sections of parts, boilers, &c. of the steam boat **NEW WORLD**.
 Sections, details, and paddles.
 Engines of the U. S. mail steamers **OHIO** and **GEORGIA**. Longitudinal section.
 Elevations and cross sections of ditto.
 Details of steam-chests, side-pipes, valves, and valve gear of ditto.
 Section of valves, and plan of piston of ditto.
 Boilers of ditto, sections of ditto.
 Engine of the U. S. steamer **WATERWITCH**. Sectional elevation.
 Steam-chests and cylinders of ditto.
 Boilers, sections, &c. of ditto.
 Boilers of the U. S. steamer **POWHATAN**.
 Front view and sections of ditto.
 Elevation of the Pittsburg and Cincinnati American packet **BUCKEYE STATE**.
 Bow view, stern view.
 Plan of the **BUCKEYE STATE**.
 Model, &c. of ditto, wheel-house frame, cross section at wheel-house, and body plan.
 Plan and side elevation of ditto.
 Sheer draught and plan, with the body plan, of the U. S. steam frigate **SARANAC**.
 Longitudinal section of ditto, cross section.
 Engines of the U. S. steamer **SUSQUEHANNA**.
 Elevation of the U. S. **PACIFIC** steam packet engine.
 Plan of ditto.
 Boilers of ditto, end views.
 Ditto ditto.

Eighty-five engravings and fifty-one wood-cuts.

TREDGOLD ON THE STEAM ENGINE.

DIVISION C. TO G., FORMING VOL. III.

STATIONARY ENGINES, PUMPING ENGINES, MARINE BOILERS, &C.

- Side elevation of pumping engine, U. S. dock, New York.
- End elevation of ditto.
- Elevation and section of the pumps, ditto.—2 plates.
- Boilers of pumping engines, ditto.
- Boilers, Details, &c. of pumping engines, ditto.
- Plan of the boilers, ditto.
- Isometrical projection of a rectangular boiler.
- Plan and two sections of a cylindrical boiler.
- Brunton's apparatus for feeding furnace-fires by means of machinery.
- Parts of a high-pressure engine with a 4-passaged cock.
- Section of a double-acting condensing engine.
- Section of a common atmospheric engine.
- On the construction of pistons.
- Section of steam pipes and valves.
- Apparatus for opening and closing steam passages.
- Parallel motions.—2 plates.
- Plan and elevation of an atmospheric engine.
- Elevation of a single-acting Boulton and Watt engine.
- Double-acting engine for raising water.
- Double-acting engine for impelling machinery.
- Maudslay's portable condensing engine for impelling machinery.
- Indicator for measuring the force of steam in the cylinder, and diagrams of forms of vessels.
- Section of a steam vessel with its boiler, in two parts—diagrams showing fire-places—longitudinal section through boiler and fire-places.
- Isometrical projection of a steam-boat engine.
- Plan and section of a steam-boat engine.
- Ten horse-power engine, constructed by W. Fairbairn and Co.—4 plates.
- Forty-five horse-power engine, constructed by W. Fairbairn & Co.—3 plates.
- Plan and section of boiler for a 20-horse engine, at the manufactory of Whitworth & Co., Manchester.
- Messrs. Hague's double-acting cylinder, with slides, &c.
- Sixty-five-inch cylinder, erected by Maudslay, Sons, and Field, at the Chelsea Water-works.—5 plates.
- Beale's patented rotary engine.
- Double-story boilers of H.M.S. DEVASTATION, 400 H. P.
- Refrigerator feed and brine pumps.
- Feed and brine apparatus, as fitted on board the West India Royal Mail Company's ships.
- Boilers of H. M. steam sloop **BASILISK**, 400 H. P.
- Boilers of the **SINGAPORE**, 470 H. P., Peninsular and Oriental Company.
- Original double-story boilers of the **GREAT WESTERN**.
- Telescopic chimney, or sliding funnel, of H. M. ship **HYDRA**, 220 H. P.
- Seaward's patent brine and feed valves.
- Boilers of H. M. mail packet **UNDINE**, (Miller, Ravenhill, & Co.) 100 H. P.
- Cross sections of engines of H. M. mail packet **UNDINE**.
- Longitudinal elevation of ditto.
- Brine-pumps as fitted on board H.M.S. **MEDIA**, 220 H. P. (Maudslay, Sons, and Field.)
- Boilers of H. M. S. **HYDRA**, 220 H. P.
- Plan of the four boilers, with the supplementary steam-chests and shut-off valves, of the **AVENGER**.
- Boilers of H. M. steam ship **NIGER**, 400 H. P., fitted by Maudslay, Sons, and Field.
- Experimental boiler, Woolwich Yard.
- Boilers of H. M. S. **TERRIBLE**, 800 H. P. (Maudslay, Sons, and Field.)
- Boilers of the **MINX** and **TEASER**, 100 H. P. (transferred to **WASP**.)
- Boilers of the **SAMSON**, 450 H. P.
- Daniel's pyrometer, full size.
- Boilers of the **DESPERATE**, 400 H. P. (Maudslay, Sons, and Field.)
- Boilers of the **NIGER** (2nd plate).
- Boilers of H. M. S. **BASILISK** (2nd plate).
- Boilers of the **UNDINE**.

TREGGOLD ON THE STEAM ENGINE.

- Boilers of the Royal Mail steam ships **ASIA** and **AFRICA**, 768 H. P., constructed by R. Napier, Glasgow.
- Longitudinal and midship sections of ditto.
- Boilers of H. M. S. **LA HOGUE**, 450 H. P. (Seaward & Co.)
- H. M. S. **SIDON**, 560 H. P. Plan of telescope funnel.
- Boilers of H. M. S. **BRISK**, 250 H. P.
- Copper boilers for H. M. S. **SANS-PAREIL**, 350 H. P. (James Watt & Co.)
- American marine boilers, designed and executed by C. W. Copeland, Esq., of New York, as fitted on board the American packets.
- Midship section of the hull of the steam packet **PACIFIC**, New York and Liverpool line.
- Elevation of pumping engines of the New Orleans Water-works, U. S., arranged and drawn by E. W. Smith, Engineer, constructed at the Allaire Works, New York.
- Elevation of pumps and valves, chests, gearings, &c.
- Elevation at steam cylinder end.
- General plan of a turbine water-wheel in operation at Lowell, Massachusetts, U. S., by J. B. Francis, C. E.
- Elevation of ditto.—Section of ditto.
- Plan of the floats and guide curves, ditto.
- Large self-acting surfacing and screw-propeller lathe, by Joseph Whitworth & Co., Manchester.
- Longitudinal section, showing arrangement of engine-room for disc engine applied to a screw propeller, and Bishop's disc engine, by G. & J. Rennie, with details.
- Arrangement of engine-room for engines of 60 horse-power, for driving propellers of H. M. steam vessels **REYNARD** and **CRUISER**, constructed by Messrs. Rennie. Longitudinal section and engine-room.
- Ditto. Transverse section at boilers and at engines.
- Very elaborate diagrams showing experiments and results of various paddle-wheels.—8 plates.
- Steam flour-mills at Smyrna, constructed by Messrs. Joyce & Co. Double cylinder pendulous condensing engine, side elevation.
- Side elevation, horizontal plan, ditto.
- Longitudinal section.
- Horizontal plan of mill-house and boilers.
- Transverse section through engine-house and mill.
- Boilers, longitudinal and transverse sections, front view.
- Section through mill-stones, elevation of upper part, section of lower part, plan of hopper, &c.

SUMMARY OF THE ILLUSTRATIONS.

	Plates.	Wood-cuts.
Vol. I. Locomotive Engines	41	55
II. Marine Engines	85	51
III. Stationary Engines, Pumping Engines, Engines for Flour-Mills, Examples of Boilers, &c., &c. .	100	58
Total	226	164

FULL-LENGTH PORTRAIT OF

HENRY CAVENDISH, F.R.S.

Some few India paper proofs, before the letters, of this celebrated Philosopher and Chemist, to be had, price 2s. 6d.

HINTS TO YOUNG ARCHITECTS:

COMPRISING

ADVICE TO THOSE WHO, WHILE YET AT SCHOOL ARE DESTINED
TO THE PROFESSION;

TO SUCH AS, HAVING PASSED THEIR PUPILAGE, ARE ABOUT TO TRAVEL
AND TO THOSE WHO, HAVING COMPLETED THEIR EDUCATION,
ARE ABOUT TO PRACTISE:

TOGETHER WITH

A MODEL SPECIFICATION:

INVOLVING A GREAT VARIETY OF INSTRUCTIVE AND SUGGESTIVE MATTER,
CALCULATED TO FACILITATE THEIR PRACTICAL OPERATIONS;

AND TO DIRECT THEM IN THEIR CONDUCT, AS THE RESPONSIBLE
AGENTS OF THEIR EMPLOYERS,

AND AS THE RIGHTFUL JUDGES OF A CONTRACTOR'S DUTY.

BY GEORGE WIGHTWICK, ARCHITECT.

CONTENTS:—

Preliminary Hints to Young Archi-
tects on the Knowledge of
Drawing.

On Serving his Time.

On Travelling.

His Plate on the Door.

Orders, Plan-drawing.

On his Taste, Study of Interiors.

Interior Arrangements.

Warming and Ventilating.

House Building, Stabling.

Cottages and Villas.

Model Specification:—

General Clauses.

Foundations.

Well.

Artificial Foundations.

Brickwork.

Rubble Masonry with Brick

Mingled.

Model Specification:

Stone-cutting.

—, Grecian or Italian only.

—, Gothic only.

Miscellaneous.

Slating.

Tiling.

Plaster and Cement-work.

Carpenters' Work.

Joiners' Work.

Iron and Metal-work.

Plumbers' Work.

Drainage.

Well-digging.

Artificial Levels, Concrete,

Foundations, Piling and

Planking, Paving, Vaulting,

Bell-hanging, Plumbing, and

Building generally.

Extra cloth boards, price 8s.

THE ENGINEER'S AND CONTRACTOR'S POCKET BOOK,

WITH AN ASTRONOMICAL ALMANACK,

REVISED FOR 1855-6. In morocco tuck, price 6s.

CONTENTS.

- AIR**, Air in motion (or wind), and wind-mills.
Alloys for bronze; Miscellaneous alloys and compositions; Table of alloys; Alloys of copper and zinc, and of copper and tin.
Almanack for 1855 and 1856.
American railroads; steam vessels.
Areas of the segments of a circle.
Armstrong (R.), his experiment on boilers.
Astronomical phenomena.
Ballasting.
Barlow's (Mr.) experiments.
Barrel drains and culverts.
Bell-hanger's prices.
Blowing a blast engine.
Boilers and engines, proportions of; Furnaces and chimneys; Marine.
Bossut's experiments on the discharge of water by horizontal conduit or conducting pipes.
Brass, weight of a lineal foot of, round and square.
Breen (Hugh), his almanack.
Bricks.
Bridges and viaducts; Bridges of brick and stone; Iron bridges; Timber bridges.
Burt's (Mr.) agency for the sale of preserved timber.
Cask and malt gauging.
Cast-iron binders or joints; Columns, formulæ of; Columns or cylinders, Table of diameter of; Hollow columns, Table of the diameters and thickness of metal of; Girders, prices of; Stanchions, Table of, strength of.
Chairs, tables, weights, &c.
Chatburn limestone.
Chimneys, &c., dimensions of.
Circumferences, &c. of circles.
Coal, evaporating power of, and results of coking.
Columns, cast-iron, weight or pressure of, strength of.
Comparative values between the present and former measures of capacity.
Continuous bearing.
Copper pipes, Table of the weight of, Table of the bore and weight of cocks for.
Copper, weight of a lineal foot of, round and square.
Cornish pumping engines.
Cotton mill; Cotton press.
Current coin of the principal commercial countries, with their weight and relative value in British money.
Digging, well-sinking, &c.
Docks, dry, at Greenock.
Draining by steam power.
Dredging machinery.
DWARF, Table of experiments with H. M. screw steam tender.
Earthwork and embankments, Tables of contents, &c.
Experiments on rectangular bars of malleable iron, by Mr. Barlow; on angle and T iron bars.
Fairbairn (Wm.), on the expansive action of steam, and a new construction of expansion valves for condensing steam engines.
Feet reduced to links and decimals.
Fire-proof flooring.
Flour-mills.
Fluids in motion.
Francis (J. B., of Lowell, Massachusetts), his water-wheel.
French measures.
Friction.
Fuel, boilers, furnaces, &c.
Furnaces and boilers.
Galvanized tin iron sheets in London or Liverpool, list of gauges and weights of.
Gas-tubing composition.
Glynn (Joseph), F. R. S., on turbine water-wheels.
Hawksby (Mr., of Nottingham), his experiments on pumping water.
Heat, Tables of the effects of.

THE ENGINEER'S AND CONTRACTOR'S POCKET BOOK.

- Hexagon heads and nuts for bolts, proportional sizes and weights of.
 Hick's rule for calculating the strength of shafts.
 Hodgkinson's (Eaton) experiments.
 Hungerford Bridge.
 Hydraulics.
 Hydrodynamics.
 Hydrostatic press.
 Hydrostatics.
 Imperial standard measures of Great Britain; Iron.
 Indian Navy, ships of war, and other vessels.
 Institution of Civil Engineers, List of Members of the, corrected to March 15, 1852.
 Iron balls, weight of cast; bars, angle and T, weight of; castings; experiments; hoop, weight of 10 lineal feet; lock gates; roofs; tubes for locomotive and marine boilers; weights of rolled iron.
 Ironmonger's prices.
 Just's analysis of Mr. Dixon Robinson's limestone.
 Latitudes and longitudes of the principal observatories.
 Lead pipes, Table of the weights of.
 Leslie (J.), C.E.
 Lime, mortar, cements, concrete, &c.
 Limestone, analysis of.
 Liquids in motion.
 Locomotive engines; Table showing the speed of an engine.
 Log for a sea-going steamer, form of.
 Machines and tools, prices of.
 Mahogany, experiments made on the strength of Honduras. [wheels.
 Mallet's experiments on overshot
 Marine boilers; engines.
 Masonry and stone-work.
 Massachusetts railroads.
 Mensuration, epitome of.
 Metals, lineal expansion of.
 Morin's (Col.) experiments.
 Motion; motion of water in rivers.
 Nails, weight and length.
 Navies — of the United States; Indian Navy; Oriental and Peninsular Company; British Navy; of Austria; Denmark; Naples; Spain; France; Germanic Confederation; Holland; Portugal; Prussia; Sardinia; Sweden and Norway; Turkey; Russia
 Royal West India Mail Company's fleet.
 New York, State of, railroads.
 Numbers, Table of the fourth and fifth power of.
 Paddle-wheel steamers.
 Pambour (Count de) and Mr. Parkes' experiments on boilers for the production of steam.
 Peacocke's (R. A.) hydraulic experiments.
 Pile-driving.
 Pitch of wheels. Table to find the diameter of a wheel for a given pitch of teeth.
 Plastering.
 Playfair (Dr. Lyon).
 Preserved timber.
 Prices for railways, paid by H. M. Office of Works; smith and founder's work.
 Prony's experiments.
 Proportions of steam engines and boilers.
 Pumping engines; pumping water by steam power.
 Rails, chairs, &c., Table of.
 Railway, American, statistics; railway and building contractor's prices; carriages.
 Rain, Tables of.
 Rammell's (T. W.) plan and estimate for a distributing apparatus by fixed pipes and hydrants.
 Rennie's (Mr. Geo.) experiments; (the late J.) estimate.
 Roads, experiments upon carriages travelling on ordinary roads; influence of the diameter of the wheels; Morin's experiments on the traction of carriages, and the destructive effects which they produce upon roads.
 Robinson (Dixon), his experiments and material.
 Roofs; covering of roofs.
 Ropes, Morin's recent experiments on the stiffness of ropes; tarred ropes; dry white ropes.
 Saw-mill.
 Screw steamers.
 Sewage manures.
 Sewers, castings for their estimates, &c.

THE ENGINEER'S AND CONTRACTOR'S POCKET BOOK.

Signs and abbreviations used in arithmetic and mathematical expressions.

Slating.

Sleepers, quantity in cubic feet, &c.

Smeaton's experiments on wind-mills.

Smith and founder's prices.

Specific gravity, Table of.

Steam dredging; Navigation; Tables of the elastic force; Table of Vessels of war, of America; of England; of India; and of several other maritime nations.

Steel, weight of round steel.

Stone, per lb., stone, qr., cwt., and ton, &c., Table of the price.

Stones.

Strength of columns; Materials of construction.

Sugar-mill.

Suspension aqueduct over the Alleghany River; Bridges over ditto.

Table of experiments with H. M. screw steam tender DWARF; of gradients; iron roofs; latent heats; paddle-wheel steamers of H. M. Service and Post-Office Service; pressure of the wind moving at given velocities; prices of galvanized tinned iron tube; specific heats; the cohesive power of bodies; columns, posts, &c., of timber and iron; the comparative strength, size, weight, and price of iron-wire rope (A. Smith's), hempen rope, and iron chain; corresponding velocities with heads of water as high as 50 ft., in feet and decimals; dimensions of the principal parts of marine engines; effects of heat on different metals; elastic force of steam; expansion and density of water; expansion of solids by increasing the temperature; expansion of water by heat; heights corresponding to different velocities, in French metres; lineal expansion of metals; motion of water, and quantities discharged by pipes of different diameters; power of metals, &c.; pressure, &c., of wind-mill sails; principal dimensions of 23 merchant steamers with screw propellers; of steamers with paddle-wheels; progressive dilatation of metals by heat, &c.; properties of real to theoretica

discharge through thin-lipped orifices; quantities of water, in cubic feet, discharged over a weir per minute, hour, &c.; relative weight and strength of ropes and chains; results of experiments on the friction of unctuous surfaces; scantlings of posts of oak; size and weight of iron laths; weight in lbs. required to crush $1\frac{1}{2}$ -inch cubes of stone, and other bodies; weight of a lineal foot of cast-iron pipes, in lbs.; weight of a lineal foot of flat bar iron, in lbs.; weight of a lineal foot of square and round bar iron; weight of a superficial foot of various metals, in lbs.; weight of modules of elasticity of various metals; velocities of paddle-wheels of different diameters, in feet per minute, and British statute miles, per hour; the dimensions, cost, and price per cubic yard, of ten of the principal bridges or viaducts built for railways; the height of the boiling point at different heights;—to find the diameter of a wheel for a given pitch of teeth, &c.

Tables of squares, cubes, square and cube roots.

Tech of wheels.

Temperature, the relative indications of, by different thermometers.

Thermometers, Table of comparison of different.

Timber for carpentry and joinery purposes; Table of the properties of different kinds of.

Tin plates, Table of the weight of.

Tools and machines, prices of.

Traction, Morin's experiments on.

Tredgold's Rules for Hydraulics, from Eytelwein's Equation.

Turbines, Report on, by Joseph Glynn and others.

Values of different materials.

Water-wheels.

Watson's (H. H.) analysis of limestone from the quarries at Chatburn.

Weight of angle and T iron bars; of woods.

Weights and measures.

West India Royal Mail Company.

Whitelaw's experiments on turbine water-wheels.

THE ENGINEER'S AND CONTRACTOR'S POCKET BOOK.

<p>White's (Mr., of Cowes) experiments on Honduras mahogany.</p> <p>Wicksteed's (Thos.) experiments on the evaporating power of different kinds of coal.</p>	<p>Wind-mills; of air, air in motion, &c. Woods.</p> <p>Wrought iron, prices of.</p> <p>Zinc as a material for use in house-building.</p>
--	---

In one Volume 8vo, extra cloth, bound, price 9s.

THE STUDENT'S GUIDE TO THE PRACTICE OF DESIGNING, MEASURING, AND VALUING ARTIFICERS' WORKS;

Containing Directions for taking Dimensions, abstracting the same, and bringing the Quantities into Bill; with Tables of Constants, and copious memoranda for the Valuation of Labour and Materials in the respective trades of Bricklayer and Slater, Carpenter and Joiner, Sawyer, Stonemason, Plasterer, Smith and Ironmonger, Plumber, Painter and Glazier, Paper-hanger. Thirty-eight plates and wood-cuts.

The Measuring, &c., edited by EDWARD DOBSON, Architect and Surveyor. Second Edition, with the additions on Design by E. LACY GARBETT, Architect.

CONTENTS.

<p>PRELIMINARY OBSERVATIONS ON DESIGNING ARTIFICERS' WORKS. Preliminary Observations on Measurement, Valuation, &c.—On measuring—On rotation therein—On abstracting quantities—On valuation—On the use of constants of labour.</p> <p>BRICKLAYER AND SLATER. DESIGN OF BRICKWORK—technical terms, &c. Foundations—Arches, inverted and erect—Window and other aperture heads—Window jambs—Plates and internal cornices—String-courses—External cornices—Chimney shafts—On general improvement of brick architecture, especially fenestration.</p> <p>MEASUREMENT. Of diggers' work—Of brickwork, of facings, &c.</p> <p>DESIGN OF TILING, and technical terms. Measurement of Tiling—Example of the mode of keeping the measuring-book for brickwork.</p>	<p>ABSTRACTING Bricklayers' and Tilers' work. Example of bill of Bricklayers' and Tilers' work.</p> <p>VALUATION of Bricklayers' work, Earthwork, Concrete, &c. Table of sizes and weights of various articles—Tables of the numbers of bricks or tiles in various works—Valuation of Diggers' and Bricklayers' labour—Table of Constants for said labour.</p> <p>EXAMPLES OF VALUING. 1. A yard of concrete.—2. A rod of brickwork.—3. A foot of facing.—4. A yard of paving.—5. A square of tiling.</p> <p>DESIGN, MEASUREMENT, AND VALUATION OF SLATING.</p> <p>CARPENTER AND JOINER. DESIGN OF CARPENTRY—technical terms, &c. Brestsummers, an abuse: substitutes for them—Joists, trimmers, trimming-joists—Girders, their abuse</p>
--	---

DESIGNING, MEASURING, AND VALUING ARTIFICERS' WORKS.

and right use—Substitutes for girders and quarter-partitions—Quarter-partitions—Roof-framing—Great waste in present common modes of roof-framing—To determine the right mode of subdividing the weight, and the right numbers of bearers for leaded roofs—The same for other roofs—Principle of the truss—Considerations that determine its right pitch—Internal filling or *tracery* of trusses—Collar-beam trusses—Connection of the parts of trusses—Variations on the truss; right limits thereto—To avoid fallacious trussing and roof-framing—Delorme's roofing; its economy on circular plans—Useful property of regular polygonal plans—On combinations of roofing, hips, and valleys—On gutters; their use and abuse—Mansarde or curb-roofs.

DESIGN OF JOINERY—technical terms, &c.

Modes of finishing and decorating panel-work—Design of doors.

MEASUREMENT of Carpenters' and Joiners' work—Abbreviations.

Modes of measuring Carpenters' work—Classification of labour when measured with the timber—Classification of labour and nails when measured separately from the timber.

EXAMPLES OF MEASUREMENT, arch centerings.

Bracketing to sham entablatures, gutters, sound-boarding, chimney-grounds, sham plinths, sham pilasters, floor-boarding, mouldings—Doorcases, doors, doorway linings—Dado or surbase, its best construction—Sashes and sash-frames (examples of measurement)—Shutters, boxings, and other window fittings—Staircases and their fittings.

ABSTRACTING Carpenters' and Joiners' work.

Example of Bill of Carpenters' and Joiners' work.

VALUATION of Carpenters' and Joiners' work, Memoranda.

Tables of numbers and weights.

TABLES OF CONSTANTS OF LABOUR.
Roofs, naked floors—Quarter-par-

titions—Labour on fir, per foot cube—Example of the valuation of deals or battens—Constants of labour on deals, per foot superficial.

CONSTANTS OF LABOUR, and of nails, separately.

On battening, weather boarding—Rough boarding, deal floors, batten floors.

LABOUR AND NAILS together.

On grounds, skirtings, gutters, doorway-linings—Doors, framed partitions, mouldings—Window-fittings—Shutters, sashes and frames, staircases—Staircase fittings, wall-strings—Dados, sham columns and pilasters.

VALUATION OF SAWYERS' WORK.

MASON.

DESIGN OF STONEMASONS' WORK.

Dr. Robison on Greek and Gothic Architecture—Great fallacy in the Gothic ornamentation, which led also to the modern 'monkey styles'—'Restoration' and Preservation.

MEASUREMENT of Stonemason's work.

Example of measuring a spandril step, three methods—Allowance for labour not seen in finished stone—Abbreviations—Specimen of the measuring-book—Stairs—Landings—Steps—Coping—String-courses—Plinths, window-sills, curbs—Columns, entablatures, blockings—Cornices, renaissance niches.

ABSTRACTING AND VALUATION.

Table of weight of stone—Table of Constants of Labour—Example of Bill of Masons' work.

PLASTERER.

DESIGN OF PLASTER-WORK in real and mock Architecture.

Ceilings and their uses—Unnecessary disease and death traced to their misconstruction—Sanitary requirements for a right ceiling—Conditions to be observed to render domestic ceilings innocuous—Ditto, for ceilings of public buildings—Barbarous shifts necessitated by wrong ceiling—Technical terms in Plasterers' work.

MEASUREMENT of Plaster-work.

DESIGNING, MEASURING, AND VALUING ARTIFICERS' WORKS.

Abbreviations — Abstracting of Plasterers' work — Example of Bill of Plasterers' work.

VALUATION.

Memoranda of quantities of materials — Constants of Labour.

SMITH AND FOUNDER.

ON THE USE OF METAL-WORK IN ARCHITECTURE.

Iron not rightly to be used much more now than in the middle ages — Substitutes for the present extravagant use of iron — Fire-proof (and sanitary) ceiling and flooring — Fire-proof roof-framing in brick and iron — Another method, applicable to hipped roofs — A mode of untrussed roof-framing in iron only — A principle for iron trussed roofing on any plan or scale — Another variation thereof — On the decoration of metallic architecture.

MEASUREMENT of Smiths' and Founders' work.

PLUMBER, PAINTER, GLAZIER, &c.

DESIGN, &c. OF LEAD-WORK.

MEASUREMENT OF PAINT-WORK — Abbreviations.

Specimen of the measuring-book — Abstract of Paint-work — Example of Bill of Paint-work.

VALUATION of Paint-work.

Constants of Labour — Measurement and Valuation of GLAZING — Measurement and Valuation of PAPER-HANGING.

APPENDIX ON WARMING.

Modifications of sanitary construction to suit the English open fire — More economic modes of warming in public buildings — Ditto, for private ones — Warming by gas.

In 12mo., price 5s. bound and lettered,

THE OPERATIVE MECHANIC'S WORKSHOP COMPANION, AND THE SCIENTIFIC GENTLEMAN'S PRACTICAL ASSISTANT;

Comprising a great variety of the most useful Rules in Mechanical Science, divested of mathematical complexity; with numerous Tables of Practical Data and Calculated Results, for facilitating Mechanical and Commercial Transactions.

BY W. TEMPLETON,

AUTHOR OF SEVERAL SCIENTIFIC WORKS.

Third edition, with the addition of Mechanical Tables for the use of Operative Smiths, Millwrights, and Engineers; and practical directions for the Smelting of Metallic Ores.

2 vols. 4to, price £ 2. 16s.,

CARPENTRY AND JOINERY;

Containing 190 Plates; a work suitable to Carpenters and Builders, comprising Elementary and Practical Carpentry, useful to Artificers in the Colonies.

MATHEMATICS FOR PRACTICAL MEN.

Sect.

CHAPTER III.—DYNAMICS.

1. General Definitions.
2. On the general laws of uniform and variable motion.—Motion uniformly accelerated.—Motion of bodies under the action of gravity.—Motion over a fixed pulley, and on inclined planes.
3. Motions about a fixed centre, or axis.—Centres of oscillation and percussion.—Simple and compound pendulums.—Centre of gyration, and the principles of rotation.—Central forces.
4. Percussion or collision of bodies in motion.
5. Mechanical powers.—Levers.—Wheel & axle.—Pulley.—Inclined plane.—Wedge and screw.

CHAPTER IV.—HYDROSTATICS.

1. General Definitions.—2. Pressure and equilibrium of Non-elastic Fluids.—3. Floating Bodies.—4. Specific gravities.—5. On capillary attraction.

CHAPTER V.—HYDRODYNAMICS.

1. Motion and effluence of liquids.
2. Motion of water in conduit pipes and open canals, over weirs, &c.—Velocities of rivers.
3. Contrivances to measure the velocity of running waters.

CHAPTER VI.—PNEUMATICS.

1. Weight and equilibrium of air and elastic fluids.
2. Machines for raising water by the pressure of the atmosphere.
3. Force of the wind.

Sect.

CHAPTER VII.—MECHANICAL AGENTS.

1. Water as a mechanical agent.
2. Air as a mechanical agent.—Coulomb's experiments.
3. Mechanical agents depending upon heat. The Steam Engine.—Table of Pressure and Temperature of Steam.—General description of the mode of action of the steam engine.—Theory of the same.—Description of various engines, and formulæ for calculating their power: practical application.
4. Animal strength as a mechanical agent.

CHAPTER VIII.—STRENGTH OF MATERIALS.

1. Results of experiments, and principles upon which they should be practically applied.
2. Strength of materials to resist tensile and crushing strains.—Strength of columns.
3. Elasticity and elongation of bodies subjected to a crushing or tensile strain.
4. On the strength of materials subjected to a transverse strain.—Longitudinal form of beam of uniform strength.—Transverse strength of other materials than cast iron.—The strength of beams according to the manner in which the load is distributed.
5. Elasticity of bodies subjected to a transverse strain.
6. Strength of materials to resist torsion.

APPENDIX.

- I. Table of Logarithmic Differences.
- II. Table of Logarithms of Numbers, from 1 to 100.
- III. Table of Logarithms of Numbers, from 100 to 10,000.
- IV. Table of Logarithmic Sines, Tangents, Secants, &c.
- V. Table of Useful Factors, extending to several places of Decimals.
- VI. Table of various Useful Numbers, with their Logarithms.
- VII. Table of Diameters, Areas, and Circumferences of Circles, &c.
- VIII. Table of Relations of the Arc, Abscissa, Ordinate and Subnormal, in the Catenary.
- IX. Tables of the Lengths and Vibrations of Pendulums.
- X. Table of Specific Gravities.
- XI. Table of Weight of Materials frequently employed in Construction.
- XII. Principles of Chronometers.
- XIII. Select Mechanical Expedients.
- XIV. Observations on the Effect of Old London Bridge on the Tides, &c.
- XV. Professor Farish on Isometrical Perspective.

