

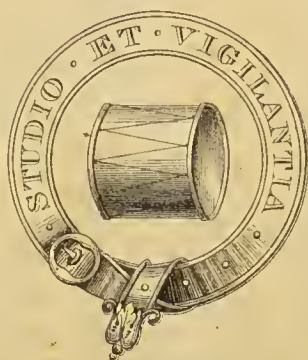

EX BIBLIOTHECA



CAR. I. TABORIS.



22501693334





PHOTOGRAPHY







*J. Gale, Photo.*

*Dawsons Ph. Co.*

## *Village News.*

*(By kind permission of J. Gale, Esq.)*



# PHOTOGRAPHY:

*ITS HISTORY, PROCESSES, APPARATUS,  
AND MATERIALS.*

COMPRISING

WORKING DETAILS OF ALL THE MORE IMPORTANT  
METHODS.

BY

A. BROTHERS, F.R.A.S.

*WITH PLATES BY MANY OF THE PROCESSES DESCRIBED,  
AND ILLUSTRATIONS IN THE TEXT.*

LONDON:  
CHARLES GRIFFIN AND COMPANY, LIMITED,  
EXETER STREET, STRAND.

1892.

[*All rights reserved.*]

Wellcome Library  
for the History  
of Understanding  
of Medicine

(2) ZHE / BRO

TO

*HENRY WILDE, Esq., F.R.S.,*

AS

A SLIGHT MARK OF THE ESTEEM IN WHICH HE IS HELD

BY

THE AUTHOR.



## PREFACE.

IN the preparation of the following work, my aim has been to produce a Handbook for the use of Students of Photography, which should both give the results of practical experience, and include—as far as possible within a moderate compass—information gathered from many sources, and not readily accessible.

The newer methods have been dealt with in sufficient detail, but I have also throughout given special attention to the processes in use prior to the introduction of the gelatino-bromide method. Some of these processes are in danger of being neglected through the facilities which the newer methods have introduced. But, as I have shown, the new processes do not give results equal to the old, and are totally unsuitable for some purposes—such as for making negatives for photolithography, and in various other ways.

To these older processes, therefore, I have given such prominence as their practical usefulness demands.

Where practicable, the plates illustrate the processes described, and these plates make the work distinctly more serviceable to students. To those who have rendered aid in this respect, the Publishers, with myself, desire to offer the fullest acknowledgment. Our thanks are particularly due to

Messrs. Billing, Son, & Co., Mr. Brennan, Messrs. Boussod, Valadon, & Co., Mr. Chapman, Messrs. A. & C. Dawson, Mr. J. H. T. Ellerbeck, Mr. Gale, Mr. G. J. Johnson, the Meisenbach Company, Messrs. Norbury & Sons, Mr. H. P. Robinson, Miss E. G. Thomson, Messrs. Thornton & Pickard, Messrs. Waterlow & Sons, Mr. Wolfe—and to these I would add the name of my son, Mr. H. E. Brothers, B.Sc. (Lond.), who revised Chapters II. and III. in Part I.

A. BROTHERS.

MANCHESTER, *April* 1892.

# GENERAL CONTENTS.

## PART I.—INTRODUCTORY.

### CHAPTER I.

	PAGE
HISTORICAL SKETCH . . . . .	I-17
Niépce . . . . .	1
Daguerre . . . . .	2
Talbot . . . . .	7

### CHAPTER II.

CHEMISTRY OF PHOTOGRAPHY . . . . .	17-36
Physical action . . . . .	18
Chemical action . . . . .	18
Oxidation by light . . . . .	19
Reduction by light . . . . .	20
Theory of sensitisers . . . . .	22
Orthochromatic photography . . . . .	24
Solarisation . . . . .	25
Developing . . . . .	27
Restrainers and accelerators . . . . .	30
Intensifying . . . . .	31
Printing . . . . .	33
Use of iron salts . . . . .	34

### CHAPTER III.

OPTICS OF PHOTOGRAPHY . . . . .	36-55
Light . . . . .	36
Lenses . . . . .	39
Focus . . . . .	41
Defects in lenses . . . . .	44
Objectives . . . . .	49

### CHAPTER IV.

LIGHT IN PHOTOGRAPHY . . . . .	55-66
Electric light . . . . .	55
Oxyhydrogen light . . . . .	61
Continuing action of light . . . . .	62
Compressed gas . . . . .	62
Ethoxo-limelight . . . . .	63
Magnesium light . . . . .	63

## PART II.—PROCESSES.

Alabastrine process . . . . .	67
Albumen process . . . . .	68
Albumen substratum . . . . .	69
Amphitype . . . . .	70
Aniline process . . . . .	71
Aristotype . . . . .	71
Autotype . . . . .	72
Becchey's emulsion process . . . . .	75

	PAGE		PAGE
Bitumen process . . . . .	76	Magic photographs . . . . .	128
Black lines . . . . .	77	Meisenbach process . . . . .	128
Bromide printing process . . . . .	78	Micro-photography . . . . .	129
Calotype . . . . .	80	Mounting and mountants . . . . .	129
Canvas, printing on . . . . .	81	Obernetter's etching process . . . . .	131
Carbon printing . . . . .	83	Opal glass . . . . .	131
Celerotype . . . . .	84	Orthochromatic photography . . . . .	132
Ceramic photographs . . . . .	86	Panoramic photography . . . . .	138
Chloro-bromide process . . . . .	87	Paper negatives . . . . .	139
Chromatype . . . . .	87	Pedestal portraits . . . . .	139
Cleaning glass . . . . .	87	Photochrome-lithography . . . . .	139
Clearing and reducing solutions . . . . .	88	Photo-engraving—photogravure . . . . .	140
Coffee process . . . . .	88	Photo-filigrane . . . . .	144
Collodio-albumen process . . . . .	89	Photochromo-typography . . . . .	144
Collodio-bromide process . . . . .	90	Photogenic drawing . . . . .	144
Collodio-chloride of silver process . . . . .	90	Photographing on wood . . . . .	145
Collodion pellicle . . . . .	90	Photography and colour . . . . .	146
Collodion process . . . . .	91	Photo-lithography . . . . .	152
Collotype . . . . .	98	Photo-micrography . . . . .	159
Colouring lantern-slides . . . . .	104	Phototint . . . . .	162
Contretype negative . . . . .	104	Photo-typography . . . . .	162
Crystal cubes . . . . .	104	Pinhole photography . . . . .	162
Cyanotype . . . . .	105	Platinotype process . . . . .	163
Daguerreotype process . . . . .	106	Plumbago process . . . . .	172
Drying gelatine plates . . . . .	108	Primuline or diazotype process . . . . .	173
Dry-plate making . . . . .	109	Printing and toning . . . . .	175
Dry processes . . . . .	109	Printing on ivory . . . . .	183
Dusting-on process . . . . .	110	Reproduced negatives . . . . .	183
Eburneum process . . . . .	110	Reversal of the image . . . . .	184
Electro-phototypy . . . . .	111	Reversed negatives . . . . .	185
Enamelling paper prints . . . . .	111	Retouching . . . . .	187
Enlarging and copying . . . . .	112	Ruby medium . . . . .	189
Ferrottype . . . . .	115	Screen-plates . . . . .	189
Ferrotypes . . . . .	114	Silvering glass . . . . .	189
Film photography . . . . .	115	Stains . . . . .	190
Fixing . . . . .	115	Stannotype . . . . .	191
Fluorotype . . . . .	116	Steel-facing copper-plates . . . . .	192
Gelatino-bromide process . . . . .	116	Tannin process . . . . .	193
Gelatino-chloride paper . . . . .	119	Taupenot process . . . . .	193
Gold-printing process . . . . .	120	Tea process . . . . .	194
Green photographs . . . . .	121	Telescopic photography . . . . .	194
Gum-gallic process . . . . .	121	Transferotype process . . . . .	197
Heliography . . . . .	121	Typogravure . . . . .	197
Indian-ink outlines . . . . .	121	Uranium printing . . . . .	198
Iridescent photographs . . . . .	122	Vignetting . . . . .	199
Kallitype . . . . .	122	Waxed-paper process . . . . .	200
Kennett's pellicle . . . . .	125	Woodbury-type . . . . .	200
Lantern-slide making . . . . .	125	Woodbury gravure . . . . .	201
Leimtype . . . . .	127	Writing titles . . . . .	202
Litho-heliogravure . . . . .	127	Yellow negatives . . . . .	202
		Zinc-etching . . . . .	202



## PART III.—APPARATUS.

	PAGE		PAGE
Actinometers and exposure tables	205	Lamps for dark rooms	237
Balance	208	Level-indicator	237
Baths and dippers	208	Optical or magic lantern	238
Bellows	209	Oscillating tables or rockers	242
Buckle's brush	209	Pantascopic camera	242
Burnishers and rolling machines	210	Photometers	243
Cameras	210	Plate-boxes	243
Camera-stands and tripods	226	Plate-racks	243
Condenser	227	Pneumatic plate-holder	243
Dark room	227	Printing-frames	244
Diaphragms and stops	227	Retouching desk	245
Dishes and trays	229	Roller-slide	245
Dropping bottles	229	Sky-shade	245
Focussing and focimeter	229	Solar camera	245
Focussing cloth	230	Squeegee	246
Focussing glass	231	Stoppers	246
Focussing screen	231	Tents	247
Head-rests	232	Thermometers	247
Hydrometer	232	Trimming prints	248
Instantaneous shutters	232	View-finder	248
Iris diaphragm	236	Washing apparatus	248

## PART IV.—MATERIALS USED IN PHOTOGRAPHY.

Acetic acid	251	Celloidin	258
Acids	251	Cellulose	258
Albumen	251	Chloride of lime	258
Albumenised paper	252	Chloroform	258
Alcohol	253	Chlorophyll	258
Alpha paper	254	Chromate of silver	258
Aluminium	254	Chromium-potassium sulphate	259
Amber	254	Citric acid	259
Ammonia	254	Collodion	259
Ammonium compounds	255	Copper	260
Anglöl	256	Copper sulphate	260
Aniline	256	Dextrin	260
Animal charcoal	256	Eau de Javelle	260
Aqua regia	256	Ebonite	261
Aurin or corallin	257	Eikonogen	261
Barium compounds	257	Emery	262
Benzene	257	Encaustic paste	262
Benzolene	257	Eosin	262
Bitumen	257	Erythrosin	262
Borax	257	Ether	262
Bromine	257	Ferric compounds	262
Cadmium compounds	257	Ferrous oxalate	262
Calcium chloride	257	Fluoresceïn	263
Canada balsam	258	Formic acid	263

	PAGE		PAGE
Gallic acid . . . . .	263	Methylated spirit . . . . .	273
Gelatine . . . . .	263	Mounts . . . . .	274
Glass . . . . .	264	Nitric acid . . . . .	274
Glucose . . . . .	264	Oxalic acid . . . . .	274
Glycerine . . . . .	264	Ox-gall . . . . .	275
Gold chloride . . . . .	265	Palladium . . . . .	275
Ground glass . . . . .	265	Paper . . . . .	275
Gum arabic . . . . .	266	Paraphenylene-diamine . . . . .	276
Gum dammar . . . . .	266	Platinum . . . . .	276
Gutta-percha . . . . .	266	Poisons . . . . .	276
Hydrochloric acid . . . . .	266	Potassium compounds . . . . .	277
Hydrofluoric acid . . . . .	266	Pyrocatechin . . . . .	278
Hydrogen dioxide . . . . .	267	Pyrogallol . . . . .	279
Hydroquinone . . . . .	267	Pyroxylin . . . . .	279
Hydroxylamine . . . . .	269	Ready sensitised paper . . . . .	281
"Hypo" eliminators . . . . .	269	Rodinal . . . . .	282
India-rubber . . . . .	270	Sandarac . . . . .	282
Iodine . . . . .	270	Shellac . . . . .	282
Iron . . . . .	271	Silver and silver compounds . . . . .	283
Isinglass . . . . .	271	Sodium compounds . . . . .	284
Jena glass . . . . .	271	Starch . . . . .	290
Kaolin . . . . .	271	Strontium chloride . . . . .	290
Lavender oil . . . . .	271	Sulphuric acid . . . . .	290
Lead . . . . .	272	Tannic acid . . . . .	290
Lead nitrate . . . . .	272	Turpentine . . . . .	291
Lithium chloride . . . . .	272	Uranium . . . . .	291
Litmus . . . . .	272	Uranium nitrate . . . . .	291
Magnesium . . . . .	272	Varnish . . . . .	291
Mastic . . . . .	272	Water . . . . .	292
Mercuric chloride . . . . .	272	Wax . . . . .	293
Mercury . . . . .	273	Zinc . . . . .	293
Meta-gelatine . . . . .	273		

## PART V.

## CHAPTER I.

APPLICATIONS OF PHOTOGRAPHY . . . . .	294-321
Architectural photography . . . . .	294
Astronomical photography . . . . .	294
Cameo . . . . .	298
Carte de visite . . . . .	299
Clouds . . . . .	299
Composite portraits . . . . .	300
Composition . . . . .	300
Distance . . . . .	300
Interiors . . . . .	301
Impressionism in photography . . . . .	302
Landscape photography . . . . .	303
Muybridge's photographs . . . . .	305
Photo-meteorology . . . . .	305
Portraiture . . . . .	305
Rembrandt portraits . . . . .	309
Spectroscope in photography . . . . .	309
Stereoscope . . . . .	310

CHAPTER II.

		PAGE
PRACTICAL HINTS . . . . .		321-354
	PAGE	
Accelerator . . . . .	321	Frilling . . . . . 334
Alkaline development . . . . .	321	Halation . . . . . 334
Anhydrous . . . . .	321	High lights . . . . . 335
Argentometer . . . . .	321	Hygiene in photography . . . . . 335
Backing plates . . . . .	322	Intensifying . . . . . 335
Bichromate and cyanide poisoning . . . . .	322	Mealiness . . . . . 338
Broken negatives . . . . .	322	Negatives . . . . . 338
Combination printing . . . . .	323	Over-exposure . . . . . 338
Copyright . . . . .	324	Pinholes . . . . . 339
Cracks . . . . .	324	Positive . . . . . 340
Density . . . . .	325	Reduction of density . . . . . 340
Detail . . . . .	325	Reflected light . . . . . 341
Developing and developers . . . . .	325	Residues . . . . . 341
Dialysis . . . . .	331	Saturated solution . . . . . 343
Diffused light . . . . .	331	Sizes of drops . . . . . 345
Dust . . . . .	331	Specific gravities . . . . . 345
Expansion of paper . . . . .	332	Studios . . . . . 346
Fog . . . . .	332	Symbols . . . . . 347
Freezing mixtures . . . . .	333	Weights and measures . . . . . 348

---

INDEX . . . . .	355
-----------------	-----



## LIST OF PLATES.

	PAGE
1. "Village News" . . . . .	<i>Frontispiece</i>
2. Collotype by Waterlow & Sons . . . . .	<i>facings</i> 98
3. Chromo-collotype by Waterlow & Sons . . . . .	,, 104
4. Indian-ink outlines—"Manchester Royal Exchange" . . . . .	,, 122
5. Meisenbach process—"Landscape" . . . . .	,, 128
6. Chromo-lithograph by Norbury & Sons . . . . .	<i>between</i> 138 <i>and</i> 139
7. Photochromo-lithograph copy, reduced by photography . . . . .	,, 138 ,, 139
8. Photogravure—"En Penitence"—by Boussod, Valadon, & Co. . . . .	<i>facings</i> 140
9. Pletsch process—"Clewer Churchyard"—by A. & C. Dawson . . . . .	,, 143
10. Photochromo-typography illustration by Boussod, Valadon, & Co. . . . .	,, 144
11. Photo-lithograph—"Irish Lace"—by West, Newman, & Co. . . . .	,, 152
12. Photo-lithograph—"Lace Curtain"—by A. Brothers & Co. . . . .	,, 156
13. Photo-lithograph, original design by Miss E. G. Thomson . . . . .	,, 158
14. Microscopic object—"Diatoms and Caterpillar of Moth"—reproduced in collotype by M. Billing, Son, & Co. . . . .	,, 160
15. Microscopic object—"Section of Optic Nerve"—showing healthy and diseased parts, reproduced in collotype by L. Danielsson . . . . .	,, 162
16. Zinc-etching—"The Oldest House in Pennsylvania." Built in 1681 at Berwyn. Plate by Wolfe . . . . .	,, 189
17. Typogravure, illustration by Boussod, Valadon, & Co. . . . .	,, 198
18. Woodbury-type, from negative by F. C. Brennan . . . . .	,, 201
19. Photo-relief printing-block—"Hogarth's House" . . . . .	,, 202
20. Copying and enlarging camera . . . . .	,, 224
21. Instantaneous photograph—"Lord of the Isles" . . . . .	,, 233
22. Woodbury-gravure—Rutherford's "Photograph of the Moon" . . . . .	,, 298
23. Landscape photography—Ellerbeck's "View in Norway" . . . . .	,, 305
24. Composition photograph—Robinson's picture, "A Strange Fish" . . . . .	,, 324

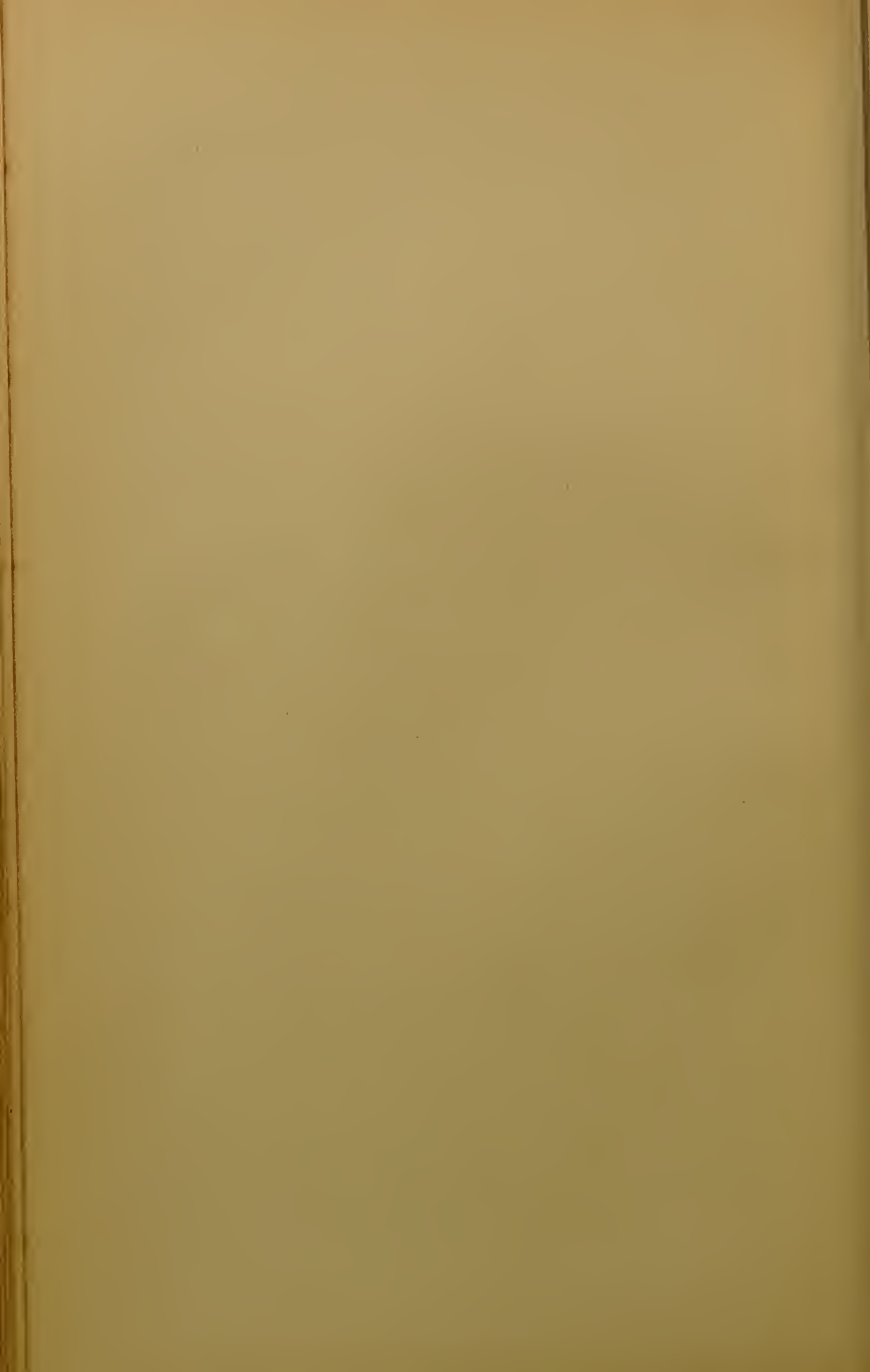

# MANUAL OF PHOTOGRAPHY.

---

## PART I.

---

### INTRODUCTORY.

---

#### CHAPTER I.

##### HISTORICAL SKETCH.

EARLY in the present century, the idea that light could be made to impress images produced by itself on paper and other material made sensitive by chemical means, appears first to have been thought of, and to have been put to practical test. All that was known until 1834 has comparatively little interest, if we except what was done by Niépce. The fact that the substance called *horn silver* turned black when exposed to daylight was known to some of the alchemists; but it was the chemist Scheele who, in 1777, first investigated the action of light on compounds of silver. Next, we have the fact that Wedgwood and Davy, in the first years of this century, made prints on paper and white leather by means of silver salts. The importance of these early experiments does not appear to have occurred to those who made them, probably from the fact that the pictures so produced could only be examined in feeble light, as they were not fixed or made permanent; and, at that time only such objects as were capable of being printed by their own shadows, or could be placed directly on the paper or leather could be photographed, the parts darkened by the sun giving a negative impression of their forms.

In the experiments of M. Niépce of Chalons (1814) we have another substance introduced, bitumen of Judea; and although he did not use salts of silver, he may be said to have experimented in the direction which led to most valuable discoveries, as, in the present day bitumen is utilised in various ways. Niépce seems to have used the *camera obscura*, the invention of Baptista Porta, who was

born at Naples in 1538. The bitumen, as employed by Niépce, was spread on metal plates, and exposed in the camera much in the same way as we now expose our more sensitive plates. It is the singular property of bitumen that the parts which have been acted on by daylight when exposed in the camera, or when placed under an object in contact with it, become hardened, so that the solvents employed to develop the picture will only affect those parts which have been protected from the light, and this makes it valuable in photography. The action of light on bitumen is, however, so very slow, that an exposure of many hours is required to produce any result in the camera.

The wonderful beauty of the pictures formed by the camera lucida and camera obscura appears to have suggested both to Daguerre and Talbot the possibility, or at least the desirability, of discovering some means by which the picture could be permanently fixed on paper. Daguerre, as a painter of scenery for the diorama which he opened in Paris in 1822, used the camera for sketching, and his desire to utilise the picture as produced by light led to his introduction to Niépce. A partnership was the result (in 1829). After trying the methods of Wedgwood, Davy, and Niépce, Daguerre used plates of silver made sensitive to the action of light by the vapour of iodine, but the picture was latent, or invisible to the eye. By a fortunate accident, one of the plates which had been exposed to light in the camera was placed in a cupboard to be cleaned off and used again, the exposure not having been sufficient for Daguerre's purpose; but he was surprised to find, some hours afterwards, that a perfect picture had developed, and on a careful investigation it was found that the result was caused by the vapour of mercury. Here, then, was a most valuable discovery, the result of an "accident," and the process was at once of commercial as well as scientific importance.

The difficulty of "fixing" the picture remained. Sodium chloride (common salt) was used for the purpose, but the discovery by Sir John Herschel of the action of hyposulphite of soda on the salts of silver enabled Daguerre's discovery to be made more complete. The results of Herschel's experiments are referred to under the title *Sodium Thiosulphate*.

Daguerre attempted to form a company to carry out his discovery; but that failed. He, however, showed his pictures to M. Arago, who brought the matter before the Academy of Sciences in Paris in 1839, and with the immediate result that the French Government granted Daguerre 6000 francs as a pension for life, and to Isidore Niépce (successor in the partnership to his father) a pension of 4000 francs, on condition that the process should be published and not patented—a present to the whole civilised world. The process, however, was



patented in England, and large sums were paid for the right to use it; as much as £1000 was paid for the exclusive rights in some large towns.

Since the foregoing was written a manual or pamphlet by Daguerre has come into the writer's hands. It was translated by Dr. Memes, and published in 1839 by Messrs. Smith, Elder, & Co., of London. The title is, "History and Practice of Photogenic Drawing on the True Principles of the Daguerreotype, &c.," by L. J. M. Daguerre. Of this little manual, consisting of about ninety pages, and six plates of drawings of the apparatus used in the process, the translator says: "In presenting this little work to the British public, the translator may perhaps be permitted to observe of his original, that, in all the circumstances, it is one of the most interesting works ever given to the world. It is the first manual of a new science."

In this manual is given, first a series of plates with details of all the apparatus necessary for producing the pictures on silver plates. Next is given the "Bill for rewarding the authors" (Daguerre and Niépce). This is followed by the speech by M. Duchâtel to the Chamber of Deputies, describing the nature of the discovery, and proposing the amount of the pensions. After this follows a most interesting address to the Chamber by M. Arago, who gives a concise history of the subject, beginning with the invention of the camera by Porta. Amongst other matters in the eloquent address by M. Arago, remarks occur on the cost of the material, which for the plates was about three or four francs; if this amount appeared much, it is observed that the same plate "is capable of receiving in succession a hundred different designs;" and following this is a remark by the translator to the effect that a set of apparatus cost about £20—a sum which at the present day seems little, when it is remembered that a small camera alone might cost one-half the sum named. Arago's address was delivered before one of the largest meetings of the Assembly ever held, so great was the interest felt in the announcement of Daguerre's discovery. The address is too long to be given in full here, but a few extracts will convey a tolerable idea of its purport. The following passages occur:—

"The daguerreotype, then, does not demand a single manipulation which is not perfectly easy to every person. It requires no knowledge of drawing, and does not depend upon any manual dexterity. By observing a few very simple directions, any one may succeed with the same certainty and perform as well as the author of the invention. The promptitude of the method is perhaps that which has most astonished the public. In reality, ten or twelve minutes in the dull weather of winter are amply sufficient for taking a view of a monument, a section of a town, or a landscape. In summer this time

may be reduced one-half. Under the skies of the South not more than two or three minutes will be necessary.

“But it is of importance to remark that these ten or twelve minutes in winter, these five or six minutes in summer, these two or three minutes in southern regions, express merely the time during which the plate of metal is exposed to the lenticular image. To this space must be added the time of unpacking and adjusting the camera, the time spent in preparing the plate, and the few minutes necessary for the final operation of rendering the picture thus obtained insensible to the future action of light. Added together, all these different stages of the process may extend the whole period employed to thirty minutes or three-quarters of an hour. Those persons are deceived, then, who suppose that during a journey they may avail themselves of brief intervals while the carriage slowly mounts a hill to take views of a country.”

This last paragraph has peculiar interest with reference to the facilities now offered to the tourist, who can carry in his pockets all he requires for taking half-a-dozen pictures, each of which would not occupy more than a few moments!

Of the greatest interest is the following paragraph:—“Let us not hesitate, then, to announce the fact: the re-agents discovered by M. Daguerre will speed onwards the progress of those sciences which confer the highest honour on the human mind. By their aid the philosopher will be enabled henceforth to proceed on the principle of absolute intensities; he will compare lights by their effects. If he find it useful, the same tablet will present him with the impression of the dazzling beams of the sun, and with the pencillings of rays three hundred thousand times fainter than those of the moon—the rays of the stars.”

At the end of his important address (the object of which, it should be stated, was to recommend the Chamber of Deputies to adopt unanimously the Bill for granting the annuities) Arago says: “The importance of this latter engagement” (to make known all future improvements) “will certainly not appear doubtful to any person when we inform you, that a very slight advance beyond his present progress will enable M. Daguerre to apply his processes to executing portraits from life.” So that at this date, 3rd July 1839, the process was not adapted for portraiture; and although Arago speaks of the “eagerness of foreign nations to lay hold of an erroneous date, of a doubtful fact, of the slightest pretext, in order to stir up questions of priority for the purpose of adding to their own crown of discovery the beautiful ornaments which the photographic inventions will ever form” (of course alluding to Talbot’s claim), it was reserved for an Englishman to complete Daguerre’s discovery, and

the name of John Frederick Goddard should ever be remembered in connection with the daguerreotype process.

The commission of which Arago was the mouthpiece was composed of MM. Arago, Etienne, Carl, Vatout, de Beaumont, Tournouër-Delessort (François), Combarel de Leyval, and Vitet, all names distinguished in science.

The matter of the pensions was brought before the Chamber of Peers on the 31st July 1839 by M. Gay-Lussac, who was one of the commission, composed of the following peers:—Barons Athalin, Besson, Gay-Lussac, the Marquis de Laplace, Vicomte Siméon, Baron Thénard, and the Comte de Noé.

In his address, Gay-Lussac goes over very much the same ground as that traversed by Arago, while urging Daguerre's claim for the pension, and says: "The principal advantage of Daguerre's process consists in obtaining quickly, and yet with the utmost exactness, representations of objects, whether to preserve this identical image, or to reproduce it by engraving or lithography. Hence it is conceived that, limited to the possession of a single individual, an art like this could not find sufficient exercise.

"On the contrary, given to the public, this process will receive in the hands of the painter, architect, traveller, naturalist, innumerable applications, all more or less useful to mankind. Lastly, as the secret of an individual, the invention itself would long remain stationary, and perhaps might retrograde; rendered public, it will be extended and improved by a general emulation."

Viewed in the light of all that has passed connected with the art of photography since the addresses by two of the most eminent scientific men who ever lived were delivered, the words of Arago and Gay-Lussac have the highest interest; and as the originals are not generally available, the writer regrets that space prevents the reproduction, entire, of the speeches from which these short extracts have been made.

In the second chapter of his little pamphlet, Daguerre gives descriptions of the discoveries of Niépce; in the third there is a practical description of the daguerreotype; and in the concluding chapter is described the method of dioramic painting.

To the enthusiast in photographic matters, this, the first of the very large number of manuals devoted to the art, is of the greatest possible interest, and it is scarcely equalled by the description which Talbot has recorded of his own experiments.

The early daguerreotype pictures required very long exposures in the camera, and for that reason portraiture was scarcely practicable. Portraits, however, were taken, fifteen or twenty minutes in the strongest light being necessary to obtain a picture. After the dis-

covery of the action of iodine on the silver plate and the effect of the vapour of mercury in causing the image to develop, it only required the great improvement introduced by the late Mr. J. F. Goddard in 1840 of the exposure of the iodised plate to the vapour of bromine, to make Daguerre's discovery perfect.<sup>1</sup> The effect of this discovery was to reduce the time of exposure from twenty minutes to twenty seconds, and a little later pictures could be taken in a small fraction of a second. The image on the silvered plate is of a very delicate character, and liable to injury by the tarnishing of the silver on exposure to the air. This defect was lessened by "*gilding*" the picture, as it was termed, by means of *sel d'or*. This process, however, although it added to the permanence of the picture, did not entirely remove the defect, as the photographic image was easily destroyed by the slightest friction, and the silver still in the course of time became tarnished, unless carefully protected from the air. The daguerreotype possesses one advantage over all other kinds of photograph—the surface of the silvered plate, no matter how badly it may be discoloured, the picture remains perfect beneath the tarnished film; and on carefully removing the tarnish by chemical means, the picture is restored to all its original beauty. Fine daguerreotypes are indeed "things of beauty," and since after fifty years many of those wonderful pictures are as perfect as the day they were finished, we may perhaps hope that some will remain "joys for ever." It is not too much to say that no photograph can exceed in beauty a good daguerreotype.

Beautiful as is the daguerreotype, however, it has the disadvantage of showing the picture reversed when taken direct in the camera, and although this defect can be removed by the use of a reversing prism or mirror, it was not always convenient to use the camera in that way. There was yet another disadvantage, viz., the picture was a positive, and could not be multiplied on paper. Great as these drawbacks were, the process was very popular for many years, large prices, from one to five or six guineas, being commonly charged for portraits; and when the work was of the best kind, the results were worth the money paid, as it is very unlikely that the process will ever be revived, and every year the old pictures become more valuable.

Concurrently with what has been said about Daguerre's process, it is felt that Talbot's method should have been described; but there

<sup>1</sup> In 1864 Mr. Talbot claimed that he first used potassium bromide in photography; but as Hunt in his "Manual," 5th edition, 1857, states that Mr. Goddard first used the vapour of bromine as early as 1839, and from other evidence, it is clear that the only practical use of bromine in photography was that referred to above, and that Mr. Goddard must at least be considered an independent discoverer, as there is no doubt whatever that the daguerreotype process owed its success to the application named.

cannot be much doubt that Niépce and Daguerre are entitled to the claim of priority as discoverers. Daguerre was the inventor of an excellent process; but Talbot's method, that is, the negative process, and the consequent means of reproduction, has become of far greater use, as it is practically Talbot's paper, prepared with silver chloride, which is used so largely at the present time.

It has already been noticed that Daguerre used the camera *obscura*—that is, a dark box in which the image is produced by the lens placed at one end. The landscape or other object is seen on the ground glass opposite the lens with all the colour of nature, and it might occur to any one—how desirable a thing it would be to be able to preserve the pictures depicted by the instrument. This was Daguerre's idea, which he realised by his method in all respects excepting the colour. Such also was Talbot's thoughts as early as 1833, but he was using the camera *lucida*—both instruments give similar results, but the cameras are used in different ways. In the one case, the image is viewed in the box or on the surface placed to receive it; but in the other, the image is viewed on a white or other surface placed horizontally and without a dark box, and by careful manipulation an outline of the picture viewed may be made with considerable accuracy. Such was Talbot's method of sketching from Nature.

The account of Talbot's discovery, as related by himself, is important. It will be found in "The Pencil of Nature," published in 1844, and as the facts stated are valuable in the history of photography, it may be appropriately introduced here. The experiments referred to undoubtedly led to the first practicable method of photography in this country.

Talbot says: "One of the first days of the month of October 1833, I was amusing myself on the lovely shores of the Lake of Como, in Italy, taking sketches with Wollaston's camera lucida, or rather I should say, attempting to take them; but with the smallest possible amount of success. For when the eye was removed from the prism—in which all looked beautiful—I found that the faithless pencil had only left traces on the paper melancholy to behold.

"After various fruitless attempts, I laid aside the instrument, and came to the conclusion, that its use required a previous knowledge of drawing, which unfortunately I did not possess.

"I then thought of trying again a method which I had tried many years before. This method was, to take a camera obscura, and to throw the image of the objects on a piece of transparent tracing paper laid on a pane of glass in the focus of the instrument. On this paper the objects are distinctly seen, and can be traced on it with a pencil with some degree of accuracy, though not without much time and trouble.

“I had tried this simple method during former visits to Italy in 1823 and 1824, but found it in practice somewhat difficult to manage, because the pressure of the hand and pencil upon the paper tends to shake and displace the instrument (insecurely fixed, in all probability, while taking a hasty sketch by a roadside, or out of an inn-window); and if the instrument is once deranged, it is most difficult to get it back again, so as to point truly in its former direction.

“Besides which, there is another objection, namely, that it baffles the skill and patience of the amateur to trace all the minute details visible on the paper; so that, in fact, he carries away with him little beyond a mere souvenir of the scene—which, however, certainly has its value when looked back to in long after-years.

“Such, then, was the method which I proposed to try again, and to endeavour, as before, to trace with my pencil the outlines of the scenery depicted on the paper. And this led me to reflect on the inimitable beauty of the pictures of Nature’s painting which the glass lens of the camera throws upon the paper in its focus—fairy pictures, creations of a moment, and destined as rapidly to fade away.

“It was during these thoughts that the idea occurred to me . . . how charming it would be if it were possible to cause these natural images to imprint themselves durably, and remain fixed upon the paper!

“And why should it not be possible? I asked myself.

“The picture, divested of the ideas which accompany it, and considered only in its ultimate nature, is but a succession or variety of stronger lights thrown upon one part of the paper, and of deeper shadows on another. Now light, where it exists, can exert an action, and, in certain circumstances, does exert one sufficient to cause changes in material bodies. Suppose, then, such an action could be exerted on the paper; and suppose the paper could be visibly changed by it. In that case surely some effect must result having a general resemblance to the cause which produced it: so that the variegated scene of light and shade might leave its image or impression behind, stronger or weaker on different parts of the paper according to the strength or weakness of the light which had acted there.

“Such was the idea that came into my mind. Whether it had ever occurred to me before amid floating philosophic visions, I know not, though I rather think it must have done, because on this occasion it struck me so forcibly. I was then a wanderer in classic Italy, and, of course, unable to commence an inquiry of so much difficulty: but, lest the thought should again escape me, between that time and my return to England, I made a careful note of it in writing, and also of such experiments as I thought would be most likely to realise it, if it were possible.

“And since, according to chemical writers, the nitrate of silver is a substance peculiarly sensitive to the action of light, I resolved to make a trial of it, in the first instance, whenever occasion permitted on my return to England.

“But although I knew the fact from chemical books, that nitrate of silver was changed or decomposed by light, still I had never seen the experiment tried, and therefore I had no idea whether the action was a rapid or a slow one; a point, however, of the utmost importance, since, if it were a slow one, my theory might prove but a philosophic dream.

“Such were, as nearly as I can now remember, the reflections which led me to the invention of this theory, and which first impelled me to explore a path so deeply hidden among Nature’s secrets. And the numerous researches which were afterwards made—whatever success may be thought to have attended them—cannot, I think, admit of a comparison with the value of the first and original idea.

“In January 1834, I returned to England from my Continental tour, and soon afterwards I determined to put my theories and speculations to the test of experiment, and see whether they had any real foundation.

“Accordingly I began by procuring a solution of nitrate of silver, and with a brush spread some of it upon a sheet of paper, which was afterwards dried. When this paper was exposed to the sunshine, I was disappointed to find that the effect was very slowly produced in comparison with what I had anticipated.

“I then tried the chloride of silver, freshly precipitated and spread upon paper while moist. This was found no better than the other, turning slowly to a darkish violet colour when exposed to the sun.

“Instead of taking the chloride already formed, and spreading it upon paper, I then proceeded in the following way. The paper was first washed with a strong solution of salt, and when this was dry, it was washed again with nitrate of silver. Of course, chloride of silver was thus formed in the paper, but the result of this experiment was almost the same as before, the chloride not being apparently rendered more sensitive by being formed in this way.

“Similar experiments were repeated at various times, in hopes of a better result, frequently changing the proportions employed, and sometimes using the nitrate of silver before the salt, &c. &c.

“In the course of these experiments, which were often rapidly performed, it sometimes happened that the brush did not pass over the whole of the paper, and of course this produced irregularity in the results. On some occasions certain portions of the paper were observed to blacken in the sunshine more rapidly than the rest.

These more sensitive portions were generally situated near the edges or confines of the part that had been washed over with the brush.

“After much consideration as to the cause of this appearance, I conjectured that these bordering portions might have absorbed a lesser quantity of salt, and that, for some reason or other, this had made them more sensitive to the light. This idea was easily put to the test of experiment. A sheet of paper was moistened with a much weaker solution of salt than usual, and when dry, it was washed with nitrate of silver. This paper, when exposed to the sunshine, immediately manifested a far greater degree of sensitiveness than I had witnessed before, the whole of its surface turning black uniformly and rapidly: establishing at once and beyond all question the important fact, that a lesser quantity of salt produced a greater effect. And, as this circumstance was unexpected, it afforded a simple explanation of the cause why previous inquirers had missed this important result, in their experiments on chloride of silver, namely, because they had always operated with wrong proportions of salt and silver, using plenty of salt in order to produce a perfect chloride, whereas what was required (it was now manifest) was, to have a deficiency of salt, in order to produce an imperfect chloride (or perhaps it should be called), a *subchloride* of silver.

“So far was a free use or abundance of salt from promoting the action of light on the paper, that on the contrary it greatly weakened and almost destroyed it: so much so, that a bath of salt water was used subsequently as a fixing process to prevent the further action of light upon sensitive paper.

“This process, of the formation of a subchloride by the use of a very weak solution of salt, having been discovered in the spring of 1834, no difficulty was found in obtaining distinct and very pleasing images of such things as leaves, lace, and other flat objects of complicated forms and outlines, by exposing them to the light of the sun.

“The paper being well dried, the leaves, &c., were spread upon it, and covered with a glass pressed down tightly, and then placed in the sunshine; and when the paper grew dark, the whole was carried into the shade, and the objects being removed from off the paper, were found to have left their images very perfectly and beautifully impressed or delineated upon it.

“But when the sensitive paper was placed in the focus of a camera obscura and directed to any object, as a building, for instance, during a moderate space of time, as an hour or two, the effect produced upon the paper was not strong enough to exhibit such a satisfactory picture of the building as had been hoped for. The outline of the roof and of the chimneys, &c., against the sky was marked enough; but the



details of the architecture were feeble, and the parts in shade were left either blank or nearly so. The sensitiveness of the paper to light, considerable as it seemed in some respects, was therefore, as yet, evidently insufficient for the purpose of obtaining pictures with the camera obscura; and the course of experiments had to be again renewed, in hopes of attaining to some more important result.

“The next interval of sufficient leisure which I found for the prosecution of this inquiry was during a residence at Geneva in the autumn of 1834. The experiments of the previous spring were then repeated and varied in many ways; and having been struck with a remark of Sir H. Davy’s which I had casually met with, that the *iodide* of silver was more sensitive to light than the *chloride*, I resolved to make trial of the iodide. Great was my surprise on making the experiment to find just the contrary of the fact alleged, and to see that the iodide was not only less sensitive than the chloride, but that it was absolutely insensible to the strongest sunshine; retaining its original tint (a pale straw colour) for any length of time unaltered in the sun. This fact showed me how little dependence was to be placed on the statements of chemical writers in regard to this particular subject, and how necessary it was to trust to nothing but actual experiment; for although there could be no doubt that Davy had observed what he described under certain circumstances, yet it was clear also, that what he had observed was some exception to the rule, and not the rule itself. In fact, further inquiry showed me that Davy must have observed a sort of subiodide in which the iodine was deficient as compared with the silver: for, as in the case of the chloride and subchloride the former is much less sensitive, so between the iodide and the subiodide there is a similar contrast, but it is a much more marked and complete one.

“However, the fact now discovered proved of immediate utility; for the iodide of silver being found to be insensible to light, and the chloride being easily converted into the iodide by immersion in iodide of potassium, it followed that a picture made with the chloride could be *fixed* by dipping it into a bath of the alkaline iodide.

“This process of fixation was a simple one, and it was sometimes very successful. The disadvantages to which it was liable did not manifest themselves until a later period, and arose from a new and unexpected cause, namely, that when a picture is so treated, although it is permanently secured against the *darkening* effect of the solar rays, yet it is exposed to a contrary or *whitening* effect from them; so that after the lapse of some days the dark parts of the picture begin to fade, and gradually the whole picture becomes obliterated, and is reduced to the appearance of a uniform pale yellow sheet of paper. A good many pictures, no doubt, escape this fate, but as they all seem

liable to it, the fixing process by iodine must be considered as not sufficiently certain to be retained in use as a photographic process, except when employed with several careful precautions which it would be too long to speak of in this place.

“During the brilliant summer of 1835 in England, I made new attempts to obtain pictures of buildings with the camera obscura; and having devised a process which gave additional sensibility to the paper, viz., by giving it repeated alternate washes of salt and silver, and using it in a moist state, I succeeded in reducing the time necessary for obtaining an image with the camera obscura on a bright day to ten minutes. But these pictures, though very pretty, were very small, being quite miniatures. Some were obtained of a larger size, but they required much patience, nor did they seem so perfect as the smaller ones, for it was difficult to keep the instrument steady for a great length of time pointing at the same object, and the paper being used moist was often acted on irregularly.

“During the three following years not much was added to previous knowledge. Want of sufficient leisure for experiments was a great obstacle and hindrance, and I almost resolved to publish some account of the art in the imperfect state in which it then was.

“However curious the results which I had met with, yet I felt convinced that much more important things must remain behind, and that the clue was still wanting to this labyrinth of facts. But as there seemed no immediate prospect of further success, I thought of drawing up a short account of what had been done, and presenting it to the Royal Society.

“However, at the close of the year 1838, I discovered a remarkable fact of quite a new kind. Having spread a piece of silver leaf on a pane of glass, and thrown a particle of iodine upon it, I observed that coloured rings formed themselves around the central particle, especially if the glass was slightly warmed. The coloured rings I had no difficulty in attributing to the formation of infinitely thin layers or strata of iodide of silver; but a most unexpected phenomenon occurred when the silver plate was brought into the light by placing it near the window. For then the coloured rings shortly began to change their colours, and assumed other and quite unusual tints, such as are never seen in the ‘*colours of thin plates*.’ For instance, the part of the silver plate which at first shone with a pale yellow colour, was changed to a dark olive-green when brought into the daylight. This change was not very rapid: it was much less rapid than the changes of some of the sensitive papers which I had been in the habit of employing, and therefore, after having admired the beauty of this new phenomenon, I laid the specimens by, for a time, to see whether they would preserve the same appearance, or would undergo any further alteration.

“Such was the progress which I had made in this inquiry at the close of the year 1838, when an event occurred in the scientific world, which in some degree frustrated the hope with which I had pursued, during nearly five years, this long and complicated, but interesting series of experiments—the hope, namely, of being the first to announce to the world the existence of the new art—which has been since named Photography.

“I allude, of course, to the publication in the month of January 1839, of the great discovery of M. Daguerre, of the photographic process which he has called the Daguerreotype. I need not speak of the sensation created in all parts of the world by the first announcement of this splendid discovery, or rather, of the fact of its having been made (for the actual method made use of was kept secret for many months longer). This great and sudden celebrity was due to two causes: first, to the beauty of the discovery itself; secondly, to the zeal and enthusiasm of Arago, whose eloquence, animated by private friendship, delighted in extolling the inventor of this new art, sometimes to the assembled science of the French Academy, at other times to the less scientific judgment, but not less eager patriotism of the Chamber of Deputies.

“Some time previously to the period of which I have now been speaking, I met with an account of some researches on the action of light, by Wedgwood and Sir H. Davy, which, until then, I had never heard of. Their short memoir on this subject was published in 1802 in the first volume of the Journal of the Royal Institution. It is curious and interesting, and certainly establishes their claim as the first inventors of the photographic art, though the actual progress they made in it was small. They succeeded, indeed, in obtaining impressions from solar light of flat objects laid upon a sheet of prepared paper, but they say that they found it impossible to fix or preserve those pictures; all their numerous attempts to do so having failed.

“And with respect to the principal branch of the art, viz., the taking pictures of distant objects with a camera obscura, they attempted to do so, but obtained no result at all, however long the experiment lasted. While, therefore, due praise should be awarded to them for making the attempt, they have no claim to the actual discovery of any process by which such a picture can really be obtained.

“It is remarkable that the failure in this respect appeared so complete, that the subject was soon after abandoned both by themselves and others, and, as far as we can find, it was never resumed again. The thing fell into entire oblivion for more than thirty years: and therefore, though the daguerreotype was not so entirely new a conception as M. Daguerre and the French Institute imagined, and though my own labours had been still more directly anticipated by

Wedgwood, yet the improvements were so great in all respects, that I think the year 1839 may fairly be considered as the real date of the birth of the photographic art, that is to say, its first public disclosure to the world."

In one of the parts of "The Pencil of Nature" the following "Notice to the Reader" was given:—"The plates of the present work are impressed by the agency of light alone, without any aid whatever from the artist's pencil. They are the sun-pictures themselves, and not, as some persons have imagined, engravings in imitation." Many of the plates in this "Pencil of Nature" in the writer's possession are apparently in the same state as when issued, others are much faded. One of Abbotsford, with the words in Talbot's own autograph, "From Nature, 1844, H. F. T.," is pale but still distinct.

Fox Talbot's wish for a process to reproduce the camera-image thus appears to have been realised as early as 1835, when views of his residence, Lacock Abbey, were taken, but it was not until January 1839 that he made his discovery known, through Professor Faraday, at a meeting of the Royal Institution, London, and a few days later the full details of the process were given at a meeting of the Royal Society under the name of *Photogenic Drawing*. Various improvements were made, and ultimately it was found that by treating the paper in a certain way the exposure necessary could be very much reduced. The photographic image which was found to be latent and invisible could be developed by the application of gallic acid. It has been said that the discovery of the latent image and the possibility of its development in this case, as in that of the daguerreotype, was the result of "accident." One of Talbot's prints on paper came in contact with a solution of nut-galls, which developed the picture, and in consequence of this gallic acid became a most valuable substance in the hands of the photographer. The fact that gallic acid could be used to develop the photographic image was independently discovered by the Rev. J. B. Reade, who claimed that in 1837 he succeeded in making negatives by using that acid, but he admits that the discovery of "the *master* fact, that the latent image which had been developed was the basis of photographic manipulation," was due to Talbot and to him only. That Reade missed this important discovery is very remarkable.

Talbot's process was patented, but after a few years he gave up his patent rights, and his most valuable discoveries were henceforward public property.

The pictures produced by Talbot were negatives, and from them positives could be made in quantities, so that his success in this respect possessed a distinct advantage over the daguerreotype, but the texture of the paper was a drawback which was difficult to overcome. Waxing the paper gave better results. Glass was, of course,

thought of and tried, but the difficulties to be overcome were great. Herschel, Le Gray, and others tried albumen and gelatine in which to form the silver compounds on the glass, but with very little success. Collodion had also been suggested, but it remained for Mr. F. Scott-Archer to introduce a process in which collodion on glass took the place of paper, and which in a very few years came into almost universal use.

The process is unlike the others already named, inasmuch as it is capable of producing both positives and negatives. The process was not patented, but presented to the world—a free gift, and it is impossible to exaggerate its importance. The details were published in 1851, and the method has remained to the present time unrivalled, as in certain respects the processes which have to a large extent superseded it do not give results equal to collodion. There are disadvantages attending every process as yet introduced, especially when they are to be worked away from home, and attempts were very soon made to displace the wet process by others which dispensed with the silver bath. The most successful rival to collodion for many years was the collodio-albumen process, and there were many others, all having the same end in view, that of getting rid of the silver bath, and at the present time gelatine for all outdoor work has entirely taken the place of collodion. The camera, as now constructed, is so reduced in weight as to leave very little to be desired, but the weight of the glass still remains, although even that difficulty appears in a fair way to be removed by the introduction of films or sheets of celluloid coated with gelatine emulsion, used from roller slides attached within the camera.

A method was introduced by Talbot whereby the silver plate was etched in such a manner that it could be printed from in the copper-plate press. Within the last few years many methods have been invented, and in some cases patented, having for their object the production of blocks or plates which could be used as illustrations for books.

The uncertainty of the stability of prints in silver led to the invention of two methods of much importance: first, the Autotype—a process by which pictures are made in carbon, or any other pigment, and as to the permanence of which there can be no doubt. Then, following this, Mr. Walter Woodbury invented the process called by his name. It would, however, be almost impossible to enumerate even the names of all the processes which have been introduced within the last thirty years, not to go farther back. The most important, which may be named here, are Photo-lithography, Collotype (under various names), Zinc-etching, and Photogravure.

The wonderful results already attained naturally make us hesitate

in forming an opinion as to the possibility of producing photographs in the colours of nature. The colours of the spectrum have been produced and fixed, but no means have as yet been found by which the mixed colours found in natural objects can be reproduced in a permanent form.

In the following pages will be fully described the most useful processes and the apparatus necessary to work them ; the less important will be referred to more briefly.

The progress made within the last thirty years has been chiefly in the direction of rapidity, and for general working the advantage obtained is very great. Even with the daguerreotype, a picture of a wheel in rapid motion was possible, and by one of the slowest processes, the calotype, pictures of objects in motion have been photographed, the development being very prolonged. By the collodion process, again, subjects requiring great rapidity, such as breaking waves, have been taken. There can, however, be no doubt that the introduction of the gelatino-bromide process has made the practice of photography extremely simple, and has very greatly increased the usefulness of the art. Gelatine has for many purposes superseded collodion ; but the latter process has advantages which will be sufficient to prevent its going out of use, as so many others have done.

Looking back upon the last fifty years, we can trace the influence which photography has exerted on the sister arts of drawing and painting, and there can be no doubt that the influence has been helpful. In Portraiture, artists are undoubtedly indebted to photography for more natural effects, and the photograph can often be used in the absence of the sitter, thus saving time, and probably securing a more truthful rendering. The influence of photography in art can, moreover, be seen in other ways. The prejudice of artists against photography is wearing away ; there should be no rivalry between the two arts, for they can be of mutual assistance, and there are probably few artists now who do not themselves use the camera and find great advantage from it.

The various applications of photography in other directions are too numerous to be referred to here in detail ; to the Scholar, in the faithful reproduction of precious MSS. and the treasures of antiquity, it is simply invaluable ; the Physiologist registers by its means the secrets of Nature, whilst the Pathologist chronicles in the same way departures from Nature's laws, and so gains a clue to the detection of disease ; the Astronomer, the Meteorologist alike press it into their service, and thus obtain results which could be gained in no other way. In the Army, the Navy, photography is a faithful agent ; to the Traveller bent upon scientific research it is indispensable ; to the Tourist abroad for pleasure the camera is the most delightful of comrades. In

short, it would be hard to say where the line is to be drawn, what science or what art does not make some use of photography, for its applications are extending daily. The object of this brief introduction is to show how, step by step, the early attempts to fix the light-pictures have been improved until they may now be said to be almost perfected. It is, at least, difficult to imagine in what direction, except in regard to the fixing of natural colours, further discoveries may be looked for.

---

## CHAPTER II.

### CHEMISTRY OF PHOTOGRAPHY.

OF the many branches of Chemical Technology, it would be difficult to point to one which offered a wider field for new work than the chemistry of photography. It is only a few years since a commencement was really made in unravelling the mysteries of the processes involved in the production of a finished photograph; but already—thanks to the researches of Hunt, Abney, Carey Lea, Vogel, and others—considerable progress has been made in this branch; and their work will form a safe starting-point for further investigation into the many operations remaining unexplained. At first, the beauty of the results obtained by photography caused the workers in the art to turn their attention mainly towards the discovery of new processes with the object of facilitating the mere mechanical routine, in order to gain greater perfection, or to extend its many applications and uses; and this success was so great as, perhaps, to have delayed advance in the discovery of the principles concerned.

The object of this chapter is to explain, as far as space will allow, the chemistry of those changes necessary to the building up of a photographic picture. No doubt there are numbers, probably the majority, of persons successfully practising photography who have only a technical knowledge of the subject; to such, however, any irregularities in results present almost insuperable difficulties, which might easily, or, at least, more certainly and readily, be overcome by a knowledge of what is taking place or might take place among the chemicals in use. In fact, the possession of a knowledge of chemistry, and especially of the chemistry of photography, makes all the difference between a mere operator, the slave of formulæ, and one who can make the processes the slaves of his wishes.

As the name implies, the chief factor in photography is Light. The result of its action may be physical only, or it may produce chemical changes in the substances upon which it falls.

**Physical Action.**—Although the purely physical action of light is of but little importance in photography, there are several well-known instances in which it produces some physical alteration, as in the case of phosphorescence, change of crystalline form, the setting up of electric currents, and the change by which water-vapour will deposit on a plate after exposure to light so as to reveal, in a film of condensed moisture, the otherwise invisible picture.

Bordering upon each mode of action—that is, action both of physical and of chemical nature—is the formation of molecular compounds and addition-products. As an example of this, the explanation given by Keyser of the action of light upon asphalt, which he regards as due to polymerisation, may be cited. He adduces in support of this view the fact that the formation of the insoluble substance is not accompanied by a gain in weight, and that fusion is sufficient to again render it soluble. In such cases there is no close chemical union; the change is a physical alteration in the state of molecular aggregation; but it may also be looked upon, in certain cases, as a feeble union, due to residual chemical affinity. A further illustration of the relation between physical and chemical changes is the influence of pressure on chemical change (*Spring*), and the production of an image capable of development by shearing stress (that is, pressure applied to the prepared film), although the amount of chemical change was found by Abney not to be in proportion to the pressure.

**Chemical Action.**—The cause of the chemical action may be found, in many cases, in the physical explanation of the nature of light or radiant energy, the undulations, of which it is supposed to consist, exerting their energy in bringing about chemical union, or decomposition. This undulatory theory will be here assumed, together with the chemical theory that bodies are composed of molecules which are not only themselves in a continual state of oscillatory movement, but whose constituent atoms are also subject to an intra-molecular motion of a similar kind. Now, on the principle of the superposition of small impulses, such impulses, repeated at regular and suitable intervals, may produce a considerable effect, as in the gradual raising of the extent of motion in a swing. In a similar way, it can easily be conceived that if either the wave-length, or the amplitude of vibration of the light-rays, bore any simple relation to the molecular or atomic movements in a substance, the energy contained in the former might be imparted to the molecules or atoms, and cause chemical change. In fact, whenever light is absorbed by a body, whether wholly or partially, it must have done work of some kind; in general, perhaps, a rise in temperature results, but in special cases the effect upon the atoms or molecules may suffice to cause them to enter into fresh combinations.



It will be seen in Chapter iii. (*Optics of Photography*) that ordinary white light is made up of rays whose wave-lengths vary widely and regularly, and this difference is utilised in separating the rays from each other into a spectrum. Then, while chemical change may be produced by a ray of a certain wave-length or amplitude, one is prepared to find that a ray of another oscillation-period, or of lesser intensity, will have no such power. The former will be an *actinic ray* for the body under consideration, which will undergo chemical change only, or to a greater extent, in that portion of a spectrum than in another. This difference may be well illustrated by means of a box about 4 inches square and 8 inches high, having red glass on one side, yellow on another, and blue or plain glass on a third side; this last also having a sliding opaque shutter. If a glass bulb containing a mixture of hydrogen and chlorine gases be placed in the middle of the box, and then a flash of magnesium powder be used in front of the red or yellow glass, no result will follow; but when the shutter is withdrawn and the magnesium light is burnt in front of the blue or plain glass, the bulb is at once shattered by the two gases uniting to form hydrogen chloride; thus showing that the actinic light in this case is not contained among those rays whose wave-lengths produce a red or yellow effect.

But if in any way the energy of a ray of light becomes converted into another form of energy, the ray, as a ray, must cease to exist; it will have been absorbed, while those which produce no alteration (in other words, have themselves undergone no alteration) will be transmitted, so that on examining the spectrum after passing through any substance affected by light, certain rays will be wanting—it will give an “absorption spectrum.” Draper has enunciated the statement that there is a relationship between absorption and photo-chemical effect; and the same investigator has also shown the amount of chemical change to be proportional to the light-intensity. Absorption spectra, however, are no measure of chemical action; for Bunsen and Roscoe have demonstrated that but a small portion of the absorbed light falling on a sensitive substance is employed for chemical purposes.

The chemical action of light may be that of oxidation or reduction; or it may produce mere decomposition or photo-dissociation, as in the case of the dissociation of hydrogen iodide, and of the oxides of the heavy metals (mercury, gold, &c.), under the influence of light.

**Oxidation by Light.**—This action was one of the first employed in devising photographic processes, Niépce having in 1824 utilised the oxidation of asphalt in his invention of the bitumen process; for, as in this method air is an essential, it appears to be a case of oxidation. The actual action is as yet unexplained. Indeed, it has already been

mentioned (p. 18) that other authorities regard the change as one of polymerisation, while a recent experiment seems to show that the addition of sulphur increases the sensitiveness of asphalt. It has been discovered, however, that one of the constituents of ordinary asphalt will dissolve in alcohol, and is insensitive to light; that another dissolves in ether; and that a third is insoluble in either. The third portion is the one which undergoes change most readily; so that a more sensitive material is prepared by dissolving out the less sensitive ingredients.

**Reduction by Light.**—This may be utilised in two ways—we may either have an easily reducible substance from which a picture is formed by light, by its reduction in the presence of oxidisable matter; or it may be the oxidisable substance which builds up the picture on exposure to light in the presence of an oxidising agent. The second substance, the presence of which enables the light to exert its photo-chemical action upon the first, is called a “Sensitiser.” Examples of the first mode of action are the processes in which salts of the heavy metals are employed. Take iron as an example:—ferric chloride in presence of oxidisable organic matter is reduced to ferrous chloride, or a salt of iron with an oxidisable organic acid may be employed, such as the oxalate or citrate—

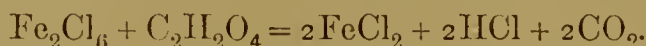

The amount of reduction will depend, by Draper's second law, upon the intensity of the light. A picture will be formed on a piece of paper coated with the chloride (for paper alone acts as a sensitiser) after exposure to light; but as the ferrous chloride differs little in colour from the ferric salt, the picture is as yet hardly visible, and on washing the paper with a solution of  $\text{K}_6\text{Fe}_2\text{Cy}_{12}$ , the ferrous chloride will give a precipitate of *Turnbull's blue* of a density depending upon the amount of reduction undergone, and, therefore, proportional to the intensity of light, that is, to the brightness of the objects depicted—

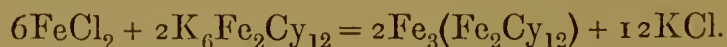

Thus the picture is “developed” by converting an invisible compound into a visible one, and may be *fixed* by washing away all unaltered ferric chloride, since this will prevent any further chemical action when the picture is brought into the light. Uranium compounds have been used in a similar way.

Of the second mode of action, the oxidation of gelatine by chromic acid is the best example. Upon this reaction depends the well-known “Autotype” process. The  $\text{CrO}_3$  is reduced to  $\text{Cr}_2\text{O}_3$ , and the oxygen thus lost oxidises the gelatine and gives rise to the formation of various

products, such as formic acid, &c. It may be interesting to note that with an exposed paper, which is not developed at once, the oxidation is continued, and after a time the image cannot be developed. Advantage may be taken of this peculiarity to underprint the subject, and allow the after-action to complete the process. But with silver bromide, or other emulsion plate, there appears to be no further action, and a good picture may be developed years after the exposure was made.

But the haloid salts of silver are those upon which the action of light is of the most importance. It is not yet determined whether this action is one of reduction or of oxidation, or, indeed, what it is. Remembering the similar situation of silver and copper in the periodic arrangement of the elements, and their consequent similarity in chemical properties, it has been argued that the evidence is in favour of the existence of a sub-chloride. But the  $\text{AgCl}$  is itself the chloride analogous to cuprous chloride, which is the lowest chloride of this metal known; while no one has yet succeeded in isolating the  $\text{Ag}_2\text{Cl}$  generally assumed to exist in the product darkened by exposure to light. The only well-established fact so far is, that this darkened chloride is poorer in chlorine, and that there is always a largely preponderating amount of chloride remaining unaltered—a fact which has suggested the existence of a physical combination between the silver chloride and the reduction product; but this hardly seems probable, since the ratio of the two would be about twenty to one. That it does not contain metallic silver, seems evident from the fact that the darkening takes place under nitric acid. Hodgkinson has endeavoured to prove the formation of an oxygenated body,  $\text{Ag}_4\text{OCl}_2$ , comparable to the oxychloride of copper; and in favour of this view is the sensitising action of the presence of water; but the necessity of oxygen or water is denied by other experimenters, since the dry chloride darkens under dry benzene, and even in a vacuum, so that perhaps at present it is as well to adopt the suggestion of Meldola, that the constitution of the coloured product may vary in the different cases. Bearing upon this question of the composition of the chloride darkened by light, are (1) the photo-salts and coloured bodies obtained by Carey Lea, and others, and prepared in a way to lead one to expect the formation of a sub-salt could such exist; and (2) the experiments of Güntz upon the action of gaseous hydrogen chloride upon silver fluoride; but the uncertainty surrounding the whole subject shows how much remains to be done in photo-chemistry, and how difficult a matter it is for investigation.

The process of **Ripening** and theory of sensitisers also belongs to this division of the subject. The former—ripening—refers to the molecular change undergone by the silver haloid by which it is

rendered more sensitive to light. Thus in the gelatino-bromide emulsion, when the silver bromide is first precipitated, it is in a very finely divided state, the particles being estimated by Eder to have only a diameter of 0.0008 to 0.0015 mm.; but after standing a few days, or by heating to 60° C. (140° F.) for a few hours, the sensitiveness is increased, and there is a gradual accretionary change in the state of molecular aggregation, the particles having the maximum sensitiveness being 0.0034 mm. in diameter (*Eder*). The physical change is noticeable in the alteration of the absorption spectrum, the ripened bromide transmitting much less of the red. The chemical change is probably a molecular union between the gelatine and bromide forming a gelatino-bromide,<sup>1</sup> the formation of which causes increased sensitiveness, as it is more easily reduced than the haloid salt alone. But if the heating be continued too long, further chemical action sets in, the silver bromide is reduced, and the plate will on development appear fogged. The accretionary process is probably owing to hot gelatine solution, in presence of potassium bromide, having a slight solvent action on silver bromide, and this dissolved silver salt on being redeposited attaches itself to the particles of the salt already existing. This property of gelatine and potassium bromide together is a reason for the necessity of an excess of the latter salt in the preparation of the emulsion. The action of ammonia as a ripening agent depends on precisely similar principles, its solvent action on silver bromide being well known.

**Theory of Sensitisers.**—A sensitiser, as has been pointed out, is a body whose presence is essential, or accessory, to the photo-decomposition of a second body. In many cases the action is one of mass, on the principle that when any body undergoes separation into two or more substances there is a limit beyond which the action will not advance, since the products of decomposition then tend to reunite to form the original body. A state of equilibrium is reached where we have a quantity of the products of decomposition in presence of some of the undecomposed body. Probably molecules continue to be split up, but beyond a certain point the number of recombinations of the liberated bodies exactly counterbalances the number of molecules split up; if, then, there is present a second body which combines with one or other of the decomposition products, thereby removing it from the sphere of action, equilibrium is destroyed, and a further number of molecules can be decomposed until equilibrium is again restored. The second body whose presence acts in this manner is the sensitiser. The activity depends upon the affinity the sensitiser has for the liberated body, and upon the relative affinities of the constituents of the bodies concerned.

<sup>1</sup> Meldola, Cantor Lectures, 1891.

Taking the silver haloids, there is in the collodion process a film of collodion which is salted with an iodide or bromide, or both. When the plate coated with the salted film is immersed in the silver nitrate bath, the silver haloid is formed—

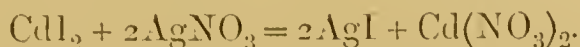

and the plate being exposed wet, with a thin layer of solution of silver nitrate remaining upon it, it is this excess of the nitrate which acts as the "sensitiser" by appropriating to itself any halogen liberated, and thus preventing the inverse action by which the products of photo-decomposition might be reconverted into the original body. In dry-plate photography an excess of  $\text{AgNO}_3$  cannot be allowed to remain, as it would dry into small crystals and render the film useless; and, further, according to Vogel, it forms with the silver haloid an insoluble white crystalline body,  $2\text{AgNO}_3 + \text{AgI}$ , which is insensitive to light. The  $\text{AgNO}_3$  is, therefore, all removed by washing, and the sensitiveness of the plate restored by other sensitisers, or, as they are sometimes called, preservatives. Organic bodies are found to be the most suitable for this purpose, such as tannin, albumen, gelatine, morphine, and some others.

Reviewing the chemical changes likely to occur in the formation of the latent image, an idea can usually be got as to what body is playing the part of sensitiser. In the daguerreotype, with its film of  $\text{AgI}$  on a layer of metallic silver, it is probably the latter which, by absorbing any liberated iodine, acts as sensitiser, though the  $\text{AgI}$  itself may play the same part if it is able to combine with more iodine, as is the case with some iodides.

Silver nitrate is the sensitiser in the wet collodion process; the reaction is usually written thus:—

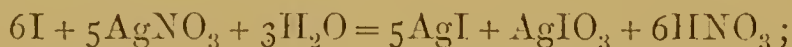

and there is in fact a considerable amount of nitric acid liberated. In dry-plate photography the preservative, and in the emulsion processes the gelatine itself, or other vehicle holding the photo-sensitive salt, acts as sensitiser. In one or two cases the sensitising medium has only an indirect action; for example, in Obernetter's process the sensitised paper contains both cupric chloride and ferric chloride; the latter on exposure is reduced to ferrous chloride, the paper acting as a halogen absorber, and the cupric chloride is then at once reduced by the iron salt—

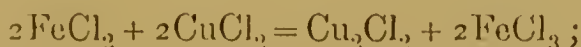

and it is the cuprous chloride thus indirectly produced which yields the brown print by treatment with thio-cyanate and ferricyanide.

In the platinotype process there is a paper-reducing surface containing ferric oxalate and potassium chloro-platinite. The iron salt on exposure is reduced to ferrous oxalate, and the platinum compound is unchanged; but on dissolving the reduced oxalate in hot potassium oxalate it at once reduces the platinite to metallic platinum.

As regards the silver-positive process, or silver printing, the paper again is the sensitiser; but it must be remembered that albumen is able to form salts, and that silver albuminate, which is present in albumenised paper, is itself coloured by light, and plays an important part in the formation of the printed image.

**Orthochromatic Photography.**—Besides these means of increasing the sensitiveness of a film is the use of colouring matters. Draper's law of absorption says it is only rays which are absorbed that can produce any chemical effect. One can tell from its absorption-spectra to what rays a body may be photo-sensitive. Thus silver bromide mainly absorbs violet or blue rays, and it is light of this colour by which it is mostly affected, while the yellow rays which it transmits produce no effect. To this is due the defect in photography that objects are not reproduced in the relative brightness as seen by the eye; a bright yellow object is depicted but dimly, while a dark blue one may come out comparatively light. Vogel, however, has shown that it is not only the rays absorbed by the sensitive body which can produce photo-chemical effect upon it, but that the rays absorbed by a second body with which it is mixed may also decompose it; and his explanation, as modified by Eder, of the effect of dyes is that their action is physical—hence the name optical sensitisers. The colours are supposed to form "lakes" with the silver salt, thus causing a more intimate contact whereby the energy absorbed by the colours is to some extent transmuted into chemical energy, which effects the indirect photo-decomposition of the silver haloid. Abney's experiments, and Vogel's observation that the less stable the colour the more readily it acted as sensitiser, on the other hand, go far to prove that the dyes, like the other sensitisers, act chemically; for this requires the bodies to be unstable, since Abney maintains that it is the decomposition products of the colour set free by the action of light that exert a direct reducing action upon the silver bromide; and although it is generally considered to be an act of oxidation when a colour fades, it has already been mentioned in the case of gelatine that the products of oxidation of complicated organic bodies are frequently active reducing agents, *e.g.*, formic acid.

Whatever the cause, it is now possible, by using certain colouring matters, which must be of the complementary colour to that it is desired to absorb, to render the film sensitive to any particular rays,

and to obtain photographs true to the aspects of Nature as regards relative brightness of tints.

Silver bromide is much more readily influenced by the absorptive powers of colours than is silver chloride, and the latter more than the iodide. It is usually necessary, as one would suppose, to have an ordinary sensitiser present.

**Solarisation.**—To return to the influence of mass; the sensitiser itself may have absorbed so much of the liberated halogen that here also the influence of mass upon a reaction sets in, and the compound formed with the sensitiser begins to decompose as fast as it is formed. This is what takes place in solarisation or reversal of the image; but it is not so simple as here roughly indicated; for, although Abney obtained reversal on exposing a gelatino-bromide plate under benzene, his experiments otherwise tend to show that oxygen plays a part in the phenomenon. The nature of the changes cannot be fully explained as long as the composition of the photo-salts remains undetermined; but an idea of it may be gained by first looking at the case of the fading of the invisible image spontaneously in the dark. Oxidising agents, *e.g.*, the halogens, will destroy the latent image, and probably the unstable halogenised sensitiser and reduced silver haloid when removed from the influence of light begin to react, re-forming the more stable normal salt. In the daguerreotype, if AgI is the sensitiser by formation of AgI<sub>2</sub>, the image will probably fade from this AgI<sub>2</sub>, parting with its excess of iodine to the reduced silver image. In the wet collodion process, where AgNO<sub>3</sub> is the sensitiser, the action of the liberated iodine has been supposed to be—

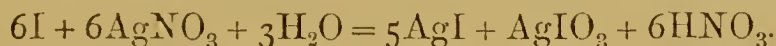

There is thus free HNO<sub>3</sub>; and the image is more permanent if this is washed away, or its formation prevented; so that it is probably the oxidising action of this free nitric acid which causes the destruction of the image.

In dry plates, most likely, the sensitiser again gives up the absorbed halogen owing to the action of oxygen upon it. What thus takes place in time without other aid may be more rapidly brought about by reversing agents in the light, that is, by bodies which readily part with the halogens in air and light. Potassium iodide is an example—

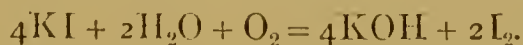

The iodine would destroy any reduced haloid with which it came in contact; and on this fact has been based a positive-printing process, in which a sheet of sensitive paper coloured by a preliminary exposure was afterwards coated with a solution of potassium iodide, and then used for printing engravings and other line subjects, since all

parts on which the light acted would, by reason of the photo-decomposition of the potassium iodide, bleach the coloured silver paper, and reproduce dark lines as dark lines.

Solarisation is destruction of the image by over-exposure followed by reversal, the reversed image again being destroyed and brought back to the original state ; this cycle is repeated so long as exposure continues.

*Pseudo-solarisation*, or reversal by exposure to light towards the end of development, is, of course, purely optical. The light cannot readily penetrate the dark silver deposited on development, and therefore reacts upon the unaltered silver haloid in the film to a greater extent in those parts where but little silver has been formed. If, then, this second illumination be stronger than the first, the latter will, on completing the development, give the less dense deposit of silver and a positive result.

That solarisation is accelerated by oxidising agents, and that potassium iodide in presence of air loses iodine, explains the necessity of removing all excess of the iodide from a film, and why emulsion prepared with excess of the haloid instead of excess of silver nitrate is the less sensitive of the two ; for, in precipitation by double decomposition the precipitate very generally tends to carry down traces of the precipitant which is in excess either mechanically or in some undetermined molecular combination ; therefore, in preparing silver iodide with an excess of potassium iodide, traces of the latter will be carried down and remain in the film, tending to neutralise the action of the sensitiser and thus facilitating reversal. By using an excess of  $\text{AgNO}_3$  it is traces of this salt which get carried down, and, acting as a sensitiser, render plates prepared in this way much more sensitive.

The assumption that solarisation is largely caused by the saturation of the halogen absorber, *e.g.*, gelatine, explains the fact that the more sensitive the plate—that is, the more rapidly the halogen is set free by light—the more readily does reversal set in ; and it explains also why a preliminary exposure hastens solarisation, for the sensitiser by this exposure is already partly halogenised, and is to that extent nearer saturation or the first stage of equilibrium. Oxidation now probably plays an important part, for the intervals between the stages of the cycle lengthen rapidly, and the action too is retarded by the application of reducing agents to the film.

The strength of developer may also affect the result obtained from an over-exposed plate, for the sensitive film on oxidation, or after absorption of halogen, is less pervious to solutions, so that a strong developer will act more readily on the unreversed portions and produce a positive ; while a weak developer, having more time to work in, and finding but little reduced haloid to act upon in the weak



lights, produces a normal negative with greatest density of silver deposit in the portions most strongly illuminated.

An interesting case of reversal has been recently investigated by Colonel Waterhouse, that of reversal by the addition of thiocarbamide to the eikonogen developer. His experiments have an important bearing upon the growing opinion as to the part which electrolytical actions play in development; for the reversal was found to be accompanied by reversal of the current, in other words, the shadows became the negative pole, thus attracting the positive element, silver, and causing its deposition upon the portions of the negative which should have remained clear. This action of the thiocarbamide Colonel Waterhouse suggests to be due to the formation of silver sulphide on the unexposed parts, and this body acting as negative element towards silver, the metal is deposited upon the shadows while the halogen goes to the silver, converting it into haloid, which is then dissolved away. Photographic reversal is, as thus explained, a case of electro-chemical reversal. (See *Reversal of the Image.*)

**Developing.**—Only in exceptional cases does the photo-chemical effect of light produce on the sensitive film any visible alteration, the image “photographed” upon the sensitive plate is invisible or latent; the light, then, having done its work, means have to be found by which the change in the photo-sensitive salt may be made visible. The agents so used are called “developers.” The action of developers is in the main chemical, and as their chemical nature, and the reaction they bring about, changes as the kind of film is changed, the rationale of development in the various processes will be dealt with separately; but in all cases the result of development, the production of a negative or of a positive, must depend upon whether the agent employed exerts its action upon that portion of the sensitive substance which has or has not been affected by exposure; as in the case of the photo-reduction of ferric chloride, from which either a positive or negative may be obtained according to the manner of treatment in developing.

In the *Daquerreotype Process* the vapour of mercury is the developer; but nothing definite can be said as to the way it acts. It is known that the mercury vapour attaches itself to the body altered by light, but whether from a physical or chemical cause is uncertain, for the vapour of water alone is sufficient to produce a visible picture, which vanishes as the condensed particles are dissipated again. At any rate, the amount of metal deposited is proportional to the quantity of sensitive compound which has undergone photo-decomposition, and in this respect the process is typical of the action of all developers.

The *Wet Collodion* process depends upon the reducibility of silver

nitrate by readily oxidisable substances. Ferrous sulphate is such a body, being oxidised to ferric sulphate and nitrate—

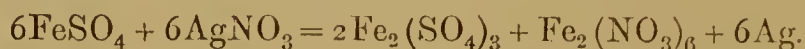

It is usually mixed with acetic acid and alcohol, the latter to ensure the even flow of the solution, and the former to prevent immediate reduction of the silver nitrate, and consequent deposition of silver over the whole plate with production of fog, instead of being formed only upon the altered sensitive salt by the setting up of an electrolytic couple; for a current of electricity is produced when silver is placed in a solution of silver nitrate, the metal in which deposits itself upon the silver, thus an image can be built up by reduced silver continuing to deposit upon that already formed; but whether the initial step of development is the deposition of silver or reduction of altered haloid to silver is undetermined. The use of acetic acid and the mode of formation of the image by deposit of silver from above upon that already existing has given this class the name of *acid* developers and accretional or *physical* developers. The necessity for having the solution acid is probably because on adding ferrous sulphate to an alkaline solution of silver nitrate, metallic silver is not precipitated, but a black compound of silver and iron oxides. This, too, explains the difficulty of working with alkaline waters such as those containing much calcium carbonate.

In *Dry-plate Photography*, on the other hand, the developer is alkaline, and there is no silver salt upon the plate itself or in the developer from which to obtain the silver necessary to form the image. The action is most likely electrolytical here, as with wet plates; but the distinguishing feature is that the film supplies the requisite silver by reduction of the haloid salt which it holds; this class is therefore sometimes called the *reductional* or *chemical*, but usually the *alkaline* developers, from the necessity of using an alkaline reducing agent. A great number of readily oxidisable organic bodies have been suggested and employed as developers, such as glucosides, sugars, ethereal oils, &c. The oxy-derivatives of benzene and naphthalene are the most useful. Ferrous sulphate is here of no use, as it cannot reduce the silver haloids, and only acts upon silver nitrate in an acid solution; whereas pyrogallol, as an example of the alkaline or chemical developers, is an active reducing agent towards the silver haloids in the presence of an alkali. It has been mentioned that in consequence of the silver which goes to form the picture in a wet collodion plate being supplied by the silver nitrate upon it, the image grows by *physical* accretion above, or that it must exist in relief; and that this is so is shown by the possibility of entirely dissolving it away and

leaving the clean film beneath unaltered. But in alkaline development the image grows by continued reduction of the silver haloid downwards, as may be seen by the image only becoming visible at the back towards the end of the development; consequently when this silver is removed by acid, a sunken cast of the image is left in gelatine. But as alkaline solutions of pyrogallol and similar bodies are able to reduce the silver haloids, the difficulty arises that, were they allowed to act alone, the whole plate would be fogged. The action must be restrained so as to allow their greater reducing action upon the photo-altered compound to set in before any action can take place upon the unaltered haloids. The first action, then, in developing a dry plate is the reduction of the photo-salt to metallic silver, and as the light cannot have produced any effect throughout the whole thickness of the film, it has to be accounted for why reduction in development should continue downwards in the way it has been proved to do. It is here the electrolytical action commences between this first deposit of silver and the silver bromide beneath it in the film. Taking pyrogallie acid as typical of all the organic developers, its action upon silver bromide may be thus represented:--



the  $\text{K}_8\text{C}_6\text{H}_8\text{O}_9$  representing the product of oxidation of the developing agent employed; but by adding a restrainer the reducing action can only exert itself upon the more susceptible body forming the invisible image.

Many organic iron salts can be used as alkaline developers, as the double oxalate of iron and potassium,  $\text{K}_2\text{Fe}(\text{C}_2\text{O}_4)_2$ , which acts very powerfully, and has to be restrained by means of potassium bromide from acting directly upon the unaltered haloid, and the silver thus set free enables the action to be continued upon the unaltered bromide beneath, either by a chemical action between it and the nascent silver, or electrolytically as above indicated. The latter view seems the more probable, since particles of silver merely pressed into a gelatine-bromide film can be developed so as to produce an impression of themselves in metallic silver out of the haloid within the film. This is accounted for by supposing an electrolytic action to be set up between the silver particles and the silver bromide, causing the reduction of the latter, and the liberated bromine oxidises the developer or solution, which, with the two elements referred to, constitutes the electrolytic cell; and in further support of this is an experiment made by Colonel Waterhouse, who actually measured the strength of currents generated in using ferrous oxalate as developer, and found an E. M. F. of 0.09 volt.

As it is possible by means of restrainers to differentiate between the relative reducibilities of altered and unaltered silver bromide, it is not surprising to find that any portion of the bromide the reduction of which has been commenced, or the stability of which has been lessened, can be detected by applying a developer. Thus, it is not only possible to develop a photographically produced image, but one chemically or even mechanically formed. By applying a solution of some body which has a reducing action upon silver bromide, the portions so treated will be developed in silver on applying a suitable developer, and marks made on a plate by pressure can be similarly developed, due probably, as the experiments of Spring and others show, to some slight alteration or incipient decomposition in the silver salt. It is facts such as these which give greater probability to the invisible image differing chemically from the unaltered haloid, than to its being a mere physical modification of lesser stability.

**Restrainers and Accelerators.**—Mention has been made of the addition of certain bodies to a developer to retard or hasten its reducing action. Of the former class, potassium bromide is mostly used with dry plates, while acetic acid plays the same part in acid developers by lessening the reducing power of ferrous sulphate upon silver nitrate. The use of potassium bromide as restrainer probably rests upon the formation of a double salt between it and silver bromide, this double salt being less reducible than the silver haloid alone.

Accelerators produce the contrary effect, but not exactly in an analogous manner; for, whereas most restrainers act by increasing the stability of the reducible body in presence of the developer, an accelerator generally acts by increasing the activity of the reducing agent; for example, sodium thiosulphate is an accelerator towards the ferrous oxalate developer, since it reduces the ferric salt resulting from the oxidising action of the bromine, the two reactions being probably as follows:—

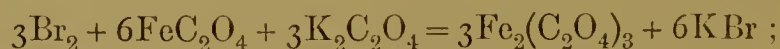

and this in presence of the accelerator is followed by—



thus maintaining the strength of the developer. The salt has no accelerating action towards such developers as hydroquinone, pyrogallol, &c. Many other reducing agents have been employed or suggested, such as sodium sulphide, formaldehyde, &c.

**Fixing.**—The developed negative still contains unaltered sensitive salt, and the whole of this has to be removed to prevent any further action on bringing it into the light. This operation is termed *fixing*.

The negative is usually treated with a solution of some chemical which will dissolve out and so remove the remaining silver haloid. Sodium thiosulphate is most generally used. On treating a plate with a strong solution of this body, a double salt of silver and sodium is formed which dissolves readily in water, thus enabling it to be washed away—

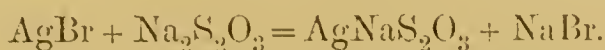

Though it appears very simple as thus stated, there are precautions necessary, for with a weak fixing solution an insoluble double salt may be formed,  $\text{Ag}_2\text{Na}_4(\text{S}_2\text{O}_3)_3$ . The solution must therefore not only be used sufficiently concentrated, but also, in fixing prints, it should not be used a second time, as the thiosulphate can only take up a certain proportion of silver before the insoluble body begins to separate out.

The use of potassium cyanide for fixing purposes also depends upon the formation of a soluble double salt—

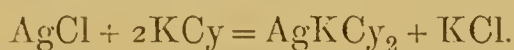

There is no danger of an insoluble body being precipitated, but this reagent has the disadvantage of being a powerful poison; moreover, it cannot be used for fixing gelatino-bromide plates owing to its solvent action on the gelatine.

**Intensifying.**—A negative which, when fixed, is found to be weak, that is, wanting in density, due to insufficient deposit of silver, caused by under-exposure or under-development, has to be intensified or strengthened. With wet plates this can be done by merely repeating the development process, that is, by continuing the deposition of silver upon that already existing. For dry plates, mercuric chloride is most favoured as an intensifier. On covering the negative with a solution of mercuric chloride, the silver deposit is bleached with formation of silver chloride, and reduction of the mercury salt to white insoluble mercurous chloride—

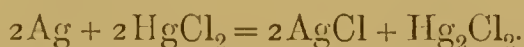

According to Chapman Jones, although the above equation is true, it is more probable that the chlorides unite to form a double chloride of silver and mercury—

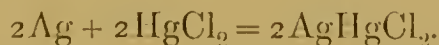

After washing off the excess of intensifier, treatment with dilute ammonia gives black mercurous ammonium chloride—

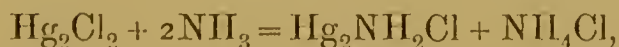

adding greatly to the density of the negative.

Other substances will convert the chloride into a dark compound. Ammonium sulphide will give an image in silver and mercury sulphides, or the chlorides may be reduced by ferrous oxalate to metallic silver and mercury, the addition of mercury to the original deposit of silver naturally causing an increase in strength, while the silver may again be utilised to obtain increased density by merely repeating the treatment. A mixture of lead nitrate and potassium ferricyanide finds favour as an intensifier. Either lead ferricyanide is formed and acts directly upon the metallic silver, producing a mixture of lead and silver ferrocyanides—



or the production of the lead and silver ferrocyanides may be indirect—

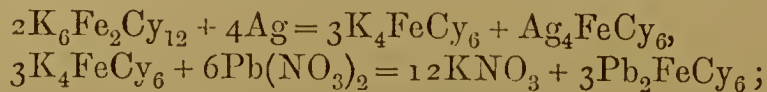

subsequent treatment with ammonium sulphide converting them into the black sulphides. Among the many other ways of utilising (for intensifying) the ferrocyanide thus formed is treatment with potassium chromate or permanganate.

Another plan of increasing the strength of the negative is to replace the silver by a metal of greater density, an operation analogous to toning prints. Gold or platinum would act as follows:—

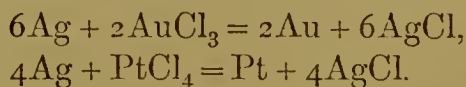

On the other hand, it is sometimes advantageous to be able to lessen the density of a negative; this may be done by superficially converting the silver into a salt, which can be readily removed. Eder takes a solution of ferric oxalate to which sodium thiosulphate has been added. The iron-and-silver salt is reduced to silver and ferrous oxalates—



the former being at once dissolved out by the thiosulphate in a manner similar to the fixing of a negative—

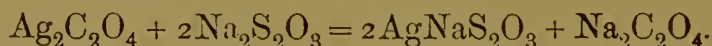

The ferric oxalate may be replaced by potassium ferricyanide, the action of which is quite similar, being a reduction of the ferricyanide, formation of silver ferrocyanide, and solution of this in the thio-sulphate.

Other methods of reducing intensity are the use of potassium cyanide, and of a mixture of cupric bromide and sodium chloride,

which dissolve the silver of the image. Duchoichois recommends that the negative be soaked in water and then immersed in very dilute aqua regia, or in a mixture of nitric and hydrobromic acids. The silver haloid is formed and the plate is then dried and exposed to diffused light. If the transformation of metallic silver has been carried too far, the negative can be redeveloped or intensified.

**Printing.**—There are numbers of ways of obtaining a print or positive image from a finished negative, but the most generally known is that of silver printing on albumenised paper, in which, instead of obtaining an invisible image to be afterwards developed, the action of the light is continued till the alteration in the sensitive compound is visible, and it only remains to fix the visible picture thus obtained, which must, therefore, be formed of the darkened silver photo-salt, the composition of which is still undetermined. "Bromide" printing, on the contrary, resembles the making a negative; a short exposure is given, and the invisible image is developed, washed, and fixed as in the case of a negative. The reddish colour of the silver print necessitates *toning*, the object of which is to give the print a more pleasing tint. This is usually effected by depositing finely divided gold upon it by immersion in a bath of gold trichloride. Gold being a more electro-negative element than silver, the latter replaces it from solution—

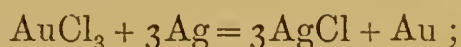

but the bulk of the deposited gold results from the readily oxidisable products of photo-decomposition (which constitute the coloured positive image) exerting their reducing action upon the gold chloride.

The change of colour varies according as the bath is acid, neutral, or alkaline. A solution of auric chloride which has been made alkaline by the addition of borax or other alkaline salt will after a time give rise to the formation of aurous chloride—

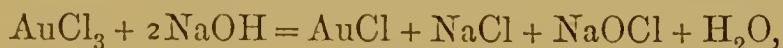

causing the bath to be useless; but its toning power may be restored by the addition of hydrochloric acid, as this decomposes the hypochlorite, and the chlorine then set free re-oxidises the aurous chloride—

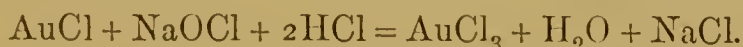

The salt from which toning baths are prepared is the sodium salt of chloro-auric acid,  $\text{NaAuCl}_4 + 2\text{H}_2\text{O}$ ; or it may be regarded as merely the double chloride of gold and sodium.

That the toning solution must not be acid arises from the necessity of having the gold precipitated as rapidly as possible to ensure its

being deposited in the blue form (that from an acid solution being reddish), so as to neutralise the objectionable red tint of the altered silver albuminate; for the colour of the gold, as has been said, varies with the reaction of the solution, that is, with the rapidity with which the gold is deposited; and as hydrochloric acid acts as a restrainer, it is removed as fast as it is formed by adding chalk, borax, &c., as already mentioned. But it is wrong to suppose that the tone of a print may be varied at will by the method adopted in toning, for it is impossible to obtain a print with good contrasts of light and dark from a negative of inferior quality.

In fixing the toned print by means of sodium thiosulphate, the action of course is the same as in fixing a negative; but here the formation of the insoluble double thiosulphate must be more carefully guarded against, as well as the washing away all the soluble salt, for either will bring about fading, due to decomposition of the thiosulphate, if left in the print. Using a sufficiently strong solution of the fixing agent, followed by thorough washing, is the best way of ensuring permanency, but any traces of thiosulphate which may possibly remain can be destroyed by treatment with a weak solution of iodine in potassium iodide—



The chemical principles of a few of the other many printing processes will now be shortly referred to.

**Use of Iron Salts.**—The behaviour of ferrous and ferric chlorides towards potassium ferri- and ferro-cyanides has been mentioned as affording means of obtaining a positive or negative according to the developer employed. When light falls upon paper coated with ferric chloride, it reduces the salt to ferrous chloride to an extent varying with the intensity of the light; so that on immersing the paper in a bath of potassium ferricyanide a blue positive is obtained, since the ferricyanide and ferrous chloride together form *Turnbull's blue*—

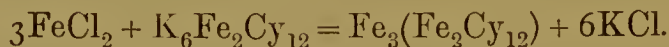

But if the bath be made up with potassium ferrocyanide instead, a deposit of *Prussian blue* results from the action of the ferric chloride upon the ferrocyanide,



thus the portions unaffected by light are developed as a blue image, and a negative is the result.

Of the several other ways of obtaining prints by the reduction of ferric salts by light, may be mentioned Herschel's Chrysotype, where



the ferrous chloride produces a brown deposit of gold on treatment with a solution of gold chloride—

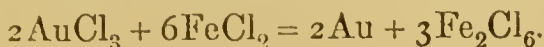

A solution of potassium chromate gives a brown print by reduction of the  $\text{CrO}_3$  to an insoluble lower oxide, and in Phypson's process ferrous oxalate formed by photo-reduction of ferric oxalate reduces a solution of potassium permanganate with production of a brown oxide of manganese.

The *Platinotype* process of Willis is the most interesting of those involving the photo-reduction of iron salts, and it is also very simple. The paper contains ferric oxalate and potassium chloro-platinite. On exposure ferrous oxalate is formed—

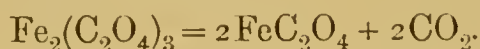

The ferrous oxalate is dissolved by immersion in a bath of potassium oxalate, the insoluble ferrous oxalate being then converted into a soluble double oxalate of iron and potassium, which at the moment of solution reduces the chloroplatinite to metallic platinum—

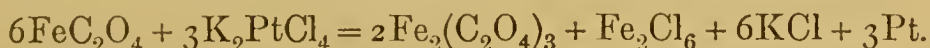

*Obernetter's* process, like the platinotype, obtains its results indirectly, for the cupric chloride is present in the exposed paper, just as the potassium chloro-platinite is, but any photo-chemical action they may undergo is either too slow or unadaptable to obtaining prints. The paper contains cupric and ferric chlorides; the latter on exposure is reduced to ferrous chloride, and this in turn reduces the copper salt—

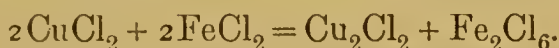

The paper is then immersed in a solution of potassium thiocyanate, which produces thiocyanate of copper; and this is followed by treatment with potassium ferricyanide, yielding cupric ferricyanide, of which the picture is formed. The exposed paper, if left undeveloped, is found to lose its latent image by oxidation from the atmosphere, and the same paper may then be used again upon which to take a fresh picture.

There are many other printing processes, and bearing in mind the vast, and continually increasing, number of chemical bodies, so many of which are readily susceptible to change, it is not surprising that new processes continue to be devised. For example, the Feer-type, where the diazo bodies are employed; the Primuline process, and so on, in all of which the chemistry involved may be surmised with considerable certainty, as in the case of the older methods; indeed, it is not in the printing where the difficulties of the subject are met

with, but in the earlier stages of the production of a photograph, where authorities begin to differ so widely as to the exact nature of the reactions, and where the difficulties surrounding their investigations have still left such a wide field for future experimenters.

In this chapter the writer makes no claim to originality in the opinions expressed. All he has attempted is to give a general idea of what are supposed to be the reactions which take place in the formation of the photographic picture. The writings of the workers on this subject, Hunt, Abney, Carey Lea, Vogel, Bothamley, Meldola, and others, have been carefully considered, and, so far as space has permitted, the conclusions here recorded may be taken as representing the present state of what is known on the subject. The student is referred to the works of Meldola, who has perhaps given the subject more careful consideration than any other living authority, and whose "Chemistry of Photography" should be specially mentioned as being the most complete, as well as the recognised, work of reference on the subject.

---

## CHAPTER III.

### OPTICS OF PHOTOGRAPHY.

**I. Light.**—Light is one of the forms of radiant energy, being transmitted from place to place by means of transverse vibrations of the medium ether, which fills the whole of space. This mode of transmission is known as "wave motion," the nature of which is well illustrated by the progression in water of the disturbance due to an impulse given to it at any point—*e.g.*, by dropping in a stone—the disturbance travels onward as an undulation, as a succession of waves, while the water particles oscillate about their point of rest, but do not undergo any motion of permanent translation. The distance from crest to crest of two succeeding waves is the *wave-length*, differences in which do not cause any change in velocity of propagation of a wave of light through the ether.

Although the length of the waves which constitute radiation is extremely small, being measured in millionths of a millimetre, the various effects produced by this radiant energy, *viz.*, those of heating, illumination, and chemical change, are due solely to differences in wave-length; in other words, heat, light, and actinic rays are not different things, but a ray of radiant energy possesses the property of producing thermal, luminous, and actinic effects to an extent depending upon its wave-length. But, whereas all rays are thermic to some degree, provided they fall on a suitable surface, it is not *all*

rays which are capable of producing a luminous or actinic effect. With sunlight, we find that a length of 600 to 800 millionths of a millimetre produces the greatest *thermal* effect; with lengths of 400 to 600 millionths of a millimetre, we get a *luminous* effect; while a powerful *photographic* effect is produced by those rays having wave-lengths between 200 and 400 millionths of a millimetre. In speaking, therefore, of light rays, it must be understood that what follows does not refer only to those rays which, by the constitution of the eye, happen to produce a luminous effect.

But besides differences in wave-length, or distance from crest to

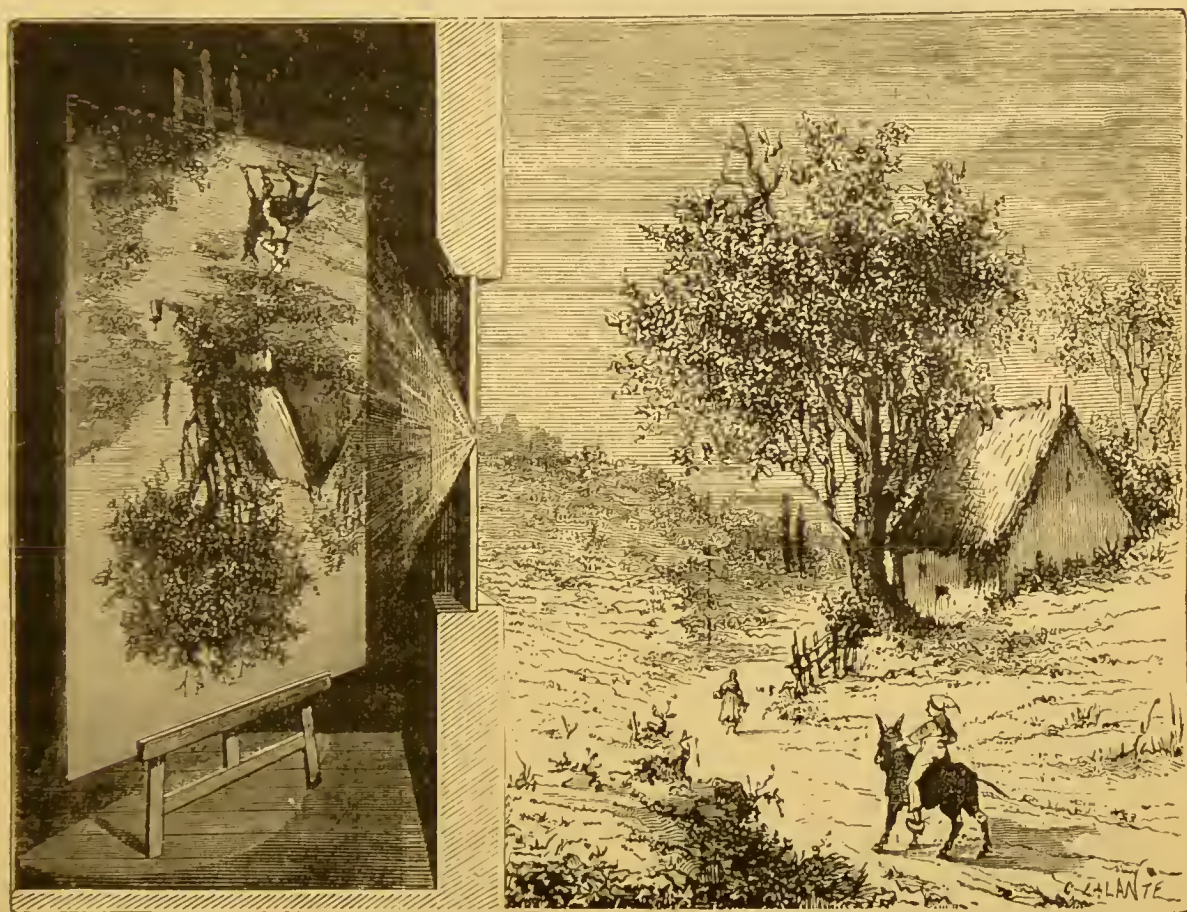

FIG. 1.

crest of two succeeding waves, the extent of vibration of the ether particles—their *amplitude*—may vary; just as we can imagine the size or height of sea-waves to vary without altering the distance from one wave to the next, the hollows and crests being only more marked. Now, since this is caused by the particles moving to a greater distance from their position of rest, they must possess greater energy or be capable of doing more work; in other words, increase in amplitude causes increase in intensity, and many photographic and other phenomena are dependent upon, and can be explained by, differences in the intensity of the vibrations.

Rays of light travel in straight lines. To this fact is due the production of a shadow identical in form with any object placed in the path of light. The pin-hole camera is also dependent upon the principle of the rectilinear propagation of light; for, taking any small hole in a shutter, then, since each point of a luminous object causes light rays to travel in every direction from it in straight lines, each point can only send a ray to a corresponding point upon a screen placed behind the hole, all rays from other points being cut off by the shutter. This is shown in Fig. 1, where a single ray from each point of the luminous object is seen to produce an image which must necessarily correspond in colour and intensity to that of the object from which it came, and of which the whole, therefore, forms a reproduction.

Only a few bodies are self-luminous, the majority being visible because they reflect light received from other sources; part of this they absorb, part is scattered; with transparent bodies part is transmitted, the remaining portion being reflected and producing the impression of the object from which they come. The extent to which light is reflected depends on the regularity or polish of the reflecting surface, on its colour, and on the angle of incidence. Instruments with a highly polished surface are employed as mirrors, and their use in photography is mainly to reflect the sun's rays (see *Solar Camera*), and for reversing an image (see *Reversing*).

But when light has to travel through space occupied by substances besides ether, the properties of the ether are modified within the substance; in transparent bodies it has suffered but little modification, while opaque bodies are those in which its properties have been so modified that it is no longer able to transmit the undulations which form light rays.

The most important effect produced by transparent substances is that of retardation, the extent of which change also depends upon the wave-length of the ray; consequently, a ray falling upon a transparent substance at an angle has its direction changed within the substance (or, in other words, is *refracted*) to an extent depending upon the velocity of the ray within the body and upon the substance itself, *e.g.*,

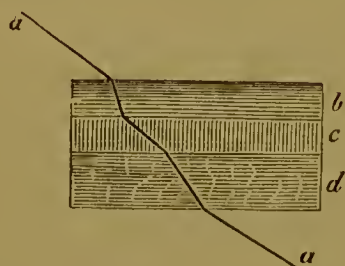

FIG. 2.

its density, as illustrated in Fig. 2, where the ray *a a* has its direction changed on entering the layers, *b, c, d*, of substances differing in density. The ratio of the velocity of light in free space to its velocity within the substance is the *index of refraction* of the substance. But since velocity depends upon wave-length, we have a means of separating rays of light

differing in wave-length. A pencil of rays (a beam of white light)

falling upon one side of a prism of glass will be bent from its direct route (see Fig. 3), and we get an elongated band of coloured light, a *spectrum*, each point in the band corresponding to a ray of a certain wave-length, determined by the amount of deviation, that is, its *refrangibility*.

The amount of separation or difference in deviation between two given points in the coloured band measures the *dispersion* of a prism,

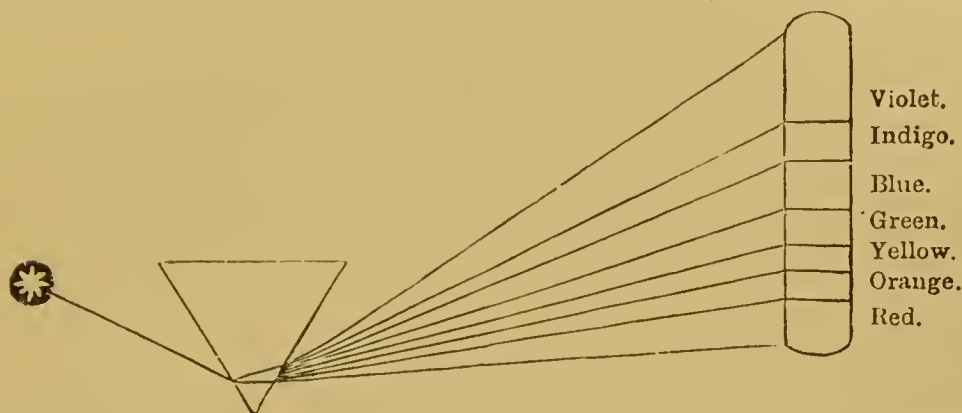

FIG. 3.

but its *dispersive power* is the ratio of this dispersion to the deviation of some particular ray selected for reference.

As already stated, light rays may produce three distinct effects; one of which, that of heating, is, however, common to all. The following interesting experiment enables us by the use of the spectrum to show that it is only those rays having actinic properties which produce any photographic effect. If by means of a prism and a strong light, such as the electric or lime-light, or better still the light from the sun (but the experiment has succeeded perfectly with the limelight, and may be most conveniently repeated by this means), a beam of light be spread out as a spectrum of all the colours, it will be found that if a negative in contact with a gelatine plate be exposed in the blue rays a picture may be printed, but if exposed in the red rays no result will be produced. The experiment may be shown on one plate by first exposing one half in the blue and the other half in the red rays. On developing the plate, one half will be found blank, while the other will show half of the image.

**II. Lenses.**—A lens is a piece of transparent substance, usually glass, bounded by two surfaces which are generally portions of spheres. The relative direction of curvature of the two surfaces divides lenses into two classes: (1) converging, (2) diverging lenses. In each class one of the surfaces may become plane, and we then get a plano-convex (No. 1) or plano-concave lens (No. 4). The six forms are represented in Fig. 4. No. 2 is biconvex, No. 5 biconcave, while Nos. 3 and 4 are called a converging and a diverging meniscus respectively. The line joining the centres of curvature of the lens surfaces, or

drawn through the centre of curvature perpendicular to the plane surface, is the *principal axis* of the lens, and a point distant from the two surfaces in the ratio of their radii of curvature is the *optical centre*, all rays passing through which emerge parallel to their original direction, *i.e.*, undergo no deviation. In a meniscus this point will



FIG. 4.

lie outside the lens, and with plano-convex or plano-concave lenses it must be on the curved surface. The principal axis necessarily passes through the optical centre, and any other line passing through this point is a *secondary axis*.

Neglecting for the present the influence which differences in wave-length has upon refrangibility, it has already been stated that light in passing through a prism is deviated to an extent depending upon the angle of incidence. Lenses produce the same effect; indeed, a lens may be looked upon as a series of prisms; a convergent lens being two prisms united at the base (see Fig. 5), and a divergent one two prisms united at their summits.

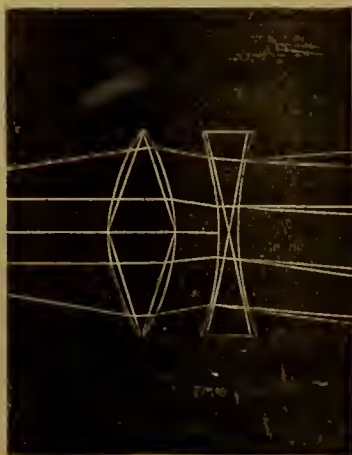

FIG. 5.

The **Working Aperture** of a lens used without either diaphragm or stop is, of course, its full diameter; when otherwise employed, its working aperture depends upon the aperture of the diaphragm or stop in use, being identical with the diameter of a stop, but by no means the same as that of a diaphragm. This distinction between working aperture of a lens and diameter of diaphragm is shown in Fig. 6; which also illustrates the way in

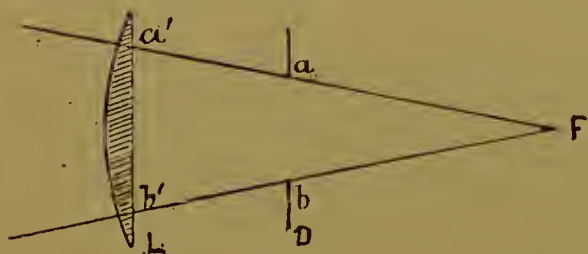

FIG. 6.

which the former is determined. F is the principal focus of the lens L, D is a diaphragm placed behind (as with the front lens of a doublet); then, while  $a$   $b$  measures the diameter of this diaphragm, the working aperture of the lens is measured by  $a'$   $b'$ .

The **Angular Aperture** of a lens is the relation between its focal

length and working aperture ; the former being a constant, it follows that angular aperture is diminished by the use of a smaller diaphragm.

**Angle of View** is the relation between the focal length of a lens and the width of plate upon which it can produce an image, so that of two lenses that with the shorter focal length has (other things being equal) the greater angle of view. Increased width of angle of view is secured by the use of a smaller stop, but this is accompanied by loss of rapidity. It is not advisable for general work to use a lens which includes an angle greater than the angle of view of the eye, which may be taken to be within  $50^{\circ}$ .

The angle of view may be ascertained in the following way:— Upon a sheet of paper draw a line equal to the length of the plate ; that is, ten inches for a  $10 \times 8$  plate. Find the centre of this line ; from it draw a perpendicular equal to the length of focus of the lens to be tested. By joining the three points forming the extremities of these two lines an isosceles triangle is formed having the length of the plate as base. The vertical angle of this triangle is the angle of view required, and may be measured by applying a protractor.

**Rapidity** is a term which refers to the greater or less time of exposure which the use of the lens requires in order to allow the transmitted light to produce a sufficient photographic effect upon the sensitive plate. Rapidity will, therefore, vary with the intensity of illumination, which depends upon the working aperture of the lens. The rapidity of a lens, in fact, is the relation between its working aperture and focal length ; in other words, it depends upon the angular aperture, which explains the necessity for using a large angular aperture in instantaneous work. It is evident, then, that what is gained in rapidity is lost in depth of focus and fineness of definition. The rapidity of all objectives is taken to be the same when used with diaphragms the sizes of which are the same proportion of the respective focal lengths, but in reality this is only true when comparing single lenses.

**III. Focus.**—(a.) **Definitions and Formula.**—Rays parallel to the principal axis of a convergent lens are deviated in such a manner as to all meet at a point on this axis on the other side of the lens ; this is the *principal focus*. Rays which are not parallel, but diverge from a point on any axis, will, after passing through the lens, converge to a second point on that axis ; the two points related in this way are *conjugate foci*. With a concave lens which causes light rays to increase their divergence the rays necessarily do not meet at a point, but they appear to diverge now from a new position, where they form a *virtual image*. The *equivalent focus* of a lens-combination is the focal length of the simple lens which will produce an image of a distant object of the same size as that produced by the combination ;

the image must be small and central to ensure absence of distortion. As the point from which the focal length is measured is the optical centre, and this centre is situated somewhere between the lenses of the combination, it is customary, and near enough, to take this point at the diaphragm. A rough estimate of focal length can thus be formed by measuring the distance between the diaphragm and ground glass when some object over 200 yards away is focussed upon the glass, for the rays from the object will be practically parallel, and consequently form their image at the principal focus.

The distance of the principal focus of a lens from its optical centre is its *focal length*. A convex lens has a negative focal length, since the image it forms is on the opposite side of the lens to the object. The focal length of a concave lens is, on the contrary, positive, since object and image (virtual) are on the same side of the lens. If we measure the distances of object and image from the lens and call them  $p$  and  $p'$ , the focal length  $f$  is given by the formula

$$\frac{1}{f} = \frac{1}{p'} - \frac{1}{p};$$

distances on the opposite side of the lens to the object being negative, the focal length of a concave lens cannot be measured directly in this way since it forms no real image from which to measure.

(b.) **Determination of Focal Length.**—Evidently from the above formula, knowing the value of  $f$  for a lens or combination of lenses, and the distance,  $p$ , of the object from the lens, we can calculate the distance  $p'$  at which the image will be formed on the ground glass. Or, by measuring  $p$  and  $p'$ , we can find by its means the focal length of a lens. An easier method of doing this (which requires no calculation) is to arrange any suitable object (such as a foot-rule) and obtain the image of a small portion centrally on the ground glass and of exactly the same size as the object; the object and image will now be distant from one another exactly four times the focal length of the lens, which is, therefore, found by measuring this distance and dividing by 4. As has already been said, in finding the focal length of a combination, it is necessary to measure from a point situated between the lenses. This point will be in the middle or nearer the front or back lens, according to their relative strength. In a portrait combination, for example, the optical centre is rather nearer to the front than to the back lens.

But the method generally recommended for finding focal length is that devised by Grubb, which is simple and accurate. Draw two vertical pencil lines upon the ground glass of the camera at equal distances from the margin at each side and about 4 inches apart;



place the camera upon a sheet of white paper on a table fronting a window ; then focus some distant object, say 200 yards away, to coincide with one of the vertical pencil lines ; draw a line upon the paper along the side of the camera ; then turn the camera so that the object shall coincide with the other line on the ground glass, and draw a second line on the paper along the side of the camera. Suppose in

Fig. 7, AB and CD are the two lines thus drawn on the paper ; prolong them with a ruler till they meet ; let E be the point where they meet. Across these lines draw the line GH equal in length to the distance between the

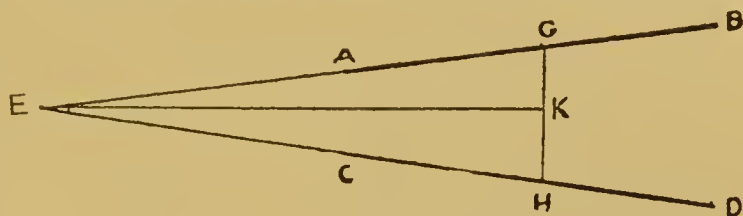

FIG. 7.

pencil lines on the ground glass, and in such a direction as to make the triangle isosceles, *i.e.*, making  $EG = EH$  (as near as practicable). Bisect GH in K and join EK ; then the length of EK is equal to the focal length (the equivalent focus) of the camera-objective.

(c.) **Size of Image.**—The size of the image is to that of the object in the ratio of their distances from the lens, *i.e.*, as  $p'$  is to  $p$  : thus, with the object 20 feet away and focussed on the ground glass 1 foot behind the objective, the image will be  $\frac{1}{20}$ th the size of the object. As we often require to reduce or enlarge a picture a certain number of times with a lens of which we know the focal length, it is important to be able to find, at least approximately, where the picture and focussing screen should be placed in order to obtain the required reduction or enlargement. This is effected by means of the table given on another page with an explanation as to method of using ; but it might be added that this table has been deduced by means of the formulæ

$$U = (n + 1)f$$

$$V = f + \frac{f}{n}$$

where  $f$  is the focal length of the lens,  $n$  is the number of times the picture is to be reduced or enlarged, and  $U$  and  $V$  the required distances at which picture and ground glass are to be placed from the lens. It must of course be remembered that  $U$  and  $V$  give the distance of object and image to produce a reduced picture and *vice versa* for an enlargement.

(d.) **Depth of Focus** is the power of a lens to give clear images of

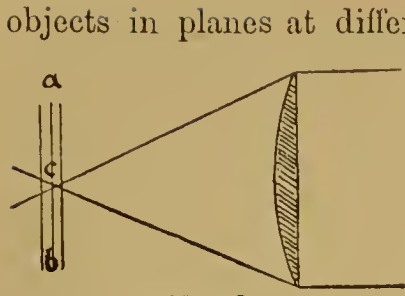

FIG. 8.

the ground glass to be moved to a limited extent without impairing the sharpness. The depth of focus varies inversely as its aperture, and is greater for objects at greater distances from the lens. This effect of aperture and relative distance is explained by the figures. In Fig. 8 a

very slight movement of the ground glass, *a b*, would put the point *c* out of focus and produce a broad circle; whereas, in Fig. 9, the angle

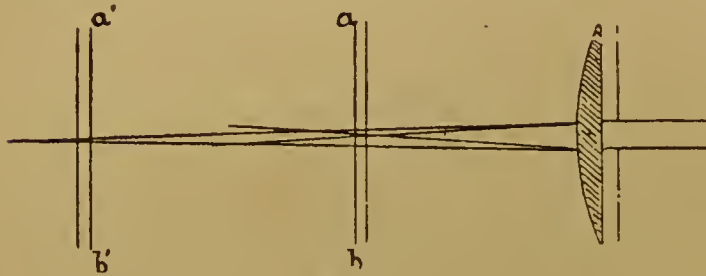

FIG. 9.

being so much less, moving *a b* would not produce so great a change in definition; and at *a' b'* it could be still more moved to or from the lens, and yet a sharp image be maintained.

This effect is not a contradiction of the law of conjugate foci, for the focussing at the same point of objects in different planes depends upon their being sufficiently distant, so that their image is formed near the principal focus.

Among simple lenses depth of focus is greatest for a convergent meniscus with its concave face towards the object, and for a small angle a practically flat field is obtained. With combinations the orthoscopic has the greatest, and the double combination the least depth of focus; this difference being due to the second lens in the former causing the rays emergent from the lens facing the object to be less convergent, while the back lens of the latter renders them more convergent.

**IV. Defects in Lenses.**—The statements as to foci are not rigorously true in practice, as lenses are subject to the defects called *Aberrations*.

(a.) **Spherical Aberration** is so named from being due to the

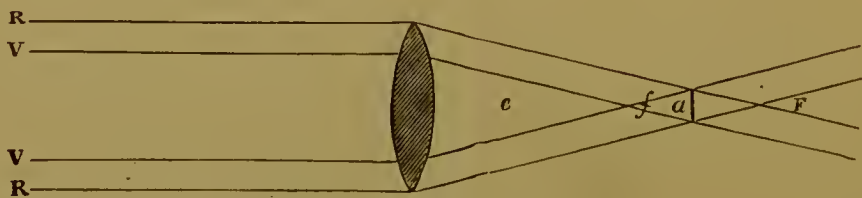

FIG. 10.

spherical shape of the lens surfaces, which causes the rays *R, R*, passing through the margin of a lens to converge to a point different

to that at which rays meet when refracted through the central portion, as illustrated in Fig. 10, while  $a$  is the circle of least aberration, as it is the smallest area which includes all the refracted rays. This effect increases as the curvature of the surfaces increases, and is therefore less for a given focal length with a lens of greater refractive index.

The spherical aberration of a single lens can be nearly overcome by the use of a diaphragm placed at such a distance in front of the lens as to cause the image to be formed at the centre by rays passing through the centre only, and the outer portions of the image by rays passing through the margin of the lens obliquely through the diaphragm, as in Fig. 11, all those rays which (as the previous figure shows) would render the image indistinct being now cut off. A meniscus lens used in this way gives the flattest field; but a plano-convex permits of the use of a larger aperture, and is thus preferable where the angle of view is limited and rapidity is required.

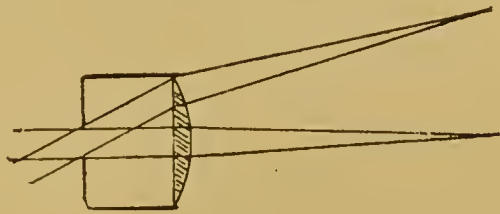

FIG. 11.

The other method of destroying spherical aberration is by the use of a second lens to produce a contrary effect. A divergent lens is associated with a convergent, and *vice versa*, in such a way that the associated lens brings the marginal rays to the same point as the central rays. In thus correcting spherical aberration, the second defect in lenses, chromatic aberration, is also corrected; therefore, the two associated lenses must be of glass of different kinds; further, chromatic aberration being the more important, spherical aberration is often over-corrected, and the combination has negative spherical aberration, the marginal rays focussing to a point farther away than the central rays, or it may be insufficiently corrected and have positive spherical aberration, the marginal rays having the nearer focus.

Objectives corrected for spherical aberration, so that they may be employed with their entire aperture, are aplanatic. A non-aplanatic lens produces only confused images if used with its full aperture.

(b.) **Chromatic Aberration** is a necessary consequence of the refrangibility varying with wave-length, for the red and violet rays will be brought to a focus at different points; thus the image of a point is not sharp, but surrounded by rings of colour. Besides, as some rays exceed others in luminous effect, and others, again, have greater actinic power, the focus for the visual rays (*i.e.*, the focus as judged by the eye) will not be true for the actinic or chemical focus (*i.e.*, for the rays which produce the photographic effect).

A diaphragm is here of no practical use, and chromatic aberration

must be corrected by combining suitable lenses, made of material with different dispersive powers. The convergent lens is usually crown glass, and the divergent lens flint glass, the two being cemented together face to face. Still, a lens achromatic for two central rays of a certain wave-length (*i.e.*, a lens which brings them to a focus at the same point) will not be achromatic for marginal or oblique rays, nor for those having refrangibility different from the two selected rays; combinations are, therefore, made so as to bring the most luminous and most chemically active rays to the same focus, thus ensuring that the photographically produced image will equal in sharpness that as judged by the eye. But though the visual and chemical foci may be coincident at the centre of the ground glass, they will not be so at the margin, where there will be what is called a chemical focus; and though the image will appear sharp all over, the photographic reproduction will not be sharp at the margin.

Chromatic aberration may be over- or under-corrected, as is the case with spherical aberration. When over-corrected, the chemical focus is farther from the lens than the visual focus, and *vice versa* when under-corrected; experiment will soon show the difference between the two foci, and the ground glass can then, after focussing, be pulled out or pushed in to this extent to place it at the chemical focus. (See *Focimeter*.)

(c.) **Aberration of Form of Image**, called also *Curvature of Field*, means that the image formed by a lens does not lie upon a plane, but on a curved surface; thus any number of points A, B, C (Fig. 12), all in one plane and so far away as to be practically equidistant

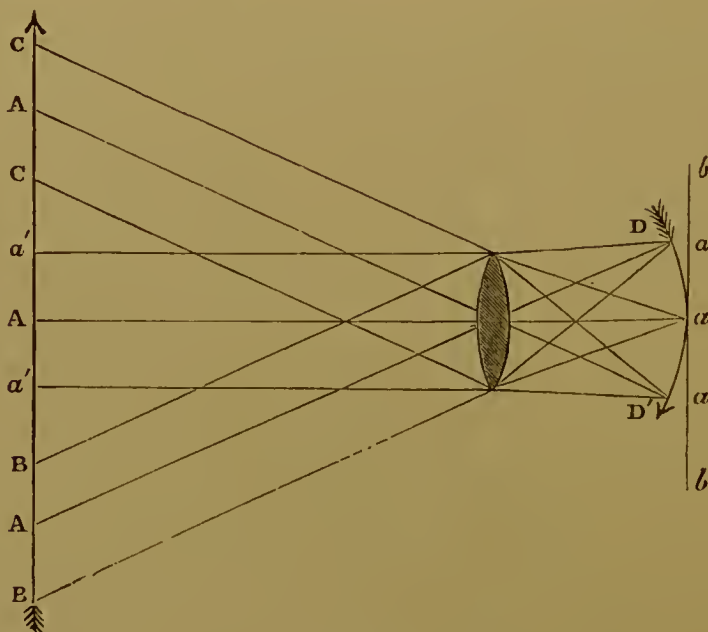

FIG. 12.

from the lens, will form images  $a D D'$  at a distance from the optical centre nearly equal to the focal length; the images will therefore lie on a curved field as shown in the figure; and the photographic plate being a plane surface, cannot receive a sharp image over its whole area at the same time.

(*d.*) **Flatness of Field.**—It is evident that a portrait lens constructed to give good definition for a sitting figure would not be equally well adapted for taking a standing figure. Before the introduction of quick plates lenses of large aperture were necessary, and the requisite flatness of field and depth of focus could not be obtained with the same lens without the use of diaphragms; therefore the curves of the lens had to be adapted for the purpose, and “flatness of field” was one of the requirements when good definition of a figure in a standing position was desired. As lenses of the rectilinear type are now often used in place of those specially constructed for portraits, and as the quickness of the processes now employed permits the use of diaphragms, the defects of the older forms of lenses may be avoided.

Referring to Fig. 9, we see that a stop will, to a certain extent,

overcome curvature of field, since it increases the depth of focus; thus in Fig. 13 the ground glass could be moved to somewhere behind  $f$ ,  $g$ , and in front of  $e$  without sensibly impairing the definition of  $e$ ,

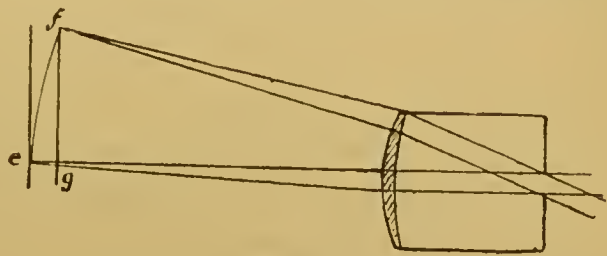

FIG. 13.

but at the same time bringing a greater number of points of the curved image upon the ground glass. The effect, however, is small compared with the amount

of curvature, so that a combination of lenses must be used together with a diaphragm.

Take the case of a simple convergent meniscus, used with a diaphragm; direct and oblique parallel rays focus on a curved surface, since the marginal rays have a smaller focal length than central rays; but

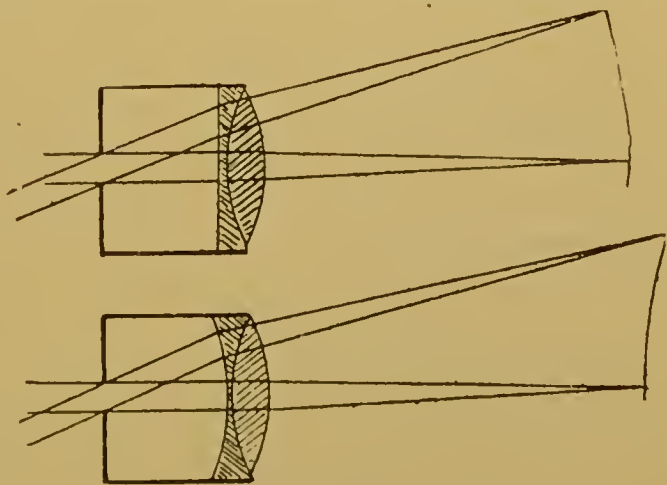

FIG. 14.

with a divergent lens the marginal rays will have the greater focal length and the curvature of field is reversed; therefore, by a combination of a positive with a negative lens the two effects can be

neutralised ; and, since the same association is used to produce achromatism, it is possible to so select the two lenses and the position of the diaphragm as to obtain flatness of field as well as securing achromatism ; but, as with spherical and chromatic aberration, there may be under- or over-correction, so we can have negative aberration of form with a convergent and positive with a divergent combination (Fig. 14). Although a comparatively flat field can be obtained with single achromatic combinations, the greatest flatness has been secured by associating a convergent with a divergent achromatic lens at a suitable distance apart.

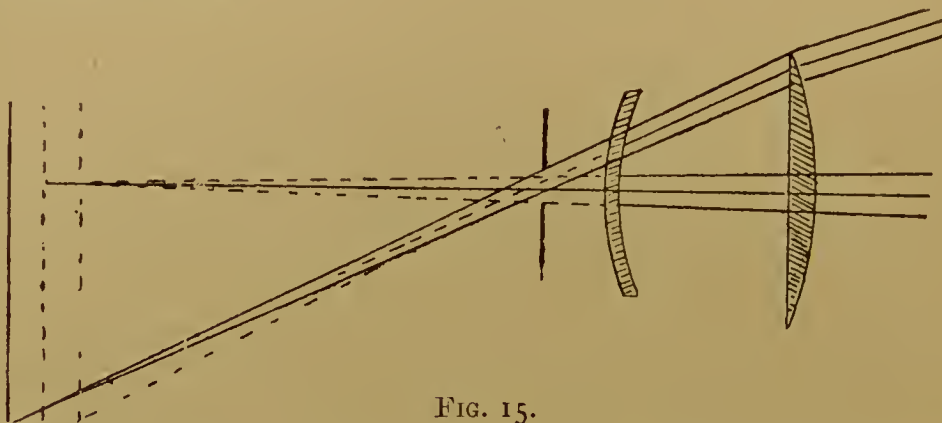

FIG. 15.

The orthoscopic and triplet lenses are thus arranged, as will be explained in the description of these objectives.

(e.) **Distortion.**—Any departure from the rules of perspective of an image formed by a lens is called distortion. As the lens varies in thickness, being thickest at the margins or at the centre in divergent and convergent lenses respectively, the refraction of a ray will be greater or less according as it falls nearer to or farther from the margin, or *vice versa* ; so that the distortion which this produces has been called *Aberration of Thickness*.

The effect consists either in the curvature of the images of straight lines produced by marginal rays causing barrel-shaped or “pincushion distortion” (Figs. 16*a* and 16*b*), or in the exaggeration of certain objects with respect to others. As these defects are most apparent in the reproduction of buildings and similar rectilinear objects, a single achromatic lens is sometimes known as a landscape lens, from the work for which it is most suited.

With the simple objective the direction of distortion is altered according as the diaphragm is before or behind the lens (as is shown in the figures above) ; so that by placing the diaphragm between two similar simple lenses their distortion neutralises each other ; and we get straight lines as images of straight lines, *e.g.*, globe-lens, periscopic ; a single simple lens will also give an image free from distortion provided it is merely a reproduction of the same size as the object.

The distance of the diaphragm from the lens must also influence the amount of distortion, since the nearer it is to the lens the nearer do the rays pass through the centre, and, therefore, the less is the aberration due to differences in its thickness, until, when used as a stop, there is no distortion.

Distortion can also be remedied by using a third and divergent lens, as negative and positive lenses produce opposite effects (*e.g.*, Sutton's triplet, Dallmeyer's triplet and rectilinear, &c.).

(*f.*) **Astigmatism** is a defect most general in portrait lenses, and refers to the impossibility of focussing at the same time vertical and horizontal lines, the rays from which pass obliquely through the lens; this is because a lens has two focal lengths in perpendicular planes for rays passing obliquely through it; *e.g.*, a point cannot be focussed as a point when, viewed through the margin of the lens, we get in one

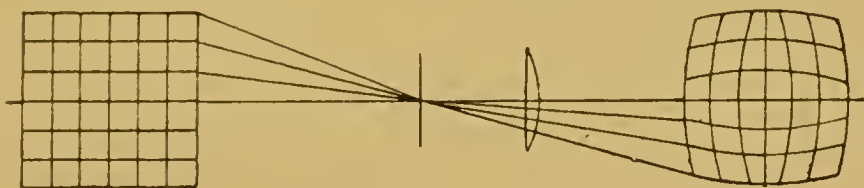

FIG. 16a.

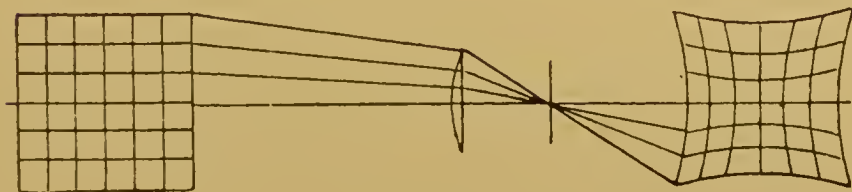

FIG. 16b.

position a line, the primary focal line, and by moving the ground glass a line is obtained, the secondary focal line, which is perpendicular to the primary.

Astigmatism cannot be entirely removed; so it has to be reduced to a minimum by the use of the diaphragm, which acts in the usual manner by dividing the lens into as many separate lenses as there are radiating points of different incidence.

**V. Objectives.**—The irregularities of refraction, extent of depth of definition, and other optical peculiarities to which lenses are subject, necessitate the use of particular combinations for special purposes; for this reason a lens is frequently known by a name signifying the photographic uses to which it is adapted. We thus have landscape lenses, portrait and copying lenses.

(*a.*) **Landscape Lenses.**—The special requirements of a lens for landscape uses depends upon whether the view to be reproduced

contains living figures or not; whether it is of animate or inanimate nature; and also upon the relative size and nearness of any buildings which may be included within the picture; besides these, there is the consideration as to the size of plate the lens will cover, *i.e.*, its angle of view.

*The Single Achromatic Objective* is a meniscus composed of two lenses, a flint-glass lens cemented to one of crown-glass, in which, with the exception of the Ross view lens (Fig. 17, 2), the convex side of the meniscus is turned towards the ground glass (Fig. 17, 2). The flatter the lenses the greater the rapidity obtained, as a diaphragm with larger aperture may be used; with the deeper forms the diaphragm can be placed farther back, thus including a wider angle, producing less distortion, and yielding a picture covering a wider area, but the definition is impaired owing to the field being less flat.



FIG. 17.

Dallmeyer's single landscape lens (fig. 17, 3) has the flint meniscus placed between two crown-glass lenses, the whole forming a slight meniscus, turned, as usual, with its concave surface towards the object. It includes a large angle; but, as with all non-aplanatic combinations, it requires a very small diaphragm; hence it is most suited for landscapes without figures. One advantage of this lens is the absence of the luminous spot or flare upon the focussing screen, caused it may be by the lens surfaces acting as reflectors where the light is not transmitted nearly normal to the refracting surfaces, or by reflection from the bright edges of the lenses or diaphragm.

*Steinheil's Periscopic Lens* consists of two meniscus crown-glass lenses (Fig. 18) having the convex surfaces outwards and a diaphragm midway between them. It is symmetrical, non-achromatic, and non-aplanatic. The correction for the chemical focus is made by advancing the plate, before exposure, by  $\frac{1}{40}$ th of the focal length of the lens. It requires very small diaphragms, and is but little used.

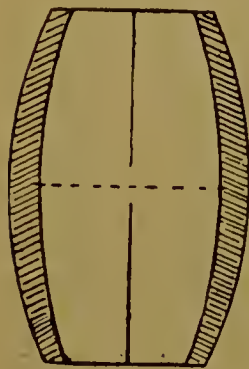

FIG. 18.

*The Globe Lens* is another non-aplanatic symmetrical objective. It is free from distortion, has no chemical focus, and includes a very large angle. Its name is taken from its globular shape, the two deep meniscus lenses being achromatised by concavo-convex flint-glass lenses forming portions of the same sphere (Fig. 19). Its great spherical aberration requires the use of a very small diaphragm, so that it is only available for inanimate landscapes, architectural reproductions, &c.; but, as regards the first, the long exposure produces solarising, and there is always an absence of cloud effects.



*Sutton's Panoramic Lens*, like the above, has a globular outline, and is formed of two concavo-convex spherically curved lenses with water in the hollow between them (Fig. 20). It is symmetrical, non-aplanatic, but achromatic. The fact that the picture is entirely formed by axial rays, which fall normally upon the plate, causes it to produce a panoramic picture, each portion of which is correctly seen only when brought directly opposite the eye. But as it requires the use of curved plates, it can never be of general utility.

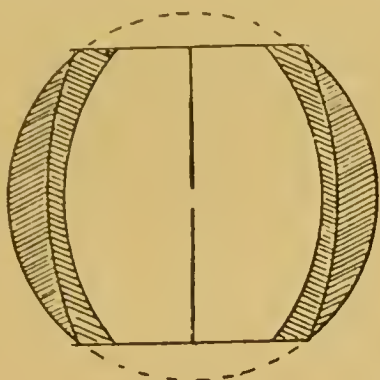

FIG. 19.

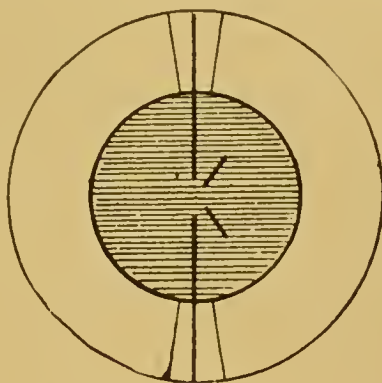

FIG. 20.

*The Orthoscopic Lens*.—Unlike the four combinations just described, this is aplanatic. Its composition is a front achromatic meniscus lens with the convex side towards the object, and formed, like the portrait combination, of a biconvex crown-glass lens cemented to a biconcave lens of flint-glass (Fig. 21). The back lens, which is smaller and placed very near the front, contains a biconcave crown-glass and a flint-glass meniscus, with its concavity towards the crown-glass lens; thus the two cannot be cemented together. The back combination lengthens the focus considerably, and enables it to cover a much larger plate. The orthoscopic lens can be used with a large aperture, and very great sharpness can be obtained. Lack of freedom from distortion prevents its use for architectural reproductions, engravings, &c.; but its rapidity and intensity of definition makes it suitable for outdoor groups, while portraits may be taken with it in a very good light. It does not include a wide angle, and when such a view is required the single landscape lens is to be preferred.

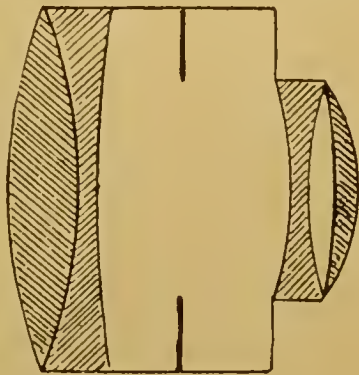

FIG. 21.

*Steinheil's Aplanatic Lens* consists of two cemented achromatic meniscus lenses all composed of flint-glass (Fig. 22). Its aperture is as much as  $\frac{f}{7}$ ; and it is, therefore, very rapid and useful for outdoor portraits, groups, &c. It is symmetrical. There is also a wide angle aplanatic.

*Doublets.*—A doublet consists of two combinations, which mutually neutralise distortion, and with a diaphragm placed between them. Some of the lenses already described are doublets. When the two lenses of the doublet are similar, they form a symmetrical combination; when dissimilar, an unsymmetrical.

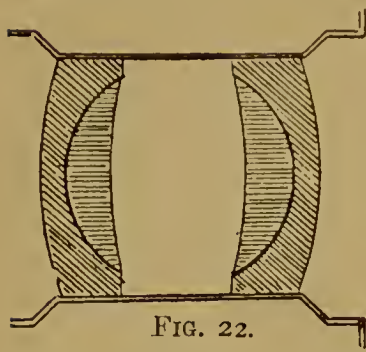

FIG. 22.

*Goddard's* lenses have a deep meniscus. In his combination landscape lens it is behind a biconcave crown-glass, forming the back lens.

His double periscopic has the meniscus touching a front combination of a biconvex crown-glass lens, cemented to one of bi-concave flint-glass.

*Ross's Wide-Angle Doublet* (Fig. 23) is non-aplanatic. It includes as wide a field of view as any, with equal freedom from distortion and flare, and with equal definition. Each lens is an achromatic meniscus, and the two are of nearly equal focal length. It includes an angle of at least  $80^\circ$ , and has less spherical aberration than the globe lens. Its great utility is as a view-lens and for photographing buildings at short distances, owing to its freedom from distortion. It is corrected for astigmatism; but as the large field of view covered requires a diaphragm of small aperture, it cannot be used for anything but inanimate nature.

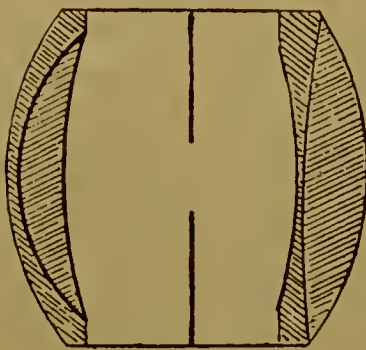

FIG. 23.

*Ross's Instantaneous Doublet* is also non-aplanatic. It includes a very much smaller angle, allowing a correspondingly larger aperture to be employed, and thus acts with

great rapidity. The lenses are farther apart than in the wide-angle lens, as it is intended to define sharply with a larger aperture. As smaller diaphragms can be employed, so as to include an average and sufficient angle of view, this lens is the more generally useful of the two. It is also an excellent lens for copying purposes.

*Dallmeyer's Wide-Angle Rectilinear* (Fig. 24) includes almost as

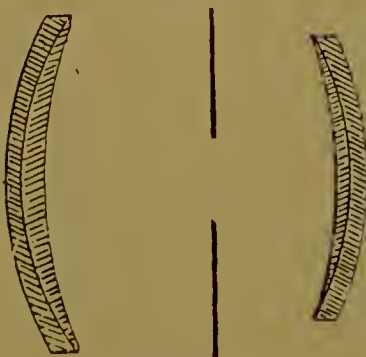

FIG. 24.

much as  $100^\circ$ . The front lens has a longer focus than the back, and also a greater diameter, distortion being corrected by placing the diaphragm nearer the back lens. It must not be forgotten, however, that in any lens including a very wide angle considerable skill and judgment is necessary to produce anything of artistic value.

*Dallmeyer's Rapid Rectilinear* (Fig. 25), like the former "Rectilinear," and unlike the other doublets, has both its flint-glasses on the outside. The

crown-glass meniscus is cemented to the flint-glass lens by its convex surface. This lens is aplanatic, and, giving sharp definition without a diaphragm, works with great rapidity. It can be used to include a sufficiently large angle by taking a smaller diaphragm, and is also very useful as a copying lens. With gelatino-bromide plates and in a good light this form of lens may be used for portraits.

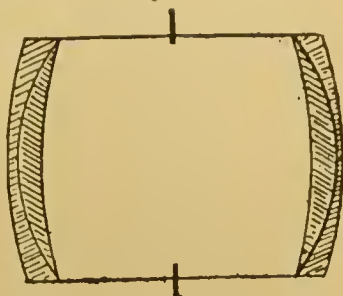

FIG. 25.

*Triplets* are composed of three combinations of lenses, and include those of Sutton, Goddard, Ross, and Dallmeyer. *Sutton's Symmetrical Triplet* was the first view-lens constructed free from distortion. The use of a triplet is not so general as formerly, as many of its advantages are now included in the more simple, and therefore less expensive, doublets; but its power of use with a large aperture still makes it of value for photographing animate nature, groups, &c., being in this respect much superior to the orthoscopic.

*Dallmeyer's Triple Achromatic Lens* (Fig. 26) has an achromatic convergent meniscus at both back and front, formed of a biconcave flint-glass lens cemented to a biconvex crown-glass lens; the back combination has the greater diameter and longer focus, and the concave face of each is directed towards the centre of the combination. Between these two lenses is the third; it is nearer the front lens and has its convex surface towards it. It is also an achromatic meniscus, but divergent, and is composed of a biconvex flint-glass lens cemented to a biconcave crown-glass lens. The diaphragm is introduced just in front of the centre lens. It is aplanatic, and free from both flare and distortion. With full aperture it can be used for groups and instantaneous pictures; and, when time is unimportant, greater depth of focus will of course be secured by the use of smaller diaphragms. The triplet is an excellent copying lens, and for enlargements is reversed, so as to place its largest lens facing the object to be enlarged. But it does not surpass the doublets and rectilinears for this purpose. The triplet of Ross has plano-convex and plano-concave lenses in place of the weak meniscus in the objective.

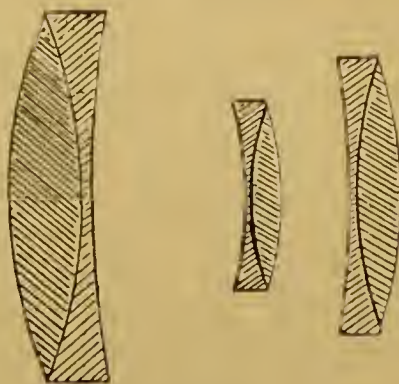

FIG. 26.

(b.) **Portrait-Lenses**, from the use made of them, require to be rapid; and must, therefore, be used with a large diaphragm; they only include a small angle of view. Though the axis of the objective may be capable of being slightly inclined, any departure from a truly

horizontal position should only be resorted to under exceptional circumstances, as it will not cause so great a deformation when the objective has a long focus. In general the axis of the objective should be kept horizontal. Portrait-lenses of the present day are almost all made on the pattern of the original objective devised by M. Petzval.

*The Double Portrait-Lens* (Fig. 27) consists of an achromatic meniscus or nearly plano-convex cemented front combination with a biconvex back combination composed of a divergent meniscus of flint-glass at a short distance from a biconvex crown-glass lens.

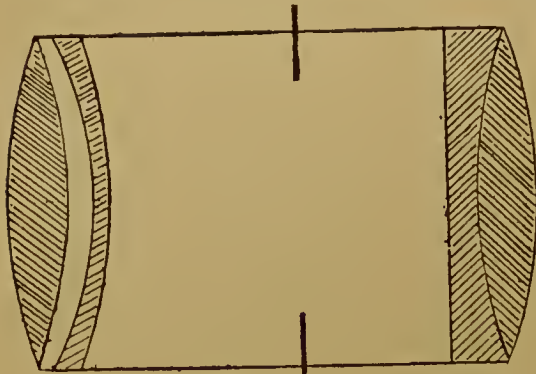

FIG. 27.

The diaphragm is placed between the two combinations, the front one of which is usually slightly the smaller. Dallmeyer constructs a portrait-lens (Fig. 28) which has a meniscus for the back lens composed of a flint-glass diverging meniscus next the ground glass and a crown-glass meniscus slightly separated from it, and an arrangement by which the two lenses of the back combination may be further separated allows any desired degree of want of sharpness to be obtained by the introduction of spherical aberration.

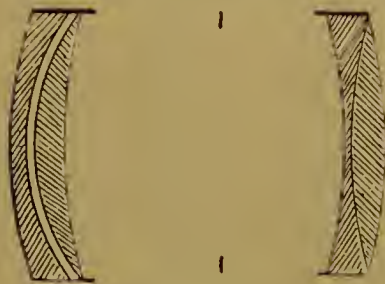

FIG. 28.

The use of these lenses in portraiture depends upon their comparative rapidity with a diaphragm of at least  $\frac{f}{8}$  aperture.

They have but little astigmatism, and are free from distortion, provided the diaphragm is placed between the lenses. By the use of smaller diaphragms the same lenses may be used for groups, say with  $\frac{f}{16}$ ; or for landscapes, with  $\frac{f}{20}$  to  $\frac{f}{30}$  aperture.

The use of the triplet, orthoscopic, and rectilinear for taking portraits has already been referred to in the description of these lenses.

It now only remains to be said, that as regards the camera in which the photographic objectives are used, its axis may, in landscape-work, be inclined up or down, the absence of uniform straight lines causing any deformation of image to be imperceptible. On the other hand, when buildings are present, or when a building is to be reproduced photographically, the camera must be kept strictly horizontal, any departure from which will produce an effect which can only be

corrected by using a camera with a *Swing-back*. Also the distortion given by the orthoscopic and single objectives makes them unsuited to this kind of work. Lastly, in copying engravings, maps, &c., the camera must not only be kept horizontal, but the object to be copied must also be vertical and the image symmetrically placed upon the ground glass. The lens most suitable for copying is the rectilinear.

---

## CHAPTER IV.

### LIGHT IN PHOTOGRAPHY.

UNDER the heading *Developing and Developers* will be found an account of experiments by M. Moser and others on the peculiarities of the action of light. The question which a photographer generally has to consider is—whether the light is *good* or *bad*, as upon the one or the other will depend the result of his work. He does not, as a rule, concern himself as to the qualities which light possesses, or whether the true theory is the *corpuscular* or the *undulatory*. He knows that if he is using a collodion plate, a certain amount of yellow light in the room he is working in will not injure his picture; but, on the other hand, if he is using gelatine plates, he is aware that if the light is not of a certain quality, his work will be “fogged;” and further, that, with very sensitive plates, he must use still greater care to exclude the actinic rays.

This is not, however, the place for a treatise on light, and the reader is referred to works specially devoted to the subject, such as Hunt’s “*Researches on Light*.” It is well to remember that light acts in “inverse proportion to the square of the distance from its source.” This is correct as to light generally, but it will be more readily noticed when working with artificial light. (See also *Optics of Photography*.)

**Electric Light.**—Various methods may be adopted for producing the electric light for photographic purposes. The voltaic battery, necessitating the use of acids, zinc, and cells, is not only troublesome, but costly. Next we may use storage batteries. This also is costly, as many batteries would be required for a large light; and to this must be added the cost of charging. When required as a substitute for daylight in dull weather, a complete installation for the production of the electric light is desirable, and in the dynamo, driven by a gas-engine, we have the most convenient method. In situations where a steam-engine could be used, that method of producing the power should, perhaps, be preferred. But a gas-engine can be erected in

situations where a steam-engine could not be, and it has the advantage that the power can be brought into use in the course of a few minutes. The dynamo may produce the current in the alternating or direct way. When it is desirable to keep the light quite central, the alternating machine is preferable, as, for instance, when optical

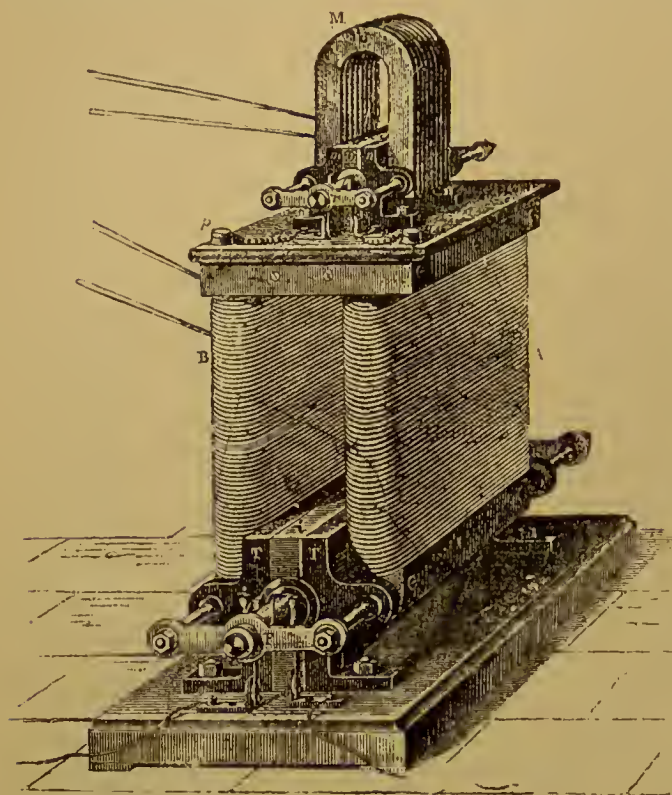

FIG. 29.

appliances are used in enlarging; but for most purposes in photography the direct-current machine is most suitable. In this machine the point of light is constantly falling as the carbons are consumed, the top carbon burning twice as fast as the bottom one, but this is of very little consequence. There are many kinds of dynamo in use—one of several forms invented by Mr. Henry Wilde, F.R.S., is shown in Fig. 29. Mr. Wilde was not only the inventor of the dynamo, but

was the discoverer of the principle by which quantities of electricity and magnetism indefinitely large were induced from quantities indefinitely small, and it is this principle which makes the electric light practicable for illuminating purposes. Some of the earliest experiments with the light for photographic use were made by Mr. Wilde. It is perhaps needless to say that with any kind of dynamo of sufficient power a light suitable for photography may be obtained; but the writer, in what follows, speaks from experience with a machine made by Messrs. Crompton & Co. of Chelmsford. The light is used for copying and sometimes for printing. The engine for producing the power is of the "Otto" form, vertical, of 2 horse-power nominal, or about 3 or  $3\frac{1}{2}$  actual. It runs at about 170 revolutions per minute, and this from the fly-wheel of 4 feet diameter on the 6-inch pulley of the dynamo gives a speed of about 1350 revolutions per minute, and this power is said to give from the lamp burning carbons of 13 mm. a light of 2000 candles; but whether the light be 1000 or 2000 candle-power, the effect produced is adequate to enable copies to be made with sufficient rapidity. To specify the number

of minutes required for exposures would be useless, as the time varies from many causes, such as the lens and stop used and the distance of the object from the light; it may, however, be said that the electric light is many times quicker than ordinary daylight in the winter-time.

The light must of course be used naked—that is, without the opal or other glass globe; but as pieces of hot carbon are apt to fly off, some kind of protection should be adopted. This may be made of tin or zinc, and may be suspended from the lamp; the bottom of the shield will collect much of the dust from the burning carbons; the back acts as a protection to the eyes; and the inside may be white-washed so as to form a reflector. The carbons should be adjusted so that the crater burns as shown in Fig. 30. This has the effect of throwing the light in the direction required. As much of the effectiveness of the light depends on this adjustment, some care should be taken to have it right. As to the distance apart of the carbons, the most effective light is obtained when the distance is about  $\frac{3}{16}$ ths of an inch. When the current is too strong, an arc of  $\frac{1}{4}$  inch or more may be formed, and at the same time a less effective light. By lowering the speed of the engine the proper arc may be maintained; but when the lamp is once adjusted it should not be altered; the slight variation in the speed of the dynamo is not of much consequence. It is chiefly in examining the light to see that this adjustment is correct that it will be necessary to look at the arc, and this should seldom be done without the protection of a piece of smoked glass. Looking at the naked light too frequently may cause very unpleasant effects from inflammation; “dust in the eyes” is the sensation experienced. A saturated solution of boracic acid may be used to bathe the eyes when this occurs, but it will seldom happen if the precaution named be adopted.



FIG. 30.

The power of the electric light is inversely proportional to the square of the distance from the object to be copied, or of the frames in printing; therefore, whether it can be utilised in printing must depend on the possibility of arranging the frames in such a way that the time required will not be excessive. The frames must not be too close to the light, or the heat will probably crack the thick glass, or it may injure the varnish on the negative. To use the light exclusively for printing would not be economical, as to be effective the frames must be within two or three feet of the light, and at that distance, with the light here referred to, a print could not be obtained from a negative of ordinary density in less than thirty minutes.

When the electric light is used for portraiture the arrangement must be quite different from what is required in copying or printing,

and a much more powerful light will be required owing to the necessity for diffusion. If used direct, the light would cause intense shadows, and therefore the interposition of some semi-transparent material between the light and the sitter is essential.

The engine-power should be somewhat in excess of what would theoretically be sufficient for the dynamo and lamp, as resistance sometimes occurs; and when the driving-power is too evenly balanced with the dynamo, the light is affected; but this would not occur if there were power to spare in the engine.

The following information may be useful:—For a lamp to give 2000 candle-power the driving-power should be 2 horse-power and the dynamo capable of yielding 8 ampères = 50 volts. For 5000 candle-power the horse-power of the engine should be 3, and the dynamo 15 ampères = 50 volts; and for 20,000 candle-power the engine should be 6 horse-power and the dynamo 80 ampères = 50 volts.

On the management of a small installation very little need be said. The engine should be carefully and regularly cleaned and all the parts should be well oiled. The cups supplying the bearings of the armature of the dynamo with oil should be kept well supplied, and the brushes should be carefully adjusted and kept quite clean. When “sparking” occurs, the cause should be discovered at once and remedied, as, if neglected, the commutator will be damaged. The dynamo referred to above, and used by the writer during five seasons (that is, from November to March in each year), is now in perfect condition. This is partly due to the excellence of the machine, and it may be chiefly to the care taken in the adjustment of the brushes.

It can only be in exceptional cases when the electric light may be advantageously used for portraiture; but for copying and printing purposes it is often of much importance to be independent of daylight.

**The Electric Arc Lamp.**—Much of the pleasure of using the electric light for photographic purposes depends on the kind of lamp selected. There are many kinds of lamps in use, and probably one kind may be quite as useful as another; but as the writer has had very little experience with any other than the one supplied by Messrs. Crompton, and as that has fulfilled its purpose in a very satisfactory way, the following description is given by their permission. The lamp illustrated is a double one, that is, it contains two pairs of carbons and the necessary regulating apparatus, but both pairs do not come into use at the same time. The lamp used by the writer is a single one, but the description is equally correct for either.

The lamp referred to is known as the D.D. (double differential) form, and is the joint invention of Messrs. Crompton and Crabb, and is an improvement on the older forms in point of simplicity of construction, and also in regulation. This latter is effected by a brake-



wheel driven by the rack-rod attached to the upper carbons. In

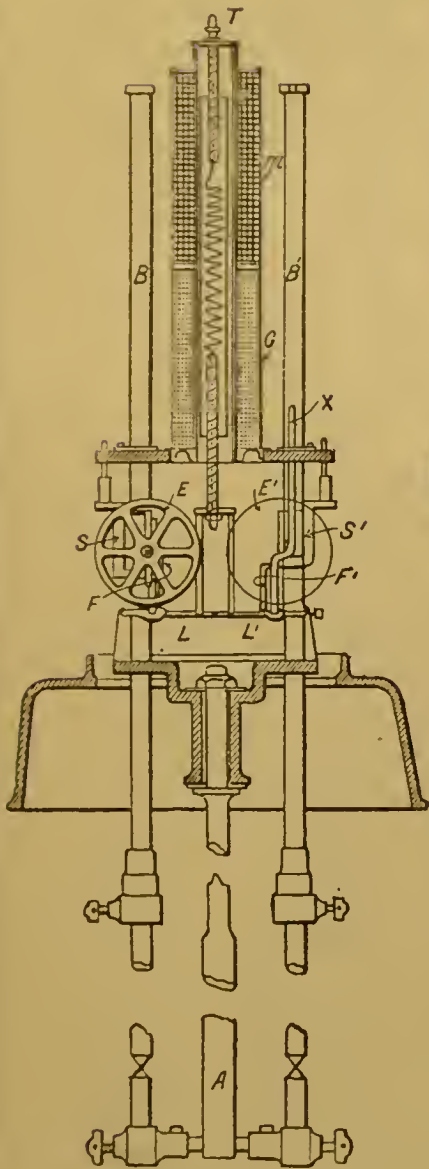

FIG. 31.

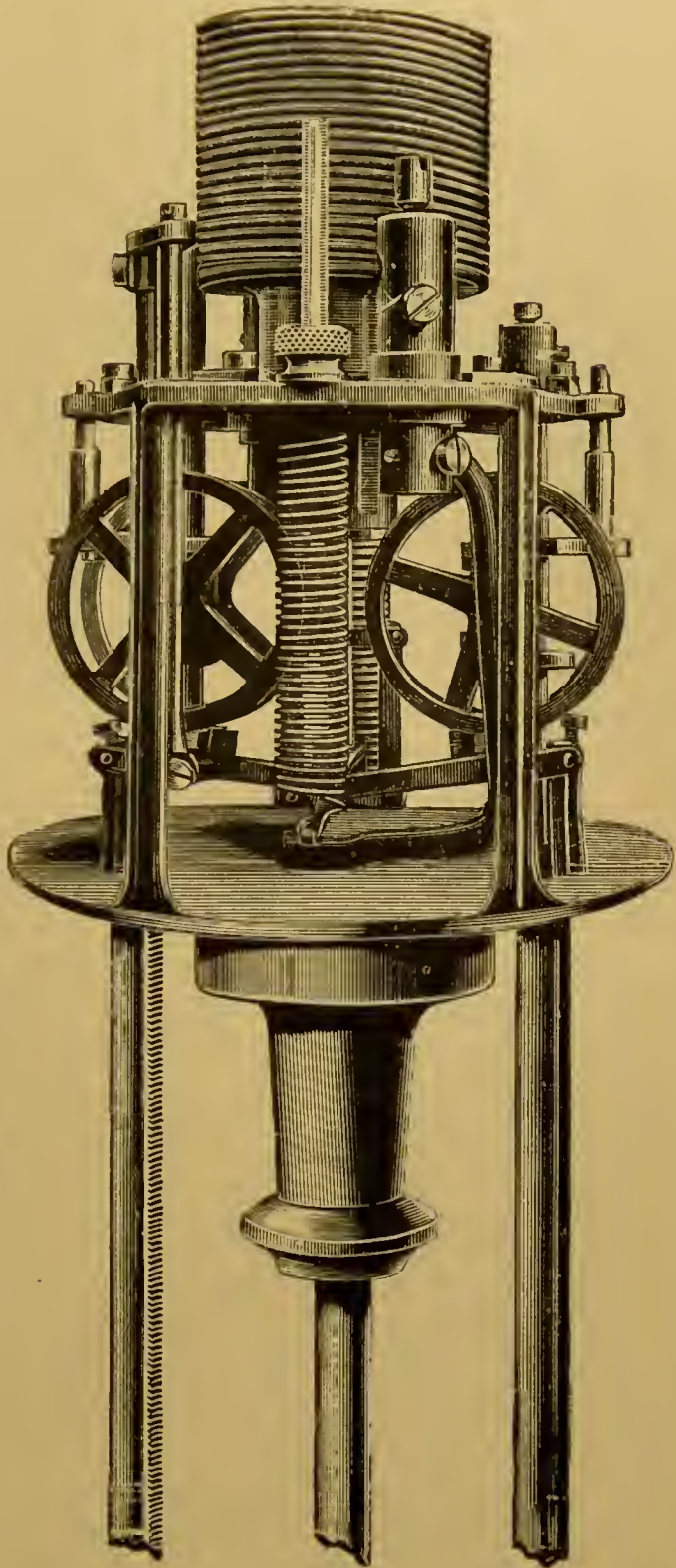

FIG. 32.

the D.D. lamp also the intermediate gearing between the brake-wheel and the pinion driven by the rack-rod is dispensed with.\* Referring

\* Since the description of this lamp was written Messrs. Crompton have introduced some changes in the construction, as will be seen by reference to the second figure.

to Fig. 31, B and B<sup>1</sup> are rack-rods carrying the positive carbons. Sliding on each of these is a light gun-metal sleeve, S S<sup>1</sup>, carrying spindles to which are attached the two large brake-wheels E E<sup>1</sup>, and between them the pinion which gears into the racks. These brake-wheels rest upon a pair of levers, the outer ends of which are pivoted to the framework of the lamp, their inner ends being connected by links to the core of the solenoid, which is placed in a central position vertically above the two inner ends of the levers. This solenoid is differential, G being the shunt and M the main coil, and the core is partially supported by a spring, whose tension can be regulated by means of the screw T. This is the only adjustment required in the lamp for the regulation of the arc. The proper length of the latter is from three thirty-seconds of an inch to three-sixteenths of an inch. The screw T is turned to the right to increase its length, and to the left to decrease it. Projecting vertically downwards from each sleeve to a distance from the centre of the spindle about equal to the radius of the brake-wheels is a stout pin or finger, F F<sup>1</sup>, the action of which is as follows:—

Suppose the rack-rod to be drawn up, then, if the lever be pulled by the solenoid above the horizontal position, the whole weight of the rod and carbon is supported on the edges of the two brake-wheels, and the friction of them on the surface of the levers is sufficient to prevent their revolution; hence this rack-rod cannot run down. But if the levers be below the horizontal, then the weight is carried by the finger projecting from the sleeve, as shown at F, the wheels are free to turn, the rack runs down, and continues to do so until the positive and negative carbon points come in contact. Now, let the current be switched on by its passage through the main wire of the solenoid; the levers are raised, striking the arc, and at the same time applying the brake to the wheels. The combined action of the shunt and main currents on the solenoid core automatically adjust the length of the arc. If this becomes too great, the increased current through the shunt draws down the core and levers, the brake-wheels are left free to revolve, and the arc shortens. On the other hand, if the carbon points be too close, the levers are raised, bringing with them the rack-rod and upper carbons. The fact of making the finger projecting from one sleeve longer than that from the other determines which pair of carbons shall begin to burn first, because on switching on, that pair which has the longer pin will be the last to break contact, and will therefore originate an arc in so doing.

When fitted with the full length of  $19\frac{1}{2}$  in. of carbon 13 mm. in diameter, the lamps will burn from 12 to 18 hours, according to the current passing, which may vary from 20 to 8 ampères, the light varying from 4000 to 1000 candles, the candle-power being measured

at an angle of  $30^\circ$  below the horizontal line, cutting the arc itself. The electromotive force required is 45 to 50 volts. This description refers to the lamp carrying two carbons. The single lamp with carbons of the same length will, of course, only burn half the time named.

**Oxyhydrogen Light.**—For convenience and quality there is perhaps no light to surpass that obtained by means of a jet of oxygen gas projected through a flame of hydrogen which is made to impinge on a disc or cylinder of lime, when the lime becomes incandescent and a very brilliant light is produced. This light was originally used for signalling purposes in Ireland by Lieut. (afterwards Captain) Drummond—hence the name, the “Drummond light”—and was found to be much superior to the Argand lamp, then in use in the Trigonometrical Survey for fixing the positions of distant signal-stations. The date of Captain Drummond’s adaptation of the light is about 1830. One of the earliest applications of the limelight was for the exhibition of microscopic objects by projection on to a disc or screen, and when used in the “magic” or optical lantern became a valuable means of illustrating lectures. The introduction of photography added greatly to the popularity of the lantern; and, with the improved optical appliances, the limelight is now generally used where formerly rough diagrams formed the means of illustrating lectures. The wonderful perfection of photographic views and pictures of all classes of subjects, whether shown by the single or the dissolving lantern, has tended to make limelight illustrations so deservedly popular.

The preparation of oxygen is a simple matter, but requires care. Take of powdered potassium chlorate 16 ounces, and 4 ounces of black oxide of manganese; these should be mixed together and placed in a retort, which may be heated over a clear fire or Bunsen burner. The gas which is evolved should be passed through a “wash-bottle,” then into the india-rubber bag, all atmospheric air being first forced out. The principal caution to be observed in making oxygen is to see that the manganese dioxide is pure, and this is roughly ascertained by heating a small quantity with three times its weight of potassium chlorate in a test-tube. The mixture should not show any combustion or sparking within itself, for this indicates the presence of impurities such as soot. Hydrogen is troublesome to make, and as common coal-gas forms a good substitute, it is generally used in producing the limelight. When the pressure from the gas-main is not sufficient, the gas can be stored in a bag and pressure applied in the usual way.

Oxygen gas is now supplied in steel cylinders, and this form is in every way more convenient than making it at home, as it renders

gas-bags and weights unnecessary. The condensed gas is safe to use when the supply is carefully regulated.

An excellent light is produced when the oxygen is blown through a flame of spirits of wine, and it is then called the oxycalcium light. The vapour of ether when mixed with oxygen gives a good light, but although the apparatus has been improved, it cannot be said that there is no danger in its use. (See *Ethoxo-Limelight*.)

It is difficult to estimate the intensity of very bright lights; the eye alone cannot do it; and therefore a comparison with a standard light becomes necessary; that from a spermaceti candle burning two grains per minute is generally adopted. With this light the flame of an Argand burner can be adjusted, and against this the more intense limelight can be tested. Determinations made in this manner give from 250 to 800 candles as the value of the light from incandescent lime. The great difference arises from the kind of burner used, the size of the aperture through which the oxygen is passed, and the degree of pressure. The kind and form of the lime used also affects the quality of the light. Great care must be taken to avoid *pitting*—an effect caused by the jet of gas burning away the lime in the form of a hollow or pit, which not only reduces the light, but endangers the condenser in the lantern by causing the jet to project the heat on to the glass. The remedy for this fault is to cause the lime to revolve, either by clockwork or by hand.

**Continuing Action of Light.**—The fact is well established that the light has a *continuing action* on a gelatine film which has been made sensitive to light with potassium bichromate, that is, paper prepared for carbon-printing, after exposure to light for less time than would be necessary if the picture were to be developed *at once* will, after a few hours, become fully printed; thus proving that the change set up by exposure to light continues when the picture has been removed into the dark.

It has been stated that gelatine negatives have been known to possess this quality of continuing the action of light after exposure; but on this point the writer has some doubt, as quite recently in his own experience a negative was developed on a gelatine plate six years after the exposure had been made; and the result showed that there had been no continuing action of light, as also that a good negative may be developed six years after exposure. It may happen that gelatine negatives become more dense in the printing frame or when left exposed to light; but the cause of this is quite different from the case under consideration.

**Compressed Gas.**—The ordinary method of using bags to contain oxygen and hydrogen gases is now being superseded by cylinders in which the gas is compressed. The cylinders are made of iron or

steel; the latter, being the lighter and stronger, is more generally used; and are made to hold 15 or 30 cubic feet of the compressed gas. As the compression may amount to over 100 atmospheres it is too great for use with the optical lantern, and the control of the admission of the gas to the lantern is obtained by the use of a pressure gauge. As the cylinders are lighter and less cumbersome than the pressure boards, bags, and the weight necessary to produce the pressure, the convenience of the cylinder is very great.

**Ethoxo-Limelight.**—Now that oxygen and hydrogen gases can be obtained compressed in cylinders of convenient size, it is scarcely advisable to use any substitute for the hydrogen. Ether can be used, and various plans have been proposed by which danger is minimised; but in the hands of inexperienced persons there is danger, and as the gas cylinders may be considered safe, the use of ether is not recommended.

**Magnesium Light.**—The extensive use now made of the metal magnesium renders it desirable that some facts relating to it should be stated here. About the year 1808 Sir Humphry Davy, at the Royal Institution, London, by means of large electric batteries, succeeded in decomposing earths and alkalis and demonstrated their metallic bases. A new field of research was thus opened, and one result was the discovery of the metal magnesium. Although the metal was known, it remained for about half a century little more than a scientific curiosity. When combined with oxygen, in the form of magnesia, the substance was used as a medicine; the smoke or fumes which are seen when the metal is burning, and which remains for some time suspended in the atmosphere, is this magnesia. Sir H. Davy did very little more than prove the existence of the metal, and for about twenty years after nothing appears to have been done to carry the experiments further, until in 1827 it was shown by Wöhler that by the decomposition of the chloride of aluminium by potassium the metal aluminium was formed, and it occurred to M. Alexandre Bussy, a Parisian chemist, that it would be possible to separate magnesium in the same way from its chloride. By fusing that chloride with potassium he succeeded in obtaining globules of the metal magnesium. Bunsen and other chemists succeeded in obtaining the metal by electrolysis, and in 1856 the chloride of magnesium was reduced by *sodium*, the fluoride of calcium being used as a flux. By this method the metal was obtained in larger quantities. While effecting this, Deville and Caron at the same time showed that the metal was very volatile, and this property was later on utilised in its purification. Magnesium was still little more than a laboratory curiosity. In 1859 Bunsen of Heidelberg and Dr. (now Sir) H. E. Roscoe of Manchester pointed out the value of magnesium as a source of light for photographic purposes. About this time the

Memoir of Bunsen and Roscoe was seen by M. Edward Sonstadt, and it occurred to him that the metal could be made on a commercial scale. In 1862 he had so far succeeded that he took out his first patent for "Improvements in the manufacture of the metal magnesium," at the same time he was enabled to show specimens of the metal varying in size from a pin's head to that of a hen's egg. By a further series of experiments Sonstadt succeeded in purifying the metal by distillation, and in 1863 one of the first lumps of the purified metal was presented to Professor Faraday at the Royal Institution, London, the place where the metal was first discovered. "This is indeed a triumph," was the remark made by Faraday when he first handled the mass of metal; and a year later, when he saw a still larger mass, he is reported to have said, "I wonder it does not take fire spontaneously," so great is the affinity of the metal for oxygen.

The manufacture of magnesium was commenced in Manchester in 1863, a company having been formed for the purpose. There are three stages in the manufacture of the metal:—I. The preparation of the anhydrous magnesium chloride; II. the release of the magnesium from the chlorine; and III. the purification of the metal by distillation. I. In the first stage, lumps of rock-magnesia (magnesium carbonate) are placed in jars and saturated with hydrochloric acid. The metal magnesium is contained in the rock combined with carbon and oxygen; the magnesium combines with the chlorine of the acid, and chloride of magnesium is formed in solution. The solution is next evaporated, and when sufficiently dried the salt is heated in a crucible to drive off the whole of the water, and the chloride is then stored in air-tight vessels. II. The metal sodium is next required to reduce the magnesium from the dried salt. Sodium itself is a very curious metal, having great affinity for oxygen and decomposing water in a way similar to potassium. Five parts of the dry magnesium chloride with one part of sodium are placed in a crucible, which is covered and heated to redness, when the chlorine leaves the magnesium and goes over to the sodium. On cooling, the new metal is found in nuggets of various sizes, and in this state is called crude magnesium. III. In the third stage the distillation is effected; the metal is vapourised; the vapour is condensed in a finely divided state, and in the solid subsequently melted and cast into any form desired. As at this time no other use for the metal was known than that of a means for producing a brilliant light, it became a question as to how to utilise it. The wire form was found to be the most convenient. As the metal is not ductile, the wire was made by pressure, and this is effected in a very ingenious way. The nuggets are put into an iron vessel which is heated to redness by gas, one end being open to receive the ram of the hydraulic press, and the other having a hole

the size of the wire required, and through which the wire is forced. In this form the metal could be used as a source of light. The first notice of experiments with it may be found in one of the Manchester papers about the end of 1863 or early in 1864. "*Interesting photo-chemical discoveries.*—At a recent meeting of the Manchester Literary and Philosophical Society, Professor Roscoe exhibited the light emitted by burning a portion of a fine specimen of pure magnesium wire 1 mm. in diameter and 10 feet long, which had been manufactured by M. Sonstadt." After the meeting a small lump of the metal was presented to the writer, which was hammered into a thin sheet, and with strips cut from it experiments were made which are alluded to in the paragraph referred to above, as follows: "The result of an experiment I have just made is that in fifty seconds with the magnesium light I have obtained a good negative copy of an engraving, the copy being made in a darkened room." At this time the wire was sold at two shillings and sixpence per foot! It is now one shilling and sixpence *per ounce*.

But although the metal was still only produced in small quantities, sufficient was placed at the disposal of the writer, who at once showed the value of the new source of light for photographic purposes by producing portraits which required about twenty grains of the metal burnt in strands of ribbon lightly held together with wire of the same metal. In the form of wire the combustion was somewhat uncertain, and it was found by the writer that by passing the wire between rollers, or when it was flattened into a thin narrow ribbon, the combustion was much more regular and rapid, and in this form the metal is now generally used. Early in 1864 a stereoscopic picture of the Blue John Mine in Derbyshire was made by the writer, assisted by Mr. Mather and Mr. Mellor, and in May of the same year the portrait of Dr. Faraday was taken at the Royal Institution in London. In 1865 Professor Piazzzi Smyth obtained some good photographs of the chamber in the interior of the Great Pyramid, and since then the metal has become useful to science in many ways. To the lecturer, when a brilliant light is required for a short time only, the metal is invaluable, and now that we have quick plates, magnesium in the form of fine powder, and the price sufficiently low to make its use not extravagant, it is much employed for flash-light experiments and in other ways.

To obtain the flash, the magnesium powder may be used alone by simply causing its quick combustion in a spirit or other flame, but the most simple and, if carefully managed, successful way of using the flash-light is by burning a mixture of 15 parts of magnesium powder, 30 parts of potassium chlorate, and 15 parts of crushed white sugar. These should be quite dry and then intimately mixed to-

gether with the fingers—not ground in a mortar—and sprinkled over a tuft of gun-cotton. This mixture can then be placed on a plate or sheet of metal in the position where the light is required, and ignited. In some cases two flashes may be made simultaneously, one being larger than the other—the smaller one being used to give some relief to the heavy shadows liable to be produced by the light being on one side only. This defect may also be remedied by the use of reflectors of white calico or paper. As the ordinary light in a room at night is not sufficiently bright to enable objects to be seen for focussing by, the light of a taper or candle may be used if held near the principal object. The place for the flash should be as near as convenient to the objects to be photographed, but not so that the light can enter the lens. This may be avoided by holding a screen to protect the lens. The cap of the lens should not be removed until just before the flash is made, and all the ordinary lights in the room should be left burning—they will have only one result on the picture, and that is keeping the eyes of the sitter (if a portrait is to be taken) in a natural state.

As photographic portraits are usually taken in a light more or less diffused, the shadows are less marked than they would be if taken in a light such as that in which an artist works; but heavy shadows of the kind referred to, although perhaps artistic, are not generally approved of; and, therefore, if two lights are not used, the flash may be diffused by using tissue paper placed between the sitter and the light.

So-called *lamps* have been introduced for igniting the magnesium, but the method named answers every purpose and requires no apparatus.



## PART II.

### PROCESSES.

DURING the fifty years which have elapsed since the discovery of photography, a very large number of processes and modifications have been introduced, and, of course, amongst them many of very little importance. The science of chemistry may, perhaps, be said to present a parallel with photography in the rapid development which it has undergone within the period named. The beautiful daguerreotype was in a very few years superseded by the almost equally beautiful collodion process, and this, in its turn, has to a very large extent been displaced by gelatine. The range of usefulness of the daguerreotype was limited. The convenience of the paper process of Talbot did not prevent its entire supersession by the collodion negative. The gelatine dry plates for outdoor work displaced collodion, and in the near future films of various kinds will take the place of glass. Already it may be said that, for negatives of moderate size, films are available.

It would involve much, and possibly useless, labour to give here a full account of all the processes which have been employed in photography. It will be sufficient for the purpose to point out what has been done. In many cases very little more than the names of the processes will be given; but the more important will be treated with as much detail as space will permit.

**Alabastrine Process.**—The term *alabastrine* is applied to positive pictures made by the collodion process which have been treated with mercuric chloride. The positive should be of good quality, and have clear glass in the shadows. After being thoroughly fixed and washed, and while wet, the bleaching is effected by pouring on the plate a solution composed of

Hydrochloric acid . . . . .	1 drachm
Nitric acid . . . . .	1 „
Water . . . . .	2 ounces

to which must be added sufficient mercuric chloride to saturate the solution; the excess will remain in crystals; one drachm of alcohol must then be added. This solution will first darken the picture, but

in the course of a few minutes it will be entirely whitened ; it should be allowed to remain on the levelling stand until this occurs. The picture must now be thoroughly washed and dried. Powder colours may be applied, if required ; and, as the effect of the whitened picture is much the same on either side of the glass, the colour effect may be made to penetrate by applying a suitable varnish, which should be used while the plate is warm. A varnish composed of

Turpentine	.	.	.	.	.	.	.	$\frac{3}{4}$ ounce
Mastic varnish	.	.	.	.	.	.	.	1 $\frac{1}{2}$ ounces

will be found to answer.

These bleached positives, if not varnished, must be well protected from the atmosphere, and, if so protected, are very permanent. The bleaching effect produced by the mercuric chloride was one of the discoveries of Mr. Scott-Archer.

**Albumen Process.**—It was M. Niépce de Saint-Victor who, in 1848, first used albumen on glass for the purpose of making negatives. Albumen was also used by M. Blanquart Everard ; and the process was successfully practised by M. Le Gray, who prepared his plates in the following way :—Five fluid ounces of the white of fresh eggs were mixed with 100 grains of iodide and 20 grains of potassium bromide and 10 grains of common salt. After beating this into a thick white froth it was allowed to stand all night ; on the following day the clear fluid was poured or syphoned off, and was then ready for use in preparing the glass plates. To coat a plate with albumen is a matter of some difficulty. Le Gray used a straight-edge of glass to distribute the albumen on the glass surface. The plate must be perfectly level, and when prepared with the albumen it must be allowed to dry so as to preserve an even coating. When dry, the plates were held before a bright fire and heated to about 180° Fah., by which means the albumen became insoluble and was then ready to be made sensitive to light by immersion in a solution of aceto-nitrate of silver. Plates thus prepared could be used while the albumen was wet, but great care was necessary in immersing them in the solution of silver to avoid markings. If the albumenised plates were to be used dry, they were dipped in a bath of gallic acid after they were taken out of the silver solution ; they were then well washed in distilled water and dried. The plates were developed in a saturated solution of gallic acid and fixed with sodium thiosulphate. Negatives thus prepared had the great advantage of transparency in the shadows ; would yield positive prints on paper with much greater facility than paper negatives, and were free from the defects inherent in the paper process.

Le Gray's method was modified in many ways, and in this case (as

in most other photographic processes) the variations in the manipulation led to results differing very little from each other.

**Albumen Substratum.**—Clean glass is absolutely necessary in all photographic processes in which glass is used. No matter how careful the manipulation has been, the surface often retains sufficient dirt to cause a collodion film to leave its support in the process of drying, if not before. This is always a source of annoyance and loss. The act of polishing a glass surface induces an electric state which causes particles of fluff and dust to collect, and these, if not removed, would make defects in the developed picture. A clean glass surface also readily attracts moisture. A very effectual remedy is found in a substratum of albumen. It may be said that the introduction of albumen into the negative bath is objectionable, but unless it has been allowed to run over the back of the glass it does not affect the bath, as the collodion covers it. The experience of many years has proved that no harm whatever results to the silver bath, and the almost perfect certainty that the effect of dirt or grease, if present to a slight extent, will not be seen when a plate has been properly coated with the substratum of albumen makes its use desirable. If the glass has not been previously used, it should be placed in water with sufficient nitric acid ( $1\frac{1}{2}$  oz. of acid to 20 oz. of water), and allowed to remain an hour or two. The glass is then thoroughly rubbed under a stream of water with a pad of calico or flannel. The surface water is then drained off and the dilute albumen is poured over. To prepare the albumen, take the white of one egg and whisk it into a froth; add 20 ounces of water and a few drops of ammonia. When required for use, run some of the solution through a filter of lint (this is an excellent material for filtering some solutions, using the lint side upwards), and then cover the wet plate, allowing the albumen to run off to waste; then coat again with albumen, returning the surplus to the cup or glass measure; place in a rack to dry, and the plate is ready for use. Plates which have been used may be left in the acidulated water for a few hours, when the film will readily leave the glass, and the process of cleaning is the same as with new glass. The acid may be repeatedly used, and strengthened when necessary; it should be occasionally filtered through a coarse cloth to remove the films, which may be dried and placed with the silver residues, as they contain much silver. The acid also contains silver, which may be recovered by the addition of common salt or hydrochloric acid. When treated with the substratum, sheets of glass may be used repeatedly, or until they become scratched and unfit for further use.

Varnished glass must be dealt with in a different manner, by the method described under the heading *Cleaning Glass*.

**Amphitype.**—Many curious and interesting processes resulted from the experiments of Sir John Herschel; one of the most remarkable he called *Amphitype*; and at a meeting of the British Association held at York he thus described the process:—

“Paper proper for producing an amphitype picture may be prepared either with the ferro-tartrate or the ferro-citrate of the protoxide or the peroxide of mercury, or of the protoxide of lead, by using creams of these salts, or by successive application of the nitrates of the respective oxides, singly or in mixture, to the paper, alternating with solutions of the ammonio-tartrate or ammonio-citrate of iron, the latter solution being last applied, and in more or less excess. . . . Paper so prepared and dried takes a negative picture in time varying from half an hour to five or six hours, according to the intensity of the light; and the impression produced varies in apparent force from a faint and hardly perceptible picture to one of the highest conceivable fulness and richness both of tint and detail, the colour in this case being a superb velvety brown. This extreme richness of effect is not produced except lead be present either in the ingredients used or *in the paper itself*. It is not, as I originally supposed, due to the presence of free tartaric acid. The pictures in this state are not permanent. They fade in the dark, though with very different degrees of rapidity, some (especially if free tartaric or citric acid be present) in a few days; while others remain for weeks unimpaired, and require whole years for their total obliteration. But, though entirely faded out in appearance, the picture is only rendered dormant, and may be restored, changing its character from negative to positive, and its colour from brown to black (in the shadow), by the following process:—A bath being prepared by pouring a small quantity of solution of pernitrate of mercury into a large quantity of water, and letting the subnitrated precipitate subside, the picture must be immersed in it (carefully and repeatedly clearing off the air-bubbles), and allowed to remain till the picture (if anywhere visible) is entirely destroyed, or, if faded, till it is judged sufficient from previous experience; a term which is often marked by the appearance of a feeble positive picture of a bright yellow hue on the pale yellow ground of the paper. A long time (several weeks) is often required for this, but heat accelerates the action, and it is often complete in a few hours. In this state the picture is to be very thoroughly rinsed and soaked in pure warm water, and then dried. It is then to be well ironed with a smooth iron, heated so as barely not to injure the paper, placing it, for better security against scorching, between smooth clean papers. If, then, the process has been successful, a perfectly black positive picture is at once developed. At first it most commonly happens that the whole picture is sooty or dingy to such a

degree that it is condemned as spoiled, but on keeping it between the leaves of a book, especially in a moist atmosphere, by extremely slow degrees this dinginess disappears, and the picture disengages itself with continually increasing sharpness and clearness, and acquires the exact effect of a copperplate engraving on a paper more or less tinted with pale yellow."

**Aniline Process.**—This process was the subject of a patent by Mr. Willis, of Birmingham. Paper is prepared with

Potassium (or ammonium) bichromate . . . . .	30 grains.
Phosphoric acid (dilute) . . . . .	1 drachm.
Water . . . . .	1 ounce.

The paper may be floated on or brushed over with the solution. When dry, a print is obtained by exposure under a transparency. It is developed by exposing it to the fumes of aniline dissolved in benzole, sprinkled on blotting-paper, and placed in a shallow box; the print to be developed being pinned to the lid. When fully developed the print is washed, and afterwards placed in water containing a few drops of sulphuric acid, and then again washed. This is one of the processes which are of very little value; it is interesting, as are many others which will be referred to, but is now seldom or never used.

A process by Herr Endemann for producing prints in black lines with aniline may be mentioned as an instance of the kind.

**Aristotype.**—Dr. Liesegang, of Dusseldorf, introduced paper prepared with gelatine and chloride of silver to print out in the same way as albumenised paper. The prints can be toned and fixed at one operation. When a print with very highly glazed surface is preferred, this paper gives perfect results.

*Solution A.*

Water . . . . .	12 ounces.
Sodium thiosulphate . . . . .	2 „
Alum . . . . .	2 drachms.
Ammonium sulphocyanide . . . . .	1 drachm.
Common salt . . . . .	4 drachms.

This solution must be mixed and allowed to stand eight days, and then filtered.

*Solution B.*

Water . . . . .	3 ounces.
Gold chloride . . . . .	15 grains.

Take of solution A. 60 parts, solution B. 7 parts, and add 40 parts of combined toning and fixing bath which has previously been used. In ten minutes the prints become red, in fifteen minutes brown, and

in twenty minutes brownish violet. The prints may be taken out of the toning bath after five minutes and laid flat. They continue to tone, and when the desired colour is reached they may be washed in water.

Instead of gold, the prints may be toned with platinum, as suggested by Stieglitz.

## I.

*Solution A.*

Potassium oxalate . . . . .	3½ ounces.
Potassium phosphate . . . . .	1¼ „
Water . . . . .	1 quart.

*Solution B.*

Potassium chloro-platinite . . . . .	15 grains.
Water . . . . .	6 drachms.

To tone, mix 6 parts of A. with 1 part of B.

## II.

Potassium chloro-platinite . . . . .	15 grains.
Water . . . . .	1 quart.
Nitric acid . . . . .	25 minims.

The prints before toning are washed, put into the toning solution for ten minutes, and then thoroughly washed. If an alum bath is necessary, it should be used after toning. The prints may be toned to any tint between light brown and black. If a matt surface be preferred, the prints should be dried on ground glass.

See *Gelatine Chloride Paper* (Ilford).

**Artotype** (see *Collotype*).

**Autoglyphic Process** (see *Half-tone Engraving*).

**Autotype** (also called the *Carbon Process*).—In 1871 the late Mr. J. R. Johnson wrote, “Silver printing, like the daguerreotype, will soon be a thing of the past, and at no distant period there will be no distinction, in a chemical and physical sense, between the palette of the photographer and that of the artist in oil or water colours.” The meaning of this is that prints in silver being often unstable, the process would go out of use, and pigments of any colour combined with gelatine would alone be used in the production of photographs. Nearly twenty years have elapsed since Mr. Johnson wrote the words quoted, yet silver printing is still used very largely. The beautiful process of carbon printing, advocated by Mr. Johnson, has come extensively into use, and the undoubted permanence of the prints produced by it give the process an importance which it is impossible to exaggerate.

The action of light upon organic matter when combined with the bichromates of ammonia or potash is the basis of all the processes which come under the term *carbon printing*. This effect of the action

of light on paper which had been immersed in the bichromates was first observed by Mungo Ponton. Becquerel showed that *sized* paper acted much more rapidly, and for that reason gelatine or gum is employed in combination with the bichromates. The addition of coloured pigments to the gelatine was first proposed by Poitevin, who found that when paper was so prepared and exposed under a suitable negative, those parts on which the light had acted became insoluble, while the parts not acted on could be washed away, thus leaving the picture with black or coloured lines on a white ground. In this manner the first permanent photograph in pigments was produced. This result was not quite what was desired, owing to the absence of half-tone; and it was the Abbé de Laborde in France, and Burnet and Blair in England, who pointed out the cause of Poitevin's failure. They showed that the pigmented gelatine was entirely insoluble on the surface which had been next to the negative, being covered with a kind of skin which prevented the action of the warm water used to wash away the unaltered gelatine; and it was shown that the picture must be washed from the other side of the film. In order to effect this, Fargier coated a sheet of glass with the sensitised gelatine, which, when dry, was exposed under a negative; the plate was then coated with collodion, and, when dry, was placed in warm water, which caused the gelatine to leave the glass; and, as the collodion was not affected by the warm water, the picture was caught with the collodion side downwards on a sheet of paper. The picture could then be washed from the back, and in this way the first photograph in pigmented gelatine with half-tone was produced. The process was much too difficult and troublesome to be of practical use.

Mr. J. W. Swan, of Newcastle-on-Tyne, took out a patent in 1862 for pigmented tissues and their use. Instead of coating the gelatine with collodion, Mr. Swan first coated the glass with collodion, and upon this spread his gelatine film, which, when dry, was stripped from the glass and placed with the gelatine side next to the negative to be printed; therefore, in developing the picture, it could be attacked from the *back*, while the soluble gelatine was removed with warm water. While this was being done the picture was supported on paper which had been coated with a solution of india-rubber, and as the tissue holding the picture was also coated in the same way, they were passed through a copper-plate press, and were thus made to adhere firmly together. Pictures so prepared were in slight relief, and gave a true impression of the negative in half-tone.

The next great improvement effected by Mr. Swan was in doing away with collodion and glass. The gelatine was spread at once on the paper and printed. India-rubber solution was next applied and was pressed into contact with another piece of paper coated in the

same way. Soaking in warm water now softened the gelatine, and the picture could be pulled off from the first paper, and could then be washed to free it from the unaltered gelatine; but the picture thus produced was *reversed*. To bring it into its correct position a paper coated with gelatine made partially insoluble with alum was placed in warm water; the softened gelatine surface was brought into contact with the print, and the two surfaces pressed together. When dry, benzene was applied to the back of the picture, and passing through the paper, softened the india-rubber; when the paper was removed, the picture appeared in its natural position. Very beautiful results were obtained in this manner.

The next improvement was effected by Mr. J. R. Johnson (in 1868), who found that no cement was necessary to fix a print on its support, if that support were made impervious to air and water. In 1874 Mr. J. R. Sawyer patented a "flexible temporary support." This temporary support is a hard tough paper coated with gelatine which is insoluble when dry; this is coated with an alkaline solution of lac, and then rolled between polished plates; the surface is next treated with a waxing compound, which enables the picture to leave the support when the transfer to paper is applied. The advantages of this support are that the picture can be seen while being developed. The pieces of support can be used repeatedly, and the finished pictures have a pleasing surface.

In 1874 M. Lambert introduced some improvements. He showed that glass coated with collodion could be used, but the surface must be made greasy before the collodion was applied.

Sufficient time has now elapsed to show that photographs printed in pigmented gelatine are permanent. Gelatine is known to be a permanent body, and provided the colour used be also permanent, there seems to be no reason why absolute permanence should not be attained by the use of such bodies in combination. Experience has shown the kind of colour to use, and in the preparation of the tissues only such colours as are known to be permanent are now employed.

The Autotype process possesses advantages which can be claimed for no other. Drawings of all description can be copied in exact fac-simile as to colour, and, if necessary, the copy may be in the same pigment as the original. Photographs on albumenised paper may be so exactly imitated in autotype that the difference is very difficult of detection.

In printing on carbon tissue two methods are adopted—double and single transfer. When prints are required from negatives taken in the ordinary way, they must be transferred twice, otherwise the copies would be inverted, that is, the left side would appear as the right-hand side, and *vice versâ*; so that, unless the negatives are taken with



the image inverted, the single transfer method cannot be used, except when the inversion may be disregarded. The double transfer may be avoided by using a *reversing mirror*, or by taking the negative *through the glass*, which would have the effect of reversing the subject. By stripping the film from its glass support, it may be used so that the second transfer is avoided. The trouble, however, of using the temporary support in the double transfer is not very great.

As the preparation of the carbon tissue is a somewhat difficult and troublesome process, and as it can be purchased ready prepared, and also, when desired, ready sensitised, very few will care to prepare their own paper. Generally, it may be said that the tissue is merely paper coated with gelatine with which carbon or colouring matter of some kind has been mixed. This is prepared in rolls, and when dry will keep for any length of time. As the paper will not keep many days after it is made sensitive to light with the bichromate, it is usually ordered only in such quantities as can be used at once. Where there is convenience for drying the tissue after sensitising, there is some advantage in purchasing the plain tissue in rolls. The importance of the process requires that minute details should be given for its successful manipulation, but space here is too limited. The fullest instruction may be found in the "A. B. C." guide issued by the Autotype Company. There are no difficulties in the working details which cannot be overcome with very little practice.

It may be mentioned that most of the patents connected with the carbon process have now lapsed.

**Beechey's Emulsion Process (Collodion).**—In 1876 the Rev. Canon Beechey introduced a modification of the collodio-bromide process, and in 1879 he gave further particulars in the *British Journal Almanack*. As the use of collodion emulsion is very limited, it will be sufficient to say here that when such plates are required they may be prepared as under. Take

A. Cadmium bromide (anhydrous)	. . . . .	400 grains.
Alcohol, absolute	. . . . .	10 ounces.

When clear, decant and add

Strong hydrochloric acid	. . . . .	80 minims.
--------------------------	-----------	------------

Then prepare in yellow light the day before it is required for use—

Gun-cotton	. . . . .	10 or 12 grains.
Ether.	. . . . .	9 drachms.
Solution A.	. . . . .	$\frac{1}{2}$ ounce.

To make this sensitive, dissolve 40 grains of fused silver nitrate, powdered, in 1 ounce of alcohol. The quantity given above will

prepare two dozen half plates. The emulsion must be kept in the dark and shaken a few times. The plates must have a substratum of gelatine, 5 grains soaked in 1 ounce of water, for an hour, and then dissolved in 3 ounces of boiling water, filtered while hot.

As the plates are coated with the emulsion they are placed in a dish containing filtered rain-water, and then in another dish containing 30 ounces of table-beer with 30 grains of pyrogallic acid, used as a preservative. About six plates may be prepared one after the other, passed through the water and preservative, and rinsed in succession. The plates are developed with

A. Pyrogallic acid . . . . .	96 grains.
Alcohol, methylated . . . . .	1 ounce.
B. Potassium bromide . . . . .	12 grains.
Water (distilled) . . . . .	1 ounce.
C. Ammonium carbonate . . . . .	60 grains.
Hot water . . . . .	1 ounce.

Mix of A. 30 drops, B. 30 to 60 drops, C. 2 drachms. First rinse the plates under a tap to remove greasiness, and then pour on the developing solution. The plates may be intensified, if necessary, with "pyro" and silver. Fix with weak cyanide or with sodium thiosulphate as usual.

The exposure necessary in a good light will vary from thirty seconds to three minutes for a landscape. For lantern slides or transparencies a few seconds' exposure to gas-light will be sufficient.

**Bitumen Process.**—Bitumen or asphaltum varies very much in its properties; some kinds are soft, others hard, and some are fluid, as naphtha and petroleum. The kinds used in photography are found in Syria, the Island of Trinidad, and some other places.

The discovery by Niépce that the resinous substance bitumen or "Jew's pitch" was made insoluble by exposure to light has proved of great value in some of the recent applications of photography. Niépce's first experiments were made by spreading a film of bitumen on a lithographic stone; by means of acid the picture was then "bitten in" and could be printed from in the usual way. This in his hands never became of any value, owing to the want of sensitiveness, an exposure of many hours being necessary to obtain an image; but he also tried glass and metal plates in his later experiments, when iodine was introduced, eventually leading to the discovery by Daguerre of the process known by his name. A thin film of bitumen is now made use of in most of the processes for printing on zinc, and the best results are obtained by this means. Bichromated gelatine can be used; but the results for the finer kinds of work are not equal to those obtained with the bitumen.

The best Syrian bitumen should be used, and this should be puri-

fied. The powdered bitumen must be dissolved in twice its weight of essence of turpentine and well shaken up until it forms a thick syrup. Some of this thick syrup must now be mixed with sulphuric ether, well shaken together, and then allowed to settle. The fluid portion is now to be poured off, and more ether added two or three times, until very little of the bitumen is taken up. The bitumen left as a thick sediment may now be spread over plates until it becomes nearly dry, which will require a few days. This must be done at a sufficient distance from any artificial light to prevent any chance of igniting the vapour of the ether, and it may be done in daylight. The bitumen thus purified may be dissolved in benzene or chloroform, and must be just sufficiently fluid to become a film of a golden brown colour when spread over and dried on a zinc plate, and a zinc or copper plate having been well polished, may now be coated with the bitumen (which must be filtered) by holding the plate with the left hand (not by one corner as when coating a plate with collodion, but poised on the fingers and thumb), and then allowing the fluid to completely cover the metal—pouring the superfluous fluid back into the bottle; a “whirler” can be used if preferred. As the film is not very sensitive, this coating may be done in diffused daylight. When quite dry, the plate is placed in perfect contact with the negative in a printing frame and exposed to light. The time necessary to make the print varies very much, and can only be ascertained by experiment. It may require from a few minutes to two or three hours, and in dull weather very much longer. When printed, the development is effected by holding the plate in the hand in the same way as when coating it; then it must be flooded quickly with turpentine, which will at once dissolve the bitumen; and, as soon as the subject is seen to be fully developed, a gentle stream of water from a tap is allowed to flow over it to wash off the turpentine. If the printing has been correctly timed, we have now a very delicate and perfect picture in bitumen on the metal, which, when dry, can be etched with acid in the usual way.

**Black Lines** (see *Cyanotype*).—Tracings for reproduction with black lines on a white ground should be prepared with good black Indian-ink, and the paper should be as transparent as possible. The print is fully exposed when the sensitised paper has changed from yellow to white. The developing solution is composed of—

Gallic acid . . . . .	1 ounce.
Citric acid . . . . .	1 „
Alum . . . . .	8 ounces.

Of this take 1½ ounces to 1 gallon of water.

This should be mixed and used the same day. The print should be

immersed until the lines are black. The developing solution may be repeatedly used. The prints must be thoroughly washed in cold water.

**Bromide-Printing Process.**—When opal glass and paper are coated with silver bromide emulsion in gelatine, they may be used for contact-printing or for enlargements, either by artificial or by day light; but for contact-printing artificial light is to be preferred. Paper is prepared in two degrees of sensitiveness, the slow kinds being more suitable for printing by artificial light and for enlarging by daylight, while the rapid paper may be used for enlarging by artificial light. With suitable negatives (the kind called “plucky” gives the best results) very beautiful prints may be obtained, and enlargements, when very carefully worked upon by a skilful artist, have qualities which are possessed by no other kind of prints, with the exception of carbon; and there is this difference in favour of the bromide print, that an enlarged negative has not to be made. On the other hand, it cannot be said that the bromide print has the same permanent quality which the carbon print is known to possess, although great permanence is claimed for the bromide. Chemical tests have shown that the bromide prints will withstand a damp atmosphere impregnated with sulphuretted hydrogen, which proved destructive to prints by most other processes. The effects of exposure to atmospheric influence can only be tested by time, and the introduction of this process is of too recent a date for this test to have been effectual.

Bromide papers are prepared by the manufacturers of many kinds of plates, and all possess qualities which may require special treatment by the methods for which directions are given with each packet of paper.

The following are the directions given for treatment of prints on the “Ilford” bromide paper:—

No. 1. Solution potassium oxalate (neutral)	16 ounces	} filter.
Warm water . . . . .	64 „	
Ammonium bromide . . . . .	20 grains	
No. 2. Iron protosulphate . . . . .	16 ounces	} filter.
Warm water . . . . .	48 „	
Citric acid . . . . .	$\frac{1}{2}$ ounce	

Add 1 ounce of No. 2 to 5 ounces of No. 1. If added in the reverse order a precipitate would be formed. The prints, as developed, and without washing, are placed in the following clearing solution for a few minutes:—

Alum . . . . .	6 ounces.
Citric acid . . . . .	1 ounce.
Warm water . . . . .	50 ounces.

This solution may be used for a few prints, and then thrown away. After rinsing in three or four changes of water, the prints are fixed in a fresh solution of sodium thiosulphate (4 ounces to 20 ounces of water). After washing in several changes of water for about two hours, the prints may be passed through an alum bath; but this may be omitted in cold weather.

Absolute cleanliness must be observed in every part of the process, and the dish used for developing must be used for no other purpose; stains will certainly result if the prints are touched with fingers that are not perfectly clean. Blisters may be avoided by passing the prints through a solution of common salt after fixing and before washing.

All solutions must be used cold.

The directions given by the Eastman Company for developing their bromide papers are as under:—

No. 1.	Potassium oxalate	. . . . .	16 ounces.
	Acetic acid	. . . . .	3 drachms.
	Hot water	. . . . .	48 ounces.
No. 2.	Iron protosulphate	. . . . .	16 ounces.
	Acetic acid $\frac{1}{2}$ drachm, or citric acid	. . . . .	$\frac{1}{4}$ ounce.
	Hot water	. . . . .	32 ounces.
No. 3.	Potassium bromide	. . . . .	1 ounce.
	Water	. . . . .	1 quart.

To develop, take, in a suitable tray, of No. 1, six ounces; No. 2, one ounce; and No. 3, half a drachm. Mix in the order given and use cold. After exposure soak the paper in water until limp, then immerse in the developing solution. The image should appear slowly, and should develop up strong, clear, and brilliant. When the shadows are sufficiently black, pour off the developer and flood the print with the *clearing solution*:—

Acetic acid	. . . . .	1 drachm.
Water	. . . . .	32 ounces.

Do not wash the print after pouring off the developer and before applying the clearing solution. Use a sufficient quantity to flow over the print; say, two ounces for a 10 × 8 print. Allow it to act for one minute, and then pour it off and apply a fresh portion; repeat the operation a third time, and then rinse in water, and immerse for ten minutes in the *fixing bath*:—

Sodium thiosulphate	. . . . .	3 ounces.
Water	. . . . .	6 „

Wash thoroughly for two hours, and then hang the prints up to dry.

With a tray having a glass bottom, seven ounces of the developer are sufficient for a print  $30 \times 25$  in. The tray used for developing should be kept exclusively for that purpose.

In *contact-printing*, very thin negatives should be printed by weak yellow light, like that obtained from a kerosene lamp turned down a little below the normal intensity. Strong, intense negatives are best printed by daylight.

For enlarging by artificial light the negative should be thin and clear; but if the enlargement is made by daylight the negative may be of ordinary density.

Bromide paper may be utilised for making proofs from negatives as soon as developed, without waiting to dry them, in the following manner:—Wet a piece of the A. paper, and squeegee it face down on to the negative as soon as the latter is fixed and washed; wipe the water off from the back of the plate and expose it to light for a few seconds; lift the paper from the negative, and develop the print with the oxalate developer.

If prints are squeegeed face down on to a polished sheet of hard rubber and allowed to dry, they will have a glacé surface when removed from the support.

Prints on bromide paper should be mounted dry—that is, they should be allowed to dry before pasting; they should not be treated like albumenised prints, but should be hung over a line, or laid back down upon glass or clean paper. When dry they may be brushed on the back with thin starch-paste, and rubbed into contact with the mount with a soft cloth. When the prints are to be burnished, they must be quite dry, and if a lubricator is to be used, it should be made with Castile soap. Prints on smooth paper may be enamelled in the usual way.

To avoid yellow prints four things are necessary:—The developer must be acid; the clearing solution must be used; fresh “hypo” is required for fixing each batch of prints; the washing must be thorough.

“Mealy” prints are caused by over-exposure. An over-exposed bromide print may be reduced as follows:—Make a saturated solution of chloride of lime and filter it. Take of this one part, and of water four to eight parts, and immerse the print in the mixture, the print having been already washed and fixed.

By masking the negative, prints with white margins may be printed suitable for book illustrations. For this purpose paper of medium thickness should be used.

**Calotype** (called also *Talbotype*).—All the early experiments of Talbot were made with silver nitrate. It was necessary to *print out* the pictures, whether produced by contact, with the microscope,

or with the camera. The next great step was the discovery that the latent or invisible image produced on paper could be developed by the application of a solution of gallic acid. The process is described with full working details in the specification of the patent which was granted to Mr. Talbot in 1841, of which the following is a summary:—

Fine writing paper was washed over with a solution of silver nitrate, 100 grains to six ounces of water. When dry the paper was dipped in a solution of potassium iodide, 500 grains to one pint of water, for two or three minutes, and then rinsed in water and dried. In this state the paper was called *iodised paper*, and may be stored in a portfolio for use as required. For use take 100 grains of silver nitrate dissolved in two ounces of water, to which add one-sixth of its volume of strong acetic acid. This solution was called A. Solution B. was a saturated solution of crystallised gallic acid. Equal parts of the two solutions were mixed as required, and the solution was called *gallo-nitrate of silver*. The solution was brushed over the paper or floated on it for half a minute, then rinsed in water and blotted off. It may be used wet or dried, care being taken to exclude white light, as the paper is extremely sensitive to light. The picture was developed by being washed over with gallo-nitrate of silver, and was fixed by first washing in plain water and afterwards in a solution of potassium bromide (100 grains in 8 to 10 ounces of water), allowed to remain in the solution for a minute or two, and then again washed and dried.

This process was much altered and greatly improved by Mr. Cundell and others. Hyposulphite of soda,<sup>1</sup> as it was then called, was introduced for fixing the negative, and to make the paper more transparent waxing was resorted to. The process was very popular for some years, but was superseded by the collodion process.

In the *Year-Book of Photography* for 1890 will be found a list of photographs done by Talbot and exhibited by Mr. F. H. Talbot at a meeting of the Bath Photographic Society, and there is an account also of early pictures made by the late Mr. R. Hunt.

**Canvas, Printing on.**—The canvas used in oil painting has not a surface on which a photograph can be printed without some kind of preparation. The surface is more or less greasy, and resists all preparations containing water only. If coated thinly with gelatine,

<sup>1</sup> Next in importance to the discoveries of Talbot and Daguerre of the processes bearing their names was the means by which their pictures could be permanently fixed. For this we are indebted to Sir John Herschel, who, in 1840, published the fact that sodium hyposulphite would fix the photographic image more perfectly than by the means until then adopted. Under the heading *Sodium Thio-sulphate* will be found a letter giving full particulars on this interesting matter. As no substance has yet been found to supersede this salt as a fixing agent, the importance of the discovery will at once be seen.

the canvas may be prepared and printed on in the ordinary way, or the carbon process may be employed; but it has been found that any preparation which prevents the oil colours coming into direct contact with the original surface of the canvas (that is, the surface prepared for painting upon) is liable to cause cracking, and in some cases the peeling off of the picture. Many processes have been published, but none, as far as the writer is aware, so completely meets the difficulties of the case as one he has used for about twenty-five years, and now publishes for the first time.

The canvas should first be freed from the surface dust of whitening by wiping with a cloth. When the canvas is large and a portrait is to be printed on it, the head only need be printed, or so much of the subject as will cover a 16 × 14 plate; the rest of the picture can readily be sketched in. In some cases a convenient method is to place a small negative or transparency of the subject in a sciopticon or other lantern, project the picture on to the canvas of the size required, and then to go over the outline with pencil or red chalk. This will give exactly the size required for the head, and from this the proportion for the enlarged negative can be taken. When dry, the negative may be placed on the canvas and fitted accurately to the outline already made. With a pencil now mark the outline of the glass negative to serve as a guide for placing the plate when the canvas is prepared, and to allow for ready adjustment afterwards.

To prepare the canvas take—

Calcium chloride . . . . .	1 drachm.
Spirits of wine (methylated) . . . . .	5 ounces.

As soon as the calcium chloride has dissolved, pour a small quantity on to the part of the canvas which is to be sensitised; take a tuft of cotton-wool or lint and rub the surface until the salting solution is well incorporated with the canvas preparation. The canvas will be nearly dry when the spirit has evaporated, but it may be held for a few minutes before a fire. Then sensitise with—

Silver nitrate . . . . .	80 grains.
Water . . . . .	1 ounce.

Go over the surface with this in the same way as with the salting solution. Dry by the fire.

As the canvas will, probably, be too large for any printing frame, take a flat board rather larger than the negative and place it where the canvas is to be printed; then, in a dull light, place the negative in position, and expose to sunlight, keeping the whole covered until placed on the board. The board is for the purpose of permitting good contact between the canvas and negative, as the stretcher of the



canvas prevents any other method being adopted. A thick glass out of a printing frame may be used as a weight when placed on the top of the negative.

In a good light the printing will be very rapid as compared with paper. The colour of the part not covered by the negative may be watched, and when the printing appears to be sufficient, the canvas may be taken into a feeble light and examined, or by shading the print the negative may be lifted by one edge and the effect judged without taking the canvas into a darkened room. No difficulty will be experienced in again fitting the negative in position if the printing has not been sufficient. In case the canvas has not been evenly sensitised the salting and silver solutions may be applied again and the printing repeated. When the printing is finished the canvas should be washed by allowing a stream of water to flow over it, and then fixed with

Ammonia . . . . .	1 ounce
Water . . . . .	5 ounces

or in the same proportion for as much as will be required. A thorough washing under a stream of water for a minute or two completes the process. As soon as dry the canvas is ready for the artist to paint upon; and as there is nothing between his colours and the original preparation of the canvas, he may feel perfectly sure that his work will not crack or peel off. As to *cracking* of the paint, it may be remarked that this defect is not altogether unknown to artists quite apart from photographic preparations. Should it occur where a photograph has been used, it cannot in any way be attributed to the photographic preparation. It will be noticed that the novelty of this process is in the use of a salt dissolved in spirit and the use of ammonia as a fixing agent. An aqueous solution of salt would not combine with the canvas surface, and consequently the silver solution would leave the canvas unequally sensitised. The use of ammonia is quite as effective as a fixing agent as sodium thiosulphate, and it has the advantage that a very slight washing removes the fixing agent.

In case of over-printing, or failure with the printing in any other way, the print can be removed by brushing over it a weak solution of potassium cyanide, and, after well washing under a tap, the process of printing can be repeated; but care must be taken not to remove too much of the surface preparation of the canvas.

**Carbon Printing (Pouncey's Process).**—One of the earliest processes for producing photographs without silver was introduced by Mr. Pouncey of Dorchester, and was published by him in *Photographic Notes* on January 1, 1859. The following is the method of preparing the paper and the materials required :—

1. Saturated solution of potassium bicarbonate.
2. Gum arabic of the consistency of varnish.
3. Vegetable carbon ground fine with a muller on a slab of stone mixed with water.

Take equal parts of 1 and 2 (half an ounce of each to an ounce of water) and then add one drachm of 3.

When well stirred together, the solution must be strained through the finest muslin.

The paper must be laid on a slab of glass and levelled. The solution is spread freely by means of a camel's-hair brush and then allowed to stand for two minutes. The superfluous fluid is then removed with a four-inch hog's-hair "softener" and worked over the paper in both directions until the whole is evenly spread and partly dry. The drying may then be completed by fire heat. This operation must not be conducted in daylight.

The paper is exposed to light under a negative in the usual way. When printed, the picture is placed face downwards in a dish of water, carefully excluding air bubbles. After about five hours' immersion, if the print has been over-exposed, the picture will be developed. The final washing is done under a gentle stream of water from a tap, assisted, if necessary, by passing a camel's-hair pencil over the paper.

The process was modified in various ways, and the system of printing through the paper was introduced. A subsequent improvement was made by using bitumen and mixing lithographic ink with the pigment. The picture was developed with turpentine. By using ceramic pigments the picture could be transferred to porcelain ware and burnt in. Mr. Pouncey was awarded a silver medal and a prize of four hundred francs by the French Photographic Society.

**Catalysotype.**—A process called by this name was invented by Dr. Wood ; but, as it was more curious than useful, further detail is unnecessary here.

**Celerotype.**—The following are the instructions for using paper prepared by the Blackfriars Photographic and Sensitising Company, and called *Celerotype*. It is a gelatino-chloride paper, and is used for "printing out" :—

The paper, ready sensitised, is cut to size and placed in the printing frame in the ordinary manner. The surface must be handled as little as possible. Printing should be carried on until the print is slightly darker than required for the finished picture ; the deepest shadows should have a bronzed appearance.

The prints are washed in two or three changes of water, and are ready for toning. Almost any toning bath may be used.

The following will be found a very serviceable bath, giving rich purple tones :—

Sodium tungstate . . . . .	¼ ounce.
Gold chloride . . . . .	4 grains.
Water . . . . .	20 ounces.
No. 1. Sodium acetate (recrystallised) . . . . .	¾ ounce.
Gold chloride . . . . .	4 grains.
Water . . . . .	20 ounces.
No. 2. Ammonium sulpho-cyanide . . . . .	100 grains.
Water . . . . .	8 ounces.
Gold chloride . . . . .	2 grains.

Keep Nos. 1 and 2 separate. For toning take in the proportion of 20 oz. No. 1 to 6 oz. No. 2, and mix twelve hours before using.

After toning, the prints are washed in two or three changes of water and placed in the fixing bath, containing—

Sodium thiosulphate . . . . .	2 ounces.
Water . . . . .	20 „

From fifteen to twenty minutes suffice to fix.

A combined toning and fixing bath may be used, composed of—

Water . . . . .	24 ounces.
Sodium thiosulphate . . . . .	6 „
Ammonium sulpho-cyanide . . . . .	1 „
Sodium acetate . . . . .	1½ „
Alum (saturated solution) . . . . .	10 „

Fill the bottle containing this solution with scraps of sensitised paper, bad prints, &c., which have not been fixed. Filter, and allow to stand for one day; then add—

Water . . . . .	6 ounces.
Gold chloride . . . . .	15 grains.
Ammonium chloride . . . . .	30 „

With this bath the prints require no preliminary washing. The prints are plunged direct into the solution, and allowed to remain until the desired tone is arrived at.

The prints, on removal from the fixing bath, are well washed in water, changed frequently. If the water be repeatedly changed, one hour will suffice. The prints should then be laid in a saturated solution of alum for a few minutes, and again well washed.

When thoroughly washed, the prints are removed and laid face downwards upon a sheet of crown or plate glass, well cleaned and rubbed over with a little French chalk. With a squeegee they are then pressed well into contact with the glass. When dry, they can easily be removed by placing a sharp knife under one of the corners. To obtain a matt or dull surface, use fine ground glass instead of polished.

To retain the perfect gloss of the print the mountant should be laid on round the edges of the print in a rim not more than a sixteenth of an inch wide.

**Ceramic Photographs.**—Vitrified or burnt-in photographs may be made in various ways. When the processes have been carefully performed, the results are very beautiful, and, of course, absolutely permanent. Probably owing to the difficulties in manipulation, vitrified photographs are not commonly met with. To the skill of the photographer must be added that of the enameller; and when colour is attempted, that also of the miniature painter. The following is an outline of the process as described by Mr. N. K. Chevrill:—A perfectly clean sheet of glass is coated three times with collodion, and, before this has completely set, the plate is put into the silver bath; after it has drained for several minutes, the plate is exposed in the usual way in the copying camera to produce a *transparency*. The picture is developed with pyrogallic acid. Great care must be taken at this stage, and after being thoroughly washed the picture is fixed with potassium cyanide. The film at one corner of the plate must now be broken and a stream of water allowed to flow so as to completely loosen the film. The whole of the film not required is now removed, and the picture is slipped off the glass into a dish of water. The picture has now to be caught on a piece of glass of suitable size and toned with iridium chloride and gold chloride. The next process is to fix the film on the tablet where it is to remain. The tablets are made of copper covered with white enamel and are curved; so that to get the film evenly on the tablet a long camel's-hair brush must be used. The plate or tablet is now ready for *burning-in*, and the greatest care is necessary to secure the best results. The burning-in is effected in a muffle-furnace, in the most convenient form of which gas-heat is used. At this stage the effect has chiefly been to burn away the collodion supporting the picture, and to fix the metals which form it on the enamelled surface of the tablet. In this part of the process all the beauty of the picture seems to be lost. To restore the picture the surface must be *glazed*. The enamel glaze is mixed with specially prepared collodion diluted with alcohol. When quite cold the tablet is covered with the glaze and burnt in. The process is repeated several times until the full beauty of the picture is brought out.

Another method by which excellent results may be obtained requires a totally different treatment. Take the following:—

Potassium bichromate, saturated solution	. . . . .	6 parts.
Albumen	. . . . .	3 "
Honey	. . . . .	3 "
Water	. . . . .	10 "

Mix together and keep in a dark place. After filtering the solution the opal glass or copper tablet may be coated, dried by heat and exposed under a transparency. The printed plate is then left for a few minutes in a room in which there is no fire, to enable the surface to become slightly damp. The enamel colour in a fine powder is then *dusted on* and the picture is developed. The tablet or glass is then put into water containing six drops of sulphuric acid to each ounce of water, and allowed to remain half an hour to remove all trace of the bichromate. Remove the plate to another dish of water and allow it to remain an hour. When dry, the picture is ready for the burning-in, which must be conducted as already described; as also the glazing.

**Chloro-Bromide Process.**—This modification of the collodio-bromide process was suggested by Mr. M. Carey Lea. By the addition of copper chloride to the collodion increased sensitiveness was obtained, and also perfect clearness in the negative.

**Chromatype.**—Many photographic processes are curious and interesting from a scientific point of view. The late Mr. Robert Hunt originated several of this kind. The *Chromatype* is a good example. Mr. Hunt says: "This process is a pleasing one in its results; it is exceedingly simple in its manipulatory details, and produces very charming positive pictures by the first application." The chromatype is founded on a process by Mr. Mungo Ponton, and is described in Hunt's "Manual," 5th edit., p. 143.

**Chromo-Collotype.**—A method of printing from collotype plates in a way similar to chromo-lithography has lately been introduced by Messrs. Waterlow & Sons. (See *Collotype*.)

**Chromo-Photographs.**—Photographs attached to curved glass, made transparent, and then coloured on the back in oil colour, have been introduced under many different names. Crystoleum is a name applied to this kind of coloured picture.

**Chromotype.**—This is another name for the autotype process, modified somewhat in the details of working.

**Chrysotype.**—This process was one of the results of the researches of Sir John Herschel. It is analogous to the cyanotype, but gold chloride is one of the agents used.

**Cleaning Glass.**—In addition to what has already been said on pages 91 and 92, the following methods of cleaning glass have been recommended. The films on plates which have not been varnished may be removed by soaking for an hour or two in water acidulated with nitric acid; the films can be rubbed off with a strip of wood if they have not completely left the glass. Then each plate must be rubbed while water is allowed to flow over it, albumenised, and allowed to dry; or a final rub with Tripoli powder or fullers' earth may be

given and the plates dried with cloths or leather in the usual way. The following method is sometimes used:—

Citric acid . . . . .	½ pound.
Hydrochloric acid . . . . .	1 pint.
Water . . . . .	1 gallon.

When the plates have been varnished it is necessary to use strong common washing-soda or caustic potash, used in boiling water and left till cold. In the latter case the plates should be touched by the fingers as little as possible.

Plates of small size which have been coated with gelatine are scarcely worth the trouble of cleaning. The most effectual method for removing such films is by the use of weak hydrofluoric acid, about 1 ounce of acid to 50 of water. The acid should be used in a gutta-percha dish, and great care be taken not to handle the plates more than can be helped.

The old films may be filtered out, dried, and put with the silver residues. An old felt hat serves as a good filter for this purpose.

**Clearing and Reducing Solutions.**—In developing gelatine dry plates with pyrogallic acid, it often occurs that there is a want of clearness in the shadows, or there may be too great density. After fixing, the negative should be well rinsed in water, and the following solution poured on and off till the desired effect is attained:—

Alum . . . . .	1 ounce.
Sulphuric or nitric acid . . . . .	¼ „
Iron protosulphate . . . . .	3 ounces.
Water . . . . .	20 „

The solution may be used repeatedly, as it does not deteriorate by keeping.

Amongst other clearing solutions which have been employed are the following:—

Alum . . . . .	1 ounce.
Iron protosulphate . . . . .	2 ounces.
Perchloride of iron . . . . .	4 drachms
Water . . . . .	20 ounces.

Or—

Iron protosulphate . . . . .	3 ounces.
Citric acid . . . . .	1 „
Ferric oxalate . . . . .	3 drachms.
Water . . . . .	20 ounces.

Many other solutions are used, but the first one named will usually be found to be sufficient.

**Coffee Process.**—As a preservative of collodion, so that it could be

used in a dry state, an infusion of coffee was used by Colonel Baratti. As it proved to be one of the best, this process was popular for a time.

**Collodio-Albumen Process.**—The Taupenot process led the way in the preparation of plates to be used in the dry state, and, under the name of the *Collodio-Albumen Process*, became very popular. Fothergill, Acland, Russell, England, and many others, introduced modifications of great value. Some of the most beautiful photographs ever produced were made by this method. The time of exposure was long—ten or twenty times longer than with collodion; but over-exposure was of little consequence, as this could be corrected in the development. Under-exposure was not so easily corrected. Every one who practised this process had his own modification, and each, in his own way, could produce satisfactory results. The following is one of the simplified processes:—The collodion should be old and porous, and the plate, after coating with the collodion, should be washed until all greasiness disappears, and then drained for a short time on blotting-paper. The plate must now be coated with iodised albumen prepared as follows:<sup>1</sup>—“Into 12 ounces of white of egg pour 2 drachms of water, to which 40 minims of glacial acetic acid have been added, stirring the whole with a glass rod so as to mix only, not to convert into a froth; after this has stood six or eight hours, filter through sponge, add 1 drachm of strong ammonia, and iodise with

Potassium iodide . . . . .	70 grains.
Ammonium bromide . . . . .	15 „
Water (distilled) . . . . .	1 ounce.

The sensitising bath is made as follows:—

Silver nitrate . . . . .	50 grains.
Glacial acetic acid . . . . .	45 minims.
Water (distilled) . . . . .	1 ounce.

This bath should be iodised by adding a crystal or two of ammonium iodide to each pint of solution, and then filtered. The plates, which should be quite dry, must not be allowed to remain in the bath longer than a minute in winter, or for more than forty seconds in summer. After removal from the bath they are to be immersed in a dish of distilled water until they cease to appear greasy, and then well washed under a tap to remove the last trace of silver nitrate; they should then be flooded with a one-grain solution of gallic acid, and allowed to dry spontaneously. They will keep good for years; and may also be successfully developed many years after the exposure has been made. The plate should be coated twice with

<sup>1</sup> *British Journal Almanack*, 1876, p. 164.

once if the surface be clean; and, if not clean, the picture will probably show stains of some kind, or the film may leave the plate while under development, or in the course of drying. There are some advantages in using albumen as a substratum, as has already been explained on page 69.

While coating with collodion, small plates may be held between the finger and thumb of the left hand, but for large plates it is better to use a pneumatic holder. The collodion should, by preference, be poured from a "collodion pourer," which is a tall narrow bottle having a wide mouth and a glass cover. The advantage of a bottle of this kind is that the sediment settles at the bottom and is not readily disturbed; the bottle should be replenished when about two-thirds of the collodion have been used, and occasionally the sediment should be poured into another receptacle, and used up with other stock. If preferred, the collodion may be poured off the plate into another bottle, but long experience has shown this to be scarcely necessary. After the plate has been fixed on the pneumatic holder, it should be examined for particles of dust, which should be brushed off with a broad camel's-hair brush; the dust should not be blown off, as not unfrequently spots of saliva may be carried with the breath, and cause defects when the picture is developed.

The next process is to coat the plate with collodion. Whether held with or without the plate-holder, the glass must be as level as possible; then pour on as much collodion as may appear rather more than sufficient to cover the plate; let the collodion flow first to the right-hand corner farthest from you, then to the left, next, to the left corner nearest the hand; then tilt the plate so that the superfluous fluid may flow into the collodion bottle.

A little practice will soon give confidence and enable the operation to be conducted without any of the collodion being spilled. There is no necessity for haste, but there should be no time lost. If the coating is not effected in daylight, no flame of any kind should be near, owing to the highly inflammable nature of the solution. While the collodion is running back into the bottle, the plate should be gently moved from side to side, with a kind of rocking motion, to prevent the film setting irregularly. When the collodion has almost ceased to drip, the cover may be put on the bottle and attention given entirely to the plate to ascertain when it is ready to be put into the *bath*. To ascertain this, touch the corner from which the collodion was poured, and the finger will at once show if it is too wet; after a few seconds (the plate meanwhile being constantly rocked) touch the plate again, and if the collodion will not adhere to the finger it is then ready to be sensitised.



The solution forming the bath should contain—

Silver nitrate . . . . .	35 grains.
Water . . . . .	1 ounce.

This must be made slightly acid with pure nitric acid. If good distilled water can be obtained, it should be used in making the silver bath, unless the ordinary water available is known to be approximately pure, as is the case in Manchester and Glasgow. Rain-water may be used; but this often contains organic matter, which may be got rid of by exposing the solution in sunlight for a few hours. If used fresh as thus prepared, the bath will not be found to work well, owing to its readiness to attack the iodide contained in the collodion; therefore, it is better to coat a plate with collodion and leave it for a few hours in the silver solution; a small quantity of collodion poured into it will answer the same purpose, or a crystal of potassium iodide may be dissolved and added to the bath. Care must be taken not to over-iodise the solution, as the presence of too much iodide causes pinholes in the film.

It is better not to use the bath at once, but to allow it to stand for a day or two, when it should be filtered. The vessel to contain the bath solution may be of glass, porcelain, or vulcanite, preferably the first; and for most purposes it is better to use a "dipping bath." A porcelain or glass dish may be used, but for large plates a "well bath" made of wood thoroughly coated with black varnish is efficient. The flat bath has the advantage of not requiring so much solution of silver. The bath being ready and the plate coated as described, it must be placed on the dipper with the thin end of the collodion film foremost. This is the end opposite to that from which the collodion was poured off, the film being thinner here because during drying the lower end, in pouring off, retains more collodion. The plate must be lowered with a continuous motion, since, if any hesitation occurs, a mark will be formed across it and it will be spoilt. When a flat dish is used, care must be taken to tilt the dish so that all the fluid is at one end; the plate is then placed in the dish, which is at the same time lowered, and the silver solution at once flows over the film. The collodionised plate will be seen at once to change; a tinge of milkiness appears, which continues to increase until it becomes of a creamy whiteness, or, when seen in daylight, of a delicate yellow tint. What occurs is that the iodide and bromide held in the collodion are colourless; so also is the silver solution; but the iodide and bromide of silver, which are formed when the plate is placed in the solution, are not colourless. When the decomposition is complete, the coated plate has acquired the quality of extreme sensibility to light. That it is ready for exposure in the camera may be known

from the streaky greasiness which it at first assumes having disappeared. No definite time can be fixed for allowing the plate to remain in the bath, as temperature affects the result. Cold has a retarding effect; so that in cold weather, if practicable, the dark room should be warmed.

The operation of making the plate sensitive to light must be conducted in the "dark room;" that is, in the room into which only yellow light is admitted. When removed from the silver bath, the plate must be allowed to drain; it is then transferred to a sheet of blotting-paper, and while resting, the back is wiped with blotting-paper. This not only saves the silver, but also prevents injury to the dark slide. Next, place the plate in the dark slide of the camera. It is better to put slips of blotting-paper in the lower corners of the slide to keep the film from touching the wood, as well as to collect silver from the plate. Everything having been arranged before the plate was prepared, the exposure in the camera is the next operation. The time necessary to impress the image depends on many circumstances; the quality of the light, the kind of lens, the size of the "stop" or diaphragm, and the character of the object to be copied. No rule can be laid down for the time to expose the plate; a few failures will soon teach what is proper in every case, and experience will make the practice of the process one of great certainty. The exposure being complete, the picture has now to be developed. Pyrogallic acid may be used, but the following is to be preferred:—

Iron protosulphate . . . . .	4 ounces.
Alcohol (methylated) . . . . .	4 "
Acetic acid (commercial). . . . .	3 "
Water . . . . .	65 "

The commercial acetic acid is cheaper than the glacial, and answers the same purpose. The quantity of iron may be varied to suit circumstances.

If the exposure has been perfectly timed, the picture will appear very soon after the developing solution has been flowed over the plate. Take more than sufficient of the iron solution than will cover the plate, in a glass measure, and pour it gently along the plate at the bottom, beginning near the thumb, and allow it to run towards the top with a regular flow; if possible, do not allow any of the developer to run off, as the silver on the plate would otherwise be washed away, whereas it is desirable to keep it on the glass, as it is wanted to assist in producing the image. The picture will be seen to gradually increase in vigour, and when fully developed the developer may be thrown off and a stream of water allowed to flood the plate until all greasiness disappears. The picture thus developed may be perfect so far as detail is concerned, but it may also happen that the image is



In the practice of the wet collodion process the operator will often meet with defects, the causes of which are not easily discovered. In most cases the cause will be that the bath is "out of order;" but in what way? and what is the remedy? These are questions which the most experienced worker may not be able to answer; but usually, after experience, the causes of most defects will be seen. When the bath is newly made, there should be no difficulty of any kind; but after a time it will become charged with ether and spirit from the collodion, and will probably cause the plates to look streaky. By leaving the plates rather longer in the bath, these defects will disappear, but after long use it will be better to pour the solution into an evaporating dish, drive off the spirit, and then add water to bring the bath to its proper strength. The bath by constant use will become weakened, and fresh silver must be added. Roughly the strength of the bath may be ascertained by means of an *argentometer*, and for all practical purposes this is sufficient. The best advice is, Do not tamper with the bath; simply add fresh silver as required, occasionally giving it a few days' rest, and it will be found to work well. If pin-holes appear on the developed plate the cause probably is an excess of iodide; the addition of silver remedies this. Water may be added and the solution filtered; this will remove some of the iodide; fresh silver must of course be added in proportion to the water used.

After very long use it may be necessary to remove organic matter from the bath solution. In this case add sufficient carbonate of soda to neutralise the acid, and then place the bottle in sunlight for a few days; acidify with nitric acid—see that there is sufficient silver in the solution—and filter; the bath should then be in good working condition. The addition of anything to the bath beyond what is required to make it is not recommended; the more simple its composition the better.

In warm weather, and when the plate has been longer than usual in the dark slide, a deposit of silver sometimes occurs, forming what are called "oyster-shell" markings. The use of blotting-paper in the corner of the dark slide is often a remedy. Contact with the wood of the frame is almost certain to cause the markings in warm weather. (See *Oyster-shell Markings*.)

There are two kinds of *fog* which are sometimes troublesome. Fog may be caused either by too much light in the dark room, or by the plate not being clean. This may be detected by its being entirely on the surface of the plate, and with care can be removed by gently rubbing with a pad of lint under running water. The remedy for this is the addition of a drop or two of pure nitric acid to the bath.

Dust on the plate or particles in the collodion will cause "comets" and other defects.

In filtering the bath solution, only the best filter-paper should be used; with care the same paper may be used many times. After use, of course, the paper should be dried, put with the waste to be burnt and the silver recovered.

If from any cause the nitrate bath should become unusable, the silver should be thrown down in the form of chloride and a new bath prepared. With care a bath will remain in good condition for a very long time, no matter how much it has been used, provided, of course, that silver has been added when necessary.

*“Oyster-shell” Markings.*—Few workers with dry plates have ever seen “oyster-shell” markings, as they never occur on gelatine plates.



FIG. 33.

The defect is sometimes very troublesome when wet collodion is used, as it is often difficult to discover its cause. One plate may be marked near where it has rested on the silver-wire corners of the carrier, although they may have been protected with chemically pure filtering paper; another plate may have a mark on its centre or at the top of the plate; but wherever they occur, they are always of the same

character. The deposit is metallic, showing that the silver may have been in contact with organic matter of some kind; but, it may be asked, how has the organic matter got on to the centre of the plate? These troublesome markings occur most frequently in warm weather and when the plate has been longer than usual in the slide. Partial drying of the film is to some extent the cause; and dirt on the plate, which would have no effect when the plate was used quickly, might set up the deposit in warm weather during a long exposure. It is better to take every care in keeping the carrier well varnished and to use bibulous paper at each corner. The paper itself is not likely to be the cause of the markings, as they occur even when every precaution is taken. The accompanying figure shows a very reduced copy of this defect—the most remarkable example ever seen by the writer, as it covered the greater part of a 12 × 10 plate.

**Collographic Printing** (see *Collotype*).

**Collotype.**—Of all the photo-mechanical processes, the collotype is perhaps one of the most useful. It has a variety of names, such as *Lichtdruck*, *Phototype*, *Photophane*, *Phototint*, *Albert-type*, *Artotype*, and many others.

The principle involved in the production of prints by any of the allied processes is the same. A surface of gelatine is supported on a plate of glass of sufficient thickness to bear the pressure in printing. In some respects the process is similar to lithography. Printer's ink is used, and is applied by means of a roller worked in a press, which may be similar to the lithographic press; or it may have a downward pressure, similar to a hand-press used in letterpress printing. If the plates are sufficiently true in surface, impressions can be taken in a letter-copying press. The printing may also be done on a machine.

The glass used must be patent plate about three-eighths or quarter inch thick, and quite level; this is important, as the glass is sometimes slightly thicker at one end than the other. If not true, fracture is likely to occur when passing through the press. The plates must be ground to a fine surface with emery powder by rubbing two plates together, or a piece of fine stone may be used. The condition of the surface must be ascertained by washing off the emery, when the glass, if found to be evenly ground and the grain very fine, must be thoroughly washed and allowed to dry.

The plate may be prepared in very many different ways; the chief point to be aimed at is the character of the grain in the gelatine, which depends on the kind of gelatine used and the temperature at which it is dried.

A collotype picture presents to the unaided eye the effect of an ordinary photograph, the chief differences being in the colour. There is the same gradation of light and shade; the same beauty of half-

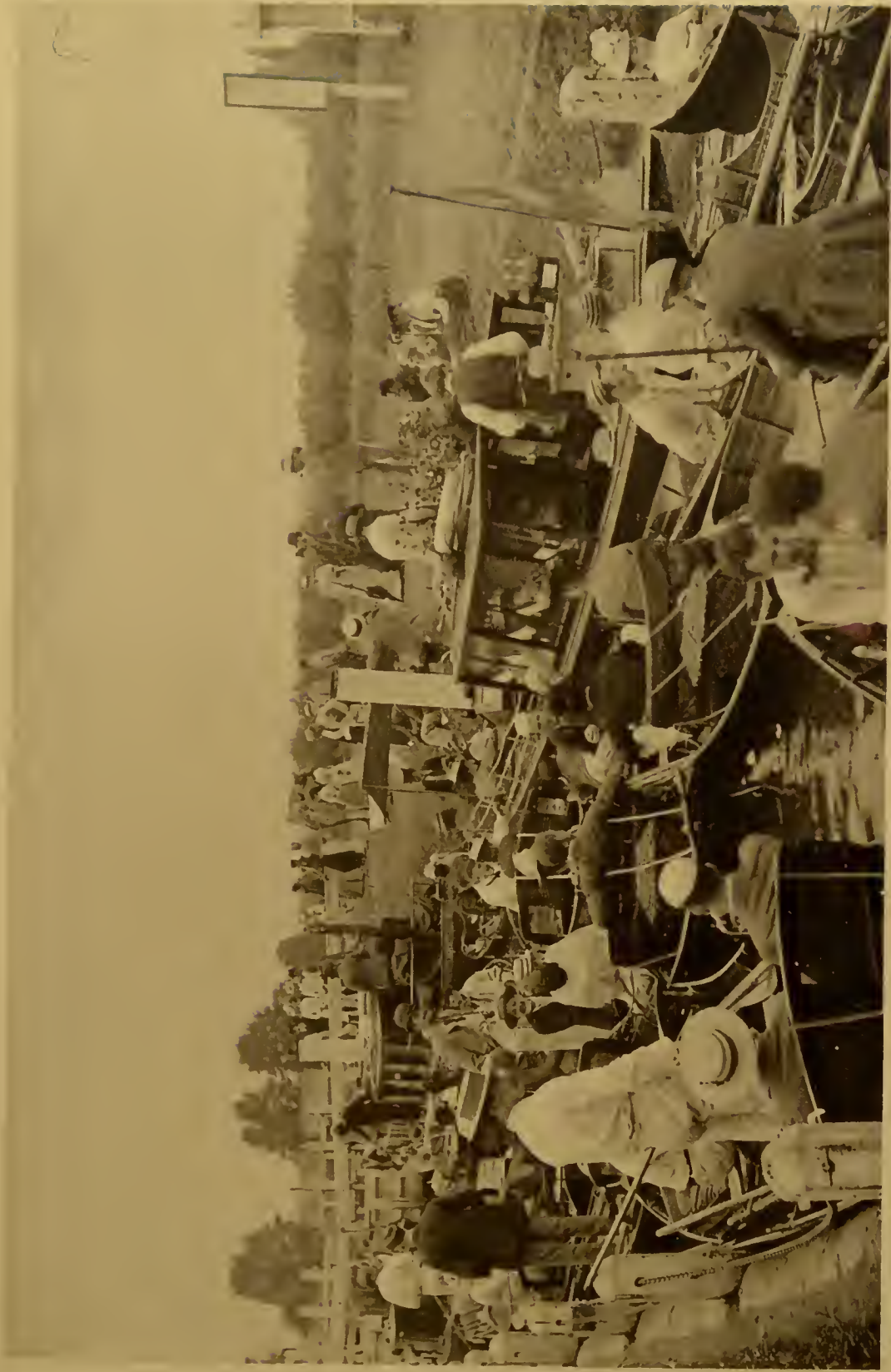

*Collotype Waterlow & Sons Ltd.*

“COOKHAM LOCK.”





tone; and, when printed in ink to imitate the print on albumenised paper and varnished, the resemblance is almost perfect. A difference can, however, be detected if a lens of low power be used, when it will be seen that the image is entirely produced by minute dots, which are distributed over the whole surface of the plate. This granulation is the result of the combination of the potassium bichromate and gelatine, and of the drying at the proper temperature; the size of the grain being determined by the degree of heat applied and the quantity of gelatine left on the plate. The extreme beauty of the resulting picture in collotype depends on the granulation of the gelatine surface, as the ink is taken up in exact proportion to the action of light on the sensitive surface. In working, the gelatine surface requires to be damp, as the moisture prevents the ink adhering on those parts; the hardened gelatine takes the ink just as the greasy lines on a lithographic stone take up ink, while the wet surface of the stone resists it; the resemblance between the two processes being perfect in this respect.

The successful working of the collotype process depends very much on the temperature at which the plates are dried. To effect this, a drying-box or oven is necessary. Its dimensions will be determined by the size of the plates in use, and whether one or more should be dried at the same time. For plates  $15 \times 12$ , two of which are to be dried at the same time, the box may be of the following dimensions:—The length should be 30 inches, width 18 inches, and depth 18 inches; four legs support the box 18 inches from the floor. The bottom is a sheet of thin iron, and around the sides of the box sheet iron 6 inches wide is nailed, the purpose of which is to confine the heat from the gas jets placed below the oven. At the bottom of the box, on one side, an aperture an inch wide is left to admit air, and the iron bottom is covered about an inch deep with clean river or silver sand to equalise the heat. Strips of wood are nailed at each end of the box about 8 inches from the top, and upon these rest two iron bars the length of the box, and 2 inches wide by about  $\frac{3}{8}$ ths of an inch thick. Through these bars screws are passed, on which to rest the plates for the purpose of levelling; three screws in each bar are so placed that the plates will rest on three of the pointed ends, the bottom ends of the screws being made so that they can be conveniently turned. To get at the screws, the front of the box is hinged about half way down. The top of the box is framed together, so that flannel may be tacked on as a cover, while the centre rib serves to hold a stem thermometer passed through a cork for testing the temperature. Heat is applied by means of gas jets from burners of the ordinary kind fixed in iron gas-piping, thus  each arm of

the pipe having four or five burners regulated by a tap. The connection may be made with india-rubber tubing. Much of the success in this process depends on the drying oven, which should be carefully constructed.

The preparation of the plate may now be proceeded with.

In order to ensure the perfect adhesion of the gelatine film to the ground surface of the glass plate, it must be coated with a substratum of—

Soluble glass (sodium silicate)	. . . . .	3 parts
Albumen	. . . . .	7 „
Water	. . . . .	10 „

or stale beer or ale may be substituted for the albumen and water. The sodium silicate must not contain caustic potash. The mixture must be well shaken or beaten into a froth, and then allowed to settle. Filter the solution, coat the plate, and allow the excess to run off into another bottle. It must not be used for another plate until it has been filtered. Next place the plate in the drying oven, where the temperature may range from 130° to 150° F., and when dry allow it to cool. It must now be rinsed under a tap, and then allowed to dry without artificial heat. While drying it should stand on one corner on blotting-paper.

When dry, the plate is ready for the coating of sensitised gelatine.

The kind of gelatine to be used is of the greatest importance. It must be neither too hard nor too soft, but of the quality called “middle hard.”

The plate may now be coated with sensitised gelatine:—

Gelatine	. . . . .	180 grains.
Potassium (or ammonium) bichromate	. . . . .	20 „
Water	. . . . .	4 ounces.

Soak the gelatine in three ounces of the water, then melt and keep at 150° F. for fifteen minutes. Grind the bichromate in an ounce of water, add to the gelatine, stir well, and boil; then filter through fine muslin, if necessary using two thicknesses, and then allow the mixture to set. This will keep a few days. One and a half ounces will coat a 15 × 12 plate.

The gelatine must be melted in a porcelain vessel, which may be placed in a saucepan over the fire, carefully protecting the surface from dust. Many other formulæ have been published, but with care the above will give satisfactory results. Each operator will in time find out modifications to suit his own way of working.

In coating the plate, filter into a pouring glass more than sufficient

of the fluid gelatine than will be required, and cover the top with muslin tied over so that the fluid will pass through it on to the plate. The plate must be warmed in the oven to about  $150^{\circ}$  F., and when carefully levelled the solution of gelatine (at about the same temperature) is now poured on to the plate, which may be held level on the points of the fingers and thumb of the left hand, the excess being allowed to run off at the corners. When it is judged that sufficient is retained on the plate, it is at once placed in the drying oven, and the temperature maintained at about  $120^{\circ}$  F. until dry. The proper temperature is important, as already explained. When dry, the plates may be stored in a dry dark box or cupboard until required; they will keep for a few days. It is, however, better to use them soon after they are dried. The temperature will be ascertained by frequently examining the thermometer, which is placed in the lid of the drying-box as soon as the plates are ready for drying.

If used at the proper temperature, the gelatine will flow readily over the plate, but should any difficulty be found, a bent glass rod may be used to guide the flow of the fluid.

The negative should be prepared by masking. Place narrow strips of thin tinfoil (which may be obtained from Messrs. Winstone, 100 Shoe Lane, London) up to the edge of the part of the negative to be printed; the outside not covered with the foil may be covered with thin opaque paper. Remove the back-board of an ordinary printing frame and also the screws; place the negative in the frame, and upon it the prepared plate; and then, instead of screws, apply pressure by means of wedges. When the image can be seen distinctly by examining the back of the plate, it may be removed and placed in water until all the bichromate is washed out; this will take an hour or two. After a final rinsing under a tap, the plate may stand on one corner on blotting-paper until dry. The image should now be faintly visible, and the film when viewed by transmitted light should have a granulation suitable to the subject; this, as already stated, is determined by the temperature at which the plate has been dried.

It may be stated here that if, by accident, the heat of the drying-box should become excessive, the gelatine will contract and leave the glass; at the same time probably the *surface of the glass itself* will be pulled off in patches. If, however, the temperature be regulated automatically, this accident cannot happen.

An entirely different series of operations come into use in the next process, that of printing from the plate.

The pressure in an ordinary lithographic printing press is applied by means of a scraper. Impressions from the collotype plate may be taken on a press of this kind, but it is found that a roller is preferable to the scraper. In some large establishments machines driven

by steam-power are used ; such machines are very costly, and are not necessary, unless very large quantities of prints are required.

The plate holding the collotype print may be fixed on the bed of the press, if the bed is quite level. Two or three sheets of blotting-paper may be placed on the press, wetted, and the glass plate laid on it ; the adhesion will be sufficiently firm to hold the glass in its place while passing under the roller. It is somewhat safer to bed the glass on a lithographic stone with plaster of Paris. The back of the glass plate must be examined, and any roughness caused by gelatine which may have run over the plate must be carefully removed, as the least irregularity in the plate may cause it to break under pressure while printing.

As soon as the plate is adjusted in the press the surface must be *etched*, as the process of damping is called. There is really no *etching* produced on the plate, and the process is merely necessary to bring the surface into working condition. The solution for this purpose consists of glycerine and water in about equal parts. In some cases a few grains of common salt are added. Sufficient of the etching fluid may be poured on and spread over the plate with the finger, so as to cover it completely, and then left for a time ; in some cases a few minutes will be sufficient, or it may require an hour or two. With a sponge now remove the fluid, and return it to the stock bottle, to be used again. With a soft damp cloth *dab* the plate so as to leave it just moist. The picture is now ready for inking. This part of the process is so completely technical, and difficult to describe clearly, that much time and trouble would be saved by obtaining a little instruction from a lithographic printer. Ink is sold specially for collotype printing. The kind used for printing chalk drawings on stone is very suitable. A portion of ink is removed with a palette-knife to a clean smooth lithographic stone or slate. This is mixed with sufficient *middle varnish*, and, if necessary, a very little turpentine ; the whole is mixed on the stone with the palette-knife, and then scraped together and placed at one corner of the stone. The roller for distributing the ink may be of leather of the best kind. It must be kept for the purpose and regularly scraped before use, and, if necessary, cleansed with turpentine. With the palette-knife a little of the ink is now dabbed on different parts of the roller and distributed over the stone until it is quite even ; very little ink is required on the roller. The plate may now be inked by passing the roller several times over the gelatine surface in all directions. When it is seen that the *inking up* is sufficient, paper may be placed in position and the impression pulled. The first rough print will serve to show the position on the plate, and from it a mask may be cut, so that if a clean margin of white paper is to be shown around the print, a mask must be used and

placed in position while each impression is taken. It will soon be found that according to the pressure applied while "rolling up" will be the quantity of ink deposited on the picture. If the pressure is heavy and the motion slow, more ink will be left on the plate; with light pressure and quick motion, ink is taken off; so that if too much ink has been put on, careful rolling will remove it. The first few impressions may not be satisfactory, but by careful damping and rolling the effect will improve. A plate which at first looked very unpromising may ultimately prove to be very good, and with care will yield some hundreds of impressions. If only a few impressions are required, they may be printed as soon as the condition of the plate will allow; but after the *proving* (that is, ascertaining that the plate will give good prints), it is better to stand it aside for a few days, as it will permit more impressions to be taken from it if not used at once.

In some cases better effects in the inking are obtained by having two rollers. After distributing the ink with the leather roller, a *glue composition* roller may be used to modify the quantity of ink already on the plate. For some purposes two kinds of ink may be used; the first applied is thick, while with the glue roller a much thinner ink is required; but by the use of the two rollers the inking may be modified to a large extent and excellent work obtained.

When a mask is used while taking the impression, it must be placed in position after each inking; the paper on which the print is to be taken is then adjusted to marks on the top and left-hand side, so that each impression may be properly placed on the paper. Any kind of smooth paper may be used; the surface should be even, and, when the paper is not enamelled, it should be used damp. Damping is effected by passing three or four sheets of the paper through clean water, and then the same number of dry pieces are placed alternately; a weight may then be placed on the whole and left for a few hours. Enamelled paper is very suitable for collotype prints, but if it is new the surface sometimes comes off. A kind called *dull enamel* gives excellent results. When the surface of the paper comes off on to the plate, it may be removed with a wet cloth. Sometimes many impressions may be taken after each damping; other plates require to be damped for each impression. No rule can be laid down as to damping, but the effect must be watched as the printing proceeds. After each damping the surface is dabbed over with a soft cloth.

As often as necessary the surface of the gelatine picture may be cleaned off with turpentine and then washed with water. It should always be left clean after use. The inking slab and roller should also be left clean.

Care must be taken that the leather roller is scraped always in

one direction, and one of the handles should, therefore, be marked as a guide. A good scraper may be made out of an old table-knife. The steel may be softened by being heated to redness; when cold, the edge may be filed or ground away, so as to leave a hollow following the curve of the roller. If again heated and plunged into cold water, the temper will be restored. Resting the roller against any convenient support, the knife is held by its handle and tip, and then dragged along *in one direction* until all the old ink is removed. Glue rollers should be cleaned with turpentine only.

While handling the roller and working the press, the fingers become soiled, and marks may show on the paper. To prevent this, the finger and thumbs should be slightly touched with French chalk occasionally.

Collotypes may be printed without white margins and mounted in the ordinary way. When this is done, the object is to imitate silver prints. To effect this the collotype must first be sized by brushing over the surface a thin solution of gelatine; about 1 ounce of gelatine to 10 of water. When dry, the prints are varnished with varnish composed of 15 parts of white shellac in 100 parts of wood naphtha.

Negatives to be used for the purpose of collotypes must be reversed. (See *Reversal of Negatives*.)

One of the most recent applications of the collotype process is for printing in colour. Very promising specimens of this class of work have been issued by Messrs. Waterlow & Sons after a method applied by Mr. J. D. Geddes. This process is the application of a method similar to colour-printing by lithography. The special mode of working cannot be described here, but by the kind permission of Messrs. Waterlow a specimen of the work is given on the opposite page.

**Colouring Lantern Slides.**—The beauty of a good photograph as a lantern slide can scarcely be enhanced by colour, however delicately it may be applied. There is much difference in taste in this respect. Those who wish to colour their transparencies may do so with transparent oil-colours. The work requires knowledge as to working in oil-colour; for, unless great care and judgment be used, a photograph otherwise good may be rendered useless.

**Contretype Negative.**—A gelatine plate, which has been made sensitive to light with potassium bichromate, is exposed under a negative, and then placed in water which is coloured with Indian-ink or any other pigment. The parts not acted on by light absorb the coloured fluid, and when the plate is fixed a negative is the result.

**Crystal Cubes.**—A process was patented by Mr. Swan of London for making small pictures with stereoscopic effect by means of glass prisms so arranged that two pictures taken in a stereoscopic camera were made to appear in relief. The effect was produced by placing one picture on one side of the combined prisms and the other at the back.



*Chromotype. Waterlow & Sons Ltd.*

*From a Painting by Rossi.*

“ CONTEST.”

*Direct Reproduction of a Water Colour Painting.*





These little pictures had a very pretty effect, but they were costly and difficult to produce.

**Cyanotype.**—Between the years 1839 and 1851 one of the most active workers in perfecting the art of photography was Sir John Herschel, to whom is due the discovery of several important processes, one of which he named *Cyanotype*. The process is also known under the name of the *Ferro-prussiate* or *Blue* process. It is interesting to notice that when the attention of scientific men was directed to the subject, it was quickly found that many substances were affected by the action of light, and this discovery by Herschel was one of much importance. The manipulation of the process is very simple, and is now very extensively used for the reproduction of plans. The formulæ for the preparation of the paper have been varied in many ways; but, as practised by Herschel, equally good results may be obtained. In describing the process Hunt gives the following:—The paper is washed over with—

Ammonio-citrate of iron . . . . .	40 grains.
Water . . . . .	1 ounce.

When dry, the paper may be kept for some weeks. It is printed in the ordinary way, and the time of exposure may vary from ten to twenty minutes. The parts exposed to light are of a brown colour owing to the decomposition of the iron salt, and the rest of the paper remains yellow. Soaking in water will remove the yellow colour, leaving the printed image unchanged. To change the colour of the picture, it must be treated, before placing in water, with a strong solution of potassium ferro-cyanide, which changes all the unexposed parts to a blue colour, and the colour may be strengthened by soaking in a solution of sodium carbonate, which at the same time dissolves the unchanged salt and fixes the image; a slight washing in water completes the process. As already stated, the formulæ may be varied, and the following are given as examples:—

No. 1.	
A. Ammonio-citrate of iron . . . . .	4 ounces.
Water . . . . .	14 „
B. Potassium ferricyanide . . . . .	2½ „
Water . . . . .	15 „

Equal parts of A. and B. are mixed, filtered, applied to the paper with a broad camel's-hair brush, and dried quickly.

No. 2.	
A. Ammonio-citrate of iron . . . . .	64 grains.
Water . . . . .	1 ounce.
B. Potassium ferricyanide . . . . .	48 grains.
Water . . . . .	1 ounce

Equal parts of each are used. Paper for this process should be well sized. If preferred, the paper may be prepared with solution A. and afterwards placed in solution B. The colour forming the picture is Prussian blue. And if desired, this colour may be changed in various ways, some of which are described by Herschel in his original experiments.

In the process as thus described, the image appears white on a blue ground, and in this way is very commonly used for copying plans. The reverse of this method may be obtained, and a process by Pellet was patented for producing blue lines on a white ground. The formula as given by Pellet is cumbrous, and has been given in different terms by others:—

Iron perchloride . . . . .	616 grains.
Oxalic acid . . . . .	308 „
Water . . . . .	14 ounces.

The paper is brushed over with this or floated on the solution, dried, and printed in the usual way. The necessary exposure in sunlight is very short, and the prints are developed by floating on a saturated solution of potassium ferricyanide, washed in water for a few minutes, and then placed for ten minutes in a 3 per cent. solution of sulphuric acid.

Various other processes based on Herschel's<sup>1</sup> original discovery have been described in the *Photographic Journal*; and in the *British Journal Photographic Almanack* for 1889 Mr. J. Traill Taylor gives a number of these methods and some results of his own experiments.

By a modification of the process black lines may be produced. (See *Black Lines*.)

**Daguerreotype Process.**—This process, although it yielded some of the most beautiful work ever done by the action of light on a chemically-prepared plate, and was for ten or twelve years most extensively used, is now entirely superseded. It is one of the processes the pictures made by which are quite unalterable in their proportions, so that for delicate detail requiring exact measurement (as in astronomical work) the daguerreotype possesses advantages; and, although the process may never be revived for practical use, a few lines of description here are necessary.

The plates used were of silver plated on copper—that is, a plate of copper on which one of silver was soldered, and then rolled to the required thickness. The silver required to have a perfect polish (a *black* polish, as it was called), and this was obtained by means of

<sup>1</sup> Herschel's experiments are given in papers published by the Royal Society, and are fully described also by Hunt in his "Manual of Photography," 5th edit., pp. 215-221.

very fine rouge powder or powdered pumice-stone mixed with oil on *buffs* of velvet, and the fine burnish was often given by means of a lathe, the buff being made to revolve while the plate was held against it. In the absence of a lathe the more laborious plan of buffing by hand was used. The plate was then placed face downwards on a frame or box of a size suitable to the plate, and at the bottom of the box was a vessel containing crystals of iodine. The ordinary temperature of the room was sufficient to produce fumes of iodine, which attacked the polished surface of the plate. It was next exposed over a dish containing lime on which a few drops of bromine were sprinkled, when the plate turned to a rose colour, after which it was again exposed to the iodine vapour. As soon as the plate appeared of a golden yellow colour it was ready to be placed in the camera. Success greatly depended on the correct exposure of the plate to the fumes of the iodine. After exposure the next operation was to develop the picture. This was effected by placing the plate in a box over a cup containing mercury. A spirit-lamp under and outside the box caused the mercury to vaporise, a temperature of  $140^{\circ}$  to  $167^{\circ}$  F. sufficing for this purpose, while the effect could be carefully watched by artificial light through an aperture in the side of the developing box. When the proper temperature was reached the spirit-lamp was removed and the temperature allowed to fall to  $130^{\circ}$  F. The hitherto invisible image gradually appeared, and as soon as the development was seen to be complete, the plate was removed to a grooved box and protected from the light until it was convenient to complete the operation. The iodine on the silver plate which has not been acted on by light has next to be removed; in other words, the picture had to be *fixed*. This was effected by plunging the plate in water to *harden* it. It was then placed in a saturated solution of common salt, or, as was soon found preferable, in a solution of sodium thiosulphate. The effect of this was to remove the yellow colour from the plate, thus making the picture unalterable by the action of light, and merely requiring to be protected from the air to prevent tarnishing of the silver surface.

Plates, as at first prepared, were very "slow," an exposure of from three to thirty *minutes* being required to produce the picture. In consequence of this slowness, the process was not adapted for portraiture. The process was improved by exposing the plate to the fumes of bromine, which acted as an accelerator. By this means the time of exposure was reduced to *seconds*, and, consequently, portraiture became practicable, owing to the reduced time of sitting. Further improvements were introduced, such as gilding the picture, which was the discovery of M. Fizeau. It was effected by covering the plate with a solution of gold hyposulphite. On the application

of heat from a spirit-lamp the picture was seen to be strengthened, and, consequently, was made more permanent. Such is a general outline of the process.

Although, in a sense, absolutely permanent, a daguerreotype, if it has not been properly protected from the air, is liable to become tarnished, although the *gilding* is, to some extent, a protection. The entire surface of the plate may become darkened, so that the picture is scarcely visible; but when the tarnish is removed, the picture is found to be as perfect as ever. If the edges only of the plate are tarnished, it is not advisable to attempt the removal of the defect; but if it is desired to copy the picture, then it is necessary to clean the surface. Dust may be removed with a soft camel's-hair brush used very lightly. On no account should the surface be touched with the fingers or even the softest material, as this would injure the delicate film forming the picture. To remove the tarnish, place a small lump of potassium cyanide in a glass measure and upon it pour about an ounce of water. Take the daguerreotype plate by the corner with a pair of pliers and rinse it well under a stream of water; then pour over it some of the cyanide solution, and return to the glass; repeat this several times until the discolouration is removed. At first the solution of cyanide will be weak, and, in cases of slight discolouration, will be sufficient to remove the tarnish; but, generally, a strong solution will be necessary. As the water is gradually dissolving the cyanide the strength will increase, and in a short time (never more than a few minutes) the surface of the picture will be as clean as on the day it was taken. Wash well under a tap, and then hold the plate over a spirit-lamp, applying the heat to the top of the plate first, when the heat will drive off the water downwards; the plate must not be held too long over the flame, or the silver film may become separated from the copper. The picture must now be replaced in its case, first carefully fastening it to the edges of the glass with goldbeater's skin or thin gummed paper; this should be very carefully done to exclude air.

When the picture is to be copied, it will be found better to turn the plate on its side. Owing to the absence of granulation, a copy of a good daguerreotype is generally more perfect than enlargements of any other kind.

**Drying Gelatine Plates.**—As the direct application of heat to a wet gelatine plate would result in the film melting, and as it may not be convenient to wait for drying by simple exposure to the air, a quick way of desiccating the film is desirable at times. If the plate, after it is taken from the washing trough, be carefully pressed against blotting-paper, much of the water will be removed; and the film will bear some degree of heat without injury, while the drying will thereby be

hastened, but great care must be used not to make the film too warm. The safer way is to immerse the plate in methylated spirit for a few minutes, or the spirit may be poured on and off a few times, then the plate may be placed in the rack in a current of air, where it will become quite dry in a very short time. The spirit may be used two or three times and then thrown away; or the water may be removed from the spirit, but this is scarcely worth the trouble. If the negatives are not required to be dried quickly, they may be left in the drying rack; but they should not be too close together, or they will dry unevenly, and possibly may become stained when the drying has been arrested.

**Dry-Plate Making.**—In the early days of dry-plate photography the whole of the processes were often conducted by the photographer himself. Hence many of the improvements in this branch of the art are due to experimental work on the part of enthusiastic amateurs. There can be no doubt that the greatest amount of pleasure may be derived from conducting the whole of the process from the beginning. The facilities now offered make the photographer less dependent on himself; he can purchase the plates ready prepared; he may not even develop them himself, and his share in the production of pictures may be no more than exposing the plates in the camera. As the gelatine plates can now be purchased of great excellence and uniform quality, there is some reason for not troubling to manufacture his own. The process is not very difficult, but it involves much careful work, and is better done in a commercial than in an amateur manner. In all other branches the amateur should do the work himself. Formulæ for the preparation of gelatine emulsion plates will be found treated separately.

**Dry Processes.**—Although the possibility of using collodion in the form of emulsion with silver was suggested as early as 1853, it was not until 1864 that the first practicable process was published. The credit of this is due to Messrs. Sayce & Bolton of Liverpool. Various modifications and improvements were made in subsequent years until 1871, when Dr. Maddox published a notice of the preparation of a *gelatine* emulsion and exhibited his results. A gelatine emulsion was first offered for sale in 1873, and in the following year Kennett introduced the first washed emulsion in the form of a pellicle. This was modified by Wratten & Wainwright in 1878, since which date the modifications and improvements have been too numerous to mention here. A very large part of what has been written on photographic matters during the last few years has had reference to the preparation of gelatine plates, and their proper development. The convenience of dry plates is undoubted; but opinions differ as to the superiority, or otherwise, of prints from such plates as compared with those done by the collodion

process. A good collodion negative cannot be surpassed, and one in gelatine may, perhaps, equal the collodion; but the majority of gelatine work certainly is inferior to the collodion; the negatives do not present the same qualities, they are generally weaker, and in many cases too dense, and consequently prints from them are often deficient in vigour.

**Dusting-on Process.**—This process is referred to under the heading *Ceramic Photographs*, but it has other applications, such as making reversed negatives; transparencies on plain glass or opal, and backgrounds may be added to negatives. In addition to the formula already given the following may be used:—

Gum arabic . . . . .	6 parts.
Potassium bichromate . . . . .	2½ „
Grape-sugar . . . . .	4 „
Water . . . . .	72 „

The object is to obtain a picture having a *tacky* surface. As the powder used may be black or coloured, much variety may be obtained in the results. The picture when printed is dusted over with the powder colour, when the powder will be found to adhere where the light has acted.

**Eburneum Process.**—Many processes have been practised for utilising collodion transparencies. One of the best, introduced by Mr. Burgess, is known by the name *Eburneum*. A good transparency is necessary; the glass upon which it is taken should be previously waxed to facilitate stripping, and it is important that the transparency should be of the proper kind. Either of the following developing solutions, as recommended by Mr. Burgess, may be used:—

Iron protosulphate . . . . .	5 grains.
Citric acid . . . . .	5 „
Glacial acetic acid . . . . .	10 minims.
Water . . . . .	1 ounce.

Or—

Pyrogallic acid . . . . .	3 to 6 grains.
Citric acid . . . . .	3 „
Glacial acetic acid . . . . .	20 minims.
Water . . . . .	1 ounce.

Fix the picture with potassium cyanide, and, after well washing, tone it with gold. When dry, strips of paper should be pasted round the plate on the back, so as to allow them to be turned up to form a kind of dish. When carefully levelled the plate is ready for the next part of the process. Take of good gelatine 5 ounces, water 20 ounces, glycerine ½ ounce, and zinc oxide 1 ounce. Soak the gelatine, then dissolve and filter it. The zinc must now be rubbed up in a mortar

with the glycerine and 1 ounce of water, and then poured into the gelatine. After a few hours the coarser parts of the zinc will have settled, and then, if carefully heated, the solution may be poured off, leaving the sediment; or the mass may be turned out when *set* and the bottom part cut away. Sufficient of the gelatine emulsion (at about 100° F.) may now be poured on to the levelled plate; 2½ ounces will be sufficient for a 10 × 8 plate. When set, the plate may be allowed to dry spontaneously or in a drying box, and when dry the film may be detached in the usual way.

**Electro-Phototypy.**—A patent has been granted to Mr. H. Sutton for “an improved process for converting a photographic image on a gelatine surface into a relief or intaglio printing surface.” The object of this process is, to a certain extent, to supersede the half-tone etching processes on zinc or copper. A negative is taken on a gelatino-bromide plate through a screen of lines in the usual way, and by heating up to 212° F. a relief is obtained, which is then converted into a block by electrotyping. The process is capable of yielding a printing surface in half-tone; but as there is no apparent means of modifying the surface, as can be done in the half-tone zinc etching process, the usefulness of the new method must be limited to such subjects as do not require the finer class of work.

**Enamelling Paper Prints.**—A very highly polished surface may be given to photographs on albumenised paper by means of hot rolling; but a glaze very much exceeding this is obtained by enamelling, as it is termed. A plate of glass free from defects is thoroughly cleaned and then rubbed over with French chalk, or a few drops of a solution of white wax in ether may be rubbed over the plate with a piece of lint, and then cleaned off with a dry soft cloth. A coating of collodion (not iodised) is now applied to the plate; when quite dry, this is covered with a solution of gelatine. Soak half an ounce of gelatine in six ounces of water for an hour or two, then dissolve it by placing the vessel containing it in hot water. If the gelatine is not sufficiently clear, it may be clarified by boiling in it some albumen which has been whisked in a small quantity of water. When filtered through lint or two thicknesses of muslin, the plate may be coated with the hot gelatine. When set, it can be put away till required. When many prints are to be enamelled, sheets of glass large enough to hold several prints may be used. There are several ways of applying the prints. They may be wetted and then placed on the gelatinised plate, care being taken to remove all air-bubbles. The prints may be coated with the gelatine and applied as soon as the surface has *set*. When the plates and prints are small, they may be placed in contact in the gelatine solution and the surplus squeezed out. The greatest care must be taken to exclude air-bubbles. When quite dry,

the prints will readily leave the glass if a penknife be passed under one edge. Prints treated in this manner have a very beautiful appearance, as details will be shown which otherwise would not be seen. There can be no doubt that the collodion acts as a protection to the print, which, if it has been carefully finished in other respects, may thus be rendered more permanent. There is, however, one disadvantage; the surface is very liable to injury by rubbing against the opposite prints if placed in an album. In mounting, the prints must be attached by the edges only.

A silver print on albumenised paper may have its gloss increased by being allowed to dry on a ferrotype plate, on to which it has been squeegeed.

**Enlarging and Copying.**—When an object is to be enlarged, an ordinary camera may be used, if it can be extended to a sufficient length; but it is more convenient to use apparatus which has been specially constructed for the purpose. A camera of this kind is described and illustrated in Part III., and the solar camera is also referred to.

If a special camera is not available, one of the ordinary kind may be arranged on a board at one end, secured by a screw running in a slot cut in the board; at the other end of the board is a stand sliding between strips of wood attached to the sides of the board, which stand is made to hold carriers for the different sizes of plates to be copied. Laths of wood placed at the top of the camera and the negative carrier will serve to hold a cloth to exclude light between the lens and the negative or positive which is to be enlarged or reduced.

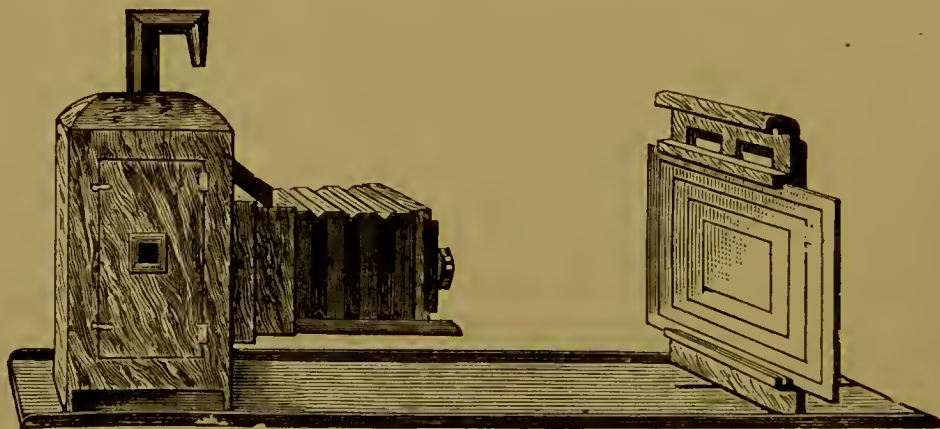

FIG. 34.

Fig. 34 shows a method for using artificial light from a sciopticon or other form of lantern; it also illustrates what is described in the previous paragraph, substituting the ordinary camera for the lantern. If attached to a board, as above described, it may be



used in the way indicated, or may be turned towards the sky. It will be noticed that two cameras may be utilised in this manner; in the arrangement described above it may be turned towards the sky, and used without darkening the room. Fig. 35 shows a convenient way for making enlargements or reductions, the lens being placed in the central division.

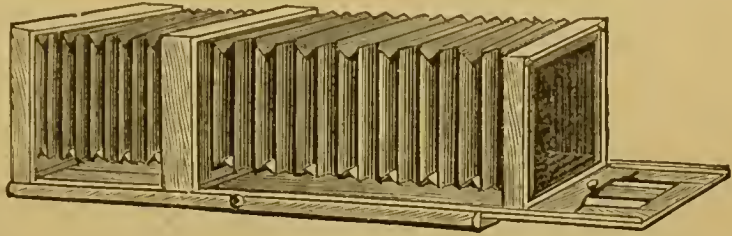

FIG. 35.

Another simple and convenient way to produce enlargements is

to adapt a room so that a reflector (which may be a mirror, a sheet of white cardboard, or opal glass) may be made to reflect light through an opening in the window, through the negative or positive to be enlarged, the lens being arranged on a table and the plate or paper fixed to a movable easel, the various parts being capable of adjustment to the sizes required. (See *Camera*.)

In countries where solar light may be used more constantly than in England, the solar enlarging camera is very convenient when the object is to *print out*; but, as the modern processes have simplified the operation of enlarging, this form of instrument is not much used on account of the necessity for constantly regulating the reflecting mirror.

In using a camera, or any other enlarging apparatus, it is convenient to know at what distance the lens should be from the object and the plate from the lens, in order to produce copies (larger or smaller) of the required dimensions with as little trouble and loss of time as possible. This can be done by referring to the table.

To use the table, suppose the copy is to be enlarged five diameters and that the equivalent focus of the lens is 4 inches; the ground glass of the camera must then be 24 inches from the lens centre, and the object  $4\frac{4}{5}$  inches distant. In a reduction, the positions are exactly the reverse. For lenses of greater focal length than 9 inches the table can be used by doubling the figures, which will represent the focus of the lens to be used.

The principle on which this table is constructed is as follows:—The focal length of the lens must be multiplied by *one* more than the number of times of the enlargement—that is, suppose the focus of the lens to be 10 inches and the times to be enlarged 3; multiply the 10 by 4, and we have 40 inches as the distance of the lens from the sensitive plate; and if we divide 40 by 3, we have  $13\frac{1}{3}$  as the distance of the lens from the object.

TABLE FOR ENLARGEMENTS.

Focus of Lens.	Times of Enlargement and Reduction.							
	1.	2.	3.	4.	5.	6.	7.	8.
Inches.	Inches.	Inches.	Inches.	Inches.	Inches.	Inches.	Inches.	Inches.
2	4 4	6 3	8 $2\frac{3}{4}$	10 $2\frac{1}{2}$	12 $2\frac{2}{5}$	14 $2\frac{1}{3}$	16 $2\frac{2}{7}$	18 $2\frac{1}{4}$
$2\frac{1}{2}$	5 5	$7\frac{1}{2}$ $3\frac{3}{4}$	10 $3\frac{1}{3}$	$12\frac{1}{2}$ $3\frac{1}{8}$	15 3	$17\frac{1}{2}$ $2\frac{1}{2}$	20 $2\frac{6}{7}$	$22\frac{1}{2}$ $2\frac{1}{6}$
3	6 6	9 $4\frac{1}{2}$	12 4	15 $3\frac{3}{4}$	18 $3\frac{3}{5}$	21 $3\frac{1}{2}$	24 $3\frac{3}{7}$	27 $3\frac{3}{8}$
$3\frac{1}{2}$	7 7	$10\frac{1}{2}$ $5\frac{1}{4}$	14 $4\frac{2}{3}$	$17\frac{1}{2}$ $4\frac{3}{4}$	21 $4\frac{1}{5}$	$24\frac{1}{2}$ $4\frac{1}{2}$	28 4	$31\frac{1}{2}$ $3\frac{1}{8}$
4	8 8	12 6	16 $5\frac{1}{4}$	20 5	24 $4\frac{2}{5}$	28 $4\frac{2}{3}$	32 $4\frac{2}{7}$	36 $4\frac{1}{2}$
$4\frac{1}{2}$	9 9	$13\frac{1}{2}$ $6\frac{3}{4}$	18 6	$22\frac{1}{2}$ $5\frac{3}{8}$	27 $5\frac{2}{5}$	$31\frac{1}{2}$ $5\frac{1}{4}$	36 $5\frac{1}{7}$	$40\frac{1}{2}$ $5\frac{1}{8}$
5	10 10	15 $7\frac{1}{2}$	20 $6\frac{2}{3}$	25 $6\frac{1}{4}$	30 6	35 $5\frac{5}{8}$	40 $5\frac{5}{7}$	45 $5\frac{5}{8}$
$5\frac{1}{2}$	11 11	$16\frac{1}{2}$ $8\frac{1}{4}$	22 $7\frac{1}{8}$	$27\frac{1}{2}$ $6\frac{7}{8}$	33 $6\frac{1}{2}$	$38\frac{1}{2}$ $6\frac{1}{2}$	44 $6\frac{2}{7}$	$49\frac{1}{2}$ $6\frac{1}{8}$
6	12 12	18 9	24 8	30 $7\frac{1}{2}$	36 $7\frac{1}{6}$	42 7	48 $6\frac{6}{7}$	54 $6\frac{3}{4}$
7	14 14	21 $10\frac{1}{2}$	28 $9\frac{1}{3}$	35 $8\frac{3}{4}$	42 $8\frac{2}{5}$	49 $8\frac{1}{8}$	56 8	63 $7\frac{7}{8}$
8	16 16	24 12	32 $10\frac{2}{3}$	40 10	48 $9\frac{3}{5}$	56 $9\frac{1}{3}$	64 $9\frac{1}{7}$	72 9
9	18 18	27 $13\frac{1}{2}$	36 12	45 $11\frac{1}{4}$	54 $10\frac{3}{5}$	63 $10\frac{1}{2}$	72 $10\frac{2}{7}$	81 $10\frac{1}{8}$

**Ferrotypes.**—One of the many processes worked out by Hunt was called by him *Ferrotypes* (also *Energiatypes*). The paper was prepared by washing over with—

Succinic acid . . . . .	5 grains.
Common salt . . . . .	5 "
Gum arabic (mucilage) . . . . .	$\frac{1}{2}$ drachm.
Water . . . . .	1 ounce.

When dry, the paper was drawn over the surface of a solution of silver nitrate containing 60 grains in 1 ounce of water. The paper was dried in the dark, and when dry was ready for use. It would retain its white surface if preserved in a portfolio. The paper could be used in the camera for landscapes, when an exposure of half a minute was sufficient, and about three minutes for a portrait. The

image remained invisible until developed in one drachm of a saturated solution of iron protosulphate, and two or three drachms of mucilage of gum arabic. When the picture was completely developed, which was very rapid, the further action of the solution of iron was stopped by sponging the surface of the print with water. The fixing was with ammonia or sodium thiosulphate, after which the print was thoroughly washed.

In this process Hunt showed the value of the salt of iron as a developing agent.

**Ferrotypes.**—Thin plates of iron covered with black varnish (to protect the metal from the silver solution) are used in this process instead of glass. There is no difference in the manipulation; the same collodion, bath, and developing solution which will give good positives on glass will yield good ferrotypes. Gelatine emulsion may be used on ferrotype plates. The ferrotype process is now almost out of date.

**Film Photography.**—The discovery of some means by which photographs could be taken without the use of glass or paper has been the wish of all photographers who make landscape-work their study. Many methods have been proposed. As early as 1871 the late Mr. Walter Woodbury suggested a method of using films instead of glass for negatives; and also, that the film should be used in bands in a suitable carrier, so as to avoid the use of the ordinary dark slides. Mr. Warneke in 1876 used collodion or bromide emulsion on paper so prepared that the film could be separated from the paper after use, a roller-slide being used in the camera instead of separate dark slides. Pumphrey of Birmingham, Carbutt, and Vergara introduced films; but the Eastman Company appear to have made the nearest approach to perfection in the substitution of glass by celluloid. The composition of this substance is allied to pyroxylin, being formed by the action of sulphuric and nitric acids on paper (or cellulose in any other form); it is then dissolved after complete washing, and mixed with camphor. The celluloid film is coated in the same way as glass with the sensitive gelatine, and the after-treatment is the same as for glass. As the flexible and transparent film is composed of matter nearly allied to gun-cotton, it is necessary that precautions be taken to avoid decomposition and possible explosion, although it is said that some kinds are not explosive. The films form a very perfect substitute for glass.

**Fixing.**—The term *fixing* as applied to the daguerreotype picture, means boiling a solution of *sel d'or* upon the plate, and so fastening the image that it could not be easily removed. In other processes *fixing* signifies the removal from the film of the sensitive material which forms no part of the image. Potassium cyanide, sodium thio-

sulphate, or ammonia are usually employed for this purpose. As the sensitive haloid salts of silver are soluble in a solution of one or other of these substances, the solvent to be used in each case is referred to in the descriptions of the various processes.

**Fluorotype.**—In 1844 Hunt published experiments with the fluorides, showing that pictures could be taken on paper in the camera by using solutions having the following formulæ :—

1. Potassium bromide . . . . .	20 grains.
Water . . . . .	1 ounce.
2. Sodium fluoride . . . . .	5 grains.
Water . . . . .	1 ounce.

Mix a small quantity of these solutions together when the papers are to be prepared, and wash the papers once over with the mixture. When dry, apply a solution of silver nitrate, sixty grains to the ounce of water. These papers keep for some weeks without injury, and become impressed with good images in half a minute in the camera. The impression is not sufficiently strong when removed from the camera for producing positive pictures, but may be rendered so by a secondary process.

The photograph should first be soaked in water for a few minutes, then placed upon a slab of porcelain, and a weak solution of iron protosulphate brushed over it; the picture almost immediately acquires an intense colour, which colouring action should then be stopped by plunging it into water *slightly* acidulated with muriatic acid, or the blackening will extend all over the paper. It may be fixed by being soaked in water, and then dipped into a solution of sodium thiosulphate, and again soaked in water as in the other processes.

**Fothergill Process.**—It was one of the earliest and best of the dry-plate methods, but is now entirely superseded by the gelatino-bromide process.

**Gelatino-Bromide Process.**—This process has in the last dozen years made a complete revolution in the practice of photography. As early as 1853 Gaudin had experimented with gelatine. Still earlier, albumen had been extensively used; but for dry-plate work collodion emulsion appears to have received almost exclusive attention until 1871, when Dr. Maddox published a process in which gelatine took the place of collodion. Various modifications were suggested in the preparation of the emulsion between 1871 and 1878, when, in the latter year, Mr. Bennett published the fact that by digesting the emulsion at 90° F. great sensitiveness was obtained. The importance of gelatine emulsion for making dry plates may be dated from this valuable discovery. Mr. Bennett's discovery was first published in the *British Journal of Photography* in 1878.

In 1880 Mr. W. J. Wilson was awarded the prize of £50 offered by Mr. Paget for the best emulsion process. In a very condensed form the method is as follows, and this may be taken as representative of the process generally. The following is the formula employed :—

	No. 1.	
Hydrochloric acid (pure)	. . . . .	1 fluid drachm.
Distilled water	. . . . .	12½ ounces.
	No. 2.	
Distilled water	. . . . .	3 ounces.
Ammonium bromide	. . . . .	210 grains.
Nelson's No. 1 gelatine	. . . . .	80 „

“Twenty minims of the No. 1 solution are introduced into the whole of the No. 2 solution, and the gelatine left to swell. In another glass vessel 330 grains of silver nitrate are dissolved in three ounces of distilled water. A small quantity, about two fluid drachms, of the latter is poured into a test-tube, and diluted with an equal bulk of distilled water. The solution of the bromised gelatine is then rendered complete by immersing the bottle in hot water, and the dilute silver nitrate is added all at once. The bottle is then shaken, and the remainder of the strong silver solution added in quantities of half-an-ounce at a time, shaking, as before, after each addition. The emulsion is then boiled for fifty-five minutes, and, when cooled down to 90° Fahr., one ounce of Nelson's No. 1 gelatine or the X opaque, which has been previously swelled and dissolved in water, so as to measure four ounces, is added. When set, the emulsion is squeezed through canvas into a pan containing three ounces of a saturated solution of potassium bichromate in three pints of cold water, and allowed to remain in it for one hour. The emulsion is then squeezed through canvas into clean cold water, and the operation repeated immediately, the emulsion remaining in the last wash-water for half-an-hour. The addition of two ounces of alcohol and sufficient water to make up the solution to twenty ounces completes the process, and the emulsion, when filtered, is ready for use.”<sup>1</sup>

It is of the greatest importance that the proper kind of light be used while preparing any sensitive emulsion. Mr. Bennett gives prominence to this, and recommends the use of a ruby-coloured hock bottle to shield the light. The bottle is prepared by cutting off the neck and bottom; a candle can then be inserted and held in position by a suitable holder, which serves as a stand, while a cap of tin held in place at the top allows of the escape of smoke from the candle, and also prevents the escape of white light.

Another important point to be observed in the preparation of gela-

<sup>1</sup> *Year-Book of Photography*, 1882, p. 130.

tine emulsion is that the most suitable gelatine be used. Some samples are acid, and this kind should be employed when ammonia is not in the formula. The gelatine should take up very little water and make a hard jelly. If spots occur where the film is dry, the gelatine contains fat, and this may be corrected by the addition of ammonia.

In his work on "Modern Dry Plates," Dr. Eder describes three methods. The first refers to the preparation of the emulsion with ammoniacal silver nitrate, which gives plates about six or seven times the sensitiveness of wet collodion.

In the second method the emulsion is prepared by boiling and subsequent digestion with ammonia. In this way plates of great sensitiveness are obtained; but much care is required. The extreme sensitiveness depends on the fact that the modification of silver bromide forms very rapidly at temperatures between 60° C. (140° F.) and 100° C. (212° F.), and that the sensitiveness of such emulsion, in itself very great, can be still further increased by subsequent treatment with ammonia at a low temperature.

The third method is for the preparation of an emulsion at low temperature.

When a small quantity of emulsion is examined on a piece of glass by transmitted light it appears red. As the boiling proceeds this colour changes to blue; and the completion of the process is determined in this manner.

One of the most important parts of the process of making gelatine plates is the drying, and special means must be adopted to effect this. A drying cupboard is usually employed. This may be a box of suitable size, having rods across it inside, on which the plates, when the films have set, are placed. Air is admitted through a hole at the bottom, protected so that no white light can enter; while another aperture at the top of the box permits the exit of the air, which has been warmed by means of a small gas jet in the bottom air-tube. Other ways for drying the plates may be adopted. A suitable box or cupboard may have a coil of piping, through which water flows that has been heated in a cistern connected with a small gas-stove. Apertures are left in the bottom and top of the box to admit air and allow its escape.

Gelatine emulsion may be spread on paper, and can also be used for lantern slides or for printing out.

If kept dry, gelatine plates will retain their sensitiveness for a long time, and the development of exposed plates may be delayed, in the writer's experience, at least six years. It is important that the sensitive plates be kept excluded from the air as much as possible, otherwise there may be deterioration, which is seen as a darkening of the plates, starting from the edges.

The subject of the preparation of gelatino-bromide plates is alto-

gether too large to be treated in a few pages: the number of processes and modifications is very great. In 1888 a list of the different kinds of dry plates in the market contains over a hundred names; probably all were prepared by formulæ differing more or less from each other, and therefore it will be seen that to do more here than to indicate the method of production is quite impossible. The special works on the subject, such as those by Eder, Abney, Burton, and others, should be consulted.

**Gelatino-Chloride Paper (Ilford).**—Papers prepared with gelatine in place of albumen have been introduced (see *Aristotype*), and amongst others is one by the Ilford Company. The uncertain stability of prints on albumenised paper has, from its first introduction, made it desirable that some substitute for albumen should be found; but although many processes, which gave results of great beauty, and in some cases equalling those on albumen, have been introduced, albumenised paper is still used to a greater extent than any other. The cause of the preference, probably, is that detail is not lost in the shadows, as is the case in some other processes; and the gloss given to the paper by the albumen is not so objectionable as that obtained when prints by other methods have been dried on glass. The most recent introduction is that by the Ilford Company. It is a gelatino-chloride paper, to be printed-out in the same way as albumenised paper. It may be dried either with a glazed or a matt surface. The paper can be purchased ready for use; its price is about the same as that of albumenised paper, and it has the advantage of not deteriorating by keeping.

The prints, which do not require to be deeply printed, as they lose little in the after processes, must first be washed for ten minutes in several changes of water. The toning bath is—

Ammonium sulphocyanide . . . . .	30 grains.
Gold chloride . . . . .	2½ „
Water . . . . .	16 ounces.

This solution is recommended for the paper, but any of the older formulæ may be used if desired. The prints must be constantly moved to prevent their adhering together, which would cause the toning to be irregular. The toning is complete in three or four minutes, and the effect may be judged by looking through the prints, when, if the ordinary purple tone is desired, the colours should appear warm in the deepest shadows. The appearance of over-toning is lost in the fixing. Careful washing is necessary after toning, or the action of the toning solution will be continued. The fixing bath contains—

Sodium thiosulphate . . . . .	3 ounces
Water . . . . .	20 „

in which the prints must remain ten minutes.

If there should be any tendency in warm weather for the gelatine to become soft, or if the prints are to be burnished, an alum bath should be used before toning—4 ounces of alum to 20 ounces of water.

There can be no doubt that prints on this paper have a very near approach to those on albumenised paper, but time must determine if they are permanent. There are now so many processes all capable of yielding most excellent results that it is impossible to say that any one is the best, while tastes differ even more than the processes. The process employed should be adapted to the picture; a matt surface will suit some subjects, while others would be improved by adopting a glazed surface.

**Gold-Printing Process.**—In 1852 some prints on plain paper were shown by Mr. Hennah at the first Exhibition of the Photographic Society in the room of the Society of Arts. Referring to these prints, Mr. Spiller, in the *Photographic Year Book*, 1883, refers to their exceptionally good quality; and, as the result of his own experience, says as follows:—Instead of employing gold for the toning of his silver prints by a subsequent operation, Mr. Hennah commenced by adding gold to the salting solution, and then had only to fix with plain sodium thiosulphate to get the neutral tones so much desired. He prescribed—

Gold chloride . . . . .	60 grains.
Ammonium chloride . . . . .	120 „
Water . . . . .	20 ounces.

On this the plain paper (Towgood's or Turner's) was floated, and hung up to drain and dry, then sensitised in a 60-grain bath of ammonio-nitrate of silver made as usual. The paper quickly dried, and was exposed to light under the negative until moderately over-printed. Without washing, the prints were immersed in a fixing bath prepared as follows:—

Sodium thiosulphate . . . . .	5 ounces
Silver iodide . . . . .	10 grains
Water . . . . .	1 pint

to which was added 1 ounce of a 60-grain ammonio-nitrate of silver solution; “stress being laid upon the maintenance of alkaline conditions by further addition, if necessary, of ammonia. The prints were washed in several changes of boiling water, or in the ordinary way with cold water, and being now very tender, were taken out and dried upon glass rods; finally, laid face downwards on glazed bibulous paper, and ironed on the back. The finished proof should have pure whites and fine ivory-black shadows. The author, in his original paper, vouches for ten years of permanence, and he told me in 1872 that he had



never known a case of fading wherever the process had been fairly carried out. The somewhat increased consumption of gold was more than compensated by the perfection of the result."

**Green Photographs.**—If paper prepared with a solution of uranium nitrate (60 grains to the ounce) be exposed for a few minutes under a negative, very little visible effect is produced, but when washed in water and then brushed over with a weak solution of potassium ferricyanide, a red picture is the result. While still wet after washing, if placed in a solution of sesquichloride of iron (10 grains to the ounce) the colour of the print is changed to green.

**Gum-Gallic Process.**—In this process, introduced by Mr. R. Manners-Gordon, the collodionised plates are well washed after being sensitised. The following preservative is used :—

1. Gallic acid . . . . .	3 grains.
Water . . . . .	$\frac{3}{4}$ ounce.
2. Gum arabic (picked white) . . . . .	20 grains.
Sugar-candy . . . . .	5 "
Water . . . . .	$\frac{1}{4}$ ounce.

The two solutions are mixed together and filtered shortly before use. The preservative solution is flowed over the plate twice, and after the first time the solution is returned to a separate cup, used once more, and then thrown away. After the second application the plates are allowed to dry spontaneously in the dark. Plates thus prepared were said to keep well, and were about as quick as wet collodion.

**Heliography.**—The process in which he used bitumen of Judea was named by Niépce *Heliography*. Bitumen possesses the property of hardening when exposed to sunlight, so that any part of a surface covered with a thin layer which had not been affected by light could be washed away with any substance which would dissolve the bitumen; for this purpose Niépce used oil of lavender. In this process the object was to form a picture on a lithographic stone, so that, after treatment with acid to etch away the stone, the picture could be printed in the usual way; but no satisfactory result was obtained, and afterwards metal plates were substituted for the stone. As this was the foundation of the process of zinc-etching as at present largely used, the process will be described under its modern name of *Zinc-etching*.

**Honey Process.**—One of the methods of keeping collodion plates moist was the use of honey, as suggested by Mr. Shadbolt.

**Indian-ink Outlines** (see *Magic Photographs*).—Make a print on plain salted paper, not too darkly printed, and fix without toning. The print may now be worked over in Indian-ink lines in the manner of an etching or woodcut, and any degree of finish may be given to the drawing. The Indian-ink should be of good quality, which may

be determined by making a few lines on paper and then allowing a stream of water to flow over it after the ink is dry. If the ink does not *run*, it will answer for coating the drawing. The print may now be placed on a solution of mercury chloride, which will remove all trace of the photograph, leaving the lines of the drawing. The print must be thoroughly washed. If placed in a solution of copper sulphate, to which has been added a pinch of sodium chloride, the picture will bleach; but it must be very thoroughly washed afterwards, or the photograph will reappear on exposure to the light. When a photo-lithograph or line block is required from a half-tone photograph, this method will be found very useful, as when the drawing is skilfully done the effect is good. If any defects appear after the print is bleached, they may be corrected with Indian-ink. The plate giving a view of the Manchester Royal Exchange was made in this way.

**Iridescent Photographs.**—The following process is said to give pleasing results. It is described by Mr. Burbank, who states that M. Geymet is the inventor. All parts of the process may be conducted in full daylight. A glass plate is coated with the following solution:—

Gum arabic . . . . .	75 grains.
Glucose (sat. sol.) . . . . .	1 drachm.
Ammonium bichromate (sat. sol.) . . . . .	3 drachms.
Distilled water . . . . .	3½ ounces.

This must be filtered three times and then exposed to light for some hours. To facilitate the coating, the plate should be dipped in water before pouring on the sensitive solution. The fluid is flowed over two or three times; the first is thrown away, and the next returned to a separate bottle to be used for the first of the next plate. Expose well under a strong negative. To develop the picture, bronze powder is rubbed over the plate with a tuft of cotton-wool; if necessary to make the image take the powder, the plate must be breathed upon. As soon as dry, the collodion is washed to remove the yellow colour, and then dried. The iridescent effect is produced by coating the plate with collodion as under:—

Alcohol . . . . .	7 drachms.
Ether . . . . .	18 „
Gun-cotton . . . . .	5 grains.

The positive is again washed, and dried quickly without heat. After development the plate is coated with plain collodion. The plate may then be coated on the back with black or coloured varnish.

**Kallitype.**—A process has been patented by Messrs. J. Lewis &

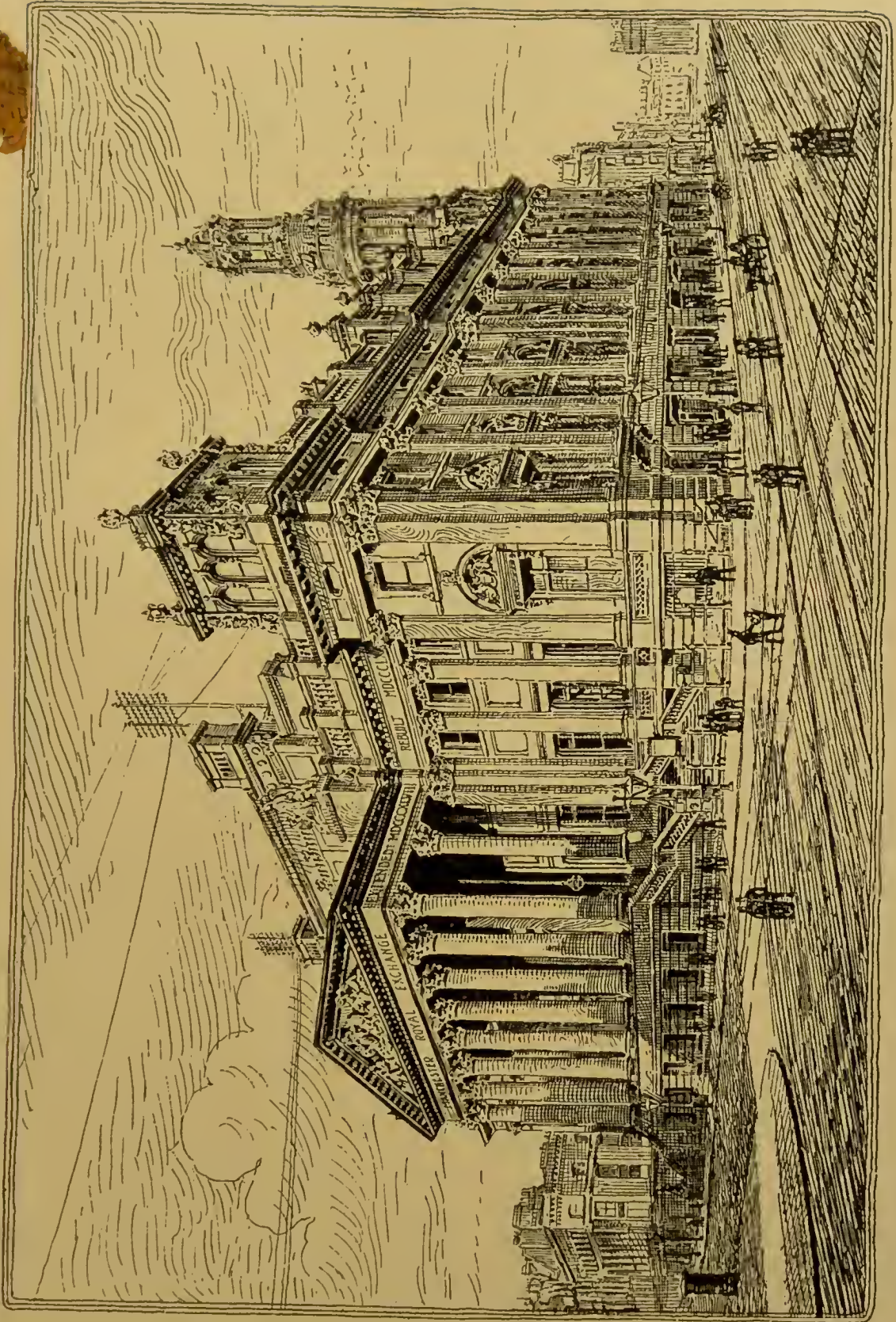

101

Co. of Birmingham which they call *Kallitype*. The paper is prepared with a strong solution of neutral ferric oxalate, and, when dry, is printed until the detail in the densest part of the negative is faintly indicated.

As this paper is said to be six times more sensitive than the ordinary silver paper, it must be used, in filling the printing-frames, in yellow or weak daylight. The following are the instructions given by the patentees :—

Care must be taken that the paper is quite dry when put out to print, or it will not be so easy to determine the proper exposure, and the resulting print will not be so good a colour. It may be necessary in damp weather to dry it carefully, but it must not be made too hot in drying, or the paper will be fogged. Five to ten minutes in a good light, or from two to three minutes in sunlight, is an average exposure. When the detail in the densest parts of the negative is faintly indicated, the printing must be stopped, remembering that the whole shows but faintly before development.

The prints must be quite dry before developing ; they are floated face downwards upon the developing solution (used cold) for ten to twenty seconds, and are then placed face upwards upon a piece of clean glass for a minute or two, to gain brilliancy and depth. They are next immersed in washing solution No. 1, where they must remain for at least twenty minutes. This washing solution may be used repeatedly, as long as it serves its purpose of removing the yellowness from the prints. When developing prints with plain flat backgrounds, be careful to well shake the developing solution in the dish before floating, otherwise markings will sometimes occur.

The prints are next washed consecutively in No. 2 and No. 3 washing solutions ; they must remain in each of these baths for about ten minutes, and after the last bath they are washed for a few minutes in water and dried. The prints must be moved about freely in the washing solutions, and as soon as No. 3 shows the least tinge of yellow when viewed in bulk, it must take the place of No. 2 and fresh solution poured out for No. 3, otherwise the prints will be yellow.

*Developing Solution.*

Silver nitrate	. . . . .	50 grains.
Sodium citrate	. . . . .	1 ounce.
Potassium bichromate	. . . . .	1 grain.
Water	. . . . .	10 ounces.
Ammonia, '880	. . . . .	$\frac{1}{2}$ drachm.

Dissolve the silver nitrate in about an ounce of the water, and the sodium citrate and potassium bichromate in the remainder, and mix. Add the ammonia and filter.

*Washing Solution No. 1.*

Kallitype developer . . . . .	½ ounce.
Sodium citrate . . . . .	2 ounces.
Water . . . . .	20 „

To be returned to bottle for future use, as previously described.

*Washing Solution for Bath Nos. 2 and 3.*

Sodium citrate . . . . .	1 drachm.
Ammonia, '880 . . . . .	2 drachms.
Water . . . . .	1 quart.

If the print has been insufficiently exposed, it will develop very slowly, and will require a longer floating upon the developing solution.

The developing solution may be used over and over again, and with care will serve for a great quantity of prints. The developer which has been used should be kept separate, and when the prints show any lack of brilliancy, should be set aside to be restored. This is effected by adding to every 10 ounces 20 grains of silver nitrate dissolved in a small quantity of water. Prints not developed the same day as printed must be carefully kept quite dry.

Washing solutions for baths No. 2 and No. 3 must always smell distinctly of ammonia, or the prints will not be properly fixed.

When printing from very thin negatives, greater contrast may be secured by the addition of more bichromate of potash to the developer. A stock solution containing 8 grains to the ounce will be found useful. One drop, or more if necessary, added to each 10 ounces of developer, will give greater brilliancy and contrast. This process gives excellent results.

A process called *Kallitype* No. 2 has been introduced, in which the prints are developed. Albumenised paper can be used, or prints with a matt surface can be made. The same care in printing must be observed as in the other process. To obtain black tones the prints are immersed singly in the following solution :—

No. 1. Rochelle salt . . . . .	1 ounce.
Borax . . . . .	¾ „
Potassium bichromate, 10 to 12 minims of a solution, 20 grains to the ounce.	
Water . . . . .	10 ounces.

*For Purple Tones.*

No. 2. Rochelle salt . . . . .	1 ounce.
Borax . . . . .	2 drachms.
Potassium bichromate solution . . . . .	10 to 12 minims.
Water . . . . .	10 ounces.

*For Sepia Tones.*

No. 3. Rochelle salt . . . . .	½ ounce
Potassium bichromate solution . . . . .	6 minims.

Several prints may be developed at the same time, the usual care being taken to avoid air-bubbles. The prints are fixed by immersion for ten or fifteen minutes in—

Ammonia (strong)	. . . . .	4 drachms.
Water	. . . . .	1 quart.

To ensure perfect fixing, a second bath of the ammonia solution is recommended. A few changes of water during about fifteen minutes is sufficient for washing the prints; after which they may be dried and mounted.

The paper is prepared with ferric oxalate and ferric nitrate, silver oxalate and silver nitrate. On exposure to light the ferric oxalate is reduced to ferrous oxalate  $\text{Fe}_2(\text{C}_2\text{O}_4)_3 = \text{Fe}_2(\text{C}_2\text{O}_4)_2 + 2\text{CO}_2$ ; which by contact with the Rochelle salt ( $\text{NaKC}_4\text{H}_4\text{O}_6$ ) in the developer reduces silver salt in contact with it to the metallic state. At the same time the Rochelle salt and the iron salt form ferric tartrate,  $\text{Fe}_2(\text{C}_4\text{H}_4\text{O}_6)_3$ ; the ammonia dissolves the silver salt, but does not precipitate the ferric tartrate.

**Kennett's Pellicle.**—One of the earliest workers with gelatine emulsion was Mr. R. Kennett, who patented a process for the use of gelatine instead of collodion combined with salts of silver. The compound of iodide or other salt of silver with gelatine was cut into strips, washed to remove the free salts, and afterwards dried. In the dried state the "pellicle" could be stored for use. When required, it could be dissolved in water and plates coated with it in the usual way. Plates thus prepared were much more rapid than wet collodion. This appears to have been partly the cause of the want of commercial success with the pellicle, as over-exposure was generally the result in hands used to slow processes. Fog also was complained of, but this was probably due to the presence of too much light, as the yellow light suitable for wet collodion was not suitable for the new pellicle. (See *Collodion Pellicle*.)

**Lantern Slide-making.**—A good transparency on glass is perhaps one of the most beautiful kinds of photograph, and a good lantern-slide exhibited by the oxy-hydrogen or electric light, enlarged as it may be to 20 or 30 feet in diameter, forms one of the most valuable aids to the lecturer, who thus has the means of affording his audience pleasure and instruction in a way that no other kind of illustration permits. There are many points to consider in making lantern-slides; the original negative must be of good quality; the proportion should be considered, and, although the proportion of a picture  $7 \times 5$  more nearly resembles the shape of landscape pictures as usually painted, it does not follow that when that size is reduced to  $3\frac{1}{4} \times 3\frac{1}{4}$ , the size now considered to be the standard, the effect on the screen

will be satisfactory. To make a square picture out of  $7 \times 5$  necessitates some of the subject being cut away at the sides, or, if reduced in the same proportion, the picture on the screen will appear long and narrow. Therefore, as the screen has a better appearance when fully covered, it is necessary to bear in mind, while taking the negative, what is ultimately to appear when used in the lantern. For lecture purposes it matters very little what shape the pictures are made; but for a lantern exhibition of photographs much of the effect depends on uniformity of size. The shape may be square, circular, or cushion-shaped, and, provided the sheet or screen is filled, the effect will generally be good. The good effect also depends on the quality of the pictures, as no system of exhibition shows defects more than the lantern. It is, therefore, necessary, in preparing lantern-slides, to keep constantly in view the purpose for which the picture is to be used. Nothing looks worse than to have a thin and weak picture followed by a dark one, or for one to appear as a snow scene when the true effect should be that of a bright summer's day. A really good transparency can only be obtained from a negative of the best quality. It may, however, be possible in some cases to make a fairly good transparency from a negative which will not give a good paper print; the defects may to some extent be modified by careful exposure, development, and intensification.

Good lantern-slides may be made by any of the photographic processes capable of yielding pictures on glass. A process which may fail altogether in some hands will yield excellent results in others. It may, therefore, seem superfluous to give instructions, and it might suffice to say: Use the process you know best how to work. Some of the best lantern-slides were made by Ferrier of Paris. The process, so far as known to the writer, is still a secret, but is believed to have been the old albumen process. Good work was done on plates by methods now entirely out of use, and it is difficult to say which process now practised will give the best pictures. Wet collodion will give pictures of the very highest quality, and if amateurs would take the trouble to acquire a knowledge of this process, they would probably give it the preference over all others for making lantern-slides. Carbon tissue prepared specially for transparencies, and the Woodbury process give beautiful results. Gelatine plates in some hands are successful, and now that special attention is given by makers of plates for lantern-slides in the preparation of plates for this purpose, slides equal to the wet process can be produced. Gelatino-chloride plates are generally preferred. With care in developing, very beautiful pictures and variety of tone may be obtained.

When negatives of the same size as the lantern-slide are available, they can be printed by contact, and this is the best way; but when



the negatives are larger, the transparency must be made in the copying camera. Makeshift appliances may be used, but the best work can only be done with apparatus specially constructed. (See *Copying Camera*.)

Two cameras may be utilised in making lantern-slides: one large enough to hold the large negative to be reduced, and the other having the lens and plate-holder; these cameras, when placed on a board, may be used in the way which placing the two instruments together will suggest.

Artificial light may be used for making lantern-slides. The source of light may be one or two gas-flames or oil-lamps; but the light must be diffused by means of ground glass.

As to the method for developing pictures for the lantern, if gelatine plates are used, the best advice which can be given is to keep to the formulæ sent with the plates. If wet collodion plates are used, the development may be varied by diluting the solution of iron; and the intensification should be made with pyrogallic acid in the usual way, great care being taken to watch the intensity. Gold or platinum toning may be used if desired.

Lantern-slides are sometimes coloured. Whether it is desirable to attempt to colour a photograph which is to be enlarged many diameters is entirely a question of taste. The colour should be applied with skill, or the effect will not be artistic; while nothing can be worse in a lantern exhibition than a crudely coloured slide. As a rule, such slides are crude in the extreme. To attempt to improve a good lantern-slide by the application of colour is, in the writer's opinion, a mistake, and it should not be attempted except by those who are skilled in painting.

**Leimtype.**—This process was invented by Professor J. Husnik of Prague, and is a variation of the photo-etching and collotype processes. The printing surface is prepared with sheets of chrome-gelatine, which are fastened to zinc plates with resin. After developing by rubbing with a certain fluid, the plate is finished and ready to be printed from in an ordinary type-press. The only difference between a Leimtype and a zinc block in line or half-tone is that the surface of the glue or gelatine is used to print from. The process is said to be easy to manipulate, skilled labour not being required, while 50,000 prints can be taken from one plate, which, if necessary, can be reproduced by the galvanic method. The process is patented. The appearance of a Leimtype print is very much the same as a print from a Meisenbach block, and in printing from half-tone blocks the same care will be required as in the Meisenbach method. A line block in Leimtype is in every way equal to a zinc-etched block of the best quality.

**Litho - Heliogravure.**—In this process a lithographic stone is

covered with a very thin coating of asphaltum, composed of 5 parts of asphaltum, 6 parts of white wax, and 6 parts of stearic acid, to which, while boiling, 2 parts of soda solution are added. This preparation of asphaltum is dissolved in turpentine. After filtration, a portion is poured on to the lithographic stone and distributed by a litho-ink roller, so that a thin film is left on the stone. By means of the ruling machine, the stone is then ruled with fine lines. It is then etched with—

Nitric acid . . . . .	0.10 part.
Alcohol . . . . .	6 parts.
Water . . . . .	35 „

The etching fluid is allowed to remain on the stone for thirty seconds, and is then washed off. The stone is then dried, oiled, and the asphaltum washed off with turpentine; after which it is rolled up with ink and used for transfer of the lines. The lines having been ruled in one direction, transfers may be made diagonally or in any other way desired. The picture has next to be transferred. It is prepared by making a diapositive on carbon tissue. The print is then wetted with cold water and squeegeed on to the lined stone; then the paper is moistened with water at about 110° F. and removed in the usual way. After careful drying, which may occupy five or six hours, the stone is ready for etching. Ferric chloride is used for etching the stone, beginning with a strength of 40° Beaumé and finishing with 30°. The stone may be printed from in one kind of ink, or ink of various colours can be applied to the parts desired, and the impression of all taken at the same time. The process is the invention of Herr C. Eckstein, and is described by Herr O. Volkmer, who states that the results are very fine.

**Magic Photographs** (see *Indian-ink Outlines*).—When Sir John Herschel suggested that a photograph could be bleached by saturating it with mercury chloride, he did not anticipate that his discovery could have any artistic or commercial value. Reference to the article *Indian-ink Outlines* will show that the process has a great practical application. As “magic photographs” a very pretty result may be shown. After the photograph, prepared as described on p. 121, has remained in the bleaching solution a few minutes (until the picture has entirely disappeared), it should be thoroughly washed and dried. If the print is now placed in a solution of sodium thiosulphate, the photograph will reappear. Blotting-paper may be saturated with the thiosulphate and dried. If now the dried and bleached print be placed with the blotting-paper in water, the “magic” picture will appear.

**Meisenbach Process.**—Owing probably to the fact that the Meis-



*Engraved from a Photograph*  
BY THE  
MEISENBACH IMPROVED PROCESS OF PHOTO-ENGRAVING.



enbach Company patented a method of producing half-tone blocks which could be printed with type, the name *Meisenbach* is often used to designate any block which shows cross lines on the picture, although such picture may be produced by means to some extent different from the process as patented by Meisenbach. The special method used by the Company is very similar to much of the same kind of work produced in this country, on the Continent, and especially in America. One of the earliest of the process blocks was produced by Pretsch, and was printed in the *Photographic Journal*, No. 131, 1860. Most excellent work can be produced by breaking up the half-tone by means of the line screens; but, no matter how perfect the block may be, there is risk of spoiling by careless printing, as the very fine lines soon fill up with ink. Unless the block be most carefully "made ready" and judiciously printed, the effect produced may be anything but artistic. On the other hand, a good half-tone block carefully printed on good paper leaves nothing to be desired as to artistic beauty, as the plates in this volume show very perfectly.

**Micro-Photography.**—Photographs which require a lens to make them visible are called *Micro-Photographs*. If these minute photographs are to be used under the microscope and magnified many diameters, the image must be as free as possible from granulation and crapiness in the film. Photographs of objects enlarged by means of the microscope are sometimes called *micro-photographs*, but the proper term for such pictures is *photo-micrographs*, the method of producing which is described under that heading.

**Mosstype.**—This is a variety of the method of making half-tone blocks for printing with type.

**Mounting and Mountants.**—Too little attention has, from the first discovery of photography, been given to the best way to mount photographs. Talbot's method was to attach the prints by their outer margins only. The importance of this is seen in the prints made by himself which still exist, and which, in some cases, have faded only at the parts touched by the mountant. But prints mounted partially in this way have not the same finished appearance as those which are completely attached to their mounts. Hence the importance of using a mountant which shall not have any chemical effect on the print. The mountants usually employed are starch, freshly made flour-paste, gelatine, india-rubber dissolved in benzole or chloroform, and many others. In themselves some of these substances are quite harmless so long as the prints are kept quite dry; but damp may set up decomposition, producing acidity and the probable destruction of the print; this applies to silver prints only, as they are most liable to be injured by chemical decomposition. Another difficulty arises in mounting prints with substances such as

starch and gelatine ; these hold a large quantity of water, and the consequent expansion of the paper when moistened by the mountants produces a contraction on drying which causes the mount to *cockle* or to be drawn out of shape ; this result is certain to follow except the mount be of unusual thickness. It is generally believed that professional mounters use the best glue. With this material, and by means of a press, prints may be mounted on paper or thin cardboard without cockling ; but the amateur has not the appliances to effect this. The india-rubber solution answers very well ; but, after a time, decomposition may occur, and the prints will peel off the mounts. Gum arabic is not recommended, as it will not keep, and it takes some hours to make. Starch that is not too stiff answers extremely well ; it is very clean ; it does not set too quickly, and is very easily made. The dry starch should be smoothly mixed with cold water, and then boiling water poured on to it until the required consistency is attained, stirring while mixing. When cool it is ready for use, after taking off the skin which forms in cooling, as this, if mixed with the starch, causes it to be lumpy. Some kinds of starch require to be boiled. There is one disadvantage with starch ; it is difficult to remove a print from the mount without injury. Gelatine is a good mounting material ; it must be used warm, and prints can be readily removed from their mounts when placed in hot water. The gelatine should not be too strong. If it sets in a thin jelly when cold, it has sufficient consistence for mounting prints. No starch nor gelatine should be used which is at all acid.

Bleached shellac dissolved in spirits of wine is recommended by Professor Rood as a mountant. The shellac, which should be rather thick, is applied to the dry prints, which are then rubbed down in the usual way, care being taken that the mountant does not touch the face of the prints. This would appear to be a desirable mountant, as the prints do not cockle, and the shellac protects the prints from any injurious matter which may be in the mounts.

When photographs are to be mounted in books or on thick paper, every care should be taken to keep the paper from cockling ; and, if the prints are attached completely to the paper, india-rubber or the shellac mountant should be used. With care, prints may be mounted by using the best glue, touching only about a quarter of an inch of the print all round, and using a piece of paper half an inch smaller than the print to protect it while the glue is applied. The prints should be carefully trimmed, and, if not flat, they may be placed on a soft cloth and a thin smooth-edge drawn across the back several times. This will flatten the prints and make them easy to handle.

Prints should always be trimmed before they are toned, and, if left

face down while drying or between cloths or blotting-paper, they are not so liable to curl when dry.

Very little experience will enable any one to place a print correctly on its mount without any marks as guides. It is sufficient to place the print while dry on the place where it is to be fixed, and make pencil-marks at two corners where such marks are required.

Photographs mounted in optical contact with glass have a very finished appearance. To mount prints in this manner is not difficult. A solution of good gelatine, not quite so strong as would be necessary for mounting on cardboard, should be used. Gelatine 60 grains, water 3 ounces, filtered through muslin while warm, should be poured into a flat dish. Into this immerse the print face downwards; place the glass, which must be perfectly clean and free from defects, under the print, and then carefully withdraw the glass with the print on it. Squeeze all superfluous gelatine from the print and set aside to dry.

Prints which have been enamelled, or bromide or other prints which have been dried on a glass surface, must be attached to their mounts by their outer margins only.

A convenient way of trimming prints is to use a glass of the size the print is to be, and a sheet of thick glass or zinc as a bed for cutting on.

**Obernetter's Etching Process.**—In this process a negative is first converted into a chloride of silver positive, which is then placed in contact with a copper plate connected with an electric current. The chloride of silver is decomposed, and the copper is etched in proportion to the quantity of chloride of silver in contact with the plate. The picture can then be printed by the ordinary method of copper-plate printing. It is claimed that by this process a printing plate can be prepared much more expeditiously than by any other.

**Opal Glass.**—The term *opal* has been applied to glass which is *flashed* on one side with a glass which is opaque white, or which is composed altogether of the white substance. In the latter case it is called *pot-metal*. Both kinds are made in two ways, one having a polished surface and the other having a ground or matt surface. The pot-metal kind is altogether to be preferred for photographic purposes, as it presents a surface on which photographs have a very beautiful appearance. There are various means by which the picture may be made on this material. When the wet collodion process is used, a negative may be copied in the camera, which on development becomes a positive. The following formula is suitable for the purpose, and gives a positive of a pearly grey colour :—

Iron protosulphate . . . . .	30 grains.
Citric acid . . . . .	90 „
Acetic acid . . . . .	2 drachms.
Water . . . . .	15 ounces.

Or

Iron protosulphate . . . . .	2½ drachms.
Citric acid . . . . .	6 „
Acetic acid . . . . .	3 „
Water . . . . .	20 ounces,

which will give a blacker tone.

The collodio-chloride process may be used for printing on opal glass, but the gelatino-bromide plates are better for the purpose. Carbon pictures have an admirable effect when transferred to the opal.

The pot-metal presents an excellent surface for artistic work, either in monochrome or water-colour. When well finished, pictures on this material are almost equal in effect to those on ivory.

**Orthochromatic Photography.**—The importance of the use of dyes in rendering colour-values in photography is now generally recognised, although there is much difference of opinion as to the best method of using the colours and coloured (yellow) screens. The term *orthochromatic*, a compound of two Greek words meaning “right colour,” is considered better than *isochromatic*, meaning “equal colour,” as in the latter case it might be supposed that the word referred to actual colour reproduced, which is not the case. The difficulty has always existed that certain colours could not be represented in the photograph as they appeared to the eye; yellows and reds always translate darker than they should be, and blues and violets lighter.<sup>1</sup> That something could be done to make the contrasts in copying oil-paintings less defective than was usually the case was first suggested by Mr. Crookes in 1858, who, in a leading article in the *Photographic News* (Mr. Crookes was then its editor), pointed out that “the collodion should not be iodised, but bromised with four grains of cadmium

<sup>1</sup> Very soon after the discovery of the daguerreotype process, Dr. Draper of New York found that the film of iodine on the silver plate assumed various colours, and that these tints were variously acted on by light. The addition of turmeric to give a yellow colour to collodion was found by Professor J. M. Sanders in 1860 to give additional detail, intensity, and extra-sensitiveness to negatives; but it does not appear to have been noticed that the addition of colour assisted in the more correct rendering of the objects copied. It was, however, pointed out by Mr. Crookes about 1857 that collodion in which ammonium bromide had been used had advantages not possessed by collodion simply iodised. He says: “The chief advantages it seems to possess over the ordinary iodised collodion, besides its great sensitiveness, are the following:—In a landscape the required opacity of the more strongly illuminated parts (the sky, for instance) is not lost by over-exposure; vegetation is also more easily copied. Its superior sensitiveness to light colour is, however, most strikingly shown when coloured glass or sulphate of quinine (as suggested by Sir John Herschel) is employed to absorb the strongly invisible rays. To prove this I arranged several flowers and plants with a view to obtain great contrast of colour, light, and shade.”



bromide to an ounce of collodion; and the lens, which must have a sheet of yellow glass close in front of it, should be a portrait combination working with full aperture, as the time of exposure to the feeble rays which alone can filter through the yellow glass will be enormous, even when a picture is illuminated as perfectly as possible." The difficulty as to the "enormous" length of exposure no longer exists; but the value of the suggestion is seen in the fact that the yellow screen is now used in connection with plates which have been chemically treated to make them sensitive to certain of the coloured rays of the spectrum. Dr. H. W. Vogel of Berlin was the first to suggest the use of dyes in 1873. In a communication to the writer, dated Berlin, 6th June 1890, Dr. Vogel says: "Colour-sensitive or orthochromatic photography is already an old thing, invented seventeen years ago, but only estimated by the photographic fraternity during the last seven years. There are, however, a great many people interested in photography who know nothing at all about orthochromatic photography, who don't even believe in it; others have heard about it, but remain sceptical. Only in Germany, where colour-sensitive photography was invented, is it duly appreciated. In the establishments of Braun (Dornach), Albert & Naunfstängel, Obernetter, Bruckmann (Munich), the Photographische Gesellschaft (Berlin), are many thousands of subjects reproduced by colour-sensitive collodion, and in the British Museum such plates have been used. Colour-sensitive gelatine plates are already made in at least six manufactories in Germany, one in England, and one in America. In using these plates, a *yellow screen* is required to diminish the action of the blue rays; but there is one kind of plate by which the right colour effect is produced without the yellow screen in taking landscapes; this is the *eoside of silver* plate. Who invented orthochromatic photography? One says Ives, another says Waterhouse, another Tailfer, my name also is mentioned in the second or fourth order. Dr. Eder says in the Report of the Vienna Academy, vol. xciv., 1886, p. 380:—'By the discovery of the action of colouring matters or sensitisers for the less refrangible rays by Dr. H. W. Vogel, the means are obtained to make bromide of silver sensitive for green, yellow, and red by suitable colouring matters.' Further, Dr. Eder says in the *Photographic Times*, 1886, p. 483:—'Dr. H. W. Vogel discovered in 1873 the property of many colouring matters to increase the colour-sensitiveness of the bromide of silver of those rays of the spectrum which they absorb,' &c. I could cite here also the astronomer Dr. Nasselberg of Pulkowa, and Dr. Becquerel of Paris, who is mentioned now in French papers as the first in order of the discoverers of colour-sensitive photography, but who has mentioned myself as his predecessor in his publication (*Comptes Rendus*, July 1874). In fact, I published my first observations on the

matter of making bromide of silver sensitive for the so-called non-actinic rays in 1873 (*Berichte der deutschen chemische Gesellschaft*, 1873, p. 1305; *Photographische Mittheilungen*, 1873, vol. ix. p. 236). I made my first experiments with the sun's spectrum, but I went a step further in employing the newly discovered fact practically. I fastened a dark-blue silk ribbon on a piece of yellow silk, and took a picture from it with an ordinary wet collodion plate. The result was a white ribbon on a dark piece of silk. It was obvious that I could not succeed much better with a corallin-dyed bromide of silver plate, because the action of the yellow in the spectrum on it was much stronger than that of the blue. Therefore I interposed a yellow screen between the subject and the lens, depressing the intensity of the blue rays; and now I got indeed a negative which was a true positive print, wherein the dark blue ribbon was dark and the yellow silk was light. This was published in the paper named in 1873. It is seen from this that I succeeded in taking the first so-called isochromatic picture; and therefore the claim that Mr. Ives was the first is incorrect, as his results came four years after mine. I am not astonished at mistakes of this kind, for we have an instance here in Germany where the Senate of a University has elected a gentleman as 'honorary doctor' for an invention which he had not made at all.

"I called the dyes which absorb red or green or yellow rays of the spectrum and make bromide of silver sensitive for those rays, *optical sensitisers*. As such sensitisers I recognised corallin, aldehyde green, magdala red, cyanin, and fuchsine. In 1876 Waterhouse recognised eosine as a first-rate sensitiser. In 1875 Becquerel used chlorophyll. In 1878 Ives tried the same with success. Ducos du Hauron's brother continued to work with eosine in collodion. In 1883 Tailfer used the same dye in gelatine plates. In 1884 I introduced azaline, a combination of cyanin and chinolin red, as a good sensitiser for gelatine plates. All these sensitisers require a yellow screen for taking pictures in the right value (yellow bright, blue dark). In 1885 I observed with Obernetter that the chemical combination between eosine and silver (eoside of silver gives the best results for yellow and green) gave plates ten times more rapidly for the yellow of the sun's spectrum than for the blue. With such plates it is possible to take green landscapes without any yellow screen with far better effects than with ordinary plates. For bringing out the clouds and misty distance and foliage, the eoside of silver plate is really superior to the ordinary kind."

In 1879 Mr. F. E. Ives suggested the use of chlorophyll of blue myrtle or periwinkle leaves for making collodio-bromide plates colour-sensitive. The chlorophyll is prepared by steeping the leaves when cut into small pieces in pure alcohol and heating for a few minutes.

The solution of chlorophyll is in its best state when fresh, but will keep for some weeks in a cool place, if not exposed to light. To prepare the plates, flow with collodio-bromide emulsion, and when set cover for a few seconds with the chlorophyll solution, after which wash in distilled water until smooth. The plates must be used with the yellow screen, which Mr. Ives prepares by making a tank with plate-glass sides which is filled with a solution of potassium bichromate; the strength of the yellow solution may be increased or diminished according to the subject to be copied. Excellent results have been obtained by this method.

Many kinds of colouring matter have been used for making plates colour-sensitive, amongst them eosine, erythrosine, cyanine, fuchsine, azaline, aurantia, rose Bengal, quinoline red, chlorophyll, xanthophyll, gallocyanin (a blue dye), chrysanaline, corallin, aldehyde green. Most of these are derived from coal-tar distillation.

Since Dr. Vogel first suggested the use of dyes, many names occur connected with the subject of orthochromatic photography in addition to those already mentioned, amongst them Eder, Becquerel, Ducos du Hauron, Abney, Bothamley, Drs. Mallmann and Scolic, Hyslop, Wellington, Obernetter, Waterhouse, Carey Lea, and many others.

In 1883 a patent was granted to Messrs. Tailfer and Clayton for the preparation of gelatine plates with eosine and ammonia, one of the special points claimed being the use of ammonia.

From all the evidence available it does not appear that any one of the substances hitherto used is, in itself, sufficient to render plates colour-sensitive to all the rays, and that no single one is altogether satisfactory for the red. Yellow is well under control, as plates may be over-sensitive for that colour, so that it may have the same value in a copy as blue or violet.

As to the best method of preparing colour-sensitive plates, the following is Mr. B. J. Edwards' opinion:—"Since the publication of Tailfer and Clayton's specification many formulæ have been published for preparing isochromatic plates by bathing ordinary gelatine plates with an ammoniacal solution of eosine or erythrosine. This method, although it is described in the specification as an alternative process, does not give the best results; also it is found that plates so prepared will not keep, but commence to deteriorate from the moment of their preparation. The only practical way of making perfect isochromatic plates is to coat them with a prepared emulsion which is made isochromatic or colour-sensitive in the first instance. Plates made in this way are more perfectly colour-sensitive and will work without the yellow screen; they will also keep without deterioration equally as well as ordinary plates."

As to whether it is better to mix the dye with the emulsion at the

time of preparing the gelatine plate, or merely to bathe a plate (which is already dry) and then allow it to dry again in the dark, there is a very wide difference of opinion. As Mr. Ives, writing in 1888, said: "By this method" (using erythrosine or cyanin) "some of the most rapid ordinary plates in the market can be made as sensitive to the orange red, orange yellow, and green of the prismatic spectrum as they are originally to blue and violet. . . . The sensitisers are dissolved in alcohol, a quarter grain to the ounce, and the plates are prepared by simply flowing with the alcoholic solution, drying, and then waiting." Mr. Ives recommends the use of the yellow screen, and he says that plates prepared in this manner keep well, but that if they are to be used dry, they should be coated with a thin film of gelatine. If it be taken for granted, as Mr. Edwards says, that plates prepared with the original emulsion keep well, and when only dipped do not keep (although Mr. Ives finds that there is no difference), there can be no doubt that there is some advantage in being able to make an ordinary gelatine dry plate orthochromatic by merely pouring over it an alcoholic solution of the dye.

On the keeping qualities of plates which have merely been steeped in the colour-sensitising solution, Lieutenant-Colonel Waterhouse says that he has developed plates which have been laid aside for two months, and were quite free from defects.

In preparing orthochromatic dry plates, Dr. J. M. Eder recommends the following method:—"Ordinary gelatino-bromide plates are immersed in the following bath:—

Erythrosine solution, 1 part in 500 . . . . .	1 to 2 parts.
Ammonia . . . . .	$\frac{1}{2}$ part.
Water . . . . .	100 parts.

When properly prepared orthochromatic plates are not available, the use of a yellow screen alone will be found of some advantage in copying objects or paintings in which yellow occurs; also, when there is much blue in a picture, the yellow screen may be employed.

It has been found that clouds may be photographed with good effect when orthochromatic plates are used.

The use of the yellow screen is generally advocated by those who have investigated the advantages of orthochromatic plates, and many different suggestions have been made as to the kind of screen required. All admit that glass ground so as to be optically true is better than any other medium; but such glass is expensive and difficult to obtain. The plan used by Mr. Ives has already been described. The surfaces of ordinary patent plate-glass are not sufficiently true, but the very thin glass used for covering microscopic objects may be coated with a yellow dye and attached to the diaphragm to be used between

the lenses. Collodion may be stained with tincture of iodine and dried on a sheet of glass which has been rubbed over with French chalk so as to strip easily. To make the film sufficiently thick to handle, the collodion may be applied as frequently as necessary. When quite dry, the film may be removed from the glass and carefully placed over the aperture of the diaphragm. Gelatine may be obtained and used in the diaphragm slot, or the back of the lens nearest to the plate may be coated with the yellow dye; this, however, is a troublesome makeshift, and cannot be recommended. When the glass screen is to be used, it may be placed either within the lens mount in front or at the back of the combination. Shades of varying density should be available, as a darker tint may be necessary in certain cases.

The time which has elapsed since the subject of orthochromatic photography first received recognition is too short to permit any definite theory to be formed as to whether the results are due to physical or chemical causes. Experiments by Abney have shown that the gelatine film itself need not be dyed, but that if protected by a varnish containing the colouring matter, the same results may be obtained as when the gelatine emulsion itself is dyed. This would seem to favour the physical theory. "There are other considerations which tell in favour of the chemical hypothesis, such, for instance, as the fact that the addition of ammonia increases the special sensitising action of the dyes; but some of the experiments described by Abney appear to me to prove most conclusively that it is in this direction that we must look for the explanation of this phenomenon."<sup>1</sup>

Meldola says further, "Before taking leave of this part of the subject, I am tempted to offer a suggestion which may be of use in guiding future experiments. The chemical hypothesis of orthochromatic action rests upon the fact that the best special sensitisers are the most fugitive dyes. Now there is reason for believing that the bleaching of a colouring matter by the action of light is due to photochemical oxidation. If this be the case, atmospheric oxygen may be essential for the production of orthochromatic effect, and the formation of a second maximum in the less refrangible part of the spectrum might be prevented by immersing the dyed plate in a reducing solution, or in some inert liquid or gas which prevented access of air. Experiments of this kind might easily be made, and if the action on the green, yellow, or orange did not take place under these circumstances, the chemical hypothesis of orthochromatic photography would be raised to the rank of a proved theory; while, on the other hand, if the second maximum still appeared, this hypothesis would not be disproved, because it is possible that the breaking down of the

<sup>1</sup> Meldola, *Chemistry of Photography*, p. 317.

complex molecule of the colouring matter by the action of light might take place in the absence of oxygen, and thus also give rise to the formation of products of a reducing character."<sup>1</sup>

Colour-sensitive plates may be developed by any of the ordinary methods, but the following is recommended for the plates prepared under the Tailfer patent by Mr. Edwards. The plates should be carefully protected from all light, except that of a ruby colour; and the exposure necessary in the camera is less than for plates of the ordinary kind:—

No. 1 Solution.	
Pyrogallic acid . . . . .	1 ounce.
Alcohol (methylated) . . . . .	7 ounces.
Glycerine . . . . .	$\frac{1}{2}$ ounce.

Mix the glycerine and spirit and add the pyrogallic acid. The following is another formula:—

Pyrogallic acid . . . . .	1 ounce.
Citric acid . . . . .	40 grains.
Water . . . . .	$7\frac{1}{2}$ ounces.

No. 2 Solution.	
Potassium bromide . . . . .	60 grains.
Distilled water . . . . .	7 ounces.
Ammonia, '880 . . . . .	1 ounce.

If kept separate and well corked, these solutions will not deteriorate for some weeks. To use, take one part of No. 1 to fifteen parts of water, and the same proportion of No. 2. These dilute solutions should be mixed in quantity as required; and as much as will cover the plate to be developed may be poured from the bottles into a measure and poured over the plate, taking care to avoid air-bubbles. Fix with sodium thiosulphate as usual, and clear with—

Alum . . . . .	1 ounce.
Sulphuric acid . . . . .	$\frac{1}{4}$ ,,
Iron protosulphate . . . . .	3 ounces.
Water . . . . .	20 ,,

There would seem to be very little reason why commercial plates prepared for orthochromatic work should be more expensive than the ordinary kinds, as no extra labour in their preparation is incurred. When the time arrives that the distinction in price is removed, it will probably be found that orthochromatic plates will be used for all purposes, as the presence of the dye is no disadvantage; and, in very many cases, the photographic result is much superior to that of work which has been produced on an ordinary plate.

**Panoramic Photography.**—Views embracing an angle greater than any ordinary lens can give may be taken by carefully levelling the camera, and then, after taking the first plate, revolving the camera

<sup>1</sup> Meldola, *Chemistry of Photography*, p. 320.





CHINESE MANDARIN.  
(Copyright.)

61799148





PRINTED BY JAMES C. NORBURY & SONS,  
MANCHESTER.



so that the next view will slightly overlap the first one. In this way a series of pictures may be taken embracing the entire circle. The disadvantage of this method is that the exposures, and also the development of the negatives, must be identical, in order that the prints when joined may be alike; the printing, also, requires equal care. A camera was invented by the late Mr. Sawyer by which the picture was taken through a narrow slit, the proper motions being given to the lens and plate by means of clockwork.

A very wide angle of view may be obtained by means of a specially constructed lens, such as the *panoramic lens* patented by the late Mr. Sutton. A sphere of flint-glass was filled with water, and in the centre was fixed a small diaphragm. It was necessary to use a curved glass plate when the collodion process was employed, the manipulation of which was somewhat difficult.

A camera was invented by Mr. Ross of New York having a lens of  $3\frac{1}{4}$ -inch focus, by which a plate of 8 inches by 3 was covered, the angle of view included being 120 degrees. The instrument was called the *scioptic camera*. A fuller description will be found in the *Liverpool and Manchester Photographic Journal* for March 1857.

**Paper Negatives.**—Now that celluloid films are available, it is scarcely probable that paper will ever again be used for negatives, unless some means can be found for entirely removing the granularity of the paper. Although glass superseded paper in the early days of the photographic art, very beautiful work was done on paper negatives, and the existence at the present time of many of the earliest negatives (which it will be remembered were developed with gallic acid and aceto-nitrate of silver) proves that they were permanent.

**Pedestal Portraits.**—The effects of statuary busts may be simulated by photographing a portrait, with the bust suitably draped, against a black velvet or other very dark background, while powder must be freely used on the hair and face to assist the effect. By the aid of double printing the pedestal can be introduced. When carefully arranged, the effect is excellent.

**Photochromes.**—Many methods have been proposed for treating photographs with colour, so as to get rid of the monochrome effect, and the name of M. Leon Vidal is associated with a process called *Photochrome*. Under the heading *Photography and Colour* this subject is treated in full.

**Photochromo-Lithography.**—One of the most useful applications of photography is in making transfers for lithographs of designs which have been printed in colours. Each colour is printed from a different stone, and as reduced or enlarged copies are often required from such work, the different sizes may be obtained by photographic means, thus saving the cost of re-drawing. Impressions from each stone are taken

in black, and from these transfers can be made. The accompanying plate shows the original design printed in eleven colours; the reduced copy was made in the way indicated.

**Photo-Engraving—Photogravure.**—Under various names processes have been invented, often patented, for the purpose of producing on a copper, steel, or zinc plate a picture or photograph having half-tone. Dating almost from the invention of photography, attempts were made to enable impressions to be taken from the daguerreotype plate. Some of this early work was almost equal in quality to the productions of the present day. The failure of commercial success was probably due to the soft character of the metal, as very few good impressions could be taken, a defect which is remedied now by the process of steel-facing, by which the engraved surface of the plate is protected by a hard metal renewable at pleasure.

The discovery that an image can be produced by the effect of light in the camera on bitumen is due to Nicéphore Niépce, who, in 1829, coated plates of pewter and copper having a surface of silver with bitumen (glass was also tried) dissolved in oil of lavender (which was also used as a solvent to develop the picture); the parts acted on by light, being insoluble, remained on the plate, thereby protecting the metal from the acid used to *etch* the image. Specimens of Niépce's process were exhibited by Mr. Malone at a lecture delivered by him at the Royal Institution, London, in 1857; they were presented to a Mr. Bauer, who resided at Kew at the time of the visit of Niépce to England. If these pictures are still in existence, it seems desirable that they should be available for inspection in some public institution. The perfect work now practicable is done mainly by a process almost identical with that invented by Niépce. Many names are connected with the process for obtaining pictures on metal plates; amongst them Talbot, Pretsch, Claudet, Poitevin, Fizeau, Grove (who used the galvanic method), and many others. The next step was the introduction in 1852 by Talbot of a process he named *Photoglyphy*.<sup>1</sup> In this, gelatine made sensitive to light by potassium bichromate takes the place of bitumen. It has the advantage of printing quicker, and for line-work is better than the older process, but for half-tone it is inferior. In 1854 Herr Paul Pretsch of Vienna patented a process which he called *Photogalvanography*. A jelly formed of one part of gelatine to ten of water was mixed with a strong solution of potassium bichromate. To this was added gelatine containing silver nitrate. A third portion of gelatine containing a small quantity of potassium iodide was added. After being well mixed and strained, glass plates

<sup>1</sup> The full specification of Talbot's patented process of *Photoglyphic Engraving* will be found in the *Liverpool and Manchester Photographic Journal*, vol. ii. p. 269.

*Estampe Miniature N° 2.*



*En Pénitence*



were coated with the emulsion and dried ; when dry, the plates were exposed under a negative. Up to this point the processes of Talbot and Pretsch are very similar ; but the after treatment is quite different. The plates after exposure to light were not washed, but were placed in water to allow the gelatine to swell in those parts not acted on by light, the picture appearing in relief. At this point the gelatine could be printed from if the surface would bear pressure ; but as it would crush, a mould was taken and the surface of this mould was electrotyped. This electrotype was used as a matrix, and from it blocks for printing with type were made. By a variation in the method plates for printing in the copper-plate press were produced. In order to obtain a granular or stippled surface necessary to produce the effect of half-tone, advantage was taken of the peculiarity which gelatine combined with potassium bichromate has of drying with a grain. This grain breaks up the shadows and gives the effect of half-tone. The same effect is produced and taken advantage of in (and indeed is the foundation of) the collotype process.

The plate facing page 143 is an example of Pretsch's process, and will compare favourably with work recently done. Plates executed in any process producing half-tone effects are more or less worked upon by the engraver. As an example of half-tone process engraving, it is remarkably good. The illustration is by Messrs. A. & C. Dawson.

Improvements in the preparation of plates for intaglio-printing were slowly made ; but there was no great advance upon Pretsch's method until the late Mr. Walter B. Woodbury took the matter in hand. In 1874 he wrote :<sup>1</sup> " Of all the photo-mechanical processes, perhaps photo-engraving has made the least progress during the past few years ; simply owing, I imagine, to the fact that engraving, or rather the printing from engraved plates, is, and must always be, a slow and expensive process." Mr. Woodbury then says that excellent results have been produced by M. Rousselon, of the firm of Goupil & Co. of Paris, by the method suggested by Mr. Woodbury to them ; and he claims that the excellent work done by Rousselon is based on the idea he suggested to Goupil & Co. As was the case with many other ideas suggested by Mr. Woodbury, great results have followed, and we see them in the extremely beautiful works executed by Goupil & Co. and their successors, Boussod, Valadon, & Co., called photogravure. The plates are made by the process of electro-deposition of copper ; but whether Woodbury's method is still followed, or any modification of it, is not known to the writer. The plates, while being very perfect reproductions of the originals, in some cases owe much of their excellence to the very skilful retouching by the engraver ; and the printing

<sup>1</sup> *British Journal Almanack*, 1874, p. 106.

qualities of the plate are often due to the same cause. It should be stated, however, that some of the best work in photogravure is quite untouched. The preparation of the plate by this method—that is, from an *intaglio*—requires from one to three months. The plates are steel-faced, and the steel surface is renewed after each thousand impressions have been printed.

One of the chief difficulties with plates in half-tone is that the etching cannot be carried very deep, thus involving very careful printing.

The term “photogravure” was first applied to this process by Goupil & Co., and is sometimes called *Goupilgravure*. The plate facing page 140 is an example of the excellent work done by the Company.

The process known as “Klic’s process” produces effects almost exactly similar to those done by what is called “Goupil’s process.” Messrs. Annan of Glasgow at one time worked this process, and it is now used by Messrs. Annan & Swan of London, who produce work very closely resembling the Goupil productions, and certainly not inferior.

The working details of Klic’s method are printed in the *Photographic News* for 28th January 1887. It varies from Talbot’s process merely in the use of powdered asphalt. The copper-plate must be absolutely clean, the polish being effected with whitening in water. The plate must now be covered with the asphalt, which is most simply done by shaking the powder in a box. When the larger particles have settled, the plate must be introduced at the bottom, an opening being made at one side of the bottom so that the plate may be placed without disturbing the dust floating in the upper part of the box. The fineness of the grain depends on the time the plate remains in the box, as the more dust collected the finer will be the grain. When it is judged that the plate is sufficiently dusted, it is removed from the box, and, by the heat from a Bunsen burner, the asphalt is partially melted, until the dull surface is changed to a gloss, when the heat must be at once removed. A reversed positive being now required, a piece of carbon tissue is exposed under it, and squeegeed on to the copper. When printed, the picture is developed in the usual way. The etching is effected with iron perchloride, a strong solution being first used, as its action is less energetic than a weak solution. The plate is treated with the iron in three or four degrees of strength. A strip of copper placed in the iron solution until the colour changes causes the solution to act evenly. The etching takes place through the gelatine, and the plate is protected by the asphalt. When the etching is complete, the gelatine can be removed with caustic alkali and the asphalt with turpentine. Experience alone will show when the etching is complete, and its progress can be watched through the film. The temperature of the iron etching fluids should be 70° Fahr. Plates by this method may be prepared in a few days.





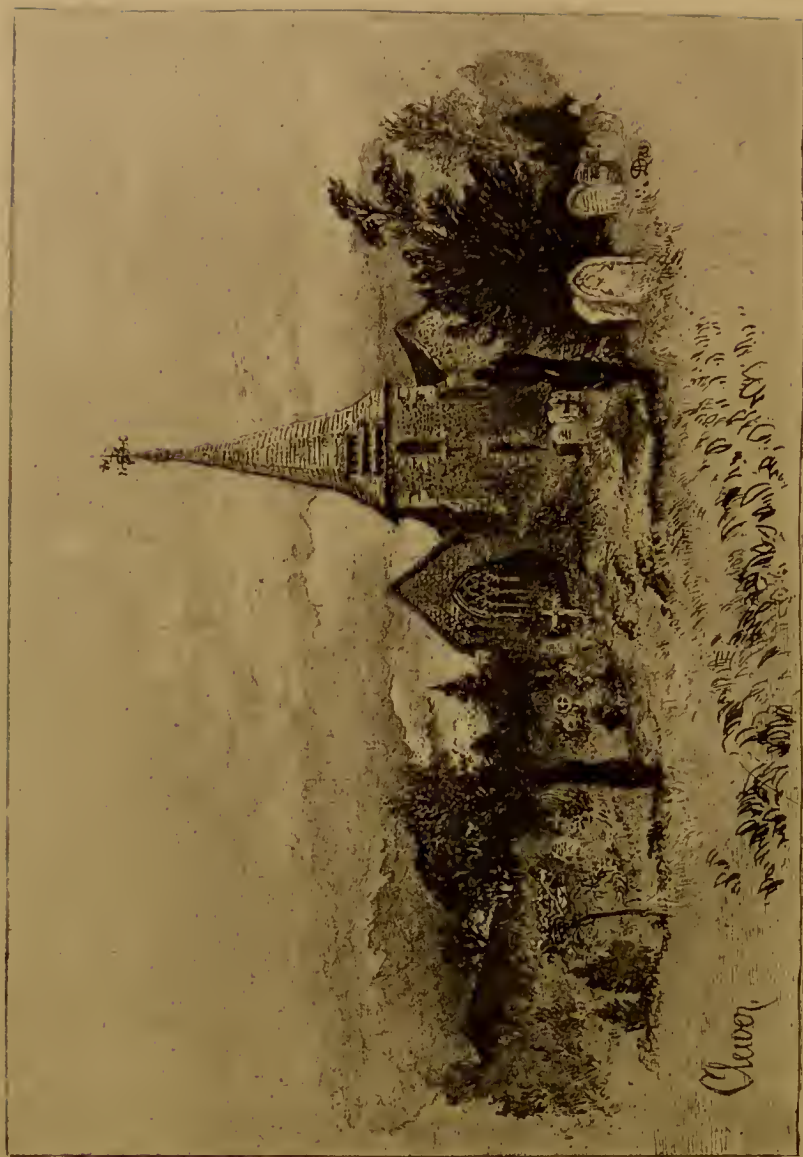

Claver

A. Dawson, Del.

Claver Churchyard

by Mrs. M. J. J. J.

A. & C. Davis, n. P. S.

Many other processes or modifications have been introduced; the names of Obernetter, Waterhouse, Zuccato, and Sawyer may be mentioned. Similar processes under various names are used in America. The appearance of the finished work is very much the same, and all are probably variations of the processes described here.

The Frontispiece is a very perfect illustration of the photogravure method.

The perfect success in the production of process blocks depends on technical details. None of the patented methods are published with sufficient description to permit the working of any one of them satisfactorily without the knowledge which is kept secret.

*Half-Tone Zinc Etching.*—Generally the half-tone block process may be said to be practised as under:—A copper or steel plate is ruled or engraved with lines, from 100 to 130 to the inch, running in one direction diagonally across the plate or crossing at right angles, also diagonally. The plate may be of any proportion; but, as negatives of various sizes have to be made, the plate should not be less than 16 inches square. From this plate a perfect impression must be made on the best paper, mounted and carefully preserved. Very perfect line-screens or plates may be produced by ruling a glass plate through an etching-ground of wax, and acting on the glass with hydrofluoric acid. Printing-ink can then be rubbed into the lines, producing a very perfect screen with black lines on clear glass. A copy must now be made from the lined sheet of the size required for the half-tone block, and the negative must be placed in the dark slide of the camera in front of the prepared plate, separated from the film, at a suitable distance to produce the dotted effect required to break up the half-tone of the subject. As the light passing from the object to be copied must pass through the screen to the sensitive plate, the result is that the negative is covered with the lines of the screen, and the half-tones are so broken up that a block can be obtained, which, with careful printing, gives a very satisfactory copy of the original. The line-screen need not be in actual contact with the sensitive film, as the light passes through in direct lines and a sharp copy is transmitted. Much mystery has been made as to *shifting the screen-negative*; but, beyond the necessity for reversing the negative when a sheet ruled in one way only has been used, it is difficult to see how any other kind of shifting can be necessary. Of course, when the negative with lines in one direction only is used in front of the sensitive plate, while the copy is being made some method must be adopted so as not to disturb the plate while the line-screen is shifted.

When the line-negative is varnished (and the greatest care must be taken in every step of the process, so as to produce a perfect

result, for there must be no spots or blemishes of any kind on the negative), the printing on the zinc or copper may be proceeded with. For very fine work it is preferable to use the bitumen method (see *Bitumen Process*). The preparation of the metal plates with albumen and the other processes required to complete the block are described under *Zinc-Etching*.

In some cases the zinc blocks are worked up during the etching process to improve the effect by stopping out parts requiring higher light; but this has to be done with much care and skill, otherwise the work will be patchy and unsatisfactory.

**Photo-Filigrane.**—One of the numerous applications of photography due to the inventive genius of the late Mr. Woodbury was called by him *Photo-filigrane*, and was made the subject of a patent. The object of the process is to impress an image on paper, so that, when viewed by transmitted light, some of the effects of light and shade are produced. This is effected by attaching to a metal roller a gelatine relief, so that when sheets of paper are passed between the relief and another roller, the impression is taken by the paper, producing an effect similar to a *water-mark*, but with half-tone in place of mere lines.

**Photo-Galvanography.**—This name was given to the process invented by M. Pretsch. It is referred to under the heading *Photo-Engraving*.

**Photochromo-Typography.**—One of the most beautiful methods for the application of colour to the half-tone zinc process is shown in the illustration by Messrs. Bousod, Valadon, & Co., on the opposite page, in which it will be seen that, after the original block for the black is printed, by a process of printing from blocks for the colours a very effective picture is produced.

**Photogenic Drawing.**—In this process fine writing-paper or white leather was brushed over with, or was steeped in, a solution of sodium chloride (or common table-salt). This was allowed to dry, and was then washed over with, or floated upon, a solution of silver nitrate. When dry, the object to be photographed was placed on the paper and then exposed to sunlight, perfect contact being made by pressure under glass. Talbot found that when paper was prepared so that there was an excess of silver nitrate, he obtained better results. The picture was of course negative—that is, if the object to be copied was an engraving, the black lines would be white in the copy. The fixing was a difficulty which Wedgwood and Davy could not overcome; but Talbot found that by washing the prints, so as to free the paper from the silver salt as much as possible, and then steeping the prints in a solution of salt or potassium iodide, the prints were, to a certain extent, *fixed*, and that the action of light on them was so far lessened that the negatives could be used for producing copies having the



*M. J. G. G. G.*

*Chromotypographie & Imprimerie Boussod, Valadon & Co. Paris.*

1044



natural light and shade. Paper prepared in the manner described is very sensitive to direct daylight, or when used with the solar microscope; but, if used in the camera, a very long exposure was necessary; yet Talbot succeeded, as already stated, as early as 1835, in producing pictures in the camera by this process, which he named *Photogenic Drawing*.

**Photographing on Wood.**—The blocks of boxwood used by wood-engravers have to be carefully seasoned in order to prevent the possibility of splitting after the surface has been engraved, hence the difficulty of utilising photography; but it has been found that a well-seasoned piece of wood, after it has been wetted, is soon in a fit state to be engraved. Any kind of brittle film on the surface of the wood



FIG. 36.

is liable to chip under the graving tool; therefore, when a film is used, it must be of the thinnest possible kind. A collodion positive loosened from the glass with nitric acid, floated on water, and then caught on the wood block in the reversed position, is found to answer. The surface of the wood being blackened, the image is perfectly distinct and the film is too thin to cause chipping. Many other methods have been proposed.

One of the earliest engraved blocks produced with the assistance of photography was the work of Mr. Robert Langton of Manchester, to whom the writer is indebted for the permission to use the block (Fig. 36). The engraving was printed in the *Art Journal* of August 1854, and is an excellent example of this kind of work.

**Photography and Colour.**—In these days of enlightened chemical research, the pursuit of the discovery of the *philosopher's stone* (which, it is almost necessary to explain to the junior readers of these pages, was the desire to find some means of converting the baser metals into gold) is never heard of; but the pursuit of photography in colour has almost taken the place of the older chimera;—it is a kind of *ignis fatuus*—something which is visible, but which eludes the grasp. To say that the object sought is unattainable would be unwise, seeing that little more than fifty years ago the thing we have now in such wonderful perfection was something dreamed of, was sought for, and was found. But this image of the camera, the marvellous beauty of which set the mind of Talbot reflecting on the possibility of its being fixed on his drawing-paper, is a very different thing, as it *was* first fixed by Talbot and Daguerre, to the matter which they would have preferred,—the picture with all its charm of colour. This is the problem which has baffled the efforts of all who have attempted to solve it. Let us inquire what has been done towards the fulfilment of the desire, so that we may possibly be in a position to ask whether, judging from the little produced by over fifty years of experiment, how much more may be anticipated in another half century.

As early as the first year of the present century, Ritter, Berard, Seebeck, Berthollet, Herschel, Sir H. Englefield, and others had investigated the *calorific* and *colorific* effects of the sun's rays; and about the same time it was discovered that the *chemical* were different from the *actinic* rays of light. Wedgwood and Davy used the chemical rays to produce their images on paper and leather, but they do not appear to have observed any effect of colour on the surfaces made sensitive to light; they used coloured glasses, and noticed that when light passed through red glass very little change was produced, but through yellow and green the change increased, and when blue and violet glasses were used more active changes occurred—that is, their leather and paper darkened quicker. They speak of the changes of colour, but it is evident that they mean only the difference in *tint* caused by the light. One of the earliest investigators of the effects of light in producing colour on silver chloride was Dr. Seebeck of Jena, who, in 1810, found that when silver chloride was spread upon paper and exposed while wet to the solar rays, received on a prism through a narrow aperture in a shutter, changed colour; in the blue it became blue, and in the red rays it changed to rose colour, and there were other changes in the various tints. This appears to have been an experiment to show the chemical change produced in sunlight, not in the nature of a photograph; and it is chiefly interesting as showing that nearly thirty years before Talbot's discovery it was



known that one of the properties of light was to produce a change on silver chloride corresponding with the colour of the light which had been caused to fall upon it.

A few months after Talbot's discovery, Sir J. Herschel published some experiments which show that when a bright spectrum was thrown on a piece of sensitive paper the change effected was not that of darkening only, but *colours* were produced. Herschel's experiments were continued; and, although he failed to discover any means of fixing the colours, he found that when washed in water some degree of permanence was given; he also found that the colours deepened when the paper had been kept for some days *in the dark* (one of the effects in the continuing action of light, which is noticed in carbon printing and in prints on paper prepared with gelatine and potassium bichromate). Herschel's experiments led him to think that it might be possible to produce pictures by the aid of light in natural colours.

About the same time (1840), Hunt published observations on the effects of light passing through pieces of coloured glass on to paper prepared with silver nitrate combined with salts of different kinds; but no advance was made in the direction of the production of photographs in the colours of Nature.

It is unnecessary to follow the researches step by step, as each experimenter seems to have advanced very little beyond what his predecessors had done. The experiments were varied by Becquerel, who, after confirming what had been done by Herschel and Hunt, showed that a silvered plate which had been coated with silver chloride, produced in various ways, was sensitive to the yellow as well as to the other colours. He found also that after prolonged exposure to the spectrum the first effects disappeared and the plate became grey. Becquerel next prepared silver plates with chlorine electrically produced. The preparation of the plates was a very tedious and troublesome matter. To obtain the best effects, a kind of annealing process had to be gone through, the ultimate result being something like what had been previously done. From the description of the appearance of these coloured impressions of the spectrum, it is difficult to imagine what they were like or what was the intensity of the colours produced. One is almost tempted to ask whether some of the effects may not have been due to iridescence.

The name of Niépce de St. Victor is often mentioned in connection with photography in natural colours; but he does not appear to have made any original discoveries, nor to have done more than repeat Becquerel's experiments. Many other names occur in connection with this subject, but so far no advance has been made towards what is so eagerly desired, and what has repeatedly been announced — photo-

graphy in the colours of Nature. Coloured photographs have been produced, but the colours have not been impressed on the paper by the agency of light. Light and chemistry have produced the picture, but the colours have been put in by hand in various ways; generally by first making the picture transparent, and then, *on the back*, distributing the colour roughly to produce the desired effect. Things of this kind are of no artistic value, and cannot deceive the eye of the skilled artist or photographer.

By accident curious effects are sometimes produced. In the *Liverpool and Manchester Journal* of 15th April 1857 it is reported that at a meeting of the Manchester Photographic Society on the 8th April the late Mr. Joseph Sidebotham made a communication on this subject. He said: "In the ordinary collodion positives on glass we occasionally meet with examples of partial natural colouring, such, for instance, as a green tinge on the foliage. I have had one where the green and red in a photograph of some scarlet geraniums were tolerably bright, and I have here on the table a landscape with trees and a red brick house, taken in bright sunshine, and you will see the green foliage and the red house are tolerably well marked in colour." The picture showing these colours was taken in 1852. The writer saw the picture at the time it was shown by Mr. Sidebotham, and again in 1887, when it was lent for the historical collection in the photographic section of the Exhibition at Old Trafford, Manchester, in that year. There had been no change that could be detected in the thirty-five years since it was taken; and, although the appearance of colour in this case was the result of accident, all attempts to reproduce them having failed, the picture remains as evidence of the production of colour under certain conditions of light and chemicals. The difference between this curiosity, the result of Mr. Sidebotham's experiments in 1852, and all that has been done in producing colours by the aid of light on chemically prepared plates, appears to be that in the one case the colours which could not be reproduced remain permanent, while in the other the colours which can be obtained under certain conditions are fleeting and cannot be fixed.

Many names could be mentioned of those who have repeated the early experiments for producing the colours of Nature in a photograph; amongst them Poitevin, Ducos du Hauron, Vidal, and Carey Lea. Recently M. Veresetz has produced some results which are claimed to surpass everything previously done, especially as regards the fixing of the colours. The writer is not aware that the method by which these results have been obtained has been made public. Professor Vogel has published his opinion to the effect that no advance has been made, the results not being superior to those obtained by Becquerel. Professor Vogel says in a communication to the *Bulletin*: "If I compare

the sample before me with the pictures I have seen in 1867 of Niépce de St. Victor, Becquerel, and Dr. Zenker, I must confess that those much older productions were richer in colour, although the tones deviated likewise considerably from the natural ones. An essential progress I can, therefore, not recognise in the present pictures." The most recent contribution on this subject is from the French correspondent of the *British Journal of Photography*, who, in the number for July 18, 1890, writes to following effect :—" At the late meeting of our society, M. Vallot presented some prints in natural colour. Since the experiments of M. Verescz the attention of a great number has been drawn to this subject. M. Vallot has been repeating the experiments of M. Poitevin, and I myself cannot see that progress has been made. A few years ago (twelve years) I travelled 200 miles to pay a visit to the father of photo-mechanical printing. When receiving his hospitality, he showed me his collection of experiments of printing in natural colours. His results were far superior to what was shown last Friday, or to what had been obtained by M. Verescz (fixing apart). In case any amateur should like to procure a few proofs in natural colours or to have a start on the road to some wonderful discovery, I will here give the *modus operandi* employed by M. Vallot, which he himself gave us last Friday evening :—Float strong photographic paper for three minutes on the following solution :—

- |                              |                         |
|------------------------------|-------------------------|
| 1. Sodium chloride . . . . . | 20 grammes = 5 drachms. |
| Water . . . . .              | 100 c.c. = 3½ ounces.   |

Dry the paper as rapidly as possible, then float for five minutes in the sensitising bath.

- |                             |                         |
|-----------------------------|-------------------------|
| 2. Silver nitrate . . . . . | 20 grammes = 5 drachms. |
| Water . . . . .             | 100 c.c. = 3½ ounces.   |

Allow to drain a few seconds, and then wash the paper for ten minutes under a stream of water.

"3. Plunge the paper for five minutes into a 20 per cent. bath of sodium chloride, and wash a few minutes in running water. Prepare the following solution :—

- |                                |                        |
|--------------------------------|------------------------|
| Distilled water . . . . .      | 100 c.c. = 3½ ounces.  |
| Protochloride of tin . . . . . | 3 grammes = 46 grains. |
| Sulphuric acid . . . . .       | 10 drops.              |

Of the above solution take 20 grammes (5 drachms) and water 500 c.c. (17½ ounces).

"4. Plunge the paper into this bath, and then take the tray containing the solution and the paper into the light, and expose the paper until it becomes of a dark violet hue ; wash five minutes and

dry the paper. During the drying prepare the two following solutions :—

A. Potassium bichromate . . . . .	5 grammes = 77 grains.
Water . . . . .	100 c.c. = 3½ ounces.
B. Saturated solution of copper sulphate.	

“ 5. Mix equal quantities of the two solutions and plunge the dry paper into the bath, and that for two minutes. When dry the paper is ready to be exposed.

“ ‘The subject before you,’ said M. Vallot (a transparent poly-coloured design for a stained window), ‘was exposed three-quarters of an hour in full sun.’

“ 6. When the paper is taken out of the printing-frame the colours are very faint ; in order to revive them, the print is plunged into the following bath :—

Sulphuric acid . . . . .	20 c.c. = 5 drachms.
Water . . . . .	100 c.c. = 32 ounces.

Care must be taken not to allow the prints to remain too long a time in this bath, or the acid, after having revived the colours, would soon destroy them. The proofs are now well washed, dried, and albuminised, which gives vigour to the tones. ‘Naturally,’ said M. Vallot, ‘the image must be preserved from the light, as no means of fixing has yet been discovered.’ ”

A few years since the writer was shown by Sir H. E. Roscoe a photograph of the solar spectrum in colour, faint but yet distinct, which had been produced by Captain Abney ; this also had to be viewed by artificial light, as no means of fixing the colours had been attempted.

It should perhaps be mentioned that the late Mr. Woodbury introduced an ingenious method of giving photographs the effect of natural colours. By arranging colours in a kind of matrix following the forms in a photograph, the colour was made to set off on to the photograph, and when carefully done a very pleasing effect was produced. A similar effect may be obtained by using lithographic tints.

Mr. R. E. Ives in 1888 proposed a means of producing the effect of colour. He says : “ There is much yet to be done in perfecting the print-making part of the process. For the present I am satisfied to obtain perfect heliochromatic prints on glass, so that the results may be shown with the optical lantern, and have adopted the following procedure :—The blue print is made by the cyanotype process, on a film of gelatine attached to glass. The red print is made by the so-called carbon process, with eosine for the colouring matter,—a reversed print being thereby produced upon another glass. The

yellow print is made by the collotype printing process, or a specially prepared film of collodion and gelatine. Several of the red and yellow prints are made, and such prints selected as are found to produce a neutral black in the shadows when superimposed with the blue print over a white surface; the colours are then correct in every shade of the picture. After placing the yellow film picture between the blue and red picture on a glass, and therefore in contact with them, they are moved until the images are exactly superimposed; and then fastened together by binding to complete the lantern-slide heliochrome."

In a lecture delivered before the Franklin Institute in December 1890, Mr. Ives, after giving the history of the subject of producing the colours of Nature by the aid of photography, refers at length to his own experiments in this matter, and he describes the means he adopted in taking negatives and making the copies to be used in the optical lantern. The concluding paragraph of the lecture is as follows:—"Composite heliochromy must always remain a comparatively costly process, when carried out in a manner calculated to yield the finest results, and can most profitably be brought before the public in the form of optical lantern-lecture illustrations, not with the triple lantern, but with the transparent colour-print heliochromes mounted as lantern-slides. If the colour-prints are made by the Woodburytype process, such heliochromic lantern-slides, infinitely superior to hand-painted ones, can be made in quantity at a cost not exceeding one dollar each."<sup>1</sup>

In solving the difficulty of making pictures which can be used as slides for the optical lantern showing the colours of Nature, Mr. A. W. Scott of Weston-super-Mare has succeeded in a very remarkable way.

The photographs are obtained in the following manner:—A camera arranged with four lenses is used, and the negatives are taken on orthochromatic plates, the light passing through colour screens, green, blue, red, and violet. As the exposure is different for each colour, diaphragms of suitable sizes are used. Transparencies for the negatives are made in the usual way. Although presenting to the eye representations of the subject of the ordinary kind, each picture has different gradations of intensity according to the colours through which the negatives were made.

In projecting the pictures on to the screen, the same colour plate as that through which the early picture was taken is used, and as the four pictures can, by the mechanical arrangement of the lantern, be made to overlap or superpose, the effect, when the pictures are carefully registered, is a very near approach to a picture of the object in

<sup>1</sup> From more recent description Mr. Ives appears now to adopt a method similar to that used by Mr. Scott.

the colours of Nature. The apparatus is called by the inventor the *Verak*. A large range of subjects have already been produced, such as a scarlet geranium with its green leaves, which has a most natural appearance; sunrise; a wall covered with bills in many colours; and many others, which the writer has seen. It appears to him that in this direction a great advance has been made in making pictures which imitate the colours of Nature. It must be noted that to produce these effects four pictures are required, and that this in no way solves the problem of the production of pictures in colours at one operation.

In what has been said, the work of fifty years has been passed in review; and if we omit the Veresch experiments, about which so little appears to be known, we have arrived at about the same point as we started from—the experiments with silver chloride and the changes produced in the light of the solar spectrum; in fact, we are no nearer now to a solution of the problem of *photography in natural colours* than we were in 1839. As already remarked, it would be unwise to say that the object sought for *never can be realised* owing to the difficult character of the chemistry of the subject; but as so much has been done within the last fifty years to advance ordinary photography and chemistry, the next half century may witness the evolution of a process by which the objects photographed may at the same time possess their natural colours, although it must be confessed there seems to be very little probability of success attending efforts in this direction.<sup>1</sup>

**Photo-Lithography.**—One of the earliest applications of photography was the attempt by Niépce to obtain pictures on lithographic stone by means of bitumen, which he dissolved in oil of

<sup>1</sup> Since the above was written, a statement has appeared in the *Daily News* of February 11, 1891, to the effect that at a recent meeting of the Academy of Sciences at Paris, it was announced that M. Lippmann had succeeded in obtaining photographs in the colours of Nature. The method was only partly described, but the chief means employed was said to be a mirror or a trough of mercury placed behind the sensitive gelatino-bromide plate. Writing a day or two later to the *Photographic News*, M. Leon Vidal stated that he had seen one of the plates; that the colours were very faint; and that he would not have suspected it was a reproduction of the solar spectrum if he had not been told so. It appears certain that some results have been obtained, and in a way different from all former methods; but all that was claimed for the discovery in the first announcement appears to be far short of what is necessary to realise the effect of natural colours on the photographic plate. Probably the specimen exhibited was not a good one, or, if seen by artificial light, the perfection of the colours may not have been apparent. The writer has seen two specimens of M. Lippmann's work, and both were good, showing very perfectly all the colours of the spectrum, not faintly, but bright and distinct (in daylight) by reflected light. M. Lippmann does not claim to have done more than to have obtained the picture of the spectrum; but this is fixed and varnished on the glass plate, and is therefore permanent. The colours are of the character called iridescent.

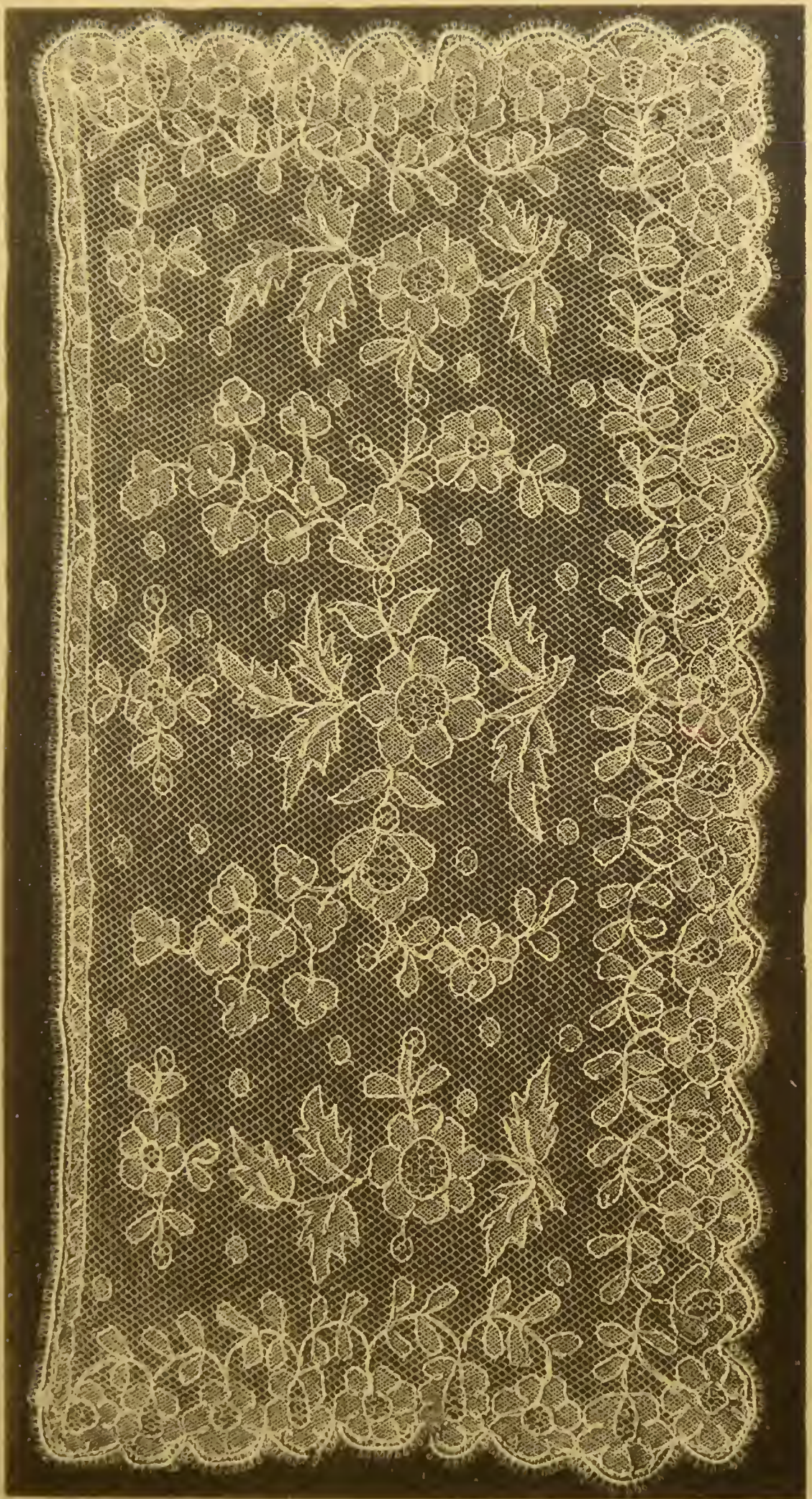

IRISH LACE

Photolithographed by Mess<sup>rs</sup> West, Newman & Co

Hatton Garden London





lavender and then spread as a thin film on the stone. The image obtained after long exposure was developed by washing away the bitumen which had not been affected by the light with oil of lavender and petroleum. The picture or design left on the stone was etched in the usual manner, and could then be printed from. The principle involved in this process, although it led to no immediate result, has been applied in a very practical way during the last few years, and is referred to in these pages in connection with zinc-etching. Many attempts were made to utilise the method of printing direct on to the lithographic stone, but with only partial success; and it was not until the system of transferring an image originally produced by photographs on paper prepared with gelatine and potassium bichromate, and causing this image to take lithographic ink, that the process became of commercial importance. It has for many years been extensively used for the reproduction of all kinds of drawings in line and stipple; and, by modifications, half-tone pictures are now practicable.

Closely allied to photo-lithography is a modification, *Photo-Zincography*; the only difference being that in one case stone is used, and in the other zinc. Amongst lithographers there appears to be a prejudice against zinc, but the process has been largely employed by the Ordnance Survey Department at Southampton, where the beautiful maps produced there are enlarged or reduced by means of photography, and transferred to, and printed from, zinc plates.

As the success of a photo-lithograph depends on the character of the negative, the greatest attention must be given to its production. Many attempts have been made to utilise gelatine plates, but as the lines in the negatives must be clear glass, the collodion process is usually employed. The gelatine process is not yet capable of yielding negatives of suitable character for all purposes.

Success also in this process depends very largely on the kind of drawing to be copied. When plans or drawings are specially made for reproduction, the ink should be black, not *grey*, as Indian-ink very often appears in drawings otherwise perfect. This greyness makes it almost impossible to obtain the requisite clearness in the negative, and the result is rottenness in the lines of the print from stone. Another defect in drawings is that the lines are *too thin*. When closely examined, it will be found that the pen has not made a *continuous* line. On some kinds of drawing-paper the ink may only have touched the top surface, thus causing broken lines in the transferred copy; hence the lithographer is often blamed for what is really the fault of the original drawing. Another defect in drawings is the *gloss* in the drawing where large masses of black occur; but this, although it gives trouble to the lithographer, can be corrected by him on the stone. Prout's brown is an excellent colour for line draw-

ings; but the artist must not be tempted to improve the effect in his drawing by diluting his colour. The drawing should in all cases be made on white paper. Tracing-paper gives the photographer much trouble; it is often very dark coloured; the lines drawn on it are often not black, and as it is almost impossible to make a large tracing lie flat, the consequence is that the lines may be out of focus. When the tracing is separated from the white paper against which it is pinned, there is a further defect introduced by the full effect of the black line not being seen.

The collodion may be of the ordinary kind used for negatives, or collodion specially prepared for photo-lithography may be used, the only difference probably being that it may contain more pyroxyline. The silver bath should be distinctly acid, so that there may be no tendency to fog.

The plate should not be removed from the bath until all streakiness has disappeared, and it should be developed with iron protosulphate (see *Collodion Process*); the proportion of iron may be varied at discretion to suit the work in hand or the season of the year. Less iron may be used in warm weather, but the proportions given are quite suitable for all purposes.

The exposure in the camera should be as accurately timed as possible, and should be slightly under- rather than over-exposed. If over-exposed, the clearness of the lines may be endangered, but when slightly under-exposed a good result may be obtained. If the subject to be copied makes it difficult to obtain density, development with the iron should be continued until it is seen that no more detail will appear, care being taken not to push the development too far; and then, after washing, the plate may be redeveloped with pyrogallie acid and silver; but here again care must be taken to avoid filling up the lines. After fixing, the negative must be intensified to blackness. This may be done with mercury bichloride in the usual way, and after thorough washing, a solution of ammonia or sodium thiosulphate will blacken the image. The following, however, is found by the writer to give negatives in every way more suitable for photo-lithographic work. Take—

Potassium ferricyanide (red prussiate of potash, commercial)	. . . . .	4½ ounces.
Lead nitrate (commercial)	. . . . .	3 „
Water	. . . . .	65 „

Place the negative in this solution and watch the result. If the negative has been fully exposed and developed, the lead solution will cause sufficient intensification in a very short time, but a few minutes' immersion in the lead bath may be necessary; the density may be

judged by looking through the negative. The lead changes the grey colour of the collodion film to a bright yellow, but prolonged washing under running water changes the colour to white. It is not necessary in all cases to continue the washing till the yellow colour entirely disappears. Take next—

Ammonium sulphide . . . . .	4 ounces.
Water . . . . .	20 „

Pour sufficient of this solution on to the plate, and allow it to flow to all parts, then throw it away. The film is instantly changed to a dense black (by transmitted light), but if looked at in a strong light by reflection, it is seen that the colour is a rich purple. To ascertain if it is completely blackened, look at the back of the plate, when, if any part appears white, allow the sulphide solution to remain on longer, or add more. The plate must now be carefully examined: if any part appears to be over-dense or the lines filled up, the negative must be cleared with the following solution:—

Nitric acid (commercial) . . . . .	$\frac{1}{2}$ ounce.
Water . . . . .	20 ounces.

or stronger if required. The necessity for using the clearing acid solution appears to arise from imperfect washing. The negative should be thoroughly fixed, and *very thoroughly washed* to free it from the least trace of cyanide, when that salt is used. Careful treatment with the nitric acid will clear the lines, but if they still appear filled up, another negative must be taken, as the best work cannot be made from a negative which has not clear lines.

The best possible negative having been obtained (and it cannot be too strongly urged that upon the quality of the negative the success of the succeeding parts of the process very much depends), the preparation of the transfer-paper may next be considered.

It is usual to say that the best kind of paper is that called *bank-post*; but any paper of good quality which is hard and well-sized will answer perfectly, provided it is not too thin. Most paper is different on its two sides; it may be noticed, by looking obliquely at a sheet of paper with the light fully on it, that one side looks coarser than the other; it is the smooth side which should be used. Look over all the paper to be coated, and mark the right side. When many sheets are to be treated, it is necessary to have some means of keeping the solution of gelatine warm. A vessel rather larger than the paper should be made in the form of a dish, with a reservoir to contain water; or the dish and vessel for the water may be separate, the dish to contain the gelatine resting in the lower dish over the water. Beneath the dish a Bunsen burner must be arranged to keep

the water warm and to prevent the gelatine becoming unusable by thickening on cooling. Now take—

Nelson's gelatine . . . . .	3 ounces.
Water . . . . .	50 „

Soak the gelatine in as much of the water as will cover it; when soft, the remainder of the water may be boiled and the gelatine added. Filter through two or three thicknesses of fine muslin, and pour into the dish, taking care not to form air-bubbles; remove any such as may have formed, and proceed to float the paper. As soon as the sheet lies flat, raise it to see if any air-bubbles have formed; remove them, and allow the paper to remain two or three minutes. Raise carefully and slowly, and at once place the sheet on a flat table, then proceed to float another sheet. As soon as a sheet or two have been floated the first one will have *set*, and can be pinned or held by clips to a line to dry.

Paper prepared in this manner will yield good results, but a second coating is sometimes given of the same solution of gelatine; or albumen may be substituted, taking—

Albumen . . . . .	4 ounces.
Water . . . . .	16 „

and proceeding as with gelatine; but in this case heat is not necessary.

If the paper is to be used as soon as dry, it may be sensitised while coating it with gelatine; but if the gelatine paper is to be made sensitive to light at the same time as it is coated, the potassium bichromate must be added to the gelatine solution; 2 ounces of the bichromate to 10 ounces of water. It must be remembered, however, that paper so prepared will not keep, and should be used within a day or two of its preparation. Before sensitising the paper will keep indefinitely. The remarks in this paragraph apply also to paper prepared with gelatine and albumen.

When the paper is made sensitive after the coating with gelatine or gelatine and albumen, take—

Potassium bichromate . . . . .	2 ounces.
Water . . . . .	30 „

Float or immerse the paper, and hang up to dry, which is better done in a drying cupboard where the temperature can be raised to 80° F.

Paper for transferring to zinc may be prepared with arrowroot. The process, as used in the India Survey Department at Calcutta, is as under:—

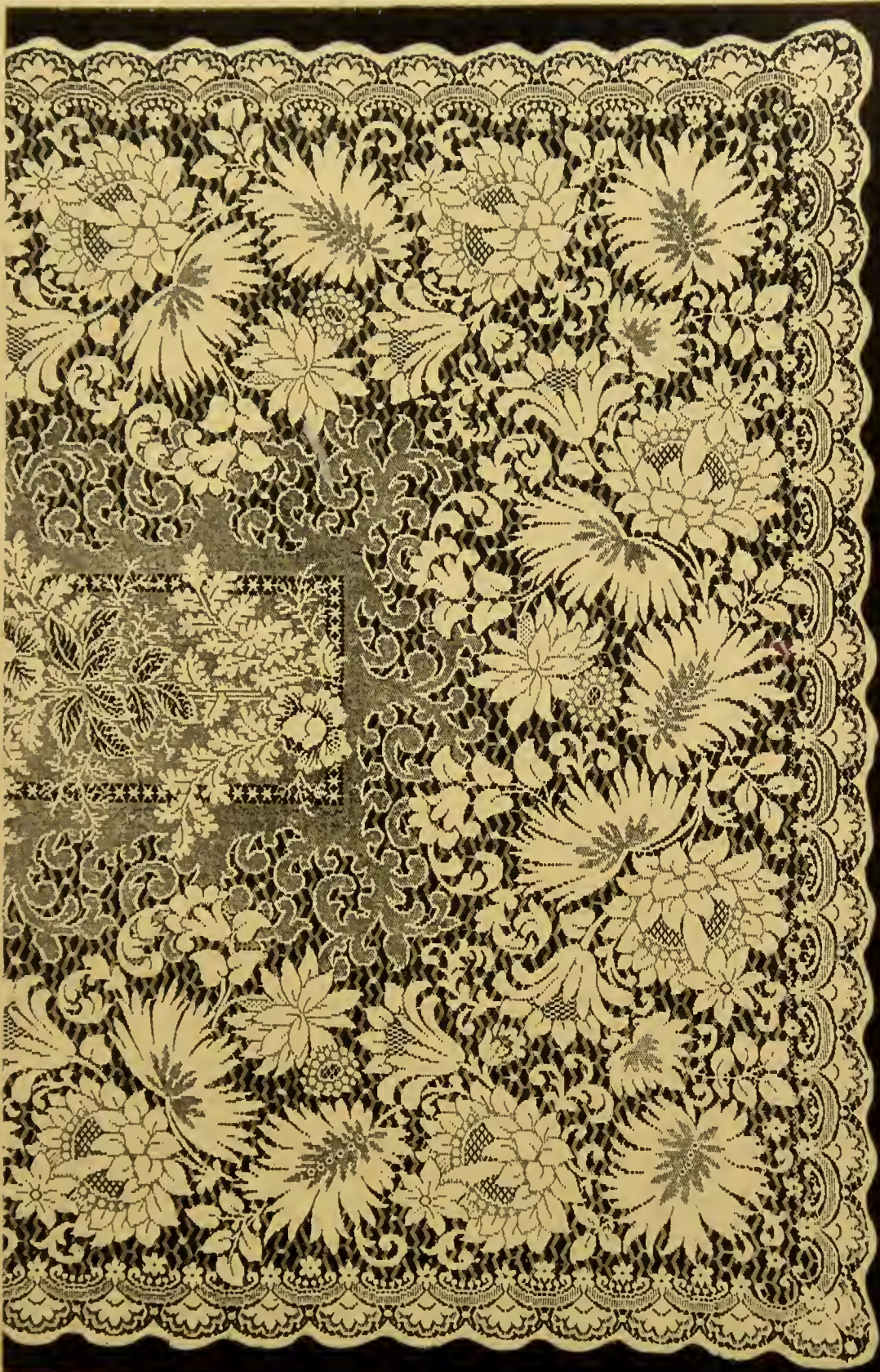

*A. Brothers & Co. Photo-Litho.*

LACE CURTAIN.



Arrowroot . . . . .	140 parts.
Potassium bichromate . . . . .	70 „
Water . . . . .	3500 „

Hot water is used for washing off the ink in this process.

The paper when quite dry should be rolled to produce as fine a surface as possible. If not rolled, the sheets may be placed face down on a clean lithographic stone, and pulled through with considerable pressure.

Some other methods have been used for preparing paper for photolithography. This paper may be purchased ready prepared, but not sensitised.

The printing is the next matter to be considered. As great pressure is necessary to bring the paper and negative into close contact, glass at least three-eighths of an inch thick should be used in the printing-frame. The filling in—that is, placing the paper on the negative—should be done in a darkened room by yellow or artificial light. Exposure to daylight requires much care, and the time necessary will depend on the density of the negative and the quality of the light. With a good negative and bright sunlight two or three minutes may be sufficient, but in a dull light an hour or two is sometimes necessary. When fully exposed, the image may be seen on the yellow paper in brown lines; if the thin lines are just visible, the exposure has been sufficient. If the prints are large, great care must be taken in examining them while in the printing-frame to ascertain the depth of the printing, as, if the exposure has been long and the weather damp, the paper may have expanded; so that when the pressure on one side of the frame has been released, it will be found that the image has shifted on again screwing up the frame (spring frames should not be used). With practice, it is possible to judge of the depth of the print by the exposed margin of the paper, or by covering up a small portion outside the frame, when the depth to which the paper has changed colour can be seen without opening the frame.

The print must now be coated with ink. As most lithographic printers have a preference for ink of a certain kind, and as the operator is not likely to be his own printer, it is better to obtain a supply of *re-transfer* ink from the printer who is to transfer the work to stone. The same assistance may be useful in inking the print, two or three methods of doing which are available. The ink, when thinned with turpentine, may be rubbed on to the print with a fine sponge or with a tuft of lint. Others prefer to use the lithographic stone, and, as a very thin layer of ink is required, this is the preferable way to proceed. The lithographer will reduce the ink and spread it over a clean stone in the usual way; the print must then be placed face down on the stone and pulled through the press

two or three times. The ink will adhere to the print, and, after about ten minutes (to allow the turpentine to evaporate), it may be placed in cold water. The effect of this is to soften the gelatine where the light has not acted, and to which the ink will not adhere. After a few minutes, a clean sponge or tuft of lint gently rubbed over the surface will remove the ink and leave the picture perfect, as the ink cannot be rubbed off from the parts which exposure to light has hardened. The prints must now be returned to the water for the bichromate to soak out, when a final rub with the sponge will remove all trace of the superfluous ink. Blot off the water and pin by the four corners to a board to dry. When dry they may be handed to the lithographer to be treated in the usual way. It is sometimes stated that the damp prints may be at once transferred to the stone; but, in doing this, there is danger that the fine lines of the transfer may be crushed and made thicker than necessary. The prints should dry *in air*, as fire-heat would cause the gelatine to run. When quite dry they may be placed in the damping-book, and treated as ordinary transfers. Re-transfer ink does not readily dry; consequently, a transfer will not spoil by keeping a few days. The state of the print may be tested by touching any part where there may be ink outside the work; if the ink will rub off, the print may be used. But a good workman, by having his stone at the proper temperature, may succeed in making a good transfer from a print which may be apparently dry.

In writing of photo-lithography, as of most other processes, it is difficult to lay down rules for any difficulty which may arise; a little practice will soon show the cause of failures. But it may be said that the most likely causes of failure will arise from the negative being too thin, over-printing, or over-inking. The effect of the first will be seen in the over-printing, as the light passing through makes the gelatine insoluble, so that the ink will not leave the surface; over-inking will be seen on transferring to stone, as the lines will thicken. The remedies are obvious.

In processes where hot water is used to remove the superfluous ink, the gelatine not acted on by light leaves the paper; but when the prints are washed in cold water the surface of gelatine is not removed. The writer gives this method the preference.

The accompanying illustrations show how admirably the process of photo-lithography is adapted for the reproduction of designs. The first is from a piece of Irish lace. Another is from a lace curtain reduced about thirteen diameters; and, although the reduction is so great, every thread of the design is distinct. The third plate is from designs drawn by Miss E. Gertrude Thomson for the *Gentlewoman* (to the proprietors of which paper the writer is indebted for the loan





A. Brothers & Co. Photo-Litho.

FROM ORIGINAL DESIGNS BY MISS E. C. THOMSON.



of the original drawings). For *fac-simile* work, such as the copying of old books, manuscripts, maps, drawings of architectural and other subjects, no process is perhaps so economical as the one by which these illustrations are made; and it is probably the one which is most extensively used.

A process called **Papyrotype** was patented by Captain Abney. Paper is coated twice with gelatine and made sensitive with chrome alum. The print is passed through cold water and then squeegeed on to a zinc plate. The water is blotted off, and with a gelatine roller the print is rolled up with ink—chalk-ink four parts, softened with one part of palm-oil. The gelatine surface is thus treated as a lithographic stone; water has been taken up by the soft gelatine, and these parts will not take ink; therefore the rolling has developed the picture in lines. As the bichromate has not been washed out, the paper is still sensitive to light; hence, when dry, the print is again exposed to light to harden the entire surface.

**Photo-Micrography.**—The possessor of a good microscope, and one who is a photographer, has in his power the means of endless interest for the practice of his two hobbies. The microscope enables us to see objects and reveals details of structure which, without its aid, would be invisible; and photography gives us the means of delineating such objects in a manner very much superior to any kind of hand-drawing, although the eye may be assisted by the camera lucida.

There is, however, a very large class of objects which can be photographed without a microscope, and which, when reproduced as lantern-slides, become something more than diagrams. A small rectilinear or other good lens suitable for enlarging attached to an enlarging camera becomes, for the time, a low-power microscope, with which excellent work can be produced. All insects, which are usually mounted whole, and such other objects as are used with the lowest power of the microscope, are suitable for enlarging with a photographic lens. The only addition to the ordinary camera required is a means of extending the body so as to give sufficient length for the negative to be made a few diameters larger than the object. The copy thus obtained can be, if necessary, still further magnified when making the transparency for the lantern, and in this optical lantern we have the power of still further enlargement.

There are many ways of arranging microscopical apparatus to be used for photographic purposes. It may be extremely simple or very complex, as the temporary apparatus which will permit a fair negative to be made from an object suitable for a one-inch objective would be altogether unsuitable for use with the higher powers of the microscope.

When the photographic lens is adapted for enlarging microscopic objects, there is no difficulty as to the chemical and visual foci, as the

correction is already made in the lens. When the image is sharply defined on the ground glass, all difficulty as to definition in the negative disappears. When the object-glasses of the microscope are used, it rarely happens that they are corrected for the actinic rays; therefore trial must be made to determine the correct place for the prepared plate.

When the enlargement required necessitates the use of microscopic objectives, the simplest method of procedure is as follows:—Place a camera of any kind adapted to use with the size of plate required (say half-plate,  $6\frac{1}{2} \times 4\frac{3}{4}$ ) on a table, as shown in Fig. 37, or, preferably, on a board about 4 feet long, having ribs at the sides between which the camera may slide. At the other end place a microscope, one which can be turned horizontally, and at a suitable position place a lamp, as also, if necessary, a condenser to illuminate the object to be copied. Arrange the slide on the stage, remove the eye-piece of the microscope,

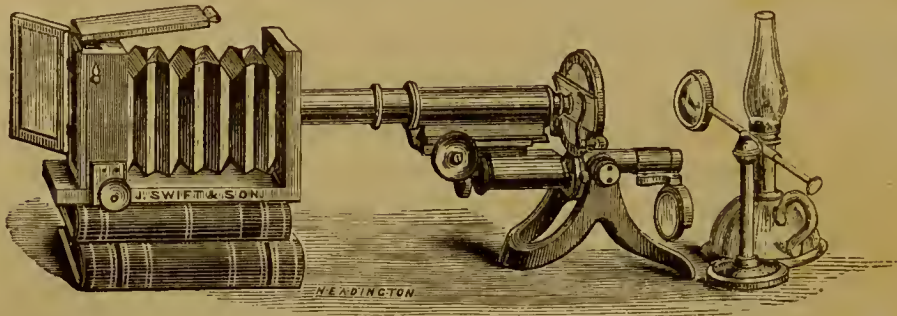
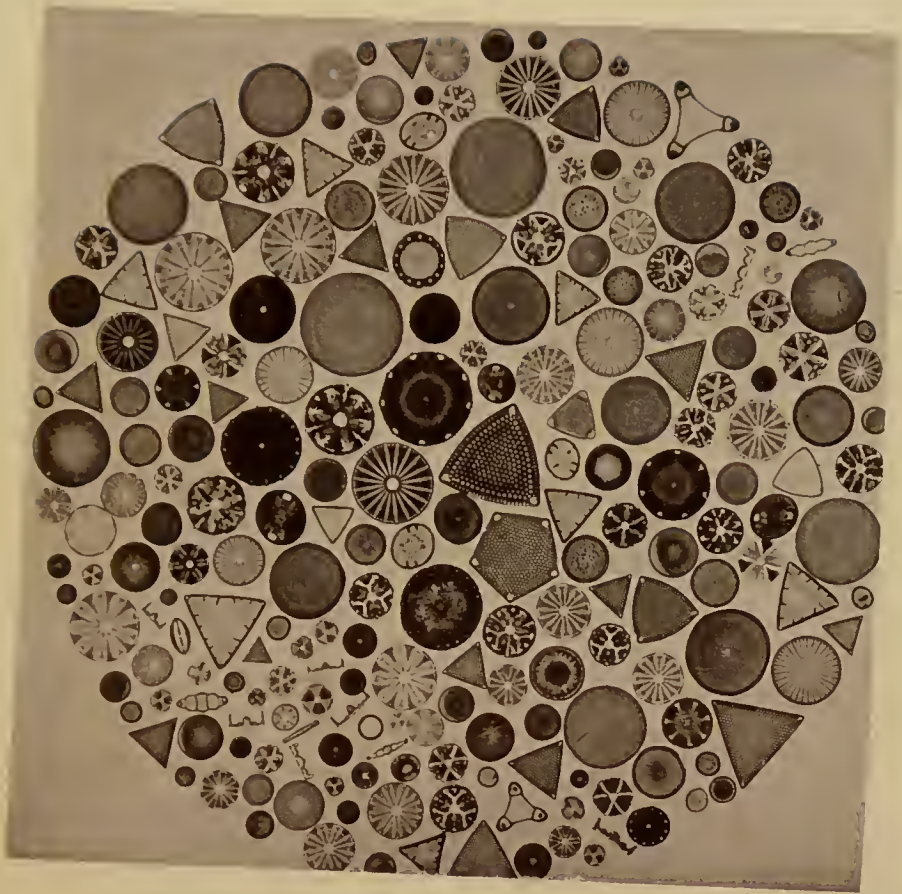

FIG. 37.

the stand of which must be raised so as to be central with the centre of the camera, and, after covering the space between the microscope and the camera with a black cloth, proceed to find the object on the ground glass, arrange the size and focus. Excepting when it is absolutely necessary to use the fine adjustment for focussing the object, the screw of the camera may be used for that purpose. The black cloth must now be carefully arranged so as to exclude all light, when the object may be photographed. If the negative is not so sharp as the image appeared on the ground glass, the fault will be in the object-glass, assuming that there has been no tremor in the apparatus. The lens may now be slightly drawn back from the object, using the fine adjustment and noticing how many turns have been made to assist in finding the focus at another time. If the slide carrying the sensitive plate is capable of being moved into more than one position, a second trial may be made on one plate.

The writer is indebted to Mr. G. J. Johnson for a description of a very ingenious camera for microscopic work; and also for the use of the photographs reproduced in collotype by Messrs. Martin, Billing, Son, & Co. of Birmingham.



DIATOMS,  $\times 30$ .



CATERPILLAR OF MOTH,  $\times 3$ .

PHOTOGRAPH BY MR. J. J. JOHNSON.

COLLOTYPE BY MESSRS. MARTIN BILLING, SON, AND CO.,  
LIVERY STREET, BIRMINGHAM.



Mr. Johnson says: "I use a long extension camera, fitted for the purpose of taking both photo-micrographs and micro-photographs.

"The bellows is divided into two removable sections by the insertion of a frame which supports the middle. The frame, being interchangeable with the end containing the lens, can be used for holding negatives for enlargement, different-sized carriers being provided for the several dimensions of plates.

"For photo-micrography, or the enlarged delineation of microscopic objects, the microscope is provided with a short tube, in place of the usual 10-inch body, to allow photographs to be taken without the use of the eye-piece, thus giving a wider field. It is also provided with a mechanical stage giving rectangular motions.

"In front of the dark slide a small removable cardboard shutter, about 2 inches deep and 4 inches wide, is worked perpendicularly by a square wooden rod, sliding stiffly through a hole cut in the top of the camera, about half an inch in front of the sensitised plate. By means of this shutter various periods of exposure can be given to successive bands on the same plate, the square rod being depressed at stated intervals. This method of testing the strength of the illuminant at the outset of a night's work is found to be a great saving in time and plates, the correct exposure varying in character with every change of lens, object, or length of camera employed. Transparent objects, such as the wing of a gnat or a thin section of the stem of the dog-rose, require much less exposure than, say, the proboscis of a blow-fly or a vegetable section stained deep crimson.

"As correct focussing is of great importance in this class of work, a one-inch focussing lens is mounted in a small tube, inserted in a stout level lath about 12 inches long, in such a manner that when the lath is pressed home to the back of the camera, the focus of the lens coincides with the plane of the ground-glass screen. The screen can then be removed, and, by moving the lath laterally or perpendicularly, any portion of the field may be brought into view and adjusted to focus by the use of this temporary eye-piece.

"The necessity of stops for some lenses may thus be proved by actual visual inspection, a 2-inch objective sometimes requiring to be stopped down to  $\frac{1}{4}$ -inch or  $\frac{1}{16}$ -inch of aperture, to ensure clear definition and depth of focus. Care, however, must be exercised to avoid excess of reduction in aperture, which impairs definition.

"Micro-objectives are now sold as corrected for photography, but many of the ordinary microscopic lenses of good make give better results when once the difference between the visual and the actinic focus is determined and allowed for."

The instrument is fitted with various mechanical adjustments, which cannot very well be indicated without elaborate diagrams.

For illuminating the object the ordinary microscope paraffin oil-lamp may be used, or, with some objects, daylight. For very opaque objects sunlight may be preferable; but the light should be passed through a medium, such as ground glass, to take away scintillations caused by the direct light.

The illustration is a collotype from a negative by Mr. L. Atkinson, from one reproduced by Mr. Danielsson. The subject at the top of the plate represents a section from a portion of a healthy eye; it shows the entrance of the optic nerve, its connection with the retina and the *Lamina cribrosa*. The lower figure shows the same parts of an eye affected with glaucoma. The section was made by Prof. Delépine of the Owens College, and represents the subjects enlarged 20 diameters. These illustrations are admirable, as showing the perfection of the photographic delineation, and the value of the process of collotype for the purpose of book illustration.

**Photophane.**—Collotype prints, varnished or unvarnished, are, by the Company producing them, called *Photophane*.

**Phototint.**—This title was given by Mr. Cocking to a method of double-printing; first, from an ordinary negative, portrait or landscape; and, secondly, from a negative prepared by hand in such manner that effects were obtained to enhance the light and shade and at the same time to tint portions of the original picture. Collotype prints transferred to and printed from stone have been called *Phototints*.

**Photo-Typography.**—Any drawing in line or stipple may, by the aid of photography, be converted into a plate, which, when mounted on wood, may be printed with type. The process is now very largely used, and for many purposes is quite equal to wood engraving, and of course is very much cheaper. The drawing should be made in clear firm lines, and preferably somewhat larger than the etching is intended to be.

When a line block is to be produced on zinc, and to be printed direct on the metal, a *reversed* negative must be used; but when the outline is transferred to the plate, an ordinary negative is necessary. The illustration is an etching on zinc made from a drawing in line and stipple on smooth paper. It is produced by the swelled gelatine process used in America, and in England by the Typo-Etching Company. (See *Zinc Etching*).

Another method of producing a block from a drawing and photograph is described in the article on *Indian-Ink Outlines*.

**Pinhole Photography.**—It has long been known that photographs can be taken without a lens; that the light passing through a minute hole punctured in a card will produce an image, and that if a sensitive plate be placed to receive the image, a picture may be developed. The





*Section of portion of healthy Optic Nerve.*



*Section of the same part, showing Glaucoma cup.*

FIELD 20 DIAMETERS.



experiment is an interesting one, and may be tried by any one possessing a camera. The size of plate is of little consequence, but the length should not be too great, owing to the increased exposure necessary. Remove the lens, and in the diaphragm slot place a card or *thin* strip of metal, such as a ferrotype plate, in the centre of which an aperture has been punched of about  $\frac{1}{50}$ th of an inch diameter. This may be made by breaking a needle of the proper thickness and making the hole with the blunt end. Lay the thin plate on a piece of lead, and then use the broken needle as a punch; holes of various sizes may be made, to be used as may be found desirable. The view having been selected and the camera arranged (using the lens and ground glass in the usual way), the plate may be inserted, the lens removed, and the pinhole diaphragm put into its place and the exposure made, care being taken to carefully cover the camera and lens slot so as to exclude all light excepting that passing through the pinhole. The exposure will vary, according to the length of the camera, the light, and the size of the aperture, from five to twenty minutes or more. The image is visible no matter what the length of the camera may be, but its sharpness will depend on the size of the pinhole. It will be seen, of course, that an ordinary camera is not necessary. A box of suitable size, with some means of holding the plate perpendicular at one end, and an aperture at the other (which may be covered with the thin plate or card in which the hole is pierced) may be made use of in this experiment. See page 37, where the principle of the pinhole camera is shown.

**Platinotype Process.**—The red colour of photographs on paper when silver alone is used is not pleasing to the eye. This defect led to the method of *gold toning* for the purpose of changing the colour. At the same time it was supposed to add to the permanency of the photograph by the chemical substitution of the more permanent gold for the silver compound forming the picture. It was soon found, however, that, from some cause never quite satisfactorily explained, the gold-toned silver print was very little more permanent than the untoned print. This led to the introduction of forms of printing about which there could be no uncertainty, the basis being carbon, as in the carbon process, collotype, and allied methods. One of the most beautiful, and at the same time one which gives permanent results, is the platinum process, which has been brought to great perfection by Willis in England and by Pizzighelli of Benjaluka, Bosnia. That the process will entirely supersede the old form of print on albumenised paper may be doubtful, owing partly to the extra cost of the platinum method, the necessity for purchasing the paper from one source, and the precaution that has to be observed in keeping it; but the chief reason is probably owing to the simplicity of the method of printing on albu-

menised paper, which is now in such universal use. There can be no doubt also that the beautiful effect in a good print on albumenised paper has much in its favour; but, at the same time, it must be conceded that the artistic effect in a perfect platinum print is superior to any other kind of photograph, although a good print on silver bromide paper approaches the platinum effect very closely.

As early as 1832 the salts of platinum engaged the attention of Sir John Herschel, and he found in 1840 that light reduced the *ferric* salts to the *ferrous* state. Hunt also experimented with platinum. It was, however, reserved for Mr. Willis to bring into use the platinum salts in combination with ferrous oxalate in his process, by which the most perfect kind of print may now be produced.

The Willis process is patented; the paper can only be obtained from the Platinotype Company; and, until recently, a license was necessary for its use. The paper may now be used without restriction, if obtained direct from the Company. Owing to the care required in the various manipulations, even if the patent restrictions did not prevent the photographer making his own paper, it is unlikely, until the process is still further simplified, that home-made paper will be used. As in the case of the ready sensitised silver papers, the operator will prefer to purchase the paper rather than have the trouble of making it.

Without going fully into detail as to the mode of preparing the paper, it may be stated generally that platinotype printing has been the subject of three patents by Mr. Willis. In the first, dated July 1878, 1 part of potassium chloro-platinite was dissolved in 48 parts of water. The paper was coated with this solution, dried, and then dipped in lead-nitrate 1 part, and water 48 parts. After drying, the paper was brushed over with 1 part ferric-oxalate in 8 parts of water, to which oxalic acid was added. When dry, the paper was ready for printing, and was afterwards floated on a hot solution of potassium oxalate. The print was then washed in a solution of oxalic acid, again in "hypo," and finally in water. A modification was made by using, instead of the lead, 1 part of silver nitrate in 60 parts of water; and after treating with the oxalic acid, the prints were dipped in a strong solution of ammonium chloride, and then washed. For a third modification, the film was dipped in 1 part of platinic bromide in 40 parts of water, dried, and then dipped in a strong solution of ferric tartrate; the after process being the same as in the first method. The foregoing contains the instructions as given by Willis, but in a very condensed form. In 1878 the process was further modified, and a second patent was taken out. The formula for the preparation of the paper contains—

Potassium chloro-platinite . . . . .	1 part.
Ferric oxalate . . . . .	4.5 parts.
Lead chloride . . . . .	0.13 part.
Water . . . . .	30 parts.

After drying and exposure under a negative, the picture was developed by dipping in or floating on—

Potassium chloro-platinite . . . . .	0.5 part.
Potassium oxalate . . . . .	8 parts.
Water . . . . .	30 „

All further manipulations are the same as previously described, and the specification claims that the salts of gold, iridium, and other metals can be used, and that the lead chloride can be omitted; various other alternatives are named, as is usual in patents. Instructions are usually given in general terms only; minute details necessary to the full working of a process are often not given, particularly in cases where the patentees keep the preparation of the article patented in their own hands.

A third patent was taken out in 1880, the process being further improved and simplified, the quantity of platinum in the sensitising solution being increased and the lead omitted; no platinum was used in the developing solution. The latter solution is given as—

Potassium chloro-platinite . . . . .	4.2 parts.
Ferric oxalate . . . . .	4.2 „
Water . . . . .	30 „

It will be seen in the full instructions that this formula is modified.

In the *Photographic News*, 1882, p. 157, the following is given by the late Mr. H. B. Berkeley as the reaction which takes place in the formation of the platinum image.

For the platinous chloride—

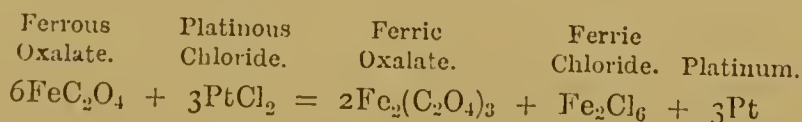

For the platonic chloride :—

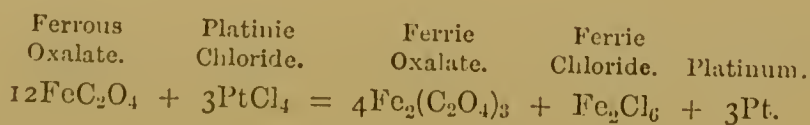

The platinotype process may now be worked by two methods; in one, the prints are developed with a hot solution of potassium oxalate; and in the other, the solutions, the composition of which is not pub-

lished, are used cold. The following is a summary of the instructions issued by the Company for using the hot-bath process :—

To secure the most brilliant results, the sensitised paper *before, during, and after* its exposure to light must be kept as dry as possible. It is necessary to place between the sensitised paper and the pads a sheet of thin vulcanised india-rubber, as it is of the first importance that the pads in contact with the paper be quite dry. The effect of damp is seen in a want of vigour, a general muddiness of tone, and, where the sensitised paper has been exposed to its influence for some days, in the impaired purity of the whites.

*The correct exposure* (about one-third of that required with silver-printing) is ascertained by inspection of the paper in a rather weak white light in the usual manner. A little experience will enable the exposure to be determined very accurately. As a general rule, all parts of the picture except the highest lights should be visible when the exposure is complete. When examining the prints in the printing-frames, care should be taken not to expose them unduly to light, for the degradation of the whites of the paper due to *slight* action of light is *not visible until after development*. Remove prints to a calcium tube as soon as exposure is complete, unless they are to be at once developed.

*Development* should be conducted in a feeble white light, similar to that used when cutting up the paper, or by gas-light. The developer is made by dissolving one pound of the potassium oxalate in 54 ounces of water. Use hot water for making the solution, of which a large quantity may be made up; it will keep indefinitely. It is well to have at hand some unused solution, since, in the event of inferior prints being made, a new bath may at once be tried. The solution is conveniently contained in a flat-bottomed dish of enamelled iron, heated by a small Bunsen burner.

The development is effected by *floating* the *printed surface* of the paper for five or six seconds upon the developing solution. To avoid air-bubbles, lay one edge of the print upon the solution near the right-hand end of the dish; then, with a sliding motion towards the left, lower the print, with an even movement, without stoppage, until it is entirely in contact with the liquid, where it must remain until *complete* action has taken place.

A temperature of about 140° Fahr. may be considered the standard temperature for the developer, though higher and lower temperatures may be used. A thermometer must be employed. The bottom of the developing dish should be covered with the developing solution to the depth of *at least* half an inch. After the prints have been developed, put the solution, without filtering, into a bottle for future use; it should not be exposed to a strong light. When next developing,

the solution will be found to be *nearly clear, but, of course, tinted by previous use*. If this clear solution be not sufficient, add to it some of the fresh solution of the potassic oxalate.

The following formula is very strongly recommended by the Company as a new developer. It gives more brilliant prints than the oxalate developer, with pure tones and transparent shadows. Dissolve half a pound of "developing salts" (used in the cold-bath process) in 50 ounces of hot water.

The best temperature for developing is from 120° to 130° Fahr. Below 120° the development is slow, and can be watched, which is sometimes advantageous.

To clear the developed prints, they must be washed in a series of baths (not less than three) of a weak solution of hydrochloric acid. This solution is made by mixing one part of hydrochloric acid with 60 parts of water. The specific gravity of the acid should not be less than 1.16; if lower, more acid should be used. The acid should be colourless. Or citric acid, in the proportion of 1 ounce to 20 ounces of water, may be used. This softens the paper in less degree than does the hydrochloric acid. *A white opalescence of the bath shows the necessity for more acid.*

As soon as the print has been removed from the developing dish, it must be *immersed, face downwards*, in the first bath of this acid, contained in a porcelain dish, in which it should remain about five minutes; meanwhile, other prints follow until all are developed. The prints must then be removed to a second acid bath for about ten minutes; afterwards to the third bath for about fifteen minutes. While the prints remain in these acid baths they should be moved so that the solution has free access to their surfaces, but care should be taken not to abrade them by undue friction. It is impossible to affect the image *per se* by leaving the prints for a long time in the acid baths; but such treatment, continued for an hour or more, tends to make the paper soft and porous, and to damage the surface. The prints should not communicate to the last acid bath the slightest tinge of colour. If the bath, after the prints have been washed in it, does not remain as colourless as water when a depth of fully two inches is viewed in full daylight, the prints should be treated to yet another acid bath. For each batch of prints fresh acid solution must be used. After the prints have passed through the acid baths, they should be well washed in three changes of water during about a quarter of an hour. It is advisable to add a pinch of washing-soda to the second washing water, to neutralise any acid remaining in the print. Use a mountant which does not stain or show through the print. Gelatine alone is not suitable, except for thick paper. Thick cold starch (or, better, starch and gelatine) is a good mountant. Paper to give sepia tones may be

used, but, with few exceptions, the method of carrying out the operations is the same as for the "black" kinds of platinotype paper.

The cold process for developing platinum prints must be conducted as follows, and it will be observed that every care must be taken to keep the paper dry when the hot process is used, but in the cold process a certain degree of moisture is necessary :—

The following is a summary of the method of printing by the cold-bath process :—

The paper, sensitised with salts of iron, is exposed under the negative in the usual manner ; it is then suitably moistened by floating, or otherwise, upon a solution of the developing salt, to which has been added a prescribed proportion of the platinum salt. Immediately after this the print is washed in a weak solution of hydrochloric acid, and finally in water.

It is important to avoid the contact of metallic dust and metallic surfaces with the sensitised surface of the paper. The following precautions should be taken :—The lower half of the calcium tube must be lined inside with paper. The prepared paper is then placed in the lined portion with its sensitive surface bent outwards or convex. And in putting paper into the tube, and also in removing it, care must be taken that its surface does not touch any of the unprotected metallic surfaces of the tube.

Spots and streaks are also caused by the contact of platinum salt with the surface during its exposure to light. It is, therefore, important to avoid handling the paper with fingers which have just previously come in contact with paper containing platinum salt, such as hot bath paper ; and if the negatives have been used for printing on such paper, they must be carefully dusted to free them from any platinum salt which they may have derived during contact.

*General treatment of the paper.*—The presence of moisture in the paper, either during its exposure to light, or afterwards and before development, is important. Sufficient moisture will be present when the paper has lost its crispness, but if allowed to become limp the moisture will be excessive.

If it should be necessary to delay development for one or two days, the prints must be dried before a fire soon after they are removed from the frames, and then stored in a calcium tube until wanted for development.

*Exposure to light.*—This is effected in a printing-frame in the usual manner. When exposed to light behind a negative, the lemon colour of the paper receives an image of a greyish tone. The exposure is somewhat less than that required with the old process—perhaps about one-third less. As a general rule, all details observable on the exposed print are developable, and the converse of this is also generally true ;



but here it should be observed that the action of light on skies is not often clearly seen unless the rebate of the negative has been previously rendered opaque by painting with opaque varnish, so that the tint of the sky may be compared with the original colour of the paper which is preserved by the opacity of the "rebate."

It is important to remember that if paper be exposed in a damp state, the visibility of the image is less than if exposed in a dry state. On this account beginners will find it easier to expose dry, and damp the prints afterwards.

*Development.—Stock solutions.*

*Developing-salts (D.).*—Half a pound to be dissolved in 50 ounces warm water, and the solution labelled D.

*Platinum salt (P.).*—Sixty grains to be dissolved in 2 ounces of water, and labelled P.

*Solution D.* must, for general use, be diluted in the following proportion :—

D. solution . . . . .	3 parts.	} Label this solution "Diluted D."
Water . . . . .	2 parts.	

The *standard developer* is made by mixing 1 part of solution P. with 5 parts of "Diluted D." solution.

All these solutions should be accurately made up and correctly proportioned.

The mixed developer keeps in good condition for some hours after mixing, but it afterwards slowly deteriorates; and in order to secure due economy in the use of the developer, it is important to mix no more at a time than is sufficient for the prints to be developed. In developing a very large batch, perhaps the best way is to mix the whole quantity necessary, but to put into the developing dish only sufficient to render the floating of the prints an easy matter, and then to add the remainder by degrees as may be found necessary.

In order to develop, pour sufficient of the developer into a porcelain tray to well cover the bottom, and then float the print, with its printed surface downwards, upon the solution; after the lapse of two or three seconds it may be lifted from the solution and held in the hand. A few seconds after the print has thus been removed from the developer, it should be again similarly floated and raised; and these operations may require to be repeated, but this will depend on the strength of the print.

The object of refloating the print is thus explained. When a print is first raised from the developer, the liquid adhering to its surface contains only a small quantity of platinum salt (the developer being weak in this ingredient), and the amount of salt so taken up is usually insufficient to supply the necessary quantity of platinum pigment to

the shadows and darker parts of the print; by refloating, a fresh supply of this pigment-forming liquid is supplied, and the number of floatings required is determined by the strength of the print.

After the print has been twice floated it should be held in the hand, face upwards, and the progress of development carefully watched. When the half-tones have sufficiently appeared, and have become free from the granulation usually visible in the first stages of development, and the shadows also are sufficiently strong, the print should be at once immersed in the acid-clearing bath.

The clearing and washing are the same as in the methods adopted for these purposes with the earlier processes.

After the prints have passed through the acid bath, they should be well washed in two or three changes of water during about a quarter of an hour. They are then finished.

These prints being on plain paper, are better dried face upwards across glass tubes, or, if large, suspended by clips or pins. The prints also may be dried between *clean* blotting-paper. Any mountant which is clean may be used.

Paper which has been kept some time, and which will not give good results in the ordinary way, may be left in the printing frame until fully printed, and then developed, or rather fixed, in a nearly cold solution of ferric oxalate.

*Pizzighelli's Process.*—Captain Pizzighelli and Baron Hubl have published two methods for producing photographs in platinum; one is very similar to Willis's, but the other permits the full printing of the picture as in other direct printing processes. In Anthony's *International Annual* for 1888, as also in the late Mr. Iselin's translation of Pizzighelli's and Hubl's description of the processes, full directions will be found for the preparation of both kinds of paper—one for development and the other for direct printing. Of the latter the following is a very condensed description. Any kind of paper with a hard surface may be used, but to prevent the sensitising solution penetrating the paper too deeply, the surface is brushed over with paste (formed of arrowroot 2 parts, water 100 parts) applied cold; it is then hung up to dry and the process repeated; but in drying the sheet the second time, it must be suspended by the opposite end of the paper. To make the paper sensitive take—

A. Potassium platinous chloride . . . . .	1 part.
Distilled water . . . . .	6 parts.
B. Sodium ferric oxalate . . . . .	40 parts.
Solution of sodium oxalate (3 : 100) . . . . .	100 „
Glycerine (to be added in very dry weather) . . . . .	3 „

In mixing the solution B. the soda oxalate solution is heated to  $(40^{\circ}-$

50° C.) about 120° F. and then soda ferric oxalate is dissolved in it, followed by filtration when the solution has cooled. This solution may be mixed in large quantity and kept in stock.

C. Iron solution B.	. . . . .	100 parts.
Potassium chlorate	. . . . .	0.4 part.
D. Mercury chloride solution (5 : 100)	. . . . .	20 parts.
Sodium oxalate solution (3 : 100)	. . . . .	40 „
Glycerine	. . . . .	1.8 „

Different effects may be obtained by using the solution in varying proportions. For black pictures, and where the negatives are of ordinary density (it may be stated here that the results in platinum printing depend very much on the quality of the negative, and that no good results can be had from a weak one), take—

Platinum solution A.	. . . . .	5 cc. 85 minims.
Iron solution B.	. . . . .	6 „ 102 „
Iron chlorate solution C.	. . . . .	2 „ 34 „

When the negatives are dense, reduce the quantity of solution C., and for softer negatives increase the quantity.

For brown pictures use—

Platinum solution A.	. . . . .	5 cc. 85 minims.
Iron chlorate solution C.	. . . . .	4 „ 68 „
Mercury chloride solution D.	. . . . .	4 „ 68 „

For tones between the black and brown the proportions of solutions C. and D. are varied. The solutions are applied, first, with a bristle brush (without tin mounting), and then spread evenly with a camel's-hair brush; the paper should then be dried quickly in a warm room. When dry, the paper must be kept in calcium-chloride tubes.

Paper without the special preparation with arrowroot may be used if 30 parts of powdered gum arabic (picked white) be added to solution B. The gum when heated to 120° F. is mixed with oxalate and glycerine solution by stirring in a mortar. When mixed the solution is strained through a cloth. The other solutions are used in the same proportions for both kinds of paper.

“The printing is continued until the picture has the appearance it is intended to have finally. If many pictures are done, they are placed in—

Muriatic acid	. . . . .	1 vol.
Ordinary water	. . . . .	8 vols.

Change this two or three times, until no more green colour is visible, and then wash the pictures in two or three changes of water.

“If the prints are not to be finished, they can be finally developed in the following solution :—

Sodium carbonate . . . . .	5 parts.
Water . . . . .	100 „

“In damp, warm weather, it is sufficient to have them lay in the dark, where they will complete themselves, the action of light introduced causing decomposition even in the dark.”

In this process (the Pizzighelli) the paper while in the printing-frame requires a certain amount of moisture, and this can be effected by breathing on the paper in the printing-frame. Since Captain Pizzighelli wrote the article from which the above is summarised, it has been pointed out by a writer in the *International Annual* for 1890-91, that when damp platinum paper was left in contact with an unvarnished gelatine negative for a week, a reduction of density had taken place to the extent of 50 per cent. ; and it is also stated that a single coat of varnish must not be relied on to prevent the mischief. Another writer in the same *Annual* states that one great advantage of the Pizzighelli paper is that it does not deteriorate rapidly if not kept in calcium tubes.

The platinum process of printing has many advantages, as, omitting the preparation of the paper, the various manipulations can be carried through in much less time than is required for silver-printing. The exposure to light is less by about one-third, and the subsequent operations, including mounting the print, may be rapidly completed. The prints are undoubtedly permanent, as the tests to which they have been subjected show. The picture is formed of metallic platinum, which metal is one of the most stable known. None of the chemical tests which have been applied have any effect in destroying the image, excepting *aqua regia* (which is a mixture of nitric and hydrochloric acids), to which, under ordinary conditions, no platinum picture is ever likely to be exposed. The process has become very popular during the last three or four years ; but the recent increase in the price of the metal may check the demand for platinum prints, owing to the extra cost. That platinum will supersede silver-printing may be a matter of doubt. A good print on albumenised paper has to some persons a specialty which the print on salted (silver) paper or platinum does not possess ; but the artistic quality of platinum prints has advantages which the silver (albumenised) print has not. The two kinds of photographs should not be seen side by side, as their qualities are totally different.

**Plumbago Process** (see *Dusting-on Process* and *Ceramic Photography*).—Formulæ have already been given, but the following may be added :—

1. Gum arabic . . . . .	1 drachm.
Glucose . . . . .	$\frac{3}{4}$ "
Glycerine . . . . .	10 drops.
Potassium bichromate . . . . .	30 "
Water . . . . .	2 ounces.
2. Ammonium bichromate . . . . .	5 drachms.
Honey . . . . .	3 "
Albumen . . . . .	3 "
Water (distilled) . . . . .	30 "

The process is useful in making duplicates and increasing density in negatives. The solution should be kept in the dark.

Preference is given by Mr. W. K. Burton to the following formula, given in two solutions, as, when separate, they do not deteriorate. They must be filtered and used in the proportion of three parts of A. to one part of B. :—

A. Gum arabic (best) . . . . .	1000 grains.
Loaf-sugar . . . . .	1000 "
Mercury bichloride . . . . .	5 "
Methylated alcohol . . . . .	10 ounces.
Water . . . . .	40 "
B. Ammonium bichromate . . . . .	2 "
Water . . . . .	20 "

A sheet of suitable glass, preferably patent-plate, must be coated with the solution in the same way as collodion, and well drained, so that after it is dried by fire heat—about the temperature used in varnishing, not hotter—the plate appears of a pale yellow colour. While still warm, the plate is exposed to light under a negative. Experience only will show the correct exposure. Plumbago powdered very fine is used to develop the negative, and must be applied to the plate, which has been again warmed, with a camel's-hair brush, and great care is necessary to apply the powder evenly. Density may be given to any part as desired, but success depends very much on correct exposure and skill in applying the powder. When the "dusting on" is finished, the plate is coated with plain collodion, and washed till the water flows evenly; then it must be placed in a strong solution of alum, where it must remain until the yellow colour has been removed. The negative thus obtained will, of course, be reversed, which is an advantage for some purposes; but if required for ordinary printing, it may be stripped from the plate and floated on again in the reversed position.

**Primuline or Diazotype Process.**—Processes for printing on textile fabrics have hitherto been of little commercial value, owing probably to the necessity of separate exposures to light, as in ordinary silver and other printing methods; and it may be that the newest will not possess more than scientific value. There is certainly novelty in the fact that amongst the derivatives of coal-tar one should be found

which is sensitive to light, and possesses qualities unlike those of other salts used in photographic processes; this new salt is primuline. At the last meeting of the British Association held at Leeds a paper by Messrs. Green, Cross, & Bevan was read, but at the time of writing, that paper is not published. The following information is derived from a leading article by the editor, Mr. J. T. Taylor, in the *British Journal of Photography* for 17th October 1890.

The calico or other material to be used must be thoroughly washed in hot water, or boiled to free it from impurities. It is then cut into pieces of convenient size, placed in the solution of primuline, and kept in constant motion as when toning prints. The dye is prepared by boiling 150 grains of the commercial primuline in 10 ounces of water in a flask on a sand-bath. The solution is poured off from the sediment into a porcelain dish, and the calico after ten minutes' immersion will be found to be sufficiently stained. The quantity of solution will be sufficient for sixteen pieces of cloth 8 × 6. The dyed cloth or calico must now be rinsed in water and wrung out, and then placed singly in the following solution:—

Sodium nitrite (commercial) . . . . .	100 grains (dry).
Hydrochloric acid (commercial) . . . . .	$\frac{1}{2}$ fluid ounce.
Water . . . . .	30 ounces.

In this solution the cloth changes to a reddish brown tint, owing to the primuline being converted into a diazo derivative. It is now sensitive to light, which both destroys the azo-derivative and prevents its reaction with certain developers. The resulting print is a positive from a positive.

After the pieces of cloth have been turned over several times in the nitrite bath, they must be rinsed in several changes of water to remove the free hydrochloric acid; they may then be placed between blotting-paper to dry.

To obtain the best effect in the prints, the object used in printing should be somewhat denser than is necessary in other processes; natural objects, such as ferns and leaves, being very suitable. The progress of the print may be seen in the change of colour from reddish brown to a dingy yellow. The density in the object to be printed is necessary, as the printing should go through the material. When this cannot be effected, the back of the cloth should be exposed to light for about a fifth or sixth of the time required for the original printing.

The printed pieces of cloth are now steeped in water and wrung out, to secure equal action of the developing solution, which for red prints is prepared as under:—

Beta-naphthol . . . . .	40 grains.
Caustic soda or potash . . . . .	60 „
Water . . . . .	10 ounces.

Dissolve the alkali in a small quantity of water rubbed up with naphthol, and then add the remainder of the water. Orange coloured prints are obtained with—

Resorcin . . . . .	30 grains.
Water . . . . .	10 ounces.

Dissolve, and then add 50 grains of caustic soda or potash. For purple prints—

Naphthylamine . . . . .	60 grains.
Hydrochloric acid (commercial) . . . . .	1 fluid drachm.

Mix in a mortar and then add 10 ounces of water.

Other developers have been indicated by Messrs. Green, Cross, & Bevan, but they do not appear to have used any of the salts now commonly employed in developing dry plates, such as eikonogen, pyrogallol, or hydroquinone, which Mr. Taylor finds will give the black tone desired by the discoverers of the process :—

Eikonogen . . . . .	60 grains.
Water . . . . .	10 ounces.

The eikonogen (white crystals) should be ground in a mortar, the water added, and the prints on cloth put into the solution, in which they are moved till the development is complete. For brown tones—

Pyrogallol . . . . .	50 grains.
Water . . . . .	10 ounces.

The “fixing” is effected by washing in water. The prints, when wrung out, may be washed in soap and water, which is found to improve the colour, and ironed between sheets of paper, but this should be done before the prints are quite dry.

It may be stated that the process as introduced by Messrs. Green, Cross, & Bevan is patented, but that the patent does not appear to cover the modification adopted by Mr. Taylor.

One of the peculiarities of this process is that the image is formed by the parts which have not been acted on by daylight.

By modifying the manipulation the process may be used for paper, but it is not very clear to what useful purpose it may be applied; and although the dye may be capable of withstanding chemical tests, it has not yet been proved that the test of light may not be fatal to the results, as is the case with other dyes derived from coal-tar.

**Printing and Toning.**—Until the last few years the majority of photographs were printed on albumenised paper, which is perhaps, even now, the most popular process. Bromide and platinum papers

are also largely used. Descriptions of those methods of printing will be found elsewhere in these pages. Albumen has the effect of keeping the picture which is printed on it upon the surface, and it thus retains a more effective appearance than when printed on paper without the albumen, called in that case "plain salted paper." Prints of the latter class, when looked at by transmitted light, will appear to have the picture more *in* the paper than *on* the surface; the brilliant appearance of albumen prints is thus due to the albumen, the picture being on the surface of the paper. Everything in these latter days is done for the convenience of the photographer, so that he need not prepare the albumen nor float the paper upon it; he can, if he please, sensitise this paper by floating it on silver nitrate solution, but paper so prepared must be used at once, as it turns brown by keeping. Here the convenience of the photographer is again studied, for he can purchase his paper ready sensitised, which keeps its colour for some weeks, while the cost is very little more than that of the paper and silver. There is this difference, however: much of the ready sensitised paper sold does not give satisfactory prints. To sensitise albumenised paper, it should be floated on a bath of silver containing from 50 to 60 grains of the nitrate to each ounce of water, and be left in the solution about three minutes. Whether large or small pieces of paper be used, the sheets should be held by two opposite corners, so that the middle of the sheet shall just touch the solution, and then be gradually lowered. When the paper is in contact with the fluid, it should be raised to see that no air-bubbles have formed. The sheet, after three minutes, may be slowly raised to allow the silver to run off, and, after draining, may be suspended from a line to dry, being held by wooden clips and a strip of blotting-paper attached to the lowest corner. Sometimes the paper is drawn over the edge of the dish or a glass rod to assist in the removal of the surplus silver solution. As already-stated, paper freshly prepared should be used at once, as in a few hours it is liable to turn brown, when it becomes useless if clean whites are to be preserved. The manipulations in the subsequent processes are the same, whether the paper is newly prepared or ready sensitised.

The method of printing needs very little description, as practice will quickly show what is required. Whether the printing should be deeper than the finished print is intended to be, depends very much on the kind of toning bath to be used. The progress of the printing should be carefully watched by lifting one side of the back of the printing-frame, which is hinged for the purpose. In the case of freshly-prepared paper, the toning and fixing must be done at once—that is, the same day; but with the other kind, the toning may be deferred. In either case, the prints must be placed in water to remove the excess of silver chloride, and the toning is necessary to



alter the colour of the print, which would be of an unpleasing red colour unless altered by the gold used in toning ; this changes the red to any tint of brown approaching purple and purple-black which may be desired. The prints are first put into plain water ; after a few minutes' soaking, the water is poured into a jar kept for the purpose, and the dish again filled with water. Or two dishes may be used, and the prints changed from one to the other. The first washing water is kept for the purpose of saving the silver, which, in case of paper freshly prepared, soon accumulates when much paper is used. Ready sensitised paper is not so rich in silver, but still the first washing water should not be thrown away. (The chloride is thrown down by adding hydrochloric acid or common salt, and the water can be poured off as soon as it becomes clear.)

The toning solution is made as follows:—Take a tube containing 15 grains of gold chloride ; break the glass, and put it with its contents into a bottle containing 1 drachm of water for each grain of gold. Put as much water as will be required in toning the prints into a dish, and add 1 drachm of the gold solution to each 8 ounces of water (each whole sheet of paper will require about 1 grain of gold to tone it). This solution must now be made alkaline by placing in it a lump of common washing-soda (sodium carbonate), as also a small piece of red litmus paper ; move the soda about in the water until the paper turns blue ; the solution is then ready for toning. By noticing the sensation between the thumb and fingers—a kind of soapy feeling—the proper state of the solution may in future be determined without the use of test paper. Place the prints, a few at a time, in the toning bath, keeping them in motion by turning them over, and watch the effects of the gold. As soon as the colour desired is reached, place the prints at once in a dish of water, and so proceed until all are toned. There are two effects produced by toning, one the change of colour, and the other the substitution of gold for silver ; or perhaps it is more correct to say that one is the effect of the other. Much has been written on this subject, and it is perhaps safe to say that what takes place in toning is not certainly known. Instead of saying that gold is “substituted” for the silver, it would be more correct to say that a kind of “gilding” is effected. The silver is not removed from the paper by the gold, but a change has been effected. When thoroughly done, there is no doubt that the print is more permanent when toned, and is certainly more pleasing in colour. It has been stated that untoned prints are unstable ; but the very earliest prints were not toned, such as those made by Mr. Talbot in 1844, some of which are apparently in the same state as when first printed, but have, however, the red colour ; this shows that untoned prints do not necessarily fade.

Some authorities say that a toning bath should be neutral. This is correct when chalk forms part of the formula, but the alkaline method of toning is more generally practised; the results are about equal in each case. The formula with sodium carbonate, already described, gives very satisfactory results; and, although it is generally stated that it will not keep, the writer finds that, with the addition of gold as required, the solution need not be renewed until it has been used several times. The old bath should not be thrown away, but the solution should be poured into a vessel and sufficient iron proto-sulphate added to precipitate the gold which it may contain.

The acetate toning bath is preferred by some printers, and is formed as under:—

Gold chloride . . . . .	1 grain.
Sodium acetate . . . . .	20 grains.
Water . . . . .	10 ounces.

Make up much more of the solution than will be required for toning a few prints. The soda must first be dissolved in the water and the gold then poured in. The strength of the bath must be kept up by the addition of one grain of gold—that is, one drachm of the normal gold solution for each sheet of paper to be toned.

The following gives good results. The bath will keep and remain in good condition when replenished with gold as required:—

Gold chloride . . . . .	2 grains.
Calcium chloride . . . . .	2 „
Chalk (powdered) . . . . .	1 teaspoonful.
Water . . . . .	16 ounces.

The bath should be mixed some hours before it is to be used.

Platinum may be used for toning in the place of gold. Take—

Platinum perchloride . . . . .	1 grain.
Water . . . . .	16 ounces.

Neutralise with potassium carbonate and then add half a drachm of formic acid. This is recommended for toning plain paper prints. Prints on this kind of paper and suitably toned have very much the appearance of those made by the platinotype method.

A very large number of formulæ have been published for toning, but for all ordinary purposes the selection given here will be found to be sufficient.

Toning takes place slowly when the solutions are cold; therefore, in the cold season of the year the solution should be warmed. In the summer this is not necessary.

Too many prints should not be placed in the toning solution at one

time ; and, as the toning is completed, each print should be placed in a dish of water to stop the further action of the gold.

It is quite immaterial what formula be used if the prints are from weak negatives. The vast majority of negatives now produced are too thin, consequently weak prints are the result, which no system of toning will make worth looking at. A good negative by the collodion process has sufficient density to enable vigorous prints to be made. When toned, more gold is taken up, so that there is altogether a brighter character about such prints which none but the very best gelatine negatives will equal. If prints made from negatives by the collodion and gelatine processes are made on the same kind of paper, and are treated in every way the same, the prints from the gelatine negative may appear to the ordinary observer to be equal to those from the collodion negative ; but any skilled person could detect the difference. It is generally believed that the cause of the want of stability in prints made during the last few years arises from the want of density in the modern negatives ; and, as the printing cannot be carried to the same depth, the toning action of the gold is not so effective ; hence the fugitive character of the prints.

When the whole of the prints are toned, they may be placed at once in the fixing solution, formed of—

Sodium thiosulphate ("hypo")	. . . . .	4 ounces.
Water	. . . . .	20 „

If the thiosulphate solution should be at all acid, a small quantity of liquor ammonia may be added. The prints must be kept in the solution at least ten minutes, and should be kept in constant motion, to ensure every part being acted on by the fixing agent. The prints may be examined by transmitted light. If they are not completely fixed, patches darker than the rest of the paper will be seen, and the fixing must be continued until this disappears.

Some kinds of paper are liable to blister, the albumen rising sometimes in patches as large as a shilling, while at other times the paper is covered all over with small blisters, which usually disappear in drying ; but the larger ones seldom dry flat and therefore spoil the print. To prevent blistering, the addition of salt to the first washing water is recommended, and ammonia in the fixing bath is also supposed to remedy the evil. It cannot be said, however, that either is wholly effectual, as the blisters sometimes appear although the supposed remedies have been applied. Changing from warm to cold solutions is also said to conduce to blistering.

After the prints have been passed through the salt and water they must be placed in a clean dish with water, and changed frequently during the first few minutes. They may then be left for a time, the

water being changed at intervals, and then left all night, and changed again two or three times before they are taken out to be dried. It is sometimes recommended that the last washing water should be warm, to remove the least trace of the sodium thiosulphate.

It may be noticed here that every care should be taken to have the dishes quite clean. The most effectual way to clean them is first to wash them with water, and then to rub them thoroughly with common salt, using it as if it were damp sand; when thoroughly rubbed in this way, *inside* and *out*, the dish is made quite clean. This should be done every time before use.

When large numbers of prints are dealt with, it becomes worth while to preserve the fixing solution to recover the silver. When a convenient vessel can be placed in the open air, the solution, after each day's fixing, should be thrown into it, and potassium sulphide (liver of sulphur) added in solution. As the vessel becomes filled a tap placed 4 inches above the bottom can be opened to draw off all the top part, and the vessel can then be filled again.

It should be stated that the fixing solution should never be used a second time. Some writers recommend that two baths (that is, two applications of the "hypo") be used to ensure perfect fixing of the prints.

*Blisters.*—It frequently happens when prints on albumenised paper are removed from the fixing solution into the dish or trough for washing, that blisters appear, in some cases small and covering the whole surface of the paper, or the blisters may be large and few in number. Many opinions have been formed as to the cause of this troublesome defect; the true explanation probably is that the albumen has not been perfectly coagulated. The suggested remedies are numerous. To prevent the formation of the blisters the addition of a strong solution of sodium chloride to the washing water may be tried. The change from the fixing solution to the washing water should be gradual, as the differing densities of the fluids appear to influence the formation of the blisters. Steeping in methylated spirit to coagulate the albumen before the prints are washed is one of the remedies, and also the immersion in boiling water, as suggested by Mr. A. W. Clarke in the *St. Louis Photographer*, to effect the same purpose. The hot water, however, would probably take out the size, thus rendering the paper very tender and difficult to handle. When the blisters are small, they generally disappear on drying; but when large, by puncturing the paper on the *back* of the blister the film may dry flat, but it often occurs that large blisters entirely spoil the print.

*Fading.*—One of the most serious defects in photographic printing is that, however perfect and beautiful a print may be, there is no certainty that it will remain so for any length of time. There are many

prints in existence which are in the same state as when first produced. As already stated, the writer has in his possession prints made by Mr. Fox Talbot in 1844; some of these are evidently unchanged, excepting at the edges where the prints have been mounted. At the date named, toning with gold had not been brought into use, so that the prints retain the reddish-brown colour common to all untoned photographs on plain salted paper. The use of albumen, because it has a trace of ammonia in its composition, is said to be one cause of fading; but prints on albumenised paper and toned with gold exist which show no sign of deterioration, although thirty or forty years may have elapsed since they were made. It would seem, therefore, that there is no reason why silver prints should not be permanent; and, although some of the causes of fading are not known, it is quite certain that no reliance can be placed on silver prints unless certain precautions are taken in their production. Chief amongst these precautions are the importance of using fresh sodium thiosulphate solution for fixing, and thorough washing.

One reason why early photographs are apparently more permanent than those done recently is that the negatives in use were stronger, consequently, the printing was deeper; and for such printing a larger proportion of silver was used in preparing the paper.

The very old photographs by Talbot were mounted only by the edges—that is, they were touched with the mountant (probably gum arabic, not freshly made) around the margin for about a quarter of an inch; and it is only this part which has faded. This is clear evidence that when prints are made to adhere entirely there is greater chance of fading, and it shows also that the mounting material should be of a kind which could have no chemical effect on the print.

It is a fact which should be carefully noted, that paper negatives made nearly fifty years ago have not changed. Such negatives were *developed*; and it is generally believed that developed prints are more permanent than any others.

On the point of permanence of silver prints the following remarks of Mr. M. Carey Lea should be remembered:—

“The conclusion to be drawn from all this is simple enough. Silver prints can be made to be perfectly permanent, if the use of hyposulphite be liberal and judicious, and by throwing away every bath that has stood even for an hour or two after the prints were first placed in it. It may be said without exaggeration that every penny saved in hyposulphite costs the loss of dozens of prints by fading.

“Of course, nothing can take the place of good washing. By this is to be understood, not exaggerated soaking in water, but lying for some hours in water which is continually changing. No system of washing can be considered effectual which does not alternately fill and

empty the washing vessel, so that the fresh supplies of water are not contaminated by mixing with the previous portions."

*Fuming Albumenised Paper.*—It is claimed that albumenised paper, if exposed to the fumes of ammonia, gives more brilliant prints, and that the toning is more easily effected. When large quantities of paper are to be manipulated, a suitable cupboard or box should be used; but on a small scale, a less elaborate method may be adopted. Take a box, such as drapers use, made of cardboard, eighteen inches square, larger or smaller according to the size of paper to be dealt with. Spread on the bottom a sheet or two of blotting-paper, and over this some tissue-paper crumpled so as to rest lightly on the blotting-paper; but, before putting in the tissue-paper, sprinkle a drachm or two of liquor ammonia, which may be diluted with one half water, on to the blotting-paper; the paper to be fumed may rest on the tissue-paper for ten or fifteen minutes. If preferred, muslin may be strained across the box, over, but not touching, the blotting-paper, and the paper to be fumed may rest on the muslin. The printing and toning are conducted in the usual way.

*Plain or Salted Paper, Printing on.*—The change of taste during the last two or three years has brought again into notice the very earliest kind of printing—that on the plain salted and unglazed paper. There can be no doubt that the detail in a photograph is made more apparent when it is kept on the surface by albumen or other means than when the matt surface of the paper is used. This perfection of detail is made more prominent when aristotype and other kinds of paper are used, while enamelling has much the same effect. A photograph treated in this way has an exquisite beauty of its own, and it can be seen in no other way; but there can be no doubt that, from an artistic point of view, a print without the very high glaze is better; this kind of effect may be obtained by using paper of fine quality, salted and sensitised in the usual way. The best toning bath for this kind of paper is the one containing platinum. Prints of this kind are very suitable for painting in water-colours, and they should be kept light for this purpose. With care in handling, Whatman's drawing-paper may be salted and treated in the same way as other papers; and, for the artist in water-colours, this is perhaps better than any other kind, at least for large work. As the paper when wet is heavy, great care must be taken in handling, as it will scarcely bear its own weight. This kind cannot be purchased ready prepared, and must be salted and sensitised as required. Take—

Ammonium chloride . . . . .	8 grains.
Water . . . . .	1 ounce.
Gelatine (if the paper is not well sized) . . . . .	2 grains.

Pin the paper to a board, and with a piece of lint brush over the paper in all directions until completely covered, and then allow to dry. Then take—

Silver nitrate . . . . .	60 grains
Water . . . . .	1 ounce.

and brush over the paper as in salting. See that this is thoroughly done, or the printing will not be even. All the subsequent processes are the same as in ordinary silver printing.

In 1855 Mr. Sutton introduced a process for producing prints on plain paper in which the serum of milk was used instead of a salt, and the prints were developed. The process was new, and at the time attracted considerable attention. A print in the writer's possession, prepared by this process, and issued from St. Brelade's Bay, Jersey, where Mr. Sutton at that time resided, is in fair condition, and apparently not much altered. It is some proof that the claim for the process that the prints were permanent is to a large extent justified. At the time referred to the toning and fixing were effected at one operation, and it was to remove the possible cause of fading due to this method that Sutton's process was introduced. (See *Aristotype*; also *Gelatine Chloride Paper, Ilford*).

**Printing on Ivory.**—As a surface for the artist to paint upon in water-colours, ivory has always had the preference; but miniature painting was almost a lost art for many years, owing to the great popularity of photography; the daguerreotype plate took the place of the ivory miniature for brooches and lockets; then the glass positive, which was superseded by the portrait on paper, treated usually in a very inartistic way, and by hands much less competent than the old miniature painters. To print a photograph on ivory was difficult; but a process was introduced by Mr. Beard, the patentee under Daguerre of the daguerreotype process in England, which gave very good results. The ivory was salted with calcium chloride, the silver nitrate was dissolved in alcohol, and the picture was fixed with potassium sulpho-cyanide. The method is somewhat uncertain, but time has proved that the prints do not fade. The true surface of the ivory in this process is used, which is not the case when a film of gelatine is made to cover it, as in the carbon process; but, as the film is thin and transparent, in the hands of a skilled artist a good carbon print on ivory has all the appearance of a real ivory miniature, with the advantage of the correct drawing which the photographic basis gives.

**Reproduced Negatives.**—It frequently occurs that more than one negative is required of the same subject. When they cannot be obtained direct from the object, recourse must be had to some method by

which the original negative may be reproduced. The simplest way of course is to copy a print, but the effect in this case is far from perfect, owing to the texture of the paper showing. A transparency may be printed of the same size, and from this again a negative. In this case care only is required, and excellent reproductions of the original may be obtained.

**Reversal of the Image.**—There are several methods by which the picture may be developed as a positive instead of a negative—that is, a positive as seen by transmitted light. An ordinary gelatine dry plate, if much over-exposed when developed, will yield a positive image. By recent experiments by Mr. A. P. Okell and others, it has been shown that when the exposure has been more than sufficient to produce a positive, a negative result may be obtained, and that the change from positive to negative recurs in successive order. These experiments were conducted with much care, and the exposures varied from a few seconds to many hours. For some purposes a process by which a positive picture could be produced with the same certainty as a negative would be useful, and from experiments recently conducted by Colonel Waterhouse, some success in this direction appears to have been attained. It is found that when a small quantity of phenyl-thio-carbamide or allyl-thio-carbamide (substances which are produced by treating mustard-oil or thio-carbamide with ammonia) is added to the eikonogen developer, and used for developing gelatino-bromide plates, if the exposure has been correctly timed the result will be a positive picture. So far as experiments have yet shown, the best results are obtained with eikonogen, and Colonel Waterhouse gives the following formula:—

A. Eikonogen . . . . .	5 parts.
Sodium sulphite . . . . .	10 „
Water . . . . .	100 „
B. Sodium carbonate, crystals . . . . .	4 „
Water . . . . .	100 „
C. Phenyl-thio-carbamide . . . . .	1 „
Water . . . . .	2000 „

The developer is formed by taking one part of A., two parts of B., one part of C., to which is added half to one part of a 10 per cent. solution of potassium bromide, and, if the contrasts are too strong, a few drops of ammonia. Colonel Waterhouse states that satisfactory results may be obtained when suitable plates are used, quite equal to those made by the old method in the camera—that is, making a positive from a negative. Other forms of carbamide, such as thio-sinamine, thio-carbamide, or sulph-urea, have been used.

Colonel Waterhouse also states that although there are some difficulties in working by this new method, it is probable that satisfactory positives will be obtained; that is, this process of making positives will



be as certain as the making of negatives in the usual way, and will be of much value in making copies for working the photo-mechanical processes. The process is quite new, and opens a field for interesting research.<sup>1</sup>

The reversal of the photographic image is a matter which, from the first discovery of the art, has occupied the attention of many minds, and under the term *Solarisation* these effects are generally alluded to. The result sometimes seen when photographing an interior, where there is a window through which a landscape may be visible, the interior being a negative, and the exterior by the reversing action of the light becoming a positive, is an illustration of this effect.

A reversal of the image obtained direct in the camera may be made by immersing the developed picture on collodion emulsion in nitric acid, when the reduced silver will be dissolved, leaving an image in silver bromide. This is exposed to light for a short time and the plate is redeveloped; or ammonium sulphide may be used, when the result will be a positive picture. Another method by Mr. Brooks may be given. A gelatine plate is developed until the image is seen on the back. It is then placed in the following solution:—

Potassium iodide . . . . .	1 to 2 parts.
Potassium bromide . . . . .	10 „
Water . . . . .	100 „

The plate is washed and then redeveloped with pyrogallic acid or ferrous oxalate, and fixed in the usual way. (See *Reverse Action of Light*.)

**Reversed Negatives.**—There are several methods by which the negative picture may be reversed, and for certain of the photo-mechanical processes it is necessary that the image be in the reversed position either on glass or on a film. The methods may be treated in the following order:—(1.) By a prism of solid glass ground true and fitted to the hood of the lens, so that when the camera is placed at right angles to the object to be copied, the image is reflected on to the plate in a reversed position. (2.) As the solid prism is costly, a prism of patent plate-glass may be formed thus— $\Delta$ . Make a drawing of the size of the prism required, and then cut pieces of glass carefully selected and free from defects; take two pieces of thin metal with the edges turned up, and made to fit the glass as a top

<sup>1</sup> Since this was written a letter from Colonel Waterhouse has been published in the *British Journal of Photography* of January 30, 1891, in which he states that “the tetra-thio-carbamide ammonium bromide compound salt, prepared as described in Professor Reynolds’ paper, gives under favourable conditions exceedingly good reversals, much better than the thio-carbamide does itself. I found five drops of the saturated alcoholic solution to the ounce of eikonogen developer answer well for line-work, but have yet to make further trial. I find that the nitric acid treatment is beneficial with this salt also in the case of line-work.”

and bottom. The glass must now be cemented with marine glue (or in any other way), so as to be water-tight. Through an opening at the top, water (or castor-oil) may be introduced. This prism, although not so perfect as the one made of solid glass, will answer the same purpose at a very trifling cost. It may be fitted in front of the lens.

(3.) A piece of glass silvered at the back in the usual way may be used, but the reflection is not perfect. If silvered on the face, a mirror of silvered glass ground quite true and polished answers very well, although there is some loss of light, and great care must be taken that the surface is not injured; it must never be exposed excepting while in use, or the surface will become tarnished. For the method of silvering see *Silvering Glass*, page 189.

(4.) The negative may be reversed by placing the film so that the image is formed through the glass. If made on a wet plate, the plain side of the glass must be wiped dry; and if a dry plate be used, it must be carefully cleaned. It must be noticed that reversing the plate makes it necessary either to reverse the ground-glass while focusing, or to allow for the thickness of the plate.

(5.) The film may be reversed by stripping; if a wet collodion plate be used, proceed as follows:—Paste strips of paper around the edges on the back of the plate, so that when dry they may be turned up to form a kind of dish. Then take gelatine 2 ounces, loaf-sugar  $1\frac{1}{2}$  ounces (or a small quantity of glycerine instead of the sugar, either being used to make the stripped film flexible), and water 2 ounces; dissolve in the usual way, and filter through muslin. Place the negative on a sheet of plate-glass on a levelling stand, and pour on sufficient of the gelatine solution to completely cover it. When set, the negative may be stood on edge to dry; and when quite dry, by running a knife around the edge the film may be stripped. The glass should be rubbed over with French chalk before coating and sensitising.

(6.) Unvarnished gelatine negatives may be stripped as follows:—Place the negative on a levelling stand and cover it with transfer collodion. When this has set, the negative must be put into a dish of water and washed till all greasiness disappears. Into an ebonite tray pour a solution of hydrofluoric acid (one drachm of the acid to two ounces of water) and then place the negative in it. The film will soon show signs of leaving the glass; at this point remove it from the acid and wash carefully, then put it face upwards on blotting-paper, and on the film put a piece of smooth paper, wetted and larger than the glass, pressing it in contact with a squeegee. On turning the plate over, the film may now be removed with the paper. Then place in water, when the negative will float off, and may be caught in its proper position on a clean glass. It is then allowed to dry, or it may be transferred to a plate prepared with gelatine in the

usual way. (7.) India-rubber dissolved in benzole may be poured on to the dry collodion film (the negative being taken on a plate which has been rubbed over with French chalk and then coated with transfer collodion). When quite dry, the film may be stripped as before described. With care, any one of the methods given above will be found quite effectual.

**Retouching.**—The “art” of retouching a photograph may be compared with what is called “flattering” a portrait painted in oil or water-colours, or it may be as monochrome—that is, endeavouring to make the portrait different from, if not better than, Nature made the subject. There was a time when a photograph was considered to be something to “swear by”—that is, a truthful representation, and not a thing which had been altered by hand to meet the idea of the “retoucher” as to what Nature *ought* to have made the subject. This retouching, however, is now carried to such perfection (?) that it is no longer safe to “swear by” the thing which the light, in the first instance, had made almost the exact resemblance of the image it had impressed on the sensitive plate, but which the lead-pencil in the retoucher’s hand has altered to such an extent that it no longer can claim to be a true image of the original. Retouching—that is, working upon the negative with lead-pencil to remove photographic defects—may be allowed. It is no fault of the sitter if Nature has endowed him with a skin covered with minute yellow spots or “freckles;” these appear on the sensitive plate in such a manner that the result when printed is to show them too prominently. They may be scarcely visible to an ordinary observer on the face of the sitter, but they are very noticeable in the photograph, and are very objectionable. To remove these, but at the same time not to alter the likeness, is perfectly legitimate. The use of orthochromatic plates assists the photographer here, but is not altogether sufficient. It is not possible in a page or two to say all that might be desirable on this subject. Treatises devoted to the subject have been written in which minute directions what to do in all cases are given, and to which the reader is referred. The writer admits that retouching is necessary, but the experience of many years confirms him in the opinion that, beyond what has been said above, and the general smoothing away of defects, retouching as now practised is not legitimate. Excessive retouching is practised chiefly because people “will have it.” But it is in the power of the photographer to a large extent to guide the public taste. It is the abuse of the “art,” and not the use which should be condemned. That public taste may be led is manifested in the preference which is beginning to be shown for prints without the glaze of albumenised paper, platinum and bromide printing largely taking its place. What can be said in defence of remarks of this kind, which

appear in one of the most influential of the photographic journals? "To the most casual of observers the nose will always appear a leading, if not absolutely *the* most prominent feature of the face; and, indeed, the success of the portrait will depend very materially upon the degree of success with which we treat it. Many times the retoucher will be called upon to give absolute form to the nose, and this, it is needless to say, will often tax his ability to the fullest." Very full instructions are given as to the treatment of this very important feature in the face, showing how the *bridge* may be improved and altered so as to make it what the retoucher considers it ought to be; other parts of the nose and other features of the face are directed to be modified; the eye even does not escape attention. It is fair to say that the author of these instructions concludes one of his papers with these remarks;—"Over-work, in the treatment of a negative, will only produce a hard, *wooden* effect, and in nine cases out of every ten falsify the natural expression and ruin the resemblance. Needless to say, retouching carried out on the over-work principle can have no pretensions whatever to the artistic." This is perfectly true, and it is true also that retouching carried to the extent recommended *must* result in injury to the portrait. In many cases the face is covered with retouching to such an extent that the result in a print is the appearance of the sitter having recently recovered from small-pox.

It has been admitted that a certain amount of retouching in most portraits is necessary, and, provided it is not carried so far as to detract in any way from the picture as a portrait, the work may be improved; but this is only necessary because prints on paper from untouched negatives are not so perfect as portraits by other processes were in former times. Bad negatives are allowed to pass because the retoucher is supposed to make good the defects left by the photographer.

For the purpose of retouching a portrait or other negative, hard lead-pencils are used. Faber's HH, HHHH, and even six H are employed. The lead must be cut to a very fine point, and the point kept by rubbing on a piece of fine emery paper. The negative must be placed so that the light may be reflected through it—a retouching desk is generally used. To obtain the best effect in the negative, the head of the retoucher should be protected from the surrounding light as much as possible. The negative is usually worked upon before it is varnished; and, to make the pencil "bite," the gelatine film is sometimes slightly roughened with fine pumice or cuttlefish powder. In other cases the plate may be coated with varnish, which leaves a "tooth." Suitable varnishes may be purchased. Success or otherwise will depend upon the skill of the retoucher, and the "art" can only be acquired by practice. From what has been said, it is clear that



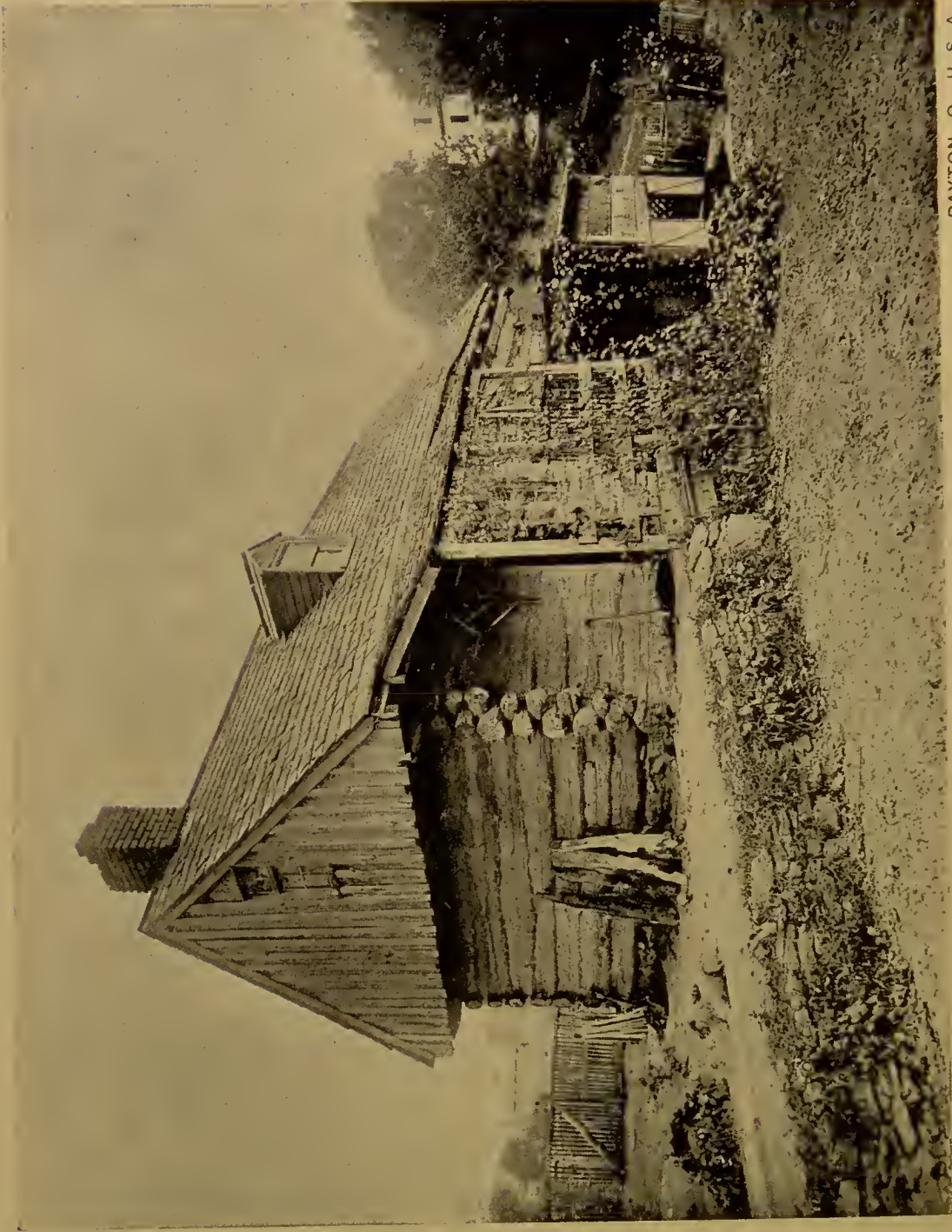

M. WOLFE.

DAYTON, O., U. S. A.

ZINC ETCHING

MADE WITH

M. WOLFE'S FINE LINE SCREEN PLATES AND HALF-TONE PROCESS.

the writer would advise that as little as possible should be done with the pencil. The aim of the photographer should be to make his negative as perfect in light and shade as possible. Consequently, if *modelling* and all other technical details have been carefully attended to, very little need should arise for the so-called retoucher's "art." The art should be in the photographer, and the less aid he requires from the lead-pencil the better his work will be.

**Ruby Medium.**—When it is not possible to obtain ruby glass, it is convenient to have the means of preparing a transparent sheet as a substitute. Mr. W. K. Burton recommends the following :—

A. Gelatine . . . . .	100 grains.
Water . . . . .	4 ounces.
Potassium bichromate . . . . .	20 grains.
B. Silver nitrate . . . . .	20 „
Water . . . . .	1 ounce.

The gelatine must be softened in the usual way; then add the bichromate, and apply heat until the whole is dissolved. Solution B. must then be added. Coat the glass with the emulsion, and the result will be a film of a deep ruby colour.

**Screen Plates.**—On page 143 will be found a description of one of the methods for obtaining a lined screen to be used in making half-tone zinc blocks. Since that description was written, the writer has seen a screen made by Mr. M. Wolfe of Dayton, Ohio. The ruled surface is sealed between two glass plates, and is therefore not liable to injury from scratches, or by the silver solution coming in contact with it. The accompanying illustration is the result of Mr. Wolfe's skill in preparing the block, as also the ruled screen.

**Silvering Glass.**—The following solutions are necessary for silvering glass by the Brashear method :—

Loaf-sugar . . . . .	840 grains.
Distilled water (to dissolve the sugar) . . . . .	300 „
Nitric acid . . . . .	39 „
Alcohol . . . . .	25 drachms.
Distilled water to make . . . . .	26 ounces.

The glass, if to be used as a reversing mirror, must have a perfectly true surface (ordinary patent plate is not sufficiently perfect), and must be chemically clean. On the back must be cemented with pitch a couple of corks, by which the glass may be held level and in contact with the silver solution—

Silver nitrate . . . . .	50 grains
--------------------------	-----------

dissolved in 2 ounces of distilled water.

Potassium oxide hydrate (caustic, pure by alcohol) . . . . .	50 grains
--	-----------

dissolved in 2 ounces of distilled water. Put a tenth part of the silver solution into another bottle to be kept in reserve. Liquor

ammonia is added to the silver solution until the brown precipitate is redissolved. The potassium solution is now to be added. Add a few more drops of ammonia, and leave the solution to precipitate. The reserve solution of silver is now to be added carefully until the solution becomes yellow-brown. Add sufficient distilled water to cover the edge of the mirror when it is suspended in the fluid. Add four drachms of the reducing solution and stir well together. After the mirror has been suspended in the solution about ten to thirty minutes, according to the temperature of the room, the silvering will be complete, and the mirror may be rested on blotting-paper to dry. When perfectly dry, the surface may be polished with rouge in the usual way. Success depends very much on the temperature of the room, which should not be under 60° F., and the glass and solutions should have been in that temperature at least twenty-four hours before the silvering process was commenced.

Another method is recommended by Mr. Common. Three solutions are used :—

A. Silver nitrate . . . . .	1 ounce.
Water (distilled) . . . . .	10 ounces.
B. Caustic potash (pure) . . . . .	1 ounce.
Water (distilled) . . . . .	10 ounces.
C. Glucose or grape-sugar . . . . .	$\frac{1}{2}$ ounce.
Water (distilled) . . . . .	10 ounces.

The quantities must be determined by the size of the glass to be silvered. About 4 ounces would be sufficient for a mirror 10 × 8.

The silver is converted into ammonio-nitrate as previously described, and the remaining operations are the same.

When not in use, the silvered mirror should be carefully wrapped in chamois leather and enclosed in a box to exclude air as much as possible, otherwise the surface will tarnish and necessitate repolishing with rouge; but the frequent repetition of this will injure the surface, and re-silvering will be necessary.

**Stains.**—In the various manipulations, when the skin comes in contact with silver and some other solutions, stains occur which are unsightly and cause an unpleasant roughness. This kind of stain may at once be removed by touching the parts with solution of iodine, made by adding iodine to methylated alcohol, and then rubbing with a piece of potassium cyanide; care, of course, being taken that no part of the skin is cracked or cut. If the stains have been caused merely in developing gelatine plates, a little of the “clearing solution” will remove them to a large extent; or the parts may be rubbed with pumice-stone when the hands are washed. If the stains are on linen (or the skin), the following has been recommended :—



Iodine . . . . .	1 part.
Nitric acid . . . . .	1 „
Hydrochloric acid . . . . .	1 „
Alcohol (methylated) . . . . .	20 parts.

Touch the stain with some of this solution, and afterwards with “hypo” or potassium cyanide in solution, when the stain will disappear. The linen or skin must then be well washed.

Stains of any kind on negatives are difficult to remove. Potassium cyanide solution may be rubbed on the part. Gelatine negatives should never be printed from in damp weather, unless they have been varnished, as they are otherwise very liable to be stained.

The best remedy for a stained paper print is to print another.

**Stannotype.**—Another of the clever inventions of the late Mr. Woodbury was named by him *Stannotype*. The necessity for using hydraulic pressure in making the printing-plates for the Woodbury type process has always made that beautiful method less available than it deserved to be. In the Stannotype process we are enabled to prepare a plate by very simple means, which can be printed from in the same manner as the Woodbury-type.

Stannotype (derived from the Latin *stannum* and Greek *typeo*) is so called because tin is used in the form of tinfoil to receive the impression. A carbon transparency is prepared, and this, when dry, is used to obtain a negative intaglio image, which is then covered with tinfoil as the printing-plate. For this intaglio plate a thick film of gelatine must be used, which, when dry, is coated with tinfoil, or, when large numbers are to be printed, with foil which has been covered with a thin coat of steel. The intaglio negative, having been developed on a sheet of plate-glass and dried, is now ready to be coated with the foil, and this is done by rolling between two india-rubber rollers. The plate is first put into position between the rollers, and the pressure adjusted to the centre of the image on the plate, and the rolling motion is given by moving the handle backwards and forwards until the ends are reached. The plate between the rollers will bear sufficient pressure to embed the foil in the gelatine negative. The kind of press used for printing from the Stannotype mould or plate is the same as for the Woodbury-type. The mould is placed on the bed of the press upon a sheet of thick blotting-paper which has been wetted. The top plate of the press has attached to its under surface a sheet of glass perfectly flat, and this plate is movable when the screws are loose. When the mould is in its place, the screws are adjusted, so that when the arched bar is lifted the whole remains rigid, and will always come into perfect contact with the mould when taking the impression. All being ready, the surface of the mould is oiled slightly with a mixture of equal parts of paraffin and olive oils.

The ink is composed of 4 ounces of gelatine to 24 to 30 ounces of water, determined by the temperature, as the ink must be thicker in warm weather. To the gelatine may be added Indian-ink or colour of any kind. The ink is poured into a wine-bottle, which must stand in a vessel holding water which can be maintained at a temperature of 125° to 130° F. In printing, a pool of the ink is poured from the bottle on to the mould, the paper placed in position on it, and the arch of the press brought down and tightened by means of the handle. In a few minutes the gelatine will have *set*, when the pressure can be released and the paper lifted, on which will be found the picture. The surplus ink pressed out at the sides of the mould can be scraped off and re-melted for further use. In printing large numbers, it is usual to have three presses in use; they are fixed to a revolving table, so that as each press is used the table is turned; and when the third is filled, the first print is ready to be removed.

**Steel-Facing Copper-Plates.**—As copper is usually employed for the best half-tone blocks obtained by the aid of photography, it becomes necessary to coat the surface with a hard metal, as the fine detail on the copper is rapidly deteriorated by the cleaning process necessary in printing. By the deposit of iron electrically the rapid wearing of the plate is prevented; and as the iron will, if a large number of prints are required, also wear, it is necessary to re-face the copper. The colour of the surface will show when this becomes necessary.

“The copperplate to be re-faced first has all ink removed from its surface by chloroform or turpentine, is then washed and carefully dabbed over with a hog’s-hair brush dipped in a potash lye or in a 5 per cent. solution of potassium cyanide, then washed again. The plate is then laid into a flat bath, along the bottom of which a bare copper wire is laid, which is to serve as the negative pole of the current. The appropriate steel-depositing fluid is then added, so as to avoid oxidation. A plate of pure steel serves as anode; it is placed at the positive pole above the copper-plate when the current is opened. A silvery-like film of steel is immediately deposited upon the copper-plate. Air-bubbles are easily removed with a feather. The plate should be completely steel-faced in about five minutes. The composition of the fluid used is as follows:—Dissolve in warm water 35 ounces—

Ammonium chloride . . . . .	60 grammes = 2 ounces.
Crystallised ferric sulphate . . . . .	30 „ = 1 ounce.
Crystallised ammoniac ferrous sulphate . . . . .	30 „ „

The solution should stand two days and be twice filtered, and should be filtered again before each time of using. After the facing is completed, the plate should be cleaned as before, and greased to prevent it from rusting.”<sup>1</sup>

<sup>1</sup> *British Journal Almanack*, 1889, p. 606.

**Stenochromy.**—Under this name a method of applying colour to photographs made by the Woodbury-type was introduced by Mr. Ingerstein.

**Tannin Process.**—Amongst the variety of substances used for preserving the sensitiveness of dry collodion plates, tannin was one of the most popular, and was first successfully used by Colonel Russell. A plate was coated with collodion and sensitised in the usual way, and placed in a dish of distilled water for one minute, keeping the plate in motion to remove greasiness; then it was well washed under a tap for two minutes, giving it a final rinse with distilled water. A solution of tannin was now poured on to the plate, which must be on a levelling stand, and the solution allowed to remain two or three minutes. The plate was then allowed to stand on one corner in the dark till dry. The plates required to be “backed” with some opaque colour to prevent blurring, to which tannin plates were very liable. A border of varnish was necessary to prevent the film loosening.

To develop, the plate was first covered with spirits of wine and water in equal proportions, and then rinsed off with distilled water. The developing solution was composed of—

1. Pyrogallic acid	. . . . .	2 grains.
Distilled water	. . . . .	1 ounce.
2. Citric acid	. . . . .	10 grains.
Silver nitrate	. . . . .	10 „
Distilled water	. . . . .	1 ounce.
3. Citric acid	. . . . .	40 grains.
Silver nitrate	. . . . .	10 „
Distilled water	. . . . .	1 ounce.

To sufficient of No. 1 to cover the plate was added one drop of No. 2 to each drachm of No. 1. The plate was developed with this. If the negative appeared quickly, it had been over-exposed, when the developing solution was poured off, and the development continued with distilled water in which a few drops of No. 3 were added. The fixing was done in the usual way with “hypo.” It was claimed for this process that it was simpler, and that the results compared favourably with other processes.

**Taupenot Process** (see *Collodio-Albumen*).—One of the most extensively used processes, prior to the advent of collodion and gelatine emulsions, was the Taupenot or Collodio-Albumen process. The negatives produced by it were of the best quality, and the plates, when carefully preserved, retained their sensitiveness for many years. The plates, after very careful cleaning, were coated with weak albumen solution. This substratum was for the purpose of keeping the collodion from slipping, and preventing blisters in the subsequent parts of the process. The albumenised plate, when dry, was coated with

collodion (old was preferred), sensitised in an acid silver solution, and then thoroughly washed. The next coating consisted of iodised albumen made as under :—

Albumen . . . . .	8 ounces.
Potassium iodide . . . . .	50 grains.
Potassium bromide . . . . .	10 „
Ammonia . . . . .	2 drachms.
Water . . . . .	2½ ounces.

After these are well beaten together, and after the solution had settled, the plates were coated twice, a great quantity of the solution being used each time; the first may be thrown away, and the second used for the first coating of the next plate. At this stage it was dried. The plates were made sensitive by immersion in the following bath :—

Silver nitrate . . . . .	30 grains.
Glacial acetic acid . . . . .	½ drachm.
Distilled water . . . . .	1 ounce,

About one minute in this bath was sufficient. A thorough washing under a tap was now given, and a final rinse with distilled water. The plates when dry were ready for use. The plates were usually developed with pyrogallic acid, three grains to the ounce of water, and when the details of the picture were well seen, the full printing density was obtained by redeveloping with—

Pyrogallic acid . . . . .	2 grains
Citric acid . . . . .	½ grain
Water . . . . .	1 ounce

to which three or four drops of a thirty-grain solution of silver nitrate were added. Any deposit which might be formed in developing was removed with a tuft of cotton-wool. “Hypo” of the usual strength was used for fixing.

The process was modified in many different ways. The prolonged exposure necessary was the chief objection to the process.

**Tea Process.**—In this process an infusion of black tea (10 ounces of boiling water to half an ounce of tea) was used as a preparation to preserve collodion plates in the dry state when only required to be kept a few days.

**Telescopic Photography.**—Any telescope may be arranged horizontally, so that the ground-glass of an ordinary camera may be made to receive the image of the distant object through an eye-piece. The writer used a *Barlow's lens* for this purpose about thirty years since, and obtained photographs about twice the diameter of the image as seen at the principal focus of the object-glass. An instrument called a

*Photo-heliograph* has for many years been used at Kew for photographing sun-spots. Practically this is a telescope to which an enlarging lens has been added; such instruments were made by the late Mr. J. H. Dallmeyer, having the chemical and visual foci coincident. It appears from a recent discussion of the subject that as early as 1869 Dr. Hugo Schroeder constructed refracting telescopes with an arrangement of lenses suitable for photographing distant terrestrial objects. Mr. T. R. Dallmeyer has also constructed an instrument with which an object may be enlarged about four diameters, as will be seen by comparing Figs. 39A and 39B, the larger one having been taken with a telescope. The value of such an instrument when used for photographing the moon will at once be seen; and for some purposes, when distant terrestrial objects cannot be photographed in the ordinary way, the use of the new telescopic photographic lens will be valuable.

In his recent work, "The Optics of Photography," Mr. J. Traill Taylor states that in 1870 he showed how a telescopic view of a distant object could be obtained, and he also says that he had long since used one of the barrels of an ordinary opera-glass with the large lens towards the object for obtaining enlarged views telescopically.

The following is an abridged description of a teleo-photographic lens recently introduced by Mr. T. R. Dallmeyer. Mr. Dallmeyer says:—

"Hitherto only two methods of producing large images had been employed—first, the use of very long focus positive ordinary lenses; and second, the production of a primary image by one positive lens, and placing a secondary magnifier or second positive lens behind the plane of the primary image, which enlarges it more or less, according to its focal length, and its adjustment between the positions of the planes of the primary image and that of the focussing screen, as in the photo-heliograph, &c.

"The first of the older methods had been seldom employed except in astronomical photography, on account of its unwieldy dimensions; and the second method referred to is practically useless for ordinary photographic work on account of the great loss of light involved, rendering the length of time necessary for proper exposure so great as to cause it to be almost prohibitive, except in the case of inanimate objects."

The diagrams in Fig. 38 sufficiently explain the construction of the new lens.

The introduction of an instrument of this kind will add very much to the interest of the possessors of telescopes, who are at the same time photographers, in the prosecution of their work. Photographing celestial or terrestrial objects through small telescopes necessitated a

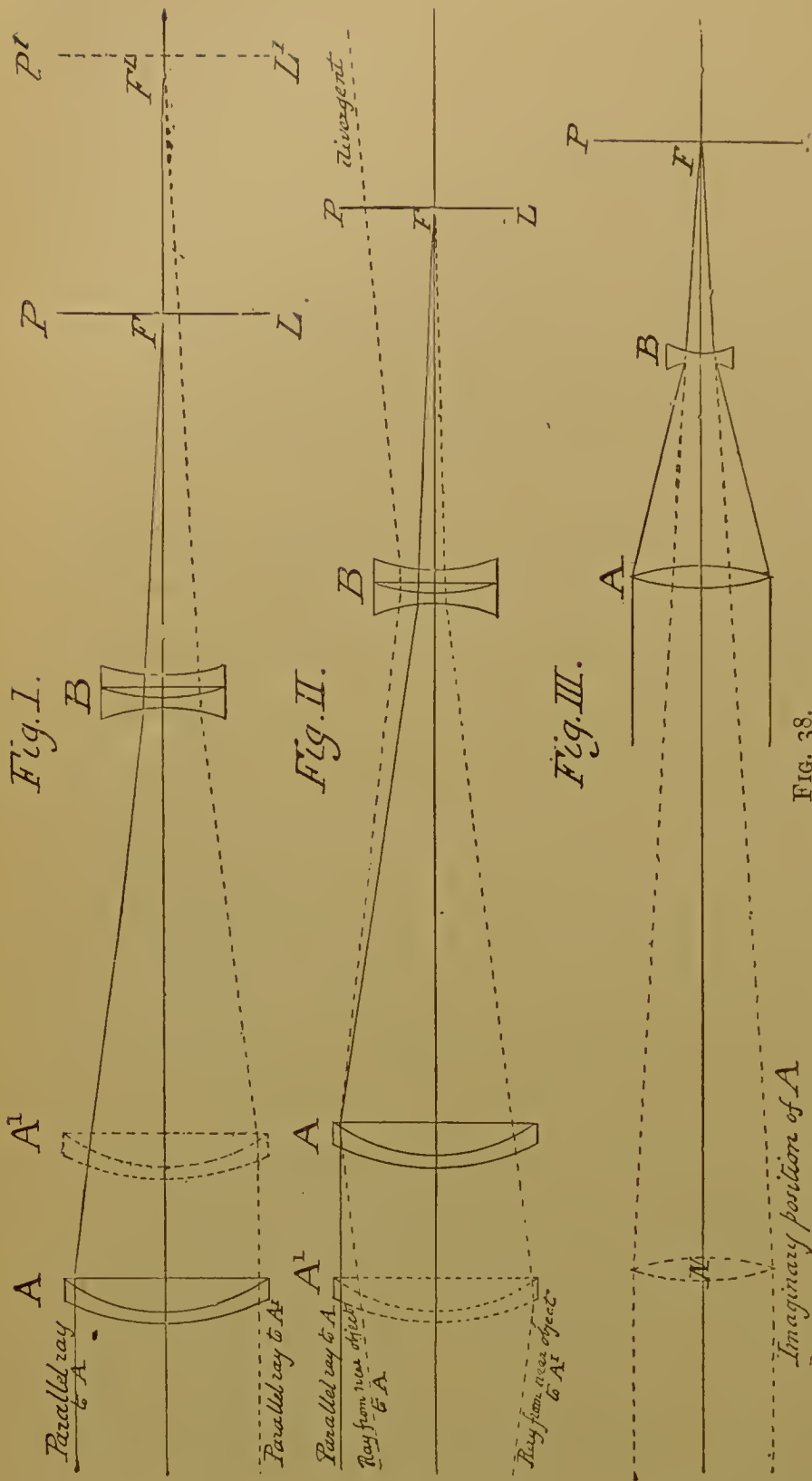

FIG. 38.

FIG. I.—The upper back ray meets the lens, A, parallel to the axis, and by a proper adjustment between A and B, comes to focus at  $F'$  upon the plate PL. If PL be removed farther from the lens, B, to take the position  $P'L'$ , the lens A will have to be moved slightly nearer to B, and take the position  $A^1$ .

FIG. II.—On the upper side of the axis a parallel ray to A finds its focus as in the dark line on the plate at F. If, however, some ray from a near object falls upon the lens, A, in the direction of the dotted line, after passing through the lens, B, is found divergent, and no positive focus is obtainable.

FIG. III. represents a beam of rays passing through the two component elements, A and B, coming to focus upon the plate PL. To estimate the rapidity, it is necessary to consider the full aperture placed at the principal focal plane passing through the nodal point at N. A is thus made to take up an imaginary position. The position of the nodal changes for different positions of the plate PL.

cumbrous addition to the instrument, while with the compact arrangement now available the work will be both convenient and useful.

**Transferotype Process.**—Paper prepared on one side with soluble gelatine, and then with sensitised gelatine emulsion, is supplied by the Eastman Company. The paper is printed upon in the usual way by artificial light, and is then developed with iron oxalate and fixed ;



FIG. 39A.

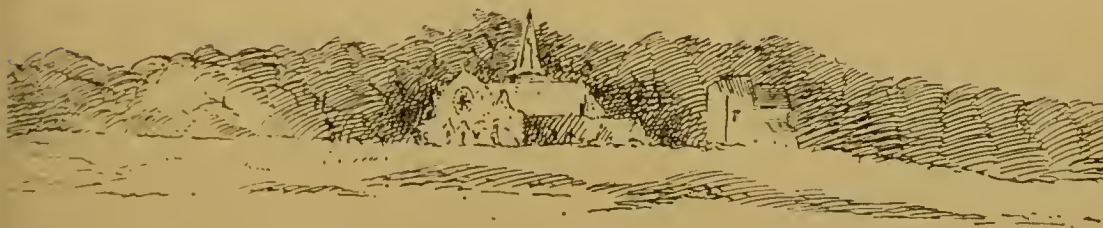

FIG. 39B.

FIG. 39A.—Shows view of a church about half a mile distant, taken with the new lens. Exact size of image on plate.

FIG. 39B.—The same object taken from the same point with a 10 by 8 R.R. (13-inches equivalent focus). Exact size of image on plate.

and, after washing, is placed on the support where it is to remain, and squeegeed. Water sufficiently hot to melt the gelatine next the paper is then poured on, and the paper, when loosened, can be removed.

**Typogravure.**—The illustration facing page 198 is copied from an oil-painting. The writer is not in possession of the details of the special mode of preparation ; but a careful inspection will show that

it is a combination of the half-tone zinc etching process and the engraver's art. The plate is a very beautiful production, and shows the invaluable aid of photography in the arts of mechanical reproduction of pictures. It is the work of Messrs. Goupil & Co.

**Uranium Printing, &c.**—In photography uranium is chiefly used in the form of nitrate, which is obtained from pitch-blende dissolved in nitric acid, dried, and again dissolved in water. Yellow crystals are formed from the concentrated solution; these may be further purified by solution in ether and recrystallisation. The crystals are very deliquescent.

Many attempts have been made to utilise uranium for printing, but the results have not been equal to platinum, and the prints will not stand the same tests as the last-named metal. Paper is first floated on a solution of—

Uranium nitrate . . . . .	1 ounce.
Water . . . . .	5 ounces.

Expose in sunlight until a faint image is visible, and then develop by floating on a solution of—

Silver nitrate . . . . .	1 ounce.
Water . . . . .	20 ounces.

To which add a few drops of acetic acid. Fix with sodium thio-sulphate. The prints may also be developed with—

Potassium ferricyanide . . . . .	50 grains.
Water . . . . .	1 ounce.

The following process, recommended by Mr. Bedding, appears to be one of the most practical for utilising uranium for printing purposes. It will be noticed that the process is very similar to the platinotype.

The paper must first be coated with ferric oxalate in the proportion of one grain to each superficial inch of paper. If preserved from light and damp, the paper in this state will keep some weeks, but the addition of one grain of mercuric chloride to each ounce of the ferric oxalate solution assists in causing the paper to keep.

“When the dried iron-paper has been exposed in contact with the negative, and the characteristic ferrous image obtained, it should be floated upon a solution compounded in the following proportion:—

Uranium nitrate . . . . .	15 grains.
Gold chloride . . . . .	1 grain.
Water . . . . .	1 ounce.

After the desired depth of definition has been obtained, the picture should be passed through plain water, followed by immersion in dilute





*Edouard Knight Paris*

*Typographeur & Imprimerie Roussod, Valudon & Co. Paris.*



hydrochloric acid (1 : 100), again treated with water, and finally allowed to dry."

Uranium may be employed to tone silver prints on albumenised paper. The salt of the metal was also used in the preparation of dry plates by a method advocated by the late Colonel Stuart Wortley, who described his process in 1872. It is an emulsion process in which collodion is used, and is made as follows:—

Collodion (plain)	. . . . .	1 ounce.
Cadmium bromide (anhydrous)	. . . . .	7 grains.
Uranium nitrate	. . . . .	30 "
Silver nitrate	. . . . .	13 "

The uranium and cadmium salts are dissolved in the collodion, and the silver is then added. The plates, which have been prepared with a substratum, are then coated with the emulsion in the usual way, and washed until the greasiness disappears. A preservative must then be poured over the plate. The developing solution is composed of:—

1. Ammonium carbonate	. . . . .	64 grains.
Water	. . . . .	1 ounce.
2. Potassium bromide	. . . . .	4 grains.
Water	. . . . .	1 ounce.
3. Pyrogallic acid	. . . . .	96 grains.
Alcohol	. . . . .	1 ounce,

used in the following proportions:—No. 1, 60 minims; No. 2, 60 minims; No. 3, 15 minims; water, 2 drachms; alcohol,  $\frac{1}{2}$  drachm.

As the plates are liable to halation, aurin is used in the plain collodion. The process was well spoken of in 1873, but has been superseded by the more popular and useful gelatine methods.

*Wothlytype*.—Under this title a process was patented by Herr Wothly of Aix-la-Chapelle in 1864, and a Company was formed in England for working the process. The nitrates of uranium and silver were combined with the collodion with which the paper was prepared. Results were obtained which were certainly very effective, but the Company was not a success. A print in the possession of the writer since about 1865 remains in the same condition as when printed.

**Vignetting**.—A photograph is said to be vignettted when the outer parts of the negative are protected from the light, thus causing the picture to shade off into the white paper. The best way to effect this is to cut a suitable opening in stout cardboard and serrate the edges, and place tissue-paper over the opening. Thin sheet-lead may be used for the same purpose, and has the advantage that by bending the serrated edge the tissue-paper may be raised or lowered as required. If printed in the shade, the tissue-paper may be dispensed with.

**Waxed-Paper Process.**—Now that films almost as perfect as glass are available on which negatives may be made, it is very improbable that waxed paper will ever again be brought into use, although, for large work, much may be said in its favour. The name of Gustave le Gray will be remembered in connection with the waxed-paper process, and the fact that a translation of his pamphlet on the subject passed through several editions shows that the method was popular about thirty years ago.

**Woodbury-type.**—In 1865 the late Mr. Walter Woodbury published a process which he named *Photo-Relief Printing*, but which is now known universally by the name of the inventor. About the same time Mr. Swan of Newcastle invented a similar process. The Woodbury-type is altogether unlike any other process connected with photography, as will be seen from the following description in Mr. Woodbury's own words :—

“The production of pictures either on white paper, on opal glass, or on transparent glass, or on porcelain, by this method of printing, is based on the principle that layers of any semi-transparent material seen against a light ground produce different degrees of light or shade according to their thickness. Therefore, by having a mould in intaglio, produced by the action of light on bichromatised gelatine, and filling the intaglio so produced with a semi-transparent material, we obtain a mould in which the parts that are the thickest give a dark colour; and the thinner the layer of material becomes, so it gradually merges into white. By pouring a mixture of gelatine and colour on to the intaglio mould, and placing a piece of paper on to the gelatine, and squeezing the whole between two perfectly true planes, the superfluous colour is all squeezed out, and the gelatine, having set, adheres to the paper, and on being separated from the mould leaves it perfectly clean. This picture, being in relief when leaving the mould, has suggested the name I have given to this process; but the contracting of the gelatine on drying leaves hardly any perceptible relief on paper, which might otherwise be considered an objection.

“I will now proceed to describe my method of operating.

“*The Gelatine Relief.*—Select several pieces of talc of the required size, being perfectly uniform in thickness, and by wetting them affix them to a large sheet of glass; squeeze out all the superfluous moisture, and polish the whole of the pieces; next prepare the bichromatised gelatine as follows :—Dissolve in water, 28 ounces, 4 ounces of Nelson's opaque gelatine; clarify with white of egg, and filter. To 4 ounces of this solution add 60 grains of bichromate of ammonia dissolved in a half ounce of warm water and a small quantity of prussian blue (this serves to give the finished relief a colour by which to judge of its printing qualities, and does not interfere with the action of the light





CRAB INN, WIGHT, VIRGINIA

CRAB INN, HANLON, LI OF WIGHT

WIGHT, VIRGINIA

in penetrating the gelatine). When well mixed, filter through muslin, and pour over the talc-covered glass, place on a levelling-stand, and allow to set. When set, cut with a sharp knife round the edges of each talc, and strip from the glass; lay on a piece of blotting-paper the same size, and clean the talc side; then place in contact with the negative, and having placed a piece of glass behind, fasten all together with india-rubber bands, and place in the light of a condenser of six to nine inches diameter at a distance of about two feet; after exposing from an hour to two hours, according to the density of the negative, to the sun's rays (a little over- or under-exposure is of no consequence), lay in a dish, and pour some hot water over them until no soluble gelatine is left; then allow to dry at a gentle heat. When nearly dry, let the remainder of the drying be done spontaneously, otherwise the gelatine would split from the talc. Having obtained the relief supported by the talc, they can be kept in a book ready for the next operation.

“*The Metal Intaglio.*—In my early experiments I used the electrotype process to obtain an intaglio from the gelatine relief, but found that for any practical purposes it was impossible to obtain uniform results.

“The result of my experiments has been the producing of the moulds by hydraulic pressure, by placing a sheet of soft metal (a mixture of lead and type metal) in contact with the gelatine relief, and subjecting the same between two perfectly true plates of steel to 50 to 200 tons pressure, according to size, four tons to a square inch being about the pressure necessary. The result is a perfectly sharp intaglio, obtained in less than a minute's time; the same gelatine relief will serve for several moulds where a large number of prints are wanted.”

The method of printing is the same as described in the *Stannotype Process*, p. 191.

By this beautiful process prints may be made so perfectly to imitate prints on albumenised paper that it is almost impossible to distinguish one kind from the other. The accompanying plate of the Crab Inn, Shanklin, photographed by Mr. Charles F. Brennan with the “British” camera, is a very perfect illustration of the process here described.

**Woodbury-gravure.**—Until a few months since it was necessary to mount Woodbury-type prints, but, by an improvement in the manipulation, prints can now be made on paper which do not require to be mounted. The method of obtaining this result is by printing in the usual way; when dry the prints are trimmed and then transferred on to the paper, on which they appear as if so printed originally. The process is termed *Woodbury-gravure*. This improve-

ment removes what was a great disadvantage in the old process, and for book illustrations, both as to cost and beauty of result, this method holds its own with any of the other mechanical processes. The print of the moon in the section *Astronomical Photography* is an excellent example.

**Writing Titles.**—The following method of affixing titles to negatives, so that the name will appear white on the print, is given by Mr. Sylvester Parry:—Write the name in block letters, or in any other way, in Indian-ink on thin strips of talc, which may be attached when dry to the varnished negative, and if carefully done the outline of the talc will not be visible.

**Yellow Negatives** (see *Intensifying*).—A wet collodion negative is seldom dense enough for printing purposes when developed with iron and redeveloped or strengthened with pyro and silver. The late Mr. G. W. Simpson introduced a method by which the image is changed to a yellow colour, which is effected in the following way:—The plate, after fixing and washing, is placed in a dilute solution of potassium permanganate of about ten grains to an ounce of water. As soon as the change of colour is visible on the back of the picture, the process is complete.

**Zinc-Etching.**—The method of producing zinc blocks in half-tone is described under the heading *Photo-Engraving*. The process now to be dealt with is for making blocks in line to be used in the type-printing press. The negative should be of the same quality as described for photo-lithography, having clear lines, and the whites must be represented in the negative by a perfectly opaque film; and the image, if it is to be printed direct on to the zinc plate, must be reversed. By using a print prepared as for photo-lithography, a transfer may be made direct to the zinc (which must have a slight grain given to it by means of nitric acid and alum); this must be rubbed up with ink in the usual way before treatment with the etching acid. A second method is by preparing the zinc with bichromated albumen:—

Albumen . . . . .	1 ounce.
Potassium bichromate (saturated solution) . . . . .	1 „
Water . . . . .	7 ounces.

The albumen and water are placed in a bottle containing broken glass and well shaken; the bichromate is then added. The albumen must be filtered, and the zinc plate may then be coated. To obtain an even film, the plate must be “whirled,” or made to revolve quickly, so as to throw off the superfluous fluid. The film must now be dried over a spirit flame, and care must be taken to avoid dust or air-bubbles. As the rigid surfaces of the glass and zinc have to be brought in close contact in the printing-frame, the glass must be perfectly level, and



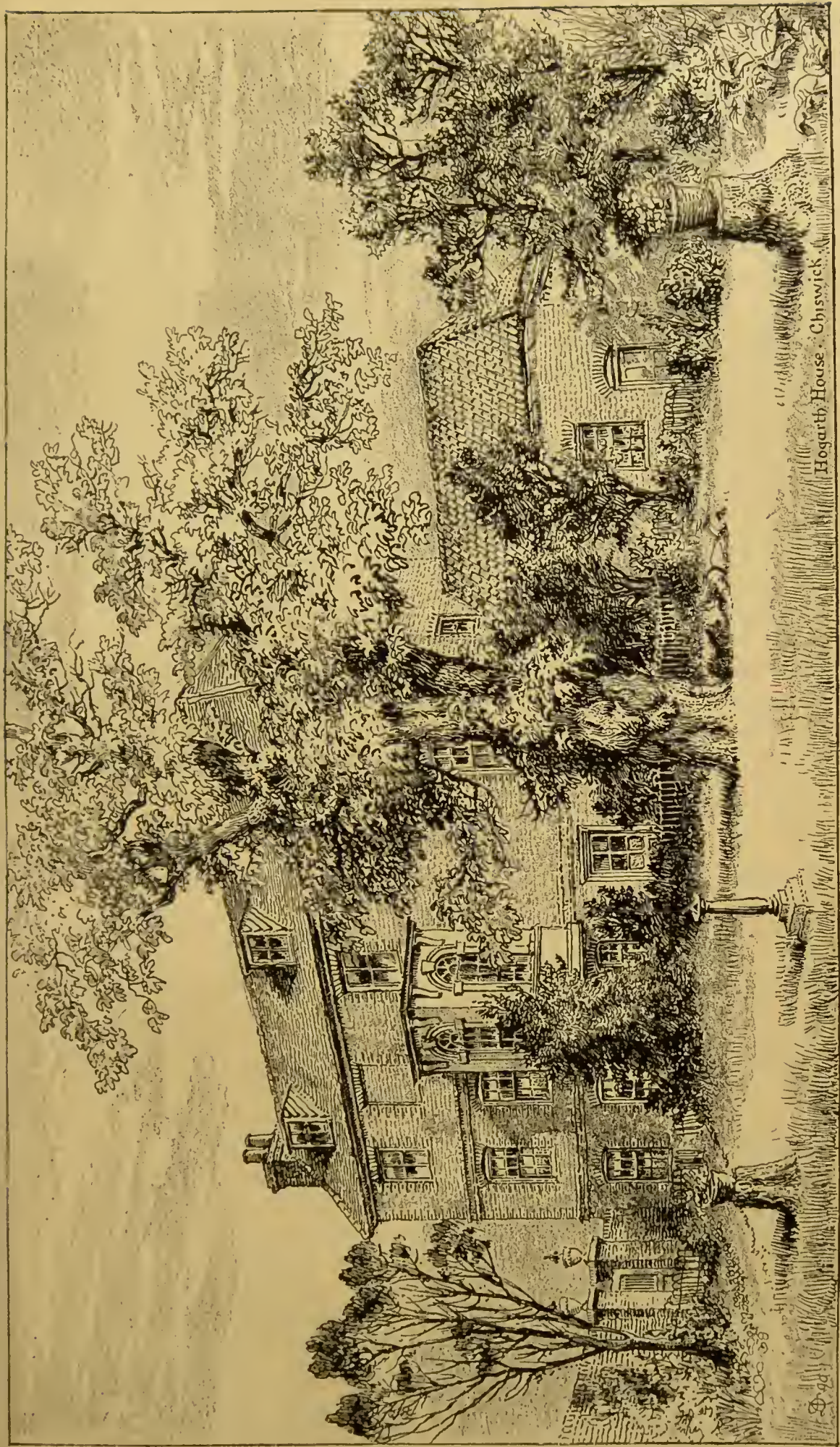

Alfred Dawson del.

Hogarth House, Chiswick.

Dawson's Ph. Sc.

# HOGARTH HOUSE, CHISWICK.



all the surfaces must be perfectly free from all grit, otherwise fracture may occur.

As great pressure is necessary, the glass of the printing-frame should be thicker than usual. The negative in contact with the zinc may now be exposed to light, and by using an actinometer, experience will quickly show when the right exposure has been made. The plate must now be inked with the kind of ink used for photo-lithographic purposes, but reduced with turpentine so that it can readily be distributed with a roller on to the zinc plate. The rolling is continued until the film of ink, by the evaporation of the turpentine, is so thin that the printed image may be seen through it.

When the inking is complete, the plate is placed in a tray in cold water, and with a piece of lint the surface is gently rubbed to remove the superfluous ink, and the image, if proper care has been taken, will be found perfect on the metal. As soon as the plate is dry it is ready for the next stage of the process—that is, the etching. Heat is now required. A metal plate should be placed on a stand so that gas or other heat may be applied to keep the plate warm—that is, at about the temperature used when drying a varnished plate. After the plate has been warmed, it is allowed to cool. It is next covered or sponged over with a solution of gum-arabic of about the consistence of cream, and then allowed to dry without the application of heat. When dry, the plate is sponged over with water to remove the gum, after which it may be inked with a litho-ink reduced with middle varnish. The zinc is now coated on the back, and all parts which are to be protected from the acid, with bitumen varnish.

The plate, slightly warmed, may now be placed in the first etching bath. The quantity of fluid must depend on the size of the zinc, and the tray to contain it should be sufficiently deep to allow rocking. At first a weak acid solution must be used, sufficient nitric acid being added to the water to make it distinctly acid to the taste; and when the zinc is in the tray it must be rocked constantly, to prevent the formation of bubbles of gas on the surface. After about a minute, the plate is removed from the acid, rinsed under a tap, and the surface sponged. The plate is now warmed, gummed, and then fanned until dry. It is then washed and sponged, and, while wet, is inked as before, and again warmed on the metal plate until the ink is caused to run down the sides of the etched lines. After cooling, the plate is ready for the second etching, a few drops of acid being added to the water, and the tray rocked as before. The plate is left in the acid about three times longer than at first, and the washing, sponging, and gumming are repeated. In the next part of the process, the plate is dusted over with powdered resin and the surplus removed with a soft camel's-hair brush. The ink is now covered

with resin, and the etching process is repeated after the plate has been heated so as to melt the resin. After each etching, the strength of the acid solution is increased, and the various operations are repeated until it is seen that the plate is etched sufficiently deep.

In some cases an after process, called "clean etching," is necessary, to clear away irregularities left in the earlier state of the process; as also when the parts which are to appear white when the block is printed may require to be cleared away with the graver or with a "router." The zinc may be cut to shape with a fret-saw, and then mounted type-high in the usual way.

## PART III.

---

### APPARATUS.

**Actinometers and Exposure Tables.**—To the beginner in the practice of photography there is perhaps nothing so uncertain as the exposure required to produce a picture, and until he has had experience he must expect many failures. He may have read about exposure tables, and may have tried to apply them, but he will quickly find that some knowledge of the actinic value of the light is necessary; he must know whether the plates he is using are quick or slow (and for his purpose *slow* plates should be preferred, as being more under control); and he must know something about the lens and the value of the diaphragms he is about to use. The light has very different power as the seasons change; the time of the day must be considered, and the mere passing of a cloud will have to be allowed for. All these matters have to be considered in using exposure tables or other kinds of aid in exposing plates. When experience has been gained, the appearance of the picture on the ground-glass will be a sufficient guide; but, at the same time, exposure tables may afford the means, when used intelligently, of greater uniformity in results.

Many methods have been devised for assisting the tyro in the matter of exposure. One of the most simple is called the *Bijou Actinometer and Exposure Table*, contrived by Mr. I. Watts of Bowdon, Cheshire.

Among the many devices for ascertaining the chemical intensity of the light by exposing a strip of sensitive paper to its action, this actinometer is very convenient, owing to its portability. On the inside of the lid of the small box which contains it the maker has ingeniously inserted a set of tables of subjects and stop-ratios, by the use of which (as explained in the instructions sent out with the instrument) a very simple arithmetical operation gives the exposure required in seconds. The basis or zero of the tables is an open landscape subject, for stop the ratio  $f8$  (or an aperture equal to one-eighth of the focal length of the lens employed), and for the light a tenth of the time (in seconds) which the paper takes to assume the

depth of colour of the standard tint of the actinometer. These factors multiplied together and divided by a number representing the sensitiveness of the plate (which has to be found by experiment) gives the exposure required. As a guide, especially for the novice, it may be found useful; but it is necessary to remark that neither this nor any other form of actinometer or exposure tables can be expected to be more than this, and it must not be supposed to be a substitute for the exercise of judgment on the part of the operator.

In the following example the number representing the rapidity of the plate, developed with the normal developer, is 40, but each operator must ascertain the plate number for himself by actual experiment (decreasing it if the exposure proves too short, and increasing it if too long), so as to adapt it to the plates used, and to the exact method of development employed:—

Subject: An open landscape with strong foreground . . . . .	2
Actinometer 20 seconds; one-tenth of which is . . . . .	2
Stop <i>f</i> 64, equivalent stop number is . . . . .	64

$$\text{Thus:—} \quad \frac{2 \times 2 \times 64}{40} = \frac{256}{40} \text{ or } 6\frac{1}{4} \text{ seconds.}$$

or say  $6\frac{1}{2}$  seconds, which is the exposure required. If a large stop is used, say *f*16, the equivalent stop number of which (or, as it is sometimes called, intensity ratio) is 4, then the formula will stand as follows:—

$$\frac{2 \times 2 \times 4}{40} = \frac{16}{40} \text{ or say half a second.}$$

With its aid and careful attention to the directions given, it will lead to results as satisfactory as any kind of mechanical aid will afford.

Careful observation and experiment in exposing and judgment in developing will do more to assist in producing good results than any amount of study with actinometers.

Mr. Watkin, of Hereford, has patented a very ingenious form of

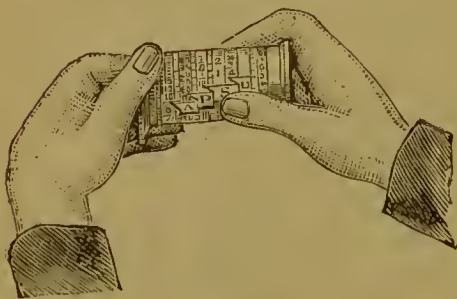

FIG. 40.

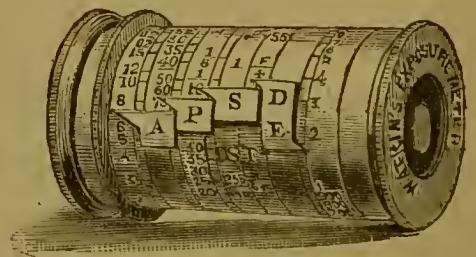

FIG. 41.

actinometer, shown in Figs. 40 and 41. This handy little instrument is only  $2\frac{1}{2}$  inches long, and  $1\frac{3}{8}$  inches in diameter, and is neatly finished

in brass ; its one defect is the *weight*, which, for so small a thing, seems excessive. It consists of an actinometer for testing the actinic force of the light which falls upon the subject ; a set of four circular slide rules for calculating the exposure ; and a time measurer in the shape of a short chain pendulum, by means of which seconds may be counted.

The instrument contains a strip of paper coated with a specially prepared bromide of silver emulsion ; this darkens rapidly in light, and the number of seconds which a small disc of it (the only part exposed to the light) takes to equal in depth of tint an equal-sized disc of a standard tint expresses the value of the light.

The values of the other factors (plate, subject, and diaphragm) are also expressed by numbers.

The calculating slide rules are manipulated in a very simple manner. Each one carries a pointer, one for each factor, and when they are adjusted in succession to the value of each factor, a fifth pointer indicates the correct exposure in seconds or fraction of a second.

Another form of actinometer is the invention of Messrs. Hurter and Driffield, of Appleton, near Widnes, who have recently published an important paper on photo-chemical investigations. The laws which the authors have found indicate that, beyond a control over the general opacity of the negative, little or no control can be exercised by the photographer during development. Careful experiments made by themselves and by others fully bear this out, and show that neither under- nor over-exposure can be really corrected by modifications of the developer, but that truth in gradations depends almost entirely upon a correct exposure, combined with a development which must vary in duration according to the purpose for which the negative is required.

They also found that when light acts upon sensitive plates, the action at first is proportional to the light-intensity : it then becomes more and more nearly proportional to the logarithm of the light-intensity. A point is next reached when an increase in the exposure produces no further increase in the density, and the action is finally reversed.

The law may be shortly stated thus : the amount of silver salt affected at any moment of the exposure by the light is proportional to the light-intensity, and to the amount of unaltered silver salt on the plate at that moment.

Considering a correct exposure an absolute essential in the production of a satisfactory negative, Messrs. Hurter and Driffield have invented an instrument for estimating the exposure to be given under various circumstances and with plates of various rapidities. This instrument they call the "Actinograph."

The accompanying engraving (Fig. 42) represents the instrument. It consists of four scales corresponding with the light, the lens, the speed of the plate, and the exposure. The light-scale is wrapped round a revolving roller, which also bears on its outside edges a calendar. When it is desired to calculate an exposure, this roller is turned till the date is level with the edge of the lens-scale. The intersection of the edge of this scale with the curves on the roller represents the intensity of the light at the various hours of that particular day. The lens-scale is marked with the various lenses and diaphragms in common use. The next proceeding is to set the lens and diaphragm to be used opposite this hour curve on the roller scale. The "speed index," marked on a small slide, is now set to the speed

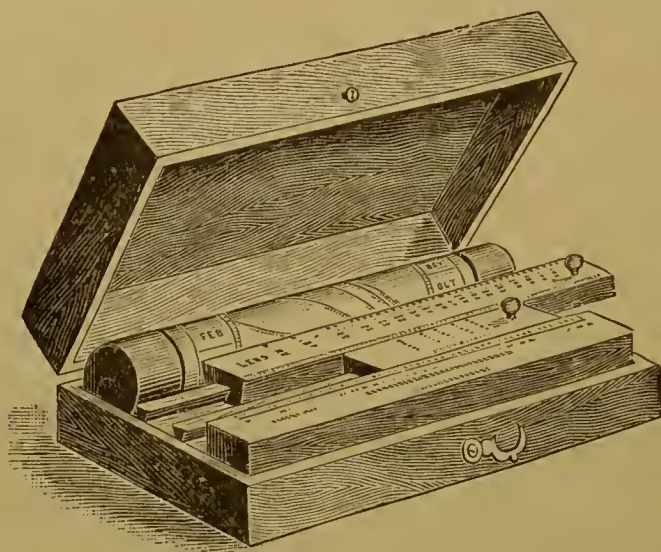

FIG. 42.

of the plate, when five points on this same small slide point to five different times of exposure, and the photographer has only to select the one appropriate to the state of the atmosphere.

**Balance.**—Used in an artistic sense, this term refers to the arrangement of lines and other effects in the composition of a picture.

An instrument of the greatest value in the laboratory of the chemist is called a *balance*. For ordinary photographic purposes the delicacy attainable with this instrument is not necessary; the ordinary scales and weights answer every purpose, as it can only be in very rare cases that a difference of a grain or two can affect results; but with ordinary scales considerable accuracy can be obtained.

**Baths and Dippers.**—The best material for a bath for silver nitrate solution is glass. When, however, large plates are used, the quantity of solution required is much greater than when a flat dish is used, and involves much more trouble and waste in filtering; but for plates of moderate size,  $8 \times 6$  and less, the glass dipping bath is more con-



venient than any other. Porcelain answers for a time, but the glaze cracks. Ebonite is very brittle, but is a good material for the purpose, and it has the advantage of being light. For large plates a well-bath is the best, and, when made of seasoned wood and well varnished with black varnish, is very serviceable. A deep porcelain dish may, with care, be used; and as very little more solution than will cover the plate is necessary, the dish may be tilted without fear of throwing the silver over the end of the dish.

Dippers of glass are useful for small plates, but they are scarcely safe, as they are very liable to be broken. Well-varnished wood is a good material. The piece on which the plate rests may be fastened by rivets of silver wire. When varnished with shellac varnish, such a dipper will last many years; but, in course of time, will become saturated with silver. Dippers may be made of stout silver wire, but for all practical purposes wood should be preferred.

The term *bath* is often applied to solutions employed for various processes.

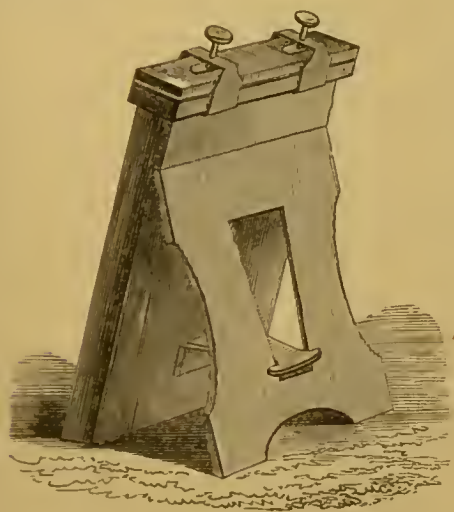

FIG. 43.

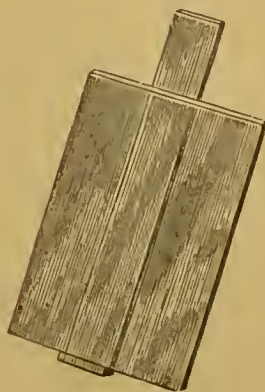

FIG. 44.

Fig. 43 shows a form of bath with water-tight top suitable for travelling; and Fig. 44 shows the dipper and plate.

**Bellows.**—In cameras which are made to fold, the calico or leather portion uniting the front and back parts is called the “bellows.” A rectangular or cone-shaped box is first made of the required dimensions. This is covered with calico, and upon this strips of thick paper, properly cut so as to fold correctly at the angles, are glued, and the whole is then covered by glueing on the calico or leather. When dry, the pleats are carefully drawn together, and, with care, will always keep their shape when folding.

**Buckle's Brush.**—In cases where solutions require to be spread with a brush, and where the ordinary camel's-hair would be destroyed, a convenient substitute may be formed by drawing (by means of a

bent wire) a tuft of cotton-wool partly within a glass tube. The projecting tuft of wool can be renewed as often as necessary.

**Burnishers and Rolling Machines.**—Most photographs on paper are improved by rolling. The necessity for passing the paper through water changes the surface; the rolling restores the paper to its original condition, and gives the print a more finished appearance. Prints with a matt surface are improved by simple rolling. When a very high polish is required, heat is necessary. This is obtained with the machine called a burnisher, one form of which is shown in Fig. 45. A bright steel bar is made very hot by means of gas or a

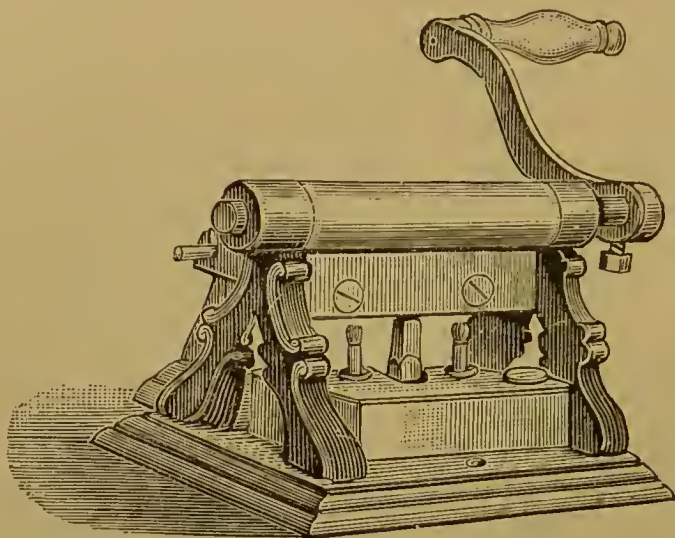

FIG. 45.

spirit-lamp. After the pressure is regulated for the thickness of the card, the print is *dragged* by means of the roller, which is roughened, over the steel bar, and the operation is repeated until the required polish is obtained. It is usual to lubricate the print by rubbing it over with Castile soap dissolved in methylated spirit (about five grains of the soap to an ounce of spirit), which must be allowed to dry before passing the print over the burnisher. With care, a very high polish may be given to the print by this means; but there is always the possibility of spoiling the work, and particularly is this the case with vignettes. A safer method is to use a machine having two rollers, one of which is hollow and heated by a row of small gas-jets. One of the rollers is of burnished steel, and the pressure and heat give the prints a very fine surface. If the rollers are kept bright, no injury can result to the print.

Many varieties of rolling-machines and burnishers are in the market, and with care a good surface may be given to prints by any of them.

**Cameras.**—The more correct term for this important, and, to the

photographer, indispensable instrument is *camera obscura*, so named by the inventor, Baptista Porta, three hundred years ago. The term "camera" signifies merely a box or chamber; for the photographer's use it is necessarily *dark*, excepting to the light which enters by the lens. The camera is so well known that it may seem unnecessary to describe it, but as it has been greatly altered and improved since Daguerre's time, some detailed notice may be given.

The simplest form of camera is shown in Fig. 46, which may be readily constructed out of a common cigar box, *a*. A spectacle lens of suitable focus is placed at *b*, in a sliding tube made of cardboard; and a piece of looking-glass at an angle of  $45^\circ$ , at *c*. A part of the lid

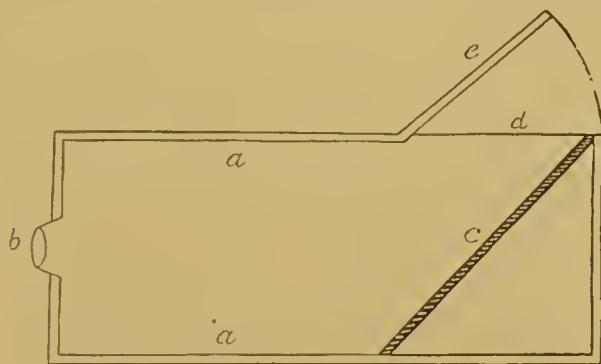

FIG. 46.

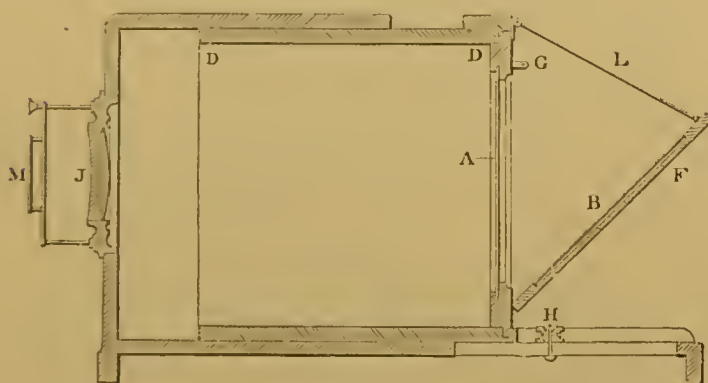

FIG. 47.

having been removed and hinged, *e*, side-pieces are added for the purpose of partly cutting off the side-light; and a piece of ground-glass is then placed to receive the image at *d*. This is an interesting toy. The engraving Fig. 47 shows the camera as used by Daguerre. The improved instrument for photographic use is shown in Fig. 48. It is made to fold.

The Fig. 49 shows another improvement, having a *sliding front* and contrivance for using lenses of different foci; this form could be used for portraits as well as landscapes. Another great improvement was in the construction of cameras for use in outdoor photography; the front and back of the instrument were connected by means of what was then termed a flexible bag, now known as the *bellows*. The

base-board of the camera was made to fold, as shown in Fig. 50, and the bellows to fit into the box part, forming a very handy instrument when compared with Figs. 48 and 49.

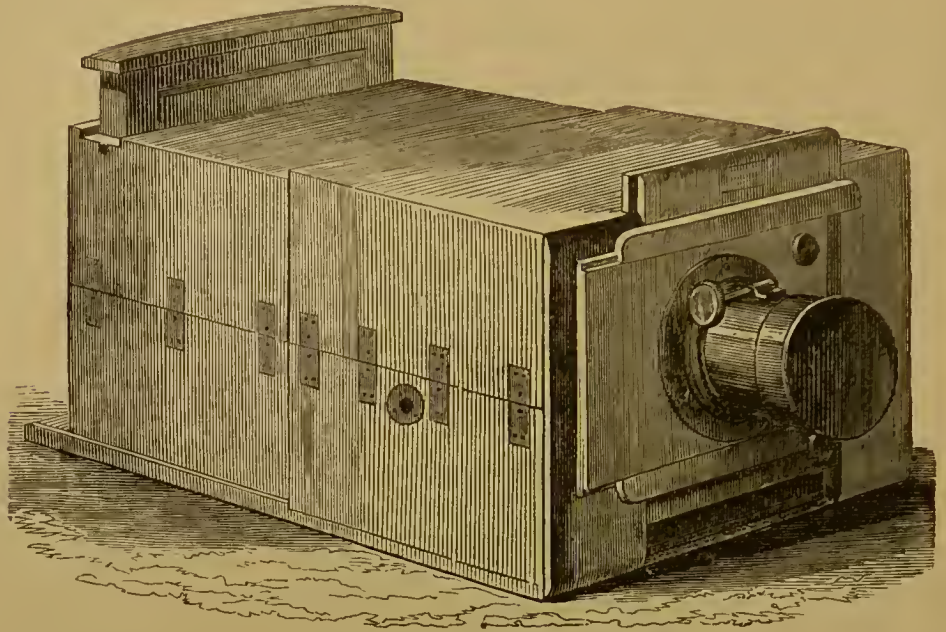

FIG. 48.

For studio-work a camera should be square and strongly made, and should have a bellows body. If desired, a sliding front may be added,

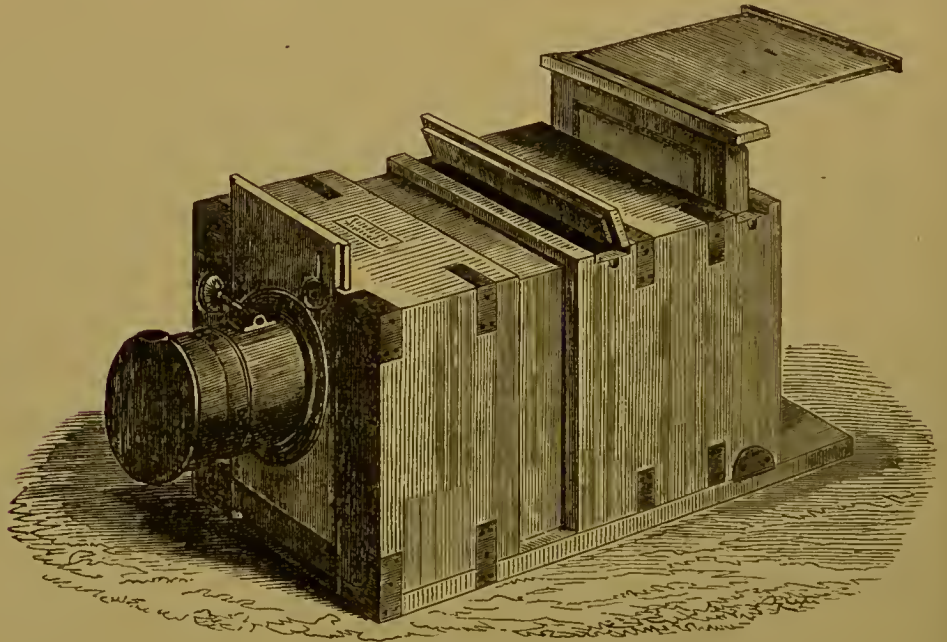

FIG. 49.

but this is scarcely necessary, as the camera stand is usually sufficient to give the various levels. The back of the camera may be arranged to take a single as well as a sliding-back, so as to make one or more

exposures on the same plate. A swing-back will often be found useful.

One of the earliest forms of the improved folding cameras was the "Kinnear." For many years it held its place, and little improvement was effected prior to the advent of gelatine dry plates; but when the silver bath was superseded for outdoor-work, the demand arose for an instrument of less weight and greater portability, which demand has been met in a very abundant manner. It is almost unnecessary to say that with any camera which is light-tight perfect success may be attained, and that expensive brass fittings are not at all necessary; neither are many of the small accessories which, in some instances, have been patented; but it would almost appear, from the demand which exists for work of the most expensive kind, that the purchasers are under the belief that they will be unable to make respectable

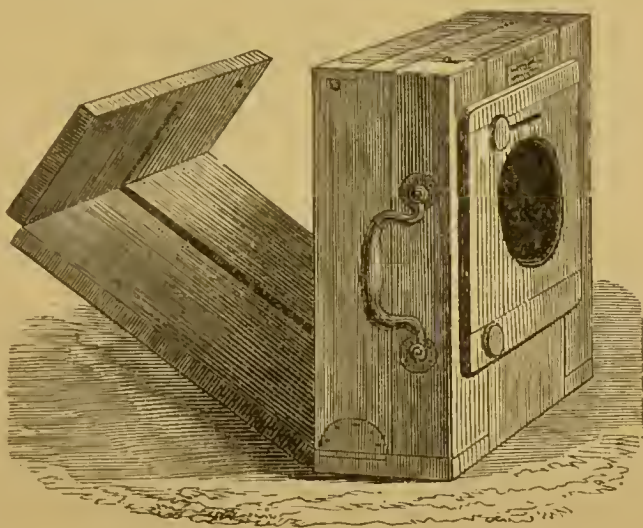

FIG. 50.

pictures unless they are provided with everything the ingenious cabinetmaker or the skilful brassfinisher can add to the dark box or case we call the "camera." This is all a mistake. What is wanted is an efficient instrument. Some brasswork there must be, but all that is used beyond what is required for strength is so much money thrown away. Utility is often sacrificed for lightness. The names of Hare and Meagher occur as makers of some of the first improved portable cameras, and their work is of a very high class. M'Kellen made some improvements, which were patented, and some of these patented improvements are now used by many makers of cameras. It was the writer's intention to describe and illustrate Mr. M'Kellen's cameras, but the necessary information has not been supplied. For work of a very high class the name of Mr. Billcliff is well known. Figs. 51, 52, and 53 show one form of his cameras. It is made square; but as plates are usually oblong, and as an upright picture is often required,

a ready means of reversing the plate is necessary. Mr. Billcliff accomplishes this by using what he calls a "revolving adaptor." Fig. 52

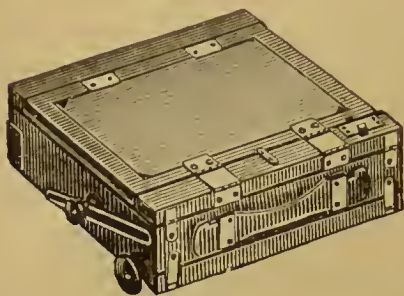

FIG. 51.

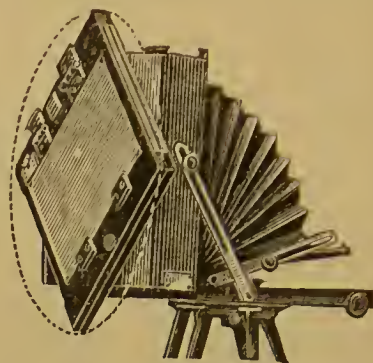

FIG. 52.

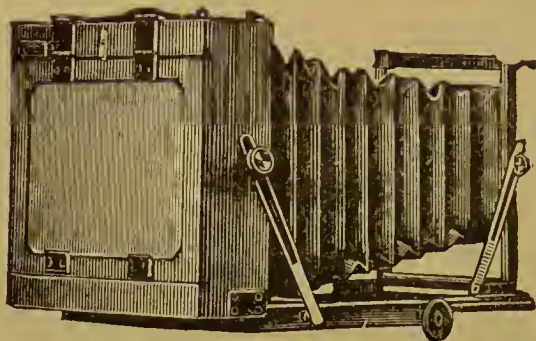

FIG. 53.

shows how the plate can be used in either position without the necessity for reversing the camera.

Another camera of excellent quality and workmanship is called the "British," and is supplied by Mr. Chapman of Manchester.

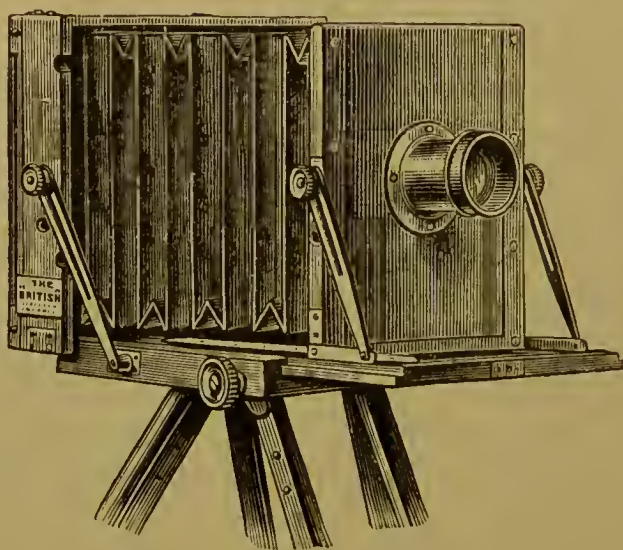

FIG. 54.

Fig. 54 shows the camera on a tripod stand, and in the position it is required for general work—that is, perfectly *level*.

Fig. 55 shows the use of the rising front. If the camera has not been disturbed, and the subject is a building, the image will be quite true to nature, or, in other words, the lines will be correct and *not* distorted. Supposing, however, that after raising the lens as high as

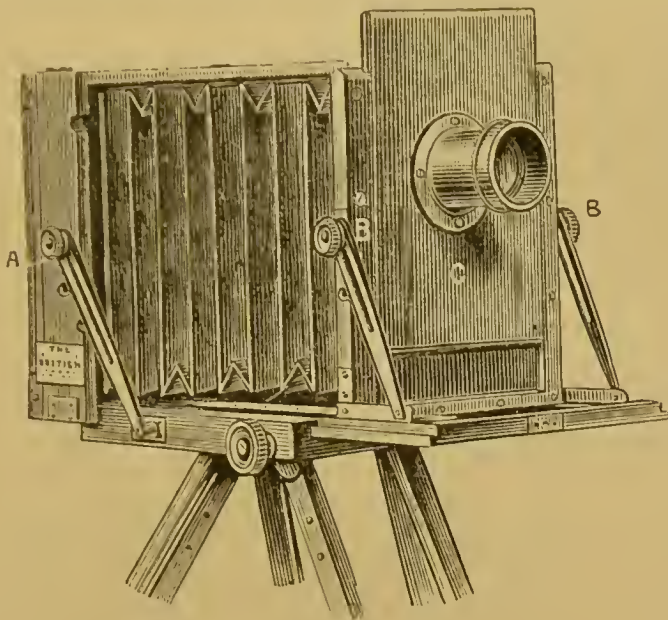

FIG. 55.

possible, as shown in Fig. 55, the upper part of the subject is not included, we must then *tilt* the camera and bring it into the position shown by Fig. 56, which indicates that the front part of the camera is pointing upwards and the back *vertical* or *plumb*; or we may say

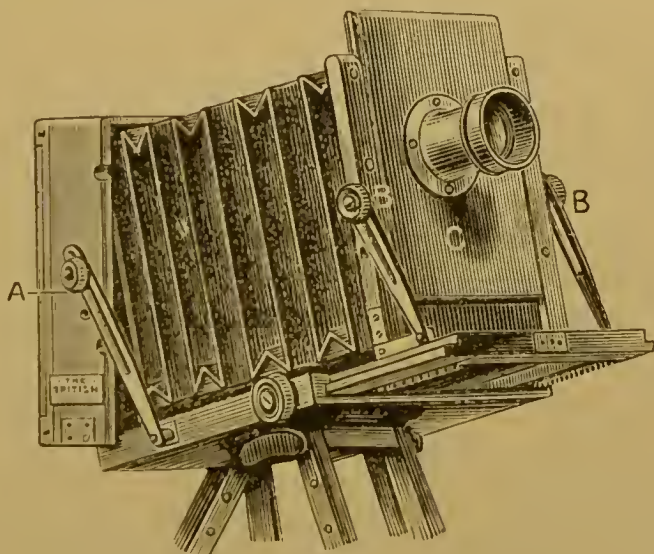

FIG. 56.

that the sensitive plate is made parallel with the sides of the object being photographed. And here may be stated the one rule in photography to which there is no exception, and that is, when a building or any object has parallel, upright, and horizontal lines, and the lens

used is of the *rectilinear* type, the sensitive plate *must* be perfectly *plumb*, or the resulting picture will not be true to nature. This is one of the first principles to be thoroughly understood by the beginner in photography.

Few persons can judge correctly when an article is *set square* by merely looking at it, and as most modern cameras are built in such a manner, that when opened out, the *back* and *front* parts require setting square, it becomes necessary to use some mechanical means for showing when the camera is level. The simplest of all methods is no doubt the use of the *spirit-level*. Another plan is to use a plummet-line in the way indicated in the woodcut, Fig. 57.

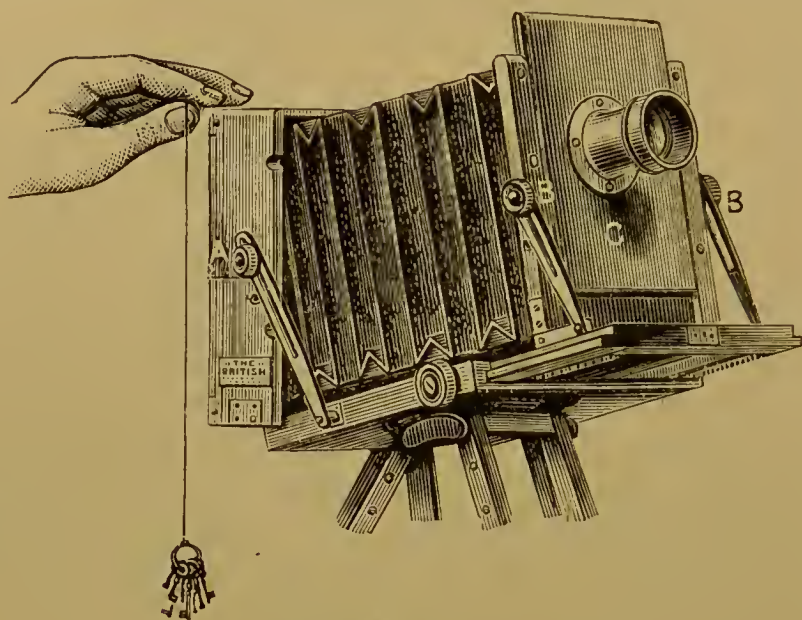

FIG. 57.

This figure shows the back of the camera parallel with any *upright* included in the view; but, as will be noticed, the front part of the camera, upon which the lens is fixed, is not parallel with the back, but *leaning* towards it. It may be considered by some that such a position is not correct, and that there will be distortion. This is not so; there is, however, a necessity for working with small stops with the lens when used in such a manner, because the *axis* is thrown out of the horizontal line. If the lens is one that will *cover* much more than the size of plate in the camera, then the lens can be brought to the horizontal position by loosening the two front screws B B, pushing the lens board *down*, and bringing the *top* portion forward until the front is parallel with the vertical back, as shown in Fig. 58.

This arrangement is useless if the lens will not cover a much larger plate than the one in use, on account of the centre being so much *above* the centre of the plate. This movement is, however, useful when the worker wants to take *two* pictures on the same plate—that



is, one above the other—or two horizontal views. When this is required, a piece of opaque material such as thin vulcanite, or a piece of ferrotype plate, is placed in the reversing back of the camera, and arranged so that by sliding it up or down we *cut* off that portion of

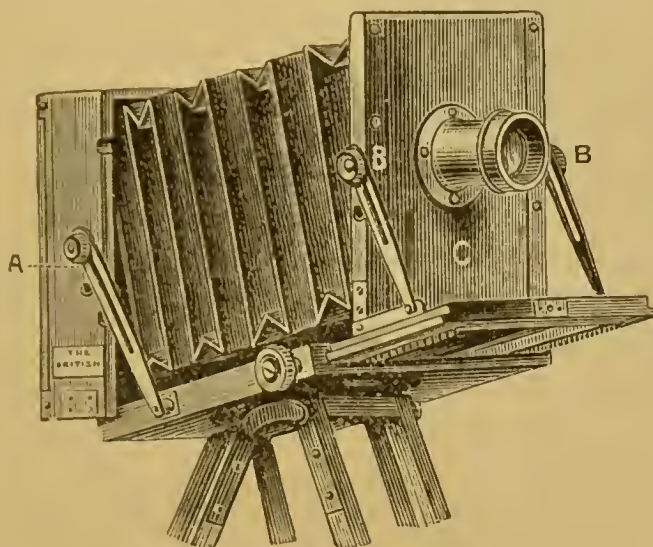

FIG. 58.

the plate we do not wish the light to act upon during the exposure of its counterpart.

Fig. 59 shows the camera tilted, with back and front brought vertical, and the lens-board, C, raised so as to include a very extreme height. Such a position is seldom required, and is really of no use

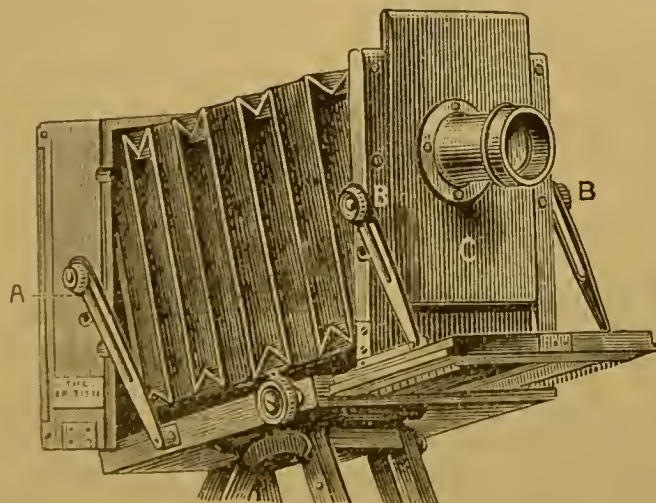

FIG. 59.

unless the lens used is one that will cover a *very* large area. The position, however, shows one great advantage this camera has over many others, viz., that no light is cut off by the bellows.

When it is necessary to use the lens pointing downwards, as, for instance, in taking a view from a great elevation, the camera will have to be placed in the reverse position to that shown in Fig. 59, *i.e.*, the

screws A and B B will require removing to the lower holes shown in the sketch; the back and front can then be made *vertical*. This adjustment is so seldom required, that the fact of having the camera perfectly square when opened out far outweighs any objection offered against the trouble of shifting the screws.

This somewhat lengthy description is given, as the remarks apply to many other cameras. This one particular camera is selected, not for any peculiarities in itself, but because it is quite impossible to describe many forms of the instrument, and all cameras of the better kind are so made that a description of one good one may almost be taken as sufficient for dozens of others. Each maker usually contrives to introduce some little alteration, which may or may not be an improvement; but as such slight alteration or addition may not be at all necessary for the production of good work, it need not be described.

One of the great advantages of the modern portable camera is that

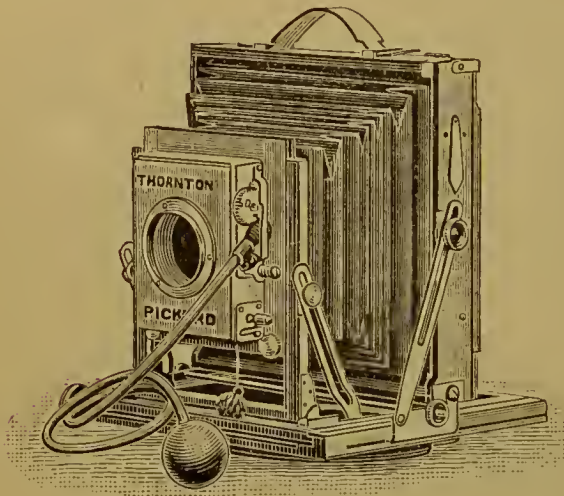

FIG. 60.

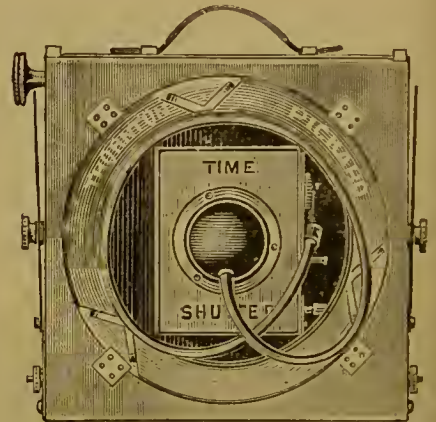

FIG. 61.

there are, in some cases, no loose parts. The instrument is complete in itself, and only requires to be set upon its tripod or other stand and opened. By adopting the turntable, the old triangular top of the stand is dispensed with. By an ingenious arrangement Messrs. Thornton and Pickard have so attached their shutter as to permit of its being used at the *back* of the lens, and of falling within the turntable opening when the camera is closed. Figs. 60 and 61 show this recent adaptation.

In all the early forms of camera the focussing was effected by sliding the back part by means of a long screw worked by a handle in front, excepting in cases when the lens was supplied with an accessible rack-and-pinion movement; the latter is the most convenient method. The swing-back and swing-front movements are comparatively modern

improvements in cameras, and they have certain advantages. By swinging the back, objects can be brought into focus which otherwise would not be properly defined. The use of this will particularly be seen in taking groups of figures and in defining the foreground of a landscape subject. The use of the swing-front will be seen by referring to Fig. 58. It is important that the camera should have a rising front—that is, the part to which the lens is attached should be movable. The advantage of having the front to move is that when objects do not appear just as required on the plate the rising movement permits the proper adjustment, and, in cases where the lens covers more than the plate, this is often very important. With lenses which will do very little more than cover the largest plate used with the camera, raising the front may cause the corners of the picture to be cut off. In some cameras the front has both vertical and horizontal motions.

It is often convenient to be able to use lenses of long and short focus in the same camera. This is effected by what is called a *double extension*. The methods by which this is carried out are very varied; sometimes two sets of racks and pinions, and sometimes a rack and pinion which can be used when the back and front are fully extended on the base-board, are employed. However carried out, this is a very important addition to a camera to be used for landscapes.

Cameras, in great variety, are made for special purposes. For taking pictures for the stereoscope, any camera which will hold a plate  $6\frac{3}{4}$  by  $3\frac{1}{4}$  inches (or the half-plate, if preferred) may be used, if the lens be attached to a front capable of movement, so as to bring the centre of the lens opposite to the centre of the place to be occupied by each picture. Whether one or two lenses be used, the camera must have a division, so as to separate the interior into two parts.

Fig. 62 shows a camera fitted with twin lenses for stereoscopic work, as also with the Thornton-Pickard instantaneous shutter. When two lenses have to be uncovered, much care is required to prevent the camera moving. Two caps may be used, but must be so attached as to be removable together. When the twin lenses do not project beyond the camera front, a cover may be attached by the centre between the lenses, and both lenses uncovered and covered by one motion, up and down; the cover should move freely, and the camera should be firmly fixed on the stand. A simple way to make exposures with two lenses is to use

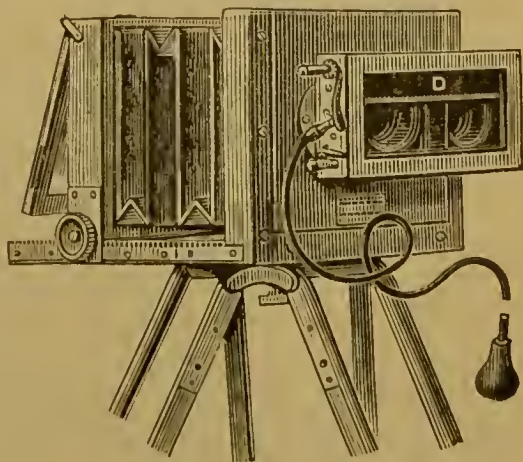

FIG. 62.

the focussing cloth or any other dark object. With care, very rapid exposures may be made in this way.

The great popularity of photography has called into use a variety of instruments by which pictures of small size may be taken without much trouble—cameras which may be used without a stand, and called “detective” or hand cameras. Some of these show much ingenuity in their construction. They are generally made to contain many plates, or are fitted with roller slides, so that films of sensitive material may be used. The plates and films must be of the most sensitive kind, and the method of making the exposure must be rapid. All these requirements are met in cameras of this class when of the best kind, and for tourists it would be difficult to suggest anything more convenient when pictures of small size only are wanted. At the same time it should be remarked that, unless great care be taken in using these instruments, much disappointment will be caused. Many cameras of this type are fitted so that a miniature of the scene to be photographed can be viewed by reflection. “Snap-shots” will as often fail as succeed if the camera is not fitted with the reflecting mirror. Excepting as toys, the very cheap detective and hand cameras cannot be recommended; although it must be admitted that, under favourable conditions, fairly good photographs may be made with these cheap instruments.

As an example of the better class, the “Kodak” has been selected for description; not because it is better than many others, but as a

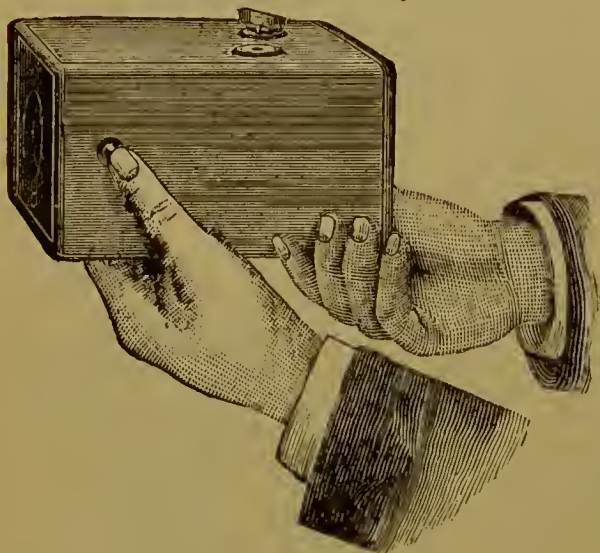

FIG. 63.

type of the whole. With this camera the roller slide and flexible sensitive film is used. The illustrations obviate the necessity of lengthened description. Fig. 63 shows the camera, and the way it is held when in use. Fig. 64 shows the general appearance of the instrument, which is made in five or six different sizes. It has a very neat appearance, being well finished. It is packed in a case, which can be carried by means of a sling, or by

a strap in the usual way, as shown in Fig. 65. Of course the lens is covered with a shutter for quick exposure. The shutter is *set* by pulling a cord; while the exposure is made by pressing a button in the side of the camera, and may be very rapid or prolonged, as necessary,

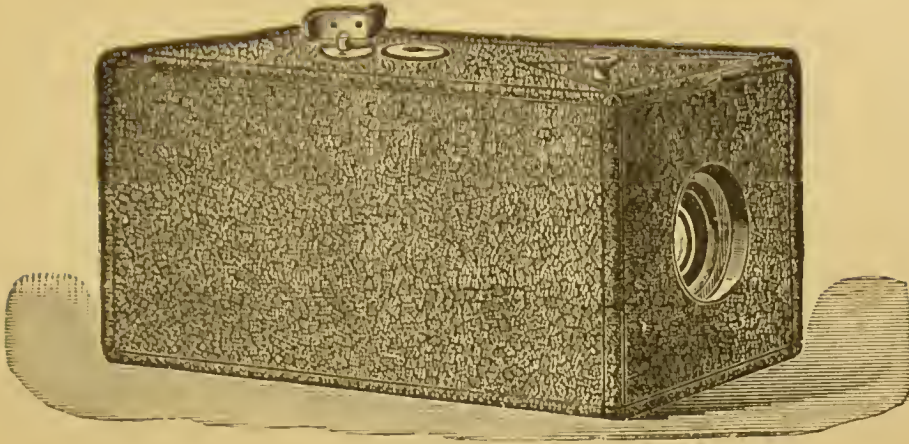

FIG. 64.

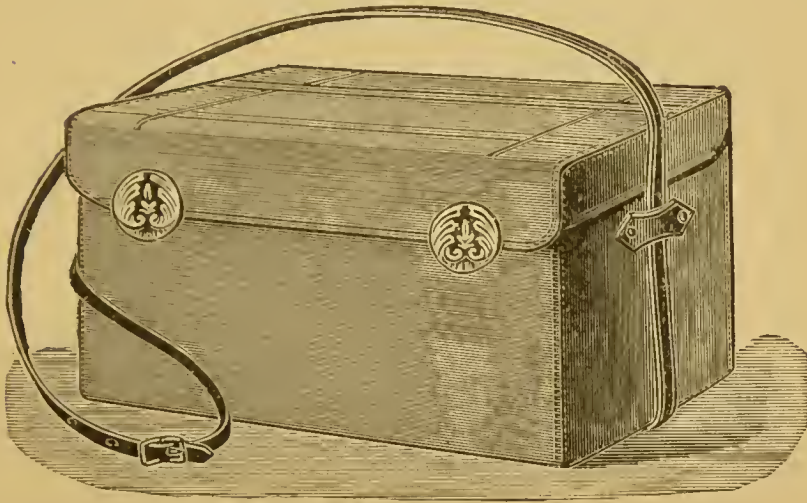

FIG. 65.

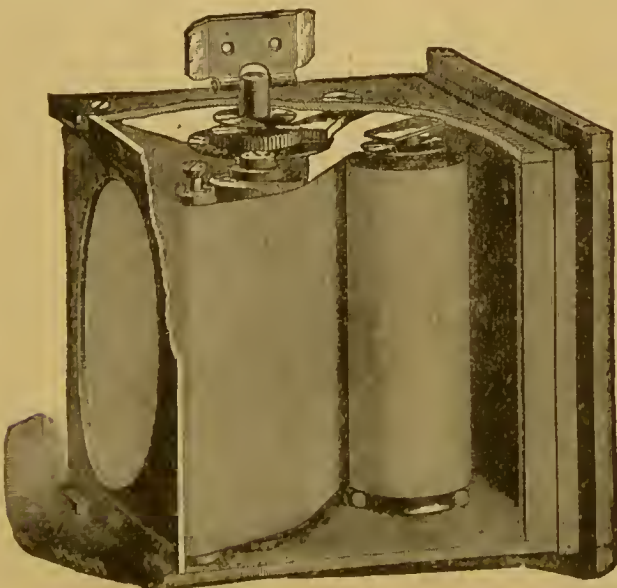

FIG. 66.

according to the light or subject. Fig. 66 shows the "roll-holder." The small as well as other sizes of the camera are made to carry sufficient length of flexible film for a hundred pictures, having dimensions varying from  $2\frac{3}{4}$  to 5 inches. In some of the other sizes the film is sufficient for sixty, forty-eight, or thirty-two exposures. The illustration shows the spools within the camera, and Fig. 67 shows the spool itself. For use, the film is wound on a wooden cylinder, and, as required, is drawn off on to a second cylinder. The lengths are marked automatically during use, so that the exposed part may readily be detached.



FIG. 67.

An ingenious form of hand-camera has recently been introduced by

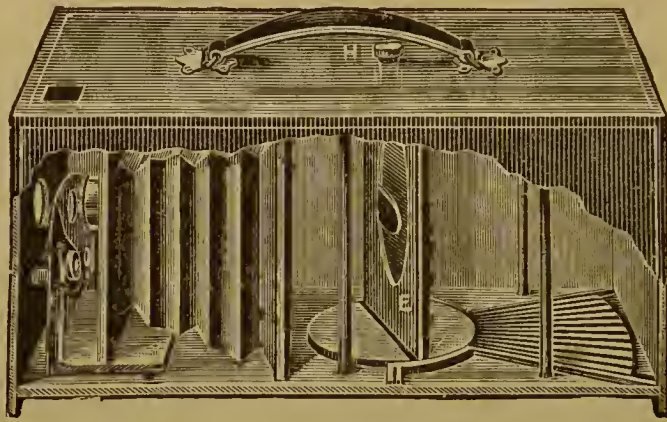

FIG. 68.—Side View showing Interior.

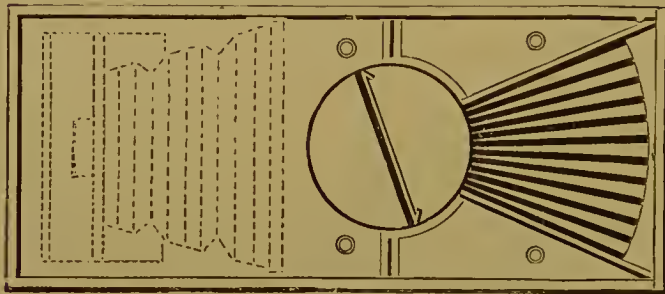

FIG. 68A.—Interior Cross Section.

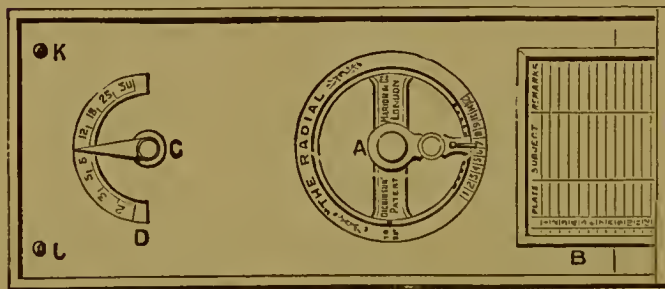

FIG. 68B.—Base Fittings.

Messrs. Marion & Co. (Dickenson's patent), which they call "The Radial;" it is illustrated in Figs. 68, 68A, 68B.

This camera takes its name from the novel method of carrying the plates in radiating grooves, which find their common axis in the centre of the exposing position.

The exposing groove runs across the axis of a drum. The drum is made to revolve in such manner that this groove can with great exactness be brought to, and made to form a continuation of, *any one* of the radiating grooves wherein the plates are stored. When the plate is transferred from the one half of this now combined groove into the other half, the drum is again turned to a defined position,

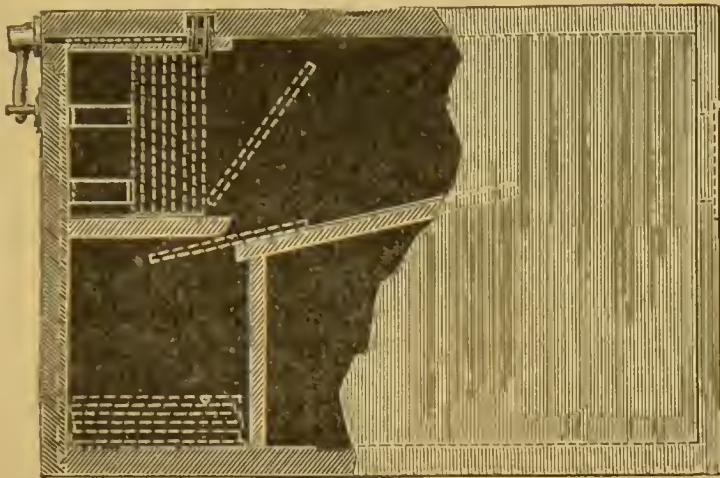

FIG. 69.

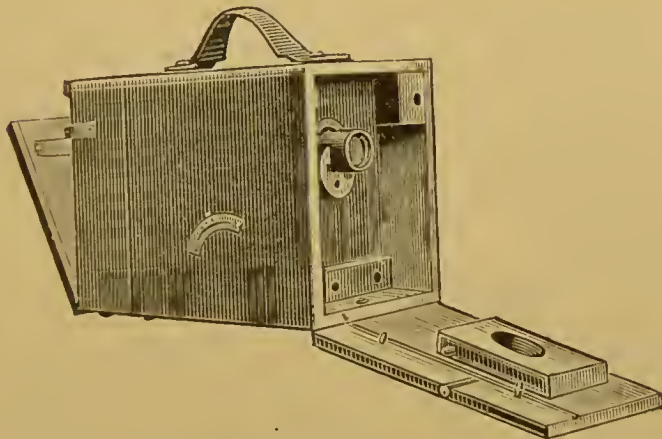

FIG. 70.

and the plate is then in its exposing position. It will be seen that to transfer the plate into its original groove and to obtain another, it will only be necessary to repeat the action already taken, until all the twelve plates have been exposed. The size of plates used is  $4\frac{1}{4} \times 3\frac{1}{4}$ .

In Figs. 69 and 70 a camera of a different class is shown. Miller's "Adelphi" hand-camera is certainly one of the simplest kind. It is made to carry a dozen plates,  $4\frac{1}{4} \times 3\frac{1}{4}$ ; each plate is protected by a sheath, and when a plate has been exposed a simple movement allows it to fall forward on to the inclined part shown in the figure, and then by tilting the camera the plate falls into the receptacle below.

When enlargements of more than ordinary dimensions are required, it becomes inconvenient to use dark slides, and for sizes beyond two feet in diameter it is preferable to have a room specially fitted for the purpose; the room then becomes the camera, the object to be copied being outside, while the lens may be fixed in a suitable aperture in a shutter, and the stand for holding the sensitive plate may be on rails, so as to be always parallel and easily moved for different sizes of work.

In Figs. 71, 72, and 73 is represented a camera which may be used for all kinds of copying up to the limit of the size of the apparatus, which in this case is 24 inches by 24 inches. This form of copying camera, so far as it differs from all others, was suggested by the writer, and was made for him by Mr. Billcliff of Manchester. The woodwork is of well-seasoned mahogany throughout. The importance of the wood being properly seasoned is tested by all the parts being interchangeable with a duplicate instrument of the same size. The base, *a*, Fig. 72, is framed very strongly, and is 6 feet long by 1 foot 9 inches wide. Two focussing screws run from end to end, and can be worked from either end of the frame by means of the handle *s'*, which is loose, and is used for either screw. The camera, as in the figure, is arranged for using plates 22 inches by 18 inches. The piece, marked *b*, slides on to the base, and can then be attached to the focussing screw, while the bellows part, when extended, slips into the back of *c*, in the groove which holds the dark slide when this part is used without *b*. The piece *c* is not attached to the focussing screws when *b* is in use, but slides in the groove of the base. The part *d* is merely a frame to carry the bellows, *g* and *h*. The front piece, *e*, which carries the lens, is attached to the base by screws at *i* on either side, and is worked by the handle at *s'*. Screws at *j* hold the front of the conical bellows to *e*. This part, *e*, has the front carrying the lens made to slide vertically and horizontally, for the purpose of centering the object to be copied. These sliding parts are seen in Fig. 73. Lenses of various sizes can be used by means of square boards to which the lens flanges are attached, and these boards are made to fit, as shown in Fig. 73, in the place of the reversing box. When the end-piece for plates 24 × 24 is to be used, it takes the place of *b*. Blocks are placed under the screws at *i* to raise the lens to the proper height, and by proper adjustment the bellows at *g* and *h* do not interfere.

The parts *n* and *o*, Fig. 71, are used when transparencies, or enlargements from negatives or transparencies, are to be made. The part *n* is screwed on at *i*, and the piece *o* merely slides in the base. This part, it will be seen, supports the carriers for holding the negative or transparency to be copied, as also a mirror when one is to be



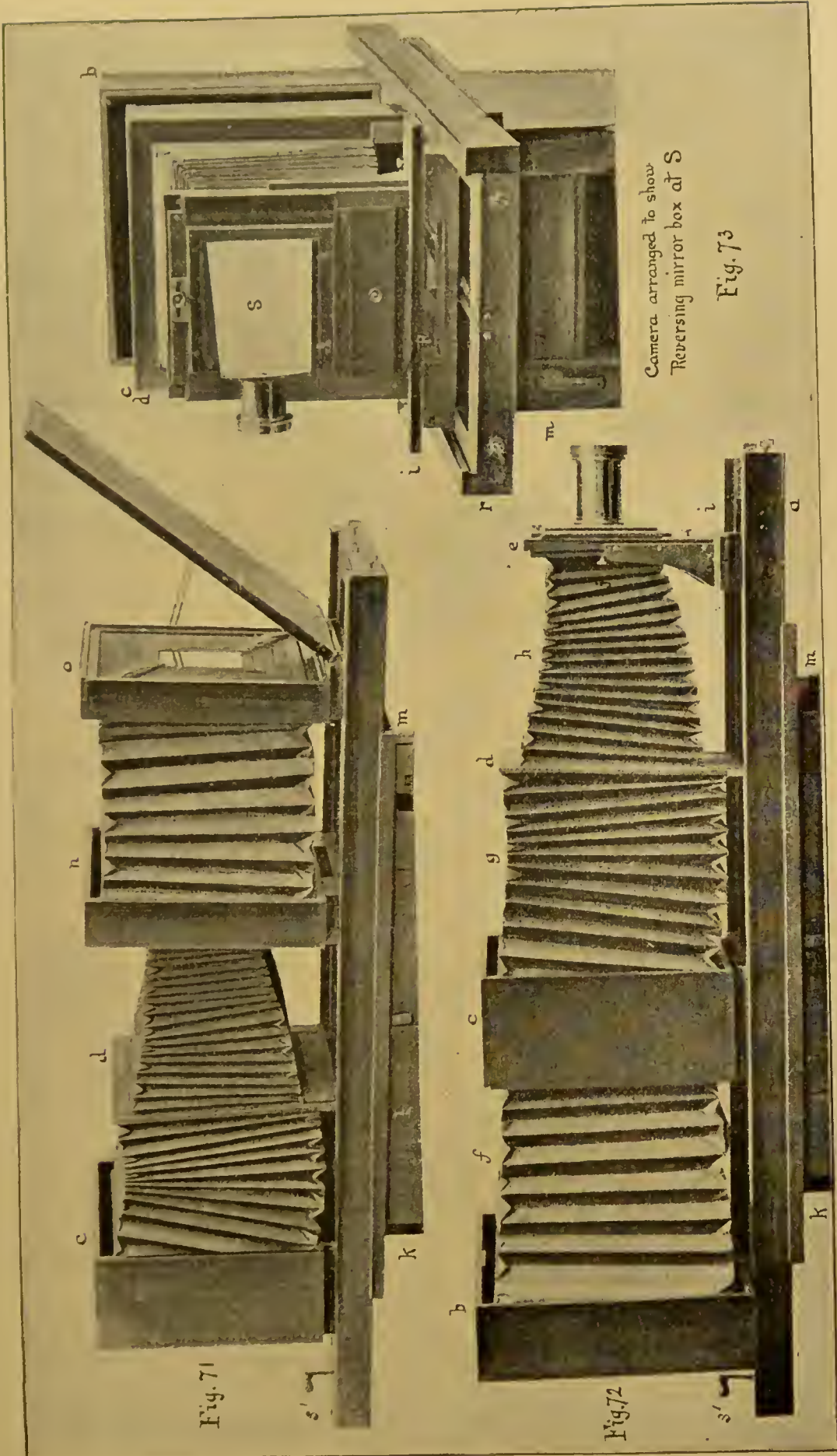

Fig. 71

Fig. 72

Fig. 73

Camera arranged to show  
Reversing mirror box at S

COPYING AND ENLARGING CAMERA.



used; but this is not always necessary, as the camera may be turned towards the sky, or a sheet of white paper will serve as a reflector. The frame, *n*, is fitted in front (not seen in the figure) with vertical and horizontal movements, as previously described; and the lens is also carried on this part. As *n* is attached to the piece at *i*, it is controlled by the screw at *f*.

In Fig. 73 the position of the box holding the reversing mirror is shown. At *p* the head of the screw clamping the front to the focussing screw is seen. The two screws at *r* are used for attaching a small copying-board to this end of the camera, and it is sometimes useful when working with lenses of short focus.

The camera is carried on a strong stand on 3-inch wheels which run on rails attached to the floor. The stand is enclosed and forms a cupboard, which is utilised to hold the various parts of the camera not in use. When not in its usual place in the camera, the focussing screen stands underneath, and is held in its place by the catch at *m*.

However fine the ground-glass may be, it is almost impossible to focus accurately upon it. This difficulty is removed by fixing small pieces of thin glass, such as are used for covering microscopic objects, on various parts of the ground-glass, as described on page 231. (See *Focussing-Screens*.)

With this camera plates of every size up to  $24 \times 24$  may be used, but the part *c*, which is 16 inches square, will be oftener required than the two larger parts. Separate backs are provided, which slide into the place of the one used for 16-inch plates, but these will only take plates up to 12 inches by 10 in one case, and sizes from  $4\frac{1}{4} \times 3\frac{1}{4}$  up to  $8\frac{1}{2} \times 6\frac{1}{2}$  in the other. The advantage of using these backs for different sizes of plates needs no description.

*Double Dark Slides and Changing Boxes*.—When using the camera away from home, it is often necessary to have the means of carrying more than one plate. The simplest way of effecting this is to have the plate-holder made to carry two plates, so that, by reversing, each plate may be exposed in succession. This is, without doubt, the best method; but the weight and inconvenience of carrying many such double dark slides has brought into use changing boxes, changing bags, and other contrivances for lessening weight. One of the earliest of these changing boxes was contrived by the late Mr. Dancer. It consisted of a box upon which the camera was fixed. As each plate was required it was brought into position for exposure by means of a brass rod, which was screwed into the frame carrying the plate, and returned to the box in the same way. Hare's changing box is good; but all contrivances of this kind have the disadvantage that, unless the plates are of one uniform size, there is the possibility that the plate will not drop into its place when required.

As a dozen plates can be carried in six dark slides, and as the difference in the weight of the woodwork in the slides and the box to hold twelve plates is not very great, preference should be given to the double backs. Amateurs too often think more of obtaining a number of photographs than a few of good quality. Six well-selected views will give much greater pleasure than a dozen which have been taken without sufficient care having been bestowed on the selection of subject; therefore it is better to be satisfied with three dark slides (holding six plates) than double the number (and weight) if the plates only yield subjects of no artistic value. For one good picture seen in an amateur's collection there may be fifty very indifferent ones; but this would not be the case were more care taken in the selection of

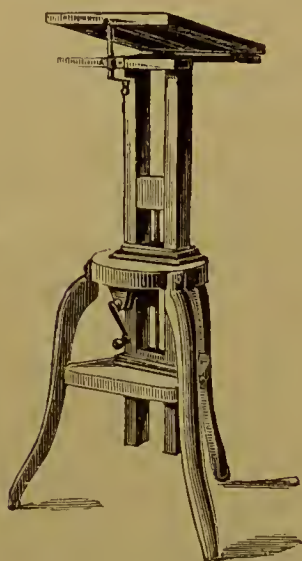

FIG. 74.



FIG. 75.

subjects, which care would be induced if the number of plates carried were limited to a few for each day's work.

What has just been said should always be remembered when using the *roller-slide*. To some extent this method of carrying sensitive films will supersede the dark slide and glass plates.

**Camera Stands and Tripods.**—For indoor work the stand or table for the camera should be solidly made. The form shown in Fig. 74 is one of the best of its kind, and sufficient for cameras up to 12 or 14 inches. The stand shown in Fig. 74 would be useful for copying, so far as the limit of the length of the bellows will allow; but when used for that purpose, care must be taken that the back is perfectly upright. The swing-back is quite useless in a camera employed for copying purposes.

For cameras of large size, used out of doors, a tripod of the old-fashioned kind shown in Fig. 75, strong and firm, will perhaps be more useful than the lighter and folding kind now generally made.

Folding tripod stands are now made in so many patterns that it is difficult to select one for description. It should be said that the points to be desired are lightness and rigidity, and that these are to be found in all of the best kind. It is often useful to have the lower joints made to slide, so that on uneven ground the difference in level may be adjusted by means of the legs. Tripods are also made in telescope form.

**Condenser.**—When artificial light is used for enlarging purposes, many of the rays will not pass through the object-glass employed for making the copy unless a *condenser* is used. The effect of the condenser is to bring together the rays which would be lost—that is, would pass outside the enlarging lens; but by interposing the condenser (which should be of a diameter equal to the negative or positive to be enlarged) the full effect of the light is utilised. Two plano-convex lenses are generally required, placed with the convex sides towards each other, and in close contiguity. Other forms may be used, but in no case is it necessary that they should be achromatic, as the enlarging lens itself achromatises the light.

**Dark Room.**—Upon the proper lighting and arrangement of the dark room much of the pleasure of working photographic processes depends. If possible, the position should be chosen so that the room has a “borrowed” light, such as one facing the north. A safe light for working the wet collodion process in such a room is yellow glass; if this be found insufficient, another sheet of glass may be added, or yellow paper, or a screen with yellow paper may be arranged so that it can be drawn when required. For the more sensitive gelatine plates the light must be tested and modified according to circumstances. If artificial light be used, a candle protected by a “hock bottle” is useful. Numberless contrivances have been proposed, all more or less effective, but the operator will soon discover what is required in his own case. The fittings of a dark room need be very simple, viz., a sink, over which to develop plates and to get rid of water, and a supply of water by means of a tap, or in some other way. Plates can, of course, be developed over a dish with water poured from a jug, but something more is necessary if comfort is to be considered.

It adds very much to the pleasure of working if everything after use be put away clean. All dishes and glass measures should be washed and put in their places.

**Diaphragms and Stops.**—These accessories of a lens are used to limit its aperture, and are sets of metal slips with a central circular hole.

When the slip is placed in contact with the lens, it is called a stop; otherwise, it is a diaphragm. The use of a diaphragm to correct

spherical aberration is referred to in the article on the "*Optics of Photography.*" An oblique diaphragm has been suggested; when inclined, a larger pencil of light is admitted to the lens from the foreground than from the sky; in this way greater cloud detail can be secured.

The diameter of diaphragm that can be used will be greater the smaller the spherical aberration; if too small, the image, though flat, is wanting in relief. The minimum useful size is  $\frac{1}{30}$ th of the focal length. On the other hand, by using a single lens with a diaphragm having too large an aperture, the spherical aberration is not completely neutralised, so that a hazy or out-of-focus portrait can thus be obtained. The use of the diaphragm in portrait combinations is to increase the depth of focus; for, being capable of use with a large aperture, these lenses lack depth of definition—*i.e.*, they only bring to a focus on the ground-glass objects in a single plane near the lens. Hence the nose and ears of a sitter, or the several figures of a group, cannot all be sharply focussed at one and the same time without the use of a diaphragm.

The object should not be focussed with the stop intended to be used (particularly if it is to be a small one), as in that case the position of the ground-glass is not distinctly fixed; for, when focussing on a distant object, it will be noticed that a slight change in the place of the ground-glass produces no material difference in the sharpness of the image; this is most noticeable in *non-aplanatic* lenses. With any kind of lens it is better to focus, not the centre, but a point about one-fourth from the side of the plate, using a diaphragm about twice the diameter of the one necessary prior to inserting the smaller one; the smaller the diameter the greater will be the sharpness of the image. A small stop has the tendency to lessen the vigour of the picture; moreover, it must be remembered that the time of exposure is increased in proportion as the diameter of the stop is diminished. By the U.S., or *uniform system*, adopted by the Photographic Society of Great Britain, a series of apertures is arranged, so that, starting with  $\frac{f}{4}$  as a unit, the diameter of No. 1 is always one-fourth of the equivalent focus of the lens in use. The diaphragms are numbered 1, 2, 4, 8, 16, &c., and the numbers show at once what the exposure should be; thus, if  $\frac{f}{4}$ , the unit stop, required one second, the second stop would require two seconds, the third four seconds, and the fourth stop eight seconds, and so on. By adopting this system the exposure with different lenses can be made uniform.

The diaphragms in use with most lenses are marked so as to show their focal value. That is, if a lens has a focal length of 8 inches,

and the largest size stop be one inch aperture, it will be marked  $\frac{f}{8}$ ; and so on to the end of the series.

An excellent rule to be remembered is that all lenses are equally rapid if the *ratio* between the aperture of the stop and the focal length of the lens be the same; that is, if, in comparing the two lenses to be used, the aperture of the stop be  $\frac{f}{8}$  or  $\frac{f}{16}$  or any other definite *ratio* of the aperture of the lens, the exposure will be the same in both cases.

**Dishes and Trays.**—There appear to be difficulties in the way of making dishes of large sizes in glass, but there can be no question that glass is much to be preferred to porcelain or any other material. Dishes or trays may be made with glass bottoms, wood being used for the sides, but the tendency to breakage makes them unsafe to use. No kind of cement appears to be capable of making vessels of this description perfectly watertight for any length of time when in use. Porcelain is very satisfactory while the glaze remains perfect; but after a while, when silver has been used, the silver seems to find its way under the glaze, and cracks and other defects then appear in all directions. For water and many solutions the porcelain trays answer perfectly. Vulcanite, also, is very satisfactory for trays up to 16 inches; but the material is thin, and as brittle as glass. In the *Amateur Photographer*, January 16, 1891, it is stated that ebonite trays may be repaired with Proutt's elastic glue. The glue is applied like sealing-wax. A hot wire may be used to spread the glue. If the manufacturers of ebonite trays would make them of thicker material, and if the elastic glue will make a fractured tray again serviceable, vulcanite or ebonite trays would be used more extensively than at present, as they are easily cleaned, are not affected by acids, and are lighter than glass or porcelain. Dishes are also made in a material called *granatine*, in celluloid and in enamelled metal.

Willesden paper answers for certain purposes. Dishes made of zinc may be employed when the solutions do not affect the metal.

**Dropping Bottles.**—When solutions in small quantities are required, it is convenient to have a ready means of obtaining them without the necessity of using both hands. Bottles are made with stoppers adapted so as to enable this to be done.

**Focussing and Focimeter.**—When an object is distinctly visible on the ground-glass of a camera, it is said to be *in focus*. With a properly corrected lens the photographic image will be correctly represented if the plate be placed in the same position on the ground-glass. If, after careful experiments, the developed image is found not to be sharp, the defect may arise from the face of the ground-glass

not registering exactly the same as the sensitive plate. This can be tested by removing the lens and then measuring accurately from the opening in the camera to the ground-glass, and afterwards to a plate placed in the dark slide; should there be any difference, it may be corrected by altering the ground-glass. In cases where the chemical and visual foci are not coincident, the instrument devised by Claudet, and called a *focimeter*, may be used. When it has been determined that the ground-glass is in its proper place, and that the focus is not distinct when a plate has been tried, by using the focimeter, the perfect coincidence of visual and chemical foci may be determined by the simple arrangement of the numbered cards placed at

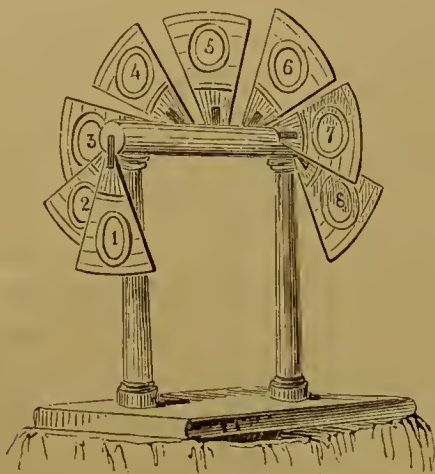

FIG. 76.

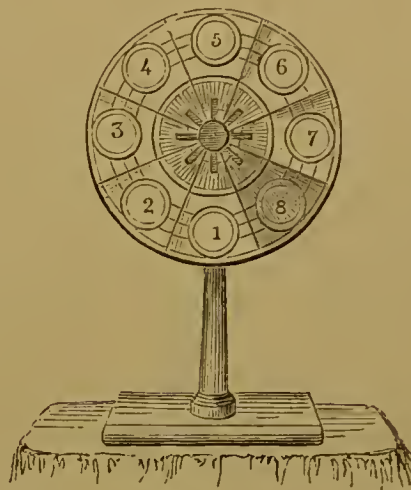

FIG. 77.

gradually increasing distances from the lens, as shown in Figs. 76 and 77. Focus accurately for the middle one, insert a sensitive plate, expose, and develop. If the focussed card comes out as sharp in the proof as its image on the ground-glass, the two foci are coincident. If another of the cards appears the sharpest, the lens must have a chemical focus longer or shorter than the visual, according as this card was farther away or nearer than the one focussed for; and after each focussing, were such an uncorrected lens being used, the camera would have to be drawn out or pushed in sufficiently to allow for the difference in focal strength.

It is very rare now to find a lens in which the chemical and visual foci are not coincident.

**Focussing Cloth.**—There is a kind of twill-cloth sold which is better for the purpose of excluding light while focussing than velvet or any other material; but any description of cloth is suitable if opaque. If to be used out of doors, some means of fastening the cloth should be adopted, as the wind is sometimes very troublesome. Attempts have been made to dispense with this useful but inconvenient part of the apparatus by adopting a focussing tube attached



to the apex of a cone. This, when placed against the ground-glass, enables part of the picture to be viewed and the focus to be obtained; but there is the disadvantage that the whole of the subject cannot be seen. Hence the cone is of little use, owing to the view being limited.

**Focussing Glass or Magnifier.**—A magnifier of some kind is a useful aid in obtaining a sharp focus. It is formed of two plano-convex lenses mounted with the convex surfaces inwards, and fixed in sliding tubes to allow of adjustment of focus. The focus is found by placing the end of the tube against the plain side of the focussing screen and sliding the lenses until the ground surface of the glass is seen perfectly sharp, when, by means of a screw-collar, the two tubes are clamped together; thus, while the same camera is used, the magnifier is always in focus.

**Focussing Screen.**—All cameras (except those in which lenses of fixed focus are used) are supplied with a screen of ground-glass upon which the image to be copied is focussed. The finer the texture of the ground-glass the better will be the definition; but, however finely the glass may be ground, the slight roughness will sometimes interfere with good definition. This glass should be of patent-plate ground to a fine surface with emery powder mixed with water. By rubbing two pieces of glass together the emery will soon remove the polish, leaving a very fine ground surface; the finer this is the clearer will be the image projected on it. As a temporary substitute for the ground-glass, a piece of clear glass may be made dull by dabbing it over with putty, or a plate may be coated with collodion, sensitised, washed, and then dried. Matt varnish may also be used.

When it is seen that the subject to be photographed is in the proper position on the ground-glass, a stop larger than the one to be used should be inserted to obtain the focus. If photographing a landscape, an object in the mid-distance should be selected as the focussing point; the stop to be used should then replace the one with which the focus was taken. If a flat object is to be copied, a part of the subject midway between the centre and side should be focussed on. (See *Diaphragms*.)

If a focussing eye-piece could be held exactly in the place where the plate should be, a ground-glass screen would not be necessary, as the image *in the air* would be visible in the eye-piece. As, however, the eye-piece cannot conveniently be held in such a position, we may attain the same result in another way. Take some pieces of glass, square or circular (such as are used for covering microscopic objects); carefully clean them, and touch each with a very small quantity of Canada balsam. Then place them in contact with the ground surface of the glass, and press gently so that the balsam shall spread just to

the edges of the glass. After a few hours the edges will have become dry and the glass will be fixed. We have now a transparent patch of clear glass through which a very distinct readily focussed image is visible with the eye-piece. As it is useful to see various parts of the picture, these little patches of glass may be fixed in different parts of the screen without in any way interfering with the ground-glass.

**Head-Rests.**—The process of taking a portrait now occupies so short a time that there is very little necessity for using a head-rest; but there are some persons who cannot keep their heads perfectly still, even for five seconds; therefore, a support of some kind is required. For studio purposes the rest made by Harrison of Leeds is one of the best. There are various contrivances for attachment to the back of a chair, but they are all inconvenient. If used at all, the rest should be on a separate stand. In all cases the pose should be first arranged, the rest brought into position, and the fork made to touch the head very lightly; otherwise, the effect will be stiff and unnatural. In many cases it is sufficient to place the rest against the shoulder.

**Hydrometer.**—The form of this instrument is similar to that described as the *Argentometer*. The graduation and use of the *hydrometer* is varied by different makers; but the purpose of all is the same, viz., that of determining the specific gravities of the fluids in which they are floated.

**Instantaneous Shutters.**—For most purposes dry plates of ordinary rapidity will be found to work better than the more rapid kinds; and when slow plates are used (as those working at about ten times the rapidity of wet collodion would be called), there is no necessity for any kind of shutter; as the exposure can be made by hand. The slower plates are more reliable in every way; they are more under control in the exposure and also in the development; but when very quick plates are used, some mechanical means must be adopted for making the exposure. One of the simplest is the *drop* shutter,

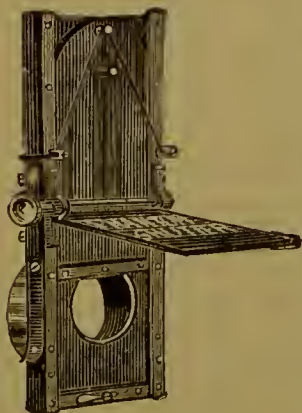

FIG. 78.

which consists of a frame attached to the front of the lens, in which there is a movable part having an aperture, and exposure occurs only while the aperture passes in front of the lens. This can be controlled by sloping the shutter, so that the drop is lessened by friction, and the fall of the shutter may be quickened by the tension of an elastic band.

Another shutter of a simple kind is shown in Fig. 78. It combines the *drop* with the flap. The flap acts as a sky-shade, and, when turned to a certain point, can be held for time exposures, while the drop may be accelerated by means of an elastic band.





ADAMSON & SON, PHOTOS.

THE LORD OF THE ISLES.

INSTANTANEOUS PHOTOGRAPH.

A. BROTHERS & CO., HALF-TONE ZINCO.

The "Kershaw" shutter (shown in Fig. 79) is of a different class, and can be used for *time* as well as quick exposures, the speed being

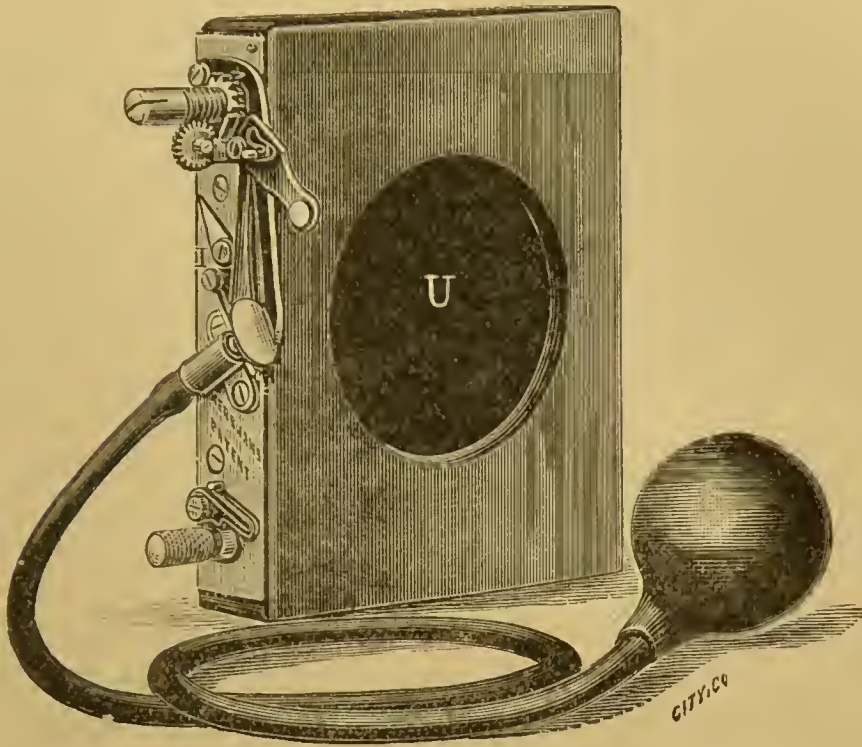

FIG. 79.

regulated by means of a spring. This shutter is very simple in construction and use, and with it objects in rapid motion have been photographed. One of the most important advantages claimed for this shutter is that it causes no vibration.

Fig. 80 shows the Thornton-Pickard shutter, adapted for a stereoscopic camera.

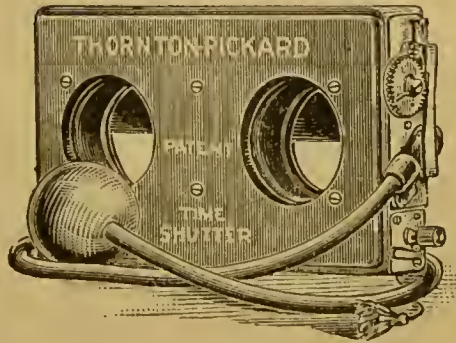

FIG. 80.

Out of so great a variety of shutters it is impossible to say that any one is the *best*; all have their good qualities, and the purpose for which they are required must determine which should be selected. Those described are for use outside the lens, but there are others which can be adapted so as to act in the diaphragm slot. The illustration on the opposite page is an example of instantaneous photography.

In selecting a shutter, care should be taken that it shall work without causing motion in the camera. Any vibration in stopping the motion of the shutter can do no harm, but there are other possible causes of motion which should be looked for.

If it were practicable in all cases, the best place for a shutter would be inside the camera, either at the back of the lens or in front of the

plate. For studio-work this can be done, but for landscapes a shutter is generally used in front of the lens.

One of the earliest of the mechanical shutters was the invention of the late Mr. Noton of Manchester. In this shutter there are two metal slides, working in grooves and having diamond-shaped apertures; one of these is in a sliding piece, which, when drawn to the top, closes the fixed aperture. A spring at the top controls the motion, which may be quick or slow; and as the top slide falls the exposure is made. The shutter may be used between the lenses or outside, as required.

A simple method for adapting shutters to lenses has been patented by the Thornton-Pickard Company. The illustrations, marked No. 1



FIG. 81.

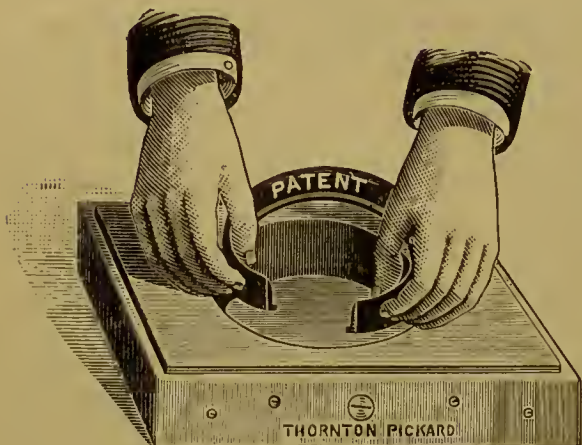

FIG. 82.

to 7, Fig. 81, show sections of the india-rubber moulding, which is supplied in strips; these strips can be cut and applied to the shutter, as shown in the next illustration, Fig. 82. The perfect adjustment may be made by rubbing down the moulding with sand-paper, or, where the fitting is too loose, the rim may be packed with cardboard. This useful invention removes the difficulty of the shutter only fitting one lens. The next illustration (Fig. 83) shows a fan which can be adapted to the Thornton-Pickard shutter, and which causes it to work

more smoothly and quietly. Another very neat contrivance is a new

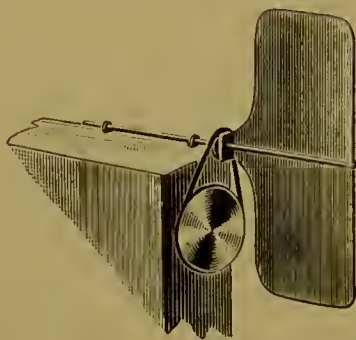

FIG. 83.



FIG. 84.

speed indicator (Fig. 84). It shows at what speed the shutter is set, and it prevents the possibility of over-winding the spring.

The term "instantaneous" is perhaps convenient to use as applied to shutters, but it is not correct. *Quick* or *quick-acting* would be a better term. Perhaps the quickest motion used in a shutter is when photographing the sun, for which an extremely short exposure is requisite; the shutter is actuated by a spring which is held by a cord, and is released when this is burnt through.

When exposures are made with a drop shutter, and the slide containing the aperture falls by its own weight, the duration of the exposure may be seen by the following figures:—

In 1st inch the fall is	·072, or	$\frac{1}{14}$ th	of a second.
„ 2nd „ „	·029, or	$\frac{1}{34}$ th	„
„ 3rd „ „	·023, or	$\frac{1}{43}$ rd	„
„ 4th „ „	·019, or	$\frac{1}{52}$ nd	„

These figures are approximate only, and will be slightly affected by the friction of the slide; as the height of the fall increases, the shorter will be the exposure.

*Measuring Rapidity of Shutters.*—Without mechanical assistance it is difficult to make exposures in less than half a second, and as some watches are provided with long seconds-hand and dials marked to fourths of a second, it is possible to time exposures within such limits. When, however, shutters are used, it is often desirable to know at what rate exposures can be made. Many ideas have been suggested to effect this, and when approximate correctness is sufficient, the speed of a shutter may be found by means of a swinging pendulum. A clock-pendulum swinging seconds—that is, one which is thirty-nine inches long from the point of suspension to end of weight, will serve the purpose. In the absence of a clock-pendulum, a weight attached to the end of a string thirty-nine inches long, suspended so that it will swing freely, and provided with a pointer at the bottom to indicate the distance travelled over the scale which is to be used in the experiment, will answer very well. The pointer may be black or white, or, better still, something which will reflect the light as a bright point. If the pointer be black, the scale must be white (or, perhaps, black divisions on a white ground), and in the other cases the ground must be black. The scale may be of any length, following the line of a circle having a radius of thirty-nine inches. As the pendulum will indicate seconds, whether the arc be long or short, the scale may be two feet or one foot; in either case it should be divided into a hundred parts. It is clear that if a photograph be taken of the pendulum while in motion, the portion travelled over while the plate is exposed will indicate the time of the exposure in one-hundredths of a second. This is merely a rough method of rating a shutter, but for most purposes it will be sufficient. Care

must, of course, be taken not to make the exposure until the swing of the pendulum coincides with the markings of the scale. Allow the pendulum to swing so that it passes beyond the scale and then watch till the oscillations fall to the proper distance.

A more correct method is by means of a clock-dial, over which the long hand is made to travel in one second. This may be effected by removing the pendulum and increasing the rate of speed as the clock runs down until the hand just makes one revolution in a second. If, then, the circumference of the circle over which the hand travels be marked in one hundred divisions, a photograph taken of the hand while in motion will show the speed of the shutter. As in the pendulum method, the dial must be light or dark according to the way in which it is to be used; on a white ground the point over the end of the hand must be a dark object, or, if preferred, something to reflect a bright point of light—a small thermometer bulb will answer the purpose.

The method of using an instrument of this kind can scarcely need description. The speed of some shutters is controlled by elastic bands, others by springs, while others again are affected by gravity alone; therefore each case must be treated as appears to be necessary.

**Iris Diaphragm.**—The origin of the iris diaphragm is somewhat curious. It was originally used, not as a diaphragm, but as a cover for bottles and preserve-jars. Two rings of metal, one moving within the other, are attached to a ring of thin india-rubber in such a way that when one of the metal rings is revolved it causes the india-rubber to stretch and close the opening. The principle of this was adapted in 1863 by the writer for the purpose of diminishing the aperture of a telescope without leaving the seat at the eye-piece end of the instrument. A rod was attached to a pinion and half-wheel at the object-glass end of the telescope, so that when the handle was turned by the observer, he could determine when the light of the star was cut off by the diaphragm, and the size of the aperture could be read off by means of the scale. This system of diminishing apertures was used for observing variable stars. It answered perfectly while the india-rubber remained in good condition, but the varying temperature of the observatory in time caused the india-rubber to become less elastic, and it required to be renewed. The principle of the *iris* as a diaphragm was next applied by Messrs. Smith & Beck to the microscope. In this case thin plates of metal were moved by rack-work, and formed a very neat diaphragm. This kind of iris diaphragm was next adapted to the photographic lens, and is perhaps quite as convenient as the revolving disc of apertures, while it has the advantage that the full aperture of the lens may be used, as also all sizes of diaphragm down to a pin-hole. The apertures are practically circular.



**Lamps for Dark Rooms.**—The necessity for using non-actinic light while developing plates, and for many other purposes in the practice of photography, has brought into use many contrivances in which gas, oil, or candles may be used. For temporary purposes a sheet of yellow paper may be arranged round the light. In changing plates, it will be quite safe to use such a light by taking care to be some distance from it—just sufficient light to see by is all that is necessary. Sometimes the white light reflected from a ceiling might cause fog; this is a point to be remembered.

Fig. 85 is a lamp, three-sided, in which gas may be used; Fig. 86 is useful for throwing the light direct on to the plate; and Fig. 87 makes a convenient reading-lamp during lantern exhibitions.

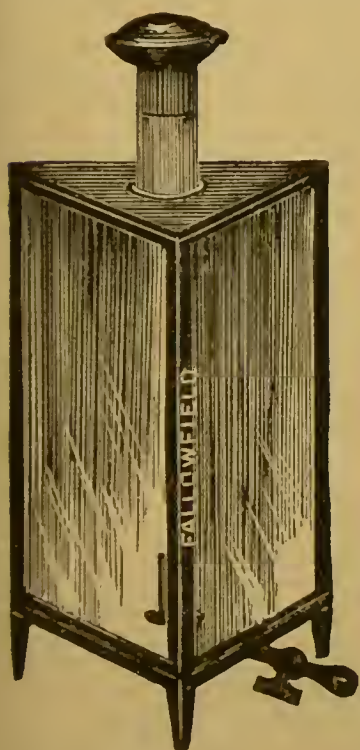

FIG. 85.

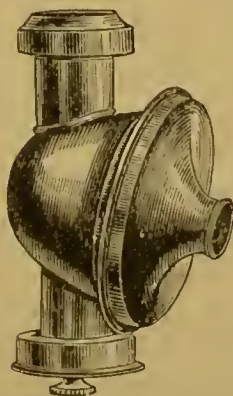

FIG. 86.

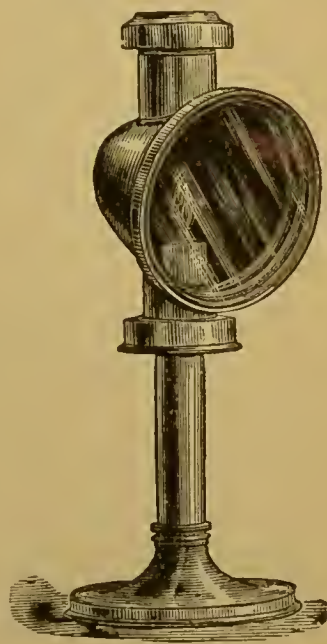

FIG. 87.

Electricity may be used, if desired; but there appears to be very little advantage over oil or candles for a purpose so simple as a lamp required for occasional use only.

Magnesium wire or ribbon is a convenient source of light for temporary purposes. A simple form of lamp was contrived by the writer, and used in his early experiments. It is simple in construction, being made of tin, and painted white inside, or left bright. Owing to irregularities in the burning of the wire or ribbon, any kind of clockwork for regulating the supply of the metal is seldom effective. It is better to take just so much of the metal as will give the light required and use it at once.

**Level Indicator.**—In Fig. 57 (see *Cameras*) is seen a simple means

of finding when a camera is upright or "plumb" by using a string with weight. Fig. 88 shows a simple "plumb indicator," patented by Messrs. Thornton and Pickard.



FIG. 88.

**Optical or Magic Lantern.**—From being little more than a toy, the "*Magic*," or, as it is now generally called, the *Optical Lantern*, has become a very valuable scientific instrument. When oil was the illuminant employed, the light was, of course, very feeble as compared with the incandescence of lime produced by the oxyhydrogen flame, and hence the increased popularity of the instrument when the more powerful light became available. With the improved light came more perfect instruments, and, as now constructed, even the cheapest form of lantern is useful. The more expensive kinds are marvels of construction, ranging from the single lantern to the "three-decker." When required merely for display-

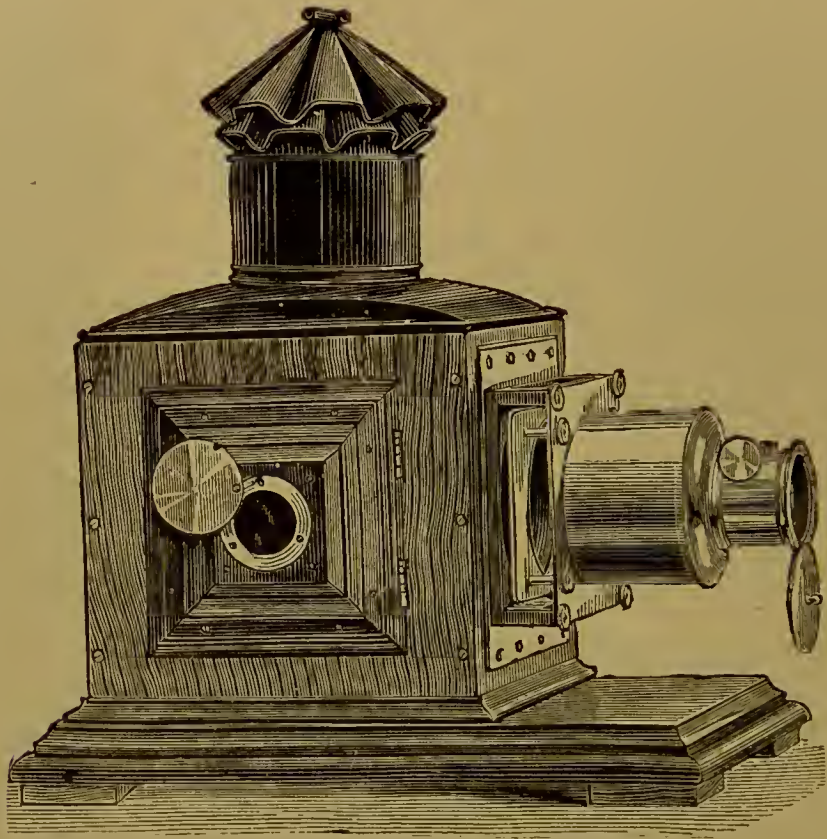

FIG. 89.

ing transparent photographs or simple diagrams, the single lantern answers every purpose. But for "dissolving views"—that is, for the display of photographs in such a manner that, while one view is fading away another is taking its place—a pair of lanterns is necessary; or one lantern with two sets of lenses arranged side by side, one over the other, or in any other way, so that the images when projected on to the screen can be made to overlap or "register" correctly, as on

this greatly depends the success of this method of showing pictures. When "effects" are to be shown, three lanterns are used ; not necessarily three distinct instruments, but three sets of the apparatus combined and arranged one over the other in such a way that all three lights may be used at the same time if desired. Dissolving effects were first shown with a double lantern in the early part of the present century, but it was not until photography made it possible to show something superior to hand-painted slides that the lantern became popular and valuable for educational and other purposes. The lime-light was first adapted to the lantern by Mr. J. B. Dancer of Liverpool (afterwards of Manchester), and the first popular application of the lantern and dissolving views was made by him, and carried out in a very successful manner by the Directors of the Manchester Mechanics' Institution (now the Technical School). Views of the monuments of ancient Egypt, and other photographs, including statuary, formed most attractive exhibitions during several seasons, and, as displayed by Mr. Dancer's apparatus, established the lantern, not only as a means of popular recreation, but as a scientific or philosophical instrument.

Figs. 89 and 90 show the single form of lantern.

In the *Novelty Lantern*, Fig. 92, an entirely new plan of showing slides is seen. By using a double sliding stage the pictures are raised or lowered quickly, and readily changed. Much of the success in using the optical lantern for the display of photographs, or for various lecturing purposes, depends on the manipulation of the apparatus. All lecturers have seen the importance of this, and one of the most successful "lanternists," Mr. H. M. Whitefield, has superintended the construction of a "single" lantern for the Manchester Photographic Society, in which some improvements of his own have been carried out.

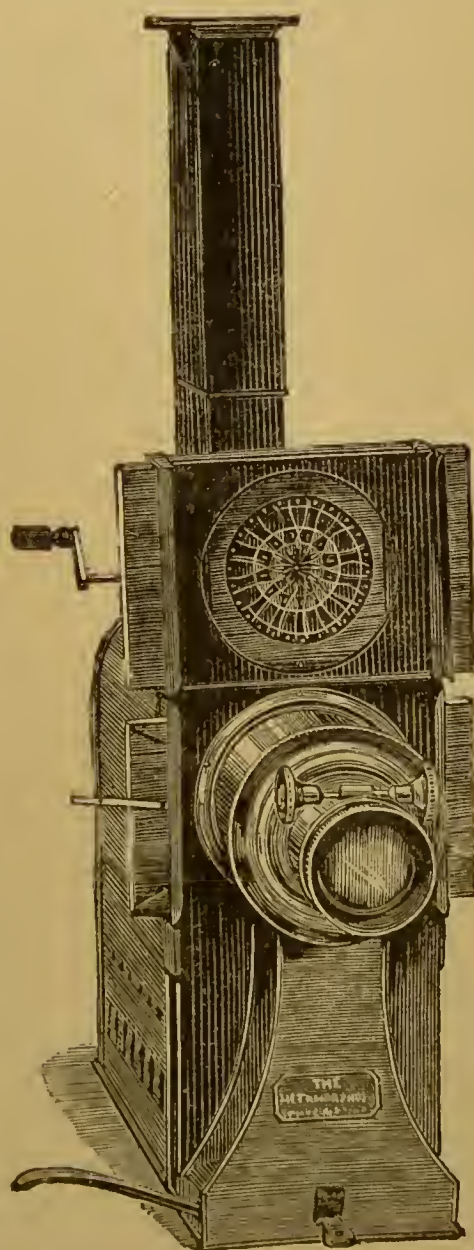

FIG. 90.

As to the *jet*, this is usually placed loose on a pillar, and requires

adjustment, being capable of motion in all directions. In addition to the difficulty of fixing the jet when the pillar and set-screw have become worn, there is always the liability of displacement by accidentally moving the india-rubber tubing during use. In this lantern the jet is fixed on a sliding plate central with the optical system, and the only movement possible is to and from the condenser parallel to its axis; this is all that is necessary, whatever objective or size of disc is employed.

*As to the stage*, this is constructed quite open at the top, so that a tank, or other piece of apparatus, can be inserted from the top as well as pushed through, and also provided with a set-screw to clamp a carrier in position. The stage is set off from the condenser to assist evaporation of the moisture which sometimes forms on cold slides; and by turning a button the whole of the stage can be removed to allow of other apparatus being used, and to permit the withdrawal of the condenser without disturbing the limelight.

*As to focussing*, to effect this conveniently the milled head of the rack should be convenient to the hand; in this lantern this is brought close under the stage, but the ordinary rack-work is retained on the objective.

*With respect to the objective*, a fault in lanterns when long focus lenses are necessary is that draw-tubes are used, and there is a tendency for the weight to cause the front part to drop. In this new lantern the lens-tube is carried by an independent support, and thus the defect referred to is removed. This part can be entirely removed to permit other apparatus to be used.

The aperture at the back for the insertion of the jet is so arranged that the light is trapped without a curtain, and the lime-burner and stopcocks are readily accessible. A flat top may be used over the lantern, on which slides may be warmed when necessary.

As to the kind of *screen* to be preferred, while paper mounted on a roller makes an excellent surface on which to exhibit photographs, the kind known as continuous cartridge is as good as any other, and can be obtained  $4\frac{1}{2}$  feet wide, so that when a small disc will suffice no joining is necessary. For all large screens white calico becomes necessary, and when strained will give a very satisfactory surface.

The lantern is now often used for other purposes than for the display of ordinary photographs. Microscopic objects, when very minute, require a more powerful light than the incandescent lime will give, and the display of experiments with the spectroscope also requires a very strong light. For this purpose the electric light is now available in a form which a few years since was not thought of. The use of batteries is now seldom resorted to, and, excepting in colleges, the direct production of the light by means of the dynamo is not prac-

ticable on account of the cost, but, as electricity can now be stored in what are termed *accumulators*, the electric light becomes available for lantern purposes. When the electric light is used, the lamp must be capable of adjustment so that the carbon points may be kept central with the condenser.

It may be stated here that a very interesting experiment in photography may be shown with the limelight and lantern by projecting the spectrum on to the screen and exposing one-half of a plate under a negative in the red end of the spectrum and the other half in the blue rays, when it will be found, on developing the plate, that there has been no effect in the red light, while the blue has printed the picture. The time of exposure must depend on the strength of the light. This experiment is generally thought to be possible only with the electric light; but the writer has tried it successfully with the limelight, and as a lecture-experiment it is very effective.

Photographs on paper and other opaque objects may be exhibited

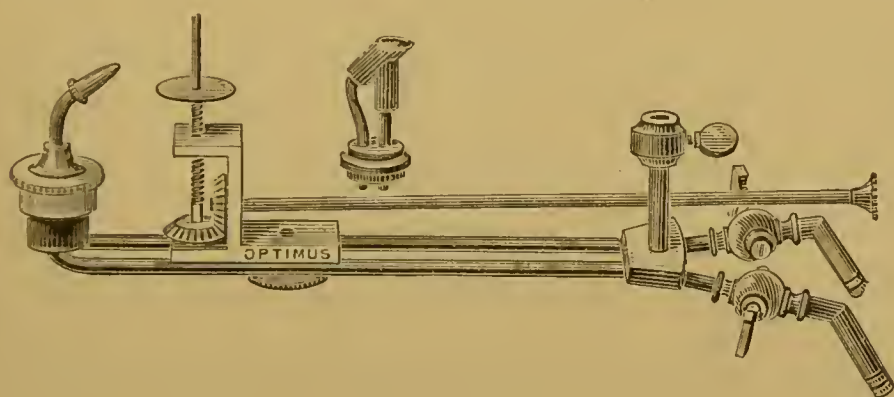

FIG. 91.

by the limelight when the lantern is adapted with an arrangement for reflecting the light instead of transmitting it in the usual way.

When the limelight is too close to the condenser, the heat is sometimes too great, and causes fracture of the glass. This may happen, also, if the lime is allowed to *pit*, as the heat is then focussed on one part of the condenser, and is almost certain to cause fracture. This may, to some extent, be avoided by arranging a piece of thin patent plate-glass between the light and close to the back of the condenser. This thin glass will break if the heat is too great, and the noise of the fracture will give warning of what is wrong.

It is quite unnecessary here to go into the question of condensers, jets, dissolvers, back-pressure valves, gas bags and bottles, and all the other details connected with the use of the optical lantern; but in Figs. 91, 92, and 93 are shown some appliances which will be found useful. Fig. 91 is an interchangeable jet, which, by a screw-collar arrangement, can be converted from a jet of high-pressure to one of

the safety or blow-through pattern. Fig. 92 shows a triple dissolving arrangement for use with the bi-unial or triple lantern, and is so arranged that whereas formerly three taps had to be used with the triple lantern, the work is done with one, which gives the operator perfect control over the lantern. The tap is fitted with bye-passes.

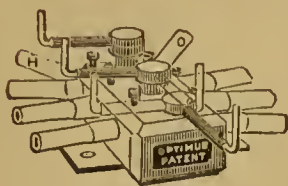

FIG. 92.

When the lantern is employed to display photographs in a room of ordinary dimensions, a screen from four to nine or ten feet diameter is quite sufficient. The kind of lantern to be used must be determined by the purpose for which it is required; generally, the single form will be sufficient. The size of the condenser must be considered and the quality of the lens, as upon these and the light depend the success of the projected pictures.

When it is not intended to use the oxyhydrogen light, the form of lantern known as the *Sciopticon* is a very good substitute, and with it (using an oil lamp) photographs may be shown with good effect from six to ten feet in diameter.

In using oil, inconvenience sometimes arises from the wicks not being properly trimmed. Fig. 93 shows a wick-trimmer, by which a clean edge is given to the wick. It will often be found preferable to rub off the charred wick, but when it must be cut, the edge should be perfectly regular, or the flame will be imperfect.



FIG. 93.

**Oscillating Tables or Rockers.**—The necessity for keeping the developing solution in motion when dry plates are undergoing development is a somewhat tedious operation when the motion has to be given by hand. The oscillatory motion may be obtained by means of a pendulum to which a heavy weight is attached; the other end of the pendulum-rod must be fixed to a board in such a way that when set in motion the rocking will be conveyed to the solution in the developing tray resting on the board, so that the wave will be carried over the plate as when the tray is held in the hand. At the point of suspension there need be very little friction, and when the

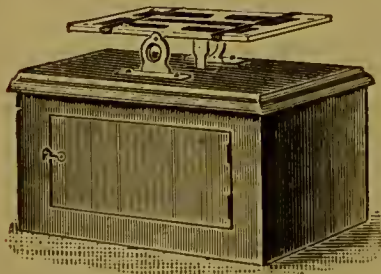

FIG. 94.

“bob” or weight is tolerably heavy, the rocking motion will be continued longer than is required for one plate; while a slight touch with the foot will keep up the motion as long as necessary. Clock-work has been used for the same purpose. Lewis & Co. of Birmingham have a contrivance of this kind, which is shown in Fig. 94.

**Pantascopic Camera.**—Under this name a camera was introduced

by its inventor, Mr. J. R. Johnson, for the purpose of taking panoramic views. The pictures were taken on flat plates, and could be made to embrace any angle of view. Specimens which the writer has seen were very successful, and the definition as good as in views taken in the ordinary way. Very little has been heard of this, or any other kind of camera for taking pictures of the panoramic kind during the last few years, probably because single pictures have a more pleasing effect than those with a range of view which the eye cannot embrace at once.

**Photometers** (see *Actinometers and Exposure Tables*).—In addition to what has already been said on the subject of exposure tables and actinometers, it may be mentioned that Mr. Woodbury invented an instrument called a *Photometer*, differing only in name from an actinometer, the principle being very similar in all such aids to exposure. Captain Abney suggested that, in using silver bromide plates, the paper used in the photometer should be thus prepared with silver bromide:—"Take a sheet of plain photographic paper, and soak it for ten minutes in a solution of potassium bromide (40 grains to the ounce); hang it up to dry, and float it on a 50-grain bath of silver nitrate. I should then wash and pass the paper through a bath of potassium bromide of 5 grains to the ounce. would then wash thoroughly, and finally give a soak for five minutes in a bath of tannin (1 grain to the ounce)." To use this paper in Woodbury's photometer the tints would have to be repainted.

**Plate-Boxes.**—For storing and preserving negatives, boxes made of pine wood with grooves are perhaps better than any others, but they occupy much space. In the days of wet collodion the convenient cardboard boxes were not available; but, with paper between each negative, there is, perhaps, no better way of preserving negatives than by keeping them in the boxes supplied with the plates.

**Plate-Rack.**—A rack of some kind in which to put plates to drain or dry is necessary, or rather is to be preferred to standing the plates on blotting-paper, as there is less chance of injury from dust collecting through capillary attraction. Pieces of grooved wood attached to side-pieces, so as to form X-shaped legs and side supports at the same time, can readily be made; and, if necessary, the sides may be made to fold.

**Pneumatic Plate-Holder.**—For holding plates of any size over 8 × 6 it is convenient to use the pneumatic holder. It consists of an india-rubber disc, attached to a vulcanised india-rubber ball, contained within a wooden case. On pressing the ball with the thumb while the plate rests on the india-rubber the plate becomes firmly attached when the thumb is removed. Care must, of course, be

taken that the glass is secure when large plates are used. Pressure on the ball at once releases the plate.

**Printing Frames.**—For small work, frames without glass may be used for printing. The negative is placed face uppermost, with the prepared paper upon it in the frame, when, the back being put into its place, the light pressure from the spring is sufficient to make perfect contact, and there is very little danger of breaking the negative; but for larger work a stronger frame becomes necessary, with thick glass upon which to place the negative, and stronger springs must be used. For still larger work, screws must take the place of springs to bring the paper into perfect contact, and in cases where very great pressure is needed, the frames must have glass at least half an inch thick. The pressure from the screws should be released as soon as convenient, as prolonged strain on the glass may lead to fracture, par-

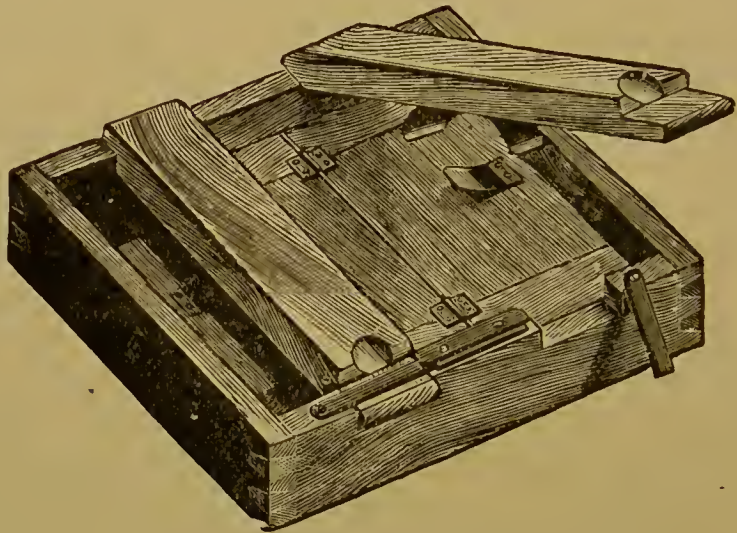

FIG. 95.

ticularly with a change of temperature. A frame should never be left all night without the screws being loosened.

Frames for special purposes have been contrived. When printing on opal glass from a glass negative it is necessary to examine the progress of the prints. This is effected by fixing the opal to one part of the frame and the negative on the top, so that when the top is lifted it can be replaced in exact position. Special frames are also made for vignetting, but these are scarcely necessary, as will be seen by reference to what is said under the heading *Vignetting*. Fig. 95 shows a simple form of printing frame. Some annoyance by the breaking of the plate-glass will be avoided by taking care that the glass has a good bed on the rim of the frame, and in large frames india-rubber between the glass and frame-bed is a good protection against unevenness. The india-rubber may be purchased of about the size of stout picture-cord and round in section, and may be glued to the frame.



**Retouching Desk.**—Some kind of desk is very useful for stopping out skies and removing defects in negatives. Fig. 96 shows one of the forms in general use. When placed in a good light, a sheet of white paper is usually sufficient to reflect light. It may be necessary to throw a dark cloth over the head and top of the desk when using it.

**Roller-Slide.**—The substitution of sensitive paper and films for glass made it possible to use either in a continuous sheet or roll, so that, as required in the camera, after each exposure, another portion of the film could be brought into use; and mechanical means were devised in many ways for superseding the ordinary dark slide. The *roller-slide*—that is, a roll within the camera—is charged with a length of the paper or film sufficient for many exposures, and as used is wound on to another roll until the entire length has been utilised.

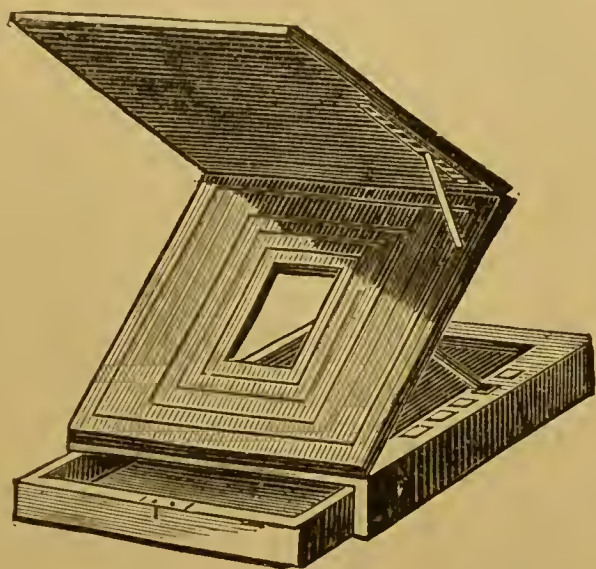

FIG. 96.

The Eastman *Roll-Holder* is a device by which a transparent film is used instead of glass.

**Sky-Shade.**—The hood of a lens is seldom sufficient protection from extraneous light; hence, when required out of doors, or in a room having top light, some kind of shade should be used; and the hand will often be sufficient. Care should be taken that no part of the lens is covered.

**Solar Camera.**—In countries where the direct light of the sun is available with more certainty than in England the solar camera is a useful instrument in the hands of the photographer. As its name implies, the direct solar rays are used for the purposes of printing and enlarging. The instrument is of American origin, and was invented by Mr. Woodward. It consists of a box which can be fixed so that a reflecting mirror is outside, and the remainder of the apparatus inside a darkened room. The reflector has a rack motion, so that it

can be kept turned towards the sun in such manner that the rays are made to pass through a condensing lens of large aperture. At a point within the camera the negative is placed, with means of adjustment. The sun's rays pass through the condenser and negative to the enlarging lens, and thence to an easel arranged to hold the sensitised paper or plate. This apparatus can be used for "printing out" as well as for other enlarging purposes, but unless continued sunshine can be depended on, other methods of enlarging will have the preference.

**Squeegee.**—A strip of vulcanised india-rubber attached to strips of wood to form a handle is a convenient means of causing intimate

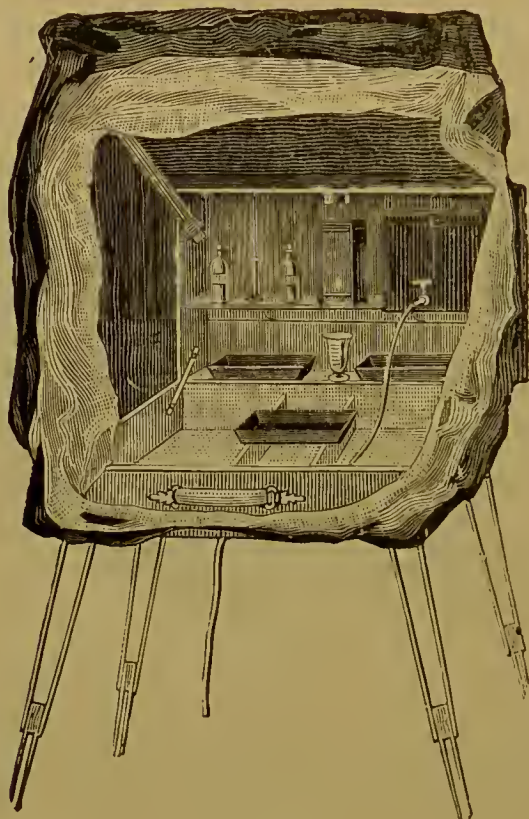

FIG. 97.

contact between prints and glass, paper, or cardboard. The india-rubber in the form of a roller may also be used.

**Stoppers.**—From various causes glass stoppers in bottles occasionally become fast. The best method for their removal depends on the cause of their being fast. If the contents of the bottle are adhesive, a solvent, warm water in most cases would be sufficient, and may be applied. If the thumb of the left hand be placed against a tight stopper, and then it is gently tapped with a piece of wood, the glass will be released. If the bottle be held with the stopper between a door partly open and the door jamb, a gentle turn will often loosen the stopper. In some cases a drop or two of oil may effect the same purpose, if left for a time.

A reverse operation is to keep a stopper *in* a bottle. Bottles containing ether or ammonia should be looked at occasionally. If rubbed with a little vaseline, there is less chance of the stopper being forced out.

**Tents.**—In cases where it is necessary to develop plates away from home, and no convenient place may be found fit for the purpose, the portable tent supplied by Messrs. Houghton & Sons, and shown in

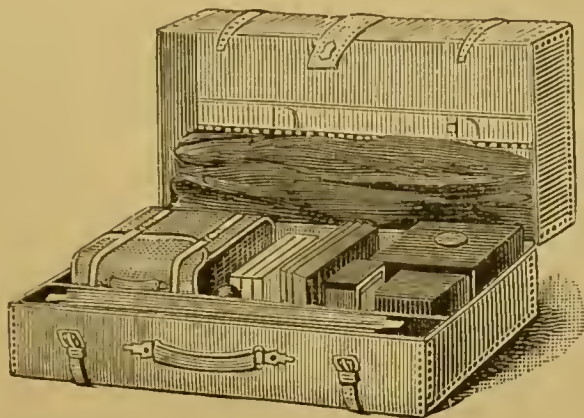

FIG. 98.

figs. 97, 98, and 99, would be found very suitable. The woodcuts are sufficiently explanatory. There are many forms of portable tents to be obtained, but the principle is the same in all; they must be as light and strong as possible, and compact.

For changing plates of small size a black bag large enough to hold the plates, dark slide, and the hands answers every purpose, as the touch enables the difference between the two surfaces of the plates to be detected. In other cases the bag is contrived so that by means of

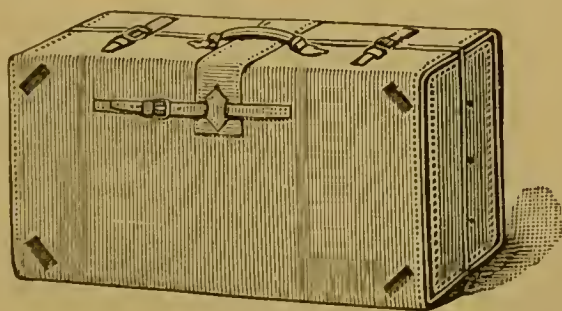

FIG. 99.

sleeves and apertures covered with non-actinic glass the operator can see what he is doing. (See *Dark Slides and Changing Boxes* under *Camera*.)

**Thermometers.**—For the purpose of ascertaining the changes of temperature the instruments called *thermometers* are used. Metals and gases expand on the application of heat, but the change in metal is too small, and in gases too great. The liquids mercury and alcohol

are generally used. The range with mercury is very large, hence it is usually employed; but as alcohol cannot be frozen, that fluid is used when very low temperatures are to be measured. In England and America the Fahrenheit scale, in France the Centigrade, and in some other countries Reaumur's scale is employed. Fig. 100 shows the different methods of marking:—

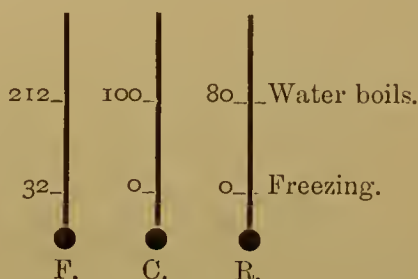

FIG. 100.

The various scales may be reduced as under:—

Centigrade to Fahrenheit:—Multiply by 9, divide by 5, and add 32; as,  $100^{\circ} \text{C.} \times 9 \div 5 + 32 = 212^{\circ} \text{F.}$

Fahrenheit to Centigrade:—Subtract 32, multiply by 5, and divide by 9; as,  $212^{\circ} \text{F.} - 32 \times 5 \div 9 = 100^{\circ} \text{C.}$

Centigrade to Reaumur:—Multiply by 4 and divide by 5.

Reaumur to Centigrade:—Multiply by 5 and divide by 4.

Reaumur to Fahrenheit:—Multiply by 9, divide by 4, and add 32.

Fahrenheit to Reaumur:—Subtract 32, multiply by 4, and divide by 9.

**Trimming Prints.**—A sharp knife is the best instrument to use for trimming prints. A sheet of glass, cut to the size the print is required to be, serves as a convenient guide for the knife, and enables the proper position to be seen. A thick piece of plate-glass serves as a bed on which to cut the prints, or a sheet of zinc may be used for the same purpose. Glass is preferable, as it is only after

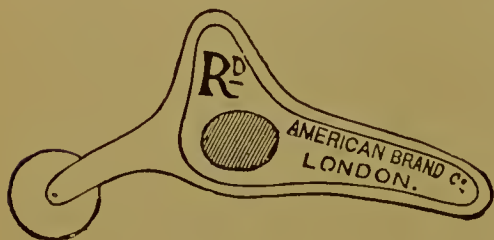

FIG. 101.

very long use that the surface becomes scratched, whereas every cut with the knife leaves a mark on the metal plate. Prints of large size must be carefully squared and then cut, using a straight-edge to guide the knife. The little tool shown in Fig. 101 may be used as a print-

trimmer, and is very useful for cutting paper while wet.

**View-Finder.**—When photographing moving objects, it is necessary to have some means of knowing where the object will appear on the plate. The simplest method is to have two points, one on the

front of the camera and the other on the back, so that the two points and the object to be photographed may be seen in line.

Many contrivances are in use for keeping objects in view and for measuring the shape of the picture to be taken. Fig. 102 shows one of these little instruments. It can be carried in the pocket and attached or detached from the camera at will. It forms its image on a

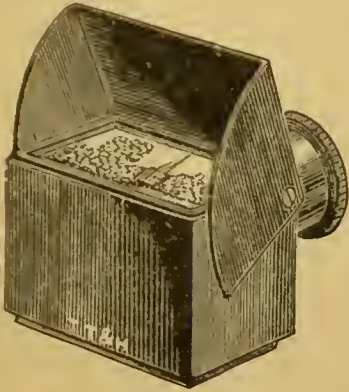

FIG. 102.



FIG. 103.

ground-glass screen, viewed from above, and is especially designed for hand-cameras. Fig. 103 is another form.

If every landscape photographer could carry in his pocket what is called a "Claude Lorraine Mirror" he would have a view-meter of a very perfect kind; but, in the absence of this, an oblong aperture cut in a piece of cardboard and held at such a distance from the eye as would about include the same angle of view as the lens to be used, would give a good idea of the appearance of the finished picture. The view-meter is useful as showing, without the trouble of erecting the camera, what the "composition" of the picture would be.

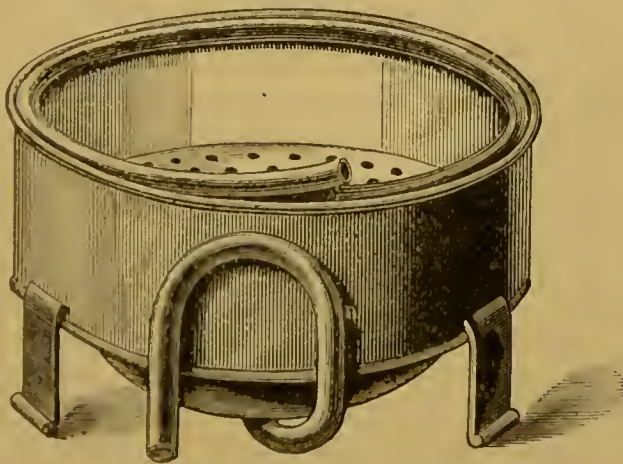

FIG. 104.

**Washing Apparatus.**—Many contrivances have been used for saving trouble in washing prints. This part of the photographer's work may be the least interesting; but it is certainly one of the most important, as upon its being properly done depends to a very large

extent the permanence of his work. Running water is usually recommended for washing prints. This is not only wasteful, but cannot be effectual unless the prints are constantly separated, as the motion of the water is certain to cause the prints to become matted together; consequently there can be very little circulation of the water between the prints. One of the oldest and best methods of washing prints is not to leave too many in one dish, to change the water at least a dozen times in the course of ten hours, and to *turn each print over* at each change of water. By this means it will be seen that each print has been turned. As the toning and fixing are usually not done till late in the day, the prints should have several changes of water, and then be left in the dishes until the next morning, when they may be again washed several times. Finally, each print should be laid on a sheet of glass, and sponged with warm water. The experience of many years, and the possession of unfaded prints which are at least thirty years old, the writer considers some proof that, when the greatest care has been taken in washing and mounting prints, they do not necessarily fade. Causes of fading, difficult to discover, arise in other ways, and, unless every care be taken in the proper washing of prints, there is much probability that they will change colour, it may be in a few weeks, or it may be months or years. Fig. 104 shows a simple form of washing-trough.

For washing gelatine plates grooved zinc boxes are generally used; and when the water is changed frequently, or by allowing a gentle stream to pass through by means of a syphon, so that the *bottom water* may be drawn off, this mode of washing answers every purpose. Large plates may be washed in flat dishes, or by allowing water to run over the surfaces of the negatives. If placed *face down* in a vessel, which will allow plenty of water below, the fixing agent will be washed out more effectually than by any other means, as the denser fluid will fall to the bottom of the vessel.

## PART IV.

---

### MATERIALS USED IN PHOTOGRAPHY.

**Acetic Acid** ( $C_2H_4O_2$ , also called Pyroligneous Acid, Vinegar).—This acid in a dilute form is commonly known as *vinegar*. It is obtained by the oxidation of alcohol and by the dry distillation of wood, in which case the crude product is called pyroligneous acid. The pure acid is obtained by heating sodium acetate with strong sulphuric acid, forming a colourless fuming liquid which boils at  $118^\circ C.$  ( $245^\circ F.$ ), becomes a white crystalline solid at  $17^\circ C.$  ( $62.5^\circ F.$ ), and in this state is called *glacial* acetic acid. It mixes with water in every proportion. The glacial acid is the form generally used in photography, but the commercial acid is sufficiently pure for some purposes, and may be used in the developing solution for the collodion process, in which it acts as a restrainer, and also facilitates the flow of the solution over the surface of the collodion. It is also used as a solvent for gelatine, one part of which dissolves in five parts of the acid. A mixture of glacial acetic acid and alcohol is also used for dissolving pyroxylin.

**Acids.**—The acids used in photography are referred to in alphabetical order. Of acids generally it may be said that they are nearly all soluble in water; that they have a pungent “acid” taste; they change the colour of blue litmus paper to red, and form with metallic oxides a series of compounds termed “salts;” but these properties, though characteristic, are possessed by the different acids in very varying degree. Care must always be taken in the manipulation of acids, as, although not in reality “poisons,” their corrosive and inflammatory action is, in most cases, such as to cause death when introduced into the stomach. When clothes are marked by acids falling upon them, the stain may best be removed by immediately adding ammonia. When strong sulphuric acid gets spilt, it is better to add a considerable quantity of cold water before attempting to remove the mark by means of ammonia.

**Albumen.**—Albumen is an organic substance found in the blood and muscle of animals, and also in vegetable matter. For photo-

graphic purposes the white of eggs, in which it is found in a very pure state combined with water, is generally used. Liebig's analysis gives:—Carbon, 53.5; hydrogen, 7.0; nitrogen, 15.5; oxygen, 22.0; sulphur, 1.6; phosphorus, 0.4 = 100. Phosphoric acid is an impurity, and the analysis then is:—C. 53.6, H. 7.0, N. 15.6, O. 22.2; S. 1.6 = 100.

Albumen is soluble in water, but on heating the solution to 60°–70° C. (150° F.) the albumen becomes insoluble, and separates out in large flocks of the coagulated substance. If the albumen has been diluted, the heat necessary to coagulate it will be higher, according to the state of dilution, the action being in all cases complete on reaching the boiling temperature. Albumen may also be coagulated by the addition of nitric acid, some metallic salts, and in other ways. The action of metallic salts is usually accompanied by the formation of so-called albuminates. Silver albuminate is the most important of these photographically, as it is formed when the albumen paper is floated on the silver bath. On account of its solubility in water, care must be taken in using albumenised paper that the silver bath is not too dilute, for in this case the albumen coating will be dissolved wholly or in part before it can be coagulated by formation of the silver compound.

Albumen is utilised in many photographic processes, but chiefly in the preparation of paper for printing, to which it gives a high gloss, valuable for keeping the picture on the surface of the paper. Its uses in various other ways are referred to in the processes described. It quickly decomposes, but the addition of ammonia acts as a preservative.

**Albumenised Paper.**—Until the introduction of the platinotype and other methods of printing photographs, paper prepared with a surface of albumen was almost exclusively used in photographic printing. If without preparation, or *plain*, as it is termed, the surface is dull or *matt*, but with albumen the picture is prevented sinking into the paper, and consequently has a bright appearance, and this brightness depends on the quantity of albumen on its surface. The paper may be used coated with albumen twice if a highly glazed surface is required.

Very few photographers now sensitise their own paper, as it can be purchased of excellent quality from the dealers ready sensitised; at the same time it may be remarked that better prints can be made on freshly prepared paper.

As effects can be obtained on the albumen surface which are somewhat different from any other, this kind of paper will probably always be in demand. For experimental, if not for commercial, purposes it is useful to know how the paper is prepared. The albumen of fresh eggs should be used. The eggs are broken separately in a cup, and



the yolks carefully removed. To each ounce of the albumen 5 or 10 grains of ammonium chloride are added. Other salts, such as those of barium or sodium, may be substituted; but the ammonium salt is to be preferred, as the silver solution used in sensitising is not discoloured when this is employed. Add  $1\frac{1}{2}$  drachms of alcohol, and water to make up to two ounces. The albumen must be thoroughly beaten into a thick froth. The salt should be added some hours previously, and then allowed to settle. After filtering through cotton wool or lint, the albumen should now be poured into a clean dish, the paper floated upon it for two minutes, and then hung up to dry. The paper is better when dried quickly; therefore the temperature of the room should be sufficiently warm. To float the paper requires a little skill, and the tyro will find it better to use half or quarter sheets, taking the paper by opposite corners; the bent sheet is brought into contact with the albumen and gradually lowered, then gently raised, and any air bubbles removed. The surface is improved by rolling. The paper should be stored in a dry place.

Paper with a very high glaze may be made by what is called "double albumenising." The first coat of albumen must be coagulated by steeping in, or floating on, a mixture of methylated spirit and water, four parts of spirit to one of water. The operation of floating on the albumen may be repeated when the paper has been dried.

It is said that paper with a very highly glazed surface may be obtained by using albumen which has been fermented.

**Alcohol** ( $C_2H_6O$ ).—This spirit is seldom used in photography in its pure or anhydrous form. The commercial, so-called absolute, alcohol, contains about 5 per cent. of water. The trade name of alcohol depends upon its strength and purity, the former being determined by the amount of water it contains. *Proof spirit* contains 49.2 per cent. water to 50.8 per cent. alcohol, while methylated spirit is strong alcohol, to which 10 per cent. of wood-spirit has been added.\*

Alcohol is obtained by the fermentation of solutions containing saccharine matter. The fermented liquid is distilled, and the dilute aqueous *spirits of wine* is concentrated by re-distillations which, however, cannot reduce the water contents below 10 per cent., the last portions having to be removed by distillation over such bodies as quick-lime or potassium carbonate, which combine with and retain the water. A 95 per cent. strength suffices for the many purposes in which alcohol is employed in photography. In the collodion process it is one of the solvents for the pyroxylin in making collodion, and it is used to cause the developing solution to flow evenly. The ether

\* Since this was written, new excise regulations have come into force. See *Methylated Spirit*.

in the silver bath causes the sensitised collodion to resist water, and the alcohol becomes necessary to counteract this.

For many of the varnishes required in photography, alcohol is largely employed as a solvent for the gums and resins used in making them.

A very useful property of alcohol is that it takes up water, and mixes with it in all proportions; for, as gelatine plates dry very slowly after they are developed, immersion in methylated spirit absorbs the water, and the plate becomes dry in a few minutes.

Pure alcohol has a pleasant smell, and the presence of impurities, that is, fusel oil, can be recognised by the disagreeable odour when the spirit is volatilised. The purity of the alcohol for some photographic purposes is very essential; and that used for collodion, or in the gelatine emulsion process, should remain clear when warmed with a few drops of ammoniacal silver nitrate solution.

*Methyl Alcohol* ( $\text{CH}_3\text{OH}$ ).—Wood spirit is prepared by the dry distillation of wood. The pure alcohol is used as a solvent for certain colours more readily soluble in it than in "ordinary" ethyl alcohol, as in the preparation of strongly coloured sensitising solutions for Alberts' colour.

**Alpha Paper.**—Paper coated with gelatine, which contains a mixture of silver chloro-citrate and bromide, is known as *Alpha paper*. The prints may be obtained by exposure to artificial light, the exposure being about three times longer than is required for bromide paper. Excellent results may be obtained by following the formulæ given by the makers of this kind of paper.

**Aluminium.**—(Al. Atomic weight = 27.)—One of the lightest of the metals. It was at one time thought that it might be used with advantage where brass is now almost exclusively employed; but its use for such purposes has hitherto been limited.

**Amber.**—The only use for this fossil resin in photography is in the form of varnish, which may be applied cold. The resin may be dissolved in benzole or chloroform. It has the advantage of forming a very hard surface.

**Ammonia** ( $\text{NH}_3$ , Spirits of Hartshorn).—As employed for photographic purposes the volatile gas, ammonia, is dissolved in water, and is usually called *liquor ammoniæ fort.*, the specific gravity of which should be .880, its richness in ammonia being greater the less its specific gravity. Unless very carefully kept in stoppered bottles, the gas at ordinary temperatures escapes, as may be detected by the stopper flying out of the bottle. This may be prevented to some extent by rubbing the stopper with vaseline. If diluted to half strength, by the addition of water, the tendency to force out the stopper is lessened; but it must be remembered when required for use that the alkali has been diluted.

Ammonia is now generally prepared from the ammoniacal liquor formed in the manufacture of coal-gas.

The alkali is employed as an accelerator in developing gelatine plates with pyrogallol. It may also be used as a fixing agent, as described in the article on *Printing on Canvas*; and other uses to which it is applied will be referred to in the descriptions of the various processes. Ammonia is also used in fuming albuminised paper.

**Ammonium Bichromate** ( $(\text{NH}_4) \text{Cr}_2\text{O}_7$ ).—This salt may be used in some cases instead of the potassium bichromate. It is said to be more sensitive to light when combined with gelatine.

**Ammonium Bromide** ( $(\text{NH}_4) \text{Br}$ ).—This salt is largely used as a restrainer in the development of gelatine plates. It is also used in the emulsions for dry plates, both collodion and gelatine, when, acting on the silver nitrate combined in the film, silver bromide is formed.

**Ammonium Carbonate** (Sesquicarbonate of Ammonia, Sal Volatile, or Smelling Salts).—The common commercial sesquicarbonate of ammonia may be considered as a compound of acid ammonium carbonate,  $\text{NH}_4\text{HCO}_3$ , with ammonium carbamate,  $\text{NH}_2\text{CO}_2\text{NH}_4$ , and may be written  $(\text{CO}_2) (\text{NH}_3)_3 \text{H}_2\text{O}$ . It is made by heating a mixture of ammonium chloride and chalk, when the ammonium carbonate forms a white sublimate smelling of ammonia. This evolution of ammonia permits of its use instead of ammonia for fuming albumen paper, for which purpose the bicarbonate is valueless, as it does not evolve ammonia in the air. It is sometimes used in developing solutions for dry plates, but it is not found to be so suitable as liquor ammoniæ.

**Ammonium Chloride** ( $\text{NH}_4\text{Cl}$ , also called Muriate or Hydrochlorate of Ammonia, Sal Ammoniac).—This chloride is largely used in the preparation of albumenised paper. It has the advantage that the solution of silver does not change colour, as is the case when some other salts are used. Mercuric chloride is soluble in water; but when ammonium chloride is added, much more of the mercury salt is dissolved; and advantage is taken of this in making strong solutions of the mercuric chloride when used for bleaching collodion plates (the double chloride of mercury and ammonia is formed). Ammonium chloride is also used in the preparation of chloride emulsion.

**Ammonium Iodide** ( $\text{NH}_4\text{I}$ ).—The chief use of the iodide of ammonium is in the preparation of collodion, in which it usually forms the iodiser, as it is readily soluble in alcohol and ether.

**Ammonium Nitrate** ( $\text{NH}_4\text{NO}_3$ ).—When collodion is iodised with ammonium iodide, the nitrate of ammonium is gradually formed in the silver bath, but its presence is usually disregarded. Care should be observed in using the dry form of ammonium nitrate, since, when

silver is combined with it, the dangerous fulminate of silver, which is one of the most violent explosives, may be formed.

When water is added to ammonium nitrate, cold is produced; and advantage may be taken of this when it is difficult to develop dry plates in hot climates. The dish containing the plate to be developed is placed in the moistened salt, which is held in another dish; and, by evaporating off the water, the ammonium salt is recovered, and can be used again. The process can be repeated as often as required.

**Ammonium Oxalate**  $((\text{NH}_4)_2\text{C}_2\text{O}_4)$ .—Oxalic acid, when neutralised with ammonia, forms ammonium oxalate. This salt is used in some of the formulæ for platinotype printing.

**Ammonium Sulphide**  $((\text{NH}_4)_2\text{S}$ ; also called Sulphuret of Ammonia).—The chief use of this form of ammonia is in blackening the films of collodion which have been bleached in the lead solution described under the heading *Intensifying*. It may also be used for the same purpose when mercuric chloride has taken the place of lead nitrate.

**Ammonium Sulphocyanate**  $(\text{NH}_4\text{CNS}$ ; also called Sulphocyanide of Ammonia).—Used as a toning agent for prints on gelatine-chloride paper when mixed with sodium thiosulphate and carbonate. It may also be used as a fixing agent in place of sodium thiosulphate; but there is no advantage gained. The salt is very deliquescent.

**Anglol**  $(\text{C}_{10}\text{H}_5\text{NH}_2\text{OH}_2\text{SO}_3)$ .—This substance was discovered by Professor Meldola. Its use in photography has been superseded by eikonogen, which is the sodium salt of anglol.

**Aniline**  $(\text{C}_6\text{H}_5(\text{NH}_2)$ , Amido-benzene, Phenylamine).—Aniline is one of the most important bodies in the formation of various colouring matters. It is a coal-tar derivative, and forms a very poisonous liquid, which is usually coloured brown. Its use in photography is chiefly confined to the preparation of orthochromatic plates in which *cyanin* is used, and in the manufacture of this aniline is employed. (See *Aniline Printing Process*.)

**Animal Charcoal**—The charcoal formed when horn, bone, or other animal matter is carbonised may be used to clear solutions of silver nitrate which have become discoloured by contact with organic impurities, as in sensitising albumenised paper. As this charcoal contains phosphates and other salts, and as these tend to weaken the silver solution, it is better to use kaolin, which effects the same purpose as the charcoal.

**Aqua Regia, or Nitro-Hydrochloric Acid**.—When four parts of hydrochloric acid and one part of nitric acid are mixed together, the mixture is termed *aqua regia* from its power of dissolving the noble metals, such as gold and platinum; this power is increased on using the acid warm. The solvent power of the mixture depends on its

containing free chlorine. Aqua regia is used to dissolve gold, when it forms the trichloride of that metal.

**Aurin, or Corallin** ( $C_{19}H_{14}O_3$ , also called Rosolic Acid).—It is made by heating phenol and anhydrous oxalic acid with sulphuric acid. The only use for this substance to the photographer is as a dye for making fabric suitable for excluding white light.

**Barium Bromide** ( $BaBr_2 + 2H_2O$ ).—The bromide and iodide of barium are used in formulæ for the manufacture of collodion, and the chloride is sometimes used instead of ammonium chloride in salting albumenised paper.

**Barium Chloride** ( $BaCl_2 + 2H_2O$ ).—This salt may be used in the preparation of paper for photography in place of the other chlorides more commonly employed.

**Barium Nitrate** ( $Ba(NO_3)_2$ ).—This substance may be used in the developing solution for wet collodion combined with ferrous sulphate, but is seldom employed. It prevents pin-holes.

**Benzene** ( $C_6H_6$ , also called Benzol).—A colourless volatile liquid with characteristic odour. It boils at  $80.5^\circ C.$  ( $177^\circ F.$ ) and is very inflammable. It is used as a solvent for caoutchouc and asphalt, and a solution of amber in benzene may be used as a cold varnish.

**Benzolene**.—A mixture of benzene naphtha and benzene is known as benzolene or petroleum spirit. It may be used as a solvent for some of the gums, and for removing grease spots.

**Bitumen** (also called Asphaltum, Jew's Pitch, or Bitumen of Judæa).—The various uses for this substance will be found under the headings of the processes in which it is employed. In its crude state bitumen is not suitable for photographic printing, and must be purified as described under the heading *Bitumen Process*.

**Borax** ( $Na_2 B_4 O_7 + 10H_2O$ . Sodium Biborate).—Occasionally used in toning-formulæ for photographs on paper.

**Bromine** (Br. Combining weight, 79.75. Sp. gr. 3.18).—The various salts of bromine are used extensively in photographic processes. This element resembles chlorine in its properties and compounds. It is a reddish black heavy liquid, very volatile and poisonous.

**Cadmium Bromide** ( $CdBr_2 + 4H_2O$ ).—A white crystalline efflorescent salt. One part of the bromide dissolves in three to four parts of alcohol, and in sixteen parts of a mixture of alcohol and ether. It, like the iodide, forms double salts, and is used in some formulæ for the preparation of collodion.

**Cadmium Iodide** ( $CdI_2$ ).—Cadmium readily forms double salts, and the double ammonium-cadmium iodide ( $CdI_2 + 2NH_4I + 2H_2O$ ) has been used for iodising collodion.

**Calcium Chloride** ( $CaCl_2 + 2H_2O$ . Muriate of Lime).—The anhy-

drous chloride is a white porous substance. It is very deliquescent, and on this account is chiefly used in photography for the purpose of absorbing moisture. In its dry state it is kept in the tubes in which platinotype paper is stored. After it has been in use for some time, it becomes wet; this moisture may be driven off by applying a strong heat. As the salt is cheap, it is better to use fresh than to attempt to dry the old stock. The salt is used in the preparation of plates for the collotype process and for other purposes.

**Canada Balsam.**—This substance has a limited use in photography. It is a resin obtained from the *Pinus balsamea*, which grows in Canada and North America. It hardens on exposure to the atmosphere; and, reduced with turpentine, is used in cementing lenses together, and occasionally in varnish.

**Celloidin.**—This substance is pure gun cotton, and is prepared by Schering for making collodion, in place of the ordinary pyroxylin. The advantage of celloidin is that its composition is uniform, as impurities, such as dextrin, xyloidin, &c., are removed.

**Celluloid.**—(See *Film Photography*).

**Cellulose** ( $(C_6H_{10}O_5)_n$ ).—Pure cellulose is obtained by boiling linen and cotton fibre (cotton-wool, paper, &c.) with dilute caustic potash, and then extracting with alcohol and ether. A short immersion in strong sulphuric acid converts cellulose into parchment paper, and nitric acid oxidises it to oxalic acid; but a mixture of the two acids, produces gun cotton, or pyroxylin, the latter of which forms collodion, when dissolved in ether and alcohol.

**Chloride of Lime, or Bleaching Powder.**—The approximate formula is  $CaCl_2 + Ca(OCl)_2 + CaO + 3H_2O = Ca_3H_6Cl_4O_6$ . It is made by passing chlorine gas over dry slaked lime in a series of chambers. A product containing at least 35 per cent. "available chlorine" should thus be obtained. Bleaching powder may be used with gold chloride as a toning bath for prints on paper prepared with silver nitrate.

**Chloroform** ( $CHCl_3$ . Sp. gr. 1.525).—A colourless, very volatile liquid of sweet smell, which boils at  $61^\circ C.$  ( $142^\circ F.$ ). Its vapour must not be inhaled, as it produces unconsciousness. The chief use of chloroform is as a solvent for india-rubber, amber, and other gums, and also in the preparation of the bitumen solution required in printing on zinc.

**Chlorophyll.**—The green colouring matter of plants, extracted by digesting for a short time in warm alcohol, is used in the preparation of orthochromatic plates, which, by that means, are made sensitive to the red of the spectrum.

**Chromate of Silver.**—The use of this salt has been suggested by Mr. W. K. Burton for the purpose of preventing halation. The colour of the chromate is deep ruby, and it may be formed by

mixing a solution of chromate of potassium with silver nitrate. An emulsion with gelatine was made in the usual way, and was used as a substratum in the preparation of gelatino-bromide plates. This experiment proved that the chromate of silver emulsion was itself sensitive to light, a fact which Hunt pointed out many years prior to Mr. Burton's investigations. Hunt also suggested that this salt of silver "has the most pleasing result of bringing within the range of probabilities the production of photographic pictures in their natural colours."

**Chromium Potassium Sulphate, or Chrome Alum** ( $K_2SO_4Cr_2(SO_4)_3 + 24H_2O$ ).—When this salt is mixed with gelatine, the latter becomes insoluble; and this property, as it will still absorb water, makes it useful in some of the photo-mechanical processes of photography. It is also used in the preparation of gelatino-bromide plates; a small quantity added to the emulsion hastens its hardening, and lessens its tendency to wash loose.

**Citric Acid** ( $C_6H_8O_7 + H_2O$ ) is derived from the juice of the lemon and some other fruits, and forms colourless crystals, soluble in water and alcohol. It often occurs as one of the components of developing solutions, in which it acts as a retarding agent. It is used also in some formulæ for toning prints on albumenised paper, and in the preparation of ready sensitised paper.

**Collodion.**—Pyroxylin, dissolved in ether and alcohol, is called collodion, which, on evaporation on glass, leaves a transparent film; and it is this quality which has made it so valuable to the photographer. It has been claimed for M. Le Gray that he first suggested its use in photography, but a letter received by the writer in 1887, from Mr. C. T. Hervé, who was a friend of Mr. F. Scott-Archer, contains this sentence, "Gun-cotton had just begun to be known, and Mr. Archer said, 'I think I can dissolve gun-cotton in some spirit. . . .' I was away from London a month; on my return I was shown a *true negative on talc*. Archer had solved the question." It appears therefore that, if the idea had occurred to M. Le Gray, it was equally original with Mr. Archer; and to him is certainly due the discovery of one of the greatest improvements ever introduced in the working of photography.

Full directions for making collodion will be found in the various editions of Hardwich's "Photographic Chemistry." Particulars as to the manufacture of *pyroxylin* will be found under that heading.

In the first instance, what is called *plain* collodion, so named to distinguish it from the iodised form which is ready for photographic use, is made as follows:—

Pyroxylin . . . . .	55 grains.
Alcohol .820 . . . . .	4½ ounces.
Ether .725 . . . . .	5½ "

This is considered more suitable for use in winter ; but, by adding half an ounce each of alcohol and ether, a modification occurs, making the collodion more useful for work in warm weather. This is recommended by Abney ; but, in the writer's experience, no change is necessary. The directions given by Hardwich should be strictly followed in making collodion, and attention should be paid to the quality of the pyroxylin, as upon this depends the character of the collodion.

The iodising solution is composed of :—

Ammonium iodide . . . . .	3 grains.
Cadmium iodide . . . . .	$\frac{1}{2}$ grain.
Ammonium bromide . . . . .	$1\frac{2}{3}$ grains.
Plain collodion . . . . .	1 ounce.

The iodides may be employed in various proportions, necessitating longer keeping before the solutions are fit for use ; but the above answers for most purposes, and can be used three or four days after it has been mixed.

If the photographer wished to study economy, he might make his own collodion, as it would certainly be cheaper to do so, provided he had no failures.

**Copper (Cu).**—The chief use of metallic copper in connection with photography is in making blocks for printing with type, when it takes the place of zinc. In the preparation of plates by the photogravure process, copper is used when the bitumen method is employed ; and, in the Goupil process, copper is electrically deposited in forming the printing plate.

**Copper Sulphate** ( $\text{CuSO}_4 + 5\text{H}_2\text{O}$ , also called Cupric Sulphate, Blue-Stone, Blue Vitriol, and Blue Copperas).—A solution of this salt, to which a small portion of sodium chloride has been added which will change the colour to green, due to the formation of cupric chloride, may be used to bleach untuned photographs (or bromide prints) which have been outlined in indian ink for the purpose of reproduction in line.

**Dextrin** ( $(\text{C}_6\text{H}_{10}\text{O}_5)_n$ . Also known as British Gum).—Dextrin is formed when starch is boiled with a 3 per cent. solution of sulphuric acid, or on heating it to  $200^\circ\text{C}$ . ( $390^\circ\text{F}$ ). It is usually employed in making paper adhesive, such as gummed labels, strips for mounting lantern slides, and similar purposes.

**Eau de Javelle.**—As a reducing agent for negatives which are too dense and for removing the last traces of sodium thiosulphate, the following solution, which forms *eau de javelle*, may be used :—

Chloride of lime . . . . .	2 ounces.
Potassium carbonate . . . . .	4 "
Water . . . . .	40 "



The lime must be mixed with thirty ounces of the water, and the potassium carbonate in the rest; when boiled and filtered the solution is ready for use.

**Ebonite.**—Indiarubber combined with sulphur is formed into a substance called *ebonite*. It is used chiefly in photography in the form of dishes and trays. It is very light, and almost as brittle as glass. (See *Dishes and Trays*).

**Eikonogen** ( $C_{10}H_5NH_2ONaHSO_3 + 2H_2O$ ).—This acid was first described by Professor Meldola in 1881, but its first use in photography appears to have been proposed by Dr. Andresen of Berlin in 1889. It is the sodium salt of amido- $\beta$ -naphthol- $\beta$ -sulphonic acid. It occurs in large yellow crystals not readily soluble in cold water. Its use as a developer is now well established; but so short a time has elapsed since Dr. Andresen first suggested its use, that it must be premature to say that eikonogen is equal or superior to pyrogallol, to which, in its chemical relationship, it is closely allied. It cannot even be said that the best formula for its use has yet been discovered; but there can be very little doubt that the new substance will establish its claim to be useful in photographic formulæ.

The following is selected from a large number of published formulæ:—

1. Eikonogen . . . . .	8 parts
Sodium Sulphite (pure) . . . . .	5 "
Distilled water at 140° F. . . . .	500 "
2. Sodium carbonate . . . . .	25 "
Potassium carbonate . . . . .	25 "
Distilled water . . . . .	500 "

Equal parts of 1 and 2 are to be mixed for use.

Dr. Andresen claims for it:—

1. That while eikonogen reduces the bromide of silver so far as it has been subject to the action of light, the bromide in dry gelatine plates which has not been exposed to the light remains unaffected by it.

2. That concentrated solutions of eikonogen (1 : 20 to 1 : 50) produce, even with instantaneously exposed plates, minutely detailed negatives.

3. The minuteness of detail produced by eikonogen is supposed to be due to the fine grain of the silver precipitate.

4. The tone of the negatives given by eikonogen is well adapted for printing, and in this respect it excels pyrogallol.

5. The solutions of eikonogen containing sodium sulphite are durable even after the addition of carbonate of soda, and the same solution can be used for several pictures in succession.

6. Eikonogen is not poisonous, which cannot be said of pyrogallol or hydroquinone.

**Emery.**—This useful mineral, which is one of the forms of alumina, is chiefly employed by photographers for grinding the surface of glass for camera focussing screens and the glass plates used in the collotype process.

**Encaustic Paste.**—The following preparation was used by M. Salomon of Paris to increase the brilliance of the surface of albumenised paper prints. White wax is mixed with gum elemi in oil of lavender, in proportion to form a kind of pomade or paste. With this the surface of the print is rubbed until the required polish is obtained. White wax and Venice turpentine dissolved in spirits of turpentine may be used for the same purpose.

**Eosin.**—The eosin of commerce is the potassium salt ( $C_{20}H_6K_2Br_4O_5$ ) of tetrabromfluoresceïn. It is one of the substances derived from coal-tar, is used as a dye, and also in making colour-sensitive dry plates. Mineral acids decompose the eosin with liberation of tetrabromfluoresceïn, which has a quite different absorption spectrum from eosin.

**Erythrosin** ( $C_{20}H_6K_2I_4O_5$ ).—Gelatine dry plates may be made orthochromatic by steeping in a bath of erythrosin. (See *Orthochromatic Photography*).

**Ether** ( $(C_2H_5)_2O$ . Sp. gr. 0.736. Also called Diethyl Ether, Ethylic Oxide).—In the manufacture of collodion, ether is used mixed with alcohol as a solvent for the pyroxylin. Ether is also used in purifying bitumen. As the vapour of ether is highly inflammable, and its boiling point so low as  $35^\circ C.$  ( $95^\circ F.$ ), the greatest care should be observed when using it where a light is burning. The fumes are heavy, and therefore a light below the ether is more dangerous than one above it.

**Ferric Ammonium Citrate** ( $Fe_2(NH_4)_2(C_6H_5O_7)_3$ . Called also Ammonio-citrate of Iron).—It is used in the preparation of paper for the ferro-prussiate or "blue" process.

**Ferric Ammonium Oxalate** ( $Fe_2(NH_4)_2(C_2O_4)_4$ , or Ammonio-oxalate of Iron).—In the platinotype process this salt is used to develop the image, when the iron is converted to the ferrous state.

**Ferric Oxalate** ( $Fe_2(C_2O_4)_3$ , or Oxalate of Peroxide of Iron).—Chiefly used in the platinotype process.

**Ferrous Oxalate** ( $FeC_2O_4 + 2H_2O$ , Oxalate of Iron).—Used in alkaline developing solutions by mixing, as required, solutions of ferrous sulphate and potassium oxalate.

**Ferrous Sulphate** ( $FeSO_4 + 7H_2O$ , also called Sulphate of Iron, Protosulphate of Iron, Copperas, or Green Vitriol).—In the develop-

ing solutions for the wet collodion process this salt of iron is very largely used.

**Fluoresceïn** ( $C_{20}H_{12}O_5 + H_2O$ , Resorcin-phthaleïn).—Some of the derivatives of this substance are used in the preparation of orthochromatic plates.

**Formic Acid** ( $H_2CO_2$ ).—A colourless liquid resembling acetic acid. The strong acid blisters the skin. At one time it was used (instead of acetic acid) in developing solutions for the collodion process. It was also used as a preservative of solutions of pyrogallol.

**Gallic Acid** ( $C_7H_6O_5$ ).—Formed by the fermentation of tannic acid. It dissolves in 100 parts of cold water, and gives a dark-blue colouration with ferric salts. Gallic acid reduces silver solutions much more quickly than tannin does, and in the early processes of photography it was used as a developing agent for paper negatives. It was with this acid that the discovery of the latent image was made by Talbot.

**Gelatine**.—This is one of the most valuable substances used in photography. In addition to the place it takes in the preparation of dry plates, some of its important properties are taken advantage of in mounting and enamelling prints on paper, and in stripping films from glass.

When bones, hoofs, and other parts of animals are boiled, a jelly is formed on cooling, and in this state it is known as *size*; when dried, as *glue*, both of which have a brown colour; and when purified, as *gelatine*, which should be colourless, and without taste or smell. Isinglass is a form of gelatine obtained from the air-bladder of the sturgeon.

The properties of gelatine are that it will swell in cold water, but will not dissolve until heated. The melting-point of a gelatine solution is several degrees higher than its solidifying point, and both points are raised by increase in strength of solution, although they vary with the quality of gelatine employed. Acids and alkalies both lower the point of solidification. When gelatine has been heated and cooled many times, or kept in a fluid state for any length of time, it loses its power of setting. The presence of an acid assists this peculiarity. In making emulsions, the bulk of the gelatine is added after one portion has been boiled, owing to the fact referred to.

When potassium bichromate and some other salts are mixed with gelatine it is rendered insoluble after exposure to light. Chrome alum and some other substances render it insoluble without exposure to light. It is these peculiarities which make gelatine one of the most valuable materials used in the mechanical processes of photography.

Dry gelatine is one of the hardest substances, and this is taken

advantage of in the Woodbury process, in which the gelatine transparency relief is subjected to a pressure of many tons without injury.

In the manufacture of dry plates the kind of gelatine to be used is of the greatest importance; and this is also the case in the collotype process,—it may be hard or soft, and the kind recommended should always be used, if possible.

As a test of the quality of gelatine, the common kinds are very brittle, while the better sorts are tough and difficult to break.

Inferior samples of gelatine may be purified by soaking in water, which must be repeatedly changed, during many hours. It must then be dissolved in about twenty times its weight of water. If not already acid, acetic acid may be used to acidify the solution; the whole is then mixed with egg-albumen in the proportions of about one egg to twenty ounces of solution, and well beaten to a froth. After boiling and then allowing to cool, the coagulated albumen will be found to have removed the impurities, which remain in the top portion of the mass. The further purification is effected by squeezing the gelatine through canvas into water and well washing; then, by steeping it in spirits of wine, the water is removed and the process is finished by drying.

**Glass.**—The varieties of glass used by photographers are patent plate, flatted crown, and polished sheet. The slight greenish tint of the latter kind is not objectionable in any way except when used for covering objects when the purity of the colour is to be preserved. In this case colourless glass may be employed; but, as salts of lead are used in its manufacture, a change occurs in the course of time by a decomposition of its surface, producing what is called *sweating*. Glass of this kind is quite unsuitable for taking negatives on. For most purposes, flatted crown or sheet glass are suitable.

**Glucose or Grape Sugar.**—A sugar found in the juice of the grape and other fruit, and also in honey. At one time it was used as a preservative for dry plates, or rather to keep plates moist. It is also employed in the process of silvering glass.

**Glycerine** ( $C_3H_5O_3$ ; sp. gr. 1.260).—The principal use of glycerine in photography is for preventing the too rapid drying of any substance it may be mixed with; also for rendering gelatine more flexible when stripped as a film from glass or other plates. The quality possessed by gelatine of being very hygroscopic was made use of in the *Glycerine Process*. A collodion plate was prepared in the ordinary way and then dipped in a bath formed of glycerine 2 oz., honey 1 oz., silver-bath solution  $1\frac{1}{2}$  oz., water 7 oz.; these were mixed together and a quarter of an ounce of kaolin was added, the whole being well-shaken together and then exposed to daylight for two or three days. The clear solution was filtered, used as a preser-

vative, then returned to the bottle with the kaolin, and was again ready for use after filtration. Any kind of developing solution could be used, and the time of exposure was somewhat longer than for wet collodion.

**Gold Chloride** ( $\text{AuCl}_3$ ).—This salt of gold, used chiefly for toning photographs, is sold in glass tubes containing 15 grains. When it is used in large quantities it is cheaper to make it, and to keep it in solution, as in the crystalline form the salt is very deliquescent. To make it proceed as follows:—Take a half-sovereign, preferably a coin but little worn; bend or break it in two and place it in a bottle. Mix  $\frac{1}{2}$  drachm nitric acid,  $2\frac{1}{2}$  drachms hydrochloric acid, and 3 drachms of water, and pour the mixture into the bottle; place it on a stove so that the fumes will pass up the chimney. Shake the bottle occasionally, and in three or four hours add more of the acids (the two acids form *aqua regia*) until all the gold is dissolved. Now add a few ounces of water, and then neutralise the solution by adding sodium carbonate until effervescence stops. The precipitate will contain copper carbonate and some silver chloride, the presence of which may be disregarded. The solution of gold chloride will be alkaline, and if left in that state the gold will precipitate; therefore, as much hydrochloric acid must be added as will redden blue litmus paper. As the coin weighs 61 grains, there will be 56 grains of pure gold, which is equal to 86 grains of the chloride. Add more water to bring the quantity to about 11 ounces, each drachm of which will contain 1 grain of gold chloride.

There are other methods of preparing the gold chloride, but the above is sufficient for all practical purposes.

Ammonia should not be used to neutralise the acids, as *fulminating gold* (which is dangerous to handle when dry) would be formed.

The *hyposulphite of gold* (*Sel d'or*) is now seldom used in any photographic process.

**Ground Glass.**—By using diffused light in studios for portraiture much better effects can be obtained than by allowing the light to pass through clear glass. When it was necessary to admit all the light possible owing to the slowness of the processes in use, the case was different, and the direction of the light could be controlled by blinds; but now it is possible to use obscured glass, blinds being still necessary to control the direction of the light. The roof glass may be obscured with white paint stippled, but ground glass, although more costly, is much to be preferred. For this purpose, glass coarsely ground will answer as well as the best. Another very important use for ground glass is for the focussing screen in cameras; for this purpose the finest grain should be used. Patent plate-glass is flatter than crown or sheet, so that when two pieces are rubbed together with

finely-powdered emery and water the surfaces are more quickly and evenly ground ; any other kind of glass will show transparent places when the remainder of the surface is finished. Care should be taken that no coarse particles are in the emery, or scratches will be produced which will be difficult to remove. To obtain the emery in the best state, the powder should be shaken in a bottle with water and allowed to stand for a very short time, when, the coarse particles having sunk to the bottom, the remainder can be poured off and allowed to settle for use. The emery can be used without washing when the surface of the glass is to be coarsely ground.

**Gum Arabic or Gum Acacia.**—Owing to its bad keeping qualities this gum cannot be recommended for mounting photographs. It readily becomes acid. Salicylic acid may be used as a preservative, but other mountants should have preference. This gum has a limited use in the preparation of paper for the photo-lithographic process.

**Gum Dammar** dissolved in turpentine may be used as a medium for retouching gelatine plates. The gum is also used in making varnish.

**Gutta-percha.**—The hardened juice of *Isonandra gutta* is largely used for photographic purposes in the form of dishes, bottles for hydrofluoric acid, and in other ways.

**Hydrochloric Acid** (HCl, also called Muriatic Acid and Spirits of Salt).—The pure substance is a colourless gas of suffocating odour, and is prepared by the action of sulphuric acid on common salt. It forms a clear solution with water, in which form it is used in the platinotype process. The yellow colour of some solutions of this acid is due to impurities, such as iron and chlorine. This impure form must be avoided for photographic work.

**Hydrofluoric Acid** (HF = 20).—The use of this acid requires great care, owing to its corrosive properties. It should be kept in a gutta-percha bottle. In photography its chief use is in stripping gelatine films from glass plates and for reversing gelatine negatives. Take one part of the acid and twenty parts of water, and in this place the plates to be stripped ; in a short time the gelatine film will leave the glass readily. For reversing a gelatine negative, take a clean glass larger than the negative, rub it over with French chalk, and then coat it with collodion. The negative to be stripped may now be placed in the acid solution, and, when loosened, the film should be removed to a dish of water. When the acid has been washed away, the collodionised plate may be placed under the film in the dish, and removed with the film carefully adjusted as required. A sheet of india-rubber may be placed over it and the water squeegeed out. When dry, the negative may be stripped in the usual way, or left in a reversed position on the glass.

**Hydrogen Dioxide** ( $\text{H}_2\text{O}_2$ , also called Peroxide of Hydrogen).—The name of oxygenated water has been given to this substance, as in its composition there is no other difference than the presence of one atom more of oxygen, and as it readily decomposes into oxygen and water. It is sold as a solution in water, and is known as “20 vol” or “10 vol” solution, according to the amount of oxygen which it will evolve. One of its uses is as a bleaching agent, and it may be used to remove stains from paper. By passing prints which have been fixed with sodium thiosulphate through a solution of hydrogen peroxide the action is supposed to be the elimination of the sulphur salt.

**Hydroquinone** ( $\text{C}_6\text{H}_4(\text{OH})_2$ ; the synonyms are Quinol and Dihydroxybenzene).—This substance has been known to chemists for many years, but it is only recently that its use as a reducing agent in photography has become general. It is sometimes referred to under different names, but quinol is a correct term for it, and probably will be generally adopted. The opinions of those who have tried quinol as a developing agent are very various; some give the preference to “pyro;” but there can be no doubt that the qualities of quinol are good, and that in some cases it gives superior results. The literature of the subject is already very voluminous. It is, perhaps, too early to pronounce an opinion on the qualities of this recently introduced substance.

The following is the method for the preparation of hydroquinone. A fuller description may be found in the *Berliner Berichte*, ii. 1103.

Aniline, the basis in the manufacture of so many colours used in dyeing, is dissolved in sulphuric acid and water with potassium bichromate, the proportions being—

Aniline . . . . .	1 part.
Sulphuric acid . . . . .	8 parts.
Potassium bichromate in powder . . . . .	$2\frac{1}{2}$ „
Water . . . . .	30 „

A brown liquid is the result, to which potassium sulphite is added, and is then extracted with ether by distillation, and the residue is dissolved in hot water to which sulphurous acid and mineral charcoal are added, and the solution is then boiled and filtered. The quinol crystallises out in hexagonal rhombohedral prisms, which are soluble in water, alcohol, and ether. By sublimation quinol takes a different form on crystallisation, showing that it is dimorphous. Its solution reduces silver nitrate, which property makes it useful in photography.

Solutions of hydroquinone become brown in the air, and quinone is formed, but they are more permanent in presence of sulphurous acid. “Permanent hydroquinone” occurs in commerce in yellow needle-

like crystals. On account of the mode of manufacture it contains traces of sulphurous acid, which renders the material less liable to oxidation than the ordinary quinol.

The following formulæ for developing solutions for gelatino-bromide plates are selected from a large number. The first are the results of experiments by Mr. Green, and are said to give a fine quality of image, a good colour, and to develop in the same time as "pyro" and ammonia:—

<i>a.</i> Quinol . . . . .	80 grains.
Citric acid . . . . .	10 ,,
Sodium sulphite (recrystallised) . . . . .	80 ,,
Water . . . . .	20 ounces.
<i>b.</i> Caustic potash (fused) . . . . .	160 grains.
Sodium sulphite (recrystallised) . . . . .	160 ,,
Water . . . . .	20 ounces.
<i>c.</i> Potassium bromide . . . . .	24 grains.
Water . . . . .	1 ounce.
<i>d.</i> Caustic potash (fused) . . . . .	160 grains.
Water . . . . .	20 ounces.

For normal exposures use equal parts of *a* and *b*, adding 5 minims of *c* for every ounce of solution. For over-exposed plates use *d* instead of *b*, with an extra quantity of *c*, and for under-exposed plates omit *c*, and in extreme cases add 6 to 8 grains more of sodium sulphite to every ounce of developer. If the plates show a tendency to frill, they must be immersed for one minute in a 5 per cent. solution of alum before fixing. Sodium thiosulphate, in the proportion of 4 ounces to 20 ounces of water, should be used for fixing.

In the next formula the solutions are used in the proportion of 4 ounces of *a* and 30 drops of *b*.

<i>a.</i> Quinol . . . . .	25 grains.
Water . . . . .	20 ounces.
<i>b.</i> Ammonia . . . . .	1 drachm,
Water . . . . .	9 drachms.

In the following formula potassium bromide is used:—

No. 1. Quinol . . . . .	1 part.
Sodium sulphite . . . . .	2 parts.
Sodium carbonate . . . . .	10 ,,
Water . . . . .	67 ,,
No. 2 <i>a.</i> Quinol . . . . .	4 grains.
Potassium meta-bisulphite . . . . .	4 ,,
Potassium bromide . . . . .	1 grain.
Water . . . . .	1 ounce.
<i>b.</i> Potassium hydrate . . . . .	10 grains.
Water . . . . .	1 ounce.



Use equal parts of 2 *a* and 2 *b* with No. 1, and with some plates the bromide may be omitted. In all cases distilled water should be used.

If, as is alleged, negatives having the qualities of wet plates can be obtained with quinol, there will be much advantage in its use for some purposes, particularly in cases where clear glass in the shadows is necessary, as, for instance, for negatives for any of the mechanical processes, such as photo-lithography and zinc etching. By the ordinary method with "pyro" such negatives are scarcely to be obtained, and the wet process must be used. Amongst amateurs the collodion process has gone so completely out of use that, for them, to make comparisons is little better than useless; but those who know what a really good collodion negative is should keep such in view as a guide in working with dry plates.

As an advantage in favour of quinol it is claimed that many plates may be developed in the same solution; but it should be borne in mind that the first plate will most certainly be better than the last. It is also recommended to commence the development with old solution, and finish with new.

Quinol may be used as a developer for bromide paper. (See *Developing and Developers*.)

**Hydroxylamine** ( $\text{NH}_3\text{O}$ ).—Although this substance has been known for some years as a reducing agent, it has not come into general use. The crystals are tabular and colourless. For developing gelatino-bromide plates the following formula is recommended by Messrs. Egli and Spiller:—

1. Alcohol . . . . .	15 parts.
Hydroxylamine . . . . .	1 part.
2. Water . . . . .	8 parts.
Caustic soda . . . . .	1 part.

For use, five parts of each are added to sixty parts of water.

The following gives good results with all kinds of dry plates:—

1. Alcohol . . . . .	4 ounces.
Hydroxylamine . . . . .	2 drachms.
2. Water . . . . .	4 ounces.
Caustic soda . . . . .	4 drachms.
3. Potassium bromide . . . . .	50 grains.
Water . . . . .	3 ounces.

For use, one drachm each of 1 and 2 are mixed with half a drachm of 3 to each ounce of water. It is claimed that, although more costly than "pyro," more plates can be developed with hydroxylamine; but the same remark must apply as in the use of hydroquinone, viz., that the first plates developed will be better than the last.

**"Hypo" Eliminators.**—The cause of the instability of silver prints

has occupied the attention of many chemists, with the result that remedies have been suggested which cannot be said to have been so successful in practice as was desirable. That "hypo" left in the paper after fixing is primarily the cause of fading is generally acknowledged, and to eliminate the last trace of this valuable, but here objectionable, substance has been the object aimed at. Eau de Javelle (potassium hypochlorite), Labarraques' solution (sodium hypochlorite), Holmes' ozone bleach, Frandreau's eliminator (zinc hypochlorite), and some others have been used. These substances are all unstable, and the oxygen which they yield combines with the "hypo," which becomes sodium sulphate. There is more or less danger to the prints from the use of any of these substances, the products of the reactions being as detrimental as the trace of "hypo" they were intended to remove. Danger from these supposed "eliminators" is likely to arise from the possibility of less careful washing and relying on the "eliminator" to make up for the defective washing. One of the safest remedies was proposed by the late Dr. Angus Smith more than twenty years ago. The prints, after fixing and washing, are to be placed in water to which has been added a small quantity of peroxide of hydrogen. The effect of this is to convert the "hypo" into sulphate, which, if left in the photograph, will do no harm; but it should be removed by washing in a few changes of water. The prints should not be left many minutes in the water containing the peroxide of hydrogen, as its action is very energetic, and would soon attack the print itself. There is another objection to this eliminator—it is itself unstable; so that, if effectual in removing the "hypo" while freshly made, it could not be relied on after it had been kept some time. The best "eliminator" is water. (See *Washing*.)

**Hypo-sulphite of Soda** (see *Sodium Thiosulphate*).

**India-rubber or Caoutchouc.**—This is a compound of hydrogen and carbon. It is the dried juice of certain tropical trees, such as the *Ficus elastica*; when pure it is white. If some of the white part of the substance is dissolved in one part of methylated ether and two parts of benzolene, it may be used as a mountant for photographs. It has the advantage of not cockling the mount, but it has the disadvantage that in course of time the india-rubber may decompose, so as to cause the print to leave the mount. When combined with sulphur in various proportions we have vulcanite and other forms of india-rubber, which serve many useful purposes in photography, as also in other branches of science and art. In a very dilute form india-rubber is sometimes used as a substratum.

**Iodine** (I. At. wt. 126.53; sp. gr. 4.95).—This element is derived from kelp, which is the ash from certain kinds of seaweed in which it is found as the iodides of magnesium and sodium. Iodides

are now largely obtained from the Chili nitrate and from Stassfurt. It is a dark-coloured crystalline solid, but slightly soluble in water, and more readily in alcohol and potassium iodide. With alcohol it forms tincture of iodine. It forms salts (iodides) with the metals, many of which find an application in photography. Stains of silver nitrate may be easily removed from the skin by first touching the parts with the tincture and then with potassium cyanide. Care must be taken that the skin is whole when these remedies are applied. The vapour of iodine was one of the earliest substances used in photography. (See *Daguerreotype Process*.)

**Iron** (Fe.; At. wt. 55.9; sp. gr. 7.8).—Although one of the most widely distributed and valuable of the metals, iron in its metallic state is very little used in photography. In what are called “ferrotypes” thin plates of the metal are used to hold the collodion pictures, the iron being coated with varnish to protect it from the silver solution, or, in other words, to prevent the iron causing the solution of silver to decompose.

Various salts of the metal form some of the most energetic and valuable reducing agents, as will be seen by reference to the formulæ given for developing solutions. Amongst the processes in which salts of iron are used may be named the *Blue process* (Ferro-prussiate), the *Platinotype*, and some others, which are described under their several headings.

**Iron, Ammonio-Citrate of** (see *Ferric Ammonium Citrate*).

**Isinglass**.—The best isinglass is made from the swimming bladder of the sturgeon. It is a pure form of gelatine, and takes the place of that substance in some of the photo-mechanical processes.

**Jena Glass**.—Lenses are now being made by Zeiss and others with a new kind of glass, manufactured under the direction of Professor Abbe in Jena, Austria. A lens 9 inch focus is said to cover a plate 20 by 16, and one of 14 inch focus will cover 30 inches for landscape work. Until the introduction of this new glass opticians were limited to the use of about a dozen different kinds; the new kind is made in ninety varieties, all possessing different qualities.

**Kaolin** (China or Porcelain Clay).—The principal use of this substance, which is formed by the disintegration of the felspar of granite, is in decolorising silver solutions. When albumenised paper has been floated on the silver solution it becomes discoloured, if certain salts have been used, and the effect of shaking up the solution with a small quantity of kaolin is to cause it to become clear, the colouring matter settling with the kaolin. Animal charcoal produces the same effect.

**Lavender, Oil of**.—This oil is prepared by distillation from the plant *Lavandula vera*. Under the name of *oil of spike* a common

kind is sold. Bitumen is soluble in oil of lavender, and was thus used in the earliest photographic experiments. The oil is still used as a solvent, but turpentine answers the same purpose.

**Lead (Pb).**—For most purposes, when acids are not present, leaden vessels may be used in photographic processes. In the etching methods, where nitric acid is used, care should be taken that the waste acids are not thrown into places where the waste pipes are of lead or other metal. Lead acetate has been used as a “hypo” eliminator.

**Lead Nitrate** ( $\text{Pb}(\text{NO}_3)_2$ ).—The use of this salt of lead is referred to under the heading *Intensifying*.

**Lithium Chloride** ( $\text{LiCl}$ ).—This chloride forms a white deliquescent mass, readily soluble in water and alcohol. It is occasionally used in emulsions. The bromide and iodide are but seldom employed.

**Litmus.**—For the purpose of testing the alkalinity or acidity of solutions, strips of paper which have been stained with litmus are used, and for all practical purposes in photography this test is sufficient. In the delicate operations conducted by the practical chemist this test is not always reliable, as the litmus is not affected by some acids; substances such as methyl-orange, turmeric, phenolphthalein, and some others, are then used. Litmus is prepared from some kinds of lichen which grow on rocks near the sea. The colouring matter is extracted by a peculiar process in which potash is used, and for commercial purposes is made up into cakes with chalk. When required for making test-paper the colour is softened with hot water, and the unsized paper is soaked in the blue solution. This forms the blue test-paper required for ascertaining the presence of acids. The paper is also supplied reddened. For this purpose the blue paper is steeped in water acidified with sulphuric or hydrochloric acid. An alkaline solution turns this red paper to a blue colour. Test-paper should be kept in a bottle to exclude the air. If the paper should by exposure become red, the colour may be restored by being held over the mouth of a bottle containing ammonia.

**Liver of Sulphur** (see *Potassium Sulphide*).

**Magnesium** ( $\text{Mg}$ ).—For the use of this metal for photographic purposes see *Magnesium Light*.

The bromide ( $\text{MgBr}_2 + 3\text{H}_2\text{O}$ ) and iodide ( $\text{MgI}_2$ ) of this metal may be used in collodion, and the chloride ( $\text{MgCl}_2$ ) is used in gelatino-chloride emulsion.

**Mastic or Gum Mastic.**—This gum may be dissolved in alcohol, chloroform, and other solvents. It is used in the preparation of varnish.

**Mercuric Chloride** ( $\text{HgCl}_2$ ; also called Bichloride of Mercury and Corrosive Sublimate).—A highly poisonous white compound, soluble in 16 parts of water. It dissolves in  $2\frac{1}{2}$  parts of alcohol or 3 parts of

ether. It is used for intensifying negatives. When the plate has been thoroughly washed after fixing, a solution of mercuric chloride, if left for a time on the plate (which must be in a dish covered with the solution or on a levelling stand), whitens or bleaches the film; the mercuric chloride has reacted with the silver in the film, and another substance, calomel ( $\text{Hg}_2\text{Cl}_2$ ) has been formed. The white image may be changed in various ways. A solution of ammonia turns it black. Sodium thiosulphate answers the same purpose, but ammonia is generally used.

**Mercury or Quicksilver (Hg).**—In its liquid state there is now no use for this metal in photography, but in the daguerreotype process the *vapour* produced by the application of heat was used to develop the latent image.

**Meta-Gelatine.**—A solution of gelatine which has been boiled and allowed to cool several times loses its power of forming a jelly on cooling, and in this state is called *meta-gelatine*. It has been used in the collodion process as a preservative. The preparation of the substance was thus described by Mr. Maxwell Lyte:—Dissolve  $1\frac{1}{2}$  ounces of white gelatine in 10 ounces of boiling water, and then add 60 minims of strong sulphuric acid, diluted with  $2\frac{1}{2}$  ounces of water. Boil for five minutes and allow to cool. Boil again for five minutes and again cool. The operation must be repeated if it should still gelatinise. When it remains fluid, the acid is neutralised with powdered chalk, and the sulphate of lime which is formed is removed by squeezing the fluid through a cloth.

**Methylated Spirit.**—When 10 parts of wood-naphtha are added to 90 parts of rectified spirit, what is called *methylated spirit* is formed. This was allowed to be sold duty free. For most purposes in photography this inferior spirit answers as well as the best. In the collodion process it may be used in the developing solutions, and when it is required to dry gelatine plates quickly; if they are immersed in this spirit for a few minutes, most of the water is absorbed, and the plates are quickly dried in a current of air. It is also the solvent in the preparation of varnishes.

Another and inferior kind of methylated spirit is sold under the name of *finish*. This contains three ounces of shellac or sandarac to each gallon of spirit. If when water is added to methylated spirit the solution turns milky, it shows that it is the inferior kind.

As some change has recently been made by the Excise Department of the Inland Revenue in the quantity of gum to be added to the spirit before it may be sold duty free, what has been said as to its use for photographic purposes may require to be modified. If, instead of the methyl spirit now used to degrade the alcohol, any kind of

mineral spirit is substituted, such degraded spirit would no longer be suitable for photographic purposes.<sup>1</sup>

**Mounts.**—The difference in appearance between a mounted and an unmounted photograph is so marked that some consideration should be given to the kind of mount to which the print should be attached. There can be very little doubt that *plate* paper (that is, the kind of paper on which large engravings are usually printed, having printed on it a tint to imitate india-paper about an inch larger in every way than the photograph) has the best appearance, especially when the mounting has been done under pressure, so as to leave a *plate-mark* on the mount. The professional mounters of photographs have a method for effecting this kind of mounting which leaves nothing to be desired. If cardboard mounts are used, they should be thick, at least six-sheet, otherwise, when the prints are large, the cockling of the board has a bad appearance. It is entirely a matter of taste whether photographs should have border lines of any kind when mounted on cardboard. When the india-tinted mounts are used, border lines are altogether unsuitable and unnecessary.

**Nitric Acid** ( $\text{HNO}_3$ ; also called *Aqua fortis*).—This is generally obtained of sp. gr. 1.42, but acid of sp. gr. 1.2 is used for most photographic purposes. The pure acid is employed for dissolving silver to form silver nitrate. The strong acid is mixed with sulphuric acid in the preparation of pyroxylin. For acidifying the silver bath the pure acid must be employed. Nitric acid of the “commercial” quality is used as a solvent for the zinc in etching the plates for making blocks for printing purposes. A weak solution of the acid is used as a clearing solution after collodion plates have been strengthened with lead nitrate. The acid is employed in various other ways in photographic manipulation; amongst others, the commercial kind is useful, when diluted, for cleaning glass plates. Care should be observed in handling nitric acid, as it produces stains on the skin, while the fumes given off by the acid, especially on dissolving the metals in it, are of a highly poisonous nature.

**Oxalic Acid** ( $\text{H}_2\text{C}_2\text{O}_4 + 2\text{H}_2\text{O}$ ).—A crystalline white solid, somewhat easily soluble in water and alcohol. The free acid may be used in the platinotype printing process to acidify the sensitising and developing solutions. Many of its salts are of importance in photography, as the potassium, sodium, and iron oxalates. It is highly poisonous.

<sup>1</sup> The duty-free spirit is now sold mixed with mineral naphtha or oil. In order to obtain the spirit methylated so that it is fit for photographic use, application must be made to the Board of Inland Revenue, who will grant a special authority on satisfactory evidence being given that the spirit is to be used for the purpose stated. Application must be made to an officer of the Inland Revenue, and when the order is granted, the spirit may be obtained from a distiller.

**Ox-Gall.**—The gall of the ox, when purified and evaporated, is the substance used by artists to cause water-colours to flow readily. The surface of albumenised paper is repellent to aqueous solutions; and as water-colour is often used on such paper, it will be found that a small quantity of ox-gall mixed with the colour will entirely remove the greasiness of the surface.

**Palladium (Pd).**—This metal was discovered by Wollaston in platinum ores. The salt used in photography for toning is the palladious chloride,  $\text{PdCl}_2$ . The following is said to give good colour to prints on plain salted paper:—

Palladious chloride . . . . .	1 grain.
Sodium sulphite . . . . .	60 grains.
Water . . . . .	10 ounces.

The result is very similar to platinum toning, but, as the metal is much more costly (about 6d. per grain) than platinum, it is not likely to take the place of the latter metal or gold.

**Paper.**—At the time when photographers had to prepare their own paper, the proper kind to select was a matter of great importance; they had very little choice, and Whatman's writing-paper was generally used, but after a time paper was manufactured specially for photographic purposes. Amongst the makers the names of Canson, Marion, Hollingworth, and Harrison occur; later, the papers known as *Saxe* and *Rive* came generally into the market, and are now almost exclusively used. The qualities of paper of different make are almost as varied as their makers, although the materials used are in all cases the same—that is, cotton and linen. The difference arises chiefly in the kind of size used. As, however, the photographer in these latter days takes advantage of the convenience of using paper which he can purchase ready prepared, so far as the plain or albumenised papers are concerned, his choice lies between the *Saxe* and *Rive*, which may be had of different thicknesses, and generally of the size about  $22 \times 18$  inches. When the paper is required ready sensitised, the purchaser has many varieties to select from, and no advice can be given, as one operator will succeed with a certain kind when another will fail.

When a sheet of paper is examined by reflected light, it will be found that the two surfaces are not alike; one side is slightly smoother than the other. The smooth side should be selected and marked. Whatman's drawing-paper may be used when a photograph is to be finished in water-colours. When selecting the proper surface, it should be examined for minute specks of metal, which sometimes causes serious defects in the print.

**Cardboard.**—When two or more sheets of paper are pasted together,

we have a substance on which it is convenient to mount photographs, and care should be taken to select the best. The surface should be perfectly even, as it not unfrequently happens that the paper forming the middle of the sheet of cardboard is of inferior quality to the exterior sheets; and, should there be any irregularities, the effect of the mounted print will certainly be deteriorated. Another important matter in selecting the best is that prints mounted on inferior board frequently fade owing to impurities in the paper. Generally it may be said that cardboard of the best quality will be free from the defects referred to.

**Paraphenylene-diamine** ( $C_6H_4(NH_2)_2$ ).—This is another of the substances allied to hydroquinone, which can be used to develop gelatino-bromide plates, but there appears to be no advantage gained by its use.

**Platinum** (Pt).—This valuable and rare metal, owing to its not being soluble in acids, excepting in aqua regia, and to its great infusibility, is used for many purposes in the chemical laboratory. The salts of the metal are used in the platinotype process.

There are two series of the platinum salts, the platinous and platonic compounds. The most important of these is *Platonic chloride* ( $PtCl_4$ ), a brown deliquescent solid, soluble in water, alcohol, and ether. It is sensitive to light, and forms double salts with the chlorides of the alkali metals, *e.g.*,  $PtCl_4 + 2 KCl$ . *Platinous Chloride* ( $PtCl_2$ ) plays, together with its double salt  $PtCl_2 + 2KCl$ , an important part in the platinotype process. Ferrous oxalate reduces it to platinum black. Platinum salts can also take the place of gold compounds as toning agents.

**Poisons.**—Many of the substances used in photography are of a most poisonous nature; but, as such substances should always be kept in bottles of a blue colour, carefully labelled, and placed out of the way of children, very little need be said excepting by way of caution. It is difficult to conceive that fluids in use in the workroom of a photographer, whether amateur or professional, would ever be swallowed by accident, while the poison in the solid state could scarcely be used for suicidal purposes. The precautions to be observed when using potassium bichromate have already been alluded to in treating of the carbon process, but should any be taken into the stomach, an emetic, powdered chalk or magnesia, should be administered. The antidote for potassium cyanide is a solution of iron proto-sulphate as used for developing. There are others, but they would take too long to prepare, and in cases of poisoning with cyanide the antidote must be given at once. Mercury bichloride, another of the most active poisons in common use, permits of no delay in administering an antidote. The white of an egg or a mixture of flour and water



should be given at once. For silver nitrate a solution of common salt is the best remedy. If acids have been taken, any alkali will be the most effectual; chalk, or a lump of plaster knocked from a wall, would be a good substitute if powdered and mixed with water.

**Potassium Bromide** (KBr).—A white crystalline solid, soluble in 10 parts of water, and but slightly soluble in alcohol or ether. It is used in the gelatine emulsion, and acts as a restrainer in the developing solutions for gelatine plates.

**Potassium Carbonate** ( $K_2CO_3$ ).—This salt is known under various names, such as potashes, pearl-ash, salt of tartar, and subcarbonate of potash. It is used in the development of gelatine plates. The crude potashes should not be used in developing solution on account of impurities which have a deleterious influence.

**Potassium Chlorate** ( $KClO_3$ ; Chlorate of Potash).—It crystallises in shining plates, not readily soluble in water. It easily parts with oxygen, and is therefore a powerful oxidising agent. It is used in the platinotype process as an ingredient of the sensitising solution.

**Potassium Chloroplatinite** ( $K_2PtCl_4$ ).—In the platinotype process this is called *red salt*, and its use is, that with ferrous oxalate, it reduces the platinum to the metallic state.

**Potassium Cyanide** (KCN; commonly called Cyanide, or Cyanide of Potassium).—A most powerful poison. It is generally used in the collodion process in preference to sodium thiosulphate to dissolve the iodide of silver from the film, or, in other words, to *fix* the image. The solution should be used only of such strength as will be sufficient to dissolve the iodide, as the cyanide salt possesses the power of acting on metallic silver, and thus would weaken the image. Potassium cyanide cannot be used to fix gelatine plates, as it has a solvent action on the gelatine.

**Potassium Dichromate** ( $K_2Cr_2O_7$ ; also called Bichromate of Potash and Red Chromate of Potash).—In the presence of gelatine this salt is acted on by light and the gelatine is made insoluble. It is this quality which makes it valuable in all processes such as photolithography and zinc-etching. The salt in the latter case is used with albumen, in which the action is similar to that with gelatine.

**Potassium Ferricyanide** ( $K_3FeCy_6$ ; also called Ferridecyanide of Potash and Red Prussiate of Potash).—When chlorine gas is passed into a solution of potassium ferrocyanide the oxidising action of the chlorine produces the ferricyanide. This substance is employed in many of the formulæ described. The ferricyanide gives a dark blue compound with ferrous salts, ferrous ferricyanide,  $Fe_3Fe_2Cy_{12}$ , or *Turnbull's blue*. It is used in the preparation of blue prints, and, with sodium thiosulphate, as a reducing agent for negatives that are too dense.

**Potassium Ferrocyanide** ( $K_3FeCy_6 + 3H_2O$ ; also called Yellow Prussiate of Potash).—In the cyanotype process, in which the image on the paper is white on a blue ground, this salt is employed, together with a ferric salt. The two compounds produce a blue insoluble body, ferric ferrocyanide or *Prussian blue* ( $(Fe_2)_2(FeCy_6)_3$ ).

**Potassium Iodide** (KI).—This salt is used in the preparation of gelatine emulsion. It is made by dissolving iodine in solution of caustic potash; it is then evaporated, and the solid mass is ignited to redness. It is soluble in 70 parts of alcohol and in 120 parts of alcohol and ether.

**Potassium Oxalate** ( $C_2K_2O_4 + H_2O$ ; Oxalate of Potash).—A colourless crystalline solid, readily soluble in water. Its solution must not have an alkaline reaction. The water employed should be free from calcium, otherwise it forms a white precipitate of calcium oxalate.

The principal use for this salt is in the platinotype process, in which it is used as the developer; in the production of ferrous oxalate the salt is also used for developing gelatino-bromide plates.

**Potassium Permanganate** ( $KMnO_4$ ; Permanganate of Potash).—This salt forms dark metallic-looking crystals. It is freely soluble in water, with which it gives a deep violet solution. It may be used to intensify plates in the wet collodion process. In the form known as Condyl's fluid it is a disinfectant. Its action depends on its being a powerful oxidising agent, for which reason it can also be used for purifying the silver bath by oxidising the organic matter which has become dissolved in it.

**Potassium Sulphide** ( $K_2S_3$ ; commonly called Liver of Sulphur).—It consists of a mixture of sulphides of potassium made by heating sulphur and potassium carbonate in closed vessels, and is used to precipitate silver from solution of sodium thiosulphate.

**Pyrocatechin** ( $C_6H_4(OH)_2$ ; Ortho-dihydroxybenzene, Catechol, Oxyphenic Acid, Brenzcatechin).—This substance is one of the derivatives of coal-tar, and is isomeric with hydroquinone (the para-dihydroxybenzene), and can be used as a developing agent in photography. It was first employed by Toth and Eder in 1880, who claim for it a more energetic action than hydroquinone. The formula is:—

A. Pyrocatechin . . . . .	1 part.
Sodium sulphite . . . . .	4 parts.
Water . . . . .	40 „
B. Potash . . . . .	4 „
Water . . . . .	40 „

Mix one part of A. to two parts of B.

The high price at present prevents the general use of this substance, but (as has been the case with its relatives eikonogen,

hydroquinone, and pyrogallol) if there were advantages in its use, the discovery of cheaper modes of production would quickly cause a reduction in price.

**Pyrogallol** ( $C_6H_3(OH)_3$ ; Pyrogallic Acid, Pyro, Trihydroxybenzene).—Pyrogallol is a trihydroxybenzene derived from gallic acid by destructive distillation, carbon dioxide being driven off as one of the products of decomposition, the reaction being:—

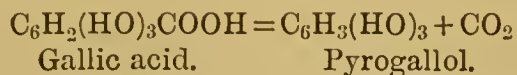

Gallic acid was one of the earliest reducing agents used in photography, but, although the substance derived from it (pyrogallic acid) was known as early as 1831, it was not until 1851 that it was first suggested by Liebig and Regnault as a developing agent, and it still maintains its position, although the allied substances hydroquinone, eikonogen, and some others, have recently become established as rivals.

In the manufacture of pyrogallol, gallic acid is subjected to a temperature of about  $410^\circ$  F., when the latter is decomposed and the pyrogallol is condensed in lamellar shining-white crystals. The substance is soluble in water, alcohol, and ether, and quickly decomposes on exposure to the air or in aqueous solution; so that the addition of sodium sulphite, citric acid, or some other substance is necessary to arrest the decomposition.

When the collodion process was first introduced, pyrogallic acid was almost exclusively used as a developing agent; but it was superseded by iron protosulphate, and is now used in the wet collodion process, chiefly in redeveloping (or strengthening) the negative image. When, however, dry processes were introduced, pyrogallol became of the utmost value, as it was found by Colonel Russell that in presence of ammonia its action was that of a powerful developing agent for tamin plates; and it has the same properties and advantages with gelatino-bromide plates. The affinity of an alkaline solution of pyrogallol for oxygen makes it necessary to restrain its action, and for this purpose potassium bromide is used.

Pyrogallol or pyrogallic acid can lay no claim to the title of an acid; it is more correctly a triatomic phenol. It is a neutral compound, which neither reddens litmus nor forms any well-defined salts.

**Pyroxylin** or **Gun-Cotton**.—That used in photography is essentially a tetra-nitrate and penta-nitrate of cellulose,  $C_{12}H_{16}(ONO_2)_4O_6$  and  $C_{12}H_{16}(ONO_2)_5O_5$ , which dissolve in alcohol and ether, forming collodion. These compounds are formed by warming cotton for some time with 20 parts nitre and 30 parts concentrated sulphuric acid.

The peculiar properties of pyroxylin depend on the character of the

fibre from which it is made, the proportions of the acids used in its manufacture, and the temperature at which the cotton is immersed.

As the preparation of pyroxylin is a somewhat troublesome operation, very few amateurs will make it for themselves; but, for those who wish to attempt its preparation, two of the formulæ with the necessary directions are given here. Hardwich is the authority usually quoted, and the following is condensed from his "Photographic Chemistry."

*The Nitre Process.*—Only the best nitrate of potash should be used. It must be reduced to a powder, dried on a hot metal plate in an oven, and again pulverised. Take of—

Oil of vitriol (sulphuric acid)	. . . . .	6 ounces.
Dried nitre (potassium nitrate)	. . . . .	3½ "
Water	. . . . .	1 ounce.
Best cotton-wool	. . . . .	60 grains.

The acid and water must be mixed in a cup or other porcelain vessel, the sulphuric acid being poured into the water (on no account must the water be poured into the acid, as serious explosions and burns through the scattered acid may result), and the powdered potassium nitrate stirred in with a glass rod. The cotton must be pulled into balls about the size of a walnut, and when a thermometer placed in the acid remains at 60° C. (140° F.), the cotton balls must be put in singly and pressed against the sides of the cup with a glass rod.

If the temperature of the acid falls below 140° F., the cup must be floated on boiling water to raise the heat. The cotton must remain in the acid ten minutes, the excess of acid must be poured off, the pyroxylin pressed against the cup with the glass rod, and the whole then quickly placed in cold water and moved about until it is itself quite cold.

*The Process with Mixed Acids.*—In this process larger quantities of cotton may be treated, as the temperature has less chance of alteration. Take of—

Nitric acid, sp. gr. 1.45	. . . . .	6 ounces.
Sulphuric acid, sp. gr. 1.84	. . . . .	18 "
Water	. . . . .	4½ "
Cotton	. . . . .	400 grains.

Into a deep narrow porcelain vessel pour first the water, then the nitric acid, and the sulphuric acid last, and stir well with a glass rod. The temperature at first will indicate from 165° to 170° F. (70° to 80° C.), which will in about twenty minutes fall to 140° F. (60° C.), the proper temperature for immersing the cotton. This is very important, and the acids must be stirred with the thermometer to ensure accuracy. The 400 grains of cotton must be separated into two

equal weights—one-half set aside to be dealt with afterwards, the other divided into about twenty portions, all to be pulled out loosely, and each portion put separately into the acids when the temperature has reached the proper point. This must be quickly done, and the cotton moved about and pressed against the side of the vessel to ensure the acids being properly taken up. The vessel must now be covered up and left for ten minutes. The cotton is then taken out quickly, if possible in one mass, and pressed against the side of a shallow vessel; then pour away the acid into the deep vessel, at once put the cotton and the vessel containing it into a large quantity of water, and immediately take hold of it with the hand, rapidly moving it about until it is cool and separates in the water.

The second half of the cotton may now be treated, the acids being warmed in a hot-air bath to  $144^{\circ}$  F., and 6 drachms of sulphuric acid added; allow to cool to  $140^{\circ}$  F., and put in the 200 grains of cotton, treating it like the first half.

The pyroxylin must now be washed. Pour off all the water, and then allow running water to pass through the wool for forty-eight hours. When thoroughly washed, squeeze out all the water, pull the fibre out well, and expose it in the air to dry on blotting-paper. In the summer, sun heat may be used to complete the drying; at other times a drying dish containing sulphuric acid must be used.

The pyroxylin when thoroughly dry should be kept in stoppered bottles.

Pyroxylin may also be made from linen, wood, calico, paper, and other substances.

**Quinol** (see *Hydroquinone*).

**Ready Sensitised Paper.**—Directions for preparing paper with silver nitrate will be found under the heading *Printing and Toning*. When paper is required only in small quantities, it may be purchased ready for use; and although the results after printing may not be equal to the freshly prepared paper, the saving of time and trouble is considerable. Many formulæ have been published for preserving paper in a sensitive state, (the tendency of freshly prepared paper is to turn yellow after a few days, and in some cases hours); amongst them is the following, recommended by Mr. Ashman:—

White gum-arabic, picked	. . . . .	3 parts.
Tartaric acid	. . . . .	2 „
Hydrochloric acid	. . . . .	2 „
Citric acid	. . . . .	2 „
Water	. . . . .	100 „

The paper is sensitised in the usual way, and when dry it must be floated on the back on the above solution for four or five minutes, dried, and then stored under pressure.

Another method for preserving paper is given by Mr. Burton as under:—

“For ordinary printing, where the highest degree of sensitiveness is desired, the proportion of silver must be increased, and the paper should be fumed with ammonia before being used:—

Nitrate of silver	. . . . .	75 grains.
Citric acid	. . . . .	75 „
Water	. . . . .	3 ounces.

“Take one-fourth of this quantity ( $\frac{3}{4}$  oz.), and having formed a full sheet of ordinary albumenised paper into a dish by turning up the edges—say one-fourth of an inch all round—pour upon it the sensitising fluid, and spread it with a Buckle’s or Blanchard’s brush.”

If it is only required to keep for a short time paper which has been freshly sensitised, it may be placed between paper which has been saturated with sodium bicarbonate. When the soda paper is quite dry the sensitised sheets are placed face to face between the preserving paper.

It must be borne in mind that ready-sensitised paper will not keep indefinitely, also that there is much difference in the keeping qualities of the various kinds in the market.

The best results on albumenised paper can only be obtained when the paper is freshly prepared, and not subjected to any “preserving” process; but the great convenience of having paper always ready, and the trouble of preparing it avoided, has made ready-sensitised paper almost an absolute necessity, and it is now probably used by every amateur and most professional photographers.

**Rodinal.**—This fluid, recently introduced for developing gelatino-bromide plates, is a concentrated solution of *Para-amidophenol*. For negatives which have received a normal exposure, the rodinal should be diluted with 30 parts of water; but with 40 parts of water the development would be more under control. When a plate has been over-exposed potassium bromide should be added, or a portion of the developing solution which has already been used. If under-exposed, the negative should be developed with a weak solution of rodinal. From 100 to 200 parts of water may be added to the developing solution if used for gelatino-bromide paper. It will be noticed that this is a *one-solution* developer, and it is well spoken of by many of those who have tried it. This new developing solution is patented by Dr. M. Andresen. It is supplied ready for use.

**Sandarac or Juniper Resin.**—This gum or resin is soluble in turpentine and alcohol, and is sometimes used in making varnish.

**Shellac or Gum Lac.**—This is a brown gum, which may be bleached till nearly white. It is used in making varnish, and for some other

purposes, such as the preservation of wood from the action of fluids. It is readily soluble in alcohol.

**Silver** (Ag. At. wt. = 108; sp. gr. 10.5).—In its metallic state silver is used in the form of wire for dippers for the wet collodion silver bath; the small quantity of nitric acid in the solution has very little effect on the wire; the wire is also used as the corner supports in the carrier frames. It was formerly used in the daguerreotype process in thin sheets attached to a thicker plate of copper, and upon the silver surface the picture was formed. When dissolved in nitric acid, silver nitrate is formed. Sulphuric acid also acts as a solvent, forming sulphate of silver.

This metal is found combined with various substances as a chloride in *horn silver*, the term by which it was known to the alchemists; it also occurs in lead and copper ores, and it is found combined with sulphur, antimony, and bromine. The purity of the colour of the metal is preserved unless exposed in the air to sulphuretted hydrogen, which causes the surface to tarnish.

The various salts of silver enter very largely into most of the photographic processes.

**Silver Bromide** (AgBr = 188).—The precipitate formed when an alkaline bromide is added to silver nitrate, is known as *silver bromide*, and when used in the preparation of gelatine plates gives the extreme sensitiveness to light which such plates possess. The reactions which light causes in the haloid salts of silver are still matters of speculation amongst chemists, and although the subject has caused much experimental research, it cannot be said that satisfactory results have yet been arrived at. It was with the vapour of bromine that the daguerreotype plate was made extremely sensitive to light when used with the vapour of iodine, and it is the presence of the bromide with the silver in the gelatine film which gives the value to the latest improvement in photography known as the *gelatino-bromide* process.

**Silver Chloride** (AgCl = 143.5).—The earliest record we have of the chemical change produced by light was the observation that in its native state *horn silver*, which is the chloride of the metal, changed colour when exposed to light in the presence of organic matter of any kind, changing from all shades of grey to blackness. This quality of changing colour renders this salt of silver of the greatest value to photographers, as upon it depends the various processes of printing in which it is used.

**Silver Iodide** (AgI = 235).—It is distinguished from the bromide and chloride by its yellow colour. In the wet collodion process the iodide contained in the collodion becomes converted into silver iodide when acted on by the silver nitrate in the silver solution or *bath*, and

in this state is highly sensitive to light. The image produced on the film is invisible, but on the application of suitable reducing salts the picture is revealed, and we have either a *negative* or *positive* image, according as the manipulation is modified. Silver iodide is also used in the preparation of emulsions.

**Silver Nitrate** ( $\text{AgNO}_3 = 170$ ; called also Lunar Caustic).—As generally employed for photographic purposes, this salt is either in flat crystals, or, when fused, in cakes and sticks, when it is called *lunar caustic*. The recrystallised salt should be used by preference. Fused nitrate was at one time recommended, but it is possible that *silver nitrite* may be formed in fusing the salt, and this, if employed in the wet collodion process, causes *fog*, when the solution cannot be used for some days, during which a change occurs, and the addition of a small quantity of nitric acid puts the bath in working order again.

**Silver Oxide** ( $\text{Ag}_2\text{O} = 232$ ).—The oxide of silver has very little use in photography. It is occasionally used to neutralise solutions of silver nitrate, as it is dissolved by any free acid with the formation of the neutral nitrate.

**Silver Sulphide** ( $\text{Ag}_2\text{S}$ ).—This is the compound formed when liver of sulphur is added to old sodium thiosulphate fixing solution. It is converted into metallic silver by fusion or by mixing with an alkaline carbonate, the latter being the simpler process.

**Sodium Acetate** ( $\text{NaH}_3\text{C}_2\text{O}_2 + 3\text{H}_2\text{O}$ ).—A crystalline solid which melts without decomposition. It is used with gold chloride in certain formulæ for toning prints.

**Sodium Carbonate** ( $\text{Na}_2\text{CO}_3 + 10\text{H}_2\text{O}$ ). It is known under various names, such as Washing Soda, Sal Soda, Carbonate of Soda).—This salt may be obtained in various degrees of purity, but the common washing-soda is sufficiently pure for making the toning bath alkaline. Soda-ash, a calcined form of the carbonate, free from water of crystallisation, is used in the reduction of silver residues.

**Sodium Chloride** ( $\text{NaCl}$ ).—One of the most widely distributed salts, known as common salt, rock-salt, and by various other names. It is generally used, together with silver nitrate, to render paper sensitive to light. Amongst its other uses are its addition to silver solutions to recover the silver, and it may be employed in a moist state for cleaning porcelain or glass, the salt being well rubbed over the dish with the hand.

Silver chloride is slightly soluble in a solution of sodium chloride, a difficultly soluble double salt ( $\text{NaCl} + \text{AgCl}$ ) being formed. It was this property which enabled the salt to be used for fixing silver prints before the use of sodium thiosulphate was discovered.

**Sodium Nitrate** ( $\text{NaNO}_3$ ; also called Saltpetre).—A compound



little used in photography, but it is occasionally added to the silver bath used in the collodion process. Silver nitrate has been adulterated by mixture with it.

**Sodium Oxalate** ( $\text{Na}_2\text{C}_2\text{O}_4$ ).—A crystalline solid, very readily soluble in water, and used in one of the platinotype processes.

**Sodium Silicate** or **Water Glass**.—The chief use for this salt is in the preparation of the substratum on glass used in the collotype process. It generally occurs in commerce as a syrupy liquid.

**Sodium Sulphite** ( $\text{Na}_2\text{SO}_3 + 7\text{H}_2\text{O}$ ).—Sometimes used as a preservative of “pyro” and its congeners, as its great affinity for oxygen retards the oxidation of those substances. This ready oxidisability necessitates its being kept in well-closed bottles, otherwise it is soon converted into sodium *sulphate*. It may also be used for fixing prints; but sodium thiosulphate is cheaper and answers the purpose better.

**Sodium Thiosulphate** ( $\text{Na}_2\text{S}_2\text{O}_3 + 5\text{H}_2\text{O}$ ; commonly known as “Hypo” or Hyposulphite of Soda).—In the preparation of this salt a current of sulphur dioxide is passed into a mixed solution of sodium sulphide and caustic soda, and when purified by crystallisation the sodium thiosulphate is obtained in large colourless crystals, soluble in their own weight of water. It can now also be prepared from the residue of the soda manufacture. As no substitute for the substance so long known under the name *hyposulphite of soda* has yet been discovered, and as its history is not generally known by those who use this valuable fixing agent, no apology is perhaps necessary for introducing here matter which the writer published in 1866. It may be stated that the early photographs on paper were partially fixed by washing with a solution of potassium iodide or bromide. Ammonia had also been tried, but common salt was found to be better for the purpose.

The following is quoted from the *Proceedings of the Manchester Literary and Philosophical Society* of April 12, 1866, Photographic section, “Note on the First Use of Hyposulphite of Soda in Photography” :—

“During an investigation into the early history of photography, I met with the statement that Daguerre used hyposulphite of soda in his process for fixing the pictures, and also that in Mr. Talbot’s patent the use of that substance was included. I was under the impression that Sir John Herschel had pointed out that hyposulphite of soda would fix the photographic image, but was unable to ascertain where or when the discovery was first published. In order to determine this point, I wrote to Sir John Herschel, requesting him to inform me whether the discovery was his, and the date when it was published. To these questions I received the following reply :—

‘COLLINGWOOD, October 29, 1864.

‘SIR,—I think I may very fairly claim the discovery of the hyposulphites as fixing agents, as I believe I was the first to call the attention of chemists to that class of salts and their peculiar habits, especially in relation to the insoluble salts of silver.

‘In my paper “On the Hyposulphurous Acid and its Compounds,” which bears date January 8, 1819, and which appeared in Brewster & Jamieson’s *Edinburgh Philosophical Journal*, 1819, occur these words:—

‘“One of the most singular characters of the hyposulphites is the property their solutions possess of dissolving muriate of silver and retaining it in considerable quantities in permanent solution” (p. 11).

‘“*Hyposulphite of Potash*.—It dissolves muriate of silver, even when very dilute, with great readiness” (p. 19.)

‘“*Hyposulphite of Soda*.— . . . Muriate of silver newly precipitated dissolves in this salt when in a somewhat concentrated solution in large quantity, and almost as readily as sugar in water” (p. 19).

‘“*Hyposulphite of Strontia*.— . . . Like the rest of the hyposulphites, it readily dissolves muriate of silver, and alcohol precipitates it as a sweet syrup” (p. 21).

‘“*Hyposulphite of Silver*.—Muriate of silver newly precipitated is soluble in all liquid hyposulphites, and, as before observed, in that of soda with great ease and in large quantities. This solution is not accomplished without mutual decomposition, as its intense sweetness proves—a sweetness surpassing that of honey, and diffusing itself over the whole mouth and fauces, without any disagreeable or metallic flavour” (p. 27).

‘In a second paper on the same subject, which appeared in the same journal, vol. i. p. 396 *et seq.*, it is shown (*inter alia*) that the affinity of this acid for silver is such that oxide of silver readily decomposes hyposulphite of soda, and likewise the soda in a caustic state, “the only instance, I believe, yet known of the direct displacement of a fixed alkali *viâ humidâ* by a metallic oxide” (p. 397).

‘“*Hyposulphite of Ammonia and Silver*.—Its sweetness is unmixed with any other flavour, and so intense as to cause pain in the throat. . . . One grain communicates a perceptible sweetness to 30,000 grs. of water” (p. 399).

‘In a third communication, dated November 1819—“The habits of this acid with the oxide of mercury are not less singular than its relation to that of silver.”—“The red oxide is readily dissolved by . . . hyposulphite of soda, while the alkali is set at liberty in a caustic state,” &c. &c.

‘The very remarkable facts above described I have reason to

believe attracted a good deal of attention at the time, and thenceforward the ready solubility of silver salts, usually regarded as insoluble, by the hyposulphites was familiar to every chemist. It would not, therefore, be surprising if Daguerre tried to *fix* his plates (*i.e.*, to wash off the iodide coating); but I have been informed, though I cannot cite a printed authority for it, that at first he fixed with ammonia, or with a strong solution of common salt.

‘For my own part, the use of the hyposulphites was to myself the readiest and most obvious means of procedure, and presented itself at once. My earliest experiments were made in January 1839, and in my notebook I find :—

“Exp. 1012.—1839, Jan. 29.—Experiments tried within the last few days, since hearing of Daguerre’s *secret*, and also that Fox Talbot has got something of the same kind.” . . . [Here follow some trials of the relative sensitiveness of the nitrate, carbonate, acetate, and muriate of silver. I should observe that at that time I did not even know what kind of pictures Daguerre had produced. This process was not revealed till August 1839.]

“Exp. 1013.—Daguerre’s process—attempt to imitate. Requisites—1st, very susceptible paper; 2nd, very perfect camera; 3rd, means of arresting further action. Tried hyposulphite of soda to arrest the action of light by washing away all the chloride of silver or other silver salt; succeeds perfectly. Papers half acted on, half guarded from the light by covering with pasteboard, were withdrawn from sunshine, sponged over with hyposulphite, then washed in pure water, dried, and again exposed. The darkened half remained dark, the white half white, after any exposure, as if they had been painted with sepia.”

“Jan. 30, 1839.—Formed image of telescope with the aplanatic lens . . . and placed in focus paper with carbonate of silver. An image was formed in white on a sepia-coloured ground . . . which bore washing with hyposulphite of soda, and was then no longer alterable by light. Thus Daguerre’s problem is so far solved,” &c., &c.

“Exp. 1014.—Jan. 30.—Tried transfer of print and copper-plate engraved letters,” &c., &c.

‘The publication of Daguerre’s process (according to Dr. Monckhoven, for I cannot refer at present to the original document) took place on the 19th August 1839. My early experiments, printed in the notices of the Proceedings of the Royal Society of March 14, 1839, in which occurs this passage in the abstract of a paper read to the Society :—

“Confining his attention in the present notice to the employment of chloride of silver, the author inquires into the method by which the blackened traces can be preserved, which may be effected, he

observes, by the application of any liquid capable of dissolving and washing off the unchanged chloride, but leaving the reduced oxide of silver untouched. These conditions are best fulfilled by the liquid hyposulphites."

'“Twenty-three specimens of photographs made by Sir J. Herschel accompany his paper—one a sketch of his telescope at Slough, fixed from its image in a lens.'

'This is the image above mentioned as having been taken on January 30, 1839, and was, I believe, the first picture ever fixed from an optical image ever taken in this country—at least I have heard of none earlier.

'At the time of making these experiments, as already mentioned, I had no knowledge of M. Daguerre's process further than the mention of the existence of *a process* (a secret one) in a note from Admiral (then Captain) Beaufort some time about January 23, 1839. Of course I used *paper*, not silver—and it was not a *suggestion*, but a regular and uniform *practice* to use the hyposulphite—I never used anything else.—I am, Sir, your obedient servant,

'J. F. W. HERSCHEL.'

“In reference to the subject of *fixing* the photographic image, I find the following passage in a paper read before the Royal Society on January 31, 1839, by Mr. Talbot. After referring to the improvements of Wedgwood and Davy in 1802, and the difficulties they found in making the paper sufficiently sensible to receive the impression in a camera obscura, and their inability to *fix* the pictures, the author states that 'his experiments were begun without his being aware of this prior attempt; and that in the course of them he discovered methods of overcoming the two difficulties above related. With respect to the latter he says that he has found it possible by a subsequent process so to fix the images or shadows formed by the solar rays that they become insensible to light . . . and states that he has exposed some of his pictures to the sunshine for the space of an hour without injury.'”

From this it is quite clear that “hypo” was first used for fixing the photographic image by Sir J. Herschel early in 1839.

Until 1869 it was not suspected that the “hypo” was not the substance its name implied. In July of that year M. H. Saint-Claire Deville communicated a paper, by M. P. Schützenberger, to the Academy of Sciences, Paris, entitled “Note on a New Sulphur Acid,” in which he describes experiments which led to the isolation of a new acid. This new acid he calls “hyposulphurous acid.” Without going into particulars, it will be sufficient to say that this discovery showed that the name borne by a substance already known was really

correct for the newly discovered substance. The old "hyposulphite" therefore required to be re-named; and as its composition showed that it was sulphuric acid, in which one atom of oxygen was replaced by sulphur, it was called *Thiosulphate of Soda*.

In chemical notation the hyposulphite of soda is  $\text{NaHSO}_2$ , and *thiosulphate of soda* is  $\text{Na}_2\text{S}_2\text{O}_3$ . It is the last-named substance which is so extensively used in photography.

In works dealing with photographic matters the term *sodium thiosulphate* is occasionally met with, but as chemists now recognise two substances, and call the one used in photography by its true name, there seems to be no reason why photographers should not be exact. Pyrogallic acid is another instance in which a change of name has occurred, and *Pyrogallol* is now recognised as the more correct term; but "pyro" is still used as the diminutive, and if the name must be shortened, instead of "hypo" it would be just as convenient to say "thio," while there may be some inconvenience in using a term which is not correct. If a photographer were to speak of *sodium hyposulphite* to a chemist, he would at once think it something different from what was in the mind of the photographer. It seems to the writer that this necessary alteration in the nomenclature of a term now so generally used incorrectly rests very much with the editors of the journals devoted to photography. By them other changes have been introduced, and the change in question presents no greater difficulties. If the term *hypo* must still be used, it would be better to write it "hypo," and thus show that a quoted, and not the correct term is intended.

The use of the sodium thiosulphate as a fixing agent depends upon its power of forming soluble double salts with the haloid compounds of silver, the portion unaltered by exposure being thus removed, and the plate or paper rendered indifferent to light.

In using sodium thiosulphate for fixing photographs on paper, it should always be remembered that the solution must be strong. If a weak solution be used, instead of the very soluble double salt  $\text{Ag}_2\text{Na}_4(\text{S}_2\text{O}_3)_3$ , there is formed an insoluble one having the formula  $\text{Ag}_2\text{Na}_2(\text{S}_2\text{O}_3)_2$ , which would remain in the film.

Solutions of sodium thiosulphate should never be used a second time, as, after a certain quantity of silver salt has been dissolved, another insoluble double salt begins to be formed, and is precipitated upon the film. It is, therefore, better to use two solutions, each containing not less than 4 ounces of the salt to 20 ounces of water.

As it is very difficult to get rid of the last trace of this salt when it has been used for fixing prints on paper, many substances have been suggested as eliminators, amongst them sodium hypochlorite, hydrogen perchloride, and iodine, but they are seldom employed.

**Starch** ( $C_6H_{10}O_5$ ) $n$ .—This substance is prepared from wheat, rice, potatoes, Indian-corn, and other substances. Its principal use to the photographer is for the purpose of mounting photographs, for which it is preferable, as it can be used cold, and if the skin which forms in cooling be taken off, it works smoothly. To prepare starch-paste, sufficient of the powder may be put into a eup, and worked into a paste with cold water; boiling water may then be poured in, and the whole stirred until it is seen that sufficient water has been added. Another way to prepare the starch, after it has been mixed with cold water, is to boil it. The paste does not keep long, and should not be used when it is the least acid. It is difficult to remove prints from the card or paper when starch has been the mountant. The print must be covered with boiling water, and allowed to remain some hours, if it does not come away at once, and in some cases the card-board may be peeled away from the back.

The purest form of starch is known as arrowroot. Unlike ordinary starch, it gives an almost clear solution when boiled with water; this form is, therefore, used in the preparation of some kinds of photographic paper.

Starch is sometimes used in sizing paper.

**Strontium Chloride** ( $SrCl_2 + 6H_2O$ ).—Soluble in water, less readily soluble in alcohol. It can take the place of the other chlorides in photographic processes; but the salts of strontium are very little used.

**Sulphuric Acid** or **Hydrogen Sulphate** ( $H_2SO_4$ ; commonly called Oil of Vitriol).—It is employed with nitric acid in the manufacture of pyroxylin. It has been used in some developing solutions, but, although one of the most important of the acids, its use in photography alone is very limited. It is used largely in the preparation of other acids. The acid generally obtained is a heavy, oily, nearly colourless liquid, of sp. gr. 1.83. If exposed in an open vessel in a confined space, such as the glass case containing a balance, this acid, by its strong affinity for water, has the effect of drying the air; this affinity for water necessitates great care in mixing the two substances (as when the acid has to be diluted). The acid must always be poured into the cold water with constant stirring, and never the water into the acid, as explosions would then almost certainly result.

**Tannic Acid** or **Tannin** ( $C_{14}H_{10}O_9 + H_2O$ ).—It occurs largely in gall-nuts. The pure acid is a colourless mass, and very soluble in water. It is precipitated from its aqueous solutions by many salts, and forms an insoluble compound with gelatine. In the manufacture of ink tannic acid is used with ferric salts. Glucose and gallic acid are formed when tannin is exposed to the air, or when treated with dilute acids. When heated to  $215^\circ$  F. the result is pyrogallie acid. It was at one time used as a preservative for collodion plates.

**Test-Paper** (see *Litmus*).

**Turpentine** ( $C_{10}H_{16}$ ; also called Terebine and Terebenthine).—From various trees of the pine and fir tribe a fluid exudes from which turpentine is prepared. From *Pinus sylvestris*, *P. nigra*, and *P. abies* common turpentine is obtained, and from the larch the kind called Venice turpentine. The oil of turpentine is made by distilling the crude turpentine with water; the residue is resin. Turpentine is chiefly used in photography as a solvent for resins used in the zinc-etching process.

**Uranium** (U. At. wt. = 239).—This metal is found in the mineral pitchblende, and has recently been discovered in Cornwall.

**Uranium Nitrate** ( $UO_2(NO_3)_2$  or **Uranyl Nitrate**).—It is used as described under *Uranium Printing Process*.

**Varnish**.—All photographs on glass are liable to injury in various ways if not protected by some kind of varnish. With care, albumen and gelatine films may be used without varnish; but as paper prepared with silver nitrate is to some extent hygroscopic, there is danger in stains being caused, and consequent injury to the picture if the negative is not protected.

Many substances are used in the manufacture of varnish, but to the amateur, as well as the professional photographer, it is of little consequence of what the varnish is composed, provided it will not crack, and is sufficiently hard to protect the film; and as the manufacture is a somewhat "sticky" operation, and the cost of the ready-made article is not excessive, it is advisable to purchase as required rather than make it.

As it is not possible always to obtain a *matt* varnish from the dealer, it may be made, as recommended by Mr. J. Wingrave, as under:—

Gum sandarac (picked)	. . . . .	$\frac{1}{4}$ ounce.
White lac	. . . . .	$1\frac{1}{2}$ "
Alcohol (methylated)	. . . . .	20 ounces.

Dissolve and filter. To four ounces of the above add two drachms of tartaric acid, shake well, and set aside to clear, and then decant into a clear dry bottle for use.

The negative to be varnished should be warmed, but not made too hot, and, after the varnish has been drained off, it should be held before a bright fire until the plate is hotter than the hand can bear, when it may be set aside till quite cold before being used.

A varnish to be used cold may be made from—

Powdered amber	. . . . .	1 ounce.
Chloroform	. . . . .	16 ounces.

Or, in place of the chloroform, the same quantity of benzole may be used.

As a protection to the film of a wet collodion plate, when it may be required only for a temporary purpose, it is often sufficient to cover it with a solution of gum arabic, which must be applied while the plate is wet. The solution of gum may also be used before varnishing in the ordinary way when the collodion has a tendency to split from the plate.

*Varnish, Black.*—To one ounce of asphaltum and 20 grains of india-rubber add 20 ounces of benzole. For varnishing brass-work, to produce a dead black, lamp-black should be added to thin shellac varnish, and tested until, when dry, no gloss is shown. The varnish may be applied with a camel's-hair brush. A good black for wood-work may be made with turpentine 16 ounces, lamp-black 8 ounces, and gold size 2 ounces. The lamp black is formed into a paste with turpentine, and then the rest of the turpentine and gold size is added.

**Water** ( $H_2O$ ).—For many purposes in photography the absolute purity of water is of very little consequence; but when chemical substances are to be used in certain cases, and distilled water is specified in the formula, it is necessary that the water should nearly approach the purity obtained by distillation; not condensed water from steam-engines, but distilled for chemical use. The question of the purity of water does not affect the photographer now as it did when the process in general use was wet collodion, and the proper mixture of the silver nitrate bath was of the utmost importance. A few years since the writer was engaged in an experiment of much scientific interest many miles from home, and he took with him silver in solution which he knew was in good working order; but, as a reserve, he also took a supply of the purest fused silver nitrate. He required to use this, but no distilled water was to be had. A supply of rain-water was obtained, and on sunning the solution, a dense black deposit was soon formed. After filtration, the bath was found to be in good order, and was successfully used. The solution was left in the hands of a local photographer, who informed the writer some months afterwards that he had used the bath in various parts of Sicily, and he had “never had anything like it before.” Filtered rain-water, then, may be used as a substitute when distilled cannot be had, and for most purposes filtration is sufficient. It should be stated, however, that if the water is collected from house-roofs, time should be allowed for impurities to be washed away. Melted snow is said to be purer than rain-water, and may be safely used. River-water is to be preferred to that taken from wells, if it is not contaminated with sewage matter. It would be a simple matter here to give directions for testing water for lime, iron, carbonates, or chlorides,



but for the small quantity of water the amateur may require when away from home he would be very unlikely to test it himself, and he may use rain-water as suggested above.

Manchester and district has a supply of water which contains very little impurity, as the following analysis shows:—

Total solid matter in solution . . . . .	4.7 grains per gallon.
Free ammonia . . . . .	.0024 "
Albuminoid ammonia . . . . .	.0033 "
Nitrates and nitrites . . . . .	absent
Oxygen contained in permanganate of potash to oxidise organic matter, &c., in solution:—	
Acting for two minutes at 80° F. . . . .	.011 "
Acting for four hours at 80° F. . . . .	.086 "
Combined chlorine . . . . .	.061 "
Phosphates . . . . .	absent
Total hardness . . . . .	1.3 "
Permanent hardness . . . . .	1.2 "
Temporary hardness . . . . .	0.1 "

When heated to 100° F. in a bottle, no smell was produced, and the appearance of the water when a column two feet in depth was examined was slightly turbid and was faintly yellow. For this analysis the writer is indebted to Mr. W. Thomson, F.R.S.E., F.C.S., &c., of Manchester.

The Manchester water, then, may be used for most purposes in photography without distillation, and has been so used by the writer for many years in preference to any distilled water which he could purchase. Glasgow also has a supply of water of excellent quality.

**Wax.**—The use of wax in photography is very limited. It is useful for making paper semi-transparent, and dissolved in turpentine or benzole is made into encaustic paste.

**Zinc** (Zn. At. wt. 64.9).—The salts of this metal have very little use in photography, but the metal is largely used in the processes for obtaining printing blocks in half tone and line. The metal may also be used for reducing metallic silver from the chloride.

## PART V.

---

### CHAPTER I.

#### APPLICATIONS OF PHOTOGRAPHY.

**Architectural Photography.**—No special *process* is necessary in making photographs of architectural subjects; but there are certain precautions to be taken which may be referred to here. The camera must be kept quite horizontal, if practicable; this can be done approximately by the eye, but a small weight attached to a string and used as a plumb-line, or a spirit-level, may be used to ensure perfect leveling. A lens of the rectilinear type should be employed. Tilting the camera either up or down should be avoided. In photographing tall buildings, the sliding front to raise or lower the lens and the swing back, should be used to correct the distortion which would appear by tilting the camera, which process is only necessary when the rising front will not otherwise permit all the subject to be brought in. In photographing interiors it is often difficult to keep the tripod legs from slipping on smooth floors. This can be prevented by fixing corks on the pointed iron tips of the legs.

**Astronomical Photography.**—Although attempts were made to produce photographs of celestial objects by the daguerreotype method, very little success was attained, and it was not until De la Rue, Rutherford, the writer, and some others produced pictures of the moon that the value of photography in astronomical matters was fully appreciated. Some important scientific facts connected with astronomy have been established by the aid of photography. In all total eclipses of the sun, certain phenomena appeared which were difficult to explain. An aureola of light, the corona, was always visible, and certain coloured objects close to the edge of the moon, known as "red prominences," were the cause of much speculation until the eclipse of 1860, when an expedition was sent to Spain, where Mr. De la Rue and Father Secchi made photographs, from which it appeared that, as the moon passed over the sun, the red prominences were gradually covered and

uncovered; and as the photographs taken at different and distant stations showed the same effects, it was, of course, concluded that the phenomenon was an appendage of the sun. To settle the matter experiments were made in India in 1868 by Colonel Tennant, which fully confirmed the results obtained by De la Rue and Secchi in Spain.

Total eclipses of the sun, visible at places within convenient distance of England, do not often occur. The cause of the corona being still unknown, it was decided to send expeditions to Spain and Sicily in December 1870, one object of which was to obtain photographs of this phenomenon. It had been contended that the beautiful corona of light, always seen during total eclipses, was an effect produced in our atmosphere; and it was also maintained that the appendage really belonged to the sun. This point was settled in a very satisfactory way by a comparison of two photographs, one taken at Cadiz, in Spain, by Mr. Willard, and the other taken at Syracuse, in Sicily, by the writer. Mr. Willard's photograph was taken about two hours before the one at Syracuse, and yet the two photographs showed features in this aureola of light which were common to both. This could not have been the case unless the corona was actually connected with the sun. Rifts or V-shaped markings were shown at the same places in the pictures, and these peculiarities which appeared at stations hundreds of miles apart must have been persistent during the whole time of the eclipse, or they could not have been visible in both photographs. This seemed to be sufficient proof that our atmosphere was not the cause of the phenomenon.

The collodion process was used in these experiments; but as soon as gelatino-bromide plates became available, the use of photography was extended to the spectroscope, and in subsequent total eclipses pictures of the spectrum of the corona were obtained, thus adding another proof of its solar origin. When it was found that comets, the nebulæ, and stars could be photographed, there seemed to be no limit to the possibilities which might be effected by photographic aid; and a great work has recently been commenced, that of photographing the entire heavens, including stars, to the fourteenth magnitude, which will require, it is said, 10,000 negatives, and will include 20,000,000 stars, an achievement the importance of which cannot be exaggerated. Objects which the most powerful optical aid had failed to reveal have been photographed. The explanation of this, no doubt, is that the very long exposure required to impress the light of stars of very small magnitude and faint nebulæ had enabled the very delicate nebulous light to show itself on the sensitive plate.

It may, perhaps, be permitted to the writer to point out that in taking photographs of celestial phenomena prior to 1870, the ordinary telescope had been employed, and it was used in Spain in that year;

but it occurred to him that in photographing the corona a *picture* was wanted, and that the size given by the greater focal length of a telescope was of very little consequence compared with the importance of showing the extent and detail of the corona, which could only be obtained by having a suitable lens and larger plates than could be advantageously used in a telescope. This idea was proved to be correct, as although the only instrument available was one which gave an image only about three-tenths of an inch in diameter, the corona was displayed extending several diameters of the sun, and in a way never before seen on a photographic plate.

In the second edition of his work on the "Sun," the late Mr. R. A. Proctor gives a full description of the results of this experiment, and he says that the explanation of the success is to be found in the fact that a new method was adopted in photographing the eclipsed sun.

Mr. Willard's photograph was taken with a telescope in the old way; and, as it showed detail of the same character as in the photograph taken with a different instrument at Syracuse, it established the fact that the corona was a solar appendage. It also showed that a telescope was not a proper instrument to use for the purpose; and this was proved in the following year, when some very beautiful photographs were made in India for the Earl of Crawford (then Lord Lindsay) by Mr. Davis, and by other observers in different places. The instruments were of the same kind as the one used in Sicily, but were specially mounted, with the result that the pictures were superior to anything hitherto done; and in all subsequent eclipses suitable apparatus has been employed, showing that the method adopted by the writer for the first time was the proper one. It may also be pointed out that in all the important work in astronomical photography since 1870, the apparatus employed has been either silvered mirrors or lenses constructed as for ordinary photographic work, thus carrying out the idea that *pictures* of the objects photographed are required, as also larger plates than can be used with an ordinary telescope.

The cameras and lenses in ordinary use by photographers cannot with advantage be adapted for photographing such objects as the sun or moon. The size of the image of the moon (or sun), given by a lens of ten inches focus, will be only one-tenth of an inch, so that a lens of fifty inches focus would be necessary to make the photograph half an inch in diameter. Therefore, something more handy must be found. The astronomical telescope, when mounted equatorially and with clockwork, can be readily adapted. A photographic camera, with suitable lens, may be attached to the telescope so as to be driven with it to counteract the apparent motion of the stars or moon, really

that of the earth. The moon's motion in her orbit may be disregarded when quick plates are used ; indeed, the moon may be photographed when full while the telescope is at rest, the exposure necessary being much less than one second.

Although not so suitable as a lens corrected for the chemical rays, or as a reflecting telescope, the ordinary achromatic telescope may be

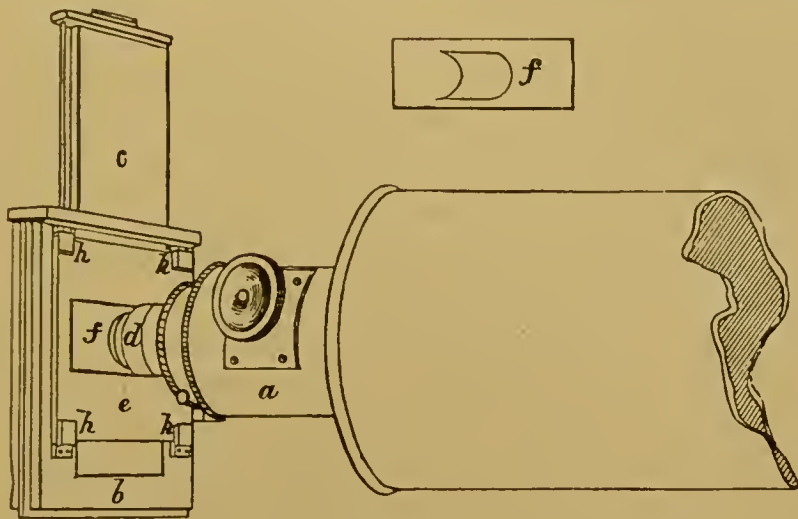

FIG. 105.

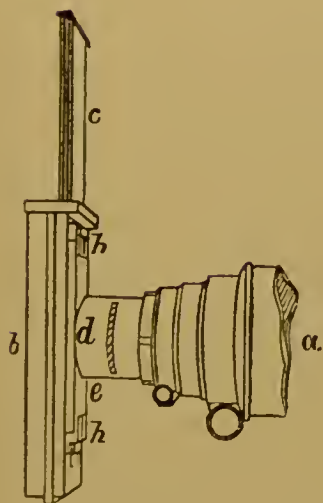

FIG. 106.

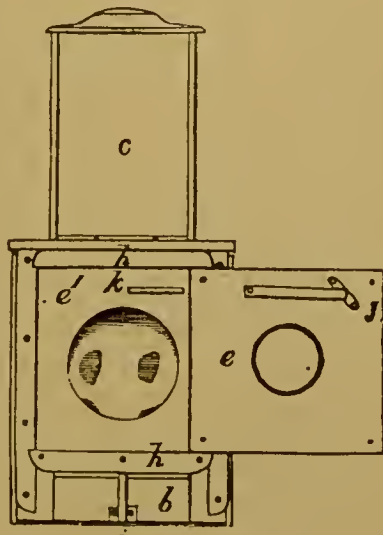

FIG. 107.

*a*, draw-tube of telescope ; *b*, dark frame ; *c*, slide ; *d*, brass tube sliding into place of eye-piece ; *e*, outer metal frame screwed to *d* ; *e'*, inner metal plate ; *f*, diaphragm ; *h*, clips to hold plate *e* ; *i*, spring to hold frame in first position ; *k*, groove in the plate *e*, in which the spring-pin *j* slides.

used for photographing the moon. The accompanying Figs., 105, 106, and 107, show the method of carrying the sensitive plate, which will be found convenient when the picture is to be taken at the principal focus.

In this case the telescope itself forms the camera, and the plate-holder is very little more than the dark slide of a camera. If any

kind of enlarging lens be used with the astronomical telescope, a camera must be attached, as the image may be larger than can be taken on the small plates used in the apparatus described.

The method for ascertaining the actinic focus is as follows:—With the rack motion adjust the focus for distinct vision, and then mark the tube *d*, and also the sliding part of the telescope, so that any change of their position may be readily seen. Although it is very unlikely to be of the slightest use, unless taken with a reflecting telescope, a picture may now be made; it will at least give some idea of the proper exposure. If the chemical and visual foci are not coincident, the image will have a blurred appearance. Before exposing the next plate turn the adjusting screw so as to draw out the tube about one-sixteenth of an inch, and so proceed until, by the greater distinctness of the image, it is seen that the chemical focus is found. At every change of position a slight mark should be made on the tube, and when the true focus is satisfactorily determined, the marks should be made distinctly visible, and in all future experiments with the same instrument the focus will be always at or very near the same place. Should it be found that the indistinctness increases, it will, of course, be necessary to try in the other direction, that is, to shorten the focus.

The appearances arising from atmospheric disturbances are very much the same as when the object is out of focus; experience alone will enable the operator to determine from which cause the defect proceeds.

Some of the best photographs of the moon ever taken were made by the collodion process, an example of which is seen in the plate on the opposite page, which is from a negative by Mr. L. M. Rutherford of New York; but the great convenience of dry plates, and the extra rapidity, give the preference to gelatine plates; indeed, some of the work now undertaken could only be accomplished on such plates. The MM. Henry, of the Paris Observatory, have exposed plates during three hours while making negatives of the stars, and Mr. Common, of Ealing, in producing the exquisite pictures of the great nebula in "Orion," gave very long exposures. Mr. Roberts also did the same while making his pictures of nebulae and stars.

The fascinating occupation of photographing celestial objects may be undertaken by all who possess the necessary apparatus; and no more than ordinary care and patience are required to ensure success.

A very full account of celestial photography by the writer will be found in the *Proceedings of the Manchester Literary and Philosophical Society*, 1865, *British Journal of Photography*, December 22, 1865, and in Chambers' "Astronomy," second and third editions.

**Cameo.**—This term was applied to photographs which, after they



*Woolbury-Gravure.*

L. M. RUTHERFORD, *Photo.*

THE MOON—FIRST QUARTER.





were mounted, were pressed so as to raise the surface to a convex form, giving the portrait somewhat the shape of the ordinary cameo.

**Carte de Visite.**—When first introduced this name was given to a very small kind of portrait which was intended to be used on the cards called *visiting cards*, or *cartes de visite*. The original purpose was soon abandoned, but the convenience of the small-sized portrait was at once appreciated, and for many years was most popular, and is still largely used. The title was a misnomer. *Album* or *card* portrait better described the picture. Portraits of a larger size, with the title *Cabinet*, have to a large extent taken the place in public favour of the smaller photograph.

**Clouds.**—It very rarely happens at the time when a landscape is photographed that the clouds are the most suitable for the subject, or such as we should like to see in our picture, though at all times it must be borne in mind that the landscape is affected by the sky. The effect in the foreground and distance will be quite different under a blue sky, or when cumulus clouds are present; and, as we cannot command the kind of effect we wish to produce in the picture, great care must be taken if clouds are introduced which have perhaps been taken under totally different conditions. It was at one time rare to see a landscape photograph with clouds; the purest white paper appeared to be the aim of the photographer; and, even at the present day, sufficient attention is not given to this very important feature in a picture. Assuming that the sky at the time a picture is taken is just what is desired, it will of course be desirable to preserve the effect on the plate exposed for the landscape, and in some cases, with care in the development, this may be done. But in the majority of cases the exposure necessary for the landscape will be too great for the sky, and this may necessitate double printing to obtain the cloud effect. The landscape photographer should always be on the *qui vive* to obtain good cloud negatives; the negatives need not be taken on large plates. If on plates  $6\frac{1}{2} \times 4\frac{3}{4}$ , or less, they can be enlarged; and one negative may be utilised to make two effects by reversing. When the sky portion of a landscape negative is not sufficiently dense to leave the paper white when the landscape is fully printed, it must be either shielded or stopped out. If carefully done, shielding is preferable to stopping out. The sky will probably be sufficiently dense to permit shielding, which is effected by placing a sheet of thick paper or cardboard shaped to follow the outline of the picture roughly. The shield should not be placed too close to the negative. If the printing-frame has thick glass, probably the thickness of the glass will be sufficient to prevent a hard line when the shield protects the sky, the object being to shade off the unshielded part into the white paper. Remove the print from the frame, and place it on a sheet of glass or

on a board which is quite flat ; select a cloud-negative which is suitable for the picture (taking care that the light and shade in the clouds correspond with the effect in the landscape) ; place the negative carefully on the print, and then protect the photograph from the light with a piece of cardboard, with the part nearest the sky turned up,

thus—  This will permit the clouds to print

FIG. 108.

and shade off the part near the landscape, so as to blend with the part already printed. If carefully done, the effect will be almost as good as if the clouds had been taken with the picture. The clouds will print very quickly, and great care should be taken not to make them too dark—the merest indication of clouds is often sufficient.

Special care must be taken that the clouds do not spoil a church tower or spire, or tall trees forming prominent features in the picture. This may be readily avoided by so placing the cloud-negative that a dense part covers the projecting object.

When a sky is stopped out, the result is often a hard line which no amount of care in printing-in the sky will remove.

Very good indications of clouds may sometimes be made by painting on the back of the negative ; but this must be skilfully done, or the effect will be anything but natural. The same may be said if cotton-wool be used. In all cases preference should be given to natural clouds.

Cloud effects to represent moonlight are easily produced by taking the negative when the *sun* is behind the clouds, and then printing darkly. If the moon is to be shown in the picture, it must be of the proper size. Suppose a lens of 10-inches focus be used, the size of the sun or moon will be one-tenth of an inch. It is always better to use a negative which has been taken direct when the moon is to be shown in a picture. To ensure the correct representation, the lens used for the landscape should be employed in making the negative of the moon.

The *vignette* form of picture is very effective in landscape. (See *Vignetting*.)

**Composite Portraits.**—By printing several portraits over each other, a composite effect is obtained ; the result is supposed to give the type of the whole.

**Composition.**—The value of a photograph depends very much on what is termed *composition*. It is not sufficient in taking a picture to place the camera and allow chance to arrange how the lines will *compose* to form the effect. Two persons may make totally different effects from the same subject, taken at the same time, and

the difference will be caused merely by the different positions of the camera ; a tree, a rock, or a figure, may be so arranged in composing the picture as to be effective in one case and obtrusive in the other. The possession of a camera does not make an artist of its owner ; and unless some study be given to what is required in making artistic pictures, photographs, good from an artistic point of view, will only be the result of accident. Treatises on the qualities necessary to form pictures have been written and should be studied. If the student will carry out hints he may derive from what he reads, defects too often met with in photographs will be avoided. The introduction of figures in a landscape is in many cases desirable, but if they are badly placed an otherwise good picture may be spoilt.

**Distance.**—Much of the beauty of a landscape depends on the proper rendering of the distance. This becomes difficult owing to the effect of the atmosphere, the pale blue and grey of the distance having almost the same actinic power on the plate as the sky. When the objects in the foreground are dark, the difficulty is increased, and the greatest care must be taken that the distance does not become lost while the foreground is developed.

**Interiors.**—The photographer is sometimes required to photograph places where very little light penetrates. In the days before gelatine plates were available, the difficulties were almost insurmountable ; but there are very few places which cannot now be photographed, as where daylight does not penetrate the magnesium flash-light is available. Probably the first attempt to photograph below the surface of the earth was made by the writer in the "Blue John" mine in Derbyshire. This was in 1865, and the photograph was made on a collodion plate, while the mine was illuminated by means of burning magnesium wire and ribbon. Soon after this Professor Piazzzi Smyth made photographs of the interior of the Great Pyramid. Owing to the slowness of the plates, and the quantity of magnesium which had to be burnt, the white fumes interfered very much with the results, as the want of ventilation in such places made it necessary to wait for the particles of magnesia forming the mist to settle before a second plate could be exposed. The quick plates now in use make such subjects comparatively easy, and one or two good flashes will generally be sufficient—care being taken, of course, to protect the lens from the light. When the external air is colder than the interior, the condition of the lens as to condensed moisture should be noticed. When daylight, however feeble, is available, it is only a question of time as to obtaining a picture. A basement floor in which was a quantity of machinery, and lighted only by one or two small windows, has been photographed, the exposure lasting twenty-six hours ; that is, the camera was left in the place for that length of time so as to

utilise all the daylight possible (the place was too extensive for artificial light to be used), and the result was an excellent negative, some halation around the window being the only defect. Difficult interiors must be dealt with according to the peculiarities of each case. In photographing buildings, such as cathedrals and churches, lenses of long focus may sometimes be used ; but, usually, wide angle lenses are the best for the purpose, owing to the difficulty of placing the camera sufficiently far back so as to obtain as much of the interior as possible. Where windows appear in the picture they should, if practicable, be covered during the greater part of the exposure.

**Impressionism in Photography.**—During the past year or two there has been much discussion as to whether it was legitimate to attempt to produce by photographic means work in imitation of what is called the “Impressionist” school of art, the effect in a photograph being what is called *out of focus*. Much may be said on both sides of the question. In art all styles are permitted, and each artist has, as a rule, a style of his own which, in course of years, may change. The eminent artist, Sir J. E. Millais, is an instance. In the early part of his career he was one of the Pre-Raphaelite school, and a comparison of the work he did at that time with what comes from his brush now will show quite as great a difference as there is between a photograph containing the most minuté detail and one of the very opposite kind. If we refer to some of the earliest works which have been preserved, the wall paintings of Pompeii, for instance, we have hard lines and minute detail. Coming down to a later date, a visit to the National Gallery will show us work of the earliest period in oil colours, in which the lines are still hard and the detail well defined. After that period the style changed, a more naturalistic manner being introduced, and the lines and tones becoming more blended. We have another contrast between the work of Canaletti (whose pictures of Venice and street scenes show hard lines and wonderful “photographic” detail) and that of Turner (whose later work showed a total absence of detail). His pictures are “impressions,” and are supposed to give the artist’s ideas of the scenes depicted ; they are as far removed from Canaletti’s style as the most *out of focus* photograph is from one giving the sharpest possible detail. We may take another example in a different style of art. Van Huysum painted flowers with the most exquisite finish ; and in the present day Fantin paints pictures of flowers equally beautiful, but quite without detail. Some landscape painters give minute detail in their pictures, representing the colours and form, so they tell us, as they are shown in nature, while others leave out the detail and give very little more than the form, and in some cases colour very far removed from that of nature as seen by other eyes. Some artists paint the forms just as they see them, while others consider that they

improve nature by altering the forms. When so much latitude is permitted in one branch of art, why should not there be equal variety permitted in another style of art? The work of Rejlander had many admirers, but in many cases he appeared to work for effect rather than minute detail; and, in another case, we had in the work by Mrs. Cameron portraits in the widest contrast to much that is done in the present day, and yet the work of that artist had many admirers.

Much of the discussion of this subject has arisen through some of the pictures shown at the Exhibition of the Photographic Society in the autumn of 1890. The pictures referred to were very much *out of focus*; they were printed on rough paper, and were totally unlike most of the other landscape photographs in the room; and they were pointed out to the writer with the remark that there "was a great change in photographic matters when *such things* could have medals awarded to them." An examination of the *things* referred to showed that there was something to admire, something quite different from what had previously been done in photography, and there seemed to the writer there was no reason why the style of Corot or Millet should not be imitated in treating such subjects.

In portraiture (apart from photography) no kind of art is superior to a well-executed ivory miniature; the same effect could not be obtained on rough drawing-paper. And in photography there is nothing to surpass a perfect daguerreotype portrait; a portrait on paper, however smooth or highly glazed, is not equal to it; and an album portrait may be very good when printed, as usual, on albumenised paper, but would not be equally perfect if printed on rough paper.

**Landscape Photography.**—Judging from the number of unsatisfactory photographs of landscape subjects to be seen, there is much room for advice as to how to proceed in the way of improvements. To succeed fully, the amateur or professional should have some knowledge of the rules of art. To obtain a picture something more is necessary than to place the camera before a scene and expose a plate just because it looks pretty and "forms a picture." The result to an artistic eye may be anything but pretty or artistic. The tyro with his camera and slides, charged with six or a dozen plates perhaps, naturally makes a stop at the first pretty bit he comes to and exposes a plate; it may be that within the next hundred yards he finds another view of the same subject which pleases his eye better, and another picture is taken; and so on during the day or few hours he gives to his subjects. The result may be that not one possesses the true quality of a picture; he may have excellent negatives, but all may be wanting in what is termed artistic quality or composition. The scene presented to the eye of the photographer, although he may

be standing in the middle of a road, may be very beautiful; but, if a photograph be taken from the same point of view, the result would not be equally pleasing—the road straight in front, running away to a point and opening out to the full width of the plate in the foreground, would be far from artistic. A little consideration would show that the same scene, taken from a point not far removed, would have a very different effect. The greatest care, then, should be taken to consider well what will appear on the plate before making an exposure. For landscape views the lighting of the subject should be carefully considered, as when there are great extremes in the lighting of the distance and that of the foreground, the distance will be lost in developing the detail in the foreground. Landscapes should always have some object of principal interest, but this interest may often be given to a subject by the proper introduction of figures such as a group of cattle. Here again the greatest care is requisite. Figures are not always necessary in a landscape; indeed, a figure badly introduced will mar a picture which in other respects may be good. Rustic figures may occasionally be introduced with satisfactory results; but it must never appear that they have been placed for the purpose. This defect is seen in many pictures to which medals have been awarded; but the artistic eye sees at once that the figures do not belong to the surroundings. Figures are also sometimes valuable to show the relative sizes of objects. It is always desirable to study beforehand the landscape subjects to be photographed. The middle of the day will seldom be the best time. To get the best results the subject must be studied in just the same way as an artist would study it for the purpose of painting a picture, for in no other way can good photographs be expected excepting by chance. It may be that the photographer cannot give the necessary time for this process of selection. In this case his good pictures will probably be few in number. Success in photography can only be obtained by the same means as in any other art. Landscape photography is one of the most fascinating pursuits, and as such deserves all the study which can be given to it. Architecture affords scope for interesting work, and to the architect the camera is an aid which should be often used. Rustic “bits” make pictures of a most pleasing character, and should always be looked for.

It very rarely happens that clouds can be secured on the same plate with a landscape, but when it is possible to do so the general effect will be better than when clouds are printed in. Plain paper to represent sky never looks well, and the paper toned down in printing looks very little better; therefore negatives of clouds should be secured whenever practicable. They need not be of large size, nor necessarily of the size of the plate generally used. Small negatives





A. BROTHERS & CO., HALF-TONE ZINCO.

J. H. T. ELLERBECK, PHOTO.

SÖRFJORD, FROM TYSSDAL.



can be made into transparencies, and from the transparency two negatives can be made, giving right- and left-handed effects. For instructions as to printing in skies, see *Clouds*.

The plate facing this page is from a negative by Mr. J. H. T. Ellerbeck of Liverpool, and is a very perfect illustration of what a good landscape photograph should be.

**Muybridge's Photographs.**—There is no novelty in using a number of cameras for the purpose of obtaining a series of views of subjects in different positions; but, as applied by Mr. Muybridge, some very curious and interesting effects have been obtained, showing that the real motions of animals are very different from what artists have generally depicted. The illustration on page 306 shows a sketch from photographs of horses in positions in which no artist would draw them from life. The horses only are from photographs, but the effect would perhaps have been more natural if the figures also had been from photographs instead of from the imagination of the artist. The photographs were of course taken instantaneously, by means of a machine carrying a number of lenses, the exposure being effected by electric contacts as the figures passed. Many of the curious photographs taken by Mr. Muybridge, when arranged so as to revolve, show the objects (as they pass in rapid succession before the eye) as if in motion.

**Photo-Meteorology.**—Photography has had a very important application as the means of recording automatically the readings of the various instruments used in a meteorological observatory. The variations of the magnetic needle are made to record themselves by means of a small mirror attached to the magnet, the light being reflected as a point on to a sheet of sensitive paper which, on development, shows the slightest changes throughout the day and night. The barometer and thermometer also are made to record their own variations.

**Portraiture.**—The best advice on this subject which can be given to amateurs would, perhaps, be that it is better not to attempt portraiture. Satisfactory pictures can only be made when the light is entirely under control, that is, the room in which they are taken should have blinds and other conveniences, which are not often available in the case of an amateur. There is no reason why a portrait by an amateur should not be as good as one taken by a professional photographer; but it is very rarely the case, owing to the want of experience as well as of the appliances which give the advantage to the professional. But although an amateur may find success in any other branch of the art, there are times when he will certainly wish to take portraits, and it then becomes a question how to obtain the best results. If taken in the open air, a shady place should be chosen so that the eyes need not be directly facing a strong light;



direct sunlight should always be avoided. If suitable preparation be made, fairly good portraits may be taken in the open air; but some kind of screen should be placed to prevent too much top light, and light from one side should be stronger than that from the other. A photograph taken full-face seldom has a satisfactory appearance unless the light be so managed that one side has more light than the other. Excellent effects may sometimes be obtained in a room now that prolonged sittings are not necessary. The sitter should be near a good source of light, and a white reflection should be used to modify the light. Good effects may often be arranged in a greenhouse or conservatory. One of the chief things to be avoided is the appearance of "sitting for a portrait." For single figures the head and bust are to be preferred to full-length studies, and in groups the mistake should not be made of allowing all the figures to look in one direction. In many portraits the eyes have an unnatural appearance. This can often be avoided by the sitter looking at a dark object, which is not too near.

As to the kind of lens to be employed, of course one made for the purpose of portraiture should be preferred; but the amateur might use any kind he happened to possess. With the rectilinear type his results may be as good as if taken with a portrait combination. Avoid making the head too large, as, no matter what kind of lens be used, if a small one, there will be distortion if certain limits as to size be exceeded. In focussing for a head, the eye should always be the point selected. What has been said must be regarded more as hints than as directions what to do. The subject of portraiture is too wide to be dealt with in a few lines, and, no matter how full such directions might be, the taste and skill of the amateur will determine what success he may have.

*Backgrounds.*—The success of a portrait as a picture depends very much on the background, and this may be said of all other kinds of pictures where backgrounds are necessary. The portrait painter, if not pleased with one effect, can repaint his work until a satisfactory result is attained. Not so, however, in the case of a photograph, for which only such backgrounds should be used as will not be obtrusive. Painted backgrounds are seldom the work of skilled artists, and when architectural effects are attempted, we have too often bad perspective, and surroundings which are inharmonious; therefore, it is better to use either plain or graduated shades, and as seldom as possible painted windows, balustrades, and other imaginary effects. For vignettes, a light shade of tone graduated is to be preferred. Canvas is generally used, but thick paper with care will be equally serviceable. The painting may be done either in distemper, with sufficient size to prevent chipping, or oil colour, *flatted*—that is, painted with colour mixed with turpentine and oil.

*Large Heads.*—When the difficulties of taking large heads direct are considered, it is somewhat surprising that the attempt is ever made. When the size is the same as life, the difficulties are great, and only in some degree less when half life-size is the limit. Any dimension between the half and full size of life is not considered artistic, since it has the appearance of being “neither one thing nor the other.” A seven-inch head for a man looks as if intended for life-size, and so with other sizes over four or five inches. If a portrait is to hang at some height, a size rather over that of life may be adopted, as the distance diminishes the apparent size. Heads taken direct the size of life can seldom be made sufficiently perfect to remain untouched; that is, they require to be “worked up” by an artist. Mrs. Cameron’s work was much praised for its artistic *quality*, and this quality consisted in the out-of-focus effect always present in the portraits. This evidently was the design of the artist, and her effects were probably due to two causes, viz., the long time required for the sitting, the wet collodion process being used, and the diffusion of the focus of the lens. When viewed at a proper distance, Mrs. Cameron’s work had a very excellent appearance, but to most photographers the want of sharpness was looked upon as a defect. Her method of working was never imitated to any extent, as it certainly would have been if the public taste could have been educated in that direction.

The introduction of gelatine plates has made the production of large work more practicable. Full-length or half-length figures on plates  $22 \times 18$ , or larger, are made very satisfactorily; but in conversation with a photographer who had paid over one hundred pounds for a lens for this kind of work, the writer was informed that “it did not pay.” Seeing that such perfect work can be made by the methods of enlarging now available, it seems very questionable whether better results cannot be obtained by enlarging than by any other means. A head of moderate or small size can be made much more perfect than any taken direct over two inches; and as the large direct negative must require much time in retouching, perhaps more time than the artist would devote to the finishing of the enlarged print on paper, the advantage would appear to be in favour of enlarging. It may be said that the retouched negative would give perfect prints without further artistic labour. That may be true, but the work of the artist with the brush would excel that of the retoucher.

When negatives are sent to be enlarged, the instruction should never be “make it life-size.” This term is very misleading, as heads are not all of the same size. The head of an adult male is usually about one inch longer from chin to hair than that of the adult female. Therefore it is better always to give the size in inches, and, when

practicable, the measurement should be from the chin to the hair. A foot-rule should be held so that it just touches the face by the side of the nose; one end of the rule should appear even with the line of hair, and the inches read off the scale at the chin. As a check to this measure, it is well to give also the length from the corner of the mouth to the inner corner of the eye.

**Rembrandt Portraits.**—By placing the sitter with the light partly behind and at the side, a strong effect of light and shade may be obtained. When carefully done, this produces a pleasing result, which is supposed to resemble that seen in the portraits painted by Rembrandt.

**The Spectroscope in Photography.**—Investigations upon the band of colours given when white light is separated into its component elements, have proved of great service in building up the knowledge of the relation between the constituent rays of white light and the various sensitive salts in use, and have caused photography to be of considerable assistance to astronomy and other sciences. In its former aspect much valuable information has been obtained, both as to what rays are of most photographic value and the relative sensitiveness of the bodies employed as photo-sensitive agents, and as to the influence upon this sensitiveness exerted by colours used in orthochromatic plates. By its means it has been shown that the greater general sensitiveness of silver bromide over the other silver salts is due to its being influenced by a wider range of rays, and much other interesting information has been obtained as to the effects of mixtures of the haloids and the presence or absence of sensitisers; but in work on these subjects it is important to take into account the effect of the prisms and other transparent media through which the light has to pass, that is, their absorption-spectra must be known and discounted.

In the second place, photo-spectroscopy has given an insight into the chemical composition, physical state, and motion of celestial objects. This application rests upon the fact that, while an incandescent gas emits rays of a certain refrangibility, it also has the power of absorbing rays of identical wave-length; so that, when a glowing solid which emits white light, and would ordinarily give a continuous band of colour as its spectrum, is surrounded by any kind of vapour, it will exert its characteristic selective absorption, and so cause those particular rays to be replaced by thin black lines. By making the solar or stellar spectrum to fall upon one half of the spectroscopic slit and photographing it, and then, with the instrument in precisely the same position, allowing the spectrum of the vapour of a metal (heated to incandescence in an electric arc) to be photographed upon the same plate through the other half of the spectroscopic slit, two spectra are obtained exactly under each other; the first is a

continuous band intersected by dark lines ; the second, a series of lines only, which are characteristic of the element ; and, if the dark lines are due to absorption by the same element as the bright-line spectrum produced by the incandescient vapour, these lines will coincide exactly. This coincidence is a proof of the presence of this element in or about the sun or star which gave the dark band spectrum. With stellar spectra, the stars being but points, they would produce a mere line of but slight breadth in which cross-lines would be hardly visible ; but Huggins overcame this difficulty by slightly altering the declination of the telescope. The star travelled up or down the slit, and thus broadened its band. With nebulæ, spectra of lines only are obtained, thus showing them to be masses of glowing vapour similar to the incandescient gases around the electric arc. The coincidence of the photographs of the lines given in the two cases will, of course, prove that the nebulæ contain the elements in question.

As regards the determination of motion in distant stars, this rests upon the change in wave-length caused by motion towards or from the observer ; but refrangibility is determined by wave-length, so that alteration in the latter must cause change in the former, and the lines characteristic of a certain element will not occupy the same position that they would were the star fixed and the wave-lengths normal. By photographing the spectrum of a known element side by side with that of the star, and noting the extent, if any, of variation of the characteristic line from the true position, the data are obtained for calculating the extent of motion required to produce the observed lateral displacement ; while the displacement to the right or to the left of the normal position indicates the direction in which the star is moving.

**Stereoscope, The.**—It is a curious fact that comparatively few persons are aware until their attention is called to it, that their eyes see two distinct pictures of every object to which they are directed. A very simple experiment proves this. Hold up the hand at arm's length and look at one finger held before a distant object, such as a window bar. Now look at the finger and one image (opaque) will be seen, but two window bars (transparent). Now look at the window bar, and two fingers will be seen, both of which are apparently transparent. Close the eyes alternately, still looking at the finger, and its position with respect to the window bar will appear to change, shifting from side to side, as seen by the right or left eye. This experiment may be varied in many ways. Take a solid body, and, keeping the head in one position, make a sketch first with one eye and then with the other, closing the eyes alternately. On comparing the drawings it will be found that the two sketches do not agree, and that by "squint-

ing," the two images (if about  $2\frac{1}{2}$  inches apart) may be made to coalesce and form apparently a solid, as seen by the two eyes. This squinting to obtain the uniting of two dissimilar images is difficult

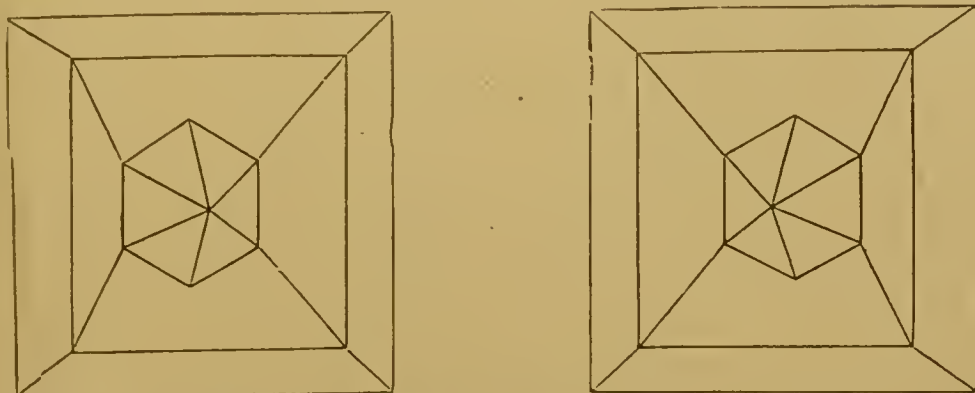

FIG. 109.

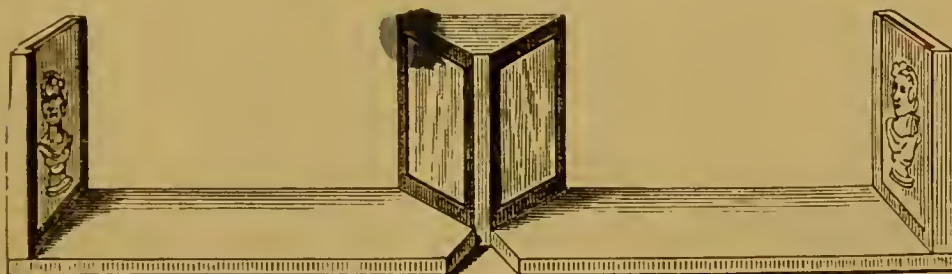

FIG. 110.

with some persons without the aid of an instrument. Fig. 109 shows the result of sketches made as seen by each eye separately. To show



FIG. 111.



FIG. 112.

this curious optical effect many geometrical drawings in outline were made before photographs were used for the purpose. To assist in viewing these designs, Professor Wheatstone invented the reflecting stereoscope, the form of which is shown in Fig. 110. It will be noticed that two mirrors are fixed so that, when suitably dissimilar pictures are placed at each end, their images are seen as a single picture having the effect of solidity. The advantage of this form of stereoscope is that pictures of larger size can be used. Sir David Brewster intro-

duced an instrument in which half-lenses were used; that is, a lens was cut in two and the outer edges reversed, as shown in Figs. 111 and

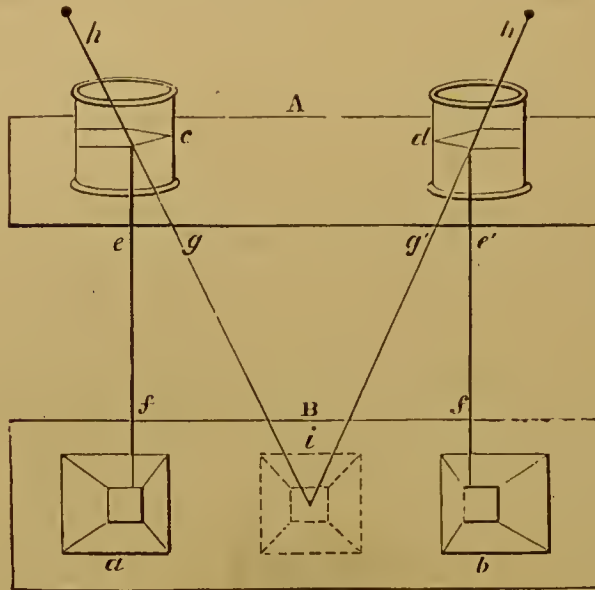

FIG. 113.

112. But, as the width of the eyes varies in different persons, it was arranged that the lenses could be adjusted to different distances

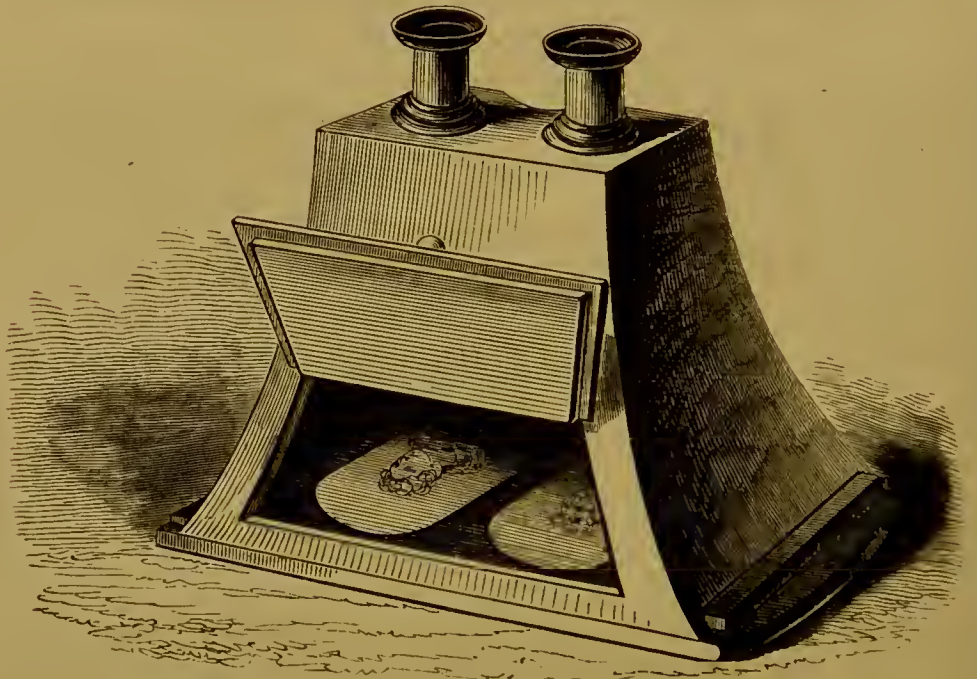

FIG. 114.

apart. Fig. 113 shows a section of the instrument, and Fig. 114 the appearance of this early form of the stereoscope. An improved form is shown in Fig. 115.

Fig. 116 is an engraving from an early stereoscopic print, from which



it will be seen that the two pictures have been taken at far too great a distance apart, and the effect in the stereoscope is consequently unnatural.

The construction of the instrument has been improved in various ways, both for single slides and for arrangement of a number of pictures to be viewed one after another; but this once popular optical instrument is not much used now. This is much to be regretted, as, when viewed in a suitable stereoscope, this form of picture gives the representation precisely as the two eyes saw it in nature, but without the colour. It is scarcely possible that the stereoscope will go entirely out of use; indeed, at present there appears to be a revival of interest in stereoscopic photography.

There is always something interesting in the facts concerning the

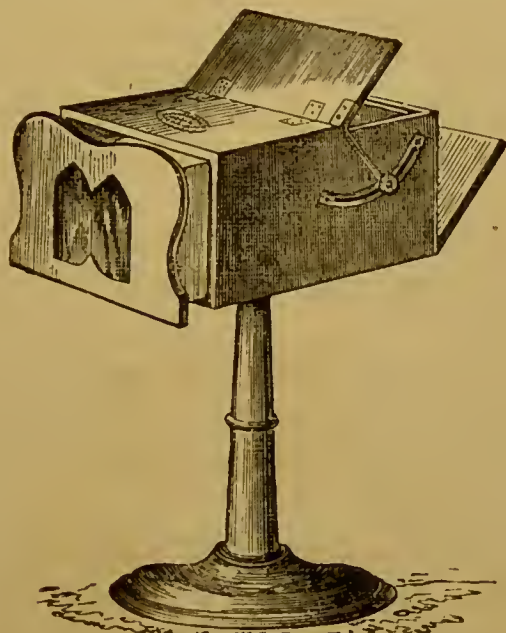

FIG. 115.

early history of an invention, and the stereoscope is not an exception. In October 1856, Sir D. Brewster, under the signature "A," wrote to the *Times*, pointing out that M. Faye, an astronomer and a member of the Academy of Sciences, Paris, had communicated to that society, on October 6th, an account of a new and simple stereoscope, and which the Abbé Moigno described in his *Cosmos* on the 12th of the same month, as follows:—"M. Faye presented a new stereoscope, of his invention, of extreme simplicity. It is indeed a simple piece of cardboard or paper, in which are pierced two holes whose centres are on the same horizontal line, and at the distance which separates the two eyes of the person who uses it. In looking through these two holes, about twelve millimètres wide (less than half an inch), at a stereoscopic slide, we see but one image, and for that reason we see it

as much in relief as in the reflecting or refracting stereoscope. This is certainly a happy idea. The paper or the cardboard of M. Faye has the effect of making the optic axes rigorously parallel, as if they were directed to a point situated at an infinite distance. It is for this reason, and not, as Mr. Grove maintains, by crossing the optic axes by a forced and voluntary squinting, that the two images are superimposed."

Sir David then shows that Mr. James Elliott, of Edinburgh, contrived the same thing as early as 1834. Professor Wheatstone, referring to this, points out that his investigations respecting binocular vision were published in 1833. Sir D. Brewster, in reply, acknowledges the letter signed "A." to be his, and then cites the fact that Elliott's and Faye's instruments were alike, and that Wheatstone's was different; in fact, that they were independent inventors of an instrument for uniting dissimilar pictures. He then quotes from an article by Wheatstone, in which the name of the painter, Leonardo da Vinci (who lived in the fifteenth century), occurs, and from which it appears that, if his observations had taken a slightly different form, he would have discovered binocular vision. Other names are introduced into the discussion, which is altogether very interesting, but much too long to be discussed further here, except to say that there can be no doubt that Wheatstone produced an instrument for showing stereoscopic relief. It is also a fact that Wheatstone's instrument is not suitable for stereoscopic views as now taken, and that Brewster's stereoscope in various forms has, after many years, proved a most valuable scientific instrument.

About thirty-five years ago it was with some authorities a matter of doubt at what distance apart the two pictures should be taken to produce the true stereoscopic effect. It was said that, to give great effect of solidity, a distant view must be taken with the camera at stations twelve feet apart, and in such cases all foreground objects must be avoided. For nearer views the distance must be changed from *feet to inches*. The late Mr. Dancer, of Manchester, was the first to point out that the proper position for the station was the distance between the two eyes, two and a half inches, and he constructed a camera with twin lenses, so that the two dissimilar views could be taken at one operation. These pictures, when viewed in the stereoscope, give perfect relief in all cases, excepting when only *very distant* objects are shown. In such cases very little relief can be seen; but, such as it is, the effect can be exaggerated by taking views many feet apart. That Mr. Dancer's was the true method of taking stereoscopic pictures was doubted, and an interesting discussion occurred between him, Mr. Sutton, and others, in which details of experiments were given proving that Mr. Dancer was correct. More-

over, the fact that all stereoscopic pictures are now taken with lenses about two and a half inches apart, is one proof of the scientific

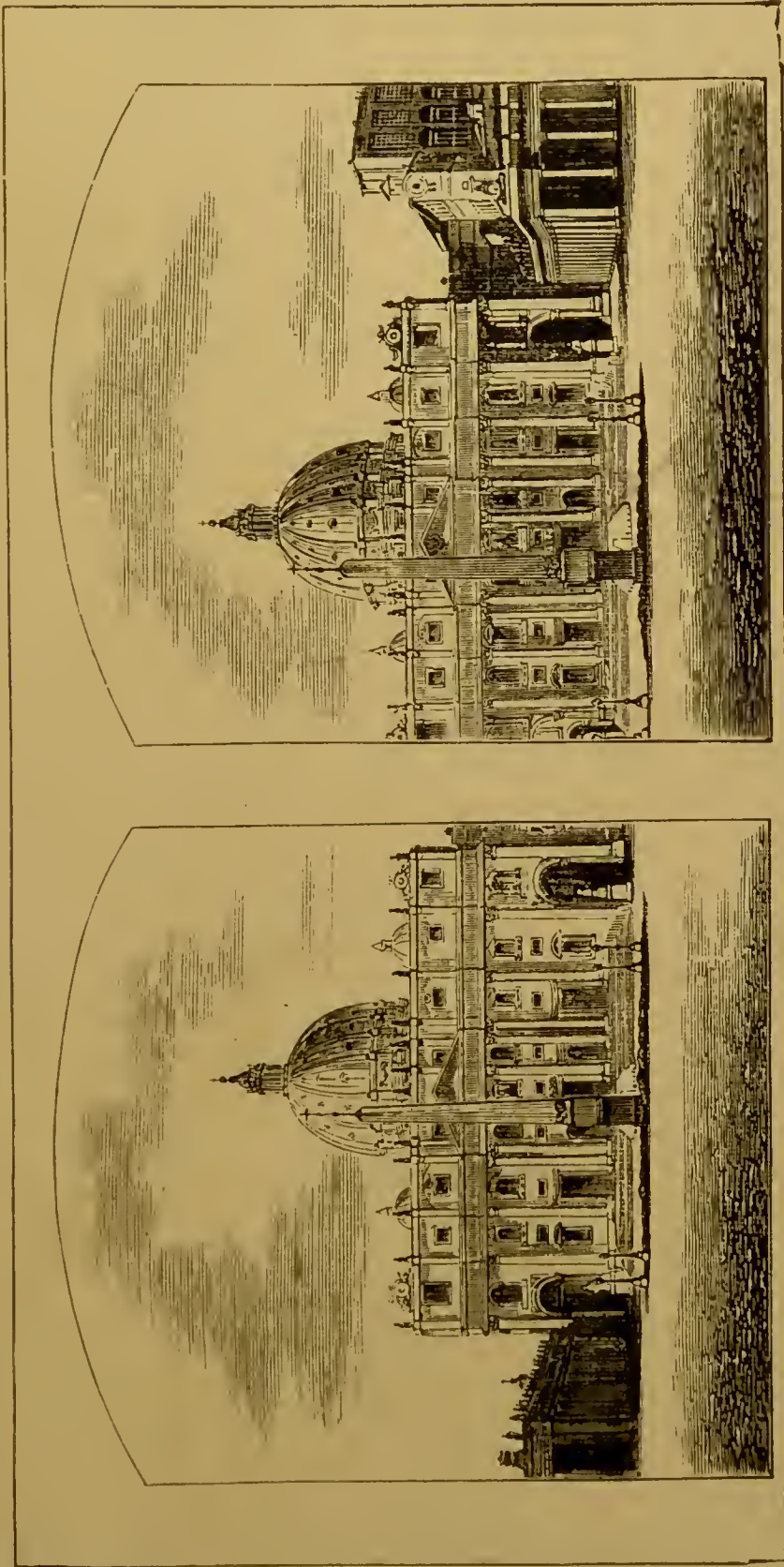

FIG. 116.

accuracy of Mr. Dancer's method. It may be mentioned, however, that Sir. D. Brewster admitted about the same time that, for taking

portraits, twin lenses should be used, and their distance apart only that of the two eyes, two and a half inches. No doubt greater relief can be obtained when views of buildings, landscapes, &c., are taken with cameras many feet apart, but the effect is more that of a model than the real object photographed; and, when objects occur in the foreground, it is impossible to see them in relief at the same time as the more distant parts of the picture are looked at. In taking views it should always be carefully arranged that some object be well placed in the foreground, not necessarily near the centre, but at the sides of the picture. These parts, as they show greater parallax, assist in the stereoscopic relief, and give reality to the scene.

Cameras for stereoscopic work are usually constructed for taking the two views on one plate (the size of the plate being  $6\frac{3}{4} \times 3\frac{1}{4}$ ), twin lenses being fixed on the camera; but a camera having only one lens may be used, and the plates need not be larger than quarter-plate,  $4\frac{1}{4} \times 3\frac{1}{4}$ ; or, by making the back of the camera to slide, the two pictures may be taken on a half-plate,  $6\frac{1}{2} \times 4\frac{3}{4}$ . But any camera will answer, provided the small size plate can be used; or, if the pictures are for the reflecting stereoscope, plates of any other size may be used. The camera must be placed on a stand with a level top, on which a line may be drawn along the side of the camera to indicate the position from which the first picture was taken. The negative having been taken in this position, the second exposure is made, with the camera shifted so that the centre of the lens is two and a half inches from the first position. Then, after adjusting the position of the object on the ground glass, another line may be drawn on the board at the side of the camera to show the second position. The lines marked on the board will show accurately the places for the camera for future exposures. Portraits may be taken in this manner; but it is absolutely necessary that there should be no variation in the expression or in the position of the sitter. Negatives of subjects for the stereoscope, when two views are taken on the same plate, give pictures which are *pseudoscopic*; that is, instead of showing objects in relief as in nature, they give the opposite effect, and the prints have to be cut and reversed in mounting. The necessity for this change may be avoided by suitably arranging the lens, the sliding back and the front. When only one lens is used there must be a division in the camera to prevent the pictures overlapping, and when twin lenses are employed the camera must also have a division for the same purpose.

When twin lenses are used (that is, when the camera is binocular), it is necessary that the lenses be exactly of the same focal length. Experience has shown that the advantage is on the side of the twin lens system, as it ensures the pictures being identical. There is

another advantage: each plate will hold two pictures  $3\frac{1}{4}$  inches square, the correct size for lantern pictures; and, therefore, dissimilar views may be taken on the same plate, if the stereoscopic picture is not required. In using twin lenses it is as well occasionally to see that they are properly adjusted (that is, screwed home), and that the lenses in their mounts are in their proper places; a very slight change in the position of the lens will cause defects of focus.

It is a very simple matter to take pictures for the stereoscope when a binocular camera is used, and there is no extra labour in the printing; but the pictures are comparatively useless until they are mounted; at this point there is some trouble, and much care is required to do the work properly. Amongst amateurs this has probably had something to do with the unpopularity of stereoscopic work during the last few years; but it ought not to deter any one from producing stereoscopic pictures, for they certainly give a more pleasing representation of a place than a single view, no matter how large it may be. It must not be forgotten that, by contact-printing, positives of the exact size for lantern work may be produced.

As already stated, prints from negatives taken with a binocular camera are not in their correct position for mounting. They must be divided in the centre, and the left hand one placed on the right hand side of the mount, and *vice versa*. When taken on plates  $6\frac{3}{4} \times 3\frac{1}{4}$ , the prints are very near the size required, and very little more than trimming is necessary; but, whether trimmed before toning, or after, each print should be marked on the back, so that in mounting each will have its own pair. Therefore proceed to mark the prints in order, 1, 1\*, 2, 2\*, 3, 3\*, and so on; the meaning of the marks being that 1 and 1\* are the prints to be mounted side by side, and that 1\* is the left-hand picture. If these marks be carefully made, mistakes in mounting cannot occur. If they are carelessly done, the prints may be pseudoscopic instead of stereoscopic. The illustration (Fig. 116) will serve to show what to avoid, both in taking the negative and in trimming the print before mounting. The illustration is from negatives which are taken with the stations too far apart. No portion of the colonnade seen in the right hand picture is shown in the left; it also shows that the prints were mounted too close, the centres being very little more than two inches apart. The distance may be  $2\frac{1}{2}$  inches or  $2\frac{3}{4}$  inches, but not more nor less. Many persons cannot use the stereoscope. They say that they can see the picture better when one eye is closed. This may arise from the eyes of the person being closer together or wider apart than the average, and the stereoscope may not admit of the necessary adjustment; or it may be that the prints have been unsuitably mounted. Avoid the mistake shown in Fig. 116, but always allow some portion of the

object at either side to be seen, not, however, exaggerated, as shown in the engraving.

As it is necessary in making transparencies for the stereoscope that the two pictures should be on one piece of glass, the negative must be cut and transposed if the transparency is to be printed in contact; but, if the transparency is to be made in the camera, the lenses used in taking the negative may also be used in making the copies, and the reversal of position will take place in the camera. The lenses must be arranged so that adjustments may be made to give the proper position of the two pictures on the ground glass. The beautiful pictures produced many years ago by the late Mr. Breeze, were made in a copying camera of the kind referred to. With care, many of the effects introduced by Mr. Breeze can be imitated, as, for instance, in moonlight scenes the moon may be shown; but, as it would be impossible to photograph any scene by aid of the light of the moon, the effect must be obtained in another way. That is done by taking an instantaneous picture of a landscape when the sun is hidden by clouds, so quickly that, when viewed as a transparency, the effect must appear as moonlight; that is, no part must be so distinctly visible as in a daylight picture. To introduce the moon, a stereoscopic negative of that luminary must be taken with the camera used in taking the landscape. This can readily be done at the time of full moon, and the size of the moon will be exactly what is required for the picture. When the moon is introduced into pictures, artists almost always exaggerate the size. The moon is a small object as we see it in nature. This is shown by the fact that it can be seen through a hole one-tenth of an inch in diameter, held at 10 inches from the eye. The size, then, as taken by the twin camera is what is required for the transparency. We have now to fix the proper position for the moon, which naturally must be near where the sun was supposed to be when the clouds were photographed; therefore, a clear place must be selected for it, and the print from the original negative may be taken on the glass to be used for covering the picture, or, if preferred, a separate glass. Mr. Breeze frequently used three very thin glasses in his pictures. The glass can be obtained of such thinness that three will be about equal to two pieces of the ordinary kind.

To obtain stereoscopic pictures of the moon, a telescope (or a camera with a lens of very long focus) is necessary. A telescope of 5 inches aperture, and 6 feet focal length, will give a picture of the moon of about seven-tenths of an inch in diameter at the principal focus. A landscape or other photographic lens of 30 inches focus will give a picture of the moon about three-tenths of an inch in diameter. Therefore it will be seen that, as the image must be enlarged very much to

make an effective picture for the stereoscope—say at least to  $1\frac{1}{2}$  inches diameter, there will be much loss of detail if a very small negative be used; hence the picture taken with the telescope should have the preference. Owing to the very great distance of the moon from the earth, it would produce very little stereoscopic effect if two pictures were taken on the same night with cameras placed 3000 miles apart; but advantage may be taken of what is called the *libration* of the moon. It may be seen by close observation that the moon shows at certain times a little more of her surface on either side, that is, east and west or north and south. If photographs are taken at such times, it will be found, on viewing enlarged copies in the stereoscope, that the effect of rotundity is distinctly brought out, and a reality of effect produced which can be gained in no other way. If the views are selected from the times of extreme libration, the moon will appear as a kind of cylinder with a rounded end. A good stereoscopic picture of the moon is a very desirable thing to possess, and is worth much trouble to obtain. According to a statement made by Sir J. Herschel, libration causes an apparent change of place, as seen from the earth, equal to 52,000 miles, the stereoscopic angle being  $12\frac{1}{2}^{\circ}$ ; that is, the cameras may be supposed to have been placed that distance apart when the pictures were taken. As the distance of the sun is too great for any effect of libration to be seen, Sir J. Herschel suggested that advantage might be taken of the sun's rotation on his axis; and as a spot on the sun's surface is made to shift by one day's motion about  $13^{\circ}$ , photographs suitable for the stereoscope might be made. The writer has never seen a stereoscopic picture of the sun, and he is not aware that Sir J. Herschel's suggestion has ever been acted on. Photographs taken at short intervals during a partial eclipse of the sun show stereoscopic effect of the moon's passage across the sun's disc when combined in the stereoscope.

By careful manipulation in taking the two pictures, either by the single or binocular camera, and care in mounting the prints, chiefly by seeing that their centres are not less than  $2\frac{1}{2}$  inches or more than  $2\frac{3}{4}$  inches apart, much pleasure may be derived from stereoscopic photography. Robert Hunt wrote thus more than thirty years ago:—“Even when fully accustomed to the phenomena of the stereoscope, there is so indescribable a charm in the beautiful pictures that they are gazed at again and again with increasing admiration.”

As these words have additional force when the picture is viewed as a transparency on glass, it will be convenient here to describe a method of printing photographs in this form. At the period when stereoscopic pictures were very popular, Messrs. Ferrier & Soulier (now Messrs. Levy & Co.), of Paris, produced pictures of this kind

which were exceptionally beautiful. Their excellence was due in a great measure to the process used in their manufacture, a process worked out and really known only to the makers themselves, but supposed to be a simplified collodio-albumen process.

To print stereoscopic transparencies, the plates should be  $6\frac{3}{4} \times 3\frac{1}{4}$ . Having then negatives, &c., of this size, and a printing-frame as shown in Fig. 117, proceed as follows:—

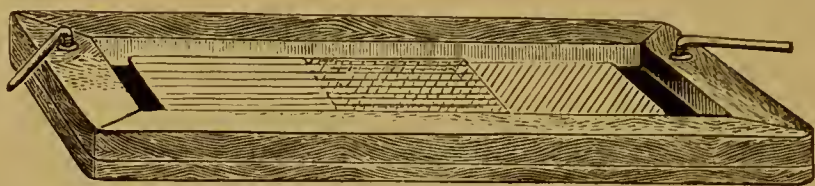

FIG. 117.

First examine the negative carefully, and note if *all* the subject you wish to reproduce is on *both* portions of it.

Now, in the dark room lay the negative, *face upwards*, in the printing-frame; then, holding up the frame by the *left* hand, arrange the selected portion of the negative over the aperture of frame by sliding it either to the right or left by means of the right hand fingers. Next lay the prepared transparency plate, *face downwards*, on to the negative, as shown in Fig. 117, where the diagonal lines represent

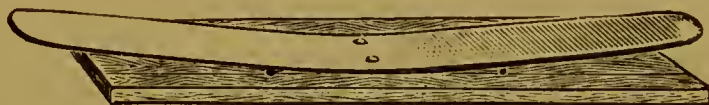

FIG. 118.

the *negative* with the left end *over* the aperture of frame, and the lines parallel with the frame represent the *transparency* plate with its right end *over* the opening in the printing-frame.

Now place the back of the printing-frame, Fig. 118, in its position, and expose to a gas flame for the necessary length of time. Go back

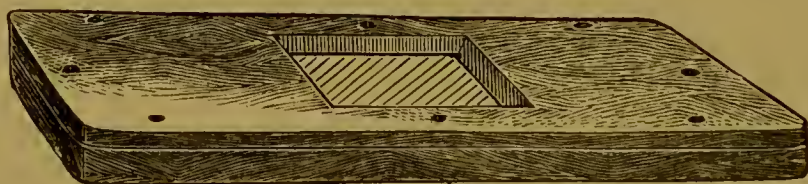

FIG. 119.

to the dark room, unclamp the back of the frame carefully, and take out the sensitive plate; but, before disturbing the negative from its position, hold the frame towards the dark room light, and notice particularly some part of it which touches or rather is opposite one



edge of the square opening of the frame. Now arrange the opposite ends of the negative and transparency plate over the opening, so that the counterpart of the former image may be printed, as shown in Fig. 117; expose as before, and all that is now required is to take the plate from the frame and develop it in the usual manner.

A little care is all that is necessary for securing perfect adjustment between the negative and transparency.

The printing-frame, as described above, is made by Mr. Chapman, of Manchester.

## CHAPTER II.

### PRACTICAL HINTS.

**Accelerator.**—Any substance used to assist in the development of the photographic image, *e.g.*, the alkali added to the pyro-developer to quicken its action, is called an *accelerator*. The term is generally applied in working with gelatine plates. In the wet collodion process the application of heat will accelerate the action of the developing solution. When it is found that the exposure has not been sufficient, slightly warming the plate while the developing solution is on it will increase the density of the image.

**Alkaline Development.**—The use of an alkali to assist in the development of the latent image was first introduced by Major Russell, the author of the *Tannin Process*, in 1862. With the alkali it was necessary to use a soluble bromide to act as a “restrainer.” Without the bromide the development was too energetic, and *fog* was caused. Ammonia is the alkali generally preferred, but soda and potash are recommended by some operators. The results are very much the same whichever alkali is used.

The action of pyrogallie acid alone is very slow, and the addition of the alkali is to cause a quicker development; the restrainer is used to keep the action of the developing solution under control.

**Anhydrous.**—When a substance contains water of crystallisation or has an affinity for water, as calcium chloride, acetic and sulphuric acids have, the removal of the water renders the substance anhydrous. In general, an anhydrous substance is one which does not contain any water.

**Argentometer.**—When water contains nothing but silver nitrate, the quantity of which is not known, the instrument called an *argentometer* will indicate accurately how much silver is present. When,

however, the silver solution has been used (as in the case of a bath for collodion plates or in the preparation of paper), the solution becomes contaminated with other matter, and the correct quantity of silver can no longer be ascertained by means of the argentometer. But for very rough purposes this convenient little instrument may be used, since, although the bath may contain ether and alcohol, the indication of strength in silver may be sufficient. A more accurate method of testing the strength of a silver solution is to titrate as chloride with a standard salt solution; but this is rarely necessary in practice.

**Backing Plates.**—The object of backing plates, as it is termed, is described under the heading *Halation*. Any method may be adopted by which the back of the plate will be prevented from reflecting the light. Lamp-black mixed with alcohol or with water and rubbed on the back of the plate may be used, or, if preferred, the following:—

<i>a.</i> Gum arabic . . . . .	1 ounce.
Water . . . . .	4 "
<i>b.</i> Glycerine . . . . .	1 "
Water . . . . .	2 "

Mix the two solutions, and incorporate with it any suitable pigment, such as drop-black, which may be ground in water. With this paint the backs of the plates, and allow to dry protected from the light.

**Bichromate and Cyanide Poisoning.**—In working the carbon printing and other processes in which potassium bichromate is used, it is next to impossible to prevent contact of the bichromate solution with the hands; hence, when the skin is cracked or sensitive, ulcers or a very irritating "rash" may appear. So far as the rash is concerned, the writer's experience has been that the remedy is to cease putting the hands into the solution. When the rash is very troublesome, a dilute solution of carbolic acid in alcohol has been found effectual; and carbolic soap should be used when washing the hands. When practicable, india-rubber gloves should be worn, and the hands should always be thoroughly washed after they have been in the bichromate solution. With ordinary care this irritating disease may be avoided altogether.

Potassium cyanide, applied to the skin after the hands have been touched with tincture of iodine to remove silver stains, will do no harm to health if the skin is not cracked; but sores may be caused, and therefore the cyanide should be used with the greatest care.

**Broken Negatives.**—Negatives taken by the collodion method, if not too badly broken, may be printed from if the parts are carefully held together by the edges of the plate with gummed paper, and then printed under tissue paper in the shade, or by suspending the frame

so that it may be kept revolving while printing. If the negative should be on a gelatine plate, the film may not be broken, in which case it may be removed and remounted as described under the heading *Stripping Film*.

**Combination Printing.**—The most simple form of combination printing has been referred to under the head of *Clouds*. To combine several figures taken from separate negatives in one picture, so as to give a natural effect, some skill and much patience on the part of the photographer is necessary. The desire may be to produce a picture of twenty figures in a room, which also is to be represented with its furniture and decoration, and with the figures occupied so as to look *natural*. First of all we must *design* the picture, and then carefully photograph the figures, singly or in groups, to fit the design; and the lighting must be the same as adopted in the sketch; also the figures must be in their true relative sizes. The room also must be photographed, and an enlarged negative made to be printed as a background for the figures. If a photograph cannot be taken, a correct drawing must be made. A print of each figure must now be arranged and mounted in the position it is to occupy in the finished picture, and this is to be used as a guide in printing the figures, which in a case of this kind will require the aid of an artist to harmonise the whole. Each negative must now be masked so that only such part as is required for the picture will be printed and the portions cut out preserved. To proceed with the printing: First draw a line at one side of the guide print, and a line also at the bottom. Lines to correspond must be drawn on the sheet of sensitised paper to be used as guides in printing in the figures. A printing frame the full size of the paper must be used. Place the prepared paper on the backboard of the frame, and upon it arrange the first negative, measuring the distance carefully from the side and the bottom to a fixed point on the negative. If there should be room, two negatives may be arranged and printed at the same time. The whole of the paper not under exposure must be carefully protected from the light. The glass of the printing-frame must now be placed in position, the frame put over, and the whole then carefully turned over so that the negatives are not disturbed. When the frame is a large one, this can be done with bolts and the bars *wedged* down (wedges are preferable to screws) when the frame is turned. The progress of the printing can be watched in the usual way, and great care must be taken to have the prints of equal depth. When all the negatives are printed, the portions of the prints cut out must be arranged over the printed parts, and the background can then be printed in. The greatest care is necessary in every part of the printing, otherwise dark and light lines will appear around the figures. It is difficult to produce a work of this kind so perfect that

no touching-up or artistic finishing is required; but, when printed on salted paper, such photographs can be finished in water-colour or black and white, and, in the hands of a skilful artist, the result may be highly satisfactory. If the work is to be finished in oil colour, the photograph should be on albumenised paper.

Figures can be introduced into landscapes in such a way as to appear as if part of the original picture, and, when skilfully done, the effect is excellent. The difficulties to be overcome are many, the chief, perhaps, being with the models, as it is not easy to make them pose or to assume the expression desired. In most photographs of the kind the figures look as if they had been posed for the occasion, and there is a *photographic* appearance about the work which the artist has failed to conceal. A few works of the kind have been produced which possess much artistic excellence, thus proving that in the hands of a skilled photographer a photograph may also be a work of art. The illustration on the opposite page is from a picture by Mr. H. P. Robinson, who has given much attention to the production of pictures of this kind. Two negatives are used in this picture, and the printing is so carefully effected that no retouching has been necessary.

**Copyright.**—By an Act of Parliament (25 and 26 Viet. c. 68, s. 1) it is provided that when the photograph has been made or executed for or on behalf of any other person for a good or valuable consideration, the photographer shall not retain the copyright unless it has been secured to him by a written agreement signed by the person for whom it was made; the copyright in the photograph belongs to the sitter. Therefore, if a portrait is required for publication or sale for the benefit of the photographer, consent in writing must be obtained and a money payment of some kind made, the amount being stated in the agreement. Registration at Stationers' Hall is necessary to prevent infringements. This is the law of the case. The custom amongst photographers as to portraits is, that the negative is the property of the photographer, and can be destroyed by him after his sitter has been supplied with copies; but if the negative be retained, it is exclusively for the sitter's use. This rule applies also to all kinds of copies.

A photograph of a landscape or of any other kind is protected by registration, so that that particular work may not be pirated; but this does not prevent any other person making photographs of the same objects.

**Cracks (to fill up).**—Old, and perhaps valuable, negatives taken by the collodion process are sometimes found to be cracked,—that is, the film becomes reticulated more or less after they have been stored away. A little soot applied with the end of the finger will generally

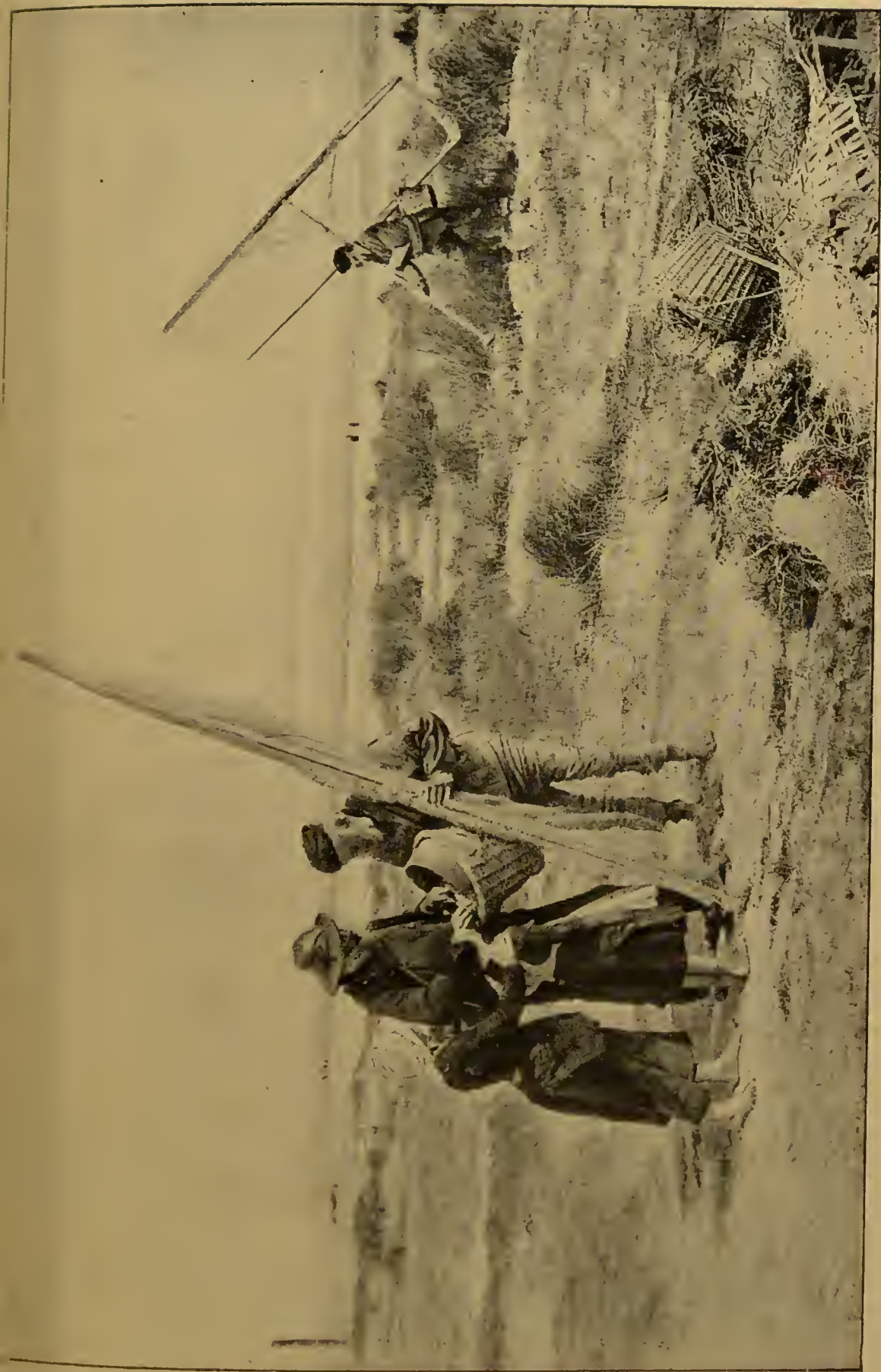

A. BROTHERS & CO., HALF-TONE ZINCO.

### A STRANGE FISH.

PRINTED FROM TWO NEGATIVES.

H. P. ROBINSON, PHOTO.



fill up such cracks, and when re-varnished the negative will be as serviceable as ever. Storage in a damp place is the probable cause of cracks of this kind. Insufficient washing after fixing also may have originated them.

**Density.**—Upon the proper *density* of the image depends the printing quality of the negative. By experience alone can this quality be determined when the plate is under development. The necessary density varies with the purpose for which the negative is required. For landscapes or portraits absolute opacity may be necessary only in certain parts, but for some purposes, such as photo-lithography, absolute opacity in every part is essential, the transparent subject excepted.

**Detail.**—A picture, when correctly exposed and developed, will be full of *detail*—that is, each part is correctly seen in sufficient perfection; another picture of the same subject, through insufficient exposure, is said to be wanting in detail, because the parts in shadow are black, and contain no detail. Over-exposure may produce a similar defect, but in a different way, as the excess of light may cause the more delicate details in the picture to be lost.

**Developing and Developers.**—The action of light on a prepared plate produces an effect which is invisible, or, as it is termed, *latent*. Of the composition of this photographic effect or image we have no certain knowledge; but we do know that by the application of reducing agents certain reactions occur, and a picture is formed; in other words, the image is *developed*.

The development of the image on the daguerreotype plate presents a case different from any other process—a *vapour* of iodine being employed, in the first place, to make the silver surface sensitive to light, and then to develop the image the vapour of mercury is used. As this vapour consists of particles of mercury, it may be assumed that they adhere to those portions of the plate on which light has acted, and the unaltered iodide of silver rejects the mercury particles.

In illustration of this idea, Professor Meldola suggests that if a design be drawn on a sheet of glass in gun-water, and then if a powder or sand be dusted over the plate, the image would be *developed*. This illustration of the production of a picture in molecules is complete, but it affords no idea of the chemical nature of the compound formed by the mercury on the silvered plate.

Since the days of Daguerre many substances have been prepared and used as developers. Talbot made use of gallic acid. Hunt and Herschel introduced iron. Pyrogallie acid (this substance is not really an acid, its proper name being *pyrogallol*), although known since 1831, was only first used in photography in 1851. Within the last few years other substances, such as eikonogen and hydroquinone, have been introduced.

The action of pyrogallic acid as a developing agent in the wet collodion process is much slower than iron, at least three times, and it is now seldom employed. For gelatine plates, however, pyrogallol is largely used, and by some is preferred to eikonogen and other similar substances.

One of the most energetic of the reducing agents is iron protosulphate, used now almost exclusively in the wet collodion process. Ferrous oxalate produces excellent negatives when used to develop gelatine plates.

The question as to how the various reducing agents act on the invisible image is one which has occupied the pens of some of the best authorities on photographic matters, and the literature of the subject is very extensive.

The development of the image has been compared to the formation of the "silver tree," which may be produced by suspending a slip of zinc in a solution of silver nitrate. The action set up soon becomes visible on the zinc by the deposition of particles of metallic silver, and these continue to form and adhere to each other until the whole of the silver contained in the solution is exhausted. The deposit of silver from its salt solution may be shown in another way, and is an interesting experiment when seen under the microscope. A few drops of silver solution are placed in a cell on the stage of the instrument, and on the addition of some fine copper filings the silver will be seen at once to form and attach itself to the particles of copper, building up a miniature "tree" or fern-like structure. In the case of the photographic image the particles of silver are deposited in a very finely divided state, and the density of the picture is caused by the deposit being thicker on those parts of the plate which have received the most light. In the case of the collodion picture the film contains an iodide of silver formed by the combination of the iodine in the collodion and the silver nitrate in which it is immersed. On exposure in the camera a change is produced by the action of the light, and this change is made visible on the application of the developing solution, which, in this case, is assumed to be iron protosulphate. If a solution of a proto-salt of iron be added to a solution of silver, the latter metal is at once thrown down; but when the iron solution is used to develop the image, the silver contained in the silver nitrate in the film is deposited in the metallic state only on those parts of the plate where the light has caused some change in the molecular condition of the film containing the silver, and it is usual to say that the picture is built up by the atoms clustering together in proportion as the light has affected the sensitive film. How the image has been formed in the first instance by the light is difficult to explain; in fact, very little is known about it, but that the picture is built up by



atoms or particles of metallic silver can be seen under the microscope, and the metallic silver can also be shown by gently rubbing the dry film, which will at once exhibit its character.

A few facts not generally known to the present generation of photographers may be stated. They are of as great interest now as when published in 1842, and are contained in a summary of a paper by M. Ludwig Moser "On the Formation and Development of Invisible Images." It will be found in Hardwich's "Manual of Photographic Chemistry," 5th edit., p. 42. A portion only of the summary is given here:—

"From Moser's experiments we learn that the surfaces of various bodies are capable of being modified by contact with each other, or by contact with a ray of light, in such a way as to impart an affinity for a vapour; and further, that the salts of silver are in the list of substances admitting of such modification. But the same condition of surface which causes a vapour to settle in a peculiar manner also affects the behaviour of the silver salt when treated with a mixture of nitrate of silver and a reducing agent. Thus, if a clean glass plate be touched on certain spots by the warm finger, the impression soon disappears, but is again seen on breathing upon the glass; and if this same plate be coated with a very delicate layer of iodised collodion and passed through the nitrate bath, the solution of pyrogallie acid will often produce a well-defined outline of the figure even before the plate has been exposed to the light. This experiment is an instructive one, and shows the necessity of cleaning the plates used in photography with care. If there be any irregularity in the manner in which the breath settles upon the glass when it is breathed on, a condition of surface exists at that point which will probably so modify the layer of iodide of silver that the action of the developing fluid will be in some way interfered with.

"Glass plates with collodion pictures on them should be cleaned very carefully before being used again, or the old impression will reappear during development. Plates packed in sheets of newspaper often show the letters in the same way when the pyrogallie acid is applied. Traces of organic matter, in all probability, are present in the superficial pores of the glass, and it is only by long soaking in chemical solutions that these invisible images can be destroyed."

It will be convenient here to give a few hints as to the development of gelatine dry plates. The operation is very simple, but until experience has been gained many failures may occur. It is assumed that the worker has made himself master of the way of using the camera and focusing. The necessary exposure will depend on the kind of lens in use, the size of the diaphragm, the state of the light, and the make of plate, whether slow or quick. Experience alone is

required, but a few hints from a friend who has mastered the difficulties would be useful. The plate having been exposed, the carrier holding it must be opened in a darkened room. We will suppose that the plate is an "Ilford,"  $6\frac{1}{2} \times 4\frac{3}{4}$ , and that the formula for that kind of plate is to be used. In a glass measure pour one ounce of No. 3 solution, and add to it half an ounce of No. 2 solution. Put the plate, film-side uppermost, into a dish of suitable size, that is, somewhat larger than the plate, and then pour over it the mixed developing solution. If it is found that the image shows itself very slowly, more of No. 2 may be added. The picture should not develop too quickly. If the exposure has been correct, the film will gradually darken, and the density may be ascertained by examining it by holding the plate towards the light. The proper density can only be determined by trial. The appearance of the plate at the back may be some guide, as the image shows darker than the rest of the surface. When it is known that the exposure has been correctly timed, the full quantities of the two solutions, Nos. 2 and 3, may be used at once. The object of taking only half the quantity of ammonia, or even less than half, is to retain some control over the development. In an over-exposed plate the image will start up at once, and it will be found on fixing that the image is weak and probably useless. As soon as it is seen that the exposure has been too great, the developing solution may be poured back into the glass, and more of No. 3 added, and with care a fairly good negative may result. In cases of under-exposure, prolonged development and the use of more of No. 2 solution may permit a picture to be developed, but the result is too often that the shadows are dark and the contrasts too great; therefore the greatest care should be taken to make the exposures correct and to develop to the proper density. No words can properly convey the necessary instruction for this; a few plates may be spoiled, but the information gained will compensate for the loss.

When the picture is fully developed the plate should be rinsed with water, and then at once placed in the fixing solution, consisting of sodium thiosulphate ("hypo") 4 ounces, and water 20 ounces. As soon as all trace of the white film has disappeared, which may be ascertained by examining the back of the plate, the fixing is complete. After thorough rinsing, the picture must be "cleared" by flowing over it sufficient of the solution named for that purpose (see *Clearing Solutions*). The object of this part of the process is to remove a yellowish veil, which, under certain conditions, appears after development.

It is sometimes recommended to place the plate when developed in a saturated solution of alum; when there is any tendency for the film to "frill" this is necessary, but not otherwise.

It now only remains to thoroughly wash the finished negative, and

this may be done by allowing water to flow over it for an hour or two, or the plate may be placed in a dish and the water changed frequently. When many plates are to be dealt with, it is convenient to use a grooved washing trough, through which the water is changed by means of a syphon.

The negative should be allowed to dry in a rack, or by standing it on end on blotting paper. Any attempt to dry it by fire-heat would cause the film to melt. If, however, it is necessary to dry the plate quickly, it may be placed in methylated spirit, and after a few minutes, when all greasiness has disappeared, it may be removed (the spirit can be used again), and reared up to dry.

The makers of gelatine-bromide plates always recommend that the formulæ they give should be used. This is, perhaps, excellent advice to the tyro; but good results on any kind of plate may be obtained with pyrogallol and ammonia development, and perhaps with any one of the various methods in use. Failures are more likely to arise from changing from one kind of plate to another, and experimenting with various formulæ. It is far preferable to select a plate known to work well, to persevere with it until its peculiarities are known and mastered, and to use the developing solution known to give good results with the particular plate in use. When experience has been gained, failure is unlikely to occur, no matter what kind of plate may be used.

Gelatine plates are made of various degrees of rapidity, and in some cases plates of the quickest kinds may advantageously be used; but for ordinary work the slowest (say, ten times the rapidity of wet plates) will be found to give the best results. The exposure is more under control and the development more certain. With the quickest plates there is less control of the exposure and more depends on the development. It has been asserted, as the outcome of careful experiments, that no modification of development can correct an error in the exposure outside certain limits depending on the character of the plate. This opinion, if proved correct, will greatly emphasise the necessity for care in the exposure.

In the description of the various processes will be found the necessary formulæ for development. As already stated, in working with gelatine dry plates, it is better to use the formulæ recommended by the makers, but for convenient reference the following may be useful:—

*Developing Solution for "Edwards' XL Plates."*

No. 1. Pyrogallol	. . . . .	1 ounce.
Alcohol (methylated)	. . . . .	7 ounces.
Glycerine	. . . . .	$\frac{1}{2}$ ounce.
No. 2. Potassium bromide	. . . . .	120 grains.
Ammonia, .880	. . . . .	1 ounce.
Water	. . . . .	7 ounces.

For use, take one part of No. 1 to fifteen parts of water, and, in a separate bottle, mix one part of No. 1 with fifteen parts of water. Equal parts of these two solutions are required when a plate is to be developed. The dilute solutions will not keep, and should be mixed just before they are required.

*For the "Ilford" Plates.*

No. 1. (Stock) Solution.	
Pyrogallol . . . . .	1 ounce.
Ammonium bromide . . . . .	600 grains.
Water . . . . .	6 ounces.
Nitric acid (pure) . . . . .	20 drops.
No. 2. Liq. ammonia, '880 . . . . .	3 drachms.
Water . . . . .	20 ounces.
No. 3. Solution No. 1 . . . . .	1 ounce.
Water . . . . .	19 ounces.

Equal parts of No. 2 and No. 3 are to be mixed for use. If the plate is found to be over-exposed, at once remove it from the dish, and pour over the plate some of the No. 3 solution, which may be allowed to mix with the solution in the dish. When the development is slow, more of the No. 2 solution may be used, and in case of doubt as to the exposure, take only half the quantity of No. 2, and add more as required to produce the proper density.

For the *Pall Mall* plates the makers recommend the following:—

No. 1. Pyrogallol . . . . .	1 ounce.
Sodium sulphite . . . . .	4 ounces.
Citric acid . . . . .	$\frac{1}{2}$ ounce.
Water to make . . . . .	20 ounces.
No. 2. Potassium carbonate . . . . .	3 "
Sodium sulphite . . . . .	2 "
Water to make . . . . .	20 "

To an ounce of water add one drachm of each of the above solutions.

With ammonia the following is the formula for the same plates:—

No. 1. Pyrogallol . . . . .	1 ounce.
Sodium sulphite . . . . .	3 ounces.
Citric acid . . . . .	$\frac{1}{4}$ ounce.
Water, boiled or distilled, to make . . . . .	10 ounces.

Of the above ten minims equal 91 grains of pyrogallol.

No. 2. Liquor ammonia .880 . . . . .	1 ounce.
Water to make . . . . .	10 ounces.

Ten minims of this equal one minim of ammonia.

No. 3. Potassium bromide . . . . .	1 ounce.
Water to make . . . . .	10 ounces.

Ten minims of this equal 91 grains of bromide.

To each ounce of water add ten minims of each of the three solutions, and to increase density add ten minims of No. 2, if necessary.

With hydroquinone the following formula may be used :—

No. 1. Hydroquinone . . . . .	160 grains.
Sodium sulphite . . . . .	2 ounces.
Citric acid . . . . .	60 grains.
Potassium bromide . . . . .	40 grains.
Water to make . . . . .	20 ounces.
No. 2. Sodium hydrate . . . . .	160 grains.
Water . . . . .	20 ounces.

Equal parts of these solutions may be used in cold weather. In hot weather the solution may be diluted.

With iron the following may be used :—

No. 1. Potassium oxalate (neutral) . . . . .	6 ounces.
Potassium bromide . . . . .	20 grains.
Water to make . . . . .	20 ounces.
No. 2. Iron protosulphate . . . . .	8 „
Sulphuric acid . . . . .	$\frac{1}{2}$ drachm.
Water to make . . . . .	20 ounces.

To three ounces of No. 1 add one ounce of No. 2 (see *Hydroquinone*).

**Dialysis.**—The process of *dialysis* is useful in photography when it is desired to separate certain salts from colloidal substances, as in the case of gelatine emulsion. Parchment paper is strained over a vessel so as to form a kind of dish—the *dialyser*—in which the emulsion is placed. When brought into contact with water, the crystallisable salts pass through the parchment paper, while the colloidal substance remains in the dialyser.

**Diffused Light.**—For many purposes in photography direct sunlight is not desirable. When the processes used were very slow, as was the case when Daguerre's method was first used, the strongest light was necessary, but by the quicker processes now practised this is unnecessary. For portraiture blinds are employed, and, in some cases, the glass roof is stippled with colour to give the effect of ground glass. By this means the light is *diffused*, and the contrasts of light and shadow are given with the best effect.

**Dust.**—Whether in the wet or dry processes, one of the most troublesome annoyances arises from dust particles. Pinholes, couets, and various other defects are caused by dust; and as for some purposes (such as a *screen* for the half-tone block process) an absolutely perfect plate must be used, every care must be taken to avoid dust. The plates must be carefully brushed, whatever the process may be, and when gelatine plates are placed in a draught-box, the entrance for

the air should be protected with cotton-wool lightly placed over the aperture.

**Expansion of Paper.**—Most kinds of paper when wetted expand. This is very observable in paper on which portraits are printed. The expansion is greater in one direction than the other, and it is therefore necessary to cut the sheets so that the defect will be least observed. If the prints are allowed to dry, then brushed over with the mountant, and again dried, they may be mounted by damping the mount, when no distortion will be observable. The following differences were found in a sheet of paper very accurately measured:—

A sheet of paper, already coated with gelatine and dry, measured  $23\frac{1}{8} \times 17\frac{1}{4}$  inches. It was then sensitised in the bichromate solution and dried at  $80^{\circ}$  F., when it was found to measure  $23 \times 17\frac{5}{16}$  inches. The sheet was then printed, inked, and cleared from the ink, and while wet measured  $23\frac{1}{4} \times 17\frac{1}{16}$  inches. When dry and finished, the transfer measured  $22\frac{1}{16} \times 17\frac{3}{16}$  inches, showing a loss in length of one-eighth of an inch, and a loss in width of one-sixteenth of an inch. The importance of this will be at once seen by those who prepare transfers for photo-lithography, when several transfers are required to form one subject and to fit accurately.

**Fog.**—The extreme sensitiveness of gelatine dry plates makes them very liable to show the defect known as fog. As a consequence, every care should be taken to prevent the access of light to the plate, excepting through the lens at the time of exposure. A very minute hole in any part of the camera, dark slide, or in the diaphragm slot may admit light, or the sliding parts of the dark slide may be in fault. Therefore in a strong light the camera and slide should be kept covered as much as possible. The plate may be fogged through the light in the dark room not being of the proper quality. *Light fog* may be produced by any of these causes. There is another defect, which is *chemical*, and may arise in the process of manufacture of the plates or in developing. A tinge of greenish colour around the sides of the plates is called *green fog*, and often occurs when ammonia is used in developing and under prolonged development. This defect does not always interfere with the printing qualities of the negative. An appearance around the sides is often seen in some plates after development which is very like the defect referred to, but is evidently caused by tarnish, owing probably to the age of the plate. By careful rubbing with the finger while the plate is wet the defect may be removed. *Red fog* was at one time a defect in dry plates, but is now seldom seen. Green fog may sometimes be removed by soaking the film in a solution of potassium bichromate. Hydrogen peroxide may also be used.

Plates which have been exposed to light and thereby “fogged,” so

as to be useless for ordinary purposes, may, as stated in the *British Journal of Photography*, be restored by treatment as under. Take—

Chromic acid . . . . .	30 grains.
Potassium bromide . . . . .	60 „
Water . . . . .	10 ounces.

The plates are to be immersed in this solution for five minutes, thoroughly washed, and then allowed to dry. Another solution is as under, and is applied in the same manner:—

Potassium bichromate . . . . .	1 ounce.
Hydrobromic acid (sp. gr. 1.4) . . . . .	2 drachms.
Water . . . . .	10 ounces.

After treatment with either of these solutions the plates are much less sensitive than before, but if, after thorough washing, they are treated with one of the alkaline or the chromatising solutions, much of the sensitiveness will be restored.

Plates which have been exposed in the camera may be restored for use again if treated with either of the solutions named, but the immersion must be more prolonged. Care must be taken while drying the plates that no white light acts upon them.

In placing plates in the dark slide, care should be taken not to be too near the light, and as little light as possible should be used in the room. In developing, also, the plate should be kept away from the light, and until the image begins to appear it is not safe to expose the plate to the yellow light.

**Freezing Mixtures.**—The following mixtures will be found useful when the temperature requires to be reduced. When snow is available, the addition of common salt (sodium chloride), two parts by weight of the chloride to five of snow, will reduce the temperature from 84° F. (20° C.) to 5° F. The vessel containing the fluid to be reduced in temperature must stand in the freezing mixture.

The mixtures given below will also cause intense cold:—

Ammonium muriate . . . . .	5 parts
Potassium nitrate . . . . .	5 „
Water . . . . .	16 „

reduces the temperature from + 50° F. to + 10° F.

Ammonium nitrate . . . . .	1 part
Water . . . . .	1 „

reduces the temperature from + 50° F. to + 4° F.

Sodium sulphate . . . . .	3 parts
Nitric acid (dilute) . . . . .	2 „

reduces the temperature from  $+ 50^{\circ}$  F. to  $- 30^{\circ}$  F. With ice or snow still lower temperatures may be produced.

Snow . . . . .	12 parts
Sodium chloride . . . . .	5 „
Ammonium nitrate . . . . .	5 „

will reduce the temperature to  $- 25^{\circ}$  F.

Snow . . . . .	4 parts
Calcium chloride . . . . .	5 „

reduces the temperature to  $- 40^{\circ}$  F. Other mixtures may also be used.

**Frilling.**—This defect is caused by the expansion of the gelatine film, and as some plates are more liable to frill than others, some peculiarity in the process of manufacturing the plates may be the cause. If the sample of gelatine is too soft or is partly decomposed, or if the film is too thick, frills may appear after the developing or fixing solutions are used. If the developing solution is used too warm, the film may begin to leave the edges of the plate. In a case of this kind an edging of grease or india-rubber may be a remedy. When there is a tendency to frill, the plates should be placed in a bath of alum or chrome-alum before or after development, using a 5 per cent. solution of the alum. Steeping in spirits of wine is also said to prevent frilling. A thorough washing should follow the use of alum or chrome-alum before subjecting the plate to the action of an alkaline solution. Gelatine plates rarely, if ever, frill with the ferrous-oxalate developer.

**Halation.**—This is a defect frequently seen when a dark object is strongly lighted from behind—as dark foliage against a light sky; the light encroaches on the dark edges and causes a fringe of light around the object. The effects of *halation* are also seen in photographs of interiors where a bright light shines through a window, but are still more noticeable when the interior is dark, as in some churches, and the exposure is consequently prolonged. One of the causes is reflection from the back of the plate. Many remedies have been suggested; amongst others, backing the plates—that is, coating them on the back with an opaque colour, which can be easily removed before development. In plates thickly coated with emulsion the defect is not so noticeable. When an interior is sufficiently lighted by windows not shown in the picture, it may be practicable to cover the window facing the camera for most of the time during an exposure. Of course it is desirable that the picture should be taken when the sun does not shine directly on such a window. One of the best means to remove the defect is to carefully rub the over-exposed



part with methylated spirits of wine, using a tuft of cotton-wool or lint. In addition to backing the plate, it is said that staining the film with erythrosine, 1 part to 500 of water, is an effectual remedy. The following may be used as a reducing solution for halation—

Potassium ferricyanide . . . . .	20 grains.
Water . . . . .	2 ounces.

To about half an ounce of this solution add two drops of “hypo” (4 ounces of “hypo” to 20 ounces of water) when required for use. It may be applied locally with a camel’s-hair brush. After soaking in water, the plate must be well washed.

**High Lights.**—In a portrait, if well lighted, there should be parts which are brighter than the rest of the face—on the forehead and nose, for instance; they are called *high lights*. If they do not exist in the negative, the “retoucheur” generally marks such parts with the pencil. In a landscape the high lights give brilliancy to the picture.

**Hygiene in Photography.**—Although in the present day there is nothing in the practice of photography so prejudicial to health as was the case when the fumes of mercury were always present during the development of the daguerreotype plate, there is still the necessity for care. Probably the small quantity of ether fumes breathed during an ordinary day’s work when collodion was in general use did very little, if any, harm. Care should be taken, when large plates are coated with collodion, that the room should be properly ventilated, otherwise the ether fumes cause a very unpleasant effect on the eyes. The writer has never heard of any permanent injury from breathing ether fumes, nor has he experienced any injury himself after a long use of collodion; the effect on the eyes is unpleasant, but soon passes off. The fumes of ammonia in the small quantities used in developing dry plates can do very little harm; but when the strong ammonia is used, care should be exercised in every possible way. The bottle containing the fluid should never be unstopped when held near the face, and the fumes should be breathed as little as possible.

As collodion is so little used by amateurs, it is scarcely necessary to advise them to be cautious, while in large establishments every care will be taken to avoid accidents by fire; the stoppers of bottles should be looked to, and care as to naked lights observed.

**Intensifying.**—For certain purposes a negative taken in the ordinary way is not sufficiently *intense*—that is, the image is not completely opaque. For general purposes the collodion negative, when redeveloped or intensified with pyrogallie acid, is all that can be desired, but when used in photo-lithography, or other mechanical processes, the image must be black in order to obtain the best results. A collodion negative developed with iron may be intensified by steeping in a saturated

solution of mercury bichloride ; but as water alone will only take up a small quantity of the mercuric salt, it will be found that equal parts of mercury and ammonium chloride (sal ammoniac) will be found more energetic in its action. When the negative has changed to white, the intensification is complete, and the plate must now be *thoroughly* washed. If not completely washed stains will occur in the next operation. A dilute solution of ammonia poured over the film will instantly change the colour to black, when the plate must be again thoroughly washed. Incomplete washing causes the image to fade in course of time, although the film may have been varnished. Exposure to the atmosphere for a few hours will often be sufficient to cause the image to bleach in parts, so that varnishing must be resorted to as soon as the plate is dry. An unvarnished negative must not be used on silver paper, nor on a bichromate preparation, since stains may be thus produced.

Instead of ammonia chloride, hydrochloric acid may be used, one ounce of acid to six ounces of water, to which the mercury bichloride must be added : the undissolved portion may remain in the bottle. Instead of ammonia for blackening, "hypo" will answer the same purpose. Potassium cyanide, to which silver nitrate has been added, may also be used after the plate has been bleached.

The following formula for collodion negatives developed with iron, and, *if necessary*, redeveloped with pyrogallic acid, will be found preferable to the bichloride solution :—

Potassium ferricyanide . . . . .	4½ ounces
Lead nitrate . . . . .	3 "
Water . . . . .	65 "

which can be used repeatedly, and should be occasionally filtered. This will change the colour to a light yellow, and when sufficiently intense—which can be seen by transmitted light—the plate should be well washed in running water. The washing will take out the yellow colour, leaving the film white, but it is not always necessary to reach this point. Then take—

Ammonium sulphide . . . . .	4 ounces
Water . . . . .	12 "

and pour it over the plate until the film is completely blackened, that is, until no patches of the bleached picture are visible on the back of the plate. The ammonium solution should not be used twice. If any part of the picture appears discoloured where clear glass should be, a cleaning solution of—

Nitric acid . . . . .	1 drachm
Water . . . . .	12 ounces

may be poured over the plate. This must be used carefully, otherwise the density of the image may be injured.

Other methods are in use for intensifying collodion negatives, but the above are quite efficient.

Owing to the difficulty experienced in determining when a gelatine dry plate is sufficiently developed, many negatives are found to be too weak to give good prints. Unless the negative is very much under-exposed, a good result for printing may be obtained by careful intensification. The negative must be very thoroughly washed to avoid the risk of stains.

Intensification with silver nitrate is not always successful on gelatine plates, but the following is recommended by Mr. E. Howard Farmer:—

No. 1. Silver nitrate . . . . .	1 ounce
Distilled water . . . . .	12 ounces.
No. 2. Potassium bromide . . . . .	$\frac{3}{4}$ ounce.
Water . . . . .	2 ounces.
No. 3. Sodium thiosulphate ("hypo") . . . . .	2 "
Water . . . . .	6 "

Add No. 2 to No. 1, and after washing the precipitated silver bromide thoroughly by decantation, dissolve it with agitation in No. 3. The muddy liquid thus obtained is filtered or placed aside for a day and the clear solution decanted off; it is then made up to 16 ounces with water, and kept for use.

To intensify a plate, wash after fixing, and flood with the following mixture:—

Sulpho-pyrogallol . . . . .	40 minims
Water . . . . .	2 ounces
The above silver solution . . . . .	60 minims

to which is added, immediately before use, about 30 minims of 10 per cent. ammonia solution. If the silver shows no tendency to reduction, add more ammonia, or, if it be thrown down immediately, use less. With a little experience, a peculiar browning of the liquid shows when sufficient ammonia has been added. Rock the plate, and apply fresh solution as the density increases. Finally, place the negative for a short time in the fixing bath and wash.

Gelatine plates may be intensified with mercury bichloride. The solution as recommended for wet collodion plates, diluted, will answer, but it will be better to mix a solution specially, say—

Mercury bichloride . . . . .	10 grains.
Ammonium chloride . . . . .	10 "
Water . . . . .	1 ounce.

When sufficiently intensified, wash thoroughly and blacken with

Ammonia . . . . .	1 ounce.
Water . . . . .	9 ounces.

If found to be too energetic, the solution of mercury may be reduced with water; one-half water would in most cases be strong enough, as, if fully bleached, the negative may become too dense.

The following method for intensifying a gelatine plate immediately after fixing is recommended by Mr. W. Brooks:—Wash the negative, after fixing, for at least half an hour. Make a saturated solution of alum, and add to it one ounce of citric acid. To one part of this stock solution add three or four parts of water, in which soak the plates for a few minutes. Take two drachms of the alum and citric acid solution, and add six grains of pyrogallic acid and a few drops of a 20-grain solution of silver nitrate. Use this to intensify the plates in the ordinary way by holding the plate in the hand; watch the result, and stop just before full intensity is gained, as it will be denser when dry. Now wash the plate, replace it in the “hypo” fixing solution for five minutes; and after thoroughly washing it again, immerse it in the diluted alum and citric acid solution. If the plate has been allowed to dry, intensification by this method may be adopted, but it is better done while wet.

**Mealiness.**—Paper that has been floated in a bath containing too little silver will appear, when printed, with an irregular surface and deficient in brightness. This is frequently the case with some kinds of ready-sensitised paper. If the paper itself is of good quality, and sensitised a short time before it is used, the remedy is to add silver to the bath. It occasionally happens that the albumen dissolves in the bath, and this will cause mealiness.

**Negatives.**—The illustrations, figs. 120 and 121, show one of the most simple experiments in photography, and they also illustrate the difference between a negative and a positive. The figures show that a leaf placed on a piece of sensitive paper will produce a negative if exposed to light long enough to leave the impression on the paper, and that this negative, if fixed and made semi-transparent with wax, will produce a positive when exposed to light in the same way. The first photographs were produced in this manner. A sheet of paper sensitive to light, or a plate of glass, as in the collodion, gelatine, or other processes, and exposed in the camera, yields a negative when the object copied is a landscape, portrait, or other subject; but by using the camera as described in another section, a *positive* may be made from the negative. The fact that in pictures taken as described the lights are the reverse of nature constitutes them *negatives*.

**Over-Exposure.**—When a plate has received an excess of light

through the lens, it is said to be *over-exposed*. In some cases there is no remedy for this. In the wet collodion process an over-exposed plate can seldom be made into a good negative; but in some cases, when the exposure has not been very excessive, the picture may be saved by careful redevelopment or intensifying. In the case of gelatine plates, the effect of over-exposure may often be corrected by varying the proportions in the developing solutions. The picture will flash up too soon when the exposure has been over-long, and the resulting negative will be weak unless most carefully manipulated while under the action of the developer. It is, however, strongly



FIG. 120, Positive.



FIG. 121, Negative.

controverted whether over-exposure can be properly corrected by this or any other means. The evil can, at best, be only somewhat mitigated, in the opinion of some writers on this subject.

**Pinholes.**—The small transparent spots often seen in all kinds of negatives are called *pinholes*. The causes of these are various. In wet collodion plates the defects are chiefly due to *dust* and excess of silver iodide in the bath solution.

In gelatine plates the cause may arise from dust, or defects in the preparation of the plates; they can scarcely arise during development.

**Positive.**—This term is applied to all photographs which, when viewed by reflected light, appear with the lights and shadows as in nature. A *transparent* positive is a picture on glass or other diaphanous material which necessitates the view being seen by transmitted light. The term was at one time chiefly used to indicate a picture on glass specially developed to be seen by reflected light (the same when seen by transmitted light became a weak negative). All lantern slides are *positives*.

**Reduction of Density.**—Since the introduction of gelatine dry plates the possibility of getting too much density in the negatives has been much more probable than with collodion negatives, when additional density is given by re-development and the requisite intensity obtained without difficulty. With gelatine, the necessity for using a weak light, and the veil which causes the film to have a greater density than the finished negative will require, make the difficulty of judging the proper depth much greater than in some other processes. From these causes it happens too often that greater density is obtained than is desirable, and this excess must be removed or the resulting prints will not be satisfactory. So many methods are in use for reducing the density of over-developed negatives that it is difficult to select the best. In the writer's own practice the following is generally found sufficient; it is also used as a clearing solution:—

Alum . . . . .	1 ounce.
Sulphuric acid . . . . .	½ "
Iron protosulphate . . . . .	3 ounces.
Water . . . . .	20 "

As a clearing solution it is merely necessary to use sufficient to cover the plate, and then return the solution to the bottle. To reduce density the solution may be poured on and off till the required reduction is effected.

The following solution is also recommended as a means for reducing very dense negatives:—

Potassium ferricyanide . . . . .	1 ounce.
Water . . . . .	10 ounces.

The negative should be placed in a dish with sufficient water to cover it; then take one drachm of the ferricyanide solution and an equal quantity of the "hypo" solution used for fixing; pour the water out of the dish into the glass with this mixture, and then return to the dish. More of the mixture may be added if the first quantity does not cause sufficient reduction. The plate must be thoroughly washed.

The following is recommended by Mr. Spiller:—

<i>a.</i> Alum . . . . .	4 ounces.
Copper sulphate . . . . .	4 „
Common salt . . . . .	8 „
Water . . . . .	40 „
<i>b.</i> Saturated solution of common salt.	

Both solutions should be filtered and the negative immersed in equal parts of *a* and *b*. Watch the effect of the reduction. When complete, rinse in a fresh quantity of solution *b.*, and then thoroughly wash.

Prints on bromide paper may be reduced in the same manner as negatives. By using a solution of copper sulphate, to which a little salt has been added, bromide prints and untuned prints on salted paper may be entirely bleached out, but the image will reappear if the paper is exposed to strong light.

Reduction invariably interferes with the due gradation of density, and should therefore be used with caution.

**Reflected Light.**—When a portrait is taken with the light coming in one direction (as from the window of an ordinary room) the effect of contrast is too great, and it becomes necessary to modify it by means of *reflected light*. This is done by placing a white sheet or white paper at a suitable distance from the sitter, care being taken that there is not too much reflection, or the effect will be unpleasing. A little reflected light, judiciously used, is generally advantageous in a portrait. Reflected light is also useful in making copies as tending to equalize the effect and, in some cases, to get rid of the roughness of paper. Reflected light is often used in making transparencies in a copying camera, a sheet of white paper being placed at a suitable distance in front of the camera. A silvered mirror may be employed for the same purpose. In the solar camera the light is reflected from a mirror, but it is seldom that a mirror can be used in an ordinary glass house, as the window bars interfere with perfect reflection.

**Residues.**—The prevention of waste of the precious metals is very desirable. In the case of silver and gold the quantity used in the processes of photography is very large, and the loss, which is usually also very large, may be considerably lessened. In all large establishments every care is taken to save solutions and paper cuttings where silver or gold have been used; but the amateur, whose operations are on a small scale, too often considers it not worth the trouble to collect his waste. This is a mistake, as it occupies very little time to put all spoilt prints and cuttings and papers which have been used for filtering silver solutions into a bag. The “hypo” used for fixing and old toning solutions should not be thrown away, as in course of

time sufficient will accumulate to be worth sending to the refiners. In a paper print only about 3 per cent. of the silver originally used in its preparation is left in the picture ; so that 97 per cent. of the metal is lost if no care be taken to collect the waste. The waste in other directions is also very great, but much of it may be easily prevented. Paper prints should always be placed for some minutes in a dish with plenty of water previous to toning ; the water poured into a jar ; and a solution of common salt, or, preferably, hydrochloric acid, added thereto. The milky solution thus formed is allowed to become quite clear by settling. The water is then poured off, leaving the silver chloride at the bottom. The water from the next washing may then be added and treated in the same way until the chloride has collected in quantity sufficient to be removed, washed, and dried. The quantity of silver recovered from paper of the ready-sensitized kind will be very small when compared with that specially prepared.

The sodium thiosulphate solution used for fixing should be poured into a receptacle of wood or earthenware having a tap at a few inches from the bottom, which will serve to draw off the upper part of the solution after the silver sulphide has subsided. Potassium sulphide (liver of sulphur) is added in solution and the silver precipitated. The solution may be tested by taking a little in a test-tube ; if on the addition of a few drops of the sulphide no further precipitate is formed, the solution may be drawn off and thrown away. As the mixture of sulphide and "hypo" has an unpleasant odour, the vessel containing it should be kept in the open air.

As the sodium thiosulphate solution used for fixing gelatine plates dissolves all the silver not reduced in forming the negative and can be used repeatedly, it becomes rich in silver, and should be thrown into the tub to be reduced by potassium sulphide.

In establishments where the collodion process is still used and when the plates in use are large there is considerable room for waste. The sink over which the plates are developed should be large and deep, preferably of earthenware ; they may be obtained fitted with a plug, which permits the washing water to be collected and, after the sediment has subsided, to be drawn off into the waste-pipe. If the plug is simply withdrawn much of the sediment will be carried down the waste-pipe with the water. This is prevented by quickly substituting for this plug another which is made of lead pipe, and which has a hole about half an inch in diameter an inch or so above the level of the sink bottom. This permits the water to run off and prevents the disturbance of the sediment. The iron used in developing the plates gives rise to a highly argentiferous deposit, which, after drying, may be sent to the refiner. The developing solution remaining on the plates may be thrown into a separate receptacle or into the



sink, but the deposit of silver being richer than when mixed with the water, it is better to keep it separate. The cyanide bath used for fixing should also be kept and treated with potassium sulphide.

The films from spoilt collodion plates or old negatives should be preserved and thrown into the bag with the paper cuttings.

Old toning solutions may be poured into a large bottle, and a solution of iron protosulphate added to throw down the gold. When sufficient has been collected the sediment may be filtered out.

The films of unvarnished plates, which have been removed by steeping in weak nitric acid and water, should be kept and burnt with other residues. The acid solution should also be kept, and the silver recovered by adding a solution of common salt.

The various kinds of waste may be treated to recover the gold and silver, but as the cost of reduction, if sent to a refiner, is so small, it is not worth the trouble entailed in doing it at home.

There are other ways of treating the waste, but the above will answer every purpose, and the silver recovered will amply repay the trouble.

It is estimated that at least 75 per cent. of the silver used may be recovered.

It is a common practice to use sodium chloride (common salt) to precipitate silver from solutions, but as that salt has the power of dissolving silver chloride when there is a large excess of sodium chloride, it is better to use commercial hydrochloric acid, which does not dissolve the silver chloride.

**Saturated Solution.**—For many purposes in photographic manipulations it is convenient to have solutions containing as much of certain substances as can be held in solution. In such cases the solution is said to be *saturated*. The quantity which can be retained in solution by the fluid depends on the temperature. Water when cold will usually retain less of the substance than when hot, and in some cases the solution on cooling will part with the surplus in the form of crystals, leaving the water saturated. Some salts dissolve readily, while others require to be frequently agitated in the water. When no more of the substance can be dissolved the solution will be “saturated;” the surplus crystals may be left in the vessel and more water added as required until all the substance is dissolved. If merely poured on to the crystals the water immediately surrounding them will be saturated, but all above will contain very little until the whole is agitated; and in some cases this must be frequently done to obtain saturation. The process is facilitated when the substance to be dissolved is suspended in the fluid; then, as solution occurs, the denser fluid will sink and the water will be self-saturated. In all cases where saturated solutions are referred to the substances and fluids require to have been treated as explained here.

The following **Table of Solubility** will be found useful, as by its aid it may be seen at once how much of the substance will be taken up at the temperature shown :—

DR. JANEWAY'S TABLE OF THE SOLUBILITY OF PHOTOGRAPHIC CHEMICALS.

ABBREVIATIONS.—*s.*, soluble ; *ins.*, insoluble ; *sp.*, sparingly ; *m.*, moderately ; *v.*, very ; *dec.*, decomposed.

CHEMICALS.	WATER.		COLD ALCOHOL.
	59° F.	212° F.	
One part of—	Parts.	Parts.	
Acid, citric . . . . . is soluble in	0.75	.6	v.s.
„ gallic . . . . . „	100	3	m.s.
„ oxalic . . . . . „	8	1	v.s.
„ pyrogallic . . . . . „	3.5	v.s.	v.s.
„ tannic . . . . . „	6	v.s.	v.s.
Alum . . . . . „	10.5	v.s.	ins.
„ chrome . . . . . „	10	dec.	ins.
Ammonium, bromide . . . . . „	1.5	0.7	sp.s.
„ carbonate . . . . . „	4	dec.	m.s.
„ chloride . . . . . „	3	v.s.	sp.s.
„ iodide . . . . . „	1	0.5	m.s.
„ nitrate . . . . . „	0.5	v.s.	v.s.
Barium, nitrate . . . . . „	8	3	...
Cadmium, bromide . . . . . „	v.s.	v.s.	m.s.
„ iodide . . . . . „	v.s.	v.s.	v.s.
Copper acetate . . . . . „	15	5	sp.s.
„ sulphate . . . . . „	2.6	0.5	ins.
Gold chloride . . . . . „	v.s.	v.s.	v.s.
Gold and sodium chloride . . . . . „	v.s.	v.s.	m.s.
Iron iodide (ferrous) . . . . . „	v.s.	v.s.	sp.s.
„ perchloride . . . . . „	v.s.	v.s.	v.s.
„ protosulphate . . . . . „	1.8	0.3	ins.
„ and ammonia sulphate . . . . . „	3	0.8	ins.
Iodine . . . . . „	7000	...	m.s.
Lead acetate . . . . . „	1.8	0.5	m.s.
„ chloride . . . . . „	v.sp.	33	ins.
„ nitrate . . . . . „	2	0.8	ins.
Lithium bromide . . . . . „	v.s.	v.s.	m.s.
„ iodide . . . . . „	v.s.	v.s.	m.s.
Magnesium nitrate . . . . . „	v.s.	v.s.	m.s.
Mercury bichloride . . . . . „	16	2	v.s.
„ cyanide . . . . . „	12.8	3	ins.
Potassium acetate . . . . . „	0.4	v.s.	v.s.
„ bicarbonate . . . . . „	3.2	dec.	ins.
„ bichromate . . . . . „	10	1.5	ins.
„ bromide . . . . . „	1.6	1	sp.s.
„ carbonate . . . . . „	1	0.7	ins.
„ cyanide . . . . . „	2	1	m.s.
„ ferricyanide . . . . . „	3.8	2	ins.
„ ferrocyanide . . . . . „	4	2	ins.
„ iodide . . . . . „	0.8	0.5	m.s.

DR. JANEWAY'S TABLE (*continued*).

CHEMICALS.	WATER.		COLD ALCOHOL.
	59° F.	212° F.	
One part of—	Parts.	Parts.	
Potassium nitrate . . . . .	4	0.4	ins.
„ oxalate . . . . .	3	v.s.	ins.
„ permanganate . . . . .	20	3	ins.
„ sulphate . . . . .	9	4	ins.
„ sulphite . . . . .	4	5	sp.s.
„ sulphuret . . . . .	2	I	sp.s.
Silver, nitrate . . . . .	0.8	0.4	m.s.
„ oxide . . . . .	v.sp.s.	v.sp.s.	ins.
Sodium, acetate . . . . .	3	I	m.s.
„ bromide . . . . .	1.2	0.5	m.s.
„ bicarbonate . . . . .	12	dec.	ins.
„ carbonate . . . . .	1.6	0.25	ins.
„ citrate . . . . .	v.s.	v.s.	sp.s.
„ iodide . . . . .	0.6	0.3	m.s.
„ nitrate . . . . .	1.3	0.6	sp.s.
„ phosphate . . . . .	6	2	ins.
„ sulphate . . . . .	2.8	0.4	ins.
„ sulphite . . . . .	4	0.9	sp.s.
„ thiosulphate (“hypo”) . . . . .	I	v.s.	ins.
„ tungstate . . . . .	4.0	2.0	ins.
Uranium, nitrate . . . . .	v.s.	v.s.	m.s.
Zinc, bromide . . . . .	v.s.	v.s.	m.s.
„ chloride . . . . .	0.33	v.s.	m.s.
„ iodide . . . . .	v.s.	v.s.	v.s.

**Sizes of Drops.**—It frequently occurs that the quantities of fluids to be used are given in *drops*, and as the drops of different fluids vary very much in size errors may be caused when more than a very few drops are required. The following table, given by Dr. Eder, shows the number of drops required to make a cubic centimetre:—

Water . . . . .	20	Castor oil . . . . .	44
Hydrochloric acid . . . . .	20	Olive oil . . . . .	47
Nitric acid . . . . .	27	Oil of turpentine . . . . .	55
Sulphuric acid . . . . .	28	Alcohol . . . . .	62
Acetic ether . . . . .	38	Ether . . . . .	83

If 140 drops of sulphuric acid are required, divide that quantity by 28, which gives 5 as the number of cubic centimetres required, and as 1 cubic centimetre equals 17 minims, it is easy to convert that quantity into English measure.

**Specific Gravity.**—By using an instrument called a *hydrometer* the specific gravity of a fluid may be determined with sufficient accuracy for photographic purposes. A more accurate method is by using a *specific-gravity bottle*, which is made to hold 1000 grains of distilled water. When used, the bottle is filled with the fluid to be tested,

placed in the balance, and weighed against a brass weight sold with the bottle. Equilibrium is restored by adding the required weight to the lighter side of the balance. If the addition is made to the pan with the brass weight, it is added to the 1000; if to that with the bottle, it is subtracted therefrom. The resulting figure is the specific gravity required. The temperature of the fluid should be about 60° Fahr.

**Studios or Glass-rooms.**—To the professional photographer questions of the greatest importance are the aspect of his studio or glass-room and the plan of its construction. To a very large extent these points must be determined by the position in which the structure is to be built. Probably every form in which such a place could be contrived has been adopted, and good results obtained in each; as, when the operator has determined the best way to overcome the difficulties of



FIG. 122.

the form of his room, he will do good work, and in another place would have to unlearn his previous experience. Rooms with ridge roofs and glass all round, roofs with high pitch, roofs with low pitch and high or low side-lights, have been built. The last novelty which the writer has seen is the room at the People's Palace, London, where photographic work is done without a top-light, the glass being all on one side of the room and *very high*, and the shade side of the subject being illuminated by reflected light. Over another part of the room there is a top-light, to show the difference in the two effects. Of the results of the high side-light illumination the writer is unable to speak, as he has seen none of the work done there. At the time when the slow photographic processes were used it was of the utmost importance to have as much light in the room as possible, but much less light has been needed since the introduction of the quicker methods; hence the glass is now often ground or made dull by thin

paint on the inside. This, of course, gives a very soft effect. By means of blinds the light is entirely under control, so that the skill of the artist is shown in the manner in which it is managed. Very little can be said by way of instruction as to the construction of glass rooms, as the circumstances of each case must be considered.

The amateur in attempting portraiture has many difficulties to encounter, particularly when his roof is the clear sky. Outdoor portraits are of very little value when there is no means of controlling the light, but this difficulty is to a large extent met by Houghton's Lawn Studio, shown in Fig. 122, which seems in many ways to be all that the amateur need have. The question of backgrounds and accessories must be left to individual taste, but it may be remembered that the less ornament there is about a portrait the better.

Very effective portrait studies may often be made in conservatories or greenhouses.

**Symbols.**—The following is a Table showing the symbols and atomic weights of the elements—

Name.	Symbol.	Atomic Weight.	Name.	Symbol.	Atomic Weight.
Aluminium . . . . .	Al	27	Nickel . . . . .	Ni	58.5
Antimony . . . . .	Sb	120	Niobium . . . . .	Nb	94
Arsenic . . . . .	As	75	Nitrogen . . . . .	N	14
Barium . . . . .	Ba	137	Osmium . . . . .	Os	199
Beryllium . . . . .	Be	13.6	Oxygen . . . . .	O	16
Bismuth . . . . .	Bi	210	Palladium . . . . .	Pd	106
Boron . . . . .	B	11	Phosphorus . . . . .	P	31
Bromine . . . . .	Br	80	Platinum . . . . .	Pt	195
Cadmium . . . . .	Cd	112	Potassium . . . . .	K	39
Caesium . . . . .	Cs	133	Rhodium . . . . .	Rh	104
Calcium . . . . .	Ca	40	Rubidium . . . . .	Rb	85.4
Carbon . . . . .	C	12	Ruthenium . . . . .	Ru	104
Cerium . . . . .	Ce	141	Samarium . . . . .	Sm	150
Chlorine . . . . .	Cl	35.5	Scandium . . . . .	Sc	44
Chromium . . . . .	Cr	52.2	Selenium . . . . .	Se	79
Cobalt . . . . .	Co	59	Silicon . . . . .	Si	28
Copper . . . . .	Cu	63.4	Silver . . . . .	Ag	108
Didymium . . . . .	Di	146	Sodium . . . . .	Na	23
Erbium . . . . .	Er	166	Strontium . . . . .	Sr	87.5
Fluorine . . . . .	F	19	Sulphur . . . . .	S	32
Gallium . . . . .	Ga	69.8	Tantalum . . . . .	Ta	182
Germanium . . . . .	Ge	72.3	Tellurium . . . . .	Te	128
Gold . . . . .	Au	197	Terbium . . . . .	Tr	148
Hydrogen . . . . .	H	1	Thallium . . . . .	Tl	204
Indium . . . . .	In	113.4	Thorium . . . . .	Th	232.5
Iodine . . . . .	I	127	Tin . . . . .	Sn	118
Iridium . . . . .	Ir	193	Titanium . . . . .	Ti	48
Iron . . . . .	Fe	56	Tungsten . . . . .	W	184
Lanthanum . . . . .	La	139	Uranium . . . . .	U	240
Lead . . . . .	Pb	207	Vanadium . . . . .	V	51.3
Lithium . . . . .	Li	7	Yttrium . . . . .	Y	90
Magnesium . . . . .	Mg	24	Ytterbium . . . . .	Yb	173
Manganese . . . . .	Mn	55	Zinc . . . . .	Zn	65
Mercury . . . . .	Hg	200	Zirconium . . . . .	Zr	90
Molybdenum . . . . .	Mo	96			

In some cases the symbols are composed of letters taken from the Latin names of the elements, as—Antimony, *Stibium* ; Copper, *Cuprum* ; Gold, *Aurum* ; Iron, *Ferrum* ; Lead, *Plumbum* ; Mercury, *Hydrargyrum* ; Potassium, *Kalium* ; Silver, *Argentum* ; Sodium, *Natrum* ; Tin, *Stannum*.

**Weights and Measures.**—The photographer in his formulæ has seldom to consider more than grains and ounces, or, in the metric system, grammes and cubic centimetres ; but as German and French formulæ (the systems used in other countries need scarcely be considered in this matter) must in most cases be converted from one system into the other before they can be used by English and American photographers, it is a matter for serious consideration which of the two systems should be preferred or whether a compromise should be adopted. A very large part of the scientific literature comes from the continent of Europe, and as the metric system is used throughout that literature, it becomes a matter of necessity that the English-speaking men of science must be familiar with the terms used. Also, a very large number of Englishmen receive part of their education in some foreign university, where they are compelled to use the metric system, and, as a consequence, in the scientific literature of England and America the metric system is used to a much larger extent than was the case only a few years since. The effect of this is to make a large part of what is written very difficult to understand unless the trouble be taken to convert one kind of measure or weight into the other. The great bulk of the people of this country and America are no nearer now to the adoption of the metric system than they were at the time the English Parliament made its use permissive. It has been suggested that a joint commission of Englishmen and Americans should be appointed to settle this question. If that course were taken there can be very little doubt what the decision would be. “Scientific” men would form that commission—men to whom the metric system is familiar and, of course, by them considered the best. But suppose a commission of “non-scientific” men, say *business* men, formed a similar commission, it may be asked, Would they arrive at a similar decision? Meanwhile an informal “commission” has sat and deliberated on this momentous question, and the decision they have arrived at appears to meet the difficulties so far as they concern photographers in all parts of the world.

At the meeting of the Photographic Convention held at Chester in June 1890 a report on this subject was read, and the following “Recommendations” were unanimously adopted:—

“A. *Weights and Measures.*—1. If the metric system be used, weights will naturally be expressed in grammes, and measures in cubic centimetres.

“2. If the English units be used, the minim and the drachm should not be employed at all. All weights should be expressed either in grains or decimal parts of a grain, or in ounces or fractions of an ounce; all measures in fluid grains, or in fluid ounces and fractions of a fluid ounce.

“B. *Formulae*.—3. Formulae should give the number of *parts* of the constituents, by weight or measure, to be contained in some definite number of *parts, by measure*, of the solution. The mixture can then be made up with (a) grammes and cubic centimetres, or (b) grains and fluid grains, or (c) ounces and fluid ounces, according to the unit selected.

“4. The standard temperature for making up solutions should be 15° C. or 62° Fahr. No appreciable error will be introduced by the fact that these two temperatures are not quite identical.

“5. Formulae should give the quantities of the constituents to be contained in  $x$  parts of the finished solution, and not the quantities to be dissolved in  $x$  parts of the solvent. When a solid dissolves in a liquid, or when two liquids are mixed, the volume of the solution or mixture is, as a rule, not equal to the sum of the volumes of its constituents. The expansion or contraction varies with the nature of the solids and liquids and the proportions in which they are brought together. In making up a solution, therefore, the constituents should first be dissolved in a quantity of the solvent smaller than the required volume of the finished mixture, and after solution is complete, the liquid, cooled if necessary to the ordinary temperature, is made up to the specified volume by addition of a further quantity of the solvent.

“6. It is very important to specify in the case of liquids whether parts by weight or parts by measure are intended. The equivalence between weight and measure only holds good in the case of water and liquids of the same specific gravity: a fluid ounce of ammonia solution or of ether weighs less than an ounce; a fluid ounce of strong sulphuric acid weighs nearly two ounces.

“7. Whenever possible, formulae should give the quantities of the constituents required to make up 10, 100, or 1000 parts of the solution.

“8. When a mixture (*e.g.*, a developer) is to be prepared just before use, from two or more separate solutions, it is desirable that the proportions in which the separate solutions have to be mixed should be as simple as possible—*e.g.*, 1 to 1, 1 to 2, 1 to 3, 1 to 10.

“9. When metric units are employed the original French spelling, ‘gramme,’ should be used in preference to the contracted spelling ‘gram,’ in order to avoid misreading and misprinting as ‘grain.’

“ *Weighing and Measuring.* ”

“ A brief description of the correct methods of weighing and measuring may be of service to photographers who have had no laboratory training.

“ *Measuring.*—The correct reading is the horizontal tangent to the meniscus ; that is, the horizontal line which touches the lowest point of the curved surface of the liquid in the case of water and all liquids which wet glass, or the highest point of the curved surface in the case of mercury and similar liquids. When the liquid is so opaque that the meniscus cannot be seen, the reading must be taken at the apparent horizontal surface of the liquid. The measuring vessel should be exactly vertical, and the eye of the observer should be exactly on a level with the surface of the liquid.

“ *Weighing.*—To assume that the weights in the two pans are equal when there is a distinct deflection of the index of the balance towards one side is obviously incorrect. To take the weights as equal when the beam is at rest, and there is no deflection at all, also gives untrustworthy results. The balance should be made to vibrate, and the weights in the two pans are equal when the index makes *equal excursions on either side of the position of rest*, which is usually the centre.”

All who are interested in this subject will find a most valuable article in Sir John Herschel’s “ *Familiar Lectures,* ” p. 419.

The following tables of the English and metric systems will be found convenient for converting the one into the other. They are taken from the *British Journal Almanack*, 1890.

THE METRIC SYSTEM.

In the French decimal system, Greek prefixes are used to denote the multiples of the units, and Latin prefixes the fractional parts of the units.

The Greek prefix	Deka	means	10 units.
“	“	Hecto	“ 100 “
“	“	Kilo	“ 1,000 “
“	“	Myria	“ 10,000 “
The Latin prefix	Deci	“	$\frac{1}{10}$ of a unit.
“	“	Centi	“ $\frac{1}{100}$ “
“	“	Milli	“ $\frac{1}{1000}$ “

To give an illustration of this in a measure of length (the metre)—

Myriamètre = 10,000 metres.	Mètre = 1 metre.
Kilomètre = 1,000 “	Decimètre = $\frac{1}{10}$ of a metre.
Hectomètre = 100 “	Centimètre = $\frac{1}{100}$ “
Dekamètre = 10 “	Millimètre = $\frac{1}{1000}$ “



And so on with other units—such as the gramme, with its various prefixes; and the litre, with those by which it is qualified.

For general purposes it will be found to be sufficiently near to consider a metre as  $39\frac{1}{3}$  inches, and a decimetre as  $3\frac{1}{10}$  inches.

In order to aid in the more ready introduction into practice of the decimal means of calculating, the relative values in inches from the millimètre to the mètre are given :—

Millimètre.	Mètre.	Inches.	Centimètre.	Mètre.	Inches.
1 =	.001 =	.03937	6 =	.06 =	2.3622
2 =	.002 =	.07874	7 =	.07 =	2.7560
3 =	.003 =	.11811	8 =	.08 =	3.1497
4 =	.004 =	.15748	9 =	.09 =	3.5434
5 =	.005 =	.19685	Decimètre.	Mètre.	Inches.
6 =	.006 =	.23622	1 =	.1 =	3.9371
7 =	.007 =	.27560	2 =	.2 =	7.8742
8 =	.008 =	.31497	3 =	.3 =	11.8113
9 =	.009 =	.35434	4 =	.4 =	15.7484
Centimètre.	Mètre.	Inches.	5 =	.5 =	19.6855
1 =	.01 =	.3937	6 =	.6 =	23.6226
2 =	.02 =	.7874	7 =	.7 =	27.5597
3 =	.03 =	1.1811	8 =	.8 =	31.4968
4 =	.04 =	1.5748	9 =	.9 =	35.4339
5 =	.05 =	1.9685	1 metre	=	39.3685

But what is the mètre itself? It is the standard of length, of which the  $\frac{1}{10000000}$  of a quadrant of the earth's meridian is equivalent to 39.371 inches (*De la Rue*).

The standard of the weights by which chemicals are calculated is the gramme, which is, roughly speaking, the equivalent of  $15\frac{1}{2}$  grains.

The unit of fluid measurement is the cubic centimètre, based upon the gramme, the weight of one gramme of water at maximum density being termed one cubic centimètre.

The proportions of fluid measurements on this basis will be apparent by the following table :—

Names.	No. of Grammes.	Weight of Water.	Avoirdupois Weight.
Millier or tonneau	1,000,000	1 cubic mètre	2204.6 lbs.
Quintal	100,000	1 hectolitre	220.46 lbs.
Myriagramme	10,000	10 litres	22.046 lbs.
Kilogramme or kilo	1,000	1 litre	2.2046 lbs.
Hectogramme	100	1 decilitre	3.5274 ozs.
Dekagramme	10	10 c. centimètres	.3527 ozs.
Gramme	1	1 c. centimètre	15.432 grs.
Decigramme	.1	$\frac{1}{10}$ "	1.5432 grs.
Centigramme	.01	10 c. millimètres	.1543 grs.
Milligramme	.001	1 c. millimètre	.0154 grs.

### FRENCH FLUID MEASURES.

The cubic centimètre, usually represented by "c.c.," is the unit of the French measurement for liquids. It contains nearly seventeen minims of water; in reality, it contains 16.896 minims. The weight of this quantity of water is one gramme. Hence it will be seen that the cubic centimètre and the gramme bear to each other the same relation as our drachm for solids

and the drachm for fluids, or as the minim and the grain. The following table will prove to be sufficiently accurate for photographic purposes :—

1 cubic centimètre	=	17 minims	(as near as possible).		
2 cubic centimètres	=	34	„		
3	„	=	51	„	
4	„	=	68	„	or 1 drachm 8 minims.
5	„	=	85	„	„ 1 „ 25 „
6	„	=	102	„	„ 1 „ 42 „
7	„	=	119	„	„ 1 „ 59 „
8	„	=	136	„	„ 2 drachms 16 „
9	„	=	153	„	„ 2 „ 33 „
10	„	=	170	„	„ 2 „ 50 „
20	„	=	340	„	„ 5 „ 40 „
30	„	=	510	„	„ 1 ounce 0 drachm 30 minims.
40	„	=	680	„	„ 1 „ 3 drachms 20 „
50	„	=	850	„	„ 1 „ 6 „ 10 „
60	„	=	1020	„	„ 2 ounces 1 „ 0 „
70	„	=	1190	„	„ 2 „ 3 „ 50 „
80	„	=	1360	„	„ 2 „ 6 „ 40 „
90	„	=	1530	„	„ 3 „ 1 „ 30 „
100	„	=	1700	„	„ 3 „ 4 „ 20 „

#### THE CONVERSION OF FRENCH INTO ENGLISH WEIGHT.

Although a gramme is equal to 15.4346 grains, the decimal is one which can never be used by photographers; hence in the following table it is assumed to be  $15\frac{2}{5}$  grains, which is the nearest approach that can be made to *practical* accuracy :—

1 gramme	=	$15\frac{2}{5}$ grains.		
2	„	=	$30\frac{4}{5}$	„
3	„	=	$46\frac{1}{5}$	„
4	„	=	$61\frac{3}{5}$	„
5	„	=	77	„
6	„	=	$92\frac{2}{5}$	„
7	„	=	$107\frac{4}{5}$	„
8	„	=	$123\frac{1}{5}$	„
9	„	=	$138\frac{3}{5}$	„
10	„	=	154	„
11	„	=	$169\frac{2}{5}$	„
12	„	=	$184\frac{4}{5}$	„
13	„	=	$200\frac{1}{5}$	„
14	„	=	$215\frac{3}{5}$	„
15	„	=	231	„
16	„	=	$246\frac{2}{5}$	„
17	„	=	$261\frac{4}{5}$	„
18	„	=	$277\frac{1}{5}$	„
19	„	=	$292\frac{3}{5}$	„
20	„	=	308	„
30	„	=	462	„
40	„	=	616	„
50	„	=	770	„
60	„	=	924	„
70	„	=	1078	„
80	„	=	1232	„
90	„	=	1386	„
100	„	=	1540	„

## ENGLISH WEIGHTS AND MEASURES.

## APOTHECARIES' WEIGHT.

*Solid Measure.*

20 grains	= 1 scruple	= 20 grains.
3 scruples	= 1 drachm	= 60 „
8 drachms	= 1 ounce	= 480 „
12 ounces	= 1 pound	= 5760 „

*Fluid.*

		Symbol.
60 minims	= 1 fluid drachm	f. $\overline{3}$
8 drachms	= 1 ounce	f.
20 ounces	= 1 pint	O. $\overline{3}$
8 pints	= 1 gallon	gall.

The above weights are those usually adopted in formulae.

All chemicals are usually sold by

## AVOIRDUPOIS WEIGHT.

$27\frac{1}{3}\frac{1}{2}$ grains	= 1 drachm	= $27\frac{1}{3}\frac{1}{2}$ grains.
16 drachms	= 1 ounce	= 437 $\frac{1}{2}$ „
16 ounces	= 1 pound	= 7000 „

Precious metals are usually sold by

## TROY WEIGHT.

24 grains	= 1 pennyweight	= 24 grains.
20 pennyweights	= 1 ounce	= 480 „
12 ounces	= 1 pound	= 5760 „

NOTE.—An ounce of *metallic* silver contains 480 grains, but an ounce of *nitrate* of silver contains only 437 $\frac{1}{2}$  grains.

## FRENCH WEIGHTS AND MEASURES,

## AND THEIR EQUIVALENTS IN ENGLISH.

1 cubic centimètre	= 17 minims nearly.
$3\frac{1}{2}$ „	= 1 drachm.
28.4 „	= 1 ounce.
50 „	= 1 ounce 6 drachms 5 minims.
100 „	= 3 ounces 4 drachms 9 minims.
1000 „	} = 35 ounces 1 drachm 36 minims.
or 1 litre, = to	
61 cubic inches	

The unit of French liquid measures is a cubic *centimètre*.

A cubic *centimètre* of water measures nearly 17 minims (16.896); it weighs 15.4 grains, or 1 *gramme*. A cubic *inch* of water weighs 252.5 grains.

The unit of French weights is the gramme = to 15.4 grains ; thus a drachm (60 grains) is nearly 4 grammes (3.88). An easy way to convert grammes into English weight is to divide the sum by 4, which gives the equivalent in drachms very nearly thus :—

Grammes.		Drachms.	Oz.	Drachm.	Grains.
100	÷ 4	= 25	= 3	1	+ 43

# I N D E X.

- ABERRATION, chromatic, 45  
 — of form, 46  
 — spherical, 44  
 — of thickness, 48  
 Absorption, laws of, 19  
 — -spectra, 19  
 Accelerators, chemistry of, 30  
 — definition of term, 321  
 Acid, acetic, as restrainer, 28, 30  
 — — manufacture and use of, 251  
 Acids, characteristics of, 251  
 Actinic rays, 19  
 Actinometers and exposure tables, 205  
 — Hurter and Driffield's actino-  
   meters, 207, 208  
 — Watkin's actinometer, 206  
 — Watts' exposure tables, 205, 206  
 — — formula for using, 206  
 Alabastrine process, 67  
 Albert-type, 68  
 Album or "carte" portraits, 299  
 Albumen, 251  
 — process, 68  
 — substratum, 69  
 Albumenised paper, 252  
 Alcohol, 253  
 — methyl, 254  
 Alkaline development, 321  
 Alpha paper, 254  
 Aluminium, 254  
 Amber, 254  
 Amido-benzene, 256  
 Ammonia, 254  
 — as fixing agent, 255  
 — in intensifying, 31  
 — sulphide intensifier, 32  
 Ammonio-citrate of iron, 262  
 Ammonium bichromate, 255  
 — bromide, 255  
 — carbonate, 255  
 — chloride, 255  
 Ammonium iodide, 255  
 — nitrate, 255  
 — oxalate, 256  
 — sulphide, 256  
 — sulphocyanate, 256  
 Amphitype, 70  
 Angle of view, 41  
 Anglol, 256  
 Anhydrous, 321  
 Aniline, 256  
 — process, 71  
 Animal charcoal, 256  
 Aperture, working, 40  
 — angular, 40  
 Aplanatic lens, Steinheil's, 51  
 Aplanatism in lenses, 51  
 Application of photography, 294  
 Aqua fortis, 274  
 Aqua regia or hydrochloric acid, 256  
 Arago, address to Chamber of Depu-  
   ties, 3  
 Archer, collodion used by, in 1851,  
   15  
 Architectural photography, 294  
 Argentometer, 232, 321  
 Aristotype, 71  
 Artotype, 68, 72  
 Asphalt, solubility of, 20  
 Asphaltum, 257  
 Astigmatism, 49  
 Astronomical photography, 294  
 — apparatus for, 297  
 — eclipse photographs, 296  
 — Rutherford's moon, 298  
 Aurin or corallin, 257  
 Autoglyphic process, 72  
 Autotype process, 15, 20, 72  
  
 BACKGROUNDS, 307  
 Backing plates, 322  
 Balance, 206

- Barium bromide, 257  
 — chloride, 257  
 — nitrate, 257  
 Baths and dippers, 208  
 Bellows, 209  
 Benzene or benzol, 257  
 Benzolene, 257  
 Bichloride of mercury, 272  
 Bichromate of potash, 277  
 — poisoning, 322  
 Bitumen of Judea, 1, 257  
 — — action of light on, 2  
 — process, 76  
 Black lines, 77  
 — varnish, 292  
 Bleaching-powder or chloride of lime, 258  
 Blue process (ferro-prussiate), 105  
 Boracic acid, 57  
 Borax, 257  
 — in toning bath, 33  
 Brenzcatechin, 278  
 Broken negatives, 322  
 Bromide printing process, 78  
 — of potassium, 292  
 Bromine, 257  
 Buckle's brush, 209  
 Burnishers and rolling machines, 210  
 — lubrication of prints for, 210
- CABINET portraits, 299  
 Cadmium bromide, 257  
 — iodide, 257  
 — — chloride, 257  
 Calotype, 80  
 Camera, 210  
 — Billcliff's, 214  
 — Chapman's "British," 214  
 — copying and enlarging, 224  
 — Daguerre's, 211  
 — "detective" or "hand," 220  
 — double extension, 219  
 — Kinnear's, 213  
 — "Kodak," 220, 221  
 — — roll-holder for, 222  
 — M'Kellan's, 213  
 — Miller's "Adelphi," 223  
 — "pin-hole," 38  
 — "radial," 222  
 — simplest form of, 211  
 — stands and tripods, 226  
 — stereoscopic, 219  
 — swing-back and swing-front, 55, 218, 219
- Camera, "Thornton-Pickard," 218  
 Camera lucida, 2  
 — obscura, invention of, 1  
 — use of, by Daguerre, 7  
 — use of, by Talbot, 7  
 Canada balsam, 258  
 Canvas, printing on, 81  
 Caoutchouc, 270  
 Carbon process (autotype), 15  
 — — Pouncey's, 83  
 Carbonate of potassium, 277  
 Cardboard, 275  
 Cartes de visite, 299  
 Catalysotype, 84  
 Catechol, 278  
 Celerotype, 84  
 Celloidin, 258  
 Celluloid, 258  
 Cellulose, 258  
 Ceramic photographs, 85, 110  
 Changing boxes, 225  
 Chemistry of photography, 17  
 China clay, 271  
 Chloride of lime, 258  
 — of potash, 277  
 Chloro-bromide process, 87  
 Chloroform, 258  
 Chlorophyll, 258  
 Chromate of silver, 258  
 Chromatype, 87  
 Chromium - potassium sulphate or chrome alum, 259  
 Chromo-collotype, 87  
 — photographs, 87  
 Chromotype, 87  
 Chrysotype, 87  
 — chemistry of, 34  
 Citric acid, 259  
 Cleaning glass, 67, 87, 91  
 Clearing and reducing solutions, 88  
 Clouds, 259  
 — how to print-in, 300  
 Coffee process, 88  
 Collodio-albumen process, 89  
 — -bromide process, 90  
 — -chloride of silver process, 90  
 Collodion, 259  
 — emulsion, 90  
 — pellicle, 90  
 — process, 90  
 — — best kind of glass for, 91  
 — — defects in negative, 96  
 — — developing solution for, 94  
 — — fixing image, 95

- Collodion process, fog of two kinds, 96  
 — — — how to coat plates for, 92  
 — — — how to re-develop negatives,  
     95  
 — — — how to rectify silver bath, 96  
 — — — how to varnish plates, 95  
 — — — kind of bath for solution, 93  
 — — — oyster-shell marking, 96,  
     97  
 — — — positives, 95  
 — — — silver bath for, 93  
 — — — to clean glass for, 91  
 — — — water for, 93  
 Collographic printing, 98  
 Collotype, 98  
 — best kind of paper for, 103  
 — care of and cleaning ink rollers,  
     104  
 — cleaning plate, 103  
 — damping, 103  
 — drying oven for plates, 99  
 — etching plate, 102  
 — ink for printing, 102  
 — kind of gelatine for, 100  
 — kind of glass for, 98  
 — marking position for paper, 103  
 — masking plate for printing, 101  
 — method of printing, 98  
 — preparation of plate, 100  
 — principle of, 98  
 — printing from plate, 101  
 — printing without margin, 104  
 — rolling up or inking plate, 103  
 — temperature in drying, 101  
 — varnish for, 104  
 Colouring lantern slides, 104  
 Combination printing, 323  
 — — — Robinson's picture, 324  
 Composite portraits, 300  
 Composition, 300  
 Compressed gas, 62  
 Condenser, 227  
 Contretype negative, 104  
 Copper, 260  
 — salts, printing with, 35  
 — sulphate, or blue vitriol, 260  
 Copyright, 324  
 Corallin (or aurin), 257  
 Corrosive sublimate, 272  
 Cracks, to fill up, 324  
 Crystal cubes, 104  
 Cyanide of potassium, 277  
 — poisoning, 322  
 Cyanotype, 104  
 Cyanotype, discovered by Herschel, 105  
 — formulæ for, 105  
 DAGUERREOTYPE process, 106  
 — fixing by "hypo" of soda, 2  
 — gilding by *sel d'or*, 6  
 — how to copy a, 108  
 — method of cleaning, 108  
 — permanence of, 108  
 Daguerre's Manual or History of Pho-  
 tography, 3  
 Dark room, 227  
 Defects in lenses, 44  
 Density, 31, 325  
 Depth of focus, 43  
 Detail, 325  
 Developers, acid and alkaline, 28  
 — influence of strength of, 26  
 Developing and developers, 325  
 — E. M. F., in, 29  
 — formulæ for, 329, 330, 331  
 — illustration of, 326  
 — instruction for, 328  
 — Meldola's experiment, 326  
 — Moser's images, 327  
 — theory of, 20, 27  
 Dextrin or British gum, 260  
 Dialysis, 331  
 Diaphragms and stops, 282  
 — ratio between apertures and focal  
     length, 229  
 — "uniform system," 282  
 — uses of, 40, 41, 45, 49  
 Diazotype or primuline process, 172  
 Diffused light, 321  
 Dihydroxybenzene, 267  
 Dippers and baths, 208  
 Dishes and trays, 229  
 Dispersion by lenses, 39  
 Distance, 301  
 Distortion, 48  
 Double dark slides and changing boxes,  
     225  
 Doublet lenses, 52  
 Dropping bottles, 229  
 Drying gelatine plates, 108  
 Dry plate making, 109  
 — processes, 109  
 Dust, 321  
 Dusting-on process, 110  
 Dyes as sensitisers, 24  
 EAU de Javelle, 260  
 Ebonite, 261

- Eburneum process, 110  
 Eikonogen, 261  
 Electric arc lamp, 58  
   — light, 55  
   — ——— inflammation due to, 57  
   — ——— Wilde's discovery in, 56  
 Electro-chemical reversal, 27  
 Electro-motive force of development, 29  
 Electro-phototypy, 111  
 Emery, 262  
 Enamelling paper prints, 111  
 Encaustic paste, 262  
 Enlarging and copying, 112  
   — artificial light for, 112  
   — formula for, 43  
   — simple methods for, 112, 113  
   — table for, 114  
 Eosin, 262  
 Erythrosin, 262  
 Ether, 262  
 Ethoxo-lime light, 63  
 Expansion of paper, 332  
 Exposure tables and actinometers, 205
- FADING of invisible image, 25  
 Ferric ammonium citrate, 262  
   — ammonium oxalate, 262  
   — oxalate, 262  
 Ferridcyanide of potash, 277  
 Ferro-prussiate or blue process, 105  
 Ferrous oxalate, 262  
   — sulphate, copperas, or green vitriol, 262  
 Ferrotypes or energiatype, 114  
 Ferrotypes, 115  
 Film photography, 115  
 Fixing, 115  
   — negatives, chemistry of, 30  
   — prints, chemistry of, 34  
 Flare in lenses, 50  
 Flatness of field, 47  
 Fluorescein, 263  
 Fluorotype, 116  
 Focal length, 42  
 Focus, 41  
   — depth of, 43  
   — equivalent, 41  
   — visual and chemical, 45  
 Focussing and focimeter, 229  
   — cloth, 230  
   — glass or magnifier, 231  
   — screen, 231  
   — substitutes for ground glass, 231  
 Fog, 332
- Fog, to restore fogged plates, 333  
 Formic acid, 263  
 Formula for enlarging, 43  
   — for focal length, 42  
 Fothergill process, 116  
 Freezing mixtures, 333  
 Frilling, 334  
 Fuming albumenised paper, 182
- GALLIC acid, 263  
   — first used by Talbot, 14  
 Gay-Lussac, address to Chamber of Peers, 5  
 Gelatine, 263  
   — oxidation of, 20  
   — test for quality, 264  
   — to purify, 264  
 Gelatino-bromide process, 116  
   — Bennett's improvements, 116  
   — drying plates, 118  
   — Eder's method, 118  
   — emulsion on paper, 118  
   — formula for, 117  
   — keeping plates, 118  
   — kind of gelatine to be used, 118  
   — kind of light to be used in preparing emulsion, 117  
   — Paget prize awarded to Wilson, 117  
   — use of gelatine by Maddox, 116  
 Gelatino-chloride paper (Ilford), 119  
   — fixing, 119  
   — stability of prints, 120  
   — toning bath for, 119  
 Glass, 264  
 Glass-room and studios, 346  
 Globe lens, 50  
 Glucose or grape-sugar, 264  
 Glycerine, 262  
 Goddard, J. F., discovery of use of bromine, 6  
 Gold, chloride, 265  
   — hyposulphite, 265.  
   — printing process, 120  
   — toning with, 33  
   — trichloride, printing with, 35  
 Green photographs, 121  
 Ground glass, 265  
 Gum-arabic or gum acacia, 265  
   — dammar, 265  
   — lac, 282  
 Gum-gallic process, 121  
 Gun-cotton, 279  
 Gutta-percha, 266



- HALATION, 334  
 Head-rests, 232  
 Heliography, 121  
 High lights, 335  
 Historical sketch, 1  
 Honey process, 121  
 Horn silver, 1  
 Hydrochloric acid or spirits of salt, 266  
 Hydrofluoric acid, 266  
 Hydrogen dioxide, 267  
 — sulphate, 290  
 Hydrometer, 232  
 Hydroquinone, 267  
 — formula for developing solution, 268  
 — method of preparing, 267  
 Hydroxylamine, 269  
 Hygiene in photography, 335  
 "Hypo" eliminators, 269, 289  
 Hyposulphite of soda, 270, 285  
 — experiments with, by Herschel, 286  
 — first use of, by Herschel, 285  
 — necessity for using strong solutions, 289  
 — Schützenberger's note on new acid, 288
- ILFORD, gelatino-chloride paper, 119  
 Image, aberration of form of, 46  
 — reversal of, 25  
 — size of, 43  
 — latent, 14, 325  
 — virtual, 41  
 Impressionism in photography, 302  
 India-rubber, 270  
 Indian-ink outlines, 121  
 Instantaneous shutters, 232  
 — — adaptors for, 234  
 — — drop, 232  
 — — duration of exposure tables, 235  
 — — — fau for, 234  
 — — — Kershaw's, 233  
 — — — measuring rapidity of, 235, 236  
 — — — Noton's, 234  
 — — — speed indicator, 234  
 — — — Thornton-Pickard's, 233  
 Intensifying, 335  
 — chemistry of, 31  
 — formulæ for, 336, 337  
 Iodide of potassium, 278  
 Iodine, 270  
 Iodine, use of, in fixing prints, 34  
 Iridescent photographs, 122  
 Iris diaphragm, 236  
 Iron, 271  
 — ammonio-citrate of, 271  
 — salts, reduction by light, 20  
 — — use of, 34  
 Isinglass, 271
- JENA glass, 271  
 Jew's pitch or asphaltum, 257  
 Juniper resin or sandarac, 282
- KALLITYPE, 122  
 — care in printing, 123  
 — chemical reaction in, 125  
 — formulæ, 123, 124  
 — No. 2, 124  
 Kaolin or China clay, 271  
 Kennett's pellicle, 125
- LAMPS for dark rooms, 237  
 Landscape lenses, 49  
 — photography, 303  
 Lantern slides, artificial light for, 127  
 — — colouring, 127  
 — — making, 125  
 — — toning, 127  
 Lavender, oil of, 271  
 Lead, 272  
 — nitrate, 272  
 — salts in intensifying, 32  
 Leimtype, 127  
 Lenses, 39  
 — aplanatic, 51  
 — astigmatism in, 49  
 — axes of, 40  
 — defects in, 44  
 — focus of, 41  
 — symmetry in, 52  
 Level indicator, 237  
 Lichtdruck, 98  
 Light, actinic rays of, 19  
 — continuing action of, 21, 62  
 — electric, 55  
 — in photography, 55  
 — oxidation and reduction by, 19, 20  
 — oxy-hydrogen, 61  
 — physical and chemical action of, 18  
 — physical and chemical nature of, 36  
 — refraction of, 38  
 Lithium chloride, 272

- Litho-heliogravure, 127  
 Litmus, 272  
 Liver of sulphur, 272, 278  
 Luminous spot in lenses, 50
- MAGIC (or optical) lantern, 238  
 ——— photographs, 121, 128  
 Magnesium, 272  
 ——— flash-light, 65  
 ——— light, 63  
 ——— ——— first use of, 65  
 ——— ——— manufacture of, 64  
 Mass, action of, 22, 25  
 Mastic or gum mastic, 272  
 Mealiness, 338  
 Meisenbach process, 128  
 Mercuric chloride, 272  
 Mercury or quicksilver, 273  
 ——— salts in intensifying, 31  
 Meta-gelatine, 273  
 Methylated spirit, 253, 273  
 ——— ——— new excise regulations, 273,  
 274  
 Micro-photography, 129  
 Mosstype, 129  
 Mounting and mountants, 129  
 ——— in optical contact, 131  
 Mounts, 274  
 Muriate or hydrochlorate of ammonia,  
 255  
 ——— of lime, 257  
 Muriatic acid, 266  
 Muybridge's photographs, 305
- NEGATIVES, 338  
 ——— illustrations of, 339  
 Nitric acid, 271  
 Nitro-hydrochloric acid, 256
- OBERNETTER'S process, chemistry of,  
 23, 35  
 ——— etching process, 131  
 Objectives, 49  
 Oil of lavender, 271  
 ——— of spike, 271  
 ——— of vitriol, 290  
 Opal glass, 131  
 ——— ——— collodio-chloride on, 132  
 ——— ——— formula for positives on, 131,  
 132  
 Optical or magic lantern, 238  
 ——— ——— dissolving views with, 238  
 ——— ——— electric light for, 241  
 Optical or magic lantern, exhibition of  
 opaque objects with, 241  
 ——— ——— experiments in exposures  
 with, 241  
 ——— ——— first use of, by Dancer, 239  
 ——— ——— interchangeable jet for, 241  
 ——— ——— "Novelty" lantern, 239  
 ——— ——— Sciopticon, 242  
 ——— ——— screen for use with, 242  
 ——— ——— to avoid fracture of con-  
 denser, 241  
 ——— ——— triple dissolver, 242  
 ——— ——— Whitefield's improvements,  
 239, 240  
 ——— ——— wick trimmer, 242  
 Optics of photography, 36  
 Orthochromatic photography, 132  
 ——— ——— Abney's method, 137  
 ——— ——— chemistry of, 24  
 ——— ——— chlorophyll, suggested by  
 Ives, 134  
 ——— ——— clearing solution for, 138  
 ——— ——— dyes used for, 135  
 ——— ——— Eder's method of, 136  
 ——— ——— Edward's opinion on, 135  
 ——— ——— formula for developing, 138  
 ——— ——— Ives's method of preparing,  
 136  
 ——— ——— Meldola's hypothesis, 137  
 ——— ——— Tailfer & Clayton's patent,  
 135  
 ——— ——— theory of, 137  
 ——— ——— use of yellow screen, 136  
 ——— ——— Vogel's experiments in, 133  
 Ortho-dioxybenzene, 278  
 Orthoscopic lens, 51  
 Oscillating tables or rockers, 242  
 Over-exposure, 338  
 Oxalate of iron, 262  
 ——— ——— peroxide of iron, 262  
 ——— ——— potash, 278  
 Oxalic acid, 274  
 Ox-gall, 275  
 Oxy-calcium light, 62  
 Oxy-hydrogen light, 61  
 Oxyphenic acid, 278  
 Oyster-shell markings, 97
- PALLADIUM, 275  
 Panoramic lens, Sutton's, 51  
 ——— photography, 138  
 Pantoscopic camera, 242  
 Paper, 275  
 ——— as sensitiser, 23

- Papyrotype, 159  
 Paraphenylene-diamine, 276  
 Pencil of Nature, 7  
 Periscope lens, Goddard's, 52  
 — Steinheil's, 50  
 Permanganate of potash, 278  
 Peroxide of hydrogen, 257  
 Phenylamine, 256  
 Photochromo-typography, 144  
 Photo-engraving, 140  
 — early discovery of, 140  
 — half-tone zinc etching, 143  
 — — Pretsch's method, 140  
 — — screen plate for, 143  
 Photo-filigrane, 144  
 Photo-galvanography, 144  
 Photogenic drawing, 140  
 Photography and colour, 146  
 — — Abney's spectrum, 150  
 — — Beequerel's experiments, 147  
 — — early experiments in, 146  
 — — Ives' heliochromatic prints, 150  
 — — Lippmann's spectrum, 152  
 — — Scott's method, 151  
 — — Sidebotham's photograph, 148  
 — — Vallot's method and formula, 149  
 — — Vogel's opinion on, 149  
 — — Woodbury's method, 150  
 — its value to artists, 16  
 — Langton's moon, 145  
 — on wood, 145  
 Photogravure, 140  
 — Goupil's method, 141  
 — Klie's process, 142  
 Photo-lithography, 152  
 — advantages of, 159  
 — albumen coating for paper, 156  
 — clearing solution, 155  
 — coating prints with ink, 157  
 — formula for blacking negatives, 154  
 — ink for, 157  
 — kind of negatives for, 153  
 — paper prepared with arrowroot, 157  
 — photo-zincography, 153  
 — printing transfers, 157  
 — sensitising solution, 156  
 — suitable drawings for, 153  
 — transfer paper for, 155  
 — transferring to stone, 158  
 Photo-lithography, washing transfers, 158  
 Photo-meteorology, 305  
 — — micrography, 159  
 — — — Delépine's illustration of, 262  
 — — — Johnson's camera for, 161  
 — — — Johnson's illustration, 160  
 — — — methods of procedure, 159  
 Photometers, 243  
 Photophane, 98, 162  
 Photo-tint, 98, 162  
 Photo-typography, 162  
 — illustration by swelled gelatine process, 162  
 Pin-hole camera, 38  
 — photography, 162  
 Pinholes, 339  
 Plate-boxes, 243  
 — rack, 243  
 Platinotype process, 163  
 — — acid baths for, 167  
 — — Berkeley's formulæ of reaction in, 165  
 — — chemistry of, 35  
 — — clearing solutions for, 167  
 — — cold process, 168  
 — — correct exposure for paper, 166  
 — — development, 166  
 — — formulæ for, 165, 170, 171  
 — — Herschel's experiments with platinum, 164  
 — — mountants for prints, 167  
 — — paper to be kept dry, 166  
 — — permanence of prints, 172  
 — — Pizzighelli's process, 170  
 — — two methods, hot and cold, 165  
 — — Willis's process, 164  
 Platinum, 276  
 Plumbago process, 172  
 — — formulæ for, 173  
 Pneumatic plate-holder, 243  
 Poisons, 272  
 Portrait lenses, 53  
 Portraiture, 305  
 — backgrounds, 307  
 — large heads, 308  
 Positive-printing process, 25  
 Positives, 340  
 Potassium bromide, 277  
 — — as restrainer, 30  
 — carbonate, 277  
 — chloride, 277

- Potassium chloroplatinite, 277  
 — cyanide, 277  
 — cyanide in fixing, 31  
 — dichromate, 277  
 — ferricyanide, 277  
 — ferrocyanide, 277  
 — iodide, 278  
 — — in solarisation, 26  
 — oxalate, 278  
 — permanganate, 278  
 — salts in developing, 20  
 — — in intensifying, 32  
 — sulphide, 278  
 Pouncey's carbon process, 83  
 Practical hints, 321  
 Preservatives, 23  
 Primuline process, 35, 173  
 — — J. T. Taylor's modification  
 of, 175  
 Printing, chemistry of, 33  
 — frames, 244  
 — — for opals, 244  
 — on ivory, 183  
 — and toning 175  
 — — blisters on paper, remedies  
 for, 179, 180  
 — — Carey Lea's remarks on, 181  
 — — fixing solution, 179  
 — — fuming albumenised paper,  
 182  
 — — method of printing, 176  
 — — necessity for using fresh  
 "hypo," 181  
 — — printing on drawing paper,  
 182  
 — — printing on plain paper, 182  
 — — quality of negative for, 179  
 — — stability of prints, 177, 180  
 — — Sutton's serum of milk pro-  
 cess, 183  
 — — to clean dishes for, 180  
 — — to recover silver, 180  
 — — to sensitise paper, 176  
 — — toning solutions, 177, 178  
 Processes, 67  
 Proof spirit, 273  
 Proto-sulphate of iron, 262  
 Prussian blue in printing, 34  
 Pseudo-solarisation, 26  
 Pyrocatechin, 278  
 Pyrogallol or pyrogallie acid, 279  
 — first use of, 279  
 — manufacture of, 279  
 Pyroxylin or gun-cotton, 279  
 Pyroxylin, nitre process, 280  
 — preparation of, 280  
 — process with mixed acids, 280  
 QUICKSILVER or mercury, 273  
 Quinol, 267, 281  
 RAPIDITY of lenses, 41  
 — of shutters, measuring, 235, 236  
 Reade, Rev. J. B., negatives on paper,  
 14  
 Ready sensitised paper, 281  
 — — Ashman's formula for, 281  
 — — Burton's, 282  
 Rectilinear lenses, 52  
 Red chromate of potash, 277  
 — prussiate of potash, 277  
 Reducing and clearing solutions, 88  
 Reduction of density, 340  
 Reflected light, 341  
 Refraction, index of, 38  
 Rembrandt portraits, 309  
 Reproduced negatives, 183  
 Residues, 341  
 Restrainers, chemistry of, 29, 30  
 Retouching, 187  
 — desk, 245  
 — pencils, 188  
 Reversal of image, 25, 184  
 — — Brook's method, 185  
 — — experiments by Mr. A. P.  
 Okell, 184  
 — — experiments by Colonel  
 Waterhouse, 184  
 — — formulæ for, 184, 185  
 — — solarisation effects, 185  
 Reversed negatives, 185  
 — — by prism, 185  
 — — by silvered mirror, 186  
 — — by stripping, 186  
 — — through the glass, 186  
 Ripening of emulsion, 21  
 Rockers or oscillating tables, 242  
 Rodinal, 282  
 Roller slide, 245  
 Rolling machines, 210  
 Rosolic acid (or aurin), 257  
 Ruby medium, 189  
 SAL ammoniac, 255  
 — volatile, 255  
 Sandarac, gum, 282  
 Saturated solution, 343  
 Sciopticon, 242

Screen-plates (Wolfe's), 189  
 Sel d'or or hyposulphite of gold, 265  
 Sensitisers, theory of, 20, 22  
 Sesquicarbonate of ammonia, 255  
 Shellac or gum lac, 282  
 Silver, 283  
 — bromide, 283  
 — — ripening of, 22  
 — chloride, 283  
 — haloids, action of light on, 21  
 — iodide, 283  
 — nitrate, 284  
 — — as sensitiser, 23  
 — oxide, 284  
 — plates used by Daguerre, 2  
 — — action of iodine vapour and mercury on, 2  
 — salts, use of, by Davy and Wedgwood, 1  
 — sulphide, 284  
 Silvering glass, 189  
 — — Mr. Common's method, 190  
 Single achromatic lens, 50  
 Size of drops, 345  
 Sky-shade, 245  
 Sodium acetate, 284  
 — baborate or borax, 257  
 — carbonate, 284  
 — chloride, 284  
 — nitrate, 284  
 — oxalate, 285  
 — silicate or water-glass, 285  
 — sulphite, 285  
 — thiosulphate, 285  
 — — accelerator, 30  
 — — in fixing, 31, 34  
 — — "hypo" used by Daguerre, 2  
 Solar camera, 245  
 Solarisation, 185  
 — chemistry of, 25  
 Specific gravity, 345  
 Spectroscope, the, in photography, 309  
 Spectrum, the, 39  
 Spirits of hartshorn, 254  
 — of wine, 253  
 Squeegee, 246  
 Stains, to remove, 190  
 Stannotype, 191  
 Starch, 290  
 Steel-facing copper plates, 192  
 Stenochromy, 193  
 Stereoscope, the, 310  
 — Breeze's transparencies, 318  
 — Brewster's, 311, 312

Stereoscope, cameras for, 316, 317  
 — Chapman's printing-frames for transparencies, 320  
 — Dancer's method of taking pictures, 314  
 — discussion as to invention of, 314  
 — diagrams for, 311  
 — method of mounting prints, 317  
 — size of plates, 316  
 — Wheatstone's, 311  
 Stoppers, 246  
 Stops and diaphragms, 227  
 — uses of, 41, 49  
 Stripping films from glass, 186  
 Strontium chloride, 290  
 Studios or glass rooms, 346  
 — Houghton's lawn, 347  
 Sulphate of iron, 262  
 Sulphocyanide of ammonia, 256  
 Sulphuret of ammonia, 256  
 Sulphuric acid, 290  
 Swing-back camera, 55  
 Symbols, 347  
 Symmetrical lenses, 52

TABLE of solubility, 344  
 Talbot, H. Fox, account of his discoveries, 7  
 — discovery of latent image, 14  
 — etched silver plates, 15  
 — experiments with iodine on silver leaf, 12  
 — fixing with iodide of potassium, 11  
 — pencil of Nature, 7  
 — produces images of lace, 10  
 — use of silver chloride, 10  
 — — silver iodide, 11  
 Talbotype, 80  
 Tannic acid, 290  
 Tannin process, 193  
 Taupenot process, 193  
 — — formulæ for, 194  
 Tea process, 194  
 Telescopic photography, 194  
 — — Dallmeyer's instrument for, 195  
 — — use of opera-glass by J. T. Taylor, 195  
 Tents, 247  
 Test-paper, 291  
 Thermometers, 197  
 Toning and printing, 175  
 — — chemistry of, 33  
 Transferotype, 197

- Trays and dishes, 229  
 Trihydroxybenzene, 279  
 Triplet lenses, 53  
 Tripods and camera stands, 226  
 Turnbull's blue in printing, 34  
 Turpentine, 291  
 Typogravure, 197
- URANIUM, 291  
 — nitrate, 291  
 — printing, 198  
 — toning with, 199  
 — Wothlytype, 199  
 Uranyl nitrate, 291
- VARNISH, 291  
 — black, 292  
 View, angle of, 41  
 — finders, 248  
 — — Claude Lorraine mirror,  
 249  
 — lens, Ross, 50  
 Vignetting, 199
- WASHING apparatus, 249  
 Water, 292  
 Water-glass or sodium silicate, 285  
 Wave-length of light rays, 36  
 Wax, 293
- Waxed-paper process, 200  
 Weights and measures, 348  
 — conversion of French into English,  
 352  
 — English, 353  
 — French, 353  
 — French fluid measure, 351  
 — metric system, 350  
 Woodbury-gravure, 201  
 Woodbury-type, 15, 200  
 — Swan's process, 200  
 — description of, by Woodbury, 200  
 Wothlytype, 199  
 Writing titles, 202
- YELLOW negatives, 200  
 — prussiate of potash, 277
- ZINC, 293  
 — "clean etching," 204  
 — etching, 202  
 — etching-bath for, 203  
 Zinc-etching, formula for sensitising  
 plate, 202  
 — printing-frame for, 203  
 — to develop plate, 203  
 — to gum the plate, 203  
 — to protect plate with varnish, 203  
 — transfers for, 202

THE END.

# Griffin's Recent Introductions.

THE

## "Garrick" Perfected Camera

Has every desirable Movement.

$\frac{1}{2}$ -plate size. { Weighs but 42 ounces.  
Measures, when closed,  
8 x 8 x 2 inches.

Of excellent Workmanship.

Altogether it is a Model Field Camera.

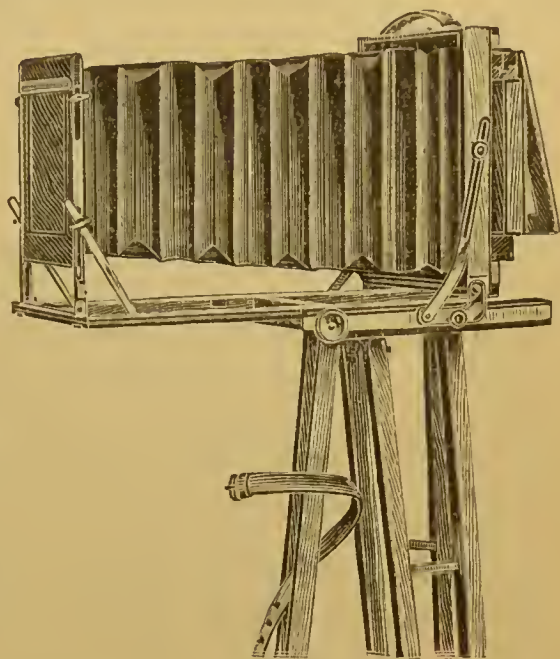

### PRICE LIST.

	6½ x 4¼	7½ x 5	8½ x 6½	10 x 8
Camera, with 3 Double Slides . . .	£8 8 0	£9 10 0	£10 10 0	£13 10 0
Rapid Rectilinear Lens, with Iris Diaphragm . . . . .	2 5 0	2 15 0	3 10 0	5 0 0
Tripod Stand, 3-Fold . . . . .	1 5 0	1 5 0	1 10 0	1 10 0
	£11 18 0	£13 10 0	£15 10 0	£20 0 0

The "Griffin" Magazine Hand Camera. Improved form, with Sunk Identical View-Finder, Time and Instantaneous Shutter, and good R. R. Lens. £5, 10s.

#### ADVANTAGES.

1. Can be recharged in broad daylight.
2. Plates of different rapidities can be used.
3. Any desired plate can be exposed.
4. No sheaths or backing.
5. Focussing adjustment.
6. Quite simple in working.
7. No complications.
8. Weight under 4 lbs.

Griffin's "Rex" Complete Set. An efficient Outfit at a moderate price. Comprising ½-Plate Camera, Lens, Shutter, Dark Slide, and Stand. £6, 6s.

Griffin's "Climax" Dry Plates are the nearest approach to the vigour and tone of the old Collodion Plate yet obtained. Write for Samples.

WRITE FOR PRICE LIST.

PHOTO-SUPPLY DEPARTMENT: { JOHN J. GRIFFIN & SONS, L<sup>D</sup>.  
22 GARRICK STREET,  
COVENT GARDEN, W.C.

# DANIELSSON & CO.

52 BEAUMONT STREET,  
PORTLAND PLACE,  
LONDON, W.

---

DANIELSSON & CO. have made it their Specialité to prepare all kinds of Illustrations for Scientific, particularly Medical, Works.

## ORIGINAL DRAWINGS

Made from Life, Pathological Specimens, and from the Microscope.

## LANTERN SLIDES

Prepared from any kind of original.

## SPECIMENS

Of MESSRS. DANIELSSON'S work will be found in the "Transactions" of the Royal Medical and Chirurgical Society, Pathological Society, Clinical Society, Ophthalmological Society, and in many other high-class Medical Works.

\* \* \* *For collotype reproduction of microscopic sections, see page 162 of this book.*

---

DANIELSSON & CO.

52 BEAUMONT STREET,

PORTLAND PLACE,

LONDON, W.



THE  
**TYPOGRAPHIC ETCHING COMPANY.**

---

**ALFRED & CHARLES DAWSON**

Beg to direct the attention of Artists, Authors, Publishers, and Printers to their various and unique Processes for the production of Surface-Printing Blocks and Intaglio Copperplates, by special methods practised only by them, and yielding results superior to any of the ordinary zinc processes.

---

**Their No. 1, or TYPOGRAPHIC ETCHING PROCESS,**

From the facilities it presents for employing type in an ingenious manner for lettering, is unrivalled for the production of Maps, Plans, and Diagrams; while for Landscapes, Architecture, and general Illustrations, effects can be produced which vie with the most elaborate and artistic wood engraving.

**Their No. 2, or PHOTO-RELIEF PROCESS,**

Is most specially suited for the reproduction on any scale, either enlarged or reduced, of Wood, Copper, and Steel Engravings; Pen-and-Ink, and especially Pencil and Crayon, Drawings; Impressions from Type, &c., for Letterpress Printing, in all of which results can be shown which are not to be equalled by any other Photo-relief Process.

*As specimens, please see the Engravings in "The Graphic," "The Illustrated Catalogue of the Royal Society of Painters in Water Colours," English Illustrated Magazine," and all the highest class Technical and Educational Publications.*

**Their No. 3, or PHOTO-GRAVURE PROCESS,**

Is adapted for the reproduction of Copper Plates from all kinds of Line and Mezzotint Engravings, Drawings in Line or Washes, Oil Paintings, Nature or Objects, or, in fact, *anything* from which a photographic negative can be obtained. See "The Portfolio," "The Late Duke of Clarence's Indian Tour," "The Laureate's Country," &c.

The T. E. CO. are the **ONLY FIRM** in this Country who work these Letterpress and Copperplate Processes, which are applicable to high-class Book Illustrations, and which are extensively used by the leading Publishers, and also by the Trustees of the British Museum, and many of the Learned Societies.

*Estimates and Specimens of any of the Processes will be sent on application to the Office, stating information as to Requirements.*

SPECIAL PHOTOGRAPHY AND ELECTROTYPING UNDERTAKEN AT MODERATE CHARGES.

---

THE  
**Typographic Etching Company,**  
AUTOMATIC, PHOTOGRAPHIC, AND GENERAL  
ENGRAVERS,

**3 LUDGATE CIRCUS BUILDINGS, LONDON, E.C.**

*Registered Telegraphic Address—"Engravers, London."*

Engraving Departments—Hogarth Works, Chiswick, Middlesex.

# WEST, NEWMAN, & CO.

PHOTO-LITHOGRAPHERS.

CHROMO-LITHOGRAPHERS, ENGRAVERS,

LETTERPRESS PRINTERS.

54 HATTON GARDEN, LONDON.

---

**WEST, NEWMAN, & CO.** especially undertake the printing of works on Science and the Plates which illustrate them. Specimens of their work may be seen in the "Transactions" of the Royal Society, the Zoological Society, the Linnean Society, the New Sydenham Society, the Obstetrical Society, the Pathological Society, and many other Learned and Medical Societies, as well as in Scientific Books, not only in this country, but in India, South Africa, New Zealand, and various other parts of the world.

WEST, NEWMAN, & CO. are at all times ready to advise with Authors and Artists as to the best or cheapest means of printing their work, and to give estimates of cost. See specimen of their Photo-Lithographic Illustration at page 152 of this book.

---

WEST, NEWMAN, & CO. 

 54 HATTON GARDEN, LONDON.



# HORNE, THORNTHWAITE, & WOOD,

MANUFACTURERS OF

PHOTOGRAPHIC APPARATUS, PLATES, AND CHEMICALS.

**WOOD'S BEST QUALITY CAMERA.**—Double Extension, Turntable, 4-fold Stand, and Three Double Backs.

$\frac{1}{2}$ -plate, £8, 8s. ;  $\frac{1}{4}$ -plate, £10, 10s.

**WOOD'S ENGLISH LENSES** for Landscapes, Portraits, or Architecture. Carefully Corrected, Centred, and Mounted.

	Focus.	Rapid Rectilinear.		Wide Angle.		
		Water Diaph.	Iris Diaph.	Focus.		
$4\frac{1}{4}$ by $3\frac{1}{4}$	5 in.	£2 15 0	£3 5 0	3 in.	£3	0 0
$6\frac{1}{2}$ „ $4\frac{3}{4}$	7 in.	3 10 0	4 4 0	4 in.	4	0 0
$8\frac{1}{2}$ „ $6\frac{1}{2}$	11 in.	5 5 0	6 6 0	5 in.	5	0 0

**COMPLETE SETS OF APPARATUS**, including Best Camera, English Rapid Rectilinear Lens, 4-fold Stand, Leather Case, and Materials, &c., all of the best quality.

$\frac{1}{4}$ -plate, £14, 10s. ;  $\frac{1}{2}$ -plate, £18, 10s. ;  $\frac{1}{1}$ -plate, £28, 10s.

**WOOD'S "TRAFALGAR" PLATES.**—The best Plate for Amateurs. Three Rapidities. "Landscape."  $\frac{1}{4}$ -plate, 1s. ;  $\frac{1}{2}$ -plate, 2s. 3d.

**WOOD'S CELLULOID FILMS.**— $\frac{1}{4}$ -plate, 1s. 6d. ;  $\frac{1}{2}$ -plate, 3s. 8d. ;  $\frac{1}{1}$ -plate, 6s. 6d. ; 10 × 8, 10s.

**WOOD'S LANTERN PLATES (Chloride).**—Per dozen, 1s.

**WOOD'S HYDROKINONE DEVELOPER.**—The finest Developer for Celluloid Films, Bromide Papers, Ordinary Plates, and Chloride Plates. Eight ounces (concentrated) in two solutions, in Case, 2s.

**ACKLAND'S EXPOSURE SCALE.**—For use with Stanley's Actinometer. Indicates the correct exposure for a plate without calculation, 3s. 6d.

"A PHOTOGRAPH, AND HOW TO TAKE IT,"

With CATALOGUE Gratis. Post Free, One Stamp.

416 STRAND, and 74 CHEAPSIDE, LONDON.

JOSIAH T. CHAPMAN,  
**Photographic Chemist,**  
ALBERT SQUARE,  
MANCHESTER.

---

Every Photographic Article of note is kept in Stock, and any new requisite of value to the Amateur or Professional will be obtained promptly if requested.

---



ESTABLISHED

1874.



---

PRICE LISTS  
AND USEFUL PAMPHLETS  
POST FREE.

—◆◆◆—  
Telegrams—"CAMERA, MANCHESTER."

Gold Medals and Highest Awards at all great Exhibitions.

# ROSS

## CELEBRATED PORTRAIT AND VIEW LENSES.

(Over Fifty Thousand of these Lenses have been Sold.)

MANY RECENT IMPORTANT IMPROVEMENTS, SEVERAL NEW SERIES.

**ROSS' PATENT CONCENTRIC LENSES. F 22.**

For Architecture, Copying, Landscapes, &c. The greatest advance ever made in Photographic Lenses. Send for Press reports.

**ROSS' PORTABLE SYMMETRICALS. F 16.**

Very popular for Landscapes, Architecture, and Copying. The first ten of the series screw into same flange.

**ROSS' WIDE ANGLE SYMMETRICALS. F 16.**

Embracing an angle of 90 degrees and upwards. Very suitable for Interiors and Confined Situations.

**ROSS' RAPID SYMMETRICALS (NEW). F 8.**

For Groups, Views, Copying, Enlarging, &c. The Most Useful all-round Lens for Out-door Work.

**ROSS' UNIVERSAL SYMMETRICALS. F 5,657.**

A New Extra Rapid series for Portraits, Groups, and Instantaneous Work. Highly recommended.

**ROSS' SINGLE LANDSCAPE LENSES. F 16.**

Introduced to meet the demand for a cheap series for purely Landscape Work.

**ROSS' PORTRAIT AND CABINET LENSES. F 4.**

Used by Leading Professional Photographers everywhere. Great brilliancy and exquisite defining power.

**ROSS' HAND CAMERA LENSES. F 5,6. and F 8.**

Bronzed Mounts, Iris or Waterhouse Diaphragms. Can be supplied in pairs, when so required.

**ROSS' DIVIDED HAND CAMERA.**

Has met with great success. Thoroughly reliable. Highly recommended by numerous purchasers.

**ZEISS PATENT ANASTIGMATIC LENSES.**

Manufactured by Ross & Co. in Three Series, for Portraits, Groups, Architecture, Copying, &c.

**ROSS STUDIO AND FIELD CAMERAS, &c. &c.**

**ROSS & CO.,**  
Manufacturing Opticians,  
112 New Bond Street, LONDON, ENGLAND.

M. WOLFE'S

PERFECT LINED SCREEN PLATES

FOR

HALF-TONE ENGRAVING,

ADAPTED TO ALL

WASHOUT SWELLED GELATINE

AND

ZINC ETCHING PROCESSES.

---

RULED ABSOLUTELY PERFECT.

---

In these days of low prices and sharp competition, it is necessary to cater for the Commercial trade, and by the turning out of good work you will receive satisfactory results. Cuts of Views, Machinery, &c., &c., for Book Illustrations, can be made by the *above Screens*, to be surpassed by no others.

---

FULL INSTRUCTIONS IN HALF-TONE ETCHING, \$40.

---

INVESTIGATE THIS:—

8 × 10 Plates, each	. . . . .	\$20
10 × 12	” ” . . . . .	30
13 × 13	” ” . . . . .	50
14 × 14	” ” . . . . .	70

My Plates are in use by the finest Etchers in the States. For full particulars and samples of work send 6d. for postage to

**M. WOLFE,**

106 SOUTH MAIN STREET,

DAYTON, O.

# WOODBURY PERMANENT PHOTOGRAPHIC PRINTING COMPANY,

EYRE & SPOTTISWOODE, PROPRIETORS.

**B**EG to call the attention of Publishers to the advantages of the Woodbury-Gravure process for the purpose of High-class Book Illustrations, it being a process which reproduces with equal facility copies of wash or line drawings, portraits from life, landscapes, photographs, paintings, engravings, and sketches of all kinds. Woodbury-Gravure approaches nearest to photo-engraving in results, but without the initial expense of preparing the plate.

The WOODBURY COMPANY are also the original holders of the patent for Woodbury type printing, and which they have most successfully worked for many years, the results produced being far superior to any other mechanical process for the reproduction for either Book Illustrations, Trade Catalogues, &c., &c., where mounting is not an objection.

Examples of both the above-mentioned processes will be found in this Publication.

The WOODBURY COMPANY also undertake

- Collotype Printing . . for Book Illustrations.
- Carbon Printing . . . for Publication Purposes.
- Platinotype Printing . for all Requirements.
- Silver Printing . . . of the Best Description.
- Carbon Enlargements on the Company's own special make of Tissue from Amateur or Professional negatives.
- Carbon Tissue . . . in Cut Pieces for small Consumers.



*PRICE LISTS and all Information on application to*

**6 GREAT NEW STREET,**

LONDON, E.C.

WORKS—CASTLE BAR, EALING, W.

"The firm have sent us some magnificent specimens of their half-tone blocks. One we may mention in particular, which appeared in the *Illustrated London News*, "Grouse upon the Moors," reproduced from a drawing in black and white, which is one of the most perfect photo-engraved blocks that has ever been made in this country. Messrs. MEISENBACH have succeeded admirably in their attempt to give these blocks all that brightness and delicacy that are so much admired in the American and Continental work. It is, indeed, doubtful if any country whatever, in spite of fine climatic influences, can surpass some of the work we have seen done at the Norwood studio."—*British and Colonial Printer and Stationer*.

"Many improvements which have recently been introduced have brought their process to the highest point of perfection."—*Photographic News*.

---

# MEISENBACH

IMPROVED PROCESS

OF

# PHOTO-ENGRAVING,

For the illustration of **Fine Art and Scientific Publications, Books of Travel, Pictorial Guides, Catalogues, Art Magazines, Newspapers, &c.**, the MEISENBACH PROCESS is unequalled, and is the most perfect Photo-Engraving method in use.

These Illustrations can be reproduced from

OIL PAINTINGS, WATER COLOURS, PHOTOGRAPHS,  
SKETCHES IN WASH, CHALK, CRAYON, LEAD PENCIL.

or, in fact, anything from which a negative can be made.

#### PRICES AND VARIETIES OF TINT OR GRAIN USED.

<b>Open Grain Blocks, 1/3</b>	per square inch; minimum,	<b>15/-</b>	net.
<b>Medium Square Blocks, 1/4½</b>	„ „	<b>15/-</b>	„
<b>Fine Grain Blocks, 1/6</b>	„ „	<b>15/-</b>	„

POSTAGE ADDITIONAL.

*Terms—Cash, with Order, or London Reference and net Monthly Settlements.*

**Special Price** for a series or for a large number of subjects, depending on nature of copy, size, and number of blocks.

**The Open Grain** is especially suitable for Newspapers and other work printed at a high speed with inferior ink and paper.

**The Medium Grain** is, as the name implies, an intermediate tint between the Fine and Open Grain, and is generally used for the illustration of such Publications as are printed with medium quality ink and paper.

**The Fine Grain** is recommended for high-class Art Reproductions, and best results are obtained with well-rolled soft-sized dry paper, hard packing, and good ink.

**N.B.—Points to Remember.**—In sending instructions, special care should be taken to state clearly the grain to be used, and the required size of block in inches one way; also state whether the whole or only a portion of the picture has to be engraved. **Unmounted photographs** should always be sent flat between cardboards or in roller, as creases and marks are difficult to keep out of the reproduction.

**Abridged Particulars** and **Specimens** post free.

**Art Specimens** engraved from paintings and printed in tinted colour, sent free on receipt of 4½d. for postage.

The facilities of the MEISENBACH COMPANY for the production of engraved plates surpass any establishment in Great Britain.

---

**THE MEISENBACH COMPANY, LIMITED,**  
WOLFINGTON ROAD, WEST NORWOOD,  
LONDON, S.E.

Chief Offices and Works—WEST NORWOOD.]

[City Office—188 FLEET STREET, E.C.



GOLD MEDAL, INTERNATIONAL INVENTIONS EXHIBITION.

SILVER AND BRONZE MEDALS, LEEDS EXHIBITION.

# **WATERLOW & SONS,** **LIMITED,**

Photographic Art Printers and Engravers,  
FINSBURY WORKS, LONDON, E.C.  
Photo-Zincography.

Photo-Lithography.

Photo-Mechanical Printing.

Collotype.—Hand and Machine Printing for Art Publications, Scientific and Antiquarian Periodicals, Machinery, Landscapes, Portraits, Pottery, Furniture Designs, Trade Advertisements, &c. The superior results given by this process, and the rapidity and cheapness by which the prints are produced, together with the advantage of printing with or without margins, place it in the first rank of processes for commercial purposes.

MESSRS. WATERLOW & SONS, LIMITED, have given this branch of the Photo-Printing Department special facilities for the production of good work, and have introduced the most perfect machinery and plant obtainable.

Woodbury Prints.—High-class permanent copies, equal in appearance to the best Silver Prints, of Portraits, Landscapes, Furniture, Pottery, &c. Prints may be obtained in almost any colour from Customers' own Negatives, or from the original objects. These reproductions are specially suitable for Portrait work, and are valuable for every description of Artistic or Commercial Illustrations.

Photo-Zinco Engraving.—Blocks for Surface Printing, from Line and Grained-paper Drawings, Steel and Copper Plates, Wood Engravings, &c., &c. Letter-press Blocks in "Half-tint" (stipple or dot) direct from Photographs from Nature, without drawing.

Accurately registered Blocks for Chromographic Printing. Intaglio Engraving in Line and Half-tone on Copper and Zinc.

The greatest care and skill is employed in the production of these Blocks, and the results are the finest which it is possible to obtain.

The new and extensive Photographic Works, being fitted with Modern Appliances, Machinery, Electric Lighting, &c., rapid and accurate work is always obtainable, irrespective of weather or season.

---

PRICE LISTS, ESTIMATES, and full particulars on application.

---

WATERLOW & SONS, Limited, Finsbury Works, E.C.

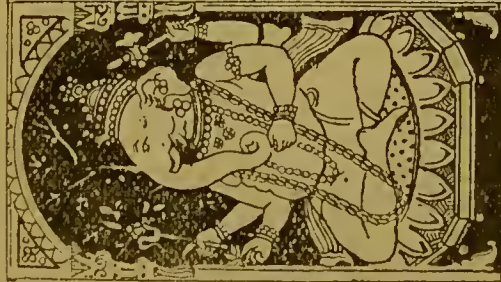

HINDU

ESTD

1848  
**J. C. NORBURY & SONS**  
CHROMO LITHOGRAPHERS  
**DESIGNERS OF TRADE MARKS**  
108 PORTLAND ST. MANCHESTER

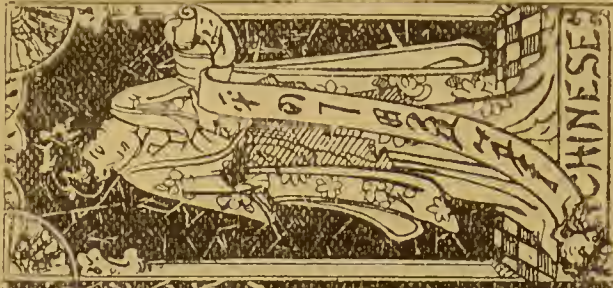

CHINESE

**Tickets**

in every description of CHROMO & EMBOSSED STYLES.  
SPECIALITE.—Indian, Chinese & Japanese Native Subjects.

**Stamps.**

White & Grey Goods Stamps in the ordinary and by the New "Norbrotype" Process.

A staff of Artists employed to originate subjects suitable for every description of Tickets and Stamps.

# The Manchester Trade Marks Association,

108 PORTLAND STREET, MANCHESTER.

TRADE MARKS Originated, Registered, Assigned, and Transferred.  
PROTECTION OF TRADE MARKS. On specified Terms the Association undertakes to maintain a Scrutiny on all New Marks advertised by the Comptroller, and inform Clients as to Infringements on their deposited Marks.

F. J. NORBURY, MANAGER.

PURE  
CHEMICALS.

# HINTON & CO

38 BEDFORD STREET  
STRAND, W.C.

SERVICEABLE  
APPARATUS.

Pharmaceutical and Photographic Chemists.

## CHEMICALS

FOR

THE ARTS, SCIENCES, TRADES, AND MANUFACTURES,  
WHOLESALE AND RETAIL.

Solutions, Papers, Plates, and Apparatus for Photography  
and for All Scientific Occupations or Recreations  
of Students and Amateurs.

GOODS WELL PACKED FOR INDIA AND THE COLONIES.

SEND FOR A PRICE LIST.

# THE THORNTON-PICKARD PATENT "TIME" SHUTTER

*Gives both Time and Instantaneous Exposures.*

IS THEORETICALLY AND PRACTICALLY THE BEST.

Simple and Serviceable. Has the Largest Sale in the World.

"Its action is really admirable, the mechanism being both ingenious and simple. It is well made, and the various actions are effected without any jar."—J. TRAILL TAYLOR, Esq., *Editor, British Journal of Photography.*

"It is certainly capable of answering every possible requirement. This last improved form will make the shutter even more popular than it is."—*Amateur Photographer*

"A very good instrument. We have used one for the past two seasons with considerable pleasure and success."—*Photography.*

"As near perfection as possible, and for variety of speeds, combined with the utmost simplicity of working, it could not be excelled."—*R. B.*

"I have several of your shutters in constant use, and find them all that can be desired. I never use a lens-cap now at all."—*J. B. Y.*

"Still holds the palm."—*Globe.*

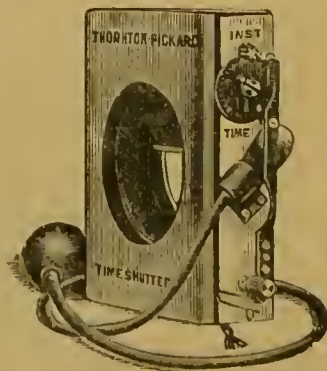

Price from 18s. 6d. Instantaneous only from 11s. 6d. Speed Indicator, 3s. 6d. extra.

*Illustrated Catalogue post free on application to the*

**THORNTON-PICKARD MANUFACTURING COMPANY,**  
ST. MARY'S STREET, DEANSGATE, MANCHESTER.



A  
CATALOGUE  
OF  
STANDARD WORKS

PUBLISHED BY  
CHARLES GRIFFIN & COMPANY.

---

	PAGE
I.—Religious Works, . . . . .	4
II.—Works on Medicine and the Allied Sciences, . . . . .	9
III.—General Scientific and Technical Works, . . . . .	21
IV.—Educational Works, . . . . .	49
V.—Works in General Literature, . . . . .	58

---

LONDON:  
12 EXETER STREET, STRAND.

# INDEX TO AUTHORS.

	PAGE		PAGE
AITKEN (Sir W., M.D.), Science and Practice of Medicine, . . . . .	9	JAKSCH (v.) and CAGNEY, Clinical Diagnosis, . . . . .	14
——— Outlines, . . . . .	9	JAMES (W. P.), From Source to Sea, . . . . .	53
ANDERSON (M'Call) on Skin Diseases, . . . . .	14	JAMIESON (A.), Manual of the Steam Engine . . . . .	32
ANGLIN (S.), Design of Structures, . . . . .	21	——— Steam and the Steam Engine—Elementary, . . . . .	32
BELL (R.), Golden Leaves, . . . . .	58	——— Applied Mechanics, . . . . .	33
BERINGER (J. J. and C.), Assaying, . . . . .	22	——— Magnetism and Electricity, . . . . .	33
BLYTH (A. W.), Hygiene and Public Health, . . . . .	10	JEVONS (F. B.), A History of Greek Literature, . . . . .	54
——— Foods and Poisons, . . . . .	10	——— Athenian Democracy, . . . . .	54
BROTHERS (A.), Photography, . . . . .	22	KEBLE'S Christian Year, . . . . .	4
BROUGH (B. H.), Mine-Surveying, . . . . .	23	LANDIS (Dr.), Management of Labour, . . . . .	18
BROWNE (W. R.), Student's Mechanics, . . . . .	23	LANDOIS and STIRLING'S Physiology, . . . . .	13
——— Foundations of Mechanics, . . . . .	23	LEWIS (W. B.), Mental Diseases, . . . . .	15
——— Fuel and Water, . . . . .	23	LINN (Dr.), On the Teeth, . . . . .	19
BRYCE (A. H.), Works of Virgil, . . . . .	50	LONGMORE (Prof.), Sanitary Contrasts, . . . . .	19
BUNYAN'S Pilgrim's Progress (Mason), . . . . .	4	MACALISTER (Prof.), Human Anatomy, . . . . .	13
BURNET (Dr.), Foods and Dietaries, . . . . .	11	MACKEY (A. G.), Lexicon of Freemasonry, . . . . .	61
CAIRD and CATHCART, Surgical Handbook, . . . . .	12	MAYHEW (H.), London Labour, . . . . .	61
CHEEVER'S (Dr.), Religious Anecdotes, . . . . .	4	M'BURNEY (Dr.), Ovid's Metamorphoses, . . . . .	55
COBBETT (Wm.), Advice to Young Men, . . . . .	58	MEYER and FERGUS' Ophthalmology, . . . . .	14
——— Cottage Economy, . . . . .	58	MILLER (W. G.), Philosophy of Law, . . . . .	55
——— English Grammar, . . . . .	50	M'MILLAN (W. G.), Electro-Metallurgy, . . . . .	34
——— French do., . . . . .	50	MUNRO (R. D.), Steam Boilers, . . . . .	33
——— Legacy to Labourers, . . . . .	59	MUNRO and JAMIESON'S Electrical Pocket-Book, . . . . .	35
——— Do. Parsons, . . . . .	59	NYSTROM'S Pocket-Book for Engineers, . . . . .	35
COBBIN'S Mangnall's Questions, . . . . .	50	OBERSTEINER and HILL, Central Nervous Organs, . . . . .	15
COLE (Prof.), Practical Geology, . . . . .	24	PAGE (H.W.), Railway Injuries, . . . . .	15
COLERIDGE on Method, . . . . .	50	PARKER (Prof.) Mammalian Descent, . . . . .	19
CRAIK (G.), History of English Literature, . . . . .	51	PHILLIPS and BAUERMAN, Metallurgy, . . . . .	38
——— Manual of do., . . . . .	51	POE (Edgar), Poetical Works of, . . . . .	60
CRIMP (W. S.), Sewage Disposal Works, . . . . .	25	PORTER (Surg.-Maj.), Surgeon's Pocket-Book, . . . . .	19
CROOM (Halliday), Gynæcology, . . . . .	16	RAMSAY (Prof.), Roman Antiquities, . . . . .	55
CRUDEN'S CONCORDANCE, by Eadie, . . . . .	6	——— Do. Elementary, . . . . .	55
CRUTTWELL'S History of Roman Literature, . . . . .	52	——— Latin Prosody, . . . . .	55
——— Specimens of do., . . . . .	52	——— Do. Elementary, . . . . .	55
——— Early Christian Literature, . . . . .	4	RANKINE'S ENGINEERING WORKS, . . . . .	39, 40
CURRIE (J.), Works of Horace, . . . . .	50	REED (Sir E. J.), Stability of Ships, . . . . .	41
DAVIS (J. R. A.), An Introduction to Biology, . . . . .	26	ROBERTS-AUSTEN (Prof.), Metallurgy, . . . . .	42
——— The Flowering Plant, . . . . .	26	ROBINSON (Prof.), Hydraulics, . . . . .	43
——— Zoological Pocket-Book, . . . . .	27	SANSOM (A. E.), Diseases of the Heart, . . . . .	16
DICK (Dr.), Celestial Scenery, . . . . .	4	SCHRADER and JEVONS, The Prehistoric Antiquities of the Aryan Peoples, . . . . .	56
DOERING and GRÆME'S Hellas, . . . . .	53	SCHWACKHÖFER and BROWNE, Fuel and Water, . . . . .	44
D'ORSEY (A. J.), Spelling by Dictation, . . . . .	53	SEATON (A. E.), Marine Engineering, . . . . .	45
DUCKWORTH (Sir D., M.D.), Gout, . . . . .	14	SEELEY (Prof.), Physical Geology, . . . . .	36
DUPRÉ & HAKE, Manual of Chemistry, . . . . .	27	SENIOR (Prof.), Political Economy, . . . . .	57
EADIE (Rev. Dr.), Biblical Cyclopædia, . . . . .	6	SEXTON (Prof.), Quantitative Analysis, . . . . .	44
——— Cruden's Concordance, . . . . .	6	——— Qualitative Analysis, . . . . .	44
——— Classified Bible, . . . . .	6	SHELTON-BEY (W. V.), Mechanic's Guide, . . . . .	44
——— Ecclesiastical Cyclopædia, . . . . .	6	SOUTHGATE (H.), Many Thoughts of Many Minds, . . . . .	64
——— Dictionary of the Bible, . . . . .	6	——— Suggestive Thoughts, . . . . .	7
ELBORNE (W.), Pharmacy and Materia Medica, . . . . .	12	——— (Mrs.), Christian Life, . . . . .	7
EMERALD SERIES OF POETS, . . . . .	60	STIRLING (William), Human Physiology, . . . . .	13
ETHERIDGE (R.), Stratigraphical Geology, . . . . .	37	——— Outlines of Practical Physiology, . . . . .	20
EWART (Prof.), The Preservation of Fish, . . . . .	27	——— Outlines of Practical Histology, . . . . .	20
FIDLER (T. Claxton), Bridge-Construction, . . . . .	28	TAIT (Rev. J.), Mind in Matter, . . . . .	8
FLEMING (Prof.), Vocabulary of Philosophy, . . . . .	53	THE MASSES: How shall we reach them? . . . . .	8
FOSTER (Chas.), Story of the Bible, . . . . .	5	THOMSON (Dr. Spencer), Domestic Medicine, . . . . .	63
FOSTER (C. Le N.), Ore and Stone Mining, . . . . .	29	THOMSON'S Seasons, . . . . .	57
GARROD (Dr. A. E.), Rheumatism, . . . . .	14	THORBURN (Wm), Surgery of the Spine, . . . . .	15
GILMER (R.), Interest Tables, . . . . .	59	THORNTON (J. K.), Surgery of the Kidneys, . . . . .	15
GRÆME (Elliott), Beethoven, . . . . .	59	TRAILL (W.), Boilers, Land and Marine, . . . . .	46
——— Novel with Two Heroes, . . . . .	59	WHATELY (Archbishop), Logic, and Rhetoric, . . . . .	57
GRIFFIN'S ELECTRICAL PRICE-BOOK, . . . . .	29	WORDS AND WORKS OF OUR LORD, . . . . .	8
GRIFFIN (J. J.), Chemical Recreations, . . . . .	29	WRIGHT (Alder), The Threshold of Science, . . . . .	47
GURDEN (R.), Traverse Tables, . . . . .	29	YEAR-BOOK OF SCIENTIFIC SOCIETIES, . . . . .	48
GUTTMANN (O.), Rock Blasting, . . . . .	29		
HADDON (Prof.), Embryology, . . . . .	13		
HORSLEY (Victor), The Nervous System, . . . . .	18		
HUGHES (H. W.), Coal-Mining, . . . . .	29		
HUMPHRY, Manual of Nursing, . . . . .	18		

# INDEX TO SUBJECTS.

	PAGE		PAGE
ANATOMY, Human, . . . . .	13	LITERATURE, English, . . . . .	51
ANECDOTES, Cyclopædia of, . . . . .	4	—Greek, . . . . .	54
ANTIQUITIES, Prehistoric, . . . . .	56	—Roman, . . . . .	52
—Greek, . . . . .	54	LOGIC, . . . . .	57
—Roman, . . . . .	55	MACHINERY, Hydraulic, . . . . .	43
ARYAN PEOPLES, . . . . .	56	—and Millwork, . . . . .	39
ASSAYING, . . . . .	22	MAGNETISM, . . . . .	32, 33
BIBLE (The Holy), Classified, . . . . .	6	MAMMALIAN Descent, . . . . .	19
—Concordance to, . . . . .	6	MARINE Engineering, . . . . .	45
—Cyclopædia of, . . . . .	6	MECHANICS, . . . . .	23, 33, 35, 39, 40, 44
—Dictionary of, . . . . .	6	MEDICAL Series, . . . . .	13-16
—Story of, . . . . .	5	—Works, . . . . .	9
BIOLOGY, . . . . .	26	MEDICINE, Science and Practice of, . . . . .	9
BOILERS, Marine and Land, . . . . .	46	—Domestic, . . . . .	63
—Management of, . . . . .	33	MENTAL Diseases, . . . . .	15
BOTANY, . . . . .	26	—Science, . . . . .	55
BRAIN, The, . . . . .	15	METALLURGY, . . . . .	38, 42
BRIDGE-CONSTRUCTION, . . . . .	21, 28	MINE-SURVEYING, . . . . .	23
CHEMISTRY, Inorganic, . . . . .	27	MINING, Coal, . . . . .	29
—Experiments in, . . . . .	47	—Ore and Stone, . . . . .	29
—Qualitative Analysis, . . . . .	44	MYTHOLOGY, Greek, . . . . .	53
—Quantitative „, . . . . .	44	NAVAL Construction, . . . . .	41
—Recreations in, . . . . .	29	NERVOUS ORGANS, Central, . . . . .	15
CLINICAL Diagnosis, . . . . .	14	—System, . . . . .	18
DAILY Readings, . . . . .	7, 8	NURSING, Medical and Surgical, . . . . .	18, 63
DICTIONARY of Anecdotes, . . . . .	4	OBSTETRICS, . . . . .	18
—of the Holy Bible, . . . . .	6	PALÆONTOLOGY, . . . . .	24, 36, 37
—Ecclesiastical, . . . . .	6	PHARMACY, . . . . .	12
—of Medicine (Domestic), . . . . .	63	PHILOSOPHY, Vocabulary of, . . . . .	53
—of Philosophical Terms, . . . . .	53	PHOTOGRAPHY, . . . . .	22
—of Quotations, . . . . .	64	PHYSICS, Experiments in, . . . . .	47
—of „ (Religious), . . . . .	7	PHYSIOLOGY, Human, . . . . .	13
DIETARIES for the Sick, . . . . .	11	—Practical, . . . . .	29
EDUCATIONAL Works, . . . . .	49	POCKET-BOOK, Electrical, . . . . .	35
ELECTRICAL Price-Book, . . . . .	29	—Engineering, . . . . .	35
ELECTRICITY, . . . . .	32, 33, 35	—Surgical, . . . . .	12, 19
ELECTRO-METALLURGY, . . . . .	33-4	—Zoological, . . . . .	27
EMBRYOLOGY, . . . . .	13, 19	POETS, Emerald Series of, . . . . .	60
ENGINEERING, Civil, . . . . .	39	POISONS, Detection of, . . . . .	10
—Marine, . . . . .	45	POLITICAL ECONOMY, . . . . .	57
—Useful Rules in, . . . . .	35, 40	POOR, Condition of the, . . . . .	8, 61
EYE, Diseases of the, . . . . .	14	RAILWAY Injuries, . . . . .	15
FISH, Preservation of, . . . . .	27	RELIGIOUS Works, . . . . .	4
FOODS, Analysis of, . . . . .	10	RHETORIC, . . . . .	57
FOODS and Diets, . . . . .	11	RHEUMATISM, . . . . .	14
FREEMASONRY, . . . . .	61	ROCK-BLASTING, . . . . .	29
FUEL and Water, . . . . .	44	ROOFS, Design of, . . . . .	21
GEOLOGY, Practical, . . . . .	24	SCIENCE, Popular Introduction to, . . . . .	47
—Physical, . . . . .	36	SCIENTIFIC Societies, Papers read before, . . . . .	48
—Stratigraphical, . . . . .	37	SEWAGE Disposal Works, . . . . .	25
GOUT, . . . . .	14	SHIPS, Stability of, . . . . .	41
GRAMMARS, . . . . .	50	—Wave-forms, Propulsion, &c. (Rankine), . . . . .	40
GYNÆCOLOGY, . . . . .	16	SKIN, Diseases of the, . . . . .	14
HEART, Diseases of the, . . . . .	16	SPINAL Cord, . . . . .	15
HISTOLOGY, . . . . .	20	STEAM-ENGINE, . . . . .	32, 40
HORACE, Works of, . . . . .	50	STRUCTURES, Design of, . . . . .	21
HYDRAULIC Power, . . . . .	43	STUDENTS' Text-Books, . . . . .	17, 31, 32, 49
HYGIENE and Public Health, . . . . .	10, 19	SURGERY, Civil, . . . . .	12
INTEREST Tables, . . . . .	59	—Military, . . . . .	19
LABORATORY Handbooks—		—of Kidneys, . . . . .	15
Histology, . . . . .	20	—of Spinal Cord, . . . . .	15
Pharmacy, . . . . .	12	SURVEYING, . . . . .	23, 29
Physiology, . . . . .	20	TEETH, Care of the, . . . . .	19
LATIN Prosody, . . . . .	55	THERMODYNAMICS, (Rankine), . . . . .	40
LAW, Philosophy of, . . . . .	55	TRAVERSE Tables, . . . . .	29
LITERATURE, General, . . . . .	58	VIRGIL, Works of, . . . . .	50
—Early Christian, . . . . .	4	ZOOLOGY, . . . . .	19, 27

# CHARLES GRIFFIN & COMPANY'S LIST OF PUBLICATIONS.

---

## RELIGIOUS WORKS.

---

### ANECDOTES (CYCLOPÆDIA OF RELIGIOUS AND MORAL). With an Introductory Essay by the Rev. GEORGE CHEEVER, D.D. *Thirty-sixth Thousand.* Crown 8vo. Cloth, 3/6.

\*\* These Anecdotes relate to no trifling subjects; and they have been selected, not for amusement, but for instruction. By those engaged in the tuition of the young, they will be found highly useful.

THE LARGE-TYPE BUNYAN.

### BUNYAN'S PILGRIM'S PROGRESS. With Life and Notes, Experimental and Practical, by WILLIAM MASON. Printed in large type, and Illustrated with full-page Woodcuts. *Twelfth Thousand.* Crown 8vo. Bevelled boards, gilt, and gilt edges, 3/6.

### CHRISTIAN YEAR (The): With Memoir of the Rev. JOHN KEBLE, by W. TEMPLE, Portrait, and Eight Engravings on Steel, after eminent Masters. *New Edition.* Small 8vo, toned paper. Cloth gilt, 5/.

\*\* The above is the only issue of the "Christian Year" with Memoir and Portrait of the Author. In ordering, Griffin's Edition should be specified.

### CRUTTWELL (REV. CHARLES T., M.A.) A HISTORY OF EARLY CHRISTIAN LITERATURE. In large 8vo, handsome cloth. *[In preparation.]*

\*\* This work is intended not only for Theological Students, but for General Readers, and will be welcomed by all acquainted with the Author's admirable "*History of Roman Literature*," a work which has now reached its Fourth Edition.

### DICK (Thos., LL.D.): CELESTIAL SCENERY; or, The Wonders of the Planetary System Displayed. This Work is intended for general readers, presenting to their view, in an attractive manner, sublime objects of contemplation. Illustrated. *New Edition.* Crown 8vo, toned paper. Handsomely bound, gilt edges, 5/.

---

LONDON: EXETER STREET, STRAND.



Now Ready. FIFTH AND GREATLY IMPROVED EDITION. In ROYAL 8VO.  
Cloth Elegant, 6/. Gilt and Gilt Edges, 7/6.

## THE STORY OF THE BIBLE,

*From GENESIS to REVELATION.*

Including the Historical Connection between the Old and New Testaments.  
Told in Simple Language.

BY CHARLES FOSTER.

With Maps and over 250 Engravings

(Many of them Full-page, after the Drawings of Professor CARL SCHÖNHERR and others),

*Illustrative of the Bible Narrative, and of Eastern  
Manners and Customs.*

### OPINIONS OF THE PRESS.

"A book which, once taken up, is not easily laid down. When the volume is opened, we are fairly caught. Not to speak of the well-executed wood engravings, which will each tell its story, we find a simple version of the main portions of the Bible, all that may most profitably be included in a work intended at once to instruct and charm the young—a version couched in the simplest, purest, most idiomatic English, and executed throughout with good taste, and in the most reverential spirit. *The work needs only to be known to make its way into families*, and it will (at any rate, it ought to) become a favourite Manual in Sunday Schools."—*Scotsman*.

"A HOUSEHOLD TREASURE."—*Western Morning News*.

"This attractive and handsome volume . . . written in a simple and transparent style. . . . Mr. Foster's explanations and comments are MODELS OF TEACHING."—*Freeman*.

"This large and handsome volume, abounding in Illustrations, is just what is wanted. . . . The STORY is very beautifully and reverently told."—*Glasgow News*.

"There could be few better Presentation Books than this handsome volume."—*Daily Review*.

"WILL ACCOMPLISH A GOOD WORK."—*Sunday School Chronicle*.

"In this beautiful volume no more of comment is indulged in than is necessary to the elucidation of the text. Everything approaching Sectarian narrowness is carefully eschewed."—*Methodist Magazine*.

"This simple and impressive Narrative . . . succeeds thoroughly in riveting the attention of children; . . . admirably adapted for reading in the Home Circle."—*Daily Chronicle*.

"The HISTORICAL SKETCH connecting the Old and New Testaments is a very good idea; it is a common fault to look on these as distinct histories, instead of as parts of *one grand whole*."—*Christian*.

"Sunday School Teachers and Heads of Families will best know how to value this handsome volume."—*Northern Whig*.

\* \* \* The above is the original English Edition. In ordering, Griffin's Edition, by Charles Foster, should be distinctly specified.

LONDON: EXETER STREET, STRAND.

## STANDARD BIBLICAL WORKS

BY

THE REV. JOHN EADIE, D.D., LL.D.,  
*Late a Member of the New Testament Revision Company.*

This SERIES has been prepared to afford sound and necessary aid to the Reader of Holy Scripture. The VOLUMES comprised in it form in themselves a COMPLETE LIBRARY OF REFERENCE. The number of Copies already issued greatly exceeds A QUARTER OF A MILLION.

- I. EADIE (Rev. Prof.): BIBLICAL CYCLOPÆDIA (A); or, Dictionary of Eastern Antiquities, Geography, and Natural History, illustrative of the Old and New Testaments. With Maps, many Engravings, and Lithographed Fac-simile of the Moabite Stone. Large post 8vo, 700 pages. *Twenty-fifth Edition.*

Handsome cloth, . . . . . 7/6.

"By far the best Bible Dictionary for general use."—*Clerical Journal.*

- II. EADIE (Rev. Prof.): CRUDEN'S CONCORDANCE TO THE HOLY SCRIPTURES. With Portrait on Steel, and Introduction by the Rev. Dr. KING. Post 8vo. *Fifty-third Edition.* Handsome cloth, . . . . . 3/6.

\*\* Dr. EADIE'S has long and deservedly borne the reputation of being the COMPLETEST and BEST CONCORDANCE extant.

- III. EADIE (Rev. Prof.): CLASSIFIED BIBLE (The). An Analytical Concordance. Illustrated by Maps. Large Post 8vo. *Sixth Edition.* Handsome cloth, . . . . . 8/6.

"We have only to add our unqualified commendation of a work of real excellence to every Biblical student."—*Christian Times.*

- IV. EADIE (Rev. Prof.): ECCLESIASTICAL CYCLOPÆDIA (The). A Dictionary of Christian Antiquities, and of the History of the Christian Church. By the Rev. Professor EADIE, assisted by numerous Contributors. Large Post 8vo. *Sixth Edition.*

Handsome cloth, . . . . . 8/6.

"The ECCLESIASTICAL CYCLOPÆDIA will prove acceptable both to the clergy and laity of Great Britain. A great body of useful information will be found in it."—*Athenæum.*

- V. EADIE (Rev. Prof.): DICTIONARY OF THE HOLY BIBLE (A); for the use of Young People. With Map and Illustrations. Small 8vo. *Thirty-eighth Thousand.*

Cloth, elegant, . . . . . 2/6.

LONDON: EXETER STREET, STRAND.

"No one who is in the habit of writing and speaking much on a variety of subjects can afford to dispense with Mr. SOUTHGATE'S WORKS."—*Glasgow News*.

THIRD EDITION.

## SUGGESTIVE THOUGHTS ON RELIGIOUS SUBJECTS:

A Dictionary of Quotations and Selected Passages from nearly 1,000 of the best Writers, Ancient and Modern.

Compiled and Analytically Arranged

By HENRY SOUTHGATE.

In Square 8vo, elegantly printed on toned paper.

Presentation Edition, Cloth Elegant, . . . . .	10/6.
Library Edition, Roxburghe, . . . . .	12/.
Ditto, Morocco Antique, . . . . .	20/.

"The topics treated of are as wide as our Christianity itself: the writers quoted from, of every Section of the one Catholic Church of JESUS CHRIST."—*Author's Preface*.

"Mr. Southgate's work has been compiled with a great deal of judgment, and it will, I trust, be extensively useful."—*Rev. Canon Liddon, D.D., D.C.L.*

"A casket of gems."—*English Churchman*.

"This is another of Mr. Southgate's most valuable volumes. . . . The mission which the Author is so successfully prosecuting in literature is not only highly beneficial, but necessary in this age. . . . If men are to make any acquaintance at all with the great minds of the world, they can only do so with the means which our Author supplies."—*Homilist*.

"Many a busy Christian teacher will be thankful to Mr. Southgate for having unearthed so many rich gems of thought; while many outside the ministerial circle will obtain stimulus, encouragement, consolation, and counsel, within the pages of this handsome volume."—*Nonconformist*.

"Mr. SOUTHGATE is an indefatigable labourer in a field which he has made peculiarly his own. . . . The labour expended on 'Suggestive Thoughts' must have been immense, and the result is as nearly perfect as human fallibility can make it. . . . Apart from the selections it contains, the book is of value as an index to theological writings. As a model of judicious, logical, and suggestive treatment of a subject, we may refer our readers to the manner in which the subject 'JESUS CHRIST' is arranged and illustrated in 'Suggestive Thoughts.'"—*Glasgow News*.

"Every day is a little life."—BISHOP HALL.

## THE CHRISTIAN LIFE:

Thoughts in Prose and Verse from 500 of the Best Writers of all Ages. Selected and Arranged for Every Day in the Year.

By MRS. H. SOUTHGATE.

Small 8vo. With Red Lines and unique Initial Letters on each page.  
Cloth Elegant, 5/. *Second Edition*.

"A volume as handsome as it is intrinsically valuable."—*Scotsman*.

"The Readings are excellent."—*Record*.

"A library in itself."—*Northern Whig*.

LONDON: EXETER STREET, STRAND.

**MIND IN MATTER:**  
A SHORT ARGUMENT ON THEISM

BY THE  
REV. JAMES TAIT.

*Second Edition.* Demy 8vo. Handsome Cloth, 8/6.

GENERAL CONTENTS.—Evolution in Nature and Mind—Mr. Darwin and Mr. Herbert Spencer—Inspiration, Natural and Supernatural—Deductions.

“An able and original contribution to Theistic literature. . . . The style is pointed, concise, and telling to a degree.”—*Glasgow Herald*.

“Mr. TAIT advances many new and striking arguments . . . highly suggestive and fresh.”—*Brit. Quarterly Review*.

**THE MASSES:**  
HOW SHALL WE REACH THEM?

Some Hindrances in the way, set forth from the standpoint of the People, with  
Comments and Suggestions.

BY  
AN OLD LAY HELPER.

Cloth, 2s. 6d. *Second Edition.*

\* \* \* An attempt to set forth some deficiencies in our present methods of reaching the poor, in the language of the people themselves.

“So full of suggestiveness that we should reprint a title of the book if we were to transcribe all the extracts we should like to make.”—*Church Bells*.

“‘Hindrances in the way’ exactly describes the subject-matter of the Book. Any one contemplating Missionary work in a large town would be helped by studying it.”—*Guardian*.

“‘The Masses’ is a book to be well pondered over and acted upon.”—*Church Work*.

“A very useful book, well worth reading.”—*Church Times*.

“A most interesting book. . . . Contains a graphic description of work among the masses.”—*English Churchman*.

**WORDS AND WORKS OF OUR BLESSED LORD:**  
AND THEIR LESSONS FOR DAILY LIFE.

Two Vols. in One. Foolscap 8vo. Cloth, gilt edges, 6/.

LONDON: EXETER STREET, STRAND.

---

# Works in Medicine, Surgery, and the Allied Sciences.

---

\* \* *Special Illustrated Catalogue sent Gratis on application.*

---

## WORKS

By SIR WILLIAM AITKEN, M.D., Edin., F.R.S.,

PROFESSOR OF PATHOLOGY IN THE ARMY MEDICAL SCHOOL; EXAMINER IN MEDICINE FOR THE MILITARY MEDICAL SERVICES OF THE QUEEN; FELLOW OF THE SANITARY INSTITUTE OF GREAT BRITAIN; CORRESPONDING MEMBER OF THE ROYAL IMPERIAL SOCIETY OF PHYSICIANS OF VIENNA; AND OF THE SOCIETY OF MEDICINE AND NATURAL HISTORY OF DRESDEN.

---

SEVENTH EDITION.

### THE SCIENCE AND PRACTICE OF MEDICINE.

In Two Volumes, Royal 8vo., cloth. Illustrated by numerous Engravings on Wood, and a Map of the Geographical Distribution of Diseases. To a great extent Rewritten; Enlarged, Remodelled, and Carefully Revised throughout, 42/.

#### Opinions of the Press.

"The work is an admirable one, and adapted to the requirements of the Student, Professor, and Practitioner of Medicine. . . . The reader will find a large amount of information not to be met with in other books, epitomised for him in this. We know of no work that contains so much, or such full and varied information on all subjects connected with the Science and Practice of Medicine."—*Lancet*.

"The SEVENTH EDITION of this important Text-Book fully maintains its reputation. . . . Dr. Aitken is indefatigable in his efforts. . . . The section on DISEASES of the BRAIN and NERVOUS SYSTEM is completely remodelled, so as to include all the most recent researches, which in this department have been not less important than they are numerous."—*British Medical Journal*.

---

## OUTLINES

OF THE

### SCIENCE AND PRACTICE OF MEDICINE.

A TEXT-BOOK FOR STUDENTS.

*Second Edition.* Crown 8vo, 12/6.

"Students preparing for examinations will hail it as a perfect godsend for its conciseness."—*Athenæum*.

"Well-digested, clear, and well-written, the work of a man conversant with every detail of his subject, and a thorough master of the art of teaching."—*British Medical Journal*.

---

LONDON: EXETER STREET, STRAND.

WORKS by A. WYNTER BLYTH, M.R.C.S., F.C.S.,  
Public Analyst for the County of Devon, and Medical Officer of Health for  
St. Marylebone.

## I. FOODS: THEIR COMPOSITION AND ANALYSIS. Price 16/. In Crown 8vo, cloth, with Elaborate Tables and Litho-Plates. *Third Edition.* Revised and partly rewritten.

### General Contents.

History of Adulteration—Legislation, Past and Present—Apparatus useful to the Food Analyst—"Ash"—Sugar—Confectionery—Honey—Treacle—Jams and Preserved Fruits—Starches—Wheaten-Flour—Bread—Oats—Barley—Rye—Rice—Maize—Millet—Potato—Peas—Chinese Peas—Lentils—Beans—MILK—Cream—Butter—Cheese—Tea—Coffee—Cocoa and Chocolate—Alcohol—Brandy—Rum—Whisky—Gin—Arrack—Liqueurs—Beer—Wine—Vinegar—Lemon and Lime Juice—Mustard—Pepper—Sweet and Bitter Almond—Annatto—Olive Oil—Water. *Appendix:* Text of English and American Adulteration Acts.

"Will be used by every Analyst."—*Lancet.*

"STANDS UNRIVALLED for completeness of information. . . . A really 'practical' work for the guidance of practical men."—*Sanitary Record.*

"An admirable digest of the most recent state of knowledge. . . . Interesting even to lay-readers."—*Chemical News.*

\*\* The NEW EDITION contains many Notable Additions, especially on the subject of MILK and its relation to FEVER-EPIDEMICS, the PURITY of WATER-SUPPLY, the MARGARINE ACT, &c., &c.

### COMPANION VOLUME.

## II. POISONS: THEIR EFFECTS AND DETECTION. Price 16/.

### General Contents.

Historical Introduction—Statistics—General Methods of Procedure—Life Tests—Special Apparatus—Classification: I.—ORGANIC POISONS: (a.) Sulphuric, Hydrochloric, and Nitric Acids, Potash, Soda, Ammonia, &c.; (b.) Petroleum, Benzene, Camphor, Alcohols, Chloroform, Carbolic Acid, Prussic Acid, Phosphorus, &c.; (c.) Hemlock, Nicotine, Opium, Strychnine, Aconite, Atropine, Digitalis, &c.; (d.) Poisons derived from Animal Substances; (e.) The Oxalic Acid Group. II.—INORGANIC POISONS: Arsenic, Antimony, Lead, Copper, Bismuth, Silver, Mercury, Zinc, Nickel, Iron, Chromium, Alkaline Earths, &c. *Appendix:* A. Examination of Blood and Blood-Spots. B. *Hints for Emergencies:* Treatment—Antidotes.

"Should be in the hands of every medical practitioner."—*Lancet.*

"A sound and practical Manual of Toxicology, which cannot be too warmly recommended. One of its chief merits is that it discusses substances which have been overlooked."—*Chemical News.*

"One of the best, most thorough, and comprehensive works on the subject."—*Saturday Review.*

## HYGIÈNE AND PUBLIC HEALTH (a Dictionary of): embracing the following subjects:—

- I.—SANITARY CHEMISTRY: the Composition and Dietetic Value of Foods, with the Detection of Adulterations.
- II.—SANITARY ENGINEERING: Sewage, Drainage, Storage of Water, Ventilation, Warming, &c.
- III.—SANITARY LEGISLATION: the whole of the PUBLIC HEALTH ACT, together with portions of other Sanitary Statutes, in a form admitting of easy and rapid Reference.
- IV.—EPIDEMIC AND EPIZOOTIC DISEASES: their History and Propagation, with the Measures for Disinfection.
- V.—HYGIÈNE—MILITARY, NAVAL, PRIVATE, PUBLIC, SCHOOL.

Royal 8vo, 672 pp., cloth, with Map and 140 Illustrations, 28/.

"A work that must have entailed a vast amount of labour and research. . . . Will become a STANDARD WORK IN PUBLIC HEALTH."—*Medical Times and Gazette.*

"Contains a great mass of information of easy reference."—*Sanitary Record.*

LONDON: EXETER STREET, STRAND.

Now Ready. Large Crown Svo. Handsome Cloth, 6s.

# FOODS AND DIETARIES:

## A Manual of Clinical Dietetics.

BY

R. W. BURNET, M.D.,

Member of the Royal College of Physicians of London; Physician to the Great Northern Central Hospital, &c.

In Dr. Burnet's "Foods and Dietaries," the *rationale* of the special dietary recommended, is briefly stated at the beginning of each section. To give definiteness to the directions, the HOURS of taking food and the QUANTITIES to be given at each time are stated, as well as the KINDS of food most suitable. In many instances there is also added a list of foods and dishes that are UNSUITABLE to the special case. References are given, where required, to the RECIPES for Invalid Cookery, which form the Appendix, and which have all been very carefully selected.

### GENERAL CONTENTS.

DIET in Diseases of the Stomach, Intestinal Tract, Liver, Lungs and Pleuræ, Heart, Kidneys, &c.; in Diabetes, Scurvy, Anæmia, Scrofula, Gout (Chronic and Acute), Obesity, Acute and Chronic Rheumatism, Alcoholism, Nervous Disorders, Diathetic Diseases, Diseases of Children, with a Section on Prepared and Predigested Foods, and Appendix on Invalid Cookery.

"The directions given are UNIFORMLY JUDICIOUS and characterised by good-sense. . . . May be confidently taken as a RELIABLE GUIDE in the art of feeding the sick."—*Brit. Med. Journal.*

"To all who have much to do with Invalids, Dr. Burnet's book will be of great use. . . . It will be found all the more valuable in that it deals with BROAD and ACCEPTED VIEWS. There are large classes of disease which, if not caused solely by errors of diet, have a principal cause in such errors, and can only be removed by an intelligent apprehension of their relation to such. Gout, Scurvy, Rickets, and Alcoholism are instances in point, and they are all TREATED with ADMIRABLE SENSE and JUDGMENT by Dr. Burnet. He shows a desire to allow as much range and VARIETY as possible. The careful study of such books as this will very much help the Practitioner in the Treatment of cases, and powerfully aid the action of remedies."—*Lancet.*

"Dr. Burnet's work is intended to meet a want which is evident to all those who have to do with nursing the sick. . . . The plan is METHODOICAL, SIMPLE, and PRACTICAL. . . . Dr. Burnet takes the important diseases *seriatim* . . . and gives a Time-table of Diet, with Bill of Fare for each meal, quantities, and beverages. . . . An appendix of cookery for invalids is given, which will help the nurse when at her wits' end for a change of diet, to meet the urgency of the moment or tempt the capricious appetite of the patient."—*Glasgow Herald.*

LONDON: EXETER STREET, STRAND.

FOURTH EDITION, *Pocket-Size, Leather, 8s. 6d. With very Numerous Illustrations.*

## A SURGICAL HANDBOOK, For Practitioners, Students, House-Surgeons, and Dressers.

By F. M. CAIRD, M.B., F.R.C.S. (ED.),

AND

C. W. CATHCART, M.B., F.R.C.S. (ENG. & ED.),

*Assistant-Surgeons, Royal Infirmary, Edinburgh.*

### GENERAL CONTENTS.

Case-Taking—Treatment of Patients before and after Operation—Anæsthetics: General and Local—Antiseptics and Wound-Treatment—Arrest of Hæmorrhage—Shock and Wound Fever—Emergency Cases—Tracheotomy: Minor Surgical Operations—Bandaging—Fractures—Dislocations, Sprains, and Bruises—Extemporary Appliances and Civil Ambulance Work—Massage—Surgical Applications of Electricity—Joint-Fixation and Fixed Apparatus—The Syphon and its Uses—Trusses and Artificial Limbs—Plaster-Casting—Post-Mortem Examination—Sickroom Cookery Receipts, &c., &c., &c.

“THOROUGHLY PRACTICAL AND TRUSTWORTHY. Clear, accurate, succinct.”—*The Lancet.*

“ADMIRABLY ARRANGED. The best practical little work we have seen. The matter is as good as the manner.”—*Edinburgh Medical Journal.*

“THIS EXCELLENT LITTLE WORK. Clear, concise, and very readable. Gives attention to important details, often omitted, but ABSOLUTELY NECESSARY TO SUCCESS.”—*Athenæum.*

“A dainty volume.”—*Manchester Medical Chronicle.*

*In Extra Crown 8vo, with Litho-plates and Numerous Illustrations. Cloth, 8s. 6d.*

## PHARMACY AND MATERIA MEDICA

(A Laboratory Course of):

*Including the Principles and Practice of Dispensing.*

Adapted to the Study of the British Pharmacopœia and the Requirements of the Private Student.

By W. ELBORNE, F.L.S., F.C.S.,

*Late Assistant-Lecturer in Materia Medica and Pharmacy in the Owens College, Manchester.*

“A work which we can very highly recommend to the perusal of all Students of Medicine. . . . ADMIRABLY ADAPTED to their requirements.”—*Edinburgh Medical Journal.*

“Mr. Elborne evidently appreciates the Requirements of Medical Students, and there can be no doubt that any one who works through this Course will obtain an excellent insight into Chemical Pharmacy.”—*British Medical Journal.*

“The system . . . which Mr. Elborne here sketches is thoroughly sound.”—*Chemist and Druggist.*

LONDON: EXETER STREET, STRAND.



## GRIFFIN'S MEDICAL SERIES.

*Standard Works of Reference for Practitioners and Students,*  
ISSUED UNIFORMLY IN LIBRARY STYLE.

Large 8vo, Handsome Cloth, very fully Illustrated.

~~~~~  
*Full Catalogue, with Specimens of the Illustrations, sent Gratis on application.*  
~~~~~

### VOLUMES ALREADY PUBLISHED.

#### HUMAN ANATOMY.

BY ALEXANDER MACALISTER, M.A., M.D., F.R.S., F.S.A.,  
*Professor of Anatomy in the University of Cambridge, and  
Fellow of St. John's College. 36s.*

"BY FAR THE MOST IMPORTANT WORK on this subject which has appeared in recent years."  
—*The Lancet.*

"Destined to be a main factor in the advancement of Scientific Anatomy. . . . The  
fine collection of Illustrations must be mentioned."—*Dublin Medical Journal.*

"This SPLENDID WORK"—*Saturday Review.*

#### HUMAN PHYSIOLOGY.

BY PROFESSOR LANDOIS OF GREIFSWALD

AND

WM. STIRLING, M.D., Sc.D.,

*Brackenbury Professor of Physiology in Owens College and Victoria University, Manchester;  
Examiner in the University of Oxford. FOURTH EDITION. 2 Vols., 42s.*

"The BOOK is the MOST COMPLETE *résumé* of all the facts in Physiology in the language.  
Admirably adapted for the PRACTITIONER. . . . With this Text-book at command, NO  
STUDENT COULD FAIL IN HIS EXAMINATION —*The Lancet.*

"One of the MOST PRACTICAL WORKS on Physiology ever written. EXCELLENTLY CLEAR,  
ATTRACTIVE, and SUCCINCT."—*British Medical Journal.*

#### EMBRYOLOGY (An Introduction to).

BY ALFRED C. HADDON, M.A., M.R.I.A.,

*Professor of Zoology in the Royal College of Science, Dublin. 18s.*

"AN EXCELLENT *RÉSUMÉ* OF RECENT RESEARCH, well adapted for self-study. . . . Gives  
remarkably good accounts (including all recent work) of the development of the heart and  
other organs. . . . The book is handsomely got up."—*The Lancet.*

LONDON: EXETER STREET, STRAND.

GRIFFIN'S MEDICAL SERIES—*Continued.*

## CLINICAL DIAGNOSIS.

The Chemical, Microscopical, and Bacteriological Evidence of Disease.

BY DR. VON JAKSCH, OF PRAGUE.

From the Second German Edition, by JAS. CAGNEY, M.A., M.D., of St. Mary's Hospital. With an Appendix by Prof. STIRLING, M.D., Sc.D.

With all the Original Illustrations, many printed in Colours. 25s.

"Prof. v. Jaksch's 'Clinical Diagnosis' stands almost alone in the width of its range, the THOROUGHNESS OF ITS EXPOSITION and the clearness of its style. . . . A STANDARD WORK, AS TRUSTWORTHY as it is scientific."—*Lancet.*

## GOUT (A Treatise on).

BY SIR DYCE DUCKWORTH, M.D. EDIN., F.R.C.P.,

Physician to, and Lecturer on Clinical Medicine at, St. Bartholomew's Hospital. 25s.

'At once thoroughly practical and highly philosophical. The practitioner will find in it an **NORMOUS AMOUNT OF INFORMATION.**'—*Practitioner.*

## RHEUMATISM AND RHEUMATOID ARTHRITIS.

BY ARCH. E. GARROD, M.A., M.D. OXON.,

Assistant-Physician to the West London Hospital, &c. 21s.

"We gladly welcome this Treatise. . . . The amount of information collected and the manner in which the facts are marshalled are deserving of ALL PRAISE."—*Lancet.*

## DISEASES OF THE SKIN.

BY T. M'CALL ANDERSON, M.D.,

Professor of Clinical Medicine in the University of Glasgow. 25s.

"Beyond doubt, the **MOST IMPORTANT WORK** on Skin Diseases that has appeared in England for many years."—*British Medical Journal.*

## DISEASES OF THE EYE.

BY DR. ED. MEYER, OF PARIS.

From the Third French Edition,

BY A. FREELAND FERGUS, M.B.,

Ophthalmic Surgeon, Glasgow Royal Infirmary. 25s.

"AN EXCELLENT TRANSLATION of a Standard French Text-Book. . . . Essentially a PRACTICAL WORK. The publishers have done their part in the tasteful and substantial manner characteristic of their medical publications."—*Ophthalmic Review.*

LONDON: EXETER STREET, STRAND.

GRIFFIN'S MEDICAL SERIES—*Continued.*

## THE CENTRAL NERVOUS ORGANS (The Anatomy of), in Health and Disease.

BY PROFESSOR OBERSTEINER, OF VIENNA.

TRANSLATED BY ALEX. HILL, M.A., M.D.,

Master of Downing College, Cambridge. 25s.

"Dr. Hill has enriched the work with many Notes of his own. . . . Dr. Obersteiner's work is admirable. . . . INVALUABLE AS A TEXT-BOOK."—*British Medical Journal.*

## MENTAL DISEASES:

*With Special Reference to the Pathological Aspects of Insanity.*

BY W. BEVAN LEWIS, L.R.C.P. (LOND.), M.R.C.S. (ENG.),

Medical Director of the West Riding Asylum, Wakefield. 28s.

"Without doubt the BEST WORK in English of its kind."—*Journal of Mental Science.*

"This ADMIRABLE TEXT-BOOK places the study of Mental Diseases on a SOLID BASIS. . . . The plates are numerous and admirable. To the student the work is INDISPENSABLE."—*Practitioner.*

## The SURGERY of the SPINAL CORD.

BY WILLIAM THORBURN, B.S., B.Sc., M.D., F.R.C.S.,

Assistant-Surgeon to the Manchester Royal Infirmary. 12s. 6d.

"Really the FULLEST RECORD we have of Spinal Surgery, and marks an important advance."—*British Medical Journal.*

## RAILWAY INJURIES:

*With Special Reference to those of the Back and Nervous System, in their Medicò-Legal and Clinical Aspects.*

BY HERBERT W. PAGE, M.A., M.C. (CANTAB), F.R.C.S. (ENG.),

Surgeon to St. Mary's Hospital; Dean, St. Mary's Hospital Medical School, &c., &c. 6s.

"A work INVALUABLE to those who have many railway cases under their care pending litigation. . . . A book which every lawyer as well as doctor should have on his shelves."—*British Medical Journal.*

## THE SURGERY OF THE KIDNEYS.

Being the Harveian Lectures, 1889.

BY J. KNOWSLEY THORNTON, M.B., M.C.,

Surgeon to the Samaritan Free Hospital, &c.

*In Demy 8vo, with Illustrations, Cloth, 5s.*

"The name and experience of the Author confer on the Lectures the stamp of authority."—*British Medical Journal.*

LONDON: .EXETER STREET, STRAND.

GRIFFIN'S MEDICAL SERIES—*Continued.*

TO BE ISSUED SHORTLY.

DISEASES OF THE HEART  
(THE DIAGNOSIS OF).

BY A. ERNEST SANSON, M.D., F.R.C.P.,

Physician to the London Hospital; Consulting Physician, North-Eastern Hospital for Children;  
Examiner in Medicine, Royal College of Physicians (Conjoint Board for England), and  
University of Durham; Lecturer on Medical Jurisprudence and Public Health,  
London Hospital Medical College, &c.[*Shortly.*]

## GYNÆCOLOGY

(A PRACTICAL TREATISE ON).

BY

JOHN HALLIDAY CROOM, M.D., F.R.C.P.E., F.R.C.S.E.,

Physician to the Royal Infirmary and Royal Maternity Hospital, Edinburgh; Examiner in  
Midwifery, R.C.P., Edinburgh; Lecturer, Edinburgh School of Medicine, &c., &c.

WITH THE COLLABORATION OF

MM. JOHNSON SYMINGTON, M.D., F.R.C.S.E., AND

MILNE MURRAY, M.A., M.B., F.R.C.P.E.

[*Shortly.*]

\* \* Volumes on other subjects in active preparation.

 For a COMPLETE RECORD of the PAPERS read before the MEDICAL SOCIETIES throughout the United Kingdom during each year, *vide* "THE OFFICIAL YEAR-BOOK OF THE SCIENTIFIC AND LEARNED SOCIETIES OF GREAT BRITAIN AND IRELAND" (page 48).

"The value of these Lists of Papers can hardly be over-rated."—*Lancet.*

"INDISPENSABLE to any one who may wish to keep himself abreast of the Scientific work of the day."—*Edinburgh Med. Journal.*

LONDON: EXETER STREET, STRAND.

# Griffin's Medical Students' Text-Books.

	PAGE
Anatomy, . . . .	PROF. MACALISTER, . . . . 13
Biology, . . . .	AINSWORTH DAVIS, . . . . 26
Botany (Elementary),	AINSWORTH DAVIS, . . . . 27
Brain, The—	
Central Nervous	
Organs, . . . .	OBERSTEINER AND HILL, . . . . 15
Mental Diseases, . . . .	BEVAN LEWIS, . . . . 15
Chemistry—	
Inorganic, . . . .	DUPRÉ AND HAKE, . . . . 27
Qualitative Analysis,	PROF. SEXTON, . . . . 44
Quantitative „	PROF. SEXTON, . . . . 44
Electricity, . . . .	PROF. JAMIESON, . . . . 33
Embryology, . . . .	PROF. HADDON, . . . . 13
Eye, Diseases of the,	MEYER AND FERGUS, . . . . 14
Foods, Analysis of, . . . .	WYNTER BLYTH, . . . . 10
Foods and Dietaries,	R. W. BURNET, . . . . 11
Gynæcology, . . . .	HALLIDAY CROOM, . . . . 16
Histology, . . . .	PROF. STIRLING, . . . . 20
Medicine, . . . .	SIR WM. AITKEN, . . . . 9
Nursing, . . . .	L. HUMPHRY, . . . . 18
Obstetrics, . . . .	H. G. LANDIS, . . . . 18
Pharmacy, . . . .	W. ELBORNE, . . . . 12
Physiology—	
Human, . . . .	LANDOIS AND STIRLING, . . . . 13
Practical, . . . .	PROF. STIRLING, . . . . 20
Poisons, Detection of,	WYNTER BLYTH, . . . . 10
Skin, Diseases of the,	PROF. ANDERSON, . . . . 14
Surgery—	
Civil, . . . .	CAIRD AND CATHCART, . . . . 12
Military, . . . .	PORTER-GODWIN, . . . . 19
Zoology, . . . .	SELENKA AND DAVIS, . . . . 27

SIXTH EDITION. *In Extra Crown 8vo, with Numerous Illustrations, Cloth, 3s. 6d.*

# NURSING (A Manual of):

## Medical and Surgical.

BY LAURENCE HUMPHRY, M.A., M.B., M.R.C.S.,  
*Assistant-Physician to, and Lecturer to Probationers at, Addenbrooke's Hospital, Cambridge.*

### GENERAL CONTENTS.

The General Management of the Sick Room in Private Houses—General Plan of the Human Body—Diseases of the Nervous System—Respiratory System—Heart and Blood-Vessels—Digestive System—Skin and Kidneys—Fevers—Diseases of Children—Wounds and Fractures—Management of Child-Bed—Sick-Room Cookery, &c., &c.

\* \* *A Full Prospectus Post Free on Application.*

“In the fullest sense Mr. Humphry's book is a DISTINCT ADVANCE on all previous Manuals. . . . Its value is greatly enhanced by copious woodcuts and diagrams of the bones and internal organs, by many Illustrations of the art of BANDAGING, by Temperature charts indicative of the course of some of the most characteristic diseases, and by a goodly array of SICK-ROOM APPLIANCES with which EVERY NURSE should endeavour to become acquainted.”—*British Medical Journal.*

“We should advise ALL NURSES to possess a copy of the work. We can confidently recommend it as an EXCELLENT GUIDE and companion.”—*Hospital.*

HORSLEY (Victor A., M.B., F.R.S., Assistant-Surgeon, University College Hospital; Professor of Pathology, University College, &c.):

THE NERVOUS SYSTEM: Its Structure and Functions. Being the Fullerian Lectures on Physiology for 1891. In Demy 8vo, with Numerous Illustrations. Cloth.

LANDIS. (Henry G., A.M., M.D., Professor of Obstetrics in Starling Medical College):

THE MANAGEMENT OF LABOUR AND OF THE LYING-IN PERIOD. In 8vo, with Illustrations. Cloth, 7/6.

“Fully accomplishes the object kept in view by its author. . . . Will be found of GREAT VALUE by the young practitioner.”—*Glasgow Medical Journal.*

LONDON: EXETER STREET, STRAND.

LINN (S.H., M.D., D.D.S., Dentist to the Imperial Medico-Chirurgical Academy of St. Petersburg):

THE TEETH: How to preserve them and prevent their Decay. A Popular Treatise on the Diseases and the Care of the Teeth. With Plates and Diagrams. Crown 8vo. Cloth, 2/6.

LONGMORE (Surgeon-General, C.B., Q.H.S., F.R.C.S., &c., Professor of Military Surgery, Army Medical School):

THE SANITARY CONTRASTS OF THE CRIMEAN WAR. Demy 8vo. Cloth limp, 1/6.

"A most valuable contribution to Military Medicine."—*British Medical Journal*.  
 "A most concise and interesting Review."—*Lancet*.

PARKER (Prof. W. Kitchen, F.R.S., Hunterian Professor, Royal College of Surgeons):

MAMMALIAN DESCENT: being the Hunterian Lectures for 1884. Adapted for General Readers. With illustrations. In 8vo, cloth, 10/6.

"The smallest details of science catch a LIVING GLOW from the ardour of the author's imagination, . . . we are led to compare it to some quickening spirit which makes all the dry bones of skulls and skeletons stand up around him as an exceeding great army."—Prof. Romanes in *Nature*.

"Get this book; read it straight ahead, . . . you will first be interested, then absorbed; before reaching the end you will comprehend what a lofty ideal of creation is that of him, who, recognising the unity and the continuity of Nature, traces the gradual development of life from age to age . . . and has thus learned to 'look through Nature up to Nature's God.'"—*Scotsman*.

"A very striking book . . . as readable as a book of travels. Prof. PARKER is no Materialist."—*Leicester Post*.

---

FOURTH EDITION. Revised and enlarged Foolscep 8vo, Roan, with 152 Illustrations and Folding-plate. 8s. 6d.

## THE SURGEON'S POCKET-BOOK.

Specially adapted to the Public Medical Services.

BY SURGEON-MAJOR J. H. PORTER.

*Revised and in great part rewritten*

BY BRIGADE-SURGEON C. H. Y. GODWIN,

Assistant-Professor of Military Surgery in the Army Medical School.

"Every Medical Officer is recommended to have the 'Surgeon's Pocket-Book,' by Surgeon-Major Porter, accessible to refresh his memory and fortify his judgment."—*Précis of Field-Service Medical Arrangements for Afghan War*.

"The present editor—Brigade-Surgeon Godwin—has introduced so much that is new and practical, that we can recommend this 'Surgeon's Pocket-Book' as an INVALUABLE GUIDE to all engaged, or likely to be engaged, in Field Medical Service."—*Lancet*.

"A complete *vade mecum* to guide the military surgeon in the field."—*British Medical Journal*.

---

LONDON: EXETER STREET, STRAND.

---

## WORKS

By WILLIAM STIRLING, M.D., Sc.D.,

Professor in the Victoria University, Brackenbury Professor of Physiology and Histology in the Owens College, Manchester; and Examiner in the University of Oxford.

---

SECOND EDITION. *In Extra Crown 8vo, with 234 Illustrations, Cloth, 9s.*

### PRACTICAL PHYSIOLOGY (Outlines of):

Being a Manual for the Physiological Laboratory, including  
Chemical and Experimental Physiology, with  
Reference to Practical Medicine.

PART I.—CHEMICAL PHYSIOLOGY.

PART II.—EXPERIMENTAL PHYSIOLOGY.

\* \* In the Second Edition, revised and enlarged, the number of Illustrations has been increased from 142 to 234.

"A VERY EXCELLENT and COMPLETE TREATISE."—*Lancet*.

"The student is enabled to perform for himself most of the experiments usually shown in a systematic course of lectures on physiology, and the practice thus obtained must prove INVALUABLE. . . . May be confidently recommended as a guide to the student of physiology, and, we doubt not, will also find its way into the hands of many of our scientific and medical practitioners."—*Glasgow Medical Journal*.

"This valuable little manual. . . . The GENERAL CONCEPTION of the book is EXCELLENT; the arrangement of the exercises is all that can be desired; the descriptions of experiments are CLEAR, CONCISE, and to the point."—*British Medical Journal*.

---

*In Extra Crown 8vo, with 344 Illustrations, Cloth, 12s. 6d.*

### PRACTICAL HISTOLOGY (Outlines of):

A Manual for Students.

\* \* Dr. Stirling's "Outlines of Practical Histology" is a compact Handbook for students, providing a COMPLETE LABORATORY COURSE, in which almost every exercise is accompanied by a drawing. Very many of the illustrations have been prepared expressly for the work.

"The general plan of the work is ADMIRABLE. . . . It is very evident that the suggestions given are the outcome of a PROLONGED EXPERIENCE in teaching Practical Histology, combined with a REMARKABLE JUDGMENT in the selection of METHODS. . . . Merits the highest praise for the ILLUSTRATIONS, which are at once clear and faithful."—*British Medical Journal*.

"We can confidently recommend this small but CONCISELY-WRITTEN and ADMIRABLY ILLUSTRATED work to students. They will find it to be a VERY USEFUL and RELIABLE GUIDE in the laboratory, or in their own room. All the principal METHODS of preparing tissues for section are given, with such precise directions that little or no difficulty can be felt in following them in their most minute details. . . . The volume proceeds from a MASTER in his craft."—*Lancet*.

---

LONDON: EXETER STREET, STRAND.



## GENERAL SCIENTIFIC WORKS

RELATING TO

CHEMISTRY (THEORETICAL AND APPLIED); ELECTRICAL  
SCIENCE; ENGINEERING (CIVIL AND MECHANICAL);  
GEOLOGY, &c.

## THE DESIGN OF STRUCTURES:

A Practical Treatise on the Building of Bridges, Roofs, &c.

BY S. ANGLIN, C. E.,

Master of Engineering, Royal University of Ireland, late Whitworth Scholar, &c.

With very numerous Diagrams, Examples, and Tables.

Large Crown 8vo. Cloth, 16s.

The leading features in Mr. Anglin's carefully-planned "Design of Structures" may be briefly summarised as follows:—

1. It supplies the want, long felt among Students of Engineering and Architecture, of a concise Text-book on Structures, requiring on the part of the reader a knowledge of ELEMENTARY MATHEMATICS only.

2. The subject of GRAPHIC STATICS has only of recent years been generally applied in this country to determine the Stresses on Framed Structures; and in too many cases this is done without a knowledge of the principles upon which the science is founded. In Mr. Anglin's work the system is explained from FIRST PRINCIPLES and the Student will find in it a valuable aid in determining the stresses on all irregularly-framed structures.

3. A large number of PRACTICAL EXAMPLES, such as occur in the every-day experience of the Engineer, are given and carefully worked out, some being solved both analytically and graphically, as a guide to the Student.

4. The chapters devoted to the practical side of the subject, the Strength of Joints, Punching, Drilling, Rivetting, and other processes connected with the manufacture of Bridges, Roofs, and Structural work generally, are the result of MANY YEARS' EXPERIENCE in the bridge-yard; and the information given on this branch of the subject will be found of great value to the practical bridge-builder.

"Students of Engineering will find this Text-Book INVALUABLE."—*Architect*.

"The author has certainly succeeded in producing a THOROUGHLY PRACTICAL Text-Book."—*Builder*.

"We can unhesitatingly recommend this work not only to the Student, as the BEST TEXT-BOOK on the subject, but also to the professional engineer as an EXCEEDINGLY VALUABLE book of reference."—*Mechanical World*.

"This work can be CONFIDENTLY recommended to engineers. The author has wisely chosen to use as little of the higher mathematics as possible, and has thus made his book of REAL USE TO THE PRACTICAL ENGINEER. . . . After careful perusal, we have nothing but praise for the work."—*Nature*.

LONDON: EXETER STREET, STRAND.

With numerous Tables and Illustrations. Crown 8vo. Cloth, 10/6.  
*Second Edition*; Revised.

## ASSAYING (A Text-Book of):

*For the use of Students, Mine Managers, Assayers, &c.*

BY

C. BERINGER, F.I.C., F.C.S.,

Late Chief Assayer to the Rio Tinto Copper Company, London,

AND

J. J. BERINGER, F.I.C., F.C.S.,

Public Analyst for, and Lecturer to the Mining Association of, Cornwall.

### General Contents.

PART I.—INTRODUCTORY; MANIPULATION: Sampling; Drying; Calculation of Results—Laboratory-books and Reports—METHODS: Dry Gravimetric; Wet Gravimetric—Volumetric Assays: Titrometric, Colorimetric, Gasometric—Weighing and Measuring—Reagents—Formulæ, Equations, &c.—Specific Gravity.

PART II.—METALS: Detection and Assay of Silver, Gold, Platinum, Mercury, Copper, Lead, Thallium, Bismuth, Antimony, Iron, Nickel, Cobalt, Zinc, Cadmium, Tin, Tungsten, Titanium, Manganese, Chromium, &c.—Earths, Alkalies.

PART III.—NON-METALS: Oxygen and Oxides; The Halogens—Sulphur and Sulphates—Arsenic, Phosphorus, Nitrogen—Silicon, Carbon, Boron.

*Appendix.*—Various Tables useful to the Analyst.

“A REALLY MERITORIOUS WORK, that may be safely depended upon either for systematic instruction or for reference.”—*Nature*.

“Of the fitness of the authors for the task they have undertaken, there can be no question. . . . Their book ADMIRABLY FULFILS ITS PURPOSE. . . . The results given of an exhaustive series of experiments made by the authors, showing the effects of VARYING CONDITIONS on the accuracy of the method employed, are of THE UTMOST IMPORTANCE.”—*Industries*.

In Preparation. Large 8vo.

## PHOTOGRAPHY (A Text-Book of):

Its History, Processes, Apparatus, and Materials. Comprising  
 Working Details of all the more important Methods.

By A. BROTHERS, F.R.A.S.

With Illustrations by many of the Processes described.

LONDON: EXETER STREET, STRAND.

# MINE-SURVEYING (A Text-Book of):

*For the use of Managers of Mines and Collieries, Students  
at the Royal School of Mines, &c.*

By BENNETT H. BROUGH, F.G.S.,  
Instructor of Mine-Surveying, Royal School of Mines.

With Diagrams. THIRD EDITION. Crown 8vo. Cloth, 7s. 6d.

## GENERAL CONTENTS.

General Explanations—Measurement of Distances—Miner's Dial—Variation of the Magnetic-Needle—Surveying with the Magnetic-Needle in presence of Iron—Surveying with the Fixed Needle—German Dial—Theodolite—Traversing Underground—Surface-Surveys with Theodolite—Plotting the Survey—Calculation of Areas—Levelling—Connection of Underground- and Surface-Surveys—Measuring Distances by Telescope—Setting-out—Mine-Surveying Problems—Mine Plans—Applications of Magnetic-Needle in Mining—*Appendices.*

“It is the kind of book which has long been wanted, and no English-speaking Mine Agent or Mining Student will consider his technical library complete without it.”—*Nature.*

“Supplies a long-felt want.”—*Iron.*

“A valuable accessory to Surveyors in every department of commercial enterprise.”—*Colliery Guardian.*

---



---

## WORKS

By WALTER R. BROWNE, M.A., M. INST. C.E.,  
Late Fellow of Trinity College, Cambridge.

---

### THE STUDENT'S MECHANICS:

An Introduction to the Study of Force and Motion.

With Diagrams. Crown 8vo. Cloth, 4s. 6d.

“Clear in style and practical in method, ‘THE STUDENT'S MECHANICS’ is cordially recommended from all points of view.”—*Athenæum.*

---

### FOUNDATIONS OF MECHANICS.

Papers reprinted from the *Engineer.* In Crown 8vo, 1s.

---

### FUEL AND WATER:

A Manual for Users of Steam and Water.

By PROF. SCHWACKHÖFER AND W. R. BROWNE, M.A. (See p. 44).

---

LONDON: EXETER STREET, STRAND.

# PRACTICAL GEOLOGY

## (AIDS IN):

WITH A SECTION ON PALÆONTOLOGY.

BY

GRENVILLE A. J. COLE, F.G.S.,

Professor of Geology in the Royal College of Science for Ireland.

With Numerous Illustrations and Tables. Large Crown 8vo. Cloth, 10s. 6d.

THIS work is intended as a companion to any ordinary Text-book of Geology; and will be of special service to those students who have made excursions into the field, and who wish to determine their specimens for themselves.

A large section of the book has been devoted to rocks and to the ordinary minerals of the earth's crust, since these will always present themselves to the observer during any expedition or in any country.

The section on Blowpipe-work has been inserted as an aid to Travellers; while the description of the hard parts of fossil invertebrates will probably assist those readers who find it impossible to distinguish genera by means of mere names and figures.

### GENERAL CONTENTS.

#### PART I.—SAMPLING OF THE EARTH'S CRUST.

Observations in the field. | Collection and packing of specimens.

#### PART II.—EXAMINATION OF MINERALS.

Some physical characters of minerals.	Blowpipe-tests.
Simple tests with wet reagents.	Quantitative flame reactions of the felspars and their allies.
Examination of minerals with the blowpipe.	Examination of the optical properties of minerals.
Simple and characteristic reactions.	

#### PART III.—EXAMINATION OF ROCKS.

Introductory.	The more prominent characters to be observed in minerals in rock-sections.
Rock-structures easily distinguished.	Characters of the chief rock-forming minerals in the rock-mass and in thin sections.
Some physical characters of rocks.	Sedimentary rocks.
Chemical examination of rocks.	Igneous rocks.
Isolation of the constituents of rocks.	Metamorphic rocks.
The petrological microscope and microscopic preparations.	

#### PART IV.—EXAMINATION OF FOSSILS.

Introductory.	Scaphopoda; Gastropoda; Pteropoda;
Fossil generic types.—Rhizopoda; Spongiæ;	Cephalopoda.
Hydrozoa; Actinozoa.	Echinodermata; Vermes.
Polyzoa; Brachiopoda.	Anthropoda.
Lamellibranchiata.	Suggested list of characteristic invertebrate fossils.

"A more useful work for the practical geologist has not appeared in handy form."—*Scottish Geographical Magazine.*

"This EXCELLENT MANUAL . . . will be a VERY GREAT HELP. . . . The section on the Examination of Fossils is probably the BEST of its kind yet published. . . . FULL of well-digested information from the newest sources and from personal research."—*Annals of Nat. History.*

LONDON: EXETER STREET, STRAND.

# SEWAGE DISPOSAL WORKS:

A GUIDE TO THE CONSTRUCTION OF WORKS FOR  
THE PREVENTION OF THE POLLUTION BY  
SEWAGE OF RIVERS AND ESTUARIES.

BY

W. SANTO CRIMP, M.INST.C.E., F.G.S.,  
Assistant-Engineer, London County Council.

With Tables, Illustrations in the Text, and 33 Lithographic Plates.  
Medium 8vo. Handsome Cloth, 25s.

## PART I.—INTRODUCTORY.

Introduction.	Settling Tanks.
Details of River Pollutions and Recommendations of Various Commissions.	Chemical Processes.
Hourly and Daily Flow of Sewage.	The Disposal of Sewage-sludge.
The Pail System as Affecting Sewage.	The Preparation of Land for Sewage Disposal.
The Separation of Rain-water from the Sewage Proper.	Table of Sewage Farm Management.

## PART II.—SEWAGE DISPOSAL WORKS IN OPERATION—THEIR CONSTRUCTION, MAINTENANCE AND COST.

Illustrated by Plates showing the General Plan and Arrangement adopted  
in each District.

- |  |   |
|--|---|
| 1. Doncaster Irrigation Farm.                      | 12. New Malden, Chemical Treatment and Small Filters.     |
| 2. Beddington Irrigation Farm, Borough of Croydon. | 13. Friern Barnet.  |
| 3. Bedford Sewage Farm Irrigation.                 | 14. Acton, Ferozone and Polarite Process.                 |
| 4. Dewsbury and Hitchin Intermittent Filtration.   | 15. Ilford, Chadwell, and Dagenham Sewage Disposal Works. |
| 5. Merton, Croydon Rural Sanitary Authority.       | 16. Coventry.   |
| 6. Swanwick, Derbyshire.                           | 17. Wimbledon.  |
| 7. The Ealing Sewage Works.                        | 18. Birmingham.   |
| 8. Chiswick.                                       | 19. Newhaven.   |
| 9. Kingston-on-Thames, A. B. C. Process.           | 20. Portsmouth.   |
| 10. Salford Sewage Works.                          | 21. Sewage Precipitation Works, Dortmund (Germany).       |
| 11. Bradford, Precipitation.                       | 22. Treatment of Sewage by Electrolysis.                  |

"All persons interested in Sanitary Science owe a debt of gratitude to Mr. Crimp. . . . His work will be especially useful to SANITARY AUTHORITIES and their advisers . . . EMINENTLY PRACTICAL AND USEFUL . . . gives plans and descriptions of MANY OF THE MOST IMPORTANT SEWAGE WORKS of England . . . with very valuable information as to the COST of construction and working of each. . . . The carefully-prepared drawings permit of an easy comparison between the different systems."—*Lancet*.

"Probably the MOST COMPLETE AND BEST TREATISE on the subject which has appeared in our language. . . . Will prove of the greatest use to all who have the problem of Sewage Disposal to face. . . . The general construction, drawings, and type are all excellent."—*Edinburgh Medical Journal*.

LONDON: EXETER STREET, STRAND.

---

# WORKS

BY J. R. AINSWORTH DAVIS, B.A.,

PROFESSOR OF BIOLOGY, UNIVERSITY COLLEGE, ABERYSTWYTH

---

## BIOLOGY (A Text-Book of):

Comprising Vegetable and Animal Morphology and Physiology. In Large Crown 8vo, with 158 Illustrations. Cloth, 12s. 6d.

---

### GENERAL CONTENTS.

PART I. VEGETABLE MORPHOLOGY AND PHYSIOLOGY.—Fungi—Algæ—The Moss—The Fern—Gymnosperms—Angiosperms.

Comparative Vegetable Morphology and Physiology—Classification of Plants.

PART II. ANIMAL MORPHOLOGY AND PHYSIOLOGY.—Protozoa—Coelenterata—Vermes—Arthropoda—Mollusca—Amphibia—Aves—Mammalia.

Comparative Animal Morphology and Physiology—Classification of Animals.

*With Bibliography, Exam.-Questions, complete Glossary, and 158 Illustrations.*

---

“As a general work of reference, Mr. Davis's manual will be HIGHLY SERVICEABLE to medical men.”—*British Medical Journal*.

“Furnishes a clear and comprehensive exposition of the subject in a systematic form.”—*Saturday Review*.

“Literally PACKED with information.”—*Glasgow Medical Journal*.

---

## THE FLOWERING PLANT,

AS ILLUSTRATING THE FIRST PRINCIPLES OF BOTANY.

Specially adapted for London Matriculation, S. Kensington, and University Local Examinations in Botany. Large Crown 8vo, with numerous Illustrations. 3s. 6d.

“It would be hard to find a Text-book which would better guide the student to an accurate knowledge of modern discoveries in Botany. . . . The SCIENTIFIC ACCURACY of statement, and the concise exposition of FIRST PRINCIPLES make it valuable for educational purposes. In the chapter on the Physiology of Flowers, an *admirable résumé* is given, drawn from Darwin, Hermann Müller, Kerner, and Lubbock, of what is known of the Fertilization of Flowers.”—*Journal of the Linnean Society*.

“We are much pleased with this volume . . . the author's style is MOST CLEAR, and his treatment that of a PRACTISED INSTRUCTOR. . . . The Illustrations are very good, suitable and helpful. The Appendix on Practical Work will be INVALUABLE to the private student. . . . We heartily commend the work.”—*Schoolmaster*.

\*.\* Recommended by the National Home-Reading Union; and also for use in the University Correspondence Classes.

---

LONDON: EXETER STREET, STRAND.

---

PROF. DAVIS'S WORKS—Continued.

---

**A ZOOLOGICAL POCKET-BOOK;**  
**Or, Synopsis of Animal Classification.**

*Comprising Definitions of the Phyla, Classes, and Orders, with explanatory Remarks and Tables.*

BY DR. EMIL SELENKA,  
 Professor in the University of Erlangen.

Authorised English translation from the Third German Edition. In Small Post 8vo, Interleaved for the use of Students. Limp Covers, 4s.

“Dr. Selenka's Manual will be found useful by all Students of Zoology. It is a COMPREHENSIVE and SUCCESSFUL attempt to present us with a scheme of the natural arrangement of the animal world.”—*Edin. Med. Journal.*

“Will prove very serviceable to those who are attending Biology Lectures. . . . The translation is accurate and clear.”—*Lancet.*

---

**INORGANIC CHEMISTRY (A Short Manual of).**

BY A. DUPRÉ, Ph.D., F.R.S., AND WILSON HAKE,  
 Ph.D., F.I.C., F.C.S., of the Westminster Hospital Medical School.

With Coloured Plate of Spectra. Crown 8vo. Cloth, 7s. 6d.

“A well-written, clear and accurate Elementary Manual of Inorganic Chemistry. . . . We agree heartily in the system adopted by Drs. Dupré and Hake. WILL MAKE EXPERIMENTAL WORK TREBLY INTERESTING BECAUSE INTELLIGIBLE.”—*Saturday Review.*

“There is no question that, given the PERFECT GROUNDING of the Student in his Science, the remainder comes afterwards to him in a manner much more simple and easily acquired. The work is AN EXAMPLE OF THE ADVANTAGES OF THE SYSTEMATIC TREATMENT of a Science over the fragmentary style so generally followed. BY A LONG WAY THE BEST of the small Manuals for Students.”—*Analyst.*

---

**HINTS ON THE PRESERVATION OF FISH,**

IN REFERENCE TO FOOD SUPPLY.

BY J. COSSAR EWART, M.D., F.R.S.E.,  
 Regius Professor of Natural History, University of Edinburgh.

In Crown 8vo. Wrapper, 6d.

---

LONDON: EXETER STREET, STRAND.

*Royal 8vo. With numerous Illustrations and 17 Lithographic Plates.  
Handsome Cloth. Price 30s.*

# BRIDGE-CONSTRUCTION

(A PRACTICAL TREATISE ON):

Being a Text-Book on the Construction of Bridges in  
Iron and Steel.

FOR THE USE OF STUDENTS, DRAUGHTSMEN, AND ENGINEERS.

BY

T. CLAXTON FIDLER, M. INST. C.E.,  
Prof. of Engineering, University College, Dundee.

“Of late years the American treatises on Practical and Applied Mechanics have taken the lead . . . since the opening up of a vast continent has given the American engineer a number of new bridge-problems to solve . . . but we look to the PRESENT TREATISE ON BRIDGE-CONSTRUCTION, and the Forth Bridge, to bring us to the front again.”—*Engineer*.

“One of the VERY BEST RECENT WORKS on the Strength of Materials and its application to Bridge-Construction. . . . Well repays a careful Study.”—*Engineering*.

“AN INDISPENSABLE HANDBOOK for the practical Engineer.”—*Nature*.

“The science is progressive, and as an exposition of its LATEST ADVANCES we are glad to welcome Mr. Fidler’s well-written treatise.”—*Architect*.

“An admirable account of the theory and process of bridge-design, AT ONCE SCIENTIFIC AND THOROUGHLY PRACTICAL. It is a book such as we have a right to expect from one who is himself a substantial contributor to the theory of the subject, as well as a bridge-builder of repute.”—*Saturday Review*.

“This book is a model of what an engineering treatise ought to be.”—*Industries*.

“A SCIENTIFIC TREATISE OF GREAT MERIT.”—*Westminster Review*.

“Of recent text-books on subjects of mechanical science, there has appeared no one more ABLE, EXHAUSTIVE, or USEFUL than Mr. Claxton Fidler’s work on Bridge-Construction.”—*Scotsman*.

LONDON: EXETER STREET, STRAND.



FOSTER (C. Le Neve, D.Sc., Professor of Mining,  
Royal College of Science; H.M. Inspector of Mines, Llandudno):

ORE AND STONE MINING (A Text-Book of). With numerous  
Illustrations. Large Crown 8vo. Cloth. [Shortly.]

GRIFFIN'S ELECTRICAL PRICE-BOOK:

For the Use of Electrical, Civil, Marine, and Borough Engineers, Local  
Authorities, Architects, Railway Contractors, &c., &c. Edited by  
H. J. DOWSING, M. INST. E.E., &c. In Crown 8vo. Cloth. [At Press.]

GRIFFIN (John Joseph, F.C.S.):

CHEMICAL RECREATIONS: A Popular Manual of Experimental  
Chemistry. With 540 Engravings of Apparatus. Tenth Edition. Crown  
4to. Cloth.

Part I.—Elementary Chemistry, 2/.

Part II.—The Chemistry of the Non-Metallic Elements, including a  
Comprehensive Course of Class Experiments, 10/6.

Or, complete in one volume, cloth, gilt top, . . . 12/6.

GURDEN (Richard Lloyd, Authorised Surveyor  
for the Governments of New South Wales and Victoria):

TRAVERSE TABLES: computed to Four Places Decimals for every  
Minute of Angle up to 100 of Distance. For the use of Surveyors and  
Engineers. Second Edition. Folio, strongly half-bound, 21/.

\* \* Published with Concurrence of the Surveyors-General for New South  
\* Wales and Victoria.

"Those who have experience in exact SURVEY-WORK will best know how to appreciate  
the enormous amount of labour represented by this valuable book. The computations  
enable the user to ascertain the sines and cosines for a distance of twelve miles to within  
half an inch, and this BY REFERENCE TO BUT ONE TABLE, in place of the usual Fifteen  
minute computations required. This alone is evidence of the assistance which the Tables  
ensure to every user, and as every Surveyor in active practice has felt the want of such  
assistance, few knowing of their publication will remain without them."—*Engineer*.

GUTTMANN (O., A.M.I.C.E.):

ROCK-BLASTING (A Text-Book of). The use of Explosives as  
applied to the blasting of Rocks, &c. With numerous Illustrations.  
Large Crown 8vo. Cloth. [At Press.]

HUGHES (H. W., F.G.S.):

COAL MINING (A Text-Book of). With numerous Illustrations  
and Tables. Large Crown 8vo. Cloth. [Shortly.]

# Griffin's Standard Publications

FOR

ENGINEERS, ELECTRICIANS, ARCHITECTS, BUILDERS,  
NAVAL CONSTRUCTORS, AND SURVEYORS.

		PAGE
Applied Mechanics, . . .	PROF. RANKINE, . . .	39
,, (Student's), . . .	W. R. BROWNE, . . .	23
Civil Engineering, . . .	PROF. RANKINE, . . .	39
Bridge-Construction, . . .	PROF. FIDLER, . . .	28
Design of Structures, . . .	S. ANGLIN, . . .	21
Sewage Disposal Works, . . .	SANTO CRIMP, . . .	25
Traverse Tables, . . .	R. GURDEN, . . .	29
Marine Engineering, . . .	A. E. SEATON, . . .	45
Stability of Ships, . . .	SIR E. J. REED, . . .	41
The Steam-Engine, . . .	PROF. RANKINE, . . .	40
,, (Student's), . . .	PROF. JAMIESON, . . .	32
Boiler Construction, . . .	T. W. TRAILL, . . .	46
,, Management, . . .	R. D. MUNRO, . . .	33
Fuel and Water (for Steam Users), . . .	{ SCHWACKHÖFER AND BROWNE, . . . }	44
Machinery and Millwork, . . .	PROF. RANKINE, . . .	39
Hydraulic Machinery, . . .	PROF. ROBINSON, . . .	43
Useful Rules and Tables for Engineers, &c., . . .	{ PROFS. RANKINE AND JAMIESON, . . . }	40
Electrical Pocket-Book, . . .	MUNRO AND JAMIESON, . . .	35
Nystrom's Pocket-Book, . . .	DENNIS MARKS, . . .	35
Electrical Price-Book, . . .	H. J. DOWSING, . . .	29

 For a COMPLETE RECORD of the PAPERS read before the ENGINEERING, ARCHITECTURAL, and ELECTRICAL SOCIETIES throughout the United Kingdom during each year, *vide* "THE OFFICIAL YEAR-BOOK OF THE SCIENTIFIC AND LEARNED SOCIETIES OF GREAT BRITAIN AND IRELAND" (page 48).

LONDON : EXETER STREET, STRAND.

# Griffin's Standard Publications

FOR

MINE OWNERS AND MANAGERS, GEOLOGISTS,  
METALLURGISTS, AND MANUFACTURERS.

		PAGE
Geology (Stratigraphical),	R. ETHERIDGE, . . .	37
„ (Physical), . . .	PROF. SEELEY, . . .	36
„ (Practical), . . .	PROF. COLE, . . .	24
Mine-Surveying, . . .	B. H. BROUGH, . . .	23
Coal Mining, . . .	H. W. HUGHES, . . .	29
Ore and Stone Mining, . . .	PROF. LE NEVE FOSTER, . . .	29
Rock-Blasting, . . .	O. GUTTMANN, . . .	29
Metallurgy, . . .	PHILLIPS AND BAUERMAN, . . .	38
„ (Introduction to), . . .	PROF. ROBERTS-AUSTEN, . . .	42
Assaying, . . .	C. & J. J. BERINGER, . . .	22
Electro-Metallurgy, . . .	W. M'MILLAN, . . .	34

# Griffin's Students' Text-Books.

	PAGE		PAGE
Biology, . . . . . Davis,	26	Magnetism and Electricity,	
Botany, . . . . . Davis,	26	„ Jamieson,	33
Chemistry—		Mechanics, . . . Rankine,	40
Inorganic, Dupré & Hake,	27	Physics (Experiments),	
Qual. Analysis, Sexton,	44	„ Wright,	47
Quant. „ „	44	Physiology, . . . Stirling,	20
Recreations, Griffin,	29	Steam-Engine, Jamieson,	32
Experiments, Wright,	47	Zoology, . . . Davis,	27

LONDON: EXETER STREET, STRAND.

---

## WORKS

BY ANDREW JAMIESON, M.INST.C.E., F.R.S.E.,  
*Professor of Engineering, Glasgow and West of Scotland Technical College.*

SIXTH EDITION, Revised and Enlarged. Crown 8vo, Cloth, 7s. 6d.

### A TEXT-BOOK ON STEAM AND STEAM-ENGINES.

WITH OVER 200 ILLUSTRATIONS, FOUR FOLDING-PLATES, AND  
EXAMINATION QUESTIONS.

“Professor Jamieson fascinates the reader by his CLEARNESS OF CONCEPTION AND SIMPLICITY OF EXPRESSION. His treatment recalls the lecturing of Faraday.”—*Athenæum*.

“The BEST BOOK yet published for the use of Students.”—*Engineer*.

“Undoubtedly the MOST VALUABLE AND MOST COMPLETE Hand-book on the subject that now exists.”—*Marine Engineer*.

---

### A POCKET-BOOK OF ELECTRICAL RULES AND TABLES.

*FOR THE USE OF ELECTRICIANS AND ENGINEERS.*

Pocket Size. Leather, 8s. 6d. *Eighth Edition*, revised and enlarged.  
(See under *Munro and Jamieson*.)

---

### ELECTRICITY & MAGNETISM (An Advanced Text-Book on)

For the Use of Science and Art, City and Guilds of London, and other  
Students. With Illustrations.

[*Shortly.*]

---

## PROF. JAMIESON'S ELEMENTARY MANUALS FOR FIRST-YEAR STUDENTS.

### 1. STEAM AND THE STEAM-ENGINE

(AN ELEMENTARY MANUAL ON):

Forming an Introduction to the larger Work by the same Author. With very numerous Illustrations and Examination Questions. *Second Edition*.  
Crown 8vo. Cloth, 3s. 6d.

“Quite the right sort of Book . . . well illustrated with good diagrams and drawings of real engines and details, all clearly and accurately lettered. . . . CANNOT FAIL TO BE A MOST SATISFACTORY GUIDE to the apprentice and Student.”—*Engineer*.

“Should be in the hands of EVERY engineering apprentice.”—*Practical Engineer*.

---

LONDON: EXETER STREET, STRAND.

---

 PROF. JAMIESON'S ELEMENTARY MANUALS—*Continued.*

SECOND EDITION. Crown 8vo, with very numerous Illustrations.

## 2. MAGNETISM AND ELECTRICITY

(AN ELEMENTARY MANUAL ON).

With very Numerous Diagrams and Examination Questions.

Part I.—Magnetism. Part II.—Voltaic Electricity. Part III.—  
Electro-Statics, or Frictional Electricity.

Complete in One Volume, 3s. 6d.

---

“The arrangement is as good as it well can be, . . . the diagrams are EXCELLENT. . . . The subject treated as an essentially practical one, and very clear instructions given. Teachers are to be congratulated on having such a THOROUGHLY TRUSTWORTHY TEXT-BOOK at their disposal.”—*Nature*.

“An excellent and very PRACTICAL elementary treatise.”—*Electrical Review*.

“An ADMIRABLE Introduction to Magnetism and Electricity . . . the production of a skilled and experienced teacher. . . . Explained at every point by simple experiments, rendered easier by admirable illustrations.”—*British Medical Journal*.

“A CAPITAL TEXT-BOOK. . . . The diagrams are an important feature.”—*Schoolmaster*.

---

## 3. APPLIED MECHANICS (An Elementary Manual on).

With Diagrams and Examination Questions. Crown 8vo.

[*Shortly.*]

---

SECOND EDITION. *In Crown 8vo, very fully Illustrated. Cloth, 3s. 6d.*

## STEAM - BOILERS :

THEIR DEFECTS, MANAGEMENT, AND CONSTRUCTION.

BY R. D. MUNRO,

*Engineer of the Scottish Boiler Insurance and Engine Inspection Co.*

This work, which is written chiefly to meet the wants of Mechanics, Engine-keepers, and Boiler-attendants, also contains information of the first importance to every user of Steam-power. It is, above all, a PRACTICAL work written for PRACTICAL men, the language and rules being throughout of the simplest nature.

### GENERAL CONTENTS.

Explosions caused by Overheating of Plates: (a) Shortness of Water: (b) Deposit—Explosions caused by Defective and Overloaded Safety-Valves—Area of Safety-Valves—Explosions caused by Corrosion—Explosions caused by Defective Design and Construction, &c., &c.

“The volume is a valuable companion for workmen and engineers engaged about Steam Boilers, and ought to be carefully studied, and ALWAYS AT HAND.”—*Colliery Guardian*.

“The subjects referred to are handled in a trustworthy, clear, and practical manner. . . . The book is VERY USEFUL, especially to steam users, artisans, and young engineers.”—*Engineer*.

---

LONDON: EXETER STREET, STRAND.

## ELECTRO-METALLURGY (A Treatise on):

Embracing the Application of Electrolysis to the Plating, Depositing, Smelting, and Refining of various Metals, and to the Reproduction of Printing Surfaces and Art-Work, &c.

BY WALTER G. M'MILLAN, F.I.C., F.C.S.,

*Chemist and Metallurgist to the Cossipore Foundry and Shell-Factory; Late Demonstrator of Metallurgy in King's College, London.*

With numerous Illustrations. Large Crown 8vo. Cloth, 10s. 6d.

### GENERAL CONTENTS.

Introductory and Historical—Theoretical and General—Sources of Current—General Conditions to be observed in Electro-Plating—Plating Adjuncts and Disposition of Plant—Cleansing and Preparation of Work for the Depositing-Vat, and Subsequent Polishing of Plated Goods—Electro-Deposition of Copper—Electro-typing—Electro-Deposition of Silver—of Gold—of Nickel and Cobalt—of Iron—of Platinum, Zinc, Cadmium, Tin, Lead, Antimony, and Bismuth; Electro-chromy	—Electro-Deposition of Alloys—Electro-Metallurgical Extraction and Refining Processes—Recovery of certain Metals from their Solutions or Waste Substances—Determination of the Proportion of Metal in certain Depositing Solutions—Glossary of Substances commonly employed in Electro-Metallurgy—Addenda: Various useful Tables—The Bronzing of Copper and Brass Surfaces—Antidotes to Poisons.
---	--

“This excellent treatise, . . . one of the BEST and MOST COMPLETE manuals hitherto published on Electro-Metallurgy.”—*Electrical Review*.

“Well brought up to date, including descriptions such as that of Elmore's recent process for the manufacture of seamless copper tubes of extraordinary strength and tenacity by electro-deposition of the pure metal. . . . Illustrated by well-executed and effective engravings.”—*Journal of Soc. of Chem. Industry*.

“This work will be a STANDARD.”—*Jeweller*.

“Any metallurgical process which REDUCES the COST of production must of necessity prove of great commercial importance. . . . We recommend this manual to ALL who are interested in the PRACTICAL APPLICATION of electrolytic processes.”—*Nature*.

LONDON: EXETER STREET, STRAND.

MUNRO & JAMIESON'S ELECTRICAL POCKET-BOOK.

EIGHTH EDITION, Revised and Enlarged.

## A POCKET-BOOK

OF

## ELECTRICAL RULES &amp; TABLES

FOR THE USE OF ELECTRICIANS AND ENGINEERS.

BY

JOHN MUNRO, C.E., &amp; PROF. JAMIESON, M.INST.C.E., F.R.S.E.

With Numerous Diagrams. Pocket Size. Leather, 8s. 6d.

This work is fully illustrated, and forms an extremely convenient POCKET COMPANION for reference on important points essential to ELECTRICIANS AND ELECTRICAL ENGINEERS.

## GENERAL CONTENTS.

UNITS OF MEASUREMENT.  
MEASURES.  
TESTING.  
CONDUCTORS.  
DIELECTRICS.  
SUBMARINE CABLES.  
TELEGRAPHY.  
ELECTRO-CHEMISTRY.

ELECTRO-METALLURGY.  
BATTERIES.  
DYNAMOS AND MOTORS.  
TRANSFORMERS.  
ELECTRIC LIGHTING.  
MISCELLANEOUS.  
LOGARITHMS.  
APPENDICES.

"WONDERFULLY PERFECT. . . . Worthy of the highest commendation we can give it."—*Electrician*.

"The STERLING VALUE of Messrs. MUNRO and JAMIESON'S POCKET-BOOK."—*Electrical Review*.

## NYSTROM'S POCKET-BOOK

OF

## MECHANICS &amp; ENGINEERING.

REVISED AND CORRECTED BY

W. DENNIS MARKS, PH.B., C.E. (YALE S.S.S.),

*Whitney Professor of Dynamical Engineering, University of Pennsylvania.*

Pocket Size. Leather, 15s. TWENTIETH EDITION. Revised and greatly enlarged.

LONDON: EXETER STREET, STRAND.

*Demy 8vo, Handsome cloth, 18s.*

# PHYSICAL GEOLOGY AND PALÆONTOLOGY,

*ON THE BASIS OF PHILLIPS.*

BY

HARRY GOVIER SEELEY, F.R.S.,

PROFESSOR OF GEOGRAPHY IN KING'S COLLEGE, LONDON.

With Frontispiece in Chromo-Lithography, and Illustrations.

“It is impossible to praise too highly the research which PROFESSOR SEELEY'S ‘PHYSICAL GEOLOGY’ evidences. IT IS FAR MORE THAN A TEXT-BOOK—it is a DIRECTORY to the Student in prosecuting his researches.”—*Extract from the Presidential Address to the Geological Society, 1885, by Rev. Professor Bonney, D.Sc., LL.D., F.R.S.*

“PROFESSOR SEELEY maintains in his ‘PHYSICAL GEOLOGY’ the high reputation he already deservedly bears as a Teacher. . . . It is difficult, in the space at our command, to do fitting justice to so large a work. . . . The final chapters, which are replete with interest, deal with the Biological aspect of Palæontology. Here we find discussed the origin, the extinction, succession, migration, persistence, distribution, relation, and variation of species—with other considerations, such as the Identification of Strata by Fossils, Homotaxis, Local Faunas, Natural History Provinces, and the relation of Living to Extinct forms.”—*Dr. Henry Woodward, F.R.S., in the “Geological Magazine.”*

“A deeply interesting volume, dealing with Physical Geology as a whole, and also presenting us with an animated summary of the leading doctrines and facts of Palæontology, as looked at from a modern standpoint.”—*Scotsman.*

“PROFESSOR SEELEY'S work includes one of the most satisfactory Treatises on Lithology in the English language. . . . So much that is not accessible in other works is presented in this volume, that no Student of Geology can afford to be without it.”—*American Journal of Engineering.*

“Geology from the point of view of Evolution.”—*Westminster Review.*

“PROFESSOR SEELEY'S PHYSICAL GEOLOGY is full of instructive matter, whilst the philosophical spirit which it displays will charm many a reader. From early days the author gave evidence of a powerful and eminently original genius. No one has shown more convincingly than the author that, in all ways, the past contains within itself the interpretation of the existing world.”—*Annals of Natural History.*

LONDON: EXETER STREET, STRAND.



*Demy 8vo, Handsome cloth, 34s.*

# STRATIGRAPHICAL GEOLOGY AND PALÆONTOLOGY,

ON

*THE BASIS OF PHILLIPS.*

BY

ROBERT ETHERIDGE, F. R. S.,

OF THE NATURAL HIST. DEPARTMENT, BRITISH MUSEUM, LATE PALÆONTOLOGIST TO THE  
GEOLOGICAL SURVEY OF GREAT BRITAIN, PAST PRESIDENT OF THE  
GEOLOGICAL SOCIETY, ETC.

With Map, Numerous Tables, and Thirty-six Plates.

"In 1854 Prof. JOHN MORRIS published the Second Edition of his 'Catalogue of British Fossils,' then numbering 1,280 genera and 4,000 species. Since that date 3,000 genera and nearly 12,000 new species have been described, thus bringing up the muster-roll of extinct life in the British Islands alone to 3,680 genera and 16,000 known and described species.

"Numerous TABLES of ORGANIC REMAINS have been prepared and brought down to 1884, embracing the accumulated wealth of the labours of past and present investigators during the last thirty years. Eleven of these Tables contain every known British genus, zoologically or systematically placed, with the number of species in each, showing their broad distribution through time. The remaining 105 Tables are devoted to the analysis, relation, historical value, and distribution of specific life through each group of strata. These tabular deductions, as well as the Palæontological Analyses through the text, are, for the first time, fully prepared for English students."—*Extract from Author's Preface.*

\* \* PROSPECTUS of the above important work—perhaps the MOST ELABORATE of its kind ever written, and one calculated to give a new strength to the study of Geology in Britain—may be had on application to the Publishers.

It is not too much to say that the work will be found to occupy a place entirely its own, and will become an indispensable guide to every British Geologist.

"No such compendium of geological knowledge has ever been brought together before."—*Westminster Review.*

"If PROF. SEELEY'S volume was remarkable for its originality and the breadth of its views, Mr. ETHERIDGE fully justifies the assertion made in his preface that his book differs in construction and detail from any known manual. . . . Must take HIGH RANK AMONG WORKS OF REFERENCE."—*Athenæum.*

LONDON: EXETER STREET, STRAND.

THIRD EDITION, Revised by Mr. H. Bauerman, F.G.S.

## ELEMENTS OF METALLURGY:

A PRACTICAL TREATISE ON THE ART OF EXTRACTING METALS  
FROM THEIR ORES.

By J. ARTHUR PHILLIPS, M.INST.C.E., F.C.S., F.G.S., &c.,

AND

H. BAUERMAN, V.P.G.S.

With Folding Plates and many Illustrations. Med. Svo.  
Handsome Cloth, 36s.

### GENERAL CONTENTS.

Refractory Materials.	Antimony. †	Iron.
Fire-Clays.	Arsenic.	Cobalt.
Fuels, &c.	Zinc.	Nickel.
Aluminium.	Mercury. †	Silver.
Copper.	Bismuth.	Gold.
Tin.	Lead.	Platinum.

\* \* Many NOTABLE ADDITIONS, dealing with new processes and developments, will be found in the New Edition.

“The value of this work is almost *inestimable*. There can be no question that the amount of time and labour bestowed on it is enormous. . . . There is certainly no Metallurgical Treatise in the language calculated to prove of such general utility.”—*Mining Journal*.

“‘Elements of Metallurgy’ possesses intrinsic merits of the highest degree. Such a work is precisely wanted by the great majority of students and practical workers, and its very compactness is in itself a first-rate recommendation. The author has treated with great skill the metallurgical operations relating to all the principal metals. The methods are described with surprising clearness and exactness, placing an easily intelligible picture of each process even before men of less practical experience, and illustrating the most important contrivances in an excellent and perspicuous manner. . . . In our opinion the best work ever written on the subject with a view to its practical treatment.”—*Westminster Review*.

“In this most useful and handsome volume is condensed a large amount of valuable practical knowledge. A careful study of the first division of the book, on Fuels, will be found to be of great value to every one in training for the practical applications of our scientific knowledge to any of our metallurgical operations.”—*Athenæum*.

“A work which is equally valuable to the Student as a Text-book, and to the practical Smelter as a Standard Work of Reference. . . . The Illustrations are admirable examples of Wood Engraving.”—*Chemical News*.

LONDON: EXETER STREET, STRAND.

## SCIENTIFIC MANUALS

BY

W. J. MACQUORN RANKINE, C.E., LL.D., F.R.S.,

Late Regius Professor of Civil Engineering in the University of Glasgow.

THOROUGHLY REVISED BY W. J. MILLAR, C.E.,  
Secretary to the Institute of Engineers and Shipbuilders in Scotland.

In Crown 8vo. Cloth.

## I. RANKINE (Prof.): APPLIED MECHANICS:

comprising the Principles of Statics and Cinematics, and Theory of Structures, Mechanism, and Machines. With numerous Diagrams. *Thirteenth Edition*, 12/6.

"Cannot fail to be adopted as a text-book. . . . The whole of the information is so admirably arranged that there is every facility for reference."—*Mining Journal*.

## II. RANKINE (Prof.): CIVIL ENGINEERING:

comprising Engineering Surveys, Earthwork, Foundations, Masonry Carpentry, Metal-work, Roads, Railways, Canals, Rivers, Water-works, Harbours, &c. With numerous Tables and Illustrations. *Eighteenth Edition*, 16/.

"Far surpasses in merit every existing work of the kind. As a manual for the hands of the professional Civil Engineer it is sufficient and unrivalled, and even when we say this, we fall short of that high appreciation of Dr. Rankine's labours which we should like to express."—*The Engineer*.

## III. RANKINE (Prof.): MACHINERY AND

MILLWORK: comprising the Geometry, Motions, Work, Strength, Construction, and Objects of Machines, &c. Illustrated with nearly 300 Woodcuts. *Sixth Edition*, 12/6.

"Professor Rankine's 'Manual of Machinery and Millwork' fully maintains the high reputation which he enjoys as a scientific author; higher praise it is difficult to award to any book. It cannot fail to be a lantern to the feet of every engineer."—*The Engineer*.

LONDON: EXETER STREET, STRAND.

PROF. RANKINE'S WORKS—(*Continued*).

IV. RANKINE (Prof.): THE STEAM ENGINE and OTHER PRIME MOVERS. With Diagram of the Mechanical Properties of Steam, Folding-Plates, numerous Tables and Illustrations. *Thirteenth Edition*, 12/6.

V. RANKINE (Prof.): USEFUL RULES and TABLES for Engineers and others. With Appendix: TABLES, TESTS, and FORMULÆ for the use of ELECTRICAL ENGINEERS; comprising Submarine Electrical Engineering, Electric Lighting, and Transmission of Power. By ANDREW JAMIESON, C.E., F.R.S.E. *Seventh Edition*, 10/6.

“Undoubtedly the most useful collection of engineering data hitherto produced.”—*Mining Journal*.

“Every Electrician will consult it with profit.”—*Engineering*.

VI. RANKINE (Prof.): A MECHANICAL TEXT-BOOK. by Prof. MACQUORN RANKINE and E. F. BAMBER, C.E. With numerous Illustrations. *Fourth Edition*, 9/.

“The work, as a whole, is very complete, and likely to prove invaluable for furnishing a useful and reliable outline of the subjects treated of.”—*Mining Journal*.

\*\* THE MECHANICAL TEXT-BOOK forms a simple introduction to PROFESSOR RANKINE'S SERIES of MANUALS on ENGINEERING and MECHANICS.

VII. RANKINE (Prof.): MISCELLANEOUS SCIENTIFIC PAPERS. Royal 8vo. Cloth, 31/6.

Part I. Papers relating to Temperature, Elasticity, and Expansion of Vapours, Liquids, and Solids. Part II. Papers on Energy and its Transformations. Part III. Papers on Wave-Forms, Propulsion of Vessels, &c.

With Memoir by Professor TAIT, M.A. Edited by W. J. MILLAR, C.E. With fine Portrait on Steel, Plates, and Diagrams.

“No more enduring Memorial of Professor Rankine could be devised than the publication of these papers in an accessible form. . . . The Collection is most valuable on account of the nature of his discoveries, and the beauty and completeness of his analysis. . . . The Volume exceeds in importance any work in the same department published in our time.”—*Architect*.

LONDON: EXETER STREET, STRAND.

Royal 8vo, Handsome Cloth, 25s.

# THE STABILITY OF SHIPS.

BY

SIR EDWARD J. REED, K.C.B., F.R.S., M.P.,

KNIGHT OF THE IMPERIAL ORDERS OF ST. STANILAUS OF RUSSIA; FRANCIS JOSEPH OF AUSTRIA; MEDJIDIE OF TURKEY; AND RISING SUN OF JAPAN; VICE-PRESIDENT OF THE INSTITUTION OF NAVAL ARCHITECTS.

*With numerous Illustrations and Tables.*

THIS work has been written for the purpose of placing in the hands of Naval Constructors, Shipbuilders, Officers of the Royal and Mercantile Marines, and all Students of Naval Science, a complete Treatise upon the Stability of Ships, and is the only work in the English Language dealing exhaustively with the subject.

The plan upon which it has been designed is that of deriving the fundamental principles and definitions from the most elementary forms of floating bodies, so that they may be clearly understood without the aid of mathematics; advancing thence to all the higher and more mathematical developments of the subject.

The work also embodies a very full account of the historical rise and progress of the Stability question, setting forth the results of the labours of BOUGUER, BERNOULLI, DON JUAN D'ULLOA, EULER, CHAPMAN, and ROMME, together with those of our own Countrymen, ATWOOD, MOSELEY, and a number of others.

The modern developments of the subject, both home and foreign, are likewise treated with much fulness, and brought down to the very latest date, so as to include the labours not only of DARGNIES, REECH (whose famous *Mémoire*, hitherto a sealed book to the majority of English naval architects, has been reproduced in the present work), RISBEC, FERRANTY, DUPIN, GUYOU, and DAYMARD, in France, but also those of RANKINE, WOOLLEY, ELGAR, JOHN, WHITE, GRAY, DENNY, INGLIS, and BENJAMIN, in Great Britain.

In order to render the work complete for the purposes of the Shipbuilder, whether at home or abroad, the Methods of Calculation introduced by Mr. F. K. BARNES, Mr. GRAY, M. REECH, M. DAYMARD, and Mr. BENJAMIN, are all given separately, illustrated by Tables and worked-out examples. The book contains more than 200 Diagrams, and is illustrated by a large number of actual cases, derived from ships of all descriptions, but especially from ships of the Mercantile Marine.

The work will thus be found to constitute the most comprehensive and exhaustive Treatise hitherto presented to the Profession on the Science of the STABILITY OF SHIPS.

“Sir EDWARD REED'S ‘STABILITY OF SHIPS’ is INVALUABLE. In it the STUDENT, new to the subject, will find the path prepared for him, and all difficulties explained with the utmost care and accuracy; the SHIP-DRAUGHTSMAN will find all the methods of calculation at present in use fully explained and illustrated, and accompanied by the Tables and Forms employed; the SHIPOWNER will find the variations in the Stability of Ships due to differences in forms and dimensions fully discussed, and the devices by which the state of his ships under all conditions may be graphically represented and easily understood; the NAVAL ARCHITECT will find brought together and ready to his hand, a mass of information which he would otherwise have to seek in an almost endless variety of publications, and some of which he would possibly not be able to obtain at all elsewhere.”—*Steamship*.

“This IMPORTANT AND VALUABLE WORK . . . cannot be too highly recommended to all connected with shipping interests.”—*Iron*.

“This VERY IMPORTANT TREATISE, . . . the MOST INTELLIGIBLE, INSTRUCTIVE, and COMPLETE that has ever appeared.”—*Nature*.

“The volume is an ESSENTIAL ONE for the shipbuilding profession.”—*Westminster Review*.

LONDON: EXETER STREET, STRAND.

*In Large Crown 8vo, Handsome Cloth, with Numerous  
Illustrations, 7s. 6d.*

# METALLURGY

(AN INTRODUCTION TO THE STUDY OF).

BY

W. C. ROBERTS-AUSTEN, C.B., F.R.S.,

CHEMIST AND ASSAYER OF THE ROYAL MINT; PROFESSOR OF METALLURGY IN  
THE ROYAL COLLEGE OF SCIENCE.

## GENERAL CONTENTS.

RELATION OF METALLURGY TO CHEMISTRY.	MATERIALS AND PRODUCTS OF METALLURGICAL PROCESSES.
PHYSICAL PROPERTIES OF METALS.	FURNACES.
ALLOYS.	MEANS OF SUPPLYING AIR TO FURNACES.
THE THERMAL TREATMENT OF METALS.	TYPICAL METALLURGICAL PROCESSES.
FUEL.	ECONOMIC CONSIDERATIONS.

"No English text-book at all approaches this one either in its method of treatment, its general arrangement, or in the COMPLETENESS with which the most modern views on the subject are dealt with. Professor Austen's volume will be INVALUABLE, not only to the student, but also to those whose knowledge of the art is far advanced."—*Chemical News*.

"This volume amply realises the expectations formed as to the result of the labours of so eminent an authority. It is remarkable for its ORIGINALITY of conception and for the large amount of information which it contains. . . . The enormous amount of care and trouble expended upon it. . . . We recommend every one who desires information not only to consult, but to STUDY this work."—*Engineering*.

"Will at once take FRONT RANK as a text-book."—*Science and Art*.

LONDON: EXETER STREET, STRAND.

*Medium 8vo, Handsome cloth, 25s.*

# HYDRAULIC POWER

AND

## HYDRAULIC MACHINERY.

BY

HENRY ROBINSON, M. INST. C.E., F.G.S.,

FELLOW OF KING'S COLLEGE, LONDON; PROF. OF CIVIL ENGINEERING,  
KING'S COLLEGE, ETC., ETC.

With numerous Woodcuts, and 43 Litho. Plates.

### GENERAL CONTENTS.

The Flow of Water under Pressure.	Hydraulic Coal-discharging Machines.
General Observations.	Hydraulic Machinery on board Ship.
Waterwheels.	Hydraulic Pile Driver.
Turbines.	Hydraulic Excavator.
Centrifugal Pumps.	Hydraulic Drill.
Water-pressure Pumps.	Hydraulic Brake.
The Accumulator.	Hydraulic Gun-Carriages.
Hydraulic Pumping-Engine.	Jets.
Three-Cylinder Engines and Capstans.	Hydraulic Ram.
Motors with Variable Power.	Packing.
Hydraulic Presses and Lifts.	Power Co-operation.
Movable Jigger Hoist.	Cost of Hydraulic Power.
Hydraulic Waggon Drop.	Tapping Pressure Mains.
The Flow of Solids.	Meters.
Shop Tools.	Waste Water Meter.
Cranes.	Pressure Reducing Valves.
Hydraulic Power applied to Bridges.	Pressure Regulator.
Dock-Gate Machinery.	

"A Book of great Professional Usefulness."—*Iron.*

A full Prospectus of the above important work—giving a description of the  
Plates—may be had on application to the Publishers.

LONDON: EXETER STREET, STRAND.

## SCHWACKHÖFER and BROWNE:

FUEL AND WATER: A Manual for Users of Steam and Water. By Prof. FRANZ SCHWACKHÖFER of Vienna, and WALTER R. BROWNE, M.A., C.E., late Fellow of Trinity College, Cambridge. Demy 8vo, with Numerous Illustrations, 9/.

GENERAL CONTENTS.—Heat and Combustion—Fuel, Varieties of—Firing Arrangements: Furnace, Flues, Chimney—The Boiler, Choice of—Varieties—Feed-water Heaters—Steam Pipes—Water: Composition, Purification—Prevention of Scale, &c., &c.

“The Section on Heat is one of the best and most lucid ever written.”—*Engineer*.

“Contains a vast amount of useful knowledge. . . . Cannot fail to be valuable to thousands compelled to use steam power.”—*Railway Engineer*.

“Its practical utility is beyond question.”—*Mining Journal*.

## SHELTON-BEY (W. Vincent, Foreman to the Imperial Ottoman Gun Factories, Constantinople):

THE MECHANIC'S GUIDE: A Hand-Book for Engineers and Artizans. With Copious Tables and Valuable Recipes for Practical Use. Illustrated. *Second Edition*. Crown 8vo. Cloth, 7/6.

GENERAL CONTENTS.—Arithmetic—Geometry—Mensuration—Velocities in Boring and Wheel-Gearing—Wheel and Screw-Cutting—Miscellaneous Subjects and Useful Recipes—The Steam Engine—The Locomotive—Appendix: Tables for Practical Use.

“The MECHANIC'S GUIDE will answer its purpose as completely as a whole series of elaborate text-books.”—*Mining Journal*.

## WORKS by Prof. HUMBOLDT SEXTON, F.I.C., F.C.S., F.R.S.E., *Glasgow and West of Scotland Technical College.*

### OUTLINES OF QUANTITATIVE ANALYSIS.

FOR THE USE OF STUDENTS.

With Illustrations. THIRD EDITION. Crown 8vo, Cloth, 3s.

“A practical work by a practical man . . . will further the attainment of accuracy and method.”—*Journal of Education*.

“An ADMIRABLE little volume . . . well fulfils its purpose.”—*Schoolmaster*.

“A COMPACT LABORATORY GUIDE for beginners was wanted, and the want has been WELL SUPPLIED. . . . A good and useful book.”—*Lancet*.

“Mr. Sexton's book will be welcome to many teachers; for the processes are WELL CHOSEN, the principle which underlies each method is always CLEARLY EXPLAINED, and the directions are both SIMPLE and CLEAR.”—*Brit. Med. Journal*.

BY THE SAME AUTHOR.

### OUTLINES OF QUALITATIVE ANALYSIS.

FOR THE USE OF STUDENTS.

With Illustrations. THIRD EDITION. Crown 8vo, Cloth, 3s. 6d.

“The work of a thoroughly practical chemist . . . and one which may be unhesitatingly recommended.”—*British Medical Journal*.

“Compiled with great care, and will supply a want.”—*Journal of Education*.

LONDON: EXETER STREET, STRAND.



Now Ready, Tenth Edition, Revised and Enlarged, Price 18s.

*Demy Svo, Cloth. With Numerous Illustrations, reduced from Working Drawings.*

# A MANUAL OF MARINE ENGINEERING:

COMPRISING

THE DESIGNING, CONSTRUCTION, AND WORKING OF  
MARINE MACHINERY.

BY A. E. SEATON,

*Lecturer on Marine Engineering to the Royal Naval College, Greenwich; Member of the Inst. of Civil Engineers; Member of Council of the Inst. of Naval Architects; Member of the Inst. of Mech. Engineers, &c.*

## GENERAL CONTENTS.

Part I.—Principles of Marine Propulsion.	Pistons, Valves, Expansion Valves, &c.
Part II.—Principles of Steam Engineering.	Part IV.—Propellers.
Part III.—Details of Marine Engines: Design and Calculations for Cylinders,	Part V.—Boilers.
	Part VI.—Miscellaneous.

“In the three-fold capacity of enabling a Student to learn how to design, construct, and work a modern Marine Steam-Engine, Mr. Seaton’s Manual has NO RIVAL as regards comprehensiveness of purpose and lucidity of treatment.”—*Times*.

“The important subject of Marine Engineering is here treated with the THOROUGHNESS that it requires. No department has escaped attention. . . . Gives the results of much close study and practical work.”—*Engineering*.

“By far the BEST MANUAL in existence. . . . Gives a complete account of the methods of solving, with the utmost possible economy, the problems before the Marine Engineer.”—*Athenaeum*.

“The Student, Draughtsman, and Engineer will find this work the MOST VALUABLE HANDBOOK of Reference on the Marine Engine now in existence.”—*Marine Engineer*

LONDON: EXETER STREET, STRAND.

SECOND EDITION, *Revised and Enlarged.* Pocket-Size, Leather, also for Office Use, Cloth, 12s.

# BOILERS, MARINE AND LAND; THEIR CONSTRUCTION AND STRENGTH.

A HANDBOOK OF RULES, FORMULÆ, TABLES, &C., RELATIVE TO MATERIAL,  
SCANTLINGS, AND PRESSURES, SAFETY VALVES, SPRINGS,  
FITTINGS AND MOUNTINGS, &C.

For the Use of all Steam-Users.

BY T. W. TRAILL, M. INST. C. E., F. E. R. N.,  
Engineer Surveyor-in-Chief to the Board of Trade.

\* \* In the New Issue the subject-matter has been considerably extended ;  
\* Tables have been added for Pressures up to 200 lbs. per square inch, and some  
of the Tables have been altered, besides which new ones and other matter  
have been introduced, which have been specially prepared and computed for  
the SECOND EDITION.

"Very unlike any of the numerous treatises on Boilers which have preceded it. . . . Really  
useful. . . . Contains an ENORMOUS QUANTITY OF INFORMATION arranged in a very convenient  
form. . . . Those who have to design boilers will find that they can settle the dimensions for any  
given pressure with almost no calculation with its aid. . . . A MOST USEFUL VOLUME . . .  
supplying information to be had nowhere else."—*The Engineer*.

"As a handbook of rules, formulæ, tables, &c., relating to materials, scantlings, and pressures, this  
work will prove MOST USEFUL. The name of the Author is a sufficient guarantee for its accuracy. It  
will save engineers, inspectors, and draughtsmen a vast amount of calculation."—*Nature*.

"Mr. Traill has done a very useful and unpretentious piece of work. Rules and tables are given in  
a way simple enough to be intelligible to the most unscientific engineer."—*Saturday Review*.

"By such an authority cannot but prove a welcome addition to the literature of the subject. In the  
hands of the practical engineer or boiler-maker, its value as a ready, reliable, and widely comprehensive  
book of reference, must prove almost inestimable. . . . Will rank high as a standard work on the  
subject." We can strongly recommend it as being the MOST COMPLETE, eminently practical work on the  
subject."—*Marine Engineer*.

"To the engineer and practical boiler-maker it will prove INVALUABLE. Copious and carefully  
worked-out tables will save much of the calculating drudgery. . . . Many exceedingly useful and  
practical hints are given with regard to the treatment of iron and steel, which are exceedingly valuable,  
and the outcome of a wide experience. The tables in all probability are the most exhaustive yet  
published. . . . Certainly deserves a place on the shelf in the drawing office of every boiler shop."—  
*Practical Engineer*.

"We give it a hearty welcome. . . . A handy pocket-book. . . . Our readers cannot do better  
than purchase a copy. . . . Cheap at five times the price. The intelligent engineer can make a  
safe investment that will yield him a rich and satisfactory return."—*Engineers' Gazette*.

"From the author's well-known character for thoroughness and exactness, there is every reason to  
believe that the results given in the tables may be relied on. . . . The great experience of the author  
in all that relates to boiler construction constitutes him an authority that no one need be ashamed of  
quoting, and a guide as safe as any man in Britain."—*Shipping World*.

LONDON: EXETER STREET, STRAND.

With very Numerous Illustrations, in large Crown 8vo, Handsome Cloth, 6s.  
Also Presentation Edition, Gilt and Gilt Edges, 7s. 6d.

# THE THRESHOLD OF SCIENCE:

## A VARIETY OF EXPERIMENTS (Over 400)

ILLUSTRATING

SOME OF THE CHIEF PHYSICAL AND CHEMICAL PROPERTIES OF SURROUNDING OBJECTS,  
AND THE EFFECTS UPON THEM OF LIGHT AND HEAT.

BY

C. R. ALDER WRIGHT, D.Sc., F.R.S.,

Lecturer on Chemistry and Physics in St. Mary's Hospital Medical School, London.

In this work the object aimed at is to provide a kind of "Playbook," which, in addition to affording the means of amusement, shall also to some extent tend in the direction of the course of mental education advocated by the British Association Committee, so that whilst the young philosopher finds pastime and entertainment in constructing simple apparatus and preparing elementary experiments, he may at the same time be led to observe correctly what happens, to draw inferences and make deductions therefrom.

"An ADMIRABLE COLLECTION of Physical and Chemical Experiments . . . a large proportion of these may be performed at home without any costly apparatus."—*Journal of Education*.

"Just the kind of book to add to a school library."—*Manchester Guardian*.

"Clear, terse, and attractive, the volume is to be most highly recommended."—*Public Opinion*.

"Dr. Alder Wright has accomplished a task that will win for him the hearts of all intelligent youths with scientific leanings. . . . Step by step the learner is here gently guided through the paths of science, made easy by the perfect knowledge of the teacher, and made flowery by the most striking and curious experiments. Well adapted to become the TREASURED FRIEND of many a bright and promising lad."—*Manchester Examiner*.

"The work is quite as instructive as it is entertaining. . . . The language throughout is clear and simple."—*School Guardian*.

"From the nature of gases to the making of soap-bubbles, from the freezing of water to the principles of 'pin-hole' photography, Dr. Alder Wright's book is an authority."—*Liverpool Mercury*.

LONDON: EXETER STREET, STRAND.

*Ninth Annual Issue. Now Ready.*

## THE OFFICIAL YEAR-BOOK

OF THE

SCIENTIFIC AND LEARNED SOCIETIES OF GREAT  
BRITAIN AND IRELAND. PRICE 7/6.

COMPILED FROM OFFICIAL SOURCES.

*Comprising (together with other Official Information) LISTS of the PAPERS read during 1891 before the ROYAL SOCIETIES of LONDON and EDINBURGH, the ROYAL DUBLIN SOCIETY, the BRITISH ASSOCIATION, and all the LEADING SOCIETIES throughout the Kingdom engaged in the following Departments of Research:—*

- |  |   |
|--|---|
| § 1. Science Generally: <i>i.e.</i> , Societies occupying themselves with several Branches of Science, or with Science and Literature jointly. | § 6. Economic Science and Statistics.     |
| § 2. Mathematics and Physics.  | § 7. Mechanical Science and Architecture. |
| § 3. Chemistry and Photography.  | § 8. Naval and Military Science.          |
| § 4. Geology, Geography, and Mineralogy.   | § 9. Agriculture and Horticulture.        |
| § 5. Biology, including Microscopy and Anthropology.   | § 10. Law.                                |
|  | § 11. Medicine.                           |
|  | § 12. Literature.                         |
|  | § 13. Psychology.                         |
|  | § 14. Archæology.                         |

"The YEAR-BOOK OF SOCIETIES is a Record which ought to be of the greatest use for the progress of Science."—*Sir Lyon Playfair, F.R.S., K.C.B., M.P., Past-President of the British Association.*

"It goes almost without saying that a Handbook of this subject will be in time one of the most generally useful works for the library or the desk."—*The Times.*

"The YEAR-BOOK OF SOCIETIES meets an obvious want, and promises to be a valuable work of reference."—*Athenæum.*

"The YEAR-BOOK OF SCIENTIFIC AND LEARNED SOCIETIES meets a want, and is therefore sure of a welcome."—*Westminster Review.*

"In the YEAR-BOOK OF SOCIETIES we have the FIRST ISSUE of what is, without doubt, a very useful work."—*Spectator.*

"The YEAR-BOOK OF SOCIETIES fills a very real want. The volume will become a Scientific Directory, chronicling the work and discoveries of the year, and enabling the worker in one branch to try his hand in all that interests him in kindred lines of research. We trust that it will meet with an encouraging reception."—*Engineering.*

"The OFFICIAL YEAR-BOOK OF SOCIETIES, which has been prepared to meet a want long felt by scientific workers of a Representative Book, will form a yearly record of Scientific Progress, and a Handbook of Reference. . . . It is carefully printed, and altogether well got up."—*Public Opinion.*

Copies of the FIRST ISSUE, giving an Account of the History, Organisation, and Conditions of Membership of the various Societies [with Appendix on the Leading Scientific Societies throughout the world], and forming the groundwork of the Series, may still be had, price 7/6. *Also Copies of the following Issues.*

The YEAR-BOOK OF SOCIETIES forms a complete INDEX TO THE SCIENTIFIC WORK of the year in the various Departments. It is used as a ready HANDBOOK in all our great SCIENTIFIC CENTRES, MUSEUMS, and LIBRARIES throughout the Kingdom, and will, without doubt, become an INDISPENSABLE BOOK OF REFERENCE to every one engaged in Scientific Work.

We predict that the YEAR-BOOK OF SOCIETIES will speedily become one of those Year-Books WHICH IT WOULD BE IMPOSSIBLE TO DO WITHOUT."—*Bristol Mercury.*

LONDON: EXETER STREET, STRAND.

## EDUCATIONAL WORKS.

*\* \* \* Specimen Copies of all the Educational Works published by Messrs. Charles Griffin and Company may be seen at the Libraries of the College of Preceptors, South Kensington Museum, and Crystal Palace; also at the depôts of the Chief Educational Societies.*

## Griffin's Standard Classical Works.

	PAGE
Prehistoric Antiquities, . . .	SCHRADER and JEVONS, . . . 56
Greek Antiquities, . . .	F. B. JEVONS, . . . 54
Roman Antiquities, . . .	Prof. RAMSAY, . . . 55
,, Elementary, . . .	Prof. RAMSAY, . . . 55
Greek Literature, . . .	F. B. JEVONS, . . . 54
Roman Literature, . . .	Rev. C. T. CRUTTWELL, . . . 52
,, Specimens of, . . .	CRUTTWELL and BANTON, . . . 52
Greek Geography and My- thology, . . .	DOERING and GRÆME, . . . 53
Latin Prosody, . . .	Prof. RAMSAY, . . . 55
,, Elementary, . . .	Prof. RAMSAY, . . . 55
Virgil: Text and Notes (Illustrated), . . .	Dr. BRYCE, . . . 50
Horace: Text and Notes (Illustrated), . . .	JOS. CURRIE, . . . 50

**BRYCE** (Archibald Hamilton, D.C.L., LL.D.,  
Senior Classical Moderator in the University of Dublin):

THE WORKS OF VIRGIL. Text from HEYNE and WAGNER. English Notes, original, and selected from the leading German and English Commentators. Illustrations from the antique. Complete in One Volume. *Fourteenth Edition.* Fcap 8vo. Cloth, 6/.

Or, in Three Parts:

Part I. BUCOLICS and GEORGICS, . . . 2/6.

Part II. THE ÆNEID, Books I.-VI., . . . 2/6.

Part III. THE ÆNEID, Books VII.-XII., . . . 2/6.

"Contains the pith of what has been written by the best scholars on the subject. . . . The notes comprise everything that the student can want."—*Athenæum*.

"The most complete, as well as elegant and correct edition of Virgil ever published in this country."—*Educational Times*.

"The best commentary on Virgil which a student can obtain."—*Scotsman*.

**COBBETT** (William): ENGLISH GRAMMAR,  
in a Series of Letters, intended for the use of Schools and Young Persons in general. With an additional chapter on Pronunciation, by the Author's Son, JAMES PAUL COBBETT. *The only correct and authorised Edition.* Fcap 8vo. Cloth, 1/6.

**COBBETT** (William): FRENCH GRAMMAR.  
*Fifteenth Edition.* Fcap 8vo. Cloth, 3/6.

"Cobbett's 'French Grammar' comes out with perennial freshness. There are few grammars equal to it for those who are learning, or desirous of learning, French without a teacher. The work is excellently arranged, and in the present edition we note certain careful and wise revisions of the text."—*School Board Chronicle*.

**COBBIN'S MANGNALL: MANGNALL'S**  
HISTORICAL AND MISCELLANEOUS QUESTIONS, for the use of Young People. By RICHMAL MANGNALL. Greatly enlarged and corrected, and continued to the present time, by INGRAM COBBIN, M.A. *Fifty-fourth Thousand. New Illustrated Edition.* 12mo. Cloth, 4/.

**COLERIDGE** (Samuel Taylor): A DISSER-  
TATION ON THE SCIENCE OF METHOD. (*Encyclopædia Metropolitana*.) With a Synopsis. *Ninth Edition.* Cr. 8vo. Cloth, 2/.

**CURRIE** (Joseph, formerly Head Classical  
Master of Glasgow Academy):

THE WORKS OF HORACE: Text from ORELLIUS. English Notes, original, and selected from the best Commentators. Illustrations from the antique. Complete in One Volume. Fcap 8vo. Cloth, 5/.

Or in Two Parts:

Part I.—CARMINA, . . . . . 3/.

Part II.—SATIRES AND EPISTLES, . . . . . 3/.

"The notes are excellent and exhaustive."—*Quarterly Journal of Education*.

## CRAIK'S ENGLISH LITERATURE.

A COMPENDIOUS HISTORY OF ENGLISH LITERATURE AND OF THE ENGLISH LANGUAGE FROM THE NORMAN CONQUEST. With numerous Specimens. By GEORGE LILLIE CRAIK, LL.D., late Professor of History and English Literature, Queen's College, Belfast. *New Edition.* In two vols. Royal 8vo. Handsomely bound in cloth, 25/.

## GENERAL CONTENTS.

## INTRODUCTORY.

- I.—THE NORMAN PERIOD—The Conquest.
- II.—SECOND ENGLISH—Commonly called Semi-Saxon.
- III.—THIRD ENGLISH—Mixed, or Compound English.
- IV.—MIDDLE AND LATTER PART OF THE SEVENTEENTH CENTURY.
- V.—THE CENTURY BETWEEN THE ENGLISH REVOLUTION AND THE FRENCH REVOLUTION.
- VI.—THE LATTER PART OF THE EIGHTEENTH CENTURY.
- VII.—THE NINETEENTH CENTURY (*a*) THE LAST AGE OF THE GEORGES. (*b*) THE VICTORIAN AGE.

*With numerous Excerpts and Specimens of Style.*

"Anyone who will take the trouble to ascertain the fact, will find how completely even our great poets and other writers of the last generation have already faded from the view of the present, with the most numerous class of the educated and reading public. Scarcely anything is generally read except the publications of the day. YET NOTHING IS MORE CERTAIN THAN THAT NO TRUE CULTIVATION CAN BE SO ACQUIRED. This is the extreme case of that entire ignorance of history which has been affirmed, not with more point than truth, to leave a person always a child. . . . The present work combines the HISTORY OF THE LITERATURE with the HISTORY OF THE LANGUAGE. The scheme of the course and revolutions of the language which is followed here is extremely simple, and resting not upon arbitrary, but upon natural or real distinctions, gives us the only view of the subject that can claim to be regarded as of a scientific character."—*Extract from the Author's Preface.*

"Professor Craik has succeeded in making a book more than usually agreeable."—*The Times.*

Crown 8vo. Cloth, 7/6. TENTH EDITION.

## A MANUAL OF ENGLISH LITERATURE,

for the use of Colleges, Schools, and Civil Service Examinations. Selected from the larger work, by Dr. CRAIK. *Tenth Edition.* With an Additional Section on Recent Literature, by HENRY CRAIK, M.A., Author of "A Life of Swift."

"A Manual of English Literature from so experienced and well-read a scholar as Professor Craik needs no other recommendation than the mention of its existence."—*Spectator.*

"This augmented effort will, we doubt not, be received with decided approbation by those who are entitled to judge, and studied with much profit by those who want to learn. . . . If our young readers will give healthy perusal to Dr. Craik's work, they will greatly benefit by the wide and sound views he has placed before them."—*Athenæum.*

"The preparation of the New Issue has been entrusted to Mr. HENRY CRAIK, Secretary to the Scotch Education Department, and well known in literary circles as the author of the latest and best Life of Swift. . . . A Series of TEST QUESTIONS is added, which must prove of great service to Students studying alone."—*Glasgow Herald.*

LONDON: EXETER STREET, STRAND.

WORKS BY REV. C. T. CRUTTWELL, M.A.,  
Late Fellow of Merton College, Oxford.

A HISTORY OF ROMAN LITERATURE:

From the Earliest Period to the Times of the Antonines.

*Fourth Edition.* Crown 8vo. Cloth, 8/6.

"Mr. CRUTTWELL has done a real service to all Students of the Latin Language and Literature. . . . Full of good scholarship and good criticism."—*Athenæum*.

"A most serviceable—indeed, indispensable—guide for the Student. . . . The 'general reader' will be both charmed and instructed."—*Saturday Review*.

"The Author undertakes to make Latin Literature interesting, and he has succeeded. There is not a dull page in the volume."—*Academy*.

"The great merit of the work is its fulness and accuracy."—*Guardian*.

"This elaborate and careful work, in every respect of high merit. Nothing at all equal to it has hitherto been published in England."—*British Quarterly Review*.

*Companion Volume. Second Edition.*

SPECIMENS OF ROMAN LITERATURE:

From the Earliest Period to the Times of the Antonines.

Passages from the Works of Latin Authors, Prose Writers, and Poets:

Part I.—ROMAN THOUGHT: Religion, Philosophy and Science, Art and Letters, 6/.

Part II.—ROMAN STYLE: Descriptive, Rhetorical, and Humorous Passages, 5/.

Or in One Volume complete, 10/6.

Edited by C. T. CRUTTWELL, M.A., Merton College, Oxford; and  
PEAKE BANTON, M.A., some time Scholar of Jesus College, Oxford.

"'Specimens of Roman Literature' marks a new era in the study of Latin."—*English Churchman*.

"A work which is not only useful but necessary. . . . The plan gives it a standing-ground of its own. . . . The sound judgment exercised in plan and selection calls for hearty commendation."—*Saturday Review*.

"It is hard to conceive a completer or handier repertory of specimens of Latin thought and style."—*Contemporary Review*.

\* \* KEY to PART II., PERIOD II. (being a complete TRANSLATION of the 85 Passages composing the Section), by THOS. JOHNSTON, M.A., may now be had (by Tutors and Schoolmasters only) on application to the Publishers. Price 2/6.

A HISTORY OF EARLY CHRISTIAN LITERATURE:

For the use of Students and General Readers.

8vo, Handsome Cloth.

[*In Preparation.*]

LONDON: EXETER STREET, STRAND.



# HELLAS:

AN INTRODUCTION TO GREEK ANTIQUITIES,

*Comprising the Geography, Religion and Myths, History, Art and Culture of old Greece.*

On the Basis of the German Work by E. DOERING,  
With Additions by ELLIOTT GRÆME.

*In Large 8vo, with Map and Illustrations.*

## PART I.

The Land and the People: the Religion and Myths of Old Greece.

\*\* In the English version of Mr. Doering's work, the simple and interesting style of the original—written for young Students—has been retained; but, throughout, such additions and emendations have been made as render the work suitable for more advanced Students, and for all who desire to obtain, within moderate compass, more than a superficial acquaintance with the great People whose genius and culture have so largely influenced our own. The results of the latest researches by Dr. SCHLIEMANN, MM. FOUQUÉ, CARAPANOS, and others, are incorporated. *[Shortly.]*

D'ORSEY (Rev. Alex. J. D., B.D., Corpus Christi Coll., Cambridge, Lecturer at King's College, London):

SPELLING BY DICTATION: Progressive Exercises in English Orthography, for Schools and Civil Service Examinations. *Sixteenth Thousand.* 18mo. Cloth, 1/.

FLEMING (William, D.D., late Professor of Moral Philosophy in the University of Glasgow):

THE VOCABULARY OF PHILOSOPHY: PSYCHOLOGICAL, ETHICAL, AND METAPHYSICAL. With Quotations and References for the Use of Students. Revised and Edited by HENRY CALDERWOOD, LL.D., Professor of Moral Philosophy in the University of Edinburgh. *Fourth Edition, enlarged.* Crown 8vo. Cloth, 10/6.

"The additions by the Editor bear in their clear, concise, vigorous expression, the stamp of his powerful intellect, and thorough command of our language. More than ever, the work is now likely to have a prolonged and useful existence, and to facilitate the researches of those entering upon philosophic studies."—*Weekly Review.*

JAMES (W. Powell, M.A.):

FROM SOURCE TO SEA: or, Gleanings about Rivers from many Fields. A Chapter in Physical Geography. Cloth elegant, 3/6.

"Excellent reading . . . a book of popular science which deserves an extensive circulation."—*Saturday Review.*

LONDON: EXETER STREET, STRAND.

---

**WORKS BY F. B. JEVONS, M.A.**

Now Ready. SECOND EDITION, Revised. Crown 8vo, Cloth, 8s. 6d.

**A HISTORY OF GREEK LITERATURE.**

*From the Earliest Period to the Death of Demosthenes.*

BY FRANK BYRON JEVONS, M.A.,

Tutor in the University of Durham.

Part I.—Epic, Lyric, and the Drama.

Part II.—History, Oratory, and Philosophy.

SECOND EDITION. With Appendix on the *Present State of the Homeric Question* and Examination-Questions for the Use of Students.

"It is beyond all question the BEST HISTORY of Greek literature that has hitherto been published."—*Spectator*.

"An admirable text-book."—*Westminster Review*.

"Mr. Jevons' work supplies a real want."—*Contemporary Review*.

"Mr. Jevons' work is distinguished by the Author's THOROUGH ACQUAINTANCE with the OLD WRITERS, and his DISCRIMINATING USE of the MODERN LITERATURE bearing upon the subject. . . . His great merit lies in his EXCELLENT EXPOSITION of the POLITICAL AND SOCIAL CAUSES concerned in the development of the Literature of Greece."—*Berlin Philologische Wochenschrift*.

"As a Text-Book, Mr. Jevons' work from its excellence deserves to SERVE AS A MODEL."—*Deutsche Literaturzeitung*.

---

**THE DEVELOPMENT OF THE ATHENIAN DEMOCRACY.**

Crown 8vo, 1s.

---

**A MANUAL OF GREEK ANTIQUITIES.**

FOR THE USE OF STUDENTS.

With Maps and Numerous Illustrations.

[*In Preparation.*]

---

**PREHISTORIC ANTIQUITIES OF THE ARYAN PEOPLES,**

Translated from the German of DR. O. SCHRADER by F. B. JEVONS, M.A.

(See page 56, under SCHRADER.)

---

LONDON: EXETER STREET, STRAND.

McBURNNEY (Isaiah, LL.D.): EXTRACTS  
FROM OVID'S METAMORPHOSES. With Notes, Vocabulary, &c.  
Adapted for Young Scholars. *Third Edition*. 18mo. Cloth, 1/6.

MENTAL SCIENCE: S. T. COLERIDGE'S  
celebrated Essay on METHOD; Archbishop WHATELY'S Treatises on  
LOGIC and RHETORIC. *Tenth Edition*. Crown 8vo. Cloth, 5/.

MILLER (W. Galbraith, M.A., LL.B., Lecturer  
on Public Law, including Jurisprudence and International Law, in the  
University of Glasgow):

THE PHILOSOPHY OF LAW, LECTURES ON. Designed  
mainly as an Introduction to the Study of International Law. In 8vo.  
Handsome Cloth, 12/. *Now Ready*.

"Mr. MILLER'S 'PHILOSOPHY OF LAW' bears upon it the stamp of a wide culture  
and of an easy acquaintanceship with what is best in modern continental speculation.  
. . . Interesting and valuable, because suggestive."—*Journal of Jurisprudence*.

---

## WORKS BY WILLIAM RAMSAY, M.A.,

Trinity College, Cambridge, late Professor of Humanity in the University of Glasgow.

---

### A MANUAL OF ROMAN ANTIQUITIES.

For the use of Advanced Students. With Map, 130 Engravings, and very  
copious Index. *Fourteenth Edition*. Crown 8vo. Cloth, 8/6.

"Comprises all the results of modern improved scholarship within a moderate com-  
pass."—*Athenæum*.

---

AN ELEMENTARY MANUAL OF  
ROMAN ANTIQUITIES. Adapted for Junior Classes. With numerous  
Illustrations. *Eighth Edition*. Crown 8vo. Cloth, 4/.

---

A MANUAL OF LATIN PROSODY,  
Illustrated by Copious Examples and Critical Remarks. For the use  
of Advanced Students. *Seventh Edition*. Crown 8vo. Cloth, 5/.

"There is no other work on the subject worthy to compete with it."—*Athenæum*.

---

AN ELEMENTARY MANUAL OF  
LATIN PROSODY. Adapted for Junior Classes. Crown 8vo. Cloth, 2s.

Just Published, in Large 8vo, Handsome Cloth, Gilt Top, 21s.

## PREHISTORIC ANTIQUITIES OF THE ARYAN PEOPLES,

A Manual of Comparative Philology and the Earliest Culture.  
Being the *Sprachvergleichung und Urgeschichte* of

DR. O. SCHRADER.

Translated from the SECOND GERMAN EDITION by  
F. B. JEVONS, M.A.

In DR. SCHRADER'S great work is presented to the reader a most able and judicious summary of all recent researches into the Origin and History of those Peoples, Ancient and Modern, to whom has been mainly entrusted the civilisation and culture of the world.

Dr. Schrader's pictures of the Primeval Indo-European Period in all its most important phases—The Animal Kingdom, Cattle, The Plant-World, Agriculture, Computation of Time, Food and Drink, Clothing, Dwellings, Traffic and Trade, The Culture of the Indo-Europeans, and The Prehistoric Monuments of Europe (especially the Swiss Lake-Dwellings), Family and State, Religion, The Original Home—will be found not only of exceeding interest in themselves, but of great value to the Student of History, as throwing light upon later developments.

### GENERAL CONTENTS.

- PART I.—HISTORY OF LINGUISTIC PALÆONTOLOGY.  
PART II.—RESEARCH BY MEANS OF LANGUAGE AND HISTORY.  
PART III.—THE FIRST APPEARANCE OF THE METALS.  
PART IV.—THE PRIMEVAL PERIOD.

### OPINIONS OF THE PRESS.

“DR. SCHRADER'S GREAT WORK.”—*Times*.

“MR. JEVONS has done his work excellently, and Dr. Schrader's book is a model of industry, erudition, patience, and, what is rarest of all in these obscure studies, of moderation and common sense.”—*Saturday Review*.

“ABLY translated by that well-known scholar Mr. Jevons, will be found the best COMPENDIUM of the last thirty years' research into the early history and speech of the Aryan race. . . . INTERESTING FROM BEGINNING TO END.”—*Manchester Guardian*.

“THE work of the translator has been SINGULARLY WELL PERFORMED.”—*Daily Telegraph*.

“IN comparison with the First, the Second Edition has gained greatly—not merely in point of size, but of worth. We are convinced that the success which it deserves must attend, in its new form, a book so interesting and STIMULATING.”—*Litterarisches Centralblatt*.

LONDON: EXETER STREET, STRAND.

DR SCHRADER'S "PREHISTORIC ANTIQUITIES"—*Continued.*

"When a book like this reaches a Second Edition, we have in the fact a proof that it has, in a happy way, solved the problem how to rouse the sympathy of the reader. . . . Special interest attaches to the section on the ORIGINAL HOME of the Indo-European race."—*Allgemeine Zeitung.*

"A work which in every respect may be described as of CONSPICUOUS EXCELLENCE, and as ensuring to its author a place among the foremost of those engaged in research."—*B(ru)gm(ann)—Literarisches Centralblatt.*

"I must confess that, for long, I have read no work which has roused in me so lively an interest as Dr. SCHRADER'S. In it, the fault to which philologists especially are prone—that of building up the history of civilisation too much in the atmosphere of the study—is avoided in the happiest way. Here all is FRESH, LIVING INSIGHT, AND SOLID WELL-BALANCED REASONING."—*Wilh. Geiger—Deutsche Litteraturzeitung.*

"A MOST REMARKABLE BOOK—may be heartily recommended to ALL who take an interest in prehistoric times."—*Sl(einhal)—Zeitschrift für Völkerpsychologie und Sprachwissenschaft.*

"One of the BEST WORKS published of late years. . . . Every one who, for any reason whatsoever, is interested in the beginnings of European Civilisation and Indo-European Antiquity, will be obliged to place Dr. SCHRADER'S book on his library shelves. The work addresses itself to the general reader as well as to the learned."—*Gustav Meyer—Philologische Wochenschrift.*

"As the work is INDISPENSABLE alike to the Student of Language, of History, and of Anthropology, every Institution will feel obliged to procure it for its library."—*Zeitschrift für Oesterr. Mittelschulen.*

"The Section on the Names of the Relatives, the position of the Wife, and the primitive FAMILY, is exceptionally significant, since it rests mainly on ethnology. Dr. SCHRADER is a genuine CRITIC, and therefore, with his colossal knowledge, a guide to whom we willingly entrust ourselves."—*Am Ur-Quell, Monatschrift f. Volkskunde.*

"We have only to look into Dr. SCHRADER'S work—its fulness of material, the great caution with which inferences are drawn, its clearness in method and treatment—to be at once won over to the Author and his researches."—*Karl Friedrichs—Deutsche Revue.*

SENIOR (Nassau William, M.A., late Professor of Political Economy in the University of Oxford):

A TREATISE ON POLITICAL ECONOMY: the Science which treats of the Nature, the Production, and the Distribution of Wealth. *Sixth Edition.* Crown 8vo. Cloth. (*Encyclopædia Metropolitana*), 4/.

THOMSON (James): THE SEASONS. With

an Introduction and Notes by ROBERT BELL, Editor of the "Annotated Series of British Poets." *Third Edition.* Fcap 8vo. Cloth, 1/6.

"An admirable introduction to the study of our English classics."

WHATELY (Archbishop): LOGIC—A Treatise on. With Synopsis and Index. (*Encyclopædia Metropolitana*), 3/.

——— RHETORIC—A Treatise on. With Synopsis and Index. (*Encyclopædia Metropolitana*), 3/6.

---

## WORKS IN GENERAL LITERATURE.

---

BELL (Robert, Editor of the "Annotated Series of British Poets"):

GOLDEN LEAVES FROM THE WORKS OF THE POETS AND PAINTERS. Illustrated by Sixty-four superb Engravings on Steel, after Paintings by DAVID ROBERTS, STANFIELD, LESLIE, STOTHARD, HAYDON, CATTERMOLLE, NASMYTH, Sir THOMAS LAWRENCE, and many others, and engraved in the first style of Art by FINDEN, GREATBACH, LIGHTFOOT, &c. *Second Edition.* 4to. Cloth gilt, 21/.

"'Golden Leaves' is by far the most important book of the season. The Illustrations are really works of art, and the volume does credit to the arts of England."—*Saturday Review.*

"The Poems are selected with taste and judgment."—*Times.*

"The engravings are from drawings by Stothard, Newton, Danby, Leslie, and Turner, and it is needless to say how charming are many of the above here given."—*Athenæum.*

---

## THE WORKS OF WILLIAM COBBETT.

THE ONLY AUTHORISED EDITIONS.

COBBETT (William): ADVICE TO YOUNG

Men and (incidentally) to Young Women, in the Middle and Higher Ranks of Life. In a Series of Letters addressed to a Youth, a Bachelor, a Lover, a Husband, a Father, a Citizen, and a Subject. *New Edition.* With admirable Portrait on Steel. Fcap 8vo. Cloth, 2/6.

"Cobbett's great qualities were immense vigour, resource, energy, and courage, joined to a force of understanding, a degree of logical power, and above all a force of expression, which have rarely been equalled. . . . He was the most English of Englishmen."—*Saturday Review.*

"With all his faults, Cobbett's style is a continual refreshment to the lover of 'English undefiled.'"—*Pall Mall Gazette.*

---

COTTAGE ECONOMY: Containing information relative to the Brewing of Beer, Making of Bread, Keeping of Cows, Pigs, Bees, Poultry, &c.; and relative to other matters deemed useful in conducting the affairs of a Poor Man's Family. *Eighteenth Edition,* revised by the Author's Son. Fcap 8vo. Cloth, 2/6.

---

LONDON: EXETER STREET, STRAND.

WILLIAM COBBETT'S WORKS—(Continued).

COBBETT (Wm.): EDUCATIONAL WORKS.  
(See page 25.)

——— A LEGACY TO LABOURERS: An Argument showing the Right of the Poor to Relief from the Land. With a Preface by the Author's Son, JOHN M. COBBETT, late M.P. for Oldham. *New Edition.* Fcap 8vo. Cloth, 1/6.

"The book cannot be too much studied just now."—*Nonconformist.*  
"Cobbett was, perhaps, the ablest Political writer England ever produced, and his influence as a Liberal thinker is felt to this day. . . . It is a real treat to read his strong racy language."—*Public Opinion.*

——— A LEGACY TO PARSONS: Or, have the Clergy of the Established Church an Equitable Right to Tithes and Church Property? *New Edition.* Fcap 8vo. Cloth, 1/6.

"The most powerful work of the greatest master of political controversy this country has ever produced."—*Pall Mall Gazette.*

GILMER'S INTEREST TABLES; Tables for Calculation of Interest, on any sum, for any number of days, at  $\frac{1}{2}$ , 1,  $1\frac{1}{2}$ , 2,  $2\frac{1}{2}$ , 3,  $3\frac{1}{2}$ , 4,  $4\frac{1}{2}$ , 5 and 6 per Cent. By ROBERT GILMER. Corrected and enlarged. *Eleventh Edition.* 12mo. Cloth, 5/.

GRÆME (Elliott): BEETHOVEN: a Memoir. With Portrait, Essay, and Remarks on the Pianoforte Sonatas, with Hints to Students, by DR. FERDINAND HILLER, of Cologne. *Third Edition.* Crown 8vo. Cloth gilt, elegant, 5/.

"This elegant and interesting Memoir. . . . The newest, prettiest, and most readable sketch of the immortal Master of Music."—*Musical Standard.*

"A gracious and pleasant Memorial of the Centenary."—*Spectator.*

"This delightful little book—concise, sympathetic, judicious."—*Manchester Examiner.*

"We can, without reservation, recommend it as the most trustworthy and the pleasantest Memoir of Beethoven published in England."—*Observer.*

"A most readable volume, which ought to find a place in the library of every admirer of the great Tone-Poet."—*Edinburgh Daily Review.*

——— A NOVEL WITH TWO HEROES.  
*Second Edition.* In 2 vols. Post 8vo. Cloth, 21/.

"A decided literary success."—*Athenæum.*

"Clever and amusing . . . above the average even of good novels . . . free from sensationalism, but full of interest . . . touches the deeper chords of life . . . delineation of character remarkably good."—*Spectator.*

"Superior in all respects to the common run of novels."—*Daily News.*

"A story of deep interest. . . . The dramatic scenes are powerful almost to painfulness in their intensity."—*Scotsman.*

---

## THE EMERALD SERIES OF POETS.

Illustrated by Engravings on Steel, after STOTHARD, LESLIE, DAVID ROBERTS, STANFIELD, Sir THOMAS LAWRENCE, CATTERMOLLE, &c.  
Fcap 8vo. Cloth, gilt.

Particular attention is requested to this very beautiful series. The delicacy of the engravings, the excellence of the typography, and the quaint antique head and tail pieces, render them the most beautiful volumes ever issued from the press of this country, and now, unquestionably, the cheapest of their class.

**BYRON (Lord): CHILDE HAROLD'S PILGRIMAGE.** With Memoir by Professor SPALDING. Illustrated with Portrait and Engravings on Steel, by GREATBACH, MILLER, LIGHTFOOT, &c., from Paintings by CATTERMOLLE, Sir T. LAWRENCE, H. HOWARD, and STOTHARD. Beautifully printed on toned paper. *Third Thousand.* Cloth, gilt edges, 3/.

**CAMPBELL (Thomas): THE PLEASURES OF HOPE.** With Introductory Memoir by the Rev. CHARLES ROGERS, LL.D., and several Poems never before published. Illustrated with Portrait and Steel Engravings. *Second Thousand.* Cloth, gilt edges, 3/.

**CHATTERTON'S (Thomas) POETICAL WORKS.** With an Original Memoir by FREDERICK MARTIN, and Portrait. Beautifully illustrated on Steel, and elegantly printed. *Fourth Thousand.* Cloth, gilt edges, 3/.

**GOLDSMITH'S (Oliver) POETICAL WORKS.** With Memoir by Professor SPALDING. Exquisitely illustrated with Steel Engravings. *New Edition.* Printed on superior toned paper. *Seventh Thousand.* Cloth, gilt edges, 3/.

*Eton Edition, with the Latin Poems. Sixth Thousand.*

**GRAY'S (Thomas) POETICAL WORKS.** With Life by the Rev. JOHN MITFORD, and Essay by the EARL of CARLISLE. With Portrait and numerous Engravings on Steel and Wood. Elegantly printed on toned paper. Cloth, gilt edges, 5/.

**HERBERT'S (George) POETICAL WORKS.** With Memoir by J. NICHOL, B.A., Oxon, Prof. of English Literature in the University of Glasgow. Edited by CHARLES COWDEN CLARKE. Antique headings to each page. *Second Thousand.* Cloth, gilt edges, 3/.

**KEBLE (Rev. John): THE CHRISTIAN YEAR.** With Memoir by W. TEMPLE, Portrait, and Eight beautiful Engravings on Steel. *New Edition.*  
Cloth, gilt edges, . . . . . 5/.

**POE'S (Edgar Allan) COMPLETE POETICAL WORKS.** Edited, with Memoir, by JAMES HANNAY. Full-page Illustrations after WEHNERT, WEIR, &c. Toned paper. *Thirteenth Thousand.* Cloth, gilt edges, 3/.

---



## MACKEY'S FREEMASONRY:

A LEXICON OF FREEMASONRY. Containing a definition of its Communicable Terms, Notices of its History, Traditions, and Antiquities, and an Account of all the Rites and Mysteries of the Ancient World. By ALBERT G. MACKEY, M.D., Secretary-General of the Supreme Council of the U.S., &c. *Eighth Edition*, thoroughly revised with APPENDIX by Michael C. Peck, Prov. Grand Secretary for N. and E. Yorkshire. Handsomely bound in cloth, 6/.

"Of MACKEY'S LEXICON it would be impossible to speak in too high terms; suffice it to say, that, in our opinion, it ought to be in the hands of every Mason who would thoroughly understand and master our noble Science. . . . No Masonic Lodge or Library should be without a copy of this most useful work."—*Masonic News*.

## HENRY MAYHEW'S CELEBRATED WORK ON THE STREET-FOLK OF LONDON.

### LONDON LABOUR AND THE LONDON

POOR: A Cyclopædia of the Condition and Earnings of *those that will work and those that cannot work*. By HENRY MAYHEW. With many full-page Illustrations from Photographs. In three vols. Demy 8vo. Cloth. Each vol. 4/6.

"Every page of the work is full of valuable information, laid down in so interesting a manner that the reader can never tire."—*Illustrated London News*.

"Mr. Henry Mayhew's famous record of the habits, earnings, and sufferings of the London poor."—*Lloyd's Weekly London Newspaper*.

"This remarkable book, in which Mr. Mayhew gave the better classes their first real insight into the habits, modes of livelihood, and current of thought of the London poor."—*The Patriot*.

*The Extra Volume.*

### LONDON LABOUR AND THE LONDON

POOR: *Those that will not work*. Comprising the Non-workers, by HENRY MAYHEW; Prostitutes, by BRACEBRIDGE HEMYNG; Thieves, by JOHN BINNY; Beggars, by ANDREW HALLIDAY. With an Introductory Essay on the Agencies at Present in Operation in the Metropolis for the Suppression of Crime and Vice, by the Rev. WILLIAM TUCKNISS, B.A., Chaplain to the Society for the Rescue of Young Women and Children. With Illustrations of Scenes and Localities. In one large vol. Royal 8vo. Cloth, 10/6.

"The work is full of interesting matter for the casual reader, while the philanthropist and the philosopher will find details of the greatest import."—*City Press*.

*Companion volume to the preceding.*

### THE CRIMINAL PRISONS OF LONDON,

and Scenes of Prison Life. BY HENRY MAYHEW and JOHN BINNY. Illustrated by nearly two hundred Engravings on Wood, principally from Photographs. In one large vol. Imperial 8vo. Cloth, 10/6.

This volume concludes Mr. Henry Mayhew's account of his researches into the crime and poverty of London. The amount of labour of one kind or other, which the whole series of his publications represents, is something almost incalculable.

\* \* This celebrated Record of Investigations into the condition of the Poor of the Metropolis, undertaken from philanthropic motives by Mr. HENRY MAYHEW, first gave the wealthier classes of England some idea of the state of Heathenism, Degradation, and Misery in which multitudes of their poorer brethren languished.

LONDON: EXETER STREET, STRAND.

---

## MR. SOUTHGATE'S WORKS.

No one who is in the habit of writing and speaking much on a variety of subjects can afford to dispense with Mr. SOUTHGATE'S WORKS."—*Glasgow News*.

FIRST SERIES—THIRTY-FIFTH EDITION. SECOND SERIES—  
NINTH EDITION.

### MANY THOUGHTS OF MANY MINDS:

Selections and Quotations from the best Authors. Compiled and  
Analytically Arranged by

HENRY SOUTHGATE.

In Square 8vo, elegantly printed on Toned Paper.

Presentation Edition, Cloth and Gold, . . . . .	Each Vol.	12/6.
Library Edition, Roxburghe, . . . . .	„	14/.
Ditto, Morocco Antique, . . . . .	„	21/.

*Each Series complete in itself, and sold separately.*

“The produce of years of research.”—*Examiner*.

“A MAGNIFICENT GIFT-BOOK, appropriate to all times and seasons.”—*Freemasons' Magazine*.

“Not so much a book as a library.”—*Patriot*.

“Preachers and Public Speakers will find that the work has special uses for them.”  
*Edinburgh Daily Review*.

---

### BY THE SAME AUTHOR.

*Now Ready, THIRD EDITION.*

### SUGGESTIVE THOUGHTS ON RELIGIOUS SUBJECTS:

A Dictionary of Quotations and Selected Passages from nearly 1,000 of  
the best Writers, Ancient and Modern.

Compiled and Analytically Arranged by HENRY SOUTHGATE. In  
Square 8vo, elegantly printed on toned paper. (See page 7.)

---

### THE CHRISTIAN LIFE.

By MRS. HENRY SOUTHGATE.

Thoughts in Prose and Verse from the Best Writers of all Ages. Selected  
and Arranged for Every Day in the Year. *Second Edition.*

(See page 7.)

---

LONDON: EXETER STREET, STRAND.

A BOOK NO FAMILY SHOULD BE WITHOUT.

---

New issue of this important Work—Enlarged, in part Re-written, and thoroughly Revised to date.

TWENTY-SEVENTH EDITION. *Royal 8vo, Handsome Cloth, 1cs. 6d.*

A DICTIONARY OF  
DOMESTIC MEDICINE AND HOUSEHOLD SURGERY,

BY

SPENCER THOMSON, M.D., EDIN., L.R.C.S.,

REVISED, AND IN PART RE-WRITTEN, BY THE AUTHOR,

AND BY

JOHN CHARLES STEELE, M.D.,

OF GUY'S HOSPITAL.

With Appendix on the Management of the Sick-room, and many Hints for the Diet and Comfort of Invalids.

---

In its New Form, DR. SPENCER THOMSON'S "DICTIONARY OF DOMESTIC MEDICINE" fully sustains its reputation as the "Representative Book of the Medical Knowledge and Practice of the Day" applied to Domestic Requirements.

The most recent IMPROVEMENTS in the TREATMENT OF THE SICK—in APPLIANCES for the RELIEF OF PAIN—and in all matters connected with SANITATION, HYGIENE, and the MAINTENANCE of the GENERAL HEALTH—will be found in the New Issue in clear and full detail; the experience of the Editors in the Spheres of Private Practice and of Hospital Treatment respectively, combining to render the Dictionary perhaps the most thoroughly practical work of the kind in the English Language. Many new Engravings have been introduced—improved Diagrams of different parts of the Human Body, and Illustrations of the newest Medical, Surgical, and Sanitary Apparatus.

\* \* \* *All Directions given in such a form as to be readily and safely followed.*

---

FROM THE AUTHOR'S PREFATORY ADDRESS.

"Without entering upon that difficult ground which correct professional knowledge and educated judgment can alone permit to be safely trodden, there is a wide and extensive field for exertion, and for usefulness open to the unprofessional, in the kindly offices of a *true* DOMESTIC MEDICINE, the timely help and solace of a simple HOUSEHOLD SURGERY, or, better still, in the watchful care more generally known as 'SANITARY PRECAUTION,' which tends rather to preserve health than to cure disease. 'The touch of a gentle hand' will not be less gentle because guided by knowledge, nor will the *safe* domestic remedies be less anxiously or carefully administered. Life may be saved, suffering may always be alleviated. Even to the resident in the midst of civilization, the 'KNOWLEDGE IS POWER,' to do good; to the settler and emigrant it is INVALUABLE."

---

"Dr. Thomson has fully succeeded in conveying to the public a vast amount of useful professional knowledge."—*Dublin Journal of Medical Science.*

"The amount of useful knowledge conveyed in this Work is surprising."—*Medical Times and Gazette.*

"WORTH ITS WEIGHT IN GOLD TO FAMILIES AND THE CLERGY."—*Oxford Herald.*

---

LONDON: CHARLES GRIFFIN & CO., EXETER STREET, STRAND.

FIRST SERIES—THIRTY-FIFTH EDITION.

SECOND SERIES—NINTH EDITION.

# MANY THOUGHTS OF MANY MINDS:

A Treasury of Reference, consisting of Selections from the Writings of the most Celebrated Authors. FIRST AND SECOND SERIES. Compiled and Analytically Arranged  
By HENRY SOUTHGATE.

*In Square 8vo., elegantly printed on toned paper.*

Presentation Edition, Cloth and Gold	...	...	12s. 6d. each volume.
Library Edition, Half Bound, Roxburghs	...	...	14s. "
Do., Morocco Antique	...	...	21s. "

*Each Series is complete in itself, and sold separately.*

" 'MANY THOUGHTS,' &c., are evidently the produce of years of research."—*Examiner*.

"Many beautiful examples of thought and style are to be found among the selections."—*Leader*.

"There can be little doubt that it is destined to take a high place among books of this class."—*Notes and Queries*.

"A treasure to every reader who may be fortunate enough to possess it. Its perusal is like inhaling essences; we have the cream only of the great authors quoted. Here all are seeds or gems."—*English Journal of Education*.

"Mr. Southgate's reading will be found to extend over nearly the whole known field of literature, ancient and modern."—*Gentleman's Magazine*.

"We have no hesitation in pronouncing it one of the most important books of the season. Credit is due to the publishers for the elegance with which the work is got up, and for the extreme beauty and correctness of the typography."—*Morning Chronicle*.

"Of the numerous volumes of the kind, we do not remember having met with one in which the selection was more judicious, or the accumulation of treasures so truly wonderful."—*Morning Herald*.

"The selection of the extracts has been made with taste, judgment, and critical nicety."—*Morning Post*.

"This is a wondrous book, and contains a great many gems of thought."—*Daily News*.

"As a work of reference, it will be an acquisition to any man's library."—*Publishers' Circular*.

"This volume contains more gems of thought, refined sentiments, noble axioms, and extractable sentences, than have ever before been brought together in our language."—*The Field*.

"All that the poet has described of the beautiful in nature and art, all the axioms of experience, the collected wisdom of philosopher and sage, are garnered into one heap of useful and well-arranged instruction and amusement."—*The Era*.

"The collection will prove a mine rich and inexhaustible, to those in search of a quotation."—*Art Journal*.

"Will be found to be worth its weight in gold by literary men."—*The Builder*.

"Every page is laden with the wealth of profoundest thought, and all aglow with the loftiest inspirations of genius."—*Star*.

"The work of Mr. Southgate far outstrips all others of its kind. To the clergyman, the author, the artist, and the essayist, 'Many Thoughts of Many Minds' cannot fail to render almost incalculable service."—*Edinburgh Mercury*.

"We have no hesitation whatever in describing Mr. Southgate's as the very best book of the class. There is positively nothing of the kind in the language that will bear a moment's comparison with it."—*Manchester Weekly Advertiser*.

"There is no mood in which we can take it up without deriving from it instruction, consolation, and amusement. We heartily thank Mr. Southgate for a book which we shall regard as one of our best friends and companions."—*Cambridge Chronicle*.

"This work possesses the merit of being a MAGNIFICENT GIFT-BOOK, appropriate to all times and seasons; a book calculated to be of use to the scholar, the divine, and the public man."—*Freemason's Magazine*.

"It is not so much a book as a library of quotations."—*Patriot*.

"The quotations abound in that thought which is the mainspring of mental exercise."—*Liverpool Courier*.

"For purposes of apposite quotation, it cannot be surpassed."—*Bristol Times*.

"It is impossible to pick out a single passage in the work which does not, upon the face of it, justify its selection by its intrinsic merit."—*Dorset Chronicle*.

"We are not surprised that a SECOND SERIES of this work should have been called for. Mr. Southgate has the catholic tastes desirable in a good Editor. Preachers and public speakers will find that it has special uses for them."—*Edinburgh Daily Review*.

"The SECOND SERIES fully sustains the deserved reputation of the FIRST."—*John Bull*.

LONDON: CHARLES GRIFFIN & COMPANY.





glasses where the  
lenses are usually let  
into the mount & generally  
only one in front is used  
the whole series of <sup>lenses</sup>  
in a dry objective ~~of~~  
~~glasses~~ may be subject  
to flare

It is said the dots on  
Blum's <sup>or</sup> light may  
be seen with some  
but it is really a question  
of illumination  
My <sup>1/25</sup> shows them well  
and though given as a  
test for dry <sup>1/50</sup>

