



Calhoun: The NPS Institutional Archive
DSpace Repository

Theses and Dissertations

1. Thesis and Dissertation Collection, all items

2014-03

Supply chain management model for modular or flexible optimally manned ships

Bonagrazia-Healey, Viviane; DeLeon, Alain; Nguyen,
Hang; Chun, Raymond; Faulk, David; Oostdyk, Aaron;
Woods, Victoria; Crane, Zachary; Ligman, Julie; Will, Brandon...

Monterey, California: Naval Postgraduate School

<http://hdl.handle.net/10945/41439>

Downloaded from NPS Archive: Calhoun



Calhoun is a project of the Dudley Knox Library at NPS, furthering the precepts and goals of open government and government transparency. All information contained herein has been approved for release by the NPS Public Affairs Officer.

Dudley Knox Library / Naval Postgraduate School
411 Dyer Road / 1 University Circle
Monterey, California USA 93943

<http://www.nps.edu/library>



**NAVAL
POSTGRADUATE
SCHOOL**

MONTEREY, CALIFORNIA

**SYSTEMS ENGINEERING
CAPSTONE PROJECT REPORT**

**SUPPLY CHAIN MANAGEMENT MODEL FOR
MODULAR OR FLEXIBLE OPTIMALLY MANNED
SHIPS**

by

Team RSRP
Cohort 311-123L

March 2014

Capstone Advisor:

Brigitte T. Kwinn

Approved for public release; distribution is unlimited.

THIS PAGE INTENTIONALLY LEFT BLANK

REPORT DOCUMENTATION PAGE			<i>Form Approved OMB No. 0704-0188</i>
Public reporting burden for this collection of information is estimated to average 1 hour per response, including the time for reviewing instruction, searching existing data sources, gathering and maintaining the data needed, and completing and reviewing the collection of information. Send comments regarding this burden estimate or any other aspect of this collection of information, including suggestions for reducing this burden, to Washington headquarters Services, Directorate for Information Operations and Reports, 1215 Jefferson Davis Highway, Suite 1204, Arlington, VA 22202-4302, and to the Office of Management and Budget, Paperwork Reduction Project (0704-0188) Washington DC 20503.			
1. AGENCY USE ONLY (Leave blank)	2. REPORT DATE March 2014	3. REPORT TYPE AND DATES COVERED Capstone Project Report	
4. TITLE AND SUBTITLE SUPPLY CHAIN MANAGEMENT MODEL FOR MODULAR OR FLEXIBLE OPTIMALLY MANNED SHIPS		5. FUNDING NUMBERS	
6. AUTHOR(S) Cohort 311-123L/Team RSRP			
7. PERFORMING ORGANIZATION NAME(S) AND ADDRESS(ES) Naval Postgraduate School Monterey, CA 93943-5000		8. PERFORMING ORGANIZATION REPORT NUMBER	
9. SPONSORING /MONITORING AGENCY NAME(S) AND ADDRESS(ES) N/A		10. SPONSORING/MONITORING AGENCY REPORT NUMBER	
11. SUPPLEMENTARY NOTES The views expressed in this thesis are those of the author and do not reflect the official policy or position of the Department of Defense or the U.S. Government. IRB protocol number ____N/A____.			
12a. DISTRIBUTION / AVAILABILITY STATEMENT Approved for public release; distribution is unlimited.		12b. DISTRIBUTION CODE A	
13. ABSTRACT (maximum 200 words) Implementation of modular or flexible design ships has introduced gaps in the United States Navy's logistics and sustainment operations regarding parts support. The Navy's supply chain management system must consider ship weight and space constraints, reduced onboard manning, and a new concept of shore-based support in order to permit efficient identification and assignment of spare parts to multiple distribution and maintenance locations to ensure ship mission availability. Following a systems engineering management process the team identified the problem, relevant stakeholders, and the system requirements. An analysis of alternatives was conducted on existing models to determine which one could be suitable for altering to meet the stakeholders' requirements. Modeling and simulation was used to simulate system operations. A model based systems engineering approach using CORE enabled requirements management and traceability, identification of system functionality, and development of system diagrams and architectural views. These techniques resulted in a conceptual and partial preliminary design of the supply chain management model. This model addresses the need for a parts sparing system in support of modular or flexible design ships. This research confirms the need for such a model and the project output provides a basis for continuation of system development.			
14. SUBJECT TERMS Supply chain management, modular design, flexible design, supply chain management model, systems engineering management, model based systems engineering, parts sparing system		15. NUMBER OF PAGES 269	16. PRICE CODE
17. SECURITY CLASSIFICATION OF REPORT Unclassified	18. SECURITY CLASSIFICATION OF THIS PAGE Unclassified	19. SECURITY CLASSIFICATION OF ABSTRACT Unclassified	20. LIMITATION OF ABSTRACT UU

THIS PAGE INTENTIONALLY LEFT BLANK

Approved for public release; distribution is unlimited.

**SUPPLY CHAIN MANAGEMENT MODEL FOR MODULAR OR
FLEXIBLE OPTIMALLY MANNED SHIPS**

Cohort 311-123L/Team RSRP

Viviane Bonagrazia-Healey
Alain DeLeon
Hang Nguyen

Raymond Chun
David Faulk
Aaron Oostdyk
Victoria Woods

Zachary Crane
Julie Ligman
Brandon Will

Submitted in partial fulfillment of the
requirements for the degree of

MASTER OF SCIENCE IN SYSTEMS ENGINEERING MANAGEMENT

from the

**NAVAL POSTGRADUATE SCHOOL
March 2014**

Lead editor: Viviane Bonagrazia-Healey

Reviewed by:
Brigitte T. Kwinn
Capstone Project Advisor

Accepted by:
Cliff Whitcomb
Chair, Systems Engineering Department

THIS PAGE INTENTIONALLY LEFT BLANK

ABSTRACT

Implementation of modular or flexible design ships has introduced gaps in the United States Navy's logistics and sustainment operations regarding parts support. The Navy's supply chain management system must consider ship weight and space constraints, reduced onboard manning, and a new concept of shore-based support in order to permit efficient identification and assignment of spare parts to multiple distribution and maintenance locations to ensure ship mission availability.

Following a systems engineering management process the team identified the problem, relevant stakeholders, and the system requirements. An analysis of alternatives was conducted on existing models to determine which one could be suitable for altering to meet the stakeholders' requirements. Modeling and simulation was used to simulate system operations. A model based systems engineering approach using CORE enabled requirements management and traceability, identification of system functionality, and development of system diagrams and architectural views.

These techniques resulted in a conceptual and partial preliminary design of the supply chain management model. This model addresses the need for a parts sparing system in support of modular or flexible design ships. This research confirms the need for such a model and the project output provides a basis for continuation of system development.

THIS PAGE INTENTIONALLY LEFT BLANK

TABLE OF CONTENTS

I.	INTRODUCTION.....	1
A.	OVERVIEW	2
B.	PROJECT BACKGROUND.....	3
C.	PROJECT TEAM.....	5
D.	SYSTEMS ENGINEERING PROCESS.....	6
1.	Needs Analysis.....	8
2.	System Requirements	9
3.	System Architecture.....	9
4.	Conceptual Design	10
5.	Modeling and Simulation	10
6.	System Integration and Test	10
7.	Component Verification	11
8.	System Analysis.....	11
9.	System Validation	12
10.	SE Process Status	12
E.	SYSTEM LIFECYCLE.....	13
F.	TECHNICAL TOOLS.....	15
G.	SUMMARY	16
II.	NEEDS ANALYSIS.....	19
A.	PROBLEM DEFINITION	19
1.	Research Questions.....	19
2.	Literature Review	20
B.	PROBLEM STATEMENT	29
C.	STAKEHOLDER ANALYSIS	30
D.	FUNCTIONAL ANALYSIS	32
E.	SUMMARY	55
III.	SYSTEM REQUIREMENTS	59
A.	SYSTEM MODELING	59
B.	SYSTEM BOUNDARIES	60
C.	REQUIREMENTS ANALYSIS	75
1.	Originating Requirements.....	76
2.	Requirements Analysis Framework	77
3.	Input/Output Requirements	78
4.	Technology and Suitability Requirements	79
5.	System Trade-Off Requirements.....	82
6.	System Qualification Requirements.....	83
7.	Derived Requirements.....	85
D.	SUMMARY	93
IV.	SYSTEM ARCHITECTURE	95
A.	DODAF ROADMAP	95
B.	DODAF VIEWS	97

1.	CV-1	97
2.	OV-1	99
3.	OV-2	100
4.	OV-3	103
5.	OV-4	103
6.	OV-5b	104
7.	SV-1	106
8.	SV-4	108
9.	SV-5a	116
C.	SUMMARY	122
V.	CONCEPTUAL DESIGN	125
A.	ANALYSIS OF ALTERNATIVES	125
1.	Determining the Alternatives	126
2.	Analysis of Existing Systems	127
B.	DETAILED DESCRIPTION OF THE TOP THREE ALTERNATIVES	133
1.	ME-RBS: Multi-Echelon Readiness Based Sparing	133
2.	ARROWS: Aviation Readiness Requirements Oriented to Weapon Replaceable Assemblies	133
3.	OSRAP: Optimum Stock Requirements Analysis Program	134
C.	RESULTS OF ANALYSIS OF ALTERNATIVES	135
1.	Space and weight constraints	135
2.	Operational availability	135
3.	Cost	135
4.	Multi-Nodal and Multi-Mission	135
D.	SUMMARY	136
VI.	MODELING AND SIMULATION	139
A.	SYSTEM MODELING	139
B.	SYSTEM SIMULATION	141
1.	Microsoft Excel Simulation	141
2.	ExtendSim Simulation	148
C.	SUMMARY	154
VII.	SYSTEM INTEGRATION AND TEST, COMPONENT VERIFICATION, SYSTEM ANALYSIS, AND VALIDATION	157
A.	SYSTEM INTEGRATION AND TEST	157
1.	Strategy	158
2.	Testing Risks	160
3.	Features To Be Tested / Not To Be Tested	161
4.	Testing Summary	161
B.	VERIFICATION AND VALIDATION	162
1.	Component Verification	162
2.	System Analysis	163
3.	System Validation	164
C.	SUMMARY	164

VIII.	COST ANALYSIS	167
A.	CONSTRUCTIVE SYSTEMS ENGINEERING COST MODEL AND COST ANALYSIS	168
B.	RESULTS	169
1.	OSRAP.....	169
2.	ME-RBS.....	170
3.	SCMM System (Full Development).....	171
4.	SCMM System (Partial Development).....	172
5.	Effort.....	173
6.	Schedule.....	174
7.	Cost.....	175
C.	RESULTS OF THE COST ANALYSIS.....	176
D.	SUMMARY	176
IX.	RISK ANALYSIS.....	179
A.	RISK ANALYSIS PROCESS.....	179
B.	RISK MITIGATION.....	180
C.	RISK ANALYSIS OF ALTERNATIVES	183
D.	SUMMARY	185
X.	CONCLUSION	187
A.	SYNOPSIS.....	187
B.	RESULTS	188
C.	RECOMMENDATIONS.....	189
APPENDIX A.	FUNCTIONAL FLOW BLOCK DIAGRAM.....	191
APPENDIX B.	ADDITIONAL DODAF VIEWS INFORMATION	197
APPENDIX C.	ANALYSIS OF ALTERNATIVES SCORING MATRIX.....	201
APPENDIX D.	EXCEL SIMULATION MACRO	203
APPENDIX E.	ADDITIONAL AND EXPANDED TEST DOCUMENTATION.....	205
A.	TEST MEASURES AND METRICS TABLE.....	205
B.	TEST RESULTS REPORT	209
C.	CONFIGURATION MANAGEMENT AND CHANGE CONTROL....	215
APPENDIX F.	COSYSMO FACTORS	217
APPENDIX G.	SUPPLY CHAIN MANAGEMENT MODEL RISK MANAGEMENT PLAN	225
A.	RISK IDENTIFICATION AND ANALYSIS.....	226
B.	RISK MITIGATION.....	232
C.	RISK TRACKING.....	233
	LIST OF REFERENCES.....	235
	INITIAL DISTRIBUTION LIST	239

THIS PAGE INTENTIONALLY LEFT BLANK

LIST OF FIGURES

Figure 1.	Tailored Systems Engineering Process (after Forsberg and Mooz 1991).....	8
Figure 2.	Systems Engineering Process Status (after Forsberg and Mooz 1991)	13
Figure 3.	Life Cycles of the System (from Blanchard and Fabrycky 2011, 30)	14
Figure 4.	Current Readiness Based Spares Functional Scope (from RBS Working Group 2005)	25
Figure 5.	Multi-Indenture, Multi-Echelon RBS (from Assistant Secretary of Defense, Logistics and Materiel Readiness 2012).....	26
Figure 6.	Use Case for “Support Single Mission Module” Scenario	35
Figure 7.	SCMM System Top-Level Functional Flow Block Diagram	36
Figure 8.	SCMM System Functional Flow Block Diagram	37
Figure 9.	SCMM System Function 1: Enable Graphic User Interface.....	42
Figure 10.	SCMM System Function 2: Receive Data	43
Figure 11.	SCMM System Function 3: Process Data.....	44
Figure 12.	SCMM System Function 4: Provide Output.....	45
Figure 13.	SCMM System Function 5: Maintain System	46
Figure 14.	SCMM System Function 6: Secure System.....	47
Figure 15.	SCMM System Top-Level Functions Hierarchy Block Diagram.....	48
Figure 16.	SCMM Function 1: Enable Graphic User Interface Hierarchy Block Diagram.....	48
Figure 17.	SCMM System Function 2: Receive Data Hierarchy Block Diagram	49
Figure 18.	SCMM System Function 3: Process Data Hierarchy Block Diagram	49
Figure 19.	SCMM System Function 4: Provide Output Hierarchy Block Diagram	50
Figure 20.	SCMM System Function 5: Maintain System Hierarchy Block Diagram.....	51
Figure 21.	SCMM System Function 6: Secure System Hierarchy Block Diagram	51
Figure 22.	SCMM System High-Level ICOM Diagram.....	61
Figure 23.	SCMM System IDEF0.....	65
Figure 24.	SCMM System Functions 1 and 5: Enable Graphic User Interface and Maintain System IDEF0 (Function 1 Emphasis).....	66
Figure 25.	SCMM System Functions 2, 3, and 4: Receive Data, Process Data, and Provide Output IDEF0 (Function 2 Emphasis).....	67
Figure 26.	SCMM System Functions 2, 3, and 4: Receive Data, Process Data, and Provide Output IDEF0 (Function 3 Emphasis).....	68
Figure 27.	SCMM System Functions 2, 3, and 4: Receive Data, Process Data, and Provide Output IDEF0 (Function 4 Emphasis).....	69
Figure 28.	SCMM System Functions 5 and 1: Maintain System and Enable Graphic User Interface IDEF0 (Function 5 Emphasis)	70
Figure 29.	SCMM System Function 6: Secure System IDEF0	71
Figure 30.	SCMM System Context Diagram	73
Figure 31.	SCMM System N-Squared Diagram	75
Figure 32.	Hierarchies of Requirements (after Buede 2000, 122)	77
Figure 33.	Top-Level Requirements	78
Figure 34.	System Inputs/Outputs Hierarchy	78

Figure 35.	System Technology and Suitability Requirements Hierarchy	80
Figure 36.	System Suitability Requirements Hierarchy	81
Figure 37.	System Cost Requirements Hierarchy	81
Figure 38.	System Schedule Requirements Hierarchy	82
Figure 39.	System Trade-Offs Requirement Hierarchy	83
Figure 40.	System Qualification Requirement Hierarchy	84
Figure 41.	SCMM System DODAF Roadmap.....	96
Figure 42.	SCMM System Capability Vision—CV-1.....	98
Figure 43.	SCMM System High Level Operational Concept—OV-1	100
Figure 44.	SCMM System Operation Resource Flow Description—OV-2.....	102
Figure 45.	SCMM System Operational Activity Model—OV-5b	105
Figure 46.	SCMM System System Interface Description Model—SV-1	108
Figure 47.	SCMM System Systems Functionality Description—SV-4.....	110
Figure 48.	SCMM System Systems Functionality Description—Function 1: Enable Graphic User Interface.....	111
Figure 49.	SCMM System Systems Functionality Description—Function 2: Receive Data.....	112
Figure 50.	SCMM System Systems Functionality Description—Function 3: Process Data.....	113
Figure 51.	SCMM System Systems Functionality Description—Function 4: Provide Output	114
Figure 52.	SCMM System Systems Functionality Description—Function 5: Maintain System.....	115
Figure 53.	SCMM System Systems Functionality Description—Function 6: Secure System.....	116
Figure 54.	Alternative Models Down-Selection Process	130
Figure 55.	Final Swing Weight (Unsorted).....	131
Figure 56.	Final Swing Weight (Sorted)	132
Figure 57.	Drop-Down Input Boxes.....	143
Figure 58.	Misc. Data Tab.....	144
Figure 59.	Data Validation Application	144
Figure 60.	Data Validation Window	145
Figure 61.	CDMD-OA Tab	146
Figure 62.	Executive Block	149
Figure 63.	Routing: Create Block.....	149
Figure 64.	Activity Block.....	150
Figure 65.	Attributes Block	150
Figure 66.	Random Variable Block.....	150
Figure 67.	User Ship and Mission Inputs	151
Figure 68.	ExtendSim Simulation Overview	151
Figure 69.	Exit Block	152
Figure 70.	Plotter, Discrete Event Block.....	152
Figure 71.	Simulation Plot.....	153
Figure 72.	COSYSMO Inputs for ME-RBS.....	169
Figure 73.	COSYSMO Results for OSRAP.....	170

Figure 74.	COSYSMO Results for ME-RBS	171
Figure 75.	COSYSMO Results for SCMM (Full Development)	172
Figure 76.	COSYSMO Results for SCMM (Partial Development)	173
Figure 77.	COSYSMO Comparison of Effort (Person-Months).....	174
Figure 78.	COSYSMO Comparison of Schedule(months)	175
Figure 79.	COSYSMO Comparison of Cost	176
Figure 80.	OSRAP and ME-RBS System Risk Matrix	184
Figure 81.	SCMM (Full) System Risk Matrix	184
Figure 82.	SCMM (Partial) System Risk Matrix	185
Figure 83.	SCMM System FFBD Section A	192
Figure 84.	SCMM System FFBD Section B	193
Figure 85.	SCMM System FFBD Section C	194
Figure 86.	SCMM System Section D.....	195
Figure 87.	Analysis of Alternatives Scoring Matrix	202
Figure 88.	Configuration Management Change Tracking List for SCMM Excel Simulation.....	216
Figure 89.	Configuration Management Change Tracking List for SCMM ExtendSim Simulation.....	216
Figure 90.	DOD Risk Management Process (from Department of Defense 2006, 4).....	225
Figure 91.	Types of Consequence Criteria (after Department of Defense 2006, 13).....	231
Figure 92.	Risk Report Matrix (after Department of Defense 2006, 11)	232

THIS PAGE INTENTIONALLY LEFT BLANK

LIST OF TABLES

Table 1.	Team Project Roles and Personnel	5
Table 2.	Acquisition Phase Technical Activities and the Vee SEP	15
Table 3.	Tenets of Army Operations (from Department of the Army Headquarters 2000, 1–2)	23
Table 4.	Stakeholder Analysis for SCMM.....	31
Table 5.	Functions and Functional Requirements.....	41
Table 6.	SCMM System—Input and Output Function Allocation	55
Table 7.	SCMM System Detailed ICOM Table.....	64
Table 8.	SCMM System Requirements.....	92
Table 9.	SCMM System Operational Activity to System Function Traceability Matrix—SV-5a	121
Table 10.	List of the 22 Existing Models for Swing Weight Evaluation.....	129
Table 11.	Swing Weight Criteria	130
Table 12.	Risk Management Spreadsheet for System Risk	182
Table 13.	SCMM System Organizational Resources Linkage Matrix depicted by OV-2	199
Table 14.	Test Measures and Metrics	209
Table 15.	COSYSMO Factors Defined for the SCMM System	223
Table 16.	Risk Management Responsibilities (after Team Liberty 311–114G 2012) ...	226
Table 17.	Capstone Project Lifecycle Risk Analysis	227
Table 18.	Cohort 311–123L Risk Management Spreadsheet for Project Risk	229
Table 19.	Cohort 311–123L Risk Management Spreadsheet for System Risk.....	230
Table 20.	Levels of Likelihood Criteria (from Department of Defense 2006, 12).....	231

THIS PAGE INTENTIONALLY LEFT BLANK

LIST OF ACRONYMS AND ABBREVIATIONS

AAW	anti-air warfare
AEL	allowance equipage list
AMPS	Afloat Master Planning System
Ao	operational availability
AoA	analysis of alternatives
AOM	Aegis optimization model
APL	allowance parts list
ARROWS	aviation readiness requirements oriented to weapon replaceable assemblies
ASUW	anti-surface warfare
ASW	anti-submarine warfare
AV	all view
CAIV	cost as an independent variable
CD	Crane Division
CDMD-OA	Configuration Data Managers Database—Open Architecture
CI	configuration item
CIO	chief information officer
CONUS	continental United States
COSYSMO	constructive systems engineering cost model
COTS	commercial-off-the-shelf
CV	capability view
DAU	Defense Acquisition University
DLA	Defense Logistics Agency
DOD	Department of Defense
DODAF	DOD Architecture Framework
DoN	Department of Navy
ERP	enterprise resource planning
FFBD	functional flow block diagram
FLC	Fleet Logistics Center
GAO	Government Accountability Office

GIG	global information grid
GUI	graphical user interface
HAZMAT	hazardous material
HBD	hierarchy block diagram
HM&E	hull, mechanical, and electrical
HSI	human systems integration
IA	information assurance
IBM	International Business Machines
ICOM	input, control/constraint, output, and mechanism
IDEF0	integrated definition for function modeling
IMS	integrated master schedule
INCOSE	International Council on Systems Engineering
IPR	in-process review
IRB	Institutional Review Board
ISEA	in-service engineering agent
JCA	joint capability area
KPP	key performance parameter
KSA	key system attribute
LCS	littoral combat ship
LCSRON	littoral combat ship squadron
M&S	modeling and simulation
MBSE	model based systems engineering
MCM	mine countermeasures
MDT	mean down time
ME-RBS	multi-echelon reliability based sparing
MIME	multi-indenture, multi-echelon
MIW	mine warfare
MLDT	mean logistics delay time
MOE	measure of effectiveness
MOSA	modular open systems approach
MPSF	mission package support facility
MS	Master of Science

MSSEM	Master of Science Systems Engineering Management
MTBF	mean time between failure
N ²	N-squared
NAVSUP	Naval Supply Systems Command
NMCI	Navy Marine Corps intranet
NPS	Naval Postgraduate School
NSN	national stock number
NSWC	Naval Surface Warfare Center
OCONUS	outside the continental United States
OEM	original equipment manufacturer
OMN	Operation and Maintenance, Navy
OSEE	Open System Engineering Environment
OSRAP	Optimum Stock Requirements Analysis Program
OV	operational view
PAA	product area of accountability
PHD	Port Hueneme Division
R&D	research and development
RBS	readiness based sparing
RMC	regional maintenance center
RMP	risk management plan
RSRP	Right Spare Right Place
S/W	software
SA	system architecture
SCM	supply chain management
SCMM	supply chain management model
SE	systems engineering
SEM	systems engineering management
SEMP	systems engineering management plan
SEP	systems engineering process
SIPRNET	secret internet protocol router network
SME	subject matter expert
SV	system view

TYCOM
U.S.

type commander
United States

EXECUTIVE SUMMARY

This report addresses the need for a spare parts allocation system in support of modular or flexible design ships. The research conducted confirmed the need for the supply chain management model (SCMM) system, development of which the team pursued, and the project's outputs provide a basis for continuation of system development. The team concluded that the existing Multi-Echelon Readiness Based Sparing (ME-RBS) system is the best alternative suitable for adaptation to support the stakeholders' needs and requirements. This model requires additional research to determine whether modification is viable in terms of design and cost. Another option is the development of a new system rather than adaptation of an existing system. This option would be preferred if the ME-RBS system's design could not be altered and/or if the cost were above that of new system development. Initial cost analysis, based on assumptions, indicates that adapting the ME-RBS system would be less costly than constructing a new system. The team recommends that research and analysis continue in support of the development of the SCMM system, whether it is the alteration of the ME-RBS system or the creation of a new system, to meet the identified stakeholders' needs.

The systems/programs currently in use for determining spare parts allocation do not provide information that takes into account the ability to modify ships rapidly to introduce warfare-specific capability through the use of mission modules nor do they take into account shipboard constraints including manning, space, and weight which impact ships' and fleet's readiness and operational availability, based on the team's research and project sponsor input. The Navy's supply chain management system must consider these constraints and also a new concept of shore-based support to permit efficient identification and assignment of spare parts to multiple distribution and maintenance locations to ensure single or multi-ship and single or multi-mission availability.

To determine and address the problem, Team RSRP's methodology began with identifying team member roles and responsibilities to ensure efficient project development coverage. After a team structure was established, a systems engineering process was implemented based on a tailored vee model that included the following main

developmental process phases: needs analysis, system requirements, system architecture, conceptual design, modeling and simulation (M&S), system integration and test, component verification, system analysis, and system validation.

The objective of the needs analysis phase was to understand the stakeholders' needs, wants, and desires, to further develop the initial problem statement, and to refine the primitive need statement into an effective need statement. A literature review was conducted to examine the material related to supply chain management (SCM) for modular or flexible design ships, and to discover the challenges associated with it. The problem statement was then finalized as follows: *As the U.S. Navy drives toward modular and flexible designs, the currently used surface Navy SCM models do not support modular or flexible design ships. These ships require an off-ship maintenance support structure consisting of multiple logistics and repair nodes due to shipboard constraints including manning, space, and weight.*

The gap, which is the difference between the current state of the system and how the stakeholder needs the system to perform and operate, was identified as: *The systems/programs currently in use for determining spare parts allocations do not provide information that takes into account the ability to modify ships rapidly to introduce warfare specific capability through the use of mission modules nor do they take into account shipboard constraints including manning, space, and weight which impact ships' and fleet's readiness and operational availability.* A functional analysis was performed next to identify the functions of the system through the utilization of use case scenarios.

The capabilities of the system were identified with the sponsor at this time, also. These were *convert (or process) data inputs into information to be used for providing spare parts at various locations based on the use case scenarios and allow the users to conduct sensitivity analysis based on the inputs for trade-off analysis for cost, operational availability (Ao), personnel requirements, weight, and/or space,* both derived from the need statement. Research was conducted during the needs analysis phase to include stakeholder "wants" until the system's functions were identified. The top-level functions of the system were determined to be as follows:

- Enable graphic user interface
- Receive data
- Process data
- Provide output
- Maintain system
- Secure system

Once the problem and effective need statements were defined, agreed upon by the sponsor, and understood by the stakeholders, the system requirements analysis was conducted based on the Buede method for requirements analysis. The top level system requirement, the originating requirement for the SCMM system, is the need statement: *The stakeholders need information to determine sparing of parts at existing and multiple supply points in order to support the Navy's modular/flexible ships within the constraints of manning, space, weight, location, and cost/budget.* Input-output analysis was conducted to scope and bound the problem. An input, control/constraint, output, and mechanism (ICOM) diagram and context diagram were developed as a result of these analyses. Functional and non-functional requirements were identified from the system requirements development based on the previously conducted functional analysis of the system. The system's requirements were captured in Vitech's CORE, a systems engineering and project management toolset that was used to trace the system requirements to stakeholder needs, document system functionality, and document the system architecture (Vitech 2013).

The system architecture phase was used to capture the logical sequencing and interaction of system functions or logical elements. The system architecture was documented using CORE, which also provided a model based systems engineering (MBSE) capability. The team utilized the Department of Defense Architecture Framework v2.02 (DODAF) to define the different architecture views of the system design. Three architectural views, capability view (CV), operational views (OVs), and system views (SVs), were created to show the relationship of inputs and outputs and constraints and mechanisms of the system design. The output of this phase was a high level system design and a generic architecture that met the needs of the stakeholders.

During the conceptual design phase a methodology to identify a system design that met the functional and performance requirements of the SCMM system was followed. To screen established and operational models within the Department of Defense (DOD) community for possible adaptation, Team RSRP used weighted criteria based on the SCMM system requirements to conduct an analysis of alternatives (AoA). Twenty-three alternatives were generated, and the three highest scoring alternatives were further analyzed. The benefits and disadvantages of each were determined resulting in recommendation of a model for further investigation and possible modification to fill the Navy's supply chain gap.

In the modeling and simulation phase, the SCMM system and the current system used to support modular and flexible design ships were simulated using Imaginethat Inc.'s ExtendSim to simulate operations and determine expected system performance versus current system performance. Microsoft Excel was used to provide a proof of concept of the SCMM system. A model based systems engineering approach using CORE enabled requirements management and traceability, identification of system functionality, and development of system diagrams and architectural views. These techniques resulted in a conceptual and partial preliminary design of the SCMM system.

The system integration and test phase was accomplished concurrently with the M&S phase to demonstrate that the expected system performance would be effective and suitable. A test plan was created, and level one and level two testing were accomplished. Due to this capstone project's schedule constraint, the design was not mature enough to conduct trade-off studies or testing to ensure readiness and maturity of the system design.

In the integration and test phase the intent was to assemble, integrate, and test the system elements to evaluate its design. Performance characteristics were to be verified and the design issues were to be identified to the stakeholders. Trade-off studies, including readiness and maturity of the system design, should have been conducted. Due to this capstone project's schedule constraint, system integration and test did not include the assembly, integration, and test of the system elements, but did include system verification, system analysis, and system validation of the SCMM system simulation that was created in the M&S phase.

Due to an immature design, the team did not perform the component verification phase of the systems engineering process (SEP). This phase is conducted through an effective combination of analysis, inspection, demonstration, and testing that gauges the maturity of each component of the design (i.e., software [S/W] and supportability) prior to integrating the overall system design solution.

In the system analysis phase, design alternatives were evaluated during the AoA conducted in the conceptual design phase; cost and risk analyses were also performed. The AoA was conducted using value modeling, based on a weighted chart, and with a numerical evaluation matrix to determine the model that best satisfied the stakeholders' requirements. Cost analysis was conducted using the constructive systems engineering cost model (COSYSMO), a model used to help assess the cost and schedule implications of systems engineering decisions. COSYSMO was used to evaluate the different alternatives that resulted from the AoA. The risk analysis focused on the SCMM system and capstone project risks. This analysis was conducted throughout the SEP and resulted in the development of the Risk Management Plan addressing the programmatic and technical risks of the project and system. The output of the system analysis phase was the identification of a system alternative suitable for adaptation to support the stakeholders' needs and requirements.

The last phase of the tailored SEP, system validation, ensures that the as-designed system meets the system requirements in conformance with the stakeholders' needs (Blanchard and Fabrycky 2011). This process also demonstrates that the designed system achieves its intended use in the intended operational environment (Blanchard and Fabrycky 2011). Although this phase was not performed in its entirety due to the immaturity of the system design, it is recommended that system validation continue throughout the design of the SCMM system by performing progressive and iterative integrated system testing to validate the maturity of the system and assess overall system readiness.

Team RSRP was able to apply a tailored SE approach to define and conceptually design a solution to a U.S. Navy supportability problem. It is hoped that additional research supports further development and that analyses are conducted in support of finalizing the design of this SCMM system.

LIST OF REFERENCES

- Blanchard, Benjamin S., and Wolter J. Fabrycky. 2011. *Systems Engineering and Analysis*. 5th ed. Upper Saddle River, NJ: Pearson Education, Inc., publishing as Prentice Hall.
- Vitech. 2013. "CORE Delivers Product Design and Development Success through Integrated Systems Engineering." Vitech. Accessed December 28, 2013. <http://www.vitechcorp.com/products/core.shtml>.

ACKNOWLEDGEMENTS

The students of the Systems Engineering Management Cohort 311-123L would like to thank our advisor and professor, Brigitte Kwinn, for her guidance and patience throughout the duration of our program. It is fitting that our master's program schedule began with Professor Kwinn teaching the Fundamentals of System Engineering (SE), and is ending with Professor Kwinn as our capstone project advisor. She not only taught us the fundamentals of SE but she ensured that we understood the material and retained the information imparted. She was by far the most influential person throughout this process, and we are grateful for her knowledge and guidance. Ultimately, thank you for your patience with the 10 of us.

We would also like to thank our sponsor, Mr. Bob Howard, who played an integral role in helping us to determine the problem definition and the need for the supply chain management model (SCMM) system. His availability to the team was necessary in completing this capstone project, and was very much appreciated. You have given your time and patience, and we thank you for being part of the team.

Many thanks to the faculty and staff at the Naval Postgraduate School, (NPS). A special thank you to Mary Vizzini, Barbara Berlitz, and Catherine Grant who guided and advised our team with editorial comments and formatting of the capstone report.

We would like to thank our respective commands, Naval Surface Warfare Center Port Hueneme Division (NSWC PHD) and NSWC Crane, for providing us with this learning opportunity.

Finally, we would like to thank our families and friends for their patience, support, and understanding. It was a very long two years, and we would not have made it through the Masters of Systems Engineering Management (MSSEM) program without their love and encouragement. We owe everyone much gratitude, thank you.

THIS PAGE INTENTIONALLY LEFT BLANK

I. INTRODUCTION

Today, the United States (U.S.) Navy continues to be the world's most powerful navy when considering the factors of size, harnessed technology, and the geographical area the U.S. Navy covers (Work 2008). In fiscal year 2012, \$38,120,800,000 was enacted to support the sustainment operations of the many different classes of ships within the Navy (Under Secretary of Defense [Comptroller] 2012). According to the Under Secretary of Defense (Comptroller) as indicated on the "Under Secretary of Defense (Comptroller)" website:

The Operation and Maintenance, Navy (OMN) appropriation finances the day-to-day costs of operating naval forces, including fuel, supplies, and maintenance of ships, Navy and Marine Corps aircraft, related weapon systems, and the support establishment ashore. The primary focus of the Department's budget is to continue to ensure the readiness of deployed forces. (Under Secretary of Defense [Comptroller] 2012)

The supply chain personnel are responsible for overseeing a diverse assortment of goods, material, and equipment that must be integrated, transported, and maintained to keep the Navy's ships afloat and fully operational. The supply chain that is used to coordinate the parts and personnel for the operations and sustainment of the Navy's fleet is extensive. This supply chain is operated and supported by defense contractors, private industry suppliers, and Department of Defense (DOD) supply organizations that cover the globe with sustainment logistics from a multitude of facilities and locations. The geographical breadth in which the Navy operates presents a major challenge with sustainment activities being able to meet operational requirements such as ship mission availability, maintenance times, and personnel support. Logistics and sustainment operations must now provide support to modular or flexible optimally-manned classes of ships taking into account weight, space, and personnel constraints that limit parts sparing methods and maintenance actions onboard ships while taking advantage of off-ship support structures. Parts sparing methods use models that are in current use to determine which parts to allocate shipboard in order to support a ship's operational availability requirement.

A. OVERVIEW

The amount of material required to support a ship is vast and varies by ship class and configuration which may include integrated weapon systems, electronic equipment for communication and detection, aircraft support and additional personnel assigned to the ship for mission support. The personnel considerations necessary to complete the maintenance actions on a ship require training and planning for effective support. The majority of today's traditional U.S. Naval ships' supply chains rely on readiness based sparing (RBS) to supply the various ship classes. According to the Assistant Secretary of Defense, as described on the "Supply Chain Integration" webpage, RBS

...is the practice of using advanced analytics to set spares levels and locations to maximize system readiness. RBS has been part of Department practice since the 1960s, when it was used to optimize aircraft availability, and is incorporated into *DOD Supply Chain Materiel Management Regulation (DOD 4140.1-R)* as the preferred method for calculating inventory levels. (Assistant Secretary of Defense, Logistics and Materiel Readiness 2012)

In recent years, the U.S. Navy, along with naval forces around the world, has begun to plan and build new ship classes to be flexible in design, resulting in each ship having modular equipment that can be integrated for specific mission requirements. The idea of being able to switch out modular equipment has come to the forefront with regard to ship design because it will allow a specific ship to be able to support many different missions with varying configurations that can be integrated for each mission. The intent is to reduce the number of different ship classes while increasing the capabilities of each individual ship class. However, this has resulted in the need for a more flexible and responsive supply chain to support the sustainment of these configurations and the supportability and maintenance of the modular mission packages.

Team Right Spare, Right Place (RSRP) has developed a conceptual design of the supply chain management model (SCMM) that will serve as a sparing tool to bridge the gap that currently exists in the support of modular or flexible optimally-manned ships. This project is sponsored by Mr. Robert (Bob) Howard of the Naval Surface Warfare Center (NSWC), Port Hueneme Division (PHD). Mr. Howard is the Supportability

Manager for the Land Attack Systems Engineering (SE) and Test & Evaluation Division (L20). This capstone project report summarizes the results of the NPS Cohort 311–123L’s efforts on this NSWC PHD sponsored capstone project. It also outlines the SE process used and documents the findings in each phase of that process.

B. PROJECT BACKGROUND

Mr. Howard, in a July 2013 meeting, explained that the U.S. Navy has begun to focus acquisition strategies to incorporate more modular and flexible designs for surface ship architecture in an effort to improve procurement and life cycle costs and to support rapid introduction of capability. Modularity in this emphasis defines an approach that subdivides systems into smaller parts (modules) that can be independently created and then used in different systems to drive multiple functionalities (Chief Information Officer, Department of Defense 2007). Mr. Howard added that given the emphasis on modularity, the Navy is also placing importance on personnel requirements that are optimized to modular or flexible constructs. However, Mr. Howard suggested, as the U.S. Navy drives toward more modular and flexible designs, the current surface Navy supply chain models do not support a modular architecture nor an off ship maintenance support structure that requires multiple logistics and repair nodes to reflect optimal personnel requirements or supply points constrained by space and weight. Examples of the modular or flexible optimally-manned ships Mr. Howard referred to include the littoral combat ship (LCS) and DDG-1000. DDG-1000 will be a new class of guided missile destroyers. It was developed as part of the twenty-first century destroyer program.

In an interview with Mr. Howard and the team on August 23, 2013, he made clear that currently LCS personnel originate a spares list but not from a model or quantitative analysis because the current RBS model does not support this maintenance concept. Mr. Howard advised that the Naval Supply Systems Command (NAVSUP) also affirms that existing models or algorithms do not support this maintenance concept; they are interested in efforts to solve this problem because, according to Mr. Howard, the LCS program office needs an improved means to maintain ships and naval readiness.

The primary objective of this project was to address the needs of the stakeholders using a documented systems engineering process (SEP) to develop a supply chain management (SCM) model in support of modular or flexible optimally-manned ships. During the stakeholder analysis, critical assumptions and constraints were also identified. According to an article posted on the Loyola University Chicago website:

Each assumption is an ‘educated guess,’ a likely condition, circumstance or event, presumed known and true in the absence of absolute certainty. Each constraint is a limiting condition, circumstance or event, setting boundaries for the project process and expected results. Once identified, these assumptions and constraints shape a project in specific, but diverging ways - assumptions bring possibilities, and constraints bring limits. (Loyola University Chicago n.d.)

Some key assumptions used in this analysis were:

- Funding was available to implement this SCMM.
- No classified information was transmitted through the SCMM.
- The model can be used by any modular or flexible design system. (Although the team’s model focused on LCS as a proof of principle, it was assumed that the model can be used by any modular or flexible designed system.)

In addition to the assumptions listed here, the team assumed certain constraints. Team RSRP’s SCMM was constrained by the requirement to be interoperable with other software systems currently used by the stakeholders and hosting platform requirements.

In the same August 23, 2013, discussion with Mr. Howard, he continued to explain that as a part of Department of Navy (DoN) acquisition strategy, acquisition personnel are looking at continuing to apply a modular or flexible design to future ships to support rapid introduction of capability in support of multiple missions. As part of this capability, a process and approach for optimizing the allocation of spares at the war fighters’ level and at multiple maintenance nodes are required. The current manual process comprises a team of logisticians and engineers who gather recent failure data and, along with the subject matter experts’ knowledge of the system, use this information to compile a spares list to stock parts in the mission module container that will be employed onboard ship. The process used to calculate spare parts to support the ship, maintenance,

and warehouse facilities is based on the current RBS model, which has proven not to meet the manning, space, and weight constraints imposed by this modular or flexible design.

Mr. Howard continued to articulate that from a stakeholder perspective, this supply chain issue is a very real problem. As he explained, even after many meetings and many hours spent trying to resolve the issue of supply chain management and spares allocation, there are still ships operating with a list of spares no one confirmed is correct—(i.e., it may not actually match up with the spares that are needed based on actual or quantitatively derived failures). The efforts made in this report will help to rectify this problem, and it is hoped that these efforts will contribute significantly to support the U.S. Navy fleet.

C. PROJECT TEAM

The Systems Engineering Management (SEM) cohort 311-123L, called Team RSRP, consisted of 10 Naval Postgraduate School (NPS) students. Eight students were from NSWC PHD and two students were from NSWC Crane Division (CD). In order to address the problem, the team organized and completed tasks according to the roles shown in Table 1.

Role	Team Member
Team Lead	Alain DeLeon
Scheduler	Victoria Woods (lead), Raymond Chun
Secretary	Julie Ligman (lead), Hang Nguyen
Modeler	David Faulk (lead), Aaron Oostdyk, Alain DeLeon
Editor	Viviane Bonagrazia-Healey (lead), Victoria Woods, Julie Ligman, Brandon Will, Zachary Crane
Sponsor Liaison	Viviane Bonagrazia-Healey
Librarian	Brandon Will
Literature Reviewer	Hang Nguyen (lead), Victoria Woods

Table 1. Team Project Roles and Personnel

The Systems Engineering Management Plan (SEMP) has additional details on the team roles and responsibilities. To obtain the SEM, please contact Mr. Raymond Chun at Raymond.Chun@navy.mil.

D. SYSTEMS ENGINEERING PROCESS

To develop the SCMM system, a suitable SEP was determined for the project. There are various lifecycle development models that have been created and applied to system development projects. These models are used throughout government and industry and are based on one of three influential process models: the waterfall process model, the spiral process model, and the “vee” process model.

The waterfall process model is a sequential design process in which progress is seen as flowing steadily downwards, like a waterfall, ranging from a series of five to seven steps performed sequentially (Blanchard and Fabrycky 2011). Introduced by Royce in 1970, it was initially used for software development; in 1981, Boehm expanded the model into eight steps (Blanchard and Fabrycky 2011). Each step is completed prior to beginning the next step; the phases must be repeated when deficiencies are found (Blanchard and Fabrycky 2011). The main drawback of the waterfall model is its serial nature as this requires problems to be fixed before proceeding to the next phase (Blanchard and Fabrycky 2011). This serial nature, thereby, makes it difficult to tailor to the engineering methodology needed to support this project, which is iterative in nature, meaning that as the team progresses through the various phases it will revisit those as more information becomes available and changes are required.

The spiral model is another well-known example of engineering methodology used for software development. It was developed by Boehm in 1986 using Hall’s work in systems engineering, and is an incremental model that places more emphasis on risk analysis (Blanchard and Fabrycky 2011). The project repeatedly passes through various phases in iterations (spirals) when creating a prototype, and risk within the prototype is evaluated prior to proceeding to the next phase of the design (Blanchard and Fabrycky 2011). The spiral model is a variation of the waterfall model (Blanchard and Fabrycky 2011).

The third well-known example of engineering methodology is the vee process model developed in 1991 by Forsberg and Mooz (Blanchard and Fabrycky 2011). It also can be used for software development but it is more a graphical representation of a sequence of steps in developing a system using various systems engineering phases (Blanchard and Fabrycky 2011). On the left side, the vee model identifies the decomposition, architecture, and detailed design; while on the right, the component integration and system validation verifies readiness of the system (Blanchard and Fabrycky 2011). This model is simple and straightforward with analysis, verification, and testing conducted early in each phase. It includes a top down and bottom up approach that allowed for process tailoring.

Based on the three different SE processes researched, the waterfall model, the spiral model, and the vee model, team RSRP selected the vee model. The other two models are more sequential, and were not a good fit for the concept of the capstone project. The vee model is more suitable to tailor for the system being developed and the availability of the team's personnel, time, and expertise

The team tailored the vee model to reflect the unique needs of the SCMM system development accounting for the project schedule, organizational structure, and the type of system being developed. The vee model and the team's tailored SE vee model are shown in Figure 1. The tailored SE vee model started with defining customer wants on the upper left and ended with validation on the upper right. The left side had the decomposition and definition activities, including identification of the system requirement, system architecture, conceptual design and modeling and simulation. The system integration and test activities flow upward to the right as different levels of the design were verified and validated: this included component verification, system analysis and system validation. At each level of verification, the original requirement was compared to ensure the design met the specification. A concurrent approach was used to ensure the design was supportable, functionally capable, and maintainable. This resulted in the design of the product meeting the customers' needs as the team progressed through the various phases of the Systems Engineering Process (SEP). The review, evaluation, and feedback process

were continuous throughout system design and development. (Forsberg and Mooz 1991). The end result of this SEP should be a conceptual design of the SCMM system to support modular and flexible design ships.

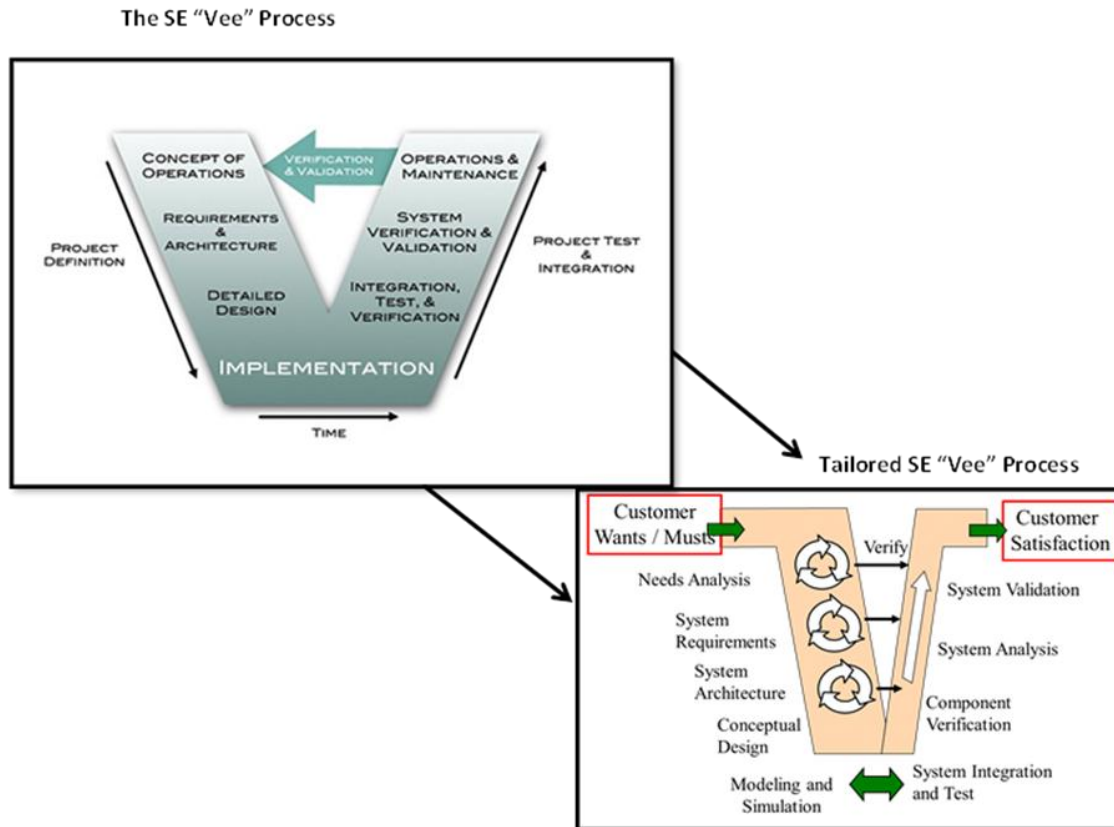

Figure 1. Tailored Systems Engineering Process (after Forsberg and Mooz 1991)

1. Needs Analysis

The first phase of the tailored SEP was to understand the stakeholders' needs, wants, and desires. Stakeholder and need analyses were conducted to further develop the initial problem statement and to refine the primitive need statement into an effective need statement. The problem statement and effective need statement were accepted by the sponsor. Following these steps, a functional analysis was conducted to determine what the SCMM system must do. A functional flow block diagram (FFBD) was created in CORE. Blanchard and Fabrycky state that functional flow block diagrams (FFBDs) are used "...to describe the system and its elements in functional terms" (2011, 699). FFBDs

reflect “...operational and support activities...and they are structured in a manner that illustrates the hierarchical aspects of the system” (Blanchard and Fabrycky 2011, 699). It was very important to identify and organize the functions and sub-functions in a meaningful way allowing for generation (or analysis) of alternatives during the conceptual design phase (Chapman, Bahill and Wymore 1992). It also helped to ensure that, during the team’s SEP conceptual design phase, the design alternatives would meet the needs of the stakeholders (Chapman, Bahill and Wymore 1992).

2. System Requirements

Once the problem and effective need statements were defined, agreed upon by the sponsor, and understood by the stakeholders, a system requirements analysis was conducted based on the Buede method for requirements analysis. Input-output analysis was conducted to scope and bound the problem. An input, control / constraint, output, and mechanism (ICOM) diagram and Context diagram were developed as a result of these analyses. Functional and non-functional requirements were identified from the system requirements development based on the previously conducted functional analysis of the system. The system’s requirements were captured in Vitech’s CORE, a systems engineering and project management toolset that was used to trace the system requirements to stakeholder needs, document system functionality, and document the system architecture. This phase was needed to complete the design to sufficient detail for a specification to be delivered to the design teams responsible for the configuration items of the system. The team was unable to develop the design to the level of detail required for configuration items to be identified, but did provide a set of requirements that could be further decomposed to reach this level of specification.

3. System Architecture

The system architecture (SA) phase captured the logical sequencing and interaction of system functions or logical elements. The system architecture was documented using CORE, which also provided a model based systems engineering (MBSE) capability. The team utilized the Department of Defense Architecture Framework v2.02 (DODAF) to define the different architecture views of the system

design. This framework outlines a common approach for DOD architecture description, development, presentation, and integration (Vickers and Charles-Vickers 2006). Three architectural views, capability view (CV), operational views (OVs), and system views (SVs), were created to show the relationship of inputs and outputs and constraints and mechanisms of the system design. The output of this phase was a high level system design and a developing architecture that met the needs of the stakeholders.

4. Conceptual Design

The purpose of this phase was to initially identify a system design that met the functional and performance requirements of the SCMM system. The conceptual design was accomplished in conjunction with the system analysis phase by conducting an analysis of alternatives (AoA). The team used this phase to narrow down the best alternative to meet the needs of the stakeholders/sponsor.

5. Modeling and Simulation

During this phase, the conceptual design of the SCMM system was modeled using various methods, including simulation, to determine expected system performance or behavior. The modeling and simulation (M&S) output provided insights about the design solutions, empirical data on performance, effectiveness, and processes.

6. System Integration and Test

In this phase, system elements are assembled, integrated, and tested to evaluate the system design. The system integration and testing verifies performance characteristics and identifies design issues to stakeholders. Trade-off studies, including readiness and maturity of the system design, should be conducted. Due to this capstone project's schedule constraint, system integration and test included system verification, system analysis, and system validation of the SCMM system simulation that was created in the M&S phase. This phase was accomplished concurrently with the M&S phase to ensure the simulated system's effectiveness and suitability.

7. Component Verification

Component verification of all levels of the architecture is conducted through an effective combination of analysis, inspection, demonstration, and testing. This gauges the maturity of each component (i.e., software [S/W] and supportability) prior to integrating the overall system design solution. The team did not perform this phase of the SEP due to the immaturity of the system design.

8. System Analysis

During the system analysis phase design alternatives were evaluated by conducting an AoA to identify potential solutions that could satisfy the requirements and support a decision based on the most effective solution. Blanchard and Fabrycky state that an AoA "... facilitates determination by the customer of the best design alternative based on the results of modeling and analysis..." (2011, 169). The AoA was conducted using value modeling, based on a weighted chart, and with a numerical evaluation matrix to determine the model that best satisfied the stakeholders' requirements (Buede 2000).

Cost analysis was conducted during this phase to evaluate the different alternatives. The constructive systems engineering cost model (COSYSMO) was used to evaluate the different alternatives that resulted from the AoA conducted during the conceptual design phase. Use of COSYSMO allowed the team to help assess the cost and schedule implications of systems engineering decisions.

Risk analysis was conducted throughout the SEP focusing on the SCMM system and capstone project risks. This analysis resulted in the development of the Risk Management Plan addressing the programmatic and technical risks of the project and system.

The output of this phase was the identification of a system alternative suitable for adaptation to support the stakeholders' needs and requirements. The risk analysis resulted in the development of the Risk Management Plan addressing the programmatic and technical risks of the project and system.

9. System Validation

System validation ensures that the as-designed system meets the system requirements in conformance with the stakeholders' needs (Blanchard and Fabrycky 2011). This process also demonstrates that the designed system achieves its intended use in the intended operational environment (Blanchard and Fabrycky 2011). Although this phase was not performed in its entirety due to the immaturity of the system design, it is recommended that system validation continue throughout the design of the SCMM system by performing progressive and iterative integrated system testing to validate the maturity of the system and assess overall system readiness. Recommendations on how to conduct the validation can be found in the System Integration and Test chapter.

10. SE Process Status

The SEP in its entirety was not completed due to the time constraints of the capstone project's timeframe. Figure 2 provides a reference point for each of the phases and their completion. The needs analysis phase is complete, signaled by a star; the system requirements, system architecture, conceptual design, modeling and simulation, system integration and test, system analysis, and system validation phases require additional time and development to complete the SCMM system, signaled by a check. The component verification phase could not be accomplished, signaled by an "x."

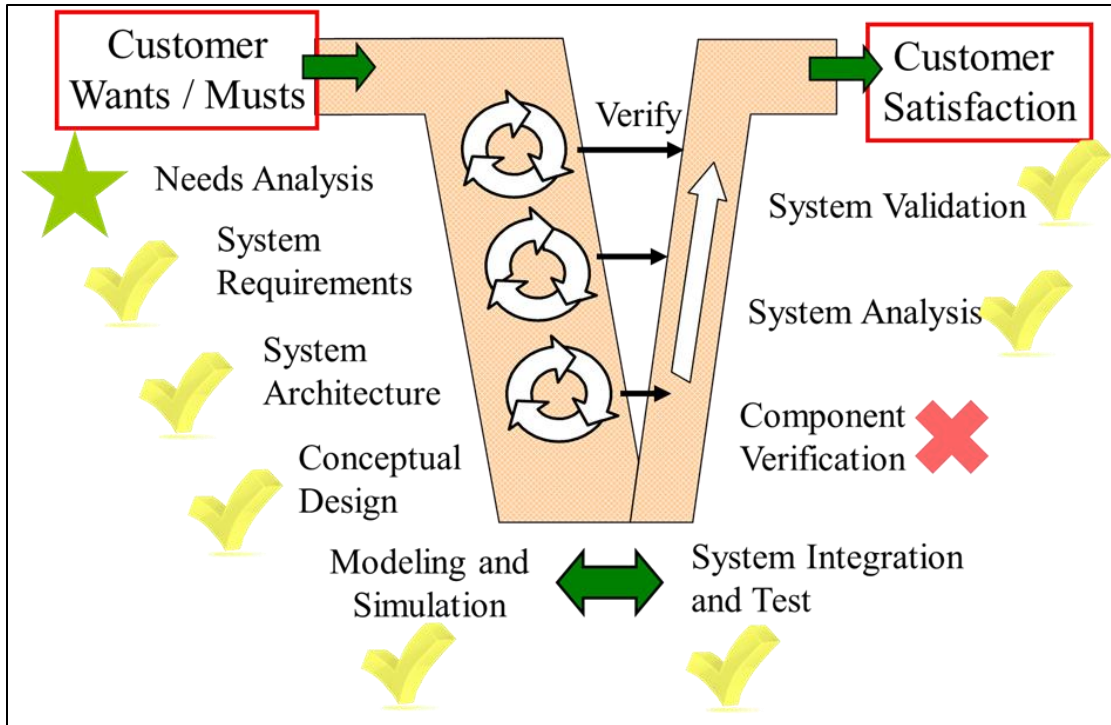

Figure 2. Systems Engineering Process Status (after Forsberg and Mooz 1991)

E. SYSTEM LIFECYCLE

In order to develop the SCMM system, it was important to consider the system lifecycle, and break down the product life cycle into two phases: the acquisition phase and the utilization phase (Blanchard and Fabrycky 2011). The acquisition phase begins with the need and conceptual / preliminary design stage, followed by the detailed design and development and production stages. The utilization phase includes the operations and support stage of the system and the disposal stage. These phases and stages are illustrated in Figure 3. The work for this capstone project was conducted under the acquisition phase, in particular, the need and conceptual / preliminary design stage.

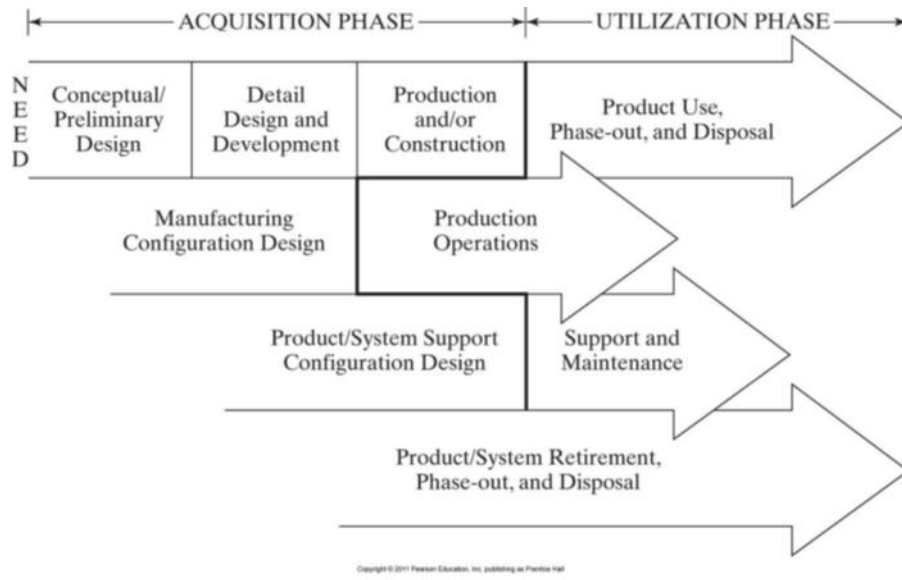

Figure 3. Life Cycles of the System (from Blanchard and Fabrycky 2011, 30)

According to Blanchard and Fabrycky:

Life-cycle guided design is simultaneously responsive to customer needs (i.e., to requirements expressed in functional terms) and to life-cycle outcomes. Design should not only transform a need into a system configuration but should also ensure the design's compatibility with related physical and functional requirements. Further, it should consider operational outcomes expressed as producibility, reliability, maintainability, usability, supportability, serviceability, disposability, sustainability, and others, in addition to performance, effectiveness, and affordability. (Blanchard and Fabrycky 2011, 30–31)

Correspondingly, and in line with the team's modified vee systems engineering process, Table 2 depicts the technical activities that were conducted during the acquisition phase, in particular the conceptual / preliminary design stage, and how each of those corresponds to the team's modified vee SEP, using as a guide the information found in *Systems Engineering and Analysis* (Blanchard and Fabrycky 2011, 32 and 34).

Acquisition Phase	Technical Activities	Vee SEP Phase
Conceptual Design	Problem Definition, Need Identification, Stakeholder Analysis, Functional Definition of System; Functional Analysis	Needs Analysis
Conceptual Design	Requirements Analysis; Operational Requirements, Performance Measures	System Requirements
Preliminary Design	Requirements Allocation	System Requirements
Conceptual Design	Capability and Operational Views	System Architecture
Preliminary Design	System Views	System Architecture
Conceptual Design	Evaluation of Technology	Conceptual Design/System Analysis
Preliminary Design	Trade-off Studies, Analysis of Alternatives, Synthesis	Conceptual Design/System Analysis
Preliminary Design	Evaluation of Design, Evaluation of Design Alternatives	Modeling and Simulation/Integration and Test/System Validation

Table 2. Acquisition Phase Technical Activities and the Vee SEP

The system integration and test phase and the system validation phase were performed to some extent but not in their entirety due to the immaturity of the system design. The component verification phase was not performed for the same reason. System analysis for risk was performed throughout the project and design/development of the SCMM system.

F. TECHNICAL TOOLS

Tools for this project included the Microsoft Office suite, Vitech's CORE, Imaginethat Inc.'s. ExtendSIM, and Ricardo Valerdi's COSYSMO, as applicable. CORE is a robust systems engineering and project management tool that allows the user to quickly house and document important data pertinent to systems engineering problems.

ExtendSIM is a simulation program for modeling discrete and continuous events. COSYSMO, the constructive systems engineering cost model, estimates the person-months required to staff hardware and software projects. The NPS Sakai site and the services it provided were used as the primary collaboration environment for the team members. These tools were provided for use by the Naval Postgraduate School during the course of the Systems Engineering Management program.

G. SUMMARY

The Navy's supply chain is an extensive and integral component for sustainment operations ensuring ship mission readiness. A new approach to allocating repair parts in support of readiness must be developed and implemented to optimally sustain emerging ship classes that utilize modular or flexible design equipment for increased mission capabilities. Project team RSRP began the research and development of closing this capability gap in the Navy's supply chain management by applying system engineering techniques to create the foundation for the supply chain management model (SCMM) system that considers ship constraints for weight, space, and available manpower to provide the user with identified repair parts and allocation.

Team RSRP's methodology began with identifying team member roles and responsibilities to ensure efficient project development coverage. After a team structure was established, the team tailored the vee SEP to reflect the unique needs of the SCMM system development. This tailored vee included the following main developmental process phases: needs analysis, system requirements, system architecture, conceptual design, modeling and simulation, system integration and test, component verification, system analysis, and system validation. The system lifecycle was considered during project development. While the majority of the work completed during this capstone was conducted under the acquisition phase, system characteristics of the utilization phase were considered during development to help transition to future system fielding and use. The technical tools utilized were made available by the Naval Postgraduate Systems Engineering Management program and were implemented during the research, architecting, design, and modeling and simulation phases of the project.

The team worked in conjunction with the project sponsor, Mr. Howard, NSWC PHD, to identify and understand the problem, gaps, and requirements necessary for system development. Chapters within this report will show how the system development evolved from an identified need to conceptual design of the SCMM system, following the vee SEP, to sustain the emerging flexible and modular ships of the U.S. Navy.

THIS PAGE INTENTIONALLY LEFT BLANK

II. NEEDS ANALYSIS

The objective of the needs analysis phase was to understand the stakeholders' needs, wants, and desires and to further develop the initial problem statement and refine the primitive need statement into an effective need statement. A literature review was conducted to examine the material related to SCM for modular ships, and to discover the challenges associated with it. The problem statement was finalized, and the gap (the difference between the current state of the system and how the stakeholder needs the system to perform and operate) was identified. A stakeholder analysis was conducted to determine their needs and develop the effective need statement. A functional analysis was then performed to identify the critical functions of the system by developing use case scenarios.

A. PROBLEM DEFINITION

The purpose of the problem definition was to develop a final problem statement approved by the sponsor. This required analysis and communication with the sponsor that resulted in the final project scope and an understanding of the system boundaries. Mr. Howard's statement in the July 23, 2013, meeting with the team provided the original problem definition: *Current surface Navy supply chain models do not support a modular architecture and an off ship maintenance support structure requiring multiple logistics and repair nodes to reflect optimal manning or constrained physical and weight constrained supply points.*

1. Research Questions

Based on the problem statement, the team used the following questions to guide the literature review and research:

- What are modular or flexible ship designs?
- What is meant by "optimal manning"?
- What are other organizations using for SCM models in support of modular or flexible design?

- How do shipboard space and weight constraints affect modular or flexible designed ship?
- What metrics can be used to assess sparing model performance?
- Why does the gap (problem) exist? What sources help to explain the gap?
- What metrics can be used to assess sparing model performance?

2. Literature Review

Using the research questions, the team searched available literature including scholarly articles, journals, and reports to examine the material related to SCM for modular ships and to discover the challenges associated with it. In the review of the literature, the team found information that included examples of SCM in the DOD: information about warehouse management processes; examples of time-based distribution of parts and supplies; examples of different inventory management methods; and sea-frame constraints of the U.S. Navy's modular ship class LCS. The capstone team used the research questions to focus the research on areas related to modular or flexible ship design characteristics, logistics support requirements, supply chain management methods, and modeling methods. Systems engineering processes were also investigated to determine a methodology suitable for project use.

A portion of literature review focused on the Navy's LCS use of emerging technology associated with robotic packages (unmanned air, surface, and underwater vehicles) and modular weapons and sensors (Sayen 2012). The modular systems utilizes different payload packages (modules), which are each designed to fit a common cargo/weapons bay or slot and focus the ship on a specific mission: LCS mission modules include packages for mine warfare (MIW), anti-submarine warfare (ASW), anti-air warfare (AAW), and anti-surface warfare (ASUW) (Sayen 2012). When a ship's mission changes, it can quickly exchange its current module for one that reinforces the alternate mission; a quick exchange of modules is an attempt to obtain the benefits of both single and multi-mission platforms (Sayen 2012). SCM plays a critical role in achieving the end goal of supporting modular or flexible design ships. Military supply chain management is the discipline that integrates acquisition, supply, maintenance, and transportation functions with the physical, financial, information, and communications networks in a

results-oriented approach to satisfy joint force materiel requirements (Joint Chiefs of Staff 2013). SCM works to develop, design, and deliver optimal material support while maximizing resources to provide the right parts at the right time to better allow for the sustainment of weapon systems throughout their life cycle (Joint Chiefs of Staff 2013).

LCS operates with a minimal but cross-trained ship force (Defense Industry Daily 2014). A cross-trained crew is one that can operate multiple systems on the same ship. On other ship classes these systems are normally operated by a system specific trained operator. For example, a sailor is specifically trained to become a subject matter expert (SME) and operate the Rolling Airframe Missile system. A different sailor's specialty might be the 57mm gun. These two sailors typically do not have training on how to operate each other's equipment. According to the Defense Industry Daily website, the LCS class ships are "...intended to operate with a core crew of 40 sailors, plus a mission module detachment of 15 crew and an aviation detachment of 25 crew" (Defense Industry Daily 2014). Mission types include mine warfare (MIW), 24 crew planned; anti-submarine warfare (ASW), 16 crew planned; and anti-surface warfare (ASUW), 24 crew planned (Defense Industry Daily 2014). Each ship has a pair of 40-person crews (Blue and Gold), which will shift to three crews over time that can deploy in four-month rotations. (Defense Industry Daily 2014) The website, on its webpage "LCS: The USA's Littoral Combat Ships," states that "There are concerns that this is a design weakness, leaving the LCS crew at the edge of its capabilities to just run the ship, with insufficient on-board maintenance capabilities" (Defense Industry Daily 2014). The team concluded that due to the personnel constraint on the LCS ship class described on the "LCS: The USA'S Littoral Combat Ships" webpage, the ships will rely heavily on SCM for distance support processes and applications to fully enable the operational-manning of these optimally crewed ships. The preventative, predictive, condition-based, and corrective maintenance and logistics functions for spare parts and repairs will be partially or completely absorbed by shore-based infrastructure due to the reduced shipboard personnel.

In a 2013 article on the America's Navy website, Sky M. Laron, Yokosuka Director of Corporate Communications at NAVSUP's Fleet Logistics Center (FLC),

quoted Commander Mark Sheffield, NAVSUP FLC Yokosuka Operations Director, who stated: “[Logistics Support Teams] conducted a continual planning analysis to ascertain both the known and unknown of the very specific support requirements that are needed by the Navy’s newest minimally manned platform” (Laron 2013). Laron, in the same 2013 article, also quoted Commander Jerry King, NAVSUP FLC Yokosuka, Site Singapore Director, who stated: “Fast, efficient and comprehensive support in logistics and contracting continues to be challenging but very successful. By ensuring our shore infrastructure is resourced properly we will maintain long term success of multiple LCS platforms abroad” (Laron 2013). Laron credits flexibility as a key factor in successfully meeting LCS’s requirements portside (Laron 2013). These statements further justify the need for an effective SCM model to support modular or flexible design ships.

For the Army, the supply concepts have to be integral to the modern battlefield. The Army must optimal logistical support to maximize its combat power in order to provide timely, efficient, and effective logistical support to operational units. The Army supply chain management process provides items necessary to equip, maintain, and operate a military command. If there is a supply shortage such as ammunition, fuel, or repair parts during the missions, it can cause units in the missions to reach their terminating point before they accomplish the operation. (Department of the Army Headquarters 2000) These same concepts are analogous to the needs of the Navy, as well, in terms of supply concepts. Army logistics needs to demonstrate five essential characteristics: initiative, agility, depth, versatility, and synchronization for successful support operations. (Department of the Army Headquarters 2000, 1-1) These five characteristics are defined in Table 3 and the supply applicability is detailed therein. These characteristics are also applicable to Navy logistics for successful support of operations.

TENET	DEFINITION	SUPPLY APPLICABILITY
INITIATIVE	Setting or changing the terms of battle by action.	Thinking ahead and anticipating future requirements while planning supply needs beyond the current operation.
AGILITY	The ability of friendly forces to act faster than the enemy.	Physical agility depends upon the right quantity of supplies, both enough but not too much. Mental agility can be affected by low morale or poor health, which can be caused by the wrong amount of supplies, for example; food, water, clothing.
DEPTH	The extension of operations in space, time, and resources.	Proper use of supplies plays a critical role in achieving and maintaining momentum in the attack and elasticity in the defense.
VERSATILITY	The ability to tailor forces and move rapidly and efficiently from one mission to another.	The successfulness of moving from one mission to another will not be efficient if the supplies are not in the right place at the right time.
SYNCHRONIZATION	The arrangement of battlefield activities to produce maximum combat power at the decisive point.	If supply support, especially ammunition and fuel, is not correctly synchronized, units will fail to achieve maximum combat power at critical moments.

Table 3. Tenets of Army Operations (from Department of the Army Headquarters 2000, 1-2)

Team RSRP identified metrics from the Defense Acquisition University (DAU) that could be used to assess the performance of the SCMM. Common supply support metrics include:

- Customer Wait Time: The time (days or hours) a system is inoperable due to delays in maintenance caused directly by delays in obtaining parts.
- Stock Availability: The percentage of requisitions that are filled immediately from stock on hand.
- Backorder Rate: The ratio of “Out of Stock Material” to “Total Demand” for a given weapon system.

- Order/Ship Time: The elapsed time between the initiation of a stock replenishment action by a specific activity and the receipt of material by that activity. (Defense Acquisition University 2012, 17)

In the article titled “The Wrong Ship at the Wrong Time,” Commander Patch, U.S. Navy (retired) stated that the basic problem of the LCS is that from inception the Navy inadequately attempts to design, build, deploy, and sustain a fragile size warship to do too many things (Patch 2011). Commander Patch also identified that staging of the modules and personnel requires a forward sea-base or shore facilities which results in a heavy logistics footprint (Patch 2011). In addition, Commander Patch discussed the impact of weight, and that the excessive high-end requirements increasing hull machinery and combat system weight negatively affect the ship’s stability (Patch 2011). Plus, the insufficient passageway and support requirements for aircraft, unmanned vehicles, and module detachments have exceeded ship capacity (Patch 2011). A Government Accountability Office (GAO) report, *Defense Acquisitions: Navy’s Ability to Overcome Challenges Facing the Littoral Combat Ship Will Determine Eventual Capabilities*, stated that the Navy is at risk of “investing in a fleet of ships that does not deliver its promised capability” (Government Accountability Office 2010, 24).

In order to address the sponsor’s concern about the current Navy SCM process the next step was to define the current Navy SCM process. Following is the result of research conducted into the current Navy supply chain management process.

According to the Assistant Secretary of Defense:

RBS is the practice of using advanced analytics to set spares levels and locations to maximize system readiness. RBS has been part of Department practice since the 1960s, when it was used to optimize aircraft availability, and is incorporated into DOD Supply Chain Materiel Management Regulation, (DOD 4140.1-R) as the preferred method for calculating inventory levels. The Services and the Defense Logistics Agency (DLA) have agreed to work together to implement Commercial-Off-The-Shelf (COTS) based RBS models. (Assistant Secretary of Defense, Logistics and Materiel Readiness 2012)

RBS is a requirements determination process that computes the levels of secondary item spares needed to support a weapon system readiness goal at the lowest possible cost. RBS algorithms determine, for each inventory location (supply and

maintenance), the lowest cost spares mix that will provide the required operational readiness level for a weapon system. Figure 4 depicts the current readiness based spares functional scope, obtained from the RBS Working Group presentation located on the “Supply Chain Integration” webpage.

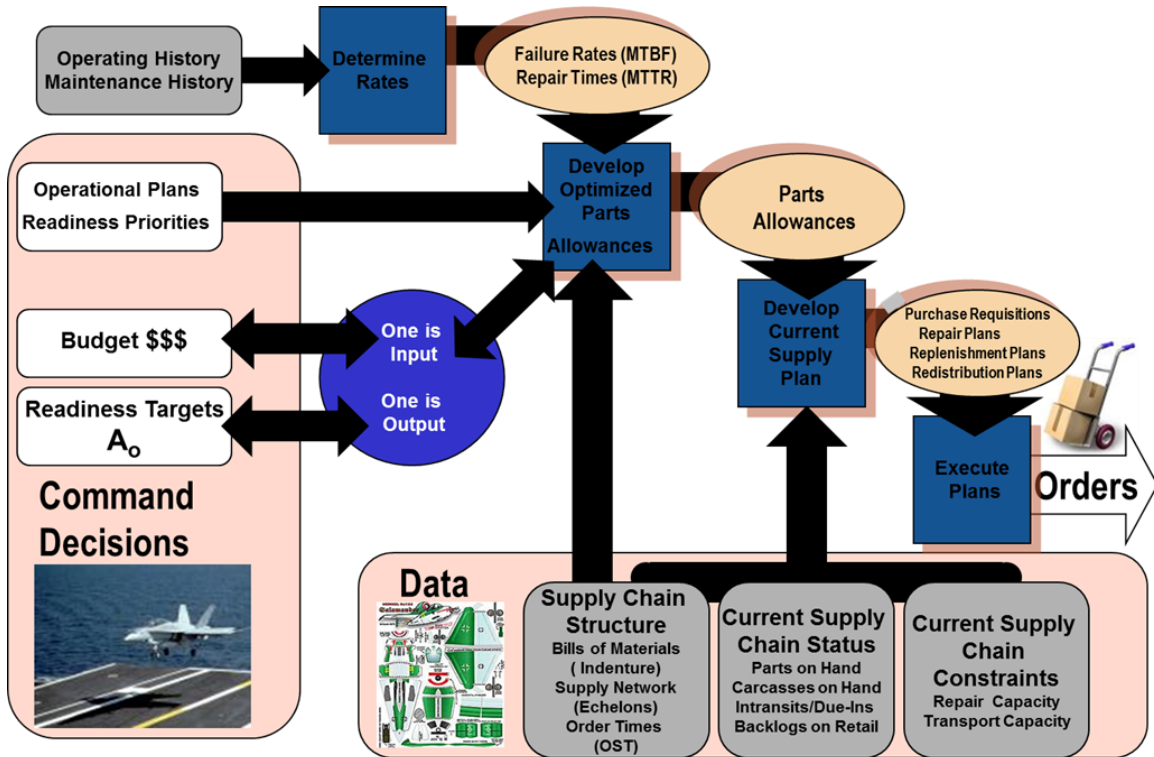

Figure 4. Current Readiness Based Spares Functional Scope (from RBS Working Group 2005)

The *DOD Supply Chain Materiel Management Regulation, DOD 4140.1-R*, mandates that RBS models be used whenever possible to assess inventory investment required for fielding new programs (i.e., weapon systems or subsystems) and to set sparing levels for secondary items that have support goals related to weapon system readiness (DOD Supply Chain Materiel Management Regulation, DOD 4140.1-R 2003). In addition to these primary objectives, RBS analytical capabilities are used to negotiate performance-based supplier agreements; assess the effect of reliability, maintainability, and supportability improvements on weapon system readiness; budgets; and conduct what-if exercises related to deployments (Assistant Secretary of Defense, Logistics and

Materiel Readiness 2012). The military uses RBS models in various levels of detail and complexity. See Figure 5, Multi-Indenture, Multi-Echelon (MIME) RBS, for a graphical representation of an example model, obtained from the “Supply Chain Integration” webpage. Several excellent examples of legacy software tools were developed internally by the Services and are now used to support high levels of system readiness (Assistant Secretary of Defense, Logistics and Materiel Readiness 2012).

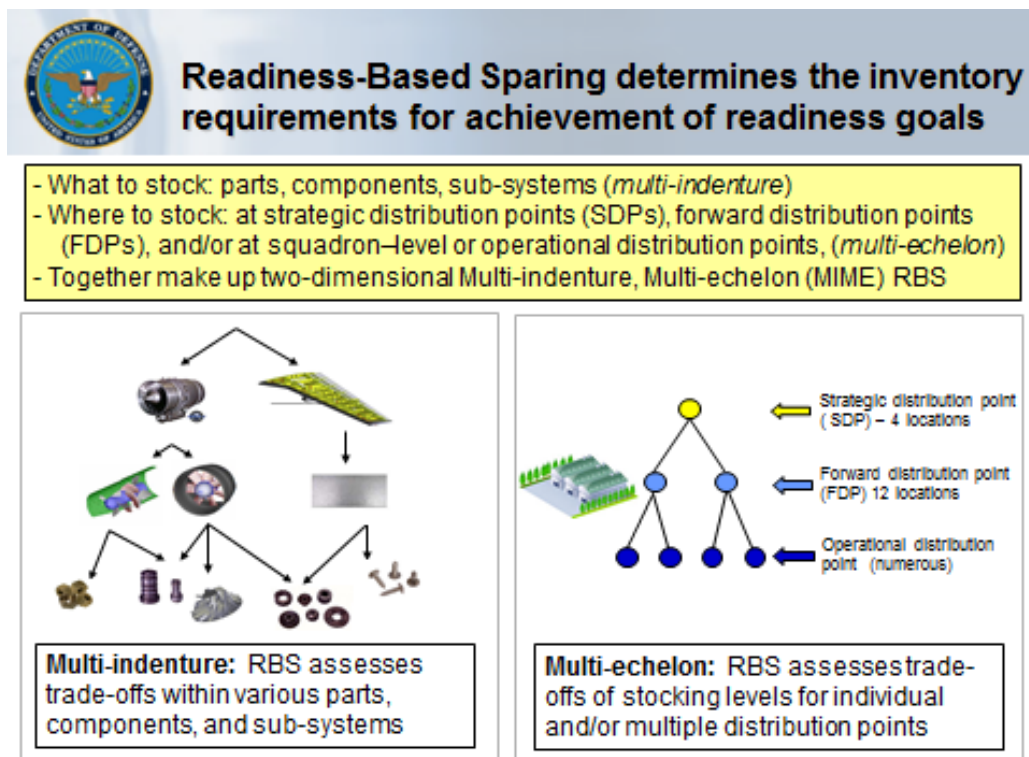

Figure 5. Multi-Indenture, Multi-Echelon RBS (from Assistant Secretary of Defense, Logistics and Materiel Readiness 2012)

Having no weapon systems of its own, DLA does not tie its inventory levels directly to a weapon system readiness target—the traditional definition of RBS; however, DLA does take advantage of the mathematical approach inherent in RBS models to determine more efficient and effective inventory levels in a multiple-echelon environment (Department of Defense 2008). In this context, DLA must compute requirements to meet a different goal, such as customer wait time (Department of Defense 2008).

The Assistant Secretary of Defense states that “Individualized RBS solutions address the service-unique missions, forces, maintenance philosophies, weapon systems requirements, and ERP systems environment, as indicated on the Readiness Based Sparing Overview presentation located on the “Supply Chain Integration” webpage (Assistant Secretary of Defense, Logistics and Materiel Readiness 2008, 3).” The Assistant Secretary of Defense also stated that a

...RBS Working Group was established by the Supply Chain Capabilities Group to share knowledge and research about RBS; share progress and lessons learned from RBS efforts’ to define interoperability; and to implement a DOD-wide approach for managing and collaborating on sparing requirements for common items. This group meets...to foster the exchange of ideas and to collaborate on cross-DOD RBS efforts. (Assistant Secretary of Defense, Logistics and Materiel Readiness 2012)

The purpose of this group was further defined, by the working group members, to help with the development of:

- Criteria for choosing RBS solution(s) that will move into production
- RBS joint operational requirements
- Gaps between joint requirements and current capabilities and prioritization of these gaps to be addressed by further efforts
- Impacts of having multiple RBS solutions (Assistant Secretary of Defense, Logistics and Materiel Readiness 2012)

This research defines how parts sparing is currently conducted for U.S. Navy ships. It demonstrates that the Navy allows multiple sparing systems, each designed for a weapon system’s specific needs to support weapon system readiness. Based on this information, the team determined that the development of the SCMM system would be accepted for use in the support community, that it is, in fact, warranted by the *DOD Supply Chain Materiel Management Regulation, DOD 4140.1-R*, and that changes to existing RBS models could be initiated in collaboration with the RBS working.

Different systems engineering processes were investigated to determine which one would be the most suitable for use in the project. There are various SE development models that have been created and applied to system development projects. These models are used throughout government and industry and are based on one of three influential

process models: waterfall process model, spiral process model, and vee process model. More specific information for each of these models can be found in the System Engineering Process section in the Introduction chapter. Team RSRP determined that the waterfall and spiral models being more sequential than the vee model made them difficult to tailor for this project based on the type of system being developed and the personnel, time, and expertise available. Therefore, the vee model was selected to permit the systems engineering process to be tailored to allow for the necessary steps and activities to be performed.

Modeling and Simulation is considered to be a staple in any field of engineering. According to the International Council on Systems Engineering (INCOSE),

The objective of modeling and simulation is to obtain information about the system before significant resources are committed to its design, development, construction, verification, or operation. To that end, modeling and simulation helps generate data in the domain of the analyst or reviewer, not available from existing sources, in a manner that is affordable and timely to support decision-making. Adequate, accurate, and timely models and simulations inform stakeholders of the implications of their preferences, provide perspective for evaluating alternatives, and build confidence in the effects that an implemented system will produce. (INCOSE 2011, 150)

The team researched various software applications, such as Vitech's CORE, Eclipse's Open System Engineering Environment (OSEE), and IBM's Rational line of products, which could be used for graphical representations of DODAF models and requirements analysis. CORE and OSEE are purchasable software that users can install but IBM Rational is more of a service that is provided for systems engineering. Both OSEE and CORE offer an assortment of equivalent tools. However, CORE was chosen due to its availability for use in the project and the team's familiarity with the software. Software to conduct simulations was also researched. ExtendSim and Simulink offer visualized block simulations and have similar capabilities. ExtendSim was chosen due to the team's familiarity of the software and its availability. The team also wanted to simulate an output report of the SCMM system. The manual input for information into

the system to be modeled came from databases that provide information using Microsoft Excel. It was decided to maintain this format and not look into outside software since Excel was available for use.

B. PROBLEM STATEMENT

An initial problem statement was provided to the team by the sponsor. The statement was general and required refining. In order to refine the problem, the team conducted research and requested clarification about the boundaries of the system. During an interview conducted with team members on July 24, 2013, Mr. Howard stated that “Current resupply and maintenance points will/have two different paths potentially. One path will be established for the modular equipment or systems while the host platform may/will have a different path.”

After additional research and sponsor feedback to clarify the initial problem statement and background, the capstone team was able then to expand on the knowledge of the topic via the research questions. The team then focused on the problem background. Through an iterative process, the final background description was approved by the sponsor on August 30, 2013: *The U.S. Navy has begun to focus acquisition strategies to incorporate more modular and flexible designs for surface ship architecture in an effort to improve procurement and life cycle costs and to support rapid introduction of capability. Given the emphasis on modularity, the U.S. Navy is also placing importance on manning requirements that are optimized to support modular/flexible constructs.*

The problem background allowed the team to develop the finalized problem statement in the same iterative process with the sponsor. The final problem statement was approved by the sponsor on August 30, 2013: *As the U.S. Navy drives toward modular and flexible designs, the currently used surface Navy SCM models do not support modular or flexible design ships. These ships require an off-ship maintenance support structure consisting of multiple logistics and repair nodes due to shipboard constraints including manning, space, and weight.*

Working with the sponsor, the team then identified and finalized the gap, which is the difference between the current state of the system and how the stakeholder needs the system to perform and operate. The sponsor approved the gap analysis statement on August 30, 2013: *The systems/programs currently in use for determining spares allocations do not provide information that takes into account the ability to modify ships rapidly to introduce warfare specific capability through the use of mission modules nor do they take into account shipboard constraints including manning, space, and weight, which impact ships' and fleet's readiness and operational availability.*

C. STAKEHOLDER ANALYSIS

Having defined the problem and identified the gap, the team then conducted a stakeholder analysis to determine their needs and develop the effective need statement. Stakeholders are those people/entities that have a vested interest in the system, problem and/or solution. A stakeholder analysis was performed to identify the people/entities that are germane to the problem and also those who interact with the system. This analysis was used to determine the stakeholders' needs, wants, and desires; critical assumptions and constraints were also identified. To begin, the stakeholders for the SCM problem were identified. The team established all the applicable stakeholders through conversations with Mr. Howard during the problem definition process. Once the team had a list of stakeholders, their needs for the SCMM system were identified, again with the assistance of Mr. Howard. The stakeholders and their needs are recorded in Table 4. It is important to note that the stakeholders are not listed in any particular order. Because the stakeholders were not readily available, the need statements for the stakeholders were approved by the sponsor and not by the individual stakeholders directly.

Stakeholder	Need
Sponsor	Ensure a system engineering process is followed to develop a sparing model that can be developed to support modular/flexible ships and their support facilities to have the required parts on-hand to support system maintenance—preventive and/or corrective—within manning, space, weight, location, and cost/budget constraints.
Maintenance Facilities	Have the required parts on-hand to support system maintenance—preventive and/or corrective within manning, space, weight, location, and cost/budget constraints.
In-Service Engineering Agent (ISEA)	Know what parts and where to allocate those parts to allow other entities to perform maintenance—preventive and/or corrective within manning, space, weight, location, and cost/budget constraints.
Program Office	Ensure modular/flexible ships and their support facilities have the required parts on-hand to support system maintenance—preventive and/or corrective—within manning, space, weight, location, and cost/budget constraints.
Defense Logistics Agency (DLA)	Know what parts and where to allocate those parts to allow other entities to perform maintenance—preventive and/or corrective within manning, space, weight, location, and cost/budget constraints.
Navy Supply Systems Command (NAVSUP)	Know what parts and where to allocate those parts to allow other entities to perform maintenance—preventive and/or corrective within manning, space, weight, location, and cost/budget constraints.
Sailor	Have the required parts on-hand to support system maintenance—preventive and/or corrective.
Littoral Combat Ship Squadron (LCSRON) / Type Commander (TYCOM)	Have the required parts on-hand to support system maintenance—preventive and/or corrective within manning, space, weight, location, and cost/budget constraints.

Table 4. Stakeholder Analysis for SCMM

After conducting the stakeholder analysis, the team finalized the effective need. This need is what the stakeholder/sponsor needs the SCMM system to do. Through feedback from the sponsor, the following need statement was developed and approved on August 30, 2013: “The stakeholders need information to determine sparing of parts at

existing and multiple supply points in order to support the Navy's modular/flexible ships within the constraints of manning, space, weight, location, and cost/budget.”

D. FUNCTIONAL ANALYSIS

According to INCOSE, a function is a characteristic task, action, or activity that must be performed to achieve a desired outcome. Functional analysis is an examination of a defined function to identify all the sub-functions necessary to accomplish that function. (INCOSE 2011) The functional analysis describes what the system must do at several levels: the analysis results in the “whats”—what the system must do; it does not identify nor result in the “hows”—how the system will do it (Chapman, Bahill and Wymore 1992). Buede also makes this quite clear:

The very strong position being taken here is that the input and output requirements are the key to defining the needs of the stakeholders in terms that they can understand. Stakeholders in each phase of the system's life cycle can relate to quantity, quality, and timing aspects of the outputs delivered by the system under question and the ability to deal with quantity, quality, and timing of inputs. The engineers of the system develop the system's functions during the design process. This development of a functional architecture...is a very valuable means for dealing with the complexity of the engineering problem. But the stakeholders should not care a whit about the functions being performed by the system as long as they are happy with the characteristics of the inputs being consumed and the outputs being produced by the system. The concept of having a major section of requirements devoted to the functions of the system is misguided and guaranteed not to elicit the needs of the stakeholders. (Buede 2000, 132)

Focusing on the “what” rather than the “how” allows for innovative solutions by enlarging, rather than limiting, the design space.

There are two steps in the functional analysis: the functional decomposition, derived from the problem statement or the need statement, which results in a list of functions and sub-functions; and the organization of this list in order to provide meaningful information (Chapman, Bahill and Wymore 1992). Either a hierarchy of functions diagram or a FFBD may be used to organize the list. The selection of either depends on whether the functions flow sequentially or not; if so, then a FFBD should be

selected, if not, a hierarchy diagram should be used (Chapman, Bahill and Wymore 1992). It is necessarily an iterative process whereby the relationship of the various functions noted in the decomposition will likely influence the revision of the hierarchy or functional flow block diagram as these relationships are made clearer during the decomposition process (Chapman, Bahill and Wymore 1992).

Team RSRP performed a functional analysis, in conjunction with the systems requirements phase, to identify the critical functions of the system after the problem and need statements had been finalized. For convenience, the need statement is restated, as follows: *The stakeholders need information to determine sparing of parts at existing and multiple supply points in order to support the Navy's modular/flexible ships within the constraints of manning, space, weight, location, and cost/budget.* The capabilities of the system were identified with the sponsor at this time, also. These were *convert (or process) data inputs into information to be used for sparing of parts at various locations based on the use case scenarios and allow the users to conduct sensitivity analysis based on the inputs for trade-off analysis for cost, operational availability (Ao), personnel requirements, weight, and/or space,* both derived from the need statement. Research was conducted during the needs analysis phase to include stakeholder “wants” until the system’s functions were identified. The team held several discussions with the sponsor, Mr. Howard, to ensure that the required functions of the system were meeting the stakeholders’ requirements, which were being developed simultaneously.

Based on the need statement, and in order to better determine the functions of the system, use case scenarios were identified with the sponsor, Mr. Howard. Use cases depict how the system will be used by the user to achieve an objective (Visual Paradigm 2011). The various scenarios that the SCMM system would be used to support are as follows:

Support of:

- Humanitarian mission—single ship
- Humanitarian mission—multi-ship
- Multi-nodal, single ship event (includes mission package)
- Multi-nodal, multi-ship event (includes same mission packages)

- Multi-nodal, multi-mission event (includes multiple ships and mission packages)
- Test/single event
- Single ship system
- Multiple ship systems
- Single mission module
- Multiple mission modules
- Single mission package (no hull, mechanical, and electrical [HM&E])
- Multiple mission packages (no HM&E)

For the SCMM system, development of the use cases entailed determining the operational sequence of system use based on a specific user scenario with the required user inputs to obtain a required output. The use case for the “support single mission module” scenario was partially developed using CORE based on the operational activities, and is depicted in Figure 6. The user’s objective is to support a single mission module onboard an operational ship to meet Ao and cost requirements. The user would perform the following actions with the SCMM system in order to support this objective:

- Launch system
- Enter login information
- Execute login
- Enter input/selection
- Execute system (for system to perform)
- Assess results (of output)
- Log off

Based on the assessment of the output, the user would allocate spare parts to multi-nodal locations to support a single mission module. The figure also depicts the generalized inputs required to use and obtain the necessary information from the system; and it also depicts the queries from the various users; these are depicted as the small round-edge boxes that have arrows towards the “D—Enter Inputs/Selection” box

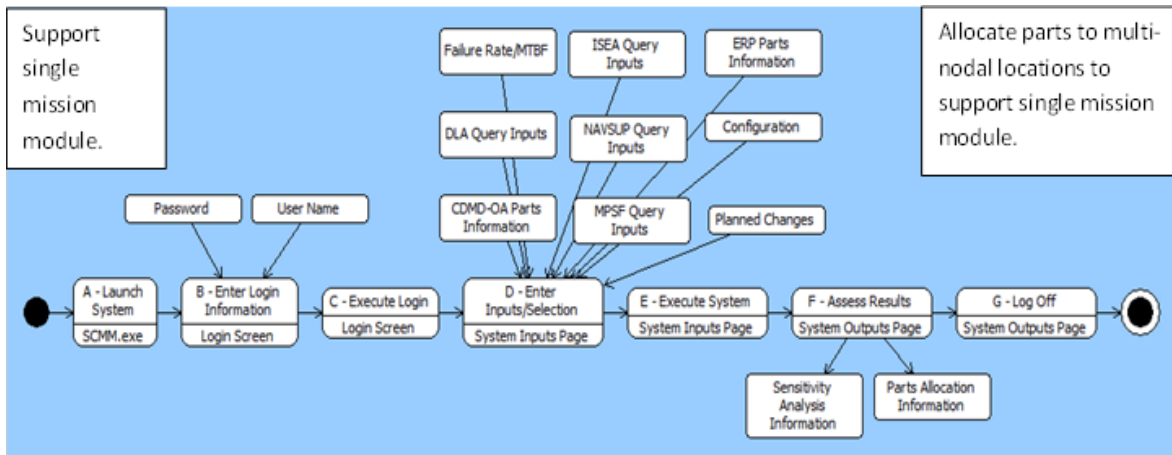

Figure 6. Use Case for “Support Single Mission Module” Scenario

The system requires inputs to process into outputs to support the use case scenarios. Inputs, in this case, are the user entered or selected inputs and the data pushed from the various databases that have the needed information for the system to transform them into the required outputs. The analysis of the inputs and outputs of the system are further described and illustrated in the System Boundaries section of the System Requirements chapter.

It was very important to identify and organize the functions and sub-functions in a meaningful way, allowing for an analysis of alternatives to be conducted during the conceptual design phase (Chapman, Bahill and Wymore 1992). It also helped to ensure that the design alternatives would meet the needs of the stakeholders (Chapman, Bahill and Wymore 1992).

The functional analysis continued by deriving the system’s top level functions based on the capabilities of the system and the use cases. The top level functions can be seen in the FFBD as shown in Figure 7 (developed in CORE, as are all subsequent figures in this section). These are:

- Enable graphic user interface
- Receive data
- Process data
- Provide output

- Maintain system
- Secure system

“Maintain system” and “secure system” are performed concurrently with the other functions, as shown by the “And” in the circles. The system functions are depicted by the rectangular numbered boxes.

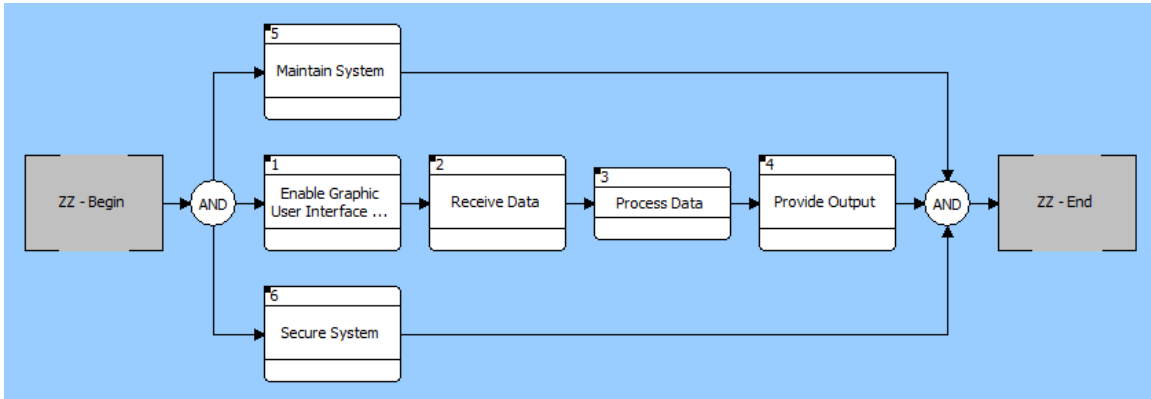

Figure 7. SCMM System Top-Level Functional Flow Block Diagram

These top-level functions were further decomposed into the sub-functions supporting them. These can be seen in Figure 8 and are shown in segments in subsequent figures for readability.

Following is a description of this figure that also applies to the subsequent function figures. The rectangular boxes depict the functions and sub-functions of the system. Each has arrows that show the flow of the functions. The items found in circles denote the following:

- “AND”: concurrent function
- “LP”: loop; repeated until a specific objective has been achieved
- “LE”: loop end; the end of the loop
- “OR”: does otherwise; used to link two or more alternatives

This analysis also yielded the SV-4—system functionality diagram—that is found in the DODAF views section of the System Architecture chapter. The only difference between the two is that the SV-4 describes the resources that flow between the functions.

The complete listing of the functions and the functional requirements are shown in Table 5.

Requirements and Functions			
Number	Requirement	Number	Function
1.4	System Functionality/Functional Requirements		
1.4.1	The system shall enable a graphical user interface (GUI).	1	Enable Graphic User Interface (GUI)
1.4.1.1	The system shall display a login screen in no more than 1 minute.	1.1	Display Log-in Screen
1.4.1.1.1	The system shall accept a user name and password in no more than 5 seconds.	1.1.1	Accept User Name and Password
1.4.1.2	The system shall perform a login credential security verification in no more than 2 seconds.	1.2	Perform Login Credential Security Verification
1.4.1.2.1	The system shall invalidate a login due to an incorrect password entry in no more than 1 second.	1.2.1	Invalidate Password
1.4.1.2.2	The system shall invalidate a login due to an incorrect username entry in no more than 1 second.	1.2.2	Invalidate User Name
1.4.1.2.3	The system shall validate a login due to a correct username and password entry in no more than 1 second.	1.2.3	Validate Username and Password
1.4.1.3	The system shall display a graphic user interface in no more than 5 seconds.	1.3	Display GUI
1.4.1.4	The system shall enable data entry/selection fields in no more than 5 seconds.	1.4	Enable data entry/selection fields
1.4.2	The system shall receive data.	2	Receive Data
1.4.2.1	The system shall accept a user's input/selection in no more than 2 seconds.	2.1	Accept User Input/Selected Data

Requirements and Functions			
Number	Requirement	Number	Function
1.4.2.1.1	The system shall verify the user's inputs/selected data in no more than 2 seconds.	2.1.1	Verify User Input/Selected Data
1.4.2.1.1.1	The system shall invalidate incorrect user inputs in no more than 2 seconds	2.1.1.1	Invalidate User Inputs
1.4.2.1.1.2	The system shall validate correct user inputs in no more than 2 seconds.	2.1.1.2	Validate User Inputs
1.4.2.2	The system shall accept data from external databases in no more than 1 hour.	2.2	Accept Data from External Databases
1.4.2.2.1	The system shall verify data integrity (complete/correct/does not contain errors) in no more than 30 minutes.	2.2.1	Verify Data Integrity (Complete/Correct/Does Not Contain Errors)
1.4.2.2.1.1	The system shall invalidate incorrect database data in no more than 30 minutes.	2.2.1.1	Invalidate Database Data
1.4.2.2.1.2	The system shall validate correct external database data in no more than 30 minutes.	2.2.1.2	Validate External Database Data
1.4.2.2.2	The system shall integrate the data into a repository in no more than 15 minutes.	2.2.2	Integrate the data into repository
1.4.2.2.3	The system shall save data in a system repository in no more than 15 minutes.	2.2.3	Save Data in System Repository
1.4.3	The system shall process data.	3	Data Processing
1.4.3.1	The system shall process requests in no more than 1 second.	3.1	Process Request
1.4.3.2	The system shall execute queries in no more than 1 second.	3.2	Execute Query
1.4.3.3	The system shall verify query requirements are being met in no more than 1 second.	3.3	Verify Query Requirements Are Being Met
1.4.3.3.1	The system shall invalidate incomplete/incorrect queries in no more than 1 second.	3.3.1	Invalidate Query

Requirements and Functions			
Number	Requirement	Number	Function
1.4.3.3.2	The system shall validate complete/correct queries in no more than 1 second.	3.3.2	Validate Query
1.4.3.4	The system shall obtain filtered data from the repository in no more than 2 minutes.	3.4	Obtain Filtered Data From Repository
1.4.3.5	The system shall perform sparing analysis in no more than 5 minutes.	3.5	Perform Sparing Analysis
1.4.4	The system shall provide outputs.	4	Provide Output
1.4.4.1	The system shall display sparing results (graphical output based on user's query) in no more than 1 second.	4.1	Display Sparing Results (Graphical Output Based on User's Query)
1.4.4.1.1	The system shall allow the user to save sparing results in no more than 1 second.	4.1.1	Save Sparing Results
1.4.4.1.2	The system shall allow the user to print sparing results in no more than 1 second.	4.1.2	Print Sparing Results
1.4.4.1.3	The system shall allow the user to perform sensitivity analysis in no more than 1 second.	4.1.3	Perform Sensitivity Analysis
1.4.4.1.4	The system shall allow the user to delete results in no more than 1 second.	4.1.4	Delete Results
1.4.5	The system shall provide self-maintenance through a series of checks and display the information to the user.	5	Maintain System
1.4.5.1	The system shall execute self-checks in no more than 2 seconds.	5.1	Execute System Self Check
1.4.5.1.1	The system shall execute a repository check in no more than 0.5 seconds.	5.1.1	Execute Repository Check
1.4.5.1.2	The system shall execute an interface check in no more than 1 second.	5.1.2	Execute Interface Check

Requirements and Functions			
Number	Requirement	Number	Function
1.4.5.1.2.1	The system shall execute an interface check of the system side in no more than 0.5 seconds.	5.1.2.1	Execute System Side Check of Interface
1.4.5.1.2.2	The system shall execute an interface check of the external databases in no more than 0.5 seconds.	5.1.2.2	Execute External Database Check of Interface
1.4.5.1.2.2.1	The system shall display a status of the external databases in no more than 0.5 seconds.	5.1.2.2.1	Display External Database Status
1.4.5.1.3	The system shall execute a processes check in no more than 0.5 seconds.	5.1.3	Execute Processes Check
1.4.5.2	The system shall provide the user with a maintenance history in no more than 1 second.	5.2	Provide Maintenance History
1.4.5.2.1	The system shall display the time and date of the last database data download in no more than 1 second.	5.2.1	Display Time/Date of Last Data Download
1.4.5.2.2	The system shall display the time and date of the last login in no more than 1 second.	5.2.2	Display Last Login Information
1.4.6	The system shall secure itself.	6	Secure System
1.4.6.1	The system shall comply with DOD and DoN Information Assurance (IA) policies and procedures.	6.1	Ensure Information Assurance Compliance
1.4.6.2	The system shall secure the GUI continuously.	6.2	Secure the GUI
1.4.6.3	The system shall secure the log-in process when in login screen.	6.3	Secure Login Process
1.4.6.4	The system shall secure the repository continuously.	6.4	Secure Repository
1.4.6.5	The system shall secure the interfaces with the external databases continuously.	6.5	Secure the Interfaces with External Databases

Table 5. Functions and Functional Requirements

Figure 9 displays the functions and sub-functions of function 1: enable graphic user interface.

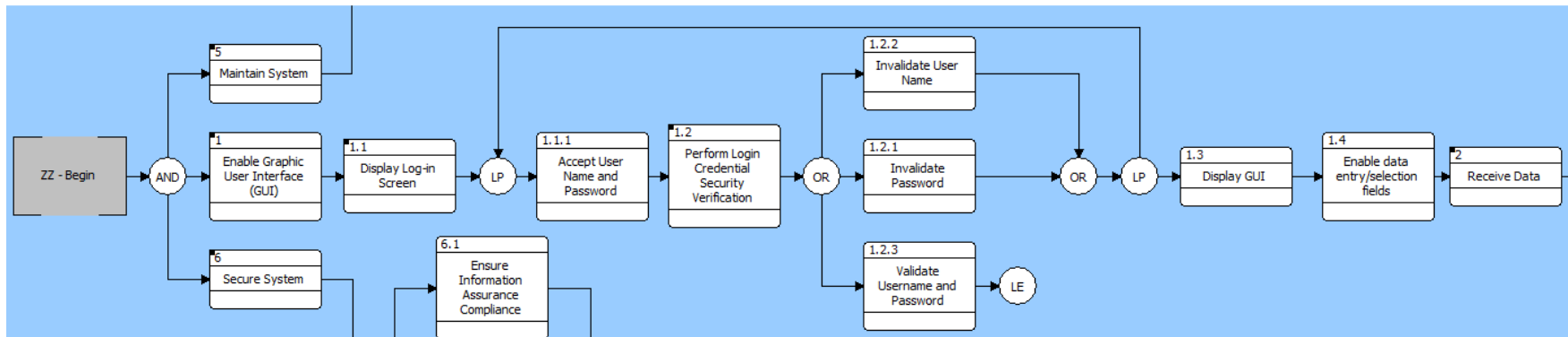

Figure 9. SCMM System Function 1: Enable Graphic User Interface

Figure 10 displays the functions and sub-functions of function 2: receive data.

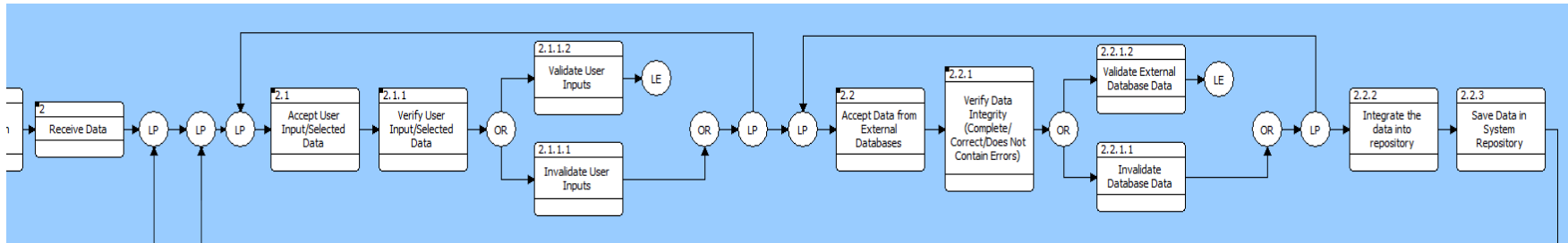

Figure 10. SCMM System Function 2: Receive Data

Figure 11 displays the functions and sub-functions of function 3: process data.

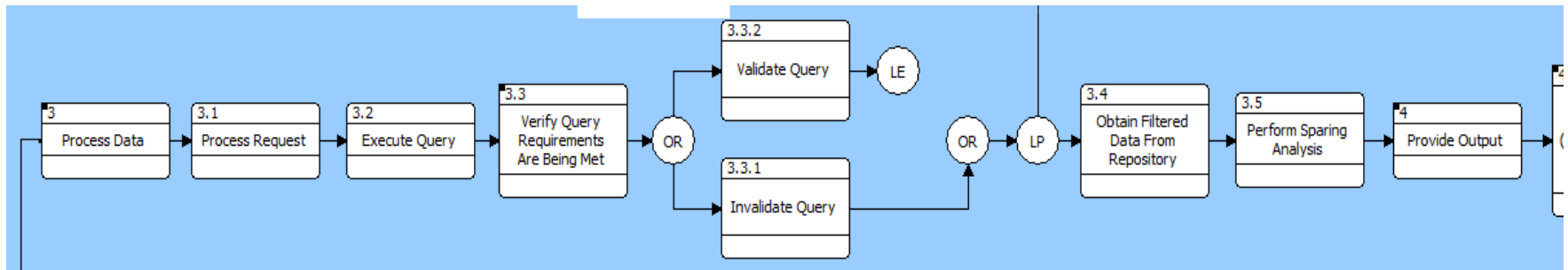

Figure 11. SCMM System Function 3: Process Data

Figure 12 displays the functions and sub-functions of function 4: provide output.

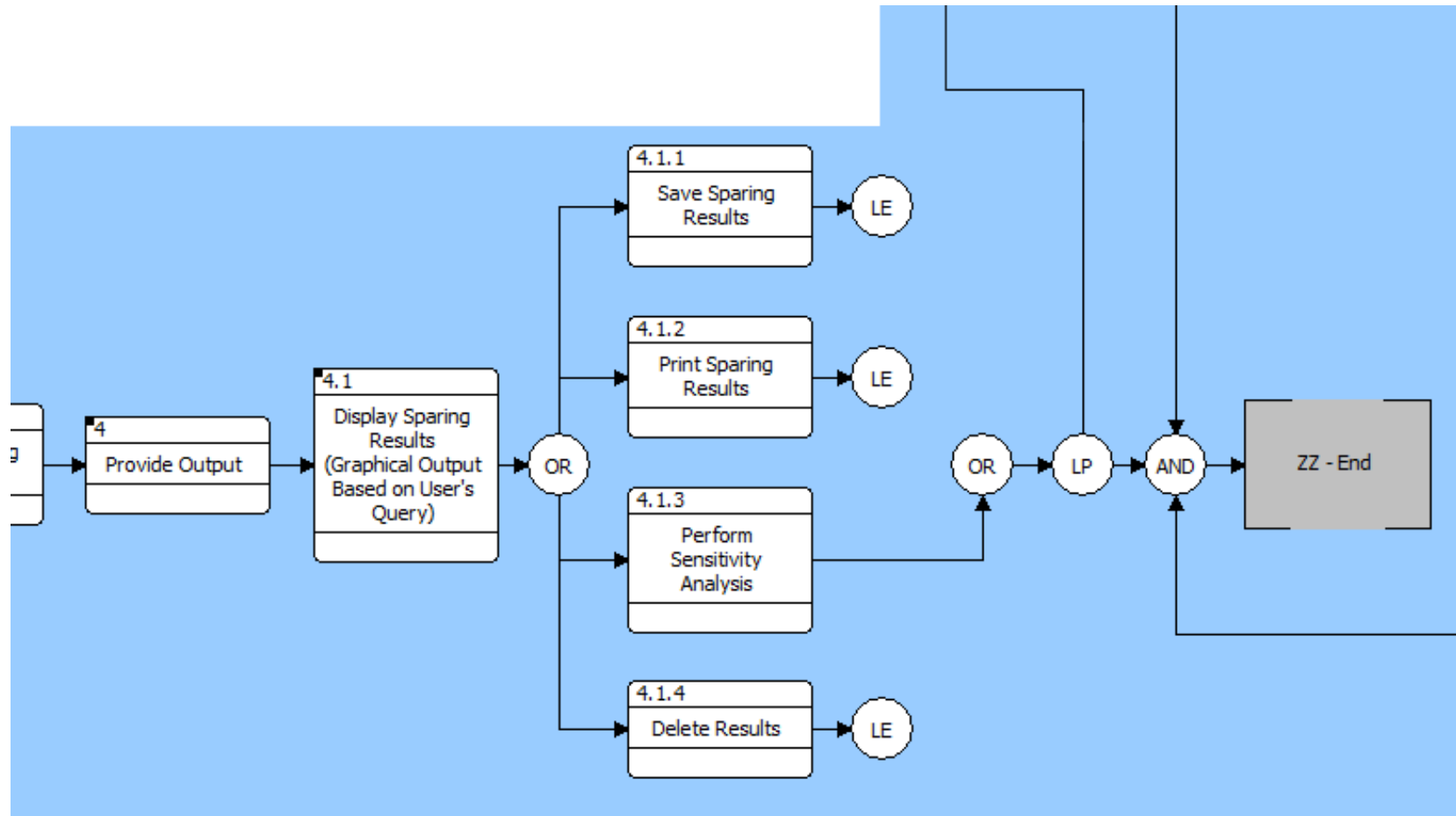

Figure 12. SCMM System Function 4: Provide Output

Figure 13 displays the functions and sub-functions of function 5: maintain system.

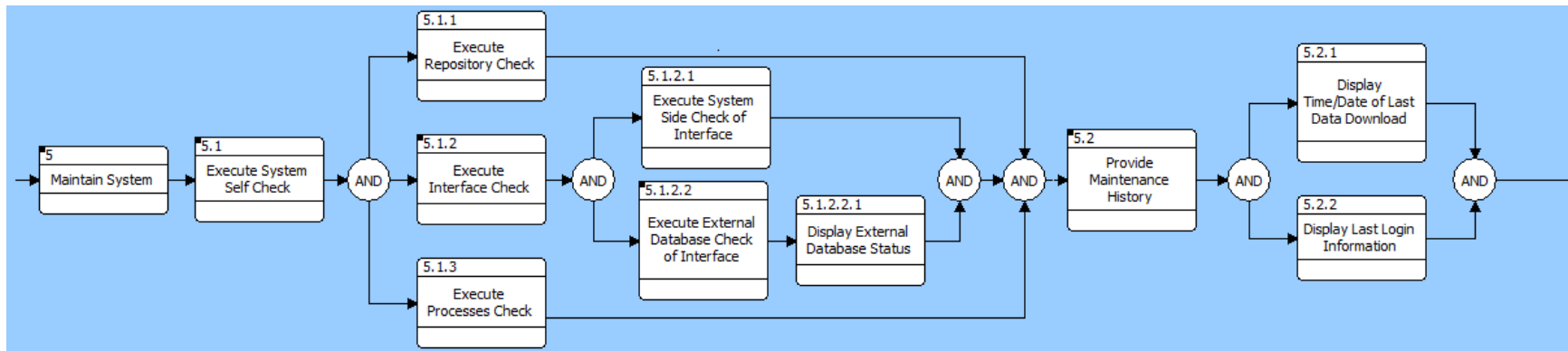

Figure 13. SCMM System Function 5: Maintain System

Figure 14 displays the functions and sub-functions of function 6: secure system.

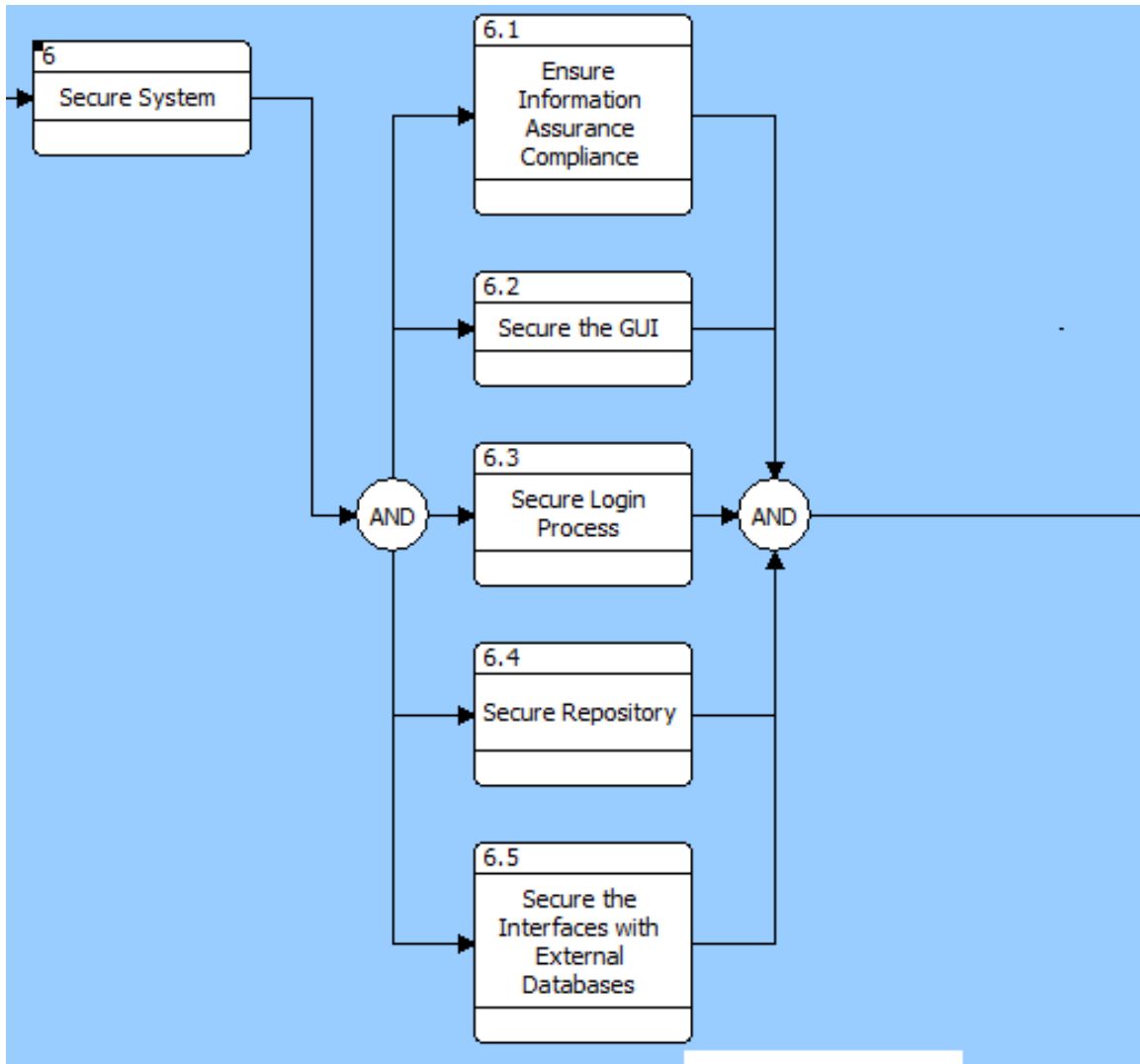

Figure 14. SCMM System Function 6: Secure System

A hierarchy block diagram (HBD) was also developed using the CORE tool. This diagram was developed to model the hierarchy of functions and sub-functions. Figure 15 shows the top-level functions of the SCMM system. Functions 1–6 can be seen in more detail in the succeeding figures.

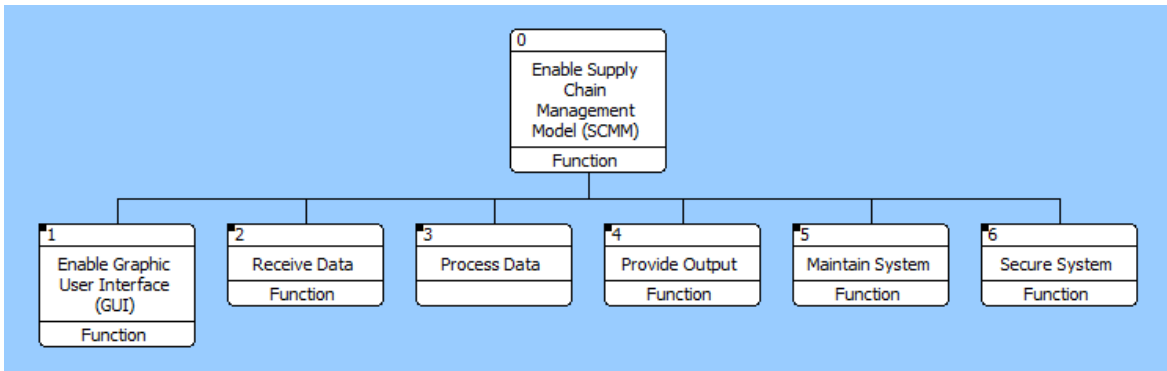

Figure 15. SCMM System Top-Level Functions Hierarchy Block Diagram

Figure 16 depicts the HBD of function 1: enable graphic user interface (GUI).

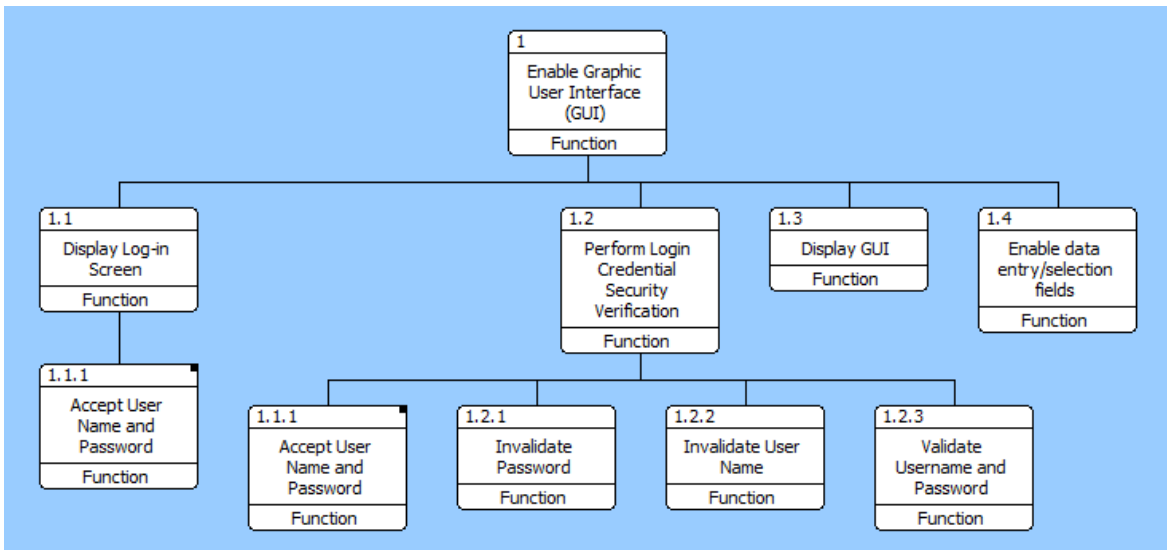

Figure 16. SCMM Function 1: Enable Graphic User Interface Hierarchy Block Diagram

Figure 17 depicts the HBD of function 2: receive data

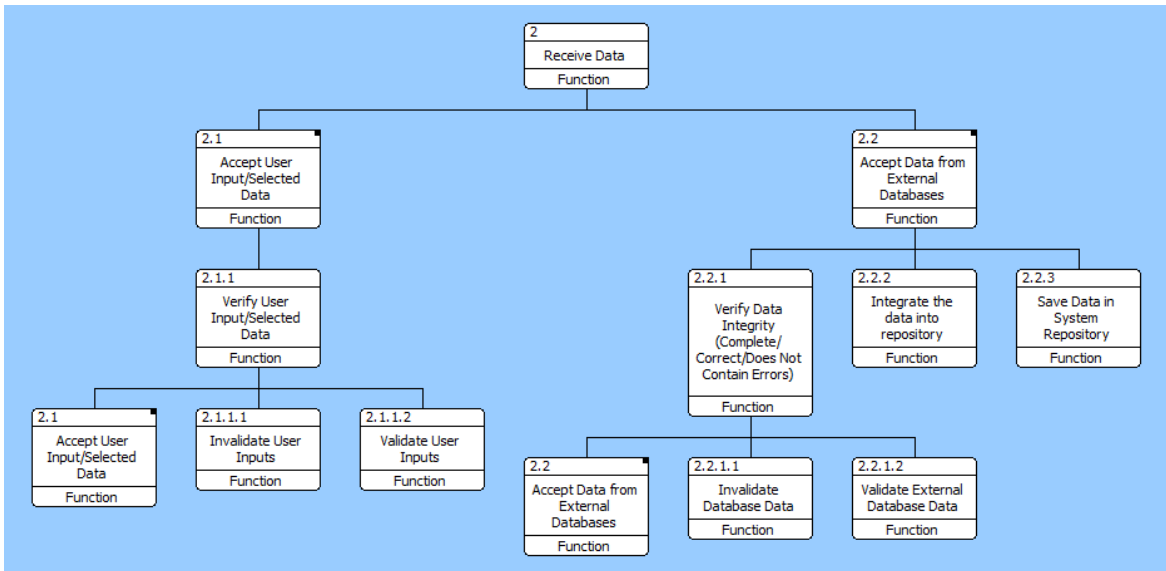

Figure 17. SCMM System Function 2: Receive Data Hierarchy Block Diagram

Figure 18 depicts the HBD of function 3: process data.

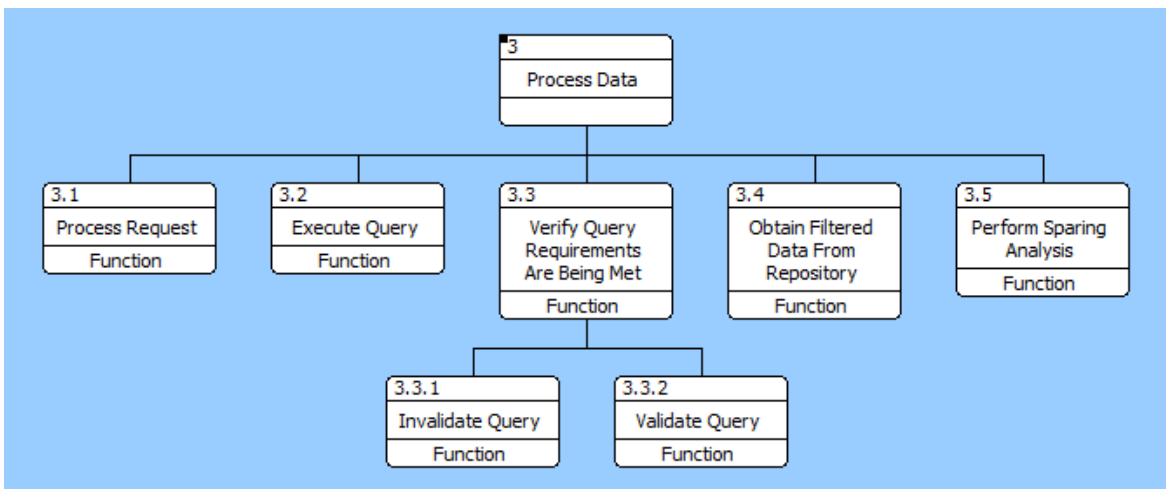

Figure 18. SCMM System Function 3: Process Data Hierarchy Block Diagram

Figure 19 depicts the HBD of function 4: provide output.

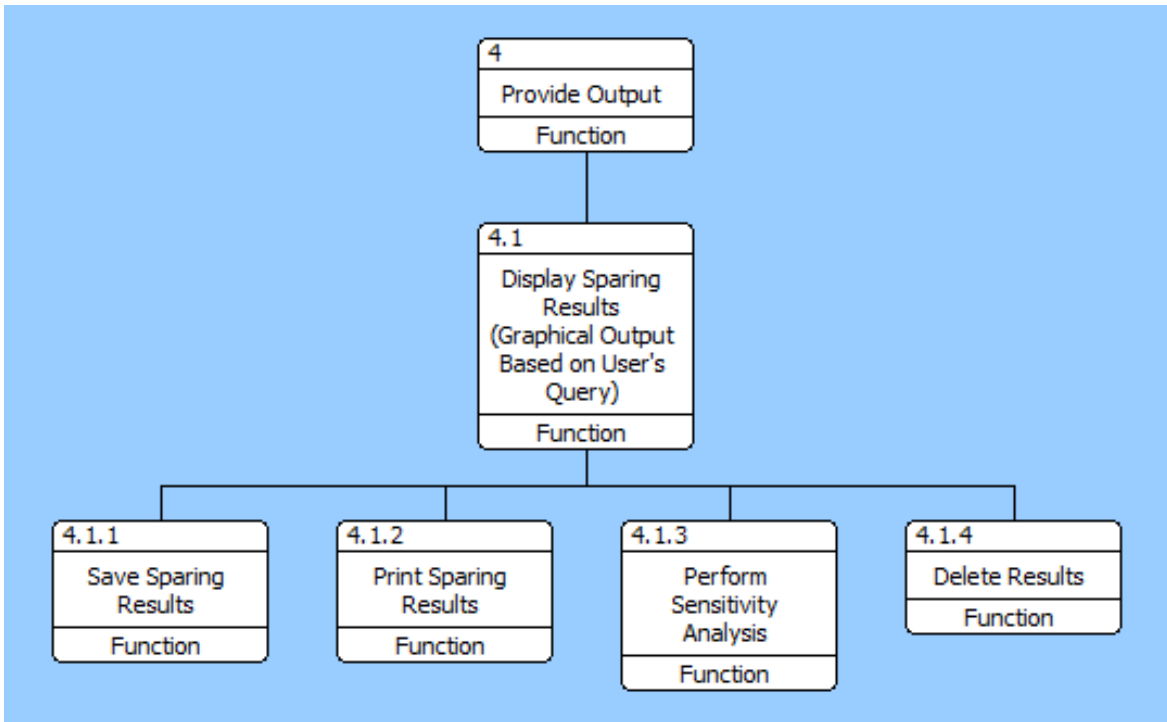

Figure 19. SCMM System Function 4: Provide Output Hierarchy Block Diagram

Figure 20 depicts the HBD of function 5: Maintain System

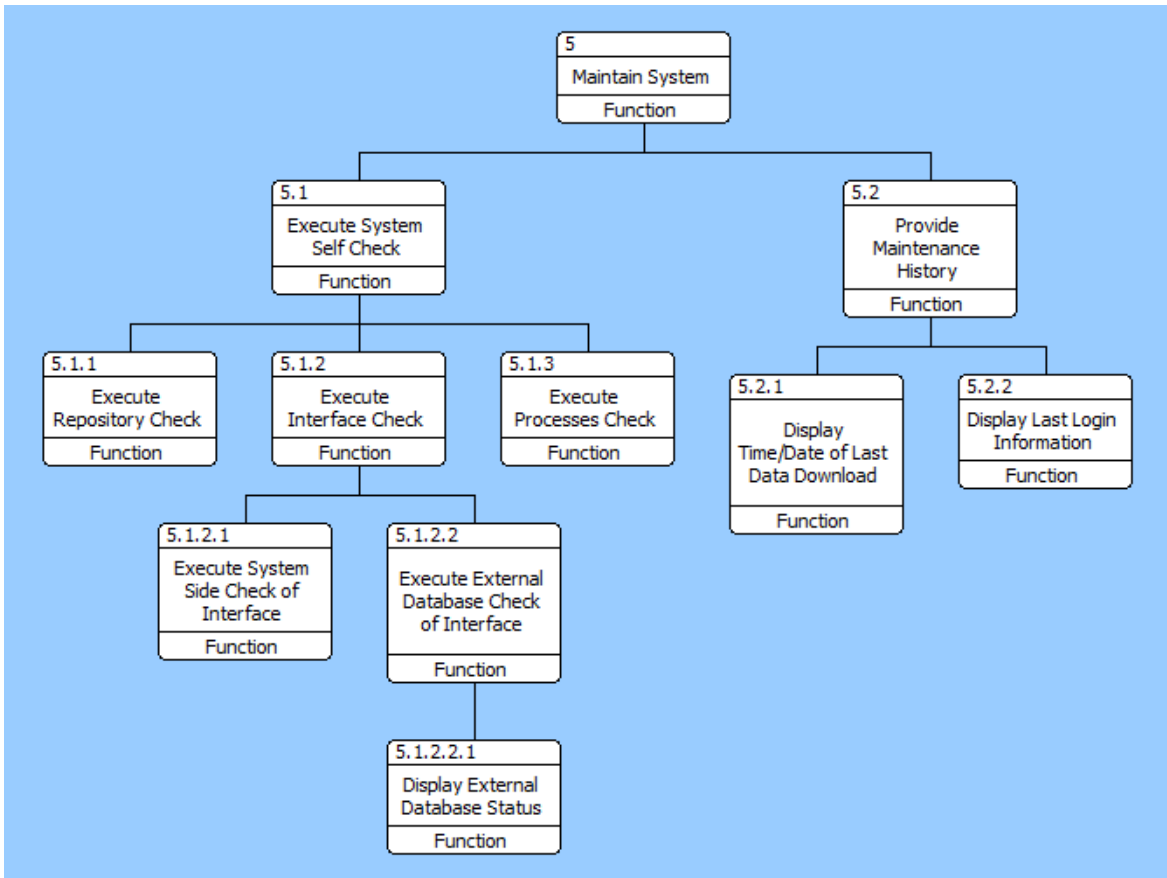

Figure 20. SCMM System Function 5: Maintain System Hierarchy Block Diagram

Figure 21 depicts the HBD of function 6: secure system.

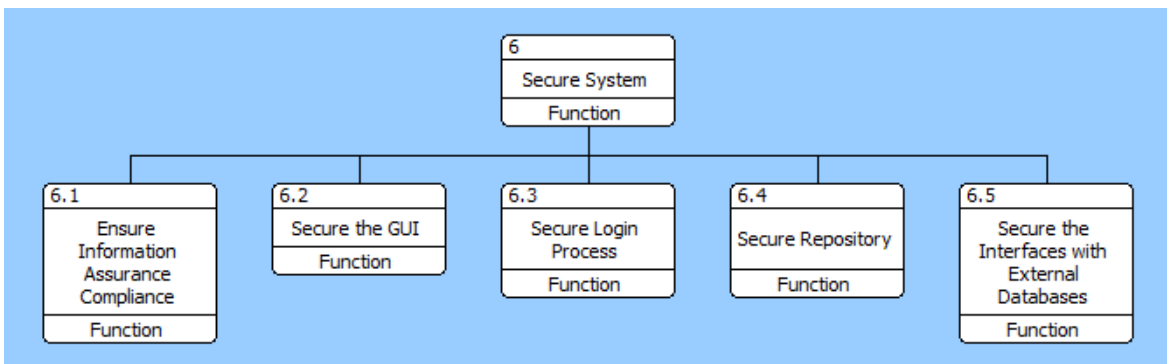

Figure 21. SCMM System Function 6: Secure System Hierarchy Block Diagram

A matrix listing each input and output (defined as an “item” in CORE) allocated to a specific function was created with the SCMM system’s information resident in CORE. The inputs and outputs allocated to the functions can be seen in Table 6.

Function Input Output Table		
Items (inputs or outputs)	Input to	Output to
Activated Data Entry Fields	Function 2 Receive Data	Function 1 Enable Graphic User Interface (GUI)
Activated Maintenance Access	Function 5 Maintain System	Function 1 Enable Graphic User Interface (GUI)
Assigned Regional Maintenance Center (RMC)	Function 2 Receive Data	
Budget	Function 2 Receive Data	
Database Side Interface Status		Function 5 Maintain System
DLA Distribution Centers	Function 2 Receive Data	
Duration of operation(s)	Function 2 Receive Data	
Fleet area of operation	Function 2 Receive Data	
Fleet Logistics Centers (formerly FISCs: Fleet and Industrial Support Centers)	Function 2 Receive Data	
Graphical Output GUI		Function 4 Provide Output Function 1 Enable Graphic User Interface (GUI)
Maintenance facility locations(s)	Function 2 Receive Data	
Maintenance History		Function 5 Maintain System
Mission module(s)	Function 2 Receive Data	
Mission module(s) Ao to support the mission/multi-mission	Function 2 Receive Data	
Mission Module(s) availability requirement (Ao, etc.)	Function 2 Receive Data	

Function Input Output Table		
Items (inputs or outputs)	Input to	Output to
Mission module(s) configuration Allowance Parts List (APLs)/Allowance Equipage List (AELs)	Function 2 Receive Data	
Mission module(s) container available space / dimensions allowance for parts	Function 2 Receive Data	
Mission module(s) container available weight allowance for parts	Function 2 Receive Data	
Mission package (man.)(e.g., SUW, ASW, MCM, humanitarian)	Function 2 Receive Data	
Part cage code(s)	Function 2 Receive Data	
Part cost(s)	Function 2 Receive Data	
Part criticality	Function 2 Receive Data	
Part dimensions	Function 2 Receive Data	
Part estimated shipping time	Function 2 Receive Data	
Part failure rate/mean time between failure (MTBF)	Function 2 Receive Data	
Part hazardous material (HAZMAT) information	Function 2 Receive Data	
Part item manager point of contact (POC)	Function 2 Receive Data	
Part maintenance code(s)	Function 2 Receive Data	
Part nomenclature(s)	Function 2 Receive Data	
Part national stock numbers (NSNs)s	Function 2 Receive Data	
Part number(s)	Function 2 Receive Data	
Part weight	Function 2 Receive Data	
Planned changes to mission module's configuration/dates for changes	Function 2 Receive Data	

Function Input Output Table		
Items (inputs or outputs)	Input to	Output to
Planned changes to ship's configuration/dates for changes	Function 2 Receive Data	
Processes Status		Function 5 Maintain System
Projected Ao of ship(s)	Function 4 Provide Output	Function 3 Process Data
Repository Data	Function 3 Process Data	Function 2 Receive Data
Repository Status		Function 5 Maintain System
Sensitivity Analysis - Ao	Function 2 Receive Data	Function 4 Provide Output
Sensitivity Analysis - Budget	Function 2 Receive Data	Function 4 Provide Output
Sensitivity Analysis - Space	Function 2 Receive Data	Function 4 Provide Output
Sensitivity Analysis - Weight	Function 2 Receive Data	Function 4 Provide Output
Ship hull number(s) (man)	Function 2 Receive Data	
Ship seaframe system(s)	Function 2 Receive Data	
Ship(s) availability requirement (Ao)	Function 2 Receive Data	
Ship(s) available space / dimensions allowance for parts.	Function 2 Receive Data	
Ship(s) available weight allowance for parts.	Function 2 Receive Data	
Ship(s) configuration (APLs/AELs)	Function 2 Receive Data	
Ship(s) system	Function 2 Receive Data	
Spares allocation at land-based maintenance facilities	Function 4 Provide Output	Function 3 Process Data
Spares allocation at OCONUS warehouse locations	Function 4 Provide Output	Function 3 Process Data
Spares allocation for mission module(s) container(s)	Function 4 Provide Output	Function 3 Process Data
Spares allocation on ship	Function 4 Provide Output	Function 3 Process Data
Summary of inputs	Function 4 Provide Output	Function 3 Process Data

Function Input Output Table		
Items (inputs or outputs)	Input to	Output to
System Side Interface Status		Function 5 Maintain System
System status		Function 5 Maintain System
Total cost of parts allocated	Function 4 Provide Output	Function 3 Process Data
Total ship Ao by mission (does not include HM&E)	Function 2 Receive Data	
Total ship Ao by mission (includes HM&E)	Function 2 Receive Data	
Total space of mission module(s) container(s) spares	Function 4 Provide Output	Function 3 Process Data
Total space of shipboard spares	Function 4 Provide Output	Function 3 Process Data
Total weight of mission module(s) container(s) spares	Function 4 Provide Output	Function 3 Process Data
Total weight of shipboard spares	Function 4 Provide Output	Function 3 Process Data
User Inputs	Function 3 Process Data	Function 2 Receive Data
User Name and Password	Function 1 Enable Graphic User Interface (GUI)	

Table 6. SCMM System—Input and Output Function Allocation

E. SUMMARY

The first phase of the team’s tailored SE process was to analyze the stakeholder needs. The first step in this process of needs identification was defining the problem definition, which was accomplished by conducting interviews with the sponsor resulting in the agreed upon problem background: *The U.S. Navy has begun to focus acquisition strategies to incorporate more modular and flexible designs for surface ship architecture in an effort to improve procurement and life cycle costs and to support rapid introduction of capability. Given the emphasis on modularity, the Navy is also placing importance on manning requirements that are optimized to support modular/flexible constructs.*

Team RSRP conducted a literature review of available published materials, including scholarly articles, journals, and reports to research and substantiate the challenges of the current supply chain and to identify relevant terms included in the problem statement. The team then developed questions to focus the research to areas related to modular or flexible design ships. The research questions were posed in subsequent interviews to the sponsor to understand the organizations that are involved with ship sustainment operations and would be affected by the development of a new SCM model supporting modular ship classes. Through an iterative process of interviews with the sponsor and topic research, the final problem statement was defined and approved by the sponsor on August 30, 2013: *As the U.S. Navy drives toward modular and flexible designs, the currently used surface Navy SCM models do not support modular or flexible design ships. These ships require an off-ship maintenance support structure consisting of multiple logistics and repair nodes due to shipboard constraints including manning, space, and weight.*

Upon final problem statement definition, the project team finalized the identification of the relevant stakeholders for the SCMM system, and established the individual stakeholder needs for the system. The stakeholders were identified to be: project sponsor, maintenance facilities, ISEA, program office, DLA, NAVSUP, the sailor, and LCSRON TYCOM. Through analysis of the stakeholder needs the team finalized the overall system effective need statement: *The stakeholders need information to determine sparing of parts at existing and multiple supply points in order to support the Navy's modular/flexible ships within the constraints of manning, space, weight, location, and cost/budget.* This was confirmed by the sponsor on August 30, 2013.

Team RSRP began the functional analysis upon establishment of the needs statement by determining what the system must do. The functional analysis was accomplished by defining several use case scenarios which identified the functions of the system and the necessary inputs and outputs of the system. These were approved by the sponsor and would be utilized during the design phase of the project. A use case, FFBDs, HBDs, a table listing the functions and functional requirements were developed during

this phase, and a matrix allocating the inputs and outputs to functions were created during the functional analysis (in conjunction with the requirements development phase).

THIS PAGE INTENTIONALLY LEFT BLANK

III. SYSTEM REQUIREMENTS

To enable commencement of the conceptual design of a system to satisfy the determined capability gaps, a complete and iterative analysis of system requirements was embarked upon. An investigation of the existing system structure and interoperability requirements between designated stakeholders was documented to allow for implementation of the developed system. Model based systems engineering was performed to show requirements traceability and to define system boundaries. A requirements analysis was performed based on the stakeholders' originating requirement (need statement), which was then used by the team to develop derived requirements to include: input/output requirements, technology and suitability requirements, system trade-off requirements, and system qualification requirements. The development and confirmation of system requirements allowed the system architecture and conceptual design phases to continue.

A. SYSTEM MODELING

The system's architecture, functions, requirements, and various DODAF views were modeled in Vitech's CORE. CORE is explained in detail in the System Modeling section of Chapter VI Modeling and Simulation.

A baseline was created in CORE that allowed the team to maintain system architecture validity throughout refinement and discussions with the sponsor. The baseline was the initial set of data that the team developed to model the system. This data included the initial functions, requirements, and views based on early discussion with the sponsor. Modeling a baseline of the system was important because it provided a detailed view of the system, which was used for future meetings with the sponsor to elicit feedback. All models in CORE are built around and linked to a central repository (Vitech 2013). This allowed for a change that was made in one diagram to be reflected across all diagrams (Vitech 2013). These diagrams were not only useful in creating DODAF deliverables, but also they were used to effectively communicate the architecture to the team and sponsor.

B. SYSTEM BOUNDARIES

The system boundary determines whether something belongs in the system or not; it is used to separate the system from its environment while the system is connected to the environment by the inputs and outputs that cross the system boundary. When defining the problem, the team used system models / diagrams to determine what entities would be interfacing and influencing the system. The team first developed an ICOM diagram to scope and bound the problem. By scoping the problem one ensures that it is broad enough to contain all relevant matters; by bounding the problem, one defines the limits so that the problem is controllable (Sage and Armstrong 2000). ICOM diagrams also allow the analysis of the inputs and outputs while sequestering the system while the form and function of the system remain undefined during this process (Sage and Armstrong 2000).

The team created a high-level ICOM diagram, shown in Figure 22. A function box representing the SCMM was used to establish the context of the system the team modeled. Four types of information lines were drawn into or out of this function box. Inputs are shown as arrows entering the left side of the function box. The SCMM system's inputs were the data from the various databases that provide information to the system as well as user entered inputs. Outputs are shown as exiting arrows on the right side of the box. For the SCMM, the outputs were the supply information for the stakeholders' use. Controls/constraints are displayed as arrows entering the top of the box. Controls and/or constraints are a form of input, but are used to direct the activity in the process. The SCMM system's controls and constraints were initially identified as economic, environmental, political, sociological, and technical. Mechanisms are displayed as arrows entering from the bottom of the box. Mechanisms are the resources and tools that are required for realizing the function including operating personnel, maintenance support personnel, and machines/tools such as computers.

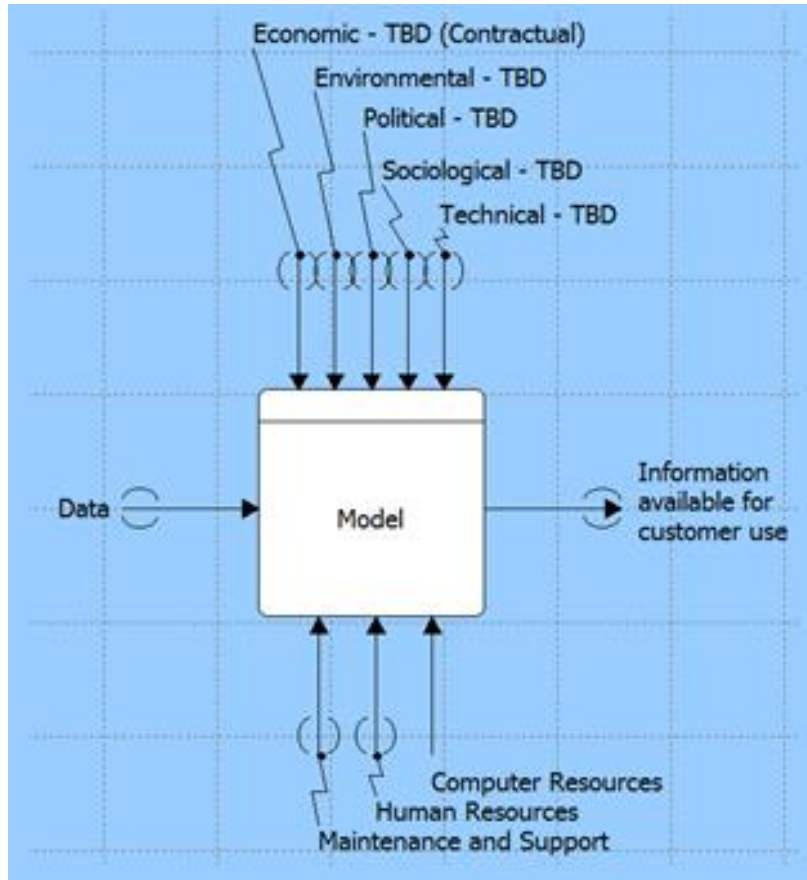

Figure 22. SCMM System High-Level ICOM Diagram

A detailed ICOM diagram based on specific inputs, outputs, controls/constraints, and mechanisms was then developed in conjunction with the sponsor. The information used in this diagram is shown in Table 7. The inputs, outputs, controls/constraints, and mechanisms are independent of each other within the table.

Inputs	Outputs	Controls/Constraints	Mechanisms
Assigned RMC	Database Side Interface Status	The system shall interface with NDE: AMPS	Computer Resources
Budget	Maintenance History	The system shall interface with NDE: CDMD-OA	User: DLA
DLA Distribution Centers	Processes Status	The system shall interface with NAVSUP ERP.	User: ISEA
Duration of operation(s) per applicable entry	Projected Ao of ship(s)	The system shall interface with user host platform(s).	User: MPSF

Inputs	Outputs	Controls/Constraints	Mechanisms
Fleet area of operation	Repository Status	The system shall be interoperable with DOD GIG.	User: NAVSUP
Fleet Logistics Centers (formerly FISCs: Fleet and Industrial Support Centers)	Sensitivity Analysis—Ao	The system shall comply with DOD and DoN Information Assurance (IA) policies and procedures.	
Maintenance facility locations(s)	Sensitivity Analysis—Budget	The system shall be hosted on a DOD authorized platform.	
Mission module(s)	Sensitivity Analysis—Space	The system shall conform to a modular open systems approach (MOSA).	
Mission Module(s) availability requirement (Ao)	Sensitivity Analysis—Weight	The system shall conform to MOSA by adapting to evolving requirements.	
Mission module(s) configuration (APLs/AELs)	Spares allocation at land-based maintenance facilities	The system shall conform to MOSA by enhancing access to cutting edge technologies and products.	
Mission module(s) container available space / dimensions allowance for parts	Spares allocation at OCONUS warehouse locations	The system shall conform to MOSA by enhancing commonality and reuse of components among systems.	
Mission module(s) container available weight allowance for parts	Spares allocation for mission module(s) container(s)	The system shall conform to MOSA by enhancing life-cycle supportability.	
Mission package (man.)(e.g., SUW, ASW, MCM, humanitarian)	Spares allocation on ship	The system shall conform to MOSA by ensuring that the system will be fully interoperable with all the systems with which it must interface without major modification of existing components.	
Part cage code(s)	Summary of inputs	The system shall conform to MOSA by facilitating systems integration.	
Part cost(s)	System Side Interface Status	The system shall conform to MOSA by mitigating the risk associated with technology obsolescence.	

Inputs	Outputs	Controls/Constraints	Mechanisms
Part criticality	System status	The system shall conform to MOSA by mitigating the risk of a single source of supply over the life of the system.	
Part dimensions	Total cost of parts allocated	The system shall conform to MOSA by reducing the development cycle time.	
Part estimated shipping time	Total space of mission module(s) container(s) spares	The system shall conform to MOSA by reducing total lifecycle cost.	
Part failure rate/MTBF	Total space of shipboard spares	The system shall comply with DOD human system integration standards/specifications.	
Part HAZMAT information	Total weight of mission module(s) container(s) spares		
Part item manager POC	Total weight of shipboard spares		
Part maintenance code(s)			
Part nomenclature(s)			
Part NSN(s)			
Part number(s)			
Part weight			
Planned changes to mission module's configuration/dates for changes			
Planned changes to ship's configuration/dates for changes			
Ship hull number(s)			
Ship seaframe system(s)			
Ship(s) availability requirement (Ao)			

Inputs	Outputs	Controls/Constraints	Mechanisms
Ship(s) available space / dimensions allowance for parts.			
Ship(s) available weight allowance for parts.			
Ship(s) configuration (APLs/AELs)			
Ship(s) system			
Total ship Ao by mission (does not include HM&E)			
Total ship Ao by mission (includes HM&E)			
User Name and Password			

Table 7. SCMM System Detailed ICOM Table

The IDEF0 model provides a “graphical representation of the interaction of the functional and physical elements of a system” according to Buede (Buede 2009, 85). Figure 23 shows the entire detailed ICOM or IDEF0, which is also shown in segments in the subsequent figures for readability. The rectangular boxes represent the system functions; arrows or arcs represent the data flows. Inputs enter the functions boxes from the left, are transformed by that function, and leave as outputs from the right of the boxes. Controls/constraints enter from the top of a box while the mechanisms enter from the bottom of the box.

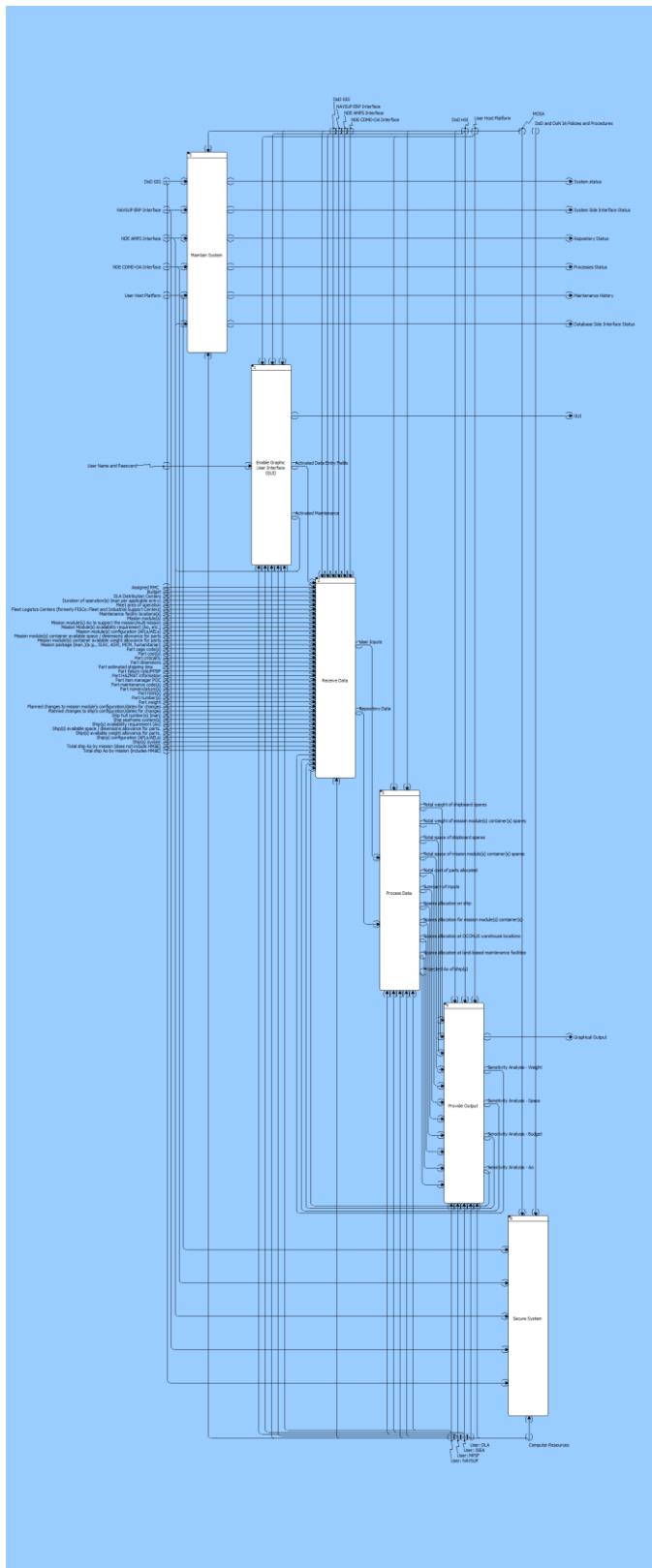

Figure 23. SCMM System IDEF0

Figure 24 depicts the SCMM system functions 1 and 5: enable graphic user interface and maintain system IDEF0 with emphasis on function 1.

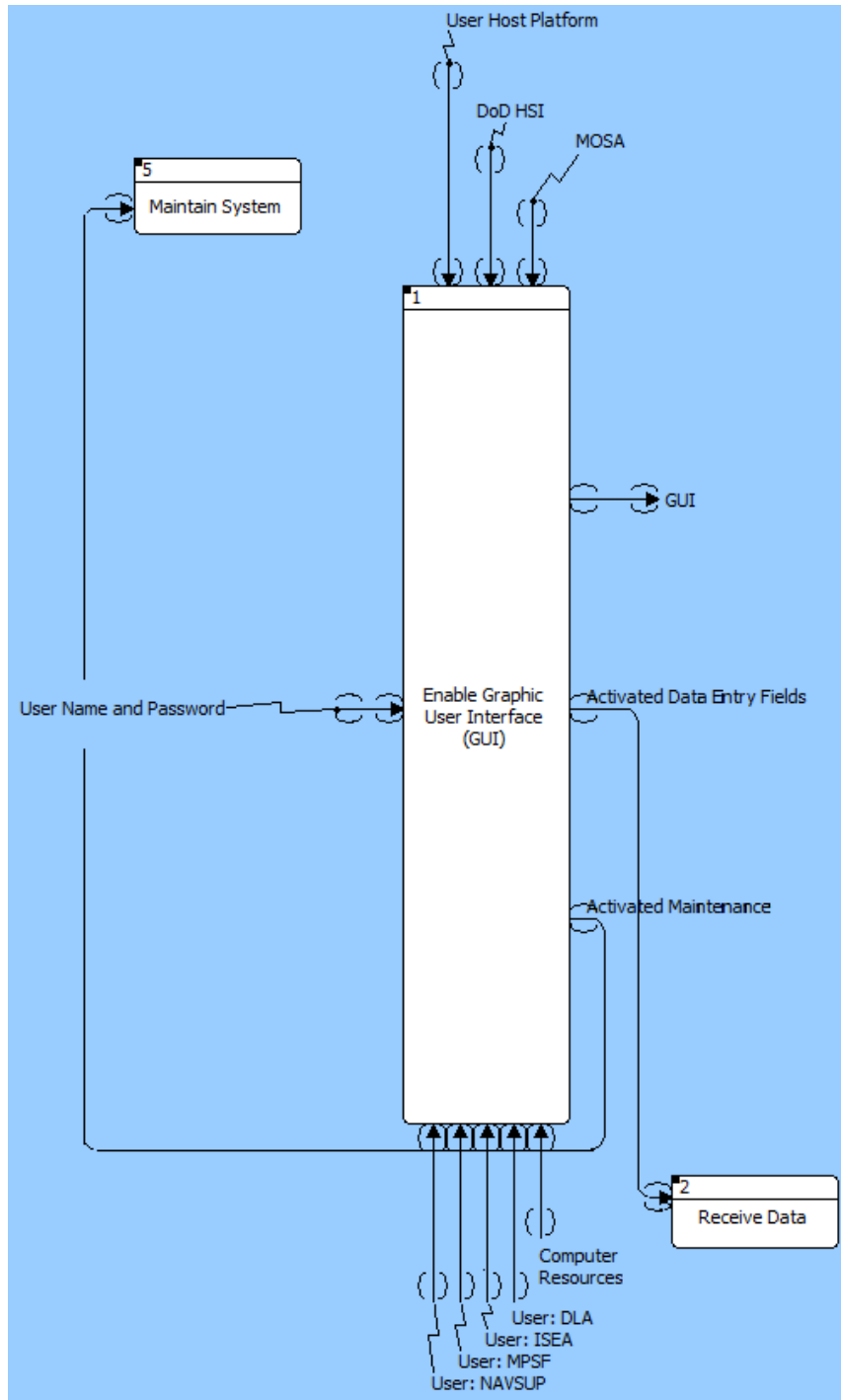

Figure 24. SCMM System Functions 1 and 5: Enable Graphic User Interface and Maintain System IDEF0 (Function 1 Emphasis)

Figure 25 depicts the SCMM system functions 2, 3, and 4: receive data, process data, and provide output IDEF0 with emphasis on function 2.

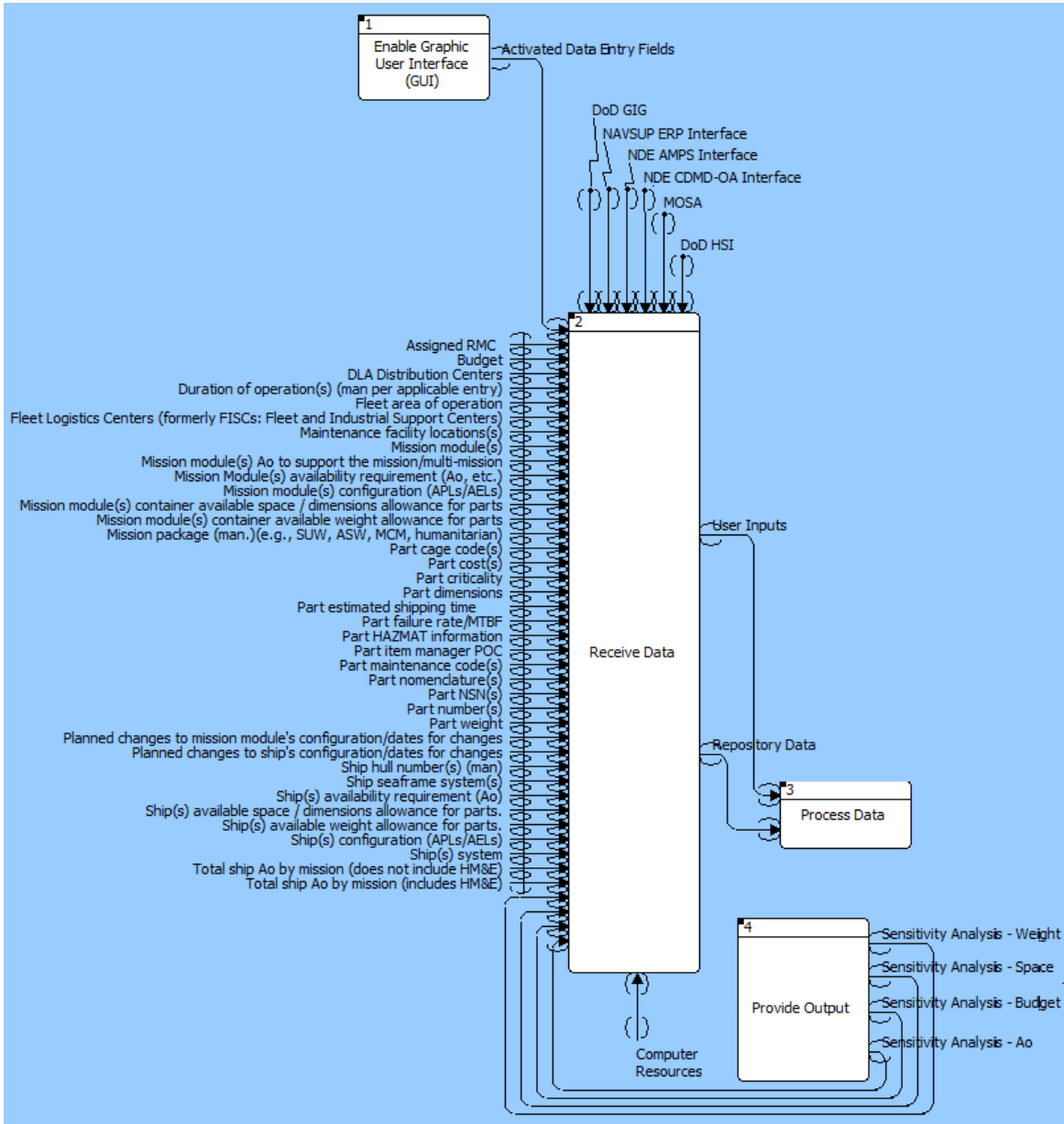

Figure 25. SCMM System Functions 2, 3, and 4: Receive Data, Process Data, and Provide Output IDEF0 (Function 2 Emphasis)

Figure 26. depicts the SCMM system functions 2, 3, and 4: receive data, process data, and provide output IDEF0 with emphasis on function 3.

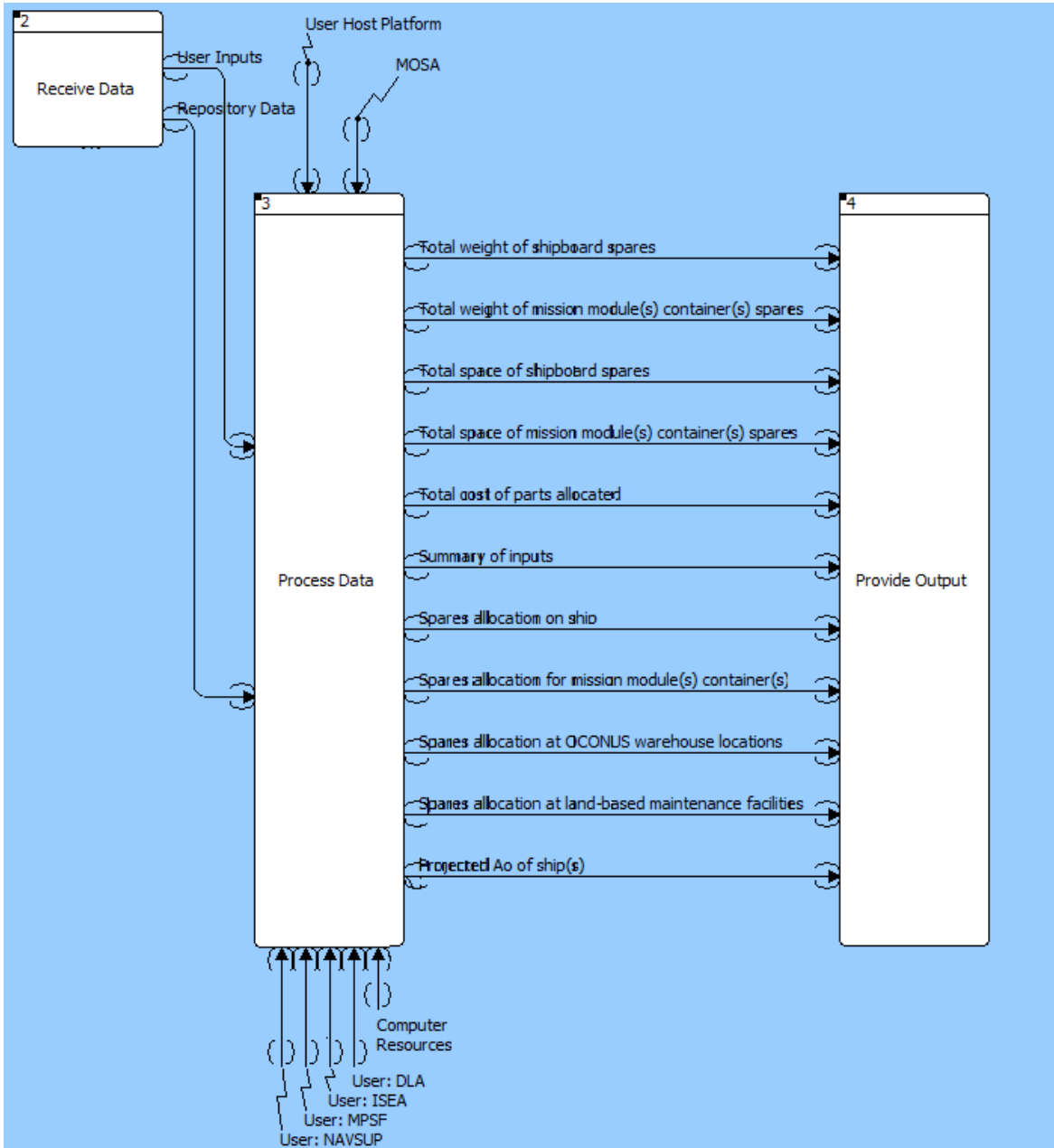

Figure 26. SCMM System Functions 2, 3, and 4: Receive Data, Process Data, and Provide Output IDEF0 (Function 3 Emphasis)

Figure 27 depicts the SCMM system functions 2, 3, and 4: receive data, process data, and provide output IDEF0 with emphasis on function 4.

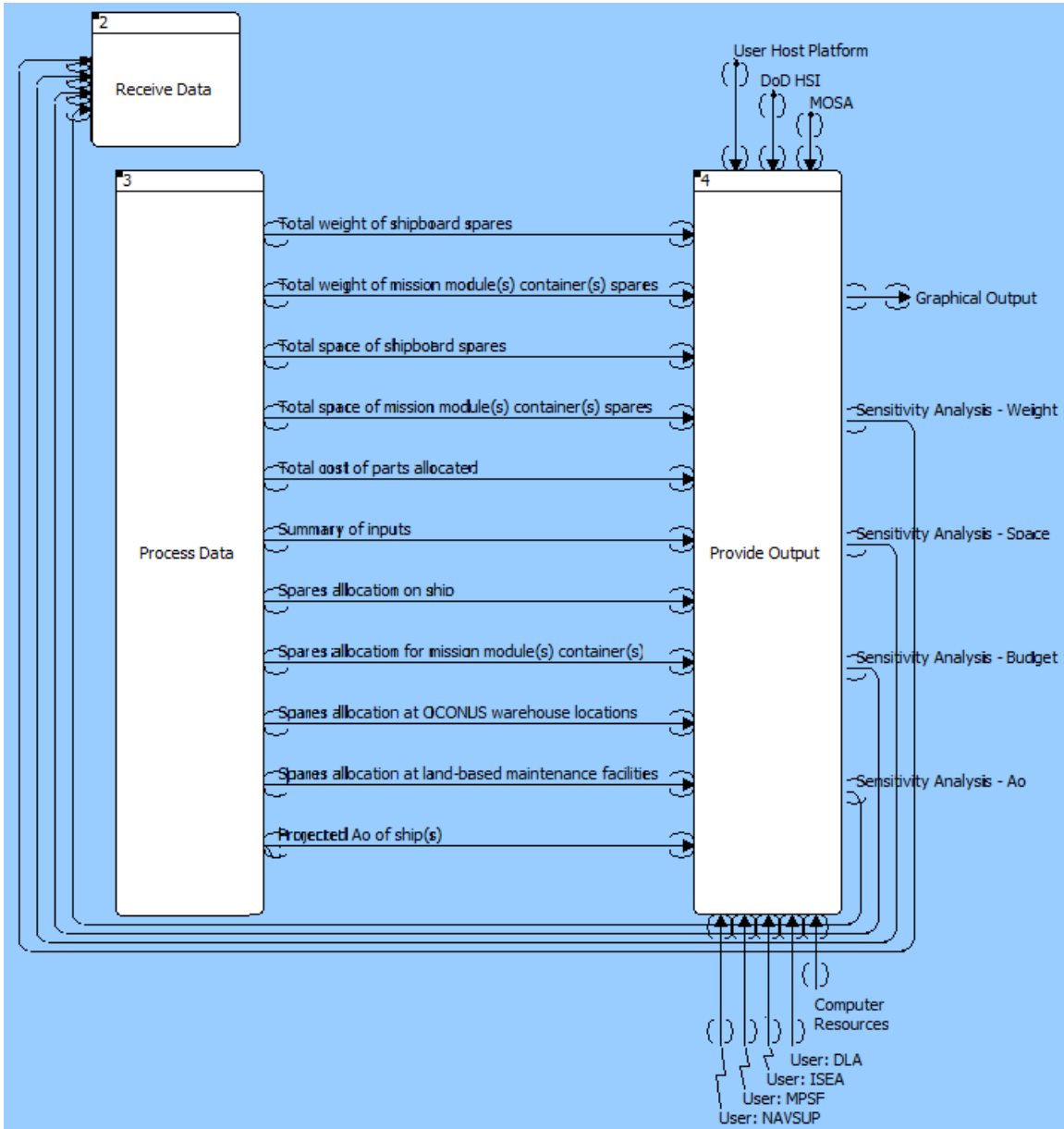

Figure 27. SCMM System Functions 2, 3, and 4: Receive Data, Process Data, and Provide Output IDEF0 (Function 4 Emphasis)

Figure 28 depicts the SCMM system functions 5 and 1: maintain system and enable graphic user interface IDEF0 with emphasis on function 5.

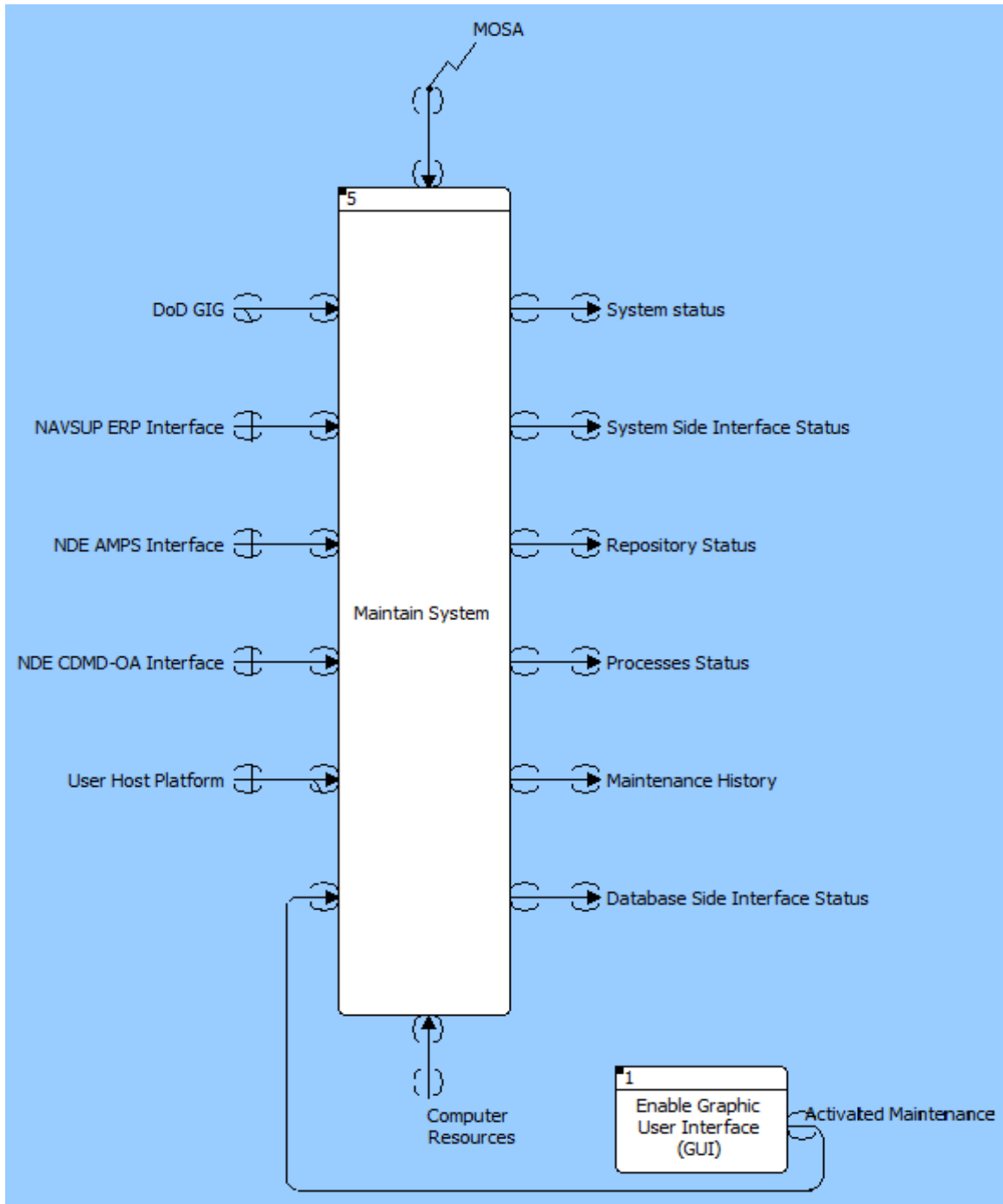

Figure 28. SCMM System Functions 5 and 1: Maintain System and Enable Graphic User Interface IDEF0 (Function 5 Emphasis)

Figure 29 depicts the SCMM system function 6: secure system IDEF0.

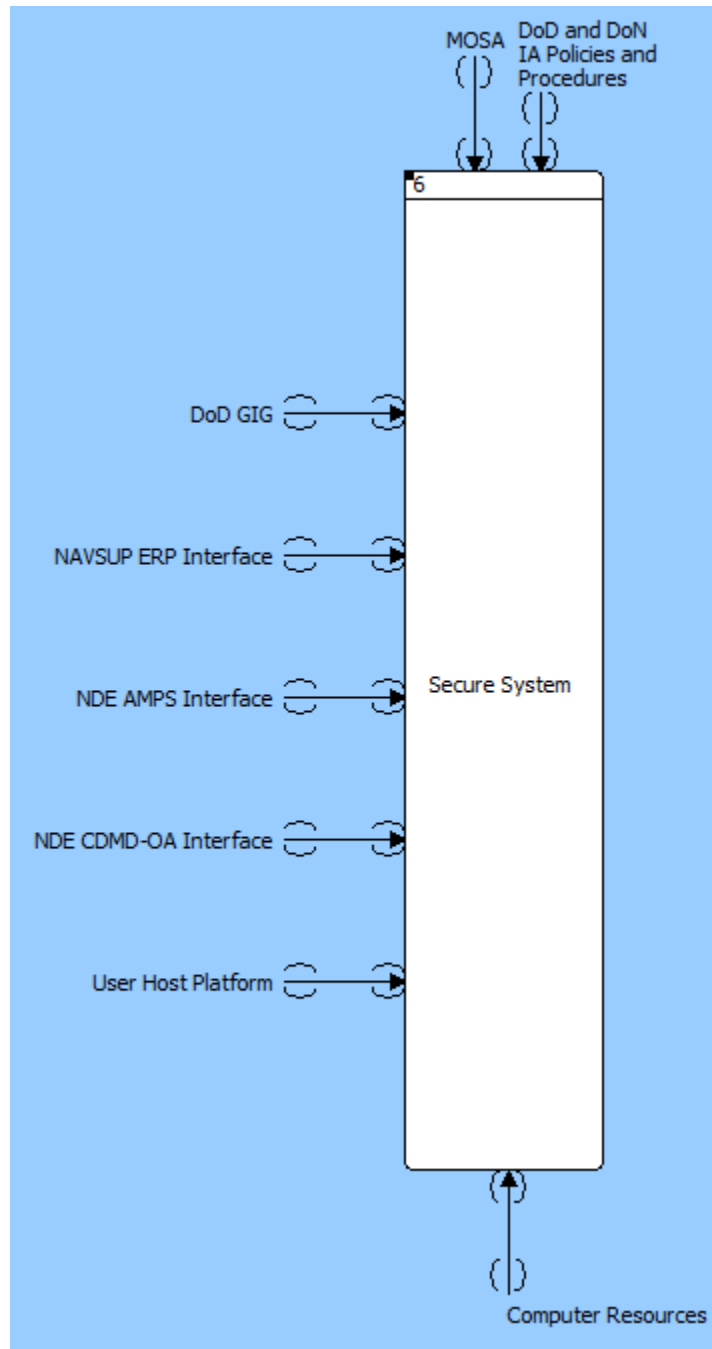

Figure 29. SCMM System Function 6: Secure System IDEF0

Based on the detailed ICOM diagram, the team created a context diagram, as shown in Figure 30. The context diagram helped us to better define the system's interfaces, as well as to better define the boundaries and collaborating system relationships (Sage and Armstrong 2000). According to Buede, "The context of a system is a set of entities that can impact the system but cannot be impacted by the system. The entities in the system's context are responsible for some of the system's requirements" (Buede 2000, 124). Figure 30. Figure 30 shows the SCMM in the center box with arrows going in and out of the model. Arrows only feeding into the model depict a one-way relationship in which the SCMM receives data from the external system interfaces, represented by the other white boxes. The two-way arrows connecting the SCMM system to external system interfaces denote a relationship in which both the SCMM system and the external systems exchange information with each other. The outside boxes without any connecting lines are actors in the SCMM system's environment that influence the system but do not directly interact with it.

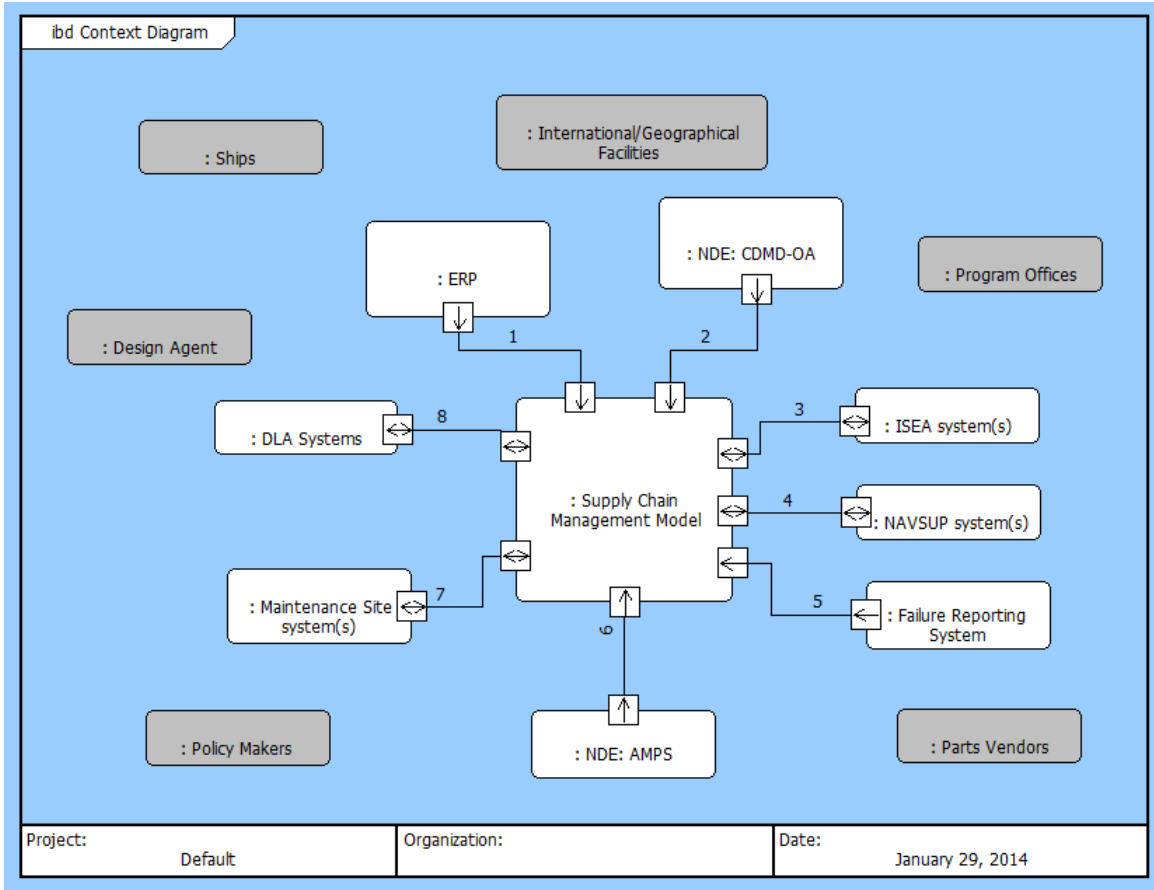

Figure 30. SCMM System Context Diagram

The external systems diagram is created to make the boundaries (where the system starts and stops) between the external systems and the system clear (Buede 2000). Buede writes that in identifying the system’s boundaries, “...the inputs to and outputs of the system are established, as well as the context with which each input and output is associated” (2000, 125).

Buede states that when looking at the system and modeling the system, “...everything within the boundaries of the system is open to change..., and nothing outside of the boundaries can be changed...” (2000, 144), allowing us to identify many of the system’s constraint requirements. He also says “The external systems diagram is the model of the interaction of the system with other (external) systems in their relevant contexts, thus providing a definition of the system’s boundary in terms of the system’s inputs and outputs” (2000, 144).

An N-squared (N^2) diagram was also created in CORE. The N^2 diagram depicts the interfaces of the system. It can show where conflicts may be present and also serves to display assumptions and requirements for inputs and outputs (National Aeronautics and Space Administration and Arizona State University n.d.). According to a presentation by the National Aeronautics and Space Administration and Arizona State University posted on the Arizona State University website, the diagram can also “Demonstrate where there are feedback loops between subsystems...and... identify candidate functional allocations to subsystems” (National Aeronautics and Space Administration and Arizona State University n.d.). The N^2 diagram for the SCMM system is shown in Figure 31. The numbered functions are depicted in a diagonal line. The other blocks represent the interface inputs and outputs: the inputs are in the “columns” and the outputs are in the “rows.” In CORE, blocks with additional text that is not shown is represented with a small black square in the upper right-hand side of the block. Based on this diagram the team determined that interface conflicts did not currently exist in the system development.

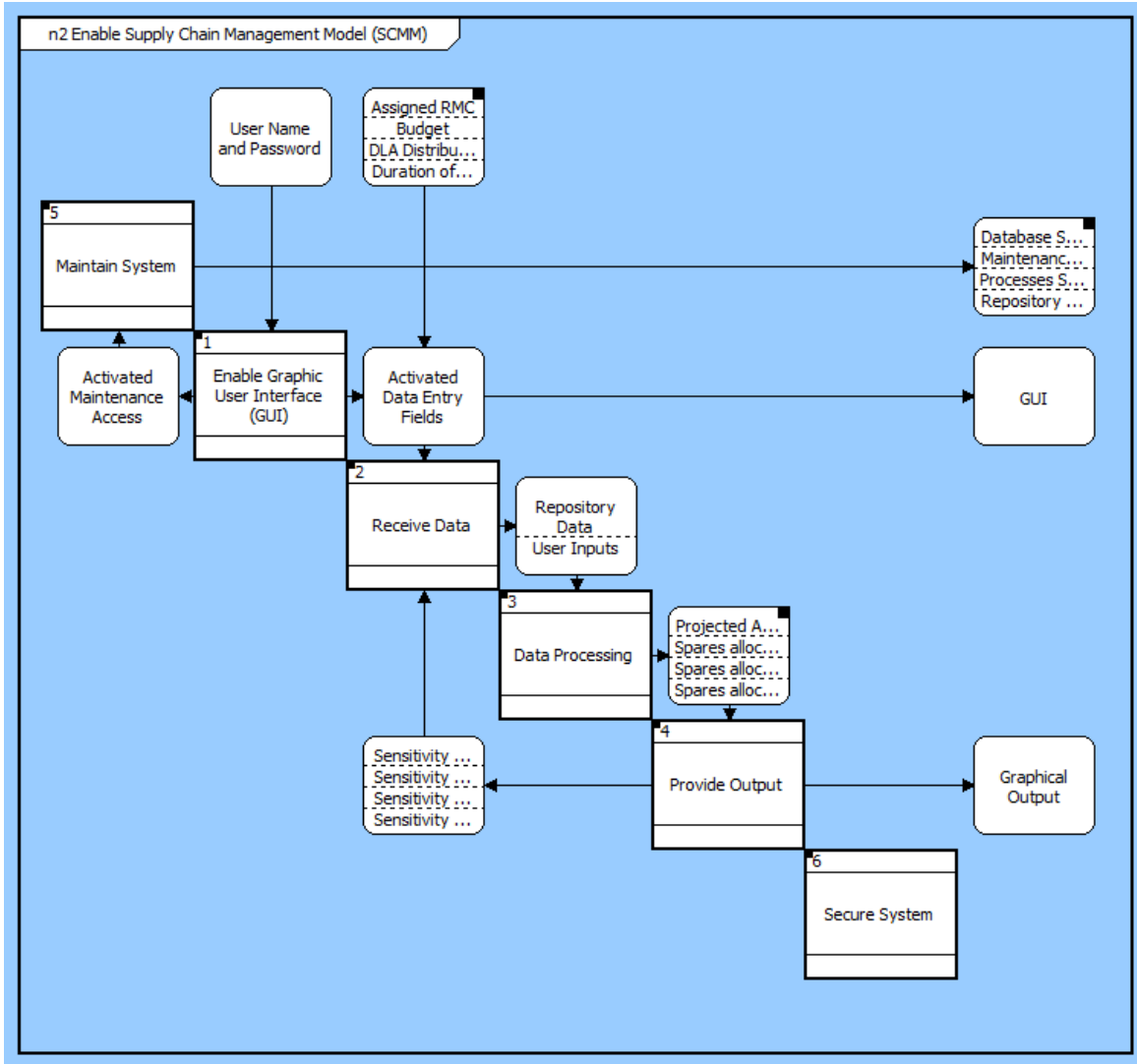

Figure 31. SCMM System N-Squared Diagram

C. REQUIREMENTS ANALYSIS

The purpose of requirements analysis is to refine customer objectives and requirements; define initial performance objectives and refine them into requirements; identify and define constraints that limit solutions; and define functional and performance requirements based on customer provided measures of effectiveness. Requirements analysis should result in a clear understanding of:

- Operational requirements
- Input and output performance requirements

- Functional requirements
- Interface constraints
- Suitability requirements
- Other requirements and constraints.

1. Originating Requirements

System requirements definition and management began with originating requirements. According to Buede, these are derived from operational needs: "...top-level statements defined in language that is understandable to the stakeholders, leaving room for design flexibility" (2000, 128). They "...define the essence of the stakeholders' needs clearly for the stakeholders to be completely satisfied with whatever system results from the systems engineering process" (Buede 2000, 128). Design independence is a major emphasis when developing the originating requirements: the originating requirements should not overly constrain the solution space because this would impede the design process (Buede 2000). Buede states that defining the originating requirements takes into account the "...need to have and define a large tradable region in [the] design space for the system engineers to search with quantitative techniques utilizing the priorities of the stakeholders" (2000, 123).

Once the originating requirements were defined, the team developed the derived requirements, the requirements defined by the team in engineering terms during the design process. Derived requirements were needed to complete the design to sufficient detail for the specification to be delivered to the design teams responsible for the configuration items of the system. According to Buede, "...the goal of the design process is to create a system specification that can be developed into specifications for the system's components, which are then segmented into specifications for the system configuration items (CIs)" (Buede 2000, 121). A result of this design process was the creation of two hierarchies of requirements, as shown in Figure 32.

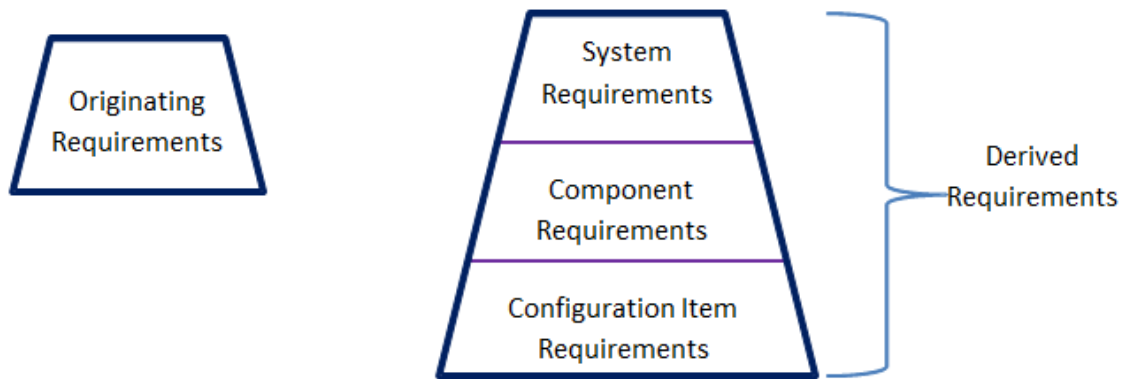

Figure 32. Hierarchies of Requirements (after Buede 2000, 122)

Although the team was unable to derive the full set of requirements for the SCMM system, the ones that were identified were captured and modeled in CORE, and are shown and discussed in the subsequent pages.

The originating requirement for the SCMM system is the need statement, previously identified as: *The stakeholders need information to determine sparing of parts at existing and multiple supply points in order to support the Navy's modular/flexible ships within the constraints of manning, space, weight, location, and cost/budget.* The capabilities identified by the sponsor were also taken into account during the derivation of the requirements. Those capabilities are *convert (or process) data inputs into information to be used for sparing of parts at various locations based on the use case scenarios and allow the users to conduct sensitivity analysis based on the inputs for trade-off analysis for cost, operational availability (Ao), personnel requirements, weight, and/or space,* both derived from the need statement.

2. Requirements Analysis Framework

The team based the requirements analysis on Buede's methodology, creating a framework for the SCMM system's requirements. Figure 33 shows the top-level system requirements diagram. Requirements 1–4 are further decomposed and explained in the following sections. A table listing the requirements was also developed, and will be discussed following the requirements framework figures.

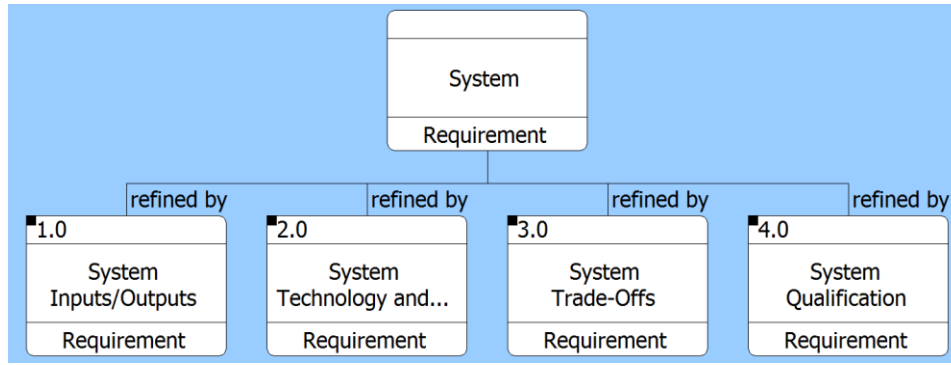

Figure 33. Top-Level Requirements

3. Input/Output Requirements

According to Buede, “Input/output requirements include sets of acceptable inputs and outputs, trajectories of inputs to and outputs from the system, interface constraints imposed by the external systems, and eligibility functions that match system inputs with system outputs...” (2000, 130).

Buede states that there are four subsets in this category: “(a) system input performance (b) system output performance, (c) system interoperability/external interface constraints, and (d) system functionality/functional requirements” (2000, 132), as shown in Figure 34.

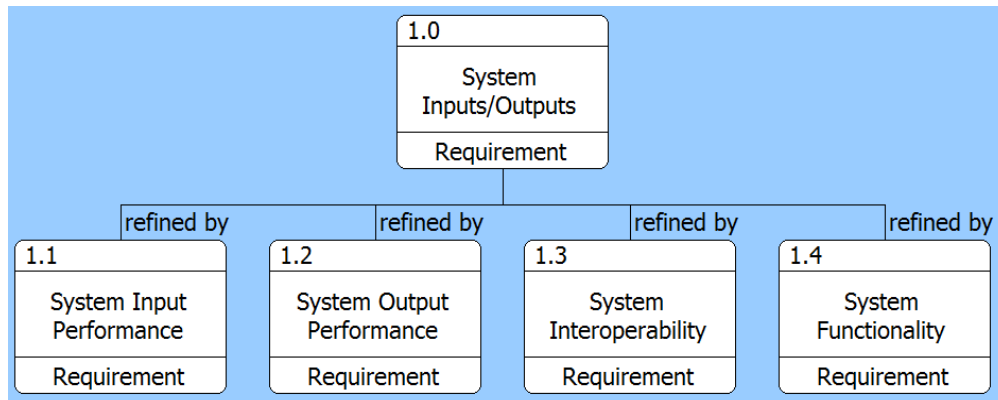

Figure 34. System Inputs/Outputs Hierarchy

a. System Input Performance

System input performance requirements state what inputs the system must receive and the performance or constraint attributes of each (Buede 2000).

b. System Output Performance

System output performance requirements state what outputs the system must produce and the performance attributes of each (Buede 2000).

c. System Interoperability/External Interface Constraints

According to Buede, system interoperability / external interface constraint "...requirements are usually constraints that define the reception of inputs and transmission of outputs between the system and the system's environment (2000, 130). The interface requirements consist of the constraints, processes, and specifications required for the system to interface with other systems outside the boundaries set for the SCMM system. These interfaces can be divided as hardware-to-hardware, software-to-software, or hardware-to-software. Interface requirements are necessary to ensure that the SCMM system is able to share data, communicate, and function with the required external systems.

d. System Functionality/Functional Requirements

Buede writes that

...functional requirements relate to specific functions (at any level of abstraction) that the system must perform while transforming inputs into outputs. As a result, a functional requirement is a requirement that can be associated with one or more of the system's outputs (2000, 130).

4. Technology and Suitability Requirements

The technology and suitability requirements, according to Buede,

...consist of constraints and performance index thresholds (e.g., the length of the operational life for the system, the cost of the system in various life-cycle phases, and the system's availability) that are placed upon the

physical resources of the system. Many of the requirements from each phase of the system’s life cycle are found in this category because these requirements specifically relate to the physical manifestation of the system. This category can be partitioned into four subsets: (a) [system] technology (b) [system] suitability and quality issues, (c) cost for the relevant system (e.g., development cost, operational cost), and (d) [system] schedule for the relevant life cycle phase (e.g., development time period, operational life of the system). (2000, 132)

Figure 35 depicts the system technology and suitability requirements hierarchy.

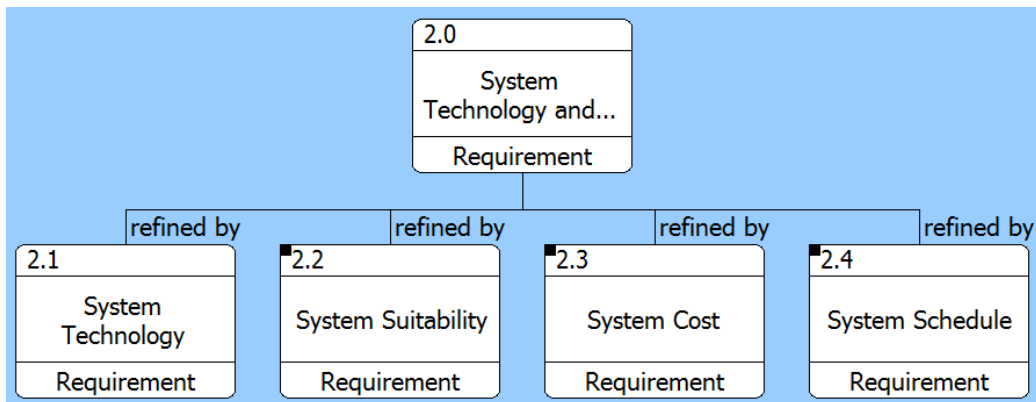

Figure 35. System Technology and Suitability Requirements Hierarchy

a. System Technology

System technology requirements constrain the system design; therefore, it is preferable to have as few as possible. They should be included to ensure compatibility or interoperability with existing systems and/or products, which should result in cost savings (Buede 2000).

b. System Suitability

System suitability requirements are system-wide in scope. They include the “ilities,” which have parameters assigned to ensure the security, usability, availability, reliability, maintainability, durability, and supportability of the system (Buede 2000). Figure 36 shows the next level of the SCMM system’s suitability requirements hierarchy. It includes system availability, extensibility (growth potential), maintainability, security, testability, usability, duration, form and fit, reliability, supportability, and trainability.

Requirements were derived for some of these areas but further decomposition is required to ensure the system meets the needs of the stakeholders.

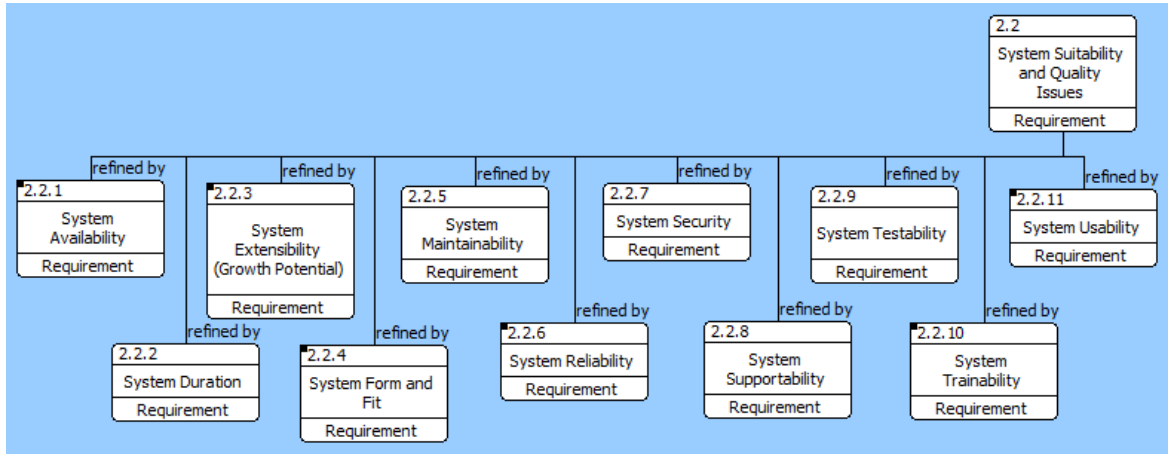

Figure 36. System Suitability Requirements Hierarchy

c. System Cost

System cost consists of the SCMM development cost, the production cost, the deployment cost, and the decommission cost (Buede 2000). Overall, the system cost is the affordability for operating and maintenance (Buede 2000). Cost requirements were not identified for the SCMM system due to the time constraints of the capstone project’s timeframe. Figure 37 depicts the next level of the system cost requirements hierarchy.

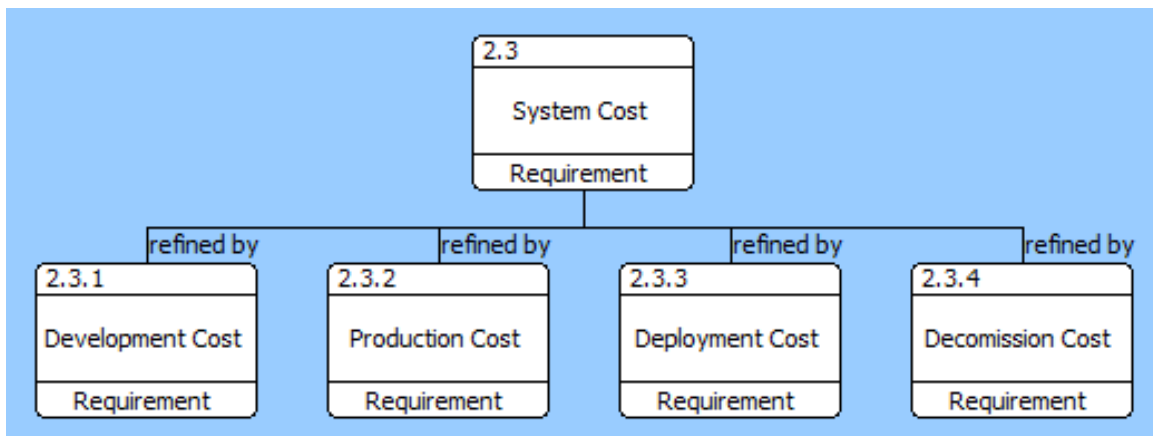

Figure 37. System Cost Requirements Hierarchy

d. System Schedule

System schedule contains the required time frame for development, manufacture of each unit, training time to reach proficiency by category of the users, deployment, and durability or operational life of the system (Buede 2000). Cost requirements were not identified for the SCMM system due to the time constraints of the capstone project’s timeframe. Figure 38 displays the next level of the system schedule requirements hierarchy.

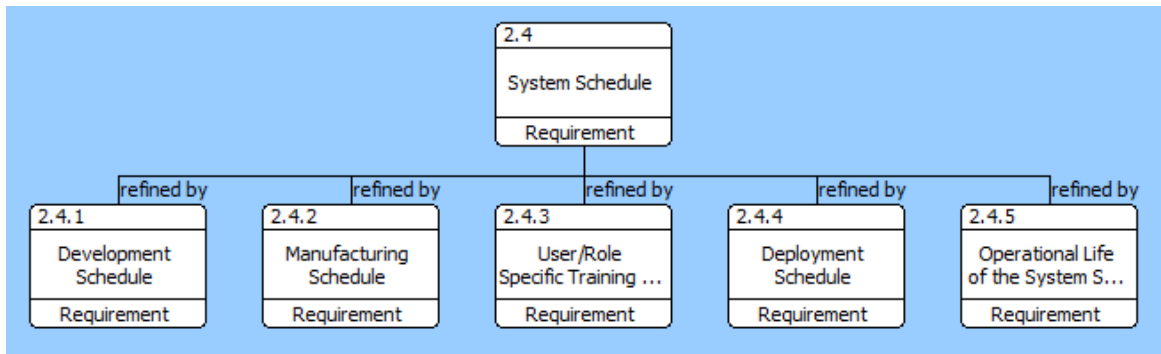

Figure 38. System Schedule Requirements Hierarchy

5. System Trade-Off Requirements

As stated by Buede, the system trade-off requirements:

...are algorithms for comparing any two alternate designs on the aggregation of cost and performance objectives. These algorithms can be divided into (a) [system] performance trade-offs, (b) [system] cost trade-offs, and (c) [system] cost-performance trade-offs. The performance trade-off algorithm defines how the relative performance of any two alternate designs can be compared in terms of the system’s performance objectives. These performance objectives are defined within the input/output and non-cost system-wide requirements. (Buede 2000, 132–133)

Figure 39 depicts the system trade-offs requirements hierarchy.

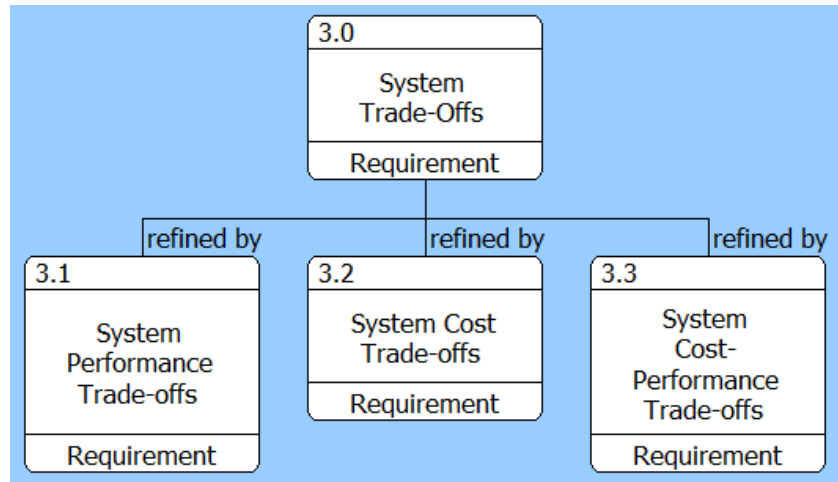

Figure 39. System Trade-Offs Requirement Hierarchy

a. System Performance Trade-offs

Buede writes that the system performance trade-off is performed with an algorithm that “...defines how the performance parameters are to be compared to each other” (Buede 2000, 133).

b. System Cost Trade-offs

The system cost trade-off is performed with an algorithm that “...defines how the relative cost of any two alternate designs can be compared across all cost parameters (life-cycle phases) of interest to the stakeholders,” according to Buede (2000, 133).

c. System Cost-Performance Trade-offs

Buede continues that the system cost-performance trade-off is performed with an algorithm that defines “...how performance objectives should be traded with cost objectives” (Buede 2000, 133).

The team was unable to address the system trade-off requirements within the timeframe allotted for this project.

6. System Qualification Requirements

According to Buede, the system qualification requirements “...address the needs to qualify the system as being designed right, the right system, and an acceptable system”

(Buede 2000, 133). This area is composed of four primary elements: system observance, system verification, system validation, and system acceptance, as shown in Figure 40.

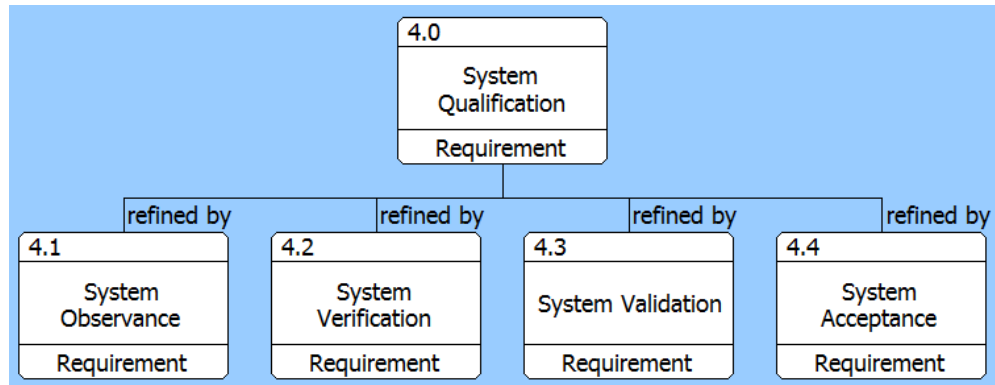

Figure 40. System Qualification Requirement Hierarchy

a. System Observance

Buede writes that system observance is used “...to state which qualification data for each input/output and system-wide requirement will be obtained by (i) demonstration, (ii) analysis and simulation, (iii) inspection, or (iv) instrumented test” (2000, 133).

b. System Verification

A system verification plan is developed “...to state how the qualification data will be used to determine that the real system conforms to the design that was developed,” according to Buede (2000, 133).

c. System Validation

Buede articulates that a system validation plan is developed “...to state how the qualification data will be used to determine that the real system complies with the originating performance, cost, and trade-off requirements” (2000, 134).

d. System Acceptance

A system acceptance plan is developed, as Buede says, “...to state how the qualification data will be used to determine that the real system is acceptable to the stakeholders” (2000, 134).

Although the team was unable to address the qualification requirements in CORE within the timeframe allotted for this project, a test plan was developed and testing was performed on a simulation of the SCMM system that was developed during the modeling and simulation phase. Information on testing can be found in the Integration and Test section of Chapter VII.

7. Derived Requirements

The originating requirement was decomposed to obtain the system requirements. Table 8 was developed from the SCMM system’s requirements information entered into CORE. The numbering shows the indented structure of the requirements, which correspond to the requirements framework discussed in the previous paragraphs. Requirements derivation was not completed to the fullest extent possible, but did allow for a conceptual design to be developed, simulated, and tested. An analysis of alternatives and cost analysis were also conducted based on a number of the requirements.

Requirements	
Number	Name
1	System Inputs/Outputs
1.1	System Input Performance
1.1.1	The system shall receive Assigned RMC information with 100% accuracy.
1.1.2	The system shall receive Budget information with 100% accuracy.
1.1.3	The system shall receive DLA Distribution Centers information with 100% accuracy.
1.1.4	The system shall receive Duration of operation(s) information with 100% accuracy.
1.1.5	The system shall receive Fleet area/location of operation information with 100% accuracy.
1.1.6	The system shall receive Fleet Logistics Centers (formerly FISCs: Fleet and Industrial Support Centers) information with 100% accuracy.
1.1.7	The system shall receive Maintenance facility locations(s) information with 100% accuracy.
1.1.8	The system shall receive Mission module(s) information with 100% accuracy.

Requirements	
Number	Name
1.1.9	The system shall receive Mission module(s) Ao information with 100% accuracy.
1.1.10	The system shall receive Mission module(s) configuration (APLs/AELs) information with 100% accuracy.
1.1.11	The system shall receive Mission module(s) container available space / dimensions allowance for parts information with 100% accuracy.
1.1.12	The system shall receive Mission module(s) container available weight allowance for parts information with 100% accuracy.
1.1.13	The system shall receive Mission package (e.g., SUW, ASW, MCM, humanitarian) information with 100% accuracy.
1.1.14	The system shall receive Part cage code(s) information with 100% accuracy.
1.1.15	The system shall receive Part cost(s) information with 100% accuracy.
1.1.16	The system shall receive Part criticality information with 100% accuracy.
1.1.17	The system shall receive Part dimensions information with 100% accuracy.
1.1.18	The system shall receive Part estimated shipping time information with 100% accuracy.
1.1.19	The system shall receive Part failure rate/MTBF information with 100% accuracy.
1.1.20	The system shall receive Part HAZMAT information with 100% accuracy.
1.1.21	The system shall receive Part item manager POC information with 100% accuracy.
1.1.22	The system shall receive Part maintenance code(s) information with 100% accuracy.
1.1.23	The system shall receive Part nomenclature(s) information with 100% accuracy.
1.1.24	The system shall receive Part NSN(s) information with 100% accuracy.
1.1.25	The system shall receive Part number(s) information with 100% accuracy.
1.1.26	The system shall receive Part weight information with 100% accuracy.
1.1.27	The system shall receive Planned changes to mission module's configuration/dates for changes information with 100% accuracy.
1.1.28	The system shall receive Planned changes to ship's configuration/dates for changes information with 100% accuracy.
1.1.29	The system shall receive Ship hull number(s) information with 100% accuracy.

Requirements	
Number	Name
1.1.30	The system shall receive Ship seaframe system(s) information with 100% accuracy.
1.1.31	The system shall receive Ship(s) availability requirement (Ao) information with 100% accuracy.
1.1.32	The system shall receive Ship(s) available space / dimensions allowance for parts information with 100% accuracy.
1.1.33	The system shall receive Ship(s) available weight allowance for parts information with 100% accuracy.
1.1.34	The system shall receive Ship(s) configuration (APLs/AELs) information with 100% accuracy.
1.1.35	The system shall receive Ship(s) system information with 100% accuracy.
1.1.36	The system shall receive Total ship Ao by mission (includes HM&E) information with 100% accuracy.
1.1.37	The system shall receive Total ship Ao by mission (does not include HM&E) information with 100% accuracy.
1.1.38	The system shall receive Password with 100% accuracy.
1.1.39	The system shall receive Username with 100% accuracy.
1.2	System Output Performance
1.2.1	The system shall output Total weight of mission module(s) container(s) spares with an accuracy of 100%.
1.2.2	The system shall output Total space of shipboard spares with an accuracy of 100%.
1.2.3	The system shall output Total space of mission module(s) container(s) spares with an accuracy of 100%.
1.2.4	The system shall output Total cost of parts allocated with an accuracy of 100%.
1.2.5	The system shall output Summary of inputs with an accuracy of 100%.
1.2.6	The system shall output Spares allocation on ship with an accuracy of no less than 99%.
1.2.7	The system shall output Spares allocation for mission module(s) container(s) with an accuracy of no less than 99%.
1.2.8	The system shall output Spares allocation at OCONUS warehouse locations with an accuracy of no less than 99%.
1.2.9	The system shall output Spares allocation at land-based maintenance facilities with an accuracy of no less than 99%.
1.2.10	The system shall output Projected Ao of ship(s) with an accuracy of no less than 99%.
1.2.11	The system shall output Graphical Output with an accuracy of 100%.

Requirements	
Number	Name
1.2.12	The system shall output Sensitivity Analysis - Weight with an accuracy of 100%.
1.2.13	The system shall output Sensitivity Analysis - Space with an accuracy of 100%.
1.2.14	The system shall output Sensitivity Analysis - Budget with an accuracy of 100%.
1.2.15	The system shall output Sensitivity Analysis - Ao with an accuracy of 100%.
1.2.16	The system shall produce a graphical output within a maximum time of 5 seconds.
1.3	System Interoperability/External Interface Constraints
1.3.1	The system shall interface with NDE: AMPS
1.3.1.1	The system shall accept a data push from NDE: AMPS every 24 hours at midnight (PST).
1.3.2	The system shall interface with NDE: CDMD-OA
1.3.2.1	The system shall accept a data push from NDE: CDMD-OA every 24 hours at midnight (PST).
1.3.3	The system shall interface with NAVSUP ERP.
1.3.3.1	The system shall accept a data push from NAVSUP ERP every 24 hours at midnight (PST).
1.3.4	The system shall interface with user host platform(s).
1.3.5	The system shall be interoperable with the DOD GIG.
1.4	System Functionality/Functional Requirements
1.4.1	The system shall enable a graphical user interface (GUI).
1.4.1.1	The system shall display a login screen in no more than 1 minute.
1.4.1.1.1	The system shall accept a user name and password in no more than 5 seconds.
1.4.1.2	The system shall perform a login credential security verification in no more than 2 seconds.
1.4.1.2.1	The system shall invalidate a login due to an incorrect password entry in no more than 1 second.
1.4.1.2.2	The system shall invalidate a login due to an incorrect username entry in no more than 1 second.
1.4.1.2.3	The system shall validate a login due to a correct username and password entry in no more than 1 second.
1.4.1.3	The system shall display a graphic user interface in no more than 5 seconds.
1.4.1.4	The system shall enable data entry/selection fields in no more than 5 seconds.

Requirements	
Number	Name
1.4.2	The system shall receive data.
1.4.2.1	The system shall accept a user's input/selection in no more than 2 seconds.
1.4.2.1.1	The system shall verify the user's inputs/selected data in no more than 2 seconds.
1.4.2.1.1.1	The system shall invalidate incorrect user inputs in no more than 2 seconds
1.4.2.1.1.2	The system shall validate correct user inputs in no more than 2 seconds.
1.4.2.2	The system shall accept data from external databases in no more than 1 hour.
1.4.2.2.1	The system shall verify data integrity (complete/correct/does not contain errors) in no more than 30 minutes.
1.4.2.2.1.1	The system shall invalidate incorrect database data in no more than 30 minutes.
1.4.2.2.1.2	The system shall validate correct external database data in no more than 30 minutes.
1.4.2.2.2	The system shall integrate the data into a repository in no more than 15 minutes.
1.4.2.2.3	The system shall save data in a system repository in no more than 15 minutes.
1.4.3	The system shall process data.
1.4.3.1	The system shall process requests in no more than 1 second.
1.4.3.2	The system shall execute queries in no more than 1 second.
1.4.3.3	The system shall verify query requirements are being met in no more than 1 second.
1.4.3.3.1	The system shall invalidate incomplete/incorrect queries in no more than 1 second.
1.4.3.3.2	The system shall validate complete/correct queries in no more than 1 second.
1.4.3.4	The system shall obtain filtered data from the repository in no more than 2 minutes.
1.4.3.5	The system shall perform sparing analysis in no more than 5 minutes.
1.4.4	The system shall provide outputs.
1.4.4.1	The system shall display sparing results (graphical output based on user's query) in no more than 1 second.
1.4.4.1.1	The system shall allow the user to save sparing results in no more than 1 second.

Requirements	
Number	Name
1.4.4.1.2	The system shall allow the user to print sparing results in no more than 1 second.
1.4.4.1.3	The system shall allow the user to perform sensitivity analysis in no more than 1 second.
1.4.4.1.4	The system shall allow the user to delete results in no more than 1 second.
1.4.5	The system shall provide self-maintenance through a series of checks and display the information to the user.
1.4.5.1	The system shall execute self-checks in no more than 2 seconds.
1.4.5.1.1	The system shall execute a repository check in no more than 0.5 seconds.
1.4.5.1.2	The system shall execute an interface check in no more than 1 second.
1.4.5.1.2.1	The system shall execute an interface check of the system side in no more than 0.5 seconds.
1.4.5.1.2.2	The system shall execute an interface check of the external databases in no more than 0.5 seconds.
1.4.5.1.2.2.1	The system shall display a status of the external databases in no more than 0.5 seconds.
1.4.5.1.3	The system shall execute a processes check in no more than 0.5 seconds.
1.4.5.2	The system shall provide the user with a maintenance history in no more than 1 second.
1.4.5.2.1	The system shall display the time and date of the last database data download in no more than 1 second.
1.4.5.2.2	The system shall display the time and date of the last login in no more than 1 second.
1.4.6	The system shall secure itself.
1.4.6.1	The system shall comply with DOD and DoN Information Assurance (IA) policies and procedures.
1.4.6.2	The system shall secure the GUI continuously.
1.4.6.3	The system shall secure the log-in process when in login screen.
1.4.6.4	The system shall secure the repository continuously.
1.4.6.5	The system shall secure the interfaces with the external databases continuously.
2	System Technology and Suitability
2.1	System Technology
2.1.1	The system shall be hosted on a DOD authorized platform.
2.1.1.1	The platform shall have a GIG compatible connection device.

Requirements	
Number	Name
2.1.1.2	The platform shall have a storage device (i.e., harddrive, server, cloudserver)
2.1.1.3	The platform shall have a viewing device (i.e., monitor, viewscreen)
2.1.1.4	The platform shall have an input device(s) (i.e., keyboard, mouse, touchscreen).
2.1.1.5	The platform shall have an output device (i.e., printer)
2.1.2	The system shall conform to a modular open systems approach (MOSA).
2.1.2.1	The system shall conform to MOSA by adapting to evolving requirements.
2.1.2.2	The system shall conform to MOSA by enhancing access to cutting edge technologies and products.
2.1.2.3	The system shall conform to MOSA by enhancing commonality and reuse of components among systems.
2.1.2.4	The system shall conform to MOSA by enhancing life-cycle supportability.
2.1.2.5	The system shall conform to MOSA by ensuring that the system will be fully interoperable with all the systems with which it must interface without major modification of existing components.
2.1.2.6	The system shall conform to MOSA by facilitating systems integration.
2.1.2.7	The system shall conform to MOSA by mitigating the risk associated with technology obsolescence.
2.1.2.8	The system shall conform to MOSA by mitigating the risk of a single source of supply over the life of the system.
2.1.2.9	The system shall conform to MOSA by reducing the development cycle time.
2.1.2.10	The system shall conform to MOSA by reducing total lifecycle cost.
2.2	System Suitability and Quality Issues
2.2.1	System Availability
2.2.1.1	The system shall be available at all times other than during a data push.
2.2.2	System Duration
2.2.3	System Extensibility (Growth Potential)
2.2.3.1	The system shall be modifiable.
2.2.4	System Form and Fit
2.2.4.1	The system shall be contained on a portable device (i.e., CD, USB stick, DVD)
2.2.5	System Maintainability
2.2.6	System Reliability

Requirements	
Number	Name
2.2.6.1	The system shall have a failure rate of no less than 0.000002.
2.2.7	System Security
2.2.8	System Supportability
2.2.8.1	The system shall be supportable over the DOD GIG.
2.2.9	System Testability
2.2.10	System Trainability
2.2.10.1	The system shall have a built-in help menu/function.
2.2.10.2	The system shall have a built-in user's guide.
2.2.10.3	The system shall have an accompanying user's manual.
2.2.11	System Usability
2.2.11.1	The system shall comply with DOD human system integration standards/specifications.
2.3	System Cost
2.3.1	Development Cost
2.3.2	Production Cost
2.3.3	Deployment Cost
2.3.4	Decommission Cost
2.4	System Schedule
2.4.1	Development Schedule
2.4.2	Manufacturing Schedule
2.4.3	User/Role Specific Training Time and Schedule
2.4.4	Deployment Schedule
2.4.5	Operational Life of the System Schedule
3	System Trade-Offs
3.1	System Performance Trade-Offs
3.2	System Cost Trade-Offs
3.3	System Cost-Performance Trade-Offs
4	System Qualification
4.1	System Observance
4.2	System Verification
4.3	System Validation
4.4	System Acceptance

Table 8. SCMM System Requirements

D. SUMMARY

After the identifying the system capability gaps during the needs analysis phase of the tailored SE process, the team began the process of identifying system requirements and proceeding with a detailed requirements analysis to establish parameters during the design of the system. Investigation of current system structures and interoperability was documented to allow for development of a system to satisfy the stakeholders' needs. A model based systems engineering approach was used to create the architecture, functions, requirements, and DODAF views in Vitech's CORE to maintain traceability and refinement throughout the process. CORE's inherent traceability allowed for efficient refinement for detailed requirement iterations from an established baseline during discussions with the sponsor. The constructed models were significant in visualizing and communicating system functions to the sponsor for verification of the system architecture.

Boundary definition of the system was completed to separate and connect the SCMM system to inputs and outputs that were determined to be a part of the system environment. The creation of diagrams and models were completed to fully scope and bound the identified problem. The RSRP team created an ICOM diagram to identify; the inputs that would be entering the system, the outputs that the system would be producing, the controls that would direct the process activities, and the resources and tools that would act as mechanisms to realize the functions. A context diagram was created based on the detailed ICOM diagram to show the system interfaces and relationships with external systems. To help identify any interface conflicts an N2 diagram was developed, thus ensuring the development of the system could proceed.

Project Team RSRP defined the originating requirements by analyzing the individual stakeholder needs and determining the critical requirements for the overall system through discussions with the sponsor. Once these critical requirements were determined the team was able to develop derived requirements including system requirements and component requirements that were further analyzed during the system design phase for system alternatives. The system requirements were decomposed into the following categories: System Inputs/Outputs requirements, System Technology and

Suitability requirements, System Trade-Off requirements, and System Qualification requirements. Subsequent requirements for each top level category were created by the team in CORE and were to be used during the conceptual design phase for development of the system components.

IV. SYSTEM ARCHITECTURE

The system architecture phase captured the logical sequencing and interaction of system functions or logical elements. The system architecture was documented using CORE, which also provided a MBSE capability. The team utilized DODAF v2.02 to define the different architecture views of the design. The DODAF was used to ensure that architecture descriptions were compared and related across organizational boundaries; it defined a common approach for DOD architecture description, development, presentation, and integration (Vickers and Charles-Vickers 2006). Three architectural views, capability view (CV), operational views (OVs), and system views (SVs), were created to show the overall system capability along with the relationship of inputs and outputs and constraints and mechanisms of the system design. The output of this phase was a high level system design and a generic architecture that met the needs of the stakeholders.

A. DODAF ROADMAP

According to the Deputy Chief Information Officer, the Department of Defense Architecture Framework (DODAF) is a document that provides an:

...overarching, comprehensive framework and conceptual model enabling the development of architectures to facilitate the ability of Department of Defense (DOD) managers at all levels to make key decisions more effectively through organized information sharing across the Department, Joint Capability Areas (JCAs), Mission, Component, and Program boundaries. The DODAF serves as one of the principal pillars supporting the DOD Chief Information Officer (CIO) in his responsibilities for development and maintenance of architectures required under the Clinger-Cohen Act. DODAF is prescribed for the use and development of Architectural Descriptions in the Department. It also provides extensive guidance on the development of architectures supporting the adoption and execution of Net-centric services within the Department. (Deputy Chief Information Officer 2010, 3)

Every view of the DODAF 2.02 cannot be used due to redundancy or inapplicability. In the DODAF it is suggested to use a “fit-for-purpose” methodology. The Deputy Chief Information Officer states:

The DODAF enables architectural content that is “Fit-for-Purpose” as an architectural description consistent with specific project or mission objectives. Because the techniques of architectural description can be applied at myriad levels of an enterprise, the purpose or use of an architectural description at each level will be different in content, structure, and level of detail. Tailoring the architectural description development to address specific, well-articulated, and understood purposes, will help ensure the necessary data is collected at the appropriate level of detail to support specific decisions or objectives. (Deputy Chief Information Officer 2010, 3)

This allowed the team to select various views to create the DODAF “roadmap” for the SCMM system. The selection of views that Team RSRP chose to define and communicate the system design to the sponsor and stakeholders included a CV-1, OV-1, OV-2, OV-5, SV-1, SV-4, and SV-5. Figure 41 displays the links between these views.

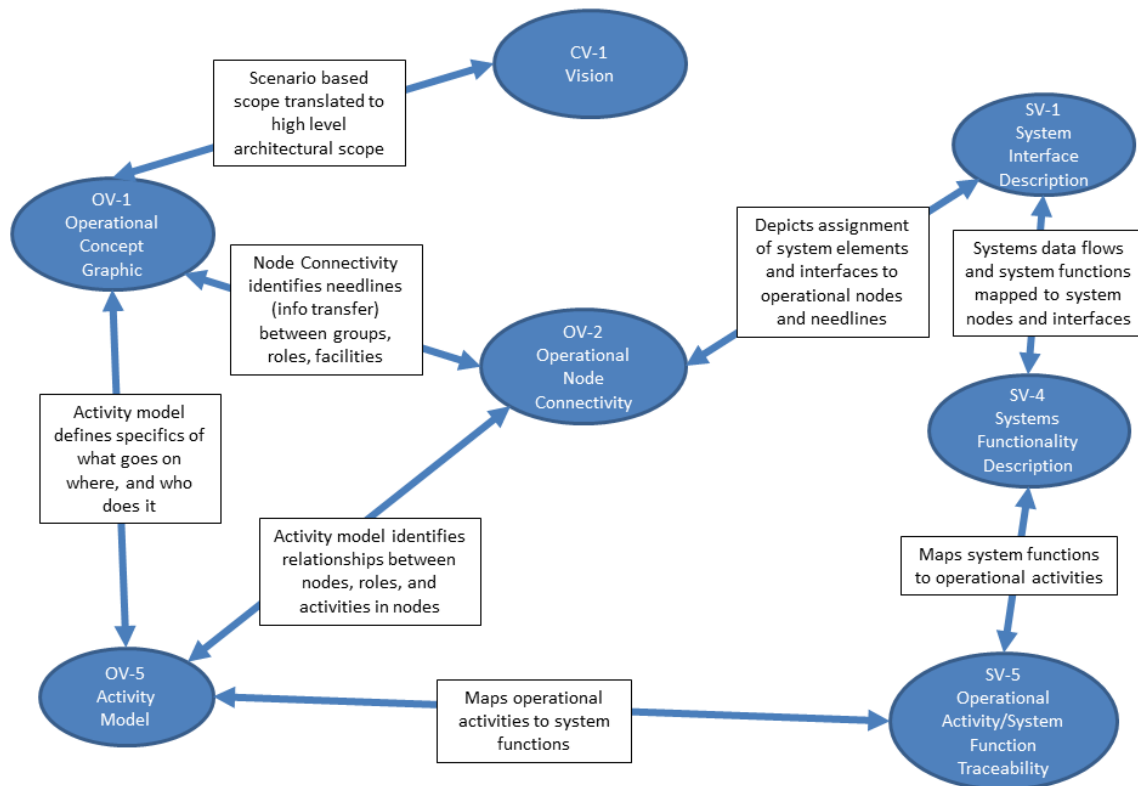

Figure 41. SCMM System DODAF Roadmap

B. DODAF VIEWS

The views are explained and depicted in the ensuing paragraphs.

1. CV-1

The CV-1 is a capability viewpoint diagram that was created in PowerPoint. The Deputy Chief Information Officer defines the CV-1 as:

The CV-1 addresses the enterprise concerns associated with the overall vision for transformational endeavors and thus defines the strategic context for a group of capabilities. The purpose of a CV-1 is to provide a strategic context for the capabilities described in the Architectural Description. It also provides a high-level scope for the Architectural Description which is more general than the scenario-based scope defined in an OV-1.

The intended usage is communication of the strategic vision regarding capability development. (Deputy Chief Information Officer 2010, 117)

The CV-1 for the SCMM system lists the capabilities of the system, the overall system goals, the desired outcomes, and how those outcomes are measured. The capabilities for the SCMM system are “convert (or process) inputs into information to be used for sparing of parts at various locations to support use case scenarios” and “allow the users to conduct sensitivity analyses based on the inputs for trade-off analysis for cost, operational availability (Ao), personnel requirements, weight, and/or space.” The goals are to obtain information and recommendations of parts allocation to meet or increase Ao and to meet or decrease budget/cost. The desired outcome is to support program specific documented key performance parameters and key system attributes through parts allocation. Measurable benefits include Ao (through mean logistics delay time [MLDT]) and budget/costs.

The CV-1, Figure 42 displays how the system intends to meet the goals: The SCMM model is used on the user’s hosting platform; it receives inputs from the users and obtains necessary data from external databases. The output from the system is in the form of report that includes information and recommendations of parts allocation to the users to support program specific documented key performance parameters (KPPs) and key system attributes (KSAs). The system can also perform sensitivity analyses based on the

user's needs in regards to cost, Ao, personnel requirements, weight, and/or space. Based on the report, the users allocate parts to homeports, maintenance facilities, operational ships, mission module container, and outside the continental United States (OCONUS) warehouses.

OCONUS warehouses store parts available to maintenance facilities and deployed ships on an as-required basis. Allocation at and storing of parts at OCONUS warehouses versus continental United States (CONUS) warehouses decreases the shipping time to deployed ships and OCONUS maintenance facilities. Allocation of these parts onboard ship, mission module containers, and maintenance facilities also decreases the shipping time to deployed ships which should reduce the MLDT that is a component of mean down time (MDT), thereby positively impacting the Ao.

The CV-1 helped to convey what the system should do and why, and how that would be measured. It allowed the system to be viewed in its operational context so that the necessary interfaces, resources, and requirements of the system could be framed.

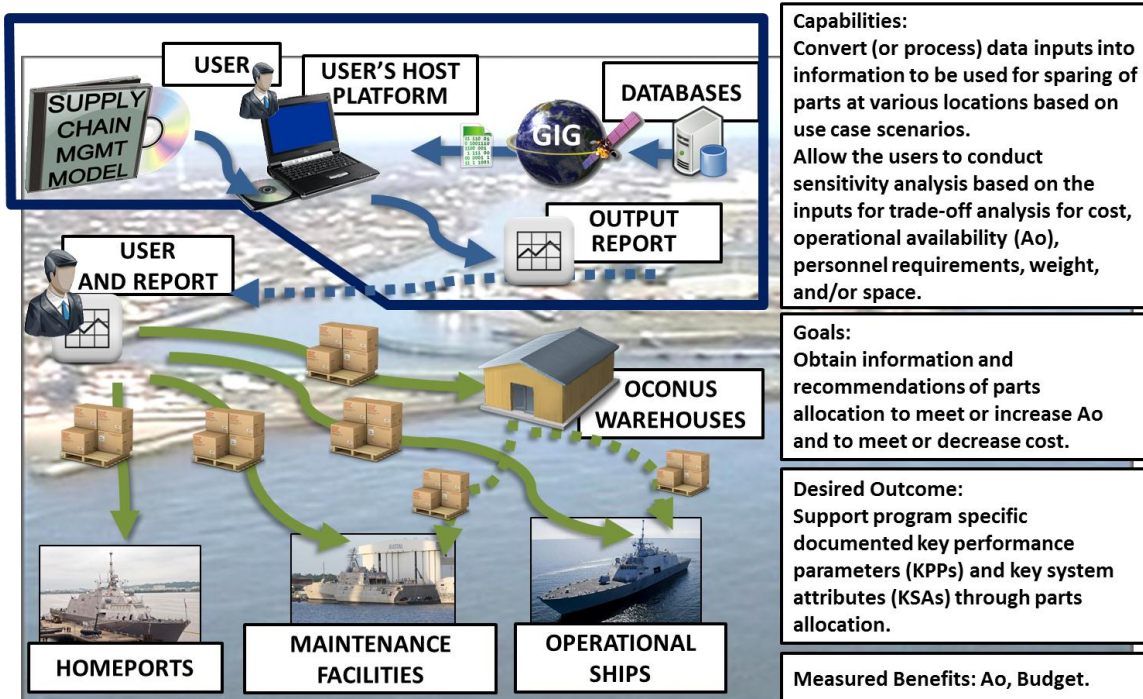

Figure 42. SCMM System Capability Vision—CV-1

2. OV-1

The OV-1 is a high-level graphical/textual diagram of the operational concept. The Deputy Chief Information Officer defines the OV-1 as:

The OV-1 describes a mission, class of mission, or scenario. It shows the main operational concepts and interesting or unique aspects of operations. It describes the interactions between the subject architecture and its environment, and between the architecture and external systems. The OV-1 is the pictorial representation of the written content of the All Views 1(AV-1) Overview and Summary Information. Graphics alone are not sufficient for capturing the necessary architectural data.

The OV-1 provides a graphical depiction of what the architecture is about and an idea of the players and operations involved. An OV-1 can be used to orient and focus detailed discussions. Its main use is to aid human communication, and it is intended for presentation to high-level decision-makers. (Deputy Chief Information Officer 2010, 142)

The OV-1 for the SCMM system, seen in Figure 43 displays the main operational concepts in the system's context. The SCMM system is loaded onto a user's host platform where the user can activate it for operational use. The system, via the host platform, and connects to the global information grid (GIG), which allows it to interface with external databases. The databases provide necessary data that the system will use in order to support the user's query, based on a user defined scenario. Users input or select inputs, such as ship hull number, budget, etc., the system uses the information from the databases to process the information via an algorithm, and it then provides an output report. This report provides multi-nodal optimized sparing/inventory recommendations based on single or multi-ship/mission scenarios with inputs such as seaframe, mission module, geographical location, required Ao, spare parts budget, and mission duration, for example. It also allows for trade-off analyses to be conducted for budget, personnel requirements, Ao, weight, and/or space constraints.

The OV-1 helped to display the system in its operating environment. It showed the interactions between the users, the system, and the external environment and what the output of those interactions would be.

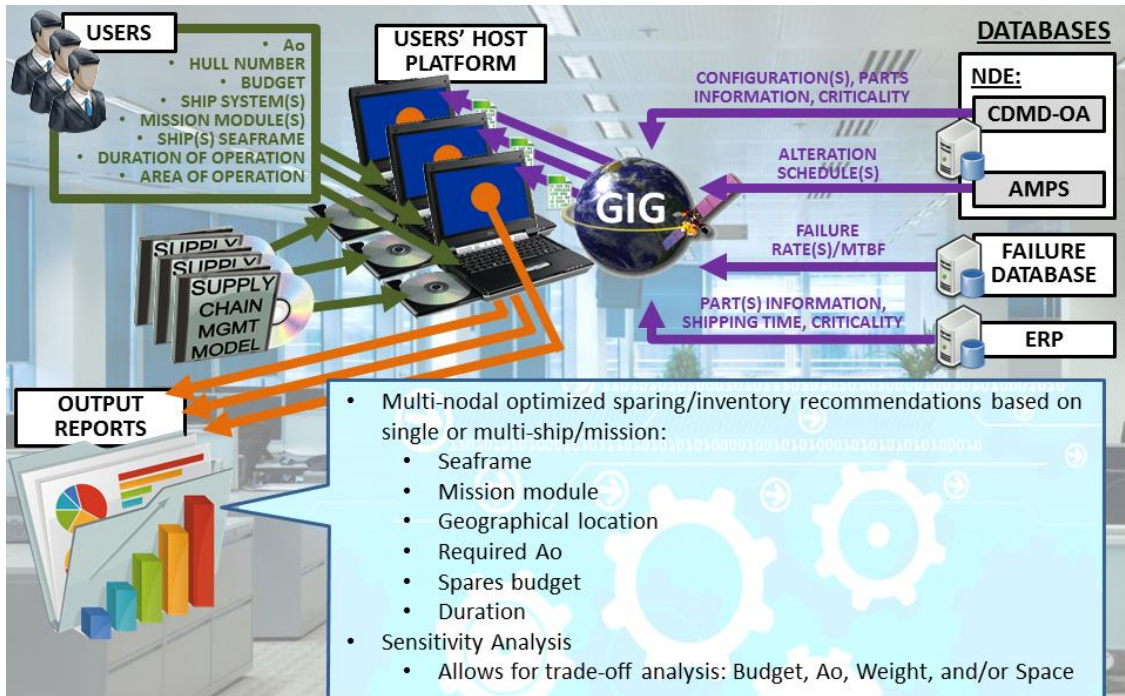

Figure 43. SCMM System High Level Operational Concept—OV-1

3. OV-2

The OV-2, operational resource flow description, describes the resource flows exchanged between operational activities. The Deputy Chief Information Officer defines the OV-2 as:

The OV-2 DODAF-described Model applies the context of the operational capability to a community of anticipated users. The primary purpose of the OV-2 is to define capability requirements within an operational context. The OV-2 may also be used to express a capability boundary.

New to DODAF V2.0, the OV-2 can be used to show flows of funding, personnel and materiel in addition to information. A specific application of the OV-2 is to describe a logical pattern of resource (information, funding, personnel, or materiel) flows. The logical pattern need not correspond to specific organizations, systems or locations, allowing Resource Flows to be established without prescribing the way that the Resource Flows are handled and without prescribing solutions. (Deputy Chief Information Officer 2010, 144)

Figure 44 is the SCMM system's operation resource flow description diagram. It depicts the resource flows into and out of the SCMM system, the users, the external

interfaces (databases), and the eventual resource flows to external entities. Beginning at the bottom of the figure, the external databases (ERP, NDE: AMPS, failure reporting database, NDE: CDMD-OA) have one-way lines with arrows going into the SCMM system depicting the resources that will be flowing from them to the system. Moving up to the next level of the figure, the resource flow lines are depicted as one way lines with arrows showing the resource flows between the users and the system: User queries flow from the users to the system while parts allocation information and sensitivity analysis results flow from the system to the user. The next and last level depicted in the diagram shows the flow of resources with one way lines with arrows going from the users to the external organizations that are the recipients of the system processed resources, once acted upon by the users. The resource flow lines contain the parts that will be going to support the operational ships, homeports, OCONUS warehouses, and shore-based maintenance facilities based on the SCMM system's output to the users and the users' subsequent review, analysis, and decisions of that output.

The OV-2 helped to place the SCMM system in an operational context depicting the required resources from each entity. It also helped to ensure that the flow of resources was sound and that the necessary resources were accounted for. The specific organizational resource flows are captured in a matrix that can be viewed in the Additional DODAF Views Information appendix.

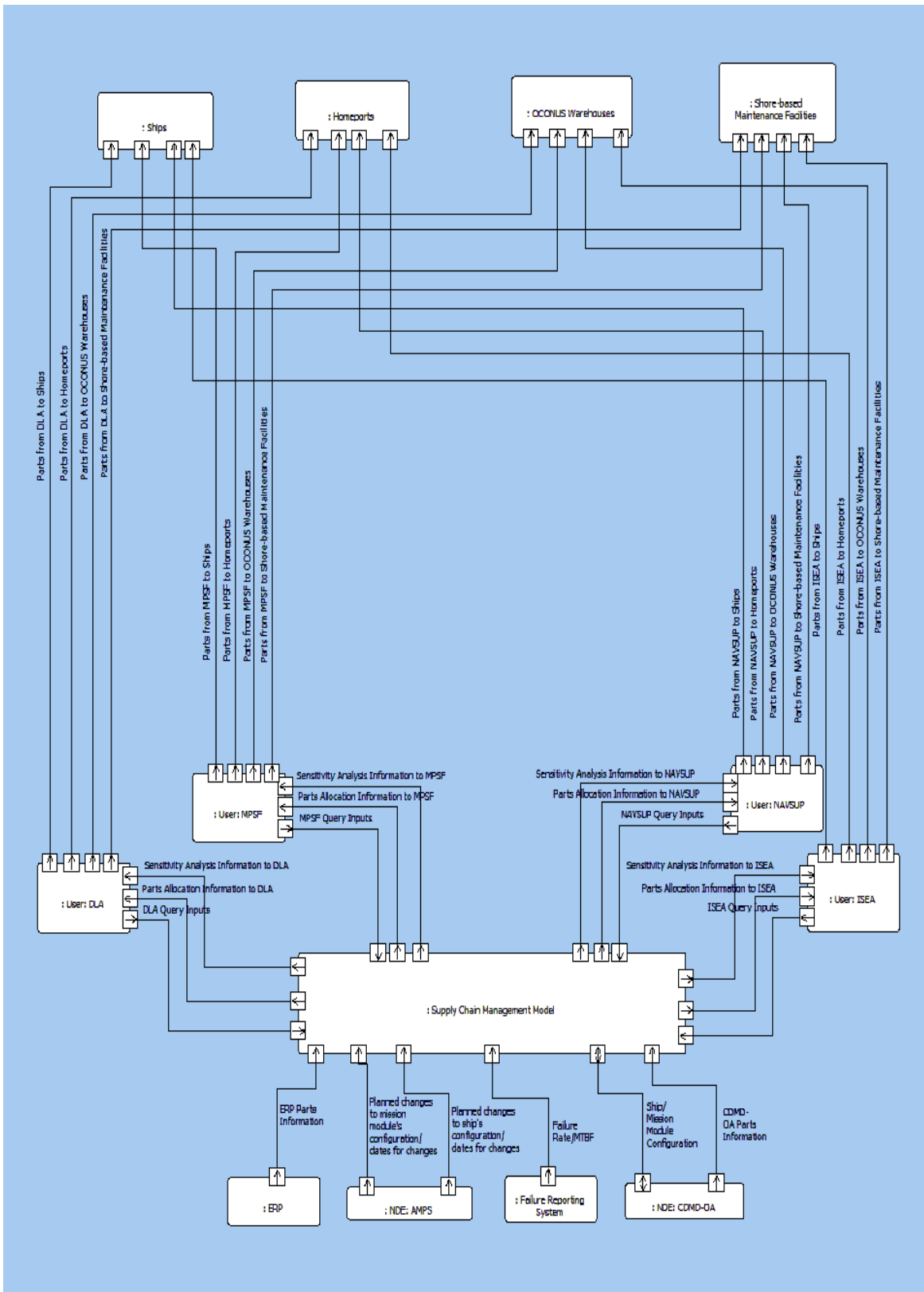

Figure 44. SCMM System Operation Resource Flow Description—OV-2

4. OV-3

The OV-3 is the operational resource flow matrix. This matrix provides a description of the resources exchanged and the relevant attributes of the exchanges. The Deputy Chief Information Officer states the following:

The OV-3 addresses operational Resource Flows exchanged between Operational Activities and locations.

Resource Flows provide further detail of the interoperability requirements associated with the operational capability of interest. The focus is on Resource Flows that cross the capability boundary.

The intended usage of the OV-3 includes the definition of interoperability requirements. (Deputy Chief Information Officer 2010, 148)

The matrix developed for the SCMM system includes the resources exchanged and the high level requirements pertinent to each.

This view was not completed but is recommended for future work to define the resource flows and the characteristics of the exchanges (Deputy Chief Information Officer 2010).

5. OV-4

The OV-4 is the organization relationships chart. This chart shows the organizational relationships among organizations. According to the Deputy Chief Information Officer:

The OV-4 shows organizational structures and interactions. The organizations shown may be civil or military. The OV-4 exists in two forms; role-based (e.g., a typical brigade command structure) and actual (e.g., an organization chart for a department or agency).

A role-based OV-4 shows the possible relationships between organizational resources. The key relationship is composition, i.e., one organizational resource being part of a parent organization. In addition to this, the architect may show the roles each organizational resource has, and the interactions between those roles, i.e., the roles represent the functional aspects of organizational resources. There are no prescribed resource interactions in DODAF V2.0: the architect should select an appropriate interaction type from the DM2 or add a new one. Interactions illustrate the fundamental roles and management responsibilities, such as

supervisory reporting, Command and Control (C2) relationships, collaboration and so on.

An actual OV-4 shows the structure of a real organization at a particular point in time, and is used to provide context to other parts of the architecture such as AV-1 and the CVs.

The intended usage of the role-based OV-4 includes:

- Organizational analysis.
- Definition of human roles.
- Operational analysis.

The intended usage of the actual OV-4 includes:

- Identify architecture stakeholders.
- Identify process owners.
- Illustrate current or future organization structures. (Department of Defense 2010, 150)

This view was not completed but is recommended for future work. The role-based OV-4 should be selected to show the relationships between the organizational resources of the SCMM system.

6. OV-5b

The OV-5b is the operational activity model, depicting the operational activities and their relationship with the inputs and outputs of the system. The Deputy Chief Information Officer defines the OV-5b as:

...OV-5b describe[s] the operations that are normally conducted in the course of achieving a mission or a business goal. It describes operational activities (or tasks); Input/Output flows between activities, and to/from activities that are outside the scope of the Architectural Description.

...OV-5b describes the operational activities that are being conducted within the mission or scenario.

... OV-5b can be used to:

- Clearly delineate lines of responsibility for activities when coupled with OV-2.
- Uncover unnecessary Operational Activity redundancy.

- Make decisions about streamlining, combining, or omitting activities.
- Define or flag issues, opportunities, or operational activities and their interactions (information flows among the activities) that need to be scrutinized further.
- Provide a necessary foundation for depicting activity sequencing and timing in the OV-6a Operational Rules Model, the OV-6b State Transition Description, and the OV-6cEvent-Trace Description. (Deputy Chief Information Officer 2010, 152)

The operational activity model—OV5b—for the SCMM system can be seen in Figure 45. Beginning from left to right, it shows the operational activities that the user performs with the SCMM system. Above the operational activities are the inputs with arrows going into the applicable activity. Below the activities can be found the outputs from an activity, depicted with a one-way arrow.

The OV-5b for the SCMM system was used to show how the user would operate the system and what the inputs to and outputs from a particular operational activity would be. It showed the team that operational redundancy was not apparent and that there were not any interaction issues that needed further scrutiny. The OV-5b was also used to depict the use case scenarios previously discussed in the Functional Analysis section of the Needs Analysis chapter.

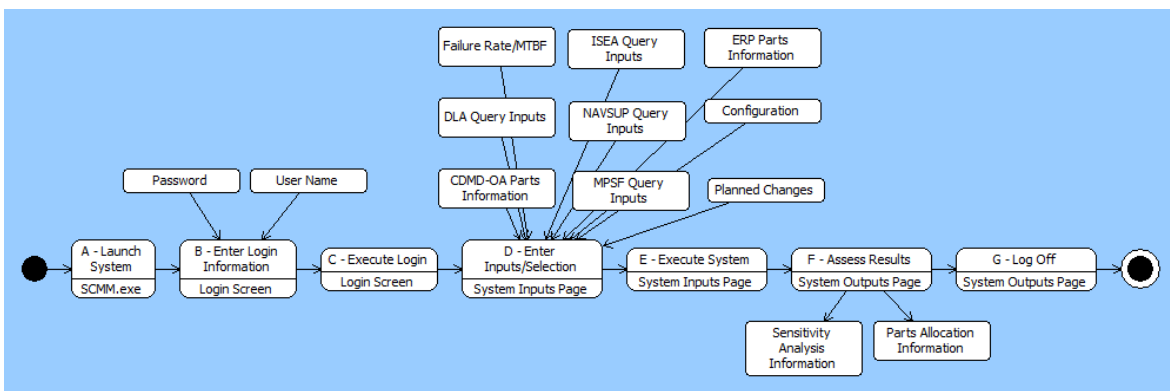

Figure 45. SCMM System Operational Activity Model—OV-5b

7. SV-1

The SV-1, system interface description model identifies the system, system items, and their interconnections. The Deputy Chief Information Officer states the following:

The SV-1 addresses the composition and interaction of Systems. For DODAF V2.0, the SV-1 incorporates the human elements as types of Performers - Organizations and Personnel Types.

The SV-1 links together the operational and systems architecture models by depicting how Resources are structured and interact to realize the logical architecture specified in an OV-2 Operational Resource Flow Description. A SV-1 may represent the realization of a requirement specified in an OV-2 Operational Resource Flow Description (i.e., in a “To-Be” architecture), and so there may be many alternative SV models that could realize the operational requirement. Alternatively, in an “As-Is” architecture, the OV-2 Operational Resource Flow Description may simply be a simplified, logical representation of the SV-1 to allow communication of key Resource Flows to non-technical stakeholders.

A System Resource Flow is a simplified representation of a pathway or network pattern, usually depicted graphically as a connector (i.e., a line with possible amplifying information). The SV-1 depicts all System Resource Flows between Systems that are of interest. Note that Resource Flows between Systems may be further specified in detail in SV-2 Systems Resource Flow Description and SV-6 Systems Resource Flow Matrix.

Sub-System assemblies may be identified in SV-1 to any level (i.e., depth) of decomposition the architect sees fit. SV-1 may also identify the Physical Assets (e.g., Platforms) at which Resources are deployed, and optionally overlay Operational Activities and Locations that utilize those Resources. In many cases, an operational activity and locations depicted in an OV-2 Operational Resource Flow Description model may well be the logical representation of the resource that is shown in SV-1.

The intended usage of the SV-1 includes:

- Definition of System concepts.
- Definition of System options.
- System Resource Flow requirements capture.
- Capability integration planning.
- System integration management.

- Operational planning (capability and performer definition).

The SV-1 is used in two complementary ways:

- Describe the Resource Flows exchanged between resources in the architecture.
- Describe a solution, or solution option, in terms of the components of capability and their physical integration on platforms and other facilities. (Deputy Chief Information Officer 2010, 204)

The SV-1 for the SCMM system depicts the flow of resources between the systems of interest, including the users of the system. Figure 46 has several boxes that surround the system box, noted as “SCMM.” The SCMM box is partitioned into two areas: “user inputs” and “repository.” The surrounding boxes have arrows denoting the flow of information from them to the partitioned areas of the SCMM system. The information (resources) that flows into the “repository” area is shown with a one-way arrow that comes from the external databases which push data into the system. This data is then integrated into the system’s repository and made available to the SCMM system when needed. The information that flows into the “user inputs” area is depicted with a one-way arrow that comes from the users (users enter data into the system in order to obtain the necessary output). The one way arrow from the system to the user depicts the output that the system provides to the user. (The output is a report that provides multi-nodal optimized sparing/inventory recommendations based on single or multi-ship/mission scenarios, see the scenarios described in the Functional Analysis section of the Needs Analysis chapter.) The two-way arrow within the box depicts how the system uses the external information flows: the “user inputs” are used as filters to obtain the pertinent information from the “repository”; the “repository” makes this information available to the system to process and then outputs a report that contains the spare parts recommendations based on a use case scenario.

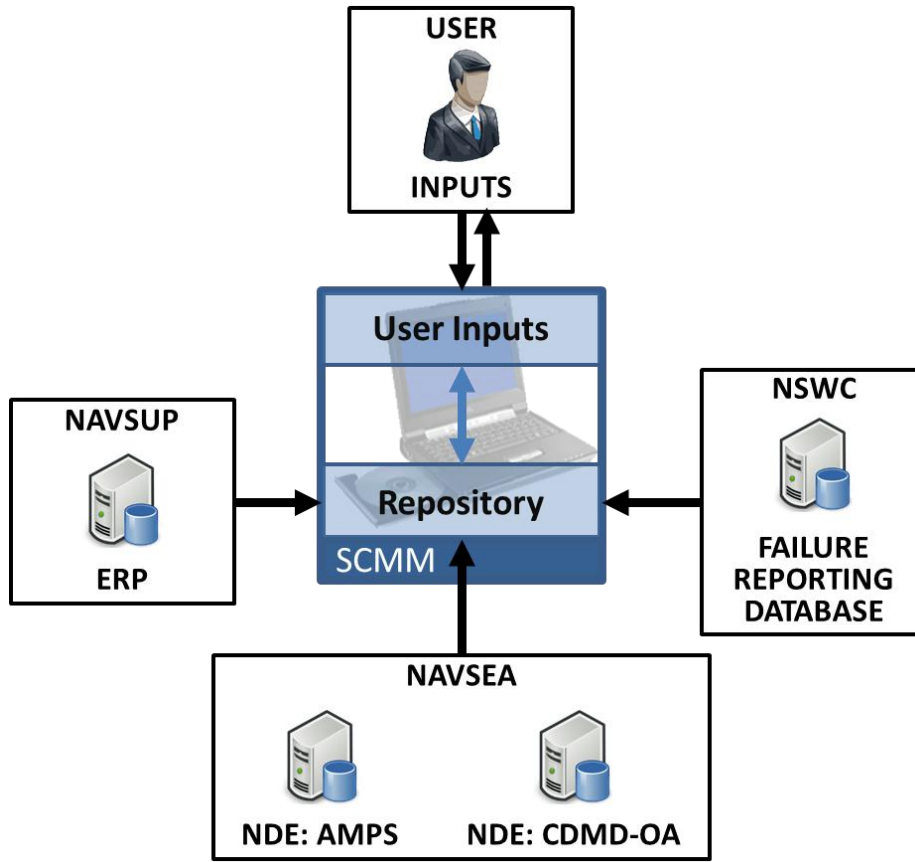

Figure 46. SCMM System System Interface Description Model—SV-1

8. SV-4

The SV-4 diagram is a systems functionality description that depicts the functions performed by the system and the system data flow among the functions. The Deputy Chief Information Officer defines the SV-4 as:

The SV-4 addresses human and system functionality. The primary purposes of SV-4 are to:

- Develop a clear description of the necessary data flows that are input (consumed) by and output (produced) by each resource.
- Ensure that the functional connectivity is complete (i.e., that a resource's required inputs are all satisfied).
- Ensure that the functional decomposition reaches an appropriate level of detail.

The systems functionality description provides detailed information regarding the:

- Allocation of functions to resources.
- Flow of resources between functions.

The SV-4 is the systems viewpoint model counterpart to the OV-5b activity model of the operational viewpoint.

The intended usage of the SV-4 includes:

- Description of task workflow.
- Identification of functional system requirements.
- Functional decomposition of systems.
- Relate human and system functions. (Deputy Chief Information Officer 2010, 211)

Figure 47 displays the SV-4, in its entirety, for the SCMM system. This figure is shown in segments for readability in the subsequent graphics with a brief description of each. The SV-4 contains the functions of the SCMM system as determined during the functional analysis (described in the Functional Analysis section of the Needs Analysis chapter). It also includes the flow of resources between the functions. The SV-4 was developed during the functional analysis of the system, allowing for identification of the functional system requirements and the functional decomposition of the system. It helped to “ensure that the functional connectivity [was] complete” and that “the functional decomposition reached an appropriate level of detail,” as prescribed by the Deputy Chief Information Officer (2010, 211).

Following is a description of this figure and the subsequent ones. The rectangular boxes depict the functions and sub-functions of the system. Each has arrows that show the flow of the functions. The resource flows are shown as text with a line leading into the arrows. The items found in circles denote the following:

- “AND”: concurrent function
- “LP”: loop; repeated until a specific objective has been achieved
- “LE”: loop end; the end of the loop
- “OR”: does otherwise; used to link two or more alternatives

Figure 49 displays the functions and sub-functions of function 2: receive data with the resource flows between the functions.

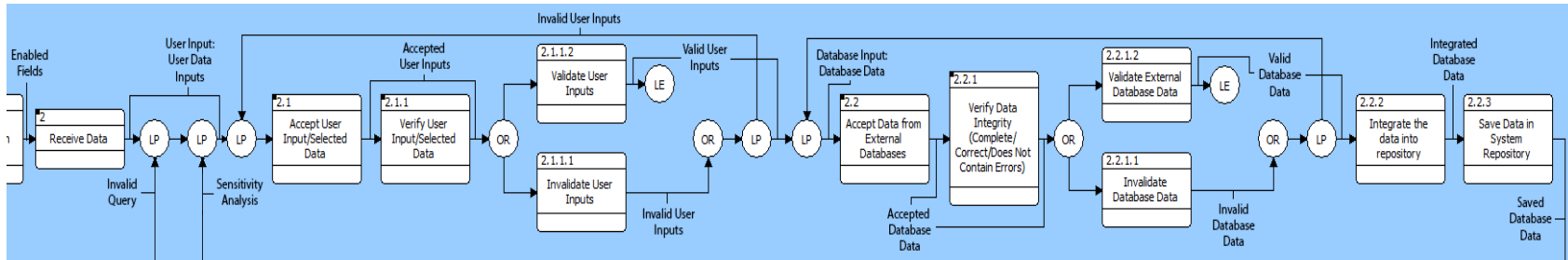

Figure 49. SCMM System Systems Functionality Description—Function 2: Receive Data

Figure 50 displays the functions and sub-functions of function 3: process data with the resource flows between the functions.

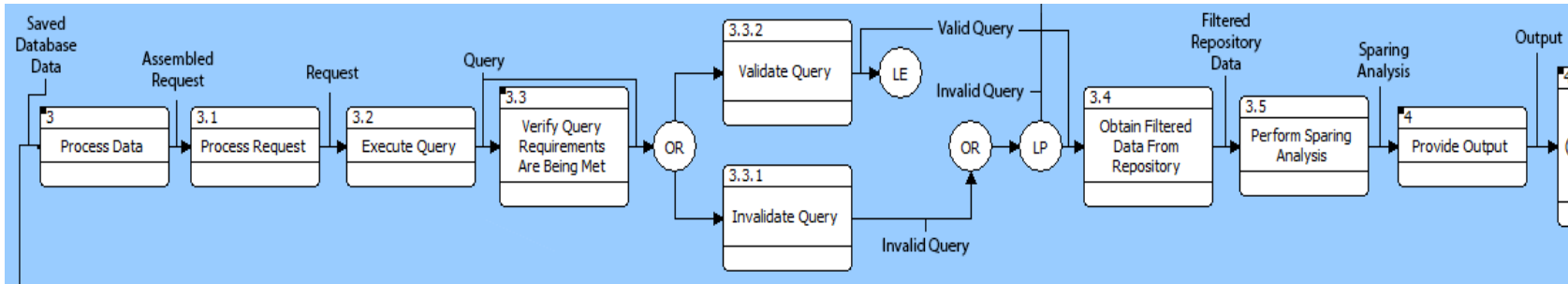

Figure 50. SCMM System Systems Functionality Description—Function 3: Process Data

Figure 51 displays the functions and sub-functions of function 4: provide output with the resource flows between the functions.

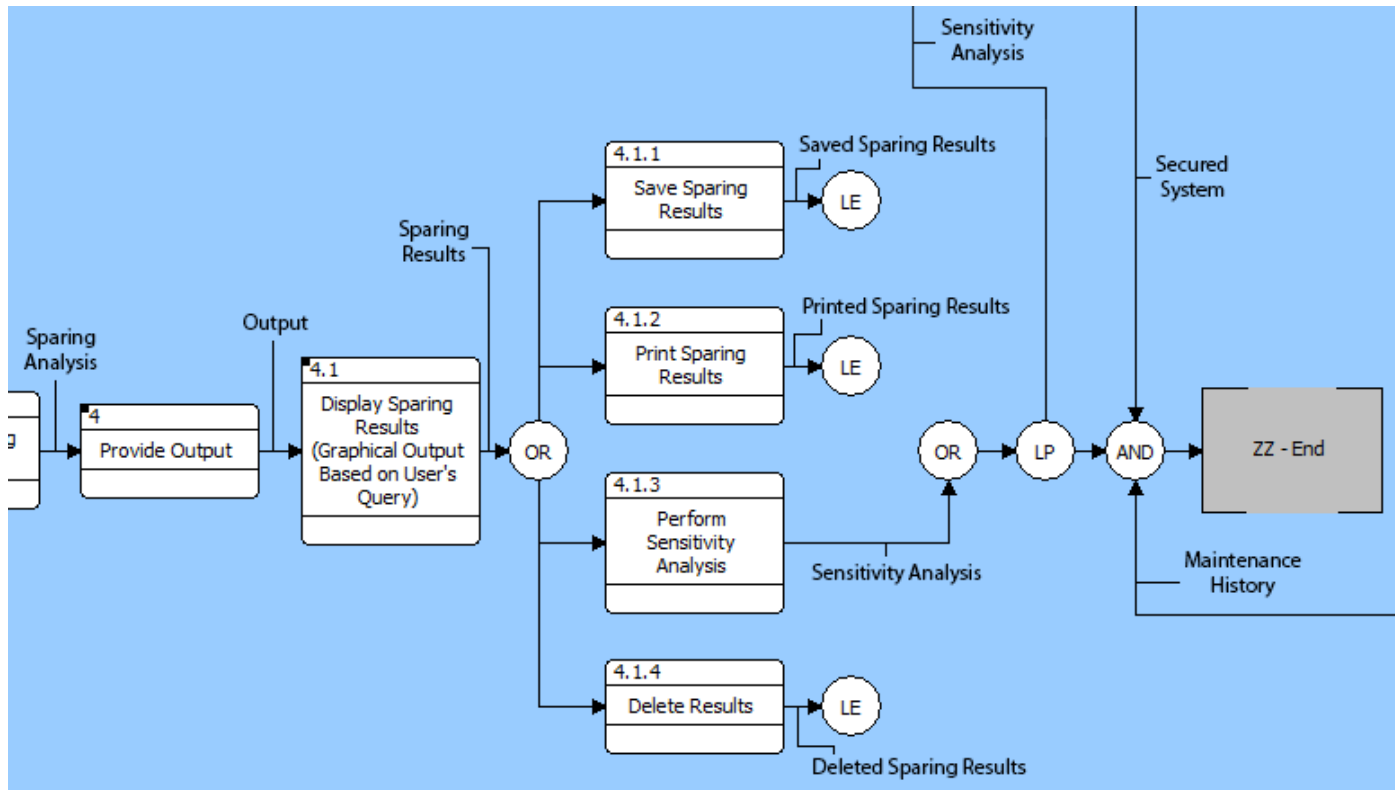

Figure 51. SCMM System Systems Functionality Description—Function 4: Provide Output

Figure 52 displays the functions and sub-functions of function 5: maintain system with the resource flows between the functions.

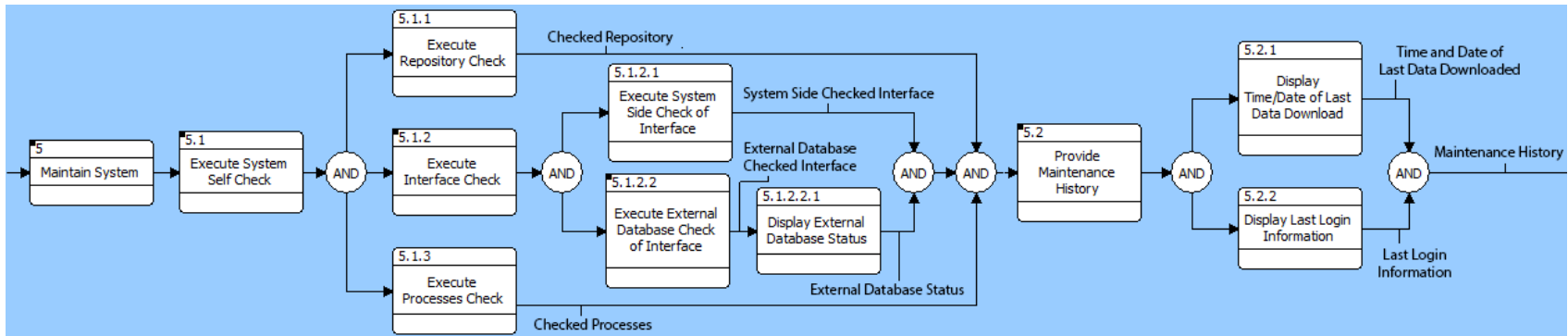

Figure 52. SCMM System Systems Functionality Description—Function 5: Maintain System

Figure 53 displays the functions and sub-functions of function 6: secure system with the resource flows between the functions.

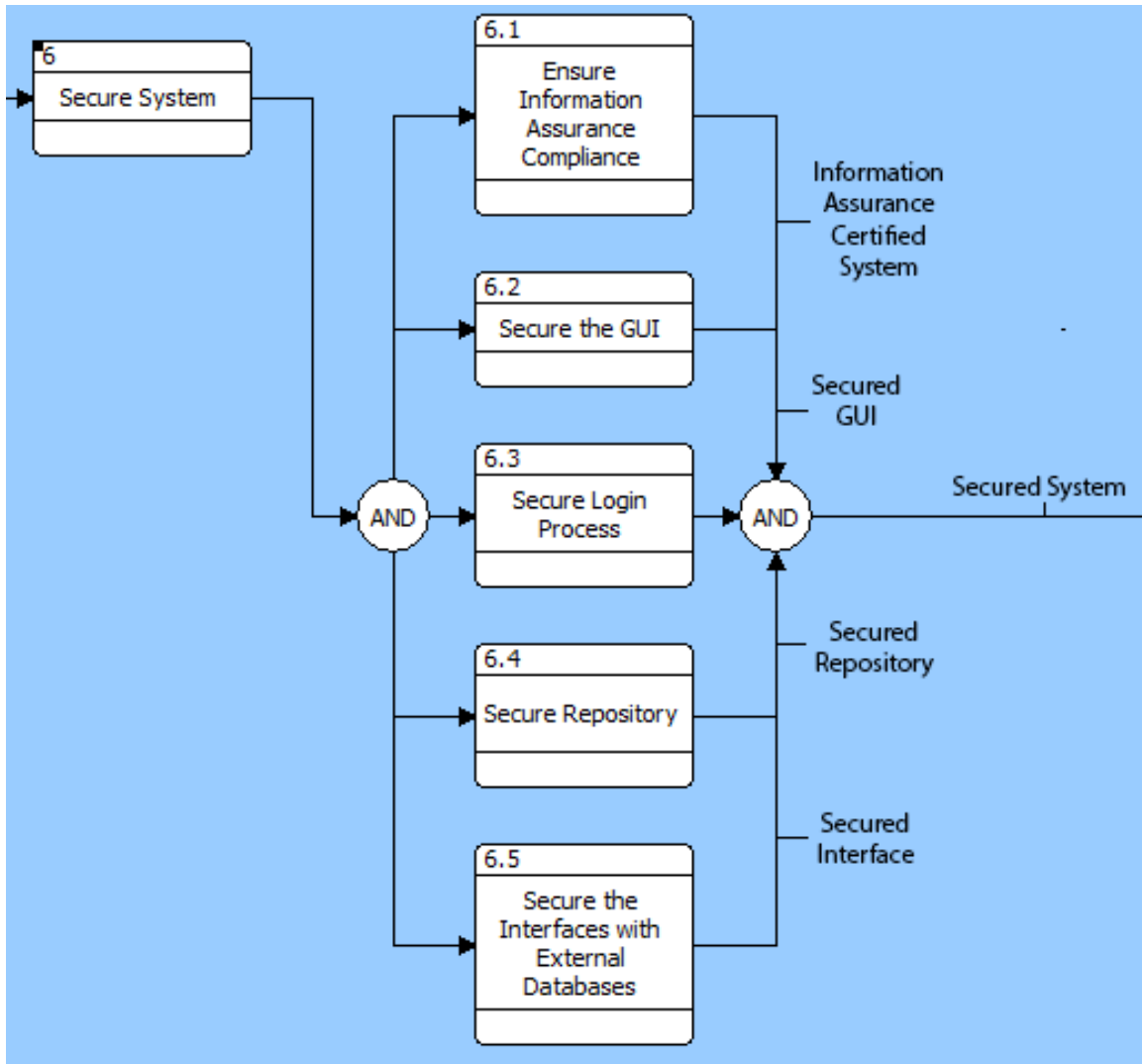

Figure 53. SCMM System Systems Functionality Description—Function 6: Secure System

9. SV-5a

The SV-5a is the operational activity to system function traceability matrix, which provides a mapping of the operational activities to the system functions. The Deputy Chief Information Officer defines the SV-5a as follows:

The SV-5a addresses the linkage between System Functions described in SV-4 Systems Functionality Description and Operational Activities specified in...OV-5b Operational Activity Model. The SV-5a depicts the mapping of system functions and, optionally, the capabilities and performers that provide them to operational activities. The SV-5a identifies the transformation of an operational need into a purposeful action performed by a system or solution.

During requirements definition, the SV-5a plays a particularly important role in tracing the architectural elements associated with system function requirements to those associated with user requirements.

- The intended usage of the SV-5a includes:
- Tracing functional system requirements to user requirements.
- Tracing solution options to requirements.
- Identification of overlaps or gaps. (Deputy Chief Information Officer 2010, 213)

Table 9 captures the mapping of the SCMM system's operational activities to its system functions. This mapping allowed the team to ensure that there was a system function to perform an identified operational need. It also served to illustrate that there were not any overlaps or gaps in the designed system.

Operational Activity								
Number	Function	A 1.0 Launch System	A 2.0 Enter Login Information	A 3.0 Execute Login	A 4.0 Enter Inputs / Selection	A 5.0 Execute System	A 6.0 Assess Results	A 7.0 Log Off
1	Enable Graphic User Interface (GUI)	X	X	X				
1.1	Display Log-in Screen	X	X	X				
1.1.1	Accept User Name and Password		X	X				
1.2	Perform Login Credential Security Verification			X				
1.2.1	Invalidate Password			X				
1.2.2	Invalidate User Name			X				
1.2.3	Validate Username and Password			X				
1.3	Display GUI			X	X	X	X	X
1.4	Enable data entry/selection fields			X	X			
2	Receive Data				X			
2.1	Accept User Input/Selected Data				X			
2.1.1	Verify User Input/Selected Data				X			
2.1.1.1	Invalidate User Inputs				X			
2.1.1.2	Validate User Inputs				X			

Operational Activity								
2.2	Accept Data from External Databases						X	
2.2.1	Verify Data Integrity (Complete/Correct/Does Not Contain Errors)						X	
2.2.1.1	Invalidate Database Data						X	
2.2.1.2	Validate External Database Data						X	
2.2.2	Integrate the data into repository						X	
2.2.3	Save Data in System Repository						X	
3	Process Data						X	
3.1	Process Request						X	
3.2	Execute Query						X	
3.3	Verify Query Requirements Are Being Met						X	
3.3.1	Invalidate Query						X	
3.3.2	Validate Query						X	
3.4	Obtain Filtered Data From Repository						X	
3.5	Perform Sparing Analysis						X	
4	Provide Output						X	X

Operational Activity								
4.1	Display Sparing Results (Graphical Output Based on User's Query)						X	
4.1.1	Save Sparing Results						X	
4.1.2	Print Sparing Results						X	
4.1.3	Perform Sensitivity Analysis				X	X	X	
4.1.4	Delete Results						X	
5	Maintain System	X		X		X	X	X
5.1	Execute System Self Check	X		X		X	X	X
5.1.1	Execute Repository Check	X		X		X	X	X
5.1.2	Execute Interface Check	X		X		X	X	X
5.1.2.1	Execute System Side Check of Interface	X		X		X	X	X
5.1.2.2	Execute External Database Check of Interface	X		X		X	X	X
5.1.2.2.1	Display External Database Status	X		X		X	X	X
5.1.3	Execute Processes Check	X		X		X	X	X
5.2	Provide Maintenance History				X		X	

Operational Activity								
5.2.1	Display Time/Date of Last Data Download				X		X	
5.2.2	Display Last Login Information				X		X	
6	Secure System	X	X	X	X	X	X	X
6.1	Ensure Information Assurance Compliance	X	X	X	X	X	X	X
6.2	Secure the GUI	X	X	X	X	X	X	X
6.3	Secure Login Process	X	X	X	X	X	X	X
6.4	Secure Repository	X	X	X	X	X	X	X
6.5	Secure the Interfaces with External Databases	X	X	X	X	X	X	X

Table 9. SCMM System Operational Activity to System Function Traceability Matrix—SV-5a

C. SUMMARY

The system architecture phase of team RSRP's tailored vee captured the logical sequencing and interaction of system functions within a model based systems engineering architecture based on DODAF v2.02 principles. DODAF views were used in the construction of the system architecture to ensure consistency when describing the system components, functions, boundaries, and interactions. The SCMM system capabilities and relationships were documented with capability, operational, and system views to develop a high level system design to meet the stakeholders' needs.

A CV-1 diagram was developed using Microsoft PowerPoint to help establish the system capabilities and illustrate the strategic context of the system. The CV-1 not only illustrated what the desired system capabilities are for the SCMM system but also showed how the system would satisfy these goals. The CV-1 gives a high level view of what the system interfaces are in an operational context and why the system should function in this way to provide the determined outputs.

The operational views that were constructed for the system architecture were the OV-1, OV-2, and OV-5b. The OV-1, which is the high level graphical diagram of the system's operational concept, was developed to show the interactions of the SCMM system within its intended environment and external systems. The OV-1 illustrated the dependence on external databases to provide the user with relevant data for optimal parts sparing based on defined inputs. The OV-2 gave a description of the resource flows between operational activities. It depicts the resource flows into and out of the SCMM system, the users, the external interfaces (databases), and the eventual resource flows to external entities. The development of the OV-2 ensured the accountability of resources exchanged between entities internal and external to the SCCM. The creation of the OV-5b was to show interaction of the operational activities with the inputs and outputs of the SCMM system. It was used to highlight any redundancy apparent within the architecture of the system and to validate the use case scenarios.

The system views constructed for the SCMM architecture were the SV-1, SV-4, and SV-5a. The SV-1 was used to identify the interconnections with the established

system and system resources to conceive the resource flows depicted in the OV-2. The SV-4 illustrated the functions performed by the system and the data flow between the functions. Concurrent diagrams were created showing the detailed data flow between the functions determined in the functional analysis phase: enable graphic user interface, receive data, process data, provide output, maintain system, and secure system. The SV-5a was developed to map the operational activities to the system functions via a traceability matrix. The matrix identified a system function to perform a determined operational need of the SCMM and ensured the coverage of gaps by the designed system.

The development of the system architecture ensured traceability to the system requirements and established a roadmap for the conceptual design of the system while ensuring coverage of the stakeholders' needs.

THIS PAGE INTENTIONALLY LEFT BLANK

V. CONCEPTUAL DESIGN

The purpose of this phase was to identify a system design that met the functional and performance requirements of the system. A conceptual design was created in conjunction with system analysis by conducting an AoA. This phase was used to narrow down the best alternative to meet the needs of the stakeholders/sponsor. The AoA was conducted using the requirements identified during the functional and system requirements analyses. These include the operational, input/output, and functional requirements.

A. ANALYSIS OF ALTERNATIVES

The AoA methodology was used to identify potential solutions that could satisfy the requirements and support a decision based on the most effective solution. The AoA identifies a wide range of solutions that have a reasonable likelihood of providing the needed capability for the defined requirements (Department of Defense 2013).

The following questions were answered by the AoA:

- Do the alternatives meet the requirements?
- Are the alternatives operationally effective and suitable?
- Can they be supported?
- What are the risks and costs for each alternative?

The AoA is a key factor in selecting a final solution, but it is not the only factor. The final decision must consider not only the criteria/requirements but also domestic policy, technological maturity of the solution, the environment, and the budget (Office of Aerospace Studies 2008).

Because of fielding and implementation time constraints for the SCMM system, the primary purpose of this AoA was to find an existing model that could provide the right spare in the right place to meet and/or improve the operational availability (Ao) of modular or flexible class ships using the criteria of space, weight, cost, criticality, multi-nodal, and multi-mission input capability, as approved by the sponsor. The team made several assumptions during the AoA analysis:

- Cost associated with increasing the Ao was not a factor in the selection process.
- All reviewed models can be re-programmed to meet the SCMM system's requirements.
- None of the models are proprietary.
- The model selected will be made available to be re-programmed; and will become either a new system or the next version of the existing system.

These assumptions were necessary so that the team could complete this analysis within the required timeframe. The team made these assumptions for the AoA analysis only, and they were not applicable to other sections of this project.

The AoA process included a swing weighting assessment methodology adapted from *Making Hard Decisions with Decision Tools* (Clemen and Reilly 2001). The swing weighting assessment directly compares the individual criteria against each model. The assessment process is described in more detail in the Analysis of Existing Systems section of this chapter.

1. Determining the Alternatives

The team researched and discussed many potential solutions to the problem. Three primary options were identified as follows:

a. Option 1

Do nothing—maintain the current modular or flexible design ship parts sparing methodology. Using the LCS class ships as an example, the current process is for the original equipment manufacturers (OEM) to provide a list of recommended spare parts. This created a problem because the initial spare parts proposals exceeded the allowable shipboard space and weight constraints. In order to support early deployment, the list was reduced by subject matter experts (SMEs) without use of any analytical techniques to justify the reduction of parts.

b. Option 2

Modify existing DOD part sparing models/tools to accommodate all of the SCMM system requirements, which includes the space and weight limitations of the ship

to support the multi-nodal infrastructure and multi-mission operational scenarios of modular or flexible design ships. According to Blanchard and Fabrycky, "...it is necessary to (1) identify various...alternatives that could be pursued in response to the need; [and] (2) evaluate the most feasible approaches to find the most desirable in terms of performance, effectiveness, maintenance and sustaining support, and life-cycle economic criteria..." (Blanchard and Fabrycky 2011, 60). There are many existing models that might be sufficient to address a majority of the requirements. But, as Blanchard and Fabrycky state, "...the number of these must be narrowed down to those that are physically feasible and realizable within schedule requirements and available resources" (Blanchard and Fabrycky 2011, 60).

c. Option 3

Develop a new system to optimize part sparing based on the space and weight constraints of the ship to support the required multi-nodal infrastructure and multi-mission operational scenarios of modular or flexible design ships.

After discussing these options with the sponsor, option 2 was determined to be the most feasible and was selected for further research and analysis. Option 1 was deemed as not an acceptable solution to the problem; the current parts sparing process was determined to be not acceptable during the literature review segment of this capstone project. Option 3 was assumed to be time consuming and costly because the development of a new system has to begin from very early system advance planning and architecting after the problem has been defined and the need has been identified, which have already been performed during the course of this project (Blanchard and Fabrycky 2011). Option 2 was then considered to be the most reasonable based on the availability of current DOD parts sparing models and the community's willingness to adapt these to meet current and/or future needs, as described in the Literature Review section of this report in the Needs Analysis chapter.

2. Analysis of Existing Systems

The analysis for option 2 was based on the initial research conducted in 2013 by Ms. Breanna Newton, a logistics intern working for NSWC PHD Land Attack-

Department. She was given a list of various models from the different services (Air Force, Army and Navy), by the team’s current sponsor, Mr. Howard, to assist with her efforts for her intern senior project. This list of models was created based on the models’ inclusion of software, analytical techniques, processes, logistics footprint, and path for decisions. A list with a total of 406 models was provided to her, which she initially reviewed and scaled down to 201 for further comparison. The scaling criteria used were that the models had to be related to supply support or parts sparing.

She then compared the 201 models on the list and excluded those that did not include operational availability impacts and cost tradeoff assessment capabilities. Based on this very high level assessment the list was further down selected to 22 tools (B. Newton, unpublished data). The team used this list of models to conduct the AoA. In addition, a new tool called OPUS10 was added to the list after determining it could be a potential solution to the parts sparing problem. The models reviewed for the AoA are included in Table 10.

Model Name	Acronym	Service
Availability Centered Inventory Model	ACIM	Navy
Aegis Optimization Model	AOM	Navy
Automatic Requirements Computation System Initial Provisioning	ARCSIP	Army
Aviation Readiness Requirements Oriented to Weapon Replaceable Assemblies	ARROWS	Navy
Aircraft Sustainability Model	ASM	Air Force
BlockSim	BLOCKSIM	Multiple
Customer Oriented Leveling Techniques	COLT	Air Force
Computerized Optimization Model for Predicting and Analyzing Support Structure	COMPASS	Multiple
Fleet Logistics Support Improvement Program	FLSIP	Navy
Logistics Composite Model	LCOM	Air Force
Logistics Analysis Model	LOGAM	Army
Multi-Echelon Readiness Based Sparing	ME-RBS	Navy
Software tool in Opus Suite System	OPUS10	Multiple
Optimum Stock Requirements Analysis Program	OSRAP	Army

Model Name	Acronym	Service
Quanterion Automated Reliability Toolkit	QUART	Navy
RAPTOR	RAPTOR	Multiple
Readiness Based Leveling (RBL)	RBL	Air Force
ReliaSoft	RELIASOFT	Multiple
Support Enterprise Model	SEM	Army
Selectable Essential Item Stock and Availability Method	SESAME	Army
System of Systems Analysis Tool Set	SoSAT	Multiple
Service Planning and Optimization	SPO	Navy
TIGER-Availability Centered Inventory Model	TIGER-ACIM	Navy

Table 10. List of the 22 Existing Models for Swing Weight Evaluation

In order to evaluate these 23 models, the team used the linear combination of weighting methodology to evaluate them as discussed in the paper *Quantitative Methods for Tradeoff Analyses* (Daniels, Werner and Bahill 2001). Six criteria were derived from the SCMM system’s requirements that were determined to have a significant effect on the model alternatives under evaluation. These selected criteria were independent of each other so “preference order and the trade-off for different levels of the criteria do not depend on the levels at which all other criteria occur” (Blanchard and Fabrycky 2011, 181). The sponsor assessed and agreed with the selected criteria and he assigned equal weighting (equal importance) to them. A weight is used to establish the importance of the criteria in the overall evaluation of the alternatives (Daniels, Werner and Bahill 2000). A criterion with a higher importance is given more weight (Daniels, Werner and Bahill 2001). Since the sponsor specified equal weighting of the six criteria, each criterion was assigned a weight of 1/6 for the evaluation—the weights need to add to one. Table 11 displays the criteria and assigned weight.

Criteria	Weight
Space input	0.1667
Weight input	0.1667
Operational Availability input	0.1667
Cost input	0.1667
Multi-Nodal input	0.1667

Criteria	Weight
Multi-Mission input	0.1667
Sub-total	1.0000

Table 11. Swing Weight Criteria

Figure 54 shows how the initial 406 models were down-selected to 23 models; the swing weighting method was then used to identify the top alternatives.

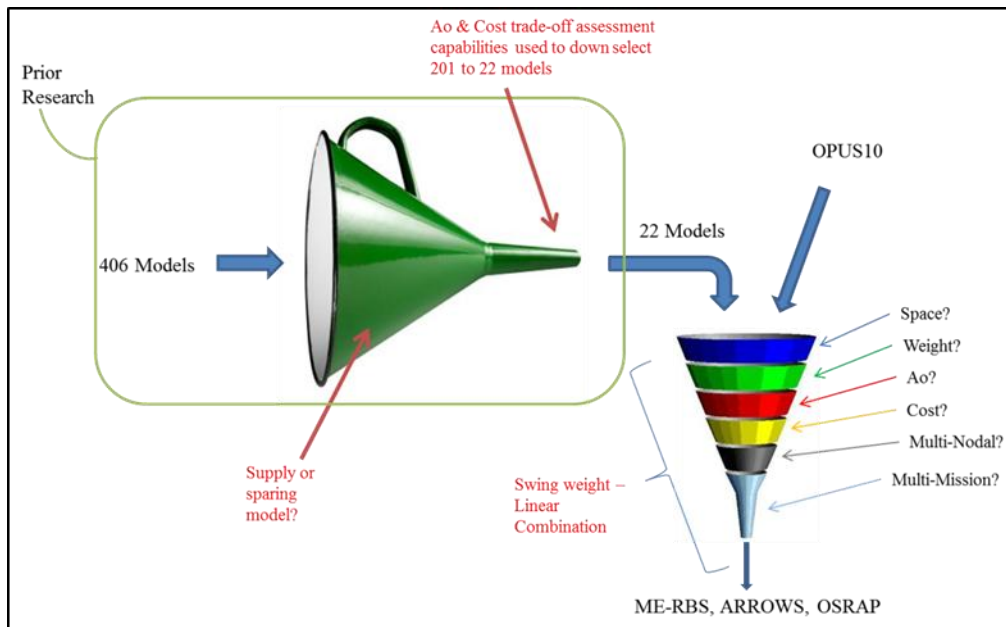

Figure 54. Alternative Models Down-Selection Process

Each of the 23 models was evaluated against each criterion using a score between zero to five. A model that completely met the criteria was assigned a score of five. A zero score meant the model did not include that criterion. The resultant score under each criterion was then multiplied by its corresponding weight. The final scoring was the summation of the weight-times-score for each criterion. The objective of this analysis was to select the highest performing existing system alternatives. An alternative that completely met all six criteria will have a final score of 5. The highest remaining alternatives would be further analyzed and researched in order to recommend use of, modification to, or new development of a model to meet the requirements of the

stakeholders. The specific scores in each criterion category can be found in the Analysis of Alternatives Scoring Matrix appendix.

Figure 55 shows the final scoring (un-sorted) for all 23 models.

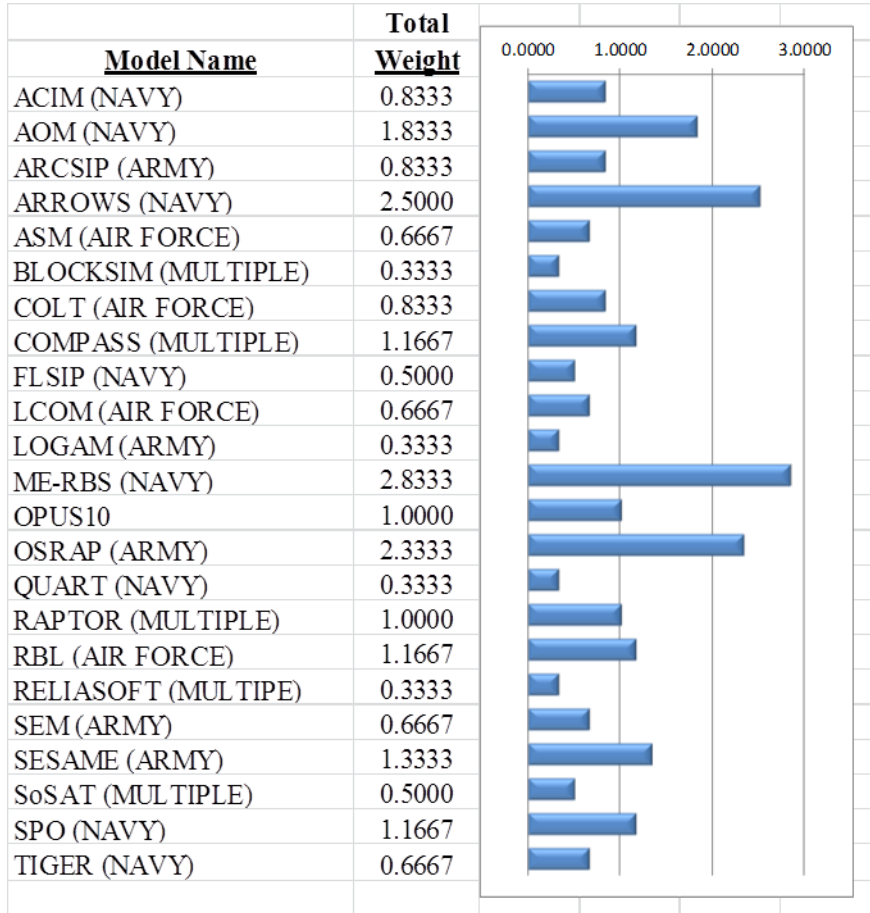

Figure 55. Final Swing Weight (Unsorted)

Figure 56 shows the sorted final scoring for each alternative. The alternative that scored the highest based on the six criteria is listed first.

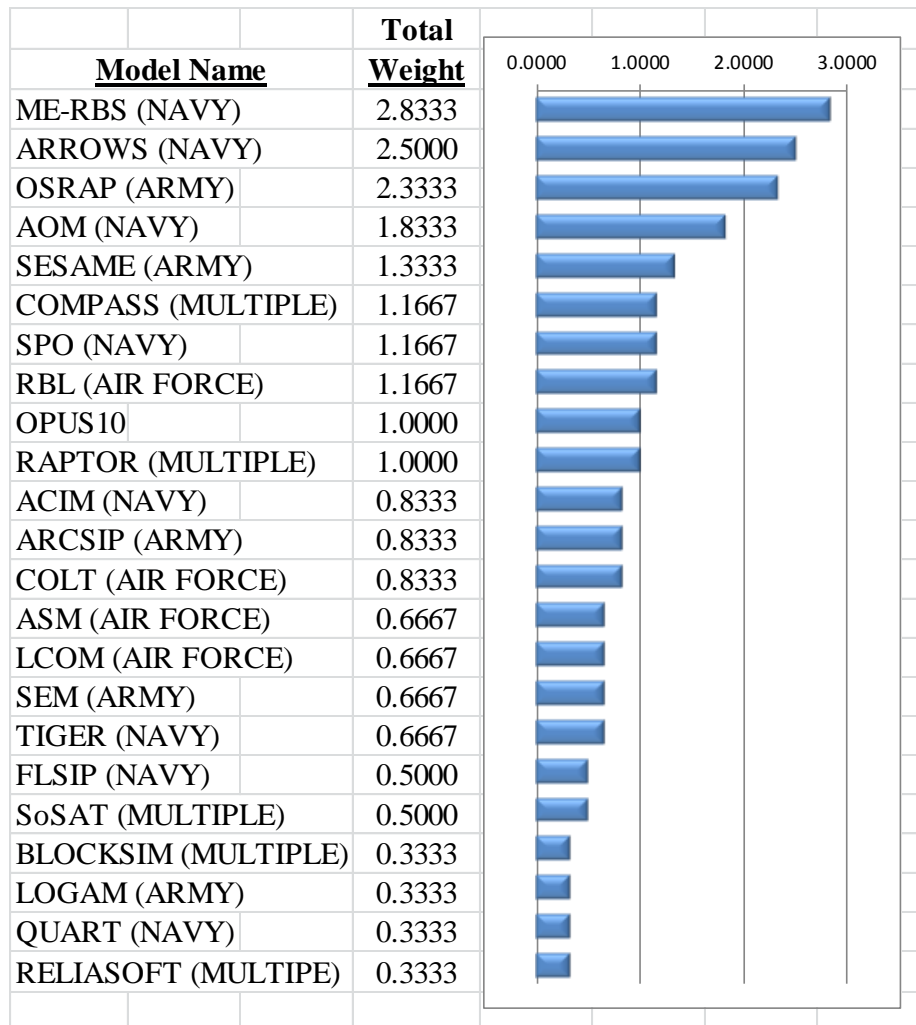

Figure 56. Final Swing Weight (Sorted)

This analysis yielded three alternatives with the highest scores for potential adoption and modification:

- ME-RBS (Navy)
- ARROWS (Navy)
- OSRAP (Army)

ME-RBS had the highest score of 2.8333, ARROWS had a final score of 2.5, and OSRAP had a final score of 2.3333. As discussed earlier, any alternative that met all of the criteria would have a final scoring of 5.0. ME-RBS currently satisfied approximately 57 percent of the criteria requirements, while both ARROWS and OSRAP met approximately 50 of the criteria requirements. Any other alternative that satisfied less

than 50 percent of the criteria requirements would not be considered due to the amount of changes required to accommodate all the SCMM system requirements.

B. DETAILED DESCRIPTION OF THE TOP THREE ALTERNATIVES

The AoA identified three alternatives that may be suitable to adapt to the SCMM system requirements.

1. ME-RBS: Multi-Echelon Readiness Based Sparing

ME-RBS is a Navy RBS tool used by the Naval Supply Systems Command (NAVSUP) to achieve a desired operational availability (Ao) or full mission capability (FMC) of weapon systems (CACI 2006). This tool is used to minimize inventory cost of spares while supporting readiness response time for parts support (minimizing MLDT) (CACI 2006).

ME-RBS integrates ARROWS, ACIM (Availability Centered Inventory Model), and TIGER spare models into its workstation (CACI 2006). ME-RBS determines Ao for readiness (Ao/FMC) by calculating the input data (CACI 2006). Input data such as mean time between failure/mean times to repair (MTBF/MTTR), essential missions, funding constraints, and spares requirements are processed based upon engineering criticality for reliability block diagrams (RBDs) that depict the effect of an item's failure on a system's functional performance (CACI 2006). ME-RBS highly focuses on the evaluation of weapon system readiness at optimum Ao with minimum cost per unit and reduced waiting time (CACI 2006). ARROWS, ACIM, and TIGER are embedded in ME-RBS imparting the capabilities to support multi-nodal requirements to support operational readiness (CACI 2006).

2. ARROWS: Aviation Readiness Requirements Oriented to Weapon Replaceable Assemblies

The ARROWS model is a Navy readiness based sparing model used to develop a spare part inventory list (Strauch n.d.). ARROWS uses operational and logistics requirement inputs in the model to evaluate and to compute the spare parts needed to support the operational availability of aviation weapon systems (Strauch n.d.).

The output parts list from ARROWS consists of necessary parts to support full mission capability of weapon systems as well as the non-critical mission requirements (Strauch n.d.). ARROWS uses the required input data for each part of the weapon system to compute the Ao increment along with the associated cost (Strauch n.d.). It then determines the parts list based upon the ratio of Ao-cost and the total cost and the availability of the weapon systems according to the available spare part stock (Strauch n.d.).

ARROWS has the capability to process data for support of multiple weapon systems, sites, and levels of repair (Strauch n.d.). It also has the ability to compute a spare parts list based on:

- critical repairable parts versus cost and part availability (Strauch n.d.).
- cost minimization for high price repairable parts versus low cost repairable parts (Strauch n.d.).
- cost effectiveness of available spare part stock for critical versus non-critical missions (Strauch n.d.).

3. OSRAP: Optimum Stock Requirements Analysis Program

OSRAP was developed to produce a part list to support the readiness of Army weapon systems. For optimal part requirements, OSRAP uses the following input data: unit costs, repairable levels of parts, time to repair, and awaiting part time (Department of Defense 2011).

OSRAP produces the essential parts list to guarantee the critical mission availability of weapon systems in consideration of minimizing cost, weight, and space while increasing the operational availability (Department of Defense 2011). It also provides the available stock for non-essential mission readiness to conserve cost (Department of Defense 2011).

OSRAP focuses on the mission readiness of multiple weapon systems along with cost, performance, mobility, space, and weight that can overall decrease operational cost and significantly increase the critical operational availability due to the improvement of availability of forward based sparing (Department of Defense 2011). As a result, it

reduces the logistic footprint by the advance of supply support in available repairable parts (Department of Defense 2011).

C. RESULTS OF ANALYSIS OF ALTERNATIVES

The analysis of alternatives compared the results from the calculation of each alternative's multi attributes. Based on the results, three alternatives, ME-RBS, ARROWS, and OSRAP, had the highest scores providing the decision to support viable solutions for the capstone project's most preferable alternative to offer improved Ao, comparative cost, and effective support to the current modular ship configuration.

1. Space and weight constraints

OSRAP was the only alternative considering space and weight in the process to provide a mission essential part list. The overall focus on space and weight limits made OSRAP a serious alternative deserving consideration.

2. Operational availability

All three alternatives were focused on optimizing the Ao of a weapon system. The calculation of data inputs produced a repairable parts list with the forecast value of Ao that related to the supply of parts. The three alternatives were at the same level in consideration of providing a higher Ao for weapons systems readiness.

3. Cost

All three alternatives minimized parts cost while providing a recommended parts list to achieve the best Ao. OSRAP and ARROWS are standalone systems. ME-RBS is embedded with ARROWS, ACIM, and TIGER. ME-RBS provides optimized aggregated spares through the use of its multi-echelon capability. This provides support of critical missions based on weapon system readiness while minimizing the total cost of parts inventory.

4. Multi-Nodal and Multi-Mission

ME-RBS, ARROWS, and OSRAP support multi-nodal and multi-mission needs from a variety of input data sources in order to deliver a spare parts list with a target Ao.

ARROWS has the ability to take in multi-nodal and/or multi-mission data, while OSRAP could be modified to take in the required multi-nodal or multi-mission criteria as needed. In view of that, these two alternatives had lower capability in supporting multi-nodal and multi-mission requirements than ME-RBS, which had all capabilities, with the exception of the space and weight requirements, from the embedded models in its work station.

D. SUMMARY

The conceptual design phase consisted of identifying a system design to meet the functional and performance requirements of the SCMM system. To identify established and operational models within the Department of Defense (DOD) community for possible adaptation, Team RSRP used weighted criteria based on the SCMM system requirements to conduct an analysis of alternatives (AoA). The three highest scoring alternatives were further analyzed, and the benefits and disadvantages of each were analyzed. As a result of the AoA, it was determined that the ME-RBS model appeared to support a wide range of capabilities and functions including different methodologies to calculate allowance parts lists while potentially improving Ao. Even though the drawback is its limitation in space and weight calculations, ME-RBS was the recommended alternative. This decision was based on expected system performance due to its abilities to distribute spare parts at the multi-nodal (multi-echelon) level to accommodate the desired Ao and cost considerations, while accounting for the multi mission aspect of modular or flexible design ships. The SCMM system must consider the constraints of space and weight for these ship types. Spare parts recommendations are then calculated to support a multi-nodal maintenance infrastructure to sustain and/or improve operational availability, while taking into account these ships' multi-mission capability and parts support budget.

The Navy and the Army each have readiness-based sparing models that could provide some benefits as the alternative model for the SCMM system. The three alternatives mostly support the parts sparing requirements for modular or flexible design ships.

The team concluded that the Multi-Echelon Readiness Based Sparing (ME-RBS) system is the best alternative suitable for adaptation to support the stakeholders' needs and requirements. This model requires additional research to determine whether modification is viable in terms of design and cost. Another option is the development of a new system rather than adaptation of an existing system. This option would be preferred if the ME-RBS system's design could not be altered and/or if the cost was above that of new system development. The team recommends that research and analysis continue in support of the development of the SCMM system, whether it is the alteration of the ME-RBS system or the creation of a new system, to meet the identified stakeholders' needs.

THIS PAGE INTENTIONALLY LEFT BLANK

VI. MODELING AND SIMULATION

Modeling and Simulation (M&S) has become a generalized term that is used to define and demonstrate the system. The team used modeling and simulation tools separately to model the architecture views, requirements hierarchies, diagrams, and simulation of system operations. M&S allows for systems to be tested prior to implementation to discover gaps, deficiencies, or to display the extent of certain capabilities. M&S reduces cost and time in the latter stages of system test and deployment (Bailey 2013).

There were two key steps in the team's M&S process. The first consisted of modeling the requirements, functions, and DODAF views using Vitech's CORE software. The second step was two-fold: the first part consisted of simulating the SCMM system output; the second part consisted of simulating the current manual process to calculate which spare parts to allocate to the various support locations. The first simulation utilized Microsoft Excel, which simulated the generation of a sample report, and gave the team a visual tool to begin understanding the inputs and outputs of the system. The second simulation utilized ExtendSim to simulate the movement of data across various processes in the current "manual" method in comparison with the "automated" method that the system will provide.

A. SYSTEM MODELING

The system's architecture, functions, requirements, and various DODAF views were modeled in Vitech's CORE. CORE is a robust systems engineering and project management tool that allows the user to quickly house and document important data pertinent to systems engineering problems (Vitech 2013). CORE is especially useful for requirements management, behavior analysis, architecture development, and validation and verification (Vitech 2013). It was used not only as a tool but to also understand/control the design and mitigate project risk. This was done by linking the individual elements in CORE to a central model. These linkages reduced redundancy and error by creating traceability and accountability. Ultimately, CORE was used to increase

system design performance, evaluate data, and create DODAF products (Vitech 2013). DODAF products provide a standardized set of diagrams or views that allow the system designers to show or “model” key attributes of the system.

CORE enabled the team to use a model based systems engineering (MBSE) approach. MBSE is known to be a simplified, layered system design approach, which allowed the team to focus on engineering rather than the tool. CORE’s internal tool known as a “parser” allowed data to be entered into any location within CORE and have attributes assigned to them. This data would then be distributed or “parsed” into appropriate diagrams, categories, and tables, effectively updating all model data immediately. Visualization of requirements interaction was simplified with flexible model construction. This allowed for a variety of graphical views such as: hierarchies, physical block, N-squared (N^2), FFBDs, and integrated definition for function modeling (IDEF0). Automated documentation also helped create some DODAF views instantly from the system definition database (Vitech 2013). CORE also allowed the team to:

- capture the customer needs accurately through requirements management (Vitech 2013).
- identify system functionality (Vitech 2013).
- document and build system architecture through subsystems and components (Vitech 2013).
- create system design traceability (Vitech 2013).
- provide system documentation (Vitech 2013).

As discussed in in the System Requirements chapter, once a baseline was created, CORE allowed the team to maintain architecture validity throughout refinement and discussions with the sponsor. The baseline is the initial set of data that the team developed to model the system. This data included the initial functions, requirements, and views based on early discussion with the sponsor. Modeling a baseline of the system was important because it provided a detailed view of the system, which was used for future meetings with the sponsor to elicit feedback. All models in CORE are built around and linked to a central repository (Vitech 2013). This allowed for a change that was made in one diagram to be reflected across all diagrams (Vitech 2013). These diagrams were not only useful in creating DODAF deliverables, but also they were used to effectively

communicate the architecture to the team and sponsor. Deliverables included FFBDs, HBDs, use case, and the functional requirements table found in the Needs Analysis chapter; an input, control/constraint, output, and mechanism (ICOM) diagram, context diagram, and system requirements table found in the System Requirements chapter; and architecture views found in the System Architecture chapter.

B. SYSTEM SIMULATION

The system was simulated in two ways. The team decided it would be useful to simulate a sample report generation as a proof of principle, discussed below, and to also simulate system processes. The report simulation was done through Microsoft Excel and the systems processes were simulated through ExtendSim.

1. Microsoft Excel Simulation

The Excel simulation was a proof of principle that emulated the input data, processing, and output report that was expected of the system. Microsoft Excel was chosen because it is readily available throughout the Navy; it is a commonly used and accepted form of data storage and processing, and has a multitude of accepted file formats. As stated on the Microsoft Office website:

Excel is a spreadsheet program in the Microsoft Office system. You can use Excel to create and format workbooks (a collection of spreadsheets) in order to analyze data and make more informed business decisions. Specifically, you can use Excel to track data, build models for analyzing data, write formulas to perform calculations on that data, pivot the data in numerous ways, and present data in a variety of professional looking charts. Common scenarios for using Excel include:

- **Reporting** You can create various types of reports in Excel that reflect your data analysis or summarize your data—for example, reports that measure project performance, show variance between projected and actual results, or reports that you can use to forecast data.
- **Tracking** You can use Excel to keep track of data in a time sheet or list—for example, a time sheet for tracking work, or an inventory list that keeps track of equipment. (Microsoft 2013)

The approach was to begin with a simple simulation and then increase the complexity of the simulation as time permitted. The final product goal was to account for all inputs from various databases that would connect to the system. For the proof of principle and to begin the process the agreed upon user inputs were ship, mission, location, and mission duration. Database inputs of concern were failure rate (or an equivalent such as MTBF) and criticality of the part. The initial algorithm concept is detailed in the following process:

User sets the inputs of ship, mission type, location, and duration. Then the database inputs that relate to user inputs would be populated into a spreadsheet. The spreadsheet of necessary data is then sorted by highest criticality and lowest MTBF. And finally, the spreadsheet is ready for viewing by the user. In order to begin the Excel simulation six tabs were initially created:

- User input: This simulated the users selecting/entering their inputs
- Output report: This is where the report was generated per the user's inputs
- CDMD-OA: This simulated database inputs from CDMD-OA
- AMPS: This simulated database inputs from AMPS
- Total input database data: This simulated where the total Database inputs would be aggregated
- Miscellaneous data: This stored all internal data to the simulation

The user inputs were limited to ship, mission location, and mission duration. In order to limit the inputs of the user dropdown boxes were created for each input, as shown in Figure 57.

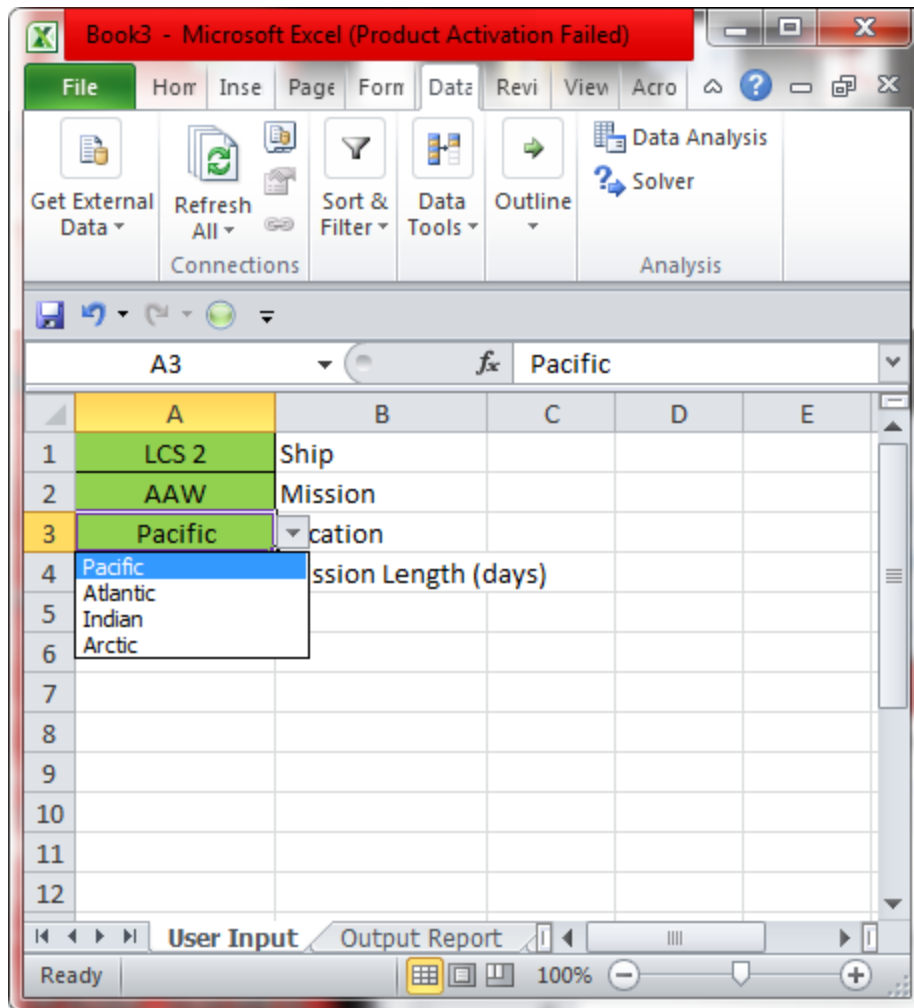

Figure 57. Drop-Down Input Boxes

Figure 58 displays the contents of the dropdown boxes, which are contained in the “Misc. Data” tab. Each user input had a given selection of options. The “Ship” input was given a selection of “LCS 1,” “LCS 2,” and “LCS 3.” The “Mission” input was given a selection of “Mine Sweeping,” “AAW,” and “SUW.” The “Location” input was given a selection of “Pacific,” “Atlantic,” “Indian,” and “Arctic.” The “Mission Duration” input was left as an open field for the user to enter a length of time in days.

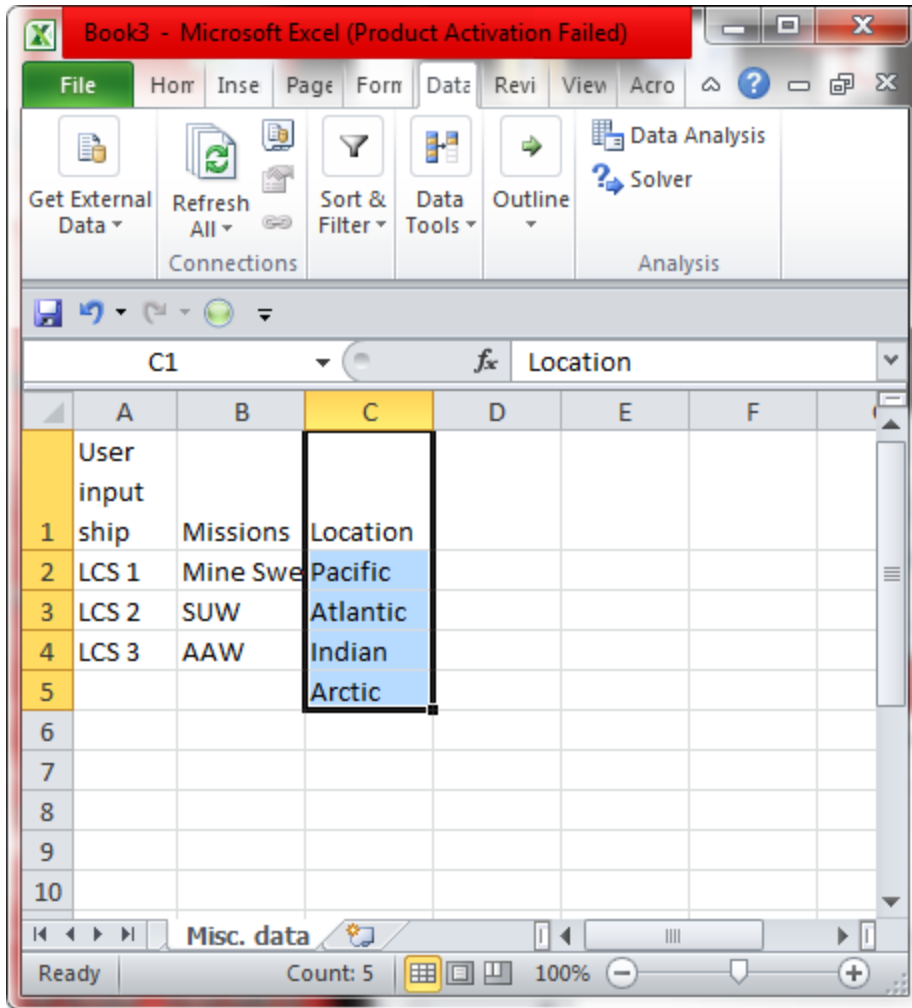

Figure 58. Misc. Data Tab

Drop down boxes were created in Excel by going to Data>Data Validation>, as shown in Figure 59.

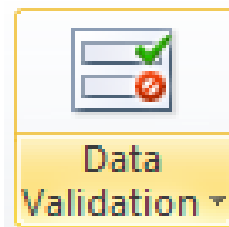

Figure 59. Data Validation Application

The data validation window Figure 60 used the following selections of “Allow” and “Source.”

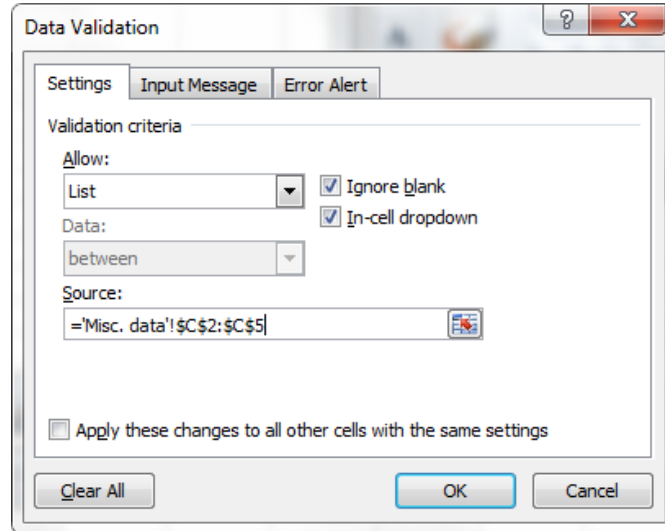

Figure 60. Data Validation Window

The CDMD-OA and AMPS tabs were populated with “Part Name,” “Part Number,” “Failure Rate (MTBF),” “Criticality,” “Numerical Criticality,” “Dimensions (weight),” “Cost,” “Config (mission),” and “Config (Ship).” The CDMD-OA tab received generic part names of “Test 1” through “Test 20” and generic part numbers of “1” through “20.” See Figure 61.

	A	B	C	D	E	F	G	H	I
1	Part name	Part number	Failure rate (MTBF)	Criticality	Numerical Criticality	Dimensions (weight)	Cost	Config (mission)	Config (ship)
2	Test 1	1	2904	low	1	4495	167191	Mine Sweeping	LCS 1
3	Test 2	2	4953	med	2	7229	3428557	SUW	LCS 3
4	Test 3	3	2732	high	3	9002	7083020	AAW	LCS 2
5	Test 4	4	2954	very high	4	3149	9274177	Mine Sweeping	LCS 1
6	Test 5	5	1705	low	1	5654	3913379	AAW	LCS 2
7	Test 6	6	1060	med	2	4259	5999560	AAW	LCS 2
8	Test 7	7	2720	high	3	8188	2968019	Mine Sweeping	LCS 1
9	Test 8	8	3822	very high	4	6512	7707002	SUW	LCS 3
10	Test 9	9	4135	low	1	8839	7966939	SUW	LCS 3
11	Test 10	10	4389	med	2	3634	8830838	Mine Sweeping	LCS 1
12	Test 11	11	4549	high	3	1369	9420371	Mine Sweeping	LCS 1
13	Test 12	12	4125	very high	4	9479	6406470	Mine Sweeping	LCS 1
14	Test 13	13	3232	low	1	8648	3499429	AAW	LCS 2
15	Test 14	14	4112	med	2	7024	8228794	SUW	LCS 3
16	Test 15	15	2158	high	3	7848	49050	SUW	LCS 3
17	Test 16	16	4597	very high	4	8942	1645965	AAW	LCS 2
18	Test 17	17	1054	low	1	3570	4010646	Mine Sweeping	LCS 1
19	Test 18	18	4909	med	2	868	4922137	AAW	LCS 2
20	Test 19	19	2810	high	3	6769	8720859	SUW	LCS 3
21	Test 20	20	3297	very high	4	3898	5189171	AAW	LCS 2

Figure 61. CDMD-OA Tab

The AMPS tab received generic part names of “Test 21” through “Test 40” and generic part numbers of “21” through “40.” Both the CDMD-OA and AMPS tabs received the following randomized Excel values for testing:

- “Failure rate (MTBF)” =RANDBETWEEN(1000, 5000)
- “Criticality” received “low,” “med,” “high,” or “very high” starting with “low” and repeating in that order until all parts received a value.
- “Numerical Criticality” was a numerical equivalent of the descriptive value given in the “Criticality” fields =IF(D2=“low,” 1, IF(D2=“med,” 2, IF(D2=“high,” 3, IF(D2=“very high,” 4, 0))))
 - low = 1
 - med = 2
 - high = 3
 - very high = 4
- “Dimensions (weight)” =RANDBETWEEN(1, 10000)

- “Cost” =RANDBETWEEN(10000, 10000000)
- “Config (mission)” received “Mine Sweeping,” “SUW,” or “AAW” starting with “Mine Sweeping” and repeating in that order until all parts received a value.
- “Config (ship)” received “LCS 1,” “LCS 2,” or “LCS 3” starting with “LCS 1” and repeating in that order until all parts received a value.

The next step was to have Excel consolidate the data that was now coming from two databases. Once the data was consolidated the Excel file would automatically apply the sort and rank with highest criticality and lowest MTBF. However, this would still include all the data, even the data that was not applicable to the user’s inputs. In order to delete the data that was not applicable to the user’s needs, the example code of “=IF(‘User Input’!\$A\$1=‘Total Database’!\$I\$2,IF(‘User Input’!\$A\$2=‘Total Database’!\$H\$2,’Total Database’!B2,0),0) was used to create a line of “0”s in the non-applicable lines of data. The “0” lines were deleted and the resulting data was placed in the “Output Report” tab. This was accomplished with a macro that can be found in the appendix titled Modeling and Simulation Macro.

Finally, once the data was displayed in the “Output Report” tab, it was conditionally formatted based on the weight constraint set by the ship selection. The output report has already been ranked by order of importance, and now the determination of which parts are to go on ship and which parts are to go to a warehouse must be determined. Starting at the top and working its way down, the conditional formatting highlighted the parts that add up to but below the set ship’s weight constraint. The rest of the parts were highlighted in a different color designating them for the warehouse.

The proof of principle simulation of the report generation worked as intended and produced the outputs expected. Based on the input data provided by the sponsor and initial processes being simulated, the output report was populated correctly. The outputs were also displayed in a readable format that the team could use and present to the sponsor. It provided a starting point that with further research and technical expertise could be developed further to conduct more complicated analysis. It can be concluded that a SCMM system could develop the necessary outputs and export the data into a useable report.

2. ExtendSim Simulation

The second simulation was with ExtendSim, which allowed for a comparison of the baseline “manual” method to the system’s “automated” method. ExtendSim was selected because of its capability to accurately represent the process and that it was offered for use by NPS’s Voyager Remote Application. Other simulation software was considered, such as MATLAB, but due to its cost and Navy restrictions for installation, the team decided to move forward with ExtendSim.

ExtendSim is a powerful, leading edge simulation tool. Using ExtendSim, you can develop dynamic models of existing or proposed processes in a wide variety of fields. Use ExtendSim to create models from building blocks, explore the processes involved, and see how they relate. Then change assumptions to arrive at an optimum solution. ExtendSim and your imagination are all you need to create professional models that meet your business, industrial, and academic needs.

ExtendSim is an easy-to-use, yet extremely powerful, tool for simulating processes. It helps you understand complex systems and produce better results faster. According to the “ExtendSim Overview” webpage, with ExtendSim you can:

- Predict the course and results of certain actions
- Gain insight and stimulate creative thinking
- Visualize your processes logically or in a virtual environment
- Identify problem areas before implementation
- Explore the potential effects of modifications
- Optimize your operations
- Evaluate ideas and identify inefficiencies
- Understand why observed events occur
- Communicate the integrity and feasibility of your plans. (ImagineThat! 2013)

The “manual” method simulation essentially depicts what a standard user did before the SCMM system was created. This included logging into various databases, entering input data for each database, retrieving relevant data (either by saving, or copy and paste), and then assembling it into Excel and analyzing it to obtain a sparing list based on high failure rates of parts. The “automated” method simulation of the SCMM

system eliminates the time required for multiple logins and extracts the data directly from the database. It also eliminates the assemblage into Excel and the processing that was normally done. Clearly, the SCMM system is more efficient.

The model in ExtendSim was built using a discrete event model because the system needed to have a time-dependent flow that depicted a process of operations. First the simulation parameters of End time (24) and Global time units (minutes) were set in the Simulation Setup tab. Next the Item Library was opened and an Executive block, Figure 62, was placed into the simulation. An executive block is a requirement for all discrete event modeling.



Figure 62. Executive Block

Next is to start the data flow by creating the “report.” This was done with the Routing: Create block Figure 63, and was set to generate a report every hour.



Figure 63. Routing: Create Block

After the report has started it receives user input data or applicability data. The first is ship input and the time it takes to accomplish this is set to one minute in the Activity block Figure 64.

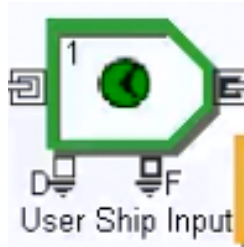

Figure 64. Activity Block

After the input has been noted, an attribute is assigned (i.e., LCS 1) through the Attributes block Figure 65.



Figure 65. Attributes Block

This is tied to a random variable block Figure 66 that is set to randomly (probability of 50 percent) assign it either LCS 1 or LCS 2.

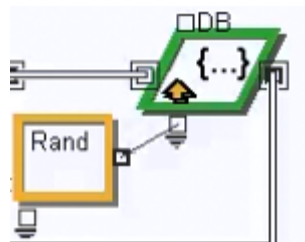

Figure 66. Random Variable Block

This was again all repeated for the second user input of mission. Figure 67 shows both sets of blocks designating the two inputs.

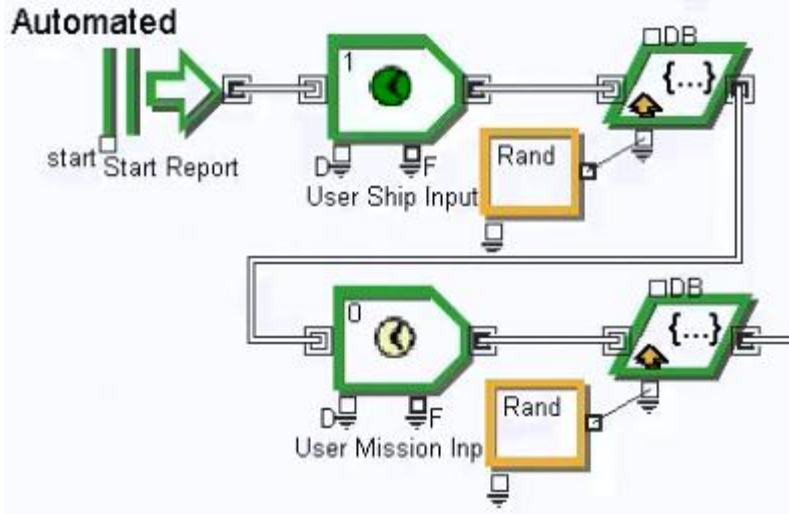

Figure 67. User Ship and Mission Inputs

This initial part of the simulation is the same for both the “automated” and “manual” methods. The only difference now is that they proceed through different follow-on activities as shown in Figure 68.

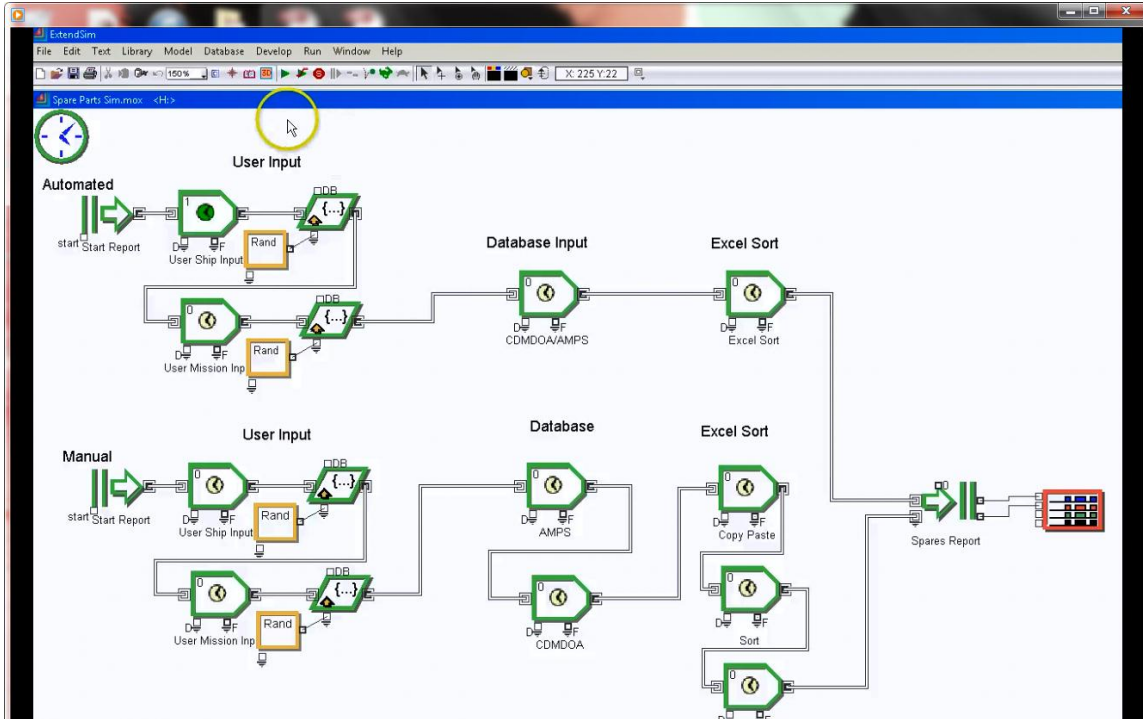

Figure 68. ExtendSim Simulation Overview

The automated process exits the user inputs and travels to a single database activity block, whereas the manual process requires each database to be accessed individually with two separate blocks. The automated process also then hits a singular Excel Sort activity block, and again, the manual process hits a multitude of Excel process activity blocks. Both processes feed into a Routing: Exit block, Figure 69. The exit block signifies the end of the route that the report takes.



Figure 69. Exit Block

The Exit block then feeds into a Plotter, Discrete Event block, Figure 70, that then populates and displays a graph called a simulation plot, Figure 71, at the end of the simulation.



Figure 70. Plotter, Discrete Event Block

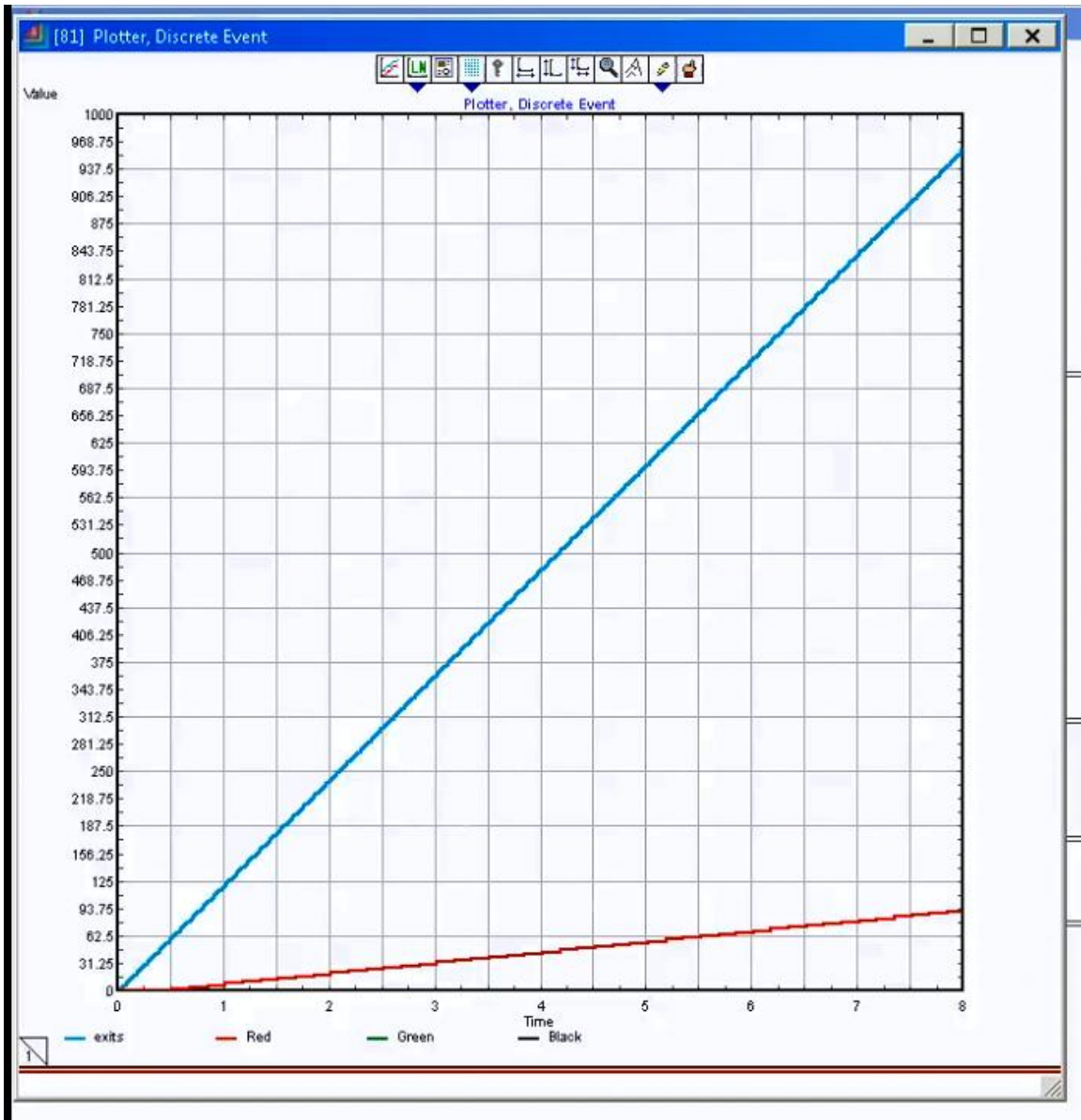

Figure 71. Simulation Plot

The plot and simulation results confirmed the hypothesis that the manual method is less productive in comparison to the automated method. This result gave the team a great base for future simulations.

The system process simulation worked as intended and produced the outputs expected. The goal was to demonstrate how time consuming the “manual” method was in comparison to the “automated method.” The team expected the “automated” method to

be faster, but was surprised at how long it took items to progress through the “manual” queue. Therefore, the team concluded that a SCMM system would improve supply chain management performance.

C. SUMMARY

The modeling and simulation phase of the tailored SE vee process consisted of modeling the requirements, hierarchies, diagrams, and creating system architecture views in CORE; while simulating the conceptual design of the SCMM system was developed using Excel and ExtendSim. Information captured in CORE allowed for the effective documentation of system requirements, design baselines, and report generation during the development of the project. The use of modeling software tools enabled the RSRP team to create DODAF architectures with software inherent linkages for traceability throughout the development of the system requirements, which was then illustrated by creating system architecture views.

The MBSE approach used by team RSRP focused on creation of the system elements and interfaces using the CORE software for a layered design. CORE allowed the team to make modifications and iterations throughout the development of the system that did not compromise the integrity or cohesion of the modeling process. CORE allows system components to retain or modify relationships depending on the developer inputs. The iterative development of system requirements was simplified by the ability of CORE to show requirement relationships and the visualization of the interfaces and boundaries of the system’s elements.

The simulation of the system was accomplished by using Microsoft Excel to emulate input data being processed to create a final output report and ExtendSim to simulate the system processes in detail. The simulations were created with a similar iterative process as the modeling approach: beginning with simple inputs and processes, observing the process interactions and outputs, and then increasing the complexity of the simulations by adding additional detailed inputs, interfaces, criticality margins, and ship and part configurations with the inclusion of a time element for system optimization. The simulation results confirmed that with sponsor identified and team developed inputs an

output report could be generated and an “automated method” surpassed the performance of a “manual method” with the team concluding that an SCMM system would improve modular and flexible design ship supply chain management performance.

THIS PAGE INTENTIONALLY LEFT BLANK

VII. SYSTEM INTEGRATION AND TEST, COMPONENT VERIFICATION, SYSTEM ANALYSIS, AND VALIDATION

The right side of team RSRP's tailored vee includes several SE phases that ensure the development of the system meets customer defined requirements and that the SCMM can be a functional system once it is fielded. These include the system integration and test, component verification, system analysis, and system validation phases. These phases are critical to the maturity of the system design with each step providing valuable feedback towards an earlier phase of the SE vee. An integrated test approach was the basic construct to test, evaluate, and facilitate the necessary verification and validation of the overall system utilizing the simulated system design solution that was developed during the M&S phase. Due to time constraints the verification and validation phases were limited to the test and analysis of the developed SCMM simulation instead of a physical prototype. System analysis was performed concurrently with the conceptual design phase using an AoA methodology. Cost and risk analyses were conducted on the output of the AoA using COSYSMO and a risk management process.

A. SYSTEM INTEGRATION AND TEST

The system integration and test phase entailed the verification, system analysis, and system validation of the simulated design solution that was developed in Excel during the M&S phase. The Excel simulation was a proof of principle that emulated the input data, processing, and output report that was expected of the system. The initially defined requirements were reviewed and evaluated to determine the level of testing necessary to verify and test the SCMM system simulation. These initial requirements are listed in the Measures and Metrics table found in the Additional and Expanded Test Documentation appendix. The initial requirements can be found in the "Requirements" column of that table. Note that these are the initial requirements, and do not match the current requirement structure that is detailed in the System Requirements chapter. Working with the sponsor, some of the requirements were changed and/or better defined during the course of the project. The initial requirements, available when the simulation was being constructed, were used as the testing criteria to ensure the system's

effectiveness and suitability. The system integration and test phase was accomplished concurrently with the modeling and simulation phase to ensure readiness and maturity of the system conceptual design within the project schedule.

1. Strategy

A testing strategy that defined the testing levels, ensured proper configuration management, described the use of appropriate tools, and used measure and metrics to ensure the requirements were met was followed.

a. Testing Levels

Testing occurred in three levels over several phases. The first level was testing the user interface. The user interface was tested to show that the user has the ability to input commands and receive outputs from the system. This level of testing was done early and often during the development of the Excel model of the SCMM system.

The second level of testing consisted of testing the requirements as defined in the System Requirements chapter. An approach for testing the high-level requirements was developed that entailed testing the requirements against specific test criteria. This level of testing was conducted towards the end of the development of the Excel model of the SCMM system.

The third level of testing consists of testing the internal algorithms of the Excel based system model. The third level of testing was not conducted due to the time constraints of the capstone project. This level of testing is intended to verify that the internal algorithms of the model function as expected. Scenarios should be run with specific inputs that would generate expected outputs to verify that the inputs match the expected outputs.

b. Configuration Management and Change Control

Prior to testing, the system model was assigned the appropriate change control / revision number. After that point, any changes to the SCMM Excel simulation spreadsheet or SCMM ExtendSim simulation spreadsheet would require a notification of

changes and a new revision number. Changes were not made during testing without prior notification and appropriate change control. The spreadsheets used for configuration management and change control can be viewed in the Configuration Management and Change Control section of the Additional and Expanded Test Documentation appendix.

c. Test Tools

Several tools were used during the test and verification of the model. They are explained in the following paragraphs.

1. MS Excel

Excel was used to run the Excel model. It was also used to develop and build the test data and scenarios used to test the Excel model.

2. ExtendSim

ExtendSim was used to run the ExtendSim simulation of the model. It was also used to develop and build the test data and scenarios used to test the ExtendSim simulation of the model.

3. Hardware

The hardware used to run and test the ExtendSim simulation and Excel model was dependent on the individual testers and the available hardware. Any hardware able to run ExtendSim or Excel was able to run and test the corresponding simulation or model.

d. Measures and Metrics

The defined functional and nonfunctional requirements were tested. Each of the identified requirements was determined to be testable or not testable, and then was incorporated into a testing schema. This became the test plan and includes the test approach used for each requirement. The test measures and metrics in the form of a table can be viewed in the Test Measures and Metrics section of the Additional and Expanded Test Documentation appendix.

The results of the testing were collected in a test results report. This test report provided feedback to the SCMM capstone team on whether the system met the requirements as defined. This feedback included:

- Test Pass/Fail status: Status of all the measures and metrics and whether the tests for such passed or failed were recorded.
- Errors or defects: All errors or defects found during the testing were identified and recorded.
- Diversions from the test scenarios: Any additional diversions or issues discovered were recorded as part of the testing report and summary.

Item pass/fail criteria was based on test scenarios and documented as required. Suspension would only occur if the SCMM system simulation was not ready for testing. Testing would resume upon the availability of the simulation of the SCMM system. The simulation was available for testing at all times during the test period. The test results report can be found in the Test Results Report section of the Additional and Expanded Test Documentation appendix.

2. Testing Risks

Not all aspects of the project were within control of the test team. There were several issues that had potential risk impact on the testing of the SCMM system. The risk issues were documented below and the risk had been accepted.

- External systems data formatting specifications: Assumptions had been made based on what data and data formatting external systems, such as NAVSUP, ERP, or CDMD-OA, would be providing to the SCMM system. These external systems are third party products in which the data formatting specifications are not known to the test team. This information had been assumed based on the SCMM System Development Plan for testing purposes.
- External systems interface specifications: Assumptions had been made based on what the interface specifications are for the external systems, such as NAVSUP, ERP, or CDMD-OA, that will be interfacing with the SCMM system. These external systems are third party products in which the interface specifications are not known to the test team. This information has been assumed based on the SCMM System Development Plan for testing purposes.

- Development constraints: Due to possible development issues and constraints, the SCMM system development may not meet the planned schedule, delaying and possibly halting the testing.

3. Features To Be Tested / Not To Be Tested

The following is a list of the areas tested during testing of the application.

- User interface: User interface was tested to show that the user has the ability to input commands and receive outputs from the system. Most of the defined user interface requirements are listed as requirements 1.1 and 1.2 in the Measurements and Metrics table.
- High-Level Requirements: A list of the high-level requirements recorded in the Measurements and Metrics table shows the high-level requirements that were tested, along with the approach for testing.

The following is a list of areas not specifically addressed or tested. Testing of these features may occur at a later date.

- Internal algorithms: In addition to testing the user interface and high-level requirements, the system will be tested to verify that the internal algorithms function as expected. Scenarios will be run with specific input and expected output against the system to verify the output matches the expected outputs.
- Lower-level requirements: Lower-level functional and nonfunctional requirements have not been fully identified. Testing will only apply to the requirements that have been identified. The risk for not testing is medium. Most of the high-level requirements will be covered to verify system functionality limiting the impact.
- Interface and integration: The interface specifications have not been identified for the external systems; therefore, the features will not be tested. The risk for not testing is high. Without testing, the verification and acceptance of the interface with external systems cannot occur.

4. Testing Summary

The test results report captures the results of the testing performed on the Excel simulation of the SCMM system. Most of the requirements were met with the exception of those detailed below:

- Data can be inputted via the tables in the program, which simulates collected data from sources, versus being able to be inputted by the user. Requirements do not specify.

- Current model does not take into consideration other facilities, such as the mission package support facility (MPSF) or OCONUS warehouses.
- Unable to verify the following until requirements are further defined (xxx denotes an unknown time specified in seconds):
 - Verify the program provides Verify the program provides a report out of the output data within xxx seconds.
 - Verify the program able to handle xxx simultaneous users.
 - Verify the program able to handle xxx transactions per minute.
- Able to save Excel file, but not the output report to a separate Excel file.

Complete details can be found in the Test Report Results section in the Additional and Expanded Test Documentation appendix.

B. VERIFICATION AND VALIDATION

The purpose of the verification and validation phases is to demonstrate the system's effectiveness as a whole. Prior to the initial system demonstration, each component should be inspected and verified to determine if it has met the requirements. An analysis of the system is performed to examine system readiness. Lastly, the system should be validated for effectiveness and suitability. Due to time constraints, the team conducted various portions of these phases but was unable to validate a prototype system for initial demonstration due to the time constraints of the capstone project's timeframe.

1. Component Verification

The SCMM system is a software intensive system with the expected components to include software code, database software, algorithm(s), software interfaces, and external database interfaces. A user's host platform will be needed to check for interoperability with the SCMM system. Component verification should be performed through an effective combination of analysis, inspection, demonstration, and testing through bench test models of the physical/software design. The verification process gauges the maturity of each component prior to integrating the overall system design solution by developing a detailed robust plan with a supporting comprehensive data collection process for analysis and reporting. The objective for verification was to accurately account for system maturity as these components are integrated and to gain

confidence that they will perform as intended. Developing a prototype of the system for component verification purposes was beyond the scope of the project due to time constraints.

2. System Analysis

System analysis comprised multiple analyses conducted throughout the design of the SCMM system. System analysis was performed during the conceptual design phase when design alternatives were evaluated by conducting an AoA to identify potential models that could be adapted to satisfy the SCMM system's requirements. The AoA was conducted using value modeling, based on a weighted chart, and with a numerical evaluation matrix to determine the model that best satisfied the stakeholders' requirements (Buede 2000). Cost analysis was also conducted during this phase to evaluate the different model alternatives. The team used COSYSMO to help assess the cost and schedule implications of systems engineering decisions. Risk analysis was conducted throughout the SEP focusing on the SCMM system and capstone project risks. This analysis resulted in the development of the Risk Management Plan addressing the programmatic and technical risks of the project and system.

The end goal of system analysis is to evaluate the integrated system's performance and characteristics for qualification of the stakeholders' requirements. The analysis of the system is conducted to examine the performance of the system and performance test results, environment and stress outcomes, software coding, latency, security, maintainability, compatibility, and safety. Each area can be qualified by measuring it against the functional performance requirements but further system demonstration needs to be scheduled to provide assurance that system integration does not disrupt any functional capability (Buede 2000). Any anomalies should be fully documented through a formal report and feedback is then provided to the designers and programmers to correct the discrepancies in the system design (Buede 2000). Due to time and resource constraints, this phase of the project was scoped to include only verification, system analysis, and system validation of the simulated design solution versus a system prototype.

3. System Validation

System validation ensures that the as-designed system meets the system requirements in conformance with the stakeholders' needs. The system should be validated by performing final formal operational testing that determines effectiveness and suitability of the system. The testing should provide insight on how the system performs under loaded operational conditions within a specified stressed environment, with live users operating the system. This system validation provides the first time to really assess the true capability of the system as a whole. This process also demonstrates that the designed system achieves its intended use in the intended operational environment (Blanchard and Fabrycky 2011). Although this phase was not performed in its entirety due to the immaturity of the system design, it is recommended that system validation continue throughout the design of the SCMM system by performing progressive and iterative integrated system testing to validate the maturity of the system and assess overall system readiness.

C. SUMMARY

The right side of team RSRP's tailored vee included several SE phases that ensured the development of the system met customer defined requirements and the SCMM system was functional once fielded. These phases included system integration and test, component verification, system analysis, and the system validation processes. They were performed iteratively during this capstone project's design of the system to refine requirements and to make modifications of the system under design. They should continue to be performed throughout future system design and development efforts to ensure the areas that were developed during the left side of the tailored vee were completed to best meet the stakeholders' needs.

During the system integration and test phase the simulated design solution was subjected to verification, system analysis, and system validation processes. The initial derived requirements were evaluated to determine the level of testing necessary to verify the SCMM simulation's effectiveness and suitability. The integration and test phase was performed concurrently with the modeling and simulation phase. The integration and test

strategy included defining appropriate testing levels, establishing a configuration management process, and identifying the necessary tools to evaluate established measures and metrics for system requirement verification and validation.

The defined system integration and test levels were partitioned into three areas: testing the user interface to ensure the user could efficiently enter inputs and receive appropriate outputs from the system; testing the defined requirements against specific test criteria; and testing the internal algorithms of the Excel based system simulation to ensure proper function. Team RSRP was able to complete the first two levels of testing, with the third not being completed due to time constraints. Configuration management during testing was ensured by implementing change control of the test events and configurations of the system under test with assigned revision numbers tracked and documented. The tools used during the test and verification of the SCCM system simulation included MS Excel to develop and build test data and scenarios, ExtendSim to test the simulated model's functions and outputs, and necessary hardware available to the testers to run the test software. Measures and metrics were defined to evaluate the functional and nonfunctional requirements of the system. Results were collected and combined in to a test results report to document whether the system under test met the requirements as defined.

Due to time constraints the verification and validation phases were limited to the test and analysis of the developed SCMM simulation instead of a physical prototype. Even with these limitations the team was able to verify and validate portions of the SCMM system under development to ensure the stakeholders' requirements were being met in order to address the identified capability gap.

During the system analysis phase, several additional analyses were conducted. Design alternatives were evaluated during the AoA conducted in the conceptual design phase; cost and risk analyses were also performed. The AoA was conducted using value modeling, based on a weighted chart, and with a numerical evaluation matrix to determine the model that best satisfied the stakeholders' requirements. Cost analysis was conducted using the constructive systems engineering cost model (COSYSMO), a model used to help assess the cost and schedule implications of systems engineering decisions.

COSYSMO was used to evaluate the different alternatives that resulted from the AoA. The risk analysis focused on the SCMM system and capstone project risks. This analysis was conducted throughout the SEP and resulted in the development of the Risk Management Plan addressing the programmatic and technical risks of the project and system. The output of the system analysis phase was the identification of a system alternative suitable for adaptation to support the stakeholders' needs and requirements.

VIII. COST ANALYSIS

Whereas the initial AoA evaluation looked at the comparison of requirements and performance between alternative models, cost analysis addresses the comparison of cost between alternatives, which includes the significant cost drivers of schedule and manning or effort that are required to complete the tasking. Cost is treated as an independent variable in DOD acquisition programs. According to Barber of the Defense Acquisition University, based on the *Defense Acquisition Guidebook*:

Cost as an independent variable (CAIV) is basically an acquisition process intended to integrate proven successful business-related practices with promising new DOD initiatives to obtain superior, yet reasonably priced, warfighting capabilities. Traditionally, the success of acquisition programs has been judged by their accomplishments with respect to three parameters: cost, schedule and performance. Of these, performance usually received the most emphasis, and, therefore, was treated as a “fixed” or “independent” variable. Schedule and cost were allowed to vary to achieve some desired level of performance. In an era of shrinking defense budgets, DOD has adopted the CAIV philosophy of treating cost as the independent variable of the three, thereby allowing performance and schedule to vary somewhat in an attempt to keep weapon systems affordable. (Barber 2011, A-11)

She summarizes CAIV as follows:

CAIV is an acquisition philosophy that emphasizes keeping system life cycle cost within an established range by trading the other system acquisition variables of performance or schedule. Since a significant portion of a system’s life cycle cost is fixed by its design, the optimum time to apply CAIV principles is early in the life of an acquisition program. The PM has authority to make some changes within the “trade space” between the thresholds and objectives documented in the capability needs document provided the change does not result in a KPP being reduced below its threshold value. (Barber 2011, A-13–A-14)

Cost analysis for the SCMM system was accomplished using the constructive systems engineering cost model (COSYSMO).

A. CONSTRUCTIVE SYSTEMS ENGINEERING COST MODEL AND COST ANALYSIS

COSYSMO is a model used to help assess the cost and schedule implications of systems engineering decisions (Valerdi 2005). Based on the initial AoA evaluation, COSYSMO was used to compare the alternatives with the highest performance scores. This comparison included OSRAP and ME-RBS. ARROWS was not compared due to its previous integration into the ME-RBS workstation. Also compared were the following two options: designing a completely new SCMM system (SCMM [full]) and designing a “partial” SCMM system (SCMM [partial]), which entails modification of the existing ME-RBS model and makes it a standalone SCMM system.

COSYSMO uses multiple factors to determine cost. These factors include size drivers, such as the number of system requirements or number of system interfaces that define the size of the program; and cost drivers, such as understanding factors and complexity factors, which may increase or decrease the cost depending on the level of difficulty. Due to limited information available on the alternatives, several of the factors were based on assumptions.

Figure 72 shows the inputs used for the ME-RBS alternative. The full list of inputs, input assumptions, and cost drivers for each alternative is in the COSYSMO Factors appendix.



COSYSMO - Constructive Systems Engineering Model

Model(s)	COSYSMO
Monte Carlo Risk	Off
Auto Calculate	Off

System Size

	Easy	Nominal	Difficult
# of System Requirements	55	30	30
# of System Interfaces		3	
# of Algorithms		1	
# of Operational Scenarios			

System Cost Drivers

Requirements Understanding	Nominal	Documentation	Nominal	Personnel Experience/Continuity	High
Architecture Understanding	Nominal	# and Diversity of Installations/Platforms	Nominal	Process Capability	Nominal
Level of Service Requirements	Nominal	# of Recursive Levels in the Design	Nominal	Multisite Coordination	Nominal
Migration Complexity	Very High	Stakeholder Team Cohesion	High	Tool Support	Very High
Technology Risk	Low	Personnel/Team Capability	Nominal		

Maintenance Off

System Labor Rates

Cost per Person-Month (Dollars) 10000

Calculate

Figure 72. COSYSMO Inputs for ME-RBS

B. RESULTS

With the assumptions defined, the data was entered into the COSYSMO program to determine costs. After the calculations, there were three outputs worth noting—effort, schedule, and cost. Effort is the estimated amount of effort required to complete the project. According to Valerdi, effort is measured in person-months, which is “a unit of measure for human effort which usually equals 152 person hours” (Valerdi 2005, 68). Schedule is an approximation of the length of time to complete the project, and is measured in months. Cost, measured in dollars, is the estimate of the cost of the project. With this information, COSYSMO provides insight into the complexity and involvement of the project as a whole.

1. OSRAP

Figure 73 shows the assumed COSYSMO results for the OSRAP system modifications.

Results

Systems Engineering

Effort =48.4 Person-months

Schedule = 5.4 Months

Cost = \$483693

Total Size =220 Equivalent Nominal Requirements

Acquisition Effort Distribution (Person-Months)

Phase / Activity	Conceptualize	Develop	Operational Test and Evaluation	Transition to Operation
Acquisition and Supply	0.9	1.7	0.4	0.3
Technical Management	1.8	3.1	2.1	1.2
System Design	4.9	5.8	2.5	1.3
Product Realization	0.9	2.2	2.3	1.8
Product Evaluation	2.7	4.0	6.0	2.2

Your output file is http://csse.usc.edu/tools/data/COSYSMO_January_31_2014_00_00_20_665194.txt

Created by Ray Madachy at the Naval Postgraduate School. For more information contact him at rjmadach@nps.edu

Figure 73. COSYSMO Results for OSRAP

2. ME-RBS

Figure 74 shows the assumed COSYSMO results for the ME-RBS system modifications.

Results

Systems Engineering

Effort =40.8 Person-months

Schedule = 5.1 Months

Cost = \$408304

Total Size =187 Equivalent Nominal Requirements

Acquisition Effort Distribution (Person-Months)

Phase / Activity	Conceptualize	Develop	Operational Test and Evaluation	Transition to Operation
Acquisition and Supply	0.8	1.5	0.4	0.2
Technical Management	1.5	2.6	1.7	1.0
System Design	4.2	4.9	2.1	1.1
Product Realization	0.8	1.8	2.0	1.5
Product Evaluation	2.3	3.4	5.1	1.9

Your output file is http://csse.usc.edu/tools/data/COSYSMO_January_30_2014_23_57_24_691475.txt

Created by Ray Madachy at the Naval Postgraduate School. For more information contact him at rjmadach@nps.edu

Figure 74. COSYSMO Results for ME-RBS

3. SCMM System (Full Development)

Figure 75 shows the assumed COSYSMO results for the SCMM system full development.

Results

Systems Engineering

Effort = 209.9 Person-months

Schedule = 8.8 Months

Cost = \$2099281

Total Size = 386 Equivalent Nominal Requirements

Acquisition Effort Distribution (Person-Months)

Phase / Activity	Conceptualize	Develop	Operational Test and Evaluation	Transition to Operation
Acquisition and Supply	4.1	7.5	1.9	1.2
Technical Management	7.9	13.6	8.9	5.4
System Design	21.4	25.2	10.7	5.7
Product Realization	4.1	9.4	10.1	7.9
Product Evaluation	11.7	17.6	26.0	9.8

Your output file is http://csse.usc.edu/tools/data/COSYSMO_January_31_2014_00_02_25_740854.txt

Created by Ray Madachy at the Naval Postgraduate School. For more information contact him at rjmadach@nps.edu

Figure 75. COSYSMO Results for SCMM (Full Development)

4. SCMM System (Partial Development)

Figure 76 shows the assumed COSYSMO results for the SCMM system (partial development).

Results

Systems Engineering

Effort = 171.6 Person-months

Schedule = 8.2 Months

Cost = \$1715757

Total Size = 302 Equivalent Nominal Requirements

Acquisition Effort Distribution (Person-Months)

Phase / Activity	Conceptualize	Develop	Operational Test and Evaluation	Transition to Operation
Acquisition and Supply	3.4	6.1	1.6	1.0
Technical Management	6.4	11.1	7.3	4.4
System Design	17.5	20.6	8.8	4.6
Product Realization	3.3	7.7	8.2	6.4
Product Evaluation	9.6	14.4	21.3	8.0

Your output file is http://csse.usc.edu/tools/data/COSYSMO_January_31_2014_00_04_16_531057.txt

Created by Ray Madachy at the Naval Postgraduate School. For more information contact him at rjmadach@nps.edu

Figure 76. COSYSMO Results for SCMM (Partial Development)

5. Effort

ME-RBS requires the least amount of effort per person-month based on the assumed COSYSMO output for effort, as shown in Figure 77.

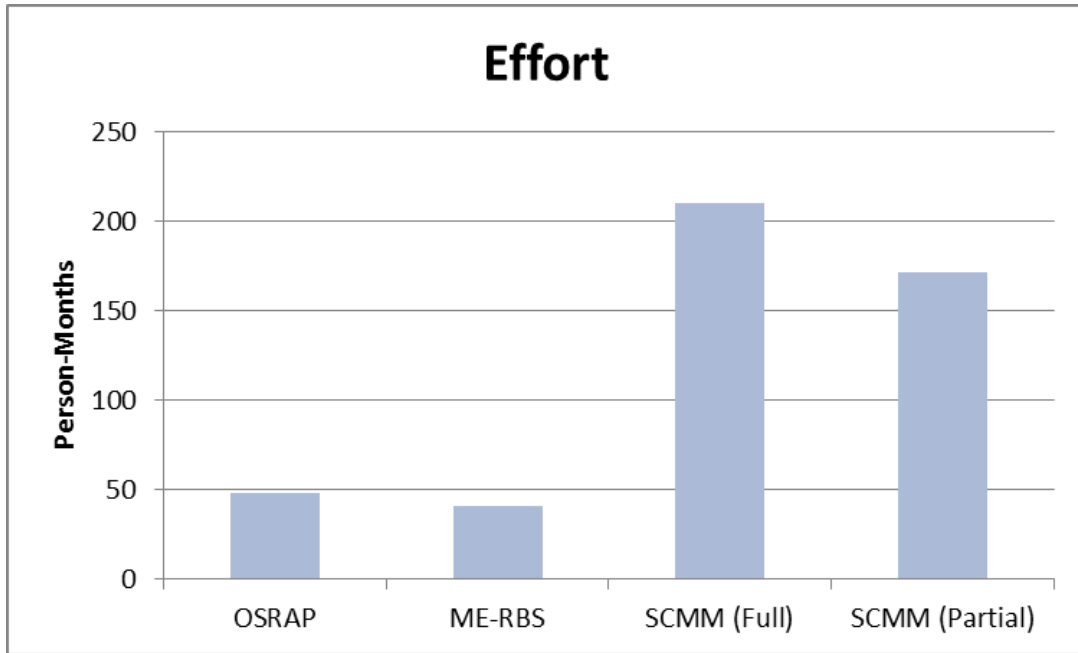

Figure 77. COSYSMO Comparison of Effort (Person-Months)

6. Schedule

ME-RBS has the shortest schedule based on the assumed COSYSMO output for schedule, as shown in Figure 78.

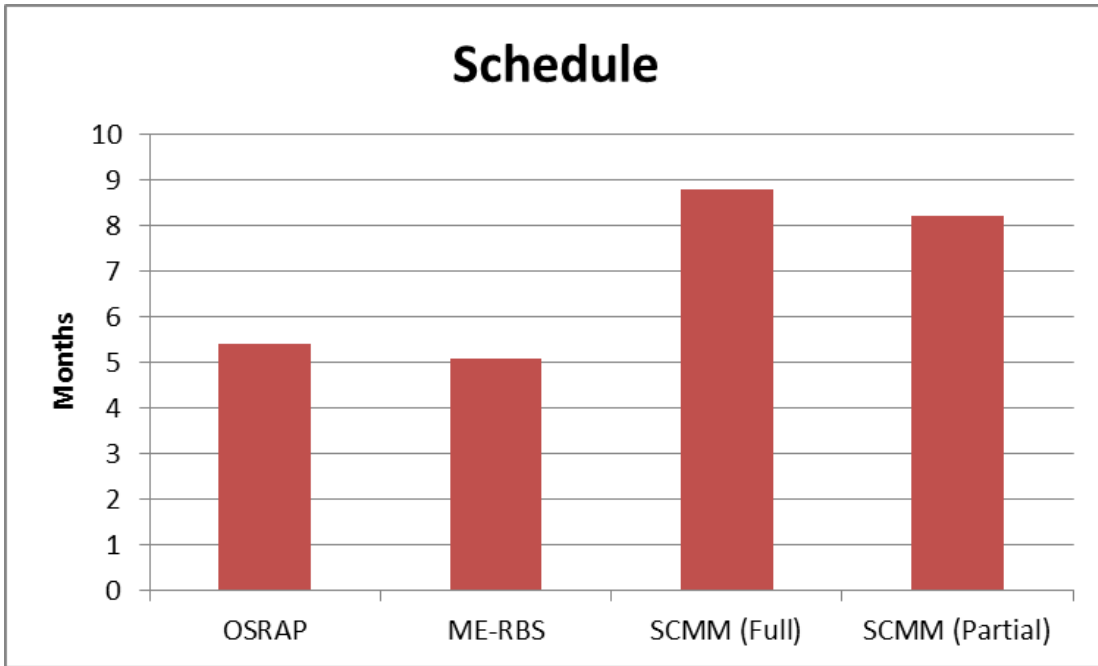

Figure 78. COSYSMO Comparison of Schedule(months)

7. Cost

ME-RBS is the least costly based on the assumed COSYSMO output for cost, as shown in Figure 79.

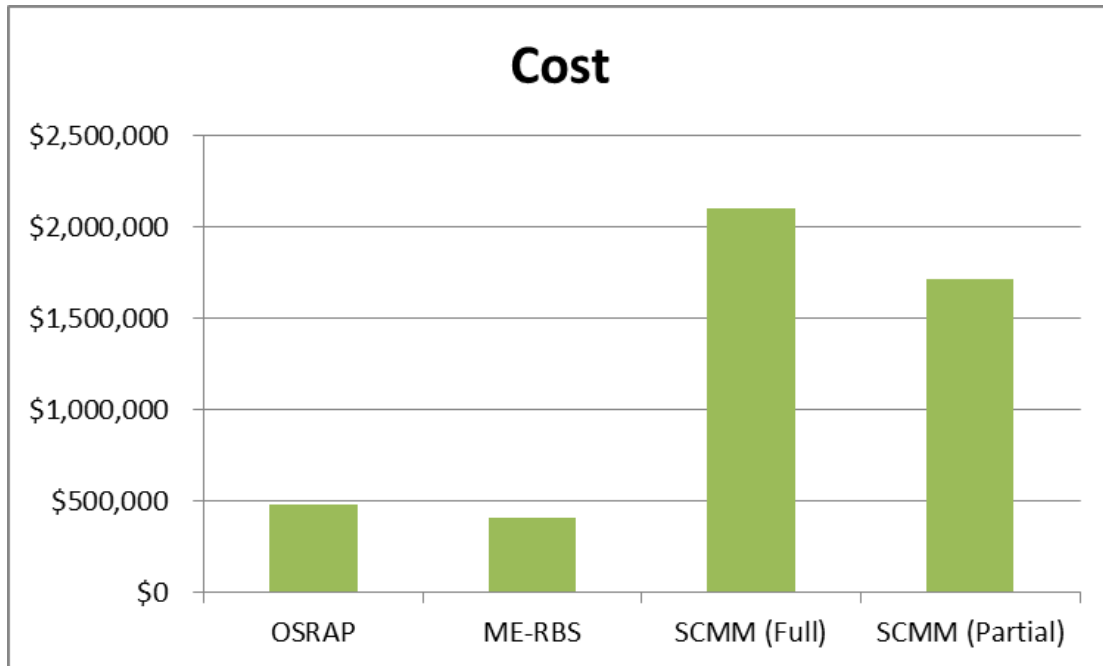

Figure 79. COSYSMO Comparison of Cost

C. RESULTS OF THE COST ANALYSIS

Based on the team’s assumptions the cost, effort, and time to implement OSRAP or ME-RBS would be much lower than implementing the SCMM options, as either full or partial development. The factors used in COSYSMO should be reevaluated as additional data is collected. COSYSMO can also be used to perform sensitivity analysis using pertinent factors as trade-offs.

D. SUMMARY

To fully compare and evaluate the alternatives to the SCMM system, cost analysis was conducted using COSYSMO. Four alternatives were compared; these included OSRAP, ME-RBS, SCMM complete construction and SCMM built-up from ME-RBS. Multiple factors were used to determine costs. Due to the limitation of information regarding the alternatives, several of the factors were based on comparative assumptions. Based on the results of the cost analysis, the time, effort, and cost required to implement OSRAP or ME-RBS proved to be lower than implementing the SCMM option. The

results from the cost analysis provided an additional layer of assessment and review, which in turn, enforced and validated the final results of the capstone project.

THIS PAGE INTENTIONALLY LEFT BLANK

IX. RISK ANALYSIS

Blanchard and Fabrycky state that risk is "...inherent in any formal program activity" (2011, 690), and that it is "...the potential that something will go wrong as a result of one or a series of events" (2011, 690). As such, "...a critical activity in the management of a systems engineering program is the establishment of a risk management capability and the development of a risk management plan" (Blanchard and Fabrycky 2011, 693). Risk management addresses the processes for identifying, assessing, mitigating, and monitoring the risks expected or encountered during a project's life cycle (Department of Defense 2006). One of key activities in risk management is the analysis of the identified risks. The goal of risk analysis, according to Blanchard and Fabrycky, is to "...determine the way(s) in which the risk can be eliminated or minimized if not eliminated altogether" (2011, 692).

Additional details on the risk management approach utilized by the team can be found in the SEMP (for a copy please contact Mr. Raymond Chun at Raymond.Chun@navy.mil) and in the appendix titled Supply Chain Management Model Risk Management Plan.

A. RISK ANALYSIS PROCESS

When identifying risks in the capstone project, the team categorized them into three areas: program management risk, technical risk and overall program risk. Program management risks are those risks related to the team's progress on programmatic goals and objectives which took into account the team's project master schedule, stakeholder expectations, and any other metrics within program management. Technical risk related to the team's progress on the technical goals and objectives and again took into account the team's project master schedule, stakeholder expectations, and any other metrics within technical execution of the capstone project. Overall program risks included risks associated with implementation, operation, and retirement of the system.

Each program management, technical, and overall program risk was further classified as either a system risk or project risk. A system risk is directly related to the

technical aspects of the system; while a project risk is directly related to the team's ability to complete the capstone project. Two examples of the project risks that were identified by the team included issues like balancing the workload between the capstone and the other classes taken concurrently, and working around team member absences.

The system risks identified were: interoperability risk, operational risk, classified information sharing, implementation risk and retirement risk. Interoperability risk focused on the risk of the supply chain management system not being compatible with current and future Navy software systems that it must interact with, such as Navy ERP, CDMD-OA, Navy Marine Corps Intranet (NMCI), etc. The possible risk of needing information from classified databases was another system risk identified by the team. While developing the supply chain management system requirements and scoping the system, it was determined that the model may need access to information that resides in classified databases, which would be a security concern. Operational risk encompassed the various risks associated with personnel training. Implementation risk incorporated the different risks with implementing a supply chain management system such as unrealistic user expectations or application complexity. Retirement risk comprised risks associated with retiring a system at the end of its life cycle. Once risks were identified, the team's risk management plan was utilized to analyze, mitigate, and monitor these risks.

B. RISK MITIGATION

Risk mitigation is defined in the *Risk Management Guide for DOD Acquisition*, the sixth edition as “the activity that identifies, evaluates and selects the best option to set a risk at an acceptable level, based on project objectives and constraints” (Department of Defense 2006, 33). Once a risk has been identified, four tools are used to evaluate and treat the risk: avoid, assume, control or transfer. Avoiding risk entails utilizing an approach to “eliminate the root cause and/or consequence of the risk,” therefore avoiding the risk (Department of Defense 2006, 18). The concern about the “classified information sharing risk” (accessing classified information via the Secret Internet Protocol Router Network [SIPRNET]) was avoided by determining whether the classified data was really required for the SCMM system, and if so, whether it could be entered as an unclassified

user input rather than having the information pushed from the classified databases. It was confirmed that the information was required but that the users could enter it as an unclassified input; therefore, the risk was avoided by not connecting the SCMM system to a classified database. If a risk can't be avoided then it becomes an assumed risk that will have to be monitored. Another tool used in risk mitigation is controlling the risk. This tool examines the root cause or consequence of a risk and uses mitigation techniques to reduce the risk to an acceptable level (Department of Defense 2006). Transferring risk transfers mitigation of the risk to another organization or entity. The team utilized these tools as applicable in mitigating the risks identified by the team as the project progressed. As risks were successfully mitigated, they were retired from being actively tracked / monitored by the team.

When it came to mitigating risks in the capstone project, the team reviewed the identified system risks documented in the team's Risk Management Spreadsheet and then identified different mitigation strategies that could be used to either minimize or eliminate the risks. Table 12 shows the team's Risk Management Spreadsheet for the SCMM system risks, which details the active system risks that the team was tracking and their associated mitigation strategies. Since the team avoided the "classified information sharing" risk, which was system risk #2, it is not listed in the table. The project risk portion of the Risk Management Spreadsheet can be found in the Supply Chain Management Model Risk Management Plan appendix.

Risk Management Status—System Risks					
Risk No.	Risk Area	Narrative	Likelihood	Consequence	Mitigation Strategy
1	Technical Risk	Interoperability with other systems	4	5	With other databases and software systems: Check software interfaces in the design phase rather than waiting until integration testing
3	Overall Program Risk	Retirement Risk	2	1	Retiring the system cannot be mitigated.

Risk Management Status—System Risks					
Risk No.	Risk Area	Narrative	Likelihood	Consequence	Mitigation Strategy
4	Technical Risk	Operational Risks	2	3	Training plan will be developed and tracked to identify required training.
5	Overall Program Risk	Implementation Risks	3	3	1) Unrealistic user expectations: To gain sponsor acceptance, we met several times to discuss implementation approach 2) Application complexity: The process model was monitored throughout the development phase to ensure it was working.

Table 12. Risk Management Spreadsheet for System Risk

The risk management spreadsheet recorded the type of risk, the specific risk/narrative, as well as the likelihood, consequence and risk mitigation strategy for each risk. The mitigation strategies for the system risks are tailored to each individual risk. Mitigating the interoperability risks will focus on examining the software interfaces that the system will have with the different databases from which it will be receiving information. In order to control this risk, a future team should check software interfaces in the design phase rather than waiting until integration testing, to ensure interoperability and reduce costs. The retirement risk is minimal; therefore, there is no mitigation plan for this risk. The operational risks mitigation strategy will be to develop a training plan based on the training requirements for users to operate the system. The final system risk the team identified was implementation risks. One of these risks was unrealistic user expectations. This can be mitigated by consistently meeting with the sponsor to ensure the team’s efforts stay on track and meet with the sponsor’s approval. The complexity of

the system application is another implementation risk. It can be mitigated by continuously monitoring the process model throughout the development process to ensure the final product is user-friendly.

C. RISK ANALYSIS OF ALTERNATIVES

The four alternatives evaluated in the cost analysis, OSRAP, ME-RBS, SCMM (full), and SCMM (partial), were assessed for system risks. A risk analysis was conducted for interoperability, operational, implementation, and retirement risks. Interoperability regards the system's ability to allow for information exchange with external databases, operational risk is the risk associated with the users' level of comfort with the system (e.g., user interface, ease of use), implementation pertains to the risks associated with the users adopting the system for use, and retirement is concerned with the ease of system disposal.

Using the risk management process, a risk score was assigned to each of the alternative systems based on the information obtained from the AoA and the cost analysis and how that information related to the system risks contained in the risk tracking spreadsheet. The risk scores were then plotted in a risk matrix for each alternative. The risk matrices depict the likelihood and consequence of the risks identified for each alternative. The level of risk was reported as low (green), moderate (yellow), or high (red). Figures 80–82 display the results of the risk assessment for the various systems.

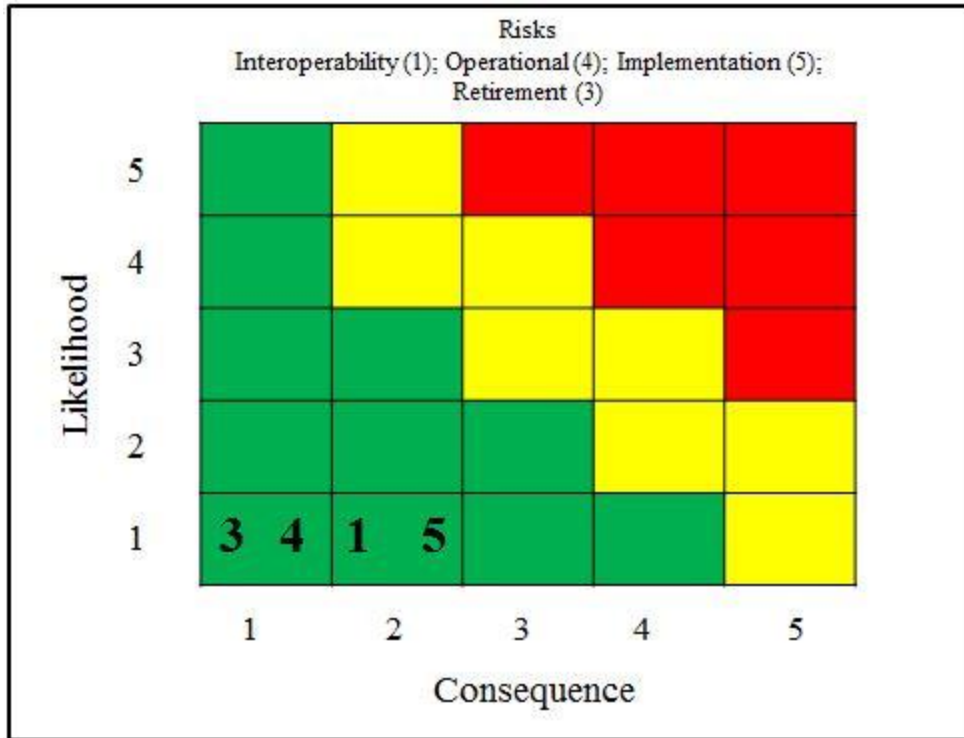

Figure 80. OSRAP and ME-RBS System Risk Matrix

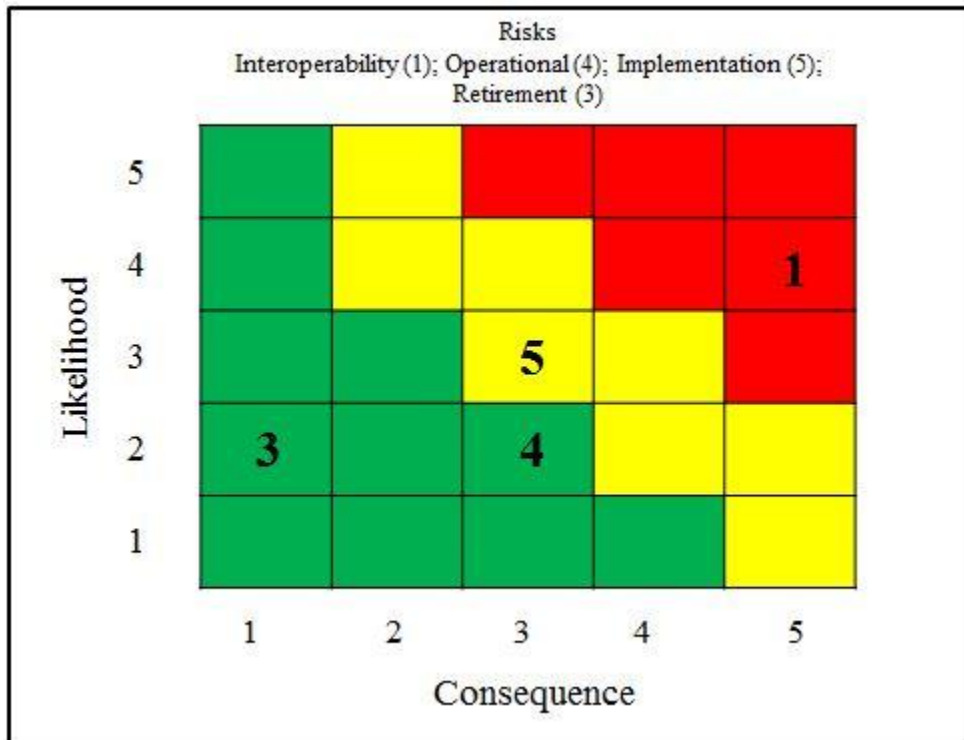

Figure 81. SCMM (Full) System Risk Matrix

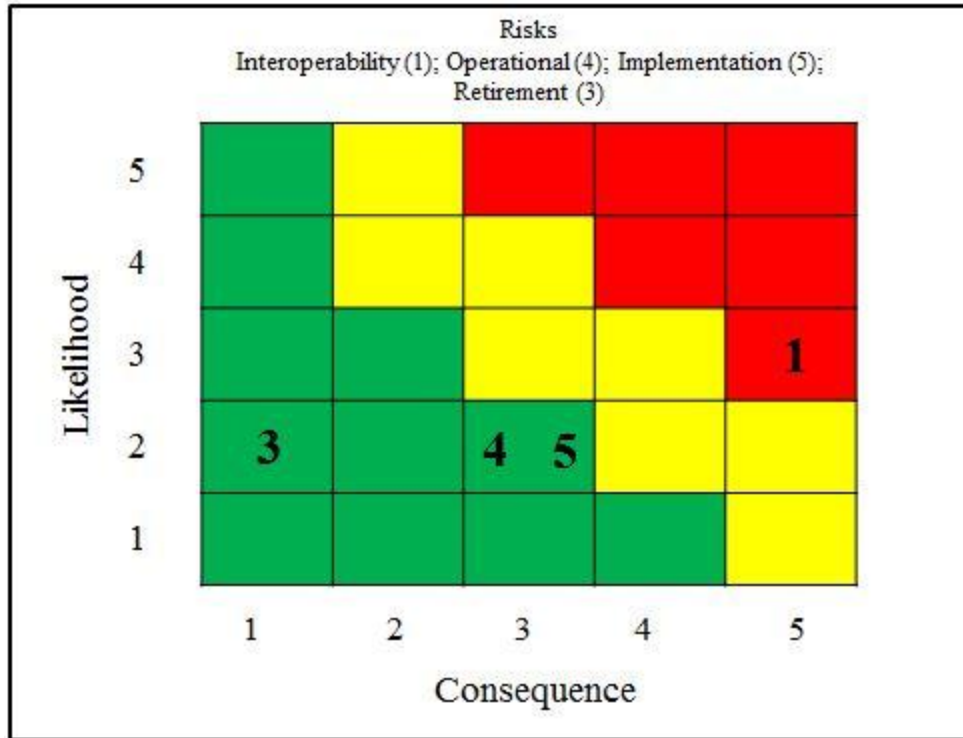

Figure 82. SCMM (Partial) System Risk Matrix

Modification of OSRAP and ME-RBS present the lowest risk overall because these systems are currently in the operational life cycle phase. Designing a completely new SCMM system (SCMM [full]) has the highest likelihood and consequence for all identified risks. The SCMM (partial), which entails modification of the existing ME-RBS model and makes it a standalone SCMM system, has lower interoperability and implementation risks than the SCMM (full), due to the opportunity to leverage off an existing system.

D. SUMMARY

Risk management was conducted early in the systems life-cycle and continued throughout the project. This iterative process included risk identification, risk assessment, risk mitigation, and risk reporting. Strategies such as avoid, assume, control or transfer, were implemented to mitigate the effects of the risks.

A risk analysis based on the information from the AoA and cost analyses was conducted on four alternatives. The risk analysis included the system risks for

interoperability, operation, implementation, and retirement. The results of the analysis were captured on risk matrices, which show that OSRAP and ME-RBS have lower risk scores than SCMM (full) and SCMM (partial).

Through successful risk management the likelihood and consequence of some of the identified risks were reduced. Results of the risk analysis were updated periodically and reported to the team. Risk management is an ongoing activity that should continue throughout the life of the project.

X. CONCLUSION

A. SYNOPSIS

This project began with the sponsor's (Mr. Howard of NSWC PHD) initial problem statement: *Current surface Navy supply chain models do not support a modular architecture and an off ship maintenance support structure requiring multiple logistics and repair nodes to reflect optimal manning or constrained physical and weight constrained supply points. As part of acquisition strategies, an increasing number of ships are looking at a modular or flexible design to support rapid introduction of capability. As part of this capability, a process and approach for optimizing the spares allocation at the war fighters' level and to support maintenance nodes is required.*

Team RSRP conducted a literature review of available published materials to research and substantiate the challenges of the current supply chain and to identify relevant terms included in the problem statement. The team then developed questions to focus the research to areas related to modular or flexible design ships. The research questions were posed in subsequent interviews to the sponsor to understand the organizations that are involved with ship sustainment operations and would be affected by the development of a new SCM model supporting modular ship classes. Through an iterative process of interviews with the sponsor and topic research, the final problem statement was defined: *As the U.S. Navy drives toward modular and flexible designs, the currently used surface Navy SCM models do not support modular or flexible design ships. These ships require an off-ship maintenance support structure consisting of multiple logistics and repair nodes due to shipboard constraints including manning, space, and weight.*

The project team finalized the identification of the relevant stakeholders for the SCMM system and established the individual stakeholder needs for the system. The finalized effective need statement is: *The stakeholders need information to determine sparing of parts at existing and multiple supply points in order to support the Navy's*

modular/flexible ships within the constraints of manning, space, weight, location, and cost/budget.

The gap, which is the difference between the current state of the system and how the stakeholder needs the system to perform and operate, was identified as: *The systems/programs currently in use for determining spare parts allocations do not provide information that takes into account the ability to modify ships rapidly to introduce warfare specific capability through the use of mission modules nor do they take into account shipboard constraints including manning, space, and weight which impact ships' and fleet's readiness and operational availability.*

To develop the SCMM system, a suitable SEP was determined for the project. The team tailored the vee SEP to reflect the unique needs of the SCMM system development. This tailored vee included the following main developmental process phases: needs analysis, system requirements, system architecture, conceptual design, modeling and simulation, system integration and test, component verification, system analysis, and system validation.

The research conducted following the vee SEP confirms the need for the SCMM system. The project's outputs provide a basis for continuation of system development. The outputs include a use case based on operational scenarios, FFBDs, HBDs, a matrix allocating the inputs and outputs to functions, an ICOM/IDEF0 diagram, a context diagram, system requirements (including functional requirements), an N-squared diagram, DODAF views (CV, OVs, and SVs), recommended existing alternatives suitable for adaptation to meet the SCMM system's requirements, simulations of the SCMM system, a test strategy and plan, cost analysis information, and a risk management plan.

B. RESULTS

Based on the analyses conducted during the SEP, the team concluded that the Multi-Echelon Readiness Based Sparing (ME-RBS) system is the best alternative suitable for adaptation to support the stakeholders' needs and requirements. This model requires additional research to determine whether modification is viable in terms of design and

cost. Another option is the development of a new system rather than adaptation of an existing system. This option would be preferred if the ME-RBS system's design could not be altered and/or if the cost was above that of new system development. Initial cost analysis, based on assumptions, and risk analysis indicate that adapting the ME-RBS system would be less costly and have lower risk than constructing a new system.

C. RECOMMENDATIONS

The team recommends that research and analysis continue in support of the development of the SCMM system, whether it is the alteration of the ME-RBS system or the creation of a new system, to meet the identified stakeholders' needs. Additional recommendations include:

- Continue developing the functional performance requirements and system requirements.
- Continue decomposing the functions.
- Develop additional architectural views such as the OV-3 (operational resource flows exchanged between operational activities and locations) and OV-4 (shows organizational structures and interactions).
- Verify performance characteristics.
- Identify design issues.
- Conduct trade-off studies, including readiness and maturity of the system design.
- Finalize component selection.
- Conduct component verification through an effective combination of analysis, inspection, demonstration, and testing that gauges the maturity of each component of the design (i.e., software (S/W) and supportability) prior to integrating the overall system design solution.
- Continue system validation throughout the design of the SCMM system by performing progressive and iterative integrated system testing to validate the maturity of the system and assess overall system readiness.
- Reevaluate the factors used in COSYSMO as additional data is collected.
- Perform sensitivity analysis with COSYSMO using pertinent factors as trade-offs.
- Mitigate the interoperability risks by examining the software interfaces that the system will have with the different databases from which it will be receiving information.

- Mitigate the operational risks by developing a training plan based on the training requirements for users to operate the system.
- Mitigate implementation risks such as unrealistic user expectations and, system complexity.

If the recommendation to continue with the development of the SCMM system is not pursued, the Navy's modular or flexible ships will not be supported within the constraints of manning, space, weight, location, and cost/budget by the current RBS models in use. The impact would be a decrease in ships' and fleet's readiness and operational availability.

It is hoped that additional research supports further development and that analyses are conducted in support of finalizing the design of this SCMM system.

APPENDIX A. FUNCTIONAL FLOW BLOCK DIAGRAM

The FFBD is a very large plottable diagram that has been cut into sections here to allow readers to print and assemble for better viewing purposes, if so desired. See Figures 83–86.

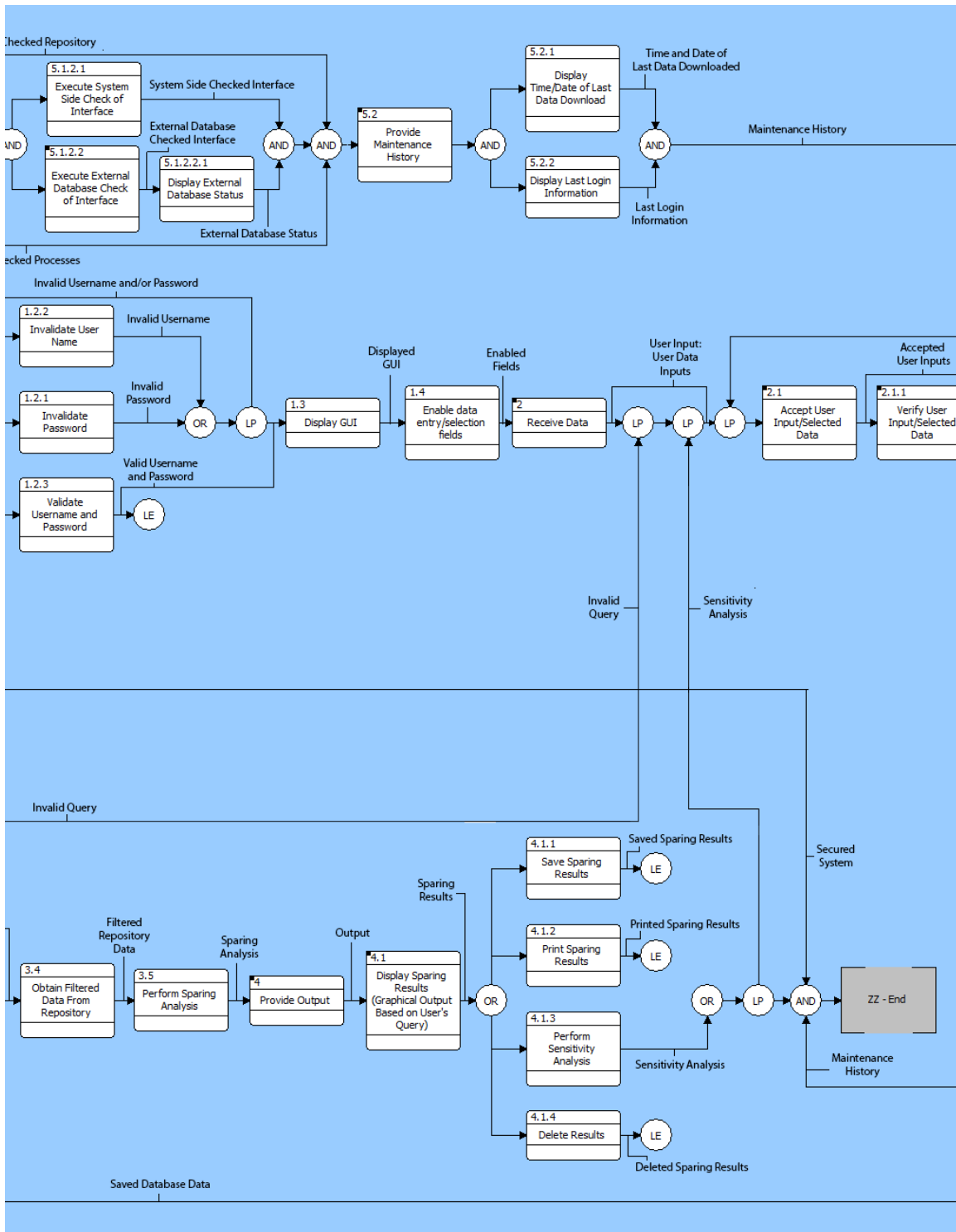

Figure 84. SCMM System FFBD Section B

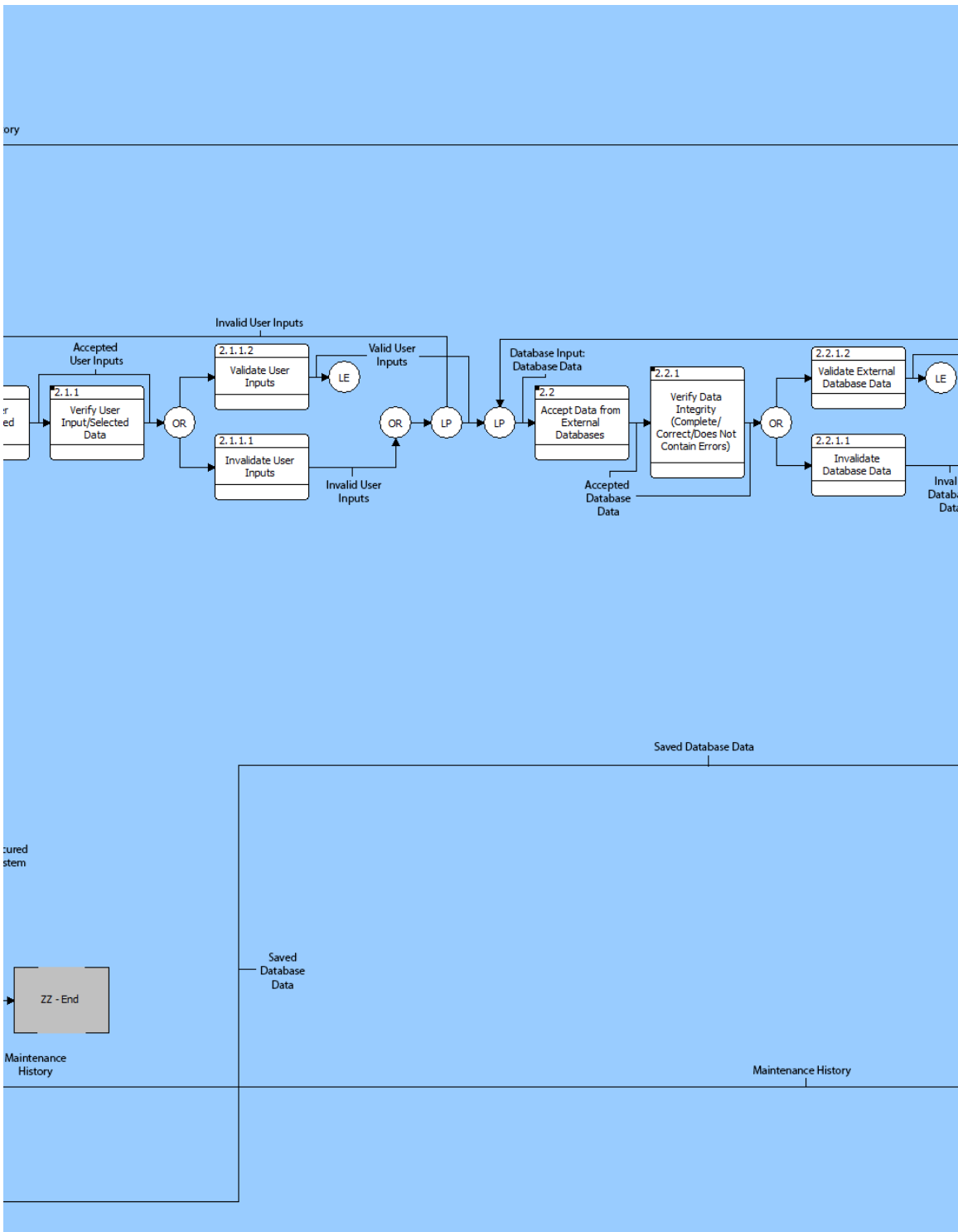

Figure 85. SCMM System FFBD Section C

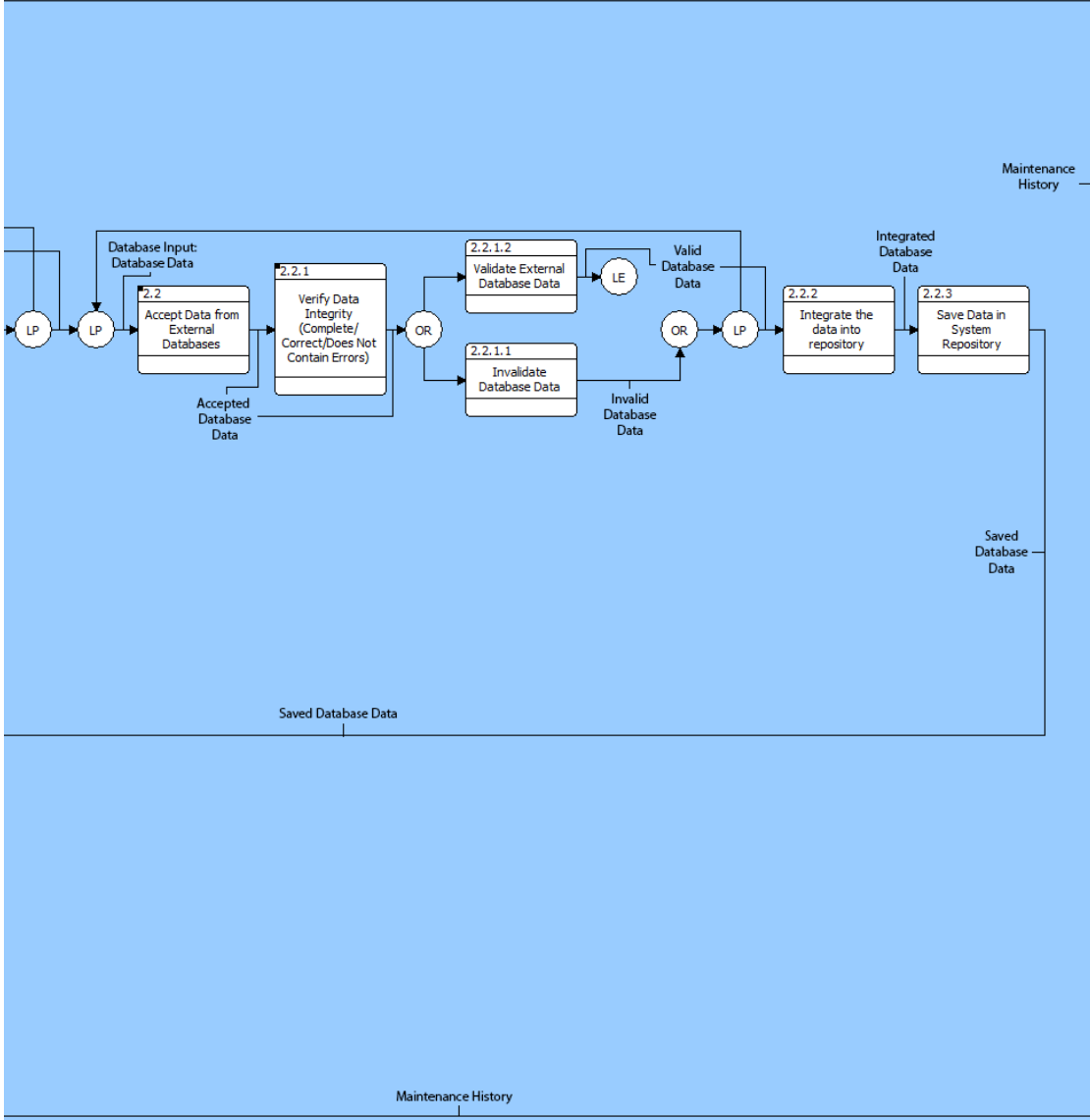

Figure 86. SCMM System Section D

THIS PAGE INTENTIONALLY LEFT BLANK

APPENDIX B. ADDITIONAL DODAF VIEWS INFORMATION

The OV-2 shown in the DODAF Views section of the System Architecture chapter helped to place the SCMM system in an operational context depicting the required resources from each entity. It also helped to ensure that the flow of resources was sound and that the necessary resources were accounted for. The specific organizational resource flows are captured in a matrix that can be viewed in Table 13.

Organization (Component) Name	Resource Link
ERP	ERP Parts Information
Failure Reporting System	Failure Rate/MTBF
Homeports	Parts from DLA to Homeports
	Parts from ISEA to Homeports
	Parts from MPSF to Homeports
	Parts from NAVSUP to Homeports
NDE: AMPS	Planned changes to mission module's configuration/dates for changes
	Planned changes to ship's configuration/dates for changes
NDE: CDMD-OA	Ship/Mission Module Configuration
	CDMD-OA Parts Information
OCONUS Warehouses	Parts from DLA to OCONUS Warehouses
	Parts from ISEA to OCONUS Warehouses
	Parts from MPSF to OCONUS Warehouses
	Parts from NAVSUP to OCONUS Warehouses
Ships	Parts from DLA to Ships
	Parts from ISEA to Ships
	Parts from MPSF to Ships
	Parts from NAVSUP to Ships
Shore-based Maintenance Facilities	Parts from DLA to Shore-based Maintenance Facilities
	Parts from ISEA to Shore-based Maintenance Facilities
	Parts from MPSF to Shore-based Maintenance Facilities
	Parts from NAVSUP to Shore-based Maintenance Facilities
Supply Chain Management	CDMD-OA Parts Information
	DLA Query Inputs

Organization (Component) Name	Resource Link
Model	ERP Parts Information
	Failure Rate/MTBF
	ISEA Query Inputs
	MPSF Query Inputs
	NAVSUP Query Inputs
	Parts Allocation Information to DLA
	Parts Allocation Information to ISEA
	Parts Allocation Information to MPSF
	Parts Allocation Information to NAVSUP
	Planned changes to mission module's configuration/dates for changes
	Planned changes to ship's configuration/dates for changes
	Sensitivity Analysis Information to DLA
	Sensitivity Analysis Information to ISEA
	Sensitivity Analysis Information to MPSF
	Sensitivity Analysis Information to NAVSUP
Ship/Mission Module Configuration	
User: DLA	DLA Query Inputs
	Parts Allocation Information to DLA
	Parts from DLA to Homeports
	Parts from DLA to OCONUS Warehouses
	Parts from DLA to Ships
	Parts from DLA to Shore-based Maintenance Facilities
	Sensitivity Analysis Information to DLA
User: ISEA	ISEA Query Inputs
	Parts Allocation Information to ISEA
	Parts from ISEA to Homeports
	Parts from ISEA to OCONUS Warehouses
	Parts from ISEA to Ships
	Parts from ISEA to Shore-based Maintenance Facilities
	Sensitivity Analysis Information to ISEA
User: MPSF	MPSF Query Inputs
	Parts Allocation Information to MPSF
	Parts from MPSF to Homeports
	Parts from MPSF to OCONUS Warehouses
	Parts from MPSF to Ships

Organization (Component) Name	Resource Link
	Parts from MPSF to Shore-based Maintenance Facilities
	Sensitivity Analysis Information to MPSF
User: NAVSUP	NAVSUP Query Inputs
	Parts Allocation Information to NAVSUP
	Parts from NAVSUP to Homeports
	Parts from NAVSUP to OCONUS Warehouses
	Parts from NAVSUP to Ships
	Parts from NAVSUP to Shore-based Maintenance Facilities
	Sensitivity Analysis Information to NAVSUP

Table 13. SCMM System Organizational Resources Linkage Matrix depicted by
OV-2

THIS PAGE INTENTIONALLY LEFT BLANK

APPENDIX C. ANALYSIS OF ALTERNATIVES SCORING MATRIX

Figure 87 displays the AoA scoring matrix. Each of the 23 models was evaluated against each criterion using a score between zero to five. A model that completely met the criteria was assigned a score of five. A zero score meant the model did not include that criterion. The resultant score under each criterion was then multiplied by its corresponding weight. The final scoring was the summation of the weight-times-score for each criterion. The objective of this analysis was to select the highest performing existing system alternatives. An alternative that completely met all six criteria will have a final score of 5. The highest remaining alternatives would be further analyzed and researched in order to recommend use of, modification to, or new development of a model to meet the requirements of the stakeholders.

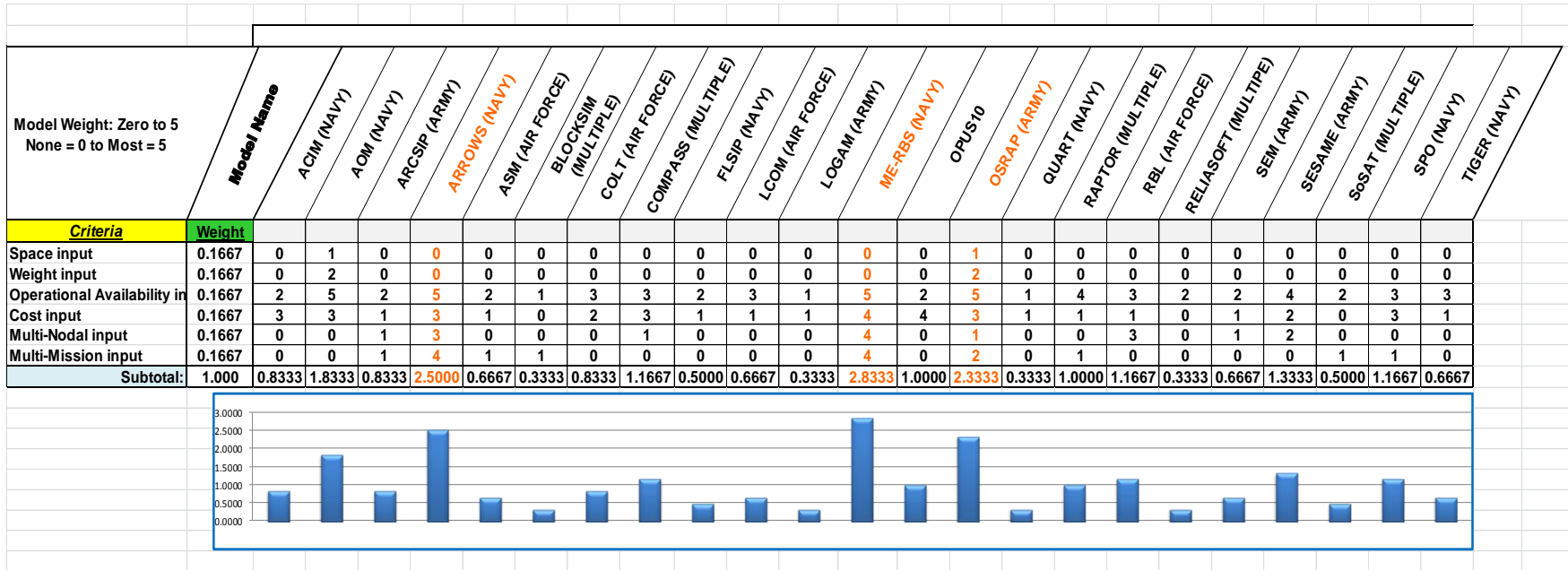

Figure 87. Analysis of Alternatives Scoring Matrix

APPENDIX D. EXCEL SIMULATION MACRO

An Excel simulation was created to emulate the input data, processing, and output report that was expected of the system. A macro was developed to delete data that was not applicable to the user's input. Excel consolidated data that was coming from two sample databases. Once the data was consolidated the Excel file automatically applied the sort and rank with highest criticality and lowest MTBF. However, this still included all the data, even the data that was not applicable to the user's inputs. In order to delete the data that was not applicable to the user's needs, the example code of " =IF('User Input'!\$A\$1='Total Database'!\$I\$2,IF('User Input'!\$A\$2='Total Database'!\$H\$2,'Total Database'!B2,0),0) was used to create a line of "0"s in the non-applicable lines of data. The "0" lines were deleted and the resulting data was placed in the "Output Report" tab. This was accomplished with the following macro:

```
Sub Macro2()  
    '  
    ' Macro2 Macro  
    '  
    '  
    Sheets("Total Database 2").Select  
    Columns("A:I").Select  
    Selection.Copy  
    Sheets("Output Report").Select  
    Columns("A:I").Select  
    ActiveSheet.Paste  
    Range("J5").Select  
    Application.CutCopyMode = False
```

```
Selection.Delete Shift:=xlUp
Range("M23").Select
ActiveWindow.ScrollRow = 9
ActiveWindow.ScrollRow = 8
ActiveWindow.ScrollRow = 7
ActiveWindow.ScrollRow = 6
ActiveWindow.ScrollRow = 5
ActiveWindow.ScrollRow = 4
ActiveWindow.ScrollRow = 3
ActiveWindow.ScrollRow = 2
ActiveWindow.ScrollRow = 1
Range("G22").Select
Dim lr As Long, i As Long
lr = Range("A1").End(xlDown).Row

For i = lr To 1 Step -1
    If Cells(lr, 1).Value = "0" Then
        Cells(lr, 1).EntireRow.Delete
    End If
    lr = lr - 1
Next i
End Sub
```

APPENDIX E. ADDITIONAL AND EXPANDED TEST DOCUMENTATION

This appendix contains the test and measures metrics table, test results report, and the configuration control / change management spreadsheets used and produced during the system integration and test phase.

A. TEST MEASURES AND METRICS TABLE

The defined functional and nonfunctional requirements of the SCMM system were tested. Each of the identified requirements was determined to be testable or not testable, and then was incorporated into a testing schema. This became the test plan and includes the test approach used for each requirement. The test measures and metrics for the simulation of the SCMM system are listed in Table 14. The table includes the test approach used for each requirement to be tested.

	Requirement	Description	Testing Approach
1	SCMM System Function	The system shall provide the user with information on parts allocation.	Sub-requirements will be tested.
1.1	Receive Input	The system shall receive user input.	Sub-requirements will be tested.
1.1.1	Ship Hull Number	The system shall receive ship hull number.	Test to verify SCMM receives the ship hull number. Can be visual confirmation.
1.1.2	Ship Seaframe System	The system shall receive ship's seaframe system(s).	Test to verify SCMM receives the ship's seaframe system. Can be visual confirmation. Multiple seaframes must be able to be entered.
1.1.3	Ship Mission Module System	The system shall receive ship's mission module(s).	Test to verify SCMM receives the ship mission module. Can be visual confirmation. Multiple mission modules must be able to be entered.

	Requirement	Description	Testing Approach
1.1.4	Ship's Dimensions/Available Space	The system shall receive ship's available space and dimensions allowance.	Test to verify SCMM receives the ship's available space and dimension allowance. Can be visual confirmation.
1.1.5	Ship's Available Weight Allowance	The system shall receive ship's available weight allowance for parts.	Test to verify SCMM receives the ship's available weight allowance for parts. Can be visual confirmation.
1.1.6	Ship's Availability Requirement	The system shall receive ship's availability requirement.	Test to verify SCMM receives the ship's availability requirement. Can be visual confirmation.
1.2	Provide Output	The system shall provide a report of the output.	Test to verify SCMM outputs report. Report may be a separate file or screenshot. Can be visual confirmation.
1.2.1	Ship Spare Allocation Model	The system shall provide a report detailing spares allocation on ship.	Test and verify SCMM report displays spares allocation on ship.
1.2.2	Mission Module Container Spare Allocation Model	The system shall provide a report detailing spares allocation in mission module containers.	Test and verify SCMM report spares allocation in mission module containers.
1.2.3	Facility Spare Model	The system shall provide a report detailing spares allocation at land-based maintenance facilities.	Test and verify SCMM report displays spares allocation at land-based maintenance facilities.
1.2.4	MPSF Facility Space Allocation Model	The system shall provide a report detailing spares allocation at MPSF facilities.	Test and verify SCMM report displays spares allocation at MPSF facilities.

	Requirement	Description	Testing Approach
1.2.5	Warehouse Spare Model	The system shall provide a report detailing spares allocation at OCONUS warehouse locations.	Test and verify SCMM report displays spares allocation at OCONUS warehouse locations.
1.2.6	Homeport Spare Model	The system shall provide a report detailing homeport spares allocation.	Test and verify SCMM report displays spares allocation at homeport locations.
1.2.7	Display Summary Report Spare Allocation Printout	The system shall provide a report summary of all spare models via hardcopy.	Test and verify SCMM report displays a summary of all spare models.
1.2.8	Display Summary Report Spare Allocation.	The system shall provide a report summary of all spare models via display of the data.	Test and verify SCMM report displays a summary of all spare models.
1.3	Interoperability		Will not be tested.
1.3.1	User	The system shall be interoperable with the systems of the user.	Will not be tested.
1.3.2	NAVSUP	The system shall be interoperable with the system used by NAVSUP WSS.	Will not be tested.
1.3.3	MPSF	The system shall be interoperable with the systems used by maintenance sites.	Will not be tested.
1.3.4	ISEA	The system shall be interoperable with the systems used by ISEA.	Will not be tested.
1.3.5	Enterprise Resource Planning (ERP)	The system shall be interoperable with the One Touch Support (or NAVSUP ERP).	Will not be tested.
1.3.6	AMPS	The system shall be interoperable with AMPS (Afloat Master Planning System).	Will not be tested.

	Requirement	Description	Testing Approach
1.3.7	CDMD-OA	The system shall be interoperable with CDMD-OA.	Will not be tested.
1.4	System Functionality	The system shall be functional.	Sub-requirements will be tested.
1.4.1	Store Data and Output to Excel	The system shall be compatible to store data and output to Excel.	Test and verify SCMM data is saved to a separate Excel file.
1.4.2	User Query Response	The system shall respond to a user's query within xxx seconds.	Test and verify SCMM responds to a user's query within xxx seconds.
1.4.3	Simultaneous Users	The system shall be able to handle xxx simultaneous users.	Test and verify SCMM is able to handle xxx simultaneous users.
1.4.4	Transaction Rate Ability	The system shall be able to handle xxx transactions per minute.	Test and verify SCMM is able to handle xxx transactions per minute.
2	SCMM System Nonfunctional		Sub-requirements will be tested.
2.1	Technology & Suitability Requirements		Will not be tested.
2.1.1	Standards and Protocols	The system shall meet DOD and DoN laws and regulations.	Will not be tested. Requires full DOD and DoN laws and regulations.
2.1.1.1	System Security		Will not be tested.
2.2	Suitability Requirements	The system shall be suitable for the user.	Sub-requirements will be tested.
2.2.1	Maintainability	The system shall be maintainable.	TBD
2.2.1.1	Software Maintainability	The system shall be able to receive software patches as required.	TBD

	Requirement	Description	Testing Approach
2.2.2	Reliability	The system shall be reliable with a MTBF of xxxxxxxx hours.	TBD
2.2.3	Availability	The system shall have an Ao of 90%.	TBD
2.2.4	System Usability: Human Systems Integration (HSI)	TBD	TBD
2.2.5	System Survivability	TBD	TBD
2.2.6	System Testability	TBD	TBD
2.2.7	System Adaptability	TBD	TBD

Table 14. Test Measures and Metrics

B. TEST RESULTS REPORT

The test results report details the results of the level 1 and level 2 testing that was conducted on the SCMM Excel simulation. This testing report provided feedback to the SCMM capstone team on whether the system met the requirements as defined. This feedback included:

- Test Pass/Fail status: Status of all the measures and metrics and whether the tests for such passed or failed were recorded.
- Errors or defects: All errors or defects found during the testing were identified and recorded.
- Diversions from the test scenarios: Any additional diversions or issues discovered were recorded as part of the testing report and summary.

Item pass/fail criteria was based on test scenarios and documented as required. Suspension would only occur if the simulated SCMM system was not ready for testing. Testing would resume upon the availability of the simulated SCMM system. The test results report ensues.

Test Title: SCMM Level 1 and Level 2 Testing for Excel Model
Program File Name: SCMM_Excel_Model_1.0.xlsm
Version Number: 1.0
Date: 03 December 2013
Tester: Team RSRP Member

Estimated Test Time: 30 minutes
 Test & Support Equipment: PC (Desktop or Laptop) capable of running MS Excel
 MS Excel Version 2007 or above.
 Timer
 General Notes: Interoperability requirements are not tested per Test and Verification Plan.

Test Procedure

<u>Step</u>	<u>Instructions</u>	<u>Expected Results</u>	<u>Actual Results</u>	<u>Pass / Fail</u>
1	Test loading of program.	-	-	-
NOTE: Exact process for step 1.1.1 may vary depending on version of MS Excel in use. Ensure Macros are allowed.				
1.1	Open MS Excel program.	-	-	-
1.1.1	Select FILE, then OPEN, then select the location of the file to be tested and the file to be tested.	-	-	-
1.1.2	Verify Excel file loads.	-	-	<u>Pass</u>
2	Testing user inputs.	-	-	-
2.1	Select worksheet "User Input."	-	-	-
2.2	In cell A1, select "LCS 1."	-	-	-
2.3	Verify "LCS 1" is displayed in cell A1.	-	-	<u>Pass</u>
2.4	In cell A1, select "LCS 2."	-	-	-
2.5	Verify "LCS 2" is displayed in cell A1.	-	-	<u>Pass</u>
2.6	In cell A1, select "LCS 3."	-	-	-

<u>Step</u>	<u>Instructions</u>	<u>Expected Results</u>	<u>Actual Results</u>	<u>Pass / Fail</u>
2.7	Verify "LCS 3" is displayed in cell A1.	-	-	<u>Pass</u>
2.8	In cell A2, select "Mine Sweeping."	-	-	-
2.9	Verify "Mine Sweeping" is displayed in cell A2.	-	-	<u>Pass</u>
2.10	In cell A2, select "SUW."	-	-	-
2.11	Verify "SUW" is displayed in cell A2.	-	-	<u>Pass</u>
2.12	In cell A2, select "AAW."	-	-	-
2.13	Verify "AAW" is displayed in cell A2.	-	-	<u>Pass</u>
2.14	In cell A3, select "Pacific."	-	-	-
2.15	Verify "Pacific" is displayed in cell A3.	-	-	<u>Pass</u>
2.16	In cell A3, select "Atlantic."	-	-	-
2.17	Verify "Atlantic" is displayed in cell A3.	-	-	<u>Pass</u>
2.18	In cell A3, select "Indian."	-	-	-
2.20	Verify "Indian" is displayed in cell A3.	-	-	<u>Pass</u>
2.21	In cell A3, select "Arctic."	-	-	-
2.22	Verify "Arctic" is displayed in cell A3.	-	-	<u>Pass</u>
2.23	In cell A4, input "01."	-	-	-
2.24	Verify "1" is displayed in cell A4.	-	-	<u>Pass</u>
2.25	In cell A4, input "123456789."	-	-	-

2.26	Verify “123456789” is displayed in cell A4.	-	-	<u>Pass</u>
2.27	In cell A4, input “a.”	-	-	-
2.28	Verify “a” is displayed in cell A4.	-	-	<u>Pass</u>
3	Test system output.	-	-	-

<u>Step</u>	<u>Instructions</u>	<u>Expected Results</u>	<u>Actual Results</u>	<u>Pass / Fail</u>
3.1	Input/select the following into sheet “User Input:” (Cell A1) Ship: LCS 1 (Cell A2) Mission: Mine Sweeping (Cell A3) Location: Pacific (Cell A4) Mission Length (days): 100	-	-	-
3.2	Select “Generate Report” button.	-	-	-
3.3	Verify sheet changes to “Output Report.”	-	-	<u>Pass</u>
3.4	Verify displayed data for columns A through I.	-	-	<u>Pass</u>
4	Test requirements.	-	-	-
4.1	Test input requirements.	-	-	-
4.1.1	Verify the program allows input of the ship hull number.	-	-	<u>Pass</u>
4.1.2	Verify the program allows input of the ship seaframe system.	-	-	<u>Pass</u>
4.1.3	Verify the program allows the input of multiple ship seaframe systems.	-	-	<u>Fail</u>
4.1.4	Verify the program allows input of the ship missile module systems.	-	-	<u>Pass</u>

4.1.5	Verify the program allows input of multiple ship mission module systems.	-	-	<u>Fail</u>
4.1.6	Verify the program allows input of the ship's dimensions for available space.	-	-	<u>Pass</u>
4.1.7	Verify the program allows input of the ship's available weight allowance.	-	-	<u>Fail</u>
4.1.8	Verify the program allows input of the ship's availability requirement.	-	-	<u>Fail</u>
4.2	Test output requirements.	-	-	-

<u>Step</u>	<u>Instructions</u>	<u>Expected Results</u>	<u>Actual Results</u>	<u>Pass / Fail</u>
4.2.1	Input/select the following into sheet "User Input:" (Cell A1) Ship: LCS 1 (Cell A2) Mission: Mine Sweeping (Cell A3) Location: Pacific (Cell A4) Mission Length (days): 100	-	-	-
4.2.2	Select "Generate Report" button.	-	-	-
4.2.3	Verify program provides a report out of the output data.	-	-	<u>Pass</u>
4.2.4	Verify the output report displays the spares allocation on the ship.	-	-	<u>Pass</u>
4.2.5	Verify the output report displays the spares allocation in the mission modules.	-	-	<u>Fail</u>
4.2.6	Verify the output report displays the spares allocation at land-based maintenance facilities.	-	-	<u>Fail</u>

4.2.7	Verify the output report displays the spares allocation at MPSF facilities.	-	-	<u>Fail</u>
4.2.8	Verify the output report displays the spares allocation at OCONUS warehouse facilities.	-	-	<u>Fail</u>
4.2.9	Verify the output report displays the spares allocation at homeport allocations.	-	-	<u>Fail</u>
4.2.10	Verify the output report displays a summary of all spare models.	-	-	<u>Fail</u>
4.3	Test system functionality requirements.	-	-	-
4.3.1	Input/select the following into sheet "User Input:" (Cell A1) Ship: LCS 1 (Cell A2) Mission: Mine Sweeping (Cell A3) Location: Pacific (Cell A4) Mission Length (days): 100	-	-	-
4.3.2	Select "Generate Report" button and note the time it takes the program to provide a report out of the output data using the timer.	-	-	-

<u>Step</u>	<u>Instructions</u>	<u>Expected Results</u>	<u>Actual Results</u>	<u>Pass / Fail</u>
4.3.3	Verify the program provides a report out of the output data within xxx seconds	xxx seconds	_____	-
4.3.4	Verify the program able to handle xxx simultaneous users.	xxx users	_____	-
4.3.5	Verify the program able to handle xxx transactions per minute.	xxx transactions/min	_____	-

4.3.6	Verify the program save the output report to a separate Excel file.	-	-	<u>Fail</u>
5	Test complete.	-	-	-
5.1	Close program.	-	-	-

Additional Comments, Issues, or Notes:

Step	Comments, Issues, or Notes
	Test Failed
4.1.1–4.1.8	Data can be inputted via the tables in the program, which simulates collected data from sources, versus being able to be inputted by the user. Requirements do not specify.
4.2.5–4.2.10	Current model does not take into consideration other facilities, like MPSF or OCONUS warehouses.
4.3.3–4.3.5	Unable to verify until requirements are further defined.
4.3.6	Able to save Excel file, but not the output report to a separate Excel file.

C. CONFIGURATION MANAGEMENT AND CHANGE CONTROL

Prior to testing, the system simulation was assigned the appropriate change control / revision number. After that point, any changes to the SCMM Excel simulation spreadsheet or SCMM ExtendSim simulation spreadsheet would require a notification of changes and a new revision number. Changes were not made during testing without prior notification and appropriate change control. Figure 88 and Figure 89 display the configuration management change tracking lists for the SCMM Excel simulation and the SCMM ExtendSim simulation, respectively.

APPENDIX F. COSYSMO FACTORS

Table 15 lists the COSYSMO factors and the prime motives for the assumptions. The factor descriptions are from Ricardo Valerdi.

COSYSMO Factor	Factor Description	System	Factor	Description / Assumption
Number of System Requirements	“This driver represents the number of requirements for the system-of-interest at a specific level of design (Valerdi 2005, 77).”	OSRAP	50 Easy, 25 Nominal, 25 Difficult	OSRAP is a mature system that already meets a number of the SCMM system requirements.
		ME-RBS	55 Easy, 30 Nominal, 30 Difficult	ME-RBS is a mature system that already meets a number of the SCMM system requirements.
		SCMM (Full Dev)	100 Easy, 50 Nominal, 50 Difficult	Starting from an initial state with all requirements to complete.
		SCMM (Partial Dev)	75 Easy, 40 Nominal, 40 Difficult	Able to reduce some of the requirements with the use of ME-RBS.
Number of System Interfaces	“This driver represents the number of shared physical and logical boundaries between system components or functions (internal interfaces) and those external to the system (external interfaces)” (Valerdi 2005, 83).”	OSRAP	0 Easy, 3 Nominal, 0 Difficult	Several of the expected system interfaces have already been completed.
		ME-RBS	0 Easy, 3 Nominal, 0 Difficult	Several of the expected system interfaces have already been completed.
		SCMM (Full Dev)	0 Easy, 7 Nominal, 0 Difficult	No system interfaces in place.

COSYSMO Factor	Factor Description	System	Factor	Description / Assumption
		SCMM (Partial Dev)	0 Easy, 5 Nominal, 0 Difficult	Some of the expected system interfaces have already been completed.
Number of System-Specific Algorithms	“This driver represents the number of newly defined or significantly altered functions that require unique mathematical algorithms to be derived in order to achieve the system performance requirements” (Valerdi 2005, 84).	OSRAP	0 Easy, 1 Nominal, 0 Difficult	Several of the expected system-specific algorithms have already been completed.
		ME-RBS	0 Easy, 1 Nominal, 0 Difficult	Several of the expected system-specific algorithms have already been completed.
		SCMM (Full Dev)	0 Easy, 4 Nominal, 0 Difficult	None of system-specific algorithms.
		SCMM (Partial Dev)	0 Easy, 2 Nominal, 0 Difficult	Some of the expected system-specific algorithms have already been completed.
Number of Operation Scenarios	“This driver represents the number of operational scenarios that a system must satisfy” (Valerdi 2005, 89).	OSRAP	0 Easy, 0 Nominal, 0 Difficult	
		ME-RBS	0 Easy, 0 Nominal, 0 Difficult	
		SCMM (Full Dev)	0 Easy, 0 Nominal, 0 Difficult	
		SCMM (Partial Dev)	0 Easy, 0 Nominal, 0 Difficult	
Requirements Understanding	“This cost driver rates the level of understanding of	OSRAP	Nominal	Some undefined areas exist.

COSYSMO Factor	Factor Description	System	Factor	Description / Assumption
	the system requirements by all stakeholders including systems, software, hardware, customers, team members, users, etc.” (Valerdi 2005, 98).	ME-RBS	Nominal	Some undefined areas exist.
		SCMM (Full Dev)	Nominal	Some undefined areas exist.
		SCMM (Partial Dev)	Nominal	Some undefined areas exist.
Architecture Understanding	“This cost driver rates the relative difficulty of determining and managing the system architecture in terms of platforms, standards, components (COTS/GOTS/NDI/new), connectors (protocols), and constraints” (Valerdi 2005, 98).	OSRAP	Nominal	Reasonable understanding of architecture and COTS with some unfamiliar areas.
		ME-RBS	Nominal	Reasonable understanding of architecture and COTS with some unfamiliar areas.
		SCMM (Full Dev)	Nominal	Reasonable understanding of architecture and COTS with some unfamiliar areas.
		SCMM (Partial Dev)	Nominal	Reasonable understanding of architecture and COTS with some unfamiliar areas.
Level of Service Requirements	“This cost driver rates the difficulty and criticality of satisfying the ensemble of level of service requirements, such as security, safety, response time, interoperability, maintainability, Key Performance Parameters (KPPs), the “ilities,” etc.” (Valerdi 2005, 101).	OSRAP	Nominal	Moderately complex level of service requirements.
		ME-RBS	Nominal	Moderately complex level of service requirements.
		SCMM (Full Dev)	Nominal	Moderately complex level of service requirements.

COSYSMO Factor	Factor Description	System	Factor	Description / Assumption
		SCMM (Partial Dev)	Nominal	Moderately complex level of service requirements.
Migration Complexity	“This cost driver rates the extent to which the legacy system affects the migration complexity, if any” (Valerdi 2005, 107).	OSRAP	Very High	Different and outside contractor requiring integration and development.
		ME-RBS	Very High	Different and outside contractor requiring integration and development.
		SCMM (Full Dev)	Nominal	Everything is new without any legacy system in place.
		SCMM (Partial Dev)	High	Some use of development team with some legacy system in place.
Technology Risk	“The maturity, readiness, and obsolescence of the technology being implemented. Immature or obsolescent technology will require more Systems Engineering effort” (Valerdi 2005, 102).	OSRAP	Low	Proven through actual use and available for adoption.
		ME-RBS	Low	Proven through actual use and available for adoption.
		SCMM (Full Dev)	Very High	Still in development.
		SCMM (Partial Dev)	High	Still in development but based on some actual use.
Documentation	The formality and detail of documentation required to be formally delivered based on the life cycle needs of the system (Valerdi 2005, 104).	OSRAP	Nominal	Consistent levels of documentation required.
		ME-RBS	Nominal	Consistent levels of documentation required.
		SCMM (Full Dev)	Nominal	Consistent levels of documentation required.

COSYSMO Factor	Factor Description	System	Factor	Description / Assumption
		SCMM (Partial Dev)	Nominal	Consistent levels of documentation required.
Number of Installs/ Platforms	“The number of different platforms that the system will be hosted and installed on. The complexity in the operating environment (space, sea, land, fixed, mobile, portable, information assurance/security, constraints on size weight, and power)” (Valerdi 2005, 105).	OSRAP	Nominal	Only a single installation and configuration is required.
		ME-RBS	Nominal	Only a single installation and configuration is required.
		SCMM (Full Dev)	Nominal	Only a single installation and configuration is required.
		SCMM (Partial Dev)	Nominal	Only a single installation and configuration is required.
Number of Recursive Levels	“The number of levels of design related to the system-of-interest (as defined by ISO/IEC 15288) and the amount of required SE effort for each level” (Valerdi 2005, 103).	OSRAP	Nominal	Required SE effort is based on more complex interdependencies and tradeoffs.
		ME-RBS	Nominal	Required SE effort is based on more complex interdependencies and tradeoffs.
		SCMM (Full Dev)	Nominal	Required SE effort is based on more complex interdependencies and tradeoffs.
		SCMM (Partial Dev)	Nominal	Required SE effort is based on more complex interdependencies and tradeoffs.
Stakeholder Team Cohesion	“Represents a multi-attribute parameter which includes leadership, shared vision, diversity	OSRAP	High	Well established program with clear rules and responsibilities.

COSYSMO Factor	Factor Description	System	Factor	Description / Assumption
	of stakeholders, approval cycles, group dynamics, Integrated Product Team framework, team dynamics, trust, and amount of change in responsibilities” (Valerdi 2005, 99).	ME-RBS	High	Well established program with clear rules and responsibilities.
		SCMM (Full Dev)	Low	Heterogeneous community with converging organizational objectives.
		SCMM (Partial Dev)	Low	Heterogeneous community with converging organizational objectives.
Personnel / Team Capability	“Composite intellectual capability of a team of Systems Engineers (compared to the national pool of SEs) to analyze complex problems and synthesize solutions” (Valerdi 2005, 107).	OSRAP	Nominal	Standard capability.
		ME-RBS	Nominal	Standard capability.
		SCMM (Full Dev)	Nominal	Standard capability.
		SCMM (Partial Dev)	Nominal	Standard capability.
Personnel Experience/ Continuity	“The applicability and consistency of the staff at the initial stage of the project with respect to the domain, customer, user, technology, tools, etc.” (Valerdi 2005, 100).	OSRAP	High	Several years of experience.
		ME-RBS	High	Several years of experience.
		SCMM (Full Dev)	Low	Few years of experience.
		SCMM (Partial Dev)	Low	Few years of experience.
Process Capability	“The consistency and effectiveness of the project team at performing SE processes” (Valerdi 2005, 108).	OSRAP	Nominal	Standard consistency and effectiveness of team.
		ME-RBS	Nominal	Standard consistency and effectiveness of team.

COSYSMO Factor	Factor Description	System	Factor	Description / Assumption
		SCMM (Full Dev)	Nominal	Standard consistency and effectiveness of team.
		SCMM (Partial Dev)	Nominal	Standard consistency and effectiveness of team.
Multisite Coordination	“Location of stakeholders, team members, resources, corporate collaboration barriers” (Valerdi 2005, 109).	OSRAP	Nominal	Some coordinated teams and resources.
		ME-RBS	Nominal	Some coordinated teams and resources.
		SCMM (Full Dev)	Very High	Coordinated teams and resources.
		SCMM (Partial Dev)	High	Mostly coordinated teams and resources.
Tool Support	“Coverage, integration, and maturity of the tools in the Systems Engineering environment” (Valerdi 2005, 110).	OSRAP	Very High	Strong and mature use of SE tools.
		ME-RBS	Very High	Strong and mature use of SE tools.
		SCMM (Full Dev)	Very High	Strong and mature use of SE tools.
		SCMM (Partial Dev)	Very High	Strong and mature use of SE tools.
System Labor Rates	Cost per Person-Month	OSRAP	\$10,000	Standard Costs
		ME-RBS	\$10,000	Standard Costs
		SCMM (Full Dev)	\$10,000	Standard Costs
		SCMM (Partial Dev)	\$10,000	Standard Costs

Table 15. COSYSMO Factors Defined for the SCMM System

THIS PAGE INTENTIONALLY LEFT BLANK

APPENDIX G. SUPPLY CHAIN MANAGEMENT MODEL RISK MANAGEMENT PLAN

Risk management addresses the processes for identifying, assessing, mitigating, and monitoring the risks expected or encountered during a project's life cycle. The risk management process used by the team was based on the following principles defined in the *Risk Management Guide for DOD Acquisition*, the sixth edition: "risk identification, risk analysis, risk mitigation planning, risk mitigation plan implementation, and risk tracking" (Department of Defense 2006, 4). Risk Management takes a proactive and well-planned role in anticipating problems and responding to them if they occur (Department of Defense 2006). Therefore, when conducting risk management, the goal is to employ a methodology that can be continuously used to identify, analyze, mitigate, and track risk (Department of Defense 2006). The team accomplished this using the process identified in the *Risk Management Guide for DOD Acquisition*, the sixth edition; see Figure 90.

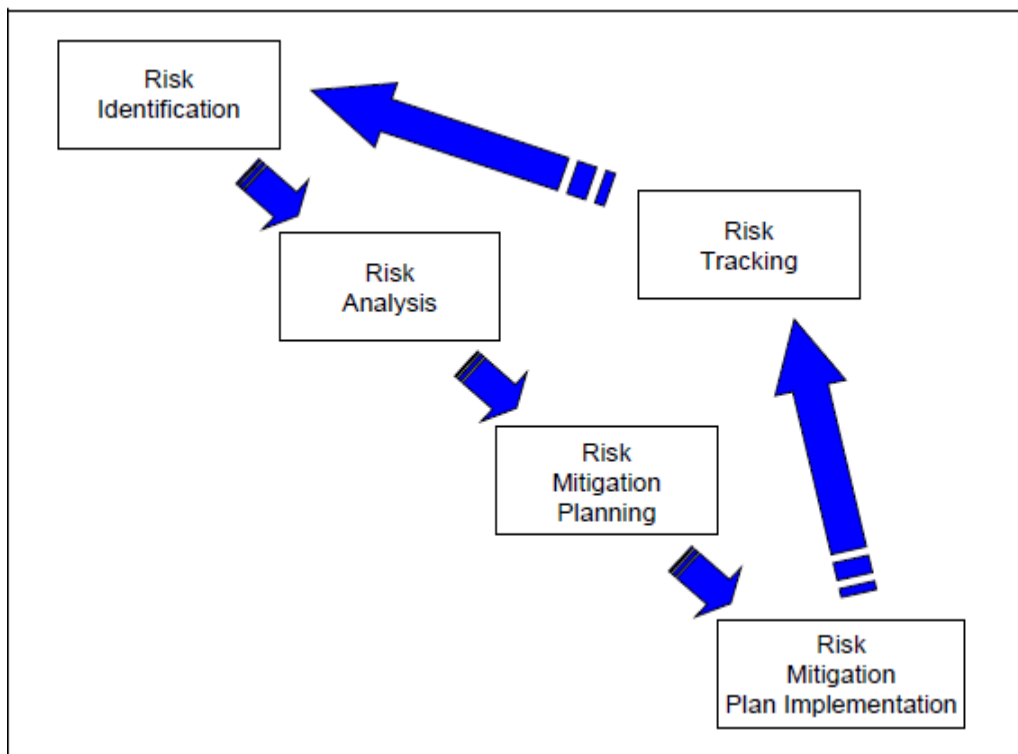

Figure 90. DOD Risk Management Process (from Department of Defense 2006, 4)

The roles and responsibilities of the team as it relates to risk management planning are identified in Table 16. This served as a guideline for how the team conducted risk management throughout the project.

Category	Responsible Role(s)	Responsibility
Program Management Risk	Project Team Lead, Scheduler, Product Accountability Area (PAA) Leads	Iteratively review the programmatic goals and objectives for progress by utilizing the Master Schedule, Stakeholder Expectations, and any other metrics necessary to determine risks within Program Management and provide input to the Risk Assessors.
Technical Risk	PAA Leads	Iteratively review the technical goals and objectives for progress by utilizing the Master Schedule, Stakeholder Expectations, and any other metrics necessary to determine risks within the technical execution and provide input to the Risk Assessors.
Overall Program Risk	Cost & Risk Analysis PAA	Responsible for advising of any potential risks by identifying issues, developing a mitigation strategy or plans, and determining if a risk should be assumed, avoided, reduced, or transferred

Table 16. Risk Management Responsibilities (after Team Liberty 311–114G 2012)

A. RISK IDENTIFICATION AND ANALYSIS

The team identified risks throughout the project lifecycle. Table 17 details potential risk the team could have encountered during the capstone project. From this analysis, the team identified and grouped the risks into three areas: technical, program management, and overall program.

Project Proposal	Preliminary Project Planning	Project Execution	Project Closure
Subject matter experts not available	No risk management plan	Information availability	Unacceptable to customer
Poor problem definition	Hasty planning	Personnel availability/workload	
Unclear objectives	Poor role definition	Scope changes	
	Inexperienced team	Technical problems	

Table 17. Capstone Project Lifecycle Risk Analysis

Each product accountability area (PAA) lead provided periodic updates to the cost and risk analysis PAA and the team lead. The cost and risk analysis PAA would then take the identified risks and document them in a Microsoft Excel spreadsheet to track the project’s risks. This spreadsheet assigned each risk a number, identified the risk area, provided details of the risk, showed the current likelihood and consequence and identified the risk mitigation strategy. The team tracked both project and system risks in the Risk Management Spreadsheet. The team classified each risk into the following two categories: system risk and project risk. A system risk is directly related to the technical aspects of the supply chain management model (SCMM); while a project risk is directly related to the team’s ability to complete the capstone project. As risks were successfully mitigated, the risks would be retired and moved to a different tab of the spreadsheet. This provided the team with a current listing of the “open” project and system risks. A sample of this spreadsheet can be seen in Table 18 and Table 19. Table 18 shows the spreadsheet for the team’s project risks. The three project risks that had been closed by the team are not listed, which is why Table 18 does not show risk numbers 2, 3, or 6. Table 19 shows the spreadsheet for the team’s system risks. There also is one system risk that was closed, which is why there is no risk number 2 in Table 19.

Risk Management Status—Project Risks					
Risk No.	Risk Area	Narrative	Likelihood	Consequence	Mitigation Strategy
1	Technical Risk	Sakai/Elluminate server issues.	3	2	Risk will be assumed by having multiple meetings. Telcons and physical meetings are also options.
4	Program Management	Planned/Unplanned team member absences.	5	1	Planned absences will be documented on the Sakai calendar. Unplanned absences will be assumed by available team members.
5	Overall Program Risk	Balancing Capstone project with other workload.	5	3	Risk will be reduced by having backups and co-leads for the various meetings and PAAs.
7	Overall Program Risk	Requirements too vague.	3	4	Risk will be avoided by making requirements more specific based on feedback from the sponsor and refinement of the problem statement.
8	Overall Program Risk	Requirements developed without defined problem statement.	3	5	Risk will be avoided by refining problem statement and revising requirement.

Risk Management Status—Project Risks					
Risk No.	Risk Area	Narrative	Likelihood	Consequence	Mitigation Strategy
9	Overall Program Risk	Stakeholder feedback requires lengthy Institutional Review Board (IRB) process.	1	4	Risk will be avoided by inviting stakeholders to IPRs and getting feedback/questions at that time. Also, feedback from sponsor's interactions with stakeholders will be used.
10	Program Management	Schedule Slip	2	5	Risk will be avoided by the team re-scoping our project and deliverables to complete the Capstone on time.

Table 18. Cohort 311–123L Risk Management Spreadsheet for Project Risk

Risk Management Status—System Risks					
Risk No.	Risk Area	Narrative	Likelihood	Consequence	Mitigation Strategy
1	Technical Risk	Interoperability with other systems	4	5	With other databases and software systems—Check software interfaces in the design phase rather than waiting until integration testing
3	Overall Program Risk	Retirement Risk	2	1	Retiring the system cannot be mitigated.
4	Technical Risk	Operational Risks	2	3	Training plan will be developed and tracked to identify required training.

Risk Management Status—System Risks					
Risk No.	Risk Area	Narrative	Likelihood	Consequence	Mitigation Strategy
5	Overall Program Risk	Implementation Risks	3	3	1) Unrealistic user expectations: To gain sponsor acceptance, we met several times to discuss implementation approach. 2) Application complexity: The process model was monitored throughout the development phase to ensure it was working.

Table 19. Cohort 311–123L Risk Management Spreadsheet for System Risk

Once identified, the risks had to be analyzed by the Cost and Risk Analysis PAA. According to the Department of Defense, “The objective of risk analysis is to gather enough information about future risks to judge the root causes, the likelihood, and consequences if risk occurs” (2006, 14). The analysis was accomplished by examining the risks that had been previously identified. The examination “...identified risks to isolate the cause, determine the effects and aid in the setting of risk mitigation priorities” (Department of Defense 2006, 14). This was done by refining the “...risk in terms of likelihood and consequence to other risk areas” (Department of Defense 2006, 14). The levels of likelihood and types of consequence of each risk listed in the risk tracking spreadsheet were established utilizing the *Risk Management Guide for DOD Acquisition*, the sixth edition specified criteria in Table 20 and Figure 91. It should be noted that the team modified Figure 91 slightly to accommodate the timeframe of the capstone project by changing the length of time in the schedule column from months to weeks.

Level	Likelihood	Probability of Occurrence
1	Not Likely	~10%
2	Low Likelihood	~30%
3	Likely	~50%
4	Highly Likely	~70%
5	Near Certainty	~90%

Table 20. Levels of Likelihood Criteria (from Department of Defense 2006, 12)

	Level	Technical Performance	Schedule	Overall Program Risk
Consequence	1	Minimal or no consequence to technical performance	Minimal or no impact	Minimal or no impact to overall program
	2	Minor reduction in technical performance or supportability, can be tolerated with little or no impact on program	Able to meet key dates. Slip <_ week(s)	Minor
	3	Moderate reduction in technical performance or supportability with limited impact on program objectives	Minor schedule slip. Able to meet key milestones with no schedule float. Slip <_ week(s) Sub-system slip >_ week(s) plus available	Moderate
	4	Significant degradation in technical performance or major shortfall in supportability; may jeopardize program success	Program critical path affected. Slip <_ week(s)	Significant
	5	Severe degradation in technical performance; Cannot meet KPP or key technical/supportability threshold; will jeopardize program success	Cannot meet key program milestones. Slip >_ week(s)	Severe

Figure 91. Types of Consequence Criteria (after Department of Defense 2006, 13)

The information contained in the risk tracking spreadsheet was then plotted in a risk reporting matrix. This risk reporting matrix was used to depict the level of risks identified with this project. The level of risk for each issue was reported as low (green), moderate (yellow), or high (red). A sample of the Risk Report Matrix is shown in Figure 92 using data from Table 18 Cohort 311–123L Risk Management Spreadsheet for Project Risk. In this example, risk #1, is shown with a circle and arrow around it, indicating that due to the used mitigation strategy the likelihood and consequence of this risk has decreased.

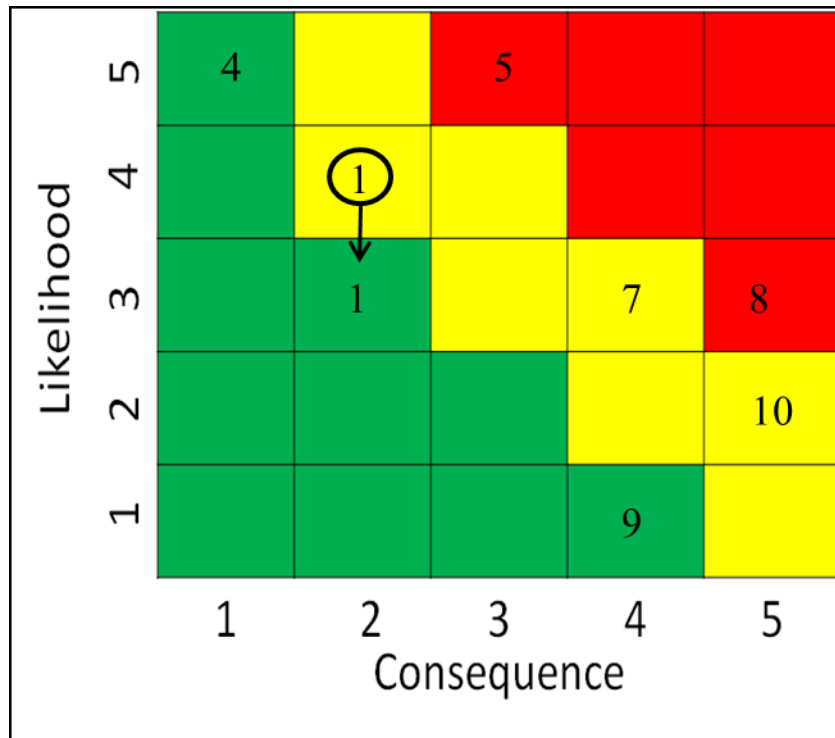

Figure 92. Risk Report Matrix (after Department of Defense 2006, 11)

B. RISK MITIGATION

According to the Department of Defense, “Risk mitigation is the activity that identifies, evaluates and selects the best option to set a risk at an acceptable level, based on project objectives and constraints” (2006, 33). Once a risk has been identified, four tools are used to evaluate and treat the risk: avoid, assume, control, or transfer. Avoiding risk entails utilizing an approach to eliminate the root cause and/or consequence of the risk, therefore avoiding the risk (Department of Defense 2006). If a risk cannot be avoided then it becomes an assumed risk that will have to be monitored. Another tool used in risk mitigation is controlling risk. This tool examines the root cause or consequence of a risk and uses mitigation techniques to reduce the risk to an acceptable level (Department of Defense 2006). Transferring risk transfers mitigation of the risk to another organization or entity. The Cost and Risk Analysis PAA utilized these tools in mitigating the risks identified by the team as the project progressed.

As previously mentioned, the team utilized the Risk Management Spreadsheet to record the type of risk, the specific risk/narrative, as well as the likelihood, consequence and risk mitigation strategy for each risk. Table 18 describes the mitigation strategies for the project risks. These strategies entailed the capstone team interacting with the sponsor, stakeholders or capstone advisor to find a way to mitigate the identified risks. The team also made decisions to cover schedule and absence risks to ensure the capstone project was completed within the established timeframe. The mitigation strategies for the system risks, shown in Table 19, are tailored to each individual risk. Mitigating the interoperability risks focused on examining the software interfaces that the SCMM system will have with the different databases it will be receiving information from. In order to control this risk, the team checked software interfaces in the design phase rather than waiting until integration testing, to ensure interoperability and reduce costs. The concern about accessing classified information via the SIPRNET may be avoided by determining whether the classified data is really required for the SCMM, and if so, whether it can be entered as an unclassified user input rather than receiving the information from the classified databases. The team avoided this “classified information sharing” risk, which was system risk #2, and so it is not listed in the table. The retirement risk is minimal; therefore, there is no mitigation plan for this risk. The operational risks mitigation strategy will be to develop a training plan for the SCMM based on the training requirements for users to operate the SCMM. The final system risk the team identified was implementation risks. One of these risks was unrealistic user expectations. This can be mitigated by consistently meeting with the sponsor to ensure the team’s efforts stay on track and meet with the sponsor’s approval. The complexity of the SCMM application is another implementation risk. It can be mitigated by continuously monitoring the process model throughout the development process to ensure the final product is user-friendly. As risks were successfully mitigated, they were retired from being actively tracked / monitored by the team.

C. RISK TRACKING

As previously discussed, risk management is an ongoing activity that will continue throughout the life of the project. This process included the continued activities

of risk identification, risk assessment, planning for newly identified risks, monitoring trigger conditions and contingency plans, and risk reporting on a regular basis. Tracking risks throughout the capstone was another necessary activity handled by the Cost and Risk Analysis PAA. This was accomplished utilizing the Risk Management Spreadsheet; see Table 18 and Table 19, during the team's weekly project status meetings. During the risk portion of the status meeting, new risks were presented along with status changes of existing risks. Some risk attributes, such as likelihood and consequence, changed during the life of this project and these were documented and presented as well.

LIST OF REFERENCES

- Assistant Secretary of Defense, Logistics and Materiel Readiness. 2012, August 31. "Supply Chain Integration." Accessed July 2013.
<http://www.acq.osd.mil/log/sci/rbs.htm>.
- ACQWeb. 2008, August 19. "Supply Chain Integration." ACQWeb. Accessed July 2013.
<http://www.acq.osd.mil/log/sci/rbs.htm#overview>.
- Bailey, Paul. 2013. "Modeling and Simulation: Its Growing Importance." *Technology Today*, 4-7. Accessed November 8, 2013.
http://www.raytheon.com/newsroom/technology_today/2013_i1/top_story.html
- Barber, Ellen. 2011, February. "DAU Teaching Note—Cost as an Independent Variable (Feb 2011)." Acquisition Community Connection. Accessed February 9, 2014.
https://acc.dau.mil/adl/en-US/30380/file/61353/A4_CAIV_Feb%2011.pdf.
- Blanchard, Benjamin S., and Wolter J. Fabrycky. 2011. *Systems Engineering and Analysis*. 5th ed. Upper Saddle River, NJ: Pearson Education, Inc., publishing as Prentice Hall.
- Buede, Dennis M. 2000. *The Engineering Design of Systems—Models and Methods*. New York, NY: John Wiley and Sons, Inc.
- Buede, Dennis M 2009. *The Engineering Design of Systems—Models and Methods*. 2nd ed. Hoboken, NJ: John Wiley & Sons, Inc.
- CACI. 2006. *U.S. Navy Control Program Uniform Inventory System Design Documentation—PC Based Multi-Echelon Readiness Based Sparing (ME-RBS) Workstation—Specifications*. Arlington, VA: CACI.
- Chapman, William Luther, A. Terry Bahill, and A. Wayne Wymore. 1992. *Engineering Modeling and Design*. Boca Raton, FL: CRC Press.
- Chief Information Officer, Department of Defense. 2007, March. "Department of Defense Net-Centric Services Strategy for a Net-Centric, Service Oriented DOD Enterprise." Chief Information Officer U.S. Department of Defense. Accessed August 2013.
http://dodcio.defense.gov/Portals/0/documents/DOD_NetCentricServicesStrategy.pdf.
- Clemen, Robert T., and Terence Reilly. 2001. *Making Hard Decisions with Decision Tools*. Pacific Grove, CA: Duxbury/Thomson.
- Daniels, Jesse, Paul W. Werner, and Terry Bahill. 2001. *Quantitative Methods for Tradeoff Analyses*. "College of Engineering Department of Systems and Industrial

- Engineering and Engineering Management.” The University of Arizona. Accessed January 15, 2014.
<http://www.sie.arizona.edu/sysengr/publishedPapers/QuantitativeMethods.pdf>.
- Defense Acquisition University. 2012, September 21. “Module 5: Establish the Life Cycle Sustainment Plan.” Logistics 101: Logistics Fundamentals. Defense Acquisition University. Accessed September 9, 2013.
https://learn.dau.mil/CourseWare/46_9/LOG101_M05/LOG101_M05L01/LOG101_M05L01T00/swfs/LOG101_M05_Printable_Version.pdf
- Defense Industry Daily*. 2014, January 20. “LCS: The USA’s Littoral Combat Ships.”
<http://www.defenseindustrydaily.com/the-usas-new-littoral-combat-ships-updated-01343/>.
- Department of Defense. 2011. *DOD Product Support BCA Guidebook*. Washington DC: Department of Defense.
- Department of Defense. 2013, November 25. *Interim DOD Instruction 5000.02, “Operation of the Defense Acquisition System*. Washington DC: Department of Defense.
- Department of Defense. 2006. *Risk Management Guide for DOD Acquisition*. 6th edition. Washington DC: Department of Defense.
- Department of Defense. 2008. “Readiness-Based Sparing Roadmap Version 1” Supply Chain Integration. ACQWeb. Accessed August 2013.
http://www.acq.osd.mil/log/sci/rbs/DL739C1-V1_report_final_10Oct08.pdf.
- Department of the Army Headquarters. 2000. *Organizational Supply and Services for Unit Leaders*. FM 10-27-4. Washington DC: Department of the Army Headquarters.
- Deputy Chief Information Officer. 2010. “The DODAF Architecture Framework Version 2.02.” DODAF DOD Architecture Framework Version 2.02 DOD Deputy Chief Information Officer.” Chief Information Office U.S Department of Defense. Accessed December 28, 2013. <http://dodcio.defense.gov/dodaf20.aspx>.
- Deputy Under Secretary of Defense, Logistics and Materiel Readiness. 2003. *DOD Supply Chain Materiel Management Regulation, DOD 4140.1-R*. DTIC Online Information for the Defense Community. Accessed August 2013.
<http://www.dtic.mil/whs/directives/corres/pdf/414001r.pdf>.
- Forsberg, Kevin, and Harold Mooz. 1991. *The Relationship of Systems Engineering to the Project Cycle*. Chattanooga, TN: International Council on Systems Engineering.
- Government Accountability Office. 2010. *Defense Acquisitions: Navy’s Ability to Overcome Challenges Facing the Littoral Combat Ship Will Determine Eventual*

- Capabilities*. GAO-10-523, U.S. Government Accountability Office, Washington DC: Office of Public Affairs.
- ImagineThat! 2013. "ExtendSim Overview." ImagineThat! Accessed December 28, 2013. http://www.extendsim.com/prods_overview.html.
- International Council on Systems Engineering. 2011, October. *INCOSE Systems Engineering Handbook v 3.2.2*. San Diego, CA: International Council on Systems Engineering.
- Joint Chiefs of Staff. 2013, December 19. *Joint Publication 4-09 Distribution Operations*. DTIC Online. Accessed January 15, 2014. http://www.dtic.mil/doctrine/new_pubs/jp4_09.pdf.
- Laron, Sky M. 2013, April 22. "Forward Deployed Logisticians Keep USS Freedom in High State of Readiness." Accessed August 20, 2013. http://www.navy.mil/submit/display.asp?story_id=73491.
- Loyola University Chicago. n.d. "Project Management Articles, Project-Speak: Assumptions and Constraints." Loyola University Chicago. Accessed December 29, 2013. http://www.luc.edu/media/lucedu/pmo/pdfs/additionalreading/Assumptions_and_Constraints.pdf.
- Microsoft. 2013. "Basic Tasks in Excel 2010". Microsoft. Accessed December 22, 2013. http://office.microsoft.com/en-us/excel-help/basic-tasks-in-excel-2010-HA101829993.aspx#_Toc256078345
- National Aeronautics and Space Administration and Arizona State University. n.d. *Interfaces Module Exploration Systems Engineering*. Version 1.0. "Arizona State University SES 405—Exploration Systems Engineering." Arizona State University. Accessed January 31, 2014. http://orion.asu.edu/Class%20Notes/Interfaces_Module_V1.0_PAS.pdf.
- Office of Aerospace Studies. 2008, July. *Analysis of Alternatives (AoA) Handbook A Practical Guide to Analyses of Alternatives*. NDIA National Defense Industrial Association. Accessed January 15, 2014. <http://www.ndia.org/Divisions/Divisions/SystemsEngineering/Documents/Committees/Mission%20Analysis%20Committee/Support%20Documentation/AoA%20Handbook%20Final.pdf>.
- Patch, John. 2011, January. "The Wrong Ship at the Wrong Time." *Proceedings Magazine*, 137/1/1, 295. Accessed August 21, 2013. <http://www.usni.org/magazines/proceedings/2011-01/wrong-ship-wrong-time>.

- RBS Working Group. 2005, August 2. *RBS Working Group*. Supply Chain Integration. ACQWeb. Accessed August 2013.
http://www.acq.osd.mil/log/sci/rbs/RBSWG_charts_Aug2005.ppt.
- Sage, Andrew P., and James E. Armstrong. 2000. *Introduction to Systems Engineering*. Chichester, NY: Wiley.
- Sayen, John. 2012, October 5. "The Navy's New Class of Warships: Big Bucks, Little Bang." *Battleland*. Accessed October 3, 2013.
<http://nation.time.com/2012/10/05/the-navys-new-class-of-warships-big-bucks-little-bang/>.
- Strauch, F. C. n.d. *ARROWS Model Evaluation*. Project Number N9324-B11-4135, Mechanicsburg, PA: Navy Fleet Material Support Office.
- Team Liberty 311-114G, NPS Cohort. 2012. *Systems Engineering Design and Development of a Decision Aid Tool Prototype*. Capstone Project, Naval Postgraduate School.
- Under Secretary of Defense (Comptroller). 2012, February. *Operation and Maintenance Overview, Fiscal Year 2013 Budget Estimates*. Under Secretary of Defense (Comptroller). Accessed December 29, 2013.
http://comptroller.defense.gov/defbudget/fy2013/fy2013_OM_Overview.pdf.
- Valerdi, Ricardo. 2005. *Systems Engineering Cost Estimation with COSYSMO*. Massachusetts Institute of Technology. Accessed January 31, 2014.
<http://web.mit.edu/rvalerdi/www/Ricardo%20Valerdi%20dissertation%20%28COSYSMO%29.pdf>.
- Vickers, Michael, and Martha Charles-Vickers. 2006, January 4. *DOD Architectural Framework (DODAF)*. International Council on Systems Engineering. Accessed October 2013.
http://www.incose.org/enchantment/docs/06Docs/06JanDOD_ArchitecturalFramework.pdf.
- Visual Paradigm. 2011, December 8. "Writing Effective Use Case." Visual Paradigm. Accessed February 1, 2014. <http://www.visual-paradigm.com/product/vpuml/tutorials/writingeffectiveusecase.jsp>.
- Vitech. 2013. "CORE Delivers Product Design and Development Success through Integrated Systems Engineering." Vitech. Accessed December 28, 2013.
<http://www.vitechcorp.com/products/core.shtml>.
- Work, Robert O. 2008. *The US Navy Charting a Course for Tomorrow's Fleet*. Report in a series comprising CSBA's "Strategy for the Long Haul," Washington DC: Center for Strategic and Budgetary Assessments.

INITIAL DISTRIBUTION LIST

1. Defense Technical Information Center
Ft. Belvoir, Virginia
2. Dudley Knox Library
Naval Postgraduate School
Monterey, California