

UC-NRLF

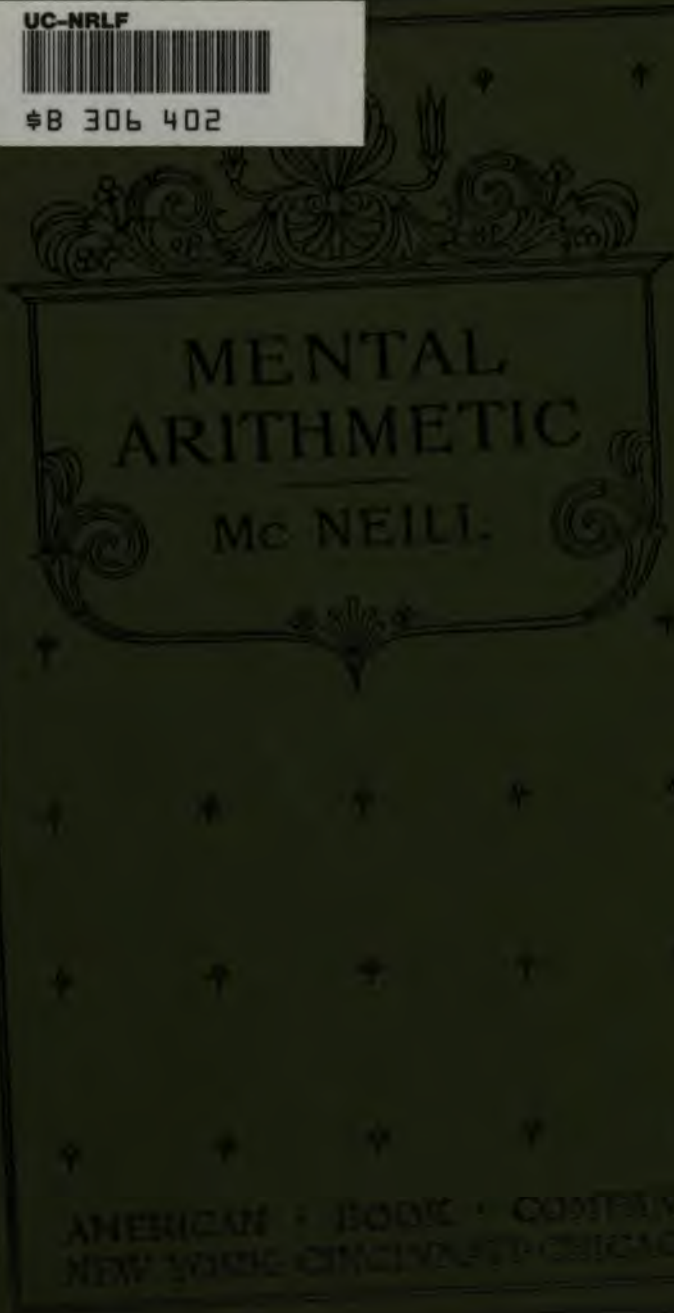

\$B 306 402



MENTAL
ARITHMETIC
—
Mc NEILL.

AMERICAN BOOK COMPANY
NEW YORK CINCINNATI CHICAGO

35

410

DEP

No. 58

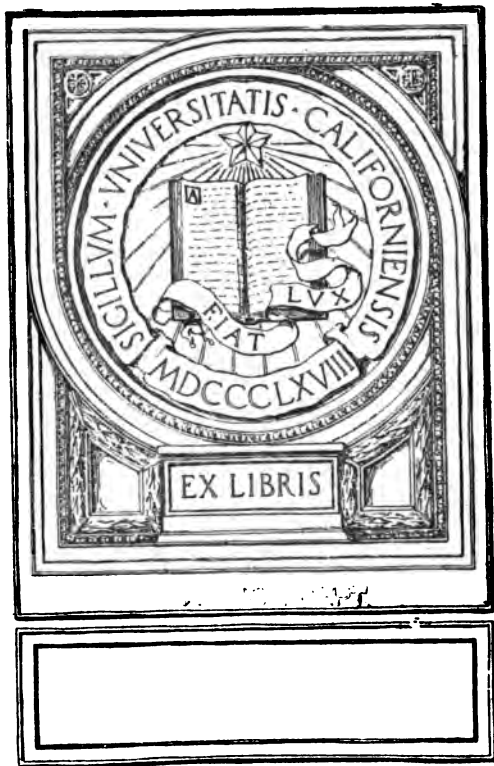

COMPLIMENTS
AMERICAN BOOK CO

A. F. GUNN, Gen'l Ag't,
PINE & BATTERY,
SAN FRANCISCO.

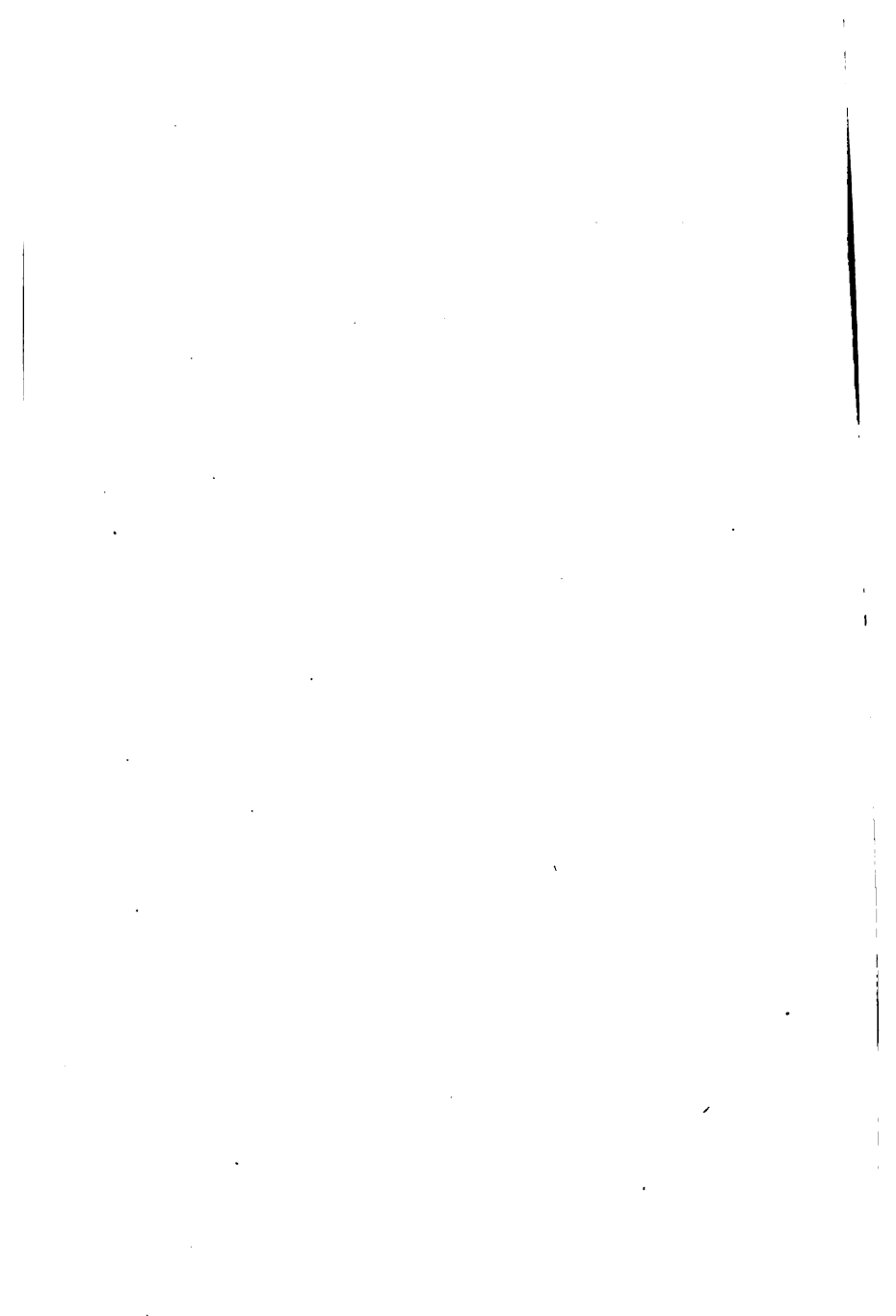

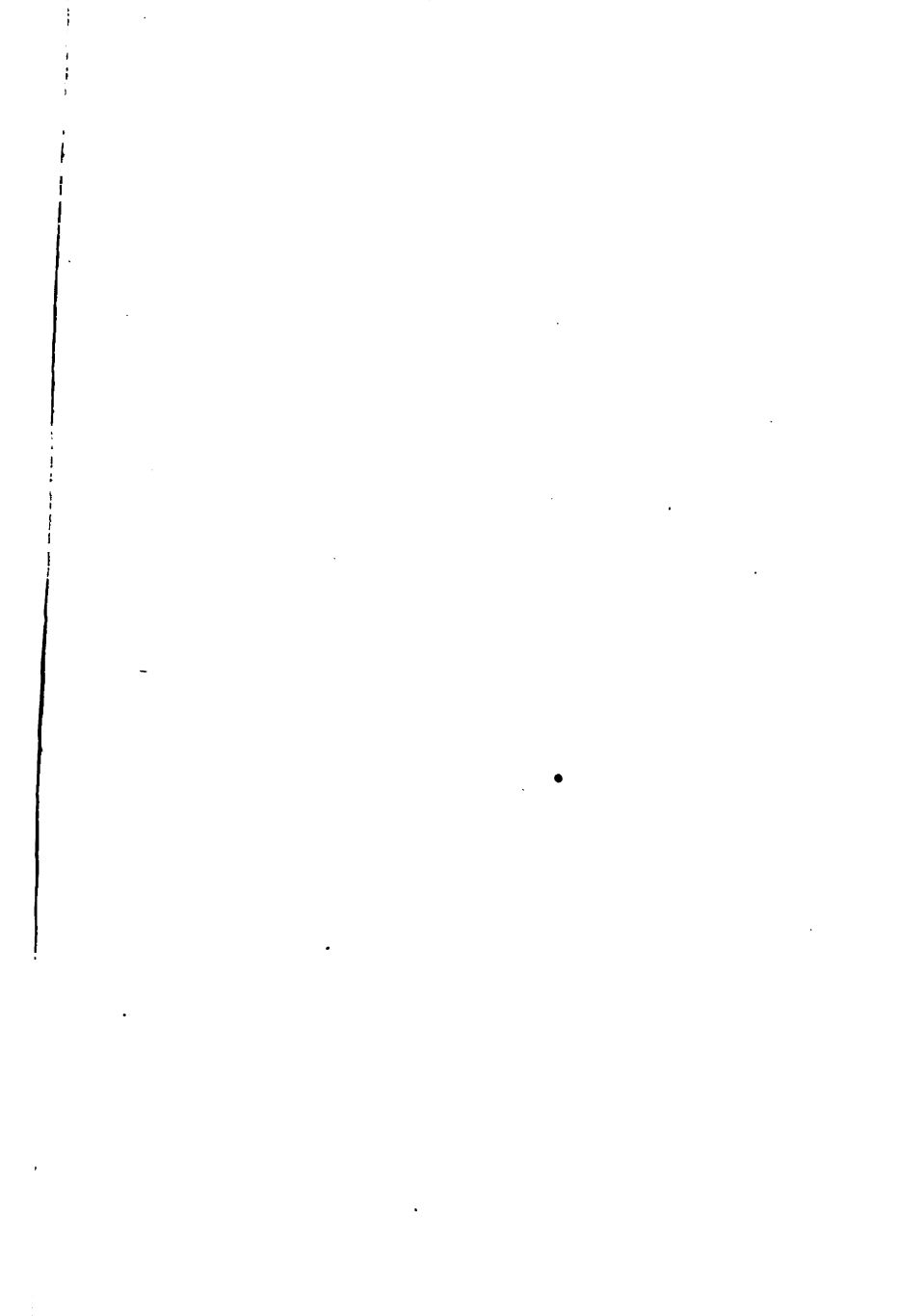



Univ. of
California

MENTAL ARITHMETIC

BY

I. C. McNEILL

PRESIDENT SEVENTH WISCONSIN STATE NORMAL SCHOOL



NEW YORK ·· CINCINNATI ·· CHICAGO
AMERICAN BOOK COMPANY

to visit
Australia

C. A. K.
M.

COPYRIGHT, 1902, BY

I. C. McNEILL.

ENTERED AT STATIONERS' HALL, LONDON.

MENTAL ARITH.

W. P. 2

EDUCATION DEPT.

PREFACE

THIS work is designed for use in grammar grades. It may also be used with advantage for review work in high schools and normal schools. Mental or oral arithmetic when properly developed and taught not only does more than any other agency in giving pupils insight into the real nature of number and numerical relations, but it also adds keenness to the mind in general and strengthens its power of concentration. To be thus efficacious, however, any course in mental arithmetic must be based upon sound pedagogic principles and proceed along sound pedagogic lines.

The principles upon which this book is based may be briefly formulated. Observation must precede comparison; sense impressions must come before thought relations can be established; rational movement proceeds from the known to the related unknown, from the simple to the complex, and from the particular notion to the concept. The method of this book recognizes the important truth that first perceptions must be clear, distinct, and vivid in order to leave in the mind correct traces of ideas through which the later impressions may be apperceived. The value of clear images in bringing before the mind the material for reasoning and in leading gradually to the formation of accurate concepts is duly emphasized.

The problems have been specially prepared to illustrate and call forth ideas. The first problem looks to the last through all that come between. The development of

each section furnishes a foundation upon which the new thoughts that immediately follow may most readily erect themselves. A constantly increasing demand upon the pupil's mental activity goes hand in hand with the progressive gain in power. But there has been rigid exclusion of problems of so unnatural a complexity as to impede instead of furthering the free movement of the mind.

The author acknowledges his indebtedness to Professor C. W. Smith of the Superior State Normal School for much valuable aid in the preparation of the problems in this book, and for testing in preparatory classes every step taken in the development of the subjects.

SUGGESTIONS TO TEACHERS

(a) *How to prepare the lesson* is the most important question for the pupils. They cannot work intelligently unless they understand the aim of each day's study. The great function of the teacher is to guide activity. *Learning* is the pupils' act. Before an intelligent assignment of the lesson can be made by the teacher, he must consider carefully just what steps are new and how far the pupils are prepared by what they already know for the advanced work. In assigning the lesson the teacher should impress upon his pupils the particular end in view, and should make sure that they understand just what they are to accomplish and by what plans and devices they may best succeed. The next day's recitation will test the pupils' understanding of such directions and their faithfulness in following them. In determining the pupils' preparation to begin a new line of work, the skilled teacher will approach the learners on their highest plane of old work, directly related to the new material to be considered. If students move from this position with ease and freedom, it is good evidence that the lower phases of the subject are well organized in their minds. If they do not show a mastery here, it is well to descend to the next lower phase or to a place where they are able to stand firm. The higher phases of the old work should be brought clearly within the field of conscious comprehension before attempting to present new ideas.

(b) As a rule it is a good plan to leave the diagrams on the board for constant use until pupils can image them. When the diagrams can be held in the mind, it is not productive of attention or study to have them before the pupils. In their study it is of great value to have pupils picture or represent in diagrams, if possible, the conditions of new problems. Mensuration is not comprehended until pupils through practice and tests perceive the relations.

(c) Good results may be reached in class by asking the pupils with

books closed to work the problem given and rise at a signal from the teacher when they have finished. This reveals at a glance the backward students who need the most assistance. Analyses should be given in simple, direct sentences. It is often a good plan to have one pupil take up the analysis when another has partly given it and complete the explanation. This will stimulate attention, especially on the part of the unprepared pupils. When by questioning or by hearing the explanation, the backward pupils have learned how to dispose of the problem in hand, they should be called upon to show that they can take all the steps leading to the correct solution. A good test is to change one condition somewhat and then ask for a solution. Questioning, in most cases, is better than telling. In questioning a pupil to bring him to an understanding of a problem or a principle, the teacher must always go back to what is known, as a starting point. It is sometimes a good plan to distribute small slips of paper, read a problem, have each pupil write the answer at a signal, after sufficient time has elapsed for its solution; then give another in the same way until opportunity to test all with several problems has been given. Analyses, explanations, and modes of solution given by the pupils should follow.

(d) Time will be saved and accuracy of results insured by encouraging pupils to use the largest measures possible in finding ratios or making comparisons between like numbers. Take, for instance, What part of an $18\frac{1}{2}$ -ft. square is a $12\frac{1}{2}$ -ft. square? If the pupil finds that the $12\frac{1}{2}$ -ft. square is twice as long as a $6\frac{1}{2}$ -ft. square, and the $18\frac{1}{2}$ -ft. square is three times as long as a $6\frac{1}{2}$ -ft. square, he readily sees that the ratio of the length of the $12\frac{1}{2}$ -ft. square to the length of the $18\frac{1}{2}$ -ft. square is as 2 to 3, or $\frac{2}{3}$. In like manner he can compare widths. After this it is an easy step to bring the compound elements together, and find that the $12\frac{1}{2}$ -ft. square is $\frac{2}{3}$ as large as the $18\frac{1}{2}$ -ft. square.

(e) The scientific teacher will find many other plans of developing ideas of subjects presented in the text. He should always feel at liberty to use his own methods and devices if they are consistent and will not confuse past or future lessons. It is, however, better to know one plan well than to have a superficial knowledge of many plans.

CONTENTS

SECTION	PAGE
I. Introducing the Idea of Ratio	9
II. Introducing the Fraction <i>One Half</i> and developing Relations	12
III. Introducing the Fraction <i>One Third</i> and developing Relations	18
IV. Introducing the Fraction <i>One Fifth</i> and developing Relations	23
V. Introducing the Fraction <i>One Seventh</i> and developing Relations	29
VI. Developing the Idea of Decimals and their Relation to Other Fractions	35
VII. Introducing the Idea of <i>Per Cent</i> and developing Relations	48
VIII. Introducing General Compound Numbers and developing Relations	56
IX. Introducing the Study of Surfaces and developing Relations	65
X. Introducing the Study of Solids and developing Relations	79
XI. Review of Measurements	92
XII. Introducing the Ideas of Analysis and Mental Algebra in solving Problems and finding Relations	101
XIII. Reviewing and extending the Idea of Percentage	122
XIV. Reviewing and extending Ideas previously presented and establishing New Relations	134

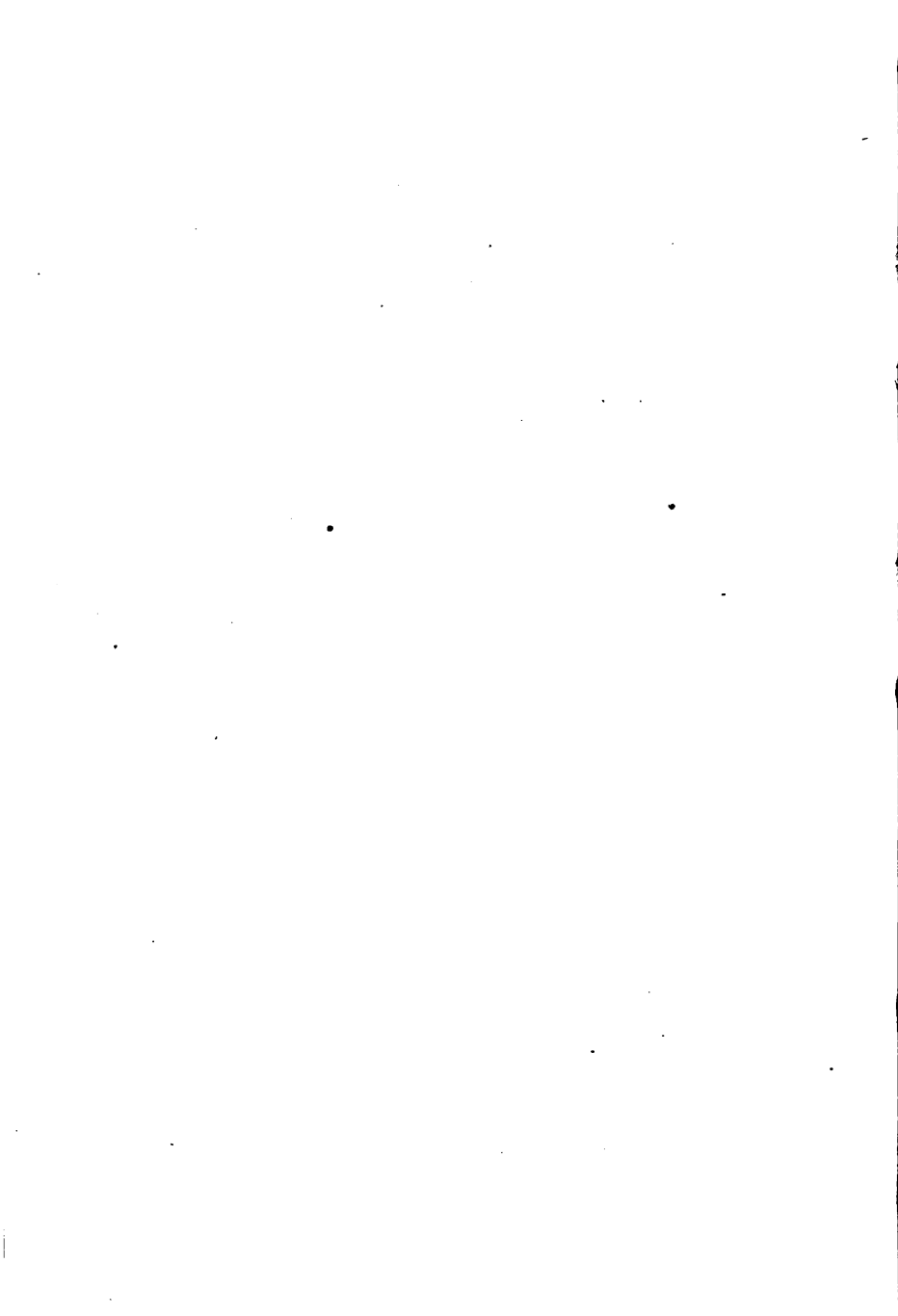

SECTION I

INTRODUCING THE IDEA OF RATIO

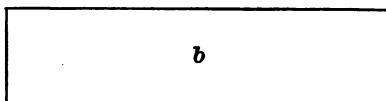
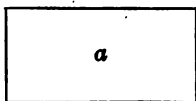

1. Rectangle a is what part of rectangle b ?
2. Rectangle b is how many times rectangle a ?
3. What is the ratio of rectangle a to rectangle b ? $\frac{1}{2}$.
4. What is the ratio of rectangle b to rectangle a ? 2.

1 in.

2 in.

5. What is the ratio of a line 1 in. long to a line 2 in. long?
6. What is the ratio of a line 2 in. long to a line 1 in. long?
7. What is the ratio of a line 4 in. long to a line 2 in. long?
8. What is the ratio of a line 2 in. long to a line 4 in. long?
9. What is the ratio of 1 qt. to 2 qt.? Of 2 qt. to 1 qt.?
10. What is the ratio of 4 qt. to 2 qt.? Of 2 qt. to 4 qt.?

11. What is the ratio of 4 bu. to 2 bu.? Of 2 bu. to 1 bu.?

12. What is the ratio of 6 in. to 3 in.? Of 6 in. to 2 in.?
Of 2 in. to 6 in.?

13. What is the ratio of 3 gal. to 9 gal.? Of 9 gal. to 3 gal.?

14. James has 9 marbles and Henry has 6 marbles. Henry's marbles equal what part of James's marbles? What is the ratio of Henry's marbles to James's marbles? Of James's to Henry's?

15. A has \$12 and B has \$9. What is the ratio of B's money to A's? Of A's to B's?

16. What is the ratio of 1 ft. to 3 ft.? Of 1 ft. to 1 yd.?

17. * What is the ratio of 1 yd. to 1 ft.? Of 1 yd. to 2 ft.?

18. What is the ratio of 1 yd. to 6 in.? Of $1\frac{1}{2}$ yd. to 6 in.?

19. What is the ratio of 6 in. to 2 yd.? Of 2 yd. to 6 in.?

20. A boy measured a stick with a 6-inch rule and found it to be 2 yd. long. How many times did he have to use the rule to measure the stick? The ratio of 2 yd. to 6 in. is what?

21. What is the ratio of 1 qt. to 1 gal.? Of 1 qt. to 5 gal.?

22. A man is dipping water from a barrel into a 5-gallon can, using a 2-quart dipper. How many times must he dip the dipper full to fill the can? The ratio of 2 qt. to 5 gal. is —?

* The student must observe that ratios can be expressed only between quantities of like name. What must be done to quantities of unlike names?

23. What part of a canful is each dipperful?
24. At 20¢ a yard, how many yards of cloth can be bought for \$1.20? What is the ratio of \$1.20 to 20¢?
25. If 22 yd. of cloth cost \$15.50, what part of \$15.50 will 2 yd. cost? 4 yd.? 5 yd.? 9 yd.? 11 yd.?
26. How many steps 2 ft. 6 in. long must a man take to walk a distance of 10 ft.? What is the ratio of 120 in. to 30 in.? Of 10 ft. to $2\frac{1}{2}$ ft.?
27. What is the ratio of 1 ft. 6 in. to 1 yd. 1 ft.?
28. From a stick 1 yd. 2 ft. long, a piece 1 ft. 8 in. long was cut off. What part of the stick was cut off?
29. From a can containing 3 gal. 3 qt. of milk, 1 gal. 1 qt. was sold. What part was sold?
30. A boy carrying a package of sugar, weighing 5 lb. 8 oz., spilled 1 lb. 6 oz. of it. What part of the sugar did he spill? What is the ratio of 1 lb. 6 oz. to 5 lb. 8 oz.?
31. What is the ratio of 5 ft. to 5 in.? Of 6 ft. to 6 in.? Of 12 ft. to 12 in.?
32. What is the ratio of 8 in. to 1 yd. 1 ft.? Of 1 yd. 1 ft. to 8 in.?
33. What part of a bushel is 1 pk. 4 qt.?
34. What part of 1 bu. 2 pk. 2 qt. of cherries is sold, if 1 pk. 2 qt. is sold?
35. How many strips of wall paper 18 in. wide will it take to cover a wall 4 yd. long?

SECTION II

INTRODUCING THE FRACTION ONE HALF AND DEVELOPING RELATIONS

SUGGESTIONS

a. Pupils should think problems through before attempting to give expression to ratios.

b. Analyses should, in the main, be the oral expression of the observations the pupils make in thinking through their problems. Analyses should, if possible, be given in short, simple sentences in which the notion of what each step is should come in its natural order.

c. Sure progress results if pupils think relations in diagrams. When the diagram of a class of problems can be carried in the mind, the pupils should image it.

d. In presenting Section II, it is advisable to let the diagram of each new step remain on the blackboard during the first recitation. In subsequent lessons it should be reproduced if pupils cannot recall and image it.

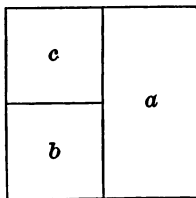

1. What part of the square is a ? What part is $b+c$?
2. a and $b+c$ together equal the whole square. What is the value of $\frac{1}{2} + \frac{1}{2}$?

3. What part of $b + c$ is b ? What part is c ?
4. What is the ratio of b to $b + c$? Of b to a ? Of c to a ?
5. What part of the whole square is b ? What part is c ?
6. What part of the whole square is $b + c$? $\frac{1}{4} + \frac{1}{4} =$ what?
7. What part of the whole square is $a + b$? $\frac{1}{2} + \frac{1}{4} =$ what?
8. $\frac{1}{2} + \frac{1}{4} + \frac{1}{4} =$ what? What part of the square are a , b , and c together?
9. If you take b from the square, what part remains?
10. If you take c , what part remains? $1 - \frac{1}{4} =$ what?
11. If you take a from the square, what part remains?
12. If you take $b + c$, what part remains? $1 - \frac{1}{2} =$ what? $1 - \frac{3}{4} =$ what?
13. What is the ratio of $\frac{1}{4}$ to $\frac{1}{2}$? The numbers must have what *like name* before the ratio can be expressed?
14. What is the ratio of $\frac{1}{4}$ to $\frac{3}{4}$? Of $\frac{1}{2}$ to $\frac{3}{4}$? Of $\frac{3}{4}$ to $\frac{3}{4}$? Of $\frac{1}{4}$ to $\frac{3}{4}$?
15. What is the ratio of $\frac{1}{2}$ to $\frac{1}{4}$? Of $\frac{1}{2}$ to $\frac{1}{2}$? Of $\frac{1}{2}$ to $\frac{3}{4}$? Of $\frac{1}{2}$ to 1?
16. What part of the whole is $\frac{1}{2}$ and $\frac{1}{4}$ of a gallon of water?
17. How much more water will it take to fill a gallon jug after a quart and a pint have been put in?
18. What is the ratio of 2 quarts and 1 pint to 1 gallon? Of $1\frac{1}{2}$ gallons to 3 pints?

19. What is the ratio of half a gallon to three pints? Of three pints to one half a gallon?

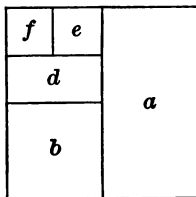

20. What part of the whole square is d ? How many rectangles like d could be made of the whole square?

21. What is the ratio of d to b ? Of $f + e$ to b ? Of $\frac{1}{8}$ to $\frac{1}{4}$?

22. What is the ratio of d to $d + b$? What part of the square is $d + b$? What is the ratio of $\frac{1}{8}$ to $\frac{3}{8}$?

23. What is the ratio of d to a ? Of $\frac{1}{8}$ to $\frac{1}{2}$?

24. What is the ratio of d to a and $f + e$? Of d to $a + b$? Of $\frac{1}{8}$ to $\frac{3}{4}$?

25. What is the ratio of d to $a + b + f + e$? Of a to d ? Of b to d ?

26. Of $a + b$ to d ? Of $a + f + e$ to d ? Of $a + b + f + e$ to d ?

27. If d is taken from the square, what part is left? If $d, e,$ and f are taken? If b and d are taken? $d, b, f,$ and e ? a and d ? a and b ? $a, b,$ and d ?

28. $b - d =$ what? $a - d$?

29. What is the ratio of $\frac{1}{8}$ to $\frac{1}{4}$? To $\frac{3}{8}$? To $\frac{1}{2}$? To $\frac{5}{8}$? To $\frac{3}{4}$? To $\frac{7}{8}$? To $\frac{8}{8}$?

30. What is the ratio of $\frac{1}{4}$ to $\frac{1}{8}$? To $\frac{1}{4}$? To $\frac{1}{2}$? To $\frac{3}{4}$?
To $\frac{5}{8}$? To $\frac{5}{4}$? To $\frac{7}{8}$? To $\frac{9}{8}$?

31. $\frac{1}{4} - \frac{1}{8} = ?$ $\frac{1}{2} - \frac{1}{8} = ?$ $\frac{3}{4} - \frac{1}{8} = ?$ $\frac{3}{8} - \frac{1}{4} = ?$ $\frac{5}{8} - \frac{1}{4} = ?$
 $\frac{7}{8} - \frac{1}{4} = ?$ $\frac{8}{8} - \frac{1}{4} = ?$

32. $\frac{1}{8} + \frac{1}{4} = ?$ $\frac{1}{8} + \frac{1}{2} = ?$ $\frac{1}{8} + \frac{3}{4} = ?$ $\frac{3}{8} + \frac{1}{4} = ?$ $\frac{5}{8} + \frac{1}{4} = ?$
 $\frac{7}{8} + \frac{1}{2} = ?$ $\frac{8}{8} + \frac{3}{4} = ?$

33. What part of the whole square is e ?

34. What is the ratio of e to f ? Of e , or f , to d ?
To b ? To a ?

35. What is the ratio of d to each of the other divisions?
Of b to each? Of a ? Of $e + d$? Of $e + b$? Of $e + a$?

36. Using the fractions $\frac{1}{16}$, $\frac{1}{8}$, $\frac{3}{16}$, $\frac{1}{4}$, $\frac{5}{16}$, $\frac{3}{8}$, $\frac{7}{16}$, $\frac{1}{2}$, $\frac{9}{16}$, $\frac{5}{8}$,
 $\frac{11}{16}$, $\frac{3}{4}$, $\frac{13}{16}$, $\frac{7}{8}$, $\frac{15}{16}$, and $\frac{16}{16}$, give the ratio of each to each of
the others.

37. Add each one to each of the others, as $\frac{1}{16} + \frac{1}{8}$, $\frac{1}{16} + \frac{1}{4}$,
etc.

38. Subtract each from each of the others, as $\frac{1}{8} - \frac{1}{16}$,
 $\frac{3}{16} - \frac{1}{16}$, $\frac{1}{4} - \frac{1}{16}$, etc.

39. $\frac{1}{2}$ of $\frac{1}{2} = ?$ $\frac{1}{2}$ of $\frac{1}{4}$? $\frac{1}{2}$ of $\frac{1}{8}$? $\frac{3}{4}$ of $\frac{1}{2}$? $\frac{3}{4}$ of $\frac{1}{4}$? $\frac{1}{4}$ of $\frac{1}{4}$?

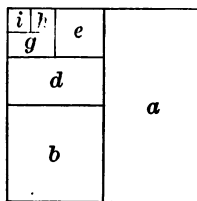

40. What is the ratio of g to e ? What part of the whole
square is g ?

41. What is the ratio of g to d ? To $e + d$? To b ?
To a ?

42. What is the ratio of h to g ? Of i to g ? What part of the square is h ? What part is i ?

43. Give the ratio of each part to each of the others. As of i to h , to g , to e , etc.; of g to h , to e , to d , etc.

44. How many 64ths in 1? In $\frac{1}{2}$? In $\frac{1}{4}$? In $\frac{1}{8}$? In $\frac{1}{16}$? In $\frac{1}{32}$?

45. How many 32ds in 1? In $\frac{1}{2}$? $\frac{1}{4}$? $\frac{1}{8}$? $\frac{1}{16}$? $\frac{1}{64}$?

46. How many 64ths in $\frac{3}{4}$?

SUGGESTION. In $\frac{1}{4}$ there are $\frac{1}{4}$; in $\frac{3}{4}$ there are 3 times $\frac{1}{4}$ or $\frac{3}{4}$.

47. How many 64ths in $\frac{3}{8}$? In $\frac{5}{8}$? In $\frac{7}{8}$? In $\frac{8}{16}$? In $\frac{5}{16}$? In $\frac{7}{16}$? In $\frac{9}{16}$? In $\frac{11}{16}$? In $\frac{13}{16}$? In $\frac{15}{16}$?

48. How many 32ds in each of the fractions in problem 43?

49. A piece of property is divided into 64 equal shares. A owns $\frac{1}{4}$ of it, B $\frac{3}{8}$, C $\frac{3}{16}$. What part of the property do all three own? How many shares do all three own?

50. A pole 32 ft. long stands $\frac{5}{8}$ in the air, $\frac{3}{16}$ in the water, and the rest in the mud. How many feet of the pole are in the mud?

51. $\frac{1}{8}$ of a certain distance is 8 miles. What is $\frac{1}{8}$ of the distance?

SUGGESTION. The ratio of $\frac{1}{8}$ to $\frac{1}{8}$ is that of $\frac{8}{8}$ to $\frac{1}{8}$, or 8. Therefore 8×8 miles, or 64 miles = $\frac{1}{8}$ of the distance.

52. $\frac{1}{32}$ of a certain distance is 5 miles. What is $\frac{1}{4}$ of the distance? What is the ratio of $\frac{1}{4}$ to $\frac{1}{32}$?

53. $\frac{3}{16}$ of a certain distance is 6 miles. What is $\frac{3}{4}$ of the distance?

54. If $\frac{1}{2}$ of a ton of coal costs \$3, how much will $\frac{3}{8}$ of a ton cost?

55. A milkman sold $\frac{2}{3}$ of his milk to one customer, $\frac{1}{16}$ of it to another, and $\frac{1}{8}$ of it to a third. What part of his milk did he sell to all three?

56. A man owning $\frac{3}{4}$ of a piece of property sold $\frac{5}{16}$ of the property. What part of it did he have left?

57. A man owning $\frac{9}{16}$ of a piece of property sold $\frac{1}{4}$ of what he owned. What part of the property did he sell? What part did he still own?

58. Count by 64ths, giving each fraction in its simplest form, thus: $\frac{1}{84}$, $\frac{1}{82}$, $\frac{3}{84}$, $\frac{1}{16}$, etc., to $\frac{64}{84}$. Note that $\frac{1}{84}$ is the difference between adjacent fractions.

59. Count by 32ds to $\frac{32}{32}$. By 16ths to $\frac{16}{16}$. By 8ths to $\frac{8}{8}$.

60. A lady bought some remnants consisting of $\frac{3}{8}$ yd. of velvet, $\frac{3}{4}$ yd. of silk, $\frac{5}{16}$ yd. of satin, and $\frac{1}{2}$ yd. of plush. How many yards of cloth did she buy all together?

61. Into how many pieces $\frac{1}{16}$ of a yard long can $\frac{7}{8}$ of a yard of ribbon be cut?

62. A man having a certain distance to ride, rode $\frac{3}{16}$ of it the first day, $\frac{1}{8}$ of it the second day, and $\frac{5}{32}$ of it the third day. What part of the distance did he travel in the three days? What part had he left to ride?

63. A boy having $\frac{1}{4}$ of a pie, divided it equally among himself and three other boys. What part of a pie did each receive?

SECTION III

INTRODUCING THE FRACTION ONE THIRD AND DEVELOPING RELATIONS

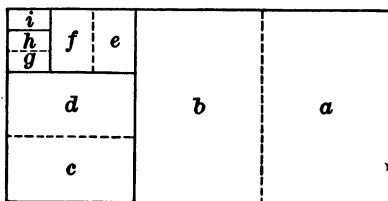

1. What divisions of the rectangle are equal?
2. What part of the rectangle is *a*? *b*? What part is all besides *a* and *b*?
3. What is the ratio of *c* to *b*? Of *d* to *b*?
4. How many parts the size of *c* are there in the whole rectangle?
5. $\frac{1}{3}$ of $\frac{1}{3} = ?$ What is the ratio of $\frac{1}{3}$ to $\frac{1}{3}$?
6. What is the ratio of *e* to *d*? To *c*? To *b*? To the whole rectangle?
7. $\frac{1}{3}$ of $\frac{1}{9} = ?$ What is the ratio of $\frac{1}{9}$ to $\frac{1}{27}$?
8. What is the ratio of *g*, *h*, or *i* to *e*? To *f*? To *d*? To *c*? To *b*? To the whole rectangle?
9. $\frac{1}{3}$ of $\frac{1}{27} = ?$ What is the ratio of $\frac{1}{81}$ to $\frac{1}{27}$?
10. Give the ratios of each part to each of the other parts.

11. What is the ratio of i to $f + e$? To $c + d$? To $a + b$? To $f + d$? To $f + b$? To $f + a$? To $d + b$?

12. What is the ratio of $\frac{1}{81}$ to $\frac{2}{27}$? Of $\frac{1}{81}$ to $\frac{2}{9}$? Of $\frac{1}{81}$ to $\frac{2}{3}$? To $\frac{4}{27}$? To $\frac{10}{27}$? To $\frac{4}{9}$?

13. What part of the rectangle is $b + c$? $b + c + d$? $b + c + d + e$?

14. $\frac{1}{3} + \frac{1}{9} = ?$ $\frac{1}{3} + \frac{2}{9} = ?$ $\frac{1}{3} + \frac{2}{9} + \frac{1}{27} = ?$

15. If $\frac{1}{3}$ is divided into 3 equal parts, what is each part called?

16. If $\frac{1}{9}$ is divided into 3 equal parts, what is each part called?

17. If $\frac{1}{27}$ is divided into 3 equal parts, what is each part called?

18. How many 9ths = $\frac{1}{3}$? How many 27ths = $\frac{1}{9}$? How many 81sts = $\frac{1}{27}$?

19. $\frac{7}{9} =$ how many 27ths? $\frac{7}{9} + \frac{5}{27} = ?$

20. Express in 9ths: $\frac{1}{3}$, $\frac{2}{3}$, $\frac{3}{3}$, $\frac{3}{27}$, $\frac{6}{27}$, $\frac{12}{27}$, $\frac{15}{27}$, $\frac{24}{27}$, $\frac{9}{81}$, $\frac{27}{81}$, $\frac{72}{81}$.

21. Express in 27ths: $\frac{1}{3}$, $\frac{2}{3}$, $\frac{1}{9}$, $\frac{2}{9}$, $\frac{4}{9}$, $\frac{5}{9}$, $\frac{7}{9}$, $\frac{8}{9}$, $\frac{9}{9}$, $\frac{3}{81}$, $\frac{15}{81}$, $\frac{45}{81}$, $\frac{57}{81}$.

22. Express in 81sts: $\frac{1}{3}$, $\frac{2}{3}$, $\frac{3}{3}$, $\frac{1}{9}$, $\frac{5}{9}$, $\frac{1}{27}$, $\frac{8}{27}$, $\frac{13}{27}$, $\frac{25}{27}$.

23. If 3ds are given, how can you change them to 9ths? To 27ths? To 81sts?

24. If 9ths are given, how can you change them to 27ths? To 81sts? To 3ds?

25. If 27ths are given, how can you change them to 81sts? To 3ds? To 9ths?

26. If 81sts are given, how can you change them to 3ds? To 9ths? To 27ths?

27. What is the ratio of any number of 81sts to the same number of 27ths? To the same number of 9ths? To the same number of 3ds?

28. What is the ratio of any number of 27ths to the same number of 9ths? To the same number of 3ds? To the same number of 81sts?

29. What is the ratio of any number of 9ths to the same number of 3ds? To the same number of 27ths? To the same number of 81sts?

30. What is the ratio of any number of 3ds to the same number of 9ths? To the same number of 27ths? To the same number of 81sts?

31. Give the ratio of:

$\frac{1}{81}$ to $\frac{1}{27}$	$\frac{1}{27}$ to $\frac{1}{9}$	$\frac{1}{9}$ to $\frac{1}{3}$	$\frac{1}{3}$ to $\frac{1}{9}$
$\frac{2}{81}$ to $\frac{2}{27}$	$\frac{7}{27}$ to $\frac{7}{9}$	$\frac{2}{9}$ to $\frac{2}{3}$	$\frac{2}{3}$ to $\frac{2}{9}$
$\frac{80}{81}$ to $\frac{80}{27}$	$\frac{1}{27}$ to $\frac{1}{3}$	$\frac{5}{9}$ to $\frac{5}{3}$	$\frac{1}{3}$ to $\frac{1}{27}$
$\frac{1}{81}$ to $\frac{1}{9}$	$\frac{2}{27}$ to $\frac{2}{3}$	$\frac{1}{9}$ to $\frac{1}{27}$	$\frac{2}{3}$ to $\frac{2}{27}$
$\frac{5}{81}$ to $\frac{5}{9}$	$\frac{1}{27}$ to $\frac{1}{81}$	$\frac{7}{9}$ to $\frac{7}{27}$	$\frac{1}{3}$ to $\frac{1}{81}$
$\frac{1}{81}$ to $\frac{1}{3}$	$\frac{10}{27}$ to $\frac{10}{81}$	$\frac{1}{9}$ to $\frac{1}{81}$	$\frac{2}{3}$ to $\frac{2}{81}$
$\frac{2}{81}$ to $\frac{2}{3}$	$\frac{25}{27}$ to $\frac{25}{81}$	$\frac{5}{9}$ to $\frac{5}{81}$	$\frac{4}{3}$ to $\frac{4}{81}$

32. Using the fractions $\frac{1}{27}$, $\frac{2}{27}$, $\frac{1}{9}$, $\frac{4}{27}$, $\frac{5}{27}$, $\frac{2}{9}$, $\frac{7}{27}$, $\frac{8}{27}$, $\frac{1}{3}$, add each one to each one following, as $\frac{1}{27} + \frac{2}{27}$, $\frac{1}{27} + \frac{1}{9}$, $\frac{1}{27} + \frac{4}{27}$, etc.

33. Using the same fractions, subtract each one from each one that follows, as $\frac{2}{27} - \frac{1}{27}$, $\frac{1}{9} - \frac{1}{27}$, etc.

34. Add $\frac{2}{27}$, $\frac{2}{9}$, $\frac{2}{81}$, and $\frac{1}{3}$.

35. What part of 9 yd. is 2 ft.?

36. If $\frac{1}{3}$ of a rectangle is divided into 2 equal parts, how many of those parts are there in the rectangle? What is $\frac{1}{2}$ of $\frac{1}{3}$? $\frac{1}{3}$ of $\frac{1}{2}$ = ? $\frac{1}{6}$ of 1 = ?

37. If $\frac{1}{6}$ of a rectangle is divided into 2 equal parts, how many of those parts are there in the rectangle? $\frac{1}{2}$ of $\frac{1}{6}$ = ? $\frac{1}{6}$ of $\frac{1}{2}$ = ? $\frac{1}{4}$ of $\frac{1}{3}$ = ? $\frac{1}{3}$ of $\frac{1}{4}$ = ? $\frac{1}{12}$ of 1 = ?

38. If $\frac{1}{12}$ of a rectangle is divided into 2 equal parts, what fraction of the whole rectangle is each of them? $\frac{1}{2}$ of $\frac{1}{12}$ = ? $\frac{1}{12}$ of $\frac{1}{2}$ = ? $\frac{1}{3}$ of $\frac{1}{8}$ = ? $\frac{1}{8}$ of $\frac{1}{3}$ = ? $\frac{1}{4}$ of $\frac{1}{6}$ = ? $\frac{1}{6}$ of $\frac{1}{4}$ = ? $\frac{1}{24}$ of 1 = ?

39. If $\frac{1}{24}$ of a rectangle is divided into 2 equal parts, what fraction of the rectangle is each of them? $\frac{1}{2}$ of $\frac{1}{24}$ = ? $\frac{1}{24}$ of $\frac{1}{2}$ = ? $\frac{1}{3}$ of $\frac{1}{16}$ = ? $\frac{1}{16}$ of $\frac{1}{3}$ = ? $\frac{1}{4}$ of $\frac{1}{12}$ = ? $\frac{1}{12}$ of $\frac{1}{4}$ = ? $\frac{1}{6}$ of $\frac{1}{8}$ = ? $\frac{1}{8}$ of $\frac{1}{6}$ = ? $\frac{1}{24}$ of 1 = ?

40. State the ways in which $\frac{1}{6}$ of anything may be found.
Ans. $\frac{1}{2}$ of $\frac{1}{3}$, $\frac{1}{3}$ of $\frac{1}{2}$, $\frac{1}{6}$ of 1.

41. State the ways in which $\frac{1}{12}$ of anything may be found. $\frac{1}{24}$ of anything. $\frac{1}{48}$ of anything.

42. If $\frac{1}{8}$ of a rectangle is divided into 2 equal parts, what fraction of the whole is each of them? $\frac{1}{2}$ of $\frac{1}{8}$ = ? $\frac{1}{8}$ of $\frac{1}{2}$ = ? $\frac{1}{3}$ of $\frac{1}{6}$ = ? $\frac{1}{6}$ of $\frac{1}{3}$ = ? $\frac{1}{18}$ of 1 = ?

43. $\frac{1}{2}$ of $\frac{1}{27}$ = ? $\frac{1}{27}$ of $\frac{1}{2}$ = ? $\frac{1}{54}$ of 1 = ?

44. State the ways in which $\frac{1}{18}$ of anything may be found. $\frac{1}{36}$ of anything. $\frac{1}{72}$ of anything. $\frac{1}{54}$ of anything.

45. Count by 72ds, thus: $\frac{1}{72}$, $\frac{1}{36}$, $\frac{1}{24}$, $\frac{1}{18}$, $\frac{5}{72}$, $\frac{1}{12}$, etc., to $\frac{72}{72}$.

46. Count by 54ths in a similar way. By 48ths. By 36ths. By 24ths. By 18ths. By 12ths.

47. A owns $\frac{1}{8}$ of a mine, B owns $\frac{1}{4}$ of it, C $\frac{1}{8}$, and D $\frac{1}{12}$ of it. What part of the mine do all four own? If E owns the rest of the mine, what part of it does he own?

48. What is the sum of $\frac{1}{8}$ and $\frac{1}{8}$?

49. Five boys bought a ball together. The first contributed $\frac{1}{8}$ of the cost, the second $\frac{2}{16}$, the third $\frac{5}{12}$, and the fourth $\frac{1}{8}$. What part did the fifth boy contribute?

50. If the ball cost 48 cts., how much did each give?

51. A farmer sold $\frac{1}{8}$ of a load of vegetables to one dealer, $\frac{1}{4}$ to another, $\frac{1}{8}$ to a third, and the rest to a fourth. What part of the load did the fourth buy?

52. How many 72ds in $\frac{1}{12}$? In $\frac{1}{24}$?

53. $\frac{5}{8}$ of a certain distance is 15 miles. What is $\frac{1}{8}$ of the distance? $\frac{1}{8}$ of the distance?

54. $\frac{7}{24}$ of a certain distance is 14 miles. What is the whole distance?

55. $\frac{5}{8}$ of a ton of coal costs \$5. How much does $\frac{1}{2}$ ton cost?

SUGGESTION. The ratio of $\frac{1}{2}$ to $\frac{5}{8}$ is $\frac{4}{5}$. Therefore $\frac{1}{2}$ ton is worth $\frac{4}{5}$ of \$5, or \$4.

56. $\frac{5}{12}$ of a ton of hay is worth \$10. How much is $\frac{2}{3}$ of a ton worth?

57. If $\frac{2}{3}$ of a yard of cloth costs 30¢, how much will $\frac{3}{4}$ of a yard cost?

58. $\frac{3}{16}$ of a certain piece of property is valued at \$3600. At that rate how much is $\frac{5}{8}$ of it worth?

59. $\frac{5}{24}$ of a mining claim sold for \$2500. At the same rate, for how much should $\frac{7}{12}$ of it sell?

60. What is the ratio of $\frac{5}{8}$ to $\frac{2}{16}$? Of $\frac{7}{12}$ to $\frac{5}{24}$?

61. What is the ratio of $\frac{2}{3}$ of $\frac{3}{4}$ to $\frac{5}{8}$ of $\frac{1}{3}$?

SECTION IV

INTRODUCING THE FRACTION ONE FIFTH AND DEVELOPING RELATIONS

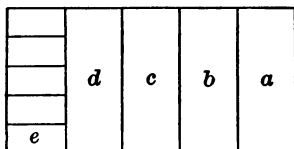

1. What part of the rectangle is a ? b ? c ? d ?
 $a + b$? $a + b + c$? $a + b + c + d$?

2. What is the ratio of e to d ? To c ? To b ? To a ? To $a + b$? To $a + b + c$? To $a + b + c + d$? What part of the whole rectangle is e ?

3. What is the ratio of $\frac{1}{2}e$ to $\frac{1}{5}$? To $\frac{2}{5}$? To $\frac{3}{5}$? To $\frac{4}{5}$? To $\frac{5}{5}$?

4. If a is divided into 2 equal parts, what fraction of the rectangle is each part? $\frac{1}{10} + \frac{1}{10} = ?$

5. What is the ratio of $\frac{1}{10}$ to $\frac{1}{5}$? To $\frac{1}{25}$? To $\frac{2}{5}$? $\frac{3}{5}$? $\frac{4}{5}$? $\frac{5}{5}$? $\frac{10}{10}$?

6. How many e 's would it take to equal $\frac{1}{2}$ of a ?

7. If b is divided into 3 equal parts, what fraction of the rectangle is each of the parts? Two of them? 3? 4? 5? 10? 15?

8. $\frac{1}{3}$ of $\frac{1}{5} = ?$ $\frac{2}{3}$ of $\frac{1}{5} = ?$ $\frac{3}{3}$ of $\frac{1}{5}$? $\frac{4}{3}$ of $\frac{1}{5}$? $\frac{5}{3}$ of $\frac{1}{5}$?
 $\frac{10}{3}$ of $\frac{1}{5}$? $\frac{15}{3}$ of $\frac{1}{5}$?

9. What is the ratio of $\frac{1}{15}$ to $\frac{1}{5}$? To $\frac{1}{10}$? How many e 's would it take to make $\frac{1}{3}$ of d ?

10. What fraction of the rectangle is one of the 4 equal parts of c ? 2 of them? 3? 4? 5? 10? 15?

11. $\frac{1}{4}$ of $\frac{1}{5} = ?$ $\frac{2}{4}$ of $\frac{1}{5}$? $\frac{3}{4}$? $\frac{4}{4}$? $\frac{5}{4}$? $\frac{10}{4}$? $\frac{15}{4}$?

12. What is the ratio of $\frac{1}{20}$ to $\frac{1}{5}$? To $\frac{1}{10}$?

13. What is the ratio of $\frac{2}{5}$ to $\frac{4}{10}$? $\frac{2}{5}$ to $\frac{8}{20}$? $\frac{2}{5}$ to $\frac{6}{15}$?

14. What is the ratio of $\frac{2}{5}$ to $\frac{2}{10}$? $\frac{2}{5}$ to $\frac{3}{10}$? Of any number of 5ths to the same number of 10ths?

15. What part of the rectangle is one of the 6 equal parts of a ? One of the 8 equal parts of a ? One of the 9 equal parts? 10? 12? 15? 16? 18? 20?

16. Give the ratio of each of the following fractions to each of the others: $\frac{1}{5}$, $\frac{1}{10}$, $\frac{1}{15}$, $\frac{1}{20}$, $\frac{1}{25}$, $\frac{1}{30}$, $\frac{1}{60}$, $\frac{1}{100}$.

17. When the numerators of two fractions are alike, what simple way do you see of telling the ratio of one to the other? The ratio of $\frac{3}{4}$ to $\frac{3}{5}$ is $\frac{5}{4}$; of $\frac{3}{8}$ to $\frac{3}{32}$ is $\frac{32}{8}$, or 4.

18. Give the ratio of:

$\frac{3}{5}$ to $\frac{3}{10}$	$\frac{2}{5}$ to $\frac{2}{40}$	$\frac{9}{100}$ to $\frac{9}{25}$	$\frac{12}{90}$ to $\frac{12}{45}$
$\frac{4}{5}$ to $\frac{4}{15}$	$\frac{3}{10}$ to $\frac{3}{50}$	$\frac{6}{25}$ to $\frac{6}{100}$	$\frac{5}{18}$ to $\frac{5}{45}$
$\frac{3}{5}$ to $\frac{3}{20}$	$\frac{7}{10}$ to $\frac{7}{60}$	$\frac{8}{80}$ to $\frac{8}{20}$	$\frac{1}{100}$ to $\frac{1}{10}$
$\frac{11}{5}$ to $\frac{11}{25}$	$\frac{17}{10}$ to $\frac{17}{80}$	$\frac{5}{24}$ to $\frac{5}{16}$	$\frac{1}{9}$ to $\frac{1}{81}$
$\frac{7}{5}$ to $\frac{7}{30}$	$\frac{2}{15}$ to $\frac{2}{45}$	$\frac{7}{84}$ to $\frac{7}{32}$	$\frac{3}{25}$ to $\frac{3}{75}$

19. Give the ratio of each of the following fractions to each of the others: $\frac{1}{25}$, $\frac{2}{25}$, $\frac{3}{25}$, $\frac{4}{25}$, $\frac{5}{25}$, $\frac{6}{25}$, $\frac{8}{25}$, $\frac{15}{25}$.

20. What is the ratio of $\frac{3}{8}$ to $\frac{5}{8}$? Of $\frac{5}{16}$ to $\frac{9}{16}$? Of $\frac{6}{8}$ to $\frac{5}{8}$?

21. When the denominators are the same, what simple way do you see of finding the ratio of one fraction to another? The ratio of $\frac{5}{8}$ to $\frac{6}{8}$ is $\frac{5}{6}$; of $\frac{7}{25}$ to $\frac{9}{25}$ is $\frac{7}{9}$.

22. What must be done before finding the ratio of fractions whose denominators are unlike?

23. What is the ratio of $\frac{1}{5}$ to $\frac{1}{2}$? Of $\frac{2}{5}$ to $\frac{2}{2}$?

24. What is the ratio of $\frac{3}{16}$ to $\frac{4}{8}$? Of $\frac{3}{8}$ to $\frac{4}{8}$?

25. If $\frac{5}{8}$ of a yard of cloth costs \$1, how much will a yard cost?

SUGGESTION. The ratio of 1 yd. to $\frac{5}{8}$ yd. is $\frac{8}{5}$. Therefore 1 yd. will cost $\frac{8}{5}$ of what $\frac{5}{8}$ of a yard costs, or $\frac{8}{5}$ of \$1, or \$1 $\frac{3}{5}$.

26. If $\frac{3}{4}$ of a yard of cloth costs \$1, what will be the cost of $\frac{7}{8}$ of a yard?

27. If $\frac{5}{8}$ of a quantity of sugar costs \$ $\frac{7}{8}$, how much will $\frac{8}{9}$ of the quantity cost?

28. If 5 lb. of sugar cost \$ $\frac{1}{4}$, find the cost of 7 lb.

29. A can mow $\frac{2}{3}$ of an acre in half a day, and B $\frac{1}{2}$ an acre in the same time. How many acres could both together mow in half a day? In a day? In 2 days?

30. A can do $\frac{2}{3}$ of a certain piece of work in one day, B $\frac{1}{2}$ of it in the same time. How many 12ths of the work can both do in a day? In $\frac{1}{17}$ of a day? If they can do $\frac{1}{12}$ of the work in $\frac{1}{17}$ of a day, how many 17ths of a day will it take them to do $\frac{1}{12}$, or the whole work?

31. A can break $\frac{5}{8}$ of an acre of new land in a day, B $\frac{3}{4}$ of an acre. How long would it take both of them to break one acre?

32. James has $\frac{2}{3}$ as many marbles as John. If John has 30 marbles, how many has James?

33. James has $\frac{2}{3}$ as many marbles as John. If James has 18, how many has John?

34. Four boys found a sum of money, and divided it in such a way that the first got $\frac{3}{8}$ of it, the second $\frac{3}{16}$, the third $\frac{1}{4}$, and the fourth the remainder. What part of the money did the fourth get?

35. A owned $\frac{7}{4}$ of a mill, and B $\frac{11}{8}$. Which owned the greater amount, and how much?

36. A man set out on a four days' journey. The first day he traveled $\frac{1}{8}$ of the distance, the second day $\frac{2}{8}$ of it, the third day $\frac{5}{8}$ of it. What part of the distance did he have to travel the fourth day?

37. A owned $\frac{5}{2}$ of a mill and sold $\frac{3}{4}$ of what he owned. What part of the mill did he sell, and what part did he still own?

38. A owned $\frac{5}{2}$ of a mill and sold $\frac{1}{4}$ of the mill to B. What part of the mill did A still own? What part of his share did he sell? What is the ratio of A's share, after selling, to B's?

39. A has 60 A. of land and B 50 A. A gives half of his land to B, receiving in return half of B's. How many acres has each after the exchange?

40. Five men together own a factory. The first owns $\frac{3}{8}$ of it, the second $\frac{2}{8}$ of it, the third $\frac{7}{4}$ of it, and the fourth $\frac{5}{8}$ of it. What part does the fifth own?

41. If the share of the fifth was \$2000, what was the value of $\frac{1}{48}$ of the factory? Of $\frac{18}{48}$? Of $\frac{9}{48}$? Of $\frac{14}{48}$? Of $\frac{5}{48}$? What was the share of each of the first four men?

42. If the yearly profits of the factory were \$9600, what should the first man receive as his share of the profits? $\frac{3}{8}$ of \$9600 = ? What should each of the others receive?

43. A, B, and C engaged in business. A furnished $\frac{1}{3}$ of the capital, B $\frac{1}{4}$ of it, and C the remainder. What part of the capital did C furnish?

44. If the whole capital was \$2400, how much money did A invest? B? C?

45. If their profits were \$600, how much should A receive? B? C?

46. A, B, and C rent a pasture. A puts in 25 sheep, B 30 sheep, and C 17 sheep. What part of the rent should each pay? If the whole rent is \$36, how much should each pay?

What is the cost for 1 sheep if the cost for 72 sheep is \$36?

47. If $\frac{7}{20}$ of a quantity of sugar cost \$ $\frac{1}{2}$, how much will $\frac{7}{10}$ of the same quantity cost? What is the ratio of $\frac{7}{10}$ to $\frac{7}{20}$?

48. $\frac{5}{8}$ of a yard of cloth cost \$ $\frac{5}{8}$. How much will $\frac{3}{4}$ of a yard cost?

49. At \$ $\frac{2}{6}$ a yard, how many yards of cloth can be bought for \$ $\frac{7}{8}$? What is the ratio of \$ $\frac{7}{8}$ to \$ $\frac{2}{6}$?

50. At \$ $2\frac{1}{2}$ each, how many hats can be bought for \$ $7\frac{1}{2}$? What is the ratio of \$ $1\frac{1}{2}$ to \$ $\frac{5}{2}$? Of \$ $7\frac{1}{2}$ to \$ $2\frac{1}{2}$?

51. At \$ $3\frac{1}{3}$ each how many hats can be bought for \$ $13\frac{1}{3}$? What is the ratio of \$ $4\frac{0}{3}$ to \$ $1\frac{0}{3}$? Of \$ $13\frac{1}{3}$ to \$ $3\frac{1}{3}$?

52. How many yards of ribbon at \$ $\frac{1}{25}$ each can be bought for \$ $\frac{8}{50}$? What is the ratio of \$ $\frac{8}{50}$ to \$ $\frac{1}{25}$?

53. If you know the cost of $\frac{5}{8}$ of a quantity, how can you find the cost of $\frac{1}{2}\frac{1}{4}$ of the quantity? What is the ratio of $\frac{1}{2}\frac{1}{4}$ to $\frac{5}{8}$?

54. Given the cost of $\frac{9}{20}$ of a quantity, how can you find the cost of $\frac{7}{30}$ of the quantity?

Ans. By taking $\frac{1}{2}\frac{1}{4}$ of the cost of $\frac{9}{20}$ of it.

55. Give the ratio of:

$\frac{1}{6}$ to $\frac{5}{12}$. $\frac{1}{4}$ to $\frac{1}{8}$. $\frac{3}{4}$ to $\frac{7}{10}$. $\frac{1}{5}$ to $\frac{1}{4}$. $\frac{6}{25}$ to $\frac{1}{4}$.
 $\frac{3}{4}$ to $\frac{2}{5}$. $\frac{7}{18}$ to $\frac{1}{2}\frac{1}{4}$. $\frac{5}{8}$ to $\frac{5}{4}$. $\frac{16}{27}$ to $\frac{13}{81}$. $\frac{3}{5}$ to $\frac{5}{8}$.

56. Given the cost of $\frac{1}{8}$ of a quantity, how can you find the cost of $\frac{5}{12}$ of it?

Given cost of:

$\frac{3}{4}$, to find cost of $\frac{7}{20}$. $\frac{7}{18}$, to find cost of $\frac{1}{2}\frac{1}{4}$.
 $\frac{1}{4}$, to find cost of $\frac{1}{8}$. $\frac{3}{4}$, to find cost of $\frac{2}{5}$.
 $\frac{6}{25}$, to find cost of $\frac{1}{4}$. $\frac{16}{27}$, to find cost of $\frac{13}{81}$.
 $\frac{1}{5}$, to find cost of $\frac{1}{4}$. $\frac{5}{8}$, to find cost of $\frac{5}{4}$.

57. If 3 yd. 1 ft. of rubber hose cost \$.90, how much will 1 yd. cost?

58. A merchant sold 1 bu. 1 pk. of timothy seed for \$1.20. At that rate how much should he charge for 1 pk. 2 qt.?

59. 8 is the ratio of what to 1 gal. 1 qt.? 8 is the ratio of 10 gal. to what?

60. The cost of one chair is $\frac{5}{4}$ of the cost of another chair. If the first chair cost \$10, how much did the second cost? If the second cost \$12, how much did the first cost? What is the ratio of 10 to 8? Of 15 to 12?

61. What is the ratio of $1\frac{3}{8}$ to $1\frac{1}{8}$? To $\frac{1}{2}$? To $\frac{1}{9}$? To $\frac{3}{8}$? To 2? To $5\frac{3}{8}$?

SECTION V

INTRODUCING THE FRACTION ONE SEVENTH AND DEVELOPING RELATIONS

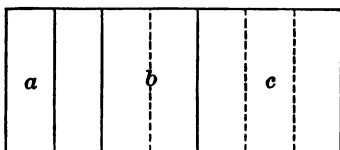

1. What part of the rectangle is a ? b ? c ?
2. What is the ratio of a to the whole rectangle? Of b ? Of c ?
3. What is the ratio of $\frac{1}{7}$ to $\frac{7}{7}$? $\frac{2}{7}$ to $\frac{7}{7}$? $\frac{3}{7}$ to $\frac{7}{7}$? $\frac{4}{7}$? $\frac{5}{7}$? $\frac{6}{7}$? $\frac{7}{7}$?
4. If a is divided into 2 equal parts, what part of the rectangle is each part? What part are both parts? 3 such parts? 4? 5? 6? 8? 10? 13? 14?
5. $\frac{2}{14} =$ how many 7ths? $\frac{4}{14}$? $\frac{6}{14}$? $\frac{8}{14}$? $\frac{10}{14}$? $\frac{12}{14}$? $\frac{14}{14}$?
6. Using the fractions $\frac{1}{14}$, $\frac{1}{7}$, $\frac{2}{14}$, $\frac{2}{7}$, $\frac{3}{14}$, $\frac{3}{7}$, $\frac{1}{2}$, $\frac{4}{7}$, $\frac{5}{14}$, $\frac{5}{7}$, $\frac{6}{14}$, $\frac{6}{7}$, $\frac{7}{14}$, $\frac{7}{7}$, give the ratio of each to each of the others.
7. If $\frac{1}{7}$ is divided into 3 equal parts, how many such parts are there in $\frac{7}{7}$? What is the name of each part? Of 2 such parts? 3? 5? 19? 21?
8. $\frac{2}{21} =$ how many 7ths? $\frac{6}{21}$? $\frac{9}{21}$? $\frac{12}{21}$? $\frac{18}{21}$? $\frac{15}{21}$? $\frac{21}{21}$?

9. $\frac{1}{2}$ of $\frac{1}{7} = ?$ $\frac{1}{2}$ of $\frac{2}{7} = ?$ $\frac{1}{2}$ of $\frac{3}{7} = ?$ $\frac{1}{2}$ of $\frac{4}{7} = ?$
 $\frac{1}{3}$ of $\frac{1}{7} = ?$ $\frac{1}{3}$ of $\frac{2}{7} = ?$ $\frac{1}{3}$ of $\frac{3}{7} = ?$

10. If $\frac{1}{7}$ is divided into 4 equal parts, how many such parts are there in $\frac{2}{7}$? In 1? If $\frac{1}{14}$ is divided into 2 equal parts, how many such parts are there in $\frac{1}{4}$? In 1?

11. $\frac{1}{4}$ of $\frac{1}{7} = ?$ $\frac{1}{2}$ of $\frac{1}{14} = ?$ $\frac{1}{4}$ of $\frac{2}{7} = ?$ $\frac{1}{2}$ of $\frac{2}{14} = ?$
 What is the ratio of $\frac{1}{4}$ of any number of 7ths to $\frac{1}{2}$ of the same number of 14ths?

12. What must be done to $\frac{1}{7}$ to produce $\frac{1}{35}$? How many times $\frac{1}{35} = \frac{1}{7}$? $\frac{2}{7}$? $\frac{3}{7}$? $\frac{4}{7}$? $\frac{5}{7}$? $\frac{6}{7}$? $\frac{7}{7}$?

13. What must be done to $\frac{1}{7}$ to produce $\frac{1}{42}$? What must be done to $\frac{1}{14}$ to produce $\frac{1}{42}$? $\frac{1}{6}$ of $\frac{1}{7} = ?$ $\frac{1}{3}$ of $\frac{1}{14} = ?$
 $\frac{1}{2}$ of $\frac{1}{12} = ?$

14. $\frac{1}{7}$ of $\frac{1}{7} = ?$ Is $\frac{1}{49}$ larger or smaller than $\frac{1}{50}$? Than $\frac{1}{48}$? How many 7ths = $\frac{25}{9}$?

15. $\frac{1}{8}$ of $\frac{1}{7} = ?$ $\frac{1}{4}$ of $\frac{1}{14} = ?$ $\frac{1}{2}$ of $\frac{1}{28} = ?$ $\frac{1}{9}$ of $\frac{1}{7} = ?$
 $\frac{1}{3}$ of $\frac{1}{21} = ?$ $\frac{1}{10}$ of $\frac{1}{7} = ?$ $\frac{1}{5}$ of $\frac{1}{14} = ?$ $\frac{1}{2}$ of $\frac{1}{35} = ?$

16. How many 7ths in $\frac{24}{5}$? In $\frac{25}{3}$? In $\frac{8}{3}$?

17. How many 11ths are there in anything? What is the ratio of 2 to 22? $\frac{1}{2}$ of $\frac{1}{11} = ?$ $\frac{1}{3}$ of $\frac{1}{11} = ?$ $\frac{1}{4}$? $\frac{1}{5}$? $\frac{1}{6}$? $\frac{1}{7}$? $\frac{1}{8}$? $\frac{1}{9}$? $\frac{1}{11}$ of $\frac{1}{2} = ?$ $\frac{1}{11}$ of $\frac{1}{3} = ?$ $\frac{1}{11}$ of $\frac{1}{4} = ?$
 $\frac{1}{5}$? $\frac{1}{6}$? $\frac{1}{7}$? $\frac{1}{8}$? $\frac{1}{9}$?

18. If a rectangle is divided into 13 equal parts, what name is given to one of the parts? To 2 of them? To 3 of them? 4? 7? 12? 13?

19. $\frac{1}{2}$ of $\frac{1}{18} = ?$ $\frac{1}{3}$ of $\frac{1}{18} = ?$ $\frac{1}{4}$? $\frac{1}{5}$? $\frac{1}{6}$? $\frac{1}{7}$?

20. What name is given to one of the 17 equal parts of a rectangle? To one of the 19 equal parts? To one of

the 23 equal parts? Of the 29 equal parts? 31? 37? 41? 43? 47? 53? 59? 61? 67? 71? 73? 79? 83? 89? 97?

21. We may think of $\frac{1}{12}$ as being $\frac{1}{8}$ of $\frac{1}{2}$, or $\frac{1}{4}$ of $\frac{1}{3}$, or $\frac{1}{3}$ of $\frac{1}{4}$, or $\frac{1}{2}$ of $\frac{1}{6}$. Why is it not possible to think of any of the fractions indicated in problem 20 in a similar way?

22. $\frac{1}{2}$ of $\frac{1}{19} = ?$ $\frac{1}{3}$ of $\frac{1}{19} = ?$ $\frac{1}{4}$ of $\frac{1}{19} = ?$ What are the values of the similar parts of $\frac{1}{17}$, $\frac{1}{23}$, and $\frac{1}{29}$?

23. If $\frac{3}{17}$ of a quantity costs \$25, how much will $\frac{9}{51}$ of it cost?

24. What is the ratio of $\frac{1}{41}$ to $\frac{1}{82}$? Of $\frac{5}{82}$ to $\frac{7}{41}$? Of $\frac{3}{74}$ to $\frac{4}{37}$? Of $\frac{4}{29}$ to $\frac{10}{87}$? Of $\frac{5}{89}$ to $\frac{7}{38}$? Of $\frac{5}{17}$ to $\frac{3}{8}$? Of $\frac{8}{19}$ to $\frac{8}{57}$?

25. $\frac{3}{7}$ of a certain distance is 21 miles. What is $\frac{5}{9}$ of the distance?

26. A owned $\frac{5}{11}$ of a mill, B $\frac{3}{22}$, C $\frac{7}{22}$, and D the rest. What is the ratio of D's share to that of each of the others?

27. If D's share is \$1000, what is the value of A's share? B's? C's? Of the whole mill?

28. A piece of property is divided into 63 equal shares. A owns $\frac{1}{7}$ of it, B $\frac{4}{21}$, C $\frac{4}{9}$, and D the remainder. How many shares does each own? What is the ratio of A's part to each of the others? Of B's? Of C's? Of D's?

29. A pole 77 ft. long stands $\frac{4}{11}$ in the mud, $\frac{2}{7}$ in the water, and the rest in the air. How many feet of the pole are in the air?

30. A miner found 5 nuggets of gold. The first weighed $\frac{2}{3}$ oz., the second $\frac{3}{8}$ oz., the third $\frac{5}{8}$ oz., the fourth $\frac{5}{11}$ oz., and the fifth $\frac{1}{3}$ oz. What was the weight of all?

31. A man owning $\frac{3}{19}$ of a piece of property sold $\frac{3}{38}$ of the property. What part of the property had he left?

32. A man owning $\frac{5}{7}$ of a mill sold $\frac{5}{8}$ of what he owned. What part of the mill did he sell? What part did he still own?

33. A can mow $\frac{5}{8}$ of an acre in half a day, and B $\frac{3}{4}$ of an acre in the same time. How many acres can both mow in half a day? In 10 days? In 16 days?

34. A can plow $\frac{7}{4}$ acres in one day, and B $\frac{7}{5}$ acres. How long would it take both of them working together to plow 1 acre? 9 acres? 21 acres?

35. A can do a certain piece of work in 7 days, B in 5 days. What part of the work can A do in 1 day? B? Both? How many days will it take both to do the work if they can do $\frac{1}{3}$ in 1 day?

36. A can plow a certain field in 4 days, B in 5 days. How many days would it take both?

37. A can saw seven cords of wood in 3 days, B in 4 days, and C in 5 days. How many days would it take all three to saw seven cords?

38. James has $\frac{6}{11}$ as many marbles as John. If John has 55 marbles, how many has James?

39. James has $\frac{6}{11}$ as many marbles as John. How many has John, if James has 42?

40. Four boys found a sum of money, and divided it in such a way that the first got $\frac{3}{7}$ of it, the second $\frac{2}{11}$, the third $\frac{1}{7}$, and the fourth the remainder. What part of the money did the fourth get? What is the ratio of the share of the first to each of the others? Of the second? Third? Fourth?

41. If the sum of money found was \$2.31, how many cents did each receive? What is the ratio of the share of each to the share of each of the others?

42. A owned $\frac{5}{11}$ of a mill, and B $\frac{2}{5}$ of it. Which owned the greater amount, and how much?

43. A owned $\frac{7}{8}$ of a mill and sold $\frac{1}{3}$ of his share. What part of the mill did he still own? What is the ratio of the part he owned after selling to the part he owned at first?

44. A owned $\frac{1}{3}$ of a mill and sold $\frac{1}{3}$ of the mill to B. What part of the mill did A still own?

45. A has 60 acres of land, and B 50 acres? A exchanges $\frac{1}{5}$ of his land for $\frac{1}{5}$ of B's. How many acres has each after the exchange?

46. The ratio of the circumference of a circle to its diameter is about $\frac{22}{7}$.* What is the circumference of a circle whose diameter is 7 inches?

47. A wagon wheel is 35 inches in diameter. What is its circumference?

48. How many times will a wheelbarrow wheel 14 in. in diameter turn in going 12 ft.?

49. A bicycle wheel turns 3 times in going 22 ft. What is its diameter?

50. What is the ratio of $7\frac{1}{3}$ ft. to 28 in.?

51. A horse is tied to a stake with a rope 14 yd. long. If he walks around the stake in as large a circle as the rope will permit, how many yards does he travel in going around once?

* This ratio is a little too large, but is close enough for small circles.

52. What is the ratio of 5 to 7? Of $\frac{1}{2}$ of 5 to $\frac{1}{2}$ of 7? Of $\frac{1}{3}$ of 5 to $\frac{1}{3}$ of 7? Of 3×5 to 3×7 ? Of $2\frac{2}{7} \times 5$ to $2\frac{2}{7} \times 7$?

53. What is the ratio of the circumferences of two circles whose diameters are 5 and 7?

54. What is the ratio of the circumferences of two circles whose radii are $2\frac{1}{2}$ and $3\frac{1}{2}$?

55. A, B, and C rent a pasture for \$23 $\frac{1}{2}$. A puts in 20 sheep, B 21, and C 6. How much should each pay? What is the ratio of what A pays to what B pays? To what C pays? Of B's share to A's? To C's? Of C's share to B's? Of the number of sheep of each to the number of each of the others? Of the fraction of the whole number of sheep each has to the fraction of the whole number each of the others has?

56. A, B, C, and D engage in business. A puts in \$1000, B \$2000, C \$3000, and D \$4000. At the end of a year they find they have gained \$5000. What is each one's share of the gain?

57. What is the ratio of the gain of each to the gain of each of the others? Of the investment of each to the investment of each of the others?

58. If you know the cost of $\frac{7}{18}$ of a quantity, how can you find the cost of $\frac{1}{10}$ of the same quantity?

59. If $\frac{7}{18}$ of a quantity of sugar is worth \$35, what is the value of $\frac{1}{10}$ of the quantity?

60. The cost of a horse was $\frac{7}{8}$ of the cost of a cow. If the horse cost \$140, how much did the cow cost? If the cow had cost \$39, how much would the horse have cost?

SECTION VI

DEVELOPING THE IDEA OF DECIMALS AND THEIR RELATION TO OTHER FRACTIONS

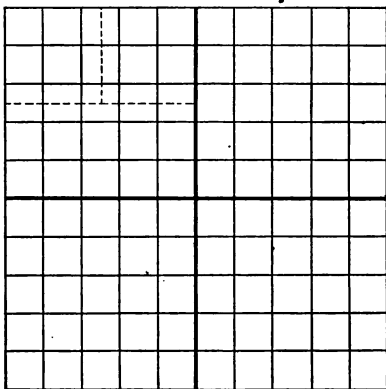

1. What part of the whole square is each of the small squares? How many small squares are there in the whole?

2. What part of the whole square are fifty of the small squares? $\frac{50}{100} =$ what? $\frac{1}{2} =$ how many hundredths? $.50$ of the square is the same as what part of the square? (Note the decimal point and learn its use.)

3. James has 24 marbles; John has $.50$ as many. How many has John?

4. How many small squares are there in $\frac{1}{4}$ of the large square? In $\frac{2}{4}$? $\frac{3}{4}$? $\frac{4}{4}$? $\frac{1}{2}$?

5. Give in fourths the values of .75, .25, .50, 1.00.

6. If $\frac{1}{4} = .25$, how many hundredths are there in $\frac{1}{8}$? How many small squares = $\frac{1}{8}$ of the large square? $\frac{1}{4}$? $\frac{2}{8}$? $\frac{3}{8}$? $\frac{1}{2}$? $\frac{4}{8}$? $\frac{5}{8}$? $\frac{3}{4}$? $\frac{6}{8}$? $\frac{7}{8}$? $\frac{8}{8}$? $\frac{1}{4}$? $\frac{2}{2}$?

7. Give in eighths the values of .25; $.37\frac{1}{2}$; $.12\frac{1}{2}$; $.62\frac{1}{2}$; $.87\frac{1}{2}$; .50; .75; 1.00.

8. If $.12\frac{1}{2} = \frac{1}{8}$, how many hundredths = $\frac{1}{16}$? $\frac{2}{16}$? $\frac{1}{8}$? $\frac{3}{16}$? $\frac{4}{16}$? $\frac{1}{4}$? $\frac{5}{16}$? $\frac{6}{16}$? $\frac{3}{8}$? $\frac{7}{16}$? $\frac{8}{16}$? $\frac{1}{2}$? $\frac{9}{16}$? $\frac{10}{16}$? $\frac{5}{8}$? $\frac{11}{16}$? $\frac{12}{16}$? $\frac{3}{4}$? $\frac{13}{16}$? $\frac{14}{16}$? $\frac{7}{8}$? $\frac{15}{16}$? $\frac{16}{16}$? $\frac{8}{8}$? $\frac{1}{4}$?

9. Give the values in sixteenths of $.31\frac{1}{4}$; .50; $.12\frac{1}{2}$; $.87\frac{1}{2}$; $.43\frac{3}{4}$; $.18\frac{3}{4}$; $.93\frac{3}{4}$; $.56\frac{1}{4}$; $.68\frac{3}{4}$; .75; $.06\frac{1}{4}$; $.37\frac{1}{2}$; $.62\frac{1}{2}$; $.81\frac{1}{4}$; .25.

10. Give the ratio of:

$.12\frac{1}{2}$ to $.87\frac{1}{2}$	$.87\frac{1}{2}$ to .25	$.06\frac{1}{4}$ to $.62\frac{1}{2}$
.50 to $.43\frac{3}{4}$	$.93\frac{3}{4}$ to .75	.25 to $.37\frac{1}{2}$
$.18\frac{3}{4}$ to $.56\frac{1}{4}$	$.93\frac{3}{4}$ to $.68\frac{3}{4}$.25 to $.81\frac{1}{4}$
.75 to $.37\frac{1}{2}$.75 to $.06\frac{1}{4}$	$.43\frac{3}{4}$ to $.18\frac{3}{4}$
$.81\frac{1}{4}$ to .25	$.62\frac{1}{2}$ to $.81\frac{1}{4}$	$.43\frac{3}{4}$ to $.37\frac{1}{2}$
.50 to .25	$.87\frac{1}{2}$ to $.93\frac{3}{4}$	$.81\frac{1}{4}$ to $.93\frac{3}{4}$
.75 to .25	$.68\frac{3}{4}$ to .75	$.68\frac{3}{4}$ to $.56\frac{1}{4}$

11. If you know the cost of $.81\frac{1}{4}$ of a quantity, how can you find the cost of $.87\frac{1}{2}$ of it? Of $.93\frac{3}{4}$ of it? Of .25? Of $.68\frac{3}{4}$? Of $.62\frac{1}{2}$? Of $.12\frac{1}{2}$? Of $.18\frac{3}{4}$?

12. If you know the weight of $.18\frac{3}{4}$ of a bag of grain, how can you find the weight of $.56\frac{1}{4}$ of it? Of $.43\frac{3}{4}$ of it? Of $.87\frac{1}{2}$ of it? Of .50? Of $.62\frac{1}{2}$? Of $.37\frac{1}{2}$?

13. If .25 of a quantity of coal weighs 3 T., how much does .75 of it weigh? .50? $.18\frac{3}{4}$? $.62\frac{1}{2}$?

14. At the rate of \$.30 for $.37\frac{1}{2}$ yd. of cloth, how much will $.87\frac{1}{2}$ of a yd. cost? $.62\frac{1}{2}$? $.12\frac{1}{2}$?

15. At the rate of \$.21 for $.43\frac{3}{4}$ of a bushel of wheat, what is the value of $\frac{5}{16}$ of a bushel? $\frac{9}{16}$? $\frac{11}{16}$? $\frac{15}{16}$? $\frac{7}{8}$? $\frac{3}{4}$? $\frac{1}{2}$?

16. $\frac{5}{16}$ of a piece of land is worth \$5000. What is the value of $.43\frac{3}{4}$ of it? $.75$? $.87\frac{1}{2}$? $.68\frac{3}{4}$? $.06\frac{1}{4}$?

17. A farmer sold $.18\frac{3}{4}$ of a load of corn. What was the ratio of what remained to what was sold? Of what remained to the whole load?

18. $.37\frac{1}{2}$ of a certain distance is 24 miles. What is $.87\frac{1}{2}$ of it? $.43\frac{3}{4}$ of it? $.56\frac{1}{4}$ of it? The whole distance?

19. James has $.31\frac{1}{4}$ as many marbles as John. If James has 25, how many has John? If John has 32, how many has James? What is the ratio of James's marbles to John's?

20. The ratio of a certain number to another is $.68\frac{3}{4}$. The larger number is 96. What is the other? If the smaller number had been 44, what would the larger have been?

21. A owned $\frac{3}{8}$ of a mill, B $.18\frac{3}{4}$, C $\frac{3}{16}$, D $.12\frac{1}{2}$, and E the remainder. What part of the mill did E own? What was the ratio of A's share to each of the others? Of B's? Of C's? Of D's? Of E's?

22. At $$.12\frac{1}{2}$ a yard, how many yards of cloth can be bought for \$.75? For $$.1$? For $$.7$? For $$.11$?

23. At $$.6\frac{1}{4}$ each, how many plows can be bought for $\frac{7}{8}$ of \$100? For $\frac{9}{16}$ of \$100? For $$.43\frac{3}{4}$?

24. At $\$.31\frac{1}{4}$ each, how many books can be bought for $\$5$? For $\$10$?

25. How many quarts are there in $.43\frac{3}{4}$ of a bushel? What is the ratio of $.18\frac{3}{4}$ pk. to $.31\frac{1}{4}$ bu.?

26. How many hundredths are there in 1? In $\frac{1}{3}$ of 1? In $\frac{2}{3}$? In $\frac{1}{2}$ of $\frac{1}{3}$? In $\frac{1}{2}$? In $\frac{1}{3}$ of $\frac{1}{2}$? In $\frac{1}{6}$? $\frac{2}{6}$? $\frac{1}{3}$? $\frac{1}{2}$? $\frac{3}{6}$? $\frac{2}{3}$? $\frac{4}{6}$? $\frac{5}{6}$? $\frac{6}{6}$?

27. Give in sixths the values of $.33\frac{1}{3}$, $.50$, $.66\frac{2}{3}$, $.83\frac{1}{3}$, $.16\frac{2}{3}$, 1.00 . Which of these can be expressed exactly in thirds?

28. Give the ratio of:

$.16\frac{2}{3}$ to $.50$	$.33\frac{1}{3}$ to $.66\frac{2}{3}$	$.66\frac{2}{3}$ to $.83\frac{1}{3}$
$.50$ to $.33\frac{1}{3}$	$.83\frac{1}{3}$ to $.16\frac{2}{3}$	1.00 to $.83\frac{1}{3}$
$.66\frac{2}{3}$ to $.50$	$.33\frac{1}{3}$ to $.50$	
$.83\frac{1}{3}$ to $.66\frac{2}{3}$	$.33\frac{1}{3}$ to 1.00	

29. If you know the cost of $.33\frac{1}{3}$ of a quantity, how can you find the cost of $.66\frac{2}{3}$ of it? Of $.50$ of it? Of all of it?

30. Given the weight of $.83\frac{1}{3}$ of a load of corn, how can you find the weight of $.16\frac{2}{3}$ of it? Of $.66\frac{2}{3}$? Of $.33\frac{1}{3}$? Of $.50$?

31. How many hundredths are there in $\frac{1}{4}$? In $\frac{1}{3}$ of $\frac{1}{4}$? In $\frac{1}{12}$? In $\frac{2}{12}$? $\frac{1}{6}$? $\frac{3}{12}$? $\frac{1}{4}$? $\frac{4}{12}$? $\frac{1}{3}$? $\frac{5}{12}$? $\frac{6}{12}$? $\frac{1}{2}$? $\frac{7}{12}$? $\frac{8}{12}$? $\frac{2}{3}$? $\frac{9}{12}$? $\frac{3}{4}$? $\frac{10}{12}$? $\frac{5}{6}$? $\frac{11}{12}$? $\frac{12}{12}$? How many new decimals are there here? What are the four?

32. Give in twelfths the values of $.91\frac{2}{3}$, $.41\frac{2}{3}$, $.58\frac{1}{3}$, $.08\frac{1}{3}$. Give in twelfths and also in lower terms the equivalents of $.83\frac{1}{3}$, $.66\frac{2}{3}$, $.50$, $.33\frac{1}{3}$, $.75$, $.25$, $.16\frac{2}{3}$, 1.00 .

33. Give the ratio of :

$.91\frac{2}{3}$ to $.41\frac{2}{3}$	$.66\frac{2}{3}$ to $.75$	$.16\frac{2}{3}$ to $\frac{3}{4}$
$.41\frac{2}{3}$ to $.58\frac{1}{3}$	$.83\frac{1}{3}$ to 1.00	$\frac{1}{12}$ to $.58\frac{1}{3}$
$.08\frac{1}{3}$ to $.50$	$.75$ to $.41\frac{2}{3}$	$.41\frac{2}{3}$ to $\frac{1}{3}$
$.50$ to $.08\frac{1}{3}$	$.66\frac{2}{3}$ to $.58\frac{1}{3}$	1.00 to $.16\frac{2}{3}$
$.33\frac{1}{3}$ to $.75$	$.25$ to $.75$	$\frac{2}{3}$ to $.41\frac{2}{3}$
$.16\frac{2}{3}$ to $.08\frac{1}{3}$	$.33\frac{1}{3}$ to $.25$	$.25$ to $.91\frac{2}{3}$
$.33\frac{1}{3}$ to $.50$		$.12\frac{1}{2}$ to $.16\frac{2}{3}$

34. If you know the cost of $.41\frac{2}{3}$ hundredths of a quantity, how can you find the cost of $\frac{1}{12}$ of it? Of $.75$ of it? Of $\frac{2}{3}$ of it? Of $.62\frac{1}{2}$ of it?

35. If you know the weight of $.58\frac{1}{3}$ of a bag of sugar, how can you find the weight of $.41\frac{2}{3}$ of it? Of $.66\frac{2}{3}$ of it? Of $\frac{1}{12}$ of it?

36. At the rate of \$.22 for $.91\frac{2}{3}$ yd. of cloth, how much will $1.83\frac{1}{3}$ yd. cost? $.50$ yd.? $.33\frac{1}{3}$ yd.? $.58\frac{1}{3}$ yd.?

37. $\frac{7}{8}$ of a farm is worth \$2100. What is the value of $.58\frac{1}{3}$ of it? Of $.50$ of it? Of $.62\frac{1}{2}$ of it? Of $.66\frac{2}{3}$ of it?

38. If $\frac{5}{8}$ of a piece of property is worth \$62.50, how much is the whole worth? $.37\frac{1}{2}$? $.66\frac{2}{3}$? $.43\frac{3}{4}$? $.58\frac{1}{3}$? $.83\frac{1}{3}$? $.93\frac{3}{4}$? $\frac{7}{12}$? $\frac{3}{8}$? $\frac{11}{16}$? $\frac{11}{12}$? $\frac{5}{6}$?

39. A owns $\frac{1}{12}$ of a factory, B $\frac{1}{6}$, C $\frac{1}{8}$, D $\frac{1}{8}$, and E $\frac{1}{16}$. What part of the whole do all own?

40. Give the ratio of :

$.50$ to $\frac{7}{16}$	$.33\frac{1}{3}$ to $\frac{2}{3}$	$\frac{1}{8}$ to $.75$	$\frac{1}{16}$ to $.62\frac{1}{2}$
$.81\frac{1}{4}$ to $\frac{1}{4}$	$.83\frac{1}{3}$ to $\frac{1}{8}$	$\frac{1}{4}$ to $.91\frac{2}{3}$	$\frac{1}{2}$ to $.66\frac{2}{3}$
$.93\frac{3}{4}$ to $\frac{3}{4}$	$.50$ to $\frac{5}{8}$	$\frac{2}{3}$ to $.50$	$\frac{1}{16}$ to $.68\frac{3}{4}$
$.43\frac{3}{4}$ to $\frac{3}{8}$	$.66\frac{2}{3}$ to $\frac{7}{12}$	$\frac{1}{16}$ to $.93\frac{3}{4}$	$\frac{1}{4}$ to $.91\frac{2}{3}$
$.68\frac{3}{4}$ to $\frac{5}{16}$	$.75$ to $\frac{5}{12}$	$\frac{3}{8}$ to $.43\frac{3}{4}$	$\frac{3}{8}$ to $.58\frac{1}{3}$

41. How many hundredths are there in 1? In $\frac{1}{5}$ of 1? $\frac{2}{5}$? $\frac{3}{5}$? $\frac{4}{5}$? $\frac{5}{5}$? Give the value in 5ths of .20, .60, .40, .80, 1.00.

42. How many hundredths are there in $\frac{1}{5}$? In $\frac{1}{2}$ of $\frac{1}{5}$? In $\frac{1}{10}$? $\frac{2}{10}$? $\frac{3}{10}$? $\frac{4}{10}$? $\frac{5}{10}$? $\frac{6}{10}$? $\frac{7}{10}$? $\frac{8}{10}$? $\frac{9}{10}$? $\frac{10}{10}$?

43. How many hundredths are there in $\frac{1}{2}$ of $\frac{1}{10}$? In $\frac{1}{20}$? In $\frac{2}{20}$? $\frac{3}{20}$? $\frac{4}{20}$? $\frac{5}{20}$? $\frac{6}{20}$? $\frac{7}{20}$? $\frac{8}{20}$? $\frac{9}{20}$? $\frac{10}{20}$? $\frac{11}{20}$? $\frac{12}{20}$? $\frac{13}{20}$? $\frac{14}{20}$? $\frac{15}{20}$? $\frac{16}{20}$? $\frac{17}{20}$? $\frac{18}{20}$? $\frac{19}{20}$?

44. Give in hundredths the values of $\frac{3}{5}$, $\frac{9}{20}$, $\frac{17}{20}$, $\frac{8}{20}$, $\frac{4}{20}$, $\frac{18}{20}$, $\frac{16}{20}$, $\frac{5}{20}$, $\frac{15}{20}$, $\frac{6}{20}$, $\frac{14}{20}$, $\frac{12}{20}$.

45. Give the ratio of:

.65 to .25	.50 to .55	$\frac{3}{4}$ to .85	$\frac{19}{20}$ to .35
.40 to .65	.75 to .85	$\frac{2}{5}$ to .55	$\frac{4}{5}$ to .25
.70 to .35	.75 to .80	$\frac{1}{2}$ to .65	$\frac{9}{20}$ to .95
.45 to .20	.90 to .15	$\frac{8}{10}$ to .45	$\frac{5}{10}$ to .50
.85 to .45	.95 to .60	$\frac{17}{20}$ to .75	$\frac{1}{3}$ to .75

46. If you know the cost of $\frac{1}{2}$ of a quantity, how can you find the cost of .25 of it?

Given cost of $\frac{2}{5}$, to find cost of .65.

Given cost of .85, to find cost of $\frac{9}{20}$.

Given cost of .90, to find cost of $\frac{3}{20}$.

Given cost of $\frac{1}{2}$, to find cost of $\frac{2}{5}$.

Given cost of .75, to find cost of .85.

47. How many hundredths are there in $\frac{1}{5}$? In $\frac{1}{5}$ of $\frac{1}{5}$? $\frac{1}{25}$? $\frac{2}{25}$? $\frac{3}{25}$? $\frac{4}{25}$? $\frac{5}{25}$? $\frac{6}{25}$? etc.

48. Give the ratio of:

.24 to .36	.20 to .64	.32 to .52	.68 to .40
.76 to .16	.72 to .48	.84 to .92	.88 to .44
.56 to .88	.60 to .64	.88 to .76	.36 to .80

49. How many hundredths are there in $\frac{1}{2}$? $\frac{1}{3}$? $\frac{1}{4}$? $\frac{1}{5}$?
 $\frac{1}{6}$? $\frac{1}{8}$? $\frac{1}{10}$? $\frac{1}{12}$? $\frac{1}{16}$? $\frac{1}{20}$? $\frac{1}{25}$?

50. Give the number of hundredths in $\frac{2}{2}$, $\frac{2}{3}$, $\frac{2}{4}$, $\frac{2}{5}$, $\frac{2}{6}$, $\frac{2}{8}$,
 $\frac{2}{10}$, $\frac{2}{12}$, $\frac{2}{16}$, $\frac{2}{20}$, $\frac{2}{25}$.

51. Give the number of hundredths in $\frac{3}{2}$, $\frac{3}{3}$, $\frac{3}{4}$, $\frac{3}{5}$, $\frac{3}{6}$, $\frac{3}{8}$,
 $\frac{3}{10}$, $\frac{3}{12}$, $\frac{3}{16}$, $\frac{3}{20}$, $\frac{3}{25}$.

52. Give the number of hundredths in $\frac{4}{2}$, $\frac{4}{3}$, $\frac{4}{4}$, $\frac{4}{5}$, $\frac{4}{6}$, $\frac{4}{8}$, $\frac{4}{10}$,
 $\frac{4}{12}$, $\frac{4}{16}$, $\frac{4}{20}$, $\frac{4}{25}$. In $\frac{5}{5}$, $\frac{5}{6}$, $\frac{5}{8}$, $\frac{5}{10}$, $\frac{5}{12}$, $\frac{5}{16}$, $\frac{5}{20}$, $\frac{5}{25}$.

53. Give the number of hundredths in $\frac{6}{6}$, $\frac{6}{8}$, $\frac{6}{10}$, $\frac{6}{12}$, $\frac{6}{16}$,
 $\frac{6}{20}$, $\frac{6}{25}$. In $\frac{7}{8}$, $\frac{7}{10}$, $\frac{7}{12}$, $\frac{7}{16}$, $\frac{7}{20}$, $\frac{7}{25}$. In $\frac{8}{8}$, $\frac{8}{10}$, $\frac{8}{12}$, $\frac{8}{16}$, $\frac{8}{20}$, $\frac{8}{25}$.

54. Give the number of hundredths in $\frac{9}{10}$, $\frac{9}{12}$, $\frac{9}{16}$, $\frac{9}{20}$,
 $\frac{9}{25}$. In $\frac{10}{10}$, $\frac{10}{12}$, $\frac{10}{16}$, $\frac{10}{20}$, $\frac{10}{25}$. In $\frac{11}{12}$, $\frac{11}{16}$, $\frac{11}{20}$, $\frac{11}{25}$. In $\frac{12}{12}$,
 $\frac{12}{16}$, $\frac{12}{20}$, $\frac{12}{25}$. In $\frac{13}{16}$, $\frac{13}{20}$, $\frac{13}{25}$. In $\frac{14}{16}$, $\frac{14}{20}$, $\frac{14}{25}$. In $\frac{15}{16}$, $\frac{15}{20}$,
 $\frac{15}{25}$. In $\frac{16}{16}$, $\frac{16}{20}$, $\frac{16}{25}$. In $\frac{17}{20}$, $\frac{17}{25}$, $\frac{18}{20}$, $\frac{18}{25}$, $\frac{19}{20}$, $\frac{19}{25}$, $\frac{20}{20}$, $\frac{20}{25}$.
 In $\frac{21}{25}$, $\frac{22}{25}$, $\frac{23}{25}$, $\frac{24}{25}$, $\frac{25}{25}$.

55.* Give the ratio of:

.25 to $.16\frac{2}{3}$.80 to $.66\frac{2}{3}$	$.06\frac{1}{4}$ to $.08\frac{1}{3}$.60 to $.37\frac{1}{2}$
.04 to $.12\frac{1}{2}$	1.00 to $.18\frac{3}{4}$	$.08\frac{1}{3}$ to 1.0	$.62\frac{1}{2}$ to $.41\frac{2}{3}$
.05 to $.33\frac{1}{3}$.90 to .75	$.12\frac{1}{2}$ to $.06\frac{1}{4}$.50 to .15
.25 to $.33\frac{1}{3}$	$.68\frac{3}{4}$ to .55	$.66\frac{2}{3}$ to .50	$.68\frac{3}{4}$ to $.91\frac{3}{4}$
.50 to .40	$.62\frac{1}{2}$ to $.83\frac{1}{3}$	$.12\frac{1}{2}$ to $.16\frac{2}{3}$.40 to $.66\frac{2}{3}$

56. A certain piece of property is divided into 120 shares. A owns $\frac{1}{6}$ of it, B $\frac{1}{8}$ of it, C $\frac{1}{5}$ of it, D $\frac{1}{3}$ of it, and

* In solving such questions as these the pupils will generally find it easiest to change the decimal form to the corresponding common fraction. But if by inspection, as in the ratio of $.12\frac{1}{2}$ to $.06\frac{1}{4}$, the pupils see that $.12\frac{1}{2}$ is twice $.06\frac{1}{4}$, it is advisable that they shall go directly to the point and state the fact. See also problem 17, page 24.

E the remainder. How many shares does each own? How many hundredths of the property does each own?

57. $.18\frac{3}{4}$ of a certain distance is $7\frac{1}{2}$ miles. What is $.50$ of the distance? The whole distance?

58. $.55$ of a certain distance is 22 miles. What is $.68\frac{3}{4}$ of the distance? $.25$ of it? The whole distance?

59. If $.33\frac{1}{3}$ of a ton of coal costs \$ $2\frac{1}{2}$, what is the cost of $.80$ of a ton? What is the ratio of $\frac{4}{5}$ to $\frac{4}{12}$? What is the value of $1\frac{2}{5}$ of \$ $\frac{5}{2}$?

60. Into how many pieces $.12\frac{1}{2}$ yd. long can $2.37\frac{1}{2}$ yd. of ribbon be cut?

61. At $12\frac{1}{2}$ ¢ per yard, how many yards of cloth can you buy for \$ $2.37\frac{1}{2}$?

62. A can mow $.66\frac{2}{3}$ of an acre in half a day; B $.75$ of an acre in the same time. How many acres can both mow in half a day? In a day? In 12 days?

63. John can do a piece of work in 1.5 days; James in $1.33\frac{1}{3}$ days. How long will it take them both to do it?

64. Charles has $.68\frac{3}{4}$ as many marbles as Henry. If Henry has 64, how many has Charles?

65. Charles has $.68\frac{3}{4}$ as many marbles as Henry. If Charles has 55, how many has Henry?

66. $.41\frac{2}{3}$ is the ratio of the cost of one chair to the cost of another. If the first cost \$10, how much did the second cost? If the second cost \$6, how much did the first cost?

67. A, B, and C engaged in business. A furnished $.37\frac{1}{2}$ of the capital, B $.31\frac{1}{4}$ of it, and C the remainder. What part did C furnish?

68. If the whole capital was \$3200, how much money did A invest? B? C?

69. If their profits were \$1600, how much should A receive? B? C?

70. What is the ratio of A's share of the profits to B's share? A's to C's? B's to C's? B's to A's? C's to A's? C's to B's?

71. What is the ratio of A's share of the capital to B's share? A's to C's? B's to C's? B's to A's? C's to A's? C's to B's?

72. Given the cost of $.41\frac{3}{4}$ of a quantity, how can you find the cost of $.58\frac{1}{2}$ of it?

Given the cost of $.16\frac{3}{4}$, to find cost of $.12\frac{1}{2}$.

Given the cost of $.25$, to find cost of $.91\frac{3}{4}$.

Given the cost of $.75$, to find cost of $.25$.

Given the cost of $.43\frac{3}{4}$, to find cost of $.50$.

Given the cost of $.87\frac{1}{2}$, to find cost of $.93\frac{3}{4}$.

Given the cost of $.18\frac{3}{4}$, to find cost of $.43\frac{3}{4}$.

Given the cost of $.81\frac{1}{4}$, to find cost of $.93\frac{3}{4}$.

Given the cost of $.85$, to find cost of $.45$.

Given the cost of $.45$, to find cost of $.20$.

73. $.18\frac{3}{4}$ is the ratio of 12 gal. to what?

$.66\frac{2}{3}$ is the ratio of 5 ft. to what?

$1.12\frac{1}{2}$ is the ratio of 18 bu. to what?

$.91\frac{2}{3}$ is the ratio of $27\frac{1}{2}$ lb. to what?

$1.93\frac{3}{4}$ is the ratio of 62 mi. to what?

74. A pole 34 ft. long stood $.31\frac{1}{4}$ in the water, $.33\frac{1}{8}$ in the mud, and the rest in the air. How many feet were in the air?

75. A pole stood $.25$ in the mud, $.41\frac{2}{3}$ in the water, and $15\frac{1}{3}$ ft. in the air. How long was the pole? How many feet were in the mud? In the water?

76. A man, owning $.80$ of an acre of land, sold $.18\frac{3}{4}$ of his share for \$6. What was the price per acre?

77. The value of a certain man's property was \$6000. $.81\frac{1}{4}$ of it was real estate, $.02\frac{1}{2}$ was cash, and the remainder live stock. What was his live stock worth?

78. A man owning $.40$ of a piece of property sold $.37\frac{1}{2}$ of his share. How many hundredths did he still own?

79. A man chops $2\frac{1}{2}$ cd. of wood in $1.12\frac{1}{2}$ days. How long should it take him to chop 20 cd.?

SUGGESTION. It will take him $20 \times \frac{1}{2}$ of $\frac{1}{2}$ days.

80. What is the cost of 6 lb. of butter, at the rate of \$ $.37\frac{1}{2}$ for $\frac{2}{3}$ lb.?

81. $.41\frac{2}{3}$ of 72 is $.31\frac{1}{4}$ of what number?

82. 50 is $.12\frac{1}{2}$ of $.66\frac{2}{3}$ of what number?

83. If $.83\frac{1}{3}$ of a quantity of sugar is worth \$14, what is the value of $.62\frac{1}{2}$ of the quantity? Why is it worth $\frac{3}{4}$ of \$14?

84. At \$. $16\frac{2}{3}$ each, how much will 33 note books cost? What is the cost of 32 note books at \$. $18\frac{3}{4}$ each?

85. How many pounds of butter can you buy for \$1.25 if $\frac{3}{4}$ lb. cost \$. $18\frac{3}{4}$?

86. How many cents are there in \$ $\frac{5}{8}$? In \$ $\frac{5}{6}$? In \$ $\frac{5}{4}$? In \$ $\frac{5}{12}$? In \$ $\frac{5}{18}$? In \$ $\frac{5}{2}$? In \$ $\frac{5}{3}$?

87. What part of a dollar is 25 cents? $33\frac{1}{3}\%$? 20% ? $18\frac{2}{3}\%$? $41\frac{2}{3}\%$? $93\frac{3}{4}\%$?

88. A owned $.66\frac{2}{3}$ of a mill and sold $.37\frac{1}{2}$ of his share. How many hundredths of the mill did he still own?

89. A man bought a horse and carriage, paying for the latter $.68\frac{3}{4}$ of what he paid for the former. If the carriage cost \$132, how much did the horse cost?

90. A man bought a horse and carriage, paying \$192 for the latter. If the ratio of the cost of the carriage to the cost of the horse was $.68\frac{3}{4}$, how much did the carriage cost?

91. One chair cost $.66\frac{2}{3}$ as much as another. If both cost \$50, what was the cost of each?

92. How many rods are there in the circumference of a circle .56 rd. in diameter?

93. What is the ratio of $.08\frac{1}{3}$ ft. to $.56\frac{1}{4}$ in.?

94. Give the ratio of:

$.16\frac{2}{3}$ to .25	.25 to $.66\frac{2}{3}$	$.62\frac{1}{2}$ to $.83\frac{1}{3}$
$.12\frac{1}{2}$ to $.08\frac{1}{3}$.75 to $.18\frac{3}{4}$.60 to $.37\frac{1}{2}$
.25 to $.33\frac{1}{3}$	$.37\frac{1}{2}$ to .25	$.43\frac{3}{4}$ to .70
.20 to .50	.30 to $.18\frac{3}{4}$.75 to $.56\frac{1}{4}$
.04 to $.16\frac{2}{3}$.80 to $.66\frac{2}{3}$	$.68\frac{3}{4}$ to $.91\frac{2}{3}$
$.16\frac{2}{3}$ to $.66\frac{2}{3}$	$.33\frac{1}{3}$ to .50	$.66\frac{2}{3}$ to $.83\frac{1}{3}$
.40 to $.12\frac{1}{2}$	$.41\frac{1}{2}$ to $.31\frac{1}{4}$	$.81\frac{1}{4}$ to $.56\frac{1}{4}$

95. $\frac{7}{12}$ of a piece of land is worth \$800. What is the value of $.43\frac{3}{4}$ of it?

96. A farmer sold $.56\frac{1}{4}$ of a load of corn. What was the ratio of what remained to what was sold?

97. .25 of a certain distance is 60 miles. What is $.58\frac{1}{3}$ of it? $.18\frac{3}{4}$ of it? $.37\frac{1}{2}$ of it? $.91\frac{2}{3}$ of it?

98. James has $.83\frac{1}{2}$ as many marbles as John. If James has 50, how many has John?

99. The ratio of a certain number to another is $\frac{2}{3}$. The smaller number is $.62\frac{1}{2}$. What is the other?

100. At $\$.18\frac{3}{4}$ a yard, what part of a yard can be bought for $\$.15$? What is the ratio of $\$.2\frac{3}{8}$ to $\$.1\frac{3}{8}$?

101. At $\$.41\frac{3}{4}$ per yard, how many yards can be bought for $\$.62\frac{1}{2}$? For $\$.31\frac{1}{4}$? For $\$1.25$? What is the ratio of $\frac{5}{8}$ to $\frac{5}{12}$? Of $\frac{5}{16}$ to $\frac{5}{12}$? Of $\frac{5}{4}$ to $\frac{5}{12}$?

102. At $\$.16\frac{3}{4}$ per yard, how many yards of cloth can be bought for $\$.25$? For $\$.33\frac{1}{3}$? For $\$.12\frac{1}{2}$? For $\$.40$?

103. At $\$.56\frac{1}{4}$ per pound, how many pounds can be bought for $\$.75$? For $\$1.12\frac{1}{2}$? For $\$2\frac{1}{4}$?

104. What is the ratio of $.37\frac{1}{2}$ pk. to $.24$ bu.?

105. How many quarts are there in $.93\frac{3}{4}$ bu.? In $.68\frac{3}{4}$ bu.?

106. If $\frac{1}{12}$ of a lot is worth $\$91\frac{3}{8}$, what is $\frac{7}{8}$ of the lot worth? $\frac{5}{8}$ of it? $\frac{9}{16}$ of it?

107. $.41\frac{3}{8}$ of a certain distance is 80 miles. What is $.31\frac{1}{4}$ of the distance? $.91\frac{3}{8}$ of it? $.58\frac{1}{8}$ of it?

108. $.68\frac{3}{4}$ of a certain distance is 99 miles. What is $.91\frac{3}{8}$ of the distance? $.75$ of it? $.93\frac{3}{4}$ of it? All of it?

109. If $.66\frac{3}{8}$ of a ton of coal is worth $\$2$, what is the value of $.50$ of a ton? Of $.25$ of a ton? Of $.12\frac{1}{2}$ of a ton?

110. Into how many pieces $.25$ yd. long can $10\frac{1}{2}$ ft. of rope be cut? $10\frac{1}{2}$ yd. of rope?

111. At $\$.06\frac{1}{4}$ each, how many pencils can be bought for $\$1.25$? For $\$1.50$? For $\$.75$? For $\$1$?

112. At $\$.08\frac{1}{3}$ each, how many blank books can you buy for $\$.75$? For $\$.25$? For $\$1.50$?

113. A can mow $.75$ of an acre in $.33\frac{1}{3}$ of a day; B can mow $.66\frac{2}{3}$ of an acre in the same time. How many acres can both mow in 5 days? In 8 days?

114. Give in hundredths the values of: $\frac{5}{8}$, $\frac{8}{16}$, $\frac{5}{4}$, $\frac{3}{8}$, $\frac{7}{16}$, $\frac{11}{12}$, $\frac{11}{16}$, $\frac{5}{8}$, $\frac{4}{5}$, $\frac{15}{16}$, $\frac{18}{25}$, $\frac{4}{4}$, $\frac{11}{20}$, $\frac{7}{12}$, $\frac{9}{16}$.

115. The ratio of the wheat in one bin to that in another is $.83\frac{1}{3}$. If there are 60 bu. in the second bin, how many are there in the first?

116. A, B, and C engage in business. A invests $\$2000$, B $\$3000$, and C $\$1000$. How many hundredths of the profits should each receive?

117. A farmer sold a cow for $\$45$, which was $\frac{3}{8}$ of what he paid for her. How many hundredths of the cost did he gain?

118. If a merchant sells goods costing $\$48$, so as to gain $.16\frac{2}{3}$ of the cost, how much does he gain?

119. $.83\frac{1}{3}$ of A's money equals $.75$ of B's. What is the ratio of A's money to B's?

120. $.31\frac{1}{4}$ of A's property is land, $.41\frac{2}{3}$ of it is buildings, and the remainder is cash. If all his property is valued at $\$48,000$, what is the value of his land? Of his buildings? How much cash has he?

121. A man bought a horse and carriage for $\$282$. If $.18\frac{3}{4}$ of the cost of the horse equaled $.40$ of the cost of the carriage, what was the cost of each?

SECTION VII

INTRODUCING THE IDEA OF PER CENT AND DEVELOPING RELATIONS

1. What is the ratio of 1 to 2? Of 2 to 4? Of 50 to 100? Another name for this relation is 50 per cent, written 50%, which means the same as .50.
2. What is 50% of 2? Of 4? Of 100? Of \$4? Of \$5? Of 18 bu.? Of 60 min.?
3. \$2 is 50% of what? \$6 is 50% of what? \$10? 40 lb.? 100 bu.?
4. What part of anything is 25% of it? (.25 or $\frac{1}{4}$.) What is 25% of \$12? Of 4 bu.? Of 100 lb.?
5. How many per cent are there in the whole of anything? In $\frac{1}{2}$ of it? $\frac{1}{4}$ of it? $\frac{3}{4}$ of it?
6. What is 75% of \$20? 50% of 7 lb.? 25% of 16 bu.? 100% of \$5?
7. Give the values in per cent of the following: $\frac{1}{2}$, $\frac{1}{4}$, $\frac{3}{4}$, $\frac{1}{8}$, $.12\frac{1}{2}$, $\frac{3}{8}$, $.37\frac{1}{2}$, $\frac{5}{8}$, $.62\frac{1}{2}$, $\frac{7}{8}$, $.87\frac{1}{2}$, $\frac{8}{8}$.
8. What is $12\frac{1}{2}\%$ of 24? $37\frac{1}{2}\%$ of 16? $62\frac{1}{2}\%$ of 32? $87\frac{1}{2}\%$ of 100? 75% of \$1? 100% of \$1?
9. The amount of grain in a certain bin was 80 bu. $62\frac{1}{2}\%$ of it was sold. How many bushels were sold? What per cent was left? 30 bu. is what per cent of 80 bu.? 50 bu. is what per cent of 80 bu.?

10. A grocer sold 50 lb. of sugar, which was $12\frac{1}{2}\%$ of what he had in stock. How much did he have in stock? What per cent did he have left after selling? How many pounds of sugar had he left? 350 is what per cent of 400?

11. Give the values in per cent of the following: $\frac{1}{16}$, $\frac{2}{16}$, $\frac{5}{16}$, $\frac{7}{16}$, $\frac{9}{16}$, $\frac{11}{16}$, $\frac{13}{16}$, $\frac{15}{16}$. Also of $\frac{1}{8}$, $\frac{2}{8}$, $\frac{1}{6}$, $\frac{5}{6}$, $\frac{1}{12}$, $\frac{5}{12}$, $\frac{7}{12}$, $\frac{11}{12}$.

12. How many pounds are there in $.16\frac{2}{3}$ of 100 lbs.? What is $16\frac{2}{3}\%$ of 100 lbs.? What is $.41\frac{2}{3}$ of 144 bu. of corn? What is $41\frac{2}{3}\%$ of 144 bu. of corn?

13. In a tank there were 132 gal. of water. $58\frac{1}{3}\%$ of it was drawn off. How many gallons were drawn off? What per cent of the whole amount remained?

14. A farmer sold at a gain of $8\frac{1}{3}\%$ a cow that cost him \$36. How much did he gain? What was his selling price?

15. A farmer sold a cow at a gain of \$3, which was $8\frac{1}{3}\%$ of what she cost. How much did she cost? If \$3 is $8\frac{1}{3}\%$, or $\frac{1}{12}$ of the cost, how many dollars equal 100%, or $\frac{12}{1}$ of the cost?

16. A farmer sold a cow for \$39, thereby gaining $8\frac{1}{3}\%$. How much did she cost? If \$39 is $\frac{12}{1}$ of the cost, what is the cost?

17. A farmer sold for \$39 a cow that cost him \$36. What per cent of the cost did he gain? \$3 is what part of \$36? What per cent of \$36?

18. A dealer sold a watch at a loss of $12\frac{1}{2}\%$. If it cost him \$48, how much did he lose? What was his selling price?

19. A dealer sold a watch for \$42, which was $12\frac{1}{2}\%$ less than it cost him. What was the cost? The loss?

20. A dealer sold a watch at a loss of $12\frac{1}{2}\%$. If his loss was \$6, what was the cost? The selling price?

21. A watch that cost \$48 was sold for \$42. What was the loss per cent?

22. A man having \$4000 invested 20% of it in corn, 30% of it in wheat, and the remainder in oats. How much did he invest in each kind of grain? What per cent of his money did he invest in oats?

23. A 50-gallon barrel is 60% full of oil. How many gallons of oil are in it?

24. A has \$1000 invested in a factory, and B \$1400. At the end of a year they find they have gained $16\frac{2}{3}\%$. What is each one's share of the gain?

25. A owned $\frac{2}{3}$ of a mill and sold 75% of his share. What part of the mill did he sell? What per cent of the mill did he sell? What per cent did he still own?

26. What part of 66 is 22? What per cent of 66 is 22? What per cent of 18 is 9?

27. What per cent of:

24 is 3?	39 is 13?	25 is 24?	100 is 80?
12 is 6?	30 is 20?	25 is 25?	100 is 125?
18 is 3?	25 is 20?	25 is 26?	75 is 125?
48 is 8?	$41\frac{2}{3}$ is $16\frac{2}{3}$?	25 is 30?	32 is 28?
50 is $12\frac{1}{2}$?	28 is 21?	10 is 10?	48 is 44?

28. A has 50 A. of land, and B 60 A. What per cent of A's land is B's? Of B's is A's?

29. A has 50 A., and that is $83\frac{1}{3}\%$ of what B has. How many acres has B? B has 60 A., which is 120% of what A has. How many has A?

30. After selling some cattle a dealer found that he had gained \$30, which was $18\frac{3}{4}\%$ of the cost. How much did they cost? What was his selling price?

31. If A has $33\frac{1}{3}\%$ more money than B, what per cent of A's money is B's? What per cent of B's is A's?

32. A dealer sold some cattle for \$190, thereby gaining $18\frac{3}{4}\%$. How much did they cost him?

33. Goods were sold at auction for \$30, at a loss of 25% . How much did they cost?

34. $16\frac{2}{3}\%$ of a certain number is 2 greater than $12\frac{1}{2}\%$ of it. What is the number?

35. The difference between two numbers is 3, and one of them is 25% greater than the other. What are the numbers?

36. One number is 3 less than another. One is 20% less than the other. What are the numbers?

37. A bicycle was sold for \$50 at a loss of 50% . How much did it cost? What was the loss?

38. A newsboy buys papers at the rate of 2 for 3 cents and sells them for 2¢ apiece. What per cent does he gain?

39. If a merchant sells $\frac{1}{2}$ a pound of butter for what $\frac{2}{3}$ of a pound cost, what per cent does he gain?

40. By selling apples at the rate of 3 for 5 cents, a dealer gains 25% . What per cent would he have lost had he sold them at the rate of 5 for 6 cents?

41. A farmer sold 2 cows for \$24 each. On one he gained 20%, and on the other he lost 20%. How much did each cost?

42. 3% of a certain number is 2 less than 5% of the number. What is the number?

43. A clothing dealer sells a suit of clothes marked \$20, at 25% less than the marked price and still gains 50% on the cost. What is the cost?

44. 8% of a certain sum is \$30 less than $14\frac{1}{4}\%$ of it. What is the sum?

45. A boy buys oranges at the rate of 4 for 10 cts., and sells them at the rate of 3 for 10 cts. What is his per cent of gain?

46. If 3 oranges are sold for what 4 oranges cost, what is the gain per cent?

47. What is the loss per cent if 4 oranges are sold for what 3 cost? 5 for what 4 cost?

48. What is the gain per cent if 3 newspapers are sold for what 5 cost? If 3 are sold for $\frac{4}{5}$ of what 5 cost?

49. A grocer buys strawberries at the rate of 5 qt. for 12 cts., and sells them at the rate of 3 qt. for 12 cts. What is his gain per cent? How much does he make on 30 qts. of berries?

50. A bicycle is marked \$48, but in order to make a sale the dealer has to allow a discount of $12\frac{1}{2}\%$. How much did the bicycle cost him, if he made $16\frac{2}{3}\%$ on the transaction?

51. If a coal dealer sold $\frac{2}{3}$ of a ton of coal for what $\frac{3}{4}$ of a ton cost, what per cent did he gain?

52. An overcoat is sold for \$ 24 at a gain of 20%. How much did it cost ?
53. If a horse that cost \$ 174 was sold for \$ 203, what per cent was gained ?
54. What is $12\frac{1}{2}\%$ of $16\frac{2}{3}\%$ of 96 ?
55. 20% of 50% of a certain number is 78. What is the number ?
56. 5 times 25% of a certain number is 375. What is the number ?
57. 24 is 12 times $18\frac{3}{4}\%$ of a certain number. What is the number ?
58. $12\frac{1}{2}\%$ of a certain number plus $16\frac{2}{3}\%$ of it equals 21. What is the number ?
59. What number is it of which 25% exceeds $18\frac{3}{4}\%$ by 20 ?
60. $31\frac{1}{4}\%$ of one number equals $41\frac{2}{3}\%$ of another. If the first is 48, what is the second ?
61. $62\frac{1}{2}\%$ of one number equals $83\frac{1}{3}\%$ of another. The sum of the two numbers is 56. What are the numbers ?
- If $\frac{1}{3}$ of the first number equals $\frac{1}{4}$ of the second, what is the ratio of $\frac{1}{3}$ of the first number to the second? Since the first number is $\frac{1}{3}$ of $\frac{3}{4}$, or $\frac{1}{4}$ of the second, both numbers are how many thirds of the second number? If $56 = \frac{1}{4}$ of the second number, what is the second number? The first?
62. $37\frac{1}{2}\%$ of James's money equals 30% of John's. If both have 81 cts., how much has each ?
63. A certain part of a pole 37 ft. long is in the ground, and the rest in the air. $18\frac{3}{4}\%$ of the part in the air equals in length $58\frac{1}{3}\%$ of the part in the ground. What is the length of each part ?

64. A watch that cost \$65 was sold for \$52. What was the loss per cent?

65. A man having \$60,000, invested 20% of it in cotton, 25% of it in sugar, 15% of it in molasses, and the remainder in corn. How much corn did he buy, if he paid \$.30 per bushel?

66. A has \$2000 invested in a factory, B \$2400, and C \$1600. At the end of a year they find they have gained 25% on the whole investment. What is each one's share of the gain?

67. A owned $\frac{3}{4}$ of a mill and sold 50% of his share for \$3000. What was the value of the mill at that rate, and what was the value of A's share, both before and after selling?

68. A has $\frac{2}{3}$ as much land as B. What per cent of A's land is B's?

69. If A has 25% more money than B, what per cent of A's money is B's? What per cent of B's is A's?

70. Goods were sold at auction for \$62 $\frac{1}{2}$, which was at a loss of 37 $\frac{1}{2}$ %. How much did they cost?

71. The difference between two numbers is 5, and one of them is 33 $\frac{1}{3}$ % greater than the other. What are the numbers?

72. By selling at the rate of 4 for 5 cents what was bought at the rate of 5 for 6 cents, what per cent is gained?

73. A farmer sold two horses for \$75 each. On one he gained 50%, and on the other he lost 50%. What was the cost of each?

74. A couch is marked \$35, but in order to make a sale, the dealer gives a discount of 20%. If he still gains 12%, what is the cost?

75. If a grocer sells $\frac{5}{8}$ of a dozen eggs for what $\frac{5}{8}$ of a dozen cost, what per cent does he gain?

76. What is $18\frac{3}{4}\%$ of $133\frac{1}{3}\%$ of 84?

77. 27 is 75% of 75% of what number?

78. 60 is $6 \times 31\frac{1}{4}\%$ of what number?

79. 28 is $33\frac{1}{3}\% + 25\%$ of what number?

80. What number is it of which $66\frac{2}{3}\%$ exceeds $56\frac{1}{4}\%$ by 65?

81. A horse and carriage are worth \$246. If $\frac{2}{3}$ of the value of the horse equals $\frac{5}{8}$ of the value of the carriage, what is the value of each?

82. A and B invest \$8800 in business. $62\frac{1}{2}\%$ of A's investment equals 75% of B's. How much does each invest?

83. What per cent of the circumference of a circle 2 inches in diameter is the circumference of a circle 3 inches in diameter? (See problem 46, page 33.)

84. What per cent of A's money is B's, if A has \$50, and B has 10% more? What per cent of B's is A's?

85. What per cent of A's money is B's if A has $33\frac{1}{3}\%$ more than B? What per cent of B's is A's?

SECTION VIII

INTRODUCING GENERAL COMPOUND NUMBERS AND DEVELOPING RELATIONS

1. What is the ratio of 8 in. to 12 in.? Of 2 ft. to 3 ft.? Of 3 yd. to $5\frac{1}{2}$ yd.? Of 32 rd. to 320 rd.?

2. What is the ratio of 8 in. to 1 ft.? Of 2 ft. to 1 yd.? Of 3 yd. to 1 rd.? Of 32 rd. to 1 mi.?

3. What is the ratio of 1 yd. to 6 in.? Of $1\frac{1}{2}$ yd. to 6 in.? Of 2 yd. to 6 in.?

4. A boy measures a stick with a 6-inch rule, and finds that he has to apply the rule exactly 12 times. How many yards long is the stick?

5. How many steps 2 ft. 4 in. long must a man take to walk a distance of 28 ft.? What is the ratio of 28 ft. to $2\frac{1}{3}$ ft.?

6. How many inches are there in 1 yd. 2 ft. 6 in.? In 1 yd. 1 ft. 3 in.? In 1 rd.? In 1 rd. 2 in.? In 1 rd. 1 yd. 1 ft. 1 in.?

7. Change 66 in. to integers of higher denominations. (66 in. = 1 yd. 2 ft. 6 in.) Change 200 in. to integers of higher denominations. 198 in. 51 in. 247 in.

8. How many feet are there in 1 rd.? In 2 rd.? In 4 rd.? In 6 rd.? In 1 rd. 3 yd.? In 1 rd. 5 yd.? In 6 rd. 2 ft.?

9. Reduce to integers of higher denominations: 33 ft.; 99 ft.; 66 ft.; $25\frac{1}{2}$ ft.; 100 ft.; $31\frac{1}{2}$ ft.

10. Five planks, 5 ft. 6 in., 7 ft. 3 in., 6 ft. 3 in., 5 ft. 7 in., and 8 ft. 5 in. long, respectively, are laid end to end. How many yards along the ground will they reach?

11. A certain fence is made of boards 8 in. wide standing upright. How many boards are there in 6 yd. 2 ft. of the fence?

12. How many feet will a boy walk in taking 10 steps of 26 in. each?

13. What is the ratio of 1 pt. (dry measure) to 2 pt.? Of 3 qt. to 8 qt.? Of 1 pk. to 4 pk.?

14. What is the ratio of 1 pt. to 1 qt.? Of 3 qt. to 1 pk.? Of 1 pk. to 1 bu.?

15. What is the ratio of 1 bu. to 1 qt.? Of 1 bu. to 1 pt.? Of 1 bu. to 2 pt.? Of 1 bu. to 2 qt.? To 3 qt.? To 8 qt.? To 1 pk.? To 1 pk. 1 qt.? To 2 pk. 3 qt.? To 1 pk. 1 qt. 1 pt.?

16. How many times must a half-peck measure be filled in measuring $2\frac{1}{2}$ bu. of beans?

17. Reduce to quarts: 4 pk. 2 qt.; 1 bu. 1 pk.; 2 bu. 2 pk. 2 qt.; 1 bu. 3 pk. 5 qt.

18. Reduce to integers of higher denominations: 48 qt.; 25 pt.; 57 qt.; 69 qt.

19. What is the ratio of 1 gi. (liquid measure) to 4 gi.? Of 1 pt. to 2 pt.? Of 1 qt. to 4 qt.? Of 1 gal. to $3\frac{1}{2}$ gal.?

20. What is the ratio of 1 gi. to 1 pt.? Of 1 pt. to 1 qt.? Of 1 qt. to 1 gal.? Of 1 gal. to 1 bbl.?

21. Give the ratio of 1 gal. to 1 qt. To 1 gi. To 1 pt. Of 1 qt. to 1 pt. To 1 gi.

22. Give the ratio of 1 gal. to 1 gal. 2 qt. To 1 gal. 1 qt. 1 pt. To 2 gal. 2 gi. Of 1 qt. to 2 qt. 1 pt. To 1 gal. 1 qt. 1 pt. To 1 pt. 3 gi. Of 1 pt. to 1 gal. 3 qt. To 2 qt. 1 pt. To 1 pt. 2 gi.

23. How many times can a dipper holding 1 pt. 1 gi. be filled from a can containing 3 gal. 1 pt.?

24. A milkman has in his wagon 5 cans. The first contains 10 gal. of milk; the second 4 gal. 2 qt.; the third 1 gal. 2 qt.; the fourth 4 gal. 1 pt.; and the fifth 1 gal. 3 qt. 1 pt. How many gallons of milk has he?

25. How many bottles holding 1 pt. 3 gi. can be filled from a cask containing 7 gal. of wine?

26. How many inch squares does a twelve-inch square contain? What is the ratio of 1 sq. ft. to 1 sq. in.? Of 1 sq. in. to 1 sq. ft.? Of 36 sq. in. to 1 sq. ft.? Of 72 sq. in. to 1 sq. ft.? Of 108 sq. in. to 1 sq. ft.?

27. What is the ratio of 1 sq. ft. to 1 sq. yd.? Of 1 sq. yd. to 1 sq. ft.?

28. How many square inches are there in a 2-inch square? In a 3-inch square? A 4-inch square? A 5-inch square? A 10-inch square?

29. What is the ratio of a 2-inch square to a 3-inch square? To a 4-inch square? To a 6-inch square?

30. Give the ratio of: A 3-inch square to a 2-inch square; a 4-inch square to a 2-inch square; a 3-inch square to a 5-inch square; a 5-inch square to a 10-inch square; a 12-inch square to a 36-inch square.

31. Rectangle a is 3 in. long and 2 in. wide; rectangle b is 5 in. long and 3 in. wide. What is the ratio of a to b ? Of b to a ? Of $\frac{1}{2}$ of b to $\frac{1}{2}$ of a ? Of $\frac{1}{3}$ of a to $\frac{1}{3}$ of b ?

32. At the rate of 10 shingles to the square foot, how many shingles are necessary for a roof 20 ft. wide and 50 ft. long?

33. A cube is a solid having six equal square faces. A 1-inch cube (or cubic inch) has each edge 1 inch in length. How many 1-inch cubes are there in a 2-inch cube? How many cubic inches are there in a 2-inch cube? In a 3-inch cube? A 4-inch cube? A 5-inch cube? A 10-inch cube? A 12-inch cube?

34. What is the ratio of: A 2-inch cube to a 3-inch cube? To a 4-inch cube? To a 5-inch cube? To a 10-inch cube?

35. What is the ratio of a 3-inch cube to a 4-inch cube? To a 5-inch cube? To a 6-inch cube? To a 10-inch cube? Of a 4-inch cube to a 5-inch cube? To a 10-inch cube?

36. How many cubic inches are there in a block of wood 4 in. long, 3 in. wide, and 1 in. thick? In a block 4 in. long, 3 in. wide, and 2 in. thick? In a block 4 in. long, 3 in. wide, and 5 in. thick?

37. How many cubic inches are there in a cubic foot? How many cubic feet are there in a 3-foot cube? In a cubic yard?

38. In digging a ditch 20 ft. long, 2 ft. wide, and 1 ft. deep, how many cubic feet of dirt are handled? How many, if the ditch is 2 ft. deep? 3 ft. deep? 4 ft.? 5 ft.?

39. A wheat bin is 10 ft. long, 8 ft. wide, and 5 ft. deep. How many cubic feet of wheat will it hold?

40. Allowing $1\frac{1}{4}$ cu. ft. of wheat to the bushel, how many bushels will the bin hold?

41. How many bushels of oats can be put into a box 4 ft. long, 2 ft. wide, and 18 in. deep?

42. There are about $7\frac{1}{2}$ gal. in a cubic foot. How many gallons will a tank 2 ft. \times 3 ft. \times 4 ft. hold?

43. An aquarium measures 4 ft. long, $2\frac{1}{2}$ ft. wide, and 18 in. deep. How many gallons of water are necessary to fill it half full?

44. A gallon contains 231 cubic inches. How deep must a box be to hold exactly a gallon, if it is 11 in. long and 7 in. wide?

45. What is the ratio of 3 bu. of wheat to $3\frac{3}{4}$ cu. ft. of wheat?

46. Give the ratio of a 5-inch square to a 6-inch square. Of a 4-inch square to a 5-inch square. Of a 4-inch cube to a 5-inch cube. Of a 10-inch cube to a 5-inch cube.

47. How many cubic inches are there in a block of wood 12 in. long, $5\frac{1}{2}$ in. wide, and $1\frac{1}{2}$ in. thick?

48. What is the cost of digging a cellar 10 ft. deep, 10 ft. wide, and 27 ft. long at \$3.50 per cubic yard?

49. How many 2-bushel grain sacks can be filled from a bin 3 ft. \times 4 ft. \times 5 ft. full of wheat?

50. About how many gallons of milk will a cheese vat 10 ft. \times 4 ft. \times 3 ft. hold?

51. If the bottom of a jar has an area of 21 sq. in., how deep must the jar be to hold exactly a gallon?

52. A steel plate 20 in. long and 1 ft. wide weighs 8 oz. to the square inch of surface. How many pounds does the plate weigh?

53. How many pieces 1 ft. square and 1 in. thick are there in an inch board 1 ft. wide and 10 ft. long? In a 2-inch plank of the same width and length?

54. How many units 1 in. thick, having a surface of 1 sq. ft., are there in a board 1 in. thick, 6 in. wide, and 12 ft. long?

Such units are called board feet. The board foot is used in measuring lumber.

55. How many board feet are there in a plank 8 in. wide, 15 ft. long, and 2 in. thick?

The surface of the plank = 10 sq. ft. Since it is 2 in. thick, for each square foot there are 2 bd. ft. Therefore there are 20 bd. ft. in the plank.

56. How many board feet are there in a 2-inch plank 6 in. wide and 16 ft. long? In 10 such planks?

57. How many board feet are there in seven 2 by 4's (i.e. plank 2 in. thick and 4 in. wide) 12 ft. long? In twenty 2 by 4's 12 ft. long? In ten 2 by 6's 20 ft. long?

58. How many feet (board feet) are there in ten 8 by 8's 18 ft. long? In ten 4 by 4's?

59. How many feet of lumber are necessary to plank the floor of a stall 8 ft. \times 10 ft. with 2 by 6's? How much will it cost at \$20 per M.?

60. Boards less than an inch thick are reckoned as though they were an inch thick. What is the value of ten $\frac{3}{4}$ -inch black walnut boards, 10 in. wide and 12 ft. long, at \$100 per M.?

61. At the rate of 10 shingles to the square foot, how much will shingles cost for a roof 20 ft. by 50 ft. at \$3 per M.?

62. At \$2.50 per M., how much will the shingles cost for a roof of two parts, each 40 ft. by 20 ft.?

63. How much would it cost to cover the same roof with inch boards at \$10 per M.?

64. What is the ratio of 2 bu. 3 pk. to 1 pk. 3 qt.? Of 1 bu. 1 pk. 1 qt. to 2 bu. 2 pk. 2 qt.? Of 4 gal. 1 pt. to 3 qt.? Of 4 rd. $2\frac{1}{2}$ ft. to 8 rd. 1 yd. 2 ft.?

65. Give the ratio of:

2 lb. Avoir. to $4\frac{1}{2}$ lb. Avoir.

6 oz. Avoir. to 2 lb. Avoir.

1 lb. 4 oz. Avoir to 3 lb. Avoir.

2 lb. 12 oz. Avoir. to 3 lb. 8 oz. Avoir.

7 oz. Avoir. to 2 lb. 3 oz. Avoir.

2 lb. Troy to $4\frac{1}{2}$ lb. Troy.

6 oz. Troy to 2 lb. Troy.

1 lb. 4 oz. Troy to 3 lb. Troy.

2 lb. 6 oz. Troy to 3 lb. 4 oz. Troy.

7 oz. Troy to 2 lb. 4 oz. Troy.

SUGGESTION. If the teacher has time, Liquid Measure and the Metric System can be easily treated in a manner similar to that in 65 above.

66. How many bushels of wheat are there in a bin $5\frac{1}{2}$ ft. \times 6 ft., and 5 ft. deep, when it is $\frac{2}{3}$ full? (See problem 40.)

67. What is the cost of digging a cellar 6 ft. deep, 10 ft. long, and 9 ft. wide, at \$2.70 per cu. yd.?

68. About how many gallons of water will a tank hold, whose inside measurements are 4 ft. \times $3\frac{1}{2}$ ft. \times $1\frac{1}{2}$ ft.? (See problem 42.)

69. At \$10 per M., what is the cost of eight 2×10 's 12 ft. long, and ten 8×8 's 18 ft. long?

70. At the rate of 1000 shingles to the 100 sq. ft., how many shingles are necessary for a roof 40 ft. \times 80 ft.?

71. The area of the bottom of a jar is 77 sq. in. How deep must it be to hold exactly 2 gal.?

72. How many times can a cask holding $3\frac{3}{4}$ gal. be filled from a tank 4 ft. long, 3 ft. wide, and 2 ft. deep?

73. How many cubic feet are there in a block of stone 30 in. \times 24 in. \times 18 in.?

74. At 40 lb. to the cubic foot, what is the weight of a block of wood 6 ft. long, 18 in. wide, and $1\frac{1}{2}$ ft. thick?

75. How many feet of lumber are necessary to cover with 2-in. plank a surface 20 ft. \times 80 ft.? How much will the lumber cost at \$20 per M.?

76. How many revolutions does a wagon wheel $3\frac{1}{2}$ ft. in diameter make in going 12 rd.? (See problem 46, page 33.)

77. At \$3 per cubic yard, how much will it cost to dig a cellar 30 ft. \times 33 ft., and 12 ft. deep?

78. How many bushels of grain can be put into a bin 10 ft. \times 8 ft., and 6 ft. deep? How many bushels can be put into a bin 20 ft. \times 16 ft. \times 12 ft.?

79. If wall paper is 18 in. wide, how many strips are needed to cover a wall 30 ft. long? How many strips are needed for the four walls of a room 30 ft. long and 24 ft. wide, making no allowance for doors and windows?

80. How many more steps must be taken in walking a mile if the steps are 2 ft. long, than if they are 3 ft. long?

81. At the rate of 8 mi. per hour, how far will a horse travel in 4 hr. 35 min.?

82. At the rate of $37\frac{1}{2}$ mi. in 90 min., how far will a train run in $3\frac{1}{8}$ hr.?

83. Reduce 208 in. to integers of higher denomination. 92 ft.; 125 in.; 144 in.

84. At \$10 per M., find the cost of ten 4×4 's 18 ft. long, and thirty 2×6 's 12 ft. long.

SECTION IX

INTRODUCING THE STUDY OF SURFACES AND DEVELOPING RELATIONS

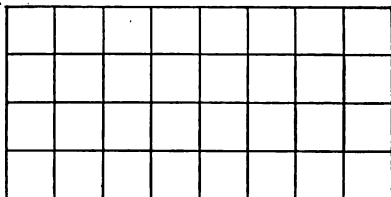

1. If the above rectangle is 8 units long, how many *square units* are there along one side? If it is 4 units wide, how many *square units* are there along one end? How many rows are there of 8 square units each? How many square units are there in the whole rectangle? How many rows are there of 4 square units each? How many square units are there in the rectangle?

2. Does 4×8 equal the *number* of square units in a rectangle 8 units long and 4 units wide? How many square units are there in a rectangle 10 units long and 7 units wide?

3. *The number of square units in the area of a rectangle is equal to the product of the numbers of the like units in the length and width.* What is the area of a rectangle 6 in. long and 4 in. wide? 1 ft. long and 5 in. wide?

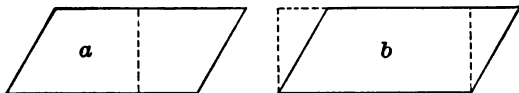

4. A parallelogram is a four-sided figure whose opposite sides are equal and parallel. Is a rectangle a parallelogram? The **base** is the side on which the parallelogram seems to stand. The **altitude** is the perpendicular distance from the base to the side opposite. In figure *a* what is the base? The altitude? In figure *b* what is the base? What two lines represent the altitude?

5. If in figure *b* we cut off a three-sided portion at the right, and add on an equal three-sided portion at the left, what kind of a figure have we? Compare the area of the rectangle with the area of parallelogram *b*.

6. If the rectangle is 8 units long and 4 units wide, how many square units are there in its area? If the parallelogram has a base of 8 units, and an altitude of 4 units, how many square units are there in its area?

7. *The area of a parallelogram is represented by the product of the numbers of like units in the base and in the altitude.* What is the area of a parallelogram whose base is 7 in. and altitude 4 in.? Base 10 in. and altitude 6 in.? Base 20 in. and altitude 7 in.?

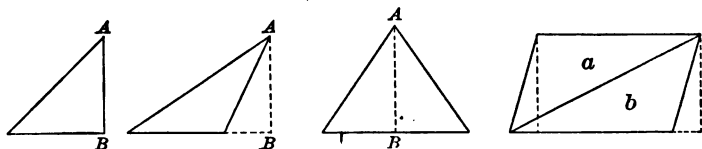

8. A triangle is a three-sided figure. Its *base* is usually considered to be the side it seems to stand on, although

any side *may* be considered the base. Its altitude, AB , is its height, measured from the highest point to the base. If a line is drawn from corner to corner of a parallelogram, into what two figures is the parallelogram divided? Compare triangle a with triangle b . Compare a with the parallelogram. Compare b with the parallelogram.

9. Is the altitude of triangles a and b the same as that of the parallelogram? Are the bases the same? If the base of the parallelogram is 7 and its altitude 3, what is its area? What, then, is the area of triangle a ? Of triangle b ?

10. *The area of a triangle is represented by one half the product of the numbers of like units in the base and in the altitude.* The base of a certain triangle is 7 units, its altitude 3 units. What is its area?

11. Give the area of a triangle whose base is 7 in. and altitude 3 in. Base 10 in. and altitude 4 in. Base 6 ft. and altitude 3 ft. Base 4 rd. and altitude 3 rd.

12. What is the area of a rectangle 12 ft. long and 7 ft. wide? Of a parallelogram whose base is 12 ft. and altitude 7 ft.? Of a triangle whose base is 12 ft. and altitude 7 ft.? What is the ratio of the rectangle to the parallelogram? Of the parallelogram to the triangle? Of the rectangle to the triangle?

13. A rectangular piece of land is divided into two parts by a diagonal line (one running from corner to corner). If the base of the rectangle is 40 rd. and its altitude 20 rd., what is the area of each of the parts?

14. A trapezoid is a four-sided figure having *two and only two* sides parallel. These sides are called the upper

base and the lower base. The altitude is the perpendicular distance between the parallel sides. If a diagonal is drawn, into what does it divide the trapezoid? If the upper base is 4 and the altitude is 2, what is the area of

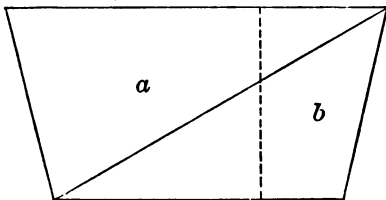

triangle *a*? If the lower base is 3, what is the area of triangle *b*? Of both triangles? The area of the trapezoid? Will you get the same area of the trapezoid if you take half the sum of the two bases times the altitude?

15. *The area of a trapezoid is represented by the product of the number of like units in half the sum of the two bases and in the altitude.* What is the area of a trapezoid whose bases are 4 units and 3 units, and altitude 2 units? Of one whose bases are 4 in. and 3 in., and altitude 2 in.?

16. Find the area of a trapezoid having:

Bases 6 in. and 8 in., and altitude 4 in.

Bases 4 ft. and 5 ft., and altitude 3 ft.

Bases 2 ft. and 18 in., and altitude 15 in.

17. A certain rectangle has an area of 72 sq. in. If its length is 1 ft., how wide is it?

18. A parallelogram having an altitude of 7 ft. has an area of 81 sq. ft. How long is the base?

19. The area of a certain triangle is 40 sq. in. If the base is 10 in., what is the altitude?

20. The area of a certain trapezoid is 85 sq. ft. If one base is 20 ft., and the other 14 ft., what is the altitude of the trapezoid?

21. Think of a circle divided into a number of equal triangles as in Fig. 1. Is the area of all the triangles greater or less than the area of the circle? Are the altitudes of the triangles equal? Is the altitude a greater

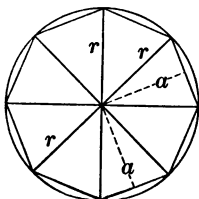

FIG. 1.

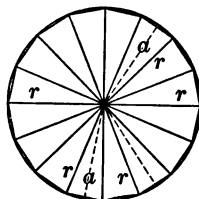
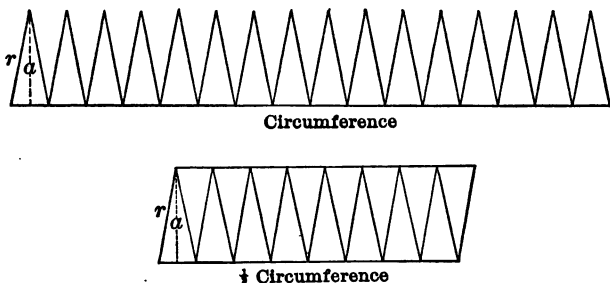

FIG. 2.

or less than the radius of the circle? Is the sum of the bases (the sides next to the circumference) greater or less than the circumference? If the number of triangles be doubled, is their area nearer to that of the circle? Is the altitude a more nearly equal to the radius? Is the sum of the bases more nearly equal to the circumference? If you think of the number of triangles indefinitely increased, what will be true of their area, altitude, and the sum of their bases, as compared with the area, radius, and circumference of the circle respectively? Can they be made as nearly equal as we please?

22. Think of the circle in Fig. 2 above as unrolled. The sum of the bases of the triangles may be represented

as below by a straight line (nearly) equal to the circumference. How is the area of each triangle found? Is the area of all of them equal to $\frac{1}{2}$ the product of the sum of the bases by the altitude? Since this is true, and since



the sum of the bases is nearly equal to the circumference, and the altitude to the radius, is the area of the circle *nearly* equal to $\frac{1}{2}$ the product of the circumference by the radius, or the product of $\frac{1}{2}$ the circumference by the radius? By increasing the number of triangles, is the result more nearly correct? (Geometry shows that *the area of the circle is exactly equal to $\frac{1}{2}$ the product of the circumference by the radius.*) In the above figure is represented a parallelogram nearly equal in area to the circle. How can you find its area?

23. Find the area of a circle whose circumference is 44 in. and radius 7 in. Of one whose circumference is 22 in. and radius $3\frac{1}{2}$ in. State the dimensions of the rectangle equal in area to each circle.

A rectangle 7 in. \times 22 in. is equal to the first circle; that is, one whose width is the radius, and whose length is $\frac{1}{2}$ the circumference.

24. What is the ratio of the circumference to the diameter? (Nearly $2\frac{2}{7}$.) How many times the radius is the diameter? How many times the radius is the circumference? What is the circumference of a circle whose radius is 7 in.? Radius $3\frac{1}{2}$ in.? Radius 14 ft.? Radius $17\frac{1}{2}$ ft.? Radius 21 ft.? How long must a rectangle 7 in. wide be to be equal to the first circle? Make a similar statement regarding each of the other circles.

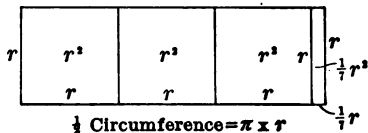
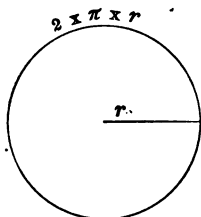

25. Find the area of a circle whose radius is 7 in. What rectangle is it equal to? Into how many squares 7 in. on each side can this rectangle be divided? (Each square may be thought of as the square of the radius represented above by r^2 .) Is the area of the rectangle equal to $3\frac{1}{7} \times$ the square of 7 in.? Using the symbol π (read $p\bar{i}$) for $3\frac{1}{7}$, is the area of the rectangle equal to $\pi \times 49$ sq. in., or $\pi \times r^2$, or πr^2 ? Is the area of the circle also equal to πr^2 ? (This way of finding the area is easier than finding $\frac{1}{2}$ the product of the circumference by the radius, since the radius, not the circumference, is usually given.)

26. Find the area of a circle whose radius is $10\frac{1}{2}$ in.

$$\left(\text{Area} = \pi r^2, \text{ or, } \frac{22}{7} \times \frac{21}{2} \times \frac{21}{2} = 346\frac{1}{2}, \text{ number of sq. in.} \right)$$

Of one whose radius is $3\frac{1}{2}$ in. ; 14 in. ; 7 ft. ; $3\frac{1}{2}$ yd. ; 14 rd. Of one whose diameter is 7 in. ; 28 in. ; 14 ft. ; 7 yd. ; 28 rd. ; 7 ft.

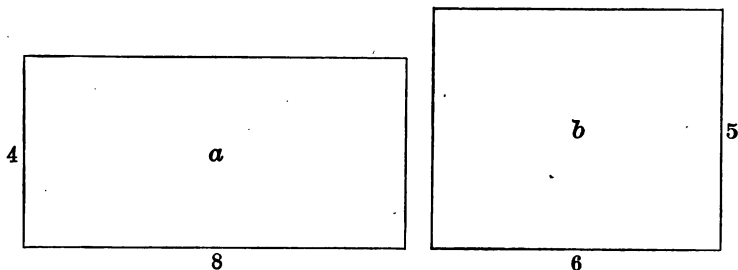

27. What is the ratio of the length of rectangle a to the length of rectangle b ? Of the width of rectangle a to the width of rectangle b ? Of the length \times the width of rectangle a to the length \times the width of rectangle b ? Of rectangle a to rectangle b ? Of b to a ?

28. If rectangle a is 36 in. long and 25 in. wide, and rectangle b is 27 in. long and 20 in. wide, what is the ratio of the length of a to the length of b ? Of the width of a to the width of b ? Of the area of a to the area of b ? Of b to a ?

29. Give the ratio of :

A rectangle 12 in. by 9 in. to a rectangle 8 in. by 6 in.

A rectangle 5 in. by 7 in. to a rectangle $7\frac{1}{2}$ in. by $10\frac{1}{2}$ in.

A rectangle $18\frac{3}{4}$ in. by 25 in. to a rectangle 25 in. by $16\frac{2}{3}$ in.

A rectangle $12\frac{1}{2}$ ft. by $8\frac{1}{3}$ ft. to a rectangle $37\frac{1}{2}$ ft. by $16\frac{2}{3}$ ft.

A rectangle $31\frac{1}{4}$ rd. by 20 rd. to a rectangle $37\frac{1}{2}$ rd. by 30 rd.

A rectangle $83\frac{1}{2}$ yd. by $33\frac{1}{2}$ yd. to a rectangle $33\frac{1}{2}$ yd. by $8\frac{1}{2}$ yd.

A rectangle $56\frac{1}{4}$ ft. by $41\frac{3}{8}$ ft. to a rectangle $62\frac{1}{2}$ ft. by $58\frac{1}{8}$ ft.

30. How many rectangles 8 in. \times 5 in., will a rectangle 32 in. \times 15 in. contain?

31. What is the area of:

A parallelogram whose base is 8 ft. and altitude 7 ft.?

A triangle whose base is 8 ft. and altitude 7 ft.?

A trapezoid whose bases are 6 ft. and 4 ft., and altitude 10 ft.?

A triangle whose base is 3 ft. and altitude 16 in.?

A rectangle 4 ft. by 4 yd.?

A circle whose radius is 7 in.?

A circle whose diameter is 7 in.?

A trapezoid whose bases are 8 ft. and 8 yd., and altitude 10 ft.?

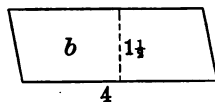
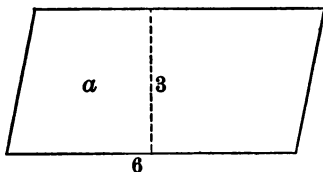

32. What is the ratio of the base of a to the base of b ? Of the altitude of a to the altitude of b ? If the ratio of the bases is $\frac{3}{2}$, and the ratio of the altitudes is 2, what is the ratio of the base \times altitude of a , to the base \times altitude of b ? Or, what is the ratio of the area of a to the area of b ? Of b to a ? ($\frac{3}{2} \times \frac{1}{2} = ?$)

33. Give the ratio of the area of parallelogram a to parallelogram b in the following. Also of b to a .

 a

Base 8 in., alt. 6 in.

Base 12 in., alt. 8 in.

Base $18\frac{3}{4}$ ft., alt. $16\frac{2}{3}$ ft.Base $91\frac{1}{3}$ rd., alt. $56\frac{1}{4}$ rd.Base $66\frac{2}{3}$ yd., alt. 25 yd.Base 50 ft., alt. $62\frac{1}{2}$ ft.

Base 100 ft., alt. 300 ft.

Base $41\frac{2}{3}$ in., alt. 50 in. b

Base 4 in., alt. 3 in.

Base 9 in., alt. 5 in.

Base 25 ft., alt. $33\frac{1}{3}$ ft.Base 75 rd., alt. $31\frac{1}{4}$ rd.Base 100 yd., alt. $37\frac{1}{2}$ yd.Base $66\frac{2}{3}$ ft., alt. $37\frac{1}{2}$ ft.

Base 200 ft., alt. 150 ft.

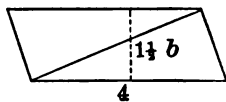
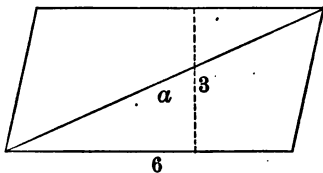
Base $33\frac{1}{3}$ in., alt. 125 in.

34. What is the ratio of the area of parallelogram a to the area of parallelogram b ? If a is $3 \times b$, what is the ratio of $\frac{1}{2}$ of a to $\frac{1}{2}$ of b ? Triangle a is what part of parallelogram a ? Triangle b is what part of parallelogram b ? What, then, is the ratio of triangle a to triangle b ?

35. What is the ratio of a triangle whose base is 6, and altitude 3, to one whose base is 4 and altitude $1\frac{1}{2}$? ($\frac{3}{2} \times \frac{2}{1} = ?$).

Why is it not necessary to consider the $\frac{1}{2}$ in comparing two triangles? (See problem 10.)

36. What is the ratio of triangle a to triangle b in the following? Of b to a ?

a	b
Base 8 in., alt. 6 in.	Base 4 in., alt. 3 in.
Base 12 in., alt. 8 in.	Base 9 in., alt. 5 in.
Base $18\frac{3}{4}$ ft., alt. $16\frac{2}{3}$ ft.	Base 25 ft., alt. $33\frac{1}{3}$ ft.
Base $91\frac{1}{3}$ rd., alt. $56\frac{1}{4}$ rd.	Base 75 rd., alt. $31\frac{1}{4}$ rd.
Base $3\frac{3}{4}$ in., alt. $2\frac{1}{2}$ in.	Base 5 in., alt. 5 in.
Base $18\frac{3}{4}$ in., alt. 25 in.	Base 25 in., alt. $16\frac{2}{3}$ in.
Base $12\frac{1}{2}$ ft., alt. $8\frac{1}{3}$ ft.	Base $37\frac{1}{2}$ ft., alt. $16\frac{2}{3}$ ft.
Base $56\frac{1}{4}$ ft., alt. $41\frac{2}{3}$ ft.	Base $62\frac{1}{2}$ ft., alt. $58\frac{1}{3}$ ft.

37. Find the ratio of a 7-in. circle to a 14-in. circle.

Find the dimensions of the rectangles equal to the two circles. (See problems 24 and 25.) If the altitudes are 7 in. and 14 in., and the bases are $3\frac{1}{2} \times 7$ in., and $3\frac{1}{2} \times 14$ in., what is the ratio of the altitudes and of the bases? The ratio of the rectangles? Of the circles? Since the ratio of the altitudes is equal to the ratio of the bases, can the ratio of the areas be found by squaring the ratio of the altitudes, or their equal, the ratio of the two radii?

38. What is the ratio of a circle of radius $3\frac{1}{2}$ ft. to one of radius 7. ft.? Of one of radius 6 ft. to one of radius 12 ft.? Of one of radius $12\frac{1}{2}$ ft. to one of radius $18\frac{3}{4}$ ft.?

What is the ratio of the radii? If the ratio of the radii is $\frac{3}{4}$, what is the ratio of the circles?

39. If the radius of one circle is twice as long as the radius of another, what is the ratio of the area of the first to that of the second? Of the second to the first?

40. If the area of one circle is 4 times that of another, what is the ratio of the radius of the first to that of the second? Of the diameter of the first to the diameter of the second? Of the circumference of the first to the circumference of the second?

41. What is the ratio of the area of a circle of radius 1 ft. to the area of one of radius 2 ft.? Of one of radius 2 ft. to one of radius 4 ft.? Of one of radius 3 ft. to one of radius 6 ft.? Of one of diameter 1 ft. to one of diameter 2 ft.? Of one of diameter 2 ft. to one of diameter 4 ft.? Of one of diameter 3 ft. to one of diameter 6 ft.? Of one of circumference 1 ft. to one of circumference 2 ft.? Of one of circumference 2 ft. to one of circumference 4 ft.? Of one of circumference 3 ft. to one of circumference 6 ft.?

42. A pipe 1 inch in diameter carries 3 gal. of water per minute. At that rate how much per minute will a 2-inch pipe carry? A 4-inch pipe? An 8-inch pipe? A $\frac{1}{2}$ -inch pipe? A $\frac{1}{4}$ -inch pipe?

43. A building is supplied with water by a 2-inch pipe. How many $\frac{1}{2}$ -inch pipes would it take to carry the same amount of water running at the same rate?

44. What is the ratio of the area of a circle of 1 in. radius to that of a circle of 3 in. radius? (See problem 27.) Of a circle of 2 in. radius to one of 6 in. radius? Of a circle of 3 in. radius to one of 9 in. radius? Of a circle of any radius to a circle of 3 times that radius? Of a circle of any diameter to a circle of 3 times that diameter? Of a circle of any circumference to a circle of 3 times that circumference?

45. What is the ratio of the area of a circle of radius 1 in. to that of a circle of radius 4 in.? Of a circle of radius 2 in., to one of radius 8 in.? Of a circle of radius 3 in., to one of radius 12 in.? Of a circle of any radius, to one of 4 times that radius? Of a circle of any diameter, to one of 4 times that diameter? Of a circle of any circumference, to one of 4 times that circumference?

46. The square of a number is the product obtained by multiplying the number by itself. What is the square of 6? Of 5? Of 8? Of $\frac{1}{2}$? Of $\frac{2}{3}$? The square of 6 may be represented thus: 6^2 ; of $\frac{3}{4}$, $(\frac{3}{4})^2$, etc. $7^2 = ?$ $9^2 = ?$ $(\frac{4}{5})^2 = ?$ $(\frac{3}{8})^2 = ?$ $(\frac{5}{2})^2 = ?$

47. The ratio of the area of one circle to that of another is the square of the ratio of the radius of the first to the radius of the second, or the square of the ratio of the diameter of the first to the diameter of the second, or the square of the ratio of the circumference of the first to the circumference of the second. Or, *The ratio of one circle to another equals the square of the ratio of two homologous (like) lines.*

Give the ratio of:

A circle of radius 1 ft. to one of radius 2 ft.

A circle of diameter 1 ft. to one of diameter 2 ft.

A circle of circumference 1 ft. to one of circumference 2 ft.

A circle of radius 2 ft. to one of radius 8 ft.

The ratio of the radii is $\frac{1}{4}$. Then the ratio of the circles is $(\frac{1}{4})^2$, or $\frac{1}{16}$.

A circle of radius 2 ft. to one of radius 10 ft.

A circle of radius 2 ft. to one of radius 12 ft.

A circle of diameter 5 ft. to one of diameter 30 ft.

The ratio of the diameters is $\frac{1}{6}$. Then the ratio of the circles is $(\frac{1}{6})^2$, or $\frac{1}{36}$.

A circle of circumference 4 ft. to one of circumference 10 ft.

The ratio of the circumferences is $\frac{2}{5}$. Then the ratio of the circles is $(\frac{2}{5})^2$, or $\frac{4}{25}$.

A circle of circumference $6\frac{1}{4}$ ft. to one of circumference $18\frac{3}{4}$ ft.

A circle of diameter $2\frac{1}{2}$ ft. to one of diameter $12\frac{1}{2}$ ft.

A circle of radius $3\frac{1}{3}$ ft. to one of radius 20 ft.

A circle of radius $2\frac{1}{4}$ ft. to one of radius 18 ft.

A circle of circumference $2\frac{1}{4}$ ft. to one of circumference 18 ft.

A circle of *radius* 3 ft. to one of *diameter* 3 ft.

A circle of *radius* $3\frac{1}{2}$ ft. to one of *circumference* 22 ft.

A circle of *radius* 100 ft. to one of *diameter* 200 ft.

SECTION X

INTRODUCING THE STUDY OF SOLIDS AND DEVELOPING RELATIONS

1. Think of a square block of wood, 6 in. wide, 6 in. long, and 6 in. high. What is a solid of this shape called? How many surfaces has it? What shape is each? How many square inches are there in the lower face of the 6-in. cube? How many cubic inches are there in a section of it 1 in. thick? How many such sections are there? How many cubic inches are there, then, in a 6-in. cube?

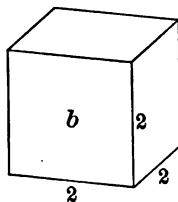
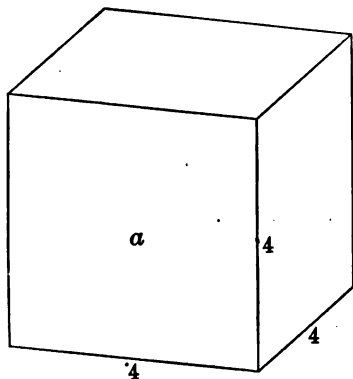

2. How many cubic inches are there in a 10-in. cube? In a 5-in. cube? In a 12-in. cube? In a 1-in. cube? In a 2-in. cube? In a 4-in. cube? In a 3-in. cube?

3. What is the ratio of the length of the base of cube a to the length of the base of cube b ? Of the width of a to the width of b ? Of the height of a to the height of b ? What is the ratio of the volume of a to the volume of b ?

4. What is the ratio of a cube whose length, breadth, and height are 4 in., to one whose dimensions are 2 in.? Of an 8-in. cube to a 4-in. cube?

5. Give the ratio of:

A 1-in. cube to a 2-in. cube.

A 2-in. cube to a 4-in. cube.

A 25-in. cube to a 75-in. cube.

A 1-in. cube to a 4-in. cube.

A $1\frac{1}{2}$ -in. cube to a 3-in. cube.

A $6\frac{1}{2}$ -in. cube to a 13-in. cube.

A $37\frac{1}{2}$ -in. cube to a $12\frac{1}{2}$ -in. cube.

A $12\frac{1}{2}$ -in. cube to a 25-in. cube.

A $56\frac{1}{4}$ -in. cube to an $18\frac{3}{4}$ -in. cube.

A 25-in. cube to a 5-in. cube.

6. A certain box measures 2 ft. each way, inside. How many 6-in. cubes of wood can be put into the box?

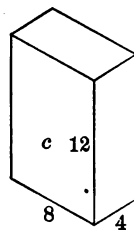
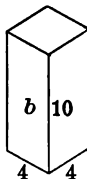
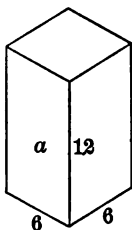

7. A solid which has two bases (or ends) which are alike and parallel, and whose sides are rectangles (or par-

allegograms) is called a **prism**. a and b are square prisms. Is c a square prism? Is a cube a prism? Is a cube a square prism? A solid like c is called a **parallelepiped**.

8. How many square units are in the base of a ? Of b ? Of c ? How many cubic units are there in a ? In b ? In c ? What is the ratio of a to c ? Of a to b ? Of b to c ?

9. What is the ratio of the length of the base of a to the length of the base of c ? Of the width of the base of a to the width of the base of c ? Of the base of a to the base of c ? Of the height of a to the height of c ? If the ratio of the bases of a and c is $\frac{3}{8}$, and the ratio of the heights is 1, what is the ratio of the volume of a to the volume of c ? Find in a similar way the ratio of a to b . Of b to c .

10. Give the ratio of a to b :

a		b	
BASE	HEIGHT	BASE	HEIGHT
12 in. by 8 in.,	15 in.	9 in. by 4 in.,	10 in. ($\frac{3}{8} \times \frac{3}{2}$)
6 in. by 7 in.,	16 in.	4 in. by 14 in.,	32 in.
$12\frac{1}{2}$ in. by $6\frac{1}{4}$ in.,	$16\frac{2}{3}$ in.	$18\frac{3}{4}$ in. by $12\frac{1}{2}$ in.,	25 in.
$31\frac{1}{4}$ ft. by $33\frac{1}{3}$ ft.,	100 ft.	$37\frac{1}{2}$ ft. by 50 ft.,	$133\frac{1}{3}$ ft.
8 ft. by 9 ft.,	20 ft.	12 ft. by 18 ft.,	30 ft.
3 in. by 3 in.,	6 in.	3 in. by 6 in.,	12 in.
18 in. by 2 ft.,	5 yd.	12 in. by 3 ft.,	10 yd.
$18\frac{3}{4}$ in. by $3\frac{1}{2}$ ft.,	$6\frac{1}{4}$ yd.	$31\frac{1}{4}$ in. by 7 ft.,	$18\frac{3}{4}$ yd.
40 ft. by 40 yd.,	200 ft.	20 ft. by 30 yd.,	$66\frac{2}{3}$ ft.
8 ft. by 8 ft.,	8 ft.	4 ft. by 4 ft.,	4 ft.

11. If a chalk box measures 6 in. \times 4 in. \times 3 in. outside, how many can be packed in a box 4 ft. \times 3 ft. \times 2 ft.?

12. How many times as much air is there in a room 30 ft. \times 20 ft. \times 15 ft., as in a room 20 ft. \times 25 ft. \times 18 ft.?

13. How many cubic feet of water are there in a tank 16 ft. long, 4 ft. wide, and 2 ft. deep, when it is half full? In a tank 32 ft. long, 4 ft. wide, and 3 ft. deep, half full?

14. How many 3-in. cubes of wood can be put into a box 14 in. long, 11 in. wide, and 10 in. deep? Can the box be filled? Why?

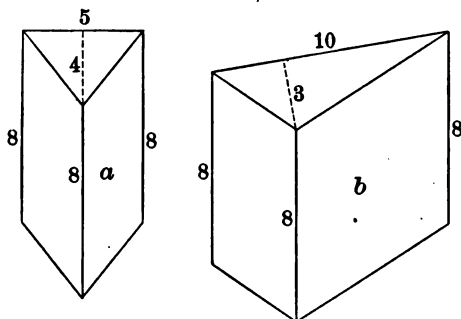

15. Prisms whose bases are triangles are called **triangular prisms**. The base of the base of prism *a* is 5 units, and its altitude 4 units. What is its area? If its area is 10 square units, how many cubic units are there in a section 1 unit thick, cut off the end of the prism? How many such sections are there in *a*, if the altitude is 8 units? How many cubic units are there in *a*? How many cubic units are there in a triangular prism 8 units high, the triangle of the base having a base of 5 units, and an altitude of 4 units?

16. What is the volume of prism *b*, which is 8 units high and whose base has a base of 10 units, and an altitude of 3 units?

17. Give the volume of the following triangular prisms:

Height 18 in., base of base 5 in., altitude of base 4 in.

Height 20 in., base of base 12 in., altitude of base 6 in.

Height 15 in., base of base 20 in., altitude of base 10 in.

Height 100 in., base of base 50 in., altitude of base 4 in.

Height 30 ft., base of base $12\frac{1}{2}$ ft., altitude of base 8 ft.

18. In the above figures, what is the ratio of the base of the base of prism a , to the base of the base of prism b ? What is the ratio of the altitude of the base of a to the altitude of the base of b ? Of the area of the base of a to the area of the base of b ? What is the ratio of the height of a to the height of b ? If the ratio of the bases is $\frac{2}{3}$, and the ratio of the heights is 1, what is the ratio of the volume of a to the volume of b ?

19. Give the ratio of prism a to prism b ; of c to d ; of e to f ; of g to h ; of i to j .

a . Base of base 12 in., altitude 8 in., height 15 in.

b . Base of base 9 in., altitude 4 in., height 10 in.

c . Base of base 6 in., altitude 7 in., height 16 in.

d . Base of base 4 in., altitude 14 in., height 16 in.

e . Base of base 3 in., altitude 6 in., height 6 in.

f . Base of base 3 in., altitude 6 in., height 12 in.

g . Base of base $18\frac{3}{4}$ in., altitude $3\frac{1}{2}$ ft., height $6\frac{1}{4}$ yd.

h . Base of base $31\frac{1}{2}$ in., altitude 7 ft., height $18\frac{3}{4}$ yd.

i . Base of base $31\frac{1}{4}$ in., altitude $33\frac{1}{8}$ in., height 100 in.

j . Base of base $37\frac{1}{2}$ in., altitude 50 in., height $133\frac{1}{8}$ in.

20. A circular solid that has length is called a cylinder. A round pencil, or a stove pipe is a cylinder. What is

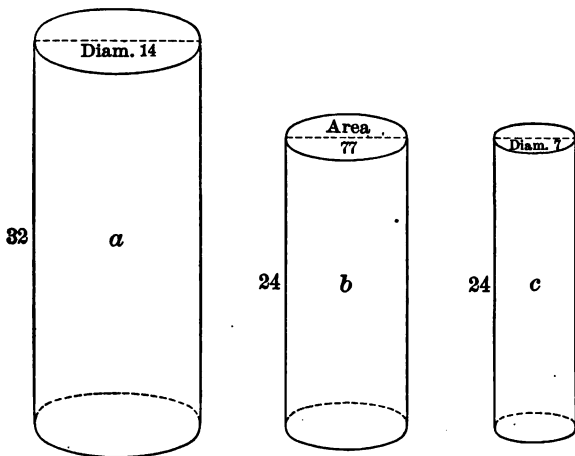

the shape of the end of a cylinder if cut off square? How can you find the area of the end or base of a cylinder if you know its radius? If you know its diameter?

21. If the diameter of the base of cylinder *a* is 14 units, what is the area of the base? If there are 154 square units in the base, how many cubic units are there in a section of the cylinder 1 unit thick? How many such sections are there if the height of the cylinder is 32 units? Are there, then, 32×154 cubic units in cylinder *a*?

22. The volume of a cylinder is represented by the number of units in the height times the number of square

units in the area of the base. What is the volume of a cylinder of radius 7 in. and height 10 in. ? (1540 cu. in.)

Of a cylinder of radius $3\frac{1}{2}$ in. and height 20 in. ?

Of a cylinder of radius 1 ft. and height 1 ft. ?

Of a cylinder of radius 1 yd. and height 2 yd. ?

23. In the above figures, what is the ratio of the diameter of a to the diameter of c ? Of the area of the base of a to the area of the base of c ? (See problem 37, page 74.) Of the height of a to the height of c ? If the ratio of the bases is 4, and of the heights is $\frac{4}{3}$, what is the ratio of the volume of cylinder a to the volume of cylinder c ? *The ratio of one cylinder to another equals the product of the ratio of the heights by the square of the ratio of the diameters or radii.*

24. Give the ratio of cylinder a to cylinder b :

a	b
Diameter 14 in., height 32 in.	Diameter 7 in., height 24 in.
Diameter 18 ft., height 50 ft.	Diameter 24 ft., height 75 ft.
Diameter $12\frac{1}{2}$ ft., height $83\frac{1}{2}$ ft.	Diameter $37\frac{1}{2}$ ft., height $16\frac{1}{2}$ ft.
Diameter $56\frac{1}{2}$ ft., height $41\frac{1}{2}$ yd.	Diameter $31\frac{1}{2}$ ft., height 75 yd.
Diameter $16\frac{2}{3}$ yd., height $66\frac{2}{3}$ ft.	Diameter $66\frac{2}{3}$ yd., height $83\frac{2}{3}$ ft.
Diameter $18\frac{1}{2}$ rd., height 20 rd.	Diameter $12\frac{1}{2}$ rd., height 25 rd.
Radius 6 in., height 2 ft.	Diameter 3 in., height 4 ft.
Radius 12 in., height 4 ft.	Diameter 2 ft., height 3 yd.
Radius $2\frac{1}{2}$ ft., height 100 in.	Diameter $12\frac{1}{2}$ ft., height 20 in.
Radius $2\frac{1}{2}$ in., height 40 ft.	Diameter 18 in., height 5 ft.
Radius 5 ft., height 72 yd.	Diameter 30 ft., height 2 yd.
Radius 32 in., height 45 in.	Diameter 40 in., height 72 in.

25. How many cubic feet of water will a cylindrical tank 2 ft. in diameter and 7 ft. high hold ?

26. A cylindrical pail 8 in. in diameter and 12 in. deep holds how many times as much as a pail 6 in. in diameter and 8 in. deep?

27. How many gallons will a cylindrical cistern 15 ft. deep hold if the bottom has an area of 30 sq. ft., and it is half full? (See problem 42, page 60.)

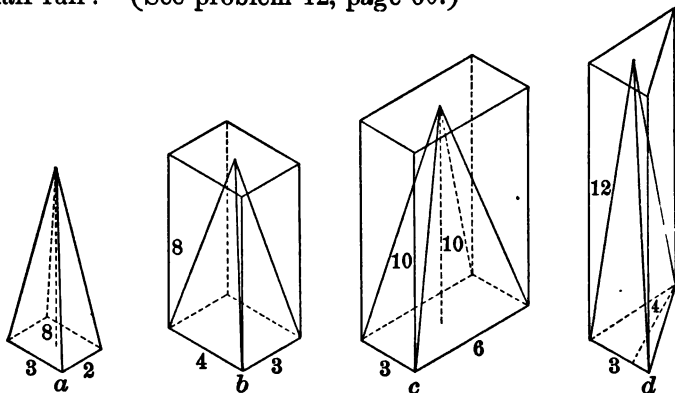

28. A solid that has a base of any number of sides, and whose other surfaces are triangles meeting at a common point at the top (the apex of the pyramid) is a **pyramid**. The altitude is the height, or usually the shortest distance from the apex to the base. Figure *a* represents a pyramid with a rectangular base. Figures *b* and *c* represent rectangular pyramids inside of prisms of base and height equal to those of the pyramids. Figure *d* represents a triangular pyramid inside a prism of equal base and height. *The volume of a pyramid is represented by $\frac{1}{3}$ the product of the number of square units in its base by the number of units in its altitude.* What is the volume of pyramid *a*,

if its base is 3 units by 2 units, and its altitude is 8 units? Of pyramid *b*, if its base is 4 units by 3 units, and its altitude is 8 units? Of pyramid *c*, base 3 units by 6 units, and altitude 10 units? Of pyramid *d*, base of base 3 units, altitude of base 4 units, altitude of pyramid 12 units?

29. Give the volume of the following pyramids :

Base, a rectangle, 8 in. by 6 in., height 20 in.

Base, a rectangle, 3 ft. by 5 ft., height 15 ft.

Base, a rectangle, 1 yd. by 3 ft., height 25 ft.

Base, a triangle, base 18 ft., altitude 10 ft.; height 20 ft.

Base, a triangle, base 8 yd., altitude 6 yd.; height 8 yd.

Base, a triangle, base 6 in., altitude 5 in.; height 8 in.

30. In the above figure, what is the ratio of the base of pyramid *a* to the base of pyramid *b*? Of the height of *a* to the height of *b*? If the ratio of the bases is $\frac{1}{2}$ unit, and of the heights is 1 unit, what is the ratio of the base \times height of *a* to the base \times height of *b*? Of $\frac{1}{2}$ base \times height of *a* to $\frac{1}{2}$ base \times height of *b*? Of the volume of *a* to the volume of *b*? What is the ratio of the base of *b* to the base of *c*? Of the height of *b* to the height of *c*? Of the volume of *b* to the volume of *c*? ($\frac{8}{15}$) Why is it not necessary to consider the $\frac{1}{2}$? (See problem 28.)

31. In the following *rectangular* pyramids give the ratio of *a* to *b* :

<i>a</i>		<i>b</i>	
BASE	HEIGHT	BASE	HEIGHT
3 in. \times 4 in.	8 in.	6 in. \times 3 in.	10 in.
25 in. \times 16 $\frac{2}{3}$ in.	62 $\frac{1}{2}$ in.	31 $\frac{1}{2}$ in. \times 66 $\frac{2}{3}$ in.	37 $\frac{1}{2}$ in.
18 $\frac{3}{4}$ ft. \times 31 $\frac{1}{4}$ ft.	33 $\frac{3}{4}$ ft.	25 ft. \times 37 $\frac{1}{4}$ ft.	41 $\frac{3}{4}$ ft.
8 yd. \times 4 yd.	10 yd.	6 yd. \times 8 yd.	15 yd.
100 ft. \times 100 yd.	100 in.	200 ft. \times 200 yd.	200 in.

32. In the following *triangular* pyramids give the ratio of a to b .

a			b		
BASE	HEIGHT		BASE	HEIGHT	
3 in. base	4 in. alt.	12 in.	4 in. base	6 in. alt.	8 in.
$18\frac{1}{2}$ in. base	$8\frac{1}{2}$ in. alt.	$31\frac{1}{2}$ in.	$12\frac{1}{2}$ in. base	$16\frac{1}{2}$ in. alt.	$18\frac{1}{2}$ in.
5 ft. base	4 ft. alt.	12 ft.	6 ft. base	10 ft. alt.	16 ft.
8 yd. base	12 ft. alt.	150 in.	6 yd. base	16 ft. alt.	100 in.
1 yd. base	1 ft. alt.	1 yd.	1 ft. base	1 yd. alt.	1 ft.

33. A solid having a circular base, and tapering to a point, is a cone. The cone bears the same relation to a cylinder that a pyramid does to a prism. *The volume of a cone is represented by $\frac{1}{3}$ of the product of the area of its base by its height.* What is the volume of a cone whose base is 20 sq. in., and whose height is 27 in.? Of a cone whose height is 30 in., and whose base has a radius of 7 in.? (1540 cu. in.) Of a cone whose height is 21 ft., and whose base has a radius of 1 ft.?

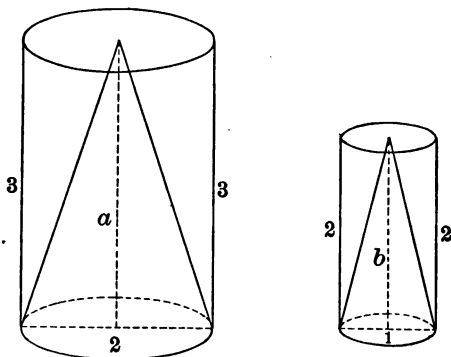

34. Cones a and b are represented inside of cylinders of height and base equal to those of the cone. What is

the ratio of the base of cone a to the base of cone b , if the diameters are 2 and 1? (See problem 23, page 85.) What is the ratio of the height of a to the height of b ? Of the product of the height by the base of a , to the product of the height by the base of b ? Of $\frac{1}{3}$ of base \times height of a to $\frac{1}{3}$ of base \times height of b ? Why is it not necessary to consider the $\frac{1}{3}$ in getting the ratio of one cone to another?

35. Give the ratio of cone a to cone b :

a		b	
RADIUS OF BASE	HEIGHT	RADIUS OF BASE	HEIGHT
10 in.	20 in.	5 in.	10 in.
12 in.	16 in.	18 in.	20 in.
$18\frac{1}{2}$ in.	$41\frac{1}{2}$ in.	25 in.	75 in.
DIAMETER OF BASE	HEIGHT	DIAMETER OF BASE	HEIGHT
50 in.	$6\frac{1}{2}$ ft.	75 in.	$12\frac{1}{2}$ ft.
25 ft.	25 ft.	25 yd.	25 yd.
CIRCUMFERENCE OF BASE	HEIGHT	CIRCUMFERENCE OF BASE	HEIGHT
60 in.	28 in.	80 in.	63 in.

36. What is the ratio of a cone to a cylinder of the same base and height? Of a pyramid to a prism of the same base and height?

37. How many times will a conical dipper 2 in. in diameter at the top, and 4 in. deep, have to be dipped full of milk to fill a cylindrical pail 6 in. in diameter and 8 in. deep?

What is the ratio of the cone to a cylinder of the same base and height? Of this cylinder to the pail? Of the dipper to the pail? Of the pail to the dipper?

38. Which is greater in volume and how much, a cone 6 in. high, whose base has a radius of 1 ft., or a square pyramid 6 in. high, whose base is 2 ft. square?

39. Which is greater in volume and how much, a cylinder 8 in. high and 2 in. in diameter, or a prism 8 in. high and 2 in. square?

40. What is the diameter of a cylindrical jar 6 in. deep that holds one gallon? Of a 2 gal. jar 12 in. deep?

41. What is the height of a square pyramid whose base is 1 ft. square and whose volume is 1440 cu. in.? Of a cone whose volume is 44 cu. in. and base 2 in. in diameter?

42. What is the radius of the base of a cone whose volume is 22 cu. ft. and height 21 ft.? Of one whose volume is 1540 cu. in. and height 30 in.?

43. How many boxes $6\frac{1}{2}$ in. \times 5 in. \times 4 in. can be packed into a box 1 ft. $7\frac{1}{2}$ in. by 1 ft. 3 in. by 1 ft. 4 in.?

44. A **sphere** is a solid that has all points in its surface equally distant from a point within called the center. A ball is a sphere. The **radius** is the distance from the center to any point on the surface. The **diameter** is twice the radius, or the distance from any point on the surface to the point of the surface farthest away. *The volume of a sphere is represented by $\frac{4}{3} \times \frac{2^2}{7} \times r \times r \times r$, that is, $\frac{4}{3} \pi r^3$.* What is the volume of a sphere of 1 in. radius? ($\frac{4}{3} \times \frac{2^2}{7} \times 1 \times 1 \times 1 = ?$)

45. If the radius of sphere *a* is 1, and of sphere *b* is 2, the volume of *a* is represented by $\frac{4}{3} \times \frac{2^2}{7} \times 1 \times 1 \times 1$; and of *b* by $\frac{4}{3} \times \frac{2^2}{7} \times 2 \times 2 \times 2$. What is the ratio of the volume of *a* to the volume of *b*? ($\frac{1}{8}$) What is the ratio of a

sphere of 2 in. radius to one of 4 in. radius? $(\frac{1}{2} \times \frac{1}{2} \times \frac{1}{2})$
 Of one of 3 in radius to one of 6 in radius? Of one of
 diameter 1 in. to one of diameter 2 in.? *The ratio of one
 sphere to another equals the cube of the ratio of the radii or
 of the diameters.* Why is it not necessary to consider
 either the $\frac{4}{3}$ or the $2\frac{2}{3}$?

46. Give the ratio of a sphere:

Of radius 4 in. to one of radius 8 in.

Of radius $3\frac{1}{2}$ in. to one of radius 7 in.

Of radius $18\frac{3}{4}$ ft. to one of radius $37\frac{1}{2}$ ft.

Of radius 1 in. to one of radius 3 in.

Of radius $6\frac{1}{4}$ ft. to one of radius $18\frac{3}{4}$ ft.

Of radius 3 ft. to one of radius 4 ft. $(\frac{3}{4} \times \frac{3}{4} \times \frac{3}{4})$.

Of radius $2\frac{1}{2}$ ft. to one of radius $\frac{3}{2}$ ft.

Of diameter 25 ft. to one of diameter $37\frac{1}{2}$ ft.

Of diameter 25 ft. to one of diameter $83\frac{1}{3}$ ft.

Of diameter $5\frac{1}{2}$ ft. to one of diameter $2\frac{3}{4}$ ft.

SECTION XI

REVIEW OF MEASUREMENTS

SUGGESTIONS

If the pupil encounters a problem he cannot solve, he should return to the development of the idea as first given on preceding pages, diagram the problem, think it through, and study to express his ideas clearly in simple scientific terms. When a technical word, representing an idea fully developed, is in the learner's mind he should use it.

1. Give the ratio of :

A 1-in. square to a 2-in. square.

A 6-in. square to a 9-in. square.

An $18\frac{3}{4}$ -in. square to a 25-in. square.

A 1-in. circle to a 2-in. circle.

A $6\frac{1}{4}$ -in. circle to a $9\frac{3}{8}$ -in. circle.

A $31\frac{1}{4}$ -in. circle to a 50-in. circle.

A 1-in. cube to a 2-in. cube.

A 21-in. cube to a 28-in. cube.

An $83\frac{1}{3}$ -in. cube to a $33\frac{1}{3}$ -in. cube.

A 1-in. sphere to a 2-in. sphere.

A $41\frac{2}{3}$ -in. sphere to a $33\frac{1}{3}$ -in. sphere.

A 75-in. sphere to a 100-in. sphere.

2. What is the length of the side of a square that contains $\frac{2}{3}$ of the area of a 4-in. square ?

If $\frac{2}{3}$ is the ratio of the areas, what is ratio of the sides? The side of the required square is then what part of 4 in. ?

3. What is the length of the side of a square that equals $\frac{9}{16}$ of the area of a 25-in. square? $\frac{81}{25}$ of the area of a $31\frac{1}{4}$ -in. square? $\frac{16}{25}$ of the area of a 35-in. square? $\frac{9}{49}$ of the area of a 21-in. square?

4. What is the diameter of a circle that equals $\frac{9}{16}$ of the area of a 25-in. circle? $\frac{25}{49}$ of the area of a 28-in. circle? $\frac{16}{9}$ of the area of a 12-in. circle? $\frac{81}{25}$ of the area of a $41\frac{3}{4}$ -in. circle?

5. What is the length of a side of a cube which equals $\frac{8}{27}$ of the volume of a 12-in. cube? $\frac{27}{64}$ of the volume of a 25-in. cube? 8 times the volume of a $12\frac{1}{2}$ -in. cube? $\frac{125}{8}$ of the volume of a 10-in. cube?

6. What is the diameter of a sphere that equals $\frac{8}{27}$ of the volume of a 15-in. sphere? $\frac{27}{8}$ of the volume of a $12\frac{1}{2}$ -in. sphere? $\frac{125}{64}$ of the volume of a $33\frac{1}{8}$ -in. sphere? $\frac{64}{27}$ of the volume of a 75-in. sphere?

7. How many $1\frac{1}{2}$ -in. cubes can be put into a box $7\frac{1}{2}$ in. each way?

8. How many steps 2 ft. 6 in. long are taken in walking 5 rd.?

What is the ratio of 5 ft. to $2\frac{1}{4}$ ft.? Then of 5 rd. to $2\frac{1}{4}$ ft.?

9. How many times must a pail holding $2\frac{1}{2}$ qt. be filled with water in order to fill a 10-gal. can?

10. In digging a ditch 40 ft. long, 3 ft. wide, and 6 ft. deep, how many cubic yards of dirt are removed?

11. A's land measures 40 rd. on each side, and B's 60 rd. on each side. What is the ratio of B's land to A's? If A's is worth \$4000, how much is B's worth at the same rate?

12. A's land is 1 mi. square, B's is 160 rd. square. If B's land is worth \$625, how much is A's worth at the same rate?

13. A's land is 80 rd. by 160 rd., B's 240 rd. by 120 rd. If A's land is worth \$8000, how much is B's worth at the same rate?

14. A city block, trapezoidal in form, measures 300 ft. and 200 ft. on its parallel sides. The distance between these two sides is 250 ft. What is its area in square feet?

15. A horse is tied to a stake by a rope $3\frac{1}{2}$ yd. long. Over how many square yards of ground can he feed?

16. If a pipe 6 in. in diameter carries 80 gal. per minute, how many gallons per minute will a 9-in. pipe carry, the water running at the same speed? A 12-in. pipe? A 15-in. pipe?

17. If a box 4 ft. \times 3 ft. \times $1\frac{1}{2}$ ft. full of sand weighs 2000 lb., how much will a box 6 ft. \times 4 ft. \times 3 ft. weigh, full of the same sand?

18. A well 70 ft. deep was bored with a 2-ft. auger. How many cubic feet of earth were removed?

19. How many cubic feet are in the loft of a barn 30 ft. long, the triangular ends having a base of 20 ft. and an altitude of 15 ft.?

20. What is the ratio of 1 rd. 1 yd. 1 ft. 4 in. to 2 ft. 1 in.?

21. How many feet of lumber are necessary to cover, with inch boards, the walls of a house 20 ft. \times 20 ft. and 15 ft. high?

22. How many cubic feet of wood are there in a log 14 ft. long and 2 ft. in diameter?

23. A piece of metal roofing is cut so that two sides are parallel, and the distance between them is 10 ft. If the two parallel sides measure 12 ft. and 8 ft., what does the piece weigh at the rate of $1\frac{1}{2}$ lb. per square foot?

24. If a $3\frac{1}{2}$ -in. iron ball weighs 16 lb., how much will a $5\frac{1}{4}$ -in. iron ball weigh?

25. If a sheet metal circle 20 in. in diameter weighs 5 lb., how much will a 30-in. circle of the same metal weigh?

26. The speed being the same, how much water will a 3-in. pipe carry in an hour if a $\frac{3}{4}$ -in. pipe carries 50 gal.?

27. Of two cylinders of wood of equal length one measures $18\frac{3}{4}$ in. around, and the other 25 in. If the first weighs 27 lb., how much does the other weigh?

28. How many $\frac{1}{2}$ -in. pipes could carry the same amount of water at the same rate as two 2-in. pipes?

29. If a block of ice 3 ft. \times 4 ft. \times $2\frac{1}{2}$ ft. weighs 1800 lb., what is the weight of a piece 2 ft. \times 6 ft. \times 5 ft.?

30. If the price asked for panes of glass 12 in. \times 15 in. is 27 cts. each, how much should a pane 10 in. \times 16 in. cost?

31. How many times as much land can a horse feed over when tied with a 30-ft. rope as when tied with a 25-ft. rope?

32. How many blocks 2 in. \times 2 in. \times 4 in. can be packed in a box 2 ft. \times 2 ft. \times 4 ft., measured inside?

33. About how many gallons of water can be put into a tank measuring $7\frac{1}{2}$ ft. \times 4 ft. \times 3 ft. ?

34. Of two cylinders of equal diameter, one is $\frac{2}{3}$ as long as the other. What is the ratio of the second to the first?

35. What is the capacity in cubic inches of a cone-shaped dipper 6 in. deep and 7 in. in diameter at the top?

36. What is the radius of the base of a cone whose volume is 22 cu. ft., and whose height is 14 ft. ?

37. Which is greater, and how much, a square 44 in. around or a circle 44 in. around ?

38. Which will hold more, and how much, a square pail 10 in. deep and 44 in. around or a cylindrical pail of the same dimensions?

39. If a carriage wheel turns 15 times in running 10 rd., what is its diameter ?

40. If a tin fruit can $4\frac{1}{2}$ in. high and 4 in. in diameter holds a quart, what is the height of a gallon can 8 in. in diameter? What would be the height of a gallon can 4 in. in diameter ?

41. What must be the dimensions of a box in order to hold exactly 420 blocks, each $1\frac{1}{2}$ in. \times 2 in. \times 4 in. ?

What are the factors of 420 that will contain $1\frac{1}{2}$ in., 2 in., and 4 in. respectively ?

42. What must be the dimensions of a box to hold exactly 36 blocks, each 2 in. \times 1 in. \times 3 in. ?

43. At \$.11 per pound, what is the value of a cheese 14 in. in diameter and 10 in. high, weighing 1 lb. to 14 cu. in. ?

44. If a cylinder 2 ft. in diameter and 7 ft. high weighs 2100 lb., what is the weight of one of the same material $5\frac{1}{3}$ ft. in diameter and 3 ft. high?

45. If a rectangular block of wood 8 ft. by 18 in. by 14 in. weighs 42 lb., what is the weight of a block of the same wood 12 ft. by 24 in. by 12 in.?

46. What is the ratio of the value of a $6\frac{1}{4}$ -in. ball of gold to a $12\frac{1}{2}$ -in. ball of silver, if the gold is worth 24 times as much as the silver, per cubic inch?

47. How many revolutions does a 28-in. bicycle wheel make in going 19 yd. 1 ft. 8 in.?

48. A vat is built in the form of an inverted pyramid. The top is 10 ft. square, and the depth is 10 ft. About how many gallons does it hold?

How many would it hold if cubical instead of pyramidal?

49. Which is larger and how much, a two-inch cube or a two-inch sphere?

50. A circular inclosure contains 154 sq. rd. How many rods in diameter is it? What would be the diameter of a similar inclosure containing 4 times 154 sq. rd.? Of one containing $38\frac{1}{2}$ sq. rd.?

51. What is the ratio of A's land to B's, if A's is 80 rd. long and 60 rd. wide, and B's is 60 rd. long and 60 rd. wide?

52. How many 2-inch cubes would weigh as much as an 8-inch cube of the same material?

53. How many feet of inch boards are needed to build a tight board fence 6 ft. high and 1000 ft. long?

54. If a round iron plate $\frac{1}{2}$ in. thick weighs 10 lb., what does a round iron plate 5 times the diameter of the first and 1 in. thick weigh?

55. What is the value of 50 $\frac{1}{2}$ -in. boards 12 ft. long and 6 in. wide, at \$20 per M. ?

56. At \$2.50 per M. for shingles and \$.50 per M. for laying them, what will be the cost of shingling a hip roof which has two equal triangular portions, base 20 ft. and altitude 30 ft., and two equal trapezoidal portions, bases 20 ft. and 10 ft., and altitude 30 ft. ?

57. How many feet are traversed at each complete revolution of the pedals by a bicycle having 28-in. wheels, if the front sprocket has 27 teeth, and the rear one 9 ?

How many turns does the rear wheel make at each turn of the pedals ?

58. How many bushels of grain will a bin 8 ft. \times 5 ft. \times 4 ft. hold ?

59. Find the ratio of areas or volumes :

A $16\frac{2}{3}$ -in. circle to a 25-in. circle.

A rectangle 6 ft. \times 4 ft. to one $7\frac{1}{2}$ ft. \times 3 ft.

A $16\frac{2}{3}$ -in. cube to a 25-in. cube.

A prism 4 in. \times 6 in. \times 4 in. to one 2 in. \times 3 in. \times 2 in.

A 4-in. square to a $6\frac{2}{3}$ -in. square.

An $83\frac{1}{3}$ -ft. sphere to a $66\frac{2}{3}$ -ft. sphere.

A 3-in. sphere to a $4\frac{1}{2}$ -in. sphere.

A $2\frac{2}{3}$ -yd. cube to a 1-rd. cube.

Any circle to a circle of twice its diameter.

Any sphere to one of twice its radius.

Any circle to one of 3 times its circumference.

Any cube to one of $2\frac{1}{2}$ times its length.

Any sphere to one of 4 times its diameter.

60. Find the ratio of a cone whose base is $3\frac{1}{4}$ in. in diameter, and whose height is 6 in., to one whose base is $1\frac{1}{2}$ in. in diameter, and height 3 in.

61. Find the ratio of a triangle of base $33\frac{1}{3}$ in., altitude $16\frac{2}{3}$ in., to one of base $66\frac{2}{3}$ in., altitude $33\frac{1}{3}$ in.

62. Find the ratio of a pyramid of rectangular base $16\frac{3}{4}$ in. \times $18\frac{3}{4}$ in., and 10 ft. high, to one of rectangular base 25 in. \times 25 in., and 20 ft. high.

63. What is the capacity in gallons of a jar 14 in. in diameter and 10 in. deep?

How deep must it be to hold 1 gal.?

64. How many cubic inches of wood are removed in boring through a timber 14 in. thick with a 2-in. auger?

65. What is the diameter of a sphere whose volume is $\frac{27}{64}$ of a $16\frac{3}{4}$ -ft. sphere?

66. How many times can a cylindrical pail 7 in. in diameter and 12 in. deep be filled from a pail 14 in. in diameter and 16 in. deep?

67. What is the ratio of the side of a cube whose volume is 125 cu. ft. to the side of a cube whose volume is 64 cu. ft. ? 27 cu. ft. ? 8 cu. ft. ?

68. Which is greater, and how much, a rectangular prism 2 ft. \times 3 ft. and 4 ft. high, or a triangular prism, base of base 4 ft., altitude of base 3 ft., and 5 ft. high?

69. Think of a sphere inside a 2-in. cube, touching all six faces. Which is larger, and how much?

70. How many bushels of wheat will a bin 8 ft. \times 10 ft. \times 4 ft. hold? A bin 5 ft. \times 3 ft. \times 6 ft.?

71. About how many gallons will a tank 15 ft. by 6 ft. by 4 ft. hold?

How many gallons are there in $15 \times 1 \times 1$ cu. ft.? In $6 \times 4 \times$ that space?

72. What must be the depth of a cylindrical jar 7 in. in diameter in order to hold a gallon (231 cu. in.)?

73. At \$10 per M., how much are twelve 2×6 's 20 ft. long, and nine 4×4 's 12 ft. long worth?

74. How many shingles are needed for a roof 40 ft. by 20 ft.? How much will they cost at \$3 per M.?

75. A certain hip roof has two equal triangular portions, base 30 ft. and altitude 20 ft., and two equal trapezoidal portions, bases 30 ft. and 10 ft., and altitude 15 ft. How much will the shingles cost for the roof at \$2.50 per M.?

SECTION XII

INTRODUCING THE IDEAS OF ANALYSIS AND MENTAL ALGEBRA IN SOLVING PROBLEMS AND FINDING RELATIONS

SUGGESTIONS

a. Analysis presents very few new ideas. This chapter contains problems which may in many instances be solved by several methods. The purpose is to cultivate "common sense" as applied to the solution of problems in arithmetic. The best work is characterized by terse statements of relations in clear grammatical sentences. Involved complex statements obscure thought processes. The learner should acquire the habit of arriving at true results; and he should feel that the clearness and accuracy of his sentences measure the growth and development of his mathematical insight.

b. Beginning with problem 61 of this section, by easy steps the learner is inducted into a new method of solving problems. Mental algebra is a very attractive field. The power to apprehend abstract relations, to hold them in the mind, and to group them so as to bring the relations into a comprehended whole is agreeable and profitable work.

c. Should there be any pupils in the class who do not see clearly the force of transposition, the teacher will find that the conception of change of signs as developed in Milne's Elementary Algebra, or any other simple statement of the idea, will help. Guidance at this point, if needed, will inspire confidence in ability to do.

1. If $\frac{2}{3}$ of A's money equals $\frac{3}{4}$ of B's, and both have \$90, how much has each?

All of A's money is what part of $\frac{3}{4}$ of A's money?

Then, since $\frac{2}{3}$ of A's = $\frac{3}{4}$ of B's, all of A's money = what part of $\frac{3}{4}$ of B's? All of A's is what part of B's? Then, if A's = $\frac{3}{4}$ of B's, A's and

B's together = how many 4ths of B's? If \$90 is $\frac{2}{3}$ of B's, how many dollars has B? How many has A?

2. If A and B together have \$92, and $\frac{3}{8}$ of A's money equals $\frac{1}{4}$ of B's, how much has each?

Ratio of A's to $\frac{3}{8}$ of A's? Of A's to $\frac{1}{4}$ of B's? Of A's to B's? Of \$92 to B's? B's, then = what part of \$92? B's = ? A's = ?

3. A and B engage in business with a joint capital of \$3800. If $\frac{5}{8}$ of A's capital equals $\frac{3}{4}$ of B's, how much does each invest?

4. John and James started from the same place and walked in opposite directions. At the end of a certain time they were 480 rd. apart. If $\frac{3}{5}$ of the distance John walked equals $\frac{2}{3}$ of the distance James walked, how far did each walk?

5. $\frac{9}{11}$ of one number equals $\frac{1}{2}$ of another number. If their sum is 270, what are the numbers? If the sum is 360? 135? 225?

6. The sum of two numbers is 12, and $\frac{2}{3}$ of the first equals $\frac{1}{2}$ of the second. What are the numbers?

7. What time is it when $\frac{2}{3}$ of the time past noon equals $\frac{1}{3}$ of the time to midnight? When $\frac{1}{4}$ of the time to midnight equals $\frac{1}{2}$ of the time past noon?

8. Two men are 105 rd. apart. They walk toward each other till they meet, at such rates that $\frac{2}{3}$ of the distance the first travels equals $\frac{1}{4}$ of the distance the second travels. How far does each walk?

9. A and B are 900 rd. apart. They travel toward each other till they meet, A at the rate of 20 rd. per

minute and B at the rate of 25 rd. per minute. How many rods does each travel before they meet?

Both travel how many rods per minute? If the whole distance is 900 rd., how many minutes do they travel? How far does A travel? B?

10. Two trains 480 mi. apart run toward each other till they meet, the first running 30 mi. per hour and the other 50 mi. per hour. How far does each travel before they pass?

11. Two horsemen start from the same place at the same time, going in the same direction. The first travels 10 mi. per hour, and the second $7\frac{1}{2}$ mi. per hour. How far has each traveled when they are 35 mi. apart?

How far apart do they get in 1 hr.?

12. A and B start together from a certain point, going in the same direction. B walks at the rate of $3\frac{1}{2}$ mi. per hour, and A at the rate of $4\frac{1}{4}$ mi. per hour. How far has each traveled when they are 12 mi. apart?

13. A mounted messenger is sent, traveling at the rate of 8 mi. per hour. Three hours later a second one is sent after him, traveling at the rate of 10 mi. per hour. How far did the latter travel before overtaking the former?

14. A man started from home at 8 A.M. and traveled horseback at the rate of 7 mi. per hour to a certain place. Then selling his horse he walked back at the rate of $3\frac{1}{2}$ mi. per hour, reaching home at 12.30 P.M. How far did he ride?

What is the ratio of the time he walked to the time he rode? Then $4\frac{1}{4}$ hr. must equal how many times the time he rode? How long did he ride? How far, at 7 mi. per hour?

15. A boy starts from home at 7 A.M. on his bicycle, riding at the rate of 10 mi. per hour. After riding a certain distance he meets with an accident and has to walk to his destination, going at the rate of 3 mi. per hour, and reaches the end of his journey at 12.20 P.M. If the whole distance is 30 mi., how far does he ride, and how far does he walk?

16. A boy walks along a road, followed by a man 10 rd. away. They step at the same rate, but the man's steps are 2 ft. 6 in. long, and the boy's 2 ft. How far must the man travel before he overtakes the boy?

How much does the man gain at each step? How many steps must he take to gain 1 rd.? How many steps does he take in gaining 10 rd.? How many rods does he gain in 330 steps?

17. A has \$150 saved, and B \$100. How long will it be before B has as much saved as A, if A is saving at the rate of \$15 per month, and B \$17½ per month?

18. A dog is 100 ft. behind a fox. The fox takes 3 leaps while the dog takes 2, but 2 of the dog's leaps are equal to 4 of the fox's. How far must the dog run before catching the fox, if the fox takes 4 ft. at each leap?

How far does the fox go in 3 leaps? The dog in 2 leaps? How many leaps must the dog take to gain 100 ft.? How many feet must he run to overtake the fox?

19. A dog is 20 yd. behind a fox. The fox takes 5 leaps while the dog takes 4, but 3 of the dog's leaps equal 5 of the fox's. How many yards must the dog run before catching the fox, if the fox takes 1½ yd. at each leap?

20. If $\frac{1}{3}$ of B's money equals $\frac{2}{3}$ of A's, and both have \$112, how much has each?

21. A rifle sending a ball 1600 ft. per second is fired 1 sec. before a rifle sending a ball 2400 ft. per second, and in the same direction. Assuming that they keep on at the same rate, how long will it take the second ball to overtake the first?

22. If a boat which can travel 10 mi. an hour in still water is going up a stream flowing 4 mi. an hour, how fast does it go? How fast can it go down stream?

23. A boat whose speed in still water is 8 mi. per hour makes a trip up and back between two cities on a stream which runs 4 mi. per hour. If it takes 40 hr. to make the round trip, what is the distance between the two cities?

What is the ratio of the rate of the boat up stream to its rate down? Of the time up, to the time down? Then 40 hr. is how many times the time it takes to go down stream? If it goes down in $\frac{1}{4}$ of 40 hr. at 12 mi. per hour, what is the distance?

24. A boat whose speed in still water is $12\frac{1}{2}$ mi. per hour takes 50 hr. to make a round trip between two points on a river running $3\frac{1}{2}$ mi. per hour. What is the distance between the two points?

25. A boat can travel down a certain stream $3\frac{1}{2}$ times as fast as it can up the stream. If the stream runs 4 mi. per hour, what is the speed of the boat in still water?

26. Two men start from the same place and walk in opposite directions until they are 35 mi. apart. If $\frac{4}{5}$ of the distance the first walks equals $\frac{2}{7}$ of the distance the other walks, how far does each walk?

27. A man agreed to work a year for \$240 and a suit of clothes, but left at the end of 10 mo., receiving \$195 and the suit of clothes. What was the value of the suit?

How much more would he have received had he worked 2 mo. longer? What then were his wages for 1 yr., if they were \$45 for 2 mo.? If his annual wages were \$270 and \$240 was cash, what was the value of the suit?

28. A man was hired for 6 mo., for \$150 and a suit of clothes. At the end of 4 mo. he left, receiving \$92 and the suit. What was the value of the suit?

29. A cistern is supplied by a pipe that can fill it in 4 hr.; it has a discharge pipe that can empty it in 5 hr. If the cistern is empty and both pipes are opened, how long will it take to fill it?

What part of the cistern would the first pipe fill in 1 hr.?

30. If a cistern has a supply pipe that can fill it in 6 hr., and a discharge pipe that can empty it in 8 hr., how long will it take to fill the cistern if both pipes are open?

31. A cistern has a supply pipe that can fill it in $3\frac{1}{2}$ hr., and a discharge pipe that can empty it in 3 hr. The supply pipe is opened, and after it has been running 2 hr., the discharge pipe is opened. How long after the latter is opened will it be before the cistern is empty?

32. Two men started from the same place and walked in the same direction, and at the end of a certain time were 39 mi. apart. If $\frac{2}{3}$ of the distance the first walked equals $\frac{1}{2}$ of the distance the second walked, how far did each walk?

33. John can do a certain piece of work in 8 days; with the help of James in 5 days. How long should it take James alone to do it?

What is the least number that contains 8 and 5? In 40 days how many times could both do the work? John? James? If James

can do the work 3 times in 40 da., in how many days can he do it once?

Or, what part of the work can John do in 1 day? What part can John and James together do in 1 day? What part can James alone do in 1 day? How long, then, would it take James to do the work alone?

34. A and B can do a piece of work in 4 days, A alone in 7 days. How long should it take B alone to do the work?

35. If John can saw a cord of wood in 8 hr., and James in 10 hr., how long will it take both to saw a cord?

How many cords can John saw in 40 hr.? James? Both? How long, then, will it take both to saw 1 cord?

Or, what part of a cord can James saw in 1 hr.? John? Both? How long, then, will it take both to saw 1 cord?

36. A can mow 3 acres in 2 days, B in 3 days. In how many days can both together mow 3 acres?

37. If John can mow a certain lawn in 3 hr., James in 4 hr., and Henry in 5 hr., how many hours will it take all three working together?

38. John, James, and Henry working together mow a certain lawn in 3 hr. It takes John and Henry 5 hr. to mow the same lawn. In what time could James do it alone? (See problem 33.)

The difference between the part all do in 1 hr. and the part John and Henry do in 1 hr. will be the part James can do in 1 hr. From this, how can you find how long it will take James alone to mow the lawn?

39. A, B, and C together can shovel a carload of coal in 3 hr., and A and B in 4 hr. In how many hours should C be able to do it alone?

40. A man agrees to work for \$2.50 a day and to forfeit \$.50 for each working day he is idle. If at the end of 26 working days he receives \$47, how many days has he worked?

How much would he have received had he worked 26 days? How much did he lose, then, by idleness? How much did he lose by each day's idleness? If he lost \$18 by idleness and \$3 each day he was idle, how many days was he idle? How many did he work?

41. At the end of 50 days a man received \$135. If he had agreed to work for \$3.50 a day, and to forfeit \$.50 each day he was idle, how many days was he idle?

42. If a man's expenses are \$7 a week, and his wages \$4 a day, and if at the end of 30 days he has saved \$70, how many days did he work?

43. What time is it when $\frac{2}{3}$ of the time past noon equals $\frac{2}{5}$ of the time to midnight?

44. Two men are 140 rd. apart. They walk toward each other till they meet, one at the rate of 15 rd. a minute, and the other at the rate of 20 rd. a minute. How long is it before they meet, and how many rods does each walk?

45. A and B are 40 rd. apart. Both walk in the same direction, reaching a certain point at the same time. If A walks at the rate of 18 rd. per minute, and B at the rate of 22 rd. per minute, how far did each walk? How many minutes did each walk?

46. A man started from home on foot and walked a certain distance at the rate of 4 mi. per hour; after resting an hour he rode back on a street car at the rate of 8 mi. per hour. If he was gone from home 7 hr., how far did he walk? (See problem 14.)

47. If a hound is 30 yd. behind a fox, and the fox takes 4 leaps to the hound's 3, 2 of the hound's leaps, of 2 yd. each, being equal to 3 of the fox's, how far will the fox run before he is caught?

48. If A, B, and C together can do a certain piece of work in 3 days, and A and C in 5 days, how long would it take B alone to do the work?

49. A, B, and C can build 100 rd. of fence in 4 da., A and B 100 rd. in 6 da., and A and C 100 rd. in 5 da. How many days would it take each one alone to build 100 rd.?

50. If A can do a certain piece of work in 8 da., and A and B the same work in 5 da., how long will it take B to finish the work after A has done $\frac{2}{3}$ of it?

51. James can pile a cord of wood in $\frac{1}{5}$ of a day, and Henry in $\frac{1}{6}$ of a day. How long would it take both together to pile a cord?

How many times in 1 da. could James pile a cord? Henry? Both? What part of a day, then, will it take both to pile a cord?

52. It takes A $\frac{1}{4}$ of a day to mow $\frac{1}{2}$ A., B $\frac{1}{3}$ of a day, and C $\frac{1}{2}$ of a day. In what time should they be able to mow $\frac{1}{2}$ A. together?

53. If Richard is 15 years old and John 8, how long will it be before John is $\frac{2}{3}$ as old as Richard?

54. How long has it been since a man who is now 38 was 20 times as old as a boy who is now 19?

55. A boy bought papers at the rate of 2 for 3¢, and as many more at the rate of 3 for 4¢. He sold them all at the rate of 3 for 5¢, thereby gaining 10¢. How many papers of each kind did he sell?

56. A grocer mixes vinegar worth 25¢ a gallon with an equal amount of vinegar worth 35¢, and, by selling the whole at 40¢ a gallon, makes \$2.00. How many gallons of each kind were there?

57. A and B gain \$550, of which A receives \$330. If A's investment is \$300 more than $\frac{6}{11}$ of the whole investment, what is the whole investment? What is the investment of each?

58. A mounted messenger is sent, traveling at the rate of 9 mi. per hour. Three hours later a second one is sent after him, traveling 11 mi. per hour. How far must the second travel before overtaking the first?

59. John, James, Henry, and Richard, working separately, can do a certain piece of work in 1, $1\frac{1}{2}$, 2, and $2\frac{1}{2}$ hr. respectively. How long ought it to take all four together?

60. A man bought a live turkey for \$1.12. After dressing, it weighed $\frac{5}{7}$ as much as when alive. He sold it at $12\frac{1}{2}$ ¢ a pound, and gained 13¢. What was the live weight of the turkey?

61. A and B have \$40, and B has 3 times as much as A. How much has each?

Let x represent the number of dollars A has; then $3x$ = the number of dollars B has. Since both have \$40, $4x = 40$. Then $x = 10$, the number of dollars A has, and $3x = 30$, the number B has.

NOTE. — x should always represent a number.

62. A, B, and C have together \$42. B has twice as much as A, and C has 3 times as much as A. How much has each?

What may x represent? How many x , then, = 42?

63. A line 24 in. long is divided into two parts, one of which is twice the other. How long is each part?

64. The sum of the ages of A and B is 55 years, and A is 15 years older than B. How old is each?

If x years represents B's age, then what represents A's age?

Then $x + x + 15 =$ what number?

If $2x + 15 = 55$, what must $2x$ equal? x ? $x + 15$?

65. Divide 60 into two parts that have the ratio of 2 to 3.

If $2x$ represents the smaller part, what represents the larger?

66. How can \$28 be divided between A and B so that A may have \$8 more than B?

67. Divide \$56 among A, B, and C, so that B may have \$10 more than A, and C \$6 more than B.

Represent the numbers by x , $x + 10$, and $x + 16$.

68. Find two numbers whose difference is 9, one of which is four times the other.

If x represents one number, what will represent the other?

How will the difference be represented? If $4x - x = 9$, $x = ?$
 $4x = ?$

69. Three men in partnership gain \$900. A's share is three times B's, and B's share is twice C's. What is each one's share?

70. Three men invested \$1200. A put in twice as much as B, and C as much as A and B together. How much did each invest?

71. A horse, carriage, and harness are together worth \$325. The horse is worth 5 times as much as the harness, and the carriage is worth \$45 more than the harness. How much is each worth?

72. A man being asked how many sheep he had, replied, "If I had 3 times as many as I have and 10 more, I should have 70." How many had he?

73. A dealer bought 100 bu. of grain. He bought twice as much wheat as oats, and $2\frac{1}{3}$ times as much corn as wheat and oats together. How many bushels of each did he buy?

74. Divide 69 into five parts in the ratio of 1, 3, 4, 7, and 8.

75. A has \$60, and B has \$25. How much must A give B in order that B may have \$5 more than A?

Let x = no. dollars A must give B.

76. A has \$5 more than B, B has \$10 more than C, and C has \$15 more than D. If all together have \$170, how much has each?

Solve first by letting x = the number of dollars in D's share; then letting x = the number of dollars in A's share. Which is easier?

77. A man walked 10 mi., then drove a certain distance, and then went by train twice as far as he had driven. If the whole distance traveled was 70 mi., how many miles did he drive?

78. The sum of two numbers is 40; their difference is 12. What are the numbers?

Let x = one number; then the other = what? If $x + x + 12 = 40$, $x = ?$

79. Divide 100 into two parts such that 3 times one equals twice the other.

80. If silk costs 3 times as much as linen and \$45 is spent in buying 20 yd. of silk and 30 yd. of linen, how much does each cost per yard?

81. A and B start from the same place and travel in opposite directions until they are 45 mi. apart. If A travels 5 mi. farther than B, how far does each travel?

82. A and B start from the same place and travel in opposite directions until they are 37 mi. apart. If A travels 3 miles less than B, how far does each travel?

83. Two men have together \$250. If one has \$30 more than the other, how much has each?

84. If the sum of two numbers is 105 and their difference is 45, what are the numbers? What are the numbers, if the sum is 98, and the difference is 12?

85. A and B have together \$500. If A has \$120 more than B, how much has each? How much has each if A has \$60 less than B?

86. James is 4 times as old as Henry, and the sum of their ages is 30 years. What is the age of each?

87. John is 4 times as old as James, who is 3 times as old as Richard. If the sum of their ages is 32 years, how old is each?

88. A father is 3 times as old as his son; in 12 years he will be only twice as old. Find their ages.

If x years is the son's age, what is the father's age? What is the age of each 12 years hence? What is twice the son's age in 12 years? If $3x + 12 = 2x + 24$, $x = ?$

89. A's age is 6 times B's, and 15 years hence A will be only 3 times as old as B. What is the age of each?

90. How can \$40 be divided among A, B, C, and D so that C may have \$2 more than D, B \$3 more than C, and A \$4 more than B?

91. How long is it since a man who is now 40 years old was 5 times as old as a boy who is now 20 years old?

$$40 - x = 5(20 - x).$$

92. The sum of two numbers is 28, and one of them exceeds twice the other by 4. What are the numbers?

93. If two men, 150 miles apart, travel toward each other, one at the rate of 8 mi. per hour, and the other at the rate of 7 mi. per hour, in how many hours will they meet?

Let x represent the number of hours each travels.

94. What number is it, to which if 30 is added, the sum will be 4 times the original number?

95. Five boys were given 52 marbles so divided that the first received twice as many as the second, the second 3 times as many as the third, the fourth twice as many as the first, and the fifth $1\frac{1}{3}$ times as many as the second. What was the share of each?

Why is it best to let x equal the third number?

96. A has \$25 more than B and 6 times as much as B. How much has each?

97. The expenses of a manufacturer for 3 years were \$21,000. If they increased \$1000 annually, what were his expenses each of the 3 years?

98. Five persons hire a coach for a certain sum. Had there been 3 more, the expense of each would have been \$1.50 less. How much was paid for the coach?

If x dollars was paid by each person, what was paid by the 5 persons?
 If each had paid $(x - 1\frac{1}{2})$ dollars, how much would the 8 have paid?
 If $8x - 12 = 5x$, $x = ?$

99. Seven men hire a coach for a certain sum. Had there been 3 more, the expense of each would have been \$3 less. How much was paid for the coach?

100. Five men go into business together making equal investments. Had there been 4 more men, and the total investment the same, the investment of each would have been \$400 less. What was the investment of each and the whole investment?

101. Six men lifted a steel rail of a certain weight. If there had been 4 more men, each one would have had to lift 100 lb. less. What was the weight of the rail?

102. Seven boys found a bag of marbles which they divided equally. Had there been only 4 boys, each would have had 9 marbles more. How many marbles were there in the bag?

103. If John is 21 years old and James 8 years, how long will it be before John is just twice as old as James?

How can the age of each at that time (x years hence) be represented?

104. How many years is it since a man who is now 36 years old was 6 times as old as a boy who is 16 years old?

105. John is 4 times as old as James, and the sum of their ages is 30 years. How long will it be before John is only twice as old as James?

106. A's age is twice B's, and B's is 3 times C's. The sum of their ages is 140 years. What is the age of each?

107. What time is it when $\frac{1}{2}$ of the time to noon equals $\frac{1}{4}$ of the time past midnight?

If x hours is the time to noon, what will represent the time past midnight? If $\frac{1}{4}x = \frac{1}{4}$ of $(12 - x)$, and $2x = 12 - x$, $x = ?$

Solve again, representing the time to noon by $4x$ hours.

108. What time is it when $\frac{2}{3}$ of the time to noon equals $\frac{2}{9}$ of the time past midnight?

Represent the time past midnight by $9x$ hours.

109. A has \$8 more than B; and if A had \$2 more, he would have 3 times as much as B. How much has each?

110. Two men have together \$24, and the difference between A's money and B's equals half the sum. How much has each?

111. A and B have together \$38, and A has \$2 more than twice as much as B. How much has each?

112. A man divided his property among his three children so that the eldest received twice as much as the second, and the second 3 times as much as the youngest. If the eldest received \$5000 more than the youngest, how much did each receive, and what was the whole amount divided?

113. Divide \$200 among 5 men, 4 women, and 3 children, so that each woman receives \$10 more than each child, and each man \$10 more than each woman.

114. In a mixture of 86 gal. of wine and water, there were 18 gal. more water than wine. How much was there of each?

115. A dealer bought 810 bu. of grain. He bought 3 times as much wheat as oats, and $1\frac{1}{4}$ times as much corn as wheat and oats together. How much of each did he buy?

116. Five men have together \$12,000, and their shares are in the ratio 1, $1\frac{1}{2}$, 2, $2\frac{1}{2}$, and 5. What is the share of each?

117. Find two numbers whose difference is 25, one of which is 6 times the other.

118. A horse, carriage, and harness are together worth \$800. The carriage is worth \$100 more than the harness, and the horse \$100 less than twice as much as the carriage and harness together. How much is each worth?

119. Four men bought a piece of property, investing equal amounts. If 3 men had bought the property, each would have had to invest \$200 more. How much was the property worth?

120. What time is it when $\frac{2}{5}$ of the time past noon equals $\frac{2}{7}$ of the time to midnight? (See problem 108.)

121. At what time between 3 and 4 o'clock are the hour and minute hands of a clock exactly together?

a. How many minute spaces does the minute hand travel while the hour hand goes one? Then, in moving 12 minute spaces while the hour hand moves one, how many minute spaces does the minute hand *gain* on the hour hand? If it has to move 12 spaces to gain 11, how many spaces must it move to gain one? At 3 o'clock how many minute spaces has it to gain? If it has to move $1\frac{1}{4}$ spaces to gain one, how many must it move to gain 15? What time is it, then, when the minute hand has moved $16\frac{1}{4}$ minute spaces from its position at 3 o'clock?

b. Think of the position of the hands at 3 o'clock. Let x represent the number of minute spaces the hour hand has to move. Then, since the minute hand moves 12 times as fast, what will represent the number of minute spaces the minute hand has to move? Since they are 15 spaces apart at 3 o'clock, what must be added to x to make it equal $12x$? If $12x = x + 15$, $x = ?$

Which solution is the easier?

122. At what time between 4 and 5 o'clock are the hour and minute hands together? (Solve in two ways.)

123. At what time between 2 and 3 o'clock are the hour and minute hands together? Between 1 and 2 o'clock? Between 8 and 9 o'clock? Between 11 and 12 o'clock?

124. A and B invest a certain amount in business and gain \$500. A's investment is $\frac{3}{4}$ of the whole lacking \$90, and his share of the gain is \$300. What is the whole investment, and the investment of each?

a. What part of the gain is A's? Then, what part of the whole investment is A's? If A's investment is $\frac{3}{4}$ of the whole, and also $\frac{3}{4}$ of the whole lacking \$90, the \$90 is what part of the whole investment? If \$90 is $\frac{1}{4}$ of the whole, what is the whole?

b. If x dollars is the whole investment, $\frac{3}{4}$ of $x - 90 = \frac{3}{4}$ of x . Complete the solution.

125. A and B gain \$450, of which A receives \$200. If A's investment is $\frac{2}{3}$ of the whole lacking \$200, what is the whole investment and the investment of each?

126. Two men cut a certain amount of wood for \$60. The first received \$25, and he cut $\frac{1}{2}$ of the whole lacking 3 cd. What was the whole amount cut, and the amount each cut?

127. Two men cut a certain amount of wood for \$60. The second received \$35, and he cut $\frac{1}{2}$ of the whole and 3 cd. more. What was the whole amount cut, and the amount each cut?

128. Seven persons hire a coach for a certain sum. Had there been 3 more, the expense of each would have been \$3 less. What was paid for the coach?

a. Had 3 more gone, how much would the expense of the 7 persons have been lessened? The 3 would have paid how much then? The 10 how much?

b. See problem 98.

129. A sum of money was found by 5 persons and divided equally. Had there been 10 more persons, each would have received \$10 less. How much money was found?

130. A sum of money was found by 7 persons. Had there been only 4 persons, each would have had \$6 more. What was the sum?

131. A man agreed to work a year for \$360 and a suit of clothes. He left at the end of 9 mo., receiving \$261 and the suit. What was the value of the suit?

a. See problem 27.

b. Represent the value of the suit by x dollars.

132. A grocer mixed tea that cost 48¢ a pound with an equal amount of 50¢ tea, and sold the mixture at 55¢ a pound, thereby gaining \$4.80. How many pounds of each kind were there? (Solve by analysis.)

133. A boy bought oranges at the rate of 4 for 5¢, and as many more at the rate of 5 for 6¢. He sold them all at the rate of 2 for 3¢, thereby gaining .11¢. How many did he buy? (Solve by analysis.)

134. A and B had the same amount of land. A bought 20 A. from B and sold 10 A. to B, and then had 3 times as much as B. How much had each at first?

135. A and B are 24 rd. apart, and are walking toward each other. A takes 3 steps while B takes 4, and 3 of A's steps equal 2 of B's. How far will each walk before they meet? (Solve by analysis.)

136. A is 22 yr. older than B, and $\frac{2}{3}$ of A's age equals $\frac{4}{3}$ of B's. How old is each?

137. Two men start from the same place and walk in the same direction, and after a certain time are 10 mi. apart. How far does each walk if $\frac{2}{3}$ of the first one's distance equals $\frac{1}{3}$ of the second one's distance?

138. If $\frac{1}{2}$ of A's money equals $\frac{5}{8}$ of B's, and both have \$147, how much has each?

a. See problem 1. b. Solve, using x .

139. A and B have together \$68; $\frac{3}{4}$ of A's money equals $\frac{2}{3}$ of B's. How much has each?

140. A and B have together \$95, and A has 4 times as much as B. How much has each?

141. A, B, and C have \$120. A has twice as much as C and \$5 more; B has 3 times as much as C, lacking \$5. How much has each? (Solve by analysis.)

142. A, B, and C can do a certain piece of work in 20 days; A and B in 30 days; B and C in 40 days. How long will it take each to do the work alone?

143. A line 90 in. long is divided into 2 parts, one of which is $\frac{2}{3}$ of the other. How long is each?

144. A and B have \$520, and A has \$75 more than B. How much has each?

145. If a man has property to the amount of \$36,000, and debts to the amount of \$16,000, how much is he worth? How much is he worth if his debts are \$36,000 and his property \$16,000?

146. If James had 4 times as many marbles and 10 more, he would have 102. How many has he?

147. The sum of two numbers is 80; their difference is 38. What are the numbers?

148. John has \$500, and James \$600. How long will it be before John has \$100 more than James, if he saves at the rate of \$18 a month, and James at the rate of \$13 a month?

149. A cistern has a supply pipe that can fill it in 5 hr., and a discharge pipe that can empty it in $3\frac{1}{2}$ hr: If the cistern is full and both pipes are opened, how long will it take to empty the cistern?

150. At what time between 7 and 8 o'clock are the hands of a clock together?

151. A and B had the same amount of money. A gave B \$10, and then B had 3 times as much as A. How much had each at first?

152. A man agreed to work for \$3 a day and to forfeit 60¢ for each working day he was idle. At the end of 45 working days he received \$81. How many days did he work?

SECTION XIII

REVIEWING AND EXTENDING THE IDEA OF PERCENTAGE

SUGGESTIONS

a. In the study of the problems of this section the learner should, in all cases of difficulty, go back to preceding sections to review the foundation of each idea which is not clear. After following the development of each fundamental idea in a given problem, the pupil will find it of great value in preparing for the recitation to diagram the problem so that there will be a clear image in the mind when oral analysis is attempted.

b. In the study of the lesson before the class is called, the learner will get much help from thinking the problem through in words as well as in images. Words embodied in short, clear sentences help much in making plain to other members of the class the analyses presented.

c. In the explanation of difficult problems, if the word used does not call up clear images in the minds of other members of the class, the pupil who gives the analysis should be afforded an opportunity to place on the board for the benefit of others the pictures or diagrams he knows to be pertinent to the expression of the thoughts in his mind.

d. At the end of this section, special applications of percentage to insurance, to stocks and bonds, and to discounts have been placed for the purpose of leading pupils to see that all operations in this division can be based on the fundamental notions already established.

1. What per cent of the cost of $\frac{3}{8}$ of a quantity, is the cost of $\frac{5}{8}$ of the quantity?

2. A man owning $\frac{5}{7}$ of a mill sold $\frac{2}{3}$ of what he owned. What per cent of the mill did he still own?

3. John's marbles are $62\frac{1}{2}\%$ of James's. If James has 32, how many has John? If John has 25, how many has James?

4. A, B, C, and D engage in business. A invests \$500, B \$1000, C \$1500, and D \$2000. At the end of a year they have gained \$2000. What per cent of the gain should each one have?

5. $18\frac{3}{4}\%$ of a certain sum is \$18. What is $37\frac{1}{2}\%$ of it? $33\frac{1}{3}\%$? 75% ? $83\frac{1}{3}\%$? $41\frac{2}{3}\%$? $43\frac{3}{4}\%$? $68\frac{3}{4}\%$? 50% ?

6. One number is $81\frac{1}{4}\%$ of another. If the larger number is 80, what is the other? If the smaller is 78, what is the larger?

7. A, B, and C engaged in business. A furnished $33\frac{1}{3}\%$ of the capital, and B $43\frac{3}{4}\%$ of it. What part did C furnish?

8. A farmer sold 2 cows at \$24 each. On one he gained 20%, and on the other he lost 20%. How much did each cost?

9. A owned $\frac{3}{4}$ of a mill and sold 75% of his share. What per cent of the mill did he still own?

10. At what price must goods costing \$200 be sold, in order to gain $12\frac{1}{2}\%$? $16\frac{2}{3}\%$? $41\frac{2}{3}\%$?

11. B has 75 A. of land, which is $37\frac{1}{2}\%$ of what A has. How much land has A?

12. An agent sells cotton for a planter, receiving 2% commission. How much should the agent remit to the owner if the selling price was \$4000?

Commission is a percentage allowed an agent for buying or selling for another, and is usually estimated on the amount of money the agent handles.

13. An agent buys 1000 sacks of flour at \$2 per sack. What is his commission at $2\frac{1}{2}\%$?

14. An agent received \$45 for buying flour. If his commission was $2\frac{1}{2}\%$, what was the value of the flour? How much did it cost the owner (commission included) per sack, if there were 1000 sacks?

15. How much money must a merchant send his agent in order that he may buy \$1000 worth of goods, commission $1\frac{1}{2}\%$?

16. A man sent his agent \$1025. The agent invested \$1000, and retained the remainder as commission. What was the rate of commission?

17. At 6% interest per year, what is the rate per cent for 1 yr. 4 mo.? 1 yr. 2 mo.? 3 yr.? 4 yr. 6 mo.? 1 yr. 1 mo.?

Interest is money paid for the use of money, and is usually reckoned as so many per cent of the principal (the amount loaned) per *annum*, or year. Then since 1 yr. 4 mo. = $\frac{4}{3}$ yr., the rate per cent in the first case is $\frac{4}{3}$ of 6%, or 8%.

18. What is the interest on \$400 for 1 year at 6% per annum? For 2 years at the same rate? 1 yr. 6 mo.? 2 yr. 8 mo.? 4 yr. 1 mo.? 2 yr. 30 da. (= 1 mo.)?

19. At 6% per annum, give the interest on :

\$100 for 2 yr. 6 mo.	\$1000 for $16\frac{2}{3}$ yr.
\$1000 for $3\frac{1}{2}$ yr.	\$32 for 3 yr. 1 mo. 15 da.
\$240 for 2 yr. 30 da.	\$50 for 3 mo.
\$300 for 5 yr.	\$40 for 7 mo. 15 da.
\$1500 for 10 yr.	\$375 for 5 mo. 10 da.

20. What is the interest of a principal of \$ 200, at 4%, for 2 yr. 6 mo. ?

21. If the interest is \$ 20, time $2\frac{1}{2}$ yr., and rate 4%, what is the principal ?

What is the rate per cent at 4% per annum for $2\frac{1}{2}$ yr. ? If \$ 20 is 10% of the principal, what is 100% ?

22. Find the principal when the interest is \$12, time 2 yr. 6 mo., rate 6%. When the interest is \$.75, time 3 mo., rate 6%.

23. A man borrowed a sum of money for 6 mo., and when paying it back at the end of the time he gave back \$6 more than he received. If the rate was 12%, how much money did he borrow ? If the rate had been 6%, what would the principal have been under the same conditions ?

24. On Sept. 1, Mr. B paid the interest on two sums of money he had borrowed, \$24 in each case. The first sum had been borrowed 1 yr. 4 mo. before at 6%, the other 1 yr. 6 mo. before at 8%. What were the two sums borrowed ?

25. What per cent of a principal of \$250 is \$25 interest ? If the time was 1 yr. 8 mo., what was the rate per annum ? If the rate per annum was 6%, what was the time in years ?

26. What per cent of a principal of \$500 is \$110 interest ? If the time was 2 yr. 9 mo., what was the rate per annum ? If the rate had been 12%, what would the time have been ?

27. Given principal \$ 200, time 1 yr. 6 mo., interest \$ 30 ;
find rate.

Given principal \$ 200, time 2 yr. 6 mo., interest \$ 20 ;
find rate.

Given principal \$ 480, time 2 yr. 1 mo., interest \$ 60 ;
find rate.

Given principal \$ 1000, time 2 yr., interest \$ 100 ; find
rate.

Given principal \$ 3600, time $1\frac{1}{2}$ yr., interest \$ 360 ; find
rate.

28. Given principal \$ 200, interest \$ 30, rate 10% ; find
time.

Given principal \$ 75, interest \$ 15, rate 8% ; find time.

Given principal \$ 60, interest \$ 20, rate 8% ; find time.

Given principal \$ 50, interest \$.75, rate 6% ; find time.

Given principal \$ 100, interest \$ 5, rate $2\frac{1}{2}$ % ; find time.

29. In what time will \$ 100 produce \$ 100 interest at
6%? In what time will any principal double itself at 6%?
At 8%? At 4%? At 7%?

30. A merchant wishes to buy goods to the amount of
\$ 1000. He borrows enough money for 3 mo. at 8% to
include the cost of the goods and a commission of $2\frac{1}{2}$ % to
his agent. At the end of the 3 mo. how much must he
pay back to the lender?

31. For how much must hats costing \$ 30 per dozen be
sold in order to gain 20%?

32. A boy buys papers at the rate of 2 for 3 cents, and
sells them for 2 cents apiece. What per cent does he
gain?

33. A boy sells papers for 3¢ each, thereby gaining 50%. How many can he buy for 6¢?

34. In order to gain $12\frac{1}{2}\%$, hats are marked at \$2.70. What is the cost?

35. A dealer's price for a carriage was \$128, but in order to make a sale he made a discount of $12\frac{1}{2}\%$. How much did the carriage cost if he still gained $16\frac{2}{3}\%$? How much would he have gained had he sold it at the price he asked?

36. 48 is 8 times $18\frac{3}{4}\%$ of what number?

37. What per cent of 1 bu. 3 pk. is 3 pk. 4 qt.?

38. $41\frac{2}{3}\%$ of one number equals $31\frac{1}{4}\%$ of another. If their sum is 280, what are the numbers?

39. How much must a bicycle costing \$48 be marked in order that a discount of $16\frac{2}{3}\%$ may be made from the price marked, and a gain of 25% still be made?

40. A man sold two horses for \$126 each. On one he gained $12\frac{1}{2}\%$, and on the other he lost $12\frac{1}{2}\%$. Did he gain or lose, and how much?

41. Which will be greater and how much, the interest on \$200 for 2 yr. 6 mo. at 10%, or the interest on \$300 for 1 yr. 6 mo. at 12%?

42. What sum of money was borrowed, if the interest at 9% for 1 yr. 8 mo. was \$75?

43. What is the ratio of the interest on \$500 for 1 yr. 9 mo. at $10\frac{1}{2}\%$, to the interest on \$1000 for 2 yr. 4 mo. at 7%?

What is the ratio of the first principal to the second? Of the first time to the second? Of the first rate to the second? Of the first interest to the second?

44. What per cent of $\frac{7}{8}$ is $\frac{3}{4}$? Of $\frac{4}{5}$ is $\frac{2}{3}$? Of $\frac{5}{6}$ is $\frac{7}{8}$?
Of $\frac{7}{8}$ is $\frac{5}{6}$? Of $\frac{2}{3}$ is $\frac{4}{5}$? Of $\frac{3}{4}$ is $\frac{7}{8}$?

45. An agent's commission for selling a piece of real estate was 3%. If he received \$270, what was the value of the property?

46. A dealer's gain on a horse was \$25, which was a gain of $16\frac{2}{3}\%$. What was the cost and the selling price?

47. If a grocer sells $\frac{3}{4}$ of a dozen eggs for what $\frac{7}{8}$ of a dozen cost him, what is his gain per cent?

48. How much must cloth that cost \$1.25 per yard be marked so that a discount of 20% may be made, and the gain be 60%?

49. A man wishing to mortgage his farm for \$1000, has to pay the agent a commission of $2\frac{1}{2}\%$ and the interest for 6 mo. in advance at 6%. How much does he receive from the agent?

50. What number is it of which $62\frac{1}{2}\%$ exceeds $41\frac{2}{3}\%$ by 100?

51. What per cent of A's money is B's, if B has $16\frac{2}{3}\%$ more than A? What per cent of B's is A's?

52. What per cent of A's money is B's if B has $16\frac{2}{3}\%$ less than A? What per cent of B's is A's?

53. A man had a note due that had run for 90 da. at 6%. If he paid the lender \$101.50, what was the amount borrowed?

54. A grocer sold sugar at 9¢ a pound, and gained $12\frac{1}{2}\%$. How much did it cost him?

55. Goods were sold at auction at a loss of $37\frac{1}{2}\%$ for \$35. What was the cost?

56. If $\frac{2}{3}$ of a lot of goods is sold for what $\frac{1}{2}$ cost, what per cent is gained?

57. If a cow is worth 50% of the value of a horse, a hog $37\frac{1}{2}\%$ of the value of a cow, and a sheep $41\frac{2}{3}\%$ of the value of a hog, how much is the horse worth, the sheep being valued at \$2.50?

58. At what rate must \$100 be loaned in order to bring in \$7 in 1 yr. 2 mo.?

59. How much interest must be paid semiannually on a \$2000 mortgage at 7%?

60. What is the ratio of the interest of \$350 for 6 yr. 2 mo. at 13%, to the interest of \$490 for 3 yr. 1 mo. at $6\frac{1}{2}\%$?

61. If A has $37\frac{1}{2}\%$ more money than B, what per cent of B's money is A's? What per cent of A's is B's?

62. $37\frac{1}{2}\%$ of A's money equals $56\frac{1}{4}\%$ of B's. If A has \$10 more than B, how much has each?

NOTES ON THE APPLICATIONS OF PERCENTAGE TO INSURANCE

a. An agreement by one party to protect another from loss or damage for a consideration is usually called **Insurance**. The contract between the insurance company and the party insured is the **Policy**. The sum paid for protection is the **Premium**.

b. The pupil who can keep the special terms in mind and see in them new names for old ideas will find no difficulty in solving problems in insurance.

63. The face of an insurance policy is \$2400; the rate is 1%. What is the premium?

64. A building is insured for two thirds of its value: the rate of insurance is 2%; the value of the building is \$1500. What is the premium? What is the face of the policy?

65. What will be the premium for insuring \$2000 worth of wheat for one half its value at $\frac{1}{2}\%$? At $\frac{3}{4}\%$? What will be the face of the policy?

66. What will be the premium for insuring $\frac{2}{3}$ of the value of a house worth \$600 at $\frac{3}{4}\%$? What will be the face of the policy?

67. At a rate of 1% what insurance will be written for \$75?

68. At a rate of 3% what insurance will be written for \$60?

69. At a rate of $4\frac{1}{2}\%$ what insurance will be written for \$9?

70. At a rate of $\frac{3}{4}\%$ what insurance will be written for \$12?

71. At a rate of $1\frac{1}{5}\%$ what insurance will be written for \$36?

NOTES ON THE APPLICATIONS OF PERCENTAGE TO STOCKS AND BONDS

a. When sold at the value written or printed on the face, stocks and bonds are rated at *par*. When they are sold at a price higher than that stated on the face, they are rated *above par*. When sold at a price lower than that stated on the face, stocks and bonds are said to be *below par*.

b. The **Par Value** may be any amount agreed upon and authorized by general law or by the **Charter** which defines the powers and limitations of a company.

c. When the business of a company is conducted at a profit, the gain is distributed among the stockholders, and each one's share of the gain is called a **Dividend**. When business is done at a loss, stockholders are required to make up the loss by an **Assessment**. Dividends and assessments are usually apportioned at some per cent upon the par value.

d. The money or commission paid a broker for buying or selling stocks and bonds is called **Brokerage**. Brokerage is estimated on the par value.

e. The learner has to use new names for ideas already in his mind. The problems in stocks and bonds are easy ones in simple percentage.

72. How much capital has a man in a company if he holds 500 shares, having a par value of \$10?

73. What is the market value of 400 shares of stock with a par value of \$10, if the stock is quoted at 5% above par (at 105%)? If quoted at 5% below par?

74. How much must I pay for bonds, quoted at $59\frac{1}{2}$, if I have to pay a brokerage of $\frac{1}{2}$ per cent, and the par value is \$100?

75. If current interest is 4%, and Black Rock Mining Stock is paying 25% annual dividends, is the stock worth more or less than par? Why?

76. What assessment must a man pay if he holds 10,000 shares in a company of \$100,000 capital, if the company is obliged to make an assessment to meet a loss of \$20,000, the par value of his stock being \$1?

77. What dividend would a man receive if he holds 10,000 shares, par value being \$1, in a company with a capital of \$50,000, if the net profits for one year are \$10,000?

78. A 6 % dividend of \$12,000 was distributed among the stockholders of a company. What was the capital stock of the corporation ?

79. A 4 % assessment of \$8000 was levied upon the stockholders of a company. What was the capital stock of the company ?

80. If stock is selling at 25 % above par, and I invest \$5000 in it, what is the par value of my investment ?

81. If stock is selling at 20 % below par, and I invest \$4000 in it, what is the par value of my investment ?

NOTES ON THE APPLICATIONS OF PERCENTAGE TO DISCOUNTS

a. A deduction from the price of an article, from the amount of a bill, or from the face of a note, is called **Discount**. The fixed price is called the **List Price**. The list price, less the discount, is the **Net Price**.

The difference between the face of a bank note and what the borrower receives is the **Bank Discount**. What a borrower receives on his note given to a bank is the **Proceeds**.

b. A discount of 15 % *off* means a deduction of 15 % from the price of an article or from the face of a bill. A discount of 20 % and 10 % does not mean 30 % off, but that 20 % must first be deducted, leaving 80 % of the price, then 10 % of 80 % of the price, leaving 72 % of the price of the article or the face of the bill to be paid. "3 *tens* and 2 % off" means three successive discounts of 10 %, and 2 % from the remainder, etc.

c. **Bank Discount** is interest taken in advance. *The term of discount* corresponds to the *time* in interest. The custom as to *days of grace* is not uniform in all parts of the United States. The expiration of the term of discount, including three days of grace, where they are allowed, is the **Maturity** of the note.

d. If the pupil can interpret his old ideas in the terms of discount, he will have no difficulty in solving and analyzing the problems given.

82. What is the net cost of a bill of goods for \$ 600, bought at 10% discount, and 5% off for cash?

83. Find the net price and discount on a bill of goods for \$ 400 at 20% and 10% off for cash?

84. Find what was paid on a bill for \$ 300 at $33\frac{1}{3}\%$, 25%, and 10% off. What was the discount?

85. What is the list price of a book which is sold for two thirds of a dollar after a discount of $33\frac{1}{3}\%$ has been taken off?

86. What is the difference between a discount of 30% and a discount of 25% and 5% off on a bill for \$ 120?

87. What is the amount of a bill, which after a discount of $12\frac{1}{2}\%$, amounts to \$ 14?

88. What are the proceeds of a note, discounted at a bank for 60 days, no grace, for \$ 80, at 6%? What is the bank discount?

89. Find the face of a note, which after being discounted at a bank for four months at 6%, no grace considered, will give \$ 49 proceeds.

90. For what sum must a note, due in 6 months at 4%, be drawn to yield \$ 196 proceeds, no grace considered?

91. A man owes a bill for \$ 100 which is not due for 3 months. He is offered a discount of 3% off for cash. If he should borrow money at the bank at 8% to pay the bill, would he gain or lose, and how much, no grace being considered?

SECTION XIV

REVIEWING AND EXTENDING IDEAS PREVIOUSLY PRESENTED AND ESTABLISHING NEW RELATIONS

SUGGESTIONS

a. In advancing through this section, the learner must see, in his private study, the fundamental ideas in his problems, in order to give oral expression to them. In many cases, the converse of ideas established in the preceding sections of the book is given. Economy of effort will follow if, through diagrams made during the hour for preparation, the new or changed relations are brought clearly before the mind.

b. The learner in preparing the lesson should realize that when he knows relations, he can through proper study express his knowledge so as to bring to the minds of others his own images and thoughts.

c. In studying a problem, the learner should always seek for the known ideas and bring them clearly before his mind before he attacks the new notions and attempts to get results.

d. Learners, who without aid from others in the class come prepared from day to day, can look forward with much pleasure to the study of higher branches of mathematics. Independent work and clearly stated analyses go along together. The best students in oral arithmetic are they who can give clearest expression to the solution of the problems of this section.

1. The ratio of two squares is $\frac{9}{16}$. If the larger is a 25-in. square, what is the other ?

2. A 3-in. circle is $56\frac{1}{4}\%$ of how large a circle ?

3. What are the dimensions of a cube that is $337\frac{1}{2}\%$ of a 25-in. cube? ($337\frac{1}{2}\% = 3\frac{3}{8}$.)

4. What is the diameter of a sphere that is $\frac{8}{7}$ of a $37\frac{1}{2}$ -in. sphere?

5. How many blocks $8\frac{1}{2}$ in. \times $5\frac{1}{2}$ in. \times 4 in., can be packed into a box $25\frac{1}{2}$ in. \times $16\frac{1}{2}$ in. \times 8 in.?

6. What may be the dimensions of a box that contains 48 cu. in.?

7. What per cent of the amount of water supplied by a 4-in. water pipe will two 2-in. pipes supply?

8. Which is larger and how much, a cone 9 in. high whose base is a 2-in. circle, or a pyramid 9 in. high whose base is a 2-in. square?

9. How many $\frac{1}{2}$ -in. water pipes have the same capacity as a 2-in. main?

10. What is the value of a 3-in. iron ball if a 2-in. iron ball is worth \$.80?

11. If a block of wood that is $6\frac{1}{4}$ in. long, 5 in. wide, and 4 in. thick weighs $3\frac{1}{3}$ lb., how much does a block of the same wood that is $18\frac{3}{4}$ in. long, 3 in. wide, and 2 in. thick weigh?

12. If a timber 12 in. \times 12 in. and 20 ft. long weighs 600 lb., what is the weight of one of the same kind 24 in. \times 24 in. and 30 ft. long? What per cent of the weight of the former is the latter?

13. Which is larger and how much, a square field inclosed with 44 rd. of fence, or a circular field requiring the same amount of fence?

14. How many gallons of water (231 cu. in. to the gallon) will a $3\frac{1}{2}$ -in. pipe carry in 10 min., if it runs at the rate of 5 ft. per second?

How many cubic inches are there in a section of the pipe 1 in. long? 8 in. long? How many gallons in a section 2 ft. long? 5 ft. long? How many gallons are carried per second? Per minute? In 10 min.?

15. What per cent of a 25-in. sphere is a $37\frac{1}{2}$ -in. sphere?

16. There are two iron cylinders of the same weight, one of which is 2 in. in diameter, the other 3 in. What is the ratio of the height of the first to the height of the second?

17. Two square iron prisms have the same weight. One is $\frac{1}{4}$ the height of the other. What is the ratio of the side of the base of one to the side of the base of the other?

18. What per cent of a trapezoid whose parallel sides are 21 in. and 9 in., and altitude 8 in., is the smaller of the two triangles into which the trapezoid is divided by a diagonal? What per cent of it is the larger triangle? What per cent of the smaller triangle is the larger?

19. What is the diameter of a sphere which is $\frac{8}{125}$ of a $62\frac{1}{2}$ -in. sphere?

20. What is the side of a cube which is $\frac{125}{1728}$ of a 72-in. cube?

21. What is the diameter of a cylinder which is 800% of a 2-in. cylinder of $\frac{1}{2}$ the height?

22. Which weighs more, a 2-in. sphere of iron or a $1\frac{2}{3}$ -in. cube of iron?

23. How many 4-in. cylinders 6 in. long can be packed into a box 10 in. \times 10 in. \times 10 in.?

24. How many railroad ties 8 in. wide, placed 22 in. apart are needed for 5000 ft. of track?

25. A hip roof has two equal trapezoidal portions whose bases are 40 ft. and 20 ft., and altitudes 20 ft., and two equal triangular portions whose bases are 30 ft. and altitudes 16 ft. How many shingles will cover the roof, allowing 1000 shingles to each 100 sq. ft.?

26. What per cent of a cone $18\frac{3}{4}$ in. high, whose base is $8\frac{1}{8}$ in. in diameter, is a cone $12\frac{1}{2}$ in. high, whose base is 25 in. in diameter?

27. How many revolutions does a wagon wheel $3\frac{1}{2}$ ft. in diameter make in going 1 mile?

How many revolutions to each rod?

28. What per cent of the area of a circle whose circumference is 8 ft. is the area of a circle whose circumference is 6 ft.?

29. How many pounds does a block of wood 2 ft. long, 18 in. wide, and 6 in. thick weigh, if a 3-in. cube of the same wood weighs $\frac{1}{2}$ lb.?

30. What is the diameter of a circle whose area is 64% of that of a $31\frac{1}{4}$ -in. circle?

31. What is the diameter of a circle whose circumference is 60% of that of a $41\frac{2}{3}$ -in. circle? (See problem 47, page 77.)

32. How many cubic inches are there in a piece of round iron 2 in. in diameter and 7 ft. long?

33. A has a piece of land 42 rd. square. A strip 1 rd. wide is taken on each of the four sides for street purposes. How many square rods of land are taken?

34. How many 4-in. cubes equal eight 10-in. cubes?
35. What is the value of a 4-ft. cube of ice weighing 50 lb. to the cubic foot, at $\frac{1}{2}$ ¢ per pound?
36. What is the greatest number of blocks 9 in. long and 2 in. square that can be put into a box 18 in. \times 12 in. and 11 in. deep? (*Ans.* 66.) How must they be arranged?
37. What is the weight of a wooden cone 21 in. high, having a 2-in. base, if a cubic inch of the wood weighs 1 oz.?
38. How many cubic inches are there in a tin pail 7 in. in diameter and 6 in. deep? How many gallons will a pail hold that is 14 in. in diameter and 16 in. deep?
39. How many revolutions does a $3\frac{1}{2}$ -ft. wheel make in running around a circle 21 rd. in diameter?
40. How many times must you dip in order to fill a cylindrical pail $10\frac{1}{2}$ in. in diameter and 9 in. deep with a conical dipper $3\frac{1}{2}$ in. across at the top and 3 in. deep?
How high is the cylinder $3\frac{1}{2}$ in. in diameter, that is equal to the $3\frac{1}{2}$ -in. cone?
41. What is the weight of a sphere that is 60% of a 9-lb. sphere? Need the dimensions be known?
42. How many $2\frac{1}{2}$ -in. cubes can be put into a box $12\frac{1}{2}$ in. each way? Into one 30 in. each way?
43. How many cubic yards of earth are removed in digging a ditch 90 ft. long, $1\frac{1}{2}$ ft. wide, and 3 ft. deep?
44. A's land measures 80 rd. on each side, B's 60 rd. on each side. What is the ratio of A's land to B's? What is the ratio of the amount of fence needed to inclose A's to the amount needed to inclose B's?

45. Over how many square rods of land can a horse feed when he is tied with a rope $57\frac{3}{4}$ ft. long?

How many rods are there in $57\frac{3}{4}$ ft.?

46. If a pipe $12\frac{1}{2}$ in. in diameter carries 2500 gal. a minute, how many gallons a minute will a 10-in. pipe carry, if the water runs at the same speed?

47. In boring a well 88 ft. deep with a 2-ft. auger, how many cubic feet of earth were removed?

48. A piece of sheet iron is cut so that two sides, measuring 8 ft. and 10 ft. respectively, are parallel, and the distance between them is 12 ft. How much does it weigh at the rate of 2 lb. to the square foot?

49. How many gallons ($7\frac{1}{2}$ gal. to 1 cu. ft.) can be put into a tank 10 ft. \times 10 ft. \times 4 ft.?

50. What is the diameter of the base of a cone whose volume is 33 cu. in., and whose height is 14 in.?

51. How many bushels of wheat ($1\frac{1}{4}$ cu. ft. to the bushel) will a bin 8 ft. \times 10 ft. \times 4 ft. hold?

52. How many times can a cylindrical pail 6 in. in diameter and 9 in. deep be filled from a pail 9 in. in diameter and 12 in. deep?

53. What is the ratio of a strip 2 rd. wide around an 80-rd. square, to a strip 2 rd. wide around a 40-rd. square?

54. How many feet of lumber are necessary to cover with inch boards a wall 30 ft. long and 20 ft. high?

55. At \$20 per M., what is the value of five 8×8 's, 18 ft. long, and ten 2×6 's 12 ft. long?

56. Of two cylinders of equal diameter, one is $\frac{7}{8}$ as long as the other. What is the ratio of their volumes?

57. Of two cylinders of equal heights, one has a diameter equal to $\frac{5}{8}$ of the diameter of the other. What is the ratio of their volumes?

58. Of two cylinders of the same material and of the same height, one measures 25 in. around, and the other $31\frac{1}{4}$ in. If the first weighs 128 lb., how much does the other weigh?

59. Which is larger, a square field 88 rd. around, or a circular field 88 rd. around?

60. What may be the dimensions of a box in order that it may exactly hold 320 blocks 2 in. by 5 in. by 8 in.?

61. How many $3\frac{1}{2}$ -in. spheres weigh as much as a 14-in. sphere of the same material?

62. At \$ 2 per M. for shingles and \$ 1 per M. for laying, what is the cost of shingling a roof consisting of four equal triangular portions, the base of each being 20 ft. and altitude 15 ft.?

63. How many cubic inches of wood are removed in boring through a timber $10\frac{1}{2}$ in. thick with a 2-in. auger?

64. What per cent of A's land is B's, if A's is 160 rd. long and 80 rd. wide, and B's is 80 rd. long and 60 rd. wide?

65. At what price must a merchant mark an article costing \$ 1.50 so as to gain 20% after making a discount of 10% to his customer?

66. At what price must I buy United States 4% bonds to realize 3% on my investment?

67. I sold two horses for \$ 96 each. On one I gained 20% and on the other I lost 20%. What was my gain or loss? What was the per cent of gain or loss?

68. A man's house cost \$8000. He insured $\frac{3}{4}$ of its value at $\frac{2}{3}\%$. The house burned. What was his loss?

69. A man paid \$15 premium on a barn. The rate was $\frac{3}{5}\%$. When the barn burned, how much was his loss if the barn was insured for $\frac{1}{3}$ of its cost?

70. A, B, and C earn \$270. A earns twice as much as B, and C earns as much as the other two. What per cent of the whole does each one earn?

71. 80% of the cost of a house equals $\frac{2}{3}$ of the selling price. What is the gain per cent?

Arithmetic Blanks

Arithmetic blanks with graded examples are a most convenient, economical, and useful aid in class room work. They assist the teacher by furnishing a large number of carefully classified and graded examples which may be used for regular class drills and for examination tests. The examples, being without answers, furnish a uniform standard of comparison and a complete test of the pupil's progress. The best and cheapest arithmetic blanks are the following:

NATIONAL NUMBER TABLETS

Twelve numbers Per dozen 90 cents

This series comprises twelve tablets or numbers and supplies sufficient work to cover the whole course of written arithmetic. The tablets and lessons are carefully graded and so arranged that two tablets furnish enough supplementary work for a school year.

RAY'S TEST EXAMPLE TABLETS

Eight numbers Per dozen \$1.00

These tablets furnish in convenient form well selected and carefully graded test examples, each sheet having printed at the head from five to ten problems. The eight numbers cover a full course of arithmetical operations.

SILVER'S PRIMARY EXERCISES IN ARITHMETIC

Numbers 1 and 2 Each 10 cents

Numbers 3 and 4 Each 15 cents

A series of graded exercises in the fundamental rules of arithmetic for beginners; one page for each school day, printed in large, bold type, giving the pupil a large amount of practice. The answers to the examples are to be recorded by the pupil on the printed page. These blanks will be found a very useful supplement to any text-book in arithmetic.

Specimen copies of any of the above Arithmetic Blanks will be sent, prepaid, to any address on receipt of the price.

American Book Company

New York

Cincinnati

Chicago

Spelling and Word Study

RICE'S RATIONAL SPELLING BOOK. By Dr. J. M. RICE.

Part I. For use in the first three grades. Boards . . . 15 cents

The Same. Cloth 17 cents

Part II. For use in all grades above the third. Boards. 20 cents

The Same. Cloth 22 cents

This is a spelling book pure and simple, designed for use in all the grades or years of school work. It has been arranged on a definite psychological plan, based upon an examination of the schools of nearly all the large cities of the country and upon a careful study of the actual spelling of many thousand pupils.

PATTERSON'S AMERICAN WORD BOOK

Graded Lessons in Spelling, Defining, Punctuation, and Dictation.

By CALVIN PATTERSON, M.A. 25 cents

This new spelling book embodies a carefully developed and progressive plan for teaching the forms and values of English words in common use. It begins with words illustrating the primary sounds, the words being printed both in Roman letters and in vertical script. Then follow graded lessons on different classes and uses of words.

HARRINGTON'S SPELLING BOOK. Complete 20 cents

Part I.—separate. For Primary Grades 15 cents

Part II.—separate. For Higher Grades 15 cents

A complete course in spelling for graded and common schools.

McGUFFEY'S REVISED ECLECTIC SPELLING BOOK . . 17 cents

Conforming in orthography, pronunciation, syllabication, and diacritical marks to the Websterian standard.

NATURAL SPELLER AND WORD BOOK 20 cents

SWINTON'S WORD BOOK OF ENGLISH SPELLING . . 18 cents

Copies of any of the above books will be sent, prepaid, to any address on receipt of the price by the Publishers:

American Book Company

New York

Cincinnati

Chicago

Maxwell's English Course

By WILLIAM H. MAXWELL, M.A., Ph.D.
Superintendent of Schools, City of New York.

FIRST BOOK IN ENGLISH

For use in Elementary Grades 40 cents

INTRODUCTORY LESSONS IN ENGLISH GRAMMAR

For use in Intermediate and Grammar Grades 40 cents

(These two books constitute a complete graded course in English for Elementary and Grammar Grades.)

ADVANCED LESSONS IN ENGLISH GRAMMAR

For Higher Grammar Classes and High Schools 60 cents

The "First Book in English" combines lessons, practice, and instruction in the elementary principles in the English language, in such a rational and practical way as to make a text-book for beginners in language study, which avoids the platitudes of modern "language lessons" on one hand, and the difficulties of "technical" grammar on the other.

The "Introductory Lessons" presents as much of the science of grammar with its applications as children can understand and appreciate, before taking up an advanced course in English. The book contains in a compact form a well-graded and perspicuous treatment of all the subjects usually taught in English Grammar. It omits no essential principle or definition or example, and is sufficiently complete to meet all the requirements of the usual course of study of Intermediate or Grammar Schools.

The "Advanced Lessons in English Grammar" embraces all the *theory* and all the *practice* that are necessary during the last two years of a grammar-school or throughout a high school course. It is intended to serve two purposes: First, that of a *text-book*, supplying the principles and rules of the science as well as their application in copious exercises; Second, a *book of reference*, to be used whenever difficulties are presented either in the student's own compositions or in literature that is subjected to critical study.

Copies sent to any address, prepaid, on receipt of price.

American Book Company

New York

Cincinnati

Chicago



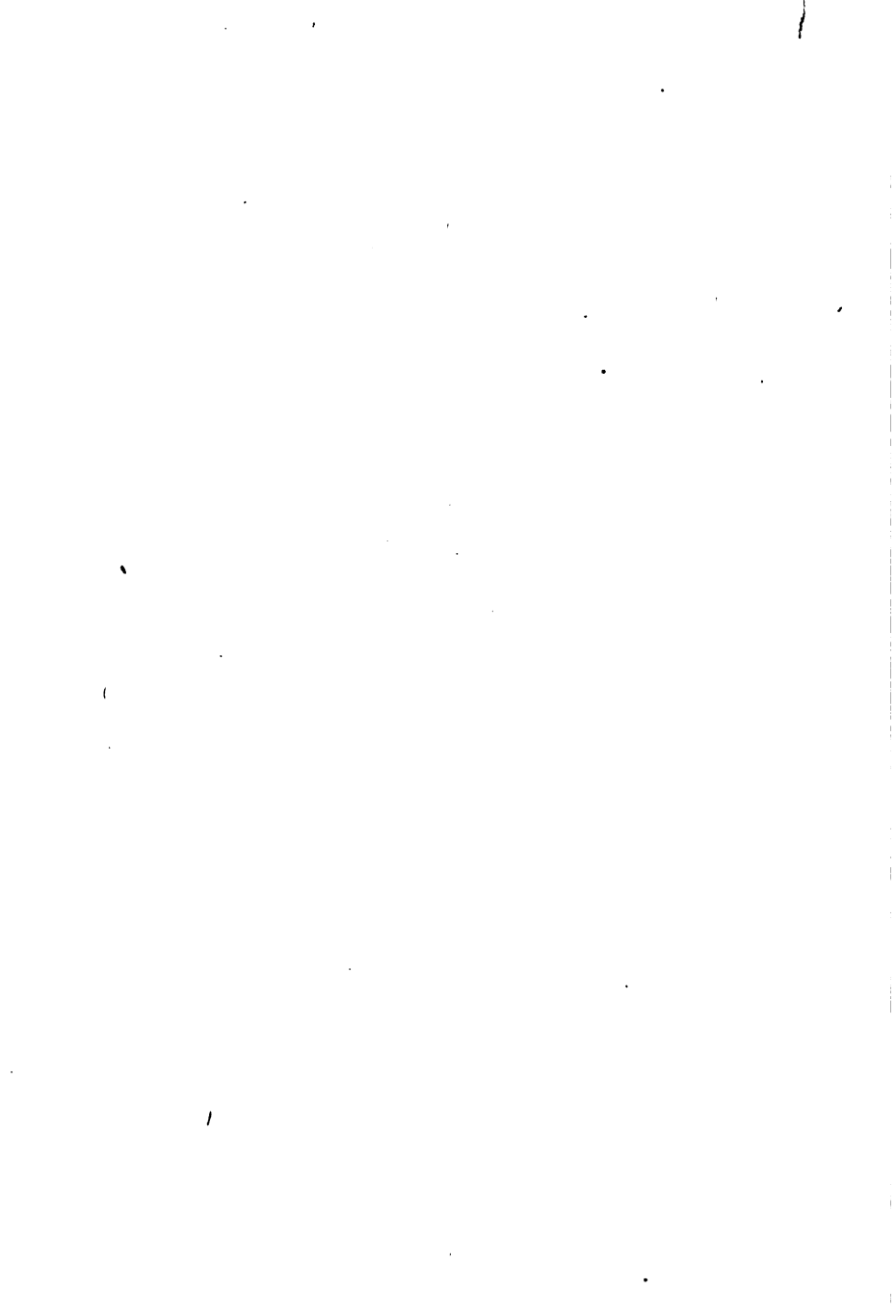

YB 35876

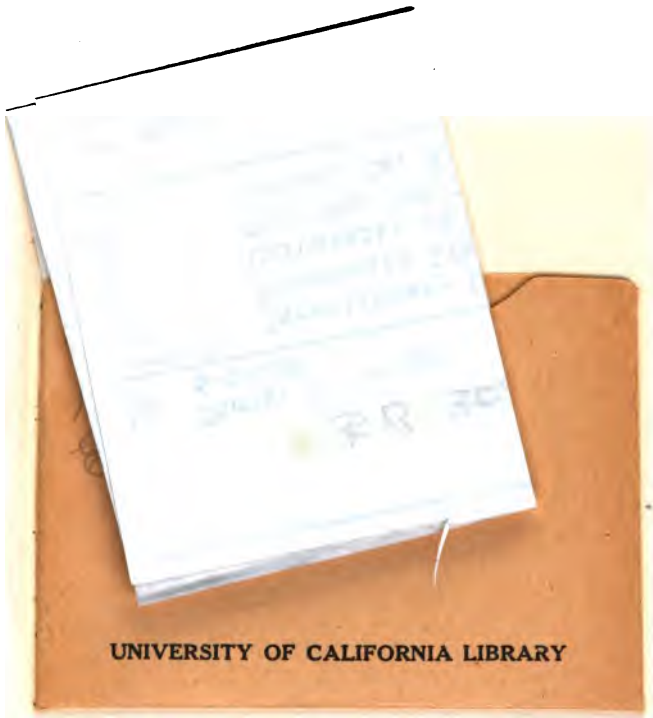

UNIVERSITY OF CALIFORNIA LIBRARY

